

**THE LARGEST RADIO CIRCULATION IN THE WORLD!**

# Popular Wireless

Every Thursday  
PRICE  
**3d.**

No. 531. Vol. XXI.

INCORPORATING "WIRELESS"

August 6th, 1932.

Lt.-Commdr. The Hon. J. M. Kenworthy, R.N.

contributes a striking article on

**BROADCASTING IN NORTH AMERICA**

FULL DETAILS FOR MAKING

**A SUPER-QUAD PORTABLE**

Read "W. L. S."—ON TOUR  
WITH A SHORT-WAVER

**HAS TELEVISION  
ARRIVED?**

(See page  
640)

### THE OLYMPIC GAMES

American amateurs are providing free radio communication with all corners of the world to the competitors at the Olympic Games. Short waves, of course—the main receiver, being the one shown.



**The World's Greatest Suppliers!**

**KITS!  
COMPONENTS!**

Eastnor House,  
Blackheath, S.E.3.  
Phone: Lee Green 5678.  
Showrooms - - - 159,  
Borough High St., S.E.1.

**READY RADIO**

**BRITISH  
MADE**

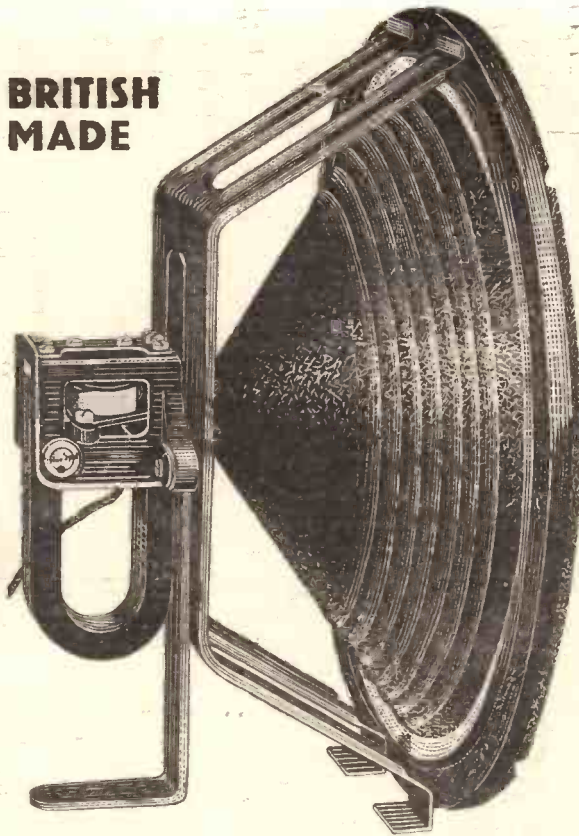

**MOVING  
COIL  
PERFORMANCE**  
*for the*  
**SMALL  
RECEIVER**

**BLUE SPOT**  
**100U · 39'6**  
*Gives Moving Coil Performance*

**BLUE SPOT PICK-UP**

You simply can't believe that music so beautiful can be had from gramophone records until you hear them played through a Blue Spot Pick-up.

*Price complete with self contained volume control - - -*



**63/-**

**I**F you are running a small set with a dry battery H.T. supply here is your chance to get Moving Coil performance with very little outlay and no structural alteration.

Blue Spot 100U is designed to work satisfactorily on very small inputs. In consequence it may be used with battery-operated receivers with every confidence as well as all mains sets.

Its performance is remarkable. It has all the sensitivity and richness of tone that distinguishes the *good* (and expensive) Moving Coil speaker. It gives the finest rendering of the difficult bass notes without detracting from the clear high notes of the treble.

For the man who wants a really good top notch speaker 100U provides good Moving Coil quality at economy price.

*Send for Catalogue. No. P.W. 44U.*



ALL BLUE SPOT PRODUCTS ARE NOW OBTAINABLE BY INSTALMENTS.

**THE BRITISH BLUE SPOT COMPANY LTD**

BLUE SPOT HOUSE · 94/96 ROSOMAN STREET · ROSEBERY AVENUE · LONDON · E C 1

Telephone: Clerkenwell 3570. Telegrams: "Bluospot, Isling, London."  
Distributors for Northern England, Scotland and Wales: H. C. RAWSON (Sheffield and London), Ltd., 100, London Road, Sheffield  
22, St. Mary's Parsonage, Manchester; 44-46, High Bridge, Newcastle; 37, 38, 39, Clyde Place, Glasgow.

# Popular Wireless

LARGEST NET SALES

Scientific Adviser:  
Sir OLIVER LODGE, F.R.S.  
Chief Radio Consultant:  
CAPT. P. P. ECKERSLEY, M.I.E.E.  
Editor: NORMAN EDWARDS.

Technical Editor: G. V. DOWDING, Associate I.E.E.

Assistant Technical Editors:  
K. D. ROGERS, P. R. BIRD,  
A. JOHNSON RANDALL.

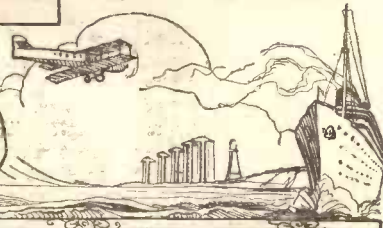

WALES AND THE B.B.C.  
THE "INKSTRAIN."  
CO-OPERATION INVITED  
A CURRENT MYTH

## RADIO NOTES & NEWS

THE SQUEALER  
ALL CHANGE  
HOW ARE YOUR NERVES?  
REMOTE CONTROL

Noted in Wales.

WELL, here we are again, all blistered and baked, but very fit, after our jaunt in Wales.

Now, here's a queer thing that I saw there. First, I noticed an aerial strung across a front garden. "No back yard," I thought. Then I saw a row of houses, each with its aerial in front. I took the trouble to go round behind, shin up a wall and survey the land. No obvious reason why the aerials should not have been behind the houses! In despair I fled to Anglesey—and found a similar state of affairs. Now—why?

The Welsh and the B.B.C.

I DID not realise fully until I talked with the cottagers in the remote parts of Snowdonia what a godsend radio is to people like them, far from neighbours, cinemas, concert-halls, theatres, etc. But there is now no doubt whatever in my mind that they believe that they have a genuine grievance because the B.B.C. does not give them, if not a national station, much more Welsh.

I found the question of the use of Welsh a rooted obsession amongst the people, and although they do not breathe fire and slaughter as the Irish would—for they are loyal Britons—they do feel that the B.B.C. treats them badly. Nothing is so convincing as observation "on the spot," and I should like to see the B.B.C. send an investigator to Wales.

What's an "Inkstrain"?

ARE you following the adventures of that "inkstrain" as related by John Scott-Taggart in "The Wireless Constructor"? If you are, you may pat yourself on the back; you have my express permission. If you are not—well, you have my sympathy.

Seriously, I do not think I have ever enjoyed anything quite so much as this "inkstrain" yarn. Its developments, as they meet the public eye in the September "Wireless Constructor," are almost too good to be true, but, as a matter of fact, I have had the opportunity of seeing the original correspondence.

I Feel Sad—

AND the reason is that S. G. Brown's are finished with radio. I mind the time when the whole world seemed to be dotted with Brown "A" type wireless headphones, and in the early days of broadcasting there weren't many other loud-speakers extant but Brown. Except, of course, Amplion, and they, too, have suspended radio operations.

There are occasions when mere words are

on Sundays he is to be heard on 80 and 150 metres as well between 9 a.m. and 10.30 p.m. He wants reports, and would also be pleased to co-operate with any other 3-letter amateur transmitter in his own locality.

A Current Myth.

NOTHING makes me hotter under the collar than to hear people talking about the radio industry as though it were so bulging with prosperity that anyone could make money out of it simply by standing in the market place with a barrow-load of pseudo sets.

It is quite true that radio has not been hit by the depression to the same extent as some industries, but I can assure you that the prosperous concerns have not achieved their satisfactory positions without ability, enterprise and hard work.

So I would ask you to charge your glasses and drink to the health of E. K. Cole, Ltd., whose trading records during the past four years are truly magnificent.

Between 1929 and 1932 their profits rose to the exhilarating tune of over one thousand per cent.

Their Due Reward.

A CONTINUED expansion of this nature in face of keen competition is wonderful testimony of the quality of the goods they manufacture, and of the calibre of the men behind this great company.

In his speech at the recent annual meeting Mr. Verrells, the chairman, stated that E. K. Cole, Ltd., provide employment for approximately 2,000 workers. He also had some interesting information regarding the radio industry in general to impart.

(Continued on next page.)

### PERMANENT WAVES AND HIGH "C's"



Here's a pretty problem for the engineers! How will they keep the mike dry when the tide comes in and splashes?

sorry vehicles for emotion; this, my masters, is one of them.

Co-operation Invited.

MR. COLE, of Wallington, operates the amateur transmitting station, 2 ACO, and he is at work on week-days at 8 p.m. in the 10- to 60-metre band, while

# NEWS—VIEWS—AND INTERVIEWS (Continued)

## The Future.

THE retail turnover value of radio in 1922, said Mr. Verrells, was practically nothing, but in 1931 it rose to about twenty-five million pounds, and is, therefore, competing very closely for first place in the electrical group of industries.

As only some three and a half million homes out of a total in Great Britain of approximately eleven millions are electrified, there is still a large undeveloped market for both battery and all-electric sets and power units. And I will wager E. K. Cole, Ltd. will tap no mean proportion of it themselves!

## A Set That Squeals.

A CHEERY chap from Ringwood, who calls himself "Jack" and who addresses me as "Dear Old Wireless Scribe," complains that he cannot lean



against his walls or sit on a chair without his wireless set screeching protests. It is a mains set, and apparently friend "Jack" has already caught a packet while experimenting with it.

He hates the squealing and wants to know if I can suggest the cause. Either a loose connection, or a gas-pipe underneath the flooring which comes into contact with the lead-covered lighting wire, I should imagine.

But mind you don't one day take a few more volts than you can stand, "Jack." It is bad practice to poke the innards of a mains set with your fingers while the juice is turned on.

## On the Other Hand—

MY recent remarks regarding C.O.D. abroad have brought me a letter from Messrs. Electradix Radio which puts the case for the trader very



clearly. They say "Reference to the G.P.O. guide will show that this system is not universal and weight limits of parcels are low."

Again, we have been stung several times on shipping goods East and South, overseas, by customers being unable or unwilling to pay on arrival. . . . Orders from tropical gentlemen with exotic names are henceforward regarded with suspicion unless accompanied by remittance."

So that is that.

## Sent to Coventry.

ONCE again I have been so fortunate as to be able to journey to Coventry in order to attend the great annual G.E.C. Convention. What a breath-taking, joyous day this event always provides.

The hospitality of the G.E.C. is lavish, there is no other word for it: and the enter-

tainment they provide for their visitors could not be bettered.

And it is all the work of the G.E.C. itself. The catering is done by their own canteen people, the music at lunch and during the excellent cabaret is produced by G.E.C. musicians, the cabaret artistes are employees of the G.E.C., etc.

And there is some hundred per cent more pep because of the enthusiasm these amateurs put into their shows.

## A Fine Show.

BUT the lunches, aeroplane flights, cabarets and other such jovialities which the G.E.C. handed out were but the trimmings of the convention. There was also serious work done.

Some two hundred wholesalers were told all about the fair trading methods of the Co., and were shown the fine range of radio receivers and loudspeakers which the G.E.C. will be marketing this coming radio season.

## "SHORT WAVES"

Philips: "Very argumentative, isn't he?"  
Brown: "Rather! He even answers back to the wireless announcers." "Answers."

"A wireless set for the car," says a headline.

We understand that this offers the motorist every facility for picking up a pedestrian.  
"Everybody's Weekly."

## "RESISTANCE" EXPLAINED.

There are two kinds of resistance—passive, negative and leased. The latter is a line leading to a thing the easiest way.

"ALL ABOUT RADIO PARTS should go with every radio; it takes you through every radio part," we read in an American advertisement.

It will take a good deal of dieting if we are to become slim enough to get between the tuning-condenser vanes; but when it comes to the filter chokes, we give in completely.

## THE RADIO MAN'S LOVE SONG.

Within my heart, throughout the past,  
Science predominated;  
And through magnetic fields it passed,  
Completely insulated.

Those bodies, charged and dangerous,  
That struggle to entwine us;  
Passed near me, registering plus,  
But I was always minus.

And when I came within your field,  
'Twas surely providential;  
For suddenly I felt, revealed,  
The force of your potential!

Your power is ruthlessly applied,  
Ever I thrill and quiver;  
More positively electrified—  
But you are negativer!

## Purely Personal.

HERE is another small paragraph dedicated to readers who have sent me invitations during the past two or three weeks. I thank you one and all.

C. S. P., of Shortlands, is particularly pressing, and the plans for my reception which he has outlined make my mouth water. C. S. P., old chap, you head my list for the Kent area.

## All Change.

WHAT a hullabaloo there is over this mains-changing business. Need there be? As far as I can see, the matter is perfectly straightforward. It

isn't fair to the Supply Company to install major electrical apparatus (and a mains set is that) without notifying them of the fact. But when they have approved the installation, then, surely, they tacitly accept the responsibility of supplying suitable power for it. Then, if they change the type of power, it seems to me that they ought to change the apparatus.

## How Are Your Nerves?

THERE has been renewed discussion as to the possibility of radio waves "tending to produce a generation of irritable men and women." The waves themselves are the subjects of suspicion, not what they carry—that is another story!

G. M. T. (of Sydenham) considers the question may be open, but, says he, "In order to account for the increase of irritability and nervous complaints, need we look further than such factors as noise, the strain and stress of modern life, and, in particular, the Summer Time Act, with its meddlesome interference in our regular habits and normal hours of sleep?"

Well, I dunno; I don't feel irritable and nervous. No doubt like to many of my readers, it quite often happens that a great and bovine complacency descends upon me when I stretch my limbs on the green turf, puff at a wholly satisfying pipe, and see nowt but rose tints.



## The Romance of a Gift.

A REAL romance of industry lies behind the recent generous gift of £25,000 to the Birmingham General Hospital.

The donor—Mr. A. W. Macnamara, founder and managing director of the Telsen Electric Co., Ltd.—was kindly and efficiently treated there, as a poor boy, and he vowed that he would repay the hospital one day for its timely aid. He has kept his word—magnificently.

## Remote Control.

DON'T believe this if you feel in a sceptical mood, but your Uncle Ariel gives his word it is true. A suburbanite installed a loudspeaker in his garden.

So that he could switch the set on and off without going into the house he ran a length of string and arranged a rough-and-ready pulley affair terminating at his garden chair.

An irate neighbour, annoyed by the open-air concert, leant over the fence and applied a match to this string. The flame trickled right up the string and fired the curtains at the window!

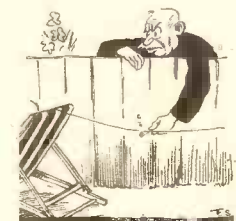

ARIEL.

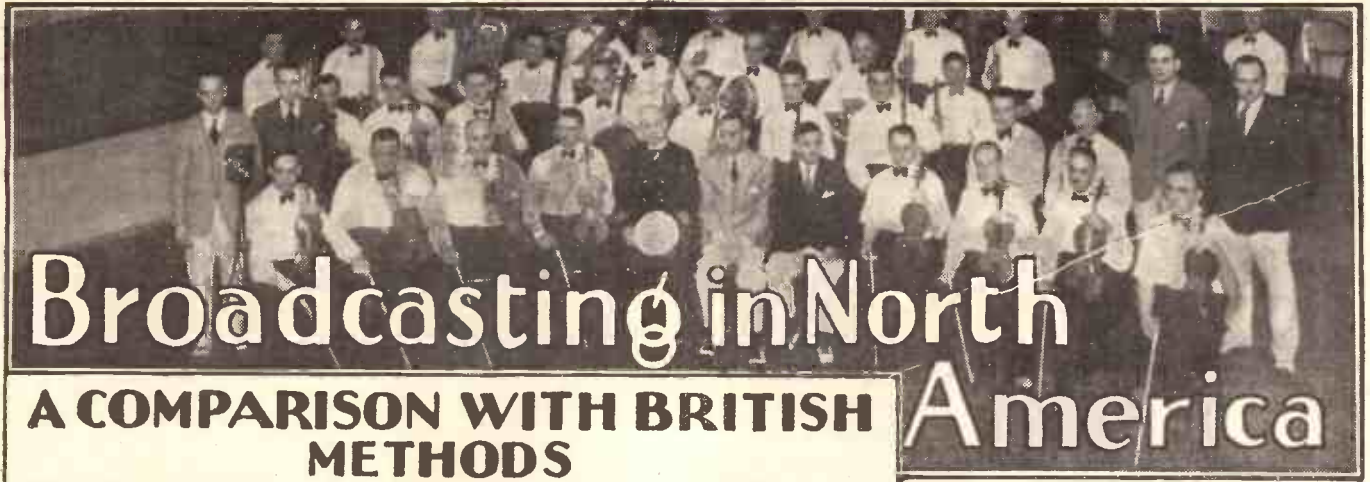

# Broadcasting in North America

## A COMPARISON WITH BRITISH METHODS

BY LT. COMMANDER THE HON. J. M. KENWORTHY R.N.

THE best comparison between British and American systems of broadcasting is to say that in England radio is used as a means of entertainment and education, and occasionally for political propaganda, while in the United States of America it is a vast advertising business organised for commercial profit and practically free of any Government control.

### The Federal Radio Commission.

True, there is now a Federal Radio Commission. It consists of five commissioners appointed by the President. They are politicians, three being members of the party in office (at present the Republicans) and two from the "outs" (now the Democrats). And one is appointed from each geographical zone of the country.

Their functions are not to control radio broadcasting, like the Governors of the B.B.C., or to see the public gets what it wants, but to ensure that each zone gets its share of the programmes and therefore of the stations. And this, again, is primarily in order that *business* interests in each zone may have facilities for advertising their wares.

The sort of programmes put on the air and the treatment the American public receives, or must put up with, is left to the combined efforts of the broadcasting stations and their clients—the super-salesmen. The idea is that the organisers of the programmes and the owners of the stations will take care to give the public what most of the listeners want to hear.

### Reputation Counts.

A station must build up a reputation for giving good programmes or the public will not tune in to it; business men will become aware of this, and the advertising fees will go down. It is just as a newspaper can charge for advertising space according to its circulation and influence.

The Federal Commissioners try to ensure the more sparsely populated and poorer areas getting their fair share of radio services, otherwise both salesmen and radio station owners would concentrate on the

three wealthiest sections—the New England States, the Chicago area, and San Francisco—and the rest of the country would "go hang." In practice there is a fairly efficient chain all over the United States with an overlap into Mexico in the south and Canada in the north.

No licence fees are charged. The revenue to the various companies comes from "selling the air." The total comes to 75 million dollars, or £17,000,000 (at par) a year. And the industry remains prosperous despite the general slump in most other businesses.

The "Big Two" are National and

**BRITAIN**—a medium of entertainment: **AMERICA**—a vast advertising business.

That is the distinction between broadcasting methods in the two countries; and there is something to be said for the American idea, too, as you will agree after reading our well-known contributor's interesting account of programmes in the States.

Columbia. National, with a revenue of £6,000,000 a year (at par), relies on its size and nation-wide organisation and its power to reach the greatest number of listeners.

National might be described as conservative and cautious. Columbia, with a revenue of £2,500,000, is lively, progressive, and relies on its reputation for novelties and springing surprises.

### A Live Concern.

For example, if Columbia could get Mussolini or Gandhi or the men who kidnapped Lindbergh's baby to broadcast, they would jump at the chance. If Gandhi, in prison in India, were allowed to speak "on the air," Columbia would fix up the relays and the submarine cables and do the trick in twenty-four hours, with a Continent-wide hook-up.

In addition, there are the independent stations, most of them established before there was any form of control. They buy talent from the "Big Two," and get what they can locally in addition. They "sell the air," too, to business firms, but only serve their own areas.

### Over Six Hundred Stations!

1927 saw the peak in the number of stations. The weaker ones then fell out or were suppressed as redundant by the Federal Commissioners. The number in 1931 was 604, and will probably stay at that figure.

And this for a country ten times the area of the British Isles and with three times the population.

(Continued on next page.)

### TALL STOREYS FROM NEW YORK

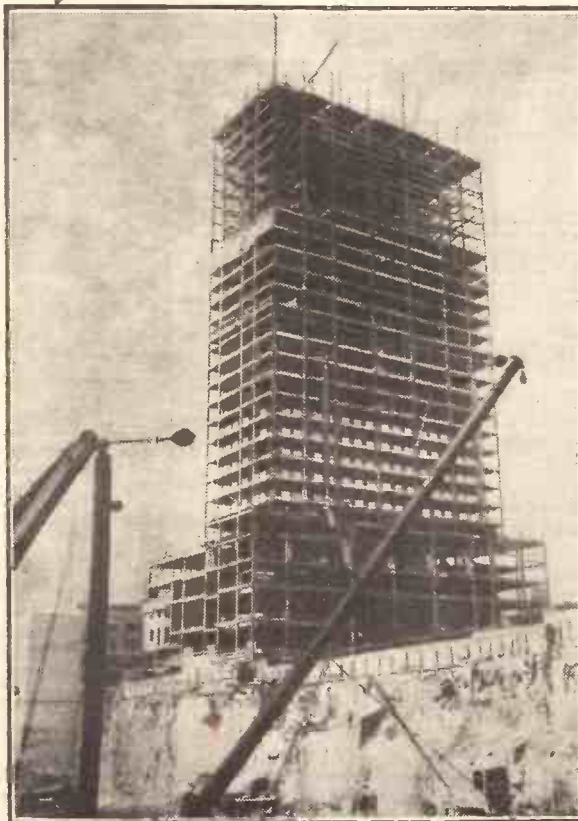

The steel framework of the fifty million pound entertainment house which will tower above the roofs of New York. Built primarily to house the radio and television interests, this vast "city" will include an hotel, theatre, cinemas, and offices, and will be entirely self-contained.

## BROADCASTING IN NORTH AMERICA

(Continued from previous page.)

In most of the north and east the ordinary listener, with a valve set, can get at least fifteen stations.

The revenue is derived from three sources. I am writing now of the "Big Two," for the others scarcely count. The independent stations are really dependent on National and Columbia, and could not live without them:

1. The air is sold direct to advertisers,

### HOT DOGS OF THE ETHER



The "Crosley Pups," celebrated American comedians, as they appear when doing their "Night Hounds" act from the Cincinnati studios.

who "put on" programmes in consultation with the broadcasting companies.

2. The companies engage artistes, entertainers, and announcers for their clients, and charge a commission on the fees paid.

3. Part of the programmes of the "Big Two" are sold to independent stations.

In addition to the "paid-for" programmes by those with goods to sell, the "Big Two" and the larger independent stations broadcast "continuation programmes." These consist of "straight" entertainment, talks, music, etc., and are broadcast between the advertising talks. The object is to attract listeners.

Here the companies spare no expense to obtain the best talent available. The large companies act as impresarios to promising singers, musicians, and orchestras, making them known to the public and, later, arranging contracts between their protégées and "big business."

#### A Really Fine Feature.

This is the best feature of American radio. The continuation programmes provide really excellent music and talks for the public, and have made the careers of many young singers and musicians. Also, artistes of international reputation are engaged and paid very high fees.

The programmes start at 7 o'clock in the

morning, to "catch" the early workers and the children getting ready for school. And they continue all day until 2 or 3 a.m. After midnight no advertiser will "pay for air" so the most famous of the dance bands in New York and Chicago are "put on the air," just as the Savoy Dance Band has been broadcast from the Savoy Hotel for so many years.

#### Nineteen Hours a Day.

The baseball and football matches, big boxing contests, race meetings, and winter sports are broadcast with descriptive speaking by the companies as part of the continuation programmes, free gratis to the public.

National and Columbia together broadcast for thirty-eight hours a day over two

chains, i.e. nineteen hours simultaneously. National employs 900 office staff and 1,600 in all, including outside "field" operators, announcers, electricians, etc. It owns a large fifteen-floor building in the heart of New York with twelve studios, and is cramped for space!

It will move to the new Radio City now

tables of the States of Illinois, New York and San Francisco.

The "fan letters" number 6,000 a day to National, New York, alone. They are classified and a digest made for each client of the comments made on his programme. The client, perhaps the President of a large firm owning multiple shops, also gets his fan mail direct. If he is wise, he will forward them to the Broadcasting Company for treatment.

Every week and every month a complete summary of this enormous mail is made for the directors. It is claimed they can keep their fingers on the public pulse by this means. And this helps them to put their client's fingers into the public purse.

#### The "Big Four."

Who are the biggest advertisers? National draws its heaviest revenue from four firms—General Motors, the American Tobacco Company, the makers of Pepsodent Tooth Paste, and a chain of Grocery Stores who advertise their tea, coffee and other specialities. Each of these spends one to one and a half million dollars a year.

The American Tobacco Company pays a Mr. Walter Winchel £700 a week for three hours' work announcing and describing a "magic carpet" programme. They switch the programme from city to city, describing a boxing match in Los Angeles, the Opera in Chicago, a fashionable wedding in New York, a race meeting in Kentucky, etc.

### A MAYOR AT THE MIKE



Mayor "Jimmy" Walker of New York increases his popularity by giving a running commentary on the final of the hockey tournament between Canada and the U.S.

being built in a group of skyscrapers in New York, and which will eventually house the main Opera House of the city. There are two similar set-ups—studios, air-salesmen, correspondents for the "fans" who write—as big as Broadcasting House, in Chicago and San Francisco. For each of these three areas must have its own programmes.

For "the coast," as the West of America is called, is only mildly interested in the doings of New York; and Chicago is only distantly interested in either. Each of these areas must be catered for separately. The vast regions of the South and Middle West take the crumbs that fall from the

Mr. Winchel, himself, never leaves New York, but broadcasts from there. The three hourly programmes cost £15,000 a week. The highest-paid announcer is an Italian-American, Tony Wons, with a very soothing voice and known as a crooner. He only made me laugh; but the matrons of America are in love with his voice.

He draws £1,500 a week.

How objectionable is the advertising? The ordinary run of citizens are either used to it, or do not object. The "highbrows" hate it, of course.

The best firms put little "straight" advertising into their talks, simply announcing

(Continued on page 650.)

# CAPT. ECKERSLEY'S QUERY CORNER

Under the above title, week by week, our Chief Radio Consultant comments upon radio queries submitted by "P.W." readers.

## MODIFICATION FOR MAINS—LONG WAVE INSTABILITY—TELEGRAPHY MODULATION—COUPLING OF AERIALS.

### Converting a Set for A.C. Operation.

R. K. O. (Acton).—"I am using a battery-type three-valve receiver of the kind with two transformer-coupled L.F. stages, and have recently obtained an A.C. mains unit supplying H.T. and 4 volts A.C. Naturally it occurred to me that it might be possible to modify my receiver to use A.C. valves, so dispensing with accumulators, but a friend advised me that the result would be severe motor-boating and L.F. instability.

"Is there any reason why the power valve only should not be of the A.C. type, the first two stages using battery valves, and do you think that this arrangement would be satisfactory?"

Your friend suggests, in effect, that battery-type valves are more stable than A.C.-heated valves. This may be true—A.C.-heated valves, type for type, may have a higher magnification.

But this is not to say, surely, that it is not possible to get A.C. valves of the same magnification as the ones you employ at present. Furthermore, motor-boating, while it may, with bad design, be more likely to occur with high-mag. valves, is not ineradicable.

One can build amplifiers with voltage mags. of hundreds of thousands and make them stable, but one requires to take care to shield, to decouple and to design rather than to guess.

### Impedance of an H.F. Choke.

J. C. (Hounslow).—"I recently cured a form of instability experienced only on long waves by connecting a grid leak in series with the lead to the grid of the L.F. valve. Later I happened to change the H.F. choke in the anode circuit of the detector valve for another believed to be of a more efficient type and found that with the new choke the grid leak was not required in the L.F. stage.

"I cannot quite see why the more efficient H.F. choke enabled the grid resistance to be dispensed with, as the resistance of the grid leak was 250,000 ohms and surely the additional impedance offered by the new H.F. choke cannot have approached this figure?"

My explanation is that, in case 1, the old H.F. choke, did not act as a sufficient stopper of H.F. (Note: it would be a less impedance to a lower frequency, i.e. longer wave) and the H.F. got on to the L.F. valve, was magnified, reacted, and set up instabilities.

Now the connection of the resistance

between source of H.F. (det. anode) and grid of L.F., while still allowing the H.F. to flow into the grid-filament capacity of the L.F. valve, so dropped the H.F. voltage as to render the H.F. across grid and filament of the L.F. valve innocuous.

But a new H.F. choke removed the trouble at its source and the resistance stopper was no longer necessary.

I do not think the quantities you give are so directly related as you might anticipate and are perfectly relevant to my explanation, assuming a reasonable grid-filament capacity.

\* \* \*

### Keying a Transmitter.

M. J. (Ongar).—"How is telegraphy sent by a wireless transmitter—does the operator use the Morse key to keep starting and stopping the apparatus, or is a carrier 'modulated' by dots and dashes instead of speech and music?"

Yes, the carrier is modulated if you like, but it's 100 per cent modulated—stopped and started, that is.

## A LITTLE VALVE LEADS THE WAY

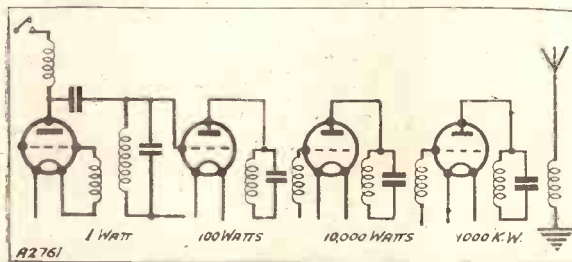

With the help of this diagram you will see how a low-powered oscillator can be made to control a powerful C.W. transmitter, as explained by Capt. Eckersley in his reply to M. J. (Ongar).

Just to illustrate this principle, you can see that in my diagram it's quite easy to arrange a key to stop and start the oscillations in a 1-watt circuit. But the 1-watt circuit drives a 100-watt, which drives a 10,000-watt, which drives a 1,000-kw. circuit, and so stopping and starting the 1 watt, simultaneously stops and starts the 1,000 kilowatts.

This is a principle, and both my diagram and my figures are merely to illustrate that principle, not to be accurate in quality or quantity.

Before the days of valves, and before we knew how to "drive" from one circuit to another, we had to make big power relays



Don't address your letters direct to Capt. Eckersley; a selection of those received by the Query Department in the ordinary way will be answered by him.

driven from hand keys through other relays to make and break huge powers. It was very noisy and very nasty!

\* \* \*

### Forcing Oscillation.

R. L. M. (Weybridge).—"I am using a very ordinary type of receiver—that is, a reacting detector and one L.F. stage. The aerial is connected to the grid end of the tuning coil via a variable condenser of 001-mfd. maximum capacity.

"When this condenser is adjusted to its maximum capacity it is not possible to obtain reaction effects, but if the value is reduced by adjustment the receiver oscillates quite well. I have only noticed this trouble since I have been using a fairly long outdoor aerial, and previously with a very short aerial reaction could be obtained irrespective of the setting of the aerial-series condenser.

"I should be pleased if you could offer a suggestion or explanation of this effect."

The effect of the size of the aerial-series condenser is to couple the aerial more

or less strongly to the tuned circuit.

A loosely-coupled aerial (when the condenser is small) has little effect on the tuned circuit, whereas a tightly-coupled aerial is very much part of the tuned circuit.

The aerial has a high effective resistance, getting higher as the aerial is bigger. A high resistance prevents the valve from being able to supply enough retroaction to overcome it, and so a tight-coupled aerial won't oscillate, and so a big series condenser prevents oscillation.

But if you can tighten, the retroaction somehow you will be able to force oscillation, even with a big aerial series condenser. (Wasn't there some phrase such as "don't do it—please don't do it"?)



**AN UNPLEASANT TIME IN MESOPOTAMIA—ATTACKED BY A SUBMARINE  
—STREWING THE OCEAN WITH DEPTH-CHARGES—SAFE AT LAST.**

In the Red Sea.

AUG. 6TH, 1918.—We are all greatly enjoying ourselves. The first heat symptoms are noticeable and all our spare time is occupied in listening to "Stiffy's" opinion of "Brave lads who volunteer for foreign service." It is really remarkable how a little personal discomfort will reveal unsuspected depths in a man's vocabulary.

"Stiffy" surpassed all expectations. For five minutes he held an audience of half-a-dozen spellbound with wonder, admiration and awe.

Poor "Stiffy"! He is inclined to stoutness, and he presents a comical sight when clad in a pair of drawers and a shirt. When he had finished his oration, which included his opinion of: (1) A sailor's life; (2) foreign service; (3) the Red Sea; (4) this ship and her officers, he lapsed into gloomy silence, whereupon the Chief Officer gravely congratulated him and remarked with suppressed emotion that "England was indeed lucky to have him as a member of the British Army."

"Stiffy" feebly cursed him and mopped his brow, and when he asked me what I was laughing at I told him I was wondering how he would care for that iced coffee he wasted on the fishes at— He leapt to his feet in a fury and chased me half a dozen times round the deck. However, I got to my cabin, bolted the door and, in due course, "Stiffy" simmered down and cooled off.

We Arrive at Basra.

AUG. 8TH.—This is our third visit to Basra, and I am about sick of the place. Yesterday V— and I went for a long walk to visit "Stiffy," who is now ashore at an A.S.C. camp some five miles inland, up the Julabea road.

When we started out it was still daylight, but when we left to come back to the ship—but I anticipate. We reached "Stiffy's" camp in a state of semi-liquefaction and, after dining with him, we started to walk back in the cool of the evening.

The sun had set and the sky was as black as pitch. As we got on to the road the first thing we encountered was a native sentry with a fixed bayonet. This he pointed at V—'s stomach and gabbled out: "Halt! Who goes there?" V— let out a loud "Accha!" and we got by in safety.

But we weren't too happy on this walk back, for the particular road we had to traverse was a favourite hunting ground for

Arab robbers, and we had heard that only a few days before a Tommy had had his throat cut on this very self-same road. Hence our uneasiness.

"There is one thing," said V— reflectively, swinging his stick. "We both have long legs if it comes to running."

Good-bye to "Mespot."

Eventually we got back to the ship safely, but I must say that on several occasions last night I woke up in a sweat, thinking about that long and lonely walk along the Julabea Road.

There's not much more to say about our third visit to Mesopotamia. Nothing at all exciting happened on this trip, and we were not very sorry when we had orders to sail for Karachi.

AUG. 18TH.—About Karachi I'll say little or nothing beyond that it is a port in India,

**AFTER A TUSSELE WITH A "TIN-FISH"**



While on a voyage from the States to this country, an American oil tanker had the misfortune to be torpedoed by an enemy submarine. By a mere chance her dangerous cargo did not catch fire and, due to the heroic efforts of the crew, the ship was successfully beached on the Scilly Isles, off the coast of Cornwall.

chiefly remarkable for its exceeding dullness and lack of local colour. When we left for Port Said again we shed tears of joy.

DOVER ROADS.—SEPT. 16TH.—Since leaving Bizerta again we have been Commodore Ship in the convoy—that is, the ship on which the Commodore of the convoy selects to take up his quarters. In consequence, we have an R.N.R. Captain aboard, as well as three extra flag signallers and three gunners.

All went well until 6 p.m. yesterday. We were just off Dungeness when—bang!—and a poor old six-knot transport at the tail end of the convoy got the bird and at once settled down with a heavy list. Things were quite lively after that. The Commodore, a man of some seventeen stone, deliberately risked apoplexy in his wrath and ordered the "O" flag to be hoisted. "O" means "Keep your stations."

Our destroyer escorts practically turned in their own lengths and went racing like greyhounds towards the sinking ship. For sheer speed I have never seen anything like it.

Deadly Depth-Charges.

Arriving at the torpedoed one they started to swing round in ever widening circles, and then we got the most amazing shock of the whole business. At intervals of about a minute there came five deafening explosions which literally shook the ship like a dice box and sent the echoes rolling.

The destroyers were dropping depth charges. These depth charges are specially constructed bombs containing T.N.T., and when they sink to a certain depth they automatically explode and blow everything within a radius of 100 yards to Kingdom Come.

By the time the first one went off we were at least a quarter of a mile away, and yet the sound and shock of it was far greater than that of the torpedo. It absolutely amazed me; so close did the sound seem that I thought we had got it in the engine room, and so did the engineers for that matter.

Another boat near us was apparently more certain than we, for with frantic haste she ran up a flag signal meaning: "Help! I have been mined or torpedoed!" The C.O. was in no mood for these little mistakes and, according to the signaller, he replied in this way: "Don't be a fool. That was a depth charge." Thereafter the "mined or torpedoed" one was bashfully silent.

Saving the Crew.

Five times these tremendous roars shook the ship, and five times tons and tons of water were heaved into the air. If that submarine was anywhere near—well, God help it!

Two trawlers took the crew off the torpedoed boat and ten minutes later she went down with a flourish. It's interesting to watch a ship sink. For some minutes there was no perceptible sign of the boat dipping beneath the water, but suddenly she was up almost on one end and, with a quick swirl, went down in a cloud of steam as her boilers blew up.

At 8 p.m. we reached Dover and anchored for the night. The Commander, relieved of the strain and responsibility, was his old self again, and seemed to think we had got off lightly. Anyway, it was an exciting finish to a dull voyage.

(To be continued.)



# On Tour with a Short-Waver

by  
W.L.S.

**L**AST week I recounted my experiences in the high and low places with my single-valver, over a period of three days or so, in the wilds of North Wales. The next item of interest should have been a trip up Snowdon, but, as luck would have it, the weather broke down on the day selected, and the top of Snowdon was not visible once during the day. Accordingly the railway did not run!

## Out of the Sunshine.

"Hiking" out of the fine weather up a steep path, with the certainty that one will get wet at the top, is all very well when one travels light, but it did not appeal to me after regarding the L.T. and H.T. supplies for a while. So the "Snowdon" episode has had to be postponed until next visit.

During that day the set was tried out at a variety of places from Bettws-y-coed up to the Great Orme, along to Bangor and back down the Nant Ffrancon pass, with no startling results except confirmation of the fact that signals from a particular direction seemed to be no better when that direction was clear than when a dripping-wet mountain was in the way!

The one fact that did stand out a mile was that reception was *always* good near a lake. So estimates for the construction of an artificial lake in the garden at home are now under way!

The next, and last, day was so wet that flooded roads made further touring impracticable. The hotel lounge was, therefore, made use of, with a special "multi-directional aerial" that performed an obstacle race round hanging flower-pots, gas-brackets, stuffed birds and pictures of Snowdon.

## A Peculiar Freak.

Here, although the location looked quite good, reception was fairly poor. During the late morning and afternoon the usual transatlantic phones and ship-to-shore telephony were heard quite well, but distant amateur signals, so good on the previous day, were very weak indeed.

A peculiar freak was the way in which comparatively local signals came in on the

Some people get the short-wave wireless fever so badly that they can't sleep without a set beside the bed—and of all such dyed-in-the-wool enthusiasts our contributor is surely the keenest! His idea of a holiday is to take a set away with him, and his adventures with "Bonzo," the car, and "Buzz" the short-wave one make delightful reading.

20-metre band. One of the loudest heard all day was G 6 Y L, Miss Barbara Dunn's station at Felton, Northumberland. According to pre-conceived ideas G 6 Y L was

detector valve and spread over several degrees even when the set was oscillating. We still have not found out who he was, owing to an interminable musical programme without announcements of any sort.

## Sad Lapse of Radio Fans.

Conditions were so thoroughly bad that I am afraid I shall have to own up to a sad lapse. The two of us forgot all about radio and braved the deluge, talking exclusively about (a) mountains and climbing; (b) streams that weren't there the previous day; and (c) getting wet. After our return the sudden arrival of the last 'bus cut short our radio conversation once more; but I did gather that F. N. B. means business when our short-wave competition comes off.

The return journey next day was uneventful except for the outrageous time in which it was completed; and on the same evening "Buzz" was rigged up on the bench in his accustomed place once more. As was expected, conditions had changed again, and signals were coming over well from all the American broadcast people, as well as from South American amateurs.

## Nothing Really Bad.

For that reason I still do not know whether North Wales enjoys a different set, or "different phase" of conditions from London. The one thing that was found out was that, as I expected, not a single location that was really bad could be found anywhere.

As a sequel to this trip, I am building a duplicate of "Buzz," which I am going to leave at home in the hands of my "junior operator," while I take the original out into the Surrey hills for an afternoon.

We are each going to keep to a schedule, listening, say, between 20 and 25 metres from 3 till 3.30 p.m.; from 25 to 30 metres from 3.30 till 4 p.m., and so on. Everything heard will be logged, and the logs carefully compared.

You may be sure, therefore, that you will hear more about this "location" business before long.

## SET IN A MOUNTAINOUS SETTING

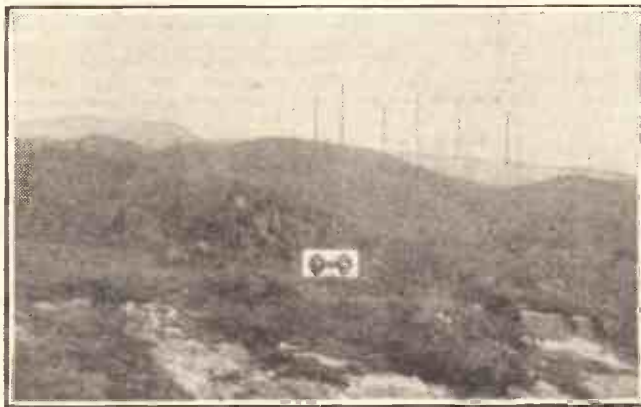

Close inspection of the white patch shows that it is "Buzz" propped into place on a heap of stones, with the wild scenery of Wales around it and the masts of Carnarvon in the background.

well within the skip distance, but her signals were a steady R7. Probably conditions were thoroughly freakish on that last day.

In the evening I had an appointment to meet F. N. B.—the gentleman from Hale, Cheshire, who won our last competition—in the flesh. And surely enough, at the appointed time, a very wet figure appeared through the deluge.

F. N. B. celebrated the occasion by tuning in several mysterious signals on "Buzz," including a telephony man just below 20 metres who completely "blocked" the

THE MIRROR OF THE B.B.C.

By O. H. M.

## THE B.B.C. STAFF AND JURY SERVICES

BAIRD SYSTEM TO REMAIN—POLITICAL BROADCASTING—  
MORE LICENCE MONEY FOR TREASURY—CANADA.

### Dr. Boulton as Juryman.

THE insistence of the authorities on Dr. Boulton carrying out jury service cost a lot of trouble, dislocation, and money to the B.B.C., and, indirectly, to the public. The performance of an important new work had to be postponed; rehearsals were disorganised, and there was much confusion and bother.

The ease with which some other less important members of the staff of the B.B.C. seem to get relieved from jury-work suggests that Dr. Boulton's case was mis-handled.

### Television.

The competition between Mr. J. L. Baird and his old colleague, Captain Hutchinson, has not materialised. As I reported exclusively a few weeks ago, Captain Hutchinson was understood to be developing a new competitive form of television which the B.B.C. might prefer to the Baird method.

I am now authoritatively informed at Broadcasting House that they have not yet tested Captain Hutchinson's system, and that there is no intention to displace the Baird system.

Meanwhile, the B.B.C. is going on with its two years' schedule of constructive experiments with the Baird system, taking over both the technical and programme work from the Baird Company which henceforth becomes like any other wireless manufacturing or development concern.

### Political Broadcasting.

The autumn is likely to see a determined attempt on the part of the B.B.C. to break away from the tyranny of the rule that there is no party political broadcasting without the concurrence of the Whips. Mr. Siepmann, the Director of Talks, and Mr. Whitley, the Chairman of the B.B.C., and former Speaker of the House of Commons, are giving this problem their joint personal attention.

What I hear they want to do is to arrange a series of six or eight political discussions, uncensored. The idea is to bring together the brightest talkers of the chief schools of political thought, whether they are prominent in their organisation or not.

I profoundly hope the B.B.C. goes on with this, because it is clear that as long as the agreement of Whips is necessary, there can be no worth-while political broadcasting.

### More Money for the Treasury.

Recently there have been several important secret conferences between the B.B.C. chiefs and the Treasury and Post Office people. Sir John Reith and Mr. Whitley have been the B.B.C. negotiators.

No announcement has been made of the result, but I am told on good authority that an agreement has been reached as to the extent of a further contribution to be made to public funds out of the already attenuated licence revenue. Presumably this was the only alternative to a more drastic exaction.

Probably the figure will be of the order of an additional £100,000 or £150,000. If it is no more than the latter figure, then it could be argued that a good bargain had been struck, because the leaders of the economy movement in the House want the whole half-million extra which the May Committee would have taken from the B.B.C.

## ROYAL HONOUR FOR BROADCASTING



When the King and Queen paid a private visit to Broadcasting House recently, they were received with much ceremony by the high officials of the B.B.C.

Canadian Broadcasting.  
The organisation of Canada's new broadcasting service on the model of the B.B.C. will begin next month.  
One of the Commissioners has been appointed in the person of Col. Steele, formerly with the Civil Service at Ottawa on the political side of wireless. Another is to be a French-Canadian. The third will be the Chairman, and as he must be a Canadian versed in broadcasting, the Government of Canada have their eye on Major Gladstone Murray of the B.B.C., which body is reported to be ready to lend him for an agreed period.

It would be interesting if Canada's broadcasting were put together by a B.B.C. official lent for the purpose: the precedent might be useful elsewhere in the Empire.

## THE LISTENER'S NOTEBOOK

A rapid review of some recent radio programmes.

IT is cheering to hear that the present bevy of broadcast speakers hasn't a monopoly of the microphone, and that the Director of Talks has a fresh batch in the offing.

Harold Nicolson, in a talk of his some time ago, expressed the speaker's point of view why a temporary retirement from the mike is advisable. There is another point of view, too—the listener's. This isn't, perhaps, as elegant an one as Mr. Nicolson's, but it is as fundamental.

We do grow tired of the same voice week after week. The best stage play can never hope to run for ever, and it is usually the public who decides when it should be taken off. The broadcast speaker's position shouldn't be very dissimilar, and certainly oughtn't to be any less precarious.

I'm afraid the 9.20 Encounters don't impress me. 'Tis true the debates aren't given much time in which to develop a first-class argument, but I think it is ludi-

crous the way they alternately challenge each other with a poser without attempting to give a decent answer in return.

### Nothing Very Original.

It's all too scrappy for my liking—there's far too much of the "My dear Smith" about it, too. The Sunday Observation question is much too hackneyed an affair to sustain one's interest now, particularly as the speakers can't have anything very original to say.

"The Round Table" soon made one forget the irritation caused by the late start. From the moment of Mary O'Farrell's first entry till the fall of the curtain one felt the fascinating charm of her Irish brogue. It dominated the whole, even triumphing over the volubility of her mother, played by Ethel Lodge—and that is saying a good deal.

(Continued on page 653.)

## ON THE OTHER SIDE

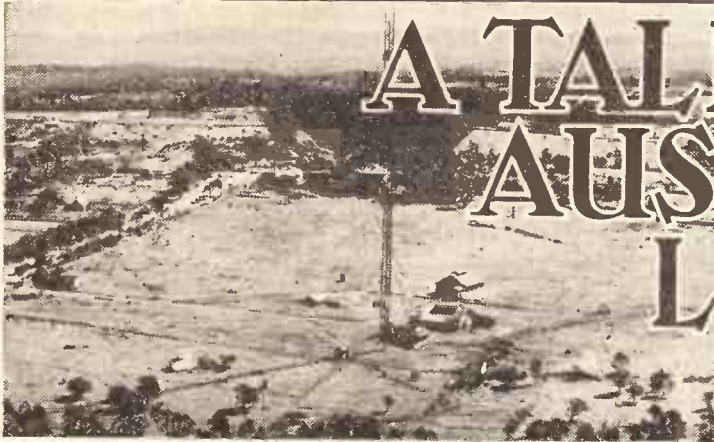

# A TALK WITH AN AUSTRALIAN LISTENER

JUST after the announcement that Capt. Eckersley was going to Australia to advise on the reorganisation of their broadcasting system I came in contact with an Australian business man spending four months over here on business. He told me that he was glad an expert from the Old Country was going out to put radio matters right, and he hinted at a certain amount of dissatisfaction with the present radio arrangements.

I pressed for an explanation.

"To give you an accurate idea of broadcasting now in Australia," he said, "I must go back into

past history. I am not a critic of the present Government, but we listeners have to face the fact that the arrangements now are unsatisfactory.

"When I explain to you how broadcasting has grown up in Australia, you will understand. I can only say how glad I am that already matters of policy are being straightened up.

### Several Competing Companies.

"Nearly seven years ago a mistake was made in granting a number of licences to separate companies. There were two in Sydney, two in Melbourne, one each in Perth, Hobart, and Adelaide. In Brisbane the Queensland Government officials themselves took out a licence.

"If I remember rightly, the idea was that each of these companies should stand for five years before broadcasting came up for review. We had to pay in Melbourne, I remember, a licence of thirty shillings a year, quite a considerable sum in those days.

"It was nearly all given to the programmes, the Government taking only about half-a-crown. That was for a sort of stamp fee, and the Government was supposed to have control of the programmes, but the station officials actually had a very free hand."

"What was your local station?" I asked.

"That was 3 L O, named after your London 2 L O station. 3 L O soon became very prosperous. The other companies weren't so fortunate.

"In Western Australia, in the sparsely populated areas, it was difficult to get listeners interested. In some cases the programmes were bad because of the lack of money, and about three and a half years ago matters came to a head.

Australia is undecided about its broadcasting system, and for this reason "P.W.'s" Chief Radio Consultant, Capt. P. P. Eckersley, is now in that country to advise the Commonwealth Government on radio reconstruction. Our Special Correspondent recently interviewed an Australian listener, who gives readers an account of the present condition of broadcasting in that country.

"A Royal Commission was set up, and after a lot of red tape discussion a working arrangement between the companies was put forth. The scheme was for the wealthier concerns to provide subsidies for the smaller ones, or to loan recorded programmes or even artistes' rights.

"In a small country it would have worked

well, but in Australia the distances are so immense that the scheme fell flat. Relays were then out of the question. Take Perth, for example. It is about 2,000 miles from

Melbourne, and there was then no line suitable for carrying broadcasting-quality speech or music.

"After a few more months the inevitable happened. The stations began to amalgamate. 3 L O and 3 A R, in Melbourne, joined forces and took over stations in Adelaide and Perth.

"A station which I expect you know very well (2 F C, in Sydney) amalgamated with 2 B L. Only the Brisbane station remained alone and ununited, under the control of the Queensland Government.

### Licences Not Renewed.

"Just as things were working very well from the listeners' point of view, the Government decided that it would be safer for the postal authorities to take charge of all broadcasting. It is not for me to say if that was a wise move. The licences to the existing stations (3 L O, 2 B L, 2 F C, 4 Q G, and the rest) were not renewed.

"Slowly the postal authorities took charge, programmes remaining about the same as they had been. Of course, the companies had a grievance. They sued the Government for nearly £100,000 compensation. There was some very bad feeling

(Continued on next page.)

## HOW SYDNEY "TOLD THE WORLD"

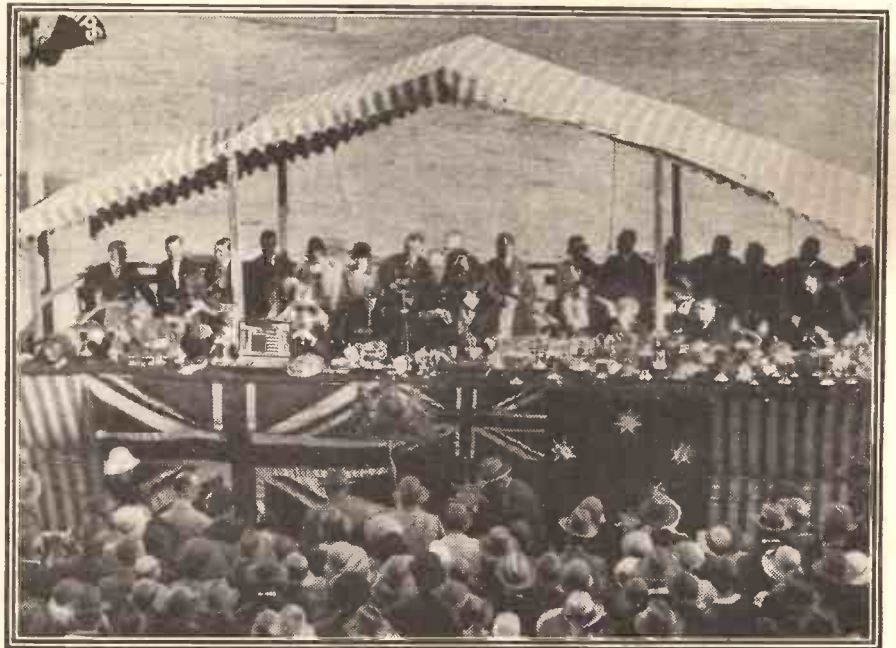

At the Sydney Royal Show recently Sir Isaac Isaacs, Governor-General of Australia, broadcast a description of the many wonders to be seen at this wonderful exhibition. His speech was radiated from the Sydney stations, and was heard in all parts of the world.

## A TALK WITH AN AUSTRALIAN LISTENER

(Continued from previous page.)

"The chief difference noticed when the Post Office took over was a stricter watch on technical accuracy, wave-length wobbling, and the like.

"Amalgamated Wireless, the concern which built the stations, is closely associated with the Government. Amalgamated Wireless engineers have always operated the stations, and the Post Office Department control merely strengthened the technical interest.

### Relay Efficiency.

"Some of the stations are very fine. There is the Radio Centre at Pennant Hills, near Sydney, where there is the 2 F C transmitter. These stations are housed in low, single-storey buildings.

"Even the relay stations are technically very efficient. The real need is for relay stations.

"The Government plan to have a dozen built within the next two years. It was intended to have them connected by land-lines and not by wireless link.

## PUSHING OUT THE PERTH PROGRAMME

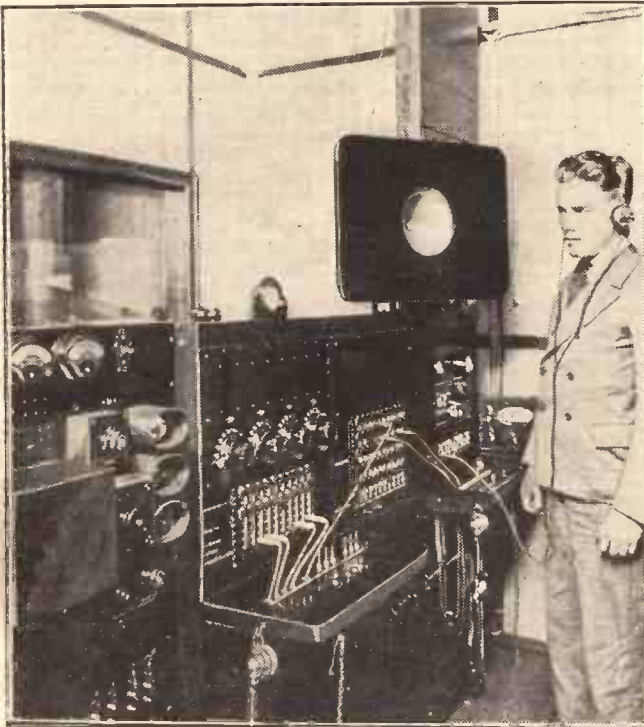

The control-room at 6 W F, the Perth broadcasting station, with the engineer in charge keeping a check on the outgoing programme. The moving-coil loudspeaker mounted on the wall is also used for checking purposes, being much favoured by the engineers, who doubtless find long spells of headphone listening very tiring.

"A figure of about £750,000 was mentioned, I remember. Most of this was to be taken up by the cost of the cables.

"As matters stand at present, there are six stations in Sydney alone, 2 F C, 2 B L, 2 C H, 2 G B, 2 U W, and 2 S M. In case anybody wants to try any real long-distance listening, here are the wave-lengths: 2 F C, 451 metres; 2 B L, 351 metres; 2 C H, 248 metres; 2 G B, 316

metres; 2 U W, 267 metres; and 2 S M, 236 metres. The famous 3 L O in Melbourne works on 375 metres and the companion 3 A R station on 492 metres.

"Take the main programme from 2 F C as an example. Practically the whole day's programme is relayed at 2 N C at Newcastle. There is the early session at 7 o'clock in the morning, the morning session at 10.30, and the lunch hour session at 1 o'clock.

### The Radio Matinée.

"Gramophone records are given. The radio matinée, commencing at about 3 o'clock, is generally a medley of recorded items and music by the station orchestra, the A.B.C. String Septet. If there is anything interesting on at the Sydney Town Hall, then an afternoon or early evening relay is made.

"The early evening session starts off with the Children's Hour, and then gramophone records are given until the news bulletin and the A.B.C. Sporting Service at 7 o'clock.

"The evening programme is generally a mixture of variety turns. The sort of programme one gets at an ordinary popular concert—light orchestral pieces, songs, a few humorous items, and perhaps a small sketch—is comparable with the 2 F C main evening programme.

"Dance music is given until a late hour either from gramophone records or from one of the popular outside broadcast dance centres, Romano's Café, for instance. A late weather forecast is given before the station shuts down.

"The 2 B L programme is generally an alternative. During the week we have broadcasts by the Australian Broadcasting Co.'s Women's Association, relays from the Grand Opera House, and broadcasts by the A.B.C. Orchestra.

### Record Trouble.

"There was recently a new trouble breaking out between the record interests (H.M.V., Columbia, and Parlophone) and the broadcasting companies. Records were given free, but the gramophone group were pressing for a royalty of 2s. 6d. on each disc. The reason put forward was that the gramophone companies were losing sales because so much recorded music was

broadcast that listeners had no need to buy gramophones!

"Our 'B' class stations, privately owned and financed, which give practically nothing but record music, were most seriously upset by the suggestion, and the Federation of 'B' class stations took up the matter with the Postmaster-General. I expect the trouble will crop up again in the new setting right of Australia's broadcasting.

"The A.B.C. Sporting Service takes up more time than our news bulletins. Most of us are keen on sport, and in the country districts some people do not see newspapers until weeks after publication.

"All cricket, football, and boxing results are broadcast, so that the farmers are just as well informed as the townspeople. Crop reports, market prices, and weather reports are important for the same reason.

"But there is no marked effect on the market caused by broadcasting. Even radio cannot break down the real difficulty of the immense distances.

## MELBOURNE'S MASTS

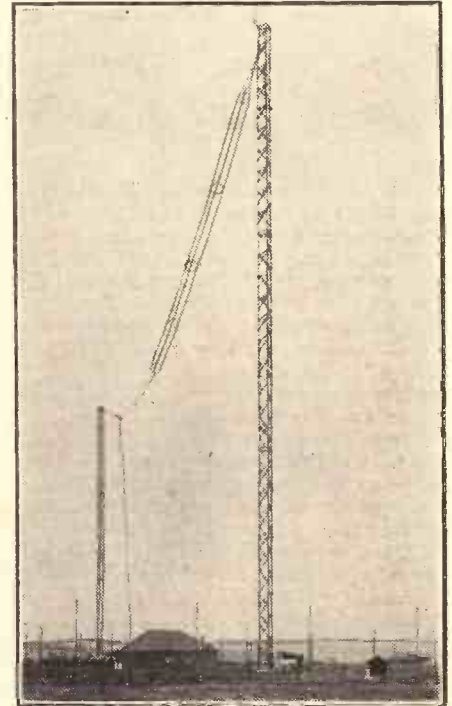

The Melbourne station, which incidentally was the first transmitter to start broadcasting in Australia, works on a wavelength of 375 metres and uses the Call Sign 3 L O.

"There are plenty of short-wave enthusiasts in the towns where radio supplies are easy to get. In spite of the number of alternative programmes available from Australian stations, I can assure you that there is no keener listener to B.B.C. programmes (via the 'wavelets') than the Australian possessor of a short-waver.

### Valves Aren't Cheap.

"Parts are not cheap. We have all the latest gadgets, such as variable-mu valves. An ordinary general-purpose valve costs 17s. 6d., a screen-grid valve 29s. 6d., and a variable-mu 32s. 6d.

"Many of the sets are American, but there are two or three Australian-built superhets, which cost £45. These give easy 10-kilocycleselectivity and have no difficulty in covering the long distances between the low-power 'B' class stations. Many American valves, and valves such as the Philips and National Union are popular.

"A great friend of mine is Mr. Charles Cousens, the new announcer at 2 G B, who was educated at Wellington in this country. He tried tobacco planting in Rhodesia, and then became a journalist.

"He now presides at the microphone in 2 G B. Directly I get back I must dig him out and find what has happened to Australian radio during my stay in England."

# FACTS YOU SHOULD KNOW...

## About the MAZDA A.C. RANGE

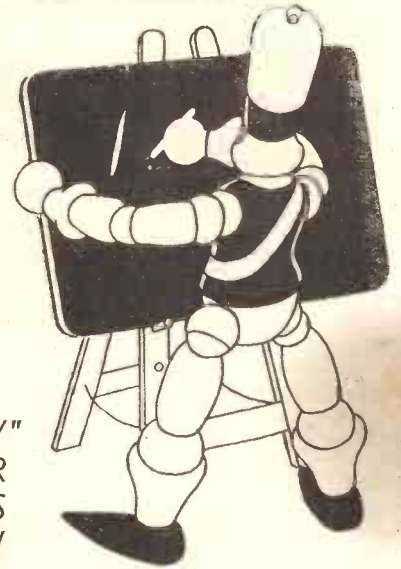

LOOK FOR "EDDY" IN YOUR DEALER'S WINDOW



There are three brand new and outstanding valves in the Mazda A.C. range.

**THE AC/SI VM.** A sensitive variable-mu screened grid valve, specially suitable for mains operated transportable sets.

**THE AC/SG VM.** A super-sensitive variable-mu screened grid valve designed specially for circuits employing grid bias volume control. Cross-modulation in the H.F. stages is reduced to a negligible amount by its use.

**THE PP 3/250.** A large output power valve requiring only a moderate anode voltage, which will deliver ample volume to large moving-coil speakers.

Full details of these and other useful Mazda A.C. types will be found in the Mazda catalogue, sent FREE on request.

**Mazda Valves are fitted by all the leading receiver manufacturers. All good radio dealers stock them.**

The amazing

# MAZDA

THE  
BRITISH  
VALVES

STAND  
Nos. 75 & 230  
RADIOLYMPIA

(Aug. 19-27)

EDISWAN RADIO

**100% BRITISH—Designed by British Engineers**

The Edison Swan Electric Co. Ltd.



155 Charing Cross Rd. London. W.C.2

Mazda Radio Valves are manufactured for The British

Thomson-Houston Co. Ltd., London and Rugby.

V.166

# HAS TELEVISION ARRIVED?

An impartial and reasoned reply to those "publicity-mongers" who insist on maintaining that television in the home is already an accomplished fact.

By  
G. V. DOWDING, Associate I.E.E.

A FEW weeks ago I wrote a short article about the Derby television broadcast and, much to my surprise, I now find that it has been construed as "An Attack On Television."

It was certainly not meant to be; it was a straightforward attempt to give a brief and impartial survey of the present state of the art.

## Be-Fogged by Exaggeration.

Probably no other single thing in the history of science has been so be-fogged by exaggeration and ballyhoo as has television; and it is this which POPULAR WIRELESS periodically endeavours to discount, not television itself.

To the earnest investigator and experimenter, we offer our very best wishes, for there is nothing we would like better than to see the dawn of "television for the masses." If you would believe the television publicist, that rosy dawn is already here; but blunt facts point in the other direction.

Let me quote a few of the current claims (as extracted from the last issue of "Television"):

(1.) "Television in the home is already an actual achievement—"

(2.) "The studio transmissions which have been broadcast for some time past and are now a part of the B.B.C. programmes, are the present criterion by which to judge television in the home."

(3.) "Only a few years ago the broadcasting of sound and music was also rather crude and quite as complex as television. We question whether vision apparatus is any more difficult to construct than the early wireless receivers."

## A Matter of Opinion.

Many may argue that the first statement is a matter of opinion. (I suppose "radio in the home" was achieved when Marconi first experimented with his crude coils in his garden in Italy over thirty years ago!)

However, let us see what was said at a lecture given under the auspices of the Television Society at University College a few weeks ago. The lecturer said:

reached its practical limits, with the possible exception of detail improvement.

Now, what about the B.B.C.?

Well, here are their own views as published in a recent Editorial article in the "Radio Times."

"The exploitation of sound and vision broadcasting has been undertaken by the B.B.C. in the hope that it will lead to progress in the development of television. It must be understood that, apart from the question of its final perfection, many difficulties strew the path ahead of television, not the least of which is that

"We must all agree that television has not yet arrived."

Further, he gave it as his opinion that the Baird method has

## MADE PLAIN FOR THE "PLANE"



Recent tests at Burbank, California, have been carried out in connection with television-equipped aeroplanes, to explore the possibility of giving visual aid to the pilot during fog or mist. Such a service would be of inestimable assistance to the navigators of the air if it were completely reliable.

of the present congestion of the ether."

Those sentences could, in effect, just as easily have been culled from the pages of POPULAR WIRELESS, for they succinctly express exactly our own views.

"Only a few years ago—etc." That third statement is a pure gem, but it is being worn rather thin by constant use. It has been trotted out at regular intervals during the past four or five years. However, I think I have dealt with it only once before, so I may be able to hasten its demise by once more paralleling facts against it.

## What You Require.

To achieve what, with amazing candour, our television friends themselves admit to be "rather crude" television in the home, you need the following:

- (1.) The power mains.
- (2.) Two radio receivers, one for sound and one for vision. The vision receiver must be capable of providing a powerful output, and the smallest practical instrument is probably a three-valve mains outfit, but often as many as four stages of L.F. amplification are used.
- (3.) A television instrument. An official kit of parts for home assembly is now advertised at £12 12s. 0d.

At the very beginning of broadcasting the programmes could be received on a simple crystal set comprising headphones a crystal detector and a small coil of wire. Anyone could install this elementary apparatus and anyone could operate it and no power mains or, indeed, any local current supply of any kind was needed.

## Beyond Comparison.

That was what POPULAR WIRELESS regarded as entertainment "service," and because its founders visualised its potentialities, POPULAR WIRELESS was actually in existence some months before the first British Broadcasting programme was transmitted.

And POPULAR WIRELESS could never have maintained its great and increasing circulation if it had not applied that word "service" in its attitude to its own public. It is no more in our interests to impede the development of television than it would be for an elephant to bite off its own tusks.

We would very much like to be able to tell our readers that "television for all is here," but all we can truthfully say is that, if you have the power mains laid on to your house and can afford to spend, say, fifty pounds on the necessary equipment, you can indulge for four half hours per week in experimental "looking-in."

And as, apart from the quality of results, this proposition can appeal only to a small percentage of the population, POPULAR WIRELESS is regretfully of the opinion that "television for all" is still in the future.

But the moment there are any indications that television is likely to assume "service" proportions, there is nothing more certain than that we will help to popularise it.

## Deceiving The Public.

In the meantime, we do wish the television publicist would cease circulating over-optimistic statements, for if and when the day arrives that inexpensive, easily-operated gear capable of giving fair results is made available, the public is likely to regard it as something in the nature of an anti-climax.

The public is even now being told that anything and everything can be televised, and is led to believe that good moving pictures by radio can already be accomplished.

So goodness knows what it will expect its first practical television to deliver!

You will enjoy reading The August  
**MODERN WIRELESS**

It contains articles covering every aspect of Broadcasting, including a special "long-distance" supplement about

The World's Programmes.

Now on Sale. Price One Shilling.

# A DUBILIER

## GRID LEAK WHICH COSTS ONLY 1/-!

There's no excuse now to have unreliable Grid Leaks in your Set. For here is a Grid Leak bearing the name Dubilier . . . and all it costs is 1/-! Only 1/- . . . and you have a Grid Leak which is the last word in efficiency . . . constant, permanent, strong mechanically . . . and tested in laboratory and factory to be quite certain that it will never fail you.

The new Dubilier Grid Leak is available in all popular values. For whatever resistance value you need, from today see that your Grid Leaks are all made by Dubilier. That name is another word for "Dependability."



**DUBILIER CONDENSER CO. (1925) LTD.**  
Ducon Works,  
Victoria Road,  
North Acton,  
London, W.3

# A BIG LISSEN RELEASE

## WAIT FOR IT!

### The LISSEN

# SKYSCRAPER 3 KIT

**THE GREATEST KIT SET EVER PRODUCED**  
Details next week



## OLYMPIA'S BIG HIT!

## MIDLAND AND WEST REGIONAL NOTES

By OUR SPECIAL CORRESPONDENT.

IN the Midland and West Regions three important buildings are at present being erected by the B.B.C. They are the Empire short-wave station at Daventry, which should be ready for service at the end of the year; the West Regional station in Somersetshire, which will probably give its first transmission in nine months time; and the new studios and offices at Birmingham, which will certainly not be finished (as stated by some newspapers) in September.

### Dual-Programmes at Droitwich.

The short-wave station will be working before the present 5 X X and 5 G B transmitters are closed down, but B.B.C. engineers do not anticipate that the short-wave station, with its big aerial system, will adversely affect the radiation from the 5 X X and 5 G B aerials. These will continue in use until the opening of a new dual-programme station at Droitwich.

This will not be for another eighteen months or two years.

The Daventry short-wave aerials are to be less than 80 feet high, but there will be 17 of them, so it will be quite an array of wires up on "Dane-tree" hill. At the time

of writing all the 80 ft. aerial masts except those for the Canadian zone are in place, and the building is nearly complete.

Unlike the new Regional stations, the short-wave station will not make its own electricity supply. This will be obtained from the local mains.

### Plans for Next Year.

Down at Watchet the West Regional building is going up rapidly and should be finished by the end of the year. In the meantime the West Regional Director is carefully preparing his plans for the big programme developments that will follow the opening of the station next year.

Activities in the West are necessarily limited at present owing to so much of the transmission time of the Cardiff station being occupied with relaying the National programme. It is possible to select only a small number of important Western events to broadcast, and studio programmes must be given sparingly.

One such important event is the Royal National Eisteddfod of Wales, which is being held this year at Port Talbot. On August 4th the ceremony of the Chaining of the Bard, and also an address by Mr.

Lloyd George, will be broadcast, and relayed also by Daventry National.

Mr. Percy Edgar, the Midland Regional Director, has recovered from a long illness and Midland listeners will be glad to hear his voice again on August 1st, when, after an absence of two months, he resumes his popular talks on "Coming Events." One of the most important events he will have to talk about will be the Malvern Festival of Drama, from which Midland Regional is taking two relays.

The first, on August 11th, will be "Tom Thumb the Great." This play was written by the novelist Fielding and presented in London about 1730.

The second Malvern relay, on August 15th, will be "Ralph Roister Doister," an earlier play. It was written nearly 400 years ago.

It looks as though once again the friendly relations between the B.B.C. and Sir Barry Jackson are going to provide good fare.

### Catching the Public Fancy.

The manner in which Mr. Robert Tredinnick has achieved popularity is one of the most interesting features of recent broadcasting. Only recently he joined the Midland Regional staff as an announcer. He is a gramophone expert, and started giving recitals of a rather unusual type, usually under the title "Rhythm."

They have caught the public fancy to such an extent that Mr. Tredinnick is now one of the Midland Region's most popular regular broadcasters, and he has already been relayed in the National programme—a mark of London's appreciation of his work.

I HAVE just tested the new R.I. "Antinodal" short-wave amplifier adaptor, an ingenious and highly efficient unit which, besides converting your set for short-wave reception, virtually adds another stage of amplification.

This is accomplished by interposing a parallel-fed L.F. transformer (included in the unit) between the valve in the adaptor and the detector of your broadcast receiver. To connect up it is only necessary to withdraw the detector valve in your ordinary set, insert the special adaptor plug supplied with the unit, and replace the valve in the sockets provided on top of the plug, where it acts as 1st L.F. amplifier.

### VERY NEAT



The adaptor is built into a very neat cabinet, and it is connected up to the broadcast receiver by means of the special plug provided.

## THE R.I. "ANTINODAL" S.W. ADAPTOR

A Test Report by a "P.W."  
Technician.

All tuning is carried out on the "Antinodal" unit, the broadcast set merely acting as a low-frequency amplifier. It is extremely easy to operate, there being but one tuning control, a reaction condenser, a wave-change switch and another switch—the feature of the Antinodal principle—for matching the unit up to your aerial and avoiding "dead spots" in the tuning. The wavebands covered are 12-30 metres, and 25-80 metres, *without coil changing.*

### Really Well Designed.

On test the "Antinodal" passed out with flying colours, it being possible to sweep from station to station with that ease which is characteristic of only a really well-designed short-waver. The station-getting powers of the unit were greatly enhanced by the delightfully smooth reaction, and the complete absence of threshold howl.

As readers are aware, conditions on the higher frequencies vary considerably, but when the unit was connected up to a small two-valve broadcast receiver on a recent Sunday (thus converting it into a three-valve short-waver), it was possible to tune in all the principle stations at good

loudspeaker strength. Moscow, Bound Brook (N.J.), Rabat, Zeesen, Radio Colonial, Rome, Vatican City, were all there.

Schenectady (New York), on his 19.56-metre wave was the "star" station, and he provided a really enjoyable programme from about 7.30 p.m., when he was first tuned in, until it was time to go to bed. A very creditable performance indeed.

The "Antinodal" short-wave amplifier adaptor unit sells complete with valve and housed in a beautifully polished cabinet for £4 10s. 0d., or alternatively the manufacturers, Messrs. Radio Instruments Ltd., of Croydon, will supply a pamphlet with the necessary instructions and list of parts required for building up the unit at home.

F.B.

### INSIDE THE UNIT

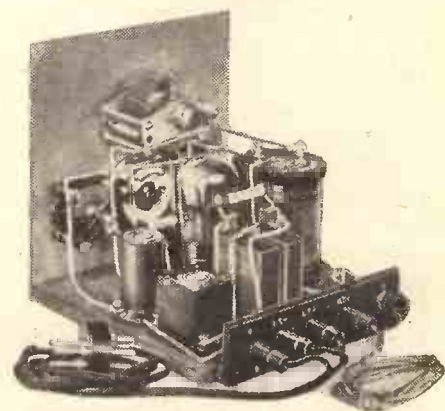

There is no waste space behind the panel, as readers will see from this illustration. Note the Parateed transformer seen in the foreground.



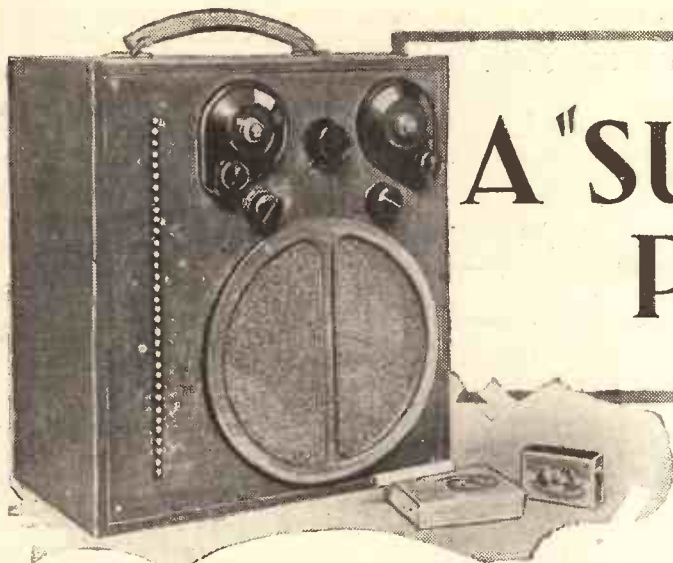

# A "SUPER-QUAD" PORTABLE

Details of a highly interesting portable design, built up on rather unusual lines. It was constructed for a specific purpose, and to achieve the highest possible degrees of compactness, quality and volume.

By A. S. CLARK.

**T**HE real value of a portable set lies, not so much in what it will do in a general sense, as in the extent to which it meets the requirements for which it was designed. Before one can draw up a design for a portable receiver it is necessary to decide exactly upon what it is desired to do.

So before dealing with the technical details of the compact little set illustrated on these pages, I will tell you just how it came to be built, and then you will see how ideal it is for the purpose. This is how my friend put it when he asked me to work out the details.

## A "Tall Order!"

"I spend many of my week-ends in the country, so when I feel like it I want to be able to take my set with me, for most of the farms I go to are completely without radio. As the set is to be used as a home-set as well, it *must* give reasonably good quality, but I am not particular whether it has much range or not; the local programmes are good enough for me.

"I know little about the technical side of radio and so the operation has simply got to be simple. I cannot stand a lot of fiddling about with reaction controls and difficult tuning, and so on.

"Finally, if it's not quite small it will not be of much use to me, although as I shall not have to carry it far, the question of weight will not worry me. That's a tall order I know, but please see what can be done about it."

So I did see what could be done about it, and was so pleased with the result that I am sure details will be of great interest to others. I'll just run over the points he made, taking the last one first.

## Designing the Set.

Size; it's only seven inches by eleven inches and thirteen inches high. If you are bad at visualising sizes (I certainly am myself), the high-tension battery in the complete back view will enable you to get a fair impression of what these figures mean.

So far as weight is concerned, it's not light for its size. But for what is in it the weight is very reasonable, which brings me to the circuit chosen.

This is given in the diagram, because there are one or two interesting points in which it differs from the original circuit. Chief among these is the special high-

frequency filter in the anode circuit of the pentode output valve.

This consists of a superhet. H.F. choke and by-pass condenser, and without it, distortion was caused by intermediate frequency currents getting into the loudspeaker. The latter is of the portable Mullard type, and an interesting point in connection with its metal chassis was the fact that it had to be connected up to L.T. negative.

Without this "earthing" of the chassis low-frequency instability made itself known by a high-pitched tone to the reproduction. Perhaps these stabilising schemes make it seem that the whole set is on the jumpy side. This is far from the case.

Actually it is as stable as anything, and the only effect of touching all sorts of points

with a finger is to reduce volume in some cases. No howling of any sort is produced.

While the circuit was being tried out experimentally on the bench a most weird thing turned up. It was before the output filter already mentioned was in place, and also before the loudspeaker chassis had been "earthed."

## "Teething" Troubles.

To overcome this low-frequency trouble that was being experienced, the most likely cure was tried—fitting a filter circuit consisting of a superhet. choke and fixed condenser to the anode circuit of the detector. The only effect of this was to produce a terrifying howl.

But if the choke were removed, the condenser by itself certainly made a slight improvement. Not until the output filter was incorporated did the choke become useable, and then it was not found necessary!

Another interesting thing that cropped up was in connection with the connection for the plate circuit of the double-grid valve used as oscillator and mixer. The connections shown in the circuit are the usual ones, and you will see that the anode current from the plate flows first through the primary of the first intermediate transformer, and then through the reaction coil on the oscillator.

## An Experiment.

Because it made a much neater and convenient layout for the components the two windings were tried the other way round first. Theoretically there is no apparent reason why this method should not be near  
(Continued on next page.)

## ORDINARY COMPONENTS USED

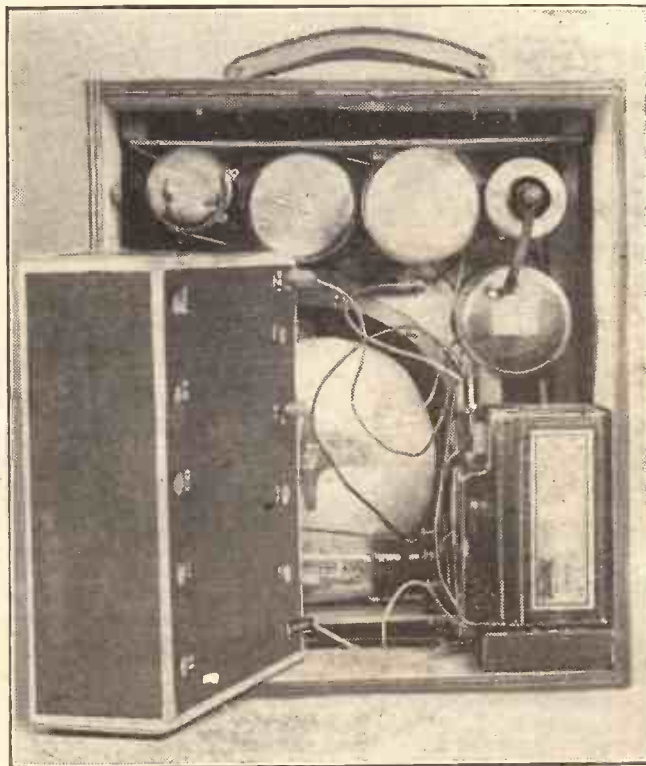

It is interesting to note, particularly in view of the set's dimensions—7 ins. × 11 ins. × 13 ins. high—that not one part was specially made. Everything is of a type normally used in ordinary receivers.

## A "SUPER-QUAD" PORTABLE

(Continued from previous page.)

enough the same thing, but in practice it resulted in about a fifty per cent decrease in the sensitivity of the receiver.

So the other way had to be used. Looking at the matter in the light of this information, it seems likely that the reason is that the reaction winding has a fairly high capacity to "earth," and consequently by-passes some of the high-frequency currents that we want to reach the transformer primary. Naturally this capacity has no detrimental effect on the reaction coupling.

### Two Aerial Windings.

Two distinct windings are utilised for the frame. The long-wave one is permanently joined across the outer grid and filament of the "mixer," and by means of the simple on-off switch the medium-wave winding can be put in parallel with it.

This scheme enables simple switching to be used, and at the same time avoids the proximity of shorted windings or unused wire near the medium-wave frame. Both important points, because efficiency on the medium waves had to be considered as it was anticipated that the frame was not going to be any too efficient a pick-up.

Actually, in spite of its small size and the mass of metal, both behind it and also inside it, it turned out to be remarkably effective. Even so, the long-wave winding proved to have more sensitivity, not being affected to the same extent by the metal.

It was because of the small frame and its being more or less buried in batteries and copper cans that provision was made for an earth and short aerial to be attached when the nearest station was a good way off. The question of radiation in such cases was no obstacle because of a small aerial being employed, and also because when it was necessary the set would be used in the country away from neighbours.

### Series Condenser.

As the aerial and earth were to be connected direct across the frame, it was intended to connect the aerial via a small fixed condenser such as a .0002-mfd. so as not to upset the tuning very much. With the aerial and earth on, stations simply romped in both on the long and medium waves, although this was not required by the specification.

No output choke for matching up the loudspeaker with the

pentode valve was incorporated because it did not increase volume noticeably and because the balance of tone was better without it. The latter point no doubt being accounted for by the fact that there was a fairly low resistance by-pass to very high audible frequencies via the H.F. filter condenser and via the condenser attached to the plate of the detector valve.

That, I think, completes the points of interest in the circuit, except to mention that no battery de-coupling at all is used. It was tried, but was not necessary because it made no apparent difference whatever. Naturally this was very welcome, for there were already enough parts to be fitted into the case.

### A Perfect Fit.

However, it turned out that there was just nice room for everything when two thin baseboards were arranged one at each end of the front panel on which the whole set is mounted. Even the frame winding supports are fixed to this, so that when the front is removed, all that is left is four pieces of wood forming the case.

The loudspeaker chassis was put in one corner of the front piece of wood and the set built round it. It starts at the top left-hand corner as you look at the back of the

receiver, and works along to the top right-hand corner.

Here it turns in a downward direction, reaching the bottom baseboard and the second detector valve at the same time. Then it worms its way along to the left again, finally finishing up in the bottom left-hand corner with the H.F. output filter.

At first it seemed that the front appear-

## THIS IS THE CIRCUIT EMPLOYED

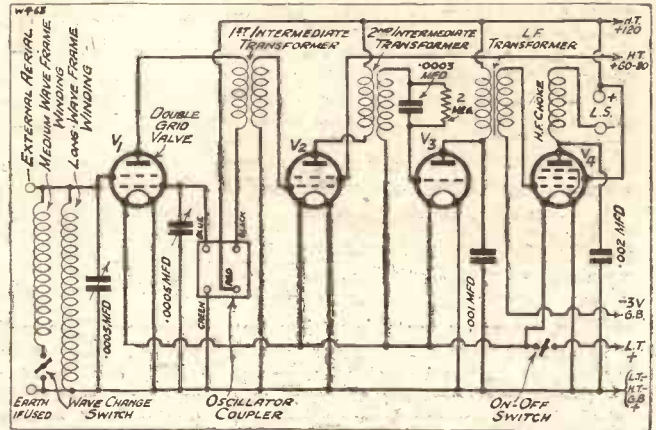

The arrangement of the four valves is very similar, apart from the input tuning, to that used in the "P.W." "Super-Quad" set, which proved so popular. A combined oscillator and first detector is used.

## NOT AN INCH OF SPACE IS WASTED

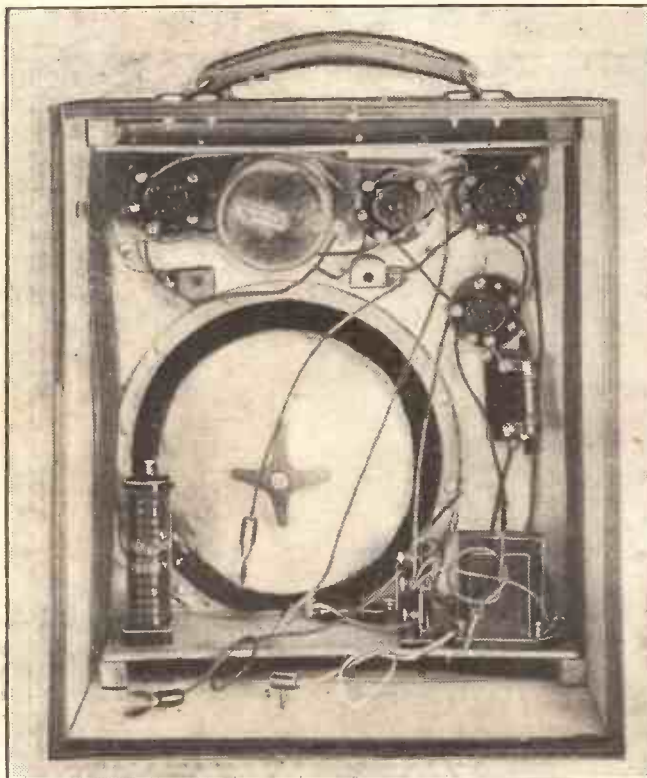

The set is built around the loudspeaker and the frame around the set. Round the whole is fitted a simple wooden case, which houses the batteries behind the set and speaker. The intermediate transformer and valves were removed for this photograph.

ance was going to be simply awful—just bits here and there—but it turned out much better, as you can see, for a symmetrical layout was obtained. The fact that the controls and speaker fret seem to have slipped to one side, is overcome by fitting a piece of beading down the side of them, producing quite a pleasing futuristic architectural effect, which is helped by the sloping slow-motion dials.

The dial on the left is the oscillator-tuning and that on the right the frame tuning. Between these two is the control knob of the oscillator-coupler, and when this is turned fully in a clockwise direction it is set for long waves, while a turn back through one notch sets it for medium waves.

The two smaller knobs are ordinary snap on-off switches. The left-hand one is for L.T. and the right for putting the two frame windings in parallel for medium waves.

### Standard Batteries Employed.

The Ever-Ready battery used was of standard 120-volt type, so that replacements could easily be obtained, while the accumulator was a jelly-type Exide, two being purchased so that one could be on charge while the other was in use, the type number being J.W.M.6. The H.T. and L.T. batteries just fit in nicely across the case.

As the pentode valve is one of the new type requiring little grid bias, a 4½-volt grid-bias battery is placed under the accumulator. An H type valve was found to be quite O.K. for the second detector, and a high-mag. S.G. valve is employed for the intermediate amplifier. The double-grid valve is of the type with a terminal on the side and not one of the five-pin variety.

As far as results are concerned, the set fulfils what it was designed for in a most satisfactory manner. An interesting point is that the efficiency seems to go up with the wavelength, no doubt due to the effect of the metal within the frame becoming less.

(Continued on page 652.)

EVERYTHING **The G.E.C.** ELECTRICAL  
*Your Guarantee*

**OSRAM**  
new automatic cushion  
filament springing  
ensures  
**ABSOLUTE CONSISTENCY**



# SATISFYING

Volume implies filament heating. When a filament expands the pre-determined position of the electrodes must vary, and you get erratic characteristics unless the expansion is *automatically compensated*. In all the OSRAM 2-volt battery valves there is a marvellous development which ensures consistency with satisfying volume. Effects of internal and external vibrations are eliminated. The OSRAM filament-springing means an end to *all* microphonics.

# VOLUME

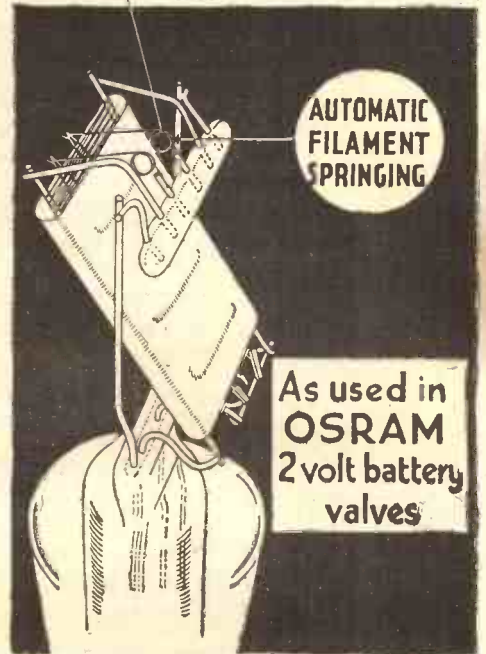

**Osram**  
2 VOLT BATTERY  
**Valves**  
MADE IN ENGLAND  
SOLD BY ALL WIRELESS DEALERS

**WITH THE WEMBLEY FILAMENT**

Advt. of The General Electric Co., Ltd., Magnet House, Kingsway, London, W.C.2

WHEN I compare the pages of this summer's long-distance log with those of previous years I am more and more struck by the extraordinary number of Continental transmissions which have kept up their strength and remained pretty reliable during the season of long days and short nights.

Each year for the past ten has naturally shown something of an improvement over its predecessors owing to the increasing power of transmitters. But 1932 is very easily the best summer that we have yet had for long-distance wireless.

#### Less Morse.

Atmospherics have certainly been rather more of a nuisance than in some past summers, though they have seldom been anything like so bad as they were in 1931. There has been very little fading and one big improvement that is not fully appreciated, unless you have old logs to turn to, is the decrease in Morse signal interference.

Long-wave Continental stations continue to be extraordinarily good. Huizen was showing a certain amount of variability until recently, but he seems now to have settled down to his old good form. Zeesen,

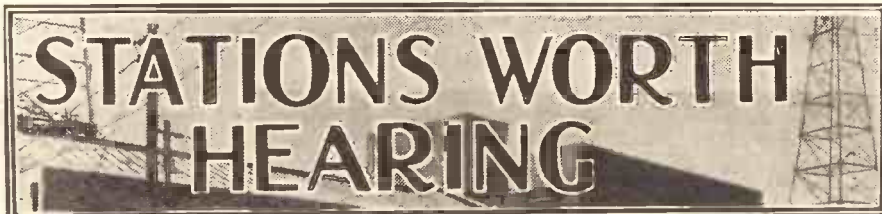

Some practical distant-programme notes compiled by a special contributor who nightly searches the ether in order to obtain really up-to-the-minute information for "P.W." readers.

too, is very much steadier than he was, and Motala seems to be coming back.

Kalundborg, Radio-Paris, and Warsaw are all first-rate; whilst the Eiffel Tower has been receivable quite often of late without any heterodyne from a Russian source. Oslo, who was badly received in the Midlands and the South of England during the early summer, is now giving much better reception on most days.

#### Medium Wave Surprises.

The medium wave-band continues to be very interesting, partly because it contains so many reliable stations and partly because hardly an evening passes without its surprises. Florence, for example, had not been much of a station for some little time past, but just lately first-rate reception from this station has been obtainable on odd nights.

Katowice is recovering from his period of depression, and Frankfurt is often quite

the look-out for him.

Munich is still on the weak side, but we shall hear a great deal of him before so very long, when his new big transmitter comes into action. Belgrade is rather under the weather at the moment, but it should not be long before he is well heard again. What has happened to Lwow?

#### Notable Improvements.

Both Breslau and Göteborg are improving noticeably, and Bordeaux now makes frequent appearances in the log. Bratislava for some reason has not been recorded for some little time, but both Gleiwitz and Toulouse (P T T) are often well received.

Nürnberg is once more suffering from heterodyne trouble—a pity, for otherwise his programmes would be well heard.

I have dealt this week only with the more variable medium-wave stations; the reliable standbys continue to give of their best.

THE latest additions to the "Heard All Continents" Club include B. G. (Eastbourne), E. H. (Bristol), and G. E. M. (Doncaster). All three send in very pretty logs, two of them using only a single-valver. (The one I described in "P.W." dated April 16th, 1932—the "W.L.S. Short-Wave One.")

The most interesting tit-bit of news that I can find for readers is that I have heard the B.B.C.'s 7-metre transmissions several times with my "super-regen." 5-metre set, slightly altered to go up to 7 metres. Strength is uniform and good, and ease of tuning comparable with that usually associated with London Regional.

#### Free From all Disturbance.

Seven metres is so completely clear of oscillation, heterodynes from Mühlacker, stray ships working off-wave, and the other annoyances of the medium-wave band that I am going to put the "family" set down there as soon as the transmissions become regular.

Just at the present time the transmissions from stations below 30 metres appear to be far better than those above. The 49-metre group of D X stations have tailed off sadly, unless one gets up in the early morning to listen to them. W 2 X A D is the strongest American, and W 2 X A F the most reliable, as usual.

#### The Eclipse Tests.

Zeesen and Skamlebaek, together with Rome, are the best stations on the air; and D X, in general, is fairly difficult to get hold of.

## SHORT-WAVE NOTES



News and views regarding an exciting and fascinating wave-band

By W. L. S.

On the evening of August 31st "P.W." readers will have an excellent chance to do something really useful. A total eclipse of the sun (not visible at Greenwich) takes place at approximately 7 p.m. (Greenwich time), and amateurs throughout the world are asked to take observations between that hour and 9 p.m.

The R.S.G.B. and A.R.R.L. have arranged for comprehensive tests to take place on the amateur bands. What is wanted now is for a large body of listeners to keep watch on some particular broadcasting station in the short-wave bands.

#### How Readers Can Help.

I suggest that "P.W." readers can help in the following way. Keep a watch on a given broadcasting station for about four days prior to August 31st, noting the average strength, amount of fading, etc., between the hours of 7 and 9 p.m. (G.M.T.). Repeat the same test on August 31st, care-

fully noting any differences from the usual results.

Write your results down on a sheet of notepaper or postcard, giving the following details: Station, wavelength, type of receiver used. Average strength from August 27th to 30th, also strength on each day. Particulars of fading.

Finally, results on August 31st, with as much detail as possible.

If a hundred or more of you will do this with some particular station and send the results in to me; c/o "P.W." immediately afterwards, I will be glad to summarise the results and send them in to the proper quarter.

#### Raise the Amateur Status.

Let the authorities see that "P.W." readers do not own short-wavers just for their own amusement and you will raise their opinion of the amateur experimenter.

I will have more to say on this subject before "zero hour" arrives, but I have mentioned it early to give readers plenty of time to make up their minds about what they are going to do. All waves between 5 and 5,000 metres are being watched by observers, but the "Short-Wave Notes Brigade" can be most useful by keeping between 10 and 100 metres.

All I ask is this: Don't all decide to watch W 2 X A D. There are other stations on the map!

Coming immediately after the conclusion of the show, this eclipse occurs at a very favourable time, when enthusiasm should be running high. Let's see what we can do.



# NEW WEARITE COMPONENTS



Should you have any special technical query, write to our "Service Dept."—they will find the solution.

HERE is the range of the NEW Wearite Components—a range covering every need of the constructor—switches of all types—resistances, plug-in and permanent mounting, potentiometers, and volume controls, individually or ganged controlled, mains transformers, chokes and so on. Thus is the experience of Wearite shown in practical form. Here is an exhibition on its own—Whatever your component need, consult Wearite.

AND REMEMBER—A GOOD EARTH ALWAYS.



No Spanner. No Screwdriver. Price 3/6 complete.

**WRIGHT & WEAIRE, LTD.**  
740, HIGH ROAD, TOTTENHAM, N.17.

Phone: Tottenham 3847/8/9.

1920

## THE BENJAMIN TRANSFEEDA (REGD.)

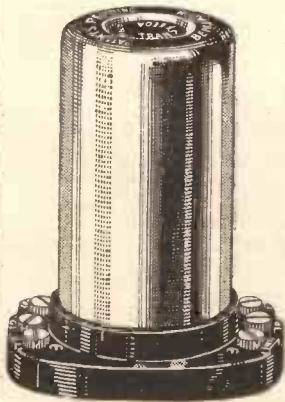

WHEREVER an L.F. Transformer can be fitted a Benjamin Transfeeda will give you what you have been looking for—wonderfully pure and powerful reproduction with a uniform response throughout the audible scale right down to the deepest bass. The Transfeeda will be the making of your receiver, giving you luxury transformer results for the modest price of 11/6.

May we send you the fully descriptive two-colour leaflet giving curves and circuits? Ask for list 1290

PRICE **11/6**

The original resistance fed transformer

The Benjamin Electric Ltd., Tariff Road, Tottenham, N.17

## CHARGE YOUR OWN BATTERIES

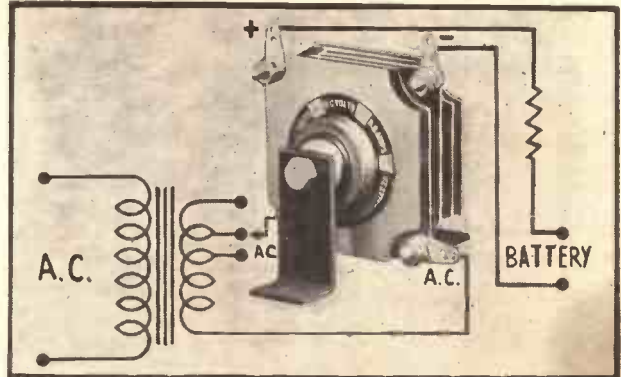

The new Westinghouse Metal Rectifiers styles L.T.1, L.T.2, L.T.4, and L.T.5 have been designed expressly for use in L.T. trickle-chargers. The apparatus necessary for the construction of such a charger is a transformer, rectifier and ballast resistance. The correct charging current is obtained by tapping either the resistance, or, a more convenient method, the secondary winding of the transformer, as is shown in the diagram.

Full particulars and prices are given in "The All-Metal Way." The attached coupon and 3d. in stamps will bring you a copy.



**METAL RECTIFIERS**

**THE WESTINGHOUSE BRAKE & SAXBY SIGNAL CO. LTD.,**  
82, YORK ROAD, KING'S CROSS, LONDON, N.1.

COUPON  
Westinghouse Publicity, 82, York Road, King's Cross, London, N.1.

"ALL-METAL WAY" please. 3d. in stamps enclosed.

NAME.....  
ADDRESS.....

P.W. 6/8/32.

## FROM THE TECHNICAL EDITOR'S NOTE BOOK.



# Tested and Found—?

## TESTING H.T. BATTERIES.

IT is a long time since I have had anything to say regarding the testing of H.T. batteries, and I feel that as we are now facing the beginning of another radio season, the time is opportune for a brief return to this important subject.

Until comparatively recently H.T. batteries were always tested on a continuous discharge basis and it was probably due to "P.W." that the practice has all but disappeared.

I have always held the opinion that in many cases laboratory equivalents can prove very misleading, and that there are

## DEPENDABLE H.T. SUPPLY



Two Ediswan H.T. batteries. The new process cells are built up into cartons of a new pattern, and we hope to be able to publish a photo of one of these in our next issue.

sometimes no alternatives to as close a duplication of the practical conditions as can be arranged.

Particularly is this the case with the H.T. battery. In the listener's hands it is expected to give reliable service for a period of some months.

To draw all its current out in a test period of a few days may tell you nothing—it may even definitely mislead you, for it must be remembered that the life of a "dry" battery is the life of its zinc and paste.

And the zinc, if of thin, poor quality, may depreciate more for a certain total discharge spaced over one month than for the same discharge compressed into one day, owing to a continuance of chemical action while the battery is ostensibly "resting." Again, corrosion and crystallisation of inter-cell connections can occur.

As for the paste, temperature and atmospheric changes must be taken into account, although I am bound to say one doesn't often meet "dry" batteries nowadays which contain easily-drying-paste.

But you should now clearly be able to see the fallacy of short-time laboratory tests.

If you examine a first-class make of H.T. battery, such as, for instance, the Ediswan (I have been dissecting one of the samples submitted), you will at once observe the precautions which have been taken against

period depreciation.

There are items in the construction which could quite well be left out (and money saved) if the policy of "sufficient for the day is the current capacity thereof" had been followed.

Nevertheless, even with such a name as "Ediswan" we do not take anything for granted, and so the new Ediswan batteries were tested in just the same way as those makes whose labels give no prima facie evidence of their quality.

Battery testing has been developed to almost a fine art in the "P.W." Research Dept. Sets are being tested all day under conditions very similar to those existing in listeners own homes, and so it is not difficult to arrange for any one H.T. battery to be given a daily three-hour discharge on an actual set having H.T. requirements somewhere within the claimed output limits of the battery. (A meter and record card follow the battery in all its travels.) A very economical and eminently practical arrangement!

And I am able to say that the Ediswan batteries are giving the first-class service which was expected of them. Radio enthusiasts can purchase them with every confidence.

Their outputs are above the average and they give a clean, steady output with an even voltage decline in all cells.

## STRAIGHT-LINE AMPLIFICATION.

Until the moving-coil loudspeaker became a popular commodity there was a tendency for all attempts to improve the L.F. ends of sets to be shrugged away with a "what's the good!" kind of attitude.

And that is not to be wondered at when the performances of earlier loudspeakers are remembered. But nowadays quality is in demand and it can almost be said that the public is "straight-line minded."

Anyway, this is a good enough explanation of the growing popularity of resistance-feeding L.F. transformer arrangements. With them quite spectacular results are obtainable, indeed, resistance-capacity purity plus transformer amplification are achieved.

Inevitably the separate components required for the method have been grouped into the one article, and thus we have the Benjamin "Transfeeda" which embodies in a compact unit, the transformer, resistance and condenser.

But although "built in" these items are not crude constructions. For example, the

condenser is contained in its own metal case and is of good quality construction, and the resistance is wire-wound and able to handle  $1\frac{1}{2}$  watts.

There is a tapping at 30,000 ohms for low impedance valves.

By virtue of the high transformer inductance and properly proportioned values, the amplification curve given is practically straight from 25 cycles to over 20,000 cycles, and even if anything better could be accomplished we could not as yet make use of it!

The Benjamin "Transfeeda" is certainly a fine proposition. And not the least original and important feature of its design is that it has a shielding metal case.

## PLEASE NOTE

Manufacturers and traders are invited to submit radio apparatus of any kind for review purposes. All examinations and tests are carried out in the "P.W." Technical Department with the strictest of impartiality, under the personal supervision of the Technical Editor.

We should like to point out that we prefer to receive production samples picked from stock, and that we cannot in any circumstances undertake to return them, as it is our practice thoroughly to dissect much of the gear in the course of our investigations!

And readers should note that the subsequent reports appearing on this page are intended as guides to buyers, and are, therefore, framed up in a readily readable manner, free from technicalities unnecessary for that immediate purpose.

## PERTRIX BATTERIES.

What a magnificent range of batteries the Pertrix people have built up. I note from their latest list that their different H.T. types number no less than some forty or so.

There are also comprehensive ranges of grid bias batteries and radio accumulators, these latter being obtainable in all the popular capacities.

## THE BENJAMIN "TRANSFEEDA."

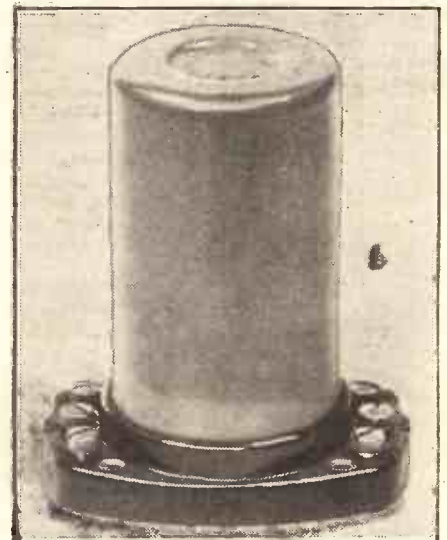

A new component which contains in one unit all the necessary parts for parallel-feed, L.F. transformer coupling.



# RADIOTORIAL

All Editorial communications should be addressed to the Editor, POPULAR WIRELESS, Tallis House, Tallis Street, London, E.C.4.

*The Editor will be pleased to consider articles and photographs dealing with all subjects appertaining to wireless work. The Editor cannot accept responsibility for manuscripts or photos. Every care will be taken to return MSS. not accepted for publication. A stamped and addressed envelope must be sent with every article. All inquiries concerning advertising rates, etc., to be addressed to the Sole Agents, Messrs John H. Lile, Ltd., 4, Ludgate Circus, London, E.C.4.*

*The constructional articles which appear from time to time in this journal are the outcome of research and experimental work carried out with a view to improving the technique of wireless reception. As much of the information given in the columns of this paper concerns the most recent developments in the radio world, some of the arrangements and specialities described may be the subject of Letters Patent, and the amateur and the trader would be well advised to obtain permission of the patentees to use the patents before doing so.*

## QUESTIONS AND ANSWERS

### HOW MANY KILOCYCLES ?

P. H. (Hartlepool).—"Since I put up the 'Cosmic' I have become very keen on short-wave reception, and W. L. S.'s notes, though I do not understand as much as I should like. One little thing, for instance, that bothers me is frequency instead of wavelength.

"Suppose I am listening to 30 metres—what frequency is that? If you could tell me

### DO YOU KNOW—

the Answers to the following Questions ?

There is no "catch" in them, they are just interesting points that crop up in discussions on radio topics. If you like to try to answer them, you can compare your own solutions with those that appear on a following page of this number of "P.W."

- (1) At what times the "Six Pips" from Greenwich are broadcast from 5 X X on week-days ?
- (2) What precaution has been taken at the exposed North Regional station to obviate the danger of the aerials being put out of action by coatings of ice ?
- (3) Which Continental station broadcasts pigeon-flying reports regularly on Sundays ?
- (4) The total resistance of a 50,000-ohms and a 100,000-ohms resistance, connected "in series" ?

a simple way to find frequency from wavelength I should feel I am getting on.

"And am I right in thinking 'mega-cycle' means 1,000 cycles ?"

To deal with the latter question first—no. You are not right about the mega-cycles. Mega means 1,000,000, so one mega-cycle equals one million cycles, not a thousand.

(The prefix "kilo" means 1,000, and thus you were referring to a kilocycle, not a megacycle in your question.)

As regards the first question, that of telling frequency from wavelength, there is one very simple

rule. It works both ways round, and thus you can convert a wavelength into frequency, or frequency into wavelength with equal ease. And you work in kilocycles, in which such frequencies are generally expressed.

The rule is "Divide it into 300,000." Thus, for example, to find the frequency of a station on 30 metres, divide 300,000 by 30. The answer is 10,000, which means the frequency is 10,000 kilocycles.

### "P.W." PANEL No. 83.—STATIONS WORKING ON A COMMON WAVEBAND.

Ideally, every broadcasting station should have its own wavelength, widely spaced from others. Not only is the latter condition impossible, but the former also is impracticable, and several stations frequently share one wavelength.

The B.B.C. has been unusually successful in effecting this class of work, and for years it worked eleven synchronised relay stations without a hitch.

The accuracy of the synchronisation obtained was of a very high order, namely, within about three parts in a million. This was accomplished by tuning-fork drives at the transmitters.

Such "coupled" stations always transmit the same programme, and should be situated far apart geographically to prevent mutual interference.

Similarly, if you want to know the wavelength of a "500-kilocycle station," simply divide 300,000 by 500. The answer is 600 metres.

### FITTING A SWITCH AND PICK-UP FOR RADIOGRAM RESULTS.

T. G. (Bentley).—"I am still using the set you brought out last year—the 'Comet' Three. But I am going to fit a pick-up for radiogramophone results, and should like a check up on the connections.

"Unfortunately, I put my copy of the 'P.W.' aside and now can't find it. It was the one describing how to put in a switch (worked from front of panel) and it gave the connections to volume control and grid bias, as well as to the pick-up, which was put on or off by a jack and plug.

"With the assistance of a chum, who made one up at the time (and later took it down for a four-valver) I have got it all schemed out, if you will check up that the new connections are right. This is how we figure it out.

"The detector's grid terminal to middle of switch, which turned to the right joins up with the .0003 mfd. and 2-meg. leak (formerly these went to grid direct). I feel sure this part is right, but is this O.K. for when switch is turned to the left?—Grid then connects with slider on middle terminal of volume control. One end terminal of this goes to one terminal of the pick-up jack.

"Remaining side of pick-up jack goes to G.B. + flexible lead, and to other end terminal of volume control. Is that right?"

Yes, except in one particular. You say "goes to G.B. + flexible lead," instead of G.B. negative. Apparently you meant negative, as it is usual to have a small negative bias of 1½ volts or so on a detector valve when used as an L.F. amplifier stage for radiogram work.

Otherwise your connections are quite O.K., and correspond with our original instructions for making the "Comet" a radiogram.

### EARTHING THE AERIAL.

T. D. A. (Nottingham).—"We live in a rather exposed position, and I have erected a 40-ft. aerial, with the wire level for 35 ft. and then coming down almost vertically to the window of a sitting-room.

"It is a fine aerial for results, and there is only one drawback. Namely my wife's fear of lightning.

"When she was a youngster a schoolfriend of hers was killed in a thunderstorm, and it always upsets her when thunder is about. Now she is scared to death of this big aerial—at our other house we had a rafter aerial indoors—so I propose to put an earth in the flower-bed under where the aerial comes down to enter the sitting-room.

"Then I am going to put a throw-over switch operated 5 ft. away by a broom-handle! How's that for safety?"

"The connections of the broom-handle-switch will be aerial to centre contact, earth to one side contact, and aerial of set to other side contact.

"As I use a separate earth to waterpipe (rising main) I calculate that when the broom-handle is turned over to join the outdoor earth to the aerial, it disconnects the set altogether and so gives me complete safety from lightning, etc.

"What do you think of the scheme?"

(Continued on next page.)

### WHAT'S WRONG?

#### S.G. ANODE CONNECTIONS

★

The anode connection of an S.G. valve is not taken from the usual "plate" pin—the one opposite the grid pin—but from the extra terminal on the top of the bulb.

Sometimes this terminal cap becomes loose, generally through misuse, as illustrated. It is not necessary to use pliers to tighten the connection, which need be only "finger-tight" for efficient operation.

Be careful not to let the anode wire touch the screen, as this may cause a short.



## RADIOTORIAL QUESTIONS AND ANSWERS

(Continued from previous page.)

It is just about as good as can be. As you say, the set when earthed separately and disconnected from aerial is absolutely safeguarded.

And so far as the aerial is concerned, by earthing it outside the house, without having to go near it, you have in effect made it a very good protector instead of a danger.

Nothing, of course, can actually stop lightning if it means to strike. But any lightning that had designs on your house would almost certainly choose the high aerial and take a direct path to the outside earth, the only damage likely to be incurred being fused wire or something easily replaced.

Without an aerial such a flash might take a fancy to a chimney, and that, of course, would be serious! So the aerial properly earthed outside is a protection.

### CONNECTING A NEW BATTERY TO AN OLD ONE.

The following letter to the Editor raises an interesting point about battery connections:

"Dear Sir,—I note in July 2nd 'Radiotorial Questions and Answers' a reply to a querist under the pseudonym J. J. (Llandudno) regarding the addition of dry cells, or of another battery, to a partially rundown H.T. battery.

"May I take the liberty of suggesting that under the circumstances outlined, in view of the fact that his present battery has only dropped to 76 volts, in practice there is nothing to prevent his coupling a new battery up.

"Unless the one he is using is of a very inferior quality, its resistance after losing only 24 volts should not have risen seriously. There is one point which must be observed, and that is that the negative end of the new battery should be connected to H.T.—of the receiver; and then the positive may be connected to the negative of the old battery.

"We need not mention the reason for this is, that if the battery has a high internal resistance, any attempt to pass the 'clean' current (for the early stages) through the old cells will make the set unstable, if not unusable.

"I hope you will not object to my pointing this out, and as the poor chap appears to have struck a bad patch it would be an act of kindness to drop him a line if you have his address.

### HOW ARE YOUR RESULTS NOW?

Perhaps your switching doesn't work properly? Or some mysterious noise has appeared and is spoiling your radio reception? Or one of the batteries seems to run down much faster than formerly?

Whatever your radio problem may be, remember that the Technical Query Department is thoroughly equipped to assist our readers, and offers its unrivalled service.

Full details, including scales of charges, can be obtained direct from the Technical Query Dept., POPULAR WIRELESS, The Fleetway House, Farringdon Street, London, E.C.4.

A postcard will do. On receipt of this an Application Form will be sent to you post free immediately. This application will place you under no obligation whatever, but, having the form, you will know exactly what information we require to have before us in order to solve your problems.

**LONDON READERS, PLEASE NOTE:** Inquiries should NOT be made by phone or in person at The Fleetway House or Tallis House.

I point this out with all due respect to yourself, and without, I can assure you, any ulterior motive.

Yours faithfully,  
R. H. C.

### SOME GOOD SETS.

P. S. B. (Redhill, Surrey).—"Not being sure of getting away for a holiday this year, I have a mind to improve the shining hour (if any!) by knocking up a two- or three-valver for winter use.

"Would you let me know what kind of two- and three-valve sets you have particulars of in the 6d. 'P.W.' Blue Print series? (In fact, I should like the four's as well, while you are about it, in case somebody asks me to knock him up one.)"

The following two-, three- and four-valve "P.W." sets are now available in Blue Print form from the Technical Queries Dept., POPULAR WIRELESS, The Fleetway House, Farringdon Street, E.C.4. Price 6d. each if stamped, self-addressed envelope is enclosed, or 7½d. post free.

(NOTE.—A number of "Modern Wireless" blue prints also are available at the same rates.)

No. 35. THE "UNIVERSAL" THREE. Detector and two resistance-coupled L.F. stages, with provision for the use of two valves in parallel in the last stage. A Reinartz detector is employed, and a tone control is also provided.

No. 42. THE "Q AND A" THREE. A simple set (Det. and two L.F.) to give full volume on the local station, with a possibility of long-distance work when a little skill in handling has been acquired.

No. 53. THE "REGIONAL" TWO. A simple but highly efficient little set (Det. and L.F.), especially

## THE ANSWERS

TO THE QUESTIONS ASKED ON PAGE 649  
ARE GIVEN BELOW:

- (1) 10.30 a.m., 1 p.m., 4.45 p.m., 6.30 p.m., 9 p.m., and 11.30 p.m.
- (2) The B.B.C. engineers are able to send a strong current of electricity through the wires, thus heating them sufficiently to melt any ice or snow adhering to them.
- (3) Brussels No. 1, on 509 metres. The reports are usually given at 5 a.m. and at hourly intervals throughout the day.
- (4) When resistances are connected in series the separate resistance values are added together, so, 50,000 + 100,000 would represent a total of 150,000 ohms.

DID YOU KNOW THEM ALL?

designed for the Regional scheme, incorporating a form of the "P.W." Brookmans Rejector.

No. 54. THE "TITAN" THREE (1930). One of the best of all single control three valvers of the H.F. type, with many up-to-the-minute refinements. An ideal set for use at some distance from the local station and on poor aerials where an H.F. stage is desirable.

No. 55. THE "MAGIC" THREE (1930). All the original special features of the famous "Magic" Three, with its super sensitivity, remarkable ease of handling and great power, with additional refinements, notably a form of Brookmans Rejector for the elimination of even the most powerful local station.

No. 56. THE "REGIONAL" FOUR. A real de-luxe receiver of exceptional selectivity, with an S.G. H.F. stage, two powerful L.F. stages and many refinements. Coil units have wave-change switches built in.

No. 57. THE "SHARP TUNE" TWO. A really simple all-wave set with a special selectivity control. Ordinary plug-in coils; wave range 20-2,000 metres.

No. 58. THE "EASY CHANGE" THREE. An efficient receiver, using plug-in coils in a special wave-change circuit.

No. 59. THE "THREE COIL" THREE. A high efficiency selective receiver, with an S.G. H.F. stage, which requires only three ordinary plug-in coils.

No. 60. THE "MAXI-POWER" FOUR. A powerful and selective long-range receiver with wave-change switching, and plug-in coils.

### USING THE "COSMIC" FOUR AS A RADIOGRAM.

"STONE CHRISTOPHER" (Caversham).—"I want to work the 'Cosmic' Four as a radiogram, by switching in the pick-up in front of the first low-frequency amplifier valve.

"The switch I have over from the last set is a push-pull type, with three contacts, the middle one making contact all the time with either one or the other outer contact. I want to use this switch again.

"My idea is to take the two leads from the pick-up to two new terminals under the on-off switch, and to place the radiogram switch from the other set beside these. Then wire up with grid of V3 to centre contact of the switch (the one always in use), so that the grid can be connected to either of the outer terminals as necessary.

"One of the outer terminals would be wired to one pick-up terminal, and the other outer terminal for 'radio.' It seemed all clear at first but when I come to do it I am a bit

stumped over the '25-meg. resistance which is connected between the grid leak and grid of V3.

"Would you give the complete wiring in words, and say whether the scheme has any snags from the point of view of efficient working, as it is outlined in this letter?"

The idea of using the pick-up in front of the first amplifying valve is a good one, but if you were going to use a rather insensitive pick-up it might be better to take in another stage of amplification by choosing the detector's grid instead of that of the first L.F. valve.

Assuming, however, that your pick-up will not need this (and that is a reasonable assumption where the modern pick-up is concerned), there is nothing against your scheme.

The complete wiring will be as follows:

The G. terminal of V3, which formerly went to the '25 meg., will be joined to the 'centre' contact on the radiogram switch. One 'outer' terminal of this switch will be wired to the bottom of the '25-meg. resistance.

As all the other wiring on the other side of this resistance will remain unaltered, the placing of the switch over to 'radio' will connect the grid of V3 exactly as formerly, and the wireless side of the set will be brought into action.

The other 'outer' contact of the radiogram switch will need to be wired to one of the new pick-up terminals. The other pick-up terminal should then be connected to that side of the '5-meg. grid leak that goes to the flex lead G.B.1, leaving this lead in position also.

In this way it will be unnecessary to have a separate grid-bias lead for the radiogram side of the set, the G.B.1 lead serving for whichever side—radio or gramophone—is in use. You thus get an easy and effective change-over from records to radio, or vice-versa, by operating the switch.

## BROADCASTING IN NORTH AMERICA

(Continued from page 632.)

that the programme is sponsored by their company, and leaving it at that. Prices are not allowed to be quoted, and the Radio Companies try to censure too blatant salesmanship.

Here are the actual words used by a firm of ginger-beer makers selling Klee-ko (Cliquot—shades of the champagne wine-grower). They have a concert party known as the Eskimos. Imagine this programme during the hot summer afternoons:

**Announcer:** "Look for the falling snow, for it's all mixed up with a lot of ginger, sparkle and pep, barking dogs and jingling bells, and there we have a crew of smiling Eskimos, none other than the Cliquot Club Eskimos, tripping along to the tune of their own march—'Cliquot.'"

**Orchestra** (plays "Cliquot," the trademark overture).

**Announcer (continuing):** "After their long, breath-taking trip down from the North Pole, the Eskimos stop in front of a filling station for a little liquid refreshment, and what else would it be but Cliquot Club Ginger Ale, the ginger ale that's aged six months? Klee-Ko is spelled C-L-I-C-Q-U-O-T. You'll know it by the Eskimo on the bottle. (Slight pause.) Up in Eskimoland where the cold wind has a whistle all its own, and a banjo is an instrument of music, the Eskimos spell melody with a capital 'M' and tell us that 'It Goes Like This.'"—and so on.

Well, I suppose they sell the ginger-beer by this means, and certainly a fine musical programme is put "on the air." My own considered conclusion is that, in all the circumstances, the B.B.C. might well lease a portion of broadcasting time to responsible business houses in England under proper safeguards. A good combination of what is best in the two methods would be an improvement on the financially-starved system of England, and some help to our industries.



He says it is  
**"ALL YOU CLAIM  
 FOR IT!"**  
 A reader's report on a "P.W."  
 2-valver.

The Editor, POPULAR WIRELESS.  
 Dear Sir,—It is now nearly six months since I made up a two-valve battery set incorporating the "Eckersley Tuner" from the circuit published in your journal. I have therefore had ample time to become thoroughly familiar with the operations of the set, and with its wonderful capabilities.

A detailed description of the performance of my "Eckersley" Two would sound exaggerated. I receive at least five British stations at excellent loud-speaker strength, and I can always rely upon more "foreigners" than I would have believed possible with a set not using H.F. amplification.

The selectivity is all that you claim for it, provided that the controls are handled with care and intelligence. I am not without musical knowledge and have a somewhat critical ear, but in my opinion the quality of reception leaves nothing to be desired. I have never heard this quality surpassed by any set, irrespective of size or type, and I have yet to hear another two-valve set which approaches within miles of it. I should add, too, that my loudspeaker is only a cheap "moving-iron" type, but the "Eckersley" Two makes it deliver a most satisfying bass response.

The tuner deserves particular credit in any case, as I have used a good deal of old "junk" in the set, an exception, however, being the L.F. transformer, which is one of the best obtainable.

The only detail in which I have departed from your exact specification is in the provision of a choke-output system, as I am now using a home-made direct-current H.T. unit (giving 200 volts on the power-valve). For local reception I find a short length of indoor aerial sufficient for excellent volume. For the benefit of others who have made up this set, I should like to stress the great improvement which resulted from "scrapping" the H.T. battery in favour of a mains unit with a really decent output (of course using corresponding grid bias).

Sets may come and sets may go, but I shall stick to my "Eckersley" Two for a long time to come.

Yours faithfully,  
 J. E. MCKNIGHT.

Stamford Hill, London, N.16.

**"BUSY AS BEES  
 AT H.M.V.'s"**  
 Some interesting facts and figures  
 about the great establishment at  
 Hayes.

SOME interesting aspects of up-to-date radio-set production were recently revealed by Mr. Richard Haigh, the English manager of The Gramophone Company, when discussing the H.M.V. plans for the coming season.

Referring to the company's great Hayes factories, covering about sixty acres of land, he told how over 7,000 workers are employed in the factories, and it is necessary to employ about forty per cent of female labour. The reason, he said, was that there were numerous manufacturing processes which could be satisfactorily accomplished only by members of this sex.

Every day more than eleven hundred miles of wire were used for making coils. And one operation in the manufacture of a pick-up involves 11,000 turns of wire only half the thickness of a hair, in a space only  $\frac{1}{2}$  by  $\frac{1}{4}$  of an inch!

Another interesting disclosure was that there are 2,461 separate parts in a medium-priced radio-gramophone, and 120 working hours are needed to manufacture it! When the great H.M.V. range for the coming season is considered the marvel is that even the huge organisation at Hayes can cope with the work with such outstanding success.

## Definitely BETTER Radio At LESS COST!

**STAND  
96**

**STAND  
96**

**8 FREE BLUE PRINTS**  
 including Kit Eliminator and All Mains  
 Band Pass 3.

*\*See the new Tunewell Super-Radio  
 Components and wonderful new Radio-  
 gram at STAND 96, Olympia.*

Tunewell Radio Ltd., 54, Station Rd., London, N.11.

# TUNEWELL



**R. Type  
 Terminal  
 Insulated  
 Non-removable  
 Head**

**NOW  
 2½<sup>D</sup>**

## BELLING-LEE

**FOR EVERY RADIO CONNECTION**

Advt. of Belling & Lee, Ltd., Cambridge Arterial Road, Enfield, Mdx.

# WILLS'S CAPSTAN ARE CAPTIVATING

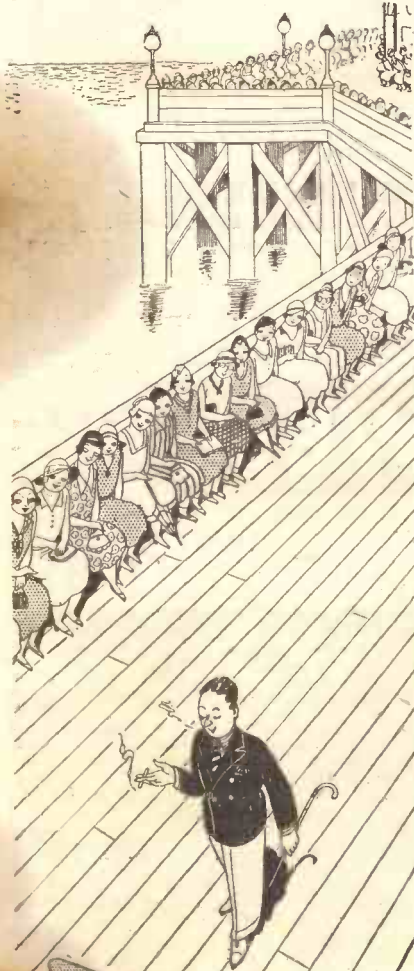

Rocwell

10 FOR 6<sup>0</sup>  
20 FOR 11<sup>10</sup>

They suit  
everyone

Save your CAPSTAN packets for  
The Imperial Tobacco Company

**POSTER COMPETITION**

**£20,000 in Cash Prizes**

Ask your Tobacconist for particulars.

C.C.M.S.

## SUPER-QUAD PORTABLE

(Continued from page 644.)

The net result is that on 5 X X the results are little short of remarkable, while in most cases a low-wave station such as the London National does not come in anywhere near so well as the longer wave medium-wave ones such as the London Regional. Few stations beyond the nearer British ones are receivable without an extra aerial and earth, but when this is fitted they all seem to be "on tap."

### A Novel Test.

The set's first real adventure was on a long train journey from London towards the north, and it provided a programme for a greater part of the way. Under bridges, of course, it shut up, and also in tunnels—except one long one, in which case, thinking perhaps that it was time the tunnel came to an end, it started up for a short period right in the middle!

Another point of interest was that the long waves were noisier on the train than the medium. Whether this was due to the greater sensitivity on the former band, or to some peculiar effect of train travel, it is difficult to say. But it was most noticeable.

Altogether the set is most fascinating, and the owner never tires of showing how easily tuned it is by setting the dials and just switching on, when the programme comes through at full strength. There are few portables with which this can be done.

The writer will be pleased to hear from any reader who cares to tackle the making of a similar set for its experimental interest as well as its usefulness as a stand-by programme provider.

## HINTS FOR RADIO- DRAMATISTS

About a book on writing for Radio.

IT is difficult to say whether the principal reaction obtained from reading Mr. Val Gielgud's little volume should be termed astonishment at the author's courage, or amazement at his impudence.

It all depends on the point of view. It is probably courageous for a man who, as the B.B.C. Productions Director, must spend a large part of his life in rejecting the work of other people, to put examples of his own radio dramatic achievement into print under the title "How to Write Broadcast Plays" (Hurst & Blackett, 2s. 6d.). The comment invited is only too obvious.

### Drawing Off the Fire.

But Mr. Gielgud is sufficiently intelligent to realise that. He has therefore taken the necessary precautions—which is where his impudence comes in. For he has taken considerable trouble to draw his own weak points carefully out of the line of critical fire by criticising himself so unmercifully as to leave little for his professional detractors to do.

Having given us his three plays, he tears them to pieces so thoroughly that the reader is compelled, willy-nilly, to believe that they can't have been as bad as all that, or

they would never have been allowed to be broadcast.

Therefore, in spite of all the criticism that has been directed against them, the final verdict upon the plays as plays is inclined to be favourable. For, of their kind, they are not bad. They cover a most interesting period in the development of radio plays, and severally they are representative of three quite separate types.

In this representative capacity, they are worth the study of any writer with aspirations to microphone production.

"Red Tabs" in particular, in my view, and in spite of the faults in its construction which Mr. Gielgud points out in his comments, gives much food for thought.

But though the plays in themselves are not without their interest, the real value of this volume lies in its introduction and its conclusion. Here there is a refreshing lack of what might easily be expected in a

## NEXT WEEK

The exclusive "P.W." series of articles dealing with radio

### "ON THE OTHER SIDE"

will continue with an extremely interesting and informative

### TALK WITH A DANISH LISTENER

And if you are thinking of your autumnal radio requirements you must not miss

### "AN L.S. AMPLIFIER"

OUT ON  
THURSDAY

ORDER  
NOW!

volume with such a title. Here are no high-falutin' theories, no abstract discussions couched in pseudo-technical language, but a number of sternly practical hints expressed in language which anyone can understand.

### The Need for Comedy.

The essentials of radio drama technique are reduced to their primary elements and set before the would-be author with the comforting assurance that the technique of radio play-writing and production is nothing like as complex as it is sometimes made out to appear.

There is one point which he makes which, if his statistics of plays on the one hand submitted and on the other rejected are accurate, should be taken most strictly to heart by all who wish to write for the microphone. Mr. Gielgud speaks of the lack of radio comedy, and advises authors to study their market. At present they are obviously not doing so, or it is inconceivable that only one out of every hundred radio plays submitted to the B.B.C. should be acceptable. It is worth the ambitious writer's while to get this book and read it, because if it does not actually teach him how to write dialogue or invent stories, it does give him a pretty shrewd idea of the market in which he is trying to sell his goods. If not actively inspiring, it is really practical.

C. S.

# THE LISTENER'S NOTEBOOK

(Continued from page 636.)

Volubility usually suggests irrelevancy, but in this case every line Mrs. "Drinnan" uttered got a really good laugh.

I am still chuckling over the lament that "motor funerals leave no time for reconciliations." This is typical of the dialogue throughout. More of this sort of comedy (announced as a serious comedy, incidentally) would make listening-in more worth while.

The overture from "Iolanthe" was a real treat. I cannot see why Sullivan should be dispensed so sparingly. The B.B.C. programme seemed to make a special feature of it by giving it a sort of "To-day Special" prominence.

I am glad, too, it was the Overture and not "Selections from." On the rare occasions these operas are given we usually get the latter.

### Infrequent Visitors.

Were you pleased to hear Troise and the Mandoliers again? Not being frequent visitors to the microphone, they can make a fresher appeal than most bands, especially as they avoid the beaten tracks.

Their soloist, too, is in quite a different class from most soloists.

Will Fyffe's last appearance was a typical farewell performance. Although his song isn't the most important part of his turn, I am always glad to hear it. Like Harry Lauder's, it is always a song with a good tune.

Will Fyffe doesn't sing as well as his more illustrious compatriot, but I think he can give him points with his patter. It is a different kind of patter, of course, but it's the stuff that makes you laugh and keeps you laughing.

In Harry's case, it is generally he who does the laughing.

Collinson and Dean are a good pair, and provided they find fresh material they can always be sure of a good hearing. Haver and Lee seem to realise the importance of this. In their case it is comparatively easy to produce another episode in their racketeering career, but with others it isn't quite so easy.

There are some, however, who seem positively unable to give us something else

for a change; they mustn't be surprised or hurt if they hear about it.

### "Hazard" Series Saved.

I shouldn't be surprised to hear that our town librarian cannot cope with the sudden demand for Wren's "Beau Guest" following Major Wren's "Hazard" talk. Not only will a new clientele wish to be better acquainted with the doings of the famous Foreign Legion, but also the odd one will find the desire to re-read past favourites irresistible—so thrilling was the author himself in his story he called "Twenty-four Hours in the Foreign Legion."

That Major Wren has repaired the damage done to the "Hazard" series by the intervention of some "high authority" is unquestionable. The series cannot peter out now; on the contrary, we shall look forward to the next on the list with as much enthusiasm as we shall look back on the last.

**HOLIDAY READING**

If you want the best radio shillings-worth on the market—get

**MODERN WIRELESS**

The August Number is

ON SALE EVERYWHERE. PRICE ONE SHILLING.

The story was told magnificently, in a language as colourful as the uniforms of that heterogeneous collection of men Major Wren found at that depot under the shadow of the Château d'I.

It is clear that if we are to enjoy any more concert parties from Aberdeen, we must begin at once an intensive study of Scotch. Ordinary Scotch à la Will Fyffe is English compared with Harry Gordon's vintage.

Notwithstanding these difficulties in translation, the concert party from Aberdeen was really good fun, and ideal for a Saturday night. Its only fault—that of being too short—seemed an unnecessary one, and to the artistes taking part in the second half of the programme from the Glasgow studio, an unfortunate one. They suffered in comparison.

Did this idea of the two halves come voluntarily from the B.B.C. or was it forced on them by Harry Gordon? It is perhaps unkind to voice this guess, but Aberdeen has a lot to live down.

# PILOT

## AUTHOR

# KITS

Exact to Specification

**CASH—C.O.D.—H.P. Immediate Delivery.**

## "COSMIC" FOUR

Described last week.

**KIT "A." Author's Kit, less Valves and Cabinet. £6-9-6**

or 12 monthly payments of 11/10.

**KIT-BITS** Selected C.O.D. Lines—We pay post charges on orders value over 10/-

Specified Valves ..	£2	2	6
Cabinet ..	17	6	
1 R.I. Cosmic Coil Unit ..	12	6	
2 Cydon '0005 Extenders with slow-motion coils ..	£1	13	0
1 Moderator Gail ..	2	6	
1 Sovereign Vario-Choke ..	3	6	

## A. C. RADIOGRAM

Described July 9, 1932.

**KIT "A." Author's Kit less Valves, Cabinet, Speaker, Power Pack, Motor and Pick-up. With Ready Drilled Panel. CASH or C.O.D. £6-4-1**

or 12 monthly payments of 11/5

**KIT-BITS** Selected C.O.D. Lines—We pay post charges on orders value over 10/-

3 Valves as specified ..	£2	7	6
<b>1 Peto-Scott Radiogram Cabinet as Specified</b> ..	£1	15	0
1 R & A Challenger Loudspeaker ..	£1	15	0
1 Heayberd Power Pack (Popular Type) ..	£4	7	6
1 Lotus 2-gang '0005-mid. Condenser with disc drive ..	£1	5	0
2 Colvern Coils (Type K, C.R. and K.G.O. with 8 in. Switch Rod) ..	19	0	

## EASIWAY ITEMS

JUST RELEASED

### GOSSOR MELODY MAKER

Complete with valves, speaker and cabinet. Employs Gossor Variable-Mu S.G. H.F. stage, Detector and Power Valves. Cash Price £7-17-6  
Balance in 11 monthly payments of 14/6. Only.

**W.B. PERMANENT MAGNET MOVING-COIL SPEAKER P.M.3.** Complete with 3-ratio input transformer. Cash Price £2/12/6. Balance in 11 monthly payments of 4/10. Only

**W.B. PERMANENT MAGNET MOVING-COIL SPEAKER.** Type P.M.4. Complete with Transformer. Cash Price £2/2/0. Balance in 7 monthly payments of 5/9. Only

**ULTRA IMP PERMANENT MAGNET MOVING-COIL SPEAKER,** with input transformer. Cash Price £2/15/0. Balance in 11 monthly payments of 5/-. Only

**BLUE SPOT SPEAKER UNIT AND CHASSIS, TYPE 100U.** Cash Price £1/19/6. Balance in 7 monthly payments of 5/5. Only

**ATLAS ELIMINATOR, TYPE A.C.244.** 3 Tappings, S.G. Detector and Power. Output: 120v. at 20 m/a. Cash Price £2/19/6. Balance in 11 monthly payments of 5/6. Only

**CARRARD INDUCTION GRAMOPHONE MOTOR.** For A.C. Mains. Model 202. Mounted on 12-in. Nickel Motor Plate with fully automatic electric starting and stopping switch. Cash Price £2/18/6. Balance in 11 monthly payments of 5/4. Only

### PETO-SCOTT CO. LTD.

77, CITY ROAD, LONDON, E.C.1.  
Dear Sirs,—Please send me CASH/C.O.D./H.P.

for which I enclose £..... s. .... d.  
CASH/H.P. Deposit.  
NAME.....  
ADDRESS.....  
P.W. 6/8/32.....

West-end Showroom: 62, High Holborn, London, W.C.1.



## OSBORN RADIO CABINETS

THERE'S A DESIGN FOR YOUR SET—WRITE TO-DAY.

**MODEL No. 218.** A Queen Anne Radio or Radio-Gramophone Cabinet. 3' 10" high, 2' 2" wide, 1' 6" deep. Size of haffle board behind fret, 24" x 24". Metallic fabric for fret front included. Opening at top and back. Cabinet takes panel 2' x 9" or smaller. Complete with motor-board. Send 3d. in stamps for Beautifully Illustrated New Season's Catalogue.

**PRICES.** Machined ready to Assemble:  
Oak .. £3. 10. 0.  
Mahogany .. £3. 15. 0.  
Walnut .. £4. 10. 0.  
Assembled ready to Polish:  
Oak .. £4. 10. 0.  
Mahogany .. £4. 15. 0.  
Walnut .. £5. 10. 0.  
Assembled and Polished:  
Oak .. £5. 10. 0.  
Mahogany .. £6. 5. 0.  
Walnut .. £7. 5. 0.  
All Models Carr. Paid.

**STAND 32, GRAND HALL, National Radio Exhibition, OLYMPIA, Aug. 19-27.**

All Applications for Advertising Space in "POPULAR WIRELESS" must be made to the Sole Advertising Agents, JOHN H. LILE, Ltd., 4, Ludgate Circus, London, E.C.4. 'Phone: City 7261

CHAS. A. OSBORN, Dept. P.W. The Regent Works, Arlington Street, London, N.1. Telephone: Clerkenwell 5095. And at 21, Essex Road, Islington, N.1. Telephone: Clerkenwell 5634.

# 2 WEEKS TO THE RADIO SHOW!

## Get the best price for your old set—NOW!

1933 models are here! Now Osram, Cossor, Ekco and many other famous manufacturers have put their new sets on the market. Now, "P.W." will be publishing the new season's sets for you to build. Now you can have better radio than you have ever had before. Sell us your old set or components. Get the best price for them, *before the Radio Show*. Send the coupon to-day!

### READ THESE TYPICAL EXAMPLES

We paid a customer 25s. for a Lamplugh Inductor Speaker, and helped him to buy an "R & A" Challenger (£1 15s. 0d.).

We paid a customer 2s. 6d. for a Telsen Ace Transformer and helped him to buy a Multitone Transformer (17s. 6d.).

We paid a customer 30s. for his Ekco Eliminator 1V20 and helped him to buy a Heayberd Power-pack (£4 7s. 6d.).

Sets and components of any type taken in part exchange. Every radio requirement supplied from new stock. Free Advice on any radio problem.

**FILL IN AND POST COUPON TO-DAY**

### WHAT WOULD YOU ALLOW ME FOR:-

### I AM THINKING OF BUYING:-

ON CASH OR H.P. TERMS.  
(Cross out whichever does not apply)

Name.....

Address.....

Post to-day to:—Co-Radio Ltd.,  
Dept. P.W.3., 78, Neal Street, W.C.

**THIS PUTS ME UNDER NO OBLIGATION**

# CORADIO

Showrooms: 78 Neal Street  
Shaftesbury Avenue, W.C.

## TECHNICAL NOTES

Some diverse and informative jottings about interesting aspects of radio reception.

By Dr. J. H. T. ROBERTS, F.Inst.P.

### Pick-up Tests.

WHEN testing a gramophone pick-up, most people simply connect it to the receiver in the ordinary way and play a number of records to which they are accustomed and then judge the result by ear. Perhaps in a general way there is something to be said for this arrangement because, after all, the ultimate purpose of the pick-up is to give you something which is pleasing to the ear, and no amount of scientific evidence as to the merits of the pick-up will carry much weight if your ears tell you that the result is displeasing.

On the other hand, if you wish to make a number of more accurate tests you can dispense with the amplifier and loudspeaker arrangement and just test the output of the pick-up directly; for this purpose it is best to use a valve voltmeter if one is available.

It is also essential, for really accurate tests, to use the so-called frequency records which are made for such purposes, and you will probably be surprised to note the many peculiarities in the output of the pick-up as the frequency is raised from the lowest up to the highest pitch available on the record.

### Effect of Scratch Filter.

Another interesting experiment which can be made at the same time is to test the effect of the scratch filter, if you use one, and to see to what extent this cuts out the higher frequencies. Some scratch filters, whilst effective enough for their purpose, go too far in the opposite direction and cut out more of the high frequencies than is necessary for the correction of scratch.

It is interesting also to try the effect of a volume control or an output transformer, first trying the output of the pick-up with the volume control or transformer, or whatever it may be, in circuit and then trying the effect without.

If you merely connect the pick-up to the receiver and then try the output of the receiver or (as you do by ear) the sound output of the loudspeaker, you are not testing the pick-up *alone* but are getting a composite effect which includes the peculiarities of the pick-up, the loudspeaker, and all the various parts of the amplifier.

### Iron-Core Saturation.

You are often advised to use output-circuit arrangements so that the steady current in the anode circuit of the last valve does not flow direct through the speaker windings. There are a number of reasons for this, one of the most important being that with any electro-magnetic device of this kind, whether it be a loudspeaker unit, transformer or an iron-core choke, the inductance is affected by the steady current.

For instance, take the case of an iron-core choke. The object of this is to prevent, or, at any rate, to cut down, low-frequency variations of current, and this it does by reason of its inductance, which in turn

depends upon the condition of the magnetic core.

If the steady current is sufficient to bring up the core to a point approaching saturation, it is obvious that any variation superimposed upon this current will have correspondingly less effect; in other words, the efficiency of the choke will be definitely reduced.

### Overloading Small Instruments.

The same thing applies to a transformer. If there is a steady current in the primary winding which saturates or nearly saturates the magnetic core, the speech-currents will have relatively little effect and, consequently, the "transfer" effect of the transformer will be reduced.

These considerations naturally depend upon the size of the instrument, transformer, choke and so on, and this must be taken in relation to the steady current. If a large transformer or choke with ample magnetic core and windings is used there will be no difficulty, but the trouble arises when a small instrument is used which is really inadequate for the purpose. Steady current overloading of such small transformers and chokes takes place much more often than you might think.

### Locating Mains Hum.

I was talking the other day about mains hum in a set and how you could test for this by connecting a pair of flexible leads to the inter-valve transformer and shifting this about into different positions until the effect was overcome.

Another well-known dodge is to connect a resistance across the primary of the L.F. transformer, first disconnecting the primary, of course, and then moving the transformer about so as to find the best position. The value of this resistance need not be exact, but it is preferably about equal to the internal resistance of the preceding valve.

As I mentioned before, when all this is done and the best position for the L.F. transformer is found and then the original connections are made, often enough the hum will come back. In many cases when this happens it is due to the H.T. supply to the preceding valve, and, obviously, the way to get over it is to apply better smoothing to the H.T. supply.

### Try Fieldless Coils.

Sometimes, however, you find that no matter what you do with the H.T. you will get this hum, and you may then turn your attention to the question of the H.F. choke, which is often used in the detector-anode circuit.

Usually we think of the stray field of a choke, especially an iron-core choke, as liable to produce interference with neighbouring components, but in this case the H.F. choke, if it is of a type which has an open or stray field, may well act as a pick-up of stray energy from the power

(Continued on next page.)

### TECHNICAL NOTES

(Continued from previous page.)

transformer. The same manœuvring should, therefore, be tried with the choke just as with the L.F. transformer.

If you "short" the choke and test with and without the short, you will soon be able to tell whether the choke is causing any trouble. A good deal depends naturally on the design of the H.F. choke itself and the nearer this is to the so-called "field-less" type, the less the danger of any stray effect taking place between it and the mains transformer.

#### That Big Power Valve.

When you are very particular about quality there is a lot to be said for having a good big power valve in the output stage. Most people realise this, but what many don't realise is that the various other factors must be to match.

It is no good just taking out the valve which you are using in the last stage and going and buying a big power valve and just expecting "power" results and wonderful quality.

You must think also of the high-tension voltage required by the power valve which you have fitted, also of the necessary gridbias and anode current. The loud-speaker, too, comes under review; it must not only be a correspondingly good instrument, but it must be coupled to the valve in the proper way. For this purpose, as I have mentioned before, a choke-condenser filter is very desirable, whilst in some cases a tapped choke or a proper transformer will be needed.

The tone of the output will depend upon the characteristics of the valve, amongst other things, and if you just change the valve without attending to all the consequential adjustments which become necessary, you will be disappointed.

#### Coil Developments.

I wonder how many sets there are in use to-day employing plug-in coils? I suppose most of us, if asked the question, would regard plug-in coils as rather out-of-date. But I am pretty certain there must be quite a lot of them knocking about. In fact, you often see designs for sets which specify plug-in coils.

If you take the single-layer coil as a standard of efficiency, it is true that the plug-in coil may seem relatively inefficient. But, on the other hand, there are some modern types of coil which, whilst they are convenient, are again not so efficient as the single-layer coil, and no better from this point of view than the plug-in type, so that looked at in this way there is still a good deal to be said for the so-called old-fashioned coil.

I am also quite sure from experience, that there are quite a lot of people who simply use their set for tuning to one station, or at any rate to stations on one waveband, which can be tuned-in over the dial with one set of coils. So that they are quite well off with the older types of coil and have practically no need for the more modern developments.

#### What About Plug-in Coils?

So far as plug-in coils themselves are concerned, I have always thought that one of their greatest drawbacks—rather a

(Continued on next page.)



## "Monarch of the Mains"

Heyberd model D250 Mains Unit is a real "Monarch" among Mains Units. For any receiver, from a one-valve to a six-valve super-het. Carefully selected Heyberd components and Westinghouse Rectifier. Complete in neat steel case. Ready to switch-on.

**HEYBERD D250 MAINS UNIT**  
Alternative Outputs: 60 ma. at 200v. or 250 volts. Tappings: S.G. 60/80v. Var., 0-150v. Var., 100-200v. Var., 250v. Fixed.  
Complete **170/-**  
L.T. 4 volts 6 amps for A.C. Valves, if required, 10/- extra.

#### POST NOW

I enclose 3d. stamps for instructive lists explaining how to electrify my receiver.

Name.....  
Address.....  
P.W. ....

**F. C. HEYBERD & CO.**  
10, FINSBURY STREET, LONDON, E.C.2.  
One minute from Moorgate Underground Station.

**ENGINEERS**—If you wish for something more than a "bread and butter" job you owe it to yourself to investigate our Service. On request we will send you a free 200-page Hand-book, which will explain many ways in which well-paid careers, carrying salaries of £4, rising to £20 per week, can be followed. The book also gives details of all leading Examinations (A.M.I.Mech. E., I.E.E., G.P.O., etc.) and outlines Modern Home-Study Courses in all branches of Elec., Mech., Motor, Radio, Talkie Engineering, etc. Do not miss this opportunity—send for your free copy of our Hand-book NOW.

**BRITISH INSTITUTE OF ENGINEERING TECHNOLOGY,**  
401, Shakespeare House, 29/31, Oxford Street, London.

## FREE A Luxury Wireless Set

or components of equivalent value

Wonderful offer to introduce the Radialaddin Club. Write, enclosing 11d. stamp for particulars. Radialaddin Club (Dept. P.W.), 47/48 Berners Street, London, W.1. Museum 1321.

The Goods as Advertised! From TWO to TWO THOUSAND metres, we can solve your Radio Problems, including Amateur Transmission! Whatever your difficulty, write us. Charges: 3/- per query, four or more 2/6 each, including diagrams.

**RADIO TECHNICAL AGENCY, DEPT. P.W. 2, Westgate Chambers, Newport, Mon.**

## 10,000 GRAMO-MOTORS FROM STOCK

**BIG SUMMER DISCOUNT ALLOWED**  
Make a Gramophone or Radiogram Order loose kits and assemble them at home. Get for 3d. our new 64-page catalogue with scale drawings and instructions how to make them. We sell motors from 7/6, tone-arms, soundboxes, 1/6, pick-ups, big volume horns, loudspeakers, radio kits, complete receiving sets, gramophones, radiograms. Established 1903.  
**THE REGENT FITTINGS CO., P.W. 120, OLD STREET, LONDON, E.C.1.**



# QUICK EASY PAYMENT SERVICE

We supply all good quality Radio Receivers, Components, and Accessories on deferred terms. Large stocks are carried and orders are executed promptly. Send list of requirements and a quotation will be sent by return of post. Price List free on request.

**NEW COSSOR MELODY MAKER,** Model 335 (just released). Complete Kit of Parts, Valves, and Loudspeaker. Cash Price £7/17/6. And 11 monthly payments of 15/- **With 10/- order**

**MURPHY NEW ALL-MAINS 3-VALVE Set.** Model A.3.A. Cash Price £19/19/0. And 12 monthly payments of 33/- **With 39/- order**  
We are appointed Murphy Dealers.

**ATLAS ELIMINATOR, A.C.244.** 3 H.T. Tappings. 20 M/A output. Cash Price £2/19/6. And 11 monthly payments of 5/6 **With 5/- order**

**ORMOND PERM. MAGNET MOVING-COIL UNIT.** Cash Price £3/5/0. And 11 monthly payments of 6/- **With 5/- order**

**EKCO H.T. ELIMINATOR A.C.18.** Suitable for 3-Valve S.G. Sets. Cash Price £3/7/6. And 11 monthly payments of 6/3 **With 6/3 order**

**NEW R & A "CHALLENGER" PERM. MAGNET MOVING-COIL UNIT.** Cash Price £1/15/0. And 6 monthly payments of 5/8 **With 5/- order**

**NEW EPOCH 20C PERMANENT MAGNET MOVING COIL UNIT** Cash Price £1/15/0. And 6 monthly payments of 5/7 **With 5/7 order**

**12 EXIDE HIGH-TENSION ACCUMULATORS** (120 volts WH-10 super-capacity, 5,000 milliamps). The cheapest form of high-tension supply where electric light mains not available. Cash Price £3/15/0. And 11 monthly payments of 7/- **With 7/- order**

**BLUE SPOT 100U INDUCTOR UNIT.** Cash Price £1/19/6. And 7 monthly payments of 5/5 **With 5/5 order**

To avoid delay, will customers kindly send deposit with order.

All above carriage paid.

# The LONDON RADIO SUPPLY COMPANY ESTD 1925

11, Oat Lane, Noble St., LONDON, E.C.2  
Phone NATIONAL 1977

## LOUD SPEAKERS REPAIRED, 4/-

(Blue Spot a Speciality, 5/-)  
Transformers 4/-, Headphones 4/-, all repairs magnetised free. Eliminator Repairs quoted for. 24 Hours Service. Discount for Trade. Clerkenwell 9069.  
**E. MASON, 44, EAST ROAD, LONDON, N.1.**

## The ACME of CRAFTSMANSHIP, High Grade RADIO GRAMOPHONE CABINET

of exclusive modern design, with record wells hand-made and polished, on Queen Anne legs. Figured Oak £7 13 6 Figured Walnut or Mahogany £9 9 0 (Carriage Paid.)  
Illustrated Catalogue Free. Cabinets made to order a speciality.

**GILBERT** Cabinet Maker, SWINDON  
Estimates Free. Estd. 1866.



**REMEMBER!** "POPULAR WIRELESS" has the largest sale of any WEEKLY WIRELESS JOURNAL.

# New Times Sales Co

## EVERYTHING RADIO EASIEST TERMS

★ **W.B. PERMANENT MAGNET MOVING-COIL SPEAKER P.M.3.** Complete with 3-ratio input transformer. Cash Price £2/12/6. Balance in 11 monthly payments of 4/10. With 4/10 order

★ **ATLAS A.C. ELIMINATOR, TYPE A.G.244.** Three tappings, S.G., detector, and power. Output, 120 volts at 20 m.a. Cash Price £2/19/6. Balance in 11 monthly payments of 5/6. With 5/6 order

★ **EPOCH J.I. PERMANENT MAGNET MOVING-COIL SPEAKER** with 3-ratio input transformer. Cash Price £2/5/0. Balance in 11 monthly payments of 4/2. With 4/2 order

**IMMEDIATE DELIVERY!**  
**COSSOR MELODY MAKER**  
 Model 335. Complete with valves, Speaker and Cabinet. Employ 3 Cossor Variable-Mu S.G. H.F. stage, Detector and Power. Cash Price £2/17/6. Balance in 11 monthly payments of 14/6. With 14/6 order

★ **BLUE SPOT SPEAKER UNIT AND CHASSIS, TYPE 100U.** Cash Price £1/19/6. Balance in 7 monthly payments of 5/5. With 5/5 order

★ **GARRARD INDUCTION GRAMOPHONE MOTOR.** Model 202. For A.C. Mains. Mounted on 12-in. Nickel Motor Plate with fully automatic electric starting and stopping switch. Cash Price £2/18/6. Balance in 11 monthly payments of 5/4. With 5/4 order

Any items advertised in this journal sent C.O.D. If value over 10/- sent all C.O.D. charges paid.

To **NEW TIMES SALES CO.** 56, Ludgate Hill London, E.C.4

Please send me (a) Free 1932 Catalogue

(b).....for which I enclose first payment of £.....d.....

Name.....

Address..... P.W. 6/8/32

**ELECTRADIX BARGAINS**  
 TRANSFORMERS. Special offer—Mains Transformers, 100/250 volt/350-0-350 v., 60/100 m.a., 4 volts, 2 amps., 4 volts, 1 amp. 15/-, 220 volts /8-12-20 volts, 2 amp. 10/-. Western Electric 1:1 Transformers, 2/6.



NAVAL TELESCOPES, gun-sighting pattern, by Ross and others. Illuminated field for night or astro. work, complete in case, cost £28. Sale Price 17/6.

PERMANENT MAGNETS, Cobalt Steel Horseshoe 1 lb. weight, 5 in. high, 2/-; smaller sizes, 1/6, 1/3 and 1/- each.

BARGAIN PARCELS of Electrical and Radio Sundries; better value than ever for experimenters, 10 lbs., 7/-, 7 lbs., 5/-. Post Free. Jewelled 1st grade meter movements, 5/-.

FULTOGRAPH RADIO PICTURE RECORDERS. Brand new £20 kits, surplus stock, 32/6 only.

1,000 other Bargains in our Sale List, post free. Send stamped addressed envelope to

**ELECTRADIX RADIOS**  
 218, UPPER THAMES STREET, E.C.4.

**EXACT TUNERS**  
 250 to 2,000 metres.  
 Thousands of these tuners are in use, and we can strongly recommend them. No further coils are required. Send P.O. for particulars and circuits—FREE.

**THE EXACT MANUFACTURING CO.,**  
 Croft Works, Priory Street, Coventry.

Make  
**THE DAILY SKETCH**  
 YOUR Picture Paper

## TECHNICAL NOTES

(Continued from previous page.)

stupid and unnecessary one—is that the contacts are often faulty, not only the contacts between the pins and sockets, but even the contact between the end of the winding and the terminal of the pin.

If the coil is rather hard to push in it seems as though the strain put upon it quickly loosens the contacts and the results are very troublesome. I am all against undue "handling" of coils, and I think it is much better to fit the coil once for all, and to operate any changes electrically, or by a switch, rather than by any actual manipulation of the coil itself.

### Tuning and Quality.

A beginner doesn't have to handle a wireless set very long before he notices that accuracy of tuning has a definite effect upon the quality of reproduction. It used to be said that a simple means of volume control was to de-tune slightly.

This was all very well in the days of non-selective sets, but in these days when sets are made more and more selective, this de-tuning dodge is not to be recommended. The fact is that with any decently selective set, as soon as you start to de-tune or go away from the best tuning position for any station you are liable to run into distortion.

If the tuning circuit is of low resistance, in other words, if the tuning is sharp, the higher audio-frequency notes are apt to be cut off. This is owing to the fact that when we tune any particular station it is not only the fundamental frequency which is tuned-in but also the adjacent frequencies or sidebands, which are due to the modulation when speech frequencies are superimposed upon the actual carrier-wave.

### Cutting the Sidebands.

As the sharpness of the tuning of the circuit is improved, the tendency to cut out these sidebands is also increased, and speech is liable to lose its crispness, whilst in the case of music the cutting-off of the upper audio-frequencies results in the reproduction having a "bass" character.

The fact is that selectivity and quality are rather conflicting requirements, and in most cases it comes down to a question of compromise between the two. If you want selectivity with quality it is necessary to employ a number of tuning circuits, whereas if you are limited to relatively few tuning circuits these individual circuits must not be unduly selective. By using a number of tuned circuits the quality can be preserved, because each tuned circuit can be made to preserve the sidebands, whilst the net effect of the operation of all the tuned circuits together is an increase in selectivity.

### How Many Tuned Circuits?

Many sets use only two tuned circuits, but it is fairly safe to say that if you want good selectivity without any appreciable loss of quality you must go to three or even to four tuned circuits. Taking the ordinary three-valve set, one H.F. stage and one L.F. stage, this generally has two tuned circuits, and consequently with such a receiver it is virtually impossible to push the selectivity too far without loss of quality.

Perhaps I should add that if you use band-pass tuning this amounts to additional

tuning circuits without an extra valve. The band-pass tuner arrangement consists of a pair of loosely-coupled circuits prior to the first valve, and it has the advantage that, whilst excellent selectivity can be obtained by its use, there is little or no cutting of sidebands, and consequently there is very little loss of quality.

### The Home Constructor.

It has often been prophesied that the home constructor would in course of time die out entirely or at any rate become of negligible account.

With the great improvements in commercially-made sets and the constant reductions in price, people said that no one would trouble about making sets at home—except a few "fans."

As we now know, nothing could have been further from the truth. I suppose home constructing of wireless sets is more widespread and popular to-day than ever it was. The fact is that we are the greatest nation of home constructors in the world.

In some of the European countries home constructing is relatively unimportant, because the people are not minded that way. But in this country the constructor has come to stay.

If any proof were needed for this, it is amply provided by the popularity of the sets described from week to week in "P.W." and month by month in "The Wireless Constructor" and in "M.W."

The continued success of these circuits and sets for home constructors is one of the most outstanding features of the radio business. I know lots of people of all ages (and I expect you do to) who have become experts in the art although in many cases they had, a few years back, no idea how to handle the simplest tools.

### Kit Sets.

Of course, it should be said that the manufacturers have played their part in fostering this national taste for home construction, as the modern "kit" sets will testify. Lots of people simply love fitting and assembling a set of parts, whereas it isn't their meat to cut and drill panels, tap holes and so on.

The makers have wisely foreseen this, and have done for them all those parts requiring a degree of engineering skill or the possession of special tools. The result is that with the modern kit of parts, anyone having the necessary interest—there is scarcely any skill needed—can make up for himself a receiver equal in every way to the commercial article.

There is a saving in cost which, it is true, is often quite important. But what really matters is the pleasure in the making and the much greater pleasure and pride afterwards in the accomplishment.

### It's Very Catching!

Once your constructor has caught the spirit, nothing will stop him from going on to greater and greater achievements. All of which is good for trade and for the technical training of the rising generation.

So the dismal jimmies who thought we would all soon be content to sit back and merely listen—with commercially made sets ("custom built" sets as they call them in the States) reckoned without their host.

# THE AUGUST MODERN WIRELESS

IS PACKED WITH  
absorbing radio reading that will appeal to all those who use a wireless set whether they are long-distance enthusiasts or ordinary listeners-in.

DETAILS OF THE  
"FIVE-GRID"

### FOUR

A fine long-distance receiver, full of the latest developments.

THERE IS SOMETHING TO  
INTEREST EVERYBODY

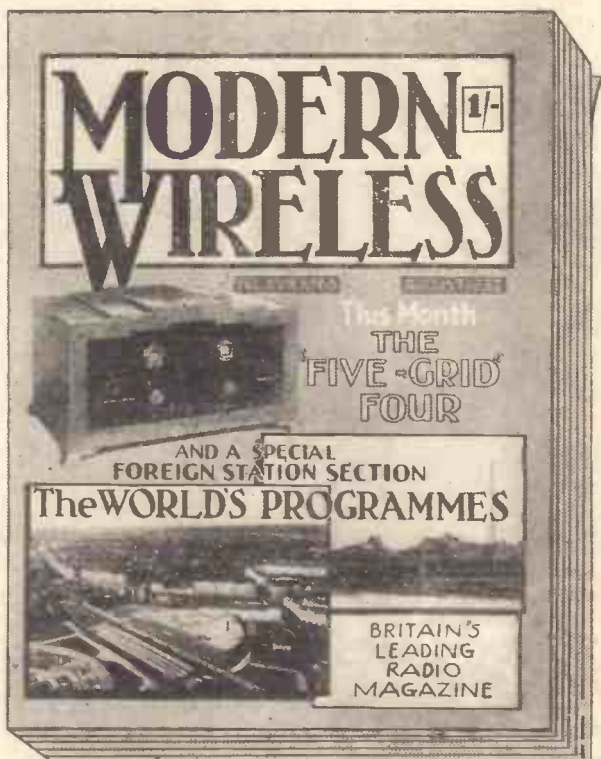

HOW TO MAKE THE  
"M.W."

"GRAMO-TONE"

AND  
CHARGER

CHARGER

BUY A COPY  
of this  
MAGNIFICENT  
NUMBER  
TO-DAY

NOW ON SALE  
at all  
LEADING  
BOOKSTALLS  
PRICE 1/-

Read  
CINEMA VERSUS  
CHURCH ORGANS

An article for all  
lovers of organ  
music.

OTHER ITEMS OF GREAT APPEAL  
INCLUDE  
A SPECIAL 16-PAGE SECTION

Also  
WINSTON  
CHURCHILL  
AND THE B.B.C.

No one concerned in  
any way with broad-  
cast programmes should  
miss it!

## THE WORLD'S PROGRAMMES

telling you all you want to know about the broadcasts of foreign stations  
and how, when and where to listen for distant stations.

THOSE VARIABLE-MU VALVES—SPOTLIGHTS ON THE  
PROGRAMMES—AUTODYNE ADAPTORS FOR SHORT WAVES,  
Etc., Etc.

DON'T MISS IT!

BUY YOUR COPY NOW

# A MULLARD 2-VOLT COMBINATION

That's all we need say. If it's Mullard you know it's the best. Mullard valves have stood the test of years: public preference has proved their quality and reliability: constant research and constant improvement makes them the valves of the moment. Now a new construction, the greatest development in modern valve design, makes them non-microphonic.

P.M.12 Screened Grid - price 16/6

P.M.1HL Detector - price 7/-

P.M.2A Power Valve - price 8/9

WE ARE EXHIBITING AT



# Mullard

THE MASTER VALVE

Advt.: The Mullard Wireless Service Co., Ltd., Mullard House, Charing Cross Road, London, W.C.2

ARKS.



ECKERSLEY'S EXCITING EXPERIENCE! (See Page 663)

# Popular Wireless

Every Thursday  
PRICE  
3d.

No. 532. Vol. XXI.

INCORPORATING "WIRELESS"

August 13th, 1932.

*Announcing* - A STAR SET FOR THE SHOW



ALSO:

A TALK WITH A DANISH LISTENER

□ □

FLORENCE—

The New Italian Station

□ □

SCOTLAND'S ONLY RELAY

□ □

THE AIRMAN'S RADIO-ROUTE

□ □

AN L.F. AMPLIFIER

etc., etc., etc.

"COCKY" CALLING!

A 64-year-old parrot broadcasting from London.

The World's Greatest Suppliers!

**KITS!  
COMPONENTS!**

Eastnor House,  
Blackheath, S.E.3.  
Phone: Lee Green 5678.  
Showrooms - - - 159,  
Borough High St., S.E.1.

**READY RADIO**

# NEW J.B. 'UNITUNE' CONDENSER - a triumph of precision

NEW J.B. PRODUCTS include the J.B. "NUGANG" Condensers in semi- or fully-screened types. New Gang Condensers for Super Kets. New Illuminated Disc Drive for use with above gangs.

New Short Wave Condensers with many novel features. New capacities in Air-Spaced Differential Condensers. J.B. "Illuminator" for use with J.B. Chassimount and "R" Type gangs. Practically all existing J.B. models are being retained.

**STAND No. 204  
NATIONAL RADIO  
EXHIBITION**

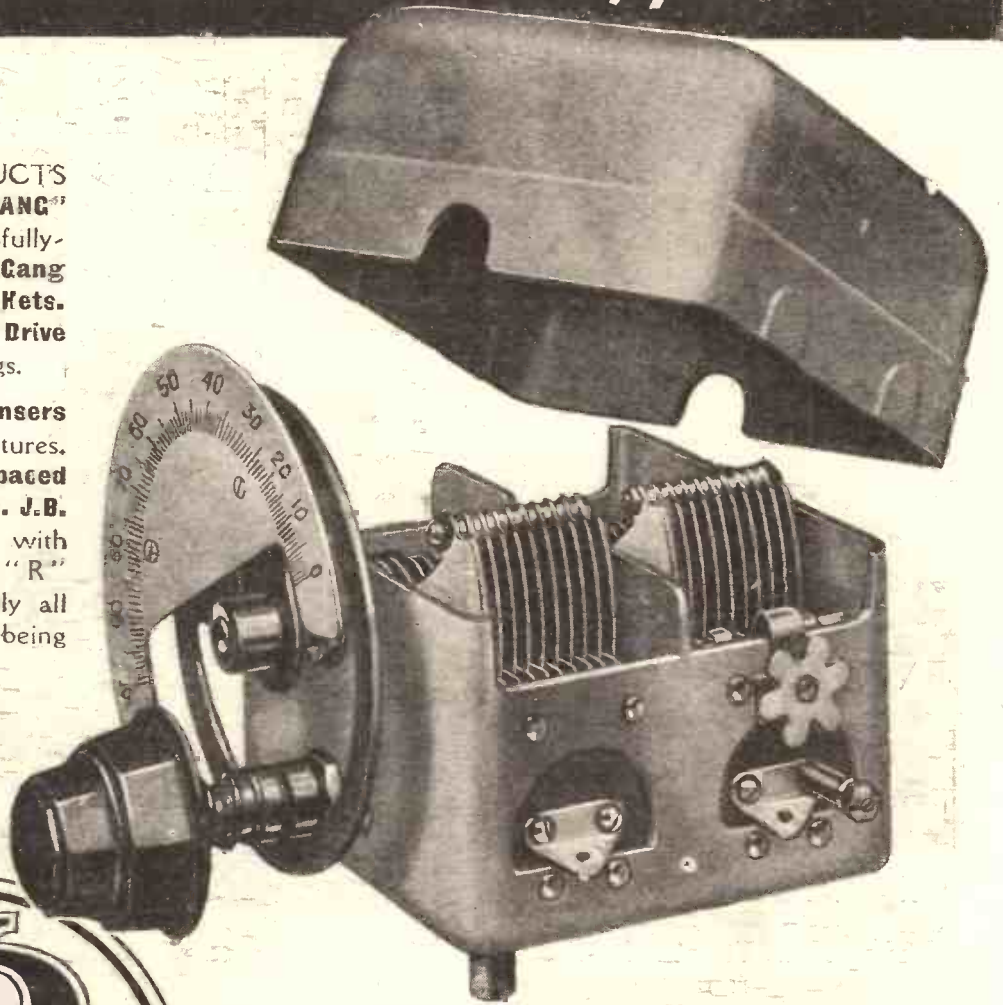

J.B. "UNITUNE" Gang Condenser.

Rigid One-piece Chassis. Very robust construction. A pre-set trimmer is fitted to one half, while the other half has a trimmer which is operated from the front of the panel. The panel-trimmer control is concentric with the main tuning knob. Capacity '0005. Complete with disc drive and bakelite escutcheon plate.

2 gang - - 18/6      3 gang - - 27/-

## PRECISION INSTRUMENTS

Advertisement of Jackson Bros., 72, St. Thomas' Street, London, S.E.1. Telephone: Hop 1837.

ENJOY THE MAGIC OF MAZDA...



LEARN ALL  
 ABOUT THE LATEST  
 MAZDA  
 MASTERPIECES AT  
 THE EDISWAN  
 STAND N<sup>o</sup>s 75 & 230  
 RADIOLYMPIA

There is nothing more enjoyable in radio than a good set equipped with Mazda valves.

Leading set manufacturers have standardised them; the experts use them. They will improve results for you too. All good radio dealers stock Mazda types to suit every receiver.

The amazing

**MAZDA**  
THE  
BRITISH  
VALVES

100 PER CENT BRITISH

The Edison Swan Electric Co. Ltd.

*Mazda Radio Valves are manufactured for The British*



155, Charing Cross Rd. London, W.C.2

*Thomson-Houston Co. Ltd., London and Rugby.*

V.171

# A WONDERFUL SIXPENNYWORTH—THE WIRELESS CONSTRUCTOR

OUT  
AUGUST 13th

SEPTEMBER NUMBER

PRICE  
SIXPENCE

*As well as the usual interesting features, there are*

## SPECIAL EXHIBITION ARTICLES

Loudspeakers  
Mains Units  
Kit Sets

Constructors' Components  
Batteries to Buy  
Valves

Complete Sets  
Mains Receivers  
Short-Waves

Also, Mr. SCOTT-TAGGART DESCRIBES IN DETAIL



# The "S.T. 300" EXHIBITION RADIO-GRAM

A Magnificent yet really inexpensive battery-driven instrument that is easy to build and which is based on the world-famous "S.T.300."

Mr. SCOTT-TAGGART ALSO  
CONTRIBUTES

## "FROM MY ARMCHAIR"

### OTHER ITEMS IN THIS ISSUE INCLUDE:

A Practical Man's Corner  
As We Find Them  
"S.T." to make Great  
"Aerial" Tour of Country

The Sets for 1933  
The Month on Short  
Waves  
L.F. Amplification

B.B.C. News  
In Lighter Vein  
Pick-Up Hints and Tips  
Round the Dials

GET YOUR COPY OF

# THE WIRELESS CONSTRUCTOR

OUT ON SATURDAY

PRICE SIXPENCE.

# FIRST IN THE PREFERENCE OF PRACTICAL MEN

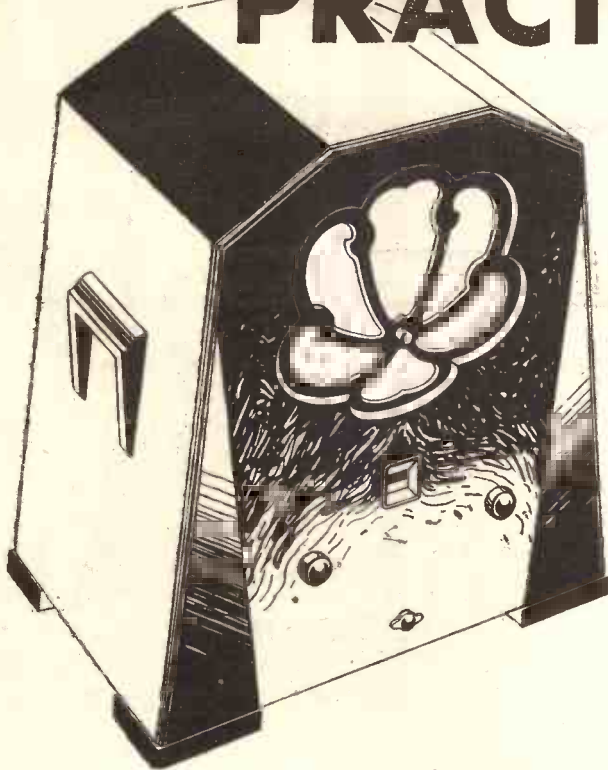

The new FERRANTI 7-Valve Super-Heterodyne was designed to satisfy the most critical of all audiences—the practical men who are able to test technical efficiency by their own exacting standards. Selectivity, reproduction, simplicity of operation—each feature has been tried and compared with an impartial mind—each has revealed definite points of superiority. Everywhere, the FERRANTI Super-Heterodyne is becoming recognised as the finest wireless receiver yet created. Among its notable developments is the new Tone Control, which enable the listener to obtain sharp, clear speech, and rich, mellow music — exactly adjusted to personal taste.

*Suitable only for 200/250 volts A.C. supplies having frequencies between 40 and 60 cycles.*

The design incorporates the most modern features, including INITIAL H.F. AMPLIFICATION, preventing interference with other sets; variable MU VALVES, providing the best form of volume control; GANGED CONDENSERS, giving one knob tuning; BAND-PASS COUPLING, ensuring high selectivity without loss of high notes; MOVING COIL SPEAKER, for high quality reproduction; TONE CONTROL, to provide sharp or mellow tone at will; ILLUMINATED WAVELENGTH SCALE, giving instant station identification; AUTOMATIC MAINS AERIAL DEVICE, enabling the Receiver to be easily moved from room to room wherever an A.C. light or power socket is available; and GRAMOPHONE PICK-UP.

SEE AND HEAR IT AT STAND **78**  
RADIO EXHIBITION, OLYMPIA. AUG. 19th-27th

# FERRANTI

7-VALVE SUPER-HETERODYNE CONSOLE

RETAIL PRICE  
**22 GNS** Or by Deferred Payments -42/- down and 12 monthly payments of 38/6.

FOR ILLUSTRATED LITERATURE, WRITE TO  
FERRANTI LTD., HOLLINWOOD, LANCS., or BUSH HOUSE, LONDON, W.C.2

# Inherent Stability

- due to abnormally low inter-electrode capacity

A remarkable degree of stability is ensured with Cossor Screened Grid Valves due to the reduction of their inter-electrode capacity to the order of .001 micro-micro - farads This negligible residual capacity results in the virtual elimination of coupling within the valve. In practice, this ensures that the full capabilities of the valve—its exceptionally high amplification — may be fully realised without fear of instability.



# COSSOR

ALL - BRITISH

## SCREENED GRID VALVES



A copy of the 40 page Cossor Wireless Book B.17 will be sent you free on application to A. C. Cossor Ltd., Melody Dept., Highbury Grove, London, N.5.

Get one of the new Cossor Station Charts price 2d. Ask your dealer for a copy of this useful novelty or write to us enclosing 2d stamp.

# Popular Wireless

**LARGEST NET SALES**



Scientific Adviser:  
 Sir OLIVER LODGE, F.R.S.  
 Chief Radio Consultant:  
 CAPT. P. P. ECKERSLEY, M.I.E.E.  
 Editor: NORMAN EDWARDS.

Technical Editor: G. V. DOWDING, Associate I.E.E.  
 Assistant Technical Editors:  
 K. D. ROGERS, P. R. BIRD,  
 A. JOHNSON RANDALL.

**AT OTTAWA  
 IN A NUTSHELL  
 REBUKED  
 BATTERIES ONLY**

## RADIO NOTES & NEWS

**IN THE AIR  
 HOT STUFF  
 BERLIN'S "B.H."  
 GREAT SCOT!**

### Radio Will Be There.

**T**WO Vice-presidents of the Radio Manufacturers' Association have gone to Ottawa to watch British radio interests as far as this country is concerned. They are Capt. J. W. Barber, C.B.E., and Mr. Millward Ellis. I expect that they will watch for U.S.A. sets being poked over the Canadian border unassembled and eventually landed here as British-made goods. Anyhow, it is just as well that four such eagle eyes will be on watch and such telling tongues available in the lobbies.

A sensible man changes *his* because his mind is developing, and his store of knowledge is growing.

Do you still hold, unaltered, the opinions which you cherished at the age of sixteen? Are you one of those people who form an opinion once and for ever, uninfluenced by new facts? Well—I am not; and when I see good reason to alter my views I have the pluck to confess. I am not ashamed to let the public know what I think, or that I have altered my mind about something.

### In the Air—

**R**ADIO and aviation are very close allies these days, although I well remember the time when aviators regarded wireless with the deepest of suspicion. That was due to the comparatively crude apparatus which was used in earlier times, and which overflowed into the pilot's already cramped quarters and gave off somewhat fearsome sparks and noises.

All the fires that broke out in aircraft were debited by some to the radio, and cases were reported of hot-headed young war pilots who, when out of sight of aerodromes, heaved their radio overboard. Their subsequent explanations and excuses were usually thin, but, to the expert, extremely humorous. One, I recollect, was that the transmitter had spontaneously collapsed amid a glow of orange and green fire!

### Wireless in a Nutshell.

**T**HIS heading does not relate to an explanation of radio in a hundred words and fifty errors (by an "expert") but to an alleged achievement of an Italian lad of Treviso, who is reported to have made a receiver which fits into a nutshell and will get six European stations. Type of nut not specified—but even a coconut shell would not make a very roomy console, would it? Who *wants* sets in nutshells, anyway? A three-valver and a pair of collapsible telephones, the whole fitting into a cigarette case, would be not only an attraction, but a miracle!

### EXCITING CHASE IN PORTLAND PLACE!



Quite a stir was caused in Portland Place by the recent rush tactics of Mr. Phillip Ridgeway and "the Parade" when they dashed from a personal appearance at a London theatre to Broadcasting House for a radio rehearsal. Mr. Ridgeway and Miss Enid Stamp-Taylor are leading!

### I Am Rebuked.

**T.** S. (Weybridge) solemnly wags

his finger at me and says that I have altered my opinion about the Welsh agitation for a national station, as last year I cast tepid water upon the uproar. My dear T. S., there is a dictum, "A foolish consistency is the mark of a small mind," to which I give my support. A woman frequently changes her mind because she is mentally unstable, capricious, etc.

### His New Battery Transmitter.

**W**ITH more optimism than power Mr. Stove, of 35, Melville Street, Glasgow, hopes to fling 42·45-metre transmissions bearing the call-sign G 5 Z X to the far corners of at least the Continent of Europe. He is using only dry batteries to drive his gear, and would welcome reports from those readers who pick up his signals.

### —And on the Ground.

**T**HERE are quite a few members of the "P.W." staff who have, at one time or another, endeavoured to emulate the birds.

One of our most enthusiastic airmen is Mr. A. S. Clark. Recently, however, he and his machine became a little too heavy for our attenuated summer air, and he landed with more vigour than grace. Fortunately,

he escaped with only a black eye and a crop of bruises. His machine was almost a total wreck.

### Still Hunting the Pirate.

**T**HE Post Office detector van has been touring the Manchester district, I hear. I trust the officials concerned are not still spinning the yarn that they

(Continued on next page.)

# NEWS—VIEWS—AND INTERVIEWS (Continued)

can detect the presence of even disused, pre-war crystal sets stored away in attics. That the bluff was successful in the London area is certain, but such methods do not reflect credit on our postal department.

At the very least they might have exhibited more *finesse*. Others could have been employed to spread the yarn, while they themselves preserved dignified "poker-faces" against inquiries for confirmation.

There would have been no suspicions aroused by a Government organisation refusing to give information!

## Hot Stuff!

**M**ORE staff, more accommodation and more gear have been secured by "P.W." in order to provide a still better service for its ever-expanding circle of readers. The technical hounds seemed to be very pleased with their new conquests and I shouldn't be surprised if they issued a challenge to the National Physical Laboratory for a ten-round curve contest.



But I don't think there will be a big rush of volunteers for service in the new "P.W." metal-lined set-testing room in the hot weather—if any, of course!

## Wireless in Coal Mines

**S**OME new experiments are being carried out in the North of England with a view to testing the possibilities of radio taking the place of telephone wires in deep coal mines.

The great advantages of radio for such work are that both transmitter and receiver can be made to be perfectly mobile, and there are no wires to be broken.

## A Dispute Settled.

**T**HE gramophone record war which has been raging in Central Europe, particularly in Germany, is all over. At the recent Conference of the International Broadcasting Union it was announced that agreements had been reached between the various broadcasting and gramophone concerns, and that broadcast concerts of the very best recorded music will be possible in the future.

## Very Sad.

**I** AM glad that at least one firm has devised a packing scheme which renders straw or masses of shavings unnecessary. What a mess such stuff makes on the floor when one unpacks a new set or loudspeaker.

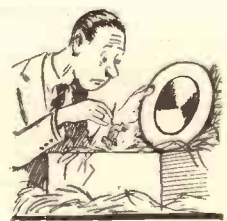

Recently a loudspeaker arrived at Tallis House, and when this was unpacked a dead mouse was discovered in the straw. And that

is, I reckon, adding insult to injury!

## Extra Special Commentary.

**W**ITH Earl Howe and Sir Henry Birkin challenging British entries by driving Italian cars, the Royal Automobile Club's International Tourist Trophy Motor Race on August 20th ought to be a thriller. Luckily for us it is to be the subject of a running commentary relayed to National listeners as well as to those of the Belfast station. The course is about fourteen miles, thirty laps of the full course being some 410 miles. Thirty-five cars are to compete, all hoping to beat Borzacchini's record of 81 miles an hour.

## A Traveller Returned

**M**R. J. JOSEPH, the genial head of Radio Instruments, paid us a visit last week. He had just returned from a tour of Belgium and Germany, and was full of interesting yarns concerning the radio industries of those two countries.

## "SHORT WAVES"

Hubby: Look at this lovely crystal set I've brought home, darling.

Wife: Oh! For my dressing table?

Hubby: Lord, no! It's a radio.

Wife: You brute!

Our Queries Department recently received a letter from a correspondent in Surrey asking them to "Please give gauge of wire and number of turns suitable for soothing choke, and how the henries are measured."

We, in turn, would like to know just how many henries it does take to soothe the poor little choke.

## TOO TRUE!

The Programme Director seems tireless  
In pushing out "school" on the wireless;  
There's too many a programme  
Sans Flotsam and Jetsam  
And Squire-less or Clapham and Dwyer-less.

"The wizard of the B.B.C. Deaf man who gave us wireless," runs a headline in a daily newspaper.

Well—that accounts for it, then.

## RECITATIONS.

Whenas my muse is bright and gay  
As le pin; fish within a stream,  
Or sunsins on a morn in May,  
I own it almost makes me scream

To hear the efforts she has tendered  
For popular consumption,  
In slow an solemn accents rendered  
By one of little gumption . . . .

Therefore, no recitations by the B.B.C.

Or other folk for me.

If o'er the ether must my verse be blown,  
Myself will stand before the microphone.  
—"Morning Post."

He expressed great appreciation of the manner of his reception in Germany, and told us that everyone was most friendly and willing to give him any information he desired.

Even at this period of the year, when all the firms are preparing their new season's models, there was no secret flumduddery, and the very latest designs were openly and proudly exhibited for his benefit.

## Berlin's "B.H." Well Organised.

**A**CCORDING to Mr. Joseph, the German radio industry is highly organised, and the factories magnificently equipped. He spoke enthusiastically about

the efficiency of their testing methods and the keenness displayed by all the workers from the highest down to the lowest grades.

He visited the great Broadcasting House in Berlin, and here, too, he found everyone taking their jobs very seriously indeed. Apparently German radio is still on the up-grade all round despite the depression.

## Slanging the B.B.C.

**T**HE other day the question of the B.B.C. and the Opera Syndicate came up in the House of Commons. Said Mr. Cocks: "Will the Postmaster-General use his persuasive powers with the B.B.C. to end this corrupt business?"

No answer was given to that, and I am not surprised. When you consider the enquiry, you will note that it would have been difficult for the P.M.G. to have answered either yes or no. Think it over.

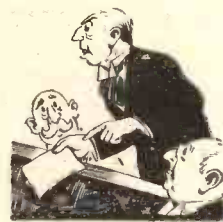

## The Radio Show.

**O**PINIONS as to the success of an August Radio Exhibition seem to be sharply divided. On the one hand are those who confidently predict that all records for attendance will be broken, and that there may be as many as a quarter of a million visitors. Others consider the show is far too early and that fewer will go to it than in any of the past three or four years.

However, there is no doubt at all but that it will be an interesting exhibition, and there would have to be very strong counter-attractions indeed to prevent me from browsing around the stands.

## Appreciative Aberdeen.

**I**N a longish letter having two P.S.'s, an Aberdeen reader tells me all about the nice way he was treated by Messrs. Ormond over a question of loudspeaker-unit modernisation. I am not surprised, for this concern has for a considerable time occupied a position on my "recommended by readers" list.

## Great Scot!

**A** SCOTS reader of "P.W." ordered a dynamo from Electradix Radios. But as he only required a proportion of the output of this generator of electricity for charging accumulators, he asked if he could employ the remainder of the current to drive an electric motor which, in its turn, would drive the dynamo.

Going one better he suggested there might be sufficient energy left over to provide electrical illumination for the house. In fact, he wants perpetual motion with knobs on!



ARIEL.



# Out of the Blue

## THE BURNING OF THE "GEORGES PHILIPPAR"

By CAPT. P. P. ECKERSLEY, M.I.E.E.



READERS of this paper might like a landsman's impressions of an accident at sea which has created a great deal of comment. It is not, strictly speaking, a "wireless" subject, although wireless played a considerable part.

Imagine me, then, a passenger on the "Otranto," glad to feel the Red Sea past, and hoping for cooler breezes round the Cape of Gendapri, out from the Gulf of Aden into the Indian Ocean.

### Peaceful—and Sinister.

Such a morning—how can we know dates or days at sea?—finds me up on deck at 9 a.m. for the usual exercise—gives me the sight of burning red sand against a calm blue sea, and for the rest, the empty circle of the horizon.

But a friend asks me, have I heard; there is a French ship burning away over there; they have picked up 200—300—400 rumour, rumour and more rumour.

She's an oil-burning ship—so are we. All this light and air and land and sea—so peaceful—seems sinister; flames must be hot in this sun.

The sea is dead calm and we can see the wash of our ship away to the horizon. We are putting on speed, it seems, and each time I lean over the ship's side I see more foam on the crests of the ship-made waves. There's a vibration, a quiver—we are hurrying.

Soon down over the horizon ahead, smoke—from the "Kaiser-i-hind," a P. & O. ship, which kept us company all down the Red Sea, which left Aden two hours ahead of us, and which is also hurrying to the scene.

Rumour and more rumour. She caught fire at 2 a.m.; we shall reach her at 12—at 1—at 2.

### Creamy to the Horizon.

There's an English boat picking up, and a Russian, and a Japanese—certainly a Russian tanker. But the sea here is empty and the red shore crawls past and our wake is creamy to the horizon.

How awful for the poor people—burnt, perhaps, and no shade from

\*-----\*

In this article "P.W.'s" Chief Radio Consultant recounts an exciting experience he had while on the way to Australia. Other random articles from his facile pen will be published from time to time as they are received "Out of the Blue."

\*-----\*

the vindictive sun. The sailors are swinging out our boats, they are getting cabins ready—we must be there soon.

Every passenger has a camera—everyone is upset to think of those poor people. But now 500 have been picked up, so it is said—so that's better.

And then, towards midday, a smudge on the horizon and a ship steaming Adenwards—then all must have been picked up? But why so far to the north? Are we heading for the wreck? Shall we be wanted? The "Kaiser" is on our course though. What does it mean?

At last, just after lunch, we see a huge pillar of smoke rising vertically and then

streaming pennant-wise through 40° of arc across the horizon.

We are not, after all, to see her; we are not, after all, wanted.

It appears, from the newspapers we have since read and from talks with people abroad, that all the survivors were picked up before we reached the vicinity of the disaster. What appears strange to a layman is that small cargo boats, tankers, and so on should "claim" the survivors while two huge liners with doctors, beds, forced ventilation, big galleys and suitable food, should be told to go on their way.

### Worth So Much a Head.

I read of survivors half dressed, stretched on decks where the pitch bubbles in the seams; of a galley fit to cope with the requirements of 30 sailors trying to feed 400 people.

It all seems a curious etiquette that claims survivors for kudos and seems to consider them worth so much a head.

Then again comes the old, old question of wireless. I have not yet learned whether

in fact the "Philippar" sent out an SOS. I do know that we did not pick it up, for the good reason that it was time for watch on 36 metres. It was only that we overheard a casual conversation about boats and burning which made our wireless people sit up and take notice.

I hear—who knows if there is truth in all this news?—that French ships have their wireless cabins over the top of the engine-room. It is compulsory on board British ships for the wireless cabin to be well forward near the captain's cabin, and obviously the last place to be affected by the ordinary accidents of sea-going.

### For Passengers' Convenience.

A modern liner's wireless is being used more and more for the convenience of passengers than for the safety of life at sea. There are, for instance, on our ships three operators, and this means, in theory, one operator on duty always.

As a matter of fact, there are frequently two, or even three helping

(Continued on next page.)

### A TRAGEDY OF THE SEA



The Georges Philippar, abandoned by her passengers and crew, was left at the mercy of the flames, to drift about the ocean until she sank.

## REPAIRING COILS

A simple method of separating the turns of single layer coils.

THE other day I found myself faced with what appeared to be a distinctly awkward problem. Whilst I was mounting a rather expensive coil of the dual-wave type, the screwdriver slipped, as screwdrivers sometimes will, and its edge must needs run across a considerable part of the medium-wave windings, which were in solenoid form.

The first hastily applied test showed that the windings were still intact; whatever else it had done, the screwdriver had not cut the wire. But another test proved that if there was still continuity, there was certainly no proper insulation between many of the turns, for the coil would not cover anything like its correct range of wavelengths.

What was to be done about it? It might have been possible to strip off the medium-

wave windings and to replace them, but this was a distinctly forbidding task, partly because I did not know the exact design of the windings, and partly because the wave-change switch was buried inaccessibly in the dark places of the base. I was beginning to fear that it might be a case for the coke hammer, when suddenly I saw a way out.

### Choose Contrasting Colours

The solution was so utterly simple that I felt like kicking myself for not having seen it sooner. Since the method can be used for repairing similar accidents to almost any kind of single-layer coil, I am sure that readers will find it useful. Here it is. The first thing to do is to obtain from the toolbox—or rather, I should say, the sewing basket—of some feminine member of the household, a reel of stout cotton.

In case you are not versed in these matters, No. 30 is the thickness that you need, where the windings are of fairly fine wire. Choose a colour that contrasts with that of the damaged insulation of the windings. Now secure the end of your cotton by means of a little blob of sealing wax

placed on an undamaged part of the windings, and just a turn or two above the place where the injury to the insulation begins.

With a little persuasion you will find that you can force the cotton in between two turns. Stretch it tightly and wind on gently. Once started, it will make its way without a protest in between the turns as you wind.

Continue to wind until you have spaced in this way all of the turns that were short-circuited or liable to be short-circuited. Then cut the cotton and make fast the end in the same way as before with a small blob of sealing wax.

### As Good as Ever

If you test the coil now you will find that it tunes just as well as it did before it was damaged. If, by the way, the windings are made with rather thick wire, you will require something stouter than No. 30 cotton in order to separate them properly. Tailors' strong thread serves admirably in this case. Finish off the job, whether you have used cotton or thread, by giving a very light dressing with thin shellac.

R. W. H.

## MRS. VICTOR BRUCE'S ATTEMPT ON ENDURANCE RECORD



The control cabin of Mrs. Victor Bruce's amphibian flying boat, "City of Portsmouth," in which she will try to break the existing duration record. Radio is to play an important part in the attempt, the transmitter and receiver being located in the bows just forward of the instrument panel.

at the same time. But only one channel can be worked at a time, so that if a long press bulletin (Rugby, Portishead or Sydney) is coming in on the very long or the very short wave, the 600-metre channel is not watched.

### Frequently Jammed

If passengers' messages are being sent by the short-wave transmitter we are off 600—and an SOS is very short in cases when a fire starts in an oil-burning ship.

The direction finder is frequently jammed

## OUT OF THE BLUE

(Continued from previous page.)

by broadcasting (particularly in the narrow waters of the channel where direction-finding is most needed) because it is not properly selective. When they take bearings they have to shut up the wireless cabin and the operator must go on to the bridge—another chance to miss an SOS.

## QUICKLY-MADE CONDENSERS

A useful tip for those who require a small capacity fixed condenser in a hurry.

By FRANK BRIGGS.

IT often happens that in the course of experiments with radio receivers, a small capacity fixed condenser is wanted at very short notice. For instance, such a condenser might be wanted for connecting in series with the aerial in an endeavour to improve selectivity.

And it is not uncommon that when such a component is required, the junk box refuses to deliver up one that is of suitable capacity. What then is the remedy?

A dodge that I have found very useful, and which has been employed with a considerable amount of success, is to use a piece of electric light flex. The larger the capacity required, the longer the flex will have to be.

It should be joined up so that each wire—there being two—forms one plate of the condenser, care being taken that they do not short at the far end. It is a very rough-and-ready idea, but nevertheless remarkably effective.

One foot of ordinary electric light flex gives a capacity of approximately 200005 mfd.

Well, we're here in Australia anyway. "Oh, had I the speed of an ether wave!"

It's an amazing distance—5½ weeks at 20 miles an hour—sea and sky, sky and sea, on and on!

### Saved from National Isolation

We who study communications may be proud of the importance of our work. Communication saved many a life in the "Georges Philipparr"; it may yet do something to save us from national isolation.

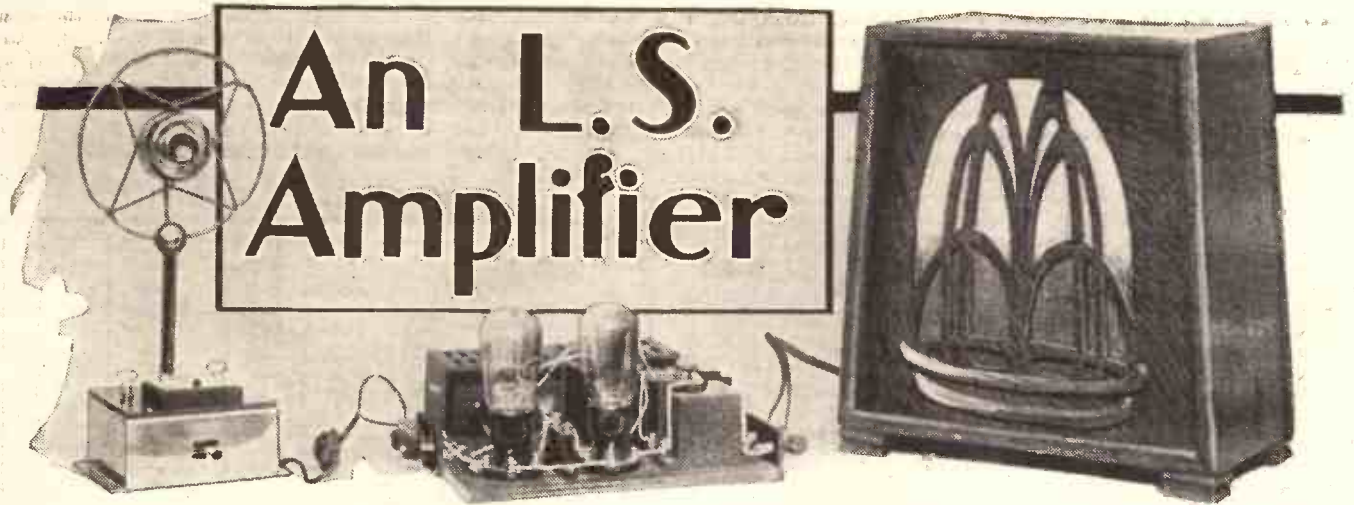

SOME little time ago it was decided that a system of loudspeaking telephones between the various offices and sections of the "P.W." staff and the London laboratories would be a great advantage in speeding up inter-staff communication, with a consequent beneficial effect upon the work of every department.

Accordingly the Research Department was set the task of devising a scheme that would enable the various rooms to communicate with each other, without having to ring up on the ordinary telephone.

**Speeding-up Communication.**

This obviously necessitated the use of microphones and loudspeakers, with the necessary amplifiers and so forth. It took some time before the system was perfected, but it is now possible for direct inter-communication to take place between the different rooms merely by the pressing of a button and speaking into microphones. A complicated system, perhaps, but easy to operate and a real boon.

You will naturally ask how this is connected with the title of this article. Actually it has a very close connection, for the loud-speaker amplifier that is illustrated in these pages is the direct outcome of the telephone system we have been telling you about.

In fact the amplifier is one of two separate ones that are used for "outlying districts," where the rooms cannot conveniently be operated from the grouped amplifiers that are used in the central section of the scheme, and consequently these are more simple than the large central one.

**Designed for D.C. Mains.**

As you will see, it is operated direct from the D.C. mains. Our reason for bringing it to the notice of readers is that it will make a very convenient amplifier for anyone who wants to do any microphone tests at home, to try his hand at home recording, or requires a separate amplifier for use with a pick-up.

In the first place, where the loudspeaking telephone scheme we have been talking about is concerned, obviously quality of reproduction was a necessary feature, and so the amplifiers have to give reasonably good quality. A second point is that they must not be too sensitive, otherwise background noises from the microphones will be noticeable, and there will be a danger of pick-up of street noises and so on if

**By THE RESEARCH DEPARTMENT.**

Here are some interesting details concerning a simple mains amplifier that can be used for several purposes. As an amplifier for use with a pick-up it is ideal, or it can be employed in conjunction with a microphone for home recording of records, or for communication between one part of the house and another.

the microphones and their amplifiers are too sensitive.

On the other hand, to preserve quality the sensitivity of the microphones themselves could not be reduced too far. The result, as we said before, was the amplifier that you see illustrated. And you will also see that there is very little in it. The mains where the system is installed are

good, so that little mains smoothing was required, and this accounts for the fact that apart from the one H.T. choke, there is not another bit of smoothing in the unit.

Decoupling between the two valves was found advisable, and you will also notice that there are two other interesting features in the diagram. The first is the alternative decoupling of the grid circuits, and the other the resistance load in the anode circuit of the second valve.

**Preserving the Low Notes.**

The decoupling scheme for the grid circuits is shown in dotted lines because it is not included in the original unit, for the simple reason that it was not required. It is included in the theoretical diagram because where the amplifier is to be used for pick-up work it is necessary to get good amplification of the low frequencies, and lack of decoupling may result in loss of bass notes in the reproduction.

*(Continued on next page.)*

**A SIMPLE BUT EFFECTIVE UNIT**

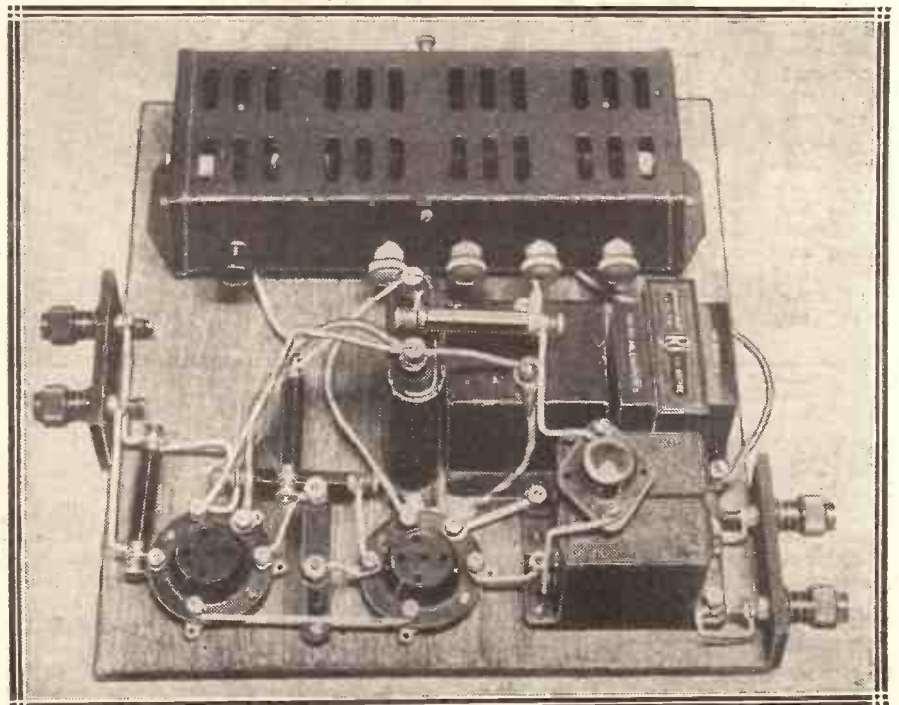

This photograph shows the main part of the unit. Note the simplicity of construction and the accessibility of the various parts. The number of components have been kept down to a minimum.

## AN L.S. AMPLIFIER

(Continued from previous page.)

When dealing with speech it is not necessary as a rule to worry about the frequencies below about 150 cycles, nor about the very high frequencies. So in our system we have concentrated on good reproduction of the ordinary speech frequencies, and it is primarily for use with microphones that we draw your attention to the unit.

The output resistance was put in further to increase the quality of the reproduction, it cuts down the amplification somewhat, but we required two low-magnification stages rather than one high one for our purpose, so that background should be completely removed, and with D.C. mains there is always the possibility of clicks, and so on, being imparted to the amplifier through the mains themselves, especially when they are in a busy district in the heart of London.

### The Output Resistance.

The value of the output resistance will depend on the output valve used. We chose the 25 amp. indirectly-heated valves for our work, and use in each amplifying unit two of these valves—a D.H. and a D.L.

Therefore, a resistance of somewhere about 7,000 ohms will do the trick reason-

ably well, taking into account the drop in load due to the parallel loudspeaker impedance. In practice anything between 5,000 and 7,000 ohms gave excellent results and, of course, there is a limit to the value of resistance owing to the drop in anode potential that it causes.

### Concerning Component Values.

Other components in the diagram are marked with their values, with the exception of the de-coupling resistances and condensers previously mentioned. These should be about 100,000 ohms or so with

### Decoupling.

Obviously in such a case the condenser is really wasted, for its reactance should be considerably less than the resistance of the cathode-grid path if it is to be effective as a low-frequency bypass. It is far better to use complete de-coupling in mains sets than to use the condenser, and all that is required is an extra high value resistance. But, as we said, in this case it made no difference, so it was omitted.

The use of such an amplifier is very simple. The input, whether it be from the secondary of the microphone transformer, or from the volume control of a pick-up, is connected to the two terminals across which is shown a 10,000-ohm resistance. This, by the way, can be omitted or altered in

of valves employed. It will be noticed that no fuse is incorporated. This is in circuit elsewhere in our system, but for home use it should be placed between the mains input leads and the heater resistance. One of the Bulgin combined mains plugs and fuses will do the job admirably.

## IN ITS SIMPLEST FORM

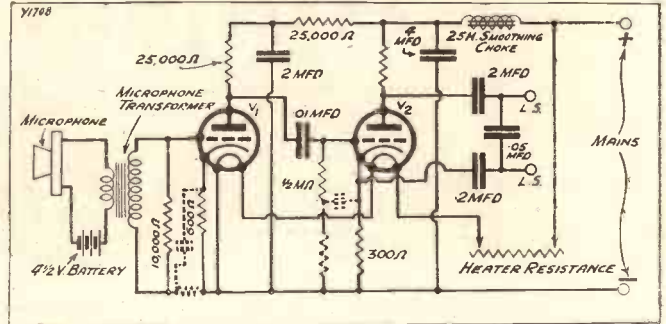

The theoretical diagram again emphasises the simplicity of the unit. There is hardly anything in it, is there? Note the dotted components and connections denoting the decoupling arrangement for the grid circuits of the valves.

The connections then are as follow: The mains go to the plug, and from there through the fuses one goes to one negative terminal of the resistance, and the other to the positive terminal on the same side and to the smoothing choke, the terminal with the correct voltage of the mains being used. The other side of the resistance is connected, as shown in the photographs, that is, the negative terminal on this side goes to the earth circuits, and the positive terminal marked 2 is connected to the first heater.

After switching on, a few moments must elapse while the valves heat up, before the unit can be used, and it will be necessary to try the mains plug first one way round and then the other to get the positive and negative mains connected to the unit correctly.

### Checking the Polarity.

So, if at first on switching on and waiting till the valves are glowing properly you hear nothing, no sign of life being present in the loudspeaker, the mains plug should be reversed and replaced, when the unit should operate.

With a pick-up it is best to use a volume control across the pick-up itself, one side of the control and the slider being connected to the two terminals of the amplifier.

A suitable microphone can be obtained from Messrs. Wright and Weaire, of Tottenham, for 42s., and this will operate very well either as a home recorder microphone or for use in communication between one room and another, or over long distances. The output of the amplifier is such that it is only suitable for use for indoor loudspeaker use; for outdoor work a larger output would be required, though the construction of an amplifier for such a purpose would not be at all difficult.

For safety, when finished, it is desirable to cover the unit with metal gauze, such as is used in meat safes, and so prevent the possibility of getting a shock. It must not be totally enclosed (i.e. without holes for cooling) because of the heat dissipated by the resistance and the heaters of the valves.

When used with a pick-up the amplifier could conveniently be placed in a small gramophone cabinet, making, with speaker and pick-up, a neat electric gramophone.

## READY FOR RECORD REPRODUCTION

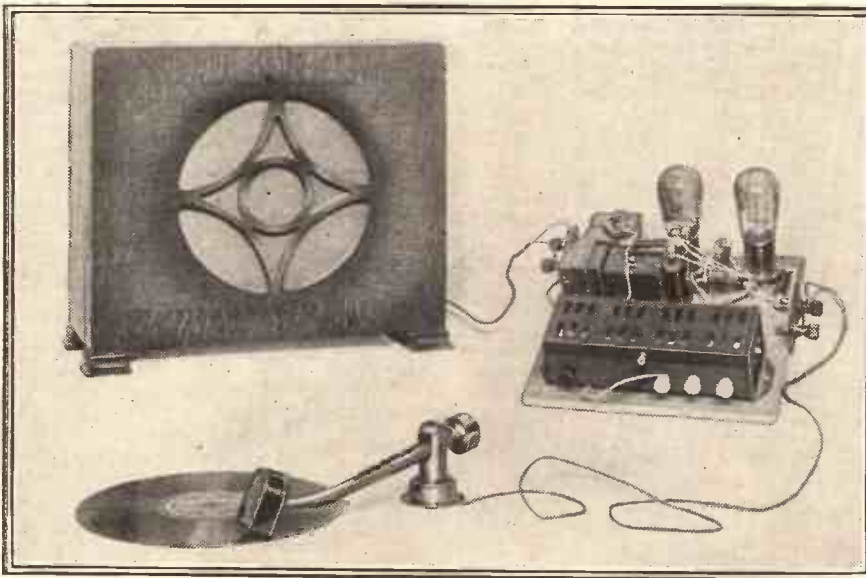

This illustration shows in pictorial form how the unit is used with a gramophone pick-up, while the heading photograph in the previous page illustrates its use with a microphone.

value as desired. It is merely for the purpose of preventing peaks in the microphone transformer characteristics.

The output is connected to the two terminals that are joined to the two output condensers. These two condensers are essential for safety purposes where D.C. mains are used, to prevent the possibility of shocks being received from the extension leads to the loudspeaker.

The mains resistance is connected between the mains and the amplifier, the terminals being adjusted in accordance with the voltage of the supply, and the number

# RADIOGRAM REMINDERS



THOSE interested in novelty records will particularly admire one that is shortly to be issued by H.M.V. As a matter of fact, I was present at the recording of a large part of it, and it struck me as being particularly ingenious.

The idea is not a new one as applied to entertainment, but it is the first time that this type of entertainment has been "canned," and the result is a very attractive record.

It consists in a round Europe programme, in the form of a tour by an "American" lady who is out to see as much of the old world as her limited time permits. So she embarks from "God's Own Country" and sets off on her travels.

### Mixed to Taste.

The making of the disc necessitated the recording of 122 artistes, comprising seven nations, and it was done at the new studios at St. John's Wood, where often three studios were used at the same time, in conjunction with the numerous effects, the whole being mixed at a special mixer panel.

Actors and singers from five nations were there in person, students from the French Lycee supplied the local colour of Paris, while young people of the Anglo-German Academic Bureau chatted and sang students' songs to suggest a Berlin beer garden.

When Venice was reached Tino Folgar, the Venetian tenor, gave a serenade to the simulated lapping of water round a gondola, and during the Madrid "visit" Señor Baeza and a company of Spaniards imparted the correct atmosphere with the famous "Ay, ay, ay."

H.M.V. were able to include individual

### A BRIGHT 'UN FROM BRIGHTON

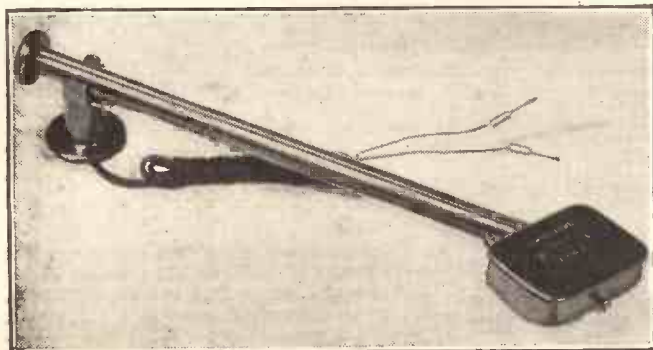

The Bowyer-Lowe A.E.D. pick-up is described on this page. It is a particularly neat model, as can be seen.

\*-----\*

**Making a "Round Europe Tour" Record at the H.M.V. Studios—a new pick-up—and a handbook that all radiogram owners should read.**

\*-----\*

performances of artistes in Arabia and U.S.A. in the tour by using records which had previously been actually made by native performers in these countries, in addition to orchestras of five other countries providing authentic music as a background to the dialogue of those in the studios.

### Seven Countries.

Thus 122 artistes of seven different countries were recorded on the one disc, and of these 20 were present in person, 102 being taken from previous records. For the effects 22 other records were used.

These were run on five different turntables and the parts of the effects were faded in and out as required from the mixing studio above the main recording room.

I heard a trial run played over (it is, of course, impossible to run over the final wax), and the result was a great success. I am looking forward to hearing the completed record when it is issued in a few weeks (from the time of writing).

### Well Up at the Top.

And now to draw your attention to a new pick-up that has just come on the market. I refer to the Bowyer-Lowe Mark 3, which sells for 30s. It has excellent characteristics, going well up at the top end of the scale, while the bass loss of the average record is compensated for by a very useful bass rise in the characteristic of the pick-up.

The impedance is low so that it is possible to use a volume control of quite low resistance across it without seriously affecting the high-note reproduction. This is particularly useful in mains sets where a very high-resistance volume control often causes a certain amount of hum, while a low

resistance of some 25,000 ohms will "earth" the grid and so prevent hum.

The value recommended as best for the pick-up is about 150,000 ohms, but I have tried down to 20,000 without serious loss of high notes. It is an important point for mains sets users to remember.

### Full of Information.

I have received a most interesting and valuable handbook on "Gramophones Acoustic and Radio." It is published at 1s. by Waterlow & Sons, and is packed full of information that will be of use to every home constructor of radio gramophones.

Compiled by G. Wilson, of the Technical Staff of "The Gramophone," it covers in concise form the main practical features of

## HAVE YOU HEARD THESE?

### RECORDS FOR YOUR RADIOGRAM.

- "When Yuba Plays the Rumba" . . . . . H.M.V.
- AMBROSE AND HIS BAND.
- "Can't We Talk It Over?" . . . . . H.M.V.
- GRACIE FIELDS.
- Aldershot Tattoo . . . . . H.M.V.
- (Two 12-inch Discs.)
- "Tell Her the Truth" . . . . . H.M.V.
- NEW MAYFAIR ORCHESTRA.
- "Good-Evening" . . . . . Col.
- HENRY HALL.
- "Paradise" . . . . . Col.
- SAVOY HOTEL ORPHEANS.
- "When Yuba Plays the Rumba" . . . . . Col.
- THE KNICKERBOCKERS.
- Mignon Overture . . . . . Col.
- ORCHESTRE SYMPHONIQUE (of Paris).
- "It Isn't Cricket" . . . . . Col.
- CLAPHAM AND DWYER.
- "A Trip to Brighton" . . . . . H.M.V.
- MABEL CONSTANDUROS & Co.

all types of gramophones, with data about records, pick-ups, loudspeakers, and so forth.

The handbook contains 120 pages, and has been most carefully put together. Much of the matter appearing in it has been published in "The Gramophone," but it is of great value to have what might be termed the cream of the articles in one volume. The book is exceedingly good value, and it should find its way into the homes of a great number of gramophiles.

## DEVELOPMENTS IN DESIGN FOR THE COMING SEASON

By J. C. JEVONS.

Each year as the annual Exhibition at Olympia comes round, one wonders what the manufacturers will produce to satisfy the natural desire of the public for something really new and attractive. Our contributor indicates some of the lines along which we may expect developments at this year's show.

### Automatic Volume Control.

In the first place, one may be quite sure that the variable-mu valve will play a big part in the new season's sets. In fact, it will probably go a long way towards superseding the ordinary S.G. amplifier.

Automatic volume control is a feature that is rapidly coming to the front in practical design, particularly in sets designed for long-distance reception, where "fading" is such a bugbear. A really efficient system should maintain a constant output in the loudspeaker, no matter how the input signal changes or fluctuates in strength.

The variable-mu valve solves this problem to some extent, though not entirely. There are also alternative methods available in which the plate current in the detector valve is passed through a resistance, which is then utilised to adjust automatically the amount of grid bias applied to the H.F. valve.

When the incoming transmission is weak, the negative bias is automatically reduced until the H.F. valve acts with maximum efficiency. For strong transmission the bias is increased and amplification falls off. In this way the loudspeaker output is, so to speak, "anchored" at a constant level.

### "Visual" Tuning.

Unfortunately, "gain" control introduces some rather unsuspected problems. For instance, it is difficult to tune in by ear alone when the signals never increase beyond a certain strength. One misses the ordinary rise and fall of sound which indicates the critical tuning-point. Accordingly, some sets are being fitted with "visual" tuning means, such as a glow lamp or milliammeter, inserted across the detector valve.

"Visual" tuning is particularly useful when adjusting the set to a nearby station, where the highest permissible level of sound is likely to persist over an appreciable movement of the tuning condenser. Unless the circuits are adjusted to the correct tuning point, the set may work on the slope of the resonance curve, and so cut off some of the sidebands, which will of course lead to distortion.

### "Tone Correction."

This naturally reminds one of another "live" feature in modern set design, namely, automatic "tone compensation" on the low-frequency side. Whenever the high-frequency circuits are sharply tuned, which is the case in most highly selective receivers, some of the sidebands are bound to be badly cut, resulting, of course, in a falling off of the high notes on the low-frequency side. To remedy this defect an inductive shunt is placed across the L.F. amplifier. This "tone correcting" circuit builds up the high-note voltage more than it does the low, and so restores the original "balance" between the two.

### Selectivity and Quality.

The problem of selectivity is, of course, always with us, and here the superhet is again likely to be a strong candidate for popular favour. The old problem of ganging the input and oscillator circuits has been satisfactorily solved, and one is pretty certain to see several alternative systems

with first-rate quality. Band-pass tuning, combined with two-range switching for the medium and long waves, has now reached a high level of excellence, in spite of the somewhat "sticky" nature of the problems involved. Where high-class reproduction is "of the essence of the contract," it is difficult to find a more satisfactory proposition than a set of this type.

A third type of receiver which deserves consideration is that in which a razor-edged H.F. input is combined with tone-correcting circuits (of the kind already mentioned) on the low-frequency side. This combination has many points in its favour and is pretty sure to find some measure of support.

### Constant Coupling.

During the past year a considerable amount of research has been carried out in what is known as "constant coupling." This is a development of the work of Loftin and White, who showed several years ago that tuned coupling circuits were not equally efficient at all points on the tuning dial.

Everyone knows that the older type of set gave greater amplification on the shorter wavelengths than on the long, the reason being that the transfer of energy from one wave to the next through tuned interval couplings varies as the wavelength setting is altered.

The problem has now been very thoroughly explored, and many of the new season's sets are being designed to give an absolutely uniform response, or amp-

lification, throughout the entire tuning range.

Again, the short-wave enthusiast is certain to find plenty of material to delight his heart.

Short-wave adaptors have not only come to stay, but are distinctly "booming," and they are certain to be well represented at Olympia next month.

## VARIABLE-MU's AND SUPERHET-SELECTIVITY

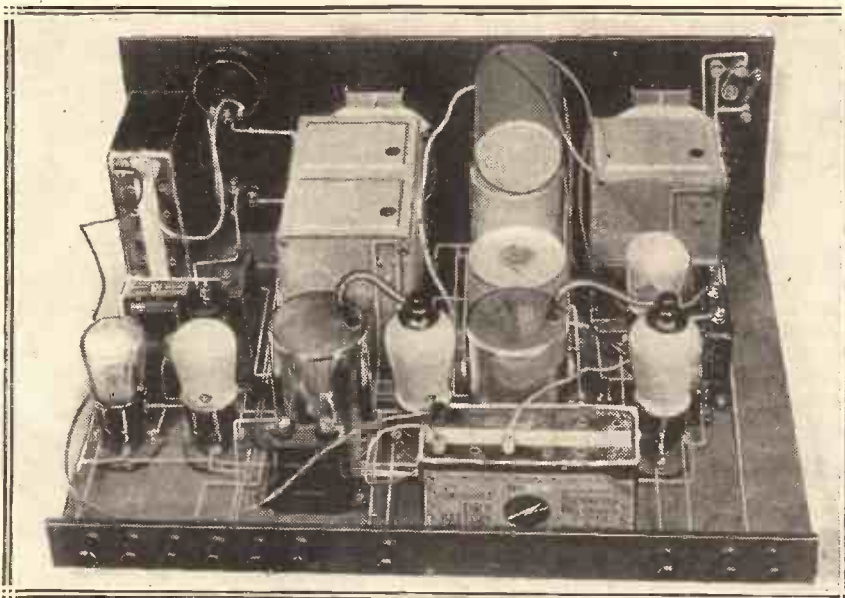

The article on this page suggests that variable-mu valves and superhet circuits will figure very largely in commercial sets next season. In this connection it is interesting to note that the above home-constructor's set, which incorporates both, was described three months ago, thus proving that those who build their own sets score over those who buy completed receivers.

adapted to give absolutely simple uni-control.

The old trouble of getting the same station on at least two different settings of the tuning condenser is now a thing of the past.

It is, of course, possible that "straight" sets fitted with a band-pass input will run the superhet close in catering for those who look for reasonable selectivity combined

wave-length of 430.4 metres.

Mains receivers which incorporate a mains aerial nearly all work on the principle of the insertion of a small fixed condenser between the aerial connecting point and the mains. (Usually a value of about .0002 mfd. is employed, and, of course, such a condenser must be of superlatively good quality to avoid leakage.)

## ITEMS OF INTEREST

For the Ordinary Listener.

The distance of the Algiers station from London is approximately, 1,030 miles.

The Belgrade station uses a metronome beating 60 times a minute on a wave-length of 430.4 metres.

# ON THE OTHER SIDE



# A TALK WITH A DANISH LISTENER

Interesting, first-hand information about broadcasting conditions in Denmark, with special reference to the "Licence Ballot"—Big Fines for "Pirates"—The Broadcasting Council—Early Morning Gymnastics—and other special features which the Danish listener enjoys.

**L**AST week I met a Danish wireless enthusiast who has spent enough time in this country to compare his native radio conditions with our own.

He said: "I left Denmark just when they were starting to build the new Broadcasting House near the Royal Theatre in Copenhagen. This is not, of course, anything like so big as the London Broadcasting House. It is in a good centre of Copenhagen, the *Kongens Nytorv*, which means King's New Square.

### New Headquarters.

"An advance sketch of this, prepared by the architect, showed it as a rather futurist building with plenty of white plaster work outside, not out of keeping with some of our new Copenhagen modernist office buildings, and 'artist's dream' futurist flats.

"An amusing fact is that there was a bumper increase in licences soon after this building was started and the Broadcasting Council had to buy the building next door to cater for the increase in office staff, which will be called for during next year.

"They have taken offices in the second floor of this building.

"Broadcasting is certainly a growing thing and we have no signs of reaching saturation. Think of this. When the building was planned there were about 160,000 people with licences. There are now 450,000 and this will shortly go up to well over the half million mark.

### A Special Council.

"It is an excellent example of good value for money, for licences are not cheap. A permit for the full year costs 10 kr., or about 11 shillings at the normal rate of exchange. There are certain privileges, such as a reduction for new listeners at the end of the year.

"The Broadcasting Council, as far as I can tell, is not a bit like your B.B.C. Board of Governors. The Council is really a kind of 'Wireless Parliament' representative of all interests—listeners, the daily papers, the Government and so on.

"Let me give you a little history of Danish broadcasting, and then you will see how the Broadcasting Council has come about.

"It was in 1922 that one or two enthusiasts got together and started broadcasting

programmes through Lyngby, the State Telegraph Service Station.

"All the Danish listeners were watching the way the B.B.C. were doing things then, and in 1925 the State decided temporarily to take over the service. It was an immediate success; so much so that within a year an Act was passed making it absolutely official.

"Three years ago the Directorate moved to Axelborg in Copenhagen. I cannot tell how many listeners there were then, but there must have been thousands.

"There was a kind of Broadcasting Council even then to represent listeners' interests, but in 1930 the new Broadcasting Council was suggested, and a new Act was passed, making the idea legal. Fifteen men were to represent all interests connected with broadcasting. The jobs were not to be voted for, but each man was to be nominated by the interest he represented. A good scheme!

### Everybody Represented.

"It is as fair an arrangement as we could arrive at. Two members are nominated by the Minister of Public Works. The newspapers have their say, and two members represent the Press. Parliament nominates four people for the Broadcasting Council, and the 'highbrow' interest is supplied by the Minister of Education, who sends in one man."

"What about listeners?" I asked.

"Listeners have the bumper share. They nominate six members of the Council. That makes up the grand total of fifteen. Immediately the new Act was passed, many prominent men were associated with broadcasting.

"Dr. A. C. Nielsen, for example, who was on the administrative side, and Mr. Emil Holm, who controlled the programmes.

"Copenhagen is only a three-quarter of a kilowatt station, but Kalundborg relays everything, and, of course, its power is ten times as great. There is also the 31.51-metre short-wave relay (Skamlebaek). So you see, Denmark is well represented in the ether.

"Listeners have their little troubles. For instance, listeners in the Lyngby and Soro districts are troubled by interference from the commercial stations. There is also a good deal of electrical interference in other parts of the country.

"Some people, too, think the licence is still too costly. Way back in 1927, it used to cost 15 kr. for a valve set, and 10 kr. for a crystal set. I am afraid they are not likely to be reduced again.

"There are still some crystal sets. The latest official figures give the total as 50,000. It does not need a very elaborate valve set to get good reception from Kalundborg.

"Mind you, as a nation, we are keen on any innovation such as broadcasting. I am told that there is one telephone to every twelve people, an extremely high average,

(Continued on next page.)

## COPENHAGEN CALLING!

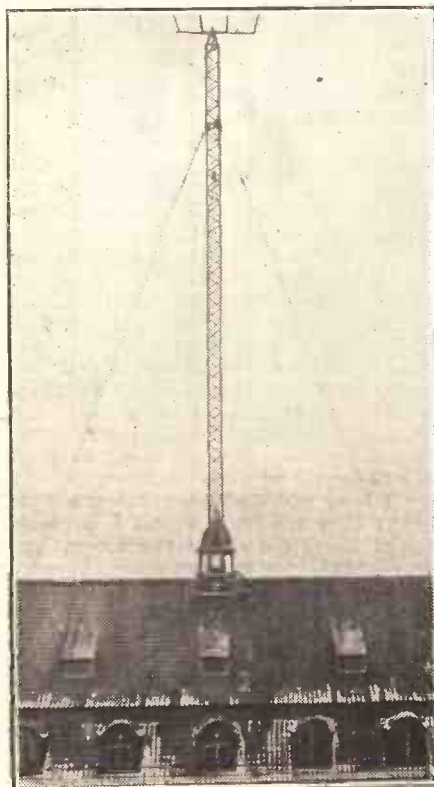

The aerial masts of the Copenhagen station are perched on top of the State Telegraph Company's roof. The programmes are relayed on 1153 metres by the long-wave station Kalundborg, where a new high-power transmitter is shortly to come into operation.

## A TALK WITH A DANISH LISTENER

(Continued from previous page.)

and I think we can boast of the highest ratio of wireless licences to population!

"In one district there is a good deal of trouble with interference from suburban electric lines. There have been nasty letters written to the papers pressing for assistance in cutting out this static. The Germans do it. They have a volunteer corps of engineers, willing to track down the source of any interference with sets.

"There has been a fair amount of official listening, but mostly to track down pirates. Incidentally, a pirate, when found out, has to pay a fine of 400 kr.—about £21!

"The programmes are good and long. Take the day's programme from Copenhagen. This is relayed by Kalundborg, and most of it by the short-wave station as well.

"Copenhagen is one of the few countries which really does run a very early morning broadcast of gymnastics. I have heard it while in England at about half-past six (British time). Household talks and special talks for women are given during the morning till about 2 o'clock.

"Afternoon light music is given by one of the many popular orchestras, such as those directed by Max Skalka, or Mogens Hansens. Sometimes a relay is made from a place such as the Hotel d'Angleterre.

"You will generally find an English lesson or a special English talk about 4 o'clock. Other important broadcasts starting then are those of the Exchange and Fish Market prices. I myself have given one or two talks on topics of interest to trade people, such as 'Barley growing in Denmark.'

### Enjoyable Programme!

"There is a good station orchestra at Copenhagen, and Emil Reesen is the conductor. This orchestra gets through an immense amount of work in operatic selections, studio recitals, and so on.

"Interesting breaks are made by having outside broadcasts from all kinds of places. The engineers at the special request of the Broadcasting Council, fitted up a van with a short-wave transmitter. This is occasionally used for broadcasts of outdoor sports when it is difficult to get telephone communication with Copenhagen; but because of the excellent 'phone scheme all over the country, this possibility does not often arise.

"I have said that the programmes are long. Here are some figures I have obtained which show how the programmes are divided.

"The Children's Hour takes up 3.3 per cent, light music 37.4 per cent, and news and talks 21.4 per cent. This last item may seem a lot, but remember that we are immensely interested in the extended weather reports in connection with Danish shipping, and in the fishing and agricultural bulletins."

I asked about the language, for I know very little Danish.

"It is not an easy language to understand, I suppose. It may help you if I give the phonetic pronunciation of the Copenhagen call, which of course is also to be heard from Kalundborg on the long

waves. It is *Karloendbor Kejob-enharven og Danmarks Kortbolgosanner.*

"A gong is struck in the studio at the beginning of some programmes, but I dare say you have noticed the relay of the bells from the old Copenhagen Town Hall. I have often heard them while over here. They are quite unlike your Big Ben."

I asked about the strange programme-voting scheme which they have in Denmark, and he told me that in his opinion it is really workable.

### A Good Idea.

"When you apply for a licence you have the opportunity of stating, on the back of the form, your views on the composition of the programmes.

"The popular items, such as dance music, talks, opera, orchestral music and so forth are listed, and all you have to do is to indicate the amount of each required. You have also to state your own trade or profession.

## MODERN BUILDING FOR MODERN NEEDS



The ultra-modern station building at Copenhagen stretches across the roadway and makes an imposing addition to the architectural beauty of the town, as well as providing capacious studio and office accommodation for the broadcasting concern.

"That, apparently, helps the postal authorities to decide in what order your tastes should come!

"The voting is not at all compulsory, and there is nothing to prevent you getting a licence even if you make rude remarks on the back of the licence form! That at least is one advantage of listening in our country.

"Every half year or so the authorities work out the statistics. They can tell you, say, that factory workers, as a class, voted for more opera, and that stockbrokers want more weather bulletins. Of course there is a long delay, for the compilation of statistics,

before the people's voting can be applied to the programmes, but our present Broadcasting Council are very keen on the idea—especially the six members who represent listeners!

## RECEIVED FROM READERS

Including Notes on the "W.L.S." One

### HI, THERE! DROP IT!

The Editor, POPULAR WIRELESS.

Dear Sir,—If the gentleman or gentlemen who entered our Works during the last week-end and removed, amongst other things, one of our "ORPHEUM" S.G.P. Three battery type chassis serial No. 0082, will be good enough to return the same to us, we shall be pleased to affix to it the appropriate "Marconi" plate, as this particular chassis was unlicensed.

We congratulate the present owners upon such a discriminating choice, and hasten with our assurances that, although the chassis did not "pass through our books" in the customary manner, and its delivery was out of strict rotation, it nevertheless carries our usual guarantee, and should it prove faulty within twelve months from date, it should be sent to us, when the matter shall receive prompt attention.

Yours Faithfully,  
SPIERS & BROWNE,  
Crown Works,  
Forest Hill,  
London, S.E.23.

### A VERY BAD AERIAL — BUT VERY GOOD RESULTS!

The Editor,  
POPULAR WIRELESS

Dear Sir,—I would like to congratulate you on the W.L.S. one valver. I put it together some three weeks back, and being my first effort on the short waves, I had my doubts about bearing anything, so hoping for the best I put the smallest coil in, turned the dial, and in came Rome at the strength. Up till now I have logged the stations on the enclosed list, at some time or other during the past three weeks; I have had them all at very good 'phone strength. My aerial is an indoor one, having about four joints in it (and bad ones at that) it is about 20 ft. long, hung around the room on nails and to crown all, it is always connected to my other set. This does not seem to make any difference at all. The parts in the set are those specified, except the tuning condenser. I am using a .00015.

I remain,  
Yours sincerely,  
F. G. SADLER,  
96, Dynevor Road,  
Stoke Newington,  
London.

	METRES	STRENGTH
Radio Colonial	25-03	Good
Rome	25-4	Good
Pittsburgh (W 3 X K)	25-25	Variable
Chelmsford (G 5 S W)	25-53	Variable
Madrid (E A Q)	30-4	Good
Lisbon (C T I A A)	31-25	Good
Schenectady (W 2 X A D)	19-56	Variable
Moscow	50-0	Good
Vatican City	50-20	Good
*Radio Neason? (Lausanne)	—	Good

\* The above station was received on the night of Saturday, July 10th, at about 10 o'clock, when he was heard calling up New York. The French prime minister then gave a speech lasting about five minutes, in French, then said a few words in English. I have not heard the station since. As you can see by the above, I get best results on the smallest coil. On the biggest coil of all I have only got one station, and that was testing, I should think, as he called out Amsterdam and gave out a few notes on a bugle.



# TELSEN

# TELORNOR

gives your home-built set the dignity and beauty of line of a commercial Radio Receiver.

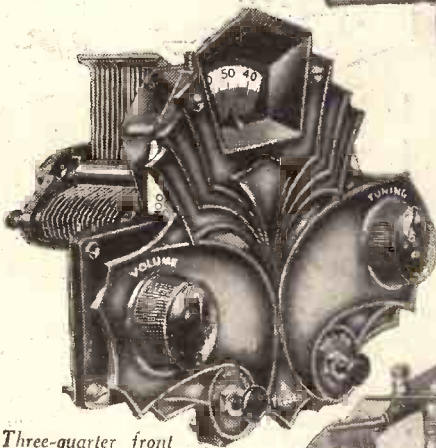
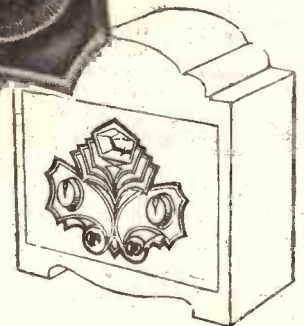
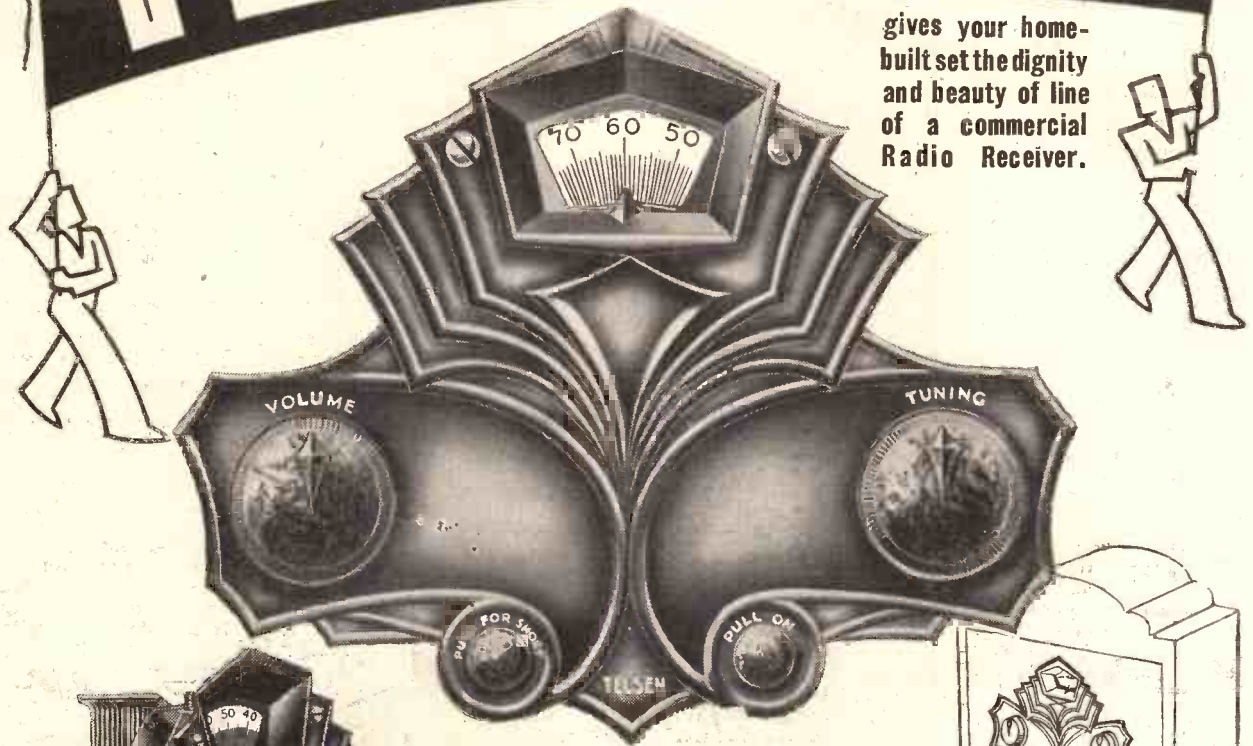

Three-quarter front view of the "Telornor."

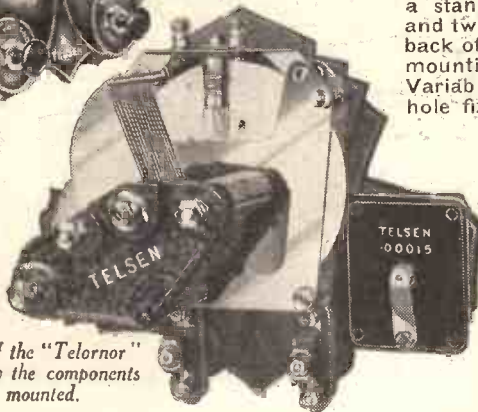

Back view of the "Telornor" showing how the components can be mounted.

THE Telsen "TELORNOR" consists primarily of a variable ratio disc drive tuning control, and is supplied with an attractive escutcheon plate finished in oxidised silver. The tuning control knob is off-set on the escutcheon plate, which is also pierced to accommodate a standard Bakelite Reaction Condenser and two switches. A small bracket on the back of the chassis frame provides for the mounting of a Telsen '0005' Logarithmic Variable Condenser, or a standard "one-hole fixing" condenser with  $\frac{1}{4}$  in. spindle

No. W.206.

# 7'6

# TELSEN

## RADIO COMPONENTS

### GOOD RADIO IS A JOY FOREVER

ANNOUNCEMENT OF THE TELSEN ELECTRIC CO., LTD., ASTON, BIRMINGHAM.

# TELSEN SCREENED TUNING COILS

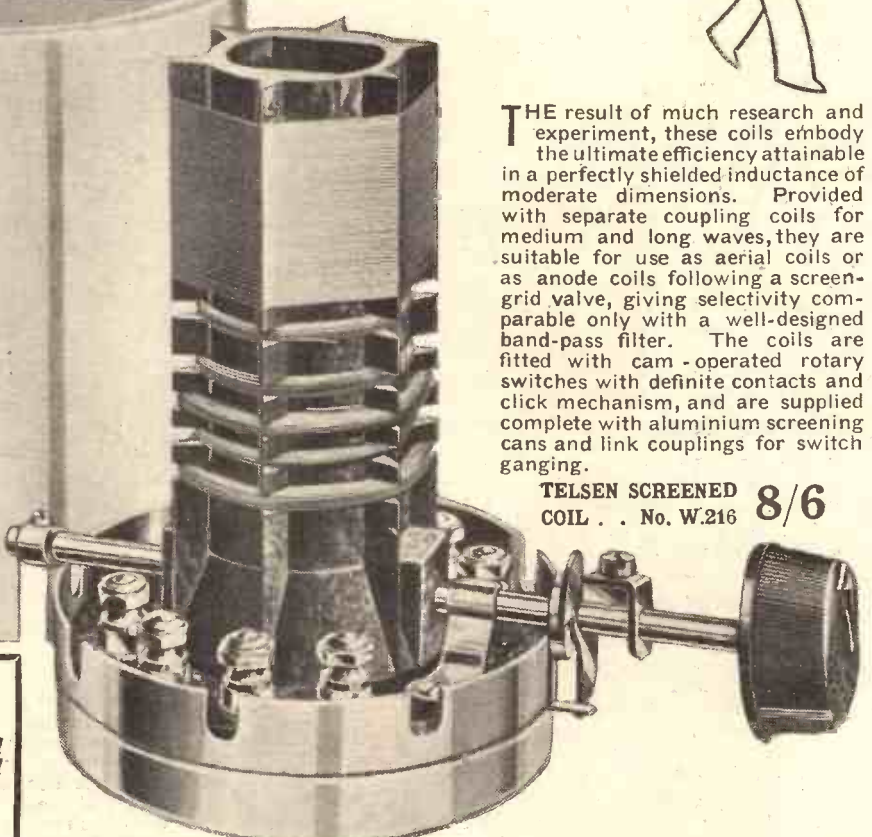
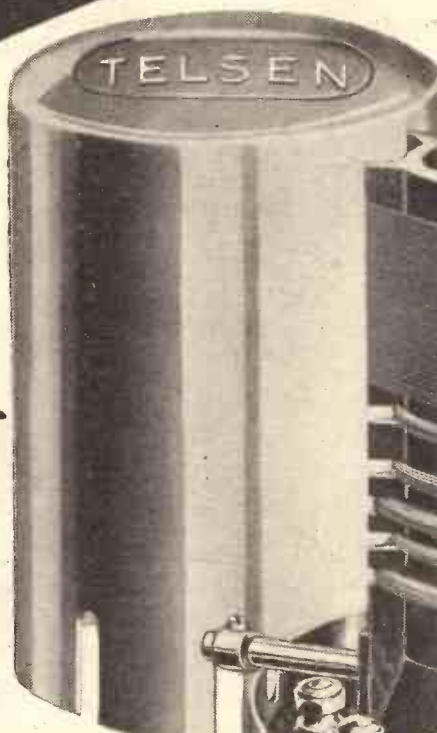

THE result of much research and experiment, these coils embody the ultimate efficiency attainable in a perfectly shielded inductance of moderate dimensions. Provided with separate coupling coils for medium and long waves, they are suitable for use as aerial coils or as anode coils following a screen-grid valve, giving selectivity comparable only with a well-designed band-pass filter. The coils are fitted with cam-operated rotary switches with definite contacts and click mechanism, and are supplied complete with aluminium screening cans and link couplings for switch ganging.

TELSEN SCREENED COIL . . No. W.216 **8/6**

**TELSEN COIL SWITCH KNOB ASSEMBLY.**  
This knob is specially designed for use with the Telsen Screened Tuning Coils. The extension on the knob spindle fits over the switch rod supplied with the Coils, a firm coupling to the rod being ensured by tightening the small screw provided. The knob assembly is suitable for mounting to any standard thickness of panel, and includes a neat disc escutcheon. The knob is of the push-on type in Black Bakelite.  
No. W.218. **1/-**



W.288 Triple Matched Screened Coils **25/6**

W.287 Twin Matched Screened Coils **17/-**

**TELSEN COIL SWITCH COUPLING ASSEMBLY**

When it is desired to mount two or more of the Telsen Screened Coils in a line parallel to the panel, and to control the wave-change switching by a single knob on the panel, this switch coupling assembly will be found indispensable. The link arms of the coupler are fitted over the switch rods of the coils, and adjusting slots are provided in the link bar to allow for the spacing of the coils varying from 3 in. to 6 1/2 in. The whole assembly has a neat nickel-plated finish, is perfectly smooth and positive in action, and free from the back lash.

No. W.217 **6d.**

# TELSEN

**RADIO COMPONENTS**

**GOOD RADIO IS A JOY FOREVER**

ANNOUNCEMENT OF THE TELSEN ELECTRIC CO., LTD., ASTON, BIRMINGHAM



# The AIRMAN'S RADIO ROUTE

**P**ICTURE to yourself a large powerhouse, with its huge whirring generators, stone floors and heavy marble panels covered with massive switches and meters. There is an atmosphere of powerful substantiality and certainty as an engineer with one hand on a small wheel, adjusts the number of cycles per second of alternating current going out to thousands of homes and factories.

But there is nothing of this solidity about the passenger-carrying aeroplane, flying through vision-obscuring clouds and buffeted about by storms and wind. The pilot, continually moving his controls to correct the "bumps," keeps one eye on a small indicator which enables him to adjust the course of the machine so that it is heading straight for home.

### Application of a Principle.

And yet the engineer and the pilot, in these widely differing circumstances, are both making use of instruments that work in the same way. The only difference lies in the application of their principle.

The frequency meter employed by the engineer, consists of a number of tuned reeds with very definite, known natural-response frequencies. These are electromagnetically under the control of the current passing through the meter, which causes one particular reed to vibrate according to the frequency of the current.

Now what about the pilot, who is using one of the latest forms of direction-finding apparatus for aircraft, known as the Marconi visual type course indicator. His instrument has only two reeds which vibrate at the same time, and so quickly that they look like two white lines upon a black background.

Both of the white lines are the same length when the machine is on its correct course. If the right-hand one gets a bit shorter, it means that the aeroplane is flying away to the left of the correct course, and must be turned to the right.

### No Tuning or Adjustments.

Similarly, if the left-hand one gets shorter the pilot has to turn that way. It is just a simple matter of turning towards the shorter line.

That is all the pilot has to do, there are no tuning or other adjustments for him to carry out. The radio side of the scheme is completely automatic, and this is how it is effected.

There are two large frame aerials at the aerodrome, set at an angle to one another. These frames radiate "beam"

It is now possible for an airman, flying in a thick fog, to keep exactly on his course by watching a small "dial" on his instrument board. How it is done is interestingly explained

By A. S. CLARK.

waves, and are so pointed that the line along which the "beams" are immediately adjacent, is the rhumb line along which the aeroplane desires to fly. (See drawing below.)

The radio waves radiated over the shaded portion are modulated at a different frequency from those over the other portion marked "second frequency." The two modulating frequencies are the same as the frequencies to which the two reeds on the instrument are tuned.

When the machine is following the proper course, the radiations from both aerials are received at the same strength,

The actual receiver used to pick up the radiations from the beacon is a special one, of which the weight has naturally been kept very small. It is a five-stage set, with three tuned high-frequency stages, a detector and one low-frequency amplifier.

The adjustments of the tuned circuits are ganged so that the initial setting is easily carried out. And once set, the receiver requires no attention apart from switching on and off.

### A Streamlined Rod.

The aerial is a very simple one, consisting of a ten-foot length of rod arranged vertically. This rod is of specially streamlined section to avoid wind resistance.

The two large frame aerials on the ground are of the Bellini-Tosi type, and are triangular in shape. They are supported by one steel lattice tower which holds the apex of each triangle.

This tower is about 100 feet high, and the bases of the two triangular frames

in the neighbourhood of 300 feet long. The two bottom corners are supported by two small masts twenty feet high, and a special system of counterweights is provided to keep things taut.

The transmitting system starts off with a single-valve oscillator, which provides the carrier for both of the low-frequency modulating notes. This oscillator will be tuned to 306 kilocycles, which is about

### SAFELY BACK TO THE FOLD

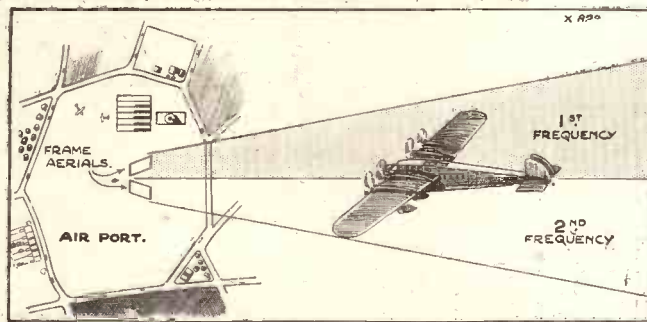

Under this scheme the air liner would fly direct to its destination as surely as if it were a train with its rails as a guide, and even though the ground were invisible.

and the conditions under which both white lines on the dial are equal, appertain. But as soon as the machine gets off the dividing line, something else happens.

Both frequencies will still be received, but one will be stronger than before and one weaker; which will be which will depend upon the side of the centre line to which the machine has deviated. Looking at the diagram, if the machine goes off the course to the shaded side, then the first frequency will be received the stronger.

The result of this will be that the reed tuned to this frequency will vibrate more strongly than the other one. That is how the two white lines are caused to vary in length.

980 metres.

The oscillations of this valve are applied to the grids of two separate intermediate valves, which serve at the same time as modulators. The modulations are superimposed upon the high-tension supplies to the two anodes of these valves.

One frequency is sixty-five and the other eighty-six point seven per second. From this point onwards the transmitters are quite separate.

On the whole the system is a very simple and straightforward affair, but it is a remarkable advance on the interlocking dot-and-dash signals that are used on other beacons, and which require the wearing of head-phones by the pilot.

THE MIRROR OF THE B.B.C.

By O. H. M.

**NO BROADCAST ADVERTISING IN ENGLAND****PUBLICITY FOR B.B.C. OFFICIALS—NEXT SEASON'S PEAKS—  
B.B.C. PRODUCER FOR VAUDEVILLE TRIAL, Etc.**

**I**NTERESTED quarters, including the Treasury, have been canvassing the idea of the introduction next year of advertising by microphone on a limited scale. Periodical "kites" have been flown; various views have been ascribed to Sir John Reith and the Board of Governors.

Although it is true that Sir John himself is not so dead against microphone advertising as some might expect him to be, I can say on excellent authority that nothing of the kind will be undertaken in Britain during the present licence—that is, until the end of 1936—and probably not afterwards either.

It would appear that a limit is at last placed to the amount of Treasury raiding the B.B.C. can stand.

**Publicity for B.B.C. Officials.**

I have noticed a tendency to allow the new rules against personal publicity for B.B.C. officials to fall into abeyance already. Dr. Adrian Boult, against whom the rule was alleged to be partly directed, appears as much as ever in the programme, although it is perhaps noticeable that nothing is now said about him in the editorial pages; nor does his photograph appear with the old frequency.

Val Gielgud, the dramatic producer, does not seem to suffer eclipse in publicity, which is all to the good from the point of view of listeners who want the microphone to be something more than a civil service "third personality," which apparently the Board of Governors would like to make it.

**Next Season's Peaks**

Plans for the autumn arrangements for play production at Broadcasting House are well on the way to completion.

John Galsworthy will be represented by a revival of "The Forest," and John Drinkwater by the first radio presentation of his comedy, "Bird in Hand."

A dramatic little Dreyfus play by Joseph Renaud, the French novelist, journalist, critic, playwright and former fencing champion of the world, who worked in Switzerland for the Secret Service during the war, should create a lot of attention; as will also Whitaker Wilson's specially written play about the life of Sir Christopher Wren, which will be produced on the tercentenary of the architect's birth in October. Lennox Robinson's "The White Blackbird" and a thriller written around the story of a haunted iceberg, by L. du Garde Peach, are also in the list.

Father Bernard Walke contributes a new play entitled "All Souls Eve," to be acted by the village players of St. Hilary in late October, and there is also a German radio play, constructed from scenes at famous balls of history, which Peter Creswell is producing under the name of "Ball and Dance." Tyrone Guthrie, who at one time was on the staff of the B.B.C.,

has adapted "The Three Musketeers" as a wireless play which strikes an entirely new note in radio drama, since it falls into two parts which will be given on successive evenings.

Another adaptation is "Ghosts at Solberge," by M. H. Allen, from a Norwegian story by Selma Lagerlof, to be presented in December, the month when

**ANOTHER ROYAL VISITOR**

Princess Helena Victoria being met by Lady Snowden on her visit to Broadcasting House, a few days after the King and Queen had been conducted over the building.

Clifford Bax's historical play, "The Immortal Lady" (which tells the story of Lady Nithsdale's rescue of her husband from the Tower of London), will be produced. Phillip Wade is the author of "The Family Tree," to be heard in November, and Shakespeare, without whom the list would be incomplete, will be represented by a production of "Romeo and Juliet."

**B.B.C. Producer for Vaudeville Trial.**

Recent changes in the personnel of the vaudeville department at Broadcasting House have caused mention of the name of Mr. J. E. Sharman in a way which does not altogether convey a correct impression of the work which that unassuming official has carried out so successfully during the last seven years.

Mr. Sharman has never sought credit for many of the ideas for which he alone was responsible. It was good enough for him that he filled a niche and, with four other producers, did one of five light entertainment shows each week, without fuss, but always well arranged and presented, and based on his thirty years' practical experience in the performing business.

Just now Mr. Sharman is working exceedingly hard, and he has the assistance of Mr. A. Martyn Webster, who has been transferred from Edinburgh to the London headquarters. There is not much that Mr. Sharman does not know about stage entertainment, having played in "straight" shows and on the halls.

**Northern Features.**

Another concert party entertainment by the Super-Optimists will be relayed from the Floral Pavilion, New Brighton, for North Regional listeners next Monday, August 15th. Two band concerts are also in the programmes for the same week, the first on Sunday being by the Abram Colliery Prize Band, which comes from Bickershaw, near Wigan.

**THE LISTENER'S NOTEBOOK**

A rapid review of some of the recent radio programmes.

**I**T'S no use, it seems, to continue our warfare against the Studio Audience.

The Director of Plays, etc., has spoken; he says that the applause and hilarity of this body of folk are indispensable to the success of the performance; without them, things would be very flat, or words to that effect.

So now we know! And perhaps he is right. He evidently thinks so himself, otherwise he wouldn't consider the question of "dressing the show" so important.

Supposing we allow him this claim. I think we might, in our own interests, warn

him of a danger he is running. If shows are produced with the studio audience in mind, the producer must tend to employ the old stage technique, and thus retard (if not totally neglect) the proper development of the new radio technique.

**A Serious Situation.**

This retrogressive step is already apparent in the vaudeville shows. There have been many artistes of late who have made no attempt to get it over to the listener. In fact, I go so far as to say that these

(Continued on page 704.)

# TELSEN

# CONDENSERS and DRUM-DRIVE

VARIABLE  
Air-Dielectric

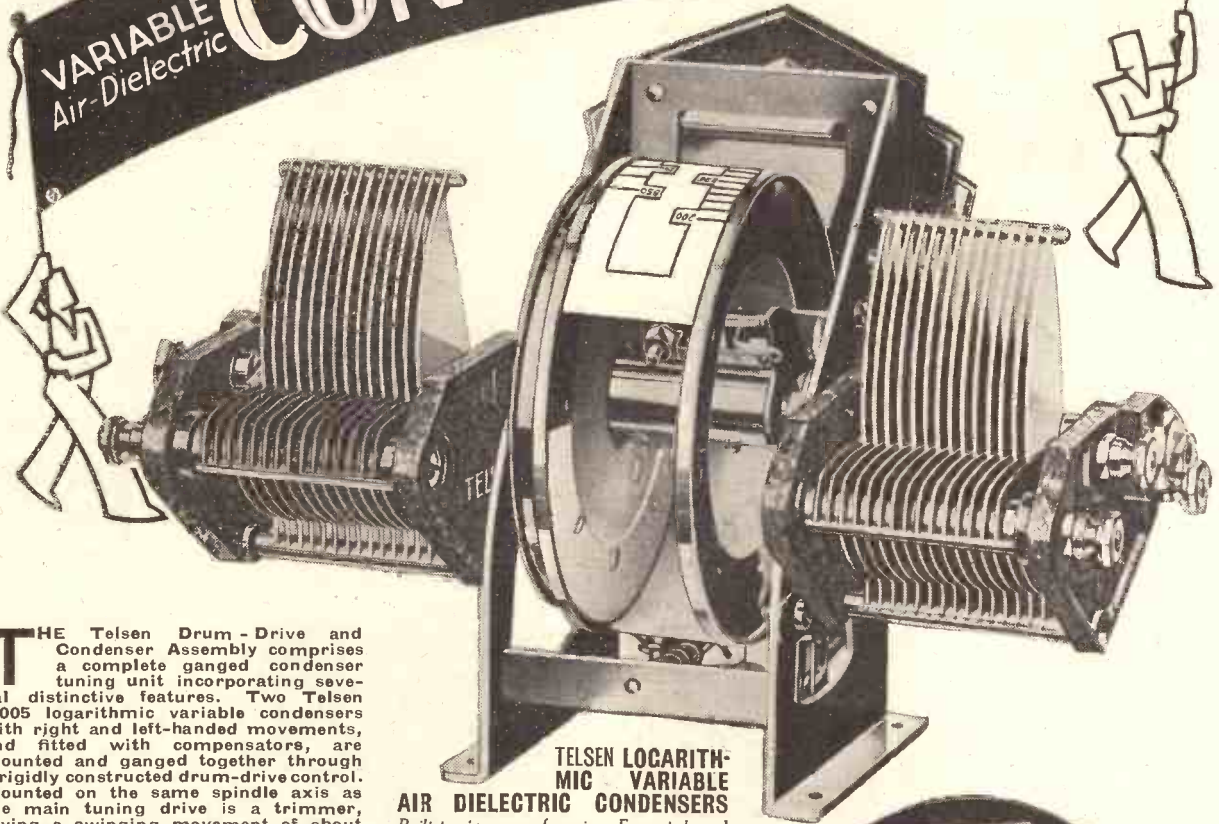

**T**HE Telsen Drum-Drive and Condenser Assembly comprises a complete ganged condenser tuning unit incorporating several distinctive features. Two Telsen '0005 logarithmic variable condensers with right and left-handed movements, and fitted with compensators, are mounted and ganged together through a rigidly constructed drum-drive control. Mounted on the same spindle axis as the main tuning drive is a trimmer, giving a swinging movement of about 10° to the stator vanes of the left-hand variable condenser, thereby enabling perfect matching of the condensers to be maintained throughout the Tuning Range. Two scales are supplied with the unit, one marked in wavelengths and one in graduations from 0-100. The scale is illuminated and has the additional advantage of being easily removable when it is desired to fit one of special calibration. The escutcheon is handsomely finished in oxidised silver, and knobs of the push-on type are fitted. Provision is made for panel and base-board mounting, and a double-ended spanner is supplied free with the unit for fitting the variable condensers. Full instructions for mounting are included with every unit. The drum drive can also be supplied separately for mounting with any standard type of variable condenser.

**17/6**

No. W.262. Price

### TELSEN LOGARITHMIC VARIABLE AIR DIELECTRIC CONDENSERS

*Built to give years of service. Frame is braced by three solid pillars, and the effective clamping of the vanes, each held at three points, makes distortion impossible. The rotor is also built into a rigid unit, the vanes being held at both ends. Generous bearings obviate backlash or end-plate. Models No. 260 and 261 left hand and right hand movements respectively. Incorporate a compensator (max. cap. 60 mfd.) for balancing out stray capacities, thus greatly facilitating ganging.*

Model	Cap.	Price	Model	Cap.	Price
No. 130	'00025	4/6	No. 260		
			(Left hand movement with trimmer)	'0005	5/-
No. 131	'00035	4/6	No. 261		
			(Right hand movement with trimmer)	'0005	5/-
No. 132	'0005	4/6			

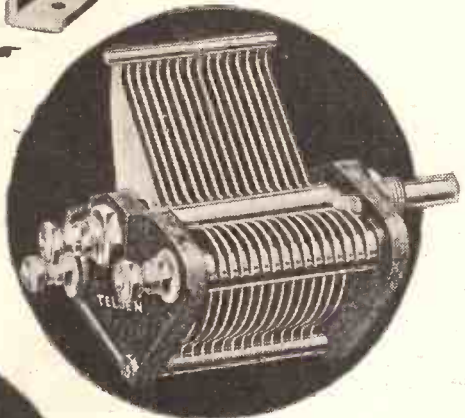

### TELSEN DRUM DRIVE

*Follows standard practice generally, but embodies several detail refinements, among which may be instanced the cord drive, arranged to reduce wear to a minimum and to prevent over-run, and the rocking stator trimmer, which gives a variation of 20°, and visual indication of setting. For use with Telsen screened coils, an extra scale, marked in wavelengths, is supplied free of charge. Illustration shows escutcheon, handsomely finished in oxidised silver.*

**8/6**  
Price

# TELSEN

RADIO COMPONENTS

## GOOD RADIO IS A JOY FOREVER

ANNOUNCEMENT OF THE TELSEN ELECTRIC CO., LTD., ASTON, BIRMINGHAM.

# TELSEN

# 10-1 COUPLING UNIT & 1-1 COUPLING UNIT

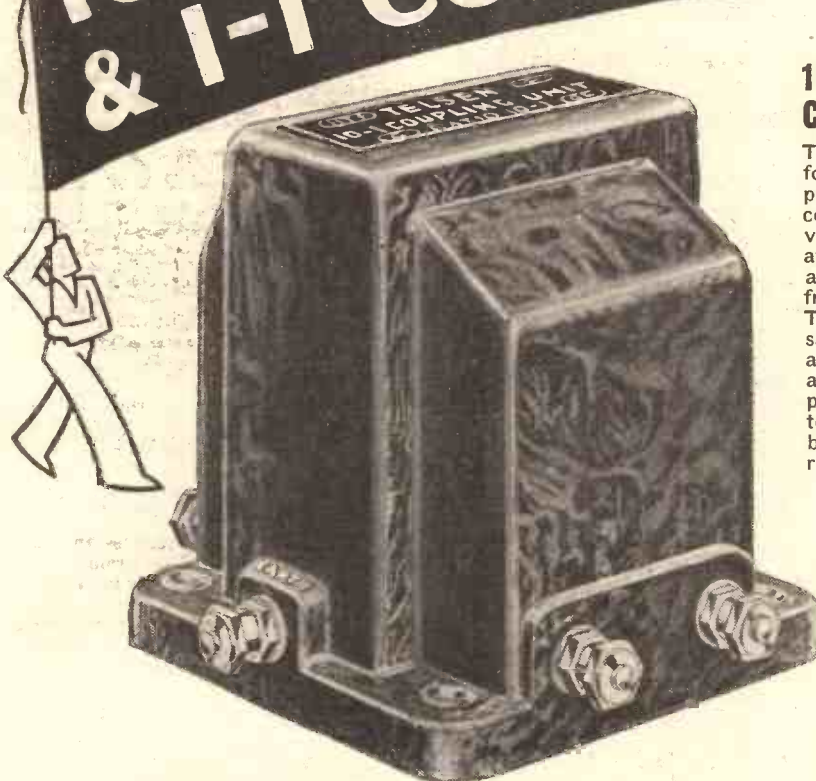

## TELSEN 10-1 INTERVALVE COUPLING UNIT

This is a filter-fed transformer using a high permeability nickel alloy core, which enables a 10.1 voltage step-up to be attained while preserving an exceptionally good frequency characteristic. The response is compensated in the higher frequencies for use with a pentode valve, this combination giving an amplification greater than anything previously achieved, equal to two ordinary L.F. stages, but with better quality of reproduction.



**12/6**

No. W.215.

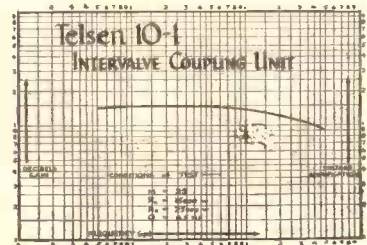

## TELSEN 1-1 INTERVALVE COUPLING UNIT

This is a modern development of the one time deservedly popular R.C. units. It incorporates a low pass filter feed in its anode circuit, thus effectively preventing "motor-boating," "threshold howl," and other forms of instability arising out of common couplings in eliminator and battery circuits. Used with an H.L. type valve it will give an amplification of about 20 and a perfect frequency response, at the same time consuming negligible H.T. current.

**7/6**

No. W.214.

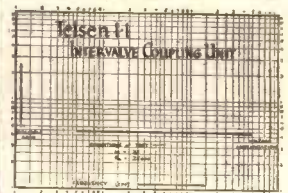
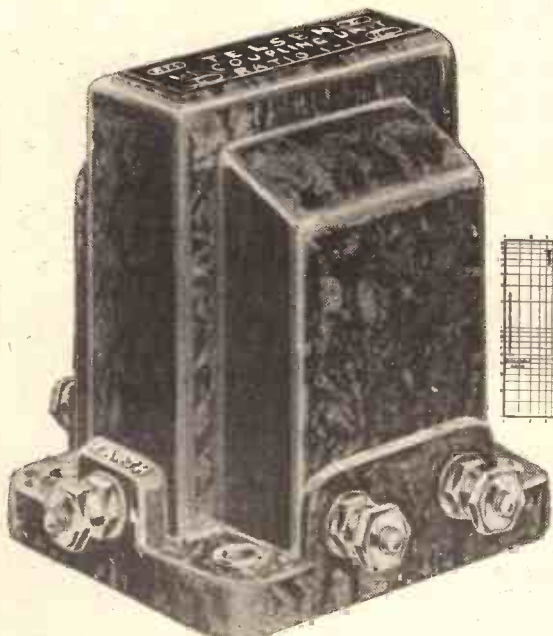

# TELSEN

RADIO COMPONENTS

**GOOD RADIO IS A JOY FOREVER**

# CAPT. ECKERSLEY'S QUERY CORNER



Under the above title, week by week, our Chief Radio Consultant comments upon radio queries submitted by "P.W." readers.

## CALIBRATED MICROPHONE—CONTROLLING VOLUME—ALUMINIUM WINDINGS

### Comparing Loudspeakers.

N. N. (Leeds).—"Is there any satisfactory method of determining the output characteristics of a loudspeaker so that one speaker may be compared with another?"

"It seems to me that it would be a distinct advantage if the response curves of different speakers were published in the same way as those of transformers."

There certainly are methods, but I doubt if any could be accurately described as satisfactory. The basic idea is to have a microphone which is calibrated as pressure of air wave against output voltage.

If this calibration can be relied upon, then the calibrated microphone is hung up in front of the speaker. Equal volts are applied at various frequencies to the speaker, the microphone response is measured and, from the calibration, the speaker characteristic plotted.

But if the output sound from the speaker is reflected from the walls of the room, obviously the results mean nothing, because the reflections are different at different frequencies. So the walls of the test room have to be most carefully and expensively treated.

Then standing waves may be set up between microphone face and speaker diaphragm, giving amazing "peaks." These are eliminated by swinging the microphone and taking an average reading of output.

At no instant is the distance between tested speaker and testing microphone the same if the latter is swung. It's all an expensive and, perhaps, rather unreliable method, and one laboratory's results seldom agree too closely with another's. This makes comparison difficult and untrustworthy.

Besides, frequency characteristics are not all of a loudspeaker's performance.

### Low Resistance—High Amplification.

H. N. P. (Boscombe).—"The volume control in my receiver consists of a variable resistance connected in parallel with the primary winding of one of the L.F. transformers.

"If the resistance is varied so that a comparatively low resistance, compared with the total resistance, is connected across the

primary, the reproduction of high notes seems to be greatly increased. I should have thought that the effect of reducing the resistance value would have been to reduce the amplification of the high notes and I should be pleased if you could explain this effect."

Do I take it that Fig. 1a is your connection? Or is it as Fig. 2a?

Assuming Fig. 1a, let's see what happens. If there is a practically open circuited secondary, the primary of the transformer looks like an inductance. So that you have in effect a variable frequency alternator in series with an inductance, which latter is in parallel with a resistance (see Fig. 1b).

With a low-frequency the current will tend to flow through the inductance L; with a high-frequency, through the resistance  $R_2$ , so we should expect, as you say, a low-frequency predominance.

Now, if we take Fig. 2a and analyse it, we get Fig. 2b, and in just the same way the current would appear to be greater

Don't address your letters direct to Capt. Eckersley; a selection of those received by the Query Department in the ordinary way will be answered by him.

sensitive, and does it give better quality than the other forms of rectifier?"

The diode just rectifies and does not amplify, and if you wanted the same performance from the two methods the diode would have to be followed by a note magnifier—the diode method involves two valves, the anode-bend and grid-leak one valve.

The anode-bend and grid-leak rectifiers are, in a sense, diodes which simultaneously amplify. The grid-filament circuit of the grid-leak rectifier, for example, is a diode, while the anode-filament circuit receives an amplified signal.

The power grid-leak type of rectifier gives as good quality—i.e. is as linear—as any diode, and so there seems no reason at all why anyone should use any other method.

### Wire for Loudspeakers.

S. R. J. (York).—"I have a large quantity of aluminium wire which I am going to use for winding the speech coil of my loudspeaker. I have been wondering, however, whether the difference in weight, i.e. as against copper, will make it worth my while to use this type of wire."

There is no sort of advantage in using aluminium wire for the field coils of an electro-magnetic moving-coil speaker or for the operating coils of the moving-iron type because the chief weight in either of these cases lies in the other parts of the speaker, e.g., magnet and baffle board for moving-coil, and pole pieces, etc., for moving-iron.

Besides, what does the weight of a moving-iron speaker matter? Aluminium wire having a higher resistance than copper wire of the same thickness reduces the possible ampere turns in a given space for a given applied E.M.F.—i.e., makes the magnet system less efficient.

Its less mass is of advantage in certain cases. But it is not easy to make connections off the ends of the aluminium wire, as it is inclined to break when bent.

## IT KILLS THE HIGH STUFF

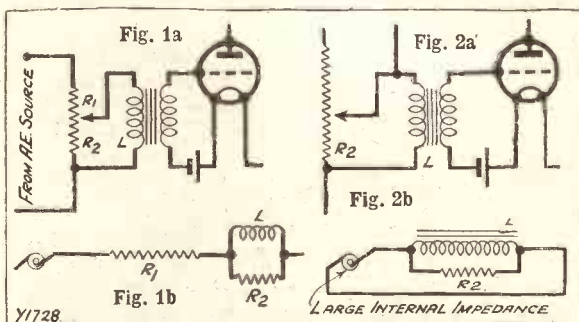

In his reply to H. N. P. (Boscombe) Capt. Eckersley explains why it is that a variable resistance connected across the primary of an L.F. transformer is not a perfect volume control.

through L at low frequencies.

But what of the valve?

If  $R_2$  is not grossly low, then the impedance of the combination does tend to rise slightly with rising frequency, and it may be that at low frequencies L is lower than  $R_2$ .

This may be the explanation—that L is lower than  $R_2$ .

### Diode Detection.

L. L. (Southend).—"Although I am fairly conversant with the anode-bend and grid-leak types of detectors, I know practically nothing about the diode. What are the advantages of the diode? Is it

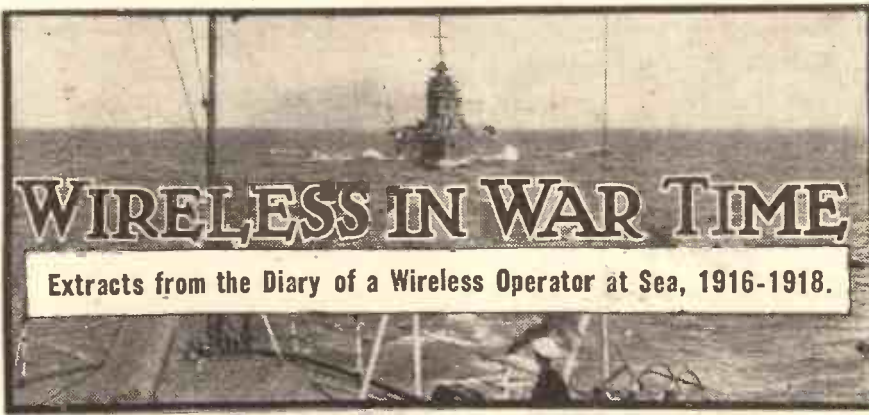

## TOO ROUGH FOR U-BOATS—RIDING THE STORM—BEDDING AND COCKROACHES—A SERIOUS ACCIDENT—RAGS AND TATTERS.

**EDITOR'S NOTE.**—Our contributor's next voyage was to Sydney (Nova Scotia) and Montreal, and his diary continues from the time when, joining a convoy of ships at Sydney, the voyage home across the Atlantic was commenced.

**SEPTEMBER 29TH, 1918.**—We left Sydney, Nova Scotia, in a convoy of thirty ships about 11 this morning. Our sailing orders are for France.

**OCTOBER 3RD.**—The weather has undergone a complete change. Early this morning a stiff wind sprang up and a heavy swell set us rolling right merrily. The rain forms such a thick mist that it is impossible to read flag signals hoisted by the escort, so all communications are being made by wireless—which affords us a busy time in the cabin. Luckily, there's not much to fear from submarines this weather.

### A Very Wet Job.

**OCTOBER 5TH. (Noon).**—Things are becoming rather annoying. The weather is growing steadily worse, and we are now in the thick of a nice little gale. The sea, although not "mountains high," is sufficiently agitated to sweep our decks continually and made crossing the well deck a very wet job. This morning none of the convoy is in sight, but we are constantly receiving orders regarding position, etc., from our escort ship, H.M.S. Devonshire.

3.30 P.M.—The main aerial wire broke an hour ago through the force of the wind. After a great deal of trouble the crew managed to get it repaired and hoisted aloft again. The weather is generally going from bad to worse, and there is now a distinct whistle in the wind which bodes no good for us.

### Less Likely to Founder.

8 P.M.—Wireless orders from H.M.S. Devonshire to "Heave to." This means we are to bring the engines to dead slow and lay head on to the sea, for in this position we are less likely to founder.

**OCTOBER 7TH.**—To-day we are in the middle of a very severe storm that is fast approaching hurricane force. About 2 a.m. the other operator came running up to the wireless cabin looking like a drowned rat.

A large wave had come clean over the

upper deck into our sleeping cabin and had practically washed him out. When I went down I found the cabin three feet deep in water, with boots, shoes, bedding, etc., and dead cockroaches floating about as though at a regatta.

### Scattered Far and Wide.

It took us over an hour, standing in icy water, to bail the cabin dry. From 6 a.m. yesterday till 6 p.m. to-day we have made good exactly 15 miles. At this rate, Lord knows when we shall get home. We are miles out of our course, and the convoy is scattered far and wide.

**OCTOBER 8TH. (8 p.m.)**—About 10 p.m. last night things began to happen, and to-day we are in some danger of paying a

## "BRINGING HOME THE BACON"

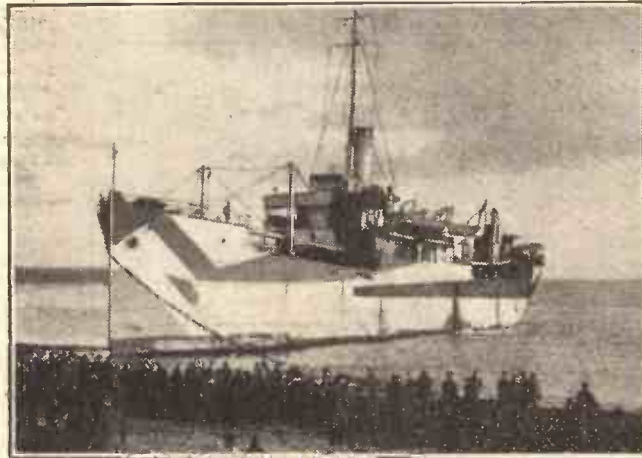

As the crowd on the beach realised, the life of a war-time merchantman was by no means an easy one. Even camouflage could not save this vessel from a torpedo, but her commander considered the sandy beach of Cornwall more pleasant than the ocean bed. So he beached his ship and saved his bacon!

visit to Davy Jones' locker. With remarkable suddenness the wind has risen to terrific force, creating one perpetual thin scream, and for the first time I have realised what the expression "sea mountains high" means.

Our sleeping cabin is again under water, so we are using the spare bunk in the wireless cabin. At 8 this morning I put on some oilskins, intending to go down and get a wash and some breakfast, but directly

outside on the main deck I had to hold tight and keep holding!

Things are in an indescribable state of confusion. Three of the starboard lifeboats, wrenched from their davits, lie smashed and broken across the boat deck. The wooden sheep pen has been pounded into a mass of splintered spars, and all the sheep—poor devils!—have been drowned.

The engineers' quarters, like ours, are under water; and the crew could be heard for'ard howling like lost souls as the water poured into their quarters. Aft, on the poop, one of our 7-in. howitzers has been wrenched from its bedding and is expected to go overboard any minute.

### Flat As Pancakes.

Nobody can get to the poop. The waves are continually smashing across the well deck, and as both the port and starboard rails have gone, it is suicidal to attempt it. On the foc'sle, the ventilators have been crushed as flat as pancakes—a thing I should never have believed possible had I not seen it with my own eyes. All the deck awning posts and stanchions are simply bits of matchwood.

I cannot get a reply through to the Devonshire, as the alternator box is flooded and the batteries—which have been giving trouble all through the trip—seem to have given up the ghost, so I can't use the emergency set.

As I went down to the lower cabin deck, a wave came right into the alleyway. It struck against the engine-room door and split it open like a piece of cardboard. The engineers are now working to rig up a substitute in order to keep the water from rushing into the engine-room!

**OCTOBER 9TH (5 a.m.)**—Our first serious accident. Whilst attempting to recover one of the lifeboats, the Second Officer was swept off the boat deck on to the main deck and had his arm smashed.

### "Right in the Neck."

I had to go to the Captain just now. He has been on the bridge for over twenty-four hours. Up there it is really a remarkable sight. As the ship slides down into a dark, white-lipped valley of water, one can look up and see a huge wave towering above and apparently about to drop right on the ship and send us to D. J., Esq.

But the ship digs her nose right into it and rides over—rather sluggishly, perhaps—and then down again with a beastly corkscrew motion which turns one's stomach inside out.

Sometimes she fails to rise on the wave—and then we get it "right in the neck." For it is

then that tons of water pour aboard with an irresistible rush, tearing ironwork and gear from the deck and making a terrible havoc and clutter.

We certainly look a bit of a mess. All the awnings that cover the bridge rails, etc., have been torn to shreds, and from all the doors and walls, which have been covered with canvas for camouflage, yards of rags and tatters flap in the screaming wind.

(To be continued.)



# TELSEN CONDENSERS

**BAKELITE DIELECTRIC**

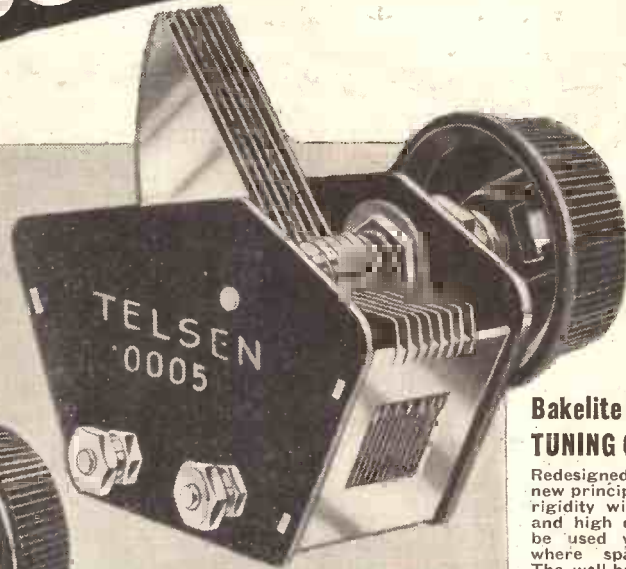

**TELSEN  
Bakelite DIELECTRIC  
TUNING CONDENSERS**

Redesigned on an entirely new principle, giving great rigidity with compactness and high efficiency. May be used with confidence where space is limited. The well-braced vanes are interleaved with a minimum of highest quality solid dielectric, ensuring complete accuracy of tuning. Supplied complete with knob.

Capacity No.  
'0005 - W.193  
'0003 - W.194

**2 1/6**

**TELSEN AERIAL SERIES CONDENSER**

This component forms an ideal volume and selectivity control. The internal construction permits of an extremely low minimum capacity. Keyed externally on the spindle is a switch arm which connects with a contact on the fixed vanes when rotated to maximum position. This short circuits the condenser for maximum volume. The rotor movement is limited by definite stops. The vanes are interleaved with the finest quality solid dielectric, and solidly constructed throughout. Supplied complete with knob.

Capacity '0003 - - - W.205

**2 1/3**

**TELSEN REACTION CONDENSERS**

Improved type, of great rigidity and precise construction. The Rotor Vanes are keyed to the spindle, and fitted with definite stops. The vanes are interleaved with finest quality solid dielectric. A strong nickel silver contact makes connection to the rotor, and a positive connection is made to the stator vanes. Complete with knob.

Capacity '0003 No. W.188  
" '0015 " W.189  
" '0001 " W.190  
" '0075 " W.191  
" '0005 " W.192

**2 1/4**

**2 1/6**

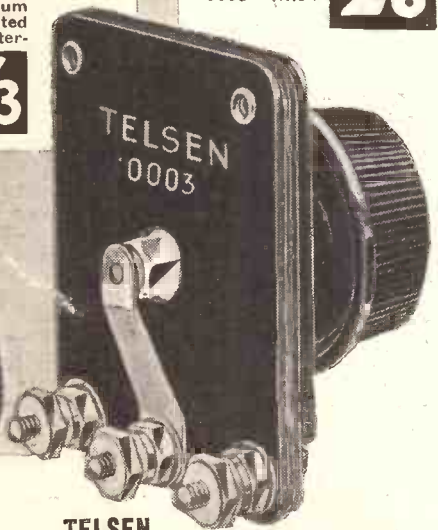
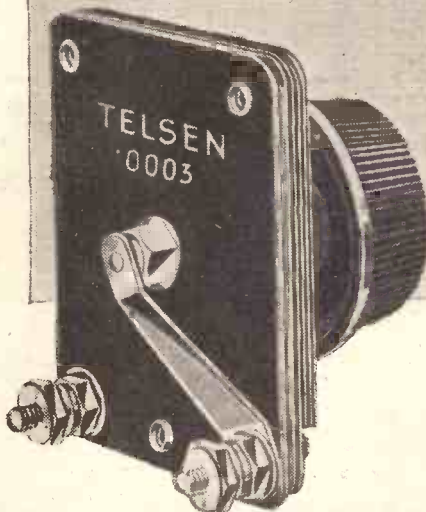

**TELSEN DIFFERENTIAL CONDENSERS**

CAPACITY NO.  
'0003 W.185  
'00015 W.186  
'0001 W.187

**2 1/6**

**TELSEN**  
RADIO COMPONENTS

**GOOD RADIO IS A JOY FOREVER**

ANNOUNCEMENT OF THE TELSEN ELECTRIC CO., LTD., ASTON, BIRMINGHAM.

The **TELSEN**

# AJAX 3



Bigger . . . better . . . packed with valuable information from cover to cover—the new Telsen Radiomag is undoubtedly the finest radio sixpennyworth ever offered. For it appeals to all—and all can profit by it. In simple language, illustrated by photographs and diagrams, and complete with 3 full size 1/- blue prints, it tells you how to build the latest circuits—how to modernise your existing set . . . how to rectify little faults . . . how to get the best out of your set in every way.

**Get a copy NOW!**

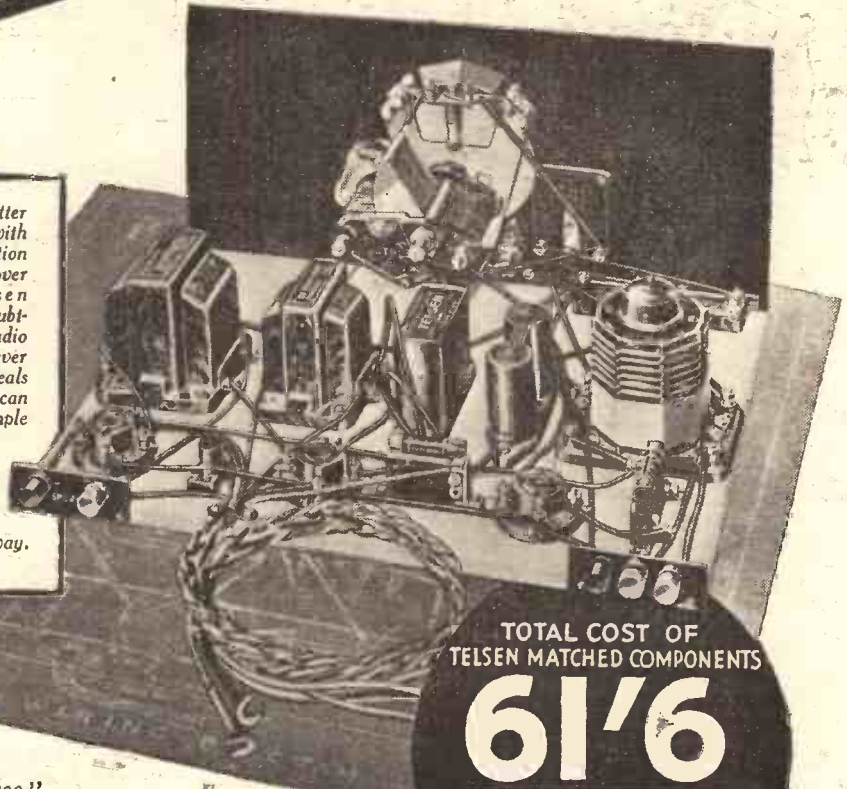

TOTAL COST OF  
TELSEN MATCHED COMPONENTS

## 61'6

FOR BUILDING THE AJAX 3,  
including panel, base-  
board, terminals,  
battery cords and all  
accessories.

**A** HIGHLY efficient "Straight Three" circuit, as easy to operate as it is to build, giving an exceptionally brilliant all-round performance, with a low initial and upkeep cost, the range, power, selectivity and general quality of reproduction setting a new standard for receivers of this type. Free full size 1/- blue print, together with full constructional details are contained in the new issue of Telsen Radiomag, which also gives full particulars of the improved and now all-embracing range of Telsen Radio Components at the still lower prices made possible by Telsen's enormous sale. Now on sale at all radio dealers and newsagents. Price 6d.



**CONSTRUCTORS' OUTFIT  
"TELORNOR"**

Contains all the sundry requirements for the construction of the Telsen Circuits using the "Telornor." Of these the "Triple" 3, the "Ajax" 3, and the "Nimrod" 2, are excellent examples. All are supplied neatly packed in a carton together with instructions.

Cat. No. 220  
**3'6**

Included in the Outfit are the following components:

- Specially cut and drilled crystalline-finish Panel. 14" x 10" Baseboard. 8-way Battery Cord. Complete set of Wander Plugs, suitably engraved, and Spade Terminals. Terminals for Aerial, Earth and Loud Speaker.
- Engraved Terminal Strips. An ample supply of 22 S.W.G. Tinned Copper Wire and necessary Sleeving for wiring up the set. A double-ended Spanner for mounting the single-hole fixing components.
- A 4-way Spanner, for tightening up all Terminal Nuts. All the Wood Screws and sundry other small accessories contributing to the complete assembly of the finished Receiver.

# TELSEN

**RADIO COMPONENTS**

## GOOD RADIO IS A JOY FOREVER

ANNOUNCEMENT OF THE TELSEN ELECTRIC CO., LTD., ASTON, BIRMINGHAM.

A Visit to Aberdeen—

# SCOTLAND'S ONLY RELAY

Listeners in northern districts of Scotland have been urging the B.B.C. to provide a more northerly relay to Aberdeen or to increase Aberdeen's power. In this article, the efforts of Scottish Engineers to prove that any such alteration is unnecessary are described by

A SPECIAL CORRESPONDENT.

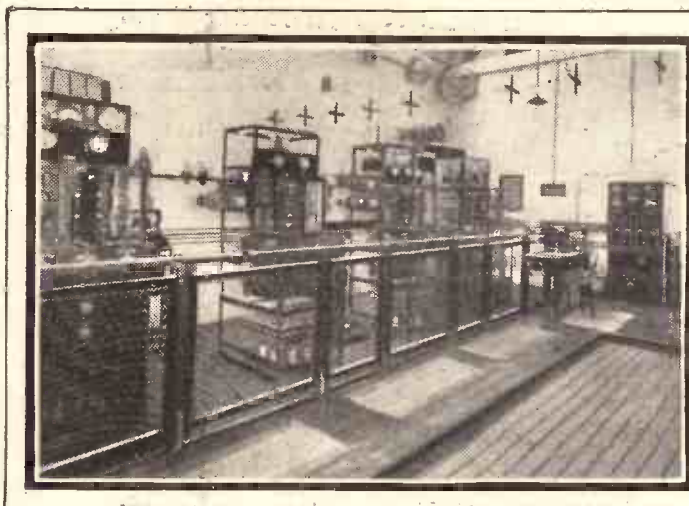

ON our way to Aberdeen my B.B.C. friend explained to me the wavelength changes which have been made in connection with Aberdeen and Newcastle.

It appears that when 288.5 metres was chosen as the National wavelength for Falkirk, the B.B.C. was not prepared to risk further tuning-fork synchronising experiments of the kind which proved rather a failure at Newcastle last year. It was going to be much safer, they thought, and better for listeners, to find a new hole in the ether for each of these relays.

**First-Hand Impressions.**

Newcastle has found a space at 211.3 metres and Aberdeen is three metres up. These wavelengths have limited service areas, but in any case an exclusive wavelength round about 200 metres gives a better service than a shared wavelength higher up in the scale and tuning-fork synchronised with another station.

Aberdeen has been going through tuning readjustments during the last few weeks, and I was anxious to see what first-hand impressions were at the station.

**Investigation of the Post-bag.**

The Aberdeen station is in Claremont Street. I found that Ian Whyte, the well-known modernist composer and formerly the man in charge at Aberdeen, had moved to Edinburgh. Apparently I had been unfortunate not to meet him there

when I visited the Scottish Broadcasting House.

Mr. Kelsall is now the "representative." They do not refer to this position as Station Director when only a relay station is concerned, although Mr. Kelsall may take on his "Station Directorship" when Aberdeen gives its own programmes.

Mr. Kelsall has a "First Mate" and five assistant engineers. There is also a small office staff, and the whole of the Aberdeen personnel will be kept busy investigating the post-bag now that the wavelength has been shifted.

Unfortunately, it is not easy on many sets to get down to about 200 metres, especially where wires have to be taken off built-in frame aërials. The engineers are busy up here giving technical advice on set alteration problems to suit 214.3 metres.

**Power Forced Up.**

The transmitter is basically the old Marconi "Q" type, which the B.B.C. used to have in the very early days at main stations. The power has been forced up, there is a good 110 ft. aerial and a fine polar diagram results.

The old tuning-fork gear which was used when Aberdeen was a 288.5-metre relay is not now used, and the tuning-fork ovens have been switched off after running continuously since Aberdeen was first "commoned."

For a while, the tuning-fork gear will not be removed in case plans are changed and

the station is again compelled to share a wavelength.

In the early days there was no good land-line connecting the station with Edinburgh and Glasgow. Aberdeen had to take all its programmes by a five-valve set permanently tuned to 5 X X. That was when Aberdeen was a National programme relay and when the 5 X X programme was the one wanted.

**A Source of Local Talent.**

Now there is good buried cable between Edinburgh and Aberdeen, and the station can take Scottish programme material from Edinburgh and Glasgow.

I understand that Mr. Kelsall believes in the movement started by Ian Whyte to use Aberdeen as a source of local talent. Just recently, in the main Falkirk programme, they broadcast Highland *Ceildirhs* and a Chaumer concert from Aberdeen in which the men of the Bothy gathered round and sang their own National songs.

There is plenty of Scottish material in old Aberdeenshire, and I am sure that Mr. Cleghorn-Thomson will back up any movement to increase the amount of national material in the programmes.

**Supplementing Edinburgh.**

I saw the first-stage amplifier on the balanced line between Edinburgh and Aberdeen. The engineers say that this cable, which is not long as landlines go,

*(Continued on next page.)*

**TWO VIEWS OF OUR MOST NORTHERLY STATION.**

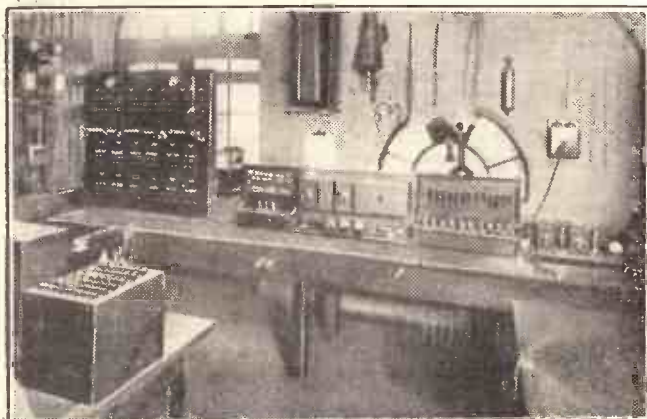

From the small studio (left) and still smaller control room, the official in charge of the Aberdeen station, Mr. Kelsall, hopes to broadcast a large amount of local musical talent in the coming months.

# THE SOLAR ECLIPSE AND RADIO.

An account of some of the wireless experiments which scientists will undertake during the eclipse on August 31st, including special investigations into the Heaviside Layer.

From A CORRESPONDENT.

latter station being within the path of totality (an astronomical term meaning where an observer will see the eclipse for the longest possible duration).

The broadcasting station will send out signals continuously for a period before the eclipse occurs until it is over. These signals will follow two paths to the receiving station. One path will be along a line just above and in the earth. Another set of waves will rise upwards and meet one of the two Heaviside Layers and be reflected back to earth again. The difference in time of the arrival of the two sets of signals will provide the necessary information with which to calculate the height of the Layers.

## Once in Four Centuries.

This interesting measurement will be carried out before, during and after the eclipse. The research party, headed by Colonel Steel of the National Research Council, Ottawa, will observe the changes in reception as the eclipse takes place. As such an opportunity comes but once in from 300 to 400 years in any one particular district, preparations will be made very carefully so that no hitch will occur.

Test broadcasts will very likely be sent out every day for a week or more in advance so that, in all, some two weeks of experimentation as well as months of planning will be involved in this study of radio receiving conditions and how they are modified by the coming of night.

**W**HY can one get greater distances on wireless sets at night than during the day?

This is a question which has proved to be one of the most baffling that has ever confronted wireless experts of all nations.

But an opportunity has at last arisen which will permit, even if not for its complete solution, at least for the shedding of greater light on it. This will be when Montreal is obscured at 3.24 p.m. (Eastern Standard Time) on August 31st next, by a total solar eclipse—the first in this district for hundreds of years.

Montreal on this day will become a Mecca for scientists and astronomers alike, and sages from all parts of the world will congregate there to watch this phenomenon. Included among these are two parties from this country—one from Cambridge University and the other from the London University.

## Measured for the First Time.

One of the more interesting investigations which are to be carried out during the eclipse will be a study of radio receiving conditions and how they are modified by an eclipse. The eclipse will provide an unique opportunity to check certain theories as to why one can get greater distances at night than during the daytime.

In these investigations the height of the Heaviside Layer will be measured for the first time in Canada. This layer, which is named after Dr. Oliver Heaviside, who discovered it in 1901, is generally thought to be an ionised stratum of atmosphere some sixty miles above the surface of the earth, the ionisation being brought about by the ultra-violet rays of the sun.

If it is true that this layer is due to the effect of the sun's rays, it should at least partially disappear during a total solar eclipse. That is, it should disappear above that portion of the earth which for a few seconds is shut off from the sun. The popular theory is that there are two layers, E and F, and that the lower layer rises to merge with the upper layer which is thought to be from 120 to 180 miles above the earth's surface.

## Waves May Be Deflected.

It has so far been discovered that wireless waves sent out by a transmitter may take a direct course over the earth's surface or may strike the Heaviside Layer and be deflected at an angle, reaching the earth again at some distant point. It has also been observed that the reflecting power of the Layer is much greater during the hours of darkness.

How is this accounted for?

Investigations have shown that short wavelengths travelling over the ground are soon absorbed and dissipated and thus

have a relatively short range, but if they are inclined upwards the waves are deflected by the Heaviside Layer and reach a distant station with comparatively little loss of strength.

In broadcasting, the effects of the Heaviside Layer are apparent in the increased range of a receiver during the hours of darkness, both ground waves and deflected waves reaching the receiver. During daylight hours it is chiefly the ground waves that are received.

## An Experimental Station.

The measurement of the height of the Heaviside Layer will involve the measurement of time in thousandths of a second. The procedure followed will be to establish an experimental broadcasting station and an experimental receiving station, the

## EVERYTHING IN THE GARDEN'S LOVELY!



A sight to be seen in many gardens at this time of year—when the Clerk of the Weather is kind! A deck-chair, a cigarette and the transportable take a lot of beating.

## SCOTLAND'S ONLY RELAY

(Continued from previous page.)

is quite O.K. over the B.B.C. limits of frequency reproduction, and a studio centre in Aberdeen may soon grow up as a supplement to those at Edinburgh and Glasgow.

Mr. Kelsall is keenly watching the post-bag from the direction of Inverness. This is supposed to be outside the B.B.C. service area, but there is no reason why quite a

strong programme should not be received over Inverness-shire from the Aberdeen aerial.

Later on, the Aberdeen engineering staff may need the assistance of the travelling field-strength van to back up listeners' opinions on the Aberdeen field-strength in this part of the Highlands.

It is not so very long since Scottish M.P.'s petitioned Sir John Reith for a more northern relay to Aberdeen, or, alternatively for an increase in Aberdeen's power. Mr. Kelsall and his worthies are out to show that these propositions are unnecessary!

# A STAR SET FOR THE SHOW



WE always endeavour to produce something extra special in the way of a home constructor's set design on the occasion of the Annual Radio Exhibition, so that the finished receiver can be exhibited on our stand and bear comparison with the best production of British factories.

For, in a sense, Olympia, with its hundreds of different commercial instruments arrayed for public inspection, constitutes a friendly challenge to home construction.

### Months of Research.

Therefore we devote months to the preparation of our show set, and a lengthy period of research and experiment is followed by the assembly of model after model built up in different ways.

To illustrate the manner in which we

Yes, a real star four valver, and one that is as easy to build as an average "three." No soldering, no screening, and absolutely nothing which suggests the slightest complication. Read all about this wonderful new "P.W." set, the "Olympus Four," in this striking article  
By  
G. V. DOWDING, Assoc. I.E.E.

go to work it can now be revealed that only three or so weeks ago I finally passed the show set design, and what were to be the last facsimile models were constructed.

But I was not one hundred per cent. satisfied. It was a fine set and gave a striking performance. Also, its assembly was of the

necessarily inexpensive and straightforward character demanded of a potential national success.

Nevertheless there were one or two features, admittedly only small and almost insignificant features, of the design which were—well, I hardly know how to describe them. Maybe we were super-critical!

However, these "final" models were all shelved, and the job of layout refinement, etc., started over again. At all times we

go all out on the motto "any job worth doing at all is worth doing well," but a "P.W." star design has to have "that something extra which others haven't got."

And thus the "P.W." "Olympus," a four-valver which we confidently anticipate will prove even more popular than any of our past great successes.

### No Screening Needed.

It is a powerful long-distance loud-speaker set using a screened grid H.F. valve in which there is not a single scrap of "screening" except that which is provided by the components themselves.

All the constructor has to do is to fix the panel and baseboard parts in position and wire them up; stability is achieved as a result of a very carefully arranged layout, which is as it should be.

(Continued on next page.)

## THE PARTS YOU WILL REQUIRE FOR "P.W.'s" NEW SEASON FOUR

- 1 Panel, 14 in. x 7 in. (Peto-Scott, Permcol, Becol, Wearite, Lissen).
- 1 Cabinet to fit, with baseboard 10 in. deep (Peto-Scott, Pickett, Camco, Gilbert, Morco, Lock, Osborn).
- 1 L.F. transformer of medium ratio (Lissen Hypernik, R.I. Hypermite, Varley Nicklet, Slektun, Tunewell, Ferranti A.F.10, Lotus, Igranic, Lewcos).
- 1 H.F. choke (R.I. Quad-astatic, Lissen, Lewcos type 11, Telsen Binocular, Ready Radio Standard, Peto-Scott Standard, Goltone, Sovereign Super, Tunewell).
- 1 0003-00035-mfd. max. differential reaction condenser (Peto-Scott, Lotus, Telsen, Cyldon, Ready Radio, Lissen, Graham Farish, Polar, J.B., Ormond).

- 1 H.F. choke, small type (Lewcos type M.C., Telsen, Lissen, [Graham Farish, Igranic]).
- 1 0003-00035-mfd. max. differential condenser (Lotus, etc.).
- 2 Screened coils (Telsen).
- 4 4-pin valve holders (Lissen, W.B., Telsen, Wearite, Bulgin, Graham Farish, Clix, Tunewell, Igranic).
- 2 0005-mfd. Telexors (Telsen).
- 1 5-meg. grid leak and holder (Graham Farish - Ohmite, Lissen, Ferranti, Telsen, Igranic, Dubilier).
- 1 100,000-ohm resistance with terminals or tags (Graham Farish Ohmite, Lissen, Igranic, Tunewell, Dubilier).
- 1 5-meg. do. (Igranic, etc.).
- 1 2-meg. do. (Igranic, etc.).

- 1 L.T. on-off switch Bulgin type S15.
- 1 0003-mfd. fixed condenser (Dubilier type 670, Lissen, Telsen, Igranic, Ferranti, T.C.C., Sovereign, Goltone, Graham Farish).
- 1 0001-mfd. condenser (Dubilier type 670, etc.).
- 1 01-mfd. condenser (T.C.C. type 34 upright, Lissen, Telsen, Ferranti, Igranic, Graham-Farish).
- 1 Five-way battery cord (Goltone R. 39/40, Belling-Lee).
- 18-gauge wire and sleeving (Wearite), or Jiffilix, Quickwyre, Glazite.
- 2 Terminal strips, 3 in. x 1 1/4 in.
- 4 Indicating terminals (Bulgin, Belling-Lee, Clix, Igranic).
- Screws, small strip of copper foil, etc.

## A STAR SET FOR THE SHOW

(Continued from previous page.)

There is no engineering for you, the constructor, to do—that has been done by the component manufacturers and ourselves.

But it must not be thought that the "Olympus" is one of those temperamental sets which will "spill over" unless the assembly is carried out to within precision limits of the specification, or unless only carefully selected accessories are employed.

We have had several models constructed in which moderate diversions of layout, etc., were made in order to test for "temperament," and it can be said right away that no trouble at all was experienced.

We are not going to advise constructors to experiment in this way, because the

which can be assembled by anyone with no previous set construction experience. And it isn't necessary for him to be told not to do this, not to do that, etc., in respect of almost every stage of the operation.

But what of the set in use? Here, again, the "Olympus" challenges comparison with any similar receiver. In the first place, there is no wave-changing.

### Can Be Controlled By Anyone.

You twist the Telexor dials and cover both medium and long waves in the single rotation. Then there is an on-off switch (which can never be confused with a wave-change switch), a reaction and a selectivity adjustment.

Obviously the receiver is one which can be manipulated by any listener without difficulty.

And its power is such that a choice between a large number of programmes

Of course, power without selectivity is useless, a set must have first-class station-separating qualities if it is to hold its own these days. The "Olympus" does not fail in this regard.

### Separates Stations Easily.

Its selectivity is impressive, and those listeners who desire to wander through the European wavebands will find it an easy matter to disentangle the various closely packed bunches of stations.

Don't Forget—  
**THE "OLYMPUS" FOUR**  
will be  
**ON SHOW AT OLYMPIA**  
on our Stand  
**No. 8.**

I must not forget to pay tribute to the direct assistance given us by the radio industry in the production of this latest star "P.W." receiver.

Such a performance as the "Olympus" achieves and much of its outstanding simplicity of construction would have been quite impossible had certain of the parts used not been available.

Indeed, the "Olympus" provides striking proof of the tremendous advancement that has been made in the design and manufacture of radio components, for in it you find items which are, as it were, hot from the factories. (Some of our initial work was actually done with hand-made samples.)

### A Value-For-Money Receiver.

Finally, I come to the question of cost. I do not intend to give figures, for some of you will mix your makes (but don't wander outside our list of recommendations), and in any case our advertising trade friends will give you all the necessary details, but our "Olympus" is a real value-for-money receiver.

We have indulged in no unnecessary extravagance, and we have achieved our de-luxe results without accumulating a de-luxe cost.

In short, the "Olympus" is a "P.W." star production.

## NO SOLDERING—NO SCREENING—NO SWITCHING!

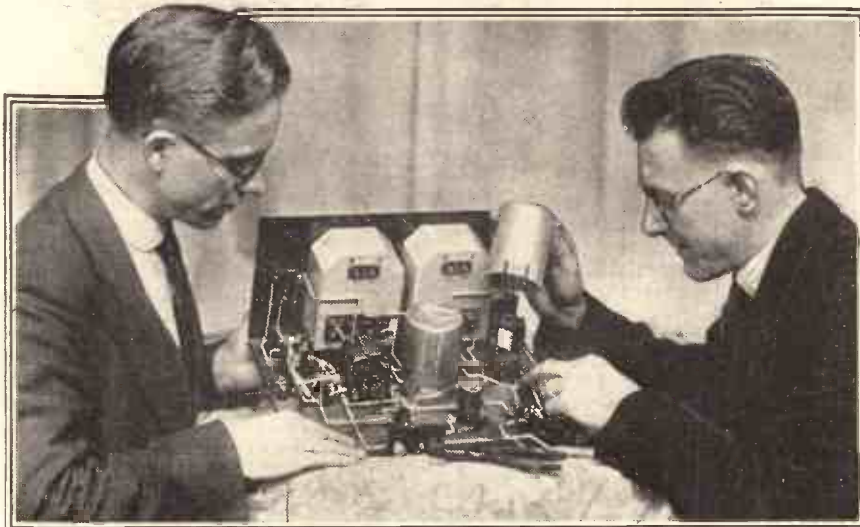

Every component that needs it has its own screening, the coils being enclosed in special metal "cans" which exclude all possibility of any mutual interference between the various sections of the circuit.

highest efficiency is obtainable only when the original model is copied closely.

It should also be noted that we have already carefully tested all our original models with pick-ups and with output filters, and that in later articles details for fitting these will be given.

Not all of you will want to have these refinements, but those of you who do can add one or other or both just when you like. You will also have the satisfaction of knowing that they haven't to be crowded in, but that the set was designed with these useful refinements as an integral part of it, although from an appearance point of view this fact is not self-evident.

### As Easy to Make as a "Three."

I think you will be able to see at once, even with nothing but the photographs accompanying this article as your guide, that the "Olympus" Four is as easy to assemble as the average three-valver. There is no baseboard foil, no vertical screening, no sideways coil or valve fixing, and no soldering—has any other S.G. set ever been produced with such a complete absence of complication?

No, I think I can safely say that the "Olympus" Four is the very first S.G. set

at full loudspeaker strength is available in even moderate conditions.

## THE SET FOR LONG-DISTANCE LOUDSPEAKER RESULTS



Quality reception of the local station is backed up by the power to select programmes from all over Europe! Easy and inexpensive construction and tuning simplicity are combined in this—"P.W.'s" latest "Star" receiver.

# The TELSEN JUPITER S.G.3

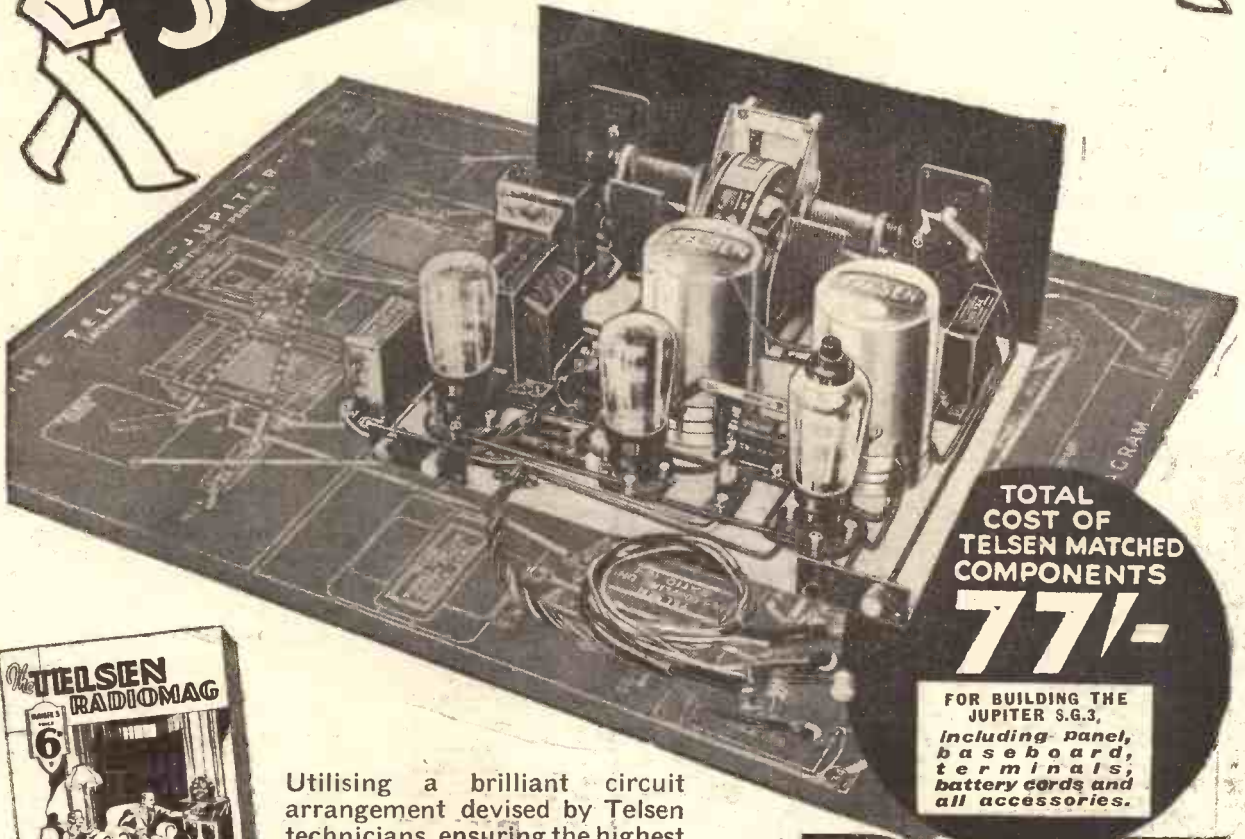

TOTAL  
COST OF  
TELSEN MATCHED  
COMPONENTS

**77/-**

FOR BUILDING THE  
JUPITER S.G.3,  
including panel,  
baseboard,  
terminals,  
battery cords and  
all accessories.



Utilising a brilliant circuit arrangement devised by Telsen technicians, ensuring the highest amplification under all conditions, with extreme selectivity, exceptionally wide range and superb quality of reproduction.

Free full-size 1/- blue prints of

this and other Telsen circuits, together with full instructions and a wealth of interesting and valuable information, including particulars of the improved and now all-embracing range of Telsen Radio Components at the still lower prices, made possible by Telsen's enormous sale, are contained in the new, bigger and better issue of the Telsen Radiomag. Get a copy NOW—price 6d. from your radio dealer or newsagent.



## CONSTRUCTORS' OUTFIT —DRUM DRIVE AND CONDENSER ASSEMBLY

This is an invaluable accessory to the Constructor building up any of the Telsen Circuits employing the Drum Drive and Condenser Assembly (e.g. the "Jupiter" S.G.3). The various components and accessories included are shown in the illustration above.

**3/6**

Cat. No. 219

# TELSEN

RADIO COMPONENTS

**GOOD RADIO IS A JOY FOREVER**

# TELSEN

# H.F. CHOKES

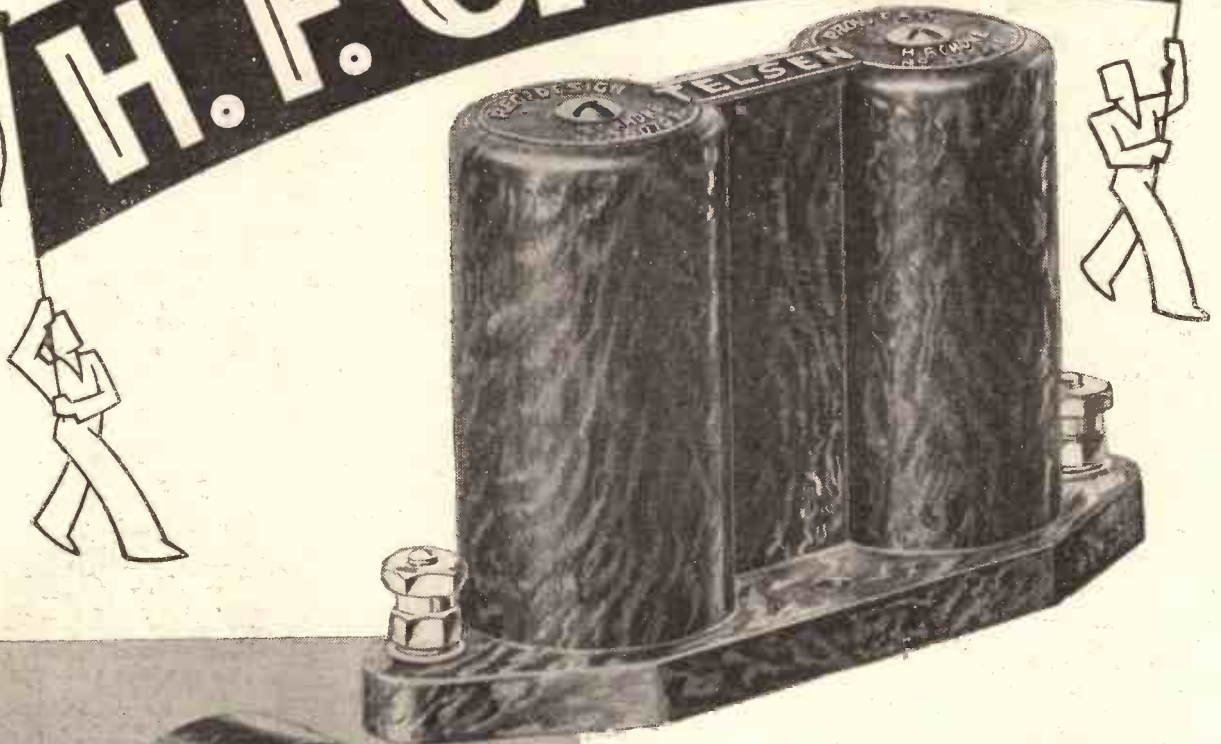

**TELSEN  
STANDARD H.F. CHOKE**

The Telsen Standard H.F. Choke utilises the minimum baseboard space. It is designed to cover the whole broadcast band, has very low self-capacity, and is highly suitable for reaction circuits. The inductance is 150,000 micro-henrys and the resistance 400 ohms. It has proved very popular and has been incorporated by set designers in many of the leading circuits.

No. W.75

**2/-**

**TELSEN  
BINOCULAR H.F. CHOKE**

In H.F. amplification the performance of a choke is of supreme importance. The Telsen binocular H.F. Choke is called for wherever the highest efficiency is required. It has a high inductance of 250,000 micro-henrys, low self-capacity, and a negligible external field, due to the binocular formation, making it the ideal choke for a high class circuit.

No. W. 74.

**5/-**

**TELSEN**  
**RADIO COMPONENTS**

**GOOD RADIO IS A JOY FOREVER**

ANNOUNCEMENT OF THE TELSEN ELECTRIC CO., LTD., ASPON, BIRMINGHAM.



THERE is, I think, something of an improvement in the long-wave European stations taken as a whole. They have been good throughout the summer, but now they are, if anything, easier to receive with good volume. The majority of them are quite steady, but one notices a tendency to vary in strength on the part of two or three of them.

Zeesen, for example, after a long run of days and nights during which full loud-speaker reception was obtained, dropped on a recent afternoon to surprisingly small strength for some hours. The Eiffel Tower and Motala have also had similar occasional lapses.

**Remarkably Good Evenings.**

Budapest, at the top of the medium wave-band, has never entirely left us during the summer and for some weeks past he has been showing remarkably good evenings every now and then. Looking over the pages of his log I see that good loudspeaker



# STATIONS WORTH HEARING

Up-to-the-minute information for the long-distance searcher.

reception has been obtainable about once in every nine days.

Lyons Doua still continues to stage his surprises. You don't receive him at all perhaps for five or six evenings—then he comes in with a roar, only to disappear again on the following evening.

Rome is a fine transmission, and Stockholm is much more reliable than he was recently. Berlin Witzleben is making himself heard again, and I can record good loud-speaker reception from Belgrade. Katowice, Frankfurt, Sottens and Toulouse have all been quite excellent; I have not noticed for some days the heterodyne that was spoiling Frankfurt.

The Poste Parisien is varying a little. Breslau frequently furnishes good reception, and Göteborg is nearly always worth attention.

Genoa is becoming a good station; with Rome, Florence, Milan, Genoa, Turin and Trieste the Italians have now a very fine team. Italy, in fact, is rapidly becoming,

from the British point of view, the best wireless country in Europe. It is curious how these things change. France was the first to occupy that proud position, then came Holland, followed by Germany, then France again.

**Italy's Winter Lead.**

In the last couple of years France and Germany have been very nearly equal, but there is little doubt that during the autumn and winter Italy will be the country possessing the largest number of stations receivable here with first-rate quality and volume.

R. W. H.

## THE FERRANTI SEVEN-VALVE SUPER-HET

Details of the new all-mains receiver made by the famous Manchester firm.

THE old belief that a super-het. receiver cannot give good reproduction has been disproved by the new seven-valve A.C. mains band-pass super-het. just produced by Messrs. Ferranti, Ltd. This well-known firm has always concentrated on quality reproduction, and the Ferranti Super-Het. has a tone equal to that of any "straight" receiver, combined with all the desirable characteristics of the super-het. principle.

**Two Variable Mus.**

The circuit includes a preliminary H.F. amplifying stage utilising a V.M.S.4 variable mu S.G. valve, coupled by means of a tuned transformer to an anode-bend first detector, which, incidentally, is another V.M.S.4.

A separate oscillator valve is employed, and this is a three-electrode valve of the indirectly-heated type, that actually used in the set being a Ferranti type D.4. The aerial, H.F. and oscillator tuned circuits are ganged together and operated by a single knob on the front of the panel.

This control has a horizontal illuminated scale, calibrated in wave-lengths.

The beat frequency from the first detector is passed on to an intermediate

amplifier utilising a third V.M.S.4 valve, and the intermediates are of the band-pass type. The second detector is a grid-rectifier, and the values of the grid-leak and condenser chosen ensure linear rectification up to 70 per cent. modulation, and thus there is no likelihood of any distortion due to detector overloading.

The L.F. stage embodies a directly-coupled L.F. transformer, which has its secondary winding de-coupled; and the Ferranti type P.4 directly-heated output valve is capable of feeding the mains-energised moving-coil loudspeaker with an undistorted output of approximately 1 watt.

**Simultaneous Input Control.**

There is a tone-control switch in the loud-speaker circuit, and on the front of the cabinet, in addition to the tuning control, there are two other knobs, one being a volume control and the other a combined on-off and wave-change switch.

The volume control operates by varying the grid bias on two of the variable mu S.G. valves, and there is, therefore, a simultaneous control of input to the first and second detectors.

The receiver is intended to be used with an aerial of conventional type, but provision is also made for a mains aerial, and this renders the set quite suitable for flats, or for other places where there is difficulty in erecting a normal aerial.

The whole set is completely shielded, and the makers have provided two sockets at the back of the chassis, so that a pick-up can be plugged into the grid circuit of the second detector when it is desired to use a gramophone.

Our laboratory tests revealed the fact that an admirable balance between tone

## EVERYTHING YOU WANT

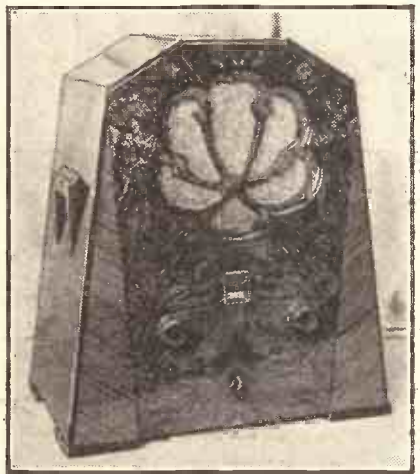

Not only does it look neat and give good quality and loud reception, but it will pick up practically every station in Europe.

quality and selectivity has been struck. There is a crispness and clarity in the reproduction indicating highly efficient tuning circuits and a scientifically designed output stage. The selectivity is fully adequate for all practical purposes, and the sensitivity is such that all the main British and Continental stations can be brought in at good volume and free from interference.

Beautifully made, this Ferranti receiver is a worthy product of a great firm. It is the acme of simplicity in operation, and selling at the "all-in" price of 22 guineas, we feel sure that it will achieve the popularity it deserves.

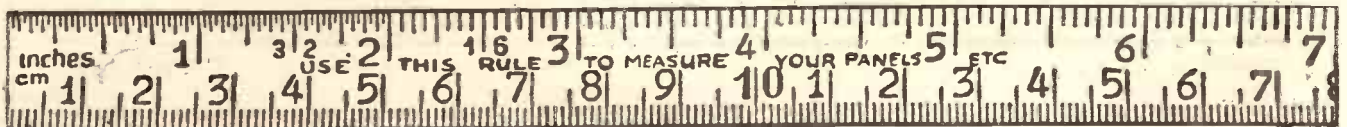

## FROM THE TECHNICAL EDITOR'S NOTE BOOK.

# Tested and Found—?



## NEW ACCUMULATOR PROCESS

THE lives of accumulators used for supplying L.T. for radio sets are not, generally speaking, particularly long.

Perhaps it is often the fault of the listener that the years and years of service that ought to be possible are not obtained. Anyhow, the fact remains that about three years represents the average useful life of the average cell, and any easily applied process which would lengthen this deserves our closest consideration.

It is one of the main claims of the D. and B. process that it does exactly this; other claims that have been made for it are that it "abolishes the use of

## AS PROMISED



The photo of a "new-process" Ediswan H.T. battery which was promised in our last issue.

sulphuric acid," "enhances the tone and range of wireless sets," is "unaffected by heat and cold" and "does not injure the battery, but improves with age and hard work."

Some two months ago the D. and B. Company sent us an accumulator which had been treated by their process, and this accumulator has been carefully tested.

In the first place, however, we extracted a small quantity of the electrolyte and subjected it to an analysis. We found that it was composed largely of sulphuric acid, there was a trace of ammonia, but this was exceedingly small in amount, and its presence may have been due either to acid impurity or absorption from the air.

The third item was a small quantity of an organic acid the name of which it is unnecessary to disclose.

However, from this we infer that the electrolyte is a normal acid solution treated by adding a little of the special material mentioned; anyway, it is obvious that the "no sulphuric acid" claim does not in this instance apply.

And we are unable to discover any justification for the claim that it "enhances the tone and range of a wireless set," unless it is meant that better results than those given when a badly deteriorated L.T. battery is used are made possible by applying the process to said "dud" battery. In which case it may be possible to substantiate the claim if one allows a point or two to be stretched on the score of enthusiasm.

From what I have said so far it might appear that we consider D. and B. is of no great value. But that is not so.

Our tests indicate that the process does benefit an accumulator in a material degree. And curiously enough the good which it appears to do is not directly referred to in the D. and B. literature sent us!

I find that it definitely retards sulphation, and, indeed, tends to remove traces of sulphation which accumulated when small surfaces of the plates were exposed above the acid level.

And an efficiency test "before and after" proved the effect to be of valuable proportions.

I am unable to say how the substance does this work; it is as mysterious in its action as it is effective. I do not doubt the permanence of the results; in any case the elimination of that creeping paralysis of accumulators, sulphation, is bound to extend the useful life of an accumulator.

Nevertheless, I shall continue to keep this test battery under observation, and may have some more to say about it later.

## A SHORT-WAVE ADAPTER

Messrs. Burne Jones & Co., Ltd., are now producing a short-wave adapter for use with sets employing American valves. Particulars of this, together with a list of short-wave stations, will be sent free on request.

## B.T.-H. ELECTRIC GRAMOPHONE MOTORS

Some striking price reductions are announced in connection with B.T.-H. electric gramophone motors, and the famous "Synchro-Blue" model is now priced at only £1 12s. 6d.

## THE NEW EPOCH SPEAKER

"Epoch" certainly move with the times and it is very pleasing to see them do so. They were, as I believe I have said before, among the very first to produce moving-coil loudspeakers.

But they haven't rested on their early laurels, and the production of the very well-known "Epoch" J1 (a precursor of the modern inexpensive permanent magnet movement) has been followed by the type 20 C, which retails, complete with three-

ratio transformer, at the most attractive price of 35s.

Thirty-five shillings for a P.M. moving-coil! Shades of my twelve guinea 1928 instrument!

Don't think that the 20 C is a mere shadow of what a moving-coil speaker ought to be, though. It is remarkably definite in its qualities.

But then, in view of its origin, it should be, for it is backed up by years of specialisation in the design of M.C. speakers.

The transformer with which it is fitted enables it to be matched against any output,

## PLEASE NOTE

Manufacturers and traders are invited to submit radio apparatus of any kind for review purposes. All examinations and tests are carried out in the "P.W." Technical Department with the strictest of impartiality, under the personal supervision of the Technical Editor.

We should like to point out that we prefer to receive production samples picked from stock, and that we cannot in any circumstances undertake to return them, as it is our practice thoroughly to dissect much of the gear in the course of our investigation!

And readers should note that the subsequent reports appearing on this page are intended as guides to buyers, and are, therefore, framed up in a readily readable manner, free from technicalities unnecessary for that immediate purpose.

including a pentode, and it is a sensitive, even-response instrument.

On bass, which it brings out creditably, it is clear-cut and free from "boom," and its high notes come out crisply and with excellent "attack."

Those who can should make a point of hearing it demonstrated, for it is, in my opinion, a first-class example of the latest technique in loudspeaker craftsmanship.

## SUMMER ACTIVITY

Tekade inform me that such is the demand for their "Motor" speakers that they have been working overtime throughout the summer months. They also announce numerous price reductions. I will shortly be reviewing a "Motor" speaker.

## AN INEXPENSIVE INSTRUMENT

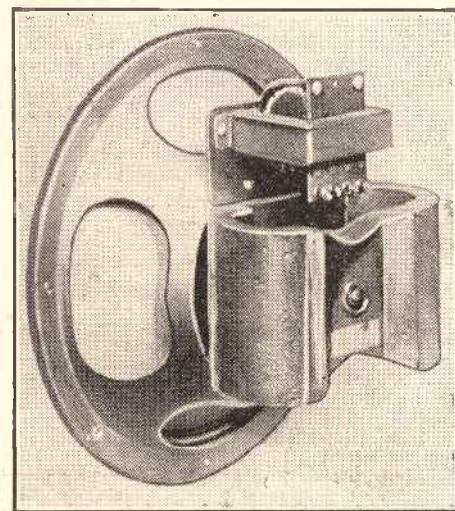

The Epoch 20 C "Twentieth-Century" permanent-magnet moving-coil loudspeaker.

# TELSEN

## DUAL-RANGE AERIAL COILS

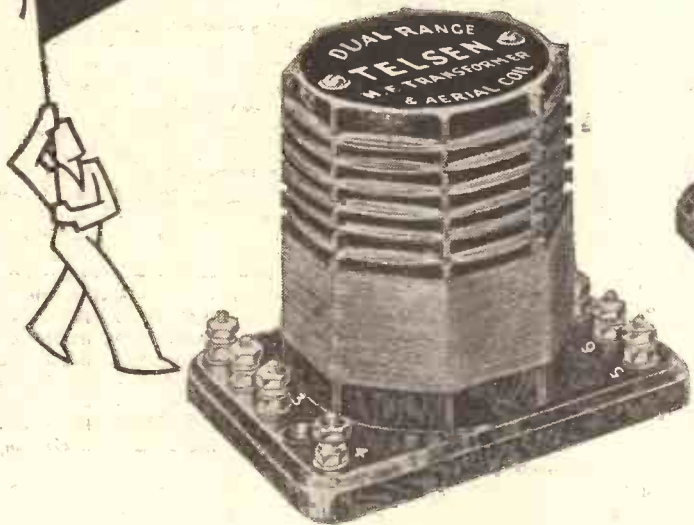

### THE TELSEN H.F. COIL

May be used for H.F. amplification with Screened-Grid Valve, either as an H.F. Transformer, or alternately as a tuned grid or tuned anode coil. It also makes a highly efficient aerial coil where the adjustable selectivity feature is not required. No. W.154

**5/6**

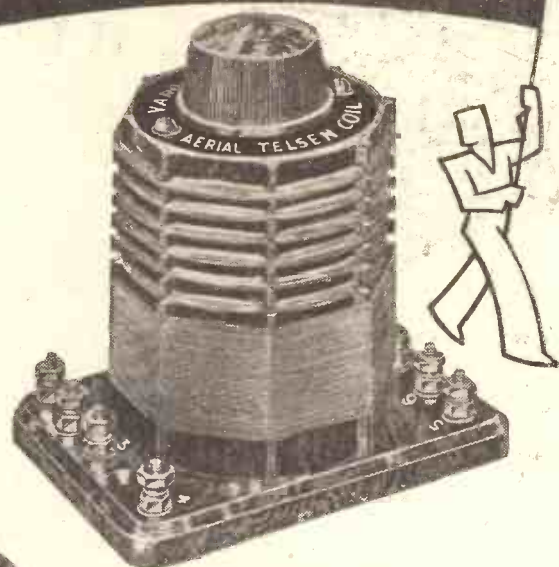

### TELSEN DUAL-RANGE AERIAL COIL

Incorporates a variable selectivity device, making the coil suitable for widely varying reception conditions. This adjustment also acts as an excellent volume control, and is equally effective on long and short waves. The wave-band change is effected by means of a three-point switch and a reaction winding is included. No. W.76

**7/6**

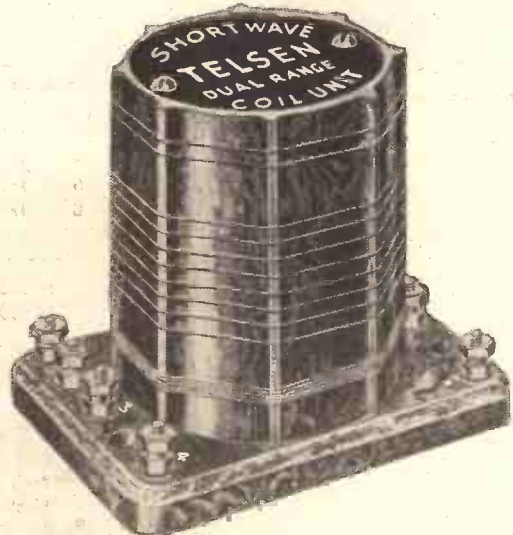

### TELSEN COMBINED DUAL-RANGE SHORT-WAVE COIL UNIT

This unit, for the first time, brings the construction of short-wave receivers into line with the simplicity of modern practice. When tuned by a Telsen .00025 Condenser, a wave range of 20 to 80 metres can be covered by the operation of a switch, as in ordinary broadcast practice. The unit incorporates windings for aerial, tuning and reaction circuits, all coils being wound with stranded wire. The coil is also suitable for use with sets covering all wave-bands with a .0005 Tuning Condenser. In this case the Dual-range feature is not employed. No. W.174

**4/6**

# TELSEN

RADIO COMPONENTS

**GOOD RADIO IS A JOY FOREVER**

ANNOUNCEMENT OF THE TELSEN ELECTRIC CO. LTD., ASTON, BIRMINGHAM.

# TELSEN

## MANSBRIDGE AND MICA CONDENSERS



### TELSEN MANSBRIDGE TYPE CONDENSERS

These are made by the most advanced processes from the finest materials it is possible to obtain, and subjected during manufacture to a series of stringent tests under laboratory conditions. They are of the true Mansbridge type, self-sealing, non-inductive and hermetically sealed. They are offered in two types, the capacities from .01 to 2 Mfd. in Bakelite cases, and in blocks of 4, 6, and 8 Mfd. in metal cases with soldering tags.



CAP. MFD.	500 Volt Test NO.	PRICE	1,000 Volt Test NO.	PRICE
.01	W.232	1/6	W.239	2/6
.04	W.230	1/9	W.237	2/9
.1	W.231	1/9	W.238	2/9
.25	W.229	2/-	W.236	3/-
.5	W.228	2/3	W.235	3/3
1	W.227	2/3	W.234	3/6
2	W.226	3/-	W.233	5/-

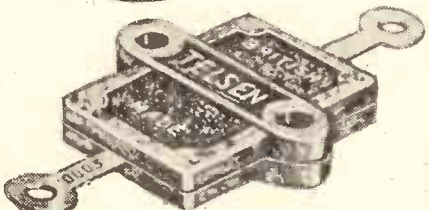

### TELSEN TAG CONDENSERS

This type is of extremely compact and sturdy construction. It may be mounted on either insulated or metal panels by utilising the two baseboard screw holes in the neatly designed moulded casing. The tags enable the condenser to be connected to any other component, either directly or by soldering. H.F. losses are negligible. The capacity is stamped on the soldering tag.

CAPACITY.	NO.
.0001	W.207
.0002	W.208
.0003	W.209
.0004	W.210
.0005	W.211
.001	W.212
.002	W.213

6<sup>p</sup>

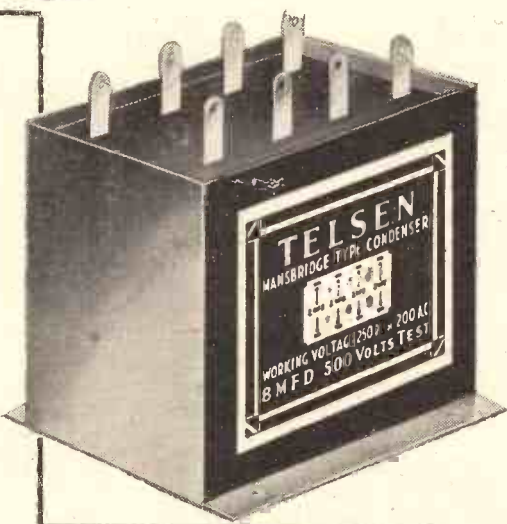

### TELSEN MANSBRIDGE BLOCK CONDENSERS

These are contained in metal cases finished in brown and with fixing holes. As with the other types of Telsen Mansbridge Condensers, they are self-sealing, non-inductive and hermetically sealed. Three types, each made having total capacities of 4, 6, and 8 mfd., each type being divided into 2-mfd. sections, so that several arrangements of capacity may be obtained. Neat and substantial soldering tags are provided for each section.

CAP. MFD.	500 Volt Test CAT. NO.	PRICE
4	W.175	5/6
6	W.176	8/-
8	W.177	10/6

CAT. NO.	1,000 Volt Test PRICE
W.178	9/6
W.179	14/6

### TELSEN "MICA" CONDENSERS

The New Telsen "Mica" Condensers represent an important advance in technique: H.F. losses have been practically eliminated even in the larger capacities. In order to distinguish them from the earlier type, now to be discontinued, the new condensers are enclosed in a re-designed case, which, while possessing all the adaptability of the previous one as to flat and vertical mounting, is of more attractive appearance. Grid-leak clips may, as heretofore, be mounted in series or in shunt and are supplied at no extra charge with capacities .0001, .0002, and .0003 mfd.

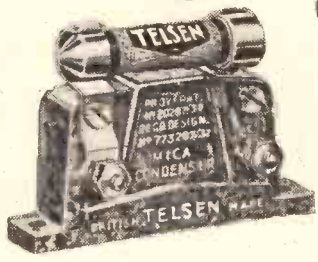

CAP. MFD.	NO.
.0001	W.240
.0002	W.241
.0003	W.242
.0004	W.243
.0005	W.244
.001	W.245
.002	W.246

PRICE.	NO.
1/-	.006 W.247



### TELSEN PRE-SET CONDENSERS

Very low minimum capacity, giving a wide range of selectivity adjustment when used in aerial circuit. Substantially made, easily adjusted and provided with locking ring. High insulation and low loss.

MAX. CAP. MFD.	MIN. CAP. MFD.	NO.
.002	.00025	W.149
.001	.00052	W.150
.0003	.00016	W.151
.0001	.00005	W.152

1/6



**GOOD RADIO IS A JOY FOREVER**

ANNOUNCEMENT OF THE TELSEN ELECTRIC CO. LTD., ASTON, BIRMINGHAM,

LET us first consider the case of a complete breakdown.

The motor is started, the needle is lowered on to the record, but all we hear is a faint buzzing reproduction from the pick-up itself.

What is wrong? Is it the set or the pick-up, or is there a fault in the leads connecting the two?

Switch on to radio. If reproduction is O.K. the fault must be between the needle and the "Gram-Radio" switch, and we will assume this is the case.

Disconnect the pick-up leads from the set and put them on to a pair of 'phone leads. Place the pick-up on a revolving record and listen for results. Reproduction should be clear, and about the strength obtained from a crystal set. Various pick-ups have different outputs, and I recommend that you try out this test while the pick-up is O.K. so as to get an idea of what you should hear.

#### Trouble in the Instrument.

Resuming our testing, if reproduction in the telephones is normal, the fault must be in the wiring of the set between the pick-up terminals and switch. Of course, I include the connections to G.B. negative and grid of valve from the switch.

But if there is no response from the pick-up we must look for the trouble in the instrument itself.

Most pick-ups have a cover that is quite easy to remove, and we can locate the soldered joints between the pick-up leads and the bobbin wires. By placing the 'phone tags on these joints we can soon tell whether the fault is in the bobbin windings or pick-up leads. If it is in the latter we can renew them, but if it appears that the bobbin windings are broken, the instrument will have to be returned to the makers for repair.

We will now examine the problem of distorted or weak reproduction.

Again headphones will tell us whether it is the pick-up or amplifier connections at fault, and we will once more assume pick-up trouble.

#### Excessive Damping Reduces Output.

As the reader is aware, the pick-up operates on the principle of a vibrating reed, or armature, placed between two or more permanent magnet poles. The reed must be damped sufficiently to prevent it touching the magnet poles and to return it to the centre position after it has been deflected by a needle movement.

On the other hand, excessive damping reduces output and increases record wear.

Most pick-ups utilise rubber pads or buffers as a damping agent, and there is generally a means of setting the reed centrally between the poles, should the armature become disarranged.

The sketch of the internal arrangements of a typical pick-up will help in demonstrating the above points.

# WHEN YOUR PICK-UP FAILS



being loose, or the rubber damping pads having perished. If the former, adjust the armature and clamp up; if the latter, renew the pads or send the pick-up away for repair.

Weak reproduction can also be caused by the gaps between the pole pieces and armature being too large. In most pick-ups the pole pieces are bolted to the pick-up, and by slackening the bolts the pole pieces can be moved, and after the required adjustment has been made, clamped tight again.

In old pick-ups, the permanent magnet may have lost most of its strength and will require re-magnetising.

*Distortion.*—Armature stuck to one of the pole pieces (see above). Gaps too small, causing armature to touch pole pieces. This gives rise to a buzzing, rattling reproduction.

#### Try Plasticine Strips.

Examine the gaps to see whether there is dust or metallic filings adhering to the armature or pole pieces. This may happen in a new instrument straight from the factory.

Dust may be cleaned out with a camel-hair painting brush, but filings will most likely just move along the surface they are on and not stick to the brush. A good plan is to use thin strips of plasticine carefully inserted in the gaps. Remove any plasticine sticking to the magnets, etc.

Distortion can be caused by an intermittent break in the pick-up windings. If everything is correct as regards armature clearance, etc., a headphone test on the soldered joints of the bobbin will prove the distortion to be in the pick-up.

*High-pitch Reproduction.*—This may be due to the characteristic of the pick-up, in which case resistances across the leads will reduce high notes and emphasise the bass. Try a 25,000 ohm first, and if this is not enough, a 10,000 ohm resistance.

High-pitched reproduction can also be caused by the pivot of the armature being stiff. Adjustments to the clamping arrangements will remedy this.

*Low-pitched Reproduction.*—May be caused by the pivot being too loose, or the damping rubbers perished. This will allow the armature to resonate to the lower frequencies and not bring it back to normal position quickly enough to respond to the higher frequencies. Remedies as above.

#### A Final Word.

One more point before closing this article. See that there is sufficient slack on your pick-up leads, so that they do not retard the movement of the arm across the record. I have met cases where the leads were so tight, or had become caught somewhere, so that after the needle had traversed a few grooves it remained in one groove until removed. This generally causes the pick-up arm joint to become under suspicion, and although this may be the case, don't forget the leads.

The armature is pivoted in rubber buffers, and the top end of it is held in a slit in a rubber damper. This damper is clamped to the pole pieces by a plate which has slots for the bolts. Consequently, the plate can be moved about until the armature is centrally between the poles and then firmly bolted down.

In some pick-ups the rubber pivots can be rotated by unbolting a front plate and then, when the armature is correctly adjusted, clamping up again.

Modern British pick-ups are so reliable, and generally give such good reproduction, that it is not surprising, when the quality or volume of our radiogram falls off when playing records, that we are inclined to look for the trouble everywhere but in the pick-up. However, some of the faults that can develop in a pick-up may be of interest and value to the reader and they are dealt with on this page

By E. J. G. LEWIS.

The above brief description will enable the reader to visualise the causes of faults which I will now give.

*Weak Reproduction.*—If accompanied by distortion, the armature may be hard up against one of the pole pieces. This may be due to the clamping arrangements

#### NEEDLE AS ARMATURE

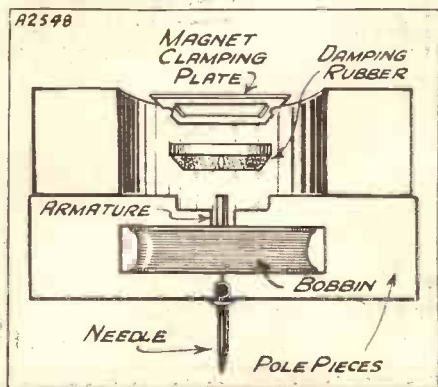

On some pick-ups the gramophone needle passes right through the coil. Special needles are required with a collar to prevent them going in too far.

# RADIO AS A LIGHTNING PROTECTOR

At this time of the year there always arises acute discussion as to whether a wireless aerial is a source of danger during a thunderstorm. This article will put the minds of many new set owners at rest, and will show them how an outdoor aerial—far from being a danger—may be made a definite safety device against damage by thunderstorms.

By G. H. DALY.

A FEW months ago two people were killed by lightning on a golf course; they were carrying steel-shafted golf clubs and were sheltering under an umbrella. So the question has arisen—were the golf clubs or the umbrella responsible for attracting the lightning, or would they have been struck, anyway?

### Sixty Thousand Amperes!

In the first place, a lightning flash is a discharge of electrons from one cloud to another or between clouds and earth. In a recent storm, in England, it was calculated that the flash was over a mile long, with a current of 60,000 amperes, and a difference of potential between the cloud and earth of one thousand million volts.

The tremendous concentration of electrical energy which occurs in a thunderstorm is thought to be due to the water drops in the air being broken up by air blast in such a manner that the spray becomes charged positively while the air is charged negatively.

In thunderclouds this takes place to such a great extent that one cloud or part of a cloud becomes highly charged positively, and the other cloud or part of a cloud becomes negative. When, therefore, the wind, or, as some think, an attractive force, causes these clouds to come together, then, when they are near enough, the lightning flash takes place. Or, if a highly-charged cloud becomes so heavy that it falls near to the earth, usually a mile or so is sufficient, then the great spark occurs.

### Few Aerials are Struck.

Now, if lightning were attracted towards the wireless aerial, as many people appear to think, then a great many more aerials would have been struck by lightning within the past few years, during which time wireless has grown to popularity.

Yet this is far from being the case, and available statistics indicate that there were just as many people and property struck by lightning before wireless was heard of, as afterwards. In fact, at the beginning of the century, when the Lightning Research Committee was set up, Britain seems to have experienced more thunderstorms (and more hot weather) than ever occurs nowadays. So that no one can say that wireless causes thunder!

It is likely that, in the few cases where an aerial has been struck by lightning, if the aerial had not received the

lightning, then the latter would have struck some part of the house or nearby building.

Thus, under certain conditions, the wireless aerial, if it is well and efficiently earthed outside the house, may form a very good lightning protector. In the same way, a tree near the house will often take the full force of the lightning.

### Protection for Property.

The only time when lightning may be said to show an inclination to be attracted by a wireless aerial is when the aerial is erected on high, open ground, such as a hill-top. But it is not the aerial which the lightning wishes to strike but the pole; it shows just as much inclination for a flag-pole.

This is because lightning, like any other form of electricity, will always take the nearest path to earth, and if the nearest point of the earth to the end of the lightning

### SAFER THAN IT SEEMS.

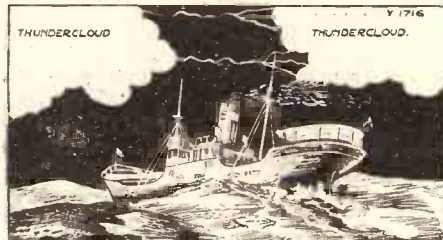

Although ships' wireless operators have often to remain on duty throughout the worst thunderstorms, no fatality from this cause has been reported in the last twenty years.

flash happens to be the top of one particular pole, then the pole literally gets what is coming to it!

When a wireless pole is erected in an exposed position it can be made to form a protection not only to the wireless set, but to the house as well, if a lightning conductor wire is run up the pole, and is allowed to protrude about 6 in. above the top of the mast. In this way the wireless pole will be of definite value in protecting the house during a thunderstorm.

Although copper strip or wire is usually employed as a lightning-conductor, ordinary iron wire, such as is used for clothes lines, is quite effective for allowing the charge to leak away to earth. The more lightning-conductors there are, the less likely there is of damage from lightning, and there can be no better protection from lightning than a lightning-conductor equipped wireless pole which is higher than the house.

### LIGHTNING STRIKES—

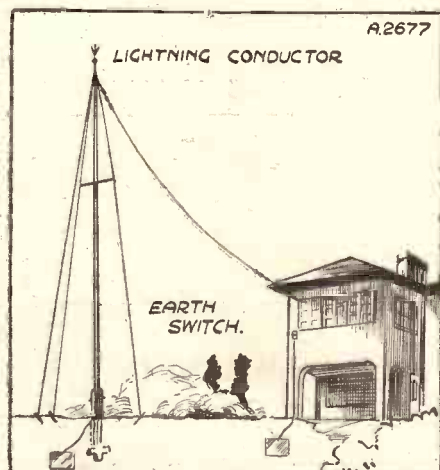
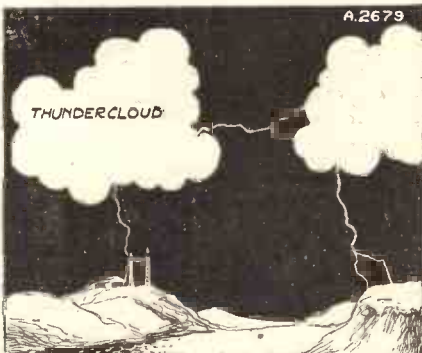

### —THE HIGHEST POINT

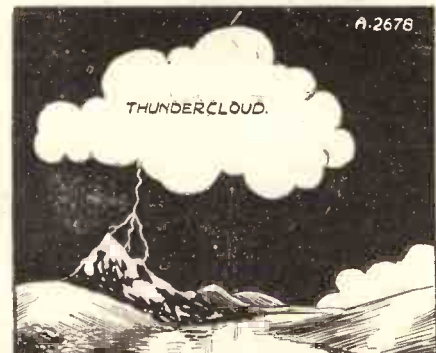

Although wireless aerials are occasionally struck by lightning (as in the sketch on the left), this usually happens when they are situated on high ground, and when the lightning would have struck the highest point of the hill in any case. (see right-hand sketch). The centre drawing shows how your wireless pole may be made a protection by fitting it with a copper lightning conductor, which is taken down the pole to a buried earth plate.

# THE BIG LISSSEN RELEASE!

## The LISSSEN SKYSCRAPER KIT 3



**PUT IT IN THIS CABINET— COMPLETELY SELF CONTAINED!**

**KIT INCLUDING VALVES**

The Lissen Constructor's Kit! Up-to-the-minute in design—a year ahead in several of the specially created Lissen parts. What will it do? The metallised Screened-Grid stage is so stable that you can push it to the limits of radio range—the Lissen Economy Pentode output valve brings up the volume of distant stations until they sound like the local station. Shielded coils, matched and balanced—metal chassis with modern under-baseplate wiring—hairbreadth tuning with geared ball bearing condensers—all these points and many more combined for the first time in a complete kit ready for assembly.

Many sets before this have given you a selection of stations—but never before has there been a home constructor's set to give you the Europe-wide, almost world-wide, range of the Lissen Skyscraper, and the mighty power of its pentode output—never such a set for *getting entertainment value out of radio!* So many alternative programmes are at full loudspeaker strength.

**89'6**

**POINTS THAT MAKE IT THE GREATEST KIT SET EVER PRODUCED!**

**1 METALLISED S.G. VALVE**

The Lissen Metallised Screened-Grid Valve employed in the Skyscraper has such a small inter-electrode capacity that it provides an almost perfectly stable H.F. stage, with a magnification figure in excess of 1,000. The extreme range and stability of the Skyscraper is due to this valve and its perfect screening.

**2 PENTODE OUTPUT**

The Lissen Power Pentode Valve gives to the Skyscraper its brilliant tone, its amazing power—yet it uses no more high tension current than an ordinary power valve. The current consumption of the Skyscraper is less than many ordinary 2-valve receivers.

**3 SHIELDED COILS**

These Lissen Shielded Coils are the result of months of research. They make the Skyscraper exceptionally selective, and one of the few sets free from "long-wave break-through."

**4 ALL METAL CHASSIS**

Notice the most expensive of commercial radio receivers to-day and you will see that they have metal chassis—so does the Skyscraper at half the cost!



**EVERYTHING YOU NEED!**

You can buy the Skyscraper Kit, complete with valves, ready to build up and put into a cabinet of your own choice with perhaps your existing batteries and loudspeaker.

The price is then 89/6 complete with valves.

Better still, Lissen have provided a beautiful walnut Console Cabinet which contains not only the chassis and loudspeaker, but batteries and accumulator as well . . . making your Skyscraper a real self-contained receiver comparable in appearance with any expensive factory assembled set, and in performance easily outstripping previous receivers.

Price, complete with walnut cabinet and loudspeaker, as illustrated . . . £6 5s.

**1/- CONSTRUCTIONAL CHART FREE.**

A two-colour, lavishly-produced Chart giving instructions down to the last detail for building the Skyscraper 3 has been published, price 1/- GET YOUR COPY FREE! Write direct to the factory, or ask your nearest radio dealer to get it for you.

**LISSSEN LTD. WORPLE RD. ISLEWORTH. MIDDLESEX**

# Short-Wave Notes *By W.L.S.*

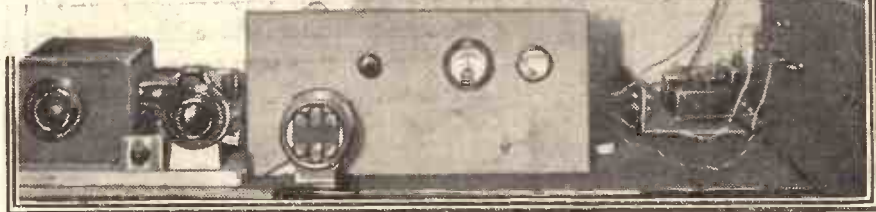

**A**LTHOUGH I have nothing of great importance to mention myself this week, it has been a record week for correspondence, and my blue-pencil, paper-knife and waste-paper basket have been receiving much attention.

To save readers further trouble, may I say here and now that all anonymous letters, abusive or otherwise, go straight into the waste-paper basket after the first reading, without a second thought.

I have not recently mentioned the matter of "Short-Wave Clubs," but the time appears ripe to do so once more. Here, however, I am in a dilemma.

Whenever I mention the "International Short-Wave Club," some member of the "International Short-Wave Radio League" writes and tells me I am not being fair to the latter organisation.

## The Eclipse Tests.

Conversely, if I dare to mention the "I.S.W.R.L." someone connected with the "I.S.W.C." writes and makes accusations. So I make public declaration herewith that these two bodies are *not* one and the same; that both have quite a large and enthusiastic membership of short-wave listeners; and, incidentally, that both *claim* to be the "original" club!

I simply dare not attempt to adjudicate between them in this last claim, for I should certainly be badly mauled by one side or the other!

**DO NOT FORGET THE ECLIPSE TESTS.** For full particulars, turn back to "Short-Wave Notes" in last week's "P.W." and read my suggestions. It is a good suggestion, too, that broadcast listeners should also keep watch on some distant station for a few days prior to August 31st, and again on the actual evening.

## Regular Calibration Signals.

The Wireless Institute of Australia is particularly anxious to receive reports on conditions during the Eclipse, on all wavelengths between 5 and 5,000 metres. I intend to tabulate all the results sent in to me by readers and to send them out to the W.I.A. as an indication of the keenness of the British listener.

Please send in your reports on short-wave stations to me, c/o "P.W."—and marked "Eclipse Tests."

[NOTE: A special article on the eclipse appears elsewhere in this issue.—ED.]

Several readers have been asking for details of any calibration signals that are sent out regularly on short waves, for the purpose of calibrating wave-meters and receivers. Here are two regular services which should be easily found by any owner of a short-waver.

G2NMB, the station of Mr. Gerald Marcuse at Sonning-on-Thames, transmits

on 3533-13 kc. (approximately 83.7 metres) on Sundays at 11 a.m. (telephony) and on Sundays and Thursdays at 11 p.m. (C.W.). Times are G.M.T. or B.S.T., as in force.

G5HW, the station of the National Physical Laboratory at Teddington, transmits on the first Tuesday in September, December, March and June, on 1,785 kc. (168.1 metres) at 9 p.m. G.M.T. The service is repeated every ten minutes until 10 p.m.

## Crystal Controlled Transmissions.

In addition to these two services, which are really of extreme accuracy, there are many amateurs using crystal-controlled transmitters in the 40- and 80-metre

## STRAIGHT TO THE POINT



No, it's not part of a switchback railway or children's slide, but the curious beam aerial used for getting down to the shortest of short waves. The actual installation to which this aerial belongs works on a wavelength of 16 centimetres!

amateur bands who give their exact frequency after every transmission. Most of them are reliable to within 2 kc., which represents an accuracy of one part in 3,500 on the 40-metre band.

A "stop-press" postcard from "F.N.B." (Hale) informs me that "W2XAF and W1XAZ have come back with a kick. W2XAD is still groggy, and W8XK suffers from fading."

It is quite impossible to keep pace with the changing conditions at this time of year, and by the time you read this note

something quite different will probably be happening.

My request for lists of all the broadcast stations received on short waves have brought forth a very encouraging set of replies. I am waiting until I have received a few more before I say much about them; but I have had beautiful lists—from the inevitable "F.N.B." of course!—and from "W.W." (Exeter).

The latter gentleman wanted to send me his log for the year, but as it runs into about 350 pages he thought the postage would be heavy!

## Stations Closing Down.

His total "bag" of legitimate broadcast stations is 40, with the addition of 23 commercial transmitters on telephony. The only readers that come anywhere near him as yet appear to be "F.N.B." and "W.H.R." (Plymouth).

The latter reader wants to know if anyone else has heard "CTA" on about 24 metres? The station looks to me rather like CT3AQ, Funchal, Madeira. He also points out that the broadcast stations are disappearing at an enormous rate owing to lack of funds. Bandoeng was the first to close down, and he is now followed by Chi-Hoa and Radio Saigon. There soon will not be any Asiatics left.

Unfortunately I had to omit the "Weekly Five" stations last week, but I am giving a further five herewith.

Richmond Hill, N.Y. (W2XE) on 49.02 metres.

Daily from 1 p.m. till 5 a.m. next morning.

Winnipeg, Canada (VE9CL) on 48.8 metres. Daily from midnight till 2.30 a.m.

Riobamba, Ecuador (PRA DO) on 45.31 metres. Fridays, midnight till 5 a.m.

Springfield, Mass. (W1XAZ) on 31.35 metres. Every evening.

Chapultepec, Mexico (XDA) on 20.5 metres. Daily, 7 till 10 p.m.

## For Identification.

Let me make it clear that these are not given merely as a reception test, but to help readers to identify unknown transmissions. We will keep up these "fives" until the entire list of short-wave broadcast stations has been covered.

Some of the stations are only audible at certain times of the year; thus there is no cause for discouragement if you cannot find them all at

once. I am trying, however, to include at least three each week that I have heard myself in the previous week.

**"W.L.S."**  
The Popular  
**SHORT-WAVE EXPERT**  
writes regularly in  
**POPULAR WIRELESS**  
and  
**MODERN WIRELESS**



# A NEW ITALIAN BROADCASTER

## FLORENCE

WHEN I was at Trieste—a station visit was described recently—I saw the engineering arrangements for the new plant at Florence. An E.I.R. (Italian edition of the B.B.C.) representative had told me of the scheme, sponsored by Mussolini, to link up a high-power relay in the Florence province with the Rome-Milan programme circuit.

And now this newcomer is fully on the ether, after rather serious "teething trouble."

While the new Trieste station was being tested and then given an official opening, British engineers were at work on the new Florence plant.

There was a long delay in opening at Florence as an aerial catastrophe occurred just as the plant was ready for its final tests. The Marconi engineers who built the new station, at Mussolini's special request, did not put up the masts, and they cannot be blamed for the fact that a huge gale brought one of the tall towers crashing to the ground before the station ever started radiating.

### They Got What They Wanted.

Two small masts were quickly put up by the station engineers, so that actual aerial tests could be made. When working with the big power of 20 kw. it is not reliable enough to use an indoor "dummy" aerial for testing the transmitter's characteristics!

The new aerial for actual broadcasting is of the quarter-wave "T" type. There are two self-supporting steel towers, nearly 300 ft. high; and, judging by their appearance, I should say it will take a strong gale to affect these!

But to continue the story of the opening at Florence, as told me by one of the officials. The station engineers were so pleased with their tests on the little temporary aerial that they asked for special permission to use this for broadcasting until the new masts could be built.

They got what they wanted and the only trouble was that the station was inundated with letters asking why, with a power of

20 kw., Florence was not reaching out so well as it should!

The aerial goes down to a little feeder housed out in the grounds, very much like the arrangement at any of our big B.B.C.

stations. Twin wires run from this into the side of the bright plaster-coated transmitter building.

Inside the feeder hut is a big H.F. transformer on a metal rack. Air-spaced coils couple the feeder leads to the aerial down-lead which runs out

through a porcelain insulator at the side of the transformer hut. This part of the gear has only just been finished, as it was delayed until the new aerial masts were put up.

The station inside has not yet been working long enough to lose its pristine polish! The grey panels and shiny aluminium supports make it look like a showroom model rather than a working broadcaster!

An interesting fact is that this transmitter is the same type as that at Reykjavik in Iceland, Bratislava, Bucharest, Lemberg and many other Continental stations, and even like that at Nogoya, one of the big Japanese broadcasting stations.

### Seeing "How It Works."

Although not very much is to be seen from the outside of the panels, practically the whole circuit of each stage can be followed out by going past the safety doors and looking through at the parts mounted at the back. The "works" were explained to me.

Tape and metal tubing connect up the

(Continued on next page.)

\*-----\*

Our Continental Correspondent, who paid a visit to this Italian station in the early days of its erection, describes some of the "teething troubles" experienced. He also deals with the type of apparatus used and explains how the station fits in with Mussolini's general scheme of broadcasting in Italy.

\*-----\*

### MADE IN ENGLAND—NOW HEARD IN ENGLAND

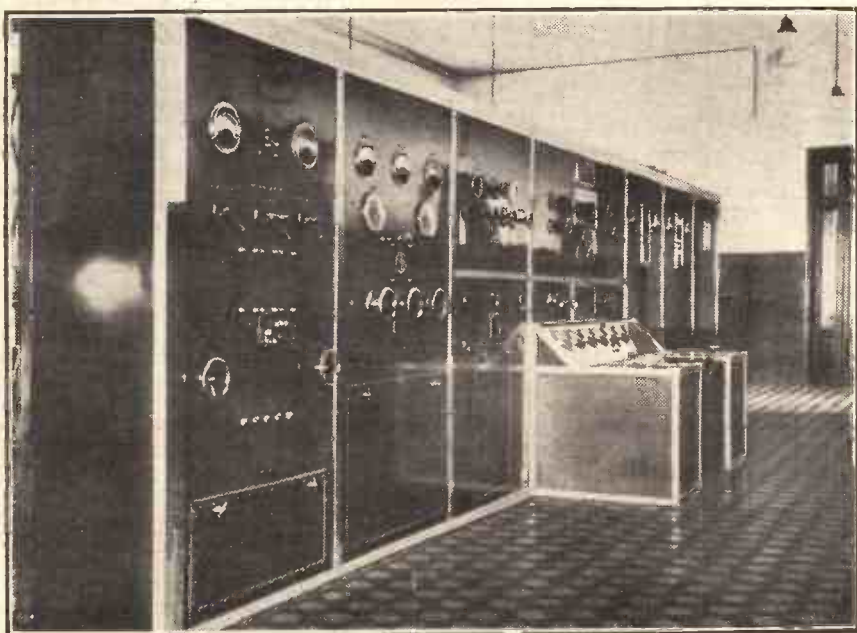

The apparatus used at Florence is of Marconi manufacture, and handles an unmodulated aerial output of 20 kilowatts. A quartz oscillating crystal is employed to stabilise the frequency of the transmitted waves.

## A NEW ITALIAN BROADCASTER—FLORENCE

(Continued from previous page.)

air-spaced condensers and coils. The main control desk in front of the row of panels is B.B.C. ish in appearance, but the control knobs do not perform quite the same functions as the power supply is different.

Florence is crystal controlled. The Marconi engineers took special note of the carrier wave specifications for broadcasting stations laid down at the Hague in 1929 and later at Copenhagen. The Florence station keeps exactly within these limits.

### A Triple-Walled Box.

The crystal at the top of one of the panels cannot be seen without dismantling its case. It is in a triple-walled box, electrically heated, and controlled by a thermostat, so that during the very cold nights experienced in this part of the country, the measurements will not alter and so upset the carrier frequency.

There are six panels, apart from the crystal control board. These are the modu-

It is not yet decided where Florence will finally rest in the broadcasting band. It is working now on a wavelength of just over 500 metres, but the engineers have installed circuits which can go up to 550 metres or down to 250 metres if necessary.

Power comes along the huge A.C. cables which are rapidly spreading all over the country, and the A.C. is stepped down and rectified by panels at the far end of the transmitter hall. The control desk has geared-down wheels, which, in case of emergency, can switch off the whole power.

### Rapidly Spreading System.

There are rotary converters for the various valve circuit supplies.

In an adjoining room is the terminal board forming one of the ends of the landline system which is rapidly spreading all over Italy. Florence takes the Trieste programme, and Rome, Naples, Milan and Genoa are all on the same programme circuit.

Trieste is still giving a number of programmes of its own in the early part of the evening, and the Florence officials will also do this when the studio arrangements are finished. All the main stations take the late evening programme which is considered to be of national interest.

## HE SENDS OUT ICEBERG WARNINGS



An operator at work in the radio room of the special cutter which patrols the North Atlantic on the look-out for icebergs, so that radio warnings can be sent out to shipping in the vicinity. The service is subscribed to by a large number of maritime nations.

lated amplifier panel, power amplifier, tuning panels, and finally, the rectifier.

These terms are not so difficult to understand. Low power modulation is used here, and the little oscillations set up by the power valve controlled by the piezo crystal are modulated by the speech (wires come in from the amplifier room) at the modulated amplifier.

### Elastic Tuning Circuits.

The next two panels along, I was told, are power amplifiers, working at high frequency and with H.F. tuning coils between the valves. The next are the two tuning panels, the sixth being connected up to the twin aerial feeders running out into the grounds.

All these stations are controlled by the Ente Italiano Audizioni Radiofoniche, and the subscriptions raised on sets are helping the E.I.R.'s policy of getting a good national programme all over Italy. Several of the Florence engineers are connected with the new Bari station, the gear of which is also British-made and which is being tested near London.

Bari, when it is finished, will be linked up with Florence and two or three engineers on duty at each station will control the broadcasting. The landline relays and amplifiers are switched on at the start of the morning's programme at about 7.15 a.m., and the operation is otherwise almost automatic.

## SUBMARINE RADIO

Communication with submerged submarines is a difficult matter and recent successful experiments are described below.

A NEW triumph in wireless communication which is of vast importance to all the navies of the world, and which makes possible an immense increase in the future activity of submarines, has just been achieved in France.

This latest scientific conquest is a special triode valve of 150 kilowatts. After months of experimenting with this and a co-operating "pilot" valve, two engineers have succeeded in making possible the long sought for perfect transmission of wireless messages to a deeply-immersed submarine.

### The Only One in the World.

Through the perfection of this new valve and the sending of radio messages on long wavelengths, which overcomes the deadening suffered by short waves, the possible activities of submarines in the future are greatly increased.

To date, the new 150 kilowatt valve just completed at the Belin Works, Malmaison, France, is the only one in the world, the most powerful of its kind ever constructed, and the only one which has made possible perfect transmission between the earth and undersea vessels. It is designed to work on a wavelength of 10,000 metres.

This valve, however, is only one unit in a very intricate and delicate set of co-operating apparatus. The 150 kilowatt valve only amplifies waves created by another valve of similar construction but with a power of 40 kilowatts.

### Providing a Permanent Pump.

The chief aim of the engineers was to perfect a system of valves that could quickly and easily be taken apart in order to verify that the electrodes were in good condition and working properly. For this the "vacuum" of the valve has to be maintained to a suitable degree.

To make this taking apart possible required perfection in the arrangement of the joints. The upkeep of the vacuum is obtained by the permanent use of a "molecular" pump.

The assisting "pilot" valve of 40 watts keeps up the oscillations of the circuit and keying is effected in the circuit of the amplifying valve which feeds directly into the aerial.

### Fifty Minutes to Start.

Seven thousand five hundred volts is applied to the plates of the triodes by a continuous current supplied by dynamos, or by mercury rectifying apparatus. The power arriving at the aerial slightly exceeds 100 kilowatts.

The starting of the gear at a maximum power takes 50 minutes (the time required to produce the vacuum in the tube), from the starting point of atmospheric pressure.

If the lamp should be momentarily stopped, one or two minutes is sufficient to start it again if the filaments are extinguished. If they are kept alight, it requires only a few seconds. F.D.

EVERYTHING **The G.E.C.** ELECTRICAL  
your guarantee

**OSRAM**  
new automatic cushion  
filament springing  
ensures  
**ABSOLUTE CONSISTENCY**



# CONTROLLED CONSISTENCY

means reliable performance — unvarying under all conditions. If the pre-determined position of the electrodes of a radio valve varies when the filament is heated—how can you have consistency? In all the new OSRAM 2-volt battery valves there is a very far-reaching advance in valve design (the OSRAM automatic cushion filament-springing). It ensures absolute consistency by maintaining absolute parallelism of the electrodes *always*. Microphonics and all effects of internal and external vibration are finally *eliminated*, securing dead silent background during longer and more useful valve life.

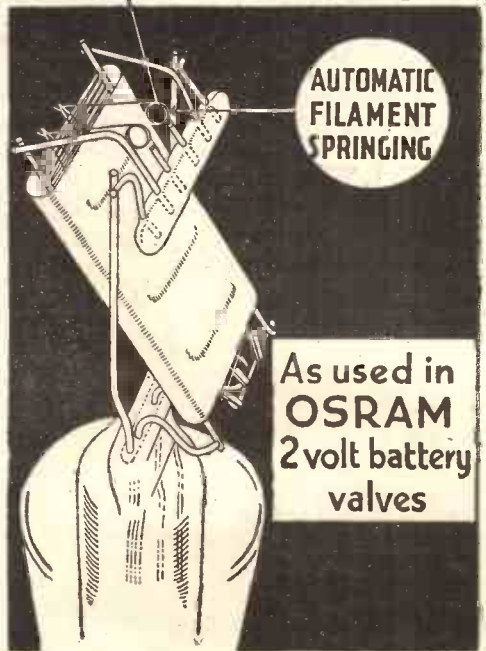

**Osram**  
2 VOLT BATTERY  
**Valves**  
MADE IN ENGLAND  
SOLD BY ALL WIRELESS DEALERS

**WITH THE WEMBLEY FILAMENT**

Advt. of The General Electric Co., Ltd., Magnet House, Kingsway, London, W.C.2.



All Editorial communications should be addressed to the Editor, POPULAR WIRELESS, Tallis House, Tallis Street, London, E.C.4.

The Editor will be pleased to consider articles and photographs dealing with all subjects appertaining to wireless work. The Editor cannot accept responsibility for manuscripts or photos. Every care will be taken to return MSS. not accepted for publication. A stamped and addressed envelope must be sent with every article. All inquiries concerning advertising rates, etc., to be addressed to the Sole Agents, Messrs. John H. Lillie, Ltd., 4, Ludgate Circus, London, E.C.4.

The constructional articles which appear from time to time in this journal are the outcome of research and experimental work carried out with a view to improving the technique of wireless reception. As much of the information given in the columns of this paper concerns the most recent developments in the radio world, some of the arrangements and specialities described may be the subjects of Letters Patent, and the amateur and the trader would be well advised to obtain permission of the patentees to use the patents before doing so.

## QUESTIONS AND ANSWERS

### HUM FROM MAINS UNIT

W. W. (Chelmsford)—“Perhaps you can help me in dealing with a case of hum from the mains. At present it has got me beat.”

“To begin at the beginning, I ought to explain that I made a ‘Cosmic Three’ from

the blueprint given away with ‘P. W.’ February 20th, and working off batteries I never had any trouble from the first time I switched it on.

“So a friend of mine, who happened to hear it working one night, asked me to help him by converting his three-valve into a ‘Cosmic,’ he being very dissatisfied with the reception he was getting. This I did, and after a first disappointment, caused by using a dud transformer, we got his going A1.

“So far, so good. I was beginning to fancy myself at putting up ‘Cosmics’ and knowing all about them, when I got an S O S from my friend’s brother.

“Knowing how his brother’s set was improved when turned over to a ‘Cosmic,’ and how mine was going, he had made one for himself. But it was spoilt by hum.

“He lives up at Barking, in a new house, and could not seem to find anyone handy there who knew enough to cut the noise out. So as my friend was going up on a motor-bike, he asked him to bring me pillion, and we reckoned a Saturday afternoon would see us all clear. But although we stuck at it till after eleven that night, we could not stop the hum. He was working off the mains, and what we did find

(Continued on page 700.)

## HOW ARE YOUR RESULTS NOW?

Perhaps your switching doesn’t work properly? Or some mysterious noise has appeared and is spoiling your radio reception? Or one of the batteries seems to run down much faster than formerly?

Whatever your radio problem may be, remember that the Technical Query Department is thoroughly equipped to assist our readers, and offers its unrivalled service.

Full details, including scales of charges, can be obtained direct from the Technical Query Dept., POPULAR WIRELESS, The Fleetway House, Farringdon Street, London, E.C.4.

A postcard will do. On receipt of this an Application Form will be sent to you post free immediately. This application will place you under no obligation whatever, but, having the form, you will know exactly what information we require to have before us in order to solve your problems.

**LONDON READERS, PLEASE NOTE:** Inquiries should NOT be made by phone or in person at The Fleetway House or Tallis House.

## You must go to the Radio Show

You’ll be going to the Radio Show, of course! This is an event that claims the attention of all modern-minded people. See all these sensational new sets for yourselves and hear, examine and discuss them with the experts on the spot. Last year’s Radiolympia broke all records. The 1932 Radio Show must be seen to be believed. It’s bigger — more spectacular — an absolute wonderland.

COME TO **RADIOLYMPIA** WHERE BRITISH IS BEST!

**AUGUST 19-27**

ADMISSION 1/6. DANCING Free

11 a.m. to 10 p.m. Daily

ORGANISED BY THE RADIO MANUFACTURERS’ ASSOCIATION

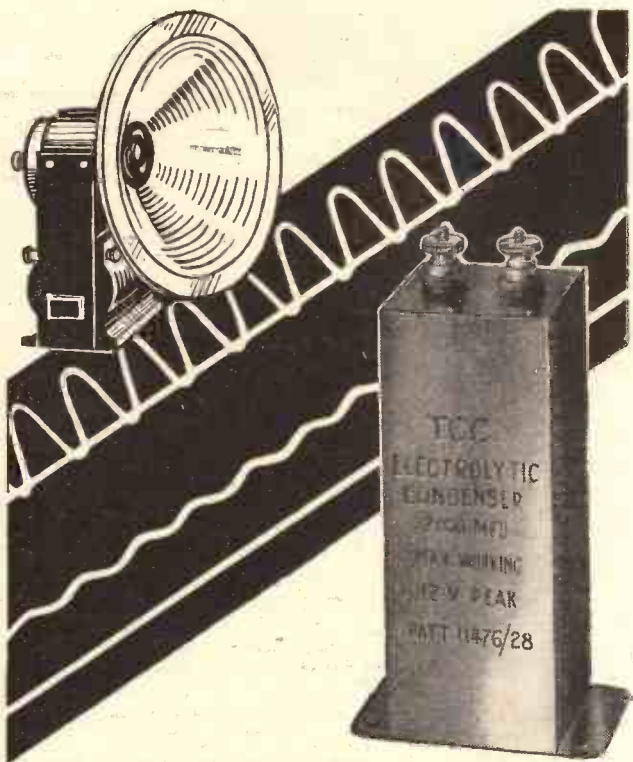

# SMOOTH your M.C. Speaker

**P**UT a 2,000 mfd. T.C.C. Electrolytic Condenser in parallel with the field winding of your moving-coil loud speaker, and, once and for all, banish that annoying mains ripple.

Look at the oscillograms reproduced above—the top curve records the voltage applied before the connection of a T.C.C. Electrolytic Condenser, and below it is shown the voltage after—the ripple is negligible.

Only with a ripple-free background can you enjoy to the full the advantages of a moving coil.

Get a T.C.C. 2,000 mfd. Electrolytic Condenser from your dealer to-day price 15/-

NOTE. This condenser is suitable for working up to 112 V.D.C. only. It is therefore only applicable to speakers energised by low voltages up to about 9V.

SEE THE  
COMPLETE  
RANGE  
on  
Stand 53

# T.C.C.

ALL-BRITISH  
CONDENSERS

The Telegraph Condenser Co., Ltd., Wales Farm Rd., N. Acton, W.3

## PLUG & SOCKET Programme 1932-33

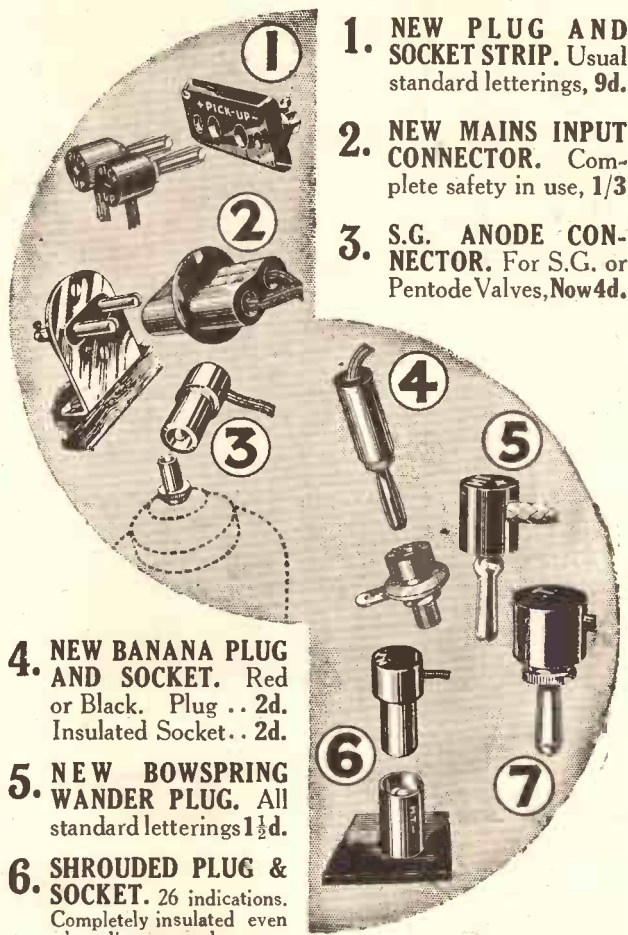

1. **NEW PLUG AND SOCKET STRIP.** Usual standard letterings, 9d.
2. **NEW MAINS INPUT CONNECTOR.** Complete safety in use, 1/3
3. **S.G. ANODE CONNECTOR.** For S.G. or Pentode Valves, Now 4d.

4. **NEW BANANA PLUG AND SOCKET.** Red or Black. Plug .. 2d. Insulated Socket .. 2d.

5. **NEW BOWSPRING WANDER PLUG.** All standard letterings 1½d.

6. **SHROUDED PLUG & SOCKET.** 26 indications. Completely insulated even when disconnected. Price complete, 6d. each

7. **MIDGET WANDER PLUG.** Red or Black. 12 permanent engravings .. .. 2d. each

### TWIN PLUG AND SOCKETS.

Non-reversible .. .. 1/3 each

### TWIN COUPLING.

Non-reversible, for insertion in any flex leads .. 1/6

### ACCUMULATOR CONNECTOR.

Wrong connections impossible .. .. 9d. per pair



Adv. of Belling & Lee, Ltd., Cambridge Arterial Road, Enfield, Middlesex.

## RADIOTORIAL QUESTIONS AND ANSWERS

(Continued from page 698.)

was this: If he took his H.T. off a battery instead the hum stopped at once. So we knew it was the mains.

"Now comes the difficult part. The eliminator (valve rectifier) was made up from a blueprint (firm's) and was marked with X, for putting in extra condenser if necessary to cure hum. So we took it out of the cabinet and put in an extra 2-mfd., and then joined up to see the effect.

"It was perfect! Very much louder than I expected, even on foreigners, and you could

only hear the very slightest buzz when you put your ear to the loudspeaker, when no music was coming through.

"Unfortunately this did not last. As soon as we put the eliminator back in the cabinet and switched on, the hum started again, yet we had not altered any of the wiring since putting in the 2-mfd., except to shorten the wires.

"We had to leave it like that and it is still the same. If he takes it out of the cabinet and uses the long flex leads it is quiet. But it looks all wrong, being only a baseboard standing near a posh cabinet. If he puts it back inside it hums. What can you make of that?

"I ought to explain that when in the cabinet it is stood up on edge, as there is not much room and he has made it to fit in with the baseboard standing on edge. But that ought not to make any difference to the hum, did it?"

It often happens that hum occurs when mains wiring (or especially when a mains transformer) is placed so close to a set that an aerial or earth lead or a grid lead runs within an inch or so of the unit. The probability is that the hum is caused by the transformer in the mains unit being placed too close to the set, or too close to one of the important leads in it.

And in such a case the cure is either to shield the set from the unit by screening the latter thoroughly, or else—what is usually a much simpler and better plan—to move the two farther apart.

Where the cabinet is small and room is therefore restricted, it may be necessary to alter both set-wiring and the lay-out of the unit to get freedom from interference.

In general the idea is so to arrange the unit that several inches—the more the better—separate its transformers and other components from any component in the set, and then to keep the set-wiring

(aerial, earth, and similar leads as well) right away from the mains unit wiring, except, of course, where the necessary H.T. leads go to the set's terminals.

### FOR THE SET-BUILDER.

R. C. E. (Uxbridge).—"You recently sent me a list of the 'P. W.' blueprints now available for set-builders, but at the time of asking for this I forgot that you also supply 'M. W.' blueprints on similar terms.

"Please give brief details of the circuits covered in the latter series."

The following are the circuits now available in "M. W." blueprint form, price 7½d. each post free:

No. 2. A "HIGH POWER" FIVE.—A powerful and selective five-valve receiver, using one neutralised and one S.G. H.F. stage.

(Continued on page 702.)

### WHAT'S WRONG?

#### TERMINAL STRIP TROUBLES.

Of the small snags that are met with in dealing with terminal strips, the most dangerous is the connection of wrong leads, due to bad marking. Indicating terminals are a good investment, as they prevent mistakes of that kind.

\* \* \*

If the terminals are rather close together, trouble is frequently caused by straggly flex leads connected to one terminal but reaching out and sometimes touching the next. Proper connectors, which cost practically nothing, will prevent this.



### DO YOU KNOW—

the Answers to the following Questions?

There is no "catch" in them, they are just interesting points that crop up in discussions on radio topics. If you like to try to answer them, you can compare your own solutions with those that appear on a following page of this number of "P.W."

- (1) About how many broadcasting stations are there in Europe?
- (2) What stations occupy the following wavelengths—1,725 metres, 1,000 metres, 356 metres?
- (3) Who is the head of British Broadcasting? (Chairman of the Board of Governors.)
- (4) How much does the B.B.C. charge to broadcast an S O S for a missing dog or other valuable animal?

# INTERESTED IN RECTIFIERS? THEN

VISIT  
**STAND 89**  
AND SEE THE LATEST  
DEVELOPMENTS IN

**WESTINGHOUSE**

**METAL RECTIFIERS**  
—the rectifiers of proved reliability.

RADIO EXHIBITION  
OLYMPIA,  
AUGUST 19th—27th.

# No Chatter

No Scratching—No Case Resonance

with the All-British



# Clarion Pick-up



**PRICE 21/-**

Handsome finished in Walnut Bakelite

Ask your dealer to let you see and hear the wonderful range of Clarion 100-per-cent British-made Radio instruments.

Table Model, Console Model, Radio-gramophone with Automatic Record Changer.

The all-British Clarion Pick-up is amazing in its realism. The entire absence of extraneous noises ensures smoothness of tone which provides an added joy from your records. This model is fitted to the famous Clarion Radio-gram. Can be fitted to any gramophone in five minutes.

**BRITISH CLARION Co., Ltd.**

Clarion Works, Miller Street, N.W.1

Telephone: Museum 3624/3625

Telegrams: Crosradela, Norwest, London

## MEMO. FOR ADVERTISERS

**THERE IS STILL TIME**  
to secure Advt. Space in our Second  
**ENLARGED EXHIBITION**  
**NUMBER**

dated Aug. 27, on sale Aug. 25  
**CLOSING FOR PRESS AUG. 18**

**POPULAR WIRELESS**



# OSBORN RADIO CABINETS

THERE'S A DESIGN FOR YOUR SET—WRITE TO-DAY.

**MODEL No. 218.** A Queen Anne Radio or Radio-Gramophone Cabinet—3' 10" high, 2' 2" wide, 1' 6" deep. Size of baffle board behind feet, 24" x 24". Metallic fabric for fret front included. Opening at top and back. Cabinet takes panel 2' x 9" or smaller. Complete with motor-board.  
Send 3d. in stamps for Beautifully Illustrated New Season's Catalogue.

CHAS. A. OSBORN, Dept. P.W. The Regent Works, Arlington Street, London, N.1. Telephone: Clerkenwell 5095. And at 21, Essex Road, Islington, N.1. Telephone: Clerkenwell 5634.

**STAND 32, GRAND HALL, National Radio Exhibition, OLYMPIA, Aug. 19-27.**

# THE NEW DUBILIER TYPE 610 & 620 CONDENSERS

## MAKE THEIR BOW

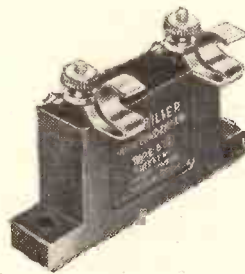

So popular has their repeated recommendations by leading radio journals made the Type 610 and 620 Dubilier Condensers that this famous range is now enlarged so that it is capable of supplying every need for this particular type of Condenser.

The new series, at low prices, are worthy bearers of the name Dubilier. From start to finish they are made with all the Dubilier tradition of dependability and long life. Use them in your next set. You will never find condensers which so well merit your implicit confidence.

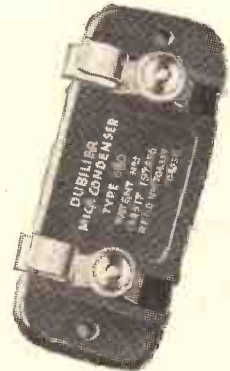

Capacities .0001-.0005 mf are now available with Grid Leak Clips only at 1/3 each, the price of the series parallel types remaining as before.

**DUBILIER CONDENSER CO. (1925) LTD.**  
Ducon Works, Victoria Road, N. Acton, London, W.3.

## RADIOTORIAL QUESTIONS AND ANSWERS

(Continued from page 700.)

No. 3. THE "SWITCH OVER" ONE-VALVER. A little set intended for use in the Regional area. A simple switching scheme enables you to change from one station to the other without re-tuning, and the twin wave-trap permits you to trap out either of the two stations at will.

A "Titan" coil provides operation on both wave-bands without coil changing.

No. 4. THE "TITAN" TWO. A very simple and straightforward little "Det.-L.F." two-valver with

### THE ANSWERS

TO THE QUESTIONS GIVEN ON PAGE 706 ARE GIVEN BELOW :

- (1) Nearly two hundred and fifty.
- (2) Radio-Paris. Leningrad. London Regional.
- (3) The Rt. Hon. J. H. Whitley. (He was at one time Speaker of the House of Commons.)
- (4) The B.B.C. makes no charge for its S O S service : but it never broadcasts an S O S for lost animals or for lost property !

DID YOU KNOW THEM ALL ?

wave-change switching based upon the use of a "Titan" dual range coil unit.

No. 5. THE "FULL TONE" TWO-STAGE AMPLIFIER. A very powerful two-stage L.F. amplifier using transformer-coupling in both stages. A standard type of anti-battery-coupling filter is provided in the input circuit, and this, together with the output filter for the loudspeaker, makes the amplifier very stable.

No. 6. A "SIMPLE CHANGE" THREE. A simply-made but highly efficient H.F. Det. L.F. receiver with wave-change switching.

No. 7. AN "EVERY PURPOSE" THREE. A very powerful detector and L.F. three-valver, with wave-change switching for medium or long waves.

No. 8. THE "SIMPLE SCREEN" FOUR. A simple and straightforward general-purpose four-valver.

Standard components are required throughout, and the H.F. stage is of the neutralised type.

No. 10. A D.C. H.T. UNIT. A simple but highly-efficient H.T. unit for D.C. mains, with a special voltage measurement scheme.

No. 11. THE "CHANGE RANGE" ONE. A very efficient little single-valve set, with wave-change switching.

No. 12. THE "SEPARATOR" TWO. A simple little detector and one L.F. with a wave-change reactor for dealing with "Regional" conditions.

No. 13. THE "INTER-STAR" THREE. A sensitive long-range receiver of exceptionally high selectivity. Will cope with the most arduous "Regional" conditions—incorporates one S.G. H.F. unit, with the famous Star Turn tuning arrangement for ordinary wavelengths, and inter-wave coupling for long waves.

No. 14. THE "MULTI-WAVE" THREE. An all-wave receiver, giving excellent results on short, medium, and long waves.

No. 15. THE "DRUM CONTROL" FOUR. A high-efficiency four-valver with wave-change switching for plug-in coils.

No. 16. THE "FILTER TUNE" FIVE. A simple but powerful and efficient long-range receiver. Normally employs only two tuned circuits, giving medium selectivity. For high selectivity an extra tuned filter circuit may be brought in by the simple movement of a switch.

### WHY THE A.C. VALVES DID NOT LAST.

M. H. F. (Norwich).—"When a set running off A.C. mains has only two valves across the L.T. transformer, although this will supply four valves with four volts, will the two valves

be getting more than four volts? I recently came across a case of a chap who can't get his valves to last as they should, and this seems to be the only possible way to account for it.

"I believe I remember reading in 'P.W.' that the volts rise if the current taken is smaller than it is supposed to be. He gets extremely lively results while the valves are working, but it's a case of a short life and a gay one.

"If you consider this is the cause of the trouble will it mean alterations to the transformer by the makers, or a new transformer, or what?"

Undoubtedly, the halving of the load, by using only two valves instead of four, might cause a considerable rise in voltage, quite sufficient to account for short valve-life.

The usual method of overcoming such a difficulty is to supply the transformer with a dummy load, equivalent to that which the missing valves would have imposed on it. Thus, if they each took one ampere the load should be arranged to take two amperes, to duplicate the normal running conditions.

As a matter of fact a somewhat smaller load than this would probably meet the case, as most transformers designed to supply four valves have sufficiently good "regulation," as it is called, not to impose excessive voltage on only three. So an extra resistance capable of carrying between one and two amperes, connected across the secondary, should meet the requirements of the case.

### "P.W." PANEL No. 81. CALIBRATING A TUNING DIAL.

It is a great advantage to be able to know what wavelength is associated with any particular setting of a tuning condenser. A chart showing wavelengths corresponding to dial-readings is known as a "tuning-curve" or "calibration-chart."

The drawing up of such a curve is an easy matter (provided the dial readings of several stations are known accurately to begin with) if squared paper (graph paper) is used.

Two scales are drawn, at right angles, one representing the wavelengths of the stations, and the other their dial-readings.

When the known stations are "placed" on this, and joined by a "curve," the latter indicates how intermediate wavelengths and dial-readings are related.

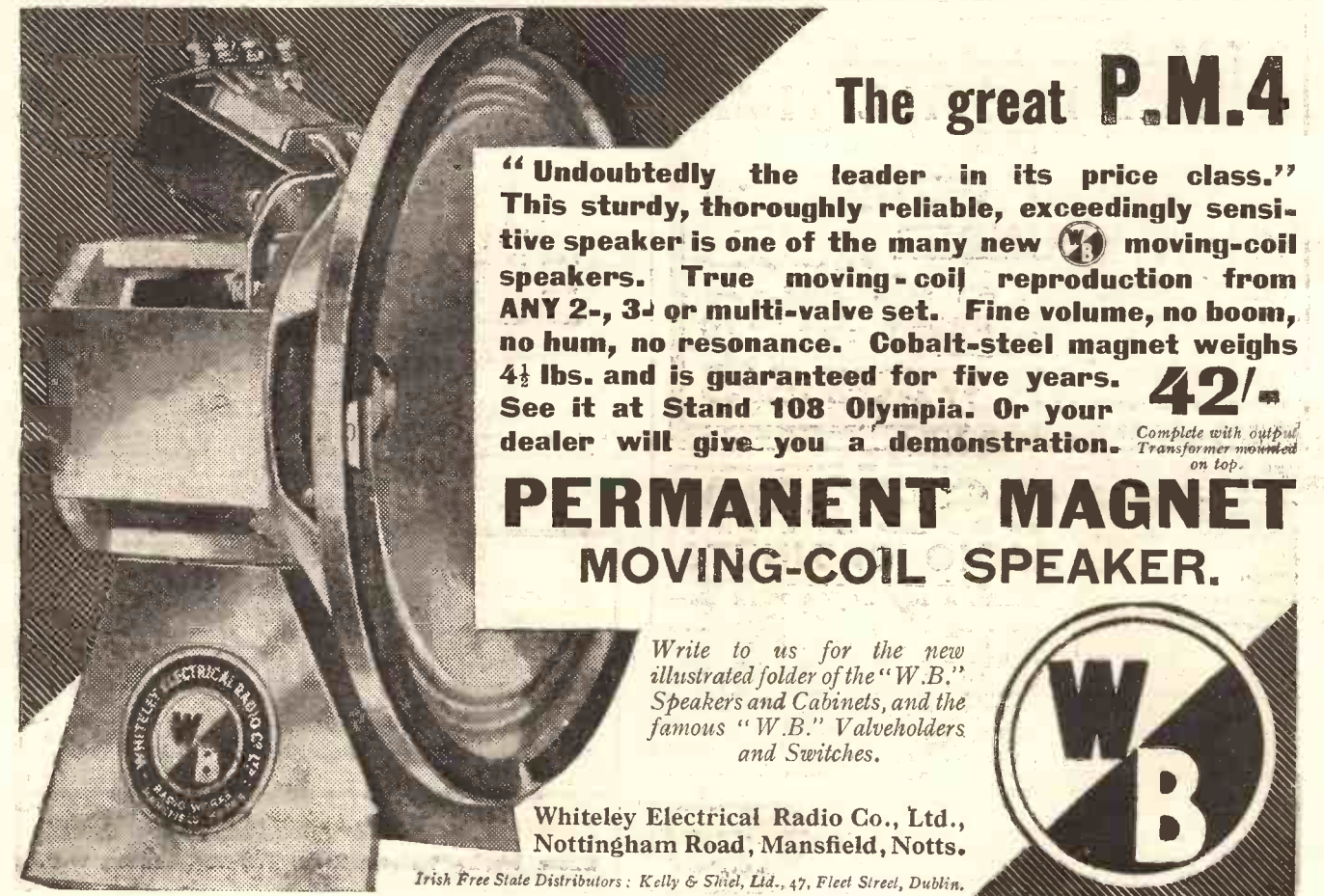

**The great P.M.4**

**"Undoubtedly the leader in its price class." This sturdy, thoroughly reliable, exceedingly sensitive speaker is one of the many new  moving-coil speakers. True moving-coil reproduction from ANY 2-, 3- or multi-valve set. Fine volume, no boom, no hum, no resonance. Cobalt-steel magnet weighs 4½ lbs. and is guaranteed for five years. 42/- See it at Stand 108 Olympia. Or your dealer will give you a demonstration. Complete with output Transformer mounted on top.**

**PERMANENT MAGNET MOVING-COIL SPEAKER.**

Write to us for the new illustrated folder of the "W.B." Speakers and Cabinets, and the famous "W.B." Valveholders and Switches.

**Whiteley Electrical Radio Co., Ltd., Nottingham Road, Mansfield, Notts.**

Irish Free State Distributors: Kelly & Snel, Ltd., 47, Fleet Street, Dublin.







**FLUXITE**  
INDISPENSABLE  
TO EVERY  
RADIO  
ENTHUSIAST  
IT SIMPLIFIES  
ALL SOLDERING

"We're Fluxite and Solder, the reliable pair, Famous for Soldering—known everywhere! Now here is a statement—bound to come true, If you'll invite US to come and help YOU!"

See that Fluxite and Solder are always by you—in the house, garage, workshop—anywhere where simple, speedy soldering is needed. They cost so little, but will make scores of everyday articles last years longer! For Pots, Pans, Silver and Brassware; RADIO; odd jobs in the garage—there's always something useful for Fluxite and Solder to do.

All Hardware and Ironmongery Stores sell Fluxite in tins, 8d., 1/4 and 2/3.

ANOTHER USE FOR FLUXITE  
Hardening Tools and Case Hardening.  
Ask for Leaflet on improved method.

NEW "JUNIOR" SIZE 4d. per tin.

**FLUXITE SOLDERING SET**

Simple to use and lasts for years in constant use. Contains special "small space" soldering iron with non-heating metal handle, pocket blow-lamp, Fluxite Solder, etc., and full instructions. COMPLETE, 7/6, or LAMP only 2/6.

FLUXITE LTD.

(Dept. 324),

ROTHERHITHE, S.E.16

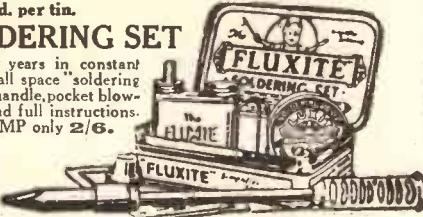

ALL MECHANICS WILL HAVE

**FLUXITE**

IT SIMPLIFIES ALL SOLDERING

**YOUR COPY OF**

**"CAMCO'S" NEW CATALOGUE**

is ready—send the coupon now and secure a copy. It contains the complete range of "Camco" cabinets with full particulars and specifications. The Camco "Popular" Radio-Gram Cabinet (rgd. design) illustrated is the finest value offered with motor board shelf, baffleboard and automatic stay, shaded walnut finish, 75/- complete!



OLYMPIA, STAND 123

**CARRINGTON MFG. CO., LTD.**

Showrooms: 24, Hatton Garden, London, E.C.1.  
Phone: HOLborn 8202.  
Works: South Croydon.

COUPON

Name.....

Address.....

1 P.W.



**POLAIR 'STARS' IN THE CONDENSER WORLD**

SIMPLE ASTRONOMY  
THE GREAT BEAR or THE PLOUGH

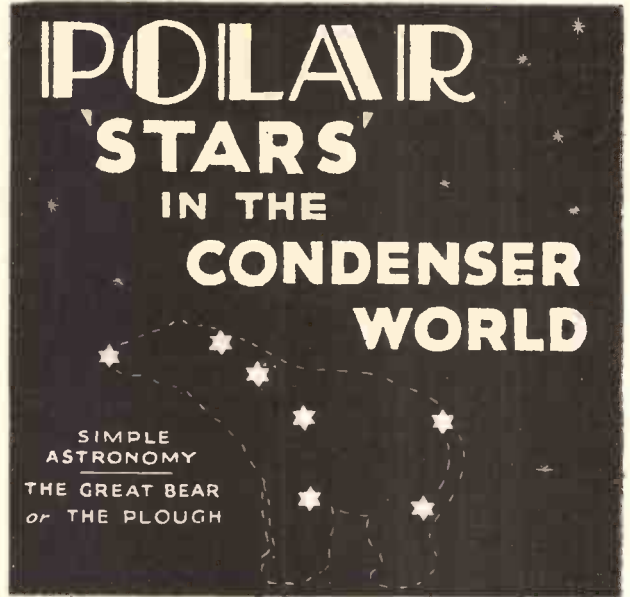

**ACCURATE SPACING OF VANES OBTAINED BY PRECISION MACHINE ASSEMBLY**

entirely eliminates the possibility of error in spacing—hence this guarantee: Polar "Star" Gang Condensers are guaranteed accurately matched to within 1/2 of 1%, plus or minus 1 mmfd. And their construction ensures that this accuracy will never vary.

Other outstanding features:

- 1: Trimmers always at constant value.
- 2: Strong spring journal bearings.
- 3: All-Steel frame.

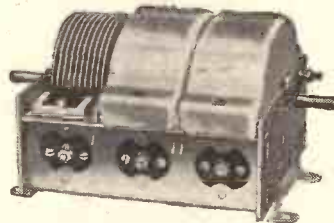

**"STAR" 3-GANG 25'6**

- Special Super-het 27/6
- 4x0005 - 34/-
- Polar Drum Drive - 7/6
- Polar Disc Drive - 5/-

SEND FOR NEW POLAR 36-PAGE FULLY ILLUSTRATED CATALOGUE "P."



**POLAIR CONDENSERS**

STAND 129 OLYMPIA.

WINGROVE & ROGERS, LTD.  
188-9 STRAND, LONDON, W.C.2  
Polar Works, Old Swan, Liverpool.

## THE LISTENER'S NOTEBOOK

(Continued from page 674.)

artists haven't given listeners a moment's thought from the start to the finish of their turn.

Such a situation is serious, and the real problem becomes that of avoiding flatness in transmission without having to revert to stage methods.

Take the recent case of Lily Morris. She sang her song—a very good one too, although we had heard it before, but the song wasn't by any means the only important part of her turn. She had the audience in fits of laughter even when to us there seemed to be nothing more than some intermission music by the orchestra.

Obviously she was indulging in some funny by-play—very nice for those who could see her. But what about us?

If it is impossible, because of the present limitations of her medium, to get this over the air, then she oughtn't to be doing it! Her turn should be altered, and better adapted to the needs of the microphone.

So cricket in the eyes of the B.B.C. is news, is it? It is a fact that a wet day (when not a single ball is bowled) means a short news bulletin. The B.B.C. must have been very grateful to Ottawa on more than one day at 6 p.m., for without it (and 6 o'clock scores) their news bulletins would have been very scrappy.

As it is, I'm sure Kuala Lumpur could give them points. There is, of course, something to be said for a poor news bulletin—it makes the newspaper on the

next morning's breakfast table a more readable article.

I'm sure that if a popular vote were taken on the popularity of the many dance bands we hear, Henry Hall would easily head the list—and deservedly too. After all, we do like melody. Henry Hall knows this, and so he gives us it.

I doubt whether he considers himself an expert in the hundred per cent. American hot-rhythms (or whatever they call them). In any case, why should he try to be?—it is a type of music that is popular only with a section of the community.

I've been listening lately to a number of "disc" recitals given by Poste Parisien, and very good they've been, too!

There has been an abundance of excellent new recordings on the French Gramophone companies' lists lately. An exceptionally fine one, I thought, was "*Je sais que vous êtes jolies*." The tune is a familiar one, but the vocal solo is about the best of its kind I've heard.

By the way, Poste Parisien seems to be particularly strong these days, since the new station was erected.

For some time now I've been of opinion that Continental stations have "got us beat" in the way of gramophone recitals. I mean, of course, in the choice of "discs." But a recent recital of light gramophone records, including novelties of celeste, glockenspiel, xylophone plus pianoforte music has perhaps put us in the running again.

Needless to say Christopher Stone wasn't responsible for this recital. He seems to be getting more low-brow than ever, or as I heard it expressed the other Friday: "His recital hadn't one intelligent record in it!"

Tennis enthusiasts still interested in the fate of the Davis Cup couldn't have wished for a better final than that staged in Paris when Borotra, after appearing to be in for a good hiding, changed his shoes, made amends and won a great victory for France.

The crowd went mad, and the commentator went with them. (How like a chorus of bookmakers he sounded, by the way!)

As far as the English listeners were concerned, it needed no commentator to tell how the games were going. The crowd was sufficiently informative.

The English commentator was hardly given a hearing, but on the rare occasions that his French colleague paused for a breather, he did contrive to get in a word or two.

His tennis parlance, however, was decidedly unique, and his information not always accurate.

"Enthusiasm run wild" just about sums up one's impressions of the whole affair; accustomed as we are to the quiet restraint of the Wimbledon crowds. In such a din one couldn't hope to hear the ping of the ball (or is it the racket?) But this is always heard in a Wimbledon broadcast.

Nothing could be heard above the tumultuous applause of the French crowds when victory began to look possible.

## SEE THE NEW COMPONENTS BY

**BOWYER-LOWE**  
AT OLYMPIA STAND No. 156

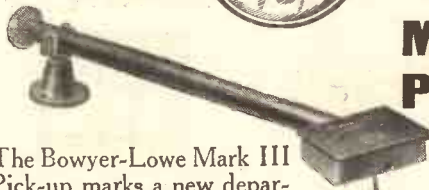

**MARK III PICK-UP 30/-**

The Bowyer-Lowe Mark III Pick-up marks a new departure in design, the frequency response of from 25 to 6,000 cycles being designed to be complementary to that of the usual moving-coil speaker. The resulting reproduction is a faithful replica of the original recording.

In the small space of 3" x 1 3/4" x 2 1/4" this unit includes all that is necessary for a complete stage of L.F. amplification, excluding only the valve. The nickel-iron cored transformer has a primary inductance of over 80 Henries, while the resistances are wire wound and non-inductive.

**P.F.T. UNIT 11/6**  
SEND FOR CATALOGUE  
BOWYER-LOWE & A.E.D. LTD.,  
DIAMOND WORKS, BRIGHTON



Post the Coupon below & a 7-day sample tube of the new 'perfected' Shaving Cream will



Enjoy a week of perfect shaving comfort, with the seven-day sample of Parke-Davis Shaving Cream offered free of all charge.

When you have enjoyed the sample, you can get a large tube from your chemist—1/6. Made in England by the makers of Euthymol Tooth Paste.

**PARKE-DAVIS Shaving Cream**

COUPON  
EUTHYMOL (125 M.), 50, Beak Street, London, W.1  
Please send FREE sample tube Shaving Cream

Name.....

Address.....

(Use block letters please)



There can be no certainty of success for the sales of a product unless backed by sound, consistent advertising. Don't gamble with sales. Advertising facilitates distribution and ensures sustained demand.

H.J.

**IT PAYS TO ADVERTISE**

Issued by the Institute of Incorporated Practitioners in Advertising in conjunction with the Federations of Master Process Engravers and Master Printers, etc.

# PILOT AUTHOR KITS

*Exact to Specification*

**CASH—C.O.D.—H.P.—** *Immediate Delivery.*

## “OLYMPUS FOUR”

**P.W.'S EXHIBITION SET** Described in this week's issue.

**KIT “A”** Author's Kit with Ready Drilled Panel, less Valves and Cabinet.

CASH or C.O.D. **£4.8.9**  
or 12 monthly payments of **8/2**

**KIT “B”**

as above, but with valves only  
CASH or C.O.D.

**£6.11.3**  
or 12 monthly payments of 12/1.

**KIT “C”** as above but with Valves and Cabinet.

CASH or C.O.D.

**£7.6.3**  
or 12 monthly payments of 13/5.

**KIT-BITS** Selected Items sent C.O.D. Orders over 10/- sent all Post and C.O.D. charges paid.

Set of 4 Specified Valves ..	£2	2	6
Specified Cabinet ..		15	0
Lissen Hypernik L.F. Transformer		12	6
2 Telsens Telecords ..	£1	5	0
1 pr. Telsens Matched Screened Coils		17	0
Celestion Permanent Magnet Speaker, Type P.P.M. ..	£2	7	6

## EASIWAY ITEMS

**RECOMMENDED FOR “OLYMPUS FOUR” ATLAS ELIMINATOR TYPE A.C.188.** H.T. and Trickle charging for L.T.-2, -4 or -6 volt. Cash Price **£6/0/0**. Balance in 11 monthly payments of 11/-.

**W.B. PERMANENT MAGNET MOVING-COIL SPEAKER. Type P.M.4.** Complete with Transformer. Cash Price **£2/2/0**. Balance in 7 monthly payments of 5/9.

**ULTRA IMP PERMANENT MAGNET MOVING-COIL SPEAKER,** with input transformer. Cash Price **£2/15/0**. Balance in 11 monthly payments of 5/-.

**BLUE SPOT SPEAKER UNIT AND CHASSIS, TYPE 100U.** Cash Price **£1/19/8**. Balance in 7 monthly payments of 5/5.

**GARRARD INDUCTION GRAMOPHONE MOTOR.** For A.C. Mains. Model 202. Mounted on 12-in. Nickel Motor Plate with fully automatic electric starting and stopping switch. Cash Price **£2/18/8**. Balance in 11 monthly payments of 5/4.

### JUST RELEASED

**COSSOR MELODY MAKER** ... Model 335 ...  
Complete with valves, speaker and cabinet. Employs Cossor Variable-Mu S.G. H.F. stage, Detector and Power Valves. Cash Price **£7-17-6**. Balance in 11 monthly payments of 14/8.

**PETO-SCOTT CO. LTD.**  
77, CITY ROAD, LONDON, E.C.1.  
Dear Sirs,—Please send me CASH/C.O.D./H.P.

for which I enclose £.....s.....d.  
CASH/H.P. Deposit.

NAME.....

ADDRESS.....

P.W. 13/8/32.....

West-end Showroom: 62, High Holborn, London, W.C.1.

# TECHNICAL NOTES

Some diverse and informative jottings about interesting aspects of radio reception.

By Dr. J. H. T. ROBERTS, F.Inst.P.

### Earthing Screens.

IF you have a number of metal screens in your set and also perhaps a number of metal covers for coils or other components, you may find that connecting these to earth is not quite so simple as it seems. On the face of it you would think that the most convenient way was to connect all these screens, metal covers, etc., together by means of a wire and then connect this to earth.

In point of fact, however, owing to the fact that the wires used are not absolutely free of ohmic and high-frequency resistance, you do sometimes get curious effects which you would hardly expect. For instance, on connecting all the screens together and then to earth you may find that the set has become unstable.

The best way is to take a wire from each of the screens, covers, etc., to the negative terminal, and these wires should be reasonably stout ones.

### Beware G.B. Connections.

It is important also to be sure that the covers of coils have not already been connected by the manufacturers to the grid-bias end of the windings of the coil; if this should be the case and you use grid bias the external earth connections will have the effect of short-circuiting the grid-bias battery. If the manufacturers of the coil do not actually state whether it is connected to the cover, you should certainly find out first for yourself before connecting the cover to earth.

I have come across a number of instances, not only with radio receivers but in other scientific experiments, where connecting a number of objects together and then to earth has given a different result from connecting them all individually to earth. I know it seems strange, but there it is, and it only emphasises that when you are dealing with very sensitive apparatus you must make refinements accordingly.

### Resistance Feed.

Quality can often be improved a good deal by very simple adjustments or additions. For instance, the resistance-feed arrangement of transformer coupling will sometimes make a marked improvement in the quality, and it involves nothing more than the use of a fixed condenser and fairly high resistance—about 0.5 microfarad and 30,000 ohms respectively.

The grid-bias terminal of the secondary of the transformer is connected to the anode terminal of the primary and then to the anode of the preceding valve via the above-mentioned 0.5 microfarad coupling condenser. The grid terminal of the secondary is connected to the power valve in the ordinary way, whilst the H.T. plus terminal of the primary becomes the grid-bias connection.

### Battery “Life.”

Several readers have asked me from time to time what is a reasonable “life” to

expect from a high-tension dry battery. You will see at once that this question, like so many questions in connection with wireless matters, is delightfully vague. The reasonable life of a battery obviously depends upon the size of the cells, the rate at which they are discharged and many other factors.

At one time it was considered that a battery was satisfactory for radio purposes so long as the voltage per 1½-volt cell had not dropped to less than about 0.8 volt.

Many people used to test batteries by simply connecting a battery to a fixed external resistance; for instance, a resistance which consumed a current of 5 milliamps, when the battery was new and leaving the battery connected in this way six hours a day for five days a week or four hours a day for seven days a week, and so on.

### A Method of Testing.

You will see that this is really a very unsatisfactory method of testing because, as the voltage of the battery falls—or alternatively as the internal resistance of the battery increases, which is really more important from the radio point of view—the actual load upon the battery will decrease if the external resistance is kept constant.

Inasmuch as we take (or at any rate, assume we are taking) a more or less constant current from a battery when it is used under fixed conditions with a radio set, clearly this forms the more appropriate basis for a test as to the life of the battery.

### A Proper Specification.

Some time back the British Engineering Standards Association laid down a system for the testing of batteries in this way and according to this scheme the battery is put on a constant current load, the external resistance being adjusted from time to time so as to keep the current to a fixed value of, say, 5 milliamps. The battery is tested six hours a day, five days a week, and is considered to be spent when the voltage per cell falls to 0.9 volt. When this stage is reached the total watt-hours is calculated and only has to be divided by the number of cells to give the watt-hours output per cell.

The watt-hours to be reasonably expected from different size cells has been laid down at 1.2 watt-hours for the standard small size cell discharged at 5 milliamps, 3½ watt-hours for the so-called “treble” size 1½ inches by 2½ inches at 10 milliamps, and 4 watt-hours for the “heavy-duty” type 1½ inches by 3½ inches at 20 milliamps.

You will see what this means if you just remember that a 1½-volt cell giving 1 ampere is delivering 1½ watts and if it goes on delivering 1 ampere for one hour it has given up 1½ watt-hours of energy. This is equivalent to 5 milliamps for 200 hours at 1½ volts. Of course, in practice the voltage will be falling all the time.

(Continued on next page.)

## THE NEW ELECTRADIX

**Sale List will save you pounds**

It is full of Bargains of Aerials, Batteries, Buzzers, Bridges, Condensers, Cable, Cabinets, Chokes, Coils, Chargers, Dynamos and Motors, Galvos, Engines, Lamps, Photo Cells, Neons, Microphones, Mains Sets, Magnets, Meters, Receivers, Spark Coils, Telephones, Valves, Wavemeters, Wire, Meggers and Capacity Bridges, etc., etc.



**NAVAL TELESCOPES**, gun-sighting pattern, by Ross and others. Illuminated field for night or astro. work, complete in case, cost £28. Sale Price 17/6.

**BARGAIN PARCELS** of Electrical and Radio Sundries; better value than ever for experimenters, 10 lbs., 7/-, 7 lbs., 5/-, Post Free. Jewelled 1st grade meter movements, 5/-.

Send addressed envelope for our Sale List of Electrical Bargains.

**ELECTRADIX RADIOS**, 218, Upper Thames St., E.C.4 City 0191.

**PATENTS, TRADE MARKS**, "Advice Handbook" and Consultations FREE.—B. T. KING, C.I.M.E., Regd. Patent Agent (G.B., U.S. and Canada), 146a, Queen Victoria Street, London, E.C.4. 45 years' references. Phone: Cent. 1682.

PLEASE be sure to mention "Popular Wireless" when communicating with Advertisers. Thanks!



**Flower Seeds to Sow NOW!**

See this week's **POPULAR GARDENING**

EVERY SATURDAY, 2d. BUY YOUR COPY TO-DAY

## TECHNICAL NOTES

(Continued from previous page.)

### Watt-hours Output.

Any battery which does not come up to these standards is certainly not up to much, because the standards laid down are on the lenient side. In point of fact, a good many of the better-class batteries on the market will put up a performance very much superior to the minimum set out in these specifications.

I should like to emphasize a point which is I think not always appreciated, especially by beginners, and that is that the total output from a battery depends very much upon how it is used. For example, suppose the maximum rated current output of a battery is 5 m.a. and you use it generally for supplying 3 m.a., then the battery will probably give you excellent service—perhaps a much longer life even than the makers stated.

On the other hand, nothing is worse for a dry battery than to be worked at an appreciably higher current than that intended—say, in the above case, 7 or 8 m.a. This will soon play old Harry with the battery and you may find yourself disappointed with its life, when in point of fact it is your own fault.

## THE RADIO EXHIBITION

Starts on FRIDAY, AUG. 19TH, so

Next Week's "P. W."

will be our

**SPECIALLY ENLARGED EXHIBITION NUMBER**

Order Now **3d.** Out on Thursday

### Don't Overwork Your Battery.

Then again, giving a battery an occasional rest makes a great difference to its life. If it is worked too many hours a day it will not have time to recover as it should. Two or three hours a day—and then not all at one go—is ample for the ordinary small size battery.

All these may seem little points, but it is just little things like this that make all the difference, not only with the battery, but with other parts of the set as well.

### Indirectly-Heated Valves.

Indirectly-heated D.C. valves have not, until comparatively recently, received the same attention as their A.C. brothers. This is, no doubt, because the application of D.C. to the heating of valve filaments is not nearly so convenient as is the case with A.C. This, by the way, applies to many other matters besides valve heating.

With A.C. we have the immense advantage that we can play about with the voltages as we think fit, by the simple process of using a suitable transformer. If we wish to operate a number of indirectly-heated A.C. valves, with heater-filaments running at, say, 4 volts, all we have to do is to employ a step-down transformer supplying the required current output for the valves in parallel at this voltage. There is thus little waste of electrical

(Continued on next page.)

**QUICK EASY PAYMENT SERVICE**

We supply all good quality Radio Receivers, Components, and Accessories on deferred terms. Large stocks are carried and orders are executed promptly. Send list of requirements and a quotation will be sent by return of post. Price List free on request.

**NEW COSSOR MELODY MAKER**, Model 335 (just released). Complete Kit With of Parts, Valves, and Loudspeaker. Cash Price £7/17/6. **10/-** order

And 11 monthly payments of 15/-.

**MURPHY NEW ALL-MAINS 3-VALVE SET**, Model A.3.A. Cash Price £19/19/0. **39/-** order

And 12 monthly payments of 33/-.

**ATLAS ELIMINATOR, A.C.244**, 3 H.T. Tappings. 20 M/A output. Cash Price £2/19/6. **5/-** order

And 11 monthly payments of 5/6.

**NEW ORMOND PERM. MAGNET MOVING-COIL L.S. UNIT** (just released) Cash Price £1/18/6. **5/4** order

And 7 monthly payments of 5/4.

**EKCO H.T. ELIMINATOR A.C.18**, Suitable for 3-Valve S.G. Sets. Cash Price £3/7/6. **6/3** order

And 11 monthly payments of 6/3.

**NEW R & A "CHALLENGER" PERM. MAGNET MOVING-COIL UNIT**. Cash Price £1/15/0. **5/-** order

And 6 monthly payments of 5/7.

**NEW EPOCH 20C PERMANENT MAGNET MOVING-COIL UNIT**. Cash Price £1/15/0. **5/7** order

And 6 monthly payments of 5/7.

**12 EXIDE HIGH-TENSION ACCUMULATORS** (120 volts WH-10 super-capacity, 5,000 milliamps). The cheapest form of high-tension supply where electric light mains not available. Cash Price £3/15/0. **7/-** order

And 11 monthly payments of 7/-.

**BLUE SPOT 100U INDUCTOR UNIT**. Cash Price £1/19/6. **5/5** order

And 7 monthly payments of 5/5.

To avoid delay, will customers kindly send deposit with order.

All above carriage paid.

**The LONDON RADIO SUPPLY COMPANY** ESTD 1925  
11, Oat Lane, Noble St., LONDON, E.C.2  
PROB. NATIONAL 1977



### WET H.T. BATTERIES

Solve all H.T. Troubles. SELF-CHARGING, SILENT, ECONOMICAL JARS (waxed), 2 1/2" x 1 1/2" size. 1/3 doz. ZINCS, new type 10d. doz. Sacs 1/2 doz. Sample doz. (18 volts), complete with bands and electrolyte, 4/3, post 3d. Sample unit, 6d. Illus. booklet free.

Bargain list free. AMPLIFIERS, 30/-, 3-valve set, 25. P. TAYLOR, 57, Studley Road, STOCKWELL, LONDON.

Make **THE DAILY SKETCH** YOUR Picture Paper

## EXACT TUNERS

250 to 2,000 metres. Thousands of these tuners are in use, and we can strongly recommend them. No further notes are required. Send P.O. for particulars and circuits—FREE.

**THE EXACT MANUFACTURING CO.**, Croft Works, Priory Street, Coventry.

## EASY PAYMENTS

"There's no place like HOLMES."

The first firm to supply Wireless parts on easy payments. Seven-year advertiser in "Popular Wireless." Thousands of satisfied customers.

	Deposit	Monthly Payments
TELSENE VICTOR 3 KIT	39/6	5/5 7 of 5/5
COSSOR KIT	£6/8/6	10/- 11 of 11/11
OSRAM KIT	£10/15	19/6 11 of 19/8
METEOR 3 KIT	£3/15	6/10 11 of 6/10
EXIDE H.T. Accum., 120v.	£3	6/- 9 of 6/8
BLUE SPOT 66R & CHASSIS	£2/2/6	5/6 9 of 4/5
BLUE SPOT 100 U	39/6	5/8 7 of 5/4
AMPLION M.C.6	67/6	7/5 9 of 7/5
CELESTION M.C.	47/6	5/3 9 of 5/3
EKCO Eliminator A.C.18	67/-	7/5 9 of 7/5

New Goods Obtained for Every Order. Send us a list of the parts you require and the payments that will suit your convenience, and we will send you a definite quotation. Anything Wireless. **H. W. HOLMES, 29, FOLEY STREET, Great Portland Street, London, W.1.** Phone: Museum 1414.

Famous Makers Offer! **£5 Radio-Gram CABINET for 65/-**  
**7 DAYS' FREE TRIAL (10/- MONTHLY).**  
 Piano built (Pat. 8123), the acoustic tone brings a fine thrill. Makers to Radio-Press, B.B.C., 3,000 clients.  
 Other Models 35/- to £15. List & Photographs Free. PICKETTS, Piano-Tone Cabinets, 'P.W.' Albion Rd., Bexleyheath



**ENGINEERS**—Sit down and think this over. Time is going by and you are still on the look-out for a worth-while job. Will you be doing the same thing next year—and the year after that? You have got to do something about it before it is too late. We believe we can show you the way to well-paid permanent and progressive employment. In any case, it costs nothing to inquire and you will at least learn of various surprising possibilities about which at present you probably know nothing. The first thing to do is to send for our 200-page Prospectus, "ENGINEERING OPPORTUNITIES." Free and without obligation. Do not delay. This is a matter which affects your very livelihood. Send for your copy now—not tomorrow, but NOW.

**BRITISH INSTITUTE OF ENGINEERING TECHNOLOGY, 401, Shakespeare House, 29-31, Oxford Street, London.**

The Goods as Advertised! From TWO to TWO THOUSAND metres, we can solve your Radio Problems, including Amateur Transmission! Whatever your difficulty, write us. Charges: 3/- per query, four or more 2/6 each, including diagrams.  
**RADIO TECHNICAL AGENCY, DEPT. P.W. 2, Westgate Chambers, Newport, Mon.**

**LOUD SPEAKERS REPAIRED, 4/-**  
 (Blue Spot a Specialty, 5/-)  
 Transformers 4/-, Headphones 4/-, all repairs magnetised free. Eliminator Repairs quoted for. 24 Hours Service. Discount for Trade. Clerkenwell 9069.  
**B. MASON, 44, EAST ROAD, LONDON, N.1.**

**THE PICTURE PAPER WITH THE MOST NEWS**  
**SUNDAY GRAPHIC**  
 and Sunday News

## SHORT-WAVE BARGAIN!

**SHORT-WAVE PLUG-IN COILS, Nos. 2 to 9 TURNS.**  
**AIR DIELECTRIC STANDARD SIZE**

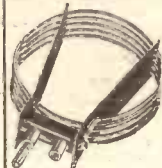

**8" EACH** USUAL PRICE 1s. 6d.

4 for 2/4, 8 for 4/6, all Post Paid. The set of eight covers whole S.W. range. Baseboard Coil Holders, 4d. Tune-in World-wide Short-wave Programmes without altering your set—on the "DYNATONE" S.W. ADAPTOR. The best Adaptor for all Battery or Eliminator Sets. BLUE PRINT, 4d. COMPLETE KIT, NO EXTRAS REQUIRED, 25/6 WIRED AND TESTED, READY FOR USE, 29/6. All Post Paid.

**SCIENTIFIC SUPPLY STORES (Dept. P.W.), 128, Newington Causeway, Elephant & Castle, LONDON, S.E.1. Tel: Hop. 4177.**

## TECHNICAL NOTES

(Continued from previous page.)

energy, assuming the transformer to be reasonably efficient.

### Playing With Voltages.

Now when it comes to D.C., we cannot juggle with voltages in the same way at all. If we use 1 amp. for a filament-heater the same 1 amp. is drawn off at, say, 200 volts and represents the consumption of 200 watts of energy. Of this, 4 watts may be consumed, in the desired way, in the valve heater, whilst the remaining 196 watts is dissipated in a resistance of some sort, which has to be used to "break down" the voltage.

What we can do, however, is to make our valve heater in such a form that it requires a higher voltage than 4 volts (and consumes a correspondingly smaller current for the same wattage) and also to connect several such valves together in series.

For instance, suppose we could design a valve which required 50 volts for the heater, the latter drawing one-tenth of an ampere of current, then we could use four such valves with their heaters in series on a 200-volt D.C. supply. We would then be using altogether 20 watts (200 volts multiplied by one-tenth of an ampere), that is, 5 watts to each valve, and nothing wasted.

### The Ideal Arrangement.

Although we have not yet reached this ideal stage for D.C. working, great improvements have been made latterly and valves

## NEXT WEEK

will be "P.W.'s"

## SPECIAL ENLARGED EXHIBITION NUMBER

Out on Thursday. Usual Price

for series operation have been produced adapted to operate at much higher filament-heater voltages. You see, the more of the available voltage which we can usefully employ in the filament-heaters themselves the less there remains to be eaten up wastefully by external resistances.

The first indirectly-heated D.C. mains valves were put on the market about the beginning of last year in the Mazda series.

### How Ideas Change.

It's funny how ideas change round in radio. I dare say you can think of quite a number of things that were simply not done three or four years ago that are done to-day, and vice versa. The super-het, for instance, had a certain limited vogue quite early on, then it was superseded and almost discarded, and now—in a very much improved form, it is true, and with very different valves and coils—it bids fair to gain a popularity altogether undreamt of in the early days.

I was thinking at the moment, however, of the old cry about "low loss." I suppose it must be about five years ago that everything simply had to be low loss. Anything to do with ebonite end plates on condensers, or mica insulation, was just heresy.

### Will They Come Back?

Whether we have realised that the craze hadn't much in it anyway, or whether it has just died a natural death, or again whether changes in other respects have rendered it relatively unimportant, doesn't matter very much, but the fact is that you scarcely ever hear the words to-day.

So far as condensers are concerned, there is still a good deal to be said for mica, from the point of view of compactness and convenience, and I think you will find that this is just another of those cases where our ideas of only a few years ago will swing with the pendulum.

### Controlling Valve Efficiency.

When this automatic volume control is incorporated in the circuit, it has the effect of controlling the efficiency of the H.F. valve in such a way that if the incoming signal fades the efficiency of the valve is automatically increased, and vice versa.

It is obvious from this that matters must be so adjusted that the H.F. valves work efficiently when the incoming signal is small, and relatively inefficiently when the incoming signal is fairly strong. You may think that this involves a sacrifice since the valve has to be operating inefficiently for a reasonably strong transmission.

In one sense this is true, and it is assumed that even in these circumstances the circuit as a whole is efficient enough to give you the required output from the loudspeaker. The second detector or control valve is connected in parallel with the normal detector with suitable bias applied to the grid, and incoming signals affect the two valves in the same way.

The ordinary detector passes these signals on in the form of low-frequency currents in the usual way, whilst in the control valve the value of the anode current will obviously depend upon the strength of the input; if the incoming voltage is large, the anode current will be relatively large and vice versa.

### Voltage and Bias.

Now if this anode current is passed through a resistance there will be a definite voltage developed at the ends, and the amount of this voltage will depend upon the strength of the signal.

If, then, the voltage developed across the ends of this resistance is used for the purpose of controlling the efficiency of the H.F. valve, we have the automatic arrangement which we require. A simple way to do this is to make the voltage across the resistance have the effect of increasing the bias on the H.F. valve, so that the efficiency of the valve is lowered, which means smaller amplification, and neutralises the effect of a stronger input. Conversely, if the strength should fall the anode current in the control valve will fall, and with it also the voltage developed across the ends of the control resistance, this in turn having the effect of reducing the bias on the H.F. valve and so increasing its efficiency.

Of course, there are a number of other points to be considered. In actual practice, in the States the variable- $\mu$  valve is largely used for this purpose to prevent cross modulation, which sometimes arises owing to the biasing of the H.F. screen-grid valve.

# ALWAYS AT THE TOP

As year succeeds year and Radio Show follows Radio Show it will be observed that Blue Spot Products remain always at the top. Blue Spot still make the majority of loudspeakers sold in this country.



Amidst a mass of competitors and not a few imitators, Blue Spot Products stand head and shoulders above the crowd—unequalled for performance, for supreme quality and for generous value for money.

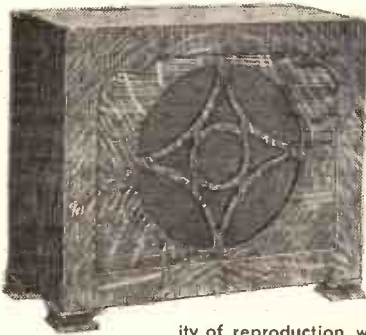

**100D**  
**57/6**

This very handsome cabinet speaker in fine quality oak has won remarkable success. The famous 100U movement ensures complete clarity

of reproduction with every note true to tone. The performance is equal to that of a good moving-coil speaker. This speaker is very sensitive even to small inputs and may be used with battery or all mains sets. Ask for Speaker Catalogue No. P.W.45.S.

BRITISH MADE



**31K**  
**31/6**

This is a fine quality Speaker at a really popular price. The movement is the new improved model of the world-famous 66K which means that the reproduction is free from distortion and rattle. Every word and

every note can be clearly distinguished and are life-like representations of the originals. The cabinet is carefully constructed from fine quality oak. Ask for Speaker Catalogue No.

P.W.45.S.

BRITISH MADE

**RADIO EXHIBITION**  
**STAND 35**  
Demonstration Room D13

BRITISH MADE

BRITISH MADE

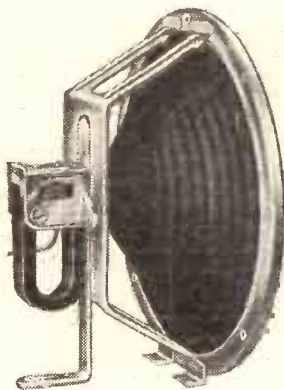

**100U**  
**39/6**

There is literally nothing to equal 100U in its price class. The quality of its performance is unique—better by far than most moving-coil speakers selling at anywhere near its price. The whole musical range is fully and truly reproduced. It is sensitive to small inputs. It may be used with Normal or

Pentode valves, no matching transformer being required. Ask for Unit Catalogue No. P.W.45.S.

**99PM**  
**59/6**

This Permanent Magnet Speaker will make history for moving-coil Speakers. No misleading figures regarding flux density are given because they give no true indication of quality. An inferior magnet will give a high flux density in a small air gap. The magnetic energy in the air gap of 99PM is

of the exceptionally high order of 1,320,000 ergs.—a fact which speaks for itself. Ask for Unit Catalogue No. P.W.45.S.

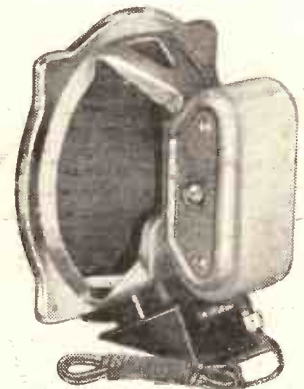

**THE BRITISH BLUE SPOT COMPANY LTD**  
BLUE SPOT HOUSE · 94/96 ROSOMAN STREET · ROSEBERY AVENUE · LONDON · E C 1

Telephone: Clerkenwell 3570. Telegrams: "Bluspot, Isling, London."  
Distributors for Northern England, Scotland and Wales: H. C. RAWSON (Sheffield and London), Ltd., 100, London Road, Sheffield; 22, St. Mary's Parsonage, Manchester; 44-46, High Bridge, Newcastle; 37, 38, 39, Clyde Place, Glasgow.

# THE ORIGINAL "PARAFEED" SYSTEM NOW IN A COMPLETE UNIT

The

# PARAFEED COUPLING UNIT



## The advantages of the PARAFEED Coupling Unit

The whole Unit is completely metal screened with provision for earthing within the bakelite case.

The "Parafeed" Transformer included in the coupling unit gives ratio changes of 1 : 2, 1 : 3, 1 : 4.

The resistance capacity unit is completely ISOLATED from the transformer and eight terminals are fitted on base, four each side so that the transformer and resistance, although encased, can be connected in ten different ways by following diagrams issued with each unit.

The facilities provided for changing the ratio permit of the valve and coupling unit GAIN to be adjusted to suit any conditions. For constructors this feature is an absolute necessity.

The internal resistances and condenser have values as originally recommended for the "Parafeed" system.

The unit is also efficient for :-

1. Utilising the "Parafeed" as a gramophone Pick-up input transformer.
2. Choke feed connection to the "Parafeed."
3. Push-pull input in a novel method employing one additional "Parafeed" only.

**R.I.** were the pioneers of the Parallel Feed System of amplification in this country.

They produced the famous 'Parafeed' type transformer which is still the acknowledged best—with an inductance of 100 henries and N.P.L. performance curve 25—10,000 cycles. This transformer coupled externally with a resistance capacity and condenser set the existing standard of 'Parafeed' (Parallel Feed) practice.

R.I. have now produced the 'PARAFEED COUPLING UNIT' which is immensely superior to any other combination because it includes the original 'PARAFEED' transformer which obviously cannot be imitated and also because the details of design are based on greater experience of the system.

Parafeed Coupling Unit.  
Overall size 2 1/2 x 2 1/2 x  
2 1/2 ins. high. List No.  
DY.32 PRICE

11'6

A comprehensive brochure on the "Parafeed" Coupling Unit is issued free and explains the advantages of the system in full. It includes diagrams clearly illustrating ten methods of connection. This brochure can be obtained from your dealer or from R.I.



## THE PIONEERS OF THE ORIGINAL "PARAFEED" SYSTEM

PURLEY WAY, CROYDON, SURREY  
TELEPHONE: THORNTON HEATH 3211



ALL ABOUT RADIO PROGRESS : PROGRAMMES : PERSONALITIES

# Popular Wireless

Every Thursday  
PRICE  
3d.

No. 533. Vol. XXI.

INCORPORATING "WIRELESS"

August 20th, 1932.

## THE RADIO EXHIBITION A COMPLETE SURVEY



### The Set of the Season!

See the **METEOR S.G.3** at the **Ready Radio Stand 106, Olympia**

Ready Radio Ltd., Eastnor House, Blackheath, S.E.3.

'Phone : Lee Green 5678.

'Grams : Readirad, Blackvil.

Advt.

153

REMEMBER THIS NUMBER —

Make a special point of seeing the large model of the new Lewcos Potentiometer on view at our stand.



The  
**LEWCOS**  
POTENTIOMETER

PRICE  
ONLY  
**3/-**

The several advantages of this component over other makes will be demonstrated on request. Only Lewcos could produce a component of such conspicuous superiority at such a low price.

*Among the well-known makes of Lewcos Wires for use in Radio construction the following grow increasingly popular.*

1. LEWCOS SPAGHETTI RESISTANCES. Manufactured in Resistance Ohms ranging from 300 to 1,000 at 9d. each; 2,000 to 10,000 at 1/- each, and 15,000 to 100,000 at 1/6d. each.
2. GLAZITE COLOURED CONNECTING WIRE. Available in 10ft. coils—18 SWG 6d. per coil—20 SWG 4d. per coil—and in the following colours.—Red, Blue, Green, Yellow, Black, White.

**BEWARE OF IMITATIONS!**

LEWCOS RADIO PRODUCTS FOR BETTER RECEPTION  
THE LONDON ELECTRIC WIRE COMPANY AND SMITHS  
LIMITED, CHURCH ROAD, LEYTON, LONDON, E.10

it's the  
**LEWCOS**  
REGD.

**STAND NUMBER**  
On the Mezzanine Floor  
**AT OLYMPIA**

*Be sure to visit us,*

and see for yourself  
the World's finest  
array of Modern  
Radio Components  
and Wires

The acknowledged pre-eminence of LEWCOS Radio Products, as used by innumerable amateur constructors and manufacturers of receivers, was first achieved by using only the finest raw materials and the skill of trained craftsmen. By the continuous use of these two elements, backed by scientific research, LEWCOS still lead the way to better reception and present at the Exhibition the proof of this statement.

WE ARE EXHIBITING AT

**RADIOLYMPIA**  
AUGUST 19-27

**STAND No. 153**

# MOST IMPORTANT OF ALL

**THE WORLD'S  
LARGEST  
& MOST  
COMPREHENSIVE  
ILLUSTRATED  
CATALOGUE  
&  
MANUAL**

## what is Bulgin doing for the coming season?

Each successive year Bulgin have shown a definite stride forward—progressing rapidly into a position of pre-eminence in the Realm of Radio Components. This year marks the greatest stride of all; never before has a new season's programme listed such a phenomenally wide selection of new and original components.

ON OUR STAND AT OLYMPIA YOU WILL SEE the NEW Transcoupler, The NEW Lightning Switch, NEW Mains Switches, NEW Chokes, NEW Transformers, NEW Fuse Plugs, NEW Wall Jacks, NEW Volume Controls, etc., etc., and a complete range

of unique components unrivalled by any firm in the industry. See them, inspect them, mark their sterling quality and advanced design. Note the price of the finest components in the world.

**LEADERSHIP** is clearly apparent in every page of the NEW and ENLARGED CATALOGUE AND MANUAL "P." 80 PAGES—FULLY ILLUSTRATED. GET YOUR COPY NOW.

Enclose 2d. postage.



**STAND  
151  
OLYMPIA**

**BULGIN**

**A. F. BULGIN & CO. LTD.** ABBEY ROAD, BARKING, ESSEX.  
Phone: Grangewood 3266 & 7.  
London Showrooms: 9, 10, 11, Cursitor Street, E.C.4. Telephone: Holborn 2072.



On Stand  
**69**

GRAND HALL · OLYMPIA

a new  
development  
in  
Moving Coil  
Reproducers  
will be exhibited—



Write for  
descriptive  
literature.



The **R & A**  
"VICTOR"  
PERMANENT MAGNET MOVING COIL  
REPRODUCER DE-LUXE

The R & A "VICTOR" is a De Luxe Reproducer in every sense of the word. Quite apart from its unique design, its massive construction, and its flawless finish, the reproduction of speech and music from the lowest to the highest frequency is a revelation. Moreover, its transformer, with 6 ratios, permits accurate matching of the speech coil, with every type of power valve, including pentodes.

If you are interested in quality reproduction, we invite you to a demonstration on our Stand 69, Olympia. We should like your candid opinion of the "VICTOR," and to this end we invite you to state briefly on a sheet of note-paper your impressions after having inspected it and heard its performance.

We will present a "VICTOR" in de-luxe Cabinet, or cheque for 5 guineas at entrant's option to the writer who sends what, in our opinion, is the most apt, comprehensive and *impartial* criticism, limited to 100 words, provided the entry form at the foot of this page is attached thereto.

Criticisms must reach us not later than the 5th September, and the result will be published in the "Wireless World" 16th September issue.

The staff and employees of R & A Ltd., and the company's Advertising Agents are excluded from this invitation.

**BRIEF SPECIFICATION.**—The "VICTOR" P.M.M.C. Reproducer-de-Luxe has a Cobalt Steel Magnet giving a flux density of 8,000 lines per sq. centimetre. Average speech coil impedance 5.5 ohms. The magnet and 6-ratio transformer are totally enclosed, and the cadmium plated grille and armoured construction eliminate all possibility of damage to diaphragm and magnet. Dimensions 10½" x 5½" deep.

REPRODUCERS & AMPLIFIERS LTD.,  
FREDERICK ST., WOLVERHAMPTON

*This portion to be attached to your criticism of the "VICTOR." Post to reach us not later than 5th September.*

(Popular Wireless)

**70%**  
including  
6 RATIO TRANSFORMER

SOMEONE ELSE HAS JOINED THE  
BETTER RADIO BRIGADE!

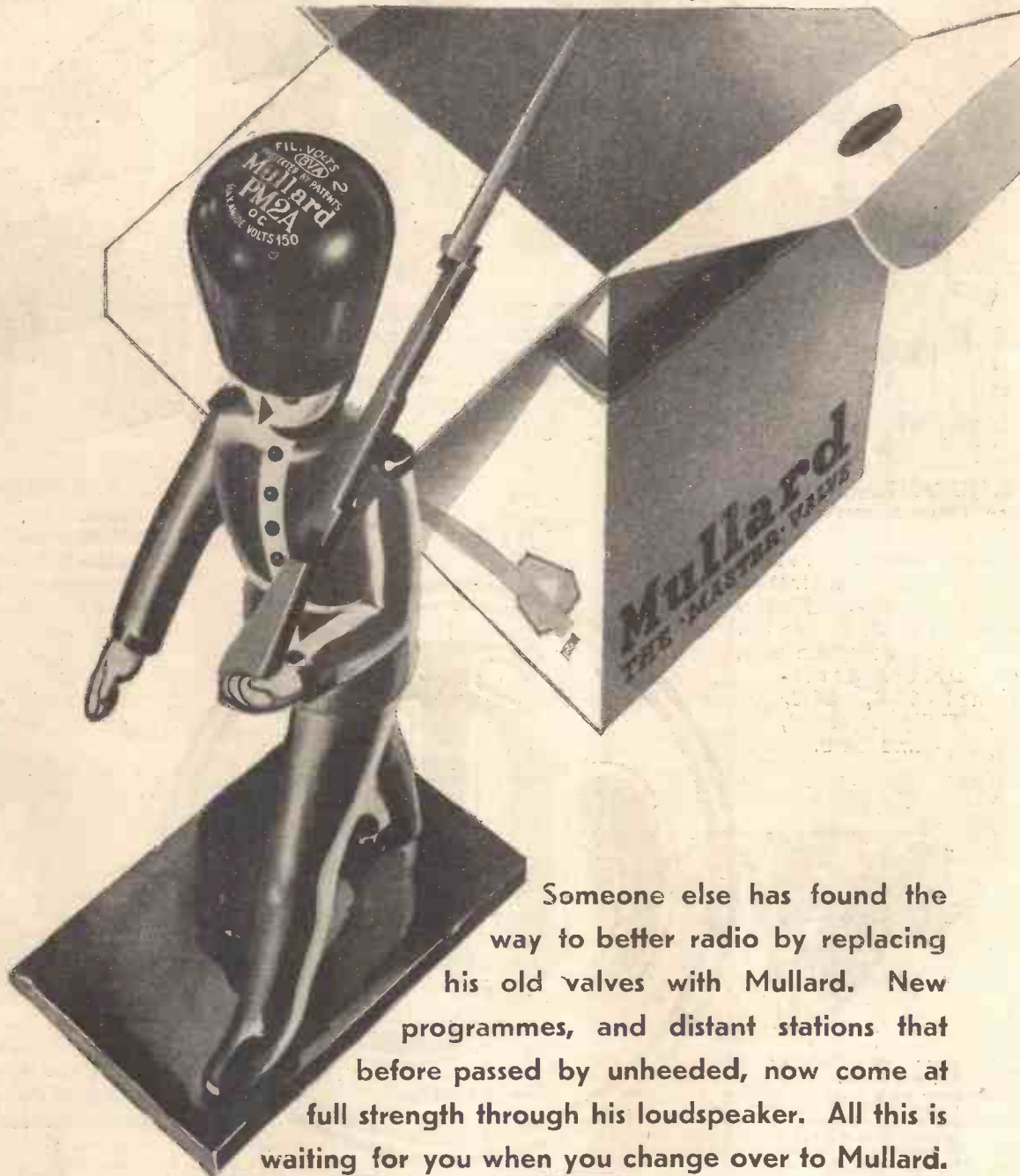

Someone else has found the way to better radio by replacing his old valves with Mullard. New programmes, and distant stations that before passed by unheeded, now come at full strength through his loudspeaker. All this is waiting for you when you change over to Mullard.

# Mullard

**THE · MASTER · VALVE**

We are exhibiting on Stand No. 79 at the National Radio Exhibition at Olympia.

Advt. The Mullard Wireless Service Co., Ltd., Mullard House, Charing Cross Road, London, W.C.2

Arks.

# SOME NEW PRECISION INSTRUMENTS

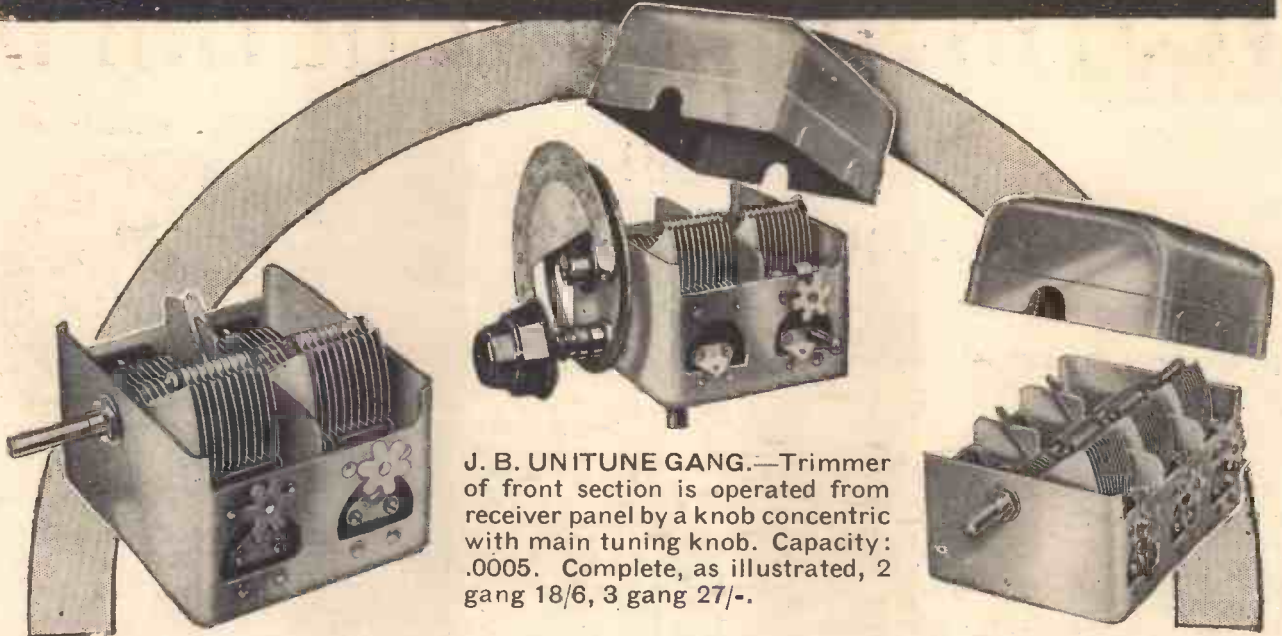

**J. B. UNITUNE GANG.**—Trimmer of front section is operated from receiver panel by a knob concentric with main tuning knob. Capacity: .0005. Complete, as illustrated, 2 gang 18/6, 3 gang 27/-.

**J. B. NUGANG.**—Rigid one-piece chassis—very robust construction. 2, 3, or 4 Gang Capacity: .0005. Prices, semi-screened, as illustrated, 14/-, 21/-, 28/-. Fully screened, 16/-, 23/6, and 31/-. TYPE "A" complete with Disc Drive. Semi-Screened 16/6, 24/6, 31/6. Fully screened, 18/6, 27/- and 34/6.

**J. B. SUPERHET GANG.**—Similar to the "Nugang," but modified for superhets. Capacity: .0005. Fully screened, 3 gang 25/6, 4 gang 33/-. Semi-screened, 3 gang 23/-, 4 gang 30/-.

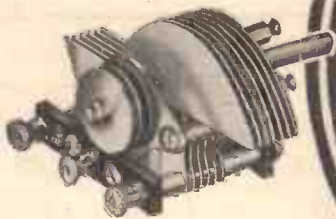

**J. B. SHORT WAVE CONDENSER.**—With many novel features, very low minimum capacity. Special screened pig-tail to rotor. Capacities: .00005, .0001, .00015, .0002, .00025, all 5/9 each.



**J. B. ILLUMINATED DISC DRIVE.**—For use with the new J. B. Gangs. Extremely powerful. Ratio 12/1. Sloping scale and hairline visor. Complete with full length escutcheon in oxy-silver or bronze finish 4/9

WRITE FOR NEW CATALOGUE.

STAND 204 Gallery, National Radio Exhibition, Olympia

# WESTINGHOUSE AT OLYMPIA

## RADIO EXHIBITION

### AUGUST 19th—27th

JUST RELEASED



GET A COPY AT STAND 89.



## METAL RECTIFIERS

—the rectifiers of to-day and to-morrow.



### H.T.

Type	D.C. Output		Price
	Volts	mA	
H.T.5	120	20	12/6
H.T.6	175	25	15/-
H.T.7	200	28	17/6
H.T.8	250	60	18/6
H.T.9	300	60	21/-
H.T.10	200	100	21/-
H.T.11	500	120	35/-
	400	150	

Year by year the Radio Exhibitions show the advances made in the Wireless Industry. This year marks another step forward . . . . and on STAND 89 will be shown the Westinghouse contribution to the march of progress.

Do not miss this exhibit. The complete range of Westinghouse Metal Rectifiers will be on view—a range covering eliminator, receiver and battery-charging needs—and there will be a demonstration of moving-coil loudspeakers, the pot magnets of which are fed from the A.C. mains by means of a Westinghouse Metal Rectifier.

### L.T.

Type	D.C. Output		Price
	Volts	Amps	
L.T.1	6	0.25	10/6
L.T.2	6	0.5	11/-
L.T.4	6	1.0	13/-
L.T.5	12	1.0	15/-
A.4	9	2.0	39/6
A.6	6	3.0	47/6

**SEE THE  
NEW COMPONENTS BY**

**Bowyer-Lowe**

AT OLYMPIA  STAND No. 156

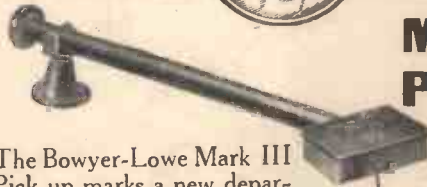

**MARK III  
PICK-UP  
30/-**

The Bowyer-Lowe Mark III Pick-up marks a new departure in design, the frequency response of from 25 to 6,000 cycles being designed to be complementary to that of the usual moving-coil speaker. The resulting reproduction is a faithful replica of the original recording.

In the small space of 3" x 1 1/2" x 2 1/4" this unit includes all that is necessary for a complete stage of L.F. amplification, excluding only the valve. The nickel-iron cored transformer has a primary inductance of over 80 Henries, while the resistances are wire wound and non-inductive.



**P.F.T. UNIT 11/6**  
SEND FOR CATALOGUE  
BOWYER-LOWE & A.E.D. LTD.,  
DIAMOND WORKS, BRIGHTON

**MODERN  
WIRELESS**

You cannot fail to find something that will interest you in the 128 pages of the specially enlarged

**EXHIBITION  
NUMBER**

of Britain's leading radio magazine.

Be sure that you get a copy from your newsagent or book-stall.

September Number  
PRICE  
**ONE SHILLING**

contains  
A Big Illustrated Supplement—

**THE WORLD'S  
PROGRAMMES**  
specially compiled  
For the Long Distance  
Listener

as well as  
A New and Comprehensive Section arranged expressly

For the Constructor  
including full details of  
**THE "DIODION"**

Also  
**BETTER RADIO**  
etc. etc. etc.

September Number  
On Sale Everywhere  
AUGUST 19th.

**MODERN  
WIRELESS**

**DUBILIER**  
OFFER YOU  
CONDENSERS OF  
**GREATER FACTOR**  
OF SAFETY AT  
**LESS COST**



Now there is no excuse for taking risks in choosing Condensers. Dubilier have brought condenser dependability within the reach of everyone. Now, at prices comparable with those you have hitherto paid for condensers of questionable quality, you can buy Dubilier Condensers and know, when your Set fails you, that it is not a condenser at fault.

The Dubilier range meets every constructor's demands. It includes the condensers you need at the prices you want to pay.



TYPE L.S.A.		TYPE B.S.		TYPE L.S.C.	
400 volts D.C. (peak) working	1,000 volts D.C. test	250 volts D.C. (peak) working	500 volts D.C. test	800 volts D.C. (peak) working	1,600 volts D.C. test
5 μf. ... 2/6	1 " ... 3/-	1 μf. ... 2/-	2 " ... 2/8	5 μf. ... 5/-	1 " ... 6/-
2 " ... 4/6	4 " ... 8/-	4 " ... 5/-	6 " ... 24/-	2 " ... 9/-	4 " ... 16/-
6 " ... 12/-	10 " ... 18/-	10 " ... 36/-		6 " ... 24/-	10 " ... 36/-

**DUBILIER CONDENSER CO. (1925) LTD.,  
DUCON WORKS, VICTORIA RD., N. ACTON, LONDON, W.3**



# RADIOPAK

(REGISTERED)

THE ONLY COMPLETE BAND-PASS TUNER

PRICE

£3

COMPLETE

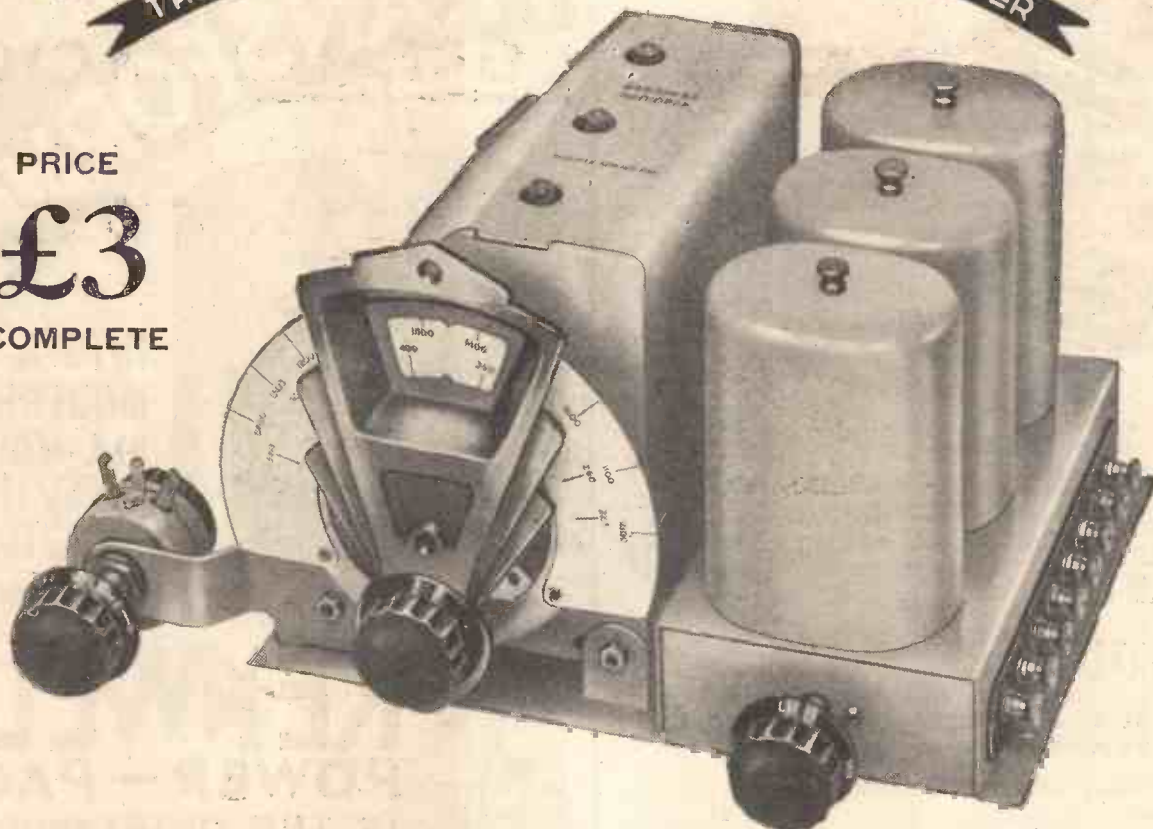

## MATCHED PERFECTION

### *Revolutionising Set Construction!*

For some time now Band-Pass tuning has been recognised as the best solution to modern problems of selectivity, but hitherto because of difficulties encountered in obtaining accurate matching of coils and condensers, true Band-pass tuning has seldom been achieved.

The British Radiophone Radiopak unit has been specially produced to bring perfect Band-pass tuning within reach of all constructors.

The unit consists of the necessary coils; the gang condenser with illuminated slow-motion

escutcheon and disc drive calibrated in wavelengths; a wave-change switch; and a wire-wound volume control complete with on-off Q.M.B. power switch. The switching arrangement is the best yet devised for any radio component and the combined volume control and switch is one of the famous Radiophone standard types needing no further recommendation. Owing to the high degree of accuracy in the matching of the coils and condensers, this unit will REVOLUTIONISE modern set construction. Write for full descriptive particulars. Dept. P.W.1.

★ SEE THE RADIOPAK AND OTHER NEW RADIOPHONE COMPONENTS ON STAND 93

**THE BRITISH RADIOPHONE LTD., Aldwych House, Aldwych, W.C.2.**

Telephone: Holborn 6744.

# FUSEHOLDERS

Programme 1932—33

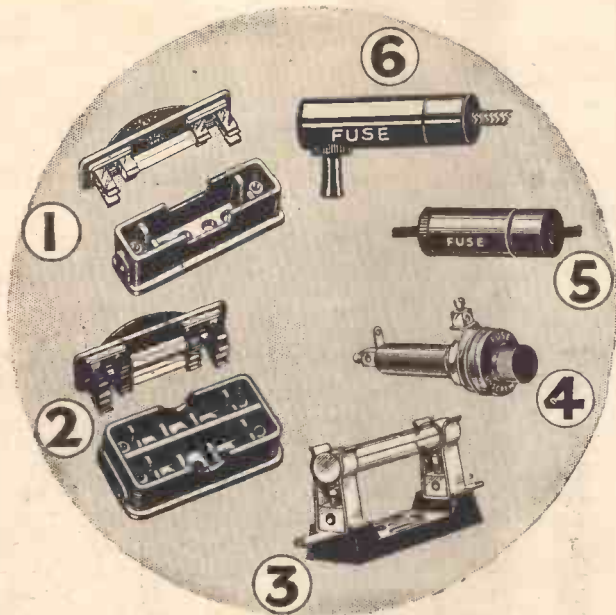

- 1 SINGLE SAFETY BASEBOARD FUSEHOLDER.  
Fuse carried on lid, making shocks impossible. Complete with 1 amp. fuse . . . . . 1/6
- 2 TWIN SAFETY BASEBOARD FUSEHOLDER.  
Fuses carried on lid, rendering shocks impossible. Complete with two 1 amp. fuses . . . . . 2/6
- 3 SINGLE OPEN FUSEHOLDER.  
With 1 amp. fuse . . . . . 9d.
- 4 PANEL FUSEHOLDER.  
For panel mounting. With 1 amp. fuse . . . . . 1/6
- 5 FLEX FUSEHOLDER.  
With 1 amp. fuse . . . . . 1/-
- 6 WANDER FUSE.  
With 150 m/a fuse . . . . . 1/-

SPARE FUSES—*Shown Actual Size.*  
LONG FUSE. All ratings, 60, 150, 250, 500, 750 m/a., 1 amp., 2 amp., 3 amp.  
SHORT FUSE. For WANDER-FUSE only, 60 and 150 m/a.

*Dealers will fit other ratings in any of these holders at the time of purchase.*



## BELLING-LEE

Advt. of Bellings & Lee, Ltd., Cambridge Arterial Road, Enfield, Middlesex.

# YOUR BATTERY SET

at once!

# TRANSFORMED

INTO A MODERN ALL-MAINS MOVING COIL RECEIVER



# KENWELL POWER-PACK

IS THE OUTSTANDING EXCEPTION AT THE SHOW

SPECIFICATION OF AC/U MODEL  
H.T. 80 v. and 150 v. (fixed).  
0-100 v. (variable) 25 m/a.  
L.T. Trickle Charger at 25 amp.  
G. B. 5 Tappings: 1, 3, 4, 9, and 15 v.  
Mains-energised moving-coil speaker.  
Price £8.15.0 Other models on request

"It's a braw pack, ye ken!" McQuality.

Stand after stand, wonderful examples of all-mains radio are exhibited. "JUST PLUG IN," they say, and hear the golden voice of the mains-energised moving-coil speaker. Fine instruments all—even at their price of 17, 20 and 25 guineas. But what about the owner of a really good battery set? Must he scrap it to enjoy this wonderfully improved radio? That is where the Kenwell Power Pack is so ingeniously designed. In a moment it can be connected to your present battery set and transforms it into an all-mains, moving-coil receiver equal to the best at Olympia. Enjoy all modern radio improvements for a few pounds, and hear your set speak with the clear and mighty voice of a mains-energised moving-coil speaker.

Descriptive folder from—  
**KENWELL RADIO LTD.,**  
200, City Road, London, E.C.1.

SEE IT!  
HEAR IT!  
ON  
STAND  
121

RADIO SHOW  
OLYMPIA  
Your local dealer will arrange a demonstration.

RADIO  
**IGRANIC**  
 DEVICES

**TRANSFORMERS**

You cannot expect IGRANIC results unless you build on IGRANIC components, and if there is one component more than any other in which you must have unquestioning faith, it is the Transformer. In the designing, construction and finishing of IGRANIC Transformers nothing is left to chance—they are built to the highest standards, and only works' efficiency of the highest order enables them to be priced so economically.

**IGRANIC "MIDGET" Transformer**  
 A masterpiece in miniature—it weighs only 6½ ounces, and its size is 2⅞" x 1⅞" x 1¾". Primary inductance over 60 Henries. Beautifully finished in brown bakelite. Ratios—3:1 and 5:1. PRICE **10/6**

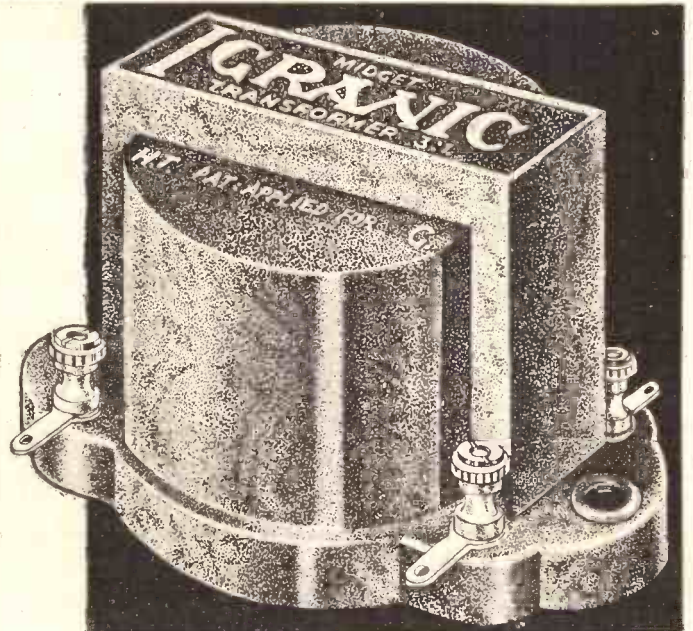

**IGRANIC T. 24 B TRANSFORMER**

A good general-purpose transformer at a popular price. Neatly cased in brown bakelite, with terminals and soldering tags. Weight 10 oz. Size 2⅞" x 2⅞" x 2". Ratios: 3:1 and 5:1. Price **5/6**

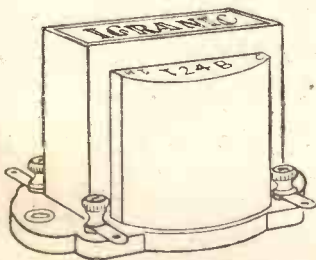

**IGRANIC 'ACME' TRANSFORMER**

The Transformer 'par excellence'—employs the Igranice patented bi-metal core which permits of high current-carrying capacity without loss of inductance. Ratios: 3:1 and 6:1. Price **17/6**

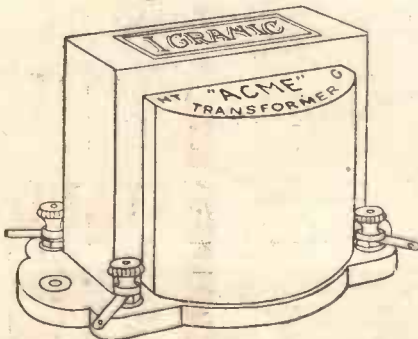

Advt. of the Igranice Electric Co., Ltd., 149, Queen Victoria Street, E.C.4.

**IGRANIC**

**COMPONENTS WILL**

**BE THE MAKING**

**OF YOUR SET.**

**OLYMPIA STAND 36**



# IT CREEPS

it creeps on you every night!

SLOWLY.....INSIDIOUSLY

Valve deterioration is not sudden like switching out a light. It is so gradual in fact that you scarcely notice any difference until you realise that your wireless receiver is failing to give you really satisfactory reproduction.

If only it were possible to compare your receiver as it is now by placing it beside the same receiver when you bought it a year ago, you would be astonished at the loss in tone value, selectivity and clarity it has suffered.

If you have had your set for twelve months, or even less with some receivers, and only one set of valves, you can be sure that it has lost some of its original purity and crispness. Fit a set of ETA valves to-day and it will be as good as

ever it was or even better. ETA valves give you the highest possible standard of reproduction. They deteriorate much more slowly than many other valves.

PRICES FROM  
**5/6**

YOU NEED NEW VALVES  
GOOD VALVES — ETA VALVES



# ETA

THE INTERNATIONAL VALVE

### SERVICE COUPON

To the ELECTRICAL TRADING ASSOCIATION LTD.,  
Aldwych House, Aldwych, London, W.C.2.

A. Please let me know the correct type of ETA valves to replace my present valves which are as under

1..... 2..... 3..... 4..... 5.....  
(Insert type letters and number)

B. Please advise me which ETA valves to use for the following receiver or circuit.

Specify Type No. and Name .....

Name.....

Address.....

P.W. 20.8.32

# TRACK RADIO TROUBLES EASILY

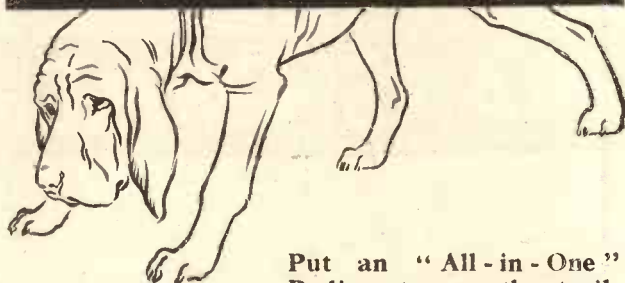

Put an "All-in-One" Radiometer on the trail, and the hunt is quickly over. In an amazingly short time this instrument will track down the trouble.

There is no other instrument in the world like the "All-in-One" Radiometer. It works with an accuracy that must be seen to be fully appreciated. Every single component of any radio set can be tested swiftly and surely.

Ask to see it at any Radio Dealer's or Electrician's.

If in any difficulty, write direct to:  
PIFCO LTD., High Street, MANCHESTER.

Standard Model "All-in-One" Radiometer for Battery Sets only, as shown here. Price **12/6**

De Luxe Model, for Battery Sets, Electric Receivers and Mains Units. Price **£2.2.0**



PIFCO  
**ALL IN ONE**  
RADIOMETER

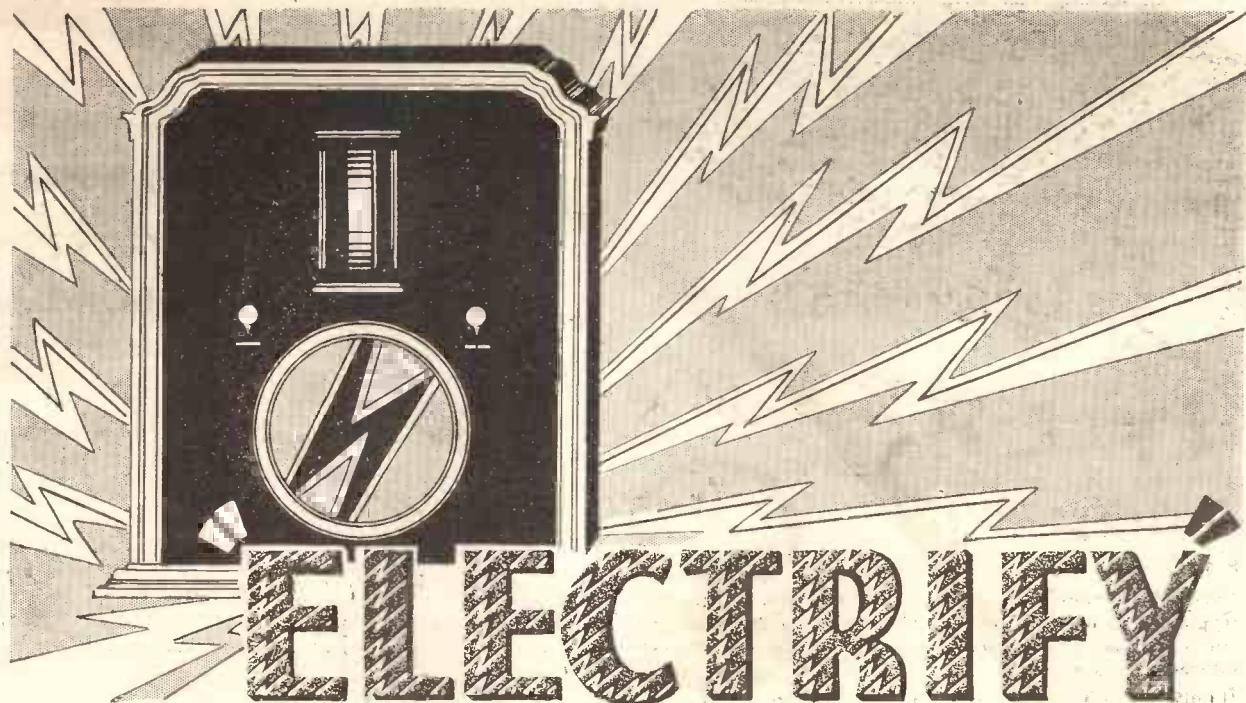

**ELECTRIFY**  
**YOUR SET WITH**  
**PERTRIX**  
 TRADE MARK  
**DRY BATTERIES**  
 AND  
**ACCUMULATORS**

SEE THEM  
 AT  
 RADIOLYMPIA  
 STAND No.  
**126**

They will put new life into your set—new power to get stations that you have never heard clearly before. And they'll last longer; definitely longer, for they are made by a patent process which provides a recuperative quality unknown to other batteries. "Electrify" your set with Pertrix Power.

**H.T. Batteries - - from 5'6**  
**L.T. Accumulators from 4'6**

Advt. of Britannia Batteries, Ltd., 233, Shaftesbury Avenue, London, W.C.2. Telephone: Temple Bar 7971 (5 lines).  
 BRANCHES: Manchester, Bristol, Glasgow, Dublin, etc. - - - - - Works: REDDITCH (Worcs.).

# THE OLYMPIC STANDARD OF "FITNESS"

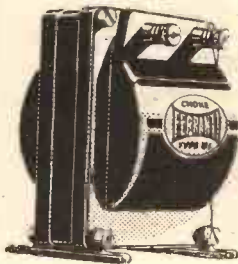

### AF TRANSFORMERS (Metal cases)

- AF3. Ratio 1/3.5 **25/=-**
- AF4. " " " **17/6**
- AF5. " " " **30/=-**
- AF6. " " " **1/7 30/=-**
- AF7. " " " **1/1.75 30/=-**

### ELIMINATORS

Prices from  
**£3. 10. 6** to  
**£11. 11. 0.**

### RADIO METERS

Prices from **£1. 5.**  
For A.C. and D.C.  
Portable and Flush  
Patterns.

### ANODE FEED UNITS

Without Resistance

**4/3**

With Resistance

**7/3**

Resistances in

holders **4/=-**

Resistances without

holders **3/=-**

### CHOKES

Prices from **7/=-** to  
**£1. 7. 6**

Ferranti Radio Components have marked each year's progress at Olympia, and have become the very structure of Radio—the standard by which others are judged.

Radio Components have come and gone: names well known in the early years are forgotten, either the products could not progress, or else they could not stand the test of time.

But through ten years of Radio development, the name Ferranti has been pre-eminent for quality, reliability, and soundness of design.

FERRANTI LTD., Head Office & Works: HOLLINWOOD, LANCASHIRE

# FERRANTI COMPONENTS



# THE VERY STRUCTURE OF RADIO AT OLYMPIA

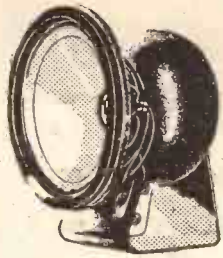

## M.C. SPEAKERS

Chassis	
M1.	£8. 18. 6
M2.	£5. 18. 6
M2T.	£6. 8. 6
M4T.	£2. 15. 0
D3.	£2. 0. 0
D3T.	£2. 10. 0
1932 Inductor	
Speaker	£1. 10. 0
Cabinet	£2 extra.
Models M2T, M4T, & D3T have built-in 2-ratio Output Transformer.	

## CONDENSERS

Prices from 2/4 to 9/6. Packs 22/6 to 28/6

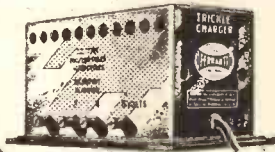

## TRICKLE CHARGERS

Prices £3. 15. 0 and £3. 15. 0

Soundness which is typified from the AF3—still in the identical form in which it was first put on the market 8 years ago—to the M1 speaker, altered and improved with every new discovery of moving coil construction, yet gaining the honour of the first choice in the "Wireless World" Olympia Ballot for the last three consecutive years.

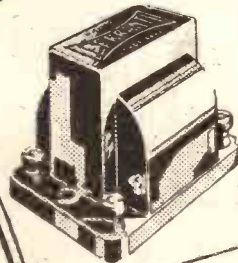

## AF TRANSFORMERS (Bakelite cases)

AF8. Ratio 1/3 5/11/6  
AF10. Ratio 1/3 6/6

Only the Very Best could have built up the FERRANTI Reputation.



## MAINS TRANSFORMERS

From 22/6

STAND NO. 78

LONDON: BUSH HOUSE, ALDWYCH, W.C.2

# FERRANTI COMPONENTS



# THE SENSATION OF OLYMPIA



P.M.5

# 27'6

COMPLETE  
with three-ratio step-down  
transformer

Go straight to Stand No. 108 and see these great W.B. achievements

## "MANSFIELD"

[P.M.5] at 27/6 complete with transformer. Fits any W.B. cabinet. Revolutionary value which brings moving-coil reproduction within the reach of everyone

AND THE NEW

## IMPROVED P.M.4

at

# 42'

COMPLETE  
with three-ratio step-down  
transformer

*These guaranteed speakers give true moving-coil reproduction from any 2-valve or multi-valve set.*



# P.M.4.

## PERMANENT MAGNET MOVING COIL SPEAKERS

Write for the new lists FREE of the whole range of W.B. Moving - Coil Speakers, P.M. and Energised,



with their attractive cabinets. Also the new W.B. valveholders and new W.B. switches.

Whiteley Electrical Radio Co., Ltd., Nottingham Road, Mansfield, Notts.

Irish Free State Distributors: Kelly & Shiel, Ltd., 47 Fleet Street, Dublin



# IMMEDIATE DELIVERY-CASH-C.O.D. or H.P.

## DEMAND A PILOT AUTHOR KIT for your OLYMPUS FOUR

*—it puts you on  
the Royal Road  
to Success*

### EXCLUSIVE FEATURES OF PILOT AUTHOR KITS

- Complete down to the last screw and piece of wire.
- Chosen and first specified by the Technical Editor and actually as used by the Author in each case.
- Officially approved by an established technical authority you can trust implicitly.
- Backed by Peto-Scott with 12 years' Radio experience and a world-wide reputation.
- Enables Author's sets to be duplicated in every respect.
- Panels and Terminal Strips ready drilled to specification.

## BUILD WITH A PILOT AUTHOR KIT

- It fits the Diagram!  
Exact to the published  
specification.

**PETO-SCOTT  
FOR**

**EVERYTHING RADIO  
CASH—C.O.D.—H.P.**

The largest Radio-by-Mail House in the World.  
Send for latest lists.

**ORIGINATORS OF  
CONSTRUCTOR KITS IN 1919**

**KIT "A"** Author's Kit of specified components including ready drilled panel and terminal strips but less valves and cabinet.

CASH or C.O.D. **£4:12:6**

or 12 monthly payments of 8/6

**KIT "B"** Author's Kit including ready drilled panel and terminal strips; with valves but less cabinet.  
Cash or C.O.D.

**£6 - 11 - 9**

or 12 monthly payments of 12/1

**KIT "C"** Author's complete Kit including ready drilled panel and terminal strips with valves and cabinet.  
Cash or C.O.D.

**£7 - 6 - 9**

or 12 monthly payments of 13/5

### KIT-BITS

Selected C. O. D. Lines for "Olympus Four." You pay the postman—we pay post charges on orders value over 10/-

1 Peto-Scott Cabinet	15 0
4 Valves: 1 Cossor S.G.220, 1 Marconi H.L.2, 1 Mazda L.210, 1 Mullard P.M.2A	1 19 3
1 Peto-Scott panel 14" x 7" ready drilled	4 6
Lissen Hypernik L.F. Transformer (medium ratio)	12 6
2 Telsen Screened Coils	17 0
2 Telsen '0005 mfd. Telexors	1 5 0
1 Keystone '0003—'00035 mfd. max. differential reaction condenser	3 0

### AUTHOR'S PART LIST

Any parts supplied separately. Orders value over 10/- sent Carriage Paid—C.O.D., we pay post charges.

	£	s.	d.
1 Peto Scott panel, 14 x 7 ins., ready drilled	4	6	
1 Baseboard, 14 x 10 ins.	1	3	
1 Lissen Hypernik L.F. transformer, medium ratio	12	6	
1 R.I. Quad-Astatic H.F. choke	3	6	
1 Keystone '0003—'00035 mfd. max. differential reaction condenser	3	0	
1 Lewcos H.F. choke, small type M.C.	2	6	
1 Lotus '0003—'00035 mfd. max. differential condenser	4	0	
2 Telsen screened coils	17	0	
4 Lissen 4-pin valve holders	1	6	
2 Telsen '0005 mfd. Telexors	1	5	0
1 Graham Farish Ohmite .5 meg. grid leak and holder	2	0	
1 Graham Farish Ohmite 100,000 ohms resistance with terminals	1	6	
1 Igranic .5 meg. resistance with terminals or tags	9		
1 Igranic 2-meg. resistance, with terminals or tags	9		
1 Bulgin L.T. on-off switch, type S.15	1	9	
1 Dubilier '0003 mfd. fixed condenser, type 670	1	0	
1 Dubilier '0001 mfd. fixed condenser, type 670	1	0	
1 T.C.C. .001 mfd. condenser, type 34, upright	3	0	
1 Goitono five-way battery cord, type R.39/40	2	3	
1 Piece of copper foil, 2 x 2 ins., screws, flex, connecting wire, etc.	2	3	
2 Terminal strips, 3 x 1½ ins. ready drilled	6		
4 Bulgin indicating terminals	1	0	
<b>KIT "A" Cash or C.O.D.</b>	<b>£4 12 6</b>		

### IMPORTANT

Part kits, miscellaneous components or accessories are available under our own Easy Way H.P. System. Send us list of your wants. We will quote by return without any obligation.

## PETO-SCOTT CO. LTD.,

77, CITY ROAD, LONDON, E.C.1.

(West End Showrooms: 62, High Holborn, London, W.C.1.)

Telephones: Clerkenwell 9405/7.

Dear Sirs, Please send me CASH/C.O.D./H.P. OLYMPUS FOUR KIT A/B/C for which I enclose £ s. d. CASH/H.P./DEPOSIT.

NAME.....

ADDRESS.....

P.W. 20/8/32.

*Buy by Post—its Quicker*



**A GREAT GIFT.**

How often have you felt that you are being denied the full enjoyment of really up-to-date radio because the cost of a truly efficient, powerful set is more than you care to expend? Or maybe you have been deterred from building a super set for yourself on account of the "snags" you may encounter in home construction.

In either case, your problem is immediately solved. A sensational set has been designed by one of England's foremost experts—designed especially for the home constructor—so that you (even if you have never made a set before) can build at very little cost a set so fully up-to-date that it will be a source of pride and pleasure for many, many years.

This remarkable achievement—for the SCOUT is a remarkable set—has been made possible by the united action of a group of leading manufacturers, each specialising in one or more of the up-to-date components which combine to make the SCOUT S.G.3 the most efficient, the most powerful and selective, and yet the most simple set to construct and operate that it has ever been possible to conceive at such an astonishingly small cost.

**250,000 FREE BLUEPRINTS**

**250,000 FREE BOOKS**

**SLEKTUN SCOUT**



**FREE COUPON**

One-knob tuning is only one of the excellencies of this remarkable set, which will bring in at least fifty stations at full loud-speaker strength. But the SCOUT reveals so many really new improvements that it will give you considerable enjoyment merely to read about them in the handsome illustrated book which we are giving away FREE to the first 250,000 applicants.

To Messrs. SLEKTUN PRODUCTS, LTD.,  
21, Douglas Street, Westminster,  
London, S.W.1.

Please send me the FREE illustrated Book of the SCOUT S-G.3, together with the full size blueprint. I enclose 1½d. stamp to cover cost of postage.

Name.....  
Address.....  
P.W.r. ....

Please write clearly in BLOCK LETTERS.

You may send the FREE GIFT Coupon by post, or if preferred, you may exchange it for the Book and Blueprint at your local dealers or at

**OLYMPIA**  
Stand No. 205

Just pin a 1½d. stamp to the coupon and post it to us to-day. You will receive, not only the Magazine, giving full constructional details, but also a full-size blueprint, also free. Send for your copy quickly!

**A GREAT SET**

# Popular Wireless

LARGEST NET SALES

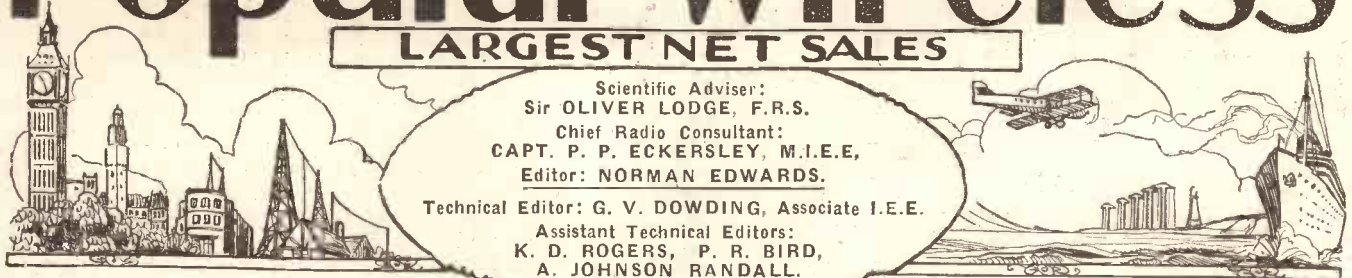

**THE SHOW  
"ALL OUT!"  
UNKNOWN TERROR  
PLEASURE'S MINE!**

## RADIO NOTES & NEWS

**COINCIDENCE  
TRUMPET TRIUMPH  
PROGRAMME TATTLE  
PAT AND JUNIE**

### The Show of Shows.

I BELIEVE that this heading was the title of a cinema film, so I hope that we shall not be sued in a copyright action. Anyhow, it is usefully employed in describing this year's magnificent Radio Show at Olympia, which opens on Friday, August 19th.

Ten years ago British Broadcasting began on the top floor of Marconi House in one room—and a three-valver with about eight controls cost £60. To-day, radio is a force, cultural and recreative, which neither principalities nor powers can stem.

### "All Out."

TO celebrate this wonderful decade of development the organisers of the Radio Show have "gone all out," and if you are lucky enough to get in you will see the great, the colossal, result. *Item:* a free dance hall, accommodating a thousand couples. *Item:* Fifty little theatres (*grchis*), each accommodating from 100 to 300 people. *Item:* The highest fountain ever seen in Britain. Colour, music and gaiety everywhere, plus a wonderland of radio models for 1933.

Take sons and nephews—and be popular for ever with those members of the rising generation.

### Not a Retrograde Step.

I OBSERVE that there is a movement in the "trade" tending towards a greater interest in the battery-driven set.

This is not retrograde and I welcome it, because there are very many more homes in this country without the blessings of electricity than otherwise, and it is time that some of the skill which has been

lavished on the development of the mains-driven receiver should be devoted to the benefit of the ears of the battery-users.

### Another Exhibition

IN spite of domestic and political troubles Germany manages to keep up-to-date in broadcasting matters, and I cannot withhold my admiration of the thoroughness of method which has influenced the authorities to set up an exhibition illustrating the various known sources of interference

Whatever the cause, the effect is intermittent and has been less troublesome lately.

A. G. (New Malden), who wants me to get "another page or so" for these Notes—as if I hadn't trouble enough!—is suffering from similar interference. We here believe that the electric railway is responsible. Is A. G. near such gear?

### The Pleasure is Mine.

I THANK H. D. (Marylebone) for his cheerful letter written from his sick bed. How many letters I have had in my time from such places! And how cheerful and brave they are! Where do the invalids get their pluck from?

Well, H. D., I have no doubt that this paragraph, devoted exclusively to yourself, will be more pleasing to you than a personal scrawl. For your sake, and at your request, I will let school radio alone for the time being—because Sir Walford Davies pleases you. Unfortunately, not all the broadcasters are Davies!

Oh, yes, do please write again! Letters like yours do us all good.

Please the pigs, we shall soon have you up and doing, and telling us about your short-wave exploit.

Ask father to buy you "Epictetus." I think it might help you.

### Bold Enterprise.

TO mark the first anniversary of the Columbia Broadcasting Company's television station, W 2 X A B has introduced a novelty, the transmission of television pictures and voice simultaneously

(Continued on next page.)

### THEY HAVE ALL BEEN HAVING A MIKE!



In an endeavour to find out which of a number of selected beauties had the best voice, a radio contest was held, and Hollywood listeners voted as each young lady took over the "mike." The winners are to appear in a talkie.

with radio, and the devices which have been designed to eliminate such interference.

Don't make the mistake of thinking that Germany has fallen behind in science. If anything, she is more intensively preoccupied with it than ever.

### That Unknown Terror.

THIS, I find, has been worrying lots more people in my town, and since I mentioned it in the July 23rd "P.W." the Post Office has been enlisted in the fight.

# NEWS—VIEWS—AND INTERVIEWS (Continued)

on one wave-length, the combination being receivable on one instrument. But it is one kettle of fish to transmit television, and quite a different one to interest the public in it.

No doubt there are in a large country like America many bright young chaps who have built television receivers and who will welcome television transmissions; but most unfortunately there is not yet enough in television to justify the general public in going in for it.

## A Perfect Coincidence.

SOMEWHERE in the heart of Yorkshire there is an implacable enemy of radio, one of those obstinate, blockheaded, narrow-minded persons who, paradoxically, are the strength and weakness of a community. He is a farmer, but nevertheless he keeps abreast of current ideas, and has told dozens of radio salesmen that he can't abide radio because it affects the "beasts," meaning his livestock. Moreover, he says it isn't decent to listen to Fat Stock Prices with his lady cattle and "the milky mothers of the flock" within hail.

One day an enterprising young airman flew over his property, did a loop over the farm as he departed, and unfortunately spilt a hard and knobby crystal set upon the farmer's pet cow. Sheer hard luck—but any would-be seller of radio sets will in future be received with a blunderbuss!

## Regarding Television.

THE radio correspondent of "The Yorkshire Observer" makes the following statement regarding television: "While I am as enthusiastic as anyone on the subject of television, I would rather face the facts and realise that television is not yet a medium for providing entertainment." That is exactly what "P.W." has been saying for some time.

## Do You Like Gleees?

IN poor imitation of some of the great London "dailies," a small country newspaper conducted a house-to-house canvas for the purpose of finding out the preferences of listeners.

One examinee, on being asked whether he liked Gleees, replied, "Yes, but only Dutch." Being a retired provision-merchant, and a

little deaf, his mind gravitated to cheese. Next day the paper came out with the statement that "our esteemed Hon. Pres. of the Bowls Club, Mr. Lardham, specialises in the study of Dutch Gleees." A more important prominent paper took this matter up, denying the existence of the Dutch Gleees

as a Glee proper, affirming that it is "no more than a common Drinking Song or Roundel." I believe the fight still rages and has reached Bandoeng!

## Trumpet Triumphant.

DID you hear Louis Armstrong's New Rhythm Band broadcasting, about three weeks ago?

Quite exciting, I thought.

This Armstrong is a remarkable coloured product of America. He comes from New Orleans, where, in his earliest possible teens, he made whoopee with tin cans, so that a beneficent government sent him to a "Home," where he collared the job of bugler.

He has blown himself into fame and fortune—even into the orbit of the B.B.C. His greatest claim to fame is, however, that he was nearly kidnapped by Chicago gangsters—rivals who vied with each other to get him to play at their night clubs!

## "SHORT WAVES"

A: "Why do yoh call it a bivalve set?"  
B: "Because every five minutes it shuts up like an oyster."—Humorist."

Many people cannot afford to go for their usual summer holiday this year, and various economical alternatives have been outlined in the newspapers from time to time. The latest is that we should fill our lounges and drawing-rooms with sand, shells and seaweed and tune in to a seaside concert. We can't think why!

"This really remarkable portable set can be taken literally anywhere," runs an advertisement in a contemporary.  
Heavens! Aren't things made easy enough for burglars already?

## POETICS AND PRONUNCIATION.

We jinglers greet you, potent, tireless,  
Encyclopaedic lords of wireless,  
Who proffer to a listening nation  
Pronouncements on pronunciation.

Advice ye lack not; learned dons,  
Armed to the teeth with etymons  
From Latin, Greek, or French disparage  
The cult of "cinema" or "garage."

How fierce the rival experts clamour,  
Some quoting usage, others grammar!  
But we who steep Parnassus climb  
Accentuate the claims of rhyme.  
Give us such sounds as freely mate,  
And ban but one, the celibate. "Punch."

## Programme Tattle.

ON August 25th the consecration ceremony of Buckfast Abbey will be relayed by Nat. I visited the Abbey last year and was deeply impressed by the beautiful work, which has been done by the Brothers on the contributions of the public.

A very Teutonic Brother got a bob out of me by explaining all about the carvings, etc., and I in turn got a fine snapshot of Dom Anseor Vonier, O.S.B., aloft on the scaffolding, holding his skirts high, and interrogating a Brother bricklayer as to progress.

I must just shove a note in here to the effect that the pianoforte works played on August 16th by Paul Wittgenstein were executed by his left hand. His right hand was lost in the Great War.

## Pat and Junie.

TWO of the most popular juvenile radio artistes in America are Pat and Junie, two little London girls. Pat is only ten years old, and her sister is her junior by four years.

They sing, recite, and cross-talk, and, as well as broadcasting, they act together in charity entertainments in New York. Every year they go to Sing Sing prison, and perform for the benefit of the convicts—good for Sikes, but I'm not sure about the kiddies.



## News by Television.

UNTIL quite recently the Marconi people have laid low about what they have been doing in television research, but they have at last revealed the fact that they have been working on lines intended to be consistent with the function which they have so admirably fulfilled for so many years—pioneering in wireless communications.

Their aim, or part of their aim, is to use television for the transmission of images of a moving tape on which characters are printed by a special typewriter, and an apparatus for the commercial transmission of news in this way has already been developed.

Pictures can be obtained from a few inches up to several feet in length.

## Gaspipes Protection Society.

THE Stalybridge Gasworks Committee is said to have empowered its gas manager to take all necessary steps to compel the removal of radio "earth" wires from its gaspipes, and to prevent new connections to said pipes for said purpose. I suppose that one of the committee has been reading a Sunday newspaper's "expert" views on the devastating effect of received H.F. currents on gaspipes. I am rather sorry for the gas manager. He is going to live underground for a long period tracking "earth" wires to their lairs.

## The Madrid Conference.

ON September 3rd there will open in Madrid an International Radio-telegraph Conference, which will be attended by the representatives of many Governments, commercial wireless companies and other interested concerns.

I note that for the U.S.A. the delegation will be headed by the Chairman of the Federal Radio Commission, and that representing the amateurs will be the well-known K. B. Warner of the A.R.R.L. I'd bet anything that the Yanks are out to collar some more wavebands.



ARIEL.

# Out of the Blue

## "LANDFALL"

By  
CAPT. P. P. ECKERSLEY,  
M.I.E.E.



WE were off the West Australian coast. It was May 30th, or thereabouts. The damp, steaming days of the Equator and the northern Indian Ocean were no more than a memory—a memory made fainter as the crew worked pulling down the awning.

A great swell ran beneath us, a swell roughened by a warm wind pouring out of the west.

The ship swung and plunged, rolled, fell, lifted upwards thirty feet, came down to the trough when the advancing swell seemed deck high.

### In the Wireless Cabin.

Above all noises, the steady thrum of the wind in the rigging—louder, weaker and louder yet. A reminder that it would be too rough to get into Fremantle on the morrow—that a P. & O. ship was 12 hours' late plugging into it down the great Australian Bight.

In the evening I staggered up to the wireless cabin. A pendulous light swung in uncanny circles; beams creaked and the wind howled. Thank heaven for 20,000 tons!

The short-wave transmitter had been reported as giving a wavering note—the "chief" and I, with the "second" and "third," spent some time messing about! It seemed all right to me; recorded very steadily on the wave indicator. But we had no local heterodyne.

### An Ingenious Compromise.

These short-wave ship transmitters have no local "drive," but make an ingenious compromise with a loose-coupled aerial and a tonic train modulation of about 30 per cent. That is to say, the rectified A.C. is only partly smoothed.

Thus, if the C.W. note is too wobbly—as it must be in a ship with wind blown aeriels and many of them—the receiver has the tonic train mixture as well. But with weak signals I imagine it's not too easy to get coherent results.

A storm at sea—giving a hand in the wireless cabin—his first impressions of Australia—these, together with many other interesting experiences while en route to Australia, are related by "P. P. E." in his own inimitable style.

To change in an unsteady cabin—to dine in a creaking saloon—to sleep with a body which weighed, was light, rolled sideways—stuck at the dizzy top of sleep, and sank into it at last!

Next morning we woke to stillness and saw below the sunrise the faint smear of land. Up betimes to see and to be inspected to see if we had little ailments such as smallpox, bubonic plague, and so on—we had not; we felt very well—we felt happy to see the islands and the ships;

a blue break in still hurrying clouds, a patch of sunlight on dripping trees and red roofs.

Stern reminders that life is real and life is earnest came in the form of men bearing pencils, paper and cameras. Our mission had begun—Australia wanted to know what was latest in England, and we told them what was latest in Europe.

Grand! Dry land! Which disobeyed the wish of he that loved land and seemed to melt beneath one's feet after ten days on a monsoon-lashed sea.

### The Transmitters of Perth.

How purry the sun, how lovely the green, how lush the land! Here the graceful swan river, broadening away as it frees itself from Fremantle and there a mast—a wireless mast—a station!

The Perth station was first built by the Germans. The steel mast is 300 feet high and was wont to support an umbrella aerial—now two or three aeriels are draped about it.

There's one for a broadcasting station licensed for 500 watts and just fitting a water-cooled valve.

There's another which connects to the ship and shore transmitter. And still another (I think) for a police set.

Certainly a police set is installed here and has done remarkable work. Thus, the police possess large and smart Bentley cars, a receiver and transmitter, and an operator.

### For Rugby Press.

It appears that the scheme has been wonderfully successful and the police calls are now reduced by 75 per cent.

Then the receiver for Rugby press, which between long and short wave has never made a mistake. Of course, the ship and shore service too.

I waited for my guide, Mr. Chapman (Amalgamated Wireless representative and in charge of the station).

(Continued on next page.)

## THE FIRST AUSTRALIAN PORT OF CALL



Fremantle, the port of Perth, was Capt. Eckersley's first port of call in Australia—and, of course, he soon found his way to the broadcasting station, to see Australia's radio service at first hand.

## NOTES FROM THE SCOTTISH REGION

Interesting details of the progress of broadcasting and of the plans for the future North of the Tweed.

By OUR SPECIAL CORRESPONDENT.

**N**OW that the Scottish Regional programme is getting into full swing B.B.C. officials in Scotland are required to produce a greatly increased quantity of programmes, and the way in which they are setting about it, at any rate with regard to studio productions, is admirable.

### Plenty of Enthusiasm

There is great enthusiasm to show the world what Scotland can do; one hopes that there will also be discretion. The mournful story of Mary Queen of Scots is, for instance, hardly suitable entertainment for the Children's Hour; but this is what Scotland provided when called upon to supply the Children's feature Nationally on August Bank Holiday (of all days!).

The great event of the immediate future is the centenary of Sir Walter Scott's death.

There will be an "oration" from London, broadcast Nationally, and the Scottish Region is also to import two eminent foreigners who will pay tribute to Scotland's most distinguished novelist. Representing Germany, Dr. Otto Schlapp will broadcast a talk on September 27th, and L'Abbe Dimnet will voice the French point of view on September 22nd. Both talks will be in English.

Sir John Reith has himself taken a keen interest in these items. As a

Scotsman he is, of course, following the progress of Scottish broadcasting with particular attention.

Mr. Compton Mackenzie will give a running commentary on the Pilgrimage to Scott's grave at Dryburgh, on September 23rd.

A concert at Galashiels, at which settings of Scott's poems will be rendered by the Scottish Philharmonic Orchestra and the Galashiels Choral Society, will be relayed in the National programme on September 21st.

### Aberdeen Plays Prominent Part

Other features of the Scottish celebrations will include a broadcast of the speeches at the Centenary lunch in Edinburgh on September 21st and the memorial service from Glasgow on the 25th.

Aberdeen is beginning to play a more prominent part in Scottish broadcasting.

### SAMPLING RADIO BY THE SEA



Scottish listeners are getting very enthusiastic about broadcasting, as this picture indicates. And, incidentally, it was a "P.W." portable that provided this happy group with programmes.

For a moment I was alone in the motor car with the engine switched off and I was conscious of an amazing silence. No fans, no sirens, no creaking ship, no swish of sea, no unstable quiver—just silence and a gaily coloured bird flying in the rain-washed silence.

But once more for wireless and sight-seeing, and so we go on and up the Swan River to Perth itself.

### Early Days of Australian Radio

Great broad streets, some fine buildings—and this is Perth. And this is Mr. Kirk who is managing the local broadcasting station. We sit down and, over a glass of real fresh-brewed ale, I listen to the history of early days of Australian broadcasting.

Yes! they'd heard of Wittie, and, sitting there, I seemed to be back in the

pioneer times of 1919 to 1922, sharing once more that glorious optimism which was afterwards so abundantly justified and then so badly let down.

On again to advertising or "B" class stations. Small power, small premises, nothing elaborate, but all served with that spirit of enthusiasm and fun which we all remember—but only remember.

Memories of early troubles crowded on me—I sniffed the air like a war-horse! I eat my lunch with a real appetite—rain-drops and sun outside and the colder nip of southern hemisphere winter.

The new Aberdonian concert party, the Silver Citizens, have arisen as rivals to the Radioptimists at Edinburgh. Mr. Martyn Webster, who originally organised the Radioptimists five years ago, has been transferred from Edinburgh to the B.B.C. vaudeville department in London. Mr. Webster is much missed in Scotland.

His job has been divided between Mr. Douglas Risk, who has been appointed chief announcer at Edinburgh, and Mr. George Gordon, of Aberdeen, who is specialising on the variety and vaudeville side of things.

### Developing Outside Talent

Referring again to the large amount of material which the North Region is able to draw from outside its studios, this is due to the unusual number of good orchestras, choirs, vocalists, etc., in the North of England. Scotland does not claim so much outside talent, but an effort to develop outside resources is being made in the programmes styled "Frae a' the Airts." The first of a new series will come on August 19th from the Selkirk Arms, Kirkeudbright.

In preparation for these programmes broadcasting officials go to various parts of Scotland, and through the local minister, laird or well-known personalities of the district discover the best singers in the neighbourhood. These, on the night of the broadcast, are gathered together round the microphone in some place well known in the neighbourhood which provides a background not too strange.

### The Local Atmosphere

Here, under the chairmanship of someone they all know, they are encouraged to sing, talk, recite and tell their tales. Thus is broadcast something of the essential quality of each local district in Scotland, and, incidentally, new singers and speakers are discovered for their microphone.

Preparations are in hand for the holding of the Scottish Wireless Exhibition from October 12th to 22nd, at Edinburgh.

Incidentally, it is surprising from how far I have had reports of the good reception of the Scottish Regional. Even in the south of England, this transmission seems to come in well in some parts.

## OUT OF THE BLUE

(Continued from previous page.)

Alas! the boat sails for Adelaide at four o'clock; we must leave this pleasant land and head for the awful horrors of the great Australian Bight—the "Bay of Biscay" of hereabouts.

### "And So To The Ship"

Through a park of great beauty and green, green, green, in spite of winter; past the lovely snatches of views of the river; and so to the ship, humming and throbbing with the stir of imminent departure.

And so away: Perth and Western Australia fading in the sunset and squalls of rain and wind pouring out of the west. The ship livens to the sea—it's time for dinner again.

Sunshine and green trees, wireless station, and smooth fresh water! Was it a dream?



# The RADIO EXHIBITION

## A Complete Survey



**T**HE primary object of holding the Radio Show in August is to allow the trade more time to cope with the rush of orders which always flood in at the beginning of a season.

In previous years there has been no breathing space, and practically the whole industry has lagged behind in deliveries.

But this year the public will be given a chance to get their orders in earlier, and wholesalers will be able to acquire good stocks.

It is also felt that as there are usually more people in London during August there will actually be a greater attendance and a figure of a quarter of a million has been confidently suggested.

Anyway, it is a grand exhibition, and we urge all who can to take this golden chance of seeing the combined efforts of British manufacturers.

### One Hundred Per Cent Increase!

The presentation is better than ever. The size of the exhibition has increased by one hundred per cent as compared with last year.

Inevitably it seems we have to use the phrase "Better and bigger than ever," or something similar, as every successive show time comes round.

Last year it seemed impossible to conceive of any further expansion, for the show had been growing at an extraordinary rate.

It would have appeared fantastic, then, that it would double its size in 1932.

But there you are, the "impossible" has happened!

Both the Main and National Halls at Olympia are

### FOR BATTERY USERS

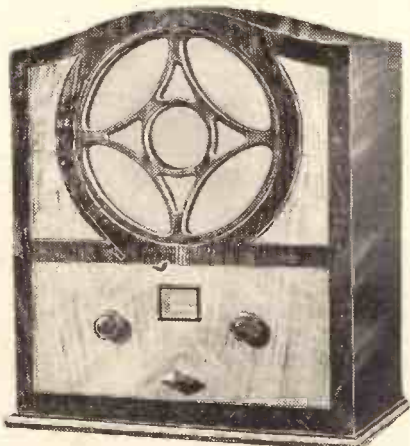

The EKCO type K.252 battery receiver, which includes a very fine loudspeaker.

packed: two hundred thousand square feet of space is used to its best advantage.

There are three hundred stands on which five miles of exhibits valued at over five million pounds are displayed.

### Fifty Demonstration Rooms.

And you must not think of it as a "dumb" show, for there are no less than fifty demonstration rooms, where the latest receivers can be heard in action.

Three hundred loudspeakers spread over the whole of the building and operated from central amplifiers will continuously relay broadcast programmes.

The B.B.C. is providing an attraction in the form

Visit Olympia if you possibly can, for this year's Show is to be larger and better than ever. And don't forget to come and see "P.W." on Stand No. 8, where we shall look forward to seeing you, and to solving your radio problems free of charge.

If you cannot go to Olympia in person, the next best thing is this interesting survey of the exhibits to be seen on the various manufacturers' stands.

of a huge model of Broadcasting House, and there will also be demonstrations of B.B.C. activities.

These alone make a visit to Olympia worth while, and we congratulate the B.B.C. for generously lend-

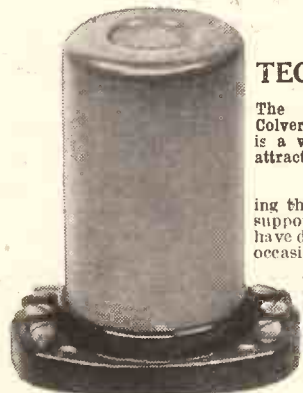

### NEW TECHNIQUE

The metal-encased Colvern type T.D. coil is a very efficient and attractive component.

ing the Show greater support than they have done on previous occasions.

But it is only fitting that this should be an extra-special show, and that the B.B.C. should give it strong backing, for it happens

to coincide with the tenth anniversary of the commencement of British Broadcasting.

As we have indicated, the organisers, who are, of course, the Radio Manufacturers' Association, have taken special steps to ensure an effective presentation.

The now standard silver and blue colour scheme has been retained, but in addition a special flood-

### A FINE MOVING-COIL



A moving-coil loudspeaker, the B.T.H. R.K. in cabinet form.

lighting system has been installed. When this is turned on the silver is gilded and the blue transformed into a striking blood-red, and a gold and crimson effect suggestive of warmth is obtained. So it won't matter if it snows!

Two great terraces have been erected in the Grand Hall, and something of the dimensions of these can be gained from the fact that no less than fifty-one tons of British steel were employed in their construction.

The lower of these terraces terminates at the foot of a fine escalator staircase and this, in its turn, is flanked by two huge illuminated pylons supporting an immense arch of multi-coloured electric lights.

Although the individual stands all conform to the general colour scheme, and have been fitted up by the same official decorators, there is plenty of variety in their design and layout.

### A Real Live Show.

And there are plenty of novelties as is always the case.

As a change from the more serious business of inspecting stands, visitors will be able to enjoy free

### NOTE THE CHASSIS WORK

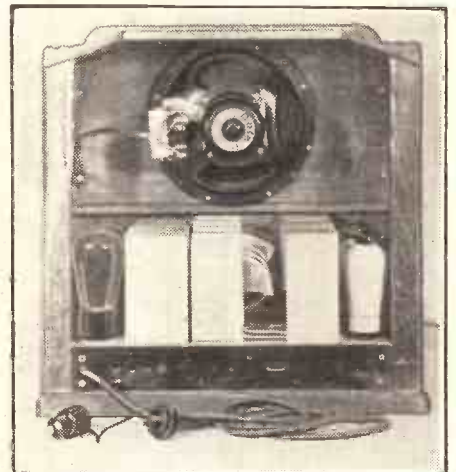

Compact construction is one of the main features of this Wates' all-electric set, which also incorporates a moving-coil speaker.

dancing on a huge dance floor where, again, ingenious lighting effects are to be found.

Now what of the actual exhibits. In previous years it has been our practice to give a detailed stand to stand review, divided into two instalments. But this time we are making a radical change.

We are going to give you in this present issue a complete survey of the whole show. This will provide guidance for potential visitors and constitute the next best thing to an actual visit for those unable to get to Olympia.

Next week there will be a detailed summary of the high-lights of the show for the benefit of those who desire intimate particulars of specific exhibits.

The first thing we hope to be able to please all our readers.

The first things which strike the observant wireless critic at this fine exhibition are that an increasing number of super-heterodyne sets are now being made,

(Continued on next page)

## THE RADIO EXHIBITION

(Continued from previous page.)

and that there is a decided "back to batteries" movement.

A further noticeable feature is that more components are on show. It will be remembered by most readers, no doubt, that two or three years ago there was a tendency for the bulk of the industry to neglect the requirements of the home constructor. The inevitable result was, of course, that those firms who stood out against this reaped a golden

### A HANDY GADGET

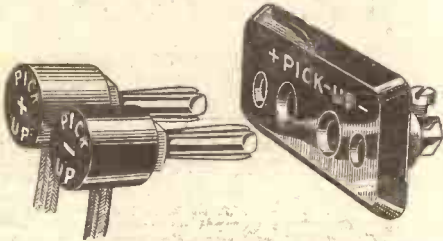

A very neat plug and socket arrangement from the factory of Belling & Lee, Ltd.

harvest, and so, just as inevitably, we now find others concentrating on this fruitful branch of the trade.

A few months back it appeared probable that there would be quite a flood of super-hets this season. As it happens, though, there is not an overwhelming display. Nevertheless, those which are shown

### MODERN L.F. COUPLING

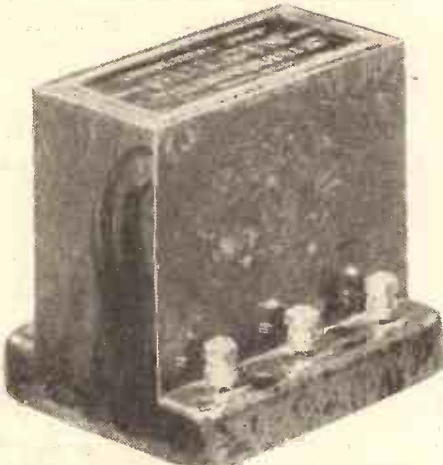

The Bulgin Transcoupler, a useful L.F. coupling unit, comprising a parallel-led transformer, condenser, and anode resistance.

reveal some very interesting aspects of modern design and are worth close inspection.

Despite the numerous battery sets, the mains varieties do not appear to have dwindled, and this is probably because the Exhibition, as a whole, is so much larger.

For example, TELSEN make their first appearance as set exhibitors, and they have celebrated their new departure by producing a range of strikingly

### NOTED MAINS UNIT



Working from the A.C. mains, this Atlas mains unit will provide hum-free H.T. for battery sets.

interesting battery and mains receivers. (Details of these will be given in our next issue.)

Among the other battery set exhibits of note is a four-valve pedestal model, due to the BLUE SPOT CO. A very up-to-date production this, with its two variable mu S.G. valves and moving-coil speaker.

SOVEREIGN are new-comers to the battery-operated set market, who have some sets on show which should occasion considerable favourable comment among visitors.

Although portable sets are no longer a craze there is a steady demand for them all the year round, and Olympia reveals that progress in their design is being well maintained.

### THE NEW MELODY MAKER



This season's Cosor Melody Maker incorporates a loudspeaker.

A quite new representative of the famous MARCONIPHONE family is a six-valve portable that is reported to provide a magnificent performance and which consumes 10 milliamperes of H.T. current.

By the way, Marconiphone have a most inexpensive two-valve battery set that is certain to command attention.

BURTON, too, must now be numbered among those who have embraced battery operation.

The STANDARD BATTERY CO. have a new portable to display. Their portable, the Wates, is a three-valve possessing several novel and attractive features.

LISSEN can be numbered with the very few concerns which seem to possess a kind of instinct or second-sight in anticipating public demand, and that is why they are so successful. And that is also why no doubt, LISSEN, have never ignored the potentially vast battery market. Perhaps the fact that Lissen H.T. batteries sell in enormous numbers operates as a constant reminder to them.

Anyway, they are again well to the fore with battery sets and have, among others, a compact two-

### GO-AHEAD CELESTION



A fine permanent magnet moving-coil cabinet loudspeaker by Celestion.

valve with built-in loudspeaker which will tempt many listeners.

COSSOR, too, have successfully catered for the battery-set market in the past and are, as is evinced by their exhibits at this year's show, still maintaining their standards in this direction. Their Model 221 should be closely examined by all enthusiasts; we have seen few other two-valvers which can live up against it.

### SOME CLARION VALVES

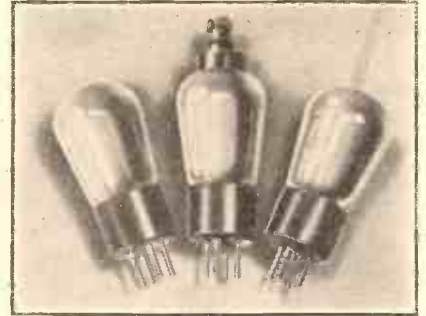

Two triodes and an S.G. from the comprehensive range manufactured by Messrs. Clarion.

And now for a few words about the super-heterodyne receivers. "Supers," as they are familiarly styled, have had a somewhat chequered career. Indeed, at one time it seemed as though they were "dead."

But what happened was this: the super-het was evolved too soon, or, rather, it escaped from the laboratory before the public wanted it, and before it had been sufficiently refined and perfected to make an attractive selling commodity.

It would be invidious to go into details, and we will say that there were just one or two pretty satisfactory instruments available in the 1927, 1928, 1929 seasons, although their prices seriously militated against their popularity.

However, the "supers" of 1932 are important additions to the classes of sets marketed, and a measure of the position they now adopt is to be gained by the names of the firms who are making them. RADIO INSTRUMENTS have entered the lists with an A.C. super of up-to-the-minute design built into a magnificent example of modern cabinet work.

FERRANTI are going "all out" on a super-het. receiver, and we should imagine all visitors to Olympia will make a point of inspecting their production. It is an all-mains seven-valver, and,

### THE LATEST "EKCO"



The works of the "EKCO" M.23 A.C. receiver. It is a three-valver and uses a metal rectifier.

together with other important exhibits, we will be giving full details concerning it later.

The OLIVER PELL CONTROL CO., makers of VARLEY apparatus, are among the others showing a super-heterodyne receiver.

Probably equal, and even greater, progress in design is to be seen in the mains sets exhibited. Metal chassis construction is almost universal, and the safety standards set and achieved are, in general, such that no one need fear the slightest danger in using these 1932 all-electric sets.

E. K. COLE, LTD., have entirely revised their range and their stand is bound to draw crowds. "EKCO" sets are distinctive in appearance and display ingenuity and enterprise in design.

The G.E.C., too, have introduced several new models, including a four-valver for A.C. mains, in which their efficient inductor speaker figures.

Messrs. H. CLARKE & CO. (MANCHESTER), LTD., are displaying a range of sets for A.C. and D.C. working which should be inspected.

And considerable interest will no doubt be evinced in the two-valve instrument on the stand taken by

(Continued on next page.)



## THE RADIO EXHIBITION

(Continued from previous page.)

### STANDARD TELEPHONES AND CABLES, LTD.

Other concerns who are showing new and interesting mains sets include BLUE SPOT, CLIMAX, F, SEWE, LISSEN, LOTUS, the STANDARD BATTERY CO., etc.

A particularly important exhibit is the H.M.V. radiogram to be seen at the stand of THE GRAMOPHONE CO. This incorporates an improved record-

### RELIABLE AND INEXPENSIVE



Compact and efficient composition resistances, ideal for grid and anode circuits. They are produced by Messrs. Graham Farish, Ltd.

changing apparatus which is almost uncanny in operation.

In comparison with only two years ago the number of moving-coil loudspeakers on view is almost unbelievable. Instead of being an aristocratic rarity it is now by far the most numerous type!

A very large proportion of the sets have built-in moving-coil loudspeakers, and there are many instruments on show at competitive prices.

Many visitors may wonder if there is a "catch" in

OUR STAND AT OLYMPIA IS  
No. 8. PLEASE PAY US A VISIT.

this sudden wealth of moving-coil speakers, and if the name is an example of pseudo-science.

There is no catch, and these moving-coil speakers, or, at least, the great majority of them, really are honest-to-goodness representatives of the "dynamic" principle.

The all-round price reduction in this type has been made possible by the discovery of new irons for the magnets, and new methods of manufacture by which the precision assembly of closely fitting parts has been vastly facilitated.

BAKERS are, of course, pioneers in the production of these instruments, and are keeping well

### S.W. ADAPTOR



Trouble-free conversion to short-waves is the feature of this fine adaptor made by Messrs. Hustler, Simpson and Webb.

up with the times. BRITISH ROLA are showing some interesting instruments, and, of course, CELESTION are strongly represented.

Messrs. CLARK & CO. are newcomers, but in view of their reputation for other classes of radio gear, success for their moving-coil speakers seems assured.

EPOCH have been "at the top of the tree" with M.C. speakers for so long that many visitors will as a matter of course pay a visit to their stand in

order to see for themselves what they are doing this year. And we do not think they will be disappointed.

Among the important new moving-coil speakers is the R. & A. "Challenger," which was the subject of a recent favourable review in "P.W."

COSSOR are showing a mains-energised "Utah," a speaker which is found in several of the Cossor all-electric sets.

WHITELEY ELECTRICAL have their P.M.4 on view, and this is one of the earliest and best of the inexpensive moving-coil speakers.

FERRANTI show an excellently graduated range from a first-class "Junior" to an impressive "seven."

### Some Fine Cabinet Work.

The MARCONIPHONE CO.'S products are graced by beautiful cabinet work—their moving-coil speakers may not all be particularly low-priced but they are fine instruments.

BLUE SPOT speak for themselves; the name is coincident with high-class speaker production and, almost needless to say, their programme this year is well representative of the times.

H.M.V. are exhibiting their "Universal" and "Super-Power" speakers, and the G.E.C. will also readily command attention for their excellent moving-coil speakers.

Again the name LISSEN must perforce be mentioned, for their M.C. speaker is far from being a negligible quantity in any exhibition. And the same applies to ULTRA, whose products have long been rightly recognised as of the highest quality.

All this talk of moving-coil loudspeakers must not lead you to think that the other types have been rendered obsolescent. If there has been progress in M.C.s, so, too, has progress been achieved in "inductors" and "electromagnetics."

LAMPLUGH, who now have a fine M.C. are exhibitors of a famous "inductor," and G.E.C. and FERRANTI are also makers of this interesting type.

BLUE SPOT, GRAHAM FARISH, CELESTION, LOEWE, LISSEN, WATES, to mention only a few at random are showing speakers constructed in accordance with balanced armature or reed electro-magnetic principles.

When possible, you should make a point of hearing them in operation (the opportunity is presented in practically every instance) for you may find your tastes as well served in this group as in the M.C. class.

The home constructor is particularly well served at Olympia in regard to kit sets. Indeed, the general attractiveness of those on show is such that he will find it difficult to choose between them.

COSSOR have a new "Melody Maker" which employs a variable- $\mu$  valve, and, as usual, there are brilliantly clear constructional charts available.

Band-passing is featured in the FERRANTI kit sets, and this is available both in battery and A.C. form.

### An Old Favourite.

The G.E.C. have also a three this year, and this is the "Osram Thirty-Three Music Magnet." It is a first-class set and "makes up" in a cabinet complete with speaker and room for batteries.

The new LISSEN screened coils figure in the Lissen "Skyscraper" kit, which is a "Three" of the S.G., Det., Pentode variety.

Our old friends "READY RADIO" present two entirely new kits, the special feature of which is the extremely simple construction, the wiring being reduced to a bare minimum.

PETO-SCOTT are offering, at small charges, constructors' envelopes fully describing two new Peto-Scott kits.

The GRAHAM FARISH "Amazing" Three, the RADIO FOR THE MILLION "Stationmaster," and the SIX-SIXTY "Chassiset" are also exhibits which enthusiasts should make a point of searching out and examining at close quarters.

Probably everyone will want to look at the new variable- $\mu$  valves, for this is their first Olympia. But they don't look different from ordinary valves,

though we doubt whether "ordinary" aptly applies to any modern valve.

Those of you who haven't inspected a mains pentode, for example, will be pleasantly surprised at the advances made in this direction.

The MAZDA range includes some outstanding examples of this type.

### A STRIKING "SUPER"

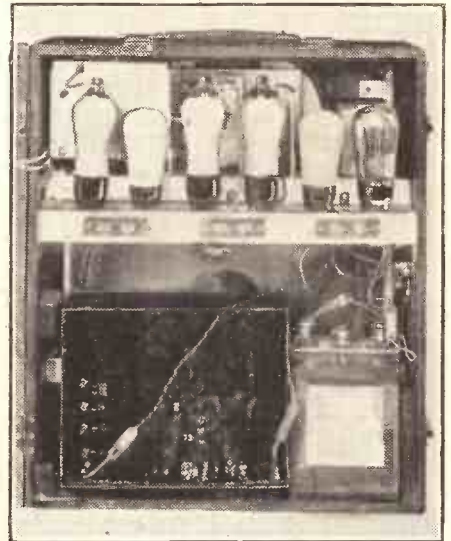

A portable six-valve superheterodyne, requiring only 10 milliamperes of H.T. current. It is H.M.V.'s latest addition to their catalogue.

As an instance of general advancement in valve construction the MULLARD display deserves special mention. Mullard valves are now made in accordance with a method known as "Rigid Unit Construction."

The electrode supports are cross-braced so as to prevent any sideways movement which might give rise to microphonic noises.

### Improvements in Valves.

COSSOR reveal that they are still going ahead, and they have a magnificent range of all types of valves on show.

The G.E.C. are exhibiting an Osram D.C. indirectly-heated mains valve rated at 16 volts—a move in the right direction for the more economical use of D.C. mains.

STANDARD TELEPHONES & CABLES will draw the crowd with their "Micromesh" valves, for which outstanding claims for efficiency are made.

The MARCONI range is particularly representative, and other valve displays of note are the CLARION, LOEWE, and SIX-SIXTY.

It is a pity that so much of the real progress and development in the radio industry remains hidden, even from the eye of an expert at the Exhibition. Much more so is it the case with the non-technical listener.

We fear that he will greet the claims of exhibitors largely with cynical suspicion. A 1932 H.T. battery, for example, looks

### 450 VOLTS PEAK

A high-voltage electrolytic condenser of very compact design.

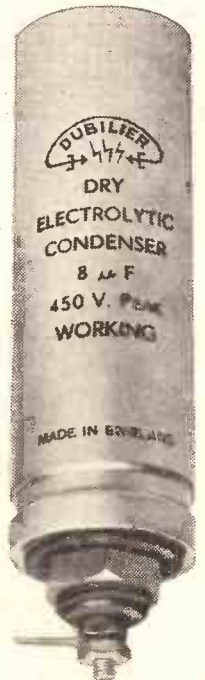

little different from one of 1928 vintage, but it is a definite fact that there has been appreciable advance in the internal construction of H.T. and G.B. batteries.

Also prices have tended to decrease as well. LISSEN are leaders in the manufacture of long-life, inexpensive H.T. and G.B. batteries, and they are featuring these in profusion at Olympia.

And both MARCONIPHONE and PERTRIX have important displays. An alternative to the "dry"

(Continued on next page.)

# THE RADIO EXHIBITION

(Continued from previous page.)

## QUITE NEW



An efficient and neat volume control due to Lewcos.

type of H.T. is found in the now famous "wet" type made by THE STANDARD BATTERY CO. The structure of the accumulator is, generally speaking, more familiar to listeners than that of the H.T. "dry" battery. For the "works" of many accumulators are plainly visible through glass and celluloid casings.

And it will be noted that on the whole the "innards" of accumulators have apparently changed but little, though there are "detail" improvements which will be appreciated only by those who have made a close study of the subject.

But one thing will be readily noted, and that is that there are more of the unspillable types of cells shown this year. EXIDE have a very wide range of them, and so have the NATIONAL ACCUMULATOR CO., OLDHAM, and EVER-READY.

## A TRIED FAVOURITE



Totally screened dual-range coils are very much in favour at the moment, the one illustrated here being a good example of modern practice. It is produced by Lissen, Ltd.

These mentions of batteries lead us inevitably to mains units. As with mains sets, mains units can nowadays be regarded as perfectly safe propositions. The Institute of Electrical Engineers have framed a very complete series of "do's and don'ts" for the designers of mains apparatus, and a mains unit can

## VARIABLE TONE



The Varitone loudspeaker, which incorporates a special switch for altering the tone of reproduction, is marketed by Loewe Radio, Ltd.

hardly hope to sell now unless its design and construction completely conform with these elaborate "safety" precautions.

The neat metal cases in which all 1932 mains units are enclosed is something of an indication of the influence of the above.

Most of the A.C. units employ WESTINGHOUSE metal rectifiers and these figure prominently in the large and most comprehensive range shown by E. K. COLE—what a wonderful firm that is! It's not often that pioneers maintain so consistent a lead as they have done.

LISSEN have two A.F. models in which Lissen rectifier valves are used. And an interesting feature of the Lissen D.C. units is that an indication lamp is connected in the earth-lead of each of these in order to give immediate visual warning of an incorrect mains connection and a short circuit in the set.

Needless to say, HEYBERD are exhibiting some fine mains gear, and our old friends RADIO INSTRUMENTS are also well represented in this respect.

"ATLAS," "FORMO," and "TANNOY" are among others whose displays are well worth inspecting if you visit Olympia.

Last but by no means least, we come to com-

## PORTABLE L.T. POWER

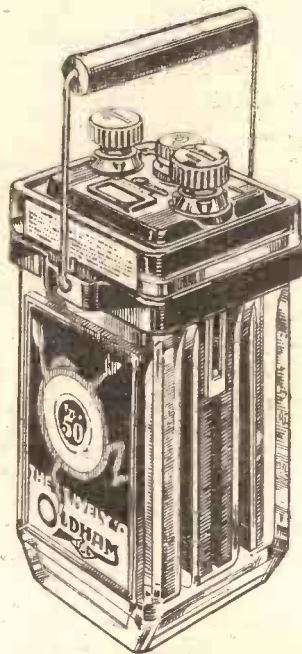

The "Lively'O," a sturdy two-volt accumulator complete with carrier from the famous battery firm of Oldham & Sons, Ltd.

ponents. No greater proof of the virility of the home constructor market can be found than in the wonderful strides made in the manufacture of components.

When there are no markedly new lines shown, and that doesn't happen at many stands, there are greatly improved models of tried favourites to be seen.

In some instances there are whole ranges of new products. TELSEN, for example, have new screened coils, "Telexors" (self-switching tuning condensers), and various other entirely new lines to show.

TELSSEN have grown amazingly during the past few years. In 1924 they were hardly known at all and yet, a mere eight years later, they have assumed a position right in the van of the industry.

Obviously this couldn't have happened if they were not able to produce the goods the masses wanted at prices within the reach of all.

MESSRS. WRIGHT & WEAIRE have added a large number of ingenious and tempting new lines to their already large list, and constructors will be particularly interested in their combination volume control and on-off switch.

READY RADIO again, have made this Olympia the occasion for the introduction of many additional

## MAGNIFICENT MARCONI MODEL

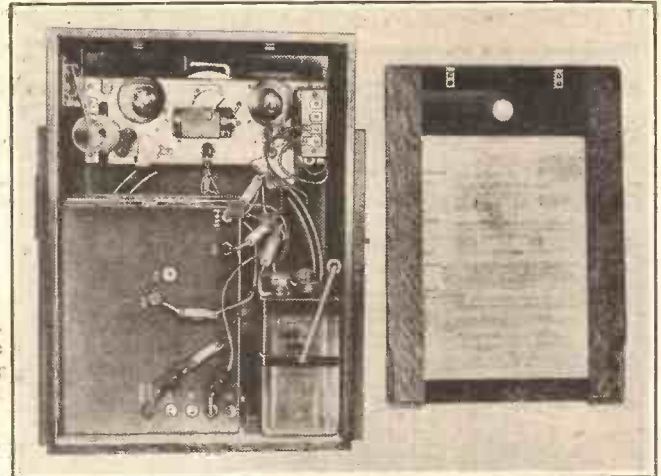

The Marconiphone Model 248 two-valve receiver seen from behind. It is a very compact little set, and, as far as batteries are concerned, is entirely self-contained.

products. Indeed, it can be said that "R. R." now join the ranks of leading component manufacturers both on account of the quality and diversity of their manufactures.

The BULGIN stand always attracts the man who "rolls his own," and he is not going to be disappointed this time. Among other things he will see the already famous "Transcoupler."

Probably the finest examples of British craftsmanship at its best are to be seen in the various condensers exhibited.

## A KELSEY ADAPTOR



A model of the Kelsey short-wave adaptor, which converts ordinary broadcast battery sets for use on short waves, made by Messrs. Peto Scott, Ltd.

Until comparatively recently dual, triple and quadruple gang assemblies were in the nature of expensive vanities, but now there are many makes of them which are both inexpensive and first-class mechanical and electrical constructions.

Next week we shall be giving descriptions of some of the representative products of this class, and in the meantime we would mention BRITISH RADIOPHONE, ORMOND, WILKINS & WRIGHT, and WINGROVE & ROGERS as being included in the select group of concerns who have mastered the finest details of the art of gang-condenser making.

(Continued on next page.)

## FOR SHORT-WAVE FANS

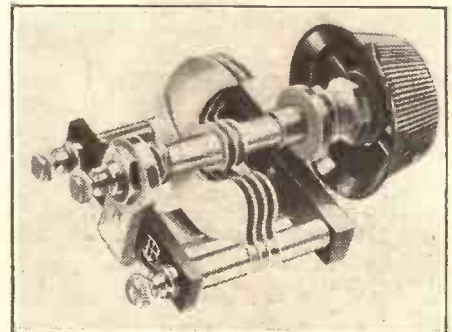

A 00004 mfd. low minimum condenser, ideal for aerial coupling purposes in short-wave receivers. It is manufactured by Jackson Bros.

## THE RADIO EXHIBITION

(Continued from previous page.)

Those mighty interesting things electrolytic condensers have gone forward in design, and **DUBILIER** and **T.C.C.** are both showing modern examples.

Many and varied are the coils displayed, from the

### READY-RADIO KIT SET

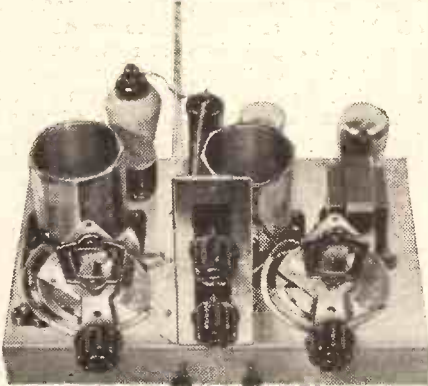

A three-valve kit set for home construction, supplied by Messrs. Ready Radio, Ltd.

short-wave "ANTINODAL" due to R. I., and the triple range short-wavers **LISSEN** and **TELSEN** are showing, to a magnificently comprehensive collection of high-grade coils of all kinds shown by **COLVERN**, who are specialists in this line. Band-pass coils are included in the **BRITISH GENERAL** display.

### THE "STATIONMASTER"



An up-to-the-minute kit set by the "Radio for the Million" people.

The above mention of short-waves reminds us that some intriguing short-wave condensers are on view at the **SYDNEY BIRD** and **JACKSON BROS.** stands.

On the L.F. side there is much to demand the

### EXIT FLAT SPOTS!

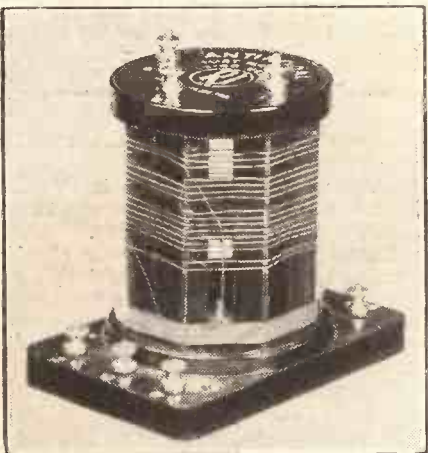

The R.I. "Antinodal" short-wave dual-range coil, which covers all wavelengths between 12 and 80 metres. It is so designed that Dead-spots in the tuning are totally avoided.

constructor's attention, including such notable items as the **BENJAMIN "Transeeda,"** a unit which embodies all the essentials for parallel-fed transformer coupling.

**LEWCOS** are exhibiting a volume control having a unique action, while **WATMEL** are displaying a useful novelty in the form of ganged volume controls.

**IGRANIC, TUNEWELL, and VARLEY** can be mentioned as further exhibitors of components of special interest.

The smaller but none the less essential classes of articles, including terminals, plugs, sockets, etc., are seen to their best advantage on such stands as those of **BELLING LEE, EASTICK, JEWEL PEN** and **LECTRO LINX**, though we must make it clear that, as in many of the preceding instances, the type of component we specifically mention in connection with a certain firm is not necessarily the only type made and exhibited by that concern.

**WE ARE SHOWING THE "OLYMPUS" FOUR AND MUCH OTHER INTERESTING APPARATUS ON OUR STAND. DON'T FORGET! NUMBER 8!**

Well, that concludes our preliminary survey, and we feel now we have said quite enough to indicate that The Show is a most absorbing affair and worth a visit even if one has to travel a long way to get there.

We trust many "P. W." readers will manage to "get along," so that we can have the pleasure of meeting them at our stand. We have a large stand—or, rather, group of stands—and experts will be in constant attendance to deal with readers' queries, free of all charge and obligation.

### THE "CHALLENGER"



A splendid moving-coil loudspeaker of the permanent magnet type, listed by Messrs. Reproducers and Amplifiers, Ltd.

The more of you who roll along to discuss radio problems and troubles, the better we shall like it. And there is also some interesting apparatus to see on our stand into the bargain. The original "Olympus" Four is there, and—but we would rather show you than tell you about the special attractions we have planned!

### TELSEN'S TRIUMPH

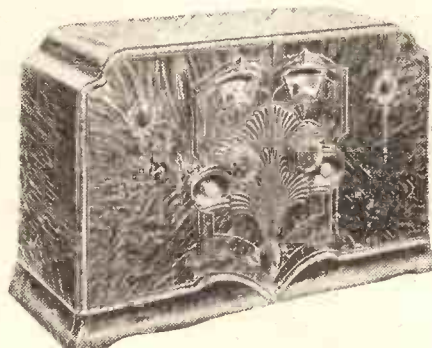

Built into an attractive bakelite case, the Telsen Model, S.92, receiver is a very good proposition. It is sold complete with valves.

### A FINE "STANDARD"

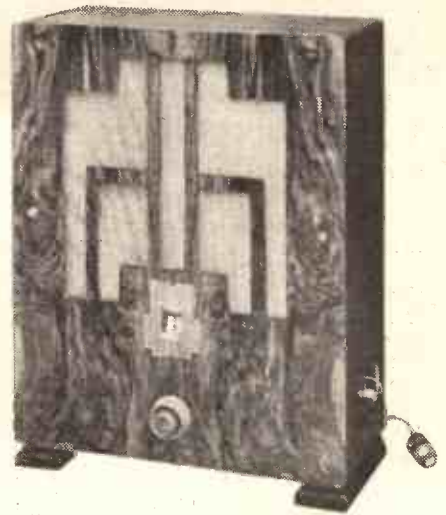

A very neat two-valve receiver for operation from A.C. mains, offered by Messrs. Standard Telephones and Cables, Ltd.

### SAFE AND SOUND



Built on sound engineering lines, this "Slektun" mains transformer is well worth attention. It appears in the catalogue of the Automatic Coil Winder Co.

### AN OUTSTANDING SET



One of the first concerns to market all-electric receivers in this country, Messrs. Philips are certainly keeping up with the times, for this is their latest set, which also incorporates a loudspeaker.

THE MIRROR OF THE B.B.C.

By O. H. M.

## THE FUTURE OF ANNOUNCERS

THE NEW REGIONAL AMBASSADOR—DROITWICH SETTLED—  
A SUMMER PEAK—STUDIO OPERA AGAIN, Etc.

AS time goes on, the problem of the future of announcers becomes more acute. The very special qualifications required by announcers are such that the majority of them are not disposed to go on indefinitely in this necessarily wearisome job. By an unfortunate paradox, the only announcers who seem to get a chance of promotion or alternative employment are those who, for one reason or another, are regarded as having fallen below the required standard of efficiency.

Those who maintain their efficiency and give satisfaction are kept on at the old job year in and year out. Mr. Hibberd, the Chief Announcer, for instance, has been doing the same job for eight years, during which people junior to him in the service have advanced to positions which, in pay and in status, leave him behind.

I commend this problem to the attention of the B.B.C. authorities. If they want to make announcing a dignified profession, with reasonably progressive status and adequate remuneration, they should do so; if, on the other hand, they wish to look upon announcing as a sort of "repetition" work, then it should be recognised that those who do well at it should have the opportunity of better jobs as they emerge.

### The New Regional Ambassador.

Mr. Lindsay Wellington, formerly responsible for the general balancing of alternative programmes, has been given a new appointment, in which he will be virtually the ambassador for the Provinces in London. This appointment is a happy outcome of the prolonged feud between the "centralisers" and the "regionalisers."

It means the creation of a solid guarantee that the B.B.C. will not allow its Regions to be gradually submerged as was threatening. Mr. Wellington will have fresh authority and will not have to take orders from any of the programme chiefs at headquarters.

The appointment is merited not only by his good work but by Mr. Wellington's personality.

### Droitwich Settled.

I understand the B.B.C. has now virtually decided on Droitwich as the site for the re-built Daventry. This, of course, was always favoured by the B.B.C. Engineers, but there was some hesitation on the possibility of subsidence. In the end, however, I gather that this risk is not judged to be sufficiently serious to outweigh the great advantages of the site.

### A Summer Peak.

On Friday and Saturday, August 26 and 27 respectively, Ashley Sterne's radio revue "Grand Slam" is to be included in the Regional and National programmes.

For the sake of those who will be unable to hear it, I hope the revue will be repeated

before the winter is out, because from what I hear it will be a good show.

Most people who enjoy the author's humorous stories will be surprised to learn he has several symphonies and some chamber music to his credit, but it explains his daring to write the music for this revue, while in the preparation of the "book" he has collaborated with a fellow humorist, A. A. Thomson.

### "Grand Slam."

"Grand Slam," which has the sub-title, "A radio rubber in thirteen quick tricks," naturally includes a feature about the game of bridge, not the ordinary sort which you and I play, but a game played for the world's championship between Mr. and Mrs. Pumbleby, who are two American experts, and two Russians.

The Championship is fought out at Chicago, where Mr. Pumbleby quite rightly deems it necessary to wear a bullet-proof

waistcoat, when he comes under the machine-gun fire of hostile gangsters as he deserves to do for trumping his partner's ace.

### Studio Opera Again.

The music department of the B.B.C. is pleased with the information that the shortened scores of about seventy operas, prepared in Germany, are now available for performance in this country. Everybody is aware of the fact that most operas in their stage form are much too long for broadcasting purposes, and the German love of this type of music led to experiments in special abbreviations for radio purposes such as that of "Euryanthe" which was recently relayed by the B.B.C. from Berlin.

These experiments have been going on for some years and with the wealth of material now available I should not be surprised if the B.B.C. decides to arrange a complete season of studio opera.

There is still room for a good deal of research work even in radio opera, as was shown recently by a Continental station which, between the three acts of an abbreviated studio version, broadcast a supposed discussion between members of an audience as though the performance was actually taking place in an opera house. It was an excellent idea of getting over some interesting details about the composer, and memories of previous performances.

(Continued on page 802)

## STUDIO FAVOURITES "PARKED" AT EASE



The Callender's Cable Works Band—prime favourites of the studio—are in great demand for open-air concerts, where they can let themselves go all out! They are shown taking a breather while the photographer takes the picture.

## THE LISTENER'S NOTEBOOK

A rapid review of some of the recent radio programmes.

I CAN strongly recommend to lovers of classical music the concerts given at the Casino de Vichy and broadcast from Paris. Listening to a Beethoven concert the other evening I was greatly reminded of our own Queen's Hall broadcasts.

I should say that the acoustic qualities of the concert hall at Vichy are almost perfect.

Another foreign broadcast I chanced to hear came from Aranjuez (Madrid). The object of this and future transmissions, which occur (politics permitting!) on Saturday evenings from 6 o'clock till 8 o'clock is, it appears, to make other European

countries better acquainted with the artistic and intellectual life of Spain.

There were announcements in Spanish, French and English, so there was no difficulty in following everything.

I mention these two discoveries of mine because they may prove helpful to those listeners who, like myself, are finding the sameness of our English programmes week after week too conducive to staleness. Incidentally, both these broadcasts, judged on their own merits alone, were well worth hearing.

I am sorry for those of you who selected "A Miscellany (No. 4)" as a likely  
(Continued on page 802)

# HOW SIR JOHN REITH GOT HIS JOB!

BY A SPECIAL CORRESPONDENT

**H**AVE you ever wondered how Sir John Reith, an engineer, and not a business man, first obtained his job?

No doubt you have; and you may add—though it is beside the point—that you have sometimes wondered why he gave up engineering as a profession.

## Originally an Engineer.

Sir John was an engineer up to the time he entered broadcasting. He served five years' apprenticeship in Glasgow; and during the war, before he was wounded, he was in the Royal Engineers, and later filled various important Government posts which involved extensive engineering knowledge.

In 1922 we find him general manager of the great engineering firm of William Beardmore, Ltd., and in the same year he comes to what is undoubtedly a turning point in his career—he steps in front of the microphone, leaving the slide-rule and the lathe behind him for good.

He became, in fact, general manager of the newly-formed British Broadcasting Company.

Many people have been anxious to find out how he got the post and why he so soon leapt to fame.

Now, Sir William Noble, the telephone pioneer, a director of the General Electric Company and formerly Chief Engineer of the Post Office, has lifted the veil:

He tells me that it was he who gave Sir John Reith his job with the B.B.C.

## Finding the Man.

"It happened like this," Sir William told me. "At the end of 1922 I had, at the request of the then P.M.G. (Mr. Kellaway), brought to a successful conclusion negotiations for the formation of a broadcasting company.

"At that time there were six big companies who would each

Sir William Noble, telephone pioneer and a director of the famous General Electric Company, tells in an interview how he chose Sir John Reith from dozens of other applicants for the job of general manager of the British Broadcasting Company—and how he regrets that the old B.B.C. is not in existence to-day. Sir William has several candid and pungent remarks about broadcasting to make to "P.W.'s" special correspondent.

have liked to run a separate broadcasting system! They were B.T.-H., General Electric, Marconi's, Metropolitan Vickers, Radio Communication Co., and Western Electric.

"Thank goodness I persuaded them to agree to form one big broadcasting organisation and to drop the silly idea of running shows on their own. The chaos, as you may imagine, would have been incredible by

knew that such a job was vacant, and I received a large number of applicants.

"Reith, on the face of things, was the man.

## Well Suited for the Post.

"After careful thought I accepted his application, and so he became general manager of the British Broadcasting Company. He took up his position right away, and I have no doubt that he has never regretted entering the field of broadcasting.

"Mind you, he knew nothing of wireless matters, but he used his opportunities to the very best advantage, and when the time came he was ready; ready, one might almost say, to take charge of the whole broadcasting system of Britain."

I pressed Sir William to continue the story. He was seated at his desk in his magnificent oak-panelled office in the huge G.E.C. factory at Coventry. I thought how well he bore his 72 years and how remarkable that, after all these years down South, he should still retain such a marked Scottish accent.

Sir William went on, and he grew quite excited as he told me of these early days of broadcasting.

## A Huge Success.

"In short," he said, "we made such a success of the old B.B.C., and things seemed so rosy, that certain quarters became jealous of us.

"An inquiry was demanded, and finally it was decided that a Corporation should be

(Continued on next page.)

## "A BUSMAN'S HOLIDAY"



Although, as Director-General of the B.B.C., Sir John Reith controls thousands of programmes a year, it is not often that he makes a personal appearance before the microphone. But the photographer caught him in this rare position on a visit to America, when Sir John spoke over the network of stations controlled by the National Broadcasting Company.

## HOW SIR JOHN REITH GOT HIS JOB!

(Continued from previous page.)

formed and all commercial interests bought out. I will tell you in a minute whether I consider this to have been a good move, but the immediate result was that we directors left, and a new board of governors was appointed, the chairman of which received a salary nearly twice as great as the whole of the old board's salaries put together!

"And, mark you, not one of the new governors knew a thing about his job. Lord Gainford was there, admittedly, but he was not a broadcasting expert in the accepted sense. Now we directors had all been experts in our own line. We understood wireless broadcasting inside and out. Our general manager, Mr. John Reith, had "picked up" all he knew about the subject.

### A Stupendous Task.

"But the fact remains that, at the time the British Broadcasting Corporation was formed, Reith was the only man there who knew anything about the tremendous task that was ahead of the Corporation. Naturally, he saw his opportunity and he leapt ahead, his influence became everywhere apparent.

"The governors knew nothing of the work he was doing; they had first to learn all about it. Sir John (as he now is) was, of course, retained by the new Corporation under the title of director-general, and when I remember that I chose him for the original position I am proud of my choice. He had made the most of his opportunities.

"As the only man with broadcasting knowledge he soon became the real power in the B.B.C., and, much as I regret the autocratic methods of the B.B.C., I must admit that he has done his work magnificently.

"But I do not think it satisfactory for any big organisation to be run as a one-man show. Quite frankly, I believe that the old company would have done much more for broadcasting than the present Corporation has done. *The old B.B.C. was the wireless industry, out to please the listener in every way and determined to encourage every person in the country to possess a wireless set.*

A striking view of the new vaudeville studio in Broadcasting House, which has been built on the lines of a theatre—complete with auditorium—to enable artists to "feel at home."

## VARIETY'S NEW HOME



WE have received for test a group of the new "micromesh" valves that are being manufactured by Standard Telephones & Cables, Ltd. They are built on the short-path principle, and have amazing characteristics. For instance, the P.A.1 is listed as a 1,050-ohm valve (like the others, it is of the indirectly-heated A.C. type), and the mutual conductance is 12. This makes the magnification factor come out at 12.6, which is a very high figure.

On test the valve gave excellent results. The test was carried out under ordinary operating conditions so that the effect of the valve as a change-over from one of lower magnification in an ordinary set (the output load being adjusted, of course) could be studied.

## THE NEW "STANDARD" VALVES

A technical review of the "micromesh" valve range, working on the short-path principle.

The increase in volume from the normal was marked, but without calculating the maximum undistorted output that the valve should give, it is difficult to know exactly what in the way of volume should be obtained, the valve was, however, exceptionally good.

The H.L. type of Standard valve, the H.L.A.1, was also tested under the same operating conditions, after its characteristics had been checked up theoretically. The results from this valve as a detector were extremely good, and

it can be taken that it works well up to the high mutual conductance figures that it has. Naturally the effect of these characteristics are more felt, or heard, when the valve is being used as an amplifier, in which rôle it behaved magnificently. The impedance is 10,000 ohms, and the mutual conductance is 8.

Both the H.L. and the P.A.1 "micromesh" valves can be confidently commended to the attention of our readers. It must be remembered that the output impedance of the set must be correct if the best amplifying power of the valve is to be obtained. And in this connection we should like to ask the valve manufacturers when they are officially going to arrange to let the public have the optimum undistorted outputs of their valves.

### A Great Help.

At the moment we understand there is a slight disagreement in the valve camp concerning the correct method of calculating the maximum undistorted output of a power valve. But surely the absolute exactness does not matter in everyday set design, and it would be extremely helpful if the figures were published.

At present the individual firms will supply their own figures on verbal request, but owing to the "agreement to disagree" on the formula, they will not supply the figures in writing. It seems to be a most ridiculous position, and one that the B.V.M.A. would do well to get out of as soon as possible.

The final valve of the three is a rectifier (the R.1) for the supply of H.T. from A.C. It has excellent characteristics, and in use is perfectly satisfactory.

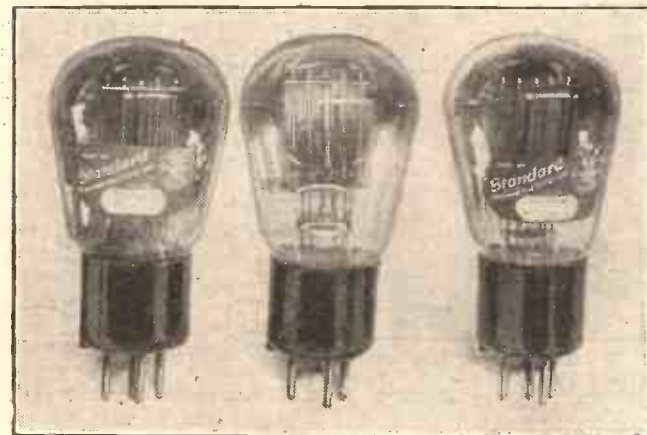

## A TRIO TO TRY

Three samples of the new "Standard" range of valves, which are confidently recommended to readers. The P.A.1, the H.L.A.1, and the R.1 (a rectifier for supply of H.T.).

# ON THE OTHER SIDE



# A TALK WITH AN INDIAN LISTENER

**T**HIS is the story of Indian broadcasting as told me by a young student now visiting London.

"At present, listeners in Bombay, Calcutta and other big centres where there is any interest at all shown in wireless reception, are congratulating themselves that the Government has decided to carry on the existing service for another year or so.

"Probably it is common knowledge to you that our broadcasting has seen more ups and downs than in any other country. There have been two glorious failures, but the present system seems likely to continue.

"A great friend of mine is Abdullah Fazalbhoy, a prominent radio merchant in Bombay and the Managing Director of the Bombay Radio Co., Ltd. Owing to the immense stock of wireless parts carried by big traders they have the first word in the practical side of broadcasting, and Fazalbhoy is the guiding light behind the present scheme.

### Not Much Interest.

"Your Marconi Co. sent some experts out to India in 1925, and transmitters were started up to see what public interest there was in broadcasting. There was practically no income and not a great deal of interest to show.

"The Europeans could not be bothered with wireless and, outside the large cities, the native population could not afford it.

"After a short lapse, further interests in England were set to work to start a new Indian broadcasting scheme. In 1927 some prominent British wireless folk came over to us to form the Indian Broadcasting Company which took over the existing stations at Bombay and Calcutta. Among them was a London station announcer.

### Did Not Realise the Handicap.

"The real reason that this second venture failed was that it was too limited. The programme allowance was thirty rupees (about £2 10s.) a day, which didn't give much scope!

"These enthusiastic Britishers found that outside Madras, Bombay, Calcutta and a few other cities, civilisation has no more progressed than in the days of the Great Moguls. No 'phone communication was possible between the Bombay and Calcutta

stations, and I feel sure that until the new enthusiasts started up they did not realise what a handicap this would be.

"I remember that the programmes weren't too bad, and they partly covered the civilisation difficulty by broadcasting in four languages, English, Hindustani, Gysyati and Mahratti.

"Well, to cut a long story short, big papers such as the *Times of India* one day

Some of our leading radio engineers have helped to put Indian broadcasting on a sound footing. So you should be specially interested to read this description of the ups and downs of radio there, and to know what an Indian listener thinks of broadcasting in his own country.

came out with huge 'splashed' features about the failure of broadcasting and the closing down of the I.B.C. And then, after a short break, there appeared further headlines dispelling the gloom, announcing that

no retrenchment was to be effected and that the Government (the 1930 Government, that is) would step in.

"Of course, they had everything to encourage them. Traders, headed by Fazalbhoy, had told the Government that they were keen enough to keep broadcasting going (probably urged on by the dread of a slump in radio goods when they had about ten lakhs of rupees' worth on their hands) even if State assistance couldn't be granted.

### Up By Leaps and Bounds.

"Also, although there wasn't a great deal of income derived from licences, the numbers were going up by leaps and bounds. The Marconi people said that there were only about 300 wireless licences in the whole of India. In 1929 there were ten times as many, and now I suppose there are about ten thousand licensed listeners.

"What I do know is that in Calcutta alone 5,000 licences have been taken out, which doesn't leave very many for the rest of the country!

"A licence costs ten rupees a year, but

(Continued on next page.)

## BEHIND THE SCENES OF BOMBAY'S BROADCASTING



The main studio of the Indian State Broadcasting Service, at Bombay Station. Note the special type of "couch" seats that are provided for the performers.

## A TALK WITH AN INDIAN LISTENER

(Continued from previous page.)

at a listeners' meeting in Calcutta in October of last year, it was urged that the fee should be raised to twelve rupees in order to get more money and thus better programmes.

"The Government has not had an easy task putting broadcasting on its feet, and so, when Sir Joseph Bore, the industry's member of the Executive Council, made the declaration in the Assembly that the Government was going to carry on, it was cheerful news for everybody.

"Indians and Europeans have put forward some bright ideas for getting more revenue and so improving the service.

### Into the Limelight Again.

"Only about eighty per cent of the revenue is paid to the service, but it has been suggested that the officials could well afford to pay ninety per cent when, because of the extra money available and the additional interest in the revenue, the service would help to fight pirates. The Government has also been asked to levy about three rupees on each valve.

"Fazalbhoy again came into the limelight when the Indian Government pro-

posed the fifty per cent. tariff on all wireless goods, in place of the twenty-five per cent. tariff.

"Your Marconi Company has again been asked to help, but some of our Indian traders could not decide whether or not, this would be to their interest.

"An American company has also asked to broadcast sponsored programmes, but the Government turned down the idea at once!

### Short Waves.

"My own opinion is that past failures have been due to lack of short-wave stations. At certain times of the day, it is practically impossible to get the medium-wave Bombay and Calcutta stations.

"Calcutta seems a better site for a short-waver than Bombay, and test transmissions from Calcutta have been heard at Peshawar. A scheme was suggested some time ago for equipping the Government stations at Delhi and Lahore with short-wave broadcasters, but I have not heard of the outcome.

"Personally, I don't think that it should be difficult to make broadcasting pay its way. I remember that a leading Calcutta newspaper gave all the figures when there was a hint of a hitch in the Government control.

"The European programmes consist of only two news bulletins a day, and gramophone records.

### It Seems Excessive.

"There is really no need for separate European staff, and yet out of the total cost of 132,000 rupees a year, they say that the European programmes cost 26,880 rupees, which seems excessive.

"Some of this money is from licences, and some from the tax. In addition they get about 6,000 rupees from the Programme Journal.

"A snag, in my mind, is that they do not increase the educational interest. The native population loves being talked to.

"In Bengal alone, there are 64,000 schools. Some of these are only small education centres, but if all the educational people were roped in, there would be

an immense increase in the licences.

### European Objections.

"The native population is keen enough to keep wireless going. It has generally been the Europeans who have raised objections.

When the Government took over the old Indian Broadcasting Company, and when the loss was actually £250 a month, the only dissident was a certain Nawab Ismail.

"Listening is really great fun, in spite of the atmospherics during the day.

## BOMBARDING BOMBAY'S ETHER

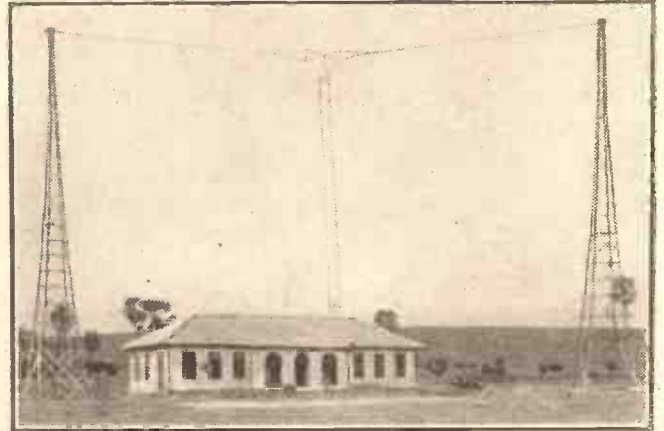

The transmitter that serves the listeners of Bombay is actually situated at Worli. A "T" type aerial is used, supported by two lattice masts.

"There are some mains-operated sets, but all the better quality batteries sold in the big towns are British.

"There is a certain amount of Continental apparatus (cheap French batteries, for instance), and mains parts. Also we have some American gear, tuners for example, and American-built short-wave sets.

### The Pirate Problem.

"One of the largest trading organisations is the I.R.R.I. (Indian Radio Corporation). I.R.R.I. recently gave twenty free sets to people who were successful in discovering wireless pirates, which only shows how serious the pirate problem is.

"I have pleasant memories of broadcasting in the very early days, when the voice of 5AF was first heard at Calcutta, and when the station was in charge of Mr. Stapleton.

"Dr. K. Mitra Khaira, of the Calcutta University, was a leading figure in wireless then and, with the help of the 5AF station officials, was responsible for starting the Radio Club of Bengal—a big organisation which did as much as anything to start wireless interest in India.

### Ancient and Modern.

"In native villages one often finds a strange clashing of ancient and modern. In some native doctor's crude house, outside which the skin drums are still hanging, is often to be found a crystal set used in the evenings!

"But the ancient methods of communication still hold their own with wireless. If, say, a Moslem trips over a sacred cow in the market place, and a squabble starts, the news travels on the native drums faster than any wireless waves!"

EDITOR'S NOTE: Everyone likes to know how "the other man" lives, which accounts for the great interest shown in this series. The next article from "The Other Side" will be "A Talk with a Chinese Listener."

## IT DOESN'T MIND THE HEAT!



Built in England for use in India, this transmitter is unaffected by the high temperatures experienced, and will work efficiently at any hour of the day.

posed the fifty per cent. tariff on all wireless goods, in place of the twenty-five per cent. tariff.

"Fazalbhoy has visited England, and been in touch with your Radio Manufacturers' Association officials. He was positive that



**TELSEN**

# TELORNOR

gives your home-built set the dignity and beauty of line of a commercial Radio Receiver.

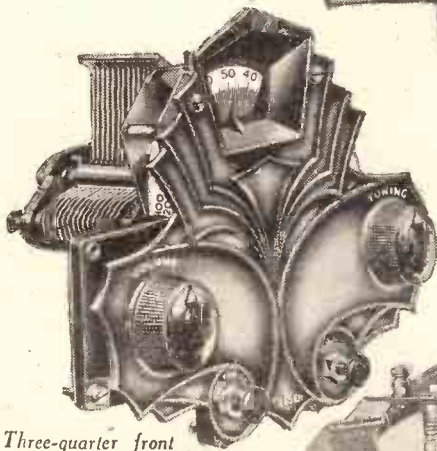
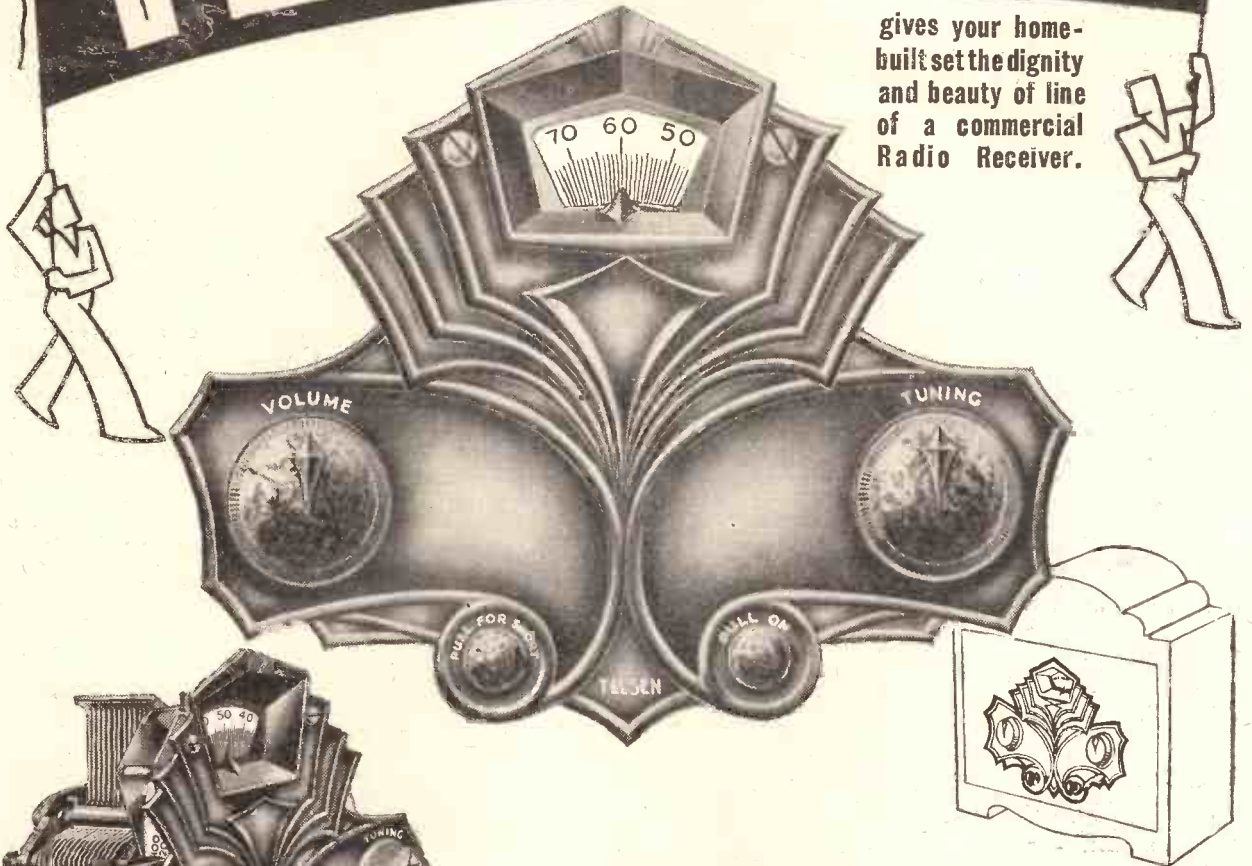

Three-quarter front view of the "Telornor."

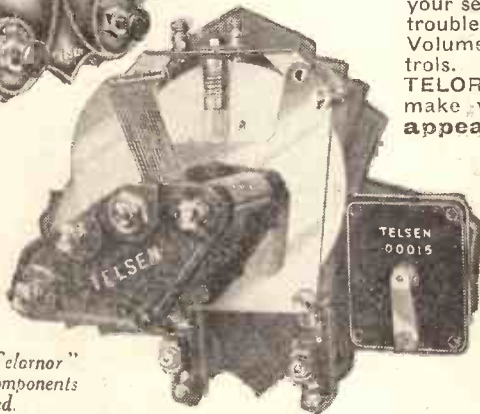

Back view of the "Telornor" showing how the components can be mounted.

**G**IVE your home-built set the dignity of an expensive commercial radio receiver with the new Telsen TELORNOR. It makes better sets easy to build! The handsome silver oxidised escutcheon plate, complete with the Illuminated Disc Drive adds immensely to the "good looks" of your set and permits, with the minimum of trouble, a very effective grouping of your Volume, Tuning, Push-Pull and On-Off controls. Ask your dealer to show you a TELORNOR Illuminated Disc Drive. It will make your set a set to be proud of—in appearance as well as in performance.

No. W.206.

**7'6**

# TELSEN

**RADIO COMPONENTS**

See the complete range of  
**TELSEN RADIO COMPONENTS**  
on STAND No. 66 at RADIOLYMPIA

**GOOD RADIO IS A JOY FOREVER**

ANNOUNCEMENT OF THE TELSEN ELECTRIC CO. LTD., ASTON, BIRMINGHAM.

# TELSEN SCREENED TUNING COILS

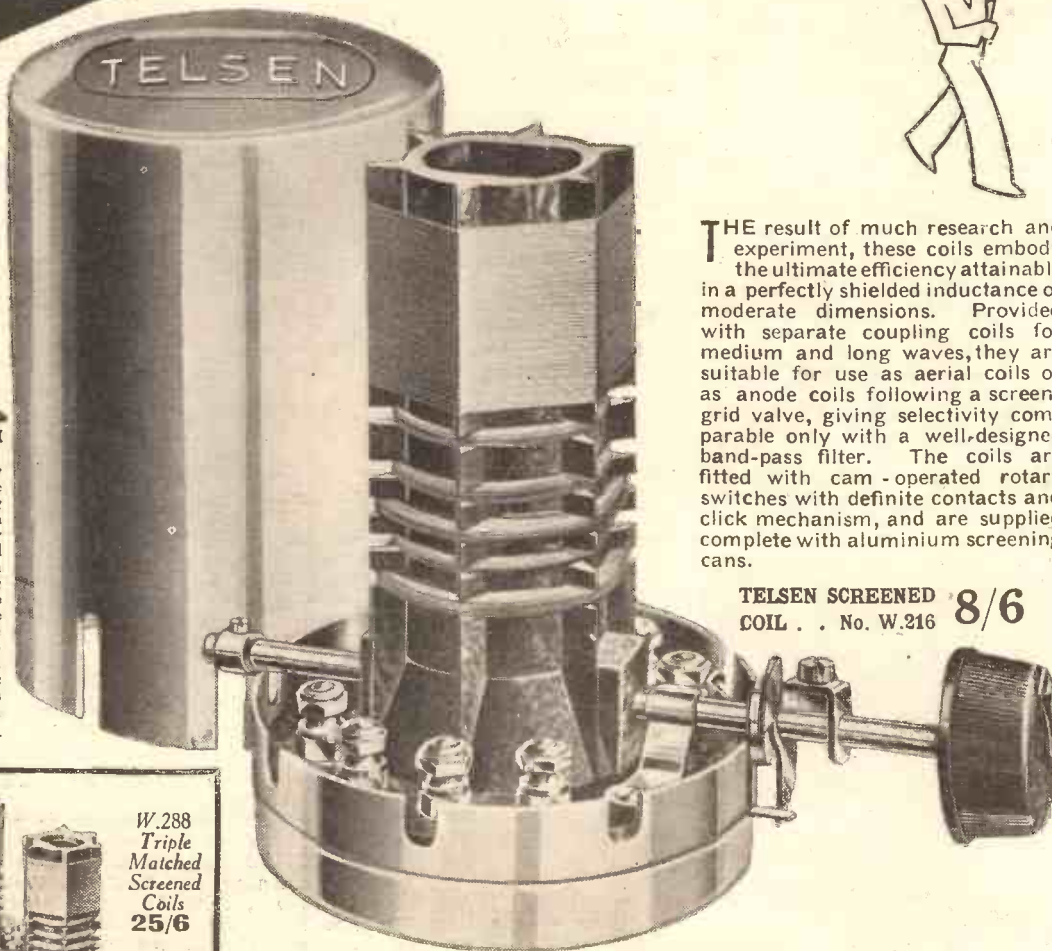

**TELSEN COIL SWITCH KNOB ASSEMBLY.**  
This knob is specially designed for use with the Telsen Screened Tuning Coils. The extension on the knob spindle fits over the switch rod supplied with the Coils, a firm coupling to the rod being ensured by tightening the small screw provided. The knob assembly is suitable for mounting to any standard thickness of panel, and includes a neat disc escutcheon. The knob is of the push-on type in Black Bakelite.  
No. W.218. 1/-

THE result of much research and experiment, these coils embody the ultimate efficiency attainable in a perfectly shielded inductance of moderate dimensions. Provided with separate coupling coils for medium and long waves, they are suitable for use as aerial coils or as anode coils following a screen-grid valve, giving selectivity comparable only with a well-designed band-pass filter. The coils are fitted with cam-operated rotary switches with definite contacts and click mechanism, and are supplied complete with aluminium screening cans.

**TELSEN SCREENED COIL . . . No. W.216 8/6**

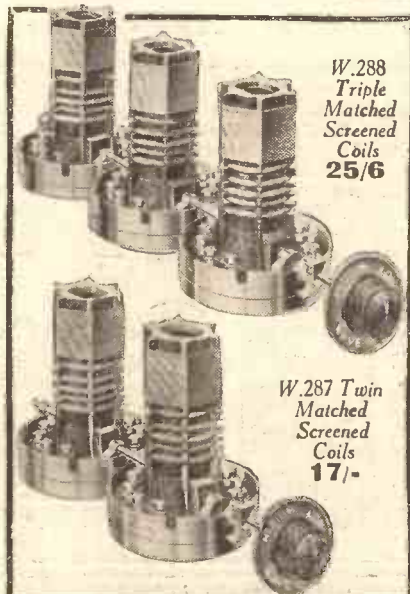

**W.288 Triple Matched Screened Coils 25/6**

**W.287 Twin Matched Screened Coils 17/-**

**TELSEN COIL SWITCH COUPLING ASSEMBLY**

When it is desired to mount two or more of the Telsen Screened Coils in a line parallel to the panel, and to control the wave-change switching by a single knob on the panel, this switch coupling assembly will be found indispensable. The link arms of the coupler are fitted over the switch rods of the coils, and adjusting slots are provided in the link bar to allow for the spacing of the coils varying from 3 in. to 6 1/2 in. The whole assembly has a neat nickel-plated finish, is perfectly smooth and positive in action, and free from backlash.

No. W.217 6d.

# TELSEN

## RADIO COMPONENTS

See the complete range of  
**TELSEN RADIO COMPONENTS**  
on STAND No. 66 at RADIOLYMPIA.

**GOOD RADIO IS A JOY FOREVER**

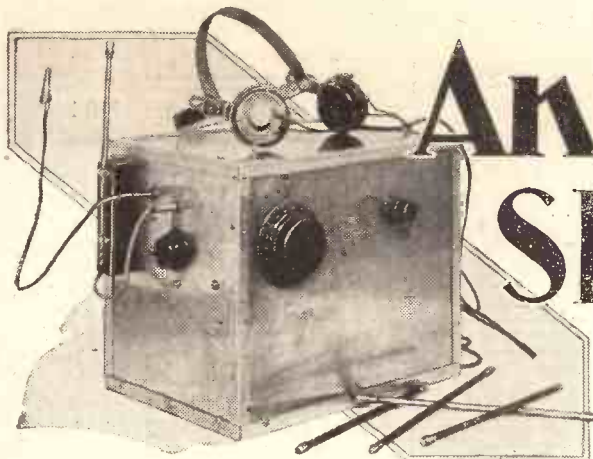

Described by  
L. W.  
SKIPPER

# An All-in Short-Waver

HOME-MADE COILS  
\*  
A COLLAPSIBLE ROD  
AERIAL  
\*  
REMARKABLE RANGE

**D**URING the winter months, when the short-wave "fans" were busy logging stations, I got the craving too. But as most of the best short-wavers, especially the Yanks, have the unhappy habit of getting on the air during the night and small hours of the morning, it meant my sitting up in a rather cold experimental station.

This did not suit me, so I decided to give up the idea of all-night sittings, by building a portable which I could have with me beside my bed or anywhere in the house. Also, as wires slung about anywhere were forbidden, I made the set portable, complete with "collapsible aerial."

**Very Compact.**

As the photograph indicates, it is a small set which works very well indeed on wavelengths from approximately 10 metres to 500 metres. Even on my copper rod aerial, this little two-valver has received Bandoeng, Java, 12,000 miles away, in a house in S.W. London. Perhaps I should here state that the set was designed to work headphones.

A very important feature about the set is the coils; they can be made by anybody at very little cost, in fact, the price of the wire is about all that has to be considered, as they are wound on old valve bases. Get six ordinary bases, and some 22 D.C.C. and 26 En. wire; also you will want a small quantity of 28 D.S.C. and 38 D.S.C. and a paxolin former 1½ ins. diam. 2¾ ins. long—these are for the broadcast coil.

**Winding the Coils.**

The former is wound for the broadcast band and then slipped over a valve base and fastened to it by a couple of nuts and bolts. Wind grid and reaction windings in the same direction, making the anode or plate pin of the valve base the grid end of the coil; the pin opposite will then be the earth end of the coil, and the two remaining pins take the reaction windings. For short waves, you will require between 4 and 16 turns of 22 D.C.C. wire on the grid coil, and 5 to 18 turns of 26 Enamelled wire for reaction.

Here is a tip: apply a little cone dope or similar substance with a soft brush to the windings. It keeps them in place.

The box is made entirely of 1/16-in. gauge aluminium, and is kept rigid by 1/2-in. angle strips of the same metal. My particular box measures 11¼ x 8¼ x 9¼ ins., but these measurements are left to individual

choice. Be sure that all the sides make good contact; this is best done by rivets, although nuts and bolts can be used.

The baseboard is of wood, lined on the underside with copper foil, and measures 11 x 5¾ x ¾ ins. thick.

The layout can be seen from the photographs, and it is of the utmost importance to see that all the wires are of the shortest length, and that the moving vanes of the tuning and reaction condensers are not only in perfect contact with the metal panel (front of aluminium box), to which they are clamped, but the condensers' moving vanes terminals must be joined together with wire and earthed to the box.

**The "Stick" Aerial.**

Now for the "stick" aerial. This is made of copper tubing, 1/8-in. diam., and about 40 ins. long, it can be lengthened to suit your own taste. The copper tubing is cut into equal lengths of a size that will lay flat in the box, and a screw socket brazed on to each piece, so that the whole can be screwed together to form a sort of "stick."

A piece of wood about one-inch thick and 4 ins. long is fixed to the aluminium cabinet and some suitable arrangement made for supporting the "stick aerial," which, of course, stands upright, as you will see from the photographs. Any ordinary indoor aerial can, of course, be

*(Continued on next page.)*

**MADE WITH THESE PARTS:—**

- 3 Valve holders (Benjamin).
- 1 Variable condenser, '00015, slow motion, with double spaced vanes (Polar).
- 1 Variable reaction condenser, '00015, slow motion (Polar).
- 1 Variable aerial condenser approx. '0004-'00005-mfd. (J.B.).
- 1 '0001 fixed condenser and clips (Dubilier).
- 1 2-mfd. fixed condenser (T.C.C.).
- 2 1-mfd. fixed condensers (T.C.C.).
- 1 '005-mfd. fixed condenser (T.C.C.).
- 1 Parafeed transformer (R.I.).
- 1 H.F. choke (DX.3 Watmel).
- 1 Vacuum resistance, 100,000 ohms (Ediswan).
- 1 Vacuum resistance, 30,000 ohms (Ediswan).
- 1 Grid leak, 5-meg. (Dubilier).
- 1 Upright grid-leak holder (Dubilier).
- 1 Horizontal grid-leak holder (Dubilier).
- 1 '0001 flat condenser (fixed) and clips (McMichael).
- 1 Fuse bulb and holder (Bulgin).
- 1 3-spring jack P. 65 (Igranic).

**SELF-CONTAINED—EVEN TO AERIAL AND "EARTH"**

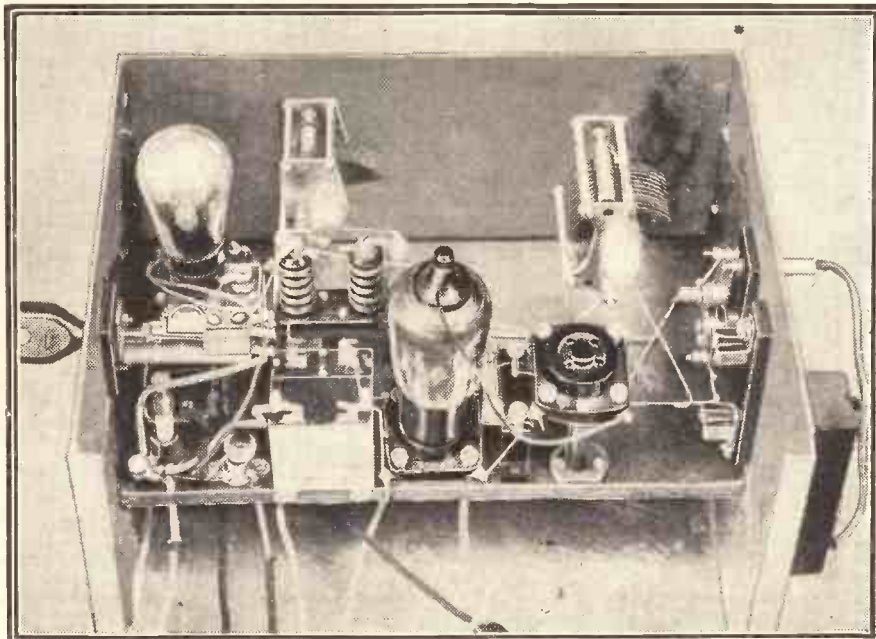

When an ordinary wire aerial is not available, a rod, which separates into small sections, is fitted into the holder seen in the bottom right-hand corner of this photograph.

# AN ALL-IN SHORT-WAVER

(Continued from previous page.)

used instead of the "stick," and either connected through the small variable condenser to the grid end of the coil, or it can be plugged into the other socket, thus bringing the .0001 fixed aerial condenser into service. For calibrating the set, this latter method is essential.

The S.G. detector valve used by the writer was a Tungram 2, and the power-valve an Osram LP.2. A pentode can be used when it is desired to work a loudspeaker, but as these valves are heavy on battery current, and as the set was made as a headphone portable, the pentode was not used by the writer.

### Points to Watch.

It should be noted in building the set, that the coil-holder (valve holder) is mounted on two ebonite pillars, 2 ins. long—but take care to keep the coil at least 3 ins. away from the metal box sides. The H.F. choke is also mounted on a 2-in. ebonite pillar. Be sure and use sleeving on all the wires which are run through the baseboard, except, of course, those which are negative—they are soldered direct to the copper-foil underneath.

Another important point is to be sure and give ample clearance around the spindle of the series aerial condenser. On no account must the metal touch, or be near

## "A PLACE FOR EVERYTHING . . ."

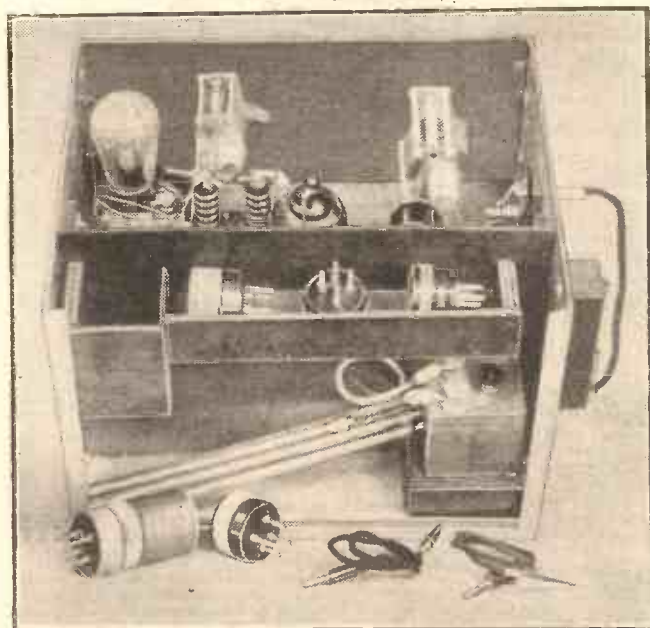

Yes, it is extremely compact, for the little coils are tucked into their own compartment, and space is left for the coil, visible rod aerial and all the leads.

the spindle; a hole of about 1-in. diam. is recommended.

Many enjoyable hours have been spent roaming around the world with my "D.X.2," American stations coming in full pelt, French amateurs and English "fans" being in many cases too loud for the headphones. On several occasions,

the writer has listened for hours to a British aeroplane station giving instructions to pilots in planes flying all over the country, and by careful tuning, was able to pick up the pilots replying to their base. At another time a two-way conversation was heard between two Spanish amateurs, whilst Morse from all parts of the globe comes in excellently.

Now, at this moment of writing, I am listening to an amateur speaking from

### IT BRINGS IN JAVA!

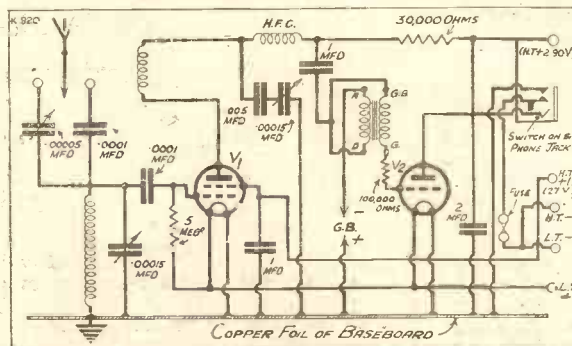

This is the circuit, and its efficiency can be judged by its success in picking up Java on the little rod aerial described.

Belgium, and I am sitting before a fire in a downstairs sitting-room, with the set beside me and just the "stick" aerial. The time is 5.15 p.m. and as I think the B.B.C. dance band is due—I put in the broadcast coil—ah! here is Henry Hall, and too loud for the phones. Moscow, the Rugby station speaking the S.S.

"Majestic," Chelmsford, Madrid, and Nauen have all been received quite clearly on the "stick."

It might be noticed that some S.G. valves do not oscillate on the smallest coil; if you find this happens, either increase the H.T.+1 from 27 to 36 volts, or try one or two other makes, as these valves vary and some oscillate better than others.

### No Earth.

Try adjusting your aerial coupling condenser, or connect an earth lead to the set. Incidentally, the set usually works better without an earth, but layouts, conditions, etc. may alter things in this respect.

In the original circuit as published, I have used a 5-meg. leak, but in many instances a 10-meg. leak

often makes the screen-grid detector valve work better. Also, use a good make of grid condenser (.0001); try several, as even these differ slightly.

Complete with accumulator, a 99 volt H.T. battery, a small G.B., and a pair of phones, the set becomes a real companion.

# OUR POWER CONSIDERATIONS!

WHICH requires more power, the sending or the receiving of broadcast programmes? The pictures of huge engine-rooms and the impressive statistics

that appear as each new B.B.C. station opens up might seem to point the answer in favour of the transmitting end; but "ilka little maks a muckle," and while the total engine capacity of the B.B.C. when the regional scheme is complete will be in the neighbourhood of 7,000 h.p., a conservative estimate shows that when all the British receiving sets are running they consume even now at least 70,000 h.p.!

The total power put into all the transmitting aerials will be rather more than 700 h.p., of which a large proportion will be actually

radiated, the remainder being unavoidably lost in the aerials.

### Tremendously Inefficient.

As regards the receivers, although they consume such a huge amount of power from batteries and mains, they push a total of only about 3,000 h.p. into their loudspeakers, of which a mere 30 h.p. is actually given out in the form of sound. Quite enough, too, some say!

The loudspeaker movements of Great Britain require more power to drive them than many a small town. And far more is wasted in heating valve filaments and anodes, and in fact more or less every part of the sets.

How is this estimate made up? To start with, we assume five million sets. There are not quite five million licences, but that is quite a different matter! Besides, sometimes one licence covers two or more receivers.

Then we write off half a million as crystal sets, which require no power. That should be quite a generous allowance in these days. The remaining four and a half millions are judged to be 2 to 1 in favour of battery drive.

The average battery-driven set takes 2 volts 0.5 amp. L.T., and 100 volts, 10 milliamps H.T.—1 watt in each case. So that is six million watts altogether. And as there are 746 watts in a horsepower, the total is 8,000 h.p.

### A Very Useful Load.

The average mains-driven set consumes at least 30 watts, so one and a half millions of them take 45 million watts, or 62,000 h.p. Total, 70,000 h.p.

There are not so very many power stations in this country that could cope with such a demand if it were all taken at once. And yet some electric supply companies despise the radio load and inflict as many pin-pricking regulations as they can devise.

M. G. S.

# TELSEN

## VARIABLE CONDENSERS and DRUM-DRIVE

Air-Dielectric

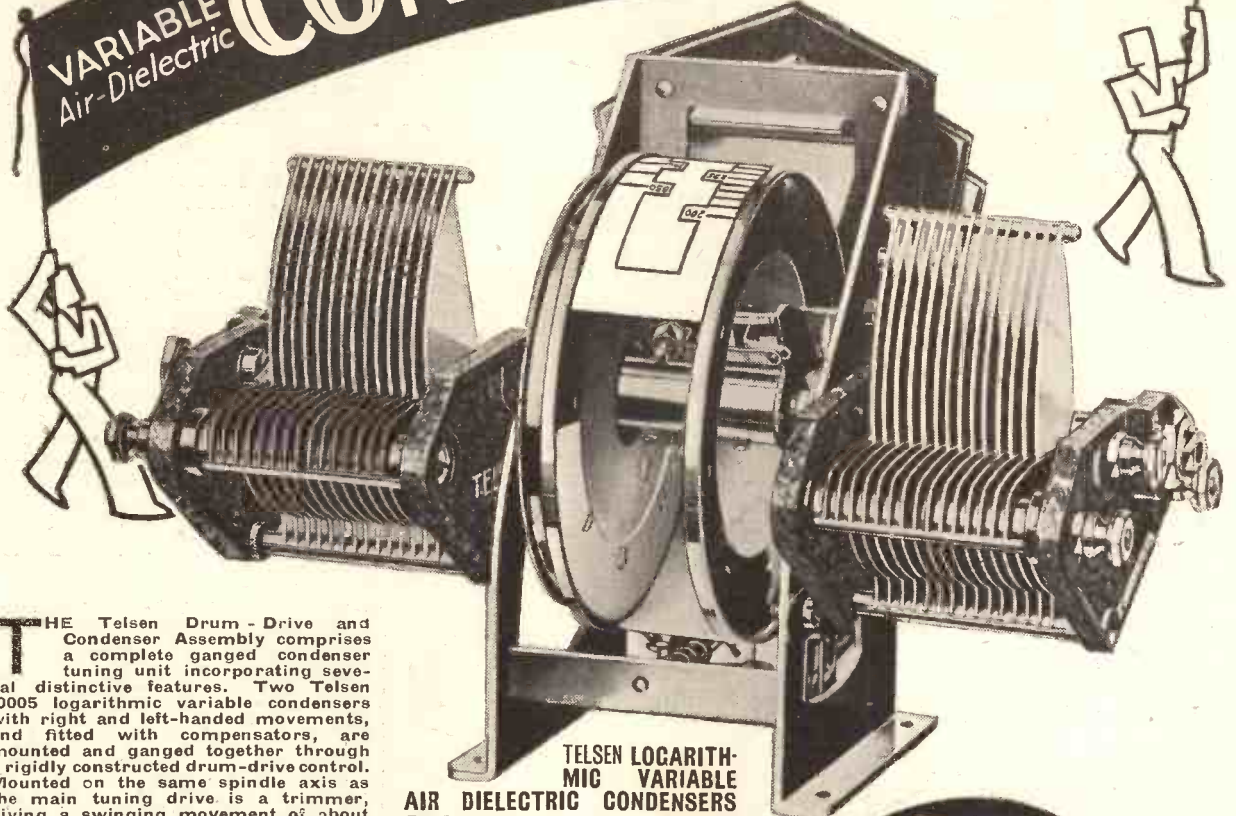

**T**HE Telsen Drum-Drive and Condenser Assembly comprises a complete ganged condenser tuning unit incorporating several distinctive features. Two Telsen .0005 logarithmic variable condensers with right and left-handed movements, and fitted with compensators, are mounted and ganged together through a rigidly constructed drum-drive control. Mounted on the same spindle axis as the main tuning drive is a trimmer, giving a swinging movement of about 20° to the stator vanes of the right-hand variable condenser, thereby enabling perfect matching of the condensers to be maintained throughout the Tuning Range. Two scales are supplied with the unit, one marked in wavelengths and one in graduations from 0-100. The Scale is illuminated and has the additional advantage of being easily removable when it is desired to fit one of special calibration. The escutcheon is handsomely finished in oxidised silver, and knobs of the push-on type are fitted. Provision is made for panel and base-board mounting, and a double-ended spanner is supplied free with the unit for fitting the variable condensers. Full instructions for mounting are included with every unit. No. W.262. Price

**17/6**

### TELSEN LOGARITHMIC VARIABLE AIR DIELECTRIC CONDENSERS

The Frame is braced by three solid pillars, and the effective clamping of the vanes, each held at three points, makes distortion impossible. The rotor is also built into a rigid unit, the vanes being held at both ends. Generous bearings obviate backlash or end-plate. Models No. 260 and 261 (left hand and right hand movements respectively) incorporate a compensator (max. cap. 60 micro-microhenries) for balancing out stray capacities, thus greatly facilitating ganging.

Model	Cap.	Price	Model	Cap.	Price
No. 130	.00025	4/6	No. 260		
			(Left hand movement with trimmer)	.0005	5/-
No. 131	.00035	4/6	No. 261		
			(Right hand movement with trimmer)	.0005	5/-
No. 132	.0005	4/6			

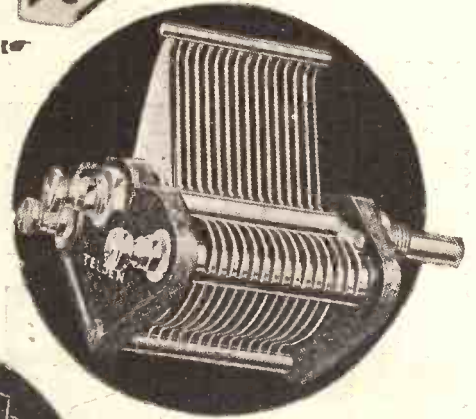

# TELSEN

## RADIO COMPONENTS

See the complete range of  
TELSEN RADIO COMPONENTS  
ON STAND NO. 66 AT RADIOLYMPIA.



### TELSEN DRUM DRIVE

Follows standard practice generally, but embodies several detail refinements, among which may be instanced the cord drive, arranged to reduce wear to a minimum and to prevent over-run, and the rocking stator trimmer, which gives a variation of 20°, and visual indication of setting. For use with Telsen screened coils, an extra scale, marked in wavelengths, is supplied free of charge. Illustration shows escutcheon, handsomely finished in oxidised silver. No. W.255. Price

**8/6**

# GOOD RADIO IS A JOY FOREVER

# TELSEN 10-1 COUPLING UNIT & 1-1 COUPLING UNIT

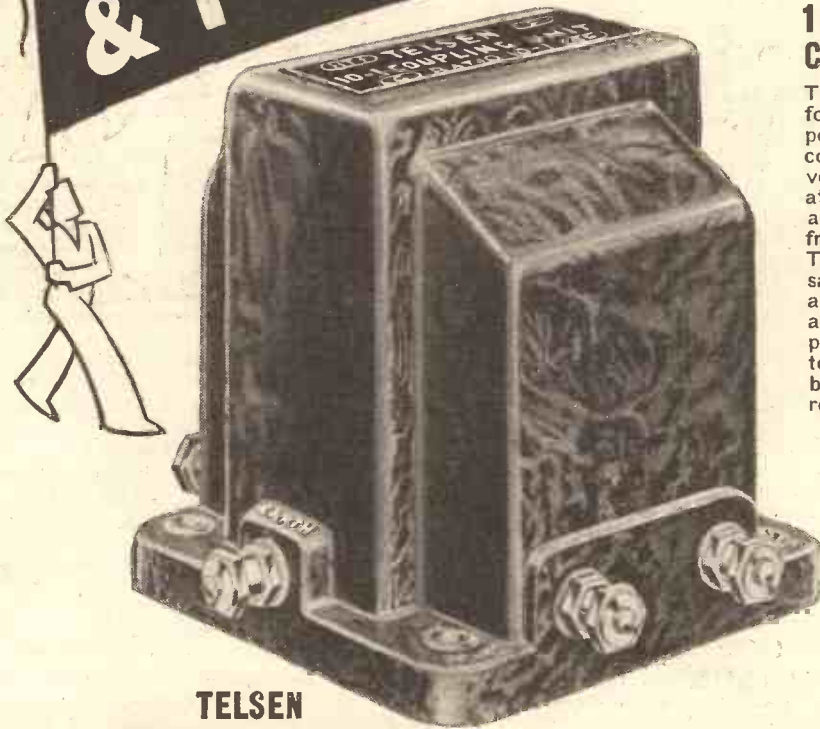

## TELSEN 10-1 INTERVALVE COUPLING UNIT

This is a filter-fed transformer using a high permeability nickel alloy core, which enables a 10-1 voltage step-up to be attained while preserving an exceptionally good frequency characteristic. The response is compensated in the higher frequencies for use with a pentode valve, this combination giving an amplification greater than anything previously achieved, equal to two ordinary L.F. stages, but with better quality of reproduction.



**12<sup>6</sup>/<sub>6</sub>**

No. W.215.

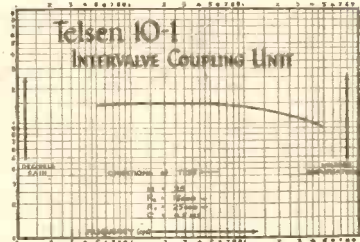

## TELSEN 1-1 INTERVALVE COUPLING UNIT

This is a modern development of the one time deservedly popular R.C. units. It incorporates a low pass filter feed in its anode circuit, thus effectively preventing "motor-boating," "threshold howl," and other forms of instability arising out of common couplings in eliminator and battery circuits. Used with an H.L. type valve it will give an amplification of about 20 and a perfect frequency response, at the same time consuming negligible H.T. current.

**7<sup>6</sup>/<sub>6</sub>**

No. W.214.

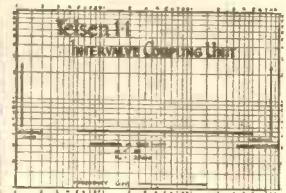
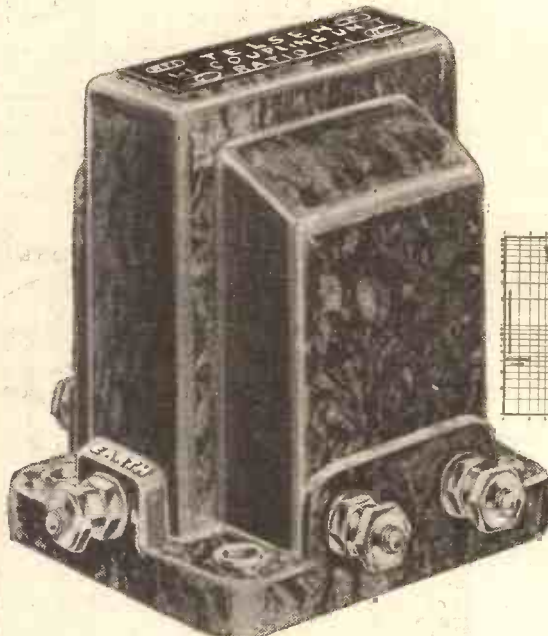

# TELSEN

**RADIO COMPONENTS**

See the complete range of  
**TELSEN RADIO COMPONENTS**  
on STAND No. 66 at RADIOLYMPIA.

**GOOD RADIO IS A JOY FOREVER**



# A Novel Broadcasting House

**I**F you have ever been to Germany you will know that there is a "futurist" craze amongst architects, and some most peculiar angular and modernist buildings are springing up in all the towns.

But I have never seen anything quite so quaint as the new broadcasting house which the North German Broadcasting Company has built just outside Hamburg.

I came down from Bremen to Hamburg recently, and at the invitation of a Norag official (N.O.R.A.G. is a very short contraction for a very long German hideousness meaning "North German Broadcasting Company") I went along to see this novelty in broadcasting houses.

## A Quaint Building.

This official, by the way, had also seen the new R.R.G. Broadcasting House in Charlottenburg—a quaint, semi-triangular building which many people say is better than our own B.B.C. headquarters in Portland Place. But that is another story. This official, I say, had seen the Berlin building, and together we were able to compare notes, but of course he was biased in favour of the Norag building.

I should explain that this building—a massive place—is not for use only with the comparatively small Hamburg 1.7 kilowatt. The idea is that when the Regional Plan is pushed forward in Germany (it has been started by the opening of Mülacker), the Hamburg station will probably be closed down, but the studio building will be used by the Norag concern for a landline link with the three 75-kilowatt regionals.

## Strikingly Futuristic.

Anyway, it is *some* studio! I could not discover whether it is entirely a new building or whether it has been converted. The outside is strikingly futuristic and looks like a crazy artist's 2,000 A.D. contraption for an *Ideal Home* Exhibition.

Buildings designed for broadcasting purposes are becoming more modernistic each day. Our own Broadcasting House caused much comment on its opening, but "Norag" (the abbreviated name for the North German Broadcasting Company) has gone one better with its new Hamburg building. Come on a tour of Hamburg's Broadcasting House with "P.W.'s" **SPECIAL CORRESPONDENT.**

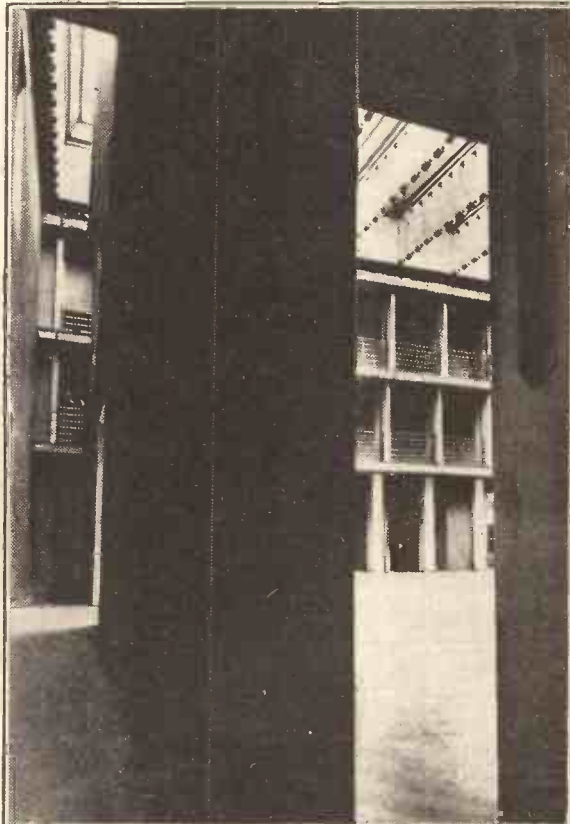

**"HAVE IT WHERE YOU LIKE"**

seems to be the motto of the Hamburg engineers who have built this wall at the end of the main studio so that it can be moved backwards or forwards to regulate echo.

Even the clock, which is outside, on top of an angular little tower, is one of those nightmare modern affairs with plain hands and only dashes where the figures should be! But the whole appearance of the building is so wholly modernistic that one can't help admiring the break away from convention: it seems quite in keeping with the spirit of radio.

But immediately you go inside you get a shock. The indirect lighting is wonderful, and the general impression is of a mass of bright chromium work and large areas of plain plaster and stone.

Can you picture a super-cinema combined with an Edgar Wallace-ish conception of a prison? That gives you a good idea of this latest "Funksaal."

## Resembles Nothing on Earth.

The entrance hall leads into a triple-deck studio, into which everything has been concentrated at the expense of smaller studios.

The Norag could honestly claim that this is the "most unique" studio in any country. Even our own Broadcasting House triple-decker resembles an ordinary large concert hall. The Hamburg studio resembles nothing on earth!

As one enters, the eye is drawn to a stage at one end, and to the two-tier balconies on each side.

The stage has sound reflectors standing about at spots previously determined by the engineers, to give the right amount of resonance for any particular broadcast. At the other end of the studio is a movable wall with a little balcony near the ceiling.

## Removable Sound Reflectors.

Elaborate mechanical arrangements allow this reflecting wall to be moved forward, and the size and acoustic characteristics of the studio are varied in this way. There are removable sound reflectors on the ceiling of our own Number Seven studio, but nobody

(Continued on next page.)

**D**URING the last few weeks those readers who follow "Short-Wave Notes" regularly will have seen that I have been appealing, on behalf of the Wireless Institute of Australia, for help from owners of short-wave receivers at the end of August.

A total eclipse of the sun (not visible in this country) takes place at about 7 p.m. (B.S.T.) on August 31st, and much valuable information may be forthcoming with regard to radio conditions.

Scientists from all over the world will travel to Canada (which is in the path of totality) with the special object of investigating and measuring the Heaviside layer. But there are other important observations which can be made by every owner of a receiver if he will spend a few hours at the task.

I have covered the short-wave side of the tests fairly completely in "Short-Wave Notes," but it is hoped that all wavelengths between 5 and 5,000 metres will be "observed."

For this reason I am appealing to broadcast listeners to do their bit as well.

#### Vast Quantities of Data.

Previous experience seems to show that the effect of a total eclipse on radio reception cannot be predicted. The sudden appearance of a belt of darkness over the surface of the earth, in an unaccustomed position, so to speak, may be responsible for all sorts of unlooked-for effects.

For this reason it is only by accumulating

## THE ECLIPSE TESTS

The total eclipse of the sun on August 31st will provide a not too frequent opportunity for investigating the effects of darkness on radio waves. The part which every listener can take in these observations is here described by W. L. S.

a vast quantity of data, from receiving points all over the earth, that any rhyme or reason may be made out of it.

Your part, as a reader of "P.W.," is this. Settle on some particular station—apart from your locals, of course—that you can be reasonably sure of receiving.

Don't choose too strong a station, but a fairly consistent one. Watch him for the two days before the eclipse—August 29th and 30th—then again on the day of the eclipse, August 31st, and once more on September 1st.

It would seem to be a good scheme to keep watch either from 6 p.m. till 10 p.m., or from 6.30 p.m. till 9.30 p.m. At any rate, choose your times so that the time of the eclipse, which is from 7.4 p.m. till nearly 9 p.m., comes within them.

#### Tabulating Results.

After you have collected all your results, set them out in a table, making sure that all the following points are included:

- (1). Station watched.
- (2). Wavelength.
- (3). Date of watching (i.e. August 29th, 30th, 31st, and September 1st).

(4). Strength at 15-minute periods (e.g. 6.30, 6.45, 7.0, 7.15, etc. See above for the best times for listening).

(5). Nature of fading (i.e. quick, slow, etc.).

(6). Period of fade.

(7). Any additional notes.

It would greatly help the work of sorting out the various pieces of information if you would send in a table having seven columns, one for each of the items listed above.

Please note particularly that it is most important that you should make it clear whether the station fades on the "non-eclipse" days, and, if so, whether the fading is regular or merely freakish. If the fading is perfectly regular, it would be worth while to time it roughly, and to notice what happens on the 31st.

If you can afford the time and patience to watch the same station for an hour or two, you will help by noting down his strength at intervals of fifteen minutes. Only by going into details like this can be analysed the effect of the eclipse on the reception of any particular station. Obviously, we want to know all about how that same station comes in on an ordinary day, and it is not safe to take merely one day.

I am taking over the job of collecting all the results together and tabulating them. If anything interesting results, you will see it in "P.W." as soon as I have finished the work!

Please address your logs to me, c/o "P.W.," marked "Eclipse Tests."

## A NOVEL BROADCASTING HOUSE

(Continued from previous page.)

has previously tried the daring experiment of moving the entire wall of a studio to change its echo period.

The balconies on each side can be used for public admission and, when I was there, two sound-booths had been fitted up for the control engineers at the line amplifiers. Each part of the balconies is railed off like a little cubicle, giving a striking appearance, and I was tempted to ask the Norag official, in guide-book style, "Was für Zimmer haben Sie zu vermieten?" But, out of politeness, I refrained!

#### Haphazard Deadening.

The ceiling is covered with hundreds of hanging slabs, for a description of which I cannot do better than refer you to the photograph on this page. These slabs diffuse the lighting and break up ceiling reflections.

I cannot make out how it is that there isn't a violent echo in this giant studio. In keeping with the modern decoration scheme there is nothing on the walls, which are hard and sound-reflecting, and there is a parquet floor; but the echo is quite normal.

It seems that instead of building a large room and haphazardly deadening the echo with velvet drapings and felt floors, the Norag engineers have deliberately built an echoing room and, by means of accurately

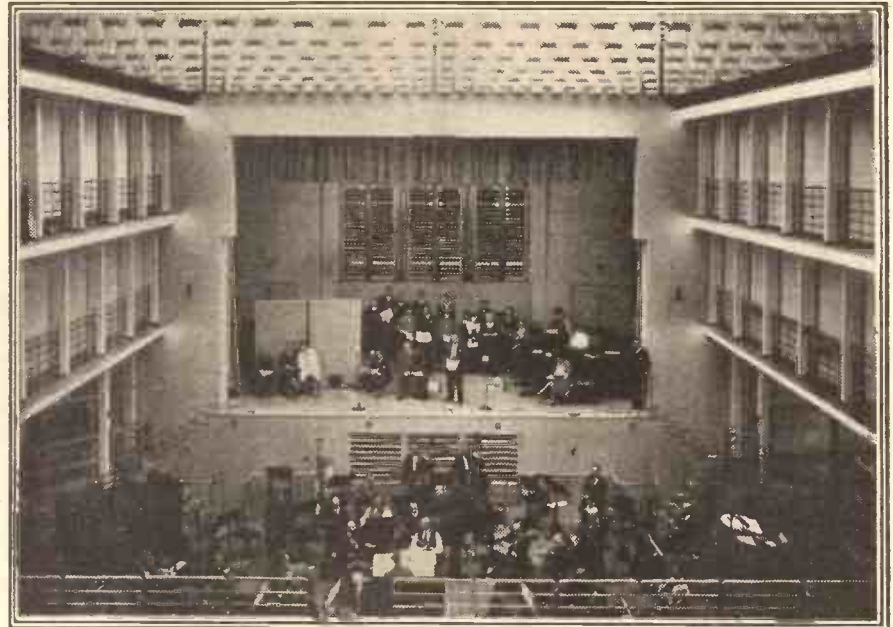

**THE TRIPLE DECKER CONCERT STUDIO**

at Hamburg, with its portable sound reflectors, and its movable wall and ceiling, is the most practical concert hall in the broadcasting world.

placed screens, they can control the echo.

On the occasion of my visit, four microphones were in use for a rehearsal of some light music for an orchestra of about fifteen players. The reverberation seemed different at various corners of this quaint room, whereas with any padded

studio there is no noticeable difference.

Altogether, this new Hamburg broadcasting house seems to be an example of Prussian scientific skill combined with the New Germany's love of modern things.

A "very novel *Funksaal*," as the Norag official said to me when we left.



# TELSEN CONDENSERS

**BAKELITE DIELECTRIC**

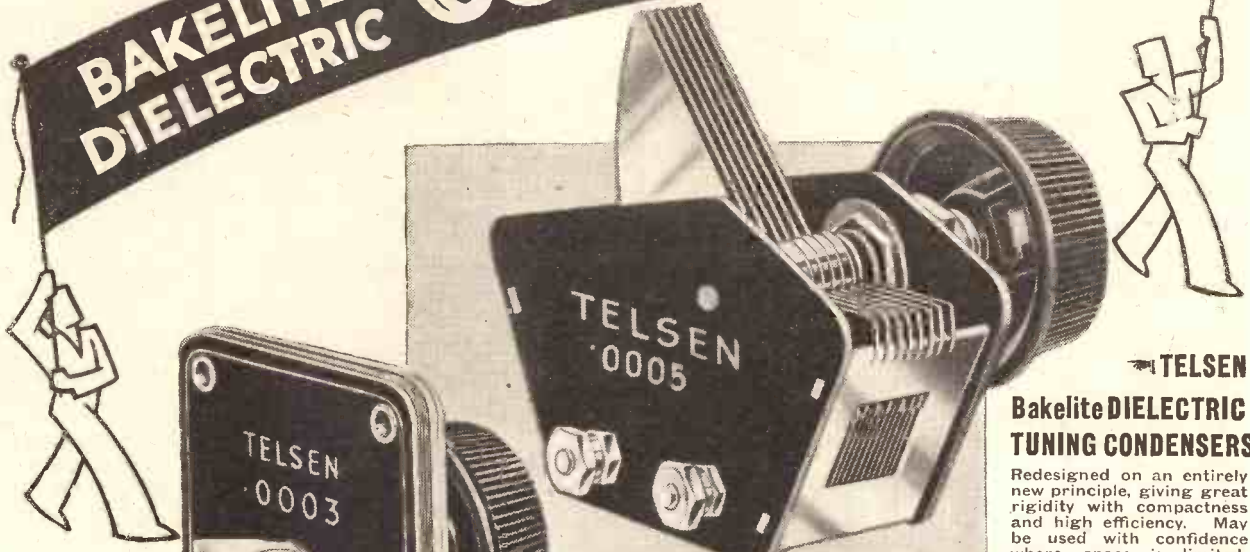

**TELSEN**

**Bakelite DIELECTRIC TUNING CONDENSERS**

Redesigned on an entirely new principle, giving great rigidity with compactness and high efficiency. May be used with confidence where space is limited. The well-braced vanes are interleaved with a minimum of highest quality solid dielectric, ensuring complete accuracy of tuning. Supplied complete with knob.

Capacity No.  
 '0005 - W.193  
 '0003 - W.194

**2 6**

**TELSEN AERIAL SERIES CONDENSER**

This component forms an ideal volume and selectivity control. The internal construction permits of an extremely low minimum capacity. Keyed externally on the spindle is a switch arm which connects with a contact on the fixed vanes when rotated to maximum position. This short circuits the condenser for maximum volume. The rotor movement is limited by definite stops. The vanes are interleaved with the finest quality solid dielectric, and solidly constructed throughout. Supplied complete with knob.

Capacity '0003 - - - W.205

**2 3**

**TELSEN REACTION CONDENSERS.**

Improved type, of great rigidity and precise construction. The Rotor Vanes are keyed to the spindle, and fitted with definite stops. The vanes are interleaved with finest quality solid dielectric. A strong nickel silver contact makes connection to the rotor, and a positive connection is made to the stator vanes. Complete with knob.

Capacity '0003 No. W.188  
 " '0015 " W.189  
 " '0001 " W.190  
 " '00075 " W.191  
 " '0005 " W.192

**2 4**  
**2 6**

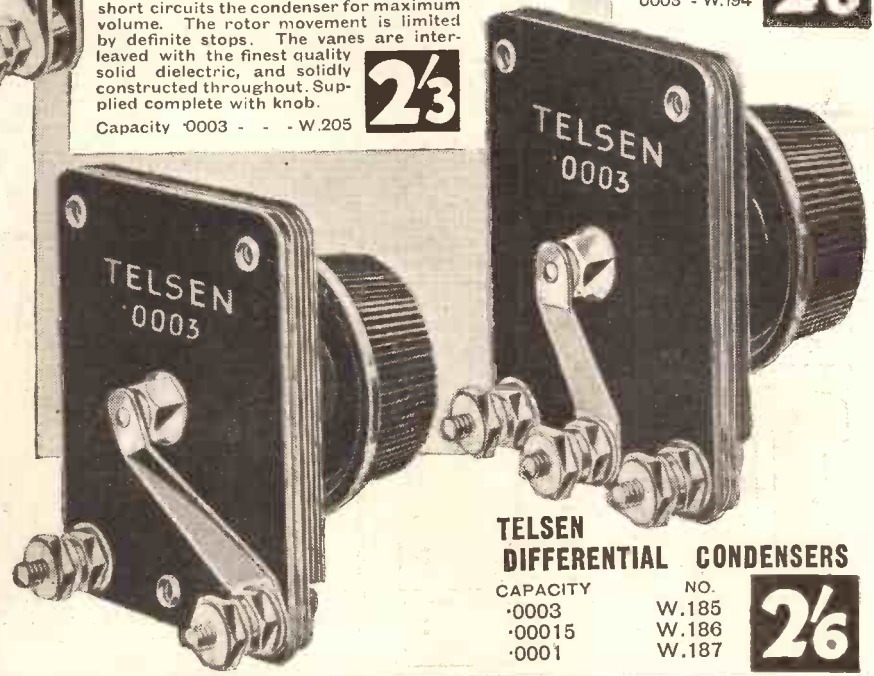

**TELSEN DIFFERENTIAL CONDENSERS**

CAPACITY NO.  
 '0003 W.185  
 '00015 W.186  
 '0001 W.187

**2 6**

## TELSEN

**RADIO COMPONENTS**

See the complete range of  
**TELSEN RADIO COMPONENTS**  
 on STAND No. 66 at RADIOLYMPIA

**GOOD RADIO IS A JOY FOREVER**

ANNOUNCEMENT OF THE TELSEN ELECTRIC CO., LTD., ASTON, BIRMINGHAM.

# The TELSEN

# AJAX 3



Bigger . . . better . . . packed with valuable information from cover to cover—the new Telsen Radiomag is undoubtedly the finest radio sixpennyworth ever offered. For it appeals to all—and all can profit by it. In simple

language, illustrated by photographs and diagrams, and complete with 3 full size 1/- blue prints, it tells you how to build the latest circuits—how to modernise your existing set . . . how to rectify little faults . . . how to get the best out of your set in every way. **Get a copy NOW!**

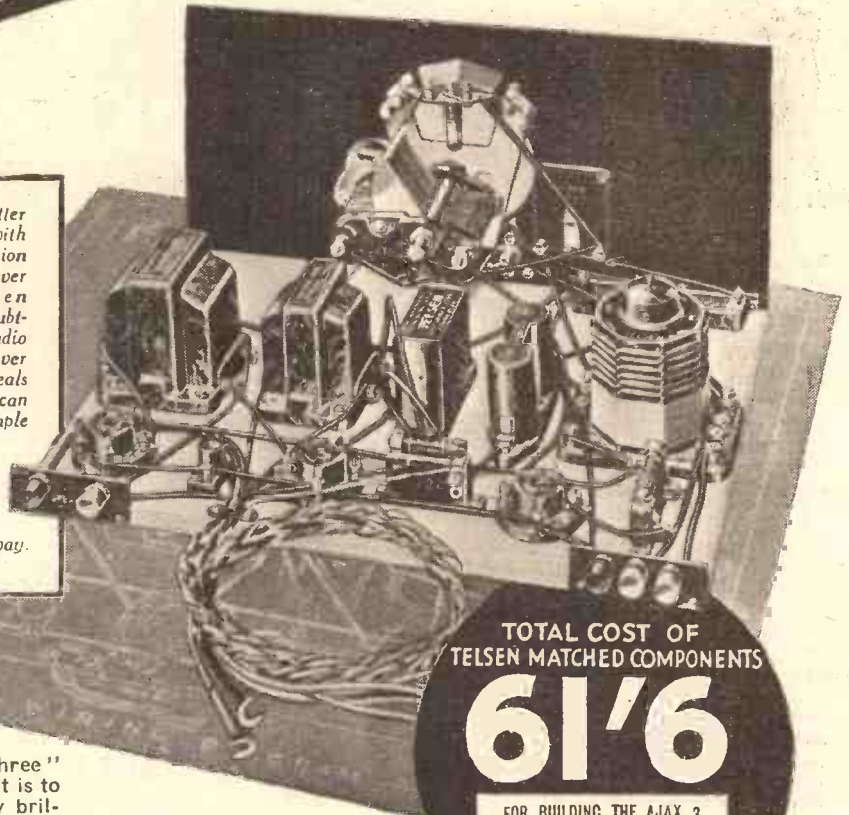

TOTAL COST OF  
TELSEN MATCHED COMPONENTS

## 61'6

FOR BUILDING THE AJAX 3,  
including panel, base-  
board, terminals,  
battery cords and all  
accessories.

**A** HIGHLY efficient "Straight Three" circuit, as easy to operate as it is to build, giving an exceptionally brilliant all-round performance, with a low initial and upkeep cost, the range, power, selectivity and general quality of reproduction setting a new standard for receivers of this type. Free full size 1/- blue print, together with full constructional details are contained in the new issue of Telsen Radiomag, which also gives full particulars of the improved and now all-embracing range of Telsen Radio Components at the still lower prices made possible by Telsen's enormous sale. Now on sale at all radio dealers and newsagents. Price 6d.

# TELSEN

## RADIO COMPONENTS

See the complete range of  
**TELSEN RADIO COMPONENTS**  
on STAND No. 66 at RADIOLYMPIA.



**CONSTRUCTORS' OUTFIT  
"TELORNOR"**

Contains all the sundry requirements for the construction of any type of receiver circuits using the "Telornor." Of these the Telsen "Triple" 3, the "Ajax" 3, and the "Nimrod" 2, are excellent examples. All are supplied neatly packed in a carton together with instructions.

Cat. No. 220  
**3/6**

Included in the Outfit are the following components:

- |   |   |   |
|---|---|---|
| <p>Specially cut and drilled crystalline-finish Panel. 14" x 10" Baseboard. 8-way Battery Cord. Complete set of Wander Plugs, suitably engraved, and Spade Terminals. Terminals for Aerial, Earth and Loud Speaker.</p> | <p>Engraved Terminal Strips. An ample supply of 22 S.W.G. Tinned Copper Wire and necessary Sleeving for wiring up the set. A double-ended Spanner for mounting the single-hole fixing components.</p> | <p>A 4-way Spanner, for tightening up all Terminal Nuts. All the Wood Screws and sundry other small accessories contributing to the complete assembly of the finished Receiver.</p> |
|---|---|---|

# GOOD RADIO IS A JOY FOREVER

ANNOUNCEMENT OF THE TELSEN ELECTRIC CO., LTD., ASTON, BIRMINGHAM.

# PUSH-PULL *or* PUSH-PUSH?

**A**LTHOUGH the first push-pull circuit dates back to 1915, it is only within the last few years that it has come into general use in amplifiers, partly in connection with the electric gramophone, and partly to supply the increasing demand for high-quality reproduction—as distinct from mere “noise”—in the more powerful type of broadcast receiver.

The importance of the modern push-pull combination is indicated by the fact that although the master patent covering the principle was due to expire last year, it was granted a further lease of life for four years by the High Court.

### Keeping on the “Straight.”

A valve can only amplify faithfully so long as it works on the straight-line part of its characteristic curve, which means that it can only handle a limited input voltage. If this is exceeded the valve works “over the bend,” the upper and lower notes are “cut,” harmonics are introduced, and the reproduction is generally distorted.

In the push-pull amplifier this difficulty is overcome by placing two valves “back and back,” and dividing the input between them, so that one half of the applied voltage is handled by one valve, and the other half by the second valve. This enables the voltage swing to be doubled without passing “off the straight,” particularly if each valve is properly biased.

In practice, each of the valves is biased approximately to the middle, instead of to the bottom of the “straight,” partly because it is found that the lower portion tends to curve away, and partly because a

“lower bend” bias necessitates a very accurate balancing of the two valves. But although a portion of the total curve is sacrificed in this way, the push-pull amplifier will give approximately double the output of a single valve—and that without distortion.

\* \* \* \* \*

**The method of increasing power output by joining two valves in push-pull is now quite popular, and paralleled valves have had quite a run in the past. Now comes a new system of using two valves. It is very ingenious and is here clearly explained**

By J. C. JEVONS.

\* \* \* \* \*

The method in which the two valves handle the input voltage is illustrated in Fig. 1, where the left-hand pair of curves represent the conditions during the first half-cycle of the applied input. The grid of, say, the upper valve V<sub>1</sub> is thrown positive, and the resulting “push” of output current is shown by the upwardly-pointed arrow. Simultaneously the grid of the lower valve V<sub>2</sub> is thrown negative, and the corresponding “pull” of plate current from that valve is indicated by the downward arrow.

### Easily Explained.

The right-hand pair of curves show the effect of the succeeding half-cycle of input voltage, where the conditions are reversed. The valve V<sub>2</sub> now takes over the rôle previously played by the valve V<sub>1</sub>, and vice versa. The next half-cycle repeats the conditions of the first, and so the process goes on.

It is, of course, true that the same result, so far as double-volume is concerned could be obtained by feeding two valves connected in parallel instead of in push-pull, but the parallel arrangement is open to certain definite objections.

In the first place the D.C. plate current from each of the valves in a push-pull circuit flows in opposite directions through the common output transformer. It is therefore automatically balanced out, so that there is no chance of its being fed back to the input circuit to give rise to undesired reaction and “parasitic” oscillations.

The absence of D.C. current in the output windings means that a much smaller and

therefore less costly type of transformer can be used with the push-pull circuit than in a “parallel” amplifier, where there is a large direct current present to saturate the core. Also if push-pull valves should occasionally work “round the bend,” any even harmonics that may be created in this way are effectively cancelled out in the transformer windings.

### Many Advantages.

The fact that the H.T. supply is “balanced” across the output transformer also lessens the tendency to mains “hum,” so that the smoothing-components in the eliminator can safely be cut down to a minimum, so far as the output stage is concerned, as can also the decoupling resistances. Finally, if there is any “hum” component in the grid-bias voltage (when this is taken from the mains) it, too, will cancel out automatically in the output transformer.

These advantages are not present when two amplifiers are connected together in parallel. Moreover, in the latter arrangement it is also necessary to work with a small load impedance, since the effective impedance of the paralleled valves is only half that of each taken independently, or a quarter of the two in series.

Still another method of coupling two valves together into a single unit has recently been developed. It is called the “push-push” amplifier to distinguish it from the push-pull arrangement, to which, at first sight, it bears a close resemblance.

(Continued on page 800.)

### HOW THE CYCLES BALANCE

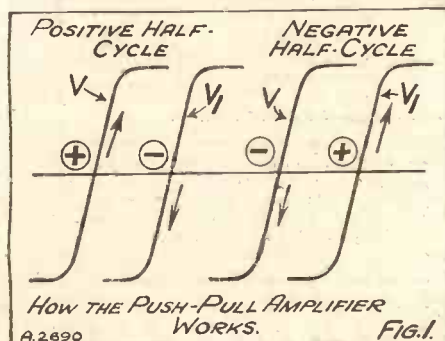

Illustrating the current in the anode circuits of push-pull valves during the various parts of a cycle.

### NO GRID BIAS USED

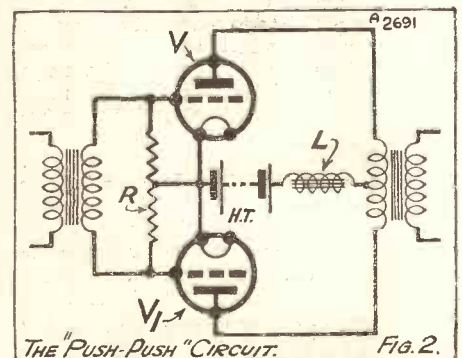

A new method of using two valves in which less H.T. than normal is required.



**TAKING OUR FOOD ON THE FLOOR—AN SOS CALL—AT BOULOGNE—  
SIR DOUGLAS HAIG—THE LAST VOYAGE.**

**Dining on the Door-mat.**

OCTOBER 9TH, 1918.—Breakfast to-day consisted of porridge and coffee, both strongly flavoured with salt water. We partook of this cheerless meal sitting on the saloon floor and attempting to drink both items from mugs.

I don't know whether to laugh or swear. It's beastly cold, and one's feet get numbed slopping about in ice-cold water. We left off wearing shoes and socks days ago; they are superfluous in this weather.

2 p.m.—The other operator has just been laid out in a curious manner. He was opening the cabin door when it flew out of his hand and swung to, catching him on the jaw and laying his cheek open. The salt water got into the cut and made him yell like blazes.

8 p.m.—Too busy to make an entry this afternoon, and even now it is difficult to do any writing. From becoming an interesting experience, this storm has turned into a tragedy.

This afternoon there came an urgent call from one of the ships that had been in the convoy. She reported her steering gear swept away, and that she was being badly hammered by the seas. H.M.S. Devonshire answered, saying that she was coming along as fast as she could to give her a tow.

**A Vessel in Distress.**

Immediately after this, another call was sent out reporting that a big wave had stove in her after-hatch, and that she was shipping water fast. The Devonshire replied that all speed was being made to reach her, and asked for the exact position; but although I have been listening carefully, no reply has yet been made, and the Devonshire has repeated her request several times.

I am afraid she will never get an answer. They were saying in the saloon, when we assembled for our grub hunt, that when a ship gets to taking water into her main hold it's time to clear out. Naturally, we are not cheered at the news. The old man looks awful.

None of us has shaved or washed for days. I opened the cabin door just now and had a look out on deck. The waves were leaping aboard one after another and in the pitch black darkness of the night they glittered with a phosphorescent sheen. It is a weird and uncanny sight. I was glad to shut the door. The cabin is fairly warm and cheerful, despite the falling seas and the screaming wind outside.

I am glad to say we are now in touch with the Devonshire. She has no fresh orders for us, but wishes all ships to carry on alone as it is impossible for the convoy to keep together in this weather.

**Calm as a Duck Pond.**

OCTOBER 14TH.—What a change! To-day the sea is as calm as a duck pond. The storm has blown itself out. This morning we got in touch with the rest of the convoy, and our orders are to proceed to Boulogne.

OCTOBER 22ND.—In peace time I never had the conventional pleasure of a trip to Boulogne, but I should imagine that anyone acquainted with the place before 1914 would scarcely recognise the Boulogne of 1918. Thousands of troops are continually arriving and departing, many of

ashore for a stroll round the town, and while walking along one of the quays we came upon a little group of soldiers with fixed bayonets. Suddenly, a big motor-car dashed up. Everybody sprang to attention and saluted. A man dashed out, returned the salute, and went hurriedly aboard a destroyer that was moored alongside the quay. It was the first time I had ever seen Sir Douglas Haig.

**Well But Not Wisely.**

In the evening I went into a local café, where I got talking to a major who had obviously dined well but not wisely. He informed me that he was returning to the Front that evening, near Cambrai, and said that if I cared to get leave he'd run me up in his car and see that I got sent back O.K.

What a chance! I sprinted back to the ship in order to get permission from the captain and, after a considerable amount of trouble, obtained his reluctant consent. Off I dashed again to the café, but, alas! the major had been busy while I was getting a few things together on the ship, and had had so many over the eight that it was quite impossible for him to get to the Front himself—and consequently I didn't either. But the persistent rumble of the guns—which in Boulogne sounds like a continuous thunderstorm in the distance—served as a reminder of the chance I missed.

**The Last Voyage.**

NOVEMBER 18TH, 1918.—A few days ago the Armistice was signed, and to-day we left Southampton for Salonika. By the irony of fate, I was ordered back to the ship the very day hostilities ceased. I was in London when the clock struck eleven

**THE FIRST OF OUR GERMAN PRISONERS OF WAR**



The first batch of prisoners to arrive in this country coming ashore at Penzance. They landed on August 13th, 1918, nine days after war was declared.

them fresh from the Front and with the mud of Cambrai still on their boots.

The streets are full of motors, from the superb chariots of the gilded staff down to the bone-shaking A.S.C. lorries. Everywhere there is activity; the wharves are thronged with German prisoners unloading stores, and ships are continually coming and going.

Yesterday morning, V— and I went

on the 11th, and I dare say, in years to come, when I read this diary, that scene will be as vivid as it is now.

Everybody on board is torn between exhilaration at victory and the cussedness of fate in sending us to sea with our holds full of shells and T.N.T. for Salonika, with the war over and the armistice already a week old.

(To be continued.)

# The TELSEN JUPITER S.G.3

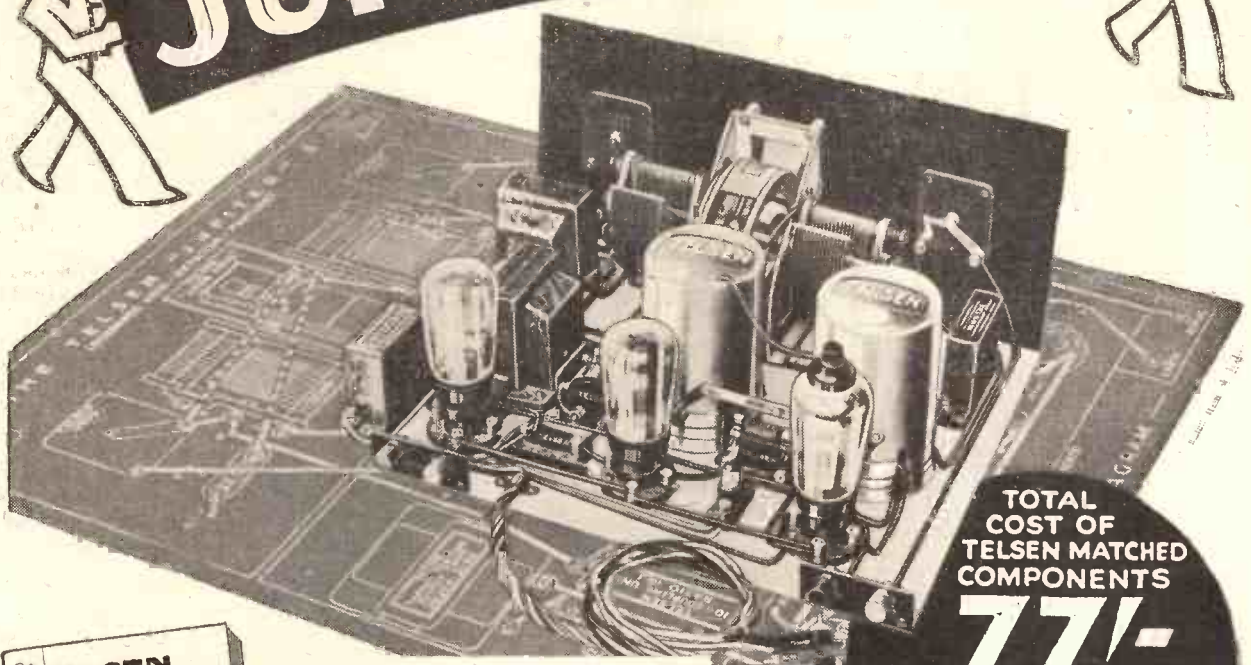

TOTAL COST OF TELSEN MATCHED COMPONENTS

**77/-**

FOR BUILDING THE JUPITER S.G.3, including panel, base board, terminals, battery cords and all accessories.



Utilising a brilliant circuit arrangement devised by Telsen technicians, ensuring the highest amplification under all conditions, with extreme selectivity, exceptionally wide range and superb quality of reproduction. Free full-size 1 - blue prints of this and other Telsen circuits, together with full instructions and a wealth of interesting and valuable information, including particulars of the improved and

now all-embracing range of Telsen Radio Components, at the still lower prices made possible by Telsen's enormous sale, are contained in the new, bigger and better issue of the Telsen Radio-mag. Get a copy NOW—price 6d. from your radio dealer or newsagent.

### DRUM DRIVE CONSTRUCTORS' OUTFIT



Contains all the necessary requirements for the construction of the TELSEN "JUPITER S.G.3," but the constructor will find the outfit of great value in the building up of any receiver circuit employing the drum drive condenser assembly, No.219 **3/6**

#### The Outfit Contains the Following :

- |  |   |  |
|--|---|--|
| 1 Metal Panel with attractive crystalline finish, specially cut and drilled for mounting the Telsen Drum Drive, and other panel-mounted components normally required in a ganged condenser receiver. | 7 Wander Plugs mounted in holder.                             | 1 Volume Escutcheon  |
| 1 Baseboard 14 by 10 in.   | 2 Spade Tags  | 1 "On-Off" Escutcheon.   |
| 1 Aerial and Earth Terminal Strip  | 1 8-way Battery Cord & Cord Clip.                             | 2 Height Plinths for the attached screened Coils.                          |
| 1 Loudspeaker Terminal Strip.  | 2 Large Insulating Washers.                                   | 1/4 in. of 3 mm. Sleeving (black)  |
| 2 Red Terminals complete and mounted in holder.  | 1 Small Thick Insulating Bush.                                | 1 1/4 in. of 3 mm. Sleeving (red).   |
| 2 Black Terminals complete and mounted in holder.  | 1 Small Thin Insulating Bush.                                 | 20 feet of 1 1/2 mm. Sleeving (green)                                      |
|  | 2 Spacing Nuts for the reaction and aerial series condensers. | 21 feet of 22 S.W.G. tinned Copper Wire.                                   |
|  | 2 Spacing Nuts for the "On-Off" Switch.                       | 1 Double-ended Spanner for lock-nuts.                                      |
|  | 1 Wave-Change Escutcheon with two screws and nuts.            | 1 Fourway Spanner.   |
|  | 1 Separator Escutcheon.                                       | Assortment of 1/4-in., 3/8-in., 1/2-in., 5/8-in., and 3/4-in. Wood Screws. |

# TELSSEN

RADIO COMPONENTS

See the complete range of TELSEN RADIO COMPONENTS ON STAND No. 66 at RADIOLYMPIA.

**GOOD RADIO IS A JOY FOREVER**

ANNOUNCEMENT OF THE TELSEN ELECTRIC CO., LTD., ASTON, BIRMINGHAM

**TELSEN**

**H.F. CHOKES**



**TELSEN  
BINOCULAR H.F. CHOKE**

In H.F. amplification the performance of a choke is of supreme importance. The Telsen binocular H.F. Choke is called for wherever the highest efficiency is required. It has a high inductance of 250,000 microhenrys, low self-capacity, and a negligible external field, due to the binocular formation, making it the ideal choke for a high class circuit. No. W. 74.

**5/-**

**TELSEN**

**RADIO COMPONENTS**

See the complete range of  
**TELSEN RADIO COMPONENTS**  
on STAND No. 66 at RADIOLYMPIA.

**TELSEN  
STANDARD H.F. CHOKE**

The Telsen Standard H.F. Choke utilises the minimum baseboard space. It is designed to cover the whole broadcast band, has very low self-capacity, and is highly suitable for reaction circuits. The inductance is 150,000 microhenrys and the resistance 400 ohms. It has proved very popular and has been incorporated by set designers in many of the leading circuits. No. W. 75

**2/-**

**GOOD RADIO IS A JOY FOREVER**

ANNOUNCEMENT OF THE TELSEN ELECTRIC CO., LTD., ASTON, BIRMINGHAM.

# CAPT. ECKERSLEY'S QUERY CORNER



Under the above title, week by week, our Chief Radio Consultant comments upon radio queries submitted by "P.W." readers.

## CHOOSING A CIRCUIT—LEAD OR COPPER—VOLTMETER PROBLEMS.

### Local Station Reception.

A. N. B. (Enfield).—"Which is the most satisfactory arrangement for local station reception only, a detector using anode-bend, followed by two L.F. stages and a fairly large aerial, or a set with an H.F. stage, detector and L.F., using a smaller aerial?"

An anode-bend detector is not so good as a leaky-grid detector. A leaky-grid detector gives more linear response, and allows retroaction to be applied easily.

The question whether to use 1 H.F., Det., 1 Note, or 1 Det. and 2 Notes for local station reception is decided in the following terms:

(a) If the local station is *very* strong, then neither a large aerial nor great selectivity is required; a high-frequency valve as typically used introduces (1) the possibility of using a smaller aerial; and (2) the addition of an extra tuned circuit.

(b) If the local station is not very strong and you cannot get a large aerial, use the high-frequency valve.

(c) If the local station is fairly strong and you can get a fairly big aerial, you might use a circuit such as the "Eckersley" Tuner when you will get all the selectivity you want and, with a reasonable aerial, all the sensitivity.

One cannot answer this question in general terms very easily.

### Suitability of Lead for Screening.

B. S. C. (Birmingham).—"Since lead is so easy to work with, and I have a quantity on hand, excluding the weight of same, is there any reason why this should not be used to make a totally screened cabinet? Of course, it will be very thin—one-tenth inch or so mounted on a wooden framework."

Lead has, of course, a higher resistance than copper, and is, therefore, theoretically not so useful as a shield. I think, however, it could be perfectly satisfactory.

Its great disadvantage is its weight. Aluminium is preferred to copper for screening work purely on account of weight—its actual screening properties are theoretically worse.

So calculate the *weight* of the lead screening-box to be sure it's not unmanageable. If you have the lead, and if you think weight is not a factor to worry about, then the screening properties should be sufficient.

### Converting a D.C. Voltmeter to A.C.

J. E. M. (Chippenham).—"I have a voltmeter of good make reading 0-500 volts, but it is only suitable for D.C. measure-

ments. Is there any simple way in which it can be adapted for A.C. measurements?"

There is no simple way, if, indeed, your first statement is correct. If your voltmeter is of the moving-coil type, it will only work if a D.C. current is passed through it; it will only read if that current passes through the coils in one direction.

The moving-coil D.C. voltmeter is recognizable because it has a terminal marked (+) and another marked (-).

The moving-iron type has no marked terminals, has a scale cramped towards the zero end, and usually has to be mounted vertically before it will work.

The moving-iron type will read A.C. or D.C. roughly right for 50 cycle A.C.)

This has helped you to know whether your voltmeter is a moving-coil or moving-iron type. Now, if it is of the moving-coil type, (+) and (-) marked, you could convert it to A.C. by using a metal rectifier, of which there are several examples on the market.

### ADDING A RECTIFIER

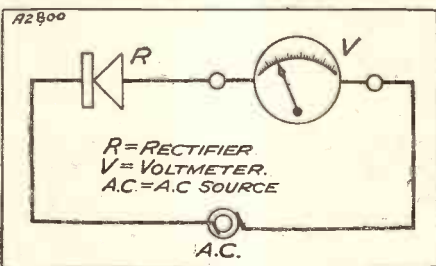

By adding a properly designed rectifier to a D.C. meter it is possible to make it work on A.C. But recalibration would be necessary.

But you would have to calibrate the voltages afresh: the addition of the rectifier would upset the scale readings.

### Leakage Fields.

A. S. T. (Highgate).—"Why is it that in the H.F. side of my set copper or aluminium is specified for screening, but for the box which contains the A.C. mains gear an iron box is used?"

I expect someone has come to the conclusion that iron screens the low-frequency disturbance set up by the power supply circuits from the low-frequency magnifying circuits.

A power transformer does certainly produce a leakage field, and this, if it couples with a valve transformer, sets up currents in that transformer and may therefore cause low-frequency "hum" in

Don't address your letters direct to Capt. Eckersley; a selection of those received by the Query Department in the ordinary way will be answered by him.

the loudspeaker. The iron box is intended to shield the leakage field. Unless the iron is *very* thick it does not act as a shield. It may distort the field and so act as an apparent shield.

The only way I know to stop coupling of this kind is to find an experimental placing of the components which eliminates the trouble.

### Dielectric Losses.

H. T. N. (Weybridge).—"I have noticed that, in a number of compact receivers, tuning condensers of the kind having a dielectric of the paxolin type between the condenser vanes are used, instead of the usual type with air dielectric. Would not the use of this type of condenser reduce efficiency and tend to cause flat tuning?"

I do not know the numerical figure expressing the dielectric losses introduced by the use of this material. I should guess that the losses are inconsiderable compared with those inevitable in a compact coil, and I am sure that by the use of retroaction the ultimate efficiency of the circuits is close enough to that of other circuits possessing air dielectric condensers.

Realise that in most receivers a turn of the reaction handle makes the difference of two stages of high frequency in selectivity and sensitivity and that, in face of these enormous changes, the little inefficiencies make very little difference.

### Plated Aerial Wire.

C. M. G. (York).—"Would there be any advantage in using plated aerial wire in place of the usual copper wire, since my aerial wire soon gets very dirty and needs replacing?"

As there would be the advantage that your aerial would not constantly want replacing, plating would not hurt the electrical performance appreciably. But surely an ordinary stranded phosphor bronze wire will last for years without attention? Never use solid copper wire. Stranded phosphor bronze is the best.

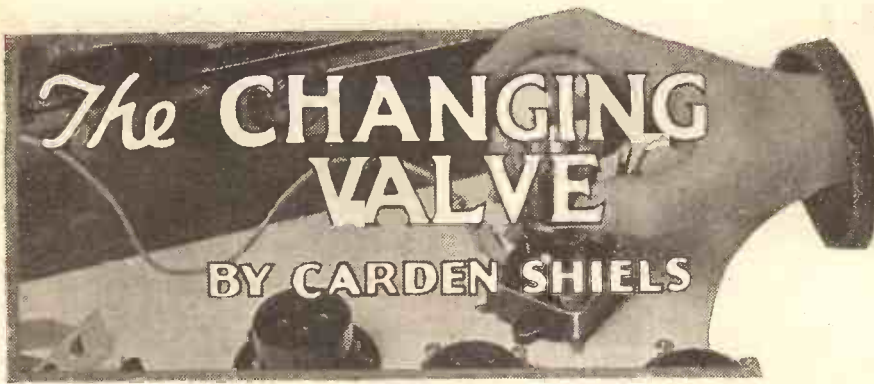

So many new developments have taken place recently which affect the interior working of the valve that readers have asked for an outline of recent improvements. A clear explanation of what goes on "inside the bulb" is given here, and very interesting reading it makes, even for the listener who does not usually read technical articles.

FROM one point of view modern valves may be classified according to the particular type of circuit with which they are intended to be used. For instance, the circuits on the high-frequency side of a wireless receiver are essentially different from those on the L.F. side.

The former are of high impedance and handle voltages rather than currents, whilst the latter must pass comparatively large currents to the loudspeaker. This, of course, distinguishes a high-resistance valve such as the S.G. amplifier from its low-resistance brother, say the pentode.

But a more interesting point of view is to consider what actually goes on inside the bulb, rather than outside it.

#### Liberating Electrons.

The normal state of affairs inside the valve may be described as follows. As the filament heats up it liberates electrons which are attracted towards the plate by the positive H.T. voltage. As they move in response to this attraction, the electrons come under the influence of the grid and are hastened on their way if the grid voltage is also positive, or are slowed up if it is negative.

This is a rough picture of what is represented more accurately by the "characteristic curve" supplied with most valves by the manufacturer.

At one end of the scale there is a limiting negative grid voltage which paralyses the valve and prevents any current from passing through. Similarly at the upper end there is a limiting positive grid voltage where the current passing through the valve reaches a maximum or saturation value. Between these two points comes the famous "straight-line" portion, indicating the extent to which the valve can be used as an amplifier without producing distortion.

The straight-line part of the curve terminates in upper and lower "bends," which are important when the valve is used for rectification. For instance, if the valve is

to be used as an anode-bend rectifier, the lower bend must be sharp and clear cut.

In a battery-driven valve the filament is not a "steady" source of free electrons, simply because it is not at the same potential throughout its entire length. Between its positive and negative ends there may be a drop of 2, 4, or 6 volts, according to the particular type of accumulator used. Now the "pull" exercised by the plate (and the grid) will be a maximum at the point of lowest potential.

This means that the electrons from the negative end leave the filament at a greater speed than those coming from the positive end.

#### Space-Charge Difficulties.

The slower-moving electrons are prone to accumulate between the grid and filament and form a space-charge, which in turn tends to block the passage of the whole stream. This difficulty was originally over-

### NON-STOP AVIATION

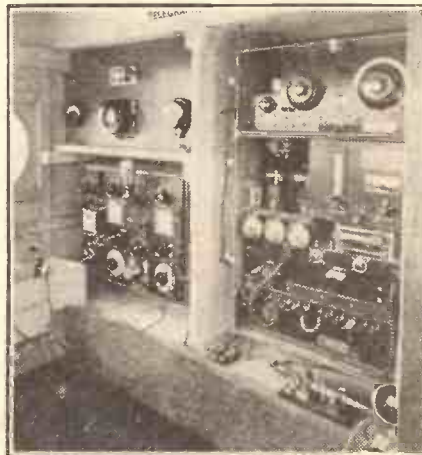

Before her attempt on the world's duration flight record, The Hon. Mrs. Victor Bruce arranged to keep in constant touch with the ground by wireless. The apparatus for this was designed by The Marconi Co., and the ground station installed in a motor van in order to follow the "City of Portsmouth" on the various stages of its flight. Our picture shows the aircraft type transmitter and receiver, and the long-wave receiver for Air Ministry weather reports.

come by the insertion of a second grid called the "space-charge" grid. It does not, of course, exist in the mains-driven valve, because here the filament is heated by radiation and so keeps the same potential throughout its length.

The original space-charge grid has now been replaced by the screening grid of the S.G. valve, which, although designed to

tackle an entirely different problem, has introduced other complications peculiar to itself. The screening grid has many good points, but it has one disadvantage—namely, that it shortens the normally straight portion of the characteristic curve.

This, in turn, limits the input voltage which can be applied to the S.G. valve when used as a H.F. amplifier. If the applied signals exceed a certain strength the valve is thrown on to the curved part of its characteristic, and "cross modulation" troubles set in.

The same difficulty arises in volume control. When a set using S.G. amplification is switched, say from a distant station on to the local B.B.C. transmitter, the increased signal voltage from the nearby transmitter will throw the valve "off the true" and again lead to distortion, unless suitable precautions are taken.

#### It Prevents Overloading.

The new variable-mu valve has been designed to solve this particular problem. Perhaps the simplest way of explaining its action is to say that it wipes out the ordinary "sharp" bend at the lower part of the characteristic curve, and replaces it by a gentle slope which falls gradually away to the zero line.

Actually the term "mu," as applied to a variable-mu valve, refers to mutual conductance rather than to amplification factor, although the latter is commonly called "mu." As a matter of fact, the mutual conductance and amplification factors both change as the input voltage is altered, so that the distinction is not of any great importance.

Whichever point of view is taken, the net result is the same. The valve acts as if it had two different characteristics, a high "mu" at the upper part of the curve and a low "mu" at the bottom part. In this way strong signals are amplified less than weak ones, and distortion is avoided.

The effect is secured by altering the "pitch" of the spirally-wound grid, so that instead of being kept uniform, as usual, the turns are close-set at one end and more open at the other. They accordingly exercise a different degree of control over electrons coming from different parts of the filament.

Another interesting example of special control over the electrons inside the valve occurs in the so-called Barkhausen-Kurz method of generating ultra-short waves. The ordinary back-coupled valve will not operate satisfactorily at very short wavelengths, owing partly to the inter-electrode capacity and partly to the wiring. The combined inductance and capacity values are, in fact, too great to allow the circuits to resonate to the required frequency.

#### For Ultra-Short Waves.

So Barkhausen and Kurz devised a method in which the frequency is determined, not by the tuning of any external circuit, but by forcing the electron stream inside the valve to oscillate to and fro at the required rate. Here again the method is comparatively simple.

Instead of applying the ordinary value of H.T. to the plate, it is left either at zero potential or with only a small positive charge, and a high positive voltage is put on the grid. This apparently simple change seems to set the electrons into a high state of excitement so that they oscillate backwards and forwards inside the valve.



# TELSEN DUAL-RANGE AERIAL COILS

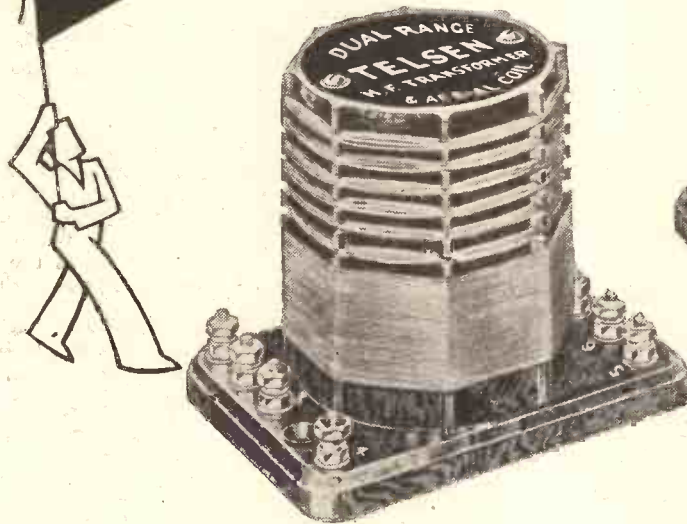

## THE TELSEN H.F. COIL

May be used for H.F. amplification with Screened-Grid Valve, either as an H.F. Transformer, or alternately as a tuned grid or tuned anode coil. It also makes a highly efficient aerial coil where the adjustable selectivity feature is not required. No. W.154

**5/6**

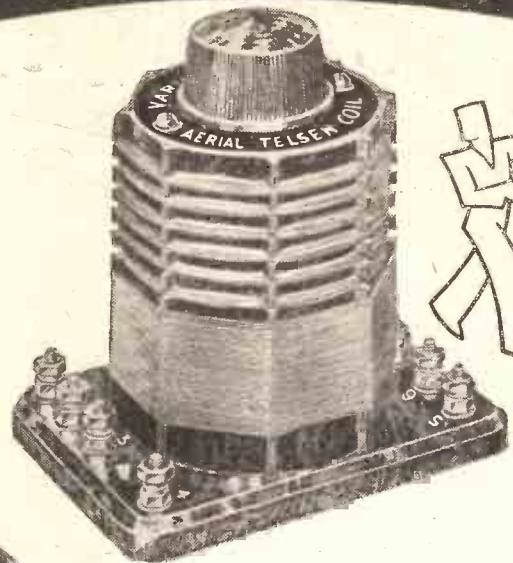

## TELSEN DUAL-RANGE AERIAL COIL

Incorporates a variable selectivity device, making the coil suitable for widely varying reception conditions. This adjustment also acts as an excellent volume control, and is equally effective on long and short waves. The wave-band change is effected by means of a three-point switch and a reaction winding is included. No. W.76

**7/6**

## TELSEN COMBINED DUAL-RANGE SHORT-WAVE COIL UNIT

This unit, for the first time, brings the construction of short-wave receivers into line with the simplicity of modern practice. When tuned by a Telsen .00025 Condenser, a wave range of 20 to 80 metres can be covered by the operation of a switch, as in ordinary broadcast practice. The unit incorporates windings for aerial, tuning and reaction circuits, all coils being wound with stranded wire. The coil is also suitable for use with sets covering all wave-bands with a .0005 Tuning Condenser. In this case the Dual-range feature is not employed. No. W.174

**4/6**



# TELSEN

**RADIO COMPONENTS**

See the complete range of  
**TELSEN RADIO COMPONENTS**  
on STAND No. 66 at RADIOLYMPIA.

**GOOD RADIO IS A JOY FOREVER**

ANNOUNCEMENT OF THE TELSEN ELECTRIC CO., LTD., ASTON, BIRMINGHAM.

# TELSEN

# MANSBRIDGE AND MICA CONDENSERS



## TELSEN MANSBRIDGE TYPE CONDENSERS

These are made by the most advanced processes from the finest materials it is possible to obtain, and subjected during manufacture to a series of stringent tests under laboratory conditions. They are of the true Mansbridge type, self-sealing, non-inductive and hermetically sealed. They are offered in two types, the capacities from '01 to 2 Mfd. in Bakelite cases, and in blocks of 4, 6, and 8 Mfd. in metal cases with soldering tags.



CAP. MFD.	500 Volt Test NO.	1,000 Volt Test NO.	PRICE
'01	W.232	W.239	1/6 2/6
'04	W.230	W.237	1/9 2/9
'1	W.231	W.238	1/9 2/9
'25	W.229	W.236	2/- 3/-
'5	W.228	W.235	2/3 3/3
'1	W.227	W.234	2/3 3/6
'2	W.226	W.233	3/- 5/-



## TELSEN TAG CONDENSERS

This type is of extremely compact and sturdy construction. It may be mounted on either insulated or metal panels by utilising the two baseboard screw holes in the neatly designed moulded casing. The tags enable the condenser to be connected to any other component, either directly or by soldering. H.F. losses are negligible. The capacity is stamped on the soldering tag.

CAPACITY.	NO.
'0001	W.207
'0002	W.208
'0003	W.209
'0004	W.210
'0005	W.211
'001	W.212
'002	W.213

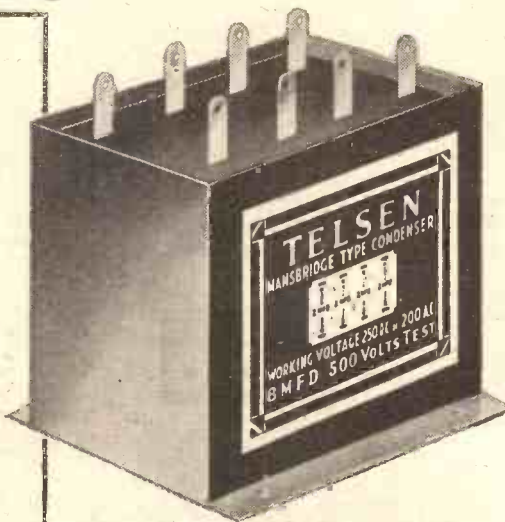

## TELSEN MANSBRIDGE BLOCK CONDENSERS

These are contained in metal cases finished in brown and with fixing holes. As with the other types of Telsen Mansbridge Condensers, they are self-sealing, non-inductive and hermetically sealed. Three types, each made having total capacities of 4, 6, and 8 mfd., each type being divided into 2-mfd. sections, so that several arrangements of capacity may be obtained. Neat and substantial soldering tags are provided for each section.

CAP. MFD.	500 Volt Test CAT. NO.	PRICE
4	W.175	5/6
6	W.176	8/-
8	W.177	10/6

1,000 Volt Test. CAT. NO.	PRICE
W.178	9/6
W.179	14/6

## TELSEN "MICA" CONDENSERS

The New Telsen "Mica" Condensers represent an important advance in technique: H.F. losses have been practically eliminated even in the larger capacities. In order to distinguish them from the earlier type, now to be discontinued, the new condensers are enclosed in a redesigned case, which, while possessing all the adaptability of the previous one as to flat and vertical mounting, is of more attractive appearance. Grid-leak clips may, as heretofore, be mounted in series or in-shunt and are supplied at no extra charge with capacities '0001, '0002, and '0003 mfd.



CAP. MFD.	NO.
'0001	W.240
'0002	W.241
'0003	W.242
'0004	W.243
'0005	W.244
'001	W.245
'002	W.246

PRICE.	NO.
1/-	'006 W.247 1/3



## TELSEN PRE-SET CONDENSERS

Very low minimum capacity, giving a wide range of selectivity adjustment when used in aerial circuit. Substantially made, easily adjusted and provided with locking ring. High insulation and low loss.

MAX. CAP. MFD.	MIN. CAP. MFD.	NO.
'002	'00025	W.149
'001	'00052	W.150
'0003	'00016	W.151
'0004	'00005	W.152



# TELSEN

## RADIO COMPONENTS

See the complete range of  
TELSEN RADIO COMPONENTS  
ON STAND No. 66 AT RADIOLYMPIA

# GOOD RADIO IS A JOY FOREVER

ANNOUNCEMENT OF THE TELSEN ELECTRIC CO. LTD., ASTON, BIRMINGHAM

**WE** have now definitely turned the corner. By this I mean that the change from reception conditions of high summer to those of autumn has begun. Already there is a noticeable improvement both in the number of stations receivable and in all-round volume. A few evenings ago I was trying out a simple and quite low-priced three-valve receiving set containing a screen-grid H.F. amplifier, a detector and a pentode output stage. The set was used in conjunction with quite a small indoor aerial.

**A Most Satisfactory Tour.**

With such a set worked under these conditions a month or so ago foreigners would have come in at full loudspeaker strength but on the evening in question I was able to make, and a full hour before lighting-up time at that, a most satisfactory tour of Europe. The stations received at full strength included Brussels No. 1, Florence, Prague, Langenberg, Rome, Katowice, Toulouse, Strasbourg, Brussels No. 1, the Poste Parisien, Hilversum, Heilsberg, Trieste and Nürnberg.

Any number of others were brought in with somewhat smaller volume.

Long-wave reception is now better than it has been at any time since the spring. Even Motala, usually a poor summertime station in the Midlands and in Southern



Some practical distant-programme notes compiled by a special contributor who nightly searches the ether in order to obtain really up-to-the-minute information for "P.W." readers.

England, is always to be heard now with fine volume and quality and Zeesen is no longer suffering from those periods of temporary weakness.

On the medium waveband the improvement is just as marked. Budapest, for example, is now quite frequently receivable at good strength, and Vienna has been coming in really well for several evenings.

Florence is rapidly becoming one of the strongest Continental transmissions. Prague has quite returned to form, and both Langenberg and Berömunster are always ready to oblige. This week I cannot record receptions of the elusive Lyons Doua, but Stockholm is now almost if not quite as good as Rome.

**Chequered Career.**

Stockholm had a distinctly chequered career during the height of summer, being often either not receivable at all or receivable with very small volume.

Both Witzleben and Belgrade are coming back, though neither is very strong. Katowice is much more regularly heard, but Sottens has not yet settled down, and the

same applies to Frankfurt. Toulouse is always good.

Curiously enough, both Strasbourg and Brno have varied rather more of late than they did in June and July, although Brussels No. 2 on a neighbouring wave-length continues to furnish excellent reception.

Milan is a very much improved transmission. I have not noticed heterodynes lately, and reception at full loudspeaker strength is generally obtainable. Breslau is still a little under the weather, but Göteborg is nearly always worth attention.

**Growing More Frequent.**

Genoa has been suffering from intermittent heterodynes, but when clear this station comes in well. Hilversum, Heilsberg and Turin are all quite reliable, and Bratislava is beginning to be well heard once more. Gleiwitz and Toulouse P.T.T. are not constant, but they have their good evenings and these are growing more frequent.

Of Trieste I have not heard very much for some days, which is rather surprising. Nürnberg is strengthening up, but heterodynes are unfortunately a nuisance on many evenings.

Since conditions are so extraordinarily good at the present time, one needs to be no prophet in order to foretell a wonderful season for long-distance wireless during the coming autumn and winter. R. W. H.

**MY** first words this week must be about the Eclipse Tests. Please do not forget them, and if you are in doubt about the details refer back to last week's "P.W." for them. The main points are these—decide on some particular short-wave station that you can "watch" for an hour or so on the two or three days before August 31st. Then continue the watch on the 31st, the day of the eclipse, and note any changes in the behaviour of the station.

We must now proceed with the rather formidable pile of correspondence that has accumulated of late.

"F. N. B." reports a new American broadcaster in the guise of W4XE, formerly a "ham," of Miami, Florida, who puts out the N.B.C. programmes on approximately 49 metres. He finds that the best station on that band is VE9DR (Quebec), in the small hours.

**Friends Turned Rebel!**

Friend "F. N. B.," by the way, has turned rebel. He concludes with these words: "I'm cutting your friend the Eleven-Year Cycle dead from now on. I find that this year has so far been better for DX than 1925-6-7-8 put together!"

"J. H. G." (Bristol) asks for a few identifications. So far as I can manage them, here they are. NYIAB is an experimental station at Panama; XZN2A

**SHORT-WAVE NOTES**



News and views regarding an exciting and fascinating waveband.

By W. L. S.

is a boat bound for Australia; OA5D lives in Peru; and XF-FNFH is a French ship. Thanks for all the other news. "J. H. G."

"H. L. B." (Colchester) has been good enough to copy out in full the particulars of W3XAL that he received as acknowledgment of a report. They are too lengthy to give in full, but interesting points are the following:

The intermediate H.F. amplifiers in the transmitter work at 5, 75, 100 and 500 watts, the 75 and 100-watt stages being of the screened-grid variety. The final stage consists of four 10-kilowatt "tubes," which can deliver 20 kilowatts to the aerial.

Modulation is effected on the last stage by means of twelve 10-kilowatt valves!

The aerial is a vertical affair supported on a 105-ft. wooden mast, the lower end being 38 ft. above the ground. (This refers to the aerial, not the mast!)

The notes conclude with an announcement that a "day shift" on 16-87 metres will soon be in operation.

The rest of the post is full of reports on the "One-Valver," which certainly seems to have created more of a stir than some of the bigger sets that I have described. I wish I could evolve something smaller still, but I am afraid that a crystal set would hardly be a success!

Scores of readers are reporting reception of Rio de Janeiro on 31.52 metres, and claiming their "Heard All Continents" membership in consequence.

**A Favourite Station.**

LSX, Buenos Aires, also appears to be a favourite station lately. I should imagine that conditions for the reception of South America on 28-32 metres must be extremely good. They are *not* good on the amateur wavebands, but I have noticed how well the Central American amateurs have been coming over this year.

The ordinary, common-or-garden "Yanks" (if they don't mind being so called) have of course, been audible in their thousands, at all times except when conditions have been downright bad. Fortunately the bad spells have been quite short this year:



**T**HE making of the "Olympus" Four is easy and straightforward. It has been arranged—as mentioned in the introductory notice last week—after many months of work in our laboratories, so that all the constructor has to do is merely to fix the parts in their positions and wire up.

**Panel Preparations.**

It is the purpose of this article to "put you wise" to those few things which the actual experience of building a model of the "Olympus" has taught the writer to look out for.

First of all, then, prepare the panel, which, as you will see from the diagrams, measures 14 inches long and 7 inches high. Make all your marks on the unpolished back, and it will be quite safe to use a pencil for this.

You can rub them all out quite easily with an ordinary eraser when you have drilled the holes.

Start, then, by drawing a line the full length of the panel exactly  $3\frac{1}{4}$  inches from one long edge. A line is next drawn across the panel from either short edge.

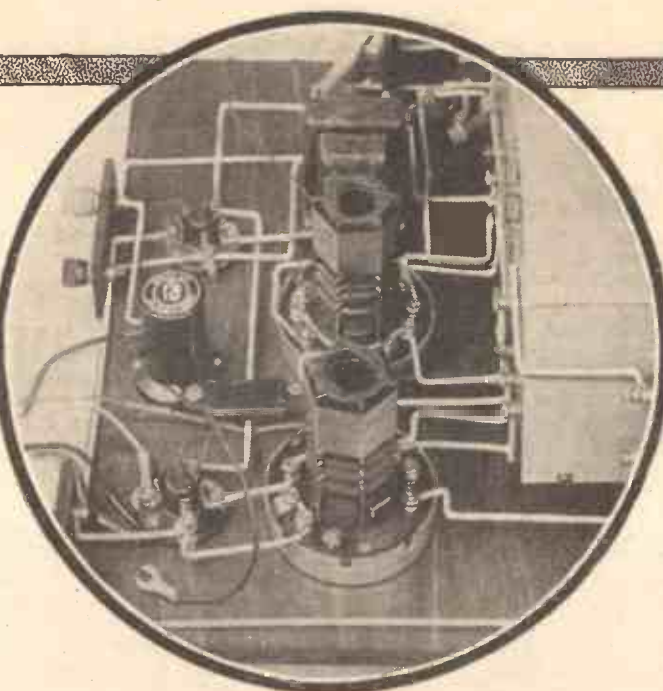

**FOR LONG-DISTANCE LOUDSPEAKER RECEPTION**

With this magnificent set the listener—even if unskilled—has a choice between a large number of programmes at full loudspeaker strength.

Impressive selectivity makes station separation an easy matter, and there is no wave-change switching to do—you just swing from long to medium waves, or vice versa—as you turn the tuning dial.

Those of you who intend adding subsequently a pick-up switch would do well to mark the panel where these two lines

cross with a sharp-pointed instrument as you will have to drill a hole at this point for the pick-up switch.

For the present, however, the longer of the two lines should be marked first of all in two places. The first mark  $1\frac{1}{2}$  inches in from one short edge and the second the same distance from the other short edge.

At these marks drill the holes for the reaction and selectivity condensers.

The Telexor Templates.

Now turn to the other line you have drawn on the panel and make a mark one inch from the bottom long edge and drill for the on-off switch.

Now comes the job of fixing the escutcheons for the Telsen Telexors. Draw two more lines on your panel, both  $4\frac{1}{2}$  inches in from each short edge and running from top to bottom long edges.

On one of these lines lay the template which will be supplied with each Telexor so that the hole through which the spindle of the Telexor protrudes comes two inches from the bottom edge of the panel.

You can then mark through the template with a sharp-pointed instrument the positions of the three fixing-screw holes

**LOC...**  
**STATI...**  
free from  
ference  
ample re  
of power  
finest qu

★

**FOREIG**  
one at a  
with la  
ness and  
that will  
you

★

**EFFICI**  
that r  
before h  
obtained  
such r  
**SIMPL**

**NO SOLDERING TO DO, NO SCREENING—**

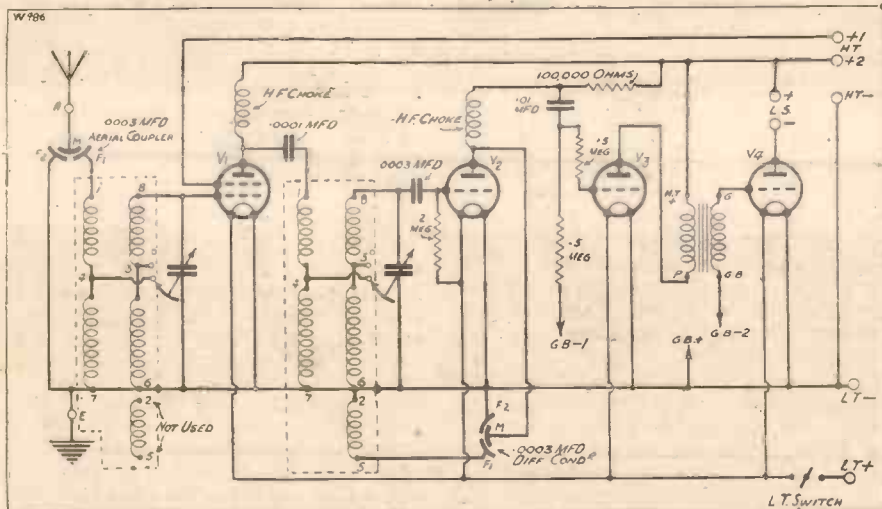

The screened-grid stage, with its shielded coils and selective tuning, precedes a sensitive detector with differential reaction. The first low-frequency stage is resistance-coupled, and is followed by a transformer-coupled stage, thus developing tremendous reserves of programme power.

**AN UP-TO-THE-MINUTE DESIGN USING**

- |  |   |
|--|---|
| 1 Panel, 14 in. × 7 in. (Peto-Scott, Permeol, Becol, Wearite, Lissen).   | 1 H.F. choke, type M.C., Telsens, Farish, Igranite.                           |
| 1 Cabinet to fit, with baseboard 10 in. deep (Peto-Scott, Pickett, Camco, Gilbert, Morco, Lock, Osborn).   | 1 0.003-0.0035-mfd. differential condenser.                                   |
| 1 L.F. transformer of medium ratio (Lissen Hypernik, R.I. Hypermite, Varley Nicklet, Sektun, Tunewell, Ferranti A.F.10, Lotus, Igranite, Lewcos).          | 2 Screened coils.   |
| 1 H.F. choke (R.I. Quadastatic, Lissen, Lewcos type 11, Telsens Binocular, Ready Radio Standard, Peto-Scott Standard, Goltone, Sovereign Super, Tunewell). | 4 4-pl valve holders (Telsens, Wearite, Farish, Clix, Tuas).                  |
| 1 0.003-0.0035-mfd. max. differential reaction condenser (Peto-Scott, Lotus, Telsens, Cyldon, Ready Radio, Lissen, Graham Farish, Polar, J.B., Ormond).    | 2 0.005-mfd. Telexors.  |
|  | 1 5-meg. grid leak (Graham Farish, Ferranti, Telsens, Biller).                |
|  | 1 100,000-ohm resistor (minerals or tags Ohmite, Lissen; Igranite, Dubiller). |
|  | 1 5-meg. do. (Igranite).  |
|  | 1 2-meg. do. (Igranite).  |

**HERE IT IS!—THE SIMPLEST-TO-BUILD HIGH-PO**

# OLYMPUS FOUR

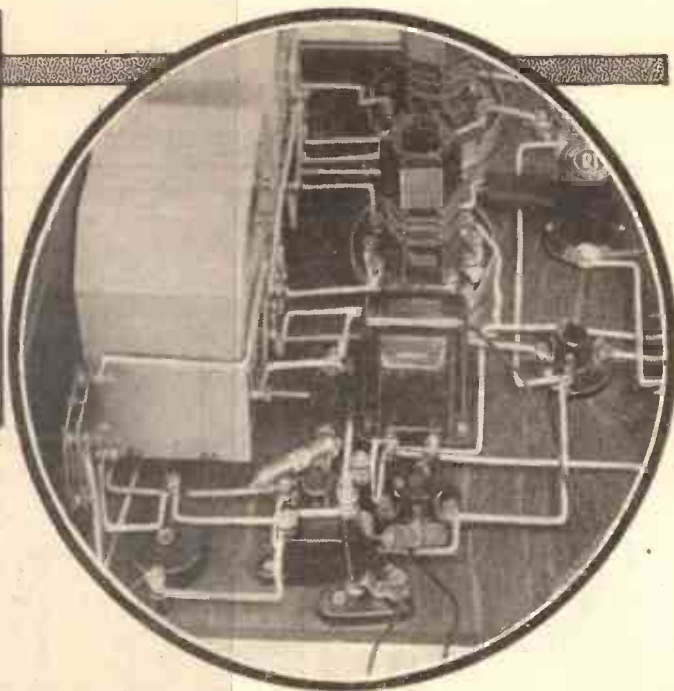

and all that is required is for the constructor to place his components on his baseboard in their relative positions shown by the diagram. Before definitely screwing down the H.F. choke the constructor should just hold the panel (with components fixed thereon) up against the edge of the baseboard to make certain that the choke clears the Telexor to which it is adjacent.

### Fix First.

Having fixed the components to the baseboard, do not immediately fix the panel thereto. Before so doing you should fix to one terminal of the on-off switch the red lead of the 5-wave battery connector.

To the other terminal of the switch attach a piece (about eight inches to be on the safe side) of the wire with which the set is being wired up. (We used 18 gauge tinned copper wire with "systoflex" sleeving.)

Then the panel may be fixed to the baseboard by passing three screws through holes drilled near the bottom edge into the edge of the board.

To the back edge of the board also fix  
(Continued on next page.)

and also the rough outline of the scale aperture. This latter has to be cut out of the ebonite and may be done with a fret-saw.

Another method is to drill a lot of holes close together along the outline of the aperture and then cut between them.

### Layout Leaves Latitude.

When the aperture space for the other Telexor has been similarly cut and the spindle and fixing-screw holes for both drilled, the panel is finished and the pencil lines may be rubbed out.

The two Telexors, the reaction condenser, selectivity control and on-off switch may now be fitted and work commenced on the baseboard.

In last week's introductory article on the "Olympus," the point was stressed by Mr. Dowding that a very precise disposition of the components was not required when building the set. It is, therefore, unnecessary for this article to give accurately detailed dimensioning of the positions of the various components.

It is, of course, a different matter where the panel is concerned, as there appearances have to be studied. The foregoing detailed instructions for measuring up the panel have been given solely to enable the constructor to secure for himself a set having the handsome outward appear-

## FIRST-CLASS RESULTS FOR "FIRST-TIME" BUILDERS

Even the novice at the game can tackle the "Olympus" Four with confidence, for it is extremely easy both to make and to handle.

Utter simplicity in manipulation is achieved by the abolition of wave-change switching. All the medium-wave stations have two-figure dial-readings (0-99) and all the long-wave stations have dial-readings between 100 and 200. Very easy tuning!

ance which he will do much admire when he sees the "Olympus" on show at Olympia.

The wiring diagram shows the layout,

## —AND NO WAVE-CHANGE SWITCHING

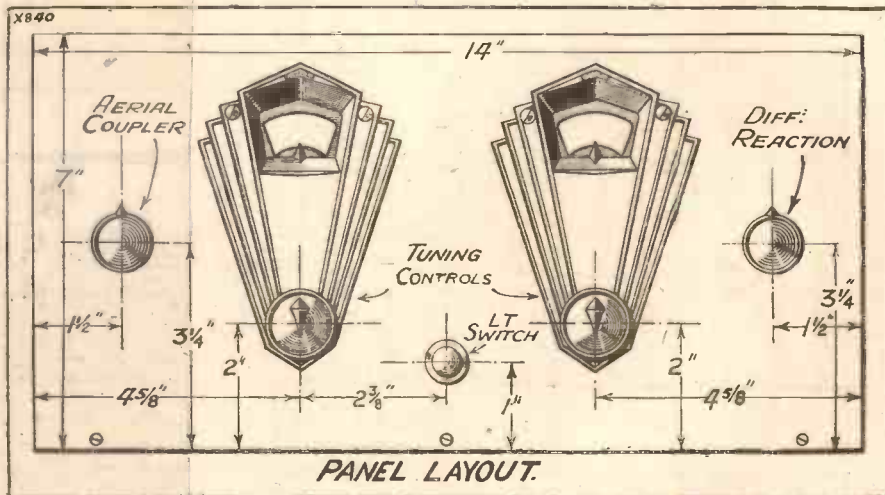

The panel is notable not only for the welcome absence of confusing wave-change switches, but also for its symmetrical lay-out and clean lines. The aerial coupling and reaction need readjustment only when searching for the very distant stations, and virtually all the control is done on the two main knobs.

## GET ALL THE LATEST COMPONENTS

- type (Lewcos Lissen, Graham)
- max. differ- (tus, etc.).
- (Lissen, W.B., Bulgin, Graham well, Igranic).
- ak and holder (Ohmite, Lissen, Igranic, Du-
- istance with ter- (Graham Farish Igranic; Tunewell,
- ic, etc.).
- ic, etc.).
- 1 L.T. on-off switch (Bulgin type S15).
- 1 .0003-mfd. fixed condenser (Dubillier type 670, Lissen, Telsen, Igranic, Ferranti, T.C.C., Sovereign, Goltone, Graham Farish).
- 1 .0001-mfd. condenser (Dubillier type 670, etc.).
- 1 .01-mfd. condenser (T.C.C. type 34 upright, Lissen, Telsen, Ferranti, Igranic, Graham Farish).
- 1 Five-way battery cord (Goltone R. 39/40, Belling-Lee).
- 18-gauge wire and sleeving (Wearite), or Jifflix, Quickwyre, Glazite.
- 2 Terminal strips, 3 in. x 1 1/4 in.
- 4 Indicating terminals (Bulgin, Belling-Lee, Clix, Igranic).
- Screws, small strip of copper foil, etc.

# POWER SCREENED-GRID FOUR EVER DESIGNED

**THE  
"OLYMPUS" FOUR**  
(Continued from previous page.)

two small terminal strips measuring 1½ by 3 inches. Each carries two terminals—aerial and earth in one case and the loudspeaker in the other.  
The A. and E. strip is at the extreme

end of the board (right-hand end viewing set from back). The L.S. strip is 4 inches from the other end.  
The only "snag" in wiring which the  
(Continued from page 798)

**FOR DISTANCE AND TONE—WIRE UP AS SHOWN**

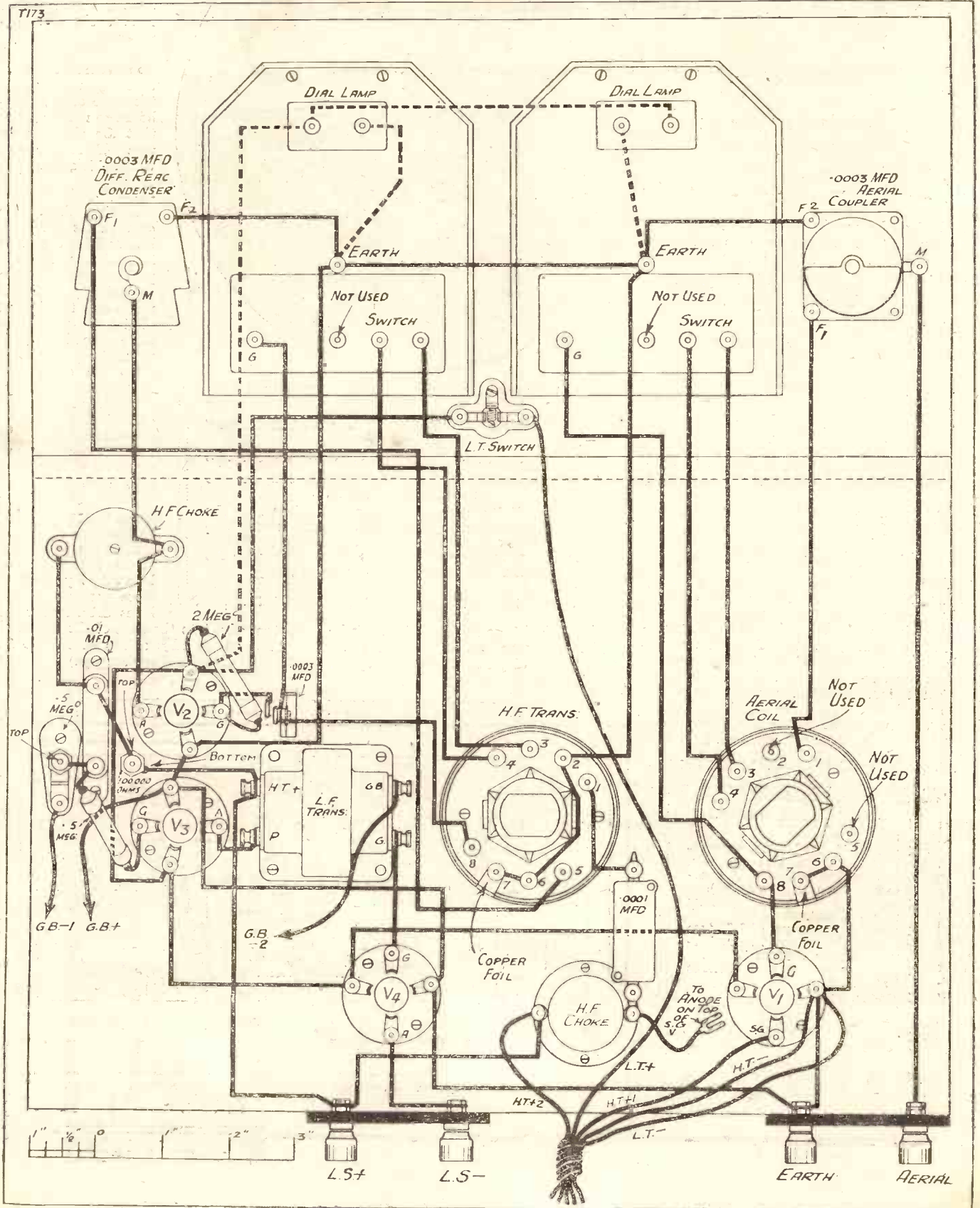

# "HIS MASTER'S VOICE"

at Olympia, STAND NO **55**  
(GRAND HALL)

In addition to the four new instruments illustrated, "His Master's Voice" will show at Olympia, the following range of models for the new season:—

	PRICE
MODEL 501 Transportable Radiogram	25 guineas
MODEL 435 De Luxe Radio Four	17 guineas
MODEL 174 Super-Power Speaker	£7. 10. 0
MODEL LS7 Universal Speaker	£4. 15. 0
MODEL 116 Record Player	7 guineas
MODEL 117 Auto-Record Player	12 guineas
MODEL 553 Auto-Electrogram	42 guineas

Current models which have proved so enormously popular during the past season, and which have established a new standard in the reproduction of broadcast and recorded music, will also be continued.

Visit the "His Master's Voice" Stand—see and hear these instruments . . . examine the many improvements in the range. And whatever else you do, you must see the pre-release showing of the most wonderful industrial 'talkie' yet made. Demonstration Room D18. Free tickets will be obtainable at Stand No. 55.



## His Master's Voice RADIO — "True to Life"

The Gramophone Co. Ltd., London, W.1.



# Unanimous Press Praise!

## NEW Ekco 3-valve Consolelette **M.23**

*The selectivity of the M.23 is remarkable. Long Wave selectivity extremely good. Quality is really pleasing. Tone clear and full. Speech clear and natural. Tone very pleasingly balanced. Full loud-speaker strength of foreigners during broad daylight. Good selection of Continental Stations.*

*Local and distant trans-  
with ease and facility.  
accurate indeed. High  
Very easy to control.  
desirable points to be*



*missions can be received  
Wavelength scales very  
quality construction.  
Embodies all the most  
expected in a 3-valve Set.*

The above are not our words. They are very brief extracts from Test Reports which have appeared in *The Wireless Trader, The Broadcaster, Amateur Wireless, etc.* The complete reports are full of enthusiasm for this wonderful new set. As one of the papers says "This set gives a performance that is incredible and for a distinctly moderate outlay—a notable set."



**EKCO CONSOLETTA M.23**  
Three-valve circuit (Screened Grid, Detector and Pentode). Complete with built-in moving-coil speaker, in figured walnut bakelite cabinet. Illuminated dial. Connections for pick-up.

PRICE **17** GUINEAS  
or 12 monthly payments of  
**32/9**

Post Coupon below for full details.

To: E. K. Cole, Ltd., Dept. A.16.  
Ekco Works, Southend-on-Sea.

Please send me full details  
of Ekco All-Electric Radio.

Name .....

Address .....



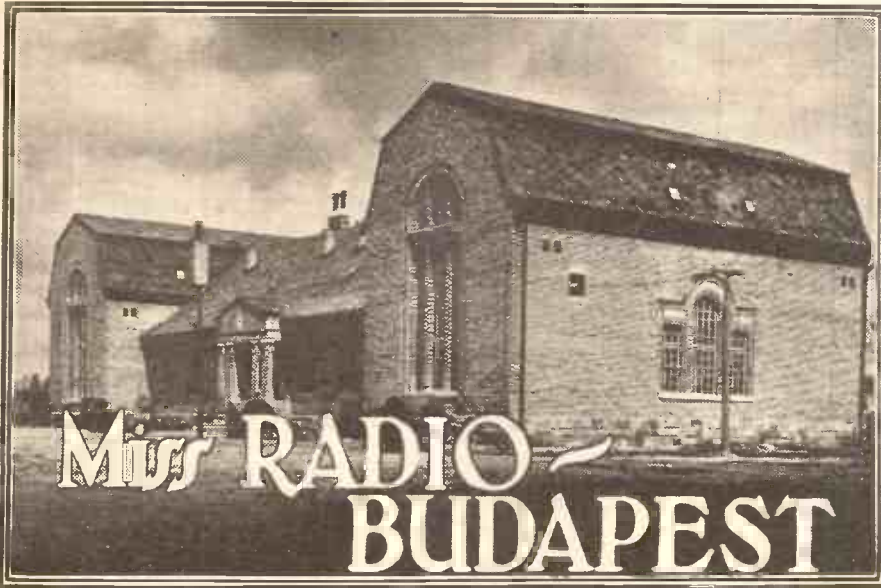

Introduced by A. A. GULLILAND.

**R**ADIO-BUDAPEST, with its gipsy music—who hasn't heard it? I am sure very few British listeners. The long wave, in fact, renders Budapest a reliable daylight signal throughout Central Europe.

Budapest is the home of radio. Mr. Huszkas away back in 1892 or '93 inaugurated a system of wired broadcasting which has been in use ever since. This was the world's first broadcasting system. Later when wireless broadcasting started Radio-Budapest took over the wired system's announcer, Mr. von Scherz, who recently retired from strenuous announcing after twenty-five years of it.

And now distant listeners hear a new voice. The voice of a girl. A real Hungarian voice with all the dark melodious sounds. Miss Lydia de Beöthy is the announcer at the world's oldest broadcasting station.

**An Accomplished Linguist.**

Her melodious Hungarian, her perfect French and excellent English all go to make her Europe's budding star announcer.

She is under thirty and over twenty. I

am sorry I cannot say exactly how old and I was too polite to ask. But I think you can judge from the photo.

Hers is quite a romance, and I would like to quote from her own words uttered to me, the lucky special "inquisitor-general" of "P.W."

"We must seize progress by the hand and keep hold of it. My grandfather, professor at the university, studies old Hungarian literature and wandered as far as Egypt in connection with this research work. My father was the founder and owner of a number of theatres and newspapers, and he was a leading spirit in the

development of the culture of his day and country.

**Her Grandmother an Actress.**

My grandmother, eighty years old, is still one of the best actresses of the first theatre of the country. She is still as fresh and lively as ever.

"My uncle, an author, a purifier of the language, the greatest living journalist of the land—and myself—lost the whole of the fortune left by my late father owing to the unhappy financial development of Central Europe after the war.

"I had to look for work. And I found

it. And found it with gusto—the very work for me. While my family helps to drag along the chariot of art, the great Queen of the world of Beauty, I myself made use of the most modern way of disseminating art, the wireless waves. And may my humble endeavour cause some people pleasure."

**A Message to "P.W." Readers.**

Miss de Beöthy, you have given me great pleasure. I often listen to Budapest, and when the station closes and I hear your voice, well, I am glad to know what you look like—even better than your voice.

And listeners, don't forget that an announcer has no visible audience. Remember Miss de Beöthy's address is : c/o Magyar Telefon Hirmondo es Radio R.T., Föheryeg Sandor ut, 7, Budapest, VIII, Hungary.

I think that Miss Lydia's (I hope I may call her so) compliment to "P.W." readers is the best ever. Here you are :

"A picture to the POPULAR WIRELESS from a speaker who hopes to become popular on the wireless." Now try and beat that !

A. A. G.

**HAVE YOU HEARD HER ?**



(Photo by Angelo, Budapest.)

Miss de Beöthy, who charmingly invites you to write to her after you have heard her voice by radio.

Among the new circuits being experimented with in connection with ultra-short-wave reception, several of the super-regenerative type have been especially successful.

Some modern ganged condensers have an earthing contact on the spindle between each section of moving plates to prevent unwanted feed-back, which, with modern high-mag. valves, takes place through what would appear to be most unlikely channels.

Where an indoor aerial must be used and adequate space is not available, there are often possibilities in using the wiring system of an electric door-bell or similar concealed conductor.

**SELECTED SHORTS**

**Indoor Aerial—Interference—Decoupling.**

Interference from electrical apparatus and machinery cannot usually be combatted at the receiving end, but should be treated at its source.

The B.B.C. is always desirous of assisting listeners to remove interference from flashing signs, illuminated advertisements, etc., and

complaints of such interference should be addressed to the Chief Engineer of the local broadcasting station.

An often unsuspected cause of "whistling" is an inefficient (high resistance) earth connection.

To improve an old set that needs decoupling it is not necessary to interfere with its wiring, as the necessary alterations can easily be made externally if there is a separate H.T. terminal for the detector. Connect a 20,000 ohm spaghetti between this and the H.T. plus lead, and join the H.T. terminal also to one side of a 2-mfd. condenser. When the other side of this condenser has been connected to H.T. negative the decoupling is complete.

# NOTES FROM THE NORTH

A monthly review and criticism of events in that important region north of the Trent.

By OUR NORTHERN CORRESPONDENT.

**A**RTISTS, orchestras, and B.B.C. staffs have been on holiday and there is the usual summer slump in concert activities in the provinces.

All this makes its mark on the broadcast programmes. North Regional activities have been further limited during August because the Region is required to relay a Promenade Concert from London on every other night.

It would be interesting to explore the question of whether Northern listeners really like the idea of the North Regional and North National transmitters being occupied on alternate evenings by Promenade Concerts. At any rate, it means that the Regional transmitter is severely restricted in its main function of giving expression to the talent, interests, and activities of the North.

## A String of Holiday Resorts.

The Proms will not last for ever, however, and preparations are now being made at Broadcasting House, Manchester, for the winter season. The present series of relays from holiday resorts will continue until the end of September.

It is indeed fortunate that the North Region can draw good-class entertainment from a string of holiday resorts at a period when other activities are at a low ebb. The Northern programme would be in a sorry plight this summer without Alick Maclean's popular Scarborough Orchestra and the excellent orchestras of Buxton, Whitby, and Ilandudno, and several concert parties which have come over well. Others have not been so good.

One of the best I have heard was the Bouquets, from Scarborough, who gave a show which had evidently been arranged with the pleasure of radio listeners always in mind, so that there were none of those confusing moments when one struggles to imagine what is happening on the stage.

After September the studio concert parties will come back into their own. The Yorkshire Mummers are at present "resting" until October. The last of their first series of eight shows was given at the end of July, and they can look forward to a warm welcome in October, for they have done much to strengthen the lighter side of North Regional radio.

## Real Credit to Organisers.

During the autumn and winter there will be relays from Northern vaudeville theatres, and negotiations are now proceeding which will result, it is hoped, in the broadcasting of a series of concerts by famous Northern orchestras and choirs, similar to the series of last winter, which was a real credit to the North Regional organisation.

On the dramatic side there will probably be a series of outstanding one-act plays of the Lancashire school, including those of Harold Brighouse and Stanley Houghton, before the end of the year. Talk about "radio pageants" is once more in the air, but these proposed feature programmes

written round the history of Northern cities have been in the offing for so long—several years, in fact—that the news that one is actually to be produced will be received with incredulity.

So far, mind you, that news has not come. Only one of the proposed pageants has yet been given—L. du Garde Peach's somewhat patchy programme about York last winter.

## In Danger of Lagging Behind.

On the other hand, news comes to me of a series of programmes about Midland Counties which are to be produced at Birmingham, and the Scottish Region is

## "HUSH YOUR MOU!"



That popular pair "Alexander" and "Mose" listening to one of the new Marconiphone receivers, with evident enjoyment.

going ahead almost immediately with programmes in honour of Edinburgh and of Glasgow. I warn the North Region, that it is in danger of being left behind by the neighbouring Regions.

Again, the proposed "behind the scenes" broadcast from Moorside Edge (with microphones installed in the various departments of the great transmitting station) seems to have fallen flat. This was actually given a date and advertised in the Radio Times. Postponement was announced, but time is slipping by and nothing is being arranged, apparently.

Is there any intention of going ahead with this relay? Does the B.B.C. intend the public to forget about it?

The public will not forget quickly, for there was keen interest amongst listeners.

It would be more than a shame if any attempt was made by London to interfere

with the Regional talks. Mr. Alfred J. Brown, the novelist, has recently concluded a series of talks on walking in Yorkshire which were extremely well received. Mr. Brown has a style in some ways reminiscent of Mr. Mais.

The Northern gardening talks have always enjoyed a big following, for the simple reason that the advice given in gardening talks from London is not always applicable to the North, owing to the difference of climate.

## Pleasant Microphone Manner.

At the beginning of each month a talk on "The Month in the North" is now being given by Mr. W. L. Andrews (Editor of the Leeds Mercury), in succession to Mr. W. P. Grozier who has been unable to continue the talks since his appointment to the editorship of the Manchester Guardian. Mr. Andrews has a pleasing microphone manner.

When changing the Newcastle wavelength from 288 to 211 metres, the B.B.C. engineers took the opportunity to carry out certain

alterations to the transmitter with the object of improving the quality of reproduction—a long-needed reform, for the transmitter was sadly out of date, and it was quite impossible for Tyneside listeners to obtain a modern standard of high quality when receiving from this station.

## New Appointment.

Mr. G. L. Marshall, who has been Station Director at Newcastle for some years, and was previously at Edinburgh, goes to Belfast to take up the Directorship vacated by Mr. G. C. Beadle, who has been appointed Assistant Director of Programmes.

The peculiar wavelength situation at Newcastle has for a long time severely restricted B.B.C. activities on Tyne-

side, and Mr. Marshall has had far too little scope for his abilities. The Belfast post is much more responsible, as this station undertakes a large amount of local programme work.

Outside of broadcasting, there are some interesting radio activities in the North to report. The Bradford police force has taken up the matter of wireless communication with mobile police patrols very seriously. A 100-watt transmitter working on 157 metres was installed at the police headquarters.

Excellent results have been obtained in communication with the patrols, which carry four-valve receivers in their motorcycle sidecars.

In some Yorkshire collieries interesting experiments are afoot to ascertain the value of wireless communication between the surface and various points below ground.

# FACTS YOU SHOULD KNOW ... ABOUT THE MAZDA RANGE OF POWER OUTPUT VALVES

**STAND  
Nos. 75 & 230  
RADIOLYMPIA**  
(Aug. 19-27)

LOOK  
FOR "EDDY"  
IN YOUR  
DEALER'S  
WINDOW

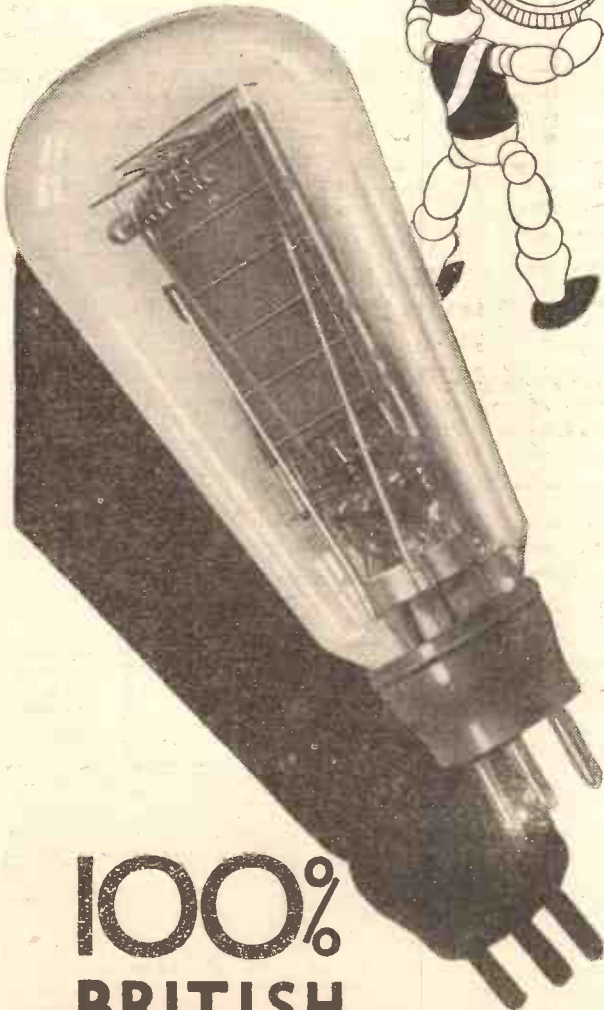
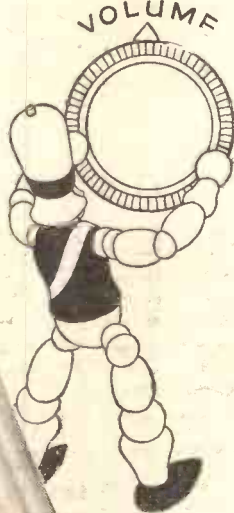

A good receiver, whether battery or mains operated, can be made or marred by the power valve. Each type of Mazda Power valve has been designed to give its most efficient performance under specific conditions. Here is a guide to the selection of the correct Mazda Mains Power Valve for your particular purpose.

**THE AC/P**—a low consumption power valve for operating balanced armature speakers. It is sensitive to comparatively small inputs, and will give good results on anode voltages as low as 150.

**THE AC/P1** will handle a bigger signal input and will satisfactorily operate a moving coil speaker. It requires 200 volts H.T.

**THE PP5/400** is a heavy power output valve capable of fully loading a large moving coil speaker. The anode current at 400 volts is 60mA with 30 volts bias.

For Battery operated receivers there are the following:

**P220 and P220A**, both capable of giving ample volume with a reasonable input. The former valve is particularly recommended where economy of anode current is a consideration.

Full details of these and other useful Mazda types will be found in the Mazda catalogue, sent FREE on request.

**Mazda valves are fitted by all the leading receiver manufacturers. All good radio dealers stock them.**

The amazing  
**MAZDA**  
THE  
BRITISH  
VALVES

**100%  
BRITISH  
Designed by British Engineers**

The Edison Swan Electric Co. Ltd.



155 Charing Cross Rd. London. W.C.2

Mazda Radio Valves are manufactured for The British

Thomson-Houston Co. Ltd., London and Rugby.

V.169



**GECophone  
ALL-ELECTRIC  
RADIO  
RECEIVER**  
(For A.C. Mains)

"GALA" Model

Cat. No. BC3335

**PRICE 18**  
including OSRAM  
VALVES and Royalty. **GNS.**  
**HIRE PURCHASE:**  
Deposit £2 os. od. and  
12 monthly payments of  
£1 10s. od.

# G.E.C. ENTIRELY RECEIVERS AND



**GECophone  
ALL-ELECTRIC  
RADIO  
RECEIVER**  
(For A.C. Mains)

"VIKING" Model

Cat. No. BC3340

**PRICE 23**  
including OSRAM  
VALVES and Royalty. **GNS.**  
**HIRE PURCHASE:**  
Deposit £2 os. od. and  
12 monthly payments of  
£2 os. od.

## BETTER RADIO for the discriminating listener

G.E.C. Radio offers discriminating listeners better radio at competitive prices—*immaculate cabinet work: superlative performance: prices to suit the times.* The models as will be seen from the illustrations are elegantly designed and finished. From the 18-guinea "GALA" model to the 30-guinea "CARNIVAL" model Radio-Gramophone there is a full selection from which to choose the set you want at the price you wish to pay.

**HIRE PURCHASE** terms are stated for each model to the value of £5 or over given in this advertisement. Equally attractive terms for other models are also stated in Folder B.C. 6312 which gives full particulars of the complete G.E.C. Radio Range. A copy will be sent you **POST FREE** for coupon at bottom right-hand corner. **WRITE FOR A COPY TO-DAY.**



**GECophone  
ALL-ELECTRIC  
RADIO-  
GRAMOPHONE**  
(For A.C. Mains)

"CARNIVAL" Model

Cat. No. BC3338

**PRICE 30**  
including OSRAM  
VALVES and Royalty. **GNS.**  
**HIRE PURCHASE:** Deposit  
£2 12s. 6d. and 12 monthly pay-  
ments of £2 12s. 6d.

**GECophone MAGNETIC  
LOUD SPEAKER  
in Bakelite Cabinet**  
Cat. No. BC1845

**PRICE £2.5**

Chassis only, Cat. No. BC1840

**PRICE 21/-**

**MADE  
IN  
ENGLAND**

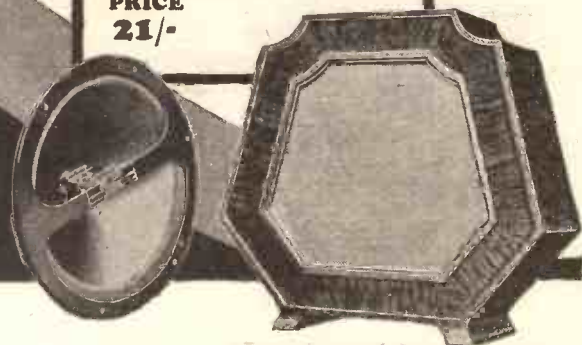

## Supremacy in Radio

Advt. of The General Electric Co. Ltd., Magnet House, Kingsway, London, W.C.2

# Radio

## NEW RANGE OF

### LOUD SPEAKERS

**SUPERB QUALITY**  
yet competitive in  
**price**

By choosing a GECophone you assure to yourself the utmost enjoyment from modern broadcasting. Qualities which have made GECophone famous — reliability, real engineering construction and simplicity of operation—are brought up-to-date to meet present-day conditions. G.E.C. offers the best investment in efficient, trouble-free and economical home entertainment—all the best broadcasting programmes delightfully rendered and gramophone reproduction as you never heard it before.

**NATIONAL RADIO EXHIBITION**

See the complete range of G.E.C. Radio Products on the G.E.C. Stands.

Sold by all  
Wireless  
Dealers

**GECophone PERMA-  
NENT MAGNET MOVING  
COIL LOUD SPEAKER**  
Cat. No. BC1825.

**PRICE £3. 15**

Chassis only, Cat. No. BC1820.

**PRICE 45/-**



**GECophone ALL-ELECTRIC  
RADIO RECEIVER**  
for A.C. Mains.

"SUPER-  
HETERODYNE"  
Model.

Cat. No. BC3358.

**PRICE**  
including  
OSRAM **26**  
VALVES  
and Royalty. **GNS.**

**HIRE PUR-  
CHASE:** Deposit  
£2 5s. od. and 12  
monthly payments of  
£2 5s. od.



**GECophone ALL-ELECTRIC  
RADIO RECEIVER**  
for D.C. Mains.

"NOMAD" Model.

Cat. No. BC3345

**PRICE**  
including  
OSRAM **23**  
Valves and  
Royalty. **GNS.**

**HIRE PUR-  
CHASE:** Deposit  
£2 0s. od. and 12  
monthly payments of  
£2 cs. od.



**GECophone ALL-  
ELECTRIC RADIO  
RECEIVER for A.C.**  
Mains

"CONSOLE" Model.

Cat. No. BC3244

**REDUCED PRICE**

including  
OSRAM **24**  
VALVES  
and Royalty **GNS.**

**HIRE PURCHASE**  
Deposit £2 2s. od. and  
12 monthly payments  
of £2 2s. od.

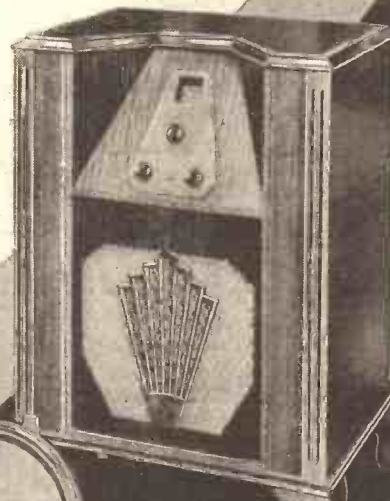

**GECophone IN-  
DUCTOR DYNAMIC  
LOUD SPEAKER  
CHASSIS**  
(Farrand Inductor Patent)  
Cat. No. BC1850.

**PRICE**  
**£3. 10**

**COUPON**

Please send me Folder No. E.C. 6312 giving particulars  
of GECophone Radio Receivers and Loud Speakers

Name \_\_\_\_\_ Address \_\_\_\_\_

The General Electric Co. Ltd.  
Magna House,  
Kingsway, London  
W.C.2  
P. 47.

Cut out and paste on a postcard, or  
enclose in unsealed envelope. 3d. postage.

**G.E.C. Radio**

Branches and Public Showrooms throughout Great Britain

# THE "MARCONIPHONE 248"

An account of some interesting tests on the new two-valver which is selling for less than five pounds.

By a "P.W." Technician.

I HAVE just had an opportunity of testing one of the finest two-valve commercial receivers I have heard for a long time. Called the Model 248, it hails from the world-famous factories at Hayes, Middlesex, in which the Marconiphone sets are born.

It is a battery instrument, and as the

## GOOD TO LOOK AT

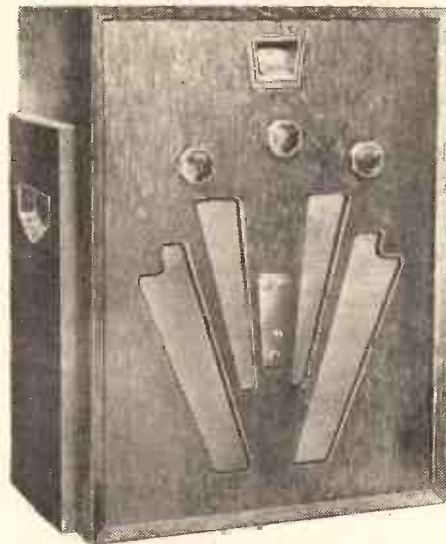

Contained in a dark-oak cabinet, the set is of unusually attractive appearance.

photographs show, is a particularly attractive piece of work. The cabinet is finished in dark oak, and incorporates a carefully matched speaker and houses all the batteries required for the operation of the receiver.

The H.T. and grid-bias batteries are combined in one unit, while the low anode current consumption (only 6-8 milliamps) makes the set extremely economical to run.

The circuit is, of course, a detector and L.F., and the controls are reduced to three. These are the tuning, reaction and combined wave-change and on-off switch. The aerial and earth sockets are on the right of the cabinet, there being three aerial taps, so that individual conditions can be well catered for.

### Surprising Strength.

On test the set behaved itself very well indeed. The strength of reproduction of the local stations some 15 miles away, being surprisingly good for so small an anode wattage (the H.T. voltage is only about 100 volts), and the LP2 used in the L.F. stage acquitted itself with honours.

Selectivity is good, and though I have not tested it, I understand that the makers claim complete separation of the local twin transmitters at 3 miles. Certainly the set is selective, and the sensitivity is such that quite a good bag of distant stations can be achieved after dark. Extra speakers can be used if desired, by means of the special terminals. Reaction was wonderfully smooth, a feature of the utmost

importance in a set that has only two valves.

At the price of £4 19s. 6d., the "248" should find a very ready sale, for it is undoubtedly excellent value. It can be obtained on the hire-purchase system, and under this scheme twelve monthly payments of 8s. 3d. following a deposit of 10s. will secure the receiver.

### Easy Access to Batteries.

The back is easily removable for access to the batteries, for which ample room is left inside the instrument, while its economy of running will appeal to all those who have no electric light supply, and are therefore confined to the use of battery receivers.

## PACKED WITH POWER

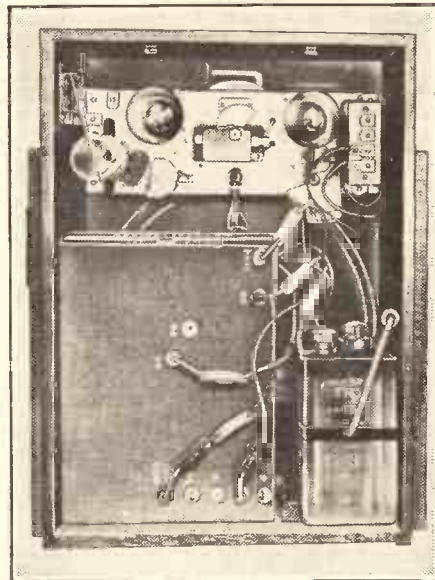

All the batteries as well as a matched loudspeaker are housed inside the set.

QUITE a number of double-gang tuning condensers are provided with a trimming condenser across one section, this trimming capacity being adjustable from the front of the panel. The idea of it is to bring both circuits dead into tune once the main adjustment of both sections has been carried out from the panel.

Sometimes the trimmer is permanently connected across one section, while in other cases it is left to the constructor to connect it across either section as he chooses. In any case, if it is to be of much help, it is most important that the right circuit shall have the trimming capacity.

### The Circuit to Trim.

Imagine for a moment, a double-gang condenser which is out of step and which controls one flat and one sharp circuit. When a station is tuned in, which section will be dead in tune, the one across the flat circuit or the other one?

Why the one across the sharp-tuned circuit, of course. Therefore the other circuit will be out of tune and will be the one that should have the external trimmer. We are assuming fairly well-matched coils and, if possible, minimum-capacity trimmers across the two sections. In the latter case the one across the section plus the trimmer should be set at zero so that the trimmer can carry the tuning of this circuit below

## RECEPTION WRINKLES

Wiring a Trimmer—Economy in Output.

that required as well as above in all cases.

You should simply decide which is the flattest tuned circuit and put the trimmer across the section of the condenser tuning it. Remember that a circuit to which reaction is applied will be sharper than others, at least when reaction is in use, namely during reception of weak stations, and it is then that good matching is most needed.

### Keeping Down Current.

So far as users of dry-battery high-tension are concerned, the keeping down of the milliamp. consumption is a vital matter. And since the output valve makes the biggest demand in this way, it is here that the question of economy comes in most.

It is pretty generally realised that the bigger the undistorted output desired, the bigger must the power valve employed be. But unfortunately, considering ordinary

triodes anyway, the bigger the valve the more current it consumes.

At the same time, there is another way of looking at it. And that is, the higher the voltage on the plate of the power valve, the more volume it is capable of dealing with.

Most battery users employ a 100- or 120-volt battery, and with a drop across the loudspeaker windings, the number of volts on the plate is not, as a rule, very large. Most of the 2-volt power valves are rated at 150 volts, and by increasing the H.T. until this voltage is obtained on the plate, will put up the undistorted power available by a surprising amount.

### To Get More Power.

But in spite of the extra battery in use and the slight increase in anode current due to the greater H.T. voltage, this is a much more economical way of getting a little greater power than buying a larger power valve. For one thing, the H.T. batteries are not so likely to have too much current taken from them, and for another there is not the expense of a new valve to be faced. Of course, if a very big increase in volume is wanted, then a bigger power valve and super capacity H.T. batteries to run it, will be absolutely necessary; unless you go in for a pentode which will give a surprising return in volume for what is really a modest consumption.

A.S.C.

# Put in 1/4d. worth of Power



# Take out 1/- worth of H.T.

### EKCO H.T. UNITS

Model	Current Output	Voltage Tappings	Price	EASY PAYMENTS	
				Initial Payment	11 Monthly Payments of
A.C. 12	12 m/A	S.G.; 80; 120/150	£2. 15. 0	6/6	5/-
A.C. 18	18 m/A	S.G.*; 50/80*; 120/150	£3. 7. 6	7/9	6/2
A.C. 25	25 m/A	S.G.*; 50/80*; 120/150	£3. 17. 6	8/9	7/1
D.C. 15/25	15 or 25 m/A	S.G.*; 50/80*; 120/150	£1. 19. 6	6/-	3/8

### Combined H.T. & L.T. Charger Units (for A.C. Mains)

Model	Current & Voltage	L.T. Output (for charging accumulators)	Price	EASY PAYMENTS	
				Initial Payment	11 Monthly Payments of
K. 12	Current Output and Voltage Tappings same as Models A.C. 12, A.C. 18 and A.C. 25.	1 amp. at 2, 4 or 6 volts	£3. 19. 6	9/-	7/3
K. 18		2 amp. at 2, 4 or 6 volts	£4. 12. 6	10/3	8/5
K. 25		3 amp. at 2, 4 or 6 volts	£5. 7. 6	11/9	9/10

Tappings marked \* are adjustable.

An H.T. battery can only give you a farthing's worth of H.T. for a farthing. An EKCO Unit will give you fifty times as much—over a shilling's worth!

A 3-valve set needs on an average four batteries a year costing approximately fifty shillings. An EKCO Unit runs your set for one shilling a year—one fiftieth of the cost!

There is an EKCO Unit for every type of radio set or portable, and all are obtainable by Easy Payments. Choose the Unit suitable for your set from the table above, or post coupon for full details.



## POWER UNITS

To: E. K. Cole, Ltd., Dept. A.17, Ekco Works, Southend-on-Sea.

Please send me full details of Ekco All-Electric Radio.

Name.....

Address.....

# The "LOTUS" SUIT-CASE FOUR



Some interesting details of one of the latest "Lotus" productions are given in this article, in which a "P.W." technician describes the results of his practical tests.

THERE was a time not so very long ago when the word portable conveyed all sorts of idealistic impressions of shady nooks by babbling brooks and (s-sh!) hot summery afternoons—in other words, radio out-of-doors.

But that, as its primary application, is a long-forgotten interpretation of radio portability. Alas, our climate has seen to that.

And the necessarily limited scope of a portable as a means of outdoor entertainment is now quite a secondary consideration. It has assumed a much more vital rôle. A rôle which it would have been difficult to fill by any other means.

#### Ideal for Flat-Dwellers.

We refer to its use by the great army of listeners in whose homes the erection of an aerial of any description is an impossibility. What a boon to the flat-dwellers, to those whose homes are but a few of the multitudinous rooms in hotels and boarding-houses! And what of the sick-room where radio can do more good than all the physicians' tonics in the world!

It is for these among dozens of other applications that we welcome anything new in the way of portable receivers—good portable receivers—and the new model which the "Lotus" people have recently introduced is good in every sense of the word.

But that, so to speak, is "spilling the beans"! Let us first tell you something of the appearance and operation of this new "Lotus" production that has been submitted for test and report.

The circuit incorporates four valves. It has wisely been built up around the increasingly-popular combination of S.G., detector and two-note mags, a sensible arrangement for which can be claimed simplicity of operation, sensitivity and, with any well-designed instrument such as the present one, stability plus reliability.

It seems a lot to claim, doesn't it? And yet—but more about that later!

Meanwhile, what of the size and, equally important, how does it look?

For purposes of impartial tests such as this we are debarred from the exercise of imagination. We endeavour to confine ourselves to blunt facts. Yet even from a

#### SPECIFICATION.

Type of Set: Four-valve suit-case portable receiver.

Circuit: S.G. H.F., Det. and 2 L.F.

Weight: 30 lbs. including batteries.

Price: £12 12s.

Makers: "Lotus" Radio Limited, Lotus Works, Mill Lane, Liverpool.

perfunctory glance at the "Lotus" Suit-case Portable the amount of careful design and detailed planning that has been put into the job is abundantly obvious.

Think for yourself of any ordinary S.G. Four, consider the bulk of the average batteries and accumulators, and then add to

want to carry about for very long, at least, not on a hot summery afternoon! But as we have previously explained, that is not the 1932 interpretation of portability, and in any case, until batteries are made from cotton-wool, weight will always be a mitigating factor against genuine take-it-where-you-will portability.

#### Splendid Results.

And now for a word or two about results. May we say by way of introduction to this final section that this set has been designed in such a way that it is about as simple to operate as could possibly be imagined for a set of this type?

On the left, there is a clearly-marked knob controlling a three-way switch which gives medium-waves, long-waves and a central-off position. In the centre there are two disc-drive tuning controls which can be operated together or independently, the scales of which are calibrated in wave-lengths.

The remaining control—with the exception of a selectivity control mounted in the lid which only comes into use on those remote occasions when it is desired to try the set with an external aerial—is marked volume control.

The set is delightfully simple to handle, and in our tests with it, at a point roughly twelve miles from Brookmans Park, we found it easily possible to receive quite a number of alternative programmes apart from the locals which, as might be expected, simply "romped" in. Such stations as the North Regional and Rome, for instance, were received at adequate strength for comfortable listening, and those were but two of dozens.

#### On Long Waves.

On the long waves, the same high standard of sensitivity is fully maintained. Huizen, Radio Paris, and Eiffel Tower, were but three of several alternatives to 5 X X, and all were received at adequate volume.

As a result of our tests, we have no hesitation in saying that the "Lotus" Suit-case Four is an excellent proposition for all those who are interested in portable radio. The price is £12 12s. and an informative instruction booklet which contains all the details relevant to the maintenance and operation of the portable is supplied with each instrument.

The makers are "Lotus" Radio Limited, Lotus Works, Mill Lane, Liverpool.

#### HOW'S THIS FOR SIMPLICITY?

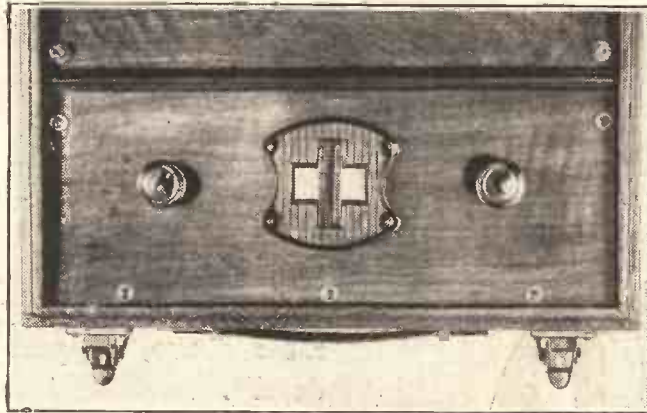

This "bird's-eye" view of the controls exemplifies the simplicity of the new Lotus Suit-case Portable Receiver.

the size of a loudspeaker and frame aeri- als. And then try to visualise getting them all into a cabinet or case roughly 15 x 14 x 10 in. without sacrificing efficiency!

Yet that is what the "Lotus" designers have succeeded in doing.

The whole thing complete with batteries weighs only 30 pounds.

We make no secret of the fact that in our opinion it is not the thing that you would



**GRAHAM FARISH COMPONENTS FOR HIGH EFFICIENCY**

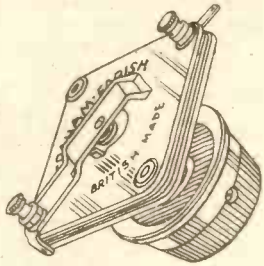

**'Litlos' Variable Condensers**

In all capacities up to .0005, log line, straight line capacity and differential. Particularly low loss. Single hole fixing. All capacities and types, 2/



**Ohmite Resistances**

Better than wire-wound. All values from 300 ohms to 5 megohms, 1/6

**Megite Volume Control**

A new design. Potentiometer type ideal for loudspeaker and pick-up. Nickel-chrome wire-wound. Slipper action making broken contacts impossible. Absolutely silent. 3 terminal type. Bakelite case. Single hole fixing. Resistance up to 25,000 ohms, 3/6 Resistance over 25,000 ohms, 4/6

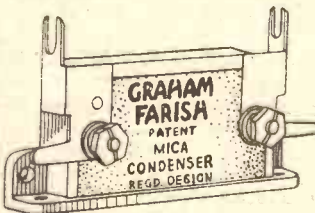
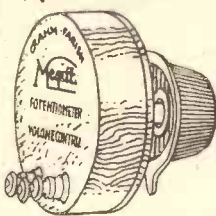

**Graham Farish FIXED CONDENSERS**

In a complete range of capacities, upright or flat mounting. Registered design No. 723,271. .0005 mfd. to .004 mfd., 1/- .005 mfd. to .01 mfd., 1/6



**The GARD Lightning Arrester**

A permanent and absolute protection against lightning and static charges. No need to switch off during thunderstorms. Definitely does not interfere with reception, 1/6

SEE OUR STAND  
**No. 50**  
AT THE OLYMPIA  
RADIO EXHIBITION

**A Sensational Radio Discovery**

**PERMANENT-EFFICIENT EVER-DAMP EARTHING**

Rejuvenates the heart of your receiver

More radio troubles come through faulty earthing than from any other single defect of a receiver. Crackling in the loudspeaker, oscillation, mains hum, weak volume and poor tone are ALL caused by an inefficient earth. PREVENT these troubles and get the last ounce of power and purity of reception by fitting a **FILT**—the wonderful new percolative earth—a sensational invention that makes perfect earthing CERTAIN.

**Wonderful New Percolative Chemical makes even Dry Soil permanently conductive**

**FILT** is based on a completely new principle of CHEMICAL earthing. It doesn't depend on the dampness of your soil or the depth at which you bury it. As soon as it is under ground, the wonderful **FILT** chemical begins to spread and percolate, attracting moisture and making a PERMANENT conductive area for several feet around and below its copper container. It works ANYWHERE, in ANY soil, in ANY climate!

**How FILT works and what it does**

Imagine dozens of chemical tentacles spreading outwards and downwards through the earth, every tentacle a high conductor of electricity, and every one leading to your earth and through the earth wire to your set. That is what **FILT** gives you. It means high efficiency earthing—always damp—always active—enabling you to get the very utmost out of your set from one year's end to the next. It is the most effective earthing system money can buy.

**GRAHAM FARISH**  
(par. applied for)

**FILT**

**PERCOLATIVE CHEMICAL EARTH**

Get a **FILT** to-day from the nearest radio dealer or order direct (post free) from the sole manufacturers:

**GRAHAM FARISH LTD.,**  
181, Masons Hill, Bromley, Kent.



See how it works



**2/6 COMPLETE**

## FROM THE TECHNICAL EDITOR'S NOTE BOOK.

# Tested and Found-?



## PROTECTION AGAINST LIGHTNING.

**N**ATURE has provided me with a perfect accompaniment to the writing of these first paragraphs. There is a terrific thunderstorm in progress and blinding flashes of lightning are followed by deafening rolls of thunder. There is a torrential downpour of rain.

And here am I about to describe the new Bulgin Lightning Switch!

It is a most ingenious article, as would, of course, be expected of Bulgin.

Although not much larger than a match-box, it includes a fuse, a lightning arrester, and an earthing switch.

## A BULGIN PRODUCT

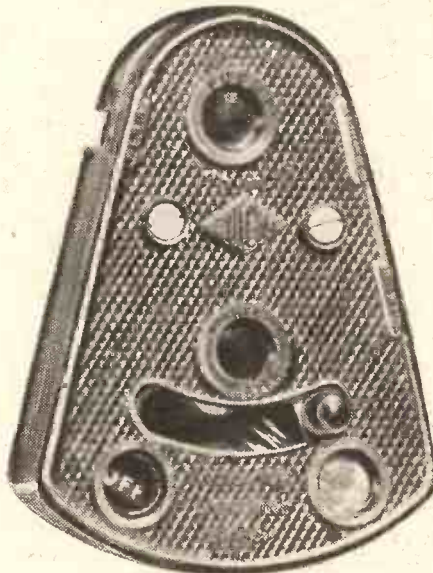

A full-size reproduction of the Bulgin Lightning Switch.

Little windows in the cover enable you to (1) see if the fuse is intact or otherwise; (2) note whether or not sparks are flying across the arrester or (2a) check up the condition of the gap; (3) verify the position of the switch. Two windows are allotted this last duty, and either the word "on" or "off" pops into vision as the device is operated.

You may or may not use the switch, but Bulgin are taking no chances. Those other two safeguards work quite independently, and stand by for action all the time—even while the set is working.

And the lightning arrester is so placed that all the energy must first go through the fuse which is, as it were, the first line of defence.

I like the switch. It has got a spring, and this enforces a proper working. Half-way positions are impossible—the switch must be either on or off. And there are

good spring contacts to ensure a satisfactory completion of the contract.

Messrs. Bulgin say "to our knowledge, this is the only lightning switch on the market with a quick make-and-break action."

Certainly, I too, have seen no other.

The device costs 2s. 6d., and it carries with it a £100 free insurance guarantee against damage to a receiver by lightning.

We have tested the switch for electrical and weather-resisting qualities, and find it to be perfectly sound.

In conclusion, I feel bound to say a few words regarding the general aspects of lightning and radio in order to offset some of the advertisements and statements—I am not referring to Bulgin's—which have rather alarmingly dealt with the subject.

I believe that about two hundred thousand thunderstorms occur during the year, while in some parts of the world lightning discharges are almost continuous for periods of weeks at a time. Now how many of the eighty million (it may be more) listeners who do not use lightning switches meet with their just deserts for this neglect? Seemingly, the odds in their favour are many more times that of winning four or five Irish Sweep first prizes in succession!

However, don't read this as an argument against the use of lightning switches. No one can justify the relaxation of a precaution against even a negligible danger so long as there is an easily applied and inexpensive safety-first measure available.

And that certainly is the case with this lightning business, as is instanced by the Bulgin gadget.

## EKCO ACHIEVEMENTS.

I have received a well-prepared brochure which outlines the progress made by E. K. Cole, Ltd., during the past seven years. "Ariel" has already referred to this matter in his cheery Notes and News, but I would like to add my personal tribute to the courage, enterprise and straight-dealing which have contributed to the building up of a mighty business and an honoured name.

I well remember, as do no doubt some of my readers, the days when Ekco were comparatively unknown to the public, and people weren't sure whether or not the "k" preceded the "c," or if it weren't "Echo" after all!

But the first Ekco mains units were then being made by hand in a tiny room 50 ft. square. One hundred and fifty thousand square feet of factory space equipped with the best modern machinery are needed nowadays!

That is expansion indeed.

## A NEW LOUDSPEAKER.

A new diaphragm technique has crept into loudspeaker design. Instead of the diaphragm being supported by a flexible surround of different material the whole structure is now frequently in one piece.

An example of this method is to be found in the new Lamplugh Silver Ghost permanent magnet moving-coil loudspeaker. The diaphragm of this instrument is of moulded pulp, and its centring and suspension are both ingenious and effective.

## PLEASE NOTE

Manufacturers and traders are invited to submit radio apparatus of any kind for review purposes. All examinations and tests are carried out in the "P.W." Technical Department with the strictest of impartiality, under the personal supervision of the Technical Editor.

We should like to point out that we prefer to receive production samples picked from stock, and that we cannot in any circumstances undertake to return them, as it is our practice thoroughly to dissect much of the gear in the course of our investigations!

And readers should note that the subsequent reports appearing on this page are intended as guides to buyers, and are, therefore, framed up in a readily readable manner, free from technicalities unnecessary for that immediate purpose.

Indeed, the whole speaker is of original, clean design, and I particularly like the well-finished, dustproof casing at the back for the magnets, etc. There is a transformer having the usual "Power," "Super-Power," and Pentode tapings.

The price is 42s. with transformer, and a small baffle board of 5-ply wood. On test this Lamplugh speaker gave good results, its response, sensitivity and power-handling qualities being of first-rate quality for the junior class of M.C. speaker.

## THE LISSEN "SKYSCRAPER."

The Lissen people have sent me a copy of their constructional folder which deals with the "Skyscraper" — Lissen's new-season S.G. Three. It is a magnificently produced folder and reflects the greatest possible credit on all concerned with its preparation and printing. Every constructor should make a point of securing a copy.

## COMPLETE WITH TRANSFORMER



The Lamplugh loudspeaker reviewed on this page.

# DIRECT RADIO OFFER—

**CASH PRICES AND EASY PAYMENT TERMS OF MANUFACTURERS' KITS.**

**Radio for the Million "Station Master 3"**

Model A. Complete Kit and Valves in Oak Table Cabinet or 15/6 down and 7 instalments of 15/6. **£5 11 0**

Model B. Complete Kit and Valves, special Celebration Speaker and Midget Type Cabinet in Walnut Finish or 17/6 down and 9 instalments of 17/6. Particulars of A.C. Kits obtainable on request.

**Gossor Melody Maker Model No. 337**

All Electric. or 25/- down and 11 monthly payments of 21/-.

Model No. 334. 3-valve Kit without Speaker or 14/- down and 9 monthly payments of 14/-.

A unique "order from home" service  
**SPEEDY DISPATCH GUARANTEED COMPONENTS**

**BUILD YOUR "OLYMPUS" FOUR WITH A DIRECT RADIO TESTED KIT**

1 Ebonite panel 14 in. x 7 in. drilled to specification	£ s. d.
1 Oak cabinet with 10 in. baseboard	4 3
1 K.I. Hypermite transformer	1 0 0
1 R.I. Quad - Astatic H.F. Choke	12 6
1 R.R. '0003 diff. reaction condenser	3 6
1 Leecos M.C. choke	2 6
1 Lotus '0003 diff. reaction condenser	2 6
2 Telsen screened coils	3 0
4 4-pin valve holders	17 0
2 Telsen Telexor condensers '0005 mfd.	2 0
1 Graham Farish 0.5 meg. leak w/holder	1 5 0
1 Graham Farish 100,000 ohm resistance	2 0
1 Graham Farish 0.5 meg. resistance	1 6
1 Graham Farish 2 meg. resistance	1 6
1 Bulgaria L.T. on-off switch—Type S.15	1 6
1 T.C.C. '0003 fixed condenser—Type 34	1 3
1 T.C.C. '0001 fixed condenser—Type M	1 6
1 T.C.C. 'or mfd. condenser—Type 34	1 0
1 Five-way battery cord	3 0
2 coils Glazite wire	2 6
2 Belling-Lee terminal blocks	1 0
4 Belling-Lee Indicating terminals—Type "R"	1 4
Screws and copper foil	1 0
1 Mullard P.M.1 H.L. valve	6
1 Mullard P.M.2 D.X. valve	7 0
1 Mullard P.M.2A valve	7 0
1 Mullard P.M.12 valve	8 9
or 13/10 down and 11 monthly payments of 13/10	16 6
	<b>£7 11 7</b>

**Recommended Accessories**

1 Pertrix 2 volt 30 amp. Accumulator	s. d.
	11 0
1 Pertrix 120 volt H.T. Battery (Ultra)	15 6
1 Pertrix 9 volt G.B. Battery	1 3

**No. 1 KIT**

(less valves and cabinet)  
or 8/6 down **£4 12 4**  
and 11 monthly payments of 8/6.

**No. 2 KIT**

(with valves less cabinet)  
or 12/1 down **£6 11 7**  
and 11 monthly payments of 12/1.

**No. 3 KIT**

(complete with valves & cabinet)  
or 13/10 down **£7 11 7**  
and 11 monthly payments of 13/10.

**CASH PRICES AND EASY PAYMENT TERMS OF MANUFACTURERS' KITS.**

**Osram "Thirty-Three"**

(complete with Cabinet and Osram Valves) or 20/- down and 12 monthly payments of 15/- **£9 9 0**

**S.T. 300**

**BATTERY MODEL**

KIT No. 1 (less valves and cabinet) or 6/9 down and 11 monthly payments of 6/9 **£3 13 6**

KIT No. 2 (with valves less cabinet) or 9/9 down and 11 monthly payments of 9/9 **£5 5 9**

KIT No. 3 (with valves and cabinet) or 11/5 down and 11 monthly payments of 11/5 **£6 4 3**

Battery (with Speaker) Equipment **£2 4 3**

# Direct Radio

**CASH, C.O.D. AND EASY PAYMENT ORDER FORM**

To: Direct Radio, Ltd., 159, Borough High Street, London, S.E.1.

Please dispatch to me at once the following goods.....

.....for which (a) I enclose (b) I will pay on delivery (c) I enclose first deposit of (cross out line not applicable) £.....

NAME.....

ADDRESS.....

It is impossible to buy any completely manufactured set (at or about the same price) which can give anything like the PERFORMANCE of these

The Quality of reproduction is superb.

Ask for a Chart, and see the Made-up Sets at OLYMPIA Stand 78

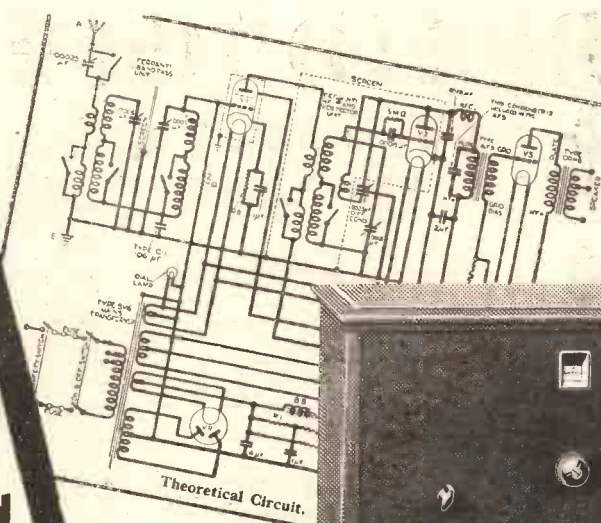

Theoretical Circuit.  
Completed Set in Walnut finish Cabinet

# FERRANTI

## CONSTRUCTORS' BAND-PASS RECEIVERS

for Battery or Mains Operation

THE FINEST 3-VALVE SETS, CONSTRUCTORS OR OTHERWISE, THAT MONEY CAN BUY



**PRICES:**

**BATTERY KIT**, without Valves, Batteries, Panel and Baseboard, £7 : 14 : 6

With Panel and Baseboard, but without Valves and Batteries, £7 : 19 : 6

With Cabinet, Panel and Baseboard, without Valves and Batteries . . . £9 : 4 : 6

**A.C. MAINS KIT**, without Valves, Panel and Baseboard, including Royalty . . £10 : 18 : 6

With Panel and Baseboard (without Valves) including Royalty, £11 : 3 : 6

With Cabinet, Panel and Baseboard (without Valves), including Royalty £12 : 8 : 6

**FERRANTI H.F. BAND-PASS STAGE** only, comprising Triple-Gang Tuning Condenser, Band-Pass Coils, etc., £4 : 6 : 6

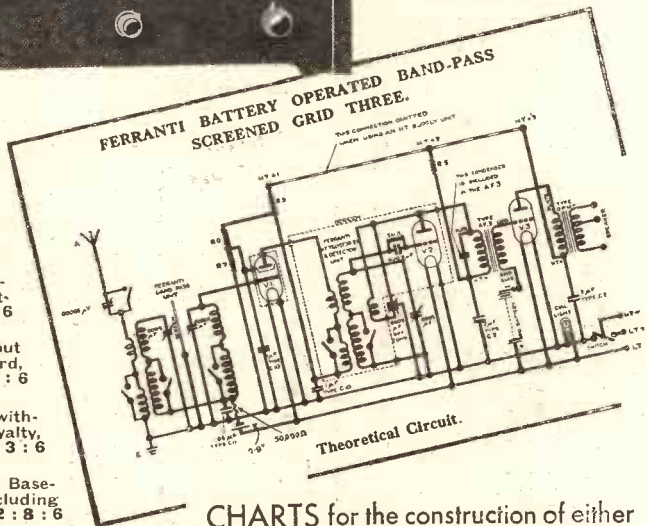

Theoretical Circuit.

CHARTS for the construction of either A.C. Mains or Battery Model may be had from your dealer, or will be sent on receipt of 1½d. stamp.

# FERRANTI

## BAND-PASS RECEIVERS

These Receivers have selectivity high enough to receive most of the worth-while Radio Transmissions available, maintaining at the same time HIGH QUALITY REPRODUCTION.

This result is largely due to our supplying the coils and tuning condensers adjusted together with great accuracy (plus or minus .000000125 mf. at minimum and plus or minus .00000075 mf. at maximum capacity) and having complete control of most of the vital parts on which success depends. Complete Kits or separate parts may be purchased and may be obtained immediately.

ALL FERRANTI COMPONENTS ARE AVAILABLE FROM STOCK

FERRANTI Ltd., Charts Dept., HOLLINWOOD, LANCASHIRE



# YOUR LOUDSPEAKER MAGNETS

By D<sup>r</sup> J. H. J. Roberts  
F. Inst. E.

Some vital details of the practical side of loudspeaker magnet design.

IT is an old proverb that a chain can never be stronger than its weakest link. We may apply this very appropriately to a loudspeaker, which, whatever its external form, can never be more efficient than its magnetic driving unit. It is true that a good unit may be counteracted (it frequently is) by a poor horn or diaphragm. But the unit is the "heart" of the speaker, and it is to the unit that

## INCREASED RELUCTANCE

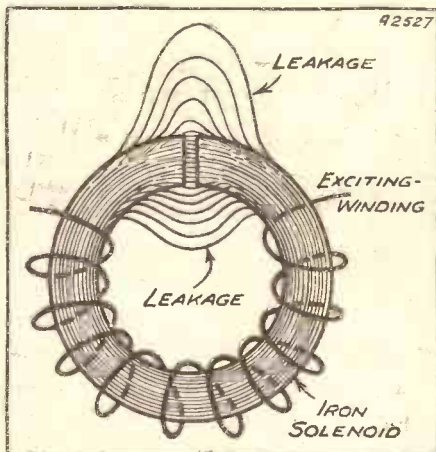

If an air gap is cut in a magnetised iron ring, a greatly increased energising current is required, owing to the "reluctance" of the gap.

our attention should in the first instance be directed.

Practically all loudspeaker units employ some form of magnet, either a permanent magnet or an electro-magnet, for the purpose of creating an intense magnetic field in the region or gap between the poles, the armature or movable part of the speaker being located in this magnetic field.

### Careful Experimental Work.

Now you might think that so long as we had a fairly strong magnetic field for the armature to move in, it would not matter very much what was the form of the armature and of the magnetic poles in relation to one another.

It may, in fact, surprise you to know that a large amount of careful experimental work has been devoted to this very point, and it is largely as a result of this work that loudspeaker units have been so greatly improved during the past two or three years.

In the first place, I should perhaps mention that to obtain a really intense magnetic field, even over a limited region, is by no means an easy task. It is

difficult enough when we have the resources of the electro-magnet at our disposal, but much more difficult if we have to rely simply upon a permanent magnet.

Sometimes we hear of magnetic systems for loudspeaker units in which a field strength of 15,000 or even 20,000 lines to the square centimetre is claimed, but I may tell you that such a specification is almost invariably on the optimistic side—very much so.

A magnet system of this type developing a strength of 5,000 lines to the square centimetre in the gap is more likely to be met with in practice, and even that strength would be very good compared with the strength of some of the units I have examined from time to time.

### Pile on the Current.

At first sight it seems a comparatively simple matter to provide an intense magnetic field, especially in the case of a moving-coil speaker with a separately excited electro-magnetic "pot." You would think that all you had to do was to pile on the exciting current, and you would be bound in time to get the required field strength.

This is not necessarily true, and, even if it were true, it would be a poor business, from a designer's point of view, to make up for bad design by the lavish use of electric current.

The great enemy which we are up against in our attempts to produce a strong field in the gap of a loudspeaker magnet is the magnetic "reluctance" both of the magnet

material itself and of the air in the gap, particularly the latter.

Owing to this factor there is a good deal of "magnetic leakage"; that is to say, the magnetic flux, instead of behaving itself and keeping strictly within the confines of the magnet, has the unfortunate habit of

## THE COURSE THEY TAKE

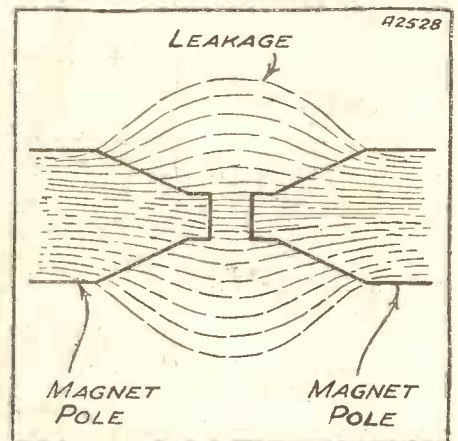

This is the course taken by the lines of force between the poles of a magnet. It will be seen that although a certain number travel in a straight line across the gap, there is an appreciable spread of the magnetic field.

forsaking the magnet and wandering about in the surrounding space. This is very awkward for us, inasmuch as our object is to concentrate the flux in the magnet and to make it jump nicely across the gap between the magnet poles.

I expect you know that if you have a closed magnetic circuit (such as a complete iron ring) with exciting coils wound around it, and you cut ever such a small gap in the ring, the exciting current necessary to maintain a given magnetic flux is very greatly increased.

### The Size of the Gap.

This is owing to the enormously greater "reluctance" in the gap. As the gap is increased in width, the exciting current required to maintain the same flux is still further increased, but not proportionately. In other words, it is not so much a question of having a wide or a narrow gap in the magnetic circuit as having any gap at all.

With an average loudspeaker magnet or pot I have found by actual test that sometimes as much as 60 to 70 per cent. of the total exciting current goes in driving the magnetic flux across the gap, only the remaining 30 per cent. odd being required for driving the flux around the remainder of the magnetic circuit.

(Continued on next page.)

## MAGNETIC LEAKAGE

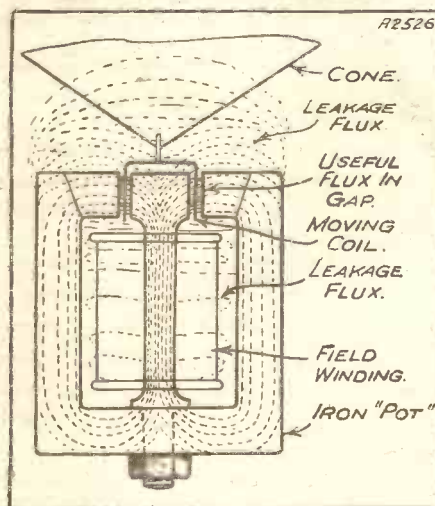

In a well-designed loudspeaker most of the magnetic lines of force are concentrated in the air gap, but even in such cases a great many are lost in the surrounding air, as indicated above.

## YOUR LOUDSPEAKER MAGNETS

(Continued from previous page.)

Now let us consider the relation between magnetic leakage and magnetic reluctance. Perhaps "reluctance" can be most simply explained by comparing it with the electrical "resistance" of a conductor.

It is convenient to regard the magnetic "flux," as its name suggests, as actually flowing through the iron and across the gap, in much the same way that electricity flows through a conductor and jumps across the gap in the form of a spark. Don't take this analogy too literally, but it may be useful as a sort of mental picture.

Now, the lines of magnetic force will crowd together into any substance which forms an easy path for them (as the iron does), but will tend to repel each other and separate—"thin themselves out," as it is sometimes expressed—when travelling in a medium which is difficult for them, or which has a high "reluctance," such as air or a vacuum.

### The Easy Path.

The result is that the magnetic flux created by the exciting coils of the magnet will, in the main, follow the easy path provided for it by the iron of the magnet, but when it comes to the gap it will spread out and wander in all directions. A certain proportion of it, however, will follow the geometrical route across the gap, just as though there had been no gap or as though the gap had been filled up with iron.

I think it will be clear from all this that the great point in the design of a loudspeaker magnet is to make the magnetic flux keep within reasonable bounds when jumping across the gap. It is only what it does in the gap that really interests us from the practical point of view, as it is in the gap that the armature is to be placed.

### So Much Wastage.

All the magnetic lines of force which are generated by the field current but which fail to cross the gap at the desired region may be regarded as so much wastage. This extraneous or lost magnetic flux is generally referred to as the "leakage flux," or

"magnetic leakage." Even in a well-designed magnet it may amount to quite a serious percentage of the whole flux generated—as much as 20 per cent.—whilst in a badly designed magnet it may be 50 to 60 per cent.

That is one of the reasons why I said that to talk about a field strength of 15,000 to 20,000 lines to the square centimetre is generally very optimistic, because even if such a strength is actually generated in the iron core itself (which is very unusual), only a percentage of it will actually pass across the central region of the gap, the rest wandering off in other directions and being lost so far as any useful purpose is concerned.

### Not As Simple As That.

You might think, as I said before, that we could just simply increase the exciting current and so bring up the field strength

## A CLOCK THAT TALKS

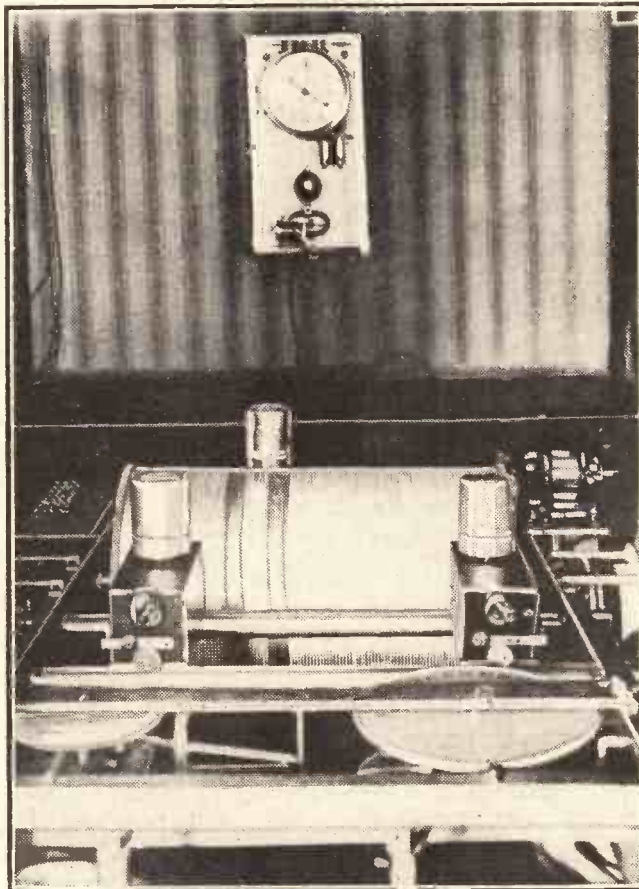

An interesting and novel clock that tells you the time when asked! It has been installed in the Paris Observatory, and when telephone subscribers ring up a certain number, the clock 'phones them the exact time. The principle of this invention corresponds very closely to that of the talking film. A vocal record is made, on a disc, to cover every hour and minute, and every ten seconds, during the day. The disc revolves in step with a master clock and can be "played back" automatically at any given moment.

in the gap to any desired amount. Owing to the magnetic leakage it is, unfortunately, not as simple as that and, unless the magnet is cleverly designed, all we do when we increase the exciting-current strength—at any rate, *practically* all we do—is to increase the leakage flux; this, of course, is no use to us at all.

So you see that it is not just a question of piling on the agony in the shape of field current: we must also have a properly-designed magnetic system if we are to get a good field strength in the gap. This is where clever designing comes in and

where one speaker magnet will score over another.

Perhaps you may be interested to know why it is that, beyond a certain point, we get little or no useful addition to the flux in the gap by increasing the field current. Well, the reason is that when the iron core of the magnet is already approaching "magnetic saturation," it ceases to be such an attractive medium (as it were) for the carrying of any additional flux, so that the extra flux might almost as well leak through the air path as travel in the iron. The inducement or temptation for the flux to travel in the iron is not so great as it was.

Another curious thing is that if the current strength in the field coils is much below the rated value, the flux in the gap will diminish far more than you might expect. This is due to the fact that, in addition to the natural reduction in the total flux (which you would expect) there will be an increase in the leakage current (which you would not expect).

### Below the Optimum.

So that not only is the total flux strength reduced by reducing the field current, but also a *smaller* percentage of this flux goes through the gap.

The reason for this rather curious effect is that the permeability of the iron—that is, as we may call it, the "attractiveness of the iron as a path for the flux"—increases as the flux increases up to a certain point; or, if you like to put it the other way round, it decreases as the flux decreases below the optimum point.

Consequently the difference between the attractions of the iron-path and the air-path is not so great as it was, and a larger proportion of the flux wanders through the air instead of passing through the iron.

### Gone To a Lot of Trouble.

For these reasons the moving-coil speaker should always be operated at the correct field voltage as specified by the makers. The makers have gone to a lot of trouble to design the magnet system and the exciting coils for maximum efficiency under definite conditions.

One of those conditions is the use of a specified current flowing in the field coil, which in turn means the application to the field of a specified voltage. So keep strictly to the specification. If you go varying things you can't expect the best results.

## HOW TO GET A GOOD EARTH

THE U.S. Bureau of Standards recently recommended the following procedure where a good earth is required for a radio set.

Dig a hole 12 in. deep and place 5 lb. of rock salt in it. Pour water in until the rock salt has dissolved.

Then drive a metal tube or rod of about 1 in. in diameter and 8 ft. in length through the centre of the hole.

The earth lead from the set is, of course, connected to the upper end of the rod by means of a short lead of generous dimensions—7-strand wire of the type used for aërials is excellent for the purpose.

# ON TOP AT OLYMPIA



Osram  
8VA

OLYMPIA

Osram  
valves

MADE IN ENGLAND

Sold By All  
Wireless Dealers.

NATIONAL RADIO EXHIBITION

See the G.E.C. Radio Products on the G.E.C. Stands

Advt. of The General Electric Co., Ltd., Magnet House, Kingsway, London, W.C.2

**LISSEN****THE GREATEST KIT****SKYSCRAPER 3  
KIT****SENSITIVE-SELECTIVE-POWERFUL**  
*Metallised S.G. - Detector - Pentode Output*

You've got something sensationally good in this new Lissen Skyscraper Three Kit Set. Far-flung range is provided by the new Metallised Screen-grid Valve whose super-efficient screening has made it so absolutely stable that you can push it to the limit of its capabilities. Mighty volume is put out by the Lissen Economy Pentode Valve, and the power you get from it imparts a brilliance of tone to Skyscraper reproduction, never before heard from

any home-constructor's set. The whole circuit is designed for the conservation of every atom of energy that comes to your aerial. Use is made of new shielded coils, which are specially matched and balanced—there is a metal chassis with modern under-baseplate wiring—hair-breadth tuning with geared ball-bearing condensers—all these points and more are combined for the first time in the Lissen Skyscraper.

**WHEN YOU HAVE  
BUILT IT!****HOW YOU BUY IT INCLUDING VALVES****89'6****LISSEN LTD.**



# FOR HOME CONSTRUCTORS EVER PRODUCED

Have you ever seen a finer looking, more compact, more complete home-built receiver?

You buy the Lissen Skyscraper Kit complete with valves—a Lissen Metallised S.G. Valve, a lively Lissen Detector Valve and a Lissen Economy Power Pentode Valve—and the whole price is only 89/6. You can start straight away and build it, using if you like your existing batteries and any suitable cabinet.

But Lissen have provided for you a beautiful walnut Console style cabinet, made in sections for you to put together yourself. That saves you a lot of money and is perfectly simple. This Lissen Skyscraper Cabinet houses batteries, accumulator, chassis and loud-speaker—a special Lissen Pentode-matched Loud-speaker is provided with it, which makes the Skyscraper the most compact and best-looking home-built receiver ever produced. The price complete with this cabinet and the loud-speaker is only £6 5s. Easy terms are available to purchasers of the Lissen Skyscraper.

## WHAT IT WILL DO!

What do you expect to-day from the finest set you can possibly build? All Europe? Yes, and all Europe at real entertainment strength. Radio Paris as loud as your local station . . . Moscow at full strength . . . Muhlacher as free from background and as strong as London . . . all the best of the European programmes like next-door neighbours, and with glorious tone and extreme ease of tuning.

SAVE MONEY—BUILD WITH YOUR OWN HANDS —YOUR SUCCESS IS CERTAIN



**FREE!**  
**1/- CONSTRUCTIONAL CHART**

A two-colour, lavishly produced Constructional Chart has been published, giving detailed instructions and photographs for every step in the building of the Lissen Skyscraper Three. Never before has such a complete Chart been published—every terminal, every wire, every screw is fully dealt with. **THERE IS A FREE COPY FOR EVERYBODY—GO AND ASK YOUR DEALER FOR YOURS!**

*Ask your dealer for it!*

**WORPLE RD, ISLEWORTH.**



Here is a gadget which will lend fascination to radio dance music. It is made up entirely of odds and ends, and the little figure will amaze you with his wonderful sense of "time."

By M. L. WENDEL.

SINCE the writer constructed this radio-operated dancing doll, both he and his family have had no end of amusement with it. It supplies some of the most humorous incidents of every evening's radio programmes, apart from being both a marvel and a mystery to visitors who cannot quite understand how radio waves can cause a little paper man to keep (at times) almost perfect time to a jazz band that may be playing a thousand miles distant.

The materials necessary to build it are of the modest sort, and the writer dares to say that the average constructor will not have to go very far beyond his own workshop to find the materials necessary for the construction of this fascinating toy.

**Relic of Yesterday.**

The relay is made from the old telephone receiver of the 1,000-ohm type. And who has not got a pair of headphones lying about the house left-over from the early days of radio broadcasting?

The cap is removed from the receiver, and two holes are drilled through the bottom of the case so that the case may be screwed down to the baseboard, as illustrated in the sketch. It will be noticed that the writer has not given any dimensions in this case, for the simple reason that they will depend to a very

large extent upon the size of the radio telephone receiver used. However, these dimensions are not in the least important, inasmuch as they do not bear upon the operation of the device.

**When the Relay is Energised.**

The armature of the relay, which is cut from a piece of soft iron, is riveted to a small length of phosphor bronze spring. This should be very thin, but with enough body to be able to hold the armature

horizontal when the relay is not energised, A machine screw holds the armature member to the brass standard. A small hole is drilled in the opposite end of the armature, and a small piece of silver is placed in it. The silver may either be held with solder or it may be hammered in. In any event, after the contact—for that is what it is—has been installed, the top of it should be dressed up with a fine file.

The contact opposite to this one is mounted in another brass standard. This is so mounted on the baseboard that the contact in the end of the armature will be in exact line with it. This contact is also dressed up with a file.

**Final Adjustments.**

Adjustment is made by means of a small bracket carrying an adjusting screw. This member may be bent into shape from ordinary sheet brass of heavy gauge. Being too thin to carry a sufficiently large number of screw threads, a clearance hole is drilled and a brass nut is soldered over the clearance hole.

A second nut is used to lock the adjustment once it has been properly made. After leads have been brought out from the telephone receiver and connected with two terminals mounted on the baseboard, the work on the relay is complete.

The dynamic unit is formed by an ordinary door buzzer or bell. If the latter is used, the clapper will have to be cut off. No other changes will be necessary, and the buzzer or bell is simply mounted as illustrated. It will be well, however, to so adjust the contact of the unit so that there will be a minimum of sparking.

The paper man doll is cut from Bristol board or stiff cardboard, and the various parts joined by pins. To prevent these pins from dropping out of place, a tiny drop of solder is placed on the end of each one after it has been clipped off.

**WATCH HIM DANCE TO THE RADIO**

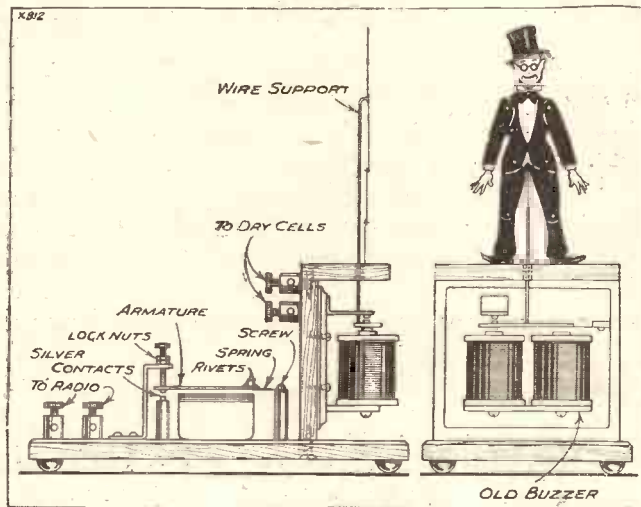

**Utterly Uncanny.**

The figure is bound to the long wire supporting member with thin copper wire of about 25-gauge.

Four terminals will be needed, two for the relay and two for the leads to two dry cells connected to the buzzer. The diagram will illustrate this and the connections.

It is a very delicate and sensitive thing, to say the least, and some adjustment will be necessary. After the adjustment has been made the device will operate perfectly, and it will supply no end of real fun, its action at times being utterly uncanny!

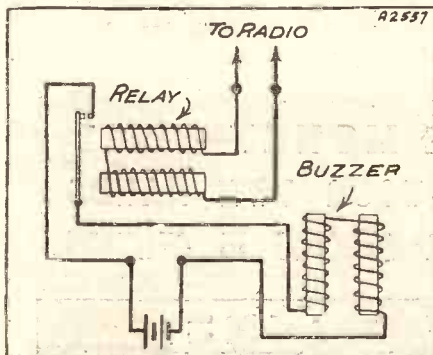

Above you see the apparatus in side and front elevations, and you can see there is nothing complicated about it.

This is fully borne out by the circuit diagram to the left, which shows the full scheme of connections between set and "robot."

The "close-up" diagram to the right shows every detail of the relay. Its actuating mechanism is an old telephone earpiece.

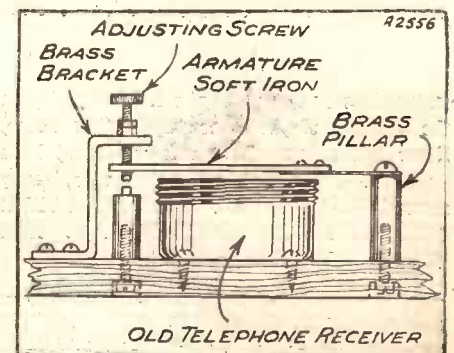



THE  
MASTER TOUCH  
OF THE  
"AUTHENTIC"  
PRODUCT



**UNIQUE**  
in their story  
in their superiority

From Fleming and De Forest to the present day, unceasing research has lifted the valve from one triumph to another, and in the van of every real development the name of Marconi can invariably be found. The first dull-emitter valve—the first power valve—the first special H.F. valve—the first British screen grid valve—the first A.C. mains valve—the first satisfactory D.C. mains valve—the first British variable-Mu valve—every one MARCONI! This is indeed a record to be proud of, but in the factory and research laboratory the work of progress even now continues unabated.

That is why MARCONI valves are the invariable choice of all who demand consistent high efficiency.

Come and see the latest MARCONI developments; and discuss your valve problems with us, at

**RADIOLYMPIA STAND No. 74**

THE MARCONIPHONE COMPANY LIMITED  
RADIO HOUSE 210-212 TOTTENHAM COURT ROAD LONDON W 1

MARCONI VALVES

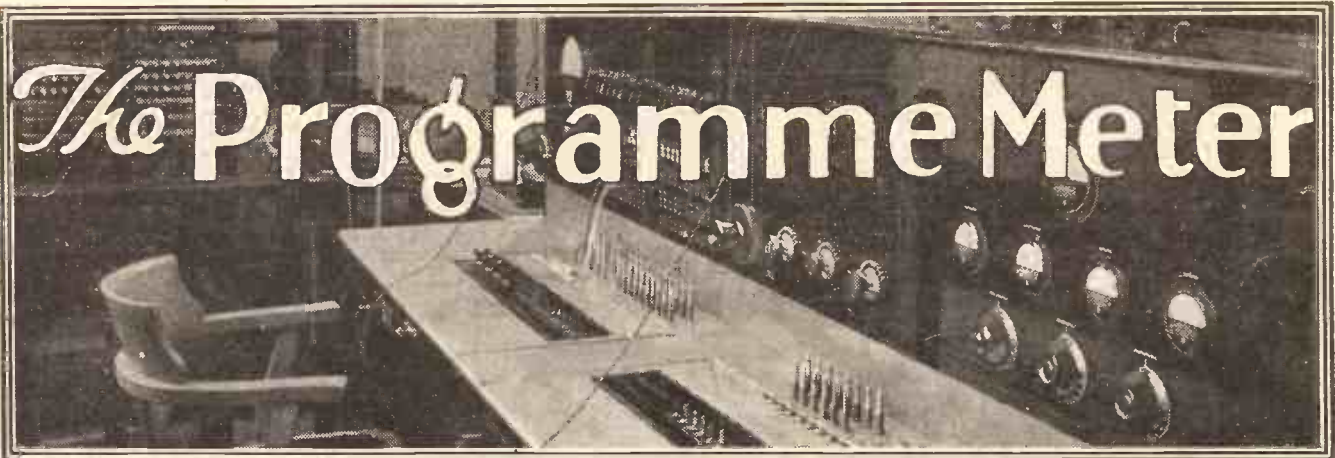

A CERTAIN amount of secrecy was maintained by the Construction Department of the B.B.C. when the new control-room panels were being fitted in place, and in my meanderings about the new building I did not find anybody very talkative about the special gear being installed!

It was not until I saw the first tests of the rehearsal and studio control panels that I found an engineer who confessed to knowing anything about the new-comers. This was specially interesting because there had been rumours going round the Engineering Department concerning a novelty known as the Programme Meter.

#### A Mystery Cleared Up.

I knew that the programme Meter was one of the group of dials on each of the new control-room panels, and at last the mystery has been cleared up by a full explanation of the programme meter, given me by one of the men who actually control the transmissions.

You know all about the way in which big potentiometers are used by the musical men for controlling the volume of sound, and no doubt you are aware that this is one of the chief jobs in the control room. Engineers refer vaguely to "meters" which show the volume but, when you come to think of it, it is not easy to devise a meter which shows the actual volume of low-frequency power handled by an amplifier.

#### Excessive Grid Swings.

You technical experts will jump at me here and say, "Well, what about a milliammeter in the plate circuit of the detector?"

Good! But if you think a little, you will see that that shows only the distortion caused by excessive grid swings, and it does not in any way show the constant volume.

A good many amateurs would like to have a volume indicator in their set, if it could be simply devised. I'm afraid the B.B.C. way of indicating volume is too complicated for

Up in the roof of Broadcasting House, in a corner of the magnificent new control room, the engineers have installed a novel arrangement by which they can measure the volume of musical or other items. Below is a full description of this interesting novelty from

A SPECIAL CORRESPONDENT

amateur use, although simple in the basic idea.

With my friend from the Balance and Control Department, I went along to see one of the programme meters—an innocent-looking 2½-inch dial in the middle of an aluminium panel. The needle was very slowly wavering up and down, and I saw that the scale was graduated from one to seven in arbitrarily chosen units of volume.

"This is far more ingenious than you may think," explained my friend. "I don't suppose, in any other set, you have

ever seen a meter which actually registers the volume handled. This meter is of a dead-beat type, although by the slow way the needle wanders up and down as the volume rises and falls, you might not think so. It reads accurately when the current does not fluctuate quicker than about twice a second.

#### No Load on the Condenser.

"In the amplifier rack there is a separate valve box for the programme meter. The idea is that a .002-microfarad is charged up by one of the power amplifiers in the microphone chain and the voltage across this is read by a valve voltmeter, so that no load is placed on the condenser. We have arranged the values so that on a loud passage the needle has time to reach its proper position before the .002-microfarad condenser discharges. There is, of course, a slow leak across the condenser and what is known technically as the "discharge time constant" can be varied between 5 and 10. As this meter is not connected directly to the transmitter, but through the valve of the valve-voltmeter, it can be switched on and off, without causing clicks to be heard."

"Then, I suppose," I ventured, "that the controller has only to watch the needle, while keeping a hand on the potentiometer volume control and see that the needle does not go off the dial?"

#### Delve into Decibels.

"Ah, that's not all," explained the engineer. "You must delve into decibels if you want to understand it fully."

"Must I delve into decibels?" I pleaded.

"It's really quite easy," he said, "and sounds most professional."

"A decibel is not a value of sound, but a ratio between two sounds. It is a logarithmic value, so that 10 decibels mean a ratio of 10 to 1, 20 decibels mean a ratio of 100 to 1, 30 decibels 1,000 to 1, and so on.

"The programme meter is graduated from 1 to 7, and each scale division (Continued on next page.)

#### THE EARS OF THE B.B.C.



Every item which is sent out from Broadcasting House must first pass through the control room, where it is given correct balance of tone and volume by the engineers, who keep a ceaseless watch on the programmes.

# COLVERN —COILS

## AN UP-TO-DATE COIL WITH UP-TO-DATE FEATURES

Type TD, an entirely new Colvern Coil, is designed to give super selectivity on both long and broadcast wave bands.

The coil is completely screened, giving a very neat appearance, and incorporates tapped aerial coupling and reaction, while the four alternative aerial tapings are arranged as sockets with a wander plug.

The first two tapings give aerial couplings similar to those normally employed but with greatly increased selectivity.

Nos. 4 and 5 give a high degree of selectivity with weak aerial coupling—suitable for use in a "swamp" area.

A most important feature of this coil is that there is no break through on the long wave band from B.B.C. stations.

This coil is specified for the "DIODION," which is being described in the Exhibition Number of MODERN WIRELESS.

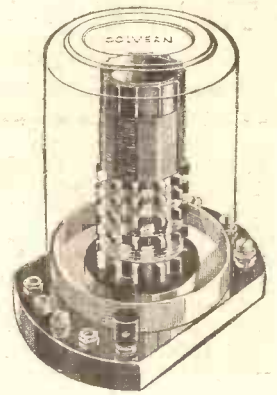

**TYPE TD**

PRICE

8/6

# —VARIABLE COLVERSTATS

Wire-Wound. For Voltage Regulation and Volume Control



Type ST10. Rating 10 watts. Standard values 500 to 50,000 ohms. 5/6



Type ST5. Rating 5 watts. Standard values 250 to 25,000 ohms. 5/3

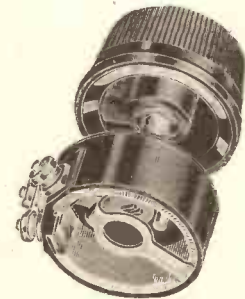

Type MT. Rating 3 watts. Standard values 25 to 10,000 ohms. 4/6

# —STRIP RESISTANCES

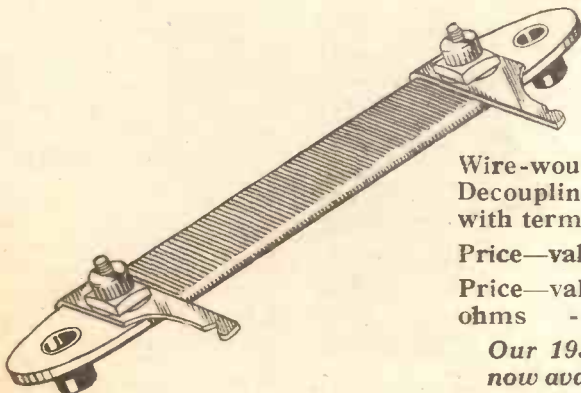

Wire-wound. For Mains Units and Decoupling. Rating 5 watts. Fitted with terminals and soldering tags.

Price—values up to 25,000 ohms - 1/9

Price—values from 25,000 to 50,000 ohms - - - - - 2/3

Our 1933 Booklet R.L. No 10 is now available and free on request.

Stand  
No. 245  
RADIO  
EXHIBITION  
OLYMPIA  
August 19-27  
1932

**COLVERN LIMITED, MAWNEYS RD., ROMFORD, ESSEX**

## THE PROGRAMME METER

(Continued from previous page.)

represents 5 decibels, a sound ratio of 3 to 1. By being graduated up to 7, the programme instrument has a range of 30 decibels or 1,000 to 1 in volume between the beginning and the end of the scale.

"Below 1 on the scale nothing can be heard, while during talks and similar steady volume items, we set the volume control so that the meter reads between 5 and 6. The needle is very steady, you see.

### Kicked Across the Scale.

"In the old days we had a square law meter which worked fairly well, but it hardly made the needle move on weak passages, and kicked it right across the scale on single loud notes. This did not give the controller confidence, and there was a tendency to turn down the volume to prevent climaxes which never actually came.

"A very cunning use of our new Programme Meter is in connection with the depth of modulation of one of the transmitters. These tests are usually done in the morning before the regular programme comes on.

"An oscillator is switched on in the control room and the howling note of this causes the transmitter to be modulated at a peak value of about one-third of the available depth of modulation. The programme meter is then set so that the needle is right over at degree 7 on the scale."

### Peaks and Harmonics.

"But surely B.B.C. stations are modulated more than 33½ per cent.?" I exclaimed.

"Of course," he continued, "when the programme meter reads 7, at the 33½ per cent. modulation, it means that this 'pure' tone of the oscillator is giving a full reading on the scale, because the volume is at its limit. Ordinary music is not made up of pure tones, as, of course, you know.

"Peaks and harmonics are developed which modulate the transmitter up to its full limit, although on a pure note there would be only a third of the full modulation."

## NEXT WEEK

### Look out for THE "MODERATOR" TWO

A little set with a  
big punch!

He showed me a key sheet which indicated the readings which should be obtained on various items. Speech, as he had explained, flicks the needle over to between 5 and 7

### Switched out of Circuit.

Ordinary orchestral music gives a reading of between 4 and 6, with loud passages up to the full scale deflection. For dance music, at the end of the evening's programme, the needle reads between 6 and 7 and the volume control is switched out of circuit.

"We are fitting one of these new programme meters in the dramatic control

panel used by the radio play producers," said the engineer.

"It's a fine idea there, because when the producer wants to switch in gramophone records of effects, he can by means of the programme meter try the gramophone record input before he turns the potentiometer knob. If the record is a loud one, he can see this on the meter before he starts to fade in the effect on the programme, so he does not turn the knob so much.

"In the old days all he could do was to listen with 'phones and trust to luck that the first movement of the potentiometer knob would not bring in the 'effects' noise too loudly. The programme meter now warns him in advance, and the main programme meter in the control room ensures that the average level of volume is not too great."

"If the programme meter failed," I asked, "would listeners' sets be overloaded by excessive volume?"

### Full Scale Deflection.

"No," explained the engineer, "for the simple reason that full-scale deflection on the programme meter is still within 100 per cent. modulation at Brookmans Park, North Regional or wherever it may be. The programme meter always works under the level of the main modulation meter at the transmitter.

"Sets tuned in as loudly as possible might be temporarily overloaded if the programme needle were not carefully watched, but the broadcaster would not be over-modulated because the engineers at the station would spot the fault at once on the landline amplifiers, and on the modulation meter in the transmitter hall."

## HUM ON THE SHORT WAVES

A simple and effective cure for an irritating trouble.

By FRANK BRIGGS.

IN ordinary battery-operated broadcast receivers it is extremely rare to find a case of interference from electric-light mains. With short-wave sets, however, this type of interference can at times be very annoying.

Only recently I was trying out a little short-wave "Two," when I experienced the trouble myself. The set was perfectly satisfactory so long as reaction was not pushed too much, but directly I tried to ginger this up to the limit a hum rose from the depths and drowned everything.

The aerial (indoor variety) was slung about a foot from the ceiling, above which were a number of electric-light cables. So it was evidently a case of direct pick-up. The aerial, by the way, was joined to the top end of the grid coil, through a small neutralising type condenser.

This gave me the idea that indirect coupling would probably improve things, so I tried using a separate aperiodic aerial coil (about two turns) loosely coupled to the tuned-grid coil. Result, no more hum!

Now, I don't say this will work in every case, but if you do suffer from the trouble, and your set is arranged with the aerial coming right on to the grid coil (through a condenser), it is certainly worth trying.

## UNDER THE EAVES OF BROADCASTING HOUSE

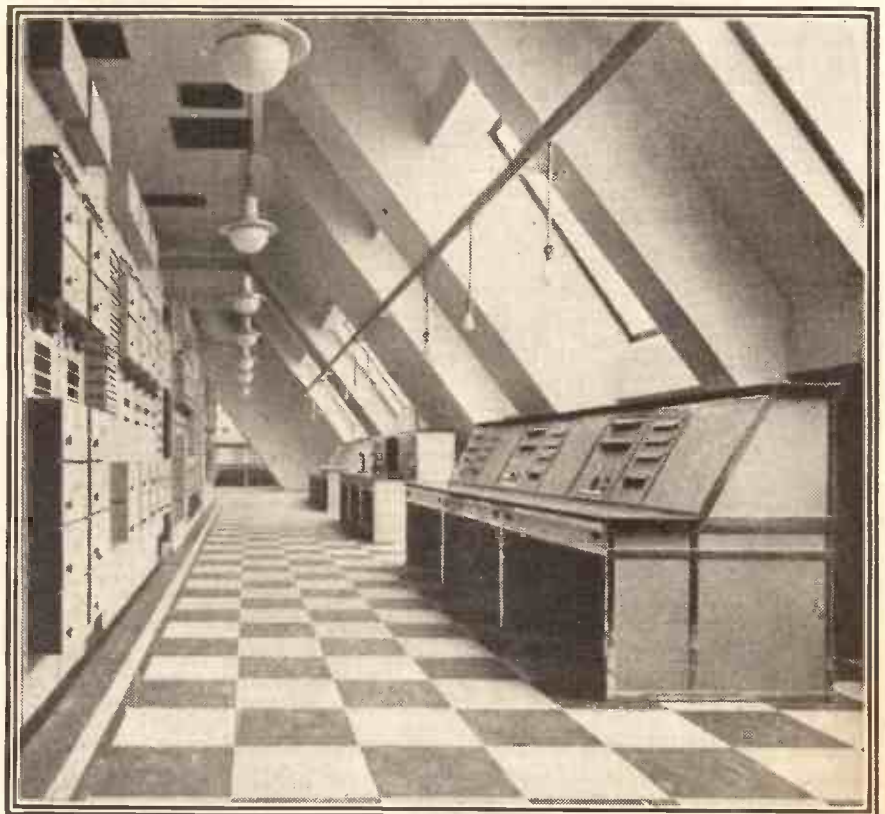

The control room at the B.B.C.'s new headquarters is one of the few parts of the tower which see the daylight. The amplifier racks and control panels combine extreme modernity of appearance with high-grade efficiency.

# THE NEW

# Varley

PROPRIETORS :- OLIVER PELL CONTROL LTD.

## "RECTATONE" L.F. TRANSFORMER

Radio reproduction with full and natural treble response. Gramophone reproduction with the bass in proper balance, without over-emphasis of treble. You can get them both from the same receiver with the Varley RECTATONE.

This new transformer compensates for high-note losses in the tuning circuits by frequency compensation in the L.F. amplifier. The RECTATONE frequency response curve is straight up to 1000 cycles per second and then rises reaching a maximum at approximately 4500 cycles—the ideal arrangement.

The degree of compensation is controlled by a variable resistance connected externally between two of the transformer terminals. If this resistance is omitted the RECTATONE functions as a normal transformer giving high and even amplification.

RECTATONE is thus the ideal L.F. coupling for sets using a pick-up or for radio-gramophones, since the tone control so valuable on radio can be switched out on gramophone where it is unnecessary.

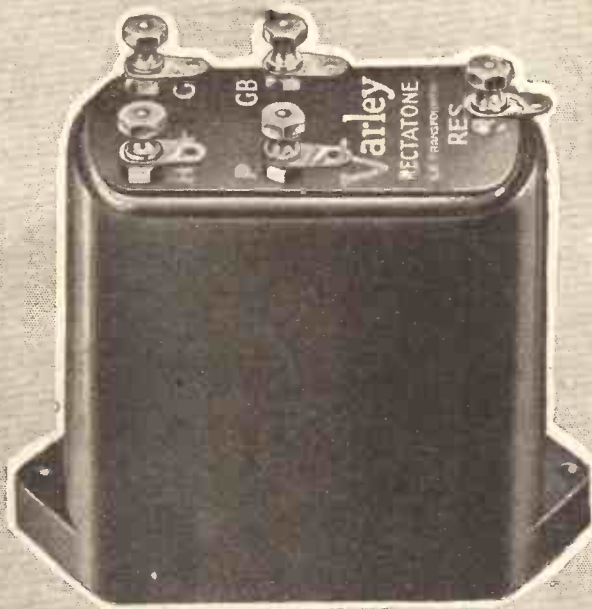

True tone-balance  
from Radio or Record  
—with *one* transformer

Price **15/-**

### GET THIS FREE BOOKLET

To Messrs. Varley, Kingsway House, 103, Kingsway, London, W.C.2.  
Please send me, free and post free, the

**BOOK of the RECTATONE**

Date .....

Name .....

Address .....

P.W.1

**G.E.C. Radio**  
**SUPREMACY IN RADIO**

**NEW—A SELF MUSIC MAGNET**

**ENTIRELY SELF-CONTAINED**

Very handsome one-piece Bakelite Cabinet

Ample room for Accumulator and Batteries **INSIDE** — no battery connections **OUTSIDE**

**2 Screen-Grid Valves**

**ONE KNOB ONLY FOR TUNING**

**Osram**  
**THIRTY-THREE**  
**MUSIC MAGNET**

MADE IN ENGLAND  
 Sold by all Wireless Dealers

A high-class home constructor's kit— all self-contained—with all the latest improvements in design and construction

**ANOTHER "OSRAM MUSIC MAGNET" SENSATION**

The new OSRAM "THIRTY-THREE" MUSIC MAGNET represents an enormous advance in the design of home constructors' kits, both in appearance and performance. Its utter simplicity will be apparent from the illustrations in this advertisement, and the beautiful one-piece Bakelite cabinet with its handsome lines gives an atmosphere of quality far above the price of the kit. It is entirely self-contained, there being no external

connections whatever. Loud speaker, accumulator and dry batteries are all accommodated neatly *inside* — no unsightly accessories are needed *outside*.

**PRICE**  
**9 GNS.**

Complete with cabinet, built-in loud-speaker and OSRAM valves.

**HIRE PURCHASE**  
 Deposit £1 and 12 monthly payments of 15/-

Dimensions:  
 18½ ins. high, 15¼ ins. wide, 10¼ ins. deep.

You can learn all about this amazing kit by sending for **POST FREE** Constructor's Instruction Chart — a most informative brochure which can be studied at your leisure.

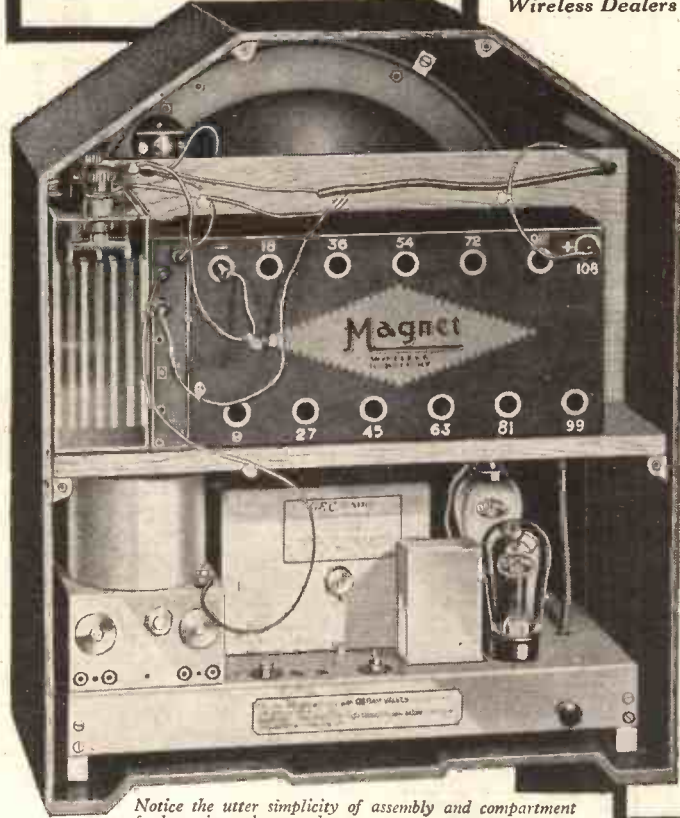

Notice the utter simplicity of assembly and compartment for batteries and accumulator.

**A SIMPLE**



# -CONTAINED HOME CONSTRUCTOR'S TRIUMPH!

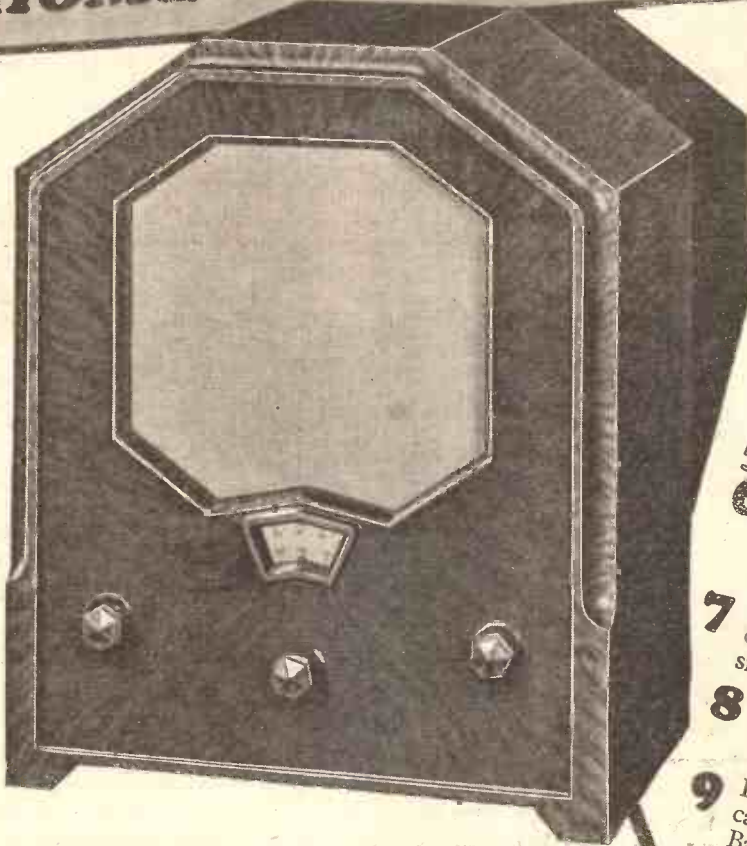

- ### SPECIAL FEATURES
- 1 A complete table model receiver with built-in loud speaker.
  - 2 Batteries housed inside cabinet—no external battery connections.
  - 3 Two metallised OSRAM screen-grid valves and latest type OSRAM power output valve.
  - 4 Screen-grid detector gives great sensitivity.
  - 5 Tuning by one knob only.
  - 6 New magnetic loud speaker chassis with floating cone ensures highest quality reproduction.
  - 7 Unit assemblies make home construction the essence of simplicity.
  - 8 Latest OSRAM valves (battery type) with the Wembley filament.
  - 9 Handsome one-piece Bakelite in moulded graining. — walnut

The OSRAM "THIRTY-THREE" MUSIC MAGNET is the latest model of the popular "OSRAM Music Magnet" series. A special feature of the circuit design is the inclusion of TWO OSRAM high-conductance metallised Screen-Grid Valves, which means that it will give a performance equal to a great many 4-valve sets on the market—sensitive and selective—powerful and pure reproduction.

A wide range of stations can be tuned in with the greatest ease at good loud speaker strength and the specially-designed built-in loud speaker gives the highest quality reproduction. Tuning is effected with one knob only.

The OSRAM "THIRTY-THREE" MUSIC MAGNET is the embodiment of all that the home constructor needs most: it is easy to assemble, extremely handsome in appearance, ENTIRELY SELF-CONTAINED, simple to operate and phenomenally low in price.

**WRITE for OSRAM "THIRTY-THREE" MUSIC MAGNET Constructor's Instruction Chart, which will be sent you POST FREE. FILL IN THE COUPON BELOW. This chart gives simple and clear instructions how to wire the various parts together, and it is crammed full of useful hints and tips as to the operation of the set. Send for your copy TO-DAY.**

**NATIONAL  
RADIO  
EXHIBITION**

See the complete range of G.E.C. Radio Products on the G.E.C. stands.



POST  
COUPON  
TO-DAY

**COUPON**

Please send me particulars of the OSRAM "THIRTY-THREE" MUSIC MAGNET

Name \_\_\_\_\_ Address \_\_\_\_\_ P.W. \_\_\_\_\_

The General Electric Co. Ltd.  
Magnet House,  
Kingsway,  
London,  
W.C.2

**STEP FROM CHART TO SET**

Cut out and paste on postcard, or enclose in unsealed envelope. Halfpenny postage in either case.

Branches and Public Showrooms throughout Great Britain

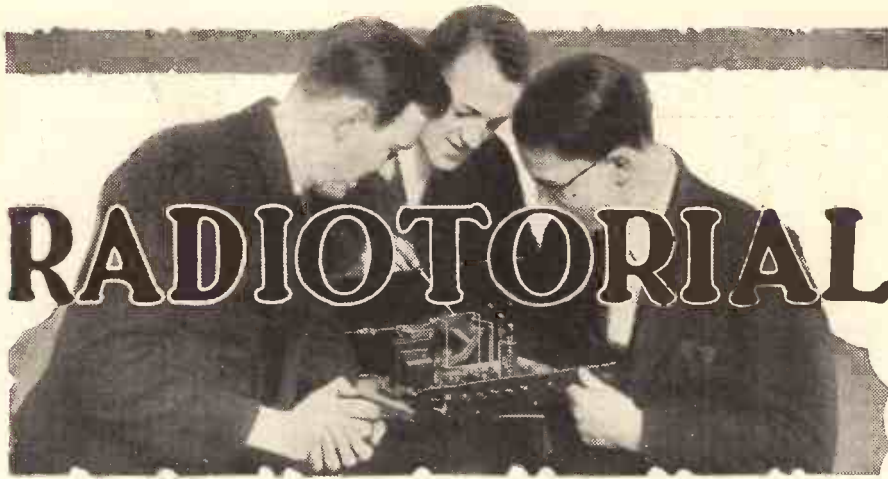

# RADIOTORIAL

All Editorial communications should be addressed to the Editor, POPULAR WIRELESS, Tallis House, Tallis Street, London, E.C.4.

The Editor will be pleased to consider articles and photographs dealing with all subjects appertaining to wireless work. The Editor cannot accept responsibility for manuscripts or photos. Every care will be taken to return MSS. not accepted for publication. A stamped and addressed envelope must be sent with every article. All inquiries concerning advertising rates, etc., to be addressed to the Sole Agents, Messrs. John H. Lile, Ltd., 4, Ludgate Circus, London, E.C.4.

The constructional articles which appear from time to time in this journal are the outcome of research and experimental work carried out with a view to improving the technique of wireless reception. As much of the information given in the columns of this paper concerns the most recent developments in the radio world, some of the arrangements and specialities described may be the subjects of Letters Patent, and the amateur and the trader would be well advised to obtain permission of the patentees to use the patents before doing so.

## QUESTIONS AND ANSWERS

### OVERCOMING "OVERLAP."

F. D. J. (Burton-on-Trent).—"Clearing out my old junk in answer to a friend's SOS for some fixed condensers I found that I had practically all the parts for a three-valver kicking about. So we made one up on the lines of the 'Decade,' but with plug-in coils.

"The reaction is different too, the condenser used being a '0001 of the tuning variety, not differential. So we omitted the lead for one set of fixed plates altogether, and used moving vanes to plate and fixed vanes to reaction coil instead.

"It worked much better than we might have expected at first, but is not much good for distance because there is a bad overlap on the reaction adjustment, which, so far, I have not been able to get over to any extent, although different detector valves make a good bit of difference to it.

"I suppose I ought to expect trouble considering the age of the components, and I know you might write back and say 'What do you expect with such old junk.' But I hope

### DO YOU KNOW—

the Answers to the following Questions ?

There is no "catch" in them, they are just interesting points that crop up in discussions on radio topics. If you like to try to answer them, you can compare your own solutions with those that appear on a following page of this number of "P.W."

1. Are any of the broadcasting stations in the European group situated at distances of more than one thousand miles from London ?
2. Which of these is farthest away, and what is the distance (approximately) ?
3. What station uses a blast on a steamer's siren as an interval signal ?
4. Where is the new Dublin station situated ?

you won't, because now it is all made it seems a pity not to use it if something can be done to stop the overlap.

"Would it be any good putting in a differential ? Or does it mean our work is wasted so far as getting foreigners with it is concerned ?"

Fitting a differential might effect a noticeable improvement, and even a '0001-mfd. fixed condenser joined between anode and L.T. negative of detector might be tried, as this sometimes helps to overcome overlap. Another easy course is worth trying, and that is the use of a different H.F. choke, or a 30,000

### HOW ARE YOUR RESULTS NOW ?

Perhaps your switching doesn't work properly ? Or some mysterious noise has appeared and is spoiling your radio reception ? Or one of the batteries seems to run down much faster than formerly ?

Whatever your radio problem may be, remember that the Technical Query Department is thoroughly equipped to assist our readers, and offers its unrivalled service.

Full details, including scales of charges, can be obtained direct from the Technical Query Dept., POPULAR WIRELESS, The Fleetway House, Farringdon Street, London, E.C.4.

A postcard will do. On receipt of this an Application Form will be sent to you post free immediately. This application will place you under no obligation whatever, but, having the form, you will know exactly what information we require to have before us in order to solve your problems.

**LONDON READERS, PLEASE NOTE :** Inquiries should NOT be made by phone or in person at The Fleetway House or Tallis House.

ohm spaghetti in its place. A smaller reaction coil, and potentiometer control of the grid-return might also prove helpful—but, as you see, it soon becomes a question of so many possible "cures" that a clean sweep and a good up-to-date set instead would appear to be the best way out.

### WHEN THE H.F. VALVE OSCILLATES.

V. H. (Southampton).—"My S.G., Det. and L.F. has been giving trouble since it was rebuilt into a smaller cabinet, and I suspect that the H.F. stage is not getting a chance to work properly. But would this cause what often happens—sudden stoppage of reception ? By switching off and slacking off volume a bit, etc., the set can be induced to start up again, but I cannot understand how with voltages, etc., O.K., there is this sudden packing up."

If your H.F. stage is unstable it is likely that a sudden "packing up" will be experienced, as this is a usual symptom when the H.F. valve goes into oscillation.

You will have to re-space and possibly re-design the H.F. circuit, adding extra de-coupling etc., and even then you may find that a too small cabinet space will be an insuperable bar to good reception and stability.

### USING THE MOVING-COIL FIELD WINDING AS A SMOOTHING CHOKE.

D. M. M. (Leicester).—"Talking about getting the last traces of hum out of the set the other day to a business friend, he mentioned the idea—new to me—of using the field winding of the M.C. loudspeaker as a choke by running the H.T. through it.

"If it could easily be done I should not mind trying to re-wire for this, but in my case the set is upstairs in an attic and the speaker on the ground floor. This would mean that part of the eliminator would be in the set, and part (the field choke) downstairs. Would that rather spoil the idea ?"

Yes. It is better to consider that the new "choke" is part of the "eliminator," and in cases where the two would be a long way apart the scheme is liable to give rise to troubles and is better left alone in such circumstances.

### CORRECTING THE TRIMMERS.

B. B. T. (Leith).—"Having been abroad for the last eleven years, almost without a break, I have returned to the old country with an insatiable zest for a good time as afforded by all the little 'trimmings' on life which I have been missing for so long.

"Wireless is one of them. I think it is the best of the lot for a returned traveller, for it takes him back north, south, east or west at the whisk of a tuning knob, without any of the snags of real-life travelling.

"The last time I was in Nairobi, for instance, I had blackwater fever, and nearly stopped there permanently, underground. Next time I go I hope it will be by short waves, to which I am introducing myself after I have thoroughly mastered tuning on an excellent four to which I have treated myself.

"But here is the little spot of trouble in which I want your help. Being a complete ignoramus about matters electrical, I chose a sealed-up set, the works of which are packed away as inaccessible as the departed Pharaohs used to be. And, out of pure contrariness, I want to fiddle with them. Especially since an acquaintance suggested that the ganging was a bit out, and needed what he called re-trimming.

"Every time I look inside and see those double sets of sheaved condenser plates locked together and swinging round as I move the tuner I think to myself, 'If only you were in trim.'

"I could send it back to the makers, but I am told this would be perhaps a three-week

(Continued on page 790.)

### WHAT'S WRONG ?



### THOSE USEFUL SPAGHETTIS.

They are so handy that one is often tempted to take liberties with them and strain the resistance wire by careless connections.

Of the two shown here the one to the left is liable to give trouble because it is strained at the connecting lug.

NEW EDITION— 20<sup>th</sup> Century Model

# EPOCH

R.M.M.C. LOUDSPEAKERS

# A CHALLENGE

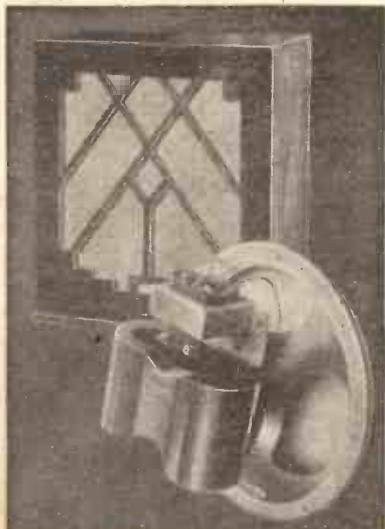
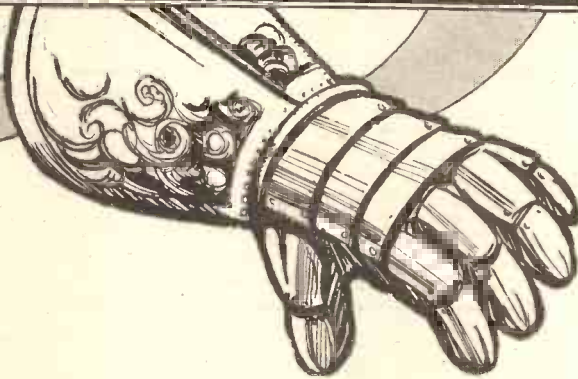

WE, the undersigned, the pioneers of the modern permanent magnet moving coil speaker, the manufacturers of the greatest range of the finest moving coil speakers in the world, claim for the New Edition 20th Century Model, priced at 35/-, that it has no peer in its class in or out of the British market. We claim for it Sensitivity, Brilliance, Body, Bass, Sharpness and Clearness of Speech and Music, Handling Power, Sturdiness and Reliability, *unrivalled* by many moving coil speakers (energised or permanent magnet) selling at much higher prices.

(Signed) Epoch Radio Manufacturing Co., Ltd.

Heavy Cobalt Steel Magnet with very high flux density—Aluminium frame (copper plated) holding 8½ in. diaphragm which is made in one piece and impregnated. Resistance of speech coil 5.50. 5-ratio matchings of input transformer ensure fine matching with power, super-power, or pentode output valve. Perfectly even reproduction between 50 and 6,000 cycles.

WITH 5-RATIO INPUT TRANSFORMER READY FOR USE.

**35/-**

FITTED IN HANDSOME OAK CABINET AS ILLUSTRATED TYPE "20CC." 47/6

## JUST RELEASED.

ASK your dealer for it and don't be put off with "Just-as-goods"—*There are none!* If in difficulty, write to the manufacturers.

Send for particulars or call for a comparative demonstration.

# RADIOTORIAL QUESTIONS AND ANSWERS

(Continued from page 788.)

job at this time of the year. And three weeks without my set is too long.

"Is there anything I can do in safety?"

"I am not an old fool, you understand, and I don't think you will catch me with anything so simple as forgetting to disconnect the batteries first—your book has taught me that much, any way.

"But having rolled up my sleeves, and undone all the batteries, and got the works out of the cabinet, is it possible for me, a non-expert, but interested party, to set about this re-trimming with any hope of improving it?"

### Quite a Simple Job.

Yes. You ought to be able to re-trim even without previous experience, for fundamentally it is as simple as any other fine tuning adjustment.

Even if your acquaintance were wrong and the set does not need re-trimming you will not be much out of pocket, for all you need to make a test is one of those small variable condensers with a low minimum capacity and a maximum of about .0001-mfd. The finer the degree of adjustment it affords the better, so one of the "tishy" variety with a very small knob is better avoided.

Fit it with two flex leads of suitable length—or rather "shortness," for unnecessarily straggling leads must not be used. And then try fitting it in turn across the two sections of the ganged condenser.

You will almost certainly find, upon inspection, that both the "moving" sets of plates are joined together, and one of your extra-condenser flex leads will need to be fixed to this common point in some convenient way, where it may be left.

The other flex is fixed first, to one of the corresponding sets of "fixed" plates. This done, with the adjustment knob placed accessibly, screw your extra condenser to the all-out position to begin with, and connect up the set for action.

Tune in a weak programme. If the extra condenser is really "all-out," you should find the

operation of the set quite normal at this stage, so choose, if you can, a steady weak foreigner, preferably in daylight.

Keep the tuning perfectly adjusted, so far as the main control goes, and then listening intently to note the effect of slowly adjusting the "trimmer," i.e. the new condenser.

If you get a distinct and worth-while improvement right away—possibly after slight re-tuning on the main control—and this appears to hold good on other stations, you have successfully re-trimmed, and are to be congratulated. But possibly the effect will be to make matters noticeably worse.

In such a case all you have to do is to rewire the trimmer across the other half of the ganged condenser—that is to say, with its flex lead to the other set of fixed vanes.

### "P.W." PANEL, No. 85.—RECORDING A BROADCAST.

When a programme is to be "preserved" for future reproduction there are three main methods available for this—disc, sound-film, or steel-strip recording.

The latter is exceptionally easy to arrange, with compact apparatus, and is favoured by the E.B.C., who use the British Blattnerphone (Stille system) for the purpose.

The principle involves the permanent magnetisation of a revolving steel tape by the programme. When this tape is later fed into suitable apparatus it can give rise to similar sounds to those recorded.

Adjust carefully, as before recommended, and if that is the side that needs the little extra capacity you will—possibly after re-tuning—get your marked improvement on a weak station, although there may be no obvious effect on louder programmes.

### REVERSING THE DIRECTION OF THE VOLUME CONTROL.

"Peterkin" (Bognor Regis).—"Is there any objection to the following alteration? At present my volume control is by means of a potentiometer, with the grid terminal of the first L.F. valve holder wired to the slider terminal. One of the end terminals (the one on the right as mounted on the panel) goes to that valve's grid bias negative, and to one secondary terminal; and the left-hand potentiometer terminal goes to the secondary terminal.

the controls act alike and find I am running my grid bias out or something like that."

The mere reversal of the leads which go to the ends of a potentiometer will not do the slightest damage, as it is exactly equivalent to the former circuit, but with the current passing through the potentiometer in the opposite direction. In other words, you will have "turned the potentiometer round" without affecting its fixing to the panel in any way.

This is exactly what you want to give the increase-to-the-right effect, so go ahead with the alteration, as suggested.

### WAS IT THE S.G.?

T. R. D. (Berwick-on-Tweed).—"Being interested in foreign languages, my chief reason for going in for an expensive wireless set was that of improving my knowledge of

(Continued on page 792.)

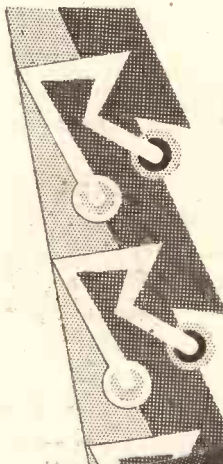

# Stop..look..listen..at Radiolympia

This is British Radio's most spectacular show—don't miss it whatever you do! If you want to know anything about your Radio, or the Radio you hope will be yours, all your queries can be answered at Radiolympia by the experts who will show you all Radio's latest developments. Everyone who realises the important part played by Radio in modern life should visit Radio's most modern show. Listeners and constructors alike can find a thousand things to interest them. See you all at Radiolympia!

# COME TO RADIO LYMPHIA

WHERE BRITISH IS BEST!

**AUGUST 19-27**  
ADMISSION 1/6 DANCING FREE

11 a.m. to 10 p.m. Daily  
ORGANISED BY THE RADIO MANUFACTURERS' ASSOCIATION

# See the "TRANSFEEDA"

at

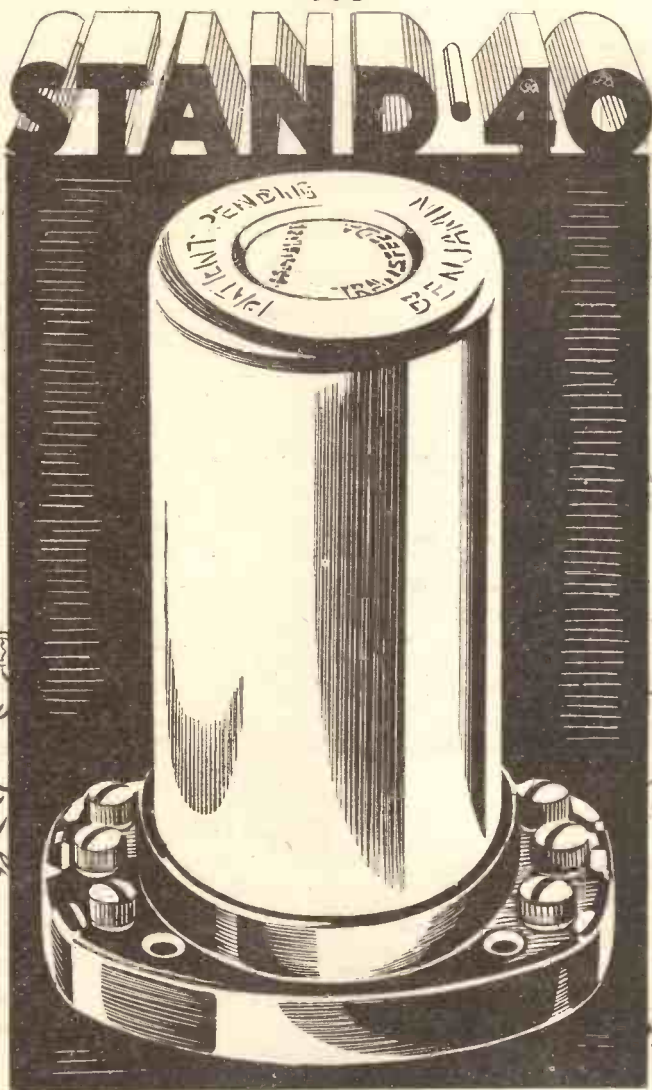

★ Note these reduced prices.....

FIVE-PIN

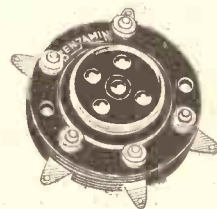

1/9d 1/3d

VIBROIDER

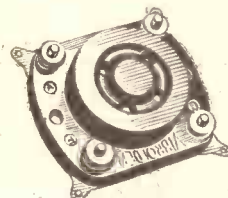

1/6d 10d

CLEARERTONE

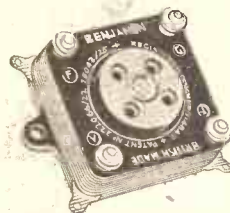

2/4d 1/6d

PUSH-PULL SWITCH

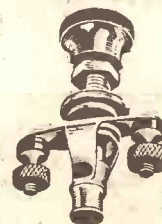

1/3d 9d

PRAISE INDEED!

*"even if anything better could be accomplished we could not as yet make use of it."*

This is what Popular Wireless has to say after testing out the BENJAMIN TRANSFEEDA—the original resistance fed transformer that is creating such a stir amongst set Designers and Constructors. The BENJAMIN TRANSFEEDA has revolutionised L.F. amplification practice. Fit a TRANSFEEDA in place of any transformer and you will be delighted with the full round distortionless volume **11/6** you will get from your receiver for the modest outlay of **11/6**. If you can't get near STAND 40 at the Exhibition let us send you List 1292 which describes the TRANSFEEDA fully and gives diagrams and circuits on how to use it.

## BENJAMIN

THE BENJAMIN ELECTRIC LTD. TARIFF ROAD, TOTTENHAM, N.17.

## RADIOTORIAL QUESTIONS AND ANSWERS

(Continued from page 790.)

these, particularly of German and Italian. My expectations have been more than fulfilled and I have come to regard some of the announcers abroad almost as friends, so familiar have they become. Imagine, then, my difficulty. Back in July I noticed that where before I had always been able to rely on the reception of at least half a dozen different German stations, I was now getting difficulty with most of them at times.

### Results Getting Worse.

"Being under the impression that mid-summer reception was liable to fall far below the normal I was not seriously alarmed until I heard from a friend who uses his set for the same purpose that he was finding reception wonderfully steady and reliable.

"The reception on my set was certainly not that, so I have been awaiting developments rather anxiously, hoping that it was only

a passing phase. Alas! No. It gets worse.

"From day to day there is no noticeable alteration, but looking back over a week or so I can detect a decided deterioration.

"The valves are new, with the exception of the S.G., which has been in use just over a twelvemonth, and all the H.T. voltages have been checked carefully.

"Grid bias, also, can be vouched for, and the total H.T. current is about right.

"Several of the components, including coil units and various fixed condensers, L.F. transformer, loudspeaker, of course, and the obvious things like aerial and earth have been carefully gone over without success. Can you suggest anything else to bring me back my foreign friends?"

Reading between the lines of your description convinces us that the likeliest place to look for the fault is that S.G. valve.

The slow development of the trouble is consistent with failing emission, and in any case this is a fault that may arise after a valve has been in use for as long as twelve months, especially when the set is used a lot, as apparently is the case with yours.

The easiest way to test for this fault is to replace the suspected valve with another of the same type. If this is done, and results in restoring the set to its full liveliness the problem is solved and the old valve can be thrown away.

To test the emission by other than the comparative method you need a milliammeter inserted in the plate circuit of the S.G. valve. Compare the total current flowing there with the makers' figures for this valve's anode current at the appropriate H.T. and grid bias voltages, being sure that these are measured carefully. (It is especially important that grid bias is measured accurately.)

If there is a decided shortage of anode current you can fairly assume that failing emission is the trouble and that a new S.G. valve will completely cure it.

### ADJUSTING A POTENTIOMETER FOR BEST LONG DISTANCE RECEPTION.

V. H. C. (Horseferry Rd., S.W.).—"When a set is provided with a potentiometer across the low tension supply and the slider of the potentiometer is joined to the detector's

grid leak, what is the correct method of setting the adjustment? I understand this arrangement is supposed to aid in getting good reaction effects, and also to increase volume—is this correct?"

The arrangement described certainly does tend to assure smooth reaction control, and if properly adjusted it can be extremely sensitive from a rectification point of view.

So far as distant stations are concerned it does, of course, increase volume, as without efficient detection such stations would often be almost in-

### A SUGGESTION.

Have you ever thought how difficult it is for a newsagent to order just the right number of copies of any particular paper each week? You can make his task much easier if you place a regular order with him. You will not only help him to order correctly and avoid waste, but will make sure of getting your copy regularly each week.

audible, whereas with correct adjustment and good reaction they will have pronounced value as programme providers.

To adjust you should first put the potentiometer slider about half-way round, and then ignore it until the other circuit conditions are satisfactorily adjusted.

When H.T., etc. is O.K., set the tuning in a mid-way position and move the potentiometer slider towards that end of the winding which is connected to L.T. positive.

Test the reaction control. You will probably find it rather "ploppy," so move the slider round slowly towards the negative end of its travel, adjusting the reaction control as you do so.

Reaction will get smoother and smoother as the slider advances towards negative, but the disadvantage of proceeding in this way is that sensitivity will fall off as you proceed.

Readjust the detector anode voltage to find a setting which enables you to bring the slider well round towards the positive end without spoiling the smooth control of reaction. When that position has been found the slider may be left set.

### THE ANSWERS

TO THE QUESTIONS ASKED ON PAGE 788  
ARE GIVEN BELOW:

- (1) Yes. Nearly twenty are 1,000 miles or more from London.
- (2) Istanbul, the Constantinople station, which is just over 1,550 miles away.
- (3) Eamburg.
- (4) Near Athlone, which is almost exactly in the geographical centre of Ireland.

DID YOU KNOW THEM ALL?

# QUALITY is the **MoToR** POLICY

Superior performance, and a high quality that will make you and your friends gasp with admiration—that is what MoToR has aimed at—and achieved, in the richness of tone, naturalness of speech, and unusual sensitivity of the MoToR Minor moving-coil speaker.

Make quality your policy too—pay a visit to our demonstration showrooms opposite Olympia and hear this and the full range of MoToR speakers under real working conditions.

Then you will realise you don't need a new set—you just need a MoToR Minor.

**Demonstration Showrooms:**  
67, HAMMERSMITH RD., W.14  
OPPOSITE EMPIRE HALL

**TEKADE RADIO & ELECTRIC LTD.**  
147, FARRINGTON ROAD, LONDON, E.C.1

Telephone: Clerkenwell 2486.

In moving coil and balanced armature type speakers MoToR is supreme. Write for fully descriptive pamphlets to:



BRITISH  
MADE

**MoToR  
MINOR**  
Permanent Magnet  
MOVING COIL  
including transformer and  
baffle board

**39'6**

**CHESTER.** Handsome walnut  
cabinet incorporating MoToR  
Minor P.M. Moving Coil  
Speaker

**65'.**

MoToR Minor Unit in attractive  
leatherette Baffle Case  
as shown below

**45'.**



# Your L.T. Accumulator

## NOW

### the source of ALL POWER

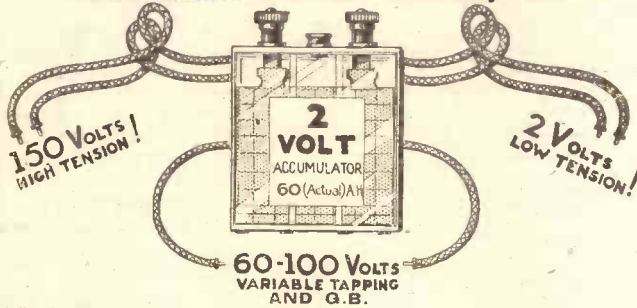

### Here is good news for Battery set users!

Electro Dynamic (of Rotary Converter fame) has produced an Anode Converter that provides a constant high-capacity H.T. current sufficient for a super-power valve and moving-coil speaker. Your present 2-volt L.T. accumulator is all that is required to give you the convenience and improved reception that only a mains set has, so far, provided.

Absolutely silent, free from interference, and housed in a box that can be fitted in place of an H.T. dry battery, this wonderful little converter is a triumph of efficiency that banishes the bugbear of dry batteries for ever.

Nothing to go wrong, fully guaranteed, and supplied with a variable tapping giving 60 to 100 volts for S.G. and detector valves.

Enjoy the pleasure of unfailing H.T. supply and the consequent improvement in reception by fitting an Anode Converter.

# Electro Dynamic

Can also be supplied for 6, 12, 24 & 50 volt input at the same price, £7 10s. 0d.

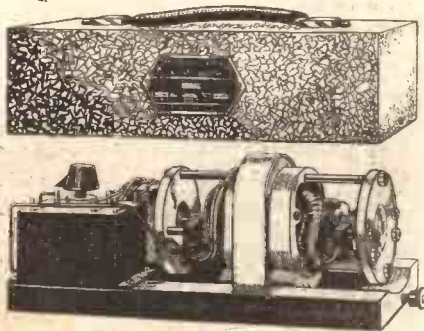

See it on  
**STAND**  
**157**

RADIO SHOW,  
OLYMPIA

or ask your dealer to arrange a demonstration.

WRITE FOR ILLUSTRATED FOLDER TO  
ELECTRO DYNAMIC CONSTRUCTION CO., LTD.,  
Devonshire Grove, London, S.E.15.

# BIG PRICE REDUCTIONS

## in 3 popular DUBILIER PRODUCTS



H.F. CHOKE  
NOW **3/-**

The Dubilier H.F. Choke is one of the most efficient made. It was good value at its old price of 4/6. At 3/-, it is one of the best bargains in radio, for, apart from its unusually low price, it is as efficient as only Dubilier products can be.

R.C.C. UNIT  
NOW **5/-**

For those building R.C.C. Circuits, the Dubilier R.C.C. Unit at its new price of 5/- will make an instant appeal. The Dubilier R.C.C. Unit gives uniform amplification over the entire range, and is supplied complete with Resistances.

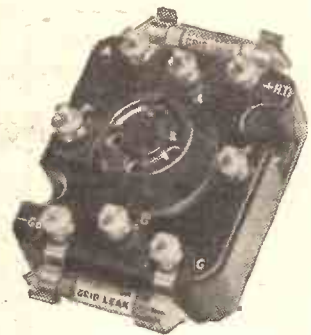

DUCON  
NOW **2/6**

The Ducon is the most efficient form of "automatic" aerial yet devised. You plug it into the electric light socket . . . and there's a perfect aerial. It is absolutely safe, 100% efficient, and uses no current. You can move it from room to room at will, and its price now is only 2/6.

**DUBILIER CONDENSER CO. (1925) LTD.**  
Ducon Works, Victoria Road, North Acton, W.3.

# THE "POPULAR WIRELESS" OFFICIAL LIST OF EXHIBITORS

Here is a list of authorised "P.W." dealers from whom you can obtain further details concerning "P.W." star sets, and the components and accessories to use with them.

## LONDON.

Alexander & Sons, Ltd., 130, Clapham Road, S.W.9  
H. Amos, 244, Earlsfield Road,  
WANDSWORTH, S.W.18.  
W. A. Andrews, 13, Burnt Ash Hill, I.E.F. S.E.12.  
Andy's Radio, 285, Edgware Road, W.  
Angel Radio Supplies.  
428, St. John's Street, ISLINGTON, N.  
C. H. Appleton, 74, Upper Clapton Road, CLAPTON.  
T. M. Barbour, 24, Knights Hill S.E.27.  
Bearnan Bros., DALSTON JUNCTION, N.  
Beresford Bros., 6, Beresford Square, WOOLWICH.  
J. H. Boddy, 819, Fulham Road, S.W.6.  
John Braham, 194-200, Bishopsgate, E.C.  
J. H. Brookman, 8, Farley Road, SOUTH  
NORWOOD, S.E.25.  
Bush Radio Stores, 184, Railway Approach, W.2,  
and  
7, Fulham Palace Road, W.  
Cadisch & Son, 56-58, Eagle Street, W.C.  
A. Clarke, 22-24, Market Hall, FULHAM,  
J. Collier & Sons, Ltd.,  
53-57, High Street, PECKHAM, S.E.15.  
S. T. Corry & Co., 52a, Southampton Row, W.C.1.  
S. & J. Crompton, Ltd., 129, High Road,  
CHISWICK, W.4.  
Direct Supply Stores, 62, Lower Marsh,  
WATERLOO, S.E.  
District Gramophone Co., 315, Old Kent Road, S.E.  
District Supplies, 11, Brushfield Street, F.  
"Electrico," 97, George Street, CROYDON.  
Elephant Electrical Co., Radio & Electrical

Engineers, 29, New Kent Road, ELEPHANT &  
CASTLE, S.E.1  
Elkay Wireless, 225, Bishopsgate, E.C.  
E. O. Ellis, 15, The Village, OLD CHARLTON, S.E.7.  
Empress Radio,  
680, High Road, TOTTENHAM, N.  
H. C. Fieldhouse,  
95, Valentine Road, Wood Street, E.17.  
Fudge, & Sons, Bendall St., LISSON GROVE,  
N.W.1.  
F. Galt  
56, Norbury Road, THORNTON HEATH, S.W.  
L. A. Gardiner & Co., 58, Church Lane, S.E.7.  
Gas Light & Radio Co., 464, Holloway Road, N.5.  
J. Glickman, 479, Cambridge Rd., BETHNAL  
GREEN, E.2.  
G. Goodwin, 6a, The Broadway, WOOD GREEN, N.  
S. Grey, & Co., 745, Barking Road, E.  
Griffin, 187, Broadway, Uxbridge Road,  
SOUTHALL.  
H. A. Wireless.  
13, Hackney Road, SHOREDITCH, E.2  
and  
139, Bethnal Green Road, E.2.  
Hackney Wireless Supplies.  
614, High Road, TOTTENHAM, N.  
Harmo Products, 46, Hoe St., WALTHAMSTOW, E.  
Harper's Radio, 430, High Street, LEWISHAM,  
S.E.13.  
H. A. Wireless, 139, Bethnal Green Road, E.2.  
Hewitt & Co., 21, South Street, GREENWICH.  
Hogben, 272, High Road, TOTTENHAM.

Hurley & Baker, 172a, Roman Road, BOW.  
James & William,  
31, Queen's Road, BATTERSEA, S.W.8.  
M. Kams & Co., 9, High Street, PUTNEY, S.W.15.  
Keen Wireless, 1, Dane Road, FALING.  
W. Kerr & Co., 107, West Green Rd., TOTTENHAM.  
M. Landau, 66, High Street, CAMDEN TOWN.  
The Lea Music & Lighting Salon, 632, Lea Bridge  
Road, LEYTON, E.10.  
The Ludgate Circus Radio, 4, Ludgate House,  
Ludgate Circus, E.C.4.  
F. Mace & Son,  
15a, Delacourt Road, BLACKHEATH, S.E.3.  
Maxims Stores, Ltd., 7a, Tothill Street, S.W.1.  
Metropolitan Lighting Co.,  
25, Atlantic Road, S.W.9.  
Morgan & Gaunt, 25a, Montpelier Vale, S.E.3.  
H. Moyer,  
111, High Street, STOKE NEWINGTON, N.16.  
Northcote Motor Co., 145, Northcote Road,  
CLAPHAM JUNCTION, S.W.11.  
A. Orstin, 154, Green St., BETHNAL GREEN, E.2.  
G. H. Pearce, 129, Sydenham Road, S.E.26.  
Pearl & Moore, 168, Strand, W.C.  
Pearl & Pearl, 190, Bishopsgate, E.C.  
Peckham Radio, 152a, Rye Lane, PECKHAM.  
The Peto Scott Company, Ltd., 77, City Road, E.C.1.  
and 62, High Holborn, W.C.1.  
Plastow Radio Service, 178, Plastow Road, E.15.  
Polchar's Wireless, Ltd., No. 5, Manifold's Market  
Rushey Green, CATFORD, S.E.,  
and  
175, High Road, BALHAM, S.W.  
Polchar's (1919), 96-98, High St., DEPTFORD, S.E.  
A. Potter, 234, Green Street, BETHNAL GREEN,  
E.2.  
Radio Supply Stores, 574, Old Kent Road, S.E.1  
Rayette, 128, King Street, HAMMERSMITH.  
Real Radio Service, 61, Cannon Street, E.C.4.  
Reliance Radio Service, 29, South Street,  
ISLEWORTH.  
D. Sacks, 130, Kentish Town Road, N.W.  
Saville Radio Company, 19, Saville Place, S.E.11.  
Service Electrical & Radio Co., 28, Windmill Hill,  
ENFIELD.  
Service Radio, 210, High Street, SHOREDITCH, E.  
R. Silverstone, Ltd.,  
186, High Street, CAMDEN TOWN, N.W.  
Sovereign Products, Ltd., 52-54, Rosebery Avenue,  
E.C.1.  
E. Spelle, 14, Lancaster Street, HYDE PARK W.2.  
G. Stern, 115, Fleet Street, E.C.4.  
M. Stone, 66, High Road, BALHAM.  
Super Radio Service, 31, Surrey Street, CROYDON.  
C. & W. Thev, 44, Blackheath Hill, S.E.10.  
(Continued on page 796.)

## YOU NEED THE GREATER EFFICIENCY of the New **FORMO** GANGED CONDENSERS

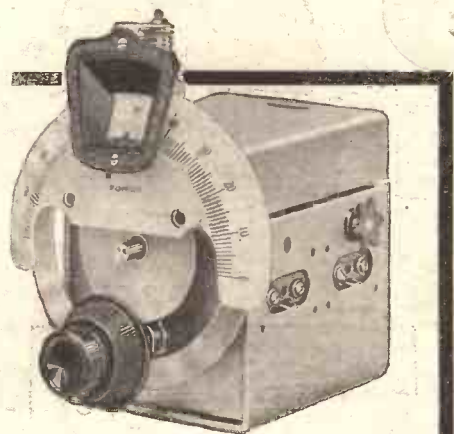

**DUAL GANG**  
Complete with dial 16/6

Many unique improvements in modern and moderately priced components are revealed in the new Formo catalogue. Get your copy quickly—to-day.

Inequalities in wiring no longer render difficult the actual matching of your circuit. Formo have solved your difficulty with the concentric trimmer introduced into these new dual and triple ganged condensers. As with all Formo components, they are "maximum efficiency" products—smooth and silent in action, accurately and sturdily assembled to eliminate any possibility of mechanical distortion, and carefully matched to all Formo dual range coils.

Use Formo components—they are still pre-eminent for high quality and dependability at a reasonable price.

Formo Dual and Triple Gang Condensers can be fixed mounted on a base plate with either two or three dual range coils. All switches are ganged and assemblies matched.

If unable to obtain Formo components locally, write to:

**FORMO CO.**  
Crown Works, Regents  
Park, Southampton.

London Office: 23, Golden Square,  
Piccadilly, W.1. Telephone: Gerrard 2088.

**OLYMPIA**  
Stand 100

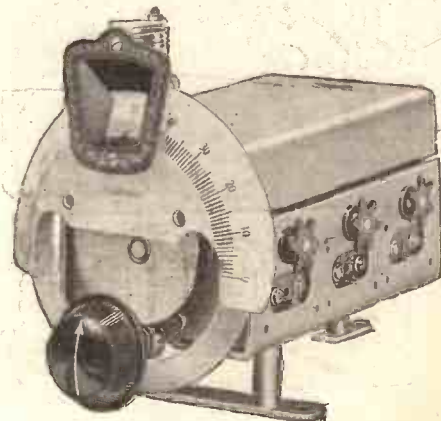

**TRIPLE GANG**  
Complete with dial 21/6  
Without dial . . . 18/6





# Here is your time signal!

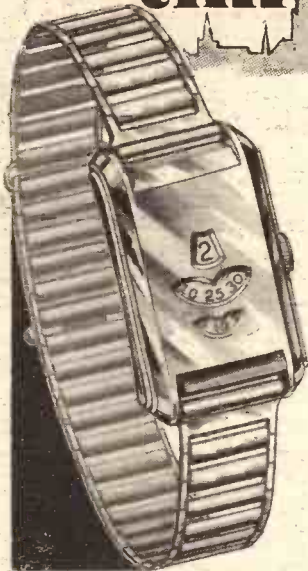

No need now to wait for Big Ben... the "Blue Bird"—heralding a new era in time pieces—is here... a masterpiece of accuracy.

- The "Blue Bird" has no glass, dial or hands, and is dust and damp-proof.
- Three little windows, mica-projected on the underside, show the correct hour, minute and second.
- 15-jewel lever movement with extra large gear train and escapement, maintains a wonderful standard of timekeeping.
- Fitted in Nickel Chromium case, curved to wrist, and with Chromium wristband. (Leather strap or moiré band if preferred).

For those who require a cheaper grade of watch, we have another model which, although not so perfectly made or finished, is of similar appearance to our standard high-grade "Blue Bird."

This is not subject to Peter Roland's guarantee, and does not bear their "Blue Bird" Hall Mark.

For cash only 30/- with leather strap.

For cash only 34/- with Chromium Wristlet.

Leaflet describing additional models on request.

**5/- DOWN**

Send 5/- with order and the balance in monthly instalments of 5/-, or 59/6 cash.

Every watch carries 12 months' written guarantee.

On reaching 60 minutes the hour instantaneously changes.

PETER ROLAND, LTD.  
(Dept. P.W.1)  
Premier House,  
12, Hatton Garden,  
London E.C.1.  
Phone: Holborn 6751.

## BLUE BIRD

*The Sportsman's Watch*



## SUPPLIES NOW READY!

Last season we were unable to cope with the demand for Simpsons Electric Turntable. Now we carry adequate stock in our factory and can deliver any quantity promptly.

**COMPLETE 39/6**

Write for full particulars—  
or see it on

**STAND NO. 71**  
or at

Simpsons Electricals Ltd.,  
Grange Road, Leyton, E.10  
Phone Leyton 2295.

# SIMPSONS ELECTRIC TURNTABLE

# 1933's GREATEST RADIO ADVANCE



A.C. & D.C. MODELS

**10 CASH**  
OR **50/-**  
GNS. DOWN

BATTERY MODEL

**6/10 CASH**  
OR **40/-**  
(Less Batteries) DOWN

The 'ATLAS TWO' starts new era of Tone True radio

● ● ● The "ATLAS TWO" now brings a completely new thrill to every music-lover: catching the very personality of the artist: with a brilliance and sparkle that seems to put you in the front row at every entertainment. You're actually there with the "ATLAS TWO."  
The specification includes "ATLAS" Moving Coil Speaker, One-Knob Tuning, provision for Pick-Up and Extra Speaker, Westinghouse Rectifier in A.C. Model, Mains Aerial in both A.C. and D.C. Models. See, hear and test it for yourself. Ask your dealer for a demonstration and insist on the "ATLAS TWO." Post the coupon to-day for full details.

## CLARKE'S ATLAS TWO

H. CLARKE & Co. (M/CR) Ltd.,  
PATRICROFT, MANCHESTER.  
Southern Offices: Bush House, W.C.2.

**POST THIS COUPON NOW**

Messrs. H. CLARKE & Co. (M/CR) Ltd., George Street,  
Patricroft, MANCHESTER.

Please send me full details of the new "ATLAS TWO" Receivers.

Name (in capitals) .....

Address .....

30/20/8.....

## OFFICIAL LIST OF EXHIBITORS

(Continued from page 794.)

Tower Radio, 5, High Street, SHOREDITCH.  
J. J. Vertue.  
25a. Brighton Road: SOUTH CROYDON.  
W. A. Waldron. 60, High Street, HOUNSLOW.  
Wal's Radio Stores.  
55. Cadogan Terrace, VICTORIA PARK, E.9.  
Western Lighting Co., 77, Mitcham Road, Tooting.  
Wholesale Components, 8-8a, Cross Street,  
ISLINGTON.  
Willesden Radio, 267, High Road, WILLESDEN  
GREEN, N.W.  
Williams Lighting, 2, High Street, TOOTING.  
The Woolwich Radio Supplies.  
22, New Road, WOOLWICH, S.E.  
V. Zeitlin & Sons, Ltd., 144, Theobalds Road, W.C.

## ABERDARE.

J. D. Williams, 65, Cardiff Street.

## ABERDEEN.

The Aberdeen Radio Co., Ltd., 9, Hadden Street.  
J. P. Christie, 29, Victoria Road.  
Miller Bros., 249-251, George Street.  
Smith, 39, Bridge Street.

## ACCRINGTON.

Frank Edmunds, 17, Abbey Street.  
H. A. Sharples, 261, Blackburn Road.  
G. V. Stephenson & Sons, 31, Blackburn Road.

## ACTON BRIDGE.

R. Manning, Nr. Northwich.

## ARBROATH.

W. McKay, 243, High Street.

## ASHFORD.

A. Edeuden, 150, Bridge Street, Wye.  
F. G. Ware, Sellindge.

## ASHTON-IN-MAKERFIELD.

G. F. Smith, 57, Gerard Street.

## AYLESBURY.

E. D. Hasberry, Radio Shop, Temple Street.  
C. R. Steggall, 52, Cambridge Street.

## BACUP.

J. Crawshaw, 149, Market Street.  
J. J. Holden, 25, St. James' Street.

BANBRIDGE, CO. DOWN.  
Messrs. T. & A. Wallace, 52, Bridge Street.

BARTON-ON-HUMBER.  
Park Bros., 11, King Street.

## BATH.

C. W. Maxim, 33, Broad Street.

## BATLEY.

W. E. Wood, Sandyfields Wireless Stores,  
Bradford Road.

## BEDFORD.

Norman Mickle, 37, Bromham Road.

## BESTON, NOTTS.

C. Hall &amp; Sons, 68, High Road.

## BELFAST.

Beliast Radio & Electric Co., Ltd., 17-19, Queen St.  
W. Houston (Everay Service Co.), 10, Newtownards  
Road.

The Wireless &amp; Electric Co., 32, Dublin Street.

## BERWICK-ON-TWEED.

Knox Bros., 25, Bridge Street.

## BEXLEY HEATH.

Bexley Heath Electric Co., 191, Broadway.

## BICKLEY.

Richardson &amp; Whitaker, Bickley Station.

## BIDEFORD, N. DEVON.

Messrs. F. H. Darch &amp; Son, 13, Chingswell Street.

## BIRKENHEAD.

A. Allen, 370, Borough Road.  
Radion Co., 237, Old Chester Road.

## BIRMINGHAM.

Dayrick's Radio Stores, 2, Hamstead Road.

## HANDSWORTH.

F. W. Beeby, 25, Winson Green Road.  
G. F. Collins, 511, Slade Road, ERDINGTON.  
The Electroset Radio Co., SOLIHULL.  
J. Elvins, 112, Stoney Lane, SPARKBROOK.  
Hopkins Bros., 210, Hawthorne Road.

## KINGSTADING.

Lees Radio Stores, 209, Lichfield Road, ASTON.  
Malcolm & Stewart, 491, Alum Rock Road.

## ALUM ROCK.

E. Matfy, 69, Lichfield Road, ASTON.  
"Scarrs," 9, Watford Road, Cotteridge. KING'S  
NORTON.

Wallace & Co., 856, Bristol Road, SELLY OAK, and  
1839, Pershore Road, GOTTERIDGE.

## BISHOP AUCKLAND.

A. M. Hunter, Evenwood House, Evenwood.

## BLACKBURN.

H. Flintoff, 47, Copy Nook.  
Snapes, Ltd., 55, Penny Street.

## BLACKPOOL.

Tom Jones, 1a, Leopold Grove.  
A. Morritt, 306, Lytham Road.  
The Radio Stores, 10, Cedar Street.  
J. Taylor (Messrs. R. H. O. Hills, Ltd.).

## BOLTON.

J. S. McLeod & Co., 34, Gt. Moor Street.  
Olympia Radio, Ltd., 74 Bradshawgate.

## BOOTLE.

L. A. Wireless, 304, Stanley Road.

## BOURNE.

E. Pearce, 32, North Street.

## BOURNEMOUTH.

Gardiner's Radio, West Southbourne.

## BRADFORD.

A. Adams, 105, High Street, WIBSEY, and  
50, Oak Lane, MANNINGHAM.  
H. Atkinson, Barkerend Music Stores,  
211a, Barkerend Road.  
A. Ridgway & Co., 23, Hall Buildings.  
J. Scurrah & Sons, 6-12, Rooley Lane, BANKFOOT.  
V. Wilson, 33, Bowling Old Lane.

## BRIDGWATER.

Whitby's Music &amp; Radio Stores, 1, Cornhill.

## BRISTOL.

H. E. Hamblin, 39-40, Bridge Street.  
H. E. Hamilton, 39-40, Bridge Street and  
45-51, Church Road, Redfield.  
Polchar's Wireless, Ltd., 20, Bridge Street.

## BROMLEY.

Chapman &amp; Son, 418, Downham Way.

## BROMSGROVE.

C. Wynne, 19, Worcester Street.

## BROWNHILLS.

Everson's Radio Depot, 93-95, High Street.

(Continued on page 798)

SEE THE COMPLETE  
RANGE OFWEARITE  
COMPONENTS  
ON STAND No. 82 at

Here is an exhibition in itself—the complete range of Wearite components—a range covering every need of the constructor—switches of all types—resistances, plug-in and permanent mounting, potentiometers, and volume controls, individually or ganged controlled, mains transformers, chokes and so on. Thus is the experience of Wearite shown in practical form. Whatever your component need consult Wearite.

Should you have any special technical query, write to our "Service Dept."—they will find the solution.

WRIGHT & WEAIRE, LTD.  
740, HIGH ROAD, TOTTENHAM, N.17

Phone: Tottenham 3847/8/9

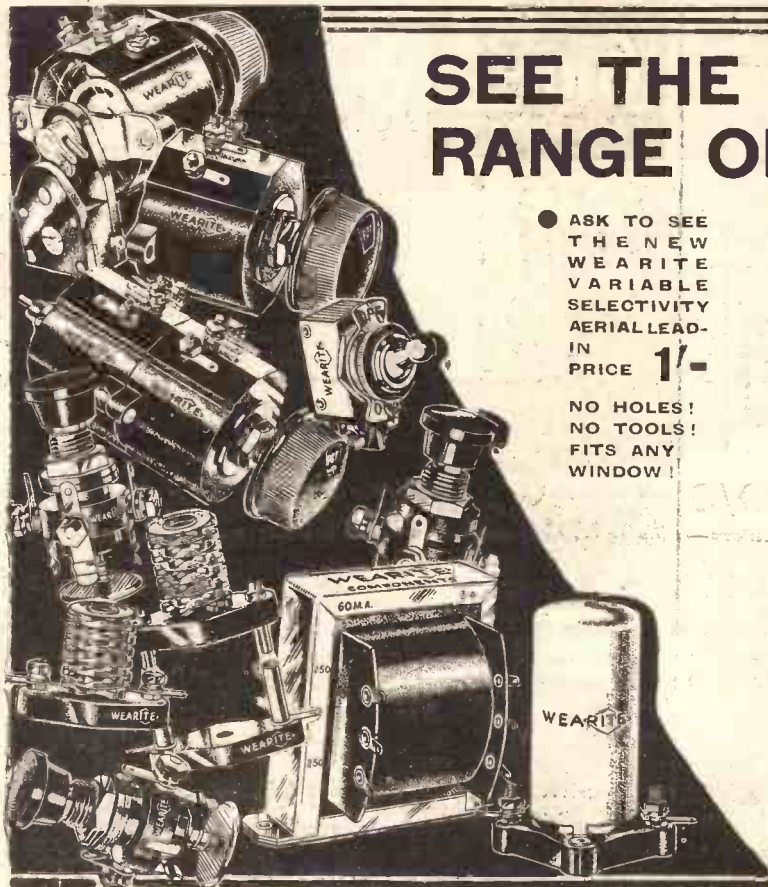

● ASK TO SEE  
THE NEW  
WEARITE  
VARIABLE  
SELECTIVITY  
AERIAL LEAD-  
IN  
PRICE 1/-

NO HOLES!  
NO TOOLS!  
FITS ANY  
WINDOW!

The famous

# BRITISH GENERAL TUNING UNIT

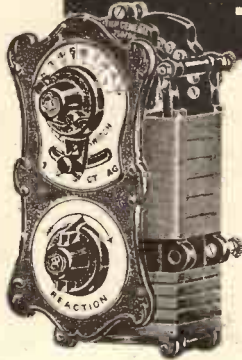

now reduced to 10'6

By reason of increased demand and enlarged production we are able this season to offer our well-known Tuning Unit at 10/6 instead of 14/6 as before. This Unit effectively replaces plug-in coils and covers the entire wave-band, from 200-2,000 metres. Easy fixing; simple tuning. Full instructions supplied with every model.

See our display at the Radio Exhibition AUGUST 19-27.

**STAND 29**

From all dealers or direct from the manufacturers—

**BRITISH GENERAL MANUFACTURING Co., Ltd.**  
Brockley Works, London, S.E.4.



## OSBORN RADIO CABINETS

THERE'S A DESIGN FOR YOUR SET—WRITE TO-DAY.

**MODEL No. 218.** A Queen Anne Radio or Radio-Gramophone Cab. Inset 3' 10" high, 2' 2" wide, 1' 6" deep. Size of baffle board behind fret, 24" x 24". Metallic fabric for fret front included. Opening at top and back. Cabinet takes panel 2' x 9" or smaller. Complete with motor-board. Send 3d. in stamps for Beautifully Illustrated New Season's Catalogue.

CHAS. A. OSBORN, Dept. P.W. The Regent Works, Arlington Street, London, N.1. Telephone: Clerkenwell 5095. And at 21, Essex Road, Islington, N.1. Telephone: Clerkenwell 5634.

**STAND 32, GRAND HALL, National Radio Exhibition, OLYMPIA, AUG. 19-27.**

**WE HAVE A WONDERFUL selection of 1933 RADIO SETS IN STOCK**

**CALL and RECEIVE OUR NEW CATALOGUE FREE**

**ALL RADIO SUPPLIED ON EASY TERMS**

**WILL DAY, LTD.** Telephone: Gervard 4476

19, LISLE STREET, LEICESTER SQUARE, LONDON, W.C.2

# POLAR 'STAR' CONDENSERS



SIMPLE ASTRONOMY  
THE LITTLE BEAR & CASSIOPEIA.

**ACCURATE SPACING OF VANES OBTAINED BY PRECISION MACHINE ASSEMBLY**

entirely eliminates the possibility of error in spacing—hence this guarantee: Polar "Star" Gang Condensers are guaranteed accurately matched to within 1/2 of 1%, plus or minus 1 mmfd. And their construction ensures that this accuracy will never vary.

Other outstanding features:

1. Trimmers always at constant value.
2. Strong spring journal bearings.
3. All-steel frame.

"STAR" 3-GANG 25'6

Prices:  
3 x '0005 - - - 25/6  
Special Super-Het - - - 27/6  
4 x '0005 - - - 34/-

All prices include covers.  
Polar Drum Drive 7/6 Polar Disc Drive 5/-  
SEND FOR NEW POLAR 36-PAGE FULLY ILLUSTRATED CATALOGUE "P."

**STAND 129 OLYMPIA**



# POLAR CONDENSERS

Wingrove & Rogers Limited, 188-9, Strand, London, W.C.2.

## OFFICIAL LIST OF EXHIBITORS

(Continued from page 796.)

**BURNLEY.**  
T. Duerdon, Westgate.  
Northern Radio Exchange Co., 150, Trafalgar Street.  
G. Pye & Son, 134, Padiham Road.

**BURY.**  
Bennett & Co., 36, Union Street.

**CAMBRIDGE.**  
Bally, Grundy & Barrett, Ltd., 2, St. Mary's Passage.  
W. K. Iship, 42, Chesterton Road.  
A. Matthews, 41, Mill Road.  
W. F. Webb, 188, Mill Road.

**CAMPBELTOWN.**  
A. P. Macgregor, 16-18, Main Street.

**CANTERBURY.**  
W. A. Goodhew, 22, Sun Street.

**CARDIFF.**  
J. F. Paull, 43, Caroline Street.  
Splott Radio & Gramophone Co., 9, Splott Road.

**CASTLE HEDDINGHAM.**  
G. H. Sylvester, Wireless Dealer.

**CHATHAM.**  
Chatham Radio, 220, High Street.

**CHELMSFORD.**  
Flexman Bros., 4, New Street.

**COLCHESTER.**  
F. W. Straw, 9, St. John's Street.

**COLWYN BAY.**  
J. Hacking, "Wireless," 7, Erwen Road.

**CONNAH'S QUAY.**  
George Coppack, 80, High Street.

**COVENTRY.**  
H. J. Cleaver, 112, Spon Street.

**COWDENBEATH.**  
H. S. Stott, 144, High Street.

**COWES.**  
J. A. Attrill, Birmingham Road.  
F. E. Doniney, 20, Shooters Hill.  
H. W. Millard, The Corner Radio and Gram. Stores, 25, Clarence Road, East Cowes.

## THE "OLYMPUS" FOUR

(Continued from page 760.)

constructor might have encountered has been dealt with as he can wire up the L.T. switch by merely connecting to the detector valve holder the piece of wire he attached to the switch before fixing the panel.

All the rest of the wiring may be copied from the wiring diagram. The wires can be connected in any order convenient to the constructor.

**Illuminating the Dials.**

The Telexors are fitted with lamps for illuminating the dials and these may be connected up as shown by dotted connections in the wiring diagram. It should be remembered, however, that the current consumption of such lamps is not inconsiderable and, if they are used, it may be necessary to re-charge the L.T. accumulator more often than would be the case if the dials were left unilluminated.

Finally, there is the question of earthing the screens of the coils. The two coils with which we were supplied by Messrs. Telsén were hand-made samples and had no provision for earthing the "cans."

We therefore connected to the No. 7 terminal of each coil a piece of copper foil  $1\frac{1}{2}$  inches long and about  $\frac{3}{8}$  inches wide so that it stuck out over the edge of the base of the screen. The screen cover was then replaced and pressed home; the foil being thereby forced into contact with the screen and effectively earthing it. Later models may be provided with earthing facilities.

## FOR THE "OLYMPUS."

**LOUD SPEAKERS.**—Blue Spot, Celebration, Marconiphone, B.T.H., R. & A., H.M.V., W.B., Cossor.

**VALVES.**—1 S.G. Cossor S.G.220, (preferably metallised), Mullard, Mazda, Marconi, Osram, Tungram, Lissen, Eta.

1 Det.—Marconi H.L.2, Mullard P.M.1H.L., Osram H.L.2, Mazda H.L.2, Cossor 210H.L., Tungram H.210, Lissen H.L.2, Eta B.Y.2020.

1st L.F.—Mazda L.210, Cossor 210L.F., Marconi L.210, Osram L.210, Mullard P.M.2D X., Tungram L.G. 210, Lissen L.210, Eta B.Y.1210.

Power (specially suitable for battery H.T.).—Mullard P.M.2A., Mazda P.220, Marconi P.215, Osram P.215, Cossor 215P., Tungram P.210, Eta B.W.604, Lissen P.220.

(Suitable for use with mains units). Mullard P.M.202, Mazda P.220A, Marconi and Osram—P.2, Cossor 230X.P., Tungram S.P.230, Eta B.W.303, Lissen P.X.240.

**BATTERIES.**—L.T.—2 volts 30 amp. or over, Lissen, A.H. Exide, Oldham, Pertrix.

H.T.—120 to 150 volts capacity to give 10 to 12 milliamps. (Pertrix, Lissen, Ever Ready, Drydex, Ediswan, Siemens).

G.B.—To suit output valve chosen (Ever Ready, etc.).

**MAINS UNITS.**—These should give 25 milliamps and at least 120 volts. Suitable manufacturers are Atlas, Type A.C.300 or D.C.15/25, R.I., Heayberd, Lotus, Tunewell, Ekco.



The most efficient valves that modern science can produce, yet at prices which are truly economical. Tungram Valves have been recently reduced in price: Valves at 7/3d. are now 5/6d., Valves at 22/6d. are now 17/-. Other prices in proportion.

Build Tungram into your set. You get the highest quality that valves can give you, at the greatest value in radio. Write for the FREE Tungram leaflet.

**TUNGSRAM ELECTRIC LAMP WORKS (GT. BRITAIN) LTD.,**  
Dept. S.T.3, 72, Oxford Street, London, W.1.

Factories in Austria, Czecho-Slovakia, Hungary, Italy and Poland.

PRICES  
FROM

5/6 to 17/6



THE FINEST THAT MODERN SCIENCE CAN PRODUCE

# GOLTONE COMPONENTS FOR YOUR "OLYMPUS FOUR"



**"GOLTONE" Super H.F. Choke**  
As recommended.

Baseboard or Valveholder Mounting. R3/46. **4/6**

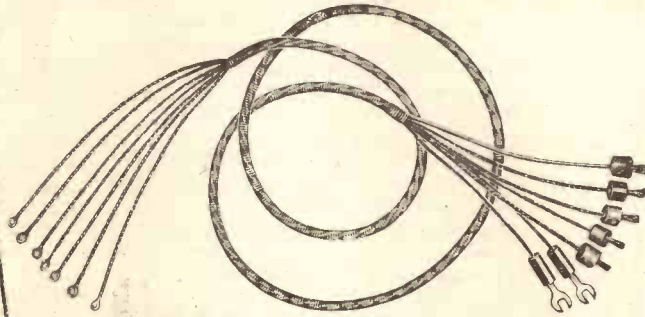

**GOLTONE 5-WAY BATTERY CORD**  
30 ins. long, as used by designer, complete, R40/40, 2/-

**GOLTONE PUSH-PULL SWITCH**

R26/744  
**7 1/2**  
each.

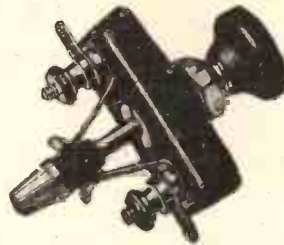

**"GOLTONE" Short Wave Choke**  
Highly recommended by Technical Press.

Baseboard or Valveholder Mounting. R3/26. **2/6**

**"GOLTONE" EBONITE PANEL.** Size: 14" x 7" x 3/2"  
**"GOLTONE" BINOCULAR H.F. CHOKE.** R3/36. 2/6  
**"GOLTONE" "GRAND" L.F. TRANSFORMER.** 3 to 1. 8/6

**"GOLTONE" COMPONENTS** are obtainable from all First-Class Radio Stores. Refuse substitutes —if any difficulty write direct.

RADIO CATALOGUE sent FREE on request.

**"GOLTONE" MIDGET CONDENSER,** 0001 mfd. 5d. each.  
**"TRIPARTE" TERMINALS,** with engraved discs. 2d. each.

**WARD & GOLDSTONE, LTD., PENDLETON, MANCHESTER**

You must see the Lamplugh **"SILVER GHOST"**

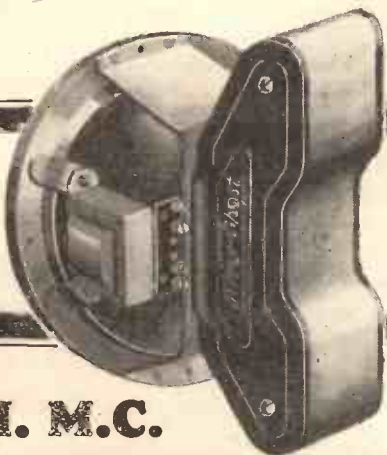

**P.M.M.C. DYNAMIC SPEAKER**

Includes 3-ratio Transformer and 5-ply Baffle Board. **42/-** Less Transformer 35/-

Together with their other range of speakers on STAND No. 99. Demonstration Room No. D.24. or full details and interesting literature on request.

**S. A. LAMPLUGH, Ltd.,**  
Little Park Street - COVENTRY

London Office: Mr. F. G. Billett, 19-20, Holborn Viaduct, E.C.1.



**ASK THE ENGINEER .. HE KNOWS**

● If you want to know which condenser to use ask the man whose job it is to know. His answer will inevitably be "WEGO."

WRITE FOR FULLY DESCRIPTIVE LEAFLET.

SEE THEM AT THE RADIO EXHIBITION STAND No. 284.

**WEGO CONDENSER Co., Ltd.**  
Spencer House, South Place, E.C.2. Phone: National 4500.



## PUSH-PULL or PUSH-PUSH ?

(Continued from page 749.)

In the original push-pull circuit each of the valves was biased to the lower end of its characteristic curve, but this practice was subsequently abandoned in favour of biasing to approximately the mid-point of the curve, chiefly because, as previously explained, this biasing tends to eliminate certain possible sources of distortion.

In the push-push amplifier neither of the grids is biased. This leads to the rather curious result that, during each half-cycle of input voltage, one of the valves is practically thrown out of commission, leaving the other valve to do all the work. On the other half-cycle the conditions are reversed, so that each valve in turn "pushes" up its output current from a minimum to a maximum under the influence of the total input voltage.

### Low Anode Voltages.

As there is no initial bias on the grid of the working valve, less H.T. is required to produce a given plate current. This is a useful point since it is often difficult to get a sufficiently high voltage to work power valves at their full capacity.

The operation of the push-push system will be more clearly understood by reference to Fig. 2.

During the half-cycle when the grid of the upper valve (V) is thrown positive, the resistance of the internal grid-filament path of this valve falls to a low value. In other words the valve becomes conductive, and practically short-circuits part of the input circuit, though the resistance (R) prevents

any excessive grid current which might damage the valve.

Owing to the low resistance of the grid-filament shunt there is very little voltage drop across it, so that practically the whole of the voltage built up across the input circuit is applied directly to the grid of the lower or operative valve (V1). By contrast, in the ordinary push-pull arrangement, the high-impedance of the grid-filament path of the upper valve absorbs practically a half of the effective voltage of the input, passing the other half on to the lower valve.

During the second half-cycle the conditions in the push-push amplifier are reversed. The lower valve (V1) now acts as

## NEXT WEEK

# ANOTHER ENLARGED EXHIBITION NUMBER

Packed with Radio Fact!

Sure to be a 3d. Out on Thursday, rush for it. Order Now!

a partial short-circuit across the input, and the upper valve (V) takes practically all the load. Since each valve is alternately made conductive, its internal resistance will fall momentarily to a low level, so that it is necessary to insert a comparatively high impedance, such as the choke (L) in the output circuit, where it is in series with both valves and the common H.T. supply.

## ITEMS OF INTEREST.

Valves with Loose Bulbs—D.C. to A.C.—Earth Connections.

"Automatic grid bias" is that which is obtained by running the anode current through a resistance of suitable value, and utilising the "voltage drop" across the resistance to produce the negative bias.

A valve which has "come unstuck" from its case can usually be repaired satisfactorily by passing a broad rubber band round base and bulb. (Bicycle-type tubing makes a good band for the purpose).

Apart from the liability to fracture the connecting wires, a valve works just as well after its bulb has been loosened from its base as before.

The conversion of British electric supplies from D.C. to A.C. is bound to take several years, as the number of houses involved is estimated at about one and a quarter millions.

The League of Nations Radio station at Geneva is now completed, and keeps in touch with all continents at all times of the day and night. Short waves play a very important part in the equipment.

Water-pipe earths are liable to be a little more noisy than the buried plate types, partly on account of the fact that other electrical equipment is frequently earthed on the main.

The detector-valve usually requires a better smoothed anode current supply than any other valve in the set.

## "NEW SETS FOR OLD"

# YOU MUST

have that new set this year and get it at practically half price by purchasing through us, disposing of your old set (if any) at a most generous allowance.

**HUNDREDS OF SATISFIED CLIENTS WILL ENDORSE THIS**

Just write for particulars, enclosing 1d. stamp naming your old set which we will buy, and the new set you fancy, and a free quotation will follow. Balance payable in cash or Hire-purchase.

**FREE Wireless Set to introduce the Radialaddin Club.**  
RADIO EXHIBITION, OLYMPIA. STAND 277, GALLERY

## RADIALADDIN, Limited,

THE LARGEST RADIO EXCHANGE DEALERS IN THE UNITED KINGDOM  
(Dept. P.W.), 47/48, Berners Street, London, W.1. Museum 1821.

Please forward this ENQUIRY FORM (without obligation).

I am interested in purchasing the undermentioned Radio Receiver:

Make ..... Model and List Price .....

Present Set: Make ..... Batteries or Mains .....

Date of purchase ..... Original cost of Set .....

Balance of purchase price would be payable by me as follows:

Plan A. Whole of balance in cash. Plan B. Whole of balance over

Six, Nine, Twelve\* months.

\*Delete unwanted words.

NAME, in Full (Block Letters) .....

ADDRESS .....

## "Red Diamond" "Red Diamond" H.F. Choke TRADE MARK Detector

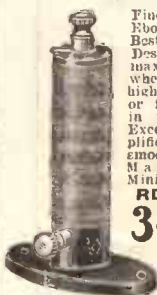

Finest Quality Ebonite Former. Best quality wire. Designed to give maximum results when used as high-frequency coupling, or for reaction purposes in the detector circuit. Exceptionally high amplification. Beautifully smooth reaction control. Maximum inductance. Minimum D.C. resistance.

RD74

3/6

each; by insured post 3/9.



Can be mounted on brackets or through panel. Once set always ready. Not affected by vibration. Each one is tested on broadcast before despatch.



RD40  
2/-

By insured post 2/3, or 2/9 with shield.

Of all high-class Radio Dealers or Sole Makers.

SEE OUR STAND, NO. 97, NATIONAL RADIO EXHIBITION  
JEWEL PEN CO., LTD. (Radio Dept. 46), 21-22, Great Sutton St., LONDON, E.C.1.

## A.C. to D.C. BATTERY CHARGERS

### THE "N.P. SENIOR"

A Real Battery Charging Plant. Will do from 1 to 8 batteries at once. For Wall or Bench.

### GUARANTEED

Fitted with Ammeter and Sliding Resistance. 14" x 7" Polished Board.

### METAL RECTIFIER

Send for lists.

NASH PRODUCTS LTD., 93, Victoria Rd., Stechford, Birmingham.



75/-

Complete 3 Amperes Output 7 days' trial given State Mains Voltage

"Plug-in and Switch on"

# TAKING THE GUESS-WORK OUT OF RADIO SET CONSTRUCTION



You need no special knowledge of wireless to build this perfect receiver—a receiver that will bring in a large number of British and Continental Stations with surprising volume, purity of tone and ease of control. The LOTUS LANDMARK THREE has been designed to combine an efficiency equal to that of any bought receiver with a simplicity of assembly within everybody's ability. It is very compact and includes the world-famous LOTUS Components, which, for many years, have been acknowledged as unequalled for efficiency and reliability.

With the aid of the simple point-to-point wiring chart and full-size print, anyone can construct the LOTUS LANDMARK THREE in about an hour.

Send the coupon below to-day for full particulars and blue print of the amazing LOTUS LANDMARK THREE.

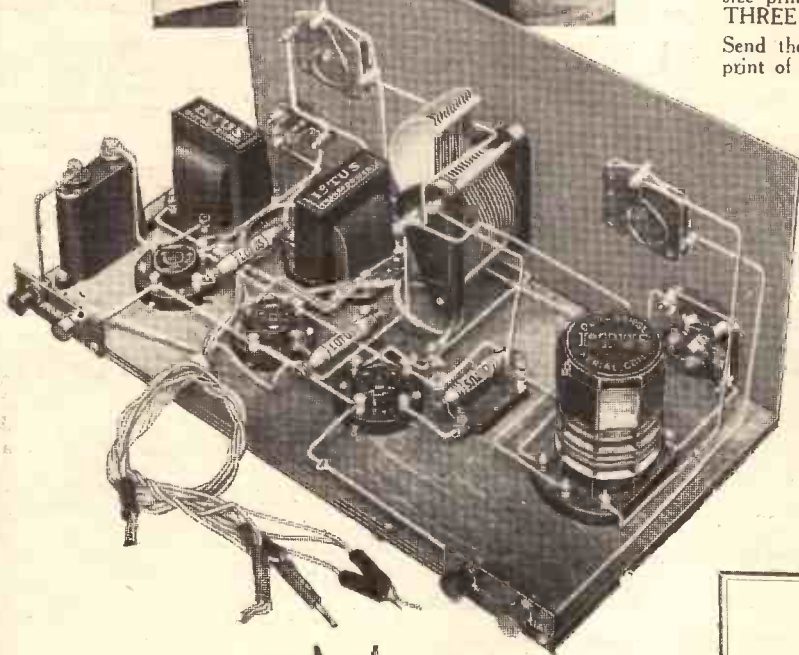

# LOTUS LANDMARK KIT 3

## LOTUS RADIO COMPONENTS

All the components in the "Landmark 3" Kit Set are obtainable separately, in addition to a big range of other components available. All are of the famous Lotus "Guaranteed" standard of quality and efficiency.

Here are a few of them:—

D.R.60 H.F. Coil	5/6	Slow-Motion Con-	
D.R.50 Aerial Coil	5/6	denser	6/6
2 Gang Condenser	19/9	Direct Drive Con-	
3 Gang "	29/6	denser	3/6
Output Choke ..	5/6	Differential Con-	
R.F. " ..	2/6	denser	4/6
L.F. Transformer		Reaction Condenser	4/-
No. 1.	5/6	Disc Drive	5/-
L.F. Transformer		Universal Switch	1/6
No. 2	7/6	Valve Holders from	6d.
A.F. Power Choke	15/-	Jack Switch JS8 from	1/6

To  
LOTUS RADIO LTD.,  
Mill Lane, Liverpool.

Please send FREE wiring diagram of "Landmark 3" and full list of Lotus guaranteed components. (N.B.—If you also require your copy of "Choosing a Wireless Set," enclose 3d. in stamps.)

Name .....

Address .....

MIRROR OF THE B.B.C.

(Continued from page 734.)

WILLS'S  
CAPSTAN  
ARE  
CAPTIVATING



10 FOR 6<sup>5</sup>  
20 FOR 11<sup>10</sup>

They suit everyone

Save your CAPSTAN packets for  
The Imperial Tobacco Company  
POSTER COMPETITION  
£20,000 in Cash Prizes  
Ask your Tobacconist for particulars.

C.C.754.8

Regional Features.

Several attractive items will be found in the North Regional programmes, for late August and early September, among them being the annual running commentary by Mr. George Aitchison on the Rydal Sheep Dog Trials which take place on Thursday afternoon, August 25th.

No more beautiful spot than Rydal, which is in the Lake District, could be found for these trials, and for those who cannot go there, which refers to almost all of us, Mr. Aitchison's description of the marvellous feats of these wonderfully trained dogs, controlling the agile sheep, will be some compensation of pleasures denied.

Sunday evening, August 28th, brings a concert by the Horwich R.M.I. Band, playing music from great oratorios, and the Bury Athenaeum Musical Circle singing some of Brahms' gipsy songs and popular part songs. On the following Tuesday Mr. Noel Bell is giving a talk in which he will describe a journey by barge from Leeds to Hull, a "holiday" he undertook with only two shillings to spend on food and bed.

A Barge Broadcast

The popular idea of barges, particularly in regard to what is known as their "language," rather places them outside the scope of subjects usually dealt with in broadcast talks, but Mr. Bell, in addition to describing his trip, will have something to say about the members of this calling, the hard life they have to live, and the fine type of British workman they undoubtedly are.

Rather more "highbrow" are some items on Tuesday and Thursday, August 30 and September 1 respectively, the first consisting of music and poetry having a country atmosphere, and the second a sonata recital by Douglas Bentley and Herbert Johnson, which includes Grieg's Violoncello Sonata in A minor, the only sonata for this combination which the great Norwegian composer wrote.

THE LISTENER'S NOTEBOOK

(Continued from page 734.)

entertainment. You deserve sympathy, particularly if you did it unwittingly!

Those of you who had heard Nos. 1, 2 and 3 knew what you would be in for, and so gave No. 4 a miss. Have you ever heard anything to beat "There and Back" for sheer dullness? And the music!

Really, Herr Hindemith, I've never listened to such strange and uninteresting stuff! I would rather hear Hilly Billy rubbish!

The James Joyce poems, too, set to Goossen's music! I thought they were never going to finish. Can Anne Thursfield possibly enjoy singing such compositions?

The Collection of Plays was a trifle better, although I've always understood that, in such entertainment "the story's the thing." In both "The Orient Express" and "A Farewell Supper," the story (if you could call it a story) could be told in a dozen words.

I will be charitable enough to hope that the other plays were the best wine of the Collection, reserved till the last. I didn't hear them, for "There and Back" finished

me off completely and sent me to bed feeling wretched. Does the B.B.C. honestly think that this is suitable fare for the masses? If so, it shows poor understanding.

"Suitable Songs" was a totally different thing, certain not to bring a frown on any forehead, young or old—not even on those who cry out for "intelligent entertainment." The claim that "Suitable Songs" will make suitable listening for all tastes was fully justified.

One number among the many that pleased me was Gounod's Serenade. Garda Hall's restraint in this item was very marked, and I only hope other sopranos will take a leaf out of her book.

The "Encounters Series" received a bit of a fillip from the discussion on sunbathing by those two great antagonists, Mr. S. P. B. Mais and Mr. Holt Marvell. Both made out a strong case, and although after it all, they agreed to differ, their arguments were sound enough to win converts.

Somehow, I prefer to hear Mr. Mais on subjects akin to "The Unknown Island" talks. I had to be reminded that last year he opposed Mr. Holt Marvell in a discussion on dangerous living. I had forgotten this, but his "Unknown Island" talks are still vividly alive.

Charles Coburn was a real surprise item, and a pleasant surprise at that. Far from suggesting an odd turn, it had all the finish and completeness of one right at the top of the bill.

The way he carried it through was amazing, but more amazing still was the way he drew everybody—announcers, conductor, friends and relations, and listeners—in for a certainty, into the choruses. We were not surprised that he sang "The Man who Broke the Bank at Monte Carlo" and "Two Lovely Black Eyes."

On such an occasion he couldn't sing anything else. The way he did this, and his continuous patter belied his advanced age.

At first, I wondered whether the B.B.C. had been respectful enough to his four score years to put him on at 10.30 p.m.; but perhaps this was a tribute to his vitality.

Listen for Henry Hall's new dance number! It's a six-eight, called "Watch the Navy." It's a real good tune, and but for a few naval melodies slipping in every now and again, it would do just as well for the Army, Air Force, or even Salvation Army.

You know the sort of thing I mean; it isn't really new, either! He's got a new melody of old songs as well, rather short, perhaps, but what are there are good!

The Proms open their 38th season with a programme of music which I shall remember if only because of Mr. Jack Mackintosh's cornet playing. This doesn't mean that the other items were inferior in any way. They weren't.

It was just the right sort of fare to set the season going with confident hopes of success. It would be impossible to place the items of this first broadcast in any order of merit, as so much depends on personal taste.

Personally, I found the Polovtsian Dances the least pleasing of all, although they took the Queen's Hall audience by storm.



## TECHNICAL NOTES

Some diverse and informative jottings about interesting aspects of radio reception.

By Dr. J. H. T. ROBERTS, F. Inst. P.

### Automatic Volume Adjustment.

I have often been asked whether automatic volume control involving the use of an additional valve or second detector is worth the extra outlay and maintenance.

This automatic volume control arrangement is much more in use in the United States than it is here, and it is regarded by many people there as practically a necessity. Perhaps I should remind you that long-distance reception is much more common in the States than in this country, and consequently people are much more troubled with the effects of fading.

### Effect on Speech and Music.

Some people criticise this automatic volume control arrangement on the ground that inasmuch as it compensates for variations in the strength of the incoming programme, it will have a similar effect upon the low-frequency modulation and will therefore "flatten" the light and shade of music, for instance.

But this objection is really without foundation because what really matters is the mean value of the current and not the instantaneous value due to low-frequency modulation. Since the mean value of the incoming H.F. does not depend upon the modulation (within limits), the control valve takes no notice, as it were, of the modulation and is only affected by the received carrier strength.

On the other hand, if this varies, due for instance to fading on long-distance reception, the volume control valve very largely regulates matters so as to keep the actual reproduced signal strength at a fairly constant level. In a sense, therefore, this automatic volume control arrangement discriminates between slow variations of the energy of the H.F. carrier-wave and rapid variations in the value of the current due to low-frequency modulation.

### Multi-Grid Valves.

It is a curious thing that, although we have had valves with four and more electrodes for many years past, it is only comparatively recently that such valves have been applied to a variety of different purposes.

The forerunner of the two-grid valve was, of course, the old four-electrode valve, of which the second grid was put in for the purpose of dissipating space charge. In present-day screen-grid valves we have a similar principle, but, of course, applied in an entirely different way; whilst in the pentode this is carried a stage further.

### For Super-hets.

The twin-grid valve, which came into prominence last year, is in some ways similar to the foregoing valves, but in some ways it is entirely different. This valve has been designed specially for use in super-hetero-

(Continued on next page)

## New Times Sales Co

### MANUFACTURERS' KITS

**COSSOR MELODY MAKER.** Model 335. Complete with Valves, Speaker and Cabinet. Employs Cossor Variable-Mu S.G. H.F. stage. Detector and Power. Cash Price £7/17/6  
Balance in 11 monthly payments of 14/10

With 10/- order

**OSRAM "THIRTY-THREE" MUSIC MAGNET.** Complete Kit, comprising all components including Valves, Cabinet with self-contained Speaker. Screen-grid H.F., Screen-grid Detector and Power output. Single-dial tuning, wave-length calibrated. Cash Price £9/9/0  
Balance in 11 monthly payments of 17/6

With 15/- order

**RADIO FOR THE MILLION. "STATION MASTER 3."** Battery "Model A." Complete with Valves and Cabinet. Cash Price £5/11/0  
Balance in 11 monthly payments of 10/-

With 10/- order

**RADIO FOR THE MILLION. "STATION MASTER 3"** (Model B), with Valves, Cabinet, and Speaker as advertised. Cash Price £7/10/0  
Balance in 11 monthly payments of 14/-

With 10/- order

### ACCESSORIES

**GARRARD INDUCTION GRAMOPHONE MOTOR.** Model 202. For A.C. Mains. Mounted on 12-in. Nickel Motor Plate with fully automatic electric starting and stopping switch. Cash Price £2/1/3  
Balance in 11 monthly payments of 5/4

With 5/4 order

**B.T.H. SENIOR PICK-UP,** complete with Arm and Base. Cash Price £2/5/0  
Balance in 11 monthly payments of 4/2

With 4/2 order

**FIRST WITH EASY TERMS in 1924 and Still leading BIGGEST STOCKS**

Strictest Privacy Guaranteed

# NEW 1933 RADIO ON EASIEST OF EASY TERMS QUICKEST DELIVERY

**BLUE SPOT SPEAKER UNIT AND CHASSIS, Type 100U.** With 5/5 order

Cash Price £1/19/6  
Balance in 7 monthly payments of 5/5

**W.B. PERMANENT MAGNET MOVING-COIL SPEAKER, Type P.M.4.** Complete with Transformer. With 5/9 order

Cash Price £2/2/0  
Balance in 7 monthly payments of 5/9

**EPOCH "20 C" PERMANENT MAGNET MOVING-COIL SPEAKER.** With 3-ratio input transformer. This speaker will handle up to 5 watts. With 6/6 order

Cash Price £1/15/0  
Balance in 5 monthly payments of 6/6

**ULTRA IMP PERMANENT MAGNET MOVING-COIL SPEAKER,** with input transformer. Cash Price £1/17/6  
Balance in 5 monthly payments of 6/10

**ATLAS A.C. ELIMINATOR, Type A.C.244.** Three tappings, S.G., Detector and Power. Output, 120 volts at 20 ma. Cash Price £2/19/6  
Balance in 11 monthly payments of 5/6

**R & A "VICTOR" PERMANENT MAGNET MOVING-COIL SPEAKER DE LUXE.** With 6-ratio input transformer and protecting grill. With 6/5 order

Cash Price £3/10/0  
Balance in 11 monthly payments of 6/5

**R & A "BANTAM" PERMANENT MAGNET MOVING-COIL SPEAKER.** With 3-ratio input transformer. With 5/- order

Cash Price £1/7/6  
Balance in 5 monthly payments of 5/-

Any items advertised in this journal sent C.O.D. If value over 10/- sent all C.O.D. charges paid.

**To NEW TIMES SALES CO.** 56, Ludgate Hill, London, E.C.4.  
Please send me (a 1933 Lists  
(b).....for which I enclose first payment of £.....s.....d.....  
Name.....  
Address.....  
P.W. 20/8/32

**ENGINEERS**—Sit down and think this over. Time is going by and you are still on the look-out for a worth-while job. Will you be doing the same thing next year—and the year after that? You have got to do something about it before it is too late. We believe we can show you the way to well-paid permanent and progressive employment. In any case, it costs nothing to inquire and you will at least learn of various surprising possibilities about which at present you probably know nothing. The first thing to do is to send for our 200-page Prospectus, "ENGINEERING OPPORTUNITIES." Free and without obligation. Do not delay. This is a matter which affects your very livelihood. Send for your copy now—not tomorrow, but NOW.

BRITISH INSTITUTE OF ENGINEERING TECHNOLOGY, 401, Shakespeare House, 29/31, Oxford Street, London.

### 10,000 GRAMOPHONE MOTORS FROM STOCK

**BIG SUMMER DISCOUNT ALLOWED**  
Make a Gramophone or Radiogram Order loose kits and assemble them at home. Get for 3d. our new 64-page catalogue with scale drawings and instructions how to make them. We sell motors from 7/6, tone-arms, soundboxes, 1/6, pick-ups, big volume horns, loudspeakers, radio kits, complete receiving sets, gramophones, radiograms. Established 1903.  
**THE REGENT FITTINGS CO., P.W. 120 OLD STREET, LONDON, E.C.1.**



**Radio Cabinet Specialists REDRUP & SON (P. W. Dept.), 178 ALBERT ROAD, SOUTHSEA.**  
Send 2d. stamp for Illustrated Catalogue.

## MODERN WIRELESS

SPECIALLY ATTRACTIVE AND ENLARGED EXHIBITION NUMBER ON SALE AUG. 19th. PRICE ONE SHILLING.

With illustrated supplement, "THE WORLD'S PROGRAMMES," for long-distance listeners.

# SOME Customer must win this fine

## 1933 COSSOR model 335

OR one of these useful  
Wates Universal Test  
Meters, invaluable to the  
wireless  
enthusiast

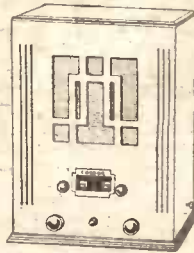

**FIRST PRIZE.**  
Complete kit for ready wired Cossor  
Melody Maker, model 335, in handsome  
polished cabinet including loud speaker  
(£21/6) and TEN CONSOLATION PRIZES  
of Wates Universal Test meters complete  
in black bakelite case (12/6).

### WHAT YOU HAVE TO DO

1. On our Competition Form there are photographs of 1933 sets, without names or identification marks. Here is a test of your radio knowledge! How many of the sets can you identify? It's not so easy as it sounds.
2. Of course, we cannot open this competition to everybody. We have had to limit it to our customers — which, when you think of it, is only fair.
3. If you have at any time been a customer of ours, write us a postcard for a FREE COMPETITION FORM.
4. If you are not already a customer and are thinking of buying a new set, why not fill in the form below and get a free quotation for your old set? Then, you will very soon be a customer.
5. If you want to buy a new set or components without selling your old apparatus, you can buy them from us just as you do from any radio mail-order firm.
6. The closing date of the competition is August 31, and the results will be published in P.W. Get moving! Sets and components of any type taken in part exchange. Every radio requirement supplied from new stock.

**FILL IN AND POST COUPON TO-DAY**

### WHAT WOULD YOU ALLOW ME FOR:-

### I AM THINKING OF BUYING:-

ON CASH OR H.P. TERMS.  
(Cross out whichever does not apply)

Name.....

Address.....

Post to-day to:—Co-Radio Ltd.,  
Dept. P.W.4., 78, Neal Street, W.C.

**THIS PUTS ME UNDER NO OBLIGATION**

# CORADIO

Showrooms: 78 Neal Street  
Shaftesbury Avenue, W.C.

## TECHNICAL NOTES

(Continued from previous page.)

dyne sets where the first valve is often used to carry out the dual functions of oscillator and first detector. It is true that the screen-grid valve has been used in this way, one grid for detector and the other for oscillator, and in some cases it can be got to operate quite well.

But it is not specially designed for the purpose, and therefore it cannot be expected to work as well as one which has been designed with this specific object in view. With the twin-grid valve the duties of detector and oscillator are effectively combined, and this is important in view of the rapidly increasing popularity of the super-het.

### Doubling the Filter Circuit.

A reader who is using an output filter circuit with his set wants to know whether he should keep this when using a moving-coil loudspeaker which is already fitted with its own input transformer. This is a question I have been asked several times before. Nowadays many loudspeakers are sold already fitted with input transformers, and so it is a little problem which must often arise since many receiving sets are also fitted with output choke filters.

Strictly speaking, it is preferable to connect the primary of the input transformer of the loudspeaker into the anode circuit of the last valve of the receiver, and if you are able to do this—that is, if it does not mean too much interference with the set—it is as well to do so.

On the other hand if, for any reason, you do not wish to make this adjustment, there is no serious disadvantage in connecting the primary of the loudspeaker input transformer to the output of the filter circuit of the set in exactly the same way as you did the loudspeaker which you were using previously.

### Record Tracking.

I have a letter from a reader who wants to know whether, when records are being made, the recording needle travels in a straight line across the face of the record—that is, along a radius—or whether it moves over an arc of a circle in the same way as the reproducing needle of a gramophone. He goes on to say that if the two systems are different, this is bound to cause unnecessary wear and tear on the sides of the record track.

The answer to this is that all professional recording machines—I am not aware of any exceptions—work on the straight-line principle, the recording needle progressing along a radius. On the other hand, practically all gramophones are provided with a tone-arm or pick-up which swivels about a point, with the result that the needle follows a circular track across the record.

It is obvious that if the plane of motion of the needle is accurately at right angles to the track at one part of the record, it cannot be so throughout the whole of the run; in point of fact I have seen many gramophones in which the adjustment is far from being accurate at any part of the record.

### Wear and Tear on Grooves.

As for the wear and tear on the sides of the record grooves, it is perfectly true that

(Continued on next page.)

The place for Contact  
at **RADIOLYMPIA**  
will be **STAND 225**

Where you can inspect every component in the wide CLIX range and be certain of finding something to meet YOUR particular contact requirement.  
Write for Folder 'P.2.' Ask your Dealer for 'CLIX.'  
**LECTRO LINX LTD., 254, Vauxhall Bridge Road, S.W. 1.**

## OSTAR-GANZ

### HIGH VOLTAGE MAINS VALVES

The first range of mains valves available in England, incorporating the most recent development in valve design—full mains voltage indirectly heated filament.

These valves work direct off either A.C. or D.C. supply. They effect considerable saving in constructional and running costs. No transformers or breakdown resistances required. Considerably lower current consumption than any other mains valves. Remarkably free from mains hum.

Descriptive leaflet on request.	G.P. Det. and Power	17/6
	Super Power	18/-
	Rectifying Valves, 50 m.a.	14/6
	" " 125 m.a.	15/6

## UNIVERSAL

### RECEIVER AND AMPLIFIER KITS

With British Components. All instructions. Complete ready for assembly. Highly efficient, yet cheap, because the Ostar Universal High Voltage Valves cut out cost of transformers and breakdown resistances. Work off either A.C. or D.C.

2-Valve Receiver with Rectifier	£6 10 0	3-Valve Receiver	Price ...	£8 8 0
2-Valve Amplifier with Rectifier	£4 4 0	3-Valve Amplifier with Rectifier	£5	5 0

**EUGEN FORBAT**  
Sole Representative for Gt. Britain.  
c/o Nivalight, Ltd., 1, Rosebery Avenue, E.C.1.

### THE PICTURE PAPER WITH THE MOST NEWS

**SUNDAY GRAPHIC**  
and Sunday News



That is the number of our Stand at the Exhibition, and if you make your way to the entrance to the Exhibition Club you will find our Stand right opposite.

### FREE CALCULATION RESISTANCE CHART.

We shall be giving away *Free copies* of this very useful chart. It is without doubt the most valuable chart yet published, as it can quickly give you the four following factors:—

- 1. Current.
- 2. Watts.
- 3. Volts.
- 4. Ohms.

See you get a copy.



### WHILE YOU ARE THERE—

ask to see the new **Watmel Non-Inductive Resistance Type 3.**

This new all-British resistance embodies many new and novel features which guarantee a far steadier performance than resistances constructed on old and obsolete principles. Price **4/6**

There is also the

### WATMEL SQUARE-LAW TAPERED RESISTANCE.

This resistance is specially wound on a tapered former which gives a perfect square-law reading.

**THIS IS THE FIRST RESISTANCE OF ITS KIND.**

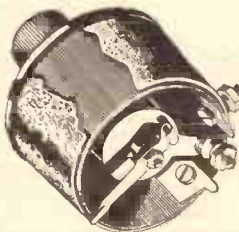

Any resistance up to 50,000 ohms.

- Standard wiring **5/6**
- Square-law type **6/6**

Send for our Component Catalogue.



**WATMEL WIRELESS CO., LTD.,**

Imperial Works, High Street, Edgware.  
Telephone: Edgware 0323.

## TECHNICAL NOTES

(Continued from previous page.)

this is made worse when there is any error in adjustment; but at the same time, with a fairly long tone-arm or pick-up arm (giving a fair approximation to straight-line progress across the record) and with correct positioning of this, I think the extra wear due to the departure from the straight-line path is negligible.

But, as I say, there are many gramophones in which the tone-arm is so short and so incorrectly placed that the wear on the record must be horrible; and, in fact, it often surprises me that the needle stays in the groove at all!

### Decoupling Resistances.

When considering the question of decoupling resistances, remember that the high-tension supply is the most likely to cause back-coupling, as this is common to all the anode circuits. The reason for using decoupling resistances is that these counteract stray fluctuating voltages which may get into the amplifier circuits.

The decoupling resistance, in fact, gets rid of any such stray voltage or reduces it to such a small amount as to be negligible. A point to bear in mind is that any high-tension source, such as H.T. battery or mains unit, which has appreciable internal resistance is liable to cause back-coupling and motor-boating unless the valves are separately decoupled.

Most mains units have quite an appreciable internal resistance—some more than others, of course, whilst a dry battery generally has a very low resistance when freshly installed, but may develop a high resistance after it has been in use for some considerable time.

In fact, a dried-up H.T. battery is one of the most fruitful sources of back-coupling, whilst, on the other hand, the H.T. battery of accumulator cells is the least liable to cause trouble in this direction, owing to its relatively very low internal resistance.

### "Pluppy" Reaction.

The end of the grid leak remote from the grid is generally connected to the positive side of the low-tension circuit, and many detector valves operate quite satisfactorily when joined up in this way. But sometimes you will find that you do not get the greatest sensitivity by this connection, and it may be that if the potential of this end of the grid leak can be brought nearer to that of the negative side of the low-tension circuit better results will be obtained.

This is quite simply done by connecting a potentiometer across the low-tension circuit and joining the grid to the slider of the potentiometer. By shifting the slider about—that is, by varying the potential of the near end of the grid to a suitable point intermediate between the positive and negative potentials of the low-tension circuits—you will be able often enough to get much better operation.

Sometimes, for instance, the reaction will be "pluppy" when the leak is connected to the positive side, but as you go to an intermediate point the reaction becomes better behaved. Often sensitivity can be adjusted nicely by this means as well. The actual point on the potentiometer will need to be found by trial. It is hardly necessary

(M.C.6)

(Continued on next page.)



We supply all good quality Radio Receivers, Components, and Accessories on deferred terms. Large stocks are carried and orders are executed promptly. Send list of requirements and a quotation will be sent by return of post. Price List free on request.

**NEW COSSOR MELODY MAKER.**  
Model 335 (just released). Complete Kit of Parts, Valves, and Loudspeaker. With **10/-** order  
Cash Price £7/17/6.  
And 11 monthly payments of 15/-.

**MURPHY NEW ALL-MAINS 3-VALVE Set.** Model A.3.A. With **39/-** order  
Cash Price £19/19/0.  
And 12 monthly payments of 33/-.  
We are appointed Murphy Dealers.

**ATLAS ELIMINATOR, A.C.244.** 3 H.T. Tappings. 20 M/A output. With **5/-** order  
Cash Price £2/19/6.  
And 11 monthly payments of 5/6.

**NEW ORMOND PERM. MAGNET MOVING-COIL LS UNIT** (just released) With **5/4** order  
Cash Price £1/18/6.

And 7 monthly payments of 5/4.  
**EKCO H.T. ELIMINATOR A.C.18.** Suitable for 3-Valve S.G. Sets. With **6/3** order  
Cash Price £3/7/6.

And 11 monthly payments of 6/3.  
**NEW R & A "CHALLENGER" PERM. MAGNET MOVING-COIL UNIT.** With **5/-** order  
Cash Price £1/15/0.

And 6 monthly payments of 5/8.  
**NEW EPOCH 20C PERMANENT MAGNET MOVING-COIL UNIT** With **5/7** order  
Cash Price £1/15/0.

And 6 monthly payments of 5/7.  
**12 EXIDE HIGH-TENSION ACCUMULATORS** (120 volts WH-10 super-capacity, 5,000 milliamps). The cheapest form of high-tension supply where electric light mains not available. With **7/-** order  
Cash Price £3/15/0.

And 11 monthly payments of 7/-.  
**BLUE SPOT 100U INDUCTOR UNIT.** With **5/5** order  
Cash Price £1/19/6.

And 7 monthly payments of 5/5.

To avoid delay, will customers kindly send deposit with order.

All above carriage paid.

The **LONDON RADIO SUPPLY COMPANY** ESTD 1925  
11, Oat Lane, Noble St., LONDON, E.C.2  
Phone NATIONAL 1977

### NOTICE

Send 6d. (post free) for UP-TO-DATE HANDBOOK of Tuning Coils for Circuits, Dual Range, Band Pass and Super-Het. Fully illustrated, with data.

**THE BRITISH EBONITE CO., LTD.,**  
Hanwell, London, W.7

### LOUD SPEAKERS REPAIRED, 4/-

(Blue Spot a Speciality. 5/-)  
Transformers 4/-, Headphones 4/-, all repairs magnetised free. Eliminator Repairs quoted for, 24 Hours Service. Discount for Trade. Clerkenwell 9069.  
E. MASON, 44, EAST ROAD, LONDON, N.1.

### WIRELESS AS A CAREER

Whether you are already engaged in the radio industry and wish to improve yourself, or if you wish to obtain employment in this interesting profession, we can help you. Write now for Booklet describing our Home Study Course, Sent post free

**NORTHERN COUNTIES WIRELESS SCHOOL,**  
57, Guildhall Street, Preston



## NEW MAINS UNITS HEAYBERD STAND 13

A complete evolution in Mains Unit design will be shown at the Heayberd Olympia stand this year. Mains Units are now enclosed in modern, clear-cut metal cases. Components are severely tested before inclusion in the units, and the interior arrangement is a triumph of engineering skill.

There are complete Mains Units to answer practically any Radio requirements. Kits of assembled parts and unassembled Kits, enable you to build your own Mains Unit if you prefer. Mains Transformers, Chokes, Condensers, etc., will be shown, as well as New Battery Chargers and Inter-valve Transformers. The Mains Unit illustrated above is Model D. 120, specially suitable for running portable receivers. Output is 120 v. at 20 ma. with a variable tapping 60-120 v., and two fixed 100 v. and 120 v. Trickle Charger 2 v. 3 amp.

**Price 85/- complete.**

**HEAYBERD**  
MONARCH OF THE MAINS.

### POST COUPON NOW!

Please send me your New 1933 Catalogue and Handbook of Radio Mains Equipment, containing useful hints and diagrams on Mains Working. I enclose 3d. stamps.

M.....

Address..... P.W. 20/8

**F. C. HEAYBERD & Co.**

10, FINSBURY ST., LONDON, E.C.2

WE ARE EXHIBITING AT

**RADIO OLYMPIA**  
AUGUST 19-27

## TECHNICAL NOTES

(Continued from previous page.)

to say that the potentiometer should not be of too low resistance, since it is connected across the low-tension battery.

### Screening Troubles.

The screening of coils, etc., has become now such a conventional practice that we are sometimes apt to forget that for the screens to operate properly they should be connected to zero potential.

I had a case the other day where a set was apparently O.K. throughout, and yet it was so extremely lively as to be quite unmanageable. I tried all sorts of dodges, altering the value of the H.T., decoupling the H.F. stage, bypassing, and so on, but nothing seemed to have much effect.

Of course, I should have thought of it at once, that such a state of affairs indicated that something that *should* have been earthed was *not* earthed, as this undue liveliness is just the sort of thing you get in these conditions. But, as I say, a casual glance, or even a reasonably careful inspection of the set seemed to show that everything was properly screened, and it never occurred to me that screens were not properly earthed.

### The "Floating" Screen.

What gave me the clue to the trouble was that on touching the screens by hand a distinct change took place in the strength of the signals. I do not mean that this was caused by removing the screens and replacing them; that you would naturally expect, because the proximity of the screen to the coil has a definite influence on the tuning, and if the screen is removed without the tuning being adjusted the tuning will be all out.

But if the screens are all properly fitted and properly connected to earth, you would hardly expect any noticeable effect to be produced on touching a screen (earthed) with the hand.

Well, on connecting the screens to earth the trouble entirely disappeared; the set was not so lively but became completely manageable and behaved itself in the proper way.

Some people have the idea that if you fit screens to coils and so on, these will have the desired effect even though they are not connected to earth. This idea is entirely wrong and, in fact, in some cases the presence of an unearthed screen may be worse than useless. The screen, in fact, when not connected to earth may actually produce interaction.

### Consistent Performance.

The same sort of thing applies to the metal casing and arm of a pick-up. Often people get the idea that because the pick-up is in a metal sheath it is in a sense protected from interaction even though the sheath is at a "floating" potential. It is quite a mistake to rely upon this, and you cannot expect to get really satisfactory and consistent behaviour from the pick-up or the coils unless the sheath or screen is fixed at a definite potential and that potential is obviously zero.

Of course, there are cases where a set will work well enough when the parts which should be earthed are not earthed, and in

(Continued on next page.)

# SEE THEM for YOURSELF ON

**STAND 239**



## THE EELEX SHORT WAVE CONVERTOR

A wonderful instrument, when fitted to your present set, that enables you to enjoy programmes on the ultra short-wave bands. No alterations necessary; just connect to the aerial and earth terminals—you will be amazed at the number of foreign stations that you can tune in. When you visit Olympia be sure to see this wonderful instrument.

### Prices:

One valve model 60/- (including valve)  
All Mains model 65/- (without valve)  
Two valve model 85/- (without valves)

## EELEX FRAME AERIAL

Originally designed for use with super-het receivers, this frame aerial has been improved and modified to suit the latest type of set. The necessary connections are made to sockets on an ebonite base which also carries the switch.

Plugs are included. Price 20/-

**OLYMPIA  
STAND 239**



Write for Booklet A 23

**J. J. EASTICK & SONS,**  
Ealex House, 118, Bunhill Row,  
LONDON, E.C.1.

Phone: Metropolitan 0314/516.

## TECHNICAL NOTES

(Continued from previous page.)

such cases you may get more lively performance and greater sensitivity; but, on the other hand, you never know from one minute to the next how the sensitivity is going to change, and even though you may sacrifice a little in sensitivity by connecting the proper parts to earth, you will gain to a much greater extent in dependable performance.

### Cathode-Ray Television.

With television talk coming to the fore again I was rather interested in some information from the United States with regard to the progress of the cathode-ray system.

This system, as most of my readers probably know, is in principle similar to the mechanical system, except that the scanning device consists of a beam of cathode rays in a discharge tube, one end of the tube being more or less flat and being coated inside with a substance which gives out a fluorescent light when the cathode rays impinge upon it.

A suitable hole is provided in the anode of this tube and the rays from the cathode shoot through this hole and so form a fine pencil of rays which falls upon the fluorescent screen. This beam is then acted upon by varying fields so that it "scans" the screen at the end of the tube, and its intensity is varied appropriately so that (by virtue of persistence of vision) the observer sees a moving picture on the screen.

### No Mass to Move.

Obviously the great advantage of the system is the virtual absence of mass in the moving element, that is, the beam. It is therefore able to respond much more instantaneously, so to speak, than any mechanical device.

I understand that cathode-ray tubes for this purpose are now being made in the States at a price which will bring them within the reach of the ordinary home user.

I mentioned some little time back the Farnsworth system of television which it is claimed produces a picture one foot square, a 400-line image, and only requires a 10-kilocycle channel. There is no separate channel required for synchronising, as special synchronising signals are transmitted over the picture channel without interference.

### Loop Aerial Peculiarities.

I have often been told by readers who use frame aerials that the direction-finding properties of the frames do not appear to be very accurate. For instance, suppose you happen to know the actual bearing of a particular station and you check this up by means of a frame aerial, you will possibly find that the reading given by the frame is different from the reading which you know to be the correct one. Readers sometimes ask whether this is due to lack of precision in the reading obtained by a loop aerial or whether it is not to be relied upon for correct readings.

The answer to this is that the frame aerial under appropriate conditions will give you a correct reading, although this may not be determinable to within a few degrees (this depends upon special precision arrangements), but it will naturally read

(Continued on next page.)

# TUNEWELL COMPONENTS RECOMMENDED FOR THE "OLYMPUS 4"

**STAND  
96**

The new range of Tunewell Components has brought **Super-reception** within everybody's reach. They have been designed for the expert, and only by **lowering our profits** are the wonderful values made possible.

The following are recommended for the "Olympus" 4, "P.W.'s" Great Exhibition Set:-

Tunewell H.F. Choke, 3/6	4 Tunewell 4-pin Valve Holders	6d. each
Tunewell L.F. Trans-former 7/6	Tunewell 100,000 ohms wire wound anode Resistance	3/6
Tunewell F.V. 150/30 Mains Unit (150 v. at 30 m/a) ..	£5	

Build this Set and remember Tunewell Components will ensure maximum efficiency at the lowest possible cost.

★ Get the Tunewell "Guide to Super Radio" FREE from Stand 96, or address below. It contains

**8 FREE BLUEPRINTS** including Kit Eliminator and All Mains Band Pass 3..

See the new Tunewell components and wonderful new Radiogram at **STAND 96 OLYMPIA.**

**STAND  
96**

TUNEWELL RADIO LTD. 54, Station Rd., London, N.11

# TUNEWELL

## RADIO AUCTION SALES

are held monthly by

# GODDARD & SMITH

in their spacious Sale Rooms at  
**70, SEYMOUR PLACE,  
MARBLE ARCH, W.1.**

The following dates have been arranged:-

**September 21st and 22nd,  
October 19th and 20th,  
November 16th and 17th,  
December 14th and 15th.**

Goods for inclusion can be accepted at once. Prompt settlements.

Every facility to the private purchaser for inspection and trial. Private Treaty sales at any time. Catalogues and entry forms free on application.

Phones: Paddington 0277-8 & 5805.

Famous Makers' Offer! **£5** Radio Gram CABINET for **65/-**

**IMPROVES PERFORMANCE 50%**

10/- monthly if desired. Polished Oak, Piano Tone Cabinet (42 in. high, 24 in. wide), ON APPROVAL at Makers' Prices!! You may return at our expense if you wish to part with it. 3,000 clients, B.B.C. Radio Press. All Models from 35/- to £15.

**PIANO TONE**

Patent 8123. Users obtain 50% to 100% greater volume. The rich, mellow tone brings a fine thrill.

PHOTOGRAPHS AND LISTS FREE.

**PICKETTS** Piano Tone Cabinets (P.W.), Albion Rd., Bexleyheath, Kent

Make  
**The DAILY SKETCH**  
YOUR Picture Paper

## EASY PAYMENTS

"There's no place like HOLMES." The first firm to supply Wireless parts on easy payments. Seven years' advertiser in "Popular Wireless". Thousands of satisfied customers.

	Monthly Deposit Payments
TELSEN VICTOR 3 KIT 39/6	5/5 7 of 5/5
COSSOR KIT - - - - -	£6/8 10/- 11 of 11/11
OSRAM KIT - - - - -	£10/15 19/6 11 of 19/8
METEOR 3 KIT - - - - -	£3/15 6/10 11 of 6/10
EXIDE H.T. Accum., 120v. £3	6/- 9 of 6/8
BLUE SPOT 66R & CHASSIS - - - - -	£2/6 5/6 9 of 4/5
BLUE SPOT 100 U - - - - -	39/6 5/8 7 of 5/4
AMPLION M.C.6 - - - - -	£7/6 7/5 9 of 7/5
CELESTION M.C. - - - - -	47/6 5/3 9 of 5/3
EKCO Eliminator A.C.18	67/- 7/5 9 of 7/5

New Goods Obtained for Every Order. Send us a list of the parts you require and the payments that will suit your convenience, and we will send you a definite quotation. Anything Wireless. **H. W. HOLMES, 29, FOLEY STREET, Great Portland Street, London, W.1.** Phone: Museum 1414.

## EXACT TUNERS

250 to 2,000 metres. Thousands of these tuners are in use, and we can strongly recommend them. No further coils are required. Send P.C. for particulars and circuits—FREE.

**THE EXACT MANUFACTURING CO.,**  
Croft Works, Priory Street, Coventry.

## FOR MAINS EQUIPMENT - USE

# GODWINEX

TRANSFORMERS - CHOKES - ELIMINATORS

See **STAND 57 - RADIOOLYMPIA**  
**J.DYSON & CO. LTD.** 2, COLMAN ST., LONDON, E.C.C.  
37, GODWIN ST., BRADFORD

PLEASE be sure to mention "Popular Wireless" when communicating with Advertisers. Thanks!

## TECHNICAL NOTES

(Continued from previous page.)

the direction in which the signals arrive at the aerial. Now this reading may be incorrect owing to deflections of the waves from various causes before they reach the loop aerial.

### Distortion and Re-radiation.

For instance, it is a well-known fact that in a large modern building, full of steel girders, the waves may be distorted in such a fashion that the reading given by a loop is very definitely out and, in fact, will vary from one part of the building to another. The same thing happens on board ship.

The large masses of metal in the ship have a distorting effect on the waves, and it is not such a simple matter as you might think to determine the true bearing of a station by means of a loop. The various masses of metal also produce what is known as re-radiation or secondary effects and these combine or conspire, as it were, with the primary waves to produce difficulties.

### Direction Finding.

As regards direction-finding on board ship, I am told that it is much easier to get a reliable bearing when the direction of the waves is approximately parallel to the centre line of the ship, from stem to stern, than when it is at a considerable angle to this direction. The various masses of metal in the ship are roughly symmetrical about this centre line, but they are by no means symmetrical about a line through the centre of the ship at right-angles to it.

### Those Silly Troubles.

A few days ago I was connecting a pick-up externally to a radio-gram set and came across one of those stupid little things which we all experience from time to time. In order to facilitate changing over from the pick-up incorporated in the radio-gram to the pick-up of the external gramophone which I wanted to use, I disconnected the leads of the first pick-up and connected them to one end of a double-pole double-throw switch, connecting the centre poles, of course, back to the terminals from which the leads had originally been removed.

A second pair of armoured leads were then run from the remaining pair of terminals from the small D.P.D.T. switch to the second pick-up. On testing out, the first pick-up now refused to work.

### A Cross-Over.

It seemed rather absurd that the mere inclusion of a double-pole switch in the leads of the pick-up could have caused any trouble. A moment's reflection, however, indicated the cause, which I expect you will have seen already. One of the terminals to which the pick-up was originally connected was earthed and one of the terminals of the pick-up was also earthed.

In putting in the double-pole switch I had connected to the wrong terminals with the result that the live terminal of the pick-up had become connected to the earth.

Printed and published every Thursday by the Proprietors, The Amalgamated Press, Ltd., The Fleetway House, Farringdon Street, London, E.C.4. Advertisement Offices: Messrs. John H. Lile, Ltd., Ludgate Circus, London, E.C.4. (Telephone: City 7261). Registered as a newspaper for transmission by Canadian Magazine Post. Subscription Rates: Inland and Canada, 17/4 per annum; 8/8 for six months. Abroad (except Canada), 19/6 per annum; 9/9 for six months. Sole Agents for Australia and New Zealand: Messrs. Gordon & Gotch, Ltd.; and for South Africa: Central News Agency, Ltd. Saturday, August 20th, 1932. S.S.



**PPM**  
**SOUNDEX**

**27/6**

**INCLUDING TRANSFORMER**

This chassis is unique where economy of space is an important factor. Although small in size—the diameter is only 6 5/8"—the volume and tone are truly remarkable. The "Soundex" gives amazing selectivity. A universal tapped transformer is built on to the chassis. Look where you will, at 27/6 greater value is unobtainable. See and hear the full Celestion range at Olympia. Stand No. 127. Demonstration Room No. 9.

**CELESTION**  
*The Very Soul of Music*

Celestion Ltd., London Road, Kingston-on-Thames.  
London Showroom: 106, Victoria Street, S.W.1.

## Our RADIO SHOW of BARGAINS is FREE

at **Electradix House** in  
the Heart of the City  
*A Visit may Save you Pounds!*

1,000 Bargains in: Aerials 6d. Buzzers 1/-.  
Bridges 35/-.. Condensers 1/-.. Cable 3d. yd.  
Cabinets 1/-.. Chokes 9d. Coils 6d. Chargers 50/-.  
Dynamos 21/6. Dials \*2d. Ebonite 1/-.. Flux  
Meters. Flickers 2/6. Galvos 7/6. H.T. Instrs. 1/-.  
Keys 2/6. Lamps 6d. Motors 4/6. Monoculars 15/-.  
Meggers various. Microphones 1/-.. Neons 2/6.  
Phones 1/-.. Photo-cells 15/-.. Recorders. Resis-  
tances 3d. Speakers 2/6. Switches 4d. Trans-  
formers 2/6. Voltmeters 4/6. Valve Relays 12/6;  
Wire 6d. 100 ft. etc., etc.

One Department Specialises in Laboratory equipment and Testing apparatus, all at wonderfully low prices.

\*Switchgear and A.C. Chargers built to any capacity by our own experts; and complete ranges of all sizes stocked for immediate delivery.

Lastly for the Experimental Amateur who wants a useful junk-box of oddments, our famous Bargain Parcels of Electrical and Radio sundries from dismantled W.D. sets—Surplus Stocks etc., with Switches, Wire, Chokes, Condensers and Coils and a host of useful parts. Post Free 10 lbs 7/-, 7 lbs, 5/- Better than ever after stocktaking.

Naval Telescopes for 50 yards to 10 miles at 17/6 each; nearly all sold, so hurry if you want one.

**BARGAIN SALE LIST, POST FREE.**  
**72 PAGE ILLUSTRATED CATALOGUE 4d.**

**ELECTRADIX RADIOS**  
218 Upper Thames St., London, E.C.4

The Goods as Advertised! From TWO to TWO THOUSAND metres, we can solve your Radio Problems, including Amateur Transmission! Whatever your difficulty, write us. Charges: 3/- per query, four or more 2/6 each, including diagrams.

**RADIO TECHNICAL AGENCY, DEPT. P.W.**  
2, Westgate Chambers, Newport, Mon.

## WIRELESS IS THE WORLD'S FINEST HOBBY,

MAKE IT A PROFITABLE ONE.

SAVE MONEY,  
MAKE MONEY,  
NO OUTLAY.

**JOIN THE ELECTROSET CLUB**

Every  
Wireless  
Salesman,  
Experimenter,  
Constructor

should write his name and address in the margin, and post in 4d. unsealed envelope for particulars, and FREE 1,000 illustration catalogue of all makes, components, kits, and sets.  
**ELECTROSETS, SOLIHULL, BIRMINGHAM**

## ADVERTISERS PLEASE NOTE!

The Rate for a one-inch single Column Advertisement is **30/-**

Minimum Space Accepted:  
Half-an-inch .. **15/-**

Send Remittance with instructions to  
**JOHN H. LILE, LTD.,**  
4, LUDGATE CIRCUS, LONDON, E.C.4.  
Telephone: City 7261.



# LATEST PHASES in MODERN RADIO

**STAND  
No. 90  
GROUND FLOOR  
GRAND HALL OLYMPIA**

To the practical minded experimenter and the highly critical listener, R.I. once again present a programme of still Better Radio in components and sets that, to-day, are greatest in their real utility, reliability and value. They set the standard of future practice and so retain a lead which, for over 10 years R.I. have never failed to hold.

Ask for your copy of the new R.I. Catalogue—free!

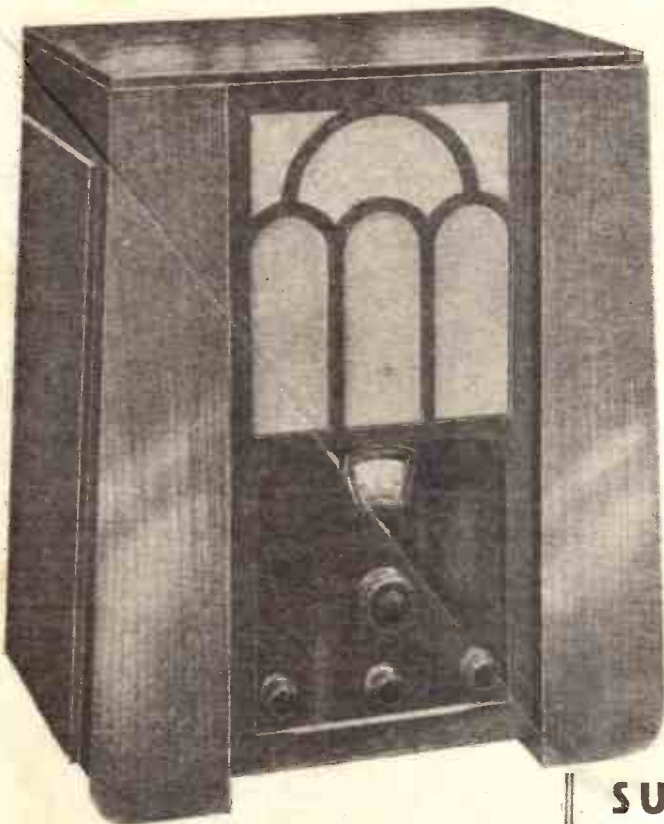

## The NEW "MADRIGAL" 3-VALVE A.C. MAINS RECEIVER

Exactly covers the changes in Broadcast Radio and Developments in Electric Mains Supply. An absolutely reliable receiver that may be safely recommended by the man who knows. Brilliantly designed circuit ensuring perfect reproduction, and full volume on the widest range of stations. Robust chassis and valves for serviceability. Handsome, figured walnut case. Simple controls. Moving coil P.M. type loudspeaker. Provision for Gramophone pick-up. No external aerial necessary for local stations. Illuminated scale calibrated in wavelengths.

**17  
GNS.**

Radio Instruments Ltd., Croydon, Surrey.

## The 'Parafeed' Amplification System now in a complete Unit The 'PARAFEED' COUPLING UNIT

R.I., the pioneers of the parallel feed system of amplification, produced the famous "Parafeed" Transformer—still the acknowledged best—with an inductance of 100 henries and N. P. L. performance curve 25-8000 cycles. This transformer, coupled externally with a resistance and condenser, set the existing standard of parallel feed practice.



R.I. have now produced the "PARAFEED" COUPLING UNIT which houses in an attractive and completely metal screened bakelite case, the complete original "Parafeed" system—a transformer exactly similar to the original "Parafeed," a Condenser and the choice of two resistances.

A comprehensive brochure on the "Parafeed" Coupling Unit is issued free and explains the advantages of the system in full. It includes diagrams clearly illustrating ten methods of connection. This brochure can be obtained from your dealer or from us.

"Parafeed" Coupling Unit. Overall size 2½ x 2¼ x 2⅞ ins. high. List Price **11/9**  
No. D.Y. 32.

## The NEW SUPER-HETERODYNE SET 6-valves, including rectifier

**25  
gns.**

A "Super-Het." of amazing performance. Reception is clear, selectivity is "knife-edged," the moving coil speaker gives volume loud enough for a dance hall. Mains hum is entirely absent. It is designed for internal and external aeriels. Gramophone pick-up facilities are provided. A novel multiple switch covers "on," "off" gramophone and wave change and operates a shutter on the illuminated dial which exposes the "short" or "long" wavelengths as desired and covers them when the pick-up is required. The cabinet is in figured walnut, beautifully polished.



# BACK AGAIN

## IMPROVED!

## BETTER THAN EVER!

### The World Famous

**B**LUESpot 66K—famous the world over — makes a welcome re-appearance — improved, brought up-to-date **AND BETTER VALUE THAN EVER.**

The new 66K has lost none of its former cunning in reproducing both speech and music to perfection. It passes on everything the broadcast station gives it without alteration or amendment. It does its job faithfully and competently—which is to let you hear the programmes *in your own home* exactly as they are sent out from the studio.

66K will have a bigger success than ever before. It represents the finest value on the market for a Loudspeaker Unit.

Write for Catalogue P.W.46U.

# 66K

**BRITISH MADE**  
RADIO  
EXHIBITION  
STAND 35.  
DEMONSTRATION  
ROOM 13.

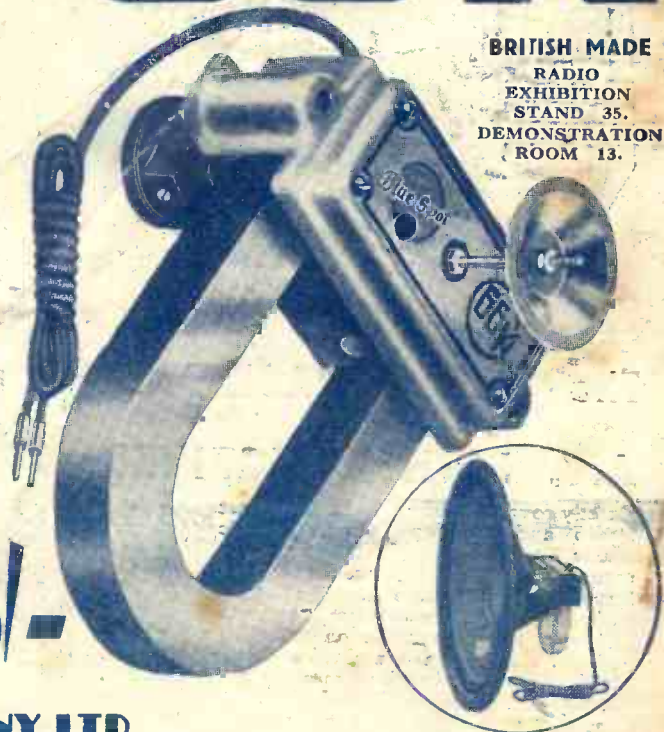

PRICE

# 15/-

**THE BRITISH BLUE SPOT COMPANY LTD**

BLUE SPOT HOUSE • 94/96 ROSOMAN STREET • ROSEBERY AVENUE • LONDON • E C 1

Telephone: Clerkenwell 3570.

Telegrams: "Bluspot, Isling, London."

Distributors for Northern England, Scotland and Wales: H. C. RAWSON (Sheffield and London), Ltd., 100, London Road, Sheffield; 22, St. Mary's Parsonage, Manchester; 44-46, High Bridge, Newcastle; 37-8-9, Clyde Place, Glasgow.

**FOR YOUR CONVENIENCE 66KC**

This is 66K mounted on a suitable chassis. In this form it is ready for screwing direct on to your baffle or into your set or cabinet.

**19/9**  
Price



**ALL ABOUT THE WONDERS OF OLYMPIA**

# Popular Wireless

Every Thursday  
PRICE  
3d.

No. 534. Vol. XXI.

INCORPORATING "WIRELESS"

August 27th, 1932.

## At the RADIO SHOW



### 1/- and 6d. Books FREE!

See pages 859, 860, 861 and 862

# 99 P.M.

RADIOLYMPIA  
STAND 35  
DEMONSTRATION  
ROOM D13

## SPECIAL FEATURES

- 1 Heavy Magnet forged from highest grade magnet steel.
- 2 Powerful and permanent energy.
- 3 Magnetic energy in air gap is exceptionally high — 1,320,000 ergs.
- 4 Pole pieces cadmium plated to prevent rusting.
- 5 Milam side plates are fitted to the Magnet to exclude dust and magnetic particles from being attracted into the air gap.
- 6 Specially designed cone and speech coil. Astonishing faithful reproduction.
- 7 Valve matching transformer incorporated. Undistorted output  $3\frac{1}{2}$  watts.

PRICE

59'6

BRITISH MADE

Write for Catalogue  
No. "P.W." 47.U.

makes Moving Coil History

### BLUE SPOT 10DU

This famous speaker has been specially recommended by J. SCOTT-TAGGART for the "S.T. 300" RADIOGRAM.  
Price, complete 39/5



TRADE MARK

There are many moving-coil speakers but only one Blue Spot 99 P.M.—and it is absolutely and completely unique.

No misleading figures as to flux density are given since these do not give a true indication of the quality of the magnet. An inferior magnet will give a very high flux density in a small air gap.

The magnetic energy in the air gap of the Blue Spot 99 P.M. is of the exceptionally high order of 1,320,000 ergs. 99 P.M. is a speaker of the highest quality from every point of view.

## THE BRITISH BLUE SPOT COMPANY LTD.

BLUE SPOT HOUSE • 94/96 ROSOMAN STREET • ROSEBERY AVENUE • LONDON • E C 1  
Telephone: Clerkenwell 3570.

Telegrams: "Bluospot, Isling, London."

Distributors for Northern England, Scotland and Wales: H. C. RAWSON (Sheffield and London) Ltd., 100, London Road, Sheffield; 22, St. Mary's Parsonage, Manchester; 44-46, High Bridge, Newcastle; 37-8-9, Clyde Place, Glasgow.

# 151 MORE PREDOMINANT THAN EVER!

## SEE ALL THESE NEW COMPONENTS

and many more of original and advanced design. Inspect them, mark their sterling quality and wonderful price value.

## BULGIN

once again anticipates and meets the public demand.

If you cannot call at **STAND 151 OLYMPIA**

Send Now for our New and ENLARGED CATALOGUE and MANUAL. 80 PAGES FULLY ILLUSTRATED

*Enclose 2d. postage*

**A. F. BULGIN & Co., Ltd.,**  
 ABBEY ROAD, BARKING, ESSEX

Telephones: Grangewood 3265 & 7

London Showrooms:

9, 10, 11, CURSITOR STREET, E.C.4.

Telephone: Holborn 2072.

# THE WORLD'S LARGEST RANGE OF QUALITY COMPONENTS

- NEW** LIGHTNING SWITCHES
- NEW** TOGGLE SWITCHES
- NEW** CHANGE-OVER SWITCHES
- NEW** DOUBLE-POLE SWITCHES
- NEW** ROTARY SWITCHES
- NEW** TRANSCOUPLER
- NEW** CHASSIS TRANSFORMER
- NEW** POWER CHOKES
- NEW** L.F. CHOKES



- NEW** PENTODE CHOKES
- NEW** SCREENED COILS
- NEW** ADAPTERS
- NEW** WALL JACKS
- NEW** VOLUME CONTROLS
- NEW** FUSE PLUGS
- NEW** MIDGET H.F. CHOKES
- NEW** SCREENED H.F. CHOKES
- NEW** SUPER-HET H.F. CHOKES
- NEW** NICKEL ALLOY TRANSFORMER
- NEW** SIGNAL LAMPS



BRITISH

# BULGIN

PRODUCTS

# TERMINAL- Programme 1932-33

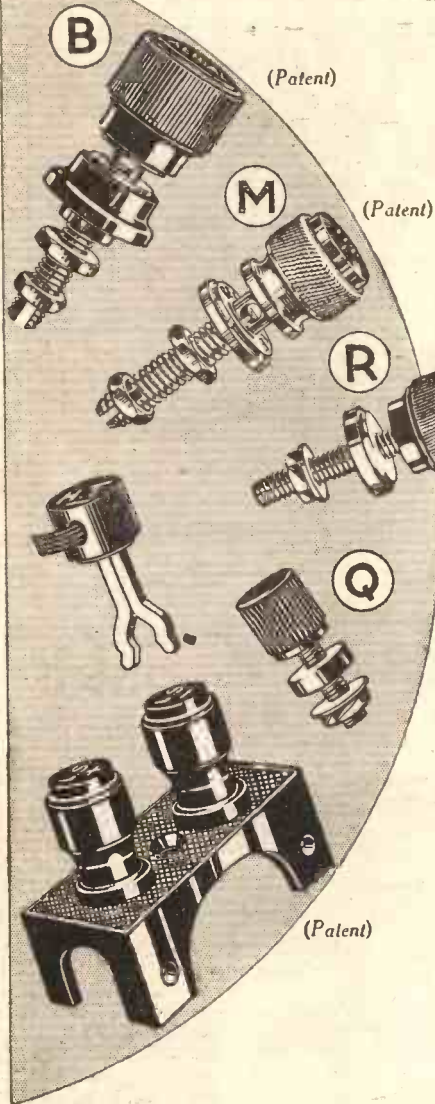

**TYPE "B"**  
Non-removable, bake-  
lite insulated head,  
non-rotating name,  
36 indications. 2B.A.  
stem.

6d.

**TYPE "M"**  
As "B" but not in-  
sulated, and smaller.

4½d.

**TYPE "R"**  
REDUCED TO  
2½d.

Non-removable, insu-  
lated head, 36 indica-  
tions. 4B.A. stem.

**TYPE "Q"**  
Rotating, removable  
head. Brown, red or  
black.

2d.

**TYPE "H"**  
A giant model of  
Type "B," for 100  
amperes and 10,000  
volts.

NOW  
1/6

**SPADE  
TERMINAL**  
Spring prongs, firm  
grip. Lettered on  
head.

2d.

**TERMINAL MOUNT**  
Mounts two terminals of any make anywhere—vertically or horizontally.  
Particularly suitable for Belling-Lee "B" type terminals.

8d.



Agents of BELLING & LEE, Ltd., Cambridge Arterial Road, Enfield, Middlesex.

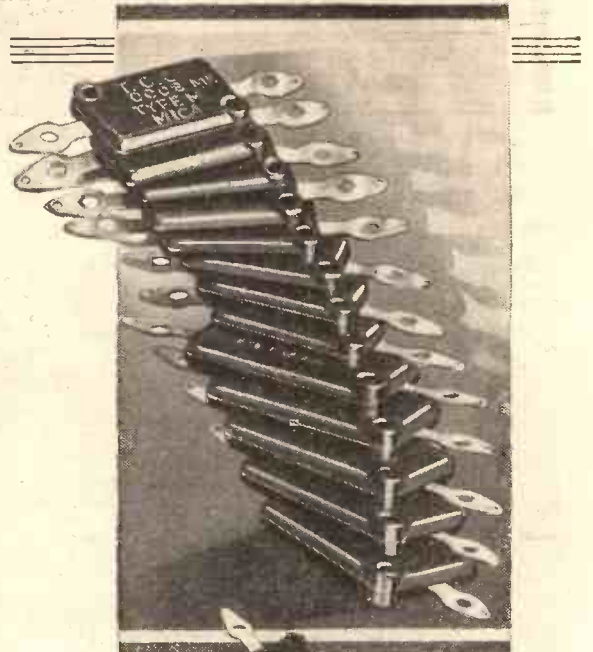

Here are shown the  
T.C.C. Type "M"  
Mica Condensers.  
Made in capacities  
from .00005 mfd.  
to .01 mfd. in-  
clusive. Prices:  
1s. 0d. to 2s. 3d.

## T.C.C. RESEARCH in tangible form

THESE mica condensers are the smallest item in the vast T.C.C. range. At the other end of the scale are to be found condensers of huge capacity for working at thousands of volts pressure.

Here is tangible proof of T.C.C.'s research. With a laboratory equipped with apparatus for every possible test and experiment, with manufacturing facilities second-to-none the world over, T.C.C. have built a reputation of over 25 years' standing for condensers of unquestioned reliability and merit. For whatever purpose—use a T.C.C. and be sure.

SEE THE  
COMPLETE  
T.C.C.  
RANGE  
ON STAND  
No. 53

# T.C.C.

ALL-BRITISH.  
**CONDENSERS**

The Telegraph Condenser Co., Ltd., Wales Farm Road, N. Acton, W.3

# SEE WHAT THE PRESS SAYS ABOUT..

## PERTRIX

**"EVENING STANDARD" — JULY 1, 1932**  
 When taken off discharge for recuperation it showed good recuperative quality. . . . Voltage distribution throughout was very even. . . . After test the Battery was broken open. . . . the zincs were in good condition. . . . No apparent sign of bursting or corrosion.

**"WIRELESS TRADER" — JULY 9, 1932**  
 a watt hour capacity of 1.73 for a cell of this size under the condition of test is very good, particularly in view of the fact that the price of the battery is very low. The Pertrix is very well made and can be recommended as very good value for money.

**"POPULAR WIRELESS" — MAY 21, 1932**  
 A GOOD BATTERY  
 H.T. Battery is passing its P.W. tests in an admirable manner. . . . Batteries are first class. . . . used many Pertrix Batteries in our Research Dept., and so far not one has ever let us down. . . . very good value for money.

**"THE BROADCASTER" — MAY 23, 1932**  
 The zincs were found to be in perfect condition. . . . The battery is excellently designed while the ingredients are well graded and mixed. . . . the battery should give a consistent performance. We can recommend it as an attractive proposition at the reasonable price.

**"AMATEUR WIRELESS" — JUNE 18, 1932**  
 Very competitive price. . . . Really very good for so cheap a battery. . . . Well in excess of our arbitrary standard. . . . They are well up to Pertrix Standard.

**"MUSIC SELLER" — JUNE, 1932**  
 The battery has good staying power it has been carefully designed to provide that extra output which makes for Sales Records. . . . The battery is well constructed and high class materials have been used. The zincs were found to be quite free from corrosion. . . . It represents very good value for money and has the Music Seller O.K.

# DRY BATTERIES & ACCUMULATORS

**H.T. BATTERIES FROM 5'6. L.T. ACCUMULATORS FROM 4'6**  
**SEE THEM AT RADIOLYMPIA, STAND No. 126**

Advt. of Britannia Batteries, Ltd., 233, Shaftesbury Avenue, London, W.C.2.  
 BRANCHES: Manchester, Bristol, Glasgow, Dublin, etc.

Telephone: Temple Bar 7971 (5 lines).  
 Works: REDDITCH (Worcs.).

# OUR RADIO SHOW

## THE BIGGEST AND MOST VARIED SHOW OF READY TO BUY ELECTRICAL AND RADIO IN THE CITY.

Many of your Aerials need renewing. Look at these prices.

**AERIALS.**—Indoor Exten. & 2 Insulators, 5d. 7/22's copper, 50 ft., 1/1d.; 100 ft., 2/-. Braided Proofed 1/16's, 50 ft., 2/-. Fellows Lead-in, 8d. pair. Under Carpet Aerial, 1/-. Indoor Aerial pair, 22 gauge, 1/- 100 ft. EarthWire, 1/3 doz. yards. Aerial Halyards, 6d. Aerial Winches, with brake, 1/6. Electronic, 100 ft., 1/4. Arresters, 1/-. Earth Tubes, 2/6. Earth Spikes, 1/-. Frame Aerials: tell us the size you want.

**ACCUMULATORS AND BATTERIES.**—Large stock all sizes. Edison steel cells at low prices.

For Signal Practice or circuit testing with a phone: **BUZZERS.**—High Note Midgits, 3/6. Power Signals, 5/-. Buzzer Signal Sets, 7/6. Electric Bells, G.P.O. Circular, 3/-. Outdoor, 1/6. Large, Ironclad Bells, 5/-.  
For smoothing ripples, eliminators and coupling: **CONDENSERS.**—Fixed 1 mfd., 1/-; 2 mfd. 1/6; 4 mfd. 4/6; 5 mfd., 5/-. 8 mfd., 8/6; 10 mfd., 9/6; .0005 mfd. for 5000 volts, 2/6; .0025 mfd., for 10,000 volts, 3/6 etc. Special bargain, 250 v. G.P.O. 2 mfd., 1/-.  
Fine Panel Goods for Set Makers at Tempting prices. **CONDENSERS, VARIABLE AND DIALS.** 2,000 Formo De Luxe .0005 mfd., new 4/6 line at 2/- only, or 3/9 per pair. 2 on slow motion dial, 12/-. Tekade bakelite Reaction .0005 mfd., 1/3, half price. Atlas .0005 mfd., 2/-. Lamplugh .0003 mfd., 2/-. Igranic balanced Diff. Trimmer, 1/3. 140 Preset .001 mfd., 10/6d.  
**DIALS.**—Edibell Twin Drum slow for two Condensers, 4/3. American type Edibell Dials, slow and quick motion flush vertical, 3/3.  
The Experimenter's Opportunity in Tuners: **COILS.**—Aerial and Reaction, long short and multiple tuning coils 2 1/2 in. x 3 in. rib former, 1/6. Former only, 9d. Small Ribbed Former, 3d. H.M.V. tuning long and short wave Band-Pass, 1/-. 8 in. long. 2-pin Short Wave, 6d.  
**A.C. GRAMO MOTORS.**—B.T.H. Universal Gramo Motor, 40/-. Blue Flyer, ditto, £3. Patent ditto, £3. 4 Victor Induction 110 volt H.M.V. type, 25/-.  
**PICKUPS.**—Phonovox, 12/-. Loewe, 15/-. H.M.V. Heavy recording type, 15/-. Electradix Special, 8/6.  
Cases for Portables, suitcase size, Rexine, 10/-. Hide 15/-.  
**MAINS TRANSFORMERS.**—Igranic 100/230 volts, 10/-. 4, Igranic 220 volts, /300-0-300 volts, 18/-. 37 Igranic E.H.I. Mains Rectifier Transformers, 120 volts, 20 m.a. output, 8/6. H.M.V. Transformers any A.C. Mains input, 300-0-300 volts, 120 m.a., 4 volts 1 amp., and 4 volts 2 amps., 15/-. Model M.D. 809, 220 volts, 500 volts 120 m.a., 4 volts 1 amp., 4 volts 2 amps., 2 1/2-0-2 1/2 volts, 20/-. Igranic Transformer 200/250 volts input, 6-8-11 volts 1 amp. output, 10/-. Transformer Bobbins wound 220 volts, 11 volts 1 1/2 amps., 7/6. 220 volts to 7 1/2 volts 1 1/2 amps., 6/6 unshrouded. Double output transformers 200/250 volts, 180

volts and 30 volts 30 m.a., 12/6. Parmeko Transformers, 200 volts/100 volts 100 m.a., 20/-. Igranic Transformers, 100/220 volts, input 500 volts 60 m.a., 7 1/2 volts 1 1/2 amps., 5 1/2 volts 2 1/2 amps., 20/-. Igranic E.B.H. 100 volts or 240 volts input, 250-0-250 volts 50 m.a. output, 20/-. 220 volts, 25 volts 5 amps., 20/-. 220 volts, 2-0-2 volts 5 amps., 15/-. B.T.H. Power Transformers 200/250 volts, three secondaries 600 volts 250 m.a., 7 1/2 volts, 6 volts, 40/-. Fellows Transformers, 200 volts/80 volts and 100 volts 20 m.a., 10/-. L.F. Transformers output 1/1 W.E., 3/6, output 1/1 1/2 W.E., 3/6. Sifam L.F. Transformers 3/1 new 4/6.  
**CHOKES.**—200 H.M.V. 10-henry, 700 ohms, 4/6. Igranic 20/80-henry 45 m.a., 8/6. 28 Igranic 5-henry, 4/6. Parmeko heavy duty Choke, 500 m.a., 21/-. B.T.H. double wound heavy duty Chokes, 500 m.a., 25/-. L.F. smoothing Chokes C.T. 160 ohms 20 m.a., 40 henry, 7/6. L.F. double-wound Chokes, 70 ohms 50 m.a., 6/6. Varley double-wound chokes, 50 m.a., 4/6.  
**TELESCOPES.**—Gunsight 2 1/2 in., 17/6. Monocular Prism Range Finders, 15/-. Sullivan Marine Reflecting Galvanometers with shunt box and Crompton Wheatstone Bridge Lamp and Scale, £16.  
**THERMOMETERS.**—30/140 F. Pocket 5 in. Clinical, 1/3, plated for wall, 1/-. Vertical Telegraph Galvos, 4/6.  
**BARGAIN PARCELS** of Electrical and Radio Sundries, better value than ever for experimenters, 10 lbs., 7/-. 7 lbs., 5/-. Adhesive tape, 1 in., new and sticky, 1d. roll.  
**STAMPINGS FOR TRANSFORMERS.**—All sizes in stock.  
**MICROPHONES.**—Broadcast Studio Western Electric, £18. Marconi ditto, £6. Cairmor, £3. Brown, £12. B.T.H. Moving Coil, £5 10. Siemens Siesmo Microphones for detection of vibration, in solid brass and teak case, 2/6 each. Microphone mouthpieces for G.P.O. phones, 6d. each. Micro Buttons, 1/-. Pendant Mikes, with cord, 4/6. Wrist Mikes, 15/-. Ring Pedestal Mikes, 16/6. Public Address Mikes from 63/-. Write for Special Leaflet.  
**TRANSFORMERS FOR MICROPHONES.**—100/1 Green Bakelite 400 7/6. Ericson 100/1, 6/6. G.P.O. Type, 3/9.  
**LIGHT & RAY CELLS.**—Selenium Raycraft Cells 24/-. Kingston, 15/-. Raycraft outfit with relay and Amplifier, 45/-. Photo-Cells R.C.A., 25/-. B.T.P. King Cells, 15/-. Beck Prisms mounted, 5/6. Exciter Lamps, 50 watt, 3/6. Focus Lens, 3/6.  
**SPEAKERS.**—50 Kolster Brandes, 6-volt, 10/-. 3 Rola M.C. 6 volt, 12/-. Gramophone sound box reproducers, 2/-. Phonovox Pickups, 12/-. Electradix Special, 7/6. Cone Units, new Millgate, 2/3. H.M.V. No. 5, special for portables, 2/6. Browns, 10/-. Lamp Shade Speakers, new. Gold Silk finish, 15/-. Royal Hexon Cabinet Speaker, Cellodion melody Cone and Tone Filter, dark oak finish. Black and green fret, 15/-. Baker Texas Cone, plated frame, 15/-. The Famous Violina Speaker, reed unit, perfect reception, 12/6. 200

R.K. Cinema Speaker Pots 110 volts D.C. less cone and chassis, 10/-. 20 large cinema sound disc tone arms, 3/6. 15 new Ever Ready Service Inspector's Headlamps with Battery Holder, 7/6. 120 Mazda 50 watt Focus Lamps and lenses, 7/-. pair. 200 Photo Cells for sound on Film, Television and Ray Work, 15/- and 25/-. 120 Beck Angle Prisms mounted in carrier, 5/6. 110 Micro-meter adjusters for lens, 1/-. 20 Eyepieces with prism and lenses for photo-cell inspection, 12/6. 18 Iron Cinema baffles, 12 in., 2/6. 20 Cinema Grilles, 2/6. 32 folding ball bearing turntables for portables, 2/- each. 3 D.C. Utah Moving Coil Speakers, 22/-.  
**RECTIFIERS.**—T.V. Static 6v. D.C. to 200 A.C. Units for H.T., 25/-. M.12 Elkon 6 volt 3 amp., 10/6. 6 volt 1 amp., 5/6. S.8. 4 1/2 volt, 4/6. S.50. 120 volt 20 m.a., 5/6. 18 Westinghouse A.3., 16/6. 8 Westinghouse A.4., 27/6.  
**Valve Rectifiers.**—Tungar type 7/15 volts 2 amps., £5. 30 volts 6 amps., £6 10. 50 volts 2 amps., £8 10. 75 volts 6 amps., £12.  
**SWITCH GEAR.**—Jacks and Plugs, 2/- pair. Hart Rotary to amp. switches, 1/6. 75 Large Marconi Morse Keys, 12/6. Sterling 8-pole Panel Radio-Gram Switches, 3/6. 4-pin Plug and Sockets, 8d. pair. 2-pin Wall 50 ditto, 10d. Adapters, 6d.  
**SWITCH GEAR.**—Mains Set Glass Fuses, 2 amps., 3d. Porcelain, 2-pin Plug, 3d., fuses 4d. Slow-motion Geared-Slide Rheos, 7/6. 147 S.P. Plug Boards, 9-way, 10 amp., 2/-. Lucas 8-way Switch Boxes, mahogany, Brass Cover, 6 S.P., 1 D.P., 1 C.O., 3/6. S.P.C.O. Switches, 1/6; H.T. send receive, 2/6; 100 or 200 v. Lamps, 6d. 2 amp. 110-volt. Lamps for charging, 2/6. 1,000 ohm Res. Bulbs, 6d. Auto Cutouts, 7/-. Switches, Controllers and Charging Boards built to order. 8-way Switches, in mahogany case, brass lid, 3/6. 3-amp. Wall Plugs for loud-speaker extension, 9d.  
**CHARGERS.**—Our enlarged Switchboard department can now build anything to specification up to 100 ft. long. Send us your enquiries for METERS, Portable, Laboratory or Switchboard, A.C. and D.C.  
**SWITCHES.**—Sunk 250 volt 5 amp by Tucker, etc., 1/- each for mains set or electric light. Surface plates oxydised silver or polished brass, 6d. each.  
**SUNDRIES.**—Neon Tubes, 2/6. Holders, 8d. Power Valves for Eliminators, 4/6. Double Scale Taylor-Hobson Protractors, 5/6. Winshurt Static Electric Machines, 45/-. Siemens Torsion Dynamometer, moving coil Lab. heavy current type, 45/-. Laboratory Variable Condensers, Table type from 18/6; by Cambridge Co. & Sullivan, Electroscopes, Metal foil, 10/6. Insulators, H.T., in porcelain and Ebonite, from 2/- each. Empire Insulating Cloth, for coils, chokes, etc., 100 sq. in. for 1/-. Magnets. Permanent Magnets, steel horse-shoe, 1 lb. weight, 5 in. high, 2/-. smaller sizes 1/6, 1/3, and 1/-. Electric Pocket Torches, with new "Ever-Ready" Battery, 2/6. Airship Safety Lamps, 7/6. 220 volt Candle Lamps, 6d. Hand Lanterns, ditto, 4/6. Radiator 250-watt 110-volt Lamps for charging, 2/6

**ELECTRADIX RADIOS, 218, Upper Thames Street, London, E.C.4**

Phone: City 0191.

Grams: Electradix Cent. London.

## POPULAR WIRELESS ADVERTISEMENT RATES

Whole Page £40 Quarter Page £10  
Half Page £20 Eighth Page £5

Narrow Column Advts. (3 cols. to page) per inch 30/-  
Minimum Space accepted - - - half inch 15/-

NO SERIES DISCOUNT. ALL ADVERTISEMENT COPY SUBJECT TO EDITORIAL APPROVAL

COPY AND BLOCKS MUST BE IN HAND 11 DAYS BEFORE DATE OF ISSUE TO ENSURE PROOFS

ALL communications respecting ADVERTISING must be made to:—

**JOHN H. LILE, Ltd., 4, Ludgate Circus, London, E.C.4.**

Telephone: City 7261.



## A NEW OSBORN MODERN RADIO CABINET

No. 226. A futuristic design Radio Gramophone Cabinet, 3' 4" high, 2' 6" wide, 1' 6" deep. Space Mahogany for speaker is 24" x 16". Accommodation for the set and any type of gramophone motor 24" x 12" high. Size of the baffle behind fret is 24" x 16". Special Silk Fabric is included. Send 3d. in stamps for Beautifully Illustrated New Season's Catalogue.

	PRICES. Machined ready to Assemble:
Cabinet, 3' 4" high, 2' 6" wide, 1' 6" deep, Space Mahogany	£3. 10. 0.
for speaker is 24" x 16". Walnut	£3. 15. 0.
Accommodation for the set and any type of gramophone motor 24" x 12" high. Size of the baffle behind fret is 24" x 16". Special Silk Fabric is included.	£4. 10. 0.
Polish: Oak	£4. 10. 0.
Mahogany	£4. 15. 0.
Walnut	£5. 10. 0.
Assembled and Polished: X 16". Special Silk Fabric is included.	£5. 10. 0.
Mahogany	£6. 5. 0.
Walnut	£7. 5. 0.

CHAS. A. OSBORN, Dept. P.W., The Regent Works, Arlington Street, London, N.1. Telephone: Clerkenwell 5095. And at 21, Essex Road, Islington, N.1. Telephone: Clerkenwell 5634.

**STAND 32, GRAND HALL, National Radio Exhibition, OLYMPIA, Aug 19-27.**



● Standard Model "All-in-One" Radiometer for Battery Sets only (shown above) Price **12/6**

# TRACK RADIO TROUBLES EASILY.

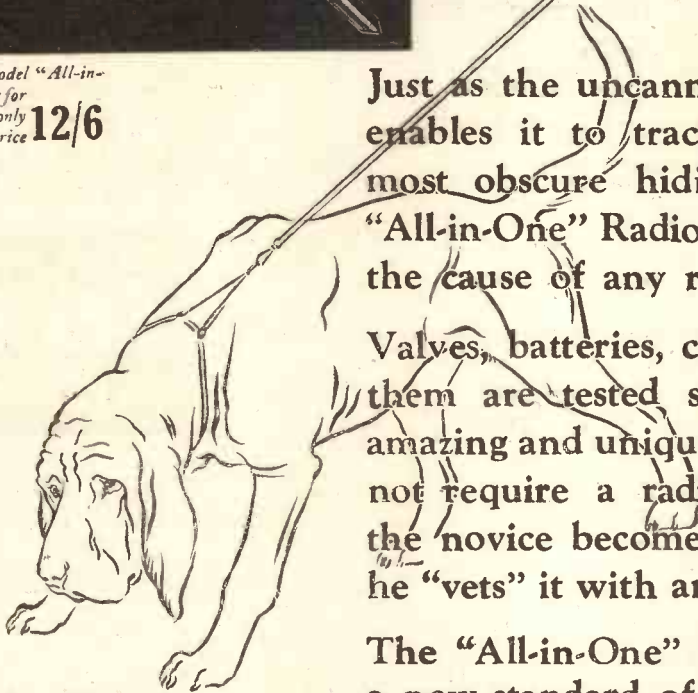

Just as the uncanny scent of the bloodhound enables it to track its quarry to even the most obscure hiding place, so the sensitive "All-in-One" Radiometer can trace and reveal the cause of any radio trouble.

Valves, batteries, circuits, components—all of them are tested surely and swiftly by this amazing and unique instrument. And it does not require a radio expert to use it. Even the novice becomes a master of any set when he "vets" it with an "All-in-One" Radiometer.

The "All-in-One" Radiometer ensures a new standard of radio performance from any set by the ease with which it tracks trouble. Ask to see it at any radio dealer's or electrician's.

● De Luxe Model for Battery Sets, Electric Receivers and Mains Units... **£2 2 0** (shown below)



# PIFCO ALL IN ONE RADIOMETER

If any difficulty write direct to :—  
**PIFCO Limited, High Street, MANCHESTER.**

**"ATLAS" AGAIN GO ONE BETTER**



**NOW THREE  
ALTERNATIVE  
OUTPUTS**

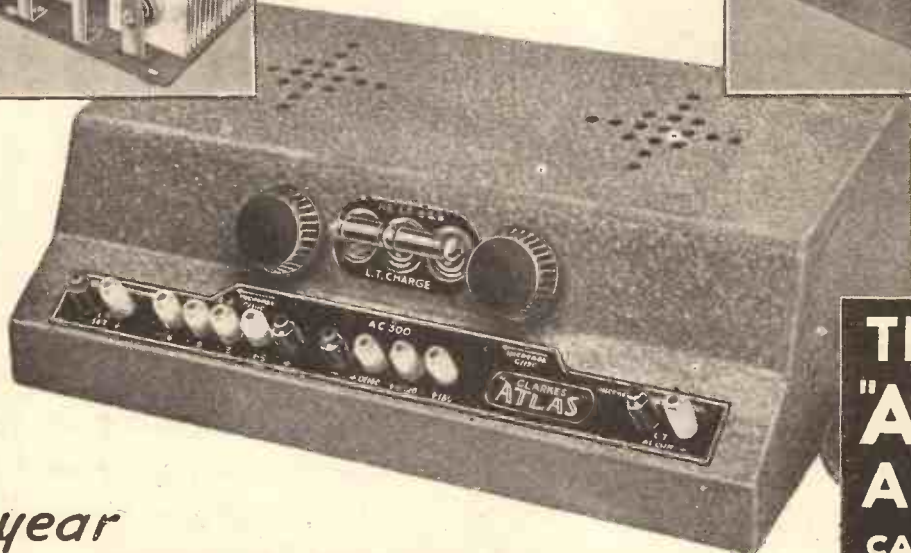

**The new  
"ATLAS"  
A.C. 300  
CASH PRICE  
£6-10  
OR 10/- DOWN**

*This year*  
experts will flock to see  
**THE NEW "ATLAS" A.C. 300  
on STAND N° 91 !**

... Experts said it could not be done. But just as "ATLAS" last year improved the Olympia Ballot Winner of 1930, so have they improved the 1931 Ballot Winner; adding amongst other refinements, the new "ATLAS" regulated output to ensure correct voltages irrespective of the milliamps consumed. And all without any increase in price!

This new "ATLAS" Model A.C.300 is emphatically the last word in mains unit design and most probably will remain the standard for years to come.

There are two variable H.T. Tappings of 0/100 and 0/120 volts and one fixed of 150 volts. Four G.B. Tappings of 1½, 3, 9, and 16 volts, independent of H.T. and

smoothed by electrolytic condensers. L.T. Trickle Charger for 2, 4 and 6 volt Accumulators at 0.5 amps. The H.T. Output is regulated by three tappings to give 12, 18 and 25 m/A at 150 volts. Tapped Input for 200/250 and 100/125 volts, 40/120 cycles. Safety Trickle Charger Isolating Switch. Combined Plug-Adapter. Westinghouse Rectifiers. Size 10½"x6"x3½". Fully guaranteed for 12 months.

See it at Olympia. Test it for yourself. Ask your dealer for a demonstration to-day. There's no comparison with "ATLAS."

Post the Coupon now for full details of "ATLAS" Mains Units for every set, and "ATLAS" Guaranteed Components.

**POST THIS COUPON NOW !**

Messrs. H. Clarke & Co. (M/cr.) Ltd.,  
George Street, Patricroft, Manchester.

Please send full details of "ATLAS" Mains Units and Components.

Name .....

Address .....

30/27/8 .....

**"CLARKE'S  
ATLAS"  
MAINS UNITS**

**H. CLARKE & CO. (M/CR.), LTD.**

"ATLAS" WORKS, GEORGE STREET, PATRICROFT,  
MANCHESTER. SOUTHERN OFFICES : Bush House, W.C.2. ©



# ON TOP AT OLYMPIA



**Osram**  
6VA

**OLYMPIA**

**Osram**  
**Valves**

MADE IN ENGLAND

Sold By All  
Wireless Dealers.

**EXTRA QUALITY WITHOUT EXTRA COST**

Advt. of The General Electric Co., Ltd., Magnet House, Kingsway, London, W.C.2.

**THE SENSATION OF OLYMPIA**



**P.M.5**  
**27"6**

**COMPLETE**  
with three-ratio step-down transformer

*PIONEERS and LEADERS ALWAYS*



**P.M.4.**

Ask your dealer to show you these great W.B. achievements.

**"MANSFIELD"**

[P.M.5] at 27/6 complete with transformer. Fits any W.B. cabinet. Revolutionary value which brings moving-coil reproduction within the reach of everyone

AND THE NEW

**IMPROVED P.M.4**

at **42'6** COMPLETE with three-ratio step-down transformer

*These guaranteed speakers give true moving-coil reproduction from any 2-valve or multi-valve set.*

**PERMANENT MAGNET MOVING COIL SPEAKERS**

Write for the new lists FREE of the whole range of W.B. Moving - Coil Speakers, P.M. and Energised,



with their attractive cabinets. Also the new W.B. valveholders and new W.B. switches.

Whiteley Electrical Radio Co., Ltd., Nottingham Road, Mansfield, Notts.

*Irish Free State Distributors: Kelly & Shiel, Ltd., 47 Fleet Street, Dublin*

# FOR EVERY SET — there's a PILOT AUTHOR KIT

CASH — C.O.D. — or H.P.

EXACT TO SPECIFICATION



## OLYMPUS FOUR

DEMAND A PILOT  
AUTHOR KIT ...

Backed by Peto-  
Scott, Founders of  
Constructor Kits in  
1919, with 13 years'  
continuous Service  
to the Radio Public

### DOMINATING FEATURES ...

- Complete down to the last screw and piece of wire.
- Panels and Terminal Strips ready drilled to specification.
- Chosen and first specified by the Technical Editor and actually as used by the Author in each case.
- Officially approved by an established technical authority you can trust implicitly.
- Enables Author's sets to be duplicated in every respect.
- Backed by Peto Scott with 13 years' Radio experience and a world-wide reputation.

... VITAL TO  
100% SUCCESS

### ● IMPORTANT

Part Kits, miscellaneous components or accessories are available under our own Easy Way H.P. System. Send us list of your wants. We will quote by return without any obligation.

EVERYTHING RADIO  
CASH—C.O.D.—or H.P.

### HERE ARE THE PARTS THE AUTHOR USED

	£	s.	d.
1 Peto Scott panel, 14 x 7 ins., ready drilled		4	6
1 Baseboard, 14 x 10 ins.		1	3
1 Lissen Hypernik L.F. transformer, medium ratio	12	6	
1 R.I. Quad-Astatic H.F. choke	3	6	
1 Keystone '0003-00035 mfd. max. differential reaction condenser	3	0	
1 Lewcos H.F. choke, small type M.C.	2	6	
1 Lotus '0003-00035 mfd. max. differential condenser	4	0	
2 Telsen screened coils	17	0	
4 Lissen 4-pin valve holders	1	6	
2 Telsen '0005 mfd. Telexors	1	5	0
1 Graham Farish Ohmite .5 meg. grid leak and holder	2	0	
1 Graham Farish Ohmite 100,000 ohms resistance with terminals	1	6	
1 Igranic .5 meg. resistance with terminals or tags	9		
1 Igranic 2-meg. resistance, with terminals or tags	9		
1 Bulgin L.T. on-off switch, type S.15	1	9	
1 Dubilier '0003 mfd. fixed condenser, type 670	1	0	
1 Dubilier '0001 mfd. fixed condenser, type 670	1	0	
1 Y.C.C. '01 mfd. condenser, type 34, upright	3	0	
1 Golfone five-way battery cord, type R.39/40	2	3	
1 Piece of copper foil, 2 x 2 ins., screws, flex, connecting wire, etc.	2	3	
2 Terminal strips, 3 x 1 1/4 ins. ready drilled	6		
4 Bulgin indicating terminals	1	0	
<b>KIT "A" Cash or C.O.D.</b>	<b>£4</b>	<b>12</b>	<b>6</b>

Any parts supplied separately. Orders value over 10/- sent Carriage Paid—C.O.D., we pay post charges.

**KIT "A"** Author's Kit of specified components including ready drilled panel and terminal strips but less valves and cabinet.

CASH or C.O.D. **£4:12:6**

or 12 monthly payments of 8/6

**KIT "B"** Author's Kit including ready drilled panel and terminal strips; with valves but less cabinet. Cash or C.O.D.

**£6-11-9** Or 12 monthly payments of 12/1

**KIT "C"** Author's complete Kit including ready drilled panel and terminal strips with valves and cabinet. Cash or C.O.D.

**£7-6-9** Or 12 monthly payments of 13/5

### KIT-BITS

Selected C.O.D. Lines for "Olympus Four." You pay the postman—we pay post charges on orders value over 10/-

	£	s.	d.
1 Peto-Scott Cabinet		15	0
4 Valves: as specified	1	19	3
1 Peto-Scott panel 14" x 7" ready drilled	4	6	
Lissen Hypernik L.F. Transformer (medium ratio)	12	6	
2 Telsen Screened Coils	17	0	
2 Telsen '0005 mfd. Telexors	1	5	0
1 Keystone '0003-00035 mfd. max. differential reaction condenser	3	0	

### IMMEDIATE DELIVERY FROM STOCK

PETO-SCOTT CO., LTD., 77, CITY ROAD, LONDON, E.C.1  
(West End Showrooms: 62, High Holborn, London, W.C.1.) Telephones: Clerkenwell 9406/7  
Dear Sirs.—Please send me CASH/C.O.D./H.P. OLYMPUS FOUR KIT A/B/C for which I enclose £

NAME

ADDRESS  
P.W. 27/8/32.

Buy by Post — it's Quicker

THE SEPTEMBER NUMBER OF  
**MODERN WIRELESS**

is the most

**COMPLETE GUIDE TO MODERN WIRELESS  
 DEVELOPMENT AT OLYMPIA**

There are

**THREE  
 SPECIAL  
 SECTIONS**

in this number:—

**OLYMPIAN RADIO**

Entirely devoted to articles dealing with this year's show, and describing all the latest components, accessories and sets in a really absorbing manner.

**FOR THE  
 CONSTRUCTOR**

Including among other constructional items, full details for building the "Diodion," the latest development in real quality powerful reception.

**HOW TO OBTAIN  
 BETTER RADIO**

Packed with little hints and tips that will enable you to get the utmost entertainment and value from your set.

Exclusive details of the Radio Exhibition, and a summary of the new season's apparatus including a long illustrated article on:

**"WHAT SET SHALL I BUY?"**

For the long-distance listener there is a

**LARGE  
 SUPPLEMENT**

entitled:—

**THE WORLD'S  
 PROGRAMMES**

Everything about long-distance listening—The latest news of new stations and alterations in wavelengths—Working on long, medium and short-waves—How to tune the stations in, etc. etc. etc.

**OTHER ARTICLES  
 INCLUDE:**

The Days of My Youth

By DE GROOT

On the Short Waves

Spotlights on the Programmes etc., etc.

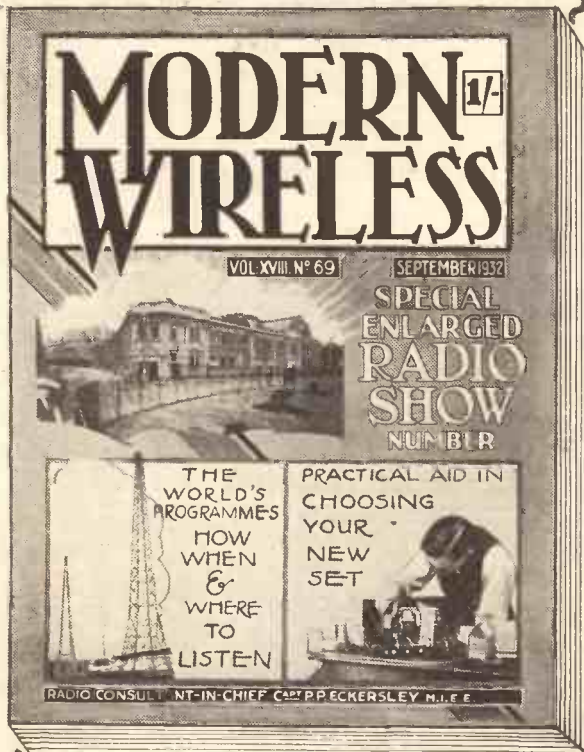

EVERY EYE IS FOCUSED ON IT

**MODERN WIRELESS**

NOW ON SALE — ONE SHILLING

The September Number is a special enlarged issue packed with illustrations and interesting articles that cover all aspects of radio—the most magnificent magazine ever published!

GET IT TO-DAY AT ANY BOOKSTALL

**MODERN WIRELESS**  
 SPECIAL ENLARGED SEPTEMBER NUMBER



# EASIWAY TO PERFECT RADIO



## BRAND NEW OLYMPIA RADIO DIRECT BY POST

### ● SPEAKERS

R & A "VICTOR" PERMANENT MAGNET MOVING-COIL SPEAKER DE LUXE. With 6-ratio input transformer and protecting grill

With 6/5 order

Cash Price £3/10/0

Balance in 11 monthly payments of 6/5 R & A "BANTAM" PERMANENT MAGNET MOVING-COIL SPEAKER. With 3-ratio input-transformer.

With 5/- order

Cash Price, £1/7/6

Balance in 5 monthly payments of 5/0 EPOCH "20 C" PERMANENT MAGNET MOVING-COIL SPEAKER. (New Edition). With 3-ratio input transformer. Cash Price, £1/15/0.

Send 6/6 only

Balance in 5 monthly payments of 6/6. ULTRA 1933 IMP PERMANENT MAGNET MOVING-COIL SPEAKER, with input transformer. Cash Price, £1/17/6.

Send 6/10 only

Balance in 5 monthly payments of 6/10. W.B. PERMANENT MAGNET MOVING COIL SPEAKER. Type PM4. Complete with transformer. Cash Price, £2/2/0.

Send 5/9 only

Balance in 7 monthly payments of 5/9. BLUE SPOT SPEAKER UNIT AND CHASSIS. Type 100U. Cash Price, £1/19/6. Balance in 7 monthly payments of 5/5.

Send 5/5 only

### ● ACCESSORIES

ATLAS ELIMINATOR. Type A.C.244. Three tappings. S.G., detector and power. Output: 120 volts at 20 m/a. Cash Price, £2/19/6.

Send 5/6 only

Balance in 11 monthly payments of 5/6. EKO A.C.12 H.T. ELIMINATOR for A.C. Mains. Tapped S.G. 80 v. 120/150 v. at 12 m/a. Cash Price, £2/15/0.

Send 5/0 only

Balance in 11 monthly payments of 5/-. B.T.H. PICK-UP (Senior Model) complete with support arm. Cash Price, £2/2/0.

Send 5/9 only

Balance in 7 monthly payments of 5/9. GARRARD INDUCTION GRAMOPHONE MOTOR. For A.C. Mains. Model 202. Mounted on 12-inch Nickel Motor Plate with fully automatic electric starting and stopping switch. Cash Price, £2/18/6.

Send 5/4 only

Balance in 11 monthly payments of 5/4. BRITISH RADIOPHONE RADIOPAK. Complete with band-pass tuner with band-pass coils 5-ganged condenser and volume control as advertised. Cash price, £3/0/0.

Send 5/6 only

Balance in 11 monthly payments of 5/6.

### ● MANUFACTURERS' KITS

COSSOR MELODY MAKER. Model 335. Complete with valves, speaker, and cabinet. Cash Price, £7/17/5. Balance in 11 monthly payments of 14/10.

Send 10/- only

COSSOR ALL-ELECTRIC MELODY MAKER. Model 336. Complete with valves, cabinet and speaker. Cash Price, £11/15/0.

Send 21/7 only

Balance in 11 monthly payments of 21/7.

RADIO FOR THE MILLION "STATION MASTER 3" (Model A.). With valves and cabinet. For battery use. Cash Price £5/11/0.

Send 10/2 only

Balance in 11 monthly payments of 10/2.

"STATION MASTER 3" (Model B.). With valves, speaker and cabinet. For battery use. Cash Price, £7/10/0.

Send 10/- only

Balance in 11 monthly payments of 14/-. "STATION MASTER 3" (Model C.). All-electric model with valves, cabinet and moving-coil speaker. Cash Price £14/0/0.

Send 25/8 only

Balance in 11 monthly payments of 25/8. OSRAM "THIRTY THREE" MUSIC MAGNET. Complete Kit comprising all components, including valves, cabinet, with self-contained speaker. Cash Price, £9/9/0.

Send 15/0 only

Balance in 11 monthly payments of 17/6. SLEKTUN "SCOUT" S.G.3. Chassis model, S.G., Detector and Power valves, less cabinet. Cash Price £4/8/6.

Send 8/1 only

Balance in 11 monthly payments of 8/1. LISSEN "SKYSCRAPER 3." Chassis model with (Lissen) S.G., Detector and Pentode valves. Cash Price, £4/9/6.

Send 8/3 only

Balance in 11 monthly payments of 8/3. FERRANTI "BAND-PASS 3." Battery model, with panel and baseboard, but less valves. Cash Price, £7/19/6.

Send 14/8 only

Balance in 11 monthly payments of 14/8. FERRANTI "BAND-PASS 3" (All electric Model) with Panel and baseboard, but less valves. Cash Price, £11/3/6.

Send 20/6 only

Balance in 11 monthly payments of 20/6 TELSEN "AJAX 3." Complete Kit less valves and cabinet. Cash Price, £3/1/6.

Send 5/8 only

Balance in 11 monthly payments of 5/8. TELSEN "JUPITER" S.G.3. Complete Kit less valves and cabinet. Cash Price, £3/17/0.

Send 7/- only

Balance in 11 monthly payments of 7/-.

## PETO-SCOTT'S

13th YEAR OF CONTINUOUS SERVICE TO THE RADIO PUBLIC



PETO-SCOTT CO. LTD., 77, CITY ROAD, LONDON, E.C.1

Telephone: Clerkenwell 9406/7

West End Show Rooms: 62, High Holborn, London, W.1

Dear Sirs,—Please send me C.O.D./CASH/H.P. ....

for which I enclose £ s. d. CASH/H.P. Deposit. ....

NAME .....

ADDRESS .....

P.27/W. 8/32.

*Buy by Post — it's Quicker*

## IMPORTANT

● Part kits, miscellaneous components or accessories are available under our own Easy Way H.P. System. Send us a list of your wants. We will quote by return without any obligation.

If you do not see it advertised here, send details of your Radio requirements to us.

# CONSISTENCY

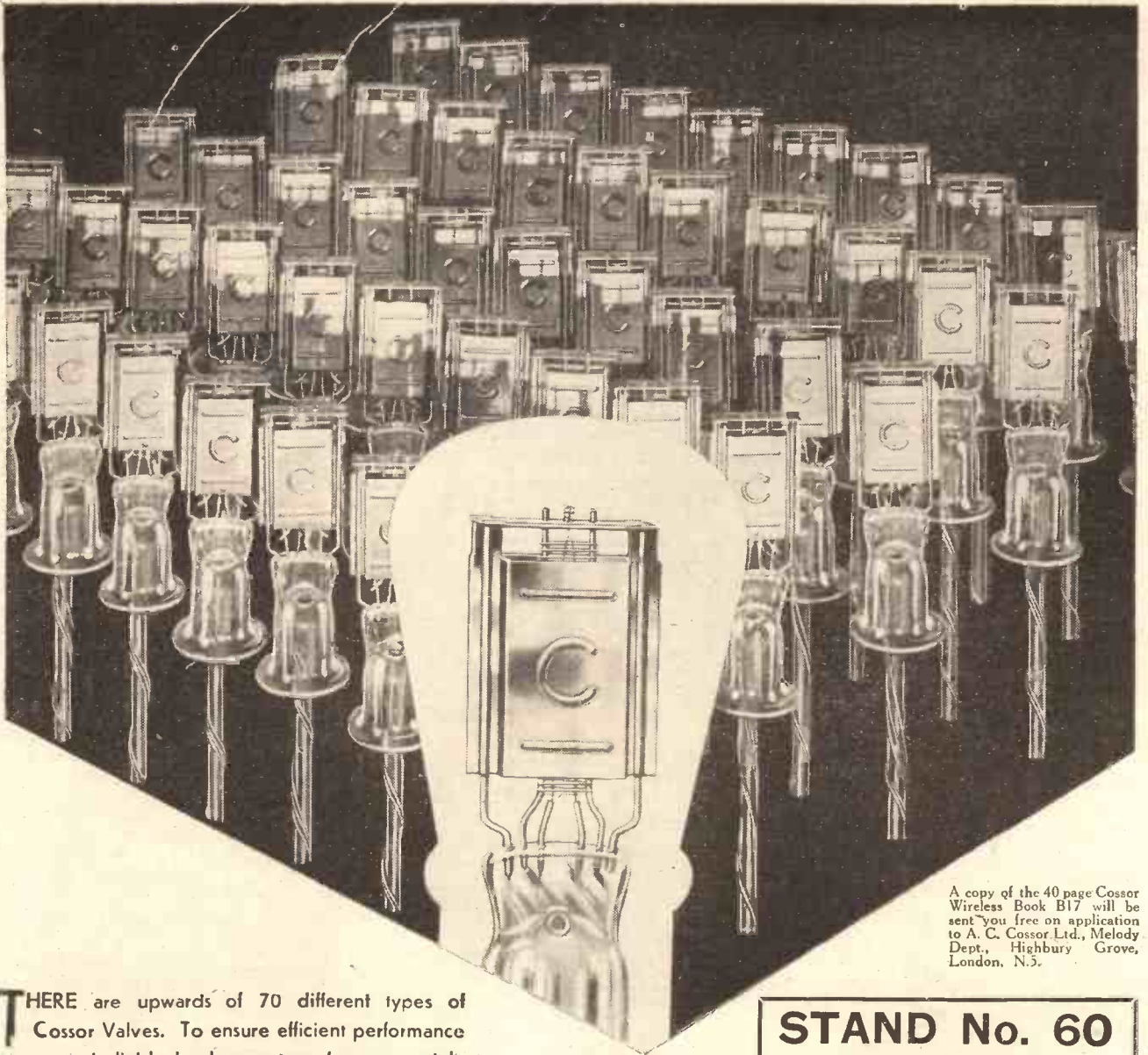

A copy of the 40 page Cossor Wireless Book B17 will be sent you free on application to A. C. Cossor Ltd., Melody Dept., Highbury Grove, London, N.5.

**T**HERE are upwards of 70 different types of Cossor Valves. To ensure efficient performance every individual valve must conform accurately to the characteristics of its type—absolute uniformity is essential. In Cossor Valves uniformity is obtained by the famous Mica Bridge, which ensures microscopic accuracy in the spacing of the elements—the factor that determines the characteristics of a valve. Thus, no matter where you buy it every Cossor Valve is an exact counterpart of the original design that was developed in the laboratory.

**STAND No. 60  
OLYMPIA**

# COSSOR

## ALL-BRITISH VALVES

# Popular Wireless

LARGEST NET SALES



Scientific Adviser:  
Sir OLIVER LODGE, F.R.S.  
Chief Radio Consultant:  
CAPT. P. P. ECKERSLEY, M.I.E.E.  
Editor: NORMAN EDWARDS.

Technical Editor: G. V. DOWDING, Associate I.E.E.  
Assistant Technical Editors:  
K. D. ROGERS, P. R. BIRD,  
A. JOHNSON RANDALL.

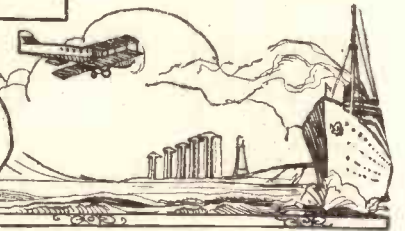

EMPIRE PLANS  
EARTHING AERIALS  
ORGANISING NOTE  
CONFESSIONS

## RADIO NOTES & NEWS

WEATHER AND NERVES  
P.C. ANSWERS  
AMATEUR D.F.  
NEW FASHIONS

### The Autumn Campaign.

INEVITABLY on my return from my annual leave things become brisker on the Tallis House sector. I suppose that my faithful critics have also returned, like giants refreshed, to sharpen their weapons for the autumn campaign, with "Ariel" as their objective.

This week has brought forth a very satisfying volley of small arms' fire, satisfying because it shows that we are worth shooting at. There are few things so annoying as to be totally ignored, as Miss Murdstone in "David Copperfield" demonstrated.

Well, carry on, chaps! I'm not supposed to be human, anyway.

### B.B.C. Plans for the Empire.

FIRST, I select a letter from Kenya Colony—from (something) *iki*—written no doubt under the stress of poor crops or the heat, or perhaps *ennui* or nostalgia. I withhold the initials for reasons which my correspondent may appreciate.

"What," he asks, "is the B.B.C. going to do for us poor d—ls who are marooned on these — plantations; and what is 'P.W.' doing?" "P.W." is doing nicely, thanks, but we do not have much voice in shaping the B.B.C.'s Empire policy.

However, the B.B.C. is working on a scheme for recording real national programmes of half an hour to an hour in length on gramophone records, and their representative will visit the Dominions and Crown Colonies with samples for demonstration to the various overseas broadcasting authorities.

Twelve programmes are expected to be completed in a few weeks. *There now!*

### "Ariel" as a Schoolboy.

NEXT, I have a note from G. S. (Liverpool), who tempers an otherwise swallowable (*pardon!*) letter with the allegation that I occasionally wander into politics and that my political views are "school-boyish."

I haven't an inkling of what paragraphs he refers to, but if he swears that I barge into politics I can only reply, like the politician whose doctor told him that his

### Earthing the Aerial.

G. S. then refers to our reply in "Radio-torial" to T. D. A. (Nottingham), August 6th. He says, "To state that an 'earthed' aerial is a protection is sheer bunk."

I don't subscribe to his view. The better the "earth" provided for lightning the more likely it is that lightning will follow the path provided. Why, Benjamin Franklin knew that!

### JACK HYLTON AND HIS "BOYS" YO-YO



Although Jack Hylton is too rarely heard direct on the air, his records are prime favourites with all radio audiences. Occasionally he and the boys take a minute or two off duty to try out their Yo-Yo's!

brain was injured, "I am not aware of that!" School-boyish? Bless yer 'art, that's nothing. Why, I know lots of men who call my political views *poisonous!*

Can I, by chance, have stirred up an Irishman? Liverpool? I wonder!

### THE RADIO SHOW

YOU ARE WELCOME TO  
OUR STAND No. 8

Come and bring your radio troubles

Users of radio sets may rest assured that by "earthing" their aerials from the outside of the house they afford protection from lightning to the rest of the house.

I hope, however, that G. S. will forgive us this "heresy" and continue to appreciate "P.W." We like intelligent and outspoken readers.

### Note for Organisers.

I PAUSE for a moment or two in this week's causerie to remark that lovers of organ music by radio will like to know that the B.B.C. has ordered a mighty organ for the concert hall of Broadcasting House from the John Compton Organ Company, Ltd., of Willesden.

The work of installation will be carried out in consultation with Dr. W. G. Alcock, the organist of Salisbury Cathedral.

### Co-operation Invited.

MR. A. G. COLE, 33, Grosvenor Road, Wallington, Surrey, operator of amateur transmitting station 2 ACCO, is at reception work on weekdays at 8 p.m. on 10-60 metres, while on Sundays he stands by to report on other transmitters' tests on 80 and 150 metres between 9 a.m. and 10.30 p.m., and invites co-operation with other three-letter transmitters, especially those in his own district.

(Continued on next page.)

# NEWS—VIEWS—AND INTERVIEWS (Continued)

### A Newcomer's Confessions.

G. H. S. (Waltham Abbey), who is a new reader of "P.W." and a "fan" of only seven months' standing, writes to express his appreciation of the spirit of help and co-operation which exists between our readers. He refers in particular to R. H. C.'s letter which we printed in our issue of August 6th.

Well, G. H. S., I am glad that you have found us the cheeriest, jolliest family of "fans" in the world. We cover the whole Empire. Our unwritten motto is, "P.W. for all, and all for each other and 'P.W.'"

We, in turn, value his letter and are at his service.

### Weather and Nerves.

I WAS much interested in Dr. Roberts' dispassionate comments in our issue of July 23rd on the effects, if any, of radio on the weather and people's nerves, because from time to time



I have written on that subject. Dr. Roberts is concerned with evidence and not preconceived ideas; therefore I should welcome his opinion about whether there is any valid evidence

that radio affects nerves and the weather; for if there is not, then I might suggest, for example, that radio has caused the undoubted increase of say, cancer, solely on the grounds that until we know more about the effect of electromagnetic waves on living tissue we ought to hesitate before rejecting my idea. Which does not carry us much farther, does it?

### Radio and Rain.

AGAIN Dr. Roberts appears to be committed to the belief that the weather has "gone to pot" during the past ten years. Now "weather" is a comprehensive term, but I presume that Dr. Roberts means that during that period the sunshine has been often absent when it should have been present; that we have had rainy summers, mild winter months,



cold summers, and so on, which indicates the belief that there is a standard of weather. I doubt whether the weather experts would agree that the weather has "gone to pot," and from readings of old diaries I know that many many years ago people used to say that the weather was getting worse, for they used to have abnormally wet summers, etc., hundreds of years ago.

### Postcard Answers to Esteemed Readers.

BRUMMAGEM (B'ham).—Of course, there are no cranks in your town. Only crankshafts! I visited B'ham in 1902 and fled, appalled; I had tried to "put it over" one of your business men!

R. T. (Glasgow).—The only remedy which I can suggest is that you should cross the border and make a noise like an Englishman. We look to Scotland for our leaders.

F. S. (Lewes).—If you cannot receive London Nat. I suggest that you write a paper on Dewponds and Flint Arrows, and read it to the Kipling Society.

L. C. (Holborn, E.C.).—Cut out the Farringdon Street barrows and save up for a "P.W." set. We give "winners"!

### Amateur Direction-Finding.

OFF and on for all too many years I have been urging skilled amateurs who are seeking a fresh field to conquer to take up D.F. work, and am glad to see that this idea is gaining ground.

### "SHORT WAVES"

"The sound waves which leave the loud-speaker," writes Dr. R. T. Beatty, "bear little resemblance to those which enter the microphone. The transformation is as profound as if Carnera should enter a Tube station and, as the result of some subterranean rearrangement of his cellular structure, should presently emerge in the guise of the Bishop of Birmingham." So it's quite possible that one day, when you think you are hearing a sermon, you may be listening to a boxing match all the time.

Allen: Do you know, I can read a modern novel and listen to the radio at the same time.

Brown: I should have thought one would have taken your mind off the other.

Allen: Yes, that's why I do it.

### TO MY POSTMASTER.

"Thank you for reminding me that my licence for my wireless receiving station expires on the last day of the current month. But aren't you flattering my two-valve set? It has been called many names in its time, but never before a receiving station. It is good of you to inquire whether it is desired to maintain the station. So glad you take an interest in the dear doings. Do you know, I can't persuade the brigand who sold me the set to take any interest in it at all."—*"London Opinion."*

"I can get no end of stations on my new wireless receiver. What does yours bring in? Well—er—chiefly the instalment collector."

### A TRAGEDY OF IMAGINATION.

There was a young sailor of Bristol Who thought he heard Mars on a crystal. But his friends wouldn't "bite," So he shot himself right Through the head with a loud-speaking pistol.

I have received a report from the Golders Green and Hendon Radio and Scientific Society of a direction-finding competition which was held this summer, in which over eighty persons took part. Entrants had to locate the direction of a mobile transmitter and to find a concealed stationary transmitter.

The groups of competitors were located in an area about twelve miles from the transmitters. Afterwards the prizes were awarded and the results discussed; photographs and cinematograph records were taken.

A great game! And a fine society, too.

### Broadcasting on Tap.

THIS radio diffusion business is still spreading! Rotherham, for example, has just given permission for a com-

pany to operate within its boundaries. A choice between two programmes is to be given at the inclusive charge of one shilling per week. Captain Wakelam of Rugby commentaries fame, and Mr. B. H. Lyon, the cricketer, are connected with the enterprise.

### Equality and Justice.

MR. A. E. BEAR, European Representative of the International Short-Wave Club, accuses "P.W." of "mixing the I.S.W. Club up with the I. S. W. League."

In the same letter he says, "It is a fact that you have in the past given us the same publicity as the League." If he admits that, then I submit that he cuts the ground from under his complaint, for the two statements are contradictory, only the second being correct. I have been so much bombarded with letters from officials of both organisations that I could not confuse the League and the Club even if I tried. "P.W." is under no obligation to advertise clubs etc., gratis, but if we do so for reasons which satisfy us, we cannot accept any implied rebukes which are inspired by squabbles with which we are not concerned.



### Expedition Joins I.S.W. Club.

I AM able to record that the Oxford Expedition to Sarawak, Borneo, has become a member of the I.S.W. Club. I have not seen any account of what this Expedition is aiming at, but if Mr. Bear can give details of its radio equipment, date of starting, call letters, wave-lengths to be used, whether communication is to be by telegraphy or telephony, and at what times, I shall be pleased to publish them.

Mr. Bear says that my friendly opponent, Mr. W. Werner, of San Diego has become offended with "P.W." I can scarcely credit the fact. Mr. Werner's last letter was full of good humour. What's up, Willie? Tell "Ariel" all about it.

### New Fashions in Pockets.

EVER since I was a boy, when ladies wore pockets hidden somewhere in the folds of their voluminous skirts, the feminine pocket has not existed. It would appear, however, that the pocket has "come in" again with a vengeance, for in the "Daily Express" recently there appeared the following concerning Miss Joan Crawford. "In Joan's pocket was a radiogram just received from father-in-law Douglas Fairbanks, Senior."







# AT THE RADIO SHOW

"All roads lead to Olympia!" That is what the Radio Show publicity people are saying, and a great many of us have proved—or will prove—the truth of the slogan. Big as it is, and well packed as it is, last Olympia has never staged a



A "G.E.C."  
L.S.

An easily mounted chassis incorporating its own transformer for impedance matching.

various attractions are but the incidental flavourings and spicy specks. The real feast is RADIO. What kind? Every kind worth having. What price? All prices. What makes? Hundreds of makes—and all British, the best in the world.

### A Really Wonderful Selection.

No matter what you want in the way of radio reception you will find it at Olympia. And for the benefit of those who cannot attend in person to view the vast selection of sets and apparatus that represents "the liveliest British Industry," let us, in imagination, stroll round among the sightseers and halt at the high-lights of special interest.

Having negotiated the entrance—what a crowd, but how jolly!—we look round for something really notable to start with. And, by Jove, there it is! Stand No. 8—"P.W.'s" stand!

### "CLEAN LINES"

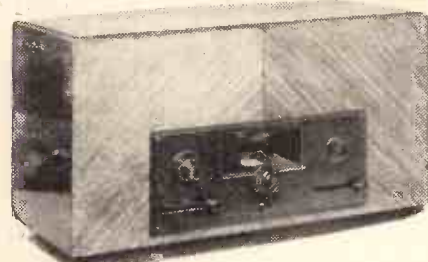

Blue Spot's latest is a set with an unusually attractive plain finish free from fret.

A review of radio progress as exemplified by the magnificent Wireless Exhibition now in progress at Olympia, London, W. The show, which is the biggest ever held, will remain in full swing until Saturday, August 27th.

As a matter of fact it might be called the stand of "P.W. and Pals," for the exhibitors at Stand No. 8 are the Amalgamated Press, the world's largest periodical publishers, who control POPULAR WIRELESS, MODERN WIRELESS, and THE WIRELESS CONSTRUCTOR. Technical experts from all these publications will be in attendance, and will welcome you for a chat upon the great and absorbing topic of radio.

### FUTURISTIC!

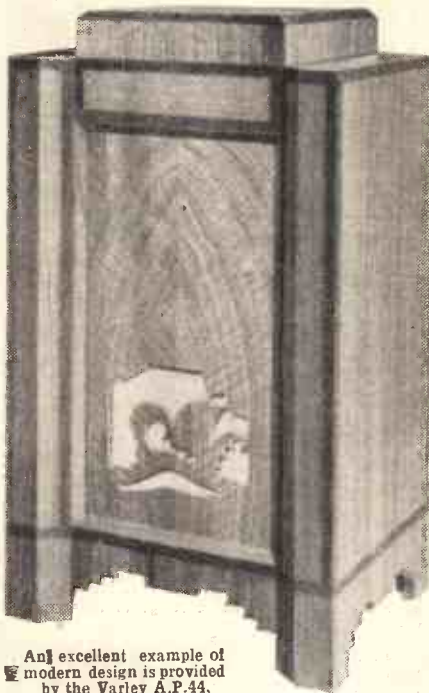

An excellent example of modern design is provided by the Varley A.P.44.

EXPERTS WILL BE IN ATTENDANCE ALL THE TIME AT OUR STAND TO DEAL, FREE OF CHARGE, WITH VISITORS' QUERIES AND PROBLEMS.

Conveniently situated near the entrance—or near the exit if you are one of the wily ones who "work round backwards" to dodge the main traffic stream—Stand No. 8 starts by striking the keynote of Olympia—helpful friendliness.

### FOR THE CONSTRUCTOR

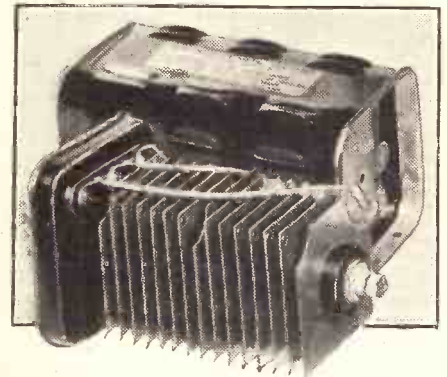

Nearly everybody must have heard of the Westinghouse Metal Rectifier. The model illustrated here is the H.T.7, which gives an output 30 milliamps at 200 volts.

Advice on what set or gadget to buy? No! That obviously must be ruled out of the question. But anything else that can be done will be a pleasure to do.

### Helping the Set Builder.

To assist the home constructor in his choice of a new design and in response to many requests, a number of original models of radio receivers will be exhibited, including the already-famous "Olympus"

(Continued on next page.)

### A NEAT SWITCH

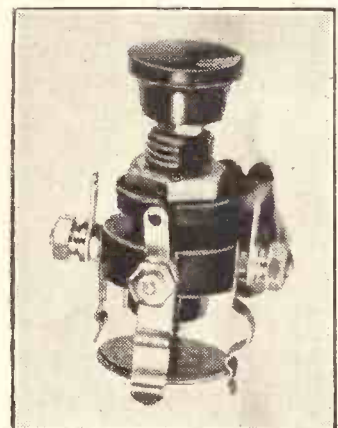

A low-capacity three-point wave-change switch by Messrs. Wright and Weale

**AT THE RADIO SHOW**

*(Continued from previous page.)*

**BIG SCALE TUNING**



Direct wavelength reading is a feature of the new Marconiphone Model 253.

Four, and "The Moderator," the little set with a big punch!

In addition, you will find here the "Diodion" and the "S.T.300 Exhibition Radiogram"—original models, of course—and members of the Construction Staff will be on the stand busily at work on sets of the future.

As this is the only opportunity of individual members of "P.W.'s" large staff meeting with their readers in person, these meetings at the Radio Show have developed along very friendly lines, many of our visitors having made a point of coming year after year for a brief chat—brief, of necessity, for the number of visitors is apt to be almost embarrassingly great!

**Come And See Us At No. 8.**

So if there is too big a crowd round Stand No. 8 when you first see it, remember to reserve time for a call, for nowhere within the four walls of Olympia will you be more welcome.

Having investigated the possibilities of "P.W.'s" stand the visitor's next move into the maelstrom of exhibits will be dictated by his needs in the way of components, accessories or, perhaps, complete set. And the first impression is: "Well, anyhow there is plenty of choice."

However, a start must be made somewhere, so let us mingle with the crowds working their way

**A PERMANENT MAGNET MOVING-COIL**



Another example of up-to-date practice in the design of permanent-magnet moving-coil loudspeakers, made by the Whiteley Electrical Radio Co.

**SAFETY FIRST**

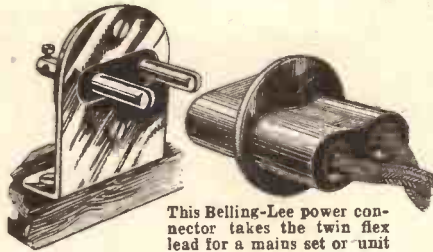

This Belling-Lee power connector takes the twin flex lead for a mains set or unit with perfect safety.

round, and keep our eyes out for anything special that we need or that strikes us as particularly worth lingering over.

And here, perhaps, it is timely to say that this year's Show is not one that depends upon a limited number of novelties for its appeal to the public.

There is plenty of new stuff to be seen, of course, but of the hundreds of firms showing, a very large proportion have settled down years ago to specialise in some particular line, and their idea is not mere novelty, but constant improvement in production, and the maintenance of their reputations with the purchasing public.

Over there at Stand No. 2, for instance, we notice that a lot of interest is being shown in a very ordinary subject—ebonite! This array of panels, coil-formers and so forth may not have a novelty appeal, but, instead, the far greater interest of a just-what-you-want article at the right price.

**EPOCH'S APEX!**



The star-turn in the Epoch range is the 99K.

It is the display of the British Ebonite Company, Ltd., famous the world over for their rods, sheets, tubes and mouldings of "Becol" ebonite goods. Last year, we remember, they were showing the largest outside in low-loss formers in the world; so there is a certain "novelty appeal" even in ebonite, if handled on the lines that the British Ebonite Co. are accustomed to!

Super-het. radio-grams, if not a complete novelty, are sufficiently unusual to be sure of attracting special attention. On Stand No. 21 Gambrell Radio, Ltd., are showing A.C. and D.C. models, and also an Auto-radiogram de-luxe, with automatic record-changer and multiple speaker unit. This is priced at sixty-two guineas.

**Up-To-The Minute Designs.**

What's all this over on Stand No. 30? A display of complete sets by Hustler, Simpson and Webb, the firm that gave the public the "Super Two," and this year are showing a whole range of attractive receivers.

Included is their screened-grid battery three, with an all-metal chassis and single-dial tuning, the loudspeaker being either a moving-coil or one of the balanced-armature type, according to the new owner's fancy. Good stunt, that.

Of particular interest to the man looking for a set that will cost less than a fiver is the new two-valver, which is built into a neat dark oak cabinet, and sold complete with batteries and valves. It incorporates a specially-designed and patented coil to eliminate all trace of break-through when working on the long waves, and has pick-up sockets so that the record enthusiast can go in for electrical reproduction with a minimum of trouble.

There is a built-in balanced-armature loudspeaker of very sensitive design, and like its big brother the

"three," the set has a metal chassis. Battery-operated, with three aerial sockets for adjustment of the selectivity of input, this is certainly a set calculated to make the two-valve man finger his fiver for the last time.

While we are on the subject of "two's," let us just take a glance at this firm's "Acrodynes" for mains operation—A.C. and D.C. models. Entirely new, the former incorporates a Westinghouse metal rectifier, and a Rola mains-energised moving-coil loudspeaker.

With its combined wave-change and mains switch, full-vision tuning scale, and rigid all-metal construction, it bristles with points of interest.

The receiver is contained in a figured walnut cabinet, and with an undistorted output rating of two watts it is a detector and pentode combination that comes out at ten guineas.

Talking about cabinets, there is a completely comprehensive display of this sort of thing at Olympia, for a great many visitors are of the fair sex, bored stiff with technicalities and so on, but with an eagle eye out for anything good in the furniture line.

**Looking After The Ladies.**

Apparently Charles A. Osborn, on Stand No. 32, are continuing to realise the importance of selling directed at the fair sex, for the slogan here is "Your friends see more of the cabinet than of the set"—a truism that is obviously not intended to appeal to the constructor, but to Mrs. Constructor!

Just a glance at Model 197 there, as a representative of what is to be found. It is of the Jacobean

*(Continued on next page.)*

**DRUM DRIVEN**

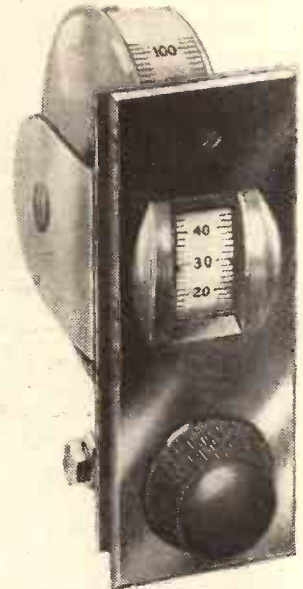

A fine drum-drive made by Jackson Bros.

**THE CLIMAX**



A self-contained radio-gram that works from the A.C. mains.

## AT THE RADIO SHOW

(Continued from previous page.)

type, in figured oak, standing three feet six inches high, two feet wide, and sixteen inches deep. It takes a panel twenty-one inches by eight inches, or smaller, and has a baffle board measuring twenty-one inches by eight and a half inches.

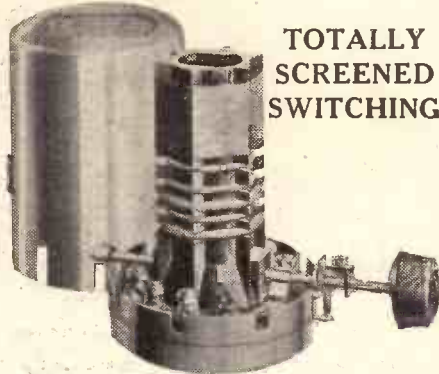

### TOTALLY SCREENED SWITCHING

Telsen's new screened dual range coil, incorporating a snap-action wave-change switch.

Inside there is ample room for whatever batteries are required, or for a mains unit, and the prices are scaled according to whether you wish to do any of the work or have the finished article already polished and so forth, when delivered.

For the man who likes to do the woodwork as far as he can it may be obtained machined ready to assemble, or, at a higher figure, it can be had completely assembled ready for polishing.

Public requirements are certainly not neglected by the makers of cabinets.

### Where Loudspeakers Lead

As the loudspeaker happens to be the last link in the radio chain—the one that “delivers the goods”—it is probably to this, rather than to any other single accessory or component, that attention is particularly directed at the beginning of a new season.

Everyone wonders what developments in this line have taken place since last year.

In general, loudspeaker performance has improved almost out of recognition, and the standard demanded by the public to-day as necessary would have been regarded as too good to be true only a couple of years ago!

Moreover, prices have come down and down as competition in this field has grown keener, and the consequence is that the visitor to Olympia will un-failingly pick out a number of attractive alternatives to consider in this field. And his mind will certainly

### A MODERN “MAGNAVOX”

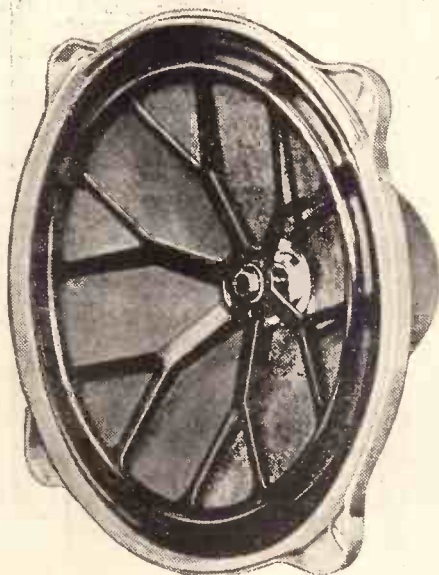

One of the latest lines by an old established firm in the moving-coil loudspeaker business.

turn to British Blue Spot as a candidate for his choice.

Their Stand No. is 55, and as an instance of the tendency to low prices referred to, this firm, which pleased so many customers with the old 66K unit, are introducing a new improved model of all-British manufacture to retail at 15s. Alternatively, it can be obtained mounted to a chassis ready to screw on to a baffle board or into a cabinet for 19s. 9d.

Of great interest, too, are the firm's two new battery sets. One is a table type at 12 guineas, embodying the well-known Blue Spot 100U as a built-in loudspeaker.

The other is a pedestal model with moving-coil loudspeaker, and comes out at a price of 16 guineas.

Newcomers to radio who are concerned about the installation of a brand new aerial will be specially attracted to the “Electron” stand, Number 48, where the New London Electron Works, Ltd., have arranged a tempting display of this class.

### All Types of Aerials

The firm is famous for Electron wire and for Superial, but the indoor-aerial man has blessed it for the Electron insulator pins, with which such an aerial can instantly be removed and re-fixed at different angles, at either end or across a room.

For positions where this is not convenient, or where space is even more limited, the Electron screen aerial was devised, this being unusually oblong in its space requirements, and capable of being placed

### FOR A.C. MAINS



An “armoured” pigtail to prevent pick-up is an excellent feature of this screened choke.

on the side of the house, on a chimney, in the loft, under the roof or behind a cupboard door.

One of the largest stands, No. 55, as well as four of the demonstration rooms, are occupied by The Gramophone Co., or, as the public will persist in naming them, “H.M.V.s.”

Incidentally, these demonstration rooms have been converted into a large private cinema theatre, seating over two hundred people, where will be shown the New Era talkie, “Voice of the World.”

Tickets for admission can be obtained only at the above-named stand, so there is sure to be crowding in its vicinity, especially as this will be the first time that the Olympia public has been able to see the firm's exhibits inside Olympia itself.

One tit-bit to be seen here is a special model of the

### MILLIAMPS EFFICIENCY



An advantage of the Ediswan is the boldly-marked discharge rating—in this case, ten milliamps.

## GANGED EXTENSER EFFICIENCY

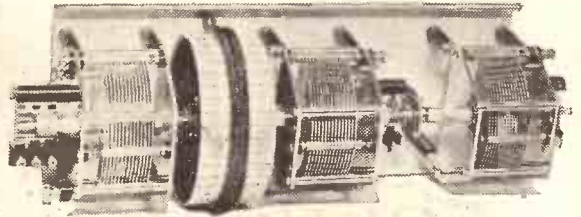

A fine job from the Sydney S. Bird's factory.

new H.M.V. 10-valve automatic record-changing super-heterodyne radio-gramophone. It is known as Model 532, and the one on show will certainly bear inspection, for it is built in a glass cabinet!

This set uses a variable- $\mu$  S.G. valve, and has two stages of L.F. with push-pull output.

On the radio side there is a special selective lighting system, illuminating the wavelength scale that is in use.

For gramophone there is a new automatic record-changer having a 3-position switch, enabling eight records to be played continuously, repeat a single record indefinitely, or permit the changer to be switched out of operation altogether.

The instrument is operated from A.C. mains of any voltage up to 260, is rated at five watts undistorted output, and costs 80 guineas.

One of the most astounding aspects of the industry revealed at the Show this year is the strong upward trend of the constructional movement. And in no department of practical radio science has there been a more healthy activity of late than in the field of kit-sets, for building at home.

### H.F. BINOCULARS



Efficiency is combined with ease of mounting in this Burton H.F. choke.

### No Signs of Saturation.

The most amazing feature of this continued development is that it was supposed to have reached its peak years ago! But just as licences are still soaring, and saturation-point is admitted by the B.B.C. to be a long way off, so the constructor market is being continually re-vitalised into new activity by better and cheaper sets.

The radio industry is, in fact, going ahead and breaking new ground all the time, and at Olympia we have the practical expression of British inventive manufacturing genius at its best.

In the complete sets of such firms as British Blue Spot, H.M.V., Lotus, Marconiphone, and Atlas, we have the finished article ready for action. And in the kit sets so temptingly displayed on all sides—by Cosser, Ferranti, G.E.C., to name but a few—we have proof that the constructional ability is

(Continued on next page.)

### PERFECTLY PORTABLE



A light-weight portable of outstanding appearance from Wates—The Standard Battery Co.

## AT THE RADIO SHOW

(Continued from previous page.)

### LISSEN'S LATEST



Lissen's attractive hand-pass receiver now has its controls on the side, which greatly enhances its appearance.

deep-seated and racial, and is to be found in the home as well as in the centres of manufacture.

Firms which have specialised in kit-sets, such as Peto-Scott, Ready Radio, are now in competition with newcomers to this field.

Last week we mentioned Telsen (Stand 66) as an example, and the comprehensive range of receivers which they announce merits close attention.

The "Jupiter S.G.3" for instance, with its shielded coil and drum-drive tuning, is claimed to achieve extreme selectivity with exceptionally wide range and superb quality of reproduction.

The total cost of its matched components, including panel, baseboard, terminals, battery-cords and all accessories, is seventy-seven shillings!

#### Economical Home Construction.

Even cheaper is the Telsen "Ajax 3." While for those who require different circuit arrangements there are such receivers as the "Triple Three" and the "Ninrod Two," full particulars of the whole attractive range being available at Stand 66.

The simplification of design attained is backed up by co-ordination of components, etc. There is, for instance, a 3s. 6d. constructor's outfit containing not only all the sundries but even such items as panel, terminals, wire, and spanners!

And special mention must be made of the "Tel-ornor"—a variable ratio disc-drive tuning control,

### SOLVES YOUR L.T. PROBLEMS

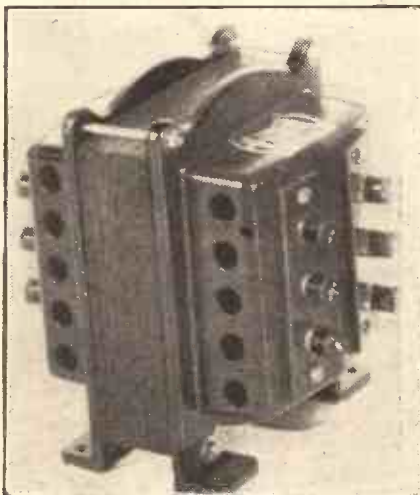

You can get L.T. supply from this transformer (designed to work with a metal rectifier), because Heyberd have added additional windings.

with oxydised silver escutcheon plate. This plate is pierced to accommodate a standard bakelite reaction condenser and two switches, while a bracket on the back of the chassis frame provides for the mounting of a Telsen '0005 logarithmic variable condenser, or a standard one-hole-fixing condenser with 1/4-in. spindle.

Another aspect of this year's Radio Show is that the tendency noted during the past season or so is for mains unit popularity to increase, has been more than maintained if the number of stands and of attractive models is any criterion.

Some firms which market a number of successful lines of such units first made their name in other branches of radio manufacture—"Atlas," for instance, was at one time synonymous with "coil," so far as the general public was concerned.

But now H. Clarke & Co. (Stand 91) have put the "Atlas" units on the map with extraordinary success, the extensive range including models specifically recommended for numbers of popular receivers, both of the manufactured types and of the made-from-"P.W." variety.

"Atlas," by the way, distribute a very handy little publication called "Power from the Mains," and if you can secure a copy of this you will find it of great interest in solving that supply problem.

Other firms have specialised from the start on mains units—the stand of E. K. Cole, Ltd. (Nos. 65 and 25), will show how successfully they can continue to do so—and a good example of the mains-

### TIME TO LISTEN



It was a bright idea to include an electric clock with this speaker made by A. Baker.

only stand is that of Regent Radio Supply Co., Stand 51.

This firm quickly gained a name for its models that were specially designed for insertion in portable receivers, and from the idea of a flex lead that was detachable from the instrument, so that a longer cord could easily be fitted in circumstances where this was necessary or convenient.

#### Making Use of the Mains.

More interesting mains units are found in almost every group of stands. Near at hand, for instance, at number 87 there are models by J. Dyson & Co., Ltd., famous for their "Godwinex" mains-choke, and for a successful earth-tube, as well as for trickle-chargers, grid-bias units, etc.

Lissen, Ltd., on Stand 59 this year, always provide "an eyeful" for the visitor! And the enormous variety of this display seems to furnish detailed improvements everywhere that old favourites reappear, as well as entirely new lines.

Set-builders will open their eyes at the "Sky-scraper" constructor's kit, in which the components are mounted on an aluminium chassis.

It is supplied complete with every component down to the screws, and the smaller parts are thoughtfully placed in numbered packets, thus facilitating recognition by those who have not previously handled similar parts.

Of special interest here also is the Lissen astatic H.F. choke, which with its exceptionally small external field is designed for use in portable sets or any receiver where space is a primary consideration.

With an inductance of 150 millihenries, a self-capacity of only three micro-microfarads, this choke combines light-weight properties which enable it to

### LOW FREQUENCY—HIGH PERFORMANCE



A low-frequency choke into which the Automatic Coil Winding Co. have packed forty henries.

be supported by the ordinary wiring of the receiver! And the price is only 3s. 9d.

So far we have not remarked upon the battery stands. They are here again, of course, and with even greater bargains than before, apparently thriving quite as fast as any of the mains devices.

The Chloride Electrical Storage Co., of "Exide" fame, who scored such a triumph with their Drydex H.T.B. last year, are again well to the fore (Stand 61), whilst at Stand 63 there is the Ever Ready display designed to meet your exact requirements.

#### Aid for the Battery Buyer.

Note the advance in the salesmanship technique of such a line as H.T. batteries. At one time you had to buy "on spec," but now you can get your battery to suit your set to a "T." An Ever Ready "Standard," for instance, is specifically sold for sets requiring 6/10 milliamps, while a "Power" is for four- and five-valve sets needing 10 to 16 milliamps.

There are models also for the super-power set taking up to 30 milliamps, even this outside capacity being available in more than one type to suit the exact demands of the purchaser!

An excellent example of specialised loudspeaker production is to be noted at Stand No. 69, where Reproducers and Amplifiers, Ltd., are showing. Their

(Continued on next page.)

### HOUSE IT HERE



A typical example of the fine cabinet-work turned out by Carrington's for radio-grams.

**AT THE RADIO SHOW**  
(Continued from previous page.)

range extends from a differential armature reproducer at 15s. to the "Victor," a permanent-magnet moving-coil instrument which embodies new and distinctive features, notable among which are the cadmium plated grille and armoured construction which entirely eliminates the possibility of damage to the diaphragm and magnet assembly.

This model has a cobalt-steel magnet and six-ratio transformer totally enclosed. The flux density is 8,000 lines per sq. centimetre, and the average speech-coil impedance 5 ohms, whilst the price is 70s.

Accumulators have not so far been mentioned specifically, but at the battery stands already named and also at number 76, where the Fuller Accumulator Co. are to be seen, there are many worthy of close attention, as reflecting the great progress made in

**PEEP AT THE PYE**

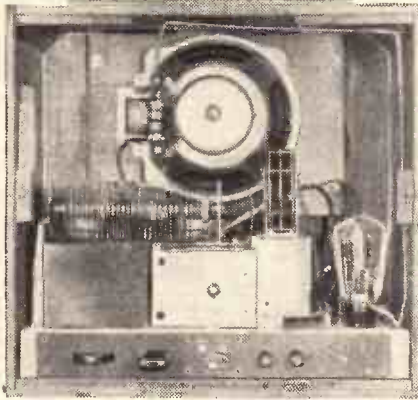

A layout of which anyone might be proud is provided by the Pye "K" receiver.

this important aspect of radio reception. The non-acid, non-spill, self-indicating never-say-die characteristics of these moderns would make the cumbersome old accumulator of the earlier Radio Shows blush for shame!

**A Fine Seven-Valver.**

The continued improvement in super-heterodyne technique is convincingly displayed at Olympia this year, and on stand number 78 Ferranti Ltd. are showing a seven-valve A.C. mains band-pass super-heterodyne radio consolette, which for 22 guineas has some remarkable features.

Of the seven valves, one is an indirectly-heated variable mu S.G., followed by an oscillator, first detector, intermediate amplifier (also variable mu), second detector, and a power valve of the directly-heated variety.

In addition there is a full-wave rectifier, and it is specially interesting to note that this rectifier, the

**SPEAKS FOR ITSELF**



The inductor dynamic loudspeaker chassis for which Messrs. Lamplugh are responsible.

**WELL ON TOP**

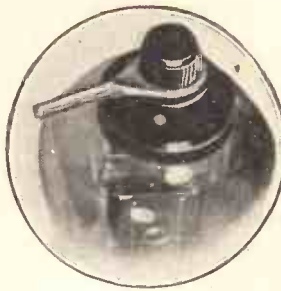

Lectro Linx have certainly scored with this handy "Clix" connection for S.G. anodes.

oscillator, the second detector and the power valves are all Ferranti-made valves—quite a new line for one of our oldest firms!

Of particular interest are the following points: Optional mains aerial; illuminated dial; single-knob for on, off, and wave-change control; and tone control by a filter across the speaker—a low-impedance moving-coil, the field winding of which provides some of the H.T. smoothing.

The power valve feeds a maximum of approximately 1,000 milli-watts undistorted power to the speaker, via a suitable output transformer.

**A POPULAR PAIR**



The S.G. to the left is the new P.M. 12A, with improved characteristics and beside it is the 904V, a high-mag. detector of the indirectly-heated type.

The second detector is of the grid-leak type, the associated values ensuring linear distortionless rectification up to at least seventy per cent modulation.

A point to be noted is that the use of transformer coupling enables the output valve always to overload before the detector.

It would probably be true to say that every improvement in design as exemplified at Olympia descended, in line more or less direct, from an improvement in valves. Certainly the valve-makers deserve tribute from the public for their go-ahead policies, to which the pre-eminence of British valves in world estimation is due.

**Many Valve Improvements.**

As an example, take Mullards, at Stand No. 79. A number of entirely new types will be introduced this year, which is all the more remarkable when it is realised that this firm has instituted an improved system of electrode supports for its battery-heated valves.

Those of the indirectly-heated type are now made under a new rigid construction system, and in both ranges there are some newcomers of outstanding interest.

Illustrating how valve-makers in the long run affect all other branches of the radio trade are the specialised lines required by innovations such as, for instance, the v. S.G. valve. Before its advent we were content with grid bias at a minimum of 1½ volts, but no sooner had a valve appeared that wanted only .9 volts than the public were provided with chubby little cells that handed out that figure.

Examples of this are to be seen at the Siemens' Stand No. 88, which also provides a wealth of

**THE "LOWBOY" SUPER-HET**



Variable-mu valves and single-knob tuning are features of the Gramophone Company's super-het, "Lowboy". The cabinet is attractive enough to please the most fastidious purchaser.

battery-power in high-tension and low-tension units, for varying needs.

**Tremendous Price Reductions.**

Probably it is on stands that offer a varied display of many different kinds of components that the great advances made by the radio trade are most apparent. For it often seems, in such cases, that every single thing is nowadays done better than before, and cheaper.

Numbers of displays will illustrate this, and a good instance is provided by Ormonds, at Stand No. 87. The eye ranges over a host of condensers and comes to rest on a loudspeaker unit that would have made Grandpa gasp, back in 1927 or so, for the price is only 5s. And that is far from being the lowest!

Whatever doubts the Jeremiahs had about the liveliness of the home-constructor business must have been severely upset by the reflection that a very large number of flourishing firms look upon this branch of the business as their meat and drink.

Gadgets of all kinds, coils, transformers, leaks, resistances, switches and whatnots for the set-builder are everywhere. And one firm, Tunewell's, on Stand No. 96, have artfully arranged for their price list to include on it a number of diagrams of special attractiveness to these knights of the kitchen-table who love nothing so well as to pull a perfectly good set to bits just for the pleasure of knocking up another!

**H.F. Progress.**

We have already referred to the progressiveness of the valve-manufacturers, and although there is not space to review examples at length, mention must be made of one exhibit by "Osram" on Stand Nos. 105 and 109.

(Continued on next page.)

**AN ADAPTABLE MOTOR**

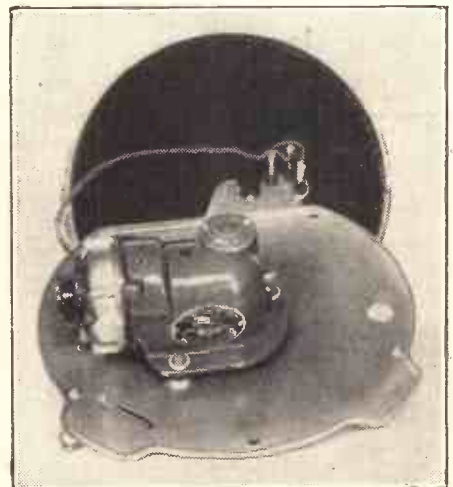

A first-class electric turntable motor which Messrs. Garrard & Co. have made to work from A.C. or D.C. mains.

## AT THE RADIO SHOW

(Continued from previous page.)

This firm produced one of the finest variable-mu valve marketed in this country, but realising that there are cases in set-design where greater over-all amplification per stage than can be provided by a valve with a maximum mutual conductance of 1 milliamp. per volt. (the figure of the original V.M.S.4) they have gone one better already.

### SMALL AND GOOD



The Varley "Nictet" L.F. transformer uses a nickel iron core of small size but high efficiency.

The modified valve (which will be known as the V.M.S.4, as before) has the advantage that where required, maximum mutual conductance can be increased from 11 to 24 milliamps per volt., at minimum bias.

Apreros of the popularity of kit-sets and home construction, the Osram "Music Magnet Four" owner will be intrigued to note that on Stand No. 123 the Carrington Manufacturing Co. are showing a "Westminster" cabinet, which converts that popular set into a complete radio-gramophone. The General Electric Co. are co-operating in the display of one of these sets with its motor and pick-up. Similarly, Carrington's are showing cabinets used in conjunction with the new "Radio for the Million" kit.

### Booming Short-Waves.

The B.B.C.'s decision to build an Empire short-wave station at Daventry seems to have been responsible for a number of interesting and comprehensive efforts in the direction of reception below the 100-metre mark. Such exhibits may be noted dotted about here and there, Stands Nos. 30, 36, 59, 66, 82, 87, 90, 91, 96, 100, 106, 118, 129, 151, 154, 204, 245, and 247 affording plenty of examples.

Halford Radio, Ltd., at Stand No. 117, are showing the Gambrell-Halford S.W. Converter.

Although the electrical reproduction of gramophone records is now so general that the pick-up has taken its place as an ordinary component, and is not—as at previous shows—anything calling for special comment, one cannot help noticing the many good models now available.

An interesting newcomer is the "Mark 111," displayed at Stand No. 156, by Bowyer Lowe & A. E. D. Ltd. In this the principle of matched response to

### SIMPLIFIED TUNING



The Formo Extender with its self-changer and contacts that automatically eliminate the need for separate wave-change switching.

the average moving-coil loudspeaker has been introduced, while the "top" response is arranged to cut off sharply in order to reduce needle-noise or "scratch," as it is generally termed.

As many radio receivers are now fitted with a pair of pick-up terminals, for electrical reproduction, a self-contained unit which embodies gramophone motor, pick-up, and volume control is the logical addition needed to convert such a receiver into a radio-gram.

Such a unit is to be found on the Bowyer-Lowe exhibit, priced at £6 19s. 6d., and suitable for running from the A.C. mains.

### Useful Instruments.

Notable among the smaller apparatus this year are numbers of "maintenance" instruments, ranging from cheap little hydrometers to really elaborate and expensive precision meters of various kinds, indicating how seriously some of us take the matter of correct voltages and currents.

There is, for instance, one portable electrical measuring instrument—claimed to be the only one in the world—that gives direct and accurate readings in amps., volts., and ohms without the use of external shunts or multipliers, and without calculations of any kind.

It is to be found on the stand of the Automatic Coil Winder and Electrical Equipment Co., Ltd. (Stand No. 206), where the well-known "Slektun" lines are displayed.

As we near the end of our tour round the stands we cannot help noting how it is merit of material, consistency of workmanship, excellence of design and, in a word, improved quality rather than novelty that make a visit to Olympia so well worth while this

### VERNIER ADJUSTMENT

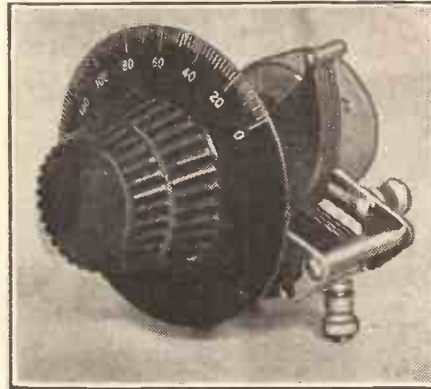

The main Ormond dial gives you quick tuning while the front section enables very fine adjustment to be made.

year. There is a continuous striving for better material and better results.

Even in the displays of raw material this is apparent (notice that "Permoil" non-discolouring emolite, over on Stand No. 220, which the British Hard Rubber Co. are showing), and as workmanship has advanced to a hitherto unknown degree of excellence there seems to be something to linger over on each individual exhibit.

### Ingenious Sideshows.

It will be remembered by the regular visitor to the British radio show that the various firms excel in staging ingenious sideshows and tableaux, and that these tend to get more and more entertaining every season. Certainly there is an attractive array of such sideshows to be found at Olympia this year.

A great many people have not realised, for instance, that it is possible to "see" speech and music as well as to hear them.

There will be visual proof of this at Stand 75, where the Edison Swan Electric Co. are showing the Edison Cathode Ray Oscillograph. By means of this apparatus callers at the Edison stand will be able to watch a beam of light that represents, in its fluctuations, the rise and fall of the voices of the King and of the Prince of Wales, as rendered by gramophone record.

This firm is also staging a tablean devoted to high-tension batteries, and on both Edison stands their whole range of low-tension accumulators for radio will be displayed. These will include the new 2-volt long-life types which have been developed as the result of long and extensive research, rendering them especially successful in standing up to the slow rates of discharge so often met with in fulfilling the requirements of radio listeners with small sets in country districts.

If previous experience is anything to go by, a very large proportion of the visitors go to Olympia with their eyes on the possibility of a really irreplaceable loudspeaker. And never before in any concentration of radio apparatus has there been anything to equal

## SOUND AND SECURE

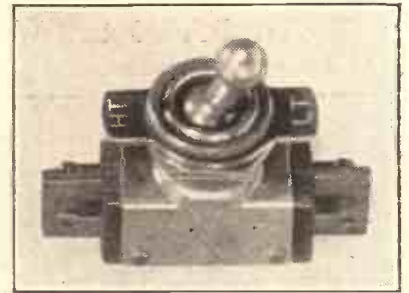

Clean contact, positive action, and sound workmanship are features of this Bulgin switch.

the high efficiency and low price of the models gathered at this memorable show.

Moreover, the ample supply of demonstration rooms will enable the wily purchaser to hear exactly what the various designs can do. And this is all to the good of trade, for many of the models are irresistibly designed, both from the view of reproduction and of appearance.

The moving coils, which imposed a new standard of realism on the public, have, ever since they appeared, been subjected to severe competition by the inductor-dynamics and improved cone types. And the prices have been cut to the bone, resulting in models being obtainable at round about the thirty-shillings mark which are better than anything that could have been purchased for ten times that price only a few years ago.

This is progress indeed, and you have only to step into one of the many "theatres" to have it demonstrated.

### Started by "P.W."

Among the attention-capturing apparatus this year one notes with pleasure that short-wave adaptors are well to the fore. But how many people—including even the salesmen who extol its superb simplicity—realise that this class of instrument was born, bred, and "brought out" by POPULAR WIRELESS? As you read these words there are untold numbers of them in use—in America, far-off Japan, China, Africa, Australia—everywhere, in fact. But it was at the British radio show that they first appeared in any quantity, and it was in the pages of "P.W." that the idea was given to the world.

### DOUBLE GANGED!



An excellent example of an efficiently screened Polar double-gang condenser.

### FOR PARALLEL FEEDING



The Igranico "Parvo" was designed especially for circuits of the parallel feed type.



# The BEST WAY TO OLYMPIA

*Olympia is easy to reach if you go the right way. The directions below will help you.*

This year the National Radio Exhibition at Olympia is being held roughly a month earlier. It is also very much larger than heretofore, and occupies the main building.

It contains something like three hundred stands, occupied by about 229 firms anxious to bring their wares to the notice of the British radio public.

It began on August 19th, and continues till the next Saturday, the 27th. Olympia is open from 11 a.m. to 10 p.m., with every attraction in the way of music, free dancing hall, demonstrations of B.B.C. studio activities, and all that is best in British Radio. The charge for admission is 1/6.

The problem of getting to the show is not difficult to solve, and the following brief directions for travelling from the main points of London will help those who have any doubt how to find this mecca of radio.

The map shows the routes taken by the buses, the chief ones being shown in black, while

the other details will tell you how to get to Olympia from the main London railroad termini, by Underground.

**KING'S CROSS.**—Metropolitan Rly. (King's Cross Station). Book to Addison Road.

**ST. PANCRAS.**—Metropolitan Rly. (King's Cross Station). Book to Addison Road.

**EUSTON.**—Metropolitan Rly. (Euston Square Station). Book to Addison Road.

**MARYLEBONE.**—Metropolitan Rly. (Baker Street Station). Book to Addison Road.

**PADDINGTON.**—Metropolitan Rly. Bishops Road to Addison Road; or Praed Street to Kensington High Street, and then bus to Olympia.

**VICTORIA.**—By District to Earl's Court and thence by train to Addison Road (every few minutes).

**CHARING CROSS.**—By District as above.  
**CANNON STREET and LONDON BRIDGE.** (Monument Station). By District as above.

Or by Hammersmith train to Baron's Court or West Kensington stations.  
**WATERLOO.**—To Charing Cross, and thence as above by District.

**FENCHURCH STREET.**—Mark Lane, District to Earl's Court as above; or by Inner Circle to High Street, Kensington and thence by bus.  
**LIVERPOOL STREET.**—Metropolitan to Addison Road.

Apart from these lines, the Piccadilly Railway goes to Baron's Court, which is quite convenient. Also a large number of bus routes pass the door of the Exhibition.

On our map, as previously indicated, these are shown in deep black, and the bus numbers are as follows: 9, 27, 28, 33, 73, 92, 102, 127, 173, 233, 273, 291, 526.

So if you see any of these buses you may be sure that you can get to the Radio Show by bus. Tram routes will not help very much except as a means to get you to one or other of the bus routes or electric railways.

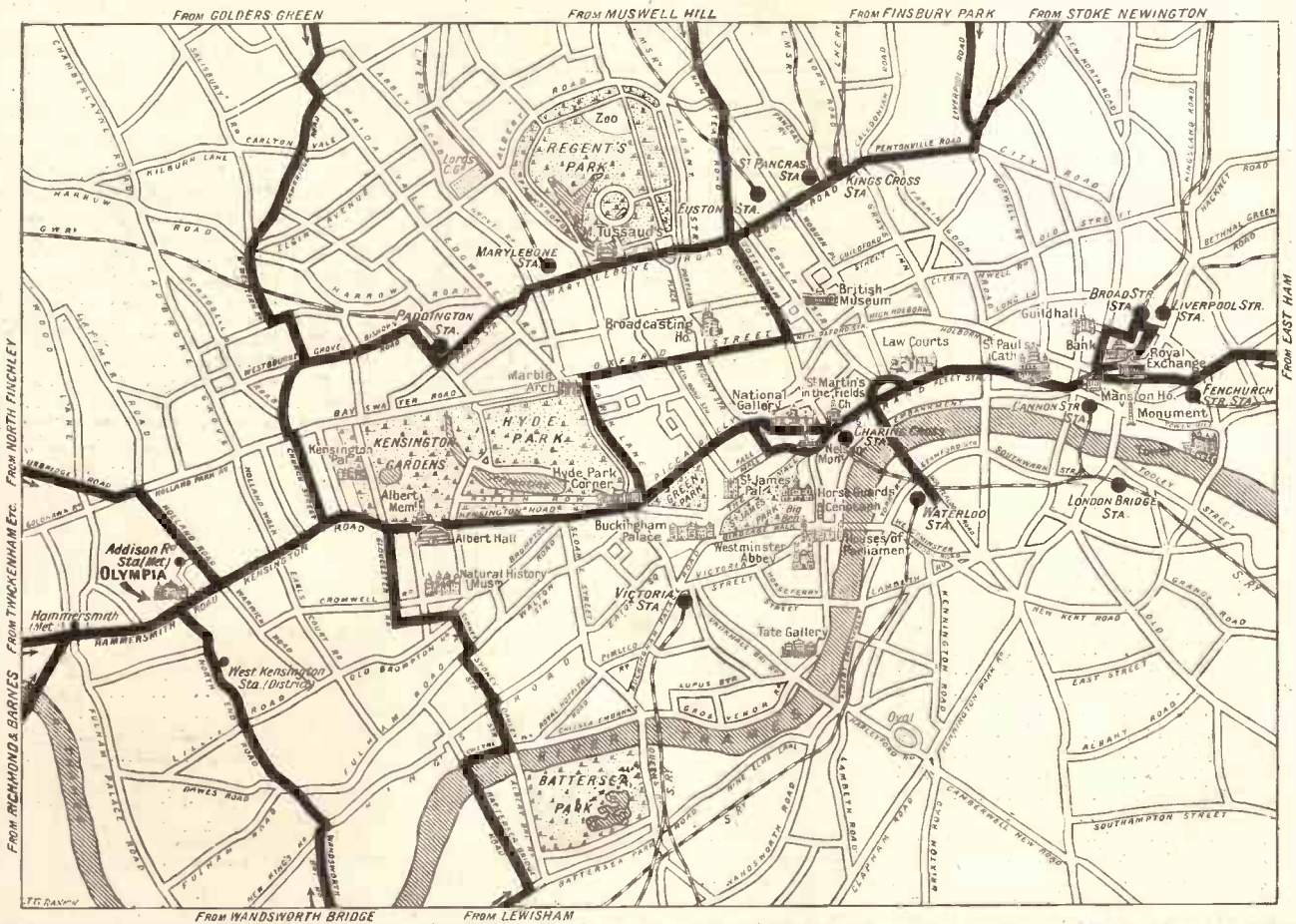

# WHERE TO FIND THE FIRMS AT OLYMPIA



NAME	STAND NO.	NAME	STAND NO.	NAME	STAND NO.
Ad-A-Grams	116	Consolidated Radio Co., Ltd.	34	Faudels, Ltd.	234
Adey Portable, Ltd.	259	Cossor, Ltd., A. C.	60	Fay Home Recorders, Ltd.	255
Alliance Radio, Ltd.	19	Dallas & Sons, Ltd., J.	202	Ferranti, Ltd.	78
Amalgamated Press, Ltd.	8	Danipad Rubber Co., Ltd.	113	Five Point Products	252
Amplion (1932), Ltd.	68	Darwins, Ltd.	70	Flinders (Wholesale), Ltd.	241
Apollo Gramophone Co., Ltd.	214	Dayzite, Ltd.	209	Formo Co.	100
Automatic Coil Winder and Electrical Equipment Company, Ltd.	206	De La Rue & Co., Ltd., T.	227	Fraser Radio, Ltd.	253
Baker, A.	83	Dew & Co., Ltd., A. J.	217	Fuller Accumulator Co. (1926), Ltd.	76
Balcombe, Ltd., A. J.	128	Dibben & Sons, Ltd., Wm.	77	Fullotone, Ltd.	203
Bell Piano Co., Ltd.	3	Dubilier Condenser Co. (1925), Ltd.	84	Gambrell Radio, Ltd.	21
Belling & Lee, Ltd.	154	Dulcetto Polyphon, Ltd.	235	Garrard Engineering and Manufacturing Co., Ltd.	122
Benjamin Electric, Ltd.	40	Dyson & Co. (Works), Ltd.	57	General Electric Co., Ltd.	105 and 109
Benn Brothers, Ltd.	281			Gilbert & Co., Ltd., C.	232
Bird & Sons, Ltd., S.S.	158			Gothic Electrical Supplies, Ltd.	201
Bowyer-Lowe & A. E. D., Ltd.	156			Graham Farish, Ltd.	50
Bernard Jones Publications, Ltd.	7			Gramophone Co., Ltd.	55
Britannia Batteries, Ltd.	126			Gripso Co.	226
Bush Radio, Ltd.	110			Grosvenor Electric Batteries, Ltd.	42
British Blue Spot Co., Ltd.	35			Gutta Percha Co. (Telegraph Construction and Maintenance Co., Ltd.)	257
British Broadcasting Corporation, Ltd.	155A			Hacker & Sons, H.	37
British Ebonite Co., Ltd.	2			Halford Radio, Ltd.	117
British General Manufacturing Co., Ltd.	29			Hambling Ltd., A. W.	224
British Goldring Products, Ltd.	20			Hampton Radio, Ltd.	12
British G.W.Z. Co., Ltd.	282			Harlie Brothers (Edmonton), Ltd.	31
British Hard Rubber Co., Ltd.	220			Haynes Radio	17
British Ideal Patents, Ltd.	72			Hayberd & Co., F. C.	13
British N.S.F. Co., Ltd.	18			Hellesens, Ltd.	221
British Pix Co., Ltd.	43			Henderson Wireless & Electrical Service	215
British Radiophone, Ltd.	93			Henley's Telegraph Works Co., Ltd., W. T.	16
British Rola Co., Ltd.	45			Hillman Brothers	210
British Thomson-Houston Co., Ltd.	119			Hobday Brothers, Ltd.	243
Brown Brothers, Ltd.	240			Hunton, Ltd.	271
Brownie Wireless Co. of Gt. Britain, Ltd.	62			Hustler, Simpson & Webb, Ltd.	30
Bulgin & Co., Ltd., A. F.	151			Igranic Electric Co., Ltd.	36
Burgoyne Wireless (1930), Ltd.	98			Iliffe & Sons, Ltd.	5
Burndept, Ltd.	46			Itonia, Ltd.	216
Burton, C. F. & H.	1			Jackson-Bell Distributors, Ltd.	11
Bridger & Co., R. O.	280			Jackson Brothers	204
"Broadcaster"	6			Jewel Pen Co., Ltd.	97
Cadisch & Sons, R.	218			Johnson Talking Machine Co., Ltd.	228
Carrington Manufacturing Co., Ltd.	123			Junit Manufacturing Co., Ltd.	39
Celestion, Ltd.	127			Kalisky (Aldgate), Ltd., S.	236
Cellgrave Co.	290			Kenwell Radio, Ltd.	121
Chloride Electrical Storage Co., Ltd.	61			Keith Prowse & Co., Ltd.	292
Churchmans, Ltd.	288			Kolster-Brandes, Ltd.	54
Cifel Products, Ltd.	285			Lamplugh, Ltd., S. A.	99
City Accumulator Co.	249			Lancashire Dynamo & Crypto, Ltd.	111
Clarion Radio Valve Co.	120				
Clarke & Co. (M/cr.), Ltd., H.	91				
Climax Radio Electric, Ltd.	81				
Cole, Ltd., E. K.	25 and 65				
Columbia Gramophone Co., Ltd.	86				
Colvern, Ltd.	245				
Concordia Electric Wire Co., Ltd.	208				
		Eagle Engineering Co., Ltd.	38		
		Eastick & Sons, J. J.	239		
		East London Rubber Co.	211		
		"Econasign" Co., Ltd.	269		
		Edison Bell, Ltd.	27		
		Edison Swan Electric Co., Ltd.	75 and 230		
		Electrical Devices Co.	47		
		Electrical and Radio Products, Ltd.	33		
		Electro-Dynamic Construction Co., Ltd.	157		
		Ensign, Ltd.	212		
		Epoch Radio Manufacturing Co., Ltd.	41		
		Erie Resistor, Ltd.	4		
		Ever Ready Co. (G.B.), Ltd.	63		

## VISIT "P.W." AT STAND No. 8

Day or night you are welcome. Technical experts will be pleased to help you solve your radio troubles and to offer you their impartial advice on all matters pertaining to better radio reception.

On "P.W.'s" stand, No. 8, you will find among other attractive and unique exhibits:

**THE ORIGINAL MODEL OF THE "OLYMPUS" FOUR  
A COMPLETE 5-METRE TRANSMITTER AND RECEIVER  
THE ORIGINAL MODEL OF THE "MODERATOR" TWO**

also  
**A Complete Amateur Radio Station incorporating a 10-watt Telephone and Telegraph crystal-controlled Transmitter, electric turntable and pick-up, microphone, main switchboard, electric clock, etc., etc., etc.**



**TELSEN**

# TELORNOR

GIVES YOUR HOME-BUILT SET THE DIGNITY AND BEAUTY OF LINE OF A COMMERCIAL RADIO RECEIVER.

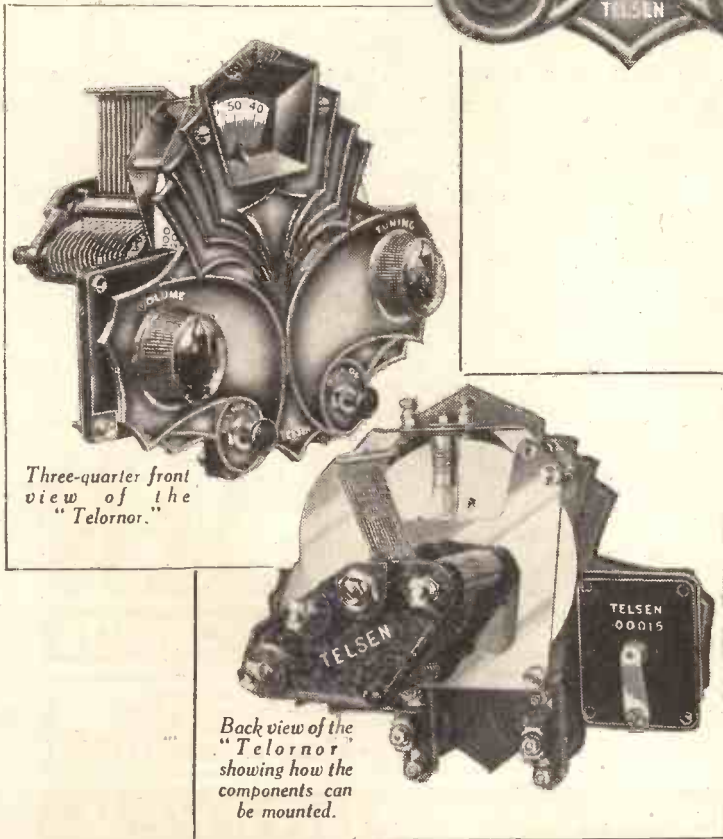
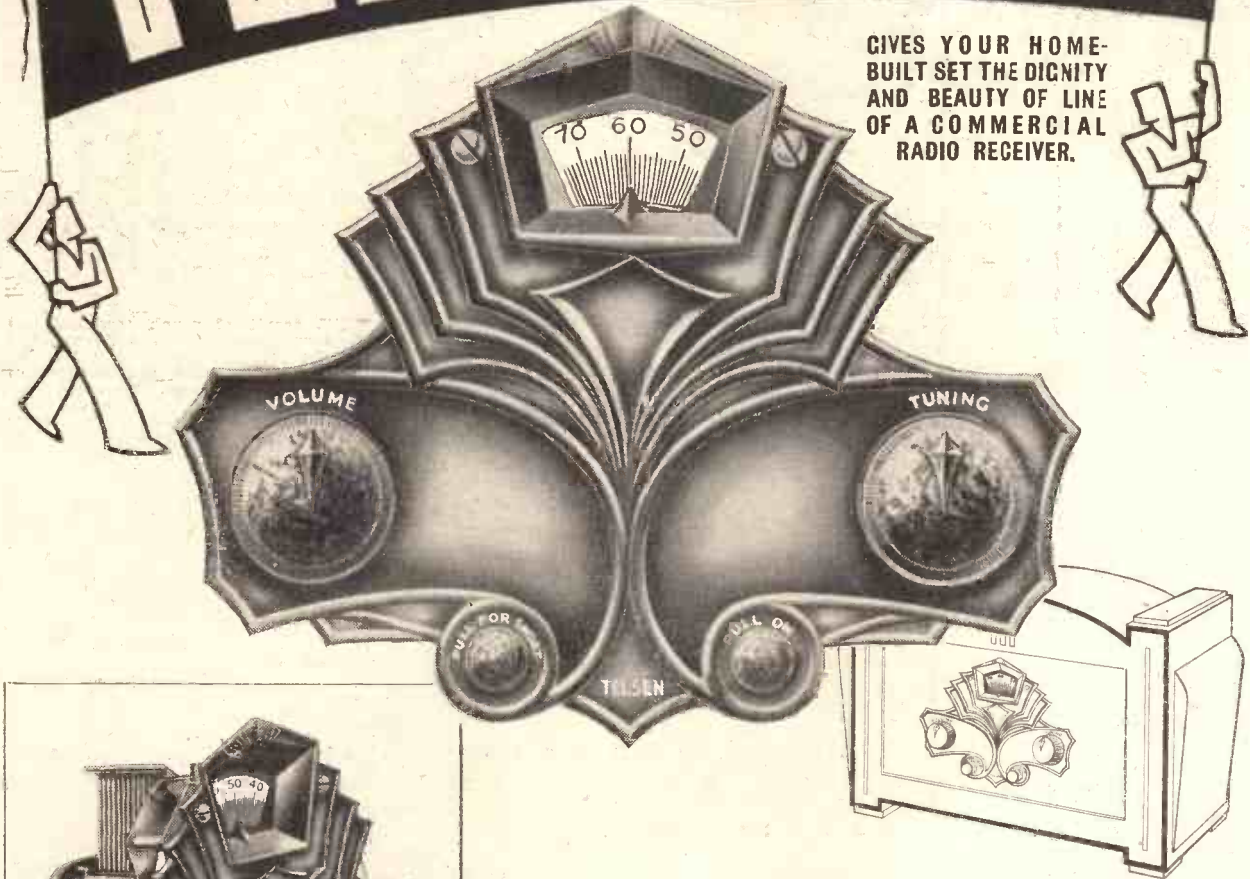

Three-quarter front view of the "Telornor."

Back view of the "Telornor" showing how the components can be mounted.

**G**IVE your home-built set the dignity of an expensive commercial radio receiver with the new Telsel TELORNOR. It makes better sets easy to build! The handsome silver oxidised escutcheon plate, embodying an illuminated variable ratio slow-motion Disc Drive, adds immensely to the "good looks" of your set and permits, with the minimum of trouble, a very effective grouping of your Volume, Tuning, Push-Pull and On-Off controls. Ask your dealer to show you a TELORNOR. It will make your set a set to be proud of—in appearance as well as in performance.

No. W.206.

**7'6**

## TELSEN

**RADIO COMPONENTS**

See the complete range of  
**TELSEN RADIO COMPONENTS**  
on STAND No. 66 at **RADIOLYMPIA**

**GOOD RADIO IS A JOY FOREVER**

ANNOUNCEMENT OF THE TELSEN ELECTRIC CO. LTD., ASTON, BIRMINGHAM.

# TELSEN

# SCREENED TUNING COILS

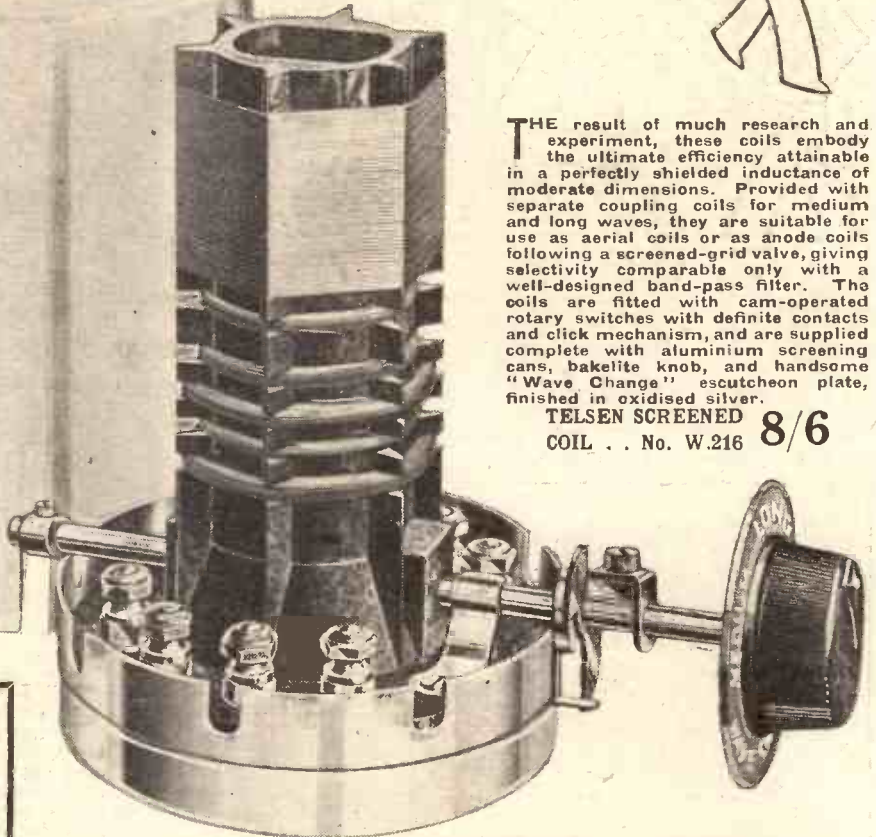
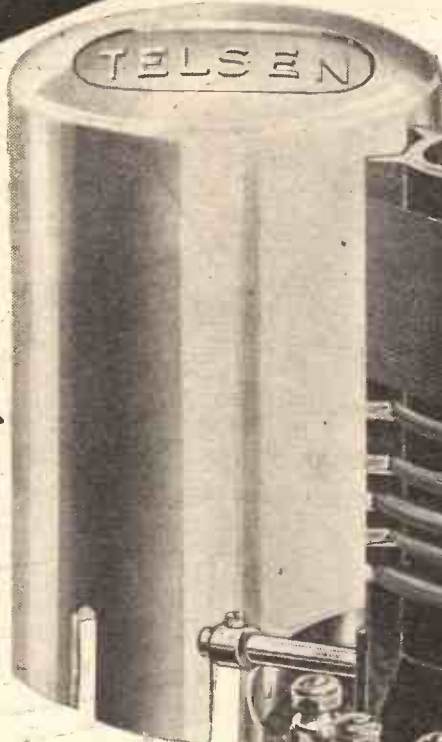

THE result of much research and experiment, these coils embody the ultimate efficiency attainable in a perfectly shielded inductance of moderate dimensions. Provided with separate coupling coils for medium and long waves, they are suitable for use as aerial coils or as anode coils following a screened-grid valve, giving selectivity comparable only with a well-designed band-pass filter. The coils are fitted with cam-operated rotary switches with definite contacts and click mechanism, and are supplied complete with aluminium screening cans, bakelite knob, and handsome "Wave Change" escutcheon plate, finished in oxidised silver.

**TELSEN SCREENED 8/6**  
COIL . . No. W.216

**TELSEN COIL SWITCH KNOB ASSEMBLY**

This knob is specially designed for use with the Telsen Screened Tuning Coils. The extension on the knob spindle fits over the switch rod supplied with the Coils, a firm coupling to the rod being ensured by tightening the small screw provided. The knob assembly is suitable for mounting to any standard thickness of panel, and includes a neat disc escutcheon. The knob is of the push-on type in Black Bakelite. **1/-**  
No. W.218.

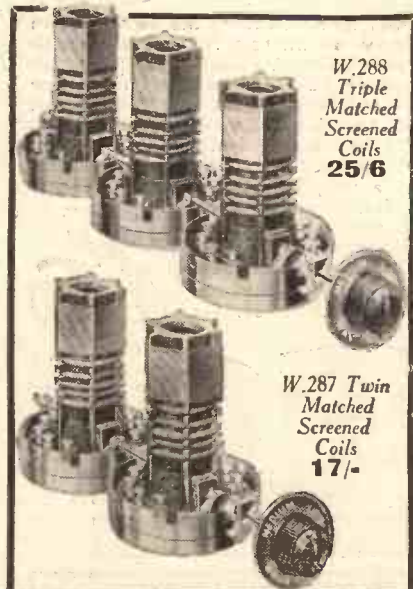

*W.288 Triple Matched Screened Coils 25/6*

*W.287 Twin Matched Screened Coils 17/-*

**TELSEN COIL SWITCH COUPLING ASSEMBLY**

When it is desired to mount two or more of the Telsen Screened Coils in a line parallel to the panel, and to control the wave-change switching by a single knob on the panel, this switch coupling assembly will be found indispensable. The link arms of the coupler are fitted over the switch rods of the coils, and adjusting slots are provided in the link bar to allow for the spacing of the coils varying from 3 in. to 6 1/2 in. The whole assembly has a neat nickel-plated finish, is perfectly smooth and positive in action, and free from backlash. **6d.**  
No. W.217

# TELSEN

**RADIO COMPONENTS**

See the complete range of  
**TELSEN RADIO COMPONENTS**  
on STAND No. 66 at **RADIOLYMPIA**

**GOOD RADIO IS A JOY FOREVER**

ANNOUNCEMENT OF THE TELSEN ELECTRIC CO., LTD., ASTON, BIRMINGHAM

NAME	STAND NO.
Lawson & Raphael	270
Lectro Linx, Ltd.	225
L.E.S. Distributors, Ltd.	233
Lissen, Ltd.	59
Lock, Ltd., W. & T.	101
Loewe Radio Co., Ltd.	223
London Electric Wire Co. & Smiths, Ltd.	153
Lotus Radio, Ltd.	64
M.P.A. Wireless (1930), Ltd.	95
Magnavox (G.B.), Ltd.	24
Mains Radio Gramophones, Ltd.	102
Manufacturers Accessories Co. (1928), Ltd.	237
Marconiphone, Ltd.	74
McMichael, Ltd.	58
Montague Radio Inventions & Development Co., Ltd.	49
Mullard Radio Valve Co., Ltd.	79
(Radio for the Million)	248
Murphy Radio, Ltd.	28
National Accumulator Co., Ltd.	244
National Radio Service Co.	200
Newnes, Ltd., George	114
New London Electron Works, Ltd.	48
Oldham & Son, Ltd.	85
Ormond Engineering Co., Ltd.	87
Osborn, Charles A.	32
Overseas Trading Corporation	291
Paroussi, E.	238
Partridge & Mee, Ltd.	67
Partridge, Wilson & Co.	159
Peto-Scott & Co., Ltd.	247
Pegasus, Ltd.	94
Phillips Lamps, Ltd.	104
Portadyne Radio, Ltd.	56
Powertone Products	229

WHERE TO FIND THE FIRMS AT OLYMPIA

NAME	STAND NO.
Priestly & Ford	213
Primus Manufacturing Co.	15
Pye Radio, Ltd.	80
Philomel Radio Equipment	279
Practical Radio Publishing Co.	254
R.C. Radio Electric, Ltd.	222
Radio Gramophone Development Co., Ltd.	92
Radio for the Million (see Mullard)	155
Radio Instruments, Ltd.	90
Radio Society of Gt. Britain	242
Ratcliff (Metals), Ltd., J. F.	258
Ready Radio, Ltd.	106
Redfern's Rubber Works, Ltd.	124
Regent Radio Supply Co.	51
Reproducers & Amplifiers, Ltd.	69
Roberts, John	272
Rotor Electric, Ltd.	283
Selecta Gramophones, Ltd.	219
Selfridge & Co., Ltd.	274
Siemens Electric Lamps & Supplies, Ltd.	88
Six-Sixty Radio Co., Ltd.	52
Smith & Sons (Motor Accessories), Ltd., S.	130
Smurthwaite, F. W.	22
Sovereign Products, Ltd.	152
Spencer Radio, Ltd.	14
Standard Battery Co.	26
Standard Telephones & Cables, Ltd.	107
Stratton & Co., Ltd.	23

NAME	STAND NO.
Sun Electrical Co., Ltd.	231
Swift, Levick & Sons, Ltd.	112
Stenibac, Ltd.	256
Sifam Electrical Instrument Co., Ltd.	289
Shaplend & Peter, Ltd.	287
Smith, Arthur (Radio), Ltd.	251
Sylvex, Ltd.	260
Tannoy Products	44
Telegraph Condenser Co., Ltd.	53
Telsen Electric Co., Ltd.	66
Terrytone Radio Products Co., Ltd.	268
Thompson, Diamond & Butcher	207
Trade Chronicles, Ltd.	10
Tunewell Radio, Ltd.	96
Ultra Electric, Ltd.	73
Unison, Ltd.	250
Unitor Electric, Ltd.	115
Vandervell, Ltd., C. A.	246
Varley (Oliver Pell Control, Ltd.)	160
Watmel Wireless Co., Ltd.	273
Westinghouse Brake & Saxby Signal Co., Ltd.	89
Whiteley Electrical Radio Co., Ltd.	108
Wilkins & Wright, Ltd.	118
Wingrove & Rogers, Ltd.	129
Wireless League	265
Wireless Retailers Association of C.B.	266
"Wireless Trader"	9
Wright & Weaire, Ltd.	82
Whiteley, Ltd., Wm.	267
Wego Condenser Co., Ltd.	284
Yagerphone Ltd.	286
Zetavox Radio & Television, Ltd.	103

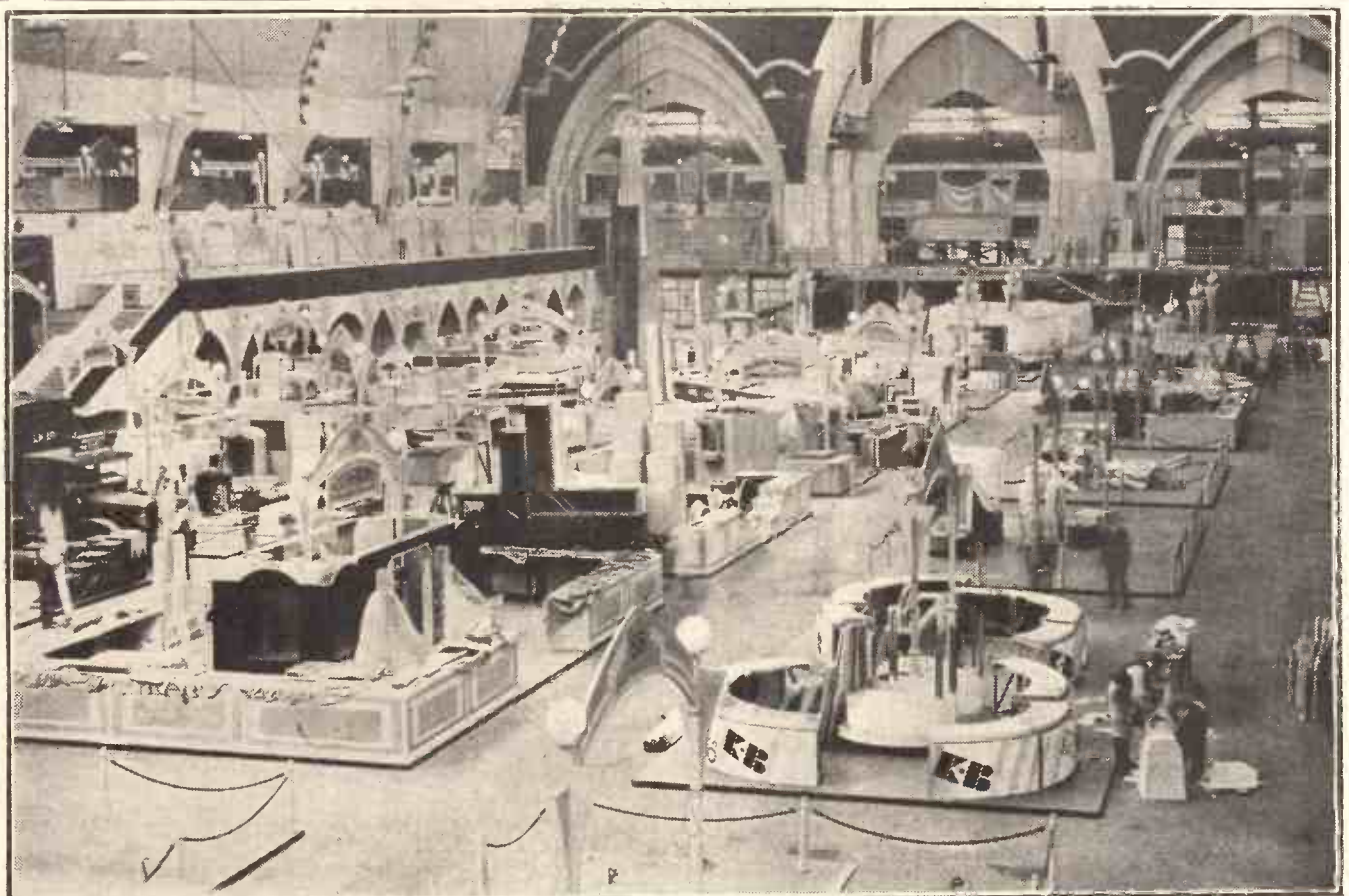

**ONLY SEVEN DAYS AGO!** The scene at dawn on the day before the show opened at Radiolympia, with a few of the all-night workers still busy!

# OLYMPIAN PEAKS

## Outstanding Exhibits At the Show



IT is a notable manufacturing achievement that sets can now be mass-produced calibrated in wavelengths. It is not so long ago that a "direct reading" receiver was an expensive rarity.

But at this year's show there are few makes which do not show wavelength scales on, at least, some of the models. This is, of course, a very important development from the listener's point of view.

However simple a set's controls may be, it is an indisputable fact that station-searching necessitates a little experience. Indeed, this is quite obvious. With nothing but arbitrary numbers to guide him the listener must either resort to a specially prepared "log," or learn the dial positions of the various stations by heart.

An excellent example of the new technique

### HOURS OF ENJOYMENT



Instead of an ordinary fret this Ferranti super-heterodyne loudspeaker is fitted with a handsome electric clock

is seen in the three-valve Lissen battery set which employs an S.G. and a Pentode. This receiver has only the one tuning dial, and this carries two scales, giving readings in actual

H.T. consumption is reduced more or less proportionally with volume controlling.

Thus the maximum consumption with full volume is  $12\frac{1}{2}$  milliamperes, and in view of the valves employed this is reasonable enough. However, as the receiver is extremely sensitive it would seldom or ever be necessary to have this full volume.

When the volume control is at its minimum position the consumption of H.T. is no more than 5 milliamperes.

So the average is something round about 9 milliamperes, which is strikingly low.

Two H.F. Variable-Mu Screened-Grid valves figure in this Blue Spot Four, and a

(Continued on page 837.)

Such an enormous variety of interesting apparatus is displayed at Olympia, and so much of it is particularly meritorious that it is impossible to deal adequately with all the exhibits that are really outstanding. However, readers will find great interest in this article, which covers a large number of the "higher spots" of the show.

medium and long wavelengths.

The wave-change is incorporated in the on-off switch—a sound scheme, for you have got to switch on anyway, so you might as well have the choice of two "on" positions.

By the way, this Lissen instrument is completely self-contained and all the batteries and the loudspeaker are neatly housed in the attractive cabinet.

### "Front-Door" Volume Control

There is an accessible trimmer with which a close initial setting of ganging can be obtained, and there is an efficient "front-door" volume control. That is to say, the received energy is regulated at the point of entry—in the aerial circuit. This is, of course, the most logical procedure, although it would fail if not carried out in accordance with certain well-defined principles.

But in the Lissen set no criticism is possible on that, or indeed on any other score. It is an interesting and important contribution to better battery radio.

One of the snags of the battery-operated type of set is that H.T. consumption may be heavy unless deliberate steps are taken to minimise it. This is done in all the first-class designs, but the method of doing it varies.

In the Blue Spot four-valve battery-operated set a splendid idea is revealed, the

### COILED EFFICIENCY



Completely enclosed to avoid unwanted interaction, these Colvern coils are simultaneously switched by the control shown.

# TELSEN

# LOGARITHMIC CONDENSERS and DRUM-DRIVE

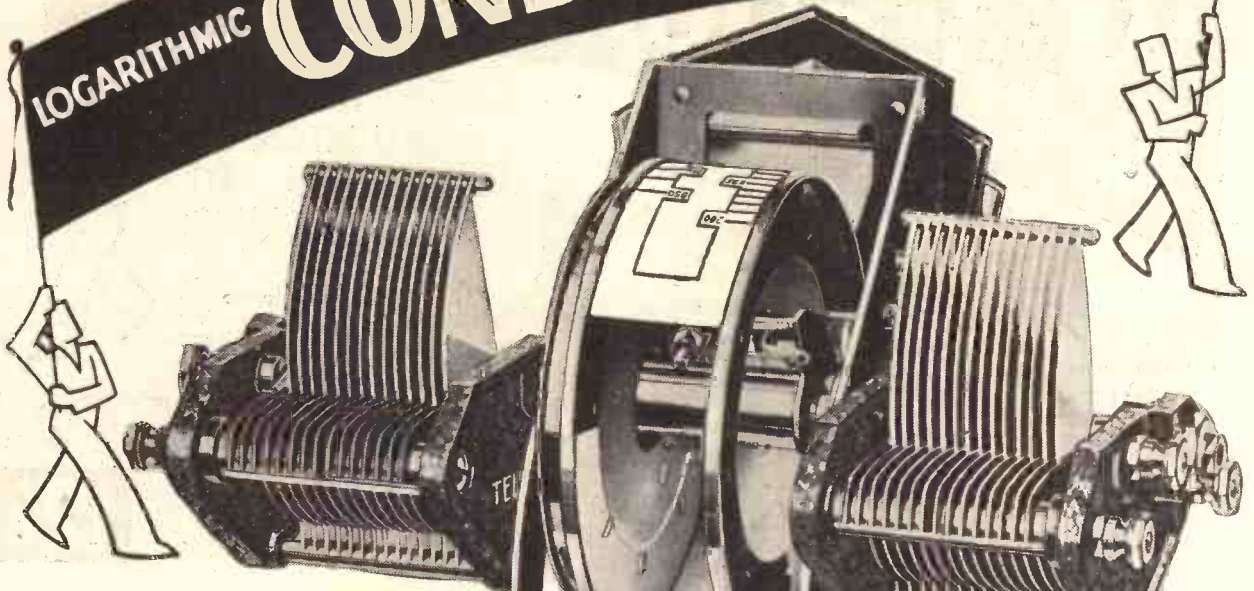

**T**HE Telsen Drum-Drive and Condenser Assembly comprise a complete ganged condenser tuning unit incorporating several distinctive features. Two Telsen "0005 logarithmic variable condensers with right and left-handed movements, and fitted with compensators, are mounted and ganged together through a rigidly constructed drum-drive control. Mounted on the same spindle axis as the main tuning drive is a trimmer, giving a swinging movement of about 20° to the stator vanes of the right-hand variable condenser, thereby enabling perfect matching of the condensers to be maintained throughout the Tuning Range. Two scales are supplied with the unit, one marked in wave-lengths and one in graduations from 0-100. The Scale is illuminated and has the additional advantage of being easily removable when it is desired to fit one of special calibration. The escutcheon is handsomely finished in oxidised silver and knobs of the push-on type are fitted. Provision is made for panel and base-board mounting, and a double-ended spanner is supplied free with the unit for fitting the variable condensers. Full instructions for mounting are included with every unit. No. W.262. Price

**17'6**

## TELSEN LOGARITHMIC CONDENSERS

The Frame is braced by three solid pillars, and the effective clamping of the vanes, each held at three points, makes distortion impossible. The rotor is also built into a rigid unit, the vanes being held at both ends. Generous bearings obviate backlash or end-plate. Models No. 260 and 261 (left hand and right hand movements respectively) incorporate a compensator (max. cap. 60 micro-microhenries) for balancing out stray capacities, thus greatly facilitating ganging.

- No. 130. .... Cap. '00025 ... 4/6
- No. 131. .... Cap. '00035 ... 4/6
- No. 132. .... Cap. '0005 ... 4/6
- No. 260 (Left hand movement with trimmer) Cap. '0005 ... 5/-
- No. 261 (Right hand movement with trimmer) Cap. '0005 ... 5/-

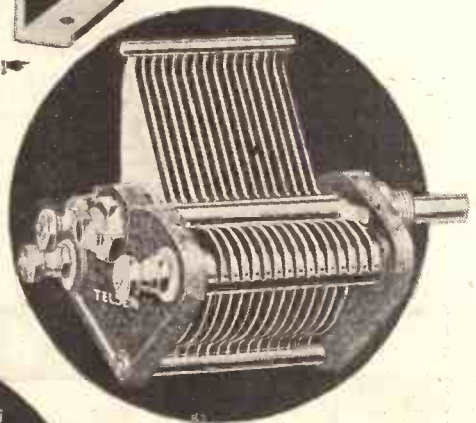

## TELSEN DRUM DRIVE

Follows standard practice generally, but embodies several detail refinements, among which may be instanced the cord drive, arranged to reduce wear to a minimum and to prevent over-run, and the rocking slot trimmer, which gives a variation of 20° and visual indication of setting. For use with Telsen screened coils, an extra scale, marked in wavelengths, is supplied free of charge. Illustration shows escutcheon, handsomely finished in oxidised silver. No. W.255. Price

**8'6**

# TELSEN

## RADIO COMPONENTS

See the complete range of  
TELSEN RADIO COMPONENTS  
ON STAND NO. 66 AT RADIOLYMPIA.

# GOOD RADIO IS A JOY FOREVER

ANNOUNCEMENT OF THE TELSEN ELECTRIC CO., LTD., ASTON, BIRMINGHAM.

**TELSEN**

**10-1 COUPLING UNIT  
& 1-1 COUPLING UNIT**

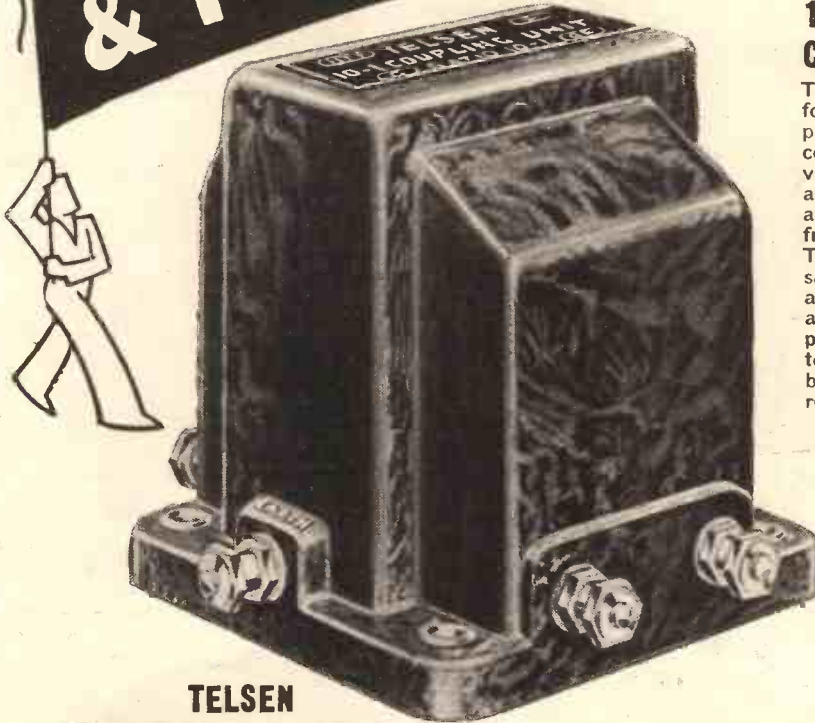

**TELSEN  
10-1 INTERVALVE  
COUPLING UNIT**

This is a filter-fed transformer using a high permeability nickel alloy core, which enables a 10-1 voltage step-up to be attained while preserving an exceptionally good frequency characteristic. The response is compensated in the higher frequencies for use with a pentode valve, this combination giving an amplification greater than anything previously achieved, equal to two ordinary L.F. stages, but with better quality of reproduction.



**12/6**

No. W.215.

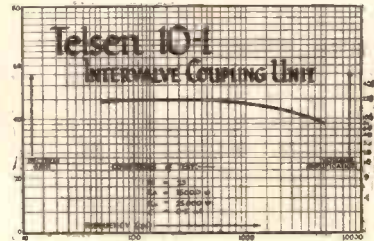

**TELSEN**

**1-1 INTERVALVE COUPLING UNIT**

This is a modern development of the one time deservedly popular R.C. unit. It incorporates a low pass filter feed in its anode circuit, thus effectively preventing "motor-boating," "threshold howl," and other forms of instability arising out of common couplings in eliminator and battery circuits. Used with an H.L. type valve it will give an amplification of about 20 and a perfect frequency response, at the same time consuming negligible H.T. current.

**7/6**

No. W.214.

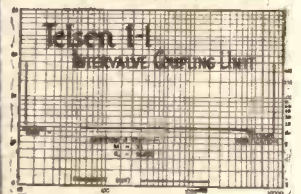
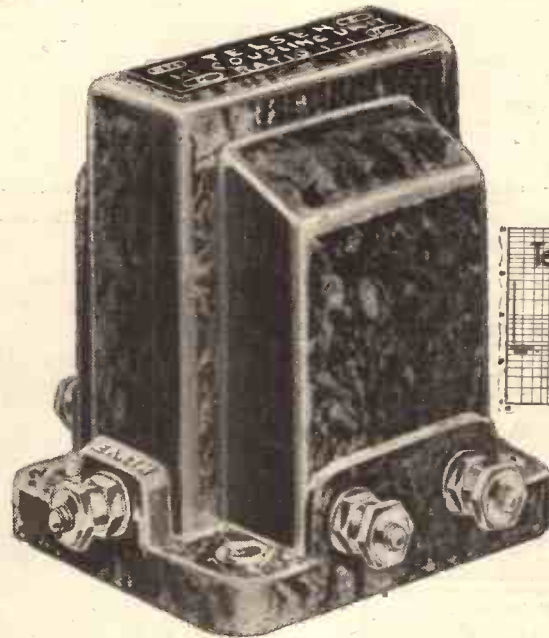

**TELSEN**

**RADIO COMPONENTS**

See the complete range of  
**TELSEN RADIO COMPONENTS**  
on STAND No. 66 at RADIOLYMPIA.

**GOOD RADIO IS A JOY FOREVER**

## OLYMPIAN PEAKS

(Continued from page 834.)

Pentode Output can be employed if desired—it is purely optional.

There are three H.F. tuned circuits controlled by single-knob tuning, and the wavelength calibration is carried out in two colours. A special reaction system makes it unnecessary to retune every time the reaction control is used.

We have remarked elsewhere on the fact that by far the largest number of sets on show are fitted with moving-coil loudspeakers. This is a significant step forward, even though some of the small moving-coils may not be better than or even as good as a well-designed balanced armature type.

However, the pace for inexpensive moving-coil speakers, which are really and truly moving-coils capable of giving first-class performances, has been set. And no small proportion of the credit for this is due to the Epoch Radio Manufacturing Co., Ltd.

### The Fruits of Pioneering Years.

They are moving-coil specialists, and have been for years. Their new edition 20th Century Model, price 35s., represents the fruits of all those pioneering years made available to the public at large.

Epoch are now entering the set market and are showing a three-valver at Olympia which is bound to bring them further bouquets.

A good moving-coil speaker is embodied in the Sovereign "Doric," a three-valve set of distinction. This set is constructed on a modern chassis principle, and is the complete antithesis of the once-common group assembled set.

By which we mean the assembly is a precision job of interlocking parts fitted to a chassis especially designed and made for this

### THEY CERTAINLY "TUNEWELL"



These "Tunewell" copper-clad coils certainly live up to their name. They provide band-pass tuning.

particular receiver—not a part drawn from stock.

The Sovereign "Doric" uses an S.G., H.F. valve and a Pentode, and is entirely self-contained. It should be noted that though Sovereign are now producing complete sets they are retaining their components on an even larger scale.

And talking of components, an important addition to the Igranic range which makes its bow at Olympia is a logarithmic type wire-wound variable volume control for use with variable-mu valves.

The object of this component being "logarithmic" instead of giving the usual direct resistance variation, is so that the

### AN IDEAL COUPLING UNIT

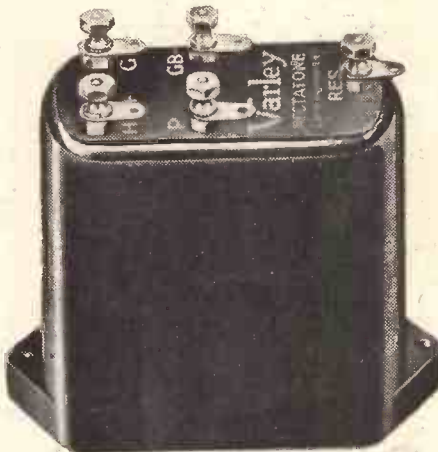

A new line introduced by a firm already famous for their intervalve transformers.

position of the control knob from maximum volume downwards shall bear a direct relationship to the volume of sound, i.e. half rotation means half volume, and so on.

You see, the volume control, by being logarithmically graded, obeys the same law as the valve itself. This new Igranic volume control is also obtainable in combination with a switch.

Band-passing is adequately represented at Olympia in a new Varley "Square Peak" three-valve set for A.C. mains.

This set is a particularly fine production, and it has unusual power and selectivity. A novel and effective item in its design is a "tapered" volume control for powerful stations.

It is built into a walnut cabinet which has a concealed handle for carrying, an attractively practical point.

### Wonderful Diversity of Apparatus.

One of the most startling revelations of Olympia, and such a fact can only emerge, at least with its full force, at an exhibition, is the diversity of the radio apparatus available to-day, both in point of price and of performance.

At one end of the scale we have such items as the new Marconi two-valve battery set which, at a cost of little over a "fiver," is capable of providing complete broadcast entertainment of quality.

And at the other end we can instance the H.M.V. Automatic Super-het. Radiogram, which is indeed a masterpiece. It employs ten valves and is capable of emitting five watts of undistorted power.

It can be said that it will get anything that is going in the way of ordinary broad-

casting, while it will give superb record renderings. And there is an automatic record changer enabling eight records to be played in succession or any one any number of times.

The price is 95 guineas, but it is as good value for money as is to be obtained.

For those who are unable to aspire to such heights there are moderately priced super-hets. deserving the closest consideration.

### Seven Tuned Circuits.

There is an all-electric super-het. by the G.E.C. at 26 guineas, which can deliver 2½ watts of undistorted power.

It has a band-pass input filter and intermediate amplifier, and there are no less than seven tuned circuits. The variable-mu intermediate valves are followed by a screened-grid detector, and it should be noted that the G.E.C. are making a strong feature of this latter in several of their other sets.

The output comprises a power pentode and there is a heterodyne filter. A mains aerial, provision for pick-up, variable-mu volume control, an automatic station index and an energised moving-coil loudspeaker are other features of this particular super-het.

### A Time-Piece Speaker.

What time is it on the loudspeaker? If anyone asked you that you would probably at once think of the broadcast time signal. But you need not wait for this if you have a Ferranti seven-valve super-het. with built-in clock.

This is a useful novelty which is already occasioned considerable comment wherever radio enthusiasts assemble. The clock takes the form of a handsome brass dial ingeniously built into the grille of the speaker, and it is driven by the mains current and requires no attention whatever.

But the clock is not switched off with the  
(Continued on next page.)

### AN "EPOCH" IN RADIO



The handsome sets made by Messrs. Epoch, Ltd., are notable for their neat chassis assemblies.

# OLYMPIAN PEAKS

(Continued from previous page.)

set. It automatically keeps perfect time.

The set itself is a fine piece of radio engineering. Ferranti are very optimistic about its success, and if it meets with the demand it deserves the mighty resources of the great Hollinwood factory will be strained to the utmost. Already, we believe, it is working to capacity.

Constructors are well served at Olympia, and in addition to all their old and well-tried friends they will find many new items to tempt money from their pockets.

### Good Looks Count.

It is of note that there is now a marked tendency to give him, the constructor, apparatus which can compare favourably in point of appearance with components specially designed for good commercial sets. It is obviously realised that people build sets to use for normal broadcast reception as well as for experimentation.

Of course, certain firms have long since realised this obvious fact, especially

### FINE "LOTUS" FOUR



Particularly attractive is this all-in receiver made by Messrs. Lotus Radio, Limited.

Ormond. And their latest dial carries the principle a stage further.

It is known as The Ormond Logging Drum Dial, and in addition to its very attractive appearance it provides for logging on both sides of the 0-180 degrees scale. The dial is also illuminated, and there is an artistic and nicely finished Bakelite escutcheon plate with a control knob which tastefully matches.

### The "Golden Voice."

No article such as this could fail to make mention of Telsen, though "Macnamara," the "Golden Voice" will soon no doubt be a household familiarity, for it is Telsen's new set, with which we wish to deal on this occasion.

"Macnamara" (we wonder how long it will be before everyone speaks of it as "Mac"—not long, we guess, if ubiquity has anything to do with it!) is an all-electric set in which an S.G. and a Pentode are employed.

It has a tuned H.F. transformer intervalve coupling, and on the L.F. side there is a parallel-fed L.F. transformer coupling.

The tuning is accomplished by means of a single dial. The undistorted output is two watts. And there is a moving-coil loud-speaker.

"Macnamara" has a most pleasant appearance, and it is obvious that there was artistic inspiration behind the cabinet

### A SUPER-HET. PORTABLE



One of the most interesting super-hets. at the Show is this Marconiphone battery portable.

design. It strikes a definitely modern note without being obtrusive. "Macnamara" is no doubt at this very moment of writing attracting very considerable attention at Olympia.

Inevitably, the term "moving-coil" must keep cropping up in any survey of modern radio, for the moving-coil loud-speaker is almost an emblem of the new radio technique which places quality of reproduction almost before anything else—and, we consider, rightly so, too.

### ALL-MAINS AND AUTOMATIC



The His Masters Voice 10-valve super-heterodyne radio-gram which incorporates their most up-to-date automatic record changer.

For this reason visitors to Olympia should make a special point of examining the R.K. speakers to be seen on the Edison Swan Electric stands.

The R.K. is the earliest and yet the latest of moving-coils, if we may be permitted to lapse into the paradoxical for once!

The R.K., short for Rice Kellog, was the first of all the practical moving-coil loud-speakers, and it is significant that fundamentally there has been no development since—with one exception. But what an exception!

### Earliest and Latest!

We refer to the introduction of permanent field magnets, and it is this which has made the moving-coil speaker what it is to-day—a popular commodity.

But the modern R.K. is available with this valuable refinement, so, as we have said, the R.K. is at once the earliest and latest! It was formerly the enviable possession of the elite; it is now to be purchased in junior models at prices within the reach of most listeners.

Also, right in the van of the new loud-speaker movement are Whiteley Electric, who were among the very first to produce an inexpensive permanent-magnet type of moving-coil. Their P.M.s are indeed among the present-day best-sellers of radio.

### PARAFEED PURITY



This component is a parallel-fed transformer incorporating its own coupling components.

Condensers constitute one of the highest Olympian Peaks, and every constructor should make a point of examining closely the examples of precision condenser engineering exhibited.

Jackson Bros. are keeping their end up in this direction right nobly, and some of their J.B. condensers are gems of the art. Indeed, they have gone from strength to strength with their "Nugang" condensers, new differentials and illuminated dials.

### Kit-Set Considerations.

It is notable that battery makers are nowadays making special batteries for certain of the more popular commercial sets instead of attempting a fixed standardisation.

All constructors ought to be interested in the kit sets our old friends Ready Radio are showing at Olympia. These are exceptionally attractive.

The assembly has been reduced to a bare minimum, and in the one case there are only three or four wires to join up. This remarkable result has been achieved by an ingenious grouping of the components.



# The TELSEN TELELEXOR

THE Telexor represents a new development in radio set construction, and renders unnecessary all existing wave change methods by switching or changing coils. In conjunction with the Telsen Dual Range Tuning Coil, the whole of the medium and long wave broadcast band may be covered by one turn of the dial, without any operation being necessary to change wave lengths. Briefly, it incorporates a special design of tuning condenser, covering the full circle and giving "log law" tuning in both directions, together with an

automatic wave change switch and illuminated disc drive.

No. W.180.

**MOUNTING INSTRUCTIONS**

Full instructions are included with every Telexor for baseboard or panel mounting, together with the necessary screws. The approx. overall dimensions, excluding the escutcheon plate, are 5 1/2" high 4 1/2" wide and 2 3/4" deep.

**10/6**

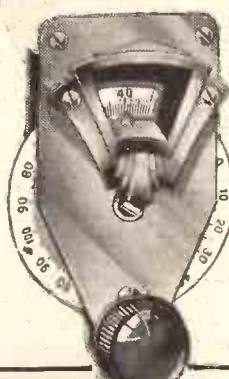
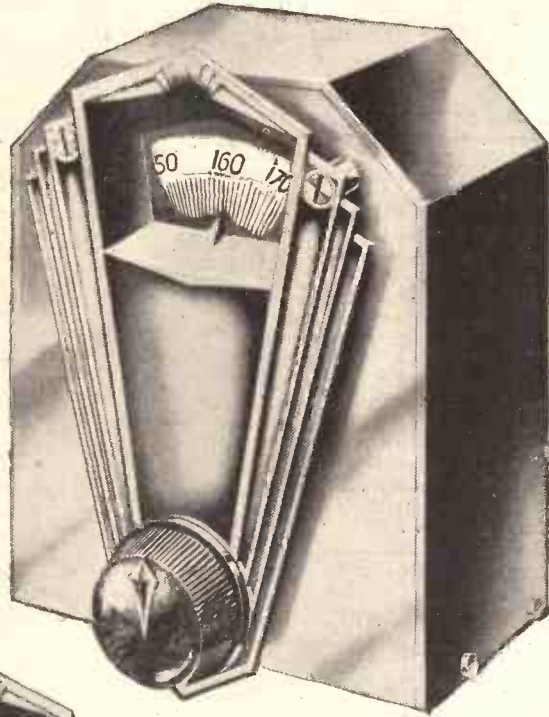

**TELSEN SMALL FRICTION DISC DRIVE.**  
A low-priced disc drive for auxiliary controls. It is extremely robust and may be used for main tuning condensers when such a course is advisable owing to considerations of space.  
No. W. 257 **2/6**

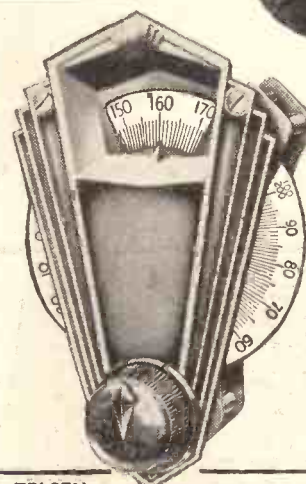

**TELSEN ILLUMINATED DISC DRIVE.**  
Fitted with a handsome oxidised silver escutcheon of modern design, this drive incorporates an improved movement. The gear ratio of approx. 5-1, and the bold and well proportioned figures, make for delightfully easy tuning. The dial may be illuminated by means of an ordinary flash lamp bulb. A double ended spanner, to fit all Telsen one-hole fixing nuts, is supplied free.  
No. W. 184 **3/6**

**TELSEN SLOW MOTION DIAL.**  
An exceptionally smooth-acting dial, with an approx. ratio of 8-1. There is no toothed gearing, so that it is impossible to strip the dial. The figures are clear and arranged to provide for right and left hand condensers.  
No. W. 141 (black)  
No. W. 141a (brown)  
**2/-**  
EACH



## TELSEN

### RADIO COMPONENTS

See the complete range of  
**TELSEN RADIO COMPONENTS**  
on STAND No. 66 at **RADIOLYMPIA**

**GOOD RADIO IS A JOY FOREVER**

ANNOUNCEMENT OF THE TELSEN ELECTRIC CO., LTD., ASTON, BIRMINGHAM

# The TELSEN AJAX 3



Bigger . . . better . . . packed with valuable information from cover to cover—the new Telsen Radiomag is undoubtedly the finest radio sixpennyworth ever offered. For it appeals to all—and all can profit by it. In simple language, illustrated by photographs and diagrams, and complete with 3 full size 1/- blue prints, it tells you how to build the latest circuits—how to modernise your existing set . . . how to rectify little faults . . . how to get the best out of your set in every way. **Get a copy Now!**



TOTAL COST OF  
TELSEN MATCHED COMPONENTS  
**61'6**  
FOR BUILDING THE AJAX 3,  
including panel, base-  
board, terminals,  
battery cords and all  
accessories.

**A** HIGHLY efficient "Straight Three" circuit, as easy to operate as it is to build, giving an exceptionally brilliant all-round performance, with a low initial and upkeep cost, the range, power, selectivity and general quality of reproduction setting a new standard for receivers of this type. Free full size 1/- blue print, together with full constructional details are contained in the new issue of the Telsen Radiomag, which also gives full particulars of the improved and now all-embracing range of Telsen Radio Components at the still lower prices made possible by Telsen's enormous sale. Now on sale at all radio dealers and newsagents. Price 6d.

## TELSEN

### RADIO COMPONENTS

See the complete range of  
**TELSEN RADIO COMPONENTS**  
on **STAND No. 66** at **RADIOLYMPIA.**

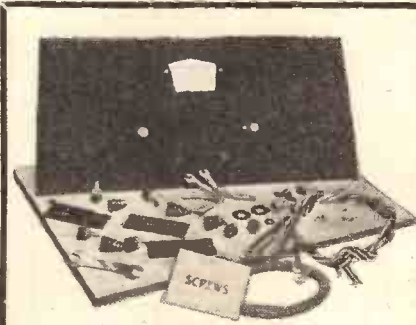

**"TELORNOR"**  
CONSTRUCTORS' OUTFIT  
Contains all the sundry requirements for the construction of any type of receiver circuits using the "Telornor." Of these the Telsen "Triple" 3, the "Ajax" 3, and the "Nimrod" 2, are excellent examples. All are supplied neatly packed in a carton together with instructions.

Cat. No. 220  
**3'6**

Included in the Outfit are the following components:

Specially cut and drilled crystalline-finish Panel. 14" X 10" Baseboard. 8-way Battery Card. Complete set of Wander Plugs, suitably engraved, and Spade Terminals. Terminals for Aerial, Earth and Loud Speaker.	Engraved Terminal Strips. An ample supply of 22 S.W.G. Tinned Copper Wire and necessary Sleeving for wiring up the set. A double-ended Spanner for mounting the single-hole fixing components.	A 4-way Spanner, for tightening up all Terminal Nuts. All the Wood Screws and sundry other small accessories contributing to the complete assembly of the finished Receiver.
--	--	--

## GOOD RADIO IS A JOY FOREVER

ANNOUNCEMENT OF THE TELSEN ELECTRIC CO., LTD., ASTON, BIRMINGHAM

# The 'MODERATOR' TWO

**A Small Set with  
a Big PUNCH!**



REGARD this receiver as a definite achievement, for it is able to do things which are beyond the powers of any conventional arrangement of two valves. This is not merely a matter of personal opinion. "P.W." is now equipped with a metal-

## WHAT THIS SET IS

An instrument which anyone can assemble without previous set-building experience. There is no soldering or other complicated mechanical work. It was specially designed (and is described) by G. V. Dowding, Associate E.E., and represents the last word in modern reception technique for its class.

screened testing room in which the qualities of a set can be accurately measured.

Thus, the "human element" is eliminated, and we do not have to rely on aural guesswork when gauging the sensitivity, selectivity and output qualities of our designs.

And a series of meter measure-

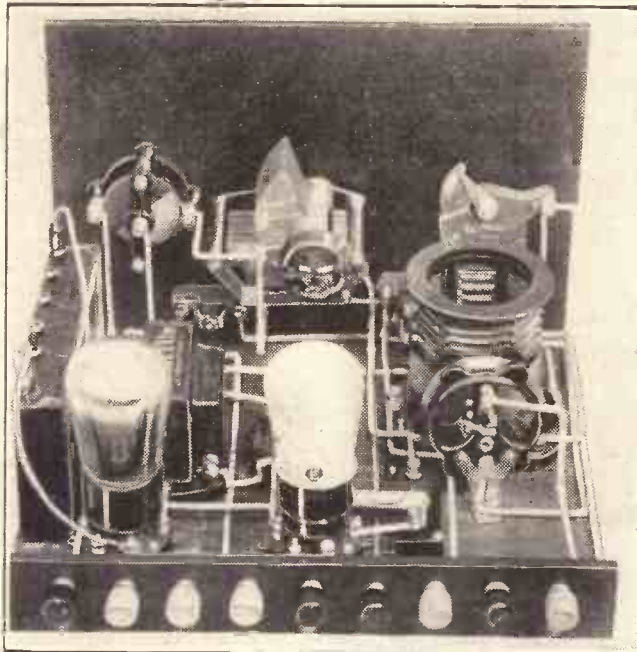

## BOTH BANDS PERFECTLY BALANCED

The long-wave stations are dealt with in the same virile manner as are those on the medium-waves.

ments discloses the indisputable fact that the "Moderator" Two is actually superior to some quite up-to-date three-valve sets, while judged as a "Two" it is very hot stuff indeed.

We do not confine our tests to the laboratory, however, and so our new "Two" has been

## WHAT THIS SET DOES

By employing the new "Moderator" scheme invented by P.W.'s Technical Editor, it enables loudspeaker results to be obtained that equal those given by many three-valvers. A perfect selectivity-power compromise is contributed by one easy-to-handle control.

well tried-out in different localities under normal home-radio conditions.

And it has set up some fine performances. On occasions, a score and more programmes have been tuned in on the loudspeaker by inexpert operators.

(Continued on next page.)

## EASY-TO-OBTAIN AND INEXPENSIVE PARTS

### LIST OF COMPONENTS.

- 1 Panel, 10 x 7 ins. (Peto Scott, Lissen, Goltone, Wearite, Permcot, Becol).
- 1 Cabinet to fit, with baseboard, 10 ins. deep (Peto Scott, Camco, Osborn, Lock, Pickett, Gilbert).
- 1 .0005-mfd. variable condenser, with slow-motion dial (J.B., Polar, Ormond, Wavemaster).
- 1 .00075-mfd. solid dielectric variable condenser (Polar, Ready Radio, Telsen, Sovereign).
- 1 .0001-.00015-mfd. differential reaction condenser (Ormond, Polar, Lissen, J.B., Igranic, Cyldon, Telsen, Ready Radio, Peto Scott, Graham Farish, Wavemaster).
- 1 Cosmic dual-range coil (Goltone, Wearite, Sovereign, Lewcos, Peto Scott, Ready Radio, Tunewell, Telsen H.F. coil).
- 1 Moderator coil (Ready Radio, Peto Scott, Goltone, Sovereign).
- 1 4-point push-pull switch (Telsen).
- 1 2-point push-pull switch (Telsen, Ready Radio, Lissen, Wearite, Tune-

- well, Peto Scott, Graham Farish, Goltone, Bulgin, Ormond).
- 1 L.F. transformer (Slektun 5-1, R.I., Ferranti, Telsen, Lissen, Igranic, Goltone, Varley, Graham Farish, Tunewell).
- 2 4-pin valve holders (Bulgin, Lissen, Telsen, Ready Radio, Wearite, Igranic, Ormond, W.B., Benjamin, Clix Goltone, Graham Farish).
- 1 .0003-mfd. fixed condenser (Lissen, Ferranti, Telsen, Graham Farish, Igranic, Dubilier, T.C.C., Sovereign, Goltone).
- 1 H.F. choke (Lissen, Telsen, Lewcos M.C., Tunewell, Peto Scott, Ready Radio, Varley, R.I., Wearite, Goltone, Sovereign, Graham Farish, Watmel).
- 1 2-meg. grid leak (with holder if required). (Dubilier, Igranic, Lissen, Graham Farish "Ohmite," Telsen.)
- 1 Terminal strip, 10 x 2 ins.
- 9 Indicating terminals (Bulgin, Belling-Lee, Clix, Igranic, Goltone, Ealex).
- Battery plugs and spades (Belling-Lee, Goltone, etc.).
- Flex, 18 gauge wire and sleeving, etc.

### ACCESSORIES.

**LOUDSPEAKER.**—(Ormond, Celestion, Blue Spot, H.M.V., Marconiphone, R. & A., Epoch, B.T.H., W.B., Clarke's "Atlas.")

**VALVES.**—1 Det. Marconi H.L.2, Mullard P.M.1H.L., Mazda H.L.2, Cossor 210.H.L., Osram H.L.2, Tungstram H210, Lissen H.L.2, Eta By2020.  
1 Power. Mullard P.M.2, Mazda P.220, Marconi L.P.2, Osram L.P.2, Lissen P.220, Cossor 215P., Tungstram P.220, Eta B.W.604.

**BATTERIES.**—L.T., 2-volt (Ediswan, Exide, Pertrix, Lissen, Oldham).

H.T. 120-150-volts, to supply 10-12 m/a. (Ediswan, Pertrix, Drydex, Magnet, Lissen).

G.B. to suit power valve (Ever Ready, Siemens, Pertrix, Lissen, Drydex, etc.).

**MAINS UNIT.**—To supply 15 m/a or upwards at 150 volts (Atlas, R.I., Heyberd, Tunewell, Regentone, Ekco).

# THE "MODERATOR" TWO

(Continued from previous page.)

The secret of the set's success is the system from which it takes its name—the "Moderator." This system is my answer, a pretty complete one too, to the problems raised by 1932 ether conditions, in so far as they affect listeners of moderate means unable to afford big bandpass S.G. and super-het. sets.

The "Moderator" system made its first appearance in the famous "Cosmic" sets, and the record reception results attained by these provide plenty of proof of the positive nature of its efficiency.

Circuits can easily be wangled about to look different, and it is no difficult matter to introduce "twists" which contribute nothing but novelty.

But the "Moderator" is not a mere

With a single-circuit tuning arrangement good selectivity plus power is indeed quite impossible. In order to achieve even a fair station-separation the aerial must be tapped so far down the tuning coil, or such a small series aerial condenser used, that the power is reduced enormously. One might just as well cut down the size of the aerial to hat-pin dimensions!

### Thrown Overboard.

But this flatness which inevitably accompanies full-power aerial tuning is a factor which I have actually turned to good account in the "Moderator"!

"Why not throw overboard any idea of sharp tuning in that

ment in order to counter unusual local conditions.

You will clearly see that the practical effect of the "Moderator" control is that

## THE ONLY SET OF ITS KIND

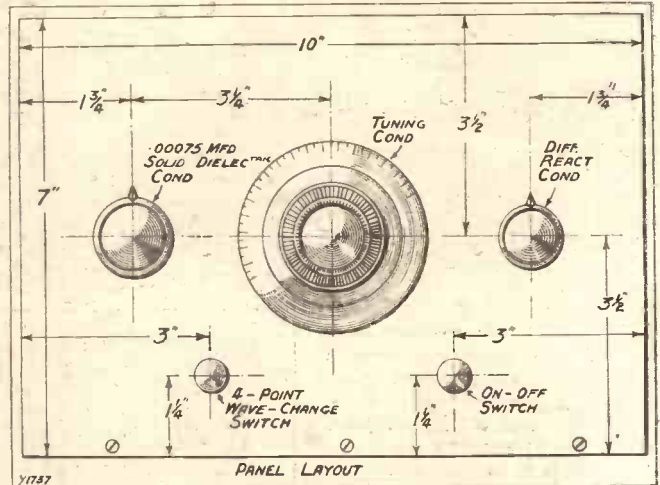

The Moderator system has not hitherto been available in a dual-wave two-valve set.

## VERY LOW RUNNING COSTS

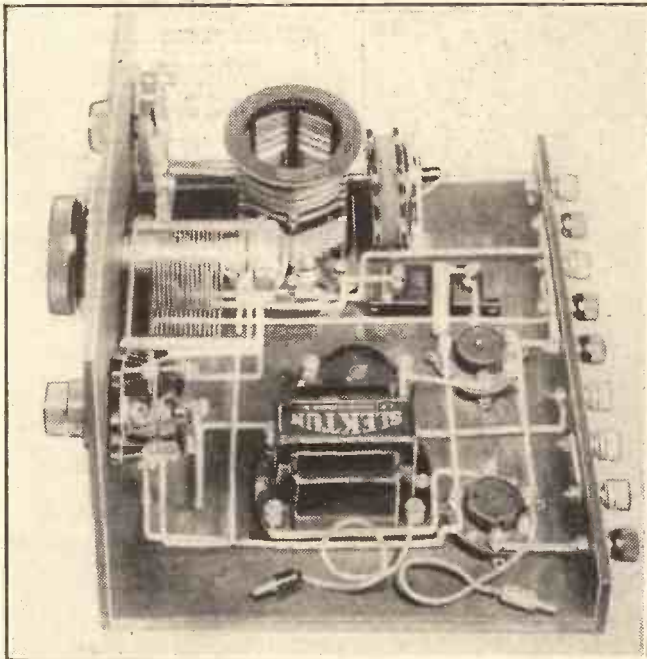

There being only two valves, this receiver costs very little in H.T. and L.T. But it uses these two valves to the very maximum of their effectiveness.

stunt like that. It does vital work and its effects can be appreciated by any listener who has handled at least one or two conventional sets.

I will briefly describe its action. First of all we must consider the standard "det" circuit. How, with no H.F. stage or stages, can sufficient selectivity be obtained to combat modern radio conditions?

### Unattainable Ideal?

Well, the only way is either to bring in the comparatively complicated band-pass, or reduce the aerial coupling and, incidentally, waste power.

Therefore, it would at first appear that an efficient broadcast receiver of an easy-to-handle, inexpensive character is an unattainable ideal.

aerial circuit characteristics as closely as is needed, and are thus able to conserve as much of the power as can be usefully employed. (In other words, the "Moderator" also operates as an ideal volume control, but this is not its main duty.)

The coupling between the "Moderator" coil and the tuner proper is variable, and this makes it possible to carry out an initial adjust-

aerial circuit altogether?" I argued. Leave the conventional aerial tuning condenser and aerial tuning coil for sharp station separation, and insert a five-shilling tuner with variable coupling—that seemed an obvious thing to do. (The two-band duties idea followed later).

And so that is, in essence, the "Moderator." You have a small compression condenser which you handle like a volume control, and a small coil.

These are capable of controlling the

by simply adjusting the "Moderator" condenser you can at once make your own compromise between selectivity and power.

### Just a Touch.

This flexibility is at your command all the time, while you are searching for stations, but you don't have to tune the

## THE "MODERATOR" TWO IS WIDELY ADJUSTABLE TO VARYING LOCAL CONDITIONS.

"Moderator" circuit closely while so doing—you just give it a touch now and then.

All this happens on the tightly-packed medium-wave band. When you work the wave-change switch and so go over to

(Continued on page 85.)

## INGENIOUS TWO-PURPOSE CONTROL

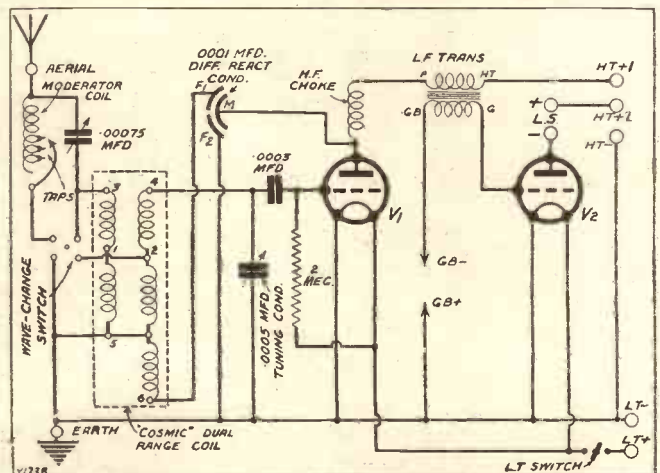

The wave-change switch automatically rearranges the Moderator coil and condenser connections, so that the control is effective on both bands.

# The TELSEN JUPITER S.G.3



**TOTAL COST OF TELSEN MATCHED COMPONENTS**  
**77/-**

**FOR BUILDING THE JUPITER S.G.3, including panel, baseboard, terminals, battery cords and all accessories.**



Utilising a brilliant circuit arrangement devised by Telsen technicians, ensuring the highest amplification under all conditions, with extreme selectivity, exceptionally wide range and superb quality of reproduction. Free full-size 1/- blue prints of this and other Telsen circuits, together with full instructions and a wealth of interesting and valuable information, including particulars of the improved and

now all-embracing range of Telsen Radio Components, at the still lower prices made possible by Telsen's enormous sale, are contained in the new, bigger and better issue of the Telsen Radiomag. Get a copy NOW—price 6d. from your radio dealer or newsagent.

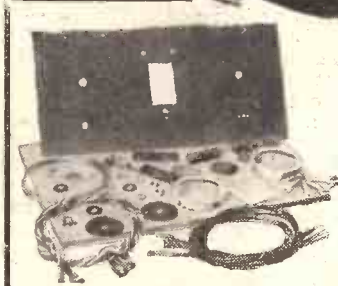

**DRUM DRIVE CONSTRUCTORS' OUTFIT**

Contains all the necessary requirements for the construction of the TELSEN "JUPITER S.G.3" but the constructor will find the outfit of great value in the building up of any receiver circuit employing the drum drive condenser assembly. No 219 **3/6**

**The Outfit Contains the Following :**

- |  |   |  |
|--|---|--|
| 1 Metal Panel with attractive crystalline finish, specially cut and drilled for mounting the Telsen Drum Drive, and other panel-mounted components normally required in a ganged condenser receiver. | 7 Wander Plugs mounted in holder                              | 1 Volume Escutcheon.   |
| 1 Baseboard 14 by 10 in.   | 2 Spade Tags  | 1 "On-Off" Escutcheon.   |
| 1 Aerial and Earth Terminal Strip  | 1 8-way Battery Cord  | 2 Height Plinths for the matched screened Coils.                             |
| 1 Loudspeaker Terminal Strip.  | 1 Cord Clip.  | 3/4 in. of 3 mm Sleeving (black).  |
| 2 Red Terminals complete and mounted in holder.  | 2 Large Insulating Washers.                                   | 1 1/2 in. of 3 mm. Sleeving (red).   |
| 2 Black Terminals complete and mounted in holder.  | 1 Small Thick Insulating Bush.                                | 20 feet of 1 1/2 mm. Sleeving (green).                                       |
|  | 1 Small Thin Insulating Bush.                                 | 21 feet of 22 S.W.G. tinned Copper Wire.                                     |
|  | 2 Spacing Nuts for the reaction and aerial series condensers. | 1 Double-ended Spanner for lock-nuts.  |
|  | 2 Spacing Nuts for the "On-Off" Switch.                       | 1 Fourway Spanner  |
|  | 1 Wave-Change Escutcheon with two screws and nuts.            | Assortment of 1/4-in., 3/8-in., 1/2-in., 5/8-in., and 1 1/2-in. Wood Screws. |
|  | 1 Separator Escutcheon  |  |

# TELSEN

## RADIO COMPONENTS

See the complete range of **TELSEN RADIO COMPONENTS** on **STAND No. 66** at **RADIOLYMPIA.**

# GOOD RADIO IS A JOY FOREVER

ANNOUNCEMENT OF THE TELSEN ELECTRIC CO., LTD., ASTON, BIRMINGHAM

# TELSEN VALVE HOLDERS SWITCHES AND GRID LEAKS

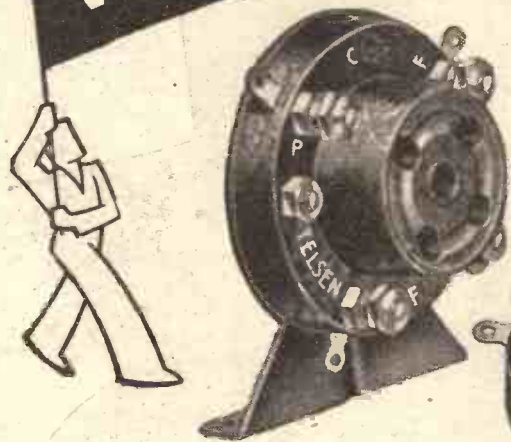

## TELSEN VALVE HOLDERS

A new range of valve holders has been introduced in both solid and anti-microphonic types. These embody special contact sockets of one-piece design with neat soldering tag ends and terminals. They have an extremely low self-capacity and are easily mounted.

SOLID TYPE		ANTI-MICROPHONIC	
NO.	PRICE	NO.	PRICE
4 Pin. W.224	- 9d.	4 Pin. W.222	- 1/-
5 Pin. W.225	- 1/-	5 Pin. W.223	- 1/3
W.198. Universal Type Valve Holder	-		- 1/-

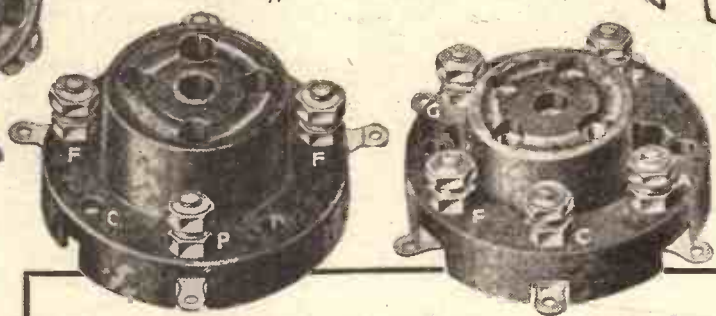

## TELSEN GRID LEAKS

These are absolutely silent and practically unbreakable, and do not vary in resistance with application of different voltages. They are non-inductive and produce no capacity effects.

CAP. MEGOHMS. NO.	W.	CAP. MEGOHMS. NO.	W.
5	W.254	1	W.250
4	W.253	1/2	W.249
3	W.252	1/4	W.248
2	W.251		

**1/4**

## TELSEN PUSH-PULL SWITCHES

employ the "knife" type of self-cleaning contact, and a positive snap action. The nickel-silver bridge-piece is driven between the springy "fixed" contacts, and the wedge-shaped plunger squeezes the inner contacts outwards, closing the jaws in a firm grip. The series gap reduces self-capacity to a minimum, and the spindle is insulated from all contacts. For use as battery switch, or as wave-change switch with the dual-range short-wave coil unit.

Two-point. No. W.107

**1/4**

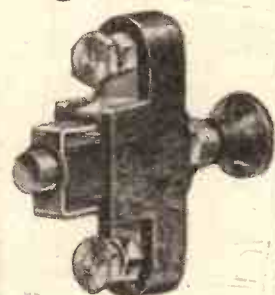

## TELSEN

### WAVE-CHANGE SWITCH

The wave-change switch for Dual Range Aerial Coil, or for breaking L.T. and H.T. circuits simultaneously.

Three-point No. W.108

**1/3**

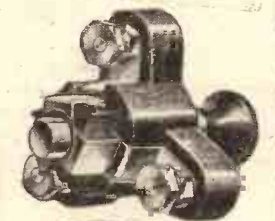

### TELSEN FOUR-POINT "TWO-POLE" PUSH-PULL SWITCH

This model is a two-pole switch highly suitable for use in wave-changing on two coils or an H.F. Transformer, or for switching pick-up leads or an additional loudspeaker.

**1/6**

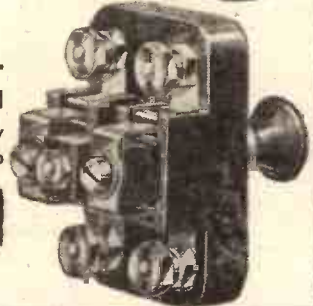

# TELSEN

## RADIO COMPONENTS

See the complete range of  
**TELSEN RADIO COMPONENTS**  
on STAND No. 66 at RADIOLYMPIA

# GOOD RADIO IS A JOY FOREVER

ANNOUNCEMENT OF THE TELSEN ELECTRIC CO., LTD., ASTON, BIRMINGHAM

**THE "MODERATOR" TWO**  
(Continued from page 842.)

long-waves, the "Moderator" condenser automatically becomes a straightforward

selectivity control, but not one that cuts the aerial coupling down to absurdly low limits—that is not needed on the long waves.

Differential reaction further assists in obtaining the highest effectiveness in regard to sensitivity. This, too, is a feature that was popularised by "P.W." And a third all-important item is the "Cosmic" tuner coil, and that completes a trio of unrivalled radio potency.

Now for a few words about the actual components. "Cosmic" coils are obtainable in two types, and either type is perfectly suitable, the only difference between them being the order and numbering of the terminals.

No Snags.  
The literature accompanying the coils shows you exactly how these terminals should be connected up—that is, in the case of the other type than the one shown in our wiring diagram.

There are no snags in this: you can't go wrong whichever "Cosmic" coil you buy, and all the makes available have been approved by us.

SEE THE "MODERATOR" TWO ON OUR STAND AT OLYMPIA.

The four-point push-pull switch is an essential item—that is, it is essential that it should be of the four-point push-pull type as specified, and the three-point kinds are not suitable alternatives.

Choose Your Own.  
All the other parts are similarly widely obtainable and are inexpensive. I can safely leave you to choose your own particular makes. In the second article, which will appear next week, I will give further constructional tips and operating notes.

**YOUR GUIDE TO THE EASY WIRING**

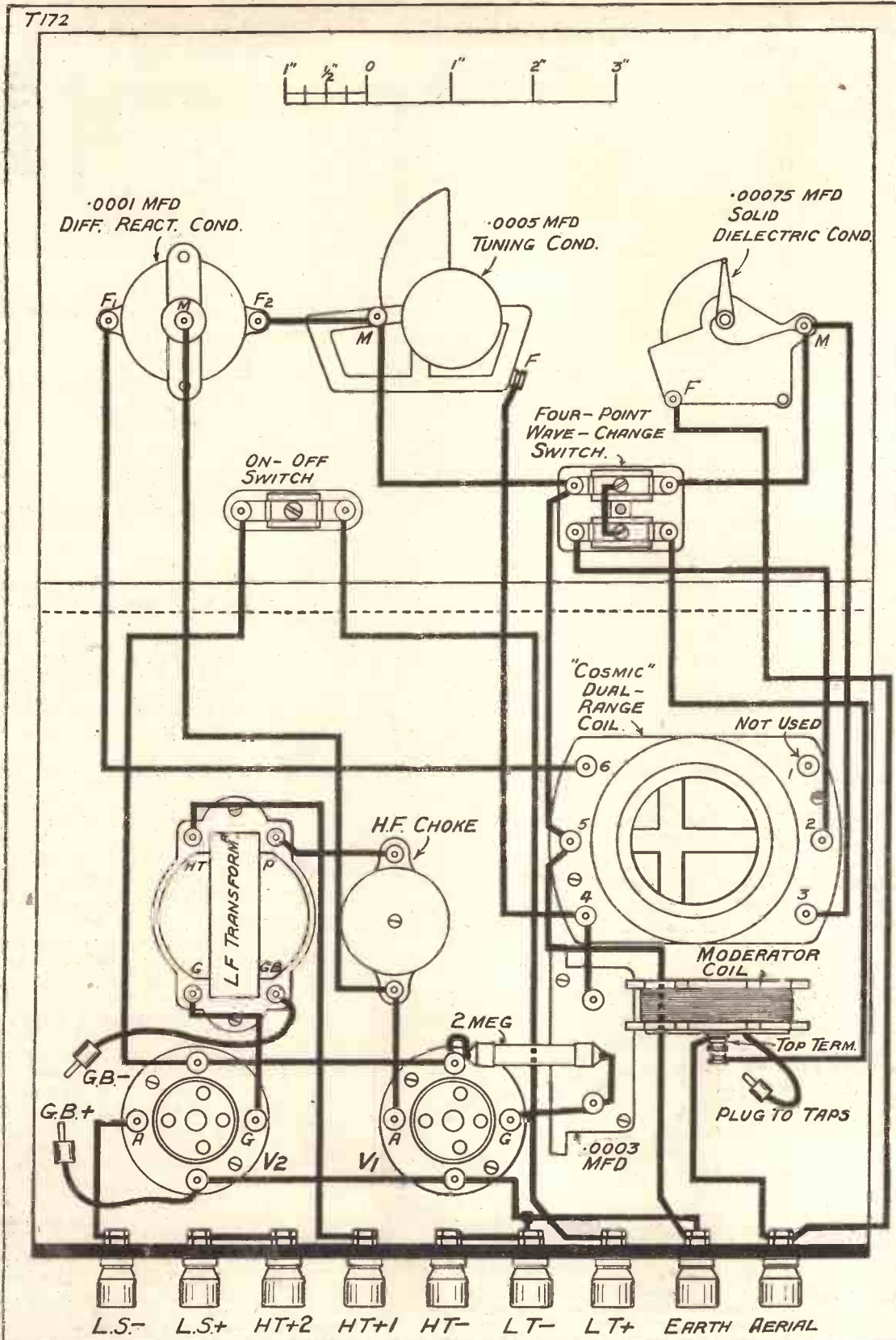

All the connections are perfectly straightforward, and there are no screens, baseboard foil covering or any such intricacy.



# A NEW TELEVISION SCHEME

By VICTOR KING.

This is the first announcement of an extremely interesting suggestion regarding television technique. Whether or not the scheme will prove to be practicable in the near future is a matter for conjecture, but our eminent contributor has certainly succeeded in opening up a prospect that seems full of possibilities.

I DO not claim that the following idea points to a solution of all television difficulties, but I, firmly believe it may indicate a way to overcome one of the biggest snags.

As you are no doubt aware, the ether is crowded and only a limited waveband can be allotted to each broadcasting station. According to the present arrangements the ether is partitioned off into bands nine kilocycles wide. From a practical point of view this means that a station mustn't spread more than 4,500 cycles.

## Sideband Spread.

The spread is caused by the speech and music modulations. If a powerful station were to transmit something having a frequency of, say, twenty thousand cycles, it would probably cause considerable jamming.

Now let us see how this limits television. For successful television the elements of at the very least  $12\frac{1}{2}$  pictures per second must be handled.

There are 4,500 cycles to play with. Each cycle can be reckoned as comprising two energy fluctuations, so there are 9,000 of these per second, i.e. 9,000 picture elements per second are possible.

But a minimum of  $12\frac{1}{2}$  pictures per second is needed, so that each picture can have only 720 of these elements. Put twenty-six rows of twenty-six dots on a piece of paper and visualise the crudity of the picture, which would result from the most skilful play on the density of these dots. Remember you can do nothing more than vary the "blackness" of individual dots—you couldn't shift their positions, though you could leave out any number in order to obtain white patches.

## Limitation of Detail.

It has been argued that the dot simile is a false one, because in actual fact the picture is built up by continuous rises and falls of energy. This can be countered by a reference to a number of disc perforations or lens analysers the television transmitter of to-day uses.

Each disc perforation (or its equivalent) takes a strip of the picture and traverses it. And the width of the resultant riband of picture is at once a limitation of the detail obtainable.

Thirty-two is the number of perforations employed in at least one well-known system, and that means rows of thirty-two picture points either vertically or horizontally. The number of rows depends upon another part of the transmitting system, but there can't be more than, say, about 25 or the transmission is going to spread too much—in passing, it can be gently hinted that television does appear to spread a bit beyond the official boundary at times!

With such elementary analysis as the above implies, the most costly and elaborate television experiment can result only in the crudest of two-dimensional pictures.

In an attempt to provide more detail the televisionists are experimenting with five and seven-metre wavelengths, for "down there" there is at present no crowding, and added to this is the confined radiation of such low wavelengths.

But I am convinced that for television to be a success within the next generation it

must be developed on the so-called medium or long waves. And at long last I come to my idea.

It is that we should take advantage of and use the harmonics of a medium or long-wave transmission. I visualise that this could be done by patterning two or three or even more closely adjacent wavelengths.

## Special Receivers.

It is not hard to design receiving equipment which will generate and emphasise the harmonics of a medium or long wavelength. (As it is, one often hears the harmonic of a medium-waver while tuning in short-wave stations.)

The harmonics are, of course, higher in frequency than the fundamental wave and so they comprise a greater number of energy fluctuations.

But, you might well say, how can a picture element representing, say, a frequency of one hundred thousand cycles be passed through the ether without causing a side-band spread of one hundred kilocycles?

Well, according to my plan, that one-hundred thousand frequency is represented in the ether by a particular patterning of a number of separate but closely adjacent wavelengths—the whole bunch being, of course, well within the 4,500-cycle boundary (each wavelength would be separately modulated).

## Using the Harmonics.

I have the idea very clearly in mind, and have actually carried out some experiments though I am finding it difficult to put it on paper in simple words. But you will gather that I use the harmonics both in transmission and reception and that I play on the coincidence in these of beats between the harmonics of the separately modulated wavelengths. The receiver picks up the transmission as a single carrier and its sidebands, though in actual fact it comprises a medley of modulated carriers.

It is a rather revolutionary scheme and I freely admit the possibility of snags when, if ever, an attempt is made to produce simple and inexpensive apparatus capable of carrying it out in practice.

*[EDITOR'S NOTE.—We should have been inclined to regard Mr. King's idea as insufficiently detailed for description in a practical journal like "P.W." had he not been able to give a demonstration. But his apparatus is at present extremely crude and his results, which are certainly rather striking, may or may not be due to the reasons he outlines in the above article. However, he has promised to give all the future news, if any, regarding his invention exclusively to "P.W."]*

## ACOUSTIC ART

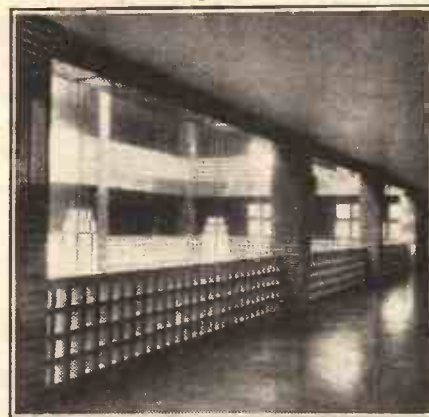

In this modern building—Berlin's Broadcasting House—the light, airy partitions have the advantage that echo is eliminated.



# TELSEN L.F. TRANSFORMERS



THE "Telsen" Ace is eminently suitable for Receivers where highest efficiency is required at low cost and where space is limited. As its characteristic curve will show, it gives a performance comparable with that of the most costly transformers—at only a fraction of their price.

RATIO 3-1 No. W.66

RATIO 5-1 No. W.65

**5/6**

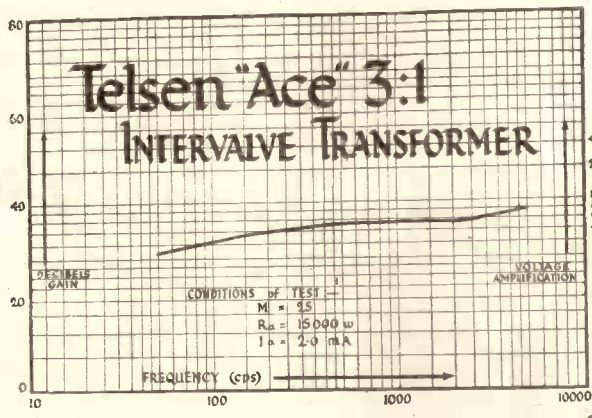
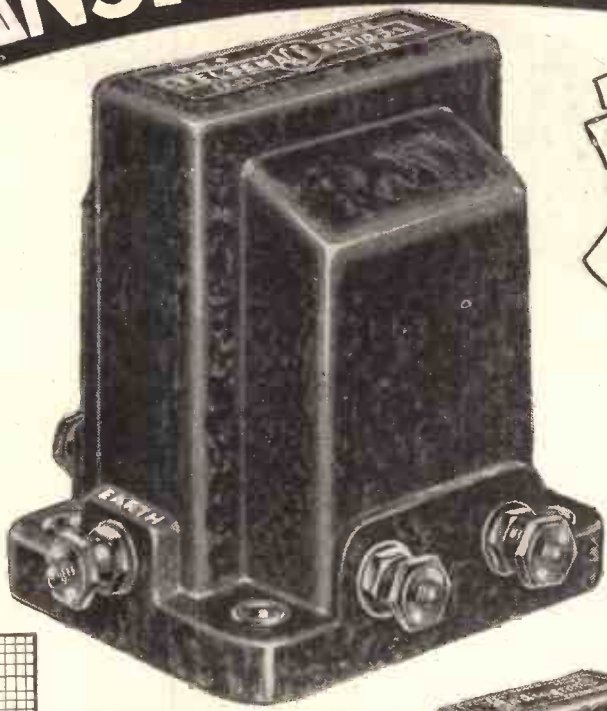

## TELSEN "RADIOGRAND" L.F. TRANSFORMERS.

Telsen "Radiogrand" Transformers have signified to expert designers and enthusiastic constructors all that is finest in British Radio craftsmanship. The design is based on the results of recent research coupled with the soundest engineering principles, tested rigorously for immaculate performance and enduring efficiency.

RATIO 3-1. No. W.59.  
RATIO 5-1. No. W.58.

**7/6**

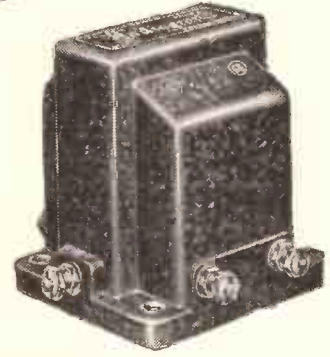

## TELSEN "RADIOGRAND" (Ratio 7-1) TRANSFORMER.

This Transformer is designed to give extra high amplification on receivers employing only one stage of L.F. amplification. It is not recommended for use in receivers employing two L.F. stages, as overloading is likely to occur.

No. W.60

**10/6**

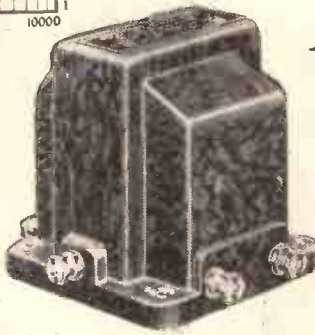
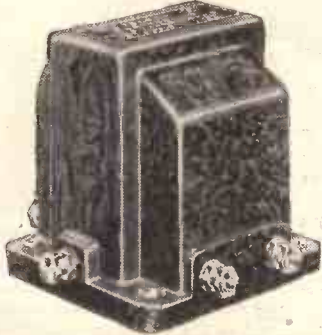

## TELSEN "RADIOGRAND" INTERVALVE TRANSFORMER. Ratio 1.75-1.

For use in receivers employing two stages of L.F. amplification, where exceptionally good quality is desired. When used following an L.F. stage employing choke or resistance coupling it will be found to give ample volume with remarkable reproduction. No. W.61.

**10/6**

See the complete range of  
**TELSEN RADIO COMPONENTS** on  
STAND No. 66 at  
RADIOLYMPIA

**TELSEN**  
RADIO COMPONENTS

**GOOD RADIO IS A JOY FOREVER**

ANNOUNCEMENT OF THE TELSEN ELECTRIC CO., LTD., ASTON, BIRMINGHAM

# TELSEN

# CHOKES

COUPLING, OUTPUT,  
AND SMOOTHING

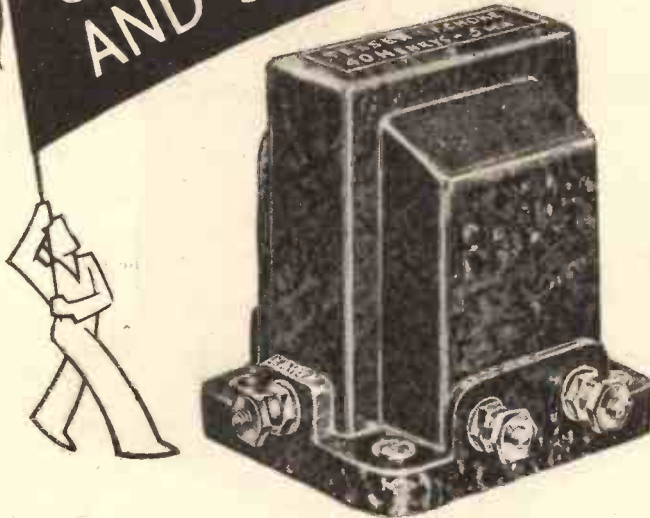

**TELSEN INTERVAL L.F. COUPLING CHOKES**  
These popular L.F. Chokes are primarily intended for use as coupling chokes, but may be used in any circuit not carrying more than the stipulated maximum current. The 100 H. type is for H. or H.L. type valves, the 40 H. type for L. type valves.

RATING	NORMAL CURRENT	MAX. CURRENT	NO.
40.H. at	5.M.A.	10.M.A.	W.68
100.H. at	3.M.A.	8.M.A.	W.69

5/-

**TELSEN TAPPED PENTODE OUTPUT CHOKE**

This choke is designed primarily for pentodes taking an anode current of not more than 20.M/A which includes the ordinary battery operated types. The single tapping provided gives (by reversing) ratios of, 1-1, 1.6-1, 2.5-1, which provide for matching under widely varying conditions. The choke is equally suitable for matching a low impedance speaker with an ordinary power valve. A coupling condenser of 1.Mfd. is recommended.

No. W.72

7/6

**TELSEN POWER PENTODE OUTPUT CHOKE**

The purpose of this power pentode output choke is to prevent direct current passing through the Loudspeaker, and also to match the speaker to the pentode valve. By using this choke in conjunction with a condenser of 1.Mfd. the quality obtained from a pentode becomes quite equal to that expected from a normal super power valve, and the volume is much increased. This model is suitable for mains power pentodes carrying currents up to 40 M/A and for correct matching gives the choice of three ratios, viz:—  
1-1, 1.3-1, and 1.7-1.

No. W.172

10/6



**TELSEN OUTPUT CHOKE**

Designed for use as an Output Filter in conjunction with a condenser not less than 1 Mfd., following any power or super power valve taking up to 40 M/A anode current. Gives an ideal response curve under all conditions.

No. W.71

7/-

# TELSEN

## RADIO COMPONENTS

See the complete range of  
**TELSEN RADIO COMPONENTS,**  
on STAND No. 66 at **RADIOLYMPIA.**

**GOOD RADIO IS A JOY FOREVER**

ANNOUNCEMENT OF THE TELSEN ELECTRIC CO., LTD., ASTON, BIRMINGHAM

# Mains Unit Problems

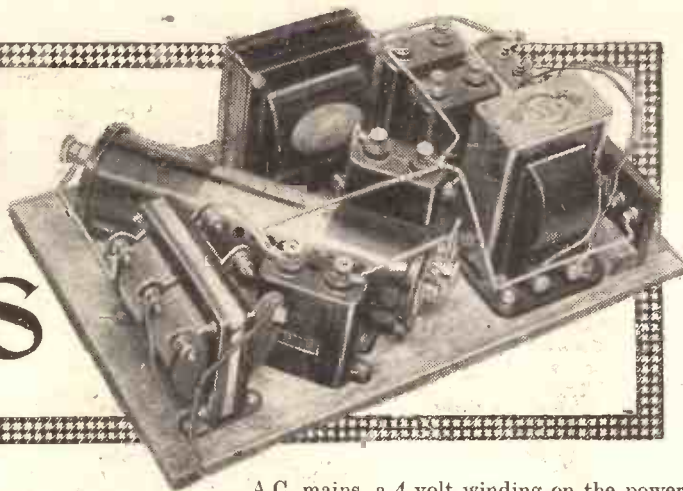

If you have not changed over to mains operation already the chances are that, when you do, you will start off with a unit for H.T. supply only. This is a sound scheme and a very popular one, too. Not only does it cut out most of the expense and trouble of battery maintenance, but it also gives new life and power to your receiver. In addition, this arrangement is more flexible and less complicated than an all-mains installation, which, of course, can follow in easy stages later.

When you finally decide to break away from the restrictions and expense of H.T. batteries, one of the first problems you will

**BY J. ENGLISH.**

When buying a mains unit the purchaser is faced with many problems that require settling before he makes his final choice. Output voltage, current required, valve or metal rectification—they all have to be considered, as our contributor explains.

A.C. mains, a 4-volt winding on the power transformer for future A.C. valves, is the only way of meeting his requirements of full flexibility.

It is easy enough to cut down an excess of H.T. voltage until the full output of the unit can be used at a later date. To save any possible scrapping of components it is a good idea to incorporate in the first place smoothing equipment capable of handling the full output of current and voltage.

If you are undecided whether to use a valve or metal rectifier, points to remember are that the latter is rather more efficient than the valve, while its useful life is very considerably longer. On the other hand the valve rectifier is cheaper and more flexible in output: there are so many

current rating, in any unit, the H.T. voltage drops rapidly and, conversely, rises as less current is taken from the unit. This interdependence of voltage and current is an important factor in mains working.

D.C. mains units are very much less expensive for a given output than the A.C. types, and if you have D.C. mains it's better to choose a unit on the generous side as regards current requirements. In addition, the maximum voltage of the unit cannot exceed that of the mains supply, while the voltage drop with increase of current is not quite so marked as in the A.C. units.

**Current is Never Steady.**

The important specification in a D.C. unit, however, is adequate smoothing. Your mains may be called D.C., but the current supplied is never a steady one; a cheap unit with inadequate smoothing will let through more hum than you can tolerate.

The keen experimenter changing over to mains H.T. for the first time is hardly likely to be satisfied with the rather restricted supply of a commercial unit. Making up an eliminator with, in the case of

**VOLTAGE CONTROL**

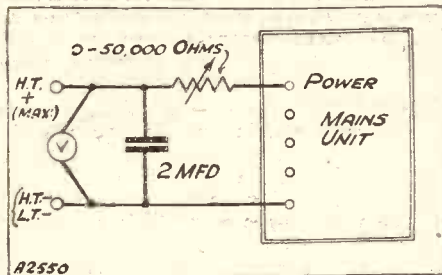

A2550  
If a mains unit gives too high a voltage, the output can be readily cut down by inserting a variable resistance and fixed condenser, as indicated.

have to solve is what type and size of mains unit to buy. Obviously, it is false economy as well as asking for trouble to purchase one which is too small for your present set, or for the bigger receiver you hope to build shortly.

The smaller commercial units rated at 12 milliamperes output have only a sufficient margin to cope satisfactorily with the demands of a two-valve receiver, where the second valve is a small power-valve. If you want to get the best results with a three-valve receiver, especially where a comfortable size power valve is used, a unit with an output of at least 20 milliamperes is desirable.

**Margin for Alterations.**

If I were choosing a unit for this type of set I should specify an output of 25 milliamperes at 150 volts, which would give a margin for possible alterations in valve stages and for a slightly larger output valve if required.

Another point to bear in mind is that the unit must be capable of delivering its full rated current at the specified maximum H.T. voltage. When you exceed this

**AN OUTPUT CURVE**

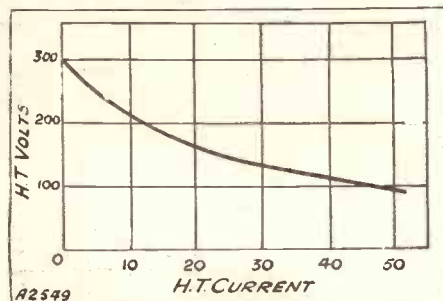

A2549  
A curve illustrating how the output voltage of a power unit varies with different currents.

different types that a valve can be chosen to give almost any desired voltage and output current.

After you have installed your mains unit you naturally begin to wonder what working voltages are being obtained at the H.T. terminals. This is often a difficult question for many people to answer to their own satisfaction, especially when they are told that readings taken with a voltmeter are all wrong.

**Something Very Near.**

A mains unit is quite unlike an H.T. accumulator or new H.T. battery of low internal resistance where terminal voltage is practically independent of the current taken. Plug in at 100 volts and you can be sure of getting something very near that voltage. Connect your output valve to the power tapping of a mains unit, however, and the terminal voltage may be anything between 100 and 150 volts.

(Continued on next page.)

**ALWAYS DECOUPLE**

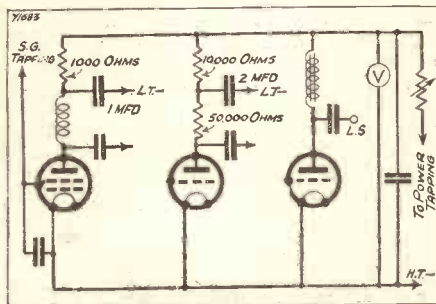

When employing a mains unit with a multi-valve receiver it is highly important thoroughly to decouple the valves. This applies most particularly to the detector.

## MAINS UNIT PROBLEMS

(Continued from previous page.)

The cause of the peculiar behaviour of the mains unit is its relatively high internal resistance, the path through which the H.T. current flows being made up of rectifier, transformer secondary, smoothing chokes, and feed resistances. Consequently, the larger the H.T. current the bigger the voltage drop across this combined resistance—the net result being a smaller voltage at the H.T. terminals.

If, on the other hand, only one or two milliamps are allowed to flow, then the H.T. voltage may be higher than the voltage of the A.C. mains. The only way to be sure that the voltages of each tapping are reasonably close to those indicated on the unit is to see that the current taken from each is just that prescribed by the makers.

variable so that no other series resistances are then required.

When this method of reducing output is adopted or when you have a little output current to spare, it is a very good idea to have a pilot voltmeter permanently connected across maximum H.T.+ on receiver and L.T.—.

### Common Feed System.

If, at the same time, you use the common H.T. feed system, which we shall come to presently, you know at a glance where you are as regards H.T. volts. This pilot voltmeter need not be an expensive instrument; the main requirement is that it should not take more than some 5 ma. at full scale reading.

Another problem that often has to be tackled when first installing a mains unit is motor-boating. You are not likely to run into this sort of trouble if the receiver is of modern design with proper decoupling. However, if the set is not quite up to date in this respect and especially if new valves

common H.T. voltage to be used. This brings us to the idea of a single H.T.+ terminal connected to the power tapping on the unit, the other tappings not being used, except perhaps in the case of the S.G. tapping. There is then only one supply voltage to watch and this can be taken care of by the pilot voltmeter already mentioned.

Any discussion of mains unit problems would be incomplete without some reference to mains hum which may or may not give you trouble when first installing your power unit, whether A.C. or D.C. Usually the trouble manifests itself as an annoying background of hum, although I have known bad cases where the hum swamped the programme. However, you are not likely to get such a bad snag as that and in any case the trouble usually yields to simple treatment if tackled in the right way.

### Not Sufficient Smoothing.

Mains hum may be due to several causes, one or all of them acting at once, the latter being more especially the case in all-mains installations. With mains H.T. supply, matters are usually not so complicated, the principal causes of hum being insufficient smoothing, an overloaded unit, interaction between mains transformer or smoothing choke and L.F. transformers or chokes in the receiver, especially in a compact home-constructed installation, or a poor earth connection.

Another type of hum which can be extremely annoying, as it eludes all remedies but the right one, is modulation hum. Here the hum actually modulates the H.F. signal and is only heard when a strong station is tuned in, usually near the lower part of the dial.

### The Only Certain Cure.

The only certain cure is two .1-mfd. condensers, high voltage test, connected in series and across the mains transformer secondary, earthing the common connection between the condensers. This eliminates all the hum, removes any previous distortion and often improves volume. The same scheme will deal with any modulated H.F. spuriously generated by a rectifier valve and also, across the mains themselves, with any unwanted H.F. filtering through from this source.

When you are making any of these adjustments for hum elimination, have the receiver detuned from any signal, with the loudspeaker adjusted to its most sensitive state. The effect of any adjustment will then show up more definitely.

## POPULARISING RADIO IN PRUSSIA



The Germans make every effort to popularise broadcasting, and their aim is to make each member of the community a radio listener. One method is to employ loudspeaker vans fully equipped for first-class reproduction to delight the villagers.

One way of making sure that your valves are not getting too much H.T. is to measure their anode currents with a milliammeter. If the current is greater than that specified by the valve manufacturers for the required H.T. and proper G.B. volts, then the supply voltage must be reduced.

There is no object in intentionally running amplifying or output valves at less than maximum rated H.T. volts when there is voltage to spare. This is sheer waste of current and the real benefits of mains operation are being thrown away.

### An Essential Condenser.

If the voltage of your mains unit is too high when drawing all the current you require at present, the excess volts can be dropped across a variable resistance, power type, in series with the lead to the power terminal on the unit. A fixed condenser of not less than 2-mfd. high voltage test, is then essential across H.T.+ on receiver and L.T.—. Incidentally, this series resistance also assists smoothing.

The other tappings on the unit will also give slightly higher voltages if the full-rated current cannot be taken from each. However, in a good unit these tappings are

are fitted, then you are almost sure to get some L.F. instability; if not an audible racket, then an insidious form of distortion even if the set has functioned quite satisfactorily with H.T. batteries.

### High Internal Resistance.

In such cases the trouble is due to the mains unit's relatively higher internal resistance, to which reference has already been made, constituting a common impedance in the anode circuits of all valves. Consequently the output stage is back-coupled more or less strongly to the preceding valves, and L.F. reaction in some form or other is the result.

The only cure worth consideration is decoupling—a resistance in the H.T.+ lead with a large fixed condenser at the anode end in shunt to earth to isolate the valve as regards L.F. impulses from the mains unit. Although the theoretical ideal is to decouple all valves but the last, you will find in practice that it is sufficient to decouple only the detector and any L.F. stage before the output valve.

The decoupling resistances can be chosen of such values that they produce just the right voltage drop for each valve for a

## IMPROVING REACTION

A useful tip for sets with insufficient feed back.

With a view to improving reaction effects, it is often advised that a small capacity should be connected between the filament and plate of the detector valve; and, in order to ensure the correct value for this, it is sometimes the practice to employ a compression-type condenser for the purpose. As such condensers are usually incapable of standing up to comparatively high voltages, such tests should be carried out with a fairly large fixed condenser, such as a .001 mfd. in series with the compression condenser.

# "HIS MASTER'S VOICE" at Olympia, STAND NO 55 (GRAND HALL)

In addition to the four new instruments illustrated, "His Master's Voice" will show at Olympia, the following range of models for the new season:—

	PRICE
MODEL 501 <i>Transportable Radiogram</i>	25 guineas
MODEL 435 <i>De Luxe Radio Four</i>	17 guineas
MODEL 174 <i>Super-Power Speaker</i>	£7. 10. 0
MODEL LS7 <i>Universal Speaker</i>	£4. 15. 0
MODEL 116 <i>Record Player</i>	7 guineas
MODEL 117 <i>Auto-Record Player</i>	12 guineas
MODEL 553 <i>Auto-Electrogram</i>	42 guineas

Current models which have proved so enormously popular during the past season, and which have established a new standard in the reproduction of broadcast and recorded music, will also be continued.

Visit the "His Master's Voice" Stand—see and hear these instruments . . . examine the many improvements in the range. And whatever else you do, you must see the pre-release showing of the most wonderful industrial 'talkie' yet made. Demonstration Room D18. Free tickets will be obtainable at Stand No. 55.



Superhet  
Portable Six.  
17 gns.  
Model 459

Superhet  
Lowboy Seven.  
32 gns.  
Model 470.



Superhet  
Ten Auto-  
radiogram.  
80 gns.  
Model 532.

Superhet  
Radiogram Seven.  
50 gns.  
Model 523.

## His Master's Voice RADIO — "True to Life"

The Gramophone Co. Ltd., London, W.I.



**WHERE ONLY THE  
BEST WILL DO**

**SLEKTUN**

**SUPER TRANSFORMER**

*Specified for*

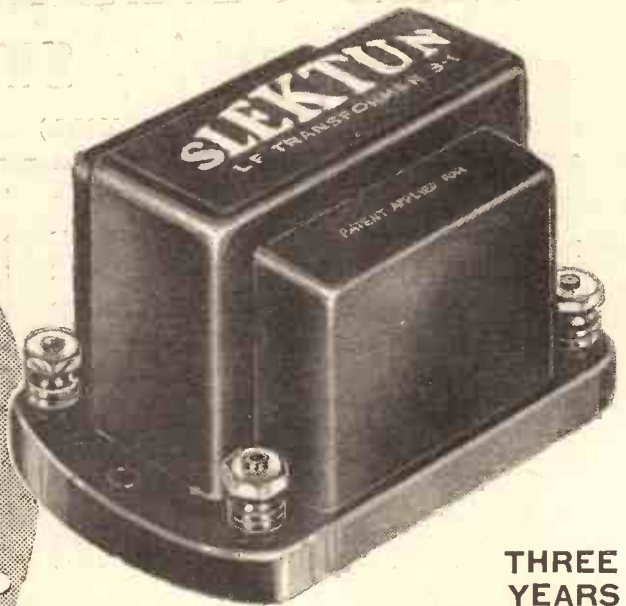

**THREE  
YEARS  
GUARANTEE**

**THE MODERATOR TWO**

**SELECTED  
FOR ITS FINE  
RESPONSE AND  
QUALITY AMPLIFICATION**

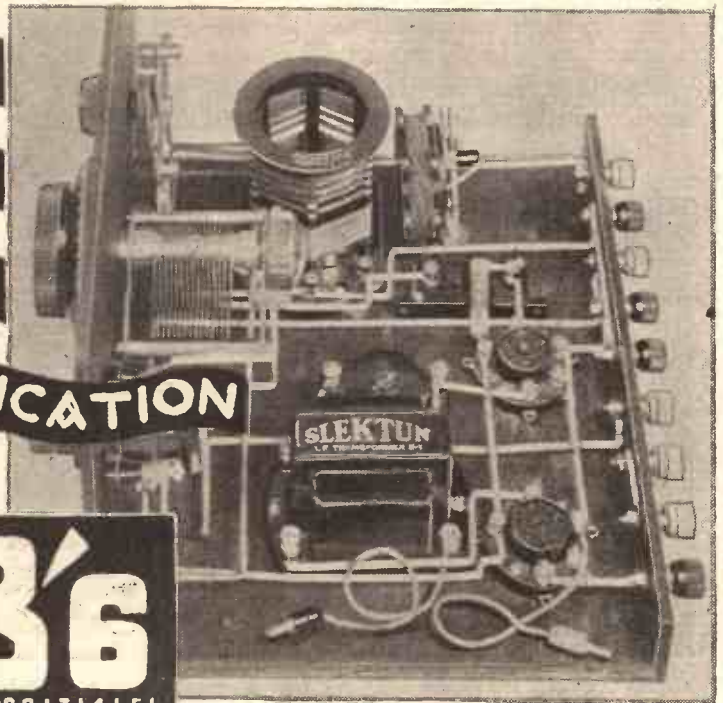

**L**EADING set designers and discriminating constructors are turning to Slektun—the Super Transformer. There is reason in their choice—four reasons for their preference:—

1. Specially constructed silicon iron core of very high permeability.
2. Patented process eliminates all possibility of short-circuited turns.
3. Ends of all windings hermetically sealed.
4. Paper insertions between every layer of windings.

These are the reasons for the Slektun Super's unfailing dependability—the reasons for the three-year guarantee.

**8'6**  
RATIOS 2-1,3-1,4-1,5-1

**SLEKTUN PRODUCTS, LTD.**  
21, DOUGLAS STREET, WESTMINSTER, S.W.1.



# What is a "Variable Mu"?

by M.G. SCROGGIE B.Sc., A.M.I.E.E.

**L**ET'S call it a Horse-Eliminator!"

"But it doesn't alminate horses, unless it runs over them, and it's not meant to do that."

"True. Well, how about a Horseless? It doesn't require a horse to pull it."

"That's just as feeble. According to that argument you might just as well call it a Kangarooless or a Hummingbirdless."

"Well, then, an All-Wheel Car."

"Doesn't that apply to the old carriage as well?"

"Yes, but there are more wheels in the new one."

"I don't think much of that either. Let's call it a Fast Wheeler."

### Silly Suggestions.

"But sometimes you want to go slow in it. What then?"

"Oh, I don't know. What about Motor-Car?"

Carried unanimously.

So one can think of an imaginary conference to decide on the name to be given to the first motor-driven road vehicle. But nobody who counts for anything seems to have sat down to think out sensible names for the most modern field of invention. The silly suggestions above are not one whit sillier than terms that are being coined now. We blame the past for queer unsuitable names and customs that survive, and yet radio seems of all things to be the most unfortunate in its nomenclature.

"Wireless" itself, for instance. To name a thing by what it is not is at all times a feeble and negative procedure, but in this case it is worse, for it is the ubiquity of wires in "wireless" apparatus that forms the basis of that hoary old joke that keeps cropping up every so often.

### Ruthless Attack on Batteries.

And is the chief function of a "battery eliminator" to eliminate batteries? There is a Keatings Powder flavour about the name that seems to be out of harmony with its real purpose. The fact that since the introduction of the device that bears this name the number of batteries in the world has vastly increased has not prevented it from carrying out its normal duty of quietly supplying current to receivers. A ruthless attack on batteries with a view

Have you ever thought of the queer, unsuitable names that are given to radio terms? "Wireless" itself, for instance, or "A.C. voltage"—these names are misapplied. And, when you come to think it out, the term "variable mu" is no exception, as our contributor points out in an amusing fashion.

to their complete extinction is far from the mind of the peaceful "battery eliminator."

Now that the use of these separate units to feed receivers is dying out in favour of self-contained sets, the unknown demons who invent these titles have handed us another to keep us up to date: "All-Electric!" Nobody has yet succeeded in explaining satisfactorily how this distinguishes receivers which are driven by electricity generated at a central station

and lift up a manhole, and besides, I am sure the Electricity Company wouldn't like it. No, it is much easier to connect it to the branch line that comes right into the house. It is uncertain whether it is pride or merely ignorance that leads people to imagine that they are given a supply of electricity direct off the mains, as if nobody else mattered.

### Does Everybody Know?

We distinguish these electricity supplies by the abbreviations A.C. and D.C., which, as everybody knows, stand for alternating current and direct current respectively. But does everybody know? If so, why is it that so many people speak of "D.C. current"? The precise significance of this term is difficult to trace: one might venture to suggest that one of the words is superfluous. A.C. voltage is bad enough. I

have a strong suspicion that what is really meant is alternating voltage. Then why mix it up with current?

"High Tension" is a term which has been clearly defined by the authorities. It refers to electrical pressures from 650 to 3,000 volts. It was ludicrous enough when this standard term was perverted to use in connection with batteries of 50 or 100 volts, but when four-electrode valves became popular some years ago the anomalous position was reached that the "high-tension" battery was sometimes

of lower voltage than the low tension!

Another expression associated with jokes—and rightly so—is "loudspeaker." It is true that it is a fair description of some of these appliances, but surely a name should embody some feature that is essential in the object named, and mercifully loudness

(Continued on next page.)

## HE MAKES THE STATIONS BEHAVE

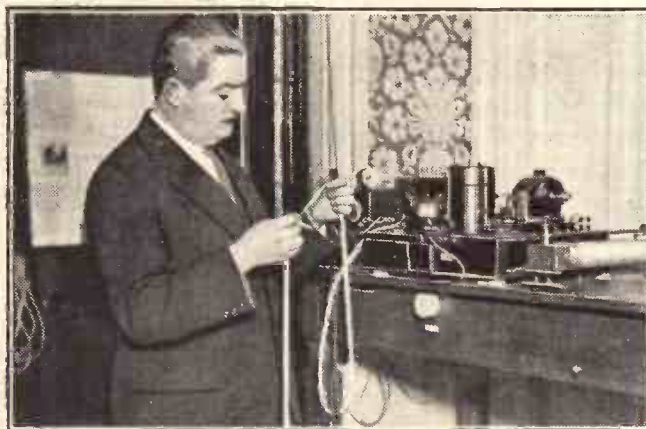

M. Brillard, of the International Union of Radiotelephony, studying the tape which shows whether any broadcasting stations are deviating from their appointed wavelengths. They hear about it if they are!

from those driven by electricity generated in the room by means of batteries. It is just another case of feeble thinking.

"Oh, well," you say, "one can always call it a mains-driven receiver." But why "mains?" I have yet to see anybody connect a receiver to the mains. It is such a lot of trouble to go out into the street

## WHAT IS A "VARIABLE MU"?

(Continued from previous page.)

is no essential feature of a loudspeaker.

I believe the origin of this misnomer is a confusion with the *Lord Speaking Telephone*, which Mr. Alfred Graham produced for use in the navy, and which was distinguished from the ordinary telephone by the fact that it could be heard without going up to it and applying one's ear to it. But that has nothing to do with radio.

The other end of the system also unhappily labours under an association with the past, a sort of ductless gland which does nothing but remind us of a distant ancestry. We used to be taught that "microphone" is derived from two Greek words meaning "small sound." My dictionary says so, any way. If so, why does the B.B.C. employ a combination of 114 musicians to make the small sound with which the microphone is intended to ideal? Is the sound emitted by the Wireless Military Band characterised by smallness?

Then, while the programme is somewhere between microphone and loud speaker, it is described as a "signal." That was quite a good word in the old days, but nobody seems to have thought of one which is more appropriate to broadcasting. After all, if you told a lady singer that you were going to the Queen's Hall to hear her signals she would assuredly be insulted. But how *can* you describe what is being handled—or mishandled—by your amplifier?

### "Electric Soundbox."

If you despise broadcast programmes and turn for entertainment to the disc, you make use of a "pick-up." Now I cannot

point to any palpable inaccuracy in this expression, but there is something about it which does not seem quite in keeping with the dignity with the art or science of electrical reproduction of sound.

I was associated at one time with a concern that manufactured what it fittingly described as an "electric soundbox." But do you think that anybody could be persuaded to call it anything else than a pick-up?

In close connection with the pick-up is a component which is grandiloquently alluded to as a "potentiometer." The word itself is a cross-breed, partly Latin and partly Greek, but it couldn't help that. What makes it blush for shame is that it really belongs to one of the most precise and

refined electrical measuring instruments, and it is not used to being tagged on to a common volume control that measures nothing, except another shilling or two into the dealer's till.

Talking about volume control, there is a valve which is supposed to make it easy, and as usual, we swallow the American name for it. America has enriched the English language by many elegant expressions, such as "Oh, yeah!" and "Sez you!" but when it comes to radio there ought to be a protective tariff.

### Pardonable Association.

This valve is known as the "variable mu." Apart from its pardonable association by the layman with the feline tribe, it is liable to confuse even the technically-minded, for one of the principal characteristics of a valve is its amplification factor, denoted by  $\mu$  (pronounced "mu"). What more reasonable than to suppose, therefore,

## THE EYES AND EARS OF BROADCASTING



The main control-room or "inner sanctum" of the engineers' department in Broadcasting House, Berlin. From this small cabinet the man in charge can keep an ear on the programmes and an eye on the rest of the department.

that the amplification factor of this valve is variable? Unfortunately it happens to be the only characteristic of the valve that does not vary to any great extent. The explanation which is commonly given is that it is short for "variable-mutual-conductance." Though the last to wish to inflict the name of "variablemutual-conductancevalve" on anybody outside Germany. I really believe something better might have been done in the abbreviating process.

Nor is confusion restricted to this very special type of valve. All valves possess something which is most often called "impedance." There are about half-a-dozen other names for the same thing—all of

which are more or less cumbersome—which are shuffled occasionally by the experts so that people have to be very quick and clever to understand what they are talking about. But "impedance."

In the elementary theory of alternating currents we are informed that impedance is the total effect of the resistance, inductance, and capacity of a circuit. When all but the resistance are negligible it is, not unnaturally, called a resistance.

One doesn't talk about the impedance of a grid leak. Therefore, the use of the word impedance in connection with a valve suggests that the inductive or capacitive effects are important. In connection with the property to which the word is applied, that suggestion is not justified. It is like all the others, confusing and misleading.

One might inquire closely into the meaning of the name "detector," and many others. But perhaps enough has been said to leave a suspicion in the mind of the reader that, when radio was being thought out, there was no intelligence left over to deal with the language. The Master Mind of fiction does not appear to have been brought to bear on the problem of concise terms. Is there still time to put it right? Or would it be another "Keep to the Left" fiasco?

## DON'T EXCEED THE SPEED LIMIT!

A caution for radiogram users.

WHATEVER else you do or don't do, it is pretty safe to say that you will not enjoy your electrical reproduction of gramophone records to the full unless you get the speed of the turntable correct. It is quite a simple matter to do this, because the one-time bugbear of different makes of records requiring different speeds is now nonexistent.

If you have a synchronous induction motor run from the A.C. mains, then you have no need to worry about this question of speed, the worrying will already have been done for you by the motor makers. In all other cases the best way to count the revs. is with the aid of a small scrap of paper, although there are other more elaborate systems, such as the stroboscope. The latter, however, needs A.C. mains and is therefore not of general application.

### Keep Your Eye on the Hand.

The speed needed is 78 turns per minute, and don't forget that this is the speed *with* the pick-up in position for playing; with it lifted, the speed will increase. So if you adjust without it on, when you come to use the pick-up you will find it slows the motor down.

Slip a little piece of paper between the turntable and a record so that it projects a little beyond the edge of the record. Set the motor going and hold a watch with a second hand near the edge of the record.

You will then be able to count the times the slip of paper comes round at the same time as you keep your eye on the watch's second hand. Start counting at a convenient mark on the watch dial and count for half a minute. This is quite long enough, but naturally you must multiply the resulting number by two. If it is not 78, increase or decrease the speed a little and then check again, keeping this up until you get it just right. A.S.C.



LOOK FOR "EDDY" IN YOUR DEALER'S WINDOW



**STAND**  
**Nos. 75 & 230**  
**RADIOLYMPIA**

(Aug. 19 - 27)

# FACTS YOU SHOULD KNOW.. ABOUT THE MAZDA PENTODES



The output stage in portable battery-driven receivers has always presented a problem to the designer on account of the limited H.T. supply available.

**THE MAZDA PEN 220** has solved this problem as, owing to its extreme sensitivity, ample volume can be obtained with only 4 M/a anode consumption. The Pen 220 has, in addition, rapidly gained favour in the case of standard battery-operated receivers where economical H.T. consumption is an important consideration.

**THE PEN 220A** is a high-power output pentode suitable for driving a large moving-coil speaker. It should be used in conjunction with an eliminator.

**THE PEN 425** for receivers operating on anode voltages above 150.

**THE AC/PEN**, the finest all-mains power pentode, sensitive enough to operate a loud speaker direct from aerial input.

Full details of these and other useful Mazda types will be found in the Mazda catalogue, sent FREE on request.

Mazda valves are fitted by all the leading receiver manufacturers. All good radio dealers stock them.

The amazing  
**MAZDA**  
THE  
BRITISH  
**VALVES**

**EDISWAN RADIO**  
**100% BRITISH—Designed by British Engineers**

The Edison Swan Electric Co. Ltd.

Mazda Radio Valves are manufactured for The British



155 Charing Cross Rd. London. W.C.2

Thomson-Houston Co. Ltd., London and Rugby.

V.167

LAST week we commenced the construction of the "Olympus" Four, the set that probably many of you have been able to examine at the radio exhibition. But we did not quite finish it and so here goes with a few more points.

We have finished the stiff wiring of the receiver and the next job is to attach the flexible battery cable.

**Battery Connections.**

A five-way battery cord is used for making connection to the L.T. and H.T. batteries.

Each wire of this cord has a distinctively coloured braided covering. The red one, of course, is attached to the on-off switch before fixing the panel to the baseboard. Regarding this, in some case it may be necessary to lengthen this lead with about 12 ins. of single flex, the join being covered with insulating tape. The yellow one is attached to the A. terminal of the S.G. valveholder.

To the negative L.T. (nearest edge of

baseboard) terminal of the same S.G. valveholder connect both the black and blue wires. The remaining green wire goes to the terminal of the H.F. choke which also connects to the L.S. + terminal.

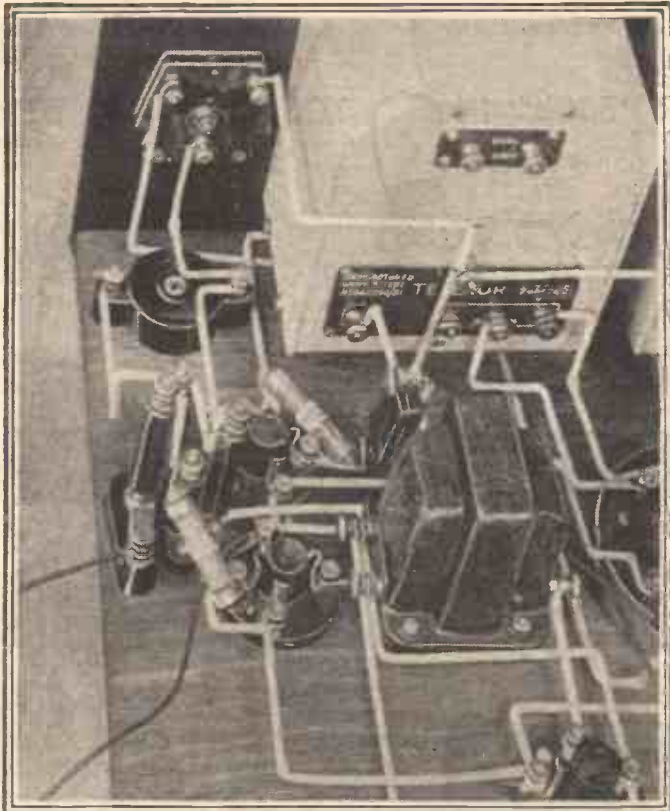

Direct attachment to the terminals concerned simplifies the grid-circuit wiring to the leak and grid-stopper resistance.

**ITS FEW CONNECTIONS HAVE MANY ADVANTAGES**

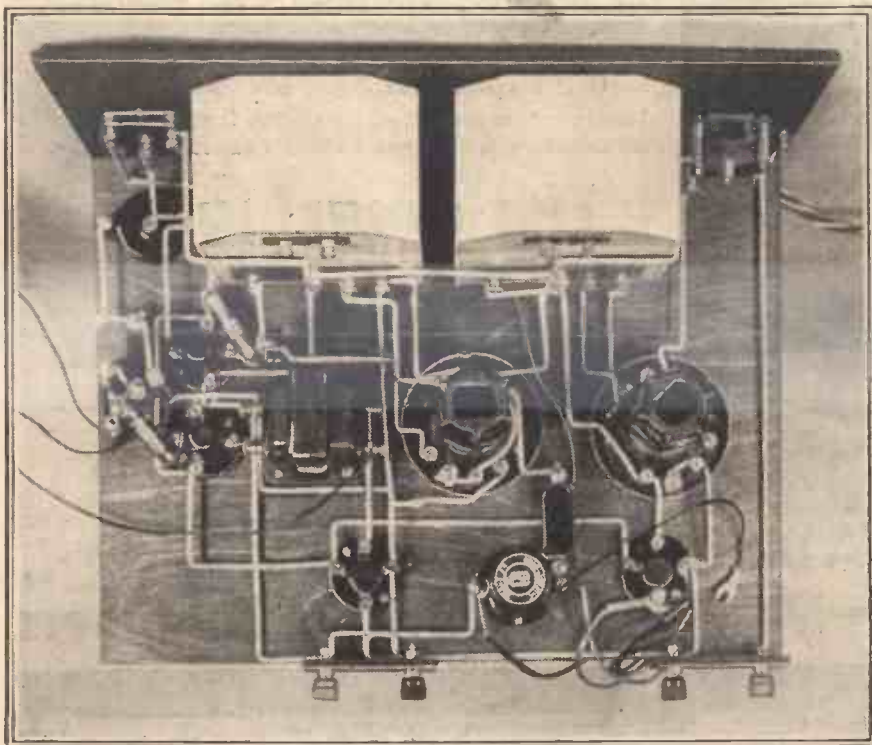

The simplified wave-change switching enables the wiring to be carried out with short leads, thus ensuring inter-stage efficiency.



**SCREENED-GRID**

With differential control of aerial-input.

**DETECTOR**

Grid leak type with differential reaction.

Three G.B. battery connections require to be made of foot lengths of rubber-covered flex. To one attach a wander-plug marked GRID+.

Wander-plugs marked GRID-1 and GRID-2 are attached respectively to the other two. Bare the ends of the leads which have no wander-plugs attached. The GRID+ lead is then connected to the L.T. negative (nearer panel) terminal of the V<sub>3</sub> valveholder.

Connect the GRID-1 lead to the bottom terminal of the grid-leak which is nearest to the edge of the baseboard. The remaining GRID-2 lead goes to the G.B. terminal of the transformer.

With only four terminals and the battery cord the Olympus Four is extremely easy to connect up. The terminals are aerial

A "P.W." FOR HIGH LONG RECE

SE IT OLYM ON STA No

**A MODERN DESIGN USING A**

- 1 Panel, 14 x 7 in. (Peto-Scott, Permcol, Becol, Wearite, Lissen).
- 1 Cabinet to fit, with baseboard 10 in. deep (Peto-Scott, Pickett, Camco, Gilbert, Moreo, Lock, Osborn).
- 1 L.F. transformer of medium ratio (Lissen Hypernik, R.I. Hypermite, Varley Nicklet, Slektun, Goltone, Tunewell, Ferranti A.F.10, Lotus, Igranic, Lewcos).
- 1 H.F. choke (R.I. Quad-astatic, Lissen, Lewcos type 11, Telsen Binocular, Ready Radio Standard, Peto-Scott Standard, Goltone, Sovereign Super, Tunewell).
- 1 -0003-00035-mfd. max., differential reaction condenser (Peto-Scott, Lotus, Telsen, Cyldon, Ready Radio, Lissen, Graham Farish, Polar, J.B., Ormond).
- 1 H.F. choke type M.C., Telsen Farish, Igranic).
- 1 -0003-00035-mfd. differential condenser (Graham Farish, Igranic).
- 2 Screened coils
- 4 4-pin valve holders (Telsen, Goltone, Graham Farish, Igranic).
- 2 -0005-mfd. Tele
- 1 -5-meg. grid condenser (Graham Farish, Ferranti, Telsen, Dubiller).
- 1 100,000-ohm resistor (Graham Farish, Dubiller).
- 1 -5-meg. do (Graham Farish, Dubiller).
- 1 2-meg. do (Graham Farish, Dubiller).



**FIRST L.F.**

Resistance-capacity with grid stopper.

**SECOND L.F.**

Medium-ratio transformer coupled.

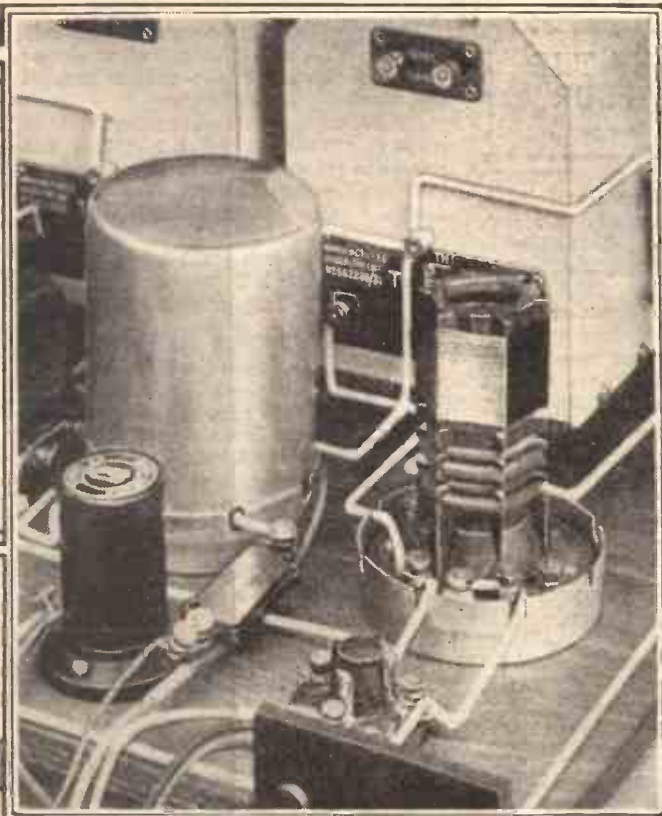

When fitting the covers to the screened coils be careful not to cut the wiring in the slots; also see that you put the lids on straight.

to the positive terminal on the battery, and the black spade on the negative terminal.

Then place the valves in their sockets. The screened-grid goes in the valve-holder near the aerial terminal, and the anode terminal on the valve is connected to the piece of flex attached to one of the terminals of the R.I. choke.

**Valve Positions.**

The detector holder is the one at the other end of the set, near the reaction condenser on the panel, and next to this holder is that for the first L.F. valve. The remaining holder on the opposite side of the R.I. choke to the screened-grid valve is for the output valve.

With valves in position place the black H.T. plug in the negative end of the H.T. battery or

that you are going to employ. This grid bias figure is stated by the makers of the output valve.

Before connecting the H.T. battery to the set, connect the L.T. battery, with the red spade terminal of the battery cord

mains unit (the latter being connected to the requisite electric light plug as explained in the unit's instructions given away by the makers), the yellow lead and plug goes into the battery about 70

*(Continued on next page.)*

E  
AT  
MPIA

and earth at one end, and loudspeaker at the other.

That is simple enough, isn't it? Then there are three H.T. plugs on the battery cord to connect, two L.T. spades to screw under the terminals of the L.T. battery, and that is the lot with the exception of grid bias.

This latter battery can be conveniently fixed on the inside of the back of the cabinet, either in clips or else by the cardboard flap that is supplied with some batteries for that purpose.

The grid bias plugs are fixed as follow: The plus one goes into the positive end of the battery, G.B. minus one goes into a position about 3 volts negative, and the remaining plug is placed at the voltage required by the output valve used with the voltage of H.T. battery or mains unit

STAR SET  
QUALITY  
RANGE  
PTION

OUR  
ND  
8

**COMPLETELY COVERED COILS AND CONDENSERS**

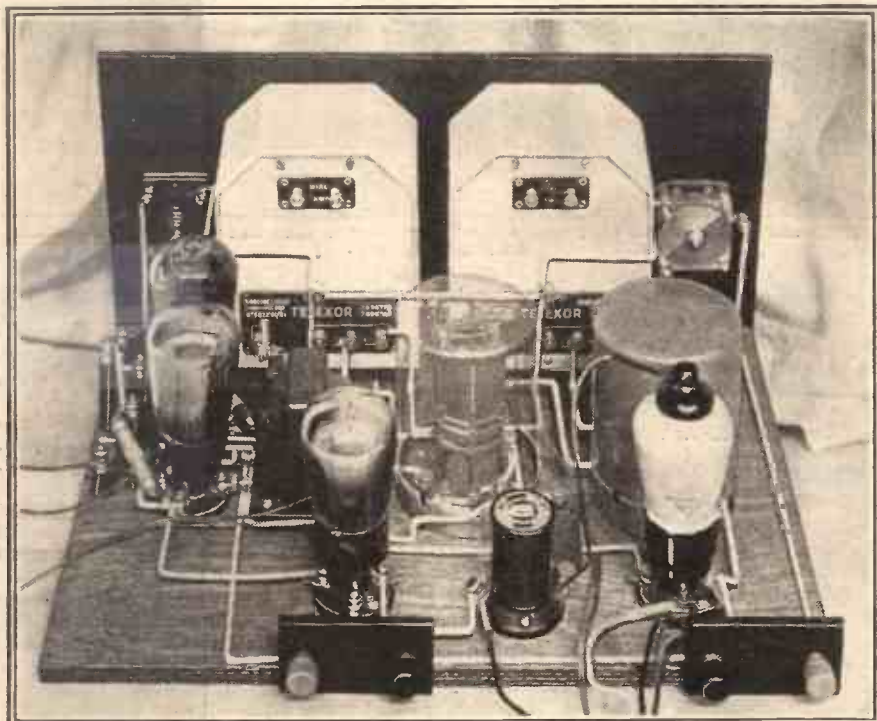

One of the Telsen screened coils is shown with a "ghostly" cover to illustrate internal details. Note also the completely enclosed tuning condensers.

**ALL UP-TO-DATE COMPONENTS**

- 1 L.T. on-off switch (Bulgin type S15).
- 1 .0003-mfd. fixed condenser (Dubilier type 670, Lissen, Telsen, Igranic, Ferranti, T.C.C., Sovereign, Goltone, Graham Farish).
- 1 .0001-mfd. condenser (Dubilier type 670, Goltone, etc.).
- 1 .01-mfd. condenser (T.C.C. type 34 upright, Lissen, Telsen, Ferranti, Igranic, Graham Farish).
- 1 Five-way battery cord (Goltone R. 40/40, Belling Lee).
- 18-gauge wire and sleeving (Wearite, or Jifflinx, Quickwyr, Glazite).
- 2 Terminal strips, 3 in. x 1 1/4 in.
- 4 Indicating terminals (Bulgin, Belling-Lee, Clix, Goltone, Igranic), Screws, small strip of copper foil, etc.

- 1 L.T. type (Lewcos Lissen, Graham)
- 1 max. differ-Lotus, etc.).
- 1 Lissen, W.B., Wearite, Bulgin, Clix, Tunewell,
- 1 xors (Telsen).
- 1 leak and holder "Ohmite," Lissen, Igranic, Tunewell,
- 1 Resistance with ter-(Graham Farish Lissen, Igranic, Tune-
- 1 anic, etc.).
- 1 anic, etc.).

## HOW TO MAKE THE "OLYMPUS" FOUR

(Continued from previous page.)

to 80 volts (in the case of the mains unit it is connected to the socket marked S.G. valve), while the third plug is taken to the maximum of the battery or mains unit, some 120 to 150 volts.

Now connect up the loudspeaker (aerial and earth having already been connected). With the reaction condenser turned right over to the left, and with the series aerial condenser (aerial coupler) to the right, turn both the tuning controls slowly between about 25 and 90 degrees.

They should be in step fairly closely—that is, they should, for this test, be reading the same within a degree or two for the whole range.

### Tuning-in the First Station

On this test you should hear your local station, provided it is at a time when it is supposed to be transmitting. If it is the London twin transmitters you should hear them at about 25-30 for the National and round about 55 or 60 for the Regional. The North Regionals comes in somewhere round about 80, and the Midland Regional a

## NEARING THE END



Like a wise constructor he is going round with a pair of pliers to make sure that all the connections are properly tightened.

few degrees above the London Regional.

With the tuning controls between 0 and 100 we are listening on the medium waveband; with the controls between 100 and 200 we are tuned on the long waveband. Thus for Daventry National the reading will be about 165 on both the dials.

### Easy Searching

It will not necessarily be the same on both tuning dials, because the so-called matching depends upon the dimensions of the aerial, and the setting of the aerial coupler. The tuning control will be sufficiently in step, however, to allow the searching to be pretty easy.

When you have found the local you will also notice in all probability that the tuning is not particularly sharp; or, in other words, the strength is so great that the station seems to spread and also to overload the output valve.

Rotating the aerial coupler to the left will cure this, and this ingenious device does in fact constitute a volume control and selectivity device in one.

For distant stations, when sometimes the inherent sensitivity of the set is not enough to get some weak transmission in at full loudspeaker strength, the reaction control can be turned towards the right.

The absence of any wave-change switching to be done is a great boon, and the tuning controls tell you exactly when you are on the long or short-wave band.

### An Important Adjustment

Due to the fact that the Telexors do the wave-changing, the switches that are incorporated in the coils are not used. But it is very important that they should be set to the long-wave position.

This is accomplished by inserting the switch rod in the coil before mounting and turning the switch cam (which can be seen by looking into the top of the coil) so that it is flatwise with the coil's base. The rod is afterwards removed.

A word here will not be amiss about the output valve. It has been listed in the accessories in several types, one set of which is shown as suitable for mains units and the other for battery use.

This is done advisedly, for the battery valves have been chosen so that their anode current demands shall not be too much for a fairly good battery of large or triple capacity. With a valve of one of the types mentioned in the battery section the total milliamp consumption of the set should not exceed about 10 to 14 milliamps. Thus, it is within the power of a large-capacity battery to supply.

With the other output valves it is advisable to use a mains unit, for the anode consumption will be much higher. Naturally the volume of sound that the set will give will also be greater, but this volume will be hard paid for, if it is attempted to run the set from ordinary dry H.T. batteries.

An H.T. accumulator would do the job if no mains were available, especially one of the new nickel iron types that will charge from a six-volt accumulator, but best of all is the mains unit if electricity

## THE COIL CONNECTIONS

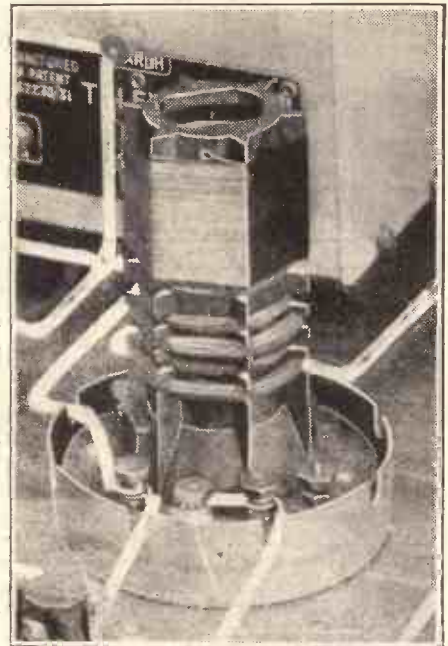

Each of the terminals on the Telsen coil is numbered, and this and the wiring diagram given last week show exactly how the wiring connections should be done.

supply is available. With such a unit H.T. up to 150 volts and 25 to 30 milliamps can be assured, and the set will then be able to give the very utmost in the way of power output.

The range of reception will not very noticeably be affected by the problem of battery or mains unit, it is the power of the output that is directly affected, for one cannot get power out of a set without putting it in.

### ACCESSORIES WE RECOMMEND TO YOU

**LOUDSPEAKERS.**—Blue Spot, Celestion, Marconiphone, B.T.H., R. & A., H.M.V., W.B., Cossor.

**VALVES.**—1 S.G.—Cossor S.G.220 (preferably metallised), Mullard, Mazda, Marconi, Osram, Tungram, Lissen, Eta.

1 Det.—Marconi H.L.2, Mullard P.M.1H.L., Osram H.L.2, Mazda H.L.2, Cossor 210H.L., Tungram H.210, Lissen H.L.2, Eta B.Y.2020.

1st L.F.—Mazda L.210, Cossor 210L.F., Marconi L.210, Osram L.210, Mullard P.M.2D.X., Tungram L.G.210, Lissen L.210, Eta B.Y.1210.

Power (specially suitable for battery H.T.).—Mullard P.M.2A., Mazda P.220, Marconi P.215, Osram P.215, Cossor 215P., Tungram P.210, Eta

B.W.604, Lissen P.220.

(Suitable for use with mains units).

Mullard P.M.202, Mazda P.220A., Marconi and Osram P.2, Cossor 230X.P., Tungram S.P.230, Eta B.W.303, Lissen P.X.240.

**BATTERIES.**—L.T. (2 volts 30 amp. or over)—Lissen A.H., Exide, Oldham, Pertrix.

H.T.—120 to 150 volts' capacity to give 10 to 12 milliamps—Pertrix, Lissen, Ever Ready, Drydex, Ediswan, Siemens).

G.B.—To suit output valve chosen (Ever Ready, etc.).

**MAINS UNITS.**—These should give 25 milliamps and at least 120 volts. Suitable manufacturers are Atlas, Type A.C.300 or D.C.15/25, R.I., Heayberd, Lotus, Tunewell, Ekco.

# “303” HIP! HIP! HOORADIO!



Lasting Quality for the battery-set user, and—you can build it in 20 minutes!

Mount five components, connect five wires and your '303' is complete! Easy? There never was an easier set to build. Then switch on and listen to it! You couldn't buy a better set for twice the price. Stations in plenty from home and abroad, all at full volume. Selective too—thanks to the wonderful Coil Unit with its unique four-in-one control. And the quality! Superb moving-coil reproduction at its best—and you don't know how good that can be until you've heard the '303.'

Designed by the famous radio scientist, Mr. G. P. Kendall, B.Sc.

**'303' KIT MODEL** **£3.10.0**  
Complete Kit of Quality Components with set of three Mullard Valves.

*Or by 7 monthly payments of 11/9.*

**'303' CABINET MODEL** **£6.17.6**  
Complete Kit and Valves as above with beautiful walnut cabinet fitted with new type moving-coil speaker.

*Or by 10 monthly payments of 16/-*



Manufactured throughout at Blackheath by **READY RADIO** Ltd.

All Kits are packed in dust-proof cellophane-covered carton, complete with full instructions.

*Free*

Ask your radio dealer, or post coupon now, for your free copy of the '303' Book, containing full instructions, photographs and plans showing how to build this wonderful set in 20 minutes.

This Book also contains complete constructional details of the 'METEOR' S.G. 3—the new set specially designed for World-Wide Reception on ALL WAVELENGTHS.

We will also tell you about our REGISTERED USERS SCHEME—your Guarantee and Safeguard.

To Ready Radio Ltd., Eastnor House, Blackheath, S.E. 3  
Please send me free, the '303' and 'Meteor' S.G. 3 Book.

Name .....

Address .....

Please put a cross against the 303 set in which you are interested | Meteor' S.G.3

P.W.I.A.

# READY RADIO

FIRST IN THE FIELD WITH

# ALL-WORLD RADIO

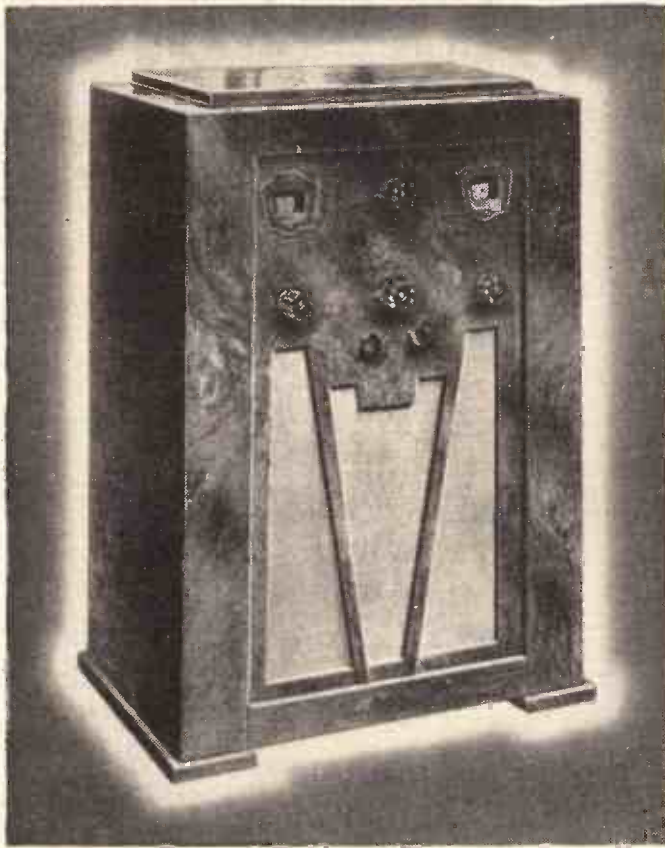

A new All-wave S.G.3 which is so remarkably efficient that we guarantee the reception of at least thirty stations on the long and medium waves. Under favourable conditions, you can definitely double, or even treble this number as well as enjoying the thrill of world-wide reception of short-wave stations. Its remarkable performance has been made possible by the introduction of "Micalog" Tuning.

Modern chassis construction, metallised S.G. Valve, quality components throughout, new type of Moving-Coil Speaker, amazing selectivity. And a beautiful walnut cabinet equal to a 25-guinea receiver.

Look for the special display carton in all radio dealers windows.

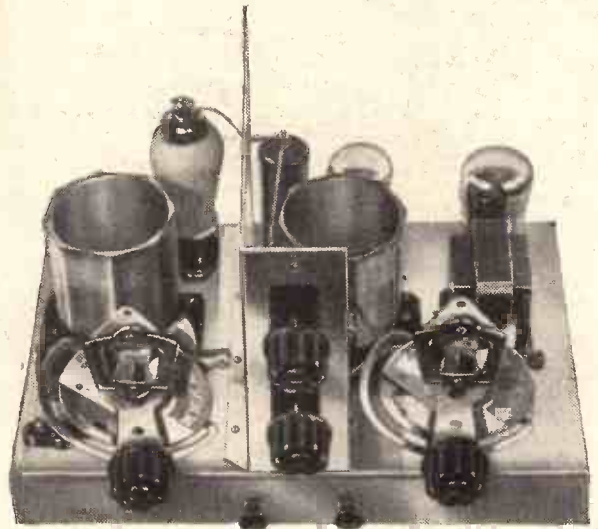

**"METEOR" S.G.3 KIT.**  
Complete Kit, together with three Mullard Valves  
**£5:7:6**  
or 10 monthly payments of 12/6

**"METEOR" S.G.3 CABINET MODEL**  
Beautiful walnut cabinet, fitted with Moving-Coil Speaker, and complete with Kit and Valves.  
**£8:17:6**  
or 12 monthly payments of 17/-

## READY RADIO

# METEOR S.G.3

*Free* A beautifully illustrated 20-page book, giving complete instructions for building this wonderful receiver (as well as the new "303") can be obtained from your radio dealer, or will be sent you free on receipt of coupon. We will also tell you about our REGISTERED USERS' SCHEME — your Guarantee and Safeguard.

To READY RADIO LTD., EASTNOR HOUSE, BLACKHEATH, S.E.3.  
Please send me free, the "303" and "Meteor" S.G.3 Book

Name .....

Address .....

Please put a cross against the set in which you are interested. "303" ..... "Meteor" S.G.3 ..... P.W.I.C.

# Convert your set to the KENDALL-PRICE S.G.3

## A.C. MODEL

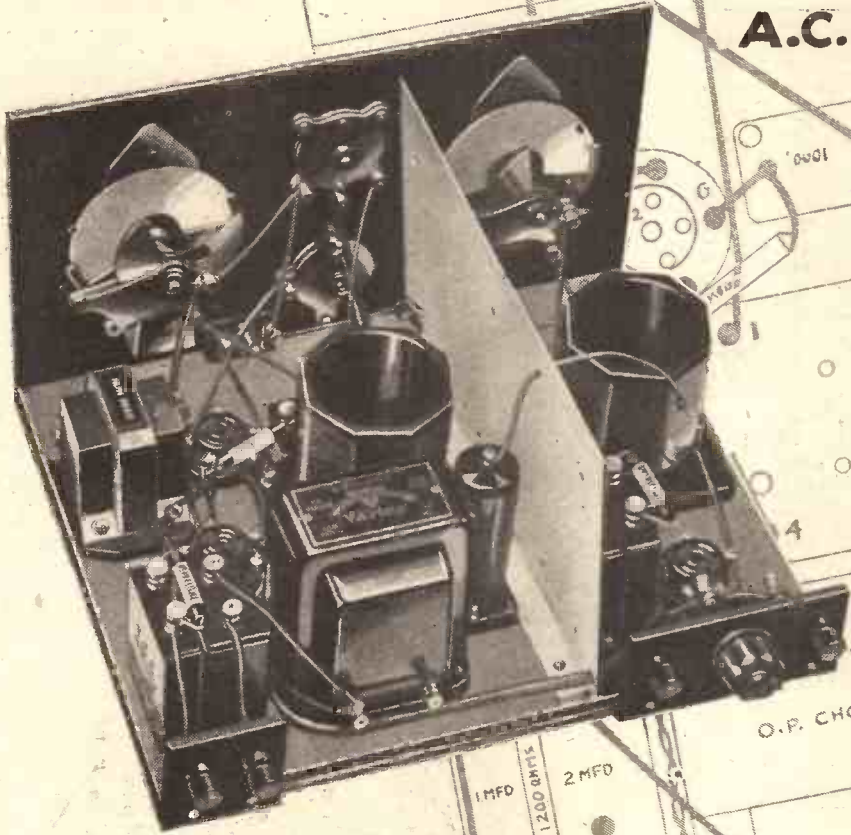

A powerful set which will give you a minimum of thirty medium and long wave stations — and probably double this figure — as well as short wave stations from all parts of the world.

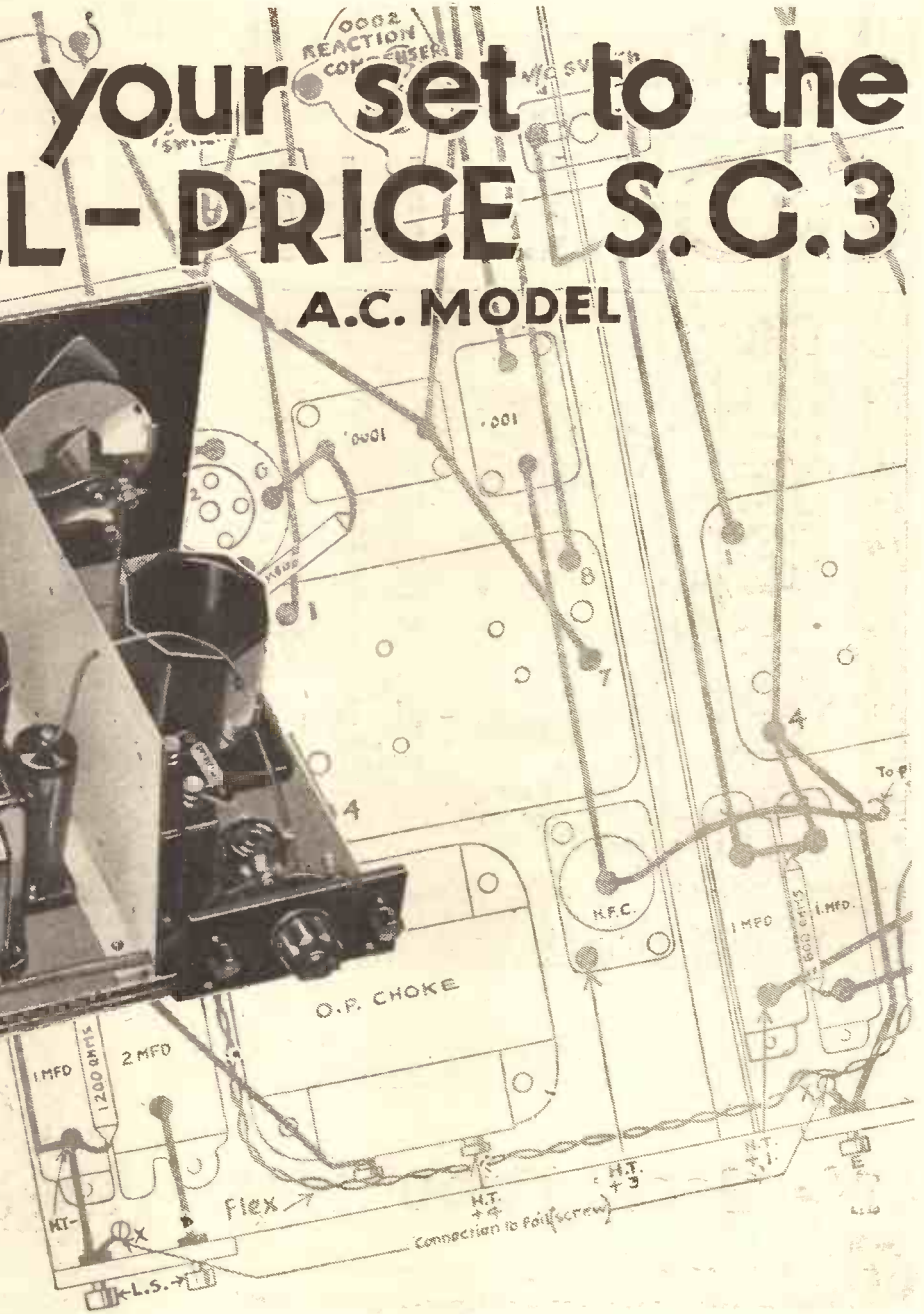

**Free** Here is the most generous offer ever made to the radio public! A 36-page Book containing full instructions, photographs, diagrams and plans for building ten modern sets. It shows you how, at the cost of a few shillings, you can bring your old radio set up-to-date. Take immediate advantage of this splendid offer — post coupon now for your free copy.

**ANOTHER GREAT OFFER**  
**TEN FULL-SIZED BLUE-PRINTS 1/- ONLY**

The sets described can be built from the diagrams in the Book but if you require full-sized dimensioned plans of the ten sets, enclose 1/- with your coupon.

To **READY RADIO LTD.**, Eastnor House, Blackheath, S.E.3.  
Please send me the Kendall-Price Book of ten circuits—free.

Name.....  
Address.....

If you wish to have with your free Book ten full-sized blue-prints, enclose 1/- in stamps with this coupon. P.W. 1B.



# A wonderful Dual Range COIL UNIT fitted with 4 in 1 control

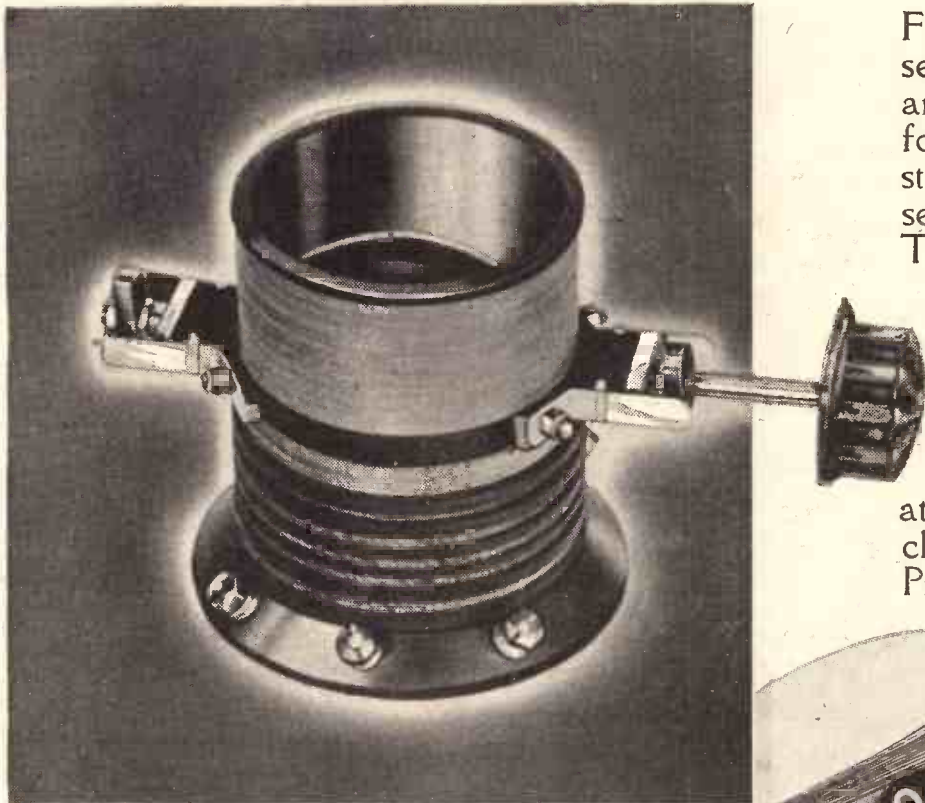

Fit this in place of your present Coil and you will be amazed at the improved performance of your set. Outstanding for its remarkable sensitivity and selectivity. The four-purpose one-knob control acts as a combined on-off switch, wavechange switch, selectivity and volume control, thus greatly simplifying wiring and operation. Instructions are included with every unit. Price 10/6.

## 1/- Book Free

Full details of how to use this amazing Coil are contained in the *Kendall-Price Book*. 36 pages describing 10 wonderful circuits, with photographs and diagrams, published at 1/-.

POST COUPON NOW AND WE WILL SEND YOU YOUR COPY FREE.



To READY RADIO LTD., Eastnor House, BLACKHEATH, S.E.3,  
Please send me the Kendall-Price Book of the ten circuits—free.

Name.....  
Address.....

If you wish to have, with your free book, ten full-sized blue  
prints, enclose 1/- in stamps with this coupon. P.W.1D.

# READY RADIO



# CAPT. ECKERSLEY'S QUERY CORNER



Don't address your letters direct to Capt. Eckersley; a selection of those received by the Query Department in the ordinary way will be answered by him.

Under the above title, week by week, our Chief Radio Consultant comments upon radio queries submitted by "P.W." readers.

## KILOCYCLES AND METRES—MICROPHONIC NOISE—REACTANCE FORMULA.

### Frequency and Wavelength.

B. H. (Cricklewood).—"The European stations are, I believe, separated from each other by 9 kilocycles. The wavelength represented by 9 kilocycles is, according to my reckoning, roughly 30,000 metres. London Regional, however, is undoubtedly not separated from Mühlacker by 30,000 metres, although the stations are 9 kilocycles apart. What is the snag?"

There is no snag!

The fundamental formula for a wave motion is that the wavelength multiplied by the frequency of the disturbance making the wave is equal to the velocity of travel of the waves through the medium.

If  $\lambda$  is wavelength,  $n$  frequency, and  $C$  velocity, then  $n\lambda = C$ .

Now, for wireless, the velocity of the waves is 3 with ten noughts after it centimetres per second. From this it follows that a wave of length 300 metres is set up by aerial circuits having a frequency of one million.

Thus:

Wavelength	Frequency
300,000	1,000
30,000	10,000
3,000	100,000
300	1,000,000
30	10,000,000
3	100,000,000

Now let us add, for the sake of argument, 9 kilocycles to the frequencies 1,000, 10,000, 100,000, etc., and see what wavelength results, and see also the difference in wavelength at each frequency.

Wave-length.	Frequency.	Frequency + 9 k.c. = $f_2$ .	Wave-length corresponding to frequency $f_1$ .	Changed wavelength by adding 9 k.c. at given wavelength.
300,000	1,000	10,000	30,000	Metres 270,000
30,000	10,000	19,000	15,789	14,211
3,000	100,000	109,000	2,751	249
300	1,000,000	1,009,000	297.3	2.7
30	10,000,000	10,009,000	29.973	0.027
3	100,000,000	100,009,000	2.9973	0.0027

You will see (and it's been a labour of love doing this table!) that the difference in wavelength for a 9-k.c. change in frequency depends upon the wavelength at which you add (or subtract) the 9 k.c.

At 300 metres adding 9 k.c. makes only 2.7 metres difference; at 30,000 metres it makes 14,211 metres difference!

Hope you see the point!

### Differences in Similar Valves.

J. B. (Glasgow).—"Why is it with two valves of the same type and make, one may be microphonic and the other immune from this fault?"

I can only suppose because the two valves have quite different characteristics even though they are of the same type and make.

If you take twenty valves (particularly high-impedance valves) of the same type and make, and compare characteristics, you will be surprised at the differences between them.

Again, the degree of microphonic noise is probably determined by the stability of the valve elements and, in the very fine construction that is used, it is easy to imagine variations in workmanship.

I did not know that similar valves could be so different in the degree of microphonic noise they could exhibit.

\* \* \*

### Impedance of an Iron-cored Choke.

N. S. (Leyton).—"How is the impedance of an iron-cored choke determined for any particular frequency?"

Let the inductance be  $L$ . Let the frequency be  $n$ . Then the impedance will be  $X = 6.28 \times n \times L$ , where  $n$  is expressed in cycles per second,  $L$  in henries, and  $X$  in inductive reactive ohms.

Thus the reactance of 2 henries at 100 cycles is  $6.28 \times 100 \times 2 = 1,256$  ohms.

\* \* \*

### Oscillating Currents.

I. V. L. (Stourbridge).—"I understand that an oscillating current varies in amplitude at regular intervals which determine its frequency. An alternating current also varies in amplitude at regular intervals, which also determine its frequency. Surely, then, both currents are of identical type, and why should two different terms be used for definition?"

You are perfectly right; the terms are loosely used, and confusion may easily arise.

Wireless began by setting up "oscillations" in a tuned circuit, which oscillations began at a relatively great amplitude and died away and were then renewed.

Fig. 1 is a picture of how "oscillations" were made for wireless purposes.

Spark transmission was of an oscillating

character, but the oscillations had a definite frequency, and only the amplitude varied. Then came the arc and the valve and continuous oscillations, as some called them (see Fig. 2).

These were all the same amplitude and the same frequency—they are really alternating currents of very high frequency,

## THEN—AND—NOW

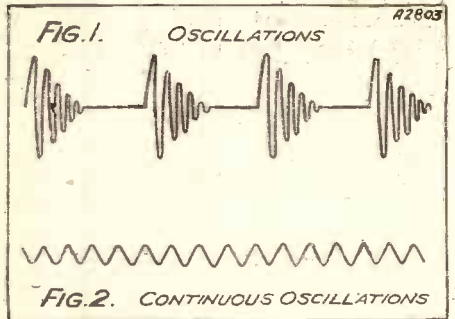

The first wireless oscillations (Fig. 1) began at a relatively great amplitude, gradually died away, and then started all over again. The introduction of the arc and the valve gave rise to continuous oscillations of a constant amplitude (Fig. 2)—actually high-frequency alternating currents.

but because they were created by using what had previously been called oscillating circuits they were still called "oscillations."

It is best to think of all wireless as based upon the use of high-frequency alternating currents, and the fundamental laws of "low" frequency alternating currents as applying to "high" frequency currents.

ONLY IN "P.W." can you read Capt. Eckersley's replies to listeners' own problems. AND REMEMBER—Captain Eckersley's technical articles appear only in "POPULAR WIRELESS" and "MODERN WIRELESS."

# Short-Wave Notes *By* W.L.S.

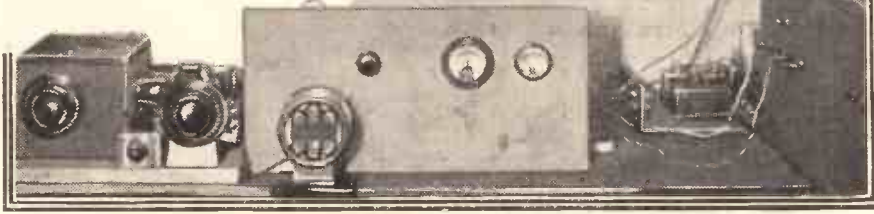

SINCE this is "positively my last appearance" before the Eclipse Tests, let me remind you once more to do all that you can from next Sunday onwards in the way of watching your chosen station. The sequel to the actual listening, too, is just as important—send in your results to me as soon as possible.

## Really Funny!

I had a severe shock on going through this morning's post, for I came across a letter beginning thuswise: "Thanks for your column, which I think is the funniest thing of its kind—" etc. My sigh of relief on discovering that it was addressed to "Ariel" and reached me by mistake must have been heard across the river.

Now let us deal with the "Heard All Continents" Club. New members who have satisfied the body of examiners (myself!) are the following: H. D. B. (Coventry), W. H. R. (Plymouth), G. N. (Herne Bay), and H. L. (Prestwick).

The first-mentioned of these gentlemen kindly sends me a copy of a local paper containing a description of G 5 M L, the station of Mr. F. W. Miles. Readers will probably remember that he gained top place in the British Empire Radio Union short-wave tests this year.

## New Stations.

That part of the description supplied by G 5 M L himself is excellent, but the reporting gent has to talk about a "power of 3,000 volts H.T." "Even the grid-bias batteries," he says, "have a power of 240 volts."

These local experts do say some funny things sometimes; I suppose they don't realise that "a power of 3,000 volts" sounds as queer to a wireless man as "a weight of three square inches" would to a grocer!

Five more stations, readers, on which to try your skill and your luck. Three of them are easy, the other two being quite difficult unless you use a single-valver!

Prague, on 58 metres; Tuesday and Friday, 8.30–10.30 p.m.

Quito, Ecuador, on 52.5 metres: daily, 1–4 a.m.

HEARD ALL CONTINENTS?  
STATIONS TO TRY FOR  
"QUEBEC CALLING"  
AERIAL LOCATION, etc., etc., etc.

Vancouver, Canada, V E 9 C S, on 49.43 metres.

Long Island, W 2 X V, on 34.68 metres; Fridays, 11 p.m. onwards.

Buenos Aires, L S Y, on 14.5 metres; Sundays, 10 p.m. onwards.

Why does the short-wave fan have so disappointing a time at the Radio Show each year, and how many years is this going to continue? He is still in the minority, it

## THE BRITISH EMPIRE IN NEW YORK

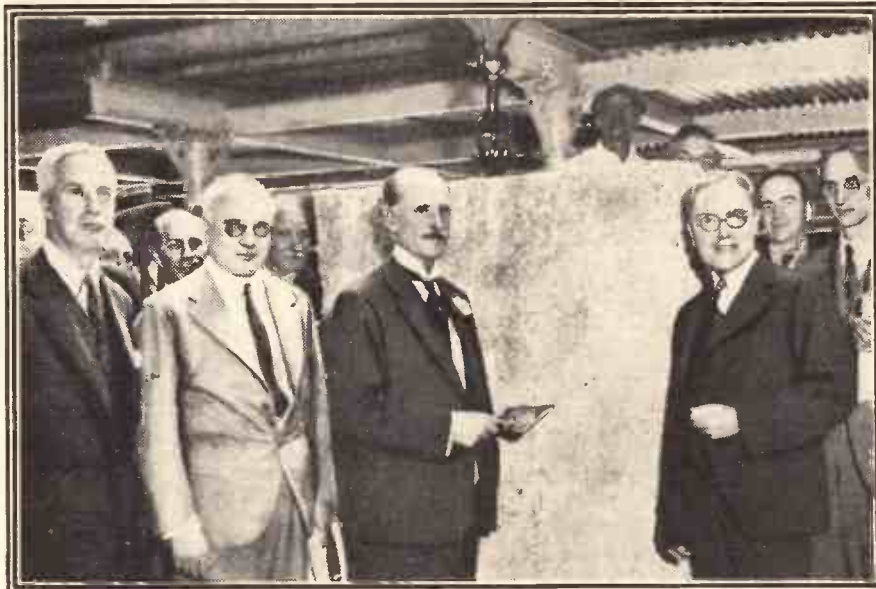

One of the most imposing of the structures of the new "Radio City" is to be the British Empire Building, the foundation stone of which was laid recently. John D. Rocketteller, Jr., is in the foreground to the right.

is true, but surely it is up to the manufacturers to lift him out of it? One really popular short-wave kit, suitably advertised, would work wonders, and make a rich man of its designer.

## Popularising Short Waves.

As things are at present, the majority of listeners who do not read any radio journal hardly know that "short waves" exist at all. And I know that there are even readers of "P.W." who glance at the heading to this page, murmur in their beards, and turn on unheeding!

We short-wave fans have the laugh over these people, at all events. Is there a single

regular reader of this page who regrets having taken up short-wave work? I'll lay my very own "buzz" to an aerial insulator that there isn't.

"E. H." (Manchester) sends me a funny report. He has made my "single," and added some ordinary medium-wave coils to it for broadcast reception.

He finds that if he leaves them connected to their appropriate terminals and plugs in the short-wave coils that short-wave reception goes on as usual, with no interference from stations on the medium band. This, of course, is what a theorist would expect, but it is the first actual case of it that I have heard.

## Letters From Readers.

"J. W." a reader from Northern Ireland, wants identification of a station announcing "Quebec calling," just above Rabat. It couldn't have been an amateur, "J. W."—probably a commercial telephone station.

"V. H. C." (Northfleet), whom I had better refer to now as B R S 732, sends me one of his periodical reports, the gist of which is "not much doing." W 8 X K seems to be the only "Yank" that any readers find at all reliable nowadays, and B R S 732 agrees with this. The only other really good stations are the Europeans.

Yes, the German station on 31 metres sending "H A" as an interval signal is Hamburg. It is a relay by Zeesen, I should imagine.

A very long and interesting letter has reached me from "C. G. E." (Bury St. Edmunds), who claims to be "a short-wave enthusiast for ever." He lives near a gentleman whose hobby is trees, as a result of which he cannot bear to hear the once-popular song, and thinks his reception is somewhat impaired.

## A Cure.

Following my suggestion in a recent article, he shifted his aerial through a right-angle, and found it made a vast difference to reception. This is interesting, as it is the only definite example of this that has come to my notice.

My reply to your technical queries, "C. G. E.," is "copper foil," as you anticipated. I think you will find that it puts matters right, although your trouble rather baffles me, particularly as you have kept faithfully to the blue-print.

"F. N. B." continues to supply me with enough information to keep me going until the other end of the eleven-year cycle, but as he suggests that readers are fed-up with seeing his initials in print I am letting it accumulate for a while, after which I will deliver it in "compressed form." Incidentally, he has recently heard Sydney for the first time, and enters the "H. A. C." in consequence.

SOMEONE ELSE HAS JOINED THE  
BETTER RADIO BRIGADE!

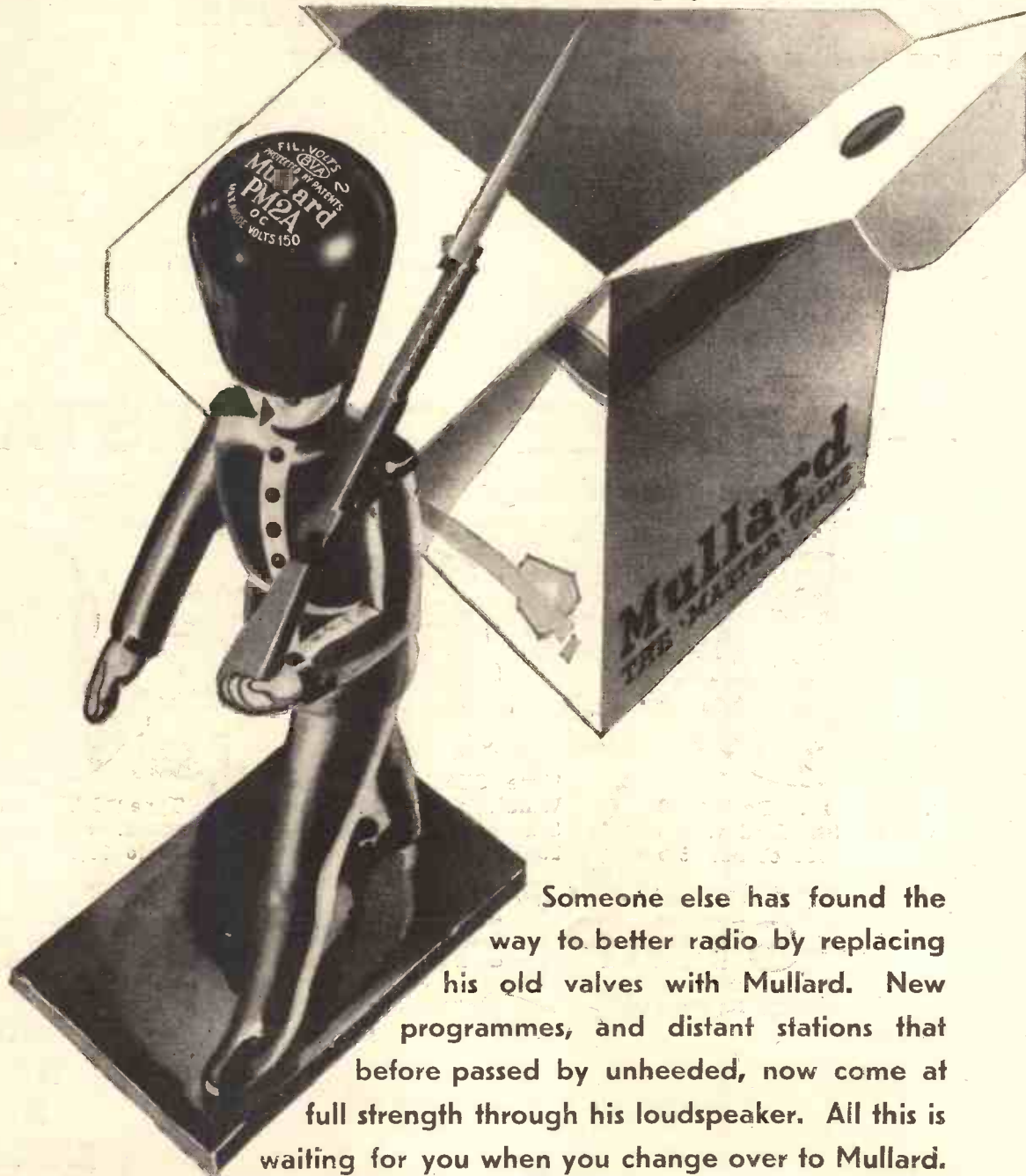

Someone else has found the way to better radio by replacing his old valves with Mullard. New programmes, and distant stations that before passed by unheeded, now come at full strength through his loudspeaker. All this is waiting for you when you change over to Mullard.

# Mullard

**THE · MASTER · VALVE**

We are exhibiting on Stand No. 79 at the National Radio Exhibition at Olympia.

Advt. The Mullard Wireless Service Co., Ltd., Mullard House, Charing Cross Road, London, W.C.2

Arks.

# COLVERN —T.D. COIL

## AN UP-TO-DATE COIL WITH UP-TO-DATE FEATURES

Type TD, an entirely new Colvern Coil, designed to give super selectivity on both long and broadcast wave-bands.

The coil is completely screened, giving a very neat appearance, and incorporates tapped aerial coupling and reaction, while the four alternative aerial tappings are arranged as sockets with a wander plug.

The first two tappings give aerial couplings similar to those normally employed but with greatly increased selectivity.

Nos. 4 and 5 give a high degree of selectivity with weak aerial coupling—suitable for use in a “swamp” area.

A most important feature of this coil is that there is no break through on the long wave-band from B.B.C. stations.

This coil is specified for the “DIODION,” which is being described in the Exhibition Number of MODERN WIRELESS.

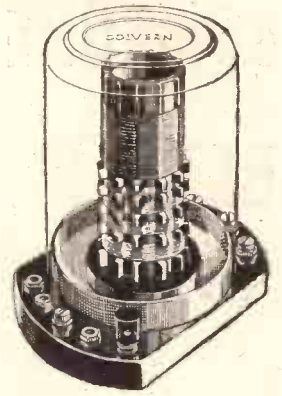

**TYPE TD**  
**PRICE**  
**8/6**

# —VARIABLE COLVERSTATS

Wire-Wound. For Voltage Regulation and Volume Control



Type ST10. Rating 10 watts. Standard values 500 to 50,000 ohms. 5/6



Type ST5C. Protected Windings. Rating 5 watts. Standard values 250 to 25,000 ohms. 5/3

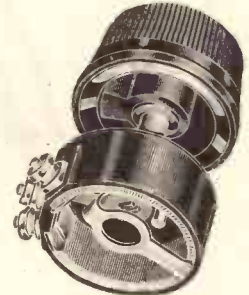

Type MT. Rating 3 watts. Standard values 25 to 10,000 ohms. 4/6

# —STRIP RESISTANCES

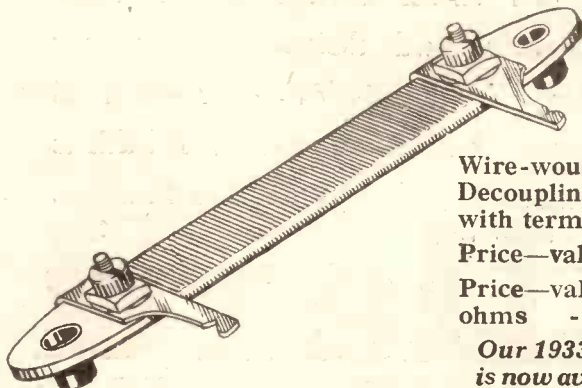

Wire-wound. For Mains Units and Decoupling. Rating 5 watts. Fitted with terminals and soldering tags.

Price—values up to 25,000 ohms - 1/9

Price—values from 25,000 to 50,000 ohms - - - - - 2/3

Our 1933 Booklet Radio List No 10 is now available and free on request.

Stand  
No. 245  
RADIO  
EXHIBITION  
OLYMPIA  
August 19-27  
1932

**COLVERN LIMITED, MAWNEYS RD., ROMFORD, ESSEX**

## ON THE OTHER SIDE

# A TALK WITH A CHINESE LISTENER



IT was my good fortune to meet, at Lloyd's, a Chinese trader who, living in the trading settlement at Shanghai, took an interest in Chinese broadcasting.

When I told him that I had already discussed local conditions with a Japanese wireless "fan," he waxed loquacious and was drawn into talking about his own listening experiences.

What he said was surprising, especially to Westerners, who have a conventional idea of a broadcasting "service."

"A proper broadcasting system would be absolutely impossible in certain parts of China, and that is why local societies have done so much to get a kind of amateur programme service 'on the air.'

### A Truly Chinese Idea.

"In Hong Kong, for instance, there could never be more than about 5,000 sets owned by people wealthy enough to pay licences (there are thousands of crystal sets owned by natives who could never be forced into paying licences) and permits would have to cost about £5 each to make the service pay.

"There are other kinds of troubles, too, because during the conflict with Japan it was realised how useful broadcasting is for propaganda.

"There is an excellent example of this. In 1928, universities in Canton and Nankin got together and, aided by a number of Chinese students who had been to Germany and seen broadcasting there, made plans for a station to disseminate educational talks. A truly Chinese idea, and a wise one.

### Hardly Educational.

"Unfortunately, some other Chinese officials were wiser, and more commercial. Directly the station was in going order it was seized by the city powers for propaganda. For quite a long time the professors were in the unfortunate position of having to see their 'dream' station used for purposes which could hardly be called educational.

"One of the city officials, a certain Chang Kai Shek, opposed the seizing of the station though, and two years ago the new Nankin Government realised its folly and plans were put in hand for a new station.

"Nankin Government officials asked the German Telefunken organisation—represented in China by the Siemens (China) Co.—for a 20-kilowatt.

The plan was an ambitious one. Two 400-ft. masts were put up at the side of

"Chu Chin Chinaman" is "muchee, muchee sad" because revenue difficulties make it impossible to have a Chinese station broadcasting for Chinese listeners.

On the other hand, no licence is needed for working a receiver in China, while clubs and amateur enthusiasts do what they can to add a local touch to the European concerts of gramophone records and news.

the Yangtse River, and a 600-horse-power station was built so that, in the event of a National emergency, the station would be self-supporting. Unfortunately, the prophecy for the need of this was soon realised.

"A special shielded cable was laid down between the transmitter site and a studio in the centre of the Republic.

"In Hong Kong there are English-speaking broadcasters and at Shanghai there is also a station which gives European programmes. The main Hong Kong station is in the local observatory at Kowloon, and there are also two others.

"It is perhaps strange to find an English-speaking station in Shanghai, for while the population of Hong Kong is mainly European, Shanghai is largely a native city.

"It is helped by one or two wireless traders and by big electrical firms handling wireless apparatus. Sets and parts are comparatively expensive. To a large extent the profit made helps to keep the programmes running.

### Practically No Revenue.

"Seeing that there is practically no revenue, the programmes aren't at all bad. The main Hong Kong station, for instance, on 330 metres, gives a lunch-time programme of gramophone records from 1 p.m. to 2 p.m., a news service at 7.30 p.m., and then a record programme until 9 p.m. Dance music practically every evening is taken from the lounge of one of the big hotels, and the station shuts down about 11 o'clock. These are local times, which are about eight hours in advance of London.

"In Hong Kong a large number of European listeners have big sets (generally bought from American traders) on which they can listen to your 5SW and a number of American stations on the U.S. sea border.

"I have heard it said, while over here, that there are no wireless stations worth talking about in China. Well, that is quite wrong.

"Station COK, on 335 metres, is a 2-kilowatt, and COHB, on 445 metres, a 1-kilowatt. Other good stations are COPK (330 metres), COTN (480

metres), KRC (345 metres) and NKS (315 metres).

### Levy on Imports.

"As I have said, there is no wireless licence tax as it would be practically impossible to make a profit out of it; but there is a levy on all imports of radio apparatus, and this makes money for the authorities in a much more effective way than set taxes.

"The local universities in every big  
(Continued on next page.)

## THE MEN BEHIND CHINESE RADIO



Dr. Wen Gu-Ching, Director of the Chinese Radio Administration, and (right) Wan Peh Chun, Minister of Communications, photographed after the opening of the Shanghai station, built to establish direct contact with San Francisco.

"The reason, I think, that European broadcasting has proved popular in Shanghai is that the city, standing by the mouth of the Yangtse Kiang, is the centre of all trade between China and the outside world. English is the accepted language in the trading settlement, and that is why an English-speaking station is popular.

"Both in Hong Kong and Shanghai the universities and local clubs have done much to put broadcasting on a firm footing, but, of course, it can never be a financial success.

## A TALK WITH A CHINESE LISTENER

(Continued from previous page.)

centre take the modern view with regard to broadcasting. Many of the students have either been to Western countries and seen German, French and British broadcasting, or else they intend to travel West when they leave college, and they have already studied broadcasting in Europe. The universities, therefore, provide many of the programmes given in the Chinese section. The European section is nearly always given by gramophone records.

"Millions of natives are too poor to own any kind of apparatus, even crystal sets, and communal receivers are installed in all the cheap eating-houses.

### An Attempt to Enjoy It.

"When the people troop in after the day's work is done, for their *chow*, the main evening programme is on. Even if it is dance music, which they cannot appreciate as the Western musical tone scale is quite different from the Chinese, they sit with bowed heads and sway in time with the music, obviously making an attempt to enjoy it.

"There are some keen American technical people in China in connection with the Radio Corporation of America developments. The Chinese authorities have been immensely keen to get wireless communication with the rest of the world, although they have not shown so much interest in broadcasting.

"Perhaps you do not know that it is now possible to get radio communication in only a few minutes between Shanghai and America or Berlin. There is a big commercial station at Chenjou.

"I do not want to bother you too much with commercial wireless as it has no bearing on broadcasting (except that there is a terrible lot of interference on super-hets.), but these new Chinese wireless stations have shown the depth of the national craftiness.

"Slowly China built up an immense debt to the cable companies, of about a million pounds. The Eastern and Great Northern services did not worry as they felt sure that, anyway, China would always have to rely on them for communication. But two years ago the Chinese authorities dropped a bombshell by opening their new station at Shanghai, making them independent of American and European aid, and

making the date of the settlement of the huge bill fade into the distance.

"It is because similar tactics might be tried with pukka broadcasting that none of your British firms has taken the risk and gone out to Hong Kong with a complete service. We should welcome the new station with open arms, but the trouble with Japan has removed any possibility of the venture being a success. Even the 'Reds' haven't started a propaganda station in Shanghai!"

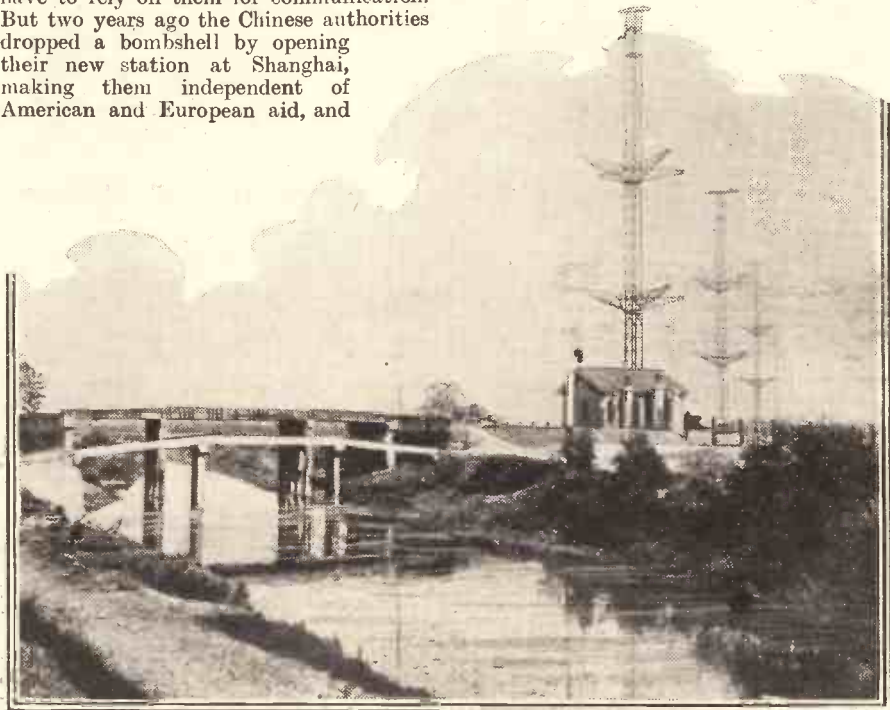

## CHATS WITH PARIS AND SAN FRANCISCO

The new Shanghai radio station, which is in daily touch with France and America, employs aerial masts of a typically Chinese nature. They are none the less efficient for that.

## "O.K. WITH ME!"



An engineer in one of the eight control rooms which handle the coast-to-coast programmes from the National Broadcasting Company's studios in New York.

Frequently the last trace of hum may be removed from a set by connecting an old L.F. transformer primary or secondary in the H.T. plus lead, a large fixed condenser being joined between earth and the set side of the transformer winding, which is thus made to act as an L.F. smoothing choke.

Now that high-power broadcasting is becoming more common a well-situated crystal set should be capable of bringing in foreign stations nightly between October and March.

Cleaning and opening the contacts of split-pin coils, etc., is one good way of improving results on an old set that has been standing aside out of use.

Be sure that the little grub-screw that holds the tuning dial on to the condenser spindle does not work loose. Otherwise you will be troubled by mysterious "jumps" in tuning.

If the fixing screw is countersunk in the tuning dial, and your smallest screwdriver is too big to reach it, remember that you can easily improvise a small screwdriver by filing flat a coarse Bradawl.

When adjusting a wavetrap critically, remember to keep your hands well away from it to avoid capacity effects. A "screwdriver"

## RECEPTION REMINDERS

Things you want to know about your set.

made from a wooden skewer is often effective where the adjustment concerned is that of a compression-type condenser.

The total length of an aerial must not be more than 100 ft., measured from the farthest insulator to the lead-in terminal (or aerial terminal).

When erecting a new aerial take care not to kink it.

Don't share your earth with a neighbour, unless you are prepared to put up with risking interference between the two sets.

If you have to use an indoor aerial, try for a good earth connection, as this often offsets aerial shortcomings.

H.F. chokes in which the windings are exposed to view should always be handled and mounted carefully, as if a section of the winding becomes shorted, unsuspected tuning effects, causing uncontrollable oscillation, may result.

The best rough-and-ready test for oscillation is to wet the finger and tap the fixed vanes of the variable condenser concerned. Loud double clicks, corresponding with the finger making and breaking contact, are an indication that the valve is oscillating.

RADIO  
**IGRANIC**  
 DEVICES

**LOGARITHMIC VOLUME CONTROL**

The IGRANIC Logarithmic Volume Control is wire wound and fitted with a specially graded resistance track. It has been evolved to afford a uniform control of volume where a valve or valves of the Variable Mu type are employed in the circuit. The graded resistance makes the volume control obey the same law as the valve. Sizes: 5,000, 10,000, 50,000 ohms, and they can also be supplied with combined switch. Price 5/6, with switch 7/6

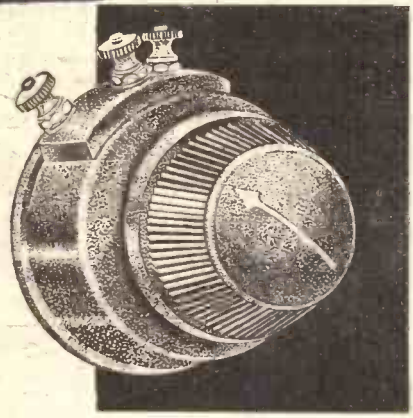

**IGRANIC**  
**COMPONENTS WILL**  
**BE THE MAKING**  
**OF YOUR SET.**

**OLYMPIA STAND 36**

*A div. of the Igranit Electric Co., Ltd., 149, Queen Victoria Street, London, E.C.4.*

**IGRANIC MIDGET RADIO SWITCH**

A neat, compact component specially suitable for switching filament current "on" and "off." Moulded bakelite with heavily plated metal front—one-hole fixing. 1 amp. at 250 volts; 3 amps. at 125 volts. Prices, with terminals, 1/8; with soldering tags, 1/6.

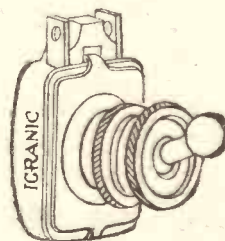

**IGRANIC ANTI-CAPACITY SWITCH**

For use in all circuits where self-capacity in a switch must be reduced to a minimum. Excellent springs ensure positive contact. Well-spaced soldering tags. Semi-rotary movement. One-hole fixing. 2-way Change-over Switch. Price 1/9. 3-way Ditto. ... Price 2/-. 4-way Ditto. ... Price 2/6.

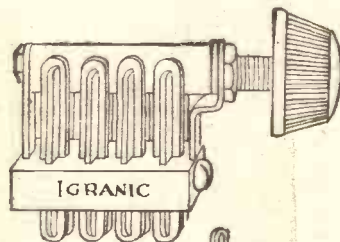

**IGRANIC PUSH-PULL SWITCH**

Smooth action and positive contacts. Terminals and soldering tags on ebonite strip. All metal parts nickel-plated, reducing resistance to a minimum. One-hole fixing. Price 9d.

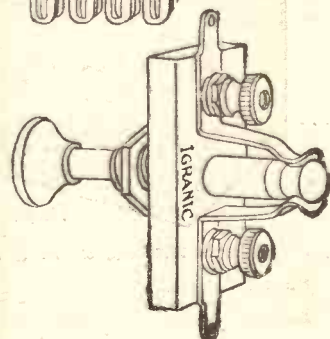

# For the First Time Home Constructors Can Build a Receiver Employing

## Metallised S.G.—High Mu Detector and Economy Power Pentode Valves



# LISSEN SKYSCRAPER KIT 3

FOREIGN STATIONS SO LOUD AND CLEAR THAT YOU'LL BE SURPRISED TO HEAR THE WAY THEY COME IN

This new LISSEN SKYSCRAPER KIT SET is the ONLY ONE on the market that you can build yourself employing a Metallised Screen Grid, High Mu Detector, and Economy Power Pentode Valves. Around these three Valves LISSEN have designed and produced a home constructor's kit the equal of which there has never been before. It is the only battery set delivering such power—yet the H.T. current consumption is far less than the average commercially designed 3-valve set. And the LISSEN SKYSCRAPER is made simple for you to build—such detailed instructions are given to you, and so clearly, in the FREE Lissen Constructional Chart that everybody with no technical knowledge or skill can build it quickly and with complete certainty of success.

Why be satisfied with whispering foreign stations when you can BUILD WITH YOUR OWN HANDS this LISSEN SKYSCRAPER that will bring in loudly and clearly distant stations in a profusion that will add hugely to your enjoyment of radio.

BUILD WITH YOUR OWN HANDS AND SAVE POUNDS—surprise your friends with this new receiver built by yourself—see them admire the fine looking job you have made with your LISSEN SKYSCRAPER—you will be proud to say "I built it myself."

**THE GREATEST HOME CONSTRUCTORS SET EVER PRODUCED**

WITH CABINET AS BELOW  
**£6.5s**

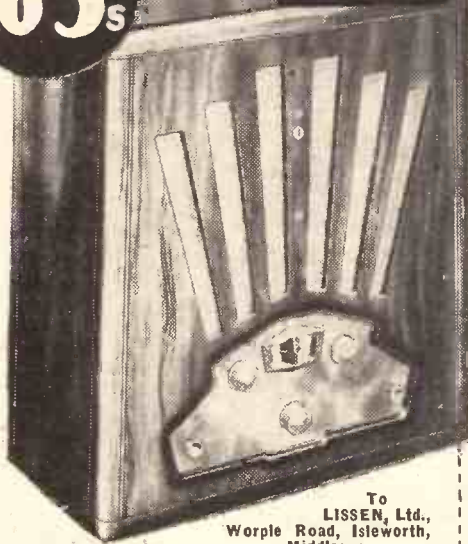

To LISSEN, Ltd.,  
Worpole Road, Isleworth,  
Middlesex.

Please send me FREE copy of your 1/- Skyscraper Chart.

Name.....

Address.....

## 1/- CHART FREE!

Lissen have published a 1/- Constructional Chart, giving the most detailed instructions ever printed for the building of a wireless set. Every part, every wire, every terminal is identified by photographs. THERE IS A FREE COPY OF THE CHART FOR EVERYBODY—GO AND ASK YOUR DEALER FOR YOURS—or fill in the coupon below.

**KIT COMPLETE WITH METALLISED S.G.—HIGH MU DETECTOR AND ECONOMY POWER PENTODE VALVES.**

You buy the Lissen Skyscraper Kit complete with valves—a Lissen Metallised S.G., a High-Mu Detector, and a Lissen Economy Power Pentode Valve—and the price complete is only 89/6.

Or you can buy the Lissen Walnut Consolette Skyscraper Cabinet and loud speaker combined as illustrated. It holds all the Batteries, and Accumulator and loudspeaker as well as the Skyscraper Kit—it makes everything self-contained. A special Lissen Pentode Matched Balanced Armature Loudspeaker of great power is supplied with the cabinet, and the price of the Skyscraper Kit complete with Valves and this cabinet and loudspeaker is only £6 5s. 0d.

Ask your radio dealer for FREE CHART, or fill in coupon to secure a copy by post.

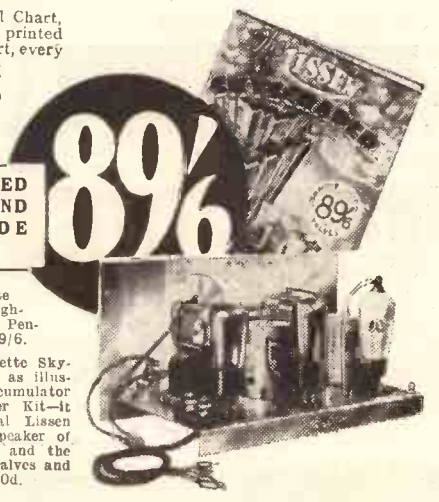



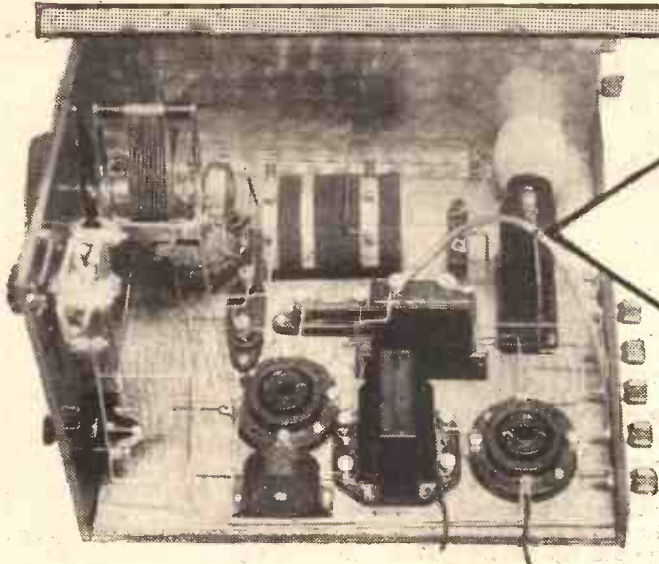

# THAT OUTPUT STAGE

BY  
J.H.T. ROBERTS D.Sc.F.Inst.P.

A clear explanation of a subject which is so often misunderstood, showing how important are the connections between loudspeaker and power valve.

WE hear endless arguments about power valves, super-power valves, pentodes and low-frequency couplings; as for loudspeakers, their name is legion. But one of the most important items in the series—the output stage—is very often neglected.

You don't hear nearly so much talk about the different types of output stage as you do about the other parts of the set, and yet I should say that quite a large percentage of inferior results is due to the link between the set and the speaker.

It is really worth while giving some thought to the question of an output arrangement between set and speaker, because this often makes all the difference in the world to the results. It gives your receiver, in fact, a chance of "showing what it can do." It is hardly fair, if the receiver and the loudspeaker have little or no relationship to one another, to expect them to work in harmony. It is like introducing a Greek to a Chinaman and expecting them to carry on a conversation. What you want is an intermediate link—an interpreter.

### The "Interpreter."

The output stage is the "interpreter." It acts as interpreter between the output of the set and the input to the loudspeaker. The output of the set itself often has very little relation to the loudspeaker, and unless there is some proper connecting link between the two, designed to take up the inequality, how can you expect them to work harmoniously together?

There are various points to be considered as between the loudspeaker and the output of the set, perhaps the most important point being the question of relative impedance. If the last valve of the set is an ordinary power valve, having an impedance, of, say, 10,000 ohms (or even sometimes a good deal more) and only a small grid swing, it is quite probable that it may be overloaded and you may get that peculiar "reedy" tone, generally denoting that a larger power valve—one having a larger power-handling capacity—is needed.

### That "Reedy" Tone.

With a good power valve, having an impedance of, say, 2,500 or 3,000 ohms, and a large grid-swing, the "reedy" tone should disappear. I should like to mention particularly, however, that many power valves are not supplied with sufficient high-tension and grid-bias voltage.

The grid-bias and H.T. voltages, as you know, bear a relationship to one another, and unless you have a sufficiently large G.B. voltage you are seriously restricting the available grid-swing of the valve. If there is not sufficient "room" for the grid-swing you will get positive voltage on the grid, which means grid current, which in turn means distortion.

### Signs of Overloading.

Now, having got the power valve working under proper operating conditions, you may be troubled with "boominess" instead of

the previous "reedy" quality, and you may find that the loudspeaker shows signs of overloading on the slightest pretext. If this happens, it is generally due to the steady output of current from the power valve passing through the loudspeaker windings, and this brings us to one of the reasons why we should employ an output filter of some kind.

The first reason for an output filter I have already mentioned, and that is that it enables us to match up the impedance of the output valve to that of the loudspeaker. So you see we have already two principal reasons for using an output filter: the one is to match up impedances and the other is to keep the steady current out of the loudspeaker windings.

### Avoid D.C. Current.

With some of the older-fashioned types of loudspeaker, the presence of steady current in the windings does not make a great deal of difference, but with the more modern types, such as dynamic speakers and the balanced armature kind, it is very important to keep out the steady current, as this will often completely upset the working of the speaker. Altogether, apart from this, there is always the danger of a breakdown in the windings due to the high voltage.

It is sometimes stated that the impedance of the valve and that of the speaker should be accurately matched by means of the  
*(Continued on next page.)*

## CHOKE AND TRANSFORMER—THE COMPONENTS THAT ENSURE GOOD QUALITY

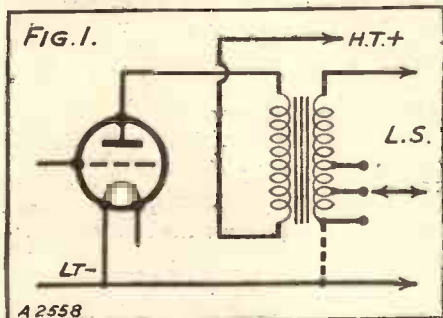

A useful form of output circuit is that of Fig. 1, where an output transformer having a tapped secondary is shown. The choice of taps enables matching-up with the loudspeaker to be carried out.

On the right is a very common output scheme—a plain choke and condenser coupling to the speaker. The arrangement enables the direct current to be kept out of the L.S. windings but does not permit of matching between valves and loudspeaker.

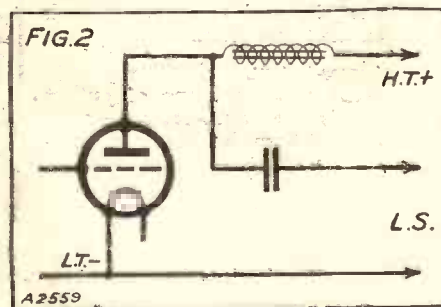

THERE are very distinct indications now of a big improvement in long-distance wireless conditions. It is worth while to begin operations much earlier in the evening than was recently the case, and the increase in the volume obtainable from stations becomes more and more noticeable.

It is very early in the year for this kind of thing to take place and the natural deduction is that not many weeks will pass before the wireless receiving set takes on that pleasant lively feeling which indicates that reception conditions are first-rate.

Daytime reception on the medium waveband is fast becoming worth while. There are at least half a dozen stations that one has a good chance of hearing, even in the morning, provided that they are working when you try for them.

#### Rapid Estimate of Reception.

These are Hilversum, the Poste Parisien, Trieste, Rome, Langenberg, and Brussels No. 1. Rome, by the way, has been extraordinarily good by daylight for some little time now, and I have more than once had him with excellent quality and at full loudspeaker volume with only the merest "whiff" of reaction.

Your reaction control knob, by the way, gives you a simple but very good means

# STATIONS WORTH HEARING

Some practical distant-programme notes, compiled by a special contributor who nightly searches the ether in order to obtain really up-to-the-minute information for "P.W." readers.

of forming a rapid estimate of reception conditions on any particular day or night.

When you find that only a small movement in a clockwise direction is needed to give your loudspeaker all the punch that it requires, then conditions are good. But if you tune in two or three stations, normally receivable with very small help from reaction, and find that to obtain good volume from them you have to move the knob nearly as far as it will go without causing oscillation, then conditions are none too favourable for long-distance work.

The odds are that the quality of distant transmissions will be poor and that interference will be troublesome since the sound-level of the wanted transmission is not sufficient to enable it to drown unwanted noises.

#### A Return to Strength.

With Huizen, Radio-Paris, Zeesen, the Eiffel Tower, and Warsaw to choose from, the long waves now provide a fine choice of programmes in the daytime or after dusk.

If you want to listen to foreign pro-

grammes on the medium waveband the choice is now so large as to be almost embarrassing. Completely reliable stations from about seven o'clock in the evening onwards are Trieste, Turin, Heilsberg, Hilversum, the Poste Parisien, Brussels No. 2,

Toulouse, Stockholm, Rome, Beromunster, Langenberg, Prague, Florence, and Brussels No. 1.

Beyond these there are many that are almost sure to be coming in well, though they do have evenings when they are not quite up to the mark. Of these the most important are Budapest (now a very much improved station), Vienna (improving rapidly), Katowice, Frankfurt, Strasbourg, Milan, Breslau, Göteborg, Genoa, Bratislava and Nürnberg.

#### Wavelength Wandering.

The volume from Nürnberg is nearly always good, but he is apt to suffer from heterodyne troubles. There would be many more first-rate stations below 250 metres were it not for the interference caused by wavelength-wandering.

The lower part of the medium waveband is by far the most unruly of all, for it contains not a few stations whose wavelength should really be stated in the tables as "Anything the engineer thinks fit."

## THAT OUTPUT STAGE

(Continued from previous page.)

filter circuit, but in practice accurate matching is not really essential. You will generally find that if the matching is within 10 or 15 per cent, the results will be quite satisfactory. You will also find, as a rule, that when the matching is about 20 to 25 per cent out, you begin to notice definite differences in tone and volume.

The impedance of a power valve may vary between, say, 2,000 ohms and 10,000 ohms, whilst the impedance of a loudspeaker may be anything from several thousand ohms down to a few ohms. By the way, the impedance of the speaker is usually a very different thing from its ohmic resistance; that is, the resistance which it offers to the passage of a steady current. Unfortunately many manufacturers state the resistance of a loudspeaker and this passes for the impedance when, in fact, the figure which we require to know is very much higher than the figure given.

#### The Transformer Output.

One of the popular forms of output arrangement is the transformer type, in which the output from the set, which otherwise would pass direct to the loudspeaker, is passed into the primary of the output transformer, whilst the loudspeaker is connected to the secondary terminals of the transformer.

In this way the loudspeaker is entirely insulated from any direct current and the voltages and speech currents which it receives are simply those generated by the transformer secondary. The primary of

such a transformer often has an inductance of 40 to 50 henries and should have a fairly low D.C. resistance. The secondary, however, is preferably provided with a number of terminals, so that by trying the different tappings, the impedance can be chosen to suit the loudspeaker.

Sometimes the secondary winding of the transformer is connected to earth, more particularly in the case of receivers working from the mains. In many cases, with battery-driven sets, there is no need to connect the secondary to earth.

A very popular type of output is the choke-filter arrangement in which a choke and condenser are used, the choke being in the

value of not less than 2 mfd. (preferably 4 mfd.). Incidentally, since this condenser is to stand up to the H.T. voltage, it should have good enough insulation for the purpose.

#### Choke-Filter.

The choke should preferably be tapped so that different values of inductance can be chosen until the best value is found. With the choke-condenser coupling it is advisable to have one of the speaker leads connected to earth, as I have indicated above, but sometimes you may wish to have the speaker entirely insulated from earth, in which case another fixed condenser should be included in series with the lead which goes to L.T. minus.

For instance, in a mains-driven set (more particularly when working on D.C. mains), the negative side of the set may not be connected to the mains earth. This is a case where it is often desirable to have the loudspeaker entirely insulated; this is done, as already mentioned, by two condensers, one in each lead.

I have often been asked whether it is better to use small power valves in parallel rather than a single power valve of larger capacity. My answer to this is that it is much better and simpler to use the single power valve.

Of course, if you happen to have a couple of small power valves on hand and you don't want to go to the expense of buying a larger valve, then there is no reason why you should not use the two smaller ones in parallel.

In such a case it is practically essential to use an output transformer, owing to the fact that with the two valves in parallel the impedance will be relatively low and this will not match with the loudspeaker.

## TAPPED FOR TONE

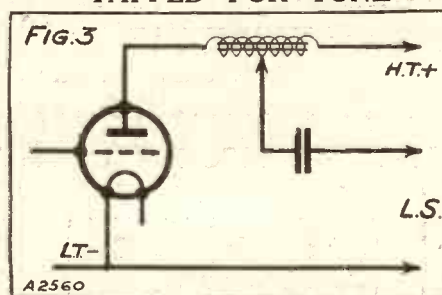

A choke-condenser output filter can be made to give a step-down effect for good quality if a tap is provided on it.

H.T. lead to the anode, and the loudspeaker being connected with one terminal to L.T. minus and the other terminal to the choke via a fixed condenser.

The choke should have an inductance of about the same value as that mentioned above for the primary of the anode transformer, whilst the condenser should have a

The only FULL SIZE Condenser selling at 6<sup>d</sup>



The only Condenser selling at 6<sup>d</sup> that requires NO SOLDERING into circuit

LISSEN GRID LEAKS 6<sup>d</sup> NOW ALSO

Now, too, you can get the finest, most reliable Grid Leaks at half the price you had to pay before. Lissen Fixed Grid Leaks are resistances that never vary; they are absolutely silent in use. Use them in every circuit. All values 6d. each.



These are exactly the same Lissen Mica Condensers for which you were paying 1/- each before. They are Leak-proof. They deliver all their stored-up energy. They are guaranteed accurate within 5% of marked capacity.

And remember—Lissen are the only FULL-SIZE Fixed Mica Condensers you can buy for 6d. each, the only condenser selling at 6d. that has standard terminals and requires no soldering into circuit.

# LISSEN FIXED MICA CONDENSERS 6<sup>d</sup>

Up to .002 mfd. WERE ~~1/-~~ NOW

Over .002 mfd. were 2/- and 1/6d. reduced to 1/-.

EXACTLY THE SAME LISSEN CONDENSERS AND THE SAME LISSEN GRID LEAKS FOR WHICH YOU PREVIOUSLY PAID 1/-

LISSEN LIMITED, WORPLE ROAD, ISLEWORTH, MIDDLESEX

FROM THE TECHNICAL EDITOR'S NOTE BOOK.

# Tested and Found-?



**TRACKING TROUBLE.**

THE Pifco people style their "All-in-One" radiometer, "The Bloodhound of Radio," and it is certainly most aptly described. I have had both the standard model (price 12s. 6d.) and the de luxe model (price £2 2s.) pass through my hands, and I have found both of them to be reliable and very useful.

The standard model is intended for battery sets only, but thorough and searching tests can be made with it.

The de luxe model has a very high resistance, and can be employed for all mains purposes as well. It is claimed that this precision instrument is capable of making twenty-two distinct tests.

Readers interested in these useful devices should make a point of writing to Messrs. Pifco, Ltd., of High Street, Manchester.

**"MOTOR" MINOR.**

The loudspeakers made by the Tekade Radio and Electric, Ltd., are well named, for "Motor" conveys an impression of mechanical force and virility better than almost any other word.

**A NEW MOVING-COIL**



The "Motor" Minor Permanent - Magnet Moving-Coil Speaker.

Its nearest competitor is "dynamic," but that word is used to denote a class of loudspeaker. In America the moving-coil speaker is invariably described as the "dynamic."

All this is not so far removed from my subject as might be thought, because it is the "Motor" Minor moving-coil loud-

speaker to which I am going to draw your attention.

The "Motor" Minor is a permanent-magnet type, and it is supplied complete with transformer and baffle-board at the attractive price of 39s. 6d. (For a mere 5s. 6d. extra you can get it built into a leatherette cabinet.)

It has a moulded diaphragm and an accurately centred coil having ample play for good bass rendering.

Its handling of high notes is also commendable, and I should say the speaker deserves a place in the first two or three of its class—the low price being regarded as an incidental and added attraction.

Tested with our new gear for linearity of response, it made an admirable showing, and it is sufficiently sensitive for use with the smaller kinds of sets, as well as being able to handle higher powers creditably.

**THE PRESSLAND AERIAL "COP."**

This is an ingenious volume and selectivity-control which entirely replaces the normal lead-in tube arrangement.

Additionally, it operates as a protection

**THE GOLTONE CONNECTOR**

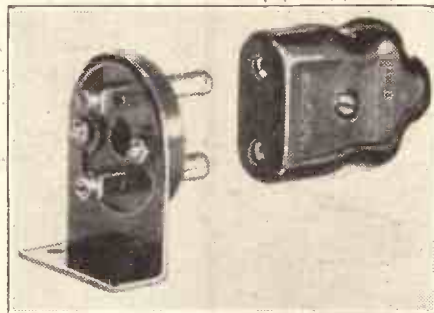

An inexpensive and very useful mains gadget.

against lightning. And all this is controllable by a simple plunger worked from indoors.

It is backed by a £100 Free Lightning Insurance policy, and costs only 2s. 6d. for the 6-in. size.

**SAFE MAINS CONNECTIONS.**

Ordinary terminal connections are unsuitable for mains units and sets when the "live" mains themselves are concerned. A protected and properly designed connection is essential.

Messrs. Ward and Goldstone are now making such an article specially designed for constructors. At least, I should imagine it to be, for the plug part is built for easy baseboard fitting.

The socket is robustly made and there is a cord grip to prevent the lead from being pulled out by accident.

The price of this useful Goltone Connection is 1s. 6d.

**A COMPACT CONDENSER.**

Even the neatest of ordinary gang condensers is a somewhat bulky component at best. It would be strange if it were not, for it comprises all the essential elements of two or more separate tuning condensers. Unusual compactness is a quality strived for by designers.

And in fairness we must admit that great success has been achieved.

Now you will know how much smaller a tuning condenser can be made if a solid dielectric such as bakelite is employed instead of air separation for the vanes. Many solid dielectric condensers are, in fact, made and used nowadays.

**PLEASE NOTE**

Manufacturers and traders are invited to submit radio apparatus of any kind for review purposes. All examinations and tests are carried out in the "P.W." Technical Department with the strictest of impartiality, under the personal supervision of the Technical Editor.

We should like to point out that we prefer to receive production samples picked from stock, and that we cannot in any circumstances undertake to return them, as it is our practice thoroughly to dissect much of the gear in the course of our investigations!

And readers should note that the subsequent reports appearing on this page are intended as guides to buyers, and are, therefore, framed up in a readily readable manner, free from technicalities unnecessary for that immediate purpose.

Messrs. Wingrove and Rogers have applied the principle to a two-gang type of construction, and the result is the smallest and, I think, cheapest gang on the market.

It hasn't the complete sectional screening or the efficiency that are needed for "gangs" in high-amplification H.F. sets, but for aerial band-passing it certainly possesses a very strong appeal.

**IT'S A GANG!**



Although at first sight this device looks like a good slow-motion dial, it is actually this plus a two-gang condenser

# When the higher notes are missing ——RECTATONE restores them.

## OVER 1,000 CYCLES—A RISING CURVE

The growing ether congestion calls for still more selectivity. The super-heterodyne and special ultra-reaction circuits have been developed to meet this requirement, the tuned circuits being made sharply resonant, deliberately cutting off the high notes. It is clear that a low-frequency coupling device is required which will restore these weakened high notes to their correct value. The new RECTATONE transformer does this. Its frequency response curve is straight up to 1,000 cycles per second and then rises reaching a maximum at approximately 4,500 cycles.

## RECTATONE THE IDEAL L.F. COUPLING

The degree of compensation is variable and may be suited to the particular tuned circuits in use or employed to correct deficiencies due to the loud-speaker or to the acoustics of the room. RECTATONE is thus the ideal L.F. coupling for all selective sets—particularly useful for those using a pick-up or for radio-gramophones, since the tone control so valuable on radio, can be cut out on "gramophone" where it is usually unnecessary.

# THE NEW RECTATONE L. F. TRANSFORMER



Compensation is controlled by a variable resistance connected externally between two of the transformer terminals. If this resistance be omitted or put out of circuit RECTATONE becomes a normal straight-line transformer giving high and even amplification.

Get your copy of  
"THE BOOK OF THE RECTATONE"  
price 6<sup>d</sup>  
**FREE**  
if you mail this coupon

# Varley

*When Bass and Treble are correctly present, Rectatone preserves them. When the higher notes are missing, Rectatone restores them.*

To Messrs. Varley, Kingsway House, 103, Kingsway, London, W.C.2.

Please send me, free and post free, the

**"BOOK of the RECTATONE"**

Date .....

Name .....

Address .....

P.W.2



**1 Cop in place of  
7 radio gadgets-he**

Get this Pressland Aerial Control Cop! Here you have (and all for half-a-crown) selectivity control to help you pick and choose your programmes . . . protection for you and yours from lightning, and £100 policy against damage to your set to back it up . . . volume control at the touch of your finger . . . elimination of atmospheric disturbances, which are shunted to earth . . . a good-looking, permanent lead-in . . . and an automatic aerial cut-out.

**Quick and Easy to Fix**

No need to buy wave-traps, condensers, selectivity gadgets, lightning arresters, earth switches—this remarkable invention combines them all. A beginning of far better reception! An end to lightning risks! Yes, it's All-British, and can be fixed in a few minutes.

Get them at your local Radio Dealers, or if there is any difficulty in obtaining, send P.O. or cheque for 2/6 direct to manufacturers—

- CONTROLS SELECTIVITY
- ARRESTS LIGHTNING
- ELIMINATES STATIC
- CONTROLS VOLUME
- acts as an
- AERIAL CUT-OUT
- and an
- AERIAL LEAD-IN

**PRICES:**

- 6 in. size - 2/6
- 9 in. size - 3/-
- 12 in. size - 3/6

**PRESSLAND  
AERIAL CONTROL  
COP**

Sole Manufacturers:  
**CLIFFORD PRESSLAND (SALES), LTD.,**  
84, Eden St., Kingston-on-Thames,  
SURREY.

*and gives you*

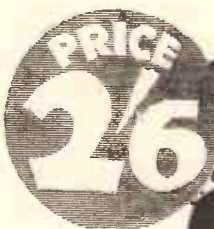

# The LISSEN

Simplicity of construction, excellent range and adequate selectivity for all normal regional requirements are outstanding features of this new Lissen Kit set. These are the impressions of the "P.W." technician who gives below his interesting experiences of this new S.G. Det.-Pentode production of Messrs. Lissen.

ALL-METAL chassis, simple construction, a tasteful and distinctive appearance, and a reliable "time-tested" circuit are features of the new Lissen "Skyscraper," a kit set selling at 89s. 6d. or £6 5s. 0d. complete with Consolette cabinet and balanced-armature loudspeaker.

It is a receiver designed for the man who doesn't possess any special constructional skill or knowledge of radio. The circuit comprises that deservedly popular combination of S.G., detector, and pentode.

### Varying Degrees of Selectivity.

Both the aerial and H.F. circuits are fully tuned, the coils employed being the well-known Lissen dual-wave screened units.

There are two alternative aerial sockets so that different degrees of selectivity may be obtained by altering the value of the series aerial condenser.

Facilities are provided for using a gramophone pick-up, the chassis being equipped with two terminals to which the pick-up leads can be connected if desired.

The L.F. coupling is looked after by that efficient little component, the "Hypernik" transformer which has a .25 meg. H.F. stopping and stabilising resistance joined between one end of the secondary winding and the grid of the pentode—evidence of careful design.

The output valve is a Lissen pentode P.T.225, and those who purchase the Consolette model will have the advantage of a speaker winding specially matched up to the valve.

### Simplicity the Keynote

Simplicity is the keynote throughout, and the veriest novice will find no difficulty whatsoever in successfully building the set.

TECHNICAL SPECIFICATION	
No. of Valves	Three.
Circuit	S.G.-Det.-Pentode.
No. of Controls	Five.
Arrangement of Controls	Two for Tuning.
	One for Reaction.
	One for Wavechange.
	On-Off Switch.
Price	Kit . . . . . £4 : 9 : 6
	Complete
	Table Model £5 : 5 : 0
	Complete Consolette Model . . . . . £6 : 5 : 0

The constructional sheet forms a complete guide.

We feel that Messrs. Lissen deserve a special word of praise for the careful way in which the constructional details have been prepared. It is obvious that they have endeavoured to be of assistance to potential constructors in every way possible, and it is difficult to imagine how anyone could possibly go wrong.

Every operation and every wrinkle concerning the construction of the "Sky-

# SKYSCRAPER

# 3

scraper" is clearly set out in a series of six step-by-step panels, and to guard against the possibility of mistakes when the wiring stage is reached every lead is shown numbered.

As proof of the thoroughness with which this new constructional chart has been prepared, the photographs showing the top and underside of the chassis are printed back to back on the sheet, and by holding it up to the light it is possible to trace the course of every lead.

### About the Controls

Both the table and consolette models are highly attractive in appearance, the panel controls being reduced to a minimum. There are two tuning controls with excellent slow-motion drives, a reaction control, a wave-change switch and on-off switch. The latter switch, incidentally, disconnects the H.T. as well as the L.T.

A feature of the cabinet work is that you can build the table and consolette models

light. The two London transmissions were easily separable on either of the alternative aerial positions. Upon switching over to the long waves, Radio-Paris came in on full volume and completely free from any interference from 5 X X.

In our practical tests with this new Lissen production, we were impressed with the smooth movement of the tuning condenser controls. This may appear to be rather a trivial matter, but in point of fact it is a factor of vital importance in any set intended for long-distance reception.

The Lissen "Skyscraper" Set is intended for long-distance reception, and as a result of our tests we have no hesitation in stating that in our opinion the maker's claims are fully justified.

### ENTIRELY HOME ASSEMBLED



Even the cabinet of the "Skyscraper" kit set, which is available in table and consolette models, is put together by the constructor.

### Where the Stations Stand

Incidentally, in connection with the station-getting abilities of this set, it is interesting to note that the constructional chart includes a very complete list of stations with dial readings as they apply to this particular instrument.

In practice, of course, these may be subject to slight variation in different models, but nevertheless they constitute an excellent guide for the newcomer who may experience station-identification difficulties, and for this purpose the list should prove invaluable.

When searching for some of the weaker distant stations we found it necessary to use reaction in order to bring them up to decent volume, but that is only what one would expect from any three-valve circuit of this type, and in any case in operation the reaction control was delightfully smooth.

Altogether, the "Skyscraper" is a really easy-to-build kit set with a good range and adequate selectivity, and we have no hesitation in recommending all potential constructors of a "kit-set" to see and hear it before buying.

yourself. The woodwork can be bought in finished sections of polished walnut and assembled in the home. This, of course, saves the cost of labour.

### Tallis House Tests

We tested the consolette model on a good outdoor aerial at Tallis House, using 120 volts H.T. and 4½ volts G.B. on the pentode as recommended by the makers. On the medium waveband we had no difficulty in tuning in such stations as the Midland and Northern Regionals at good volume in day-

# THE LISSEN "SKYSCRAPER 3" —Continued

★ ★ ★  
 The new "Skyscraper 3" Kit is available as a kit only—or it can be obtained complete with a set of parts for an easily-assembled table or console cabinet of distinctive appearance.

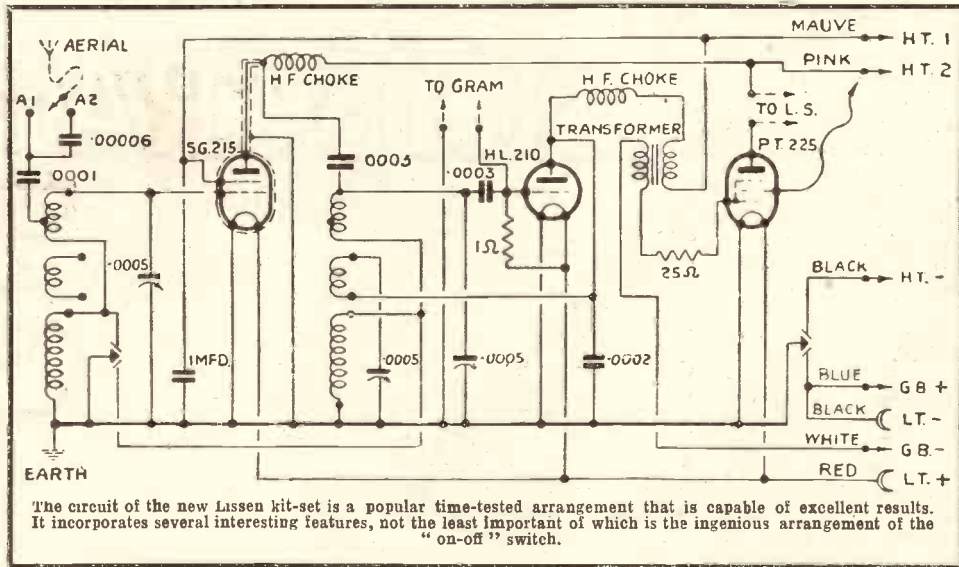

★ ★ ★  
 The step-by-step instructions for the construction of the new "Skyscraper" Set are extraordinarily clear and well worked out, and it is almost impossible to go wrong.

★ ★ ★  
 The circuit of the new Lissen kit-set is a popular time-tested arrangement that is capable of excellent results. It incorporates several interesting features, not the least important of which is the ingenious arrangement of the "on-off" switch.

## THE "STAGE-MANAGER'S" VIEW!

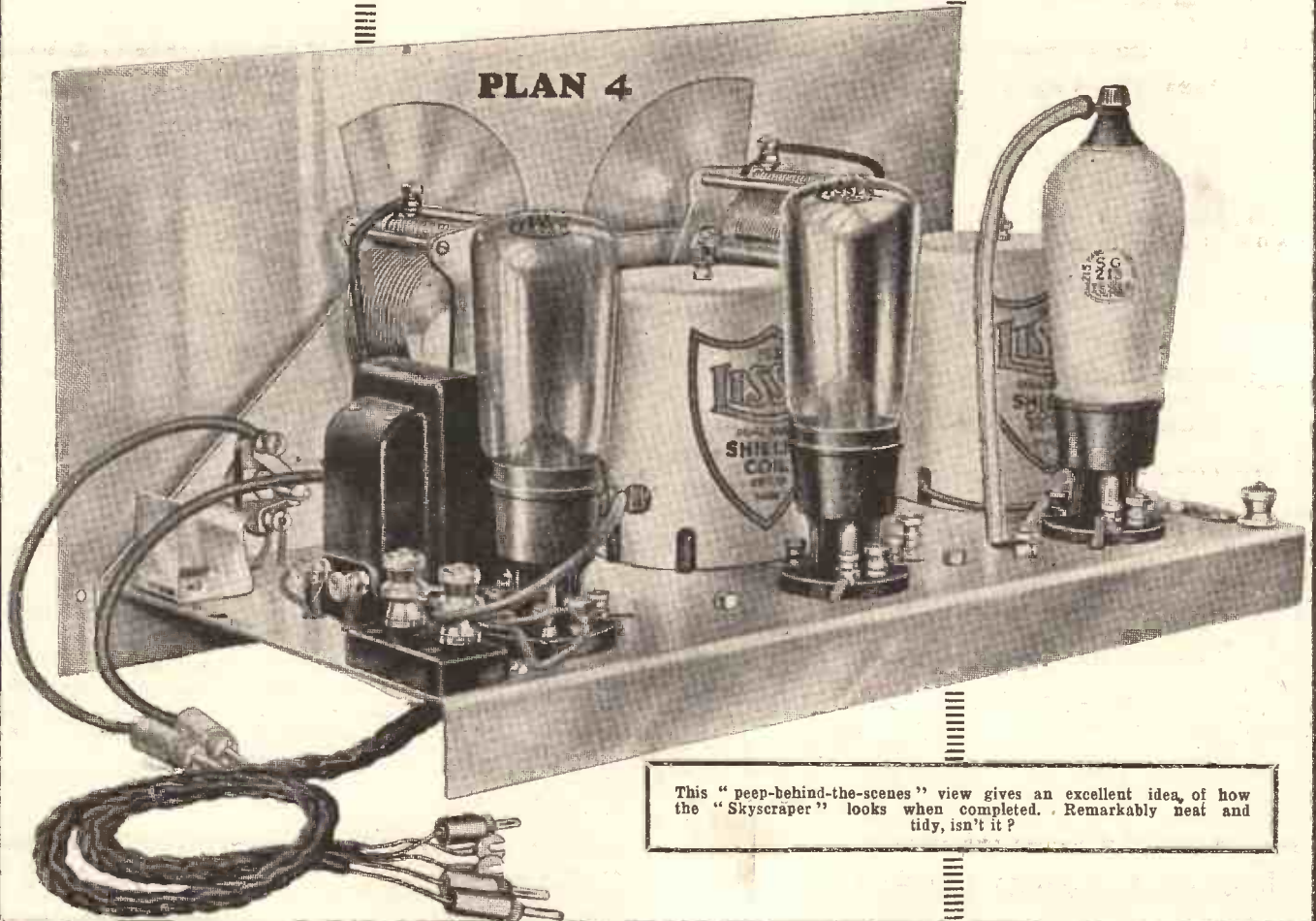

This "peep-behind-the-scenes" view gives an excellent idea, of how the "Skyscraper" looks when completed. Remarkably neat and tidy, isn't it?



**PIONEERS in 1923**  
**LEADERS in 1932**



# TRIOIRON VALVES

Retail Prices (post free)  
**THE LOWEST PRICES**  
**FOR FIRST-CLASS VALVES**  
**ANYWHERE IN THE WORLD**

Buy them from your Local Dealer. Every good-class independent Trader now stocks Triotron valves. If you should experience difficulty in obtaining any type locally please communicate with us.

2-VOLT TYPES		Retail Price	A.C. TYPES (Indirectly Heated)		Retail Price	D.C. TYPES (Indirectly Heated) App. 20 Volts, 0.18 Amps		Retail Price
S.207	Screened Grid .....	12/6	S.415N	Variable MU .....	13/6	S.2010N	Screened Grid .....	15/-
S.208	Variable MU .....	13/6	S.412N	Screened Grid .....	13/6	A.2030N	Detector .....	11/6
W.D.2	Resistance Coupling .....	5/-	S.410N	Screened Grid .....	13/6	E.2020N	Low Frequency .....	12/6
H.D.2	Detector and H.F. ....	5/6	S.430N	Steep Slope Screened Grid .....	13/6	P.2020N	Pentode .....	15/6
S.D.2	The popular Super Detector .....	5/-	D.410N	Double Grid .....	14/-	<b>POWER AMPLIFIERS</b>		
T.D.2	General Purpose .....	5/6	A.430N	Detector .....	9/6	K.435/10	Anode Dissipation, 10-W. ....	13/6
Z.D.2	Power .....	6/6	W.415N	Resistance Coupling .....	9/6	K.450/25	Anode Dissipation, 25-W. ....	25/-
U.D.2	Super Power .....	6/6	E.430N	Power .....	10/-	K.450/40	Anode Dissipation, 40-W. ....	50/-
Y.D.2	Steep Slope Power .....	6/6	P.440N	Pentode (for silent background) .....	13/6	P.430	10-Watt Pentode .....	17/6
E.235	Steep Slope Power .....	7/-	Y.N.4	Power .....	7/-	P.440	25-Watt Pentode .....	32/6
S.P.2	Magna Power .....	6/6	<b>D.C. TYPES (Directly Heated)</b> 0.1 Amp. Range			<b>RECTIFIERS</b>		
P.215	Pentode .....	12/6	S.409	Screened Grid .....	12/6	G.429	Half Wave, 30 mA .....	7/6
D.210	Double Grid .....	13/6	W.420	Resistance Coupling .....	6/6	G.431	Full Wave, 30 mA .....	8/6
<b>4-VOLT TYPES</b>			A.430	Detector .....	6/6	G.470	Full Wave, 70 mA. up to 500 anode volts .....	9/6
S.408	Screened Grid .....	12/6	P.520	Pentode .....	13/6	G.4120	Full Wave, 120 mA .....	16/6
D.410	Double Grid .....	13/6	0.07 Amp.			G.4100	Half Wave, 100 mA .....	15/6
W.412	Resistance Coupling .....	5/-	Y.G.5	Power .....	6/-	G.4150	Half Wave, 150 mA .....	48/-
H.412	High Frequency .....	5/-	<b>Ask for Catalogue with detailed characteristics.</b>			V.60	Resistance Lamp (Stabiliser) .....	7/-
A.420	Super Detector .....	5/-	<b>A FREE SERVICE!</b>			Submit your radio problems to us. Our Technical Dept. will gladly answer your Wireless problems without charge or obligation.		
E.414	Power .....	6/6						
E.420	Power .....	6/6						
E.422	Power .....	6/6						
E.425	Super Power .....	7/-						
P.420	Pentode .....	12/6						
P.425	Pentode .....	13/6						

**TRIOIRON RADIO COMPANY LTD., 91, Great Russell St., LONDON, W.C.1**

THE MIRROR OF THE B.B.C.

By O. H. M.

## B.B.C. AND POLITICS

MORE MUSIC—TIMING AND OMISSION—A SCOTTISH EXPERIMENT—EMPIRE RECORDS—EXHIBITIONS IN SCOTLAND.

[ HEAR that if Mr. Charles Siepmann, the new Director of Talks at the B.B.C., has his way, there will be a radical change in the attitude of the B.B.C., towards the political parties.

Hitherto, political debates and discussions and party statements of policy have been arranged in consultation with the Whips of the Parties, a process at once protracted and unsatisfactory from the programme standpoint. A speaker's acceptability to his Whip or Party Leader might be in inverse proportion to his capability as a broadcaster.

Now through the initiative of Mr. Siepmann, Mr. Whitley, the Chairman of the B.B.C., is taking steps to free his organisation from the incubus of consultation. If he succeeds, then we shall have real political debates this autumn. For example we may have Mr. Lloyd George let loose against Mr. Churchill,

### More Music.

The Music Department at Broadcasting House has been agitating for an afternoon period of light classical concerts and sonata recitals.

There is also a move to strengthen and vary the quality of the lunch-time music. The first step in this direction will be the sharing by London of twelve of the Birmingham Philharmonic Chamber Concerts relayed by the Midland Region from 1.15 to 2 p.m.

### Folkestone Popular.

Folkestone music stands very high in the estimation of the B.B.C. critics just now. The B.B.C. contemplates relaying a new series of concerts from Folkestone and also proposes to invite Mr. Eldridge Newman, the Folkestone conductor, to conduct in the studio.

### Timing and Omission.

One result of the earnest endeavour of the B.B.C. to keep to its advertised programme timings is that an increasing number of musical items are being cut and omitted. The conductors have begun to murmur and something is to be done to rectify the position.

### A Scottish Experiment.

The Report of the Carnegie Experiment in Scotland in Broadcast Adult Education has now been issued. It recommends the extension to Scotland of the same scheme as has been applied to the rest of the United Kingdom, namely, the formation of Adult Councils, and the organisation of group listening.

It remains to be seen whether the B.B.C. or someone else will find the money. There is certainly not much enthusiasm at Broadcasting House, where Scotland is by no means too popular.

### Empire Records.

The Tidworth Tattoo and the unveiling ceremony of the Thiepval memorial are

among the items so far recorded by the B.B.C. for circulation to distant parts of the world under the Empire broadcasting scheme. These special records are intended to supplement the Empire short-wave service, and will be used principally by small stations in outlying parts of the Empire which for various reasons are unable to obtain sufficient material of their own.

The recording of special events is of the greatest importance and I am pleased to learn that the idea is likely to be developed

### THE ONE-MAN BAND



When all was ready for the photograph, they found they couldn't get one instrument into the picture—the bass drum—but with those shown he can kick up a noise quite as convincing as that of a small jazz band! The turn is a favourite one in America and can often be heard on short waves from W 2 X E (on 49.02 metres) at 2.45 a.m. on Wednesday mornings.

still further by the preparation of what might be described as Empire News programmes.

These discs will consist of items of imperial interest which will be recorded at the time of broadcasting, and linked together with music and spoken "titles" very much on the lines of the news reels shown in picture theatres, except, of course, that the usual entertainment provided by the film will be substituted by all-sound records of outstanding current events.

### Exhibitions in Scotland.

Scotland has three radio exhibitions in September and October, at Aberdeen, Glasgow and Edinburgh respectively, and at each one the B.B.C. is co-operating with the organisers to promote a still keener interest in the efforts of manufacturers of wireless apparatus to improve the quality of broadcast reception.

The Aberdeen exhibition lasts from September 6th to September 17th, and people in the North of Scotland will have the first opportunity of seeing broadcasting being done in a model glass-sided studio and at the same time hearing it from loudspeakers in the exhibition hall.

On practically every day the Aberdeen Children's Hour programme will be given in the model studio, while on Wednesday, September 7th, a play by George Blake, entitled "Clyde Built" will be performed in full view of visitors to the exhibition. In order to make this broadcast as attractive as possible, the performers will be dressed in costume, an attraction within itself, but all the

more so since it will be given by the Scottish National Players for whom Mr. Blake, who is a Scottish journalist, originally wrote it.

The model studio will also be used for the Glasgow exhibition which takes place between September 28th and October 8th, and the Edinburgh exhibition which follows from October 12th to October 22nd.

## THE LISTENER'S NOTEBOOK

A rapid review of some of the recent radio programmes.

WITH nights of the "Proms" devoted in turn, to Wagner, Tchaikovsky, Bach, Beethoven, and to our own native composers, listeners have had no grounds for complaining that their tastes have been forgotten, for surely, here was variety rich enough to go more than round. The British concert interested me, but I hope I shall not be thought unpatriotic if I confess that it pleased me less than some, at any rate, of the others.

Mr. Edgar Bainton's "Epithalamion" was the big event of the British evening. This I enjoyed till its note of blitheness gave way to a seriousness which culminated in something akin to grimness.

It was all very correct, I suppose, but my taste is all for cheerfulness in music.

I should not be surprised to find that the 2nd instalment of Mr. Goodrich's "Ann and Harold" gave universal disappointment. To my mind, this disappointment was caused by the author's complete failure to reproduce the naturalness of his opening episode.

It is, perhaps, unfair to judge a whole story by one of its parts, which may, after all, fit in with the scheme of things. But, judged as an entity, No. 2 Episode, devoid of that crispness which was such a feature of its forerunner, was mostly boring conversation.

(Continued on page 900.)

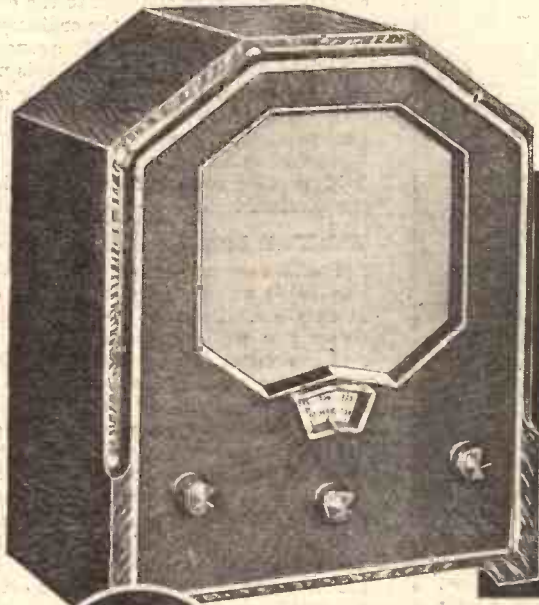

**S.E.C. Radio**  
**SUPREMACY**  
**IN RADIO**

**A REVOLUTION IN HOME CONSTRUCTORS' KITS—**  
**ENTIRELY SELF-CONTAINED—**  
**NEW AND IMPROVED RADIO TECHNIQUE**

**Osram**  
**THIRTY-THREE**  
**MUSIC MAGNET**



The new OSRAM "THIRTY-THREE" MUSIC MAGNET is a great advance on any kit set you have yet seen. It is full of improvements in technique, design, appearance, performance and construction — entirely self-

contained, with built-in loud speaker of latest design and room is provided for batteries and accumulator.

A wide range of stations can be tuned in with the greatest ease at full loud speaker strength. Tuning is effected with one knob only.

**SPECIAL FEATURES**

- 1 A complete table model receiver with built-in loud speaker.
- 2 Batteries housed inside cabinet—no external battery connections.
- 3 Two metallised OSRAM screen-grid valves and latest type OSRAM power output valve.
- 4 Screen-grid detector gives great sensitivity.
- 5 Tuning by one knob only.
- 6 New magnetic loud speaker chassis with floating cone ensures highest quality reproduction.
- 7 Unit assemblies make home construction the essence of simplicity.
- 8 Latest OSRAM valves (battery type) with the Wembley filament.
- 9 Handsome one-piece cabinet in moulded Bakelite—walnut graining.

**POST COUPON TO-DAY**

for the full-size Constructor's Instruction Chart. The clear instructions given in this chart will convince you that this is the world's best circuit and assembly kit. SEND FOR A COPY TO-DAY.

**PRICE**  
**9 GNS.**

Including cabinet, built-in loud speaker and OSRAM valves.

**HIRE PURCHASE**  
 Deposit £1 and 12 monthly payments of 15/-

Made in England  
 Sold by all Wireless Dealers.

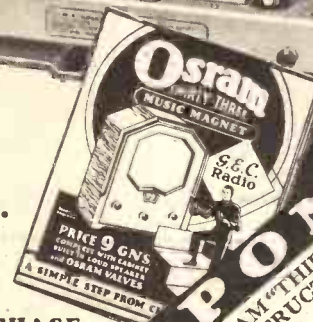

**COUPON**  
 Please send me the OSRAM "THIRTY-THREE" MUSIC MAGNET INSTRUCTION CHART  
 Name \_\_\_\_\_ Address \_\_\_\_\_  
 The General Electric Co. Ltd.,  
 Magnet House,  
 Kingsway,  
 London, W.C.2

Cut out and paste on Postcard, or enclose in unscaled envelope, Halfpenny postage in either case.

**A SIMPLE STEP FROM CHART TO SET**



## TALL SHIPS and SHORT-WAVES

HOW often do you look at the Shipping News in your daily paper? Very rarely, perhaps, but I think every Englishman feels a stirring of interest when he glances at that column of facts and figures with its prosaic records of big ships and long voyages.

We all love ships, but we cannot all live near the sea. To-day, however, where we live is immaterial, for short-wave wireless can keep every home in England in touch with liners in all parts of the world.

We can go home at night and pick up the signals of a "crack" vessel in the Atlantic

Quite a simple short-wave set is all you need to listen to ships in all parts of the world. And both liners and merchant vessels are easily recognized if you know their methods of procedure,

By B. W. COOPER.

trade, half way across to New York, or a luxury liner cruising in the Mediterranean, or big ships in the Pacific on their way to and from the Antipodes, and not only hear them, but understand what they are saying.

At the present time a large number of

the liners of several nations are fitted with apparatus for short-wave telegraphic communication, in addition to the compulsory sets for working on the ordinary shipping waves. A number of frequencies are allotted for short-wave work of this nature, but the band most widely used for general purposes is that between 8,200 and 8,300 kilocycles, or, expressed in wavelength, the 36-metre band. For long-distance daylight working several shorter wavelengths are available.

### Well Worth Learning.

The first essential to an understanding of the liner's message is a knowledge of the Morse Code. Provided you know the characters you will soon begin to read words and sentences, for the very variable conditions for reception on the short waves often make it necessary for stations to send each word of a message twice to avoid the sense being lost in a rapid "fade" or burst of atmospherics. So tune-in to 36 metres one evening, signals here begin coming in most thickly after dark, and try your luck.

To find the 36-metre band search slowly upwards from the setting for Rabat (32.26 metres). With an average set using a .00015 tuning condenser there will be about ten degrees between them. If you go carefully you will soon come across a station transmitting a string of call-signs.

### Coast Station Call-Signs.

This will be one of the short-wave coast stations calling the liners for which it has messages. It may be Norddeich (Germany) D A N, S. Maries de la Mer (Near Marseilles, France) F F S, Bergen (Norway

(Continued on page 884.)



Heavy Cobalt Steel Magnet with very high flux density—Aluminium frame (copper plated) holding 8½ in. diaphragm which is made in one piece and impregnated. Resistance of speech coil 5.50 5-ratio matchings of input transformer ensure fine matching with power, super-power, or pentode output valve. Perfectly even reproduction between 50 and 8,000 cycles.

FITTED IN HANDSOME OAK CABINET TYPE "20CC."

47'6



# EPOCH

## 20<sup>TH</sup> Century Model P.M.M.C. LOUDSPEAKER

### A CHALLENGE

35'

WE, the undersigned, the pioneers of the modern permanent magnet moving coil speaker, the manufacturers of the greatest range of the finest moving coil speakers in the world, claim for the New Edition 20th Century Model, priced at 35/-, that it has no peer in its class in or out of the British market. We claim for it Sensitivity, Brilliance, Body, Bass, Sharpness and Clearness of Speech and Music, Handling Power, Sturdiness and Reliability, unrivalled by many moving coil speakers (energised or permanent magnet) selling at much higher prices.

(Signed) Epoch Radio Manufacturing Co., Ltd.

**JUST RELEASED.** Ask your dealer for it and don't be put off with "Just-as-goods"—There are none! If in difficulty write to the manufacturers. Send for particulars or call for a comparative demonstration. EPOCH RADIO MANUFACTURING CO., LTD., Exmouth House, Exmouth St., London, E.C.1 (Junction of Rosebery Av. and Farringdon Rd.). Phone: Clerkenwell 6666.

# And Now MARCONI

## A new Variable-MU V.S.2

### Valve for Battery Receivers

**VS2** is the latest link in the long chain of Marconi developments in valve technique. It combines the high mutual conductance of 1.25 MA per volt with the typical advantages of the Variable-Mu valve, providing long range, improved selectivity and quality of reproduction and, if desired, a smooth and entirely distortionless control of volume.

If your receiver was designed for an ordinary S.G. valve, Marconi VS2 will give a far better all-round performance. If you are building a new set incorporate VS2 and the necessary grid bias circuit from the start and obtain the perfect volume control **Price** which only a Variable-Mu valve will give. **16/6**



### THE MARCONI 2-VOLT RANGE

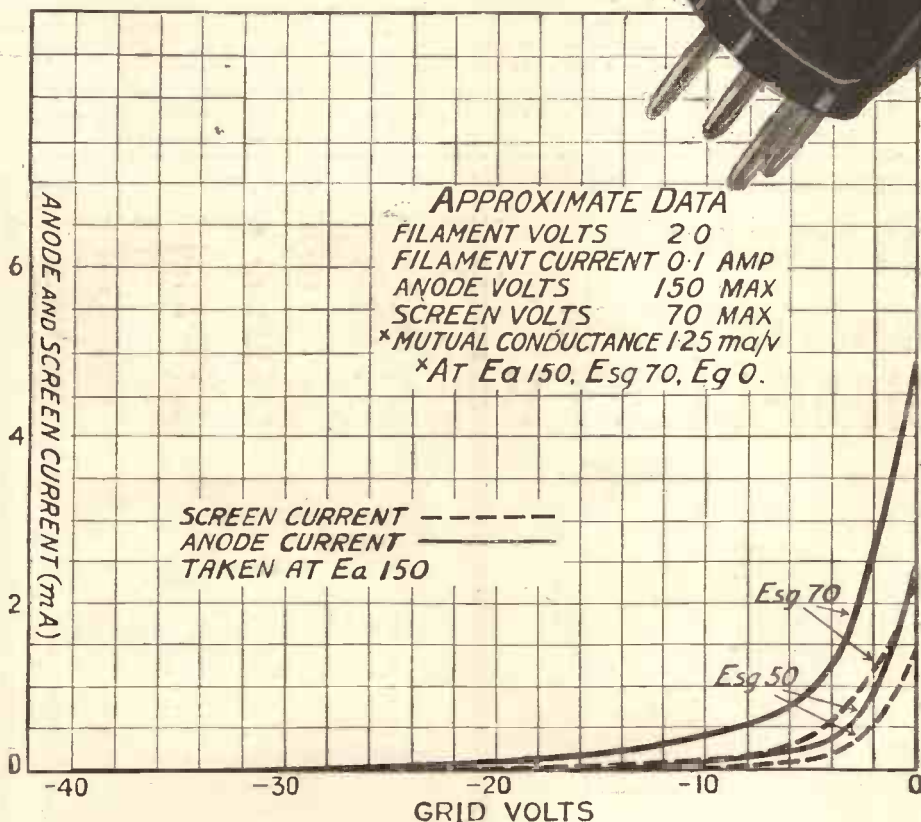

- \*VS2 Variable-Mu Screen Grid 16/6
- \*S22 Screen Grid (Single stages) 16/6
- \*S21 Screen Grid (Multi stages) 16/6
- \*H2 High Magnification . . . 7/-
- \*HL2 Medium Magnification . . . 7/-
- HL210 Medium Magnification . . . 7/-
- LP2 Power . . . . . 8/9
- P2 Super Power . . . . . 12/-
- PT2 Pentode . . . . . 17/6
- DG2 Double Grid . . . . . 20/-

\* Available metallized if desired

# MARCONI VALVES

THE MARCONIPHONE COMPANY LTD. 210-212 TOTTENHAM COURT ROAD, LONDON, W.1

## TALL SHIPS AND SHORT-WAVES

(Continued from page 882.)

L.G.N. or Gothenburg (Sweden) S.A.B. They all come over at good strength in this country.

You will also hear, so faintly that you may overlook it, our own short-wave coast station G.K.T. at Portishead, near Bristol. Portishead is within the skip distance for all receivers in Southern England.

Transmission will be in the following form: "CQ de L.G.N. (presuming it to come from Bergen) Q.T.C." Then will follow the calls of the ships for which Bergen has telegrams. Q.T.C. is a contraction meaning "I have telegrams for —"

### Standard Abbreviations.

Another standard transmission you are likely to come across from any shore station is the invitation for stations with traffic to communicate it. In this case the general call CQ is used as before, but in place of Q.T.C. the letters Q.R.U. (Have you anything for me?) are sent.

When a liner wishes to get in touch with a shore station a similar procedure is used. Let us suppose that the "Majestic" (G.F.W.V.) has five telegrams for Portishead. It would send "G.K.T. de G.F.W.V. Q.T.C.5." When making contact for the first time both call-signs would be repeated as many times as the operator thought necessary to attract attention.

Once a reply has been obtained the calls of the sending and receiving stations are sent three times only at the beginning of each message.

When a ship that has not previously been in communication with a coast station wishes to make contact it first sends the station's call-sign, followed by its own, for several minutes on end. In all cases the letters of the transmitting station come second and are separated from those of the

tions at well-known ports are freely used for shortness.

There are also international contractions that vessels can use when giving particulars of themselves to coast stations or other craft with which they are working. These are Q.R.A. (The name of my station is—), Q.R.D. (I am bound for—), and Q.R.F. (I am coming from—).

All ships have call-signs consisting of groups of four letters. Nationality is shown by the initial letter. Thus, G is used by Great Britain, F by France, D by Germany, P by Holland, S by Sweden, and K and W by the United States.

### Telephony As Well.

Finally, for the benefit of those who cannot read Morse at all, mention may be made of the large Atlantic liners working in telephony with Rugby and New York. The "Majestic," the "Olympic," and the "Leviathan" are often to be heard on wavelengths between 15 and 19 metres, near the 36-metre band, and on waves of 55 metres and upwards.

The operators frequently announce their vessels' names when testing, so identification is easy. Reference to the daily Shipping News in your paper gives a clue to the liner's whereabouts.

### YOUR NEW RADIOGRAM.

Those "P.W." readers who are contemplating the construction of a Radiogram will be interested in the announcement of the Miscellaneous Trading Co. Ltd., which appears among our advertisements.

Their new "Langmore" radiogram cabinet GL is a strongly made cabinet with an attractive solid appearance, and retails at 49/6.

## NEXT WEEK

### ANOTHER Colossal Number

OF P. W.

ORDER NOW USUAL PRICE

station being called by the sign "de" or "v."

When a reply is received the ship sends particulars of its name, destination, and so on. These particulars are always preceded by the sign T.R. which immediately follows the preliminary call-signs.

A specimen message might be, "G.K.T. de G.F.M.S. T.R. Windsor Castle bnd FFM fr Ldn." The latter part of the message means "Bound Marseilles for London." FFM is the call-sign of the Marseilles' coast station, and call-signs of sta-



# Provides Constructors with a NEW SIMPLICITY

The new FORMO Dual Range Coils offer the simplest possible means of identification. Each coil screen has its own distinguishing colour—Red for the Aerial, Blue for H.F., Green and Yellow for first and second Band-Pass coils. In addition, each coil has a permanently fixed connecting chart in its own distinctive colour. Thus you can easily see where to place each coil when building or re-wiring your set. The scientific care with which each FORMO Coil is made and matched ensures maximum efficiency. Furthermore a high degree of selectivity has been obtained over a large wavelength range.

If unable to obtain Formo Components locally, write to:

The **FORMO CO.**

Crown Works, Regent's Park, Southampton.

LONDON: 23, Golden Square, Piccadilly, W.1.

Telephone: Gerrard 2088.



### FORMO DUAL RANGE COILS

Aerial, H.F., 1st and 2nd Band Pass .. .. . **7/6**  
 Pair of matched Aerial and H.F. Coils mounted on aluminium base, with ganged switching 16/-  
 Pair of Band-Pass Coils and H.F. Coil, similarly mounted and switch-ganged .. .. . **23/6 EACH**



## FORMO GANGED CONDENSERS

Perfectly matched with Formo Dual Range Coils  
 DUAL GANG .. .. . **16/6**  
 TRIPLE GANG .. .. . **21/6**

Complete with dial and Escutcheon as illustrated  
 Formo Dual and Triple Gang Condensers can be supplied mounted on a base plate with either two or three Dual Range Coils. These complete assemblies are carefully matched, and all switches are ganged.

For fuller information on the improvements in these and other modern and moderately priced FORMO components, see the new Formo Catalogue.

Get your copy quickly, to-day.  
**Olympia Stand 100**

# "Say TRANSFEEDA"

Wherever a Low Frequency transformer is in use in your present set, or indicated in the set you are thinking of building, put in a BENJAMIN TRANSFEEDA and take advantage of this latest development in L.F. amplification.

All prominent set designers are now specifying resistance fed transformer units and the great majority have preferred the BENJAMIN TRANSFEEDA on account of its outstanding superiority in design and performance.

Follow their lead and ensure for your set the purity and volume of reproduction that only the Transfeeda can give. See the TRANSFEEDA at STAND 40, or let us forward you List 1292 which describes it fully and gives circuits and diagrams.

## STAND 40

# BENJAMIN

THE BENJAMIN ELECTRIC LTD.,  
TARIFF ROAD, TOTTENHAM, N.17.

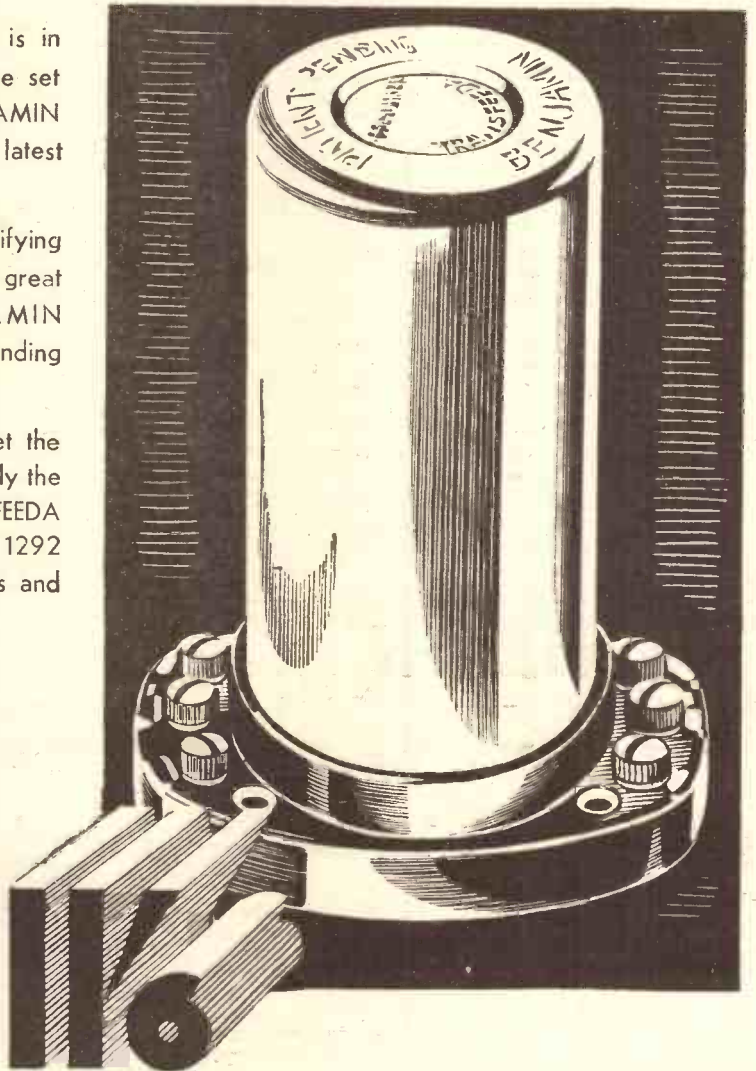

*Note these reduced prices*

CLEARERTONE

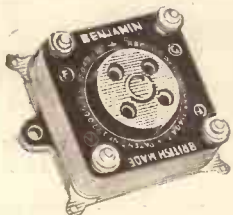

2/6d 1/6d

PUSH-PULL SWITCH



1/3d 9d

VIBROLDER

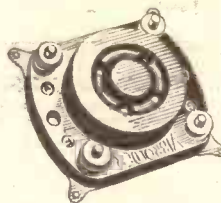

1/6d 10d

FIVE-PIN

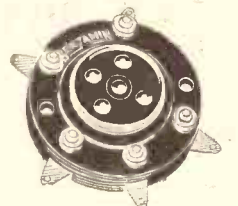

1/3d 1/3d

# COMPARING OUTPUTS

An enlightening article in which the relation between output power and actual loudspeaker volume, as estimated by the ear, is described  
By FRANK BRIGGS.

WHEN making a comparison between the merits of various power valves, it is common practice to judge them in direct proportion to their undistorted outputs. Thus if one valve is capable of delivering 200 milliwatts to the loudspeaker, and another will handle 400 milliwatts, it is often imagined that the latter valve will produce a result in the loudspeaker a great deal louder than would the former.

## Insensitive to Changes.

Unfortunately, however, this is not so, for although the human ear is very sensitive to weak sounds it is comparatively insensitive to small changes in volume. If we were to plot a curve showing the response of the ear with different loudspeaker powers, we would find that it followed a logarithmic law.

This means that at low volume levels our ears can differentiate between smaller changes in volume than at higher levels. To illustrate this point, I might mention that a change from 200 milliwatts to 400 milliwatts would just about be noticeable by the average person, and would have

about the same effect on our ears as a change from, say, 1,000 milliwatts to 2,000 milliwatts.

You see, it is the relationship between the two powers that counts, and not the actual increase stated in milliwatts.

At first sight it all seems wrong, I agree, but nevertheless it is a fact. And it was for this reason that telephone engineers conceived the idea of developing a unit for use in audibility tests.

They knew that our ears followed a logarithmic law, so they invented a unit that did the same, which, after all, was the obvious thing to do. Like all things, it had to be given a name, so they called it the Bel, after the great American engineer and inventor of the telephone, Dr. Alexander Graham Bell.

## Much More Convenient.

But when they came to use it, they found that it would be much more convenient to have a smaller unit, so they divided the Bel into ten equal parts which they called Decibels, or DB for short.

One decibel, or DB, is the smallest change in volume, either up or down, that

the average human ear can detect. (It is equal to a power ratio of 1.25 approximately, but more of that anon.)

When I said that one DB was the smallest change in volume that we can notice, I should have said theoretically, or perhaps in practice where single tones are concerned at very low volume levels. Actually, when listening to ordinary music, it is very few people who can appreciate a variation of anything less than about three DB.

## Correct Definition.

Before going any further, it would be as well for me to give you the correct definition of the decibel. It is ten times the common logarithm of the ratio of the powers.

It looks pretty terrible at first, I know, but on closer inspection it soon dwindles to more reasonable proportions. Take, for instance, the case mentioned in the opening paragraphs of this article, where one valve has an output of 200 milliwatts, and another one 400 milliwatts.

The ratio of the powers is 2, and the common logarithm of 2 is .3. (This can be found from any ordinary log. table.) Then 10 times .3 is 3. So we can say that the volume obtainable from the 400 milliwatt valve is 3 DB above that of the smaller one. Or, if you prefer it, the 200 milliwatt is 3 DB below the 400 milliwatt.

This proves the statement that I made in the first place, that the increase in volume would not be very large. In fact, we could look upon it as being just about worth while.

(Continued on page 888.)

# HEAR AND SEE IT FOR YOURSELF —THIS UNIQUE "SOUND" QUALITY SPEAKER

Full, rich tone — super sensitivity — startling realism—these are but three of the outstanding features of the unique S.40 MoTor Unit.

All who hear it have nothing but praise for its amazing performance—the secret of which lies in the PATENT COMPENSATING ARMATURE

—the greatest advance yet made towards perfect loud-speaker reproduction.

Judge for yourself—come and hear it under fair working conditions at our special demonstration showrooms opposite Olympia.

The full range of MoTor speakers is on view, and there is one amongst them that will suit YOUR set—AND your pocket.



YORK A graceful walnut cabinet, with S.40 Unit, as illus. 52/6

BRITISH  
MADE

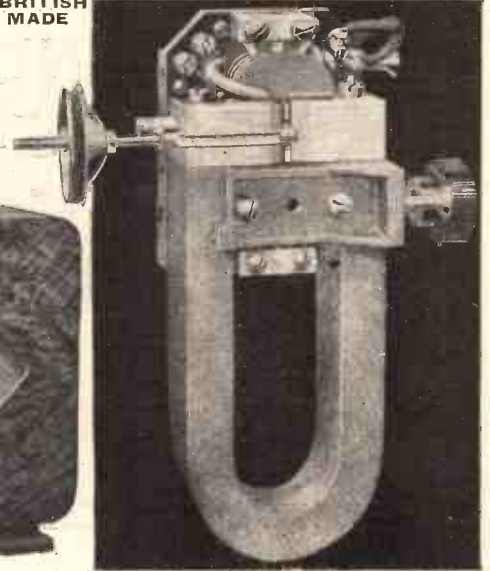

# MOTOR S.40 UNIT

as illustrated, with Patent compensating armature... 27/6

C.400 Complete chassis assembly, with S.40 Unit and Cone 39/-

MoTor leads the loudspeaker field for both moving coil and balanced armature types. Write for descriptive pamphlet to:—

at our Demonstration Showrooms  
67, HAMMERSMITH RD., W.14  
OPPOSITE EMPIRE HALL

or, after the Exhibition, at your local dealer's.

TEKADE RADIO & ELECTRIC LTD.  
147, Farringdon Road, London, E.C.1

Telephone: Clerkenwell 2486



# LOTUS STAND 64. OLYMPIA

## 2 VALVE "BUD" RECEIVER

2-VALVE LOTUS "BUD" RECEIVER, an all-electric set of exquisite tone—incorporating a Moving Coil Speaker. Gives ample volume and many alternative programmes. For D.C. Model 11 Gns., or 21/9 down. A.C. Model

**10 Gns.**  
or 19/9 down.

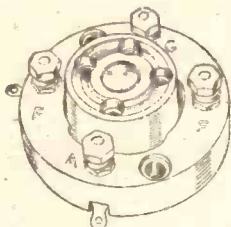

LOTUS VALVE HOLDERS in all types 4 and 5 pin, rigid or antimicrophonic, with or without terminals. Prices from **6<sup>d</sup>** each.

## 3 VALVE RECEIVER

LOTUS BAND PASS 3—an all-electric receiver for A.C. Mains of exceptional selectivity, sensitivity and TONE. One of the outstanding sets of the season. Fitted with Magnavox Moving Coil Speaker. Royalty £1.

Price **16 Gns.**  
£1 11s. 6d. down

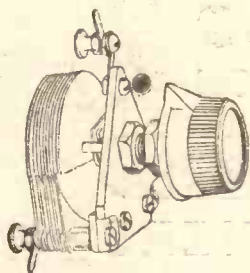

LOTUS REACTION CONDENSER in two capacities, type R.C.13 '00013 and R.C.34 '00034, both at 4/- each. Suitable for all reaction needs, may also be used for series aerial condensers.

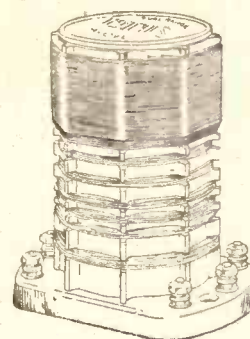

LOTUS DUAL RANGE AERIAL COIL D.R.50. This is a new component giving an extremely high degree of efficiency and selectivity. Price **5/6**. Covers the medium and high wavebands. D.R.60 new Dual Range High Frequency Coil. Price **5/6**.

## S.G.4 PORTABLE

LOTUS S.G.4 PORTABLE. Screen grid, detector, amplifier and power valves. A compact set of ample power and range. Fitted with the world famous Celestion Speaker. Complete with all batteries. Price **12 Gns.** or 23/8 down.

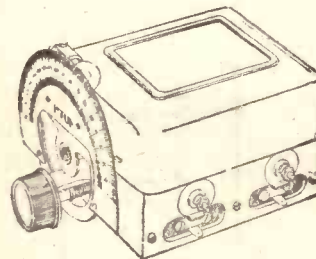

LOTUS 2 GANG CONDENSER. PC2. An extremely accurate component—suitable for practically all modern circuits. Is strongly made and is provided with a dust proof cover. Price **19/6**. Also in 3 Gang type PC3, Price **29/6**

**THE MOST INTERESTING  
STAND IN THE SHOW.**

*Don't miss it*

See also the latest "Lotus" Models: Band Pass De Luxe 3-Valve Battery Set and the De Luxe 4-Valve Receiver.

**LOTUS RADIO LTD., MILL LANE, LIVERPOOL**

## COMPARING OUTPUTS

(Continued from page 886.)

From the foregoing readers will see that, when equipping their sets with a larger power valve to get more volume, the increase in wattage, or milliwattage, as the case may be, must be considerable if any real benefit is to result. As a matter of interest, I am giving below a short table showing some useful values of DB, with their corresponding power ratios.

DB.	Approx. Power Ratio.
1	1.25
2	1.6
3	2.0
4	2.5
5	3.16
6	4.0
7	5.0
8	6.3
9	8.0
10	10.0

As a rule, no practical advantage will be gained when changing over to a larger output valve unless the undistorted power obtainable from it is at least double that of the original valve, and this applies particularly to the higher powers when several watts are being handled.

### Over the Whole Scale

Another instance when the DB is very useful is when we are designing an L.F. amplifier and trying to get equal amplification of the whole musical scale. If we plot the response curve showing voltage amplification at different frequencies we

get a very distorted idea of the overall result from a practical point of view. All manner of little peaks and troughs will appear, which if plotted against DB instead of voltage would soon fade away into mere insignificance.

In closing, I might mention that, when dealing with voltage or current ratios, the DB is equal to 20 times the ratio of the voltages or currents, as the case may be.



When a valve is used as a diode detector it does not amplify as well as detect, which is the case with an ordinary detector stage.

The aerial of the new Leipzig station is of an experimental nature, being supported on six masts arranged in circular fashion. It is supposed to concentrate most of its radiation in a horizontal direction.

When a set develops a disinclination to oscillate, although all voltages are as before, a failure in detector-valve emission should be suspected.

When an A.C. mains receiver seems to fall off in the same way that a battery set will when the accumulator is running down, a similar fault should be looked for—namely, a falling off of the rectifier valve's emission.

If your set suffers from microphonic valve trouble, and you are not sure which valve is causing the trouble, try tapping each in turn with the finger, and the culprit will be revealed at once.

Every owner of a wireless set (crystal or valve, fixed or portable), must obtain a licence to receive before doing so.

No fundamental alteration in the constitution of the B.B.C. can be effected until 1937, when its Charter comes up for renewal or modification.

Broadcasting in the U.S.A. is conducted entirely on a commercial basis, all programmes being paid for by advertisements.

While there is no monopoly of broadcasting in France, as there is in Britain, the majority of the stations are Government-owned, through the Ministry of Posts, Telegraphs, and Telephones (P.T.T.).

The total number of broadcasting stations in France is twenty-eight.

Broadcasting is prohibited in Greece, though the Government is now considering the granting of a monopoly.

The Manchester Radio Exhibition is to be held in the City Hall from Sept. 28th to October 8th.

The British radio industry represents about eighty million pounds of invested capital.

More than one million people are employed in radio and its allied trades in this country.



# SHOWING AT OLYMPIA STAND 89 RADIO EXHIBITION



## METAL RECTIFIERS

STARRING

### THE NEW H.T. AND L.T. UNITS

STYLES H.T.9; H.T.10; H.T.11; & L.T.1; L.T.2; L.T.4; L.T.5

WESTINGHOUSE METAL RECTIFIERS ARE RENOWNED FOR LONG LIFE AND HIGH EFFICIENCY. DO NOT MISS THIS EXHIBIT. IT WILL HELP YOU TO SOLVE YOUR MAINS TROUBLES

PRODUCED BY

THE WESTINGHOUSE BRAKE & SAXBY SIGNAL CO. LTD., YORK RD., KING'S CROSS, LONDON, N.1.

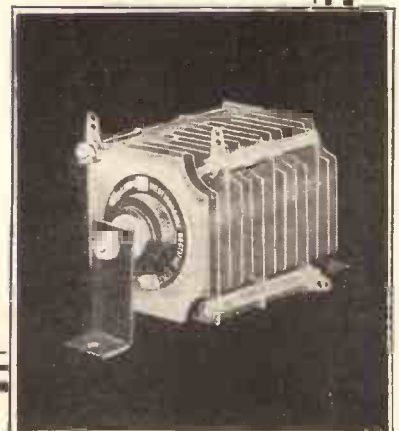

# POLAIR



## CONDENSERS

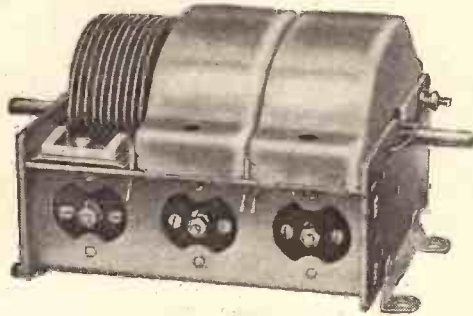

### "STAR" GANG CONDENSER

again emphasises the superiority of "Polar"

ACCURATE SPACING of vanes obtained by precision machine assembly. This entirely eliminates the possibility of error in spacing. MATCHING ACCURATE to within  $\frac{1}{2}$  of 1% plus or minus 1 mmfd. ALL-STEEL FRAME and rigid construction ensures that this accuracy will never vary. STRONG SPRING JOURNAL BEARINGS give absolute freedom from shake or endplay. TRIMMERS—conveniently operated from top.

3 x '0005 Super-het. type 4 x '0005  
**25/6 27/6 34/-**

All prices include covers.

DISC DRIVE DRUM DRIVE  
**5/- 7/6**

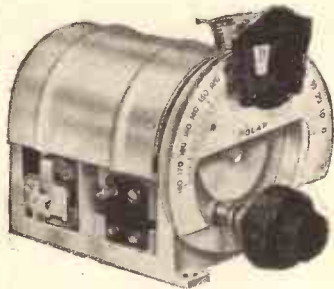

### THE "UNIKNOB"

The most outstanding feature of this popular two-gang is the solid di-electric trimmer of 35 mmfd. variation. This is in parallel with the front section of the condenser, but is controlled by a small knob situated concentrically with tuning knob. This greatly simplifies the final tuning adjustment necessary to secure maximum signal strength. Minimum trimmer on rear section. Slow motion disc drive. Lampholder supplied. 2 x '0005  
**19/6**  
 Price includes cover.

From the "Wireless Trader" test report:  
 "... remarkable accuracy in matching has been obtained."  
 "This is undoubtedly one of the best gang condensers on the market..."

SPECIFIED for the "MODERATOR TWO"

Polar "COMPAX" '00075 **3/-**

STAND 129, OLYMPIA

# POLAIR

## CONDENSERS

CATALOGUE OF COMPLETE RANGE—FREE

Correspondence in all languages.  
 French Representative: W. A. Swift, 6, Rue Daquerry, Paris XI.



Wingroove & Rogers, Limited, 188-9, Strand, London, W.C.2.

## TRUE TONE CONTROL

# MULTITONE

## WILL IMPROVE THE TONE OF ANY SET INCLUDING YOURS!

You know that there is no such thing as perfect reproduction in wireless sets. But do you know that by fitting a Multitone transformer in your set you can correct the tone whatever it happens to be? Whether you listen to British or Foreign Stations, or whether you use a Radio set or Radio gramophone, you can amplify either the high or the low notes until you obtain as near perfect response as possible. And it costs you only 17/6 with two or three shillings for a potentiometer.

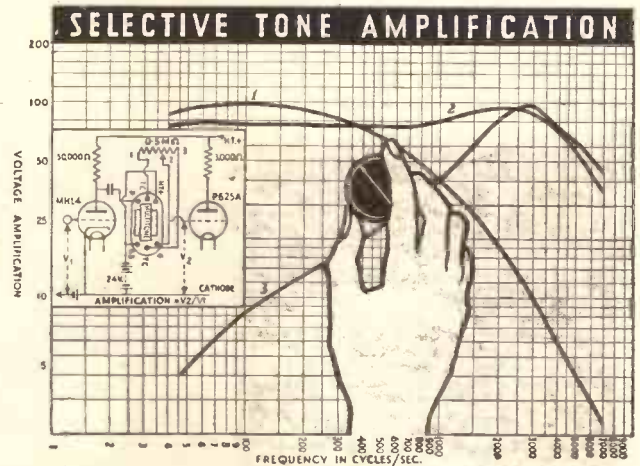

By changing the setting of the Potentiometer, the response-curve of the Multitone Transformer is progressively altered from a falling (1) through a level (2), to a rising characteristic (3). The limiting responses and an intermediate level-response are shown by these curves. When the response is level the transformer ratio is 4:1. True Two-way Tone Control is immediately at your disposal on any set. In use all that is necessary is to turn the Potentiometer until the desired overall response is obtained.



Any good Potentiometer exceeding 0.5 megohms can be used with the Tone Control Transformer, but the best results are obtained with the Multitone Graded Potentiometer (price 3s. 6d.) which has been specially designed for this purpose.

**17/6**

Our Booklet on Tone Control will be sent post free on receipt of a postcard.

# MULTITONE

TONE CONTROL L.F. TRANSFORMER

Multitone Electric Co., Ltd.

95/98, White Lion St., London, N.1. Phone: North 5063

# THE "POPULAR WIRELESS" OFFICIAL LIST OF EXHIBITORS

Here is a further list of authorised "P.W." dealers from whom you can obtain further details concerning "P.W." star sets, and the components and accessories to use with them.

**CRAWLEY.**  
W. H. Hogger, 4, Post Office Road.

**CRIEFF.**  
Frank Thomson, 7, 9, 11, East High Street

**CROMER.**  
J. B. Postle, 9, Mount Street.

**CUPAR.**  
W. T. Ross, 16, Millgate.

**CWM.**  
D. C. Osborne, Modern Music Depot, Marine Street.

**DAGENHAM.**  
Acme Wireless, 9, Goresbrook Road.

**DARTFORD.**  
J. C. Freeman & Co., 1, Spital Street.  
S. N. Hammond & Son, 62, Lowfield Street.

**DARWEN.**  
J. E. Loynds & Co., 204, Duckworth Street.

**DEAL.**  
E. D. Newing, 138, High Street.

**DERBY.**  
Hulme & Son, 8-9, Sadler Gate.  
J. & C. Wireless, 54, Green Lane.

**DEREHAM.**  
Utting & Buckingham, Ltd.

**DEVIZES.**  
James Bros. (Wiltshire), Ltd.

**DEWSBURY.**  
C. Phillips, 33, Wellington Road.

**DONCASTER.**  
Brook Hardcastle, Ltd., 21, Cleveland Street.

**DOVER.**  
Albert V. Nutley, 80, London Road.

**DOWNHAM.**  
R. S. Ewell, Nordelph.

**DUNBLANE, Perthshire**  
A. Connella, 33, High Street.

**DUNDEE.**  
Clydesdale Supply Co., Ltd., 13, Crichton Street.  
Swainstons Radio Stores, 66, King Street.

**DUNFERMLINE.**  
Clydesdale Supply Co., Ltd., 137, High Street.

**DURHAM.**  
C. N. Grundy, 27, Station Road, Stanley.

**DURSLEY, GLOS.**  
G. E. Smith, "Elmsleigh," Uley.

**EASTLEIGH.**  
Nalder C. Cox, 16, High Street.

**EDINBURGH.**  
Wm. Borthwick & Co., Ltd., 26 to 44, Cockburn Street.  
Clydesdale Supply Co., Ltd., 5, Lindsay Place, and 66, South Bridge.

**ELLESMERE PORT.**  
G. Salter, 56, Station Road.

**ELY, Cambs.**  
E. Baines Cope, 36, Back Hill.

**ENNISKILLEN, ULSTER.**  
W. H. Creighton, 14, Church Street.

**EXETER.**  
G. L. Fildew, Radio House, 177, Sidwell Street.

**EXFORD, Taunton.**  
P. E. Heywood-Bawden, Motor Works.

**FARSLEY.**  
G. Lunley, 75, Town Street.

**FROME.**  
Alce. G. Applegate, 47, Trinity Street.

**GAINSBOROUGH.**  
H. E. Cobb, 10-14, Hickman Street.  
Shiple & Co., Ltd., Market Place.

**GILLINGHAM.**  
Maningtons, Ltd., 426, Canterbury Street.

**GLASGOW.**  
Wm. Blackadder, 236, Argyle Street, C.2.  
City Wireless & Cycle Stores, 666, Govan Road.  
Clydesdale Supply Co., Ltd., 2, Bridge Street, 63, Renfield Street, and 100, Sauchiehall Street.  
S. W. Cohen, 7-15, King Street.  
Gordon & Smith, 669, Cathcart Road, S.2.  
Gramophone Radio Service, 218, Main Street, Cambuslang.  
Youngs (Glasgow), Ltd., 40, Stockwell Street.  
(Continued on page 892.)

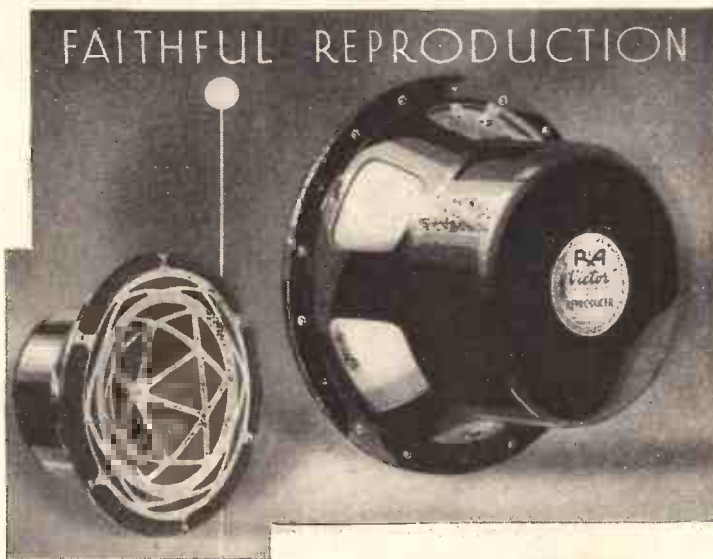

The "Victor" Permanent Magnet Moving Coil Reproducer-de-luxe. An instrument for the connoisseur representing the highest achievement possible in the present stage of P.M.M.C. design and performance. The forged cobalt steel magnet has a flux density of 8,000 lines per square centimetre, thus ensuring amazing sensitivity. The Cadmium plated grille is a distinctive feature, and the 6-ratio transformer, permitting extremely accurate matching, is completely enclosed, as also are the magnet and speech coil. Chassis finished black enamelled. Dimensions 10 $\frac{1}{2}$ " dia. x 5 $\frac{1}{2}$ " deep. Speech coil impedance 5.5 ohms.

Write for copy  
of New Leaflet.  
Sent Post Free.

**70/-** Including  
6-Ratio Transformer.

## See and hear them at Olympia—Stand 69 GRAND HALL.

"BANTAM" PERMANENT  
MAGNET MOVING COIL  
REPRODUCER.

The "Bantam" is the finest value ever offered in P.M. Moving Coil Reproducers. It is essentially a 'quality' reproducer, and is ideal for small receivers, as well as for multi-valve sets. The chassis is cadmium plated and lacquered. Speech coil impedance 5.5 ohms. Dimensions 7 $\frac{1}{2}$ " dia. x 3 $\frac{1}{2}$ " deep.

**27/6**

Including 3-Ratio  
Transformer.



# R & A REPRODUCERS

REPRODUCERS & AMPLIFIERS LTD., WOLVERHAMPTON.

# DIRECT RADIO OFFER— EVERYTHING RADIO FOR CASH C.O.D. OR EASY PAYMENTS

## BUILD YOUR "MODERATOR TWO" WITH A DIRECT RADIO TESTED KIT

	s.	d.
1 Permcoll panel 10" x 7" ..	3	0
1 Cabinet, with baseboard 10" deep ..	12	6
1 .0005-mfd. variable condenser with slow motion dial ..	5	6
1 .00075-mfd. solid dielectric variable condenser ..	3	6
1 Ormond .0001-.00015-mfd. differential reaction condenser ..	4	0
1 Cosmic dual-range coil ..	6	6
1 Ready Radio Moderator coil ..	2	6
1 Telsen 4-point push-pull switch ..	1	6
1 Telsen 2-point push-pull switch ..	1	0
1 R.I. Dux L.F. transformer ..	6	9
2 4-pin valve holders ..	1	0
1 T.C.C.-0003-mfd. fixed condenser type "8" ..	1	3
1 Lewcos M.C. H.F. choke ..	2	6
1 Graham Farish 2-meg. grid leak, Olmitite ..	1	6
1 Terminal strip 10" x 2" ..	10	
9 Belling-Lee indicating terminals ..	2	3
2 Belling-Lee battery plugs 10 ft. Glazite ..	4	6
2 Mullard valves: P.M.I.H.L. and P.M.2 ..	15	9
	<b>£3</b>	<b>12 8</b>

or 13s. 4d. down and 5 monthly payments of 13s. 4d.

### No. 1 Kit - £2 4 6

(less valves and cabinet)

or 8/2 down and 5 monthly payments of 8/2.

### No. 2 Kit - £3 0 2

(with valves less cabinet)

or 11/- down and 5 monthly payments of 11/-.

### No. 3 Kit - £3 12 8

(with valves and cabinet)

or 13/4 down and 5 monthly payments of 13/4.

## SPEEDY DISPATCH GUARANTEED KITS ALL COMPONENTS FULLY TESTED

### Cash Prices and Easy Payment Terms of Manufacturers Kits

OSRAM "THIRTY-THREE" (complete with Cabinet and Osram Valves) £9 9 0

Or 20/- down and 12 monthly payments of 15/-.

#### S.T.300 BATTERY MODEL—

Kit No. 1 (less valve and cabinet) £3 13 6  
Or 6/9 down and 11 monthly payments of 8/9.

Kit No.-2 (with valves less cabinet) £5 5 9

Or 9/9 down and 11 monthly payments of 9/9.

Kit No. 3 (with valves and cabinet) £6 4 3  
Or 11/5 down and 11 monthly payments of 11/5.

Battery equipment (with speaker) .. £2 4 3

#### RADIO FOR THE MILLION "STATION MASTER 3."

Model A. Complete Kit and Valves in Oak Table Cabinet £5 11 0  
Or 15/6 down and 7 instalments of 15/6.

Model B. Complete Kit and Valves, special Celestion Speaker and Midget Type Cabinet in Walnut Finish £7 10 0  
Or 17/- down and 9 instalments of 17/-.  
Particulars of A.C. Kits obtainable on request.

COSSOR "MELODY MAKER" MODEL NO. 337.

All Electric £11 15 0  
Or 25/- down and 11 monthly payments of 21/-.

Model No. 334. 3-valve Kit without Speaker £8 7 6  
Or 14/- down and 9 monthly payments of 14/-.

Direct Radio, Ltd., have established an organisation unequalled for dealing with Mail Order Radio. A postcard will bring you particulars of the new season's goods now on show, together with H.P. terms. Deal with Direct Radio, Ltd., and experience a new standard of satisfaction.

# Direct Radio

## CASH, C.O.D. AND EASY PAYMENT ORDER FORM

To: Direct Radio Ltd., 159, Borough High Street, London, S.E.1.

Please dispatch to me at once the following goods .....

for which (a) I enclose  
(b) I will pay on delivery { cross out line } £ .....  
(c) I enclose first deposit of { not applicable }

NAME .....

ADDRESS .....

Popular Wireless (1)

**OFFICIAL LIST OF EXHIBITORS**

(Continued from page 890.)

**GLOSSOP.**  
L. P. Penny, 65, High Street West.

**GLOUCESTER.**  
Cycle & Wireless Services, 120, Barton Street.

**GODALMING.**  
Jordan's Garage, Ltd., 11-13, Ockford Road.

**GORLESTON-ON-SEA.**  
Gorleston Cycle Depot.  
C. W. Williams, 174, High Street.

**GOSPORT.**  
Hardway Radio, 26, Grove Road, South.

**GRAYS.**  
T. H. Grylls, Electra House, Clarence Road.  
The Harbon Radio Stores, Southend Road.

**GRIMSBY.**  
Abbey Motors, Radio House, Freeman Street  
The Electrical Service Co., 323, Clethorpes Road.  
C. H. Turner & Co., 3, Corporation Road.  
W. Westoby, Hutton Road, Fish Docks.

**HALIFAX.**  
C. Ambler, 3, Woolshops, Old Market.  
C. Kinder, 49, Saddleworth Road, West Vale.

**HANLEY.**  
M. Pearson, 76, Lower Mayer Street.

**HAYES.**  
Spratley Bros., Station Road.

**HEMEL HEMPSTEAD.**  
F. Wilkins & Sons, 54-56, High Street.

**HEREFORD.**  
S. C. Jones, Clehonger Garage.

**HILLINGDON.**  
A. H. Lawton, Field Heath Road

**HITCHIN.**  
H. Shadbolt, 6, Tilehouse Street.

**HOLT.**  
Sheldrake & Son, Lion Corner.  
A. V. Ship.

**HUDDERSFIELD.**  
L. Bittcliffe, 8, Church Street, Honley.  
P. Dyson & Co., 18, Cross Church Street.  
Radio Equipment Co., Market Avenue.  
Taylors (Hudd.), Ltd., 6, Shambles Lane.

**INVERURIE, ABERDEENSHIRE.**  
The Square Engineering Works, 39a-40, Market St.

**IPSWICH.**  
Bodday Page & Co., 16, St. Margaret's Green.

**JARROW.**  
G. R. Thomas, 6a, Grant Street,

**KEIGHLEY.**  
W. S. Nicholls & Son, 187, South Street.

**KIDDERMINSTER.**  
T. F. Hancock, 117, Mill Street.

**KIMBERLEY, NOTTS.**  
J. Goulder, 10, Norman Street.

**KIRKHAM.**  
P. Croisdale, 19, Poulton Street.

**KIVETON PARK.**  
H. P. Snowdon, Snowdon's Wireless Stores,  
Station Road.

**LEEDS.**  
A. G. Radio Stores, 39, Meadow Road.  
City Wireless Supplies, 49, New Briggate.  
M. Feldman, 58, Meanwood Road.

**LEIGHTON BUZZARD.**  
Frank Griffin, 40, Hockliffe Street.  
Griffin Bros., 11, High Street, and 63, North Street.

**LETCHEWORTH.**  
P. C. Millard, 195, Glebe Road.

**LEWES.**  
E. Goldsmith, 10, The Cliffe.  
Leory & Richardson, Ltd., 170, High Street.

**LIVERPOOL.**  
The Beaver Radio Co., 60-62, Whitechapel.  
City Wireless, 80, Whitechapel.  
H. J. Coxon, 240, County Road.  
"Hobbies," 35, Manchester Street.  
Morris & Co., 230, Smithdown Road.

Tom Simm, 275, West Derby Road.  
Stanley's Radio, Ltd., 178-180, London Road,  
G. Street & Son, 16, Wavertree Road.  
The J. D. Wireless Co., 195, Breck Road.

**LLANGFENI.**  
T. Hughes Davies, High Street.

**LONDONDERRY.**  
Carlisle Radio Store, 48, Carlisle Road

**LONGSIGHT.**  
S. Abbott, 510, Stockport Road.

**LOWESTOFT.**  
Gladwells Radio, Sussex Street.  
F. J. Hughes, Junction Passage.

**LUDLOW.**  
Messrs. A. W. Packer & Son, 147, Corve Street.

**LYTHAM.**  
F. Calvert, County Garage.

**MAIDSTONE.**  
Cyco-Radio, Ltd., 3, Mill Street.  
J. W. See & Sons, 12, Earl Street.

**MANCHESTER.**  
R. H. Bradley, 53, Cobden Street, Moston Lane,  
Blackley.  
E. Butler, 178, Princess Road, Moss Side.  
Newton Radio Co., 393, Oldham Road, Newton  
Heath.  
Park Wireless Depot, 37, Raby Street, Moss Side.

**MANSFIELD.**  
J. Jennings & Sons, High Street.

**MARGATE.**  
Walker & Son, 1-2, Marine Terrace.

**MELTON MOWBRAY.**  
Sharman & Ladbury, Ltd., Sherrard Street.

**METHIL.**  
Methil Radio Stores, 21, East High Street

**MONTROSE.**  
Valentine & Son, Radio Corner, Murray Street.  
M. Wilson, 138, High Street.

**MORTIMER, BERKS.**  
F. J. Hillary, Electrical and Radio Engineer.

(Continued on page 894.)

**You must see the  
Lamplugh  
"SILVER GHOST"**

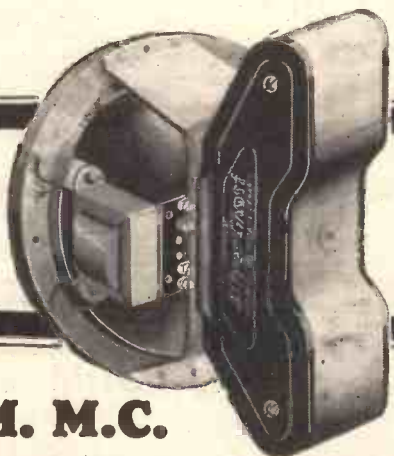

**P.M. M.C.  
DYNAMIC SPEAKER**

Includes 3-ratio Transformer and 5-ply Baffle Board. **42/-** Less Transformer 35/-

Together with their other range of speakers on **STAND No. 99.** Demonstration Room No. D.24. or full details and interesting literature on request.

**S. A. LAMPLUGH, Ltd.,**  
Little Park Street - COVENTRY  
London Office: Mr. F. G. Billett, 19-20, Holborn Viaduct, E.C.1.

**QUALITY and  
QUANTITY**

—the wonderful  
blend that makes

*Player's  
Please*



Save your Player packets for the Imperial Tobacco Company's **POSTER COMPETITION**.  
**£20,000** IN CASH PRIZES  
Ask your Tobacconist for particulars

5 FOR 3<sup>p</sup>  
10 FOR 6<sup>p</sup>  
20 FOR 11<sup>1/2</sup><sup>p</sup>



You too should use -

**PARKE-DAVIS Shaving Cream**



★ IT COSTS YOU NOTHING TO TRY

Use it for one week and you will always shave thus. That is why we gladly offer you a seven-day free trial tube. Post Coupon to-day. You will be delighted with the comfort and efficiency of the new perfected Shaving Cream

**COUPON**

EUTHYMOL (Dept. 125Q), 50 Beak Street, London, W.1

Please send FREE sample tube Shaving Cream.

Name.....

Address.....

(Use block letters please)

**PUT POWER IN YOUR SET!**

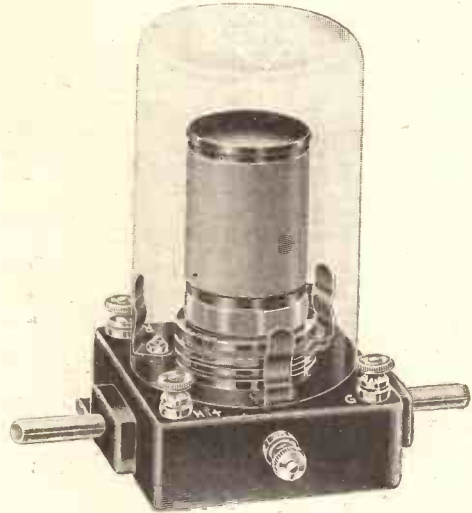

These new British General Dual Wave Coils enable you to achieve remarkable results in regard to both power and selectivity.

The ordinary cheap receiver, with these coils incorporated, can be converted into a strikingly effective modern set.

Full details and wiring diagrams supplied.

Price 9/6, Aerial and anode models (suitable for ganging).

From all dealers or direct from the manufacturers.

**BRITISH GENERAL**

BRITISH GENERAL MANUFACTURING CO., LTD. Brodley Works, London, S.E.4

YOU ONLY NEED TO HEAR KENWELL POWER-PACK

MODEL A-CIU £8.15.0 H.T. L.T. G.B. AND MOVING COIL SPEAKER

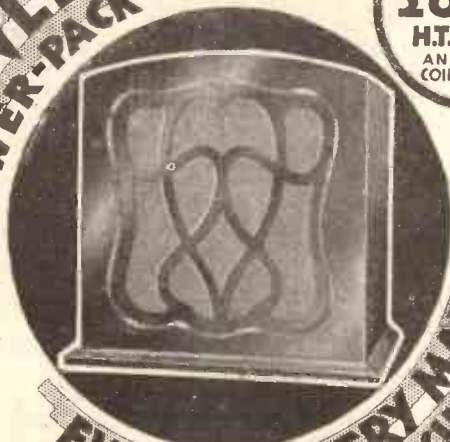

EVERY BATTERY MAN CUTS COSTS AND CURSING WITH THIS COMPLETE MAINS UNIT AND MOVING COIL SPEAKER



"It's a wee braw Set, ye ken!" McQuality.

**Turn your Battery Set into an ALL - MAINS MOVING-COIL RECEIVER**

Hundreds of Battery Set users who visited our Stand at Radiolympia discovered that the Kenwell Power Pack was just the unit they required to bring their Set up-to-date.

And then—it is so economical in current consumption that its complete cost can be written off out of savings in the first 18 months.

**DON'T SCRAP YOUR BATTERY SET**

—it has always been a good friend to you. Ask your Dealer to show you how simple it is, with the Kenwell Power Pack, to plug into the nearest mains socket and put all dry-battery troubles behind you for good! Listen to the magnificent tone of the Moving Coil Speaker and you will agree it makes your old Set as good as anything at Radiolympia.

Your Dealer can supply—or write now for illustrated folder describing this money saving and efficient Power Pack.

**KENWELL RADIO LTD.**  
200, City Road, London, E.C.1

**SPECIFICATION of AC/U MODELs**  
H.T. 80 v. and 150 v. (fixed). 0 - 100 v. (variable) 25 m/a. L.T. Trickle Charger at 25 amp. G.B. 5 Tappings: 1½, 3, 4½, 9, and 15 v. Mains energised moving coil speaker.

Price £8.15.0 Other models on request.

**See it - Hear it - and KNOW!**

**OFFICIAL LIST OF EXHIBITORS**

(Continued from page 892.)

**MOTHERWELL.**  
Glasgow Cycle & Wireless Depot, 113-115, Brandon Street.

**NELSON.**  
F. Deluce & Co., 3-5, Prospect Buildings.

**NEWCASTLE-ON-TYNE.**  
Accumulator Construction Co., Powdene House, Pudding Chare.  
W. Emerson, 255, Westgate Road.  
John Mills & Sons, 63, Grainger Street.

**NEWPORT, MON.**  
Newport Electrical Co., 3, Dock Street.

**NORTHAMPTON**  
V. O. Curtis, 86, Wellingboro' Road.

**NOTTINGHAM.**  
Pickbourne, 93, Sneinton Boulevard.  
Reliance Engineering Co., 101, Alfreton Road, and 144, Derby Road.  
World Radio Supply Stores, 78, Radford Boulevard.

**NUNEATON.**  
Collins Radio Depot, 9-11, Riversley Road.

**OLDHAM.**  
F. Fryer, 141, King's Street.  
H. Gilbert, 139, Yorkshire Street.

**OLNEY, BUCKS.**  
Minney Bros., 98, High Street.

**OSSETT.**  
A. Wainwright, Wakefield Road, Flushdyke.

**OXFORD.**  
G. R. Cooper, 40-44, St. Ebbe's.  
The Oxford Radio Supplies, 29, Queen Street.

**PAISLEY.**  
Clydesdale Supply Co. Ltd., 9, Moss Street.

**PELTON, Co. Durham.**  
H. Sayer, Front Street.

**PENRITH.**  
A. B. Bove, late Frank Smith, Corney Square.  
W. Pears, Great Dockray.

**PERTH.**  
A. Harrower, 150, South Street.

**PETERBOROUGH.**  
R. J. Croft, Main Street, Farcet.

**PEWSEY.**  
T. E. Bailey, The Bazaar.

**PONTYPRIDD.**  
D. G. Ball, 72, Taff Street.

**PORTSMOUTH.**  
W. Keost, 290-302, Commercial Road.  
L. F. Wells, 4, Fourth Street, St. Mary's Road.  
Wild Bros, 125, Arundel Street, and 60, Fratton Road.

**PULBOROUGH.**  
L. R. Willmer, Lower Street.

**RADCLIFFE.**  
The Talkie Shop, Picturedrome Buildings.

**RADCLIFFE-ON-TRENT.**  
H. S. Smith, The Wireless Stores.

**RAMELTON, Co. Donegal.**  
S. B. Corry, Market Square.

**RAMSGATE.**  
J. Corman, 65, King Street.

**RATHFRILAND.**  
S. G. Kentley, Castle Hill.

**RAWTENSTALL.**  
O. Borsay, 101, Bank Street.

**READING.**  
F. Gale & Son, Ltd., 133, Friar Street.  
G. Wilson, 45, Castle Street.

**REDHILL.**  
J. Brems, 35a, Clarendon Road.

**REDRUTH.**  
E. Russell, Higher Fore Street.

**REIGATE.**  
B. Finch & Sons, 35, Bell Street.

**RICHMOND.**  
Morley & Thuey, 14, The Quadrant.

**ROCHDALE.**  
A. K. Cotton & Co., 2, Water Street.

**ROCHESTER.**  
Clarke & Simmons, 212, High Street

**ROMFORD.**  
Filmays Radio, Filmays Corner, South Street.

**ROTHWELL, Nr. Leeds.**  
W. Gibson, Radio Co., 34a, Commercial Street.  
O. Fox, 84, Commercial Street.

**ROYSTON, YORKS.**  
J. Gordon Cheestham, 127, Midland Road.

**RUSHDEN.**  
Lektro Radio Stores, 5, Newton Road.

**ST. ANNE'S-ON-SEA.**  
E. Summer, Ltd., 14, St. Andrew's Road South.

**ST. HELENS.**  
W. Cawley, Junr., 66 Liverpool Road.  
F. Cholerton, 52, Bridge Street.

**ST. NEOTS.**  
Moore & Co., High Street.

**SAXMUNDHAM.**  
O. W. Lane, Radio Dealer.

**SEAFORTH.**  
J. Murphy, 13-15, Seaforth Road.

**SEVENOAKS.**  
F. J. Lawrence, Westinghouse, Quakers Hall Lane.

**SHEFFIELD.**  
W. H. Sherwood, 56, West Street.

**SIDCUP.**  
Sidcup Electrical Co., 72, High Street.

**SITTINGBOURNE.**  
E. & C. Landen, 55, High Street.

**SMETHWICK.**  
Lambert Bros., 326, High Street.

**SOUTHEND-ON-SEA.**  
L. V. Bridge, Warrior Square.  
London Radio Supplies, 29, Victoria Arcade.

**HERE ARE THE  
RADIO CABINETS  
YOU ARE LOOKING FOR**

**The New "LANGMORE" No. G1**

**RADIO GRAMOPHONE CABINETS**

These cabinets are very strongly constructed of selected Oak. Size overall, 3 ft. 6 in. high by 21 in. wide by 15 in. deep.

**THE TOP SECTION.** Size, 4 1/2 in. high by 18 in. wide by 14 in. deep, gives ample accommodation for gramophone or pick-up.

**THE CENTRE SECTION.** Size, 10 in. high by 18 in. wide by 14 in. deep, is for the Wireless Set, to take a panel either 18 in. by 7 in. or 18 in. by 8 in.

**THE BOTTOM SECTION.** Size, 16 in. high by 18 in. wide by 13 1/2 in. deep, gives accommodation for Loudspeaker and Batteries. With "GALLEON," as illustrated, or "CATHEDRAL" Fret Fronts.

Wooden panels to fit, with oval aperture, 12 in. by 5 1/2 in., 2/- extra.

The whole of the back is enclosed by double doors, so that all parts are easily accessible. ALL are fitted with hinged top, heavy platform to take a 12-in. turntable for the Gramophone, and a substantial baseboard for the Wireless Set. **BEAUTIFULLY FINISHED JACOBEOAN OAK.** Packed FREE and sent Carriage Paid to any address in Great Britain.



PRICE  
**49/6** EACH.

**The New "LANGMORE" No. 8A**  
**RADIO CABINET**

Very strongly constructed of selected Oak and Plywood with the well-known Langmore Finish. **SIZE OVERALL.** 33-in. high, 21 in. wide, and 12 1/2 in. deep.

**TOP SECTION.** 10 in. high, 18 in. wide, 11 in. deep inside. Wooden panel with oval opening, 12 by 5 1/2 in.

**BOTTOM SECTION.** 16 in. high, 18 in. wide, 11 in. inside.

The whole of the back is removable so that all parts are easily accessible. Fitted with hinged lid and baseboard.

**BEAUTIFULLY FINISHED JACOBEOAN OAK.**

Carriage Paid to any address in Great Britain.



PRICE  
only **19/6** each

The **MISCELLANEOUS TRADING Co. Ltd.**  
13 & 17 **NEW OXFORD STREET**  
**LONDON, W.C.1** Phone: Holborn 4894



**SMOOTHING  
CONDENSERS**

*Are designed and  
Manufactured to  
fulfil all the  
requirements of*

**ENGINEERS,  
MANUFACTURERS  
AND AMATEUR  
CONSTRUCTORS**

*Write for Fully Descriptive Leaflet*

**THE WEGO CONDENSER Co. Ltd.,**

Spencer House, South Place, London, E.C.2

Phone: NATIONAL 4500

Works, Perivale, Greenford, Middlesex.



# GOLTONE COMPONENTS FOR YOUR "OLYMPUS" FOUR & "MODERATOR" TWO



**"GOLTONE" Super H.F. Choke**  
As recommended.  
Baseboard or Valveholder Mounting. R3/46. **4/6**

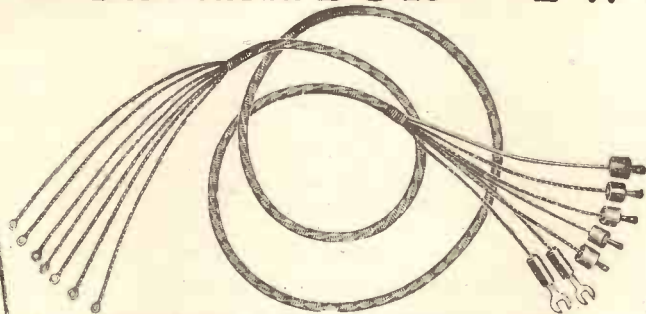

**GOLTONE 5-WAY BATTERY CORD**  
30 ins. long, as used by designer, complete, R40/40, 2/-

**GOLTONE PUSH-PULL SWITCH**

R26/744  
**7 1/2 d.** each.

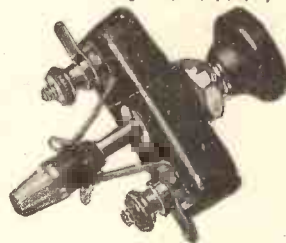

**"GOLTONE" Short Wave Choke**  
Highly recommended by Technical Press.  
Baseboard or Valveholder Mounting. R3/26. **2/6**

**"GOLTONE" EBONITE PANEL.**  
Size: 14" x 7" x 3/2"  
**"GOLTONE" BINOCULAR H.F. CHOKE.** R3/36. 2/6  
**"GOLTONE" "GRAND" L.F. TRANSFORMER.** 3 to 1. 8/6

**"GOLTONE" COMPONENTS** are obtainable from all First-Class Radio Stores. Refuse substitutes—if any difficulty write direct. **RADIO CATALOGUE sent FREE on request.**

**"GOLTONE" COSMIC DUAL RANGE COIL**  
DW/18 **5/6**

**WARD & GOLDSTONE, LTD., PENDLETON, MANCHESTER**

**No Chatter**  
**No Scratching—No Case Resonance**  
with the All-British



**Clarion Pick-up**



**PRICE 21/-**

Handsome finished in Walnut Bakelite

Ask your dealer to let you see and hear the wonderful range of Clarion 100-per-cent British-made Radio instruments.

Table Model, Console Model, Radio-gramophone, Radio-gramophone with Automatic Record Changer.

The all-British Clarion Pick-up is amazing in its realism. The entire absence of extraneous noises ensures smoothness of tone which provides an added joy from your records. This model is fitted to the famous Clarion Radio-gram. Can be fitted to any gramophone in five minutes.

**BRITISH CLARION Co., Ltd.**

Clarion Works, Miller Street, N.W.1

Telephone: Museum 3624/3625

Telegrams: Crosradela, Norwest, London



**FLUXITE INDISPENSABLE TO EVERY RADIO ENTHUSIAST**  
IT SIMPLIFIES ALL SOLDERING

"We're Fluxite and Solder, the reliable pair, Famous for Soldering—known everywhere! Now here is a statement—bound to come true, If you'll invite US to come and help YOU!"

See that Fluxite and Solder are always by you—in the house, garage, workshop—anywhere where simple, speedy soldering is needed. They cost so little, but will make scores of everyday articles last years longer! For Pots, Pans, Silver and Brassware; RADIO; odd jobs in the garage—there's always something useful for Fluxite and Solder to do.

All Hardware and Ironmongery Stores sell Fluxite in tins, 8d., 1/4 and 2/8.

**ANOTHER USE FOR FLUXITE**  
Hardening Tools and Case Hardening. Ask for Leaflet on improved method.

NEW "JUNIOR" SIZE 4d. per tin.

**FLUXITE SOLDERING SET**

Simple to use and lasts for years in constant use. Contains special "small space" soldering iron with non-heating metal handle, pocket blow-lamp, Fluxite, Solder, etc., and full instructions. COMPLETE, 7/6, or LAMP only 2/6.

**FLUXITE LTD.**

(Dept. 324),

ROTHERHITHE, S.E.15

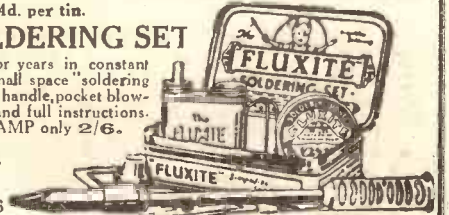

**ALL MECHANICS WILL HAVE**

**FLUXITE**

**IT SIMPLIFIES ALL SOLDERING**



# RADIOTORIAL

All Editorial communications should be addressed to the Editor, POPULAR WIRELESS, Tallis House, Tallis Street, London, E.C.4.

The Editor will be pleased to consider articles and photographs dealing with all subjects appertaining to wireless work. The Editor cannot accept responsibility for manuscripts or photos. Every care will be taken to return MSS. not accepted for publication. A stamped and addressed envelope must be sent with every article. All inquiries concerning advertising rates, etc., to be addressed to the Sole Agents, Messrs. John H. Lile, Ltd., 4, Ludgate Circus, London, E.C.4.

The constructional articles which appear from time to time in this journal are the outcome of research and experimental work carried out with a view to improving the technique of wireless reception. As much of the information given in the columns of this paper concerns the most recent developments in the radio world, some of the arrangements and specialities described may be the subjects of Letters Patent, and the amateur and the trader would be well advised to obtain permission of the patentees to use the patents before doing so.

## QUESTIONS AND ANSWERS

### REDUCING THE RUNNING COSTS FOR HIGH TENSION.

The following letter from a Coventry reader is so full of good hints and good humour that it is reproduced in full in these columns. It

is hoped that others will benefit from the excellent advice given by one who says, quite mistakenly, he hasn't anything to give away!

The Editor.

Dear Sir,—Having been placed on short time by my firm I find it a bit of a squeeze to spend money on wireless. I expect that a good many more are in the same boat.

Now, it may seem all wrong to some of

## HOW IS YOUR SET GOING NOW?

Perhaps your switching doesn't work properly? Or some mysterious noise has appeared and is spoiling your radio reception? Or one of the batteries seems to run down much faster than formerly? Whatever your radio problem may be, remember that the Technical Query Department is thoroughly equipped to assist our readers, and offers its unrivalled service. Full details, including scales of charges, can be obtained direct from the Technical Query Dept., POPULAR WIRELESS, The Fleetway House, Farringdon Street, London, E.C.4. A postcard will do. On receipt of this an Application Form will be sent to you post free immediately. This application will place you under no obligation whatever, but, having the form, you will know exactly what information we require to have before us in order to solve your problems.

**LONDON READERS. PLEASE NOTE:** Inquiries should NOT be made by phone or in person at Fleetway House or Tallis House.

**OUR LATEST & MOST WONDERFUL**

## RADIO OFFER!

**The Famous BROWN 1933**  
P.M. MOVING COIL UNIT AND CHASSIS.

A new permanent magnet moving Coil Unit and Chassis, including tapped transformer. Extremely sensitive, suitable to work with any good 2- or 3-valve set; gives volume without distortion; protected to prevent entry of dust or metal particles. Fitted complete on Baffle Board. Height 12-ins. Width 12 ins., Depth 4½ ins. Only a limited number available at this special price.

ONLY  
**2/6**  
DOWN

List Price 50/- . **OUR PRICE** only 32/6. On 7 days approval only 2/6 deposit; if satisfied, pay further 5/- at once, then 6 monthly payments of 5/- . (Cash in 7 days 32/6.) Leaflet post free.

**E. J. HERAUD, LTD., DEPT. P.W.3.**  
NUMBER ONE, EDMONTON, LONDON, N.18

**IN MAGNIFICENT WALNUT CABINET**  
The Same Speaker in cabinet of special design. List Price £3 19s. 6d. **OUR PRICE** only £2 19s. 6d. Send 2/6 deposit for 7 days trial. If satisfied send further 5/- and 8 monthly payments of 7/6.

**2/6**  
DOWN

**“RED DIAMOND”**  
**H.F. CHOKE**



Finest Quality Rhonite Ferracer. Best quality wire. Designed to give maximum results when used as high frequency coupling, or for reaction purposes in the detector circuit. Exceptionally high amplification. Beautifully smooth reaction control. Minimum D.C. resistance.

**RD74**  
**3/6** each; by insured post 3/9.

**“RED DIAMOND”**  
**DETECTOR**



Can be mounted on brackets or through panel. Once set always ready. Not affected by vibration. Each one is tested on broadcast before despatch.

**RD40**  
**2/-**

By insured post 2/3, or 2/9 with shield.

Of all high-class Radio Dealers  
or Sole Makers:

**JEWEL PEN CO., LTD.** (Radio Dept. 46), 21-22, Great Sutton St., LONDON, E.C.1.

## A Masterpiece

on  
**Stand**  
**123!**



When you visit Olympia do not fail to call at Stand No. 123 and see the complete “Camco” range of cabinets. You should make a special point of inspecting the “Gresham”—a very handsome cabinet that incorporates the outstanding workmanship and finish for which “Camco” cabinets are famous—in any case do not fail to send for your FREE copy of the new “Camco” Cabinet catalogue.



**Big New Catalogue FREE**

Showrooms:  
Carrington Mfg. Co. Ltd.  
24, Hatton Garden,  
London, E.C.1.  
Phone: Holborn 8202.  
Works: S. Croydon.

Name.....  
Address.....  
2.P.W.

A Sensational  
Radio  
Discovery

**PERMANENT-EFFICIENT  
EVER-DAMP EARTHING**

TO EARTH  
TERMINAL  
OF SET

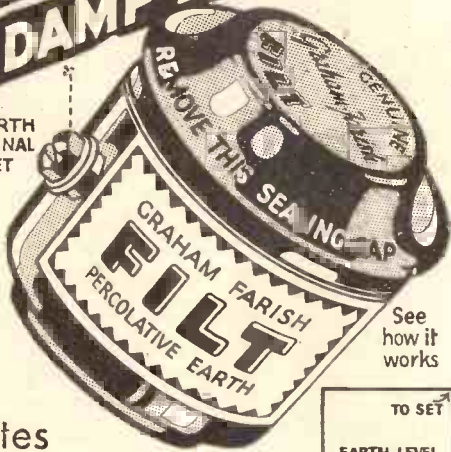

See  
how it  
works



## Rejuvenates the Heart of Your Receiver

Get the maximum power and purity from your receiver—stop crackling and minimise oscillation by fitting the most efficient earthing system ever invented—the new FILT percolative Chemical Earth. **FAULTY EARTHING CAUSES MORE RECEPTION TROUBLES THAN ANY OTHER SINGLE DEFECT OF A SET.** When you use FILT you know that your earth is SOUND.

## Wonderful New Percolative Chemical Makes Even Dry Soil Permanently Conductive

The active portion of FILT is a wonderful new chemical which, when buried in the earth, at once begins to spread and percolate, attracting moisture and forming a highly conductive network of channels spreading outwards and downwards to a depth of several feet. In ANY soil, in ANY weather, FILT makes a perfect, permanently damp earth of the highest efficiency, ensuring the best results from any kind of receiver.

## How FILT Works and What It Does

Anybody can fix a FILT successfully. Merely bury the copper container, half filled with FILT chemical, about a foot below ground. The penetrating action begins at once, and very soon a PERMANENT, highly conductive network of chemical moisture is formed, which makes your earthing system as effective as it can be. Your reception will improve, your set will be more selective, easier to control, less liable to oscillate or crackle, giving you the *best* all the time. Get a FILT to-day.

GRAHAM FARISH **FILT** PERCOLATIVE CHEMICAL EARTH  
(pat.app.for)

Obtain FILT from your nearest radio dealer or order it direct (post free) from the sole manufacturers:

GRAHAM FARISH, LTD.,  
181, MASONS HILL,  
BROMLEY, KENT

**2/6**  
COMPLETE

# DUBILIER

INTRODUCE

## A DRY ELECTROLYTIC CONDENSER WITH 6 STAR FEATURES

In the new Dubilier Dry Electrolytic Condenser you have a component of outstanding features. Read for yourself of its six great advantages . . . and think how completely this Dubilier Electrolytic Condenser fills your every demand in this type of condenser. Then remember . . . it is made by Dubilier. And that means that it is as efficient as the finest craftsmanship in the industry can make it. It has already been adopted as a standard by leading set makers.

### CONSTRUCTION.

★ The condenser consists of a positive and a negative electrode with a separator impregnated with the electrolyte. The whole is mounted inside a sealed aluminium container fitted with a moulded terminal insulator.

### VOLTAGE RATING.

★ The maximum peak voltage (D.C. and A.C.) peak on these condensers should not exceed 450 volts. The actual A.C. ripple voltage impressed may be as high as 70 volts r.m.s.

### OVERLOADS.

★ If Dubilier Electrolytic Condensers are subjected to a transient over-voltage, they reform on restoration of normal voltage.

### LEAKAGE.

★ The D.C. leakage current of these condensers is very low. It drops quickly to a fraction of a milliampere after a short period on load. The recovery after a period of rest is also very rapid.

### POWER FACTOR.

★ The power factor of these condensers is about 8%, which is less than half that of the aqueous types.

### TEMPERATURE RANGE.

★ The electrolyte in these condensers contains no free water, and since it is not liquid there can be no splashing or creeping of electrolyte from them. It will not freeze and the condensers are undamaged by exposure to any extremes of cold.



4 mfd. Price 4/6  
6 mfd. Price 5/-  
8 mfd. Price 5/6

DUBILIER  
CONDENSER  
CO. (1925) LTD.  
Ducon Works  
Victoria Road  
North Acton, W.3

# P.P.M. SOUNDEX



**27/6**  
INCLUDING TRANSFORMER

## THE TALK OF OLYMPIA

Wherever a group of men meet at Olympia you will hear them discussing Celestion's latest achievement—the wonderful P.P.M. SOUNDEX—it's the talk of Olympia—everyone agrees that the extraordinary power and tonal quality is really amazing and considering the small size it is beyond belief. If you come to Olympia hear it in the Celestion demonstration room No. 9 or ask your dealer to demonstrate. Insist on the Celestion P.P.M.—it will amaze you.

**OLYMPIA**  
STAND No. 127  
DEMONSTRATION ROOM No. 9

**CELESTION**  
*The Very Soul of Music*

Celestion Ltd., London Road, KINGSTON-ON-THAMES.  
London Showrooms: 106 Victoria Street, S.W.1.

## RADIOTORIAL QUESTIONS AND ANSWERS

(Continued from page 896.)

have two H.T. negative leads. One goes to my newest battery, and one (extra) to the oldest one I have in use. The total number is three H.T. batteries at one time.

Suppose I call them "August," "May," and "January," August meaning the one I just bought, May the one before, etc.

Well, August being newest and best, I use him with 0 socket to sets H.T.—, and + socket to 0 socket of the May battery. The + socket

of May goes to power valve plate, so I get 120 volts there, or near enough (60 each from May and August).

In addition, I can take a + plug on a flex lead out of this pair for the S.G. 100 volts. So, you see, 60 volts of that comes from August and 40 from May.

In this way August, my nice new battery, gives me half my power valve volts and more than half my S.G. plate volts. All clean H.T. and no crackles, coming from a new and a not-quite-so-new battery. (The third battery I'll explain in a moment.)

The newest H.T.B. is doing most work, so him and his partner last well together. When they get beyond it I shall have to "promote" them by getting a new one to replace August, and putting August up in place of May.

But here is my final economy wrinkle. I don't have to throw May away. I use him (or is it "her") for the detector's H.T.

As I said, there are three in use all the time, the two I linked (+ to -), and one other besides. This third one has its - to set's H.T. —, and its + plug going to the detector.

Being only one valve, this lead does not want a lot of current, and I find an old battery goes on months for it, after most people would throw it away.

January is doing the job now on my set, but I believe I ought to call him November, since it must be about nine months ago I brought him home. It's a great stunt for using batteries and getting the last volt out of them.

### DO YOU KNOW—

the Answers to the following Questions ?

There is no "catch" in them, they are just interesting points that crop up in discussions on radió topics. If you like to try to answer them, you can compare your own solutions with those that appear on a following page of this number of "P.W."

- (1) What is the greatest power employed by any broadcasting station in Europe ?
- (2) What is the (approximate) natural wavelength of a 100-ft. aerial ?
- (3) What station has as its slogan "The Pioneer Broadcasting Station of the World" ?
- (4) Which of Europe's broadcasting stations changes its power daily and its wavelength every three months ?

I hope you can put this letter in where the chaps can see it, as it is a money-saver idea. (I think it is the best I ever got out of "P.W.")

Yours truly,

"FOLESHILL."

P.S.—Please tell "Ariel" the missus says "he" is a woman writing. That pipe-smoking is "bunk."

### DOUBLE DUTCH.

R. J. D. (Hungerford).—"The announcer calls it Hilversum, which is the other Dutch station, but according to the wavelength, 1,875 metres, it should be Huizen. Have these two changed over, or is Hilversum doing both, or what ?"

### "P.W." PANEL, No. 86.—EMPIRE BROADCASTING.

The B.B.C. recently appointed C. G. Graves to be Director of Empire Broadcasting.

A new Empire Broadcasting Station is now being built at Daventry. It will employ two transmitters and sixteen aeriáls.

The power will be between 15 and 20 kilowatts in the aerial of each transmitter.

The wavelengths to be used will be decided as the result of practical experience with those available.

There is an agreement between the two stations that every three months they exchange wavelengths. So at present, Hilversum, on 296.1 metres is sending out the Huizen programmes, and Huizen, on the long waves, is announcing himself as "Hilversum."

### INTERFERENCE FROM VACUUM CLEANER.

D. S. C. (Tottenham).—"During the day my reception was continually being spoilt by an awful, roaring, scratching noise that would come on suddenly, absolutely blot out everything for a time, and then vanish as suddenly as it came.

It took me several weeks to find out what it was. Below my rooms there is a sort of dry-cleaning place and it was all caused by the vacuum cleaner.

We proved this by listening after a signal was given to switch on the cleaner, and every time the signal went the row started again. They are quite willing to do what they can, but, of course, they must use the cleaner, so can you suggest anything which might stop the noise ?"

Recent investigations into this form of interference have shown that it can generally be cured by fairly simple means.

Two large condensers of 2 mfd. or so are required, and one terminal on each should be connected together.

On the vacuum cleaner you will find two carbon "brushes"—i.e. small blocks of carbon making a rubbing contact with the moving parts, against which they are each pressed by a spring.

Each carbon or spring must be joined to one of the vacant terminals on the condensers, one to one condenser and the other to the other.

Finally, the two terminals which were first joined together must be connected as well to the framework of the machine.

A qualified electrician should carry out the job, which is extremely easy, but must be done properly to ensure safety in use.

### WON'T GO UNLESS IT IS TOUCHED!

G. M. (Preston).—"What is the matter with a set when the only way to make it go is to touch the terminal on the coil ? There is nothing the matter with the terminal and it is not loose or making bad contact, but it is the only way to make the set go."

If there is nothing wrong mechanically it is probable that the effect of touching the terminal is to allow a choked grid circuit to clear.

All valve circuits allow for some form of grid return, and in cases where the circuit becomes broken the absence of such a return causes the grid in question to "choke." Touching the grid circuit will often effect a cure, and apparently that is what is happening in your case.

To cure the trouble you must restore the faulty grid circuit. Possibly this is caused by a broken wire in the coil, whilst a dud contact in the coil unit, or a break in the grid-bias connections afford examples of the kind of fault to look for. The valve holder, the coil-holder (if any) and especially the grid leak and its clips (if used) should all be carefully checked up to see that there are good connections throughout the circuit.

(Continued on next page.)

## RADIOTORIAL QUESTIONS AND ANSWERS

(Continued from previous page.)

Dry or dirty joints, grease, and all other enemies of good conduction should be removed, and after this has been done there should be no more trouble from the choking.

### WARMING UP THE VALVES.

A. S. (Lowestoft).—"I remember that it was always considered advisable in the Service to allow a heterodyne wavemeter valve to 'warm up' before critical readings were taken. Would not this apply, and with

### WHAT'S WRONG?

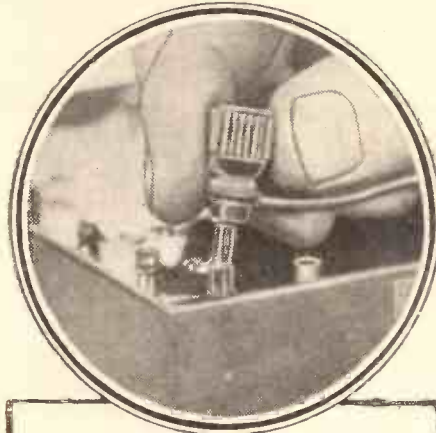

### THAT H.T. NEGATIVE PLUG.

One of the most important plugs in the set is H.T. negative. It should always be disconnected from the battery before alterations are made to the wiring, coils changed, etc., or you may get some expensive "fireworks."

Many people disconnect H.T. neg. every time the set is "off," a plan that may save leakage and expense for H.T. battery renewal.

Be sure the plug fits snugly into its socket. Otherwise—crackles!

more force, to other valves now that the indirect heating of filaments is becoming common?"

Yes. But the degree of accuracy called for in a heterodyne wavemeter is very great, and quite apart from indirect heating it was, as you say, considered advisable to allow the circuit to warm up nicely before putting the instrument into commission.

With indirectly-heated valves a generous time-lag is essential before the valve works at all, and in the case of powerful multi-valve sets it would certainly seem desirable to allow the set a quarter to half an hour to get "run in" before carrying out very fine adjustments, calibration, or trimming.

In a super-het. the oscillator valve would obviously call for a certain amount of consideration of this kind.

(Continued on next page.)

### A SUGGESTION

Have you ever thought how difficult it is for a newsagent to order just the right number of copies of any particular paper each week? You can make his task much easier if you place a regular order with him. You will not only help him to order correctly and avoid waste, but will make sure of getting your copy regularly each week.

## New Times Sales Co

### MANUFACTURERS' KITS

**COSSOR MELODY MAKER.** Model 335. Complete with Valves, Speaker and Cabinet. Employs Cossor Variable-Mu S.G. H.F. stage, Detector and Power. Cash Price £7/17/6 order  
Balance in 11 monthly payments of 14/10

**OSRAM "THIRTY-THREE" MUSIC MAGNET.** Complete Kit, comprising all components including Valves, Cabinet with self-contained Speaker. Screen-grid H.F., Screen-grid Detector and Power output. Single-dial tuning, wave-length calibrated. Cash Price £9/9/0 order  
Balance in 11 monthly payments of 17/6

**RADIO FOR THE MILLION.** "STATION MASTER 3" Battery "Model A." Complete with Valves and Cabinet. Cash Price £5/11/0 order  
Balance in 11 monthly payments of 10/2

**RADIO FOR THE MILLION.** "STATION MASTER 3" (Model B), with Valves, Cabinet, and Speaker as advertised. Cash Price £7/10/0 order  
Balance in 11 monthly payments of 14/-

### ACCESSORIES

**GARRARD INDUCTION GRAM-PHONE MOTOR.** Model 202. For A.C. Mains. Mounted on 12-in. Nickel Motor Plate with fully automatic electric starting and stopping switch. Cash Price £2/18/6 order  
Balance in 11 monthly payments of 5/4

**B.T.H. SENIOR PICK-UP,** complete with Arm and Base. Cash Price £2/2/0 order  
Balance in 11 monthly payments of 3/10

**FIRST WITH  
EASY TERMS  
in 1924 and  
Still leading  
BIGGEST STOCKS**

**NEW 1933  
RADIO  
ON EASIEST OF  
EASY TERMS  
QUICKEST DELIVERY**

**R & A "VICTOR" PERMANENT MAGNET MOVING-COIL SPEAKER DE LUXE.** With 6-ratio input transformer and protecting grill. Cash Price £3/10/0 order  
Balance in 11 monthly payments of 6/5

**R & A "BANTAM" PERMANENT MAGNET MOVING-COIL SPEAKER.** With 3-ratio input transformer. Cash Price £1/7/6 order  
Balance in 5 monthly payments of 5/-

**BLUE SPOT SPEAKER UNIT AND CHASSIS, Type 100U.** Cash Price £1/19/6 order  
Balance in 7 monthly payments of 5/5

**W.B. PERMANENT MAGNET MOVING-COIL SPEAKER, Type P.M.4.** Complete with Transformer. Cash Price £2/2/0 order  
Balance in 7 monthly payments of 5/9

**EPOCH "20 C" PERMANENT MAGNET MOVING-COIL SPEAKER.** With 3-ratio input transformer. This speaker will handle up to 5 watts. Cash Price £1/15/0 order  
Balance in 5 monthly payments of 6/6

**ULTRA IMP PERMANENT MAGNET MOVING-COIL SPEAKER,** with input transformer. Cash Price £1/17/6 order  
Balance in 5 monthly payments of 6/10

**ATLAS A.C. ELIMINATOR, Type A.C.244.** Three tappings, S.G., Detector and Power. Output, 120 volts at 20 m.a. Cash Price £2/19/6 order  
Balance in 11 monthly payments of 5/6

Any items advertised in this journal sent C.O.D. If value over 10/- sent all C.O.D. charges paid.

To NEW TIMES SALES CO. 56, Ludgate Hill, London, E.C.4.

Please send me (a) 1933 Lists

(b).....for which I enclose first

payment of £.....s.....d.....

Name.....

Address.....

.....P.W. 27/8/32

## MODERN WIRELESS

Tells you all about

"THE DIODION"

A Magnificent New-Season's Receiver.

THE WORLD'S PROGRAMMES

How, When and Where to Tune In.

BETTER RADIO

Illustrated Practical Hints.

"M.W." is Britain's Leading Radio Magazine — One Shilling

SEPT. NO. NOW ON SALE

## RADIOTORIAL QUESTIONS AND ANSWERS

(Continued from previous page.)

### FAILURE OF REACTION.

H. D. (Penarth).—"Could the alteration of a by-pass condenser affect the amount of reaction obtained, other things being the same? The reason I ask is that on my two-valver I have been troubled with a failure of reaction at the top end of the scale, and the only alteration of wiring made has been to increase the detector's fixed condenser capacity to -0005 mfd. from -0001 mfd.

"The circuit is the usual arrangement of grid-leak detector, with reaction condenser connected to one side of filament.

"The other side of reaction goes to the reaction coil, which on the other side is connected to the plate of the valve which also goes to the H.F. choke and to the by-pass condenser referred to. (The other side of this is joined to filaments.)

"As soon as the capacity of the fixed condenser was increased reaction appeared to fall off, and I see that it looks as though

### THE ANSWERS

TO THE QUESTIONS ASKED ON PAGE 893  
ARE GIVEN BELOW.

- (1) 120 kw., being the power used at Prague and at Warsaw (488.6 and 1,411 metres respectively).
- (2) Approximately 125 metres.
- (3) East Pittsburg, K D K A.
- (4) Hilversum. It changes from 7 to 20 kw. at 4.40 p.m. daily. Every three months it sends out the "Hilversum" programme via Huizen's aerial, on 1,875 metres.

### DID YOU KNOW THEM ALL?

the by-pass is across the whole reaction circuit. I have never seen this referred to and should be glad to know if I have hit upon the right explanation."

Absolutely right. As you say, the by-pass is right across the reaction circuit and the effect of increasing its capacity has been to "starve" reaction to some extent. Reaction can often be gingered-up or "tamed" by an alteration to the capacity of the by-pass, and even where differential reaction is employed it sometimes pays to load the plate filament with a small extra fixed condenser in cases where reaction is a little fierce.

### HUM FROM A MAINS SET.

W. L. (Croydon).—"My set is a four, run from the A.C. mains, and at first I was a little disappointed with the volume, though being amateur-made from low-price parts I did not expect it to behave like a very posh commercial model. However, seeing the report of the bad effect of using an L.T. transformer to supply too many valves with L.T. I thought it might be a worth-while alteration to make to replace the one I was using with a better one.

"The effect was amazing, the set coming to life in fine style, showing I was starving it before.

"But with the increased power I get hum, whereas before it was as quiet as a battery set.

"Is there a simple alteration in components that I could make that would reduce this hum? If so I should be glad to get it put right even if it cost a pound, because the set brings in any amount of stations and quality seems very good apart from this one annoying fault."

We do not think it is one of the components this time, but the circuit arrangement.

It so often happens that the "centre-tap" on an L.T. transformer is not the true electrical centre that we recommend the use of a potentiometer instead of taking the return direct to the transformer itself.

You can get a suitable potentiometer (30 ohms or so, such as a "Humdinger") at the dealers and it is easily fitted. Simply wire it across the L.T. transformer, removing the wire from the set which goes to the tap. Then join the wire from the set to the slider, and adjust carefully for the setting which removes the hum.

## THE LISTENER'S NOTEBOOK

(Continued from page 880.)

There is, however, one thing to be said beyond this, and that is that Ann Trevor did save the dialogue from becoming completely impossible. In other hands, the part of the proud mother might have been absolutely ludicrous.

\* \* \*

Nosmo King and partner with their ever-fresh humour always hit the right note. I wager they would rouse the stoggiest audience till it burst itself with laughter.

They are clever, too, for it is seldom that we know what's coming. It is true that they don't give us much time to think, although they do give us the whole of their turn in which to laugh.

\* \* \*

I think Clarice Mayne is the cleverest impersonator of Marie Lloyd that we have: and we never seem to tire of being reminded of Marie Lloyd. Her song, "I'm One of the Ruins that Cromwell Knocked About" with its patter, is a particularly good one, of course, but it is better appreciated from an auditorium than via the loudspeaker. Even so, it is quite worth while to broadcast it.

\* \* \*

When I think of some of the radio plays I have listened to, I'm bound to disagree with those who ask for shorter plays. When the play is a good one, it is never too long.

If I can't afford the time to listen-in I blame my lack of time and not the length of the play. On many occasions I've been unable to go to a theatre simply because I hadn't the time.

It never occurred to me to say that a three-act play was much too long a thing for a busy man to enjoy. When I wanted a night out the only reasonable thing to do, it seemed to me, was to make adequate preparations beforehand, and then I found ample time for the three acts.

Quite a simple arrangement, and one that should work just as well with radio plays.

\* \* \*

There's another side to the question, too. What sort of a play would it be if the beginning, middle and end of it had all to go through, say, in half an hour?

With limitations unknown to the ordinary stage dramatist, the radio dramatist is sufficiently hard put to it as it is. Don't let us add to his difficulties by imposing on him a time limit which would make it impossible for him to attempt anything at characterisation, development of plot, etc.

\* \* \*

The autumn play list is very attractive. I shall certainly find time for "The White Blackbird," if only because it is by the author of "The Round Table," which I enjoyed so much.

Du Garde Peach's "Nor West" should attract at least as many listeners as did his "Marie Celeste," while those of you who liked "Bethlehem" and "The Little Ass" will surely want to hear Father Bernard Walke's new play "All Soul's Eve."

And there are other plays, also, by authors who have pleased us in the past, so we may assume they have similar pleasures in store for us this autumn.

**FREE!**  
**RESISTANCE  
CALCULATION  
CHART  
STAND  
273**

When visiting our Stand ask for a free copy of the WATMEL Resistance Calculation Chart

## WATMEL POTENTIOMETERS AND RESISTANCES

The 1932-33 Series of Watmel Potentiometers and Resistances will also be on view and we should like you to see the novel and advanced ideas used in the construction of our Type 3 Non-Inductive Resistance.

This new All-British Resistance is guaranteed to give a far steadier performance than resistances constructed on old and obsolete principles.

Price 4s. 6d.

Trade Enquiries Invited.

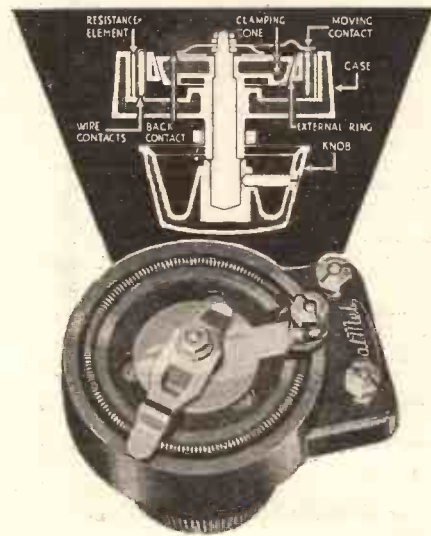

Don't Forget **STAND 273!**

**Watmel**  
**COMPONENTS**  
GET THE BEST OUT OF ANY SET

WATMEL WIRELESS Co., Ltd., Imperial Works,  
High Street, EDGWARE. Telephone: Edgware 0323

(M.C. 70)

# OSTAR-GANZ

## HIGH VOLTAGE MAINS VALVES

The first range of mains valves available in England, incorporating the most recent development in valve design—full mains voltage indirectly heated filament.

These valves work direct off either A.C. or D.C. supply. They effect considerable saving in constructional and running costs. No transformers or breakdown resistances required. Considerably lower current consumption than any other mains valves. Remarkably free from mains hum.

Descriptive leaflet on request.	G.P. Det. and Power	17/6
	Super Power	18/-
	Rectifying Valves, 50 m.a.	14/6
	" " 125 m.a.	15/6

# UNIVERSAL

## RECEIVER AND AMPLIFIER KITS

With British Components. All instructions. Complete ready for assembly. Highly efficient, yet cheap, because the Ostar Universal High Voltage Valves cut out cost of transformers and breakdown resistances. Work off either A.C. or D.C.

2-Valve Receiver with Rectifier	£6 10 0	3-Valve Receiver Price ...	£8 8 0
2-Valve Amplifier with Rectifier	£4 4 0	3-Valve Amplifier with Rectifier	£5 5 0

Write for full details to 41 ty.

EUGEN FORBAT

Sole Representative for Gt. Britain.

c/o Nivalight, Ltd., 1, Rosebery Avenue, E.C.1.

**ENGINEERS**—Sit down and think this over. Time is going by and you are still on the look-out for a worth-while job. Will you be doing the same thing next year—and the year after that? You have got to do something about it before it is too late. We believe we can show you the way to well-paid permanent and progressive employment. In any case, it costs nothing to inquire and you will at least learn of various surprising possibilities about which at present you probably know nothing. The first thing to do is to send for our 200-page Prospectus, "ENGINEERING OPPORTUNITIES." Free and without obligation. Do not delay. This is a matter which affects your very livelihood. Send for your copy now—not tomorrow, but NOW.

**BRITISH INSTITUTE OF ENGINEERING TECHNOLOGY,**  
401, Shakespeare House, 29/31, Oxford Street, London.

## LOUD SPEAKERS REPAIRED, 4/-

(Blue Spot a Speciality, 5/-).  
Transformers 4/-. Headphones 4/-. all repairs magnetised free. Eliminator Repairs quoted for. 24 Hours Service. Discount for Trade. Clerkenwell 9069.  
E. MASON, 44, EAST ROAD, LONDON, N.1.

"**PIONEER**" SWITCHES have stood the test of time. Demand them and need no replacement. Square spindles, Mahog., for black knobs and Indicating. Dials. 2pt. 1/3, 3pt. 1/6, 4pt. 2/3, S.P.D.T., 2/- D.P.D.T. 2/6, Dual 3-pt. Ganged 2/9.

**FIXING GLUE FREE** with Pioneer New Process Fret Silk. Clarifies without Muffling the Tone. No Creases. 12" sq. 1/-, 15" 1/6, 18" 2/-. Special sizes pro rata. See on stands 237, 290, etc. We will send post free, PIONEER Mfg., Co., 14, Fulwood Place, London, W.C.1. Phone: Chancery 7054.

## WIRELESS AS A CAREER

Whether you are already engaged in the radio industry and wish to improve yourself, or if you wish to obtain employment in this interesting profession, we can help you. Write now for Booklet describing our Home Study Course, Sent post free.

**NORTHERN COUNTIES WIRELESS SCHOOL,**  
57, Guildhall Street, Preston

## SHORT-WAVE BARGAIN!

**SHORT-WAVE PLUG-IN COILS,** Nos. 2-9 TURNS

**8<sup>D</sup>** AIR DIELECTRIC STANDARD SIZE  
4 for 2/4, 8 for 4/6, all Post Paid. The set of eight covers whole S.W. range. Base-board Coil Holders 4d.



**SCIENTIFIC SUPPLY STORES** (Dept. P.W.),  
128, Newington Causeway, Elephant & Castle, LONDON, S.E.1. Tel.: Hop 4177

## TELEVISION PROGRESS

An American inventor's "scanless" method.

IN the opinion of Mr. Hugo Gernsback, of America, the main problems of television will eventually be solved by some form of "scanless" transmission and reception.

And hard on the heels of the publication of the article in which those interesting views were expressed, comes the claim of an American inventor that he has devised a system which entirely dispenses with all forms of picture analysis.

He states that he takes the whole picture and deals with it in one momentary operation, and that this is accomplished without resort to the "comparatively clumsy" method of employing hundreds of separate "point units."

By the way, in a recent article in POPULAR WIRELESS we gave it as our

## NEXT WEEK

## RECORD RESULTS

on the

## "OLYMPUS" FOUR

also

## The "Moderator" in Action

ANOTHER BIG NUMBER. ORDER NOW.

opinion that "television for all" is still in the future, and on the strength of this and others of our statements a contemporary has published "A Reply and a Challenge," running to one and a half pages.

In view of the facts which we have impartially presented, we feel it is quite unnecessary for us to pursue the matter further; and it now remains for those at whom the article was directed either to justify what are, in our opinion, misleadingly exaggerated claims, or leave television alone to develop, quietly and with dignity, free from the tainting influence of misdirected enthusiasm.

G. V. D.

## ELECTRON'S SUPER-AERIAL

"Superial," the super-aerial manufactured by the New London Electron Works, Ltd., consists of seven strands of wire completely covered by vulcanised rubber and heavily waxed braiding.

Therefore, it is entirely weather-proof and also it is unnecessary to employ additional lead-in insulation with it.

It costs 2s. 6d. for a 75-foot length and a free £100 guarantee against lightning is given whether or not a lightning switch or other such device is used.

## "BLUE-SPOT" BATTERY SETS

We should like to call attention to the "Blue-Spot" K252 receiver which incorporates one of the famous Blue Spot 100 U speakers, and which was illustrated on page 729 of last week's POPULAR WIRELESS. Unfortunately, it was mentioned as being an "Ekco" receiver instead of "Blue-Spot."

Although this set employs two variable-mu S.G. valves, it is very economical to run, and has provision for the use of a pentode output valve if desired. It also has single-knob tuning.

# QUICK EASY PAYMENT SERVICE

We supply all good quality Radio Receivers, Components, and Accessories on deferred terms. Large stocks are carried and orders are executed promptly. Send list of requirements and a quotation will be sent by return of post. Price List free on request.

## MANUFACTURER'S KITS

**NEW COSSOR MELODY MAKER,** Model 335 (just released). Complete Kit of Parts, Valves, and Loudspeaker, and Cabinet. Cash Price £7/17/6. And 11 monthly payments of 14/10. With order **10/-**

**NEW OSRAM 33 MUSIC MAGNET.** A first-class Kit including Valves, Loud Speaker and Cabinet. Cash Price £9/19/6. And 11 monthly payments of 17/6. With order **14/6**

**NEW TELSEN JUPITER S.G.3 KIT.** Complete set of Components, less Valves. Cash Price £3/17/6. And 11 monthly payments of 7/- order **7/-**

**NEW TELSEN AJAX 3.** Complete Set of Parts for Det., 2 L.F. Receiver. Less Valves. Cash Price £3/1/6. And 11 monthly payments of 5/8. With order **5/8**

**MURPHY NEW ALL-MAINS 3-VALVE SET,** Model A.3.A. Cash Price £19/19/0. And 12 monthly payments of 33/- order **39/-**  
We are appointed Murphy Dealers.

**NEW MARCONIPHONE 2-VALVE BATTERY RECEIVER,** Model 248, including Valves, Batteries and Loud Speaker. Ready for use. Cash Price £4/19/6. And 12 monthly payments of 8/3. order **9/-**

**ATLAS ELIMINATOR, A.C. 244,** 3 H.T. Tappings. 20 M/A output. Cash Price £2/19/6. And 11 monthly payments of 5/6. order **5/-**

**NEW ORMOND PERM. MAGNET MOVING-COIL L.S. UNIT** (just released) Cash Price £1/18/6. And 7 monthly payments of 5/4. order **5/4**

**NEW R & A "CHALLENGER" PERM. MAGNET MOVING-COIL UNIT.** Cash Price £1/15/0. And 6 monthly payments of 5/8. order **5/-**

**NEW EPOCH 20C PERMANENT MAGNET MOVING-COIL UNIT** Cash Price £1/15/0. And 6 monthly payments of 5/7. order **5/7**

**NEW BLUE SPOT 99 P.M. MOVING-COIL UNIT.** One of the finest Units available. Cash Price £2/19/6. And 11 monthly payments of 5/6. order **5/-**

**12 EXIDE HIGH-TENSION ACCUMULATORS** (120 volts WH-10 super-capacity, 5,000 milliamps). The cheapest form of high-tension supply where electric light mains not available. Cash Price £3/15/0. And 11 monthly payments of 7/- order **7/-**

**BLUE SPOT 100U INDUCTOR UNIT.** Cash Price £1/19/6. And 7 monthly payments of 5/5. order **5/5**

To avoid delay, will customers kindly send deposit with order.

All above carriage paid.

The **LONDON RADIO SUPPLY COMPANY** ESTD 1925  
11, Oat Lane, Noble St., LONDON, E.C.2  
Phone NATIONAL 1977



## LATEST IN MAINS POWER

Really up-to-the-minute Mains Apparatus is shown by HEAYBERD at stand thirteen, Olympia. Mains Units a great improvement even over last season's models. New and original design metal covers to Mains Units and Assembled Kits. Mains Transformers, L.T. Battery Chargers, Chokes, Condensers and L.F. Inter-valve Transformers give an unparalleled choice of Radio Equipment. Best British materials used by British craftsmen produce Heayberd Mains Components. Make sure you buy from specialists.

STAND 13 OLYMPIA



MONARCH OF THE MAINS.

### POST COUPON FOR CATALOGUE

I enclose 3d. stamps for 1933 Radio Catalogue, packed with Technical information, diagrams, hints and illustrations.

M.....

Address.....

P.W./27

**F. C. HEAYBERD & CO.**  
10, FINSBURY ST., LONDON, E.C.2.



YOU  
"CLIP"  
THE  
STATION  
NAMES  
DIRECT  
ON TO  
THIS  
DIAL  
7'6

58-NAME CLIPS WITH EVERY DIAL.  
R. CUSTERTON, OLD FACTORY, REDDITCH.

PLEASE be sure to mention  
"POPULAR WIRELESS"  
when communicating with  
Advertisers. THANKS!

# TECHNICAL NOTES

Some diverse and informative jottings about interesting aspects of radio reception.

By Dr. J. H. T. ROBERTS, F.Inst.P.

### A Differential Control.

MANY readers do not seem to know that a very simple and effective volume control, and selectivity control also for that matter, of the pre-H.F. variety, can be made by means of a differential condenser. To use the condenser in this way all you have to do is to connect the moving set of plates to the tuning coil and the two fixed sets of plates respectively to the aerial and earth.

An ordinary variable condenser introduced into the aerial lead naturally affects the tuning, but the advantage of this differential arrangement is that the tuning is scarcely affected at all, since the load on the aerial coil remains virtually constant. If you have been using a pre-H.F. volume or selectivity control which upsets the tuning, it is a good plan to try this differential arrangement which, as you see, has definite advantages.

### Research on Filaments.

I have received a communication from the Department of Scientific and Industrial Research with reference to a report just published and entitled "Thermionic Emission—A Survey of Existing Knowledge with Particular Reference to the Filaments of Radio Valves."

This communication states that the Radio Research Board of the Department of Scientific and Industrial Research has arranged for the issue of this Report, which has been prepared at the National Physical Laboratory by Dr. W. S. Stiles, so as to give a clean and comprehensive survey of all the main results obtained in researches in the various branches of this subject of thermionic emission, since it forms the basis upon which the modern radio valve has been evolved and is of great importance to all those interested in the practical development of valves and allied devices.

### The Work of Different Countries.

The literature of this subject has now become very large and is widely scattered throughout journals published in various parts of the world.

Anyone wishing, therefore, to delve seriously into this subject would have before him a very formidable task. Dr. Stiles and the Radio Research Board have very greatly simplified the task by the compilation of this report.

Those of my readers who are seriously interested in the subject would do well to get a copy of this Report, which goes by the above-mentioned title and is styled "Radio Research Special Report No. 11," published by H.M. Stationery Office at 2s. 6d. net.

### Valve Amplification.

In the earlier days of receiving valves we were accustomed to manufacturers telling us about the amplification of output valves and their sensitivity rather than their power-handling capacity. Nowadays it is definitely recognised that the power-hand-

ling capacity of an output valve is one of its most important characteristics, and manufacturers go to considerable trouble to set forth the merits of their valves from this point of view.

With regard to loudspeakers, however, sensitivity and quality of reproduction seem to be the points dwelt on, and we are not told anything, or at any rate if we are told anything it is in the vaguest way, with reference to the power-handling capacity of the speaker.

### Imposing a Limit.

Now this is really a very important point, because in these days of multi-valve sets, which give generous output even on distant stations, the power-handling capacity of the loudspeaker, if insufficient, must impose a very definite limit upon the power-handling capacity of the whole outfit.

It is no use going on developing undistorted power in the receiver and pushing this into the loudspeaker if the loudspeaker has already got more than it can do with. I admit that it is not at all easy to define the power-handling ability of a loudspeaker in terms of anything really useful, especially as the quantity in question depends upon various adjustments of the loudspeaker, one or more of which it is within the scope of the operator himself to make.

### Power-Handling Capacity.

Different loudspeakers undoubtedly vary considerably in their power-handling ability, and it seems to me that other things being equal, manufacturers of those with the largest capacity in this direction should make more of a song about it. Perhaps before long we shall arrive at some workable definition of this particular and very important characteristic of a loudspeaker; when that stage is reached the would-be purchaser will have a good deal more to guide him than he has at present in making a choice.

### Ganged Condensers.

It is not so long ago since ganged condensers, commercial ones, were luxury articles, and it almost paid to gang up your own. But the prices have come down astonishingly and you cannot grumble to-day at the price of ganged condensers any more than you can criticise their efficiency and compactness.

In some ganged condensers the units are insulated from one another, whilst in others there is a single metal spindle or the different spindles have to be at the same potential. Often this is a disadvantage because you may want to use different values of grid bias with the different H.F. stages.

### Additional H.F. Stage.

I have a letter from a reader who is in trouble with an H.F. stage—an ordinary H.F. unit—which he has added to a three-valve receiver with the idea of increasing

(Continued on next page.)



## TECHNICAL NOTES

(Continued from previous page.)

the range. As this happens to be a fairly common trouble, I thought perhaps it might be worth while to mention it in these Notes. Instead of increasing the range, the effect of the addition of the H.F. unit has been to decrease the range, and also to reduce the power of the stations received.

If the set has reaction coupled to the aerial system, the effect of the reaction is virtually to neutralise the resistance of the aerial-earth system. When, however, an H.F. unit is added, in the way mentioned above, this may have the effect of preventing the reaction from counteracting the resistance of the aerial-earth system, so that this resistance is then free to reduce the strength of reception.

### Reducing the Resistance.

One remedy is to reduce the resistance of the aerial-earth system independently of the reaction.

Of course, there are other considerations which enter into the result. One thing is that, whereas the high-tension battery previously used may have been quite sufficient for operating the three-valve set, it may be insufficient when the extra valve is added. This, of course, is easily overcome by the simple process of using an H.T. battery of larger capacity, so that all the valves get the proper high-tension current and voltage for working them efficiently.

### Overhauling the Aerial.

At this time of the year many listeners take the opportunity afforded by the favourable weather to take down and overhaul their aerials. On the other hand, I am afraid a great many people neglect this precaution; they put up an aerial when they first start to operate a receiver and they expect this aerial to last indefinitely! The fact is that an aerial should be thoroughly inspected at least once every two years, and preferably every year.

An ordinary uncovered copper aerial wire soon begins to be affected by corrosion due to the atmosphere, and as the surface is eaten into, the high-frequency resistance of the aerial increases. As this process goes on, the reaction necessary to produce oscillation has to be increased, and there comes a time when the resistance of the aerial is so high that it is virtually non-oscillatory.

Apart from other considerations, it is bad to have to use excessive reaction, because this not only interferes with the quality of your own reception, but may be a serious nuisance to other people in the neighbourhood.

### Preventing Oscillation.

Enamelled wire has advantages so far as resistance to corrosion is concerned, but even if you put up an enamelled wire aerial it is no use expecting it to last more than a year or two without overhaul.

Considering that the aerial is, as it were, the prime vehicle for you: radio signals, it is really surprising how people will give all kinds of attention to the details of the receiver and yet neglect the aerial.

### Variable Choke Values.

When choosing a low-frequency choke for any particular purpose, it is important to

(Continued on next page.)

# TUNEWELL COMPONENTS RECOMMENDED FOR THE "OLYMPUS 4"

The new range of Tunewell Components has brought Super-reception within everybody's reach. They have been designed for the expert, and only by lowering our profits are the wonderful values made possible.

The following are recommended for the "Olympus" 4, "P.W.'s" Great Exhibition Set:—

Tunewell H.F. Choke, 3/6	4 Tunewell 4-pin Valve Holders .. 6d. each
Tunewell L.F. Transformer 7/6	Tunewell 100,000 ohms wire wound anode Resistance .. 3/6
Tunewell F.V. 150/30 Mains Unit (150 v. at 30 m/a) .. £5	

Build this Set and remember Tunewell Components will ensure maximum efficiency at the lowest possible cost.

★ Get the Tunewell "Guide to Super Radio" FREE from Stand 96, or address below. It contains

## 8 FREE BLUEPRINTS

including Kit Eliminator and All Mains Band Pass 3.

See the new Tunewell components and wonderful new Radiogram at

## STAND 96

OLYMPIA.

TUNEWELL RADIO LTD. 54, Station Rd., London, N.11

# TUNEWELL

## WIRELESS IS THE WORLD'S FINEST HOBBY,

MAKE IT A PROFITABLE ONE.

SAVE MONEY,  
MAKE MONEY,  
NO OUTLAY.

JOIN THE ELECTROCET CLUB

Every  
Wireless  
Salesman,  
Experimenter,  
Constructor

should write his name and address in the margin, and post in j.d. unsealed envelope for particulars, and FREE 1,000 illustration catalogue of all makes, components, kits, and sets.

**ELECTROCETS, SOLIHULL, BIRMINGHAM**

## RADIO AUCTION SALES

are held monthly by

## GODDARD & SMITH

in their spacious Sale Rooms at  
70, SEYMOUR PLACE,  
MARBLE ARCH, W.1.

The following dates have been arranged:—

September 21st and 22nd,  
October 19th and 20th,  
November 16th and 17th,  
December 14th and 15th.

Goods for inclusion can be accepted at once. Prompt settlements.

Every facility to the private purchaser for inspection and trial. Private Treaty sales at any time. Catalogues and entry forms free on application.

Phones: Paddington 0277-8 & 5805.

THE PICTURE PAPER WITH THE  
MOST NEWS

**SUNDAY GRAPHIC**  
and Sunday News

## EASY PAYMENTS

"There's no place like HOLMES."  
The first firm to supply Wireless parts on easy payments. Seven years advertiser in "Popular Wireless." Thousands of satisfied customers.

	Monthly	Deposit	Payments
TELSEN VICTOR 3 KIT 39/6	5/5	7 of 5/5	
COSSOR KIT - - - - - £8/8/6	10/-	11 of 11/11	
OSRAM KIT - - - - - £10/15	19/6	11 of 19/8	
METEOR 3 KIT - - - - - £3/15	6/10	11 of 6/10	
EXIDE H.T. Accum., 120v. £3	6/-	9 of 6/8	
BLUE SPOT 66R & CHASSIS - - - - - £2/2/6	5/6	9 of 4/5	
BLUE SPOT 100 U - - - - - 39/6	5/8	7 of 5/4	
AMPLION M.C.6 - - - - - 67/6	7/5	9 of 7/5	
CELESTION M.C. - - - - - 47/6	5/3	9 of 5/3	
EKCO Eliminator A.C.18 67/-	7/5	9 of 7/5	

New Goods Obtained for Every Order.

Send us a list of the parts you require and the payments that will suit your convenience, and we will send you a definite quotation. Anything Wireless.

H. W. HOLMES, 29, FOLEY STREET,  
Great Portland Street, London, W.1.

Phone: Museum 1414.

## EXACT TUNERS

250 to 2,000 metres.  
Thousands of these tuners are in use, and we can strongly recommend them. No further coils are required. Send P.C. for particulars and circuits—FREE.

THE EXACT MANUFACTURING CO.,  
Croft Works, Priory Street, Coventry.

## FOR MAINS EQUIPMENT - USE

# GODWINEX

TRANSFORMERS - CHOKES - ELIMINATORS

See STAND 57—RADIOLYMPIA  
J. DYSON & CO. LTD. 2, COLEMAN ST. LONDON E.C.2  
3 & 7, GODWIN ST. BRADFORD

PLEASE be sure to mention "Popular Wireless" when communicating with Advertisers. Thanks!

## TECHNICAL NOTES

(Continued from previous page.)

bear in mind that the inductive value of the choke, upon which, of course, its choking value depends, is not a constant quantity, but is itself dependent upon the actual current which is flowing in the choke.

Some chokes are designed so as to have a reasonably uniform inductive value throughout a fair range of current variation, but there are many chokes the inductive value of which varies quite rapidly with current.

You should, therefore, make a point of ascertaining what is the current which the choke is intended to carry, and then choose a choke which is rated to give the necessary inductive value for that current, or, at any rate, for a current of approximately that value.

As the current is increased beyond a certain point the inductive value of the choke falls off, so that the component ceases to function effectively as a choke.

### Full Load Smoothing.

In a mains unit, for instance, the choke used in the smoothing circuit should have the requisite inductive value for full load current, otherwise it means that when the current reaches the maximum the choke is not playing its part effectively and the smoothing may be insufficient.

The same sort of thing applies where a choke is used for the anode circuit of a power valve; the choke must be rated for the maximum current which the valve is going to carry. It goes without saying that similar considerations apply in the case of a transformer, where again the presence of a steady current has a definite influence upon the inductive value.

In the case of output transformers it occasionally happens that the transformer is too small for the job, and so the steady current more or less saturates the core, with the result that the transformer does not function at all according to calculations.

### Output Transformers.

Talking about transformers, by the way, I don't know whether you have tried the output transformers with a tapped primary winding. By the tapped primary it is possible to have a number of alternative ratios, which is often very useful in practice, because you can try first one and then another until you get the ratio which is best suited for the valve and loudspeaker.

Some of you may say that this is unnecessary because you can fairly easily work out the ratio and other details of the transformer, knowing the characteristics of the valve and loudspeaker. This is true to some extent, although it is not everybody who can make the necessary calculations.

Furthermore, it isn't at all easy to ascertain the necessary characteristics of the valve, because valves vary quite a good deal, and also their performance depends upon the conditions in which they are used. Anyhow, it is much simpler to make an actual trial, and anyone who has had any experience of experimental work knows that there is nothing like an actual tryout. All the theory in the world is no use if the results do not work out in practice.

### Matching Loudspeaker and Valve.

When you use an output transformer with a tapped primary you will probably find that as you shift over from one tapping

on the primary to another the form of the output from the loudspeaker will vary somewhat, but you should have no difficulty in finding the tapping which is best suited to your particular conditions.

It is worth while bearing in mind this question of a tapped primary when purchasing an output transformer, as even if you do not happen to use theappings on one occasion you may find the transformer very useful at some other time when you want to fit it into another set or use a different loudspeaker.

I should, perhaps, mention that it is often a good plan to connect the core of the transformer to earth, as this tends to stabilise things. Sometimes an earth connection to one end of the secondary is a good thing, whilst again an earth connection to one side of the loudspeaker coil is worth trying.

### Pentode Tone Corrector.

When a pentode is used in the output stage of a set it is a good plan to use an output transformer in order to correct the tone; this output transformer having a resistance and fixed condenser shunted across the primary. The resistance may be of the spaghetti variety of, say, 15,000

## NEXT WEEK!

### ANOTHER HUGE NUMBER

Including a profusely illustrated and striking account of

### "WHAT I SAW AT OLYMPIA"

By a "P.W." Technician.

News and Views of all the latest tendencies and apparatus.

NEXT WEEK'S P.W. ORDER NOW

ohms, and the condenser, say, .02 microfarad. These values are suitable for most pentode valves, although in some cases they may need a little variation.

### Doping Cones.

I wonder if you know that the tone from a loudspeaker is often very definitely affected by treating the diaphragm with one or other of the various "dopes" which are on the market. Sometimes after continued use the diaphragm may get a bit loose or flabby and you may get a muffled effect in the tone. As this effect comes on very gradually you get more or less used to it and perhaps it never occurs to you that it is not what it used to be until a friend points it out.

If you paint the diaphragm over with a suitable dope, applying the dope very thinly, and taking care to let it dry thoroughly between successive applications, you will often find that it "cleans up" the action of the diaphragm in a surprising way.

I had a case only a few days ago of a loudspeaker which ought to have given excellent quality, because the unit itself was first class, but the speaker was giving very disappointing results. A little attention to the cone, however, on the lines indicated above, produced a most remarkable improvement and the reproduction, from being muffled and indistinct, became fine and crisp.



### STAND 285

We are showing our products on Stand 285 at Olympia.

You should see our Two Valve All-Mains Receiver with Magnavox Moving-Coil Speaker, A.C. or D.C.

Price: £9 17s. 6d.

You will like the "Cifel" Three Valve A.C. Receiver with Band Pass Tuning—

"The Mediator with the Continent." Marvellous selectivity and volume. Price: £16.



You will want our Radio Grams incorporating the Three Valve A.C. Set, with Band Pass Tuning in new Cabinets—comprising the latest designs of Radio Grams with Dual Speakers in de Luxe Cabinets.

CIFEL PRODUCTS LTD.,  
2, Cynthia Street, N.1.

DEMONSTRATION ROOM AT: 73, HAMMERSMITH ROAD, W.6

The Goods as Advertised! From TWO to TWO THOUSAND metres, we can solve your Radio Problems, including Amateur Transmission! Whatever your difficulty, write us. Charges: 3/- per query, four or more 2/6 each, including diagrams.

RADIO TECHNICAL AGENCY, DEPT. P.W.  
2, Westgate Chambers, Newport, Mon.

### 10,000 GRAMO-MOTORS FROM STOCK

BIG SUMMER DISCOUNT ALLOWED  
Make a Gramophone or Radiogram Order loose kits and assemble them at home. Get for 3d. our new 61-page catalogue with scale drawings and instructions how to make them. We sell motors from 7/6, tone-arms, soundboxes, 1/6, pick-ups, big volume hdns, loudspeakers, radio kits, complete receiving sets, gramophones, radiograms. Established 1906.

THE REGENT FITTINGS CO., P.W.  
120 OLD STREET, LONDON, E.C.1.



## NOTICE

Send 6d. (post free) for UP-TO-DATE HANDBOOK of Tuning Coils for Circuits, Dual Range, Band Pass and Super-Het, Fully illustrated, with data.

THE BRITISH EBONITE CO., LTD.,  
Hanwell, London, W.7

Radio Cabinet Specialists  
REDRUP & SON (P. W. Dept.),  
178 ALBERT ROAD, SOUTHWSEA.  
Send 2d. stamp for Illustrated Catalogue.

WET H.T. BATTERIES  
Solve all H.T. Troubles.  
SELF-CHARGING, SILENT, ECONOMICAL  
JARS (waxed), 2 1/2" x 1 1/2" sq. 1/3 doz.  
ZINGS, new type 10d. doz. Sacs 1/2 doz.  
Sample doz. 13s. volts, complete with  
bands and electrolyte, 4/1, post 3d.  
Sample unit, 6d. Illus. booklet free.  
Bargain list free.  
AMPLIFIERS, 30/-, 3-valve set, 25s.  
P. TAYLOR, 57, Studley Road,  
STOCKWELL, LONDON

PLEASE be sure to mention "Popular Wireless" when communicating with Advertisers. Thanks!

# £100 Guarantee

FOR TWO YEARS WITH

# SUPERIAL

ELECTRON'S SUPER-AERIAL

NO LIGHTNING SWITCH NECESSARY



LIGHTNING cannot smash your receiver if your aerial is Superial—Electron's Super Aerial. The extra heavy vulcanised rubber insulation protects it! We guarantee your protection, whether you fit a lightning switch or not. This perfect method of insulation protects Superial from every weather extreme. Superial gives crystal-clear reception and receives far-distant stations more clearly than any other aerial—it is in tune to the sharpest degree. You can fix Superial in a jiffy—no separate lead-in is necessary. Protect your set and get better radio, too! Superial is the finest aerial in the world.

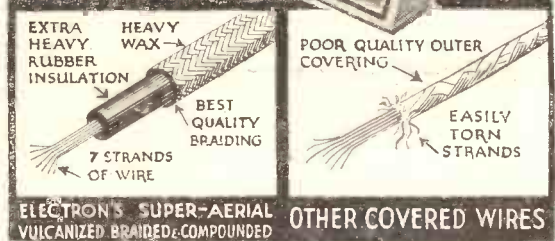

A HEARTY WELCOME AWAITS YOU  
AT  
**STAND 48**  
**OLYMPIA**  
AUGUST 19<sup>TH</sup> - 27<sup>TH</sup>  
Phone: Shepherds Bush 2109

**COMPARE SUPERIAL WITH ANY OTHER WIRE!**

Superial is built like a heavy-duty cable—its strands are completely encased in vulcanised rubber insulation, so heavy that it is actually like rubber tubing. Still further protected by best quality braiding, and finally heavily waxed to resist every weather extreme. In other aerials the strands have no protection, they are merely covered with inferior quality cotton cover. No vulcanised "inner tube"—therefore no protection. Get Superial for better Radio!

Other lengths also available:  
100 ft. **3/6**; 50 ft. **1/9**; 25 ft. **1/-**  
ON SALE EVERYWHERE. Satisfaction Guaranteed or Cash Refunded.

**£100 Guarantee**  
(NO LIGHTNING SWITCH NECESSARY)

WE, The New London Electron Works, Ltd., hereby guarantee to pay damages up to £100 to any purchaser of Superial (Electron's Super Aerial, with its extra-heavy vulcanised insulation) should it be struck by lightning, thereby causing damage to the set, for a period of 2 years from date of purchasing the aerial.

**The NEW LONDON ELECTRON WORKS, Ltd.**  
**19, EAST HAM, LONDON, E.6.**  
Phone: GRANGEWOOD 1408-9 and 1363.  
Telegrams and Cables: "STANNUM, LONDON."

**GET COVERED NOW**  
FOR THE £100 GUARANTEE AGAINST  
DAMAGE TO YOUR RECEIVER BY LIGHTNING

Fill in this form and post it, with your empty carton, and our official cover note will be sent you immediately. Post to—  
THE NEW LONDON ELECTRON WORKS, LTD.,  
19, East Ham, London, E.6.

NAME (block letters).....  
ADDRESS.....  
Where did you purchase SUPERIAL?  
(Retailer's name and address).....  
.....  
This Guarantee covers you for a period of 2 years from date of purchase.  
Date purchased..... Length.....

# One shillingworth of H.T. FREE — every week!

The average 3-valve set costs you over 1/- a week for current when you use batteries. An EKCO unit gives you the same amount of current for a farthing\*. You save a shilling a week and get better radio when you use an EKCO Unit. Think what you save as the years go by!

Whatever the size or type of your radio set or portable there is an EKCO Unit for it available by Easy Payments if required. Choose the unit suitable for your set from the table or send coupon for full details.

\*Based on 1000 hours' use of an average 3-r. set

Olympia Stand No. 65.



### EKCO H.T. UNITS

Model	Current Output	Voltage Tappings	Price	EASY PAYMENTS Initial Payment	11 Monthly Payments of
A.C. 12	12 m/A	S.G.; 80; 120/150	£2.15.0	6/6	5/-
A.C. 18	18 m/A	S.G.*; 50/80*; 120/150	£3. 7.6	7/9	6/2
A.C. 25	25 m/A	S.G.*; 50/80*; 120/150	£3.17.6	8/9	7/1
D.C. 15/25	15 or 25 m/A	S.G.*; 50/80*; 120/150	£1.19.6	6/-	3/8

### Combined H.T. & L.T. Charger Units (for A.C. Mains)

Model	Current & Voltage	L.T. Output (for charging accumulators)	Price	EASY PAYMENTS Initial Payment	11 Monthly Payments of
K. 12	Current Output and Voltage Tappings same as Models A.C.12, A.C.18 and A.C.25.	½amp. at 2, 4 or 6 volts	£3.19.6	9/-	7/3
K. 18		½amp. at 2, 4 or 6 volts	£4.12.6	10/3	8/5
K. 25		½amp. at 2, 4 or 6 volts	£5. 7.6	11/9	9/10

Tappings marked \* are adjustable.



## POWER SUPPLY UNITS

To: E. K. Cole, Ltd., Dept. A.18,  
Ekco Works, Southend-on-Sea.

Please send me full details of Ekco Power Units, Consolettes and Radiograms.

Name.....

Address.....