

The Post Office Electrical Engineers' Journal

R.A. ROE

PE12

VOL 68 PART 2 / JULY 1975



THE POST OFFICE ELECTRICAL ENGINEERS' JOURNAL

VOL 68 PART 2 JULY 1975

Contents

	<i>page</i>
Editorial	65
Design and Development of New Cable-Repair Ships for the British Post Office D. N. Dick	66
Local-Exchange Renewal Strategy: Maintenance Man-Hour Requirements C. R. J. Shurrock and A. F. Yaxley	77
Time-Division Multiplex for Telex-Customers' Lines —G. D. Skingle	84
The Anechoic Chamber in the London Test Section of the British Post Office E. W. Reaves	91
A Review of Magnetic Storage Devices —E. A. Loomes	96
Heating and Ventilating of Telecommunications Buildings Part 2—Systems —H. Williams	103
Experimental Packet-Switched Service: Procedures and Protocols Part 3—Operation of Asynchronous Terminals —W. Neil, M. J. Spooner and E. J. Wilson	110
A New-Style Telephone Instrument —G. B. Palmer and P. C. Langham	118
Regional Notes	122
Associate Section Notes	124
The Associate Section National Committee Report	125
Institution of Post Office Electrical Engineers	126
Notes and Comments	127
Post Office Press Notices	128
Book Reviews	76, 95

Published in April, July, October and January by *The Post Office Electrical Engineers' Journal*,
2-12 Gresham Street, London EC2V 7AG.

Price: 30p (45p including postage and packaging). Orders by post only.

Annual subscription (including postage and packaging): home and overseas £1.75.
(Canada and the USA \$4.50.)

Price to British Post Office staff: 27p.

The error eliminator

Marconi Spector

This error correction equipment permits ships, mobiles and any other h.f. radio station to be connected to a fixed telegraph network.

Designed for single channel ARQ operation with additional facilities for FEC and selective calling.

Provides virtual error-free communication in the ARQ mode and a high degree of protection in the FEC mode.

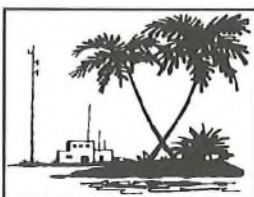
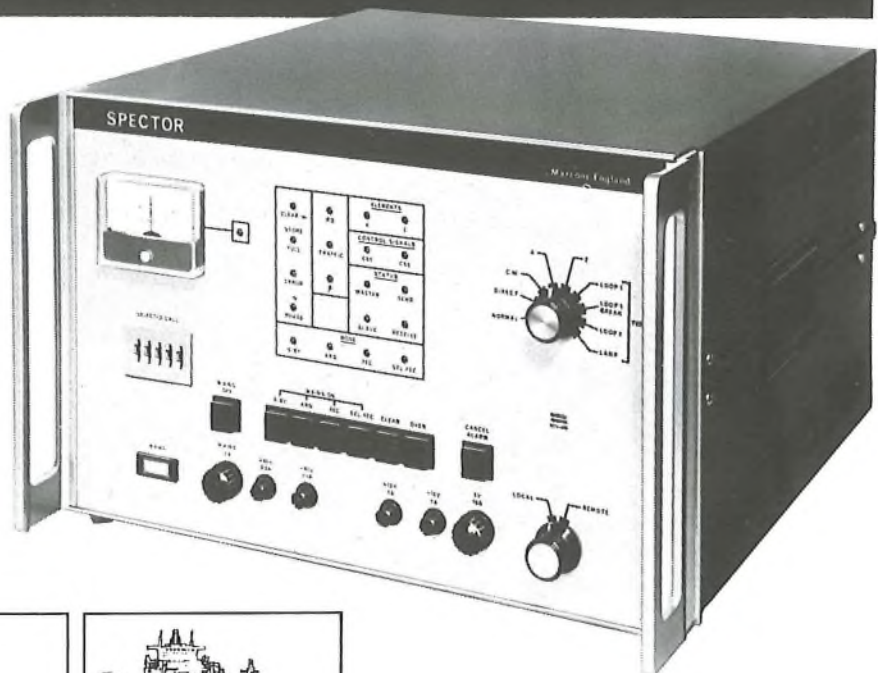

Remote stations



Oil rigs



Ships of all types



Civil airports



Aircraft



Mobiles



Coastal stations

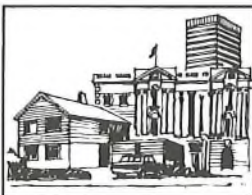

Private, public and
Government offices

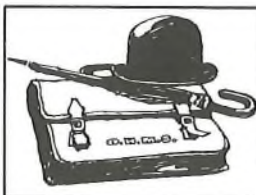

Diplomatic wireless

- CCIR recommended
- eliminates traffic loss due to noise and fading
- compact design for mobile service
- easy operation
- optional buffer store sizes for long lines
- VFT modem to ITU/CEPT recommendation

Marconi Communication Systems Limited,
Chelmsford, Essex, England

A GEC-Marconi Electronics Company

LTD/C1

Any weather, any climate, GEC take radio efficiency to extremes

In the Chilean
High Andes

Take the GEC 2GHz system. So adaptable, it is already operating successfully in various extremes of temperature and humidity – from the arctic regions of Canada to the Swiss Alps, and from the deserts of Libya and Bahrain to the tropical conditions of Nigeria and Zambia.

The GEC 2GHz system provides high system planning flexibility with complete band coverage from 1.7 to 2.3 GHz, with a capacity of 960 telephone circuits, or one colour television channel and one sound channel. Completely semiconductorized, the equipment, which is in accord with CCIR recommendations, combines high reliability with low power consumption making it particularly dependable for routes which must cross remote or difficult areas. Its modular construction, the latest example of systematic improvement to a successful and proven system, reduces field maintenance to a minimum and enables qualified maintenance engineers to work from a strategically located central depot. System-planning engineers will be pleased to show you some of the other ways in which the 2GHz system has already proved extremely successful in 18 countries.

Total telecommunications: Microwave and Line Transmission, Multiplex, V.F. Telegraphy, Data Modems, Public Exchanges, Private Telephone Systems, Telephones, Total Systems Capability.



GEC Telecommunications Limited
of Coventry, England.
A Management Company of The
General Electric Co. Ltd. of England.



In the Nigerian Bush



In the Swiss Alps

An outstanding offer to the busy executive... complete freedom to consult correspondence, make notes, draw, do anything he likes with both hands while carrying on a telephone conversation.

There's no need to use 'press to talk' switches either. GEC's LST4D loudspeaking telephone has fully automatic voice switching - so the loudspeaker and microphone cannot be 'alive' at the same time and eliminating 'sing round!'

Any number of people in the room can join in a conference with the distant party. When privacy is required, pick up the handset - the loudspeaker and

microphone are automatically disconnected.

You could call it 'the Freedom Phone'. Outside, it's neat modern appearance is at home in the most up-to-date office layout. Inside, the GEC LST4D loudspeaking telephone is a masterpiece of advanced circuitry...

Dial or pushbutton versions available for all telephones.

GEC manufacture telephones for world markets: table and wall-mounting models in a number of attractive colours, loudspeaking telephones, pushbutton telephones and switching telephone systems...

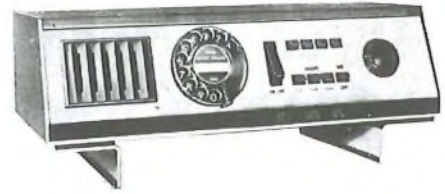

You couldn't be in better hands.

GEC Telecommunications Ltd.,
Telephone Division, Whinbank Road, Aycliffe,
Co. Durham, England.
A Management Company
of The General Electric
Company Ltd. of
England.

**Free with every GEC LST4D
loudspeaking telephone.**

Two spare hands.



Now on hand.

Three advanced developments in telephone engineering from GEC.



The GEC 746 table telephone
 -an instrument making full use of printed circuit techniques and tropicalised components. Rugged, reliable- available in attractive colours and a wide-range of options.



The GEC LST4D voice-switched loudspeaking telephone

-hand-free operation with full automatic voice switching so that loud-speaker and microphone cannot be 'alive' at the same time.



The GEC 740 1/2 and 1/3 switching telephone

-independent access to one exchange line from two or three telephones. Also provides an efficient intercom system.



Dial or pushbutton versions available for all telephones.

GEC manufacture telephones for world markets: table and wall-mounting models in a number of attractive colours, loudspeaking telephones, pushbutton telephones and switching telephone systems.....

You couldn't be in better hands.
 GEC Telecommunications Limited,
 Telephone Division, Whinbank Road,
 Aycliffe, Co. Durham, England.
 A Management Company of
 The General Electric
 Company Ltd., of England.

Spectrol Reliance potentiometers

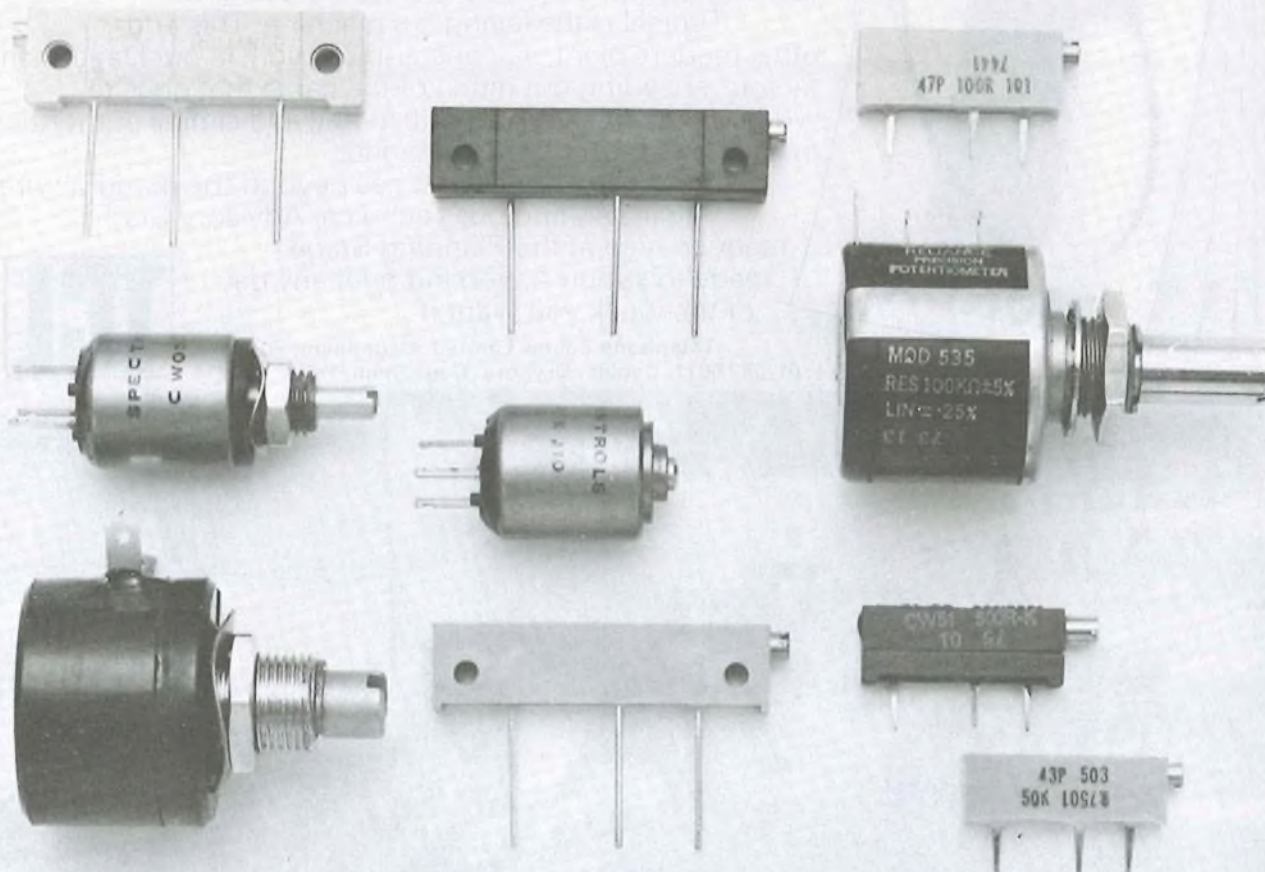

for the telecommunications industry

We manufacture a wide range of potentiometers, including some Post Office approved styles. For brief specifications on our full range of precision and trimming potentiometers, write for your copy of our short form catalogue. We think you'll approve!



Spectrol Reliance Limited,
Drakes Way, Swindon, Wiltshire. Telephone Swindon 21351 Telex 44692



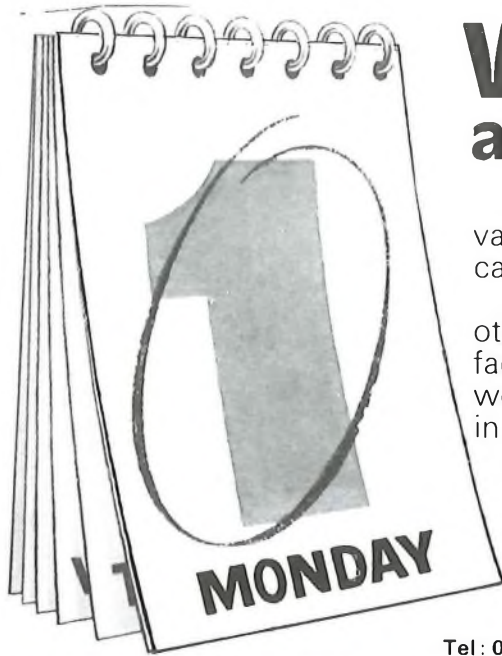

Working Day any day

From Monday through to Friday, you'll find TCL's vast plant producing more and more telecommunications cable to meet the world's increasing demands.

Typical is the laying-up machine. This and other modern plant are constantly at work in our Dagenham factory, speeding out much of the cable that goes to work for The Post Office, British Rail and similar authorities in countries throughout the world.

But, TCL service stretches beyond the manufacture. You'll also find our Technical Advisory Staff ready to help at the Planning Stage – ready to supply a working brief any day of the week you want it.

Telephone Cables Limited, Dagenham, England.
Tel: 01-592 6611. Cables: Drycore, Dagenham. Telex: 896216



The Post Office Electrical Engineers' Journal

BOARD OF EDITORS

J. F. P. Thomas, B.SC., C.ENG., M.I.E.E., Chairman
E. W. Ayers, B.SC.(ENG.), C.ENG., F.I.E.E.
A. J. Barker, C.ENG., F.I.E.E.
A. J. Barnard, C.ENG., M.I.E.E.
C. E. Clinch, B.SC.(ENG.), C.ENG., F.I.MECH.E., F.I.E.E., F.S.S.
J. Martin, B.SC.(ENG.), C.ENG., M.I.E.E.
A. Ness, C.ENG., M.I.E.E.

Managing Editor

D. Millington, C.ENG., M.I.E.E.

Assistant Editor

B. Stagg

Secretary-Treasurer

B. Farr

Advertisement Manager

R. G. Rothery

EDITORIAL

The *Journal* is read by members of the British Post Office (BPO) at all levels and in many different disciplines, and also by a significant number of people outside the BPO, both in this country and abroad. It is obviously very difficult, if not impossible, to publish articles which satisfy all of the readers all of the time. Consequently, one of the chief concerns of the Board of Editors is whether the balance of subjects of the articles published in the *Journal* and also the technical level of each article are found to be satisfactory by the majority of the readership. Any feedback of information on this subject is very helpful in matching the content of future issues of the *Journal* to the requirements of the readership. The Managing Editor will welcome any comments on, or criticisms of, issues of the *Journal* published recently, and any suggestions for improving future issues.

Information received from readers indicates that the contributions from regions and areas, published in Regional Notes, are popular, and the Managing Editor will be very pleased to receive more contributions of this nature.

The previous issue of the *Journal* included a brief account of the launching of the BPO's new cable-repair ship *CS Monarch* which, together with her sister ship, has such an important role to play in keeping the large network of submarine cables around the British Isles in working order. This issue contains a detailed description of the design and development of the new cable ships, including an account of the comprehensive tests made with models of the cable ships.

Design and Development of New Cable-Repair Ships for the British Post Office

D. N. DICK, C.ENG., F.I.MAR.E., M.R.I.N.A. †

UDC 621.315.29.001.6

From an examination of the deficiencies of the existing cable-repair ships operated by the British Post Office, the specification of the new ships is given in terms of the operational and performance requirements. The procedures involved in the design of the new cable-repair ships are then described, including an account of the tests made with models of the ships. Particular emphasis is given to a description of the manoeuvrability tests in the Solent, using a 2-man operated, 1/12th scale model. The article concludes with a brief description of the construction work so far completed.

INTRODUCTION

In April 1973, a contract was placed with Robb Caledon Shipbuilders Ltd. for the construction of 2 cable-repair ships to replace CS *Iris* and CS *Ariel*.¹ The design for these 2 new ships is the result of a number of years of development study. The deficiencies of the existing vessels, apart from those imposed by their age, have been appreciated for some time, but caused little inconvenience until recent years. However, the frequency of cable faults and the introduction of more sophisticated cable systems made it apparent that, when replacing *Iris* and *Ariel*, all their deficiencies would have to be critically examined to ensure that the new vessels met all the requirements of current and future cable-repair operations.

The principal characteristics where improvements would have to be made were in the sea-kindliness of the vessel, where a stable working platform is required in all winds and corresponding sea states up to force 7 on the Beaufort scale.* The vessel must be highly manoeuvrable to maintain station under the same conditions with the aid of thrust units. Cable is to be loaded and unloaded in the shortest possible time with the minimum of cable manipulation. Protection is to be given to the operators and the equipment. While cable ships are essentially inefficient by the nature of their occupation, which is basically to fulfil the role of a "fire engine", the propulsion plant and generating plant must be adequately proportioned so as to be sufficiently loaded at all times, to avoid unnecessary deterioration of components. The cable machinery, cable working gear and plant are all to be consistent with the requirements and limitation of the most modern cables as well as the conventional cables.

CABLE-SHIP SPECIFICATION

Having established these and other criteria, a broad specification of design aims was prepared and considered as a whole so that the various ship concepts could be examined. British Post Office (BPO) cable ships of this class normally operate in the waters around the British Isles (see Fig. 1) on the North-Western European continental shelf between about Cape St. Vincent in the south to Iceland in the north, and from the region of the 1000 m depth line on the Atlantic edge of the continental shelf in the west to the Skagerrack in the east. These ships, however, are required on rare occasions to

operate as far afield as the eastern Mediterranean, the West Indies and the north-eastern seaboard of North America.

All cable ships, of whatever class, can lay submarine cable within the capacity of the individual ship and can also repair cable, but the design of any individual cable ship is biased towards the ship's primary function. For this class of BPO cable ship, the primary function is to repair submarine cables in depths of water ranging from about 7000 m to shallow water of such depth that the ship can only just work safely afloat. In certain inshore areas where the ship herself cannot work, either because of shoal water or navigational hazards, the work has to be done from the ship's boats which have to be capable of undertaking this duty.

The ship will be worked under all weather and sea conditions, within the limits imposed by the proper and effective control of the ship and the avoidance of damage to the cable caused by the movements of the ship in the seaway. In the normal area of operation of this class of BPO cable ship, where the weather generally is not very good, the maximum passage time will usually be between 2-3 days. Because of this relatively short time, the advantages of making a fast passage economically are, therefore, more than outweighed by the economic loss sustained if the ship cannot work when she arrives on the cable ground.

Operational Requirements of the New Cable Ships

The operational requirements of the new cable ships were, therefore, established and are listed below.

(a) The ships must be highly manoeuvrable at all draughts and at all speeds, especially under working conditions and under all weather and sea conditions. Ideally, a cable-repair ship should perform equally well when going astern as when going ahead, at all cable working speeds.

(b) The ships must be sea-kindly, with good sea-keeping qualities, especially under working conditions.

(c) The ships must provide a steady working platform under all working conditions.

(d) The consumption of fuel, water and stores must have the minimum effect on the draught and trim of the ships.

(e) The prevention, detection and extinction of fire on board must be efficient, with particular reference to the isolation of machinery spaces, cable tanks, working spaces and accommodation.

Performance Requirements of the New Cable Ships

The performance objectives of the new cable ships were also established and are listed below.

† Network Planning Department, Telecommunications Headquarters.

* The Beaufort scale force number, B , and the mean wind speed, v (km/h), are related by the equation $v = 3\sqrt{B}$.

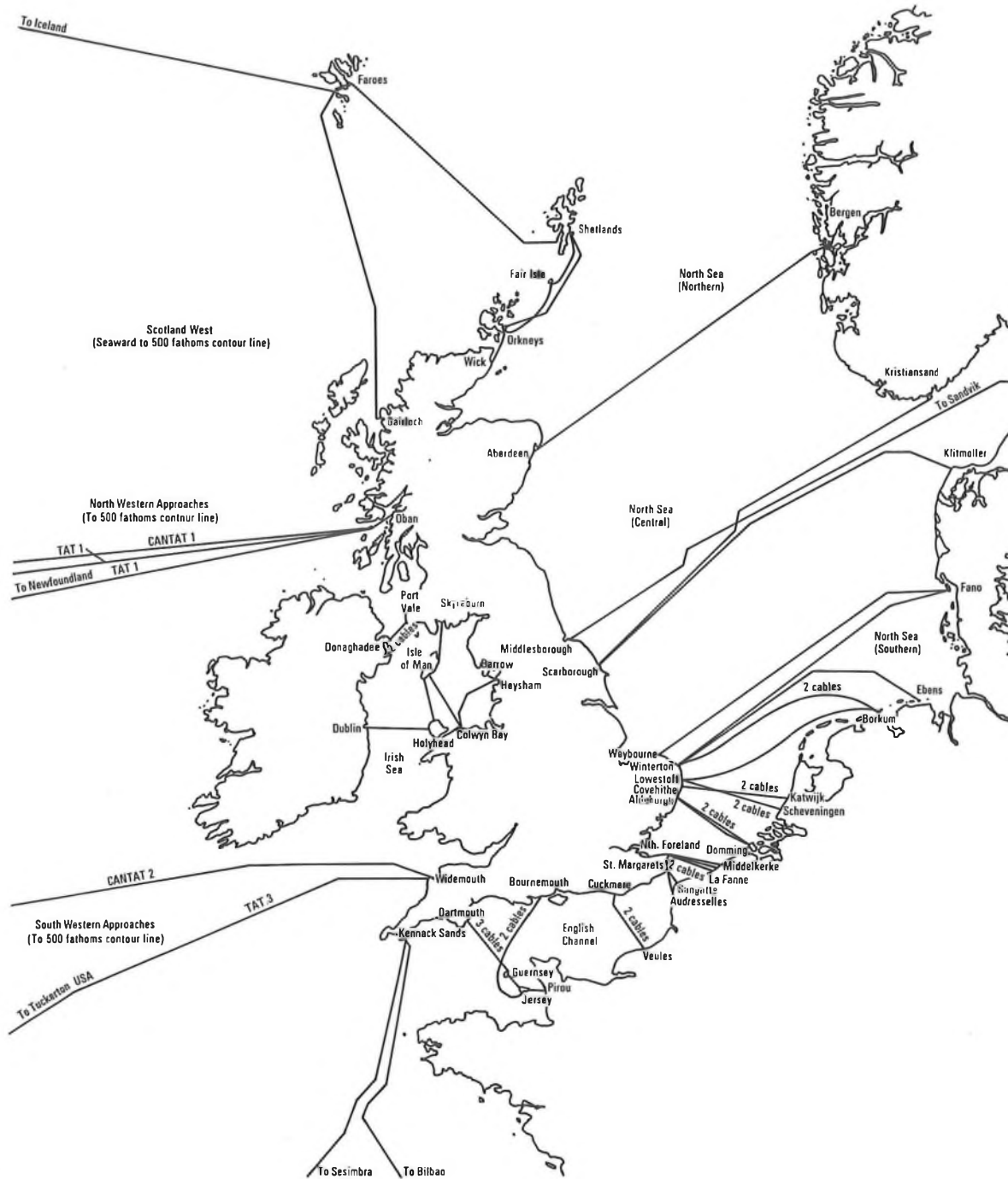

FIG. 1—Map showing submarine cables in operating area of new cable-repair ships

(a) The principal consideration of the hull design is the performance of the vessel on the cable ground. The capability of making fast economical passages, whilst of importance, is a secondary consideration.

(b) Reliability is fundamental, and comes before efficiency if it is not possible to achieve both together.

(c) Accessibility and ease of maintenance of all equipment and machinery are essential requirements.

(d) Human labour and effort to work the ship or any plant, equipment or machinery must be kept to the absolute minimum, consistent with maximum operational efficiency and long-term economy.

(e) Remote or automatic control should be used only where it be shown to increase operating efficiency and promote long-term economy.

CABLE-SHIP DESIGN

At this stage, the assistance of consultant naval architects was sought and, because of their experience in the design of specialized ships, Burness Corlett & Partners Ltd. were engaged. It is important in the design of specialist ships not to consider any part in isolation, before having first established that the basic overall design aims are sufficiently realistic to be incorporated in a hull of the limiting dimensions.

The new ships are to be essentially coastal-water repair ships, but are to be capable of deep-sea work; this establishes that the length and the draught should be kept to a minimum. It was proposed to meet the cable-handling requirements, referred to earlier, by the introduction of a container concept. Cable would be pre-loaded into circular pans and the pans, complete with cable, would then be loaded into the vessel



FIG. 2—The 1/60th scale model used for aerodynamic tests

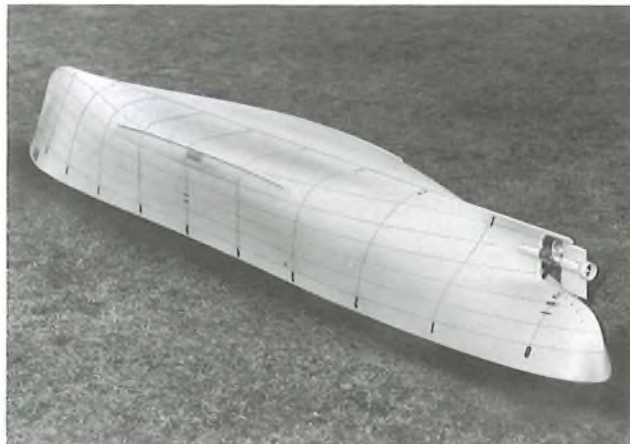

FIG. 3—The 1/30th scale model used for hydrodynamic tests

through a system of hatches and trunks, ultimately being housed in conventional fixed cable tanks. The advantage of the cable-pan concept is that it not only reduces turn-round time, but also minimizes the mechanical deterioration of cable through constant handling.

The cable machinery had to be capable of handling all types of cable, from the oldest in operation to cable currently in production or design. These include cables having a minimum bending radius of 1.5 m.

Size and Shape

The dimensions of the vessel were then set and the overall configuration agreed. From this, the naval architects prepared the "lines" of the vessel which would provide the required stable working platform. The effect of the various lines or shapes of different vessels can best be demonstrated by comparing, say, the very fine lines of a destroyer with those of a barge; at one extreme, these produce a fast but lively vessel and, at the other extreme, a stable but slow and sluggish craft which would require a lot of power to obtain any reasonable speed. To achieve the BPO requirements, a compromise shape was developed to obtain an essentially stable craft with reasonable speed.

To minimize vibration of the aft end, particular attention had to be given to the underwater shape at the aft end of the ships. Incorrect shape can produce flow separation which, in turn, creates hull vibrations induced by the propeller and shaft.

Having determined the envelope and its shape, the problem then arises of accommodating the necessary complement to man the ship, the machinery to propel it and the cable machinery and equipment. The greatest difficulty here was to design a ship small enough for the purpose and yet, to keep abreast with current practices, provide each member of the crew with a cabin to himself. As a result, the design is rather longer than would have been preferred, but it is considered that the improved manoeuvring capability provided will compensate for this handicap.

The principal dimensions of the vessels are:

overall length	94.50 m	load waterline length	86.72 m
breadth	15.00 m	(between perpendiculars)	
displacement	3500 t	depth	6.1 m
(fully loaded)		draught	4.8 m

Propulsion and Manoeuvrability

Consideration was also given to the necessary propulsion equipment and the auxiliary thrust units required to obtain a highly-manoeuverable craft. Another earlier criteria was that

the vessel should be single screw. This decision was made because of the problems of the low sinking rate of lightweight cable and the possible risk of damage by twin screws when laying lightweight cable from forward. Because of the limited machinery space available and other technical reasons, the machinery arrangement selected consists of 2 British Polar 16-cylinder 4-stroke Diesel engines, each developing a useful output power of 1.94 MW (2600 bhp), coupled to a 2-input single-output gearbox. The output is coupled to a controllable-pitch propeller to give a service speed of 15.5 knots. This also gives flexibility of propulsion and matches the loading of the prime movers to the loading of the propeller at various speeds. Two 1200 kVA alternators are also driven from the gearbox. These alternators provide power for the auxiliary manoeuvring units and hotel services, whilst the vessel is at sea. The engines, propeller shaft and alternators are all coupled by clutches, thereby giving a system with a number of possible operational alternatives. Thus, at low speed, one of the main engines can be coupled through the gearbox to the propeller shaft, with the other coupled through the gearbox to the alternator, each Diesel engine being independent of the other. The auxiliary manoeuvring units are so powered that, whilst engaged on cable work, the main propeller can be shut down.

Various possibilities of manoeuvring thrusters were considered, their merits and demerits being examined for the application envisaged. At the aft end, it was finally decided that there should be a Pleuger active rudder. This consists of a small propeller, driven by an electric motor; the whole assembly is incorporated within the rudder and is capable of producing 4 t thrust. The vane-type steering gear for this installation is produced so that, when the active-rudder propeller is in use, the rudder is capable of being turned through 180°, from 90° to port to 90° to starboard, thus providing thrust at any angle to the vessel within the arc.

A Pleuger-type bow-thrust unit was selected. This can be lowered to project from the bottom of the vessel, rotate through 360° and provide 4.3 t thrust in any direction. If there is a risk of damage to the thrust unit, either from the vessel operating in shallow water or through critical cable angles, the propeller unit can be retracted into the vessel and housed in a conventional transverse tunnel.

A passive anti-roll tank, of Flume Stabilization Systems design, is incorporated in the structure of the ships to improve the stability over a wide range of sea conditions for general and working comfort.

MODEL TESTS

During the design of the vessel, a stage was reached where, to confirm the design predictions, certain model tests had to

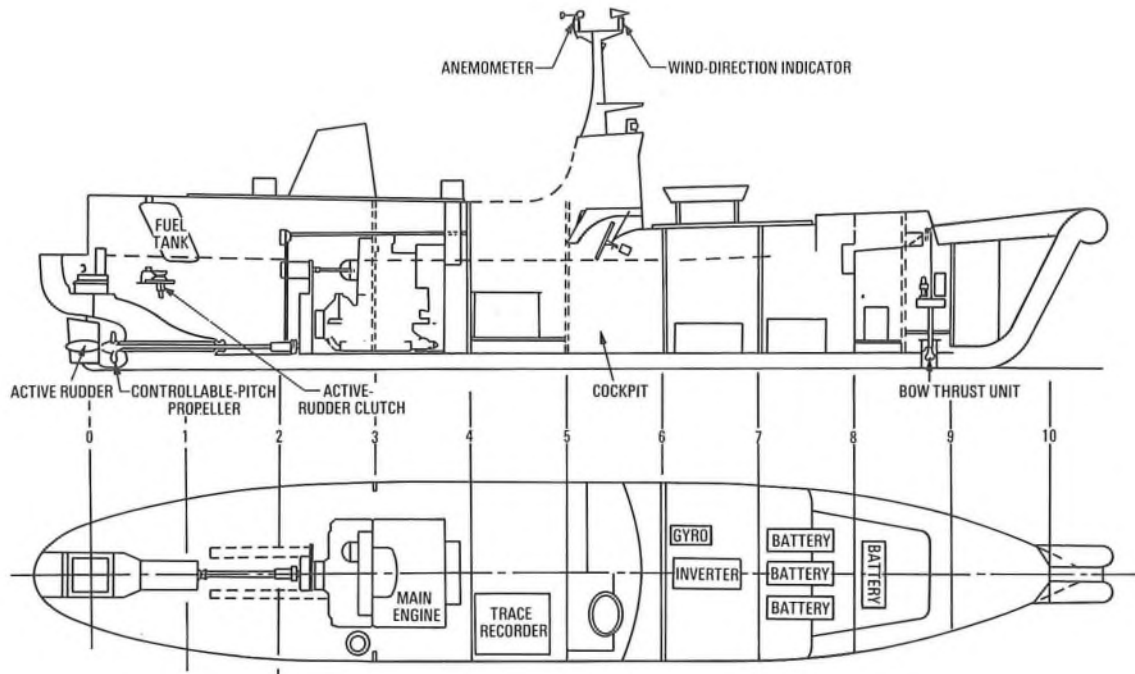

FIG. 4—Detailed drawings of 1/12th scale station-keeping model

be performed. A comprehensive model programme was, therefore, prepared, embodying aerodynamic, hydrodynamic and manoeuvring tests to cover the wide range of conditions which the full-sized vessel would be expected to encounter. Ship model establishments were contacted and the test programme discussed. Ultimately, the project was given to the Experimental and Electronic Laboratories of the British Hovercraft Corporation at East Cowes, Isle of Wight.

Aerodynamic Tests

Tests were carried out with a 1/60th scale model, shown in Fig. 2, to determine the aerodynamic characteristics in a $3.12\text{ m} \times 1.68\text{ m}$ closed-jet wind tunnel. The model was mounted on a ground board, which spanned the working section of the wind tunnel, by suspending it from a 6-component balance on twin struts at 610 mm centres. A turntable was incorporated in the ground board to permit the angle of the model to the wind to be varied. A Labyrinth-type seal was fitted between the model and the ground-board turntable to prevent the passage of air beneath the model, but to leave it completely isolated from the earthed ground board. To simulate the vertical wind-velocity profile found at sea, a grid was placed upstream of the model.

Hydrodynamic Tests

For the hydrodynamic tests, a 1/30th scale model (see Fig. 3) was manufactured to the lines produced by the naval architects. The tests included resistance, flowlines, propulsion and irregular-sea tests. A propeller was manufactured in white bronze to a drawing supplied by the naval architects and, though the proposed full-scale propeller would be a controllable-pitch propeller, for simplicity, the model was manufactured to a fixed pitch which was representative of the free-running pitch value.

The technique and method of analysis used during the tests conformed to the standard procedure for resistance and propulsion experiments with ship models, as established by the British Towing Tank Panel.

The naked hull resistance tests were carried out in an open tank, and the model was towed from a vertical post which

allowed freedom in trim and heave with restraint in roll and yaw. Turbulent flow in the model boundary layer was stimulated by means of standard pins projecting from the hull, arranged on each side of the bow below the water line. The tests were carried out at various displacements and the model was run over a range of speeds of 5–17 knots, the model's resistance being measured for each set of conditions. Astern resistance tests were also carried out. The analysis of the resistance test data was carried out using a digital computer.

For the flowline tests, the model was ballasted to its design displacement and run at a speed of 15 knots, to ascertain the flow pattern over the hull by taking underwater photographs of the model. For this purpose, woollen tufts were fitted to the underside of the naked hull, on one side of the model only, far enough away from the model surface to ensure that they were not in the boundary layer.

Resistance measurements were then made with the model fitted with bilge keels and run over a speed range of 5–17 knots.

The model propeller was initially tested in open water. The propeller was mounted upstream of a streamlined shroud which housed the propeller dynamometer. The complete assembly was supported by a towing carriage. The shaft centreline was positioned 2 propeller diameters below the water surface and the propeller was fitted with a streamlined cone at its forward boss face, together with a fairing which gave a gradual transition in diameter between the boss and the shaft at the rear. Measurements of propeller thrust, torque, angular velocity and speed of advance were recorded simultaneously during the tests.

Next followed the propulsion tests, both in calm water and in irregular waves. The model was again ballasted to its design displacement and was fitted with a propeller dynamometer, propeller and bilge keels. The active rudder was represented, although the propeller was not incorporated for reasons of simplicity. Thus, when free-running, the configuration was approximately representative of conditions with the active-rudder propeller feathered or windmilling. Simultaneous measurements of propeller thrust, torque, angular velocity, model speed, and the difference between the



FIG. 5—Model of bow-thrust unit



FIG. 6—Model of active-rudder unit

propeller thrust and the hull resistance were recorded, for a range of propeller revolutions at varying speed of advance up to and above the design speed.

For tests in irregular waves, the model was allowed freedom in surge, pitch and heave, but was restrained in roll and yaw. The craft was run at 4 speeds into irregular head seas which had a wave spectrum approximately representative of the waves generated by a wind of force 6 on the Beaufort scale in the North Atlantic. Investigations were made of waves having a significant wave height of 4 m and a wave length which varied approximately from 30–610 m. Measurements were made of the mean increases in propeller thrust, torque and angular velocity. Records were also taken of the pitch, heave and vertical accelerations at the bow and stern throughout the tests, and the pitch and heave data were later used to determine the pitch and heave responses. Envelopes of maximum and minimum vertical accelerations along the length of the craft were obtained by interpolation of the records obtained from accelerometers.

STATION-KEEPING MODEL

The station-keeping, sea-keeping and manoeuvring tests presented something of a problem because the full range of tests had to be performed with the bow-thrust unit and the active-rudder unit operable. Since there is a limit to which a propeller may be effectively scaled, this limit virtually determined the scale of the station-keeping model. Consequently, a 1/12th scale model was manufactured to lines supplied by the naval architects (see Fig. 4). This produced a model about 7.3 m long and, obviously, a model of this size could not be tested on a conventional open tank. Consequently, it was

proposed to conduct all the tests with this model in selected areas of the Solent and, as the model would therefore be required to operate in fairly severe sea conditions, it was built using conventional boat-building techniques. The keel was solid mahogany with laminated mahogany stem and stern posts scarfed into it. Bulkheads were made from marine plywood and fitted at every stage, except in the vicinity of the cockpit and main engine where frames were used. Longitudinal stringers were fabricated from laminated mahogany and the hull was made of mahogany strip planking, which was glued and nailed using galvanized nails, and screwed and glued to the bulkheads. The representative superstructure was manufactured to drawings supplied by the naval architects, and this was only sufficiently detailed

- (a) for windage to be approximately correct,
- (b) to enable the helmsman to have the same forward field of vision as the ship's bridge officer, and
- (c) to enable a correct assessment of wetness to be made, if required.

The model was designed to carry 2 personnel: a helmsman to carry out the various tests and manoeuvres, and an observer to operate the recording equipment. The helmsman's seat was placed such that his eyes were on the same level as the ship's bridge officer. A model of the Flume Stabilization System was manufactured in wood and incorporated in the hull.

Models of the bow-thrust unit (Fig. 5) and the active-rudder unit (Fig. 6) were constructed. Accurate scale models of propellers for these units were manufactured in tandem alloy to drawings supplied by the naval architects, and the nozzles for the propellers were manufactured from light alloy.



FIG. 7—Testing with the station-keeping model in the Solent

Provision was made to extend and retract the bow-thrust unit manually. The completed model was finished to the current BPO livery for cable ships: the hull had international orange topside and maroon boot tapping and bottom, the superstructure Admiralty grey and the masts, crane, funnel and boats, golden yellow. The model was equipped with navigation lights, foghorn, sniffer for detecting excessive exhaust and petrol fumes, extinguishers, bilge pump, windscreen complete with wipers, and distress flares.

The main electrical supply was provided by four 12 V heavy-duty batteries, which were kept charged by a generator run off the main engine. The engine was a Volkswagen industrial petrol engine, type 122, which was also used as the principal forward propulsion unit, driving a controllable-pitch, 3-bladed left-hand propeller. This propeller was not a correct scale model of the full-scale unit, but was the correct diameter and was selected to provide a representative wake over the rudder. The electrical supply was used to provide power for the auxiliary thrust units, gyro, recorder and transducers, where necessary. The bow-thrust and active-rudder propellers were each driven by a 24 V d.c. motor, and modified actuators were used to rotate the units.

The 3-bladed controllable-pitch propeller was driven by the main engine via a 2:1 reduction gearbox, and the angular velocity of the propeller was adjusted by means of a conventional throttle control. The pitch of the propeller could be adjusted manually from the helmsman's cockpit.

When proceeding to and from the test area, the model was manually steered using the wheel mounted in the helmsman's control panel. In this mode, the wheel was connected directly to the rudder. When at the test site, the manual steering was disengaged and rudder unit turned by using the electric actuator, which was operated from foot switches mounted in front of the helmsman on the cockpit floor.

The bow unit was raised or lowered by the observer using a control in the cockpit, and was rotated electrically via its actuator, in the same way as the rudder. In this case, however, the cockpit control consisted of a knob which could be rocked to each side to set the bow unit rotating in the selected direction. The positional angles of the units were shown on 2 dial indicators mounted on the helmsman's control panel. The

propeller speeds of the 2 auxiliary thrust units were controlled by turning 2 potentiometers mounted at the sides of the helmsman's control panel. In the case of the bow unit, the potentiometer was incorporated in the position control knob. Hence, the helmsman controlled the active rudder with his feet and left hand, and the bow unit with his right hand; the supplies to the unit drive motors were monitored on voltmeters and ammeters, watched by the observer in the cockpit to ensure that no overloading occurred.

For most of the tests, facilities were provided to measure and record a range of parameters, including angular position, angular velocity, thrust and torque of the auxiliary thrust units; in addition, the roll, pitch, vertical accelerations,

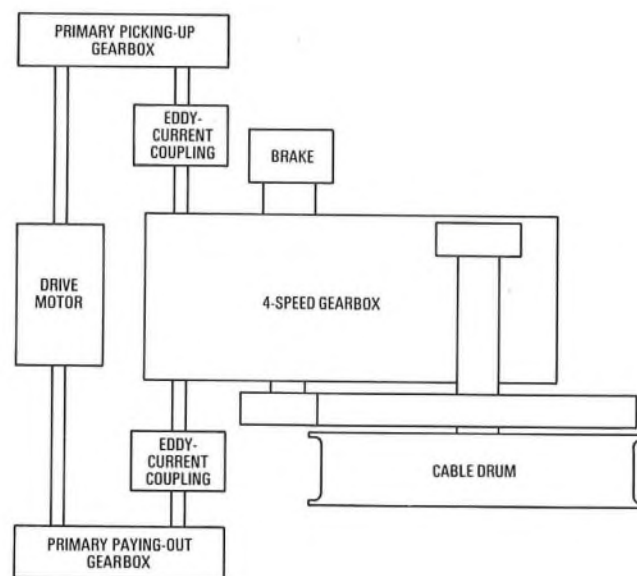
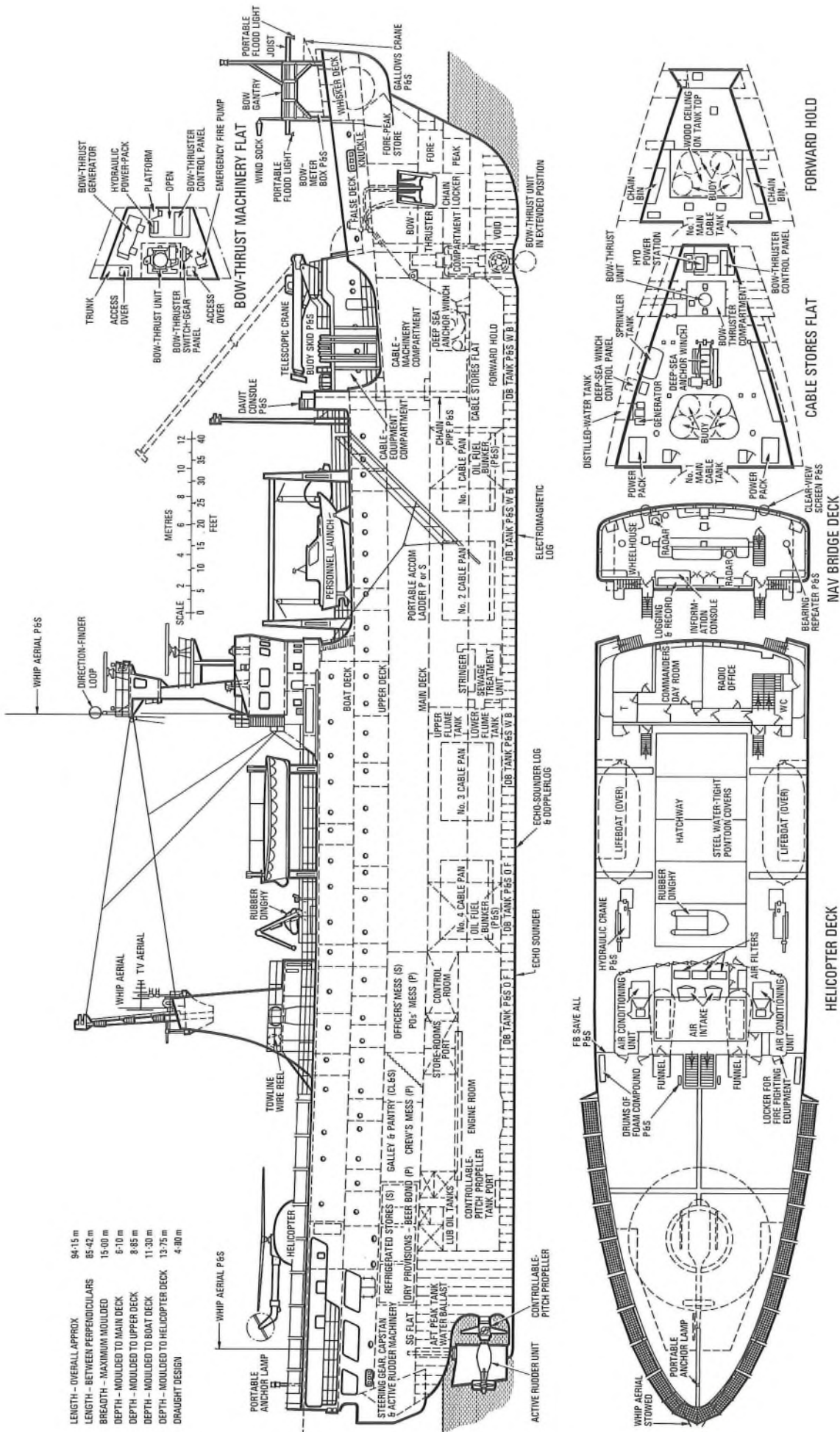
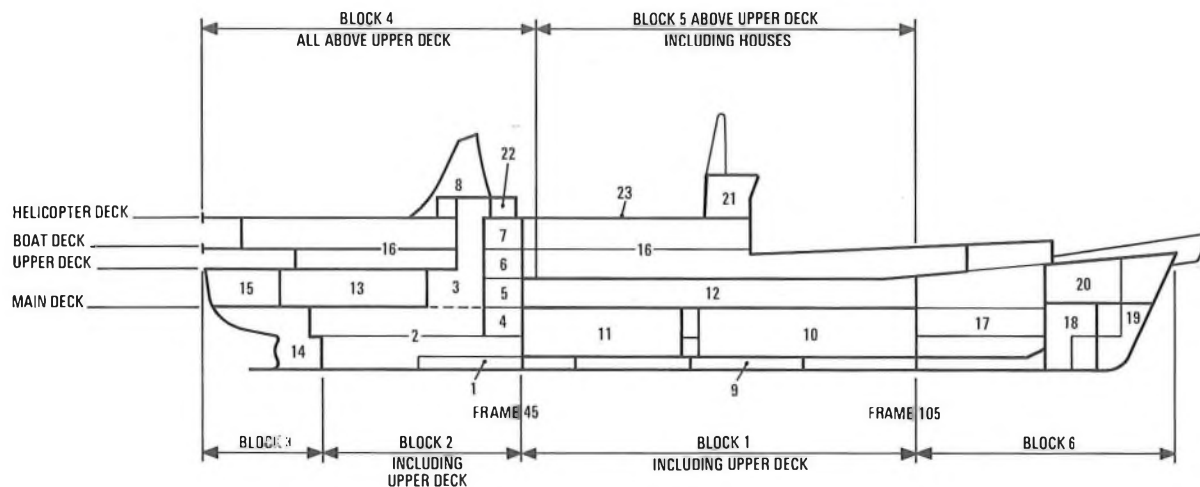

FIG. 8—Block diagram of cable machinery





- Key: 1—Engine-room double-bottom tanks 2—Engine room 3—Engine-room casings
 4—Engine-room control room 5—Engine-room boiler room 6—Engine-room stores flat
 7—Emergency-generator room 8—Funnel 9—Double-bottom tanks
 10—Forward cable tanks 11—Aft cable tanks 12—Main deck offices and workshops
 13—Galley and refrigerated stores 14—Aft-peak tanks 15—Steering-gear compartment
 16—Officers' and crew's accommodation 17—Fore-hold and cable-machinery spaces
 18—Bow-thrust machinery spaces 19—Fore-peak tank 20—Capstan-machinery spaces
 21—Bridge structure including radio room 22—Engine-room ventilation room and air-conditioning plant

FIG. 11—Production blocks for construction of new cable-repair ships

headings, and water speed of the model were recorded, together with the wind speed and direction. During the tests, a launch accompanied the model and, from it, were recorded tide rate and direction and sea state.

STATION-KEEPING TESTS

Prior to the commencement of test work, the model was taken to an area of still water on the River Medina and ballasted to the correct displacement and longitudinal wave distribution. An inclining experiment was carried out to ensure that the required metacentric height and roll period were represented. The remaining empty spaces of the craft were then filled with expanded polystyrene foam to give the craft a positive buoyancy, even when in a completely flooded condition. The tests were confined to an area in the Solent near Cowes; this area was chosen because past experience indicated that the Solent coastlines and tidal conditions could provide a wide range of sea conditions in a few days (see Fig. 7).

The manoeuvring tests conducted were the standard Kempf Manoeuvre* and Turning Circles. These were carried out in calm water and still air. The sea-keeping tests were initially carried out in a sea state representing force 7 on the Beaufort scale and, subsequently, under Beaufort scale: force 4 conditions. These tests were carried out at nominally constant heading in head seas, bow seas and beam seas. During the tests, various parameters were recorded and the movements of the ship were analysed.

For the station-keeping tests, a suitable site was selected and a buoy was dropped from the accompanying launch to be used as a mark on which to keep station. The launch was moved downwind of the mark and anchored. The ship model was brought up to the buoy under main-engine propulsion, the main engine was cut and the bow unit was lowered. Then, using only the bow-thrust unit and the active-rudder unit, attempts were made to hold the ship steady at the mark on a particular heading. The angular velocity of each unit was adjusted until the ship's drift from the buoy was reduced to a minimum. When the ship was considered steady, a recording

of the parameters, lasting approximately 5 min, was taken. The following headings were attempted, in each state of tide speed:

- (a) head to seas,
- (b) bow to seas,
- (c) beam to seas,
- (d) stern quarter to seas, and
- (e) stern to seas.

The station-keeping tests were divided into the following 2 sections:

- (a) station-keeping against the wind, waves and tide, and
- (b) station-keeping against tide only.

Investigations were carried out in tide rates from 0·3·5 knots and sea states up to that corresponding to force 7 on the Beaufort scale. Power requirements for each thrust unit were derived from the corrected thrust values.

It was demonstrated in the model that, by providing the infinitely variable combination of thrust direction of the 2 auxiliary thrust units, the proposed new ships could be held over any given position or direction regardless of reasonable prevailing conditions of weather, tide or current.

INTEGRATED CONTROL SYSTEM

The only disadvantage with the manoeuvring system used in the model is the difficulty imposed upon the controlling officer in determining the relative directions of thrust required of each unit to obtain the desired resultant position or direction. To overcome this difficulty, the possibility of integrating the controls of the bow-thrust and active-rudder units were considered. In the first instance, a feasibility study of an integrated control system was carried out without any attempt to design a practical operational control system, but to demonstrate whether an integrated system, using a joystick, was a feasible proposition.

Further model work was carried out using the resistance and propulsion 1/30th scale model to assess hydrodynamic forces and moments acting on the underwater hull form. A simple system of control was considered initially, using a simple joystick control having 3 degrees of freedom (fore and aft, sideways and rotational). The responses of the vessel and the influences of wind, tide and current were simulated using

* Kempf Manoeuvres examine the response of the ship to changes of helm by means of a series of course alterations.



FIG. 12—CS *Monarch* at the fitting-out basin

an analogue computer, and the results indicated on an XY-plotter. The ship's stem was the cursor of the XY-plotter, and the heading and yaw were indicated by meters showing relative head and rate of turn. The first system considered had weaknesses that were rectified in a second model, this also being tested on the computer.

The most significant outcome of the tests was the difficulties the operator had in holding station using the single lever. The controls were then separated into the basic movements; that is, ahead and astern, bodily sideways movement to port and to starboard, and yaw. This method proved to be highly satisfactory. Two other systems were considered on paper only, each a little more sophisticated, such that the fourth system would require a small computer because the control logic was much more complicated.

A design study was then conducted of an operational control system, based on the findings of the feasibility study. The system chosen was, in fact, a hybrid of all the possibilities, and the results were so encouraging that it was decided to modify the 1/12th scale station-keeping model and fit it with the mock-up control system. Further station-keeping tests were conducted with this model in the Solent. The results of the Solent tests were extremely successful and created such confidence that the system selected was further developed for inclusion in the full-sized vessels.

CABLE-SHIP EQUIPMENT

The cable machinery consists of 2 combined paying-out and picking-up machines on the main deck, each having 3 m diameter drums driven by 4-speed gearboxes with oil-operated clutches (see Fig. 8). The drive motor is a constant-speed unidirectional motor, with each end driving an eddy-current coupling through a gearbox. Excitation of one coupling drives the capstan drum in the picking-up direction, and excitation of the other coupling drives the drum in the paying-

out direction. Braking effort on the drum paying-out is obtained by excitation of the picking-up coupling. A hydraulic pump, pumping against variable restriction in the paying-out direction, gives additional braking. Maximum hauling capacity is 30 t at 0.5 knot, with paying-out speeds up to 8 knots at 3.5 t.

Cable tension is measured by a saddle-back dynamometer between the drum and the bow sheave deflecting the cable in its path forward. Hold-back tension is achieved by a 3-wheel pair module of the BPO-designed linear cable engine, now becoming standard on cable ships.

Equipment on the bridge is arranged ergonomically and includes control of the pitch of the main propeller and control panels for the integrated control of the bow-thrust unit and active-rudder unit. Navigation equipment to match the exacting demands of cable operations will include gyro-compass, radar, Decca Navigator, LORAN² and precision depth recorders, as well as extensive internal and external communication systems.

CABLE-SHIP CONSTRUCTION

Concurrent with the ship model tests, the preparation and agreement of arrangements of accommodation and machinery continued with the naval architects until, ultimately, final arrangements were agreed and specifications completed. Preliminary structural arrangements were prepared and submitted to Lloyd's for approval. Finally, all specifications and arrangement drawings were gathered together and, with tendering documents prepared by the Contracts Division of the BPO Purchasing and Supply Department, dispatched to a selection of UK shipbuilders. Robb Caledon Shipbuilders Ltd. were the successful tenderers, and it was mutually agreed that both cable ships would be built at their Caledon Shipyard, Dundee. The shipbuilders produced a production plan for each ship, with a time lag of about 3 months between

each. The plan basically divided the ship into production blocks and a sequence of assembly of blocks was proposed to use most effectively the available resources of manpower and materials. The shipbuilder then set to work to convert the BPO requirements and plans into detailed working drawings (see Figs. 9 and 10). Steelwork was transferred to 1/10th scale drawings on inert sheets for controlling the automatic flame cutting machines. The steelwork content of each block was pre-erected in the prefabrication sheds, and transferred to the building berth in 28 t sections.

The proposed sequence of construction was to concentrate on the central-block units, such that the work on offices, workshops and accommodation could commence as early as possible (see Fig. 11). This was then to be followed by construction of the forward and after blocks, containing the cable machinery and the propulsion machinery respectively. In this way, the timing of the installation of machinery would be unaffected by the fact that the equipment required had the longest delivery times.

This plan was followed generally, but was severely disrupted, firstly by the steel shortage toward the end of 1973, and then by the energy crisis and the 3-day working week at the end of 1973 which continued into 1974. Whilst Robb Caledon Ltd. worked 5 days/week as far as limited power and daylight would permit, the majority of sub-contractors were also affected and their contract delivery dates could not be met. This difficulty in obtaining parts from sub-contractors, representing more than half the value of the vessels, caused the shipyard considerable delays in all areas of the ships. The production plan has had to be modified regularly to suit latest delivery dates as they became known.

CS Monarch

On Wednesday 12 February 1975, the first ship, the *CS Monarch*, was launched, having all the steelwork completed.³ The bow-thrust unit, the main controllable-pitch propeller and its shafting, and the rudder and active-rudder unit have all been installed. The main propulsion machinery is all *in situ* and is being aligned; similarly, the cable machinery is installed and is also being aligned. The bridge structure is in place, complete with the mast, and all the cable-pan-loading trunk hatches and hatch covers are complete and in place. The accommodation is in an advanced state. Having been launched, the ship is now at the fitting-out basin, where all this work will continue (Fig. 12). In a ship as sophisticated as this, a lengthy period will be required to complete an extensive testing programme of each component individually, and of the components together in their systems.

Book Review

The International Telex Service. R. N. Renton, C.G.I.A., C.ENG., F.I.E.E. Pitman Publishing. 420 pp. 223 ill. £4.80 (paper), £6.00 (cased).

The title of the book would reflect the contents more accurately if qualified by the sub-title "The UK System". Purchasers, whose appetites have been whetted by the prospect of information on the world-wide Telex scene, will be disappointed. For, alas, the book extends published information only to our international boundary, by including previously unpublished information on the Telex teleprinter used currently in the UK, and switching equipment installed in the UK gateway exchanges. A comparative treatment of the world's major Telex teleprinters and switching equipment would have increased the value of the book greatly for all concerned with the Telex service.

A major shortcoming of the book is the impression created of an almost haphazard chapter arrangement. With no introductory general treatment of the material to be covered, the reader is plunged into a detailed disquisition on the International Telegraph Alphabet No. 2, and the following few chapters repeatedly either assume knowledge

Second Cable Ship

About 75% of the steelwork of the second cable ship has been erected on the berth, extending from the after bulkhead of the forehold to the engine-room bulkhead, and from the shell plating up to the upper deck. Beyond these bulkheads, the double-bottom units and engine-room forehold are *in situ* and a lot of work has been carried out in installing the engine-room auxiliary pumps and pipework. The main deck is in place and the 4 main cable tanks, the 6 auxiliary tanks and the Flume Stabilization System have all been constructed within this structure.

FUTURE USE OF STATION-KEEPING MODEL

The 1/12th scale station-keeping model has been refitted and has been converted from an experimental model to a training tool. It has been fitted with the integrated control system similar to that which is being installed in the full-sized vessel, and cable-ship officers will be given an opportunity to familiarize themselves with its use and effectiveness.

FUTURE PROGRAMME FOR THE NEW CABLE SHIPS

CS Monarch is, at present, going through the extensive and complex fitting-out and testing stages, and it is hoped that the acceptance trials will take place in September 1975. These trials will prove the ship and all its machinery. After completion of the acceptance trials, the BPO will take control of the vessel and, with Shipbuilders' representatives aboard, commence a programme of cable working trials. These will prove the cable machinery under working conditions, and familiarize the officers and crew with the new techniques required of this new type of cable-repair ship.

Upon completion of these trials, *CS Monarch* will become operational from Southampton Central Marine Depot, from where the total concept of cable operations using loading and unloading by cable pans will become complete.

The second ship has suffered considerable delay; it is not expected to be ready for launching until about October 1975 or to become operational until the Spring of 1976.

References

- ¹ FIRMIN, Capt. E. W. Recent Additions to the Post Office Fleet of Cable Ships. *POEEJ*, Vol. 39, p. 1, Apr. 1946.
- ² BATES, Capt. O. R. The CANTAT 2 Cable System: Planning and Laying the Cable. *POEEJ*, Vol. 67, p. 148, Oct. 1974.
- ³ BACK, R. E. G. New Cable-Repair Ship—CS MONARCH. *POEEJ*, Vol. 68, p. 46, Apr. 1975.

on matters not explained until later, without adequate cross references, or include avoidable repetitions.

The book is generally accurate, but contains a number of loose and, therefore, possibly misleading statements. For example, there is confusion between the facilities offered by the British Post Office's Teleprinter No. 15 and its parent machine, the Creed Model 444.

Since so much space is occupied by detailed accounts of contact operation, which no author has yet been able to deal with in an entirely satisfactory manner, the usefulness of this detail is once again open to question. Should answers to the City and Guilds of London Institute examination papers still demand this minutiae? For the international gateway equipment, in particular, a more general treatment would probably have been sufficient.

The value of this undoubtedly useful book would have been increased by the inclusion of information on the special transmission features of intercontinental working via cable, VHF radio and satellite, perhaps at the cost of omitting the chapter on power plant.

It is a pity that a book published in 1974 does not refer to the current CCITT Green Book.

R. W. B.

Local-Exchange Renewal Strategy: Maintenance Man-Hour Requirements

C. R. J. SHURROCK, M.SC.(ENG.), C.ENG., M.I.E.E., and
A. F. YAXLEY, C.ENG., M.I.E.E.†

UDC 621.395.3:654.153

This article describes the special studies carried out to determine the maintenance man-hour requirements/exchange-size relationships of Strowger, crossbar and electronic exchange systems for use in deriving the costings of various strategies for the renewal of local exchanges.

INTRODUCTION

A previous article¹ has explained the general background to, and structure of, the modernization studies which led to the adoption of the TXE4 exchange system² and the replacement policy. The central element of these studies was a series of costings for a range of replacement strategies, within which maintenance man-hour requirements were one of the more significant and sensitive factors.

A series of special studies was carried out, therefore, to determine the maintenance man-hour requirements for each exchange system considered. Because of the wide range of variables, some almost unmeasurable, particular care was taken in structuring the study and relating as many facets as possible to direct experience in the UK. For Strowger exchanges, this was relatively straightforward. For new systems, the problem was more difficult but, in this respect, the experience gained in operating the small reed-relay electronic exchange (TXE2)³, crossbar exchanges (TXK)⁴ and other items of electronic equipment (register-translators) proved most valuable.

The maintenance man-hour requirements for exchange systems can be expressed in a number of ways. Since the object of the studies was to evaluate national strategies, maintenance man-hour requirements were needed for populations of exchanges, rather than for a series of individual exchanges. This approach also has the advantage of producing a more accurate solution. Since, by its very nature, the measurement of maintenance effort is influenced by a range of factors (for example, age of equipment and management policies) of a random nature, the problem is analogous to detecting signals in a noisy environment.

In carrying out the exercise, it was necessary to produce results to a clearly defined timetable. Thus, at some stages of the study, interesting and, in some cases, potentially valuable refinements could not be followed up.

One of the difficulties encountered in evaluating maintenance man-hour requirements arises from the position of an exchange in a network. The allocation of certain items of work to maintenance, as opposed to construction, must be arbitrary and frequently a matter of convenience. For this study, it was convenient to include all items under maintenance man-hour accounting work codes appropriate to each system. The results of these studies were for use in the local-exchange computer model, ALEM.⁵

STUDY METHODOLOGY

The prime objective of the study was to establish a maintenance man-hour requirements/exchange-size relationship for each of the exchange systems included in the modernization strategy appraisal. To achieve this, it was necessary to derive maintenance man-hour requirements/exchange-size relationships for

- (a) existing in-service exchange systems using data derived from a sample of individual exchange requirements, and
- (b) exchange systems not yet in service (for example, TXE4), using exchange design information backed up by the experience gained on similar in-service systems.

Wherever possible, relationships were developed from data from exchanges actually in service, and theoretical studies were carried out on all systems so that the methodology developed for estimating the relationship for future systems could be tested and validated. Table 1 summarizes the studies carried out.

In addition, whilst data from in-service exchanges clearly indicated the level of maintenance man-hour expenditure required, this is complicated by local factors (noise). A parallel theoretical approach, unaffected by noise, could confirm the basic mechanism affecting the maintenance man-hour requirements/exchange-size relationship; for example, sensitivity to varying component failure rates. In general terms, for systems with exchanges in service, data was collected from a range of exchanges. This data consisted of the maintenance man-hour expenditure for a year and the size of each exchange expressed in terms of working connexions and

TABLE 1
Studies Carried Out

Type of Exchange	Type of Study Carried Out	
	In-service data	Theoretical data
Strowger	Yes	Yes
TXK1	Yes	Yes
TXE2	Yes	Yes
TXK3	No	Yes
TXK1 and stored-programme control	No	Yes
TXE4	No	Yes

† Mr. Shurrock is in the Operational Programming Department of Telecommunications Headquarters and Mr. Yaxley is now in the Telecommunications Management Services Department of Telecommunications Headquarters.

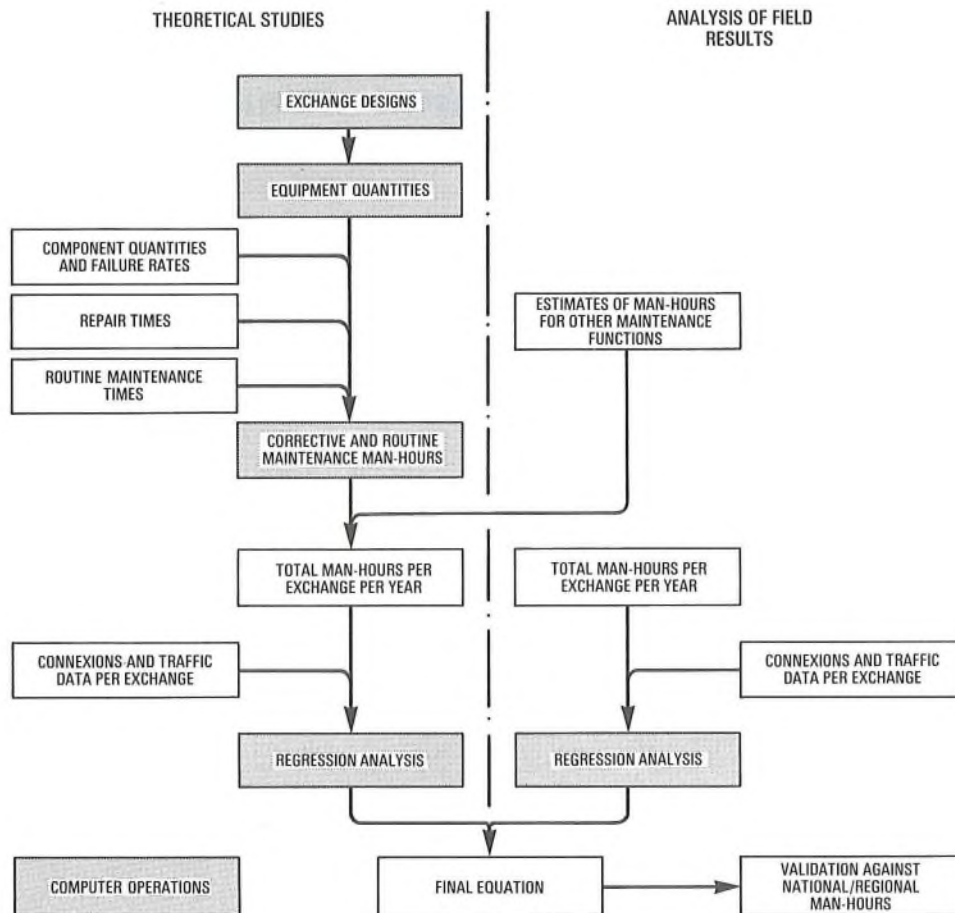

FIG. 1—Study methodology

originating traffic carried. Computer-aided analysis then enabled the maintenance man-hour requirements/exchange-size relationship to be determined in the form

$$\text{man-hour requirements} = aL + bE + cN,$$

where L is the number of connexions, E is the originating traffic in erlangs, N is the number of exchanges, and a , b and c are constants describing the maintenance man-hour requirements characteristic for the switching system.

The theoretical analysis was built up in a similar manner. A range of exchanges was dimensioned on computer models and the maintenance man-hour expenditure produced. Again, with a range of results available, it was possible to produce a formula of the type described above. The final step for systems with exchanges in service was to compare the results with those obtained in the field and, thus, validate the overall conclusion. The overall methodology is illustrated in Fig. 1.

THEORETICAL ESTIMATES FOR MODERN SYSTEMS

In maintaining exchange switching equipment, a number of general activities are performed. Equipment faults are corrected and routines are carried out, together with various miscellaneous activities; for example, travelling and record work. The first step in analysing the maintenance man-hour expenditure was, therefore, to identify the basic functions performed.

For the TXE2 and TXK1 exchanges, some consideration had been given to this problem and an analysis of the man-hour expenditure for exchanges in the field was available. The general pattern is quite clear, with corrective and routine

maintenance functions accounting for some 60% of the total effort in both cases. The detail of the particular breakdown in Table 2 has a limited significance since, in both cases, exchanges at the beginning of their lives have been included, with high maintenance expenditure due to the exchange settling in and staff acquiring expertise.

TABLE 2
Breakdown of Maintenance Activities

Activity	Percentage of Total Man-Hours	
	For TXE2 Exchanges	For TXK1 Exchanges
Corrective Maintenance	66.0	43.0
Routine Maintenance	9.0	21.0
Other Maintenance Functions	25.0	36.0

Corrective Maintenance

This function covers the repair or replacement of the main exchange plant and is clearly dependent upon the quantity of equipment provided. Consideration shows that the man-hour expenditure is a function of component failure rates, number of components and the time taken to locate and clear each fault. The collation and addition of this information to provide man-hour information per exchange was carried out on a computer model.

TABLE 3
Typical Component Quantities for TXE4 Exchanges

Size of Exchange		Number of Components								
Number of Connexions	Originating Traffic (Erlangs)	Resistors	Capacitors	Diodes	Transistors	Transformers	Reed Inserts (Control)	Integrated Circuits	Reed Coils	Reed Inserts (Switching)
3400	660	669 617	118 411	1 111 991	157 420	10 951	3648	4239	335 969	1 340 100
7000	1309	1 169 121	200 821	1 964 143	277 229	16 643	7828	5652	608 715	2 426 904
9500	1102	884 697	157 656	1 507 638	205 895	13 746	6780	4239	478 592	1 907 460
9458	264	547 109	101 640	834 371	128 414	11 242	5092	4239	196 464	780 636
9750	419	603 745	110 891	943 112	141 657	11 845	4180	4239	232 207	924 520

Basically, this model solved the following relationship for each of a range of exchanges:

$$\text{man-hours} = \sum_{i=1}^x N_i R_i (C_{i1} F_1 + C_{i2} F_2 + \dots + C_{im} F_m)$$

where x is the total number of different equipments in an exchange,

- N_i is the number of equipments of type i ,
- R_i is the repair time for equipment type i ,
- C_{i1} is the number of components of type 1 in equipment type i ,
- F_1 is the failure rate/annum of component type 1, and
- m is the number of individual types of components involved.

A range of exchange sizes was considered and the number of equipments/exchange, N , was obtained from actual exchange designs. The repair times are associated with a particular piece of equipment so that allowance can be made for the complexity of equipment. Thus, the time allowed for the location and replacement of, say, a faulty transistor in common-control logic would be greater than for one in, say, highway-drive equipment. The repair times used were based on the analysis of results from in-service TXE2 and TXK1 exchanges.

The numbers of components, C , for individual equipments were obtained by a comprehensive analysis of diagrams and design documents. An ancillary output of the local-exchange computer model is a summation of component quantities and a sample output is shown in Table 3.

Component failure rates used were obtained from the analysis of returns from in-service systems. The contribution from existing systems is clear and represents the British Post Office experience in this field. The data can reasonably be transferred from one system to another, as the results stem from a practice common to all systems; for example, maintenance practice and component application rules. In carrying out the analysis, however, care was taken to identify those areas having differences that could fundamentally influence results.

Routine Maintenance

The routine-maintenance man-hour requirement for switching equipment was also calculated on the computer programme, by associating an annual routine-maintenance requirement per item of equipment (or functional building block). The programme used the following formula:

$$\text{man-hours} = \sum_{i=1}^x N_i T_i$$

where x is the number of different equipments,
 N_i is the number of equipments of type i , and
 T_i is the annual routine maintenance time for equipment i .

The routine maintenance times were derived from field

information where available, or by analogy from field experience of similar items already in service.

Other Maintenance Functions

Annual maintenance man-hour requirements for the other maintenance functions were evaluated from the detailed man-hour information from in-service TXE2 and TXK1 exchanges.

Separate estimates were established for

- (a) power plant; corrective maintenance and routine maintenance,
- (b) records,
- (c) travelling, and
- (d) base load; for example, call tracing.

In addition, an overall allowance was made to cover miscellaneous activities, including clerical work; that is, work diaries, stores requisitioning etc.

THEORETICAL ESTIMATES FOR STROWGER EXCHANGES

The theoretical approach developed for modern systems could not be used for Strowger exchanges, since the detailed basic information was not available. An alternative method was, therefore, used. One of a range of available computer programmes uses average maintenance man-hour expenditure, including both corrective and routine maintenance, to derive the rental annual charges. It was a relatively simple process to convert the output of this programme to provide maintenance man-hour expenditure for individual exchanges.

IN-SERVICE EXCHANGE DATA

Strowger Exchanges

Information from a sample of exchanges, selected at random, was obtained after the structure of the sample had been carefully checked against exchange-connexion size and originating calling-rate characteristics of the total population. Separate samples were obtained for director and non-director systems. The distribution of non-director exchanges is shown in Fig. 2.

Individual-exchange man-hour requirements were obtained from a specially-instituted return of man-hours, giving the requirements for the period April–September 1972. This figure was checked for compatibility against overall area returns and scaled to represent a year's requirements. The scaling process took due account of the annual patterns of leave, sickness, training etc.

The number of working exchange connexions were obtained from the individual-exchange figures in official returns (customer fault report analysis procedure). Accurate representative traffic figures were more difficult to obtain. Two sources were compared and, where disagreements were apparent, further investigation was carried out.

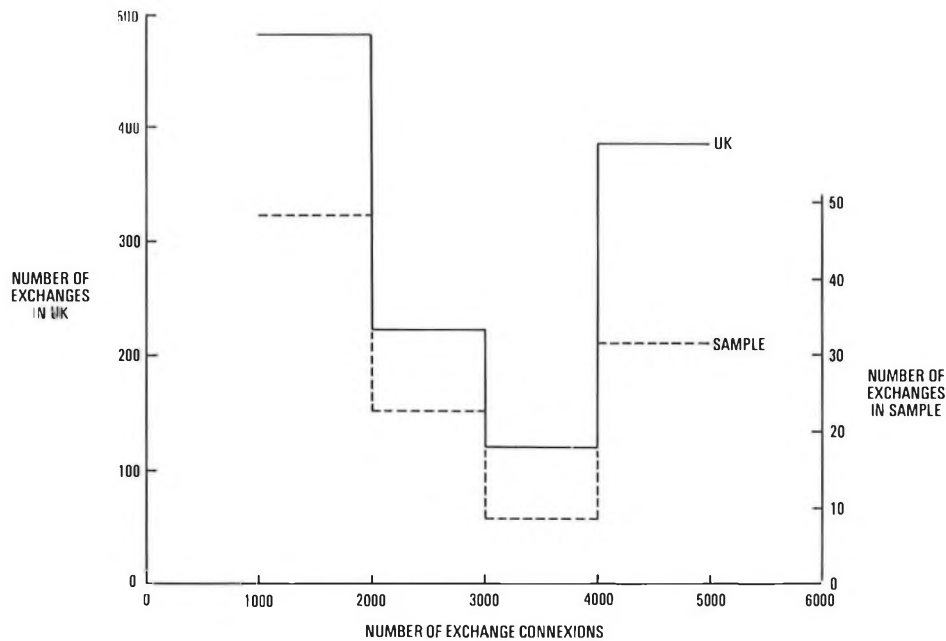

FIG. 2—Distribution of Strowger non-director exchanges by exchange connexions

Modern Exchanges

The sample of TXE2 and TXK1 exchanges was selected so that all exchanges having a service life of 1 year or more were included. Exchange-connexion and traffic data were obtained in a similar manner as for Strowger exchanges and man-hour expenditure; that is, from regular special returns for individual exchanges.

Two additional problems were present within the TXE2 and TXK1 sample exchanges. Allowance was made for exchanges still in the early months of service, to account for any additional man-hour expenditure for exchanges settling in and for the time taken for staff to acquire the necessary maintenance expertise.

DERIVATION OF MAINTENANCE MAN-HOUR REQUIREMENTS/EXCHANGE-SIZE RELATIONSHIP

The maintenance man-hour requirements/exchange-size relationship is in the form of a 3-part equation having a constant per exchange, a per-connexion term and a term dependent on traffic. Initially, it was hoped to use some form of computer package to analyse the sets of individual-exchange data and to carry out the equation-fitting exercise. In particular, the use of multiple regression analysis would have been desirable. In practice, however, it was clear that the input data did not fulfil all the mathematical conditions required for the process to be valid. The variance of errors with size was not constant over the range of the sample; that is, *heteroskedasticity* is said to exist.

A critical test of validity can be made from an examination of a plot of errors in the man-hour requirements produced by the formula for sections of the sample. A typical error plot for the non-director exchange sample is shown in Fig. 3, in which each plotted point represents the calling rate/exchange-connexion characteristic for one exchange in the sample. The sample is sectionalized using the median of the exchanges by calling-rate ranking for the vertical axis (line AB), and quartiles of exchanges by exchange-connexion ranking for the horizontal axis (lines CD, EF and GH). Percentage errors produced by using the formula in relation to the actual man-hour expenditure for the sample exchanges in each section are shown in the figure. The imperfections in the formula can readily be seen.

In practice, the equations produced by regression analysis provided a valuable starting point and, in a series of iterations, a satisfactory equation could be produced. A number of equations were tested against actual exchange data until an equation best fitting the data was found. This was determined by inspection of

- (a) error plots,
- (b) the mean percentage difference between actual and calculated total man-hours for the sample,
- (c) the standard deviation of percentage deviation of percentage differences for individual results, and
- (d) the index of determination.*

This process was carried out on all sets of exchange data, both from in-service exchanges and theoretical designs, to produce maintenance man-hour requirements/exchange-size relationship equations. Where both in-service and theoretical data existed for a system, the equations were inspected and differences in man-hour requirements investigated to determine the cause. Final equations were based on in-service exchange data. Equations for systems for which no in-service exchange data existed were developed, making maximum use of the relevant experience gained in resolving the pairs of equations where actual exchange data existed.

For each modern system, the functional analysis allows the production of a structured estimate based on a common methodology. This approach minimizes the inaccuracies due to omitted functions and ensures, as far as possible, a consistent comparison between systems.

Clearly, with the wide range of factors under consideration, perfection cannot be achieved. For this reason, sensitivity tests were carried out which, for example, enabled the failure rates for particular components to be varied and the effect on the overall man-hour requirements to be determined. Variations for a typical TXE4 exchange are shown in Fig. 4 and these results can be reflected in the main strategy costings.

VALIDATION

Throughout the study, the validation of results against large sections of the exchange population was considered important.

* The index of determination is a measure of the degree of correlation between the equation and the sample data, its maximum and ideal value being 1.0.

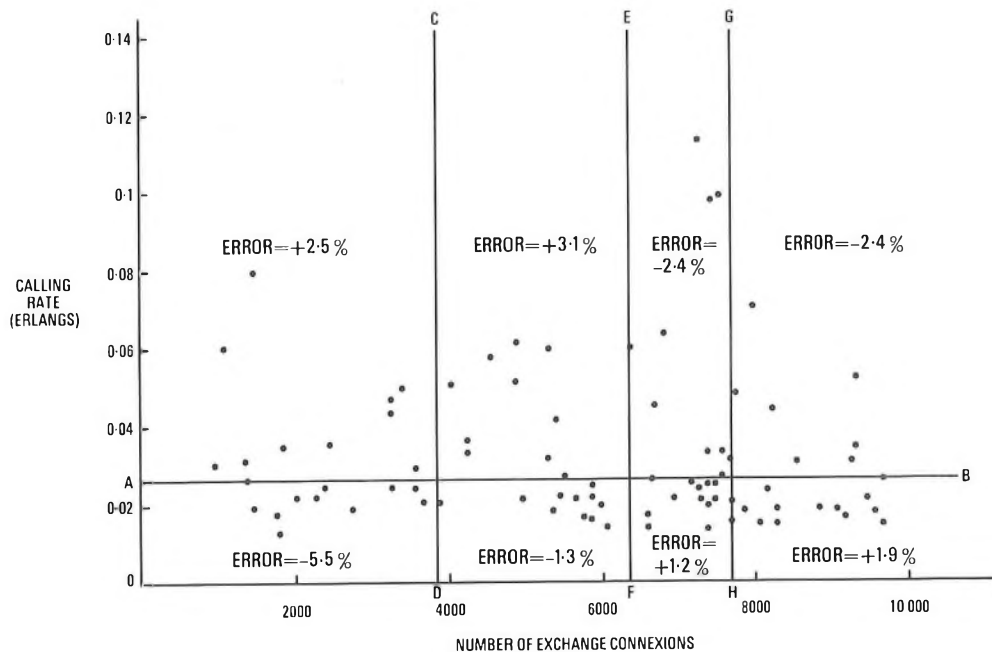

FIG. 3—Typical error plot

In deriving the basic formula, the relationship between it and the representative sample is clear. Basically, the following 3 further checks were carried out.

(a) As a spot check on accuracy, the sample was split in half and the formula tested against each separately.

(b) The results, where appropriate, were tested against the returns of individual regions, although clearly no one region could be said to be representative of the national situation.

(c) The equations were tested against the national returns.

This exercise in itself presented some problems; the number of exchanges and the working connexions were readily obtained, but the representative calling rates and the national

man-hour requirements for local exchanges were more difficult to determine.

In the case of Strowger exchanges, the regional and national returns of man-hours include man-hour expenditure for non-local-exchange maintenance; that is, for trunk switching equipment and manual-board maintenance not included in these studies. A special survey was mounted to obtain estimates of these activities to provide the correct expenditure totals against which the equations were to be validated. Table 4 shows the division of man-hours found.

TABLE 4
Division of Man-Hours

Type of Exchange	Percentage of Man-Hours	
	Local-Switching Maintenance	Non-Local Maintenance
Non-Director	68.0	32.0
Director	73.0	27.0

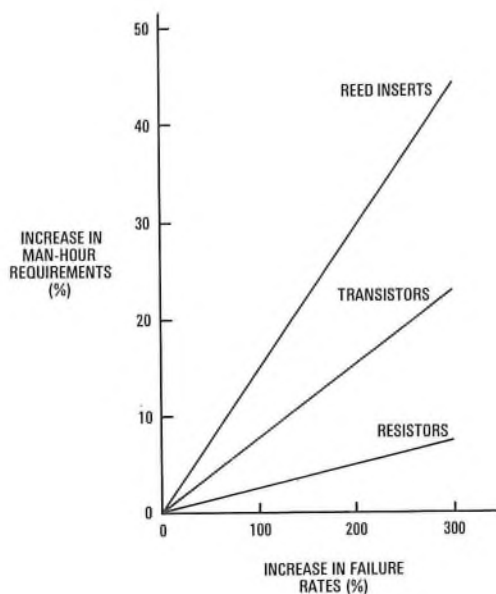

FIG. 4—Sensitivity of maintenance man-hour requirements to component failure rates for a typical TXE4 exchange

For modern systems (TXE2 and TXK1), some allowance was necessary to take into account additional man-hour expenditure incurred during the early months of an exchange's life for the settling in of the exchange and learning period of maintenance staff. In addition, for the TXE2 system, the effect of a batch of unsatisfactory reed inserts at individual exchanges was taken into account.

DISCUSSION OF RESULTS

The estimates produced in the study relate to the annual maintenance man-hour requirements as at 1972 and are valid for the circumstances that apply to a population of exchanges, rather than to individual exchanges.

The estimates represent the nominal annual man-hour expenditure, and do not include the effects of

(a) additional expenditure for the early months of service for modern exchanges; that is, settling in and learning factors,

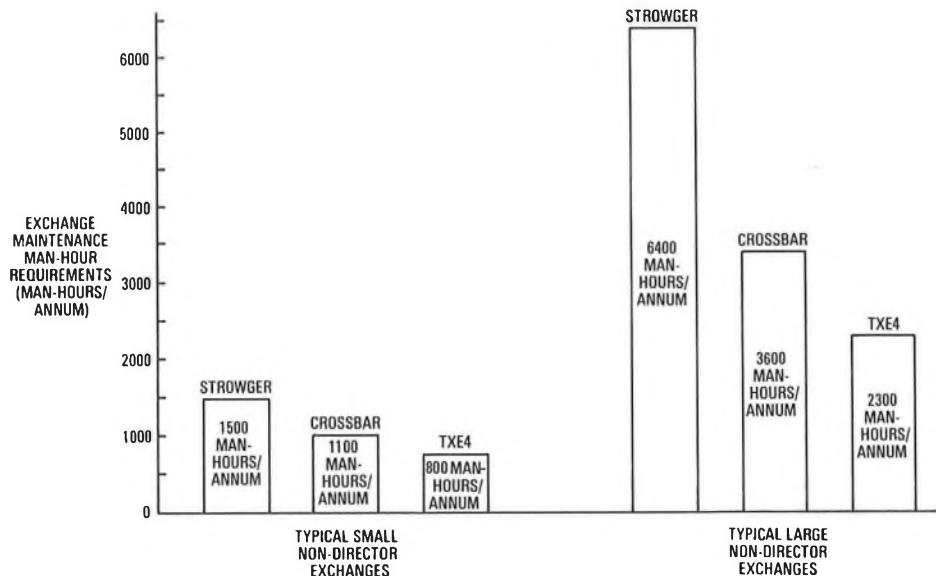

FIG. 5—Comparison of exchange maintenance man-hour requirements

(b) future productivity, and
 (c) changes in maintenance policy; that is, centralized maintenance organization for modern systems.

For modern systems, the effects of productivity and savings from centralized maintenance will be related to the degree of penetration of the system concerned, with productivity savings only becoming apparent after the number of exchanges in service reaches a level such that centralized maintenance becomes totally effective.

Strowger Maintenance Man-Hour Requirements

As for all other systems, the basic objective of the study was to establish the maintenance man-hour requirements/exchange-size relationship, but for Strowger exchanges, the problem, in several senses, was more difficult and the result more critical. The study was more critical since a 20% error on the comparatively large Strowger-equipment maintenance man-hour expenditure will be more significant than a 20% error on the lower electronic-exchange maintenance man-hour expenditure.

A cursory study of individual-exchange man-hour records shows the wide range of results that are experienced. This follows from a wide range of factors, including

- (a) age of equipment,
- (b) local environment,
- (c) efficiency of local maintenance teams,

- (d) mix of equipment, and
- (e) state of wear.

One of the most important steps in the analysis was to subdivide the national population. The first step of dividing between non-director and director exchanges is fairly obvious, and further significant improvement was obtained by splitting director exchanges between provincial and London. The studies, in general, represented a series of refinements, each step producing a more accurate result. However, no attempt was made to determine the reasons for the difference between provincial and London results. The difference arises from a range of factors and only fuller analysis would show the dominant items. Table 5 gives the Strowger non-director maintenance man-hour equation with related statistical indexes and degree of validation between the total man-hours produced by the equation for the national population of exchanges and the actual man-hour expenditure incurred.

The studies for Strowger exchanges provide an authoritative base for making estimates. The formulae produced give sensible results for groups of exchanges with differing sizes and traffic-handling capabilities. For large groups of exchanges, results within $\pm 5\%$ can be expected.

Modern Systems

The accuracy of estimates for modern systems will only be known after these exchanges have been in service for some years. For TXE2 and TXK1 exchanges, limited results are available and validation tests on these give results similar to

TABLE 5
 Strowger Non-Director Cost Equation

Equation	Index of Determination	Total Percentage Error on Sample	Standard Deviation of Percentage Errors	Percentage Validation against National Man-Hour Expenditure
$0.278L + 10.53E + 260N$	0.822	0.09	48.5	98.0

L = number of connexions
E = originating traffic in erlangs
N = number of exchanges

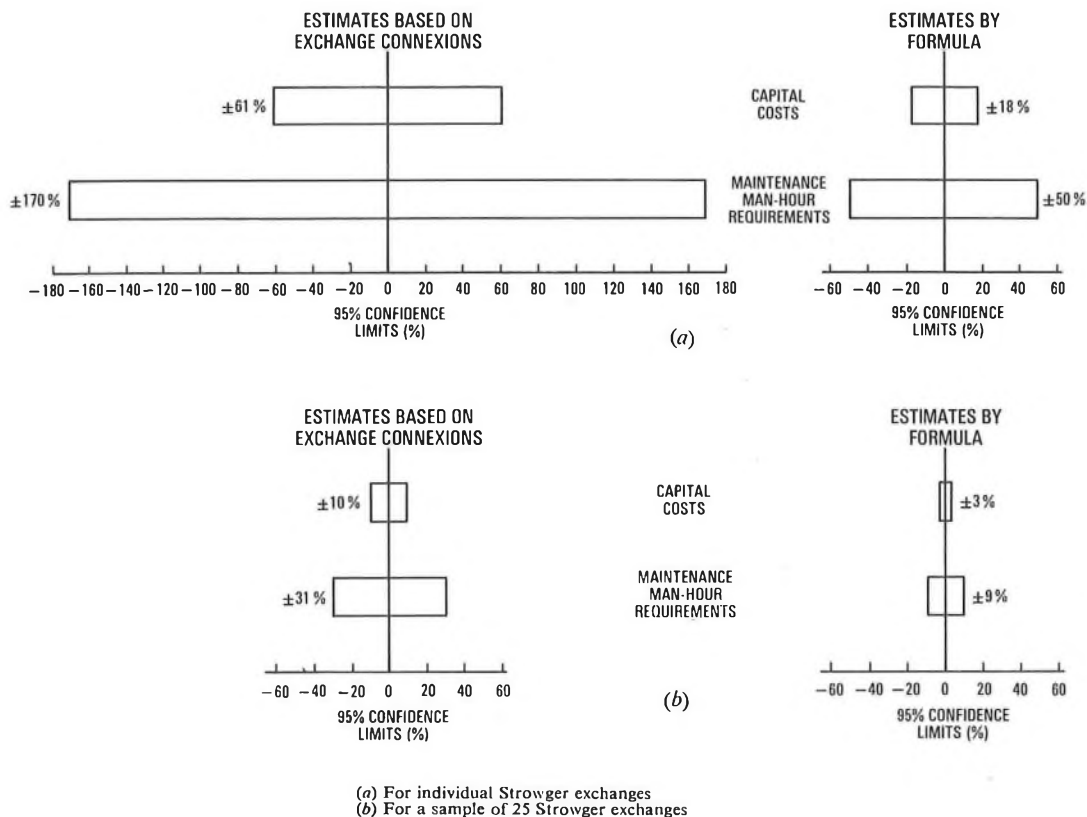

Fig. 6—Comparison of 95% confidence limits for estimates relating to Strowger director exchanges

those for Strowger exchanges. Because of the structured approach used throughout the studies, there is no fundamental reason why the estimates obtained should not become self-fulfilling prophecies or even upper limits. As the in-service performance figures for the various modern systems are collated, deviations from the expected performance of individual elements used in the build up of estimates should be readily identifiable. The sensitivity-test capability, referred to earlier, can be used to evaluate the significance of the departure and, where necessary, corrective action can be taken.

Comparisons between Systems

A comparison of maintenance man-hour requirements for exchange systems is of interest. However, with 3 factors in the basic equations, any single statistic can be misleading. A ratio that is valid for a particular exchange size or sample of exchanges will not hold true for exchanges of different sizes and from a different sample. The results for 2 non-director exchanges are shown Fig. 5.

The results of these studies, and those of the capital cost of exchange equipment, indicate the limitations of per-exchange-connexion statistics as a basis of expenditure estimation and comparison. In this respect, the traditionally quoted figure of man-hours/connexion is most misleading. For 1972, the appropriate figure for director exchanges would have been approximately 1.5 man-hours/connexion. The standard deviation of errors for a representative sample was 85%; thus 95% of the exchanges could be expected to be between the limits of $\pm 170\%$. Ancillary results, obtained when comparing derived cost/size equations with actual data for in-service exchanges, show considerably higher statistical confidence when both exchange connexion and traffic terms are included. Indeed, in many of the studies, the retention of

the per-exchange-connexion term was statistically questionable. Fig. 6 shows the range of confidence on estimates for Strowger exchanges.

CONCLUSION

The methodology developed provided the essential estimate of maintenance required for the renewal strategy studies.

The study draws attention to the complexity of the problem and relative values of estimating techniques at present available, concluding that the methodology offered provides a considerable advance over past approaches. As information and/or new systems become available, this approach provides a sound basis for synthesis and comparison of maintenance requirements.

ACKNOWLEDGEMENT

The authors wish to acknowledge the work of the team involved in the study and the many colleagues in various departments of the British Post Office Telecommunications Headquarters who assisted.

References

- ¹ BENSON, D. L. Local-Exchange Renewal Strategy: Formulating a Strategy. *POEEJ*, Vol. 67, p. 130, Oct. 1974.
- ² MAY, C. A. Electronic Exchanges: The Steps Leading to TXE4. *POEEJ*, Vol. 65, p. 134, Oct. 1972.
- ³ LONG, R. C., and GORRINGE, G. E. Electronic Telephone Exchanges: TXE2—A Small Electronic Exchange System. *POEEJ*, Vol. 62, p. 2, Apr. 1969.
- ⁴ BELL, R. L., BLOXHAM, G and CALLAGHAN, B. F. TXK3 Director-Area Local Exchanges using BXB 1112 Crossbar Equipment—Part 1—Trunking and General Operation. *POEEJ*, Vol. 67, p. 66, July 1974.
- ⁵ CROOKS, K. R. Local-Exchange Renewal Strategy: A Model for Decision. *POEEJ*, Vol. 67, p. 136, Oct. 1974.

Time-Division Multiplex for Telex-Customers' Lines

G. D. SKINGLE, C.ENG., M.I.E.E.†

UDC 621.394.34: 621.394.42

This article describes the cost studies carried out on both present Telex systems and possible alternative replacements, and a graph is given showing the relative costs on a number-of-channels/route-length basis. The article then describes the proposed new time-division-multiplex system for Telex-customers' lines and concludes with a summary of the findings from a preliminary trial and a field trial of the equipment.

INTRODUCTION

The problem of how to provide large numbers of local telegraph circuits most economically has arisen due to

(a) the rapid expansion of the Telex network, currently $12\frac{1}{2}\%$ /annum compound,

(b) the concentration of Telex customers in Greater London and its suburbs on Fleet and St. Botolphs exchanges, and

(c) the concentration of Telex customers around other large towns having Telex exchanges.

After carrying out a cost study of various alternative systems together with those currently in use, a time-division-multiplex (TDM) system, promising significant economic advantages, was proposed for development.

A feasibility-study trial model of the proposed system was made and used to carry live traffic between Fleet Telex exchange and Welwyn Garden City telephone exchange for a period of 10 months during 1971. Subsequently, a field-trial model of the system was made, incorporating certain modifications to the system control and supervisory methods used. Other physical changes to the equipment rack layout were made, the most significant being the inclusion of the test-access facilities on the rack. This model is being used in a field trial that started on 20 February 1973 between Reading Telex exchange and Maidenhead telephone exchange. Production systems will be similar to this model and are scheduled for delivery in mid-1976.

The system uses standard digital links as provided for pulse-code-modulation (PCM) telephony, and provides 184 Telex or telegraph channels at data signalling rates up to 110 bit/s with the standard channel units. Another channel unit has also been developed and tested for higher data-signalling rates, typically giving $7\frac{1}{2}\%$ isochronous telegraph distortion at 600 bit/s; this is a direct plug-in replacement for the standard channel units whilst maintaining the same system channel capacity. Main and stand-by PCM digital links and duplicated power-supply units are provided to give better security of service because of the large channel capacity of the system. The feasibility and field-trial models were designed to use only 1.536 Mbit/s PCM digital links, but production systems will be suitable for use on either 1.536 Mbit/s or 2.048 Mbit/s PCM digital links.

COST STUDY

The development of any new telegraph transmission system requires economic justification, and it was from this standpoint that the project was started in 1969.

† Telecommunications Development Department, Telecommunications Headquarters.

To make a realistic cost comparison between various systems of provision, actual forecasts and maps of Telex exchange areas were used and the following 2 methods of provision were postulated:

(a) all telephone exchange areas having direct connexion to the Telex exchange, and

(b) strategic groupings of telephone exchanges onto a parent exchange having direct connexion to the Telex exchange.

A simple computer programme was written to cost each exchange for the various systems of provision using method (a); the programme was then rerun using the net total number of circuits of the parent exchange and the new distances of the dependents from the parent. The result of the investigation showed that the most economic system of direct provision could give substantial savings compared with those at present in use. These savings could be further enhanced if the method of strategic grouping of exchanges on to a parent were adopted.

FACILITIES AND ECONOMIC REQUIREMENTS

Any system considered must

(a) accept and transmit the Telex-customer's local-line telegraph signals of +80 V and -80 V with less than 5% isochronous telegraph distortion,

(b) accept and transmit the supervisory and control signals, including 10 pulses/s dialling, without undue distortion; this also includes the transmission or interpretation of the customer *absent* no-current condition, and

(c) show a significant economic saving over the existing systems to pay for development and to achieve a reasonably short payback time from commencement of the project.

To this end, a cost study was carried out on the existing systems and 2 new systems.

INVESTIGATION OF MULTIPLEXING SYSTEMS

Over very short distances, no telegraph multiplex system can be economic. Therefore, the extra cost of using any telegraph multiplex system, compared with provision by physical pairs, was investigated. These costs were analysed in the following distinct areas, many of which are outside the multiplex designers' control:

(a) multiplex input and output interface devices such as light couplers, relays and barretter,

(b) individual channel cost of multiplexing,

(c) multiplex common equipment; for example, common multiplexing functions, power supplies, racking, rack wiring, installation, accommodation, power and signalling supplies,

(d) bearer-circuit cost,

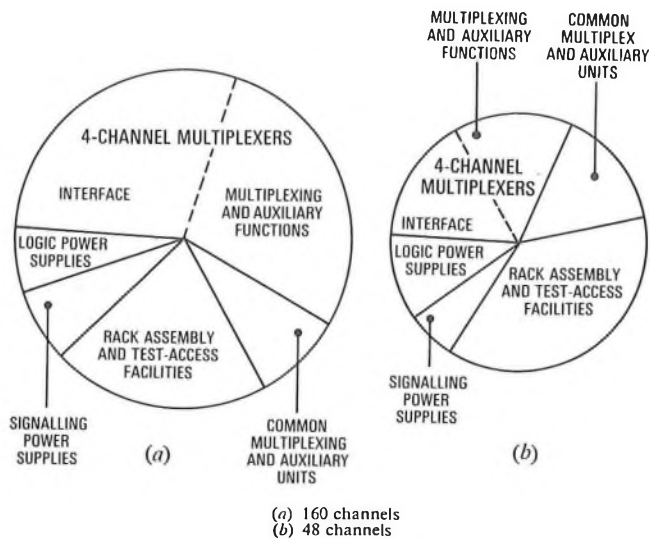

Fig. 1 — Cost breakdown for TDM terminal equipment

- (e) test equipment and facilities such as test teleprinter, telegraph-distortion measuring set, d.c. test facilities and test-access frame,
- (f) individual channel cost of auxiliary equipment such as low-pass telegraph filters and Telex signalling unit, and
- (g) training.

Items (a), (c), (e), (f) and (g) effectively set the minimum distance at which any multiplexing system could be economic. Items (a), (b) and (d) determine the number of channels that must be provided, at distances above this minimum, to be economic. Since the cost of items (e) and (g) are fixed, the system design was governed by the variations possible of the other items, the distribution of Telex-customers' line lengths, and the likely rate of growth in the particular area of application for the system. The growth rate is very important in Telex-customers' distribution schemes, where the actual location of growth is difficult to predict accurately and a capability of providing services quickly is desired. This suggested that the system should be flexible in the number of channels that could be provided, without incurring a high cost penalty per channel when not fully equipped. Fig. 1 shows the breakdown of cost for the TDM terminal equipment alone, when equipped for 160 and 48 channels. The objective set for the system was to provide large groups of circuits (49 or more), over the distance range 6.4-40 km, significantly cheaper than by existing methods.

NEW MULTIPLEX SYSTEMS CONSIDERED

System A

This was a modified form of multi-channel voice-frequency telegraphy (MCVFT) system, having the ability to transmit the 3-condition Telex-customer's line signal without the use of an external Telex signalling unit.

This system was included in the detailed cost study to decide if its development could be economically justified. It was ultimately considered to be of marginal benefit, owing to its development cost and the extra cost of providing the Telex signalling facility for telegraph circuits not requiring it. Administratively, it would also be difficult to ensure that equipments having the new facility would always be available to interwork.

System B

This was a bit-interleaved audio TDM system using a 2.4 kbit/s data modem to provide the bearer circuit.

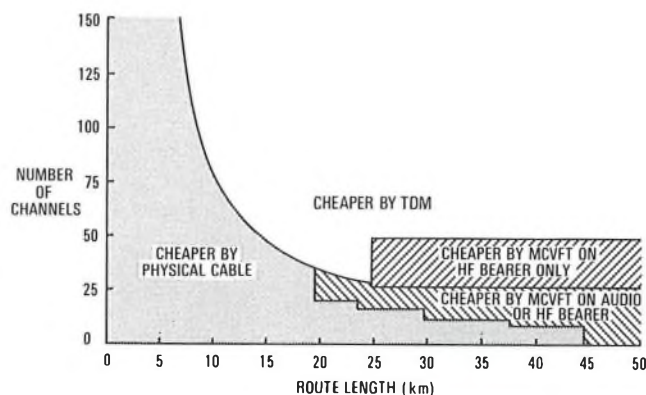

Fig. 2 — Cost comparison of systems for numbers of channels/route length

Typically, 46 channels can be provided by such a system using a 2.4 kbit/s digital bearer. This system was rejected after the preliminary costing exercise because its cost was greater than the existing systems for the distances under consideration. Its main area of application in 1969 was for long international or intercontinental trunk routes, where the higher terminal costs were justified by the extra number of channels that could be derived and used from one bearer circuit.

System C

This was a transition-encoded sampling system^{1,2} of TDM, using either a PCM telephony voice time-slot giving 56 or 64 kbit/s, or a 48 kbit/s modem to provide the digital bearer circuit.

This system was rejected after the preliminary costing exercise because it was found to be more expensive over the distances involved than existing systems. This was so both for Datel Modems No. 8 and 9,³ using a group-band circuit between Datel Modems No. 9, and Datel Modems No. 8 working baseband on unloaded cable. The range of operation, using baseband transmission, was also limited to about 12 km at the time of consideration, thus making the system even less attractive. Similarly, an economic PCM telephony voice-time-slot access equipment was not, and has not at the time of writing, been developed for all of the existing PCM telephony systems. An additional problem with the voice-time-slot access method is that the PCM telephony terminals are often not located at the Telex exchange. Therefore, physical circuits and low-pass telegraph filters must be provided at both ends of the circuit, thus imposing a further economic penalty on this system.

System D

This was a direct sampling system of TDM using a standard 1.536 Mbit/s or 2.048 Mbit/s digital link, normally provided for PCM telephony systems

This was the system adopted after the detailed economic study had demonstrated that substantial savings could be made by its development and introduction.

SYSTEMS AND METHODS OF PROVISION CONSIDERED IN DETAILED COST STUDY

At present, Telex-customers' lines can be provided by

- (a) using physical pairs, relayed or unrelayed, and
- (b) using an MCVFT channel and equipment to give the required Telex signalling facilities.

These methods were used as the yardstick by which the new methods of provision, using Systems A and D, were compared. Fig. 2 shows the resulting circuits/distance

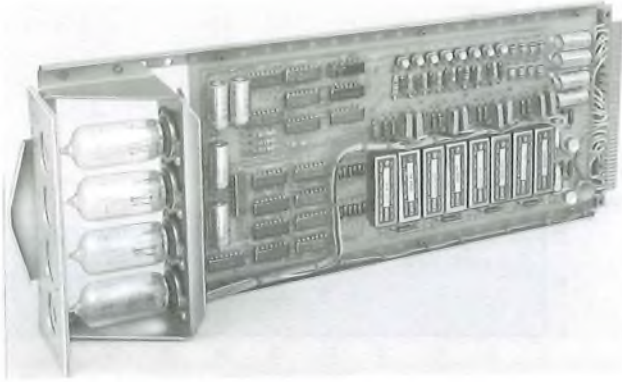

FIG. 3—Four-channel unit

planning graph produced after carrying out a discounted-cash-flow investment appraisal on the alternative systems; System A is neglected since it was abandoned.

BASIC ENGINEERING PHILOSOPHY OF THE SYSTEM

Terminal Equipment

From the cost study, the proposed field of application of the system indicated that a modular design concept would be most economic. The channel module was chosen to include the Telex signalling facility and the first stage of multiplexing, and to have a channel capacity of 4. The use of small-channel-capacity modules was justified economically because they would be a significant part of the terminal cost and could be purchased as required, using shorter forecast periods which were more accurate than those used with the 12 or 24 channels typical of MCVFT systems. This should reduce the money invested in idle equipment. Technical factors which influenced the channel module size were its simple mechanical construction, the permitted power-dissipation limits of 62-type equipment practice and an acceptable maintenance unit size in the event of a failure. A photograph of the 4-channel unit is shown in Fig. 3.

The permitted rack power-dissipation limits and, to a lesser extent, mechanical constraints limited the system capacity to 184 channels using one rack. The test-access frame, telegraph test facilities and provision for d.c.-d.c. converters, to supply ± 80 V signalling supplies when required, were also included on the equipment rack. The 80 V signalling supplies will be derived from the station 80 V supplies in the case of the Telex-exchange terminal; at the telephone exchange, they will be generated from the station battery supply by d.c.-d.c. converters on the equipment rack. These converters supply up to 96 channels on a main and stand-by basis, the converter outputs being combined by means of diodes. The field-trial model also uses this system of security for the logic supplies, but this could be changed in a manufacturer's production system. By including all functions and facilities on one rack and having it supplied fully-wired and equipped, with the exceptions of channel modules and d.c.-d.c. converters for signalling supplies, the terminal equipment is expected to be easy and cheap to plan, install and maintain.

Choice of Bearer Circuit

The choice of a PCM digital link as the bearer circuit had the following advantages:

- (a) it was cheap in terms of basic cost compared with high-speed modems over the distances considered,
- (b) it was very cheap in terms of bit/s per unit cost,
- (c) there was no cost of development, and

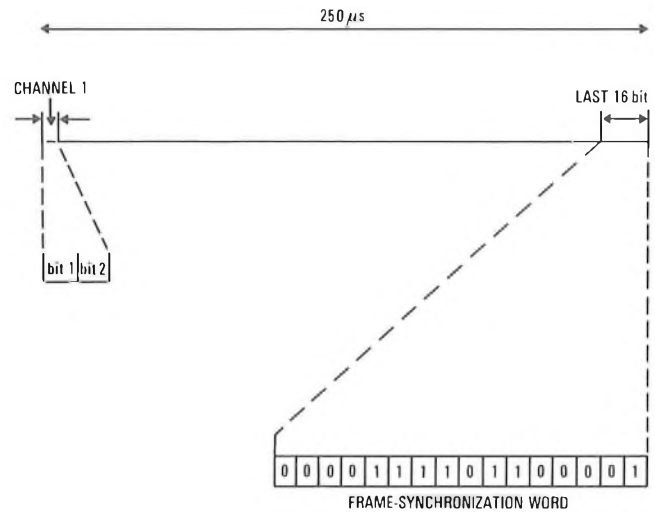

FIG. 4—Frame assembly

(d) the planning and maintenance procedures were well defined and had been in operation for a number of years.

The only possible disadvantage was a technical restriction that not more than 16 consecutive zeros should be transmitted on the 1.536 Mbit/s digital links because of the alternate-mark-inversion code used. This proved to be no real disadvantage because of the need to transmit the 3-condition Telex-customer's line signal. By using 2 consecutive bits to form the code word for each channel and using the combinations 01, 10 and 11, the 00 combination could be discarded, thus eliminating any possibility of transmitting 16 consecutive zeros. This choice also had a secondary benefit that a unique frame-synchronization word could be chosen; that is, one that could not be reproduced by the sampled channels under any normal condition. A 16-bit bunched frame-synchronization word was chosen to enable high-speed data channels to be incorporated, at a later stage, without losing this unique frame synchronization-word facility. This will be achieved by restricting data channels to non-adjacent 4-channel multiplexer time slots of 8 bit in the frame period, and ensuring that the first and second 8 bit of the frame-synchronization word incorporate unique combinations.

TDM PRINCIPLE APPLIED TO TELEX OR TELEGRAPHS

In a TDM system, the amplitude of the signal in each sending-end channel is sampled for short periods, at regularly-spaced instants of time. At each instant, a binary word, whose characteristics depend on the sampled amplitude, is sent over the common transmission path. The period between instants of sampling is the same for each channel, but the sampling instants for the different channels are staggered in time, so that consecutive binary words do not overlap each other. At the receiving end, electronic switches are arranged to operate synchronously with the incoming data and identify the binary word appropriate to each channel. The original telegraph signals can then be recreated and fed to the appropriate receiving-end channels. The accuracy with which the original signals can be recreated depends on the repetition frequency of the sampling instants. The amount of isochronous or peak start-stop telegraph distortion introduced by the sampling process is given by

$$\text{distortion} = \frac{\text{telegraph transmission rate in bauds} \times 100\%}{\text{frequency of sampling in hertz}}$$

Therefore, for a sampling frequency of 4 kHz and a transmission rate of 50 bauds, distortion = 1.25%.

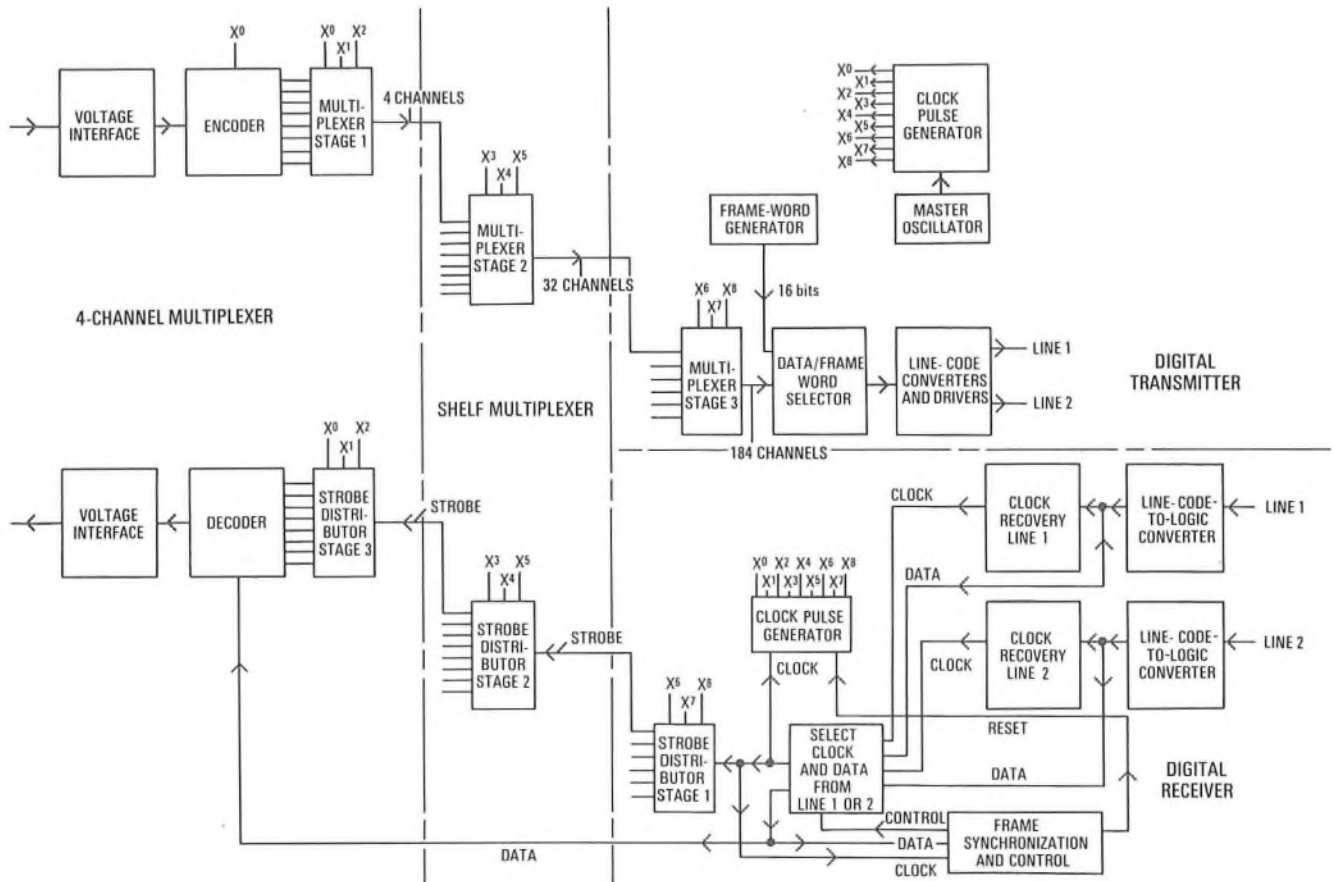

FIG. 5—Block diagram showing system structure

In addition to information peculiar to each channel, synchronization information must be transmitted to allow the receiver to be operated in step with the transmitter. A frame includes one binary word from each channel and the synchronization information. The synchronization word is unique because of encoding restrictions inherent in the design, and the synchronization information is bunched and inserted at the end of each frame, such that the start of the next frame can be identified. A unique and bunched pattern permits rapid recovery of synchronism, a necessary requirement for multiplexed telegraph or data systems. The frame structure used is shown in Fig. 4.

SYSTEM STRUCTURE

The basic system structure is simple, resulting from the use of the same basic elements at each stage of multiplexing or demultiplexing (see Fig. 5). The multiplexing element used is a standard transistor-transistor-logic integrated circuit, capable of multiplexing 8 inputs onto a common output line; the demultiplexing element is a 1-out-of-10 decoder intended for decoding 4-bit binary-coded-decimal (BCD) numbers. The organization of the frame period for 1.536 Mbit/s digital-bearer working is shown in Fig. 4. This is modified for 2.048 Mbit/s digital-bearer working, the frame period being kept at 250 μ s, equivalent to a 4 kHz sampling frequency, and the extra bits are filled with ones. This was considered to be a better solution than changing the frame period, because it allows easier access to the extra bits for other purposes at a later date.

Transmitter (Multiplex)

Encoding

A typical encoding circuit and associated logic is shown in Fig. 6(a). This circuit also provides electrical isolation between

the line input and the multiplex; an essential feature for all equipment connected to British Post Office (BPO) lines. The device used is an optical coupler and consists of a light-emitting diode and a photo transistor. They are optically aligned and encapsulated in a 6-pin dual-in-line package, with standard pin spacing. The device can withstand an alternating voltage of 1 kV r.m.s., at a frequency of 50 Hz, applied between its input and output for 5 s.

The bistable element B1 is clocked such that the output word presented to the multiplex does not change during the time it is being sampled and cause a coding violation. The gates G1 and G2 are normally enabled. If a disconnection lasting for more than 10 ms is detected, the delay circuit D1 inhibits the gates G1 and G2 such that the code 11 is presented to the multiplexer. The delay is necessary because the circuit must correctly interpret shaped (that is, band-limited) signals arriving from a customer. Referring to Fig. 6(b), during the period t , when a shaped input signal is below the threshold voltage of the input circuit, $V_T = \pm 16$ V, binary 00 is presented to the bistable element B1. The previous code is, therefore, stored and the delay circuit D1 ensures that the gates G1 and G2 are held enabled for at least 10 ms. Without this delay, the circuit would recognize a disconnection between the threshold voltages.

Eight-Channel Digital Switch

The 8-channel digital switch is used at each stage of the multiplex hierarchy. A 3-bit word, giving a maximum of 2³ discrete states, is used to address each stage, as shown in Table 1.

The logic of the switch is shown in Fig. 6(a), the AND gates being enabled sequentially such that the parallel (or simultaneous) data at the 8 inputs are converted to serial form via the OR gate.

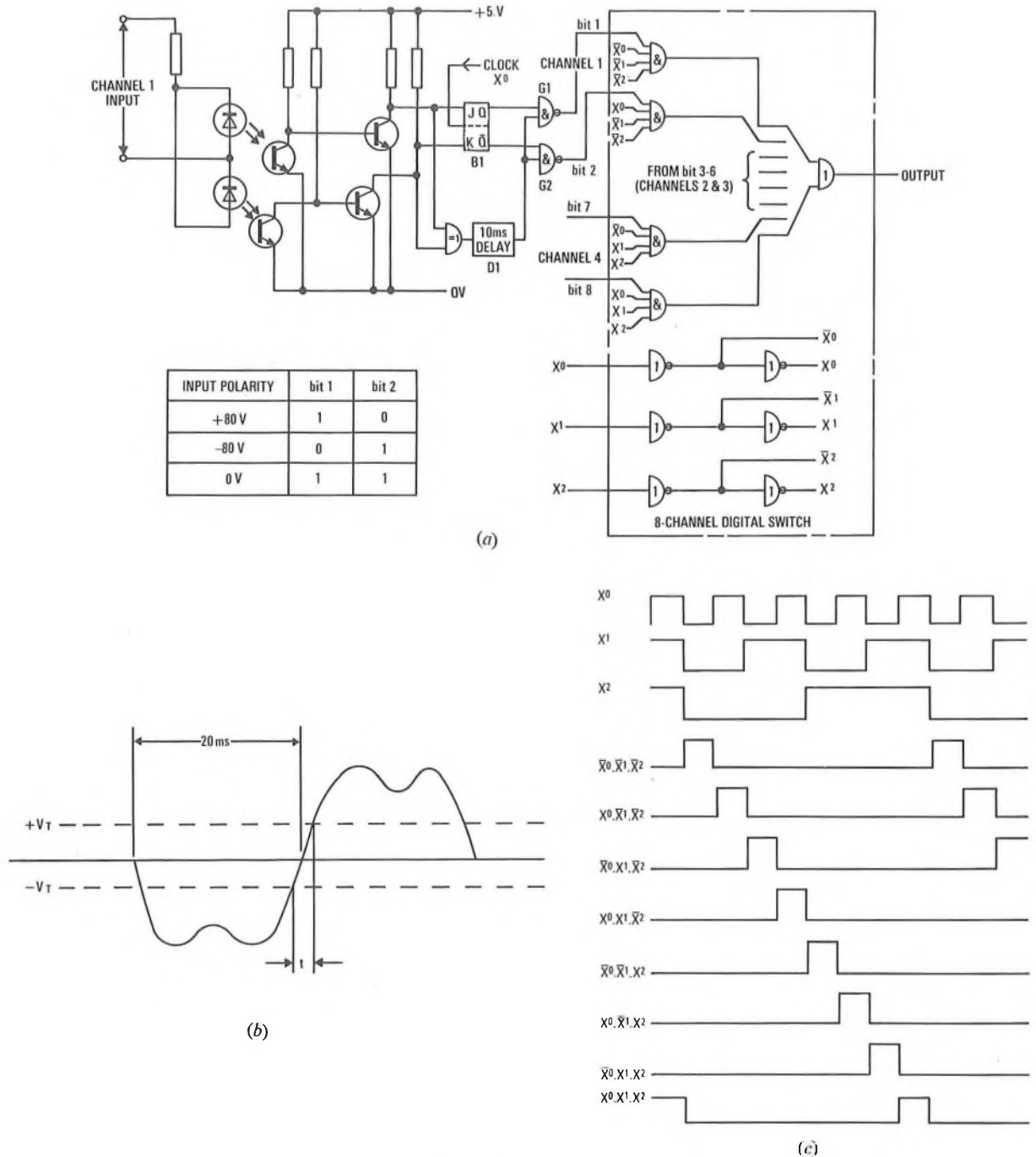

(a) Typical encoding circuit
 (b) Shaped channel-input waveform
 (c) Clock waveforms for bit selection

FIG. 6—Encoding logic

TABLE 1
 Details of Multiplexer Address

Stage	1 4-Channel Multiplexer	2 Shelf Multiplexer	3 Transmit Clock
Address	x^0, x^1, x^2	x^3, x^4, x^5	x^6, x^7, x^8

Frame-Word Generation

The 16-bit frame word is generated using two 8-channel digital switches, with their inputs pre-wired to either logic 0

or logic 1. Two serial outputs are provided, these being assembled into the time slots of the last 16 digits of the frame, after stage 3 of the multiplex.

Serial Data Regeneration and PCM Line Coding

After insertion of the frame-synchronization word, the assembled frame at the output of the third multiplex stage is regenerated to remove the effects of cumulative propagation delay. The binary digits are then converted to the relevant form for transmission; either the alternate-mark-inversion code for a 1.536 Mbit/s digital link, or the HDB3 code for a 2.048 Mbit/s digital link. Two such outputs are generated and are simultaneously transmitted on independent PCM digital links.

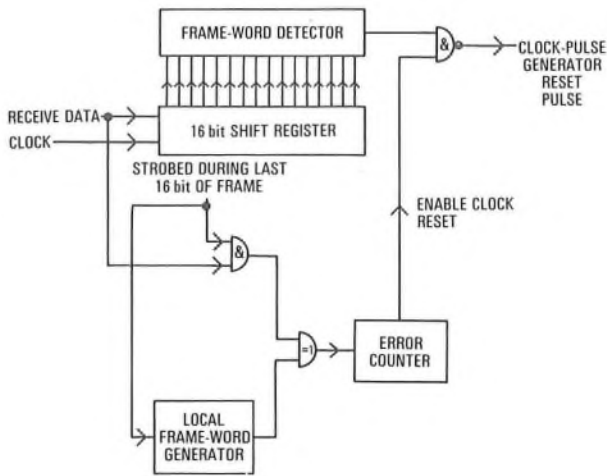

FIG. 7—Frame synchronization logic

Receiver

At the receiver, the main and stand-by digital links are continuously monitored for performance, one being used as the working link and the other providing an operational stand-by.

If a fault on the working link causes either a high error rate or loss of synchronism, the receiver automatically changes-over to the stand-by, if this is in an acceptable condition, and gives a non-urgent alarm. If the performance of the stand-by link only is affected, a change-over to it is prevented and a non-urgent alarm is given. If both links become unacceptable, all Telex calls are cleared down and an urgent alarm is given.

Receiver (Demultiplex)

Frame Synchronization

For correct operation, the demultiplexer must be maintained in correct bit and frame synchronism with the transmitter. Bit synchronization is inherent, since the receive master clock rate is recovered from the incoming line signal. Frame synchronization is maintained with the aid of the frame-synchronization word. Upon detection of this word in the 16-bit shift register, the binary counter clock-pulse generator is preset to the start condition (all zeros) such that its counting operations are brought into step (synchronization) with those of the transmitter. Once synchronism has been established, it is maintained for long periods. The synchronization apparatus is then redundant, but it must be ready to restore correct working immediately following a break in transmission or a fault. The frame-synchronization apparatus operates in the following manner.

(a) The last 16 digits of the frame are checked on a bit-for-bit basis, by comparison with a locally-generated frame-synchronization word.

(b) The receiver is deemed to be in synchronism if no errors are detected.

(c) If one or more bit errors are detected in any 2 consecutive frame-synchronization words, the receiver is deemed to be out of synchronism.

(d) The incoming binary data is then scanned in the 16-bit shift register, until the frame-synchronization word is detected.

(e) Upon detection, a pulse is applied to the clock-pulse (x^0-x^8) generator to preset it to digit time slot 1, the all-zeros condition. If the next frame-synchronization word is received correctly, it is assumed that synchronism has been regained. Assuming no violations occur from detection of loss of synchronism, correct working will be restored within 2 frames (500 μ s). The principle of operation is illustrated in Fig. 7.

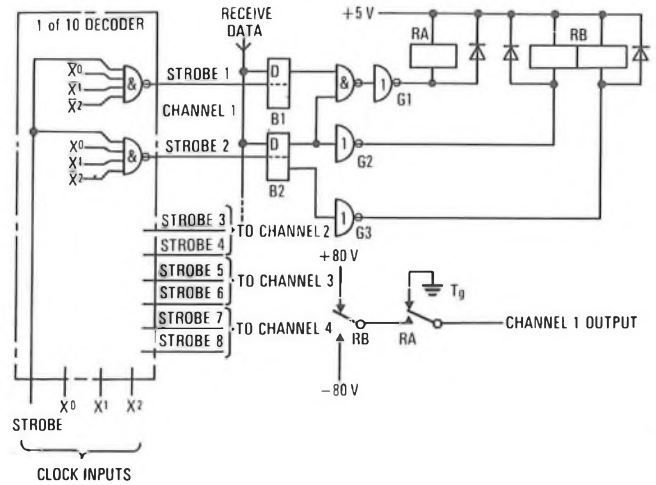

Note: Gates G1, G2 and G3 are open-collector types

FIG. 8—Decoder logic

Demultiplexing with the BCD-Decimal Decoder

The BCD-decimal decoder (demultiplexer) logic is shown in Fig. 8. This integrated circuit is used at each stage of the demultiplex hierarchy. A 3-bit word is used to address each stage as indicated in Table 2. The most significant bit of the BCD-decimal decoder is used as the strobe input.

TABLE 2

Details of Demultiplexer Address

Stage	1 Receive Clock	2 Shelf Multiplexer	3 4-Channel Multiplexer
Address	x^6, x^7, x^8	x^3, x^4, x^5	x^0, x^1, x^2

The output obtained from each stage consists of independent sequential strobe pulses. Since stage 1 address is restricted to a 6-state word, only 6 decoded outputs are available. These 6 outputs are used as strobe pulses to address each shelf multiplexer. Each shelf multiplexer has 8 outputs, since x^3, x^4, x^5 go through 2^3 states during the period of the strobe from stage 1, and these are used to strobe each of the 4-channel multiplexers on that shelf.

To minimize the risk of false strobe pulses occurring, the demultiplexer at stage 1 is strobed with the received clock pulses, such that no output pulse is produced until the address has attained a stable state; that is, any differences in edge timing are eliminated. Consequently, each stage will be strobed, since the output of each stage forms the strobe pulse for the next.

TABLE 3

Decoding Details

Channel Word		Output
Bistable Element B1	Bistable Element B2	
1	0	+80 V
0	1	-80 V
1	1	Earth

The Decoder

The demultiplexer at the third stage of the hierarchy (4-channel multiplexer) provides 8 sequential pulses, since x^0, x^1, x^2 go through 2^3 states during the period of the strobes from stage 2. These are arranged to clock D-type bistable elements, as shown in Fig. 8. Assuming correct synchronism has been established, data is read into each bistable element every 250 μ s. The outputs of the 2 bistable elements peculiar to each channel are then used to drive mercury-wetted relays, which are arranged to switch ± 80 V. The decoding details are shown in Table 3.

RESULTS OF FEASIBILITY AND FIELD TRIALS

Apart from the correction of design errors and weaknesses discovered during the commissioning and early stages of each trial, few problems have arisen in service. Both trials did highlight the difficulty of achieving an ideal control and supervisory system. The feasibility-trial system used only one digital link, whereas the field-trial system used a main and stand-by digital link, with automatic change-over at the receiver; the problems were, thus, somewhat different.

The problem encountered on the feasibility model was the lack of integrity of received-line error-rate measurement, using detection of bipolar violations in the alternate-mark-inversion signal. This gave rise to a high incidence of unnecessary alarms, not affecting service to the customer because, samples being at 250 μ s intervals, short error bursts produce only a small amount of telegraph distortion. During the trial, this was significantly improved by removing the error-rate alarm and using only the loss of frame synchronism as the measurement of received line signal quality.

The method of error-rate measurement and detection of loss of synchronism were both redesigned for the field-trial model. The error-rate measurement is now carried out by measuring errors in the frame-synchronization word over a defined period; for simplicity of logic, this is an integral number of frame periods. The number of errors counted must be greater than the frame-synchronization word length to ensure integrity and was chosen as 17, since this required the shortest measuring period. For production equipments, this has been specified as 20 over a slightly longer period, to align more accurately with the 1 in 10^3 and 1 in 10^4 error rates used for PCM telephony system maintenance. Loss of frame synchronism is now indicated only if 2 consecutive frame-synchronization words contain errors. These 2 design changes prevent a single error burst, that would not affect service to the customer, from causing unnecessary alarms or change-overs. They have proved entirely satisfactory during the field trial.

A weakness discovered in the field-trial model, during commissioning tests, was that the received stand-by line signal is only checked for its presence, no check being made of its error rate. Under certain line-fault conditions, some regenerators used on 1.536 Mbit/s digital links can go into an oscillatory mode, and subsequent regenerators emit what

appears to be a valid signal to the simple detection circuit used in the stand-by line receiver. The specification for production systems will require the received stand-by signal to be monitored for error rate and attainment of synchronism, even though no problems have occurred during the field trial due to this lack of integrity.

Other changes, which have also been specified for production systems, are described below.

(a) It will be possible to preselect either received digital link as the main, with the other automatically becoming the stand-by. This will reduce the number of change-overs necessary from one link to the other; for example, when a faulty link is restored to a working state, it can then be selected to become the stand-by.

(b) An inbuilt monitoring unit will be introduced, enabling the observer to select and display the 8 bits, either transmitted or received, by any 4-channel multiplexer from the respective binary multiplexed stream. This has been included to assist with rapid fault location to a terminal equipment, without the need for complex test equipment or unnecessary substitution of units. This should also reduce the number of units having no apparent fault on them when retested at the central repair centre.

(c) The fuse cards, alarm unit, and monitor-unit transmitter and receiver will be grouped on one shelf nearer to eye level to aid rapid fault location and clearance.

The fault rate per channel of the overall field-trial TDM system is comparable with that for modern MCVFT terminal equipment alone, and significantly better than MCVFT equipment and its bearer circuit combined. Thus, the service provided to the customer is better; customers from both feasibility and field trials have commented favourably about an improvement in service without any knowledge of the trials taking place. This is probably due to the reduced delay with the TDM system compared with the MCVFT system when initiating a call. The TDM system reduces the response time after the operator presses the call button and awaits the lamp indication to start dialling.

CONCLUSIONS

A TDM telegraph system that fulfils the set design objectives of relative cost, technical performance and operational requirements has been developed within the BPO. Apart from the capital and maintenance cost savings predicted in the original cost benefit study, some improvement in service to the customer is also expected.

References

- 1 TRAVIS, L. F., and YAEGER, R. E. Wideband Data on T1 Carrier. *BSTJ*, Vol. 54, Oct. 1965.
- 2 OSWALD, J. R. Codest: A New PCM System for Telegraph and Data Transmission. *IEEE Transactions on Communication Technology*, Vol. com.—18, No. 3, June 1970.
- 3 BIGG, R. W. Modems for 48 kbit/s Data Transmission. *POEEJ*, Vol. 64, p. 116, July 1971.

The Anechoic Chamber in the London Test Section of the British Post Office

E. W. REAVES†

UDC 534.6: 534.2.001: 620.1

This article describes an anechoic chamber built for the Quality Assurance Branch at the headquarters of their London Test Section, to permit reliable acoustic measurements to be made on a variety of transducers, transducing instruments and acoustic materials. The performance of the chamber is also given.

INTRODUCTION

Reliable and repeatable acoustic measurements, under free-field and interference-free conditions, are necessary for quality-assurance work on transducers used in hearing aids and telephones, for which the Quality Assurance Branch of the British Post Office (BPO) is responsible. These conditions demand an environment where reflected sound and ambient noise are reduced to negligible proportions.

The first of these requirements may be met by a room in which all inner surfaces are lined with sound-absorbent material (that is, an anechoic chamber); the second requirement may be achieved by providing the room with sufficient sound insulation and immunity from structure-borne vibration to ensure that interference from both sources is reduced to tolerable proportions. The field pattern from a source of sound within such a room is sensibly constant, irrespective of frequency throughout the working area. This permits measurements of the required accuracy to be made over a wide range of level and frequency. Measuring equipment used in association with the room is housed in an adjoining laboratory.

† Purchasing and Supply Department, Telecommunications Headquarters.

LOCATION

In accordance with the Quality Assurance Branch policy of centralization of London Test Section test facilities, the chamber, and its associated laboratory, has been built on the same site as that shared by existing London Test Section laboratories at Studd St., North London. Here, accommodation is very limited; the needs of other departments and branches are such that any unoccupied space has little to commend it.

However, one end of a bungalow building (see Fig. 1), comprising the ground floor and basement, offered sufficient space for both laboratory and chamber, provided the floor at ground level was removed to allow the chamber to be accommodated in the combined ground floor and basement areas. This major alteration was of little consequence since the building in this area was very dilapidated and would, in any case, have needed considerable renovation to make it habitable.

Real disadvantages were that

(a) a substantial volume of motor traffic (mail vans and delivery vans) passed along a roadway between the bungalow and the building housing the main London Test Section laboratories,

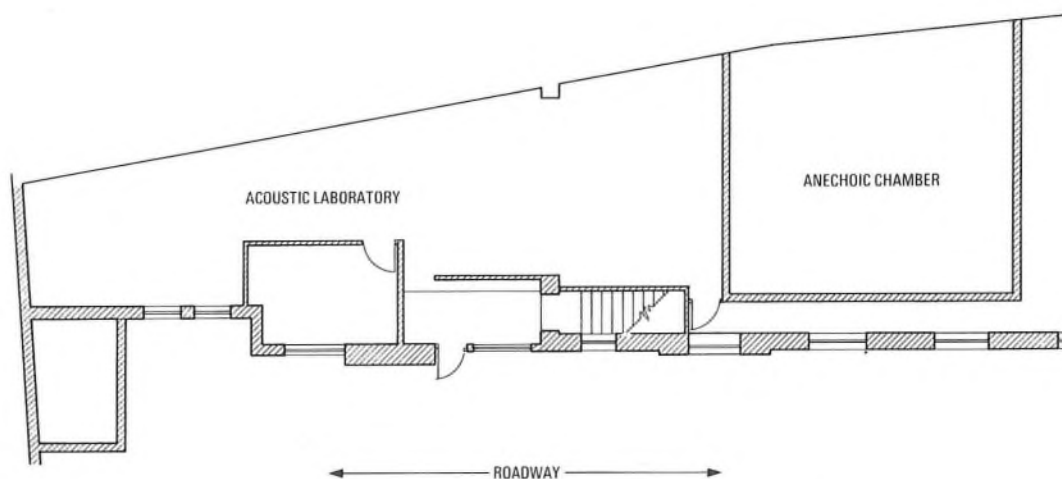

FIG. 1—Outline plan of anechoic chamber and acoustic laboratory

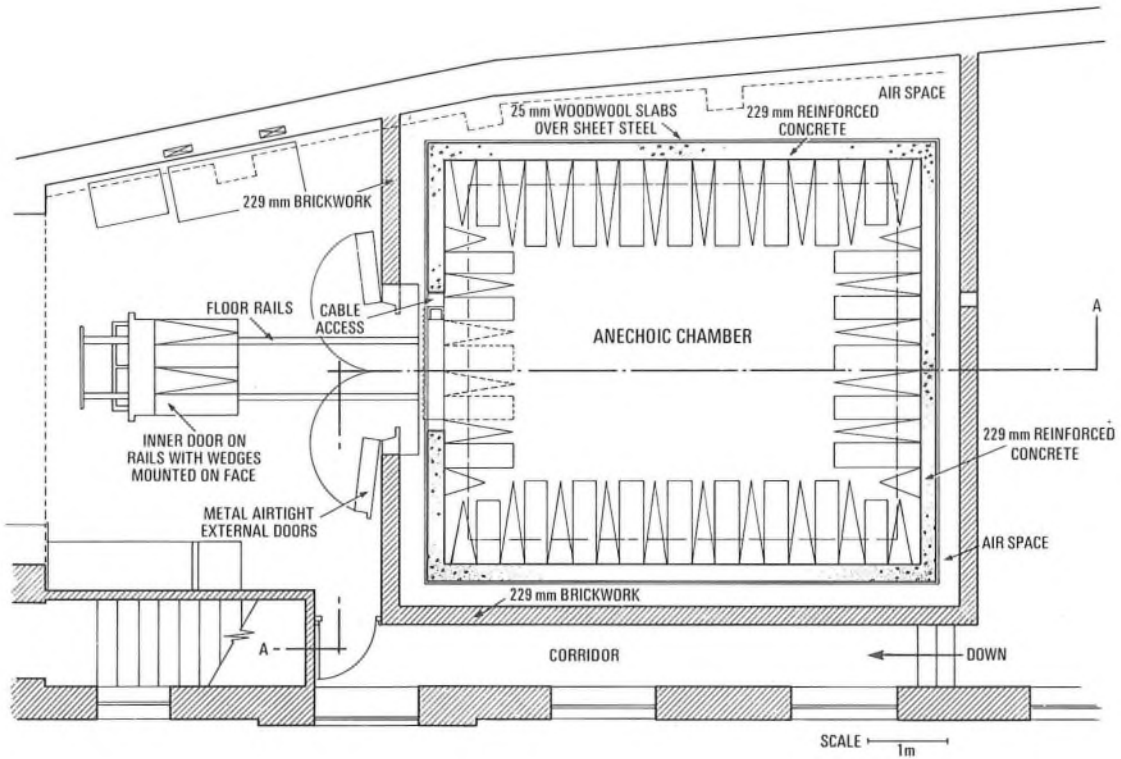

FIG. 2—Plan section of chamber

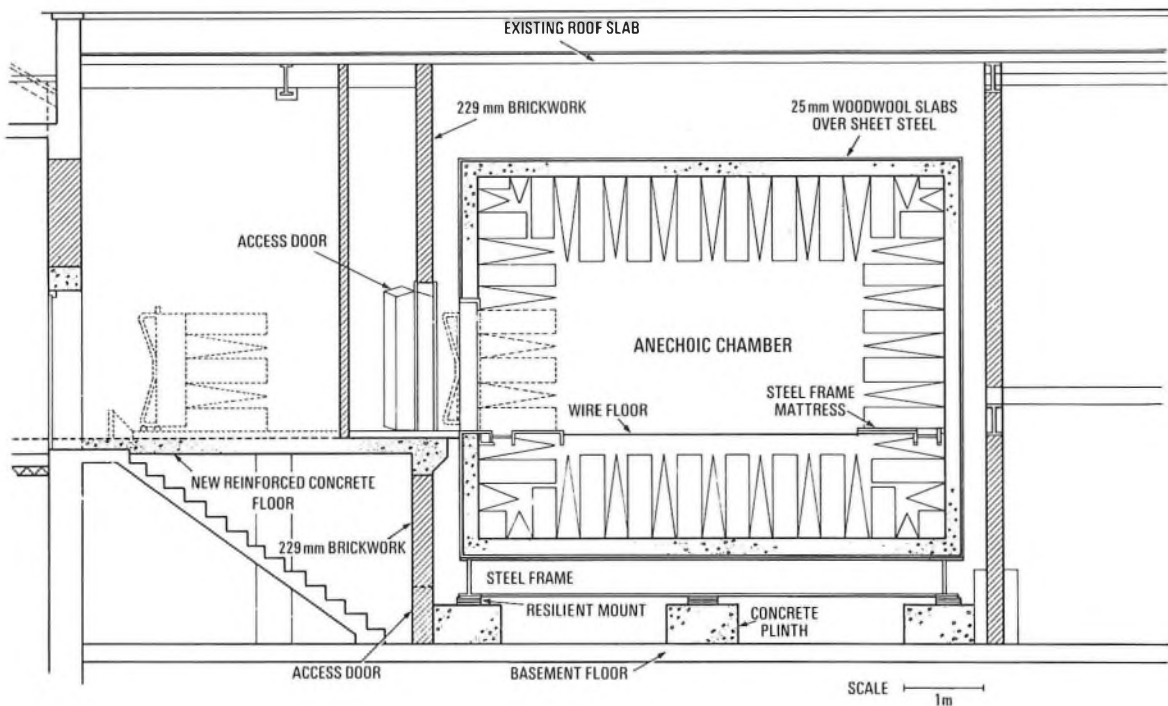

FIG. 3—Side elevation section of chamber

(b) Victoria Line trains ran underground within 61 m of the proposed chamber, and

(c) EHT and photometry laboratories were in the immediate vicinity.

The vehicles in (a) and (b) were sources of air-borne noise

and earth-borne vibration, and the laboratories in (c) were possible sources of electrical interference.

These were all serious drawbacks, but not so serious that they could not be contained within tolerable limits by suitable measures incorporated at the design stage.

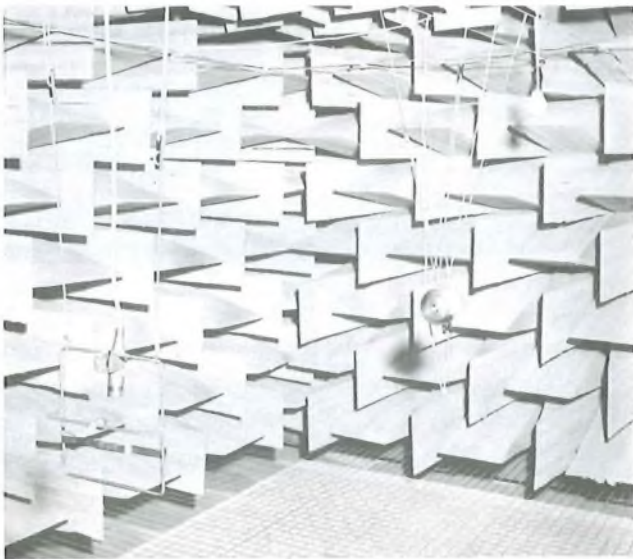

FIG. 4—Interior of inner chamber with normal test equipment in position

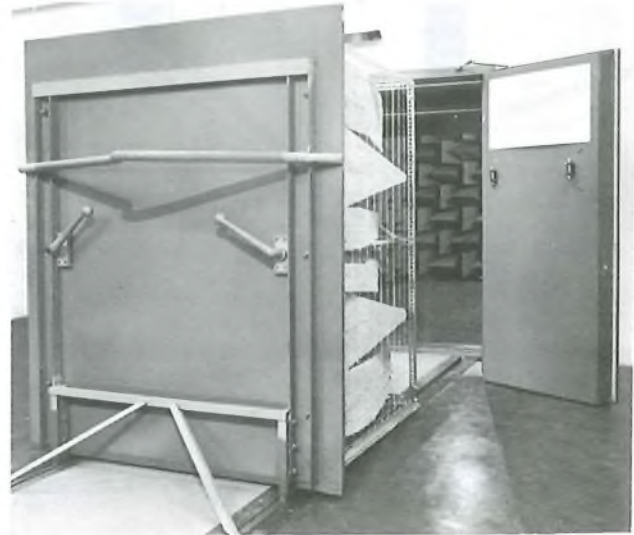

FIG. 5—Doors of both chambers in the open position

OUTLINE OF CONSTRUCTION

Figs. 2 and 3 are sectional drawings of the complete chamber. The air-borne noise has been effectively dealt with by adopting a double-shell construction, comprising 2 chambers built one inside the other and separated from one another by a layer of air. Provided each chamber is air-tight under working conditions, sufficient mass is incorporated in their construction, and the layer between the two is of adequate thickness, then externally-generated noise penetrating the inner chamber is reduced to an acceptably low level over a wide frequency range.

The inner chamber is built in 229 mm thick steel-reinforced concrete, and weighs about 120 t. The outer chamber is in 229 mm thick brickwork, and the air space separating the 2 chambers is, in general, not less than 305 mm. For structural reasons, this clearance is unavoidably reduced at some points.

OUTER CHAMBER

Fig. 2 shows a plan view of the whole chamber, from which the outer chamber can be seen to comprise three 229 mm brick walls built against the external wall of the building. The outer chamber could have been built more simply by erecting 2 walls across the width of the building reaching from basement floor-level to ground-floor ceiling-level. However, this would have isolated one end of the building from the other and contravened fire regulations which insist on free passageway between the 2 parts of the building. A corridor is, therefore, provided at both ground-floor and basement levels on the roadway side of the building.

Fig. 3 is a side elevation showing the vertical extent of the walls, and the positions of the doors giving access to the enclosed space. These doors are provided

(a) at basement floor-level for maintenance in the space between the 2 chambers, and

(b) at ground floor-level to allow entry to the inner chamber during normal operation.

Each door is so designed that, when closed, the sound-insulating properties of the walls are not significantly impaired.

INNER CHAMBER

An outline of the inner chamber and its position within the outer shell are shown in Figs. 2 and 3.

To possess good anechoic characteristics, the chamber should not be a cube; sides in the ratio of 1.0 : 1.25 : 1.6 provide a favourable basis for a successful design. The area available did not allow a very close approach to this ratio without sacrificing useful working space, but it was possible to accommodate a chamber having length, width and height of 6.4 m \times 5.56 m \times 5.03 m respectively, and these dimensions are sufficiently non-cubic for practical purposes.

The predecessor to the present chamber was lined with wedges consisting of loose glass fibres enclosed in a muslin bag. During the several years it was in use, the glass fibre disintegrated to the extent that minute particles of glass, floating in the air, caused appreciable irritation to any person working inside the chamber for any length of time. With this experience in mind, alternative materials were considered. Each had advantages and disadvantages, and the final decision to use glass fibre again was taken on the manufacturer's assurance that the current product was substantially free from disintegration. The present wedges, shown in Fig. 4, are rigid and are treated with a thin varnish to impart additional mechanical strength whilst leaving the sound-absorption qualities unimpaired. Time alone will prove whether the manufacturer's claim is valid, but analysis of air within the chamber indicates that contamination due to glass particles is negligible at present.

The working area within the chamber, measured between wedge tips, is 3.91 m long, by 2.97 m wide, by 2.44 m high. The effective height is reduced by the provision of a wire floor suspended some 0.3 m above the tips of the wedges lining the floor of the chamber (see Fig. 4). The floor consists of 3.18 mm diameter steel wires woven to form a 50.8 mm mesh, this being fixed to the chamber walls and tensioned to withstand a vertical load of 272 kg at any point without deflecting more than 38 mm. Because of its mesh construction, the floor is acoustically invisible, and adequately supports the number of staff likely to be working in the room at any one time. Fixing points and tensioning devices are sufficiently shielded by the wedges to cause no significant level of sound reflection. A fine gauze net, fitted immediately below the wire, prevents any small articles falling through the floor into the wedges below.

The door to the chamber (Fig. 5) is a single unit, with a mass and wedge treatment similar to the wall into which it fits. It is mounted on a wheeled carriage, running on rails embedded in the floor at the approach to the chamber, and

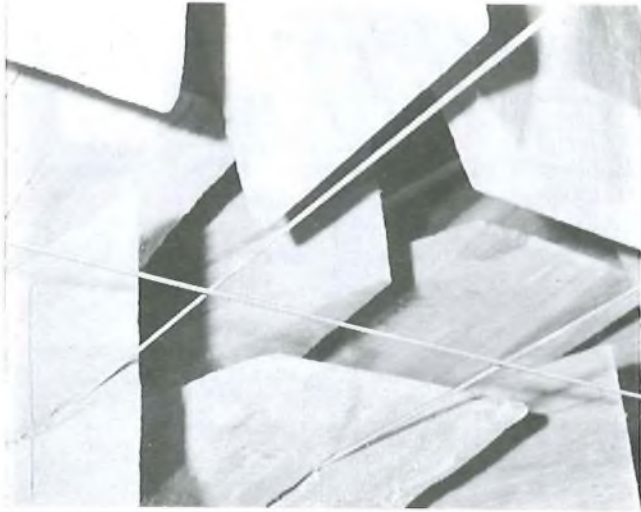

FIG. 6—Overhead support wires

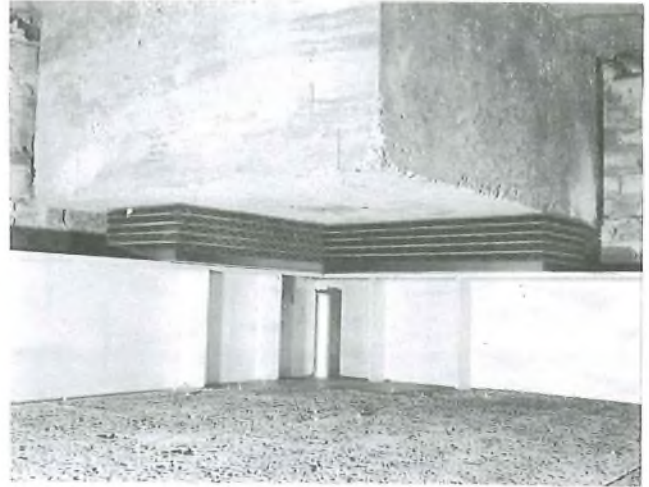

FIG. 8—Underside of chamber showing woodwool blanket, resilient pads and one concrete support block

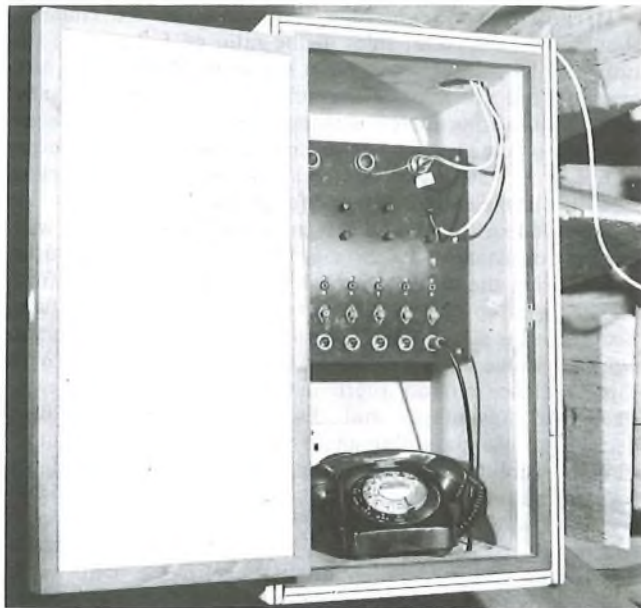

FIG. 7—Interior of termination box

when closed and locked in position, forms an air-tight and integral part of the wall. The carriage remains on its rails when the door is closed and constitutes a solid link between the inner chamber and the remainder of the building. This is obviously undesirable since it could offer a path through which structural-borne vibration may travel. Fortunately, perhaps because of the resilient nature of the seal between door and chamber, there has been no discernible interference from this source.

The door is normally opened and closed manually from outside, but because of the danger to anyone inadvertently left inside the closed chamber, provision is made to allow the door to be opened from within. Other precautions, referred to later, have also been taken to ensure maximum safety in this eventuality.

To minimize interference with the pattern of the sound

field within the chamber, fittings have been reduced to the bare essentials. Pairs of wires along the length and width of the chamber at the respective centre lines, and a single wire along each side, are tensioned to the walls just below the tips of ceiling wedges (see Fig. 6). These provide a means of suspending test equipment, usually a sound-pressure unit (loudspeaker), a capacitor microphone and the item under test.

Lighting within the chamber is also reduced to the bare essentials of 2 unshaded incandescent lamps, suspended just below the ceiling wedges. Because of their spherical shape and small dimensions, the effect on the sound field is negligible. Electrical connexions to the interior of the chamber, including test leads to the laboratory but excluding those used for normal lighting, terminate in a box attached to the wall at one side of the door aperture. This box is sunk to wedge-tip depth (Fig. 7) and its lid is faced with sound-absorbent material.

RESILIENT PADS

Ideally, the inner chamber should be physically isolated from the remainder of the building. This is easy to arrange for ceiling and walls, apart from the difficulty with the door described earlier, but some contact has to be tolerated for the base; that is, the chamber has to stand on something. Therefore, the means of support chosen must be capable of absorbing earth-borne vibration if the chamber is to be substantially free from this form of interference.

Rubber pads offer one solution to this problem when the natural frequency of the chamber is well below that of the lowest frequency likely to cause interference. Since the natural frequency of the chamber is about 9 Hz and the lowest test frequency is expected to be about 50 Hz, a worthwhile measure of isolation is anticipated.

The pads chosen, which comprise alternate layers of rubber and steel plate, are placed at all 4 corners of the base and midway along each side. The whole chamber is raised on concrete blocks (see Fig. 8), to allow it to be jacked-up should the pads need replacement. Although the chamber weighs approximately 120 t, the compression of the pads is less than 12.7 mm.

SOUND INSULATION BETWEEN THE CHAMBERS

Over the broad band of working frequencies, the sound insulation offered by the wall-air-wall construction is sufficient

to ensure that, within the inner chamber, the level of interference, caused by externally-generated noise, is insignificant. However, interference sources at certain frequencies in this band, if incident to the structural walls at critical angles, may stimulate resonances in the cavity between the chambers and this would raise the interference within the inner chamber to an unacceptably high level. This decrease in sound isolation can be offset by introducing absorbent material into the air layer, and for this purpose, a 25 mm thick blanket of wood-wool is attached to, and completely encloses, the inner chamber (see Fig. 8).

ELECTRICAL INTERFERENCE

The generation of electric fields by the adjacent EHT laboratory and passing motor traffic are both possible sources of interference and, as a precautionary measure, the inner chamber is encased in an earthed sheet-steel screen, fitted immediately beneath the woodwool blanket.

SAFETY PRECAUTIONS

Since the inner chamber is both soundproof and air-tight it is vital that any person inadvertently shut in should be able to release himself or, if this is not possible, to summon assistance. Therefore, the following provisions have been made:

(a) the doors of both inner and outer chambers may be opened from within the inner chamber,

(b) a luminous marker is fitted to the termination box to enable it to be located in darkness,

(c) a light inside the termination box automatically switches on when the lid is opened,

(d) an external alarm may be operated from within the termination box,

(e) a main lighting switch is fitted near the termination box, and

(f) a telephone is installed in the termination box.

CONCLUSION

The facilities offered by the new chamber and its measurements laboratory are a valuable addition to the services already available from Quality Assurance Branch laboratories in Birmingham and London.

The sound field pattern over the frequency range 100–6400 Hz, measured along the normal working axis, obeys an inverse square law within a spread of 2.5 dB, up to a distance of 3 m from the sound source; up to 1.5 m from the sound source, the spread does not exceed 1.5 dB.

Interference from all sources has been reduced to negligible proportions with the exception of that arising from trains on the nearby underground railway. This is responsible for an intermittent interference at a maximum level of 40 dB sound pressure level in a $\frac{1}{3}$ -octave band centred on 40 Hz, and 35 dB sound pressure level in a $\frac{1}{3}$ -octave band centred on 125 Hz. This causes some inconvenience in the use of the chamber, but since the effects are known, due precautions may be taken to safeguard the accuracy of measurements.

Book Review

Materials and Processes for Electrical Technicians. L. C. Mott, A.M.I.E.D. Clarendon Press: Oxford University Press. xii+169 pp. 71 ill. £1.95 (paper), £5.00 (boards).

I think it is useful to ask oneself what should be expected of a book of 160 pages concerning materials and processes, and aimed at the trainee electrical technician. The limitation of 160 pages demands that the writing be concise and wholly relevant to the needs and capacities of the technician grade. If the technicians' view of the subject is not to be distorted, the material presented should be factually correct, reasonably up-to-date, and should not mislead, either by ambiguity or by the omission or distortion of significant areas of the topics covered.

In this book, there are few parts which approach this ideal. Section 2, on processes, is fair, although some of the information is dated, and the workshop processes are treated at an elementary level, even by trainee-technician standards. The materials chapters, up to Chapter 7, are basically sound, although even these contain scattered errors, or misleading abbreviations of topics that could have been better explained using 2 sentences rather than one. Chapters 7–13 range from mediocre to disastrous. Unfortunately for telecommunications technicians, the 2 worst chapters are on polyethylene and underground telephone cables. These deserve detailed criticism.

In the chapter on polyethylene,

(a) no mention is made of the fact that polyethylene is available in low-density and high-density versions, with different property ranges,

(b) polyethylene is not a clear material, as stated; it ranges

from translucent at low densities to semi-opaque at high densities,

(c) to say, "It is displacing gutta percha," (for submarine cables) is to get the timing adrift by 25 years, and

(d) to say, "Polyethylene is attacked by ultra-violet light, unless protected by a black material, such as butyl rubber," is misleading. Butyl rubber is not black, unless made so by the incorporation of carbon-black, and weather-resisting grades of polyethylene, which incorporate directly-added carbon, have been available for 25 years. Butyl rubber is sometimes blended into polyethylene, but for the totally different purpose of improving its stress-cracking resistance.

In the chapter on underground telephone cables, no mention is made of the logical division of a cable network into long-haul trunk cable, short-haul trunks or junctions, exchange-area local cables, and local distribution cables. There is confusion over the construction of internal cables for distribution within buildings, which are insulated and sheathed with PVC, and external cables, which are not. Obsolete practices are described; for example, the use of enamelled-wire-plus-textile cables for distribution within exchanges ceased 30 years ago. No mention is made of the increasing use of aluminium as a conductor in underground cables, or the displacement of lead by polyethylene for cable sheaths on all except coaxial cables. Underground telephone-cable conductors are not made up as "singles and triples," only pairs and quads.

While these 2 sections are, undoubtedly, the worst, equally unfortunate lapses are scattered through the rest of the book and, in the opinion of the reviewer, it is not a suitable vehicle for the training of electrical technicians, or anybody else for that matter.

J. C. H.

A Review of Magnetic Storage Devices

E. A. LOOMES, M.B.C.S.†

UDC 681.32: 681.3.07: 681.327.0

This article explains the need for different classes of storage in digital computer systems and why magnetic devices have been used almost universally for these applications. Fixed and moving-media devices are reviewed and compared, and descriptions are given of magnetic-core and plated-wire stores, followed by magnetic-tape, drum and disc equipment.

INTRODUCTION

The storage of information is a concept with which everyone is familiar. Examples of very-large-capacity stores include the printed word, the gramophone record and the human brain. The capacity of the Concise Oxford Dictionary has been estimated as 10^8 bit, and of the brain as 10^{13} bit. In a telephone exchange, information about a subscriber, for example the directory number, is stored in a semi-permanent pattern of wires joining the incoming line to the exchange equipment. A director stores code translations in a similar fashion, or may use magnetic cores. In some electronic exchanges, the pattern is formed by threading wires through toroidal transformers in a Dimond ring store¹. These are examples of *read-only* stores, in which the contents are changed infrequently, but which can be quickly and repeatedly accessed.

Theoretically, any device that can exist in a discrete number of distinguishable states can be used as a storage element. These states may be

- (a) positional; for example, a counting frame or holes in a punched card,
- (b) electrical; for example, discrete voltage levels, or
- (c) magnetic; for example, alternative flux polarities in a ferrite toroid or oxide surface.

The magnetic toroid or core is an example of a binary storage cell capable of existing in 2 states only and, therefore, storing 1 bit. Presence of a binary *one* or *zero* is detected by determining into which of the 2 states the cell has been set.

† Telecommunications Development Department, Telecommunications Headquarters.

These states must, therefore, be stable, reproducible and detectable.

A digital computer uses binary storage, compatible with its use of binary switching to perform arithmetic and logical functions. Since, in a general review of this nature, it is impossible to treat every aspect of the subject in depth, the scope of this article has been limited to brief descriptions of various types of magnetic store, considered in relation to the requirements of digital computers.

STORE HIERARCHIES

Ideally, a computer store should

- (a) be of sufficient size to give the capacity to meet the needs of programme and data storage, and working space,
- (b) have sufficient speed of operation not to delay unduly the central processor,
- (c) be of low cost,
- (d) permit random access, so that any location is accessible in the same short time,
- (e) possess high reliability against failure or data corruption,
- (f) be non-volatile, so that data is retained if power is removed, and
- (g) be compatible with the processor, so that the interface is simple and reliable.

Storage requirements are continuously growing as regards size, speed and reliability, but limits are imposed by cost. A large, fast, random-access, non-volatile store is expensive. Other conflicts also occur; for example, the speed of a large store is limited by the propagation time of the signals.

A computer system, therefore, includes several different

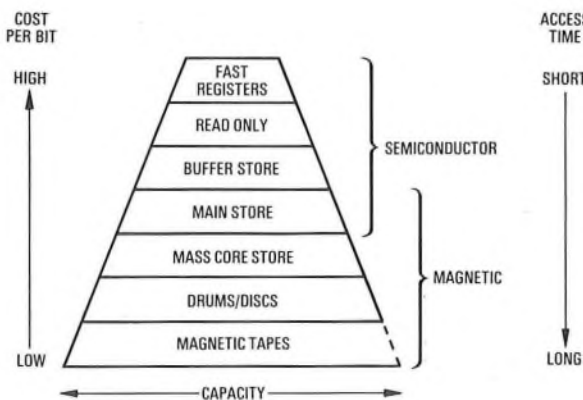

FIG. 1—Store hierarchy

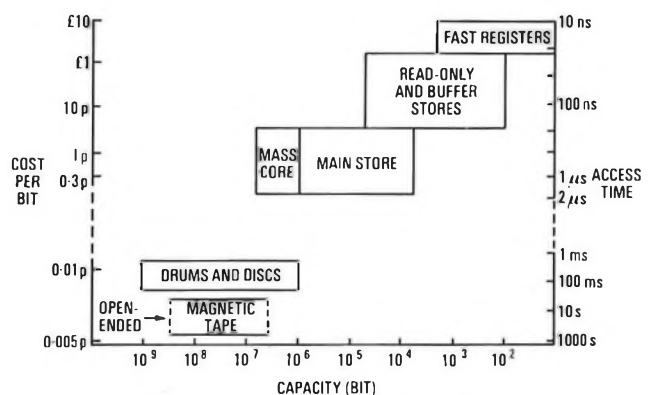

FIG. 2—Relationship between store size, access time and cost

types of store having various characteristics, the proportion of each being chosen by the system designer, and to some extent by the user, to achieve an optimum configuration. Such a hierarchy is illustrated in Fig. 1, while Fig. 2 shows the relationship between cost, speed and size for various types of store. The costs are approximate and, where appropriate, include the costs of transport and control equipment in typical systems.

Fig. 3 shows the fall in cost per bit of typical core stores from 1967, and how costs of semiconductor stores are rapidly reducing and may soon be cheaper than core stores. However, although the proportion of semiconductor storage in use is rapidly increasing, it is believed that core stores will continue to be produced in significant volume for some years, since total storage requirements are also rising rapidly.

MAGNETIC STORES

The storage of data by the polarity of magnetization, or change in magnetic polarity in a saturated ferromagnetic material, has been in common use for many years. There are 2 main categories; fixed matrices of magnetic elements as used within a computer mainframe, and moving-media devices such as drums, discs and tapes as used for backing storage. These categories may be subdivided as shown in Table 1.

TABLE 1
Categories and Types of Store

Category	Types of Store
Fixed storage	Square-loop ferrite toroids or cores Thin magnetic films, planar or plated wire
Moving media	Magnetic tape, including cassettes Magnetic drums Magnetic discs

Each of these is examined in greater detail below.

Magnetic Cores

A core store comprises a 2-dimensional or 3-dimensional array of ferrite toroids threaded by wires that enable the magnetization state to be switched when writing data and permit the states to be detected when reading. Usually, a binary one is detected by restoring the core to its zero state, this being known as *destructive read-out*. Typical cores have outside diameters in the range 0.5-0.75 mm, and a central hole of 0.33-0.5 mm diameter. The smaller sizes are more difficult to manufacture to uniform standards, and to thread. Working with wires too thin to see clearly with the unaided eye is very exacting, and is usually done where labour is cheap and where similar skills exist; for example, lace-making. However, small cores can be closer together and need lower drive currents, thus increasing speed and capacity.

The cores possess a square hysteresis loop. Referring to Fig. 4, a write current saturates the core in one direction, for example to point A, and when the current is removed, the core retains flux as indicated at point C. A current in the reverse direction reverses the flux (point D), and when the current is again discontinued, the flux in the new direction is retained as at point E. Points C and E may represent the *one* and *zero* states respectively.

There are several schemes for threading a matrix of cores to form a complete store.^{2,3} All make use of the *coincident-current* principle; currents in 2 wires threading the core in the same direction are together sufficient to switch the flux, whereas a single current only *disturbs* the core, so that when the current is removed, the original state is retained (at a slightly lower flux density, as shown at points F and G in Fig. 4).

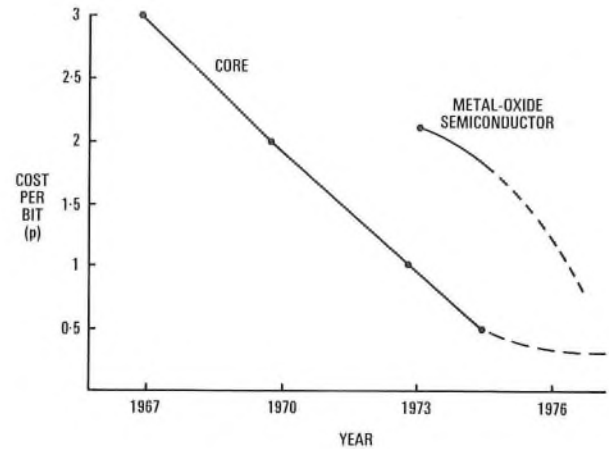

FIG. 3—Fall in store cost

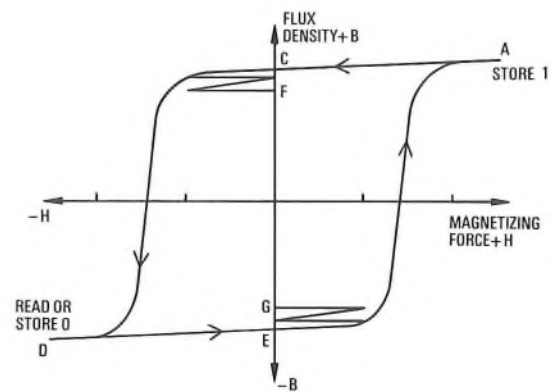

FIG. 4—Principle of storage in magnetic material

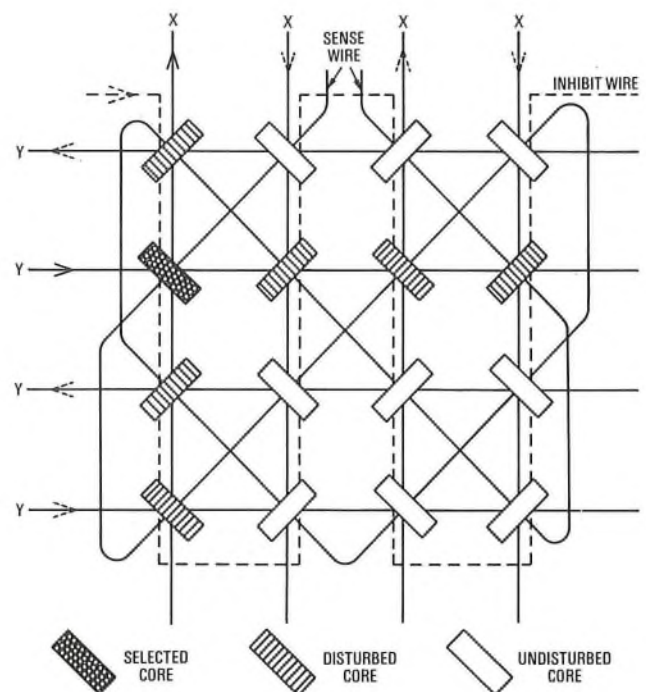

FIG. 5—Three-dimensional core store—single plane

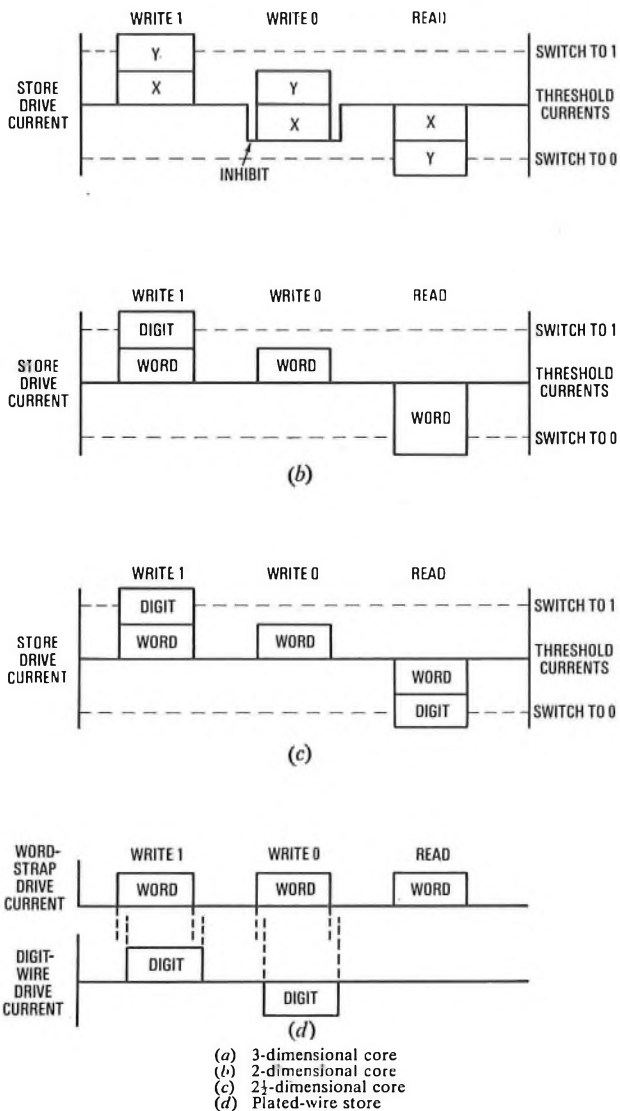

FIG. 6—Store drive currents showing superposition of pulses

3-Dimensional Store

The arrangement using least electronics is a 3-dimensional array. Consider a horizontal plane of cores threaded by wires designated X and Y (Fig. 5). Then, currents in one X -wire and one Y -wire switch only the core at the junction of these wires. In practice, a number of cores must be accessed simultaneously, such a group of cores or bits being called a *word*. This is accomplished by stacking n similar planes one above the other, where n is the number of bits in a word. Each X -wire or Y -wire threads, in turn, through the corresponding row in each plane.

To use such a stack, it is necessary to be able to write selectively, since some cores in a word must store *ones* and some *zeros*. This is done by providing a third set of wires, known as *inhibit* wires. There is one inhibit wire per plane, and each zig-zags through all cores in that plane. To write a *one*, unit current must flow in the X -wire and Y -wire, and no current must flow in the inhibit wire, so that the core switches to the *one* state. But, if the inhibit wire carries unit current in the reverse direction through the core, it does not switch and remains in the *zero* state (see Fig. 6(a)).

To read-out, the word is selected by a reverse current in both the X -wire and Y -wire. Any cores in the vertical column through the planes corresponding to the selected word which are in the *one* state are switched back to *zero*, these being detected by *sense* wires, one per plane, that thread diagonally

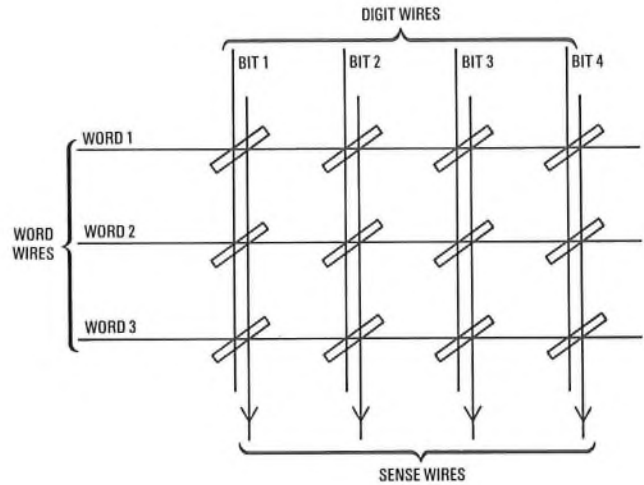

FIG. 7—Two-dimensional core store

through all cores of a plane. The identity of the core which has switched is known from the X and Y co-ordinates of the wires causing the switching. Cores switching from the *one* state produce voltage pulses in the appropriate sense wires, these pulses being used to set bistable registers. If the data is to be retained in the store, it must be restored by writing it back into the same core positions.

The access time is the time taken to read-out a word from the store. Before another access is possible, time is needed for the restore process. The total read/restore time is known as the *cycle time*.

Often, the sense and inhibit wires are combined so that 3 wires only need be threaded through each core. Suitable threading patterns are used to give maximum cancellation of noise, which occurs mainly due to the summation of low-level signals from disturbed cores. A further reduction of these signals can be effected by strobing the output at the time of maximum signal from the fully-switched cores.

2-Dimensional Store

The switching speed of a 3-dimensional store is limited by the need to restrict the magnitude of the X - and Y -currents so that, individually, they cannot switch the cores. This is avoided in a 2-dimensional scheme, in which a single plane is threaded by 2 sets of wires at right angles, called *digit* and *word* wires. A word wire threads a row of cores comprising one word, the appropriate digit wires being activated only where *ones* are to be written (see Figs. 6(b) and 7).

For reading, sense wires are used, these threading the same cores as the digit wires. A large reverse current in a word wire switches all cores in that word containing *ones* and produces output pulses in the corresponding sense wires. The sense and digit wires may be combined to give a 2-dimensional, 2-wire system. The 2-dimensional store is expensive in electronics, and is only used where the maximum speed is required.

2½-Dimensional Store

This combines features from the 2-dimensional and 3-dimensional schemes. As in the 2-dimensional arrangement, cores in a single plane are selected by current coincidence in word and digit wires. However, the digit wires are divided into 2 or more groups that are selectable (for example, by diode switches) offering a measure of Y -selection, as in the 3-dimensional scheme. This offers a reasonable compromise between cost of electronics and speed, and is commonly used for the largest stores (Fig. 6(c)).

TABLE 2
Relative Merits of Core Configurations

Feature	2-Dimensional Store	2½-Dimensional Store	3-Dimensional Store
Wiring	Simplest	Simple	Expensive
Electronics	Expensive	Cheap	Cheapest
Speed	Fastest	Fast	Slower
Optimum word length	Over 48 bit	9-36 bit	16-48 bit
Maximum capacity	0.6 Mbit	20 Mbit	1 Mbit

Table 2 summarizes the relative merits of the various configurations.

Thin-Film Stores

A film of nickel-iron, 0.1-0.3 μm thick, formed onto a suitable substrate in the presence of a magnetic field exhibits uni-axial anisotropy, having an easy direction of magnetization with a square-loop characteristic. If an applied field is reversed, the flux in the film reverses by a process known as *coherent rotation*, which is very fast.

Drive and digit lines may be plated onto the film, or consist of strips of etched foil, so that no manual wiring operation is required. A cycle time of 100 ns is feasible, but production problems exist in producing a uniform film free of faulty areas. Also, the output voltage is low and this can lead to reliability problems.

Plated-Wire Thin-Film Stores

Some disadvantages of a planar thin-film store can be obviated by the use of plated wire.³ A beryllium-copper wire, of approximately 0.13 mm diameter, is magnetically plated while a current is passing along the wire, giving a circumferential easy direction of magnetization. Word lines are in the form of strips at right angles to the plated wire, as shown in Fig. 8, the plated wire itself serving as a digit wire.

To store data, a current is passed through a word line, inducing a longitudinal field in the plating of each digit wire it crosses. The addition of a current in any digit wire results in a helical field, the sense of the helix being determined by the direction of the digit current. When the word current and then the digit current are removed, the wire remains magnetized circumferentially in a sense dependent on the digit-current direction (see Figs. 6(d) and 8).

To read out, a current in the word line swings the field towards the longitudinal direction, inducing in the digit wire a voltage pulse of polarity dependent upon the sense of the stored flux. If the word current is limited so that the field remains helical, the flux returns to its original circumferential sense when the current is removed and, thus, permits non-destructive read-out.

The plated wire can be produced by a continuous process, which includes testing, so that it can be cut into suitable lengths, any faulty lengths being rejected. A cycle time of 250 ns can be achieved.

Magnetic-Tape Systems

Magnetic tape recording^{4,5} is an inexpensive method of storing large quantities of data. A typical reel of computer tape, 267 mm diameter holding 732 m of 12.7 mm wide tape, can store 20-30 million bytes,* and costs as little as £5. A further great advantage is that storage is open-ended. This means that there is no limit to the quantity of data that can be stored off-line; for example, on racks. The data is permanent; as long as the reels are stored in suitable environmental

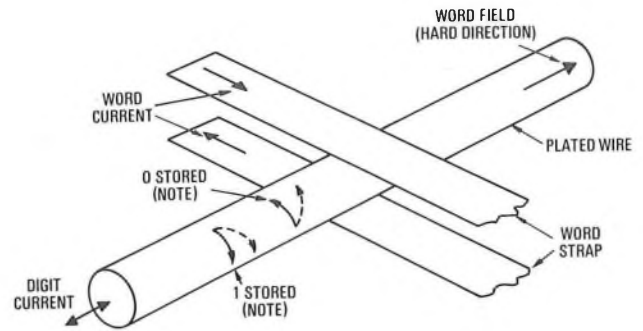

Note: dotted lines show helical magnetization vector during word-current pulse

FIG. 8—Principle of plated-wire store

conditions, there is no known limit to the length of time for which the data can be retained and recovered when required.

In addition to its use as a cheap backing store, magnetic tape can be used for data interchange, fast input/output (for example, data preparation using key-to-tape devices) and off-line output using tape-to-printer or tape-to-microfilm equipment.

The tape itself consists of a length of polyethylene terephthalate film, usually 0.038 mm thick, coated on one side with a thin layer (0.013 mm) of a strong yet flexible binder in which needle-shaped particles of magnetic iron oxide are dispersed.

The chief disadvantage of tape systems is that the computer is restricted to serial processing. Access to a random piece of data is slow, and it is not usually practical to erase a section of data and overwrite with new information. To update a file, it is necessary to read a block of data into main storage, amend the data and then write it onto another tape, repeating the process until the file is complete. A computer tape system comprises a number of tape transports and a controller, which also interfaces the transports to the computer.

Tape Transport Mechanism

The basic requirement of the tape transport mechanism is to move magnetic tape across writing and reading transducers (heads), at a constant speed, when called upon by the computer. Unlike paper tape, it is not possible to stop a magnetic tape, or bring it up to speed, within the length occupied by a single character. Thus, it is necessary to split the recorded data into blocks, separated by interblock gaps, typically 15 mm in length. The tape must, therefore, be accelerated from rest to a running speed in the range 0.63-5.08 m/s in a short time; for example, to 1.9 m/s in 10 ms. A full reel cannot be accelerated at this rate, and so it is necessary to provide tape reservoirs between the head area and the reels. The length of tape in the reservoirs is sensed and used to servo-control the reel motors.

Since the data is arranged in rows of 7 or 9 bit across the tape, and the spacing between rows may be as little as 15.9 μm , the spacing between individual rows and any displacement between the bits of a row must be closely controlled; the accuracy of tape guidance across the heads is of paramount importance.

Fig. 9 shows the elements of a transport suitable for speeds up to 1.14 m/s. The rollers, R, are mounted on swinging arms, the positions of which are sensed photoelectrically, using a disc with an eccentric slot. When an arm moves away from its central position, the associated reel-drive motor is energized, feeding or withdrawing tape to restore the arm to centre. The tape is moved over the heads by a capstan, C, driven by a low-inertia d.c. motor, servo-controlled to give a smooth start/stop characteristic. This arrangement is superior to an earlier method, using 2 capstans continuously rotating

* An 8-bit character plus parity bit

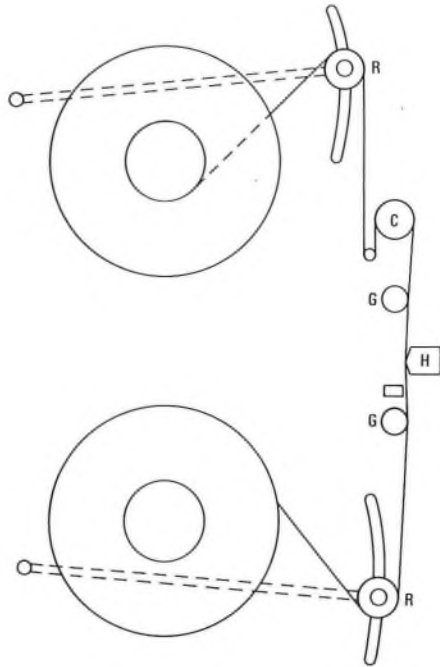

FIG. 9—Typical magnetic tape transport using swinging-arm reservoirs

in opposite directions, the tape being driven by engaging pinch rollers or applying a vacuum to the capstans. Tape is guided over the headblock, H, by 2 spring-loaded guides, G. A lamp and photocells are used to detect reflective tabs, fixed to the back of the tape to mark beginning and end of the usable area.

For faster tape speeds, the reservoirs may consist of 2 columns, into which the tape is drawn by a vacuum applied at the lower ends, as shown in Fig. 10. The position of the loops is monitored by lamps and photocells; if the loop goes beyond the area between cells, the associated reel motor is energized to feed or remove tape as required. Some transports, in this class, automatically thread the tape from reel to reel and into the vacuum columns. A reel may be enclosed in a cartridge so that the tape need not be handled when loading.

Method of Recording

A magnetic head consists of a ring of nickel-iron laminations or ferrite, having a small gap of about $12.5 \mu\text{m}$ within which the tape is moved. A winding carries a current to produce flux across the gap and magnetize the tape longitudinally as it passes. Data is recorded by reversing the flux, rather than by turning it on and off, this principle being known as *non-return-to-zero* recording. To read a tape, it is passed across a similar head having a gap of about $6.3 \mu\text{m}$. Some of the flux, external to the tape at each recorded reversal, passes through the head core and induces an e.m.f. in the winding.

Data is recorded on the tape in 7 or 9 longitudinal tracks. In a headblock there are, thus, 7 or 9 write heads side by side and, separated from them longitudinally, there are a like number of read heads. The following 2 recording formats are in common use.

(a) *Non-return-to-zero (mark)*. A flux reversal is written for each *one* bit (see Fig. 11(a)). To recover the data, the resultant pulses are used to set bistable registers (one per track), and these are reset simultaneously by means of a clock pulse before the next bit occurs; that is, approximately at the bit-cell boundaries in Fig. 11. The clock signal is derived from the recorded signals by combining the outputs of all tracks and ensuring, by use of a suitable data code, that at least one track in each row contains a *one* bit. This system is satisfactory up to 31.5 rows/mm.

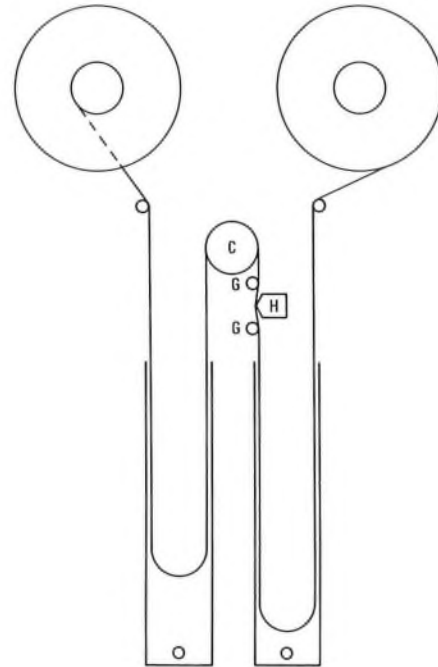

FIG. 10—Typical magnetic tape transport using vacuum-column reservoirs

(b) *Phase-encoded*. In this system, the polarity of a reversal determines whether a *one* or a *zero* is recorded (see Fig. 11(b)). Additional reversals, P, must be inserted whenever 2 like bits are adjacent. Since a reversal occurs at the centre of each bit cell, the necessary clock signals can be derived from each track individually; this is referred to as *self-clocking*. It is possible to compensate electronically, in a device known as a *de-skewing buffer*, for intertrack timing errors (*skew*) greater than are tolerable in the non-return-to-zero (mark) system. Currently, this method is used at a packing density of 63 rows/mm.

Error Control

The biggest enemy of error-free recording is dust. In spite of close environmental control, error rates of the order of 1 in 10^8 may be encountered, due chiefly to dust or oxide particles between the tape and head. Means are provided for detecting and correcting such errors. In the non-return-to-zero (mark) system, each row includes a parity bit and, at the end of each data block, a check character is inserted permitting a parity check along each track. A further character, known as *cyclic redundancy check*, may be inserted and this enables errors in a single track to be corrected during a re-read. When using the phase-encoded method, in-flight correction of single track errors is possible. If the signal level from any track falls below a certain value, the output from that track is ignored for the remainder of the block, the missing data being reconstituted from the information in the parity track.

Cassettes

A recent need for low-cost recorders, for use as minicomputer peripherals or as replacements for paper tape, has resulted in the appearance of devices using magnetic tape in small cassettes. The only systems so far accepted for international standardization use Philips type cassettes, as used in audio recorders, but containing 90 m of computer tape 3.81 mm wide, recorded serially on one or 2 tracks at 31.5 bit/mm, phase-encoded.

Drums and Discs

A magnetic drum is a rotating cylinder coated with

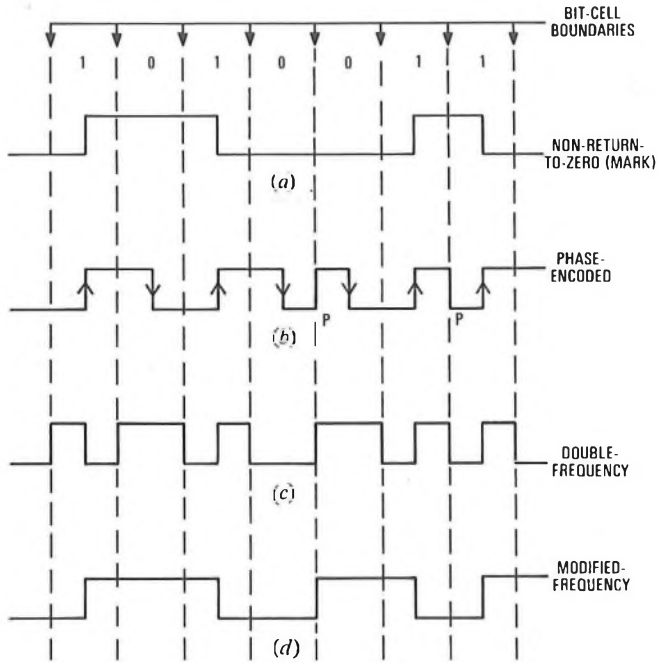

(a) and (b) used on tapes
(c) and (d) used on discs

FIG. 11—Recording waveforms on tape and disc

magnetic oxide, or sometimes nickel-cobalt, whereas a disc is a rotating circular plate similarly coated. Drums have been used since the early days of computers, when the processor was synchronized to a recorded clock signal on the drum. They are now used as reliable backing stores having capacities from 0.3–6 Mbit or more, and average access times from 2.5–10 ms. They are connected as peripherals, buffered from the processor by sophisticated control units.

High packing densities require the heads to be very close, typically 1.25–5 μm , to the magnetic surface, but contact must be avoided to prevent wear and possible catastrophic failure. The heads are mounted on pads so profiled that they fly aerodynamically on a layer of air carried round in proximity to the drum's surface. The lift increases rapidly with reduced separation, so that the flying height tends to remain constant. Thus, the head follows any imperfections or surface run-out. Means are provided to retract the heads when the drum speed falls.

Data is usually recorded serially along a number of tracks, there being, in general, one head per track. Recording may be non-return-to-zero (mark) or phase-encoded, often with separate clock-signal tracks. Alternatively, frequency modulation can be used; this being a self-clocking system in which a reversal occurs at each bit-cell boundary, with an intermediate reversal in the centre of cells containing *ones* (Fig. 11(c)). In a modified form (Fig. 11(d)), a reversal occurs at the centre of each bit cell containing a *one*, and at each cell boundary between consecutive *zero* bit cells.

Discs, in general, operate at lower rotational speeds than drums. They may be fixed, or removeable in the form of exchangeable packs or cartridges. Fixed-disc systems range between small single-head-per-track discs that are competitive with small drums, and very large assemblies of as many as 26 discs up to 990 mm diameter having a capacity as high as 5000 Mbit. Groups of heads are moved to the required track locations by means of hydraulically-operated positioners. These large systems are obsolescent now that exchangeable-disc systems are available approaching the same capacity.

A feature of the small or medium-sized single-head-per-track disc files is that they can be sealed, or filled with inert gas, for operation in adverse environments.

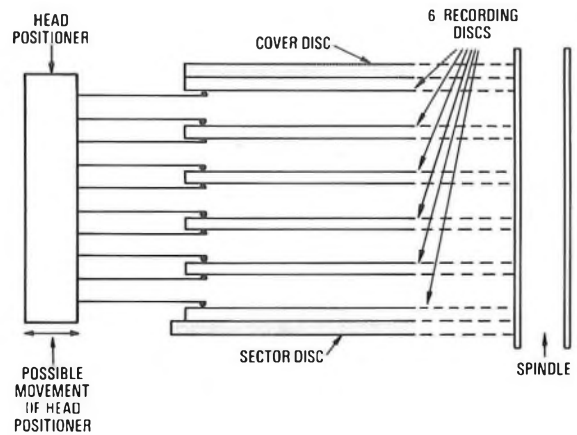

FIG. 12—Magnetic disc pack

Exchangeable Discs

The advent of a moving-head exchangeable-disc store,⁴ in 1963, marked the start of a period of rapid advance in this field. This used a pack of six 356 mm oxide-coated discs, mounted on a vertical drive-spindle. This type of disc pack is still in common use, and can hold 7 Mbyte (60 Mbit) on 10 surfaces. Average access time is 60 ms and the data transfer rate 1.25 Mbit/s. The total time to reach a wanted record is that required to position the heads over the required track, plus the time to reach the required part of that track (latency). A stack of 10 heads fly close to the surfaces; the 10 tracks accessible without head movement comprise a *cylinder*. All heads are moved together across 200 tracks by operation of a positioner which, in early models, was hydraulically driven, but now often uses the voice-coil principle. Movement may be controlled by a mechanical detent or by a servomechanism.

Fig. 12 shows the arrangement of heads and discs, including a sector disc containing slots that define the start of a track (index) and data areas within a track (sectors). When the pack is located on the drive spindle, its cover can be removed and the lid closed. The discs run up to speed (2400 rev/min), then the arms move in and the heads are automatically loaded into the flying position.

Considerably larger disc stores are now in common use. A typical system uses 11 discs, having 20 recording surfaces, and a capacity of 30 Mbyte (240 Mbit) transferred at 2.5 Mbit/s. A double-capacity version is also available. More recently, a 100 Mbyte drive has become available using a 12-disc pack, having 10 coated discs; 19 surfaces hold data and the remaining surface carries servo information which enables the heads to home accurately onto the required track. Again, a double-capacity version is already being developed.

Small-capacity requirements are catered for by drives using a single disc, supplied in a cartridge that may be arranged for either top-loading or front-loading onto a vertical spindle. Such a cartridge has a typical capacity of 2 Mbyte (16 Mbit). A mechanism is also available having a fixed disc, in addition to driving an exchangeable disc in a cartridge.

In all these systems, address information is recorded in each track so that the control equipment can check that the correct track has been accessed, and redundant information is recorded to permit the detection and correction of errors.

A recent development is a flexible oxide-coated disc (*floppy disc*), 190.5 mm diameter, and in a plastic cover. A slot in the cover allows access for a single moveable in-contact head. The disc rotates only when needed, holds 1–2 Mbit on one side only, and is used for program input to computers or off-line in conjunction with a keyboard. It may prove to be competitive with tape cassettes for these applications.

TABLE 3

Comparison of Moving-Media Magnetic Stores

Device	Area of Use	Capacity (Mbyte) Note 1	Transfer Rate (kbyte/s) Note 1	Average Access Time (ms)	Speed of Rotation (rev/min)	Storage Costs (bytes/p)	
						On-Line Note 2	Archival Note 3
Tape, 31·5 rows/mm, medium speed (1·9 m/s)	Serial processing and archival storage	15	60	190 000	—	15	25 000
		30	320	70 000	—	24	50 000
Drum, single-head-per-track Fixed disc, single-head- per-track	Fast backing store	1·2	500	2·5-10	5000	2	—
		2	500	10	3000	2	—
Exchangeable disc cartridge 6-disc pack (10 surface) 11-disc pack (20 surface) 12-disc pack (19 surface)	Large capacity file storage	3	312	60	2400	8	200
		7·5	156	60	2400	6	800
		30	312	30-60	2400	15	1500
		100	806	30	3600	50	3000

Notes: 1 for equivalent in bits, multiply by 8
 2 on-line costs include cost of drives and controller
 3 archival costs include cost of media only
 4 all parameters are average for a number of device types and do not necessarily apply to any particular system.

Comparison of Moving-Media Magnetic Stores

The properties of various types of moving-media magnetic stores are compared in Table 3.

THE FUTURE

Magnetic tape is likely to remain in use for many years to come, because of its low cost and suitability for archival storage and data interchange. Use of cartridges and cassettes can be expected to increase. Packing densities have not yet reached their limits; already a tape system operating at 246 byte/mm is becoming available. Cheapening electronics will assist by making feasible more complex error-correction facilities. A system using videotape principles can store up to 3×10^{11} bit, but head and tape wear may prove troublesome. The exchangeable disc has replaced earlier forms of mass storage and should be capable of further enhancement, though the limits may now be in sight.

Semiconductor stores will become larger, cheaper and more reliable as large-scale-integration technology develops, and will eventually supersede magnetic cores and plated wire. Looking further ahead there may well be a place for magnetic bubbles.^{6,7} Data is stored in minute domains, magnetized against the main field in a thin film of magnetic material that

has an easy axis perpendicular to the film. Patterns of bubbles can be shifted along controlled paths, several methods of detection being available. It is claimed that shift registers having a bit density of 3·875 kbit/mm² could be built. This technology could fill the gap in access time between discs and core stores (see Fig. 2).

Other techniques, such as holography, offer possibilities for mass storage, but no contender appears to be ready for commercial realization.

References

- 1 VOGAN, D. H. and PRICE, C. D. E. The TXE3 Experimental Electronic Exchange System. *POEJ*, Vol. 62, p. 142, Oct. 1969.
- 2 VAN BRUCK, H. E., Organization of Ferrite Core Memories. *Electronics Applications Bulletin*, Vol. 31, No. 1, 1972.
- 3 RILEY, W. B., (Editor). *Electronic Computer Memory Technology*. McGraw-Hill, USA, 1971.
- 4 DUDSON, M. F., and DAVIES, A. V. Magnetic Recording for Computers. *Proc. IEE*, paper No. 6699E. *IEE Reviews*, Vol. 119, No. 8R, p. 956, Aug. 1972.
- 5 PEAR, C. B. Jr., (Editor). *Magnetic Recording in Science and Industry*. Reinhold Publishing Corporation, USA, 1967.
- 6 BOBECK, A. H., and SCOVIL, H. E. D. Magnetic Bubbles. *Scientific American*, No. 224, p. 78, June 1971.
- 7 ENOCH, R. D. A million bits of data in one square inch. *POTJ*, Vol. 26, No. 1, Spring 1974.

Heating and Ventilating of Telecommunications Buildings

Part 2—Systems

H. WILLIAMS C.ENG., M.I.E.E.†

UDC 697.1: 697.97

Part 1 of this article reviewed the heating and ventilating needs in telecommunications buildings. Part 2 provides some basic information on heating and ventilating systems and attempts to highlight the need for fuel economy.

HEATING NEEDS

The British Post Office (BPO) accommodation services groups plan heating systems in certain standard buildings, but the Property Services Agency (PSA) of the Department of the Environment plans and contracts for heating schemes in most new non-standard buildings and in extensions thereto. The PSA schemes are subject to approval by the BPO; the BPO also determines the choice of fuel and keeps an oversight of plant maintenance and fuel economy.

Plant Size

The heating plant must be capable of compensating for the building transmission and ventilation losses, and maintaining the standard internal temperatures when the outside temperature is -1°C . To economize on fuel costs, it is common practice to reduce the heating at night and at weekends by automatic means, and to arrange that it is restored to normal at about 06.00 hours on each working day. This is known as *night and weekend depression*, and arrangements are made to compensate for it in rooms where staff work at night or weekends. This depression of the heating takes advantage of the heat stored in the building fabric; a heavily-constructed building with good thermal insulation takes a few days to cool down or to be reheated. To ensure a satisfactory build-up of heat after a shutdown, whether planned or unplanned, the boiler plant is given a margin of 15–20% over and above the capacity required to make up for heat losses. In operational buildings, the maximum heating is required when the building is first opened and equipment is being installed. The demand made on the plant falls as the equipment heat increases, and this results in spare boiler capacity becoming available during periods of high dissipation of heat from equipment. In certain instances, it could be more economic to heat an extension to a building from the existing boiler plant, the existing building then being heated electrically. For general estimating purposes, a heating need of 110–130 W/m^2 of heated floor area may be assumed, but some recent buildings have a much improved overall thermal insulation, and their heating needs may be as low as 50 W/m^2 .

Choice of Fuel

The Clean-Air Acts of 1956 and 1968 regulate the emission of pollution from chimneys and, because of the sulphur-

dioxide content in the flue gas, coal-fired and oil-fired boilers may have to be provided with tall chimneys. In some districts, the local planning authorities will not tolerate tall chimneys and, in these circumstances, a gas-fired boiler may have to be provided because of its low sulphur-dioxide emission, or else electric heating may be necessary.

The choice of fuel is based on economic factors unless there are inescapable operational needs which dictate otherwise. Currently, gas fuel is most economic in many buildings in the North West Telecommunications Board, based on a special tariff negotiated with the gas board. The 24 h average assessments of boiler efficiencies and of fuel calorific values for fuel comparison purposes are shown in Tables 4 and 5 respectively.

TABLE 4
Boiler Efficiencies

Boiler Type	Efficiency (%)
Coal fired	60
Oil fired and gas fired	65–70

TABLE 5
Fuel Calorific Values

Fuel	Calorific Value
Coal	30 MJ/kg
35 s oil (gas oil)	42 MJ/kg
250 s oil (light oil)	41 MJ/kg
Town gas	20 MJ/m^3
Natural gas	41 MJ/m^3

Note: 1 MJ \approx 1000 Btu

Fuel Consumption

The heating plant does not work at full capacity throughout the heating period. Night and weekend depression reduces the fuel consumption and, in operational buildings, the heat from equipment results in further fuel economy; the effectiveness of the automatic control system also affects fuel consumption.

† Liverpool Telephone Area.

Load Factor

To allow for the influence of mild weather on fuel consumption, the concept of *degree-days* has been introduced. This assumes that, in a building maintained at 18°C, no heating is required when the external temperature is 15°C or over. The difference between the daily mean temperature and 15°C is then taken as the number of degree-days for that day. The total degree-days for the heating period forms a convenient, but not an absolute, basis for comparing the fuel consumption of 1 year with another.

Difficulties arise in deciding the average outside temperature when the maximum temperature for the day is above 15°C and the minimum temperature is below that figure. A Gas-Council publication⁴ quotes Meteorological Office formulae for calculating degree-days for daily maximum and minimum temperatures. Owing to mild periods in the heating season, the actual degree-days recorded will be less than the maximum possible, and this is taken into account by means of the *weather factor* which equals $\frac{\text{actual degree-days}}{\text{maximum degree-days}}$.

In the North West of England, the average value of the weather factor is 0.49. Where the heating controls provide normal night and weekend depression, the weather factor is multiplied by a correction figure of 0.85, resulting in a modified load factor for the North West of England of 0.42. Equipment heat reduces the load factor still further in operational buildings, some of which may eventually become self-heating with a load factor approaching zero. The load factor of the heating plant is given by the ratio

$$\frac{\text{actual heat required from plant}}{\text{maximum capacity of plant}}$$

Heating Controls

The heating controls ensure the safe and economic running of the heating plant⁵; they provide for automatic start-up and shut-down and, in the case of oil-fired or gas-fired plant, they provide emergency shut-down under flame-failure conditions. The controls that maintain the water temperature are shown in Fig. 6 for a small heating system. For a non-operational room, the heating needs are closely related to the difference between the air temperature in the room and that outside. The control element that compensates for climatic conditions is an outside temperature detector or thermostat. If a room has significant internal heat gains from equipment or people, the heating requirements must be controlled locally, either by a room thermostat and a motorized valve in the pipe circuit to that room, or by individual thermostats on each radiator. In tower blocks and in large deep buildings used for non-operational purposes, the buildings must be divided into a number of separate zones, each being controlled by its own outside temperature detector.

It is no longer common practice to vary the boiler water-temperature to control flow temperature. This form of control has the serious disadvantage that it allows the flue gases to cool down to their dew point at too-frequent intervals and the resulting acids cause boiler and chimney corrosion; the thermal cycling also reduces boiler-plant life. In modern low-pressure hot-water systems, the boiler water-temperature is kept reasonably constant at 82°C by a boiler thermostat, and the plant is designed so that the return flow water-temperature is not less than 11°C below this value; that is, 71°C. This results in an expected life of 15 years for an oil-fired boiler and 20 years for a gas-fired boiler. The temperature of the water supplied to individual heating circuits is controlled by a mixing valve, which mixes boiler flow water with return flow water under the control of the appropriate thermostat. The water supply to a domestic calorifier is normally kept at a temperature of 60°C.

The control systems are usually electromechanical and include a time switch for night and weekend depression.

Overheating of BPO buildings seems to be the rule rather than the exception, resulting in an annual increase in fuel consumption of some 10% for every 1°C that the room temperature exceeds the agreed standards. Room thermostats should, therefore, be of a type that cannot be maladjusted and control panels should be kept locked. In a lightly-constructed building, there is very little heat storage and the heating plant needs a highly-responsive control system.

Combustion Efficiency

Combustion is an oxidation process requiring a large amount of air. For this reason, adequate boiler-room ventilation is vital, and it should be provided to give a crossflow of air. If this cannot be met by natural means, a ventilation fan must be provided to draw air into the boiler room and thus assist the flue draught. An extraction fan should not be provided in a boiler room unless balanced by an input fan. Insufficient air results in incomplete combustion; excess air produces unnecessary cooling of the combustion chamber and chimney. The efficiency of combustion is checked by analysing a sample of the flue gases. The carbon in the fuel oxidizes to form carbon dioxide and carbon monoxide. The carbon monoxide oxidizes with more air to form carbon dioxide, and there should be an absolute minimum of carbon monoxide in the flue gas. The approximate maximum values of carbon dioxide in flue gases are

coal	19%,
oil	15%, and
natural gas	11%.

Gas fuel contains a high proportion of hydrogen, which results in a high level of water vapour in its products of combustion, and the design of chimney lining used must take this into account. Not all the carbon is converted into carbon dioxide, some appearing as soot deposits on the flueways and smoke passages of the boiler. This build-up of soot should be cleared regularly, as a deposit of 1.6 mm increases fuel consumption by 5%.

Incomplete combustion of oil and coal fuel results in the emission of black smoke. The Clean-Air Act prohibits smoke darker than No. 2 on the Ringelmann scale, but in smokeless zones, the emission of smoke of any shade is an offence unless produced by an authorized fuel. The Ringelmann charts are a series of 4 grids of increasing darkness marked on a card, against which the smoke from a chimney may be compared. The Bacharach smoke scale is also used extensively.

Heating Systems

The low-pressure hot-water system using radiators, shown in Fig. 6, is the conventional method of heating a building. This is really a convective system as radiators radiate only about 40% of their heat output. In recent years, there has been a trend towards warm-air heating of equipment rooms, in which a low-pressure hot-water radiator, or an electric heater battery, is fitted in the main ventilation duct to the room. This system gives satisfactory heating, provided the temperature of the incoming ventilation air is not more than 5°C above room air temperature and a ventilation rate of at least 10 air-changes/h exists. Stratification is prevented by ensuring thorough air mixing. Off-peak fan-assisted storage heaters are used in small offices and welfare rooms.

In those few installations where on-peak electric heating is most economic, special equipment is necessary to monitor the maximum electrical demand of the building and to shed the heating load automatically when the maximum demand load is approached. This need arises because of the slight time lag that exists between the rise in equipment power consumption, for example at the busy hour, and the automatic reduction of heat output from the heating system due to the resulting busy-hour heat generation. A short-duration

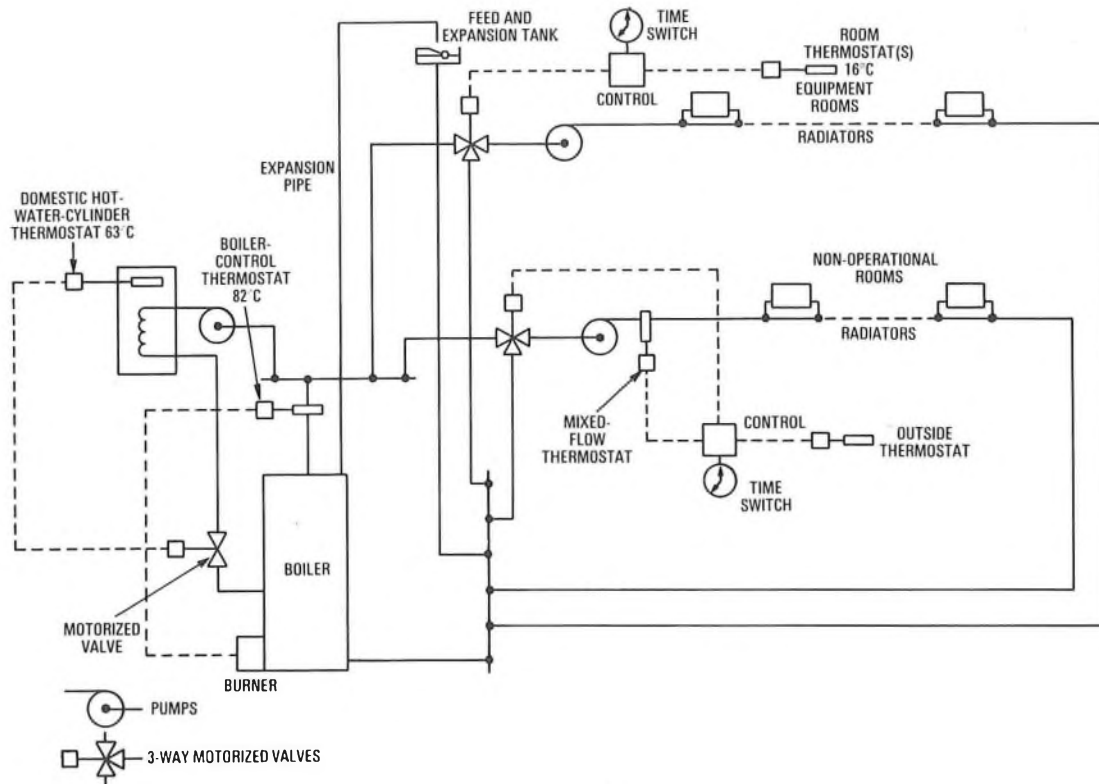

FIG. 6—Low-pressure hot-water system

excess on the maximum demand could result in higher electricity charges on the building for the whole of that year; there is a clear need to avoid this.

In operational buildings, the heating control and circulation pumps should be connected to the essential power supplies. Where electric heating is provided on a large scale, at least part of the heating load should be connected to the essential supplies if possible.

VENTILATION NEEDS

All rooms in which people work for any length of time require a flow of fresh air to ensure adequate ventilation for the occupants. The recommended minimum amount for BPO non-operational rooms is $0.008 \text{ m}^3/\text{s}$ per person and this is normally achieved by natural ventilation through openable windows. To be effective, natural ventilation requires windows to be provided on opposite walls of a room, thereby ensuring a full crossflow of air. If openable windows are not ideally situated, air movement within a room may be improved by means of portable fans. In offices of small to medium size, where openable windows are not practicable, window fans may provide a compromise solution, but these fans suffer from a number of operational disadvantages, not the least of which is their noisy operation. The Office, Shops and Railway Premises Act 1963 now restricts the provision of fans between rooms and corridors, for fire and smoke prevention reasons, and this complicates the ventilation of rooms having no external wall. Where natural ventilation is not possible and window fans are inadequate, it may be necessary to provide mechanical ventilation plant. Paint shops and motor-transport workshops have special needs.

In equipment rooms, the minimum fresh-air requirement is insufficient to extract the equipment heat, and mechanical ventilation plant is provided. This is normally designed to give 10–16 air-changes/h. Above 16 air-changes/h, duct sizes

become cumbersome, air-distribution problems arise and an economic limit has been set at this value. If a ventilation rate of 16 air-changes/h is likely to be insufficient to limit the rise in room temperature, refrigeration cooling is incorporated in the plant to reduce the temperature of the air flowing into the room. The maximum cooling duty of the plant depends on the design temperature rise, but for a rise of 4°C , plant giving 16 air-changes/h can normally cater for a busy-hour equipment dissipation of up to $120 \text{ W}/\text{m}^2$ without refrigeration cooling. With refrigeration cooling, an equipment busy-hour dissipation of $350 \text{ W}/\text{m}^2$ can be catered for, with the room temperature held at the outside shade value.

Mechanical Ventilation

The basic elements of a simple mechanical ventilation scheme are shown in Fig. 7. Each scheme is tailor-made for a particular building and consists of the following items.

(a) *Ducting*, which is usually of galvanized-iron sheet, is used to distribute the ventilation air in the room. This air (primary air) is discharged through diffusers or outlet grilles which produce a lateral air movement in the room. In this way, the primary air is mixed with the room air (secondary air) and stratification is avoided. Dampers are provided in the duct to regulate the air flow.

(b) *A fan* moves the air volume against the system resistance. Centrifugal fans are normally used because of their low noise properties. The fan should be connected to the essential power supply.

(c) *Filters* are needed because atmospheric air is contaminated by a variety of particles which, if brought into a room in large volumes, would affect the operation of equipment and result in a dirty working environment. The incoming air is, therefore, filtered and the type of filter used depends on the nature of the particles in the air; local authorities publish details of air analyses in most towns and

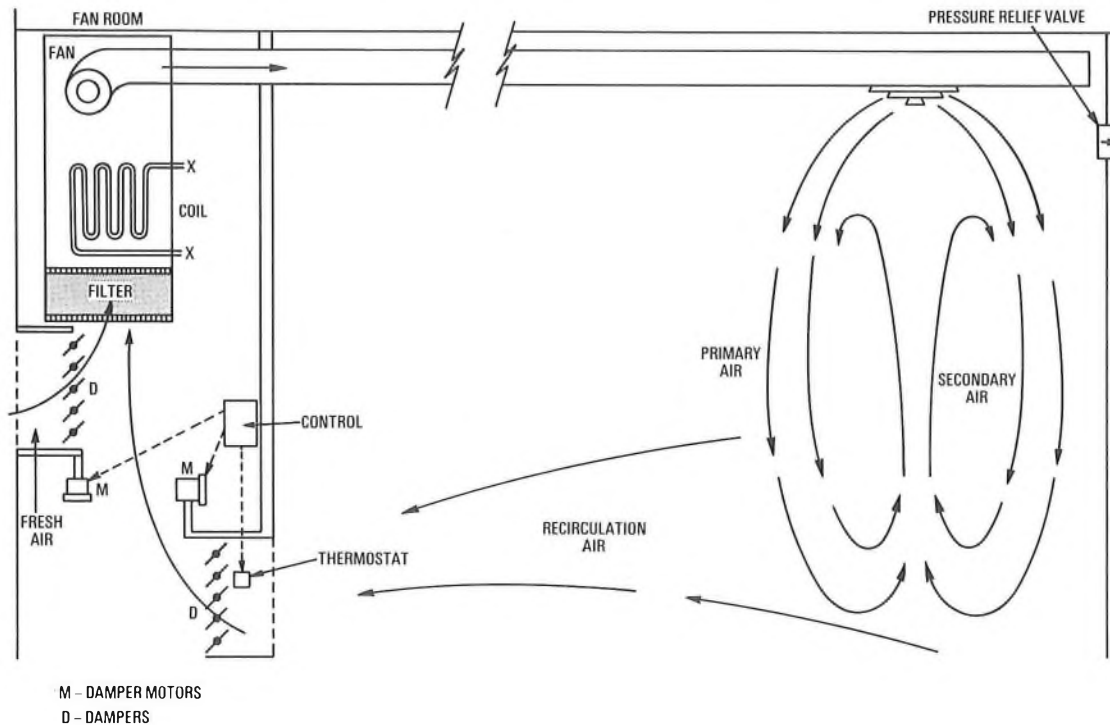

FIG. 7—Simplified block diagram of mechanical ventilation of an equipment room

these can be supplemented by local knowledge. Modern fabric-type filters are adequate in most installations, but in a few instances, electrostatic filters may be necessary. Electrostatic filters should also be fitted in board-room or conference-room installations to filter out tobacco smoke. Dust particle sizes are measured in micrometres. The collecting efficiencies of fabric and electrostatic filters are compared in Fig. 8. The newer type of electrostatic filter causes dust particles to agglomerate on the collector plates, eventually being swept off by the air stream and collected in a fabric-type filter. The agglomerator-type of electrostatic filter does not require the water cleaning facilities that are necessary for the earlier types of electrostatic filters. Dust, collecting in fabric-type filters, increases the resistance offered by the filter to the air flow and this is an indication of the need to renew the filter elements. The pressure drop across the filter is shown on a U-tube manometer, or some other device, and the pressure drop, at which the filter elements should be changed, is quoted by the filter manufacturer. The fresh-air inlet to the fan room should be located away from vehicle exhaust fumes, chimneys and any other local source of air pollution.

(d) *Controls* are required, consisting of a thermostat, which monitors the room air temperature, and fresh-air and recirculation dampers, the operation of which is controlled by the thermostat. As the room air temperature increases, recirculation is reduced and more fresh air is drawn into the room to reduce the temperature. This also increases the room air pressure, and pressure relief valves are fitted in windows or outside walls to provide an air outlet. The aim is to keep the room at a pressure slightly above atmospheric pressure.

Air Volume

The volume of air necessary to remove room heat is directly proportional to the total heat dissipated and inversely proportional to the permitted temperature rise. Dry air at normal atmospheric pressure and at 20°C has a density of 1.205 kg/m³ and a specific heat capacity of 1.012 kJ/(kg °C).

Thus, the heat required to raise 1 m³ of air by 1°C is (1.012 × 1.205) kJ = 1.22 kJ.

Therefore $Q = 1.22 Vt$,

where Q is the rate of heat energy supplied to the air (kW),
 V is the ventilation rate (m³/s), and
 t is the temperature rise (°C).

This gives the approximation, for normal estimating purposes,

$$V_1 = \frac{3Q_1}{t}$$

where Q_1 is the room heat to be removed (W), and
 V_1 is the ventilation rate required (m³/h).

This total air volume must be distributed in the room to take account of the location of equipment producing high heat output, which requires proportionately more air. The system is balanced to achieve this by means of dampers in the ducts.

Refrigeration Cooling

The load range of a mechanical ventilation system is extended by providing a cooling coil in the fan unit as shown at XX in Fig. 7. This is part of a separate refrigeration system, and the cooled air leaves the coil at a temperature of about 10°C. If the coil temperature is below the dew point of the mixed recirculation and fresh air, water condenses on the coil and this must be collected and drained off. Pipes at low temperature must be lagged and vapour-sealed to avoid surface condensation. The control of the mechanical ventilation and refrigeration plant must operate smoothly. If the equipment busy-hour load is high, but the 8 h average load is relatively low, the refrigeration plant only has to deal with peak loads. Under these circumstances, it could be argued that economy of running would be achieved by switching off the refrigeration plant at those times when a fresh-air ventilation rate of 16 air-changes/h would suffice. This is not necessarily so, as trunk buildings are located in large cities

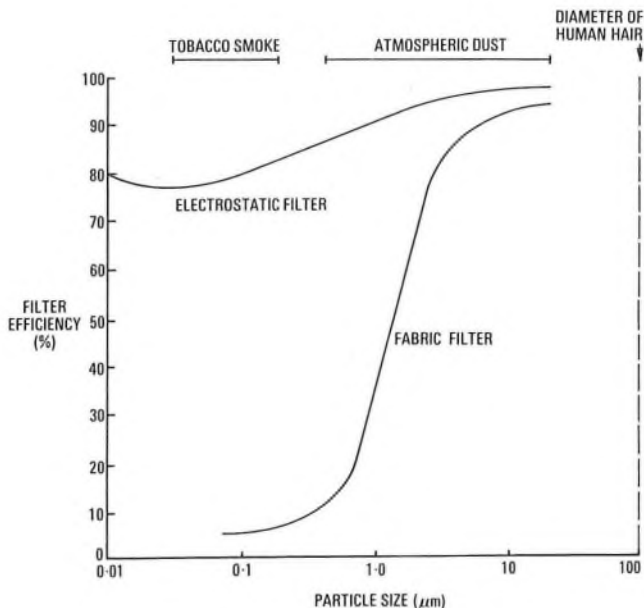

FIG. 8—Filter efficiency

and the air pollution could necessitate the use of electrostatic filters; because of the extra air volume, fabric filters would need to be changed too often. The additional capital costs of electrostatic filters and their greater accommodation needs, together with the more complicated control system, could offset the savings resulting from intermittent operation of the refrigeration plant.

With the introduction of common-control systems, the present trend is towards equipment with a higher 8 h average load. As a result, it is normal practice in the North West Telecommunications Board to vest all the controls in the refrigeration plant. The fresh-air inlet is set to give a ventilation rate of 1 air-change/h, and means are provided to increase this to 16 air-changes/h under emergency conditions. Savings accrue as smaller fan rooms are needed, less-expensive filter types can be used, no pressure relief valves are necessary, and damper requirements are reduced. Fewer faults occur due to the use of a simpler control system.

Commercial refrigeration systems are normally of one of the following types.

(a) *Mechanical refrigeration*, in which the refrigerant, or volatile fluid, is passed through an evaporation–vapour compression–condensation cycle, by application of mechanical energy and heat transfer. Final heat rejection from the condenser includes the operating energy input, and is approximately 1.2 times that transferred from conditioned zone to the evaporator. Where the major interest is in the heat rejected rather than in the heat absorbed, the system is called a *heat pump*.

(b) *Absorption refrigeration* which requires a source of high-temperature heat in place of mechanical energy. Water is the usual refrigerant and lithium bromide acts as an absorbent. The plant uses high-vacuum techniques, is quiet in operation, but is less efficient than the mechanical type; it is also more bulky. Final heat rejection from the condenser includes the operating energy input and is approximately 2.4 times that transferred from conditioned zone to evaporator. For this reason, the cooling water and final-heat-rejection plant requirements are about double those for mechanical-refrigeration plant. The absorption type of refrigeration plant, therefore, takes up more accommodation space than the mechanical type and, unless the high-tem-

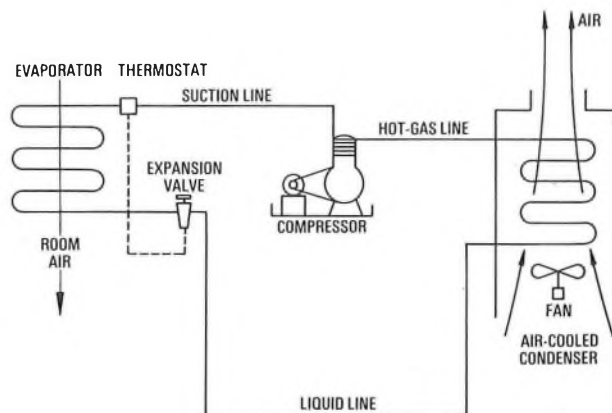

FIG. 9—Direct-expansion system using air-cooled condenser

perature heat required for operation would otherwise be wasted, it is most unlikely that the system would prove economically viable. For this reason, the more usual type of plant provided in telecommunications buildings is the mechanical refrigerator and its operation is considered in more detail below.

In the mechanical-refrigerator system, heat can be removed from the room air by the use of either direct coils (DX system) or indirect coils (chilled-water system). The direct-expansion system is used for small-sized to medium-sized plant where the pipe runs between component units are not too long, and the chilled-water system is used for the larger installations in excess of about 120 kW cooling capacity. The chilled-water system is the more flexible and provides better temperature control, but it is more expensive and requires more floor space.

The Direct-Expansion System

A block diagram of a simple direct-expansion system is shown in Fig. 9. The whole system contains a refrigerant, usually Freon or Arcton, and the operation of its units is as follows.

(a) A cooling coil, or evaporator, is located in the ventilation air stream and the pressure in this coil is maintained at a value which allows the refrigerant to boil at a suitable temperature. In boiling, the refrigerant absorbs the necessary latent heat from its surroundings which are cooled to about 4°C.

(b) A compressor draws the cold gas out of the evaporator, thus maintaining the necessary pressure. It also raises the gas pressure (and consequently its temperature) on its outlet side so that it can be condensed, the work done by the compressor motor also appearing as heat in the gas.

(c) A condenser enables the hot gas to lose its latent heat and some of its sensible heat to the cooling medium, which may be air or water; an air-cooled condenser is shown in Fig. 9. The hot gas is now condensed into a warm liquid.

(d) An expansion valve maintains the difference in pressure between the evaporator and condenser and also regulates the flow of refrigerant liquid into the evaporator, thus controlling the coil temperature.

(e) A control circuit detects the need for cooling by means of a room thermostat, which switches on the condenser fan and compressor.

The Chilled-Water System

A block diagram of a simple chilled-water system is shown in Fig. 10. The evaporator is a shell and tube heat exchanger

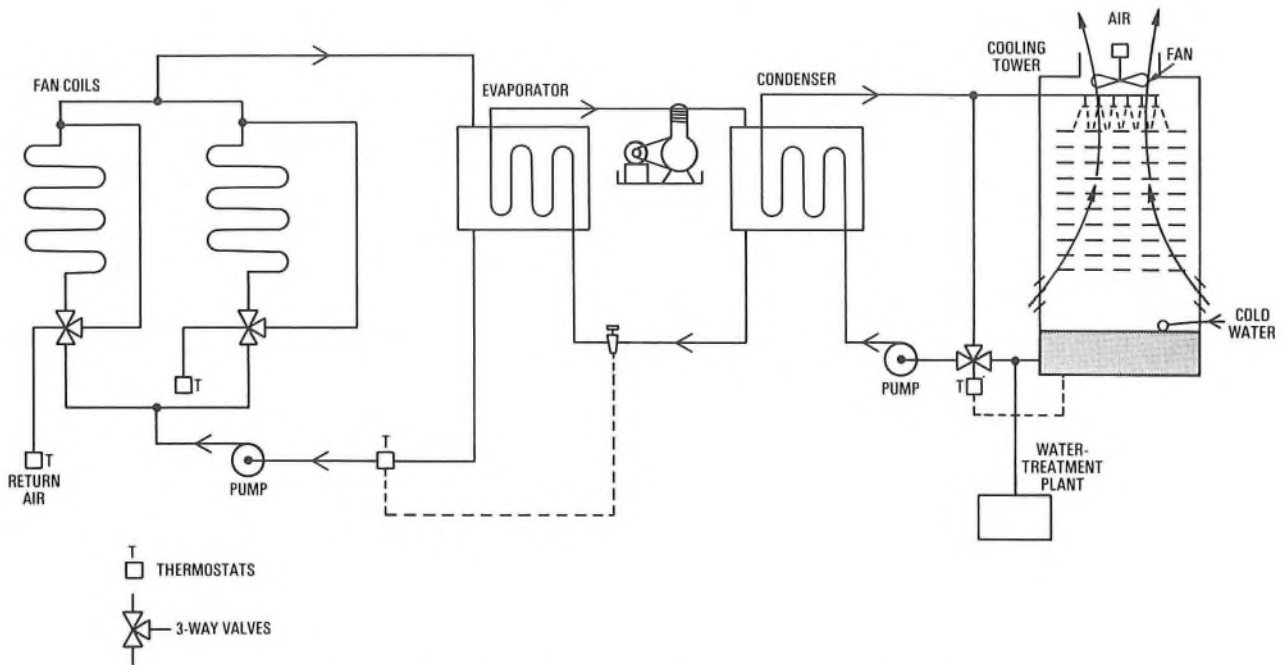

FIG. 10—Chilled-water system using evaporative cooling tower

in which heat is transferred from the water to be chilled to the refrigerant. The chilled water is then pumped round the building to the fan cooling coils at a temperature of about 4°C. The condenser, in this example, is another heat exchanger cooled by cold water, which is itself cooled in an evaporative cooling tower. The condenser water forms a fine spray in the tower and rejects its heat by evaporation. It becomes contaminated by air pollution and, for this reason, water treatment is necessary to reduce corrosion, scale and algae growth.

In installations where the fresh-air ventilation rate is set to 1 air-change/h, the refrigeration-plant control circuit operates as detailed in Table 6. Alarm features are provided and, in a large building, there is usually a need for zoning the controls and interlocking them with the heating controls.

TABLE 6

Refrigeration-Plant Control-Circuit Operation

Electric Motor Controls	Water pumps	Permanently on
	Cooling-tower fan	Controlled from contact on condenser water valve
	Compressors	Controlled from thermostat in chilled-water pipe
Temperature Controls	Room air	Room thermostat controls diverter valve in chilled-water supply to fan-coil unit
	Chilled water	Thermostat controls the compressor
	Condenser water	Thermostat controls 3-way valve in water flow to tower

Plant Provision

Plant provision is based on power-consumption forecasts for the fully-equipped building, which are produced by the long term planning group, and the following factors are taken into consideration.

(a) Accommodation requirements are called for at an

early stage in building planning and are based on plant size to meet the fully-equipped forecast load. This applies to fan rooms, chiller rooms and space for cooling towers. In major buildings, accommodation is reserved for plant which is capable of handling cooling loads up to 260 W/m².

(b) Ceiling duct becomes inaccessible when equipment racks and cable grids are erected and, for this reason, ducts are based on the size required for a ventilation rate of 16 air-changes/h. Diffusers are sized to meet the fully-equipped load.

(c) Air-handling fans are sized to meet the fully-equipped forecast load with a minimum size sufficient for a ventilation rate of 10 air-changes/h.

(d) Fan coils and chillers are provided, when necessary, to meet 5-year forecast growth stages. Multi-chiller and multi-tower layouts allow modular growth and reduce the initial outlay.

(e) When chillers are provided, pipework is also provided to meet the fully-equipped forecast load.

(f) Air-cooled condensers and cooling towers are usually installed on the roof and planning permission must be obtained from the local authority. This is a PSA responsibility.

(g) Floor strengths required for the plant are given in Table 7.

TABLE 7

Floor Strengths Required

Type of Plant	Required Floor Strength (kN/m ²)
Fan coil rooms	8.6
Chillers and compressors	9.8 (Note)
Water towers	4.8
Air-cooled condensers	3.4

Note: can be mounted on equipment-type floors (8.6 kN/m²) if the load is well distributed.

INTEGRATION OF DESIGN

The integration of the design of heating and ventilating schemes in a building is a matter of degree. It is essential, at all stages of planning, to ensure that the special needs of the heating and ventilating systems are made known to the architect and other engineers so that the integration extends to the whole building design.

With the trend towards higher day-to-busy-hour ratios in modern trunk buildings, the possibility of heat recovery and transfer should be considered, using the refrigeration plant as a heat pump. This could be achieved by transferring heat recovered from the refrigeration plant and using it to heat other rooms in the building. The heat recovered is at a relatively low temperature and, for this reason, a warm-air heating system is used. To be most economic, this scheme requires a high equipment-heat load for the greater part of the day at an early stage in the costing period.

If a large telecommunications complex is expected to have an electrical load of about 2 MW, within 1–2 years of opening, and is expected to reach an ultimate electrical load in excess of about 4 MW, it may prove economical to provide a total-energy scheme in that complex. In such a scheme, the BPO generates its own electricity in the building by means of Diesel-alternator sets and additional heat to warm the building is recovered from the engine cooling water and exhaust gases. A conventional boiler plant is not provided.

Each scheme must be considered on its merits as the costing exercise is delicately poised, particularly on fuel costs and interest rates.

FUEL ECONOMY

The energy and fuel crisis during the winter of 1973–74 highlighted the need to achieve economy in the consumption of electrical energy and fuel. Energy and fuel costs remain high and each member of the staff has a personal responsibility to economize in the use of electricity and heating fuel. If rooms are overheated, the radiators should be turned off in the first place to control temperature, and only if this is ineffective should windows be opened; the overheating should be reported to the engineering duty. All buildings, and windows in particular, should be made weatherproof and the heating and ventilating plant should be well maintained. Maloperation of controls is a prevalent practice which can be reduced by the use of non-adjustable room thermostats and by locking control cubicles.

The heat produced in a building stems essentially from the boiler fuel and from the electrical load. An approximate, but convenient, yardstick for assessing the heating efficiency of a building is given by the ratio

$$\text{heating efficiency factor} = \frac{\text{total useful heat input per annum}}{\text{total floor area heated}},$$

where the total useful heat input is the sum of the heat from the heating plant, lighting and equipment. A suggested value for this ratio, which makes some allowance for cold winters, is 1 GJ/m² of heated floor area each year. If the total heat input to all buildings could be reduced to achieve a ratio equal to, or lower than, this value, it would be a major achievement. If a higher value is obtained for a building, the reasons should be investigated and corrected where possible. This exercise can only be of value if conducted over at least a whole winter period.

INVESTMENT APPRAISAL

Heating and ventilating plant incur quite high costs on the capital and current account budgets; the latter for both maintenance and fuel costs. The capital costs of heating and ventilating plant, expressed as a percentage of the capital cost of the building in which the plant is installed, are approximately as follows for buildings which are wholly operational:

heating plant	10–12%,
mechanical ventilation plant (no refrigeration)	6–10%, and
mechanical ventilation plant (with refrigeration)	8–12%.

There is an increasing need to provide refrigeration plant in trunk switching centres, whereas few local exchanges require refrigeration cooling at present. The introduction of TXE4 and later electronic-type exchanges may well produce a greater need for refrigeration cooling in local exchanges in the not too distant future. Fuel costs, including the cost of electricity for all purposes, amount to about 25–30% of the total accommodation current-account budget in a telecommunication region.

The decision to provide plant must be based on a sound operational and financial appraisal of the available alternatives. The operational appraisal is based on field experience, whilst the financial appraisal is based on discounted cash flow (DCF) or present value of annual charges (PV of AC) techniques⁶. PV of AC has been in use for many years, particularly in the planning of external plant; DCF is a more recently introduced technique. For a particular cost comparison, both methods give the same result, but PV of AC is more convenient when items of different lives are involved, as it avoids the need to calculate outstanding capital credits; otherwise the use of DCF is recommended.

CONCLUSION

Opinions of comfort conditions vary amongst individuals, but the resultant temperature is the most realistic objective indicator of comfort conditions. The Institution of Heating and Ventilating Engineers advocates the use of environmental and sol-air temperatures for assessing plant size, but this has become a controversial issue in the profession; the use of the dry-bulb temperature does not result in serious error. All staff have their part to play in achieving fuel economy. Expenditure on plant is a significant part of the capital and current-account budgets, and the investment should be based on a sound operational and financial appraisal.

ACKNOWLEDGEMENT

The author wishes to thank his colleagues in the Accommodation Services Group, North West Telecommunications Board for their assistance in the preparation of this article.

References

- ⁴ Degree Days, their use and application for checking and computing fuel consumption (Technical Handbook No. 101—Revised edition 1965). The Gas Council, 4–5 Grosvenor Place, London SW1.
- ⁵ NESS, A. An Introduction to Automatic Controls for Central Heating. *POEEJ*, Vol. 61, p. 154, Oct. 1968.
- ⁶ HOLMES, D. C., and PARISH, K. E. Engineering Cost Study Methods in the British Post Office and their Financial Background. *POEEJ*, Vol. 65, p. 76, July 1972.

Experimental Packet-Switched Service: Procedures and Protocols

Part 3—Operation of Asynchronous Terminals

W. NEIL, DIP.ENG., C.ENG., M.I.E.R.E., M.I.E.E., M. J. SPOONER, B.SC., M.SC.,
and E. J. WILSON, B.SC.(ENG.), A.C.G.I.†

UDC 621.394.4: 681.32

The 2 previous parts of this article described the packet formats, facilities, switching and transmission procedures of the British Post Office Experimental Packet-Switched Service (EPSS). This third and concluding part describes the procedures and protocols adopted to permit asynchronous terminals to communicate with the EPSS, either by direct connexion or using the telephone or Telex network.

ASYNCHRONOUS TERMINALS

Asynchronous terminals operate on a start-stop character-by-character basis and will communicate with other terminals in the system by means of a packet assembly and disassembly facility. This function is performed for the terminals by a virtual packet terminal (VPT) accommodated in each packet-switching exchange (PSE). Asynchronous terminals gain access to the VPT either by direct and permanent connexions, or on a random basis using the Telex or telephone networks.

Unlike the synchronous terminals, the operation of which, both during and after a call, is fully automatic, an asynchronous terminal will probably require the continuous attendance of an operator for the duration of the call. The operator's task has been made as straightforward as possible by the retention of existing standards and procedures for call set-up, transfer of data and subsequent clear-down, currently being used by Telex and telephone terminals, and also the CCITT* X20 recommendations. However, packet switching has necessitated both the definition and introduction of extra protocols and rules for asynchronous terminals, to facilitate the interworking of machines of such diverse operating parameters as those using the Experimental Packet-Switched Service (EPSS).

Consider first the process of setting up a call.

CALL ESTABLISHMENT

Call Establishment from a Telex Terminal

To establish a call from a Telex terminal (see Fig. 17), the Telex-EPSS access number is dialled first, one access number being allocated to each PSE. The Telex exchange to which the PSE is connected extends the *incoming-call* signal to the VPT which responds with the normal *call-answered* signal. The PSE then receives the *who-are-you* (WRU) code from the Telex exchange, which causes the *answer-back* signal to be returned from the VPT to the calling terminal. The VPT's *answer-back* signal is then suppressed so that WRU signals may be freely exchanged between communicating terminals. To enable the VPT to identify the caller, a WRU signal is then returned to the Telex terminal which must respond with its own *answer-back* signal in a specified time.

The VPT then examines the record, known as the *terminal descriptor* and held in store for this terminal, to determine whether the *answer-back* signal received is from a terminal

which is allowed to call the EPSS. If the *answer-back* signal is invalid, the VPT returns the service signal BK, meaning "I cut off" and clears the call. However, the VPT may have been instructed to make a double check on a particular calling terminal; in this case, the service signal, RAP ("I will call you back") is returned to the caller followed by a clear from the VPT. The VPT then recalls the terminal and re-establishes the call, as described later. If neither of these 2 instances applies, then after the VPT has received the terminal's *answer-back* signal, the service signal KEY + is transmitted to the terminal, indicating to the terminal that it may now proceed to select the EPSS number of the called terminal with the machine keyboard (when calling the PSE, the dial was used).

The address which a calling terminal enters may consist of 1-3 of the following areas:

(a) a 1-character field allowing the terminal to indicate a closed-user-group and effectively permitting the setting up of private networks for public-switched-network terminals,

(b) a 5-character field containing the called-terminal's EPSS number that would be shown in an EPSS terminal directory, and

(c) a process number which is analogous to an extension in the telephone system, and consists of 3 characters.

The address selection is followed by an *end-of-address* character which is also entered by the terminal.

Following the entry of the complete address, the VPT forms a call-originating packet on behalf of the terminal, and transmits it. This results in a call-confirmation network information packet (NIP) being received by the VPT which causes it to repeat the called address to the calling terminal; the call-confirmation NIP contains the *answer-back* signal of the called end if this is a Telex terminal, and the VPT repeats this to the calling terminal following the called address.

At some later time, the VPT also receives a first-response packet from the called terminal and this causes the VPT to send the signal DF to the caller, indicating that the 2 terminals are in communication and that the caller may now enter data. At this point, the VPT may also send the signal CIC (code interchange) if the 2 terminals are transmitting with different alphabets, following which the customer's data (if any) from the first-response packet is also delivered to the calling terminal. If, during this phase, the caller fails to proceed or respond in the required way, the VPT returns the service signal BK to the caller and clears the call.

Call Establishment to a Telex Terminal

Call set-up attempts to EPSS terminals require the receipt of a call-originating packet by the VPT controlling the called

† Mr. Neil and Mr. Spooner are in the Telecommunications Systems Strategy Department, Telecommunications Headquarters, and Mr. Wilson is now with the Independent Broadcasting Authority.

* CCITT—International Telegraph and Telephone Consultative Committee.

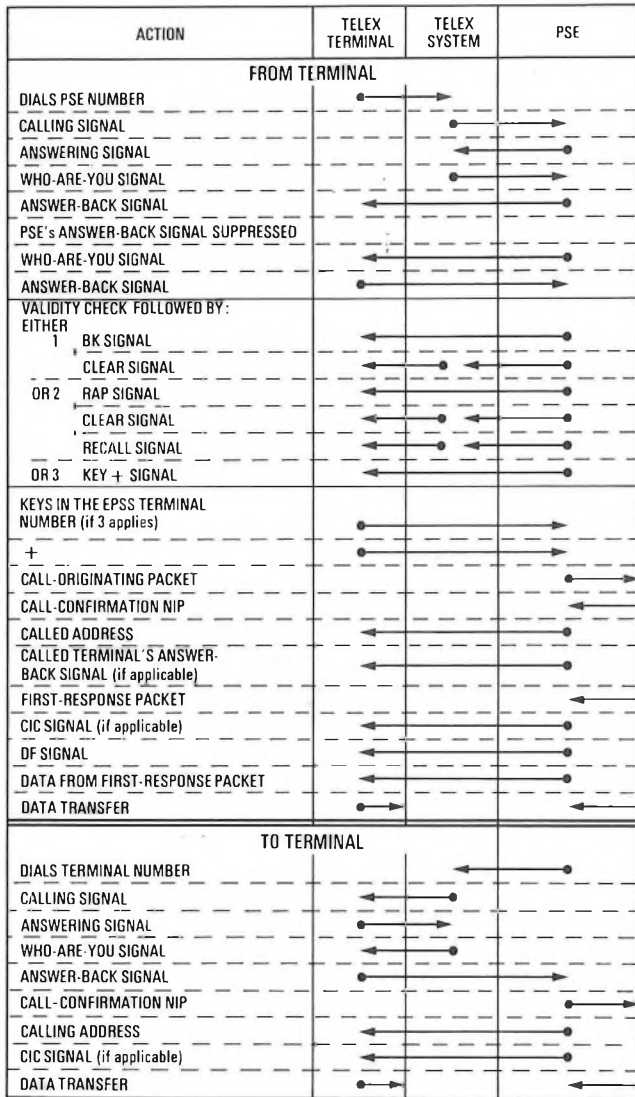

FIG. 17—Call set-up to and from a Telex terminal

terminal. The addressing information contained in the call-originating-packet header enables the VPT to examine the appropriate terminal descriptor. In this case, the terminal descriptor shows that the terminal is to be accessed via the Telex system and also gives the Telex number of the terminal. Acting on this information, the VPT then presents the Telex number to the automatic dialling equipment at the Telex-PSE interface (see Fig. 17); this eventually causes the Telex exchange to send the WRU signal to the called terminal, resulting in the *answer-back* signal being returned to the VPT. The *answer-back* signal must be returned within the required time and must be valid (as checked by the VPT), otherwise the service signal BK is returned to the terminal and the call is cleared. If the terminal is engaged, this results in a Telex service mnemonic being returned to the VPT by the Telex exchange, and on receipt of this, the VPT forms it into a NIP which is returned to the calling terminal.

After the *answer-back* signal has been validated by the VPT, it is included as part of the data field in the call-confirmation NIP, which is returned to the caller. The called terminal is made aware of the identification of the caller through the calling address which the VPT extracts from the call-originating packet and transmits to the terminal, followed, if necessary, by the signal CIC when the 2 terminals are using different alphabets.

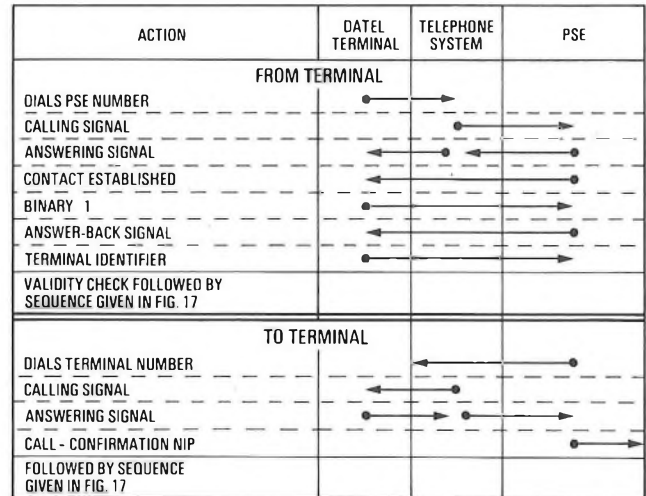

FIG. 18—Call set-up to and from a Datel terminal

Call Establishment from a Datel Terminal

Each PSE in the system is connected to a local telephone exchange and is allocated telephone numbers in the normal way, and these are used by a Datel terminal in accessing the PSE interface. Following the dialling of the PSE number (see Fig. 18), the telephone exchange extends the calling signal to the PSE which replies which an answering signal which places the calling terminal in contact with the PSE interface. The terminal must then return a binary 1 signal to the VPT, within a certain time constraint, and the receipt of this signal by the VPT causes it to transmit its *answer-back* signal to the terminal. After the terminal has received the VPT's *answer-back* signal, the operator must return an identifying sequence (the terminal identifier) to the PSE, again within a specified time, otherwise the VPT clears the call. The terminal identifier consists of a 5-character EPSS number, plus a 4-character sequence which is agreed between the British Post Office (BPO) and the customer. The terminal identifier is examined by the VPT to determine its validity; if the terminal identifier is invalid, the VPT returns the service signal BK and clears the call. As with Telex terminals, the VPT may have to make an extra check on a Datel terminal, in which case, the procedure using the signal RAP also applies. If, however, neither of these 2 cases applies, the PSE returns the service signal KEY +, which enables the terminal to begin the input of the called address, as described for the Telex terminal. Subsequent to this phase of the call, the procedures for both Telex and Datel terminals are identical.

Although these terminals communicate using a code with a parity bit, this is not checked by the VPT.

Call Establishment to a Datel Terminal

After receipt of the call-originating packet, the VPT obtains the telephone number of the called terminal from the terminal descriptor, which also indicates that access must take place through a telephone-PSE interface. As with the Telex interface, the VPT also presents the telephone number to the automatic dialling equipment which, in turn, passes this on to the local telephone exchange (see Fig. 18). If the terminal is free to receive an incoming call, it returns an answering signal to its local exchange. This signal is then passed on to the appropriate interface circuit at the VPT. The circuit is monitored by the VPT which has to form, and send off to the caller, a call-confirmation packet, when the circuit is turned on by the signal from the called terminal. The VPT then delivers the calling-terminal's address to the called end, followed, as before, by the signal CIC if this is necessary.

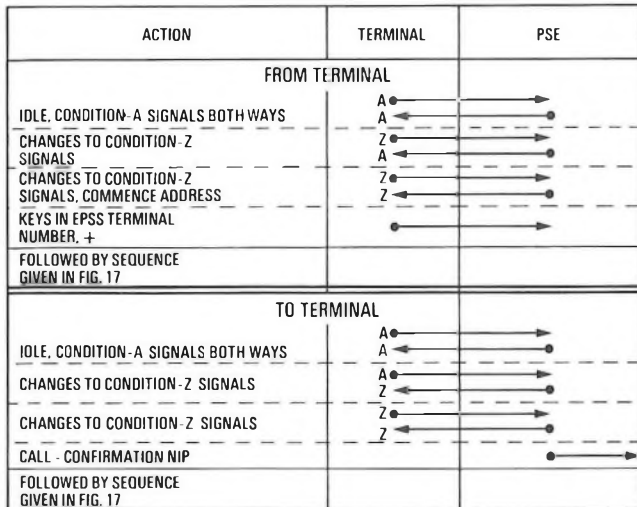

Fig. 19—Call set-up to and from a directly-connected terminal

Call Establishment from a Terminal with a Direct Connexion to the PSE

Unlike the 2 previous classes of terminals described above, this third type does not have to traverse the public switched network to establish contact with the PSE. The lines from the terminal interface are functionally connected to the VPT, which continuously monitors the state of the line signal (see Fig. 19). In the idle (no-call) condition, the VPT and the terminal transmit binary 0 signals (condition A) to each other and, when the user wishes to make a call, the binary 0 signals are changed to binary 1 signals (condition Z). The change is recognized by the VPT, which also changes the outgoing condition from A to Z and this, in turn, is recognized by the terminal as an indication that address selection may commence. Condition Z is maintained in both directions for the duration of the call. The entry of the called-terminal's address and the subsequent procedures are as described for the Telex terminal.

Call Establishment to a Terminal with a Direct Connexion to the PSE

When the PSE receives a call-originating packet for a directly-connected terminal, the VPT changes the signal from the condition A to Z (see Fig. 19). The terminal responds by changing the condition from A to Z in the direction back to the PSE. Condition Z is then maintained for the duration of the call. On receipt of the change of signal condition from the terminal, the VPT forms the call-confirmation packet and the call proceeds as described for the Telex terminal.

CALL CLEARING

Call Clearing to and from a Telex Terminal

If a Telex terminal clears a call, the clearing signal is extended to a circuit on the Telex-PSE interface, which the VPT is continuously monitoring. The appearance of the clearing signal on the circuit causes the PSE to form a clearing packet, which is forwarded to the remote end, and indicates that the interface is now available for other calls.

If the PSE receives a clearing packet for a Telex terminal, the VPT sends the service signal BK to the non-clearing terminal and inverts the signal on a Telex-PSE interface circuit which, in turn, causes the connexion between the PSE and the Telex exchange to be cleared. The VPT then forms a clear-confirmation packet, which is returned to the clearing terminal. The Telex-PSE interface is again ready for use on other calls.

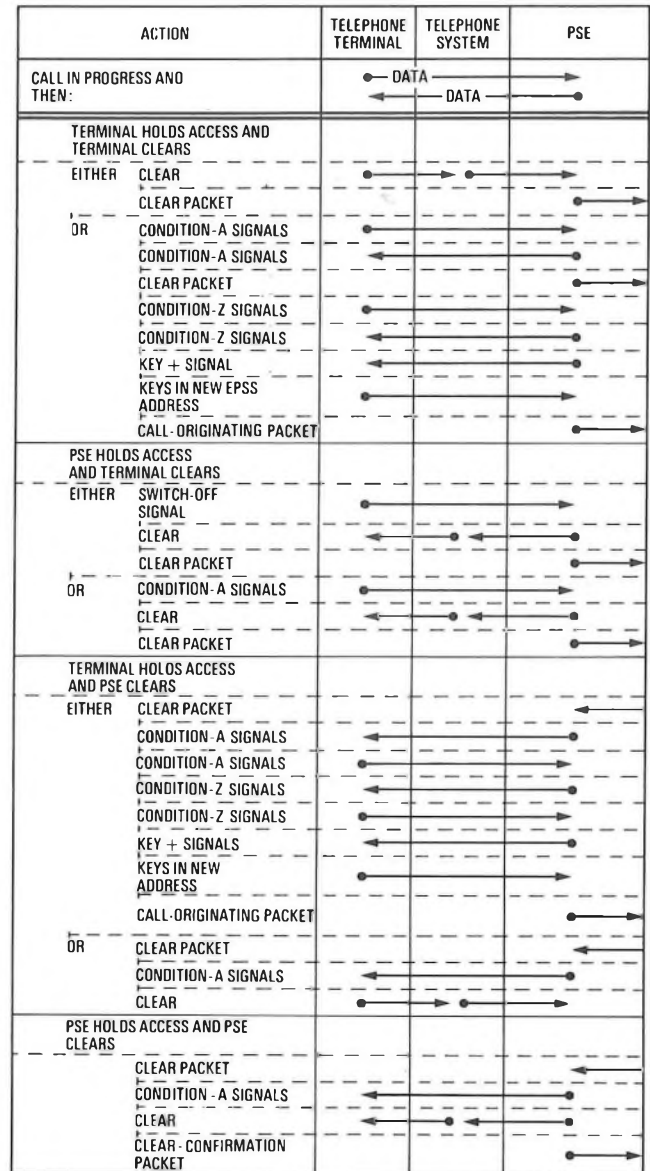

Fig. 20—Call clearing to and from a telephone terminal

Call Clearing from a Telephone Terminal

In most cases in this country, the person who makes the call must also clear it, as the called party is unable to clear the call. Hence, for these classes of terminals, it is necessary not only to define the packet-clear from either end of the call, but also to examine the direction from which the call was set-up (see Fig. 20).

Terminal Holds Access and Terminal Clears

Consider first the case where the terminal has made the call; that is, the terminal *holds access*. If the terminal clears, this is indicated on a specified interface circuit at the PSE; the interface is then available for use on another call, and the VPT forms a clearing packet and sends this off. However, the terminal is also allowed to clear only that part of the call which is established via the EPSS. This results in the packet call being cleared, but the connexion between the terminal and the PSE being maintained, so that the terminal may now make another packet call. To do this, the terminal sends condition-A signals to the PSE for longer than a specified time. The PSE also returns condition-A signals and clears the call in the direction of the other terminal. When the terminal receives the condition-A signals from the PSE, it responds by changing the

signal back to condition Z. On receipt of this, the PSE also changes back to condition-Z signals and sends KEY + signals to the terminal, which starts keying in another EPSS terminal address. This is the beginning of a new call, which proceeds as described above.

PSE Holds Access and Terminal Clears

If the PSE holds access and the terminal attempts to clear the call, the PSE is aware of this through the loss of signals on an interface circuit which is being monitored. The PSE immediately responds by clearing the call in the direction to the telephone exchange, and also forms a clearing packet for the distant end. The terminal may also indicate the wish to clear by sending condition-A signals to the PSE for greater than a specified time, in which case the PSE again clears in both directions.

Call Clearing to a Telephone Terminal

It is also necessary, in this case, to consider from which direction the access is held.

Terminal Holds Access and PSE Clears

If the terminal had made the call and, therefore, holds access, on receipt of a clearing packet from the other terminal, the PSE sends condition-A signals to the originating terminal. On receipt of this signal, the terminal may either respond with condition-A signals and proceed to make another call, as described earlier, or it may clear the connexion through the telephone exchanges. In both cases, the packet call is cleared, and the VPT sends off a clear-confirmation packet to the other terminal. If the terminal does neither of these then, after a specified time, the VPT assumes that the call has been cleared in both directions, and takes no further action with this interface except to mark it as busy and monitor it until a clearing condition is forthcoming.

PSE Holds Access and PSE Clears

If, however, the VPT had set up the call to the terminal, then the VPT sends condition-A signals, for a certain period of time, as an indication that a full clear is imminent. Following this, the VPT clears the connexion to the telephone exchange and returns a clear-confirmation packet to the other user.

Call Clearing to and from a Terminal with a Direct Connexion to the PSE

When a call is in progress, the signal on the line, both to and from the terminal, is condition Z. If the terminal wishes to clear the call, or the call is cleared from the other end (in which case, the PSE clears to the terminal), then the clearing signal is a change from condition Z to A. The non-clearing end recognizes the change to condition-A signals, for a specified period of time, and then also changes to condition A. The signal on the line, in both directions, is condition A until either end decides to make a call. When the clearing on the local end is complete, the PSE forwards either a clearing packet or a clear-confirmation packet as appropriate.

TRANSFER OF DATA

Packet Assembly

The procedures for the transfer of data from asynchronous terminals in a packet mode using the EPSS have been kept as near as possible to existing methods. Consequently, these terminals are not required to form data into packets, or to cope with data in packet form incoming from other terminals. However, the asynchronous terminal's data must be sent and received by the VPT in packets and so, a compromise between the 2 conflicting requirements is necessary. Therefore, the VPT assembles data from the asynchronous terminal into properly headed packets, and removes the headings from packets destined for these terminals, the data then being delivered at the correct rate.

The VPT can form all the packet types necessary for normal transmission on behalf of the asynchronous terminals. This

includes deciding which type of packet is required and formulating the associated header. The data (if any) is assembled by the VPT and added to the packet header, and the completed packet is handed over to that area of the PSE which adds and subtracts the main network additions.

The following 3 types of customer packets can be assembled by the VPT.

(a) Call-Originating Packets

Call-originating packets are known as *type 1* packets (see Fig. 2), and are necessarily formed by the VPT when an asynchronous terminal initiates a call, as described earlier. As shown in column 1 of Table 10, the VPT attempts to set up a call with 2 buffers on behalf of the asynchronous terminal, and also includes the closed user group and address selected by the calling terminal. All other information entered in the packet header is obtained by the VPT from the calling asynchronous-terminal's terminal descriptor. No data can be entered in a call-originating packet being formed for a calling terminal by the VPT. The VPT then passes the call-originating packet over to the packet areas in the PSE for the inclusion of the main network addition.

(b) First-Response Packets

When a call attempt to an asynchronous terminal is made via the EPSS, one of the functions of the VPT is to return a call-confirmation NIP, following which the call enters the data phase (see Figs. 17-19) and the VPT awaits the input of data from the called terminal. On receipt of this data, the VPT initiates the formation of the first-response packet, which is termed a *type 2* packet (see Fig. 2), the format and information content being shown in column 3 of Table 10. At this stage of the call, the calling terminal is barred from sending a packet (except the call-originating packet) until it has received the first-response packet from the called terminal.

The VPT does not transfer any extra buffers back to the callers, and establishes the number of buffers for the call from the call-originating packet. The length of the first-response packet is marked according to the number of bytes which the called terminal entered.

Where necessary, the VPT obtains certain information from the terminal descriptor, for example, the terminal type and charge, and enters these in the appropriate field, as shown in Table 10. Other fields in the packet header may, at this point in the call, be influenced by the called terminal; for example, the terminal may clear the call, in which case the VPT marks the *clear* bit in the header. The completed first-response packet is then passed on for the main network addition to be added.

(c) Subsequent-Response Packets

When the first-response packet is delivered to the calling terminal, the call can be said to be fully *set-up* and, following this, data may be transferred within the rules of EPSS packet-transfer protocol. The data is moved in subsequent-response packets, and any data input by the terminal must be formed into a subsequent-response packet by the VPT, the header of which is shown in column 1 of Table 11. The VPT does not transfer any extra buffers to the other terminal, since the function of transferring these between terminals is left entirely to the discretion of the other terminal, resulting in a simple, minimally interactive role for the VPT. The buffer field has now also become the user-to-user sequence number, S2, which is cycled from 0 to 7, and gives a user confidence that the correct packet has, in fact, arrived in sequence.

Requests to the distant end to *send data* are made by the VPT on behalf of the asynchronous terminal. In this way, the distant terminal is never forced to send a zero data field packet.

As before the terminal may clear the call, in which case the clear bit is marked; the completed subsequent-response packet is then passed on for the inclusion of the main network addition.

TABLE 10
Header Field Requests of Type 1 and 2 Packets at the VPT

	Type 1 (Call-Originating) Packets		Type 2 (First-Response) Packets	
	1	2	3	4
Packet Header	Assembled by VPT	Disassembled by VPT	Assembled by VPT	Disassembled by VPT
Type	Marked by VPT as <i>call-originating packet</i> when terminal sets up call	Call-originating packet, indicating that VPT must try to set up a call to an asynchronous terminal	Marked as <i>first-response packet</i> , and is in response to signal in column 2	Marked as <i>first-response packet</i> and is in response to signal in column 1
Length	Shows <i>zero</i>	Any marking is acceptable	Marked according to the data returned from the asynchronous terminal which is to be included	Any marking acceptable
Extra Buffers Transferred	Shows <i>zero</i>	Marked either 1 or 0	Shows <i>zero</i>	May be 0 or 1, although 1 will only be marked if the number of buffers is 2
Number of Buffers	Marked 2	Any marking is acceptable	As marked in column 2, unless this was 2, in which case this field is marked 2	Marked 1 or 2
S1	Shows <i>zero</i>	Ignored by VPT	Shows <i>zero</i>	Ignored by VPT
Label	Unnecessary	Noted by VPT	Unnecessary	Noted by VPT
Terminal Type	Shows <i>character</i>	May be either packet or character	Shows <i>character</i>	May be either packet or character
Delivery Confirmation	Marked <i>not delivery confirmation</i>	May be requested	Marked <i>not delivery confirmation</i>	May be requested
Reset	Marked <i>not reset</i>	Ignored by VPT	Marked <i>not reset</i>	Ignored by VPT
Clear	Marked <i>not clear</i>	May be marked <i>clear</i>	Marked <i>clear</i> if required	May be marked <i>clear</i>
Single Interaction	Marked <i>not single interaction</i>	Ignored by VPT	Marked <i>not single interaction</i>	Ignored by VPT
Charge	Shows <i>normal</i>	Any marking is acceptable	Shows <i>normal</i>	Only <i>normal</i> or <i>reverse</i>
Code	Marked as appropriate	Only IA2 or IA5	Marked as appropriate	Only IA2 or IA5
Closed User Group	As requested by the terminal	Padded	Marked <i>padding</i>	Padded
Address	As requested by the terminal	Entry is recorded by VPT	Marked as shown in column 2	Entry is recorded by VPT

Packet Forwarding Conditions

The VPT considers the first-response packet or subsequent-response packet data field to have been entered completely when the terminal has either

- (a) sent in a maximum of 255 characters, or
- (b) sent in a delimiting character which informs the VPT that the terminal has no further data to be included in the present packet.

In each case, the VPT initiates the packet-forming procedure, described above, and then forwards the packet for the inclusion of the main network addition.

Packet Disassembly

All packets destined for asynchronous terminals are forwarded from the originating PSEs in the standard EPSS packet format. The packet headers are not transmitted to terminals, however, as the VPT intercepts the incoming packet, carries out an analysis of the header (in the manner similar to a packet terminal), and performs the necessary responses on behalf of the terminals. The VPT then strips off the header and check bits, and delivers the contents of the data field to the terminal at the correct line rate and alphabet in a contiguous stream.

As with packet assembly, the VPT may receive 3 types of packet and the action which it takes in handling these is described below.

(a) Call-Originating Packets

These type 1 packets are received by the VPT (see column 2 of Table 10) when another terminal is attempting to set-up a call to an asynchronous terminal. The packet causes the VPT to examine the called-terminal's terminal descriptor to ascertain whether the terminal is free to receive a call; the VPT then puts the call-request signal on at the line interface.

The length indicator in the packet may show a data field of greater than zero bytes, in which case the VPT stores the data until the call has been established and the terminal has been fully checked before delivery is attempted. The VPT may also find that the extra-buffer-transferred field has been marked to transfer an extra buffer to the terminal. In conjunction with the number-of-buffers field, this determines how many buffers (either one or two) are allocated for the call and at which end. The label field is the virtual extension of the calling terminal, and this is noted by the VPT for attachment to subsequent-response packets later in the call. Similarly, the address field is also noted for subsequent use.

TABLE 11
Header Field Requests of Type 3 Packets at the VPT

Packet Header	Type 3 (Subsequent-Response) Packets	
	1	2
Assembled by VPT	Assembled by VPT	Disassembled by VPT
Type	Marked as <i>type 3</i> , and follows signals in columns 3 and 4 of Table 10 or column 2 of this table	Marked as <i>type 3</i> , and follows signals in columns 3 and 4 of Table 10 or column 1 of this table
Length	Marked as necessary	Marked as necessary
Extra Buffers Transferred	Shows <i>zero</i>	As in column 4 of Table 10
S2	Marked in sequence, 0, 1, 2 . . . 7, 0, 1, 2 . . .	Marked in sequence, 0, 1, 2 . . . 7, 0, 1, 2 . . .
S1	Shows <i>zero</i>	Ignored by VPT
Label	Unnecessary	Noted by VPT
Send	Marked <i>send data</i>	Marked <i>data or zero</i>
Acknowledge	Shows <i>acknowledge</i>	Ignored by VPT
Clear	Marked <i>clear</i> if requested	May be marked <i>clear</i>

(b) First-Response Packets

First-response (type 2) packets are received by the VPT in response to a call-originating (type 1) packet, which the VPT has previously sent through the EPSS in an attempt to establish a call. In the first-response packet (see column 4 of Table 10), the requests in the header fields should confirm the requirements, entered by the VPT in the call-originating packet; in particular, that the number of buffers is at the most 2. The requests should also define the number of buffers held at the terminal end of the call, resulting from the extra-buffers-transferred field (of the first-response packet) being marked either one or zero. After the VPT has sent off the call-originating packet and is awaiting the first-response packet, the asynchronous terminal can input up to 2 packets of data, but the VPT is not allowed to transmit them as subsequent-response packets until the first-response packet has been received; they are stored until this occurs.

(c) Subsequent-Response Packets

After receiving the first-response packets, the VPT can transmit subsequent-response packets, provided the terminal has input data. After this, the VPT receives subsequent-response packets from the other end of the call, and the header requests are shown in column 2 of Table 11. If the number of buffers for the call is 2, the extra-buffers-transferred field may be marked either one or zero; otherwise, it is always marked zero. The *send* field is marked either *send a data packet* or *send a zero data field packet*. This instructs the VPT either

- (i) to send data on behalf of the terminal, or
- (ii) to hold the terminal's data, and transfer all available buffers back to the requesting terminal in the form of subsequent-response packets, with no data in the data area.

The sequence number, S2, establishes the incoming packets in a definite stream and enables the VPT to detect a missing packet in the stream, since the number rotates in a strictly cyclical fashion.

The clear bit is marked in a subsequent-response packet, if the other terminal wishes to clear the call.

Packet Transfer During a Call

During a call, the transfer of, and response to, packets is greatly influenced by

- (a) the number of buffers allocated for the call,
- (b) the extra buffers transferred, and
- (c) the send bit.

Depending on the marking of these fields, the VPT must respond in a very specific way. The number of buffers for the call is determined at call set-up and does not fluctuate during the call. Therefore, as the VPT must always mark the send bit as *send a data packet* and the extra-buffers-transferred field is zero, the only 2 fields which are variable during a call are the send and extra-buffers-transferred fields on incoming subsequent-response packets; for the purposes of this discussion, the S2 sequence number is not considered variable since it rotates in a fixed cycle.

The extra-buffer-transferred bit informs the VPT of the number of buffers which are to be held at the VPT end of the call. Each packet sent out carries at least one buffer as a minimum and, in this case, the extra-buffers-transferred bit is marked zero. If the terminal at the other end of the call wishes to transfer all of the buffers (2) to the VPT, the extra-buffers-transferred bit must be marked as one.

The terminal may also request the VPT to return data packets to it (if any are available), or to return the buffers to the other end of the call by marking the send bit as *send zero*. The VPT then sends off either one or two packets, depending on whether it is holding one or two buffers at its end of the call. These packets carry no data in the data area, even if it were present when the VPT formed the packets, and their sole function is to get the buffer(s) back to the terminal which requested them. This method of interaction may be particularly useful for calls between an asynchronous terminal and a packet-mode bureau, since the bureau can output data continuously to the terminal and, at the same time, prevent the terminal's data being forwarded through the system by requesting the *send-zero-data-packet* facility. The actions taken by the VPT, resulting from the interaction of the extra-buffers-transferred and send bits for buffer sizes of one or two, are summarized in Table 12.

An example of what may well be a typical data flow between an asynchronous terminal, the VPT and a remote packet terminal is shown in Fig. 21. This indicates that the majority of data flows from the packet terminal to the asynchronous terminal, even though the number of packets to the VPT is less than the number of packets from it. This is because 2 of the packets flowing from the VPT are carrying zero data.

INTERACTION BETWEEN VPT AND ASYNCHRONOUS TERMINALS DURING A CALL

When the asynchronous terminal and VPT have established a link between themselves, the terminal may send commands to the PSE which go no further into the system than the VPT. These commands are ECHO, to start or stop the VPT echoing the terminal's input, and RESET, which causes the VPT to reset the state of the call to that applying initially at call set-up; these are both discussed below.

The VPT may also issue commands to the terminal in the form of instructions to either stop or recommence the input of further data, and these also are considered in further detail below.

Commands from the Asynchronous Terminal to the VPT

To allow terminals to send instructions to the VPT, they must be distinguishable from data which is intended for transmission across the network to the other terminal. This distinction is achieved through the use of a single shift character, known as *escape* (ESC) in the EPSS. The receipt of an ESC signal by the VPT is an instruction to act on the

TABLE 12
Action Taken by VPT During the Data-Transfer Phase

Number of Buffers for Call	Extra-Buffers-Transferred Bit	Send Bit	Subsequent-Response Packet (Type 3)	
			Into VPT	Out of VPT
1	0	Send Data	The VPT sends a data packet, if available, with the extra-buffers-transferred bit marked zero; otherwise, it awaits input from the asynchronous terminal and does nothing until this is forthcoming	All packets are marked thus if the number of buffers for the call is 1
		Send Zero	The VPT retains any data packets sent in by the asynchronous terminal and sends a ZDF instead with the extra-buffers-transferred bit marked zero	Not allowed
1	1		← Invalid →	
2	0	Send Data	The VPT returns one data packet, if available, or awaits input from the asynchronous terminal and sends this packet when complete, with the extra-buffers-transferred bit marked zero	All packets are marked thus if the number of buffers for the call is 2
		Send Zero	The VPT returns either one or two ZDF packets with extra-buffers-transferred marked zero, depending on how many of the 2 buffers are at the VPT end of the call at this point in time and regardless of how many buffers the asynchronous terminal has filled or is filling	Not allowed
2	1	Send Data	(a) If there are 2 full buffers, the VPT returns these with extra-buffers-transferred marked zero (b) if only one is full, the VPT sends this and awaits further input from the asynchronous terminal and then also sends this when available; if an SZ with extra-buffers-transferred marked zero is received from the other end after sending this first and before sending the second, the VPT returns 2 ZDFs with extra-buffers-transferred bit marked zero, or (c) if both buffers are empty, the VPT awaits input from the asynchronous terminal and goes to state (a) or (b)	Not allowed
		Send Zero	The VPT returns 2 ZDFs both marked with extra-buffers-transferred equal to zero	Not allowed
> 2			← Invalid →	

ZDF = Zero data in packet
SZ = Request to VPT to return a packet containing no data

character which follows it, to treat all characters subsequent to this second character as normal data, and to cease outputting data to the asynchronous terminal. The only 2 characters which cause the VPT to change the mode are RESET and ECHO. If the second character is also an ESC signal, this is included in a packet as data; any other second character is also treated as data. The esc signal may be returned to the VPT at any time during a call after the terminal has received the KEY + signal from the VPT.

Consider first the reset action, which may be requested by either terminal involved in the call, and assume that the asynchronous terminal has sent in the request.

Reset Requests from the Asynchronous Terminal

The asynchronous terminal can reset the call at any time after receipt, or sending of, the first-response packet by the VPT. On receipt of the RESET request, the VPT forms a reset-originating packet and, if there is any data present in the terminal's buffers, the latest buffer filled is also included in the reset-originating packet. Until the VPT informs the terminal that reset has taken place, the terminal is allowed to input only the ECHO request, all other data being discarded by the VPT. Any data being output or echoed to the terminal is also stopped at the time of the request.

Sending the reset-originating packet causes the PSE at the distant end to return a reset-confirmation NIP, which confirms to the VPT that the system's records have been reset; the distant terminal must also respond using a reset-response packet, which arrives at the VPT after the reset-confirmation NIP. When the VPT receives the reset-response packet, a

mnemonic (SET) is sent to the terminal to inform it that the call has now been fully reset and that the terminal may begin sending data. If the NIP received indicates that HOLD is in operation at the distant terminal, or that the route is congested, the VPT retransmits the reset-originating packet.

Reset Requests to an Asynchronous Terminal

When the VPT receives a reset-originating packet, it immediately commences to return a reset-confirmation NIP and to send the SET mnemonic to the terminal, followed by any data which may have been present in the reset-originating packet; any echoing of data is ceased. Any data present in the terminal's buffers is discarded by the VPT. The terminal may input further data or requests (except reset) after it has received the SET mnemonic. The VPT accepts reset requests only after it has sent the reset-response packet, which it may do only when the terminal has sent in another packet of data.

Echo Requests

The ECHO request may be initiated only by the asynchronous terminal; that is, the other terminal in the call may not request it.

The terminal descriptor indicates to the VPT the mode of echo in which the terminal has chosen to operate. This instructs the VPT either to echo all data back to the terminal and then transmit as packets into the network, or not to echo data at all and simply forward as packets.

The ECHO request is permanently written into the terminal descriptor and it may be changed only during a call, after which it reverts to the base mode which may be altered only by

BUFFERS HELD BY THE VPT	NUMBER OF BUFFERS FILLED BY THE ASYNCHRONOUS TERMINAL	PACKETS IN/OUT TO/FROM THE VPT	EXTRA BUFFERS TRANSFERRED MARKING	EXTRA BUFFERS TRANSFERRED ACTUALLY TRANSFERRED
1	0	← SD →	0	← 2 →
2	but fills 1	● DF — SD →	0	● 1 →
1	0	VPT WAITS FOR ASYNCHRONOUS TERMINAL TO INPUT DATA		
1	0			
1	1	● DF — SD →	0	● 2 →
0	0			
0	0			
1	0	← DF — SZ →	0	← 1 →
2	1	← DF — SZ →	0	← 2 →
1	1	● ZDF — SD →	0	● 1 →
0	1	● ZDF — SD →	0	● 2 →
2	1	← DF — SD →	1	← 2 →
1	0	● DF — SD →	0	● 1 →
1	0	VPT WAITS FOR ASYNCHRONOUS TERMINAL TO INPUT DATA		
0	1	● DF — SD →	0	● 2 →
0	0			
0	0			
2	0	← ZDF — SD →	1	← 2 →
2	0	VPT WAITS FOR ASYNCHRONOUS TERMINAL TO INPUT DATA		
2	0			
2	0			

← INDICATES PACKET FLOW TO VPT INDICATES FLOW FROM VPT →

DF—data field filled
SD—requests other end to return a packet containing data, if available
SZ—request to VPT to return a packet containing no data
ZDF—zero data in packet

FIG. 21—Possible data flow during a call between an asynchronous terminal and a packet terminal

written agreement. There is no limit to the number of times which a terminal may change the echo mode during a call.

If the base mode indicates ECHO at call set-up, the echoing commences after the terminal has been validated, including the echoing of the address being input by the terminal. An ECHO request refers to all data which was input by the requesting terminal still held by the VPT.

During an echo mode call, the input from, and the output to, an asynchronous terminal must be related in some controlled manner to avoid a confusing print-out, and this is organized on the following basis.

(a) If there is no output for the terminal, all input from it is echoed as it is received.

(b) If, in addition to (a), output arrives for the terminal while input is present, then the output is not delivered to the terminal until it has input either a complete packet of data or a delimiting character; otherwise, the output would be encased in the input on the terminal's print-out.

(c) If output occurs before input, then the input is not echoed until a subsequent packet marked *send data* is received by the VPT, and the input is echoed to the terminal prior to the contents (if any) of the packet which released it. However, if delivery of the packet commenced before input was present, the packet data is completely delivered first. A packet marked *send data* causes all such input to be echoed, even if this is 2 buffers. If both buffers were full, and further input is received from the asynchronous terminal, these are discarded and not

echoed. The VPT does not echo the escape character unless this is preceded by the esc signal.

Commands from the VPT

Calls from asynchronous terminals are always allocated 2 buffers of storage in the VPT, even though the number of buffers for that call may be one. The VPT controlling the terminal makes a buffer available to the terminal for every response packet which it receives from the distant end, and this buffer is used by the VPT when the other buffer is full.

If the terminal inputs data when both of its buffers are full, the VPT instructs the terminal to stop sending by returning either the mnemonic *sksk*, or nothing for terminals operating in International Alphabet (IA) 2. For those using IA5, the VPT returns DC3, BEL, or nothing. These are known as *hold-off* signals. The VPT will accept up to 3 non-delimiting characters after it has sent the hold-off signal; after that, input is ignored.

The reverse situation must also apply so that the VPT can enable the terminal to start sending again, and this is provided through *call-in* signals. When one of the buffers becomes free, the VPT requests the terminal to recommence sending by returning either the figures *JJJ*, or nothing for IA2 terminals. For IA5 terminals, it may return BEL, DC1 or 4/10, 4/10, 4/10, or nothing.

SERVICE MNEMONICS AND DATA FIELD OF NIPs

One of the functions of the EPSS is to return NIPs, where necessary, and if the VPT receives one of these during a call, it decodes the data field and forwards the appropriate translated mnemonic to the terminal. Call-confirmation NIPs may contain the answer-back of the other terminal, if this was on the Telex network, and this is delivered to the asynchronous terminal following the called-terminal's address. When calling the Telex network, the PSE may receive certain mnemonics from it, and these signals are delivered unchanged to the source asynchronous terminal. Service signals are delivered with even parity although, normally, data is delivered and received without regard to parity.

CODE CONVERSION

Code conversion takes place between terminals using IA2 and IA5, but only if the IA2 terminal operates asynchronously (that is, not if the terminal is synchronous using IA2) and only at the end of the call which is using IA2. If both are operating in IA2, no conversion takes place. Hence, at present, IA2 packet terminals cannot communicate with IA5 asynchronous terminals.

CONCLUSION

The EPSS is experimental to the extent that the protocols, rules and services offered have not been tried before. As an experiment, its future is entirely dependent upon the amount of customer support it engenders. If the results, or the reaction of customers, are not favourable, then the BPO has agreed with its users to phase out the EPSS after a set period of time. If, however, the indications show popular support for the service, then it is possible for it to continue for some time into the future, beyond its experimental phase, possibly merging with other advanced data services. At this stage, it would be necessary to accommodate such changes as may be necessary following the establishment of international standards, or to meet the requirements of customers if the service is found to have deficiencies or undesirable characteristics.

A New-Style Telephone Instrument

G. B. PALMER, C.ENG., M.I.E.E., and P. C. LANGHAM†

UDC 621.395.61 : 7.05 : 608.4.001.5

This article outlines the design criteria and development of the new-style telephone. This is followed by a description of the new instrument, with particular reference to the plastics materials used.

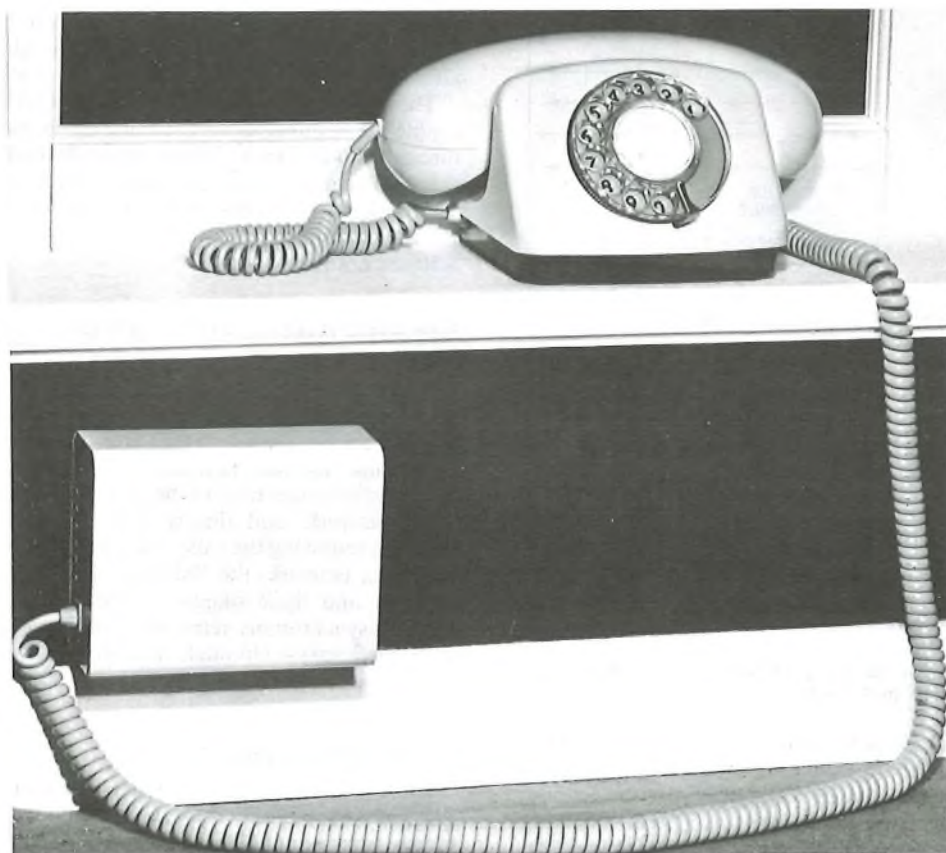

FIG. 1—New-style telephone

INTRODUCTION

During 1969, it was decided that the residential telephone market had grown to sufficient proportions to support a basic-facility-range telephone instrument designed specifically for that market. Current British Post Office (BPO) basic-facility-range telephone instruments were designed to meet the needs of both business and residential markets, and tend to be more suitable for office environments.

In the past, telephone instruments purchased by the BPO

were developed through the British Telephone Technical Development Committee¹ by a UK telephone manufacturer. With the cessation of this committee, it was decided that the development should be carried out independently of the telephone manufacturers and controlled by the BPO.

Trial instruments are currently in service in 3 telephone areas, Cardiff, Canterbury and Sheffield. Initial customer reaction to the new telephone is that the majority consider it both attractive and convenient in use.

The new telephone will not be made generally available until it is confirmed that customer reaction is favourable and that overall costs are satisfactory. Cost factors that will affect any decision include purchase price, installation productivity and in-service reliability.

† Mr. Palmer is now in the South Central Area, London Telecommunications Region and Mr. Langham is in the Telecommunications Development Department, Telecommunications Headquarters.

DESIGN REQUIREMENTS

The size of the instrument was to be such that it could be sited on the shallow window sills and shelves found in most modern British homes. The instrument should be suitable for use as a single instrument, as a parallel instrument (Plan 1A) and as a plug-ended portable telephone (Plan 4), for both exclusive and shared-service exchange connexions. It was further required that the instrument should be capable of connexion as an extension from a PBX.

DESIGN CONSTRAINTS

The major limitation placed on the design was that the installed cost of the instrument must be no greater than that of the current Telephone No. 746, the updated version of the Telephone No. 706.² This limitation would permit an increase in installation cost, provided it was offset by a reduction in purchase cost, or vice versa.

To avoid the development programme becoming too lengthy and costly, the following details of the Telephone No. 746 were specified for use in the new-style telephone instrument:

- (a) transmission components and circuit,
- (b) dial, and
- (c) Handset No. 3.

An additional advantage in using these components was that they have known reliability and, where appropriate, are already stocked as spares for maintenance requirements.

As the design developed, it was decided that redesign of the handset could be permitted, provided those dimensions of the Handset No. 3 which affect the transmission performance were retained. The requirement that the instrument should accept the Handset No. 3 was however, retained.

DEVELOPMENT PROGRAMME

In mid-1969, a development contract was placed with an industrial designer. A specification and sketches of proposed designs were produced, followed by wooden models of the design. From the wooden models, it was possible to foresee some design defects and the first hand-made working models produced incorporated solutions to the known short-comings. Further working models were made to include various improvements and, after evaluation, approval was obtained to proceed with the development and manufacture of 5000 instruments for marketing trials. Outline drawings were produced, and several moulding companies were invited to tender for the design and manufacture of moulding tools. These tools were to produce the plastics mouldings for the trial quantity and prove the mouldability of the design. At this stage, several modifications were introduced to reduce moulding costs.

Manufacture of the trial telephones was placed with the BPO Factories Division, and assembly of the instruments was carried out at the BPO factory Cwmcarn, South Wales. Transmission tests were carried out by the BPO Research Department and it was confirmed that restyling of the handset had not adversely affected its performance.

DESCRIPTION OF THE NEW TELEPHONE

The most distinctive feature of the new telephone is its small size. To achieve this small size, the bell has been accommodated separately and the telephone and bell unit interconnected by a cord that is extensible to approximately 3 m (see Fig. 1). The bell unit can also be sited remote from the telephone and the extensible cord terminated on a conventional terminal block.

When required, the bell unit, minus its cover, can be mounted within a wall bracket which also provides a shelf surface to site the telephone (see Fig. 2). The telephone is not secured to the wall bracket, thus permitting the telephone



FIG. 2—New-style telephone with wall bracket

to be both wall-mounted and portable within the limits of the extensible cord.

To provide a fully-portable telephone, the extensible cord can be replaced by one terminated on a plug, and a jack socket fitted within the bell unit. This facility can also be provided when the bell unit is mounted within a wall bracket.

The design of the telephone is such that very few adjustments are necessary during assembly and, thus, costs of production, installation and maintenance are kept down.

Bell Unit

The bell unit is slightly smaller than existing bell-sets and incorporates a new single-coil bell mechanism—Bell No. 79A. Terminals suitable for steel dropwire are incorporated in the bell unit, thus dispensing with the need for a separate terminal block. A removable cord-anchor block is provided to permit the cord entry to be readily varied without disconnection of the cord terminations. When the bell unit is fitted to a wall, the cord enters the bell unit parallel to the wall. When the bell unit is fitted within a wall bracket, the cord entry is modified such that the cord emerges from beneath the wall-bracket shelf. Complete removal of the cord-anchor block provides accommodation for a purpose-designed jack socket.

Installation of the bell unit is simplified by a metal wall-plate, which can be screw fixed to a flat surface. The bell unit slides on to the wall plate and is securely locked into position by the bell-unit cover. The bell-unit cover is a snap-on fit, but to remove it, a catch, accessible through the sound-outlet slots, must first be released. The metal wall-plate has multiple fixing slots to permit fixing to standard conduit boxes and in situations where fixings are limited. Slots are used to facilitate levelling before the screws are fully tightened. Fixing of the wall plate to skirting boards and window sills can also be made with the aid of auxiliary brackets.

Telephone Instrument

A moulded base forms the mounting for all other major items of the telephone. The dial is mounted directly into the base and retained in position by a 2-part metal strap and screw. The cover is located on the base by 2 projections at the front, and secured by a single screw which is captive in the base. The 2 cover projections locate in notches on each side of the dial-mounting area of the base. This method of

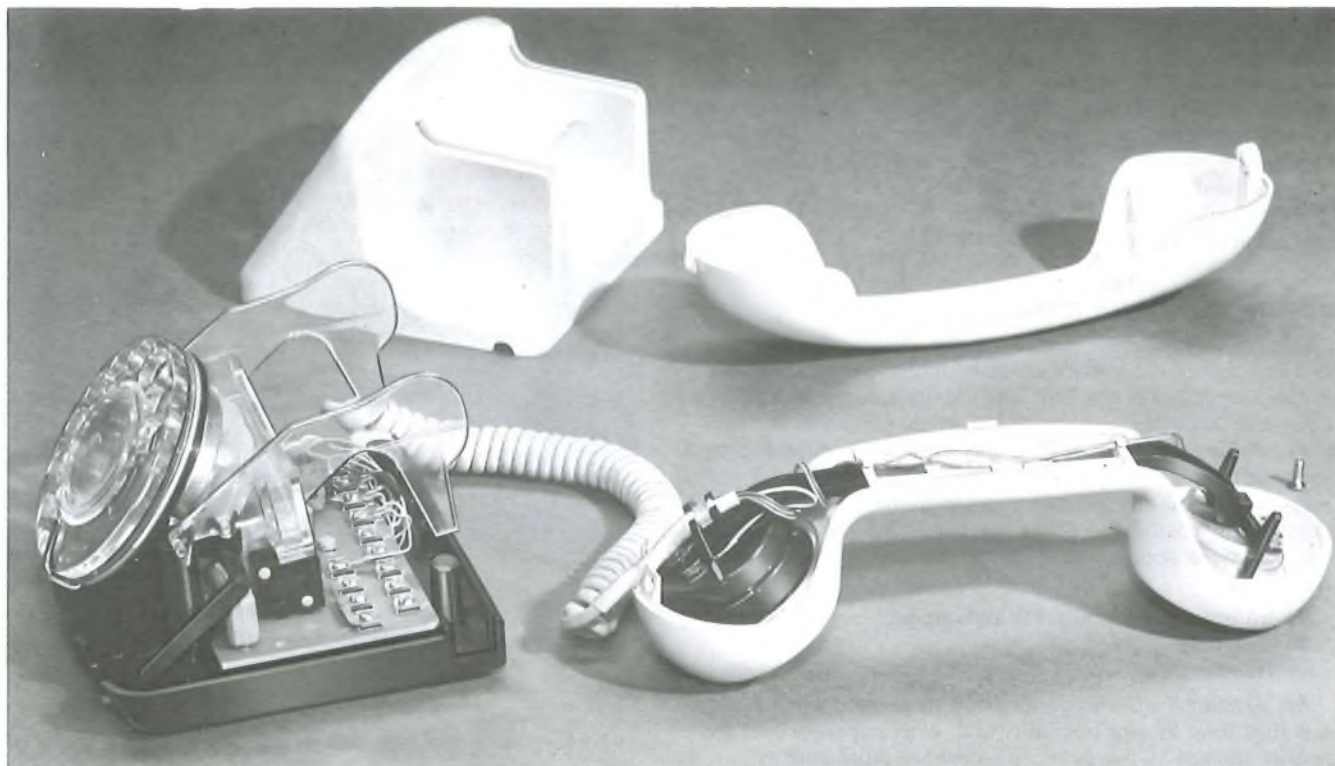

FIG. 3—New-style telephone with covers removed

mounting and locating the dial and cover on the base provides a good control of their relative positions, and has removed the need for an escutcheon plate, or label, as used on Telephone Nos. 706 and 746.

A cradle moulding, pivoted by knife edges into deep V-shaped recesses in the base, is retained to the base by 2 tension springs. These springs also provide the restoring force to the cradle. The use of plastics mouldings has ensured accurate and trouble-free bearing surfaces for the knife edges. When the cover is fitted to the telephone, the cradle projects through slots in the cover and forms the handset rest. The cradle acts directly onto the gravity switch, without the need for an intermediate lever. The normal limit of downward travel of the cradle occurs when the microswitch button is depressed flush with the switch case. Any excess force applied to the cradle causes it to pivot on the switch case and partially unseat the knife edges. When the excess force is removed, the knife edges automatically reseat themselves. This feature reduces the force that can be applied to the switch case. Projections on the telephone base act as stops to limit downward movement of the cradle and the form of the V-shaped recesses for the cradle knife edges limit upward movement. The limits of upward and downward movement of the cradle are such that normal manufacturing tolerances can be accommodated, without the need to build-in a means of adjustment.

A moulded latch, available to a faultsman after the telephone cover is removed, is snap fitted to the cradle moulding. When this latch is lifted, force is applied by the latch to the base moulding above the cradle pivot point, thus depressing the cradle and operating the gravity switch. Movement in excess of that required to operate the gravity switch fully is provided. The excess movement causes the cradle knife edges to unseat. Due to the cam design of the latch, it has an over-centre or snap action. An extension arm of the latch causes it to unlatch automatically when the telephone cover is replaced. The design of the cradle-moulding knife-edge pivot eliminates the need for a means of adjusting the latch.

The telephone base also provides accommodation for 2 auxiliary switches operated by transparent plastics levers. When fitted to the telephone, the transparent operating levers protrude from beneath the front edge of the telephone cover. These switches also take advantage of the flexibility of plastics and are a simple snap fit to the base. The switches can be easily removed by releasing a locking tag with a screwdriver. One switch is a non-locking type and its lever is engraved CALL, and the other switch is a locking type and engraved BELL. The non-locking switch is to provide the shared-service call facility, or PBX-recall facility, and the locking switch is for the bell ON-OFF facility. On production telephones, the bell ON-OFF facility will probably be provided by a switch fitted within the bell unit as an add-on unit to a mechanical bell-volume control, which is currently being developed.

The circuit components, gravity microswitch and terminals are mounted on a printed-wiring board. The printed-wiring board is similar, but not identical, to that used in the Telephone No. 746. A general view of the telephone with the cover removed is shown in Fig. 3.

Handset

The handset casing is a 2-part moulding. The 2 halves of the casing interlock with each other by means of concealed pins at the transmitter end and snap-fit catches within the handle section. A single recessed-head screw at the receiver end secures the 2 halves together. Internal ribs are moulded into the casing to provide the necessary rigidity. A moulded seating ring is fitted to the transmitter inset to provide adequate acoustic sealing and to simplify the case moulding. The transmitter and receiver insets are retained in the lower half of the casing by moulded springs, which clip into the casing. The transmitter spring also provides an anchorage for the handset cord. A general view of the handset with the upper moulding removed is shown in Fig. 3.

The design of the handset demands moulding tools made to a very high standard. The design of the tools can, however,



FIG. 4—Wall bracket with lid removed

be relatively simple compared with those required for the Handset No. 3, and shorter moulding times can be achieved.

Wall Bracket

The wall bracket consists of 3 mouldings; namely, bracket, lid and blanking plug. A bell unit, with cord entry modified or, alternatively, fitted with a jack socket, is a snap fit into the wall bracket. The bracket is fitted to the wall by the metal wall-plate normally used to secure the bell unit to the wall. The bracket slides onto the wall plate and is secured in position by 2 tongues on the snap-fit lid. A hole is provided in the side of the wall bracket to permit entry of a plug when a jack socket is fitted to the bell unit. When a jack socket is not fitted, the hole is filled by the close-fitting blanking plug. The plug is retained in position by the bell unit. A view of the wall bracket with the lid removed is shown in Fig. 4.

MOULDING MATERIALS

Originally, it was intended to use a grade of rigid PVC as the main moulding material for the telephone. Owing to a lack of moulding experience with this material, it was subsequently decided that the well-tried material ABS would be used initially. Experiments with PVC are being carried out independently of this development. Clear polycarbonate is used for the cradle moulding and switch levers. This material, although relatively expensive, provides the required strength, dimensional stability and appearance. The transmitter and receiver springs, linesman's latch and cord-anchor block are moulded in acetal resin, this material being chosen for its rigidity, toughness and resistance to creep under load. The bell-unit base is moulded in toughened polystyrene and the transmitter ring is polyethylene.

CONCLUSION

This development has produced an instrument that is both attractive, to the majority of users, and surprisingly versatile within the limited range of facilities required for the bulk of the residential market. Valuable experience has also been gained by the BPO in running projects of this nature.

The extensive use of plastics, and exploitation of their properties, has produced a design that is mechanically simple and almost devoid of assembly adjustments. The simplicity of design and reduction of adjustments should more readily produce an instrument of consistent quality and also reduce the subsequent fault hazard.

Rapid changes have occurred in material costs during the later stages of the development. These changes may affect the relative costing of the telephone and influence its viability.

ACKNOWLEDGEMENT

The original design work on the new-style telephone was carried out by David Carter Associates of Warwick.

References

- ¹ PALMER, R. W., and BRIMMER, W. L. The British Telephone Technical Development Committee. *POEEJ*, Vol. 41, p. 193, Jan. 1949.
- ² WILSON, F. A., and SPENCER, H. J. C. The New 700-Type Table Telephones—Telephone No. 706. *POEEJ*, Vol. 52, p. 1, Apr. 1959.

Trunk Transit Switching

By special request, the *Journal* has produced a reprint including all the most important articles published over the years on Trunk Transit Switching. This reprint brings all the articles together and will be a most useful reference book for those interested. Supplies are limited. Please send a Postal Order or remittance for 22p per copy to:

Mr Hunwicks
Ground Floor Lobby
2-12 Gresham Street
London EC2V 7AG

BPO staff can assist by enclosing a self-addressed label.

Regional Notes

EXTERNAL TELECOMMUNICATIONS

Communications for Pipe-Laying Barges in the North Sea

In October 1973, the External Telecommunications Executive (ETE) of the British Post Office (BPO) was approached by a number of firms, concerned with the construction of pipelines for the North Sea oil industry, with a request for exclusive radio-telephone channels for each firm.

To have met this requirement, it would have been necessary to allocate a number of separate radio-frequency channels, each having a bandwidth of at least 3 kHz. However, all the available frequencies in the ships' mobile frequency band (1.6-3.6 MHz) are already heavily used on a shared basis by the UK and Continental coastal stations. It was clearly not possible to meet this request.

As an alternative, the ETE suggested that individual teleprinter channels might meet the need, and proposed a scheme whereby an existing maritime frequency of 3 kHz bandwidth would be used to provide a public-correspondence radio-teleprinter channel and up to 9 private radio-teleprinter channels. This idea was accepted and, by October 1974, a system had been put into operation at Stonehaven Radio station. It is believed that this composite system is the first of its kind to be put into operation anywhere in the world and, currently, 8 private channels are successfully working, together with the public-correspondence channel.

The private channels are extended to the customers' shore offices via leased lines, and are operated over the radio path by the use of multi-channel-voice-frequency telegraph equipment having a frequency shift of ± 42.5 Hz. Automatic-request-for-repetition (ARQ) equipment is associated with each channel, and communication distances of up to 644 km have been achieved.

To facilitate communication with several vessels on each private channel, the built-in selective-calling facilities of the ARQ equipment have been extended to the users' offices by means of a special dialling circuit using inland voice-frequency channels.

The pipe-laying firms have expressed considerable satisfaction with the service, and work is now in hand to duplicate the system through the BPO's radio station at Wick. This will extend service to barges operating in the vicinity of the Shetland Isles, and is planned to be ready for operation by the middle of 1975.

J. A. CHAMBERS

SOUTH WESTERN REGION

Plymouth Exchange-Earth System

A new wing, under construction at Plymouth telephone exchange, will link the 2 existing buildings and virtually fill the remaining site space. The existing exchange-earth system will be inadequate for the extended exchange's power supply and, in addition, occupies a position required for fuel-storage tanks. Therefore, a completely new earthing system will have to be provided.

The new extension will incorporate a high-voltage sub-station, which places a limit of 1Ω on the resistance of the earthing system. The nature of the soil is such that the deep driving of rods is impossible, and the existing system of 20 rods in 10 positions has a resistance of 6Ω . Hence, a very extensive arrangement of earth spikes was required, and the resistance limit, coupled with the physical difficulties of the site, made this seem a formidable task.

As site excavations proceeded, the building co-ordination engineer reported the discovery of cellar-type structures, thought to be part of a brewery that occupied the site in about the year 1800. It was then agreed that, if any deep structures were found, their usefulness as earth-electrode positions would be investigated. This was shortly followed by the discovery of an old well, about 6 m deep, which, when pumped out, was found to be fed by a cast-iron pipe sunk vertically at the bottom of the well. To make full use of this good luck, and because of the future inaccessibility of the



The ancient well—a new use after nearly 2 centuries

position, a copper electrode was urgently required. This called for prompt action by the area stores co-ordinating officer and the external-works control so as not to delay the building contractor in back-filling the well with concrete.

The day prior to the back-filling, the well was again pumped out. Bare copper cable was attached to copper earth-spikes, and the assembly was lowered down the cast-iron feed-pipe. The difficulty then arose that the feed-pipe was about 50 m deep—deeper than had been expected or hoped for—and lowering the last few metres of cable proved a difficult operation for the jointers. The cable was then securely attached above ground, and the well finally back-filled.

A remote earth-test was carried out to ascertain how close the earth resistance was to the goal of 1Ω . The resultant reading was 1Ω , showing that the possibility of driving numerous earth-spikes on an already congested site has been averted. Little did our forefathers know how useful their feat of engineering would be to the technological age.

C. F. HOOKWAY

P. E. COMPTON

A Jumper-Running Machine for Distribution Frames

An experimental power-driven jumpering machine has been developed in the Southampton Telephone Area to simplify jumper-running along the horizontal fields of long distribution frames, and to improve safety by reducing the use of ladders for the higher levels. The machine has initially been installed on 7 of the upper levels of the main distribution frame (MDF) in Salisbury exchange, and another is now being installed at Winchester, with plans to equip eventually all exchanges having MDFs with more than 50 verticals. Consideration is also being given to similarly equipping large intermediate distribution frames, and fitting hand-operated models on the uppermost levels of the smaller frames; that is, those with 20-50 verticals.

The machine consists simply of a slide fitted to a curtain track, the track being suspended on brackets above the horizontal jumper field for the whole length of a frame on each level. A continuous length of nylon cord is attached to the slide, passing around pulley wheels at each end of the frame so that, when the pulley wheels are turned, the slide is drawn along the track. The nylon cord runs the whole length of the frame inside a groove in the track, and its returning side is supported on screw eyes to keep it clear of the jumper field. The jumper wire is attached to a hook on the slide, and is drawn-in as the slide travels along the track.

Simple drive mechanisms, consisting of chain transmission and clutch assemblies constructed from Meccano parts, are mounted on each level at one end of the frame. Power is

supplied by a 50 V electric motor via 2 contra-rotating shafts, which reach from the lowest level to the top of the frame. Control is by means of cords, which are associated with each mechanism. These cords run the whole length of the frame above the jumper field. One controls the drive to the left, and the other the drive to the right. When a cord is pulled, the electric motor is started and the clutch associated with that cord is engaged. This connects the drive to the pulley wheel on that level, and the slide is drawn along the track. When the cord is released, the clutch is disengaged and the electric motor stops.

The control cords enable the machine to be operated from any position along the frame, so that, to provide a jumper, the jumper wire is hooked onto the slide at the terminating position on the horizontal side of the frame, and the operation

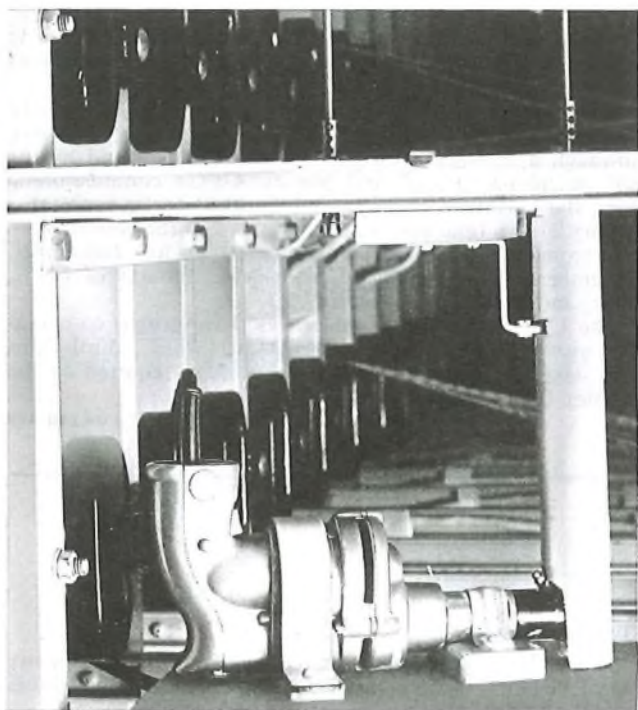

FIG. 1—The 50 V electric motor and contra-rotating shafts

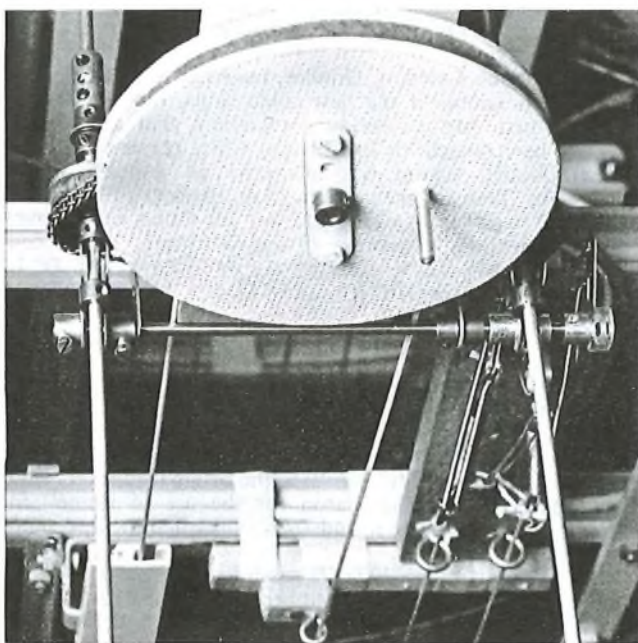

FIG. 2—Driving pulley, chain transmission and clutch assemblies, viewed from below

is controlled from the position where the jumper wire is to be fed through to the vertical side of the frame. The jumper wire is drawn in at a speed of approximately 1 m/s, and the operation is unimpeded by test cords, working parties, or any other obstruction.

On the hand-operated model, the slide can be drawn along the track either by cranking the pulley-wheel handle or by reaching into the frame at the end of the run and pulling the returning side of the cord.

Fig. 1 shows the 50 V electric motor and the 2 contra-rotating shafts. Fig. 2 is a view from below of a driving pulley, showing the contra-rotating shafts, chain transmission and clutch assemblies. The track and returning side of the cord are visible in the lower half of the photograph, and the control cords, attached to the clutch assemblies, are to the right of these. Fig. 3 shows the detail of a clutch assembly. (The photographs are by courtesy of Raymond J. Hawker of Chandler's Ford, Hampshire.)

The advantages of the machine over the conventional method of running jumpers are

- (a) a reduction in fatigue due to climbing and descending travelling ladders, particularly for long runs,
- (b) a reduction in accident hazards due to the elimination of the need to reach into the frame (apart from at each end of the run) and the reduced amount of work necessary from travelling ladders,
- (c) a reduction of approximately 75% in the time taken to run jumpers at the higher levels—a considerable productivity improvement, and
- (d) congestion of the working space is reduced.

These advantages would be most apparent where a new frame is being brought into operation.

The capital cost of providing the hand-operated system amounts to £15 for stores, plus an estimated £25/level for labour for a frame of about 70 verticals. The cost of motorizing the system is approximately £4/level for stores, excluding the cost of the electric motor. With improved mechanisms, the labour costs should reduce to no more than £20/level. The work will be considerably simplified on later models by using parts manufactured by a local engineering firm.

The introduction of this machine is one of the greatest steps forward ever made in jumpering methods, many of which have remained virtually unchanged since the first telephone exchanges were constructed, and a machine of this type could well become standard equipment on all large distribution frames at some time in the future.

L. C. PENN

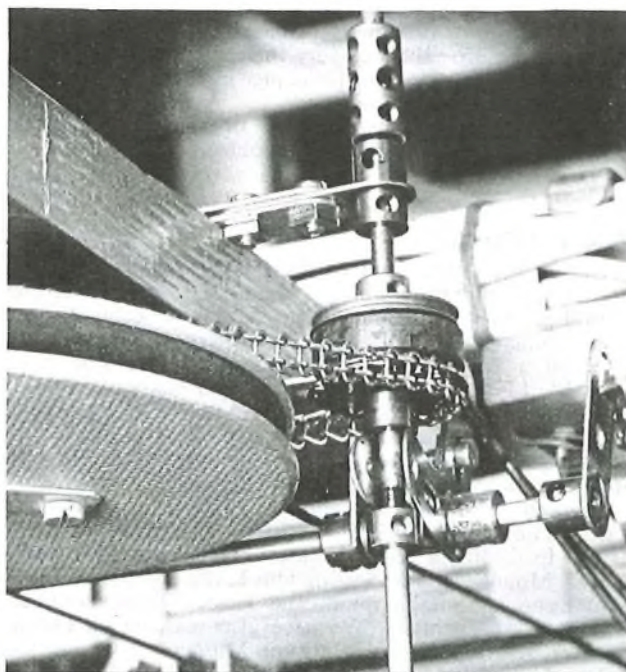

FIG. 3—Detail of clutch assembly

LONDON TELECOMMUNICATIONS REGION

The London Sectorization Project

The significant milestone, referred to by the, then, Director of the London Telecommunications Region (LTR), Mr. E. W. Weaver, in his introduction to the series of articles on the London sector plan (*POEEJ*, Vol. 67, p. 1, Apr. 1974), was achieved in September 1974 with the opening of the incoming trunk unit of the London east sector switching centre (SSC) at Ilford and the incoming 4-wire switching unit of the London main switching centre (L/MSC) at Southbank.

The incoming trunk unit at Ilford SSC—a TXK1 crossbar exchange comprising 25 routers and 7 offices, with 8 stored-programme-control register-translators, 5 of which have multi-frequency signalling facilities—is designed to handle 2472 erlangs of traffic on 3744 incoming circuits and 3918 outgoing circuits. The equipment was manufactured and installed by GEC Telecommunications Ltd., and installation of the unit commenced in June 1971. Acceptance testing, by the multiple-call-sample artificial-traffic technique, was completed, and the unit handed over to the British Post Office for commissioning, in August 1974. Careful programming by the engineering-transfer-co-ordinating officer, to avoid interference with Messrs. GEC's testing programme, had enabled all circuit line-ups and switch-switch tests to be completed prior to the acceptance tests.

Final engineering tests on trunk circuits and junctions were completed by 17 August 1974, and the joint engineering and traffic tests started on 19 August 1974. A detailed programme of test calls had been prepared jointly by the traffic liaison officer, the engineering-transfer-co-ordinating officer and the Works Division of LTR Headquarters, and issued to all regional and area liaison officers. The joint engineering and traffic tests are designed to demonstrate that sufficient circuits have been provided to meet the opening-day circuit

requirements, and that all the planned access and other facilities are being given by the exchange.

The test was conducted in 2 parts: part 1 to prove the outgoing routes, and part 2 to prove the incoming routes and to bring the routes into service. Part 1, which started on 19 August 1974, was conducted from Romford non-director group switching centre (GSC). Calls were passed over the Romford route to each circuit in each route outgoing from Ilford SSC to the dependent director-exchange units. The calls were checked for correct routing and tones, and satisfactory transmission. Part 2 was commenced on 16 September, and test calls were passed over each circuit in each incoming fully-provided route, each high-usage route with overflow via the L/MSC, and each fully-provided route to the L/MSC.

As testing on each route was completed, the distant GSC was asked to alter its translations for the London east director-area codes for SSC working, and the first route, from Basildon exchange in the Eastern Telecommunications Region, was brought into service on 23 September 1974. The whole commissioning programme for all the available routes was completed by 25 October 1974.

The performance of the unit was carefully monitored during the period 23 September 1974 to 6 January 1975 and, although a significant number of faults were found by the SSC maintenance staff and Messrs. GEC's commissioning staff, the performance of the unit proved to be very satisfactory. At no time was it necessary to stop the commissioning sequence. Service-observation results for November, December and January gave plant-defect failures of 1.4%, 1.3% and 1.38% respectively.

The LTR gratefully acknowledges the excellent co-operation given by all regions, and by Messrs. GEC, during this first stage of the massive rerouting exercise required by the London sectorization plan.

G. R. CLEMENTS

Associate Section Notes

Aberdeen Centre

On Wednesday 22 January 1975, Mr. T. C. Watters, of the Scottish Telecommunications Board's Service Division, gave a talk entitled *Maintenance in the 1970s*. The attendance for the meeting was rather disappointing, but the evening was very informal and was enjoyed by all those present.

The February meeting took the form of an evening visit to the premises of Bristow Helicopters Ltd. at Dyce Airport. This meeting proved to be very interesting, the party being shown the various types of helicopter in use by the company in their North Sea operations.

On Wednesday 26 March, one of our own members, Mr. J. McCall, gave a talk on his hobby, amateur radio.

I. BOOTH

Brighton Centre

During the second half of the 1974-75 session, we have had an eventful programme with, at the time of writing, several events still to come, all pleasurably anticipated.

On January 19, we visited the Science Museum and attended a BBC Television recording of "Are You Being Served?" In March, we went to the Ideal Home Exhibition, and on April 6, we visited Hampton Court and Kew Gardens, and attended a Thames Television recording of "Sadie, It's Cold Outside". These trips were fully supported, 53 persons attending each one, and were most enjoyable.

Between 25 January-1 February, a party of 40 enjoyed a week's holiday in Benidorm—a very welcome winter break.

Our forthcoming trips include visits to the Post Office Tower, Mount Pleasant Sorting Office, the Post Office Cable Ship Depot at Southampton, and Plessey Telecommunications Ltd. at Titchfield. We have also planned an outing, by river, to the National Maritime Museum at Greenwich, followed by a BBC Television recording of the Val Doonican show.

T. BROWN

Dundee Centre

The 1974-75 programme is over and, despite the many outside factors, morale remains high, although attendances have been lower than normal.

The last talk of the session, *Transit Switching and International Dialling*, was given by Ian McBean, a Technical Officer from Dundee exchange. The talk was well illustrated with diagrams, colour slides and tape recordings, and we were given a brief outline of this ever-expanding aspect of the telephone service.

Messrs. Robb Caledon, Dundee, have had some problems with the launching of the new cable ships, but they hope, once the first one is nearing completion, that a weekend visit will be arranged for British Post Office personnel.

The Dundee Centre has instituted an annual awards scheme for Trainee Technicians (Apprentices) (TT(A)s) in Dundee Telephone Area, based on all-round endeavour. The first awards, consisting of book tokens, have been presented to Mr. T. N. Reid (first-year TT(A)), Mr. D. I. Addison (second-year TT(A)), and Mr. J. I. Houston (third-year TT(A)).

R. T. LUMSDEN

Edinburgh Centre

On 20 February, a very interesting talk, entitled *Tunnel Complex*, was given by Messrs. Gilmore and Ginger, standing in at short notice for Mr. Pairman, the original speaker, who had been taken ill. The reason for the use of tunnels in Edinburgh was explained, and their construction illustrated by slides.

The highlight of the 1974-75 session occurred in March, when 22 Edinburgh-Centre members, together with 8 from the Glasgow and Stirling Centres, enjoyed a 3-day visit to London. We were very privileged to be given a technical tour of the Post Office Tower, and our grateful thanks go to Mr. Horne, Head of Tower Operations, for granting per-

mission for this visit. We were shown the tunnel, the trunk exchange, the television switching and control centre, the microwave-radio terminal and, of course, the panoramic view from the public gallery. The tower staff made this a very worthwhile and interesting visit. We also visited the sorting office at Mount Pleasant, and saw the unique system whereby mail is moved between various sorting offices by underground railway. The railway is about 10.5 km long and runs at an average depth of 21.3 m. There are 8 stations, consisting of 6 sorting offices and 2 main-line stations, and the system is automatic, with control desks situated at each station. Our thanks go to Mr. Varrier and his colleagues for their excellent and detailed descriptions of the system. Lastly, we attended the final of the National Technical Quiz Competition between Oxford, representing the Eastern Telecommunications Region, and Worthing, representing the South Eastern Telecommunications Region. This was an enjoyable evening, with the result in the balance until the second-last question. With all due respect to the Worthing team, we thought Oxford had to be the winners, as they must have been good to knock out the Scottish team in the quarter-finals.

Our thanks go to Peter Hewlett, Secretary of the National Committee, and Dougie Denchfield, London Visits Secretary, for their help in arranging both the technical visits and the social events which we attended. The success of the visit encourages us to hope that more joint ventures by the Scottish Centres can be undertaken in the future.

M. I. COLLINS

Glasgow Centre

Since the beginning of 1975, we have had some fascinating meetings. A visit to the Glasgow College of Nautical Studies proved most satisfying. So many things we had heard about astral navigation were explained in understandable terms by a very competent lecturer, Captain Poray.

Our February lecture was given by Insurance Services (Glasgow) Ltd. Although attendance could have been better, those present enjoyed an interesting talk on general insurance by Mr. W. Skinner, a director of the firm.

In March, we were treated to an excellent lecture and demonstration by Phillips Electrical Ltd. of Hamilton, when

their representative, Mr. J. Wilson, spoke to us on high-fidelity audio equipment and video-cassette recording. Mr. Wilson demonstrated high-fidelity audio record-player and cassette-recorder systems, and a video-cassette recorder with camera and colour-television receiver.

In April, we visited the Glasgow Telephone Area tunnel and, in May, had our annual general meeting, completing our 1974-75 session.

R. I. TOMLINSON

Newport (Gwent) Centre

A friendly quiz was held at the Civil Service Club, Bath, on Saturday 12 April, between teams from the Bristol, Bath, Gloucester and Newport Centres. After a close contest, Newport Centre was declared the winner, defeating Bristol by 55 points to 53. The question-master was Mr. L. V. Ranch, President of the Bath Centre, the adjudicator was Mr. J. Brown, President of the Bristol Centre, the time-keeper was Mr. J. Summers, and the organizer was Mr. A. G. Guy. A presentation was made to the Newport Centre by Mr. Brown, to commemorate their success.

After the quiz, the centres were entertained by a social evening with buffet by the host centre, Bath.

K. I. FLEET

Technical Training College, Stone, Centre

The Technical Training College, Stone, Centre is coming out of hibernation after 6 years. Plans have been made to organize an inter-school quiz, possibly including a contingency from the student population, and a programme is being formulated for visits and lectures, starting in October 1975.

The committee and office bearers are as follows.

Chairman: Mr. C. E. Woolley, Vice-Principal.

Secretary: Mr. M. E. Haynes.

Press Secretary: Mr. J. F. Olsen.

Treasurer: Mr. T. G. French.

Committee: Messrs. G. Stanley, I. D. Stewart, E. J. Wilkinson, D. R. F. Heaney, K. Uzzell, J. P. Donlon, and D. J. Parlett.

M. E. HAYNES

The Associate Section National Committee Report

Bray Trophy

The final of the National Technical Quiz Competition was held at the Institution of Electrical Engineers, Savoy Place, London, on 21 March. The contestants were Worthing, representing the South Eastern Telecommunications Region (SETR), and Oxford, representing the Eastern Telecommunications Region (ETR). The Oxford team won this closely-fought match by 33 points to 30½, and Sir Edward Fennessy, Deputy Chairman and Managing Director, Telecommunications, presented them with the Bray Trophy. The question-master was Mr. J. F. P. Thomas, Chairman of the Council of the Institution of Post Office Electrical Engineers (IPOEE). The adjudicators were Mr. A. H. Watkins, SETR, and Mr. R. Webb, ETR. The time-keeper was Dr. P. R. Bray, in whose honour the trophy is named, and the score-keeper was Mr. K. Stotesbury, President of the Associate Section.

After the competition, a scroll was presented to Jack McCullum, Scottish Telecommunications Board, in recognition of his service to the National Committee. Jack was last year's vice-chairman of the National Committee, and was also its first vice-chairman, but has now retired on health grounds. The presentation was made by John Dow, Vice-President of the Associate Section.

Project Competition

This year, the project organizer, Eric Philcox, will be organizing a project competition. The object is to design and construct a working model for an electronic score-board, with time-keeping equipment, for Institution quiz com-

petitions. Details will be given in the *National News*. We are hoping for a high number of entries this year.

Reflections

This is my last year in the office of secretary to the National Committee. I have had the pleasure and privilege of this office since the inception of the National Committee and now, because of promotion, I must stand down.

Since the very first meeting, in March 1971, of what was to become the Associate Section National Committee, the organization has been crystallizing itself and its aims, and trying to make the Associate Section a better known and more interesting body. We have had our critics, some justified and some, perhaps, a little unjustified, but they are the members who have kept us alert to our responsibilities.

I would briefly like to recall some of the major achievements of the National Committee to date.

(a) Before the introduction of the National Committee, relationships between Associate Section centres of different regions were tenuous; today, all regions are united, and meetings are held at regular intervals.

(b) All regions have the opportunity to put their points of view at a high level, and these points are considered and acted upon by our representative on the IPOEE Council.

(c) The National Committee set up the National Technical Quiz Competition, which has been a popular and successful venture.

(d) The Associate Section's journal, the *National News*

has been selling well in many regions since it was first printed, and I trust it will continue to do so.

These are just a few of the aspects which come to mind; there are many more. Many things have been done which, taken singly, mean little but, when added together, have meant much to centres, and even regions, at some time.

As this is probably my last report, I wish to put on record my sincere thanks to all those members of the National Committee, the IPOEE Council, the British Post Office and the Main Section, who, together with the regional liaison

officers and many others, have helped the National Committee, and myself, over the past years. Without their help and support, the National Committee could not exist.

I have enjoyed the job of secretary and, although it has been quite a tough position, it was an experience I would not have missed. I wish the National Committee well in the future, and hope it will continue to flourish, and that all its supporters will continue to stay by it in the work it tries to do.

P. L. HEWLETT
General Secretary

Institution of Post Office Electrical Engineers

Institution Field Medal Awards, 1973-74

In addition to the Institution's Senior and Junior Silver and Bronze Medals, the Field Medals are awarded annually for the best papers read at meetings of the Institution on field subjects, primarily of regional interest.

Field Medals were awarded to the following authors for papers read during the 1973-74 session.

Mr. H. Williams, North Western (Manchester and Liverpool) Centre, for his paper *Heating and Ventilating of Telecommunications Buildings*.

Messrs. T. H. H. Lloyd and T. Murphy, Northern Ireland Centre, for their joint paper *Manpower—A Precious Commodity*.

Essay Competition, 1974-75

Prizes and Institution Certificates have been awarded to the following competitors in respect of the essays named.

Prize of £16

B. Clapson, Technical Officer, Canterbury. *Local-Line Planning and its Progression*.

Prize of £12

M. T. Rowe, Technical Officer, Exeter. *The Post Office Telecommunications New Internal Works Planning and Control Procedures*.

Prize of £10

C. R. Mynott, Technical Officer, Aldershot. *The Rise and Fall of Pressurization*.

Prizes of £6

D. E. G. Coles, Technical Officer, Birmingham. *The Telegraph—A Brief History from Birth to State Take-over*.

C. M. Ellis, Technical Officer, Plymouth. *Stereophonic Programme-Circuit Planning for Plymouth*.

Institution Certificates of Merit have been awarded to the following competitors.

M. Lazenbury, Technician 2A, Telecommunications Development Department, Telecommunications Headquarters. *Work Carried Out by the Post Office Circuit Laboratory Subscribers' Apparatus Group*.

D. H. Wade, Technical Officer, Glasgow. *The 4-Channel Pen Recorder—A Worthwhile Project*.

J. C. Evans, Technical Officer, London Telecommunications Region. *Whitehall Telephone Exchange*.

M. Wood, Technician 2A, Huddersfield. *Ultrasonic Cleaning in Exchanges*.

K. E. Russell, Technical Officer, Bristol. *The Routiner Man*.

The Council of the Institution records its appreciation to Messrs. B. B. Gould, J. R. Walters and R. W. Gibson, who kindly undertook to adjudicate on the essays entered for the competition. The prize-winning essays will be kept in the Institution's central library, and will be available to borrowers.

A. B. WHERRY
Secretary

IPOEE Ties

There will shortly be available, for purchase by members of the Institution, 2 designs of tie, priced at £1.50 each. One is dark blue with a single motif of the IPOEE symbol, and is suitable for wearing with more formal attire, and the other is olive green with red stripes and a motif.

Limited quantities have been purchased in the first instance, awaiting an assessment of the demand.

A. J. BARKER

Additions to the Library

The following books have been added to the IPOEE Library since the publication of the 1974 Library Catalogue. Any member who does not have a copy of the catalogue can obtain one from the Librarian, IPOEE, 2-12 Gresham Street, London EC2V 7AG. Library requisition forms are also available from the Librarian, from honorary local secretaries, and from Associate Section local centre secretaries and representatives.

Members are reminded that prize-winning essays, Associate Section prize-winning papers and various unpublished papers are held in the Library for loan, and that a list will be sent on request. Field Medal award-winning papers are also held for loan, and are listed in the Library Catalogue.

Printed Papers of the Institution are available on loan, or can be purchased from the Library. A list of papers available will be sent on request.

5160 *The Theory and Practice of Personnel Management* (Second edition). M. W. Cumming. (1972).

A comprehensive text covering the essential aspects of personnel management, based on British rather than American practice. It includes recruitment, training, motivation, management by objectives, communication and many other aspects of the personnel-management function.

5161 *Thyristors and their Applications*. P. Atkinson. (1972).

Intended for the engineer who possesses a sound working knowledge of electronic-circuit principles, other than those associated with thyristors, triacs and specialized triggering devices. It also provides an introduction for the student of electronics, or the practising engineer, to the principles of thyristors and triacs, and their applications.

5162 *The Compleat Cybernaut*. A. B. Harris. (1973).

Designed for those who need a knowledge of programming and the care and feeding of expensive computer facilities.

5163 *The Practical Photographer*. E. A. Weber. (1973).

For every photographer who wishes to realize the full scope of his equipment and materials. The text is coupled with first-class line diagrams and photographic illustrations.

5164 *Electricity and Magnetism*. J. Yarwood. (1973).

Covers in detail the electricity and magnetism syllabi for the first 2 years of an honours-degree course, or the whole of the requirements in these subjects for an honours-degree course in which physics is allied with other subjects.

E. DOHERTY
Librarian

Notes and Comments

Correspondence

Netherlands Postal and Telecommunications Services,
Dr. Neher-Laboratory,
St. Paulusstraat 4,
Leidschendam.

Dear Sir,

I read the article *Trends in the Development of Telecommunications* by Mr. G. V. C. Pedersen (*POEEJ*, Vol. 67, p. 194, Jan. 1975) with great interest.

However, I would like to make a remark about the section on page 195 headed "Destandardization". Mr. Pedersen says that, "It must be natural, some day in the future, to programme an information centre in the same way, so that anyone can have his personal request programme on the television screen in his home". He bases his opinion on the circumstance that, "Today, it is possible to subscribe to the magazines and periodicals which deal with subjects of special interest to the individual reader".

In the Netherlands, we made extensive studies about this problem, and we came to the following conclusions.

An information centre, equipped with video tapes and video recorders in such a way that anyone living within the range of such an information centre can get, on request, his personal programme, would be very costly, especially when congestion problems should be avoided. Therefore, we do not expect such a development. It is more likely to expect a customer to buy his own video recorder and his own collection of video tapes, so that he can see the wanted programme at any time of the day in his home. We have seen the same development in the audio-recording field. Therefore, in our opinion, it is only necessary for the community-antenna television networks to distribute a number of standard programmes. Our community-antenna-television-network conception initially makes the distribution of 6 television programmes possible, which number can be extended, if necessary, to 12 or even 30 with only a limited amount of additional investment. We feel that this network, in combination with the existing telephone network, will be able to fulfil all the needs of the public, at least for the next 25 years, or even more.

It is possible that the need for broad-band 2-way connexions for special purposes, and between institutions such as schools, universities, hospitals, and banks, will arise. The above reasoning is the basis for our 3-network theory, with this as the third network.

Mr. Pedersen makes a link between the press and the television programmes. What happens nowadays in the Netherlands, and perhaps also in other countries, in the field of the printed press, is that an ever-increasing standardization or concentration occurs. Smaller newspapers and periodicals are disappearing, or are taken over by their more powerful rivals.

As a result, the choice to the public becomes more and more restricted. The situation at the moment is that, for each region, one has the choice between 2, or sometimes 3, locally-oriented newspapers, and a few newspapers of a nation-wide spread. The same can be said about periodicals and magazines. The situation in the field of the printed press is, in any case, not of such a nature that an expectation of a development in the field of television distribution using information centres, as Mr. Pedersen describes in his article, can be based upon it.

dr. ir. A. P. Bolle

Long-Term Planning Group,
North West Telecommunications Board,
Manchester.

Dear Sir,

Several recent articles in the *Journal* have dealt with long-term forecasting in telecommunications.^{1,2} Two of the main factors affecting long-term forecasts, to which reference has been made, are the rate of economic growth and the pattern of sociological change. In view of the topical interest of these questions, stimulated by the oil crisis, it would, I think,

enhance the value of the articles if additional information could be given concerning the part played by these factors in the forecasts, and the basic assumptions that have been made.

The report *Britain 2001 AD*, published in 1972, was intended to provide basic economic and sociological information for use in British Post Office long-range studies, but it seems to have been overtaken by events. The assumption of exponential growth of the national economy for the next 25 years, made in the report, is less plausible today than it was in 1972. Should this assumption be replaced by that of zero growth to the end of the century, as proposed by some experts? (It has even been suggested that negative growth will be necessary, in the western world, if the requirements of the under-developed countries are to be met.) Alternatively, we could assume that the present decline will last for 3 or 4 years only, after which the original assumption of exponential growth will again apply.

Much interest is taken today in the sociological implications of commercial and industrial activity. These factors are likely to become increasingly important in the future, as questions of the environment and the wise use of limited natural resources come to the fore. The proposals recently made by Dr. Ernst Schumacher³ for the setting up of an intermediate technology, where conditions are suitable, adapted to local circumstances and human needs, have been widely discussed. These, and similar developments, would involve some redeployment and decentralization of industry.

Economic and social changes during the next few decades could have a significant effect on telecommunications requirements. It is, of course, impossible to predict so far ahead with certainty, but with such a wide range of possible assumptions, it would add to the value and interest of long-term forecasts if some detail of the assumptions that have actually been made were included.

H. G. Gange

References

¹ BREARY, D. A Long-Term Study of the United Kingdom Trunk Network. *POEEJ*, Vol. 66, p. 210, Jan. 1974, and Vol. 67, p. 37, Apr. 1974.

² PEDERSEN, G. V. C. Trends in the Development of Telecommunications. *POEEJ*, Vol. 67, p. 194, Jan. 1975.

³ SCHUMACHER, E. *Small is Beautiful*. (Blond and Briggs, 1973).

Publication of Correspondence

The Board of Editors would like to publish correspondence on engineering, technical or other aspects of articles published in the *Journal*, or on related topics.

Letters of sufficient interest will be published under "Notes and Comments". Correspondents should note that, as it is necessary to send copy to the printer well before publication date, it will only be possible to consider letters for publication in the October issue if they are received before 14 August 1975.

Letters intended for publication should be sent to the Managing Editor, *POEE Journal*, NP 9.3.4, Room S 08A, River Plate House, Finsbury Circus, London EC2M 7LY.

Supplement

For economic reasons, the Supplement to the *POEE Journal* is now published in 32-page and 16-page sizes for alternate issues. The first 16-page Supplement is published with this issue.

Regional Notes and Short Articles

The Board of Editors would like to publish more short articles dealing with current topics related to engineering, or of general interest to engineers in the Post Office.

Also, brief reports of events of engineering interest will be published under "Regional Notes". Authors should obtain approval for publication of their contributions at General Manager or Regional Controller level.

As a guide, there are about 750 words to a page, allowing

for diagrams. Articles and Regional Notes should preferably be illustrated, where possible, by photographs or sketches. Contributions should be sent to the Managing Editor, *POEE Journal*, NP 9.3.4, Room S 08A, River Plate House, Finsbury Circus, London EC2M 7LY.

Notes for Authors

Some notes are available to authors to help them prepare manuscripts of *Journal* articles in a way that will assist in securing uniformity of presentation, simplify the work of the *Journal's* printer and illustrators, and help ensure that authors' wishes are easily interpreted. Any author preparing an article for the *Journal*, who is not already in possession of the notes, is asked to write to the Managing Editor to obtain a copy.

It is emphasized that all contributions to the *Journal*, including those for Regional Notes and Associate Section Notes, must be typed, with double spacing between lines, on one side only of each sheet of paper. Articles, and contributions for Regional Notes, must be approved for publication at General Manager/Head of Division (Controller) level.

Each circuit diagram or sketch should be drawn on a separate sheet of paper; neat sketches are all that are required. Photographs should be clear and sharply focused. Prints should preferably be glossy and should be unmounted, any notes or captions being written on a separate sheet of paper. Good colour prints can be accepted for black-and-white reproduction. Negatives or plates are not needed and should not be supplied.

Back Numbers, Special Issues and Reprints

Back numbers of *The Post Office Electrical Engineers' Journal* are available, price 45p each (including postage and packaging), for all issues from April 1970 to date, with the exceptions of April 1971 and October 1971.

Copies of the October 1966 issue are also still available. This issue contains articles dealing with the planning of London's telephone network by computer, the trunking and facilities of the 5005 crossbar system, Leaffield radio station, a semiconductor device to replace polarized relays in telegraph circuits, the functional design of core-type register-translators, and an introduction to semiconductor device developments.

The October 1973 special issue on the 60 MHz transmission system, and the April 1974 issue covering sector switching centres, are among the back numbers still available. A reprint, containing all the most important articles published over the years on trunk transit switching, is also available, price 22p.

Orders, by post only, should be addressed to *The Post Office Electrical Engineers' Journal*, 2-12 Gresham Street, London EC2V 7AG. Cheques and postal orders should be made payable to *The POEE Journal* and should be crossed "& Co." British Post Office staff can assist by enclosing a self-addressed label.

Increase in the price of the Journal

As announced recently in the *Post Office Gazette*, the price of the *POEE Journal* to British Post Office (BPO) staff has been increased to 27p/issue with effect from this (July 1975) issue. The Board of Editors regrets that this increase must be made, but it has been made necessary by the very large increases in both printing and paper costs.

Every effort has been made to minimize the increase in cost, and readers will have observed that a lighter-weight paper has been used since January 1975. The use of this lighter and, therefore, cheaper paper was made possible by changing to an offset-lithographic printing technique, which itself produced a considerable saving in printing costs. Other economies have also been made where possible; for example, printing the Supplement as alternate 32-page and 16-page issues instead of the standard 24-page size previously used.

The price of the *Journal* to BPO staff has not been increased since October 1970, and the total cost of the current issue, despite the economies described above, is approximately 70% higher than it would have been if printed at the rates applicable in October 1970. This 70% increase is composed of individual increases of approximately 90% for paper and 66% for printing. If the economies had not been made, the increase in the cost of this issue, compared with its cost at October 1970 prices, would have been about 100%, with paper contributing about 127% and printing 92%.

Correction

It is regretted that an error occurred in the article *Preliminary Engineering Design of Digital Transmission Systems using Optical Fibre*, published in the April 1975 issue of the *Journal*. The equation at the foot of the first column on page 10, and the first line of the second column, should be deleted.

Subscriptions

Those wishing to subscribe to *The Post Office Electrical Engineers' Journal* may obtain an order form from the Managing Editor, *The POEE Journal*, NP 9.3.4, Room S 08A, River Plate House, Finsbury Circus, London EC2M 7LY. Please state whether or not you are employed by the British Post Office.

City and Guilds of London Institute Telecommunications Technicians' Course

Students of the elementary, A-, B- and C-years of the City and Guilds of London Institute telecommunications technicians' course can obtain an indexed list of the subjects still available in back numbers of the Supplement to *The POEE Journal* on application to the Managing Editor. Details of the model-answer books available are given at the back of the Supplement.

Post Office Press Notices

Research Awards for Outstanding Work

In recognition of outstanding work for British Post Office (BPO) research, the 1974 Gordon Radley Awards were presented in December to 3 scientists and 5 technicians of the BPO's Research Department. The presentations were made by Mr. Murray Laver, C.B.E., Post Office Board Member for Data Processing until his retirement last year. With him was the Director of Research, Mr. John Bray.

For the first time, the ceremony was held in the lecture theatre of the BPO's new Research Centre at Martlesham Heath, near Ipswich. The exterior of the centre is complete, and contractors are now fitting out the interior. In fact, work in the lecture theatre had only just reached the point where it could be used for the presentation.

The awards—small cash prizes, worth much more in

prestige than in intrinsic value—are the annual Scientific and Craftsmanship Premiums of the Gordon Radley Fund (Christopher Columbus Award). This year, there were 3 Scientific Premiums, which are awarded to professionally-qualified researchers, under the age of 30, for a scientific paper published in a research journal.

Mr. Simon Ritchie received an award, his second, for a paper on gallium-arsenide lasers. Mr. Ken White gained an award for a paper on light transmission in glass, and Mr. John Grierson received an award for a paper on impatt diodes.

There were 4 Craftsmanship Awards, for outstandingly skilled work in engineering design and the fabrication of equipment or models used in research. The winners were Mr. Terry Evans, Mr. Rex Hardy, Mr. Howard Hines and, jointly, Mr. Alan Leach and Mr. Fred Simpson.

Cheaper Electronic Exchanges to be Developed

The programme to obtain maximum benefit for telephone users by replacing Strowger local exchanges with the TXE4 electronic system has been taken a stage further by the British Post Office (BPO).

When the decision to use the TXE4 system for the replacement programme was taken, late in 1972, it was foreseen that the system, as it then stood, would be developed using integrated circuits instead of discrete components.

Studies of the possibilities were set in hand at that time. With these successfully completed, the BPO has placed a £6M contract with Standard Telephones and Cables (STC) Ltd. to carry this line of development into the system. Production costs of the TXE4 are expected to be significantly reduced. The effect will be to increase further the economic and other benefits of the modernization programme. The new version will be called the TXE4A.

In the meantime, testing of the first exchange of the original design—due to open in Birmingham early next year—is now 90% completed. Production and design information of the TXE4, validated by the BPO, is now flowing from STC Ltd. to Messrs. GEC and Plessey.

Electronic systems are being ordered for local exchanges to meet new demands for service and to replace existing electromechanical equipment. The TXE4 design was primarily developed to meet the needs of large exchanges serving urban commercial and industrial areas. One of its features is the ease with which it can be progressively extended to a maximum of 40 000 lines as the load on the exchange rises.

To enable the new version to be brought into service as soon as possible, STC Ltd. will make 2 models of the TXE4A, for evaluation and testing, as part of the development contract. The first will be installed at their switchgear factory at New Southgate, North London, and the second will be a pre-production model, provided for detailed study by the BPO.

In its current capital-investment programme, up to 1978, the BPO is already spending more than £200M a year on exchange equipment. Beyond 1978, electronic exchanges will be the largest single element of local-exchange spending. The BPO anticipates that the savings achieved from using the

cost-reduced version of the TXE4—due to come into service from 1980 onwards—will make a significant impact on that spending programme.

The initial development of reed-relay exchange systems, which form the basis of the TXE4, was carried out by the BPO in collaboration with industry. Development of the TXE4 design was completed by STC Ltd., from whom the BPO has so far ordered 35 exchanges, to be brought into service up to 1978, at a cost of about £40M at 1974 prices.

New Submarine Cable to Link Britain and the Continent

Europe's largest submarine telephone cable, capable of carrying almost 4000 telephone calls simultaneously, will link Britain and Belgium in April 1977, the British Post Office (BPO) has announced. It forms part of a major project which will more than double the capacity of Britain's communication links with the European mainland by 1978.

The cable system will be made in Britain by Standard Telephones and Cables Ltd. One of a new generation of high-capacity submarine telephone cables, the 101 km link will run from St. Margaret's Bay, near Dover, to Veurne, in Belgium.

Costing nearly £3M, the 3900-circuit cable system is being financed by the BPO and the telecommunication administrations of Belgium, Germany and The Netherlands. The BPO is putting up 50% of the cost, and the remaining 50% will be shared by the 3 other administrations involved.

The cable will be used primarily for communications between Britain and Belgium, Germany and The Netherlands, and also for British communications which pass through these countries to other parts of Europe. It will also carry telephone calls, Telex and telegram messages, and computer data between Britain and Denmark, Sweden and Norway, until a new cable, linking Britain with Scandinavia, comes into service, probably by about 1980.

The cable is a 45 MHz system, assembled as 13 master-groups, one mastergroup being equivalent to 5 supergroups or 300 circuits, and includes 21 repeaters.

Copyright

The entire contents of this *Journal* are covered by general copyright, and special permission is necessary for reprinting long extracts, but editors are welcome to use not more than one-third of any article, provided that credit is given at the beginning or end, thus: "From *The Post Office Electrical Engineers' Journal*."

The Board of Editors is not responsible for the statements made or the opinions expressed in any of the articles or correspondence in this *Journal*, unless such statement is made specifically by the Board.

Subscriptions and Back Numbers

The *Journal* is published quarterly in April, July, October and January, at 30p per copy, 45p per copy including postage and packaging (annual subscription: £1.75; Canada and the USA \$4.50).

The price to British Post Office staff is 27p per copy.

Back numbers will be supplied if available, price 30p (45p including postage and packaging). At present, copies are available of all issues from April 1970 to date, with the exceptions of April 1971 and October 1971 which are now sold out. Copies of the October 1966 issue are also still available.

Orders, by post only, should be addressed to *The Post Office Electrical Engineers' Journal*, 2-12 Gresham Street, London, EC2V 7AG.

Employees of the British Post Office can obtain the *Journal* through local agents.

Binding

Readers can have their copies bound at a cost of £3.00 including return postage by sending the complete set of parts, with a remittance to Press Binders Ltd., 4 Iliffe Yard, London, SE17.

Remittances

Remittances for all items (except binding) should be made payable to "*The POEE Journal*" and should be crossed "& Co."

Advertisements

All correspondence relating to advertisement space reservations, copy, proofs etc., should be addressed to the Advertisement Manager, *The Post Office Electrical Engineers' Journal*, 2-12 Gresham Street, London, EC2V 7AG.

Distribution and Sales

Correspondence relating to the distribution and sale of the *Journal* should be addressed to *The Post Office Electrical Engineers' Journal* (Sales), 2-12 Gresham Street, London, EC2V 7AG.

Communications

With the exceptions indicated above, all communications should be addressed to the Managing Editor, *The Post Office Electrical Engineers' Journal*, NP 9.3.4, Room S 08A, River Plate House, Finsbury Circus, London, EC2M 7LY.

Model Answers Books

Books of model answers to certain of the City and Guilds of London Institute examinations in telecommunications are published by the Board of Editors. Details of the books available are given at the end of the Supplement to the *Journal*. Copies of the syllabi and question papers are not sold by the *Post Office Electrical Engineers' Journal*, but may be purchased from the Department of Technology, City and Guilds of London Institute, 76 Portland Place, London, W1N 4AA.

The new ITT 2300 Teleprinter



Light on cost. Light on weight. Strong on performance.

This is the new ITT 2300 Teleprinter. Today's supreme teleprinter for telex and private wire usage, and a very significant advance in teleprinter design.

Its main features include:

Telex Control Interface and control requirements, for both Telex and Private Wire operation are met by simple strapping options.

Semi Electronic Design All signal processing is electronic, using large scale integrated circuit techniques. The answer back coding consists of a printed circuit board which can be plugged into any ITT 2300. Mechanical tasks are limited to print out of page copy, punching, tape reading and keying actions.

So the 2300 is smaller, lighter and quieter.

Reliability Micro electronic techniques reduce the number of mechanical parts by two thirds, thus significantly increasing reliability.

Maintenance Minimum moving parts and modular construction result in fewer adjustments—maximum accessibility. Routine maintenance

is only necessary every 1000 hours (or one year).

Versatility Push a button to select your operational mode. All the usual modes are available. And the 'Tape Prep' mode allows the preparation of a new tape with associated printed copy, while the reader transmits existing information to line. This increases traffic throughput when necessary.

And the ITT 2300 is easy to operate—one of the keyboard arrangements has a typewriter layout to minimise training. It's also easy to change paper rolls, tape rolls and the ink roller, too. Tape preparation can be carried out at up to 75 bauds (10 cps), and transmitted to line at 50 or 75 bauds ($6\frac{2}{3}$ or 10 cps). Operation at 100 bauds ($13\frac{1}{3}$ cps) is also available. The 2300 conforms to recognised international standards of safety, and is equipped with a time-out facility for private wire usage.

For more details, write to Publicity Department D2, ITT Creed Ltd., FREEPOST, Brighton BN1 1ZW. (No stamp required if posted within the U.K.).

ITT Creed Limited **ITT**

Hang Around

Martindale – acknowledged leaders in the field of Industrial Safety – now bring you a superb new range of safety gear for working at heights. All specifically designed for a long maintenance-free working life, sheer simplicity of attachment and operation, and 100% reliability.

There's the Altochute Harness, designed to provide guaranteed safety with full freedom of movement, and in full wearer comfort. The mobile safety anchor moves freely up and down the security rope, but locks on to the rope should the operator fall.

Secondly the Martindale Elevator Chair, which provides complete mobility and unrestricted movement with double safety protection for work on all vertical surfaces up to 50m. The operator has precise control over the chair position, can change the position of the chair on the rope with no effort, and can perform two-handed operations at height in complete safety; should the chair start to fall – or the

operator overbalance – the rope lock will immediately clamp on to the independent security rope.

And finally – the Kiblock Security Rope Brake, a completely independent and automatic safety lock for use with a 16mm dia nylon security rope; it allows the operator full freedom of movement in all directions and is easily adjustable, but locks onto the security rope at the first sign of downward movement. Can also be used with a waist belt for work on poles.

Full information on this new range of unbeatable Martindale equipment is provided in new literature now freely available on request.

Martindale Protects

**Martindale Protection Limited,
Neasden Lane, London NW10 1RN,
telephone 01-450 8561.**

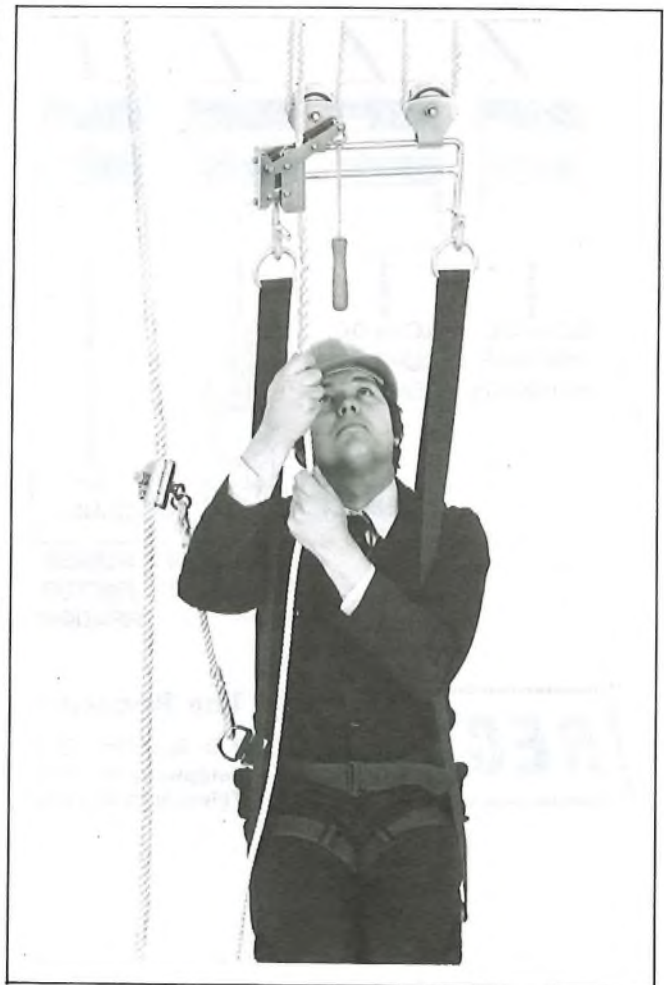

Plug in Adaptability with the Record 100 S.A.R & SERVEX Recorders

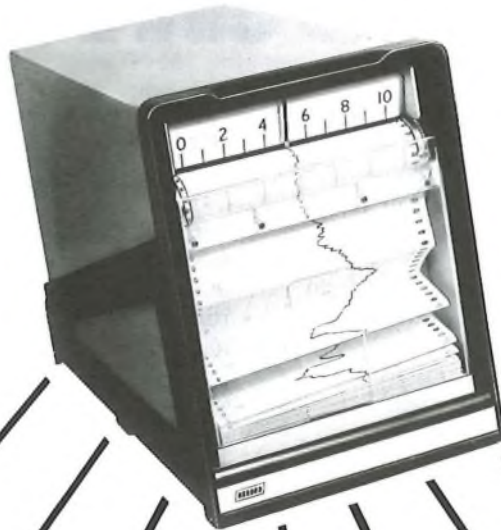

SIGNAL CONDITIONING MODULES

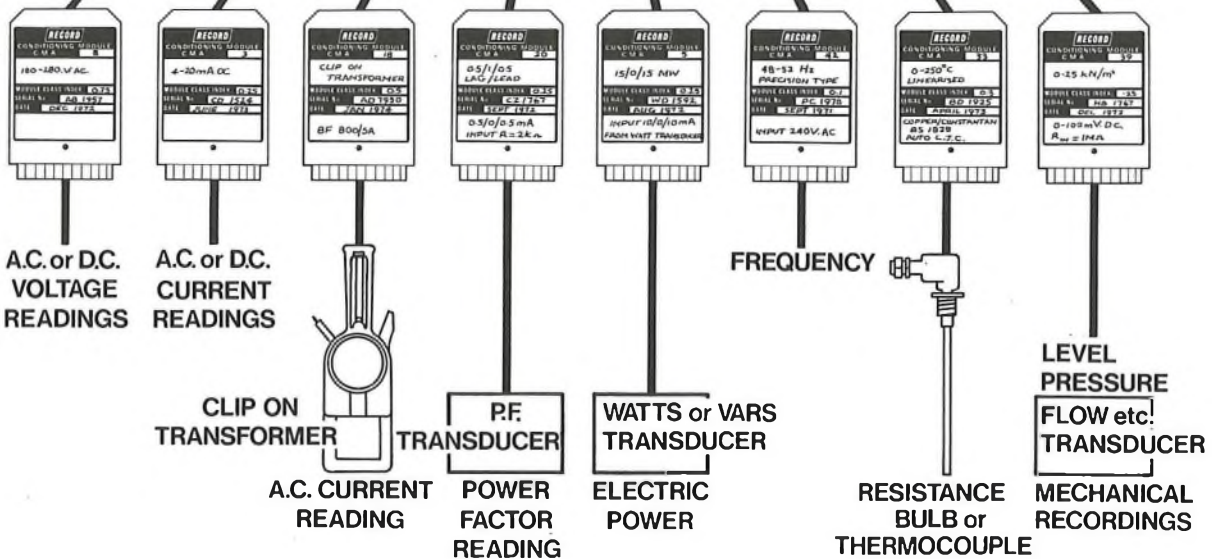

The Record Electrical Company Limited
 P.O. Box No. 19 ALTRINCHAM, CHESHIRE, WA14 5DB
 Telephone 061-928 6211 Telex 66 7212
 Telegrams & Cables, Cirscale, Altrincham.



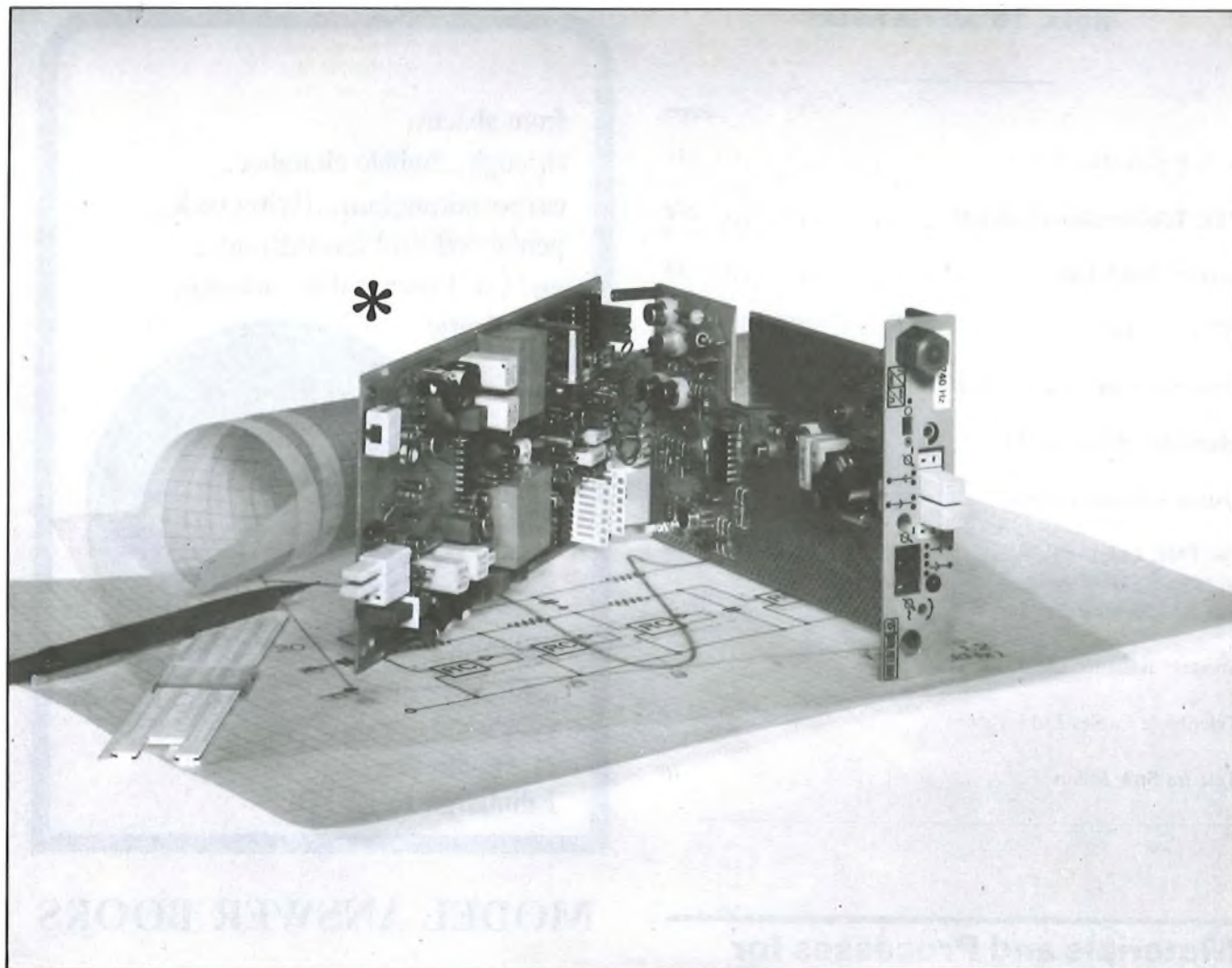

TG48 new generation voice frequency FSK multiplex equipment

Reduced size

Two complete 24-channel systems in a slim rack of dimensions 2600 H x 120 W x 225 D mm

Extensive use of advanced technologies

Digital frequency modulator and discriminator with complementary MOS integrated circuits - Active RC filters with Tantalum thin-film and beam-lead operational amplifiers

Low power consumption

32 W per 24-channel system, with typical 1 kohm/±20 mA local circuit

Simplified maintenance and reduced spare parts

Invariant channel units at equal modulation rate, except for a replaceable crystal for line frequency allocation of the channel

Excellent frequency stability with temperature and time

Line frequencies within ±0.1 Hz over the 0-50°C temperature range

Modulation rates of 50-100-200 bauds with performance according to, or better than, CCITT recommendations

* FSK voice frequency channel developed by Telettra's FDM Laboratories.

Telettra

S.p.A. LABORATORI DI TELEFONIA ELETTRONICA E RADIO - VIMERCATE MILANO ITALY

INDEX TO ADVERTISERS

	Page
W & R Chambers Ltd.	11
GEC Telecommunications Ltd.	2-4
Herman Smith Ltd.	13
ITT Creed Ltd.	7
Marconi Communications Ltd.	1
Martindale Protection Ltd.	8
Oxford University Press	11
Pye TMC Ltd.	12
Record Electrical Co. Ltd.	9
Spectrol Reliance Ltd.	5
Telephone Cables Ltd.	6
Telettra SpA Milan	10

Materials and Processes for Electrical Technicians

L. C. Mott

Technicians employed in the electrical industry need to be familiar with a wide variety of materials, with their properties, methods of production, and processes, and the associated tools and equipment. This book aims to provide that knowledge and has been written to cover the syllabus for the City and Guilds of London Institute's course 281: Electrical technicians. £5 paper covers £1.95

Telephony and Telegraphy A

An Introduction to Instruments and Exchanges (Step-by-Step and Common Control)

Sydney F. Smith

This is a complete text for the CGLI Course 270 examination in Telephony and Telegraphy A. The second edition takes account of the increasing use of common control systems and Chapter 4 has been rewritten to provide a more general systems-oriented approach. Second edition £4.95 paper covers £2.20

Oxford University Press

from abacus,
through...bubble chamber...
carposporangium...flying tuck...
pentaerythritol tetranitrate...
and (sic) uncertainty principle...
to zymetic

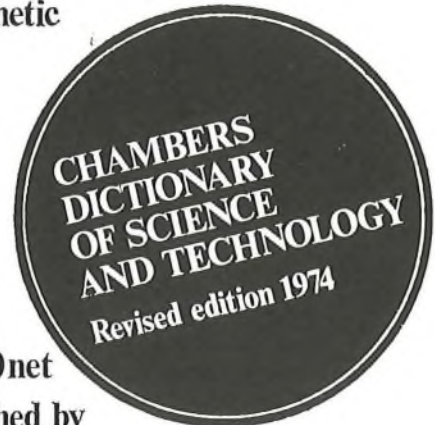

£10.00 net

published by
W & R Chambers
11 Thistle Street
Edinburgh EH2 1DG

MODEL ANSWER BOOKS

CITY AND GUILDS OF LONDON INSTITUTE
EXAMINATIONS FOR THE TELECOMMUNICATION
TECHNICIANS' COURSE

Six model answer books are available, each covering one of the following subjects:

TELECOMMUNICATION PRINCIPLES A
LINE PLANT PRACTICE A
ELEMENTARY TELECOMMUNICATION PRACTICE

Price 45p each (post paid)

RADIO AND LINE TRANSMISSION A
TELEPHONY AND TELEGRAPHY A
TELECOMMUNICATION PRINCIPLES B

New, completely rewritten editions: price 80p each (post paid)

Orders may be sent by post only, to
The Post Office Electrical Engineers' Journal,
2-12 Gresham Street, London EC2V 7AG

Pye TMC

All
the
way
down
the
line...

Pye TMC is big in advanced telecommunications.

We're not big in size, we honestly admit. But we reckon we're up there with the biggest when it comes to the best. And therein lies our strength. Not so big that we lose sight of our customers' needs. But big where it really matters—in technology, in systems and equipment.

Transmission for example—60MHz coaxial line and terminal equipment
□ data modems up to 9600 bps □ PCM (24 and 30 channel) □ FDM telephone multiplex up to 10,800 channels □ VF telegraph (6, 12 and 24 channel duplex)
□ 120Mbit/s data transmission systems.

And in switching—Stored Program Controlled telephone systems
□ Message and data switching systems □ Call Transfer Units, Changed Number Intercept Units* and Electronic Directors (all based on Pye TMC developed MOS—LSI circuitry) □ Telex systems.

Finally in subscriber apparatus—the unique SpheriCall and Instafone autodiallers and 32 Address repertory dialler □ Press button telephones (and dial types too) □ Secraphones □ All-weather telephones □ Flexicom internal communications □ PAX, PMBX switchboards.

And we have a back-up organisation to match. Write for our complete catalogue.

Try us for size—small but big.

*The first 'speaking integrated circuit' has been developed by Pye TMC and used in our CNI systems to announce 'caller specific messages'.



Pye TMC Limited

Commercial Division, Martell Road, West Dulwich,
London, England SE21 8EF Telephone 01-670 2211
Telex 28115 Cables Bubastis, London.

A member of the Pye of Cambridge Group

The Post Office approves, so will you!



Cabinet systems for
Switching Equipment

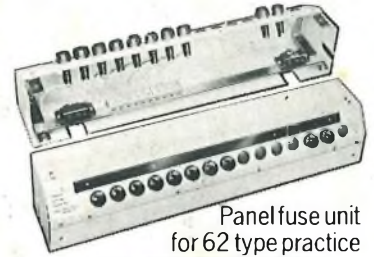

Panel fuse unit
for 62 type practice

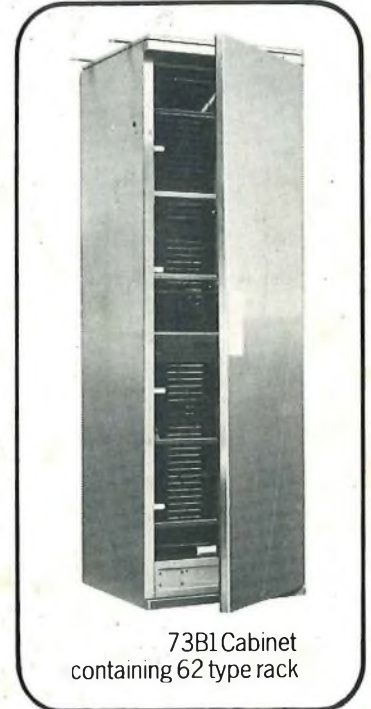

73B1 Cabinet
containing 62 type rack

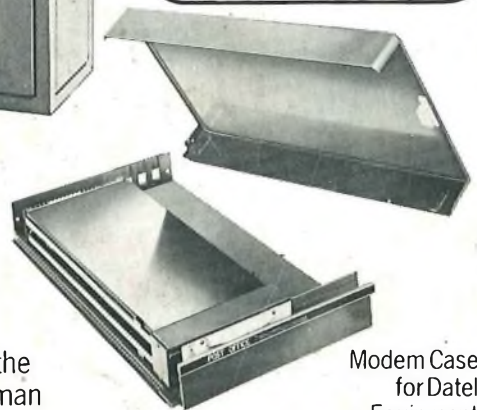

Modem Case
for Datel
Equipment

Herman Smith have long held full approval from the Post Office for the production of 62 type equipment. But that's only half the story. Wherever precision electro-mechanical work is involved Herman Smith have all the facilities and all the experience.

From simple sheet pressings to sophisticated cabinets and wired assemblies, we maintain the highest standards, our fully trained QA personnel—ensure your approval to any specification.



Contact Peter Bowen **HERMAN SMITH LIMITED**, Cinder Bank Works, Netherton, Dudley,
West Midlands. DY2 9AH Telephone Dudley 52791