

The Post Office Electrical Engineers' Journal

RA RCE
PE12

VOL 67 PART 4 / JANUARY 1975



THE POST OFFICE ELECTRICAL ENGINEERS' JOURNAL

VOL 67 PART 4 JANUARY 1975

Contents

	<i>page</i>
Editorial	193
Trends in the Development of Telecommunications—G. V. C. Pedersen	194
Engineering Innovation in a Service Industry: Post Office Telecommunications— J. H. H. Merriman	196
Telephone Traffic Recording and Forecasting—H. S. Holmes	201
A Traffic-Forecasting Technique—B. F. Yeo and J. F. Birt	206
Sources for Optical-Fibre Transmission Systems—D. H. Newman	208
Photodiodes for Optical-Fibre Transmission Systems—M. R. Matthews and D. R. Smith	213
Programming Languages for Stored-Program Control—K. F. Clements	217
Push-Button Telephones—S. E. Card and D. T. Littlemore	224
Experimental Packet-Switched Service: Procedures and Protocols Part 1—Packet Formats, Facilities and Switching—W. Neil, M. J. Spooner and E. J. Wilson	232
The Effects of Power-Supply Transients on British Post Office Cable Communication—B. Hall and C. J. Lilly	240
Signalling System A.C. No. 13 Inter-P.B.X. Working on a P.A.B.X. No. 7— R. H. Mackie and M. Hart	244
Regional Notes	247
Associate Section Notes	251
The Associate Section National Committee Report	252
Institution of Post Office Electrical Engineers	252
Notes and Comments	254
Post Office Press Notices	254
Book Review	246

Published in April, July, October and January by the *Post Office Electrical Engineers' Journal*,
2-12 Gresham Street, London EC2V 7AG.

Price 30p (45p including postage and packaging). Orders by post only.

Annual Subscription (including postage and packaging): Home and Overseas £1.75.
(Canada and U.S.A. \$4.50.)

Price to Post Office staff: 21p.

Pye TMC

All
the
way
down
the
line...

**Pye TMC is big in
advanced telecommunications.**

We're not big in size, we honestly admit. But we reckon we're up there with the biggest when it comes to the best. And therein lies our strength. Not so big that we lose sight of our customers' needs. But big where it really matters—in technology, in systems and equipment.

Transmission for example—60MHz coaxial line and terminal equipment □ data modem and multiplexers up to 6200 bauds □ PCM (24 and 30 channel) □ FDM telephone multiplex up to 10,800 channels □ VF telegraph (6, 12 and 24 channel duplex) □ 120Mbit data transmission systems.

And in switching—Stored Program Controlled telephone systems □ Message and data switching systems □ Call Transfer Units, Changed Number Intercept Units* and Electronic Directors (all based on Pye TMC developed MOS—LSI circuitry) □ Telex systems.

Finally in subscriber apparatus—the unique SpheriCall autodialler and 32 Address repertory dialler □ Press button telephones (and dial types too) □ Secraphones □ All-weather telephones □ Flexicom internal communications □ PAX, PMBX □ switchboards.

Not the complete catalogue but formidable nevertheless. And we have a back-up organisation to match.

Try us for size—small but big.

*The first 'speaking integrated circuit' has been developed by Pye TMC and used in our CNI systems to announce 'caller specific messages'.



Pye TMC Limited

Commercial Division, City House, London Road,
Croydon CR9 3QR England Telephone 01-689 2151
Telex 946949 Phonemakers Croydon

Now on hand.

Three advanced developments in telephone engineering from GEC.



The GEC 746 table telephone
 -an instrument making full use of printed circuit techniques and tropicalised components.
 Rugged, reliable-
 available in attractive colours and a wide-range of options.



The GEC LST4D voice-switched loudspeaking telephone

-hand-free operation with full automatic voice switching so that loud-speaker and microphone cannot be 'alive' at the same time.



The GEC 740 1/2 and 1/3 switching telephone

-independent access to one exchange line from two or three telephones. Also provides an efficient intercom system.



Dial or pushbutton versions available for all telephones.

GEC manufacture telephones for world markets: table and wall-mounting models in a number of attractive colours, loudspeaking telephones, pushbutton telephones and switching telephone systems.....

You couldn't be in better hands.
 GEC Telecommunications Limited,
 Telephone Division, Whinbank Road,
 Aycliffe, Co. Durham, England.
 A Management Company of
 The General Electric
 Company Ltd., of England.

An outstanding offer to the busy executive... complete freedom to consult correspondence, make notes, draw, do anything he likes with both hands while carrying on a telephone conversation.

There's no need to use 'press to talk' switches either. GEC's LST4D loudspeaking telephone has fully automatic voice switching - so the loudspeaker and microphone cannot be 'alive' at the same time and eliminating 'sing round!'

Any number of people in the room can join in a conference with the distant party. When privacy is required, pick up the handset - the loudspeaker and

microphone are automatically disconnected.

You could call it 'the Freedom Phone'. Outside, it's neat modern appearance is at home in the most up-to-date office layout. Inside, the GEC LST4D loudspeaking telephone is a masterpiece of advanced circuitry...

Dial or pushbutton versions available for all telephones.

GEC manufacture telephones for world markets: table and wall-mounting models in a number of attractive colours, loudspeaking telephones, pushbutton telephones and switching telephone systems...

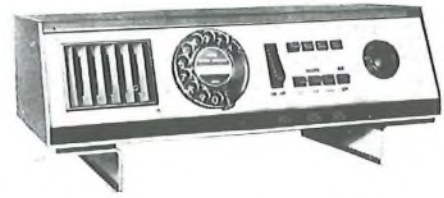

You couldn't be in better hands.

GEC Telecommunications Ltd.,
Telephone Division, Whinbank Road, Aycliffe,
Co. Durham, England.
A Management Company
of The General Electric
Company Ltd. of
England.

**Free with every GEC LST4D
loudspeaking telephone.**

Two spare hands.



Any weather, any climate, GEC take radio efficiency to extremes

In the Chilean
High Andes

Take the GEC 2GHz system. So adaptable, it is already operating successfully in various extremes of temperature and humidity – from the arctic regions of Canada to the Swiss Alps, and from the deserts of Libya and Bahrain to the tropical conditions of Nigeria and Zambia.

The GEC 2GHz system provides high system planning flexibility with complete band coverage from 1.7 to 2.3 GHz, with a capacity of 960 telephone circuits, or one colour television channel and one sound channel. Completely semiconductored, the equipment, which is in accord with CCIR recommendations, combines high reliability with low power consumption making it particularly dependable for routes which must cross remote or difficult areas. Its modular construction, the latest example of systematic improvement to a successful and proven system, reduces field maintenance to a minimum and enables qualified maintenance engineers to work from a strategically located central depot. System-planning engineers will be pleased to show you some of the other ways in which the 2GHz system has already proved extremely successful in 18 countries.

Total telecommunications: Microwave and Line Transmission, Multiplex, V.F. Telegraphy, Data Modems, Public Exchanges, Private Telephone Systems, Telephones, Total Systems Capability.



GEC Telecommunications Limited
of Coventry, England.
A Management Company of The
General Electric Co. Ltd. of England.



In the Nigerian Bush



In the Swiss Alps

A few of the world's best-known talking drums.



From the depths of Africa's dense jungle-land to the rocky heights of the Americas you'll find them:

Talking drums.

But possibly no drum turns up quite as often around the world as the ubiquitous TCL Cable Drum.

In its own way, that says a lot. That TCL cable, for example, contributes

to telecommunications as far apart as South America and Saudi Arabia.

What it doesn't say is that you can rely on TCL for either a length of telephone cable or the planning, manufacture and installation of a complete telecommunications network.

So we're saying it now. Well, why shouldn't we beat the big drum.

TCL

Telephone Cables Ltd., Dagenham, England. Tel: 01-592 6611. Cables: Drycore, Dagenham. Telex: 896216.

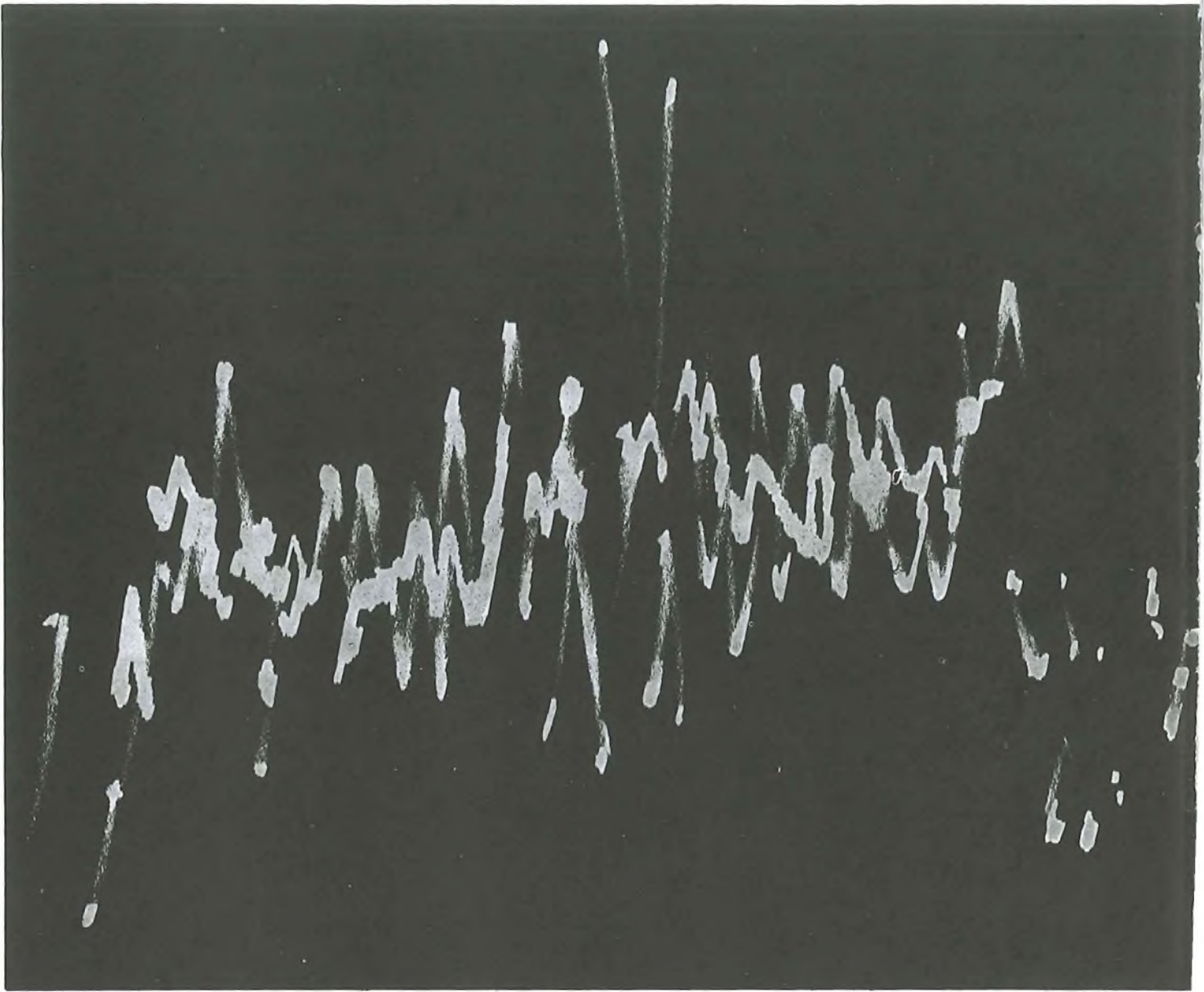

**We've added something important to
our new transceivers.**

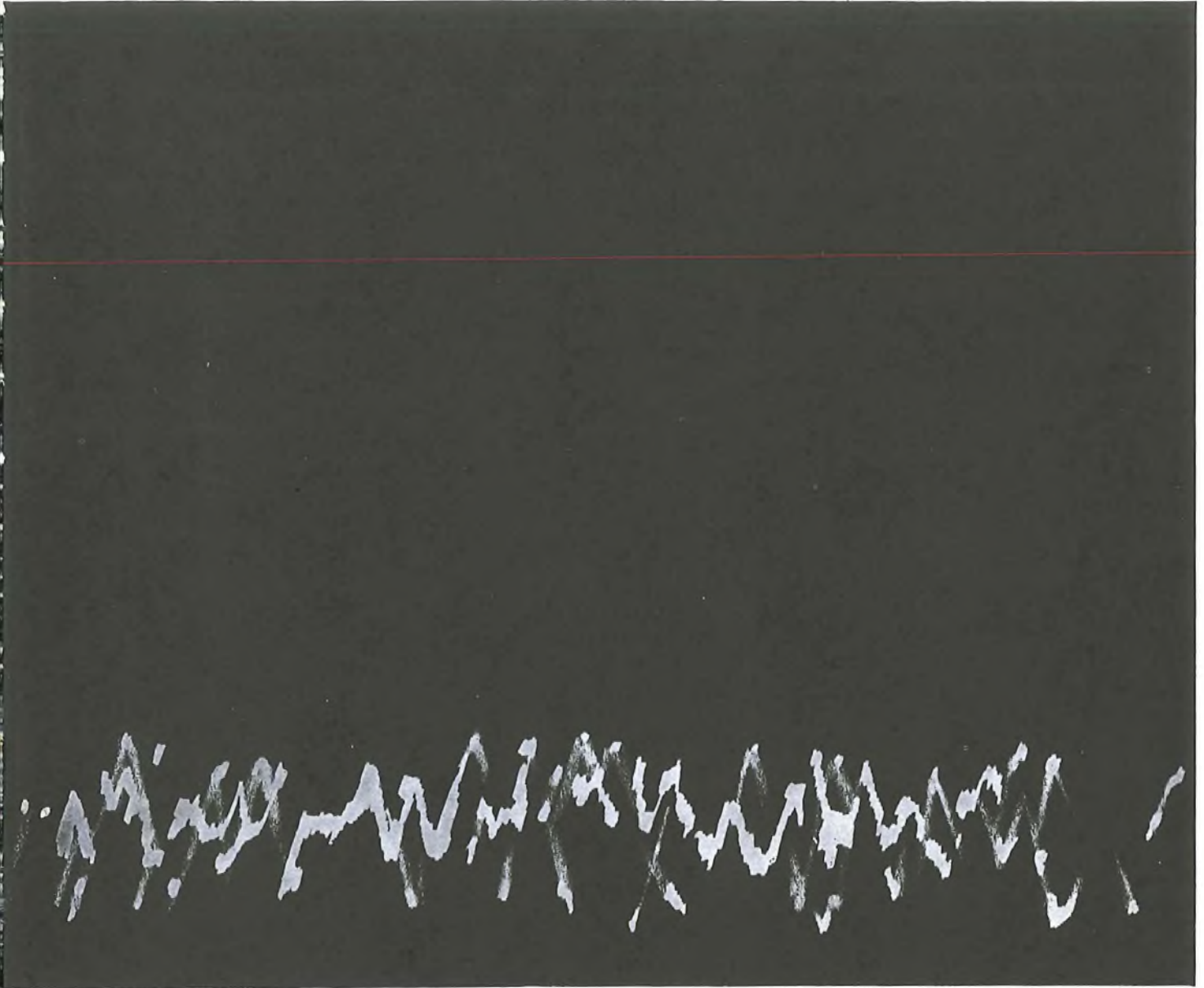

Silence.

We've reached a new low in dB and a new high in reception.

Our noise ratings are as low as 6 or 7 dB, compared to the usual 9 or 10 dB for a good, conventional transceiver.

So now—with this increased clarity of reception—it's possible to set microwave stations farther apart or eliminate one or more stations in a chain.

Our new 140-series transceivers are all high-capacity instruments. They handle from 960 to 1800 telephone calls simultaneously. The designs are all-solid-state and use integrated circuits, thin-film techniques and compact construction.

Here's a brief rundown on all four:

The CTR-140. It operates at 1700 to 2300 MHz, provides 1260 FM channels, is rated at 6 dB.

The CTR-144. 3600 to 4200 MHz. 960 to 1800 FM channels. 6 dB.

The CTR-141. 5650 to 8500 MHz. 1260 FM channels. 7 dB.

The CTR-142. 12,700 to 13,250 MHz. 960 FM channels or 480 PCM channels. Its 9.5 dB rating is outstanding for a transceiver operating at such high frequencies.

In each of the transceivers, the telephone channels can be replaced by one television channel plus four sound programmes.

We have lots more information to offer. After all, we have had systems in continuous operation in the UK since early 1970, so let us hear from you.

It's good for our transceivers to be silent, but nobody wants silence from his customers.

Please write or phone: Chris Gannon, GTE International, Central Way, Feltham, Middlesex. Tel: 01-890 1455. Telex: 934830.

Or, GTE Telecomunicazioni S.p.A., Via Turati 27, 20121 Milan, Italy GTE International, 909 Third Ave., New York, N.Y. 10022, U.S.A.

GTE INTERNATIONAL

Marconi

Line Communications

Marconi is amongst the foremost designers and suppliers of digital terminal, transmission and switching equipment. It specializes in the application of digital techniques and computer control to telecommunication systems, and has many advanced systems in operation.

It is a major contractor to the British Post Office and overseas telecommunications authorities and commercial and military users throughout the world, and has been chosen to carry out feasibility and development studies in state-of-the-art areas of equipment and system design.

Its latest range of systems and equipment includes:

- 'Autospec' and 'Spector' Automatic Error Detection and Correction Equipment
- 'Marconidata' Transmission Equipment
- 'Marconidata' Multiplexing Equipment
- 'MARS' Automatic Message and Data Switching System
- 'MARTEX' Automatic Telephone Switching System
- Marconi Pulse Code Modulation (PCM) System
- Marconidata Modems
- Marconi High-Speed Data Transmission Datel Codec
- Marconi Dataplex Interface Units
- Marconi Telegraph Regenerative Repeaters



U64

Marconi

PCM Systems

Marconi is the foremost manufacturer and exporter of PCM systems in the United Kingdom. More than 100,000 channel ends have been sold to the British Post Office, overseas telephone authorities and public utilities, because of technical quality, cost effectiveness and prompt delivery, coupled with highly experienced planning, installation and commissioning services.

Marconi interfaces with most modern automatic exchange systems, and is also suitable for future integrated switching systems. It tolerates low-quality audio cable and operates in adverse environments. It can be expanded economically and flexibly and can also provide teleprinter channels and data transmission facilities.



U65

Marconi Communication Systems

Complete civil and military static and mobile communication systems

Marconi Communication Systems Limited, Chelmsford, Essex, England

A GEC-Marconi Electronics Company

LTD

The Post Office Electrical Engineers' Journal

BOARD OF EDITORS

J. F. P. THOMAS, B.Sc., C.Eng., M.I.E.E., Chairman
E. W. AYERS, B.Sc.(Eng.), C.Eng., F.I.E.E.
A. J. BARKER, C.Eng., F.I.E.E.
A. J. BARNARD, C.Eng., M.I.E.E.
C. E. CLINCH, B.Sc.(Eng.), C.Eng., F.I.Mech.E., F.I.E.E., F.S.S.
J. MARTIN, B.Sc.(Eng.), C.Eng., M.I.E.E.
A. NESS, C.Eng., M.I.E.E.

Managing Editor

D. MILLINGTON, C.Eng., M.I.E.E.

Assistant Editor

B. STAGG

Secretary-Treasurer

B. FARR

Advertisement Manager

R. G. ROTHERY

EDITORIAL

"Telecommunications is a global business. So, awareness of developments overseas is essential. So, too, are compatibility and standardization, without which national and global connexions are impracticable."

These words formed part of Professor Merriman's inaugural address to the Institution of Electrical Engineers (a shortened version is included in this issue of the *Journal*) on becoming the tenth President of the Institution of Electrical Engineers to be elected from the Post Office.

The *Journal* hopes to contribute to these aims by including, from time to time, articles written by leaders of telecommunications administrations elsewhere in the world. The first article in the series, featured in this issue of the *Journal*, is written by Mr. G. V. C. Pedersen, Director General of Posts and Telegraphs, Denmark. Mr. Pedersen has, for many years, played an outstanding part in establishing standards for international communications through his work with many international committees, and uses this background to predict the future trends in the development of telecommunications.

This issue also marks the end of an era for the *Journal* which, since the first issue in April 1908, has been printed by traditional letterpress methods. In the last year or so, the cost of printing and, particularly, paper have risen very sharply (by approximately 25 per cent and 85 per cent, respectively), so that economies are essential if increases in the price of the *Journal* are to be restricted. Therefore, this issue is printed by offset lithographic techniques, thereby reducing the cost of printing and permitting a less expensive paper to be used, whilst maintaining the existing standards of presentation generally, and improving the quality of reproduction of photographic material.

Trends in the Development of Telecommunications

G. V. C. PEDERSEN, B.ENG., Director General of Posts and Telegraphs, Denmark†

U.D.C. 621.39:061(100)

After setting the scene by describing the evolution of the various committees of the International Telecommunications Union concerned with developments in communications, the author outlines his views on the developments likely to occur in telecommunications during the next decades, their effects on society and the influence of society itself in guiding the course of developments.

INTRODUCTION

International co-operation in the field of telecommunication started very early, and the International Telecommunication Union (I.T.U.) is the oldest of all international governmental unions. Agreement between nations was needed for facilitating the flow of telegraph and telephone communications across the frontiers.

The extensive use of the limited radio-frequency spectrum created new problems, and since the Radio Frequency Conference in Atlantic City in 1947, the I.T.U. has been actively engaged in the work of providing the possibility for all nations to make the most efficient use of the radio-frequency bands. The International Frequency Registration Board (I.F.R.B.) was created and the International Consultative Committees (C.C.I.s) were incorporated in the new structure of the I.T.U. This structure is quite unique, with I.F.R.B. and the C.C.I.s as independent bodies within the Union. But, it has worked very well in practice and the basic structure of the I.T.U. has remained unchanged since 1947.

ACHIEVEMENTS OF THE INTERNATIONAL COMMITTEES

In the Telecommunication Convention, the Radio Regulations and the Telegraph and Telephone Regulations, we have in the past worked out elaborate rules and regulations all serving to improve the telecommunication services, and I believe that we cannot find any other field of human activity where such a detailed set of rules has been so largely respected by all nations. In my opinion, the secret behind this success is the fact that the finest specialists from all over the world have taken part in the formulation of recommendations on operational and technical questions in the C.C.I.s. The rules and regulations accepted by administrations have largely been based on these recommendations, as the advice of wise men, in most cases, is accepted.

† Following a professional engineering career in London, Paris and Denmark, spanning a period of 30 years, Mr. Pedersen was appointed, in 1960, to his present position as Director General of Posts and Telegraphs, Denmark.

During his career, Mr. Pedersen has participated in many international communications conferences, notable examples being Chairmanship of the International Conference of Satellite Radio Communication, Geneva 1963, of the World Administrative Radio Conference for Space Telecommunications, Geneva 1971, and of the XIIIth Plenary Assembly of C.C.I.R., Geneva 1974.

Only within the field of sound broadcasting in the low-frequency, medium-frequency and high-frequency bands has it not been possible to obtain well co-ordinated results giving the optimum efficiency. Strong national interests and political ambitions in many countries have, in the past, prevented the implementation of frequency plans, which would be more satisfactory from a technical point of view and thereby give the listeners a greater choice of programs from various nations.

My personal feeling, however, is that it is somewhat easier to get international agreement in connexion with the use of radio frequencies in space than at the surface of our old earth, where existing investments and old traditions sometimes make it more difficult or, as for sound broadcasting, even impossible to attain agreement on optimum solutions.

The somewhat better international climate in space has also manifested itself in connexion with the successful setting up of the International Telecommunications Satellite Organization (INTELSAT). International negotiations, with a view to setting up a single global commercial satellite system, started some 10 years ago and, at first, the activities were covered by a draft agreement of a temporary nature. This agreement has now, after long and difficult negotiations at government level, been replaced by a definite agreement accepted by 83 nations. The agreement had to be based on the basic principle of a United Nations' resolution: that communication by means of satellites should be available to all nations of the world as soon as practicable and without any discrimination; and it should respect the rules and regulations for use of radio frequencies and "parking positions" in outer space, as agreed upon by all nations at I.T.U. conferences in 1963 and 1971. It should also operate under sound technical and financial principles, making it possible to provide global communication at low cost and with great flexibility for routing of traffic. The result attained is of historical significance, as it represents a permanent agreement for man's first major commercial international venture in space.

FUTURE DEVELOPMENTS IN TELECOMMUNICATIONS

It is always tempting to foresee the development in telecommunication during the next three decades in the light of the present technology and the work now being carried out in research laboratories.

However, I believe that we cannot predict the technology

to come for more than one decade, or perhaps two. I think that it is impossible to foresee the conditions of the future, in detail, by means of the logic of today. We shall need imagination based on the belief that the generations to come will be able to make unexpected new discoveries in the physical field and continue to break new ground. The discovery of the ionized layers, which give the long range to the short radio waves, and the properties of the semiconductors, which form the basis of, for example, the transistor, no doubt came as surprising discoveries to that time. And this was probably also true of the ideas of Albert Einstein and Niels Bohr. Therefore, a great many things, which must be accepted by us as being impossible to-day, may some day become realities.

For that reason, I feel that it would be much better if we try to make out the tendencies that are in the development wanted by society, and then decide which tasks telecommunication should endeavour to solve.

During the past 50 years, we have lived through an industrial period when the primitive technology has made its demands on society, which, in many respects, has hardly had any choice.

It has been necessary to *centralize* administration and production in large units, and this has contributed, for example, to the increasing population concentration in big cities.

Comparatively primitive methods of production have necessitated an extensive *standardization* of products and services for everyday life.

The rapid increase in the standard of living desired has been dependent on a growing consumption of a number of the natural *resources* of the earth, resources which are found to a limited extent only.

Now, we are at the beginning of the period of the more sophisticated technology, characterized by a wide range of possibilities originating from the progress of technology. Owing to the semiconductor technology, information in unlimited quantities may be collected, transmitted and treated for any need. Likewise, it is also possible now, with quite simple means, to control very complicated processes. Society will, therefore, gradually be able to formulate the material contents of the future pattern of life, without being bound by the limits of the earlier primitive technology.

There may be reason to believe that the development will especially be characterized by quite new tendencies as the centralization will be replaced by *decentralization* of the society of the future, and that the present standardization will be followed by *destandardization*, for intellectual as well as physical needs; perhaps it is also to be expected that greater importance will be attached to protection of the limited *resources* of the earth, than to the constant increase in the standard of living.

This development will make new demands on telecommunication. The need for communication will grow, and new forms will be required. In my opinion, the trends in the development of telecommunication should be seen with this background.

Decentralization

Let us consider the wish for decentralization. There will be a demand to live under conditions which meet the wishes of the ever increasing spare time. There is a wish to decentralize decision processes and administration, and trade and industry; the wish will also be for smaller places of work, preferably near the homes. And at the same time, there will be a wish to increase the communication between people, within the smaller communities, as well as over the ever longer distances where people move. There will be a wish for ever more technically perfect communication for ear and eye, and for easy possibilities of call, which should be made available to all, including those away from their permanent places of residence.

Also, in the mass media, in particular television, possibilities must be created for development of close democracy, partly by means of an increase in the number of local transmissions of television, and partly by introducing facilities permitting an effective dialogue with the television viewers.

Destandardization

The wish for a destandardization will make itself felt not only in the material fields, but also in the intellectual field. Some day, people will probably wish to receive individual television programs, comprising, at any time, exactly the subjects which are of special interest to the individual television viewer. Today, it is possible to subscribe to the magazines and periodicals which deal with subjects of special interest to the individual reader. It must be natural, some day in the future, to program an information centre in the same way, so that any one can have his personal request program on the television screen in his home.

Effect of Limited Resources

The limited resources will make it desirable, to an ever increasing extent, to replace transport of persons to information centres by a transmission of the information to the persons in their homes or in local centres.

We shall, therefore, see a need for increased bandwidth, and this may mean that the telecommunications technology of the future must, to an increasing extent, expect that radio frequencies must mainly be reserved for mobile forms of application, and that cable must replace radio at any place where it is possible to use fixed connexions. Before the turn of the century, it may very well become necessary to transfer, for example, some of the channels now reserved for television to be used by mobile telephones and other services which can only be performed by means of radio.

It will be of great importance in the future that circuits for all types of telecommunication should be integrated in such a way that the highest degree of economy of scale will be obtained—not only in economy of investment, but also in economy in the use of radio frequencies. This will be in the interest of all, and it must be an important duty for the telecommunication administrations to plan the future networks with this in view.

Engineering Innovation in a Service Industry: Post Office Telecommunications

J. H. H. MERRIMAN, C.B., O.B.E., M.SC., HON.D.SC., M.INST.P., F.K.C.†

U.D.C. 654.1:621.39

In this shortened version of his presidential address to the Institution of Electrical Engineers, delivered in October 1974, Professor Merriman traces the role of engineering innovation in telecommunication during the past seven decades, and by highlighting past trends, reviews future prospects for telecommunication in Britain and throughout the rest of the world.

INTRODUCTION

Telecommunication is part of the essential infrastructure of a community; it is a service industry, related to the country's economic health and prosperity. Its capital investment program is vast—now some £700 M/annum in Britain. It is a high-technology, long-lead-time enterprise, and its technological base is changing and advancing rapidly. Telecommunication is a global business. So, awareness of developments overseas is essential. So, too, are compatibility and standardization, without which national and global connexions are impracticable. The British Post Office (B.P.O.) and its suppliers, therefore, work together to establish systems' standards and strategies that are compatible with world trends, and yet which allow competition in supply, an essential element in overall cost-effectiveness.

Post Office Telecommunications has to reconcile its responsibilities under the 1969 Post Office Act with its lack of independence to take its own "business" decisions. It is not free to determine, for itself, wage and price levels. And these basic parameters of any business, together with its capital-investment program, tend to be regarded by Governments as part of the country's economic regulating machinery. Within the past 12 months, the B.P.O. has been instructed to alter them significantly, virtually overnight, in expectation that the change could take effect within a year. Such changes in basic parameters quench attempts to secure maximum cost-effectiveness; service efficiency is lower than it could be; the supplying industry is subjected to continual change, and its products fail to make the mark they could in world markets.

There is a fundamental conflict between intrinsically long lead times of high-technology enterprises, taking perhaps a decade to develop and a further decade to implement, and the typical life cycle of a Parliament. Within and between these life cycles, attitudes can reverse and decisions be deferred. Yet, cost-effectiveness in world markets and satisfaction for telecommunication users depend as much on fast and timely decisions coupled with a measure of stable, confident, continuity, as they do on brilliant engineering and management. The purpose of this article is to note the severe effects of these conflicting life cycles upon increasingly complex national infrastructure systems, and to give an account of the role innovation has played, and can play, in one industry in these circumstances.

† Professor Merriman is the Post Office Board Member for Technology and Senior Director: Development. He is the tenth President of the Institution of Electrical Engineers to be elected from the Post Office since 1873, and is also President of the Institution of Post Office Electrical Engineers.

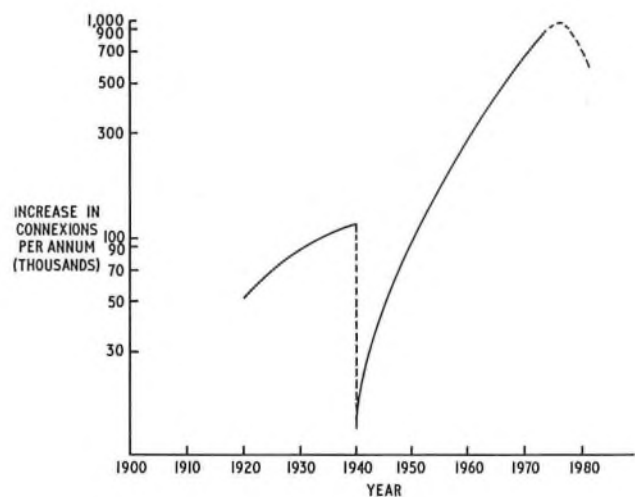

FIG. 1—Net annual increase in connexions in U.K. telephone system

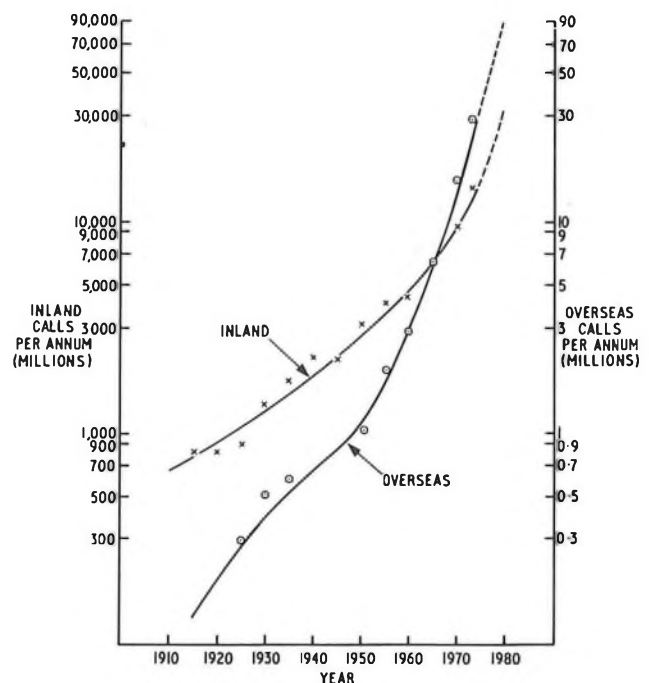

FIG. 2—Total calls handled per annum

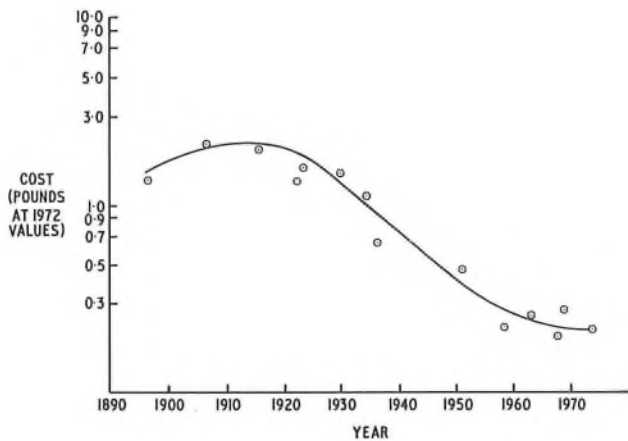

FIG. 3—Cost to customer of 3 min London-Glasgow telephone call

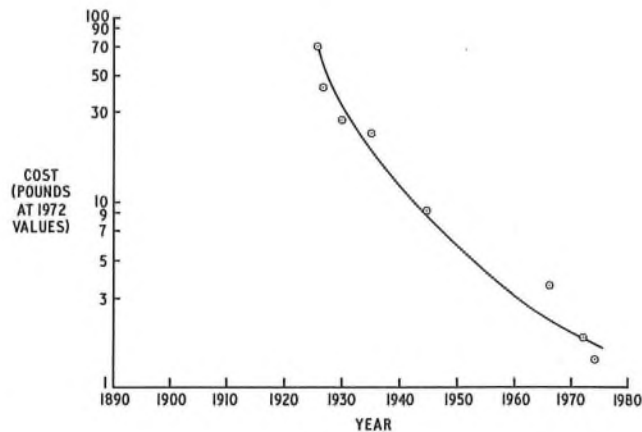

FIG. 4—Cost to customer of 3 min London-New York telephone call

POST OFFICE TELECOMMUNICATIONS

Post Office Telecommunications has grown, in its 100-years' life, to an asset base of some £4,000M. During last year, nearly one million telephone connexions were added to the system; it took 40 years to reach the first million. The system is probably at its maximum rate of growth (Fig. 1) in terms of size, but not in terms of calls handled (Fig. 2), or range of services offered. The number of local calls is doubling every 7-9 years, and inland trunk calls every 5-7 years, with even more spectacular international call growth, and new services are being added: data, Confravision, Radiopaging and facsimile services. All this involves a wide range of technologies: civil and mechanical engineering, physical science, chemistry, as well as a widening range of electrical-engineering disciplines.

Over the past 70 years, the combination of system growth, efficient management and engineering innovation has enabled the B.P.O. to reduce, steadily, the price of its services (Figs. 3-5) to its customers, in real terms. But the rate of that reduction, the ability to offset inflation, is diminishing and, in some sectors, has ceased. If, indeed, system growth rate is at its maximum, the automatic bonus that comes from growth must be expected to tail away. Opportunities for increased management efficiency and management/union productivity, of course, remain. But, the role of engineering innovation becomes crucial. Against the outstanding achievements of the past decades, it is important, therefore, to try to see what the future may hold.

THE TELEPHONE

Consider first the familiar telephone instrument. There are some 19 million telephone instruments in use in Britain today. Production costs of the design most frequently used (the 700-type telephone instrument) have fallen steadily (Fig. 6) in real terms since the early 1950s. Design, manufacturing and distribution costs have been reduced under engineering and system development and are probably approaching a lower limit. Surprisingly, the engineering concept of the telephone instrument differs very little throughout the world from its predecessor of 70 years ago. Electronic devices—metal-oxide-semiconductor integrated circuits for example—have, it is true, been introduced, and they help to open up services like Keyphones, repertory dialling, called-number indicators, data transmission and display. But such changes are not likely to reduce further the cost of the basic instrument. Their principal contribution will be to permit alternatives, or premium facilities, as additional customer options.

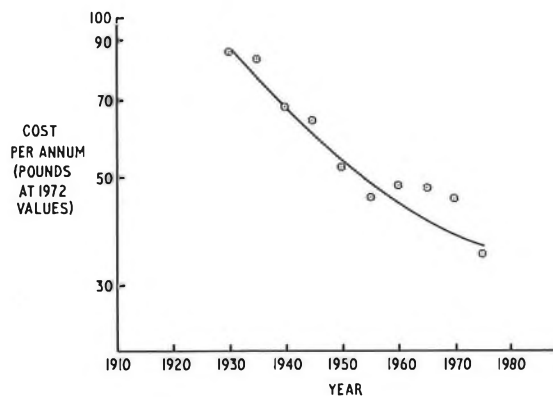

Note: Assumes exclusive service, 480 local calls and 20 trunk calls

FIG. 5—Cost per annum to customer of typical residential telephone service

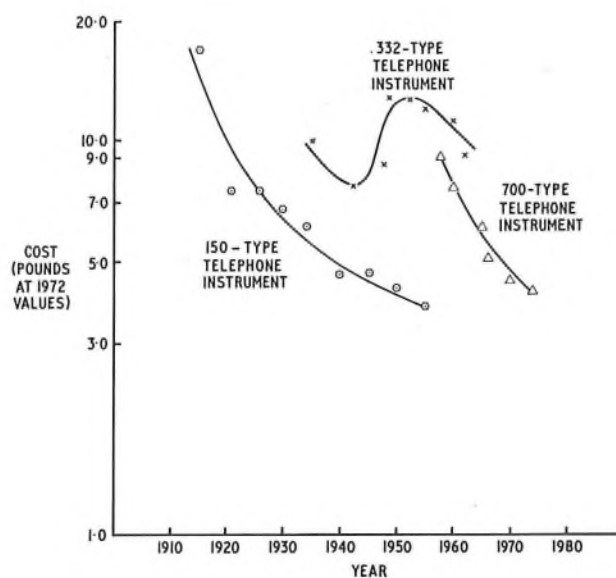

FIG. 6—Cost of different types of telephone instruments

LOCAL-LINE DISTRIBUTION SYSTEMS

The cost of connecting the subscriber's instrument to the local exchange has been reduced significantly by polythene sheathing for cables, automatic cable-jointing machines and substituting aluminium alloy for copper as a conductor, and by systematic overhauls of working practices with vigorous union co-operation. There is a progressive move, for amenity reasons, to put plant underground, on which the B.P.O. spent

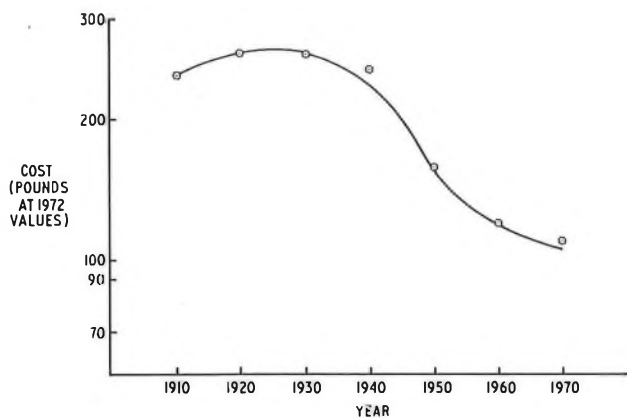

FIG. 7—Cost of average line-plant connexion

£4M last year. The latest development in a long series is in drawing very large cables into ducts by highly mechanized processes, by reducing the number of joints and, thereby, doubling each man's productivity. All this, with changes in working practice, retraining and productivity bargaining, has resulted in the cost per connexion (Fig. 7) being one-third in 1972 of what it was in 1930. But, here again, an asymptotic limit of cost reduction is in sight.

So, more fundamental changes in technology are under active study. One possibility is to introduce microelectronic active devices into the local system to boost its information-bearing capability. Another is the further development of coaxial cables. The relevance of optical-fibre systems to local distribution is also being studied. There is the added possibility that these changes, together with electronic devices in the subscriber's instrument itself, may enable the overall investment per subscriber in this cost-sensitive area of the system to be significantly reduced.

TRANSMISSION SYSTEMS

Costs of connecting subscribers to each other have fallen, as more complex modulation techniques enabled more channels to be borne on a single carrier. Transmission costs have decreased steadily as a succession of technological developments have come into service. A steady reduction, in real terms, in trunk-call charges is a direct result, s.t.d. and i.s.d. have become possible, and there have been consequent manpower savings.

Digital technologies are today the key to continuing cost reductions, and during the last decade, the design of transmission systems has been revolutionized by advances in electronics and techniques for handling digital information. Already, over 2 million channel-kilometres of 1.5 Mbit/s pulse-code-modulation systems exist in the U.K. Within the next few years, wideband 120 Mbit/s inter-city systems will be in service. By the end of this decade, waveguide and optical-fibre technologies in transmission systems will have been explored thoroughly for their economic, operational and engineering reliability. There is little doubt that they will contribute distinctively and differently to on-going cost-cutting of transmission. But their significance in profitability to the system overall and their influence on telephony costs may fall. For it seems unlikely that the present trend of a steadily diminishing proportion of overall investment in transmission systems will be reversed. But such systems will play a crucial role in bearing, profitably, wideband vision, data, facsimile and other new services. Their contribution to overall system profitability will become increasingly important.

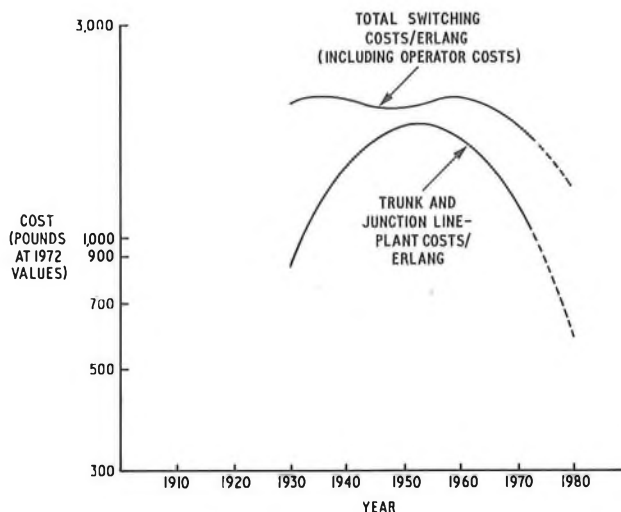

Note: Local-line plant and instrument excluded

FIG. 8—Cost per unit of traffic handled

SWITCHING SYSTEMS

The cost of switching a unit of traffic has remained constant, in real terms, for more than 40 years and started falling only recently (Fig. 8). But, during that time, new customer facilities like s.t.d., i.s.d. and Datel have been added, and their added complexity has not been reflected into higher costs. Otherwise, the charges for some long national and international calls would have been prohibitive. But the proportion of total annual capital spent on switching is increasing and this trend will continue (Fig. 9).

Programs of equipment modernization and system reorganization to improve the service, to cut running costs and to provide foundations for future service have been taking place for some 15 years. In London, for instance, a new £100M network of interconnected sector switching centres, to meet the capital's trunk communication needs beyond the turn of the century, is being provided without interfering with the free flow of traffic in the meantime. In smaller towns and rural areas, nearly 600 TXE2 electronic exchanges are already in service. For larger towns or city segments, the first of some 34 larger electronic exchanges (TXE4) now being built will come into service in Birmingham in 1975. And some 300 modern crossbar exchanges are already in service.

The benefits of this twin process of restructuring and re-equipping, with higher performance and lower maintenance costs, are showing already. Electronic exchanges in service show significantly better service to customers at half the maintenance costs of earlier systems. As the proportion of new plant increases (Fig. 10), so service improvement overall becomes more evident, and further maintenance cost reduction may become possible.

For still further economic and service benefits, changes in switching technology and design are needed. These must react and interact with changes in transmission and control/signalling technology. The key to these changes lies in the pre-existence, by the early 1980s, of a nationwide high-bit-rate transmission network. This will enable switching systems, and in particular, the large main network switching centres, to be designed on an all-digital basis. These further service improvements and cost reductions are then foreseen as stemming from innovative engineering designs based on computer-aided whole-system analysis, digital technology, micro-electronic circuitry and software control.

SERVICE DIVERSIFICATION

The outstanding change in postwar telecommunication has been the increasing range of subscriber dialling between countries. This has generated an average doubling of demand

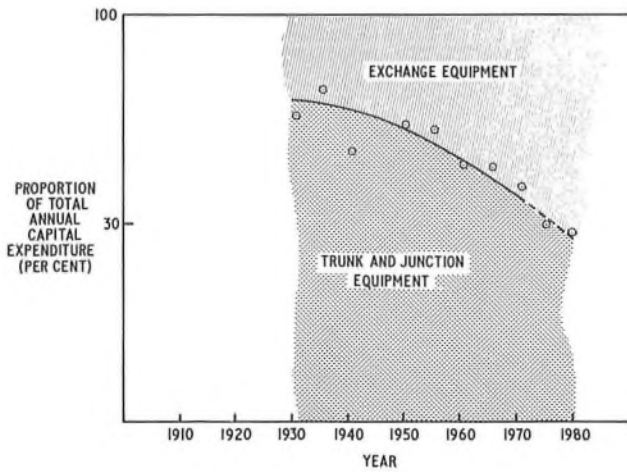
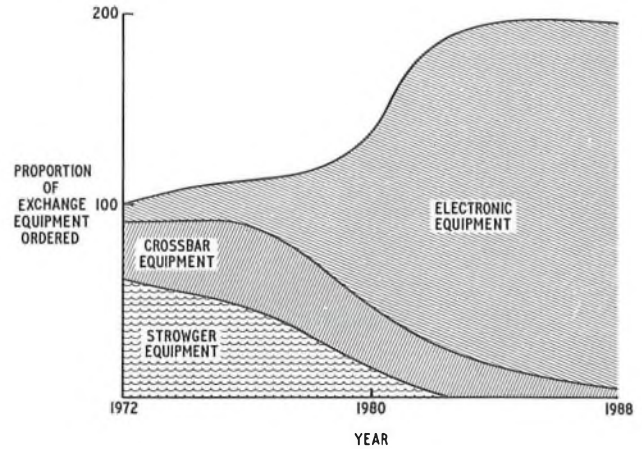

FIG. 9—Balance of expenditure between exchange equipment and trunk and junction equipment



Note: 1971-72 ordering level = 100

FIG. 10—Expected trends in exchange-equipment ordering

every 4 years, and an explosively faster rate on some routes. The time-zone conflict of business hours between London, New York and Los Angeles, for instance, generates immense surges of traffic that create severe problems in the provision of switching plant.

A £50M building and equipment program for new international switching centres is now in the commissioning stage. Further centres to serve London and the provinces are planned. After only a little over a decade of space communication, Goonhilly already has 3 aerial systems operating and there are plans for another earth station complex in Herefordshire. Three months ago, CANTAT 2, the latest wideband submarine cable system, was opened with its 1,840-circuit transatlantic capacity, and, by the end of 1974, 9,000 circuits should be operating between the U.K. and the rest of the world, compared with only 1,000 only 10 years ago.

Datel, the B.P.O.'s data-transmission service, gives Britain the lead in Europe and second place only to America in this sector. Eight Datel services are available throughout the U.K. and to 22 countries overseas. Two major enlargements of the service are planned: to offer all-digital point-to-point and multipoint services from 1977 onwards, and to open an experimental packet-switched service next year based on processor-controlled packet-switching exchanges in London, Manchester and Glasgow. About 100 dial-up access ports should be available via the public network, and about 90 more via direct leased connexions. An enlarging range of visual and facsimile service is foreseen. Confravision already exists between 5 cities in the U.K., and has been extended experimentally to Sweden and Australia. There is growing interest in facsimile. The development of standard electrical interfaces (to enable global services to be offered) and of automatic paper handling (to permit unattended operation) is in hand.

Radiophone already makes the telephone service available in cars within a 50 km radius, approximately, of Central London. It has recently been extended to Manchester and Birmingham, and will soon reach the Glasgow/Edinburgh and Cardiff/Bristol areas. Radiopaging, a complementary and perhaps even a competitive service, provides a signal alerting the customer with a *bleeper* to telephone for further information. After a successful trial in the Thames Valley, the B.P.O. is now considering an extension of the service.

SYSTEM MANAGEMENT

The British telecommunication system is large—with some £4,000M worth of assets; it is pervasive—nationwide in coverage and penetrating all business and some 40 per cent of homes; it is growing—at present doubling its size in a decade; and it is changing. It exists to provide services: telephone, telegraph, data and visual. And the demand for service is

instant, unforewarned and continuous. So, the problems of day-to-day service, maintenance and management are formidable and can be resolved only by making maximum use of computer and automation technologies.

Nearly half Post Office Telecommunications engineering manpower is involved in servicing and maintenance; the latter accounts for 12 per cent of annual costs. Broad policy is to provide automatic aids, automatic testing, self-monitoring of performance and, whenever possible, steering calls away from faulty plant, so that any failure period appears short to the customer, although it may in fact take hours to clear. This method of service protection has, for example, cut overall out-of-service time on the main trunk network to one-fifth.

But all modern exchange systems already possess an automatic, fast-acting, second-attempt feature (so that many equipment faults are not evident to the subscriber), as well as in-built fault detection, analysis and automatic print-out. The present Strowger system uses very large quantities of contacts, components and mechanisms, up to 9,000 for a single s.t.d. call, and steering around faulty items is not automatic. But a more advanced program of automatic night routines and automatic print-outs is nearing completion, which is expected to improve plant serviceability by 25 per cent and save the equivalent of 60 men in a full year. This is a precursor of a planned nationwide *measurement-and-analysis-centre* system, which is seen as an essential element of future system management and control. After highly successful field trials, centres are being built in each of the 60 telephone areas. Each centre includes a miniprocessor controlling a group of artificial test-traffic sender/detectors, connected via a switch matrix and dedicated circuits to each exchange under surveillance. Test calls can be directed through any of the exchange switching paths, and a similar provision is made in trunk units. The first such centre should be in service in 1976.

The 1960s saw consistent improvements in local automatic telephone services, owing to determined, service-oriented management helped by computer-aided supervision and control techniques. This trend will gather momentum as these techniques are further developed and as more modern and reliable plant is installed (Fig. 11). Service improvement and greater cost-effectiveness (Fig. 12) are, of course, the principal motives for system modernization. Without that modernization, engineering or management efforts could, in fact, yield little further service improvement.

INNOVATION AND SYSTEM DESIGN

Some factors, therefore, which have enabled us to contain the effects of inflation are now less effective. Engineering innovation, however, suggests a range of new opportunities.

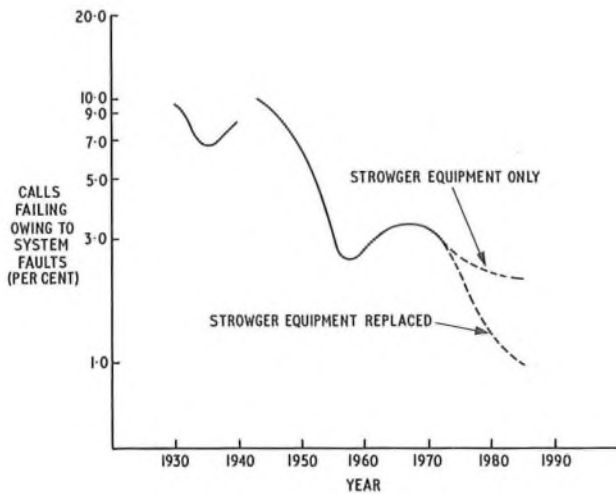

FIG. 11—Percentage of calls failing owing to system faults

The progressive change of the service and its supplying industry to one based on microelectronics, digital technology and software-controlled systems offers opportunities for more flexible and more cost-effective systems designs. (The change itself, however, also provokes new and challenging problems for solution; for example, how best to secure system and component reliabilities matched to the demands of real-time plant running 24 hours a day, 7 days a week, 52 weeks a year, or how best to “man-proof” nationwide software systems.) The progressive insertion of wideband systems into the distribution, as well as the trunk, plant offers opportunities for ranges of new services. But, in the early years at least, the viability of these will be set by the degree of success achieved in making maximum use of extensive nationwide assets that already exist. There are other changes too. Changing customer needs have to be accommodated. There are opportunities for improved efficiency through *whole-system* design, aided by computer macromodelling. There are opportunities (permissible in software-controlled digital systems) to leave specific options open in design, so that service possibilities for the year 2000, as yet undefinable, are not forceclosed and the immense infrastructure (perhaps, some £15,000M), that by then may exist, is not prejudiced.

It is upon these bases that the B.P.O. and its supplying industry is defining the strategy for a family of new systems called *System X*. These are designed to serve our customers of the 1980s who will demand the enriched services required by an ecologically sensitive, energy-conscious, fully-intercommunicating society: voice, vision, facsimile, data and entertainment.

CONCLUSION

Innovation is always risky. But risk is minimized by professionalism that is sustained by awareness of the potentials for failure and stimulated by experience of both success and failure. In a high-technology, nationwide service industry, the tasks of bringing innovative concepts through to profitable service-giving investment are too large to chance anything other than sheer professionalism that assesses coldly opportunities, possibilities and degrees of risk, and that brings sound judgment on the desirable alternative.

But professionalism implies purpose. The innovative act, be it in research and development, in planning or in investment, must be related, at all times, to the organic purposes of the enterprise. A clear definition of purpose implies a recognition of means needed to secure that purpose at every stage: research, development, design, manufacture, planning and field operations. The research and development elements

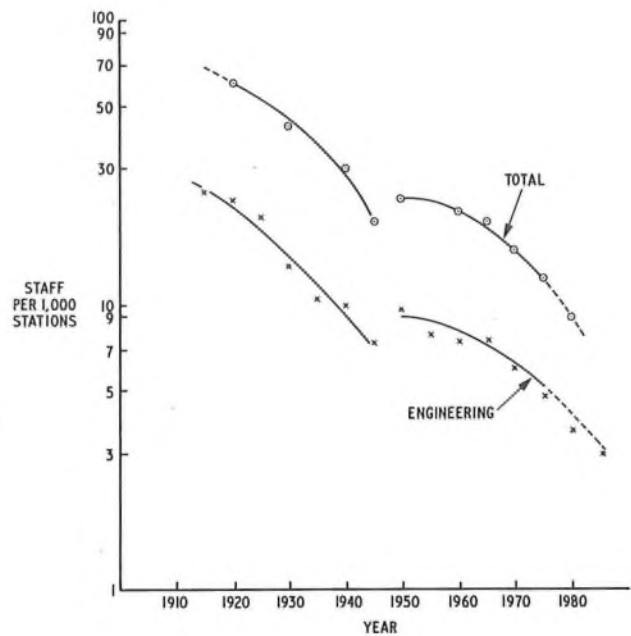

FIG. 12—Manpower productivity

alone of this innovatory process will be effective only if they are set in this wider context.

But engineering innovation on this scale has today to overcome lay attitudes of impatience, intolerance and over-expectancy. The means to achieve a “to-be-desired” end are often neither perceived nor regarded as anything other than trivial. And these attitudes are, if anything, stimulated by false emphasis by media on “breakthroughs” in development, as well as by engineering professionalism’s seeming reluctance to communicate effectively its problems or its successes.

And large-scale engineering innovation also has to overcome, in some way, its most crucial problem, the problem of its own intrinsically long lifetime and the incompatibility of the measure of that lifetime, measured in decades, set against the cycle time of most conventional democratic processes. If these processes exercise control, not only of the funding of such enterprises, but also of their engineering principles, the risks of delay and failure are gravely increased. If these processes also imply and impose frequent discontinuities in policy during this time, maximum economic and service benefits cannot be secured. And brilliant, thrustful research, development and planning fail to result in timely and effective wealth-creating, service-giving investment.

This is an issue of general, not particular, concern and needs full and open debate. But, whatever the outcome of that debate, the challenge in this for the engineering profession is to secure, through sheer professionalism in principles and practices of engineering, results of brilliance and success that, in turn, breed public confidence and understanding. There is increasing reason for engineering brilliance. Emphasis on involvement in management must never detract from sound, effective, desirably brilliant, engineering. For if that does not exist, brilliance in management is futile. The primary obligation on professional engineers is to be engineers and, as well, to be effective, vocal and relevant.

ACKNOWLEDGEMENT

This shortened version of Professor Merriman’s presidential address was originally published in *Electronics & Power*, the Journal of the Institution of Electrical Engineers, and permission to include it in this *Journal* is gratefully acknowledged.

Telephone Traffic Recording and Forecasting

H. S. HOLMES†

U.D.C. 621.395.31:519.283

This article discusses the importance of traffic recording, and describes briefly the traffic-recording equipment used and the improvements introduced recently. The setting-up of the Traffic Recording and Forecasting Working Party is outlined, and its recommendations on traffic-recording practice and control are given. The article concludes with a description of the Working Party's review of traffic-forecasting methods and its findings.

INTRODUCTION

It is convenient to look at a telephone network in two parts; namely, plant for connecting customers to the exchange and plant customers can use to extend calls throughout the network. There is, of course, an overlap. The plant necessary to connect customers to the exchange is based on requirements which can be specifically stated; that is, the number of working connexions, plus those waiting to be connected.

Forecasting future requirements is not easy because it involves assessing growth potential, which is dependent on the expected numbers and types of houses, factories and business premises, the effects of economic change tariff policy in expectation and reality, changes in social attitude and so on. Successfully to forecast the way customers will use the system, that is, the number, duration, distribution and incidence of calls, is even more difficult. However, expenditure on providing facilities for making calls is as great as that spent on facilities for connecting customers. Hence, there is an equal need for sound traffic* forecasting as well as sound connexion forecasts, and a realization that, with good planning, exchanges may well exhaust on traffic as on connexion grounds. Clearly, it is necessary to measure the traffic carried by the network and to have criteria against which to set these measurements so as to be able to decide whether there is too much or too little plant. As telephone traffic varies from day to day and hour to hour, both in volume and distribution, even the determination of the current traffic flow is more a matter of estimation and definition than of precise fact.

QUALITY OF SERVICE

The purpose of traffic records is to help to give telephone users a satisfactory service as economically as possible. Because of the variations in traffic flow, some calls will meet engaged-plant conditions. Thus, standards for plant provision must be set, and the quality of service measured to ensure that a satisfactory service is given. Excluding customer failures—no reply, number engaged and dialling errors—and plant faults, the British Post Office (B.P.O.) is currently achieving a high standard (see Table 1).

Provisioning standards are based on

- (a) the method of measuring traffic,
- (b) the grade of service on each link; defined as the proportion of lost calls in the hour used for measuring traffic, and
- (c) the period ahead for which provision is made; in practice, 1–3 years, and the growth rate used.

† Mr. Holmes has recently retired from his position as Director of the North Eastern Telecommunications Region, but is still Chairman of the Working Party on Traffic Recording and Forecasting with Equipment Currently Available.

* Traffic is the product of calls and average call duration or circuit occupancy.

The effect of the combination of these criteria is to regulate the proportion of calls which fail because plant is engaged. Calls are connected over a number of links and switching stages, varying from two for a local call through the smallest exchanges, up to 12 or more for long-distance calls; all provided on the basis of the three factors given above. The problem is to quantify the proportion of calls likely to meet plant engaged, if provisioning is done as well as can be expected. No firm answer has been found, but the best so far emerged in the middle-sixties, a satisfactory overall standard of customer service being defined as when 1 per cent of call attempts failed in a local non-director area because of plant engaged, as measured by centralized service observations taken during the day period (08.30–18.00). The corresponding figure for the s.t.d. network was 2 per cent. Experience shows that, when figures much lower than these empirical and superficially arbitrary standards are encountered, traffic records reveal that there is a fair degree of overprovision in the network. Table 1 shows the national results for March during the last few years.

TRAFFIC RECORDING

Traffic Recorders

A variety of recorders are used for traffic measurement and the more important devices are described below.

TABLE 1
Proportion of Calls Lost due to Plant Engaged
as Measured by Service Observations

Month and Year	Percentage of Calls Lost due to Plant Engaged	
	Local Dialed Calls (Non-Director)	Trunk Dialed Calls*
March 1963	—	2.7
March 1964	1.1	2.5
March 1965	1.4	4.3
March 1966	1.5	2.3
March 1967	1.1	2.4
March 1968	1.3	4.7
March 1969	1.2	4.3
March 1970	1.5	5.2
March 1971	1.0	5.5
March 1972	0.7	2.8
March 1973	0.6	2.9
March 1974	0.5	1.7

* The cumulative average for trunk dialed calls for 1973–4 was 2.3 per cent. The figures up to and including March 1967 are for trunk lines engaged and, therefore, understate the amount of congestion.

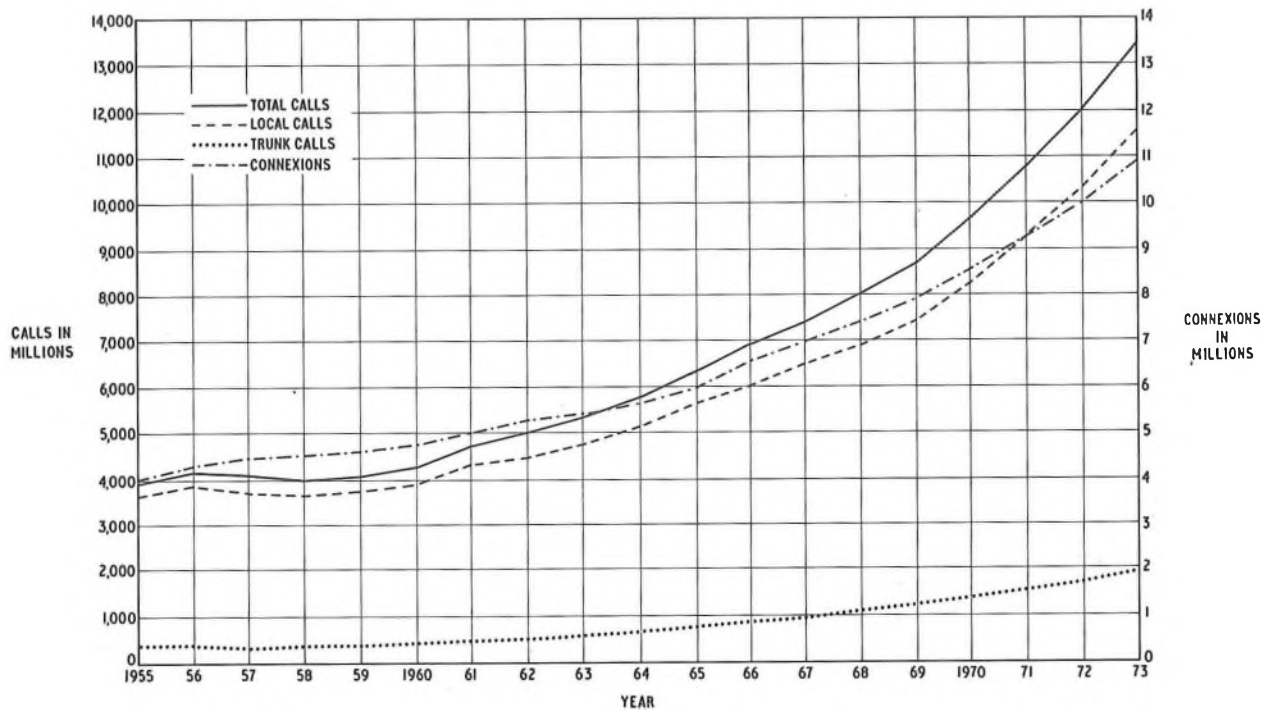

FIG. 1—Growth in numbers of calls since 1955

Erlang traffic recorders—These measure, at regular intervals, usually 3 min, the number of busy circuits or switches on each junction or trunk route or switching stage, as a gauge of occupancy. The recorders are currently operated for 1 hour in the busiest period of each of five consecutive days for 12 records/year. These are normally taken in the morning period, but records are occasionally taken in the afternoon or evening.

Congestion recorders (overflow meters)—These are permanently wired-in to monitor, continuously, the number of calls which fail due to congestion. The meters give an indication of routes or switching stages in congestion, and are an essential adjunct to busy-hour erlang traffic records. In the smaller unit automatic exchanges, they are the only indication of how effectively traffic offered is being carried. However, the readings are not completely reliable because

- (a) the method of calculating the critical number of overflows depends on reliable knowledge of average call durations,
- (b) the critical figure is based on assumptions of traffic incidence, busy-hour to day traffic relationships, etc., which are not necessarily true,
- (c) the record may seriously understate overflows during pressure periods, and
- (d) of repeat attempts after call failures.

Destination (route-call) recorders—These measure, on a sampling basis, the geographical dispersion of calls and help the assessment of whether the shape of the network is right. This is a slow, laborious and relatively expensive process.

Call-duration recorders—These measure average durations of different types of call on a sampling basis, and are particularly important for the design of the new common-control exchanges.

Together with information from counts of long-distance calls, centralized service observations and many specially-designed and locally-used types of equipment, the last three kinds of record are essential subsidiaries to the busy-hour erlang records for the satisfactory management of existing plant and the planning of additions.

Cost of Traffic Recording

The cost of collecting traffic information is substantial, but not extravagant in relation to the expenditure based upon it.

In brief, about £300M/annum is spent on trunk, junction and internal-equipment provision, and the annual cost, including labour charges, of all the records described above is currently about £3M.

Use of Traffic Records

Traffic records are used

(a) by service and planning staff, in collaboration, to ensure that existing plant is deployed to best advantage, and that day-to-day increments of plant are provided in time and in the right place, and

(b) as the basis of forecasts of traffic for 1–30 years ahead, or more, for use with connexion forecasts in assessing trunk, junction, equipment, building, site and other needs, and for special purposes; for example, the sectorization of London, assessment of the cost of national-number dialling, and tariff policy.

METHODS OF IMPROVING PROVISIONING

The telecommunication business has been growing rapidly for 10 years or more (see Fig. 1), and this looks like continuing until well into the 1980s. Thus, poor recording practices are likely to result in unnecessary expenditure, or congestion, or both. The urge to play safe is further encouraged when relief takes a long time to provide and is frequently late. Recent experience has, therefore, emphasized the crucial importance of good traffic records as well as the need for shortening the time required for designing, manufacturing and installing telephone plant. Amongst the consequential steps taken, two stand out.

Improvements in Traffic Recording

The method of taking erlang busy-hour records has been greatly simplified by the introduction, initially, of time-consistent-busy-hour, and, later, simultaneous-time-consistent-busy-hour recording. A complete simultaneous-time-consistent-busy-hour traffic record is obtained by recording during a fixed hour, each day, for five successive days. This avoids selecting representative days, necessary in the earlier post-selected busy-hour system, and permits the recorder to be started and stopped automatically. Thus, a fixed number of scans are obtained each day—20 or 200 for long-holding-time

(l.h.t) or short-holding-time (s.h.t.) equipment, respectively. Therefore, the total number of weekly scans is 100 or 1,000. Only the totals registered on the meters at the beginning and end (5 days later) of the recording operation need be taken, and inserting a decimal point in the right place then gives the average busy-hour traffic. To implement the new method, the existing traffic recorders were modified

(a) to provide for automatic starting and stopping of the traffic recorder by means of a time-switch,

(b) to change the scanning period for l.h.t. equipment from 12 s to 3 min and for s.h.t. equipment from 12 s to 18 s, thereby permitting an increase in the number of access uniselectors which can operate sequentially during one cycle, and

(c) as a result of (b), to obviate the need for manual switching between separate sets of l.h.t. and s.h.t. access switches, by enabling the scans of all l.h.t. and s.h.t. equipment to be interleaved during one 3 min scanning interval.

Simultaneous recording on all s.h.t. and l.h.t. equipment is now possible, so that a complete record for the whole exchange can be taken in 1 week. This, together with the reduced amount of work involved in meter reading and subsequent processing facilities, has made it possible to increase the frequency of traffic records.

In addition, erlang traffic record summarization is now well on the way to being computerized, and the recording process on existing records is successfully computerized in the Computer-Aided Maintenance Project in Leicester. The project was primarily intended as a maintenance aid, but the computer was not fully used at night, and this capacity is being exploited for traffic recording. Constraints were placed on the traffic-recording aspects; in particular, in the number of recorders that could be connected and the time available for running them.

The computer is linked by 2-way, 200 bit/s data channels to each of the traffic recorders in the 22 Strowger exchanges in the scheme. At each exchange, the existing traffic recorder access equipment enables recordings to be made by scanning the traffic-recorder leads (usually the P-wires) in the normal Strowger manner. The scanning rate of the recorders and the number of scanning cycles/hour is the same as for the existing Strowger recorder, although these times can be varied if required. The time-consistent-busy-hour principle is used, but up to three separate hours' recording can be made. Recorders are switched on and off under control of the computer over the data-link and the condition of each access point (*free* or *busy*) is signalled to the computer.

The computer provides the following facilities not given by existing Strowger recorders.

(a) It tests for a balance of within a tolerance of ± 5 per cent between incoming and outgoing traffic.

(b) It produces compensated figures for any circuit group which is carrying more traffic than the designers intended.

(c) It detects those access points on which no traffic has been recorded.

(d) It provides a list of access points which have tested busy continuously throughout an hour's record.

(e) It provides an analysis of the traffic flow through a grading, thereby permitting the detection of unbalance between individual groups.

The experiment has shown not only that it is possible to computerize the recording process, but also that the system provides more reliable records and more flexibility in taking them. Computers, dedicated solely to the recording process, would make possible a big increase in capacity, and extension to other areas and regions is now under consideration.

Reducing Time to Provide Equipment

A Special Studies Group at Telecommunications Headquarters (THQ), headed until recently by Mr. K. H. Ford,

has made a detailed study of procedures for the design, manufacture and installation of exchange equipment. As a result, it is now hoped to achieve a substantial reduction in the time required for these processes.

TRAFFIC RECORDING AND FORECASTING WORKING PARTY

To get the best from these valuable developments, procedures for taking and using records must be satisfactory. Therefore, the three THQ Directors concerned, together with Chairmen/Regional Directors, decided to establish a Working Party whose terms of reference were broadly: to review methods for taking and controlling records, using existing equipment, and for forecasting traffic growth, and to make recommendations. Strowger plant will be in service for many years yet, and it must be used as effectively as possible to minimize future expenditure on plant already regarded as obsolescent. Thus, the results of the review could well be of fundamental importance to management in areas, regions and THQ. The Working Party was, therefore, given a regional chairman, together with strong THQ and regional representation, and soon established a practice of visiting as many areas and regions as possible.

With the growth of new techniques and systems, there is also a need to look into the future, and a group, under the chairmanship of Mr. J. A. Povey, is examining whether, and what, new recording equipment is required. In addition, there will certainly be a need to examine whether current criteria for provision of equipment will need revision, or adding to, when new systems, giving such facilities as automatic alternative routing and automatic repeat attempts, are introduced.

The Working Party has issued a report on traffic recording and its control, and a report on forecasting should be issued early in 1975. Two predominant conclusions have emerged from the study so far.

(a) The division of responsibility between service and planning staffs, and between hierarchies, necessitates a skilled and sympathetic approach to co-ordination. A degree of mutual trust is also required to avoid, on the one hand, duplication of effort and, on the other, work falling between two stools.

(b) Existing plant must be used to best advantage to avoid congestion in one part of the exchange and overprovision in another. This demands a high degree of co-operation between planning and service staffs, but success prevents unnecessary loss of traffic, leading possibly to expensive expedients, or too early extension of capacity, or most important of all, avoidable poor service to customers. A proper deployment of plant is essential, not only for day-to-day running, but as a sound basis for future plans.

RECOMMENDATIONS FOR IMPROVING RECORDING PRACTICE AND CONTROL

The Working Party recommendations for improving recording practice and control were in three categories.

Ensuring Effective Use of Existing Equipment

The Working Party recommendations are listed below.

(a) Simultaneous-time-consistent-busy-hour recording should be extended as far as possible because, even now there are a number of exchanges without the facility.

(b) An organized routine should be established for making sure that recorders are properly connected and free from faults.

(c) Programs should be established for an adequate number of records, including those using route-call and duration recorders, and checks to ensure that erlang traffic records are taken in the busiest period of the day, whether morning, afternoon or evening. The Working Party accepted that, with

existing equipment, attempts to locate and measure the actual busiest hour on every route or switching stage were unjustified. If the hour measured, the grade of service provided and the period of advance provision combine to give a satisfactory overall quality of service, then precise location of the busiest hour is something of a luxury.

(d) Care should be taken to ensure that faulty busied circuits are properly recorded and that the amount of false traffic is known.

(e) Records should not be dropped simply because an exchange is being extended. In any event, the exigencies of extension work should not warrant dropping an entire record, or even the greater part of it.

Increasing the Awareness of Traffic Records

Recommendations to increase awareness at all levels of the nature, purpose and importance of traffic records are given below.

(a) Information regarding deployment of equipment in relation to traffic offered should be provided in telephone exchanges; for example, by graphs of total erlang capacity provided against erlangs carried and graphs of lost calls due to plant engaged. Also, maintenance staff should critically examine and compare erlang traffic records with congestion records to find areas of apparent over-provision and under-provision and to locate parts of the exchange in which busy hours occurred at periods other than those in which busy-hour records were taken; for example, coin box 0-level circuits.

(b) Training courses should be developed to stress and explain the importance to service personnel of good traffic records.

(c) A guide to the record-taking process and effective use of its results, in simple language, should be presented to all concerned.

Creating Favourable Conditions

There was the need to create a background favourable to the development of interest in, and commitment to, sound recording and record-control practices. The exigencies of the last few years have brought to all concerned, in areas, regions and THQ an increased interest in records and their uses. Indeed, the Working-Party members were struck by the interest and commitment shown, and few of their recommendations are in any way original. They are rather a distillation from the garnered experience of the country as a whole, serving to give the largest possible circulation to practices widely, but by no means generally, in use. Essentially, these were that

(a) THQ and regional personnel should get out into the field to encourage areas, and to continue to spread and exchange experience over the widest possible field, and

(b) there should be area committees charged with responsibilities for the whole recording process, from ensuring that recorders are in working order and properly connected up, through maintenance of adequate recording programs, to dealing promptly with areas of difficulty. The present congestion committees tend too frequently to end up as machinery for dealing with congestion, rather than preventing it. The whole purpose of this committee should be to help those directly concerned, whether service or planning, engineering or traffic, to do their job. The only key to success in this field is the wholehearted commitment of all these officers to an acceptance that traffic records and their proper use are as important to the success of the business as connecting customers, or clearing faults.

REVIEW OF TRAFFIC-FORECASTING METHODS

The review of forecasting methods has to be predicated on the assumption that an adequacy of good and reliable records

has been obtained, and are being used as effectively as possible to tailor plant to traffic. But, this is only the start.

Ranges of Forecasts and their Uses

There are, in broad terms, three ranges of forecast and these are

(a) long term—well into the twenty-first century and mainly for site purposes,

(b) medium term—from, say, the mid-1980s up to the end of the century for accommodation (building and duct) purposes, and

(c) short term—up to, say, the early-1980s for store orders, junction and trunk cables and equipment provision.

There are many other reasons for forecasts; for example, tariff policy and cost of special developments such as national-number dialling.

Site and Equipment Forecasts

Forecasts can be split between those on which the provision of space for plant are based, and those on which the amount of plant to be installed are based. Knowing the purpose of a forecast can help in determining how to approach it. Thus, a site in the right place is both a necessity and a realizable asset. Furthermore, though sites are expensive, they are the least costly part of the operation; the cost of moving plant because sites are inadequate can be very great indeed. At the period in time being examined to determine what size of site to buy, some sort of assessment can probably be made about the ultimate telephone development in relation to population. However, it is more difficult to assess the effect, at this stage, of the development of new types of exchange and switching equipment on space requirements. It is even more difficult to assess the effect on space requirements of facilities in early stages of growth such as data systems, and of facilities hardly yet in the development stage or, indeed, not even envisaged. Thus, for site purchase, margins must be added to forecasts, based on the ultimate relationships between telephone growth and population size. However, these margins must be clearly recognized so that they are not lightly used for other purposes.

Duct Forecasts

The margins used for site forecasts can sensibly be used for duct forecasts because of

(a) the almost certain growth in wideband systems, and

(b) the reduced cost of providing additional duct space once a trench is opened.

Requirements of Forecasts

If, by this approach, space for growth can be reasonably assured, other forecasts can be considered on the basis of realism of forecast, soundness of planning techniques and time required to do the job. The desiderata are as follows.

(a) Exhaustion dates should be met, which means that provisioning periods must, at a minimum, be long enough to allow for the generality of low forecasts. Thus, the more inefficient the planning machinery, the more expensive the operation. At present, every additional year of equipment provision costs some hundreds of millions of pounds overall.

(b) Having regard to installation costs, rearrangement costs and (a) above, the most economic overall period should be provided. This desideratum has tended to be paramount in recent years, despite its effect on congestion and waiting lists.

Accommodation Forecasts

As buildings are expensive, other things being equal, the smallest possible building that can be extended well before it

is likely to be exhausted, should be erected. However, as this could mean a building life of as little as 5 years, it is a counsel of perfection, and there any many other factors that affect building planning. Amongst these are that

(a) extra expense and much justifiable staff dissatisfaction can be caused by building extensions which create inconvenience to, and maintenance problems for, staff employed in the building,

(b) the nature of the site may demand a bigger building than economic factors alone appear to warrant, and

(c) the increase in cost for a larger building is likely to be proportionately less than the increase in space obtained.

Thus, the period of an accommodation forecast ought to be decided on the merits of the particular case, the forecast then being prepared as realistically as possible with no margins added to cater for the unknown. Similarly, the shorter-term forecasts for equipment and cable provision should be determined by economic and practical factors, unless the inadequacies in provisioning methods necessitate a longer provision period.

Summary of Forecasting Periods

Very briefly, therefore, there are two key factors in provisioning; namely, when and how much. For site purposes, a firm policy of advance purchase of sites is easily justifiable. For more costly items, too early provision is like overprovision, and is expensive. Hence, building and equipment exhaustion dates are very important.

Having related forecasting periods to some of the very real practical and policy factors, it is necessary to examine forecasting methods.

Forecasting Methods

Traffic forecasting in the B.P.O. has generally been a matter of forward projection of past experience. For short-term and medium-term purposes, neither experience nor forecasting literature suggest that any better basic method is available, although refinements could well be possible. However, the following serious limitations need always to be recognized.

(a) In addition to minor fluctuations caused by economic factors, tariff policy and so on, there can be major discontinuities. For example, forecasts based on traffic growth throughout the 1950s proved completely inadequate for the 1960s.

(b) There must be sufficient reliable historical information to form a sound base for forward projection, and this is frequently not available.

Local-Exchange Forecasting

Forecasts of traffic on local exchanges are based on a forward projection of erlang-calling-rates/connexion multiplied by the number of connexions forecast for the design date. Generally, but not always, line-finder-group and uniselector-group calling-rates are separately projected, and assumed to be equivalent to residential and business calling-rates, respectively. An additional assumption is that the rate of change of calling rate is independent of the rate of change in the number of working connexions.

However, the alternative of projecting total traffic, carries with it assumptions that can be even more dangerous for the long term. Firstly, it assumes that growth of traffic is independent of growth in connexions, and secondly, that the balance of high- and low-calling-rate customers on line-finder and uniselector groups will remain constant. Fig. 2 shows that the overall originating calling-rate is not increasing.

In the current situation, each method is likely to give reasonably acceptable results for short-term use, particularly if both are used to highlight obvious inconsistencies. However, they are both likely to be unreliable in periods of major changes and if projected forward without any adjustment into the long term.

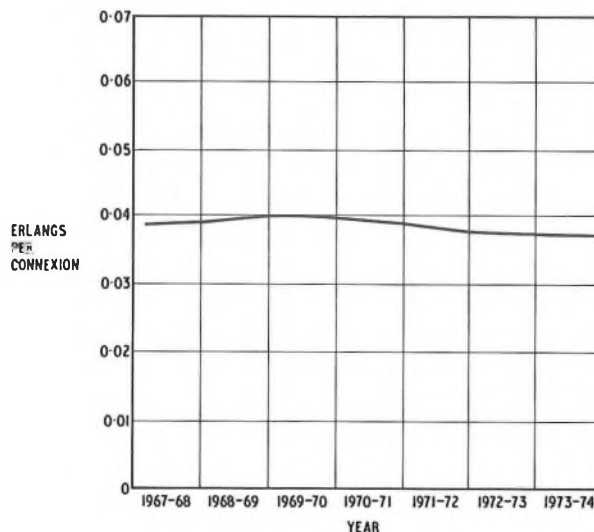

FIG 2.—Overall originating calling-rates for non-director Strowger exchanges

Another problem that arises with local-exchange forecasting is the relationship between trunk and local traffic. This is frequently brought to light when aligning a trunk and junction estimate with a total traffic estimate, and the Working Party has yet to finalize its views on this vexed issue. However, with more reliable records and the confidence they will give, the current need for aligning these two kinds of estimate may diminish, or even disappear.

Long-Term Forecasting

In the long term, forward projection is obviously very much more risky, and although forward projection by the two methods suggested above could be used, there is a need for the introduction of territorial factors, amongst which might be

- (a) business busy-hour erlang calling-rate ceilings,
- (b) residential busy-hour erlang calling-rate ceilings,
- (c) a relationship between the proportion of international, inland-trunk, and local calls, saturation in residential connexions for a given population, and saturation in business connexions for a given working or, perhaps, clerical population.

The interrelationship between these upper limits for telephone speech traffic gives a valuable check on forward projection, and a basis for interpolation for forecasts from, say, 1986 onwards. The Working Party is now trying to learn from experience in other countries whether this approach has sufficient merit to warrant its adoption.

Annual Schedule of Circuit Estimates

One other special type of forecast which has not been separately mentioned is the annual schedule of circuit estimates (a.s.c.e.). Every year, requirements on every junction and trunk route for the next one, two, three, four and five years are forecast by graphical projection separately for each route. Through the years, a variety of safeguards have been built in to attempt to ensure that the overall results are reasonable. It is, nevertheless, a mammoth task. The a.s.c.e. is used

(a) as the authority for circuit provision during the following year,

(b) as the basis for a stores order for trunk and junction terminations required in the second year,

(c) as the basis for a junction and trunk cable-provision program, and

(d) as the basis for terminations required in equipment extensions. This is a two-way process, dependent on the timing of the two operations. An a.s.c.e. forecast may become part of an equipment design, or alternatively, a junction and trunk forecast prepared for extension-design purposes may be used for the a.s.c.e.

The Working Party has some doubts about the need, and indeed validity, of individual-route forecasting on an annual basis, and consideration is also being given to the possible need for a change in the a.s.c.e. machinery. Generally, if the number of forecasts to be made could be substantially reduced, more time would be available for check by alternative forecasts, as suggested above.

CONCLUSIONS ON TRAFFIC FORECASTING

Finally, it must always be stressed that forecasts, particularly in the traffic field, will always be imprecise. Thus, the periods for which they are made should be such that, in the majority of cases, there is time to react to low forecasts. This does not necessarily require overprovision, but rather the establishment of the right relationship between provisioning periods and the time required for design, manufacture and installation of relief. Just as some calls are expected to fail, so it must be accepted that some exchanges will prematurely exhaust. Sound forecasting techniques, allied with good provisioning procedures, are essential to ensure the best balance between economy and service to our customers.

A Traffic-Forecasting Technique

B. F. YEO, C.G.I.A., C.ENG., M.I.E.E., and J. F. BIRT, A.M.B.I.M.†

U.D.C. 621.395.31:681.3

Reliable traffic forecasts are essential to the equipment planner. This article describes a computer-based forecasting technique, developed in the London Telecommunications Region, for trunk traffic.

INTRODUCTION

The economic planning of telephone-exchange equipment provision is heavily dependent on reliable traffic forecasts. This is particularly so with regard to the many existing and projected trunk-switching units in the London Telecommunications Region (L.T.R.), where a high proportion of the national trunk traffic is generated. A computer-based forecasting method has recently been developed in the L.T.R. for trunk traffic. This enables the well known trend-line method of forecasting to be applied with a specified degree of confidence, and with greater consistency than hitherto obtained. It also facilitates regular and frequent updating.

TREND LINE

Traffic forecasting—based on the trend-line method—assumes that what has happened in the past can be used to help determine what is likely to happen in the future. Thus, the traffic levels which have been achieved over the recent past are used to construct a trend line, which is projected forward to predict future levels of traffic. This approach is considered to be satisfactory for equipment-planning purposes in the short-to-medium term.

However, it is expected that, at some time in the future, the growth of trunk traffic will fall from the high rates which have been exhibited over the past decade, in association with the penetration of s.t.d., to what is regarded as the normal compound growth rate of 8 per cent/annum. In anticipation of this reduction, the annual trunk-traffic growth rates promulgated nationally have, for some time, assumed a stepped reduction to 8 per cent, following the end of the annual schedule of circuit estimates (a.s.c.e.) forecast period.

The established manual method of producing the forecast line is to plot the achieved traffic levels as traffic readings are received, and to draw a line to fit the plots, as judged by eye. This line is then projected forward as the trend line. A fore-

cast line is then constructed by selecting a specified achieved-traffic level as the starting point and drawing another line parallel to, and above, the trend line, so as to cater for peaks in demand. In practice, because trunk traffic generally exhibits exponential growth rates, the procedure is simplified by using logarithmic/linear graph paper, which enables the trend to be depicted as a straight line.

COMPUTER-BASED TECHNIQUE

The computer-based technique, used for L.T.R. trunk-traffic forecasts, produces a trend line as before, but, in addition, prints out upper and lower prediction limits corresponding to the required degree of confidence. Moreover, the computer tries up to six different formulae, including exponential functions, to determine which gives the best fit, and, also, indicates the degree of correlation. Fig. 1 shows the achieved and forecast bulk London-charging-group trunk traffic, with the computer-derived trend line and the upper and lower prediction limits at the 95 per cent probability level. The upper prediction limit is taken as the basic forecast line, which, in this case, represents that level of traffic having a 97.5 per cent probability of not being exceeded. To this line is added a modest margin to allow for slow-speed data. Suitable stepped adjustments are made, beyond the a.s.c.e. period, in anticipation of the expected decrease in growth rate. A planning line is thus derived for use as a demand indicator for equipment-provisioning purposes.

Forecasting traffic in bulk gives more reliable results than individual route forecasts, because fluctuations of individual components tend to be smoothed, and there is a mix of traffic having different characteristics. However, for equipment-provisioning purposes, it is necessary to derive forecasts for the individual trunk units which, together, generate the bulk traffic. The computer derives these forecasts in the same way as before, but, in addition, assigns prediction limits, corresponding to lower probability levels. These limits are assigned such that, when aggregated for all the units, they conform to the prediction limits for the bulk-traffic forecast.

† Trunk Planning Division, London Telecommunications Region.

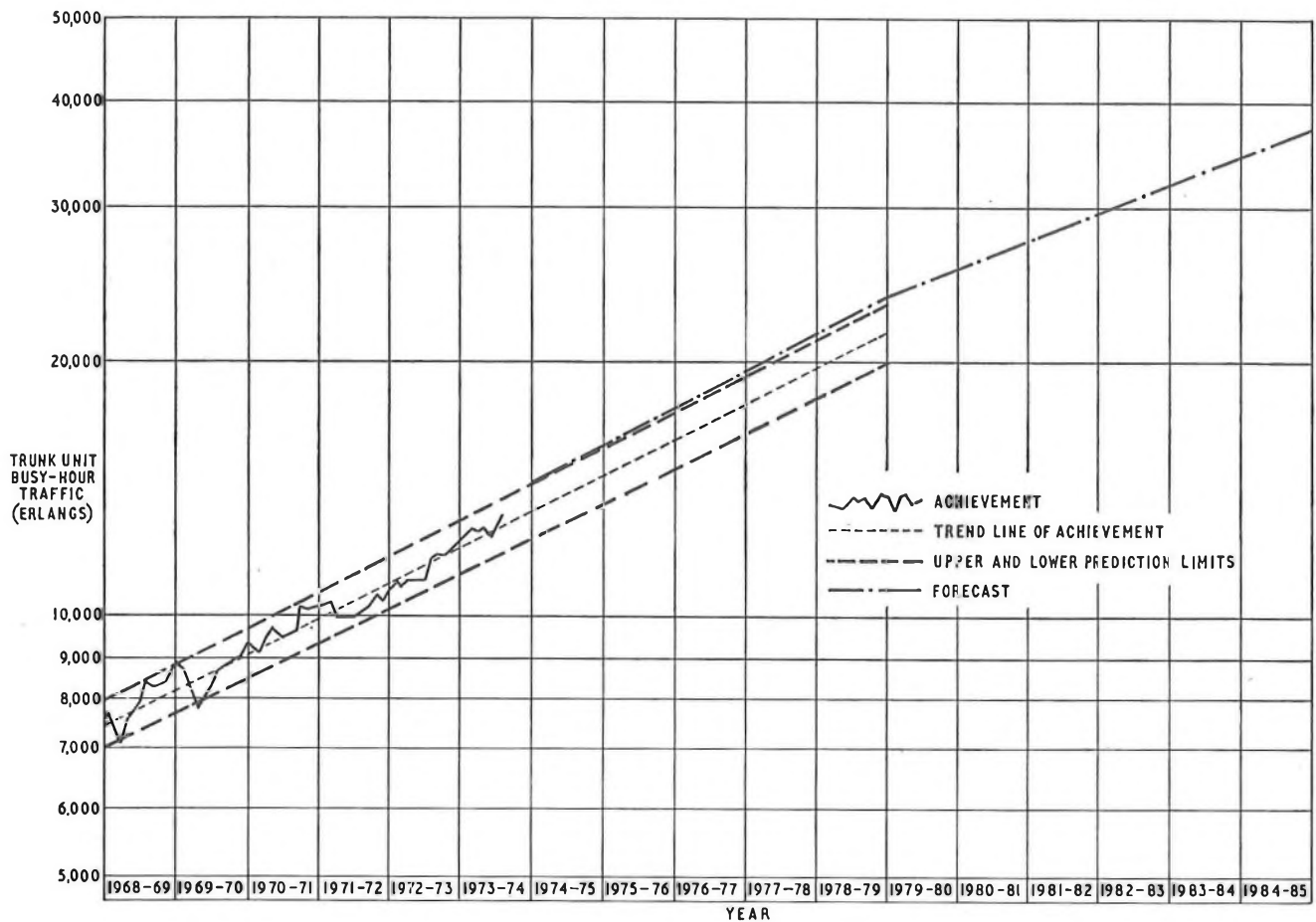

Compound growth rates per annum:
Trend line—10.04 per cent
Upper prediction limit—10.2 per cent
Forecast—10.7 per cent (upper prediction limit plus allowance for data
over the public network), 8 per cent after March 1979

FIG. 1—Forecast of inland trunk traffic originating in the London charging group

This implies that, when the bulk traffic is distributed between the component units, the degree of confidence attached to an individual unit forecast is less than that for the whole, because the volume of traffic is lower and is subject to greater fluctuations. As an example, if the prediction limits for the bulk-traffic forecast are set at 95 per cent, the corresponding limits for traffic at an individual unit could be, typically, 82 per cent.

CONCLUSIONS

The computer-based forecasting method has the following advantages.

- (a) The curve-fitting process is no longer subject to human judgement, but is consistent and repeatable.
- (b) Prediction limits are applied to the trunk-traffic growth rates of individual units, within the overall limits of the bulk forecast, so that the probability of the forecast traffic being exceeded will be the same for all units.
- (c) Forecasts can be monitored easily and quickly by feeding-in achieved-traffic levels as traffic-recorder readings become available.
- (d) Because equipment provisioning is based on an upper prediction limit, which itself corresponds to an arbitrary, but known, probability, the effect of building or equipment-installation delays can be more readily assessed, and can be expressed in quantifiable terms.

Essentially, the technique is used for forecasting in bulk, and it requires that adequate historical records are available from which a reliable trend can be established. These

conditions exist in the London charging group, where outgoing central switching units are devoted exclusively to originating trunk-traffic. It would be necessary to exercise discretion when applying the technique under different circumstances, as there may be factors having a considerable influence on past or future growth, such as through-routed traffic.

The 95 per cent prediction limits used for the bulk-traffic forecast, and the derived lower limits appropriate to the forecasts for individual units, have been chosen for planning purposes on the supposition that, on this basis, the probability of meeting the demand is at an acceptably high level. These limits are arbitrary, however, and may be readily tightened or relaxed in accordance with prevailing conditions and the aims and resources of the business. In particular, the limits chosen are used to influence the setting of national and regional trunk-traffic targets and implied growth rates, and, later, to adjust to the targets when these have been promulgated. Nevertheless, once having been established, it is visualized that prediction limits would not be changed substantially or frequently.

The curve-fitting process is such that the trend line and associated prediction limits are not unduly influenced by seasonal or isolated departures from the normal growth pattern. Thus, when a change to the underlying trend starts to assume significance, the monitoring procedure will detect it at an early stage and quantify its effect. By this means, it will be possible to determine when the expected downward turn to the normal trunk-traffic compound growth rate of 8 per cent/annum begins.

Sources for Optical-Fibre Transmission Systems

D. H. NEWMAN, B.SC., M.SC., PH.D., M.INST.P.†

U.D.C. 621.375.9:677.521:621.391.63:621.383.52

Sources suitable for optical-fibre transmission systems are introduced and their relative merits discussed, with particular reference to their modulation capability, efficiency and reliability.

INTRODUCTION

Principles of optical-fibre transmission systems, the design, technology and performance of optical-fibre waveguides and the properties of photodiodes for optical-fibre systems have been discussed in articles in this *Journal*.^{1,2,3,4} This article introduces the optical sources being developed as contenders for use in such systems and discusses their relative merits.

There are a number of basic requirements for potential sources that have to be met to a greater or lesser extent, dependent upon the specific application. These requirements include efficient operation and ease of modulation at the required system bit rate and repeater separation. Sources must also operate in a "window" of the fibre absorption spectrum,² and be capable of efficient coupling to the required optical fibre.

The requirements outlined rule out sources other than gas, solid-state and semiconductor lasers, or incoherent semiconductor light-emitting diodes (l.e.d.s). At present, the main contenders are the neodymium-in-crystal solid-state laser that operates in the fibre window at a wavelength of $1.06 \mu\text{m}$, and semiconductor lasers and high-radiance light-emitting diodes (h.r.l.e.d.s), both of which operate in the fibre window in the wavelength range 800–900 nm. Both these wavelengths are in the near infra-red region of the optical spectrum.

The neodymium laser, and other solid-state ion lasers, can be modulated directly up to only about 1 MHz, and would, therefore, require an external modulator for any sensible system application. Because of the additional complexity such a source would introduce, it has received low priority.

A considerable effort is being mounted, however, on semiconductor lasers, and to a lesser extent h.r.l.e.d.s, both of which offer the capability of modulation bandwidths compatible with systems requirements. These optical devices are based on the semiconductor, gallium arsenide (GaAs), that differs from the more familiar materials, germanium and silicon, in several important ways. As a result, carrier recombination occurs efficiently by the emission of optical radiation at wavelengths of about 900 nm rather than by the production of heat, minority carrier lifetimes being of the order of nanoseconds and minority carrier diffusion lengths of the order of micrometres. In fact, given the optical properties of the fibre and the modulation capacity requirements of the systems envisaged, GaAs occupies a unique position amongst the semiconductors known to the materials scientist.

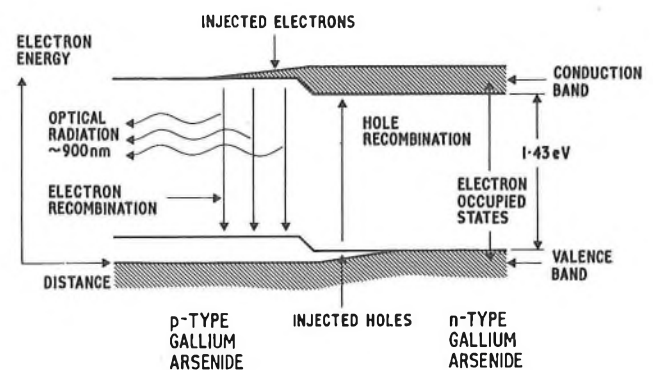

FIG. 1—Band diagram of a forward-biased GaAs p-n junction

L.E.D. SOURCES

Homostructure L.E.D.s

In its simplest form, the GaAs l.e.d. is no more than a forward-biased p-n junction diode. At high forward bias, electrons are injected into the p-type region, positive charge carriers (holes) are injected into the n-type region and recombination occurs (see Fig. 1). In practice, most of the injection is by electrons into the p-type material. On recombination, the injected electrons, which are now minority carriers, release their excess energy as optical radiation in the infra-red wavelength range near 900 nm. The recombination occurs within a minority-carrier diffusion length. Hence, radiation is emitted from a very narrow slab of semiconductor only several micrometres thick, adjacent to the p-n junction.

GaAs strongly absorbs its own recombination radiation, and so there are difficulties in extracting the radiation from the bulk of a device. In a design originated by Burrus,⁵ specifically for optical-communications applications, current is constrained to flow only through a circular contact of $50 \mu\text{m}$ diameter made to the p-type side of the device (Fig. 2). A well is etched into the n-type side of the device to within $10 \mu\text{m}$ of the junction, and optical radiation is extracted without undue loss through the residual n-type GaAs.

A multimode optical fibre can be positioned in the well to collect the optical radiation directly, or a lens coupling system might be used. Such a design of l.e.d. gives rise to a high-radiance source, where radiance is expressed as optical power emitted into unit solid angle per unit area of source. Burrus-type h.r.l.e.d.s can operate continuously at 300 mA

† Research Department, Telecommunications Headquarters.

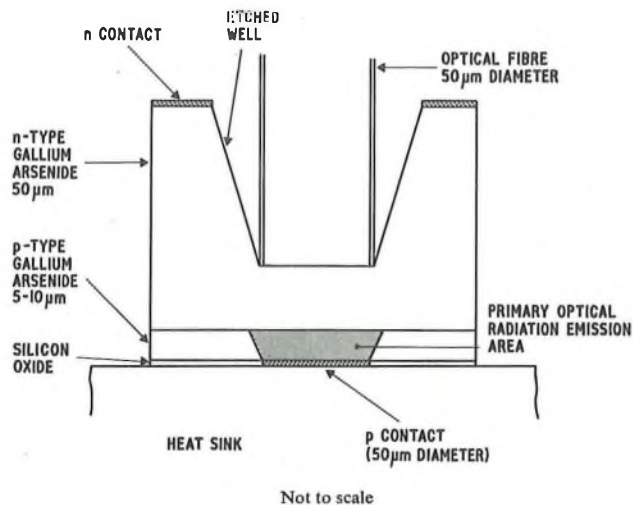

FIG. 2—Cross-section of a homostructure Burrus-type diode

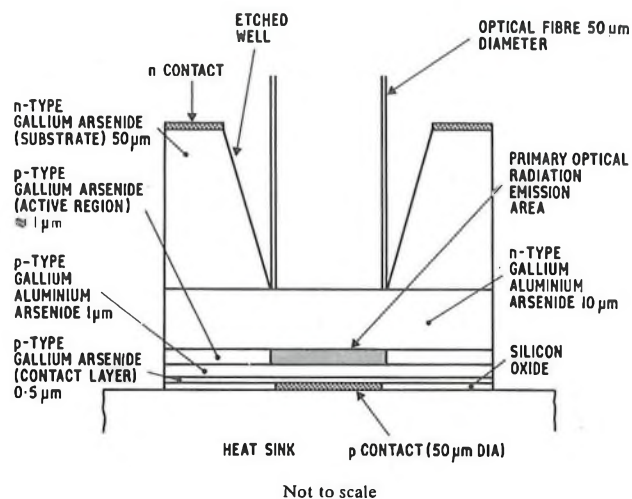

FIG. 3—Cross-section of a double-heterostructure Burrus-type diode

input drive current and emit several milliwatts of optical power or, expressed in terms of radiance, 20–50 W/sr/cm².

The relationship between voltage, V , and current, I , is similar to that for other p–n junction diodes, operating in the forward-biased direction, and has the form

$$V = a \log_e (1 + I/I_0) + IR,$$

where a and I_0 are constants for constant junction temperature and R is the device series resistance. At a current of 150 mA, V may be about 2 volts for an l.e.d. of the type described.

From the systems viewpoint, the power that can be coupled directly into an optical fibre is the important parameter. The radiation from Burrus-type h.r.l.e.d.s is emitted over a wide angle, has a spectral width of 20–30 nm and is essentially incoherent. Hence, multimode fibre of sufficient numerical aperture and cross-section must be used in order to couple as much radiation as practicable. However, if too large a numerical aperture is filled, multipath dispersion in the fibre begins to limit the usable repeater separation.³ A sensible example would be a fibre with a difference between the refractive indexes of the core and cladding materials of about 1 per cent, and a core diameter of 50–60 μm. Under these conditions, about 0.4 mW of launched power would be achievable for 150 mA input current drive to the l.e.d., assuming that the h.r.l.e.d. is 100 per cent efficient, it emits radiation uniformly in all directions and that 100 per cent reflection occurs at the p-type contact (see Fig. 2). The radiance of the source is then about 120 W/sr/cm².

In practice, available Burrus-type h.r.l.e.d.s have a radiance of 10 W/sr/cm² at 150 mA current drive, with a best reported figure for state-of-the-art devices of 50 W/sr/cm² at 300 mA current drive⁶. The devices emit at a wavelength of 900 nm, have a spectral width of 24–30 nm and a transient response time of 10 ns. The optical-power-output/drive-current characteristic is fairly linear up to 300 mA, and so analogue modulation is, in principle, possible. Amplitude linearity is not required when on–off digital techniques are used, but the pulse transient response is then important.

The transient response time is a combination of two factors, the intrinsic carrier lifetime and the need for the injected current to charge the device capacitance. As current begins to flow, the effect of series resistance limits the charging current that flows to areas of the device not under the 50 μm diameter p-type contact area. Some h.r.l.e.d.s have been fabricated where current spreading is inhibited by proton-bombardment isolation of all the p-type material not under the 50 μm diameter p-type contact⁷. Proton bombardment gives the

material high resistivity and, therefore, reduces the device capacitance to a minimum, so that transient response is controlled more by the intrinsic carrier lifetime. Overall transient response can also be improved by shaping the current-drive waveform so as to overdrive the device during the first part of the current-drive pulse.

The reasons that this simple type of h.r.l.e.d. (called a *homostructure* device) does not attain the maximum theoretical brightness are twofold: absorption in the GaAs surrounding the p–n junction, and inefficiency of the radiative recombination process.

Double-Heterostructure L.E.D.s

The double-heterostructure h.r.l.e.d. overcomes the losses inherent in the simple homostructure h.r.l.e.d. In the double-heterostructure device, the recombination layer (or active region) is sandwiched between layers of gallium aluminium arsenide, as shown in Fig. 3. Aluminium can be substituted for gallium in the semiconductor crystal lattice, and it is possible to grow material having compositions from pure GaAs right through to pure aluminium arsenide. Gallium-aluminium-arsenide (Ga_{1-x}Al_xAs) layers have different electrical and optical properties from GaAs, and the degree of difference is controlled by the percentage of aluminium, x , in the lattice.

The layers of Ga_{1-x}Al_xAs (with $x \approx 25$ per cent) on either side of the active layer provide electrical barriers that prevent carriers being lost from the recombination region (see Fig. 4). The layers are also transparent to the emitted radiation. Double-heterostructure devices have been reported having a radiance near the theoretical, at 50–100 W/sr/cm² at 150 mA current drive⁸. The typical spectral spread is around 50 nm, and is larger than for the homostructure device. This could be due to several factors, including the use of different dopants and the possibility of slight, but non-uniform, carry-over of aluminium from adjacent layers into the recombination layer during material growth. Aluminium can also be added intentionally to the recombination region to tune the emission wavelength, over the range 800–900 nm, to enable selection of that giving the lowest fibre attenuation, presently in the 800–850 nm wavelength range. However, the 50 nm spectral width imposes severe restrictions on the use of presently available double-heterostructure Burrus-type devices in systems, because of the enhanced fibre material dispersion compared with the homostructure h.r.l.e.d. Further effort is needed in tailoring the composition of the recombination region and ensuring its uniformity, if the double-hetero-

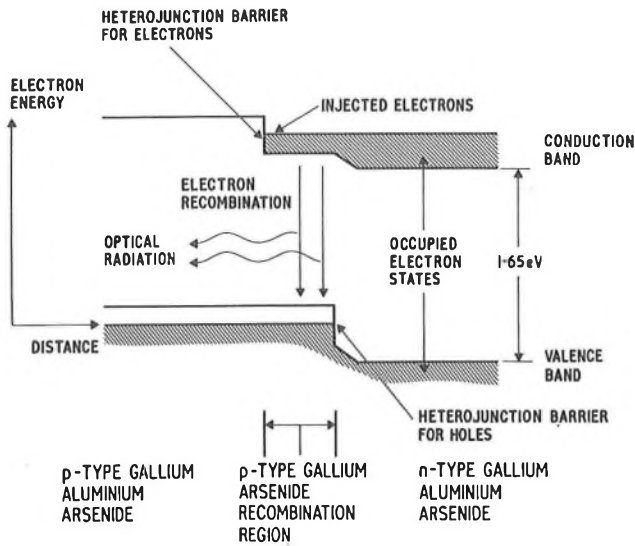

FIG. 4—Band diagram of a forward-biased GaAlAs double-heterostructure p-n junction

structure device is to compete in all respects with the homo-structure h.r.l.e.d.

H.R.L.E.D. Systems

There are drawbacks to the use of h.r.l.e.d.s in optical-transmission systems. They are inefficient devices as far as optical collection is concerned, since optical radiation is emitted over a complete sphere. Thus, even with the theoretically maximum launched power into a 1 per cent refractive-index difference fibre, the overall power conversion efficiency would be less than 0.2 per cent. Material dispersion in a silica fibre, when fed with wide spectral-width radiation (20–50 nm) from an h.r.l.e.d., limits the bandwidth to about 140 MHz over a distance of 1 km, a figure that would decrease inversely with increase in length³.

For greater system modulation capacity and for a more efficient device for the lower capacity systems, it is necessary to turn to the semiconductor laser.

LASER SOURCES

The GaAs double-heterostructure laser overcomes most of the limitations of h.r.l.e.d.s. It is fabricated in a similar fashion to the double-heterostructure Burrus-type h.r.l.e.d. and, again, is essentially a sophisticated p-n junction device (Fig 5). It is necessary to resort to the complex heterostructure arrangement in order to achieve low enough operating currents to enable continuous operation at room temperature and above. Under forward-bias conditions, carriers are injected into the recombination (active) region, as in the case of the double-heterostructure h.r.l.e.d., and optical radiation is emitted. An optical cavity is formed by making opposite ends of the device flat and parallel to each other, and perpendicular to the active region. The emitted optical radiation quanta (photons) that travel in the plane of the active region perpendicular to the end faces are partially reflected at the GaAs-air boundary. These photons stimulate the emission of more photons and the stimulated emission content of the optical flux builds up. At a critical current through the device, the *threshold current*, a round-trip gain of unity is achieved and laser action occurs. Additional current above the threshold is efficiently converted into optical radiation that is emitted from the end faces of the laser. Fig. 6 shows a typical optical-power-output/input-drive characteristic. The threshold is sensitive to

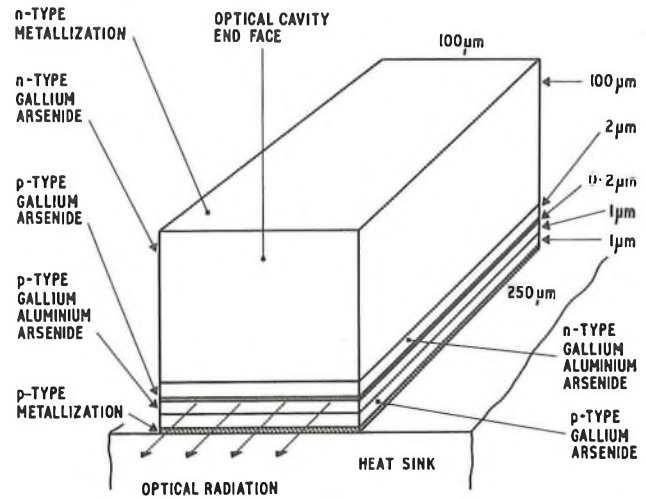

Not to scale

FIG. 5—Block diagram of a broad-contact double-heterostructure laser

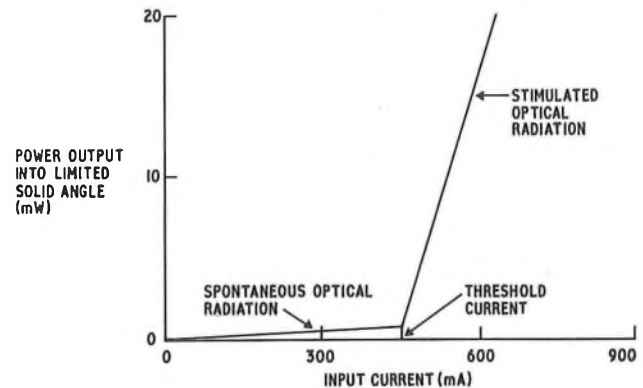

FIG. 6—Typical light-output/input-current relationship for a double-heterostructure laser

temperature, and increases by 1–2 per cent/°C rise in temperature around room temperature. The slope of the characteristic above the threshold is rather insensitive. In systems use, where significant temperature variations will occur, means of allowing for, or correcting for the temperature dependence of the threshold must be provided.

As in the double-heterostructure h.r.l.e.d., the layers of $Ga_{1-x}Al_xAs$ that sandwich the active layer ensure that recombination of current carriers can occur efficiently. In the laser, they also form a dielectric slab waveguide because, at the lasing wavelength, their refractive index is about 5 per cent lower than that of the active GaAs layer. Thus, the optical flux can be effectively guided along the narrow (typically, 0.2 μm thick) active layer. Typical dimensions of a so-called broad-contact laser are shown in Fig. 5, in which the micrometre-range thicknesses of the layer structure, the 250 μm cavity length and 100 μm device width should be noted.

A further development, that gives lower operating currents and is more compatible with launching into optical fibre, is to make the laser in a stripe configuration. In such a structure, current is controlled to flow into a region of width 10–20 μm by, for example, proton-bombardment isolation of the p-type material outside the stripe (Fig. 7). For stripe widths of about 10 μm , single-optical-transverse-mode operation ensues—optical energy, emitted from the end faces of the laser, is

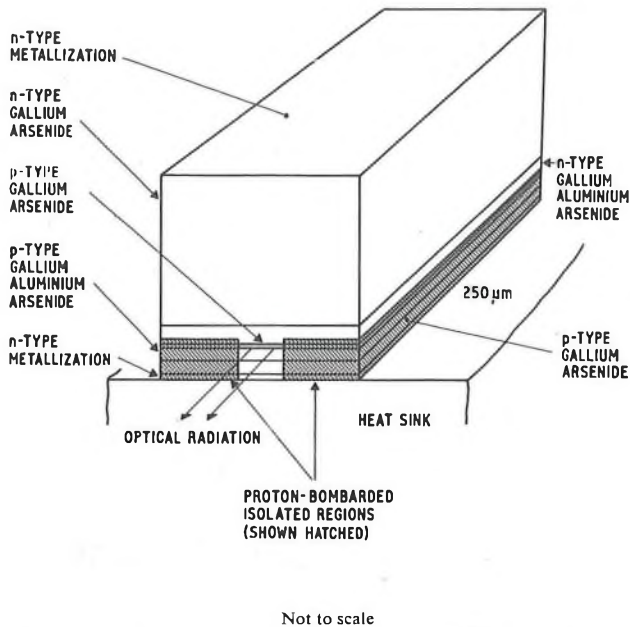

Fig. 7—Block diagram of a stripe-geometry double-heterostructure laser

contained within a single lobe. The spectrum of the emitted radiation consists of several longitudinal cavity modes separated by about 0.2 nm in wavelength, giving an overall emission spectral width of 1–2 nm, a factor of more than 10 times narrower than the h.r.l.e.d.

A continuous optical output power of 10 mW (from one end of the cavity) has been reported⁹ from a proton-isolated-stripe device, at a drive current of 200 mA. It is expected that greater than 50 per cent coupling efficiency to a monomode or graded-index fibre is achievable, giving an overall launched efficiency of 1.6 per cent.

Threshold currents down to about 50 mA have been reported for other stripe-geometry structures.¹⁰ Ideally, all current injected above the threshold should be completely converted into optical output, so that the laser need be driven only at 57 mA to give 10 mW of laser output, if one end of the optical cavity is made totally reflecting. Overall launched efficiency could then be as high as 6 per cent. In practice, fringing losses at the edges of the stripe limit the conversion efficiency of experimental lasers, at present, so that 100–200 mA drive is required to give 10 mW output. With developments now showing promise at the research stage, it is foreseeable that threshold currents could be reduced to less than 10 mA, so that drive currents of less than 50 mA will eventually be practicable.

Further work could eventually also lead to a truly single-mode laser, where the emission spectral width would be reduced to less than 0.1 nm. This would remove the limitations imposed by material dispersion in fibre, even over very long lengths of line³.

The transient response of lasers is a function of the drive current, as carriers recombining via the stimulated process do so very rapidly compared with the normal intrinsic spontaneous recombination lifetime. Hence, most additional carriers injected above the threshold recombine in a time $\ll 1$ ns. If τ is the spontaneous lifetime (typically 3 ns), and I_T the threshold current, then, under certain conditions, the delay time, t_D , after the application of a step current $I > I_T$ before lasing commences is

$$t_D = \tau \log_e \{I/(I - I_T)\}.$$

Hence, for input pulse currents $I \gg I_T$, the delay time goes to zero, so that large modulation bandwidths are possible by

this method. However, a more efficient alternative is to pre-bias the laser at a direct current, I_B , less than the threshold current. Then

$$t_D = \tau \log_e \{(I - I_B)/(I - I_T)\},$$

and t_D can be made much less than τ with very little pulse overdrive as I_B approaches I_T .

An important resonance effect occurs in the laser and can set a limit to the maximum modulation frequency. The injected carrier distribution and the optical field in the device's active region interact to produce oscillations in the light output from the laser. This relaxation oscillation is dependent on current drive and its frequency, typically, lies in a range around 1 GHz. In spite of this, 1 Gbit/s modulation capability has been demonstrated¹¹ from a d.c. pre-biased stripe laser, where the expected resonance and ringing behaviour was apparently suppressed. Further work is needed in this area to establish fully the transient behaviour under system conditions at 500 Mbit/s and upwards.

Comparison of the basic properties of h.r.l.e.d.s and lasers is summarized in Table 1, from which it is obvious that the laser wins on all counts. However, there is one important aspect not so far mentioned—device reliability.

TABLE 1

Comparison of Properties of H.R.L.E.D.s and Lasers

Property	H.R.L.E.D.	Laser
Input power	0.2–0.5 W	0.1–0.3 W
Optical output power (into hemisphere)	1–5 mW	10 mW
Coupling efficiency to fibre	1–10 per cent	50 per cent
Modulation bandwidth	50 MHz	1 GHz
Wavelength	750–900 nm	750–900 nm
Spectral width	20–50 nm	1–2 nm

SOURCE RELIABILITY

It is a general phenomenon amongst semiconductor l.e.d.s, infra-red emitting diodes and lasers that optical efficiency falls gradually during operation of the device. This degradation of efficiency is extremely sensitive to device operating current densities. In the case of h.r.l.e.d.s and lasers, where operating current densities are in the range 10^3 – 10^4 A/cm², degradation of devices is a significant factor. Basically, degradation of efficiency occurs by an intrinsic bulk process that creates defects close to, and within, the device recombination (active) region. These defects then allow carrier recombination to occur without optical emission¹².

Degradation manifests itself in two basic ways: the creation of defects is either grossly non-uniform, or occurs in a more uniform manner. Fig. 8(a) shows an example of the optical emission from the active region of a stripe-geometry laser viewed normal to the junction plane, after a period of operation. Non-emitting areas have developed during device operation over, in this case, 100 h. The stripe width is about 17 μ m, so that the black spots are around 10 μ m diameter. The regions between the black spots are degrading uniformly, and at a very much slower rate. Other types of localized dark structures have also been seen to appear as a result of device operation. Fig. 8(b) gives several examples. These different types of growth are thought to originate in strained areas of the device close to, or in, the active layer. The strain may be generated by dislocations¹³ or precipitates in the semiconductor lattice, by the effects of the nearby p-type contact metallization, or by bonding procedures.¹⁴ It should be emphasized that this localized degradation is common to

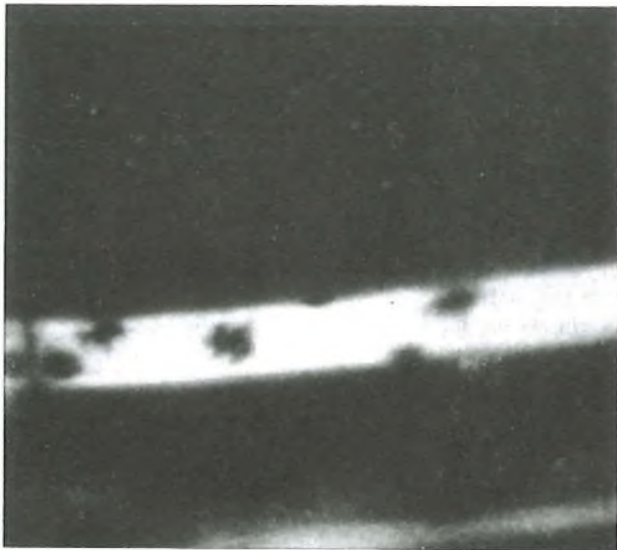

(a)

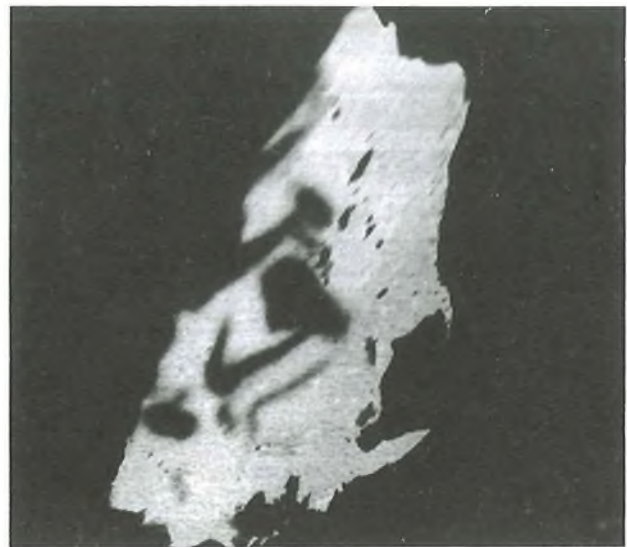

(b)

(a) Scale $20 \mu\text{m}$ (b) Scale $30 \mu\text{m}$

FIG. 8—Non-uniform degradation of double-heterostructure lasers

h.r.l.e.d.s (both homostructure and double-heterostructure) and to lasers. The mechanism is not yet entirely clear, but it is apparent that the extremely high density of carriers in the active recombination region plays a major role.

In the case of h.r.l.e.d.s, where optical radiation is taken out perpendicular to the junction plane, the intensity of the optical emission reduces proportionally to the dark areas. For a laser, however, the non-radiative areas lie in the plane of an optical cavity and act as regions of optical absorption, so introducing additional losses into the cavity and making the laser extremely sensitive to localized degradation.

With the understanding that now exists, it is becoming possible to grow suitable layer structures where localized degradation is less dominant. State-of-the-art lives approaching 10^4 h have now been achieved for stripe-geometry double-heterostructure lasers in the U.S.A.¹⁵, but such devices are not available commercially. The h.r.l.e.d. situation is somewhat more encouraging in that homostructure devices are available in the U.K., and extrapolated lives greater than 10^4 h are claimed by the manufacturers.⁶ Studies of double-heterostructure h.r.l.e.d.s also led to reports¹⁶ of extended lives, but these devices are not available commercially.

CONCLUSIONS

The semiconductor laser has been demonstrated to have properties that make it ideally suited for optical transmission systems that require modulation capabilities up to at least 1 Gbit/s, whereas the h.r.l.e.d. is only suitable up to around 50 Mbit/s. Proven homostructure h.r.l.e.d.s are available with which it will be possible to demonstrate the feasibility of low-bit-rate systems.

The long-term objective must be to develop the laser for all systems, as it will enable larger launched powers to be achieved compared with the h.r.l.e.d. in low-bit-rate systems, as well as opening up the high-bit-rate system field. Manufacturing costs are not likely to be greatly different for h.r.l.e.d.s or lasers. With the present growing understanding of the mechanisms of device degradation, and the encouraging results to date, there is every reason to suppose that the system-designers' specification of a minimum of 10^5 h useful operating life will be achieved.

ACKNOWLEDGEMENTS

The author gratefully acknowledges helpful discussions with many colleagues in the British Post Office Research Department, and with Dr. A. R. Goodwin, Dr. G. H. B. Thompson and their colleagues at Standard Telecommunications Laboratories, Harlow.

References

- ROBERTS, F. F. Optical-Fibre Telecommunication Transmission Systems. *P.O.E.E.J.*, Vol. 67, p. 32, Apr. 1974.
- BEALES, K. J., MIDWINTER, J. E., NEWNS, G. R., and DAY, C. R. Materials and Fibre for Optical Transmission Systems. *P.O.E.E.J.*, Vol. 67, p. 80, July 1974.
- DYOTT, R. B. The Optical Fibre as a Transmission Line. *P.O.E.E.J.*, Vol. 67, p. 164, Oct. 1974.
- MATTHEWS, M. R., and SMITH, D. R. Photodiodes for Optical-Fibre Transmission Systems. (In this issue, p. 213).
- BURRUS, C. A., and DAWSON, R. W. Small-Area High Current Density GaAs Electroluminescent Diodes. *Applied Physics Letters*, Vol. 17, p. 97, Aug. 1970.
- GOODFELLOW, R. High-Radiance Small-Area GaAs Lamps. Paper at Electro-Optics International '74, Brighton, Mar. 1974.
- CUTBERT, G. E., and NEWMAN, D. H. (unpublished).
- BOURNE, W. O., *et al.* High-Radiance D.H. Light-Emitting Diodes. Paper at Electro-Optics International '74, Brighton, Mar. 1974.
- HARTMAN, R. L. *et al.* Continuous Operation of GaAs-Ga_xAl_{1-x}As D.H. Lasers. *Applied Physics Letters*, Vol. 23, p. 181, Aug. 1973.
- YONEZU, H. *et al.* A GaAs-Al_xGa_{1-x}As D.H. Planar Stripe Laser. *Japanese Journal of Applied Physics*, Vol. 12, p. 1,585, Oct. 1973.
- CHOWN, M. *et al.* Direct Modulation of D.H. Lasers at rates up to 1 Gbit/s. *Electronics Letters*, Vol. 9, p. 34, Jan. 1973.
- NEWMAN, D. H., and RITCHIE, S. Gradual Degradation of GaAs Double Heterostructure Lasers. *I.E.E.E.J. Quantum Electronics*, Vol. QE-9, p. 300, Feb. 1973.
- PETROFF, P., and HARTMAN, R. L. Defect Structure Introduced during Operation of Heterojunction GaAs Lasers. *Applied Physics Letters*, Vol. 23, p. 469, Oct. 1973.
- HARTMAN, R. L., and HARTMAN, A. R. Strain-Induced Degradation of GaAs Injection Lasers. *Applied Physics Letters*, Vol. 23, p. 147, Aug. 1973.
- DYMENT, J. C. *et al.* Threshold reduction by the addition of phosphorus to the ternary layers of D.H. GaAs lasers. *Applied Physics Letters*, Vol. 24, p. 481, May 1974.
- BURRUS, C. A. Radiance of small-area high-current-density electroluminescent diodes. *Proc. I.E.E.E.*, Vol. 60, p. 231, Feb. 1972.

Photodiodes for Optical-Fibre Transmission Systems

M. R. MATTHEWS, B.Sc., and D. R. SMITH, B.A.†

U.D.C. 621.383.52:621.391.63:677.521

Semiconductor photodiodes will find widespread use as the photodetectors in optical-fibre transmission systems. The properties of avalanche and non-avalanche photodiodes are discussed, and related to the structure of the diodes and the materials from which they are made.

INTRODUCTION

This article continues the series published in this *Journal* concerned with various aspects of optical-fibre transmission systems.^{1,2,3,4} The glass fibre^{2,3} in a transmission system guides the optical signal, which carries analogue or digital information in the form of an intensity modulation, from the optical source⁴ to a receiver, where it is reconverted to an electrical signal by a photodetector. The conversion is necessary at the terminal of the optical transmission path, or at intermediate points when amplification of the signal is necessary; that is, at a repeater.

Although vacuum-tube photodetectors (e.g. photomultiplier tubes) may find limited application in some optical transmission systems, the most suitable detectors, for the fibre systems at present under consideration, are semiconductor devices, on the grounds of cost, reliability and size. Of the available semiconductor photodetectors, the photodiode best achieves the required performance of high optical sensitivity, high speed of response and low noise. These parameters are discussed in this article, and are related to the structure of the photodiode and the semiconductor from which it is made. The article is not a detailed treatment of the subject, but is intended to be an introduction for those who are not familiar with the properties of the semiconductor photodiode.

LIGHT AND SEMICONDUCTORS

To understand the operation of a photodiode, it is necessary to be aware of the following properties of light and semiconductors.

(a) Light can be considered to be a stream of particle-like energy packets called *photons*, each photon having an energy, E , which is proportional to the frequency, f , of the light and given by

$$E = hf, \text{ where } h \text{ is Planck's constant.}$$

(b) The wavelength, λ , of light having a frequency, f , is given by

$$\lambda = \frac{c}{f}, \text{ where } c \text{ is the velocity of light.}$$

(c) A photon is absorbed in the bulk of a particular semiconductor when the energy of the photon is greater than a minimum value which is characteristic of the semiconductor—the band gap energy of the semiconductor.

(d) The absorption of a photon in a semiconductor generates a pair of charge carriers; a negatively-charged electron and a positively-charged hole.

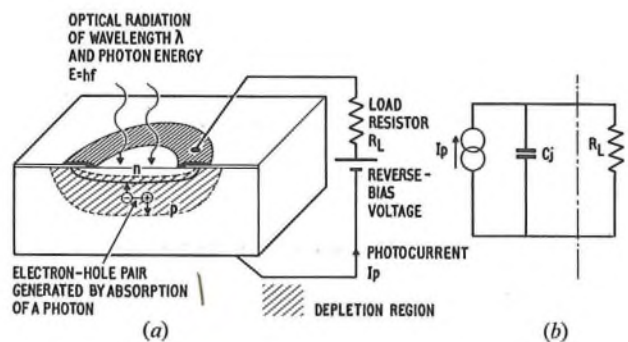

C_j is the capacitance of the junction

FIG. 1—Cross-sectional structure and equivalent circuit of a p-n junction photodiode

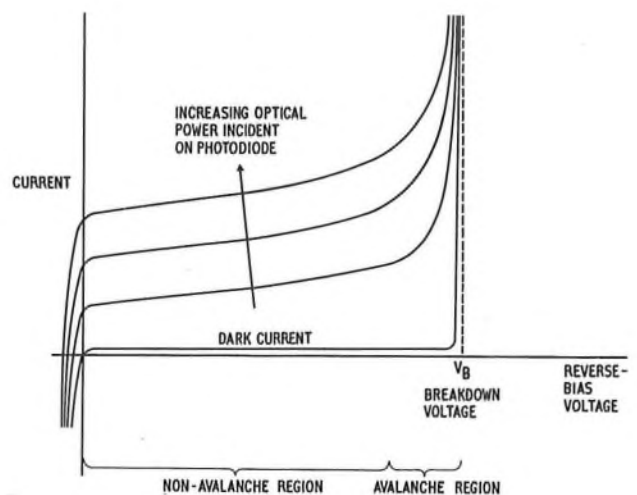

FIG. 2—Current/reverse-bias-voltage characteristic of a photodiode

PHOTODIODES

A semiconductor photodiode, in its simplest form, is a p-n junction on which the light is usually incident perpendicular to the junction plane (see Fig. 1(a)). The absorption of light in the vicinity of the junction produces electron-hole pairs, which can come under the action of the electric field present in the depletion region of the junction. The electrons and holes then drift (i.e. move under the action of the field) in opposite directions across the depletion region, thereby causing a flow of current (the photocurrent) through the load resistance in the external circuit. A simple equivalent circuit of the photodiode is shown in Fig. 1(b).

A photodiode is usually operated with a reverse-bias

† Research Department, Telecommunications Headquarters.

voltage (typically <20 volts) applied to it, and the general form of the photocurrent/reverse-bias-voltage characteristic is shown in Fig. 2. The dark current is the current that flows when there is no light incident on the photodiode. The avalanche region which occurs at high reverse-bias voltages, will be discussed later.

Sensitivity

The expression relating the photocurrent, I_p , to the average optical power, P , incident on the photodiode is

$$I_p = \frac{q\eta P}{hf} = SP.$$

P/hf is the average number of photons incident on the photodiode per second, where hf is the energy of a photon. I_p/q is the average number of electrons flowing in the external circuit of the photodiode, where q is the electronic charge. The quantum efficiency, η , is the fraction of the photons incident on the photodiode that produce electron-hole pairs which contribute to the photocurrent. S is the photosensitivity of the photodiode and has the units amps/watt.

As light passes through a semiconductor, the optical power decreases gradually due to the absorption of photons, the resulting distribution of electron-hole pairs being dependent on the semiconductor material and the wavelength, or frequency, of the incident light. At short wavelengths, the light is absorbed strongly and the carrier pairs are mostly generated close to the surface of the semiconductor: at long wavelengths, absorption is weak and pairs are generated over larger distances.

In the photodiode, only those photons which are absorbed within, or close to, the depletion region produce electron-hole pairs that can come under the action of the electric field and, hence, contribute to the photocurrent. Of the total number of photons incident, only a fraction will be absorbed in this region. This effect largely determines the quantum efficiency η , which is very low at long wavelengths when the semiconductor absorbs weakly, high at intermediate wavelengths, and low at short wavelengths, when the absorption is so strong that all the electron-hole pairs are generated very near the surface of the photodiode where they contribute less effectively to the photocurrent. The wavelength range over which a particular photodiode has an appreciable quantum efficiency depends upon the material from which it is made. The choice of material is restricted to those giving a high quantum efficiency at the wavelengths which can be both generated by available sources and transmitted by available optical fibres. The sources, at present receiving most attention, operate at wavelengths in the near infra-red region of the optical spectrum; semiconductor lasers and light-emitting diodes have wavelengths in the range 0.75–0.9 μm , and neodymium lasers have a wavelength of 1.06 μm . Fig. 3 shows typical quantum-efficiency/wavelength characteristics for photodiodes made from silicon (Si) and germanium (Ge).

Speed of Response

When selecting a photodiode for use in an optical transmission system, an important consideration is the speed of response of the photocurrent to the modulated optical signal. The speed of response, which is usually expressed as a modulation-frequency bandwidth (or, equivalently, as a pulse rise-time), must be sufficient to accommodate the information bandwidth of the received optical signal. There are a number of factors which limit the speed of response of a photodiode.

The first of these is the distribution of the transit times of the carriers in crossing the depletion region. As the electric field in the depletion region is increased, the velocity of a carrier increases until it is equal to a limiting value called the *saturated drift velocity*. The transit times can be reduced, to some extent, by the increased field that is present when a

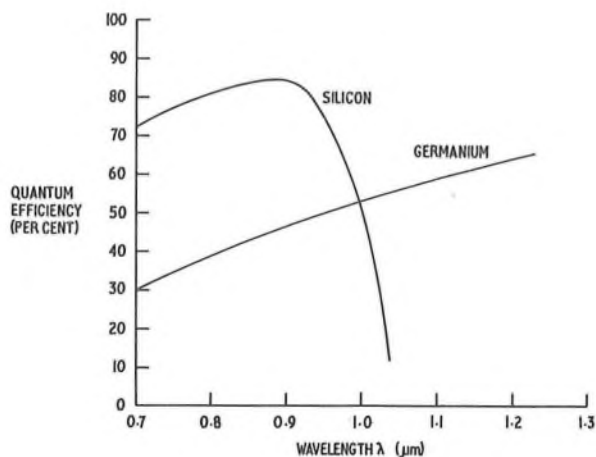

FIG. 3—Quantum-efficiency/wavelength characteristics for typical silicon and germanium photodiodes

reverse-bias voltage is applied to the diode. Transit-time effects result in rise times of, typically, less than 1 ns.

A second limitation is due to carriers, generated a short distance beyond the depletion region, contributing to the photocurrent. These carriers are generated in regions where there is, essentially, no electric field, and where the minority carriers (electrons in the p-type material in Fig. 1(a)) play the more significant part. Some minority carriers diffuse slowly to the edge of the depletion region, where they come under the action of the electric field. This slow component of the photocurrent can limit the speed of response of the diode, but the effect can largely be removed by a simple pulse-shaping circuit.

The third limitation is set by the capacitance of the diode junction, C_j , which together with the load resistance, R_L , produces a time constant, $C_j R_L$, for the photodiode circuit (Fig. 1(b)). Reducing the capacitance permits a larger value of load resistance, which leads to a higher output voltage for a given photocurrent. The junction capacitance is proportional to A/W , where A is the area of the junction and W is the thickness of the depletion region. The depletion-region thickness can be increased both by using a semiconductor of higher resistivity and by operating the diode at a higher reverse-bias voltage.

PIN Photodiodes

The performance of the simple p-n junction photodiode can be improved by using a p-i-n structured diode, known as a *pin* photodiode, in which a high-resistance intrinsic (i) layer is sandwiched between the p-type and n-type regions. On applying a reverse-bias voltage to the diode, the electric field extends across the whole of the intrinsic layer. The thickness of this layer can be made much greater than that of the depletion region in a p-n junction, with the consequent advantages of lower junction capacitance and higher quantum efficiency, particularly at long optical wavelengths. The increased thickness of the field region in the pin photodiode also results in fewer carrier pairs being generated in regions where diffusion processes limit the speed of response.

Noise

A limit to the performance of an optical communications system is determined by the noise present when the optical signal is detected. There are three major sources of noise.

(a) *Thermal noise*—Thermal (Johnson) noise arises from the detector load resistance and the amplifier which follows it. It can be expressed as a noise current, i_n , which has a mean square value (referred to the input of the amplifier) of $\overline{i_n^2} = \frac{4kTBF}{R_L}$,

where k = Boltzmann's constant, T = absolute temperature, B = bandwidth, F = noise figure for the amplifier, and R_L = load resistance.

(b) *Quantum noise*—Quantum noise arises from the random fluctuations in the rate at which photons arrive at the photodiode. These fluctuations of the optical power are converted by the photodiode into a noise current, i_s , called the *shot-noise current*, given by $\overline{i_s^2} = 2qI_pB$, where q is the electronic charge, and I_p is the photocurrent.

Of particular importance is the dependence of this noise on the photocurrent and, hence, on the optical power incident on the detector.

(c) *Dark-current noise*—The noise associated with the dark-current is given by a similar expression of $\overline{i_D^2} = 2qI_D B$.

The magnitude of the dark-current, I_D , is dependent on the semiconductor material, the area of the p-n junction and the temperature. By careful choice and design of detector for room-temperature operation, the dark-current noise may be made negligible for Si devices.

The satisfactory operation of the system requires a minimum signal-to-noise ratio after detection. For a photodiode in an optical-fibre transmission system, taking account of the most significant noise sources,

$$\text{the signal-to-noise ratio} = \frac{I_p^2}{\frac{4kTBF}{R_L} + 2qI_pB}$$

For the photodiodes considered so far, the dominant noise source in the above equation is usually thermal noise.*

The range of a transmission system is maximized when the lowest possible optical signal power, called the *minimum detectable power*, is incident on the photodiode, consistent with achieving the minimum acceptable signal-to-noise ratio.

An increase in the value of the load resistor, R_L , increases the input signal to the amplifier with respect to the thermal noise, so that the required signal-to-noise ratio is achieved with a lower optical power at the photodiode. Though the speed of response of the photodiode circuit at the input to the amplifier is then reduced, due to the increase in the time constant, the system bandwidth can be restored to that required, using a simple *CR* equalization network at a later stage.

A significant reduction in the minimum detectable power may also be obtained by using a detector with an internal current gain and, therefore, a considerably greater sensitivity. A photodiode designed to operate with an internal current gain is known as an *avalanche photodiode*.

AVALANCHE PHOTODIODES

When the reverse-bias voltage applied to a p-n junction is close to the breakdown voltage (Fig. 2), the carriers traversing the very high electric field region at the junction gain sufficient energy to create new electron-hole pairs when they interact with the crystal lattice. The process is called *avalanche multiplication*.

The photo-multiplication factor, M , at a bias voltage, V , is given by $M = I_{MP}/I_p$, where I_{MP} is the multiplied photocurrent and I_p is the photocurrent at a low voltage where no carrier multiplication occurs. The relationship between the multiplication factor and the bias voltage is given, approximately, by $M = \frac{1}{1 - \left(\frac{V}{V_B}\right)^n}$,

where V_B is the breakdown voltage determined by the doping concentration, and n is a constant dependent on the semiconductor material, the doping concentration and the wavelength of the radiation. (For a Si avalanche photodiode of $V_B \approx 80$ volts and radiation of wavelength $0.9 \mu\text{m}$, $n \approx 0.6$).

* In all but very low bandwidth (e.g. < 1 MHz) systems.

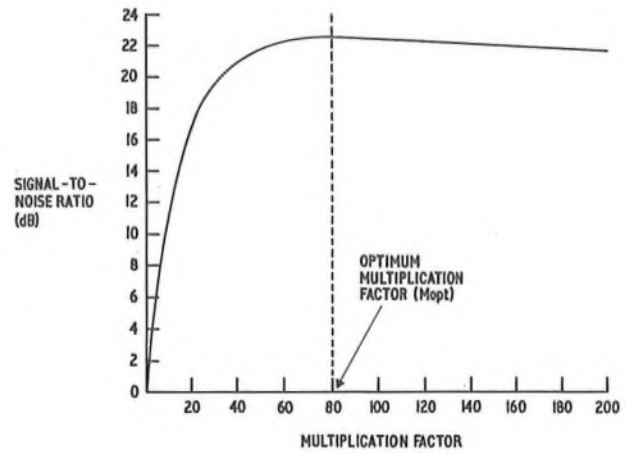

$$I_p = 20 \text{ nA}, R_L = 1 \text{ kohm}, B = 50 \text{ MHz}, x = 0.4, F = 3$$

FIG. 4—Signal-to-noise-ratio/multiplication-factor characteristic for a system using an avalanche photodiode

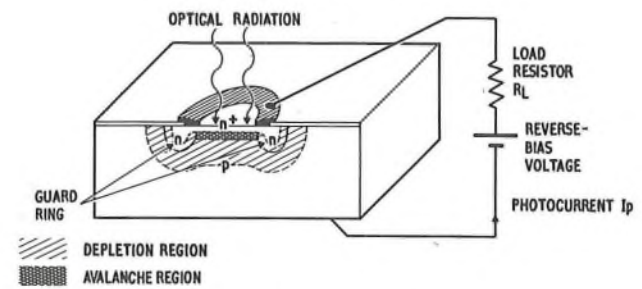

FIG. 5—Silicon n^+p avalanche photodiode with a guard ring

Noise

For an avalanche photodiode operating at a multiplication factor, M , the shot noise current, i_s , at the input to the following amplifier is given by $\overline{i_s^2} = 2qI_pBM^2F_e$. The random nature of the avalanche process introduces a gain-dependent excess noise factor, F_e , which can be represented, approximately,* as M^x (where $x > 0$). The constant x is dependent on the semiconductor material and the structure of the diode. Typical Si photodiodes have $x \approx 0.4$, whereas for Ge $x \approx 1$.

For an optical-fibre transmission system having an avalanche photodiode as the detector, neglecting dark-current noise,

$$\text{the signal-to-noise ratio} = \frac{M^2 I_p^2}{\frac{4kTBF}{R_L} + 2qI_pBM^2F_e}$$

Fig. 4 shows the signal-to-noise-ratio/multiplication-factor characteristic for a system which, at a multiplication factor of unity, is limited by thermal noise. As the multiplication factor increases, the thermal noise no longer dominates over the shot noise and the signal-to-noise ratio increases, reaching a maximum value at a particular multiplication factor, M_{opt} . The decrease of the signal-to-noise ratio at higher multiplication factors, where the dominant noise source is shot noise, is due to the increasing importance of the excess noise factor, F_e . The improvement in the system performance on using an avalanche, rather than a non-avalanche, photodiode is typically a 10–15 dB decrease of the minimum detectable power.

Diode Structures

Various structures have been developed for Si, Ge and GaAs avalanche photodiodes. The most commonly available at the present are Si devices, and a simple structure is shown in Fig. 5. In such a diode, the excess noise factor is reduced

* A more exact expression for the excess noise factor has been derived by McIntyre.⁵

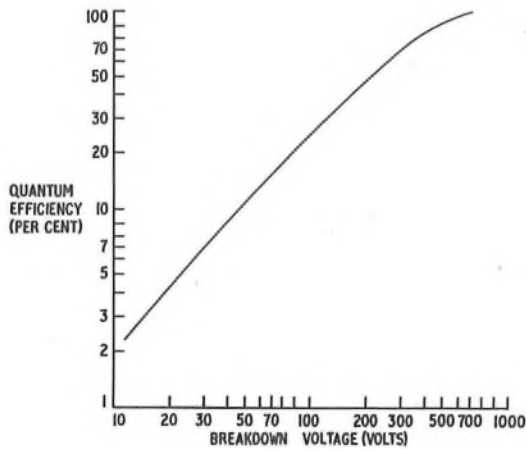

The quantum efficiency is calculated not accounting for reflection losses at the surface of the device

FIG. 6—Quantum-efficiency/breakdown-voltage characteristic of a silicon avalanche photodiode for light of wavelength $0.85 \mu\text{m}$

when the avalanche process is initiated predominantly by electrons. For this to occur, the majority of the photons incident on the photodiode must be absorbed in the p-type region, which can be achieved by forming the junction as close to the surface as possible, using a shallow, heavily-doped n-type region (n^+).

On fabricating the device, care is taken to ensure that the light-sensitive area is free of microplasmas—small localized areas having a lower breakdown voltage than the remainder of the junction. The presence of microplasmas would limit the multiplication factor and introduce an additional source of noise. Their occurrence can be minimized by ensuring that a uniform junction* is formed in good-quality (i.e. low-defect) material and that the light-sensitive area is no larger than required for the incident light beam; generally, the diameter of the area is $50\text{--}500 \mu\text{m}$. The edge of the junction has a lower breakdown voltage due to the high field in that region, but this effect is eliminated by forming a guard ring, as shown in Fig. 5. The doping and radius of curvature of the guard ring are chosen such that its breakdown voltage is greater than that of the n^+ -p junction.

Quantum Efficiency and Speed of Response

The factors which determine the quantum efficiency and speed of response of non-avalanche diodes are equally applicable to avalanche photodiodes. For an avalanche photodiode operating with a significant current gain, the reverse-bias voltage is close to the breakdown voltage of the device. Consequently, the depletion-region thickness and, therefore, the quantum efficiency, particularly at the longer wavelengths, is dependent on the value of the breakdown voltage. For a Si avalanche photodiode, this characteristic

* Uniform junction—constant doping profile across the light-sensitive area.

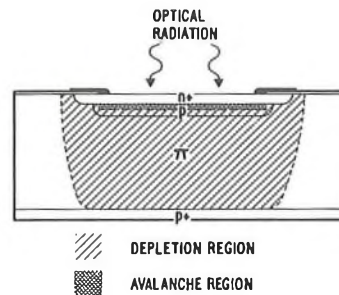

FIG. 7—Reach-through silicon avalanche photodiode

is shown in Fig. 6, the quantum efficiency being calculated for incident radiation of wavelength $0.85 \mu\text{m}$. The quantum efficiency in Fig. 6 is the fraction of electron-hole pairs generated within the depletion region, called the *high-frequency quantum efficiency*, and, therefore, discounts the slow contribution to the photocurrent resulting from pairs generated outside this region. The slow contribution can be significant in response to radiation at the longer wavelengths (for Si, $\lambda \geq 0.75 \mu\text{m}$), particularly for the lower-breakdown-voltage devices (for Si, $V_B < 200$ volts) and, consequently, distorts the photocurrent response. As for non-avalanche photodiodes, the effect may be considerably reduced by a simple pulse-shaping circuit.

Reach-Through Avalanche Photodiodes

Just as the performance of non-avalanche photodiodes is improved by forming a p-i-n structure to extend the thickness of the depletion region, so the high-frequency quantum efficiency of an avalanche photodiode can be significantly increased, particularly at long wavelengths, by the use of a more complex structure (called the *reach-through structure*) which extends the depletion region of the diode as shown in Fig. 7. In this structure, the thin high-field region at the n^+ -p junction is responsible for the avalanche gain, and the thick high-resistance π region has a lower field which sweeps the electrons, generated by photon absorption, into the avalanche region. A disadvantage of the reach-through structure is that, due to additional difficulties in manufacture, it is a more expensive device than the simple avalanche photodiode.

Operational Problems

Though significant improvements in the performance of the system may be achieved using avalanche photodiodes, several problems are associated with their operation.

The devices operate at high reverse-bias voltages (see Table 1), which must be supplied at the repeater by a d.c.-d.c. converter. The stability of the bias voltage must be such as to ensure a sufficiently stable multiplication factor and resulting signal-to-noise ratio.

An additional problem is the increase in the breakdown

TABLE 1
Parameters of Typical Avalanche Photodiodes

Photodiode		Breakdown Voltage (volts)	Quantum Efficiency η at $\lambda = 0.85 \mu\text{m}$ (per cent)	Diameter of Light-Sensitive Area (μm)	Junction Capacitance (pF)	Dark Current (nA)	Value of x in $F_e = M^x$
Material	Structure						
Silicon	n^+ -p	80	18	100	<2	<0.1	0.4
Silicon	n^+ -p	500	50	500	<3	<0.5	0.3
Germanium	p-n	40	40	250	5	200	≈ 1.0

voltage, V_B , of the device as the temperature increases,* which would result, at a constant bias voltage, in a decrease of the multiplication factor. The multiplication factor can be made relatively insensitive to temperature variations by a compensating circuit, which uses a similar diode, operating as a temperature-sensing device, to adjust the bias voltage.

For systems applications, the advantages of the avalanche photodiode must be weighed against the cost and possible reliability problems associated with the additional circuitry required for the stable high bias voltage and temperature compensation, which would not be necessary for non-avalanche photodiodes.

CONCLUSION

The performance requirements of photodetectors, for use in optical-fibre transmission systems, will be dictated by factors such as the information bandwidth of the system, the type and attenuation of the optical fibre to be used and the emission wavelength of the optical sources. At the present stage of the development of systems, in spite of the uncertainties that exist concerning many of these factors, the semiconductor photodiode is seen to be generally the most suitable photodetector.

The properties of a photodiode can be optimized for a particular optical-fibre system by the proper choice of the semiconductor material and the diode structure. An additional

* For a Si device with $V_B \approx 80$ volts, change in $V_B \approx 80$ mV/°C.

degree of flexibility also arises from the possible choice between the basic photodiode, which has the advantage of simplicity of operation, and the more complex avalanche photodiode which, due to internal current gain, leads to an improvement in the system performance.

ACKNOWLEDGEMENTS

The authors gratefully acknowledge many discussions with M. D. Gill and R. W. Brander of the British Post Office Research Department, and their work in fabricating avalanche photodiodes.

References

- ¹ ROBERTS, F. F. Optical-Fibre Telecommunication Transmission Systems. *P.O.E.E.J.*, Vol. 67, p. 32, Apr. 1974.
- ² BEALES, K. J., MIDWINTER, J. E., NEWNS, G. R., and DAY, C. R. Materials and Fibre for Optical Transmission Systems. *P.O.E.E.J.*, Vol. 67, p. 80, July 1974.
- ³ DYOTT, R. B. The Optical Fibre as a Transmission Line. *P.O.E.E.J.*, Vol. 67, p. 164, Oct. 1974.
- ⁴ NEWMAN, D. H. Sources for Optical-Fibre Transmission Systems. (In this issue, p. 208.)
- ⁵ MCINTYRE, R. J. Multiplication Noise in Uniform Avalanche Diodes. *I.E.E.E. Trans.*, Vol. ED-13, No. 1, p. 164, Jan. 1966.

Bibliography

- ¹ ROSS, M. Laser Receivers (Wiley, 1966).
- ² MELCHIOR, H., *et al.* Photodetectors for Optical Communication Systems. *Proc. I.E.E.E.*, Vol. 58, p. 1,466, 1970.

Programming Languages for Stored-Program Control

K. F. CLEMENTS, C.ENG., M.I.E.E., M.B.C.S.†

U.D.C. 621.39: 681.3.065

The use of the computer as the control element in telecommunications switching systems is becoming increasingly widespread. When the computer was used primarily as a design aid, it was desirable that users should take a pragmatic view and insist that the language should provide a tool specifically tailored to their needs. This attitude delegated to the computer scientist the tasks of reconciling the users' demands to the efficient use of the computer, and interpreting their requirements into machine-orientated orders. This is no longer the case; the communications engineer will need to be concerned with all aspects of computer-programming languages, and this article is a brief introduction to some of them.

INTRODUCTION

Before embarking on a discussion of programming languages for stored-program control (s.p.c.), it may be helpful to set the scene by describing, in general terms, what a programming language is, and what, if any, are the special problems associated with s.p.c.

Programming languages are the means whereby the rules necessary for problem evaluation (the algorithm) are conveyed to the problem evaluator (the computer). They are the link between the specification of the solution and the sequence of program steps, or machine states, through which the hardware must progress during the evaluation.

† Telecommunications Development Department, Telecommunications Headquarters.

It is possible for a solution to be specified in terms of the computer machine-code, this being a set of instructions directly-executable by the hardware. This method of control is called *machine-code programming*, and was the original means of programming computers.

Because the notations of machine codes are those of the computer, machine-code programming is very error prone, and places great demands upon the programmer. Its use results in the employment of professional programmers who understand both the problem to be solved and the idiom of the machine. Clearly, if computers were to become a universal tool, such a state of affairs could not persist, and this provided the motivation for the invention and development of *high-level programming languages*.

High-level languages allow the solution, or *program*, to be

expressed in as few statements as possible, and to be couched in terms that are commonplace to the programmer. Thus, if a program is being written to interrogate a computer-based file, then such a command as READ THE NEXT RECORD might be allowed. A program is constructed from a number of such simple or primitive statements according to the syntax of the language, and then, by a process called *compilation*, each statement is expanded, or compiled, into a set of machine instructions, called the *object code*. The program controlling this process is the *language compiler*.

The first high-level language compilers were produced during the period 1956–1958. Since then, many hundreds of programming languages have been designed and many more dialects of the existing languages produced. A number of these have been for specific purposes and are generally referred to as *problem-orientated, high-level languages*.

SPECIAL FEATURES OF S.P.C.

The term *s.p.c.* is applied to the method of providing some of the control functions of a communications switching exchange by a computer program. The rationale for such a system is the relative ease, with respect to comparable hardware provision, with which post-installation modifications can be effected; modifications made necessary by new and enhanced facilities. This argument is further reinforced if a high-level language is used to program the exchange control system. Such programs are readable, more readily understood and, therefore, more easily modified.

However, ease of program modification is not the only criterion by which to judge the use of a high-level language. Conflicts arise when other factors, such as hardware costs, are also taken into account.

In general, the closer the programming language is related to the problem, the wider its syntax diverges from the machine-code language of a typical computer. The language compilers used in the conversion process become more expensive to produce and operate, and the object codes they produce use the computer hardware in a less-efficient manner than an equivalent machine-code program.

REAL TIME

The term *real time*, in common with many others in the field of computing, is incapable of being defined in a way both precise and universally meaningful. Loosely, it is applied to that class of computer applications where the computer has to play an active or guiding part in a physical process. It refers, in particular, to the permissible reaction time of the computer part of that process. At one end of the spectrum, for physical processes involving human actions, it may be possible to allow the computer several seconds to compute its response to a stimulus. At the other end, a sophisticated weapon-guiding system may require course-correction information to be processed and acted upon in microseconds; the term *real time* is generally applied to both of these applications. If real-time problems are analysed, a good deal of commonality emerges—common problems that at first sight are not evident. A class of programming languages, again very loosely described as real-time languages, has been developed, addressing themselves primarily to the programming problems associated with the close interaction between a computer and an external process.

SYSTEMS PROGRAMMING

Most large, modern, general-purpose computer systems operate in a multi-programming environment; that is, a number of programs appear to be in the process of execution simultaneously.

The peripheral devices attached to a computer, devices that input, output and store information, usually operate

very much more slowly than the computer itself. If the program requires some further information before it can continue, and that information must be accessed from a peripheral device, then a single-programmed computer must wait, doing nothing useful, until that information becomes available. If this situation arises in a multi-programming system, then the computer turns its attention to other programs, returning to the original program when the information becomes available.

Management of multi-programming computer systems is vested in a special program suite called the *operating system*, a set of programs that are permanently resident in the computer memory, and which control the running of all other programs.

The programming of operating systems is called *systems programming*, and is a very complex real-time task. Because the operating system is an overhead that permanently occupies expensive computer resources, it should be very efficient. The main argument in favour of high-level language programming, that of minimizing programmer effort, is also valid for systems programming. This, and the equally pressing need for object-code efficiency, has given rise to the development of a class of real-time programming languages called variously, *system-implementation languages*, *high-level assemblers*, and *machine-orientated, high-level languages*. Certain of these programming languages are suitable for some types of s.p.c. programming, and this article discusses examples of this class.

PROGRAMMING LANGUAGES

The programming languages FORTRAN and ALGOL have a special place amongst the many hundreds of programming languages and language systems that have been developed. They owe their inclusion in this discussion, not because they were conceived of as s.p.c. or general real-time languages, but because the development and propagation of these languages largely mirror the development of the computer itself. Almost all other programming languages bear some generic resemblance to these languages, and they have also had some influence on the design of computer hardware.

The pre-eminence of FORTRAN and ALGOL has resulted in their becoming the vehicle for much of the formalism associated with programming-language construction and design, and many of the concepts of these languages have assumed an adjectival role; for example, languages are said to have a *FORTRAN common feature* or an *ALGOL block structure*.

Therefore, a knowledge of the basic features of these languages is essential before most other program-language descriptions can be understood.

FORTRAN

The earliest recorded existence of a formula-translating system (FORTRAN—derived from the first syllables of the two words) dates from 1954; the language specification was published in a paper issued by I.B.M. in November of that year.

From the earliest publications, it was evident that the FORTRAN language was intended to be capable of handling problems associated with the numerical computations arising within the engineering and scientific disciplines. However, the language has been adapted and used in a wide variety of ways, including real-time and s.p.c. applications.

Because so many different versions of FORTRAN exist, and are widely used, it is difficult to generalize when describing the features of the language. The rather brief, technical description of FORTRAN given in this survey is of the American Standards Association's basic FORTRAN.

FORTRAN is said to be *procedure orientated*; that is, the programmer specifies a set of executable instructions and,

also, the sequence in which these instructions are executed. It is important to realize that, as far as the programmer is concerned, every instruction written is assumed to be a single entity. The fact that each of these instructions is decomposed, by compilation, into a number of minor instructions (the object code) is completely hidden from him and, consequently, he has no control over the object-code operational sequence.

The term *non-procedural* is relative and is loosely synonymous with the level of a programming language. The closer the affinity of a language to the solution being expressed, the smaller the number of programmer-written instructions required, and the more non-procedural the language becomes. Those languages, or more properly, language systems, that are suitable for a very narrow range of problems are, by arbitrary definition, called non-procedural.

Statements

There are five types of FORTRAN statement, namely:

- (a) assignment,
- (b) control,
- (c) input,
- (d) specification, and
- (e) sub-program.

Assignment Statements

These statements control the assignment of values, either constant or computed, to data items. Assignment means, in computer terminology, to place a data item into a defined receptacle called the *variable*.

These variables are given names by the programmer, with the initial letter denoting the type of values that can be assigned to them. Variables can be of two mutually-exclusive types, *integer* or *real*, real values being those which contain a decimal point or exponent. The usual arithmetic operations can be carried out on variables, and the results of an operation can then be assigned to any variable of the correct type.

Control Statements

Generally, programs are executed by passing control from one statement to the next in strict sequential order. The purpose of control statements is to allow the programmer to modify this ordering.

For an unconditional change of control, the statement

GO TO *n*

causes control to be passed to the statement labelled *n*.

For a conditional change of control, the statement

IF (*arithmetic expression*) *n*₁, *n*₂, *n*₃

causes the arithmetic expression to be evaluated, and control passed to the labelled statement depending upon the resulting value of the expression; for example, to *n*₁ if the value is less than zero, to *n*₂ if zero, or to *n*₃ if greater than zero.

Other control statements are available, typically to halt a program execution, either temporarily or permanently, and to control program loops.

It is often necessary in program execution to obey a contiguous set of statements more than once; this is termed *program looping*. Loop control in FORTRAN is handled by the DO statement; this is of the form

DO, *n*, *i* = *n*₁, *n*₂, *n*₃.

The range of the loop is from the statement following the DO statement until, and including, the statement labelled *n*.

The sequence of statements in the loop is initially executed with the variable, *i*, assigned the value *n*₁. When the statement, *n*, has been obeyed, the value of *i* is incremented by the value of *n*₃, and control is passed to the start of the loop. This process is repeated until the value of *i* exceeds the value of *n*₂.

Specification and Input Statements

Specification statements do not directly cause object-code instructions to be generated. They are the instructions to the compiler, giving details of the format of the input and output data and the location in the computer memory where information is to be stored.

Sub-programs

A sub-program, or sub-routine, is a self-contained set of instructions that performs an often-required evaluation. Examples, such as calculating and finding the roots of a polynomial, frequently occur in scientific calculations, and can be found in every class of programming. Clearly, it is wasteful of effort for every programmer to write the same, or very similar, routines, and the idea of sub-programs was conceived.

Those sub-programs that are applicable to the general users of a programming language are made available to the programmer by a library of such functions maintained by the compiler, and are called *intrinsic functions*. The programmer can cause the code associated with these sub-programs to be inserted in his program merely by writing the name of that sub-program and including any necessary arguments. Thus, the evaluation of the sine of any angle can be included in a program by writing

SIN *x*,

x being the variable data item supplied as an argument to the sub-program.

An extension to this facility is the sub-program defined by a programmer for his own use, or for a very restricted class of users.

In FORTRAN, these sub-programs are invoked by inserting

CALL *name* (*a*₁, *a*₂, *a*₃, etc.)

in the program. *Name* is an arbitrary means of identifying a sub-program, and *a*₁, *a*₂, *a*₃, etc. are the arguments.

The statements making up the sub-program must logically terminate by the statement RETURN. This causes control to be returned to the main program at the next sequential statement following the statement CALL.

FORTRAN in Real Time

The use of FORTRAN in real-time applications was never a published design criterion of the language. Indeed, the use of computers to control or direct a physical process post-dates the introduction of FORTRAN by several years.

Within the scientific community, the use of FORTRAN quickly became entrenched, and educational establishments used FORTRAN as a vehicle to introduce the computer to a wide audience. This wide-spread acceptance of the language makes it attractive to continue to use, and conformity has been the main reason for many to adapt and modify FORTRAN to every conceivable use to which the computer has been put. An indication of the degree to which FORTRAN and its variants are being used in real-time applications is given in a recent survey¹ conducted by the National Computing Centre; 53 per cent of the organizations approached were using FORTRAN as the standard language for programming systems which had some element of process control.

ALGOL

ALGOL (derived from "algorithmic language") has made a number of significant contributions to the art of computer programming. Not least amongst these is that ALGOL was the first major language to be designed by a committee—an international committee, in fact.

A group of computer scientists met in May 1958 to set the

terms of reference of a language designed to describe computational processes. The terms agreed were that

(a) the new language should be as close as possible to standard mathematics and be readable with little further explanation,

(b) it should be possible to use the language for the description of computer processes in publications, and

(c) the language should be mechanically translatable into machine-code programs.

There is no indication, in these terms, that the designers had any desire other than to produce a language for mathematical computation, and it is reasonable to assume that the demands of real-time computing had a low priority in their original thoughts. But, as in the case of FORTRAN, the evolving concepts of ALGOL have been adapted and used in every conceivable way to program computers for a very wide range of purposes.

ALGOL 60

The language that the original committee created, ALGOL 58, was subjected to public debate. After a number of international meetings sponsored by, amongst others, the Association of Computer Machinery and the International Federation of Information Processing, there emerged, in 1962, "The Revised Report on the Algorithmic Language, ALGOL 60"².

The revised report introduced to a wide audience the use of the, then, new and rigorous formalism for syntactic description called *Backus Normal Form* (B.N.F.). This technique, introduced by J. W. Backus in 1959, uses a formal description-language to describe and define syntax. Its use largely removes the ambiguities that are present when definitions are couched in English, and B.N.F., or its derivatives, are employed in almost all modern language description.

The revised report also introduced the concept of three language levels, a *reference language*, a *publication language*, and an *individual hardware representation*.

The reference language was to be a definition, and was to be used as the basis for all implementations of compilers. The revised report's description of ALGOL 60 was, in fact, a description of the reference language.

The publication language was introduced to allow different, but equivalent, forms of the reference language. The revised report admitted that not all alphabets contained the same set of symbols, and that similar symbols were often used for dissimilar purposes in different environments. The report contained some basic rules for translating certain reference-language symbols into forms more suitable for publications, and, further, specified that each implementation of the language must be accompanied by the rules necessary to translate between publication and reference languages.

The concept of the hardware-representation level was primarily an artifice to enable the designers of ALGOL 60 to define a totally machine-independent language. Certain hardware features of a computer, such as the size of memory cell and the format of the input characters, vary considerably with different computers. If a programming language takes due account of these particular hardware features, it is said to be *machine dependent*.

It was the avowed aim of the ALGOL 60 designers to design a totally machine-independent language, and it was the purpose of the various hardware representations to show how the character-set and word-size of a particular implementation would be automatically translated from the reference-language definition.

All meaningful programs, at some stage, require to communicate with an external agency. The mechanics of this communication, called *input/output* (i/o), are very machine-dependent. Because of the desire to keep the reference language completely general and untainted by any machine-dependence, the revised report does not mention programmed

control of i/o. This omission is, perhaps, the major criticism of the revised report, and it is interesting to note that no other language definition has gone to such great lengths to maintain the purity of the reference document.

Block Structure

Amongst the innovations of ALGOL 60 was the concept of a block structure.

An arbitrary sequence of individual statements can be enclosed in a begin/end pair of delimiters to form a compound statement. The compound statement is then treated as a single statement. If, immediately following the begin delimiter, there appear some specifying instructions, called *declarations*, that assign names and types to data items, the compound statements become a *program block*.

Blocks can be nested, that is, one block wholly contained within another, to any degree, and the data declarations at the block-head are only valid within that block. When the data items declared at the block-head are no longer valid, that is, when the end delimiter of that block is reached, the items are said to be out of scope, and the memory locations they occupy become available for re-use by the compiler.

It is possible for the programmer to circumvent this general rule of scope by declaring the data item as own. This declaration is a directive to the compiler to maintain, inviolate, the value of the data item whenever it goes out of scope, and to make that value available to the programmer if, and when, the data item returns into scope.

Statements

With the exception of the input type, the statements of ALGOL 60 are broadly comparable with the categories for FORTRAN.

Data Items

ALGOL 60 introduced a data type, called *Boolean*, that can represent either of the logical values *true* and *false*.

It further allowed a subscripted data type called an *array*.

An array is a group of data items of the same type given a common name, and individual members of this group can be referred to by subscripting the array name; thus, $A(i)$ refers to the i th item of the array whose name is A . The revised report allows A to be any dimension; that is, there is no limit to the number of subscripts. Thus, $A(i, j)$ refers to the j th data item of the i th group of items within array A .

Control Statements

The conditional control statement in ALGOL can have one of three forms. The simplest is

if B then (*unconditional statement*).

B is a data item of the Boolean type. If this type has the value *true*, then the unconditional statement is obeyed. If *false*, then the unconditional statement is by-passed and the next statement is obeyed.

The second form is

if B then (*unconditional statement*) else (*any statement*).

In this case, if B is *false*, then the statement following else is obeyed.

The third form is

if B then (for *statement*).

The for statement is the basic loop-control in ALGOL. It is of the general form:

for (*list*) do (*any statement*).

The list consists of a single parameter which is to be varied

(the loop-control variable), followed by the list over which it is to be varied, and finally, one or a number of parameters with values that determine when the loop terminates.

The list, over which the loop variable may be assigned values, can be of the form:

A step B until C.

Initially, the loop variable is assigned the value *A*, and the statement following do, is then obeyed. The loop variable is incremented by the value *B*, and the process is repeated until the loop variable equates to, or exceeds, the value *C*.

An alternative form of the variable list is

A step B while C.

The loop is performed as before, but terminates when the value of the Boolean variable, *C*, is *false*.

ALGOL has the same unconditional go-to control statement as FORTRAN, but introduces a qualifiable version of this, called a *switch*.

A switch is declared, as a part of the specification process, to have a name and a sequence of references to labelled statements called the *switch list*. The switch is then used as an argument in a go-to statement. Thus, writing

go to *S(i)*,

causes control to be passed to the *i*th reference of the switch list named *S*.

Sub-Programs

The sub-programs of ALGOL, referred to as *procedures*, are similar in concept to those of FORTRAN. A procedure declaration is in two parts, called the *procedure head* and *procedure body*.

The head gives a name to the procedure, and also specifies the names, if any, of the procedure parameters.

The body of the procedure consists of a statement, a compound statement, or a program block specifying the procedure of the sub-program. This procedure declaration is a directive to the compiler to put the statements, or program block of the procedure body, in place of the procedure name, wherever this occurs within a program.

A programmer, by writing the name of the procedure in a program, is said to have *called* the procedure, and the location of the call is termed the *call site*.

A further type of procedure, the *function procedure*, allows the programmer to compute a value within the procedure body and, at the call site assigned to a variable, the value of that procedure.

ALGOL 68

Since the appearance of the revised report, a number of papers have been published, suggesting improvements and extensions to ALGOL 60. This activity culminated, in the spring of 1968, in the publication of "Report on the Algorithmic Language, ALGOL 68"³. This report described a theoretical plan of a language that was complex and very ambitious; many of the ideas introduced were in advance of the technology of language implementation and computer design. A technical committee of the International Federation of Information Processing is currently reviewing the initial report and a revised version is to be published shortly.

Versions of ALGOL 68, omitting some of the more ambitious concepts, have been implemented, and many other language designs have borrowed very heavily from the philosophy of the language.

ALGOL 68 is primarily a language for describing and manipulating data structures. Increasingly, computers are being used to process data where some, or all, of the information is contained in the structure of the data; for example, the

information content of a matrix of numbers is not wholly contained in the numerical values of the individual members, the spatial relationship of the numbers also being of significance. The processing of structured data, called *list* or *plex processing*, has a place in almost all computer applications, and ALGOL 68, by introducing a variable prefix called a *reference*, caters for this.

The concept of a data reference was used in earlier languages, notably by a language called LISP, and was also implicitly introduced by the multi-dimensional array of ALGOL 60. If a two-dimensional array is considered, it is only the second dimension that contains values, the first dimension is, in essence, a reference to the individual arrays that contain the required values. ALGOL 68 makes the reference explicit, applicable to all data objects, and clearly distinguishes between the variable and the data held in it.

In ALGOL 68, as in FORTRAN and ALGOL 60, there are a number of different kinds of data items, or objects, such as numerical values (real, integer or complex), logical values (*true* or *false*) and alpha-numeric characters. This distinction between different types of data is true for most high-level programming languages. There are some exceptions, called *typeless languages*. However, in ALGOL 68, items are classified by their *mode*. An integer number has the mode INT. A variable also has a mode, that of the object it can hold, prefixed by the word REF. Therefore, a variable capable of holding, say, a real number, (an object of mode REAL), has itself a mode, REF REAL, (a reference to a computed real value). This idea is, in principle, capable of being applied indefinitely. For example, a variable, capable of holding a reference to a further reference to a computed integer, has the mode REF REF INT. In this manner, very complicated data structures can be constructed and manipulated.

The reference concept, and its resulting implications, are perhaps the most significant advance in the field of programming-language technology that ALGOL 68 has introduced, and many of the ideas associated with it have already assumed the status of *de facto* standards.

The full ALGOL 68 language is perhaps too complex for it to be adopted generally for programming s.p.c. systems.

TELEPHONE PROGRAMMING LANGUAGES

The British Post Office (B.P.O.) have been actively interested in telecommunications-orientated programming languages since mid-1968. In that year, the B.P.O. and the University of Essex jointly financed a research project to define a language, called TPL 1, and to implement a compiler for it.

TPL 1

TPL 1 is a block-structured language, based on ALGOL 60 in the sense that, where possible, the syntax is similar. The most notable additional feature is a list-processing facility.

In s.p.c., most of the data that needs to be processed is structured in the form of lists or tables; that is, lists of the telephone calls at the various stages of switching, or tables of the facilities required by individual customers. Some of these lists need to be manipulated in a very dynamic manner. Typically, a telephone call may need to be attached to, and detached from, many different lists during the setting up of that call.

In TPL 1, a list consists of any number of records of identical size. A record may refer to a telephone call, and might contain information indicating the calling and called numbers, time of day and class of service. Records are stored in blocks of adjacent memory cells, sufficient cells being provided for the purpose of containing the information necessary to describe the record. In addition, there is one extra memory cell used as a reference. It is the purpose of this reference cell, or *pointer*, to maintain the continuity of the list by pointing to the next logical record of the list. When records are attached to, or detached from, lists during

processing, it is not necessary for the records to be physically moved within the computer memory. Instead, the list is maintained by modifying the relevant pointer; for example, if the n th logical record is to be detached from a list, the pointer of record $n - 1$, currently pointing to record n , is modified to point to the beginning cell of the record $n + 1$ and, thus, the old record, n , of that list, no longer exists.

This form of data structuring is called *one-way linked-lists*; one way, because the pointer mechanism is only capable of pointing to the next logical record. It was found, in practice, that it was often necessary for the list to have a pointer mechanism that enabled two-way linked-lists to be constructed; that is, lists with records that had pointers indicating the preceding as well as the succeeding records. This inadequacy, together with the further restriction of uniform record-size in TPL 1, led to the project being extended, within the B.P.O. Research Department, by the definition of a new language, TPL 2.

TPL 2

This language is primarily a sub-set of ALGOL 68, and, by implementing much of the reference concept, no restriction is placed on the size or shape of the structures that can be defined and manipulated.

The main difference between TPL 2 and ALGOL 68 is the degree of control a programmer can exercise in specifying the manner in which data is represented in the computer memory. Apart from one or two exceptions, a programmer, using ALGOL 68, cannot specify what size of memory cell is required for the various data objects, the allocation of cells to particular objects being a function of the compiler. Programming in TPL 2, it is possible for the programmer to give directives to the compiler, specifying how individual objects are to be stored and what, if any, data structures can share the same area of computer fast-access memory.

The facility which allows the programmer to utilize the same area of computer memory for different data structures is called *overlay*. This requires to be rigorously controlled since a programmer can inadvertently destroy vital information and, perhaps of more importance, use rubbish as valid data. Most programming languages that police the use of the overlay feature, do so in a manner that is expensive in terms of computer resources. The novel compiler-direction methods of TPL 2 permit secure and inexpensive overlaying.

The first version of the compiler is now available and is being tested.

GENERAL-PURPOSE, REAL-TIME LANGUAGES

A number of languages have been designed or adapted for use as command and control languages. As their title implies, these languages originated in the military field for controlling weapon systems. Perhaps the first language used for this purpose was JOVIAL.

JOVIAL

This language started life in 1958 as a research project to investigate the problems associated with compiler writing. Certain aspects, in particular, the concept of a set of data specifications common to a number of programs, were especially suitable for programming large, real-time systems. Others were added, and, by 1961-62, JOVIAL had evolved into a major real-time language.

The language is based on ALGOL 58, but so many features have been added that any resemblance is now difficult to detect. However, since the basic design precedes ALGOL 60, the language lacks the succinctness of those more particularly based on the ideas set out in the revised report.

The language has been adopted as standard by the United States Armed Forces, and some military s.p.c. communication systems have been, and still are being, programmed using the language.

CORAL

During the period 1963-64, the Royal Radar Establishment at Malvern decided to adapt a sub-set of JOVIAL to the on-line use of the range of small computers then available in the U.K. This sub-set was called CORAL 64.

During the initial evaluation of the early compilers, it was discovered that certain features of the language were difficult to implement in a manner which maintained the level of efficiency of usage of computer resources necessary when writing programs for small computers. This discovery led to a new language being devised, based more firmly on ALGOL 60, but retaining many of the concepts of JOVIAL. The language was called CORAL 66, and the official definition, published by H.M.S.O.⁴, was made available in 1970.

The language has been adopted by the Ministry of Defence as its standard language for real-time applications, and there are indications that the language will acquire an official status within the U.K. process-control industry. Two B.P.O. computer-based projects, the Experimental Packet-Switched Service and the computer-aided maintenance of the London sector switching centres, are being programmed using CORAL 66.

RTL

The initials are derived from those of real-time language. The original version, RTL 1, and the current version, RTL 2, were both defined by a project team from the I.C.I. Corporate Laboratory.

The RTL languages were primarily designed to program process-control systems, but their capabilities make them suitable for more general use in the field of real-time applications.

Most of the basic ideas of the current version, RTL 2, were provided by FORTRAN, ALGOL 68 and feedback from the precursor, RTL 1.

RTL 2 makes its most significant contribution to real-time language technology in the area of program control or sequencing.

Most real-time language designs, and certainly those so far discussed in this article, assume that the program control is in the form of a single thread; that is, there is a defined start to a program, the program executes its instructions sequentially, and there is defined finish. In a practical, real-time system, a number of concurrent events or processes occur. In order to control such a complex arrangement, it is necessary for the programmer to specify when, and under what circumstances, individual events can start and stop, and what events can occur simultaneously. This facility is called *multi-tasking*, and most real-time programming languages informally assume that the mechanisms for such complex control are made available by the existing software, or *operating system*. It is informal because the method of programmer-communication with an operating system varies considerably with different computers and, if a high-level programming language took formal notice of a particular system, it would become machine-dependent.

The design of RTL 2 also makes this assumption, but introduces a formalism for communication with the operating system.

HIGH-LEVEL ASSEMBLERS

The need to provide a programming tool which is efficient in terms of programming effort, that is, a high-level language, and, at the same time, allows the programmer to make optimum use of the computer hardware, has led to the development of a class of programming languages called *high-level assemblers*.

A number of high-level assemblers have been defined, all having the block structure, procedures, and IF, FOR and WHILE clauses of ALGOL 60, but each differing, in that the data items and operations on them are specifically those allowable

by the instruction-set of a class of computers. These languages are, therefore, machine-dependent.

The first of this class to appear was a language called PL 360, designed for the I.B.M. 360 range of computers. This has been followed by PL 516, designed for the Honeywell DDP computer range, and by PL 11, for the Digital Corporation PDP 11 computer.

BLISS

BLISS has been described, by its designers, as a *systems-implementation language*. This is, perhaps, an ambiguous term since all programs are, in some sense, systems that require implementing, and a brief examination of the reasons behind the design is required to obtain a clearer idea of the meaning of the term.

In 1969, the Carnegie-Mellon University, Pittsburgh, U.S.A., was engaged in a research project on computer networks. This project involved writing a large number of very complex programs to control the use of the computers. It was these programs that constituted the system.

BLISS is a language tailored for a specific computer, the Digital Corporation PDP 10. Whilst the language is, in most respects, machine-dependent, much of the design philosophy is not. Thus, it is possible for the language to be implemented (albeit much less efficiently) on other, different, computers. For this reason, BLISS is sometimes referred to as a machine-orientated language.

BLISS is an ALGOL 68 derivative, and is remarkable for its lack of the GO-TO form of program control. The designer of the language argues⁵ that the indiscriminate use of the GO-TO statement is a major source of programmer errors, due to difficulties in understanding and modifying programs.

NON-PROCEDURAL LANGUAGES

A number of non-procedural languages have been proposed for s.p.c. These are, more properly, language systems, in that the programmer supplies only the input to the system, usually in the form of entries to a pre-printed table, or by constructing flow charts, without any specification of the procedures involved.

It is possible, using non-procedural language systems, to construct a language that is very specifically tailored to particular applications. The syntax is very simple and easy to learn. However, separate, but very similar, applications require radically different languages. Each language can only be learned by rote, and this can lead to confusion.

As an example, a non-procedural language for s.p.c. could be designed to enable the system object-code to be generated from an annotated flow-diagram.

The programmer constructs a flow diagram of the required system, and writes into the appropriate blocks the relevant permitted phrase, such as CONNECT DIAL TONE or UPDATE CUSTOMER'S METER. This is now capable of automatic translation into the machine code. Each phrase is expanded into a set of machine instructions, and the blocks linked together in a manner described by the flow lines of the flow chart.

* C.C.I.T.T.—International Telegraph and Telephone Consultative Committee.

CONCLUSIONS

The computer started its life primarily as a tool for mathematicians and scientists. High-level programming languages were developed to ease the introduction of the computer to a much wider range of disciplines. For many years, the systems programmer, including the programmers of s.p.c. systems, rejected the use of high-level languages, arguing that the needs for the efficient use of the computer resources outweighed the advantages of high-level programming. Gradually, in view of the soaring cost of programmer effort and the reduction of hardware costs, most users of computers have come to recognize that programming at a higher level is economically justified. Programs are written more quickly, the resulting programs are more easily understood and, perhaps of greatest importance, programs can be more readily modified. The decision that any computer systems designer has to make is no longer between a high-level language and a machine language, but which of the many high-level languages available is the correct one. In making a choice, the designer must weigh a large number of often conflicting factors, such as the importance of machine-independence, the emphasis which should be given to the efficient use of computer hardware, and the priority to be given to the ability to modify program codes.

Designers of computer-based telecommunication systems are faced with a similar dilemma. S.P.C. is sufficiently general that almost any high-level programming language could be used, and a large number are very much suited to the task. This situation is complicated by the frequent additions of new and improved language designs and the persistence of such well-established languages as FORTRAN and CORAL.

An additional complication is international compatibility. The C.C.I.T.T.,* in common with a number of similar international organizations, recognize the merit in an agreed standard programming language, suitable for their respective fields. The activity of the C.C.I.T.T. is centred around an international committee of experts who are engaged in evaluating some 25 established programming languages. This committee is charged with the task of either recommending the adoption of an existing language, or producing a definition of an entirely new language, to be used internationally for s.p.c.

It is not the purpose of this article to attempt to solve any of the problems associated with the choice of a programming language for s.p.c., but to indicate, by a discussion of their characteristics, those classes of high-level programming languages that are relevant to that choice.

References

- ¹ FORD, F., and THOMPSON, K. Survey Report on Real-Time Language Standards for Industrial Use. Software Division, National Computing Centre, May 1973.
- ² NAUR, P. Revised Report on the Algorithmic Language, ALGOL 60. *Communications of the Association of Computing Machinery*, Vol. 6, No. 1, Jan. 1963.
- ³ VAN WIJNGAARDEN, A. Report on the Algorithmic Language. ALGOL 68. *Numerische Mathematik*, No. 14, p. 79, 1969.
- ⁴ Official Definition of CORAL 66. H.M.S.O., 1970.
- ⁵ WULF, W. A., RUSSEL, D. B., and HABERMANN, A. N. BLISS: A Language for System Programming. *Communications of the Association of Computing Machinery*, Vol. 4, No. 12, Dec. 1971.

Push-Button Telephones

S. E. CARD, B.SC., and D. T. LITTLEMORE, B.SC.†

U.D.C. 621.395.721:621.395.652:621.395.38:621.3.049.77

A range of push-button telephone instruments, known commercially as Keyphones, has been developed to function with 3 different local signalling systems: multi-frequency, d.c. code C and loop-disconnect. The use of multi-frequency and d.c. code C signalling instruments is, at present, confined to those p.a.b.x.s which are equipped with the appropriate signalling capability. Loop-disconnect signalling instruments, of which certain types are on trial, enable push-button signalling facilities to be offered to customers on public exchanges.



(a) Multi-frequency and d.c. code C signalling instrument
(b) Loop-disconnect signalling instrument

FIG. 1—Push-button telephones

INTRODUCTION

Push-button telephone signalling systems have been, and are being, developed to meet a demand from customers for a reduction both in the time taken to set up a call and the manual effort needed. High-calling-rate business users, in particular, welcome the prospect of relief from continually dialling numbers involving many digits. Telecommunications administrations also have an economic interest in adopting fast-signalling systems, since these can lead to reductions in the holding times of expensive common-control equipment.

Two types of push-button telephone, the multi-frequency and d.c. code C signalling instruments, permit the rapid setting-up of calls within p.a.b.x.s which have been specially equipped with the appropriate receiving equipment. The third type, the loop-disconnect signalling instrument, has been developed as a direct replacement for the rotary-dial telephone, and whilst no reduction in call-setting-up time is possible, it does enable some of the advantages of push-button signalling to be offered to the public-switched-telephone-network customer. The several proprietary designs, which are currently undergoing trial in a limited number of telephone areas, have been well received.

This article discusses the principles of operation of the

push-button unit, and examines each of the 3 types of telephone and signalling system individually.

THE PUSH-BUTTON UNIT

After early trials with push-button telephones having a 2×5 button layout, the British Post Office (B.P.O.) has now adopted the 4×3 layout, recommended by the C.C.I.T.T.* for the multi-frequency and d.c. code C signalling push-button telephones, illustrated in Fig. 1(a). The symbols, ✖ (the *star* signal) and ⇨ (the *square* signal), adopted for the bottom left-hand and right-hand buttons (buttons 11 and 12, respectively), are also C.C.I.T.T. recommended. It will be possible, in telephone exchange systems of the future, to make use of code structures including signals from these additional buttons to gain access to new facilities, such as call-transfer facilities and third-party connexion. International discussions on code structure are still in progress. International agreement, firstly on button layout and, secondly, on the uses of signals, is to the advantage of travellers abroad, who wish to make use of the local telephone systems.

In the case of the loop-disconnect signalling push-button telephone, illustrated in Fig. 1(b), buttons 11 and 12 are omitted, as it is not possible to make use of signals from these buttons when loop-disconnect signalling is used by the local exchange.

† Telecommunications Development Department, Telecommunications Headquarters.

* C.C.I.T.T.—International Telegraph and Telephone Consultative Committee.

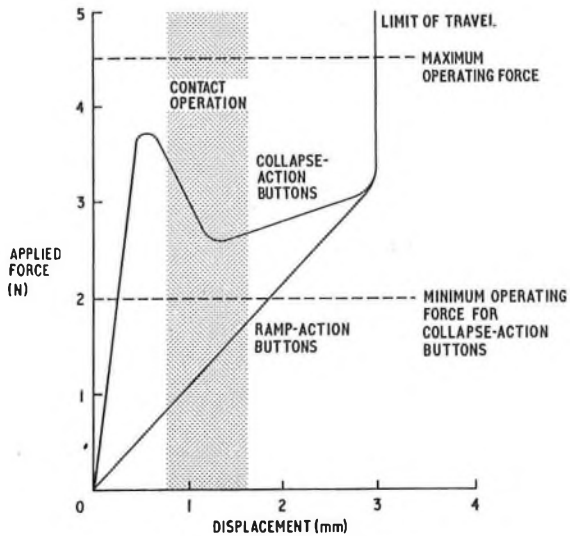

FIG. 2—Applied-force/displacement characteristics for ramp-action and collapse-action buttons

Operating Parameters

The push-button unit must be designed so that there will be a low keying-error rate, while, at the same time, allowing a reasonably high keying speed. To achieve a low error rate, it is necessary to ensure that the user, whether skilled or unskilled, will, with each depression of a button, send a unique signal of sufficient duration to be recognized by the detection equipment. Opinions differ among telephone administrations as to whether a *ramp* action or a *collapse* action is desirable for the operating-force/displacement characteristics of the buttons (see Fig. 2). The B.P.O. has decided that, for unskilled users at least, some form of feedback of information from the push-button telephone is necessary to give the user confidence that the button has been properly depressed and that the instrument is active. The feedback may be tactile, visual or aural. As visual and aural feedback cannot always be readily or economically realized, tactile feedback, in the form of collapse-action buttons, has been specified. The curve in Fig. 2 shows that the force offered by such a button falls significantly once the initial force has been overcome. This ensures that the normal user finds it difficult to prevent his finger from following the button through to its end stop. To ensure correct contact action, all contacts should have operated well before the button has reached the end of its travel.

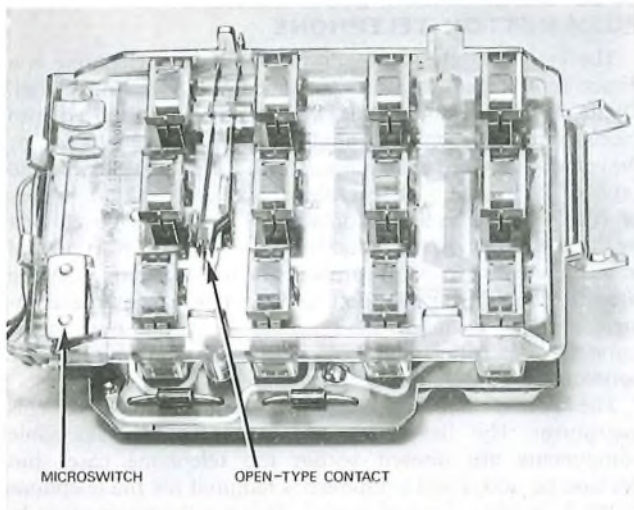

FIG. 3—Reverse side of a d.c. code C signalling push-button unit

Contact Arrangement

Current B.P.O. policy allows manufacturers a certain latitude in the design of push-button telephones. Provided that each manufacturer's product presents a common appearance to the customer, and complies with the operating parameters, the designer is free to arrange the push-button-unit contacts in whichever way he prefers. Thus, contact layouts range from one *make* contact per button for a loop-disconnect instrument, to 2 *make* contacts per button plus 3 common contacts, operated by any button, for a multi-frequency signalling instrument. In each case, contact units must be designed to have an adequate contact force and a suitably low contact resistance, of the order of a few milliohms, before and after an accelerated life-test and, also, after a severe industrial-atmosphere test. A typical contact spring is made of phosphor-bronze, the contact area being inlaid with an alloy of gold and silver.

Construction

A typical push-button unit for a d.c. code C signalling instrument, illustrated in Fig. 3, consists of a main plastic moulding, which provides guides for the button shafts and the location of the contact springs. The fixed ends of these springs are soldered to a printed-circuit board, which is mounted on the main moulding. Contact operation and the *collapse* action are achieved simultaneously as the button shaft slides against a specially formed contact spring, shown in Fig. 4. A ramp on the button shaft also causes the displacement of a metal grid, which operates the common contacts when any button is depressed. Fig. 3 shows 2 common contact units, one in the form of a microswitch, and the other in the form of an open-type *make* contact.

The tops of the buttons are manufactured in plastic, using a moulding process in which the black characters are moulded to the full depth of the body of the button, which is white. This process ensures a high degree of legibility throughout the life of the telephone.

D.C. CODE C SIGNALLING PUSH-BUTTON TELEPHONE

The Signalling System

A d.c. signalling system, using a code structure known as *d.c. code C*, has been adopted for use on privately-owned p.a.b.x. installations, as a relatively inexpensive alternative to loop-disconnect and multi-frequency signalling push-button telephones. It facilitates the rapid setting-up of calls within the p.a.b.x.

The signalling code is formed from combinations of the electrical states of the A- and B-wires. Either conductor may be earthed, disconnected, earthed via a forward-connected

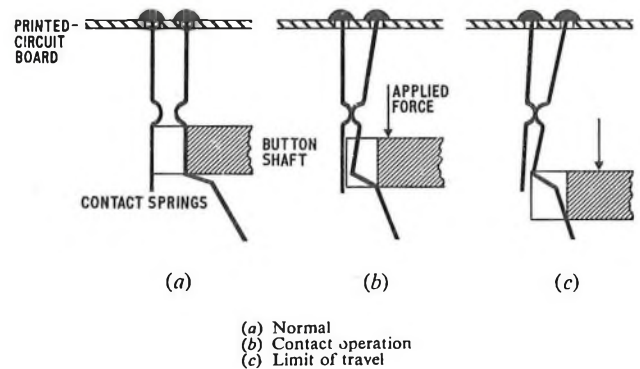
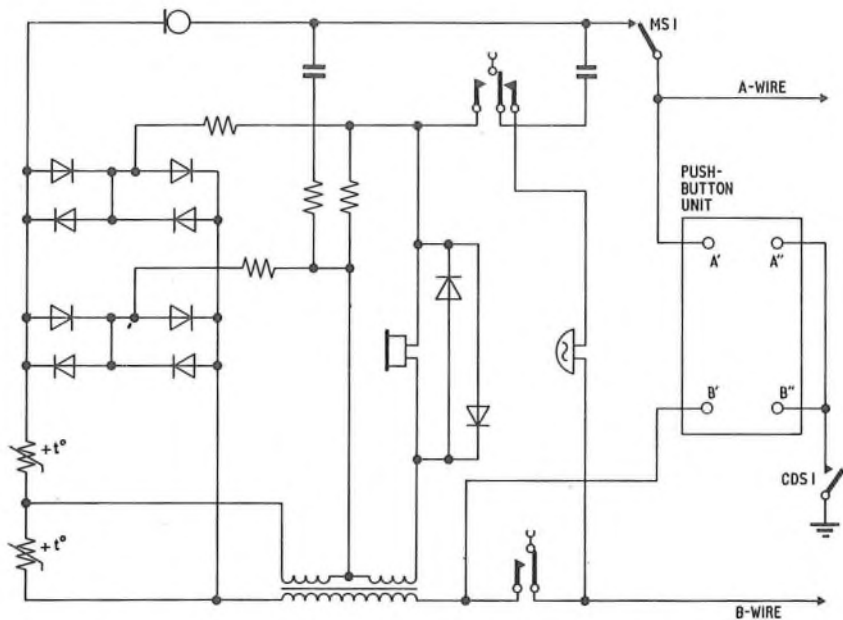

FIG. 4—Push-button-unit contacts, showing method of obtaining *collapse* action with contact operation



BUTTON	SIGNALLING CONDITIONS WHEN DIGIT BUTTONS DEPRESSED			
	A - WIRE		B - WIRE	
	A'	A''	B'	B''
1	○	○	○	○
2	○	○	○	○
3	○	○	○	○
4	○	○	○	○
5	○	○	○	○
6	○	○	○	○
7	○	○	○	○
8	○	○	○	○
9	○	○	○	○
0	○	○	○	○
*	○	○	○	○
□	○	○	○	○
	A'	A''	B'	B''

FIG. 5—D.C. code C signalling push-button telephone circuit, and A-wire and B-wire code states for each digit button

diode, or earthed via a reverse-connected diode. Of the resulting 15 useful combinations (the sixteenth being a complete disconnection), 12 are chosen to represent the numerical digits and the *star* and *square* signals.

The Telephone

The telephone is a 700-type instrument, with the dial replaced by a 12-button, push-button unit (see Figs. 1(a) and 3). Fig. 5 shows the connexion of a push-button unit in the telephone circuit, together with a table of the A- and B-wire conditions existing between the A' and A'' terminals, and the B' and B'' terminals, when each button is depressed.

When a digit button is depressed, the digit contacts prepare the appropriate code conditions, and then, common contact MS1 (the microswitch) disconnects the telephone loop. Finally, common contact CDS1 (the open-type contact) makes the earth connexion, to complete the circuit, enabling reception of the code by a receiver at the p.a.b.x. The contacts restore in the reverse order when the button is released.

Receiver Circuit

A simplified block diagram of the d.c. code C signalling-system receiver is shown in Fig. 6. It consists, essentially, of a control circuit and 4 code relays: W, X, Y and Z.

When the handset of an extension telephone is lifted, a free register is selected, and the telephone loop is extended into the associated receiver's control circuit to prepare for the reception of digit signals. When a button on the push-button unit is operated, the control circuit commences a sequence of operations in which, firstly, relays W and X are

connected to line for several milliseconds, and secondly, following the operation of relay S, relays Y and Z are connected to line for a further few milliseconds. Finally, conditions are set up to detect the release of the button. Relays W and X are connected to a negative battery potential, and relays Y and Z to a positive battery potential. Hence, combinations of these 4 relays will operate, depending upon the conditions set up by the button contacts, the combinations being stored in the register for processing the setting-up of the call. The combinations for each digit button are shown in Fig. 6.

LOOP-DISCONNECT SIGNALLING PUSH-BUTTON TELEPHONE

The loop-disconnect signalling push-button telephone is a direct replacement for an instrument with a rotary dial. Digits, keyed in by the user, are stored and converted into trains of loop-disconnect impulses, which are sent to line at the rotary-dial speed of 10 pulses/s with a break-to-make period ratio of 2 : 1, and with pre-digital and inter-digital pauses of 800-900 ms inserted automatically. The main benefit felt by the customer is in the reduction of the manual effort needed to set up a call. No claim can be made for saving time, as the overall time for a connexion to be set up, from the commencement of keying to the reception of ringing tone, is the same as for a rotary dial, provided that no pauses are made between digits.

The prefix, "self-contained", is often applied to this instrument. This has arisen, not because all the electronic components are housed within the telephone case, but because no additional equipment is required for the telephone to work into Strowger exchanges. It is a self-contained push-button signalling system.

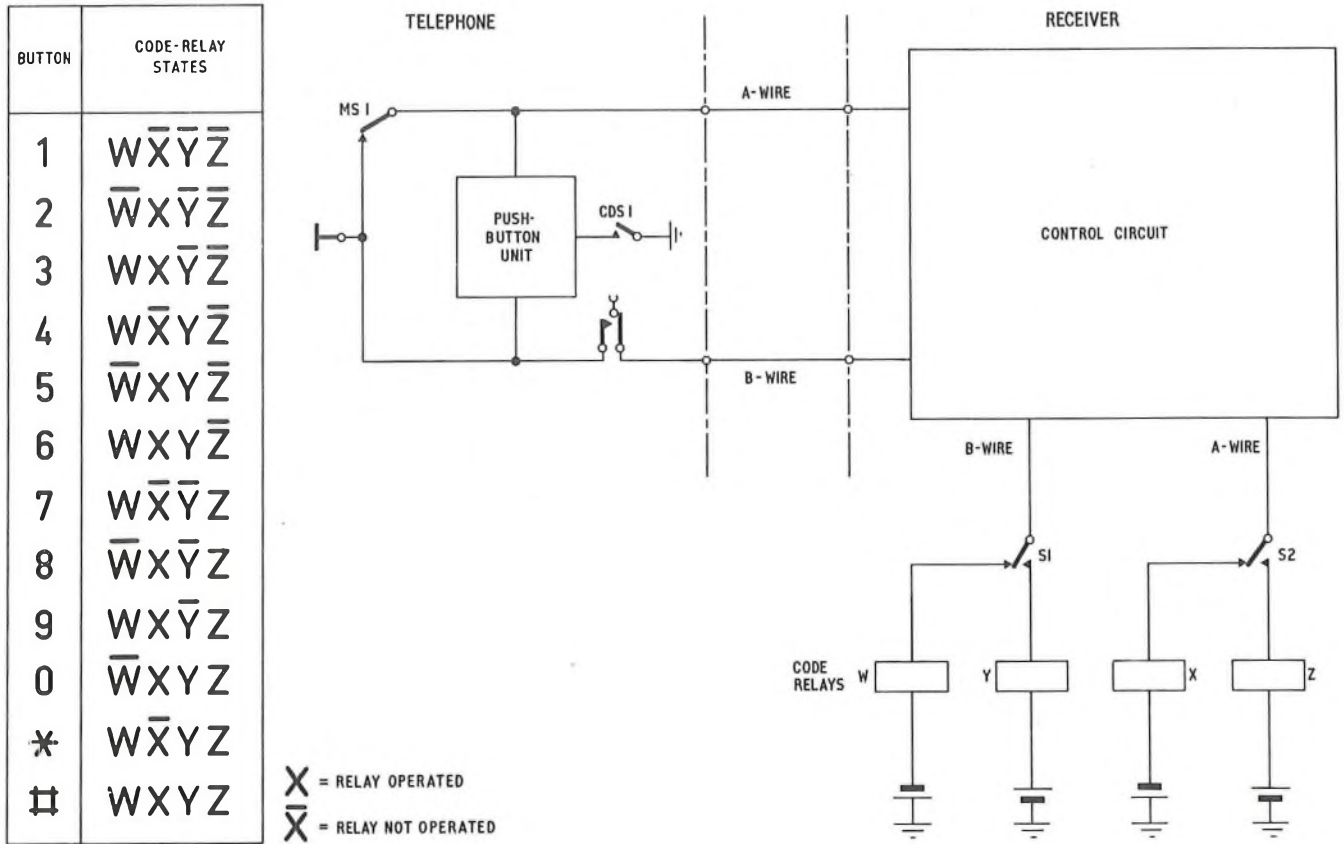

FIG. 6—Block diagram of d.c. code C signalling-system receiver arrangements, and code-relay states for each digit button

The Telephone

A dismantled loop-disconnect signalling telephone is shown in Fig. 7. It is, basically, a 700-type instrument. The push-button unit, which is normally fixed in position by the mountings used for a rotary dial, is shown on the left, partially concealed by the printed-circuit board mounted on its rear. This board carries the electronic circuitry for the storage, input and output devices, including a reed relay which provides the off-normal function. A mercury-wetted pulsing relay is mounted in the vertical position beside a nickel-cadmium battery, adjacent to the left-hand bell gong. Fig. 8 shows the circuit diagram of the telephone, with the push-button unit shown schematically.

Electronic Circuitry

The functions of digit-storage, and generation of pulse trains and inter-digital pauses, demand a highly-complex electronic circuit. A discrete-component realization of the circuit would be extremely costly, large and power-consuming. It is only with the advent of metal-oxide-semiconductor, large-scale-integration technology,¹ that the loop-disconnect signalling push-button telephone has become a viable proposition. Single-package, customer-designed integrated circuits, providing all of the necessary logic functions, which require 1,000, or more, transistors and other elements, have been developed by several telephone-equipment manufacturers.

The clock pulses for the logic circuit, and the timing waveforms for the loop-disconnect pulses, inter-digital pauses etc., are derived from a discrete-component oscillator with a fundamental frequency of the order of 20 kHz.

After processing, outputs from the integrated circuit are

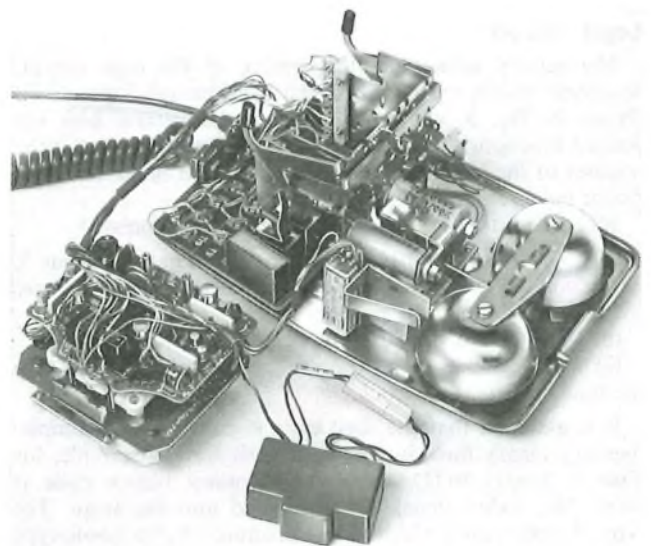

FIG. 7—Dismantled loop-disconnect signalling push-button telephone

fed, via driving transistors, to the pulsing and off-normal relays, the contacts of which replace those of the rotary dial in the telephone circuit. The heavy-duty pulsing contact is a mercury-wetted reed insert, and the lighter-duty off-normal contacts are twin dry-reed inserts.

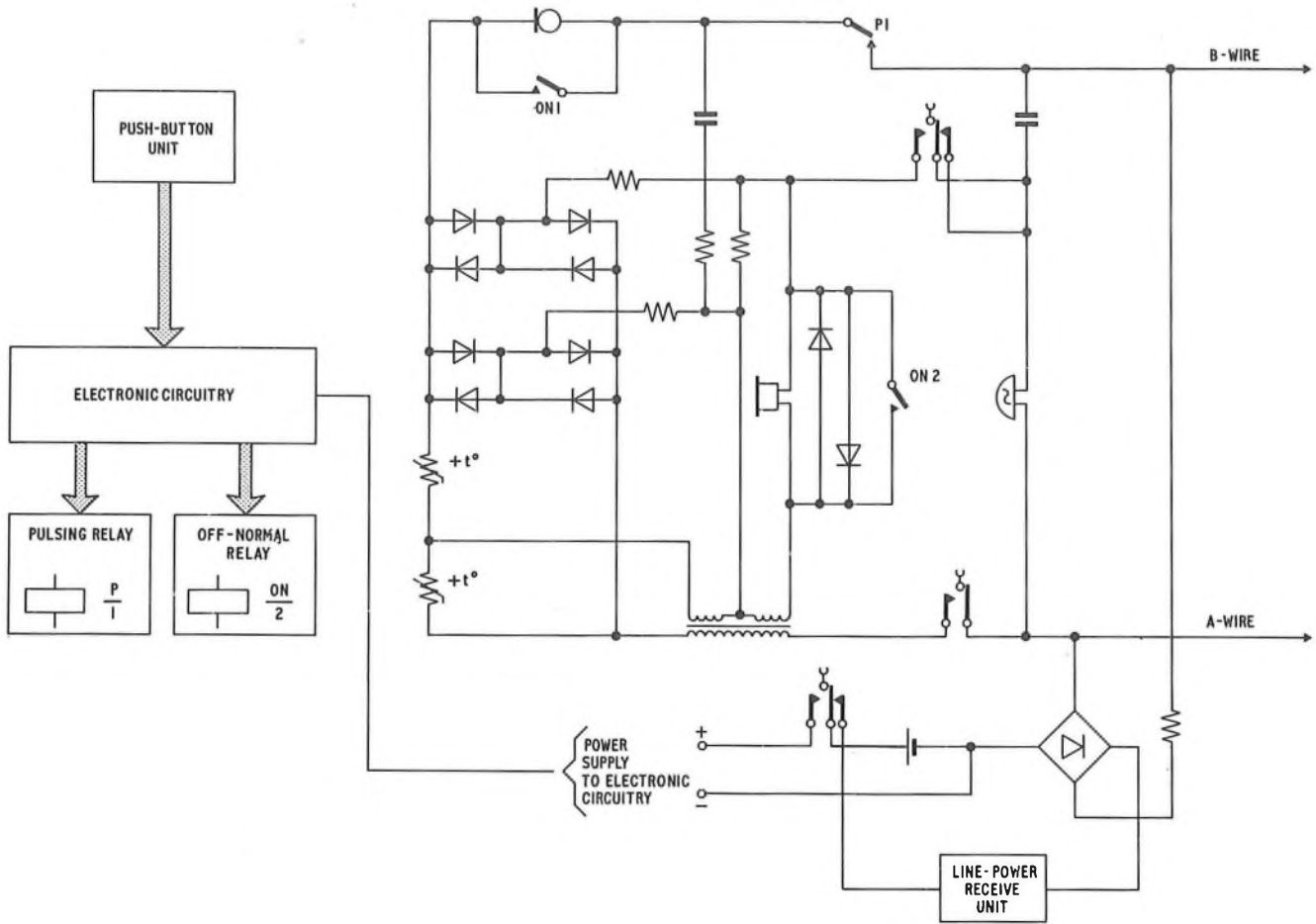

FIG. 8—Circuit diagram of loop-disconnect signalling push-button telephone

Logic Circuit

The general principles of operation of the logic circuit, described below, are based on the hypothetical logic circuit shown in Fig. 9, which is intended to illustrate how the desired functions can be implemented. It is assumed that the handset of the associated telephone has been lifted, and that power has been applied to the circuit.

When a button on the push-button unit is depressed,

(a) the off-normal drive is activated, via gating circuit 5, to operate the off-normal relay, the contacts of which prepare the telephone circuit for pulsing,

(b) the oscillator is started, via gating circuit 5, and

(c) a code representing the required digit is entered into the input register.

It is assumed that the digit code is converted to complementary binary form in the input register; for example, for digit 7 (binary 0111), the complementary binary code is 1000. The coded signal is then passed into the store. The type of store varies with the manufacturer, but a queue-type shift register is postulated here, for simplicity. The 4-bit coded digit is clocked along the shift register until it reaches the first vacant address, counting from the right-hand end. In the case of the first digit, it immediately enters the output register, since this is empty and gating circuit 1 is open.

Meanwhile, gating circuit 2 is inhibited during the pre-digital pause initiated by the *detect-off-normal* signal from gating circuit 5, via the delay circuit. At the end of this pause, gating circuit 2 opens and the digit enters the counter. In its idle state, the binary output of the counter is set at 1111, which causes gating circuit 3 to inhibit gating circuit 4, so that it is closed to the 10 pulses/s pulse drive. As soon as the

digit enters the counter, the output is set to the appropriate code; in this example, 1000. Gating circuit 4 opens, and the pulse drive is connected to the pulsing relay. Seven loop-disconnect pulses are sent to line while the counter is stepped

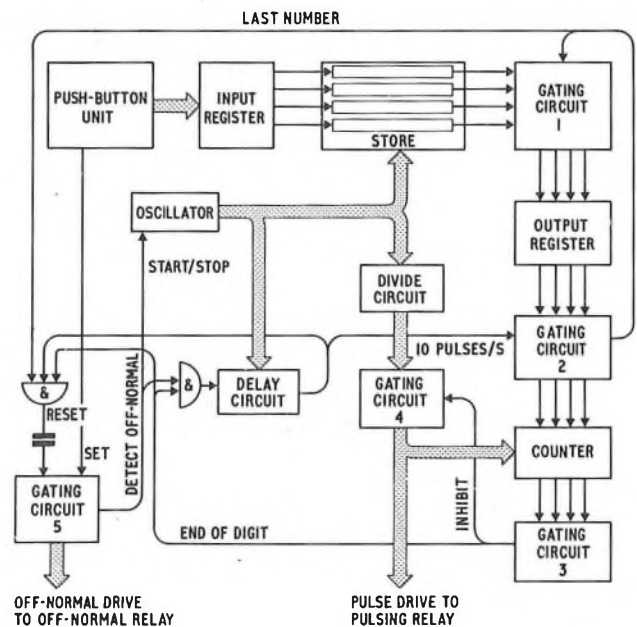

FIG. 9—Hypothetical logic diagram for the loop-disconnect signalling push-button telephone

from 1000 to 1111. This condition, which signals the end of the digit, once more inhibits gating circuit 4, to cut the pulse drive. The *end-of-digit* signal also reactivates the delay circuit, to inhibit gating circuit 2 for a further pause, this time an inter-digital pause. The cycle of events is then repeated, as long as digits remain in the store.

When the store is empty, and the last digit has been sent, the 1111 condition from the counter initiates the delay as before. In this case, the delay is the post-digital pause. At the end of the delay period, a *last-number* signal from the output register, via gating circuit 2, causes the off-normal drive to reset. The off-normal relay releases, to restore the telephone circuit to its speech-transmission mode.

Power Supply

The electronic circuitry needs a relatively constant supply voltage during the storage and pulsing-out processes, and, in the present generation of instruments, this is provided by a small nickel-cadmium rechargeable battery, which is housed inside the telephone case. The battery, which has a capacity of 120 mA h, supplies sufficient power for about 80 s.t.d. calls per day, assuming recharging occurs during idle periods, after the handset is replaced. For heavier usage, a mains-driven power unit must be associated with the instrument.

A line-power receiving unit, similar to that used for battery-charging in the 1 + 1 Subscribers' Carrier System WB 900, is incorporated² (see Fig. 8). The working resistance of the unit is 15 kohm and, hence, the charging current of 3 mA is below the current required to operate the exchange calling-equipment line-relays. Therefore, no additional apparatus, corresponding to the subscribers' carrier system line-power transmitting unit, is needed in the exchange. As with the subscribers' carrier system, the line-power receiving unit effectively disconnects the battery whenever line-testing procedures are to be carried out, by inserting an impedance of at least 2.5 Mohm into the circuit for a period of about 30 s.

Developments

Advances in electronic circuit design, and in metal-oxide-semiconductor technology, have led to a reduction in the power needed to fulfil circuit functions. As a result, developments are in hand to dispense with the local battery in the next generation of loop-disconnect signalling push-button telephones. This will reduce servicing costs. The battery will be replaced by a large capacitor, which will be charged from the line current during button depressions, inter-digital pauses and *make* pulses.

MULTI-FREQUENCY SIGNALLING PUSH-BUTTON TELEPHONE

The System

Each signal in the multi-frequency push-button-telephone signalling system^{3,4} is represented by the simultaneous transmission of a unique pair of voice-frequency tones to the exchange. Special equipment is required at the exchange to detect and interpret the keyed information. At present, only certain types of large, privately-owned p.a.b.x.s are capable of using this signalling system. The allocation of frequencies for each of the 12 push-buttons is shown in Fig. 10. Each digit is represented by one frequency from the low-frequency band and one from the high-frequency band.

The Telephone

The multi-frequency signalling push-button telephone uses the normal 700-type telephone transmission circuit, and employs a multi-frequency oscillator, controlled by a 12-button push-button unit. Fig. 11 shows the instrument, with the oscillator and push-button unit in position. The

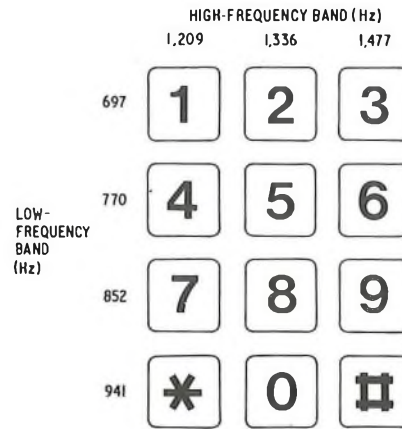

FIG. 10—Allocation of frequencies for the multi-frequency signalling push-button telephone

push-button unit takes the place of the rotary dial above the bell gongs, but it has been necessary to increase the size of the aperture in the telephone case, and to produce a special escutcheon plate to fit around the buttons (see Fig. 1(a)). The oscillator is fitted between the switch-hook gantry arms, and above the screw-type terminals. Since this space is normally used for mounting additional terminal strips, a 6-way terminal strip has been fitted to the rear of the oscillator's printed-circuit board. Two main cable forms, with gold-plated connectors, interconnect the oscillator, push-button unit and telephone printed-circuit board. Fig. 12 shows how the push-button unit and multi-frequency oscillator are wired into the basic transmission circuit.

The Push-Button Unit

Each button controls 2 individual *make* contacts, associated only with that button, and 3 common switches, which operate when any button is depressed. The 2 unique *make* contacts connect the transformer windings and capacitors of the oscillator circuit to form 2 resonant circuits, tuned to the required low-band and high-band frequencies. These contacts, the frequency-coding contacts, are shown in simplified form in Fig. 12, with their respective frequencies. These contacts are the first to operate when a button is depressed, and this ensures that both signalling frequencies are selected before power is applied to the oscillator.

The 3 common switches, S1, S2 and S3, operate in that numerical sequence, and perform the following functions.

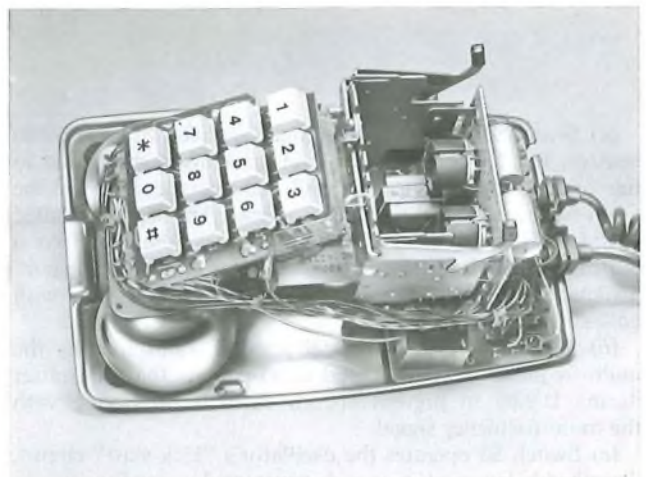
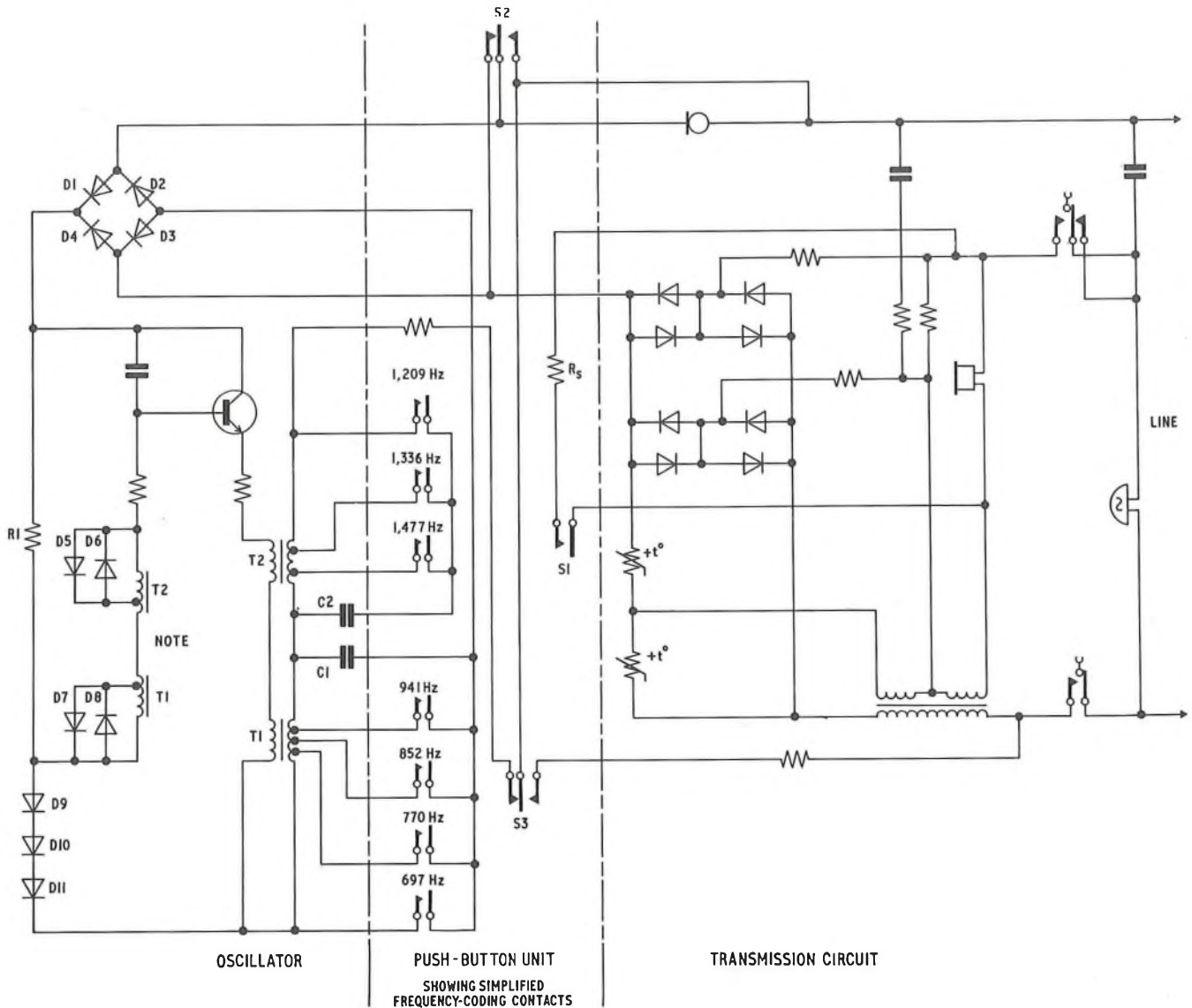

FIG. 11—Internal construction of the multi-frequency signalling push-button telephone



Note: T1 is a 3-winding transformer, consisting of the coils designated T1 in the base and emitter circuits. Similarly, T2 is a 3-winding transformer, consisting of the coils designated T2 in the base and emitter circuits

FIG. 12—Multi-frequency signalling push-button telephone circuit

(a) Switch S1 shunts the telephone's receiver with a 7.5 ohm resistor, R_s . This reduces the level of acoustic shock due to the oscillator switching on, and reduces the level of the multi-frequency signal heard by the user. This signal is called *confidence tone*, and is intended to inform the user that a button has been fully depressed, and that a signal is being sent. Switch S1 is a single-make-action, open-springset unit, with gold-silver alloy contacts.

(b) Switch S2 replaces the telephone's transmitter by the multi-frequency oscillator, and short-circuits the transmitter during keying to prevent speech currents interfering with the multi-frequency signal.

(c) Switch S3 operates the oscillator's "kick-start" circuit, described below, and maintains constant d.c. conditions.

Switches S2 and S3 are miniature, change-over-action microswitches.

The release of a button results in the switches restoring to normal in reverse order. Since the multi-frequency signalling push-button unit is required to exhibit the same collapse-action characteristics as the less heavily loaded d.c. code C signalling push-button unit, special care is necessary during adjustment of the unit, to ensure that the heavy mechanical load does not adversely affect its operation.

Oscillator

The basic circuit of the multi-frequency oscillator is illustrated in Fig. 12. The oscillator uses a single-transistor arrangement, employing transformer feedback (transformers T1 and T2) between the emitter and base circuits. A third set of windings on transformers T1 and T2 forms part of the tuned circuits, which determine the frequencies generated. The low-frequency-band signals are generated by transformer T1,

and the high-frequency-band signals by transformer T2, the transformers having ferrite cores. The 2 signals are added together by the transistor, which is biased into its linear region by resistor R1 and diodes D9–D11.

When a button is depressed, capacitors C1 and C2 are connected across the appropriate windings of transformers T1 and T2. After switch S1 has shunted the receiver, switch S2 connects power to the oscillator from the line, via the diode bridge D1–D4, which caters for reversals in the polarity of the line. Switch S3 then interrupts a small direct current which has been flowing through the tuned-circuit windings. This rapidly starts the oscillations in the circuit, and is known as a *kick-start* circuit. Diodes D5–D8 regulate the tone levels in the circuit, by controlling the voltage in the base windings. Since the oscillator replaces the transmitter while signals are being generated, the tone levels are also influenced by the telephone's regulator, resulting in a narrower range of signal levels appearing at the exchange than could be obtained with the oscillator alone.

The accidental simultaneous depression of 2 buttons short-circuits turns in the windings of either or both of the transformers. When 2 buttons in any one row or column are depressed, only the frequency common to both buttons is generated, but, if diagonally-opposed buttons are depressed, neither frequency is generated.

Choice of Components

In order to achieve a frequency stability of better than 1 per cent under worst-case conditions (for example, extremes of temperature, exchange-battery voltage, line length, or component life), closely-toleranced components are necessary for the oscillator. In particular, the transformers require a high degree of accuracy in their winding ratios, a high *Q*-factor and good stability. Negative-temperature-coefficient polystyrene capacitors have been used to offset the positive temperature coefficient of the ferrite transformers.

The consequence of the stability requirements has been that relatively large components have had to be used. There are prospects that the size of the oscillator can be reduced, in the future, by using an integrated-circuit technique, which, if used in sufficient quantity, could result in a cheaper unit. This approach could also make it unnecessary for metallic contacts to be used for coding the frequencies in the push-button unit.

P.A.B.X. Equipment

In p.a.b.x.s using multi-frequency signalling push-button telephones, the provision of special equipment in the common-control area is necessary. The additional equipment basically consists of a multi-frequency receiver, which recognizes and validates multi-frequency signals, and a loop-disconnect sender, which passes on routing information to the public exchange in the case of an external call.

Multi-Frequency Receiver

The multi-frequency receiver is essentially a detecting circuit for multiple frequencies which passes on the keyed information to the p.a.b.x. register for processing. Because signals are sent from a telephone in which the transmission circuit is connected when a button is not depressed, the multi-frequency receiver must distinguish between speech and

keyed multi-frequency signals. This attribute of the multi-frequency receiver is called *voice immunity*. The frequencies and codes used are chosen such that they are unlikely to be simulated by speech, and, before accepting a signal as valid, the multi-frequency receiver checks that

- (a) only one signal from each of the high-frequency and low-frequency bands is present,
- (b) both signal power levels are in the range expected from the telephone,
- (c) the difference between the power levels of the 2 signals is not excessive,
- (d) the level of noise is not too high, and
- (e) the duration of the signals is longer than that normally produced by imitation of the signals in speech.

All of these checks are designed to aid voice immunity. Although the receiver will not accept a signal as valid if there is excessive noise present, it must be able to function correctly in the presence of dial tone. Often, a hybrid transformer is used to feed dial tone, so that it may be heard by the user but not sent into the multi-frequency receiver, where it could interfere with a multi-frequency signal. Additionally, a high-pass filter is usually fitted as an extra safeguard against interference by dial tone.

Advances in integrated-circuit techniques could lead, in the future, to a reduction in the size of multi-frequency receivers, which, at present, tend to be rather bulky.

CONCLUSION

The advancement of semiconductor and other modern technologies has led to the development of a range of complex push-button telephone instruments. However, the maximum benefit of push-button telephones, to the majority of customers, will only be realized when the public switched telephone network takes advantage of the fast signalling and switching techniques which are currently under development. The advantages will then be fast call-setting-up times, and the possibility of using a wide variety of additional customer-controlled facilities.

The push-button telephone is the instrument of the future. The early introduction of such instruments means that valuable experience can be gained in the field of complex customer's apparatus, while customers sample the merits of push-button signalling.

ACKNOWLEDGEMENTS

The authors wish to acknowledge the advice and assistance received from colleagues in Telecommunications Headquarters and in the telecommunications industry, and to thank, in particular, Plessey Telecommunications Ltd., G.E.C. Telecommunications Ltd. and Pye T.M.C. Ltd. for permission to publish photographs of proprietary apparatus.

References

- ¹ REYNOLDS, F. H., and MORTON, W. D. Metal-Oxide Semiconductor (M.O.S.) Integrated Circuits. *P.O.E.E.J.*, Vol. 62, p. 168, Oct. 1969, and Vol. 63, p. 105, July 1970.
- ² FREER, B. R., and MATTHEWS, O. C. Local-Battery Charging over Subscribers' Lines. *P.O.E.E.J.*, Vol. 66, p. 73, July 1973.
- ³ ELKINS, A. K. Subscriber Push-Button Telephones Market-Research Trial. *P.O.E.E.J.*, Vol. 59, p. 200, Oct. 1966.
- ⁴ HORSFIELD, B. R. Fast Signalling in the U.K. Telephone Network. *P.O.E.E.J.*, Vol. 63, p. 242, Jan. 1971.

Experimental Packet-Switched Service: Procedures and Protocols

Part 1—Packet Formats, Facilities and Switching

W. NEIL, DIP.ENG., C.ENG., M.I.E.R.E., M.I.E.E., M. J. SPOONER, B.SC., M.SC., and E. J. WILSON, B.SC.(ENG.), A.C.G.I.†

U.D.C. 621.394.4:681.32

This article, which is in three parts, describes the procedures and protocols used in the British Post Office Experimental Packet-Switched Service. Part 1 describes the format of the packets used, the facilities provided for customers and the packet-switching procedures adopted. Subsequent parts of the article will describe the transmission procedures adopted, and the operation of asynchronous terminals using the service.

INTRODUCTION

This is the first part of a three-part article describing the procedures and protocols to be used in the British Post Office (B.P.O.) Experimental Packet-Switched Service (E.P.S.S.). The aims and objectives of the E.P.S.S., and further information on dimensions, locations and network details have been dealt with in earlier articles.^{1,2}

A packet-switching, or addressed-data-block, system requires a very close interaction with customer's equipment, as the switching system is controlled directly by information generated by the customer and carried in an area associated with the data. To provide a network where congestion, under heavy traffic loads, is minimized and servicing is facilitated, a comprehensive assembly of procedures and protocols must be provided. This article gives details of these, and the way in which they interact to provide a controlled switching system.

PACKET FORMATS

Basic Packet Structures

All packets used in the operation of the network are structured as shown in Fig. 1. Each packet has three fields—the *header*, *data* and *error-check-bit fields*. For remote calls, where the called and calling terminals are local to different packet-switching exchanges (p.s.e.s), the packet includes a *main network addition* when being transferred via inter p.s.e. links. In all calls between packet terminals, the use and coding of the data field is left entirely to the customer, the only restriction being that it must consist of an integral number of 8-bit bytes. Error control by packet retransmission is used on all links in the system, and for this, it is necessary to include error-check bits in the tail of the packet.

The packet header and main network additions are used to provide an information interchange between customers and the network to establish the particular facilities required for the call, to manage the flow of packets during the call and to clear down the call when the data transfer is completed. This call concept is basic to the E.P.S.S., and different types

of packet are used at different stages in the call. The packets used during the call-establishment phase have headers consisting of 12 bytes and include comprehensive information about the required call parameters. The header structure of these call-originating and first-response (termed *format 1*) packets is illustrated in Fig. 2. Once the call parameters are agreed and the call is established, transactions take place using *format 2* packets. These do not include address information, since this is implicit in the p.s.e. records of the call, and contain only those facilities which can be selected on a per-packet, rather than a per-call, basis. The format 2 packet header is 5-bytes long and is shown in Fig. 3.

Packet Header Structure

The significance of each header field is described below.

Type

The 6 different packet types used in the network are

- (a) type 1—call origination,
- (b) type 2—first response,
- (c) type 3—subsequent response,
- (d) type 5—network information,
- (e) type 6—acknowledgement, and
- (f) type 7—loop delay measurement.

For each packet type, the type byte is a unique 8-bit combination, the first 4 bits of which are the exact complement of the first 4 bits of all line-synchronization signal bytes. This provides a hamming distance* of 4 between the sets of type bytes and the set of line signals, to reduce the probability of a corrupted line signal imitating the start of a packet.

Length

Packets have variable-length data fields, up to a maximum of 255 bytes, and the length byte gives a binary count of the number of bytes in the particular packet's data field. This byte enables line transmission and reception units to locate the end of the packet, so that the polynomial error check can be performed on the check bits of the packet.

Buffer Control

The fields labelled *extra buffers transferred* and *buffer size* in format 1 packets (Fig. 2), or *customer sequence number* in format 2 packets (Fig. 3), are used to control the number and flow of packets in a particular call within the system.

† Mr. Neil and Mr. Spooner are in the Telecommunications Systems Strategy Department, Telecommunications Headquarters and Mr. Wilson is now with the Independent Broadcasting Authority.

* Hamming distance—the number of corresponding bit positions which differ in 2 binary words of the same length.

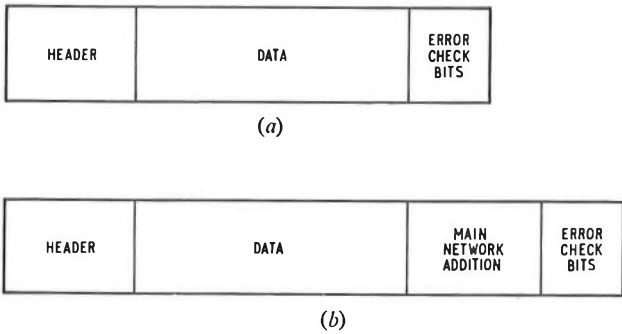

(a) Customer to p.s.e. links
(b) Inter p.s.e. links

FIG. 1—Packet structures

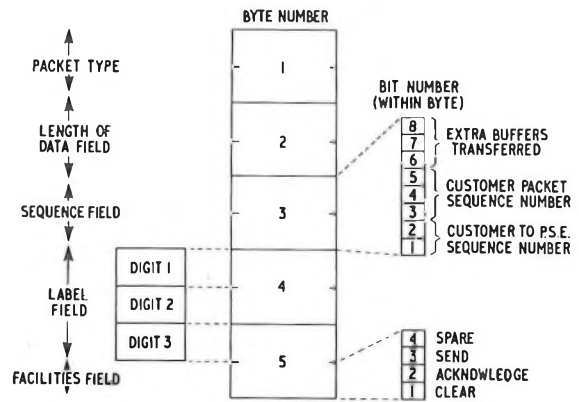

FIG. 3—Structure of format 2 packet header

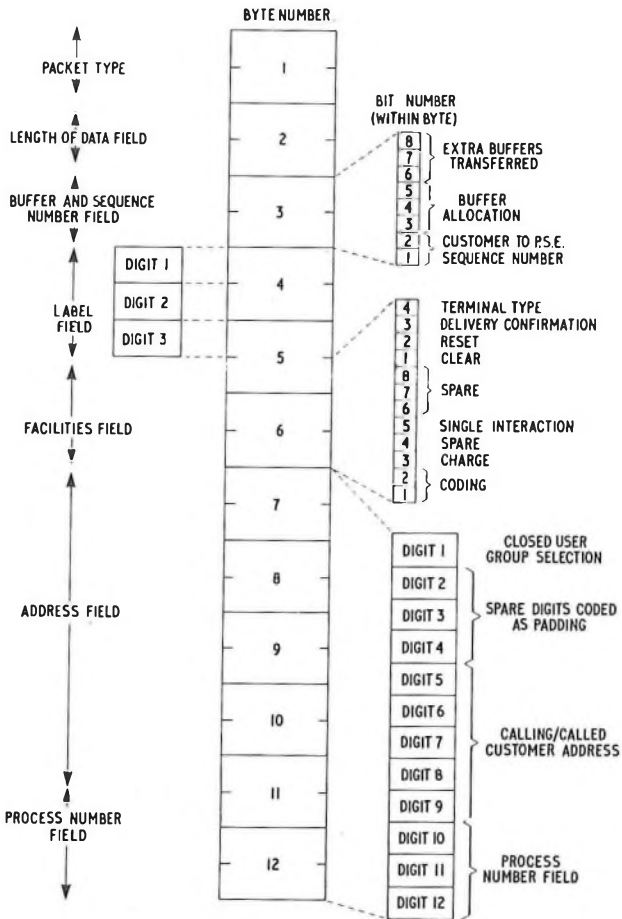

FIG. 2—Structure of format 1 packet header

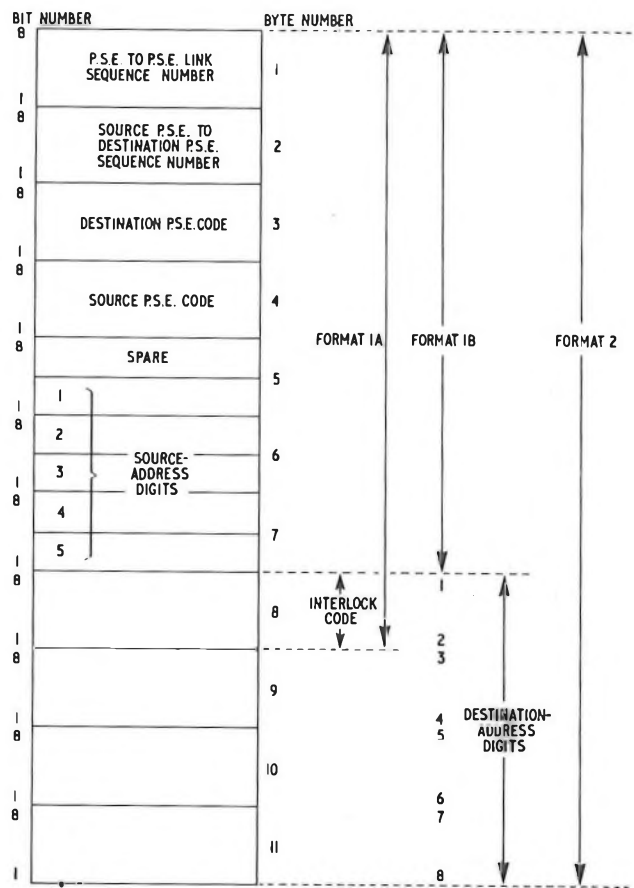

FIG. 4—Main-network-addition structure

This is particularly important in preventing an exchange being grossly overloaded with packets due, say, to a high-speed packet-terminal customer entering large numbers of packets into the system.

Link Sequence Number

This field is used in detecting the correct reception and sequence of packets on the link between the customer and the p.s.e.

Source Label

The p.s.e. is implicitly aware, from the interface via which a packet enters the system, of the source address of the packet and the location of the customer. The source label enables the p.s.e. to distinguish between simultaneous calls made by a

customer, since each one is allocated a different label number. After the call-establishment phase, this call label provides a unique reference to the call via the customer's interface, and allows the called address and label to be omitted from subsequent packets on the customer to p.s.e. link. This information, together with the calling address, is inserted into the packet by the p.s.e. as the main network addition.

Facilities Field

This field is a collection of subfields used by the customer to request particular modes of working in his call and to signal to the network when he wishes to clear or reset the call.

Closed-User-Group Selection

This semi-byte enables the calling customer to select the



FIG. 5—Loop-delay-measurement packet structure

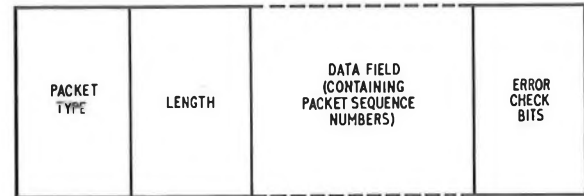

FIG. 6—Link-acknowledgement packet structure

closed user group to which his and the called terminal jointly belong. This selection causes an interlock code to be attached to the packet, and this is checked by the network against the incoming interlock codes for the called-terminal. Only authorized access is possible in the E.P.S.S., and if there is no correspondence between the interlock codes of the calling customer and the called customer, the call is rejected.

Destination Address

This address is a number (5 decimal digits initially) which uniquely defines the customer's terminal interface(s).

Process Number

When establishing a call, the calling customer may use the process-number field to indicate to the called customer which part of the called terminal is required. Where the called customer is a computer bureau, the process number might be used to indicate a particular service, such as a line print-out of the calling-terminal's data.

Main-Network-Addition Structure

For local calls, the p.s.e. has a complete knowledge of the calling and called terminals from the source-terminal interface by which the packet enters the system and the packet destination address; either explicitly in the case of call-originating and first-response packets, or implicitly from the call record for subsequent packets.

In remote calls, however, a main network addition must be included in each packet to provide transit p.s.e.s and the destination p.s.e. with full addresses of the source and destination terminals. The main-network-addition format, shown in Fig. 4 for format 1 packets, does not contain the packet destination address, since this information is contained in the packet header. For subsequent packets, a more comprehensive and, therefore, longer main network addition is required (see Fig. 3).

The use of the individual fields in the main network addition is described below.

Inter P.S.E. Sequence Numbers

These numbers are incremented on a per-link and a per-call basis and are used to trap duplicated packets on calls requiring inter p.s.e. transfers.

Destination and Source P.S.E. Codes

For routing purposes, each p.s.e. is allocated a code, which may be different from the first 2 digits of an attached terminal's address. This provides a flexibility point for the numbering scheme to allow, for instance, customers to be physically disconnected from one exchange and reconnected to another without changing their E.P.S.S. addresses.

Source Address

When a packet enters a p.s.e. from a customer's terminal, the p.s.e. can find the customer's address by referring to the terminal descriptor associated with the interface via which the packet was received. The complete address is entered in the main network addition.

Interlock Code

This 8-bit number is a translation, by the p.s.e. which is local to the calling terminal, of the closed-user-group selection of the call-originating packet. There are a total of 256 interlock codes, including the open network. The open network is simply a closed user group which can have a large number of members (equal to the total number of terminals in the network less those belonging to the closed user groups). At the p.s.e. which is local to the called terminal, the interlock code in the main network addition of a call-originating packet is checked against the incoming and bothway interlock codes allocated to the terminal. Only if there is correspondence is the call attempt allowed to proceed.

Network Control and Information Packets

In addition to customers' data packets of the two formats already described, the following packet types are used for network control and information purposes.

Loop-Delay-Measurement Packet

The loop-delay-measurement packet is used during the initial synchronization of customer to p.s.e. links. Its structure is that of a truncated packet, or simply a type byte (see Fig. 5).

P.S.E. Link-Acknowledgement Packet

This packet carries the link sequence numbers of packets correctly received after transmission over an inter p.s.e. link. The header consists of a type byte and a length indicator, this being necessary since the data field length varies in proportion to the number of packets being acknowledged (see Fig. 6). The same packet type is used on the customer to p.s.e. link under simplified protocol to acknowledge individual packets; in this case, the length indicator is always marked zero, and there is no data field.

Network Information Packets

Network information packets (n.i.p.s) are generated for two main purposes: the first is to confirm the correct reception and, in some cases, delivery of packets in the network; the second is to inform the sender of a packet when it has been discarded, either because it was in itself faulty, or the call request was invalid, or the packet could not be delivered for some reason, such as network congestion or a busy called terminal. In all cases, the n.i.p. copies the information contained in the header and main network addition of the packet to which it refers into its own header, with the exception of the type and length bytes which are inserted into the data field. A service signal is also included to enable the customer to interpret the fault, or confirmation, and act accordingly. Some n.i.p.s also record the time and date of their generation.

Construction of n.i.p.s is always as format 1 packets, so that some fields in the n.i.p. header are found in the main network addition of the packet to which it refers. The source and destination addresses of the packet to which the n.i.p. refers are reversed in the n.i.p. to enable it to travel in the reverse direction, so returning to the packet source. The

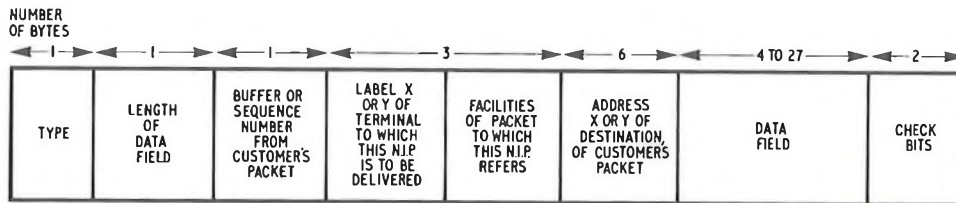

FIG. 7—Network-information-packet structure

transformation of fields from a faulty, discarded or correctly delivered packet into the corresponding n.i.p. is shown in Fig. 7.

CUSTOMER FACILITIES

Exchange of Data

The E.P.S.S. users exchange data using a packet transport mechanism, each packet having a capacity to carry a variable integral number of bytes up to a maximum of 255, where each byte consists of 8 bits. Whole messages are not constrained to one packet, and there is no upper limit to the number of packets which can be associated with one message.

Protection of Packets

Protection is provided against the possibility of errors being encountered *en route* by the packets. Both the p.s.e. and the customer must employ an encoding mechanism, which results in 16 bits being attached to packets. The packet is decoded at the receiver, and detected errors are corrected by retransmitting the packet. A packet with errors is not acknowledged, and this indicates to the sender that the packet must be retransmitted; all error-free packets are acknowledged.

Structure of Data

There is no restriction on the sequence of binary digits in the data field of packets for calls between packet terminals, provided that the data field is an integral number of 8-bit bytes. Asynchronous terminals must operate in either International Alphabet No. 2 or 5 (I.A.2 or I.A.5). Code-conversion facilities are available between asynchronous terminals using I.A.2 or I.A.5, and also between I.A.5 synchronous (packet) terminals and I.A.2 asynchronous terminals. The p.s.e. automatically provides this function. It also sets up calls to and from asynchronous terminals and assembles and disassembles the data into packets for them.

Interworking

Any E.P.S.S. user may request connexion to any other user, including those who are connected to a p.s.e. via the telex and telephone networks, except where access to the called terminal is barred by the closed-user-group and interlock-code procedure.

Multi-Call

Packet terminals, which have the processing capability, are allowed to establish a number of simultaneous calls. In this case, the packets for individual calls need not follow in any pre-determined order, being interleaved as required by the sender.

Multi-Buffer

During a call, all information entered by users must be responded to before further data can be transmitted to the p.s.e. A maximum of 8 packets can be sent from a terminal, without a response to any of them. No further packets may be sent by a terminal until the appropriate response has been received from the other terminal in the call. The terminal

requests the buffer size required, at the time of call establishment. Only packet terminals are allowed to request buffer-size variability.

Transfer of Packet Buffers

The maximum number of buffers, which has been allocated at call set-up, may be shared randomly between both terminals, such that one terminal may hold (albeit in the p.s.e.) some of the buffers, while the other terminal holds the rest. The number of buffers held by one terminal is allowed to vary during the call, and the users may move the buffers around between terminals, provided that the total is not greater than the allowed maximum.

Delivery Confirmation

Packet terminals may request the p.s.e. to confirm delivery of all packets in a call, and the destination p.s.e. assumes that a packet has been delivered on receipt of the acknowledgement to that packet. A n.i.p. is then returned to the caller, confirming delivery of the packet.

Charging

A packet terminal can ask the p.s.e. for either reverse charge, or normal charge, to apply for the call.

Coding

Packet terminals can indicate the code in which they are working. When communicating with asynchronous terminals, they are informed of the code in use, or that code conversion is taking place.

Single Interaction

A packet terminal can indicate that it wishes to send one packet only, requesting that the called terminal clear the call with the first response packet. The p.s.e. does not control such interactions, and it is not mandatory for the called terminal to mark his first response packet *clear*.

Customer Acknowledgement

Packet terminals can use the acknowledgement bit in the facility field to indicate correct receipt of a packet, or group of packets. Acknowledgement is from terminal to terminal, and does not require p.s.e. action.

Send Zero or Data

A packet terminal, communicating with an asynchronous terminal, may indicate in any subsequent packet of the call that it requires the whole buffer allocation of that call for its own use, without receiving more data. The request, *send*, is only monitored by a virtual packet terminal*, which responds by returning one or 2 zero data field packets, according to the number of buffers under its control. This inherently frees all the available buffers for use by the packet terminal. When

* The interface between the asynchronous user and the packet system.

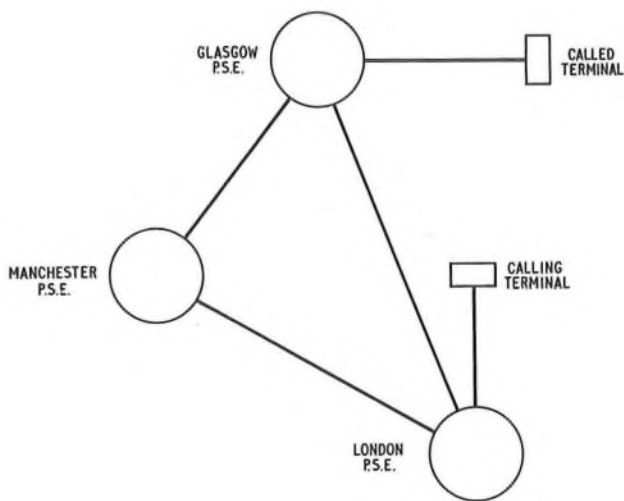

FIG. 8—Network configuration

the packet terminal does not require this facility, it requests in its subsequent packets that the virtual packet terminal returns packets containing data from the character terminal—*send data*.

Echo

The data input to the p.s.e. by asynchronous terminals can be echoed back to them, or not, in accordance with a command from the terminal, which causes the p.s.e. to invert the previous echo mode pertaining in that call.

Reset

Packet terminals can request that the records of the call in which they are engaged be reset to the state prevailing following call establishment. Upon receipt of a reset response packet from the other party of the call, the terminal making the reset is allowed to send a number of packets, according to the associated buffer allocation.

Facilities Request Agreement

Any facilities indicated in the first-response packet from a called packet terminal, which are different from those requested, cause the p.s.e. to adjust the records for that call. Some facility request changes are invalid and others are simply passed on, with the agreed facilities, to the calling terminal

Closed User Groups

The E.P.S.S. permits users to create private networks and each terminal may belong to a maximum of 4, each with outgoing, incoming or bothway access only, plus the open network.

Test Number

Automatic testing is available in selected areas of call protocol for which E.P.S.S. users call a test number, which is resident in their local p.s.e., to check the ability of their packets to set-up, maintain and clear-down a call. The test number can react dynamically to the coding of the customer packet header and can clear (or reset) and initiate calls, if requested by a customer's terminal. The packets which the user sends to the test number may contain data which will be returned to the sender by the test number in its response packets, including the time and date. When communicating with the test number, some of the fields in the customer packet

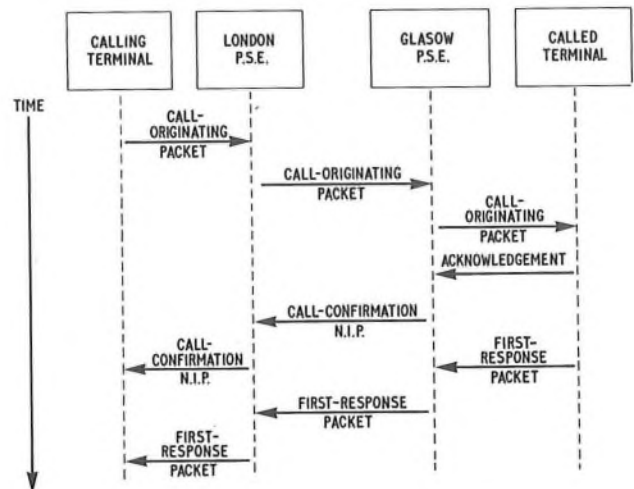

FIG. 9—Packet flow during call establishment

header assume meanings which are slightly different from their user-to-user interpretation, so that the test number may be instructed to give the correct subsequent response to the sender's requests. The user may transfer up to the maximum number of buffers (as selected in the call originating packet) to the test number in the field, or simply one at a time. The test number returns these individually, or *en masse*, as requested.

PACKET SWITCHING PROCEDURES

A normal E.P.S.S. call consists of three phases; call establishment, subsequent data transfer and clearing. The three phases may be quite distinct, but where the amount of data to be transferred is small or in one direction only, it is possible to omit the second phase and even to combine call establishment with clearing, since data can be carried during every phase of the call.

If, during a call, a customer loses his place in the sequence of packet flows, he may reinitiate the protocols by sending a *reset* packet.

Consider a call made from a packet terminal local to the London p.s.e. to another local to the Glasgow p.s.e. (Fig. 8), packets being transferred along direct links between the terminals and their adjacent p.s.e.s, and flowing directly between the p.s.e.s or indirectly using the Manchester p.s.e. as a transit exchange. The diagrams used to illustrate packet flow (Figs. 9 and 10) assume that link transmission times are negligible compared with the fixed time taken to switch packets at the exchanges and to respond with acknowledgements and further packets at the terminals. It is also assumed that the direct London-Glasgow route is used for inter p.s.e. transfer. Thus, these diagrams show accurately only the time sequence of events, and give no indication of absolute timing.

Call Establishment

This phase is characterized by the sending of a call-originating packet by the calling customer, a call-confirmation n.i.p. by the destination p.s.e. and a first-response packet by the called customer (Fig. 9). On receiving the valid call-originating packet, the London p.s.e. sets up a call record and a billing record for the call. Since the destination terminal is local to a different p.s.e., Glasgow in this case, the London p.s.e. prepares the packet for transfer over an inter p.s.e. route by attaching a main network addition, and queues the extended packet for transfer.

On arrival at the destination p.s.e., possibly via the Manchester p.s.e. if the direct London-Glasgow route is faulty or

TERMINAL A		SUBSEQUENT PACKET FLOW	TERMINAL B	
BUFFERS AVAILABLE	EXTRA BUFFERS TRANSFERRED		EXTRA BUFFERS TRANSFERRED	BUFFERS AVAILABLE
4				4
3	0	→		5
0	2	→		8
1		←	0	7
2		←	0	6
3		←	0	5
4		←	0	4
3	0	→		5
8		←	4	0
7	0	→		1
6	0	→		2
5	0	→		3

Note: Number of buffers in call = 8

FIG. 10—Subsequent packet flow

congested, the call request is checked for validity. If the call is allowed and the called terminal is not busy or out of service, the call-originating packet is queued for delivery to the called terminal. When correct delivery is signalled by the return of the acknowledgement, the Glasgow p.s.e. generates a call-confirmation n.i.p., with the time included, and dispatches it to the calling terminal. This n.i.p. reassures the calling customer that his call attempt is proceeding, and the time recorded gives him a measure of the network transit delay.

When the called customer is ready to establish the call fully, the called terminal transfers the first-response packet to the Glasgow p.s.e., and the parameters set in this packet govern the operation of the call. On receiving this packet, each p.s.e. updates its call record to indicate the facilities requested, and the p.s.e. local to the calling customer overwrites the billing record with this information. The initial distribution of packet buffers then takes place. Assuming that the first-response packet requests a buffer allocation, B , and E extra buffers transferred, then the Glasgow p.s.e. records that it retains $\{B - (E + 1)\}$ buffers; that is, the called terminal may transmit $\{B - (E + 1)\}$ subsequent packets before receiving any from the calling terminal. Similarly, the London p.s.e. records that the buffer allocation for the call is B , and that the calling customer may send up to $(E + 1)$ subsequent packets before receiving one from the called terminal. In this way, there are never more than B packets in the call within the system at any one time.

Subsequent Packet Transfer

Each time a terminal generates a subsequent packet, it is marked with a customer sequence number one greater than the last packet, the first subsequent packet in each direction being marked zero. This enables the customer to identify the packet referred to when a n.i.p. is received. The p.s.e. then allows the terminal to resend the packet, or send another packet bearing the same sequence number, without incrementing the billing record a second time. Subsequent packets also carry an extra-buffers-transferred field, whereby customers can arrange the flow of packets when unequal numbers of packets are transferred in each direction.

The buffer counters held in the source and destination

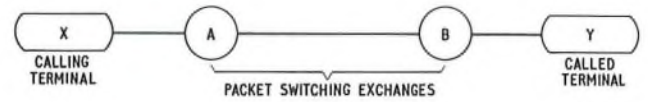

ORIGINATING PACKET

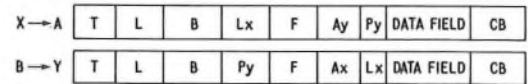

FIRST RESPONSE PACKET

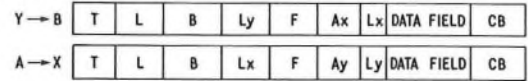

SUBSEQUENT PACKET X→Y

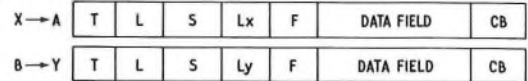

SUBSEQUENT PACKET Y→X

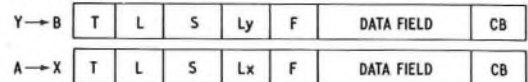

Key: T—Start of packet and type
 L—Length of data field
 B—Buffer allocation
 L_{x/y}—Label (X or Y)
 A_{x/y}—Address (X or Y)
 F—Facilities field
 CB—Error check bits
 S—Sequence field
 P_y—Called process number

FIG. 11—Packet sequence for a typical call

p.s.e.s are incremented, or decremented, when packets are transmitted to, or received from, the local terminal, respectively. The number added to, or subtracted from, the count is $(E + 1)$. A typical sequence of events in an 8-buffer call, where instantaneous imbalances occur in the amount of data to be transferred, is shown in Fig. 10.

Interchange of Addressing Fields

Process numbers, labels and full addresses are present in packets during the call-set-up phase. A calling terminal always enters its own label and may also enter the process number of the called terminal. Before delivery to the called terminal, the destination p.s.e. puts the called address in the calling-address position and places the process number of the called terminal in the label field of the calling terminal. The label field of the calling terminal is moved into the address area of the calling terminal. This ensures that the terminal always receives its own process number, or label, so that it can identify the sub-location within itself (see Fig. 11), and the address and label of the other terminal in the call. The exchange of fields means that the packet destination sees only its own label, or process number, in the label field, and the other terminal's address. Hence, during the transfer of subsequent packets, a terminal is only required to enter its own label, since the p.s.e. adds the necessary addressing information to route the packet through the network, and continue the call.

Call Clearing

To clear a packet call, the customer simply sets the *clear* bit in the packet header. Call records are then suspended pending the return of a clear-confirmation n.i.p., and after successful delivery of this n.i.p., the resources used for the call are freed for further use. All packet types—call-originating, first-response and subsequent packet—may be marked *clear*, since either terminal may wish to clear at any point in the call.

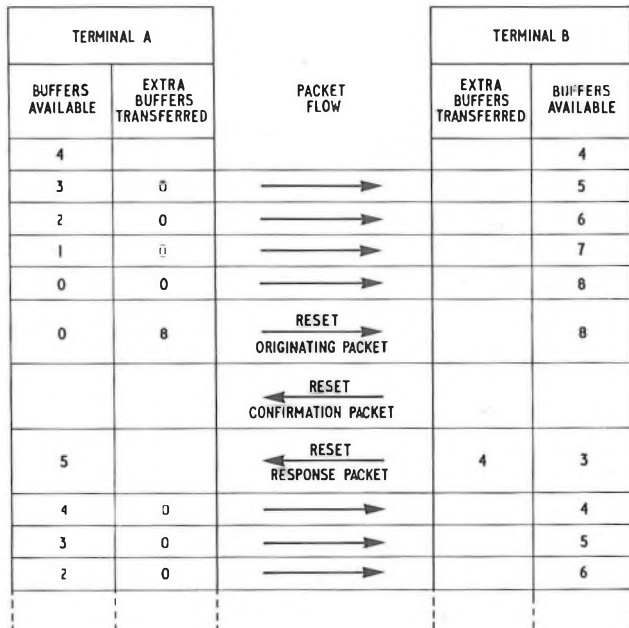

Note: Number of buffers in call = 8

FIG. 12—Reset sequence

Reset

If, for some reason, a packet call appears to have locked up, the terminal may send a call-originating packet with the reset bit marked, and so attempt to re-establish the call whilst retaining some buffers for its own use. The correct delivery of this reset-originating packet causes a reset-confirmation n.i.p. to be returned. The resetting terminal must then await the reception of a reset-response packet (a first-response packet marked *reset*) from the other terminal confirming his reallocation of buffers before sending his next packet. Either terminal may reset at any time after call establishment, and a typical sequence of events is shown in Fig. 12.

NETWORK STATISTICS AND BILLING INFORMATION

The p.s.e. design allows for production of four types of record, shown in Table 1. The immediate use of each record is indicated, but the management of the network and the location of the more subtle faults may draw upon all record types.

TABLE 1
E.P.S.S. Records

Record	Frequency	Use
Fault	One per specified fault occurrence	Maintenance
Access	One per public-switched-telephone-network dial-up access per 24-hour duration	Billing
Billing	One per call per 24-hour duration	Billing
Activity	Rate fixed by implementation (possibly every 5 s)	Network management

Fault Records

Of the 50, or so, fault types recorded, the majority result from the discarding of packets. These will have been invali-

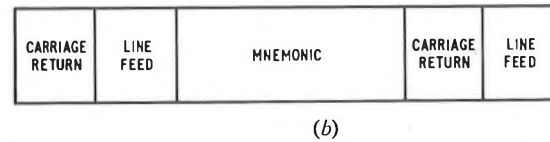
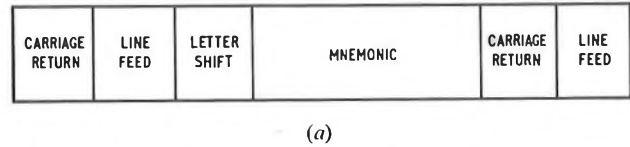

(a) For I.A.2
(b) For I.A.5

FIG. 13—Format of service signals sent to character terminals

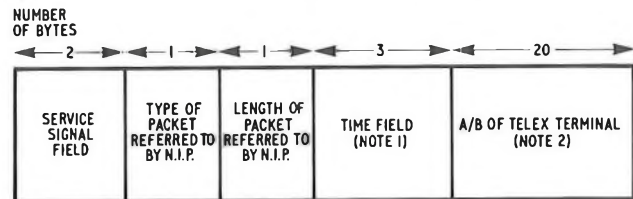

Note 1—Only included in confirmation and circuit-out-of-order n.i.p.s
Note 2—Only included in call-confirmation n.i.p.s when setting up a call to a telex terminal

FIG. 14—Format of data field of service signals sent to packet terminals

dated, either by the combination of facilities they request, or because they do not follow call protocols. The fault-record format copies the information in the header and main network addition of the discarded packet, and adds a fault number, to categorize the particular validity test failed by the packet, and a time and date stamp. The latter may enable service engineers to correlate diverse faults having similar causes.

Access Record

This record is used only for calls obtaining access to the E.P.S.S. via public-switched-telephone-network dial-up lines. The record includes access start and finish times and counts of meter pulses, at local rates, and at the appropriate rate applicable to the customer gaining dial-up access. The E.P.S.S. billing processors can calculate meter-pulse counts from a knowledge of the meter-pulse rates and date of the access. However, as supplies of meter pulses (switched automatically to cheap, standard or peak rate) are available at each p.s.e., from sources which supply adjacent telephone exchanges, it is easier to count and record the actual pulses.

Billing Record

This record contains all the information necessary for charging for the E.P.S.S. part of a customer's call. The billing record is designed to provide for complete flexibility in the final tariff structure for packet-switched data calls. This necessarily means that a very comprehensive set of information is recorded for every call; in addition to call duration times, full details are stored of the facilities requested jointly by called and calling customers.

On receiving a call-originating packet, the p.s.e. local to the calling terminal initiates the formation of the billing record by marking the time and date field, and copying the facilities field and called-address field of the packet header. A further field notes the address of the calling terminal, this being known implicitly by the p.s.e. from the incoming port on the exchange.

The call parameters may be changed by the called terminal, and when the first-response packet is returned, the facilities field (and the called-terminal label) are overwritten with the information contained in the packet header. Since

TABLE 2
N.I.P. Categories

Coding of First Byte	Reason for Generating N.I.P.
1	Due to a validity failure at the local exchange, the packet referred to being ignored by the local p.s.e. call control
2	Generated in the network or at a remote exchange and always marked clear, thus clearing the call
4	Due to the reset procedure
8	Generated in the network or at a remote exchange, allowing the sending terminal to try again to send the packet referred to by the n.i.p.
16	For call confirmation and delivery confirmation processes; the n.i.p. indicates that the call is progressing normally

delivery confirmation may be requested individually for each direction of packet transfer, the billing record includes fields for both calling and called terminal requests.

An 8-bit byte is set aside in the billing record to count the number of successfully concluded reset attempts. The remainder of the record is made up of time-unit and packet-count fields, in which, for every 10 min interval of the day during which packets are transferred in the call, one unit is added to the byte count appropriate to the direction of packet transfer. Each field has an indication of the 10 min period of the time unit, and packet counts are recorded only when packets are flowing.

Also stored in the record is the time at which the call was established, upon successful delivery of the first-response packet, and the call finish time, when a clear-confirmation n.i.p. or a clearing packet from the called terminal is received by the p.s.e. assembling the billing record.

Activity Records

These records provide the network managers with statistical information about the operation of the p.s.e., inter p.s.e. links, customer links and the characteristics and numbers of successful and unsuccessful calls. The information is gathered on a periodic basis, probably every few seconds, so that the processor loading due to the collection of these records is constant no matter how many packets are being switched. This means that when the information being recorded is likely to be most useful, such as under link and processor-failure conditions or network congestion, the processor loading due to recording network activity does not further worsen the network performance.

The activity records will be directly used by the monitor and control point processor, which will analyse the various count fields and provide alarms when preset levels are exceeded. The officer in charge of the monitor and control point may then intervene manually to accept alarms and initiate fault-correction procedures.

TABLE 3
Meanings of some N.I.P.s

Service-Signal-Field Coding	Meaning
1, 15	Calling terminal has maximum calls in progress
2, 1	Called terminal is busy
4, 37	Reset confirmation
8, 36	Packet discarded due to network congestion
16, 38	Call confirmation

SERVICE SIGNALS

During the setting up and progress of a call, the p.s.e. must inform both character and packet terminals when particular stages in the call have been reached, for example, call establishment or call clearing, or when failures occur in the normal call procedures.

The service signals sent to character terminals are generally strings of I.A.2 or I.A.5 characters, depending on the alphabet being used. Most of these service signals are intended as messages displayed on one line and, therefore, have format effectors before and after the mnemonic (see Fig. 13); for example `CIC`, which indicates to a character terminal that the p.s.e. is providing code changing for a particular call. There are also a few service signals, having no format effectors, which are intended as commands; for example `SKSK` instructs a terminal to stop sending data.

A service signal sent to a packet terminal is always in the form of a n.i.p. having a data field of 4-27 bytes (see Fig. 14). The 2 bytes of the service-signal field are used to indicate

(a) byte 1—which of 5 categories the n.i.p. is in (see Table 2), and

(b) byte 2—the specific fault or event which caused the n.i.p. to be generated; Table 3 shows one example from each category from a total of 52 different n.i.p.s generated within the network.

CONCLUSION

The packet formats, customer facilities and packet-switching procedures of the E.P.S.S. have been described in the first part of this article. Subsequent parts will describe the transmission procedures used, both between synchronous customers and the p.s.e. and between p.s.e.s, and the operation of asynchronous terminals using the service.

References

- BELTON, R. C., and SMITH, M. A. Introduction to the British Post Office Experimental Packet-Switching Service (E.P.S.S.). *P.O.E.E.J.*, Vol. 66, p. 216, Jan. 1974.
- HADLEY, D. E., and MEDCRAFT, D. W. F. Experimental Packet-Switched Data-Transmission Service: Network Design and Implementation. *P.O.E.E.J.*, Vol. 67, p. 88, July 1974.

The Effects of Power-Supply Transients on British Post Office Cable Communication

B. HALL, and C. J. LILLY, C.ENG., M.I.E.R.E.†

U.D.C. 621.395.45:621.3.015.334:621.316.937

This article discusses the effects of 50 Hz power-supply transients on British Post Office line systems, which use both balanced and unbalanced cable pairs. The causes and nature of transients affecting telephony, television and data transmission on these cables are discussed, as are the methods of protection of the equipment.

INTRODUCTION

The British Post Office (B.P.O.) operates a large network of line systems, each carrying many telephony circuits, using both coaxial and balanced-pair type cables.

Line systems on coaxial pairs are used to carry large numbers of circuits on major routes, 960-circuit and 2,700-circuit systems being the most common at present, but 10,800-circuit systems are planned to be introduced in 1977. These systems are of the frequency-division multiplex (f.d.m.) type, and use underground repeaters housed at intervals as shown in Fig. 1 and Table 1.

On balanced-pair type cables, pulse-code-modulation (p.c.m.) systems provide 24 or 30 telephony circuits using 2 pairs of balanced-pair cable. Routes are usually less than 40 km in length and have regenerative repeaters buried at intervals of 1,830 m.

CAUSES, NATURE AND INCIDENCE OF POWER-SUPPLY TRANSIENTS

Power transients affecting B.P.O. plant arise from power-supply lines, electrified railways and low-voltage (240-volt) mains supplies.

Power-Supply Lines

Both normal switching operations and fault conditions on power-supply lines induce voltages longitudinally along B.P.O. line transmission systems. These voltages are transient and of short duration, seldom persisting for more than 5 cycles or 100 ms.

Measurements have established the magnitude, duration and incidence of induced voltages arising from power-supply line disturbances, under conditions of close parallelism with 132 kV and 275 kV power-supply lines. Values of up to 800 volts r.m.s., persisting for 60 ms, have occurred approximately twice a year. Normal switching operations induce transients of 100–300 volts up to 4 times a week. The induced voltages from supergrid line interruptions, occurring 2–11 times a year, are up to 750 volts r.m.s. in magnitude and of 100 ms duration. Disturbances from 33 kV power-supply lines present problems to the B.P.O. because many of these are equipped with circuit breakers which reclose automatically.

A further hazard is that a phase conductor may fall to earth without tripping the circuit breaker, subjecting tele-

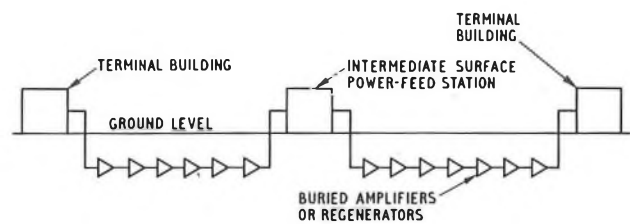

Note: Only one direction of transmission is shown

FIG. 1—A typical line-transmission system

TABLE 1
Details of B.P.O. Line Transmission Systems

System		Amplifier/Regenerator Spacing		Telephone Channels
		Small-bore cable 1·2/4·4 mm	Large-bore cable 2·6/9·5 mm	
Analogue	60 MHz	—	1·5 km	10,800
	12 MHz	2 km	4·5 km	2,700
	4 MHz	4·5 km	9·2 km	960
Digital	120 Mbit/s	2 km	4·5 km	1,680
	1·536 Mbit/s p.c.m.	1·82 km on audio cable		24
	2·048 Mbit/s p.c.m.	1·82 km on audio cable		30

communications plant to substantial continuous overload. Large numbers of 33 kV routes exist that are much closer to B.P.O. circuits than the higher-voltage routes and, therefore, present the most important hazard from the B.P.O. point of view.

Electrified Railways

On a.c. electrified railways, the current is supplied to the trains through the overhead conductor wire and returns to the power source partly through the return rails and, owing to the low insulation resistance of the rails to earth, partly through the earth. Voltages may, therefore, be induced in

† Telecommunications Development Department, Telecommunications Headquarters.

nearby communication lines by magnetic induction from this earth current. In the U.K., trains are equipped with rectifying equipment and d.c. motors, and harmonics of the fundamental frequency are present. Because these are harmonics of 50 Hz and most B.P.O. line systems do not transmit frequencies below 60 kHz, the presence of the harmonics has not been troublesome.

The position could be very different, however, if thyristor units are used to control traction motors. In one form, current is allowed to flow for only a portion of each half cycle, and is then abruptly switched off for the remaining portion. The high-frequency induction into line systems resulting from such repetitive switching 100 times per second might well present major problems to both railway and B.P.O. engineers.

For 160 km of electrified railway, approximately 400 faults per annum occur, the duration of each varying between 0.16–0.4 s. In general, these faults could occur at various points along a route and would not all give rise to the maximum induced voltage. Most of the faults are flashovers to earth.

For an unscreened cable placed at depths of up to 2 m and between 3–4 m from the nearest rail, the induced voltage is typically in the range 0.087–0.125 volt r.m.s./amp of feed current/km.

Provision of booster transformers and insulated return conductors on the railway, to keep the current out of the rails, reduces the voltage induced into B.P.O. plant under normal conditions. However, under fault conditions, the suppression provided is not effective because the booster transformers are saturated by the increased current.

Mains Supplies

Spikes of up to 100 μ s duration frequently occur on the 240-volt a.c. mains supplies. Spikes having an amplitude of 600 volts have been recorded, 400-volt spikes occur at a rate of 2/day and 200-volt spikes occur as often as 500/day. Damage by such spikes is avoided because the B.P.O. supplies all its transistorized line-system equipment from centralized d.c. power plants.

EFFECTS OF POWER-SUPPLY TRANSIENTS ON B.P.O. PLANT

Power-supply transients can affect the traffic carried on B.P.O. transmission systems, the transmission equipment itself and the safety of personnel.

Effect on Traffic Carried by B.P.O. Transmission Systems

Traffic is affected by any transient exceeding a small threshold value. On unbalanced (coaxial) cable systems, protective gas-discharge tubes are normally fitted. Transients, exceeding the threshold value, fire the gas-discharge tubes, causing the traffic to be interrupted. Transients, not large enough to fire the discharge tubes, are often still large compared with the traffic signals being transmitted, these signals having a magnitude of less than 1 volt, or even 1 mV. Traffic is, therefore, interrupted.

Systems which employ balanced-pair type cables are also susceptible, because of the small residual unbalance of the cable. Although this is quite small, it can, nevertheless, result in a large transient voltage because of the very large magnitude of the disturbing transient current.

Normal operation of the electrified railways induces varying alternating voltages into adjacent B.P.O. plant, and most systems on unbalanced cables are designed to carry traffic, without degradation of performance, in the presence of any continuous 50 Hz current up to 30 mA. Therefore, the principal hazard to B.P.O. plant from continuous 50 Hz induction is to telephone signalling systems, some of which mis-operate when the induced voltage reaches 5 volts r.m.s.

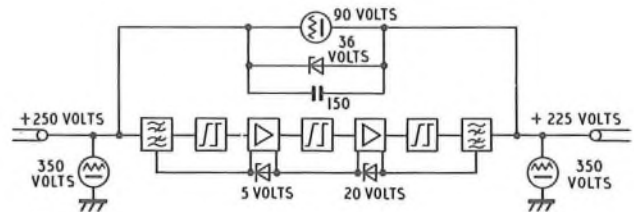

FIG. 2—Protection arrangements for a typical dependent repeater using gas-discharge tubes

The duration and frequency of breaks affecting traffic are about the same as those for the transients discussed earlier. Short-duration breaks can be tolerated on circuits carrying speech, but on circuits carrying television or data signals, such breaks can cause intolerable interference.

The Central Electricity Generating Board (C.E.G.B.) use over 2,500 B.P.O. private circuits for control, protection and telemetry, a third of which are required to be independent of mains supplies. The potential problem of the control signals being affected by induced transients under power-line fault conditions has been overcome, in part, by using two operational circuits in parallel, over physically different routes wherever possible. Furthermore, if the control signal does not reach the far terminal, it is repeated until transmission is successful. In this way, the C.E.G.B. envisage operation of their circuit breakers in under 40 ms, under all operating conditions.

Effect on B.P.O. Plant

Modern B.P.O. transmission equipment is completely transistorized and has, of necessity, to be protected against damage from lightning, 50 Hz surges etc. The protection arrangements employed on high-capacity, coaxial-cable systems are described below. However, transistorized equipment using balanced-pair type cables, such as audio and lower-order digital transmission equipment, does not require the same degree of protection. Use of the balanced pair ensures that any surge induced in the cable appears almost equally on both legs of the pair. Thus, any voltage which is presented to the input or output of the equipment is normally of small magnitude, due mainly to the small unbalance in the terminating equipment.

Safety of Personnel

High-voltage surges present safety hazards to personnel working on the cables. Unbalanced-pair systems, with the outer conductor earthed and fitted with gas-discharge tubes, can be so designed to reduce any high-voltage surge to a safe level well within the 250 ms regarded as being the safe limit.

PROTECTION OF B.P.O. EQUIPMENT

As discussed earlier, modern transmission equipment, being fully transistorized, is vulnerable to the effects of power transients. Steps are, therefore, taken to protect the equipment from damage and minimize the loss-of-service time. This is normally only just longer than the duration of the transient, a matter of milliseconds. Such protection is vital in transmission systems where the majority of the amplifiers are located underground (See Fig. 1.) If the equipment were unprotected and failed owing to a power-supply transient, then the out-of-service time could easily be several hours. Moreover, underground amplifiers, sited at 1.5 km intervals on coaxial-line-transmission systems, can carry up to 10,800 simultaneous telephone channels and any failure would result in a severe loss of revenue.

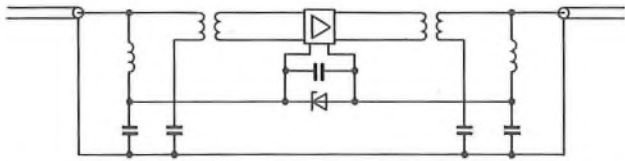
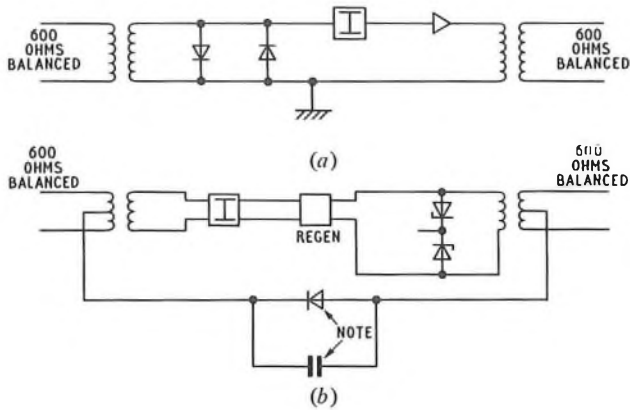

FIG. 3—Protection arrangements for a dependent repeater avoiding the use of gas-discharge tubes



Note: Longitudinal protection
 (a) Typical digital amplifier
 (b) Typical digital regenerator

FIG. 4—Protection of equipment used on balanced-pair cable systems

Protection of Coaxial-Cable Systems

On coaxial-cable systems, the d.c. power required to operate underground line (dependent) repeaters is fed along the cable from surface power-feeding stations. (See Fig. 1.) The commonest method of providing primary protection to underground repeaters is the use of gas-discharge tubes. (See Fig. 2.) The striking voltage of these tubes is arranged to be just above the d.c. power-feeding voltage; for example, 350-volt gas-discharge tubes would be used when the power-feed voltage was of the order of 250 volts. These tubes are fitted at the inputs and outputs of underground repeaters, and at surface power-feeding stations, to protect the equipment from transverse surges.

Dependent repeaters are also protected from the effects of longitudinal surges and 50 Hz induction by a parallel combination of a 90-volt gas-discharge tube, high-wattage zener diodes and a high-value capacitor connected in parallel with the repeater. The zener diodes, which are normally non-conducting, protect the equipment in the short period of time prior to the firing of the 90-volt gas-discharge tube, and the capacitor by-passes any 50 Hz longitudinally-induced currents.

Gas-discharge tubes, however, have negative-impedance regions in their characteristics, which can cause damped-sine-wave or relaxation oscillations to be generated under certain operating conditions. These oscillations contain a considerable amount of high-frequency energy which can damage the amplifier, and so additional secondary protection is required.

Secondary protection is often provided by designing the equipment such that passive networks (for example, equalizers) are fitted between the gas-discharge tubes and any active networks. In this way, the magnitude of any transients actually reaching the active devices is generally quite small. However, the emitter-base and base-collector junctions of the semiconductors used in the active devices are also often protected by diodes.

Some system designs are not able to use gas-discharge tubes because of the high power-feeding voltages, which would cause the discharge tubes to be permanently fired (See Fig. 3.)

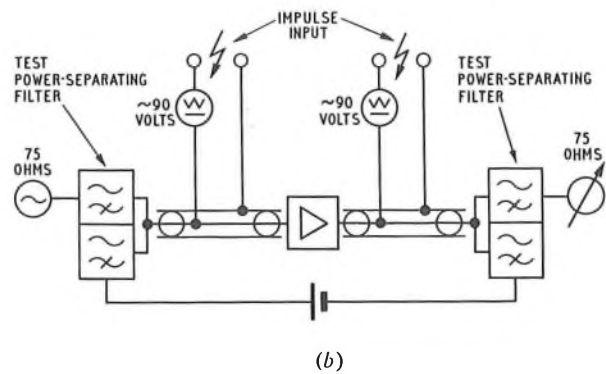
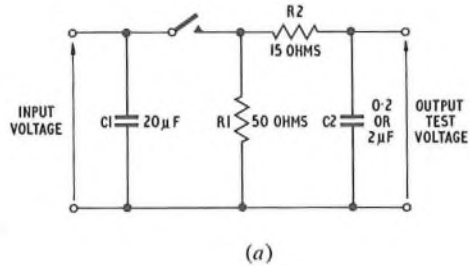

(a) Impulse generator
 (b) Impulse voltage test circuit

FIG. 5—Typical test circuits

In these cases, a low-resistance by-pass is provided from the input to the output of the repeater, making the unit "transparent" to both longitudinal and transverse surges in the frequency range of the disturbances. The amplifying portion of the dependent repeater is isolated from the cable by transformers at the input and output. Capacitors are fitted between the power-separating filters and earth, and between the earth side of the input and output transformers and earth. The value of the capacitors is such that they present a low impedance to currents at 50 Hz and at those frequencies present in lightning surges. These capacitors have a very high voltage rating. Terminal equipments have a similar protection arrangement.

Protection of Balanced-Pair Cable Systems

Modern equipments, used on balanced-pair cables, do not normally carry more than 30 telephony channels, and their failure is not as catastrophic as when a high-capacity coaxial-line system fails. Nevertheless, steps are being taken to improve the reliability of such equipments in the presence of transients.

Primary protection, of the type employed on unbalanced cable systems, is unnecessary on balanced-pair type cable because of the inherent balanced nature of the cable. However, protection against longitudinal surges is generally provided by high-power-rated zener diodes with by-pass capacitors, and, sometimes, by gas-discharge tubes.

Secondary protection varies according to the type of equipment. For instance, audio amplifiers have input and output transformers and, in addition, have passive network protection at the input, together with diodes to earth. (See Fig. 4(a).) Digital (p.c.m.) regenerators, on the other hand, have an output transformer with zener diodes across the output transistors, and only a passive network and a transformer at the input. (See Fig. 4 (b).)

The precise methods of protection vary according to the type of equipment and manufacturer.

TABLE 2

Summary of Tests of Equipment Fitted with Protective Devices and/or Circuitry

Test	Repeaters on Coaxial-Pair Type Cables					
	Voltage/Current applied on Prototype Tests			Voltage applied on Production-Acceptance Tests		
	Transverse (kV)		Longitudinal	Transverse (kV)		Longitudinal (kV)
	Input	Output		Input	Output	
High voltage d.c. impulse test	5	5	5 kV	3	3	3
50 Hz a.c. surge test	1.3	1.3	10 amps	—	—	—
50 Hz a.c. continuous test	—	—	30 mA	—	—	—

Protection of Terminal Equipment

This section relates to the protection of terminal equipment from power-supply transients entering the B.P.O. power equipment from the mains supply rather than to the transients induced into B.P.O. transmission cables.

In general, protection from such mains-supply transients is provided in 2 stages. Primary protection is provided by the filter circuits in the main station a.c.-d.c. power-supply equipment, which supplies all the transmission equipment in that station with a nominal d.c. supply. Secondary protection is incorporated in the d.c.-d.c. voltage stabilizers feeding individual equipments. Generally, the magnitude of mains-supply transients at the output of the primary protection is negligible, and they do not, therefore, present any particular problems. Further protection on individual active units is sometimes afforded by zener diodes placed across the d.c. supply.

† C.C.I.T.T.—International Telegraph and Telephone Consultative Committee.

TESTING OF PROTECTION CIRCUITRY

The C.C.I.T.T. † have, very recently, recommended various tests to ensure that equipment is able to withstand certain surges. Those relevant tests, as applied to transistorized coaxial line equipment supplied to the B.P.O., are as follows:

(a) *Transverse test.* The equipment should be tested with a transverse surge voltage of amplitude 1,300 volts r.m.s. and frequency 50 Hz, applied across input and output in turn for 0.5 s, the surge current being limited to 1 amp.

(b) *Longitudinal test.* The equipment should be tested with a longitudinal current of 10 amps and frequency 50 Hz, applied between input and output for 0.5 s, the applied voltage being immaterial, but normally derived from the 240-volt mains supply.

Other tests are applied to test the performance and reliability of the equipment to lightning surges and continuous 50 Hz longitudinal currents. These comprise the application of high-voltage surges, of amplitude up to 5 kV, to the input and output of the amplifiers, and also, longitudinally across the amplifier between the input and the output. A summary of the tests is given in Table 2, and typical test circuits are shown in Fig. 5. Tests applied to equipments used on balanced-pair cable are similar to those described above.

THE FUTURE

British Rail have proposed an electrification scheme which would add, on average, an extra 200 electrified route-kilometres/year for the next 10 years, nearly doubling the present total length of electrified routes from 3,160 km to over 5,000 km in 1983.

The C.E.G.B., on the other hand, have almost completed the installation of their 400 kV *Supergrid*, which it is hoped will provide sufficient capacity until well into the 1980s. No doubt there will be an increase in the total route length of overhead power lines, but this is only expected to be due to the addition of spurs from the main grid to new generating stations. In consequence, the present overhead route length (all voltages) of 15,600 km is not expected to increase significantly over the next 10 years.

Thus, as far as B.P.O. transmission systems are concerned, the British Rail electrification program is likely to increase the incidence of faults affecting B.P.O. traffic, but interference from overhead power lines may already have reached the worst state. Nevertheless, the protection applied to B.P.O. plant gives confidence that it will continue to give good service in the prevailing environment.

Trunk Transit Switching

By special request, the *Journal* has produced a reprint including all the most important articles published over the years on Trunk Transit Switching. This reprint brings all the articles together and will be a most useful reference book for those interested. Supplies are limited. Please send a Postal Order or remittance for 22p per copy to:

Mr Hunwicks
Ground Floor Lobby
2-12 Gresham Street
London EC2V 7AG

If B.P.O. staff enclose a self-addressed P.O. label, this will assist.

Signalling System A.C. No. 13 Inter-P.B.X. Working on a P.A.B.X. No. 7

R. H. MACKIE and M. HART†

U.D.C. 621.395.385.4:621.395.25:621.318.56

This article describes briefly the main features of a new bothway automatic inter-p.b.x. terminating relay-set and auxiliary terminating relay-set using Signalling System A.C. No. 9 as a line signalling system. The reasons prompting the development are mentioned, and the design philosophy is explained.

INTRODUCTION

Signalling System Alternating Current (S.S.A.C.) No. 13 is an inter-p.b.x. single-voice-frequency (1 v.f.) system used for automatic signalling, with or without dialling, over routes where a d.c. path is not available. Many features of S.S.A.C. No. 13 are the same as S.S.A.C. No. 9,^{1, 2} notably the signalling frequency of 2,280 Hz. The main, though not the only, difference between the systems is that the 2-wire-4-wire terminating unit forms part of the S.S.A.C. No. 9 relay-set, whereas S.S.A.C. No. 13 is 2-wire connected. There are advantages in a 4-wire connected arrangement; in particular, inserting the v.f. receiver in the receive pair gives much improved immunity from near-end noise. However, since the S.S.A.C. No. 13 relay-set is located at customer's premises, and since it is often unnecessary to bring the 4-wire line right up to the relay-set to achieve the desired transmission standard, a 2-wire connected arrangement was chosen when the system was originally designed. The S.S.A.C. No. 13 inter-p.b.x. terminal equipment consists of a 1 v.f. relay-set and a terminating relay-set peculiar to the p.b.x. concerned.

All the British Post Office (B.P.O.) rented p.a.b.x.s, except for the P.A.B.X. No. 7, are available with S.S.A.C. No. 13 inter-p.b.x. working as a standard facility. This situation can best be explained by a brief historical note. The P.A.B.X. No. 7 is adapted from, and closely resembles, a proprietary p.a.b.x., and many of the system features were already established when the B.P.O. included it in its rental range. At that time, comparatively few inter-p.b.x. circuits were provided and the inability to provide long-distance automatic signalling on inter-p.b.x. circuits did not present any particular problems. For economic reasons, high-frequency (h.f.) line plant is being installed over shorter and shorter distances and, with the exception of out-of-band signalling over wide-band channel equipment, suitable only for large users, S.S.A.C. No. 13 is the only automatic signalling system currently available for working over such plant. The demand for a medium-sized B.P.O. rented p.a.b.x. is growing all the time and the P.A.B.X. No. 7, with its capacity for 100 extensions and 20 exchange lines or inter-p.b.x. circuits, is proving very attractive to customers. The lack of long-distance automatic signalling for inter-p.b.x. working is, however, now becoming a serious disadvantage and the full potential of the P.A.B.X. No. 7 is not being realized. Inter-p.b.x. and auxiliary terminating relay-sets have been developed to make good this discrepancy.

† Telecommunications Development Department, Telecommunications Headquarters.

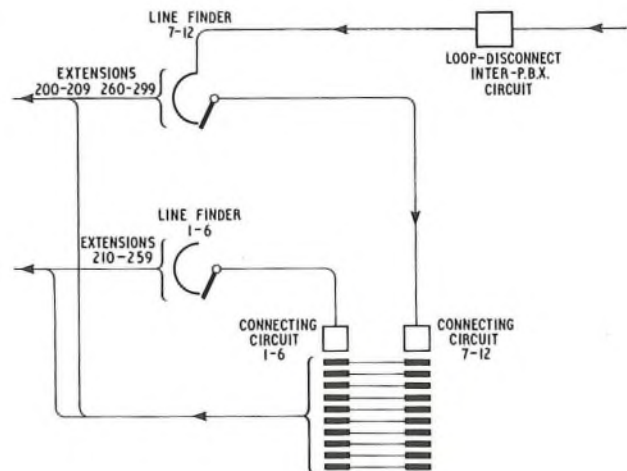

FIG. 1—Trunking diagram for incoming calls to a P.A.B.X. No. 7 extension using loop-disconnect signalling

DESIGN PHILOSOPHY

When considering a new inter-p.b.x. terminating circuit for a p.a.b.x., the existing arrangements should be studied first. The only form of automatic signalling available on the P.A.B.X. No. 7 was loop-disconnect, suitable only for comparatively short d.c. routes. This system suffers from the disadvantages that, on incoming calls to an extension, equipment shared by the p.a.b.x. as a whole is held throughout the call. Fig. 1 shows the trunking involved. This shared equipment is known as a *connecting circuit* and a fully-equipped P.A.B.X. No. 7 has 12 such circuits, although only 6 are available to any particular inter-p.b.x. circuit. Since inter-p.b.x. circuits are normally heavily used, with the loop-disconnect arrangement, traffic-handling considerations tend to limit the possible number of inter-p.b.x. circuits to well below the theoretical maximum. In addition, the use of a connecting circuit means that the incoming caller waits for dial tone before dialling the extension number. Returning dial tone over inter-p.b.x. circuits brings its own problems. Much of the power in dial tone is contained in frequencies below 300 Hz and, since the speech band is normally 300–3,400 Hz, the dial tone is likely to be greatly attenuated. This is particularly so over h.f. routes, where the band-pass filters give a sharp cut-off at the upper and lower frequency limits. Also, because it is a 2-wire connected system, dial tone

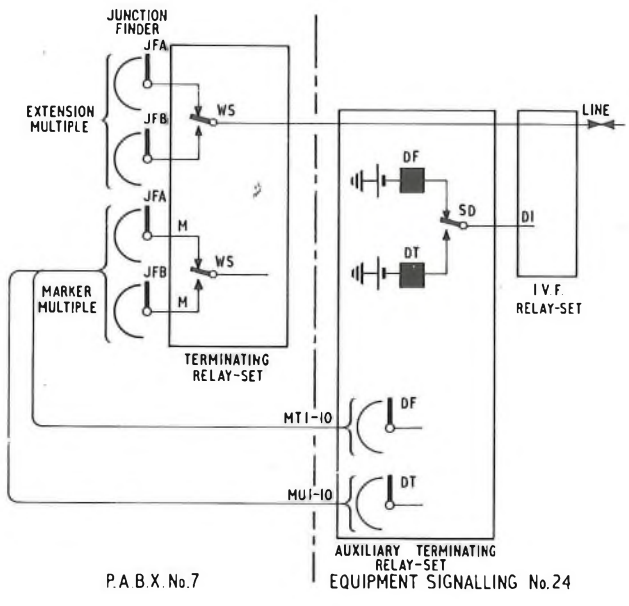

FIG. 2—Trunking diagram for P.A.B.X. No. 7 S.S.A.C. No. 13 inter-p.b.x. working

should never be injected into an S.S.A.C. No. 13 link unless the dial-tone source is filtered and filters are also fitted to the 1 v.f. receiver. These filters prevent the receiver guard circuit operating to dial tone and, thus, inhibit the receiver to the 2,280 Hz signal frequency.

Any new inter-p.b.x. termination for the P.A.B.X. No. 7 should, therefore, incorporate in its design the basic features that

- (a) shared equipment, that is, connecting circuits, should not be taken into use so as to ensure that the system can handle an appreciable volume of inter-p.b.x. traffic, and
- (b) the equipment should be ready to receive dialled digits within 100 ms of seizure to eliminate the need to return dial tone on incoming calls.

The P.A.B.X. No. 7 is similar in general principles to the

P.A.B.X. No. 1, and the S.S.A.C. No. 13 termination for the P.A.B.X. No. 1 incorporates the basic features described above. Much the same arrangement could have been used on the P.A.B.X. No. 7. The P.A.B.X. No 1 system requires the provision of a large-capacity uniselector for each inter-p.b.x. circuit. Two control leads from each extension circuit are multiplied on the outlets of these selectors, and a form of one-at-a-time selection is used to mark the junction-finder banks. However, the P.A.B.X. No. 1 has only 50 extensions and 3 inter-p.b.x. circuits and so this solution, when applied to the P.A.B.X. No. 7 having 100 extensions and up to 20 inter-p.b.x. circuits, appeared very expensive to provide. By using a novel method of marking the called extension on the junction-finder banks, considerable savings in installation costs per circuit, compared with the P.A.B.X. No. 1 method, have been achieved.

OUTLINE OF THE SYSTEM

Fig. 2 shows a trunking diagram of the system, and Fig. 3 shows the marking circuit in some detail. Consider an incoming call. The 1 v.f. line signals are converted into d.c. form by the 1 v.f. relay-set. Dial pulses on the DI-lead step 2 miniature uniselectors, DF and DT, in the auxiliary terminating relay-set. Assuming the caller is dialling an extension number, the first digit, the hundreds digit, will be 2. Uniselector DF is stepped to outlet 2. This condition is detected and uniselector DF is driven to its home contact in readiness for the next digit. The tens digit also steps uniselector DF, this time to an outlet between 1 and 10. Discrimination takes place to determine whether the call should be directed to the first or second 50-line unit. The junction-finder wiper-switching relay, WS, in the terminating relay-set operates if the second unit is chosen. The junction finder, JFA-JFB, is driven to outlet 1 of the chosen group of 10 extensions by marking one of the 10 MT-leads. During the inter-digital pause, relay SD, in the auxiliary terminating relay-set operates and the third digit steps the units uniselector, DT, to mark one out of the 10 MU-leads. The junction finder drives to the marked outlet, and the call is completed in the usual way with the appropriate supervisory tone returned to the caller.

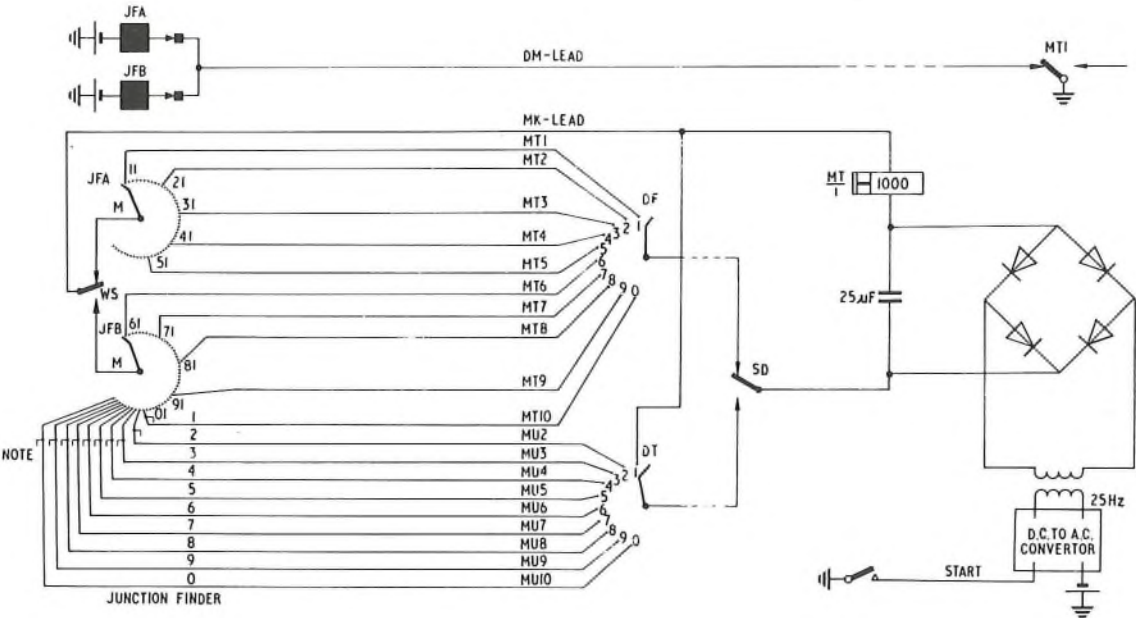

Note: 01 commond to 91, 81, 71, . . . and 11
02 commond to 92, 82, 72, . . . and 12 etc.

FIG. 3—Marker circuit for P.A.B.X. No. 7 S.S.A.C. No. 13 inter-p.b.x. working

If the first digit dialled is 0, this is detected on unselector DF and, as a result, the calling lamp on the p.a.b.x. operator's console flashes on and off. The call can be extended by the operator to an extension, if required. If the first digit is other than 2 or 0, number-unobtainable tone is returned to the caller.

Outgoing calls are made from extensions by dialling a single-digit access code. Dial tone is returned from the auxiliary terminating relay-set to indicate that an outgoing circuit has been seized. The method of setting up is similar to that for an extension to an exchange-line call. Outgoing calls can also be originated by the operator and extended to an extension, as for incoming calls.

MARKER CIRCUIT

To provide access on incoming calls to the extension multiple, a marker system seemed to have distinct advantages, principally because this method was already used for extending calls under operator control, and for enquiry and transfer. The junction finders in each of the 20 inter-p.b.x. positions are already equipped with marker arcs, with 10 MT-leads and 10 MU-leads multiplied to each position. It seemed reasonable to adapt this scheme for the new inter-p.b.x. circuits. The main difficulty is the provision of a unique mark for each circuit in order to prevent false switching when more than one junction finder is searching for a marking condition. The operator's control circuit and the enquiry and transfer circuit avoid coincidence by using, in one case, a battery and, in the other, an earth marking condition. This is quite adequate when only two circuits are involved, but is clearly unsuitable for up to 20 circuits. To resolve the problem, a separate isolated power supply is used as a marking condition for each S.S.A.C. No. 13 inter-p.b.x. circuit. This isolated power supply is derived from the common -50-volt supply by means of a d.c.-a.c. converter. The output of this converter is earth free and, after being rectified

and smoothed, provides a unique d.c. supply to operate relay MT in the auxiliary terminating relay-set, as shown in Fig. 3. Contact MT1 cuts the drive to the junction finder. Therefore, whilst the marker leads MT and MU are common to all inter-p.b.x. junction finders, a circuit cannot switch to anything other than its own marking condition.

USE OF B.P.O. TYPE-23 RELAYS

To make the maximum use of the limited equipment space available, B.P.O. type-23 miniature relays⁴ are used extensively in the design of the new relay-sets. These relays have been grouped together in each relay-set on a printed-wiring board, thereby easing problems arising from inter-wiring congestion and simplifying the manufacturing process.

CONCLUSIONS

This article has described the salient features of the provision of S.S.A.C. No. 13 inter-p.b.x. working on a P.A.B.X. No. 7 and the underlying reasons for tackling the development in the way described. The P.A.B.X. No. 7 becomes considerably more attractive to customers by the addition of a long-distance automatic signalling system on inter-p.b.x. circuits. In particular, a marked increase in its use in the growing market for customers' private-circuit networks is expected.

References

- ¹ MILES, J. V., and KELSON, D. Signalling System A.C. No. 9. *P.O.E.E.J.*, Vol. 55, p. 51, Apr. 1962.
- ² HILL, R. A., and GEE, J. H. A Miniaturized Version of Signalling System A.C. No. 9. *P.O.E.E.J.*, Vol. 65, p. 216, Jan. 1973.
- ³ ROCHE, J. J. Post Office Standard P.A.B.X.s, Part I—General Review of New Types and Details of P.A.B.X. No. 1. *P.O.E.E.J.*, Vol. 46, p. 159, Jan. 1954.
- ⁴ SCOTT, W. L., and PATERSON, J. A Miniature Relay—The Post Office Type-23. *P.O.E.E.J.*, Vol. 64, p. 123, July 1971.

Book Review

"Staff Relations in the Civil Service: Fifty Years of Whitleyism." H. Parris. George Allen and Unwin Ltd. 204 pp. £4.10.

In October 1916, a committee was appointed whose five reports, made in 1917 and 1918, had a far-reaching influence on industrial relations and, in particular, on the development of voluntary machinery for the negotiation of terms and conditions of employment. This was the committee on relations between employers and the employed, under the chairmanship of the Rt. Hon. J. H. Whitley, M.P. Its reports led to the extension of statutory minimum-wage legislation, which had first been introduced by the Trade Boards Act, 1909, and to the passing of the Industrial Courts Act, 1919. Generally speaking, however, the Whitley committee is best known for advocating the setting up of Whitley councils. These councils, composed of both employers and union leaders, were set up in several industries to discuss, at national, local, and even workshop level, not only wages and conditions, but also general problems of industrial efficiency and management.

In practice, however, the Whitley councils did not extend very far. Some industries, such as the mining, cotton and engineering industries, failed to establish them at all, largely because the unions were reluctant to accept them. In other industries, they were established only at the national level, and not in the workshops, because the employers were afraid of interference with their prerogative of management. Whitley machinery did, however, become established in the sphere of government employment, in the Post Office, Royal Dockyards and Civil Service, and it is on the basis of the successful development of staff relations in the Civil Service,

based on the Whitley model, that Henry Parris was commissioned to write this book, to mark the fiftieth anniversary of the National Whitley Council.

His aim was twofold; to produce an historical narrative, and to discuss possible future trends. In the historical narrative, he has tended to concentrate on the years following the outbreak of the second world war, since he has used material not available to L. P. White (1933) and E. H. Gladden (1943) in their reviews of the Whitley machinery.

For many people not closely connected with the National Whitley Council, the non-analytical approach to the subject, and the reliance on historical detail, although written in an anecdotal style, may prove to be a limitation to the book's general usefulness. Nonetheless, the book provides an insight into the setting-up of the national council, its workings and, more importantly, the congenial relationships between management and staff representatives, as they have developed over the years.

However, in most industries, with a strongly-organized and powerful labour force, Whitleyism has had only a minor influence, and, with the increasing fragmentation of bargaining in the 1950s and 1960s, together with the emphasis on negotiation rather than consultation, many industry-wide agreements became less significant. This has not been true of the Civil Service, but Parris does draw attention to the increased militancy of Civil Service unions, in the concluding chapter of his book, where he outlines some of the problems of change that Whitleyism has to encounter.

This book can, therefore, because of the time-scale of its study, and the appreciation it can provide of the changing nature of industrial relations, be recommended to those with a background in the Civil Service, or to those with an interest in collective bargaining, particularly regarding trade-union involvement with the state as an employer.

B. R. H.

Regional Notes

EASTERN REGION

High Wycombe's Mobile Electronic Exchange

The near exhaustion of the main exchange, coupled with delays in the provision of new equipment, resulted in High Wycombe being chosen as the first site in the country to be provided with a 2,000-line mobile electronic exchange (m.e.x.).

The three 8.2 m long trailers, which house the equipment, were delivered by Plessey Telecommunications Ltd. at the end of March 1974. These joined two existing mobile non-director exchanges and a mobile tandem exchange (m.t.x.), already providing relief for the main exchange.

Line circuits and outgoing routes are connected to the main-exchange distribution frames by two 1,000-pair cables and one 200-pair cable respectively. The incoming route to the m.e.x. is provided from the main exchange, via the existing m.t.x. Cables, linking the control and line-switching trailers, are plug-ended and of set lengths. The surplus cable is housed and protected under a wooden platform, built at floor level, joining the three trailers together. This platform also provides easy access from one trailer to another.

As this was the first 2,000-line m.e.x. to be provided, the strapping of the TXE2 equipment was carried out by Plessey Telecommunications Ltd., prior to its delivery to the site. No flood testing was considered necessary on site, and subsequent testing has proved that the equipment travelled without suffering any adverse effects.

G. L. POLLARD

NORTH WEST REGION

Damage to Pipe-Jacked Duct at Pendleton

On 9 November 1972, the Manchester-Liverpool No. 12 and Broughton-Pendleton No. 1 cables became faulty. The Manchester North Telephone Area maintenance group located the faults at identical points within the pipe-jacked duct between the deep-level manholes outside Pendleton telephone exchange and Pendleton church, a section of 1.07 m diameter concrete pipe, containing 64 polyvinyl-chloride (p.v.c.) ducts.

Roads works were in progress in the vicinity, and had reached a stage where sheet piles had been driven into the ground to form a retaining wall for a low-level by-pass. Excavations had been made to a depth of some 5 m, and anchor pins were in the process of being fitted, to strengthen the retaining wall. It was thought that the faults on the 2 cables had been caused by the drilling machine being used to provide the anchor pins. This theory was confirmed after green dye was poured into one anchor-pin hole, and was seen to flow out of the pipe-jacked duct, into the manhole outside Pendleton church. Fig. 1 is a cross-sectional view of the duct route, showing the point of damage.

The agents for the road-works contractor and the responsible authority accepted that the damage to British Post Office (B.P.O.) plant had been caused by the drilling operations.

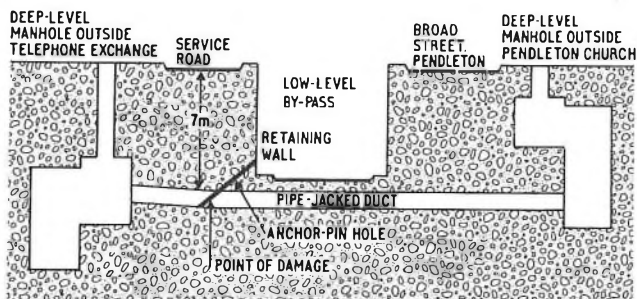

FIG. 1—Cross-section of route of pipe-jacked duct, showing point of damage

The contractor's agent thought that the drill had been deflected sideways, and that only one p.v.c. duct, containing the 2 cables, had been damaged. If this theory were correct, the B.P.O. could accept the loss of one duct, and would simply renew the damaged cables in a spare duct. However, if the drill had not been deflected, but had entered the pipe from above, then up to 13 spare ducts could have been damaged, and the B.P.O. would not accept this loss. It was, therefore, necessary to find out how many of the 64 p.v.c. ducts, contained within the pipe, had been damaged.

Since the point of damage was some 7 m below a busy service road, excavating for inspection purposes was out of the question. Arrangements were made to hire television-survey equipment, whereby a small camera could be drawn through the p.v.c. ducts.

On 11 November 1972, the inspection by television commenced, but viewing was hindered by the presence of silt and water in the ducts. All attempts to clear the obstructions, by using mandrels, compressed air and high-pressure water, failed, and the television inspection was abandoned. However, whilst forcing compressed air through the duct which contained the damaged cables, it was noticed that air was returning through other ducts; there was a definite distinction between those returning air and those not doing so.

When the ducts returning air were tabulated (see table), and plotted on a diagram of the pipe's cross-section (see Fig. 2), it was clear that the drill had entered from above, and had, in fact, cut through 9 p.v.c. ducts.

The question of how a repair should be carried out was then considered. After discarding one suggestion to tunnel below the retaining wall, and another to gain access to the pipe from the partially-excavated by-pass road, it was finally decided to excavate the service road, above the point of damage. The work would be done by the road-works contractor, who would be responsible for the excavation and reinstatement. But, since traffic along the service road was

	Ducts Returning Compressed Air Forced into Duct No. 1							
Duct No.	19	20	25	26	39	43	51	62

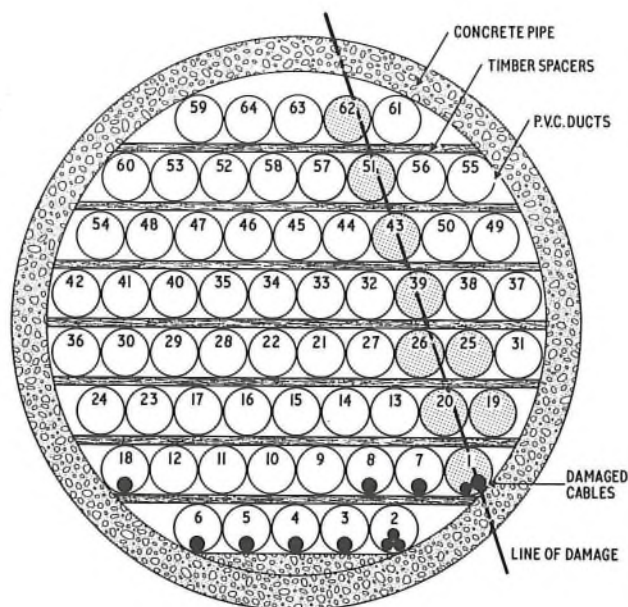

FIG. 2—Cross-section of pipe, showing damaged ducts (shaded) deduced from compressed-air tests

very heavy at that time, the repairs would have to wait until the by-pass was opened, and the traffic diverted onto it.

On 3 June 1974, excavations commenced, and, by 14 June 1974, the pipe was exposed. A hole, caused by the anchor-pin drill, was apparent in the top of the pipe, consistent with the deductions made from the compressed-air tests.

By using a horizontal grinder, a segment of the pipe, 2 m long by 0.5 m wide, was removed, so exposing the p.v.c. ducts. The damaged ducts were removed, from the top layer downwards, for a length of 2 m, it being necessary to remove some of the undamaged ducts in order to gain access to them. It was not possible to reach duct no. 1, which was left in its damaged state, but the bit used for drilling the anchor-pin holes was recovered from the hole it had made below duct no. 1. There was excessive silt in the upper, damaged ducts, which were cleared only after considerable effort, but the lower ducts were reasonably clear, and the undamaged ducts contained no silt. The removed lengths were replaced by new pieces of p.v.c. duct, the lengths being tested with a mandrel before the removed segment of pipe was made good with concrete. Final repairs were satisfactorily completed on 27 June 1974.

W. A. SAUNDERS

Unconventional Extension of Trafford Park Exchange

To meet a ready-for-hand-over (r.f.h.) date for additional apparatus space at Trafford Park Exchange, Manchester, which could not be achieved by a conventional extension to the existing building, it was decided to utilize one of a range of adjoining warehouse-type buildings, which had been acquired in order to safeguard the ultimate growth of the site.

The warehouse did not readily lend itself for adaptation to apparatus-room standards, which, in any case, would have been prohibitively expensive. To demolish it to make way for a replacement structure would not only have incurred needless expense, but would have excluded the future use of the building, which is not required to be demolished under the strategy for local development.

It was decided, therefore, to examine the range of proprietary pre-fabricated buildings to ascertain whether any of them would lend itself to erection within the warehouse. A suitable structure was chosen, and a scheme was planned by the Department of the Environment, who let the contract for its provision and erection on a specially-prepared base.

From the commencement of planning to the r.f.h. date took less than 12 months. The actual erection time for the building, with a floor space of 270 m² and accommodation for a multiple of 5,000 subscribers with stored-program-controlled directors, including a fan room, normal stock and contractor's room, was only eight weeks. The cost was £13,000. To this was added the cost of an external office and adaptation work in both buildings to provide apparatus entrances, ventilation requirements, access between the two buildings and windows in the blank walls of the warehouse. The total cost was £66/m², compared with the cost of a conventional non-standard extension of approximately £155/m². Moreover, a high proportion of the cost of the proprietary building will be recoverable when it is no longer required. The warehouse will be returned to general use after the next major building extension, which has now been deferred for at least eight years.

A significant part of the cost savings was due to there being no need for surface or domestic drainage. The new accommodation provides apparatus space and ancillary requirements only; the staff use the welfare facilities in the original exchange building. Planning time was saved because there was no need to obtain the consent of the Local Authority for the new building—only agreement to the change of use of the warehouse itself was necessary.

There remains sufficient floor area for the provision of a stand-by engine-generator set, which is in the course of being planned as a separate project. Air-cooling plant is provided in the building, and polyvinyl-chloride ducting on the roof runs from the fan room and serves diffusers in the apparatus-room ceiling. Emergency fresh-air facilities have been provided, in case of failure of the refrigeration plant. Heating is supplied by storage heaters.

R. A. YEATMAN

SOUTH WESTERN REGION

Installation of Engine Set at Gloucester

When Gloucester telephone exchange was recently extended, site restrictions resulted in a very difficult access to the base-engine and power room. The yard is small, narrow and sloping; yet it constitutes the only access for delivering telecommunications equipment.

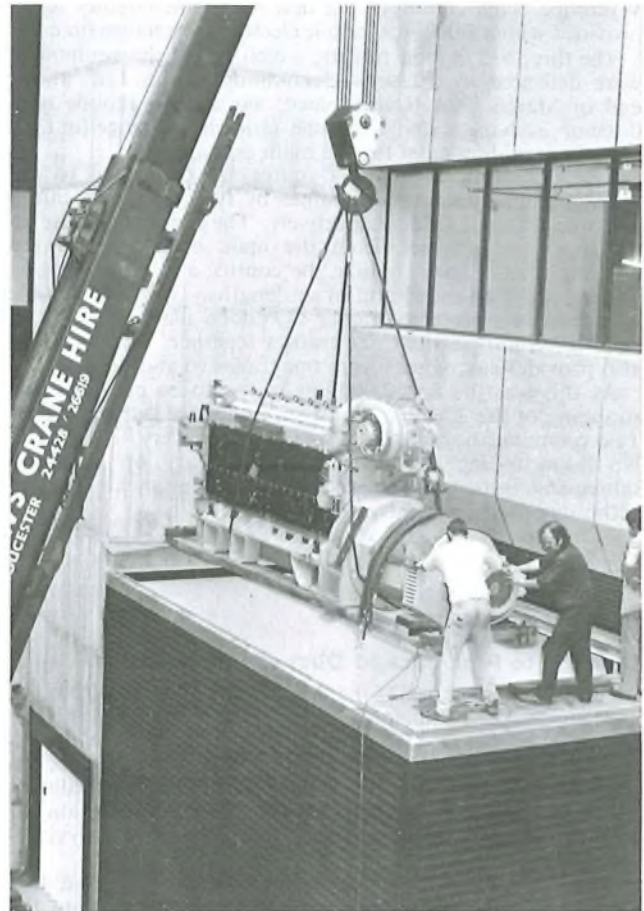

Lowering the 17 t engine-alternator set into the engine room

The first of three 500 kW standby engine-alternator sets was successfully installed with the aid of an articulated flat-truck and a 50 t crane having a telescopic jib. The crane had to be operated in a nearly-vertical position in order to deliver the 17 t engine-alternator set to the engine room.

W. I. KYNASTON

Underground Services in Unstable Ground

The line of the M5 motorway between Tickenham and Bridgwater, south of Bristol, was shown to pass through ground conditions of an unstable character. The design consultants carried out embankment-loading trials to determine the probable extent of compaction of the ground, and these revealed that it would be necessary to allow for a sinkage of up to 1.5 m under load conditions. At bridges, where rigidity was essential, deep foundations would be provided. Between the bridges and banked-up approach-roads, concrete ramps would be constructed, hinged-down at the abutments, so as to ride down with the compaction of the soil and become level at the final settling position.

Early in the design stage, the British Post Office (B.P.O.) was approached regarding alterations to its services, made necessary by the construction of the motorway. At one crossing, B.P.O. ducts, containing a coaxial cable and several

audio cables, would need to be moved, because the existing road was to be closed and replaced by a high-level interchange with new side roads.

Access to the existing services would cease at an early stage of the construction, necessitating the diversion of B.P.O. cables before the commencement of the road works. Because of the height of the proposed embankment on each side of the existing road and the movement of mechanical aids and bridge-construction equipment, temporary diversion of the services was not contemplated, and consideration was given to providing a new duct route across the approach to the interchange—an overall distance of 210 m. In view of the expected subsidence, it was the wish of the motorway engineers that the new services, when installed, should be permitted to sink with the adjoining ground. The water, gas and electricity undertakers were placed in a similar position, but, together with the B.P.O., were opposed to any such movement of their services after being laid.

At a joint meeting, the consultants explained that any static services would prevent compaction of the subsoil, and the effect of this would be transmitted up through the proposed new banking and result in surface undulations after the completion of the motorway. Although the maximum sinkage would occur during and immediately after the completion of the construction work, final settlement would take place, to a diminishing degree, over subsequent years.

A counter-suggestion, made by the B.P.O. and accepted generally, was that all services should be incorporated within, or on, an immovable beam, and this, in turn, should be surrounded by a large-diameter culvert, the latter only being allowed to sink with the adjacent ground settlement. Details of the construction work were finalized by the consultants, and plans for the execution of this work were incorporated in the contract for the motorway works.

Prior to the construction of the motorway, provision was made for the culvert. Along the proposed line of the culvert, spaced at intervals of 6 m, piles were driven to a depth varying between 18–21 m. A concrete beam was cast onto the piles at the existing ground level, encasing 12 B.P.O. ducts and two earthenware electricity service pipes. Attachments were provided on top of the beam to carry 457 mm and 102 mm diameter water mains and two 152 mm diameter gas mains. A prefabricated, corrugated-metal culvert, 3.4 m in diameter, was assembled around the beam, strengthened by a 305 mm thick concrete collar, cast along its entire length.

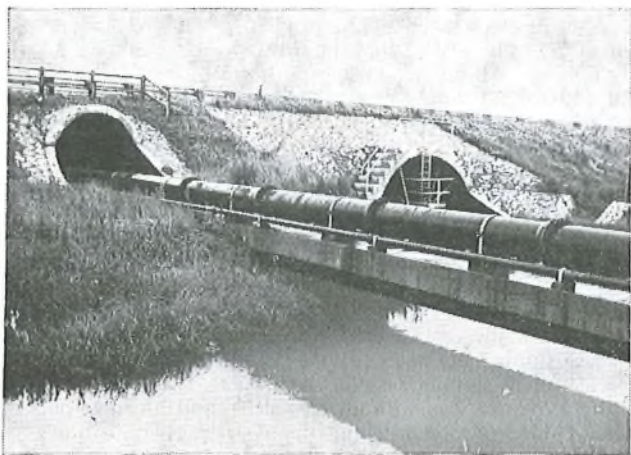

The service beam and culvert

The beam was also used to span a river. Manholes were built at each end of the crossing to link with existing duct routes, clear of the motorway works. Cables were changed over to the new route before the arrival of earth-moving equipment and before the commencement of the construction of the motorway and interchange.

A recent inspection of the tunnel showed that, at the point of maximum loading, the whole culvert had resettled to the extent that the headroom above the service beam had been reduced by nearly 1.2 m.

R. J. BONATHAN

Provision of Buildings by Direct Commission

Until recently, all new British Post Office (B.P.O.) building projects were designed and supervised by the Department of the Environment. In 1973, however, it was decided that commercial architects would be retained by the B.P.O. for a selected group of building projects, in order to assess the possible benefits of a wider use of private practitioners.

The Dorchester telephone exchange extension, which looks like being the first of the trial group of buildings to reach completion, was designed on this basis, and the result has been a time-saving of 50 per cent in the planning stage.



Artist's impression of Dorchester telephone exchange

Planning of the Dorchester development began in late September 1973, with the building contract being let slightly less than a year later, in early September 1974. The normal planning time for this £427,000 building would have been 2 years. The B.P.O. appointed a planning team for the project, comprising an architect, a structural engineer, a quantity surveyor, and a heating and ventilation engineer, together with B.P.O. representatives.

Completion of the new building is now expected by March 1976. The extra year, gained by adopting this approach, has meant that additional apparatus can be installed to meet the exhaustion date of the existing building.

I. O. HODGE

SOUTH EASTERN REGION

Fire-Alarm Systems for Brighton's Auto-Manual Centres

An efficient fire-alarm system is one which meets the requirements of the British Post Office (B.P.O.), as advised by the Department of the Environment's fire officer, with due consideration for local operational staff.

Three large group switching centres (g.s.c.s) with auto-manual centres (a.m.c.s), and with extensions nearing completion, plus a fourth g.s.c. in the late planning stage, involved the Brighton Telephone Area in seeking the latest type of equipment as a matter of some urgency. *Post Office Requirement 1063* gave details of the facilities necessary, and recommended that commercial equipment be obtained by competitive tendering from a list of possible contractors. New systems would be required to use a single sounder, which must be audible above such noises as those generated by register-translator equipment, and give two distinctive tones, one to act as an *alert* signal and the other to act as an *evacuate* signal. A single-frequency note, interrupted for 500 ms at 1 s intervals, sounded for a period of 30 s, followed by a 60 s silent period, a 4 s period of interrupted tone, and a further 60 s silent period, would constitute the *alert* signal, whilst the *evacuate* signal would be a continuous, two-tone warble.

None of the firms contacted at the planning stage could offer equipment giving the necessary timing sequence, although it is thought that some firms can now arrange to meet these requirements. However, a solid-state sounder, the pitch of which could be changed by simply reversing the polarity of the supply voltage, was readily available.

Initially, consideration was given to the use of uniselectors, ratchet relays and ringing machines to provide the timing for the *alert* signal, but it was felt to be more advantageous to use integrated-circuit elements. A circuit was evolved using set-reset flip-flop circuits and NAND gates, the whole timing

unit being built on a printed-circuit board approximately 76 mm × 102 mm, plugged into an edge-connector for easy replacement. Large power transistors were used to switch the sounders on and off, operated by the integrated-circuit logic elements, via suitable driving stages.

In designing the alarm system as a whole, reference was made to the British Standards Institution's *Code of Practice for Fire-Alarm Systems* (CP 1019), coupled with advice from the Department of the Environment. The alarm zones were rationalized to individual blocks and floors, and call-points were positioned adjacent to exits, as recommended by the Department of the Environment. A minimum number of sounders were installed, sited in prominent positions, with the intention of adding further sounders later, if this was necessary to obtain full coverage. Twin-lamp, illuminated display panels were designed to indicate the blocks and floors in pillar form, so that the source of an alarm could easily be recognized. These were placed in main entrances and on the landings of principal staircases.

From the variety of sophisticated fault-monitoring circuits suggested, a closed-circuit (or series) system was selected for simplicity. Mineral-insulated cable was used throughout the installation because of its ability to withstand intense heat and, hence, further fault-monitoring facilities were considered unnecessary.

A control console was designed to accommodate a display panel, the floor relays, fuses and the timing unit. The EVACUATE keys were mounted adjacent to their respective display lamps. Because of the intensity of the noise caused by the sounders, a SILENCE-ALARM key was incorporated on the console, the operation of which transfers the general alarm in the switchroom to a local buzzer and lamp, mounted on the console. The whole unit was mounted in the switchroom, in such a position as to give easy access for cabling, and good visibility for the operating staff. A discrete, 24-volt power supply was installed as near to the control console as possible. Standard B.P.O. type cells and rectifiers were used, in order to facilitate maintenance replacement.

An additional facility, currently being considered, is the automatic shutting down of the ventilating plant in the event of an alarm.

Several systems are being installed, wholly by B.P.O. staff, and the first to be finished, at Crawley g.s.c. and a.m.c., has passed all of its pre-service tests.

A. E. LUKE
A. B. HOLMAN

Broadstairs-Domburg No. 1 Cable

Another link between Britain and the European Continent was forged in June 1974, when the land section of the Broadstairs-Domburg (Netherlands) No. 1 cable was drawn in between Broadstairs repeater station and the beach manhole.

On Saturday July 6, the shore-end of the cable was landed from the Dutch ship *Director General Bast* onto the sandy beach at Broadstairs. External-duty staff from Canterbury Telephone Area assisted the Submarine Division staff to land and bury the cable, and winch the end to the beach manhole. The prevailing good weather attracted Post Office personnel and holidaymakers to watch the operation.

The completed coaxial cable will carry a 13 MHz transmission system and, when working to full capacity, will provide 20 supergroups (1,380 telephone circuits), a 500 mA power-feeding current being fed over the centre conductor. The repeater spacing for the land section of the cable is 8·162 km, and for the 37·3 mm diameter sea section of the cable, 12·07 km.

The land section of the cable, from the beach manhole to Broadstairs repeater station, is 3 km in length, the centre conductor being 6·1 mm in diameter and the outer conductor having an internal diameter of 23·8 mm. The insulation between the inner and outer conductors consists of solid polythene containing an anti-oxidant. The joints and core of this type of cable can be subjected to radiography, enabling faults and voids to be detected.

The shore-end of the cable was taken into the beach manhole, and the armouring wires secured by means of an anchoring clamp.



Completed shore-end anchoring clamps: exposed (right), and wrapped in preservative tape (left)

Prior to the provision of the new transmission cable, an old sea-earth cable was recovered, and a land-earth-electrode system, using platinized titanium-mesh anodes, was installed for the specific use of continental systems.

J. SIMPSON

NORTHERN IRELAND

Power Crisis During Ulster Workers' Council Strike

As a result of industrial action by the Ulster Workers' Council between 15-29 May 1974, the telephone system in Northern Ireland faced an unprecedented series of power cuts, which severely tested the stand-by power facilities at all exchanges. Although business traffic was significantly reduced, this advantage was more than offset by a considerable increase in local residential traffic. In many exchanges, traffic was, for fairly long periods, at least 50 per cent higher than normal. It was frequently noted that a widespread power cut in a particular area was almost immediately followed by a period of severe congestion in the exchange and a consequential heavy drain on the battery, as residential customers enquired after the welfare of friends in similar straits. The overall situation was particularly complicated by the nature of the power cuts. Not only were the cuts much longer than would normally be expected, for instance, during periods of load-shedding, but they also affected large parts of the service area simultaneously. At times, two-thirds of the entire Province was without electricity and, during the last day of the strike, generation of power was within hours of ceasing completely.

The fixed stand-by engines, at the 44 main exchanges, generally proved to be capable of dealing with the frequent and prolonged power cuts. Only three engine failures occurred: at one Strowger non-director exchange, the voltage-regulator developed a fault, and at two TXE2 exchanges, diesel fuel leaked into the engine sumps, thereby diluting the lubricating oil and causing engine failure due to low oil pressure. At only one of these exchanges, a TXE2, was it necessary to restrict service, and then only for 2 h.

The position was somewhat more precarious in the case of unit automatic exchanges (u.a.x.s) and small automatic exchanges (s.a.x.s). The two main complications were that maintenance staff did not know when the mains supply to u.a.x. 12 and 13 units was going to be cut off and, furthermore,

because of widespread picketing, it was not possible to gain access to several telecommunications engineering centres in order to collect emergency generating sets. The first problem was overcome by increasing the frequency of the test-call programs from two to six calls per day. The condition of the batteries in each group of u.a.x.s and s.a.x.s was monitored from a central point by measuring the voltage at the end of a junction from each exchange. This enabled maintenance staff to determine when a particular battery required additional charging. The unavailability of emergency generators would have led to serious difficulties, but timely assistance was given by the Service Department, Telecommunications Headquarters, who organized a special airlift to deliver generating sets, rectifiers and transformers, most of which were loaned by the Eastern Telecommunications Region and the Scottish Directorate. These items proved invaluable, and the co-

operation and assistance provided by all concerned with the organization of this delivery is gratefully acknowledged. As a consequence of the combined effort, it was necessary to restrict service at only four exchanges out of a total of 150 u.a.x.s and s.a.x.s, for approximately 6 h in three of the cases, and 15 h in the fourth.

The Northern Ireland Telecommunications Business faced a unique combination of problems, and it is to the credit of the staff that they succeeded in maintaining an essential service which can be, and often is, the means of preventing loss of life and property. A considerable amount of experience was gained of a telephone system close to collapse, and a detailed report has been sent to Telecommunications Headquarters.

H. KANE

Associate Section Notes

Aberdeen Centre

The 1974-75 session commenced on 5 September with a quiz, in which we competed against a combined team from the Dundee, Edinburgh and Stirling centres. After a close contest, however, Aberdeen was defeated by 3 points.

On 10 September, a party of 18 members visited the Fountainbridge brewery of Scottish and Newcastle Brewers Ltd. The party was given a short talk on the history of the company, prior to a tour around the brewery, and was afterwards entertained with a selection of the products.

I. BOOTH

Bournemouth Centre

We started our season in March 1974, with a documentary film show. The films were kindly lent by the British Airways Corporation.

The highlight of the year was in April, when a talk, backed by slides, was given by Dr. R. L. Williams of Scotland Yard. The subject was *Forensic Science*, and this was a very interesting and well-attended evening.

In July, a general meeting was held at New Milton crossbar exchange for a discussion on crossbar working.

The first round of the Regional Quiz Competition was held at Salisbury, and the result was Bournemouth: 43 points, and Salisbury: 30 points. Our next round is against Exeter Centre.

Later in the year, we will be making a visit to the Television Centre at Wood Lane, London.

G. H. SEAGROATT

Colwyn Bay Centre

The May 1974 meeting was entitled *Star Trek*, being a technical account of how satellite tracking is carried out by amateur astronomers. It was given by Howard Miles, director of the satellite section of the British Astronomical Association. He concluded with a fine account, which promoted many questions, of the discoveries made by the recent space probes to Mars, Venus, and Mercury. After a buffet, the film *We Came in Peace* was shown. This is an historical account of the race into space, which includes some notable failures as well as successes.

Members of the senior section, and of the Chester Associate Section Centre, were present. The meeting was held at the British Legion Club, Llandudno.

E. DOYLERUSH

Dundee Centre

At the time of writing these notes, our program is not complete, but we have in mind items on the Parks Department's contribution to a better Dundee, the reform of local government, and transit switching. Also in the pipeline are

visits to Messrs. Robb Caledon, Dundee, to see cable ships under construction, and to a coal mine.

Two of our members, Dick Gibson and Roddy MacLachlan, along with 2 gentlemen from Stirling and 2 from Edinburgh, made up the East Scotland team, which competed against a team from Aberdeen in a district quiz. This was held simultaneously in Dundee and Aberdeen with the aid of landlines, and was won by the East Scotland team by 35 points to 32.

R. T. LUMSDEN

Edinburgh Centre

Our 1973-74 session closed on 10 April 1974, with 27 members attending the annual general meeting and dinner. The following office-bearers and members of committee were elected.

Chairman: Mr. J. Samson.

Secretary: Mr. M. I. Collins.

Assistant Secretary: Mr. J. L. M. Alexander.

Treasurer: Mr. R. R. Thomson.

Librarian: Mr. J. H. King.

Committee: Messrs. R. B. Bailey, R. S. Elder, I. D. Hoseason, C. Little, G. Scott, J. Drummond, J. Edwardson, A. Johnstone, R. Mitchell, V. Smith, and A. M. Wilson.

In our forthcoming program, we hope to visit Chrysler (Scotland) Ltd., Linwood, and the forensic department of the Edinburgh City Police; and to see cable ships under construction at Dundee. We also hope to include the following talks: *Telecommunication Management—From the Chairman of the Scottish Telecommunications Board's Point of View* by Mr. K. C. Grover, and *The Post Office Tunnel Complex* by Mr. S. Pairman.

M. I. COLLINS

Plymouth Centre

After a moribund couple of years, an attempt is being made to revive activity at the Plymouth Associate Section Centre. Although small numbers of members have attended, a steady succession of meetings is in hand.

We visited Goonhilly Earth Station in June, and our local British Rail Diesel locomotive depot in September. At the time of writing, we have visits scheduled to the Decca Navigation Training School at Brixham, the Texas Instruments factory at Plymouth, and to see research projects at Plymouth Polytechnic. Negotiations are in hand for talks on crypton engine-tuning, road-traffic flow, Royal Naval bomb disposal, and for visits to R.A.F. St. Mawgan and Plymouth Planetarium.

There is a great need for more active members and, particularly, some keen committee members. Would anyone who is interested, please contact Gerald Scott (telephone: Plymouth 61043).

G. D. SCOTT

The Associate Section National Committee Report

National Telephone Museum

There has been some progress towards a possible united effort between the Post Office, the Senior Section of the I.P.O.E.E. and ourselves to see that we do not lose the interesting telecommunications equipment of the past. The Museum Sub-Committee has met once again, and has drafted ideas for the possible future of some established museums and the formation of some new collections. There will soon be a more positive drive by all parties to save telecommunications equipment of historical interest, and put it on display, both to Post Office staff and, possibly, in view of the popular interest in industrial archeology, the general public.

Support for the Associate Section

Although we now have an established national committee, with delegates from all member regions, plus regional liaison officers and committee members working in regions and

centres, we are still in need of assistance. No matter how well organized a region or centre is, more help at any level is always useful and will, I am sure, never be refused. The mundane tasks, such as typing, printing, preparing minutes, organizing accommodation for meetings, and many more, all have to be done. So, if you are able to help your centre, even in only a small way, please offer your services; take a bit of work from someone else.

National Technical Quiz Competition

I understand from the quiz organizer, Kevin Marden, that the National Technical Quiz Competition is being organized very quickly this year. The date and venue of the final has even been settled; it will be held at the Institution of Electrical Engineers, Savoy Place, London, W.C.2, on 21 March 1975.

P. L. HEWLETT

Institution of Post Office Electrical Engineers

Associate Section Papers: Annual Awards, 1973-74

The I.P.O.E.E. Council, on the adjudication of the Judging Committee, has awarded a prize of £25 and an Institution Certificate to Mr. L. Johnson, Kingston-upon-Hull Centre, for his paper *Post Office Telecommunications in Hull Over the Last 100 Years*.

The Council is indebted to Messrs. J. D. Cartwright, J. R. Goldsmith and F. Haworth for kindly undertaking the adjudication of the papers submitted for consideration.

Birmingham, Coventry and West Midland Centre Program, 1975

Meetings will be held at the Post Office Sports and Social Club, Thorpe Street, Birmingham, commencing at 14.00 hours.

Thursday 20 February:

Modernization by P. A. Lamont.

Thursday 20 March:

Measurement and Analysis Control by B. R. Muir and A. F. Yaxley.

Thursday 17 April:

Teletraffic Engineering by A. G. Leighton.

Colchester Centre Program, 1975

All meetings will be held at Colchester.

Wednesday 26 February:

The American Telephone System by Dr. G. White.

Wednesday 19 March:

Teletraffic Engineering by A. G. Leighton.

Wednesday 23 April:

Satellite Communications Today and Tomorrow by J. K. Jowett.

Tuesday 6 May:

High-Voltage Line and Substation Maintenance by Mr. Tiley, Central Electricity Generating Board.

East Midlands Centre Program, 1975

Meetings will be held at Nottingham University (N) or

Peterborough Technical College (P), commencing at 14.00 hours.

Wednesday 5 February (N):

External Controls—Can We Reduce Costs? by D. G. Shore.

Wednesday 26 March (N):

Teletraffic Engineering by A. G. Leighton.

Wednesday 16 April (P):

Data Transmission—Present and Future by S. C. M. Wright.

North Eastern Centre Program, 1975

The meeting will be held in the Bakery Hall of Tribute, Leeds Polytechnic, and will commence at 14.15 hours.

Wednesday 5 March:

The Application of Electronics in Postal Engineering by B. Rawding.

Northern Ireland Centre Program, 1975

Meetings will be held in the staff restaurant, third floor, Churchill House, commencing at 14.25 hours.

Wednesday 19 February:

Planning the Main Transmission Network for Digital Systems by W. G. Simpson and K. W. J. Lonnen.

Wednesday 12 March:

The New Belfast Postal Sorting Office by B. J. Hume.

Wednesday 16 April:

Measurement and Analysis Control—A New Approach to Quality-of-Service Improvement by B. R. Muir and A. F. Yaxley.

South Eastern Centre Program, 1975

Meetings will be held at the Old Telephone Exchange, 46 Holland Road, Hove (H); Lecture Theatre L, University of Surrey, Guildford (G); or the Social Centre, Culverden Park Road, Tunbridge Wells (TW). All meetings will commence at 14.00 hours.

Wednesday 12 February (H):

Outline of the TXE4 System by A. M. Belenkin.

Wednesday 5 March (TW):

Revised Appraisal Procedure for Minor Engineering Grades by J. Bluring.

Wednesday 12 March (G):

Long-Range Studies in Telecommunications by A. A. L. Reid.

Wednesday 16 April (H):

Aluminium Alloy as a Conductor for Local-Network Cables by J. Pritchett and D. W. Stenson.

South Western Centre Program, 1975

Meetings will be held at Bristol University, commencing at 14.15 hours.

Wednesday 5 February:

The Swindon Supplies Depot by R. L. Stichbury and D. C. Pring.

Wednesday 12 March:

Local Distribution—A Time for Change? by A. G. Hare.

Wednesday 2 April:

The Role of the Purchasing and Supply Department in Telecommunications by J. M. Harper.

Stone/Stoke Centre Program, 1975

Meetings will commence at 14.15 hours, unless otherwise stated.

Monday 10 February (Stone):

Service-Affecting Aspects of Power Plants by N. W. Wright.

Thursday 20 February (Stone, 19.15 hours):

Communications Bit by Bit by H. B. Law. (Joint meeting with the Institution of Electronic and Radio Engineers.)

Monday 10 March (Stoke):

The Telephone Exchange and the Customer by D. Monaghan.

Local Centre Secretaries

The following is a list of local centre secretaries, to whom inquiries about the Institution may be addressed. It would be particularly useful if members would notify any change in their own address to the appropriate secretary.

Centre	Local Secretary	Address
London	Mr. J. M. Avis	THQ/NP 7.1.3, Room 311, Lutyens House, Finsbury Circus, London, EC2M 7LY.
Stone/Stoke	Mr. G. G. Owen	TP 7.2.3D, Technical Training College, Stone, ST15 0NQ.
Eastern (Colchester)	Mr. B. J. Miller	Eastern Telecommunications Region, Planning Division, St. Peter's House, St. Peter's Street, Colchester, CO1 1ET.
Eastern (Bletchley)	Mr. R. A. Hughes	General Manager's Office, 16 Paradise Street, Oxford, OX1 1BA.
South Eastern	Mr. J. M. Smith	South Eastern Telecommunications Region, Planning Division, Grenville House, 52 Churchill Square, Brighton, BN1 2ER.
North Eastern	Mr. D. Spencer	North East Telecommunications Region, Service Division, 79 St. Paul's Street, Leeds, LS1 4LW.
Northern	Mr. L. G. Farmer	General Manager's Office, Newcastle Telephone Area, Hadrian Telecommunications Centre, Melbourne Street, Newcastle-upon-Tyne, NE1 2JQ.
Birmingham	Mr. D. F. Ashmore	General Manager's Office, ED3/7, 84 Newhall Street, Birmingham, B3 1EA.
East Midland	Mr. D. W. Sharman	General Manager's Office, Room 1301, 200 Charles Street, Leicester, LE1 1BB.
North Western (Manchester and Liverpool)	Mr. W. Edwards	North West Telecommunications Board, Planning Division, Bridgewater House, 60 Whitworth Street, Manchester, M60 1DP.
North Western (Preston)	Mr. J. W. Allison	Post Office Telephones, Clifton Road Depot, Marton, Blackpool, FX4 4QD.
Wales and the Marches	Mr. R. E. Jones	Wales and the Marches Telecommunications Board, PW 4.1.1, Planning and Works Division, 2 Plymouth Street, Cardiff, CF1 4XZ.
Scotland East	Mr. W. L. Smith	Scottish Telecommunications Board, P2.2.3, Planning Division, Canning House, 19 Canning Street, Edinburgh, EH3 8TH.
Scotland West	Mr. D. M. Dickson	Telephone House, Pitt Street, Glasgow, G2 7AH.
South Western	Mr. R. G. Willis	South Western Telecommunications Region, Planning Division, Mercury House, Bond Street, Bristol, BS1 3TD.
Northern Ireland	Mr. F. G. Cole	General Manager's Office, Churchill House, Victoria Square, Belfast, BT1 4BA.

A. B. WHERRY
Secretary

Notes and Comments

Articles on Topics of Current or General Interest

The Board of Editors would like to publish more short articles dealing with current topics related to engineering, or of general interest to engineers in the Post Office.

Engineers have a significant role in modern society, and the *P.O.E.E. Journal* is an instrument whereby themes and ideas may be exchanged.

As a guide, there are on average about 750 words to a page, allowing for diagrams. Authors who have contributions are invited to contact the Managing Editor, NP 9.3.4, Room S 08A, River Plate House, Finsbury Circus, London, EC2M 7LY.

Notes for Authors

Authors are reminded that some notes are available to help them prepare manuscripts of *Journal* articles in a way that will assist in securing uniformity of presentation, simplify the work of the *Journal's* printer and illustrators, and help ensure that authors' wishes are easily interpreted. Any author preparing an article for the *Journal*, who is not already in possession of the notes, is asked to write to the Managing Editor to obtain a copy.

It is emphasized that all contributions to the *Journal*, including those for Regional Notes and Associated Section Notes, must be typed, with double spacing between lines, on one side only of each sheet of paper. Articles, and contributions for Regional Notes, must be approved for publication at General Manager/Head of Division (Controller) level.

Each circuit diagram or sketch should be drawn on a separate sheet of paper; neat sketches are all that are required. Photographs should be clear and sharply focused. Prints should preferably be glossy and should be unmounted, any notes or captions being written on a separate sheet of paper. Negatives or plates are not needed and should not be supplied.

Back Numbers

Back numbers of *The Post Office Electrical Engineers' Journal* are available, price 45p each (including postage and packaging), for all issues from April 1970 to date, with the exceptions of April 1971 and October 1971.

Copies of the October 1966 issue are also still available. This issue contains articles dealing with the effects of telephone-circuit characteristics on data transmission, the trunking and facilities of the 5005 crossbar system, Leaffield radio station, the functional design of core-type register-translators, the push-button telephone market-research trial, and an introductory review of electronic telephone exchange developments.

The October 1973 special issue on the 60 MHz transmission system, and the April 1974 issue covering sector switching centres, are among the back numbers still available.

Orders, by post only, should be addressed to *The Post Office Electrical Engineers' Journal*, 2-12 Gresham Street, London, EC2V 7AG. Cheques and postal orders should be made payable to *The P.O.E.E. Journal* and should be crossed "& Co."

Publication of Correspondence

The Board of Editors would like to publish correspondence on engineering, technical or other aspects of articles published in the *Journal*.

Letters of sufficient interest will be published under "Notes and Comments". Correspondents should note that, as it is necessary to send copy to the printer well before publication date, it will only be possible to consider letters for publication in the April issue if they are received before 14 February 1975.

Letters intended for publication should be sent to the Managing Editor, *P.O.E.E. Journal*, NP 9.3.4, Room S 08A, River Plate House, Finsbury Circus, London, EC2M 7LY.

Post Office Press Notices

Telecommunications for the Future

"The world is now served by more than 300-million telephones; and a vast network, from ultra-reliable cables beneath the sea to satellites 22,300 miles above the equator, makes possible communications on a global scale," said Mr. Edward Fennessy, Managing Director of British Post Office Telecommunications. Speaking at the Financial Times conference *Tomorrow in World Electronics*, Mr. Fennessy said that growth, and demands for new and more advanced services, were occupying the energies of telecommunications organizations throughout the world.

Taking as his theme the future prospects of telecommunications, Mr. Fennessy said that the total global telecommunications system was growing by seven per cent per year. He said, "In the U.K. alone, nearly 20-million telephones make 15,000-million calls per annum and, extrapolating on a global scale, the total telephone traffic could be of the order of two billion calls per annum by the year 2000." Britain's own international telecommunications services were expanding by 20 per cent per year, doubling the size of the system every four years. "Currently, no moderation in this extremely rapid growth can be seen," said Mr. Fennessy.

Looking to the future, Mr. Fennessy saw the development of a wide range of services. By the year 2000, for example, viewphones would be commonplace. Wideband circuits would, by then, be available to many homes, capable of delivering, in print-out form, the daily newspaper. The same circuits would permit access to a wide range of programs and library material for television purposes. Radiopaging would enable anyone equipped with a midget receiver to be located at will over wide territorial areas, and a global network of data circuits would link groups of business organizations.

The most significant development, Mr. Fennessy said, would be the ability to provide immediate global face-to-face meetings of groups of people by means of international Confravision. "This development, already now in the experimental phase, will unquestionably, by the end of the century, become a major challenger to transport," said Mr. Fennessy. He added, "Today, the telecommunications engineer is asking why it is necessary to move people physically about the world in order to communicate. Travel by train, car, ship or aeroplane is time-consuming, expensive and frequently tedious. In the process, vast amounts of limited fossil fuels are consumed, the only end product of which is a meeting at which people communicate." There were now no technical barriers to the introduction of global services, such as Confravision. The only inhibiting factor was the cost of providing the channels needed to carry the television-type picture, which occupies the bandwidth of 1,000 telephone conversations.

Already, developments were significantly reducing the basic cost of long-distance communication. Thousands of telephone conversations could already be carried on cables, or by satellites. "By the year 2000, techniques, now under development, will enable hundreds of thousands of such conversations to be carried," said Mr. Fennessy. The means of achieving this would be by the use of waveguides and optical fibres, using strands of glass no thicker than a human hair.

Car Radiophone Service Extended

A £600,000 British Post Office (B.P.O.) project to extend Britain's car radiophone service to five new centres has made a recent advance with the opening of a new service covering the Midlands. Motorists equipped with car radiophones are now

able to make telephone calls from their cars within a 7,780 km² area, which takes in Wolverhampton, Birmingham, Coventry, Rugby, Northampton and Banbury. Until recently, the car radiophone service was available only in London and South Lancashire.

The Midlands is the first of the five new centres to get the service. Controlled from Birmingham, it can initially cater for 300 customers, using transmitters sited at Turner's Hill, near Birmingham, and Charwellton, near Rugby.

The B.P.O. plans to open four more radiophone services during the next two years. An East Pennine service, covering Leeds, Doncaster and Sheffield, and a Scottish service, covering Edinburgh and Glasgow, are due to start operating in mid-1975. By early 1976, the last two services—the Avon and South-East Wales service and the Tyneside service—should be working.

The most significant development of the service is that car radiophone users will be able to make or receive calls when they are within range of any of the service areas. Until recently, users could make or receive calls only in their home area, but the existing London and South Lancashire services have been modernized to make this new facility possible, and it will be available in all of the new radiophone service areas.

New Pillar-Box

The first of a new type of cast-iron pillar-box, which postmen will find quicker and easier to clear than the traditional type, has gone into service.

Rectangular in shape, the new pillar-boxes, known as *G-type*, have an improved internal-clearance mechanism which can reduce emptying time compared with the well-known round boxes. The postman simply hooks a bag beneath the mechanism and pulls a lever, and the letters are released from the mail container directly into the bag.

Reducing the time taken to clear a pillar-box means that bad weather has less chance to spoil mail, and the mail van spends less time at the kerb-side.

Taking the place of the plastic tablet, indicating the time of the next collection, is a small rotary dial, the use of which will avoid the loss of, or damage to, tablets. Together with the notice plate which gives information about collections, the dial indicator is protected by armoured glass. The plate itself is slightly angled to make it easy to read.

There are 100,000 posting boxes in Britain, of which about 34,000 are pillar-boxes. The first rectangular pillar-boxes,

constructed from sheet steel, were erected on 130 sites soon after 1968, but they have not been found to be as durable as cast iron.



Brenda Smith, 21, of Colchester, makes her own bit of postal history. She posted the first letter in the first cast-iron oblong pillar-box in Britain when it came into operation at Leggatt Drive, Bramford, Ipswich, on 23 October 1974. About 750 of the new boxes will be installed by the British Post Office over the next 12 months.

Copyright

The entire contents of this *Journal* are covered by general copyright, and special permission is necessary for reprinting long extracts, but editors are welcome to use not more than one-third of any article, provided that credit is given at the beginning or end, thus: "From *The Post Office Electrical Engineers' Journal*."

The Board of Editors is not responsible for the statements made or the opinions expressed in any of the articles or the correspondence in this *Journal*, unless such statement is made specifically by the Board.

Subscriptions and Back Numbers

The *Journal* is published quarterly in April, July, October and January, at 30p per copy, 45p per copy including postage and packaging (annual subscription: £1.75; Canada and the U.S.A. \$4.50).

The price to British Post Office staff is 21p per copy.

Back numbers will be supplied if available, price 30p (45p including postage and packaging). At present, copies are available of all issues from April 1970 to date, with the exceptions of April 1971 and October 1971 which are now sold out. Copies of the October 1966 issue are also still available.

Orders, by post only, should be addressed to *The Post Office Electrical Engineers' Journal*, 2-12 Gresham Street, London, EC2V 7AG.

Employees of the British Post Office can obtain the *Journal* through local agents.

Binding

Readers can have their copies bound at a cost of £2.25 including return postage, by sending the complete set of parts, with a remittance to Press Binders Ltd., 4 Iliffe Yard, London, S.E.17.

Remittances

Remittances for all items (except binding) should be made payable to "*The P.O.E.E. Journal*" and should be crossed "& Co."

Advertisements

All correspondence relating to advertisement space reservations, copy, proofs, etc., should be addressed to the Advertisement Manager, *The Post Office Electrical Engineers' Journal*, 2-12 Gresham Street, London, EC2V 7AG.

Distribution and Sales

Correspondence relating to the distribution and sale of the *Journal* should be addressed to *The Post Office Electrical Engineers' Journal* (Sales), 2-12 Gresham Street, London, EC2V 7AG.

Communications

With the exceptions indicated above, all communications should be addressed to the Managing Editor, *The Post Office Electrical Engineers' Journal*, NP 9.3.4, Room S08A, River Plate House, Finsbury Circus, London, EC2M 7LY.

Model Answers Books

Books of model answers to certain of the City and Guilds of London Institute examinations in telecommunications are published by the Board of Editors. Details of the books available are given at the end of the Supplement to the *Journal*. Copies of the syllabuses and question papers are not sold by the *Post Office Electrical Engineers' Journal*, but may be purchased from the Department of Technology, City and Guilds of London Institute, 76 Portland Place, London, W1N 4AA.

The quiet answer to your heated exchanges

Temperature Limited, leading British manufacturers of air-conditioning, have collaborated with the Post Office to design and develop air-handling equipment tailored to meet the stringent requirements of the telecommunications industry – in terms of sound level, construction and performance.

The vertical air-handling unit illustrated is one of a series produced by Temperature Limited, specifically to meet these criteria.

- Five basic models (5-20 TR refrigeration ; 3,000-12,000 c.f.m.)
- All units factory piped, wired and tested
- All basic electrical controls, modulating valves, etc, in-built as standard
- Site work limited to the coupling of water, air and electrical services
- High component quality ensures fundamental reliability and minimal servicing
- In-built fault diagnosis
- Unit designed for low noise emission
- Unit flexibility enhanced by wide range of optional features
- 'In-space' or 'Pod' application ensures maximum utilisation of apparatus room floor space

For full details, please send this coupon now.

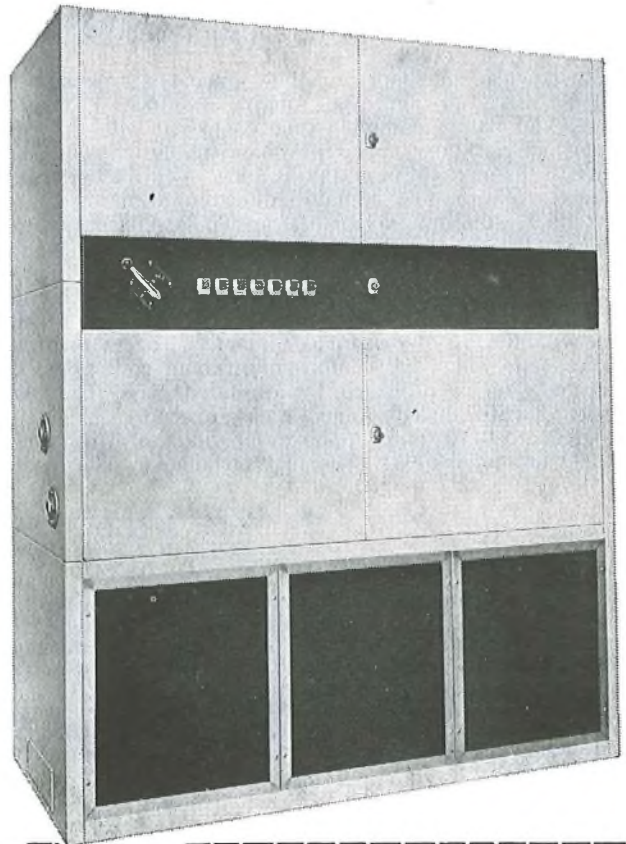

I would like to know more about the Temperature range of air-handling units for the telecommunications industry.

Name

Position

Company

Address

.....

.....

.....

POEE 1



Temperature
LIMITED

192-206 York Road
London SW11 3SS
Telephone : 01-223 0511





“It's for you”

The message is brief and simple: CANTAT 2, officially inaugurated June 21st 1974, is the latest and largest trans-Atlantic submarine telephone cable system. Developed and supplied entirely by STC, it is the first system serving the North Atlantic route to be undertaken by a single company.

Its capacity of 1,840 telephone circuits is more than the combined total provided by the seven other telephone cable links between Europe and North America that have preceded CANTAT 2. And, incidentally, STC made its contribution to no fewer

than six of those seven.

“It's for you” is where you, the user, come in. “It was undertaken by us” is where we bow out—to progress other submarine cable contracts worth, in total, some £50 million.

STC's world-wide telecommunications capability continues to forge new and better communication links throughout the world.

Standard Telephones and Cables Limited,
Submarine Systems Division,
North Woolwich, London E16 2EJ.
Telephone: 01-476 1401 Telex: 21645

Standard Telephones and Cables Limited

A British Company of **ITT**

The new ITT 2300 Teleprinter



Light on cost. Light on weight. Strong on performance.

This is the new ITT 2300 Teleprinter. Today's supreme teleprinter for telex and private wire usage, and a very significant advance in teleprinter design.

Its main features include:

Telex Control Interface and control requirements, for both Telex and Private Wire operation are met by simple strapping options.

Semi Electronic Design All signal processing is electronic, using large scale integrated circuit techniques. The answer back coding consists of a printed circuit board which can be plugged into any ITT 2300. Mechanical tasks are limited to print out of page copy, punching, tape reading and keying actions.

So the 2300 is smaller, lighter and quieter.

Reliability Micro electronic techniques reduce the number of mechanical parts by two thirds, thus significantly increasing reliability.

Maintenance Minimum moving parts and modular construction result in fewer adjustments—maximum accessibility. Routine maintenance

is only necessary every 1000 hours (or one year).

Versatility Push a button to select your operational mode. All the usual modes are available. And the 'Tape Prep' mode allows the preparation of a new tape with associated printed copy, while the reader transmits existing information to line. This increases traffic throughput when necessary.

And the ITT 2300 is easy to operate—one of the keyboard arrangements has a typewriter layout to minimise training. It's also easy to change paper rolls, tape rolls and the ink roller, too. Tape preparation can be carried out at up to 75 bauds (10 cps), and transmitted to line at 50 or 75 bauds ($6\frac{2}{3}$ or 10 cps). Operation at 100 bauds ($13\frac{1}{3}$ cps) is also available. The 2300 conforms to recognised international standards of safety, and is equipped with a time-out facility for private wire usage.

For more details, write to Publicity Department 21, ITT Creed Ltd., FREEPOST, Brighton BN1 1ZW. (No stamp required if posted within the U.K.).

ITT Creed Limited **ITT**

PST3

**New - generation medium - and high - capacity
multiplex system (60 to 2700 channels)**



**Simple and rational mechanical structure
Reduced size and power consumption
Extensive use of advanced technologies
Very high reliability and flexibility
Ease of maintenance and expansion
Performance according to CCITT recommendations
System complete with all equipment to meet any plant requirement**

Telettra

VIMERCATE MILANO ITALY

NO COMPRESSOR NEEDED



Send now for details of the powerful, portable Pionjar petrol driven drill and breaker to

ITT Flygt Pumps Limited,
Colwick, Nottingham.

Please send details of the Pionjar Rock Drill/Breaker to

NAME _____

ADDRESS _____

INDEX TO ADVERTISERS

	Page
GEC Telecommunications Ltd.	2-4
GTE Information systems Ltd.	6, 7
Gulton Europe Ltd.	13
Herman Smith Ltd.	15
ITT Creed Ltd.	11
ITT Flygt Pumps Limited	13
Marconi Communication Systems Ltd.	8
Pye T.M.C. Ltd.	1
Sperry Gyroscope Division Ltd.	14
Standard Telephones & Cables Ltd.	10
Telephone Cables Ltd.	5
Telettra Spa, Milan	12
Temperature Ltd.	9

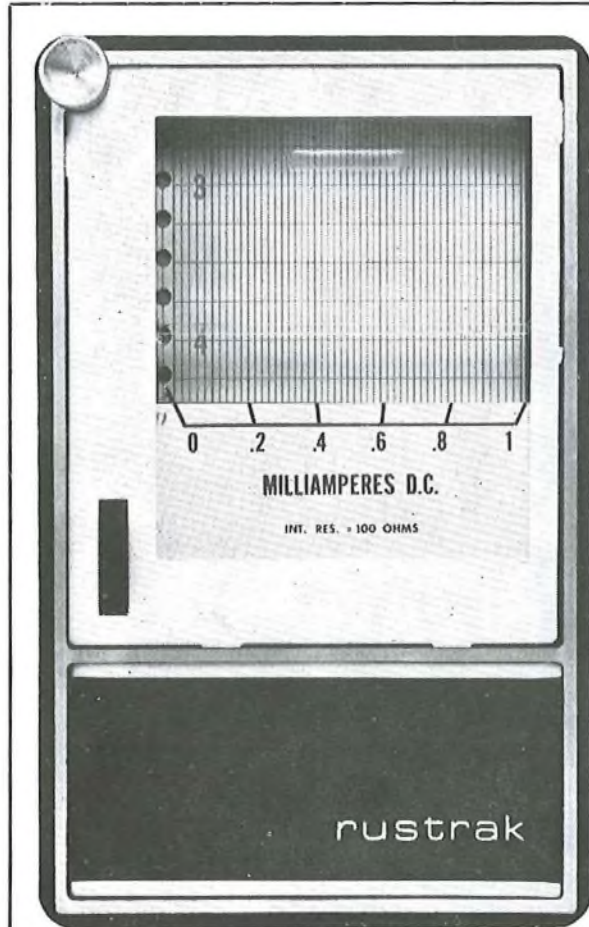

Rustrak Miniature Strip Chart Recorder

Rustrak miniature strip chart recorders are available as potentiometric or galvanometer type instruments which produce a permanent record of virtually any parameter that can be converted into an electrical signal: temperature, pressure, flow, level, watts, frequency, humidity, events and many more.

Data is recorded on pressure sensitive paper, obviating the many problems that can result from the use of ink. A wide range of motor speeds and interchangeable gearboxes is available to give over 50 chart speeds.

Of attractive design, the low-cost Rustrak recorder measures only 5½" high by 3½" wide

Considerable savings in time and cost are made by hand from indicator readings.

Delivery of the standard instrument is 2-3 weeks and a complete advisory service on your particular recorder problems is available from our experts.

Gulton
EUROPE
Rustrak Instrument Division
BRIGHTON BN2 4JU



HOW'S YOUR MEMORY?

Our's is all right. It's been working hard for the Post Office and Government for more than fifteen years.

Sperry drum memory systems are available for all fast back-up store applications and have a proven reliability. Early models supplied to the British Post Office more than fifteen years ago continue to give excellent service. Current models incorporate the latest storage techniques and provide bulk data storage for computers and message switching, telecommunications and similar data processing systems. For example, Sperry memory stores together with our 1412 mini-computers are the principal modules in the SCAMP (Sperry Computer Aided Message Processor) System.

*For more information about Sperry memory systems contact David McNaught.
Bracknell 3222.*



SPERRY
GYROSCOPE

BRACKNELL BERKSHIRE ENGLAND RG12 1QL
TELEPHONE 0344-3222 TELEX 848129



Do you know what else Herman Smith can do?

"62" type equipment is the aspect of our output you probably already know about. It's worth remembering however, that we produce many other types of presswork and sheet metal assemblies which may be of use to you.

We are acutely aware of the needs of the electrical and electronics industries and our experience in these spheres is comprehensive.

We are prepared for any challenge, complex or simple, large or small. Try us.

We produce the range of "62" type equipment, including the racks themselves, shelf assemblies, card locks, card guides, slide brackets, dummy front plates, etc. We also undertake electrical and electronic assemblies.



Contact Peter Bowen
Herman Smith Limited Cinderbank Works Netherton Dudley
Worcestershire Telephone Dudley 52791

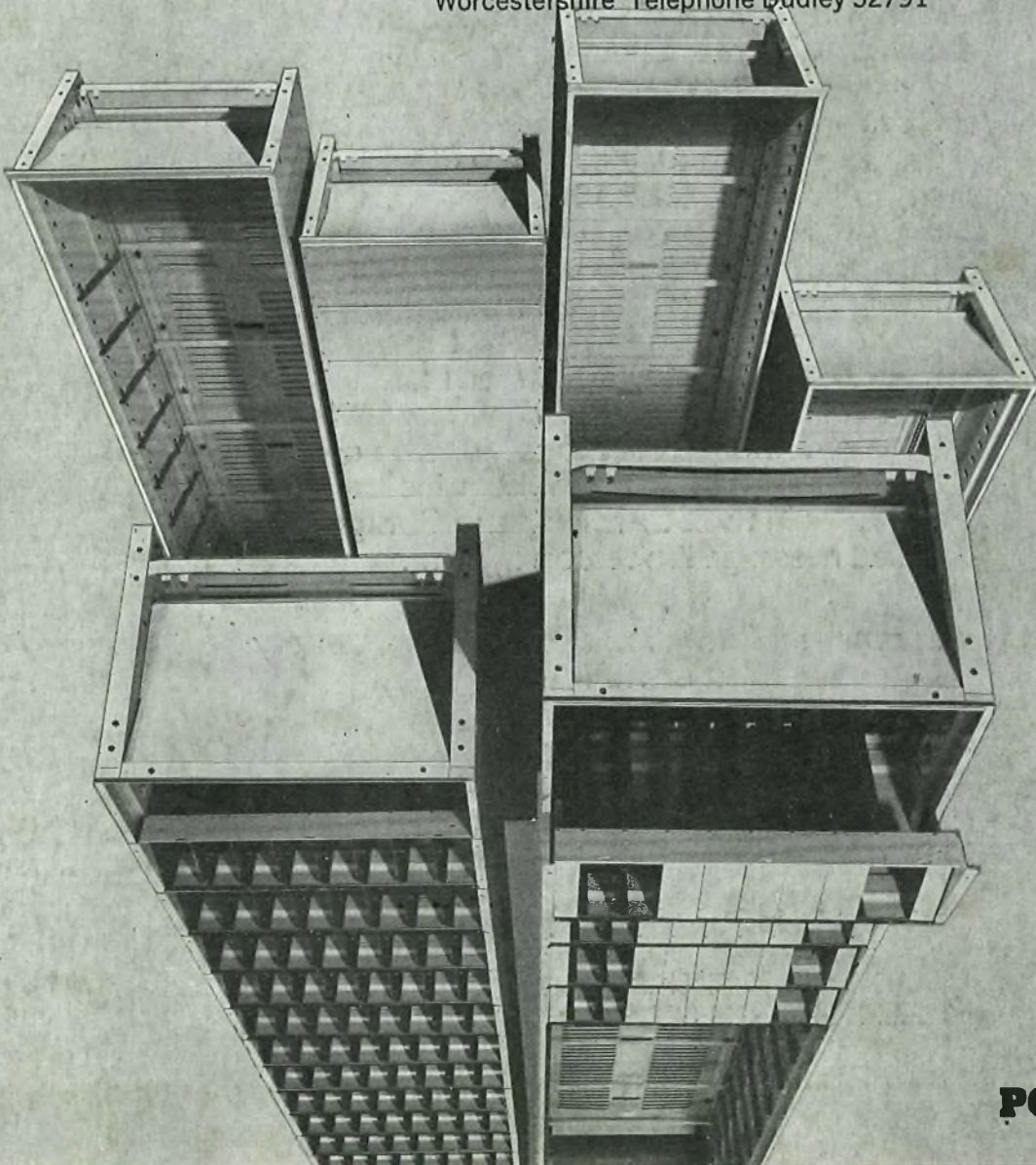

PO approved