

R. Roe PE1.2

The Post Office Electrical Engineers' Journal

VOL 66 PART 2/JULY 1973



THE POST OFFICE ELECTRICAL ENGINEERS' JOURNAL

VOL 66 PART 2 JULY 1973

Contents

	<i>page</i>
Editorial	63
A New Code Translator for the Letter-Sorting System—Part 3—The Drum-Storage and Data-Handling Systems—P. W. Dewick, G. J. Garwood and R. C. Mephram	64
Local-Battery Charging over Subscribers' Lines—B. R. Freer	73
A Time-Division Multiplexing Equipment for the Datel Services—D. E. White, R. A. Collins and P. M. Hall	77
The Evaluation of a New Computer for the British Post Office Telecommunications Headquarters—M. L. Jamison	86
Earth-Station Equipment for Intelsat IV Satellites—S. Simkins, S. A. Foulkes and J. E. Purdy	91
New Generation Channel Translating Equipment—N. P. McKay and C. A. Patel	103
Logarithmic Frequency-Plotter Speeds the Recording of Crosstalk Measurements—C. R. Harris	112
Cabling Across Estuaries—W. T. King	114
Notes and Comments	119
Regional Notes	120
Associate Section Notes	122
Institution of Post Office Electrical Engineers	124
Press Notices	126
Book Reviews	85, 90, 111, 118

Published in April, July, October and January by the *Post Office Electrical Engineers' Journal*,
2-12 Gresham Street, London EC2V 7AG

Price 21p 31p (Including Postage and Packaging). Orders by post only.

Annual Subscription (post paid): Home and Overseas £1.24. (Canada and U.S.A., 3 dollars)

comprehensive telecommunications

The World extends its links with GEC Telecommunications Networks

In every continent in the world, GEC broadband radio systems are proof of the international telecommunications capability of GEC. The range of GEC microwave radio systems, operating in over 30 countries includes:

FOR LONG HAUL MAIN ROUTES: 2GHz, 4GHz, 6GHz, and 6.8GHz, equipments for speech or television transmission.

FOR MEDIUM HAUL, SPUR AND PRIVATE USER ROUTES: 7.5GHz equipment for speech transmission.

ASSOCIATED EQUIPMENT: Frequency Division Multiplex for up to 1800 circuits, supervisory alarm indication and remote control systems, I F and baseband switching equipments, narrowband auxiliary radio for serviceband, and antenna systems.

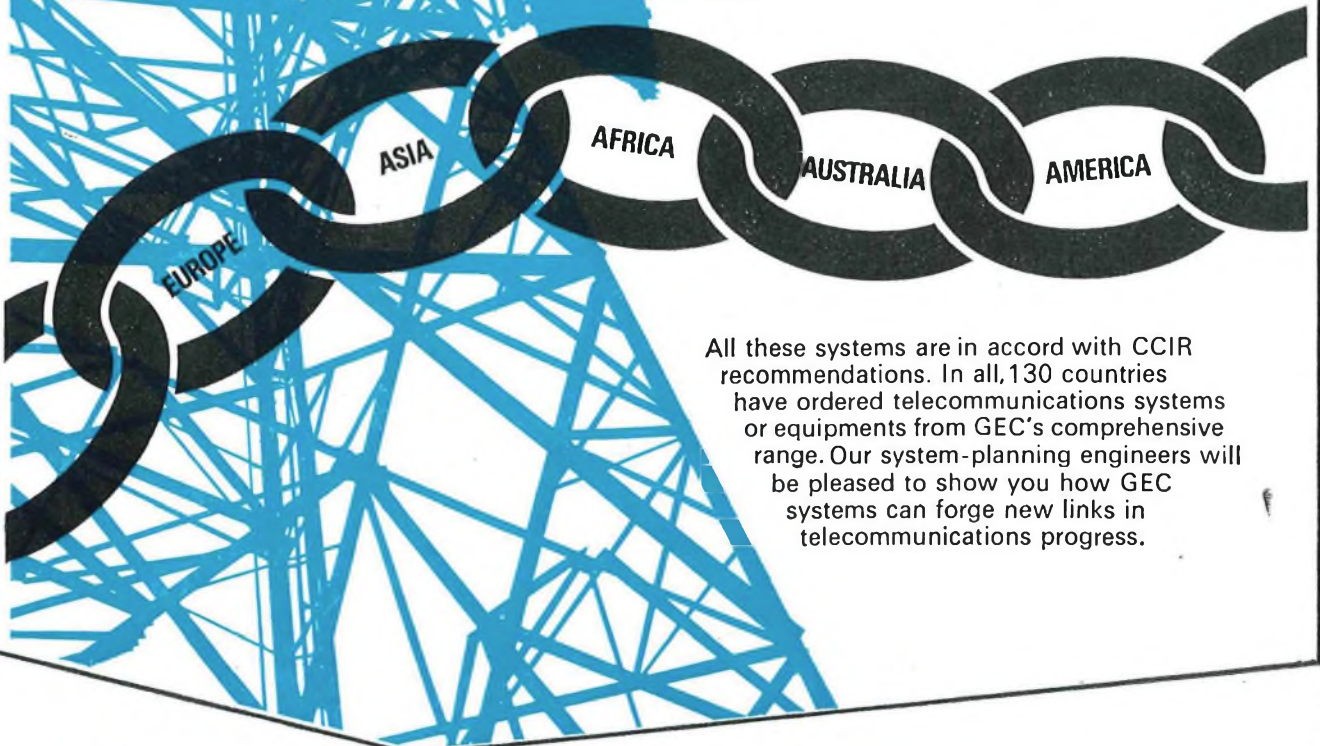

All these systems are in accord with CCIR recommendations. In all, 130 countries have ordered telecommunications systems or equipments from GEC's comprehensive range. Our system-planning engineers will be pleased to show you how GEC systems can forge new links in telecommunications progress.

G.E.C.

MICROWAVE AND LINE TRANSMISSION · MULTIPLEX · V.F. TELEGRAPHY
DATA MODEMS · TELEPHONE SWITCHING SYSTEMS · PRIVATE
TELEPHONE SYSTEMS · TELEPHONES · TOTAL SYSTEMS CAPABILITY

GEC TELECOMMUNICATIONS LIMITED of Coventry, England.
A Management Company of The General Electric Co. Ltd. of England.

18860

comprehensive telecommunications

6.8GHz microwave system— planned to suit your plans

The GEC 6.8GHz broadband radio system is planned to make the most effective use of the available radio-frequency spectrum and to provide the maximum flexibility of system planning. The facilities, which ensure that the system is planned to suit your plans, include provision for the connexion of eight bothway channels, each with a capacity of 960 telephone circuits or one colour television channel, to a single antenna; and, sixteen bothway channels within the radio frequency plan specified by CCIR Recommendation No. 384-1. With frequency allocations that do not interfere with the 4 and 6GHz frequencies used by satellite communication links, the GEC 6.8GHz system is particularly suitable for connecting satellite earth stations into national networks. Our system-planning engineers will be pleased to show you some of the other ways in which the 6.8GHz system is planned to suit *your* plans. The system includes frequency division multiplex, supervisory and control, IF and baseband switching, and antenna systems



MICROWAVE AND LINE TRANSMISSION · MULTIPLEX · V.F. TELEGRAPHY
DATA MODEMS · TELEPHONE SWITCHING SYSTEMS · PRIVATE
TELEPHONE SYSTEMS · TELEPHONES · TOTAL SYSTEMS CAPABILITY

GEC TELECOMMUNICATIONS LIMITED of Coventry, England.
A Management Company of The General Electric Co. Ltd. of England. 18853

“put me through to the manager... room service... theatre bookings...”

Our new low line Cord Switchboard is at home wherever personal service is still important....

Even in the pace of today's modern world, personal service is expected and often necessary. The GEC low line Cord-type telephone switchboard combines elegance with efficiency and boasts adaptability to suit its surroundings, wherever they may be... whether in luxury hotels, hospitals, or even cruise liners. It's the ideal PABX private telephone system for situations where personal service counts.



Registered Design
No. 940229



Takes telecommunications into tomorrow

GEC-AEI TELECOMMUNICATIONS LTD, OF COVENTRY, ENGLAND.

A Management Company of The General Electric Co. Ltd. of England.

IBS 48

Opt for Mullard in the PO

Optoelectronics technology has come a long way since the days when a limited number of photovoltaic cells were used for such familiar equipment as lightmeters, burglar alarms, door-opening devices, and so on. Nowadays, Mullard make a wide range of photosensitive components and assemblies and they are employed in much more sophisticated equipments; for example, in military reconnaissance systems and in electronic data processing equipment.

Equipment being developed by the British Post Office for automated mail handling is another outlet for Mullard optoelectronic devices. Not long ago, all your letters and parcels were hand-sorted over and over again, at various offices en route to their destinations. But recently, the BPO employed Mullard photosensitive devices in automatic sorting equipment which takes over much of the work. Quite simple photocell/amplifying circuits can be used to detect the size of packets and envelopes and operate equipment which automatically routes them to other sorting positions. Even postage stamps these days can be recognised: they are coded with a phosphor which emits detectable light when exposed to ultraviolet radiation - enabling first- and second-class mail, for example, to be identified. The next major step in the automation of mail handling is, of course, to apply OCR (optical character recognition) to machine-read postal codes. A great deal of Mullard research and development has gone into producing efficient, self-scanning, silicon photodiode arrays which are the heart of OCR systems.

Optical connections

It seems a far cry from character reading to telephones, but optoelectronic devices can also be used as coupling components in communications and other electronic circuits, and as such have some important advantages.

Mullard optically-coupled isolators consist basically of a light-emitting diode encapsulated with, but not electrically connected with a silicon phototransistor. Current passed through the diode causes it to emit radiation near the infrared, and this signal is 'followed' by the phototransistor. The advantage of optical coupling is, of course, that the two circuits are completely isolated and can be operated at widely differing voltage levels and with extremely high transfer ratios. The problems associated with common impedance coupling between such circuits are completely eliminated. Mullard make a range of isolators which will cater for input-output breakdown voltages of

up to 4kV at an economic cost. The advantages of this type of coupling to the circuit designer have led the BPO to incorporate these devices in new system designs.

Automatic dialling

One more interesting application for optoelectronic devices - punched card dialling. This technique enables a subscriber to store telephone numbers on punched cards which, when inserted into a suitable 'black box' connected to his telephone, does the dialling for him without the hazard of picking a wrong digit. The BPO are looking into various kinds of systems for this purpose, but the common denominator will be a row of

cadmium sulphide photocells which will 'read' the punched card and initiate the dialling pulses.

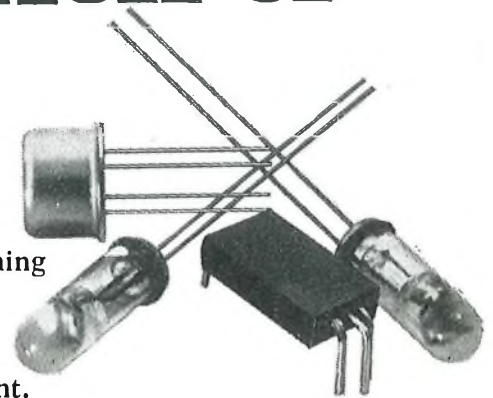

New Brochure

When you need optoelectronic components make use of Mullard's long experience in the design of advanced detection devices.

This new brochure, detailing the Mullard range of standard and custom-built components and arrays is now available. Ask your Mullard representative for a copy.

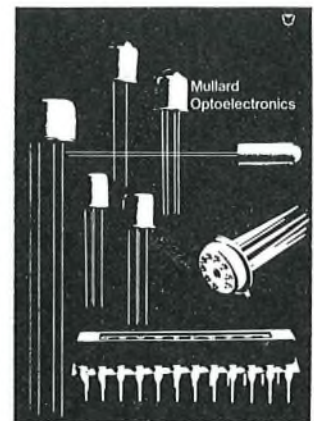

Microwave transistors for high frequency systems

With the introduction of the 551 BFY/A transistor Mullard have extended the range of transistors intended for Post Office high-frequency systems

use. This latest transistor has a typical F_t of 5GHZ, and is in a true microwave encapsulation making it suitable for 'S' band amplifiers.

CURRENT RANGE

Operation Current	F_t 1.5—2 GHZ	F_t 3—5 GHZ
14mA	BFX89 BFW92 BFY90	BFR90 551 BFY/A
30mA	BFW30 BFW93	BFR91
75mA	BFW16A/17A	412 BFY

In addition microminiature numbers BFR92/3 and of the versions of BFR90/1 are BFY90 under the number available under the type BFS17R.



Mullard

Mullard components for Post Office electronics

Mullard Limited, Mullard House, Torrington Place, London WC1E 7HD

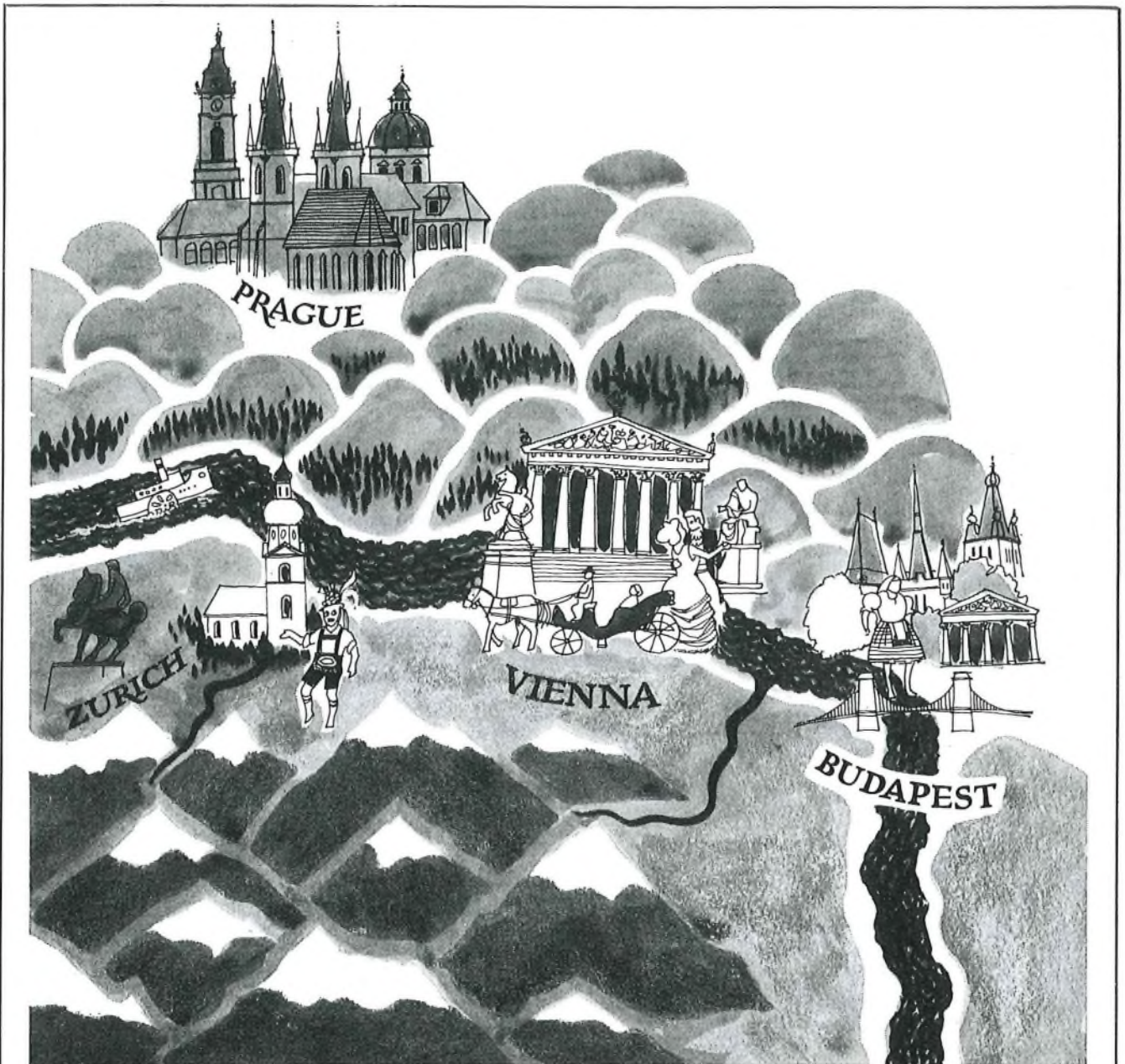

It's a new Danube thanks to STC Coaxial Cable Systems.

Communications on the Danube are now a quick waltz around a national coaxial cable network. Based on an STC 12MHz coaxial cable system, it's capable of carrying up to 2700 telephone circuits.

The first link in the new chain was an all solid state system installed by the Austrian P.T.T. between Salzburg and Bischofshofen in 1968; the first such system in Europe. The success of this operation has led to a steady build up to more than 1000 kilometres of STC 12MHz systems. In fact Austria will soon have a total of 35 terminal and main repeaters and 300 dependent repeaters.

These purely Austrian internal developments have important international ramifications, because European telephone traffic can now pass through Vienna along the Danube to Budapest and other points east like Prague and Bucharest. In fact STC transmission know-how has helped to make Vienna a highly developed communications centre for the whole of Eastern Europe. It's a new Danube thanks to STC coaxial cable systems.

Standard Telephones and Cables Limited,
Transmission Division, Chesterhall Lane,
Basildon, Essex. Tel: Basildon 3040
Telex: 99101

Standard Telephones and Cables Limited

ITT

A British Company of ITT

We've gone eight better



About three years ago we achieved a major breakthrough in the manufacture of type 174 Coaxial Cable – we produced the first one ever with 20 cores. And, as far as we know, we're still the only Company in the world to have made production quantities of a cable containing so many type 174 coaxial cores.

Now we've gone not one, but eight better.

We have manufactured an even larger multicore cable – this time with 28 cores.

Strict engineering control throughout manufacture ensured constant end impedance levels, essential to obtain the required overall transmission

characteristics, since each of the 28 cores at each jointing position must be electrically compatible with the corresponding core in the adjoining cable.

This is a good example of STC philosophy. When we come up with an idea there's no sitting back on our laurels.

We are constantly making improvements and modifications to keep our products and processes as advanced and sophisticated as possible. After all, we've our hard earned reputation to consider.

Standard Telephones and Cables Ltd.,
Telephone Cable Division,
North Woolwich, London E16 2EJ.

Standard Telephones and Cables Limited

ITT

A British Company of IIT

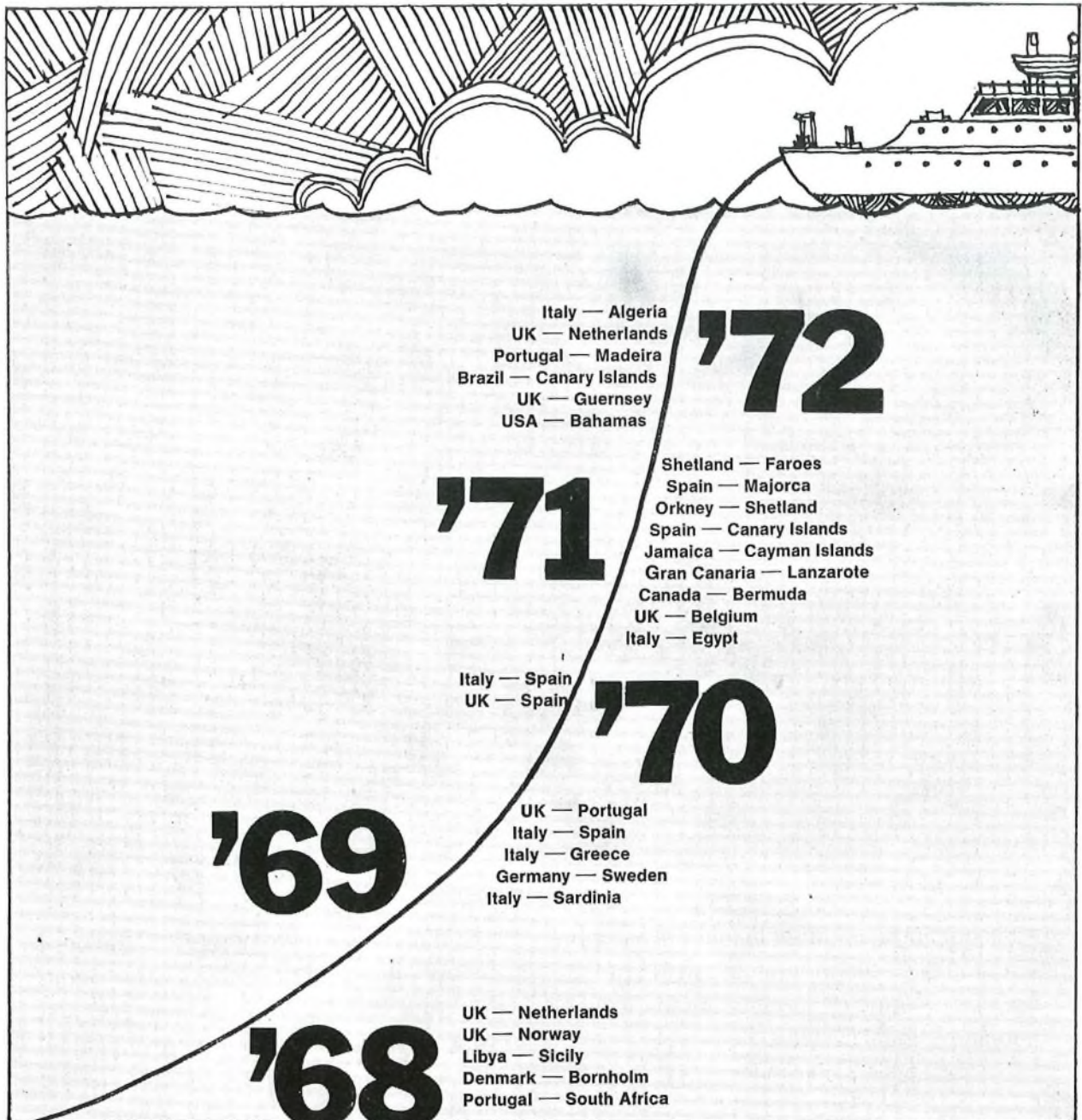

STC's success: put it down to experience.

Submarine cable systems are our business. And to measure just how successful we are at the business you've only got to look at our performance over the past 22 years.

The contracts shown above are just some of the most recent completed by STC, but the list goes back as far as 1950. Since that year we've maintained a programme of continual research and development which has led to remarkable innovations in submarine telecommunications.

And we don't intend to stop.

At present we're working on systems with far wider band widths than ever thought possible a few years ago. These will lead to even more sophisticated designs in the future.

So you can see why STC international under-sea telecommunications systems are regarded as the most advanced in the world.

Standard Telephones and Cables Limited,
Submarine Systems Division, North Woolwich,
London E.16. Tel: 01-476 1401

Standard Telephones and Cables Limited

ITT

A British Company of ITT

Subject: Consoles at monitoring and testing area of Telegraph Transmission Centre.

Location: 5th Floor, St. Botolph's House, Aldgate, London.

Built with: WIDNEY DORLEC.

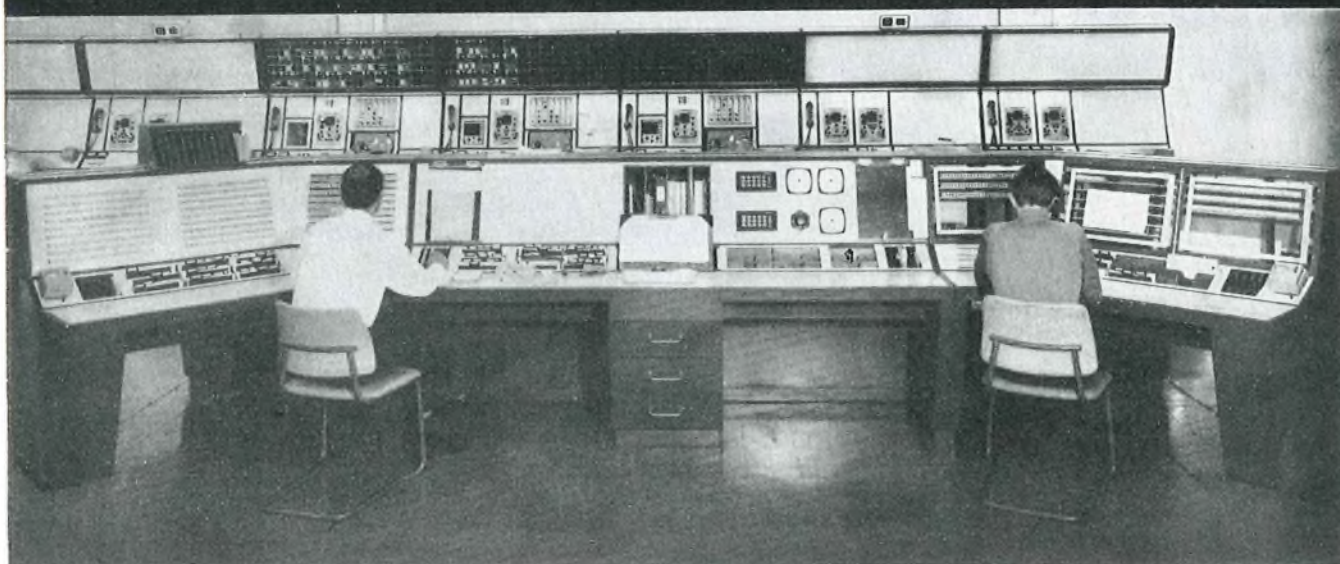

It is not surprising that leading designers in today's technological field much prefer Widney Dorlec than other constructional systems.

The consoles shown above and the desk below installed at the P.O. Radio Station, Burnham, Somerset, are just two examples of outstanding versatility, good looks, and hidden strength. The unique combination only offered by Widney Dorlec.

To Hallam Sleigh & Cheston Ltd., the makers of Widney Dorlec. P.O. Box 133, Bagot Street, Birmingham, B4 7BD. Telephone 021 359 3044 Telex 338054

Please send me the Widney Dorlec Catalogue.

Please get in touch with me personally.

Name _____

Position/Dept. _____

Company name and address _____

WD118



Widney Dorlec.

The Post Office Electrical Engineers' Journal

BOARD OF EDITORS

J. F. P. THOMAS, B.Sc., C.Eng., M.I.E.E., Chairman
E. W. AYERS, B.Sc.(Eng.), C.Eng., F.I.E.E.
D. R. BEARHAM, B.Sc.(Eng.), C.Eng., M.I.E.E.
S. H. SHEPPARD
A. J. BARNARD, C.Eng., M.I.E.E.
A. C. CROISDALE, M.B.E., B.Sc.(Eng.), M.I.E.E.
J. MARTIN, B.Sc.(Eng.), C.Eng., M.I.E.E.

Managing Editor

N. J. H. NINNIM, M.Sc., B.Eng.

Deputy Managing Editor

D. MILLINGTON, C.Eng., M.I.E.E.

Assistant Editors

P. G. STEELE, M.Sc., B.Sc.(Eng.)
T. R. K. RAITT
N. G. CRUMP, T.Eng., M.I.T.E.

Secretary-Treasurer

B. FARR, A. B. I.

Advertisement Manager

R. G. ROTHERY

EDITORIAL

The *Journal* Supplement, which gives model answers to telecommunications subjects in the City and Guilds of London Institute Examinations, has been published for many years now. There is little doubt that these model answers provide a valuable service to many of our readers and the *Journal* is likely to continue to publish them as long as the demand exists. Readers sometimes comment that some answers (and diagrams in particular) include more detail than could possibly be expected from students under examination conditions. This is certainly true and each copy of the Supplement bears a legend making this clear. A full answer to one person is a brief outline to another and each candidate needs to make up his own mind how much he will put into an individual answer; it will depend on his personal inclinations and abilities and examination tactics. The model answers aim to give reasonably complete coverage of the facts associated with the topic of a descriptive question, and to give a possible method of working, and the right answer, for a numerical problem. The rest is up to the student.

This issue of the *Journal* includes articles on topics as widely varied as subaqueous cable provision, the latest equipment installed at Goonhilly Earth Station, and postal machinery. The October 1973 issue will be a special issue devoted to articles on various aspects of the new 60 MHz coaxial cable transmission system. The topics will include the transmission aspects of the system and details of the special civil and mechanical engineering techniques that have been developed for the project.

A New Code Translator for the Letter-Sorting System

Part 3—The Drum-Storage and Data-Handling Systems

P. W. DEWICK, G. J. GARWOOD, B.TECH.(HONS.)† and R. C. MEPHAM*

U.D.C. 681.178:656.851

This, the concluding part of a three-part article on the application of the new code/sort translator to the system for the mechanized sorting of letter mail, describes the magnetic-drum memory system which stores all the routing and translating information, and the system developed to process this large amount of data for the operation of a mechanized letter office.

INTRODUCTION

Previous parts of this article^{1,2} have described how letter mail can be sorted mechanically by impressing upon the envelope a codemark which bears a known relationship to the postal address. An operator, sitting at a coding-desk, either reads the Postcode and copy-types it on his keyboard or, in the absence of the Postcode, types an extract code which he derives from specified parts of the address. The coding-desk causes the envelope to be printed with a code-mark which can then be read by machine at each subsequent sorting stage. The conversion of the Postcode (or extract code) information into codemark information, and the conversion of codemark information into sorting-machine command information, are the functions of the code-sort translator (c.s.t.).

The main storage medium of the c.s.t. is a magnetic drum. It uses a parallel-reading technique and a data layout which affords high-efficiency storage and fast data access. The data, which is different for each Mechanized Letter Office (M.L.O.), requires complex processing to assemble it into a form acceptable by the magnetic drum. The data-processing system, and the magnetic-drum equipment, are the subject of this part of the article.

THE DATA-STORAGE PROBLEM

The characteristics of the mail handled at each M.L.O. are different, both for mail destined for distant offices (outward mail) and for mail for delivery within its own area (inward mail). The relationship between the postal codes and the codemarks, and between the codemarks and the sorting-machine command signals, which are unique to a particular M.L.O., must be stored on the magnetic drum at that office.

Volume of Data

The codemark printed on an envelope may consist of one or two rows, each of 12 marks (bits). The maximum number of codes available is, therefore, 2^{24} (approximately 16 million).

To recognize such a large number of patterns and store answers for them would require a very large memory. Fortunately, all the data that is necessary for even the largest M.L.O. can be contained in a memory of five million bits, because many of the letters can be dealt with by considering only one row of codemarks.

The Coding Data

Table 1 shows the types of coding question used in the code-sort system. The answers stored for these are in a 13-bit form (12 data bits + 1 parity bit) for printing on the envelope.

TABLE 1
Examples of Coding Questions

Type of Code	Characters Keyed						
5-character Postcode	E	1	2	A	B		
6-character Postcode	N	2	2	2	A	B	
	L	S	1	2	A	B	
	N	P	T	2	A	B	
	W	1	A	2	A	B	
7-character Postcode	N	O	R	2	2	K	
	E	C	1	A	2	A	B
Outward extract code	L	S	1	2	2	A	B
	N	O	R	C	H		
	E	s/c					
	E	1	s/c				
	N	W	s/c				
	L	S	1	s/c			
	N	O	R	s/c			
	N	1	2	s/c			
Inward extract code	W	i	A	s/c			
	B	S	1	2	s/c		
	W	C	1	A	s/c		
	H	1	G	H	S		
Inward extract code	E	s/c					
	E	B	s/c				
	E	E	B	s/c			

s/c—a single keyed character used to terminate short codes.

† Postal Mechanization and Buildings Department, Postal Headquarters.

* Post Office Data Processing Service.

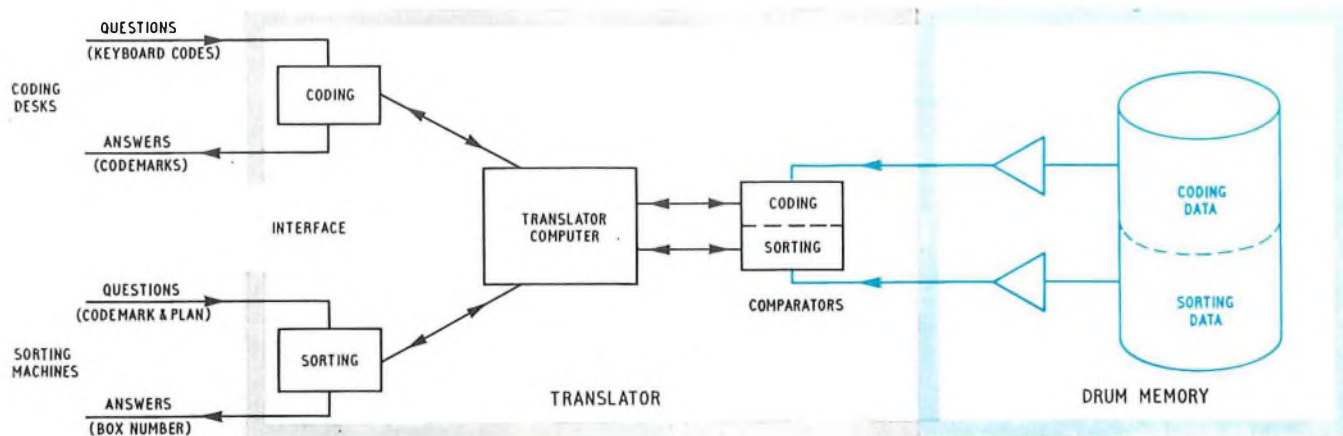

FIG. 1—The code-sort translator showing the position of the drum memory

Two sets of 13 bits are stored for Postcodes (one for the outward part and the other for the inward part), and one set is stored for other codes. The number of different outward Postcodes, inward Postcodes, and outward extract codes is about 8,000 and these are common to all M.L.O.s. The number of inward extract codes may, however, be very large (approximately 20,000) due to the number of different street names.

The Sorting Process

Depending upon the characteristics of the mail at a particular M.L.O., two letters bearing quite different codemarks may receive the same sorting treatment. Each group of different codemarks that is treated in the same way constitutes a sort unit and there may be several thousand such units in a large M.L.O. As each sorting machine can have a number of sorting-box arrangements, known as sorting plans, it is necessary to store the box information associated with these plans as answers common to all those codemarks. The binary pattern presented to the translator consists of the two 13-bit codes plus a 6-bit code for the plan information. The translated routing information is stored in eight binary bits.

MEMORY REQUIREMENTS

The selection of a memory system for the c.s.t. application was influenced by the following requirements.

The memory system must be

(a) re-programmable (the ability to effect major and minor amendments to the stored data, easily, reliably and quickly, is fundamental to the c.s.t. performance),

(b) capable of storing between two and five million data bits (the operational features and size of the M.L.O. regulate the storing requirement),

(c) capable of permitting fast interrogation of all its stored data (within 40ms),

(d) non-volatile (accidental corruption of the data must be avoided), and

(e) reliable (the working of the M.L.O. is dependent upon the ability of the translator to retrieve data, accurately and continuously, from its store).

A magnetic-drum memory system, utilizing the parallel presentation of data at a high packing density, satisfies these requirements.

The present c.s.t. has two identical drum-memory systems to provide security of data and allow off-line data changes to be carried out, while still servicing the M.L.O.'s traffic. A

block diagram of the c.s.t. is given in Fig. 1 and shows the connexion of one drum-memory system.

SYSTEM REALIZATION

Serial-operating drum systems, using a high data-packing density (greater than 1,000 bits per inch of track length) are frequently employed in computer systems. The parallel presentation of data, over a few tracks at lower packing density, has also been successfully accomplished in the past.³ However, the union of densities as great as 1,000 bits per inch with the simultaneous parallel reading of every data track is a recent technical innovation.

A considerable amount of electronic equipment is required to accomplish the parallel reading of each data track. However, the infrequent need to re-write data permits a design in which data is serially written, thus simplifying that part of the equipment.

The Equipment

A proprietary memory system, developed by specialists in this field, was chosen. This employs a magnetic drum of 10 in diameter incorporating floating-head technology to achieve a high data-packing density with reliability. (The heads float on a cushion of air within 0.0002 in of the oxide surface.) The control, read, write, data-recovery functions, and the power supplies required to complete the system, are all incorporated in the same rack of equipment (Fig. 2). The modular equipment practice used enables the system to be tailored to the storage requirement.

Read and Write Operation

Each data track is equipped with one magnetic head, which can execute both the read and write functions but not both simultaneously. The selection of the required head and, hence, of the required data track, is made by the application of a voltage to the centre-tap of its winding, to bias the required pair of diodes (Fig. 3). A positive voltage (+24 volts) is used for writing, a negative voltage (−5 volts) for reading and non-selection of the head is ensured, when required, by applying zero volts.

When serial writing is required, each head is selected sequentially, using the diode matrix and a common write amplifier. With parallel reading, all the required heads are selected simultaneously using their own individual read amplifiers (Fig. 4).

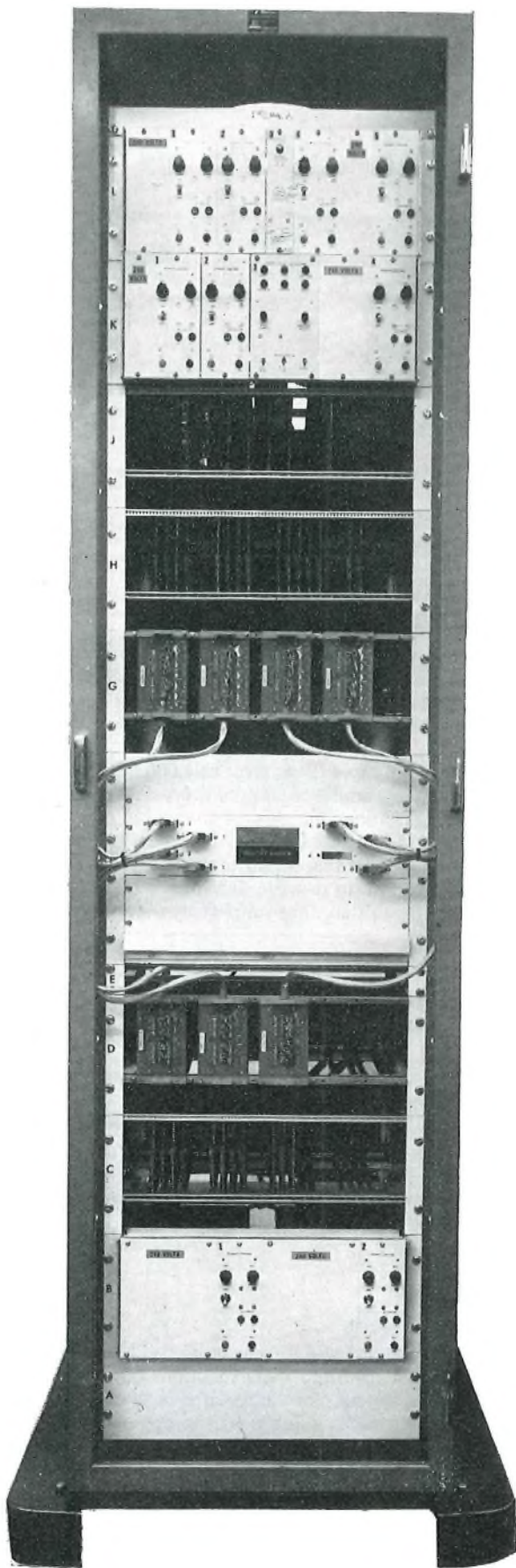

Front view

POWER SUPPLIES

CONTROL

DATA RECOVERY AND
SYNCHRONIZATION

READ AND WRITE

DRUM

READ AND WRITE

DATA RECOVERY AND
SYNCHRONIZATION

POWER SUPPLIES

FAN

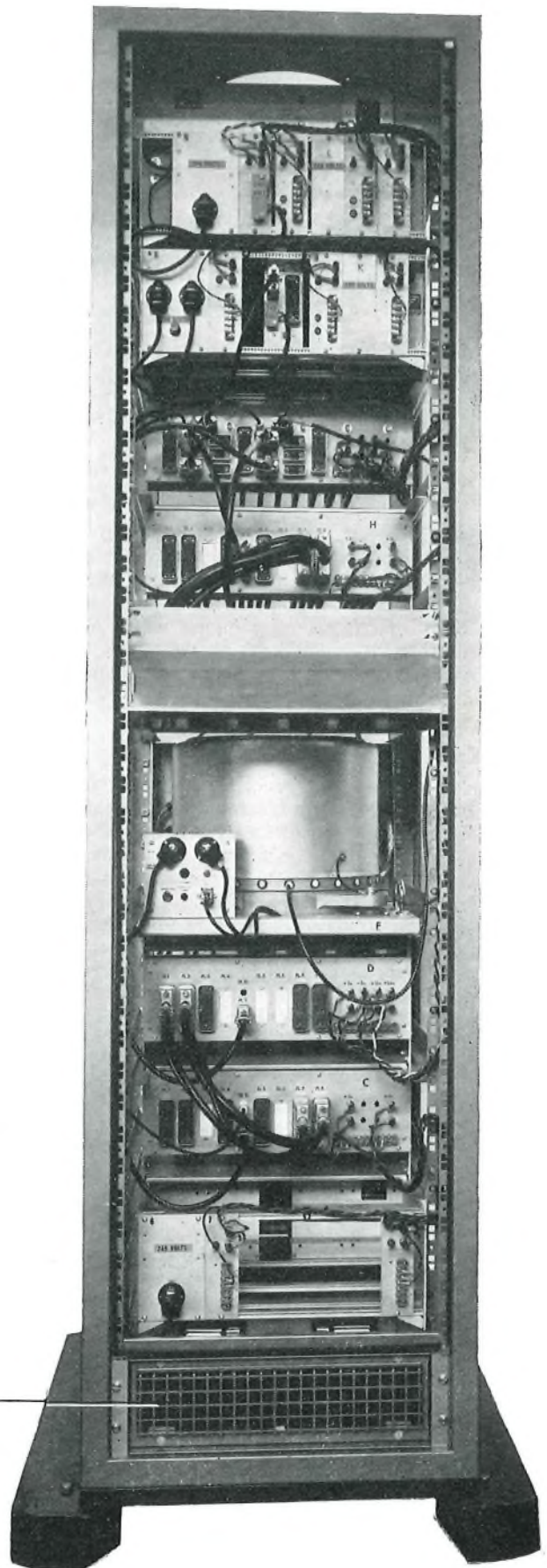

Rear view

FIG. 2—The drum-memory equipment

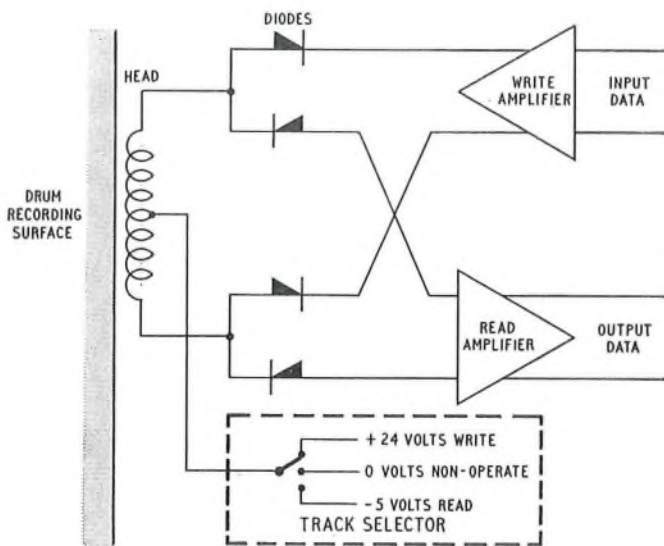

FIG. 3—Outline of read/write operations

Data Recovery

To ensure that both read and write functions are reliably executed, some form of data strobing is essential. A simple method is to use one track on the drum to produce a clock signal, from which both reading and writing strobes can be derived. However, at a packing density greater than 500 bits/in, this technique becomes unreliable since it is difficult to select a strobe position to suit every head. Although the head assemblies are made with precision, the electrical and mechanical characteristics do differ from head to head and, at the packing densities under consideration, these differences may be significant. Also, the strobe is derived from a head different to the one used for data storage, thus, relative movements of the heads between the write and subsequent read operation can result in a shift of the strobe timing. Vibration, metal fatigue, temperature and humidity are environmental factors that can cause these shifts and must be taken into consideration.

In the system adopted, a common signal, derived from the timing track, is used to control the serial-writing operation, while, when reading, each track absorbs all timing differences between tracks by generating its own read strobe. This feature is called phase-corrected strobing⁴ (p.c.s.) since the phase difference between the timing head and individual head is corrected.

Each data track is electronically divided into a number of sectors. In these sectors, a predetermined bit pattern, known as the preamble, is written, followed by the required data. Thus, each track's recovery electronics is independently synchronized by its own preamble, enabling an optimum strobe position to be selected prior to reading the sector's data. The more sectors employed per track, the more times the strobe position is adjusted, and the more reliable the data retrieval. However, since the preamble occupies recording area at the expense of data, longer sectors are desirable. An adequate compromise has been accomplished in this system by using 210 sectors per track, each comprising a group of 151 bits (23 bits for preamble and inter-sector spacing with 128 bits for data). This permits 85 per cent of the available space to be utilized by data.

During the synchronizing operation, the relative position of the last bit of the preamble data, with respect to a common-control signal, is noted and used to determine a delay. The delay selected is then added into the data path, to compensate for any movement of the heads, and results in the synchronizing of the data of every track into a time-parallel relationship. The strobe selection is made within one-sixteenth of a

bit from the nominal, with a maximum delay range of 0-6 bits.

The preamble, guard, and track-switching gap bits are automatically suppressed during each drum revolution, thus allowing only true data to be transmitted to the comparator's circuitry.

Data Organization on the Drum

A feature of the data, that each M.L.O. must store for its own use, is the way it largely falls into natural groups. Certain streets which are in the same postman's delivery round form a group that is not likely to change. On a larger scale, another group might comprise a number of postal districts associated with a central delivery point. A consequence of this is that a number of sorting-machine questions are inseparable as a group, always having the same sorting-machine outlet, i.e. provided with the same answer. When sorting arrangements are changed, this group is never split, but is sorted as a single unit. Hence, all sorting questions, and the associated answers that constitute these groups, are organized into *sort units* on the drum. Similarly, with coding, there are a number of questions which always require the same answer, hence the formation of *code units* is a natural progression.

The data synchronizing system imposes no restriction on the size of data word which may be taken in parallel from the drum store. Hence, the number of drum tracks used to present a parallel word was selected to suit the needs of the c.s.t. The comparator's circuitry in the c.s.t. staticizes the transmitted data and can be utilized further to re-assemble large parallel word formats from smaller ones. This freedom in data layout results in a reduction in the number of drum-comparator highways, with economies in drum equipment. Coding tracks have been reduced from 49 on the initial design to 37, while sorting, with the help of track-switching (see later) has been condensed from 40 data tracks to 17.

Although both coding and sorting data is stored on the same drum, it is held in two separate and independent sets of tracks.

Coding-Data Layout

There are two basic types of coding-desk question—the extract code and the Postcode.¹ The extract code is generally a 5-character keyboard signal, stored as a single 31-bit question, requiring a 13-bit codemark answer. One extra bit is used to indicate whether the code is of the outward or inward type. When codes contain less than five characters, blanks are used to augment the question to 31 bits. The Postcode, consisting of an outward and an inward part, is considered by the drum as two separate 31-bit questions requiring two separate answers. Five additional tracks are required to store the coding-desk-divertor information which must be associated with each question. The final track is used to identify question data from answer data.

There are only 2^{12} (4,096) coding answers while many more questions can exist, limited only by the number of different street names in the M.L.O. delivery area. By grouping all questions (outward or inward) into code units having the same answer, considerable saving of drum area is accomplished. The coding band in Fig. 5 shows a typical coding-data layout. The answer always appears at the beginning of a code unit with each related question on subsequent lines. (Questions 1-6 would be provided with answer 1).

Sorting-Data Layout

The arrangement of sorting data is more complex than coding, since it is conditional on each M.L.O.'s individual requirements. Flexibility in sorting is achieved by simply changing the plan machine number. It is still possible to group

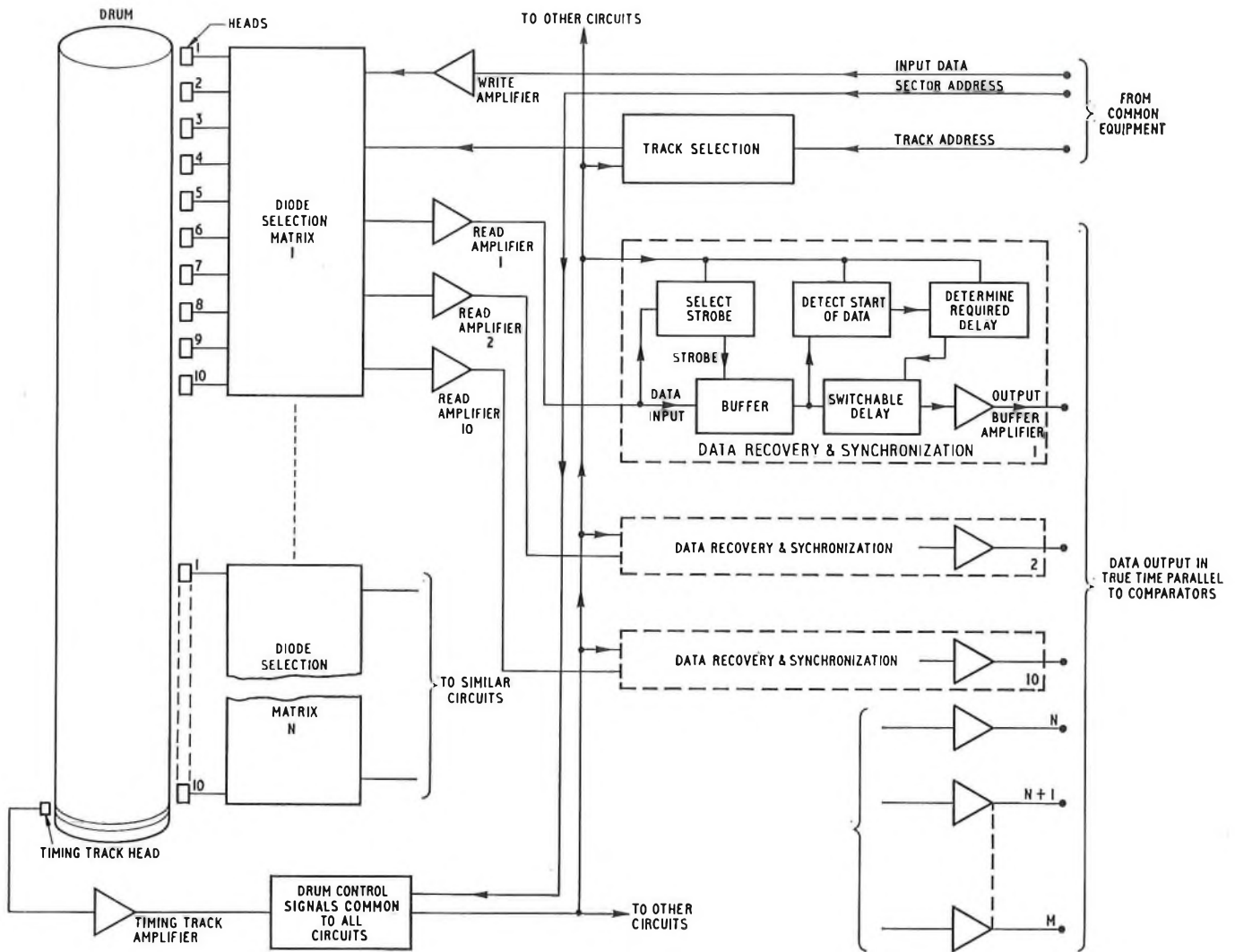

Fig. 4—Organization of drum-memory equipment

together a number of sorting questions into a sort unit. Fig. 5 shows typical sort-unit layouts. Questions are written consecutively, followed immediately by the associated plan-box arrangement.

Sorting questions of 26 bits are split into two halves and written on separate, but consecutive, lines. The comparator re-assembles these questions into full 26-bit codes for comparison purposes, thus avoiding the need to leave a large part of the memory unused, as would result if 26 parallel tracks were employed.

Each question requires 13 tracks (12 for data + one for parity), while the plan and box information requires six and eight tracks, respectively. Three control tracks differentiate the question types and plan-box answers.

SYSTEM OPERATION

The drum-memory system normally functions in the parallel-read mode, and the comparators are continuously being supplied with data for interrogation purposes. The complete coding dictionary is contained in one band, 37 data tracks wide, while the sorting information may require up to four bands, each 17 tracks wide. The use of track-switching

techniques, by selecting tracks on odd and even bands on alternate revolutions, reduces the amount of data-recovery electronics required for sorting to almost a half. However, the data search time is increased from one drum revolution to two (20–40ms).

Coding-Data Interrogation

Each coding answer is stored in the comparator for the duration of the code unit, while the questions following it are checked for equivalence. If none is found, the next answer overwrites the previous one and the process is repeated. If equivalence is detected, the answer is staticized until transferred to the computer for processing. Thus answer 1 would be held in the comparator while questions 1–6 were checked, then answer 2 while questions 7–10 were checked. If equivalence is found on question 15, for example, then answer 3 is stored.

Sorting-Data Interrogation

Each question is stored in the sorting comparators, and only when a comparison is found with the question is the plan-

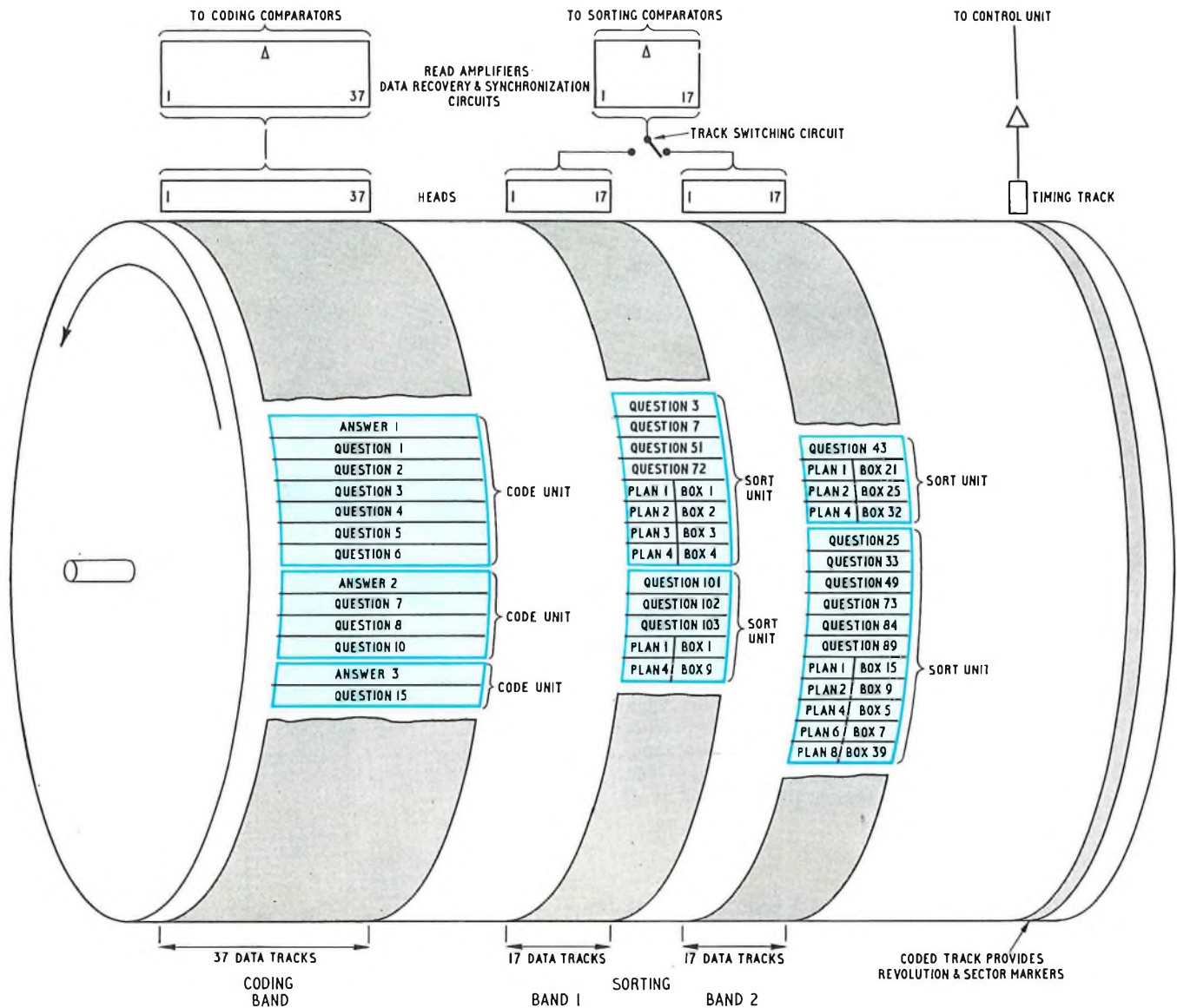

FIG. 5—Typical layout of data on the drum

box information interrogated. If comparison is found on one of the plans in the same sort-unit as the original question, the associated box answer is staticized until transferred to the computer for processing. If the plan number is not found by the end of the sort unit, the whole procedure is repeated. Thus sorting question 103 working on plan 4 would be sorted to box 9, while question 43 on plan 4 would go to box 32.

Serial Read and Write

When writing and subsequently checking the stored data, a serial write and read mode of operation is implemented, which requires that the parallel mode is interrupted and the drum made unavailable to translator traffic. The control of these functions is vested in the computer which normally exercises the monitoring functions.

By addressing a drum track, and the sector required within the track, the serial reading of 128 data bits is accomplished. The computer stores the data in eight 16-bit bytes. Serial writing is accomplished in a similar way after certain checks have been satisfied.

System Fault Detection

The drum-memory system continuously monitors the following system conditions:

- (a) drum under-speed,
- (b) magnetic heads not floating,
- (c) power-supply failure, and
- (d) control strobing out of synchronization.

Should any of these fail, then the data outputs are automatically inhibited and an alarm is generated. The system is returned to normal when all four conditions are satisfactory.

DATA ANALYSIS AT THE PROCESSING CENTRE

General

The data stored on the magnetic drum forms the program which specifies the way in which all mail is coded and routed within an M.L.O. To place this information accurately on the drum it was first necessary to evolve a system for entering all of it on standard input documents, then for checking and assembling all the data before finally returning the data to the M.L.O. for drum loading. The data is contained on punched paper tape for loading on the magnetic drum and on to printed records designed to serve operating and maintenance staff. This system may be used both for the initial insertion of data for a new M.L.O. and for the routine updating of the memory to accept changes which require to be

made later. The standard input documents which have been developed enable each M.L.O. to specify its operating program. All these input documents are sent to the Post Office Data Processing Service (P.O.D.P.S.) where they are converted into 80-column punched cards to enable the data to be entered into the processing system.

Within the processing system, the coding and sorting-translation data for each M.L.O. is held on a magnetic-tape file. When national implementation of the code-sorting system is complete, this file will contain records for the whole of the country on six reels of magnetic tape (about 120 million characters of information). Nationally-used data, common to all M.L.O.s, is held once only at the head of the file and may be updated only by Postal Headquarters. Data proper to each M.L.O. follows in a serial key order.

Security

Each M.L.O. is allocated a unique four-digit reference which is used on all inputs to the system. The reference comprises a three-digit identity plus a check digit which is verified by the program before any amending data is accepted. This system, therefore, prevents amendments for one M.L.O. from wrongly updating data for a different M.L.O. due to mis-writing or mis-punching of any input document.

Safeguards have also been built into the system to prevent data loss or corruption during processing and during data storage. Safeguards against processing corruption take the form of audit totals, held on all files, which must be reconciled as each file is processed. To secure against data-corruption during storage, historical versions of the main data file and related amendment files are retained in a secure store, remote from the computer centre. If the operational main file is found to be corrupt, then a new version can easily be re-constituted by re-processing the file prior to an updating run.

Processing Detail

The actual processing of the input data is divided among ten computer programs, each of which has a separate function to perform. A diagram of the program suite is shown in Fig. 6. The letters (a) to (k) which appear against the following paragraphs are used in the figure to identify the various operations.

(a) The 80-column punched cards, containing records of drum changes for all M.L.O.s, are read by the *Media Conversion* program, which performs certain basic checks on card alignment, reconciles the numbers of cards input, and outputs accepted card images and reports on error conditions to a magnetic tape file.

(b) Records are read from the magnetic-tape file and subjected to a series of range, radix and feasibility checks by the *Vet* program. Inward binary codemarks are calculated from inward Postcodes using a specially-derived algorithm, the check digits of M.L.O. references are verified and a complex check is made on the validity of sorting-machine box-grouping arrangements. Reports on erroneous data, together with accepted records, are written forward to magnetic tape.

(c) The file of vetted amendments is then sorted to arrange the data records for matching against the main file.

(d) The update process matches amendment records against records held on the main file, updates the file information, writes forward a newly-updated main file, and outputs records to be edited, some for printing and others for paper tape.

Whenever a new M.L.O. is added to the main file, a copy of nationally-used data is made and output for subsequent printing on to specially-designed punching documents. (The operations duty at the local M.L.O. adds sorting-translation data to the documents before submission of the documents to

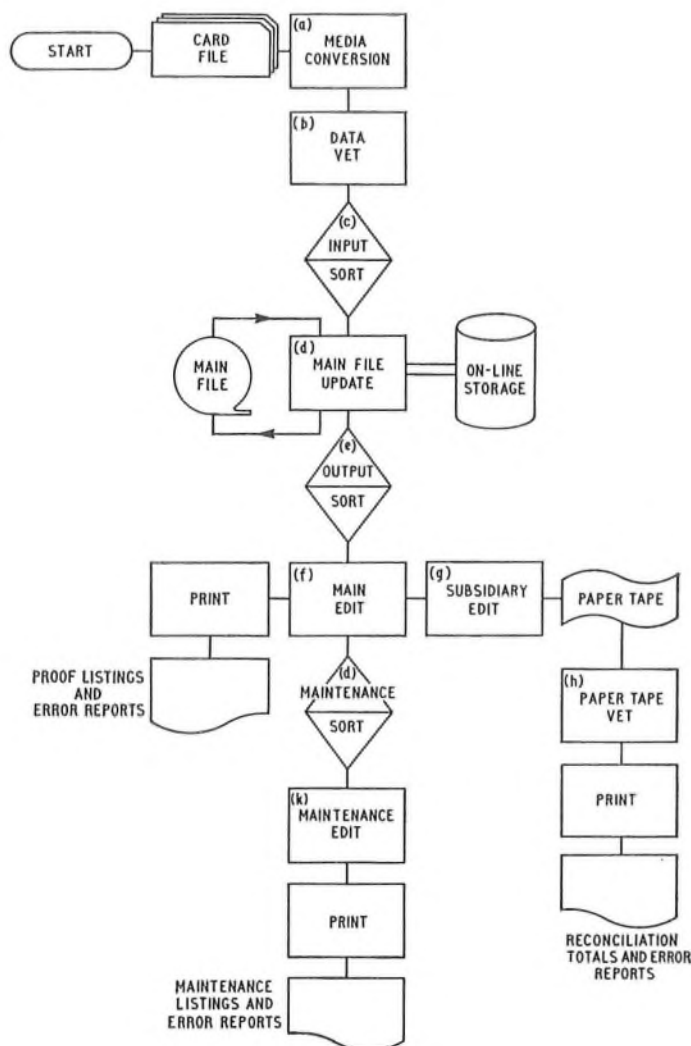

FIG. 6—Flowchart of computer-system program suite

P.O.D.P.S. for punching.) This nationally-used data, being common to all M.L.O.s, may require to be referenced by all M.L.O.s during processing, and is, therefore, held on magnetic disk and accessed as required.

(e) The file containing records rejected because they need further human editing is sorted to the required order prior to being output. A special processing routine was required to handle sorting translations for the few individual addresses requiring direct selection for distant towns.

(f) The *Main Edit* program has a dual function. It edits records into a format suitable for printing and also forms up code and sort units into sectors of information for loading the c.s.t. drum. Each sector must not exceed 128 data items but, within that limitation, sectors must be as full as possible to ensure the efficient usage of the drum. The optimization of sector usage is achieved by reading a large number of code/sort units into core store and then combining these so as to determine the optimum permutation.

(g) The drum sectors formed by the *Main Edit* program are punched on to 8-track paper tape in American Standard Code for Information Interchange (A.S.C.I.I. code) by the *Subsidiary Edit* program. Each sector has a checksum calculated by program and punched out as the last item of the sector. The identity and contents of each paper-tape reel are established by colour and by holes punched to form visual data at the head of each reel.

(h) A paper-tape punch, operating at 100 characters per second over a prolonged period, may occasionally misoperate due to random causes. Although the risk of this is low, the number of holes appearing in the data for an M.L.O. may approach one million and it was deemed prudent to build into the system design a program to read the paper tapes and verify each checksum. If errors are detected, the *Paper Tape Vet* program outputs details of erroneous reels, which can then be re-punched by the *Subsidiary Edit* program. Reports on erroneous reels are also produced to ensure that they are withdrawn and made waste by computer-centre staff. Only when all reels for an M.L.O. have been vetted and proved correct are the tapes despatched.

(j) In addition to producing the drum-loading tapes, the system produces printed listings showing, for each code and codemark, its exact position on the drum as an aid to engineering maintenance. The *Maintenance Sort* program rearranges the data into the necessary order to produce these listings.

(k) The listings of drum contents are edited for printing. Error reports are generated for any codes found to reference more than one codemark, and for any codemarks found to reference more than one sort unit.

Once the system was defined and the programs written, it was rigorously tested using specially-derived test data. Some statistics on the size and typical running times for the program suite are shown in Table 2

TABLE 2
Individual Program Details

Machine: I.C.L. System 4/70 Computer

Program	Instructions/ Statements	Language	Recent Update Run Running Time (mins)
Standard Card Read†	—‡	Usercode	2
Data Vet	1,192	Usercode	2
Input Sort†	—‡	Usercode	2
Main File Update	1,074	Cobol	14
Output Sort†	307	Usercode (User Module)	6
Main Edit	192 } 874 }	Usercode } Cobol }	4
Subsidiary Edit	1,835	Usercode	55*
Paper Tape Vet	361	Usercode	10*
Maintenance Sort†	—‡	Usercode	2
Maintenance Edit	330	Cobol	4
Print*	—‡	Usercode	23

† Standard P.O.D.P.S. software program

* Varies considerably according to volume of paper tape.

‡ Standard software package.

OPERATIONAL CONSIDERATIONS

In the formulation of the data-handling system, particular attention was paid to the following points.

- (a) The initial presentation of data was simplified by
- (i) minimizing the number of initial data-input documents,
 - (ii) simplifying the input-documents layout,
 - (iii) designing one set of input documents acceptable to all users,
 - (iv) rationalizing the input-data methods, and
 - (v) minimizing transcription work necessary to compile M.L.O. data.
- (b) Output documentation, to identify the processing, was provided
- (i) by a serially-numbered entry print-out, and
 - (ii) by a text and data print-out of data erroneously input.

- (c) Print-outs for system maintenance, suitable cross-referenced, were provided
- (i) in codemark order, and
 - (ii) in code order.
- (d) Paper tapes were provided
- (i) colour-coded to distinguish between sorting and coding data,
 - (ii) having a visual plain-text heading to identify each tape,
 - (iii) of suitable length to facilitate handling,
 - (iv) only after all data errors had been rectified, and
 - (v) with a fixed turn-round time in case of system changes.
- (e) System security was provided
- (i) by program checks on range, radix, and feasibility of input data,
 - (ii) by having checksums on all paper tapes to avoid read-in errors,
 - (iii) by making provision for identifying the latest on-line amendments,
 - (iv) by the inclusion of audit totals on computer files, and
 - (v) by the design of a special paper-tape vetting process.

INITIAL DATA TRANSFER TO DRUM STORE

The loading of the initial data into the drum store is effected by the *Drum Loading* program, contained in the computer which normally exercises the monitoring functions.

The program causes a high-speed reader (incorporated in the c.s.t.) to transfer the data from the tapes into the computer's store. Once checks have been satisfied, the data is written on the drum in locations as specified on the tape. The data is then confirmed, by reading it back and checking it against the original data in store; any errors are printed out on the control teletypewriter.

These in-built checks minimize the erroneous writing of data on the drum.

DATA AMENDMENTS

There is a continual commitment on an M.L.O. to update its data to meet the changing requirements. These amendments, or updates, are categorized into two classes:

- (a) changes that are small in number and may be urgent, and
- (b) changes that are large in number, and generally infrequent and less urgent.

Facilities have been designed into the c.s.t. to implement changes in category (a) whilst those in category (b) are passed through the processing system, and result in a new complete set of paper tapes to rewrite all the information stored on the drum. All changes to the stored data are first recorded on to standard documents which are acceptable to both the local system and the national data-processing system. Initially, these documents are used locally to implement small changes, and the P.O.D.P.S. is only involved when the number of minor changes has exhausted the spare capacity of the drum.

Local Amendments

The local changes are made through two sequential computer operations. The first, *Tape Preparation*, enables the local staff, using a teletypewriter connected to a computer operating in a conversational mode, to prepare a paper tape containing the relevant data in the required format. The second, *Drum Updating*, produces the actual data changes on the drum using the tape as its data source. The security of the drum's data is vital to the operation of the M.L.O., its loss or damage

having serious repercussion on the delivery of letter mail. Hence, when data changes are made, no data is erased from the drum; instead, any unwanted codes are nullified, by modifying the control data, thus enabling any deleted data to be recovered if required. Similarly, any additions must be distinguishable from the original data. New data, and copies of the nullified data are, therefore, always inserted in an update area which is that part of the drum left spare when all the information from a fresh set of P.O.P.D.S. tapes has been loaded on to the drum. This area always starts with the last sector of the last data band, subsequent amendments being added to sectors regressively, toward the sector containing the last of the original P.O.D.P.S. data.

P.O.D.P.S. Amendments

When local amendments have taken up the majority of the available space, P.O.D.P.S. is requested by the M.L.O. to re-arrange its data into an efficient layout once more and to supply a new master set of paper tapes. It is essential that, before the data on the new tapes is loaded on to both drums, destroying the existing data as it does so, that it is verified as being completely valid. The operating procedure given in Table 3 shows the number of necessary steps involved to

TABLE 3
Procedure for Amending Drum Data with new P.O.D.P.S. Tapes

Step	Program	Function	Comment
1	Tape Vet	Compares data on tape with data on drum 1	Ensures that all the data on the tape also exists on drum 1
2	—	Note differences	Due to tape errors or recent amendments
3	Drum loading	Loads data from tape on to drum 1	Only performed if any differences are small and accountable otherwise tapes returned to P.O.D.P.S.
4	Drum vet	Compares the contents of drum 2 against data on drum 1	Ensures that all original drum data exists on new P.O.D.P.S. tapes
5	—	Note differences	Due to tape omissions or recent amendments
6	Tape prep	Prepares tapes for local update	Corrects differences found at steps 2 and 5
7	Drum updating	Implements local amendment of drum 1	Loads data into reserved area
8	Drum vet	Compares contents of drums 1 and 2	Ensures all differences are accounted for; if not, repeat steps 6 and 7
9	Drum copy	Copies contents of drum 1 on to drum 2	Both drums identical with new P.O.D.P.S. data. Halt

ensure that this requirement is fully met. Six separate programs are used, including three that are only used under these circumstances:

Tape Verification—enables the contents of the tapes to be checked against the contents of one drum.

Drum Verification—enables the contents of one drum to be checked against the contents of the other.

Drum Copy—enables the contents of one drum to be copied on to the other.

Table 3 shows that the contents of drum 2 are only overwritten with the data from drum 1 when it has been shown that drum 1 contains all the necessary valid data of the M.L.O.

CONCLUSION

This three-part article has described a new translator which has been developed to satisfy the needs of the code-sorting system in the mechanized letter-handling system of the Postal business. The translator has been designed to make effective use of newly-proven technologies. It marries such techniques as magnetic drum storage, process-control by small computers, tailor-made integrated-circuit hardware, and conversational-type man-machine interfaces for testing the equipment and modifying the stored information.

The equipment is of modular design to allow it to be matched to both the traffic needs of an M.L.O. and the degree of security required to permit continued operation in the event of failure of individual parts. The modularity also allows individual items to be changed (the computer, store, integrated circuits, etc) should commercial or technical advances make this desirable.

When proposing the outline system design, it was seen that the Postal business would have a need in the future for much more management data than has been employed to control mail-handling in the past. The system design is capable of extension to provide that data when it is required.

The equipment was installed at Newport in March 1973 and will appear in all subsequent mechanized letter offices. The savings which may be made in the Postal business as a result of this design will make a significant contribution to the economics of the mechanized letter-handling system.

ACKNOWLEDGEMENTS

One notable feature of the development of the code-sort translator, which has not been made clear in the individual parts of this article, is the successful way in which the development has progressed as a result of the contributions of people with many different skills, working for different organizations.

The Post Office Data Processing Service developed the system for processing the M.L.O. operating data and preparing it for the magnetic drum stores.

The magnetic drum stores were produced by Sperry Gyroscope Division, Sperry Rand Limited, from a design which they had evolved for use in electronic telephone-exchange systems. The photographs in Fig. 2 are reproduced by courtesy of that company.

The whole of the translator equipment surrounding the magnetic drum and Hewlett-Packard mini-computer was designed, built and commissioned by The Plessey Company Limited.

Postal Headquarters staff proposed the original design concepts, chose and specified the component parts, designed and built a traffic generator for acceptance testing, and coordinated the whole project.

References

- ANDREWS, J. D. A New Code Translator for the Letter-Sorting System. Part 1—Postcodes and their Use. *P.O.E.E.J.*, Vol. 65, p. 198, Jan. 1973.
- PHILLIPS, K. H. C., and STURGEON, A. W. A New Code Translator for the Letter-Sorting System. Part 2—The Code-sort Translator: Design and Testing. *P.O.E.E.J.*, Vol. 66, p. 2, Apr. 1973.
- SOAR, A. and PHILLIPS, K. H. C. Optical and Magnetic Drum Translators. British Postal Engineering Conference, *Paper No. 44*, May, 1970.
- Phase-Corrected-Strobe Magnetic-Drum Storage System. Sperry Rand Limited, *Sperry Publication No. 1425*.

Local-Battery Charging over Subscribers' Lines

B. R. FREER and O. C. MATTHEWS†

U.D.C. 621.355.163:621.311.61:621.395.73

A method of charging small secondary batteries located at a subscribers' premises is described. The charging current is derived from the exchange 50-volt central battery and is fed over the telephone pair during idle periods. There is no degradation of either the transmission or signalling performance of the telephone circuit and testing procedures are not affected.

INTRODUCTION

The use of electronic equipment in subscribers' premises, whether for the provision of additional telephone facilities or for local exchange connexions using carrier techniques, often requires a local source of electrical power. Often, it is not practicable to make use of the subscribers' a.c. mains supply and, therefore, provision of a local battery has to be considered. Primary batteries, whilst being capable of providing the necessary power, have a limited life and their use reflects adversely on maintenance costs. To achieve a useful service life, large batteries are required and this leads to additional cost and accommodation problems. Secondary batteries of the sealed nickel-cadmium type, although initially more costly, are, in general, to be preferred. This type of battery has the advantages of long life and relatively small size and does not require ventilation during charging.

If the use of local a.c. mains is to be avoided, charging current must be derived from the telephone pair. Hitherto, provision of adequate charging current by this method has not been possible, and the use of local nickel-cadmium batteries has been restricted. The system described allows a charging current to be provided during the period that the line is not in use.

The system was designed for use with the 1 + 1 Subscriber Carrier System WB 900.¹ The transmit unit, forming part of the Exchange Unit WB 900/1, is shown in Fig. 1 and the receive unit, forming part of the Subscriber Unit WB 900/1 is shown in Fig. 2.

SYSTEM OPERATION

General

Fig. 3 shows the basic elements of the system and how it is connected to an exchange line.

When the subscriber's telephone is not being used the line-power transmit-unit disconnects the exchange calling-equipment from the line and connects the 50-volt exchange battery and earth to the line via contacts P1 and P2. The trigger and delay circuit in the receive unit causes thyristor CSR1 to turn on, and current flows into the battery. For the resistor values shown, the current is between 12mA and 16mA, depending upon the line resistance.

When the subscriber handset is lifted, the calling loop causes the voltage across the receive unit to fall, thereby reducing the current flowing through thyristor CSR1 to

something less than its holding value. CSR1 therefore switches off, leaving an impedance greater than 2.5 Mohms connected across the cable pair. The loop condition is also sensed by the relay trigger circuit in the transmit unit, causing relay P to release and reconnect the exchange calling-equipment to the line. The transmit unit maintains itself in the non-charging condition by sensing the drop in voltage on the B-wire caused by the current flowing through the transmission bridge. A delay circuit prevents premature reconnection of the charging circuit during dialling. P relay is prevented from re-operating for up to 55 seconds, and the thyristor does not switch on for at least 70 seconds after the handset has been replaced.

When an incoming call is received, the B-wire becomes positive, due to the reversal applied from the final selector, thereby causing relay P to release and extend the ringing voltage to line. The receive unit again switches off because the current flowing through thyristor CSR1 is reduced below its holding value.

If access to the circuit is obtained via a test final-selector, a loop extended from the test cord-circuit causes relay P to release and provide the required access. During testing, the battery and earth condition from the exchange calling-equipment is disconnected, thus causing the receive unit to switch off and restore standard line conditions.

Line Power Transmit Unit

A circuit diagram of the line-power transmit-unit is shown in Fig. 4.

When the exchange line is not in use, the B-wire is at a potential of -50 volts with respect to earth, thus causing transistors TR1, TR2 and TR3 to be switched off. Transistor TR4 is conducting and relay P is operated. The relay contacts disconnect the exchange calling-equipment from the line and allow current to flow to line via resistor R5.

Incoming Call

If ringing is applied from the final selector, the B-wire becomes positive, i.e. the potential changes from -50 volts, to earth, thus causing transistor TR1 to conduct and charge capacitor C1 via resistor R6. Transistors TR3 and TR4 form a Schmitt trigger circuit which switches via the emitter-follower transistor TR2 thereby releasing relay P and reconnecting the exchange equipment to the line. Ringing voltage is therefore extended to the telephone installation, and is inhibited by normal ring-trip when the telephone handset is

† Telecommunications Development Department, Telecommunications Headquarters.

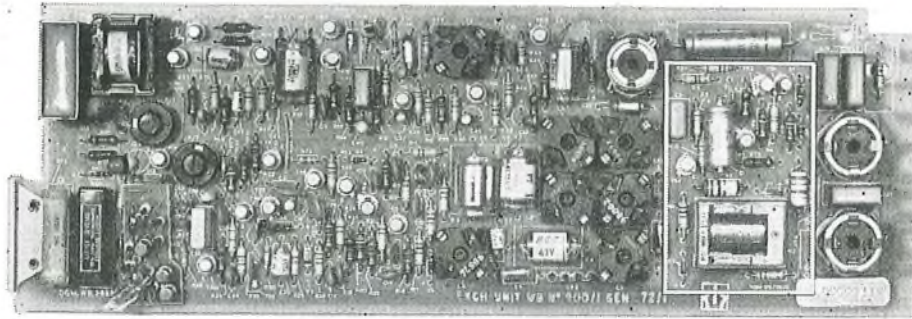

FIG. 1—Exchange Unit WB 900/1 showing transmit unit (outlined in white)

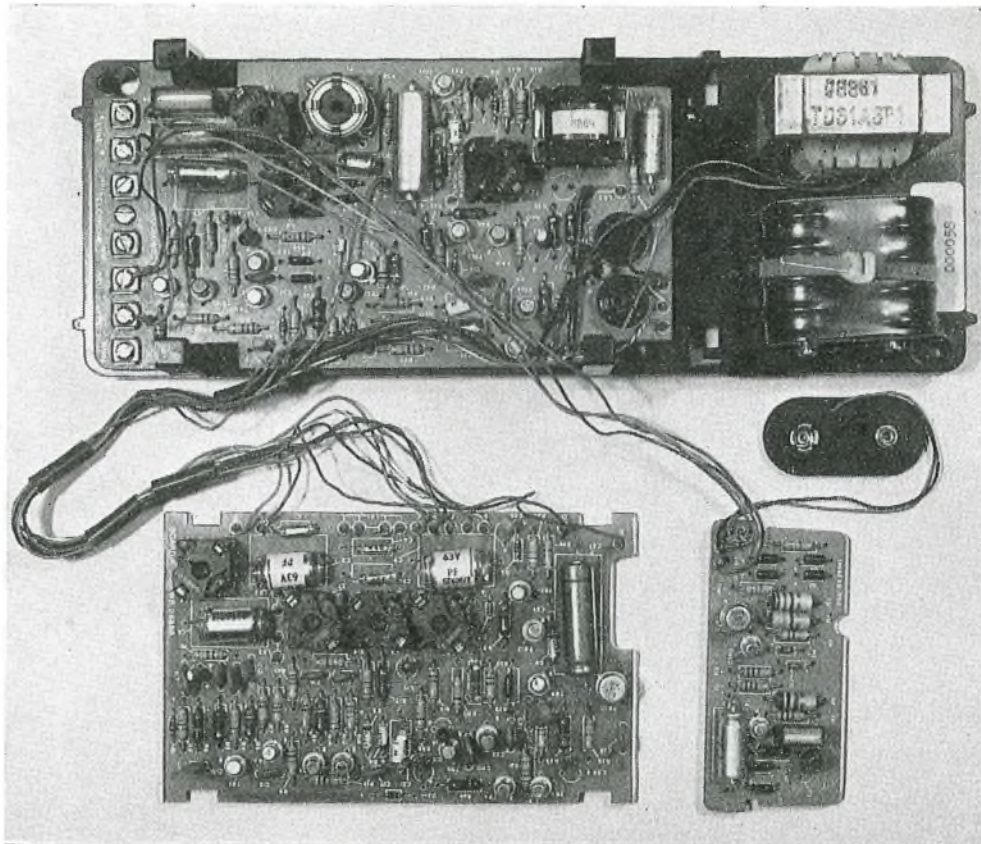

FIG. 2—Subscriber Unit WB 900/1 showing receive unit (bottom right)

lifted. The unit is held inoperative by the consequent reduction in the B-wire voltage caused by current flowing through the transmission bridge. The unit is held inoperative as long as the B-wire remains at a potential of not less than 3.5 volts positive with respect to the -50-volt supply. Diodes D2 and D3 protect the base of transistor TR1 from extreme over-voltage. Capacitor C2 provides feedback to allow capacitor C1 to fully charge when relay P releases. Diode D1 protects the unit against surge voltages, and also helps to keep the input impedance of the unit high when in the non-charging condition.

On completion of the call, the potential on the B-wire returns to -50 volts, and causes transistor TR1 to turn off. Transistor TR2 is held on for not greater than 55 seconds,

i.e. the discharge period of capacitor C1 through resistors R6 and R7, after which the Schmitt trigger switches and operates relay P.

Outgoing Call

When the subscriber's telephone handset is lifted the resultant cable-pair loop causes the junction of diode D1 and resistor R5 to become positive with respect to the -50-volt supply, allowing transistor TR1 to conduct. Transistors TR3 and TR4 then switch and release relay P, thus allowing the subscriber's line to be reconnected to the exchange calling-equipment. The unit is held inoperative during the call and reoperates up to 55 seconds after the call has terminated.

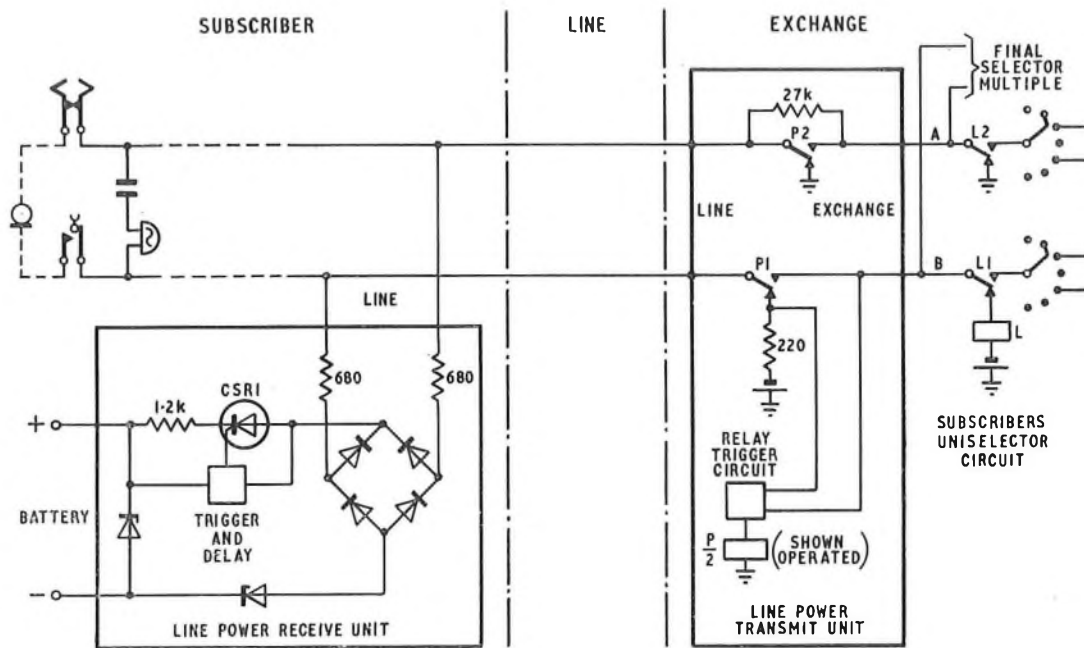
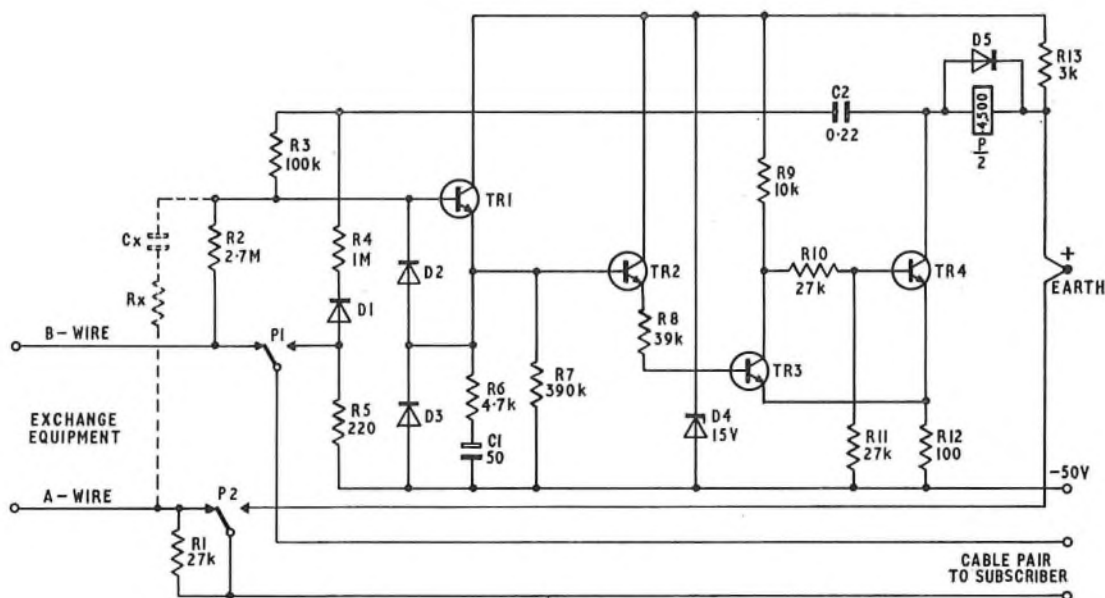

FIG. 3—Basic circuit arrangements



Note: Cx and Rx are provided for shared-service working

FIG. 4—Circuit diagram of the line-power transmit-unit

Testing

For exchange-line testing, a loop is extended from the test cord-circuit or automatic routiner, therefore the earth connected to the A-leg via contact P2, operated, and resistor R1 causes the B-leg to become positive and transistor TR1 to conduct. On removal of the loop, i.e. when the voltmeter key is operated on the test desk, the unit remains disconnected for 45–55 seconds during which period the following conditions are presented to the exchange line:

(a) resistance greater than 2.5 Mohms between the B-wire and earth, and

(b) an infinite resistance between the A-wire and earth, and between the A and B-wires.

Therefore, the presence of the unit cannot be detected by the tester and true line conditions are seen.

Line-Power Receive-Unit

A circuit-diagram of the line-power receive-unit is shown in Fig. 5.

During idle conditions, the transmit power feeding unit presents a potential of 50 volts across the line terminals.

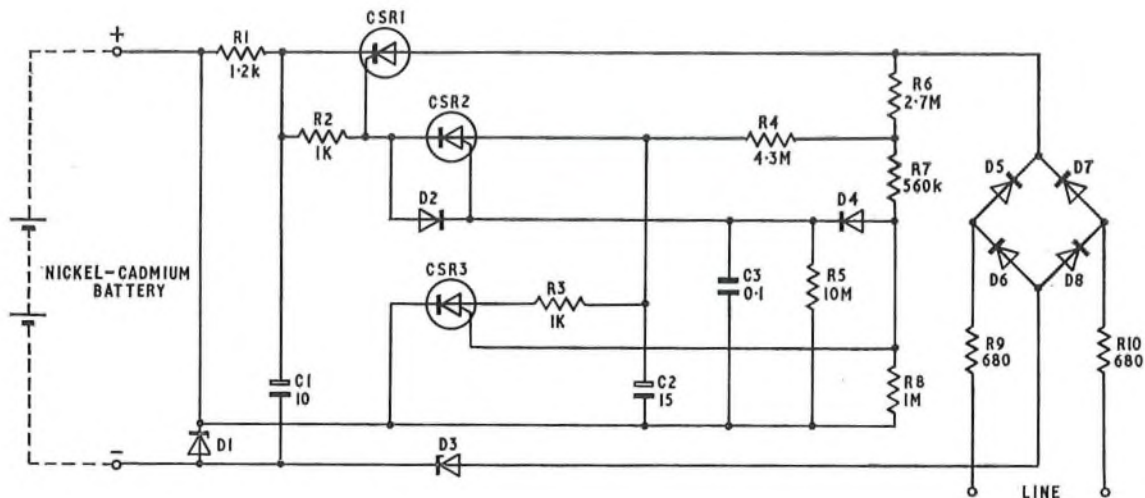

FIG. 5—Circuit diagram of line-power receive-unit

Bridge rectifier network D5–D8 ensures that the operation is independent of line polarity. The voltage across the line terminals allows capacitor C2 to charge via resistors R4 and R6. The gate potential of programmable unijunction transistor* (p.u.t.) CSR2 is fixed by the ratio of resistors R6, R7 and R8. As capacitor C2 charges, its anode potential rises until the potential becomes positive with respect to its gate voltage. P.U.T. CSR2 then turns on and provides sufficient gate current for thyristor CSR1 to conduct, and current flows into the battery. Resistor R1 and diode D1 form a shunt regulator which allows the battery charging-current to reduce as the battery becomes charged. The line current is a constant value for a given line length and is determined by resistors R1, R9 and R10 and zener diodes D1 and D3. The charging current is made dependent upon the state of charge of the battery to prolong the battery life, i.e. when the charge is low the charging current is relatively high and gradually reduces as the charge increases. Resistors R9 and R10 reduce the high-frequency shunting effect of the unit across the line, and if higher current values are required, these can be replaced by inductors.

Reduction of the voltage across the line terminals causes the current through thyristor CSR1 to fall until it is below its holding value. Its cathode potential is maintained by capacitor C1, and as its anode voltage is falling it becomes reverse-biased which enables it to switch-off. The anode potential of p.u.t. CSR3 is maintained by capacitor C2, and as the gate

* Programmable unijunction transistor—a device similar to a thyristor but triggered from the anode rather than the cathode.

potential falls, this device switches on and discharges capacitor C2 via resistor R3. Turn-on of p.u.t. CSR3 occurs before that of p.u.t. CSR2 because the gate potential of the latter is maintained by capacitor C3 and resistor R5. Thyristor CSR1 does not switch-on during the break period of dialling impulses or quiet periods of ringing because capacitor C2 takes at least 70 seconds to become charged before p.u.t. CSR2 switches on. The zener diode D3 helps to maintain the balance of the cable pair when thyristor CSR1 is switched off.

P.U.T.s CSR2 and CSR3 are used because they allow the unit to present a very high impedance (greater than 2.5 Mohms) across the cable pair when the unit is switched off. The unit is protected against transverse voltage surges up to 4 kvolts by using avalanche diodes in the rectifier bridge on the input of the unit.

CONCLUSIONS

The battery charging system described has substantial advantages over power feeding systems at present in use because it allows normal testing procedures to be used and there is no degradation in the performance of the circuits of a subscribers carrier system.

References

- ¹KINGSWELL, L. W., and TOUSSAINT, G. C. A Subscriber's Carrier System for the Local Network. *P.O.E.E.J.* Vol. 64, p. 213, Jan. 1972.

A Time-Division Multiplexing Equipment for the Datel Services

D. E. WHITE, C.ENG., M.I.E.E., R. A. COLLINS, B.SC. and P. M. HALL†

U.D.C. 621.394.42:681.328.8

As customers' requirements for Datel services increase, greater emphasis is placed on the need for bandwidth economy, particularly when a large number of circuits is required between remote sites. Great economy can be realized by customers who have access to a computer in a remote charging area via a multiplexing equipment in a local telephone exchange. To provide such a facility, the Dataplex service, based on frequency-division multiplexing techniques, was introduced in September 1971. In order to increase the number of facilities and multiplexing ability, a time-division multiplexing equipment was introduced in September 1972 under the title Dataplex Service No. 2. This article describes how the time-division multiplexing equipment operates.

INTRODUCTION

Slower-speed Datel services do not require the full use of the bandwidth available on a 4 kHz speech circuit, and multiplexing techniques enable a number of low-speed datel channels to be operated over one such circuit. Frequency-division-multiplex (f.d.m.) techniques are used by the British Post Office (B.P.O.) for a Dataplex service that enables customers of computer bureaux to have local-fee access to remote computers.¹

The B.P.O. f.d.m. Dataplex systems are based on existing 12-channel multi-channel-voice-frequency equipment with additional units to provide the necessary standard C.C.I.T.T.‡ interface with modems and computers. Although these systems have an advantage in that they use standard B.P.O. equipment, they do not cater for all requirements, their maximum channel speed being 110 bit/s and the maximum capacity per system being 12 channels.

This article describes a time-division-multiplex (t.d.m.) system based on proprietary multiplexing equipment, purchased by the B.P.O. in order to augment the existing Datel multiplexing facilities and modified to meet the B.P.O. specification.

OUTLINE OF FACILITIES

The multiplexing equipment caters for discrete channel speeds in the range 50 to 600 bit/s, certain pre-set combinations of channels at these speeds being multiplexed on to high-speed bit streams of 2,400 bit/s, 4,800 bit/s or 9,600 bit/s for transmission over a 4 kHz four-wire circuit via the appropriate modems.

One multiplexing equipment physically accommodates 45 low-speed channels, but the channel capacity of a particular system is obviously a function of the total speed requirement of the low-speed channels and the capacity in bit/s of the high-

speed line. Typical examples of the capabilities of the multiplexing equipment are:

- (a) 29 110 bit/s channels to a 2,400 bit/s circuit,
- (b) 45 110 bit/s channels to a 4,800 bit/s circuit,
- (c) 9 300 bit/s channels to a 2,400 bit/s circuit, and
- (d) 19 300 bit/s channels to a 4,800 bit/s circuit.

The multiplexing equipment selects the data from the low-speeds channels, one character at a time, for character interleaved transmission in the high-speed stream.

USE OF THE MULTIPLEXING EQUIPMENT

A block diagram of a typical arrangement for a Dataplex system using t.d.m. equipment is shown in Fig. 1. At the computer-bureau end, the multiplexing equipment is accommodated on a rack at the customer's premises together with the necessary high-speed modem and test-access facilities. (See Fig. 2). At the telephone-exchange end, modems are required for the low-speed channel access from the public switched telephone network (p.s.t.n.) and the multiplexing equipment and the necessary modems are mounted on two 9-foot 62-type racks. (See Fig. 3). Additional test facilities have been included to aid maintenance and the rack layout is arranged so that a basic 29-channel, 110-baud system using a 2.4 kbit/s modem can be expanded to 45 channels using a 4.8 kbit/s modem. To enable the multiplexing equipment to be fitted into these racks, it is broken down into sub-units which can then be mounted using special brackets.

Associated with the exchange-end installation is a busying unit, which has been manufactured to B.P.O. specifications. The function of the unit is to allow the computer-bureau operator to apply remotely a busy condition to the final-selector multiple to prevent the seizure of selected channels. The facility is termed *backward busy* and in-built to the multiplexing equipment is the option to make it *camp on*, whereby the application of the busy condition is delayed until any existing call is completed.

The system as a whole allows a remote terminal to obtain access to a distant computer bureau as if it were a local call. Neither terminal nor bureau operator needs to employ special practices other than that for the additional *backward-busy* facility. In fact, except for bureaux using *Echoplex*,

† Network Planning Department, Telecommunications Headquarters.

‡ C.C.I.T.T.—International Telegraph and Telephone Consultative Committee.

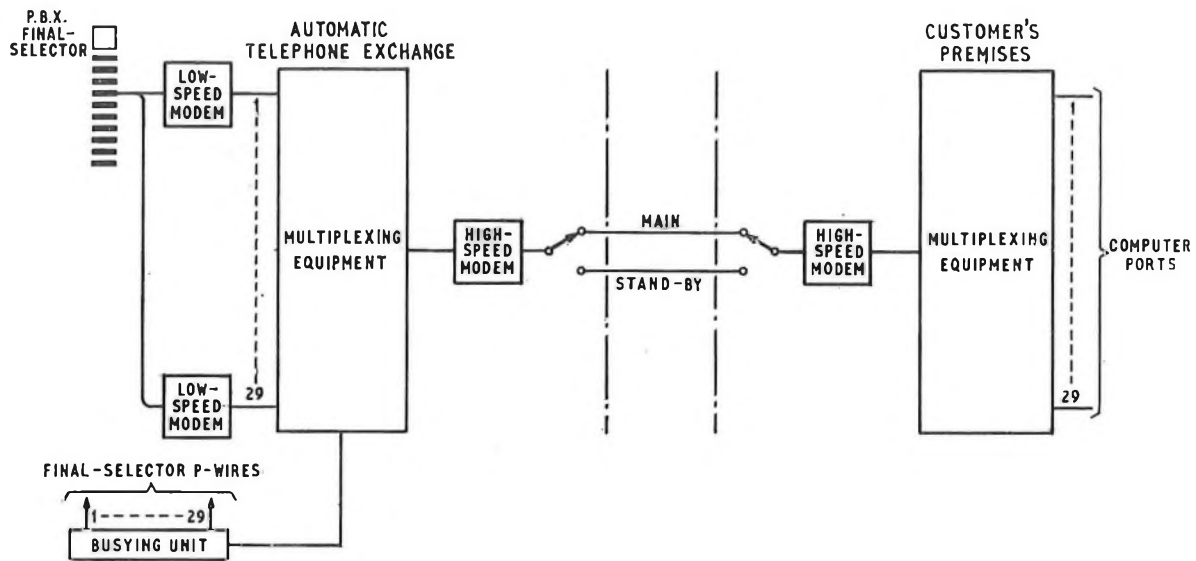

FIG. 1—Block diagram of typical Dataplex system

where terminal operators will experience a delay of about four characters between typing in and receiving copy back from the computer due to the delay inherent to the multiplexing technique, the users of the system will not be aware they are not on a direct (hard-wired) connexion.

The first t.d.m. Dataplex system using the multiplexing equipment has been installed to provide 29 channels at 110 bit/s between Lords Telephone Exchange, London, and a computer bureau at Slough. A Datal 2400 circuit links the two multiplexing equipments. The main objective throughout the physical design of the system was to keep construction and wiring detail as simple as possible to allow telephone Regions/Areas to undertake the work and minimize costs. Where circumstances allowed, existing practices, such as those specified for the rack-mounting of modems, were adopted.

MECHANICAL CONSTRUCTION

The multiplexing equipment comprises four sub-units, namely, a card cage, an interface panel, a power-supply unit, and a fan unit housed in a free-standing metal case having the dimensions 495 by 508 by 447 mm.

The fan unit, mounted in the base of the multiplexing equipment and consisting of two panel-mounted fans is provided to give additional cooling when the indicator lamps are switched on. It is controlled by a switch on the lamp-dimmer control.

The card cage, housing the printed-circuit boards, is designed to hinge open to allow access to the power-supply unit and wiring. The card guides are formed from the metal of the cage which allows the edge connectors to be accurately located and, therefore, rigidly mounted. Wired connexions to the pins of the edge connectors are by means of spring clips crimped to the end of the wires. The fibre-glass printed-circuit boards are not mounted in carriers and printed-circuit track separation is substantially less than normal in B.P.O. equipment to allow a higher packing density of components. Few discrete components are used, the majority being thick-film hybrid devices or integrated circuits. MOS shift registers are used for the 3·2 kbit dynamic recirculating memory. (See Fig. 4). Selection of optional facilities is by means of miniature plug-in straps. Most of the circuit boards are provided with lamps to indicate the status of individual channels and the common processor section, this facility being a useful aid to fault location. The designations of the lamps are indicated on coloured translucent strips incorporated in the front panel. The push-button controls are grouped on the right of the card page.

The interface panel is permanently connected to the card cage by a cable form and accommodates 45 low-speed and one high-speed interface connectors. These connectors, though similar to those in use on the B.P.O. Datal modems with respect to such features as pin spacing and dimensions, employ a 2-screw locking arrangement which gives a more secure location than the spring clip of the B.P.O. type. The power-supply unit was originally designed for the North American market and has, therefore, been substantially modified to meet B.P.O. specifications and safety requirements.

OPERATION OF THE MULTIPLEXING EQUIPMENT

The basic concept in the design of the multiplexing equipment has been to centralize, as far as possible, all storage and control, leaving the handling of individual interface circuits to relatively simple and inexpensive circuitry. Each of up to 45 low-speed data inputs is serviced, in turn, by a central processor, which extracts data from the low-speed receive wires and inserts it on to the high-speed transmit path and onto the low-speed transmit wire from the high-speed receive path. This information must be in a prescribed form; for example, a series of start/stop characters conforming to the C.C.I.T.T. Alphabet No. 5.

The multiplexing equipment can best be understood by considering the channel units which form the interface and the common-control equipment, separately.

CHANNEL UNIT

To interface a modem to the common control of the multiplexing equipment, an individual printed-circuit card, the channel unit, is required. This form of construction ensures minimum interruption to service if the card is disabled or removed. The basic function of the card is the conversion of C.C.I.T.T. V24/V28 interface conditions to logic levels in a suitable form for multiplexing by the common-control section. Each card has a lamp display indicating the status of the channel at any time and this allows the progress of a call to be monitored visually and is also an aid to fault location.

In normal computer-bureau operation, low-speed Datal modems are directly connected to the local computer equipment via the multi-wire V24/V28 interface associated with each modem. With Dataplex operation, the modems are remote from the computer and it is necessary to transfer these V24/V28 interface conditions over the multiplex link. The state—ON or OFF—of the interface conditions in a particular direction will not change whilst data is being

passed and, hence, the time-slot allocated to a particular channel may be used for either data or the passage of control information.

The modem may be under the control of the computer in either the DATA TERMINAL READY or the CONNECT DATA SET TO LINE mode. From examination of Table 1, it appears that

TABLE 1
Interface Interchange Circuits required for Auto-Answered Modems on the Public Switched Telephone Network

Mode of Operation	C.C.I.T.T. Circuit No.	Description of Function	Direction of Transmission	
			Transmission—Computer	Equipment
Data Terminal Ready	108/2	Data terminal ready	←	—
	105	Request to send	←	—
	107	Data set ready	—	→
	109	Data channel receive line signal detector	—	→
	106	Ready for sending	—	→
	Note	Backward busy	←	—
Connect Data Set to Line	125	Calling indicator	—	→
	108/1	Connect data set to line	←	—
	107	Data set ready	—	→
	105	Request to send	←	—
	109	Data channel receive line signal detector	—	→
	106	Ready for sending	—	→
Note	Backward busy	←	—	

Note: Not a C.C.I.T.T. facility, but this has been offered to bureau operators.

facilities for the transmission of at least three independent control conditions are required in each direction. However, since interface-condition changes occur sequentially and only at times when data is not being transmitted, it is possible to use a priority system using only two control codes when providing a Dataplex service with low-speed modems. For example, a control code representing calling indicator can be transmitted in the same time slot as that for data in a particular channel, since data will never be present during this time. Therefore, since this condition applies to all changes of control information, it is always possible to arrange for control information to overwrite data. This provides a simplified interface which departs from the detailed C.C.I.T.T. requirements, but is sufficiently comprehensive for existing bureau requirements.

The time-slot on the high-speed line, allocated to a particular channel, contains 8 bits. When character data is being transmitted, with the exception of break or continuous stop, bits 1-7 are transmitted on the high-speed line in the same format as received from the low-speed channel. Bit 8 is a parity bit and this can be enforced by the common-control circuitry to give system parity, odd or even, as required.

The control code characters are transmitted on the high-speed line with parity that violates the system parity and the

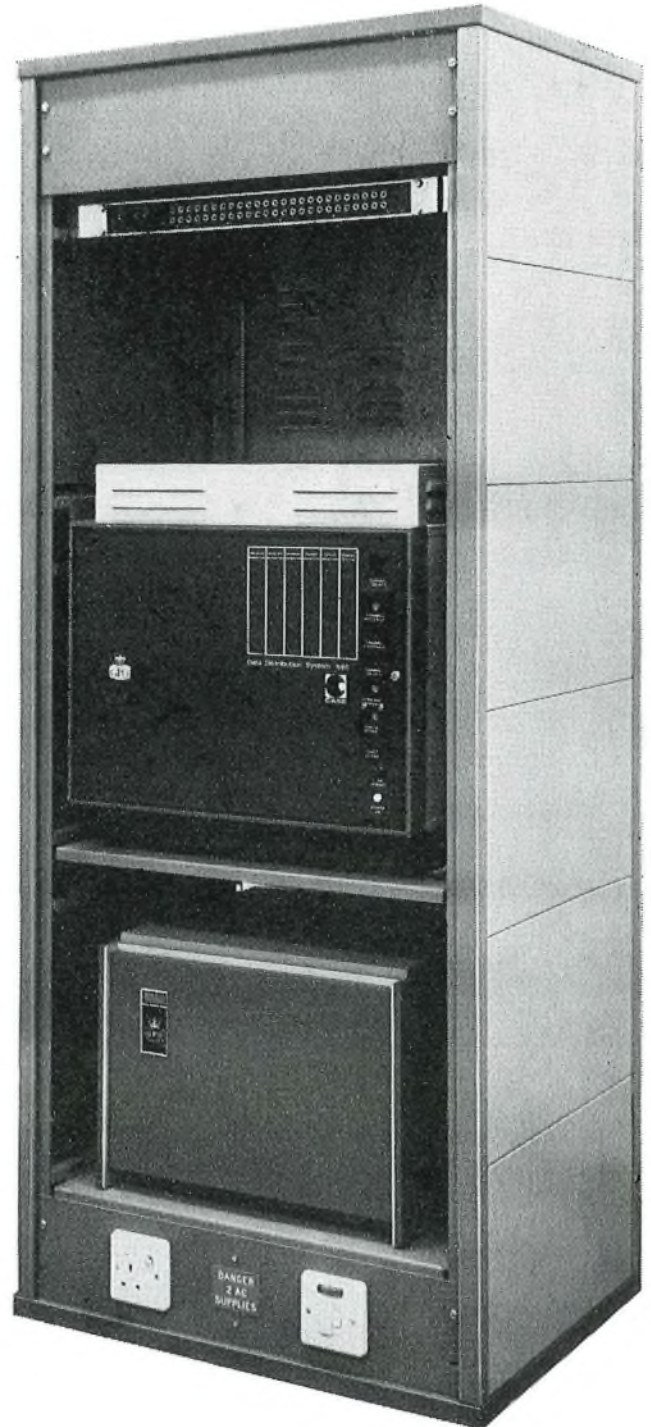

FIG. 2—Installation at the customer's end

format is dependent upon the control information. At the remote end, the control code character is identified and the channel-card interface conditions are set as required.

Fig. 5 shows a simplified block diagram of the channel unit. The logic functions are all performed using dual-in-line integrated circuits, and the C.C.I.T.T. V24 interface receivers, drivers and lamp drivers use thick-film circuits to ensure maximum reliability. Each card is addressed in turn every 417 μ s and this opens the address AND gates allowing the common control to

- (a) momentarily examine the state of all input (receive) circuits and obtain baud-rate information, and
- (b) update the latches L1-L4 which control the output circuits.

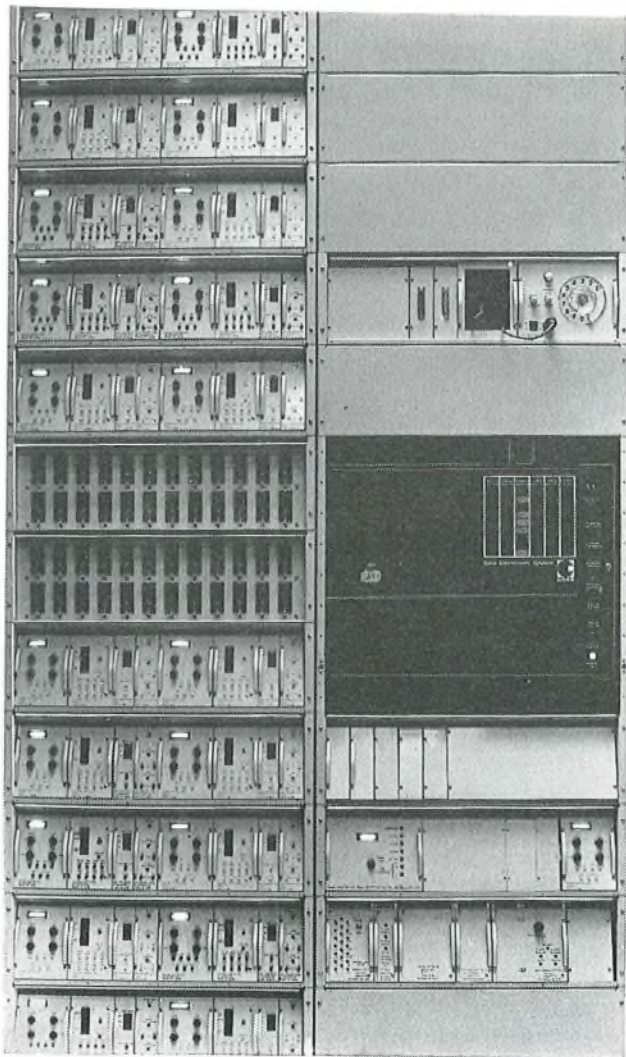

FIG. 3—Installation at the exchange end

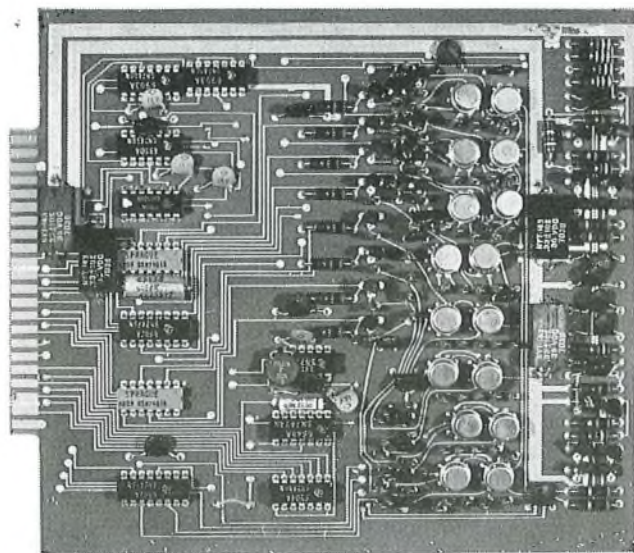

FIG. 4—Memory card in which the TO5 encapsulations each contain three 66-bit shift registers

All cards are interchangeable and flexibility is obtained by providing strap options. These straps consist of miniature plug-and-socket connexions allowing a channel unit to be restrapped in a few seconds.

The BACKWARD BUSY and LOOPBACK controls are provided

on the front panel of the multiplexing equipment. These controls are common to all channels and the required channel is selected using a digital indicating switch.

Backward busy allows the computer operator to busy out any particular line. This condition can be initiated during a call but only takes effect at the completion of the call. A control code is transmitted to the A-end multiplexing equipment which extends the condition to the busying unit. This extends a relayed loop which can be arranged to busy the P-wire on the final-selector multiple inhibiting any further incoming calls. This condition may be removed at any time by the computer-bureau operator.

Loopback allows remote testing (with local co-operation) of the multiplexing equipment by means of a Datel tester. This tests the ability of the common-control and transmission sections of both multiplexing equipments to deal with data.

Operation of Common-Control Section

The accessing of each of the 45 channel units is under the control of the master pulse generator via the 12-channel address paths. As each channel is addressed in turn, certain conditions, prestrapped for a particular channel, are immediately extended to the control I section via the program wires. These conditions are

- (a) *interface marker*, which indicates that a channel has been addressed and that a channel-unit card is present,
- (b) *baud-rate select 1*, and
- (c) *baud-rate select 2*.

The logic conditions on the latter two wires indicate at which of three possible baud-rates the channel-unit card operates.

Fig. 6 shows how information from the low-speed channel units is transferred to the high-speed modem. The processing of information received from all the low-speed channels is controlled by the processor section which accesses the memory via the master register. The current state of all the low-speed lines and the high-speed line is stored in a dynamic recirculating memory (MOS shift registers with storage capacity of 3.2 kbit) which can only be accessed and changed or read by the master register, 8 bits at a time, as they appear in its "window". This information appears every 417 μ s, which is fast enough to make it appear continuously available for all the line functions. It is, for example approximately half of one 8-bit character time at 9.6 kbit/s which is the fastest of the high-speed line rates. Apart from this requirement the rate of clocking of the memory is not related to any of the different line speeds.

The memory allocates 64 bits of storage for each channel and these are arranged in eight 8-bit words as shown in Fig. 7. Each word appears in the "window" of the master register once every 417 μ s.

Operation of Memory/Processor section

When the master pulse generator selects a channel for servicing, the condition of each of four of the status wires from the channel-unit card is examined. These wires carry the following statements:

- wire 1 carries *code I set*,
- wire 2 carries *code II set*,
- wire 3 carries *code III set*, and
- wire 4 carries *data*.

For any of the first three conditions being set, the appropriate code is inserted directly into word 5 of the memory by the master register. If none of the first three conditions is set, then any data present can pass. Every 417 μ s, the state of the *data* wire is examined and, at the commencement of a start signal, bit A is set in word 3.

During the time that only bit A is set in word 3, the trip counter increments by two for each cycle of the memory, until it registers a count equal to that set on the element-length and code-format control path selected from one of

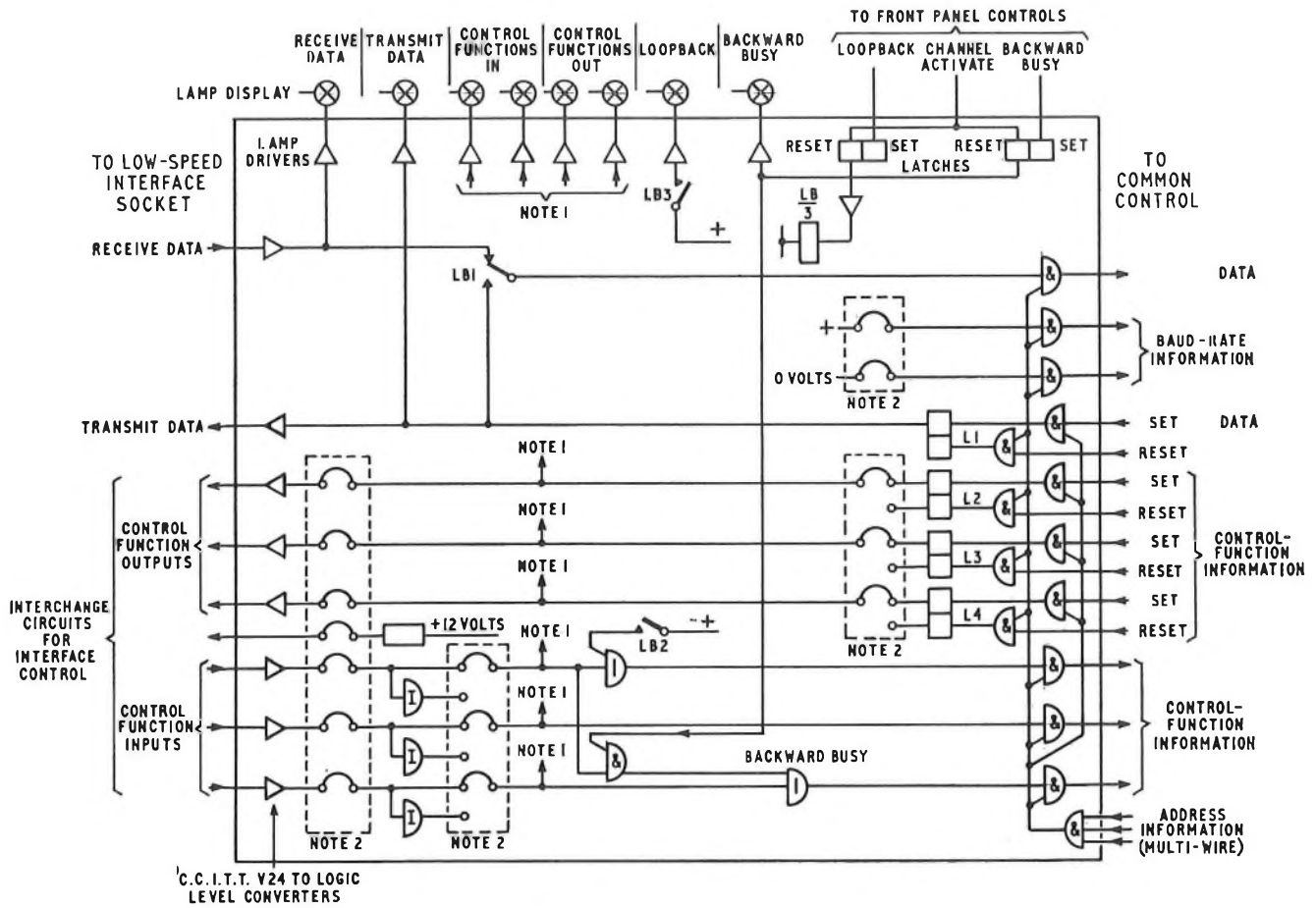

Note 1: To lamp drivers, strapping is dependent upon system configuration.
 Note 2: Flexibility points, strapping is dependent upon system configuration.

FIG. 5—Simplified block diagram of channel unit

the three read-only memories (r.o.m.). (The appropriate r.o.m. is determined by the state of the program wires.) This time is approximately half of one-element period of the data being sampled.

If bit A is still set, that is, the start bit is still present, the trip counter is cleared and bit B is set in word three. The counter increments by one for each cycle of the memory until the same number as before is reached. This represents (within $\approx 208 \mu\text{s}$) the theoretical mid-point of the first element which is present on the data wire from the channel unit. This element is then sampled and stored in position 8 of word 4 and the start bit is shifted to position 7. This continues until the start bit reaches position 1 which is recognized by the control I section and sets bit D in word 3, indicating that, after the next group of memory cycles, a complete character will have been stored in the assemble area (word 4). After assembly, the contents of word 4 are shifted into word 5 via a holding register in the processor.

The data is held in word 5 (the holding area for the high-speed transmit) until called for by the transmitter section. The transmitter is strapped to cater for the appropriate number of low-speed channels that can be accommodated in the system and always transmits information in every time-slot allocated to a channel, sampling the master register on each occasion. If there is a complete word in the holding area of the master register at this time, indicated by bits A and D being set in word 3, the word is parallel shifted into the transmit holding register and then serially transmitted to the high-speed modem under the control of either the modem clock or, if required, by clock timing from a crystal within the multiplexing equipment.

In this way, any of the three control codes or data can be transmitted during the appropriate time-slot but without

either the start or stop elements, these being unnecessary for characters interleaved on a synchronous channel. However, two other conditions which must be accommodated are that,

- (a) there may not be a complete character ready for transmission when the transmit line calls, and
- (b) sometimes a break character (continuous space) is required to be transmitted.

In the first instance, when the transmit holding register has emptied, the transmit section does not receive a character from the master register as no data has been shifted into word 5. An idle code is always set in word 5 when data is not actually for transfer from word 4 and this code is then sent into the transmit holding register and transmitted in place of data in the channel time-slot. When decoded at the remote end, this information is re-transmitted as a continuous mark.

In the second instance, no stop bit is received by the data line when it would normally be expected. All three control bits (A, B & D) are set in word 3, which indicates to the processor that the break code should be stored in the master register and then transferred when called for by the transmit holding register.

The number of memory cycles (each $417 \mu\text{s}$) required to time the sampling of the low-speed lines is a compromise to give the best telegraph distortion margin for any of the possible low-speed line-rates. For example, a character at 110 bit/s should be sampled ideally every 9.08 ms . A count of 22 cycles results in $22 \times 417 \mu\text{s} = 9.18 \text{ ms}$ which, after eight elements have been sampled, gives an actual sample of the last element (assuming the start bit was accurately sampled) at time $8 \times 9.18 = 73.48 \text{ ms}$ after the mid-point of the start bit, an error of 0.74 ms or a sampling error of 28 per cent. This reduces the margin of the receiver to about

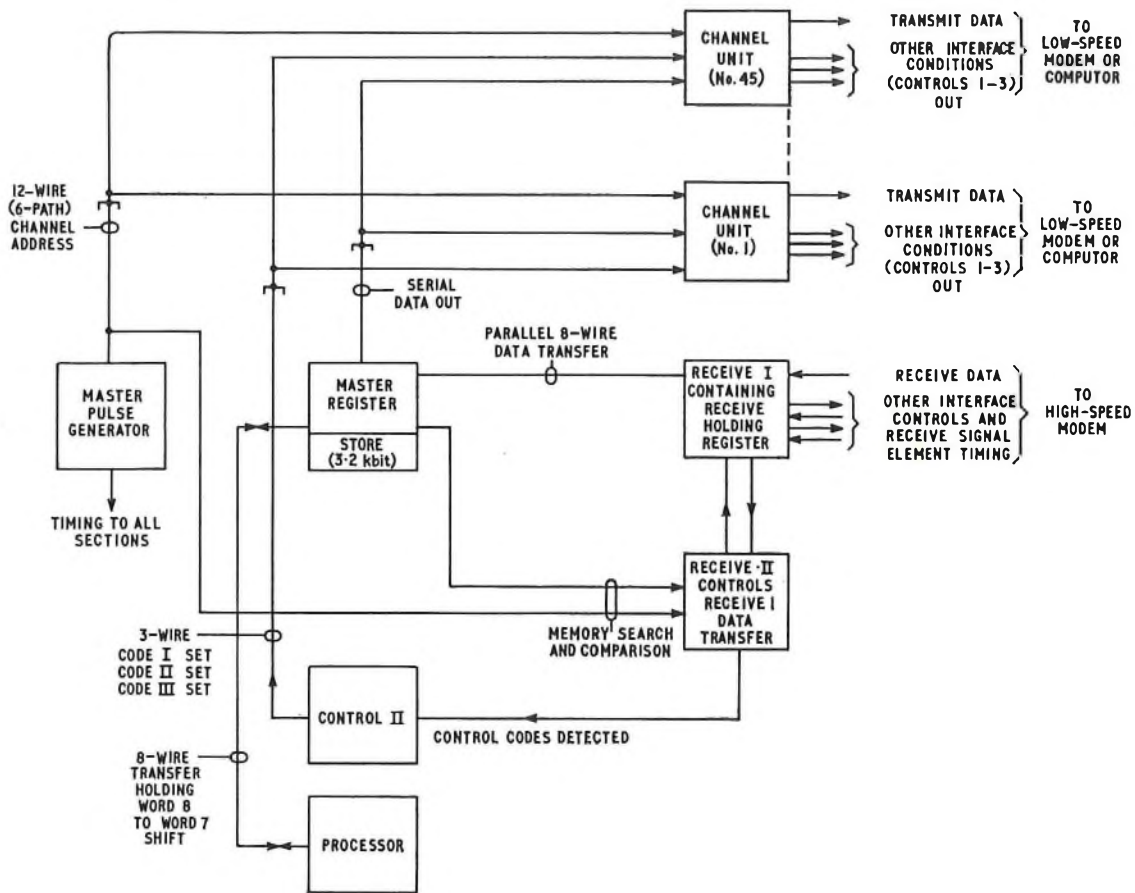

FIG. 6—Information transfer from low-speed channel units to high-speed modem

42 per cent for early elements in the 8th data bit. A count of 21 cycles, however, results in a margin of the receiver of about 23 per cent for late elements in the 8th data bit at 110 bit/s.

Fig. 8 shows how information from the high-speed modem is transferred to the low-speed channel units. Data from the high-speed modem is clocked into an 8-bit shift-register in the receive-section. As the 8th bit is received, the whole block is transferred to the receive holding register where it remains until the receive II section confirms that the correct memory block is available in the master register, by comparison with the channel-address counter. The stored character is then shifted into high-speed holding area (word 8) of the correct channel and subsequently transferred by the processor to word 7. Exceptions to this transfer are made if, during the time of storing in the receive I holding register, any of the five codes is detected, whereupon, information is passed to the control II section, which sets up the correct code condition into the appropriate channel-unit card where the code is latched for one character cycle time. It cannot be reset until instructed by the control II section as a subsequent channel address time. The master register is cleared so that the received code, which is not data, is not transmitted to the low-speed terminal. The rest of the low-speed transmission is the inverse of the low-speed reception. The low-speed interface receives one bit at a time under the control of the transmit timing (word 6) starting with a regenerated *start* bit which occurs when bits A and B are both set. At the completion of the required count, the first bit in word 7, is shifted out to the low-speed interface and so on, until the 8th element has been transmitted. After the 8th element has been transmitted, a *stop* signal is inserted by the trip counter counting to a required number, indicated by bits A and D being set in word 6, under the control of the control II section which can be strapped as required.

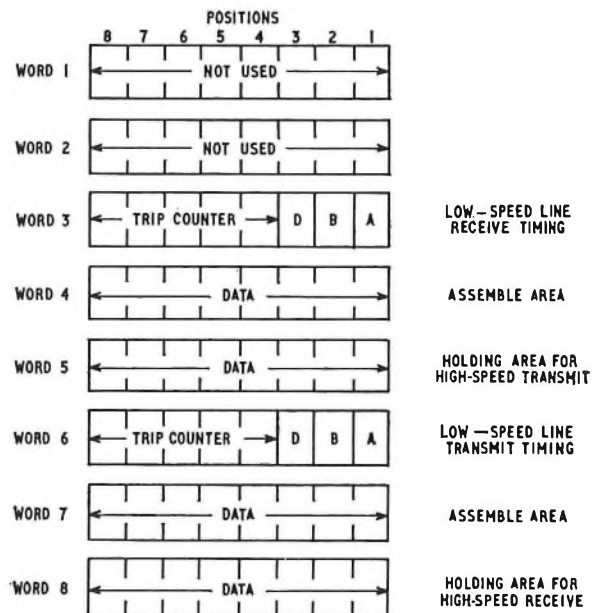

FIG. 7—Allocation of storage in the memory

Synchronization

Synchronization of the receiver with the transmitter is accomplished by transmitting a synchronizing pattern once in every six cycles (sub-frames) of the high-speed frame. When a synchronization pattern is detected by the receive I section, it is passed to the receive II where it is either confirmed, or

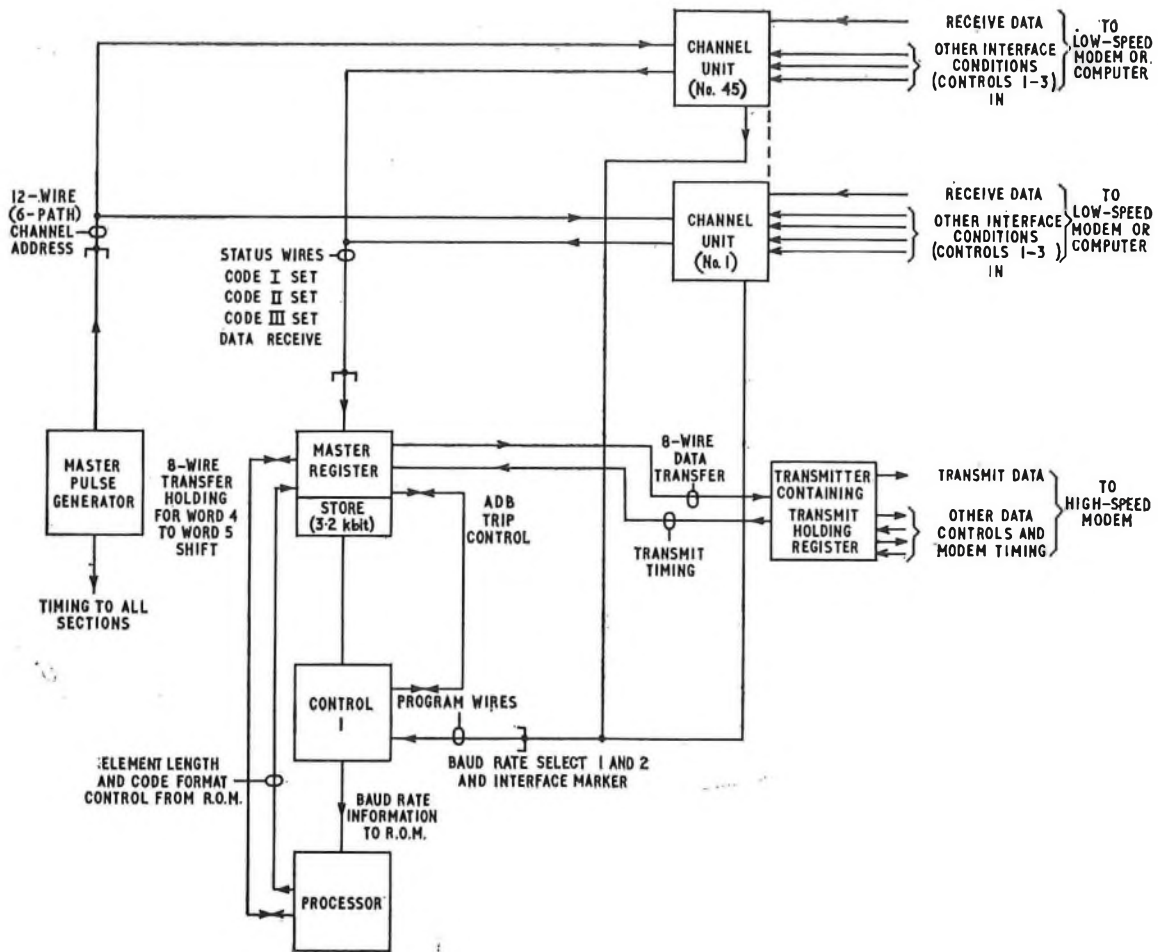

Fig. 8—Information transfer from high-speed modem to low-speed channel units

stored until confirmation is established. If the synchronization pattern is not detected, a *sync alarm* in receive II is prepared and is only cancelled if the next synchronization pattern arrives. If it does not arrive, the receive II section stops searching the memory and releases the receive holding register until a synchronization pattern is recognized by the receive I section when the memory search circuits look for the correct memory-block. During the loss of synchronization, the codes stored in any channel-unit card remain and are not reset by the control II section until synchronization is restored. This is achieved by permanently clearing the receive holding register during loss of synchronization.

Speed Variation of Low-Speed Terminal

A problem inherent in a transmission system which is based on anisochronous-to-isochronous conversion is that of low-speed terminal speed variation, particularly if a terminal runs overspeed.

If a distant transmitter is running slightly fast with no gaps between characters (that is, at cadence speed), there will come a time when, although the system can transmit the characters from the transmitter via the multiplexing equipment link, it will not be able to clear the receive assemble area (word 7) of the memory before the holding area requires to shift its own data. Such a situation would result in a lost character at regular intervals. To overcome this problem, it is arranged that the regenerated character can be transmitted with a shortened *stop* period, the length of the *stop* period required being controlled to certain preset times by the processor section.

This does not overcome the further problem of the ability of the high-speed frame to cope with incoming data at a rate greater than the nominal rate. For example, if a multiplexing equipment is designed to cope with only 10 character/s channels (eight data bits per character) and the high-speed link has a capability of 2,400 bit/s then, theoretically, 30 channels could be accommodated, since *start* and *stop* bits are removed before synchronous transmission. It is obvious that should any of the low-speed channels be transmitting slightly faster than nominal, it is not possible for the multiplexing equipment to clear the data quickly enough. This problem is overcome by allowing only 29 channels at 10 character/s to be multiplexed, which gives a margin for overspeed and permits the inclusion of a synchronization character. In this way, about 2 per cent overspeed on every channel can be accommodated.

MULTIPLEX SYSTEM CAPACITY

The capacity of a system is basically dependent upon the speeds and character format of the low-speed data inputs and the multiplexed high-speed data rates. The multiplexing equipment is character oriented and designed to operate in conjunction with high-speed data modems operating at 2.4, 3.6, 4.8, 7.2 or 9.6 kbit/s. For channels using C.C.I.T.T. Alphabet No. 5, the low-speed inputs are transmitted over the high-speed link with all start and stop information removed and, consequently, the character rate is the factor controlling the system capacity for a given high-speed link. For channels using a 5-level code (C.C.I.T.T. Alphabet No. 2), or a 7-level code (I.B.M.), dummy bits are added to the character to enable an 8-bit byte to be transmitted to the

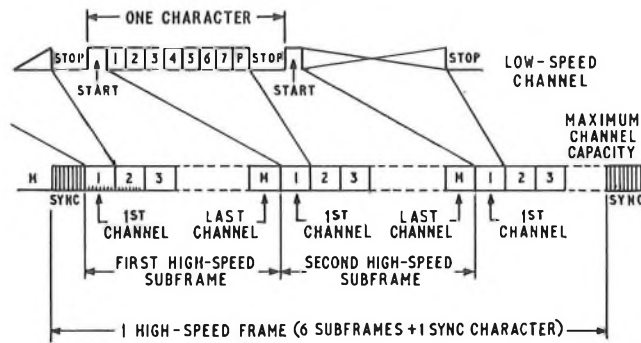

Note: 8 bits in each channel slot

FIG. 9—High-speed frame format

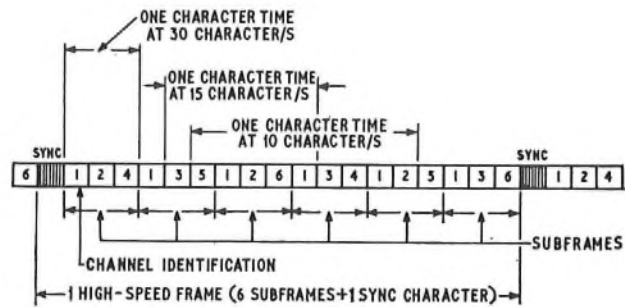

Note 1: 8 bits in each channel slot
 Note 2: Channel 1 operating at 30 characters/s,
 Channel 2 and 3 operating at 15 characters/s,
 Channel 4, 5, and 6 operating at 10 characters/s.

FIG. 10—High-speed frame format for mixed speed operation

TABLE 2
System Capacity for Single-Speed Operation

Low-Speed Channel Speed (bit/s)	Character				Character Rate (character/s)	System Capacity (Channels)		
	Format			Alphabet		High-Speed Line Rate (kbit/s)		
	Start	Data	Stop			2·4	4·8	9·6
50†	1	5	1·5	C.C.I.T.T. No. 2	6·67	42	45*	45*
75	1	5	1·5	C.C.I.T.T. No. 2	10	29	45*	45*
110	1	8	2	C.C.I.T.T. No. 5	10	29	45*	45*
134·5	1	7	1	I.B.M.	15	19	39	45*
150	1	8	1	C.C.I.T.T. No. 5	15	19	39	45*
200	1	8	1	C.C.I.T.T. No. 5	20	14	29	45*
300	1	8	1	C.C.I.T.T. No. 5	30	9	19	39
600	1	8	1	C.C.I.T.T. No. 5	60	4	9	19

* Subject to a maximum of 45 channels due to the physical construction of the multiplexing equipment.

† The master pulse generator requires modification for operation at this speed.

high-speed line. This simplifies the multiplexing and the demultiplexing procedures, particularly if channels using these codes are mixed with channels using C.C.I.T.T. Alphabet No. 5. The maximum system capacity is shown in Table 2 for the commonly-used, low-speed data rates, allowance being made for system synchronization information and other operational requirements. The high-speed frame format is shown in Fig. 9.

Operation of a system with mixed low-speed data rates is possible provided that no more than three speeds are mixed in one system. It is possible to mix any three of the speeds shown in Table 2 but the system is most efficiently used when the ratio of character rates is $3 : 1\frac{1}{2} : 1$. Typical time-sharing computer bureau may require a mixture of channels at 10, 15 and 30 character/s. To achieve this efficient intermixing of speeds, it is necessary to subdivide the high-speed frame into six sub-frames. Each sub-frame consists of an equal number of channel-time-slots in which the channels are distributed according to their character rate. The high-speed frame format for a typical mixture of low-speed channels is shown in Fig. 10.

MAINTENANCE

First-line maintenance on the multiplexing equipment is aided by the use of a number of inbuilt testing features together with the Datel Tester No 7A (a character generator

which can also reproduce any C.C.I.T.T. V24 interface condition). Replacement of printed-circuit boards enables the majority of faults to be rapidly localized to individual cards. Second-line maintenance, that is, repair to faults on printed-circuit boards or the individual units of the multiplexing equipment, will be done by the manufacturer's agents during the first year and possibly by electronic repair centres thereafter. Maintenance staff will be given special training courses.

CONCLUSIONS

The use of the multiplexing equipment has provided a means of relieving sensitive areas in the public switched telephone network from the burden of heavy traffic loads into computer bureau. It will also provide new customer services similar to, but with more extensive facilities than, the Dataplex Service 110.

ACKNOWLEDGEMENTS

The equipment described in this article has been purchased from Computer and Systems Engineering (CASE) Ltd.

References

- 1 MURRAY, W. J. and RIMINGTON, J. W. Dataplex Service 110—A New Service for Time-Sharing Computer Bureaux. *P.O.E.E.J.*, Vol. 65, p. 68, July 72.

Book Reviews

"Theory and Analysis of Phased Array Antennas." Noach Amitay, Victor Galindo, and Chen Pang Wu. John Wiley & Sons Ltd. xv + 443 pp. 210 ill. £8.85.

The potential of phased arrays for control of the aperture illumination of antennas where rapid beam steering is required has long been appreciated by radio engineers and there can be few today who are not aware of the current substantial activity and interest in the subject. The demands of the space and missile age, with its requirements for radar systems using large aperture antennas capable, not only of high speed scanning but, also, of providing simultaneous surveillance, discrimination and tracking functions, have given great impetus to the development of phased arrays over the last decade. This book is a timely presentation of the modern theory and analysis required for the understanding and design of such arrays. The authors' approach is mathematical and dealt with in some detail and is intended to provide not only a basic understanding of the properties of phased array antennas but, also, to present the analysis and synthesis techniques necessary for the economic design of these costly antennas. Since most of the frequency bands of current interest lie above 1 GHz, the book concentrates largely on the analysis of uniformly- and closely-spaced planar arrays of open-ended waveguides.

After introducing the terminology and concepts of phased arrays and directing attention to the significance of mutual coupling and its consequent "blindness" phenomenon, the authors formulate the boundary value problem and introduce methods of solution. Analyses and solutions of infinite phased arrays are then discussed followed by a chapter on the effects of dielectrics introduced into the array environment. Circular waveguide planar phased arrays, finite and aperiodic arrays, edge effects and methods of improving the array match complete the volume.

The book is intended for engineers, physicists and students who have an interest in the subject at an intermediate level. Some may be disappointed that there is no mention of active arrays. Otherwise the book may be recommended as a

modern treatment of a subject of considerable current interest well presented in a thorough and lucid style.

D. T.

"J and P Switchgear Book." R. T. Lythall, C.Eng., F.I.E.E. The Butterworth Group. 800 pp. 759 ill. £9.90.

This is a companion to the J and P Transformer Book, and the pair are virtually a power engineer's standard reference work. Now in its 7th Edition, it has been updated to include present industrial components. Items of wider potential application in the future, such as vacuum interrupters, are mentioned. S.I. Units are now used and the content confined to a.c. systems.

Although this edition states it is "an outline of modern switchgear for the non-specialist user," few professional engineers in this field will object to having it on their reference book shelf. However, it will certainly lead the student into the subject in a logical manner, and it does not make unwarranted assumptions on the basic theoretical considerations. The content includes useful practical applications of switching a.c. systems, including fault problems. In addition to the main switchgear units, it deals in adequate detail with associated items such as busbars, h.r.c. fuses, and protective relays. It also covers the use of these in combination with control and transformer plant.

Despite its size, no volume of this type can possibly cover in great depth every facet of switchgear. Nevertheless, the specialist designer will find use in this volume by its linking function of the various aspects of the subject, and the extensive references and bibliographies. The latter are sufficiently comprehensive to lead the potential designer to many works which add to the material set out in the book.

It is, of course, to power staff that this volume will be of greatest value. This is especially true where staff are involved in planning large complexes and they will welcome access to this book.

C. R. N.

The Evaluation of a New Computer for the British Post Office Telecommunications Headquarters

M. L. JAMISON, B.TECH., M.TECH., C.ENG., M.I.E.E. †

U.D.C. 681.31.001.4

The British Post Office increasingly has employed scientific computer systems in the telecommunications business over the past decade. To ensure the future availability of computing facilities it was decided to plan for the purchase of a new large powerful computer complex. This article briefly describes the desired system and explains how tendered systems were evaluated using specially-created benchmark tests.

INTRODUCTION

The use of computers for scientific and engineering work within the British Post Office (B.P.O.) Telecommunications Headquarters (THQ) has increased rapidly during the past decade. In order to meet the demand for computing facilities it has been necessary to buy a succession of more powerful computers during this period. Also, when internal facilities have been inadequate, considerable use of commercial time-sharing bureaux has been made.

At the beginning of the 1970s it again became apparent that the scientific computers in use by the B.P.O. would be unable to cope with the future demand and it would be necessary to increase the computing power and facilities. It was, therefore, decided to take advantage of modern developments in computer technology and plan for the purchase of a large, powerful computer complex. The selection of such a complex could not be undertaken lightly and consequently considerable thought and work was involved in order that the correct computing requirements could be defined and that the computer configuration finally recommended would be the best suited for meeting these requirements.

Initially, the trends in computer usage by THQ staff were investigated and a study was made of suitable large computer systems. It was then possible to set reasonable guide lines for the manufacturers who were asked to tender practical systems.

SYSTEM DESCRIPTION

The computer system is required by THQ users situated primarily in greater London and at the Research Department laboratories in the Ipswich area. The research station is based on a single site at Martlesham Heath where it was considered suitable to place the central computer and its operating staff. The London area covers many square miles and the users occupy a large number of buildings.

Existing Facilities

Many of the potential users have previous experience of two Burroughs B5500 computers and external commercial time-sharing services using teletypewriter terminals as the

main user-computer interface.¹ However, the number of terminals which the B5500 can adequately service is small in comparison with the number of potential users.

One group of users has almost exclusive use of two Elliott 503 computers to perform simulation of telephone exchanges.² These machines offer to this group the advantage of 64,000 words and 128,000 words of randomly-addressable storage, an important factor arising from the need to access, randomly, large arrays of information within simulation models. Unfortunately, the bulk of this storage has a very slow access time of 50 microseconds and program development has to be performed via paper tape. It is also found that the size of the storage limits the size of the simulation models and consequently development work is delayed.

Outline of the New System

It has been possible in recent years to provide extra computing power and facilities by acquiring duplicates of existing computers. However, this approach does not take advantage of modern computer developments and it was readily apparent that a completely new system was required in order to meet the future demand. A number of choices existed and can be summarized as follows:

- (a) two incompatible systems for (multi-access) terminal use and simulation work,
- (b) two compatible systems from the same manufacturer to meet the two types of user, or,
- (c) a single system capable of meeting both types of demand.

From past experience the first choice was considered unwise because the system software is incompatible and one system cannot be used as standby for the other in the event of equipment failure.

The general requirements of the system are indicated in Table 1.

An estimation was also made of the required processing power, backing storage requirements for both user and system files, and the quantity and types of peripheral equipment.

The communications requirements were specified in general terms, concentrating on the need for wideband transmission links between the central site and outstations in London. It was suggested that a communications or front-end processor (f.e.p.) should be associated with the

† Telecommunications Development Department, Telecommunications Headquarters.

computer to cope with a variety of terminals, line speeds and character sets. Although teletypewriters, visual display units, interactive terminals, plotters and storage tubes were specified, these were seen as external to the main computer system. Hence, provided the necessary interface and software support was available, any suitable terminal could be connected. It was thought a wise precaution to delay making decisions concerning the purchase of these units because of the fast rate of development of terminal equipment. A block diagram of the required system is shown in Fig. 1.

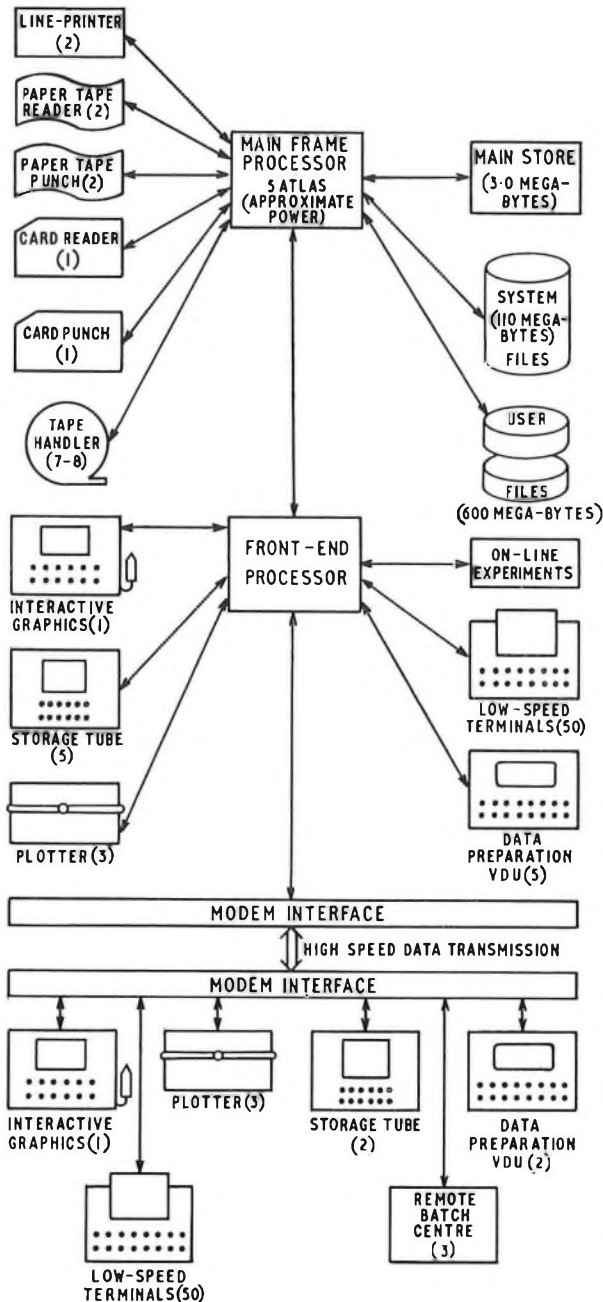

FIG. 1—Block diagram of desired computer system

Following the return of tenders it was clearly a massive task to scrutinize them all in depth, so, initially, important areas of interest were studied in order to eliminate the more unsuitable machines. These areas included power of processors, ability to access randomly a large store, availability of equipment and software, growth potential and cost. After this preliminary study a smaller number of systems remained to be compared and evaluated in depth. No single system

TABLE 1

General Requirements of the THQ Computer System

Type of System	Multiprogramming with Multi-Access and Batch Facilities
Program types	(a) Large proportion of one-off programs written by semi-skilled programmers. (b) Small number of highly-optimized programs requiring long execution runs.
Number of users	100 simultaneous multi-access users (at peak load)
Location of users	Half near central site at Martlesham Heath. Half in London area. (These users require local lineprinters and paper-tape/card-readers and punches at strategically-placed sites)
Rate of increase of users	Expected increase of 40 per cent per annum in number of users after first 2 years to a maximum of 220 users. System must be capable of expansion in all major resources to deal with this growth.
Other limiting factors	Approximately one million words of random-access storage. 40 bit precision. (These requirements were specified for the telephone exchange simulation work)

had all the desired attributes and it was necessary to compare them in detail using well-defined tests known as benchmark tests in order that an accurate comparison could be made. During this procedure further systems were discovered to be unsuitable and therefore eliminated.

EVALUATION TECHNIQUE

The task of evaluating the tendered computer systems was shared by representatives of Post Office Data Processing Service (P.O.D.P.S.) and THQ. The former concentrated on cost and contractual considerations whilst the latter investigated the technical suitability of the systems for use by THQ staff. In particular it was necessary to assess how key areas of the system affected computing performance by writing a suite of test programs to be run on the machines under consideration. These key areas were:

- the performance of the processor,
- the effect of the use of high-level languages,
- the efficiency of the operating system, and
- the effectiveness of multi-access operation.

The performance of the processor or processors of a system was considered important, as a scientific work-load is primarily dependent on the processor rather than input/output features as in a data processing environment. However, input to, and output from, mass-storage devices (discs, drums) was considered during the investigation of operating systems and multi-access operation because these require fast information-swapping speeds. Also the use of large main memories, as required for exchange simulation, was considered when studying the effect of high-level languages on the performance of each system.

The facilities offered to the users also affect the performance of the system and were a significant part of the evaluation. This is because the potential performance would not be available if facilities were poor. For example, if the error-reporting facilities are inadequate during the compilation of a program, more editing and compiling is necessary, thus increasing the amount of processing to be performed before the actual program can be executed and thereby reducing useful processing power. Unfortunately, facilities require subjective judgment but an attempt was made to highlight

where good or bad facilities affected performance. The performance of the key area was assessed by means of a series of specially designed tests called benchmark tests. Each area was investigated at a number of levels and, although some tests were created which concentrated on a specific area, usually each test was devised for the study of two or more areas. Figure 2 shows the important relationships between key evaluation areas, the benchmark groups and the analysis classifications.

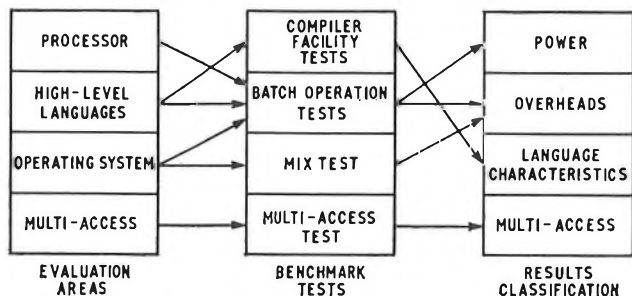

FIG. 2—Evaluation, benchmark, and results relationships

Processor

The theoretical “raw” power of each processor was measured by applying weightings to the times required to execute a set of basic instructions and hence calculating the number of average operations which could be executed in unit time.³ It was not convenient to check the average execution times obtained by this method but the results provided a rough indication of processor power, sufficient to eliminate systems which were found to be significantly underpowered.

Also, a variety of processor-bound programs were written and their execution times, when run on different systems, compared.

High-Level Languages

The effect of high-level languages on system performance was studied by investigating the following three important features:

Compiler Facilities

A set of programs was created which included deliberate errors to show the quality of diagnostic information. Further programs were devised to check correct implementation of the languages and to study the interpretation of common ambiguities. An examination was also conducted of the types and efficiency of array subscript checking, and tests made on arithmetic precision. These tests were performed to reduce the need to study the appropriate manuals which are very often inadequate or wrong.

Speed of Program Compilation

The time required to compile programs is dependent upon two factors:

- (a) a fixed period of time (called an overhead) imposed by the operating system whilst accessing and checking files, and
- (b) the rate of compilation of the high-level statements.

The overheads were measured by timing the compilation of a very small (null) program and the compilation rate was obtained by timing the compilation of long programs and calculating the number of typical statements compiled in unit time. It was necessary to investigate both optimising and non-optimising compilers as their use depends on their

relative speeds coupled with the speed of execution of the compiled programs.

Speed of Compiled Code

A technique was employed whereby the execution time of typical high-level statements was measured, weightings applied and the rate at which average instructions could be executed was calculated.⁴ These weightings were derived from studies of the use of statements within programs written by B.P.O. and external programmers. This method of performance assessment can be likened to the calculation of “raw” power previously mentioned.

The times obtained were checked by comparing processing times of real programs and times calculated using the individual statement times. The programs were synthetically produced according to the weightings previously derived from studies of programs.

The resulting timings were both useful when comparing the power of the computers available through high-level languages and in highlighting inefficient and slow machine code.

Operating System

Programs were written to measure the overheads imposed by an operating system whilst involved with the work flow within the computer. These overheads include information logging, control of file activity, entry of jobs and scheduling of the processor and memory to jobs. A multiprogramming efficiency test was devised to measure how effectively a system could switch between a processor-bound job and an input/output job which were running simultaneously.

Also a mix of jobs was created to investigate an operating system’s ability to schedule the work load using the available resources.

Multi-access Operation

In order that the multi-access performance of the systems could be assessed it was necessary to determine the future work-load profile. This was based upon current use of terminals and time-sharing computers by THQ staff. The scripts produced by users at sample terminals and the information logged about terminal use were both analysed. Thus, it was possible to predict the ratio of file editing, program compilation and program execution and to specify the quantity of typing performed, and the size of programs.

This information was used to create a number of terminal scripts to be used in some form of multi-access benchmark test. It was envisaged that a live test would be performed on each system using a cross-section of users seated at the maximum required number of terminals and following these previously defined scripts. However, due to logistic problems this method was not always practical and it was necessary to resort to some form of simulation of users. This was done by employing an external computer or processor which scanned the scripts at defined rates representing normal terminal activity.

The response times to commands, as witnessed by the real or simulated terminal users, were timed and the total throughput of work at all terminals measured in order to make realistic comparisons of systems.

BENCHMARK TESTS

The benchmark tests were divided into four parts:

- (a) compiler facility tests,
- (b) batch operation,
- (c) mix of jobs, and
- (d) multi-access tests.

Compiler Facility Tests

These tests utilised 70 programs which were designed to study the following features of Algol and Fortran compilers:

- (a) the ability of compilers to detect compile-time and run-time errors,
- (b) the quality of error diagnostic information,
- (c) the ability to compile, and run, unusual but valid codes in order to assess the rigour of the compiler, and
- (d) precision and accuracy of arithmetic operations.

Batch Operation

This benchmark test consisted of 13 tests falling into the following categories:

- (a) internal-timer accuracy check,
- (b) high-level statement timings—Algol,
- (c) high-level statement timings—Fortran,
- (d) test of simulation facilities,
- (e) operating overheads on compilation—Algol,
- (f) operating overheads on compilation—Fortran,
- (g) compilation speed—Algol,
- (h) compilation speed—Fortran,
- (i) multiprogramming efficiency,
- (j) execution speed of a typical job—Algol, and
- (k) execution of a typical job—Fortran.

Mix Tests

The mix used consisted of 12 jobs (a job is considered as a mixture of compilation and one or more executions of a program). Each job was initially run alone to obtain individual elapsed and processing times and then the whole mix was entered under multiprogramming conditions to assess how long the stream would take to be processed. The sequence of jobs was then entered an integral number of times to run for at least one hour. A comparison between the total time, assuming each job was run in turn, and the time of the mix run, indicated the ability of the multiprogramming operating system to allocate and share the computer resources.

Multi-access Test

For the multi-access test the manufacturers were asked to demonstrate 100 terminals operating simultaneously using the following mixture of terminal scripts:

- (a) Algol script 60 per cent,
- (b) Fortran script 30 per cent, and
- (c) Basic script 8 per cent.

In addition, one terminal was required to run a program which used facilities required by simulation programs. A further terminal was required to run a processing monitor program which was devised to measure the allocation of processing time to a single terminal. A version of this program was also required to be executed as a background batch job to measure the processing time available for batch work.

BENCHMARK TEST RESULTS

No individual result could be used satisfactorily as a single comparison factor. Benchmark tests generate an overall picture of each system, thus allowing a realistic comparison to be made. However, certain results proved to be of greater value, especially when grouped together under the following headings:

- (a) power,
- (b) overheads,
- (c) language characteristics, and
- (d) multi-access performance.

Power

A measurement of the power of processing performance was obtained from a number of the tests, thus allowing comparisons to be made at various levels.

In addition to the high-level statement timing tests which were primarily designed to enable processing power to be calculated, it was also possible to compare the execution times of a number of processor-bound programs used in the batch operation tests and the mix test. It was not advisable to compare execution times of all programs as many demanded the use of peripheral equipment such as discs and drums. These were not necessarily those that would be used on the system if purchased and their characteristics varied substantially. The times added to the information on the relative distribution of powers between systems.

Overheads

The overheads of each system, whereby the potential processing performance was reduced, were also derived at a number of levels. These overheads included those for which tests were specifically created such as the delay in performing compilation and program execution due to the need to access and update files. However, many factors degrade performance and results from other tests enabled these to be investigated.

The degradation due to the checking of array subscripts in high-level language programs was measured during the statement timing tests. Comparisons were made of execution times of statements with and without subscript checking and estimates made of the effect on program performance. The resultant increase in execution times on some systems significantly reduced their power.

The processing power of a computer system is normally considered with respect to a single executing program. The throughput of work in a system is, however, also dependent upon its multiprogramming capability whereby the jobs are scheduled according to the availability of resources and these resources, including the central processor are then shared between jobs being processed. The effect of multiprogramming cannot be termed an overhead, as the prime aim is to maintain a high throughput of work by optimum sharing of resources. However, inefficient multiprogramming reduces the throughput and the results from a number of tests were used to measure such inefficiencies.

The results of the test, which was devised to quantify the effect of switching between a processor-bound program and an input/output bound program, were used to calculate the reduction in throughput of each job, due to the presence of the other job. This was seen as a measurement of multiprogramming efficiency.

Also the mix throughput test produced, as was intended, results used to compare the effectiveness of job scheduling and resource sharing on the various systems.

Language Characteristics

The results of the high-level language investigations were contradictory, to some degree, and could not be used objectively to decide which language or implementation was the best. Instead, the tests were used to indicate the good and bad features, thus making it possible to make a subjective judgement concerning the usefulness of the language in the predicted environment. Particularly important were the error messages produced, both during compilation of a program and during the execution of the compiled code.

As the specification for the Martlesham computer system required that a practical time-sharing service should be available to the users, there was a demand for interactive languages. These give the terminal user control over the compilation and execution phases of programs allowing errors to be detected, values of variables to be checked and reset and the order in which instructions are obeyed to be controlled. Few of these features were investigated implicitly because such facilities are not generally available for all languages. As it was necessary to use languages in many aspects of evaluation, language characteristics which would be beneficial to the interactive user became evident.

Multi-access Performance

The benchmark tests which were performed to compare the multi-access performance of each system generated a large amount of data to be analysed. Unfortunately, as it was not possible to create identical conditions on each system (number of terminals, simulated or live users), a direct comparison was difficult, if not impossible. It was also necessary to create a realistic environment for each system utilising any batch facilities that would be maintained in the real world. This was necessary because some systems were expected to allow batch processing concurrently with a multi-access service whilst others were intended to cope separately with these demands.

The most useful results related to the measurement of delays in response to commands by the user and to the overall throughput of work. The use of standard scripts in all tests greatly enhanced this measurement technique and has also proved useful in the comparison of existing in-house computer systems.

CONCLUSIONS

Over a period of approximately nine months a dedicated team was able to conceive, create and implement a detailed evaluation investigation of a selection of large scientific computer systems. As the final computer system was intended for a variety of users it was necessary that the investigation

should be thorough in order that the overall suitability of each tendered system could be judged reliably. This necessitated a wide range of tests and consequently the development of many programs. However, by careful design and the use of synthetic programs whose characteristics could be controlled at run time, it was possible to employ some of them in more than one test and hence reduce the total program development.

Considerable experience has been accumulated concerning performance measuring and evaluation techniques, some of which have subsequently been applied to study the effect of software modifications and the use of a front-end processor with Post Office computers. Also, external bureaux services have been studied using modular programs derived from this evaluation. Similar techniques will be useful for future computer system performance measurement, evaluation and acceptance testing.⁵

References

- ¹ ROCHE, D. J. Multi-Access Computers. *P.O.E.E.J.*, Vol. 61, p. 215, Jan. 1969.
- ² BEASTALL, H. and POVEY, J. A. Teletraffic Studies of TXE4. *P.O.E.E.J.*, Vol. 65, p. 251, Jan. 1973.
- ³ GIBSON. Comparison of Computer Speeds using Mixes of Instructions. Mintech Memo 737, May 1969.
- ⁴ WICHMANN B. Basic Statement Times for Algol 60. National Physics Laboratory Report, NAC 15, May 1972.
- ⁵ LONGBOTTOM, R. and STOATE, K. W. Acceptance Trials of Digital Computer Systems. *P.O.E.E.J.*, Vol. 65, p. 91, July 1972.

Book Reviews

“Electric Network Analysis.” R. G. Meadows. The Athlone Press, 492 pp. 322 ill. £6.

The book is intended to be an introduction to electric network theory mainly for first-year students of degree and diploma courses. It is considered desirable that readers know the basic concepts of electricity and magnetism and have a knowledge of mathematics at intermediate standard.

With regards to the contents and presentation of the book, there are eight main sections, namely: Introduction to voltages, currents, and the lumped-circuit elements of resistance, capacitance and inductance; Phasor and complex—notation methods of steady-state network analysis; Transient analysis of networks by classical methods; Resonance in electric networks; Network topology and steady-state mesh and nodal methods of analysis; Network theorems, equivalence and reduction; Inductive coupling and transformer networks; Lumped circuit models for practical component and impedance measurements. In addition, there are two appendices dealing with determinants and matrix algebra.

There are numerous worked examples in the text, followed by several problems at the end of each chapter, the answers to which are supplied at the end of the book.

The number of aspects of network analysis covered is very large and, therefore, it is not possible to discuss all chapters in detail in a short review. Briefly, the early chapters deal with basic principles of Ohm's law Kirchhoff's laws and a.c. theory, and then there is a gradual progression through various network theorems to more advanced work requiring the use of matrices.

Parts of the book will be of use to most students on electrical courses. For example, sections of the Telecommunication Principles syllabuses of Courses 49 and 300 of City and

Guilds of London Institute are covered. This also applies to other lines of study of this standard. The complete range of subject matter, however, would only be required for more advanced courses.

With regards to the presentation, the only criticism of the book is that various headings are not bold enough.

This is an excellent publication, but, owing to its comparatively high price and extensive coverage, the book can only be recommended as a purchase to students on degree and diploma courses. Other classes of students should obtain the book from a library and decide for themselves whether or not to buy.

J. F.

“Principles of Telephony.” N. N. Biswas, Ph.D. (Eng.), A.I.I.Sc., D.I.I.Sc., B.Sc. (Hons.), S.M.I.E.E.E., M.A.S.E.E. Asia Publishing House, viii+138 pp. 71 ill. £1.25.

This book fails to achieve its objective. There are considerable gaps in the treatment of this subject with Non-Director systems receiving scant attention and junction working being completely ignored. The principles of U.A.X.s Crossbar and Electronic exchanges as well as s.t.d. are also ignored. A lot of the information given is years out of date. Descriptions and explanations are often sketchy and inadequate. Most figures are poorly drawn with frequent and inconsistent use of incorrect symbols. Numerous errors occur in both figures and text. There are no answers given to the problems set at the end of each chapter and some of these problems cannot be answered from the information given in the text. This book cannot be recommended for use in this country.

R. H.

Earth-Station Equipment for Intelsat IV Satellites

S. SIMPKINS, B.Sc., S. A. FOULKES and J. E. PURDY†

U.D.C. 621.396.721:621.396.946

The first of a new generation of commercial communications satellites—the Intelsat IV series—was launched towards the end of 1971. The significant features of the new spacecraft and the resultant system parameters are briefly outlined, then consideration is given to overall performance and the repercussions on equipment requirements at the earth station.

INTRODUCTION

The first of the latest generation of communications satellites—the INTELSAT IV series—was launched in December 1971 for the International Communications Satellite Consortium (I.C.S.C.) and successfully positioned over the Atlantic Ocean in the geostationary orbit. The new spacecraft (Fig. 1) is considerably larger and more complex than its predecessors,¹ because of the greatly-increased payload of modern launch vehicles.

Initially, there is no intention of departing from the well-established transmission-system techniques using frequency-division-multiplex/frequency-modulation (f.d.m./f.m.) since such systems enable satellite capacity to be optimized

by trade-off between carrier power and occupied bandwidth. The increased satellite output power now available, however, results in the satellite capacity being limited more by restrictions of bandwidth than by available power. At the earth-station, a similar transition is necessary from equipment techniques applicable to a power-limited system to those associated with a bandwidth-limited system. The repercussions on certain earth-station equipment requirements in both design and performance have been significant.

After brief discussion of the communications aspects of the spacecraft, system parameters and overall performance, this article outlines the new earth-station requirements and then describes, in some detail, earth-station equipment for a third aerial system at the United Kingdom earth station at Goonhilly Downs, Cornwall.

† Telecommunications Development Department, Telecommunications Headquarters.

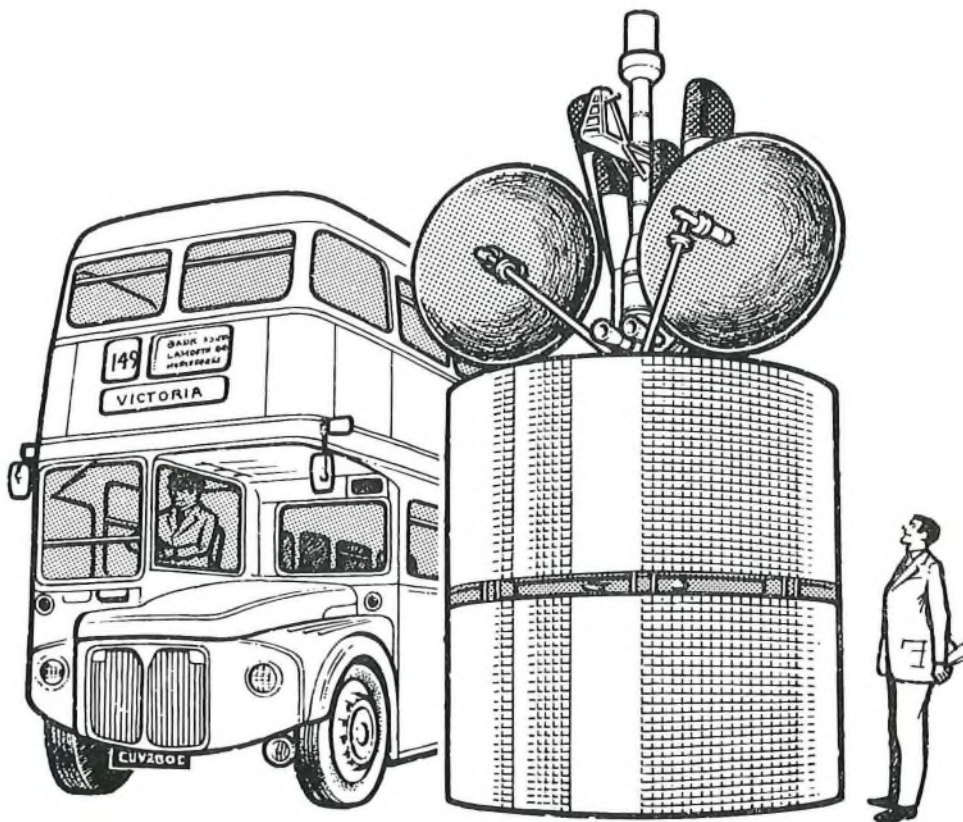

FIG. 1—Artist's impression of an INTELSAT IV satellite compared with a London bus

TABLE 1

INTELSAT IV Transmission Parameters

	Channels per Carrier	Root-mean-square Deviation for Fully-loaded Carrier	Bandwidth Module (MHz)	Occupied Bandwidth (Carson) MHz	Satellite e.i.r.p. (dBW)	Nominal Earth-station e.i.r.p. (dBW)	Carrier-to-Noise Ratio (dB)
Global Beam	24	274.7	2.5	2.0	5.8	73.7	12.7
	60	545.8	5.0	4.0	8.9	76.8	12.7
	96	799.4	7.5	5.9	10.6	78.5	12.7
	132	1,019.8	10.0	7.5	11.7	79.6	12.7
	252	1,627.0	15.0	12.4	13.9	81.8	13.6
	432	2,688.0	25.0	20.7	16.2	84.1	14.1
	972	4,417.0	36.0	36.0	22.4	89.1	17.8
Spot Beam	60	275.5	2.5	2.25	15.2	80.4	21.1
	132	528.8	5.0	4.4	17.7	82.9	20.7
	192	757.9	7.5	6.4	18.5	83.7	19.9
	252	1,009.0	10.0	8.5	19.2	84.4	19.4
	432	1,479.0	15.0	13.0	22.2	87.4	21.3
	612	1,996.0	20.0	17.8	23.9	89.1	21.9
	792	2,494.0	25.0	22.4	25.3	90.5	22.3
	1,872	3,181.0	36.0	36.0	34.2	97.6	29.5

GENERAL

Spacecraft Communications Equipment

The communications equipment of the spacecraft includes twelve frequency-selective transponders (shown in Fig. 2) each receiving a band of carriers transmitted in the 6 GHz band from various earth stations. The carriers are transposed from the 6 GHz to the 4 GHz band and then amplified prior to re-transmission back to earth. Each transponder has a usable bandwidth of 36 MHz, together with a 4 MHz guard band in which the attenuation/frequency characteristics of the multiplexing filters overlap. The filters are necessary for the selection of a specific 36 MHz band and further filters are used to combine the outputs to a common feeder to the transmit aerial.

Two types of aerial are provided. One, the global-beam aerial, is a horn with a beamwidth of 17° which illuminates all the visible earth. The second, the spot-beam aerial, is a paraboloid with higher gain and a beamwidth of 4.5°, which can be directed to illuminate a small section of the earth.² All transponders can receive and transmit on global-beam aeri- als but eight can be switched by ground telemetry com- mand to transmit on one of the two spot-beam aeri- als. The use of the spot-beam aeri- als gives a maximum effective isotropic radiated power (e.i.r.p.) of 34.7 dBW* from each transponder (the corresponding figure for the global aerial being 23 dBW) and, thus, the traffic-carrying capability of a transponder can be more than doubled. The actual capacity of a transponder varies according to the number of carriers it is handling, a transponder with a single high-capacity

* dBW—decibels relative to 1W.

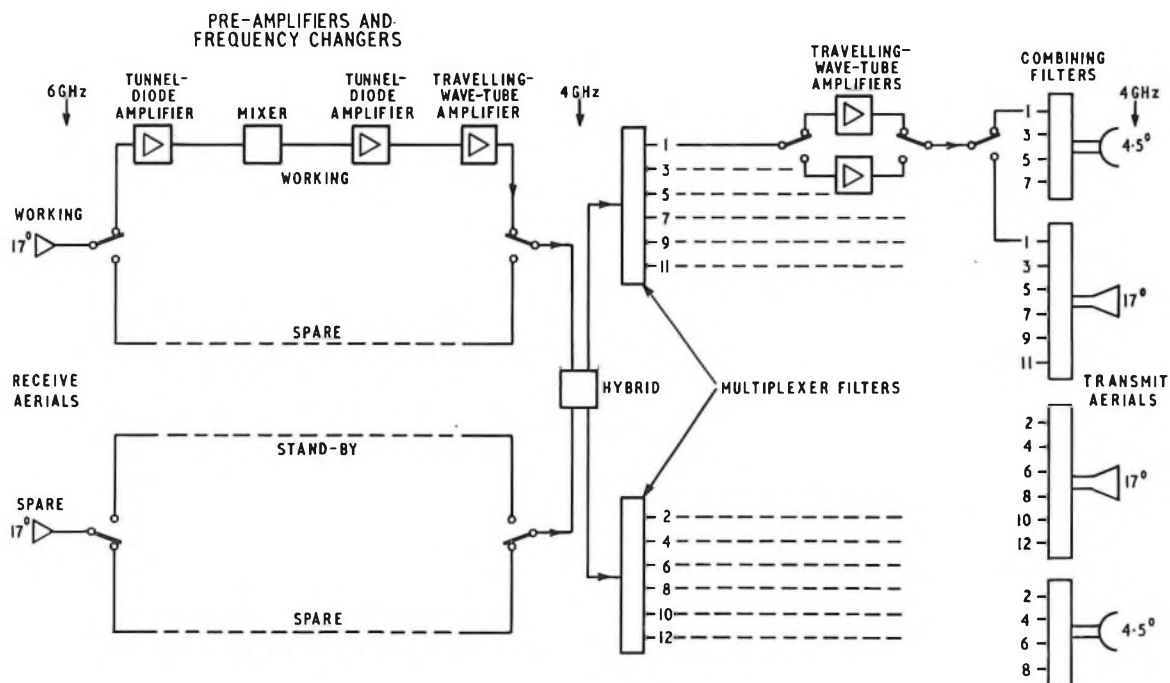

FIG. 2—INTELSAT IV communications sub-system

carrier being able to carry more traffic than a transponder dealing with many low-capacity carriers. Basically, the multi-carrier capacity is approximately 900 channels for a spot-beam and 450 for a global-beam transponder. The total operational capacity of the satellite could reach over 8,000 channels (half-circuits) plus a television video channel.

System Parameters and Overall Performance

Table 1 gives some of the most important system parameters for INTELSAT IV which have been derived from consideration of the overall economics of the system and the requirements for maximum satellite capacity.

The main effect of the higher available satellite e.i.r.p., compared with INTELSAT III, is to allow an increase in the satellite capacity per unit bandwidth. This has been achieved by reducing the frequency deviation and, hence, the bandwidth for a given carrier capacity. Since the audio-channel signal-to-noise ratio is proportional to the square of the frequency deviation, an increase in e.i.r.p. is required to restore the signal-to-noise ratio to the required objective. The result is to give the same channel capacity in a smaller bandwidth and with the advantage of a higher carrier-to-noise ratio at the earth-station receiver. Careful optimization of these parameters, taking into account intermodulation distortion (see later), has resulted in the parameters of Table 1.

The concept of satellite bandwidth modules, as used in the INTELSAT III system, has been retained but the smallest multi-channel module size has been reduced from 5 MHz to 2.5 MHz. The additional e.i.r.p. available has allowed the channel capacity per unit bandwidth to be increased by a factor of approximately two for a global-beam transponder and by four for a spot-beam transponder but, to achieve this increase in efficiency, the guardbands i.e. the difference between occupied bandwidth and module size, have been reduced to 10–20 per cent of the occupied bandwidth compared with 60–90 per cent for INTELSAT III. One of the penalties paid for the greater efficiency is increased complexity at the earth station since additional equipment is necessary to combine and separate individual carriers, to limit adjacent-channel interference, and yet to minimize the distortion introduced by the channel filters.

Earth-station costs can be reduced by keeping the number of different carrier capacities to a minimum and the number has initially been restricted to nine (excluding the special case of a single carrier per transponder), although it may be necessary to introduce additional sizes at a later date. The lowest value of carrier-to-noise ratio is 12.7 dB for the four smallest global carriers. In the INTELSAT III system, where carrier-to-noise ratios for telephony carriers are all below 10 dB, expensive threshold-extension demodulators (t.e.d.s) were required to recover the signal from the noise. They are not so essential in this respect in the INTELSAT IV system, but they do provide increased immunity from adjacent-channel interference plus a lower impulse-noise threshold, both of which are important factors when small guardbands obtain and, especially, if data transmission is likely. Threshold-extension demodulators are, therefore, still strong contenders in the INTELSAT IV system and are recommended for use with low-capacity global carriers despite their additional cost and complexity.

In arriving at the parameters shown in Table 1, consideration has been given to various sources of noise in the system, and the overall objective³ of 10,000 pW in the worst channel of any carrier when measured at a point of zero reference level and psophometrically weighted (–50 dBm0p*). A comparison of the noise allocations assumed in the INTELSAT III and INTELSAT IV systems are as shown in Table 2. This is sometimes known as the noise budget. It can be seen

that the following two significant changes have been made in introducing the INTELSAT IV system.

(a) The earth-station noise allowance, excluding the earth-station receiver (down path), has been increased from 1,000 pW to 1,500 pW. This is because the reduced guardbands between carriers demand rather stringent intermediate-frequency (i.f.) filters for carrier separation which, unavoidably, introduce in-band group-delay distortions. Although the linear and parabolic components of group delay can be closely equalized, some residual group-delay distortion is inevitable and an appropriate noise allowance has to be made. The increased noise allowance is also intended to cover a similar source of group-delay noise due to the multiplexing filters in the satellite (see later) since the onus is on the transmitting station to provide group-delay pre-equalization for this noise source. In practice, the residual group-delay noise is expected to be about 250 pW for the satellite and about 200 pW each for the earth-station transmit and receive paths.

(b) The combined noise allowance for the up-path receiver, down-path receiver and satellite intermodulation noise has been reduced by 500 pW and is given as a total rather than as separate allowances for each source. The object of this second change is to allow variations within the total of 7,500 pW. Thus, if intermodulation noise in a particular case were lower or higher than the expected value, adjustment of the e.i.r.p. would restore the total to 7,500 pW. This allows a more efficient use of satellite power and ensures a standard noise objective for all carriers.

TABLE 2

Noise Allocations for INTELSAT Systems III and IV

Noise Source	INTELSAT III	INTELSAT IV
Interference from radio relay stations sharing the 4–6 GHz band	1,000 pW	1,000 pW
Earth stations (excluding thermal noise from the down-path receiver)	1,000 pW	7,500 pW
Satellite receiver (up-path)	1,410 pW	
Earth-station receiver (down-path)	4,250 pW	
Intermodulation noise in the satellite	2,340 pW	
Total	10,000 pW	10,000 pW

Earth-Station Noise Budget

Consequent upon the foregoing changes in the system parameters and overall noise budget, INTELSAT revised the specification of earth-station performance.⁴ The earth-station noise allocation shown in Table 2 can be further broken down, with certain restrictions, at the discretion of the earth-station designer. Table 3 compares typical allocations for INTELSATs III and IV, followed by some discussion on each.

Thermal Noise

The thermal noise allowance has been increased by 50 pW but does not contribute significantly to the total.

Modem Noise

The total noise allowance for the modulator and demodulator is reduced by a half to 200 pW thus demanding a much-improved demodulator if a threshold-extension type is to be used. This recognizes that there has been much improvement since the early days of INTELSAT III.

* dBm0p—Decibels relative to a milliwatt measured psophometrically at a point of zero reference level.

TABLE 3
Earth-Station Noise Budget for INTELSAT III and IV

	INTELSAT III		INTELSAT IV	
	Transmit Path (pW)	Receive Path (pW)	Transmit Path (pW)	Receive Path (pW)
Thermal (excluding down-path receiver)	25	25	50	50
Amplitude non-linearity: Modulator Demodulator	— —	— 400	25 —	— 175
Phase non-linearity (group-delay)	75	75	200	200
Multi-carrier intermodulation distortion: Low-noise amplifier Transmitter	— 400	— —	— 500	50 —
Satellite group-delay	—		250	
Total	1,000		1,500	

Group-delay Noise

The allowances for group delay and phase non-linearity now total a large proportion of the earth-station noise and are necessary, chiefly, because of the stringent filtering specifications already discussed. It should be realized that these allowances are for residual distortion after equalization which is mainly due to high-order components (ripple) since it is possible to equalize the linear and parabolic distortion with a fair degree of accuracy.

Third-Order Intermodulation Noise

The amplitude non-linearity of any wideband amplifier carrying several carriers simultaneously generates third-order intermodulation products which are in-band and the level of these products depends on how close the amplifier is working to its saturation point. The increased allowances for multi-carrier intermodulation reflect the fact that, in general, higher powers are in use and it becomes increasingly difficult to limit the noise from this source. A small part of this allowance has now also been extended to the low-noise amplifier (l.n.a.) since the total received power at the amplifier input is some 10 dB greater than for INTELSAT III (due to the higher total e.i.r.p. from the satellite) and intermodulation distortion in the output stages becomes a distinct possibility. The chief effect of this in the receive path has been the requirement to replace the wideband tunnel-diode amplifiers, which were commonly used as output stages of the l.n.a., by amplifiers with a higher power-handling capability.

The allowance of 500 pW for intermodulation in the transmit path can be shown to correspond approximately to an intermodulation product e.i.r.p. limit in spectral density of 26 dBW/4 kHz at 10° operating angle. This limit on out-of-band radiation is mandatory in the earth-station specification and includes an additional factor for operating angle. The limit is given by $[26 - 0.06(\alpha - 10)]$ dBW/4 kHz where α is the operating angle of the earth station in degrees above the horizontal. Although this value may appear easier to meet than the figure of 23 dBW/4 kHz specified for INTELSAT III, in practice the e.i.r.p. of an INTELSAT IV carrier is considerably higher than that of a similar INTELSAT III

carrier and puts much greater restriction upon the number of carriers that can be amplified through the same power amplifier.

All the above changes in the earth-station noise budget are reflected in the earth-station performance specification.⁴ It is not proposed to identify these individually here but it is worthy of note that one major earth-station performance requirement remains unchanged. A significant source of earth-station noise comprises noise from the aerial plus the first stage low-noise amplifier and is partly determined by an aerial figure-of-merit G/T , where G is the gain of the aerial and T is the effective noise temperature of the system.⁵ The value of G/T specified for a standard earth station in the INTELSAT IV system remains the same as for INTELSAT III at 40.7 dB/K. Thus, efficient large-diameter aerials and low-noise amplifiers are still a prime requirement, with the compensatory advantage that an interchange of aerial working between an INTELSAT III system and an INTELSAT IV system is possible.

MAJOR EARTH-STATION PLANNING CONSIDERATIONS

General

The planning of an earth station is considerably affected by the amount of traffic that it is intended to carry. The planning considerations which follow are those appropriate to a large earth station, in particular, the third U.K. terminal at Goonhilly. For a small earth station, the situation is eased considerably in certain respects, such as the choice of transmit power amplifiers and the number of receive chains, although it is still necessary to meet fully all the performance requirements.

Table 4 shows one possible arrangement of carriers to meet the traffic forecast for Goonhilly at the end of 1975. Also shown are the transmit power requirements and the type of transmission, i.e. whether spot or global. It is fairly obvious when planning a new aerial that considerable scope must be allowed for changes in the carrier sizes, since in any system which is optimized for maximum channel capacity, the final carrier sizes are likely to be a compromise between many international requirements with the possibility of frequent changes in a comparatively short space of time. It is a wise precaution, therefore, to build considerable flexibility into the equipment arrangement so that rapid changes both in carrier frequency and capacity can be effected without too great a disruption to service.

TABLE 4
Carrier Requirements for Goonhilly Aerial No. 3.
Forecast for December 1975.

Carrier Capacity	Type	Maximum* e.i.r.p. (dBW)	Transmitter	Estimated Transmitter Output Power (watts)
792 Channels	Spot	91.5	H.P.A. 1	3,846
			Total	3,846
252 Channels	Global	82.8	H.P.A. 2	329
252 Channels	Global	82.8		329
132 Channels	Global	80.6		198
			Total	856
Television video	Global	88	H.P.A. 3	857
Television audio	Global	74.7		40
			Total	897

* Includes 2 dB margin

Transmitters

A comparison of the earth-station e.i.r.p. requirements in Table 4 with those for similar carrier sizes for INTELSAT III shows a 2-3 dB increase. In addition to this, careful consideration has to be given to the transmit configuration to ensure that adequate transmit power is available for future expansion without exceeding the out-of-band intermodulation limit referred to earlier.

The major area of choice lies between power amplifiers of the narrow-band type (multi-cavity klystron) or the broad-band type (travelling-wave tube) and is primarily between the higher power efficiency of the former and the greater frequency flexibility of the latter. The narrow-band klystron has smaller initial and running costs but provision is necessary on a one-per-carrier basis with the added disadvantage of long breaks if a frequency change becomes necessary. The travelling-wave tube, on the other hand, will carry simultaneously several carriers at any frequency in the 500 MHz bandwidth of the satellite. It is expensive initially, however, and inefficient to run since it is necessary to restrict the total output of the tube to some 7-10 dB below its maximum capability to avoid excessive intermodulation distortion.

For a small earth station with only one or two carriers, the choice is usually quite clear but, for a large station with several carriers, the problem becomes more complex as stand-by arrangements and methods of combining several transmitter outputs raise additional complications. A stand-by arrangement where one spare equipment may be switched-in to replace any one of a number of equipments (often called a 1-for-n system), is preferable since it reduces capital and running costs, and saves floor-space at the expense of some switching complexity. If a klystron amplifier is used, however, considerable time is necessary to tune the stand-by to the frequency of the failed unit whereas the travelling-wave tube, with its large instantaneous bandwidth, is limited only by the transit time of waveguide switches, and switching to stand-by gives no noticeable interruption to telephony or television traffic.

The transmit configuration chosen for Goonhilly is discussed in more detail later. Basically, it is a 1-for-n system with an ultimate capacity of four 8 kW wideband amplifiers with one stand-by and a complex switching system enabling transmitter maintenance to be carried out with the least interruption to traffic. The over-riding factor in this choice has been one of minimizing lost-traffic time, taking due account of the probability of transmitter failure and any out-of-service time required for maintenance.

Receivers

By 1975, the number of receive carriers at Goonhilly will probably be in excess of 20, necessitating complicated

splitting arrangements and stand-by facilities. Early methods of splitting using filter-circulators have now been superseded by much more compact wideband strip-line couplers which simply provide two outlets, introducing 3 dB loss in each. These can be added in series until the required number of outlets is achieved and, as they are not frequency-conscious, the whole 500 MHz spectrum is available at each outlet.

This arrangement lends itself to the concept of double-frequency conversion which is a method of translating the frequency from the 4 GHz band in two stages. The first i.f. is chosen sufficiently high for the image to lie outside the satellite band and a single design of i.f. filter, covering the maximum required bandwidth (40 MHz), suffices to remove the image associated with the second conversion. A fixed local oscillator then converts the signal to the second and conventional i.f. of 70 MHz where the final selectivity is obtained before demodulation. This method has the advantage of easing the filter problems of carrier separation by translating to a lower frequency, and a change of frequency is simplified by requiring only a new frequency source at the first down-converter. It can now be seen that it is fairly easy to provide stand-by receive equipment on a 1-for-n basis by the use of switchable crystals at the first oscillator. The 1-for-n switching can only be carried out between carriers of the same channel capacity but its use enables considerable economies to be made in stand-by equipment at a large earth station. The equipment provided at Goonhilly aerial No. 3 uses this principle successfully and is described in more detail later.

TRANSMIT SYSTEM

Baseband and Sub-Baseband Assembly

The 4 kHz telephony channels in satellite systems are assembled at Goonhilly in the usual way into groups and supergroups. To make the most effective use of the frequency spectrum and satellite power, these are re-assembled into basebands which start at 12 kHz instead of 60 kHz as in terrestrial systems.

A 60 kHz continuity pilot is added and failure of this is used to initiate automatic changeover to stand-by narrow-band equipment. The sub-baseband 4-12 kHz is used for 4 kHz engineering service and management circuits, each service circuit containing one speech channel of 300-2,600 Hz and up to five voice-frequency (v.f.) telegraph channels in the frequency band 2,640-3,240 Hz.

The sub-baseband below 4 kHz is used for an energy-dispersal signal of symmetrical triangular waveform which is applied to the modulator during periods of light traffic loading to ensure that, at all times, energy is spread across the available spectrum and high-energy peaks are avoided.

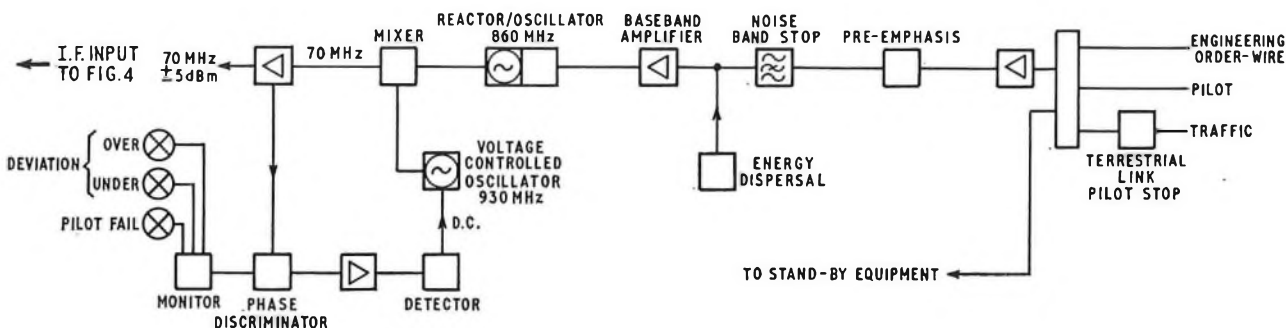

FIG. 3—Block diagram of baseband and modulator arrangements

Modulation Equipment

The composite baseband signals are split at the modulator input and fed to two similar modulator and transmit paths, thereby enabling the stand-by paths to be monitored by the traffic signals (Fig. 3). Television video, sound and cue carriers are not provided with stand-by equipment.

To ensure the necessary basic noise-performance and linearity of voltage/frequency transfer function over the wide bandwidth in use, i.e. 1 per cent over ± 10 MHz, 3 per cent over ± 16 MHz, an ultra-high frequency (u.h.f.) modulator is used in which an 860 MHz oscillator is modulated by the composite baseband signal. The frequency-modulated output is combined with a signal from a 930 MHz voltage-controlled oscillator (v.c.o.) in a diode mixer. The modulated difference-frequency at 70 MHz is amplified, then sampled by a stabilized discriminator, to produce an error signal whenever the i.f. carrier departs from its mean frequency of 70 MHz. This error is fed back to the 930 MHz v.c.o. to correct drift of the difference frequency and to maintain the mean intermediate frequency accurate to within ± 60 kHz.

I.F. Equipment

Because there is a small number of transmit carriers, coaxial cables are used for the transmit cross-site connexions rather than the costly waveguide used in the receive path. Moreover, a waveguide link would involve the double expense of a combiner at its input and a branching network at its output to feed each carrier to the appropriate high-power amplifier (h.p.a.). There is, thus, little saving in accommodation at the antenna site and the small number of up-converters there does not constitute an appreciable maintenance hazard. The main disadvantage from the station viewpoint is the loss of flexibility in the switching of signals from one antenna to another, if this is otherwise possible.

On the first floor of the antenna tower, each 70 MHz carrier is routed via amplifier/equalizer equipment which corrects cable loss and amplitude/frequency response to better than ± 0.2 dB over a 40 MHz bandwidth centred on 60 MHz (Fig. 4). The group-delay response of the complete transmit path is also corrected at this point using equalizers variable in the range 0.01 – 0.10 ns/MHz² in 0.01 ns/MHz² steps for parabolic correction, and 0.10 – 0.60 ns/MHz in 19 steps for linear correction. Sufficient linear and parabolic equalization is also added to precompensate for the group-delay distortion introduced by the satellite multiplexing arrangements. Band-limiting filters, having the characteristics defined by I.C.S.C., follow to restrict the spread of energy in each transmit carrier. The i.f. signals are then amplified in a transistor amplifier having a maximum gain of 38 dB, which can be adjusted either manually or by an automatic-gain-control (a.g.c.) circuit to provide a nominal level of 0.5 volt to the transmit drive equipment.

Drive Equipment

The 70 MHz frequency-modulated carriers are next converted to frequencies in the range 5,925–6,425 MHz in the transmit drive cabinets. Each signal is first amplified by a high-level wideband i.f. amplifier so that the following varactor diode mixer is driven into compression. This ensures that the output super-high frequency (s.h.f.) level is virtually independent of the 70 MHz input-signal level. The 6 GHz local-oscillator frequency is derived from a solid-state, crystal-controlled, phase-locked oscillator and multiplier. A built-in injection point permits the use of an external synthesizer as the source, if a temporary change of carrier frequency is required and the correct crystal is not available. The

oscillator output is connected via two isolating waveguide circulators to the mixer arm of the up-converter. The upper sideband is selected by a waveguide filter, the lower side-band and the reflected local-oscillator signals being absorbed in a waveguide load associated with the waveguide circulators. The output from the filter is taken via another circulator, a 20 dB coupler and a preset attenuator to a waveguide switch which connects the main or stand-by chain to the transmitter. The main and stand-by paths are identical, and are equipped with diode detectors and trigger units for monitoring the output of the up-converters and actuating the supervisorys. Switching is controlled, either automatically in response to a carrier-fail signal, or manually from the control console in the central building. The equipment chain carrying the traffic is connected to an electrically-variable attenuator (e.v.a.), controlled from the automatic-level control (a.l.c.) equipment associated with the high-power amplifier in use, to maintain the transmitter output power at a preset level. A 10 dB cross-coupler provides low-level signals to coaxial monitoring sockets to enable the transmitted signals to be monitored by test down-converters that give an output in the intermediate frequency range.

Coaxial cable is used at the output of the drive cabinets for economy of space and ease of installation, although it also provides a convenient test point. A coaxial-to-waveguide transition enables the main run to the high-power amplifier to be made in waveguide. A ferrite isolator presents a wide-band match to the drive-cabinet combining network and when necessary, the outputs of two drive cabinets are combined by a 3 dB waveguide coupler. No provision has been made, initially, for combining more than two carriers through one high-power amplifier. Included in the waveguide run is a crystal-diode switch, operated by reverse biasing from the arc-detector unit. This attenuates the signal by at least 30 dB in the event of waveguide arcing or high reflected power appearing at the output of the high-power stage. There is also a pre-set attenuator which is used, in conjunction with the e.v.a.s in the drive cabinets, to set the operational input level to the high-power amplifier.

A block diagram of the transmit i.f. and drive equipment is shown in Fig. 4.

High-Power Amplifier

The high-power amplifier, which has an instantaneous bandwidth of 500 MHz, is designed to amplify one or more multi-channel telephony carriers, or a television video carrier with an associated sound carrier, within the frequency range 5,925–6,425 MHz. It comprises two wideband travelling-wave-tube amplifier stages, both tubes operating in the depressed collector condition i.e. with the collector operating at a lower voltage than the delay-line, and run well below their maximum power output rating to reduce the intermodulation products. The low-power stage is a travelling-wave tube mounted in a periodic permanent-magnet focussing system and air-cooled. Its average gain over the 500 MHz band is 39 dB.

The high-power stage is a travelling-wave tube mounted in a solenoid focussing system, and having a saturated power rating of 10–12 kW. The collector, delay-line and solenoids are cooled by de-ionized water circulated via a heat-exchanger located outside the antenna structure. For single carrier operation, the tube is capable of giving a maximum output of 5 kW with a minimum gain of 28 dB. For multi-carrier operation, with a power output of 1 kW, the minimum gain is 30 dB (which occurs at the high end of the frequency band due to the mode of operation of a travelling-wave tube). The maximum gain variation allowed over the 500 MHz frequency band is 10 dB.

Depressed collector operation of the travelling-wave tubes

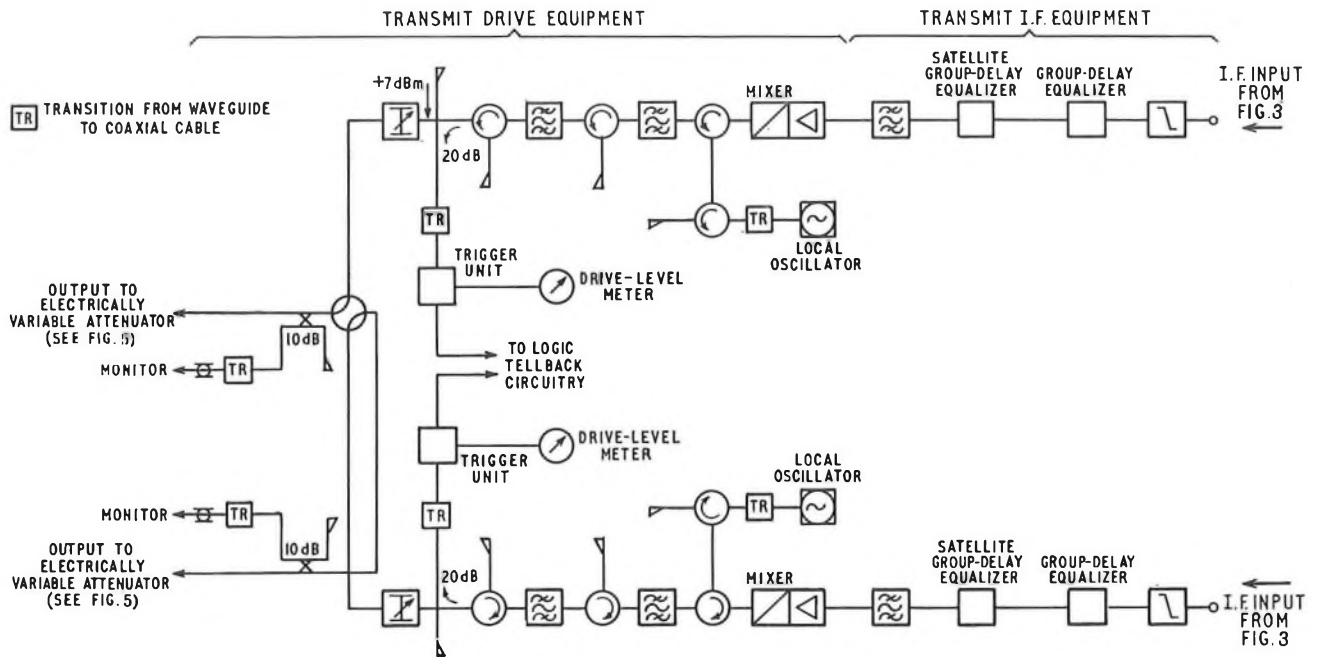

FIG. 4—Block diagram of transmit i.f. and drive equipment

increases efficiency by allowing the same amount of energy in the electron beam to be collected at a lower voltage, so decreasing the total input power required for the same output power. Also, with lower voltage, there is less energy dissipated in the collector which is easier to cool. A disadvantage of this mode of operation is that it requires an additional power unit, the whole of which is above earth potential. Because the collector is not at earth potential, de-ionized cooling water is required to reduce the leakage current through the cooling water which adds to the body current and complicates metering and protection.

The extra-high tension (e.h.t.) power supplies for the high-power transmitters are derived from large air-cooled transformers, rotary regulators and silicon rectifiers with solid-state control circuits. The delay-line voltage is derived and controlled within ± 0.1 per cent by connecting a high-voltage electronic regulator in series with the collector and depression supplies, the delay-line being at earth potential (see Fig. 6). Control circuits ensure that, in the event of excess delay-line current, the operating voltages are disconnected within 15ms by operation of the cathode switch.

A forward-power coupler and an isolator are fitted between the low- and high-power travelling-wave tubes. The coupler permits the connexion of a power-meter to monitor the level, whilst the isolator reduces the effect of the poor voltage, standing-wave ratio (input impedance) of the input of the high-power tube. The arc-detector mentioned earlier is fitted in the output waveguide followed by a reverse-power coupler, which enables the reflected power seen by the tube to be monitored. The final high-power circulator provides a good impedance match between the travelling-wave tube and the output combining system. It also prevents the tube "seeing" an open-circuit during waveguide switching and provides a matched source for the antenna feed to minimize any echo distortion. The circulator is followed by a harmonic filter to reduce the level of unwanted output signals. Both the circulator and the filter are water-cooled. A combined forward- and reverse-power coupler enables forward and reverse powers to be read on built-in power-meters. Finally, a triple

cross-coupler has auxiliary arms which provide outputs for the arc-detector unit, the monitor and a.l.c. cabinet and the test down-converter.

Monitor and Automatic-Level-Control

Each monitor and a.l.c. cabinet can selectively monitor the levels at the transmitter output and provide control signals for up to six individual carriers. The control signals are applied to e.v.a.s in the drive equipment to keep the transmitted powers within ± 0.25 dB of preset values. They also initiate appropriate automatic switching and alarms if the transmitted carrier powers go out of limits. The monitoring filters have fixed bandwidths corresponding with the satellite bandwidth modules but are tunable and provide adequate rejection of adjacent carriers. Square-law detectors provide a substantially constant d.c. control current for all normal modulation of the carriers. The e.v.a. can also be controlled manually through a motor-driven potentiometer from a remote control console.

When a transmitter is used for a single telephony carrier, a straight waveguide section is substituted for the filter. Filters are also omitted for television circuits, the combined video and sound carriers being controlled by a common e.v.a. The video-carrier-level meter at the console indicates the level of the combined video and sound carriers. During television transmission, the a.l.c. filter is replaced by a pair of series-connected coaxial attenuators, remotely switched in or out of circuit as appropriate when only one of the television audio carriers is transmitted. This arrangement ensures that the a.l.c. detector always operates at approximately the same level. As the complex automatic-level-control circuits are associated with individual high-power amplifiers, the switching of carriers through alternative high-power amplifiers is complicated, and duplication of the frequency-selective components is unavoidable.

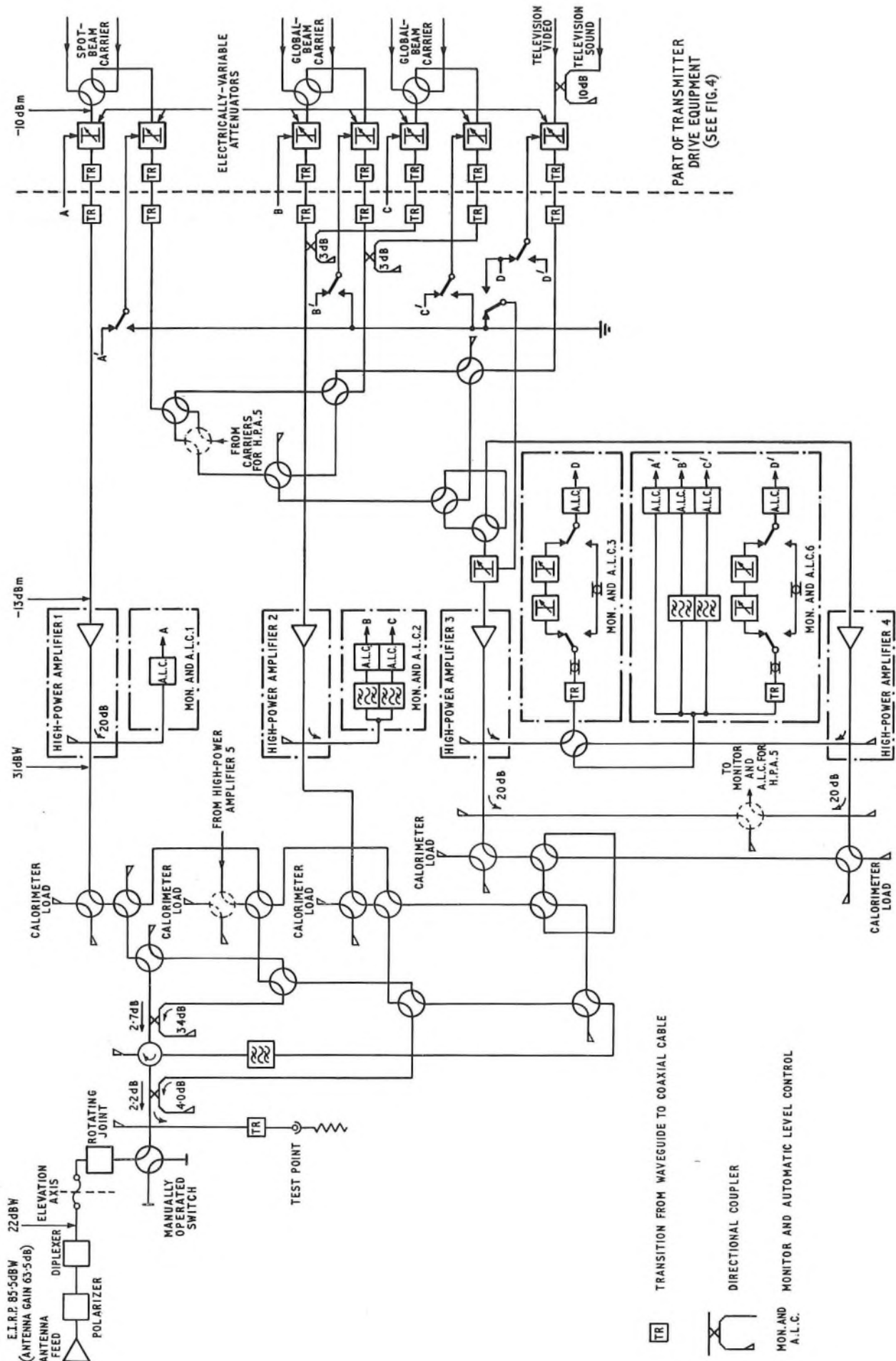

Power levels shown are for a 252-channel spot-beam carrier on h.p.a. 1.

Fig. 5—Transmit s.h.f. path—normal conditions with television video and sound transmitted

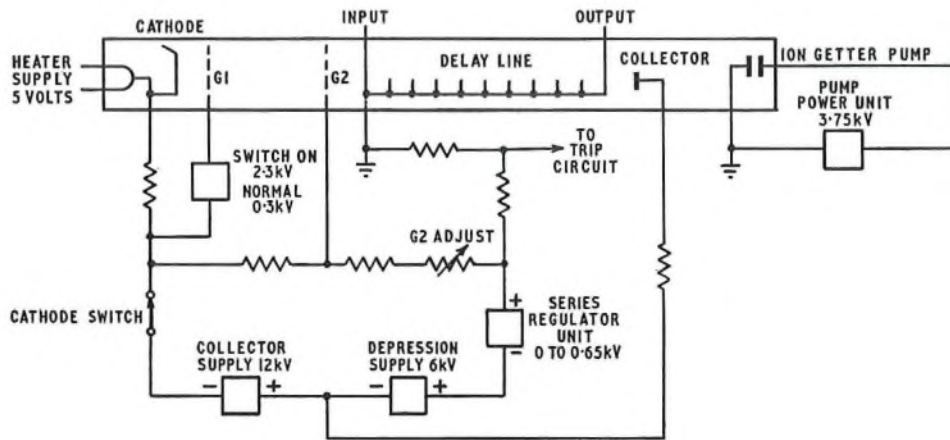

Solenoid supplies

- (a) Pre-focus coil: 0.5–8.0 amps d.c. (12 volts maximum)
- (b) Main focus coil: 8.0–13.0 amps d.c. (330 volts maximum)

FIG. 6—High-power travelling-wave-tube power supplies

Combining and Switching

Four high-power amplifiers have been provided initially, one (h.p.a.1) for the single spot-beam carrier, one (h.p.a.2) for the global-beam carriers, one (h.p.a.3) for television video and sound (with alternative use as maintenance stand-by for the telephony service) and the fourth (h.p.a.4) for use as stand-by for the other three (Fig. 5). Should one of the first three amplifiers fail when working in the automatic mode, its carriers are rerouted through the fourth. Combining the outputs of the amplifiers necessarily introduces losses which have to be offset by increased power output but, even so, the intermodulation products resulting from multi-carrier operation are kept within the internationally-agreed limits. The high-power amplifier (h.p.a.1) used for the single spot-beam carrier can be operated close to its maximum output power with no intermodulation problems, and this has allowed the inclusion of two directional couplers in its output path. The first will permit the outputs of h.p.a.1 and h.p.a.5 to be combined when the system is expanded to include a fifth transmitter, and the second combines the outputs of h.p.a.1 and h.p.a.2. A high-power circulator between these two couplers permits the coupling of the television output of h.p.a.3 via a band-pass filter. An independent water-cooling system is used to cool the high-power circulator, the band-pass filter and the loads of the two couplers.

A network of waveguide switches permits h.p.a.4 to serve as a common stand-by for the other high-power amplifiers. It is also possible to use h.p.a.3 as a secondary reserve path, when it is not in use for television transmissions, by manual switching from the console in the central building. In either circumstances, the output of the high-power amplifier which has failed is switched to its associated calorimeter load ready for testing. Failure of h.p.a.3 when it is not carrying traffic does not initiate an automatic changeover. Should a second failure occur, alarms are brought up on the control console but no automatic switching can take place. The controller can, if he wishes, switch traffic manually via h.p.a.3 to the antenna to allow maintenance to be carried out on a selected high-power amplifier. The carriers that are to be routed via h.p.a.3 must first have their drive levels adjusted manually to produce the required output power, using the e.v.a. at the input to h.p.a.3. Individual drive-level control is not possible. When television is transmitted, this e.v.a. is automatically

biased to give minimum attenuation. It is possible to use h.p.a.3 as a reserve equipment for a second failed high-power amplifier.

Test Down-Converter Cabinet

The test down-converter cabinet, located in the aerial tower, is used in conjunction with the loop-test cabinet in the main building to enable local loop tests to be made on any transmit-carrier chain during commissioning. As described previously, part of the output of each of the high-power amplifiers is fed via a 40 dB cross-coupler to this cabinet where a 70 MHz signal is derived by double down-conversion using an intermediate frequency of 770 MHz. A local oscillator is provided for each of the transmit carrier frequencies and the appropriate one can be selected by a coaxial switch either locally or by remote control from the loop-test cabinet. Double down-conversion avoids the need for filters to be switched. The derived 70 MHz signal is taken to the loop-test cabinet in coaxial cable. The test down-converter cabinet also houses a fast protective unit which generates muting commands if monitoring tell-backs indicate that an operational traffic path has been selected in error.

RECEIVE SYSTEM

Fig. 7 shows a diagram of the receive traffic path in outline form.

Low Noise Receiver

The carriers received from the satellite lie within the frequency band 3,700–4,200 MHz and are right-hand circularly polarized. They are changed to linearly-polarized signals orthogonal to the transmit signal in the antenna feed system and passed via a diplexer to the input of the low-noise receiver at, typically, -123 dBW for a 252-channel global carrier and -117 dBW for a 252-channel spot carrier. In the l.n.a., they are first amplified by 30 dB in a three-stage parametric amplifier, each stage of which amplifies the full 500 MHz bandwidth. Cooling to about 16 K is achieved with gaseous helium, in a closed-cycle cryogenic system, to give a noise temperature, referred to the input waveguide flange, of about

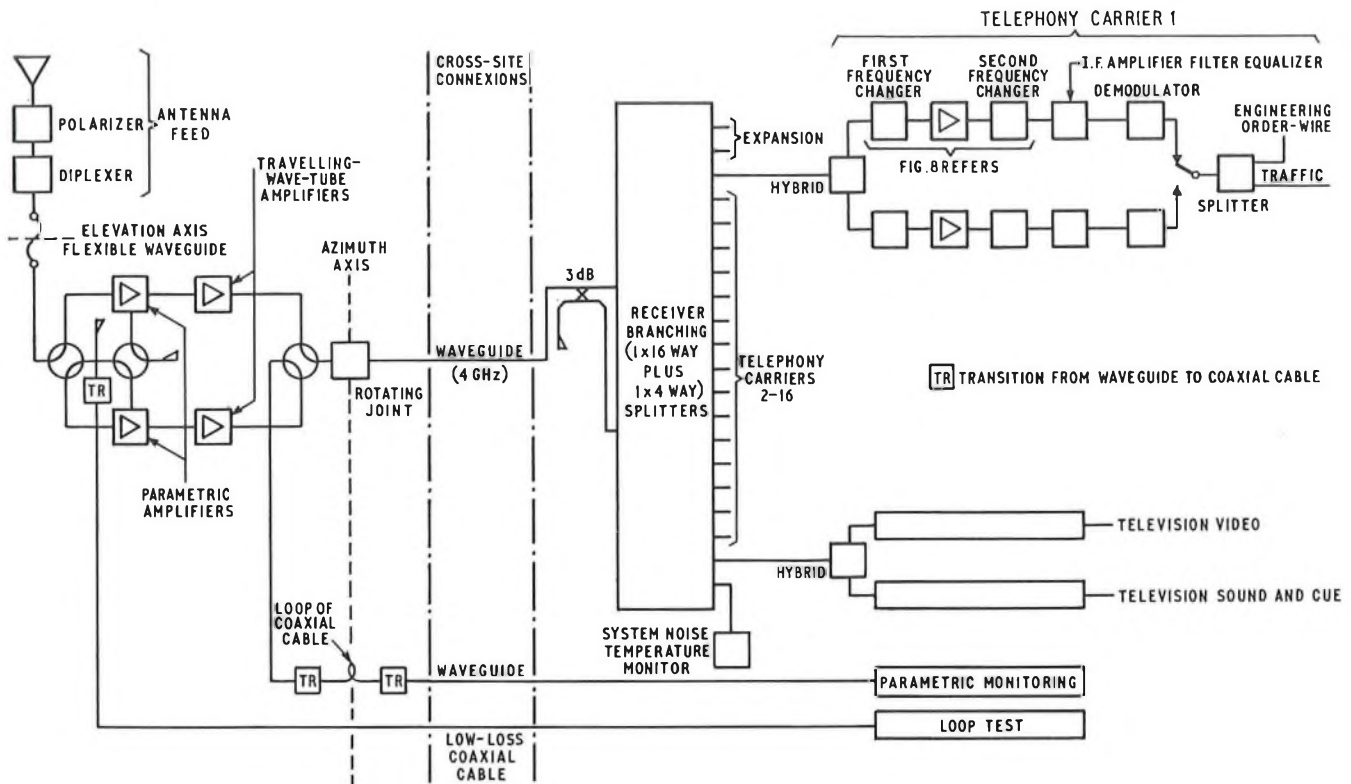

FIG. 7—Receive system—simplified block diagram

13 K. The signals are then further amplified by 40 dB in an uncooled low-noise travelling-wave amplifier, which provides compensatory gain for the losses in the intersite waveguide and branching network.

The semi-rigid elliptical waveguide used to provide a broadband intersite link has the following advantages:

(a) branching networks and down-converters can be accommodated in the main building instead of in the more costly area of the antenna structure,

(b) concentration of individual carrier equipments at the central building tends towards economy of maintenance effort, and

(c) broadband links facilitate the interchange of equipment between aerials.

Two similar low-noise receivers are provided; either can be used in the traffic path by automatic control of the waveguide switches at their input and output. The stand-by low-noise receiver is monitored continuously by test signals received from the loop-test cabinet in the central building via a cross-site coaxial cable. The amplified test signals from the stand-by l.n.a. are returned to the paramplifier monitoring cabinet in the central building via a semi-rigid elliptical waveguide.

Branching Network and Downconverter Configuration

Goonhilly No. 3 system has a stripline branching network in the central building which, together with double down-converters, reduces the space required to one-tenth of that necessary for the comparable equipment of Aerial No. 2 system. As explained earlier, changes of assigned frequency are achieved by simple replacement of the first local oscillator crystal. The branching network has twenty wideband outlets, each with an instantaneous bandwidth of 500 MHz; seventeen outlets are connected to receiver cabinets, one is used for

system-noise-temperature measuring equipment and two are available for system expansion.

Two sets of narrowband receiving equipment are mounted in a cabinet, each set comprising a double down-converter, demodulator and baseband equipment. The actual equipment configuration within each cabinet is determined by the particular stand-by arrangements for the carriers involved which, in turn, are related to channel capacity, ranging from one stand-by for five working 24-channel telephony carriers to one stand-by for each working large-capacity carrier. Stand-by equipment is not provided for the television carriers.

Receive Equipment

A simplified block diagram of the double down-converter is given in Fig. 8. Each wideband outlet of the branching network is connected via a microstrip filter/circulator to the first mixer/amplifier, also in microstrip, where the output of the first local oscillator operating in the frequency range 2.93–3.43 GHz is mixed with the required carrier frequency to produce a first i.f. of 770 MHz. The image frequency is thus in the range 2.16–2.66 GHz, well outside the satellite band. The local oscillator, phase-locked to a crystal-controlled frequency source, can be retuned easily to any frequency in the operational range. An injection point is provided to cater for substitution of the crystal-controlled oscillator by a signal from an external frequency synthesizer.

The first i.f. at 770 MHz reaches the second mixer via a stripline filter that has a passband of 40 MHz at the 0.1 dB points. Here the signal is converted to the final i.f. of 70 MHz by a fixed-frequency crystal-controlled local oscillator operating at 700 MHz. The overall gain from s.h.f. input to i.f. output is 25 dB and the arrangements are identical for each carrier path irrespective of channel capacity because the 40 MHz passband is equal to that of a satellite transponder. Automatic gain control is in-

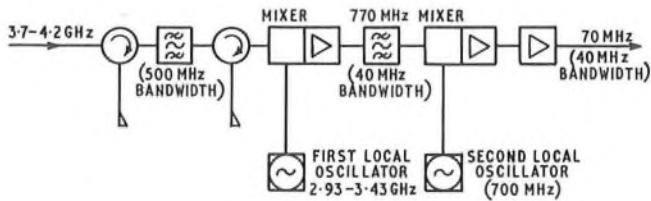

FIG. 8—Block diagram of double down-converter

incorporated in the i.f. circuits which are adapted to suit the channel loading of the carriers by modular group-delay equalizers and bandwidth defining filters. Accurate equalization of system group-delay distortion is essential to meet the noise budget and is achieved by the use of equalizers similar to those used in the transmit equipment.

Demodulator design and performance, including those of threshold-extension types, is now well documented^{6, 7, 8} and only the main features of those in service on Aerial No. 3 will be given here.

Threshold-extension demodulators have been used to improve the adjacent-channel interference performance and to lower the impulsive noise threshold. The threshold of a conventional demodulator* occurs at a carrier-to-noise ratio (C/N) of about 10 dB, giving, for a 24-channel global-beam carrier, a margin of less than 3 dB between the threshold and design operating conditions. Clearly, some improvement of this margin against C/N degradation from factors such as rain, cloud or equipment variation has to be provided. In satellite systems, the significant information content of the f.m. signal at any instant in time is contained in a bandwidth much less than that conventionally allowed for in the i.f. circuits. Techniques which allow the use of a filter with bandwidth less than that defined by the Carson Rule† enable signal-to-noise ratio (S/N) improvement, typically in excess of 4 dB, to be obtained at low levels of C/N ratio thus extending the range of C/N for which a useful S/N is obtained.

Threshold extension is obtained in frequency-modulated feed-back (f.m.f.b.) demodulators by reducing the system bandwidth preceding the limiter/discriminator by means of a narrow-bandwidth filter, and tracking the instantaneous

* The threshold of a demodulator is the point on its input C/N versus output S/N response characteristic below which occasional noise peaks exceed the carrier power at the discriminator for a significant percentage of time and degrade the S/N ratio beyond the acceptable limit.

† Carson Rule—Bandwidth = $2(\Delta f + fm)$ where Δf is the quasi-peak frequency deviation (assumed to be equal to $\sqrt{10}$ times the r.m.s. deviation) and fm is the highest modulating frequency.

frequency of the wide-deviation f.m. signal so as to keep it near the centre frequency of this filter.

A block diagram of the f.m.f.b. demodulator is shown in Fig. 9. The incoming 70 MHz i.f. signal is first upconverted to 870 MHz by an 800-MHz oscillator to obtain the necessary linearity (<3 per cent over ± 8 MHz) then mixed with the output of a v.c.o. operating at the nominal frequency of 940 MHz. The resultant 70 MHz is passed, via the narrow-band single-tuned filter and limiter stage, to the discriminator. A sample of the baseband output from the post-discriminator amplifier keeps the v.c.o. frequency tracking the signal frequency at a reduced deviation and the i.f. signal within the passband of the narrow single-tuned filter. The reduction in the deviation does not affect the signal-to-noise ratio in the baseband because the deviations due to noise are reduced in the same proportion as those corresponding to the signal. To maintain optimum phase conditions over the range of baseband frequencies, an equalizer is incorporated in the feedback loop whilst an amplitude equalizer in the baseband signal path corrects the lift introduced by a reduction in the loop feedback at the higher baseband frequencies. A sample of the difference frequency at 70 MHz is amplified, then passed to a stable discriminator which produces an error signal whenever the i.f. carrier departs from its mean frequency of 70 MHz. This error signal is fed back to the 800 MHz v.c.o. to correct the frequency drift. A de-emphasis network with characteristics recommended by C.C.I.R.‡ is included. The overall noise performance of this design of demodulator, including a modulator, when measured back-to-back, does not exceed the 200 pW limit required by the noise budget.

One Standby for N Working Carrier Chains

With every carrier in the complete 500 MHz satellite receive band appearing at the first mixer in a double down-converter, any receive path can be easily routed via a stand-by receiver provided that the stand-by has:

- (a) a first local oscillator operating at the same frequency as that of the main receiver,
- (b) means for switching to the baseband output of the main path, and
- (c) compatible channel capacity and carrier type, viz. spot-beam or global-beam.

The above principles apply to Aerial No. 3 where a 1-for-n stand-by philosophy has been adopted, the controlling factor (c) above resulting in the formation of eight stand-by groups as shown in Table 5.

‡ C.C.I.R.—International Radio Consultative Committee.

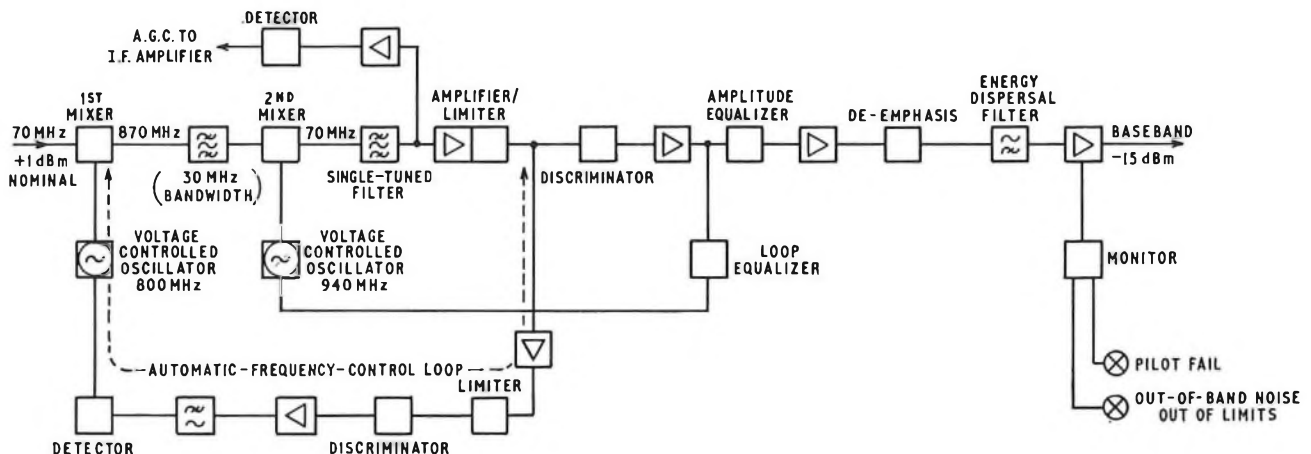

FIG. 8—Block diagram of f.m.f.b. demodulator

TABLE 5
Provision of Stand-by Groups

Group	Channel Capacity	Carrier Type	Scale of Stand-by Chain Provision
1	252	Spot	1 for 1
2	192	Spot	1 for 1
3	132	Spot	1 for 1
4	132	Global	1 for 2
5	96	Global	1 for 4
6	60	Global	1 for 3
7	60	Global	1 for 3
8	24	Global	1 for 5

Two 24-channel global-beam receivers provided for expansion do not have stand-by equipment.

CARRIER-FREQUENCY CHANGES

Changes in the transmit plan necessitate only a change of crystal local oscillator and carrier selection filter. If the frequency of a receiving chain is to be changed to meet changes in the operational frequency plan, only the frequency of the first local oscillator in the main and stand-by down-converters needs to be altered to the appropriate frequency. A small adjustment to the system-group-delay equalizer may also be required.

CARRIER-CAPACITY CHANGES

Transmit-carrier-capacity changes are effected by changing only the pre-emphasis network and out-of-band noise band-stop filter. In the receiving equipment, several narrow-band items are channel-capacity-conscious, namely the two receiver-band-width-defining filters, system-group-delay equalizer, de-emphasis network and out-of-band noise bandpass filter. If f.m.f.b. demodulators are in use, channel-capacity changes require component modules in the feedback loop and amplitude equalizers to be changed. In general, all such frequently-required changes can be made by simple interchange of plug-in printed circuit boards.

CONCLUSIONS

In a general article of this nature it has only been possible to discuss the most significant repercussions of the INTEL-SAT IV program on earth-station equipment requirements. The main problems arising from the earlier generations of satellites were associated with the recovery of the extremely small signals from the noise in the down path. The outstanding improvements in the ease of maintenance of cryogenic equipment, in the reliability of wideband parametric amplifiers and in the performance of threshold-extension demodulators have enabled these early problems to be largely resolved. The increased carrier powers now available from the INTEL-SAT IV satellites have also provided margin in these areas, but the exploitation of the new satellite capabilities has already accentuated the existing power-handling problems in the transmitting systems at large earth-stations.

The inevitable increases in traffic will have to be accom-

modated at the earth station by increases in the channel-capacity per carrier, or in the number of carriers, or both. Either method raises difficulties at the earth station; if the channel loading is increased significantly then the power per carrier will increase, thus increasing the level of intermodulation products generated in the transmitter. If this situation is avoided by transmitting single large carriers via individual transmitters, there will be consequential difficulty from excessive losses in the networks combining their outputs to the aerial. The alternative of increasing the number of carriers may require more than two carriers to be routed via each transmitter and will certainly increase the level of intermodulation noise caused by the transmitter input/output non-linearity. Existing margins are very small, so a ceiling will rapidly be reached with currently-available travelling-wave tubes.

Development work currently in progress seeks solutions to these problems and includes studies of the feasibility of linearizing high-power travelling-wave tubes and the reduction of losses in a high-power combiner. Looking even further ahead, it is expected that digital techniques will be extended to satellite communication systems. The most efficient use of the space sector may well be derived from a combination of pulse-code-modulation systems and time-division multiple-access (p.c.m./t.d.m.a.)⁹. Such systems may also include some form of demand-assignment. The first step along this road has already been taken and a 24-channel system known as SPADE will be introduced at Goonhilly by the end of 1973.

Acknowledgements

The earth-station equipment described in this article was provided by Marconi Communications Systems Limited to meet British Post Office specifications.

References

- BACK, R. E. G., and WITHERS, D. J. The Development of the Intelsat Global Satellite Communication System. Part 1—The Early Years and the Intelsat III Satellites. Part 2—Current Earth-Station Practice and Future Systems. *P.O.E.E.J.*, Vol. 62, p. 207, Jan. 1970 and Vol 63, p. 1, Apr. 1970.
- POPE, D. G. Prospects for a Maritime Satellite Communication Service. *P.O.E.E.J.*, Vol. 65, p. 48, Apr. 1972.
- Recommendation No. 353-2, C.C.I.R. XII P.A., New Delhi, 1970.
- Performance Characteristics of Earth Stations. Interim Communications Satellite Consortium, *Document I.C.S.C. 45-13 (Rev. 1)*.
- MELLER, V. C., and DUFFY, P. S. J. The Large Steerable Aerials at Goonhilly Earth Station. *P.O.E.E.J.*, Vol. 65, p. 2, Apr. 1972.
- BALLANTINE, R. J., FUDGE, R. E., and PICKERING, W. J. H. A Dynamic Tracking Filter Demodulator for Threshold Extension. Conference on Earth-Station Technology, Oct. 1970. *I.E.E. Conference Publication No. 72*.
- NIPPIERD, V. L., and BROWN, E. R. A Demodulation System for Satellite Communications. Conference on Earth-Station Technology, Oct. 1970. *I.E.E. Conference Publication No. 72*.
- FUDGE, R. E. Performance of a Threshold Extension Demodulator. U.K. Seminar on Communication Satellite Earth-Station Planning and Operation, London, May 1968.
- HOSKYNS, R. F. Digital Techniques in Communications Satellite Systems. *P.O.E.E.J.*, Vol. 65, p. 210, Jan. 1973.

New-Generation Channel-Translating Equipment

N. P. MCKAY, C.ENG., M.I.E.R.E. and C. A. PATEL, B.SC.(ENG.), A.M.I.E.E.†

U.D.C. 621.396.41:621.394.44:621.394.625.33

Development of a new version of frequency-division multiplex (f.d.m.) channel-translating equipment has recently been completed and orders have been placed with manufacturers for the first production equipments to be put into service in the latter part of 1974. The new channel equipment includes a number of new features aimed at improving the quality of service and reducing maintenance effort. This article describes the features of the new equipment that differ from those hitherto provided on f.d.m. channel equipments.

INTRODUCTION

On the British Post Office frequency-division multiplex (f.d.m.) network, the first-order multiplexing equipment that assembles twelve audio circuits into a 60–108 kHz group is referred to as channel-translating equipment. Details of the operation of the channel-translating equipment and associated group automatic gain control (a.g.c.) regulators have been described in previous articles.^{1,2} This article describes the additional features of a new type of equipment, referred to as New-Generation Channel Equipment, which combines the channel-translating and group-regulating functions and includes other features not previously provided on the f.d.m. network.

Channel-translating equipments have existed in the network since the late 1930s when the first carrier systems were introduced and, from then up to the present time, the basic multiplexing function performed by this item has remained unchanged. The need to interwork new and old equipments in the f.d.m. network also means that, looking ahead, it is unlikely that any major changes can be made to the basic functions performed by most multiplexing equipments.

In spite of this, channel equipments have been the subject of numerous studies that have led to frequent redesign. This is understandable when it is considered that these equipments are purchased in great quantities and represent an annual expenditure which, at present, exceeds that allocated to any other single item of transmission equipment. It is clear, therefore, that there is a great incentive to redesign channel equipments in order to reduce costs and this has been the primary purpose of developments that have taken place on channel equipments in the past. As channel equipment forms the interface point between the exchange, with its associated switching and signalling equipment, and the repeater station, it is desirable that features provided on the channel equipment should take account of advances made in the signalling fields and changes in circuit-maintenance procedures. To this end, a series of studies has been conducted to consider the advantages that would be gained by redeveloping f.d.m. channel equipment to reduce the cost and size of this item and also to include additional facilities aimed at improving the quality of service and reducing circuit-maintenance and line-up effort. The development of a new generation of

channel equipment based on the outcome of the studies is now completed and first orders have been placed with manufacturers. The first equipments are due to be put into service on the f.d.m. network during the latter part of 1974.

BRIEF OUTLINE AND COMPARISONS WITH CURRENT CHANNEL EQUIPMENT

The new generation of channel equipment will, like the existing type, be engineered in 62-type construction practice.³ With this method of construction a number of plug-in printed-circuit cards are housed in a shelf. A number of shelves (17 in the case of a 9 ft rack) are then stacked vertically to form the equipment rack. Fig. 1 shows the layout for a

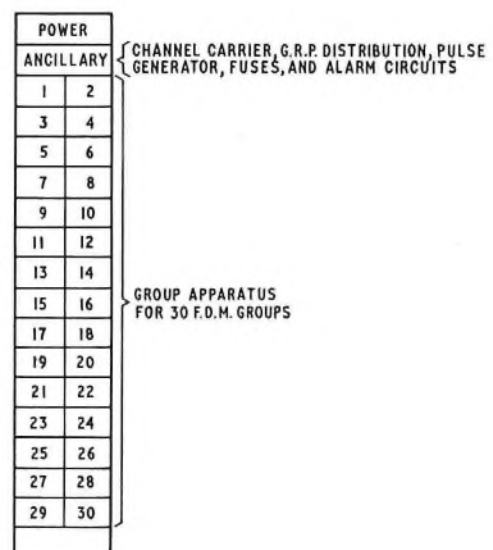

Fig. 1—Typical layout of a fully-equipped 9 ft rack of new channel equipment

† Telecommunications Development Department, Telecommunications Headquarters.

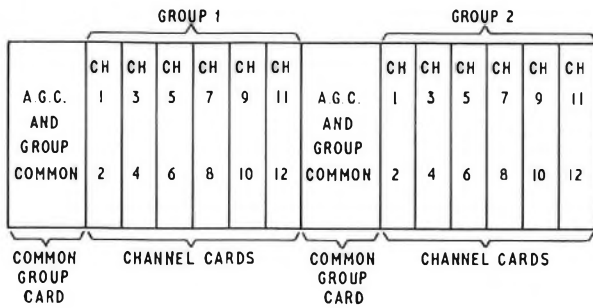

FIG. 2—Typical layout of a shelf of new channel equipment

fully-equipped rack of the new equipment. The functions of channel-translating and group a.g.c. regulating equipments have been combined and one 62-type shelf contains all the apparatus required for two complete group ends. Thirty group ends (360 audio-circuit ends) can be accommodated on a 9 ft, 62-type rack together with associated power and ancillary apparatus compared with 12 group ends (144 audio-circuit ends) for the existing equipment. To achieve this increase in the channel density of the rack, use has been made of modern miniature components including thick-film networks and integrated circuits. Fig. 2 shows a typical layout for a single shelf on the new equipment containing plug-in cards associated with two groups. A new feature is that two channels are accommodated on a single plug-in card. Fig. 3 shows a photograph of a typical channel card and a typical group common card, containing group a.g.c. and backward-busy-ing equipment etc., is shown in Fig. 4. Fig. 5 shows the block diagram for the new channel equipment and features that differ from the current type of equipment are that

- (a) the group a.g.c. regulator forms part of the equipment,
- (b) apart from station cable compensation, no level adjustments are provided on the transmit channel path,

(c) apart from station cable compensation, only one gain-adjustment control is provided on the receive channel path to set the overall circuit gain,

(d) no adjustable networks are located on plug-in units and cards may, therefore, be freely replaced without regard for the settings of various electrical networks,

(e) the receive path gain may be remotely controlled, the gain-adjustment control potentiometer being removed from the channel equipment by distances up to 500 metres,

(f) the group a.g.c. regulator has a built-in memory that allows the overall group path gain to remain constant when a group failure occurs,

(g) a backward-group-busy-ing system is included that allows outgoing circuits at both ends of a group to be automatically busied out of service when any one or both directions of transmission fail,

(h) an improved regulator end-of-range alarm arrangement is used,

(i) carrier and group-reference pilot (g.r.p.) distribution networks do not require dummy load resistors, and

(j) power units are designed specifically to meet the requirements of the channel equipment and may not be suitable for use with other equipments and an additional low-volts alarm is used.

AUDIO-LEVEL ADJUSTMENT

The new channel equipment does not provide any individual circuit adjustment for audio input and output levels and these have been fixed at -7 dBr and $+4$ dBr respectively. The removal of all circuit adjustments was considered essential when more than one channel is located on a plug-in card in order to prevent disturbance to other channels on each occasion when it is required to adjust a single channel. It is also considered that standard audio levels on channel equipments simplifies maintenance and may facilitate circuit-patching operations although much depends on facilities provided outside the channel equipment which are still under discussion.

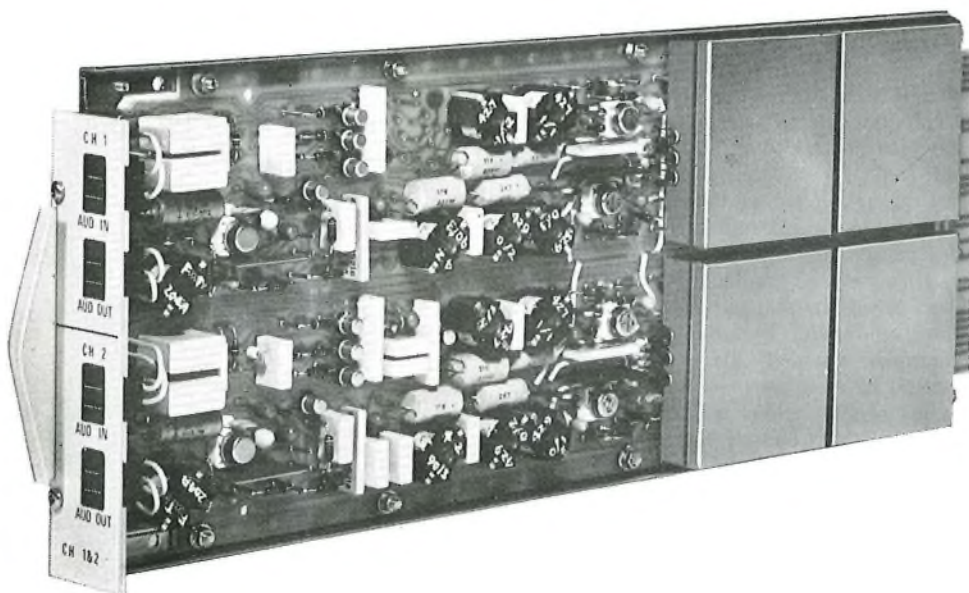

FIG. 3—Channel card

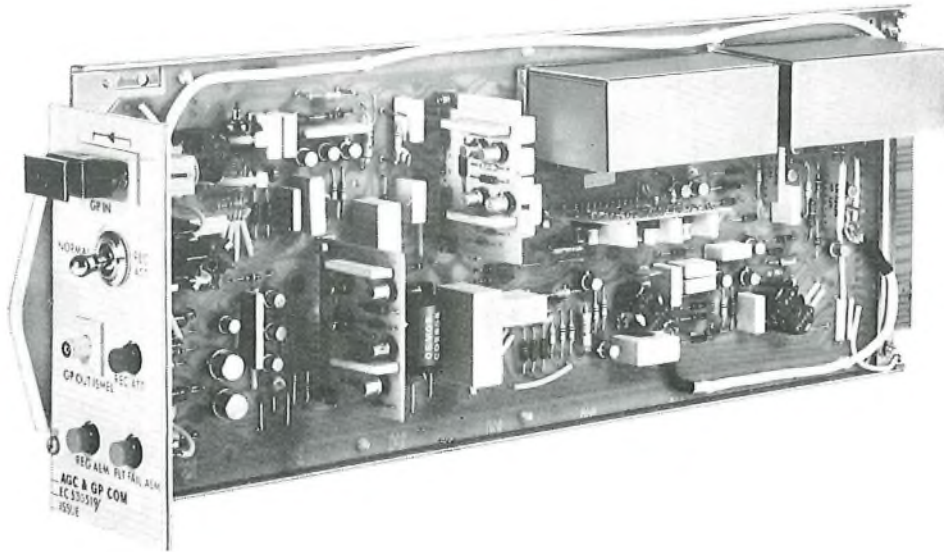

FIG. 4—Group common card

One arrangement envisaged is shown in Fig. 6 where the channel equipment audio-input and -output points are cabled to a standard-level test jack field or suitable automatic test-access arrangements. On the receive side, an attenuator is connected after the standard-level jack to reduce the +4 dBr level received from the channel equipment to a level suited to the exchange signalling relay-set or circuit terminal equipment. Similarly, an attenuator in the transmit path reduces the level received from the exchange to -7 dBr on the standard-level jack field. The eventual location of these audio-circuit-level adjustment attenuators has yet to be decided and depends on arrangements made in the exchange. These attenuators could form part of a new trunk test jack frame (t.j.f.) or, alternatively, they may be built into automatic test-access equipment that may be developed to replace the t.j.f.

Fig. 6 shows the channel remote-gain-control potentiometer located in the exchange close to the test-access point so that the overall circuit gain can be measured and adjusted as a single operation in the exchange without involving the repeater-station staff. This gain-control potentiometer is provided to allow the audio level to be set at +4 dBr on the receive test jack field when a -7 dBr test tone is applied at the distant transmit test jack field. The group a.g.c. regulators allow a highly stable overall circuit gain to be achieved and, once initially set, the gain-control potentiometers should very seldom require readjustment.

TEST-ACCESS AND GAIN-ADJUSTMENT RACK

Until the new arrangements for testing and adjusting circuits in the exchange are finalized and suitable items are developed, there is no place to locate the circuit-level-adjustment attenuators and gain-control potentiometers. As an interim measure, to avoid delaying the introduction of the new channelling equipment, an equipment referred to as the Test-Access and Gain-Adjustment Rack (t.a.g.a.r.) is being introduced to provide a location for the adjustment networks. These racks will be installed with the new channel equipments until suitable long-term arrangements for testing and adjusting circuits in the exchange can be applied. The audio input and output points on the channel equipment are cabled to the t.a.g.a.r. rack where they appear on plug-in links which may be removed to provide access to the circuit for testing. The audio levels at the links are identical (-7 dBr transmit and +4 dBr receive) for all types of circuit. Attenuators on the exchange side of

the links allow the overall circuit levels to be adjusted to suit the type of circuit and the signalling system used.

The t.a.g.a.r. racks are to be engineered in 62-type construction, one 9 ft rack accommodating the links, attenuators and gain-control potentiometers for 90 group ends (1,080 circuit ends). The components for six group ends are accommodated on a 6 in, 62-type shelf. One t.a.g.a.r. rack must, therefore, be provided for every three fully-equipped racks of channel equipment. To allow use to be made of the rack depth, the circuit attenuators and gain-control potentiometers are mounted on pull-out printed-circuit cards, each card containing the attenuators and potentiometers for six circuits as shown in Fig. 7. The associated access links for the six circuits are mounted on the card front-plate. Special narrow-depth cards and 62-type shelves are used in order to give approximately double the cabling space normally provided on a 62-type rack. Flexible connectors are provided to allow cards to be withdrawn to a forward-latched position without disturbing transmission on any of the circuits passing through the card. In the forward position, access can be gained to the attenuators and potentiometers. As the circuit test-access links are provided on the card front-plates, measurements can be made without withdrawing cards.

CARRIER AND GROUP-REFERENCE PILOT DISTRIBUTION

Integrated-circuit modulators and demodulators are used on the new equipment and these draw little current from the carrier supply which together with their tolerance to carrier-supply level variations makes the use of dummy-load resistors unnecessary. Unlike previous equipments, any number of channel cards can be removed from the rack without the need to connect resistors to the carrier supply to compensate for the load removed. To take full advantage of this, the 84.08 kHz g.r.p. and power supplies are also designed to operate over a range of load values that makes readjustment unnecessary when cards are removed. The carrier and g.r.p. inputs to each group apparatus are parallel-connected onto common supply lines. This arrangement reduces the amount of rack cabling needed.

STATION-CABLING ADJUSTMENTS

Adjustments must be provided to correct for the loss of internal cabling from the group input and output points and also for audio cable losses. These adjustments are set to suit

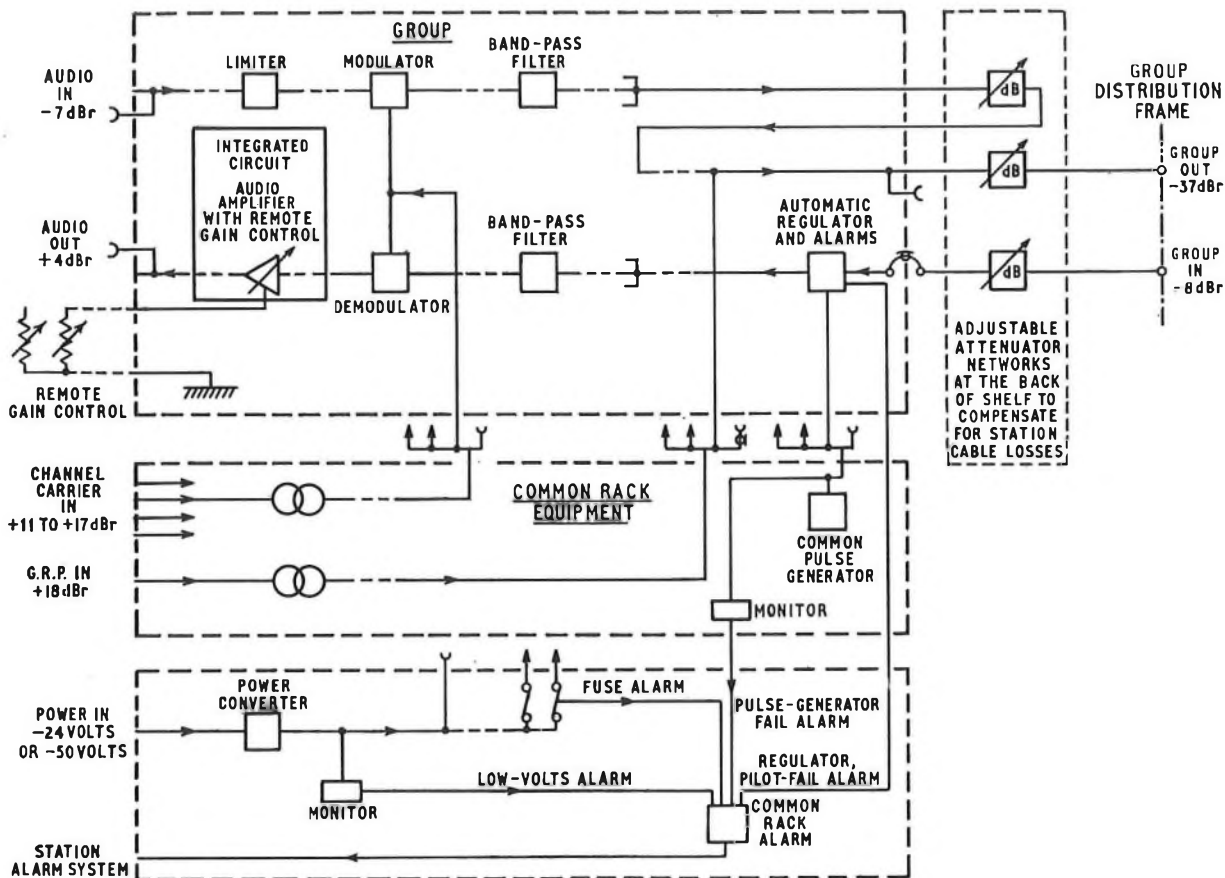

FIG. 5—Block diagram of new channel equipment

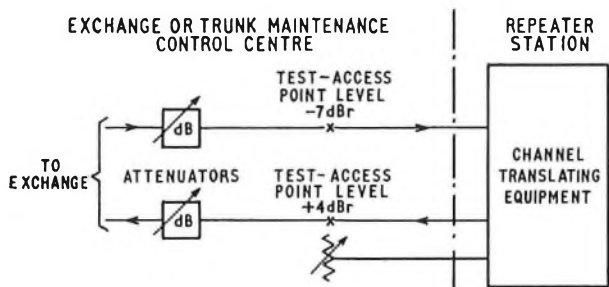

FIG. 6—Audio connexion arrangements

the particular lengths of internal cable runs used when the equipment is installed and do not require adjustment thereafter, unless changes are made to the station cabling or the equipment is re-installed in a new location. The station cable adjustment networks shown in Fig. 5 are mounted on boards fixed to the rear of the 62-type shelves. Provision of the station cable adjustments as part of the 62-type shelf, instead of on the plug-in apparatus cards, ensures that cards can be rapidly replaced without the need to re-set adjustable networks.

REMOTE GAIN CONTROL

The remote-gain-control system used on the new channel equipment allows the overall circuit gain to be adjusted at a point away from the channel equipment. The system, which controls the gain of the channel-equipment receive path,

requires wire connexions to be made from the channel equipment to the remote potentiometers controlling the gain, each group of 12 circuits requiring connexions to be made over 14 single-wire conductors (7 pairs). A single-wire connexion is required to each gain-adjustment potentiometer. The common side of a group of 12 potentiometers is returned to the channel equipment on a bunched pair of wires.

Essential features that were taken into account in the design of the remote-gain-control system were

(a) the system should be capable of working over un-screened audio-type cables and the type of cable used should not be critical,

(b) circuits should not be affected by noise induced into the remote-control wires and, similarly, the wires should not carry signals that could cause disturbance to other circuits,

(c) the system should be unaffected by the reactive components of the remote-control wires, such as, stray capacitance, and

(d) the system should be able to operate satisfactorily over a distance of, at least, 500 metres.

In order to detect and respond to changes made to the potentiometers used to control the gain, the channel equipment must apply an electrical condition to the potentiometers over the remote-control wires. To meet the requirements above, it was decided that the resistance-sensing signal should take the form of a direct current. A d.c. controlled system can be designed to be virtually unaffected by a.c. signals picked up in the remote-control wires, but it does require some form of electrical network that can give a transmission loss that is variable under the control of a d.c. signal. Such networks require careful design in order to ensure that distortion of the signal waveform is contained within accept-

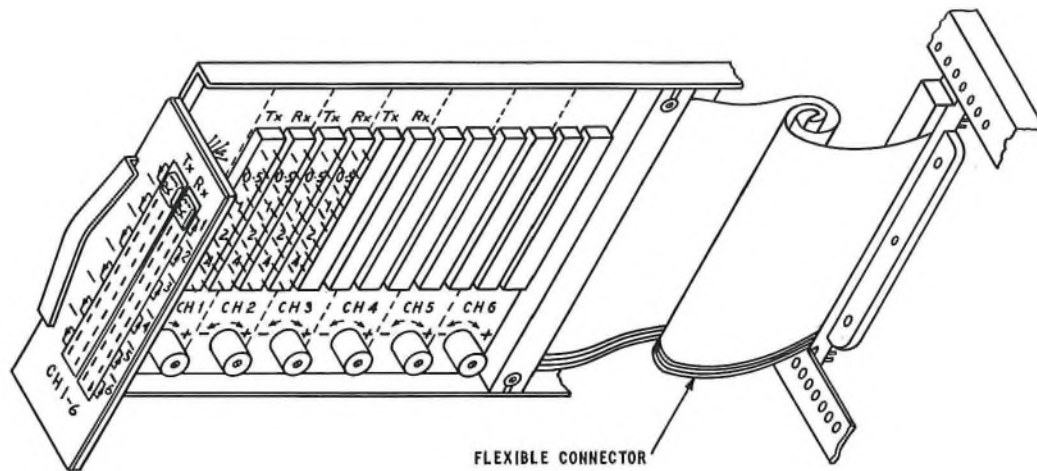

FIG. 7—Test-access and gain-adjustment equipment card

able limits. An integrated circuit containing a suitable network has been developed specifically for use in the new channel equipment and this contains the d.c. controlled variable-loss network together with the receive-channel audio amplifier mounted on a single chip and housed in a 10-lead T05 type can. Fig. 5 shows the position of the integrated circuit in the receive-channel path.

A relatively high value has been chosen for the control potentiometer (10 kilohms) and this tends to make the effect of the d.c. resistance of the control wires insignificant while ensuring that the system is not unduly sensitive to the effects of cable insulation resistance. The limitation on the distance over which the control system can operate is imposed by the d.c. resistance of the common return path which uses a bunched pair of wires. This resistance must be relatively low in order to give an acceptable degree of interaction between the gain-control potentiometers. The system allows for distances up to 320 metres using 0.4 mm copper conductors or 510 metres if 0.5 mm conductors are used. These distances result in a negligible variation in the gain of the 12th channel when the remaining 11 gain-control potentiometers are all changed from one end of their range to the other. Greater control distances can be achieved by using heavier gauge conductors or bunching more wires for the common return path.

GROUP AUTOMATIC GAIN CONTROL

The group a.g.c. system which is associated with the channel equipment includes a number of new features. Probably the most significant of these is the addition of a memory to the control circuit which allows the gain to remain unchanged when the incoming pilot fails or falls rapidly to a low level. The present type of a.g.c. system attempts to correct for a pilot failure by increasing its gain to the maximum value given by the regulation network, the gain then remaining at the maximum value until the pilot is restored to a level within the range of the regulator. In the event of a wideband coaxial line or microwave system failing, a large number of group a.g.c. units are left on the maximum-gain condition and there is a risk that the increased loop gain will cause some circuits to oscillate when the wideband transmission path is restored. The risk is further increased by the fact that some coaxial-line systems may be giving excess gain at the moment when the system is restored.

A typical electrical arrangement for the group regulator is shown in Fig. 8. The level-regulating network connected into

the group path has a transmission loss controlled by a thermistor that has a resistance dependent on the direct current applied to a heating element. The pilot level at the output of the regulating network is used to generate the control voltage for the thermistor and an error must, therefore, remain after regulation but this can be made small by arranging for the gain of the d.c. control loop to be high.

The group a.g.c. unit, in addition to regulating the overall gain of the group, also performs a monitoring function and initiates an alarm condition if the incoming pilot is outside a prescribed level range and is, therefore, indicating a group fault condition. Two alarm functions are provided which are referred to as the regulator alarm and pilot-fail alarm.

The regulator alarm is operated if the regulating network reaches loss values that nominally represent the maximum or minimum regulator gain conditions. This is an end-of-range alarm and indicates that the a.g.c. unit has reached a state where there is nothing to spare to correct further excursions of the incoming pilot away from the nominal level. The regulator gain is monitored continuously by measuring the resistance of the thermistor. Fig. 9 shows a typical arrangement where a direct current is passed through the thermistor in order to measure the resistance. The alarm is operated if the resistance approaches the fully-cold or fully-hot values indicating the ends of the regulator range. The regulator alarm on the new channel equipment, unlike previous a.g.c. alarms, operates only when the gain has reached the maximum or minimum value. With this type of gain monitor, the elaborate arrangements made in previous a.g.c. designs to prevent temporary operation of the alarms when a step variation occurs in the pilot level, become unnecessary.

The pilot-fail alarm is operated when the pilot at the output of the regulator falls to a low level indicating complete failure of the group transmission path. The operation of the pilot-fail alarm is always accompanied by the group regulator being switched to the fixed-gain condition in accordance with the information stored in the memory and this prevents the subsequent operation of the regulator alarm. When a failure occurs, the initiation of a pilot-fail alarm is delayed for a period of about 2 s. The delay is required to ensure that short-duration failures caused by momentary breaks or disturbance to the pilot by noise do not cause intermittent operation of the alarms and unnecessary busying of the group. If the incoming pilot fails, the pilot-fail detector, shown in Fig. 8, operates, causing relay contact M to open, isolating the input to the memory circuit. Under these conditions, the memory circuit maintains a voltage at its output virtually

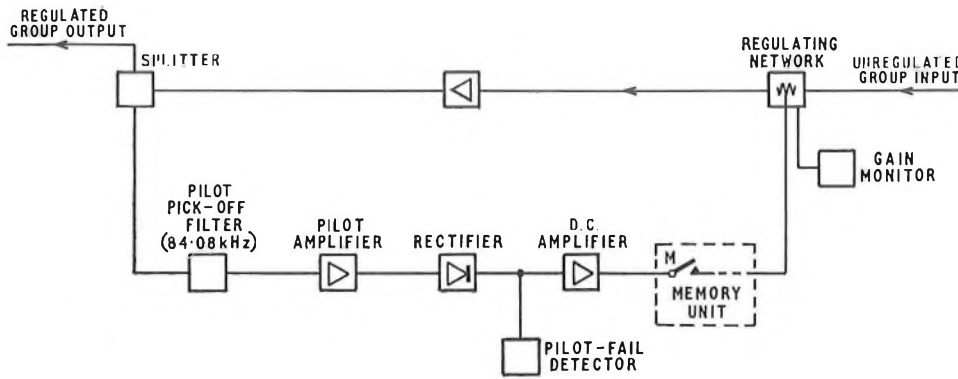

FIG. 8—Block diagram of automatic regulator

identical to that delivered when relay contact M opens. This voltage holds the thermistor at a constant temperature causing the a.g.c. system to give a constant gain identical to the gain immediately prior to the pilot failure occurring.

The production of relatively cheap memory circuits suitable for use in group regulators has been made possible by the development of field-effect transistors (f.e.t.) which allow the direct voltage on a capacitor to be continuously measured without discharging the capacitor. The electrical arrangement used in the memory is shown in Fig. 10. In the regulating state, contact M is closed and the capacitor C charges to the voltage applied to the input terminals T1 and T2. This voltage is also applied to the gate electrode of a f.e.t. which is arranged to give unity voltage gain so that a voltage equal to that applied to the input appears at the output terminals T3 and T4. Failure of the pilot causes relay contact M to open leaving the capacitor C isolated and charged to the voltage that existed at the input terminals when M opened. The f.e.t. continues to reproduce this voltage at the output terminals T3 and T4 irrespective of the voltage applied to the input terminals.

With this simple type of memory, the information stored deteriorates with time as capacitor C slowly discharges through leakage paths presented by the various insulating materials connected across the capacitor terminals and the insulation resistance of the capacitor dielectric. It is possible, however, to achieve discharge rates that represent a regulator gain drift of less than 0.1 dB over a 24-hour period. To achieve such low gain-drift rates, it is necessary for the memory circuit to be housed in a hermetically-sealed container filled with a dry gas. A reed-relay contact is used to isolate the input to the memory since no other component available, at this time, is able to give the required high degree of isolation.

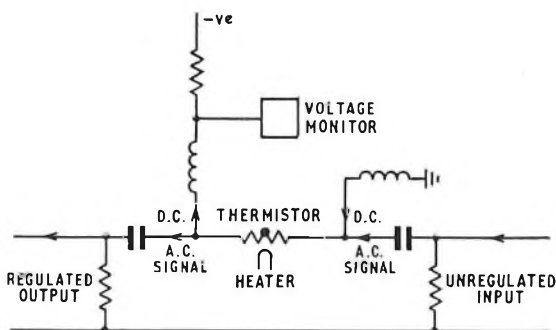

FIG. 9—Regulator gain monitoring circuit

BACKWARD GROUP BUSYING

The provision of a backward-group-busing system that would allow outgoing circuits at both group terminals to be automatically busied out of service when a unidirectional failure occurs has long been recognized as a desirable feature.

The first experimental system was installed on a number of groups between London Kingsway and Glasgow but this, and other experimental systems installed since, have all been considered too costly for widescale application. The h.f. network currently has single-end automatic busying which allows outgoing circuits to be busied only at the group terminal that detects the group failure. The use of memory-type group a.g.c. now offers the possibility of a cheap backward-group-busing system.

Fig. 11 outlines the principle of the backward-busing and group-alarm system used on the new channel equipment. Two group terminals, referred to as terminals A and B, are shown. To explain the operation of the system, the sequence of events occurring when the group transmission path from A to B fails is considered.

Such a failure causes the pilot-fail detector at terminal B to operate, switching the regulator to the fixed-gain state. After a delay period of 2 ± 0.5 s, the pilot-fail lamp at terminal B is lit and a fail condition is applied to the static-relay control gate and to the exchange-hold circuit. The application of a fail condition to the input of the exchange-hold circuit causes an earth condition to appear almost immediately at its output and this is cabled to the exchange switching and signalling equipment at terminal B where it is used to busy outgoing circuits on the failed group. The exchange-hold circuit at terminal B also applies a fail condition to the common rack-alarm relay.

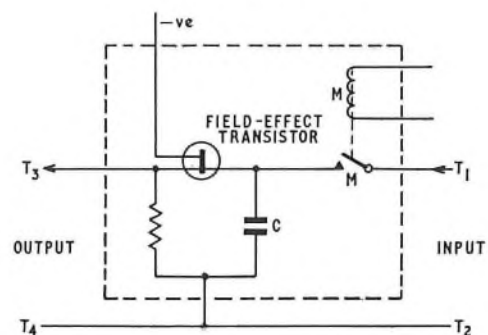

FIG. 10—Typical memory circuit

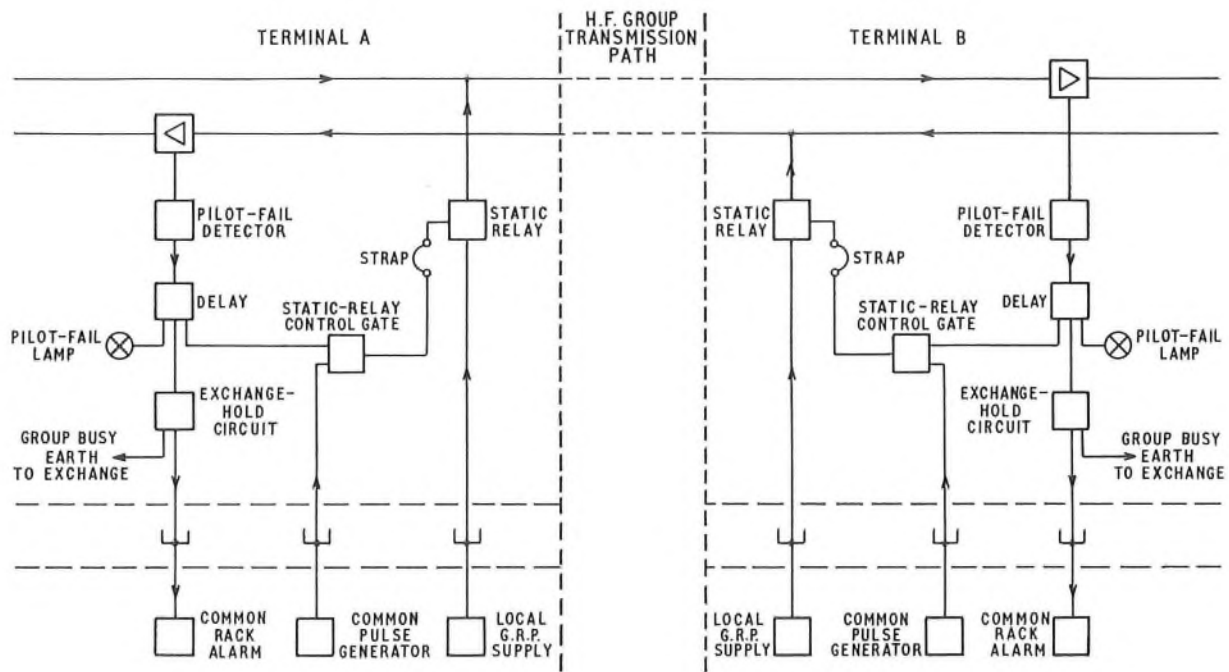

FIG. 11—Automatic group busying at both ends of a carrier link

The application of a fail condition to the static-relay control gate at terminal B causes a pulse generator (usually, a single common pulse generator is used to serve the complete rack) to be connected to the static relay and this results in the g.r.p. transmitted from terminal B to terminal A being continuously pulsed such that the pilot is cut-off for 3–4 s and then restored for a period of 4–5 s before being again cut-off.

The first pilot-off pulse causes the pilot-fail detector at terminal A to operate and this results in a sequence of events occurring at terminal A identical to those described for terminal B when the group failure initially occurred. Outgoing circuits from terminal A are, therefore, automatically busied, the pilot-fail lamp is lit and an alarm condition is initiated. After 3–4 s, the g.r.p. is restored in the terminal B-to-A direction of transmission and this causes the pilot-fail detector to release at terminal A. When this occurs, the pilot-fail lamp is extinguished and the fail condition is removed from the input of the exchange-hold circuit. The exchange-hold circuit is, however, designed to hold an earth condition at its output for a period of 5–10 s following the removal of a fail condition at its input. A busying earth is, therefore, still transmitted to the exchange switching equipment and the alarm condition is not cleared. Before the time delay in the exchange-hold circuit expires, a further pilot-off pulse is received from terminal B. An earth condition, therefore, appears continuously at the output of the exchange-hold circuit as long as the pilot transmitted from the terminal B is pulsed and a continuous alarm condition exists at terminals A and B.

At terminal B, the pilot-fail lamp glows continuously indicating that the incoming group path from terminal A has failed, or that both directions of transmission have failed. At terminal A, the pilot-fail lamp flashes in sequence with the pulse generator at terminal B and this indicates that only the outgoing path from terminal A has failed. These conditions prevail while the fault remains on the transmission path from terminal A to terminal B.

When the fault on the transmission path clears, both group terminals remain in the alarm state and continue to busy the circuits out-of-service until one of the group terminals starts to transmit a pilot-on pulse. This could take a maximum of 4 s but, in practice, this is unlikely and it is probable that at least one of the terminals will be transmitting a pilot-on

pulse at the moment that the transmission path is restored. Under these conditions, an incomplete pilot-on pulse reaches the distant terminal and this may be of insufficient duration to clear the group-alarm condition. If it is assumed that, following the restoration of the transmission path, terminal A is the first to commence a pilot-on pulse, the pilot-fail detector at terminal B releases within 2 s and, on releasing, extinguishes the pilot-fail lamp at terminal B and reconnects the pilot in the terminal B-to-A direction of transmission. Within a further 2 s, the pilot-fail detector at terminal A releases, extinguishing the pilot-fail lamp at terminal A. This also ensures that the pilot continues to be transmitted from terminal A when the pilot-on period ceases. The pilot is now restored in both directions of transmission and both pilot-fail lamps are extinguished. The circuits, however, continue to be busied and the alarm conditions remain until the exchange-hold delay period expires after a further 5–10 s.

The strap, shown in Fig. 11, is provided to allow new generation equipment to work with existing equipments not provided with backward-busying facilities. In this case, the group a.g.c. unit at one group terminal is not equipped with a memory and the pilot cannot be pulsed without disturbing the overall group-path gain in the direction of transmission that has not failed. The strap in the new generation equipment is, therefore, removed and this disables the backward-busying system and ensures that the g.r.p. is transmitted at all times by the new equipment.

Regulation under Unidirectional Group-fail Conditions

When a group fails in one direction, the regulator at the group terminal where the alarm is initiated is switched into the memory condition for the duration of the failure. Consequently, it is not possible to correct for variations that would result in a change in the gain of the overall transmission path of that direction had the failure not occurred. The regulator at the remaining group terminal is, however, constantly being switched between the memory and the regulating states and the information in the memory store is continuously being brought up to date. The regulator, therefore, corrects varia-

TABLE 1

Backward Busying System—Slowest Possible and Quickest Possible Times to Busy and Unbusy Circuits

Event	Quickest Possible Time		Slowest Possible Time	
	Event Time (s)	Total Time (s)	Event Time (s)	Total Time (s)
Failure occurs in A-to-B direction of transmission.	0	0	0	0
Pilot-fail detector at terminal B operates and busies circuits at terminal B. Terminal B generator is delivering a pilot-off pulse. Pilot cut-off in B-to-A direction.	1.5	1.5	2.5	2.5
Pulse generator at terminal B changes to a pilot-on condition just before the pilot-fail detector at terminal A operates.			2.5*	5
Terminal B pulse generator pilot-on period.			5*	10
Terminal B pulse generator commences first complete pilot-off period.			0	10
Pilot-fail detector at terminal A operates and busies circuits at terminal A.	1.5	3	2.5	12.5
Fault clears in A-to-B direction while both pulse generators are delivering a pilot-on condition.	0	0	0	0
Both generators together change to a pilot-off condition just before the pilot-fail detectors at the distant terminals are about to restore to the normal (pilot-on) state.			2	2
Pilot-off period.			4	6
Both generators commence a complete pilot-on pulse.			0	6
Pilot-fail detectors at terminals A and B release ensuring that continuous pilot is transmitted independent of the pulse generators.	0	0	2	8
Exchange-hold delay circuits expire and circuits are unbusied at terminals A and B.	5	5	10	18

Note 1: It is unlikely that the free-running pulse generators at terminals A and B will be exactly in phase resulting in the slowest possible unbusying times.

Note 2: The delay times marked * can be eliminated by using a *quick-busying* circuit.

tions that occur in the overall gain of the transmission path that has not failed.

Maintenance of Groups under Failure Conditions

In addition to providing a control signal for the group regulators, the g.r.p. is also used to measure the reference level of a group at points along the overall group transmission path. Such measurement of the pilot is particularly desirable when a failure has occurred in order to permit rapid location of the fault. When the backward-busying system is operating, the pilot level in the direction that has not failed can be measured during the 4–5 s pilot-on period. The pilot in the failed direction is pulsed at the same rate as the unfailed direction of transmission, but the pilot-on pulses are lengthened by an amount that depends on the phase relationship of the pulse generators at both group terminals. Measurement of the pilot level can, therefore, readily be made. If the two pulse generators drift into a phase relationship that results in an overlapping of the pilot-on periods, continuous pilot is transmitted in the direction of transmission which has failed.

RETROSPECTIVE PROVISION OF BACKWARD BUSYING

To make full use of the backward group busying being provided on the new channel equipment, it is desirable to provide the same facility on existing group a.g.c. units. Initially, the majority of new-generation channel equipments will work to older-type equipment at the distant group terminal and this means that the backward-busying facility on the new equipment must be strapped out of use. The desirability of retrospectively modifying existing types of

group a.g.c. equipment to give backward group busying has, therefore, been recognized and modification kits are currently being developed and are expected to become available in early 1975.

The addition of a long-term memory similar to that being provided on the new channel equipment would present technical difficulties and would also be costly. It is possible, however, to add a relatively simple memory that holds the gain constant for 5 s. This does not offer the same advantages as a long-term memory but would allow the busying system to be used on all groups irrespective of whether old or new equipments are provided. With the modified group a.g.c. units, the backward-busying system described for new-generation channel equipment will be used. When a unidirectional failure occurs, the overall group-path gain in the direction of transmission that has not failed remains constant. The gain of the remaining a.g.c. unit drifts slowly towards the maximum value over a period of several minutes as the memory capacitor discharges.

QUICK BUSYING

When a group failure occurs, circuits at the group terminal that initially detects the failure are busied out of service almost immediately, following the operation of the pilot-fail detector. The busying of circuits at the distant group terminal is, however, delayed and there is a risk of faulty circuits being seized during the unguarded period. The delay period depends greatly on the conditions being delivered by the pulse generator at the moment that the failure occurs. If a pilot-on period has just commenced, a period of 4–5 s must elapse before the outgoing pilot from the terminal detecting the failure is

cut-off for the first time. The longest possible unguarded period is 12.5 s and this is made up by adding the various delay times shown in Table 1. It is very unlikely that a delay time approaching 12.5 s would be encountered in practice, since, this is based on all delay circuits being at their maximum permissible tolerance limits and the failure occurring at the most unfavourable time during the pulse-generator cycle. By adding extra components, the delay times marked with a star in Table 1 could be eliminated and the unguarded period would then be reduced by 7.5 s. This is achieved by arranging for the outgoing pilot from the terminal detecting the failure to be disconnected immediately the pilot-fail detector operates, irrespective of whether the pulse detector is delivering a pilot-on or pilot-off condition. After a delay period sufficient to ensure that all circuits are busied, the pulse generator takes over and the outgoing pilot is pulsed in the normal manner, thereafter. This is referred to as a *quick-busy*ing circuit.

At this time, it is considered that the advantage gained by reducing the unguarded period does not justify the additional expense and complexity resulting from the addition of *quick-busy*ing arrangements to the new channel equipment. Initial designs will not, therefore, include this feature but it may be included on some future channel-equipment designs.

CONCLUSIONS

A new generation of f.d.m. channel equipment has been developed and is due to be introduced into service during the

latter part of 1974. In addition to being smaller and cheaper than the existing equipment, the new designs include features aimed at improving the quality of service and reducing circuit-maintenance and line-up effort. In order to fully exploit the benefits offered by the new channel equipment, it is necessary to introduce suitable complementary test-access and adjustment equipments in the exchange or trunk-test rooms and to adopt new circuit-maintenance and line-up procedures. As an interim measure, separate t.a.g.a.r. will be provided in the repeater stations. The introduction of new channel equipment is the first stage of a plan to re-engineer the overall circuit-testing and adjustment arrangements in order to provide facilities more suited to the needs of the future trunk network.

ACKNOWLEDGEMENTS

The cooperation of Pye T.M.C. Ltd. in allowing photographs to be reproduced in this article is gratefully acknowledged.

References

- 1 ELLIOTT, J. L. C. Group Automatic Gain-Control Equipment. *P.O.E.E.J.*, Vol. 61, p. 3, Apr. 1968.
- 2 BLACKHALL, R. W. E. F.D.M. Multiplex Equipment. *P.O.E.E.J.*, Vol. 66, p. 38, Apr. 1973.
- 3 WALKDEN, M. R. Construction Practice for Transmission Equipment. *P.O.E.E.J.*, Vol. 66, p. 25, Apr. 1973.

Book Reviews

"B.B.C. Engineering 1922-72." Edward Pawley, O.B.E., M.Sc.(Eng.), C.Eng., F.I.E.E. B.B.C. Publications. xi + 569 pp. 81 ill. £7.00.

Readers of this Journal who enjoy senior-citizenship status will no doubt recall, with an understandable touch of nostalgia, the emergence of broadcasting in this country under the auspices of the British Broadcasting Company between 1922 and 1927. Sir John Reith and Captain Eckersley will be familiar names as Managing Director and Chief Engineer of the Company, respectively. As a result of their efforts, and those of a dedicated staff, the present Corporation inherited at its inception in 1927 a vigorous and well-established industry with more than two million licence-holders, and an obviously promising future. Furthermore, the same personalities remained in control, and their enterprising outlook and versatility continued to inspire development during the ensuing decades.

"BBC Engineering 1922-72" is an account of that development and itself illustrates the same qualities. The author, retired Chief Engineer, External Relations, has based his work on materials assembled by three engineering colleagues, also retired, who in the course of their researches, interviewed more than 70 past and present members of the staff to obtain first-hand information about developments with which they were personally concerned.

The result is a highly detailed account, not by any means confined to technical matters, though of course these are treated at some length. Related aspects, such as internal organization, finance, staffing, training, buildings, international relations and so on receive equally thorough coverage. In addition to over 500 pages of text, there are 18 pages of source references together with 32 illustrations and an adequate index. The author has moreover contrived to preserve throughout a logical and often entertaining style of presentation that should find a wide circle of appreciative readers. It is an astonishing record of technical achievement in all fields, and one that can be regarded as a model of its kind; the book

will doubtless acquire the distinction of becoming a standard work.

The Post Office has of course been intimately connected with many aspects of the technical development of broadcasting in this country. Of special interest is the account of efforts made by both the B.B.C. and the Post Office over the years, from the time when overhead trunk circuits were leased on a part-time basis, to meet the requirements for land-lines of increasingly exacting performance and reliability. The great difficulty has always been of course that, as the author acknowledges, circuits for both sound and vision program transmission and control purposes have all had to be developed from the resources of a main and local line-plant network designed primarily to provide speech transmission at a reasonable cost. With increasing amounts of broadcasting material being exchanged internationally, it is fortunate that pulse-code modulation techniques being developed by the B.B.C. are a promising development in this field. Similar problems have of course confronted the Post Office in developing data-transmission techniques for use over the public switched telephone network.

It is a sad fact that, other than commercially, many broadcast programs scarcely seem to justify the lavish scientific and technical resources employed in their production. Perhaps the harsh view, reputed to have been promulgated in 1931 by no less an authority than Lord Reith, that the broadcasting system of a country is a mirror of that nation's conscience, still prevails at Broadcasting House. One questions however, whether in 1973 broadcasting authorities can afford to be that much detached. A professional engineer's views on this point would have made an interesting conclusion to this monumental work.

Perhaps it is not too much to hope that retired members of the Post Office will now feel inspired to emulate this excellent example by recording for posterity some details of their own careers and technical achievements, and those of their colleagues, before Time's winged chariot catches up with us all.

D. A. J.

Logarithmic Frequency-Plotter Speeds the Recording of Crosstalk Measurements

C. R. HARRIS, B.Sc.†

U.D.C. 621.317.76 : 621.317.341.1

The British Post Office has a large investment in local-line plant, much of which has great potential for further exploitation. In order to determine the capabilities of these cables, their crosstalk performance is being measured at high frequencies. The logarithmic frequency-plotter described in this article was primarily developed to enable crosstalk characteristics to be plotted directly on to logarithmic graph-paper by machine, although it can be used whenever the result of a sweep-frequency measurement is to be graphically recorded with a logarithmic frequency-axis.

INTRODUCTION

Results of crosstalk and insertion-loss measurements on balanced cables are best plotted with a logarithmic frequency-axis. The reasons are two-fold; a logarithmic axis enables a large range of values to be plotted with a constant resolution, and departures of the crosstalk characteristics from their respective laws are easily noticed. The laws predict that these characteristics will be straight lines when plotted with a logarithmic frequency-axis. Figs. 1 and 2 illustrate this.

measuring equipment to drive an X-Y recorder and obtain a plot with a linear frequency-axis. Both these methods have their drawbacks.

(i) An irregularity in the characteristic could exist undetected if it lay between two spot-frequency measurements and any rolls or ripples in the plotted characteristic would have to be examined by further spot-frequency measurements. In the case of crosstalk this absorbs considerable effort.

(ii) Although a linear sweep-frequency measurement over-

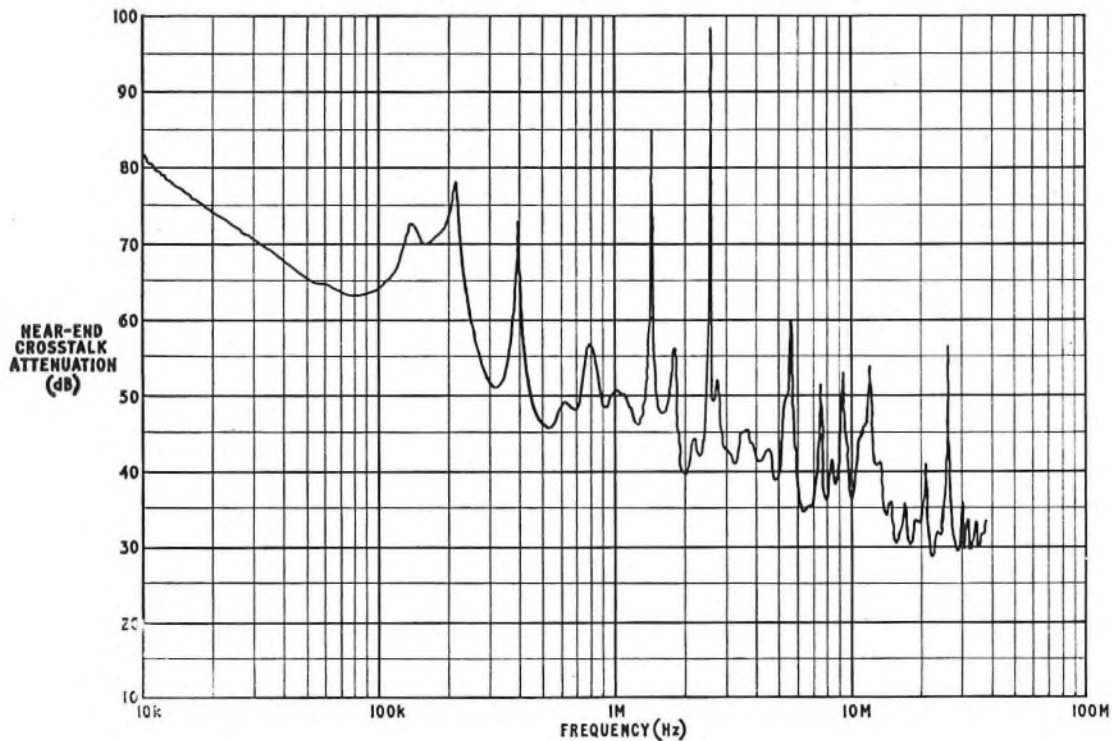

FIG. 1—Graph of near-end crosstalk attenuation against frequency

There are two existing methods for plotting the crosstalk characteristics of pair-type cables. The first is to take spot frequency measurements at logarithmically-related intervals and to transfer the results manually to the logarithmic graph-paper. The second is to use the sweep-voltage from the

comes the previous drawbacks, it is still necessary to confirm the result by spot-frequency measurements if the advantages of a logarithmic plot are to be maintained.

The following section describes the way in which accurate logarithmic frequency-to-voltage conversion has been achieved over four decades of frequency from 10 kHz to 100 MHz. The voltage is used to drive an X-Y recorder which plots the measurement result directly on to four-cycle logarithmic graph-paper.

† Operational Programming Department, Telecommunications Headquarters.

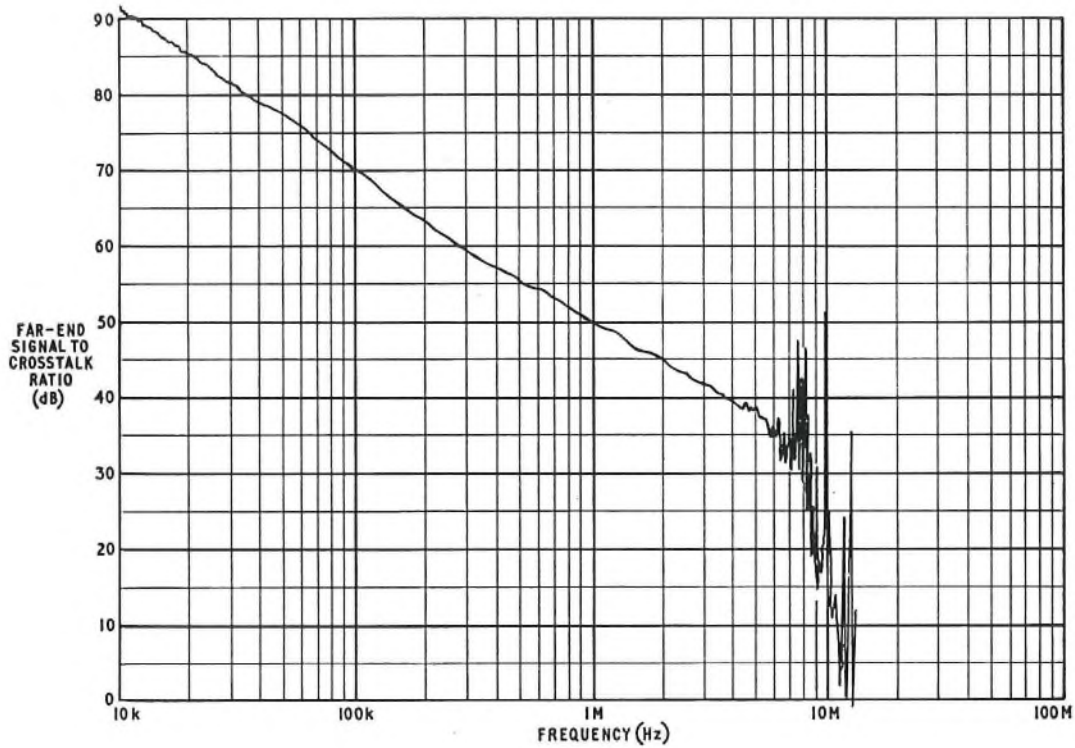

FIG. 2—Graph of far-end signal-to-crosstalk ratio against frequency

GENERAL PROBLEMS OF LOGARITHMIC FREQUENCY-TO-VOLTAGE CONVERSION

The sweep voltage from the sweep-frequency level measuring-set may be compressed logarithmically then used to drive the X-Y recorder, provided that there exists a linear relationship between the sweep voltage and the sweep frequency, and that there is negligible drift of the sweep voltage with reference to the sweep frequency over the operating temperature range and the measurement time. To plot logarithmically over four decades with plotting errors not greater than 0.1 per cent, an overall sweep voltage-to-frequency error of 0.001 per cent is required.

Clearly this method is impossible as the errors caused by drift and non-linearity are in the order of 5 per cent.

By using a digital frequency-counter with its own internal frequency-standard it is possible to count the frequency of measurement with an accuracy of 1 part in 10^6 . Again, to plot logarithmically over four decades, six numbers must be read from the counter for a maximum plotting error of 0.1 per

cent. The numbers appearing in the windows of a digital frequency counter can be converted into an analogue voltage by connecting the digital signals from each window to a digital-to-analogue converter. The number in one window is transmitted upon four binary-coded-decimal digital output lines. Present-day digital-to-analogue converters can read a maximum of twelve digital lines and yet provide an analogue output sufficiently stable and accurate for logarithmic compression. Thus, a maximum of three windows can be coupled to the digital-to-analogue converter.

THE SOLUTION

The frequency counter is programmed so that the three most significant figures always appear in the three windows coupled to the digital-to-analogue converter. The converter produces an analogue voltage which is compressed logarithmically then applied to the X-axis of the X-Y recorder. It moves the pen within any one decade with a plotting error not greater than 0.4 per cent.

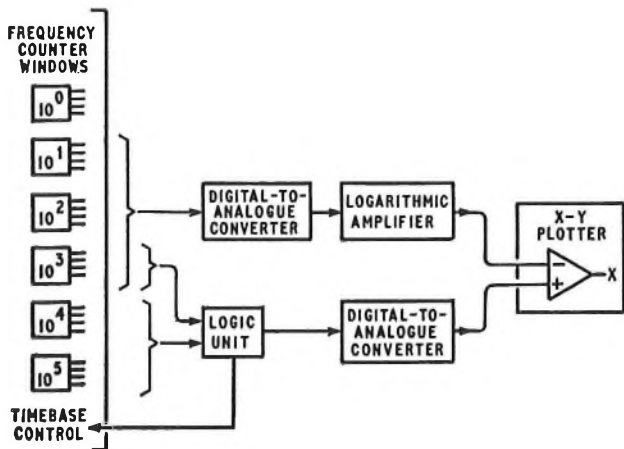

FIG. 3—Block diagram of a logarithmic frequency-plotter using analogue compression

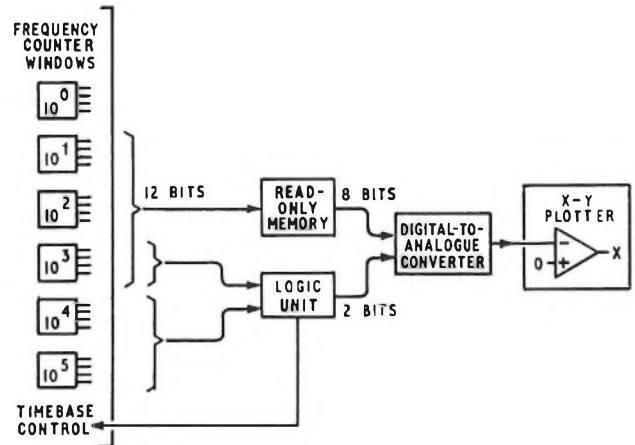

FIG. 4—Block diagram of a logarithmic frequency-plotter using digital compression

The frequency counter is programmed by a logic unit which changes the counting time in decade steps. In addition, the logic unit supplies another digital-to-analogue converter with a binary code representing the counting decade. The voltage from this converter is applied directly to the X-axis of the X-Y recorder and moves the pen in linear decade steps to the correct decade. In this way, four decades can be plotted with errors less than 0.1 per cent. The block diagram of the logarithmic frequency-plotter is shown in Figure 3.

Digital Compression

An alternative solution, more suited to large-scale production, is shown in Fig. 4. It operates on the same principle as the previous solution, but differs in the way logarithmic compression is achieved. The previous solution involved analogue compression whilst the latter involves digital compression.

The digital compression takes place inside the read-only memory. This memory contains the logarithmic law to convert the linear binary-decimal-code to a logarithmic binary-code. The memory must have 12 address lines, to read the three

counter windows, and eight output lines, to achieve an accuracy of 1 part in 256. This is compatible with the required maximum plotting error of 0.4 per cent per decade. Two binary digits from the logic unit, together with the eight binary digits from the memory, are then fed to a single digital-to-analogue converter. Again, four decades can be plotted with errors not greater than 0.1 per cent.

FURTHER USES OF THE LOGARITHMIC FREQUENCY-PLOTTER

Since this equipment measures frequency in addition to providing a plot, it is possible to use it in conjunction with a tracking receiver to make a direct recording of a remote-end measurement.

CONCLUSIONS

The development and operation of the equipment has been described and an improvement on the prototype suggested.

The equipment achieves the objective for which it was constructed as the results of sweep frequency measurements can be recorded directly on to logarithmic graph-paper.

Cabling Across Estuaries

W. T. KING†

U.D.C. 621.315.285

Provision of cables across a river estuary or sea inlet is frequently done by laying armoured cables on the bed of the water crossing where substantial armouring is usually required. If the crossing is short, it is often economic to provide a duct held down by bags of concrete or buried beneath the bed. This article describes the use of subaqueous ducts at Beaulieu Firth, Inverness and describes developments in the use of lubricants to reduce the pulling-in tension.

INTRODUCTION

To save a 32.2 km (20 mile) detour, cables to the Black Isle, north of Inverness, have for many years made an approximately 1.2 km (¾ mile) subaqueous crossing across the Beaulieu Firth. When, in 1968, it became necessary to install a new coaxial cable on this route, the B.P.O. decided to try out what was, to them, a new technique of jetting ducts into the bed of the Firth, and six high-density polyethylene ducts were installed between South and North Kessock at Inverness by this process. The site is shown in Fig. 1. The technique had previously been successfully used when a cable had been laid between Harwich and Landguard.

HISTORY

Duct Installation

The jetting-in process employs a plough fitted with high-pressure water jets which cuts its way across the bed of the sea or river. The cable, as at Harwich, or the set of six polyethylene ducts, as at Kessock, are fed down the plough and out at the bottom into the trench formed by the plough jets. The crossing from South to North Kessock is approximately 700 metres. Each of the six high-density polyethylene ducts was made in a continuous length and floated, with ends

sealed, across the North Sea from Germany. In October 1968 the six ducts were successfully jetted into the bed of the Firth at an average depth of 2 metres using the plough shown in Fig. 2. A profile of the Firth bed is shown in Fig. 3.

After placement of the ducts, draw-ropes were inserted by means of a missile forced through by a high-pressure water supply.

First Cable

In May 1969 a length of cable consisting of 4 × 1.2/4.4 mm coaxial pairs plus 5 interstice pairs of 0.63 mm copper was drawn into one of the ducts. Over the core the cable had an extra thick lead sheath covered by a polyethylene sheath over which was applied a double layer of armour wires to give strength for pulling-in. The inner layer of armour wires consisted of 63 wires of 0.048 inch diameter applied with a left-hand lay and the outer layer of 71 wires of 0.048 inch diameter with a right-hand lay. The layers were separated by a neoprene tape.

During the cabling operations difficulties were encountered due to the armour wires "birdcaging" and causing kinks. Heavy surging of the cable occurred and the maximum tension recorded was 40kN. On completion, pulse tests showed one tube of the cable to be slightly outside the electrical performance specification and this was later compensated for at the terminal.

† Operational Programming Department, Telecommunications Headquarters.

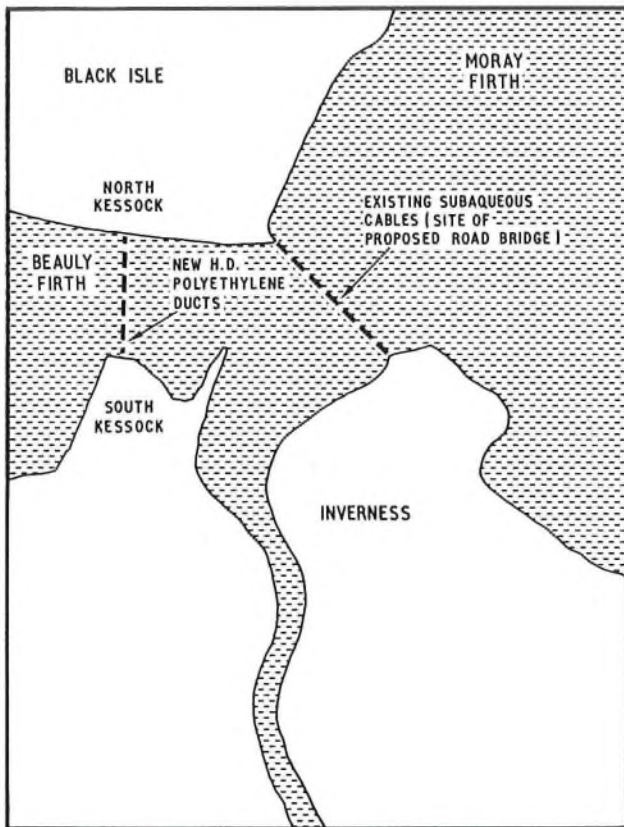

FIG. 1—Map showing the Beaully Firth crossing

Second Cable

Experience with the first cable led to a critical review of the cable design and the method of installation. It was obvious that the matter of lubrication would have to be studied and the tendency to surge overcome.

The cable manufacturer had already agreed to reconsider the cable design in the light of the surge problem and, in July 1970, experiments were conducted on lubricants and installation techniques. The second cable design is shown in Fig. 4.

The cable was of a basic design similar to the previous one and consisted of $4 \times 1 \cdot 2/4 \cdot 4$ mm coaxial pairs plus $5 \times 0 \cdot 63$ mm interstice pairs with double paper insulation. This core was again protected by a thick lead sheath oversheathed with polyethylene. Over this was applied 67 galvanized high-tensile plough-steel wires of 1.2 mm (0.046 in) diameter with a left-hand lay, followed by 74 similar wires applied with a right-hand lay. Then, 48 galvanized high-tensile steel wires, 0.5 mm (0.20 in) diameter, were applied overall to form a braid of 24 wires with a left-hand lay interwoven with 24 wires with a right-hand lay.

EXPERIMENTAL WORK FOR SECOND CABLE

Lubrication

Experiments using apparatus designed and constructed by the B.P.O. indicated a coefficient of friction (μ) of about 0.4 for the dry cable in a polyethylene duct. Tests with various lubricants suggested that this could be reduced to about 0.2 using high-grade paraffin jelly and that this would remain substantially unaltered by the presence of water. This figure suggested a maximum cabling tension for the Beaully Firth crossing of 12kN (1.2 tonf.) Earlier experience on other cables had shown that lubrication would also reduce the

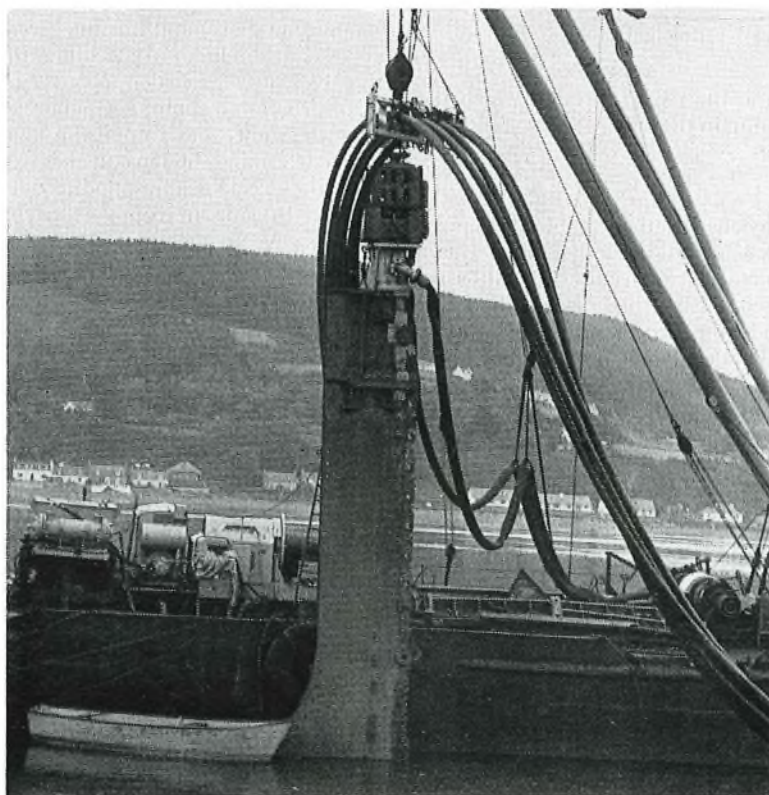

FIG. 2—The plough used for jetting-in the cable

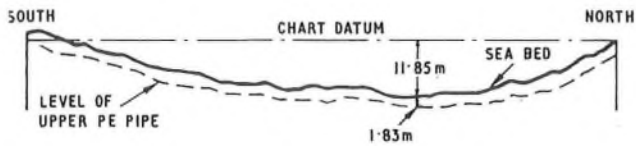

FIG. 3—Bed of Beaully Firth



FIG. 4—Second experimental cable

tendency to surging. A lubricating bath, through which the cables passed, was used to contain the jelly.

Pulling-in Speed

Experiments on polyethylene-sheathed cables in polyvinyl-chloride (p.v.c.) ducts had indicated that there was a general tendency for the coefficient of friction to fall as the pulling-in speed was increased. Also at high speeds there was less likelihood of surging. There had been no opportunity to carry out similar tests on the Beaully Firth cables but direct comparison of the cable and duct characteristics suggested that similar considerations would apply to an armoured cable in a polyethylene duct. Accordingly, a pulling-in speed of 0.5 m/s was proposed.

Installation of the Second Cable

The cable was to be pulled from the north side of the Firth to the south side. The duct selected for cabling had previously been roped and some degree of pre-lubrication was achieved by inserting about 25 kg of paraffin jelly into the duct on the north side prior to pulling-in the test mandrel. When the test mandrel arrived at the southern end another 25 kg of jelly was inserted into the duct at that end and the mandrel was pulled about half way back behind this. The mandrel was then returned to the southern end.

The cable drum was set up on the north side using a motorized cable-drum jack. The lubricating bath was mounted

inside the manhole with the cable-exit adjacent to the duct entrance and the molten lubricant was then poured into the bath through a length of polyethylene duct. At the south end a 40 kN (4 tonf) hydraulic trailer-winch was set up to pull in the cable and measure pulling tensions and speeds. The average cabling speed was about 0.5 m/s and the maximum tension registered was 9 kN (0.9 tonf).

The cabling operation was completed successfully, thus justifying the second cable design and confirming the value of paraffin jelly as a lubricant when using a steel-wire armoured cable in a high-density polyethylene duct.

SUBSEQUENT OPERATIONS

In the autumn of 1972 the Scottish Development Department requested the B.P.O. to divert all the existing subaqueous cables remaining on the old route across Beaully Firth to make way for a proposed road bridge. As it was proposed to commence test bores for the new bridge in July 1973, it was necessary to find an alternative route, purchase and install new cables, complete all jointing and changeover and clear the subaqueous cables by June 1973.

Selection of Replacement Cables

Since pulling in the successful 1970 second cable much useful experimental work and experience in the use of lubricants had been obtained, mainly in connexion with pulling-in long lengths of the 18 pair 2.6/9.5 coaxial cable with lead sheath and polyethylene protection overall which was being developed for a new 60 MHz f.d.m. transmission system.

Work in the laboratory, using a length of the German 100 mm diameter heavy-duty polyethylene duct on the inclined-plane friction machine (Fig. 5) indicated that it would be possible by the use of a polyethylene sheath² with Glover barrier^{4,5} and liquid paraffin as a lubricant to reduce the pulling in tensions substantially and thus to make the armouring of the cables unnecessary.

In the early days, the draw-rope was lost in one of the ducts. Thus of the 6 ducts, 2 were occupied by cables (one working and one spare) and one duct was not roped.

As a prelude to deciding the selection of replacement cables, it was decided to prove that the ducts were free from obstruction by pulling a mandrel through. It was also decided, at the same time, to pull through a sample length of cable to predetermine the tensions likely to be encountered in pulling in the selected cables, and to obtain the services of Inverness Fire Brigade in roping the empty bore. These pulling-in tests gave an effective value of coefficient of friction (μ_e) over the complete route of 0.35. During the initial installation the first cable (armoured) pulled in reached a maximum pulling in tension of 25 kN (2.5 tonf) giving an effective coefficient of friction (μ_e) for the crossing of 0.83. For the second cable (armoured) pulled in, laboratory tests using petroleum jelly and water lubrication gave a value for μ of 0.22 and the maximum tension during the actual cabling of 9 kN (0.9 tonf) gave a value for μ_e of 0.36. It was, therefore, considered that a figure of 0.35 for μ_e was realistic.

In all, 15 different cable types were investigated and consideration was given to overall diameter (mm), weight (kg/m) safe pulling tension (kN), weight for 704 metre length and estimated cabling tension assuming a μ_e of 0.4.

The 3 cables finally selected were:

- 2 pair 2.6/9.5E + 16/0.9 P.C.Q. + 180/0.9 P.C.Q.T. polyethylene sheathed; estimated pulling-in tension 8.5 kN (0.8 tonf).
- 8 S.P. 1.27 + 340 pair/0.9 P.C.Q.T. estimated pulling-in tension 13.15 kN (1.3 tonf).
- 434 pair/0.63 P.C.Q.T. estimated pulling-in tension 9.7 kN (0.95 tonf).

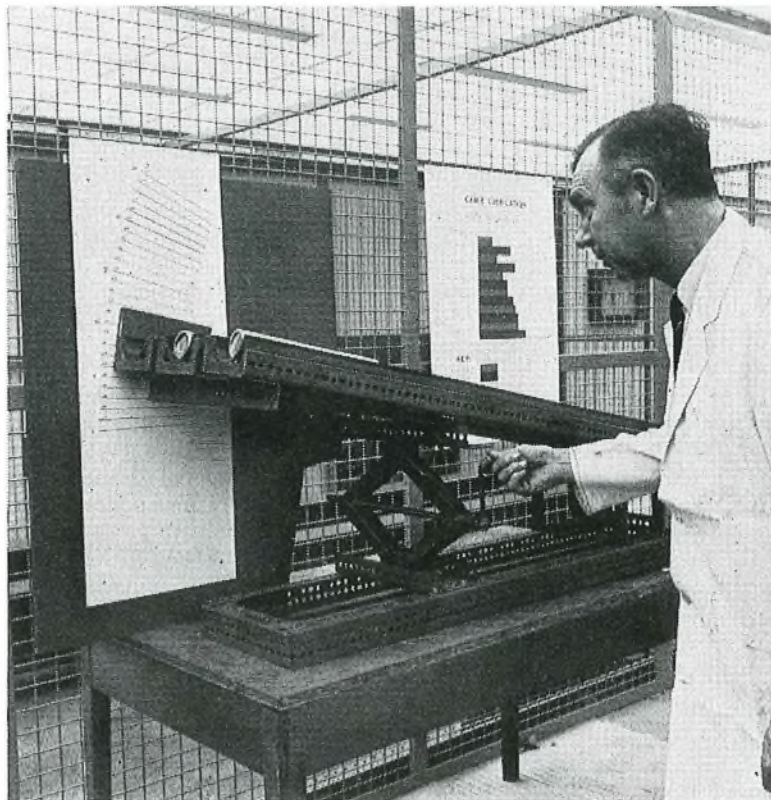

FIG. 5—The inclined-plane friction machine

Cable Preparation

In view of the success with pulling-eyes designed for trials on the new 60 MHz f.d.m. system, it was proposed to use these at Beaully Firth and laboratory tests carried out on short lengths of the cables showed the pulling-eyes to be satisfactory at tensions in excess of 40 kN (4 tonf.) Subsequent to these tests, pulling-eyes were fitted at the cable factory to the outer ends of the cables and air valves to the inner ends. The cables were then pressurized to 44 N/m² (10 lb/in²) for delivery and subsequent pulling-in.

Lubrication

The method of lubrication developed for the 60 MHz system consists of drawing through the duct at the same time as the winch rope, a purpose-made cylindrically-shaped, horsehair brush soaked in liquid paraffin. This brush, 100 mm in diameter was made for use with the standard duct (B.P.O. Duct No. 54) and a special 127 mm diameter brush had to be purchased for the 100 mm ducts at Beaully Firth.

Cabling

A new manhole was constructed approximately 30 metres west of the existing manhole at the north side and it was proposed to pull the cables from the existing north side manhole to the manhole on the south bank, remove the surplus cable from the drum and "back-end" it to the new manhole. Unfortunately, on the date on which cabling was due to start, the manhole-building contractor was still struggling to penetrate a bed of solid rock so it was decided to proceed with the cabling of the undersea bores and to coil the surplus cable in the existing manhole. The back ending would then be carried out on completion of the new manhole.

The winch was set up on the south bank of the Firth and the drum, on the motorised drum-jack, on the north bank. The following operations were involved:

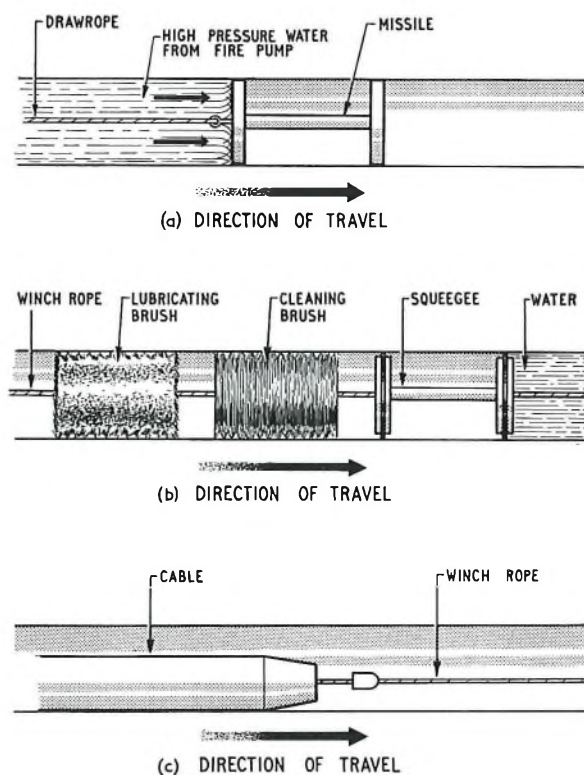

FIG. 6—Cabling operations

(a) One of the original drawropes which had been lost was replaced using a missile pumped through with the assistance of the local fire brigade as shown in Fig 6(a).

(b) A mandrel followed by a 10 m length of test cable was drawn through each duct. This proved the bores and gave an indication of the unlubricated tension which could be expected.

(c) A light steel rope was drawn into each duct using the drawrope.

(d) The light steel rope was used to draw in a squeegee, cleaning brush, lubricating brush and winch rope as shown in Fig 6(b).

(e) The cables were drawn into the now-lubricated ducts as shown in Fig 6(c).

Pulling Tensions

The pulling tensions measured are detailed in Table 1.

TABLE 1
Pulling Tensions

Cable	Length of pull (m)	Calculated tension (kN)	Measured tension (kN)
434 pair/0.63 P.C.Q.T.	704	9.70	12.40
8 S.P. 1.27 + 340 pair/0.9 P.C.Q.T. polyethylene sheathed	704	13.15	12.00
2 coaxial pairs 2.6/9.5E + 16 pairs/0.9 P.C.Q. + 180 pairs/0.9 P.C.Q.T. polyethylene sheathed	704	8.50	8.00

The high measured tension value for the 434 pair/0.63 cable was attributable to the drum-jack motor which was initially maladjusted and applying a large back tension. In the subsequent operations the drive was not used. The back-ending operation was successfully completed on 7 March 1973 which allowed ample time for final jointing and testing of the cables.

CONCLUSIONS

The installation described shows that with adequate planning it is possible to place cables successfully in sub-aqueous ducts of the order of 700 metres in length. The recorded figures for tension suggest that even longer lengths of such duct could be cabled if necessary. Successful completion of the work was dependent upon a combination of practical field work and laboratory experiment. It was this factor which led to the progressive development of the lubrication technique which was essential for the Beaully Firth operation and which will find increasing application in the cabling field generally.

ACKNOWLEDGEMENTS

The assistance of the British cable manufacturers in the development and provision of the Beaully Firth cables is gratefully acknowledged, as is the help of the author's colleagues.

References

- ¹ A new Multi-Pair Coaxial Cable. *P.O.E.E.J.*, Vol 62, p.30, Apr. 1969.
- ² HAYES, H. C. S. Polythene-Sheathed Underground Telephone Cables. *P.O.E.E.J.*, Vol 63, p. 250, Jan. 1961.
- ³ GLOVER, D. W. and HOOKER, E. J. A Moisture Barrier for Polythene Sheathed Cables. *P.O.E.E.J.*, Vol. 53, p. 25, Jan. 1961.
- ⁴ British Patent No. 886,417.

Book Review

"The Origins of Maritime Radio." R. F. Pocock, M.S.E., and G. R. M. Garratt, M.A., C.Eng., F.I.E.E., F.R.Ae.S. H.M.S.O. 90 pp. 14 ill. £1.00.

The sub-title of this Science Museum Survey is "The Story of the Introduction of Wireless Telegraphy in the Royal Navy between 1896 and 1900." It is, in fact, largely the history of early radio-communication generally, since, from the beginning of the final decade of the nineteenth century, the Admiralty had been aware of the urgent need for a superior means of communication between ships at sea to overcome the obvious limitations of the traditional visual and aural methods on which they were still wholly dependent at that time. Experiments, based, like Marconi's, on the propagative properties of high-frequency electro-magnetic oscillations, had actually been carried out by Captain (as he then was) Henry Jackson of the Royal Naval Torpedo School during the five years preceding Marconi's first appearance in this country in 1896. This, however, proved to be of some advantage to Marconi, rather than otherwise, since, as Admiralty representative at the initial Post Office sponsored trials of Marconi's equipment, Captain Jackson was in a better position than most to appreciate the potential usefulness of the latter's work, and the possibilities of developing his ideas for naval purpose.

By 1899, the Admiralty had selected Marconi's system for

further trials. Its potentialities were convincingly demonstrated during the naval exercises of 1899 when three ships were equipped with Marconi sets. With one of the ships acting as a relay station, a message was received over a total distance, unprecedented in naval history, of 95 miles.

The subsequent decision to purchase a further quantity of Marconi sets, however, ran into difficulties over the demand by the Wireless Telegraph and Signal Company, who had acquired Marconi's patent rights in 1897 in return for a controlling interest, for a royalty payment of £100 per ship per annum. In an effort to escape this imposition, the sets developed by Jackson were tried as an alternative. They were found, however, to lack the performance and reliability of the Marconi productions, and the Admiralty were reluctantly compelled to purchase Marconi sets on the Company's terms. By the end of 1900, 32 Marconi sets were in commission, together with 19 Jackson sets.

The details of these events have been recovered by the authors from the official files (fortunately preserved in the Public Record Office) of the Government departments concerned, and are skilfully re-presented as a readable, well-illustrated account which fills a gap in the early history of radio-communication. A lengthy list of original sources consulted is included: the serious student would probably have found an index equally welcome.

D. A. J.

Notes and Comments

Publication of Correspondence

The Board of Editors would like to publish correspondence on engineering, technical or other aspects of articles published in the *Journal*.

Letters of sufficient interest will be published under "Notes and Comments". Correspondents should note that, as it is necessary to send copy to the printer well before publication date, it will only be possible to consider letters for publication in the October issue if they are received before 24 August 1973.

Letters intended for publication should be sent to the Managing Editor, *P.O.E.E. Journal*, Post Office Factories Headquarters, Bovay Place, London, N7 6PX.

Notes for Authors

Authors are reminded that some notes are available to help them prepare the manuscripts of the *Journal* articles in a way that will assist in securing uniformity of presentation, simplify the work of the *Journal's* printer and draughtsmen, and help ensure that authors' wishes are easily interpreted. Any author preparing an article for the *Journal* who is not already in possession of the notes is asked to write to the Managing Editor to obtain a copy.

It is emphasized that all contributions to the *Journal*, including those for Regional Notes and Associate Section Notes, must be typed, with double spacing between lines, on one side only of each sheet of paper.

Each circuit diagram or sketch should be drawn on a separate sheet of paper; neat sketches are all that are required. Photographs should be clear and sharply focused. Prints should preferably be glossy and should be unmounted, any notes or captions being written on a separate sheet of paper. Negatives or plates are not needed and should not be supplied.

Letters to the Editor

Dear Sir,

May I be permitted to reply to your correspondents who kindly commented on my letter regarding poles?

Since the timber pole has outstripped all competitors for over a century its practical merit cannot be doubted. Beauty, however, is in the eye of the beholder, and despite the improvements mentioned by Mr. Fagg and Mr. Clark I am afraid I still find the urban D.P. more than somewhat stark. For example, why was the use of the finial ceased? Could pole steps not be equally useful and safe if made with a

rather more rounded profile? And (suggested with some trepidation) what about combining the ringhead and terminal block into one component capable of accommodating and obscuring the "bundle of string" sometimes to be seen in that area?

At the risk of disappointing Mr. Clark I still wonder if it would be useful to give the problem to somebody with artistic talents. The result would undoubtedly be impracticable to implement, but it might establish a target for engineers to bear in mind.

I thank Mr. Clark for his interesting historical note re glass poles. Even my imagination had not run so far as a "crystal colonnade".

Yours faithfully,

K. S. LAYER
"Fringill"

40 Northey Avenue
Cheam, Sutton
Surrey

Model Answer Books

Books of model answers to certain of the City and Guilds of London Institute examinations in telecommunications are published by the Board of Editors. Details of the books available are always given at the end of the Supplement to the *Journal*.

Supplement

Students studying for City and Guilds of London Institute examinations in telecommunications are reminded that the Supplement to the *Journal* includes model answers to examination questions set in all the subjects of the Telecommunication Technicians' Course. Back numbers of the *Journal* are available in limited quantities only, and students are urged to place a regular order for the *Journal* to ensure that they keep informed of current developments in telecommunications and receive all copies of the Supplement.

Syllabuses and Copies of Question Papers for the Telecommunication Technicians' Course

The syllabuses and copies of question papers set for examinations of the Telecommunication Technicians' Course of the City and Guilds of London Institute are not sold by *The Post Office Electrical Engineers' Journal*. They should be purchased from the Department of Technology, City and Guilds of London Institute, 76 Portland Place, London, W1N 4AA.

Regional Notes

Scotland

Isle of Eigg, Automatic Telephone Service

On Wednesday 22 November 1972 the magneto exchange on the island of Eigg was replaced by a 20-line automatic exchange. It is believed that magneto working on the island had been in operation since about 1910, originally through a National Telephone Company switchboard and, later, through the British Post Office switchboard which was shelf mounted in the local Post Office and general store. During the day the switchboard was operated by the Postmistress. Service outside the normal Post Office hours was given under night switching conditions; under these conditions four paralleled groups of customers' lines were connected to the four generator-signalling junctions to give access to the switchboard at Mallaig and the operator there used code ringing to call the customers. This party-line working, which involved the customers counting the number of rings, was inconvenient, had no secrecy and was sometimes abused by visiting holiday-makers gaily turning the generator handle in the call office at the end of the pier. The junctions were provided by using ex-army 1 + 4 carrier equipment over the 19-mile-long concentric-type submarine cable laid in 1947. Since there is no a.c. mains supply on the island, a.c. power was fed over the submarine cable to provide power for the carrier equipment.

With the provision of the 20-line automatic exchange, which is installed in a hut measuring 10 ft by 8 ft and centrally situated on the island, each customer now has a standard 700-type telephone. The ex-army 1 + 4 equipment has been replaced by a transistorized 1 + 3 equipment with out-band signalling facilities and 50-volt power for the installation is provided by four 12-volt 50 ampere-hour car batteries which are charged by a one amp d.c. over the centre conductor of the submarine cable.

The 20-line exchange is a P.A.B.X. No. 5 fitted with earth (E) and mark (M) signalling junction relay-sets. A 20-line parent unit at Mallaig gives access on the Mallaig exchange. Individual service is now possible to each customer and subscriber trunk dialling facilities will be provided when Mallaig TXK1 group switching centre opens.

If demand grows beyond the present capacity of the exchange a unit automatic exchange and radio links will have to be provided. This will involve providing diesel-driven alternator plants and introduce the problem of shipping and handling the fuel supplies.

Automatic working has, thus, been introduced to an island community of some 70 souls with 17 connexions to the exchange.

C. J. MACPHERSON

South Eastern Region

The New Crossbar Exchange at Dover

Dover, the last manual exchange in the Canterbury Area, was replaced by a crossbar exchange on 28 March 1973.

The first telephone exchange at Dover was provided by the National Telephone Company about the beginning of the century. It was located in Market Square and was of the magneto type. In 1912, the Post Office took over the National Telephone Company's system and, in 1914, a new telephone exchange was installed in the then new Head Post Office building in Biggin Street. This exchange continued to serve Dover until 28 June 1943, when it was destroyed by a German shell. A temporary replacement switchboard was quickly installed in the Post Office basement; this temporary switchboard was subsequently replaced by the exchange which was converted to automatic working on 28 March 1973.

The new exchange consists of 40 C.S.S.1 Switchboards and a 5005 TXK1 group switching centre crossbar exchange with a local equipped multiple of 6,000. The regional contract was placed on 28 November 1967 with Messrs. G.E.C./A.E.I. and installation commenced in October 1969. The installation was protracted, mainly due to a large number of on site modifications involving some circuit development work. This was the first completed installation of its kind in the country and type-approval of the system was carried out by Telecom-

munication Development Department during October and November 1972. The exchange opened without transit and international subscriber dialling working which are scheduled to be provided on subsequent extensions. Signalling equipment S.S.A.C. No. 9 (transistorized version) and S.S.D.C. No. 2 is designed to Strowger practice and has been available for service for some considerable time. The exchange opened with an elusive fault which it is hoped will be contained and finally eliminated.

The total cost, building and equipment, was just over £900,000.

Subscriber trunk dialling access has been provided and calls can be dialled to nearly 1,800 distant exchanges.

Included amongst the dependents are two TXE2 exchanges, St. Margaret's Bay and Ash, which were converted prior to the main Dover transfer. The network provision consists of 11 supergroups (60 channel capacity), 43 groups (12 channel capacity), 586 main-network circuits and 424 junction network circuits.

G. W. B.
H. H. S.
J. M. S.

Brighton's Farewell to the Siemens 16 Exchange System

On Wednesday, 17 January 1973, an important link with the past was broken when the Siemens 16 exchange at Portslade, Sussex, closed down.

This exchange, and the other Siemens 16 exchanges at Brighton, Hove, Preston and Rottingdean, opened simultaneously on 12 November 1927, taking over about 7,000 exchange lines from seven manual exchanges of various types. Southwick followed a few weeks later. The Brighton linked-numbering scheme remained as a complete Siemens 16 system until 21 October 1959 when the subscribers on Brighton exchange were transferred to new 2,000-type non-director exchanges in Hove and Kemp Town. Immediately prior to this change, the total exchange connexions had risen to 36,000 with a remarkably good standard of service being provided for the customers.

These old exchanges were extended to meet the demand for more exchange lines and, in many instances, equipment from recovered Siemens 16 exchanges in other parts of the country was renovated and used to cope with the growth of the system in Brighton. The present total is 71,000 exchange connexions and the forecast for the year 2001 is 172,250.

Hove Siemens 16 exchange closed on 18 January 1967 followed by Rottingdean on 23 August in the same year. Preston finally closed on 15 October 1969 but 3,300 subscribers had already been transferred to the new exchange at Withdean on 8 May 1968. A TXK1 exchange opened at Southwick on 19 May 1971 leaving Portslade as the only Siemens 16 exchange and the majority of lines on this exchange were transferred to a TXK1 exchange on 10 November 1971. The old exchange was retained as a relief and, by the time this was due to be closed, it was the last Siemens 16 exchange in England.

Many of the Brighton engineering staff had been associated with this wonderful old system for more than 49 years. They were dedicated in their task of giving the best possible service to the customer and, in the majority of cases, without any of the sophisticated maintenance aids we use today. There was a great affection for this sturdy old equipment and it was natural that a final tribute to the Siemens 16 exchange system should be arranged.

A committee was formed and decided to invite every member of the engineering staff who had worked in the Siemens 16 exchanges in the Brighton Area to attend the exchange transfer at 1.30 pm and a commemorative lunch afterwards.

The guests were welcomed by Brighton's General Manager, Mr. K. Burling, and 120 sat down to a meal attractively prepared by the Regional Headquarters catering staff. About a quarter of those present were retired members and included Mr. D. C. Blair, formerly a Deputy Director of Engineering, and Mr. A. H. Knox, retired Planning Controller, who was a Probationary Inspector in Brighton at the original transfer in 1927. G.E.C. Telecommunications Ltd (who took over

Siemens), also received invitations and one of their representatives was Mr. E. W. Saunders, retired Area Installer, who worked in the old exchange in 1927.

An exhibition of Siemens 16 items of particular interest was staged including a blue-print of the original transfer arrangements showing the names and duties of all concerned. A large replica of the original Brighton dial, showing exchange names over six of the digits on the number plate, was also on show.

Finally, copies of a souvenir program giving the history of Brighton's telephone service, the commemorative lunch menu, details of the exchange transfer, and a picture of the Siemens 16 preselector, were handed out to all in this final farewell tribute to the Siemens 16 exchange system in this country. A very enjoyable and memorable occasion.

H. W. BROWN

London Telecommunications Region

The New London Bridge

Following the report printed in the issue of July 1970, the 36-way duct route that had been suspended by means of steel hangers through the first two diaphragms of the new London Bridge was successfully completed and tested.

In order to change over the cables into this new duct work so that the centre part of the old bridge could be demolished, it was necessary to use a fair amount of temporary rigging, anchor points and cable-bearers, etc. At this time, the two large cable chambers where the cables would be changed over were at a very early stage of construction.

As the north and south cable chambers were over 300 m apart it had been decided to use the new heavy cabling unit (Figs. 1 and 2), then at its field-trial stage, to draw over the 19 cables to be changed out. Some trepidation had been expressed due to both to the length of the pull and the fact that the suspended duct had had to deviate from the horizontal because of the differing length of the steel rods at the centre of the arch and the middle of the piers. The 19 cables, including a 1,040 pair 10 lb cable, an 880 pair 10 lb cable and a 342 pair 20 lb cable, were in fact successfully pulled over the entire length without any undue strain on the cables or the duct.

Joining of the new to the old had to be carried out in rather uncomfortable and cramped conditions but having all been changed over, the old cables were removed from the centre of the bridge and the contractors were able to proceed with the work of demolishing this part of the old bridge.

At a much later stage 20 polyvinylchloride (No 54) ducts



FIG. 1—Heavy cabling unit preparing to pull cables in at the south side of London Bridge

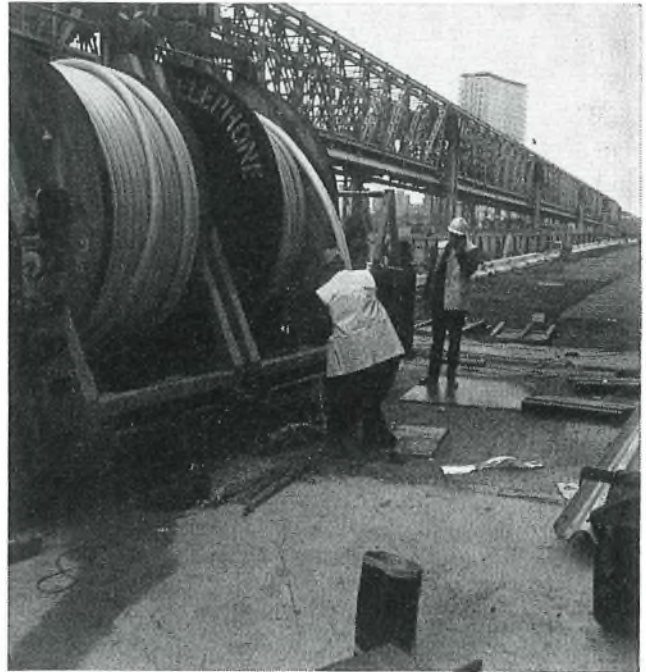

FIG. 2—Cable being fed into ducts, in the main diaphragm below, at the north side of London Bridge

were laid in horizontal formation on the downstream side of the bridge and 16 on the upstream side in the same formation.

Most of the work was carried out by the City Area engineering staff with such a lack of fuss and bother that the whole difficult undertaking was made to appear easy.

J. L. LEONARD.

Midland Region

Emergency Telephone Unit

In the event of a civil disaster e.g. a major road, rail or air crash, flooding, etc. particularly in remote areas, one of the biggest handicaps to rescue and restoration work is lack of communications. To help overcome this, the Service Division of Midland Telecommunications Region have commissioned a purpose-built vehicle to provide temporary telephones for the essential services at the scene of any disaster which may occur in the Region.

The vehicle has a Luton van-type body based on a 4-wheel drive, 110 in. Land Rover chassis, powered by a forward controlled 2,625 c.c. petrol engine. The body shell and interior were built by Telecommunications Headquarters Motor Transport Division, at their modification shop at Yeading. Painting and small additions were carried out at Lanesfield central docking and repair depot and fitting of the telephones, telephone cabling and provision of stores were completed by engineering staff of Service Division, Midlands Telecommunication Region.

Four telephone circuits in the unit are cabled to, and terminated on, a Block Terminal No. 41 mounted externally on the rear of the body to facilitate easy connexion to a flexibility point in the local network. The unit carries 450 m of 4-pair polythene cable with copper conductors, 1,000 m of cable drop Wire No. 3 and 600 m of Cable Drop Wire No. 4 to assist access into the local network. A two-section aluminium pole can be fitted to the rear of the unit which will give an 18 ft clearance above ground for the cabling to the block terminal.

The unit carries a ladder to assist in any overhead installation work that may be required to provide service. Both the pole and ladder are housed in specially-built compartments on the off-side of the vehicle when not in use. A selection of tools, small stores, protective gear and safety equipment is also provided to enable the unit to be self-sufficient, and is stored in the Luton head compartment of the vehicle body.

Inside the unit, three of the telephone circuits are terminated on wall-type telephones No. 711, each suitably modified for



The emergency telephone unit

connexion to automatic, C.B., C.B.S. or magneto exchange conditions. The fourth telephone circuit is wired as a Plan-4 installation, one jack point being terminated in the unit, and a second jack point terminating in the driving cab of the vehicle to give seclusion from within the unit if required.

An Equipment Radio No. 10A is filtered with crystals for the six allocated Post Office channels giving radio contact to External Plant Maintenance Controls in the telephone areas. The radio controls have been modified so that they can be used either from the driving cab or the telephone unit.

The gross interior dimensions of the unit are height 6 ft, length 10 ft 6 in, and width 5 ft 6 in. A clothes locker, food locker, stores locker, ladder and pole lockers are dovetailed into this space. An 18 in wide shelf fitted to the nearside and rear walls provides writing facilities. Four stackable chairs, stowed in the Luton head compartment whilst the vehicle is in transit, add to the office facilities.

The interior is lit by four 12-volt fluorescent lights and heated by a propane-gas convector heater. Additional ventilation is achieved by a 12-volt extractor fan located in the roof.

Welfare facilities include a two-ring propane-gas cooker, small sink and draining board and a small emergency food pack, primarily for the use of the driver and his colleague. Other features of the vehicle include an omnidirectional flashing light on the roof, to conform with airfield regulations, and a flame trap on the exhaust system to avoid risk of explosion when the vehicle is in a re-fuelling area or other similar dangerous location.

The emergency telephone unit is based at Leicester, the geographical centre of the Region. The General Manager has nominated technicians from his subscribers' apparatus and line maintenance staff who will drive the unit to assist in

the initial engineering aspects of connecting the unit into the local network.

N. T. WILLETTS

Datafair

The British Computer Society's biennial conference was held once again at the Nottingham University campus from 10-12 April 1973. This three-day event attracted members of the computer-using communities from many parts of the world to the exhibition put on by over 50 companies.

To the British Post Office (B.P.O.) the event presents the challenge of providing a large concentration of telecommunications facilities in the limited time available between the end of term and the commencement of the exhibition. Nottingham University has been described as one of the most pleasantly situated in Great Britain, many of the buildings being spaced in an undulating parkland setting. Whilst this may be attractive from a visitor's point of view, it makes the task of providing telecommunications that bit more difficult.

Planning for the event commenced early in 1972 and the more interesting details of the job are given below.

Line plant. The cables used for the previous Datafair were still available, these were the Nottingham/D-Nottingham University No. 1 with 150 spares, 50 pairs were also through to Beeston exchange and a further 280 pairs were diverted from the Beeston-Nottingham No. 2, making a total of 480 pairs.

On-site cabling. The main exhibition was held in the Sports Hall which is a large room with a single-span ceiling supported only at the walls. New distribution points were installed in the roof of the building and temporary cables were dropped down to the exhibition stands. For the rest of the site, existing distribution was used and temporary cables were run to the various presentation sites.

Installation. Great efforts were made by the installation staff who worked throughout the week-end and until 22.00 hours on the day before the opening. A B.P.O. caravan was used on the site to serve as a temporary engineering centre and store.

Maintenance. Faults were reported to the Regional Service Centre and a temporary Datal Test Centre was set up at the Nottingham Trunk Maintenance Central Centre.

Trunk routes. The major trunk routes to Birmingham, Cambridge, Leeds, London, Manchester and Reading were augmented to carry the increase in traffic.

From the B.P.O. point of view this was a successful operation. Altogether a total of 87 exchange lines including 27 for Data transmission, four private circuits and 17 modems were provided, working and tested ready for the opening at 09.00 hours on the Tuesday morning.

N. MILLER

Associate Section Notes

Aberdeen Centre

Our first meeting of 1973 was a film night held on January 24. The program was varied and consisted of films on mountain rescue, shipbuilding, North Sea oil and golf, the films being hired for the evening. In February, the Trade Relations Officer for "Shell United Kingdom Exploration and Production Ltd" gave the centre a very interesting and enjoyable talk on the search for oil in the North Sea. To augment his talk we were shown a very new film on oil exploration. Members were to have visited the new Police Headquarters in Aberdeen on 14 March but owing to building construction this was not possible. Instead a police officer from the city force gave an excellent talk on the role of the police. In April there was a day visit to a distillery and R.A.F. station. The session 1972-73 ended with the annual general meeting held in May.

J. H. McDONALD

Bedford Centre

Bedford Centre went on two visits of particular interests during the last session. One was to Cardington R.A.F. station, just outside Bedford and the erstwhile home of the ill-fated airships R100 and R101 of days gone by, to see the Goodyear Airship "Europa". Although quite large, it was dwarfed inside the massive hanger which once housed the old dirigibles.

The other was a tour round the local fire station during which a 999 call came in. From the time that the call was taken in the control room, it took only 90 seconds for the crew to come from their nearby homes and get the first appliance out of the Station.

The eighth annual general meeting was held on 21 September 1972, and was followed by a film show.

On 11 April 1973 an "Open Forum" was held with the Deputy General Manager, Mr. Ray Parker in the chair and the four Heads of Engineering as the panel.

On 2 May we had a film show in the Lecture Theatre of the local Public Library. Four films from the American Embassy were shown:

Apollo 16, Skylab (tentative launching on 14 May 1973), Underwater Aquanauts, and The World's Largest Solar Telescope.

There was also a film from the Ford film library called "Shooting on Ice" which deals with the filming of the James Bond stunt sequences.

A further lecture, date to be arranged, is to be on "Drugs" and will be given by the County Police.

E. PHILCOX

Cambridge Centre

The Cambridge Centre began this year with a lecture entitled "Hi-Fi in Stereo", given by Mr. A. Watling. This was Mr. Watling's second lecture on the subject and attracted as good an attendance as did his first.

The Cambridge Aircraft Preservation Society visited the centre on 1 March with a slide show and recorded lecture on the "U.S. Eighth Army Air Force in world war two". The lecture, described the work of the society, in tracking down and recovering crashed aircraft. A number of aircraft parts that have been found in the Cambridge area, were on display together with badges and insignia of local squadrons.

The Centre's annual general meeting took place on 29 March and the following officers were elected: *President*: Mr. A. E. Paterson; *Chairman*: Mr. R. S. King; *Vice-Chairman*: Mr. L. A. Salmon; *Secretaries*: Messrs P. J. Young and T. Marshall; *Treasurer*: Mr. G. R. Gow; *Committee Members*: Messrs J. Norman, S. Hurt, K. Vincent, P. Stewart, and R. Plumb; *Auditors*: Messrs J. E. Clark and P. R. Howlett.

Several suggestions were received for the forthcoming program and it is hoped these meetings will all be well attended.

P. J. YOUNG

Eastern Region Centres

On Monday, 12 March 1973 the Post Office Training School at Bletchley, Bucks. was the venue for a memorable occasion in the history of the Associate Section of the Institute of Post Office Electrical Engineers (I.P.O.E.E.) in the Eastern Region; saying farewell to their National President, Dr. Philip R. Bray, Ph.D., M.Sc.(Eng.), B.Sc.(Eng.), C.Eng., F.I.E.E., M.B.I.M. who is retiring shortly.

The event, which was jointly organized by Bill Allen secretary of the Bletchley Centre and Eric Philcox secretary of the Bedford Centre, coincided with Eastern Telecommunication Region (E.T.R.) annual regional conference of associate sections and took the form of a dinner with Dr. and Mrs. Bray as guests of honour. The dinner was attended by the Regional Director, Mr. J. E. Golothan, and Mrs. Golothan, the Regional Liaison Officer for Associate Section, Mr. S. H. Sheppard, the General Secretary of I.P.O.E.E. Mr. A. B. Wherry, the Principal of the Training School Mr. A. F. Lee and delegated representing E.T.R. associate centres.

The dinner was followed at 20.30 hours in the Mansion Ballroom by speeches and a presentation. This was attended



by many more guests and their wives including Mr. K. Hunt, General Manager of Bedford and Mr. R. Parker, the Deputy General Manager.

The chair was occupied by Mr. Sheppard who opened the proceedings by welcoming those present and thanking Mr. Lee and Mr. H. Baker, the Deputy Principal, for making the training school facilities available for the Dinner and conference.

Mrs. Mary Philcox then presented an orchid each to Mrs. Bray and Mrs. Golothan. This was followed by a few words by Eric Philcox on behalf of the Eastern Region Centres. Mr. A. Watkins as Regional Liaison Officer spoke on behalf of South Eastern Region followed by Mr. B. Wherry for the Main Institution.

Mr. A. H. C. Knox, a former President of the Associate Section (now retired) who had travelled from Morden, Surrey for the occasion spoke of the growth and progress made by the Associate Section over the past years.

The official part of the evening was concluded by Mr. Golothan presenting a parchment farewell scroll signed by many representatives of the I.P.O.E.E. Eastern Region and a magnificent engraved silver galleon tray (see photograph).

Dr. Bray replied by thanking the Associate Section for the farewell gifts.

London Centre

The London Centre lecture program has been very well attended this year so far and this is very encouraging. Activities have been well supported in the London Telecommunication Region (L.T.R.), particularly the workshops. Special mention must be made of South Central Area who had the first working group in the L.T.R. The members have been busily making toys for children in a local orphanage, top marks to the lads in this area.

Our Technical Quiz final was held on 2 May at the Regional Headquarters.

Our Annual Conference was held at the I.E.E. on 11 May. This was followed by the usual dinner in honour of the C. W. Brown Award winner or winners.

The dates and places of our summer visits are as follows: Plessey, Nottingham, 16 May; Shell, Isle-of-Grain 20 June; Pirelli, Southampton 19 September. Further details of any visits can be obtained from the London Centre Visits Secretary.

L. HEWLETT

Oxford Centre

At our annual general meeting, held on 12 April, a review of the year's activities was given. These included visits and talks—the most recent being a tour of the "Oxford Mail and Times" and a lecture by Dr. P. R. Bray on Submarine Cables.

Attendances, as a whole, were on a par with other centres, but it was thought that as nearly one quarter of the members were Technician Trainee Apprentices, efforts should be made to ensure that their involvement with local activities is catered for and developed.

Mr. D. A. Green, Secretary since 1967, was unable to stand for re-election owing to promotion. This is a sad loss to our centre as he was an energetic and enthusiastic secretary whose efforts will be difficult to match.

As for the future—we have ideas, but we need your support.

D. R. WARD

Northern Ireland Centres

Associate Centre activities continue despite none too perfect conditions. We are pleased to report the formation of a new centre at Ballymena, Co. Antrim and have high hopes of another at Coleraine, Co. Londonderry in the not too distant future.

Highlight of the current season has been the Regional Technical Quiz which drew entries from all Centres and also required preliminary heats to decide the Centre representative teams. Belfast and Londonderry met on the 26 April to decide who were Regional champions and first holders of the Wylie Shield presented by our General Manager, Mr. T. S. Wylie.

The final lecture of this season is "Preparing for an Interview" to be delivered to all Centres by our General Manager. The program commenced at Belfast on 4 April.

Summer visits are unlikely to outside industrial concerns due to the security situation but we hope to fill this gap by arranging visits to electronic and crossbar exchanges.

D. McL.

Worthing Centre

The Worthing Centre, which was started in 1967, is still going strong and is well supported by its 130 members. Senior Section members and retired members are regular guests at our evening meetings.

In the past year, we have organized visits to Radio Brighton Studios, the Royal Observatory at Herstmonceux, Kodak's at Hemel Hempstead, B.O.A.C. at London Airport, Meridian Airmaps at Lancing, I.T.T. Creeds at Brighton and Guinness at Park Royal.

Evening meetings have been well attended and have in-

cluded talks on "Sussex Archaeology" by Mr. C. Ainsworth; "Radio Astronomy" by Mr. R. Ham, F.R.A.S.; "Fire Communications in North America" by Miss Quick, Assistant Group Officer, West Sussex Fire Brigade; and "Your Water Supply" by Messrs. Loosely and Attle of Worthing Corporation Water Department.

We acquired a 16 mm sound projector in the latter part of 1972 and have held several film show evenings.

Future visits in 1973 include the Road Research Laboratory at Crowthorne, Dungeness Power Station, and a combined visit to the Royal Marine Commando Museum at Eastney and the Submarine Museum at *H.M.S. Dolphin*, Gosport.

Our Centre entered a team for the second time in the Regional Quiz but were beaten by Guildford. Another team is preparing for the 1973 Quiz.

A. J. BONSALE

Institution of Post Office Electrical Engineers

Annual Awards for Associate Papers Session 1971-72

The Judging Committee having adjudicated on the papers submitted by the Local Centre Committees, prizes and Institution Certificates have been awarded to the following in respect of the papers named:.

Prize of £15:

G. W. E. Gay, Salisbury Centre. "The Transit Network."

Prize of £5:

D. McL Duncan, Aberdeen Centre. "Datel."

Prize of £2:

R. G. Genge, Southampton Centre. "An Introduction to Subscriber Trunk Dialling"

The Council of the Institution is indebted to Messrs. W. N. Lang, S. T. March and J. I. Murray for kindly undertaking the adjudication of the papers submitted for consideration.

Retired Members:

The following members, who retired during 1972, have retained their membership of the Institution under Rule 11 (a):

S. D. Mellor, 67 Caer Wenallt, Cardiff, CF4 7HQ.

W. T. Welch, 142 Wood Street, Barnett, Herts.

E. Holkinson, Garth Cottage, Heyshaw, Sunner Bridge, Harrogate.

W. S. Davies, 16 Annefield Park, Gresford, Wrexham, Denbighshire.

R. G. Swarbrick, 76 St. Thomas Road, Preston.

E. Hoare, Frith Copse, Manningford Bruce, Pewsey, Wilts, SN9 5PE.

R. A. Seymour, 14 Woodberry Way, Finchley, N12 0GH.

W. T. Tipping, 56 Risborough Road, Bedford.

H. R. Brown, 12 Hinde Road, Summerley Fields, Felphan, Bognor Regis.

D. McDermid, 10 Hills Road, Buckhurst Hill, Essex.

L. C. Chant, 83 Firlie Road, Peacehaven, Newhaven, Sussex, BNG 7QN.

F. D. Parr, 79 Loom Lane, Radlett, Herts.

A. E. Woods, Byways, 24 Backwell Hill Road, Farleigh, Bristol, BS19 3PL.

J. H. Conbridge, 3A Hamilton Avenue, Barkingside, Barkingside, Ilford, Essex.

C. H. Peak, 13 Pelham Terrace, Lewes, BN7 2DR.

J. Rhodes, 26 Ardross Avenue, Northwood, Middlesex, HA6 3DS.

E. H. Pooley, 47A Hampton Lane, Solihull, Warwickshire.

D. C. Blair, 55 Hayes Way, Beckenham, Kent.

L. W. J. Chilver, 12 Bewley Court, Chard, Somerset.

E. J. French, Leylands, 8 Upper Golf Links Road, Broadstone Dorset, BH18 8BU.

A. B. WHERRY
General Secretary

Results of Essay Competition, 1972-73

A first prize of £14 and an Institution Certificate have been awarded to:

Mr. J. V. Buckley, Technical Officer, London Telecommunications Region, North Centre Area, for his essay "Telecommunications in the Netherlands."

Prizes and Institution Certificates have also been awarded to the following:

£9 to Mr. C. Kelly, Technician 2A, Rotherham Area, "The Development of Communications Satellites."

£9 to Miss A. J. Owen, Senior Drawing Office Assistant, Northampton Area, "Today's Juniors—Tomorrow's Seniors."

£4 to Mr. D. E. G. Coles, Technical Officer, Birmingham Area, "Critical Path Analysis."

£4 to Mr. J. Searby, Technician 2A, Liverpool Area, "An Historical Sketch of Telecommunications Development in the United Kingdom."

In addition, five certificates of merit have been awarded to:

Mr. J. F. Bingham, Technician 2A, Rotherham Area, "Thin Film Technology."

Mr. C. Little, Technician 2A, Edinburgh Area, "Capacitors for Telecommunications."

Mr. L. P. Sewell, Technical Officer, Preston Area, "Three Problems—Three Answers."

Mr. A. Buttrey, Technical Officer, Wakefield Area, "Marks and Spaces."

Mr. C. F. Newton, Instructor, Otley Area, "The Use of Visual Aids in Training."

The Council of the Institution records its appreciation to Messrs A. C. Eley, A. W. Welsh and J. R. Walters, who kindly undertook to adjudicate upon the essays entered for the Competition; it is also indebted to them for the following report on the prize-winning essays. The prize-winning essays will be kept in the Institution Central Library and will be available to borrowers.

Review of 1972-73 Essay Competition

The number of entries (24) was slightly higher than last year and once again showed a high proportion of authors from the Midlands and North of the country.

It was evident that many of the authors had taken a great deal of care, and time, in the presentation of their essays, particularly in the drawings. On the other hand, fewer of the essays this year displayed originality. Too many were summaries of already published information on some technical subject or new development, without the author's own ideas or opinions being brought out.

The first prize was awarded for "Telecommunications in

the Netherlands" by Mr. J. V. Buckley from the London Telecommunication Region. The author had been selected to visit the Netherlands as part of the staff interchange scheme and had clearly taken full advantage of his opportunity. His essay describes the organization of the network—local, trunk and international telephone as well as the telex network, and the types of plant used. Maintenance philosophy, and the results, are also discussed. Of particular interest is the multiplicity of different types of equipment used in the network. As well as describing the network as it now exists, and highlighting the differences between the

Netherlands network and our own, the essay outlines what is being planned for the future. This is a clear, concise and interesting essay.

Other entries ranged in technical complexity from the fundamental particles of physics to satellite communication and waveguides, and in general interest from the social life in an overseas country to the history of telecommunications, or the training of young ladies in the drawing office.

N.B.—Particulars of the next competition, entry for which closes on 15 January 1974, will be published later.

Local Centre Secretaries

The following is a list of Local Centre Secretaries and to whom inquiries about the Institution may be addressed. It would be particularly useful if members would notify any change in their addresses to the appropriate Secretary.

<i>Centre</i>	<i>Local Secretary</i>	<i>Address</i>
London	Mr. J. S. Gilroy	Telecommunications Headquarters, TD2, Proctor House, 100-110 High Holborn, London WC1V 6LD
Stone-Stoke	Mr. G. P. Austin	Technical Training College, Stone, Staffs ST15 0NQ
Eastern	Mr. R. A. Spanner	Planning Division, Eastern Telecommunications Region, St. Peter's House, St. Peter's Street, Colchester, Essex.
South Eastern	Mr. J. M. Smith	Planning Division, South Eastern Telecommunications Region, Grenville House, 52 Churchill Square, Brighton BN1 2ER
North Eastern	Mr. H. Teale	Planning Division, North Eastern Telecommunications Region, 36-37 Park Row, Leeds LS1 1EA
Northern	Mr. B. O. Slater	Telephone Manager's Office, Swan House, Pilgrim Street, Newcastle-on-Tyne NE1 1BA
Birmingham	Mr. H. T. Harvey	Planning Division, Midlands Telecommunications Region, 95 Newhall Street, Birmingham B3 1EA
East Midland	Mr. D. W. Sharman	Telephone Manager's Office, 200 Charles Street, Leicester LE1 1BB
North Western (Manchester and Liverpool)	Mr. S. Hart	Planning Division, North Western Telecommunications Region, Bridgewater House, 60 Witworth Street, Manchester M60 1DP
North Western (Preston)	Mr. J. W. Allison	Post Office Telephones, Clifton Road Depot, Marton, Blackpool FY4 4QD
Wales and the Marches	Mr. R. J. Jones	Planning and Works Division, Telecommunications Headquarters, Wales and The Marches, 2 Plymouth Street, Cardiff CF1 4XZ
Scotland East.. .. .	Mr. T. C. Watters	Service Division, S131, Telecommunications Headquarters, Scotland, Canning House, 19 Canning Street, Edinburgh EH3 8TH
Scotland West	Mr. D. M. Dickson	Telephone House, Pitt Street, Glasgow C2
South Western	Mr. C. W. Read	Planning Division, South Western Telecommunications Region, Mercury House, Bond Street, Bristol BS1 3TD
Northern Ireland	Mr. W. J. Gawley	Telephone Manager's Office, Churchill House, Victoria Square, Belfast BT1 4BA

A. B. WHERRY,
General Secretary.

Post Office Press Notices

Goonhilly 3 Fully Operational

Satellites now carry nearly half Britain's international telephone calls to places beyond Europe—just ten years after the world's first 'phone call by satellite was relayed across the Atlantic via Telstar.

"Although cables are used extensively for links with Europe, satellites now closely rival undersea cables as the main carriers of telecommunication services over long distances," Mr. Keith Hannant, Director of the Post Office's International and Maritime Services, said when he announced that Goonhilly 3, the Post Office's new £2½m satellite communications aerial, is now fully operational.

The Post Office satellite earth station at Goonhilly, Cornwall, is the first earth station in the world to have three aerials in commercial operation simultaneously to three satellites. "This represents the culmination of many years of effort by development and operational departments of the Post Office and its suppliers," said Mr. Hannant. Between them the three giant aerials have nearly 700 long-distance telephone circuits in operation—only 50 or so fewer than the total number of circuits used by Britain in the major intercontinental cables to places beyond Europe.

The new aerial, built for the Post Office by Marconi, provides, with aerial 2, communication to 18 countries through two satellites positioned 22,300 miles above the Atlantic Ocean. These two aerials share the workload and together guarantee a high degree of reliability on the busy Atlantic links. Each can take over the other's work in the event of a major failure of a satellite or aerial equipment. The satellite system can also step in to provide support in the event of a North Atlantic telephone cable failure.

Aerial 1 provides communication eastward to 16 countries through a satellite over the Indian Ocean.

"Few technologies have developed as rapidly or brought such immediate benefits as communication by satellite," said Mr. Hannant. "Only ten years ago worldwide communication was by cable or by h.f. radio. Today, we have a global system of geo-stationary satellites over the three main ocean regions which carries two-thirds of the world's intercontinental telephone calls."

Britain's use of satellites will increase dramatically over the coming years, with the number of circuits in service more than doubling to 1,750 in two years' time and reaching 3,500 by 1980.

The development of satellite systems, in which the British Post Office has played a major pioneering role, should not be seen in isolation, Mr. Hannant said. "Together with submarine cables they form an integrated international network designed to meet an ever-increasing demand for communication across the globe."

Britain is on the upward curve of an international telephone "boom" which shows no signs of stabilising. The magnitude of the challenge the Post Office now faces is shown in the traffic figures: five years ago the U.K. handled a total of 20 million international calls a year; today the figure is nearly 60 million; within five years the number will soar to 130 million.

Since 1962—when the first communication satellite came into service—the Post Office has contributed about £9m towards the purchase and launching of satellites by INTELSAT* and £10m developing the earth station at Goonhilly.

"We have also been developing and expanding our cable network in parallel with our satellite system," said Mr. Hannant. "Our next transAtlantic telephone cable, CANTAT 2, which comes into service in 1974, will carry nearly 2,000 telephone calls simultaneously—more than double the combined capacity of all existing transatlantic cables."

"Technological developments have been a major stabilising factor in international telephone charges—and in many cases have helped to pull our charges down," Mr. Hannant pointed out. "Today a call to America or Canada can be made on International Subscriber Dialling for as little as 50p a minute. When we first started transatlantic 'phone services 45 years

ago the minimum charge for a similar call was £15—in those days the equivalent of several weeks' wages."

Equipment of Waveguide Field Trial

Repeaters and terminal equipment for a full-scale field trial of waveguide—50 mm internal diameter hollow tube in which up to 300,000 telephone conversations could be transmitted simultaneously—is being manufactured for the B.P.O. by GEC-Marconi Electronics Ltd.

The waveguide trial, over 15 km of Suffolk countryside between Martlesham Heath and Wickham Market, is being staged in the B.P.O.'s programme of research and development to meet soaring demand for existing telecommunication services and prepare for new ones. In the waveguide, telephone calls, computer data and vision signals, are transmitted by radiowaves in the 3 mm–10 mm range.

The trial, which follows the B.P.O. Research Department's successful tests of waveguide systems up to 1 km long at its Research Station at Martlesham Heath, is being carried out in conjunction with British industry. In this work, the B.P.O. developed prototypes of repeater and terminal equipment as well as a new design of lightweight waveguide.

The equipment to be supplied by Marconi consists of band-branching units that divide the total operational frequency spectrum of the waveguide into five bands, channel separators to subdivide two of these bands into 16 channels and repeaters which amplify and demodulate input signals from several channels, process the demodulated signals to remove noise or distortion, and then transmit "regenerated" versions of the original signals.

A circuit length of 30 km will be obtained in the trial by sending signals along the waveguide at one frequency to the Wickham Market terminal where repeaters (with a frequency shift) will return them to Martlesham at another frequency. Operating in the low-loss TE₀₁ mode, the waveguide should be capable of carrying transmissions in the frequency range 32 to about 110 GHz. Equipment development is being carried out in two stages, covering 32 to 50 GHz and then 50 to 90 GHz. The remaining band will be used in the field trial for system monitoring. The frequencies in the lower range (i.e. 32–50 GHz) can give up to 16, 0.5–GHz channels in each direction, each capable of carrying simultaneously 7,200 telephone conversations or four television programmes. In the trial, signals will be sent over one or two channels each way, in digital form, at 500 Mbit/s, using pulse code modulation.

Radio-paging by Telephone

A new communication system in which people carrying tiny radio receivers can be contacted whenever they are within range—simply by dialling a telephone number—was recently announced by Mr. Edward Fennessy, Managing Director for Telecommunications. The receivers, small enough to be clipped into a pocket give a high-pitched 10-second "bleep-bleep" signal when activated by a 'phone call.

This new service—radio paging—is the first in the U.K. in which a simple 'phone call over the ordinary public network will activate pocket "bleepers".

Mr. Fennessy was inaugurating an introductory service centred on Reading and covering about 500 square miles of the Thames Valley. "If the trial goes as we expect, this could be the first tangible step towards a general radio-paging service operated by the Post Office," he said.

Several hundred radio-paging pocket beepers will be used in the Reading service. Each has its own exclusive 10-digit number. Dialling this number "instructs" transmitting equipment to send out a radio signal to activate the beeper.

Communication is one-way only, so the user must prearrange the action to be taken on receipt of a radio-paging call. For a businessman, this could be the signal to 'phone his office, or for a doctor to 'phone his surgery.

"Initially, there will be only one type of 'bleep' emitted by the radio receiver so that only one prearranged response by the user will be possible," said Mr. Fennessy. But a refinement which the Post Office may add later if this service

* INTELSAT is a consortium of nations formed to exploit satellites commercially for communications purposes.

is successful is a variation in the "bleep", to permit up to three different signals to be received, allowing users a wider choice of action.

The beepers, powered by a small battery lasting several months, will work inside buildings, in cars and on trains. Post Office engineers expect to achieve better than 95 per cent successful penetration of radio signals during the trial. At the touch of a switch the receiver can store an incoming signal if the person carrying it does not want to be disturbed. Switched "on" later, the beeper will emit its signal if a call has been received. It can also be switched off completely.

"Radio-paging adds an entirely new dimension to the telephone network," said Mr. Fennessy. "It frees people from the need to be tied to the 'phone when they have important business in hand, while increasing the utility of the telephone service for everyone. For example, the doctor on call can go out. If an emergency arises, his surgery can contact him—without necessarily knowing his whereabouts. In addition, he has the convenience and comfort of knowing that he is not wanted unless paged. The same goes for many other people who are on call."

Radio-paging helps not only people on call but their customers, too. For example, a service repair engineer on his rounds could carry a beeper enabling his firm to contact him immediately there is an urgent repair job.

Radio-paging receivers will cost £5 a month to rent, with an initial payment of £5. Calls to a receiver will be free during the introductory service. A call to a radio-paging beeper is made simply by dialling a receiver's 10-digit number. Once the call is accepted by the service's computer-controlled equipment a recorded announcement will tell the caller: "Your paging call has been accepted, please replace your receiver now." Within seconds a radio signal will be transmitted to activate the beeper. The radio-paging control equipment is in Reading trunk exchange. Five radio transmitters cover the 500 square miles in which the service operates. They are at Reading, Stokenchurch, Bagshot, Slough and Maidenhead.

The paging receivers measure 4.5 × 1.3 × 0.8 inches and weigh 4 oz. Equipped with an "AA" size 1.5 volt alkaline battery each receiver will operate for 925 hours, which represents three months or more of average use. Battery economy has been obtained by using CMOS circuitry and by the use of a battery saver clock which continuously switches the receiver on and off for 0.28 and 1.2 seconds respectively. The receiver is basically a double superhet constructed out of six integrated-circuit modules.

Reception is in the 150 MHz band and the signal pick-up is by means of a "U" shaped metal cover which partially slides out of the plastic case for battery replacement purposes. Frequency modulation is used and the receiver sensitivity is better than 10 μV/m. Following detection, the paging tones are decoded by two plug-in active filter modules; 60 frequencies are employed in the range 288.5–1,433.4 Hz and a two-tone sequence is used to provide a system capacity of 3,450 customers.

More advanced pagers to be used later in the trial will use a rapid 5-tone decadic sequence offering a potential capacity of 100,000 customers. With the present receiver the first tone is transmitted for 2.7 seconds—a long enough period for all the receivers to "switch-on" and to decode this tone. At this stage, only the receivers responding to this particular first tone will stay on ready to decode the second tone which is transmitted for 0.8 second. Once recognized, the called receiver will sound a 2 kHz "bleep" note of 80 dB sound-pressure level at 12 in. This will persist for several seconds but may be arrested by depressing the control switch. This switch, which is the only user-control on the receiver, has 3 positions: "on", "off" and "memory." In the memory position, a call will be stored, but the transducer will not sound until the switch is either moved to the "on" position or momentarily depressed—useful for people attending meetings who do not wish to be disturbed.

The radiopaging devices are activated by a ten-digit number dialled over the public network. Like a telephone, each pager has its own dedicated number. The first four digits are an STD code common to all radio-pagers and these route calls to computer-controlled terminal equipment at Reading Trunk Exchange, heart of the paging system. The remaining six digits identify individual paging devices.

These "identifying" digits, which reach the computer-control equipment as Strowger pulses, are converted by equipment at the interface between the telephone network and the computer into a binary-coded format which is suitable for handling by the control equipment.

When the number dialled into the terminal is recognized by the control equipment as valid, the caller receives a recorded announcement informing him that the call has been accepted and asking him to replace his telephone receiver. Each "valid" paging number is assigned a unique tone combination to signal the individual receiver. There is complete flexibility in the association of paging numbers and pager codes: the association is made by means of instructions entered into the computer from a control teleprinter. This makes it fairly easy to effect a pager-code change—which, for example, is required on replacement of a defective receiver.

The mini-computer used in the terminal is the Digital Equipment Corporation type PDP11 with a basic storage capacity of 192,000 bits. Calls are queued and released in batches at 15-second intervals. The tone combination for each pager code is generated in turn from instructions passed to a frequency synthesizer.

Landlines between the terminal and the transmitting stations have been time-delay equalized to maintain phase coherence of modulation of the various transmissions. The transmitters at Reading, Maidenhead, Slough and Bagshot use omnidirectional aerials but at Stokenchurch the signals are broadly-beamed into the High Wycombe area. Effective radiated powers of 100 watts are used.

Transmitters are switched on by command signals from the control terminal slightly in advance of the transmission of pager-code modulation. Alarm signals are sent back to the control station from any transmitter which fails to switch on and modulate satisfactorily. Key stations are provided with automatically-switched standby transmitters to ensure continuity of service, and the terminal control equipment is duplicated so that incoming calls can be automatically switched to the standby unit should a failure occur in the main terminal.

To assess the radio coverage, automatically repeated calls have been sent out to paging receivers carried by testing staff who visited buildings throughout the trial area. By this means a boundary was established at which the percentage probability of receiving a paging call was in the region of 95 per cent. Inside the boundary the probability of receiving a call is for practical purposes nearly 100 per cent although, of course, dead spots will exist.

Viewphone Helps in Surgical Operations

An experimental viewphone being developed by Post Office scientists has been used for the first time to assist in the care of patients during surgery.

Engineers from the Post Office's Research Department at Dollis Hill, helped by staff from London Telecommunications Region, provided a viewphone link between the operating theatre in St. Peter's Hospital, Covent Garden, and the Research Department of Anaesthetics of the Royal College of Surgeons half a mile away at Lincoln's Inn Fields.

Patients undergoing operations at St. Peter's are already linked over a telephone line to the R.C.S. where a computer has been used to monitor the patient's responses to anaesthetics and general condition.

In a new experiment the viewphone was used on two full days of surgery to enable specialists at the R.C.S. to follow the progress of operations, to see the actual administration of anaesthetics, and to relate the patient's response to them with information such as heartbeat, brain waves and blood-flow, fed into the computer over the telephone data link.

Professor J. P. Payne, Head of the Research Department of Anaesthetics, also carried out successful experiments with the examination of X-ray photographs by viewphone. He displayed a number of plates to a colleague who, over the viewphone, correctly diagnosed the conditions shown on the X-rays. Picture definition was good enough to pick out lesions in an X-ray.

Although viewphones are still at an early stage of development and unlikely to become available to the public for some time, Professor Payne feels that they could have important medical applications. Unlike closed-circuit television, view-

phone calls are made simply by dialling. A doctor could, in an emergency, call up a specialist by viewphone, show him an X-ray—or an electrocardiograph reading—and seek an opinion.

For the experiment Post Office engineers installed two viewphones and a small viewphone exchange simulator—a two-line exchange providing the audio and visual responses, such as dialling or ringing tone, needed when an ordinary viewphone call is made.

For some time an ordinary telephone line through Holborn exchange has been used by the R.C.S. and St. Peter's Hospital for input of information about the physiology of patients undergoing surgery into a computer. This on-line link is set up by dialling the theatre on an ordinary exchange line and then switching from voice to data transmission. The computer's analysis of physiological data returns to the operating theatre on a silent visual display unit. Up to three physiological conditions, for example heartbeat, blood flow and blood pressure, can be transmitted and analysed simultaneously.

A specially converted Post Office Modem 1A at the R.C.S. receives information from the operating theatre in analogue form. Feedback to the theatre is in digital mode. The Department of Anaesthetics can use either of two computers, an Elliott 903 or a PDP 12, to analyse information about patients undergoing surgery.

Speeding Cable Repairs

Repairs to polyethylene-sheathed telephone cables which are damaged accidentally—a major headache for the telephone service—will be carried out faster and cheaper by a new repair process to be adopted nationally by Post Office Telecommunications.

The new repair method involves the use of a special polymer-based material which is wrapped around the damaged section of cable—and then bonded to the cable by a heat-shrink process, providing a permanent water-resistant seal.

The Post Office deals with more than 100,000 cases of accidental damage to cables each year. About 75,000 of these affect polyethylene-covered cable, and the Post Office has for some time been seeking a faster and more economic repair process.

Using the new process, which Post Office development engineers have been testing for the past two years:

- out-of-action customer lines should be brought back into service more quickly, particularly in cases where, in the past, it has been necessary to replace a damaged section of cable;
- total time taken to complete a repair should be reduced, freeing men to undertake other work;
- the Post Office's repair costs for polyethylene-covered cable should be reduced.

Extensive field trials undertaken in London, the Midlands, North-East and South-West regions have confirmed that the new process meets these requirements. Training of engineers in the new repair method begins soon.

Repairing polyethylene-covered cable presents a number of problems—foremost among them that of providing a permanent repair to a cracked cable sheath to prevent water entering. Usually this means fitting a bulky polyethylene sleeve sealed with water-resistant putty. The very bulk of the repair means that the cable will not fit back into its narrow underground duct; and a small manhole has to be built around it.

With the new process a polymer-based "wrap" is pre-stretched and stressed at manufacture, and coated on the inside with a low-temperature adhesive. It is fastened round the damaged section and heated. The heat shrinks the wrap to half its size and melts the adhesive. When cool the adhesive hardens inside the shrunken wrap forming a permanent water-resistant seal. Temperature-sensitive paint on the outside of the wrap changes colour, indicating that the correct shrink-down temperature—125°C—has been applied.

Because the repair is only fractionally larger than the cable, the cable can be returned to its underground duct and

it can be moved without fear of damage to the repaired section.

The Post Office is to stock supplies of repair "wraps" to fit cables ranging from 10 mm to 70 mm in diameter and in lengths of up to two metres.

Main causes of accidental damage to telephone cables are construction work, road repairs and repair of underground plant by other undertakings.

Cutting Real Cost for Telephone Users

The cost of a three-minute telephone call between London and Glasgow has been reduced over the past 60 years almost to one tenth, in terms of present-day values. And a similar call from London to New York has been reduced in cost, since the service began 36 years ago, almost to one-fiftieth, again at today's values.

Delivering the annual Kelvin lecture to the Royal Philosophical Society of Glasgow, Professor Merriman, who this year was awarded the Society's Kelvin Prize, showed how the Post Office had achieved a progressive reduction in the real cost to the customer of telephone service.

In 1910, a three-minute telephone call between London and Glasgow cost 4s. 6d.—at 1972 values, £1.80p. Today the same call—made during the day—would cost 22p, or as little as 5p at the cheap evening/weekend rate. In 1927, a three-minute call from London to New York cost £15—at today's values, this would be £60.75p. On i.s.d., a three-minute London-New York call costs only £1.50p in 1973.

In parallel with this reduction in cost Professor Merriman pointed out, there had been an equally distinctive growth in the telecommunication system. Main undersea cables now link all the main continents, their capacity measured in hundreds—soon thousands—of circuits. In addition to these cable links, a complicated net of about 200 satellite earth stations, links continents, countries, islands, and even isolated communities.

"The engineering and sciences of space and deep ocean water have combined to satisfy men's needs to communicate without travel—to shrink distance and unify time," said Professor Merriman. Illustrating the pace of expanding demand in Britain for local and national telecommunication services, he forecast that by the year 2000, some of the routes required to satisfy customers' needs will each have to be able to carry 100,000 calls or more, simultaneously.

As an example of how the problems of growth in city centres are tackled Professor Merriman held up the Post Office's plan for future telecommunications in Glasgow. These involve a £5m complex—Dial House—with switching units, capable of handling, at first, 29,000 incoming and 36,000 outgoing trunk calls an hour, increasing eventually to 75,000 and 59,000 calls an hour. They also include the purchase of a 6-acre site for "Dial House 2" to cater for expansion up to the end of the century, and the construction of a 2 m diameter tunnel, costing £2 m, to carry 168 cables 2.2 km under the city.

Growth in demand can also be met, Professor Merriman continued, by using advanced technology. For example, by applying modern electronic techniques to existing local cables—in the form of digital transmission of speech in pulse code modulation—the carrying capacity of circuits can be multiplied up to 30 times.

The most striking use of advanced technology is in inter-city communications, Professor Merriman said. "Here coaxial cable and microwave radio development over a period of 30 years have led to significant changes." The planning unit for modern cable schemes was now thousands of circuits; modern cable technology, applied to modern solid-state microtechnology, made it possible to plan up to 100,000 telephone circuits on a single cable, achieving many of the cost savings of aggregation and scale.

For the future, Professor Merriman foresaw that worldwide research and development into cheaper and more effective switching systems would result in some plant cost reduction. But, he warned, these would not possibly have the same anti-inflationary effect on long-distance charges that earlier developments had brought in the past decades. "There is a limit somewhere to the pips that can be squeezed from this particular orange," he declared.

Discussing Packet Switching

A round dozen of the leading computer users and manufacturers have decided in principle to take part in the Post Office's experiment in packet-switched data transmission known as EPSS (Experimental Packet Switched Service) announced last August and due to start next year. Another fifty or so organizations have expressed interest in this project—the world's first public store-and-forward service.

To provide a test-bed for potential users, the Post Office is prepared to invest over £1 million on the EPSS in the next two years. So that customers can take advantage of the opportunities offered by this experiment, the Post Office opened the first of two "workshops"—meetings at which Post Office speakers will be joined by representatives of other organizations which have already decided to take part. Speakers will explain in detail what participation in the EPSS will mean for customers and to help as-yet-uncommitted firms to reach a decision, they are outlining the benefits which they expect EPSS will bring. Britain has more terminals linked by data transmission than the rest of Europe put together.

Packet-switching—the transmission of computer data in self-contained, addressed blocks or packets—is part of the Post Office's studies for developing its network to transmit data in digital form, instead of having to convert it to analogue form, as at present. Each packet is routed automatically; there is no end-to-end connection from customer to computer. Circuits connecting packet-switching exchanges (p.s.e.s) can then be used for carrying packets sent by other customers, in the time intervals between the packets making up a complete transmission.

For the proposed experiment, the Post Office will set up three p.s.e.s fully interconnected by 48 kHz circuits operating at 48 kbit/sec. Error control will be exercised between p.s.e.s, and automatic "re-routing" provided to cover route failure. Customers using EPSS will have a choice of two methods of working—either entirely in packets or, at one end only, character by character. In packet operation, customers will transmit and receive data in packets—each comprising a header containing the address code, data up to 2,040 bits, and an error-checking code—and will need terminals capable of assembling data into packets, and "unpacking" received data. In character-by-character operation, data from customers are assembled in packets at the p.s.e., where data returning in packet form in unpacked for serial transmission.

PO Places Development Contracts for 120 Mbit/s Digital Line System

As a first step in developing a digital trunk network, and preparing for new facilities, the Post Office has placed contracts with STC, GEC and Plessey, to develop digital transmission systems enabling pulse code modulation (p.c.m.) to be used on Britain's trunk network. At present the telecommunication "highways" between centres of population carry thousands of messages—telephone conversations, television and radio signals, and computer data—as signals in analogue form. They are kept separate by sending them at different frequencies—the technique known as frequency-division multiplexing (f.d.m.).

With f.d.m., the messages are first converted to digital signals—a stream of many thousands of on-off electrical pulses a second. Invented by a Briton (A. H. Reeves), and patented in France in 1937, p.c.m. had to await the arrival of suitable transistors before it could be used in public service. Signals transmitted over the same bearer circuit are kept separate by time-division multiplexing (t.d.m.)—slotting the pulses from one source into the intervals between the pulses of others.

Digital systems can provide the same quality of performance as the present analogue systems and may in future provide this at greatly reduced cost. They allow much simpler signalling systems to be used for routing calls through the network, simplify the multiplexing of different signals and, for complicated signals—those for television and viewphone for example—permit greater exploitation of the transmission medium. In addition they pave the way for the introduction of cheaper, quicker, switching systems using computer-like methods operating directly on the digital information under stored program control.

The decision to develop a digital system for the U.K. trunk network stems from the results of feasibility studies carried out for the Post Office by G.E.C. and Plessey in 1970–71. These studies confirmed that it is technically possible to introduce a digital system using the standard 1·2/4·4 mm coaxial cable pairs now in use for multichannel f.d.m. transmission.

Under development contracts, S.T.C., G.E.C. and Plessey, have been commissioned to design, develop, manufacture and install systems, transmitting information at a rate of 120 Mbit/s and compatible with the Post Office's existing CEL 4000, 12 MHz analogue system for 1·2/4·4 mm cables, using the same repeater spacing, housing and power feed arrangements. For this purpose, the Post Office has set aside spare coaxial pairs in its trunk cables between Guildford, Portsmouth and Southampton. S.T.C. is to provide the system for the Guildford–Portsmouth link; G.C.E. and Plessey are collaborating on the Portsmouth–Southampton link. Each system will be capable of transmitting up to 1,680 telephone conversations simultaneously by p.c.m./t.d.m. Both are scheduled to be available for Post Office evaluation early in 1975.

While digital transmission of telephony by p.c.m. is not new to the British network—it was introduced for the first time in 1967—it has so far been confined to connections between local exchanges up to 20 miles apart. In this system, two cable pairs, capable of carrying only two telephone calls in analogue form, can carry 24 p.c.m. conversations simultaneously. Twenty-four speech channels are grouped at the exchange and 'sampled' in turn 8,000 times a second. Each sampling produces a pulse whose amplitude is proportional to the amplitude of the analogue waveform at that instant and is of the same polarity: the output of the sampling unit is a series of positive or negative pulses of varying amplitude, occurring at a rate of 192,000 pulses per second. An encoder converts each analogue pulse into a group of seven binary pulses indicating amplitude and polarity, and adds an eighth, which is time shared for signalling and system alignment. The coded output—a stream of digits, at 1,536 kbit/s—is the transmitted signal. Equipment at the distant end decodes the digit stream to reconstruct the 24 individual analogue signals.

With this system successfully established for carrying telephone calls over the junction network, the Post Office decided to adopt the European standard—a 30-channel, 2,048 kbit/s system—as the basis for extending digital transmission into the main network. Existing 24-channel, 1,536 kbit/s links will need to be augmented by the 30-channel system to pave the way for high bit-rate systems to be used over the main network in the late 1970s. In preparation for this, trials of 30-channel systems from each of five manufacturers are due to start next year.

Increasing the transmission rate from 2·048 kbit/s to 120 Mbit/s, the rate initially proposed for the main network, will be achieved in two stages of time-division multiplexing—interleaving a number of separate pulse streams at one transmission rate to create a signal combined stream at a higher rate. As a first step, G.E.C. is developing, under a Post Office contract, multiplexing equipment to combine four signals, each of 2,048 kbit/s, and produce a stream at 8,448 kbit/sec.

This multiplexer, while primarily intended to work to and from 30-channel digital telephony signals, will also accept any other input signal—such as multiplexed computer data—which has the correct nominal speed. A high-density bipolar signal format has been chosen as the interface signal; this ensures that the number of consecutive zeros in the signal never exceeds three, to overcome the difficulty of extracting timing information from a signal with a large number of zeros.

It is envisaged that the second multiplexing stage will combine 14 streams, of 8,488 kbit/sec pulses to achieve a pulse rate of 120 Mbit/s, and the Post Office is now inviting tenders for multiplexing equipment to achieve this.

The Post Office will also be inviting tenders for equipment to encode a 60-channel f.d.m. supergroup—comprising five groups each of 12 analogue channels. Normally this is transmitted over the network as an analogue signal; the encoder would convert it to an 8,448 kbit/s digital signal for transmission over a digital link, enabling the Post Office to achieve flexibility between the existing analogue network and the new digital network as it is gradually introduced.

Waveguide Ordered for Field Trial

An order to supply 16 km of waveguide—50-mm hollow tube in which up to 300,000 telephone conversations could be transmitted simultaneously—has been placed by the Post Office with British Insulated Callenders Cables (B.I.C.C.). It will be used in a full-scale field trial—due to start in 1975—as part of the Post Office's program of research and development to meet soaring demand for existing telecommunication services and prepare for new ones.

Under the contract, B.I.C.C. Central Research and Engineering Division will first develop, design and construct machinery to make the waveguide and then use it to manufacture—in 3 m lengths—the 16 km of guide ordered by the Post Office. Just under 15 km of the waveguide will be laid for the trial, between the new Post Office Research Station at Martlesham Heath, near Ipswich, and the Suffolk town of Wickham Market. The remainder is for other experiments.

In the waveguide, up to 300,000 telephone calls—or an equivalent combination of telephone calls, computer data, vision and other signals—and system-monitoring information, would be carried on radio waves between 3 mm and 10 mm long—equivalent to frequencies from 32 to 110 GHz. The waveguide will be housed in a high-precision duct—4-in welded steel pipe buried about four feet deep, recently laid for the Post Office by Laing Pipelines. A contract for installing the waveguide in the duct is now being negotiated between the Post Office and B.I.C.C.

The Post Office design of waveguide that B.I.C.C. will make has for its essential electrical elements a close-wound helix of superfine enamelled copper wire surrounded by an outer wall of glass fibres impregnated with a loaded epoxy resin. The construction is completed by a layer of aluminium foil, which provides a barrier against water and oxygen, and an outer layer of resin and synthetic fabric tape for protection against mechanical damage. This type of waveguide has been developed after extensive experimental work and cost/effectiveness evaluations by the Post Office. The helical construction inhibits transmission of most parasitic modes. The wall structure is relatively cheap, provides adequate stiffness, can be formed accurately, is light in weight for ease of handling and installation, and resists corrosion.

In the waveguide system, telephony, data, vision and other signals are transmitted in digital form as pulse-code modulation of millimetric radio waves. These travel inside the guide in the low-loss TE₁₀ mode: the signal loss for straight lengths should be under 3 dB/km, reducing to less than 2 dB/km at frequencies in the middle of the useful operating frequency range. Transmission loss increases at bends in the waveguide: one purpose of the field trial is to confirm the scale of these additional losses over a typical route through town and country.

The trial, which follows Post Office Research Department tests of waveguide systems up to about 1 km long at Martlesham, is being carried out in conjunction with industry. Terminal and repeater equipment is being developed in a number of stages. For the first phase of the Martlesham-Wickham Market tests, 32–40 GHz and 41–49 GHz go-and-return frequency bands will be used, each sub-divided into 16 channels of 500 MHz nominal bandwidth. In the second phase, 52–69 and 72–88 GHz go-and-return bands will be used, each sub-divided into 8 channels of 2 GHz nominal bandwidth. The band above 90 GHz will be used for waveguide performance monitoring.

The band-branching units, Phase I channelling equipment and several sets of Phase I terminals and repeaters will be supplied by Marconi under a contract announced in January. The Post Office will be providing alternative terminals and repeaters for use on other Phase I channels and will be responsible for Phase II channelling equipment, terminals and repeaters. Most of the equipped channels will use four-phase modulation, providing digital traffic capacities of approximately 500 Mbit/s per channel in Phase I. This digit rate can simultaneously carry about 7,200 telephone calls or four colour-TV programmes or any equivalent mixture of traffic. The Phase II channels will be used for experiments with higher digit rates—approximately 1 Gbit/s at first.

A circuit length of 30 km will be obtained in the trial by using Martlesham as a terminal station and Wickham Market as a repeater. Signals will be sent along the waveguide in one frequency band to Wickham Market where repeaters will return them to Martlesham in another frequency band. Longer circuits can be simulated by multiple looping—sending the signals to Wickham Market and back several times in succession on different channels.

New Cable to have 28 Coaxials

A new telephone cable with more coaxial tubes than any yet ordered by the B.P.O., is to be used to link two of London's trunk repeater stations.

Containing 28 coaxial tubes—ten more than in any cable previously ordered—the 1.5 km cable will link Southbank repeater station near Waterloo with Faraday repeater station near St. Paul's in the City of London. The coaxial tubes, each 4.4 mm in diameter, will be equipped with fourteen 4 MHz line systems each having a capacity of 960 circuits, to give a total capacity of 13,400 circuits. This large-capacity cable will be used for a large number of trunk routes serving central and outer London and trunk routes which pass through London between other places.

Copyright

The entire contents of this *Journal* are covered by general copyright, and special permission is necessary for reprinting long extracts, but editors are welcome to use not more than one-third of any article, provided that credit is given at the beginning or end, thus: "From *The Post Office Electrical Engineers' Journal*."

The Board of Editors is not responsible for the statements made or the opinions expressed in any of the articles or the correspondence in this *Journal*, unless such statement is made specifically by the Board.

Subscriptions and Back Numbers

The *Journal* is published quarterly, in April, July, October and January, at 21p per copy: 31p per copy including post and packing (£1.24 per year) (3 dollars Canada and U.S.A., per year). Back numbers will be supplied if available, price 24p (34p post paid). At present copies are available of all issues from October 1969 to date, with the exception of April 1971 which is now sold out. Copies of the October 1966, July 1967 and January 1968 issues are also still available at present. Orders, by post only, to *The Post Office Electrical Engineers' Journal*, 2–12 Gresham Street, London, EC2V 7AG.

Employees of the British Post Office can obtain the *Journal* through local agents.

Binding

Readers can have their copies bound at a cost of £1.87½p plus 24p (40p overseas) return postage, by sending the complete set of parts, with a remittance to Press Binders Ltd., 4 Iliffe Yard, London, S.E.17.

Remittances

Remittances should be made payable to "*The P.O.E.E. Journal*" and should be crossed "& Co."

Advertisements

All correspondence relating to advertisement space reservations, copy, proofs, etc., should be addressed to the Advertisement Manager, *The Post Office Electrical Engineers' Journal*, 2–12 Gresham Street, London, EC2V 7AG.

Communications

With the exceptions indicated above, all communications should be addressed to the Managing Editor, *The Post Office Electrical Engineers' Journal*, 2–12 Gresham Street, London, EC2V 7AG.

Model Answer Books

Books of model answers to certain of the City and Guilds of London Institute examinations in telecommunications are published by the Board of Editors. Details of the books available are given at the end of the Supplement to the *Journal*.



It's a small world

The little box of tricks in the picture is our new 6 digit* Sodeco counter.

The amazing thing about it isn't that it has a life expectancy of 50 million impulses.

Or that it counts at 10 impulses a second.

Or that it's readily available in a variety of different operating voltages.

Or that it uses an escapement counting mechanism housed in a metal case.

It isn't even that it's designed to the usual superlative Sodeco standards.

What is amazing is that we could pack all this into a case with a front plate measuring just 1"x0.85".

But then, the best things always come in small packages.

If you'd like further information, complete the coupon and post it to us.

We'll send you our literature by return.

*Also available in an identically sized 5 digit version.

Name _____

Company _____

Address _____

SODECO

LANDIS & GYR

Dept POEE 7/73

Victoria Road, North Acton,
London W3 6XS
Tel 01 992 5311 Telex 21486

We'll pot your 'babies' for you



When you've got components that call for encapsulation—bring them along to Whiteley. With efficient potting, your components will be totally insulated and environmentally protected—and Whiteley experience in developing this advanced plastics technique will ensure that it is applied to full advantage.

We can encapsulate in epoxy resin or polyurethane—hot setting or cold setting as required. Where fillers offer advantages, we can apply them, expertly. We are ready to handle small quantities or volume production for you. It's one more way in which you can capitalise on our production resources. For electrical and electronic work—right through from design to final assembly—you can safely follow the example of many famous names—and call in Whiteley.

Whiteley

versatility...

ELECTRONIC & ELECTRICAL DESIGN

PRODUCTION CAPABILITY

CABINET MAKING

SHEET METAL FORMING/FINISHING

PLASTICS MOULDING

ENCAPSULATION

WHITELEY ELECTRICAL RADIO CO. LTD.
Mansfield, Notts, England. Tel. Mansfield 24762
London Office: 109 Kingsway, W.C.2. Tel. 01-405 3074

Dual Inline Reed Relays

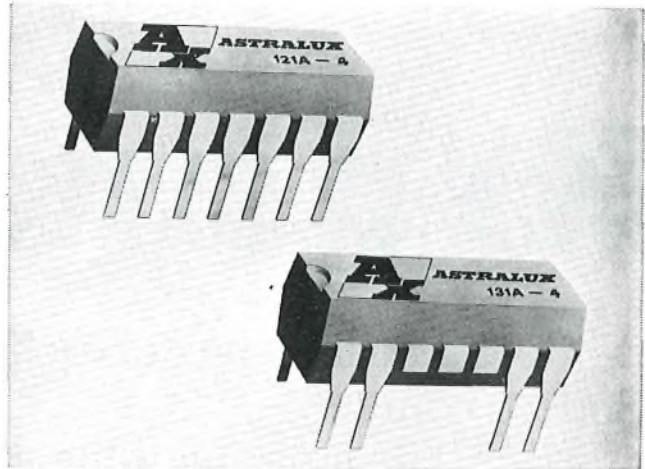

These Relays offer a high electrical specification combined with dependable performance at low unit costs.

Contact ratings range up to 10 watts in Forms A & B and 5 watts in Form C. Coil voltages of 5, 12 or 24v DC are available to interface with DTL, TTL, or HTL Logic—without additional buffering.

Pin spacing conforms to DIL standards and all models fit 14 Pin receptacles. Two versions are available either 8 Pin or 14 Pin with the option of internal Diodes.



ASTRALUX dynamics limited

Brightlingsea, Colchester, Essex CO7 0SW Tel: Brightlingsea (0206-30) 2571/5 TELEX: 987751



NO COMPRESSOR NEEDED

Send now for details of the powerful, portable Pionjar petrol driven drill and breaker to

ITT Flygt Pumps Limited,
Colwick, Nottingham.

Please send details of the Pionjar Rock Drill/Breaker to

NAME _____

ADDRESS _____

Marconi

H.F Transmitters

Marconi has been in the forefront of h.f transmitter design for more than 50 years. It has a current range of high-performance transmitters which fully meet the requirements of both international point-to-point services and the needs of users requiring economic equipment with less facilities.

H1060 1kW s.s.b/i.s.b. h.f transmitter

A new, low-cost transmitter with high quality performance and simple operation for use in such important roles as shorestations, 'tails' to trunk routes and local communications.

H1000 1kW wideband h.f transmitter

Well proven, highly reliable transmitter for more sophisticated services. No tuning required and instantaneous transmission on two or more frequencies.

H1130 Series 10kW wideband h.f transmitter

Compact, self-contained self-tuning transmitter. Can incorporate integral spot frequency synthesizer drive assembly. Remote control available.

H1200 30kW wideband h.f transmitter

A compact, high-power, fast self-tuning transmitter, with accurate antenna matching. In wide use throughout the world.

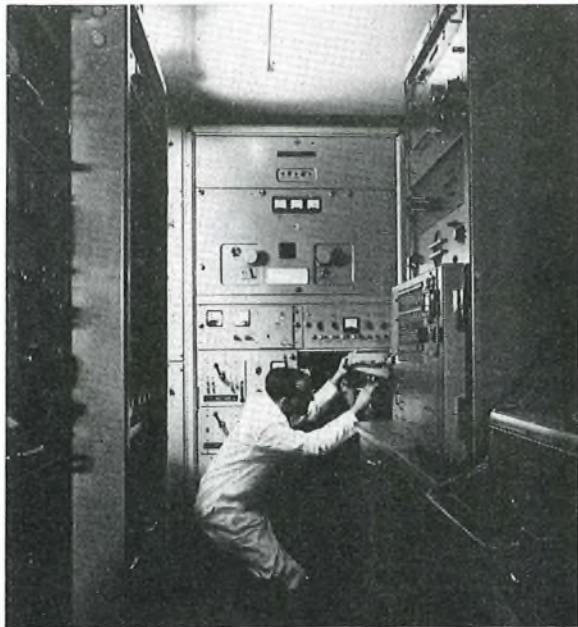

H 98

Marconi

PCM Systems

Marconi is the foremost manufacturer and exporter of PCM systems in the United Kingdom. More than 100,000 channel ends have been sold to the British Post Office, overseas telephone authorities and public utilities, because of technical quality, cost effectiveness and prompt delivery, coupled with highly experienced planning, installation and commissioning services.

Marconi PCM interfaces with most modern automatic exchange systems, and is also suitable for future integrated switching systems. It tolerates low-quality audio cable and operates in adverse environments. It can be expanded economically and flexibly and can also provide teleprinter channels and data transmission facilities.

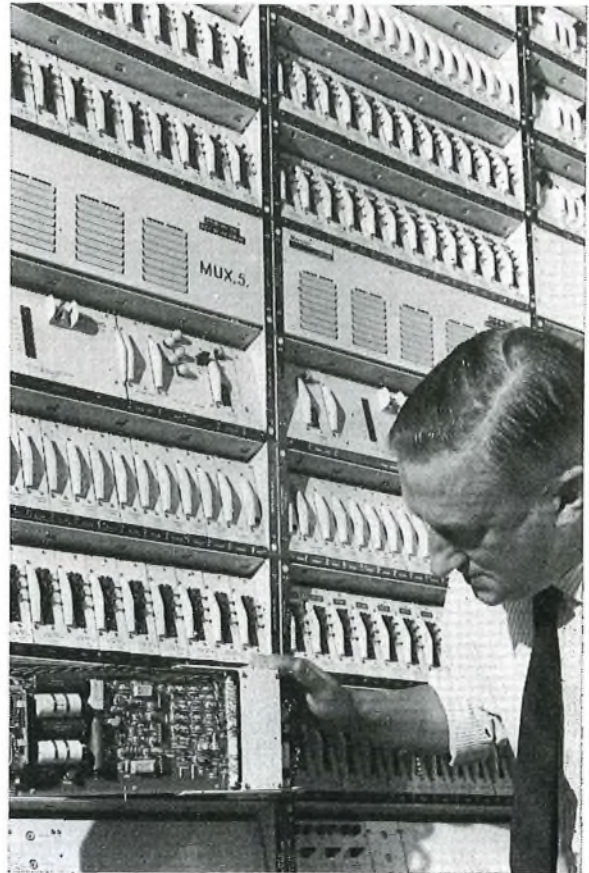

U 65

Marconi Communication Systems

Complete civil and military static and mobile communication systems

Marconi Communication Systems Limited, Chelmsford, Essex, England

A GEC-Marconi Electronics Company

LTD

**We're already at work
on the cable
you don't know
you'll need.**

**That's service
for you.**

We'd rather come knocking on your door with cable you don't yet know you'll need, than have you come knocking on our door for cable we haven't got.

That's why we are producing, experimenting, designing—all the time. Typical of this progression is the

world's first 18-tube coaxial cable we've just produced for the British Post Office.



You can rely on TCL for the manufacture of a single telephone cable or the design, manufacture and installation of a complete telecommunications network.

But there's really no need to come knocking on our door, it's forever open to you and your cable problem.

Our message is clear -



- * Redifon Telecommunications Ltd, formed less than two years ago, is rapidly finding its place in the front ranks of the world's telecommunications industry.
- * You will find our radio communication equipments and navigational aids in use on land and sea all over the world. We export over 60% of our output and we are constantly endeavouring to improve the performance which makes this possible.
- * We thank all our staff for their efforts. The honour of the Queen's Award to Industry is their achievement.



The Redifon Omega Navigator, one of the company's new products. It enables vessels to fix their position accurately, regardless of weather, at all times and anywhere on the world's surface.

**Redifon Telecommunications Ltd,
Broomhill Road, London, SW18 4JQ
Telephone: 01-874 7281 Telex: 264029**

* A member of the Rediffusion organisation

Redifon Telecommunications Limited

Here it is!

Our two new ranges of 75 ohm TV distribution cables are now made on an extrusion line unique in Western Europe.

We're one of the most technologically advanced cable manufacturers, using new techniques to produce TV distribution cables at a consistently high standard to tolerances much closer than previously possible. At very competitive prices.

The two ranges:

Aeraxial Semi Air Spaced Polyethylene dielectric copper taped braided and polythene sheathed television distribution cables. Five cables in the range, with inner conductor sizes from 1.27 mm to 3.05 mm.

Solid Polyethylene dielectric copper taped and polyethylene sheathed television distribution cables. Five cables in the range, with inner conductor sizes from 0.73 mm to 3.65 mm.

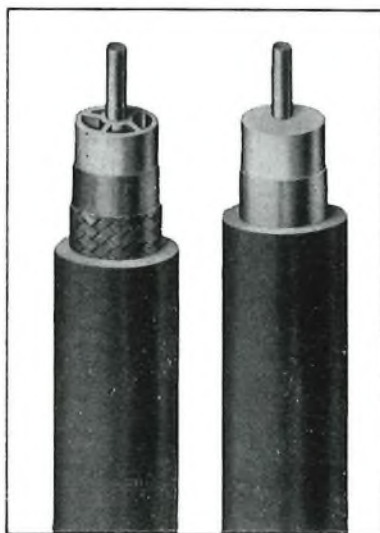

Aerialite will specially manufacture TV distribution cables for any special TV application—also, you can make use of the Aerialite free technical advisory service to help you in the selection and application of distribution cables.

For further information, send for Aerialite's new publication giving full technical specifications of the latest range of TV Distribution Cables.

Aerialite

Aerialite Cables Limited,
Castle Works,
Stalybridge, Cheshire SK15 2BS.
Telephone: 061-338 2223
Cables: Aercables, Stalybridge.
Telex: 669902

To Aerialite Cables Limited: Please send me your brochure entitled Aerialite Television Distribution Cables.

NAME _____

POSITION _____

COMPANY _____

ADDRESS _____

EHPL

it takes over where
MTBF leaves off

While others talk of MTBF, we introduce a new concept—EHPL, Estimated Half-Power Life. Our 400W and 1kW all-solid-state broadband HF linear amplifiers have over five years of it, counted in operational hours. Which, with a remarkably low Mean Time To Repair, means 99.9% up-time.

The multiple p.a. modules of these compact units, arranged in parallel for maximum reliability, ensure that even in the unlikely event of several component failures occurring together, the amplifiers go on working—long after others have stopped.

Moreover, thanks to Redifon's unique Transmit Level Control, they always deliver to any antenna—even to a badly damaged one—the maximum power that is safe, whatever the mismatch.

All of which means that the pair of transmitters in the picture represent the finest and most reliable in the world for civil and military applications, whether in fixed, mobile or containerised stations. And they are in production and service, right now.

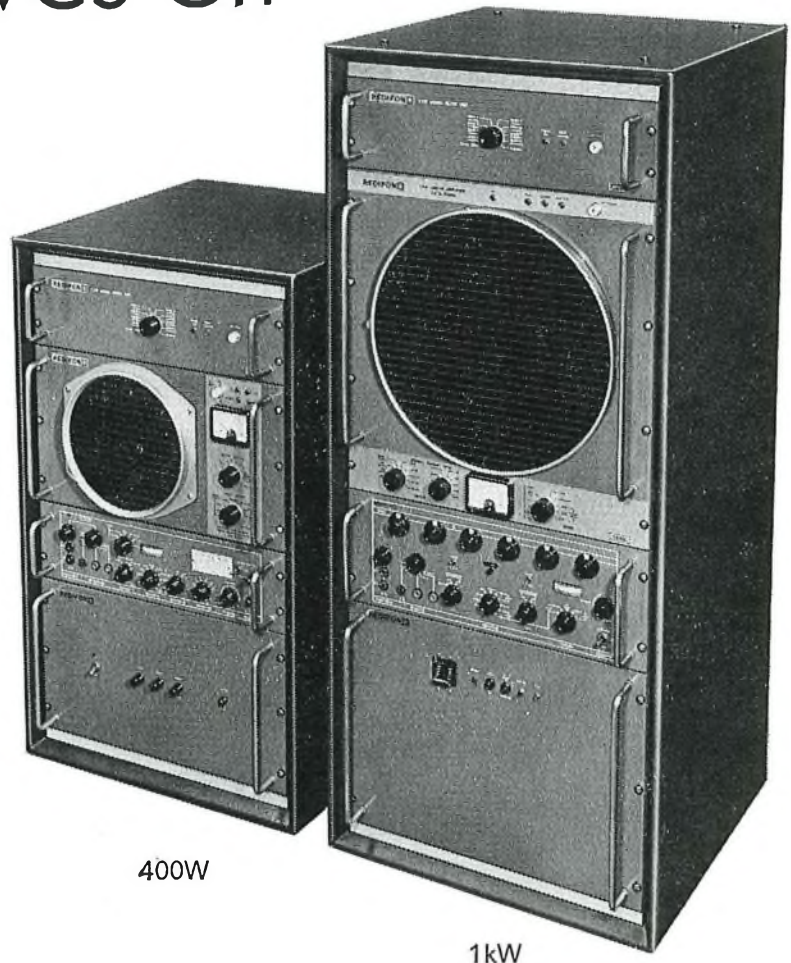

Redifon Telecommunications Ltd,
Broomhill Road, London, SW18 4JQ
Telephone: 01-874 7281 Telex: 264029

☀ A member of the Rediffusion organisation



Redifon Telecommunications Limited

When Reader's Digest wanted to enrich their word power they came to us.

With over 1.5 million copies of the Digest published in the U.K. each month, plus condensed books, reference books, gramophone records and Drive publications, the Reader's Digest Association staff lean very heavily on the efficiency of their communications system.

When a new PABX was needed, they sought advice – helpful advice. They wanted a system for now *and* the foreseeable future – to link all departments, all locations; and they wanted it installed on time, at a reasonable price. Of course they had special problems. Who hasn't?

But of the suppliers contacted, only Pye Business Communications could meet every requirement.

We kept our word. And helped to enrich the power of theirs.

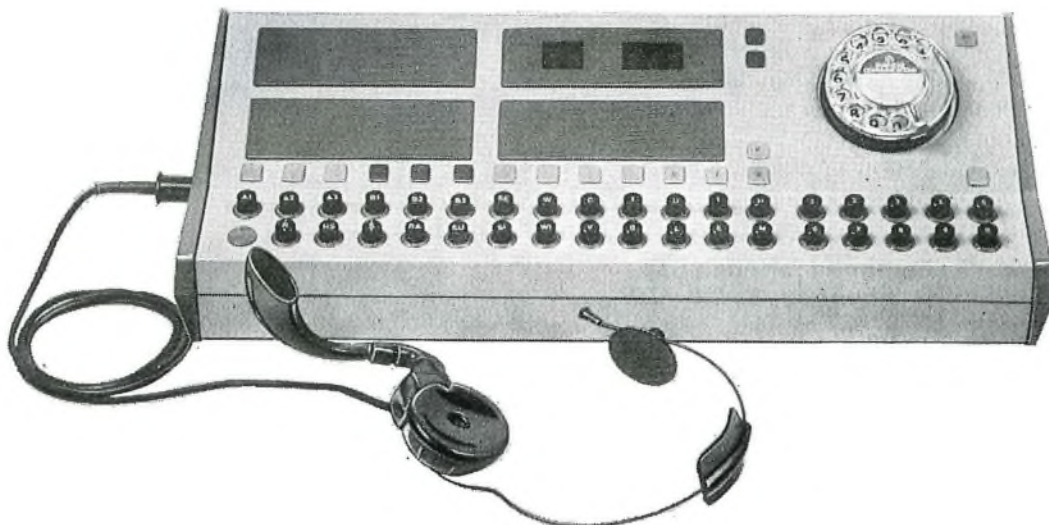



Pye Business Communications Ltd

Cromwell Road • Cambridge CB1 3HE • Tel: 0223 45191 • Telex: 81547

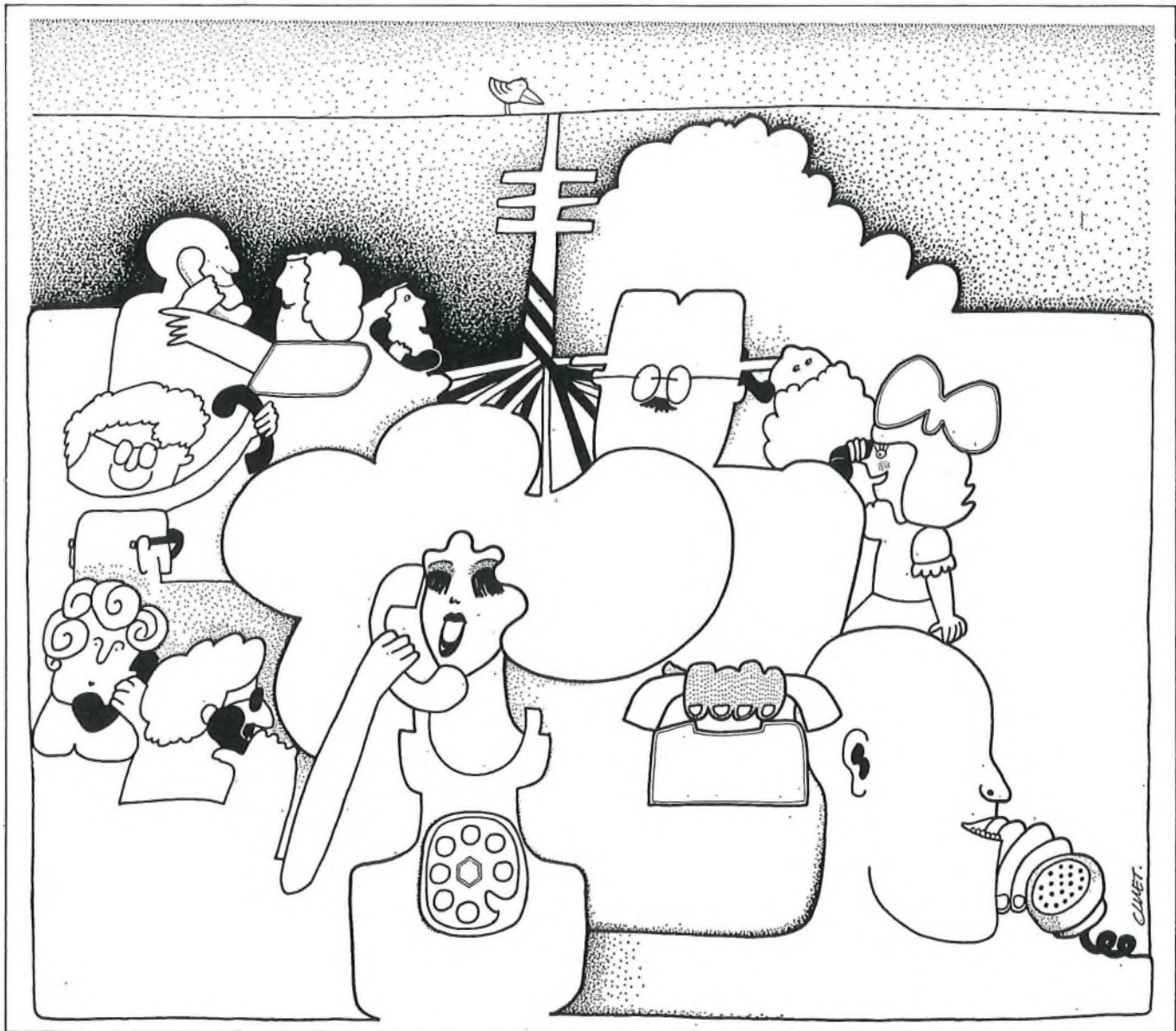

12-CIRCUIT CARRIER TELEPHONE SYSTEM FOR OPEN-WIRE LINES PST-L12

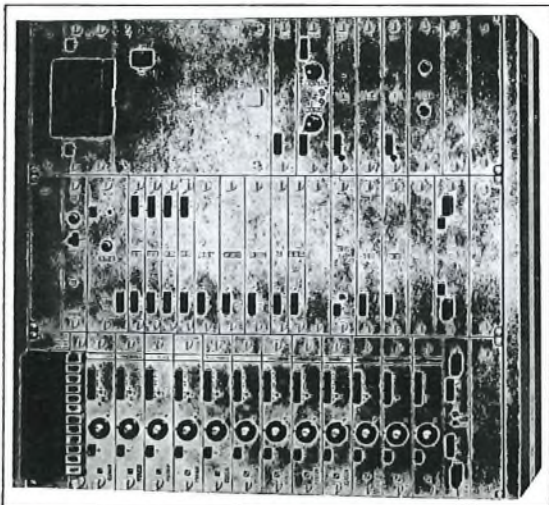

- * TERMINAL, REPEATER AND LINE EQUIPMENT
- * C.C.I.T.T. STANDARD PERFORMANCE
- * INSTALLATION IS NO PROBLEM
- * **OFF THE SHELF DELIVERY**

Telettra

LABORATORI DI TELEFONIA ELETTRONICA E RADIO
20059 Vimercate-Milano (Italy) via Trento,30 - tel.(039) 63301-63551 - telex 31158

Our electronics are a signal success



Our manufacturing resources could contribute to your success, too! We've chalked up many years of service to ministries, government departments, armed forces, and a formidable list of significant names in industry. They all come to Whiteley for the specialist knowhow and resources we have developed. Can we help you? We can build to your drawings and specification, or put our design departments at your service, as needed. From a small component to a complete system, in audio work, relay switching circuits, control systems, and many other spheres—our facilities are ready. The Whiteley organisation is self-contained. The manufacturing resources are backed by our own toolroom, sheet metal working and press shops, plating and finishing lines, coil and transformer winding shop, plastics moulding shop and a modern new cabinet factory. Capitalise on all these Whiteley facilities—call us in for a look at your next electronics need. You'll be in good company!

Whiteley

versatility...

ELECTRONIC & ELECTRICAL DESIGN

PRODUCTION CAPABILITY

CABINET MAKING

SHEET METAL FORMING/FINISHING

PLASTICS MOULDING

ENCAPSULATION

WHITELEY ELECTRICAL RADIO CO. LTD.
Mansfield, Notts, England. Tel. Mansfield 24762
London Office: 109 Kingsway, W.C.2. Tel. 01-405 3074

NEON & FILAMENT INDICATORS

For Audio Equipment
Electrical Appliances
Intercomm Systems
Control Panels

★ Made in U.K. ★ Good Delivery
★ Competitive Prices

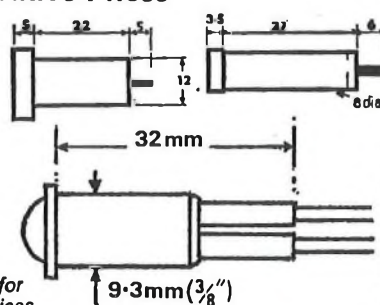

Write now for data and prices



Associates Ltd.

Cricketfield Lane, Bishop's Stortford,
Herts. Telephone: 0279-56347
Telex: 81533 REMO STORT

C.G.L.I. Telecommunication Courses for 1973-74

The following textbooks cover completely or partially the syllabuses of the subjects specified below

ENGINEERING SCIENCE IN SI UNITS

E. Hughes and C. Hughes

Third Impression 339 pages £1.20

221 *Telecom Mechanics* Part II Principles

271 *Telecom Technicians* Part I (T1) Engineering Science

PRINCIPLES OF ELECTRICITY IN SI UNITS

A. Morley and E. Hughes

Third Edition Second Impression 384 pages £1.05

221 *Telecom Mechanics* Parts I & II Principles

271 *Telecom Technicians* Part I (T2) Principles A

ELECTRICAL TECHNOLOGY

E. Hughes

Fourth Edition Third Impression 710 pages £1.50

271 *Telecom Technicians* Principles B & C

Inspection copies of the above books are available from Promotion Dept., Room 520, Longman House, Burnt Mill, Harlow, Essex

INDEX TO ADVERTISERS

	PAGE		PAGE
Aerialite Ltd.	14	J. H. Associates	19
Astralux Dynamics Ltd.	10	Llandis & Gyr Ltd.	9
GEC Telecommunications Ltd.	1-3	Marconi Communication Systems Ltd.	11
Gulton Europe Ltd.	20	Mullard Ltd.	4
Hallam Sleigh & Cheston Ltd.	8	Pye Business Communications Ltd.	16-17
Herman Smith Ltd.	22	Redifon Telecommunications Ltd.	13, 15
Hewlett Packard Ltd.	21	Standard Telephones & Cables Ltd...	5-7
Hughes Telecomms. Textbooks	19	Telephone Cables Ltd.	12
ITT Flygt Pumps Ltd.	10	Telettra Spa Milan	18
		Whiteley Electrical Radio Co. Ltd.	10, 19

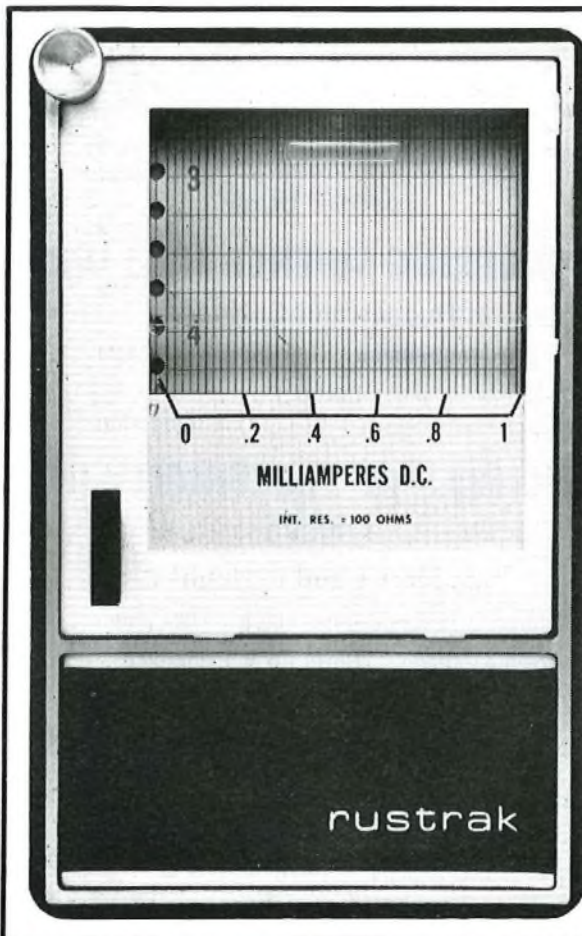

Rustrak Miniature Strip Chart Recorder

Rustrak miniature strip chart recorders are available as potentiometric or galvanometer type instruments which produce a permanent record of virtually any parameter that can be converted into an electrical signal; temperature, pressure, flow, level, watts, frequency, humidity, events and many more.

Data is recorded on pressure sensitive paper, obviating the many problems that can result from the use of ink. A wide range of motor speeds and interchangeable gearboxes is available to give over 50 chart speeds.

Of attractive design, the low-cost Rustrak recorder measures only $5\frac{3}{8}$ " high by $3\frac{3}{8}$ " wide.

Considerable savings in time and cost are made by hand from indicator readings.

Delivery of the standard instrument is 2-3 weeks and a complete advisory service on your particular recorder problems is available from our experts.

Gulton
EUROPE
Rustrak Instrument Division
BRIGHTON BN2 4JU

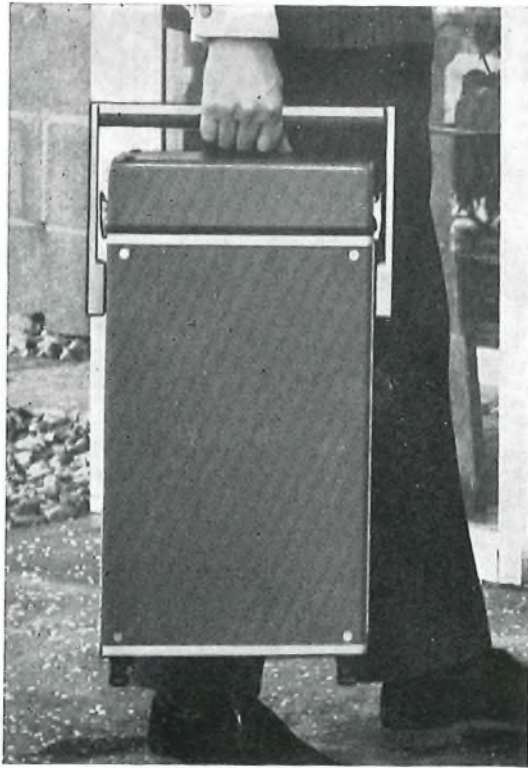

Hewlett-Packard announces a truly portable Amplitude and Delay Distortion Analyser that better CCITT recommendations

- * Transmitter and receiver combined in single, rugged, easy-to-carry case.
- * Measures group delay and attenuation distortion using CCITT approved principles.
- * Measuring frequency range 200 Hz to 20KHz
Reference frequency 400 Hz to 20 KHz.
Synthesiser accuracy of the generator gives enhanced repeatability of results.
- * Absolute level measurements from +10dBm to -50dBm from 200 Hz to 20KHz.
- * Solid state digital displays. Selectable digital averaging facility to improve noise rejection.
- * Facilities provided include: automatic continuous/single frequency sweep and incremental stepping; X-Y recorder outputs.
- * Options: loudspeaker; telephone facility; dc loop holding; flexible tone blocking.



For full details on this portable, practical instrument, which sets new standards of accuracy in this field, please contact Hewlett-Packard Ltd., 224 Bath Road, Slough, Bucks., SL1 4DS. Tel: Slough 33341.

HEWLETT  PACKARD

Sales, service and support in 172 centres in 65 countries.
U.K.: 224 Bath Road, Slough, Bucks SL1 4DS.

Do you know what else Herman Smith can do?

"62" type equipment is the aspect of our output you probably already know about. It's worth remembering however, that we produce many other types of presswork and sheet metal assemblies which may be of use to you.

We are acutely aware of the needs of the electrical and electronics industries and our experience in these spheres is comprehensive.

We are prepared for any challenge, complex or simple, large or small. Try us.

We produce the range of "62" type equipment, including the racks themselves, shelf assemblies, card locks, card guides, slide brackets, dummy front plates, etc. We also undertake electrical and electronic assemblies.



Contact Peter Bowen
Herman Smith Limited Cinderbank Works Netherton Dudley
Worcestershire Telephone Dudley 52791

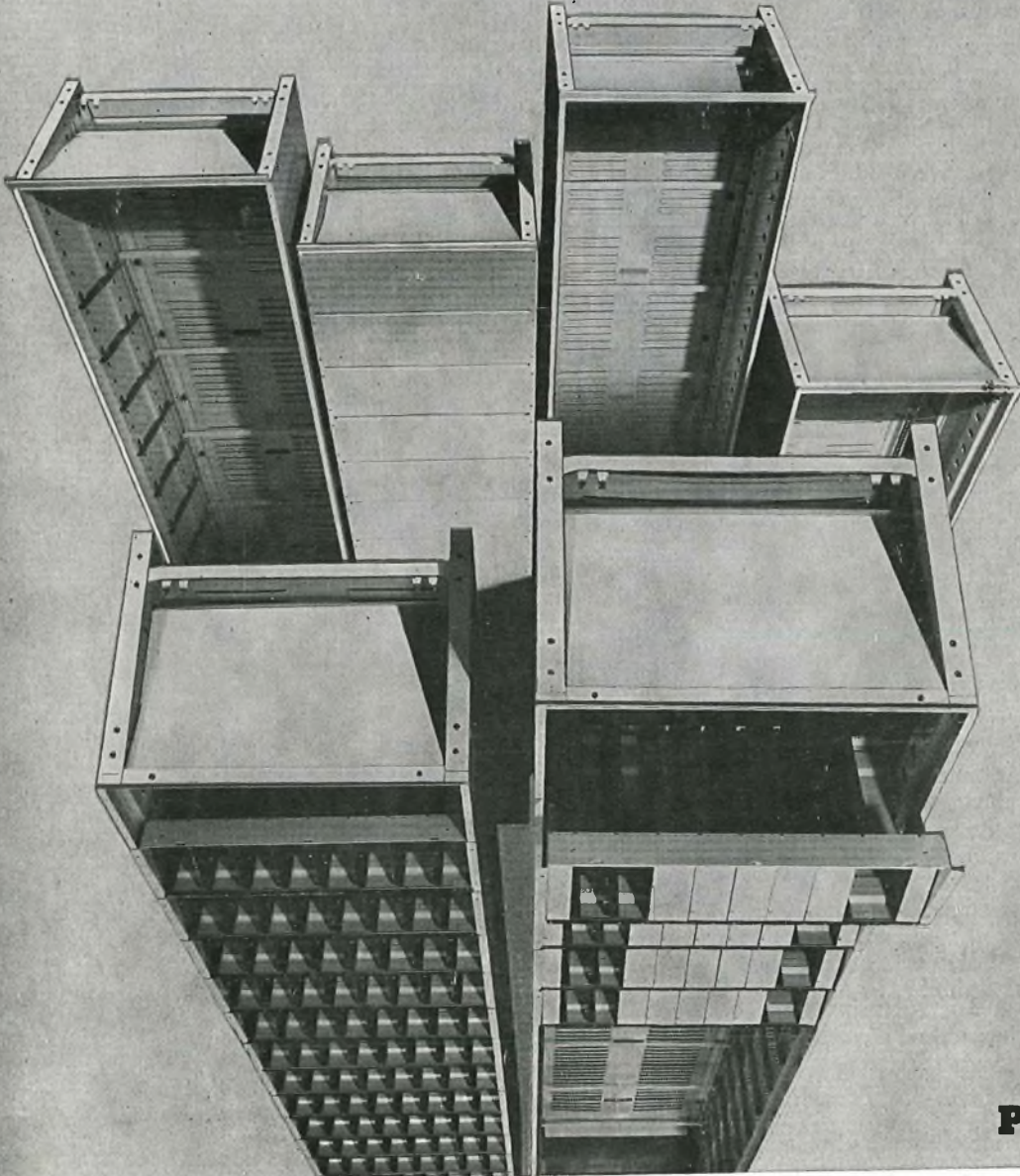

PO approved