

RARE  
P512

# The Post Office Electrical Engineers' Journal

---

VOL 65 PART 3/OCTOBER 1972



# THE POST OFFICE ELECTRICAL ENGINEERS' JOURNAL

VOL 65 PART 3 OCTOBER 1972

## Contents

	<i>page</i>
<b>Editorial</b>	133
<b>Electronic Exchanges: The Steps Leading to TXE4</b> —C. A. May	134
<b>Leicester—A Typical Parcel-Concentration Office</b> —L. A. Nokes	140
<b>Transmission Performance Assessments of Telephone Networks</b> —R. A. Fry and I. H. Banner	145
<b>Digital Switching Systems</b> —A. S. Harris	154
<b>A Digital Radio-Relay System</b> —E. S. Doe	160
<b>Improved Method of Grading: The Partially-Skipped Grading</b> —A. G. Leighton and W. Kirkby	165
<b>Letter-Office Computerized Monitor—LOCUM</b> —J. D. Andrews, H. A. J. Bennett and A. D. Pratt	172
<b>The Reliability of Coaxial Line Transmission Systems</b> —M. G. Hansen and G. G. Stephens	177
<b>Testing Techniques for 24-Channel P.C.M. Systems</b> —G. H. Bennett	182
<b>Notes and Comments</b>	190
<b>Institution of Post Office Electrical Engineers</b>	191
<b>Regional Notes</b>	193
<b>Associate Section Notes</b>	195

Published in April, July, October and January by the *Post Office Electrical Engineers' Journal*,  
2-12 Gresham Street, London EC2V 7AG

Price 21p 31p (Including Postage and Packaging). Orders by post only.

Annual Subscription (post paid): Home and Overseas £1.24. (Canada and U.S.A., 3 dollars)

# Now a graphic recorder with instant change of function

**Plug-in modules give RECORD SERIES 100 S.A. signal amplified recorders complete versatility**

In this new development, the signal is connected to any one of a wide range of readily accessible and interchangeable conditioning modules. The conditioned signal is then amplified before being fed into a high torque galvanometric pen motor. The range of conditioning modules

extends from thermocouple inputs to the measurement of AC and DC amperes and volts. External transducers with milliamp outputs are available for the measurement of Power, Power Factor and Frequency.

If it's electrical measurement put it on Record.

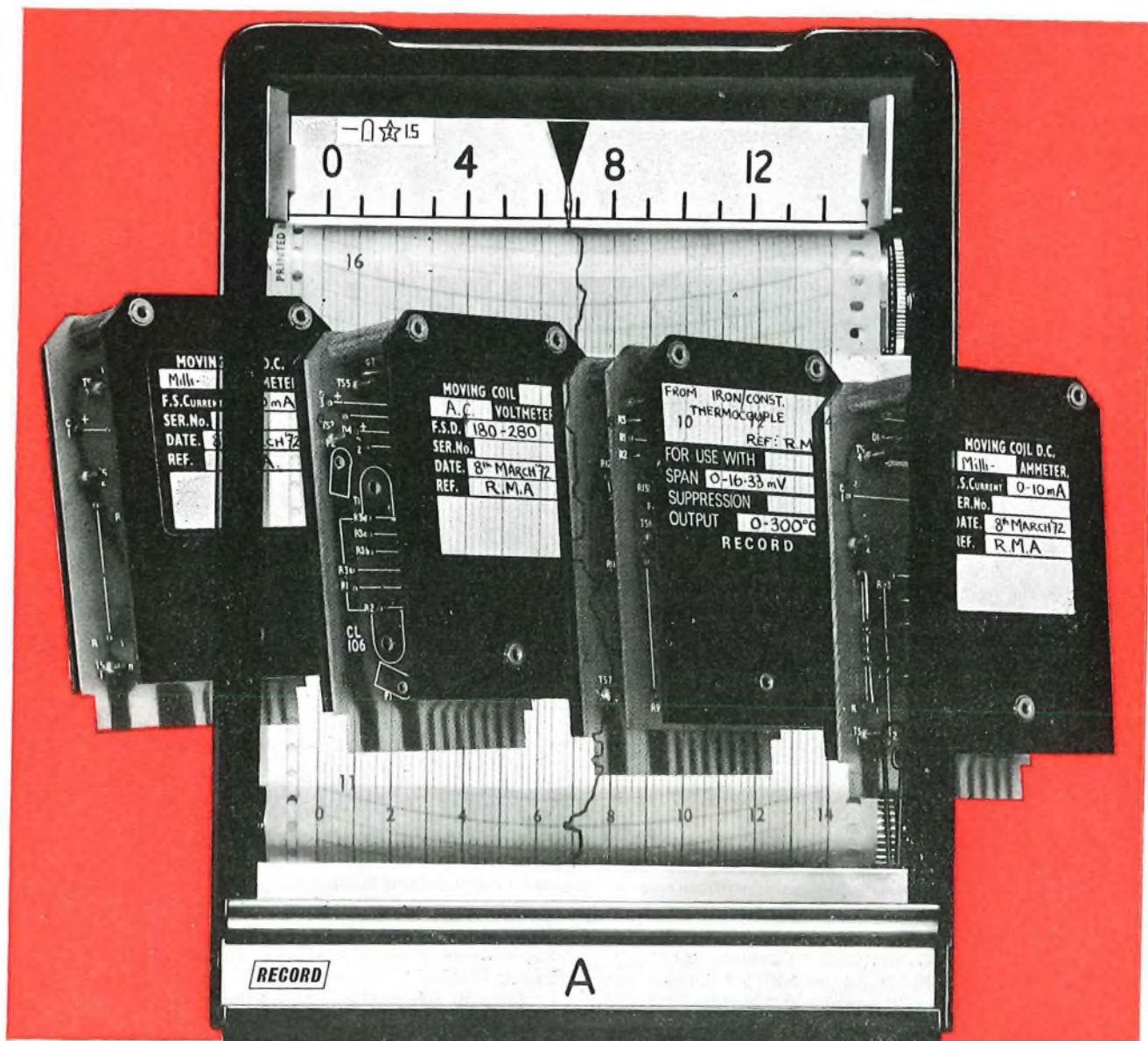

# We've done it again!



About three years ago we achieved a major breakthrough in the manufacture of type 174 coaxial cable.

We produced the first one ever with 20 cores.

And as far as we know we're still the only company in the world to have made production quantities of a cable containing so many type 174 coaxial cores.

Now we've gone one better.

We've manufactured an even larger multicore cable - this time with 28 cores.

The cable will be installed by the Post Office between Faraday and Southbank. Strict engineering control throughout manufacture ensured constant end impedance levels.

This is essential to obtain the required overall transmission characteristics, since each of the 28 cores at each jointing position must be electrically compatible with the corresponding core in the adjoining cable.

This is a good example of STC philosophy. When we come up with an idea there's no sitting back on our laurels.

We're constantly making improvements and modifications to keep our products and processes as advanced and as sophisticated as possible.

After all, we've our hard-earned reputation to consider.

STC Paper Insulated Telephone Cable Division, North Woolwich, London, E.16.

Standard Telephones and Cables Limited

**ITT**

A British Company of ITT

## STC Telecommunications

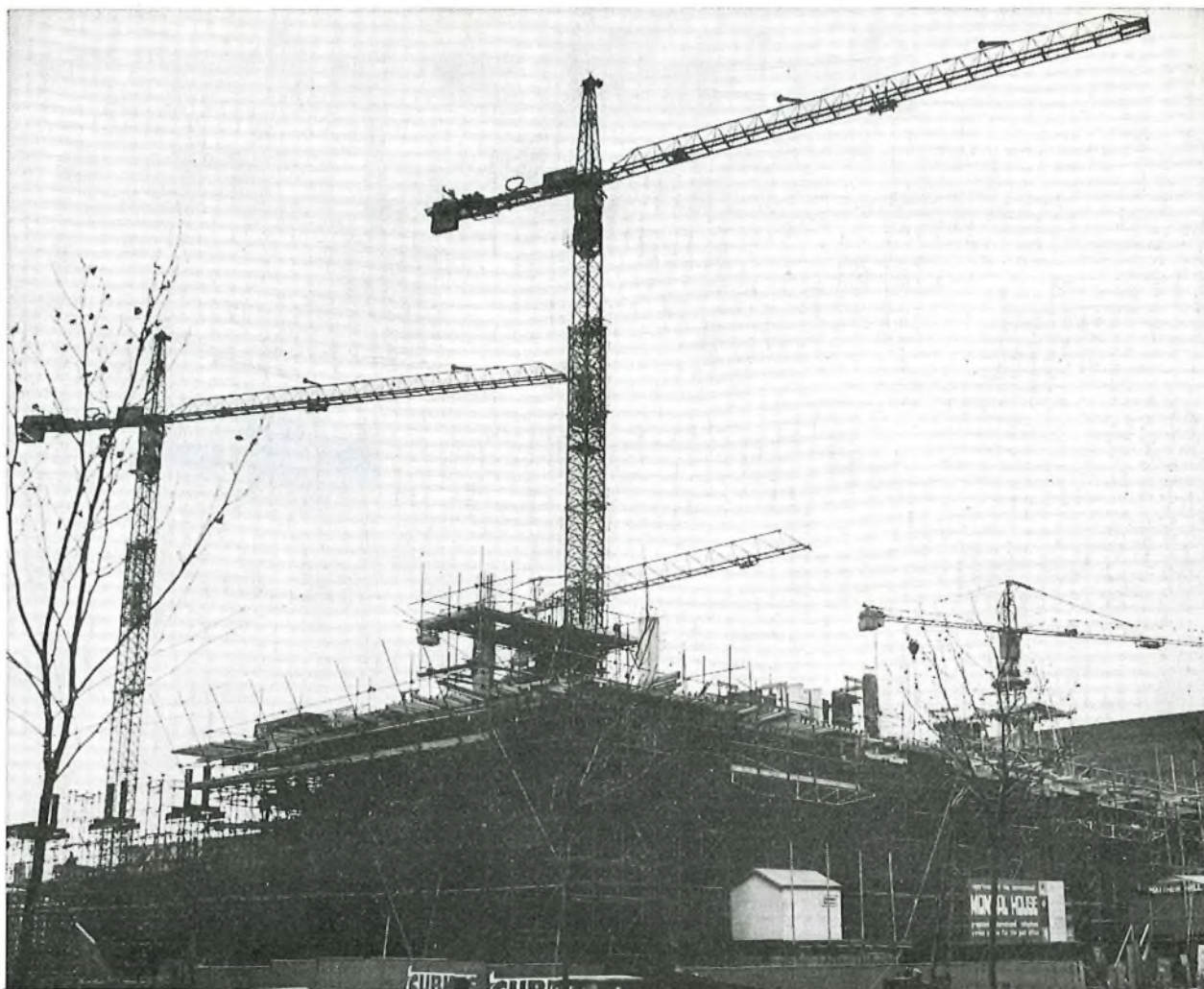

# We're putting the transmission equipment into Europe's latest international switching centre. Here's what the world gets out of it.

When London's Mondial House opens for business, new international circuits will help relieve the congested traffic routes.

It will ultimately handle around 180,000 calls an hour on 18,000 international circuits via cable, microwave and satellite links.

Linking the UK with 29 European countries — with transit facilities between the old and new world. Providing intercontinental circuits to a total of 51 countries — including the USA, Canada, Africa, India, Australia, and the Middle and Far East.

The British Post Office has entrusted STC with the contract for the manufacture and

installation of special multiplexing equipment, including frequency translating, carrier generating and supervisory equipment.

Manufactured to BPO specification, this equipment is a special version of our well-proven range in Mark 6 construction. And by the mid 1970's, it will be making a world of difference to global communications.

Contact us when your administration needs high quality multiplexing equipment for similar transmission applications.

Standard Telephones and Cables Limited, Transmission Division, Basildon, Essex, England. Telex: 99101 (STC Basildon).

Standard Telephones and Cables Limited

**ITT**

A British Company of ITT

# Put all our submarine and you could girdle the



# cables together earth two and a half times.

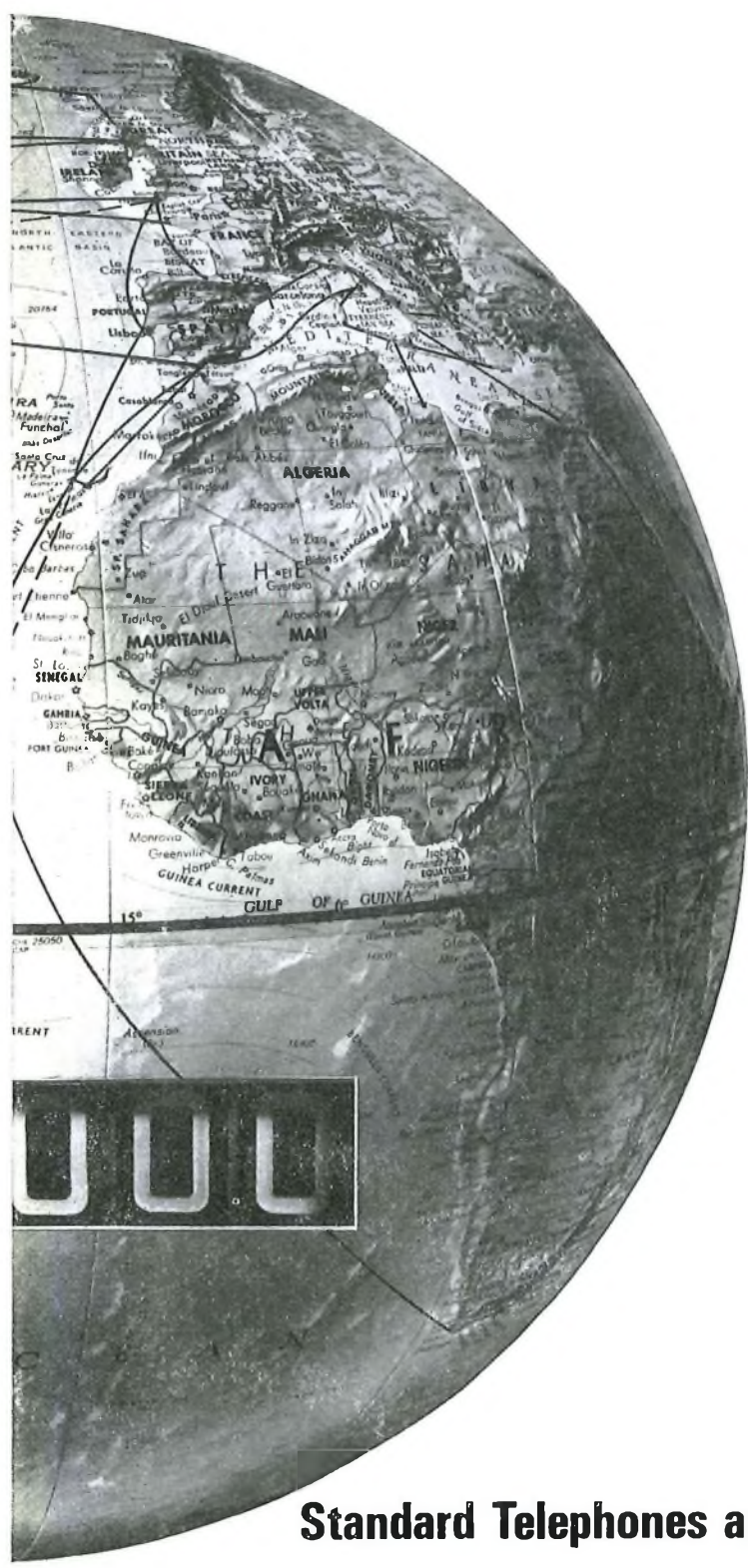

There are over 57,000 nautical miles of STC Submarine Telephone Cable at work every hour of every day.

Carrying vital communications between countries and continents, under oceans and seas.

Since 1950, we've taken part in 58 cable projects, involving 34 different countries, proving the reliability of STC equipment and system design.

Now backed by the extensive experience we've gathered over the years we're involved in no less than 10 new projects.

Included are the next two transatlantic systems - Cantat - 2 and Bracan - 1.

These will be adding a great deal more to the high quality global communications network to which we've already contributed so much.

Standard Telephones and Cables Limited, Submarine Systems Marketing and Projects, North Woolwich, London, E.16, England. Telephone: 01-476 1401. Telex: 21645.

**Standard Telephones and Cables Limited**

A British Company of ITT



STC Telecommunications



## Ring up a little extra something for yourself.

More and more people want Deltaphone in their homes.  
It's sculptured on modern lines and comes in very  
modern colours – yet still blends in beautifully with any decor.  
And with no extra outside plant investment – plus  
easy maintenance – you ring up extra income with every  
Deltaphone rental.

How does that sound?

STC Subscriber Apparatus & Acoustic Division,  
New Southgate, London N.11. Tel : 01-368 1234. Telex : 21917.

Standard Telephones and Cables Limited

**ITT**

A British Company of ITT



# STC Telecommunications



## We make light of things.

STC headsets are lighter.  
 So work's a whole lot brighter.  
 The sets themselves are really tough.  
 But at the same time really comfortable.  
 And they don't cost very much.  
 Which is why STC headsets are so popular the world over.  
 STC Subscriber Apparatus &  
 Acoustic Division,  
 New Southgate, London, N.11.  
 Tel: 01-368 1234. Telex: 21917

Standard Telephones and Cables Limited **ITT**  
A British Company of IIT

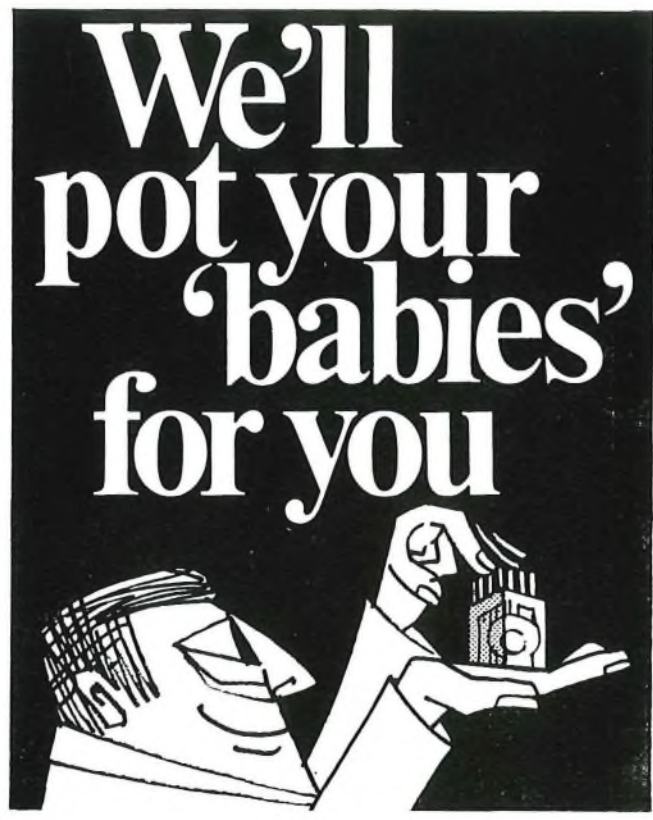

When you've got components that call for encapsulation—bring them along to Whiteley. With efficient potting, your components will be totally insulated and environmentally protected—and Whiteley experience in developing this advanced plastics technique will ensure that it is applied to full advantage.

We can encapsulate in epoxy resin or polyurethane—hot setting or cold setting as required. Where fillers offer advantages, we can apply them, expertly. We are ready to handle small quantities or volume production for you. It's one more way in which you can capitalise on our production resources. For electrical and electronic work—right through from design to final assembly—you can safely follow the example of many famous names—and call in Whiteley.

# Whiteley

*versatility...*

- ELECTRONIC & ELECTRICAL DESIGN
- PRODUCTION CAPABILITY
- CABINET MAKING
- SHEET METAL FORMING/FINISHING
- PLASTICS MOULDING
- ENCAPSULATION

WHITELEY ELECTRICAL RADIO CO. LTD.  
 Mansfield, Notts, England. Tel. Mansfield 24762  
 London Office: 109 Kingsway, W.C.2. Tel. 01-405 3074

# comprehensive telecommunications

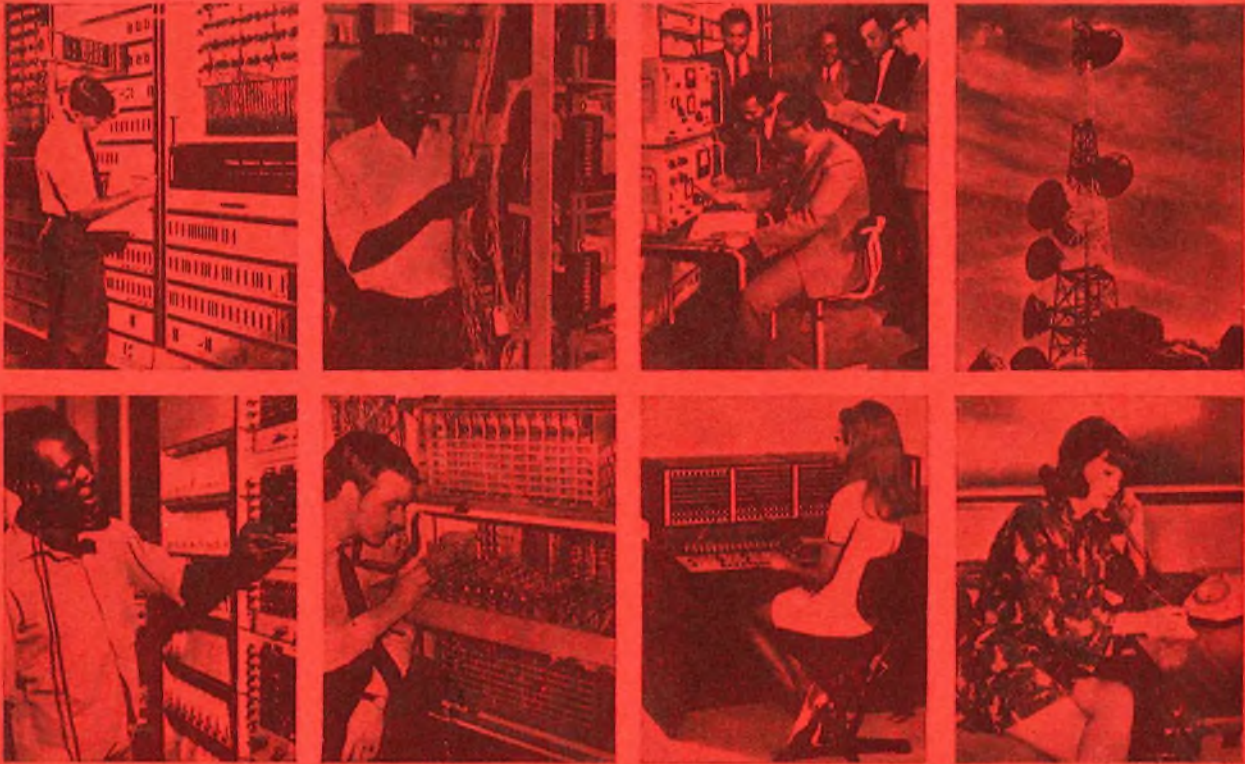

## There are many facets to all-round capability in telecommunications

All-round capability in telecommunications calls for a rare combination of experience, skills and resources to provide the coherent research, development and manufacturing complex on which complete capability in telecommunications depends. GEC Telecommunications Limited is the largest company in this field in England and one of the foremost in the world. These are some of the facets of the service offered by GEC which will help you to recognise its all-round capability in telecommunications.

- Research, Development, Design
- Surveying, Planning, Systems Design, Installation, Commissioning
- Maintenance, Training
- Transmission by Radio, Cable and Open-Wire Line, Lincompex and Echo Suppressors
- Frequency Division and Digital Multiplex, Audio, Programme, Signalling, Telegraph and Data Equipment
- Public Exchanges, Trunk Switching, RAX-UAX and Mobile Exchanges
- PABX-PAX Private Telephone Systems
- Telephones - Table, Wall, Secretarial, Loudspeaking

MICROWAVE AND LINE TRANSMISSION · MULTIPLEX · V.F. TELEGRAPHY,  
DATA MODEMS · TELEPHONE SWITCHING SYSTEMS · PRIVATE  
TELEPHONE SYSTEMS · TELEPHONES · TOTAL SYSTEMS CAPABILITY

GEC TELECOMMUNICATIONS LIMITED of Coventry, England.  
A Management Company of The General Electric Co. Ltd. of England.

IBC59

**ever  
wanted**

to improve your  
capacity for  
conversation?

**with the GEC  
small-diameter  
co-axial cable  
system 4K9B  
you can!**

- \* 960 telephone circuits.
- \* 4.4 mm. (0.174 in.) or 9.5 mm. (0.375 in.) coaxial-cables.
- \* Power-fed repeaters at a maximum spacing of 4010 m. (4,400 yd.) for 4.4 mm. cable and 9250 m. (10120 yd.) for 9.5 mm. cable.
- \* Performance to CCITT recommendations.
- \* Proven in operation with over 230 systems covering 6000 route miles being supplied in the U.K. alone.
- \* Underground repeater boxes to house up to six systems.



**Takes telecommunications into tomorrow**

GEC TELECOMMUNICATIONS LTD. OF COVENTRY, ENGLAND.

A Management Company of The General Electric Co. Ltd. of England.

# comprehensive telecommunications

Take a new look at our 6.1GHz  
Microwave system — we often do

Behind the success of GEC 6.1GHz radio systems is a policy of continuous systematic improvement to a proven system. Modifications are introduced not for the sake of change but because they represent a significant advance on previous practice. In this way, GEC builds on the success of its 6.1GHz system. One recent example of this kind of studied innovation was the introduction of phase-locked oscillators which have significantly reduced oscillator noise.

Our system-planning engineers will be pleased to show you some of the other ways in which we have improved on the proven and established 6.1GHz system, which has a capacity of 1800 speech circuits, or one colour television channel and its associated sound channels — all in accord with CCIR recommendations.

The 6.1GHz system includes frequency division multiplex, supervisory and control, I F and baseband switching, narrowband auxiliary radio for serviceband, and antenna systems.

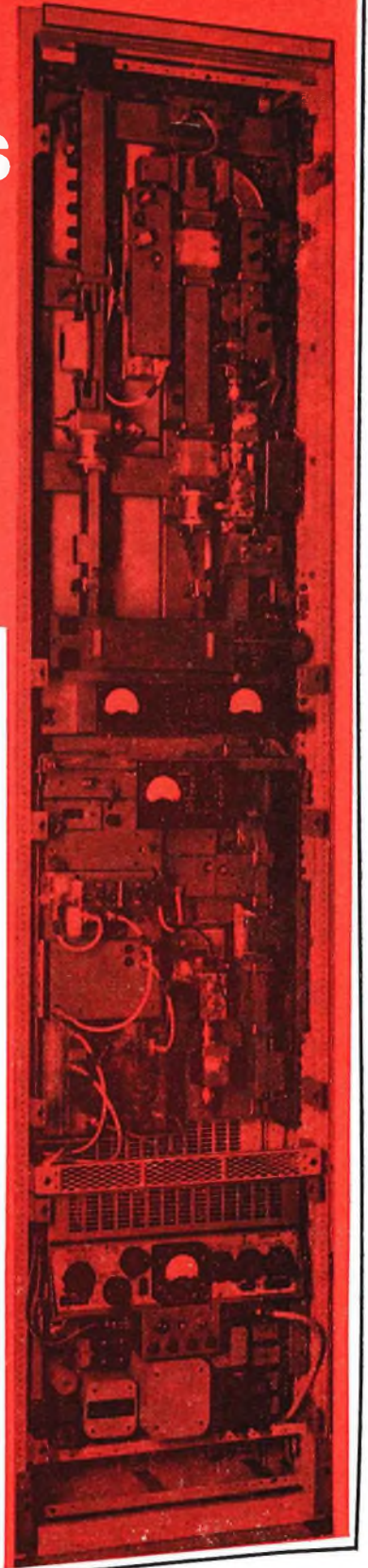
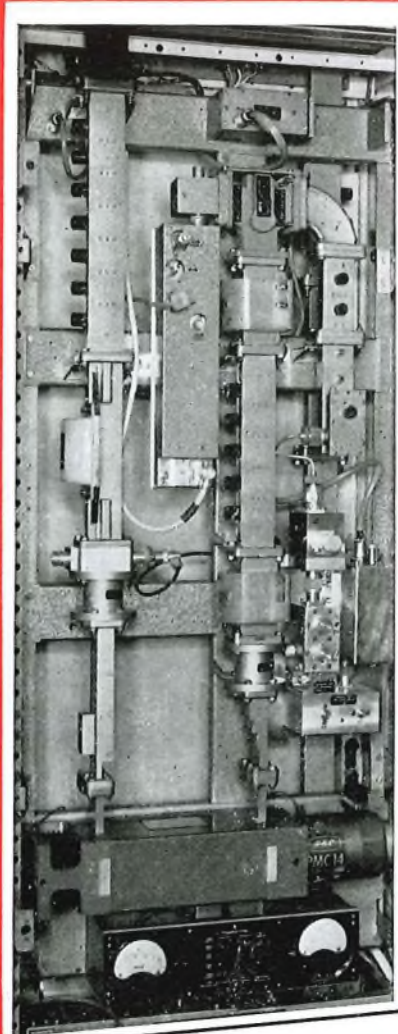

**G.E.C.**

MICROWAVE AND LINE TRANSMISSION · MULTIPLEX · V.F. TELEGRAPHY  
DATA MODEMS · TELEPHONE SWITCHING SYSTEMS · PRIVATE  
TELEPHONE SYSTEMS · TELEPHONES · TOTAL SYSTEMS CAPABILITY

GEC TELECOMMUNICATIONS LIMITED of Coventry, England.  
A Management Company of The General Electric Co. Ltd. of England.

18B57

# comprehensive telecommunications



## U.K. extends its links with GEC microwave radio systems

GEC has supplied and installed most of the British Post Office network of broadband radio links carrying an ever-increasing volume of trunk traffic. The network includes one of the most heavily loaded routes in the world, between London and Birmingham which is equipped with 50 RF channels carrying 27000 telephone circuits and 12 television programmes. With microwave systems operating in 30 other countries, GEC is one of the world's leading manufacturers. The total systems capability of GEC covers not only an extensive range of microwave radio and associated equipment but also comprehensive planning, installation, maintenance and training resources. It includes 2GHz, 4GHz, 6GHz, and 6.8GHz systems for speech or colour television on long-haul main routes and 7.5GHz for speech on medium-haul and spur routes, and the private user market, all in accord with CCIR requirements. Associated equipments include frequency division multiplex for up to 1800 circuits, supervisory alarm indication and remote control systems, IF and baseband switching, narrowband auxiliary radio for serviceband, and antenna systems.

MICROWAVE AND LINE TRANSMISSION · MULTIPLEX · V.F. TELEGRAPHY  
DATA MODEMS · TELEPHONE SWITCHING SYSTEMS · PRIVATE  
TELEPHONE SYSTEMS · TELEPHONES · TOTAL SYSTEMS CAPABILITY

GEC TELECOMMUNICATIONS LIMITED of Coventry, England.  
A Management Company of The General Electric Co. Ltd. of England.

1BB63

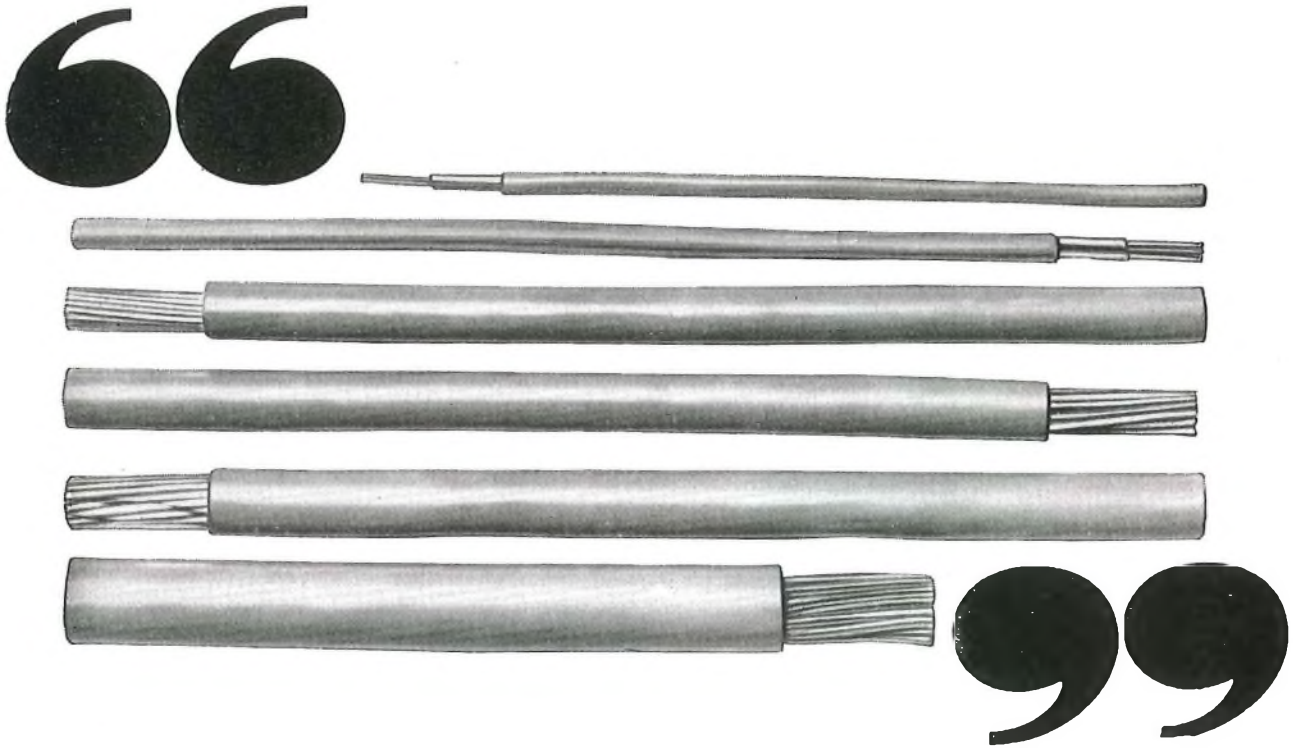

“**PIRELLI  
GENERAL**”

**and the power  
of speech**

Internal telephone communication systems call for the same degree of reliability as for national networks. Pirelli General manufactures a range of multipair and multiway internal telephone cables which are stocked for immediate delivery.

To reduce cross-talk in the multipair construction the pairs are twisted and laid-up with varying lays. Each cable has a distinct colour identification scheme for the cores or pairs which facilitates quick termination, and a Terylene ripper cord assists in quick removal of the pvc sheath. For further details ask for Publication MC3:1970.

PIRELLI GENERAL CABLE WORKS LIMITED · SOUTHAMPTON · TELEPHONE: SOUTHAMPTON 20381

# Marconi PCM systems

Marconi is the foremost manufacturer and exporter of PCM systems in the United Kingdom.

Marconi is a major supplier of PCM to the British Post Office, with equipment in operation in the London Region and many provincial regions. Marconi PCM systems are in use improving the communications efficiency of public utilities and telephone undertakings both in the United Kingdom and overseas.

Marconi has the widest experience in planning and installing complete PCM systems, adaptable to widely ranging requirements.

Marconi 24 channel PCM equipment Series U1310 is an advanced multiplexing system employing the latest microcircuit techniques.

- Low cost.
- Pulse system permits the use of regenerative repeaters to prevent noise and distortion build-up along the line.
- Deeper penetration of advanced micrologic circuits gives greater reliability.
- Advanced manufacturing processes and testing techniques increase equipment reliability.
- Suitable for future integrated switching systems.
- A range of signalling sets for different exchange conditions.

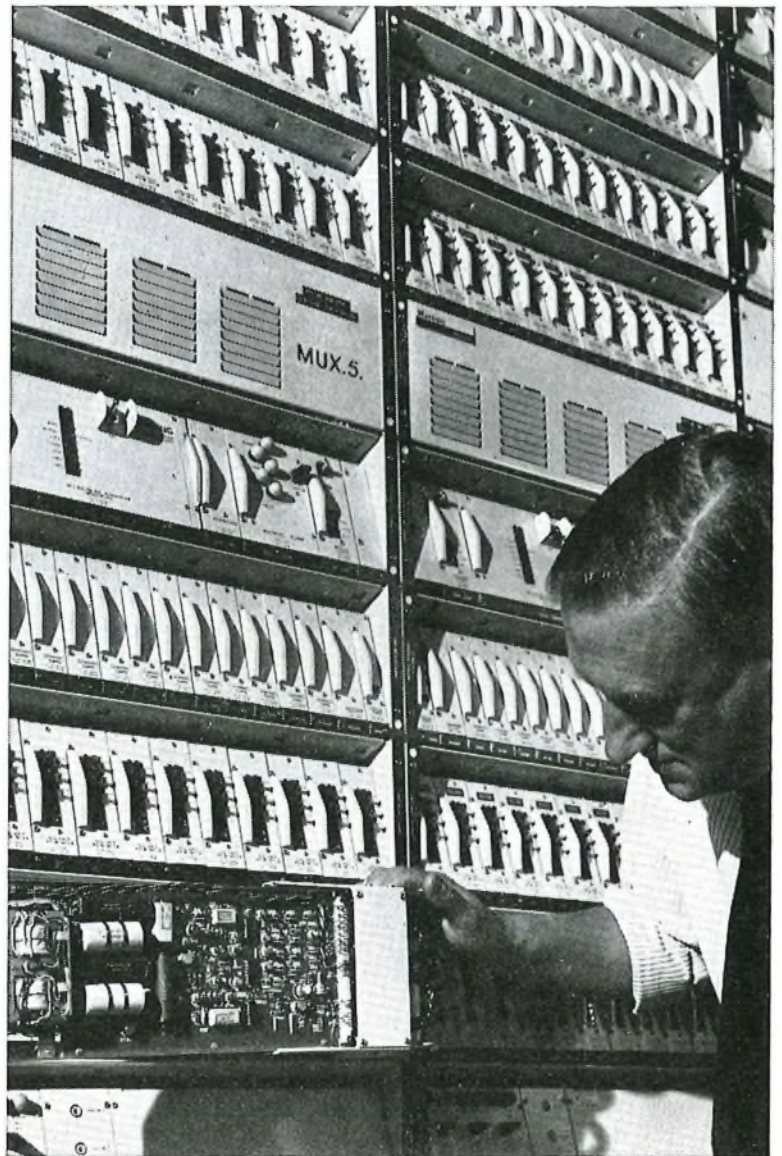

- Suitable for data transmission, and optional teleprinter facility.
- Accurate fault location and comprehensive fault alarm facility.

*Marconi Line Division, specialists in digital transmission, including message switching and error correcting equipment, part of the total systems capability of Marconi Communication Systems.*

## Marconi Communication Systems

Complete civil and military static and mobile communication systems

Message switching  
Digital and data systems  
Microwave and tropo systems  
Mobile radio telephones  
Specialized components

Satellite communications earth stations  
H.F. and l.f. point-to-point systems  
Television and broadcasting stations  
Maritime and naval systems  
Surveys, planning and commissioning

Marconi Communication  
Systems Limited,  
Chelmsford, Essex, England

*A GEC-Marconi Electronics Company*

**Subject: Consoles at monitoring and testing area of Telegraph Transmission Centre.**

**Location: 5th Floor, St. Botolph's House, Aldgate, London.**

**Built with: WIDNEY DORLEC.**

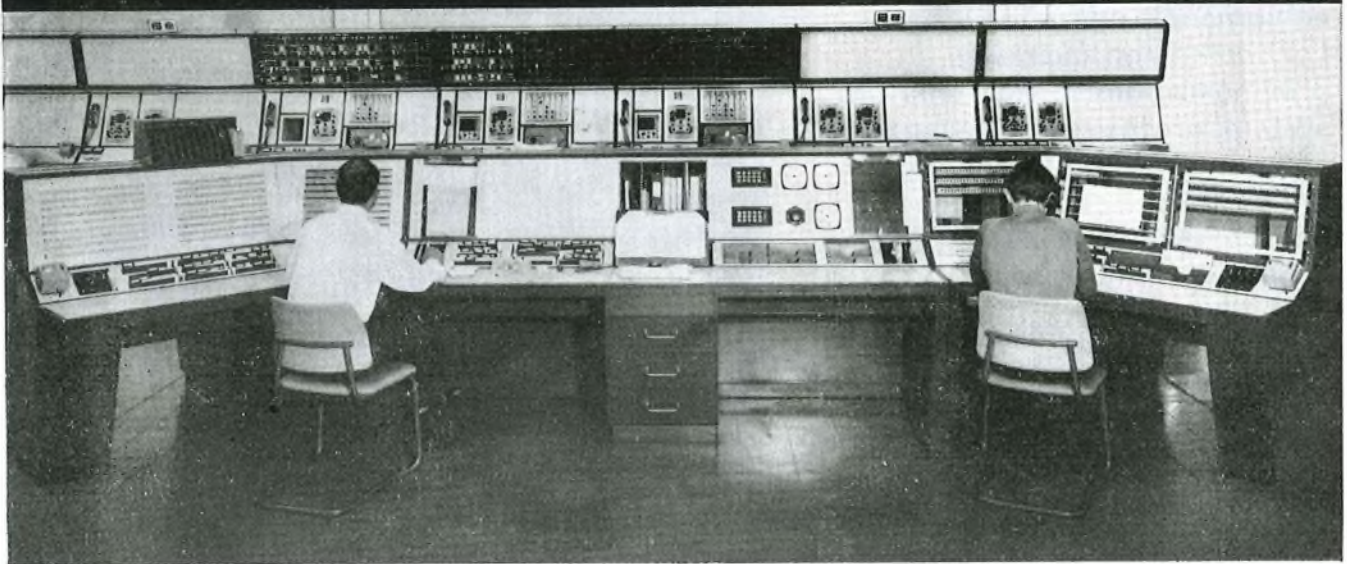

It is not surprising that leading designers in today's technological field much prefer Widney Dorlec than other constructional systems.

The consoles shown above and the desk below installed at the P.O. Radio Station, Burnham, Somerset, are just two examples of outstanding versatility, good looks, and hidden strength. The unique combination only offered by Widney Dorlec.

To Hallam Sleigh & Cheston Ltd., the makers of Widney Dorlec. P.O. Box 133, Bagot Street, Birmingham, B4 7BD. Telephone 021 359 3044 Telex 338054

Please send me the Widney Dorlec Catalogue.

Please get in touch with me personally.

Name \_\_\_\_\_

Position/Dept. \_\_\_\_\_

Company name and address \_\_\_\_\_

WD118



**Widney Dorlec.**



# The Post Office Electrical Engineers' Journal

---

## BOARD OF EDITORS

N. C. C. de JONG, B.Sc.(Eng.), C.Eng., M.I.C.E., F.I.Mech.E.,  
F.I.E.E., Chairman

E. W. AYERS, B.Sc.(Eng.), C.Eng., F.I.E.E.

D. R. BEARHAM, B.Sc.(Eng.), C.Eng., M.I.E.E.

S. H. SHEPPARD

A. J. BARNARD, C.Eng., M.I.E.E.

A. C. CROISDALE, M.B.E., B.Sc.(Eng.), M.I.E.E.

J. MARTIN, B.Sc.(Eng.), C.Eng., M.I.E.E.

## Managing Editor

N. J. H. NINNIM, M.Sc., B.Eng.

## Deputy Managing Editor

D. MILLINGTON, C.Eng., M.I.E.E.

## Assistant Editors

P. G. STEELE, M.Sc., B.Sc.(Eng.)

T. R. K. RAFT

N. G. CRUMP, M.I.T.E.

## Secretary-Treasurer

B. FARR, A.B.I.

## Advertisement Manager

R. G. ROTHERY

## EDITORIAL

In the January 1972 issue of the *Journal* it was reported that the British Post Office (B.P.O.) had placed a contract for the final development, supply and installation of electronic exchanges of the TXE4 design. This issue includes the first of a number of articles on the TX4 system. Entitled "The Steps Leading to TXE4", it outlines the history of the development of the reed electronic exchange and describes the basic TXE4 system. The author, Mr. C. A. May, is head of the Exchange Systems Division of the Telecommunications Development Department of the B.P.O. Further articles, to be published later, will deal with more specific aspects of the system.

This issue also includes an article on partially-skipped grading written by members of the recently-created Teletraffic Branch of the B.P.O. It is the first of a number of articles to be published on traffic engineering subjects. Other articles in the issue include a description of the parcel-concentration office at Leicester and an outline of the maintenance monitoring scheme (LOCUM) being introduced into mechanized postal installations. The telephone transmission field is represented in this issue by an informative article on the general subject of transmission performance assessment, as well as others dealing with the reliability of co-axial line systems and the testing techniques for p.c.m. systems.

# Electronic Exchanges: The Steps Leading to TXE4

C. A. MAY, M.A., C.ENG., F.I.E.E., F.B.C.S.†

U.D.C. 621.395.345

*The foundation work undertaken in the 1950s and 1960s by the parties to the Joint Electronic Research Agreement (now terminated) on the development of a repertoire of electronic exchanges has resulted in effective in-service experience of a small exchange (TXE2) and the concluding stages in the development of a large exchange (TXE4), both using reed-relay crosspoints. This article brings up to date the history of the development of large exchanges, culminating in the start of production of the TXE4 exchange.*

## INTRODUCTION

The development of electronic exchanges in the United Kingdom began in earnest after the signing of the Joint Electronic Research Agreement (J.E.R.A.) in 1956.<sup>1</sup> This Agreement was signed by the British Post Office (B.P.O.) and the (then) five main British telephone equipment suppliers in order that "their joint researches might be pooled to produce a viable electronic switching system, in the shortest possible time and with the minimum of duplication of highly expensive development effort".

From that time, until the ending of the Bulk Supplies Agreement in September 1969, development of electronic systems proceeded under the guidance of the Joint Electronic Research Committee (J.E.R.C.). After an early phase during which time division multiplex (t.d.m.) schemes were examined, culminating in the design and installation of the Highgate Wood exchange in 1962,<sup>2</sup> the agreed main line of development was based on the use of matrices of reed relay switches under electronic control.

Two streams of work proceeded in parallel: one led to the development of the small TXE2 exchange,<sup>3</sup> of which there are now over 280 in service and a further 400 on order. The other tackled the more complex problems inevitable in the design of a system capable of meeting the needs of the B.P.O. for the largest city centre exchanges, in both director and non-director areas. This line of development has proceeded steadily and naturally through the TXE1<sup>4</sup> and TXE3<sup>5</sup> systems. At each stage, basic design principles were established and ambiguities were resolved by trial and in-service experience. Following the ending of the J.E.R.A. and the consequent modification of relationships between the B.P.O. and its principal suppliers, the B.P.O. decided to take the development to its natural completion and placed a contract with Standard Telephones and Cables Ltd (S.T.C.) to cover the remaining work and the supply of some £15M of telephone exchange equipment based on a cost-reduced version of the TXE3 exchange. This is now known as the TXE4 system and installation of the first public exchange will start, at Rectory Exchange in Birmingham, in 1973.

From the starting date, in 1961, to the opening of the first production exchange, some 14 years of patient, progressive development work will have been completed. It is the purpose of this article briefly to discuss the various stages through which the development has passed.

† Telecommunications Development Department, Telecommunications Headquarters.

## THE DEVELOPMENT OF THE TXE1 SYSTEM

By 1963 it was clear that the problems shown up by the Highgate Wood and other t.d.m. experiments were unlikely to be resolved quickly. This applied in particular to the development at that date of semi-conductors capable of the high speed operation necessary for the time division multiplex approach. All parties to J.E.R.A., therefore, decided in 1963 that work on time division systems would be returned to the research phase, later to emerge as integrated pulse-code-modulation switching and transmission systems such as the Empress field trial.<sup>6</sup> Work was to be concentrated on the development of reed electronic systems for small exchanges (TXE2) and large exchanges (TXE1). Work on the former was continued by the General Electric Company and Ericsson Telephones Limited (now part of the Plessey Company) in collaboration with the B.P.O.; the development of the TXE1 system, covering large exchanges above 2,000 lines, was undertaken by joint collaboration between the B.P.O., Associated Electrical Industries (A.E.I.—now part of G.E.C./A.E.I.), the Automatic Telephone & Electric Company (A.T.E.—now part of the Plessey Company) and Standard Telephones and Cables Ltd. Both developments remained under the general control and policy guidance of J.E.R.C.

Fig. 1 shows the important features of the TXE1 system. The trunking principles were based, at least in part, on previous private-venture work done by British industry, modified to suit the reed-relay crosspoint which had been selected for both the TXE1 and TXE2 developments. This used specialized trunking for the different stages and types of call; three stages for subscriber-to-register connexions; five stages for outgoing junction calls; and six stages for local calls. Fixed-concentration A-stage switching was used—with, naturally, different concentration ratios for subscriber and incoming-junction A-stages.

The exchange consisted of a number of units. Each local unit (see Fig. 1) served 1,500 subscribers' lines and consisted of four sub-units of B and C switches trunked to 15 A-switches, each serving up to 100 subscribers' lines, as shown in Fig. 2. The completion of a call always required the use of a link of the appropriate type—local, outgoing, incoming or transit—between C-switch inlets of the units concerned. Each sub-unit had links of each type connected to its C-switch inlets and the overall pattern of interconnexions was arranged to provide links from each sub-unit to each sub-unit above and below it in its own and all other units. Thus, a completed call always required the use of two

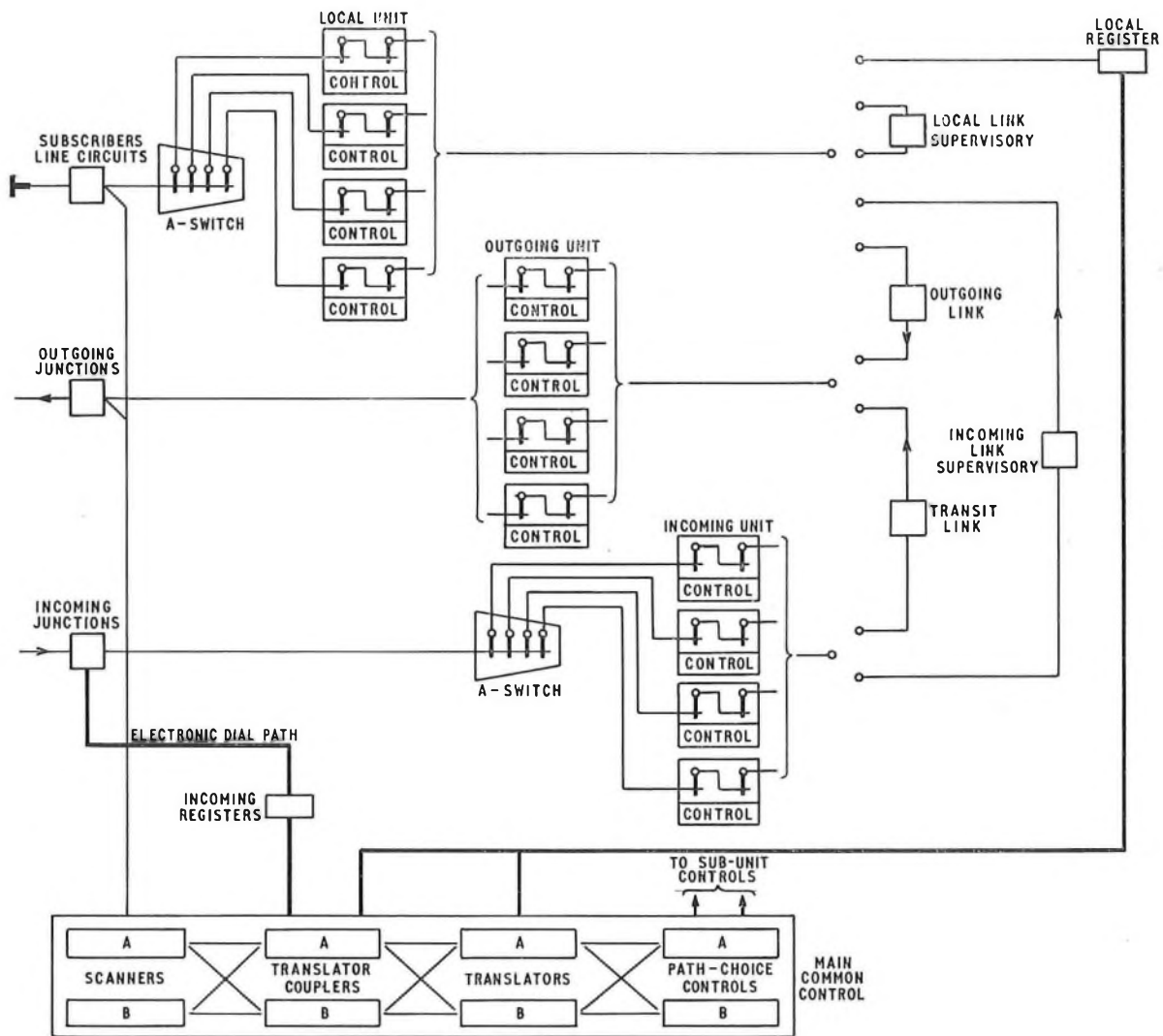

FIG. 1—The TXE1 system

sub-units, one being used for connexion to the calling subscriber or junction, and the other for the connexion on the called side.

To increase the availability and, thereby, promote efficient use of the more expensive local and incoming junction links, a proportion of these were connected to C-switch inlets of more than one sub-unit; these were known as overlying links (not shown on Fig. 1). Registers were connected to C-switch inlets and their availability was similarly increased by overlying connexions. Because of the rapid access time required by incoming registers, these were not connected by switches but through a special electronic dial path, time-shared to transfer pulsing information from the incoming junction termination to a free incoming-register.

The main common-control system comprised a duplicated lattice structure. Switching out of a faulty element was under control of an automatic fault locator which, whenever a faulty condition was encountered, performed a diagnostic routine by setting up test calls in a predetermined manner. High-speed or low-speed programs were available, depending upon the nature of the fault indication. The equipment was able to change-over the various duplicated items and, from the proportion of successes and failures obtained from the test calls, could determine the combination giving optimum serviceability. A full record of test routines and results was printed out by a teleprinter to assist in fault location. The TXE1 design was proved in a large-scale

laboratory model, following which a full-sized public exchange was installed at Leighton Buzzard.

The Leighton Buzzard exchange has provided full public service since 1968 to between 1,500 and 2,500 subscribers; the total number of calls carried to date exceeds 25 million. The performance of the exchange has been highly satisfactory, and the experience gained has pointed the way to several improvements, both technical and economical, to make it more suitable for a production system. These include standardized, instead of specialized, trunking for different types and stages of calls, variable-concentration A-stage switches, and an improved security philosophy, particularly in the common-control area.

### THE TXE3 DEVELOPMENT

As is inevitable during any major advanced development, some of the improvements that were shown to be possible during the design of the TXE1 system were recognized well before Leighton Buzzard was opened to public service. In parallel with the later stages of the TXE1 development, therefore, work started on an improved—and cheaper—version, the TXE3 system. Broadly the changes made were aimed at improving system simplicity and security, and with a view to evolutionary potential coupled with improved operational convenience. These aims were achieved by the introduction of a high degree of modularity and generality

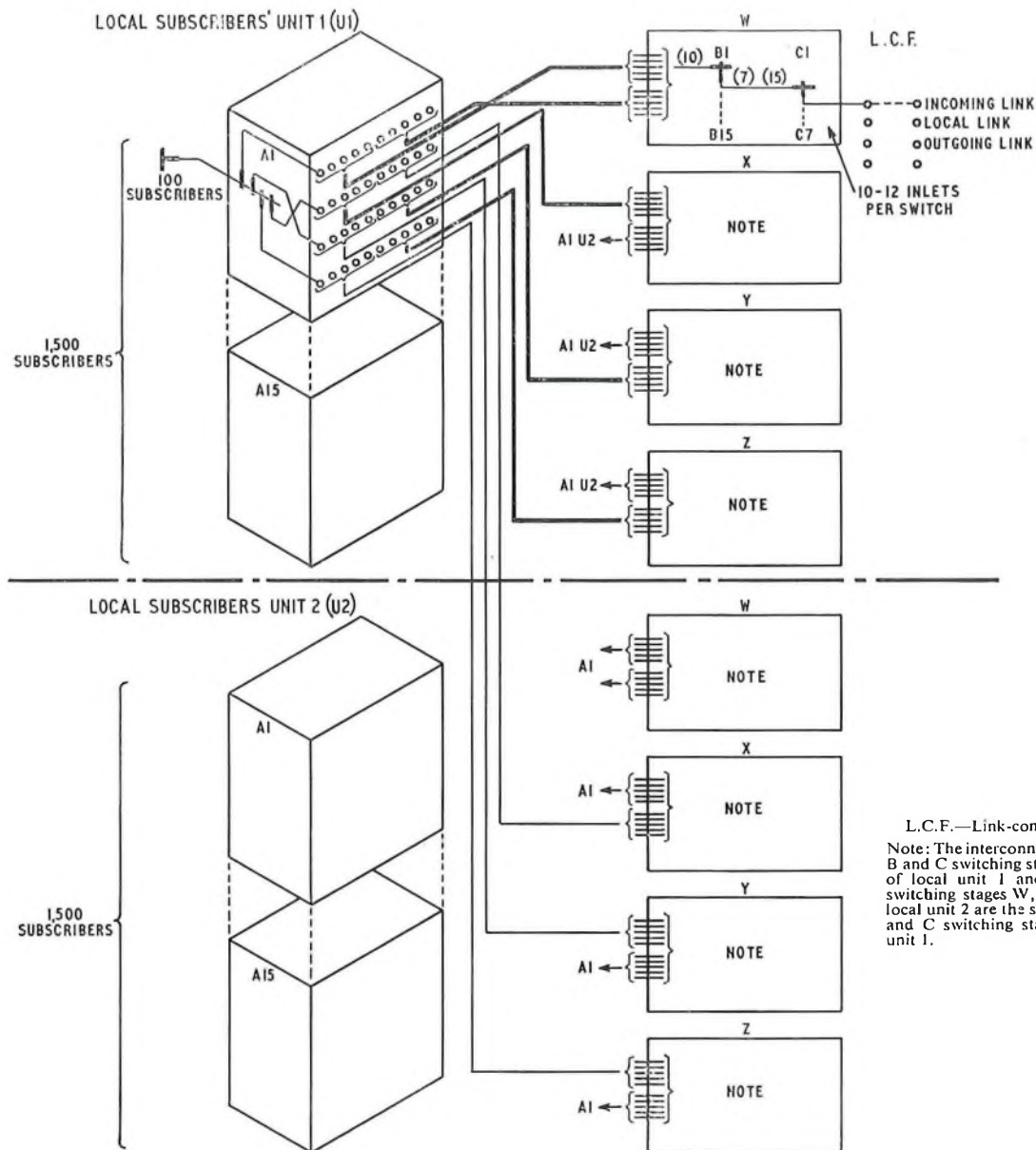

FIG. 2—Local-subscribers' unit trunking

into both the switching network and the control areas. For the switching network one single type of unit was used to which all classes of terminal were connected. All call-connexions were set in a standard manner using either a single six-stage connexion or multiple six-stage connexions arranged serially. The control was flexibly programmed to permit greater realization of the adaptive potential of a simplified switching network, and to provide scope for unforeseen facility requirements. It, too, was provided in unit fashion, each control unit being independent and capable of meeting the full range of service facilities independently of the others. The number of control units (or processors) could vary from 2 to 10 according to security and traffic requirements.

A major hardware change was the introduction of a smaller reed insert,<sup>7</sup> which enabled significant savings in overall system size to be realized. A cyclic-store was introduced to drive the line-scanner and, at the same time, to provide an electrical store of all the necessary information relating to every subscriber, or other termination, on the exchange. The information included such details as a customer's directory number, the identity of his location on the A-switches, and his class-of-service (e.g. ordinary, call-office, shared-service, etc.). A variable-concentration A-switch replaced the fixed-concentration A-stage switch used in the TXE1 system. The

principle is shown in Fig. 3 where each diagonal represents the line circuits and A-switch crosspoints of 40 customers. The diagonals are mounted on separate plug-in units, and anything from one to ten may be provided on each A-switch to match the customer traffic to the capacity of the B-switches.

By agreement under the terms of J.E.R.A. the development of the TXE3 system was carried out by the same group of parties as for the TXE1 system. It was taken to the stage at which a 200-line laboratory model was produced consisting of at least one of every unit required for a complete exchange. Comprehensive laboratory tests, in the B.P.O. circuit laboratory, occupied a period of 15 months, during which time unit designs were exhaustively assessed, both individually and in combination. Following this, a limited public service trial of 2 years duration was conducted.

### THE TXE3 SYSTEM TRIAL

For the purpose of the trial, 100 of the model-exchange lines were allocated to a block of final-selector numbers in a nearby director exchange, and changeover equipment was provided so that the high-calling-rate customers concerned obtained their service from the TXE3 equipment. During the two-year trial-period, from 1968 to 1970, it was never neces-



FIG. 4—Production of B-switches for TXE4 exchanges

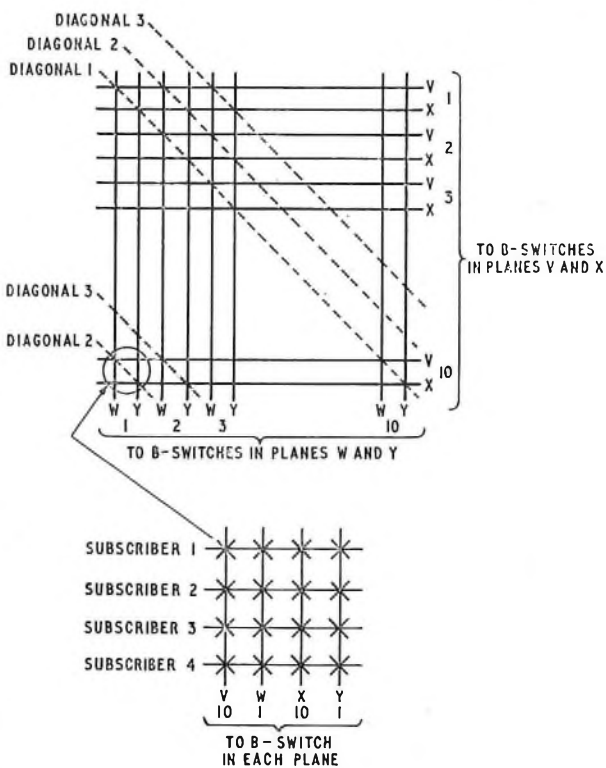

FIG. 3—Variable-concentration A-switch

sary to return the customers to the Strowger equipment for service reasons, though this was occasionally done to permit engineering tests. For the major part of the time the model was operated on an unattended basis, and the service observation results were significantly better than the average for the area. A low electronic-component failure-rate coupled with the good system performance showed that the fundamental electrical and system designs were sound.

The success of the TXE3 model, therefore, gave increased confidence that a large reed-electronic system would be

viable. Detailed economic studies indicated, however, that the production costs of the TXE3 system would still be slightly too high for it to form the basis of a major step forward from the Strowger system, which was still providing over 99 per cent of B.P.O. requirements at that time.

#### THE TXE4 SYSTEM DEVELOPMENT

During the work on the TXE3 system, and before the ending of the Bulk Supplies Agreement (and with it the Joint Electronic Research Agreement) in September 1969, the TXE4 system was jointly defined in considerable detail. Subsequently it was agreed that S.T.C., in collaboration with the B.P.O., should further examine the design and, without making major system changes, see if a satisfactory cost-effective product could be developed. Following preliminary studies, a further test-bed exchange was installed at Tudor, in North London, to check and confirm the changes that had been made since the TXE3 trial. Finally a contract was placed with S.T.C. in June 1971 to complete a production-engineered version drawing on the experience built up over the previous 10 years of effort. The contract also called for the provision of £15M of exchange equipment. This work is now in its final stages, and equipment for installation in the first public exchange is now flowing from production lines (see Fig. 4).

It is proposed to publish in later issues of the *Journal* a series of articles giving detailed descriptions of the TXE4 system. Fig. 5 merely shows the basic system organization. In the switching area the only major change from the TXE3 system has been the introduction of the D-switch, thus leading to a standardized 7-stage switching system for all stages of all calls. The number of sub-units shown in Fig. 5 is four, but, in practice, exchanges will have six or eight. The trunking principles have been proved by extensive computer simulation work occupying some 10,000 hours on a computer. During this time, over 50 million calls were simulated under a wide variety of conditions so that designers could be assured that the system would operate satisfactorily both in normal situations and under infrequently encountered conditions of traffic and the presence of a variety of faults.

As in the TXE3 system, the control area consists of a number of identical special-purpose real-time processors

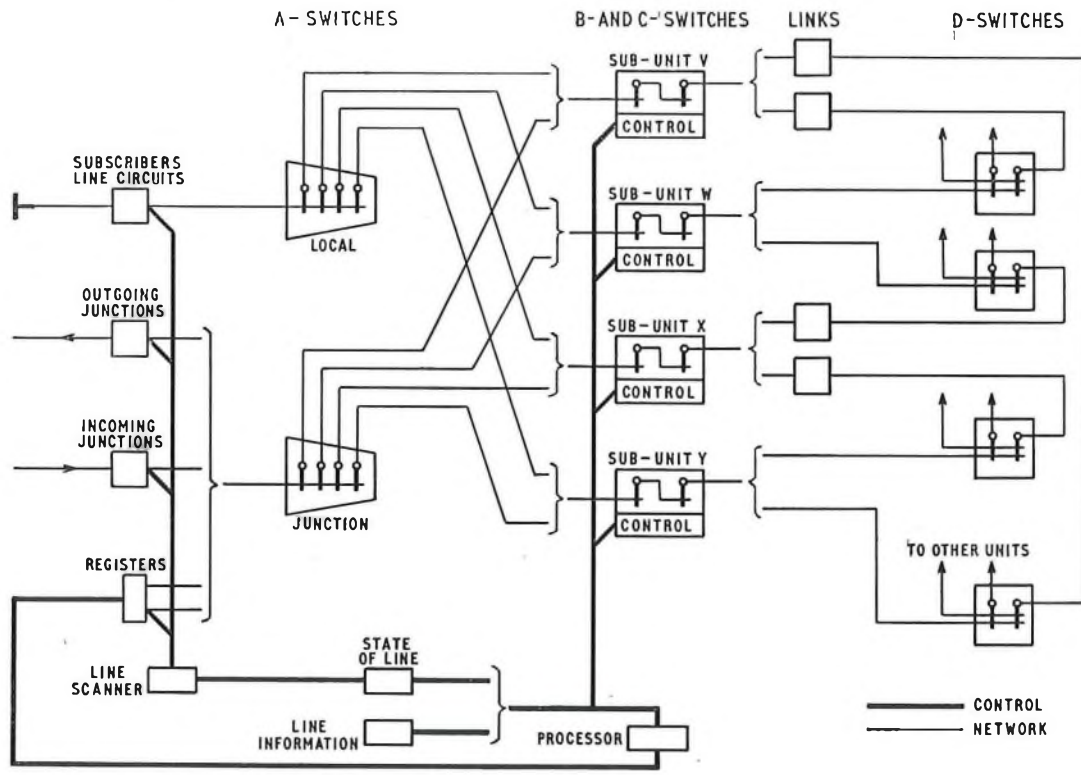

FIG. 5—The TXE4 system organization

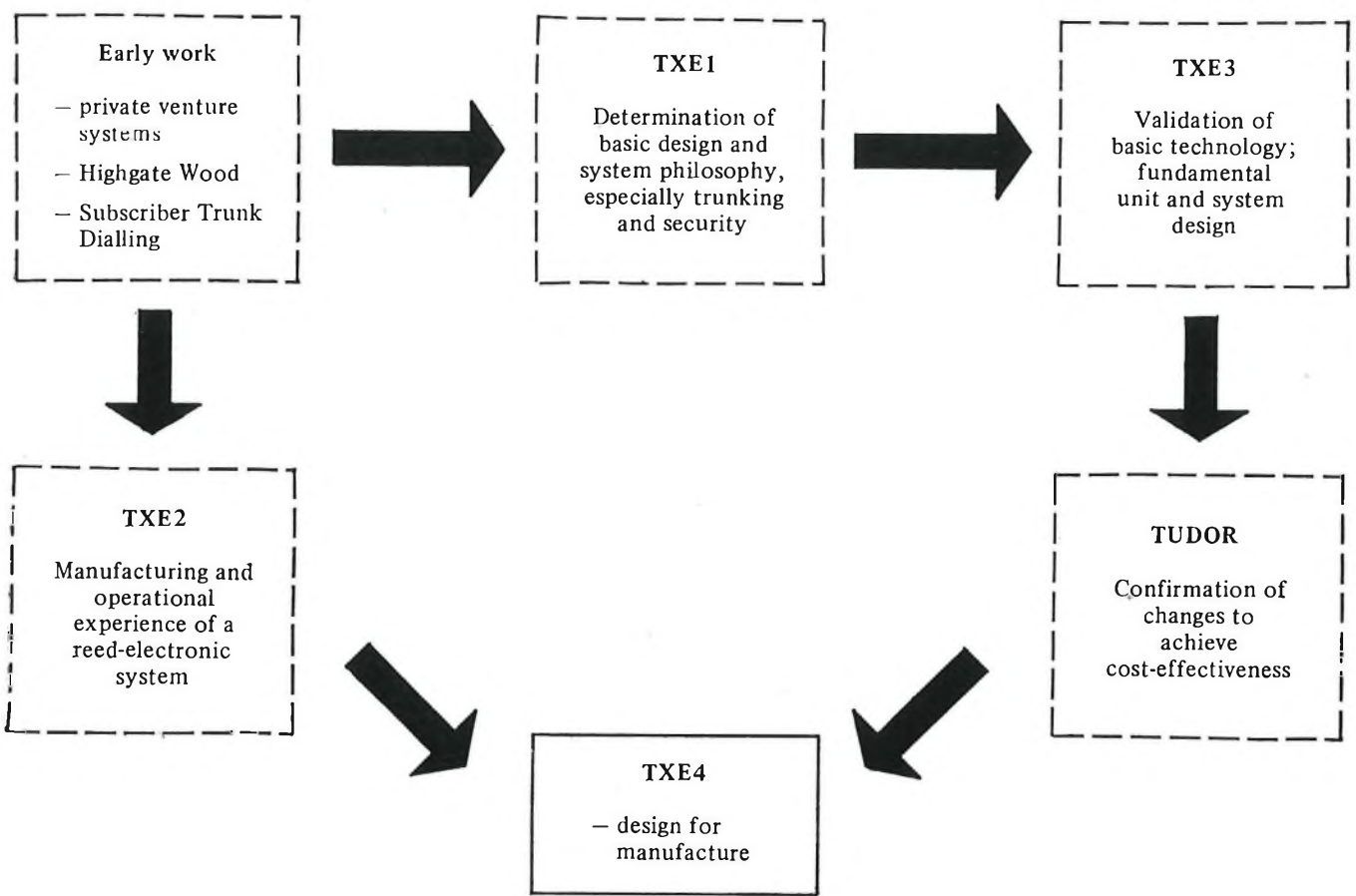

FIG. 6—Contributions to the development of reed-electronic systems

provided with conventional ferrite-core storage; each contains an operating program stored in a non-destructive-read-out store. The number of such processors is determined, on a traffic basis, to provide the necessary grade of service and the maximum number has been increased from 10 in the TXE3 system to 20 in the TXE4 system, thus doubling the maximum exchange size. The program store is provided on a series of plug-in units in the TXE4 system. This allows alterations to the general exchange facilities to be made by a simple change of unit. Facility changes, even major ones, can be accomplished rapidly, and with absolute certainty and security, by unplugging the old store and inserting a new store wired with a new program. New calls are allocated to control processors by a highly-secure allotter. The basic timing for the system is provided by a pulse generator which is highly fault-tolerant. Pulse trains are checked and sent in duplicate round the system and checked again on return to the pulse generator.

Signalling highways between cyclic stores and processors are duplicated and data is signalled in an error-checking code.

The equipment practice selected for the TXE4 exchange is very similar to one of the versions of the TXE2 system. Plug-in unit construction is used throughout, and a high proportion of the inter-rack cabling also uses plug-and-socket connexions. Apart from obvious maintenance advantages, installation and exchange extensions will be simple, and new facilities, certain to be needed during exchange life, will be easy to add. The use of general-purpose trunking also assists in simplifying future changes, since new peripheral equipment can be connected as and when required, without expensive prior provision. The complete absence of grading, the 100 per cent equipment-number/directory-number flexibility, and the simple modes of exchange growth, will considerably ease the day-to-day exchange-management problems.

One of the ways in which the cost of the system has been reduced is in the design of the supervisory circuits (particularly the links controlling local and incoming junction calls and the outgoing junction terminations). Many of the common functions involved in these circuits have been taken over by small processing units fitted one per pair of sub-units so that the supervisory circuits themselves can be considerably simplified and cheapened. Registers have been dealt with similarly.

## CONCLUSION

The TXE4 system, now being produced for service, is the result of many years consistent and logical development work by the B.P.O. and the main British telephone manufacturers. Fig. 6 shows graphically the main contributions to this development of reed electronic exchanges up to the present time.

The TXE4 system is designed to cater for a total bothway traffic of over 5,000 erlangs and can accommodate up to 40,000 subscribers' line terminations. It is capable of providing the B.P.O.'s requirements for large-scale telephone exchanges over the next decade or more. When it enters service it will have been subjected to more detailed and exhaustive testing and validation than any other system ever adopted by the B.P.O. It has been designed throughout with constant regard for operational needs, good day-to-day exchange management, ease of extensibility and overall cost-effectiveness.

## ACKNOWLEDGEMENTS

This article has attempted to sum up the work of many engineers in the B.P.O. and the telecommunications industry over some 12 years. Many of them have assisted in its preparation and their help is gratefully acknowledged.

Thanks are due to S.T.C. for permission to reproduce Fig. 4.

## References

- <sup>1</sup> The Development of Electronic Exchanges in the United Kingdom. *P.O.E.E.J.*, Vol. 50, p. 237, Jan. 1958.
- <sup>2</sup> BROADHURST, S. W. The Highgate Wood Electronic Exchange. *P.O.E.E.J.*, Vol. 55, p. 265, Jan. 1963.
- <sup>3</sup> LONG, R. C., and GORRINGE, G. E. Electronic Telephone Exchanges TXE2—A Small Electronic Exchange System. *P.O.E.E.J.*, Vol. 62, p. 12, Apr. 1969.
- <sup>4</sup> SHEPPARD, S. H. The Leighton Buzzard Electronic Telephone Exchange. *P.O.E.E.J.*, Vol. 59, p. 255, Jan. 1967.
- <sup>5</sup> VOGAN, D. H., and PRICE, C. D. E. The TXE3 Experimental Electronic Exchange System. *P.O.E.E.J.*, Vol. 62, p. 142, Oct. 1969.
- <sup>6</sup> CHAPMAN, K. J., and HUGHES, C. J. A Field Trial of an Experimental Pulse-Code Modulation Tandem Exchange. *P.O.E.E.J.*, Vol. 61, p. 186, Oct. 1968.
- <sup>7</sup> ELEY, A. C., and LOWE, W. T. Electronic Telephone Exchanges: Reed Relays for Exchange Systems. *P.O.E.E.J.*, Vol. 60, p. 140, July 1967.

# Leicester—A Typical Parcel-Concentration Office

L. A. NOKES, B.SC., C.ENG., M.I.E.E.†

U.D.C. 656.851:656.882:681.187

*The parcel-concentration office at Leicester, recently completed by the Midland Postal Region, contains a number of novel features. These are described together with the arrangements which were adopted for the training of the operating and maintenance staffs.*

## INTRODUCTION

The British Post Office (B.P.O.) parcel-post plan, described in an earlier article<sup>1</sup> in this *Journal* will, when fully implemented, concentrate parcel sorting on 30 offices throughout the country instead of about 1,200 as hitherto. Each parcel-concentration office (p.c.o.) will handle all the incoming and outgoing parcel mail for the area which it serves and will be linked by direct transport routes to all the others.

The equipment used in a mechanized sorting office, and its operation, have been described in the article referred to above and elsewhere. They are outlined here where necessary for completeness only and this article is concerned mainly with the novel features in the Leicester installation and a description of the measures taken to ensure a smooth transition from fully-manual to fully-automatic working.

The Leicester p.c.o. was brought into service in August 1971 and, although it is one of the last envisaged mechanized parcel offices in the Midland Region, it was the first to be completed, by any Region, with devolved responsibility. The

office is of a size and type typical of the majority of p.c.o.s and, as such, is of interest. Under full concentration working it will serve Leicestershire and Northamptonshire, an area of approximately 1,200 square miles.

A modern building, on an island site almost in the centre of Leicester, houses the new p.c.o. together with the Telephone Manager's office, motor transport workshops and an underground car park. The site is approximately 200 yards from the railway station and is adjacent to the old sorting office. A bridge links the new sorting office to the old and it, in turn, is linked by a bridge to the railway station; the route thus formed is used to carry traffic between the three buildings.

## MAIL-HANDLING SYSTEMS

### Outline of operation

Parcel mail arrives at the office by road and rail and is conveyed to the pre-primary storage area on the third floor. Separate routes are provided for incoming and outgoing

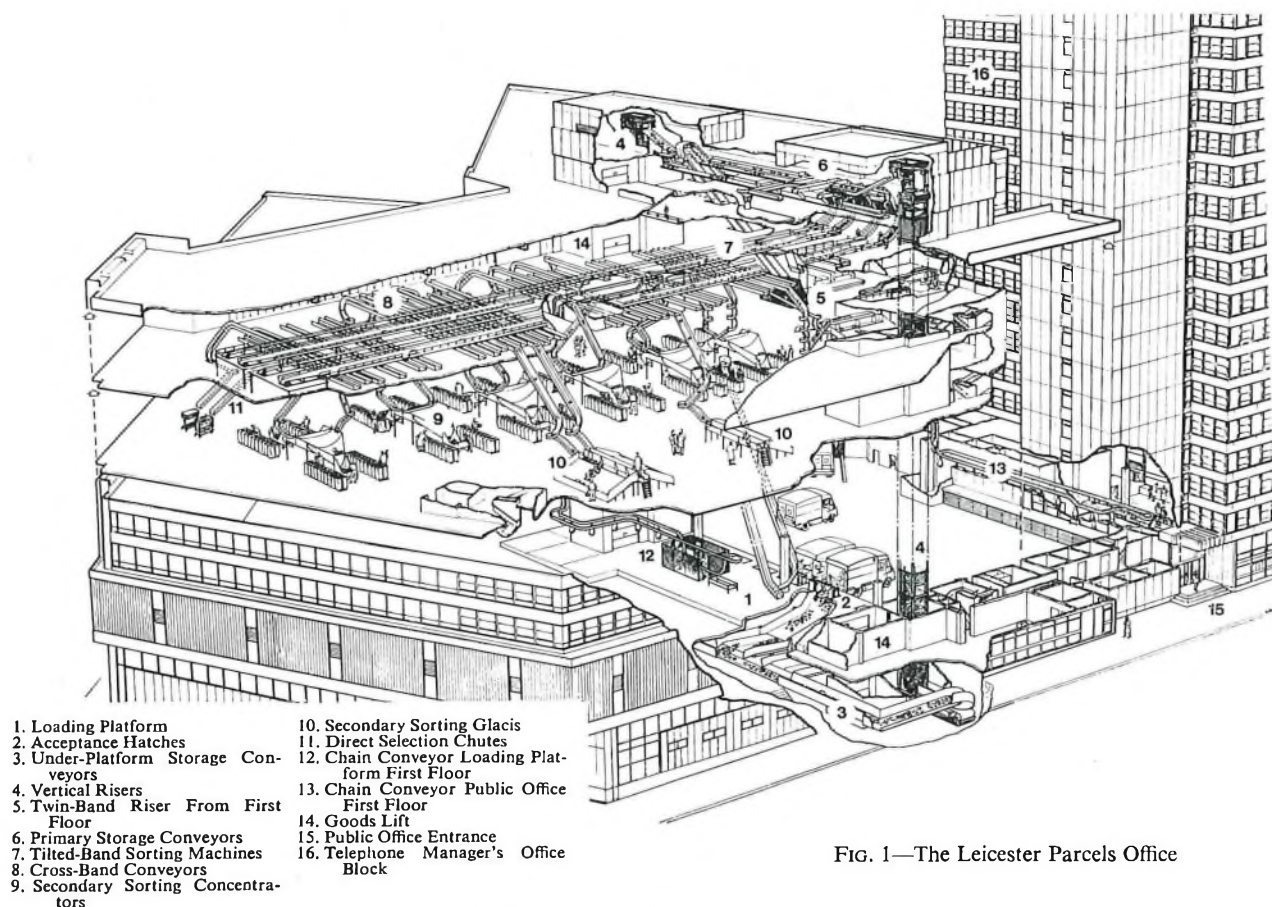

FIG. 1—The Leicester Parcels Office

† Engineering Planning Branch, Midland Postal Region.



mail and they can be regarded as two independent systems running in parallel. They have one common point—the parcel-sorting machine—to which the two classes of mail are fed at different times. The machine sorts the parcels into 28 selections then, if required, they receive a secondary, manual, sort. The sorted mail is then bagged only, or bagged and loaded into containers, for dispatch by road and rail, respectively. If it is incoming mail, it is further sorted manually ready for delivery.

### Road-Borne Mail

Vehicles carrying bags of mail unload at the island platform situated in the ground-floor covered yard. The parcels are introduced into the system through hatches set in the platform surface (see Fig. 2). Conventional chute-fed, eight-foot-wide, inclined storage conveyors are set below the hatches and form the first area of buffer storage. Two cross-conveyors, installed tail-roller to tail-roller, collect the storage discharge. Each cross-conveyor is fed normally by three hatches and storage units. The cross-conveyors feed the two vertical risers which lift the mail to the pre-primary storage area at the top of the building (see Fig. 3). The outputs from the risers feed the two diverter bands, which are in line and installed head-roller to head-roller, which, in turn, feed the pre-primary stores. Thus, there are two separate systems each consisting of three hatches and storage units, a cross-conveyor, a vertical riser, a diverter band and two pre-primary storage conveyors.

It is possible to reverse the conveyors feeding the vertical risers so that all the storage units may feed one vertical riser. Furthermore, it is possible to reverse the diverter bands so that all the pre-primary stores may be fed from one riser. If the two possibilities are combined, all the platform arrivals may be fed to all the pre-primary stores using only one riser. The various possible combinations, apart from being of operational advantage in normal circumstances, provide useful emergency arrangements in the event of failure of one or more items of equipment. The vertical risers are the tallest installed in any office, being some 100 ft from base to discharge, which gives a height of lift of 95 ft.

### Rail-Borne Mail

Mail arriving by rail is brought across the bridge-link route from the station in containers towed by an electric tractor. The route terminates on the first floor of the office near to two eight-foot-wide, chute-and-inclined-belt storage conveyors (see Fig. 4). These are fed by means of bags being emptied directly on to them. A twin-band riser collects the output from the units and transports it to the pre-primary storage area on the third floor.

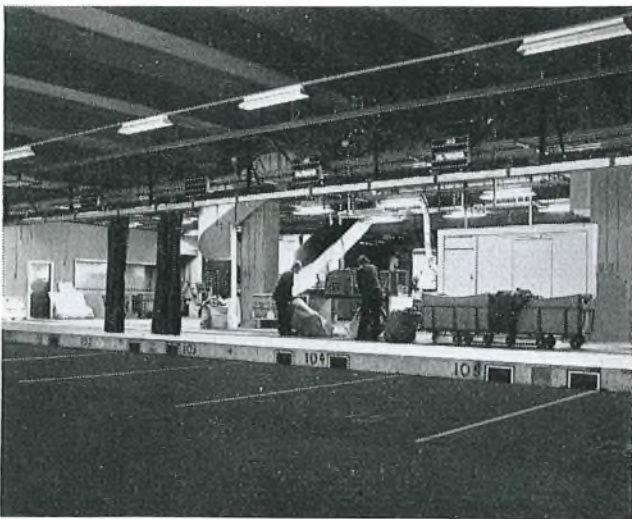

FIG. 2—Loading platform and hatches

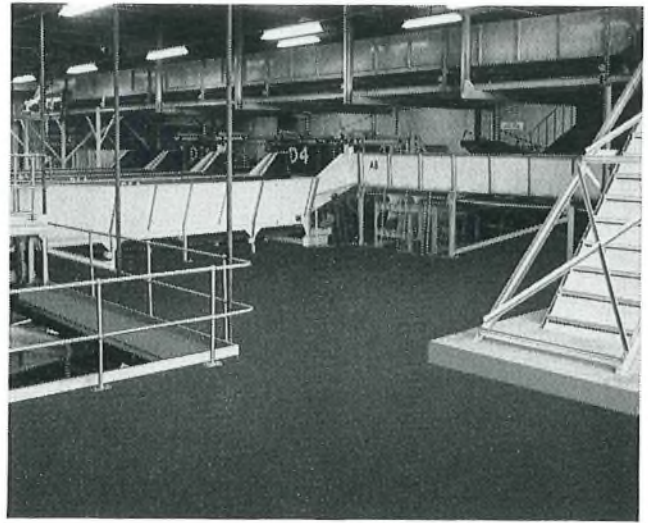

FIG. 3—Pre-primary storage area

### Pre-Primary Storage

The diverter bands are the first common points for rail- and road-borne mail. Mail is discharged from these bands on to the pre-primary storage units by means of double-acting diverters. The diverters are driven by electro-hydraulic actuators of a novel design similar to those described in the section on parcel-sorting machines. The pre-primary storage is the second buffer store and ensures a head of work for the sorting-machine operators.

### Innovations

The part of the lifting-chain guides forming the top return bend and the lower transition bends on earlier vertical risers had suffered wear of varying degrees of severity. Several methods of post-applied hardening were considered to combat this. In view of the much greater lift of the Leicester risers, which would amplify the forces responsible for the wear, it was decided it would be prudent to follow the adage that "prevention is better than cure." Thus, it was decided to manufacture the bends from a material suitable for hardening by some means. The final choice was for EN8 steel, flame-hardened to a Brinell value of 500.

There are two other novel features on the risers, the first being concerned with the maintenance platforms which require to be lowered into the vertical-riser shafts to clear obstructions. To prevent adjacent platforms being lowered to the danger of the maintenance engineers, an interlock system is required. On previous installations, these had been operated mechanically by Bowden cables which introduced additional loads and made the lowering of a platform for access to the riser an arduous task. Furthermore, the system did not fail safe, since a cable breakage destroyed the interlock.

An interlock system employing Castell keys was devised for Leicester. It is necessary to insert the unique master key at the desired level to allow the platform to be lowered. A second key in the lock is then freed and its removal prevents the master key from being freed. Thus, there are no additional loads applied and the system fails safe since a lost master key prevents access into the riser and, of course, any maintenance.

The second feature is the trip-plate release mechanism at the riser discharge. In order to prevent damage to either the parcels or the riser, the standard discharge plate is capable of pivoting. The standard release mechanism is mechanical and tends to distort due to the constant impact of parcels on the chute. To prevent this, on the Leicester risers, the chute is held by an electro-mechanical brake and this is



FIG. 4—Vertical riser discharge chute

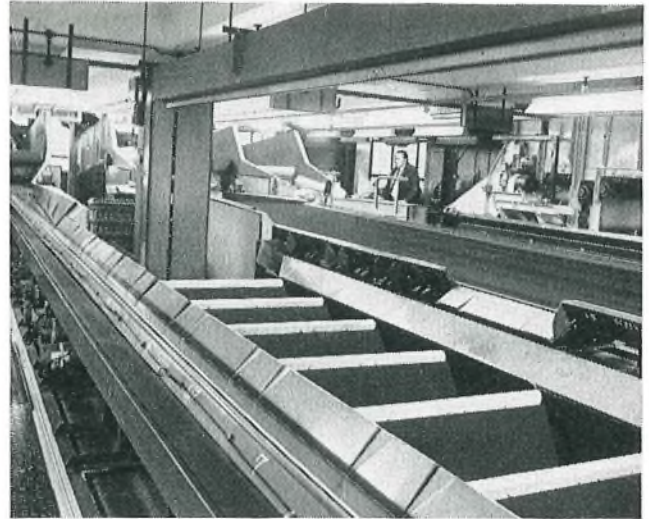

FIG. 6—Parcel-sorting-machine door arrangement

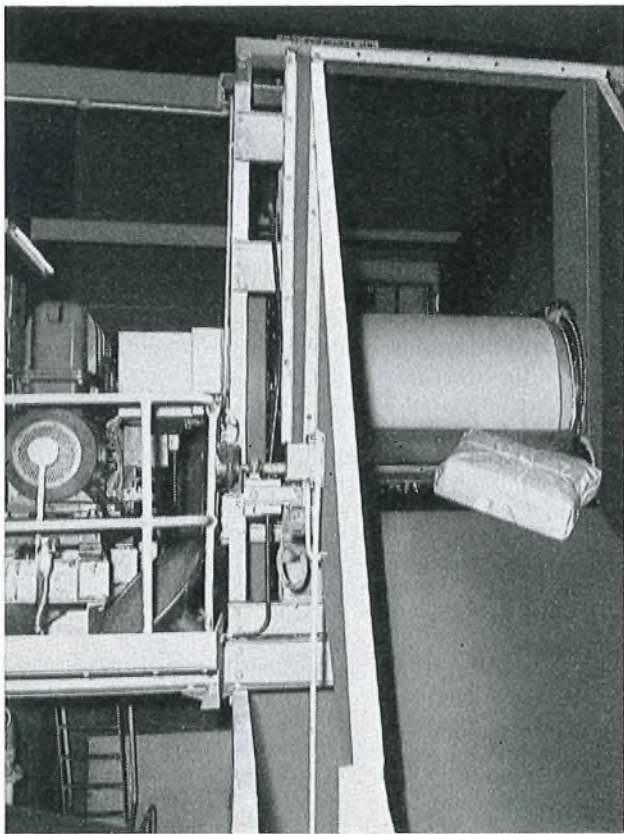

FIG. 5—First-floor storage units

released by a small secondary trip-plate operating a micro-switch. A second switch on the trip-plate breaks the interlock circuit for the control and, thus, stops the riser (see Fig. 5).

### PARCEL-SORTING MACHINES

The four parcel-sorting machines are of the tilted-belt type<sup>2</sup> and each has 49 possible outlets. These outlets, which have the triple-door configuration (see Fig. 6), feed, via the aggregating system, eleven direct selections, twelve concentrators and five glacs. Of the remaining outlets, one is used for overflow and the rest are for growth under the national concentration scheme. At present, only those in use are equipped with drive motors, gear boxes, belts, etc.

The doors forming the sorting-machine side-plates have a surface of "Flowmat," a form of fibreglass, bonded to them.

This is provided to reduce the coefficient of friction between the doors and the parcels to as low a value as possible whilst still providing a hard-wearing surface. Three of the machines have door actuators of an electro-mechanical type. On the fourth machine, two adjacent doors are driven by a single electro-hydraulic actuator (see Fig. 7) which Midland Region adopted on a trial basis as an alternative to the electro-mechanical type. This new actuator had been on trial at the Worcester office and it was decided to extend the trial to Leicester. It attracted attention originally because it was of unit construction and, thus, reduced the risk of contamination and fire due to leakage, compared with centralized hydraulic-plant installations. It retains the latter's power and speed of operation; other advantages are that a plant room is not required and noise problems of exhausts or plant are non-existent.

The actuator consists of four main parts, a motor-driven pump, a storage unit, control solenoid valves and two output jacks, and they are arranged to form a self-contained unit. The pump, of the plunger variety, is driven by a small electric motor. An accumulator is charged up to its working pressure, by the pump output, under the control of pressure switches. The accumulator is of unusual construction in as much as it is in the form of a bellows made up of disk springs which, in themselves, are basically dish-shaped plates. The energy is stored by contracting the stack of disk springs. Oil, at high pressure from the accumulator, is routed to either side of the appropriate double-acting jack by the solenoid valves. The rate of oil flow to the jacks is easily adjusted by means of a screw on the jack and this is used to set the operating speed. On the parcel-sorting-machine actuators the solenoid

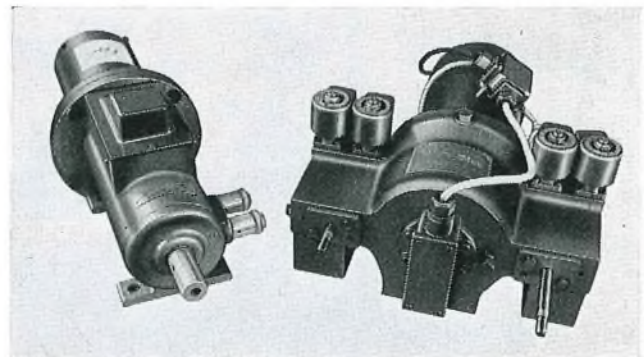

FIG. 7—Parcel-sorting-machine actuators. Electro-mechanical (left) and electro-hydraulic (right)

valves are open/close devices and the jacks are, thus, either fully-extended or retracted. As mentioned previously, a form of this actuator is used on the diverters and, on these, the solenoid valve used is different and permits the single output jack to be set in any desired position. Control of the sorting-machine actuators is effected by means of a controller associated with each machine.

### Controller

The types of controller used in earlier installations work on the principle of coding a parcel destination and placing the code on an analogue of the machine. The code is then moved through the controller in sympathy with the movement of the tilted belt. This concept is easily understood but it is very inefficient on component usage. A machine 200 feet long and requiring a tracking accuracy of 0 to +2 inches requires 1,200 store locations. Furthermore, because the doors are required to open and close at different times, up to 200 stores have to be read for a 50-selection machine. All of this is required to track a maximum of 70 parcels. Partial solutions to the foregoing are available but a complete solution is provided by the controllers used at Leicester.

The machine information required to track a parcel whilst it is in transit is held in a ferrite-core store. The information is available from the store so that the control functions can be carried out by the sub-sections of the controller as the parcel moves along the machine. The main activity to be performed is the decrementing of count words as the belt moves.

The destination of a parcel is identified and the appropriate key is pressed on the input keyboard before a parcel is placed on the machine. When a parcel breaks the beam from the photo-electric detector which forms the datum line, the asynchronous keyboard operation and the parcel placement are synchronized. At this point, a set of information which describes the location of the parcel destination is entered into the controller for storage. This information consists of a count word, which has a direct relationship with the distance the parcel has to travel from datum, and a destination/function word.

As the belt moves, pulses are generated to correspond to every two inches of belt travel. These pulses cause one to be subtracted from every count word stored at that time. Every count word is then compared with a target which, when reached, initiates the action specified by the destination word. As each parcel is sorted, a set of information is generated and processed to open its own destination door as described above. In addition, a second set is generated and processed to close the destination door of the previous parcel.

Apart from making the most economic use of the storage available, which is 1,012 eight-bit words, the controller lends itself to some other desirable features. It is so designed that the diode matrix encoders are accommodated in the controller and are fed from the keyboard via relays. The former has the advantage of allowing signal levels less susceptible to interference to be used outside the controller and simplifies the keyboard. The latter provides a most convenient form of input interface. Maintenance of the controller is facilitated by a step-by-step faulting chart, and each plug-in card making up the controller has copious indicating lamps to show the information contained in the card at any time. This combination makes possible the fast location and replacement of faulty cards.

### CONTROL AND SIGNALLING

The start-up, shut-down and routing of the systems are all controlled from one point on the first floor of the office (see Fig. 8). The central control is equipped with a console comprising a mimic diagram and a control desk which incorporates the pre-primary storage closed-circuit television



FIG. 8—Central control console

monitors and an intercommunication system. To simplify the plant control, from the operator's point of view, after a route has been selected he only needs to press one button to run it. This single action selects and advances the terminal diverter if it is not already advanced, sets the latches on the remaining diverters for correct direction of operation and then starts up the conveyors in the route sequentially. Two other buttons are associated with each route and these initiate the stop and delay-stop actions. A route, once selected and running, must be stopped before it can be changed, as the selection switches which determine the direction of running of the reversible conveyors perform only a setting function and are inoperative once the route is running.

Simplicity of operation is maintained throughout in a similar fashion. For instance, the whole secondary system is automatically batch-started after the pressing of a single button and any storage unit set to discharge is included in a sequence to ensure that parcels do not fall on to each other at the unit outlets or system junctions. The only items of plant that may be started by staff outside the central control are the chain conveyor and sorting machines.

To allow full flexibility of mimic layout to accommodate plant additions, changes, etc., and still leave the diagram aesthetically acceptable, a mosaic technique was used in its construction. The panel is constructed of aluminium-alloy castings approximately 5 inches square bolted together. These are then covered by clipping on one-inch square plastic tiles that are either plain or have some detail printed on them. Thus, if the layout needs to be changed, the tiles can be unclipped and replaced by others. The lamps, indicating the state of the plant, protrude through holes in their respective tiles and the holders are fixed to the aluminium base.

### OPERATIONAL TRAINING

Training was undoubtedly one of the most significant factors in securing the relatively quick and easy transition from a manual to a mechanical sorting process. Operational training started in late 1970 with the assessment of the areas and amounts of training required. During January 1971, training of the instructors had begun and this was completed in April 1971. The training of the operational staff which followed was carried out in three basic sections, namely, familiarization of all grades with building and equipment layouts, selected grade training on the parcel-sorting machines and central control.

#### Familiarization

Line diagrams and cut-away perspective drawings were used to introduce trainees to the plant. This was supplemented

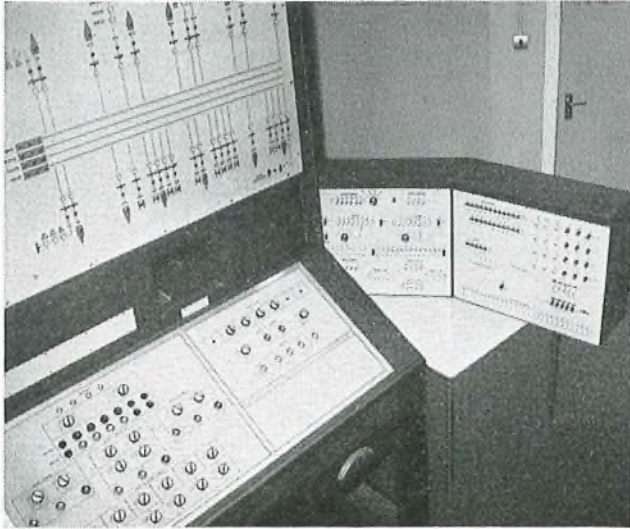

FIG. 9—Central control simulator

by viewing the actual equipment whenever possible. In this section of training, full and excellent use of the many training aids available was made and these included aides memoires, packet cards, algorithms and handbooks.

### Parcel Sorting

This training consisted of an introduction to the machine followed by some desk work and keyboard familiarization. Finally, the trainee was put on to a simulator. Here, addresses were flashed on to a screen in front of him and he pressed a key in response. The simulator assessed his selection as correct or otherwise and scored it accordingly on a meter. Sufficient time was allowed on this section to ensure that an acceptable coding speed was obtained.

### Central Control

The trainees were introduced to the console layout by means of coloured drawings of the desk and mimic. These were also used to indicate the meanings and functions of the various switches and lamps. They then moved on to a mock-up in the form of a board with dummy switches and buttons, etc., in order that they could get the feel of the console. Finally, they moved on to the simulator (see Fig. 9) and here they were able to perform all the control functions and be given situations to act out.

The simulator is a duplicate of the control console in size and appearance. Furthermore, it is possible to reproduce on it every condition, normal or otherwise, that could be encountered. In view of the time available for the construction it was decided to build the simulator using B.P.O. labour. In fact, the whole project was conceived, designed and constructed by Regional and field-force staff with the exception of the cabinet which was constructed by the B.P.O. Factories Division.

### ENGINEERING ASPECTS

The transition from manual to mechanical operation was successful, from an engineering point of view, for many reasons. They all resulted in the acceptance of the plant by the maintenance staff. The usual benefits of plant familiarity inherent in using clerk-of-works staff as the backbone of the maintenance team were enjoyed. From the outset, the clerk-of-works staff were involved in commissioning the plant. The method of commissioning adopted was to carry out tests at

each stage of installation of all pieces of plant and this had to be acceptable before the next stage was commenced. These intermediate tests were undertaken by the local staff. When an item of plant was completed, a full acceptance test was carried out on it and, in addition, the route containing that item was checked for satisfactory performance up to that item. This procedure was followed until all the plant was installed. None of the acceptance tests described so far relieved the contractors of their obligations for the plant to pass the final overall acceptance tests. The final tests were carried out by regional staff but, again, the local staff were deeply involved. In addition, it was realized by the eventual maintenance staff that, during the design stage and approval of plant drawings, a great deal of effort had been put in by the design team into providing facilities to aid maintenance. They also appreciated that any contribution that they could make during installation would be of benefit to them in the future. It is not suggested that any of the foregoing is new but it is included to show that, if staff interest can be aroused, a significant contribution to smooth plant running can be made.

### Training

During the time that the equipment was being installed, formal training of the staff for their future role was carried out. General training was by means of courses at the Post Office Technical Training College, Stone. This was supplemented by specialized training on the installed plant by local staff using notes prepared by Regional Headquarters. The latter training courses were of three weeks duration and the twenty-three staff were split between two courses, run consecutively. After an introduction to parcel mechanization in general and the building, each item of plant was examined and its maintenance discussed. A further period for discussion and questions was allowed on the last day. The training on the parcel-sorting-machine controller was given by Regional staff on two one-week courses. These consisted of defining the particular logic conventions used by the makers, an explanation of the principles employed and, finally, a detailed examination of the circuit diagrams.

### CONCLUSIONS

Each new sorting office that is commissioned makes a contribution to the rapidly-expanding store of parcel-handling knowledge and the Leicester office has been no exception. The parcel-sorting-machine controller, which has the attraction of electronics at a cost less than that for pin-wheels, could become the much-needed standard for the future if its performance to date is maintained. The actuator of the electro-hydraulic type extends the range available for handling work yet again. The success at this office has showed once again the great importance of staff involvement and training.

### ACKNOWLEDGMENTS

Acknowledgment is made to the Head Postmaster, Leicester, and his staff for their assistance in the preparation of this article. Acknowledgment is also made to the contractors, Messrs. Birtley Engineering and the Westinghouse Brake and Signal Company.

### References

- <sup>1</sup> DE JONG, N. C. C. Progress in Postal Engineering Part 2—Parcels and Packets. *P.O.E.E.J.*, Vol. 63, p. 131, Oct. 1970.
- <sup>2</sup> CASTELLANO, E.J. The Tilted-Belt Parcel-Sorting Machine. *I. Mech.E. British Postal Engineering Conference*, May 1970, Paper No. 6.

# Transmission Performance Assessment of Telephone Networks

R. A. FRY, C.ENG., M.I.E.E., and I. H. BANNER, B.A.†

U.D.C. 621.391: 621.395.74

*An important objective of transmission performance assessment is to provide information that will enable losses and other degradations to conversation to be allocated in the most economical way consistent with a performance acceptable to customers using the network. This article describes methods of building statistical transmission models of the telephone network, and the way these are analyzed to obtain a measure of customer satisfaction.*

## INTRODUCTION

With the evolution of modern high-quality telephone networks, telephone users have become more critical of the costs and quality of telephone connexions. To meet the objective of giving a good service at a fair price, methods of measuring or assessing the quality of service are needed. One important aspect of quality-of-service is the ease with which customers can converse over the mouth-to-ear transmission path of established connexions and this article is concerned with this feature.

Such assessment methods can be used to help correct deficiencies in the existing service by identifying the improvements which will give the greatest benefit. They also enable predictions to be made of the effects of introducing new technologies and techniques so that excessive short-term costs or serious degradations to the existing service are avoided.

Recent articles have given details of the design and planning of the main line<sup>1</sup> (trunk) and junction<sup>2</sup> networks. The maximum loss of each circuit, and the routing plan, are based on the limiting telephone connexion, which represents the most adverse connexion which should exist in the network. This limiting connexion was formerly known as the *transmission standard*, a term which is not now used because it implies preferred characteristics, whereas the transmission performance of the network as a whole will only be satisfactory if the limiting connexion is rarely encountered, and the majority of connexions are much better.

Fig. 1 illustrates, in the form of a flow diagram, the process of planning the transmission performance of the network. This is a continuous process, since the methods of specifying and applying the stages shown are subject to change as new equipment and assessment techniques are developed. The assessment of customers' opinions of the transmission performance of connexions is an extremely complex process because opinions are related not only to the transmission degradations of the speech path, but also to personal abilities such as the quality of the subject's voice and acuity of hearing.

In the past, transmission performance assessments were generally undertaken under laboratory-controlled conditions by conducting conversational tests over simulated telephone connexions with a great number of subjects. Because of the time and effort involved in carrying out these tests, it was only possible to examine a few examples of the wide range of connexions which could be established in the network.

† Telecommunications Development Department, Telecommunications Headquarters.

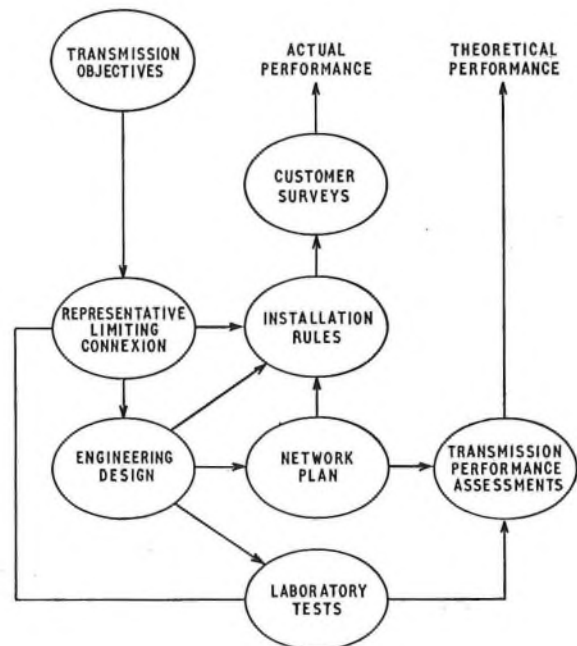

FIG. 1—A flow diagram of the network planning process

Studies by the British Post Office (B.P.O.) Research Department have enabled the various transmission degradations which occur to be expressed in relatively simple numerical terms and, from the results of conversational tests, related to customers' opinions. As a result of these studies, it is now possible to assess the transmission performance of the network as a whole by applying computer techniques to statistical models. Having developed these models, and the methods of analysis, assessments can be used to investigate alternative transmission configurations much more quickly, and with more certainty about the changes in transmission quality, than before.

It is convenient to divide these subjective assessments into three broad categories which are studied separately. These are overall transmission quality, freedom from interference due to intelligible crosstalk and estimates of the risk of encountering disturbing echo.

## OVERALL TRANSMISSION QUALITY

### Reference Standards

Before meaningful subjective tests can be undertaken to determine customers' opinions of telephone connexions, it is necessary to have some method of measuring and describing the overall (mouth-to-ear) acoustic performance. The method used is to make a comparison between a well-defined reference system and the telephone instrument under test. For the purpose of testing, the instrument is associated with networks which represent the local line and exchange feeding bridge, so that line-current effects, such as regulation, can be taken into account.

The reference system which has been used for some time by the B.P.O. and most other administrations is known as NOSFER (nouveau système fondamental des équivalents de référence—new basic system of reference equivalents). This is an assembly of high-quality telephone apparatus which is universally accepted and can be reproduced accurately. Most countries do not in fact assemble their own system, but rely on the one held in the laboratories of the C.C.I.T.T.\*

Fig. 2 shows the principle of the method, where the test assembly of instrument, exchange feeding bridge and artificial local line is compared with the reference system on a loudness basis using trained talkers and listeners. The sending, receiving or overall efficiencies are thus measured subjectively in terms of *reference equivalent decibels*, denoted by SRE (send reference equivalent), RRE (receive reference equivalent) and ORE (overall reference equivalent), by adjusting the attenuator in the reference system until the received speech is judged to be equally loud with the switch in either position.

If the part of the connexion being tested is quieter than the reference system, the additional loss  $X$  dB put into the reference system indicates that the part under test has a reference equivalent of  $X$  dB. Conversely, if  $Y$  dB is taken out of the reference system, the reference equivalent of the part under test is  $-Y$  dB.

The use of a high-quality system like NOSFER as a reference system for loudness ratings unfortunately introduces several difficulties,<sup>3</sup> one of the most serious being that the sum of the separate sending and receiving reference equivalents is not in general equal to the overall reference equivalent. As a result, it is proposed to use a different system, denoted IRS (intermediate reference system). To differentiate between the ratings obtained with NOSFER and IRS, the sending, receiving and overall loudness ratings from IRS are denoted by SLR, RLR and OLR.

The transmission properties of the IRS, and its method of use, are such that for modern telephones,  $SLR \approx SRE$ ,  $RLR \approx RRE$ , and  $SLR + RLR \approx OLR$ .

These properties not only largely overcome the discrepancies using NOSFER, but also have the important outcome that most of the commonly-used laboratory assessments based on reference equivalents are unchanged.

### METHOD OF ASSESSMENT

Having established a method of quantifying the overall mouth-to-ear performance, laboratory tests<sup>4</sup> can be carried out to determine customers' opinions of test connexions which represent those in the real network, but with the advantage that the various transmission degradations are under full control. A representative sample of customers must be employed to evaluate each test connexion to take account of variables that cannot be controlled, such as the quality of subjects' speech and their acuity of hearing, and factors such as the exact position in which the handset is held.

Subjective opinions of test connexions can be expressed in various ways. A measure which has been found particularly

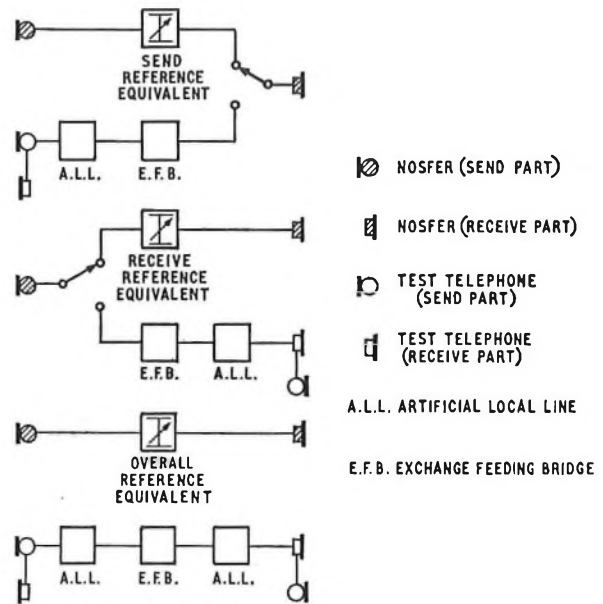

Note: the figure only shows the principle of the method—the NOSFER laboratory assembly uses amplifiers, equalizers etc.

FIG. 2—Method of comparison between the test telephone and the NOSFER reference system

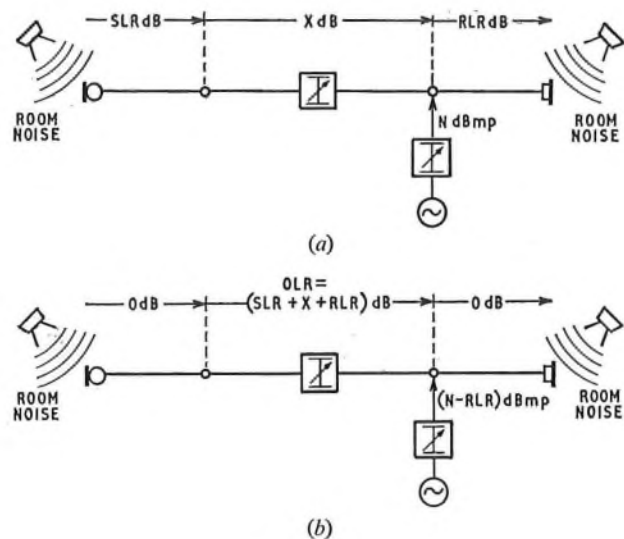

Note: Fig. (b) shows how the noise source, represented by the generator, is referred to the reference point (the input to a 0 dB RLR end)

FIG. 3—Diagrammatic arrangement for subjective assessments of test connexions

suitable, since its significance is easily grasped, is the *percentage transmission difficulty*, that is, the percentage of customers who answer "Yes" to the following question: "Did you, or the person who spoke to you, have any difficulty in talking to, or hearing, your partner?" This is also called, simply, *percentage difficulty*.

### Effect of Loss and Noise

Fig. 3(a) shows the principle of an arrangement to determine customers' opinions of connexions as a function of the nominal overall loudness rating and the line noise reaching the listener's ear. It is necessary to simulate a natural telephone environment<sup>4</sup> by using real telephone instruments.

\* International Telegraph and Telephone Consultative Committee.

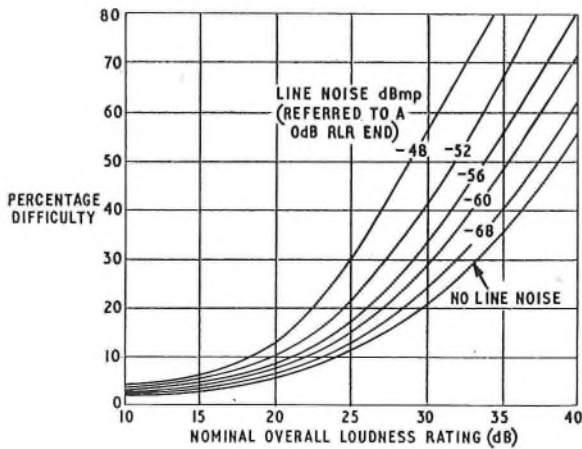

FIG. 4—Percentage difficulty as a function of overall loudness rating and line noise

Room noise equivalent to that of a small office is introduced because it has an effect on the listener by entering the ear via the sidetone and earcap leakage paths.

The nominal overall loudness-rating is obtained by adding the sending and receiving loudness-ratings to the loss of the attenuator ( $X$  dB). This attenuator represents the loss at 800 Hz introduced by the connexion between the local exchanges.

To enable results for differing receive loudness ratings and noise power levels to be compared, it is convenient to refer any noise to a reference point. This is chosen as a point at which  $RLR = 0$  dB: this equivalence is shown in Fig. 3(b). The noise source, represented by the generator, has a uniform spectrum and is limited to the 300–3,400 Hz band, whereas, on real connexions, the noise spectrum can have a variety of shapes. To relate the results of these studies to the different types of noise which occur, it is necessary to quantify the noise in a way which takes account of its subjective effect on the listener. The method used is to pass the noise signal through a shaping network before measuring its power level. Noise power levels measured in this way are known as weighted levels and are denoted by dBmp, in which the symbol p indicates that a psophometric weighting network has been used.

The relationship between overall loudness rating, line noise and the resulting *percentage difficulty* is shown in Fig. 4. The *percentage difficulty* can also be expressed as a probability by dividing by 100. This probability is denoted  $p_{l+n}$ , where the subscripts  $l$  and  $n$  refer to loss and noise.

#### Effect of Attenuation Distortion

It is impossible to generalize on the effects of attenuation distortion (i.e., the variation of loss with frequency) and bandwidth limitation because of:

- (a) the wide range of loss/frequency shapes that are encountered in the network, and
- (b) the effect that different shapes have on the *percentage difficulty* figure is also a function of the OLR.

Consequently, each particular shape has to be considered separately. Fortunately, the introduction of a hypothetical impairment value  $I$  dB simplifies this assessment. Any two connexions having the same value of  $I$  will contribute approximately the same amount of degradation, even though the loss/frequency shapes might be different.

The magnitude of  $I$  is determined experimentally by inserting a network with the required attenuation distortion, and having 0 dB loss at 800 Hz, into the test arrangement shown in Fig. 3(a). The line noise is removed, and a series of tests conducted to find the value of nominal OLR (i.e.,  $SLR + X + RLR$ ) at which the *percentage difficulty* is 25,

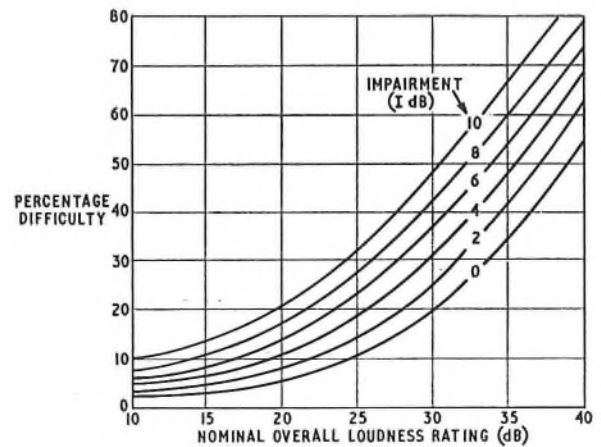

FIG. 5—Percentage difficulty as a function of overall loudness rating and impairment

In the absence of noise and attenuation distortion, this OLR is 32 dB; the difference between 32 and the new OLR is termed the impairment,  $I$  dB.

Experiments have shown that for an impairment measured in this way, a set of universal curves may be adopted to relate the nominal OLR and impairment to *percentage difficulty*, as shown in Fig. 5. The associated probability is  $p_{l+d}$ , where the subscripts  $l$  and  $d$  refer to loss and distortion.

#### Combined Effect of Loss, Noise and Attenuation Distortion

The final step in assessing the overall transmission performance of a connexion is to determine the *percentage difficulty* arising from different values of line noise and impairment combined with different values of OLR. It is clear from an inspection of Figs. 4 and 5 that any attempt to evaluate the effect of all these degradations would involve an unacceptable number of tests. Consequently, a statistical approach is used which combines the separate effects of loss and distortion and loss and noise.

The method adopted is to assume that the two probabilities already found,  $p_{l+n}$  and  $p_{l+d}$ , can be statistically resolved into three independent probabilities—those due to loss  $p_l$ , noise  $p_n$  and distortion  $p_d$ . The probability  $p_l$  is found from the curve of Fig. 4 appropriate to no line noise.  $p_n$  and  $p_d$  are calculated from the formulae:

$$p_n = \frac{(p_{l+n}) - p_l}{1 - p_l}, \quad p_d = \frac{(p_{l+d}) - p_l}{1 - p_l}$$

The overall *percentage difficulty* arising from the individual contributions is given by

$$(p_l + p_n + p_d - (p_l p_n + p_n p_d + p_d p_l) + p_l p_n p_d) \times 100.$$

#### Pulse Code Modulation Quantizing Distortion

The quantising distortion introduced by a pulse code modulation (p.c.m.) system has many of the characteristics of circuit noise, but differs from it in being partly correlated with the signal. The distortion products are only present when the signal is present, unlike noise, which is always present. However, knowing the speech input power to a p.c.m. system, the quantizing distortion can be measured (or calculated from the system characteristics) in such a way that Fig. 4 can be used to estimate the *percentage difficulty*. The associated probability, that due to loss and quantizing distortion, is denoted  $p_{l+q}$ , and can be combined with  $p_{l+n}$  and  $p_{l+d}$  in a similar manner to that in the previous section.

In general, studies of the effects of quantizing distortion are so complex that their application has been restricted to a few hypothetical connexions to ensure that the effect on a limiting

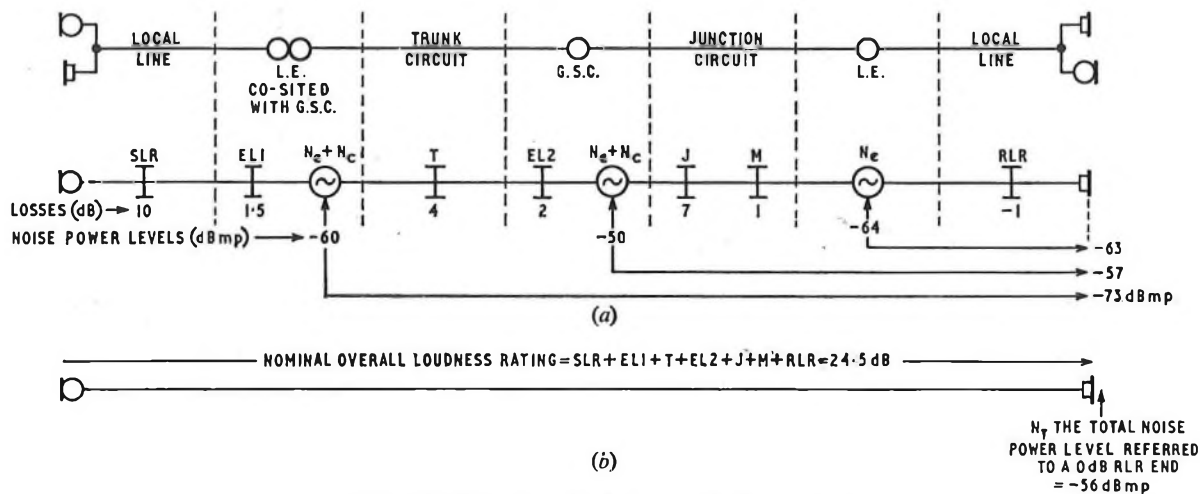

FIG. 6—An example of an s.t.d. connexion and its reduction to a simple equivalent connexion for analysis

connexion is small compared to other degradations. Consequently, it has not yet proved feasible to include quantizing distortion in the following analysis.

### RELATING CUSTOMERS' OPINIONS TO THE NETWORK PERFORMANCE

Having established a method of assessing customers' opinions of a particular telephone connexion from its transmission degradations, it is necessary to relate these opinions to the actual connexions set up in the network. It is clearly impossible—and fortunately unnecessary—to evaluate all the possible connexions which could be established, bearing in mind that there are over 10 million exchange lines in the United Kingdom (U.K.) network. In practice, a sufficiently accurate estimate can be obtained by examining broadly the various complexities or classes of routing which occur. One example is given in Fig. 6(a) which illustrates the connexion between two local exchanges, one of which is co-sited with its group switching centre (g.s.c.).

#### Evaluating a Single Connexion

Each circuit and exchange in Fig. 6(a) introduces transmission degradations into the connexion, the most important of which are shown. The pad symbols represent the various transmission losses of one direction of transmission, and

- SLR = send loudness rating of the left-hand telephone, local line and feeding bridge,
- RLR = receive loudness rating of the right-hand telephone, local line and feeding bridge,
- EL1, EL2 = g.s.c. exchange losses (the local exchange losses are included in the loudness ratings),
- T = trunk circuit loss,
- J = junction circuit loss, and
- M = an allowance for the various mismatch losses which occur.

The sources of noise are represented by generator symbols in which  $N_e$  is the noise power introduced by the exchange, and  $N_c$  the circuit noise referred back to the preceding exchange.

The nominal overall loudness rating, i.e. the overall loss, of this connexion is simply the sum of the losses of each part. Fig. 6(b) shows this to be 24.5 dB. However, before the total noise power level at the listener's ear can be calculated, it is necessary to refer each noise source to the listening-end reference point, which is the input to a 0 dB RLR end. This is done by subjecting each noise source to the amount of loss in the connexion between the source and the reference point,

and is shown by the arrows in Fig. 6(a). The total noise power  $N_T$  in the equivalent connexion of Fig. 6(b) is obtained by converting each of the decibel values to milliwatts, adding them to find the total power, and then converting back to decibels (relative to 1 milliwatt). In the example,  $N_T = -56$  dBmp.

The other transmission degradation which must be taken into account is the attenuation distortion of the connexion. This is largely independent of the individual losses, and is generally assessed separately for each routing. For a resulting impairment,  $I$ , of 1 dB, taken with the OLR of 24.5 dB and noise power level of -56 dBmp in the example, the *percentage difficulty* calculated from the graphs of Figs. 4 and 5 is approximately 18 per cent. Thus, it is estimated that 18 per cent of a population of subjects conversing over this connexion would experience transmission difficulty.

#### Building Statistical Models

So far, only a single connexion has been considered, and since the objective is to assess all connexions which can be made over each complexity of routing, it is necessary to extend the analysis to cover the range of local line lengths occurring in local networks, and the trunk and junction routes connecting these and other pairs of exchanges in the network as a whole.

As a result, each of the quantities shown in Fig. 6 must be replaced by an appropriate probability distribution which takes account of variations which occur between circuits in the same route and between circuits in different routes and connecting different exchanges. Most of these quantities are related to circuit length, or to the length of the transmission path through an exchange. Some are subject to random variations with time and power loading, and others to statistical variations such as setting-up inaccuracies.

The distributions are obtained by taking samples from the network and combining them by weighting them according to the quantities of circuits or paths involved in each route. Some samples are obtained from surveys carried out by planning groups on line plant records, and some from measurements on traffic-carrying circuits and exchanges. Often a combination of the two is needed to arrive at the required distribution. For example, the results of surveys of local line records give the distribution of local line t.e.r.\* values, which are related to the lengths and gauges of the cables used. These can be manipulated to yield distributions of sending and receiving loudness ratings with the aid of graphs showing the

\* t.e.r.—transmission equivalent resistance, a term now dropped in favour of the attenuation at 1,600 Hz.<sup>5</sup>



relationship between t.e.r. and loudness ratings. Similarly, measurements of loss and noise on trunk circuits of various lengths can be related to those that occur in the network by combining the measurement results with the distribution of trunk circuit lengths in the network.

The resultant distributions of loss and noise replace the single-valued quantities of Fig. 6, and, taken in the order shown, may be regarded as a statistical model or representation of that particular network routing. This model must be analysed to obtain the results of combining the individual distributions for completed connexions, and relating the overall result to customers' opinions. When all the distributions are combined, the interaction between loss and noise results in a three-dimensional (bi-variate) distribution.\*

The distributions of loss and noise are not capable of being expressed in straightforward mathematical terms and so a mathematical combination of the two is not practicable. Consequently, it was usual in the past to assume only an average value of noise in conjunction with the distribution of overall loudness ratings. This considerably reduced the value of the analysis in assessing the effects of changing design or planning rules.

Fortunately, the problem can now be solved by simulating the network performance—a process which has become feasible with the development of computer techniques. This does not mean that the simulation process is particularly difficult to understand or apply, but rather that the problem can be reduced to relatively simple calculations which have to be repeated many thousands of times; a situation for which a computer is ideal.

#### MONTE-CARLO SIMULATION TECHNIQUES

Monte-Carlo simulation techniques have an extremely wide field of application, and although applied to a specific case in this article, the basic principles are frequently used, and relatively easy to apply, whenever inter-related distributions are involved.

When a telephone connexion is set up, the component parts of the connexion are randomly selected from the choice available at each switching stage. With the Monte-Carlo technique, this choice is simulated by choosing values of loss and noise at random from the relevant distributions for each of the component parts of a single connexion. From these values the overall transmission characteristics, and hence the *overall percentage difficulty* for the connexion can be calculated. This procedure is then repeated a great number of times, and the individual results from each simulated connexion combined to obtain the average and the range of the *percentage difficulty* figures.

The samples taken from a distribution must be weighted according to the frequency with which each individual value occurs. If, then, a large number of samples were taken from a particular distribution and combined, the original distribution would be reconstructed. This sampling process can best be demonstrated by analogy with a roulette wheel, from which the name of the method has evolved.

Fig. 7 shows the histogram of a discrete distribution which

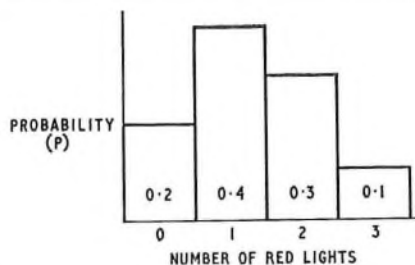

FIG. 7—Histogram showing the probability of encountering 0, 1, 2, or 3 red traffic lights

\* An example of such a distribution is given in Fig. 14, which shows the proportion of connexions that will have particular values of OLR and noise.

might, for example, relate to the probability of meeting 0, 1, 2 or 3 red lights in driving along a stretch of road having three traffic lights. The distribution is known as discrete because the variable, the number of red lights, can only be a whole number. The probability of meeting no red lights is 0.2 (or 2 chances in 10), and the probability of meeting 1, 2 or 3 is 0.4, 0.3 and 0.1, respectively.

Fig. 8 shows a roulette wheel labelled in a manner which presents the same histogram data in a form suitable for

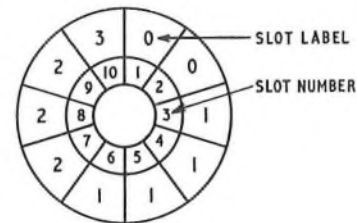

FIG. 8—Roulette wheel numbered to give the distribution of Fig. 7

sampling. The wheel is divided into ten slots; two are labelled with a 0, four with a 1, three with a 2 and the last one with a 3. It is clear that, since for each spin of the wheel the probability of the ball falling into a particular slot is 0.1, the probability of a particular label being chosen is proportional to the number of times the label appears. Thus, each spin of the wheel is equivalent to a single journey; a large number of spins will give the identical histogram to a large number of actual journeys.

In practice, most of the distributions to be represented in this way are continuous, although some may be measured discretely. Fig. 9 shows the distribution of junction losses,

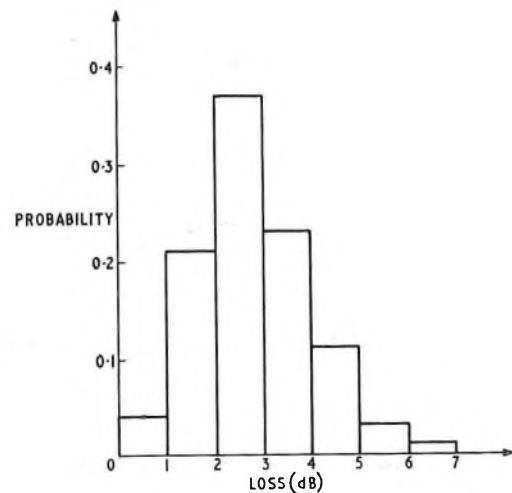

FIG. 9—Histogram of the losses of trunk junctions

and is one of the distributions used in practice. The steps of the histogram are purely arbitrary, since the value of loss can have any value in the range of interest as shown by the cumulative curve of this distribution in Fig. 10. The first histogram step shows that the probability of finding a loss in the range 0–1 dB is 0.04; alternatively, it can be restated that 4 per cent of all the losses fall into this range. To represent this by a roulette wheel containing 100 slots, the first 4 slots (4 per cent of the total) would be labelled with numbers in the range 0–1 dB. Similarly, the second histogram step, which has a probability of 0.21, is represented by labelling the next 21 slots with numbers in the range 1–2. It is of course possible

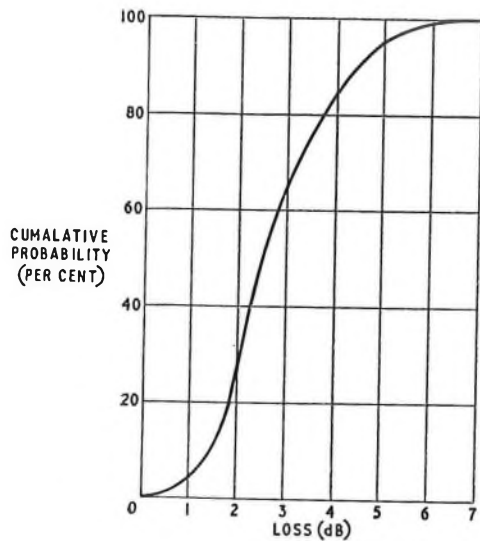

FIG. 10—Cumulative percentage curve of the histogram of Fig. 9

to label the wheel from the cumulative curve of Fig. 10 directly: the same labels will result. In all cases, the number of slots chosen will depend on the accuracy with which it is required to represent the distribution. In this way, the various distributions are expressed in a numerical form, which takes due account of the weighting needed to represent the shape.

To simulate the process of setting up a telephone connexion, values of loss and noise must be selected at random by some method which simulates the spin of a roulette wheel carrying the appropriate labels at each spin. To reproduce this sampling process with a computer, the information used to label the slots of the roulette wheel is stored in multi-cell arrays (each array having, typically, 1,000 cells). For each value of loss or noise required, a pseudo-random number\* is generated in the range 0–1,000. This number specifies from which cell the value to be used is copied. By generating a set of random numbers, a set of values of loss and noise can be generated which will describe the complete connexion that is being simulated.

The number of times the sampling process is repeated cannot always be estimated. In practice, the process is repeated until the variation in the resultant distributions or their averages is within the limits of accuracy required.

### The Monte-Carlo Method Applied to a Network Model

Fig. 11 shows the planned routing pattern of the population of connexions established between exchanges in the provincial non-director areas and the London director area in 1975, and indicates the estimated traffic incidence based on traffic forecasts. The traffic weights obey Kirchhoff's current law.

From this basic model of the network, a number of connexions can be derived which represent all the possible routings through the network. The six models are shown in Fig. 12, which also gives the percentage of traffic carried by each routing. For clarity, exchange and mismatch losses are not shown in the diagram. Associated with these models are the distributions of loss, noise and loudness ratings illustrated in Fig. 13. J1 in this figure is the smoothed curve of the histogram of Fig. 9, and the other curves are drawn in the same way. (The vertical scales are percentages.)

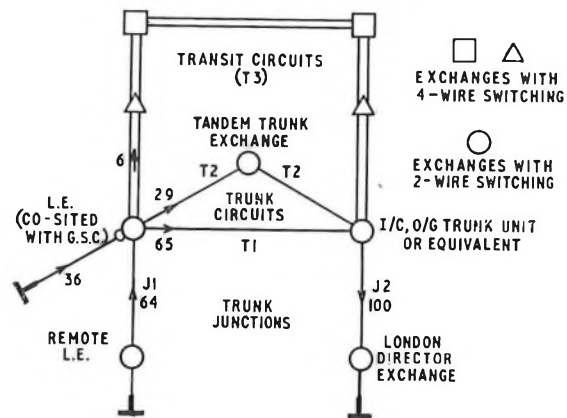

Note: Traffic figures shown by the arrows are percentages

FIG. 11—Planned routing pattern for provincial non-director to London director area traffic, showing traffic incidence

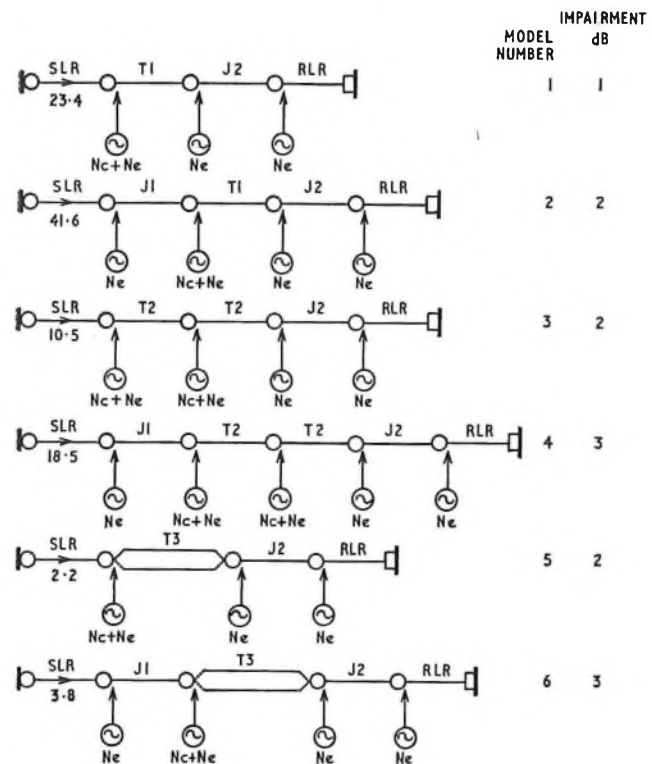

Note: The generator symbols are the exchange noise power level  $N_e$  and the circuit noise power level  $N_c$ . Traffic figures shown by the arrows are percentages

FIG. 12—The six possible routings from the network plan of Fig. 11, showing traffic incidence

The first of the models is the example used in Fig. 6, for which the *percentage difficulty* is 5·3. This figure is obtained by taking a large number of sample connexions set up over this routing, and averaging the resultant *percentage difficulty* figures for each direction of transmission. This is taken as the overall figure for this routing, although the range is also important.

Analysing each of the six models in turn gives the results shown in Table 1. The weighted *percentage difficulty* figures take account of the variation of customers' abilities, the distributions of transmission degradations and the traffic flow in the basic plan. The overall *percentage difficulty* is 10·3,

\* Pseudo-random numbers—numbers generated using one of the standard mathematical formulae. Although not truly random, because they are calculated and predictable, they have many of the properties of random numbers.

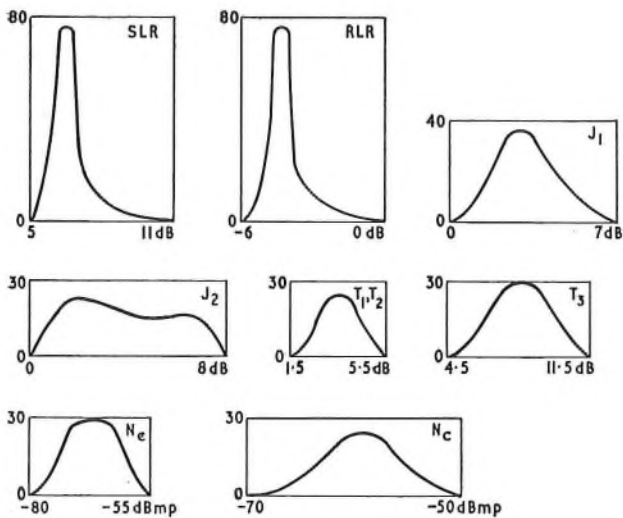

Note: SLR, RLR = sending and receiving loudness ratings  
 J1, J2 = junction-circuit losses  
 T1, T2, T3 = trunk-circuit losses  
 Ne, Nc = exchange and circuit noise power levels

FIG. 13—Distributions of loss, loudness ratings and noise for the quantities of Fig. 12

TABLE 1

Percentage difficulty figures for the models of Fig. 12

Model number ( <i>n</i> )	Percentage difficulty ( $D_n$ )	Traffic weighting ( $W_n$ )	Weighted percentage difficulty ( $D_n \times W_n$ )
1	5.3	0.234	1.24
2	9.1	0.416	3.78
3	10.4	0.105	1.09
4	18.1	0.185	3.35
5	9.7	0.022	0.21
6	16.8	0.038	0.64

Traffic weighted percentage difficulty =  $\sum(D_n \times W_n) = 10.31$

that is, it is estimated that 10.3 per cent of subscriber trunk dialled calls between provincial non-director and London director exchanges would have transmission difficulty in 1975 if the present plant were unchanged.

One important use of this method of assessment is the ability to estimate the reduction in the number of difficult calls which would result from various improvements in the network. Table 2 shows the estimated percentage difficulty

TABLE 2

Percentage difficulty figures for the models of Fig. 12 if all trunk junctions were upgraded to  $\geq 3$  dB

Model number ( <i>n</i> )	Percentage difficulty ( $D_n$ )	Traffic weighting ( $W_n$ )	Weighted percentage difficulty ( $D_n \times W_n$ )
1	4.5	0.234	1.05
2	7.0	0.416	2.91
3	8.6	0.105	0.90
4	13.8	0.185	2.51
5	8.1	0.022	0.18
6	12.7	0.038	0.48

Traffic weighted percentage difficulty =  $\sum(D_n \times W_n) = 8.03$

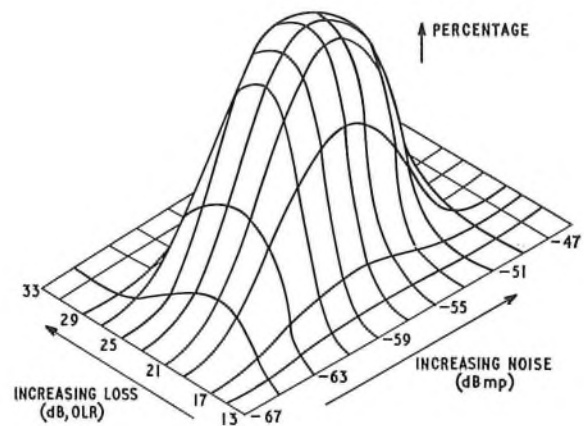

FIG. 14—Three-dimensional (bi-variate) distribution of the proportion of connexions of model 4 of Fig. 12 with given loss and noise values

figures for each model if all trunk junctions with a loss greater than 3 dB were upgraded to this figure.

The improvement of 2.3 per cent in the number of difficult calls amounts to some 43 million per annum if this were achieved throughout the network. Conversely, if all local lines and junctions were provided to the planning limit, the percentage difficulty would rise to about 40. This clearly demonstrates the necessity of ensuring that the limiting connexion is rarely encountered. Fortunately, practical considerations such as conductor gauge and signalling limits make this impossible, and the planning process takes advantage of this restriction to provide economic planning rules.

In addition to the overall figure, the detailed make-up also gives useful information. Of the six models, numbers 2, 4 and 6 represent connexions routed from remote non-director exchanges. Examination of the percentage difficulty figures shows that customers using these connexions consistently experience greater transmission difficulty.

The result of the sampling process is shown in Fig. 14, which shows the percentage of a great number of sample connexions set up over the routing of model number 4.

## ASSESSMENT OF CROSSTALK PERFORMANCE

### Thresholds of Intelligibility

Crosstalk is another important aspect of telephone network design, because improvements to the overall transmission performance may increase the risk of intelligible overhearing. The introduction of more sensitive telephones, or a reduction in line-noise power-levels, are two examples of improvements which would result in a higher proportion of customers overhearing other conversations.

Overhearing other conversations tends to undermine a customer's confidence in the privacy of his own conversation. This important subjective aspect of overhearing is difficult to quantify, for it is clear that the reactions of test subjects in laboratory experiments are not able to yield a precise or trustworthy measure of the effect.

The results of subjective laboratory tests are expressed in terms of median thresholds and the standard deviation of the thresholds as follows.

*Median thresholds.* Fig. 15 gives the value of the overall loudness rating of the crosstalk path such that in 50 per cent of combinations of talker and listener there is crosstalk intelligible to, (lower curve) or detectable by, (upper curve) the listener. These curves are briefly referred to as the median thresholds of intelligibility or detectability. The independent variable,  $N_t$ , is the total weighted-noise power-level at the

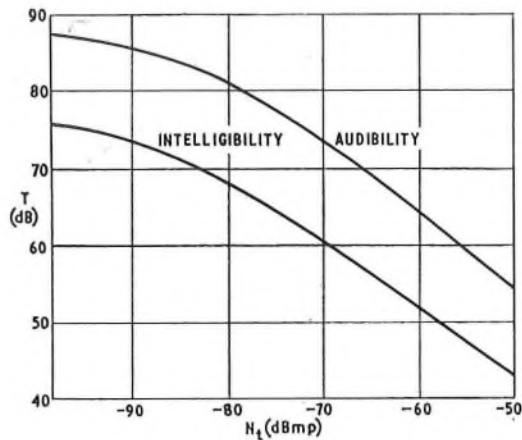

Note:  $T$  is the value of overall loudness rating between a median talker and a median listener just giving rise to intelligible or audible speech being heard by the listener;  $N_t$  is the noise power referred at the input to a 0 dB RLR end

FIG. 15—Median crosstalk threshold,  $T$ , as a function of  $N_t$  (virtually silent room)

input to 0 dB RLR end. The listener is assumed to be in a virtually silent room, i.e. one with a room noise so low that if it were absent there would be no appreciable change in the listener's reaction.

It can be argued that the additional masking effects of room noise should also be taken into account when assessing the risk of intelligible overhearing. However, this masking effect is one which cannot be relied upon since room noise is one parameter which is under the customer's control. If the customer is able to detect the presence of crosstalk in a noisy room, the effect of the room noise can be substantially reduced, by, for example, placing one hand over the transmitter. This may be sufficient to lower his hearing threshold to a point at which the crosstalk becomes intelligible.

*Standard deviation of the threshold.* The standard deviation  $\sigma_t$  of the thresholds is illustrated in Fig. 16, and is made up of two components,

- (a) a fixed component, attributable to the distribution of talker volumes, and
- (b) a variable component, attributable to the distribution of the acuity of listeners. It is a function of the line noise.

### Network Models for Crosstalk Studies

The network models used in crosstalk studies are similar to those used for studies of other transmission degradations. However, crosstalk models must be representative of very much simpler connexions than for other degradations. There is little point in studying the direct crosstalk between a pair of complicated multi-link trunk

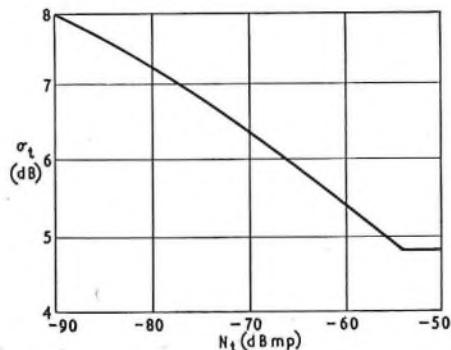

FIG. 16—Standard deviation  $\sigma_t$  of the threshold as a function of the noise power level  $N_t$

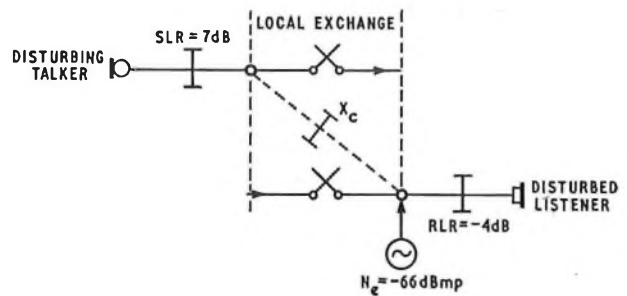

FIG. 17—The equivalent circuit for crosstalk via a local exchange

connexions in order to arrive at, for example, a limit for the crosstalk introduced by local exchanges. This is because local exchanges are used mainly for the much simpler, quieter connexions.

The probability of several crosstalk paths existing between two particular connexions is so unlikely that it is ignored for the purpose of deriving design limits or assessing existing installations. Hence, the particular crosstalk mechanism under study is assumed to be the dominant one, and all other sources are deemed to be negligible. Similarly, the possibility of several different sources crosstalking into the same connexion giving rise to unintelligible crosstalk is discounted.

Fig. 17 shows a simple crosstalk path between two connexions due, for example, to crosstalk via the exchange. For an exchange crosstalk  $X_c$  of 62 dB, the overall loudness rating of the crosstalk path (i.e. the loss from the disturbing-talker's mouth to the disturbed-listener's ear) is 65 dB ( $SLR + X_c + RLR$ ), and the exchange noise power level referred to the input to a 0 dB RLR end is  $N_e - (-4) = -62$  dBmp.

Considering a population of disturbing talkers and disturbed listeners under these conditions, the proportion of listeners who would hear intelligible crosstalk is calculated from the curves of Figs. 15 and 16. A noise power level of  $-62$  dBmp yields a median threshold of intelligibility  $T$  of 56.5 dB and a standard deviation  $\sigma_t$  of 6 dB. The proportion of listeners who would hear intelligible crosstalk for a crosstalk OLR of 65 dB can be calculated with the aid of statistical tables by finding the proportion of the normal curve between the calculated OLR and the extremity of the upper tail. This is illustrated in Fig. 18, and the shaded area is 7.9 per cent of the total.

To evaluate this crosstalk path for the network as a whole, each of the single-valued quantities shown in Fig. 17 is replaced by a distribution. The performance of the resulting statistical model is analysed by simulating connexions using

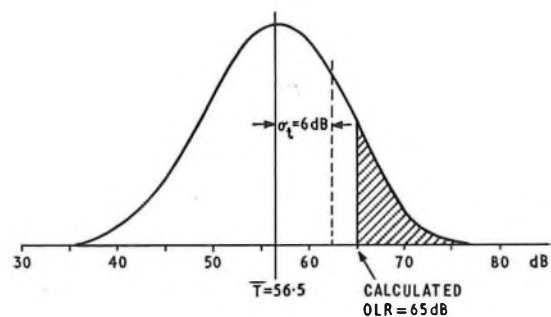

Note: The shaded area is proportional to the number of listeners hearing intelligible crosstalk

FIG. 18—The normal curve found from the graphs of Figs. 15 and 16 for the threshold of intelligibility of crosstalk in the presence of  $-62$  dBmp noise

the techniques previously described. For each sample, the proportion of listeners hearing intelligible crosstalk is calculated from the crosstalk OLR and the noise power levels (referred to a 0 dB RLR end). The proportions obtained from a great number of samples are averaged to obtain the overall risk of intelligible overhearing due to this particular crosstalk path.

Table 3 shows the calculated risks of encountering intelligible overhearing due to near-end crosstalk in local cable

**TABLE 3**  
Risks of overhearing on local calls due to cable crosstalk

Existing line plant, Strowger exchange noise	6 in 10,000
Exchange noise reduced to -75 dBmp	2 in 1000
Exchange noise reduced to -85 dBmp	1.5 in 100

pairs. The first row shows the estimated risk arising from the cable crosstalk and the distribution of noise power levels introduced by Strowger exchanges (see Fig. 13). The second and third rows show the effect of reducing this noise to -75 and -85 dBmp.

The noise performance of modern crossbar exchanges is better than the existing Strowger exchanges: current achievement appears to be better than -70 dBmp. This will result in some improvement to the overall quality of connexions, but also in an increased risk of intelligible overhearing.

Fortunately, the B.P.O. has always taken the view that a good near-end crosstalk performance for local cables is an investment for the future, so the increase is not likely to be significant. However, it is clear that any proposals to introduce more sensitive telephone instruments into the network will require further study.

## ASSESSMENT OF ECHO PERFORMANCE

### Thresholds of Objection to Talker Echo

Fig. 19 illustrates the talker echo-path in which the talker receives a delayed version of his own voice, generally reduced

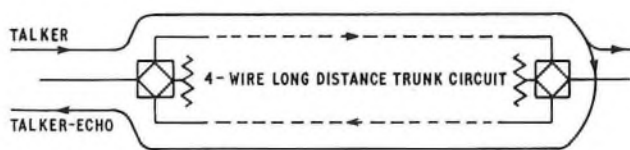

FIG. 19—The talker echo-path

in magnitude. The delay time in such a circuit is known as the round-trip delay.

The annoyance value of talker echo is, not unexpectedly, dependent on the round-trip delay time and the loss of the echo path. If the round-trip delay time is very short, then talker echo cannot be distinguished from sidetone; it is, however, still objectionable (as is sidetone) if loud enough. As the round-trip delay increases, the effect of talker echo is to destroy the rhythm of the conversation, and if echo-suppressors are not fitted to the longer international connexions, conversation may become not only difficult, but impossible.

Fortunately, in the U.K. network, few connexions are encountered with round-trip delays greater than 15 milliseconds, and as far as telephony connexions are concerned,

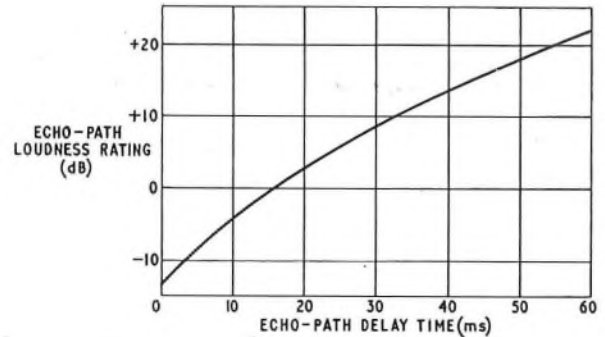

FIG. 20—Relationship between the median threshold of objection to echo and the delay time of the echo path

echo is not a difficult problem. Accordingly, echo-suppressors are not necessary in the national trunk system, except on one or two long routes provided by old-fashioned carrier systems on lightly-loaded cable, and even these are scheduled to be re-routed on modern high-velocity high-frequency systems. Listener echo (i.e. echo heard at the receiving end of the connexion) does, however, cause considerable problems for data transmission.<sup>7</sup>

The median threshold of objection to talker echo is the curve of values of overall echo-path loudness-ratings as a function of the echo-path delay-times shown in Fig. 20. The curve shows, for each value of echo-path delay-time, the value of overall echo-path loudness-rating at which 50 per cent of talkers object to the echo they hear. The distribution of talkers' opinions about the median value is approximately normal, and a suitable value of standard deviation  $\sigma_e$  for planning purposes is 10 dB.

### Application to the Network

The procedure for calculating the proportion of customers who would judge a given echo path to be objectionable is similar to that already described for intelligible crosstalk. Here, however, the standard deviation is a constant and the median threshold is a function of the delay time and loudness rating of the echo path.

Similar models can be built to describe the variations in the echo path. However, simulation techniques are not essential because, in general, the relationship between loss and distance is small compared to other factors.

Fig. 21 shows the result of analysing the simple connexion consisting of two local exchanges co-sited with their g.s.c.s,

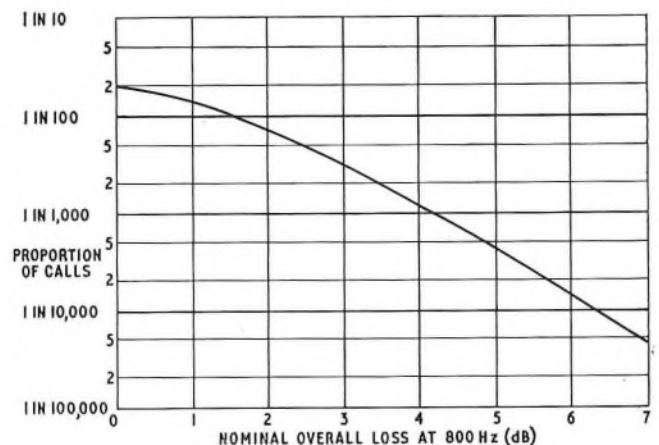

FIG. 21—Proportion of calls (traffic weighted) giving rise to objectionable talker echo as a function of the nominal loss between local exchanges

which are interconnected via the transit network. The curve shows the proportion of calls (traffic weighted) which will give rise to objectionable talker echo as a function of the nominal loss between the local exchanges. This takes into account the estimated distributions of losses and delay times in the transit network. Appropriate rules can be devised to determine whether echo-suppressors should be fitted to international connexions, taking into account the loss and length of such connexions.<sup>8</sup>

## CONCLUSIONS

This article has outlined some of the methods adopted to relate customer satisfaction to the transmission performance of the network, and has indicated ways in which the assessments can be used to predict the effects of change. It has been shown that the transmission performance of the network as a whole will only be satisfactory if the limiting connexion is rarely encountered and the majority of connexions are much better. Temporary expedients such as providing circuits which exceed planning limits, and which often become permanent,<sup>2</sup> should be avoided wherever possible, as eventually capital expenditure will have to be devoted to bring these circuits back to within the planning limits.

It has not been possible to consider all aspects which affect the transmission performance of connexions. Other factors must also be taken into account, such as ensuring freedom from singing or near-singing distortion, and an acceptable sidetone performance from telephone instruments. The

relationship which has been shown between overall loudness ratings and customers' opinions is based on current types of telephone instruments and if new types of instruments are introduced the relationship may be changed. However, current studies by the B.P.O. Research Department are aimed at reducing the necessity for subjective determinations of loudness ratings and customers' opinions, and considerable progress has been made towards developing instrumentation and calculation techniques to replace conversational and listening tests.

## References

- <sup>1</sup> BOAG, J. F., and SEWTER, J. B. The Design and Planning of the Main Transmission Network. *P.O.E.E.J.*, Vol. 64, p. 16, Apr. 1971.
- <sup>2</sup> ELLIOTT, J. L. C. The Design and Planning of the Junction Network. *P.O.E.E.J.*, Vol. 65, p. 12, Apr. 1972.
- <sup>3</sup> RICHARDS, D. L. Loudness Ratings of Telephone Speech Paths. *Proc. I.E.E.*, Vol. 118, p. 423, Mar. 1971.
- <sup>4</sup> SPENCER, H. J. A New Method of Local Transmission Planning. *P.O.E.E.J.*, Vol. 63, p. 84, July 1970.
- <sup>5</sup> RICHARDS, D. L. Transmission Performance Assessments for Telephone Network Planning. *Proc. I.E.E.*, Vol. 111, p. 931, May 1964.
- <sup>6</sup> DIECKMANN, D. J., and GRAVES, F. A. Pseudo-Random Sequence Binary-Digit Generators and Error Detectors. *P.O.E.E.J.*, Vol. 65, p. 245, Jan. 1972.
- <sup>7</sup> RIDOUT, P. N., and ROLFE, P. Transmission Measurements of Connexions in the Switched Telephone Network. *P.O.E.E.J.*, Vol. 63, p. 97, July 1970.
- <sup>8</sup> MUNDAY, S., and FRY, R. A. The New International Telephone Switching and Transmission Plan. *P.O.E.E.J.*, Vol. 61, p. 199, Oct. 1968.

---

# Digital Switching Systems

A. S. HARRIS, B.SC.(ENG.), C.ENG., M.I.E.E.\*

U.D.C. 621.395.345:621.376.56

*Two digital tandem exchanges are now in public service on a field-trial basis in the U.K. network. One is a register-controlled exchange designed by the Research Department of the British Post Office and the other is a processor-controlled exchange designed by Standard Telephones and Cables Ltd. This article describes salient features of the processor-controlled exchange, and reports on the tests that were carried out before the system was put into service. Some details of the current performance of both field trials are included together with the lessons learnt from the trials.*

## INTRODUCTION

Digital transmission systems having 24 time-slots and employing pulse-code modulation (p.c.m.)<sup>1</sup> are now being used to an increasing extent to cater for the growth in demand for junction and the shorter trunk circuits. Basically, these systems permit 24 circuits to be provided using two audio cable pairs and, thus, enable more effective use to be made of existing line plant.

The terminal multiplexes of these systems generate bit-streams at 1.536 Mbit/s and the necessary regeneration is performed by digital repeaters which are situated at intervals of up to 2,000 yards. The bit-stream is structured into frames and time-slots, each frame containing 24 time-slots and each time-slot eight bits. Seven of these bits are used for transmission of coded speech samples, the remaining one, shared over four frames, being used for the transmission of line signals and a frame-alignment pattern. These systems are

currently being installed in the U.K. network at a rate of 750 systems per year and, by the end of 1972, it is expected that 2,000 systems will be in service.

A 32 time-slot system is being developed to provide 30 eight-bit speech channels, and have separate time-slots for the transmission of line signals and the frame-alignment pattern. This system will make even more effective use of existing line-plant than the present 24 time-slot system. The use of 1.4/4.4 (0.174 in) coaxial cables for digital transmission at higher bit-rates is also being studied. Present indications are that digital transmission at about 120 Mbit/s should be feasible, and that the system could provide 1,620 channels for digitally-coded speech, the bit-streams being formed by multiplexing 54 of the primary 30-channel groups. The ultimate introduction of both these systems should result in an increasing proportion of digital transmission in the U.K. network.

In September 1968, an experimental register-controlled digital tandem exchange,<sup>2</sup> designed and built by the Research Department of the British Post Office (B.P.O.), entered public

---

\* Telecommunications Development Department, Telecommunications Headquarters.

service at Empress (now West Kensington) exchange in West London. The exchange handles traffic between three nearby director exchanges, and to date, has carried over four-million calls.

In March 1971, an experimental processor-controlled exchange,<sup>3</sup> offering similar facilities, designed and built by Standard Telephones and Cables Ltd, entered public service at Moorgate exchange in the City of London.

Both exchanges switch traffic on 24 time-slot p.c.m. transmission systems, and connexions between individual incoming and outgoing circuits are made, without demultiplexing, by employing both space- and time-switching. Basically, the space-switching function enables a connexion to be made between any two of the transmission systems for a short period during each frame, and the time-switching function provides for the mutual transfer of information between any two time-slots.

The two field trials have each served a dual purpose. They have shown the feasibility of different methods of digital switching and enabled the staff concerned to identify and correct any weaknesses in the system designs.

### PROGRESS ON THE FIELD TRIAL AT EMPRESS.

The experimental register-controlled exchange now in service at Empress (West Kensington) exchange was the world's first digital telephone exchange to carry public traffic. The exchange is connected to each of three existing director exchanges (Shepherds Bush, Acton and Ealing) by two 24 time-slot p.c.m. transmission systems. These provide the digital exchange with a total of 72 incoming and 72 outgoing circuits. Space switching is done using time-divided space-switches consisting of electronic gates on silicon integrated circuits. Time-switching is done using one of three different types of delay cord—zero, fixed and variable—the traffic being offered to the cords in this order during path selection.

Statistical studies<sup>4</sup> have described the traffic distribution likely to be achieved with this arrangement and some of the results of these studies have been confirmed by measurements taken on the model exchange.

The model exchange is mounted on two partially-filled 10 ft 6 in by 3 ft equipment racks and contains nearly 8,000 integrated circuits. Fully-equipped, the two racks could take sufficient equipment to switch 200 Erlangs of traffic, indicating the potential reduction in accommodation requirements that could result from the use of digital switching.

In a digital exchange, most of the equipment required for both switching and control can be based on integrated circuits. In a well-designed system, such circuits require no routine maintenance, and have a low failure rate. Table 1 gives details of the number of components that have required attention during the first three years' service, and shows that these expectations have been justified. Fault correction has normally involved replacement of plug-in units, with subsequent identification of faulty components.

**TABLE 1**  
**Failure Rate of Components at Empress**

Component Type	Total Number in Exchange	Number of Failures between 1 Jan. 1969 and 31 Dec. 1971	Failures per 1,000 Components per Annum
Soldered joint	$1 \times 10^6$	15	0.005
Welded joint	$5.4 \times 10^4$	4	0.025
Wrapped joint	$5.5 \times 10^4$	1	0.006
Plated-through hole	$1.3 \times 10^5$	4	0.01
Integrated circuit	$7.7 \times 10^3$	5	0.22
Transistor	$6 \times 10^2$	5	2.78
Diode	$1 \times 10^4$	5	0.17
Capacitor	$6.5 \times 10^3$	0	0
Ferrite-Core	$8.6 \times 10^3$	0	0

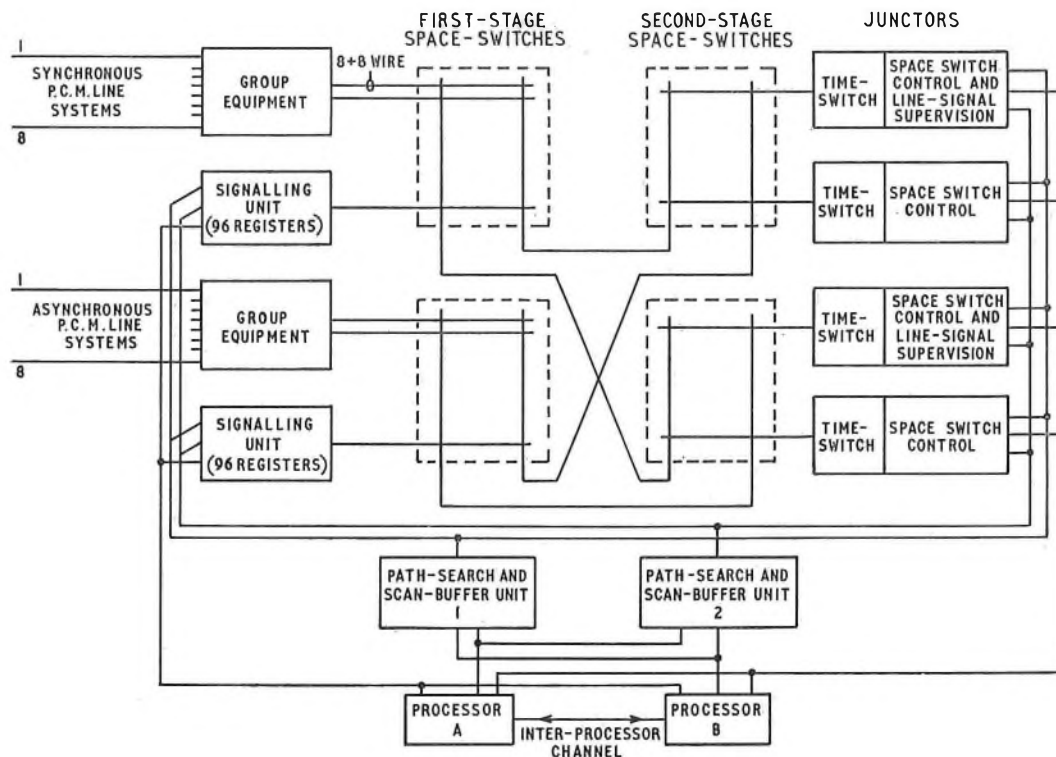

FIG. 1—Block diagram of the processor-controlled exchange as equipped for the Moorgate field trial.

## Interworking with Strowger Equipment

Previous field trials of new types of electronic equipment in the Strowger network have revealed that the new equipment, with its faster speed of operation, is often unduly sensitive to pulses of noise generated by electro-mechanical equipment. It has also been found necessary to ensure that the new equipment has timing sequences compatible with those of Strowger relays and selectors. The field trial assists the designer to identify and correct any deficiencies in the system which give rise to these conditions.

In the Empress system, the exchange registers, which examine the incoming signals, attempt to distinguish genuine signals from the spurious signals that result from noise and incorrect timing sequences. After the exchange had been in public service for a short time, measurements showed rather more false calls due to spurious signals than had been anticipated. Further investigation revealed two types of false call which occurred where:

(a) the exchange was incompatible with Strowger, these deficiencies being corrected by reducing the sensitivity of the exchange to spurious seizure signals, and by increasing a circuit guard period, and

(b) the exchange was receiving incorrect routing digits from a terminal exchange, probably as a result of two selectors switching to the same outlet. In this case, no remedial action could be taken in the field-trial equipment.

These false calls have had no effect on service, and, by incorporating comprehensive path-selection, path-checking and a repeat-attempt facility, the exchange provides good service under all normal conditions.

## THE PROCESSOR-CONTROLLED DIGITAL SWITCHING SYSTEM

The use of register control of call set-up in the exchange at Empress simplified the design and allowed effort to be concentrated on some of the more basic aspects of digital switching. However, to provide the greater range of facilities required at say, a group switching centre (g.s.c.) a more flexible control is needed.

The system using processor-control provides this flexibility. Potentially, this system is capable of providing quite a wide range of facilities, although, at the field trial, only those facilities relevant to tandem switching have been demonstrated.

### Outline Description

A block diagram of the processor-controlled system, as equipped for the field trial, is shown in Fig. 1. Eight 24 time-slot p.c.m. transmission systems terminate on a group equipment, where the incoming bit-streams are frame-aligned to the exchange clock and are then converted into a parallel format prior to entering the switching network. The group equipment performs a similar function for the outgoing bit-streams.

There are two types of group equipment, namely,

(a) the synchronous type, which contains only a small amount of buffer storage for alignment purpose and is associated with terminal multiplexes whose clocks run in synchronism with the exchange, and

(b) the asynchronous type, which contains sufficient storage for a full frame (192 bits) of information per transmission system and is associated with terminal multiplexes whose clocks are free-running.

Individual time-slots in the transmission systems can be allocated, as required, to incoming or outgoing circuits and, in practice, each system contains a mixture of both.

Two 16-wire highways (8 wires for each direction of transmission) connect each group equipment to the switching

network in which the parallel bit-streams pass through two stages of space-switching into a time-switch and then pass back through the space-switches to a group equipment or signalling unit. The time-switches form part of 96-channel, random-access, integrated-circuit stores, known as junctors, which also contain the storage used for controlling the space-switches and supervising line signals.

One outlet of each first-stage space-switch is connected to a signalling unit which contains 96 registers. Each register can perform a number of functions, the appropriate one being selected as required by instructions from one of the processors. For the field trial, the registers act only as 10 pulse/s digit receivers.

The system is controlled by two processors, each containing its own memory in which instructions and data are stored. Each processor can control the exchange independently, but, normally, the two processors share the exchange load. Duplicated path-search and scan-buffer units assist the processors in interrogating the switching network for free paths and in scanning the junctors for changes in line signals.

### Call Set-Up

A calling condition on an incoming circuit is indicated to the exchange by a change in the signalling bit (bit 1) in the appropriate time-slot. The scan-buffer unit scans the junctors in rotation and passes the circuit identity and the new signal to one of the processors. The processor allocates a small part of its memory as a call-in-process buffer, this being a temporary store for information relating to call set-up. The processor then instructs the path-search unit to interrogate the time- and space-switch stores in the junctors for a free path between the incoming circuit and a register. On receipt of the free-path identity, the processor sets the path by entering the cross-point identities into the switch stores.

The register is now connected and can receive the dialled digits which are presented to the exchange as changes in line-signalling conditions in the appropriate incoming time-slot. The switching network operates on a 192 time-slot multiplex, so that each connexion across the exchange is effectively made for a period of 650 ns in each 125  $\mu$ s. The register identifies the dial pulses and passes one digit to the processor after each inter-digital pause. The processor identifies the outgoing route required from internal translation tables, and then instructs the path-search unit to interrogate the time- and space-switch stores for a path to a free time-slot (circuit) on the outgoing route. On receipt of the path identity, the processor sets the speech path as it would a register path.

With the speech path now set-up, the calling condition passes through the exchange onto the outgoing time-slot. The incoming signalling unit at the terminating exchange acknowledges this calling condition by returning a backward-busy signal which the exchange uses to verify the connexion. The path-search unit then identifies the path connecting the incoming time-slot to the register and the processor clears the register path by erasing the contents of the appropriate switch stores. Set-up of the call is now complete, and the processor clears the call-in-process buffer.

### Call Clear-Down

When a processor has set-up and checked a path through the exchange, it takes no further action until the scan-buffer unit detects a release condition on the incoming circuit, and passes the circuit identity to the processor. The processor then identifies and disconnects the speech path in a manner similar to that for release of the register path.

## THE FIELD TRIAL AT MOORGATE

During 1968, preparations were made for a public-service field trial of a model of the processor-controlled system at Moorgate telephone exchange. As at Empress, it was



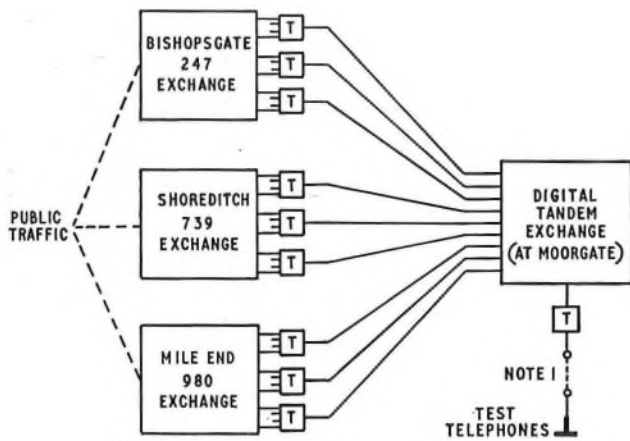

Note 1: Test telephones at Moorgate provide access via a small quantity of specially-provided Strowger switching equipment.

T—24 time-slot p.c.m. transmission terminal.

FIG. 2—Network arrangements for the Moorgate field trial.

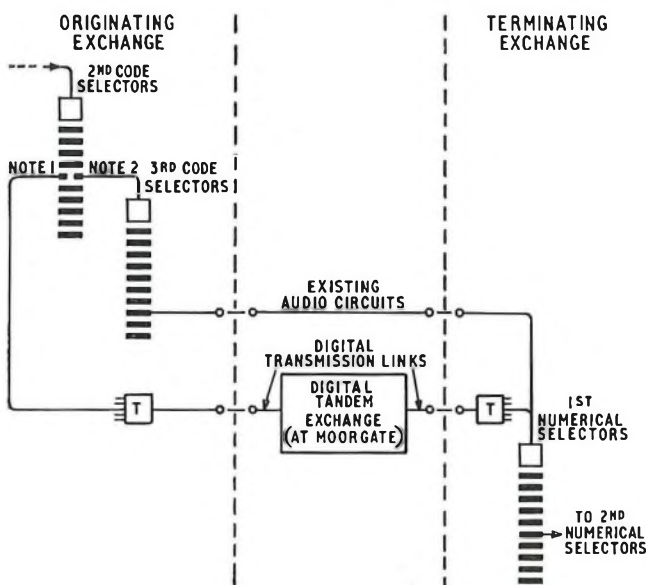

Note 1: Traffic from early choice outlets of the 2nd code selectors passes to the digital tandem exchange where the 3rd routing digit is used for route selection.

Note 2: Traffic from later choice outlets of the 2nd code selectors passes to specially-provided 3rd code selectors which use the 3rd routing digit to switch to an audio circuit on the required route.

T—24 time-slot p.c.m. transmission terminal.

FIG. 3—Standby arrangements for the Moorgate field trial.

convenient to have a model which acted as a tandem exchange. Arrangements were made for a total of 50 Erlangs of traffic originating at Bishopsgate, Mile End and Shoreditch exchanges to be diverted for switching through the field-trial model (see Fig. 2). The existing direct circuits between these three exchanges were retained, and provision made for both automatic and manual changeover. (See Fig. 3).

Sufficient switching equipment was provided to handle the traffic (see Fig. 1) but this is only a small proportion of the equipment that would be provided in a full-size exchange. However, the control equipment, illustrated in Fig. 4, most of which is duplicated, has been fully provided to permit accurate assessment of any possible security and timing problems.

Initially, each processor was provided with a single block of ferrite-core storage, with 16,384 words (or rows) per block. Each word contains 16 bits for information storage plus an additional parity-check bit. During commissioning, this amount of storage was found to be inadequate, and an extra

storage block was added to each processor. Out of the 32,768 words now available in each processor, about 22,000 are used for storing instructions and data, and about 1,500 are used as working space for data processing.

A teletypewriter is associated with the processors and is used for printing-out fault information and inserting any new network data into the processor stores. A copy of the main system program is held on paper-tape and, if any part of the program stored in a processor were mutilated, the complete program could be re-loaded from the paper-tape copy in about three minutes.

### Activities prior to public service

In 1967, an experimental processor-controlled reed-relay exchange was brought into service at Wiljrick, Belgium. This exchange,<sup>5</sup> gave encouraging results, and led to development in the U.K. of a digital exchange controlled by the same type of processor.

After the model digital exchange had been constructed, initial tests were made at the factory using a simulation program, which was designed to present the processors with information similar to that which they would have to handle in public service. Some program weaknesses were identified, but the difficulty of simulating all the conditions likely to be met in practice was recognized as the field trial proceeded.

While the model exchange was still in the factory, tests were carried out to assess the effect of variations in ambient temperature and power-supply voltage on the system as such tests would be impracticable to perform at the field-trial site.

The racks of the model exchange are interconnected by a number of 50-foot long harnesses running under a false floor. The harnesses are connected to the racks by means of plugs and sockets. This technique enables the exchange to be fully-wired for factory testing and then easily dismantled and re-assembled at the field-trial site.

When the exchange had been installed at Moorgate, work started on commissioning the system. This was made easier by providing outgoing access from the exchange so that calls could be made to test numbers at the three terminal exchanges while, at the same time, preventing public traffic from passing through the exchange.

During the commissioning phase, some changes were made to the system design, the most significant being to provide each processor with an extra storage block, and to modify the programs to make effective use of the larger stores.

When this had been completed, the B.P.O. carried out pre-service acceptance tests on all the equipment which formed part of the field trial, namely, the terminal p.c.m. multiplexes, the digital transmission links and the model exchange itself. The various tests were divided into two categories which were:

(a) functional tests, to confirm that calls could be established and released satisfactorily on every circuit, and that the equipment was tolerant to the normal variations in the timing of Strowger signals, and

(b) security tests, to confirm that any likely faults in the exchange were detected automatically, and did not degrade the service offered by the exchange. These tests were made by applying fault conditions to selected points in the exchange, and then checking the response of the system.

After defects revealed by these tests had been corrected, B.P.O. traffic staff carried out call-through tests before the exchange was put into public service.

### Operational experience

After commissioning and testing the exchange, three months were devoted to traffic trials before putting the exchange into full-time public service. During this period, limited amounts of public traffic were handled, and the

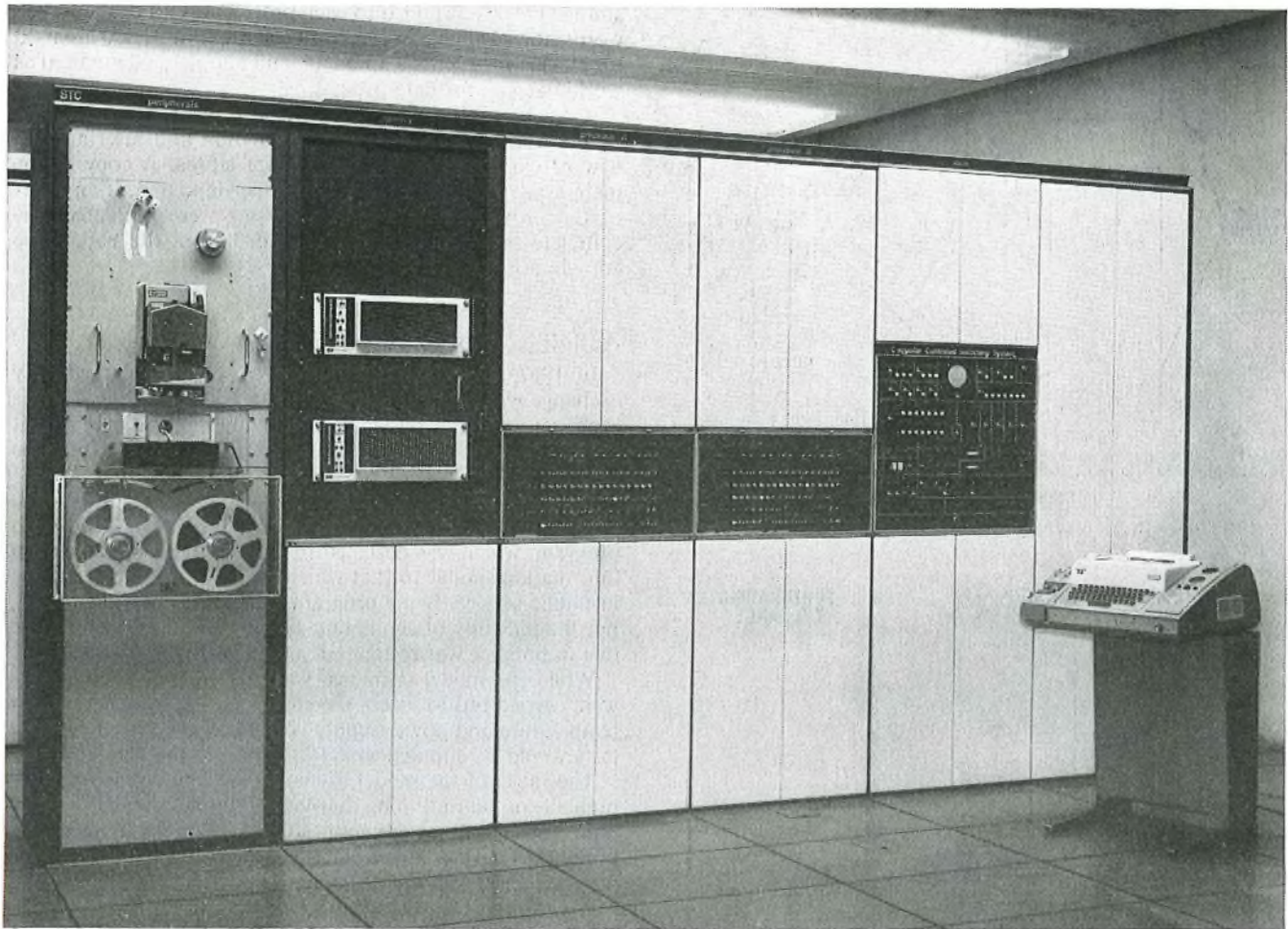

FIG. 4—Moorgate field trial—processors and ancillary equipment.

proportion of time for which the exchange was in service was gradually increased.

The traffic trials enabled the staff concerned to:

- (a) gain experience in operating the exchange,
- (b) conduct further programs of test calls, and identify any causes of call failures, and
- (c) confirm that the exchange provided an adequate grade of service for the amount of traffic which it would be handling.

As a result, some small changes were made to the system to distribute traffic more evenly within the exchange and to provide more useful records of calls handled. Also, as had been expected, some previously undetected errors in the main program were revealed.

Since June 1971, the exchange has been in service for as much time as possible. However, on seven occasions up to September 1971, the exchange has been isolated because both processors had stopped. The reasons for this were identified and, following corrective action, no such failures have occurred. In addition, the exchange has sometimes been removed from service as a precaution while attending to minor faults or making modifications. On all these occasions, subscribers' traffic has been diverted to the standby circuits.

Some components have required replacement, the total number of each type of component in the exchange and the number that have failed being shown in Table 2.

Subscribers' traffic has continued to reveal further minor program errors and, where misoperation has occurred more than once, the cause has usually been identified and the program corrected.

Experience in operating the system has identified some weaknesses in the programs used as maintenance aids and, where possible, these have also been improved and simplified.

**TABLE 2**  
**Failure Rate of Components at Moorgate**

Component type	Total Number in Exchange	Number of failures between 15 June 1971 and 14 Dec. 1971	Failures per 1,000 Components per Annum
Soldered joint	$1.8 \times 10^5$	1	0.011
Wrapped joint	$3 \times 10^4$	0	0
Integrated circuit	$1 \times 10^4$	2	0.4
Encapsulated circuit module	$8 \times 10^2$	3	7.5
Transistor	$1.1 \times 10^3$	3	5.5
Diode	$1.9 \times 10^3$	1	1.05
Capacitor	$5 \times 10^3$	1	0.4
Ferrite Core	$1.1 \times 10^6$	0	0

#### FUTURE PROSPECTS

The processor-controlled system provides facilities for tandem switching, together with some of the facilities that might be required at a g.s.c. At the field trial, however, it was felt appropriate to concentrate on tandem switching so that more attention could be given to the more basic aspects of digital switching and program control.

At the present time, some features of this system appear to have sufficient merit to justify their use in future designs of digital exchange, although technological advances will have a considerable influence on the details of the design. The more significant features, and the way in which they are likely to be influenced are detailed below:

(a) *Parallel switching.* For parallel switching of the digital bit-streams through the exchange, each bit of the coded speech signal is carried over a separate wire of a multi-wire highway. Compared with serial switching, this simplifies timing problems within the exchange and reduces the amount of equipment needed for control of the cross-points. By using faster integrated circuits than were available for this exchange, the internal multiplexing rate could be increased with a consequent reduction in the number of space-switches required to carry a given amount of traffic.

(b) *Time-switches.* Time switches consisting of random-access stores, provide a high availability and, thus, help to reduce blocking within the exchange. Over recent years, the cost of most types of electronic circuit elements has been reduced, more particularly those types that provide storage functions. A likely effect of this changing cost relationship would be the adoption of a different trunking structure, for example, one with two stages of time-switching and less stages of space-switching.

(c) *Program control.* The use of program control, in which many of the timing and decision-making functions of the exchange are carried out in central processors, is currently the subject of considerable study, since it allows the switch design to be simplified, a wide range of facilities to be easily provided on demand, and can have far-reaching effects on maintenance procedures.

## CONCLUSIONS

Models of two types of digital tandem exchange are now in service on a field-trial basis in the U.K. telephone network and are carrying public traffic. The simpler register-controlled system has been in service for nearly four years and a more complex, processor-controlled system has been in service for over a year.

In these two field trials, the systems perform almost identical functions, but there are many differences in their internal organization. Useful experience has been acquired by maintaining the two exchanges in public service and the field trials have shown:

(a) that, being almost completely electronic, negligible routine maintenance is required.

(b) that those faults that do occur are mostly due to component failures, the rates being broadly in line with the predicted figures which are used by system designers to estimate reliability, and

(c) aspects of the designs where inadequate provision has been made for the exchange to continue to offer satisfactory service when faults are present. In general, only minor modifications have been required to correct these defects.

Digital switching is likely to play an increasing part in the provision of telecommunications services, but its introduction will be as dependent on economic and planning aspects as on technical ones. In forthcoming years, the design of digital switching systems will be considerably influenced by technological changes and the resulting systems may, therefore, differ in many respects from those described in this article.

## ACKNOWLEDGEMENT

The author wishes to thank Standard Telephones and Cables Ltd for permission to reproduce the photograph of their equipment.

## References

- <sup>1</sup> BOLTON, L. J. and BENNETT, G. H. Design Features and Application of the British Post Office 24-Channel Pulse-Code Modulation System, *P.O.E.E.J.*, Vol. 61, p. 95, July 1968.
- <sup>2</sup> CHAPMAN, K. J. and HUGHES, C. J. A Field Trial of an Experimental Pulse-Code Modulation Tandem Exchange, *P.O.E.E.J.*, Vol. 61, p. 186, Oct. 1968.
- <sup>3</sup> ROSE, D. J. Pulse-Code Modulation Tandem Exchange Field-Trial Model. *Electrical Communication*, Vol. 46, No. 4, p. 246, 1971.
- <sup>4</sup> WALKER, E. and DUERDOTH, W. T. Trunking and Traffic Principles of a P.C.M. Telephone Exchange. *Proceedings I.E.E.*, Vol. 111, No. 12, p. 1976, Dec. 1964.
- <sup>5</sup> BROUX, J. A. Initial Experience with the 10C. Switching System. *Electrical Communication*, Vol. 43, No. 4, p. 323, 1968.

# A Digital Radio-Relay System

E. S. DOE, C.ENG., M.I.E.R.E.†

U.D.C. 621.396.65: 681.327.8

*Existing radio-relay systems in the U.K. trunk network use analogue transmission. A 6-GHz multi-channel digital radio-relay system is described which will be used to provide an inter-city digital transmission capability for the trunk network. Normally each channel has three 2.048 Mbit/s ports, but a single 6.336 Mbit/s port can be made available.*

## INTRODUCTION

Existing point-to-point radio-relay systems in the British Post Office (B.P.O.) trunk network use analogue transmission. The baseband signal, which consists of either frequency-division-multiplexed telephony channels or a television channel, produces analogue frequency-modulation of the carrier. These systems use frequencies in the 2, 4, lower-6, upper-6 and 11 GHz frequency bands.

Contiguous with the lower-6 GHz band is a portion of the frequency spectrum so far unexploited in the United Kingdom; this is a 75 MHz band, from 5,850–5,925 MHz. A new type of digital radio-relay system is now being developed to utilize this band. It provides transmission facilities for 2.048 Mbit/s pulse-code-modulated signals carrying telephony, program-circuit or data information. Exceptionally, 6.336 Mbit/s signals can be transmitted.

A digital system has been chosen so that inter-city transmission of digital signals can be provided in advance of digital cable systems becoming available.

This article describes the equipment being developed and explains how the basic principles involved in the transmission of digital signals are taken into account to yield a system of acceptable performance. A major factor affecting the development is the need to integrate the new system with existing lower-6 GHz analogue systems.

## SYSTEM DESCRIPTION

The new digital system comprises six bothway radio channels. Four of these channels, known as trunk digital channels, each have a capacity of 6.336 Mbit/s. Three are used for traffic, and the fourth is used as a manually-switched protection channel. Normally, each channel input and output consists of three 2.048 Mbit/s ports, but a single 6.336 Mbit/s port can be made available.

The other two channels each have a capacity of 2.048 Mbit/s. These are used for the transmission of control and supervisory signals and for engineering speaker circuits, and are known as auxiliary bearer channels.

### Frequency-Channelling Plan

In a radio system comprising a number of radio-frequency channels, the factors which have to be taken into consideration when devising a frequency-channelling plan are complex. Fundamentally, the signal in each channel has to be transmitted with the minimum amount of distortion, while at the same time, the amount of noise and interference in the channel has to be minimized. Also, interference caused to other channels has to be at an acceptable level. The unfiltered power spectrum generated by binary phase-shift modulation

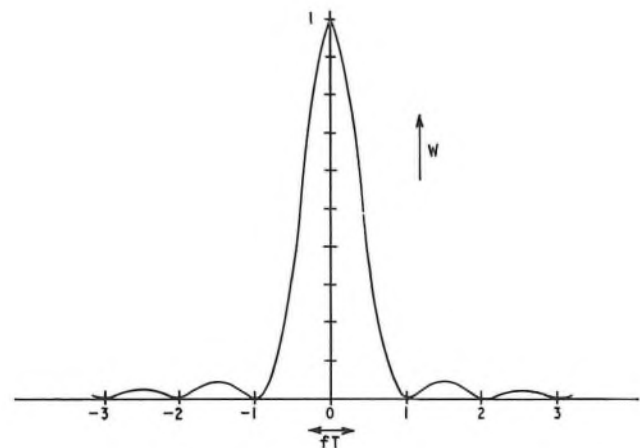

$f$  = frequency relative to carrier  
 $T$  = digit signal interval  
 $w$  = spectral power density relative to that at carrier

FIG. 1—Spectrum of a binary phase-modulated signal

is shown in Fig. 1. This, basically, is the type of modulation used, although an amplitude modulation is also imposed and this slightly modifies the spectrum. The transmission channel needs to be designed so that as a whole it does not excessively restrict this spectrum, and further, so that the receive filter does not admit excessive noise nor the transmit filter allow the transmission of excessive energy outside the band, as this would be a source of interference to other channels. The system design has been based on these factors in such a way as to produce maximum exploitation of the frequency band available.

The frequency-channelling plan adopted is shown in Fig. 2. Division of the band, giving one high set and one low set of frequencies, follows the practice adopted for analogue systems.<sup>1</sup> At any one station on a route, all transmitters operate at frequencies in one set, either high or low, while all receivers operate at frequencies in the complementary set. Orthogonal polarization of adjacent channels is used to facilitate discrimination.

The narrower channels, i.e. the auxiliary bearer channels, are positioned at each end of the two halves of the band to minimize spill-over of energy into adjacent parts of the spectrum and to reduce the transmit-to-receive interference levels.

### Radio-Frequency Multiplexing

A typical system multiplexing arrangement is shown in Fig. 3. The basic multiplexing group consists of three channels, i.e. three transmitters, or receivers, using the same polarization. In each of these groups the two trunk digital channels are multiplexed via a circulator, while the auxiliary bearer channel, being of lower capacity and requiring a smaller

† Telecommunications Development Department, Telecommunications Headquarters.

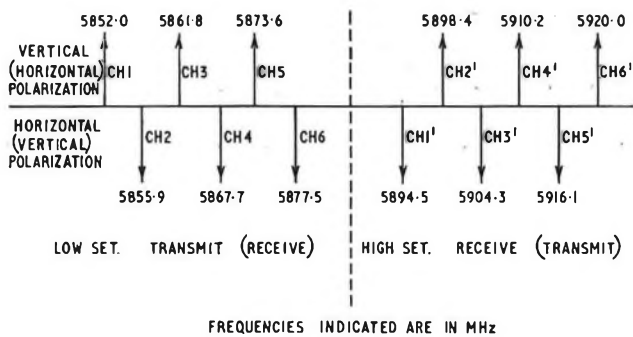

FIG. 2—Frequency-channelling plan

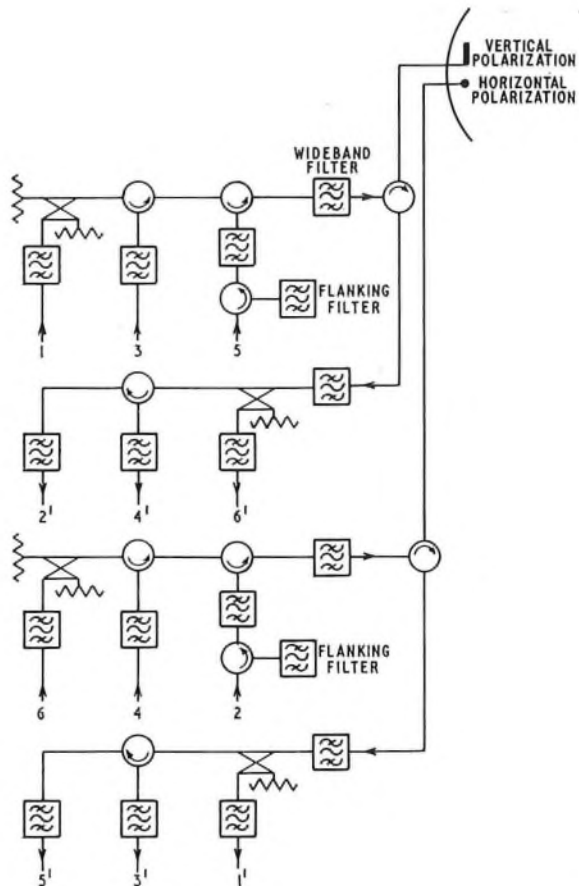

FIG. 3.—Typical multiplexing arrangement

signal power, is multiplexed via a directional coupler. Each radio-frequency filter passes the required channel and reflects the unwanted channels. Some attenuation of the side-bands takes place and dummy flanking filters are sometimes needed to restore side-band symmetry.

A group of three transmitters is multiplexed with the three receivers that use the same polarization, and hence utilize the same feeder to the antenna. Each group of three is multiplexed via a steep-sided broad-band filter to reduce transmitter-to-receiver interference. The two groups are combined via a circulator, so forming a group of six, (three high and three low). The remaining three high and three low channels, using the orthogonal polarization, are similarly multiplexed and the group, totalling six transmitting plus six receiving channels, is then connected to one bi-polar antenna.

The system is designed also to be integrated with existing lower-6 GHz analogue systems, i.e. to use the same feeder and antenna system. It is expected that the digital systems installed in the earlier stages of provision will in fact be provided on

this basis. The basic principles of multiplexing as described still apply, but the grouping of channels might need to be varied to meet the particular existing feeder and antenna configuration met in the field.

## THE BASIC PROCESSES

The basic processes involved in the transmission of a digital signal in a radio-frequency channel are given below, although not all of these may be present or separately identifiable in any particular system:

- line-code conversion,
- error-monitoring code insertion,
- pulse shaping,
- modulation,
- frequency changing,
- amplification,
- multiplexing (radio-frequency),
- propagation,
- demultiplexing (radio-frequency),
- frequency changing,
- amplification,
- regeneration,
- error-monitoring code extraction and channel supervision, and line code conversion.

In addition, the timing information (clock) might have to be extracted from the signal at the transmit end and used locally, and again at the receive end, for use in regeneration and other processes. This timing signal can also be transmitted as a separate modulation on the carrier.

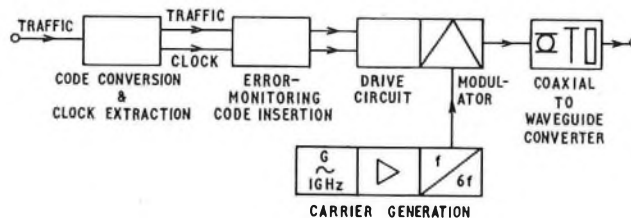

(a) Transmit

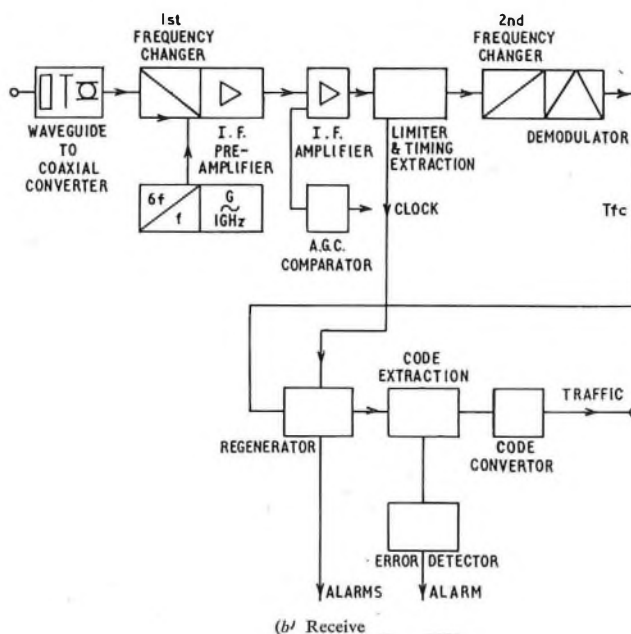

(b) Receive

FIG. 4—Trunk digital channel

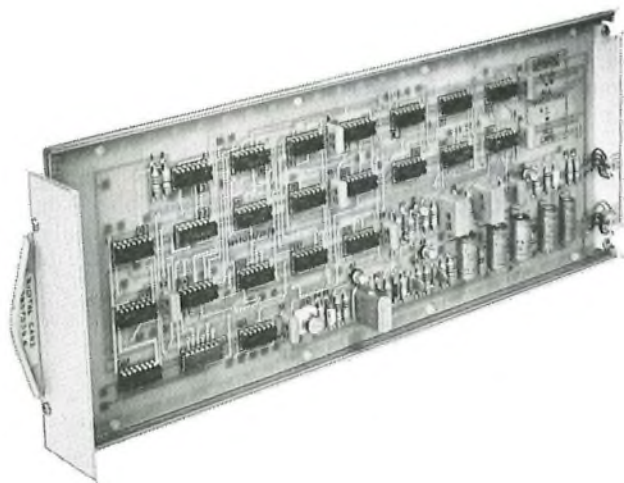

FIG. 5—Error-monitoring code generation and insertion unit

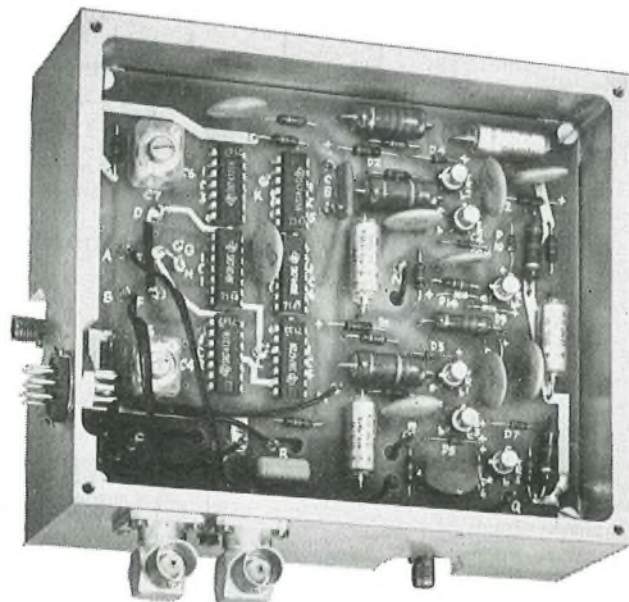

FIG. 6—Transmit unit—modulator drive circuitry

### EQUIPMENT DESCRIPTION

A block diagram of a trunk digital channel is depicted in Fig. 4, which shows the units in which the various processes are carried out, together with the ancillary units.

The equipment described below is designed for the transmission of a bi-polar, coded 6.336 Mbit/s digital signal. If a multiplex equipment is included which enables three 2.048 Mbit/s digital signals to be combined, then the 6.336 Mbit/s input and output arrangements would be different.

#### Input Unit

The trunk digital channel input unit (fitted only at a transmit-terminal) provides code conversion and clock extraction. It converts the bipolar input signal into the unipolar signal required for the method of modulation used. The unit also extracts the clock signal for subsequent use in the error-monitoring code generation and insertion unit, and for separate modulation of the transmitted carrier, as described below. The auxiliary-bearer-channel input-unit performs the same functions as the main unit, but in addition splits both the traffic and clock outputs each into two identical auxiliary bearer channels.

#### Error-Monitoring Code Generation and Insertion Unit

A photograph of this unit is shown in Fig. 5. The use of integrated circuit techniques can be seen.

This unit is used only on the trunk digital channels. Additional digits are inserted, forming a known pattern which is used for monitoring purposes. The unit generates this pattern and inserts the digits into the main stream at the transmit terminal. A 4-bit word is inserted after every 396 bits, thereby increasing the information rate from 6.336 to 6.400 Mbit/s. This 4-bit word is extracted at the receiver and used for error-monitoring purposes.

#### Transmit Unit

The transmit-unit, with covers removed, is shown in Figs 6 and 7. In Fig. 6 the integrated circuits associated with the modulator drive circuitry can be seen, while Fig. 7 shows a view of the phase and amplitude modulators which use microwave integrated-circuit techniques. The p-i-n diodes\* used in the phase and amplitude modulators are associated with the microstrip circuit but are far too small to be seen clearly in this photograph.

The transmit unit is functionally identical for both the trunk digital channels and auxiliary bearer channels. The signal is

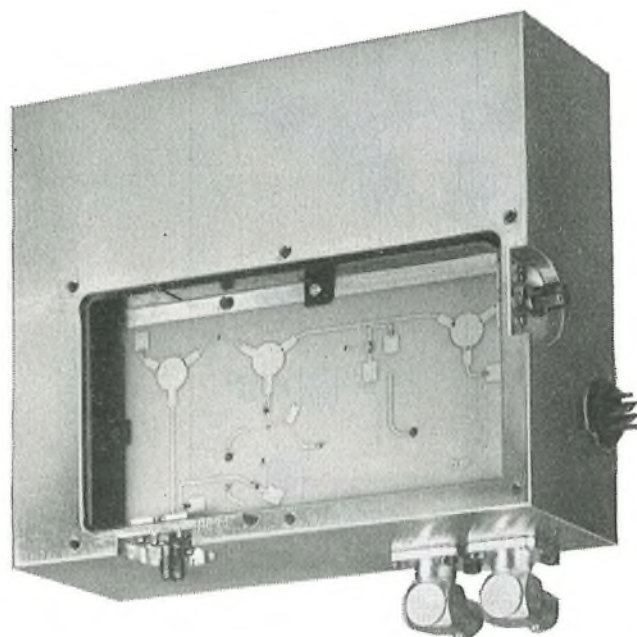

FIG. 7—Transmit unit—phase and amplitude modulators

first processed by a logic circuit to be suitable for driving the modulator. This process also includes differential encoding of the signal in order to remove ambiguity in the demodulating process at the receiver. The phase modulator consists of a switched p-i-n diode arranged to reverse the phase of the carrier when a logic 1 occurs in the digital signal. This mode of modulation is known as differential-phase-shift keying.<sup>2</sup> In this system, the output radio-frequency carrier is directly modulated—there is no intermediate frequency (i.f.) stage.

The transmit unit also includes an amplitude modulator in which timing information is used to amplitude-modulate the carrier by means of a p-i-n diode, thus ensuring that the signal received contains adequate timing information even if the traffic signal contains long sequences of zeros.

#### Carrier Generation

The radio-frequency carrier is derived from a nominal 1 GHz source which is phase-locked to a stable crystal

\* p-i-n diode—A diode with a layer of intrinsic semiconductor material between two highly-doped p and n layers.

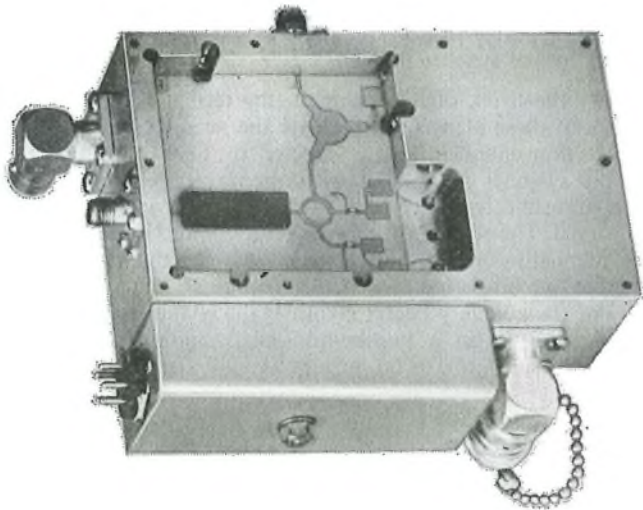

FIG. 8—Receive unit—frequency changer

oscillator, and which provides about 500 mW at the output of the phase-locked oscillator sub-unit. This is followed by a transistor amplifier which provides an output of about 4 watts at 1 GHz. A times-six frequency multiplier follows. This utilizes a step-recovery diode associated with an interdigital filter to provide a nominal 6 GHz output at about 500 mW, which is then modulated as described above.

The modulated signal then enters the radio-frequency multiplex and is fed either to a waveguide and antenna devoted to the system or, via a further circulator, to the feeder and antenna of a lower-6 GHz analogue system.

#### Receive Radio-Frequency Unit

The frequency changer of this unit is shown in Fig. 8, and the intermediate-frequency amplifier in Fig. 9.

The radio-frequency input is coaxial (at the top of Fig. 8) and is connected via a microstrip isolator to a balanced microwave frequency-changer which can be clearly seen in the photograph. This is followed by an i.f. pre-amplifier. The input from the local oscillator, shown on the left of Fig. 8, is connected via an attenuator which reduces the oscillator level to a suitable value. The 70 MHz pre-amplifier, shown in Fig. 9, is of printed-circuit-board construction.

#### Main I.F. Amplifier

The output of the receive radio-frequency unit, at an i.f. of 70 MHz, is coupled to the main i.f. amplifier via a coaxial cable which can be adjusted in length to equalize the time delay of the channel to that of the protection channel.

The maximum gain of the main i.f. amplifier is 62 dB, giving an output level of +5 dBm, closely controlled over an automatic gain control (a.g.c.) range of 40 dB. Thus, for a wide range of input levels, the amplifier output will adequately drive the limiter which follows.

The a.g.c. control voltage, together with that from the adjacent channel, is used to operate an a.g.c. comparator.

#### A.G.C. Comparator

In this unit, the a.g.c. voltages of two adjacent radio-frequency channels are compared. If, due to frequency-selective fading or other causes, there is a large disparity between the signal levels of two adjacent channels, there would be a tendency for the stronger signal to capture the signal of the weaker channel. Under conditions likely to produce this effect, however, there is also a large disparity between the control voltages of the channels. This difference is used by the a.g.c. comparator circuit to produce a signal which mutes the weaker channel and so prevents information on one channel from appearing at the output of another.

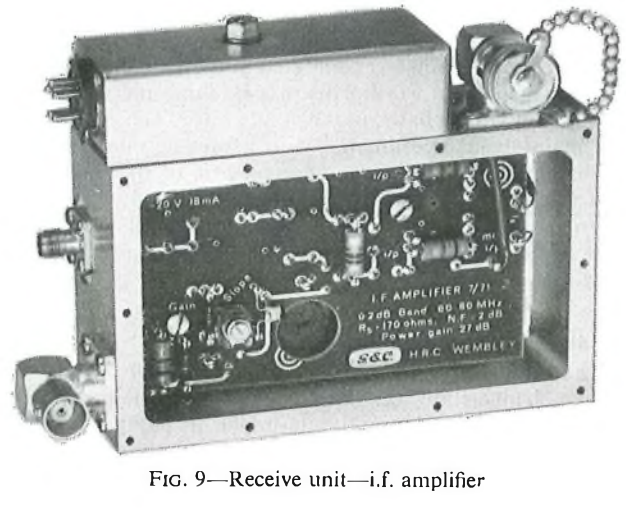

FIG. 9—Receive unit—i.f. amplifier

#### Limiter and Timing-Extraction Unit

At this point, the timing information is present as an amplitude modulation of the i.f. signal. It is extracted at the input to the limiter and timing-extraction unit. An amplitude detector extracts the information which, after amplification, filtering and shaping, is in the form of a stream of rectangular pulses at the clock frequency. This is applied to the regenerator which appears later in the chain.

The limiter suppresses amplitude modulation by at least 15 dB for a 30 per cent modulation level and provides a +5 dBm output power for application to the demodulator.

The unit uses printed-circuit-board techniques.

#### Demodulator

The demodulator unit includes a second frequency changer, producing a second i.f. of 25.6 MHz for the trunk digital channels and 12.286 MHz for the auxiliary bearer channels. The signal path then divides, one path introducing a delay of 1-bit period in excess of the other. The direct and delayed signals are then applied to the phase detector which compares these two signals.<sup>2</sup> If they are of the same phase, the detector gives an output of logic 0, while if they are opposite in phase, the output is logic 1, a process known as differentially-coherent detection. The final stage of the demodulator is a baseband amplifier.

#### Regenerator and Mute Unit

The output signal from the demodulator unit includes distortion, intersymbol interference, noise and other interference introduced in the transmission path, and in order to remove these the signal needs to be regenerated. This is effected in the regenerator and mute unit. The unit also includes a signal-deterioration detector circuit, a muting circuit controlled by the a.g.c. comparator output, a loss-of-signal detector, and alarm-drive circuits.

#### Code Extraction Unit

For the trunk-digital-channel receive-terminal the signal then passes to an error-monitoring code extraction unit where, by a reversal of the process by which it was inserted, the error-code word is extracted and the traffic signal reduced to its original rate of 6.336 Mbit/s. This signal is then passed, together with the clock signal, to the code convertor via the change-over unit. At a repeater the regenerator output is connected directly to the transmitter modulator.

#### Code Convertor

This reverses the process of its transmit counterpart and converts the signal from a unipolar binary signal to its original bi-polar form. This constitutes the output of the channel at the receive terminal.

### **Error Detector**

The error-code word, extracted in the code-extraction unit at the receive terminal, is compared in the error detector with a locally-generated word. This process takes place, on a bit-by-bit comparison basis, in the comparator. The error-rate of the main signal is estimated with a predetermined level of probability from the measured error-rate of the code word, and if this estimated error-rate exceeds a pre-set value, an alarm is generated indicating that the channel needs to be switched to the protection channel. This unit also generates an alarm if synchronization is lost.

### **Auxiliary Channel Changeover Unit**

The outputs from the regenerators on each of the auxiliary bearer channels are fed via a change-over unit to the code convertor and, at the receive terminal, in parallel with this unit to an error-detector unit. At a repeater the signal passes to the input unit via a supervisory channel extraction/insertion unit. The change-over circuit consists of logic circuitry controlled by a series of circuit condition signals from both channels, which, in the event of one channel developing a fault, will effect an automatic change-over to the other channel.

### **The Auxiliary Error Detector**

The frame-alignment word existing in the 2·048 Mbit/s signal is examined in the auxiliary channel error detector at the receive terminal by comparison, on a bit-by-bit basis, with the output from a local word generator. When the measured error-rate exceeds a preset value, indicating a high error-rate in the signal, an alarm condition is generated. This unit also generates an alarm if synchronization is lost.

### **Alarm, Monitoring and Protection Facilities**

Switching, test-access conditions and equipment-failure alarms are indicated by lamp displays. Additionally, channel-function supervision is provided on the following basis:

- (a) signal deterioration alarm,
- (b) loss-of-signal alarm,

- (c) mute alarm,
- (d) high error-rate alarm, and
- (e) loss of synchronization.

For the trunk digital channels, the receipt of any one or more of these alarms can indicate the need to switch to the protection channel. This is effected by first connecting the faulty channel in parallel with the protection channel at the transmit terminal, and then switching at the receive terminal. The change-over at the receive end is carried out by a manually-controlled electronic switch, and is effected within one bit-period.

For the auxiliary bearer channels the change-over is automatic and is on a hop-by-hop basis, initiated by alarm conditions, (a), (b), or (c), or a power-fail alarm.

### **CONCLUSIONS**

The B.P.O. has initiated the development of a multi-channel digital radio-relay system, each channel of which is suitable for the transmission of a number of digital signals, normally at an information rate of 2·048 Mbit/s. This development will conclude with a field trial and the production of a specification for the system.

### **ACKNOWLEDGEMENTS**

The system described is being developed, under contract to the B.P.O., by G.E.C. Telecommunications Ltd. at their works at Coventry and at the G.C.E. Hirst Research Centre, Wembley. The author wishes to acknowledge the assistance received from members of the G.E.C. staff.

### **References**

- <sup>1</sup> JONES, D. G., and EDWARDS, P. J. The Post Office Network of Radio-Relay Stations—Part 1. *P.O.E.E.J.*, Vol. 57, p. 152, Oct. 1964.
- <sup>2</sup> DAVIES, M. C., and HICKS, J. B. Some Aspects of Digital Microwave Radio Relay Systems. *P.O.E.E.J.*, Vol. 64, p. 256, Jan. 1972.



# An Improved Method of Grading: The Partially-Skipped Grading

A. G. LEIGHTON, B.SC.(ENG.), C.ENG., M.I.E.E., and W. KIRKBY†

U.D.C. 621.395.31:681.31:519.283

*It has been known for many years that more efficient grading formations are possible than the O'dell gradings used at present in the United Kingdom (U.K.) switching networks. However, only in recent years has it been feasible with the aid of computer simulation to analyse some of these formations sufficiently for gradings suited to the U.K. equipment to be formulated. This article describes the traffic study, carried out by the recently created B.P.O. Teletraffic Branch, which resulted in the formulation of partially-skipped gradings tailored to fit the particular limitations imposed by existing equipment practices while, at the same time, giving considerable physical and economic advantages over the present standard forms.*

## INTRODUCTION

The present British Post Office (B.P.O.) standard form of interconnexion at points on the switching network where limited availability conditions occur is the O'dell grading. Simple forms of these gradings were introduced<sup>1,2,3</sup> in the mid-1920s, their range of application being extended over the years to cover a wide variety of availabilities and grades of service. The corresponding traffic-capacity tables were developed as required, and extended as routes increased in size and as further study revealed refinements in their calculations.

O'dell gradings are symmetrical, giving a smooth progression on the choices from individual outlets to partial commons, partial commons to larger partial commons, and the larger partial commons to full commons, the grading design being optimized by applying the principle of minimizing the sum of the successive differences when the number of choices of one type are subtracted from the number of choices of the next type without respect to the signs.

As a result of these basic design considerations, O'dell gradings are sensitive to unbalanced traffic loadings of the input groups, and require substantial alterations of the interconnexion patterns as trunks are added to carry increases in traffic, or when additional input groups are required. The former leads to serious degradation of the grades of service during busy periods, while the latter uses considerable labour resources and causes service interruptions.

Other forms of gradings, some of which are in use internationally, have been considered,<sup>4</sup> but only since computer simulation<sup>5</sup> has been available has it been possible to investigate their characteristics sufficiently for a type of formation suitable for application to the B.P.O. switching plant to be selected for standardization. The studies undertaken in the B.P.O. Teletraffic Branch have had, as their objective, the selection of a method of interconnexion for limited availability points in the switching network that will

- (a) increase the traffic-carrying capacity of a given number of circuits at a given grade of service,
- (b) decrease sensitivity of the grading to unbalanced traffic loadings of the input groups,
- (c) reduce considerably the expenditure incurred when additional trunks or additional input groups are connected to the grading,
- (d) reduce considerably the interruptions to service when additional trunks or additional input groups are connected to the grading,

(e) simplify grading design, and

(f) not add appreciably to the problem of call tracing.

This article surveys the theoretical studies that have led to the selected form of grading, and describes the practical gradings that result from its application over the full range of availabilities and up to 18-group gradings.

## EARLY THEORETICAL STUDIES

The early theoretical studies were aimed at selecting grading formations which gave the greatest improvements in traffic-carrying efficiency, and at assessing their ability to handle unbalanced traffic on the input groups. Table 1 gives the results of computer-simulation tests on a standard O'dell grading and on a selection of experimental skipped-grading formations, each with 12 input groups ( $g = 12$ ), 20 availability ( $k = 20$ ), and 93 trunks ( $N = 93$ ). Three of the experimental gradings are shown in Fig. 1. Tables 2 and 3 indicate the results of applying a medium degree and a considerable degree, respectively, of unbalanced offered traffic to the most successful grading shown in Table 1, i.e. grading B, and to the equivalent standard O'dell grading.

While the fully-skipped gradings showed to advantage under test conditions, the practicality of their introduction on existing equipment required a full investigation of existing racking and cabling arrangements, particularly for racks incorporating grading facilities.<sup>6</sup>

## LIMITATIONS OF STANDARD RACKING AND CABLING

### Racks with Grading Facilities

An investigation of the methods of interconnecting selector racks with grading facilities<sup>6</sup> and intermediate distribution frames (i.d.f.s), showed that with the multiplicity of interconnexions between non-adjacent groups of a fully-skipped grading the existing rack-to-i.d.f. tie-cables would be far from adequate. Also, the use of rack-to-rack tie-cables would be severely limited as the terminations at one end of these cables are made on tags of connexion blocks directly connected to shelves A and B of the adjacent racks. Even if the provision of additional rack-to-i.d.f. tie-cables was acceptable, for those selector racks with a grading on each selector level, the additional terminating blocks required would exceed the spare fixing positions available on the racks.

The use of trunk distribution frames (t.d.f.s) was also considered but, apart from the formidable accommodation problems that would arise in many situations, large numbers

† Telecommunications Development Department, Telecommunications Headquarters.

**TABLE 1**

**Traffic Capacities of Standard O'dell and Seven Experimental Skipped Gradings Determined by Computer Simulation**

(For each grading  $k = 20, g = 12$  and  $N = 93$ )

Grade of Service	Traffic offered (in Erlangs) for Specified Grade of Service								
	From Standard Traffic Table C/20	Standard O'dell Grading	Grading A	Grading B	Grading C	Grading D	Grading E	Grading F	Grading G
0.001	52.9	56.2	60.4	61.0	55.8	56.8	56.6	56.9	57.2
0.002	55.7	58.4	62.3	62.8	58.4	59.2	59.0	59.1	59.4
0.005	59.8	62.0	65.1	65.7	62.2	62.8	62.5	62.5	62.8
0.01	63.4	65.2	67.9	68.7	65.7	66.1	65.9	65.7	66.1
0.2	67.6	69.3	71.7	72.5	69.9	70.2	70.0	69.6	70.0

of rack-to-t.d.f. and, possibly, t.d.f.-to-i.d.f. tie-cables would be required even if inter-rack tie-cables were still used for some of the grading interconnexions.

**Racks Associated with T.D.F.s**

The application of a fully-skipped grading formation on a t.d.f. is possible, but the number of jumper connexions required for the interconnexions would give considerable difficulty as the connexion blocks and jumper-distribution system were designed for a limited number of jumper connexions. It was decided that the type of interconnexion finally selected would be determined by the requirements of the racks with grading facilities, and the use of these gradings for the t.d.f.s would be considered later.

**SELECTION OF A PARTIALLY-SKIPPED GRADING FORMATION**

As a result of the investigation into the existing racking and cabling arrangements, the theoretical studies were extended to forms of improved gradings which did not use the full range of possible skipping. Furthermore, the two objectives of reducing considerably the expenditure incurred and the interruptions to service when additional trunks or additional input groups are connected to a grading are not practical with fully-skipped gradings. First, it was evident that growth of a grading to accommodate each additional trunk must be obtained only by removal of one grading interconnexion and the connexion of the trunk, and, second, the addition of an input group to a grading must be possible with

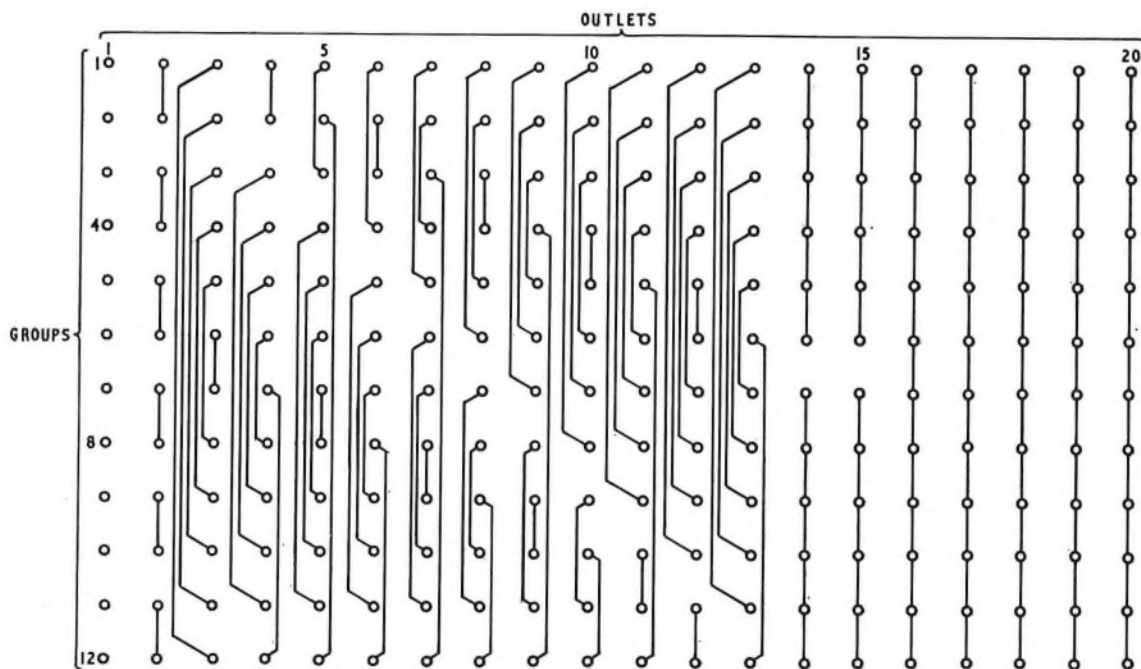

(a) Grading A

minimum rearrangement of the existing gradings interconnexions.

An improved grading meeting the first of these requirements was designed: Table 4 shows how the traffic-carrying capacity of such a grading, with  $g = 12$ ,  $k = 20$  and growing from  $N = 40$  to  $N = 120$ , compares at various grades of service, when offered balanced traffic, with that of the equivalent standard O'dell grading formations.

Further simulation studies covered a wide range of grading formations, and were used to determine those factors which lead to improvements in traffic-carrying capacity under both balanced and unbalanced input traffic. At the same time, an analysis was made of the rack-to-i.d.f. tie-cables available in exchanges. From the results of these two activities, partially-skipped grading elements were selected which could be extended to form practical gradings, incorporating the six

objectives given in the Introduction and minimizing the numbers of rack-to-i.d.f. tie-cables pairs by using as many inter-rack tie-cable pairs as possible.

Three such grading elements, X, Y and Z, were developed into full gradings and tested with balanced and unbalanced input traffic, the unbalance being at a ratio of 5:1. The grading elements used are illustrated in Fig. 2 and the results of the simulation tests over a range of grades of service from 0.001 to 0.1 are shown in Table 5, which, for comparison, includes standard traffic Table C/20 figures under balanced traffic conditions and the results of simulation of an optimized equivalent O'dell grading under unbalanced traffic conditions. From the test results, grading element Y was selected as the basis for grading formations used for further development; one such grading formation is shown in Fig. 3.

Using grading formations based on the selected grading

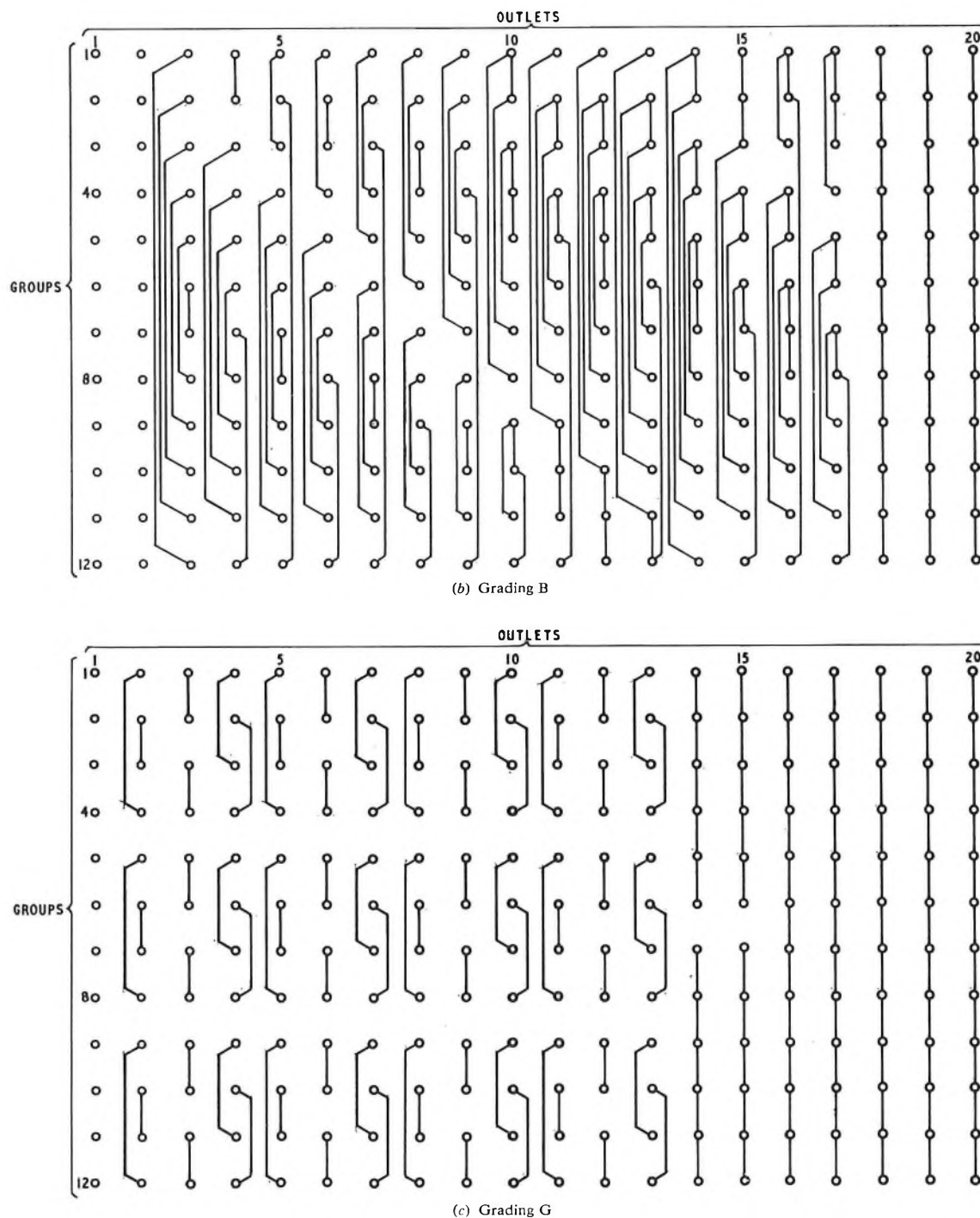

FIG. 1—Three experimental gradings used in tests summarized in Table 1

**TABLE 2**

**Results of Medium Unbalanced Traffic Offered to Grading B and Equivalent O'dell Grading**

(For both gradings  $k = 20, g = 12$  and  $N = 93$ )

Grading group	Traffic Offered (Erlangs)	Calls Offered	Grading B		Standard O'dell Grading	
			Calls lost	Proportion of calls lost	Calls lost	Proportion of calls lost
1	5.032	18,753	85	0.004533	106	0.005652
2	5.062	18,864	80	0.004241	112	0.005937
3	5.094	18,983	75	0.003951	94	0.004952
4	5.039	18,778	94	0.005006	92	0.004899
5	5.037	18,771	109	0.005807	122	0.006499
6	5.055	18,837	91	0.004831	97	0.005149
7	6.071	22,624	166	0.007337	420	0.018564
8	6.109	22,768	147	0.006456	436	0.019150
9	6.115	22,787	167	0.007329	471	0.020670
10	6.153	22,930	176	0.007676	553	0.024117
11	6.088	22,688	133	0.005862	603	0.026578
12	6.033	22,482	123	0.005471	590	0.026243
All	66.888	249,265	1,446	0.005801	3,696	0.014828

**TABLE 3**

**Results of Considerable Unbalanced Traffic offered to Grading B and Equivalent O'dell Grading**

(For both gradings  $k = 20, g = 12$  and  $N = 93$ )

Grading groups	Traffic offered (Erlangs)	Calls offered	Grading B		Standard O'dell Grading	
			Calls lost	Proportion of calls lost	Calls lost	Proportion of calls lost
1	2.516	9,375	11	0.001173	0	0.000000
2	3.028	11,284	11	0.000975	0	0.000000
3	3.539	13,190	13	0.000986	1	0.000076
4	4.060	15,132	37	0.002445	3	0.000198
5	4.578	17,059	85	0.004983	63	0.003693
6	4.997	18,624	125	0.006712	61	0.003275
7	6.062	22,591	216	0.009561	994	0.044000
8	6.570	24,486	277	0.011313	1,041	0.042514
9	7.148	26,637	433	0.016256	2,335	0.087660
10	7.679	28,618	501	0.017506	2,901	0.101370
11	8.161	30,414	529	0.017393	3,581	0.117742
12	8.548	31,855	542	0.017015	3,865	0.121331
All	66.886	249,265	2,780	0.011153	14,845	0.059555

**TABLE 4**

**Comparison of Traffic Capacities (in Erlangs) of Improved Gradings and Equivalent O'dell Gradings as Trunks are Increased from 40 to 120**

( $g = 12$  and  $k = 20$ )

Grade of Service	40 Trunks			60 Trunks			80 Trunks			93 Trunks			120 Trunks		
	Im-proved Grading	O'dell Grading	INC	Im-proved Grading	O'dell Grading	INC	Im-proved Grading	O'dell Grading	INC	Im-proved Grading	O'dell Grading	INC	Im-proved Grading	O'dell Grading	INC
0.001	23.0	22.9	0.4	36.8	36.0	2.2	51.0	49.0	4.1	58.2	56.2	3.6	75.9	72.6	4.5
0.002	24.2	24.0	0.8	38.3	37.4	2.4	53.1	50.8	4.5	60.7	58.4	3.9	79.0	75.4	4.8
0.005	26.0	25.6	1.6	41.5	39.6	4.8	56.1	53.7	4.5	64.4	62.0	3.9	83.2	79.9	4.1
0.01	27.6	27.2	1.5	43.3	41.7	3.8	58.8	56.3	4.5	67.7	65.2	3.8	87.6	84.1	4.2
0.02	29.5	29.1	1.4	45.9	44.2	3.8	62.0	59.7	3.9	71.7	69.3	3.5	92.9	89.2	4.2

INC = Increased traffic capacity of improved grading as a percentage of O'dell grading traffic capacity.

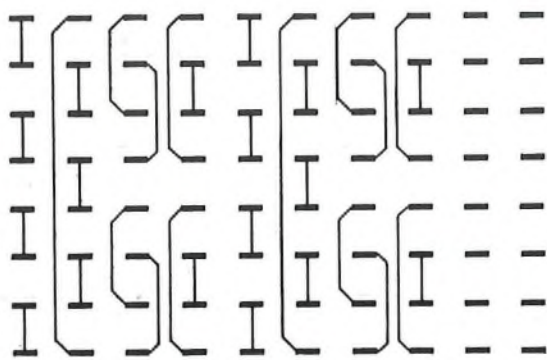

(a) Element X: basic pattern, repeated once

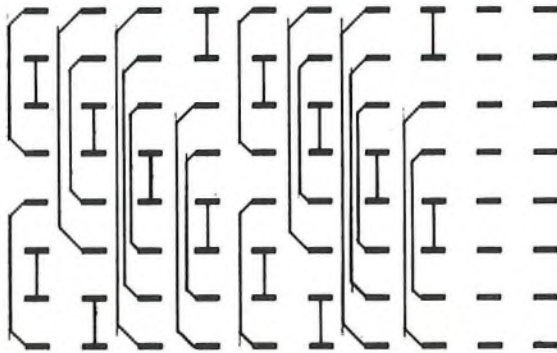

(b) Element Y: basic pattern, repeated once

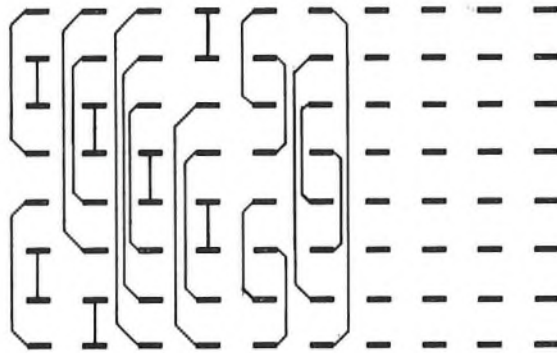

(c) Element Z: Basic pattern, once only

FIG. 2—Grading elements used to design practical gradings for comparative tests.

element, the number of wiring alterations necessary, when additional input groups are interconnected into an existing grading, were compared with those necessary when adding the same number of groups to the equivalent standard O'dell gradings. In all cases, there was considerable reductions of both alterations and of the numbers of existing trunks affected by the wiring changes. The following typical example of adding four groups to a standard O'dell 12-group grading and to a 12-group partially-skipped grading indicates the order of the improvements.

Assume that the grade of service required is 0.005 with 57.1 erlangs of traffic offered to the 12-group gradings and 75 erlangs to the 16-group gradings. Thus, the O'dell grading changes from

$$k = 20, g = 12 \text{ and } N = 89, \\ \text{to } k = 20, g = 16 \text{ and } N = 117,$$

and the partially-skipped grading changes from

$$k = 20, g = 12 \text{ and } N = 83, \\ \text{to } k = 20, g = 16 \text{ and } N = 109.$$

A study of the grading interconnexion changes required indicates that for the O'dell grading a total of 175 changes

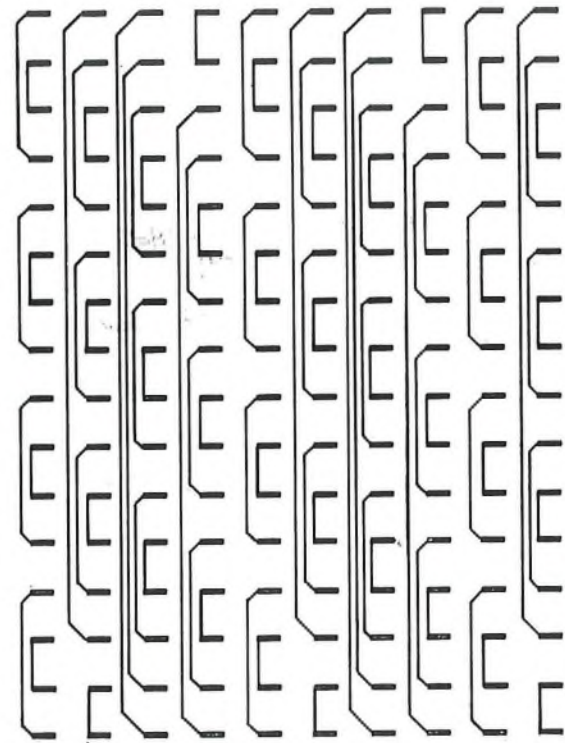

FIG. 3—Partially-skipped grading formation based on grading element Y

are necessary while for the partially-skipped grading this is reduced to 146, an improvement of 16.5 per cent on the O'dell grading. In terms of initial trunks unaffected by the grading changes the improvement is also marked: for the O'dell grading, 51 out of 89 trunks, i.e. 57 per cent, were untouched but for the partially-skipped grading 62 out of 83 trunks, i.e. 75 per cent, were untouched. There is also a much higher degree of integration of the new groups into the complete partially-skipped grading than there is with the O'dell grading.

With standard O'dell gradings, more often than not a call can be traced backwards by inspecting equipment on consecutive shelves and racks in the preceding rank of switches; sometimes newer equipment in another part of the apparatus room may be included, requiring a note to be made of equipment to be inspected and adding to call-tracing time. With complex skipped gradings, call tracing could become very time consuming and require full notes of equipment involved. However, with gradings formed from the selected grading element, there are never more than two portions of equipment which have to be inspected in the preceding rank of switches, thus only marginally increasing call-tracing time.

A further selection of gradings based on the selected grading element were tested with balanced and unbalanced traffic to see if they behaved in the same manner as those using a fully-skipped interconnexion pattern. In general, it was found that the original findings could be equally well applied to the partially-skipped gradings, although, as was to be expected, the improvement in performance over that of equivalent O'dell gradings was less marked. A separate study showed that, as for O'dell gradings, when the number of trunks in a partially-skipped grading exceeds that given by  $N = gk/2$  the grading efficiency deteriorates rapidly.

Gradings for use on t.d.f.s were reconsidered. It was clear that any additional advantage gained by using a more complex skipping pattern would be outweighed by wiring difficulties owing to limited spacing between grading tags and on the cabling and jumper connexion blocks, and by the necessity to carry out an equivalent study and development for another basic grading formation. Furthermore, apart from different

**TABLE 5**

**Comparison of Traffic Capacities (in Erlangs) of Gradings Based on Grading Elements X, Y and Z at Various Grades of Service**

(a) Balanced Traffic

Grade of Service		0·1	0·05	0·033	0·02	0·01	0·005	0·002	0·001
Grading Based on Element	X	148·0	132·2	124·3	117·5	103·3	102·8	96·5	92·7
	Y	150·4	133·7	127·0	120·0	113·2	106·2	99·9	96·1
	Z	150·1	134·4	127·4	120·6	112·8	106·6	99·7	95·0
Standard Traffic Table C/20		141·7	129·5	123·7	117·6	110·5	104·5	97·6	92·9

(b) Unbalanced Traffic (Ratio 5 : 1)

Grade of Service		0·1	0·05	0·033	0·02	0·01	0·005	0·002	0·001
Grading Based on Element	X	123·1	105·6	97·6	90·9	83·4	77·5	70·4	65·1
	Y	135·1	116·3	109·0	102·0	94·0	88·0	81·2	76·0
	Z	134·6	115·9	108·5	101·9	94·6	88·5	82·0	76·9
Equivalent O'dell Grading		118·8	102·5	96·1	90·1	83·8	78·3	73·2	69·9

documentation, another series of traffic-capacity tables would have to be produced. The one basic grading formation and its derived gradings were, therefore, considered suitable for both racks with grading facilities and racks associated with t.d.f.s, reducing the possibility for error in selecting a grading and associated traffic capacity table for any particular situation.

In view of the probability of having to limit the largest grading to 18 input groups because of cross-talk and automatic alternative routing considerations, and the increased difficulty of call tracing with large skipped gradings, it was decided that the grading designs should not extend beyond 18 input groups.

**DESIGN CHARACTERISTICS OF PARTIALLY-SKIPPED GRADINGS**

From the previous studies it is now possible to summarize the basic characteristics for the design of partially-skipped gradings.

(a) The basic interconnexion pattern is that shown as grading element Y in Fig. 2.

(b) Any grading formation shall permit the addition of each trunk by only removing one grading interconnexion and connecting the trunk to the isolated outlet or group of outlets.

(c) Any grading formation shall permit the addition of an input group with minimal alteration to the existing interconnexion pattern.

(d) Sixty per cent of the total trunks shall be connected to the first 40 per cent of the choices.

(e) There shall be between  $6k/20$  and  $gk/20$  circuits on the last  $6k/20$  choices.

(f) The grading shall be limited to a maximum of 18 input groups.

(g) The number of trunks connected to a grading shall not exceed  $gk/2$ .

In addition to the above, the methods of physically interconnecting outlets must be taken into consideration.

(a) For adjacent contacts on the same rack, the standard strapping arrangements are used.

(b) For non-adjacent contacts on the same rack, a bare tinned copper wire insulated with systoflex is used.

(c) For adjacent contacts on two different racks, the existing rack-to-rack tie-cables are used.

(d) For non-adjacent contacts on physically adjacent racks in the same suite, a jumper is provided or the interconnexion is made using rack-to-i.d.f. tie-cables.

(e) For all other interconnexions, rack-to-i.d.f. tie-cables are used.

**STANDARDIZATION OF PARTIALLY-SKIPPED GRADINGS**

Based on the characteristics listed above, a series of partially-skipped gradings have been designed covering the even numbers of input groups up to 18, and all availabilities and grades of service in use at present; the related traffic-capacity tables are being produced.

The gradings are designed by starting with the maximum allowable trunks for a given availability and number of input groups. When this grading has been completed using the basic characteristics and the interconnexion rules, interconnexions are added one at a time to reduce the grading by a trunk at a time until it has reached the lower limit of the range of trunks required; at each stage the basic characteristics and interconnexion rules must be observed.

Each grading with the minimum trunks for a given availability and number of groups becomes, in effect, the master grading (see Fig. 4) and, when associated with a trunk and cutting plan (see Table associated with Fig. 4), contains all the information for the intermediate number of trunks. Using these two documents, trunks are connected one at a time until the grading contains the required number.

Since the master grading contains more information than is required for call tracing and quick reference on the exchange floor, simplified grading charts which can be associated with the racks are drawn in a manner similar to the present charts for O'dell gradings. Supplementary charts are produced showing the grading formation at 10-trunk intervals, and by selecting the chart showing the nearest 10 trunks above the required number and adding interconnexions in accordance with the cutting plan, the simplified grading

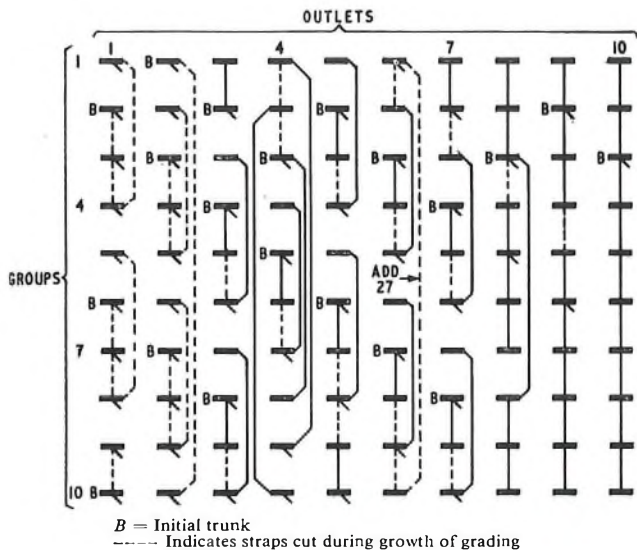

Trunk Number	On Outlet Number	Add Trunk to Group No.	And Cut Straps Between Groups
21	4	9	2-3
22	1	4	3-4
23	1	8	7-8
24	5	10	8-9
25	2	9	8-9
26	2	5	4-5
27	6	1	Note
28	3	6	5-6
29	3	10	9-10
30	8	5	3-4
31	7	2	2-3
32	4	7	6-7
33	4	10	1-2
34	5	4	3-4
35	5	8	7-8
36	1	3	2-3
37	1	7	6-7
38	1	9	9-10
39	1	1	1-4
40	1	5	5-8
41	6	9	8-9
42	6	5	4-5
43	2	10	1-10
44	2	8	7-8
45	2	4	3-4
46	7	6	5-6
47	7	10	9-10
48	2	6	6-9
49	2	2	2-5
50	9	6	4-5

Note: Cut straps between groups 1-2 and 9-10, and add strap between groups 1-10.

FIG. 4—Master grading chart, and trunk and cutting plan, for  $g = 10, k = 10, N = 20-50$

chart is produced. Fig. 5 and 6, respectively, show a simplified grading chart for a 10-group, 10-availability grading with 30 trunks, and one for 33 trunks produced from a 40-trunk simplified grading chart. In the latter case the additional interconnexions would normally be in full lines, but they are shown as dashed lines in Fig. 6 to show which interconnexions have been added.

### ENGINEERING TESTS

Now that traffic-capacity tables are being derived for the partially-skipped gradings it is possible to apply and maintain such gradings in an operational switching network. A series of practical engineering tests are, therefore, being carried out

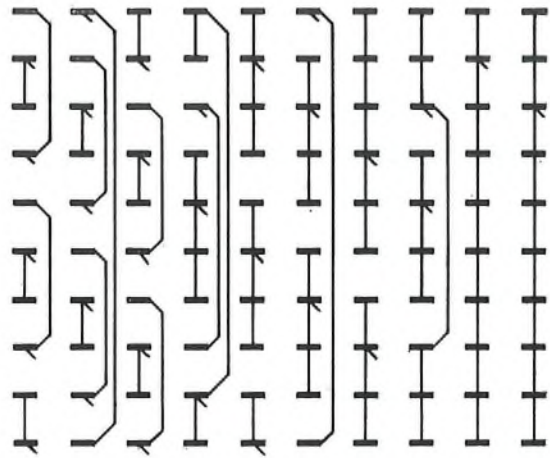

FIG. 5—Simplified grading chart for  $g = 10, k = 10, N = 30$

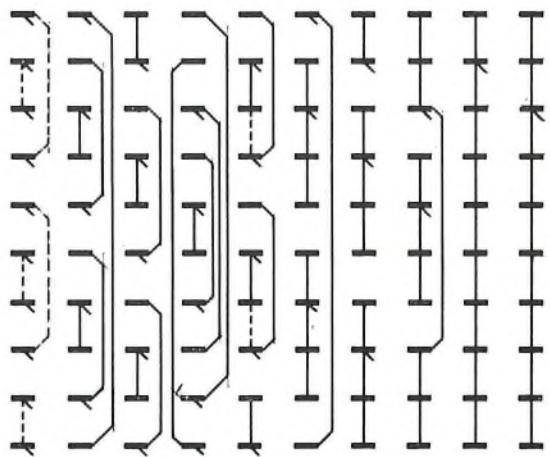

FIG. 6—Simplified grading chart for  $g = 10, k = 10, N = 33$

at selected exchanges in the B.P.O. North Eastern Telecommunications Region to ensure that there are no unforeseen engineering difficulties in converting O'dell gradings to partially-skipped gradings and that all eventualities are covered before their general introduction. Detailed measurements are being made on the existing gradings and on the replacement gradings for subsequent assessment purposes.

### CONCLUSIONS

The basic study of partially-skipped gradings suitable for use in the present B.P.O. switching networks has resulted in the formulation and standardization of partially-skipped gradings tailored to fit the particular limitations imposed by existing equipment practices. At the same time, these gradings will

- (a) increase the traffic-carrying capacity of a given number of circuits at a given grade of service,
- (b) decrease sensitivity to unbalanced traffic loadings of the grading input groups,
- (c) reduce considerably the expenditure when additional trunks or additional input groups are connected to a grading,
- (d) reduce considerably the interruptions to service when additional trunks or additional input groups are connected to a grading,
- (e) simplify grading design, and
- (f) not add appreciably to the problem of call tracing.

The replacement of the majority of the existing O'dell

gradings by partially-skipped gradings will result in very considerable savings of manpower on regrading work, and of trunks and associated switching and line equipment.

#### ACKNOWLEDGEMENTS

The authors wish to acknowledge the assistance of their colleagues, particularly Mr. A. C. Cole who pioneered the scheme and supervised the theoretical and computer-simulation studies associated with the development of the partially-skipped gradings, and the assistance of the North Eastern Telecommunications Regional staff who have installed the test gradings.

#### References

- <sup>1</sup> O'DELL, G. F. The Influence of Traffic on Automatic Exchange Design. *I.P.O.E.E.*, Printed Paper No. 85, 1920.
- <sup>2</sup> O'DELL, G. F., and GIBSON, W. W. Automatic Trunking—In Theory and Practice. *I.P.O.E.E.*, Printed Paper No. 107, 1926.
- <sup>3</sup> O'DELL, G. F. An Outline of the Trunking Aspects of Automatic Telephony. *P.O.E.E.J.*, Vol. 20, p. 121, 1927.
- <sup>4</sup> LONGLEY, H. A. The Efficiency of Gradings. *P.O.E.E.J.*, Vol. 41, pp. 45 and 67, Apr. and July 1948.
- <sup>5</sup> POVEY, J. A., and COLE, A. C. The Use of Electronic Digital Computers for Telephone Traffic Engineering. *P.O.E.E.J.*, Vol. 58, p. 203, Oct. 1965.
- <sup>6</sup> COOK, A. E., CORNELL, W., and URBEN, T. F. A. The New Standard Subscriber's Line Circuit Equipment. *P.O.E.E.J.*, Vol. 47, p. 73, July 1954.

## Letter-Office Computerized Monitor—LOCUM

J. D. ANDREWS, C.ENG., M.I.E.E., H. A. J. BENNETT, B.TECH., and A. D. PRATT, GRAD.I.E.R.E.†

U.D.C. 656.851: 691.187: 681.31

*The introduction of mechanization to handle letter mail has brought its own new problems, one of which is the monitoring of machine performance. Human observation has been found to have drawbacks and this has stimulated the development of an automatic monitoring system which is now undergoing field trials. The equipment uses an on-line data processor to continuously monitor certain parameters in a way which allows almost all causes of missorting to be identified. The equipment has been developed to be a useful maintenance aid and to provide advance warning of deteriorating margins. The design is such as to allow it to be extended as further requirements for on-line data feedback appear.*

#### INTRODUCTION

The British Post Office has developed a mechanized system for handling letter mail in which code marks are applied to each letter at the office of posting. This allows all subsequent sorting operations to be performed by automatic sorting machines without further human reading of the address. This code-sorting system forms the basis of plans to mechanize the handling of all letter mail and to concentrate this work into about 100 mechanized offices. The equipment has been developed over a number of years and has already been described.<sup>1,2</sup> To evolve an effective operating system from a number of machines is, however, a process of greater magnitude and one which offers as wide a variety of unexpected problems as did the original development of the machines. This article describes one such problem and the solution which has been evolved for it. The principle underlying the solution is not new and will undoubtedly have greater use in the future.

#### THE PROBLEM

During the development of the machines for handling mail automatically, and during their early field trials, informal arrangements were evolved for monitoring their performance. It was seen that some formal arrangements would have to be made for this purpose and the first methods adopted involved human observation of performance using defined sampling methods. This was a simple approach but it had disadvantages which are now seen to be significant.

(a) Obvious faults are observed and reported but the less obvious ones may not be noted because human judgement is involved; this differs between individuals and, for any one individual, changes with time. After a fault of low significance has been present for some days it is probable that it will be allowed to remain indefinitely. ("Oh, but it always does that!")

(b) In order to observe some faults with low occurrence rates it is necessary to employ large samples, with the following disadvantages.

- (i) It is wasteful of human labour and, therefore, expensive.
- (ii) There is a time delay before reporting a fault, both because of the time taken to make large samples and because the interval between samples may be lengthened in correspondence with the sample size.
- (iii) Faults are only observed after they have occurred. There is little that can easily be done to forewarn maintenance staff of a reduction in operating margins. This inevitably leads to maintenance which is organized on a "fire-brigade" basis with its attendant need for round-the-clock coverage and little opportunity for economical management of maintenance staff or for the advance scheduling of repair work.

In the code-sorting system, the most significant operational feature to be monitored is the accuracy of sorting. There has never been any doubt that an automatic method for monitoring the missorting rate of a sorting machine is desirable but this is not, of course, practicable; if it were, then it would also be possible to prevent the missorting occurring.

#### THE SOLUTION

The development of the new monitoring system started with the realization that a fault normally manifests itself in several ways, and while it may not be possible to measure the most undesirable effect—missorting—it is possible to measure some of the other effects. This is, of course, the basis of most medical diagnosis; the physician concerns himself with things he can measure (pulse rate, temperature, colour of skin, quality of breathing, etc.) and from these deduces the fault when a more direct measurement might be difficult or undesirable. It was this analogy that led to the expression *state-of-health monitoring* to describe the system.

† Postal Mechanization and Buildings Department, Postal Headquarters.



As an illustration of the principle of this form of monitoring, when applied to letter sorting, consider a sorting machine; this has only four basic functions:

to FEED a spaced stream of mail into a TRANSPORT system which carries it past a CODE READER to the DIVERTORS and into the separate sorting outlets.

Any of these functions may be impaired and, thus, affect the performance of the machine. By measuring three quantities for each machine it is possible to detect almost all impairments and, thus, almost all worsening performance. The quantities measured are:

(a) *The parity fail rate.* Where necessary, a parity mark is added to the information marks on the envelope to make their number even. A fault in the printer or reader will affect the number of marks which fail to register and, hence, the number of codes with odd numbers of marks.

(b) *The mail re-usable rate.* Any pair of letters which are too close together for a diverter to operate between them are both sent to a box the contents of which may be re-used, i.e. passed through the sorting machine again. The rate at which letters appear in this box indicates the state of the feed system; both unusually-high and unusually-low rates indicate that attention is required.

(c) *The overflow rate.* Letters which are not deflected by diverters are collected by overflow boxes at the end of the letter-transport system. Normally, only a very small number of letters appear in these boxes (less than 1 in 1,000 of those fed to the machine). Almost any diverter or mail-transport fault will alter this rate significantly. A data processor which is checking this quantity continuously can easily detect a change, say, from 1 in 5,000 to 1 in 500, while such a change is not, in practice, observed by operating staff.

## THE EQUIPMENT

To record the data from each machine on separate meters was seen to be unacceptable because of the human effort required to read and digest the information from the meters and because of the need to vary the alarm levels according to the duty of the machine. The practical solution to the problem employs a small data processor giving typewritten messages direct to maintenance staff. The processor used has a store of 8,000 16-bit words and a  $0.96 \mu\text{s}$  cycle time. The processor is shown in Fig. 1 and it can be seen that the unit is small. The number of applications employing such processors is now increasing rapidly and this can easily be understood when it is realized that all of the monitoring described in this article can be performed for up to 32 sorting machines (i.e. for the largest mail office) by only one processor and the cost of these has now fallen below £5,000.

The system hardware, shown in Fig. 2, consists of the processor, an alarm/control teletypewriter and a data acquisition interface constructed with standard P.E. (Postal Engineering) logic units<sup>3</sup>. Extensive use is made of highways and time-sharing techniques.

The data acquisition is made on two levels. The first level records every item passing through every sorting machine and also records every abnormality which results in the item being mistreated (routed to a special box). The type of mistreatment is also recorded. If the rate of occurrence of any particular type of mistreatment in any machine exceeds a predetermined level, then a warning is given to the maintenance engineer via the teletypewriter. The processor also automatically connects the second level of monitoring to the suspected faulty machine. This second level measures in detail both the print and read quality and the feed performance of particular machines.

The engineering performance of postal machinery has reached a sufficiently high level that, for practical purposes, the system can be considered as being fault-free and machine-mistreated items can be assumed to occur in a random manner. If the mean level of mistreated items is known, then

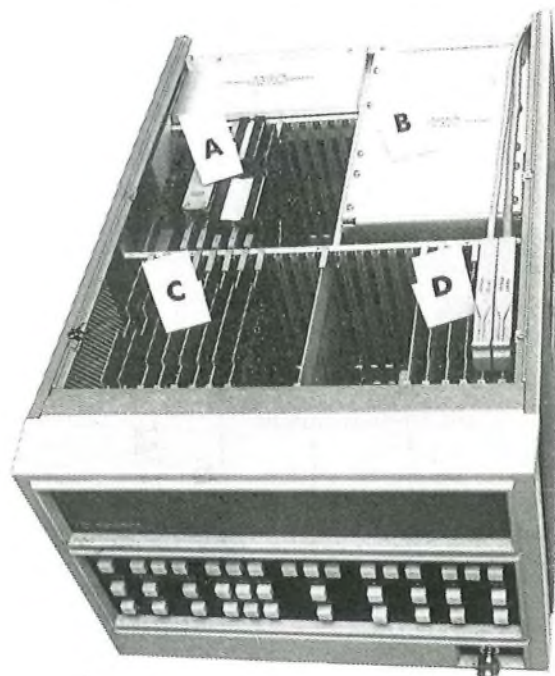

A—Ferrite core store 8,000 words.  
B—Power supply.  
C—Central processing unit.  
D—Interface to external equipment.

FIG. 1—The Hewlett-Packard 2100A data processor

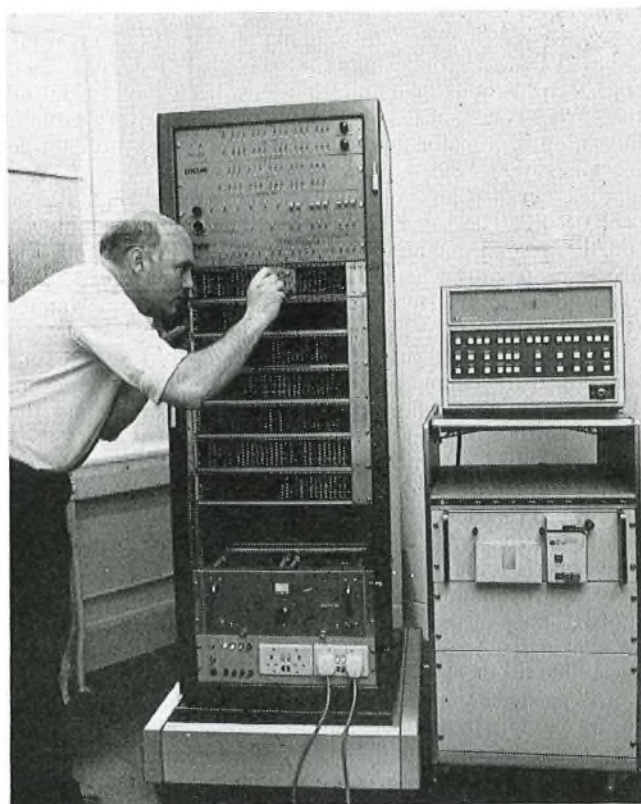

FIG. 2—LOCUM as supplied to Croydon sorting office

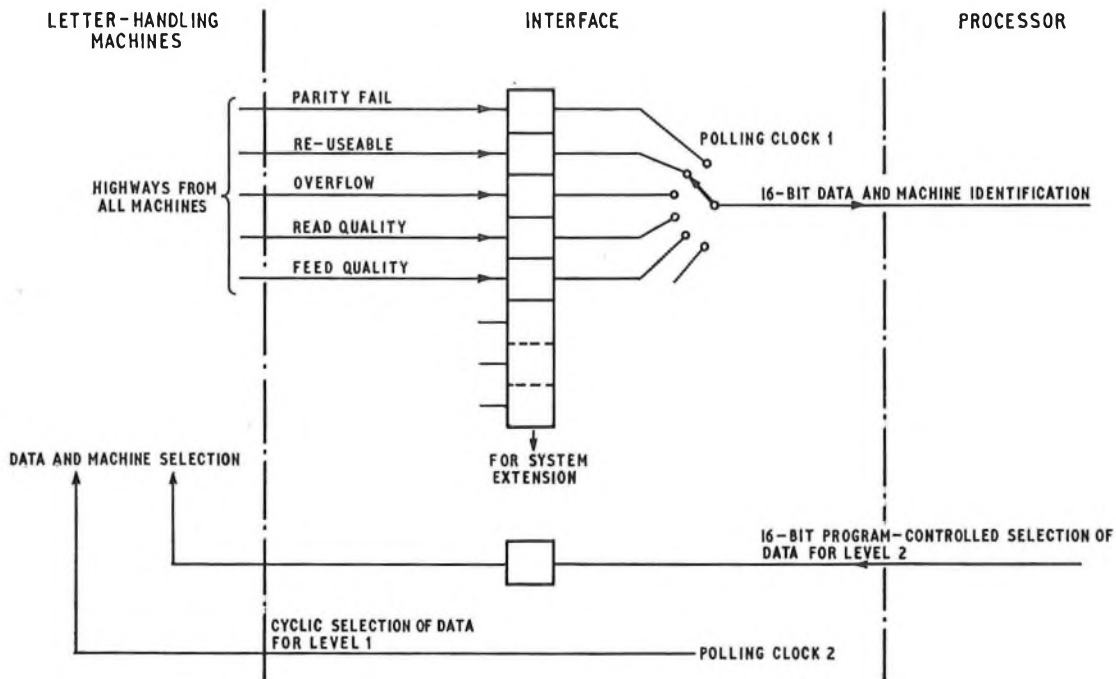

FIG. 3—Block diagram of LOCUM

the probability of any given number of items occurring in a given sample size can be predicted. Since the occurrence rate is low, a Poisson distribution is assumed.

Extensive trials covering many millions of items have enabled the mean levels of mistreatment to be determined and the alarm levels have been adjusted to permit not more than one false alarm per 100,000 items. The trials have used a data processor connected to machines, first at Croydon but later, and for most of the time, at Norwich. The processor was placed near the machines and the information was printed out, usually once a day, under the control of a teletypewriter at the design headquarters in London using dialled telephone connexions with standard modems at each end. Two methods of monitoring have been evolved during these trials. The first is not sensitive but gives a very prompt indication of a major failure. The items passing through the machine are considered as batches of 100 and a PROMPT alarm is given if any mistreatment rate greater than 10 per cent occurs. The same batches of 100 items are employed for the second method of monitoring but this time the processor records whether the mistreatment rate exceeds a much lower level. This information is passed to a counter which is incremented by one every time a sample yields an unfavourable result and decremented by one every four samples. If the count reaches five a fault indication is given. This technique permits very sensitive monitoring and the alarm that it brings up is called the TREND alarm.

Fig. 3 shows that the processor is connected to the data acquisition interface by a 16-wire highway. The 16-bit words are formed for each function by word-formers which assemble data from machines. Clock 1 polls each word-former and when one is found that has data ready, the clock stops and transfers the data, up to 12 bits, together with the 4-bit function code of the word-former, to the processor. On completion of the transfer the clock is re-started. The average cycle time for clock 1 is 500  $\mu$ s.

The particular machine that is feeding data to the word-former is determined either by a second polling clock for first-level monitoring or is under software control for other functions. For the first-level monitoring the 12-bit data word is composed of a 5-bit machine address and seven bits relating to the envelope passing through the machine (e.g. whether there is any impairment). Again, if data is found

ready to be transferred, the second clock stops, transfers the data to the word-former, waits until the word is transferred to the processor and then re-starts the cycle to the other machines. The average cycle time is 5 ms. The particular machine selected for the second level of monitoring is determined by the processor which outputs the machine address to the relevant staticizer; this energizes an identification wire, giving that machine exclusive use of the highway to the word-former.

Since this is only the first stage in automatic monitoring, an open-ended approach has been used in both the hardware and software. The hardware can be extended by adding word-formers for any extra functions when they are required and by adding output staticizers that can be decoded to control external operations. The software is based on the use of an executive program which schedules, queues and completely organizes a number of user programs. Additional independent user programs can be added at any time; these will be allocated their share of time but will not involve any reorganization of existing programs.

The notification of suspected faults to the engineer is by a print-out in the form of a fault docket as shown below.

85 11:45:8 MC24 P 15

This signifies that the docket, serial number 85, has been opened at 11.45 on the eighth of the month for machine 24 which has a parity fail count of 15 items in the last sample of 100. Any subsequent alarm for this parameter on this machine will retain the fault-docket serial number 85 and will record that it is a repeat alarm until the docket is closed.

An alarm bell is also sounded which can only be re-set if the engineer acknowledges the fault by keying, on the teletypewriter, the serial number, the code A (for acknowledgement) and his initials, as shown below. Only the initials of accredited engineers are accepted by the processor as valid.

85 A JS

After clearing the fault the engineer closes the docket with a similar input but with C (for closed) as the code. The processor stores under fault docket 85 the original information, when acknowledged, by whom, when cleared and by whom. This information can be obtained at any time and may also be printed out on the teletypewriter at a predetermined time.

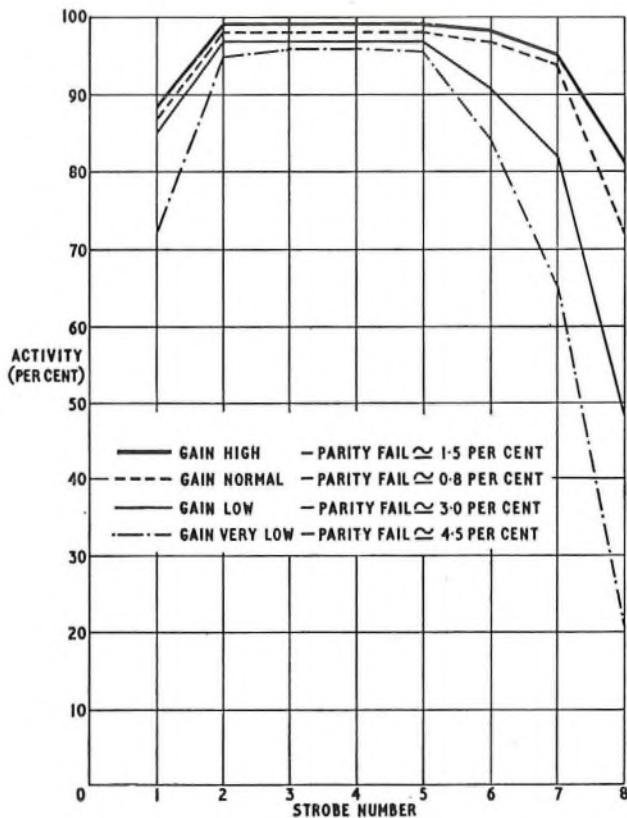

FIG. 4—The effect of change of gain when reading codemarks

#### More detailed analysis of performance

It has already been mentioned that, in addition to continuous monitoring of the handling of all mail there is a second level of monitoring in which detailed observations of events are recorded. Because this uses large amounts of both computer time and storage the recording is limited to one machine at a time and complete historical records are not kept. The information is of value to the maintenance engineer when fault finding and is also expected to lead to the provision of further automatic alarms to indicate when margins are reducing, before any mis-handling of mail has occurred at all. An example of this second level of monitoring is the measurement of the quality of printing and reading of the phosphor code marks as seen by the sorting machine. As each area of the envelope, on which a phosphor code mark might be expected to appear, passes the photo multiplier a series of eight strobes look for an acceptable light output<sup>4</sup>. If any two strobes coincide with a light signal, the area is assumed to contain a genuine phosphor mark. The gain of the photo multiplier may be monitored by recording how many strobes coincide with a light signal. The mean number of strobes coinciding with each mark is about 7.2. Mean values higher than this show over-reading, while lower values show under-reading.

The timing registration of the strobes is dependent on the instant of reading the start mark. Low gain produces a narrowing of the start mark signal, causing the strobes to occur late relative to the phosphor marks. This is detected by examining the activity of the eighth strobe. High gain causes an earlier start to the reading operation due to the increase in the apparent width of the mark and this causes the eighth strobe to see light more often because it occurs nearer to the centre of the code mark. The effect can be seen in Fig. 4 which shows the mean activity of each of the eight strobes for different gain settings in the code reader.

To record all eight strobes occurring for the 26 possible code marks on each envelope passing through all sorting machines is obviously time-consuming. To monitor only one

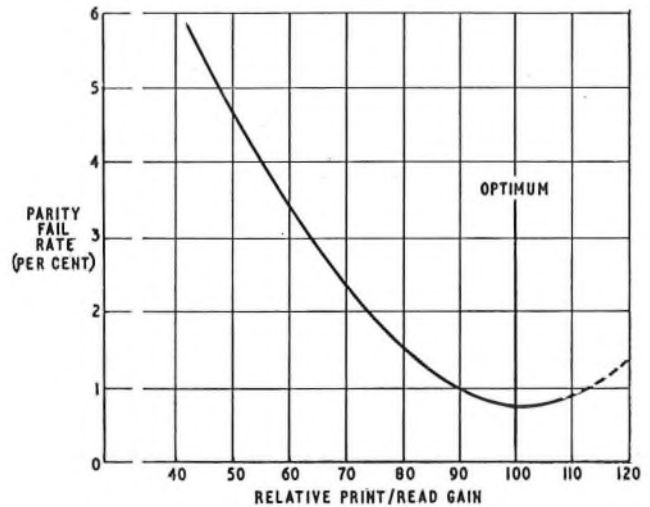

FIG. 5—The effect of reader gain on reading failures

machine at a time is, however, acceptable as most changes which can be detected will occur only slowly. In practice, each machine is examined in this detail many times per day and this is expected to call attention to most of the reductions in margin before there is any effect on mail-handling performance. In addition to the routine checking of each machine, it is possible for a maintenance engineer to direct the processor to examine a particular machine; it is also possible for the processor itself to decide to examine one machine. The processor would decide to examine a machine if the number of parity-fail items (which is monitored continuously) were to be unexpectedly high. Fig. 5 shows the effect of reader gain on the number of parity-fail items. An increased number of parity-fail items may occur for reasons other than reader gain. For example the breakage of a printer pin does not affect the print/read quality but increases the number of parity-fail items. This can be detected because poor-quality printing from one or more coding desks affects all sorting machines fed from these desks, therefore, by comparing one machine's performance against that of another, further information can be obtained for fault-finding purposes.

This illustrates the value of LOCUM to the maintenance engineer; much more information is now available for him to deduce the origin of a fault. Similar techniques are also applicable to the quality of the mail feed where the rate of occurrence of re-usable items is monitored. If this is excessive, it will automatically initiate an analysis of belt occupancy on the particular machine.

#### MONITORING THE FACING MACHINE

A very simple yet powerful means for monitoring the performance of the automatic letter-facing (ALF) machine exists because mail is fed to it in random orientation from the segregator.<sup>5</sup> (The segregator is the machine which separates letters from packets.) From this feed there should be an equal number of each of the four possible orientations that

TOTAL ITEMS	106,822
LEADING PHOSPHOR	41,084
TRAILING PHOSPHOR	42,284
LEADING OPTICAL	4,865
TRAILING OPTICAL	4,313
NO READING	10,053
REJECT	4,223

FIG. 6—Print-out of ALF data for 12.4.1972

the envelope can adopt when settled on a long edge. A lower-shelf scanning unit detects the position of the stamp and, if necessary, re-orientates the envelope about its long axis so that the stamp is adjacent to the lower long edge when the envelope is presented to the upper shelf. At the upper shelf, each face of the envelope is viewed by two scanners, one optical and one phosphor. These four scanners determine the class of the mail and also whether the stamp is adjacent to the leading edge or the trailing edge. Since the mail was originally randomly orientated there is an equal probability of either of these positions. A count of the number of stamps seen on one side should closely correspond to the number seen on the other side, given that the detecting sensitivities are the same. Fig. 6 shows a typical result obtained from one day's operation of an ALF at Norwich, in which the similarity between the leading-edge and trailing-edge figures can be seen. Unbalance between the scanner counts can be detected immediately as also can the relative performance of the optical and phosphor scanners. Unbalance at this point indicates a scanner fault. The scanner signals are interpreted in the facing machine and used to send mail to separate boxes. Unbalance between mail arriving at the different boxes can also indicate a failure in the electronic memory or in the mechanical transport and diversion mechanism.

This simple comparative monitoring system is capable of detecting faults in most of the facing machine and also allows accurate adjustments to be made which have already been shown to result in a halving of the reject rate.

#### MAN/MACHINE INTERACTION

LOCUM fits into a closed loop with the machine and the maintenance engineer. The monitoring system is capable of detecting many of the common faults that arise but cannot itself correct them. It is important, therefore, that the engineer has confidence in the monitoring system and responds to its messages. The extra effort called for from the engineer is offset by providing him with the additional data from the second-level monitoring which would not otherwise be available to him. There is the additional advantage that LOCUM will provide the maintenance staff with a more immediate and more accurate indication of the performance of the machines. It will supersede the arrangement, perhaps less acceptable to the maintenance staff, in which the operational staff report apparent faults after they have been observed.

Because the letter-handling equipment which is being monitored has only recently been developed there is little maintenance expertise available and this has limited the machine performance. The extra information which will now be available about the performance of the equipment can be expected to lead to greater maintenance expertise and, thus,

to better performance of machines. The alarm levels in LOCUM are stored in the program as pure numbers and can easily be changed. When an office is first commissioned the alarm levels are naturally set high and can easily be reduced as maintenance experience grows.

#### THE FUTURE

Much data is available in LOCUM and this is of value for purposes other than maintenance. It is of value in machine development and is already being employed for this purpose. It is also likely to be of considerable value to system managers both at local and at national levels. The equipment has been designed in such a way that some data can be given to managers immediately, e.g.

- (a) the current status of all machines,
- (b) the current performance records of all machines,
- (c) the relevant performance history for any machine,
- (d) the record of current outstanding faults, and
- (e) the records of faults cleared in the last twenty-four hours.

The effective use of available data does, however, imply a radical change from existing management techniques and will require considerable design effort. When this effort is applied then additional management data will be required. The system design is such as to allow extension to the data handled.

The introduction of LOCUM to two mechanized letter offices this year marks a significant change in mail mechanization. The continuous, tireless and accurate monitoring available from data processors will be employed for the first time and on-line data will be available, initially to maintenance engineers and, later, to management. Only when one has adequate and accurate data can one understand, optimize and properly manage a situation. The advent of data processors in sorting offices allows, for the first time, this data to be obtained and can, thus, be expected to lead to major changes in the future operation of the mail-handling system.

#### References

- <sup>1</sup> BRITISH POSTAL ENGINEERING CONFERENCE, May 1970. *Proc. I. Mech. E.*, Vol. 184, Part 3H.
- <sup>2</sup> DE JONG, N. C. C. Progress in Postal Engineering, Part 3—Letter Mail. *P.O.E.E.J.*, Vol. 63, p. 203, Jan. 1971.
- <sup>3</sup> BRITISH POSTAL ENGINEERING CONFERENCE, May 1970. *Proc. I. Mech. E.*, Vol. 184, Part 3H, Paper No. 26, p. 41.
- <sup>4</sup> PILLING, T., and HORROCKS, P. Coding Desk and Code Mark Reader for use with Automatic Letter Sorting Machines. *P.O.E.E.J.*, Vol. 54, p. 122, July 1961.
- <sup>5</sup> COPPING, G. P. C., GERARD, P. S., and ANDREWS, J. D. Mechanization in the Initial Stages of Processing Mail Part 2—Automatic Facing and Stamp Cancellation. *P.O.E.E.J.*, Vol. 53, p. 112, Apr. 1960.

# The Reliability of Coaxial Line Transmission Systems

M. G. HANSEN, C.ENG., M.I.E.R.E., and G. G. STEPHENS, GRAD. I.E.R.E.†

U.D.C. 625.395.45: 621.315.212.4

*Recent increases in the traffic capacity of coaxial line transmission systems have emphasized the need for a quantitative approach to reliability engineering. This article considers some basic theoretical aspects of reliability, analyzes the past performance of coaxial line systems and discusses future prospects.*

## INTRODUCTION

The increase in the traffic-carrying capability of coaxial line systems has led to more stringent reliability requirements. The greater the system capacity, the more the annoyance to customers and loss in revenue in the event of a failure. Realistic and adequate reliability objectives, formulated in the light of previous experience and advances in technology, need to be established for new systems at an early stage of development. Close liaison between the British Post Office (B.P.O.) and its contractors must be maintained if these objectives are to be met, since system reliability is a function of design, manufacturing and quality assurance procedures.

It is impossible in a short space to enter into a full discussion of such a complex subject, but it is hoped that what follows will give the reader an appreciation of the problems.

## RELIABILITY PRINCIPLES

A general definition of reliability is *the ability of an item to perform a required function under stated conditions for a stated period of time*.<sup>1</sup> However, in order to quantify the reliability of a component or system, it is necessary to define some reliability parameters. The most fundamental of these is the failure rate,  $\lambda$ , which is the average number of failures per component, or system, per unit time.

If the failure rate of systems or components, derived from a large number of observations, is plotted over a long period of time, the familiar bathtub curve commonly results (Fig. 1). Different types of system have differently-shaped failure-rate curves but, for the type of electronic system under discussion, the bathtub shape is usual. It will be seen that there are three distinct phases, identified by changes in the slope of the curve. In the early stages, the failure rate is high due to the breakdown of sub-standard components. Following this *burn-in* phase, the failure rate falls to a low level and remains substantially constant for a long time. At the end, the failure rate rises due to components wearing out. It is the middle phase that is of the most interest, since the useful life of line systems will occur during this period.

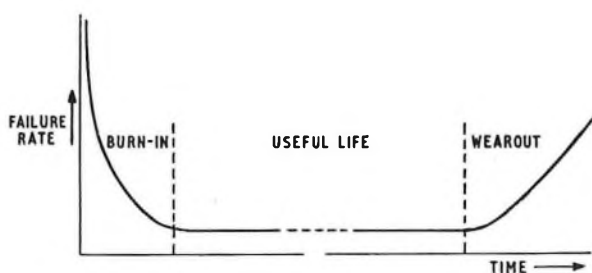

FIG. 1—Distribution of failures with time

During the middle phase, such failures as occur are due to random causes. If the failure rate is assumed to be constant, failures will occur at random intervals, the average interval being known as the *mean time between failures* (m.t.b.f. or  $\theta$ ), numerically equal to  $1/\lambda$ . It should be emphasized that the m.t.b.f. figure is not a guarantee that the system will operate successfully for that period of time.

To illustrate the implications of m.t.b.f. it is necessary to turn to a more specific, quantitative, definition of reliability as *that characteristic of an item expressed by the probability that it will perform a required function under stated conditions for a stated period of time*.<sup>1</sup>

The reliability,  $R(t)$ , of a system having a large number of components, failure of any one of which will result in failure of the system, is given by  $R(t) = e^{-\lambda t}$  (see Appendix), the curve of which is plotted in Fig. 2.

The  $x$ -axis is calibrated in multiples of  $\theta$ , and it will be seen that when

$$t = \theta, \text{ then } R(\theta) = e^{-\lambda\theta} = e^{-\lambda/\lambda} = 0.37$$

Hence, the probability of a system operating without failure for a period equal to its m.t.b.f. is only 0.37.

When considering overall system reliability, another important characteristic to be assessed is the time required for repairing failures. This may be described by the *mean time to repair* (m.t.t.r.) which can be estimated from past experience or, alternatively, a prediction can be made based on known characteristics of the system and its environment.

The parameters m.t.b.f. and m.t.t.r. may be combined to give *availability*, which may be defined as *the ratio of time*

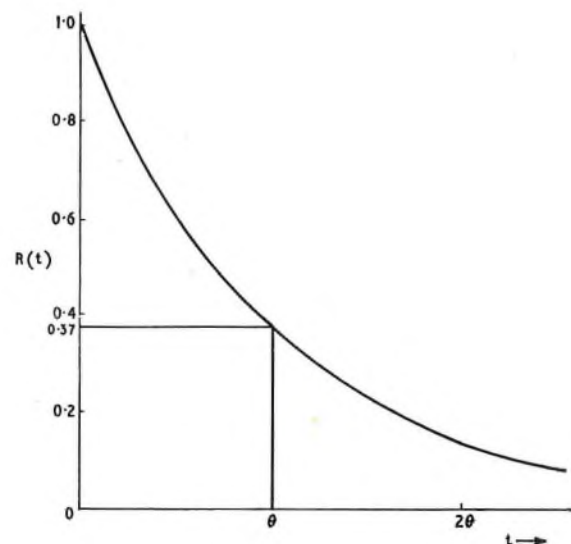

FIG. 2—Standardized reliability curve

† Telecommunications Development Department, Telecommunications Headquarters.

that an item is available for specified use in a stated period of time to the total length of the stated period of time.<sup>1</sup> Numerically,

$$\text{availability } (A) = \frac{\text{total time} - \text{downtime}}{\text{total time}},$$

$$\text{from which, } A = \frac{\text{m.t.b.f.}}{\text{m.t.b.f.} + \text{m.t.t.r.}},$$

where downtime is the time that the system was not available for use.

The overall availability of a number of systems connected in a series reliability structure is the product of the availabilities of each of the systems, provided that the failures are random.

### RELIABILITY STRUCTURE

In the simplest example of an independent serial reliability structure, that is, one in which the failure of any component causes the failure of the system, the failure rate of that system is the sum of the failure rates of the individual components. In practice, however, such a reliability structure seldom occurs. In coaxial line systems, there are many components whose failure would not lead to a system failure. For example, in the event of a smoothing capacitor failing open-circuit, the noise performance of the system might be degraded by a small amount, but traffic would not be lost. Before embarking on a reliability prediction exercise it is, therefore, necessary to determine the system reliability structure.

Firstly, the failure modes of components must be investigated. The fundamental characteristics of a component determine the manner in which it fails. Some components may fail to a short-circuit condition and are not likely to fail to an open circuit, while others are capable of failing either way. For example, the failure mode of a metal-film resistor is that it can fail to an open-circuit condition, but not to a short-circuit.

Secondly, system failure must be defined. This may be defined in two categories, one being where circuits are lost or are outside noise limits, and the other where the performance of part of the system is degraded but the end-to-end performance is adequate. Thirdly, a circuit analysis must be carried out leading to the identification of critical circuit locations, i.e. locations where a component failure could lead to a system failure. In this way, the probabilities of catastrophic and degradation failure of components can be related to system performance. Finally, an assessment of the significance of component derating and redundancy must be carried out. It should be noted that, in this context, redundant components are those provided for reserve, or stand-by, use.

When analyzing fault reports from the field, with a view to quantifying reliability performance, it is useful to regard line systems in terms of a hypothetical reliability structure

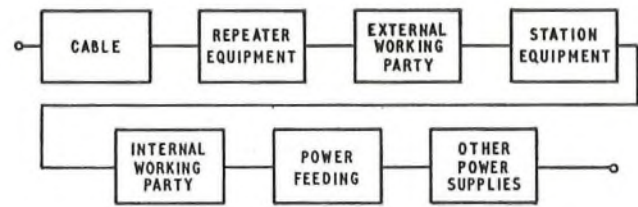

FIG. 3—Hypothetical reliability structure

(Fig. 3) which is derived from the assignment of failure causes to one of the following seven mutually-exclusive categories:

- (a) *Cable*—Cable failures not caused by human activity.
- (b) *Repeater Equipment*—Dependent repeater failures not caused by human activity.
- (c) *External Working Party*—All external failures caused by human activity.
- (d) *Station Equipment*—Failures, within main or terminal stations, not caused by working parties.
- (e) *Internal Working Party*—Failures, within main or terminal stations, caused by working parties.
- (f) *Power-Feeding System*—Failures of the power-feeding system.
- (g) *Other Power Supplies*—Failures of power supplies other than the power-feeding system and a.c. mains.

Each of the seven constituent blocks, corresponding to the seven failure categories, has equal status within the structure. For example, the structure is considered to have an external working party, series-connected so far as reliability is concerned, which will occasionally "fail." The external working party will have an m.t.b.f., an m.t.t.r., and an availability, all of which can be calculated following an analysis of faults caused by external working parties.

### RELIABILITY AIMS

In the absence of stand-by arrangements, the failure of a coaxial line system results in the loss of traffic. The cost to the B.P.O. of such failures is not only the lost revenue, but must also include the lost goodwill of those customers who find their conversations abruptly terminated. The aim must be, therefore, an availability that is as high as is practicable. There is, however, the risk of trying to attain an availability figure which can only be met by using expensive high-quality components and elaborate stand-by arrangements. The resultant cost could well be prohibitive, and there would be little advantage if the availability of the transmission equipment became high compared with that of the primary power supply, upon which the system ultimately depends. Care must therefore be taken to ensure that a realistic and

TABLE 1  
Performance of Hypothetical 160 km Reliability Structure

Category	M.T.B.F. (Years)	M.T.T.R. (Hours)	Availability (Per cent)	Contribution to Downtime per Year		Proportion of Faults (Per cent)
				Hours Mins.	(Per cent)	
External working party	2.33	16.6	99.919	7 : 05	59	15
Repeater equipment	3.18	6.88	99.976	2 : 06	17	11
Cable	13.1	19.6	99.983	1 : 29	12	3
Station equipment	0.8	0.8	99.988	1 : 01	8	42
Internal working party	1.63	0.46	99.997	0 : 17	2	21
Power-feeding system	9.36	1.44	99.998	0 : 09	1	4
Other power supplies	8.17	0.9	99.999	0 : 07	1	4
Overall	0.33	4.0	99.860	12 : 14	100	100

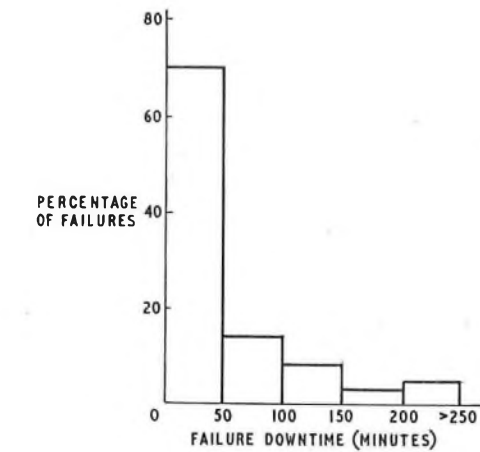

(a)

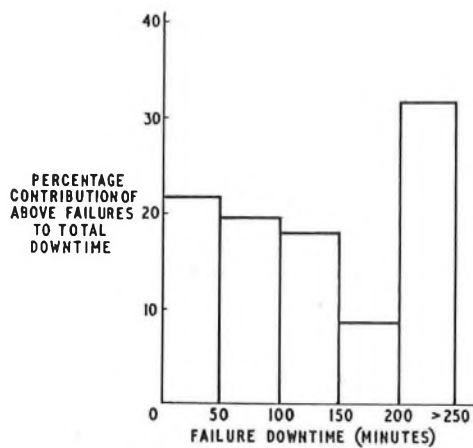

(b)

FIG. 4—Distribution of station-equipment failures

economically viable reliability target is set. The design aim for individual 60 MHz line systems, each of which will carry 10,800 telephone channels, is an m.t.b.f. of four years and an availability of 99.99 per cent per 160 km, assuming a life of 25 years.

#### PERFORMANCE OF EXISTING SYSTEMS

The contribution of each of the failure categories to the overall reliability of the hypothetical 160 km reliability structure is shown in Table 1. The figures were derived from field information on transistorized line-system faults occurring between January 1971 and March 1972.

The figures illustrate the inter-dependence of m.t.b.f., m.t.t.r. and availability. For example, *external working party*, which gave rise to only 15 per cent of the total number of faults and had an m.t.b.f. of 2.33 years, contributed nearly 60 per cent of the overall system downtime. In contrast, *station equipment* which produced 42 per cent of the total number of faults and exhibited an m.t.b.f. of only 0.8 years, contributed only 8 per cent of the overall downtime. The crucial difference between the two is the repair time. Whilst the time taken in the actual repair of external faults can be fairly low, the overall repair time is usually high due to travelling time, preparation of work area and logistic difficulties. Such factors are of little significance for internal faults. The figures emphasize the danger of quoting an m.t.b.f. and number of faults per annum without reference to the repair time which often has a greater effect on availability than the other parameters.

Figs. 4(a) and 5(a) show the frequency distributions of the downtimes resulting from failure categories, and Figs. 4(b)

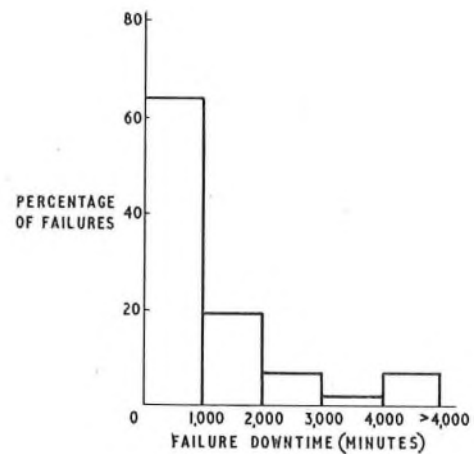

(a)

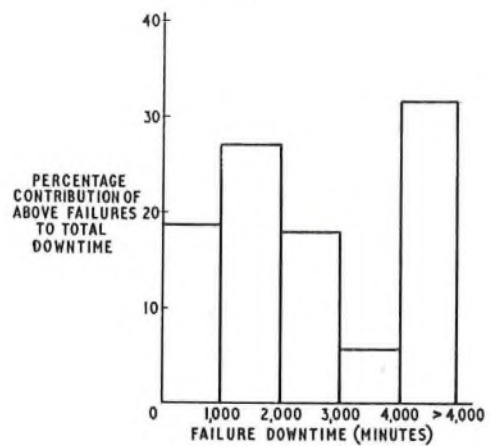

(b)

FIG. 5—Distribution of external-working-party failures

and 5(b) show the corresponding contribution to the total category downtime. In both categories, a small percentage of the faults makes a large contribution to the downtime. For *station equipment*, some 5 per cent of the faults contribute over 30 per cent of the total downtime. These performance results show that, for an average coaxial line system, a large proportion of the total downtime is due to faults caused by external working parties. Hence, although more reliable repeater equipment would significantly improve performance, the effect on overall reliability by improvements to equipment reliability is restricted. For all fault categories, one aim should be to obviate long-duration downtimes.

#### RELIABILITY PREDICTION

Fundamental to an assessment of system reliability is a knowledge of the failure rates of the constituent components but, unfortunately, failure rates cannot be measured in the same sense as other parameters such as power consumption or frequency response.

The usual method of determining the failure rate of a component is to record the number of components that fail out of a number that are either on test or in use in equipment. Since any result obtained from sampling or from a limited period of service life is only an estimate based on the amount of information available, the ratio of failures to component-hours is only an estimate of the failure rate. It is the best estimate available but it may differ considerably from the true figure. If the failure rate is low, many hours testing are required to obtain sufficient failures to enable the failure rate to be predicted with any confidence. When the number of

failures is zero, very little can be said about the failure rate unless a very large sample has been examined for a very long time.

For example, suppose that the true failure rate for a particular component is  $2 \times 10^{-4}$  failures per component per hour. If a number of these components were tested for 10,000 component-hours, one might expect two failures during the course of the test. However, it is possible that more, or fewer, failures could occur. The probability that 0, 1, 2, . . .  $n$  failures will occur when the average occurrence rate is known is given by the individual terms of the Poisson distribution and, hence, a table can be drawn up showing the probability of any given number of failures during the course of the test (Table 2). It will be seen that the probability

**TABLE 2**  
Probability of  $n$  Failures in 10,000 component hours  
for  $\lambda = 2 \times 10^{-4}$

Number of Failures ( $n$ )	Probability of $n$ Failures
0	0.13
1	0.27
2	0.27
3	0.18
4	0.09
5	0.04
6	0.01

of the best estimate being coincident with the true failure rate is only 0.27 and, indeed, it is just as likely that only one failure will occur, leading to an optimistic best estimate. For this reason, there will always be some uncertainty as to the true failure rate, and so it is usual to quote failure rates together with a stated confidence level. A typical statement might be that the failure rate of component A is  $2 \times 10^{-4}$  failures per component per hour with an upper one-sided confidence level of 60 per cent. This means the probability is 0.6 that the calculated upper confidence level ( $2 \times 10^{-4}$ ) is greater than the true failure rate.

The uncertainty difficulty is more acute for high-reliability components, where a large number of component test hours is required to establish the failure rate to a reasonable confidence level. A failure rate of the order of  $1 \times 10^{-9}$ , readily achieved by some modern components, can only be verified by many thousands of millions of component-hours.

It is sometimes possible to reduce the testing period by overstressing the components, but where no direct relationship exists between the accelerating stress and failure rate, accelerated tests cannot be used to verify failure rates. Accelerated tests are, nevertheless, most useful in identifying failure mechanisms.

Life tests on high-reliability components are generally impracticable, so recourse must be made to service data obtained from the performance of components in the field. The weakness of this method is the effect of uncontrolled conditions.

Since there is uncertainty surrounding the individual component failure rates, a statistical approach is needed when calculating system reliability. As a first step, confidence distributions for individual component failure rates may be set up. Statistical methods exist for compounding the individual component failure rate distributions to produce a distribution of system failure rate and it is, therefore, possible to make a prediction of system reliability.

As for components, predicted system failure rates are usually associated with a stated upper confidence level. By its very nature, however, an upper confidence level will, nearly always, be worse than the true system failure rate. This is one of the reasons why reliability predictions often appear to be pessimistic.

Whilst reliability prediction is a useful exercise, it represents only part of the overall reliability engineering task, and should not be regarded as a substitute for good engineering practice and effective quality control procedures.

## FUTURE TRENDS

The history of coaxial-line-system development has been one of continuing refinement in the application of basic principles. The technical requirements and operation of modern systems has been discussed in a previous issue of this *Journal*.<sup>2</sup> Line systems capable of carrying 10,800 channels are now under active development and requirements put the reliability objective for the B.P.O. 60 MHz line system at 99.99 per cent per 160 km without the benefit of stand-by redundancy.

The calculated m.t.b.f. of the series combination of transmission equipment, cable and power supply (Fig. 6) may be established at the design stage, assuming random failures. However, after manufacture and installation in a working environment, the system is subject to additional temporary and catastrophic transmission failures brought about by human activity and surges originating in natural and man-made phenomena. A reduction in the out-of-service time due to these incidents is, therefore, essential if the limit of some 53 minutes downtime per year per 160 km, set by the availability objective of 99.99 per cent is not to be exceeded. Catastrophic damage to the cable however, requiring time-consuming repairs, may make this objective unrealistic in the short term. The present-day availability of power supply, cable and transmission equipment (Table 1) require improvement if line systems are to achieve the objective of 99.99 per cent.

### Power Supply

Development of modern power plant for use with switching and transmission equipment has resulted in the production of modular power equipment<sup>3</sup> with a calculated m.t.b.f. of 1,000 years. The public electricity supply is usually the source of primary power and a stand-by battery and automatic-start engine-generator set assure continuity of supply. An availability in excess of 99.99 per cent may be expected with this arrangement.

### Cable

A cable route beside the roadway gives relatively easy access for installation and maintenance purposes. However, road traffic subjects the cable and joints to vibration leading occasionally to cable creepage and failure. A further disadvantage of this location is that the cable is vulnerable to damage by roadway and public-utilities working parties. Routing the cable away from the roadside to a less frequented environment, e.g. across fields, beside a canal bank or railway track, could result in fewer working-part-faults. Additional protection may be given by burying the cable deeper, armouring the cable and specifying a "hard" route construction.<sup>4</sup>

### Transmission Equipment

The line repeater and line-terminal equipments incorporate a wide variety of components and active devices the failure rates of which determine the reliability of the equipments. A modest improvement in the quality of components, electrical design and manufacture will be required for transmission equipment availability to exceed 99.99 per cent per 160 km (see Table 1).

### Service Protection Network

To improve the service performance of the existing coaxial line network, an overlay network of spare hypergroup links,<sup>5</sup> designated the Service Protection Network, is being provided. If a main link becomes faulty or has to be taken out of



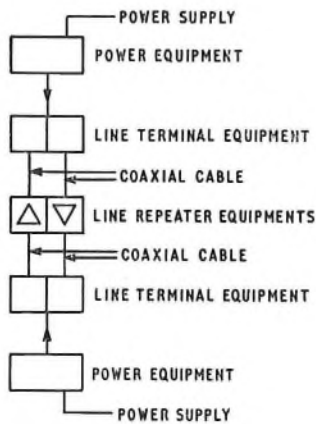

FIG. 6—Make-up of a coaxial line system

service for any other reason, a spare link can be brought into use manually by means of patching cords. The reduction in out-of-service time is directly dependent on the speed with which the alternative transmission path is brought into use.

### Automatic Switching

If a stand-by system with automatic end-to-end changeover switching is provided, the availability of a group of systems is enhanced. The availability of systems within a group (Fig. 7) may be calculated by using a variation of Bayes' probability theorem<sup>6</sup> which gives:

$$A_s = (n + 1) A^n - nA^{(n+1)}$$

where  $n$  is the number of systems protected by one stand-by,  $A_s$  is the availability with switched stand-by and  $A$  is the availability of each system. Failure of one system may occur without loss of traffic and the m.t.b.f. of the traffic paths is effectively increased. The availability of the traffic paths through the switching equipment is required to be much greater than that of the line systems being protected. Automatic switching to a stand-by has rarely been specified in the past because of the comparative stability of the line-system transmission path compared with radio-transmission systems. The benefits of automatic control include a higher m.t.b.f. and a reduction in the out-of-service time due to random failures, intermittent faults, surges and occasional operating mistakes. The reliability objectives of 60 MHz line systems warrant the provision of automatic switching equipment.

### CONCLUSION

It is expected that the specification of realistic reliability targets and the application of sound engineering practices will lead to an improvement to the reliability of coaxial line-transmission equipment. Further protection of the traffic path, by way of an improved working environment and the provision of alternative and stand-by paths, should ensure that traffic loss is kept to a minimum.

### References

- <sup>1</sup> International Telegraph and Telephone Consultative Committee (C.C.I.T.T.), Joint Special Study Group C, Contribution No. 90, Mar. 1972.
- <sup>2</sup> MILLER, J. R., and GIPP, J. A. Recent Developments in the F.D.M. Transistor Line Systems. *P.O.E.E.J.*, Vol. 63, p. 234, Jan. 1971.
- <sup>3</sup> PINE, R. Telecommunications Power Supplies—The Next Decade. *P.O.E.E.J.*, Vol. 64, p. 2, Apr. 1971.
- <sup>4</sup> BISHOP, K. G. T. A Leap Ahead in Cable Capacity. *P.O. Telecoms. J.*, Vol. 22, No. 2, Summer 1970.

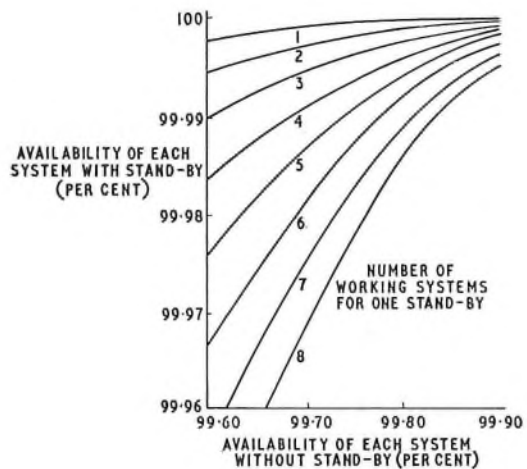

FIG. 7—Effect of stand-by arrangements on system availability

<sup>5</sup> BOAG, J. F., and SEWTER, J. B. The Design and Planning of the Main Transmission Network. *P.O.E.E.J.*, Vol. 64, p. 16, Apr. 1971.

<sup>6</sup> BAZOVSKY, I. Reliability Theory and Practice (Prentice Hall, New Jersey, 1961).

### APPENDIX

#### Derivation of the Relationship $R(t) = e^{-\lambda t}$

Let  $N_o$  components be put on test. After time  $t$ ,  $N_s$  components will have survived,  $N_f$  will have failed.

From basic probability principles, the probability of survival, or reliability  $R(t)$ , is given by:

$$R(t) = \frac{N_s}{N_o} \text{ provided that } N_o \text{ is large.}$$

$$\begin{aligned} \therefore R(t) &= \frac{N_o - N_f}{N_o} \text{ since } N_o = N_f + N_s, \\ &= 1 - \frac{N_f}{N_o}. \end{aligned}$$

Differentiating:  $\frac{dR}{dt} = -\frac{1}{N_o} \frac{dN_f}{dt}$  since  $N_o$  is constant.

Rearranging:  $\frac{dN_f}{dt} = -N_o \frac{dR}{dt}$  .....(1)

Now  $dN_f$  is the number of components failing in the interval  $dt$  between the times  $t$  and  $t + dt$ . At time  $t$  there are  $N_s$  components surviving.

$$\text{Failure rate } \lambda = \frac{dN_f}{dt} \frac{1}{N_s} \text{ failures/component/hour.}$$

Hence, from (1)  $\lambda = -\frac{N_o}{N_s} \frac{dR}{dt} dt$ ,

$$= -\frac{1}{R} \frac{dR}{dt} dt \text{ since } R = \frac{N_s}{N_o}.$$

$$\therefore \lambda dt = -\frac{dR}{R}.$$

Integrating:  $\int_0^t \lambda dt = -\int_1^R \frac{dR}{R}$  since when  $t = 0$ ,  $R = 1$ .

Now over the useful life,  $\lambda$  is constant. Hence:

$$\int_0^t \lambda dt = \lambda t.$$

$$\begin{aligned} \therefore \lambda t &= -\int_1^R \frac{dR}{R}, \\ &= -\ln R. \end{aligned}$$

$$\therefore \ln R = -\lambda t.$$

$$\therefore R(t) = e^{-\lambda t}.$$

# Testing Techniques for 24-Channel P.C.M. Systems

G. H. BENNETT\*

U.D.C. 621.376.56: 621.395.45-001.4

*This article describes, briefly, the built-in test, monitor and alarm facilities provided in 24-channel pulse-code modulation (p.c.m.) multiplex equipment and digital line systems and outlines the portable test equipment used. A description is given of installation, commissioning and maintenance procedures which make use of these facilities and enable staff in the field to provide and maintain p.c.m. systems as part of the junction network. Mention is also made of new developments which may be introduced in the future.*

## INTRODUCTION

The British Post Office (B.P.O.) has approximately 1,300 pulse-code modulation (p.c.m.) systems<sup>1</sup> in revenue-earning service. These are 24-channel systems<sup>2</sup> and it is expected that they will continue to be installed until the 30-channel C.E.P.T.† system is introduced in about 1975.

The considerable investment involved in p.c.m. systems has required careful consideration of testing techniques. This article describes the general testing facilities provided, both those built into the system and those supplied as separate items of test equipment and also describes the two aspects, commissioning and maintenance, which require different facilities and procedures.

## SYSTEM CONFIGURATION

Before describing the testing facilities in detail, it is instructive to consider a typical p.c.m. system, shown in Fig. 1, which is made up of the sub-systems described below.

### P.C.M. Multiplex Equipment

A multiplex equipment at each end of the system, multiplexes 24 audio channels, provides integral mounting on a per-channel basis for any of the 17 types of p.c.m. signalling units and also incorporates various power, monitoring, testing and alarm facilities.

### Digital Link (Digital Path)

The two p.c.m. multiplex equipments are interconnected by two unidirectional digital links which are each in turn made up of one or more unidirectional digital sections in tandem.

### Digital Section

A digital section consists of up to 18 regenerator sections and terminates at both ends on a line terminating equipment.

### Line Terminating Equipment

A line terminating equipment provides access for patching and monitoring in addition to mounting four terminal regenerators and four power-feed units. This equips four transmit and four receive digital sections. Power is fed at a nominal constant current of 50 mA on the phantoms of a cable quad which carries two digital sections having the same direction of transmission.

### Regenerator Section

One regenerator and its preceding length of cable, normally 1.8 km, forms a regenerator section. Two regenerators connected to one quad constitute a regenerator unit, 24 of which are housed in a case repeater equipment (c.r.e.) together with miscellaneous testing facilities. The c.r.e. can hold 36 of the new "slim-line" units being developed for the 30-channel, 2.048 Mbit/s system.

## MULTIPLEX EQUIPMENT ALARMS

For a number of fault conditions, the p.c.m. multiplex terminal gives visual and audible alarm indications. It also provides camp-on-busy facilities for all channels which are equipped with outgoing 2-wire signalling units. Consideration is being given to providing a modification to extend camp-on-busy facilities to remote-type signalling units which are connected 4-wire to the p.c.m. multiplex.

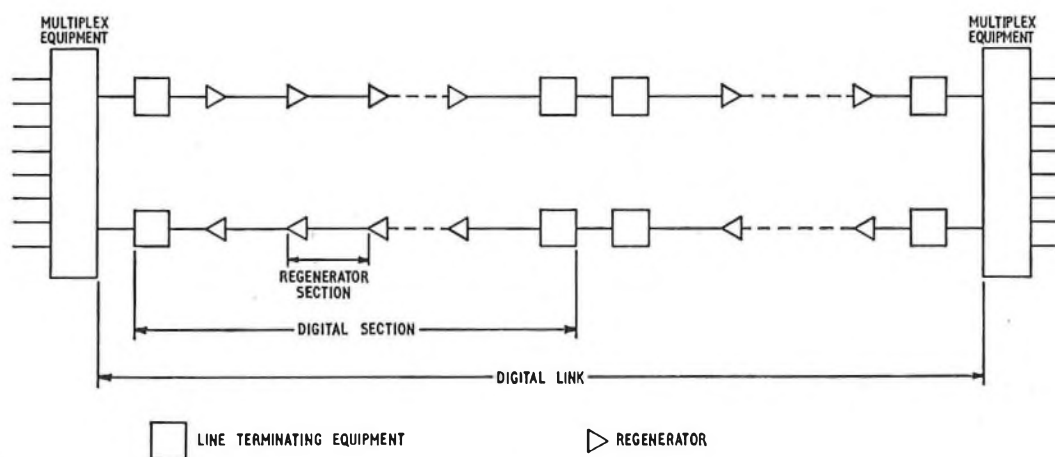

FIG. 1—Junction p.c.m. system arrangement

\* Telecommunications Development Department, Telecommunications Headquarters.

† C.E.P.T.—Conférence Européenne des Administrations des Postes et Télécommunications.

The alarm conditions given at present and any significant changes to be made in the next generation, 30-channel, p.c.m. multiplex are detailed below.

(a) *Loss of Frame Alignment.* The receive section of a p.c.m. multiplex is aligned with the received frame-alignment signal, so that this alarm generally indicates a fault in either the remote-multiplex transmit-clock or frame-generation circuitry, or in the local multiplex receive-clock or frame-alignment circuitry.

(b) *Codec Alarm.* The codec alarm is primarily intended to check the remote coder and the local decoder but other common circuits are also checked. A 2 kHz audio signal is connected to channel No. 12 when it is not carrying traffic and is detected at the receive terminal. An alarm is given if the level of this signal drops below a pre-determined value.

This arrangement has the following disadvantages:

- (i) information has to be derived from the signalling units to determine when the circuit is seized for traffic so that the 2 kHz signal and detector circuit can be disabled, and
- (ii) the timing arrangements to restore the alarm circuit, when the circuit is released, are quite critical.

To overcome these difficulties, a proposal to contain the supervision within one terminal is under consideration for the 30-channel system and a method being investigated is described below.

During channel time-slot 0 when the codec is idle, the digital codes equivalent to pre-determined positive and negative signals are applied successively to the decoder input. The resultant voltages generated by the decoder are stored in capacitive circuits with a long time-constant, to minimize the effects of asynchronism between the transmit and receive terminals, and then encoded. The resultant codes are compared with the original test codes and discrepancies noted by logic circuits so that persistent errors operate the alarm circuits. The number of codes that can be checked is being studied.

(c) *Error-Rate Alarm.* The existing 24-channel system has a coarse error detection alarm set at  $1 \text{ in } 10^3$  which detects violations of the alternate mark inversion (a.m.i.) line code. This method is satisfactory for single point-to-point digital sections between p.c.m. multiplex equipments, but, when more complex digital paths are set up over radio-relay links and higher-order line systems, the identity of digital errors in the first digital link may be lost.

To overcome this difficulty in the 30-channel p.c.m. multiplex, it is proposed to use the frame-alignment word as a

means of checking errors in the received digital signal. The accuracy of this method of error count depends on whether the distribution of errors is random, and it will take considerably longer to obtain a check on the error rate than checking for violation of the a.m.i. line code. However, as this is only regarded as an early warning of degradation of the digital path, such inaccuracies are not regarded as significant. A serious increase in the error rate will cause loss of frame alignment and a separate alarm indicates this.

(d) *No Received Digital Signal.* The alarm that responds to the loss of the received digital signal is not a reliable indication of line failure on the existing 1.536 Mbit/s line system, where some regenerators have a rather wide range of automatic gain control (a.g.c.). If a line failure occurs, the a.g.c. in subsequent regenerators can increase the pre-amplifier gain to such an extent that they respond to crosstalk and produce random digital signals. This has been overcome by specifying a limit to the a.g.c. range for the 2.048 Mbit/s regenerators required for the 30-channel system.

(e) *Power Fail.* The power-fail alarm operates if the primary (-50-volt) supply or any derived supplies on the multiplex fail.

Alarms are not normally given by the multiplex for single channel faults, reliance being placed on the fault being detected by circuit routing.

## MULTIPLEX TEST EQUIPMENT

All the parameters which need to be checked on a p.c.m. multiplex, except quantizing distortion, can be measured using test equipment which is normally available in an exchange or repeater station.

### Quantizing Distortion

Quantizing distortion arises from the processes involved in p.c.m. and, to measure this parameter, a quantizing distortion tester (Fig. 2) has been developed which is based on methods devised by the B.P.O. Research Department. The test involves the use of a noise source as a stimulus. Further studies are being made to establish whether noise synthesized from a digital source can satisfactorily replace noise from a random source. The advantages of a digital noise source are that the source can be more easily replicated and that measurements can be made more rapidly as it is possible to reduce the time constant of the associated meter circuit.

A method of establishing the performance of transmit and receive terminals separately has considerable advantage over

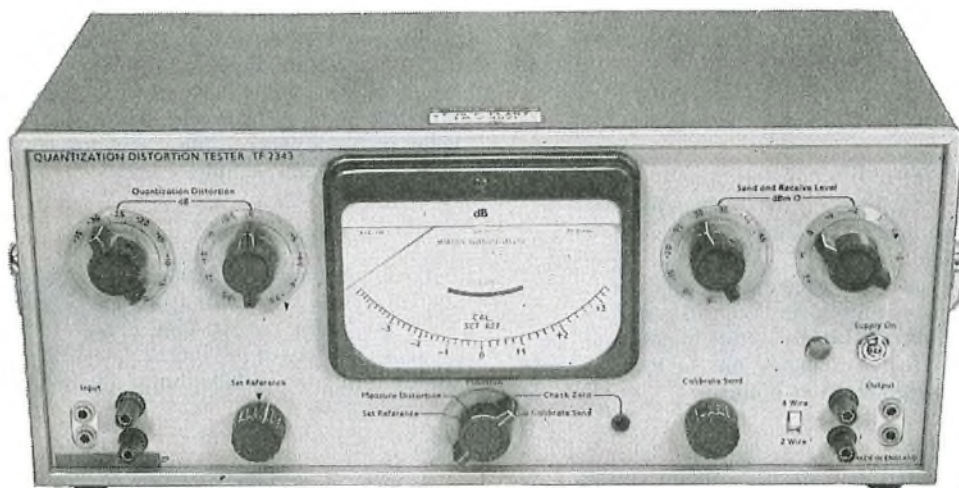

FIG. 2—Quantizing distortion tester

the methods currently used, which require two terminals to be connected back-to-back.

One method, which is currently being evaluated by the B.P.O., uses a 2 kHz sine wave obtained by filtering a 2 kHz clock waveform derived from the p.c.m. multiplex. The level of this signal is standardized by means of an accurate thermocoupled voltmeter and then connected to the audio input of a channel through an attenuator of the required accuracy. Access is obtained to the coder output and the digital signal is connected to code analysis logic which provides an illuminated display corresponding to the code. A phase-correcting circuit ensures that sampling always takes place at the zero crossing and peak of the sine wave and, by selecting the signal from every fourth frame, a constant digital signal is derived corresponding to either the positive or negative peak amplitude of the 2 kHz audio input signal. This test enables any output from the coder to be directly related to the level of the audio input signal and so permits the accuracy of the coder to be checked throughout its range.

To check the performance of the decoder, the digital signal generated at the output of the coder can be used to energize the decoder and so generate an audio signal whose level is compared with the original 2 kHz input to the coder.

An alternative method, based on a similar approach to the problem, compares the continuous digital output from the coder with the predicted digital codes for a given signal amplitude and indicates discrepancies between the two digital signals.

Both these methods are useful in evaluating the performance of the coder and decoder on a digital basis but further work is necessary to establish the relationship between inaccuracies in the coder/decoder pair and subjective effects on the voice channel.

## DIGITAL SECTION TESTING FACILITIES

### Line Terminating Equipment

Both ends of a digital section terminate on a line terminating equipment which has a patching panel, providing an in-service monitor point protected by a series resistor. It also has a break-access U-link to

- (a) make good a system on a standby digital section, when its normal digital section is faulty,
- (b) provide out-of-service testing of a digital section, and
- (c) permit looping of a multiplex for faulting purposes.

### Power Feed Faults

To identify a fault in a power-feed loop, the polarity of the normal power-feed supply to the digital section is reversed. This causes diodes, which are connected between the two regenerators in a regenerator unit, to conduct (Fig. 5). Measurement of the line current then enables the location of a fault to be determined. The reversal is achieved by means of a switch in the power-feed unit.

### Service Telephone Circuits

To provide speech facilities to the terminal stations, access to an exchange line is provided in each c.r.e. This is more satisfactory than providing access to a permanent engineers' speaker circuit to an exchange or repeater station, since, in many instances, the regenerators in any one c.r.e. may provide digital links between several different terminal stations. In addition to the exchange line, a local speaker circuit is provided between repeater points.

### Line Test Equipment

The remaining test facilities for the digital section can conveniently be described under the headings of the appropriate testing equipment.



FIG. 3—Error detector

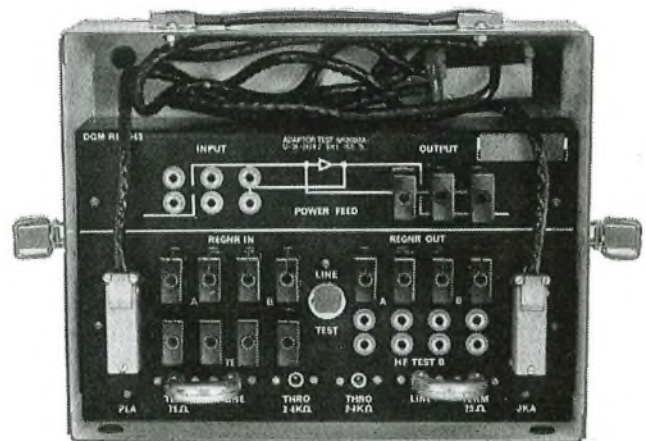

FIG. 4—Regenerator access unit

### Error Detector

The error detector (Fig. 3) detects bipolar violations of the a.m.i. line code. Although this is not a direct indication of the error rate, it is a simple technique and gives a good indication of the line performance. The present error detector has an input filter and uses a sampling technique to make its response more like that of a regenerator or a p.c.m. multiplex. An earlier version was unnecessarily sensitive and responded to noise which would not cause errors on a working system. Both testers have outputs for driving a frequency counter and a recording decibelmeter for recording the number and time of occurrence of errors. A new version of the error detector is currently being developed. This has a built-in counter to overcome the problem of occasional errors being recorded when using a separate counter, due to transients on the mains supply.

### Regenerator Access Unit

To obtain access to intermediate regenerators, it is necessary to remove the connector from the regenerator and connect the regenerator access unit (Fig. 4) between them. This enables a variety of tests to be carried out and is particularly useful during the installation of a new digital section.

### Trio Tester

A most important service requirement is to be able to locate a faulty regenerator in a digital section that has ceased to function, or in which the error rate is excessive.

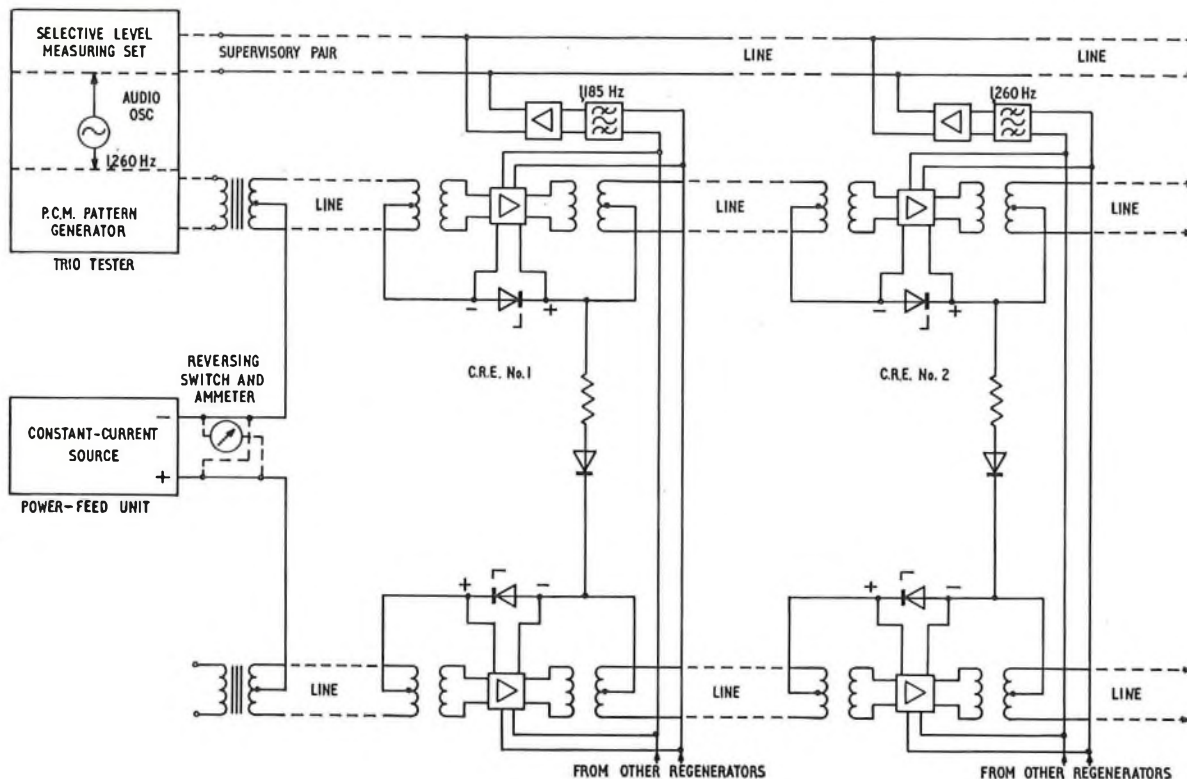

Fig. 5—Trio and reverse power testing

At present, each regenerator is provided with an auxiliary digital output and, in each c.r.e., all these outputs are connected to a common audio band-pass filter located within the c.r.e. The filter output is amplified and connected to a common supervisory pair which has access to every c.r.e. on the route. Each c.r.e. is allocated a filter having a particular band-pass frequency from a set of 18 so that each c.r.e. on a digital section is identifiable in terms of its allocated audio frequency. The general arrangement is shown in Fig. 5.

When it is required to test a digital section, a trio tester (Fig. 6) is connected to it and to the common supervisory pair. A digital signal, having the structure shown in Fig. 7, is transmitted and the audio frequency selected that corresponds to a particular c.r.e. The signal comprises groups of 3 digits, or trios, with a regular inversion of the pattern occurring at a repetition rate corresponding to the selected audio frequency. Facilities are provided in the tester for altering the density of the trio groups between 1 in 11 (three level 1 signals followed by eight level 0 signals), and 1 in 4 (three level signals followed by one level 0 signal). If all regenerators in the digital section, up to and including the one being tested, are working, the filter in the c.r.e. extracts the audio component of the signal which is transmitted back along the common supervisory pair to be identified and measured by the receive part of the trio tester. This comprises a selective level measuring set whose pass band corresponds to the audio-frequency component of the transmitted signal. By selecting the appropriate audio frequencies in turn, it is possible to progress along the route until a regenerator is identified which fails to return the allocated audio signal. However, difficulties arise if a digital section contains more than one faulty regenerator, since the test cannot progress beyond the first fault.

This test can be further developed to identify a regenerator which has not completely failed but, because of a defect, has become marginal in its performance. Since the normal line signal is bipolar, with an average d.c. component of zero, any departure from this signal configuration adversely affects

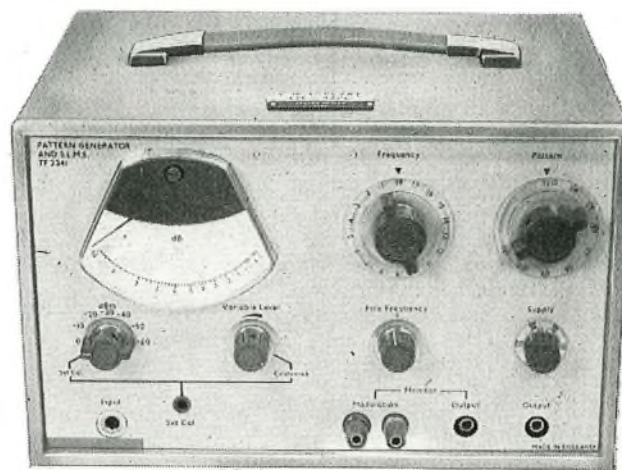

Fig. 6—Trio tester

the operating margin of the regenerator. Moreover, the test signal used has a low-frequency component whose magnitude is a function of the number of zeros occurring between each trio of 3 digits (see Fig. 7). If the pattern density is increased, without altering the audio frequency, then

- (a) the magnitude of the audio component increases, and
- (b) the operating margin of the regenerator decreases.

By observing the increase in magnitude of the received audio signal as the density of the trio groups is increased, it is possible to identify a regenerator which, although not necessarily causing digital errors, is functioning below the normal standard expected. This effect is shown in Fig. 8.

The present regenerator fault-location method has the following advantages.

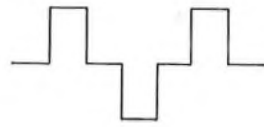

(a) A positive trio pattern

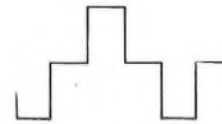

(b) A negative trio pattern

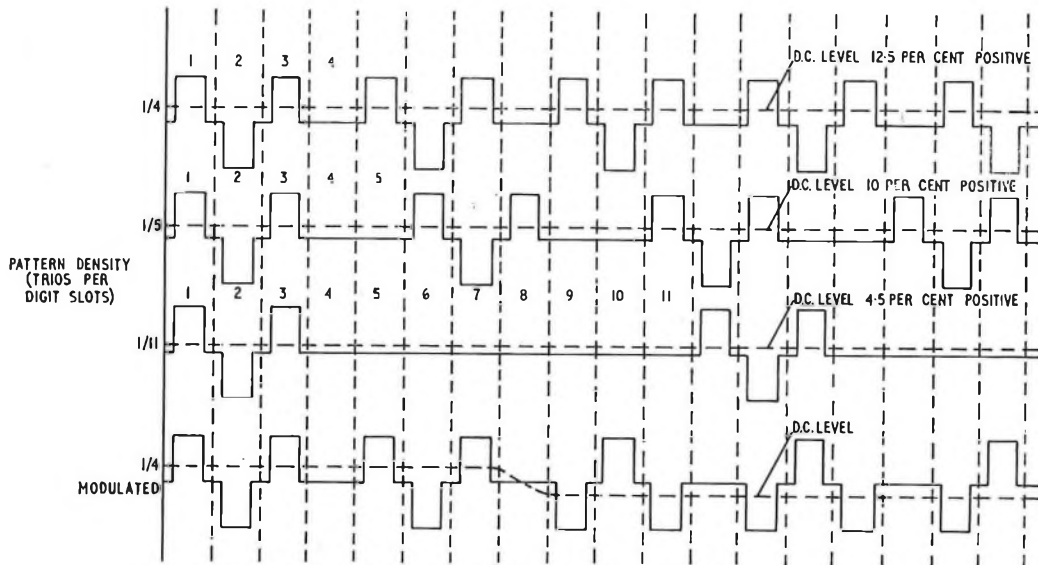

(c) Trio test patterns showing the effect of bipolar violations on the effective d.c. level of the signal

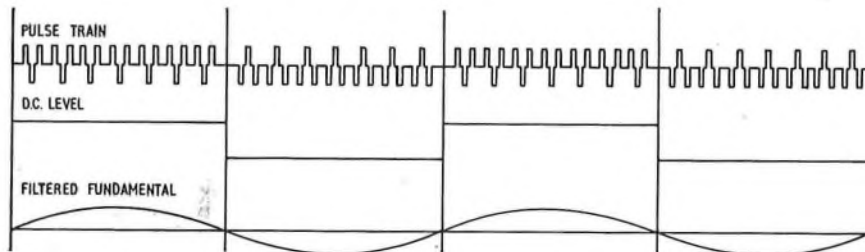

(d) Trio pulse train showing modulation

FIG. 7—Trio patterns

- (a) The only additional regenerator components are two resistors and a tertiary winding on the output transformer.
- (b) It is suitable for unidirectional digital sections.
- (c) Only a simple audio-frequency filter and amplifier is required at each regenerator housing, which can contain 72 unidirectional regenerators.
- (d) Only one test pair is required for up to 18 regenerator locations, that is, a route of about 32 km long.

Although a failed regenerator can be accurately identified, cases have occurred where a marginal regenerator is difficult to identify and then more than one regenerator location must be visited to identify the trouble.

Studies are being made with the objective of improving the consistency of the results given by the present system and new alternative methods are also under consideration.

#### Regenerator Tester

To test individual regenerators of both the intermediate and terminal type, the regenerator tester (Fig. 9) is used. This tester incorporates the basic features of error detector and

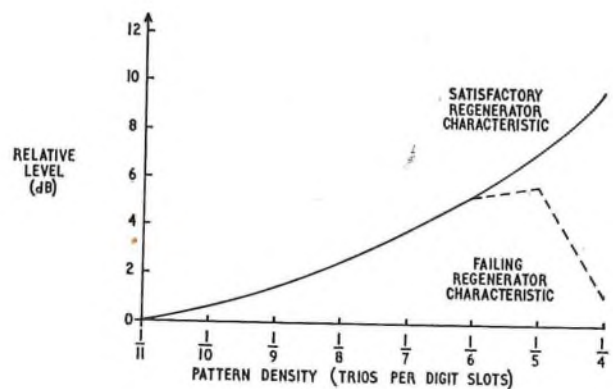

FIG. 8—Typical pattern density/level characteristic obtained with the trio test

the trio tester and also includes a range of cable simulators and an interfering signal source, with a level control calibrated in decibels relative to the test signal. It provides facilities for checking the power-fault location circuitry of the regenerator.



FIG. 9—Regenerator tester

#### *Pulse Generator*

A rack-mounted pulse generator producing six outputs of a simple 0101 . . . pattern is used for general testing of digital sections.

#### *Comprehensive Word Generator*

The comprehensive word generator (Fig. 10) produces a pseudo-random pattern of  $2^{15}-1$  bits, which provides an adequate simulation of the signal generated by a p.c.m. multiplex equipment. This is used for localizing the more obscure faults, such as a regenerator which is marginally unsatisfactory and malfunctions to certain pulse sequences. The comprehensive word generator can also generate manually-selected repetitive patterns of 15 digits.

#### *Cable Tester*

The cable tester (Fig. 11) is a transmission measuring set for measuring the attenuation of regenerator sections at 800 kHz to confirm the value of line equalizer to be fitted in the regenerator, the equalizers being available in steps of 2 dB.

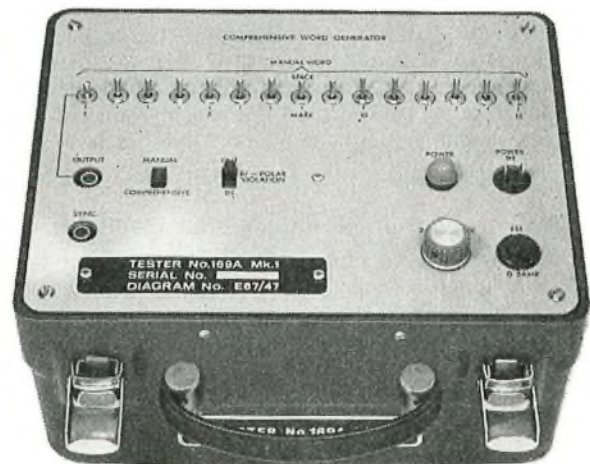

FIG. 10—Comprehensive word generator

### **INSTALLATION AND COMMISSIONING**

At present, all work associated with the installation and commissioning of p.c.m. systems is carried out by B.P.O. staff<sup>3</sup>. As the manufacturer is not involved in on-site testing, B.P.O. quality assurance procedures are employed at the manufacturer's factory. This reduces the commissioning tests required and minimizes the number of faulty items supplied.

#### **Cable Tests**

Prior to any equipment being installed, the cable pairs nominated for a p.c.m. route are diverted from the loading coils and connected to the c.r.e.s. On completion of jointing, the attenuation of each cable pair is measured at 800 kHz using the cable tester and a pulse-echo tester is used to ensure that there are no residual tees or split quads which would adversely affect the performance of the digital sections.

Crosstalk measurements are not made as this is considered to be too time consuming to be justified. Allocation of pairs in a cable is made on the basis of known crosstalk statistics, in order to obtain maximum utilization of the cable without increasing the error rate of the digital links to an unacceptable value.

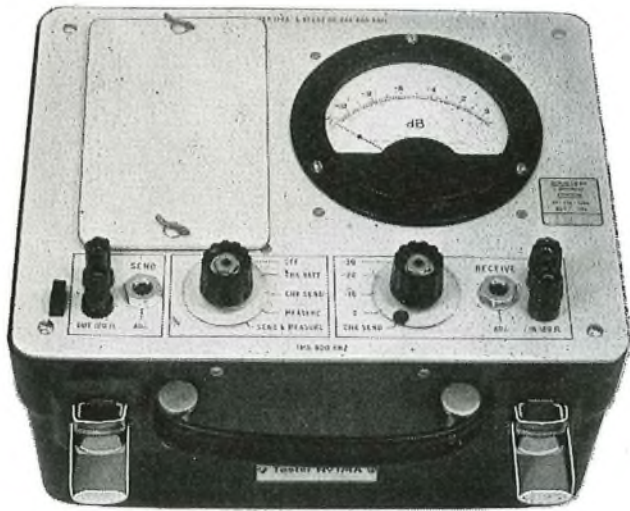

FIG. 11—P.C.M. cable tester

### Regenerator Tests

Before installing a digital section, the regenerators are fitted with equalizers, strapped for the correct power-feeding condition and tested at a commissioning centre. The value of equalizer required is obtained from a schedule prepared at the time the cable tests are made and the appropriate equalizer selected from a set available in 2 dB steps. After strapping the power circuits, the regenerator is checked using a regenerator tester with the cable simulators at the upper and lower limits of the equalizer range. Thus, a regenerator fitted with an equalizer suitable for a nominal cable attenuation at 800 kHz of 20 dB is tested with cable simulators of 19 dB and 21 dB nominal attenuation. The regenerator is tested for noise immunity and correct response to the trio test. Its timing is then checked with a recently-developed regenerator timing pattern generator which produces a digital pattern containing alternate high-densities of level 1 and level 0 signals.

### Installation and Commissioning of the Digital Section

When all the regenerators required for a digital section have been tested, installation can proceed, testing, at this stage, being mainly to locate any cable or c.r.e. common-equipment faults. Commencing from one end of the route, regenerators for both directions of transmission are inserted at a c.r.e. and, before proceeding to the next c.r.e., tests made to

- (a) check for an error-free signal out of the regenerator at the c.r.e.,
- (b) check for error-free transmission from and to the terminal via a loop between transmit and receive digital sections at the c.r.e.,
- (c) check for audio signal returned over the supervisory pair when sending a trio pattern from the terminal, and
- (d) measure and record the reverse power-line current at the terminal.

On completion of the digital section, a trio test is made to each regenerator and a record made for maintenance purposes. This is followed by a 24-hour check for errors, using a pseudo-random pattern as a signal. Although an

error rate of 1 in  $10^7$  digits would be acceptable, it is found in practice that very few errors occur. The acceptance limit set for commissioning purposes is currently 50 errors per day, or approximately 4 errors in  $10^{10}$  digits, for a looped pair of digital sections. This allowance includes any spurious errors due to excessively high transients in the power supplies to the error-counting apparatus. A very low error rate is chosen because it would be unwise, for commissioning purposes, to allow an error rate of 1 in  $10^7$  with the low cable fill that is normal at present, as this could conceal the existence of a fault due to an undetected defect in either a cable pair or a regenerator. It is of significance that the fitting of an incorrect equalizer can cause a regenerator to give an error rate which may be operationally acceptable at the time of installation but could give an unacceptable error rate when the regenerator ages or the number of pairs being used for digital transmission in that particular cable is increased. It is for this reason that new types of regenerator, incorporating automatic equalization, are being developed.

### Commissioning the Multiplex

On completion of installation, a multiplex is looped back to itself on the line side and the following tests carried out

- (a) channel gain,
- (b) attenuation distortion/frequency,
- (c) idle-channel noise,
- (d) inter-channel crosstalk,
- (e) non-linearity or harmonic distortion,
- (f) signalling conditions, and
- (g) quantizing distortion.

A considerable amount of time has been saved during commissioning by introducing

- (a) *24-Channel Access Units* which are simple multi-access switch boxes that avoid having to transfer test leads from one channel to another,
- (b) *Composite Transmission Testers* which provide facilities for making all the transmission tests including quantizing distortion, and
- (c) *Signalling Highway Testers* which plug into the signalling unit positions to provide a simple check that gating pulses are present and that the signalling highways are functioning correctly.

### Signalling-Unit Testing

Signalling units are tested in-station by connecting two multiplexes back-to-back. To speed up testing, a p.c.m. signalling-unit tester has been developed for use in commissioning centres and at large p.c.m. installations.

### Overall System Tests

Following the separate testing of digital sections, multiplexes and signalling units, the complete system is tested overall to ensure that the two terminals are interworking satisfactorily before making the circuits available for traffic. These tests include

- (a) quantizing distortion 4-wire to 4-wire,
- (b) insertion loss 2-wire to 2-wire,
- (c) basic noise,
- (d) system alarms including automatic circuit busying, and
- (e) test calls over the channels including the signalling facilities.

### MAINTENANCE

The general maintenance philosophy is to replace faulty units with spares and to provide centralized repair centres at which faulty units are repaired by specialist staff, equipped with adequate test equipment and stocks of spare components. Since the staff are wholly engaged in the repair of p.c.m. equipment, they rapidly acquire the skill and expertise which



is necessary to carry out their work efficiently. By observing the multiplex alarms and making use of the monitor and access break point on the line terminating equipment, maintenance staff can generally locate a fault quickly to a multiplex card or a digital section. If the digital section is faulty, it is patched out with a stand-by section, whereas a faulty multiplex card would be changed.

This arrangement is satisfactory in the majority of cases, but care is necessary to ensure that a fault condition does not exist which will damage the replacement card. For example, a fault causing a high voltage must be remedied before a new card is fitted. A defective card is visually examined for any obvious faults such as a badly-soldered connexion, and then labelled to indicate the faulty condition and sent to the repair centre for attention.

### Analysis of Faults

Information derived from faults found on cards in the repair centres can be used to identify undesirable fault trends, examples being

- (a) liability of faults on a particular card,
- (b) liability of a particular component on that card causing faults, and
- (c) particular components throughout the system showing high failure rates.

This information enables B.P.O. development engineers in conjunction with the manufacturer's design engineers to progressively eliminate design weaknesses and unsuitable components and, by this means, improve the quality and reliability of the equipment. This method of analysis has been particularly useful in relation to signalling units which are directly connected to the exchange two-motion selectors and are subjected to a high incidence of voltage spikes from inductive circuits. Early designs were prone to fail under

certain transient exchange conditions which were difficult to identify. However, the fault analysis arrangements have enabled the problems to be identified and remedial action taken.

### Routine Testing and Maintenance

Where possible, routine testing of p.c.m. junction circuits is carried out by the trunk and junction routine test equipment which checks signalling and continuity of the speech path.

The routine testing of p.c.m. multiplex equipment and digital links is being kept under review, but, at present, it is not envisaged that any periodic checks should be made, other than possibly a periodic check of quantizing distortion, error rate and the derived voltages in the multiplex.

### CONCLUSION

During the past five years, considerable experience has been accumulated in the field of digital systems based on the 24-channel p.c.m. multiplex equipment. A range of test equipment has been developed which enables the installation and maintenance engineers to carry out their work efficiently.

Current development work is aimed at the introduction of the C.E.P.T. 30-channel system, and where necessary, updating and improving the test equipment, fault-location and supervisory arrangements.

### References

- <sup>1</sup> WHYTE, J. S. Pulse-Code Modulation. *P.O.E.E.J.*, Vol. 54, p. 86, July 1961.
- <sup>2</sup> BOLTON, L. J., and BENNETT, G. H. Design Features and Application of the B.P.O. 24-Channel P.C.M. System. *P.O.E.E.J.*, Vol. 61, p. 95, July 1968.
- <sup>3</sup> JEYNES, E. Planning and Works Aspects of 24-Channel P.C.M. Systems. *P.O.E.E.J.*, Vol. 60, p. 33, Apr. 1967.

### Copyright

The entire contents of this *Journal* are covered by general copyright, and special permission is necessary for reprinting long extracts, but editors are welcome to use not more than one-third of any article, provided that credit is given at the beginning or end, thus: "From *The Post Office Electrical Engineers' Journal*."

The Board of Editors is not responsible for the statements made or the opinions expressed in any of the articles or the correspondence in this *Journal*, unless such statement is made specifically by the Board.

### Subscriptions and Back Numbers

The *Journal* is published quarterly, in April, July, October and January, at 21p per copy: 31p per copy including post and packing (£1.24 per year) (3 dollars Canada and U.S.A., per year). Back numbers will be supplied, if available, price 24p (34p post paid) per copy. January and April 1969, October 1968, and all *Journals* earlier than July 1967 (except January and October 1966) are no longer available. Orders, by post only, to *The Post Office Electrical Engineers' Journal*, 2-12 Gresham Street, London, EC2V 7AG.

Employees of the British Post Office can obtain the *Journal* through local agents.

### Binding

Readers can have their copies bound at a cost of £1.87½p plus 24p (40p overseas) return postage, by sending the complete set of

parts, with a remittance to Press Binders Ltd., 4 Iliffe Yard, London, S.E.17.

### Remittances

Remittances should be made payable to "*The P.O.E.E. Journal*" and should be crossed "& Co."

### Advertisements

All correspondence relating to advertisement space reservations, copy, proofs, etc., should be addressed to the Advertisement Manager, *The Post Office Electrical Engineers' Journal*, 2-12 Gresham Street, London, EC2V 7AG.

### Communications

With the exceptions indicated above, all communications should be addressed to the Managing Editor, *The Post Office Electrical Engineers' Journal*, 2-12 Gresham Street, London, EC2V 7AG.

### Model Answer Books

Books of model answers to certain of the City and Guilds of London Institute examinations in telecommunications are published by the Board of Editors. Details of the books available are given at the end of the Supplement to the *Journal*.

# Notes and Comments

## Letters to the Editor

Dear Sir,

I would like the opportunity to reply to Messrs Long & Woodward's comments on the article "Terminating External Cables in Telephone Exchanges" (published in the April 1972 issue).

Their first point is accepted. It is only the line side of the m.d.f. that can grow independently and it was not intended that the article inferred otherwise.

Point 2 is the reference to the 11th (bottom) position on the pre-rack type m.d.f. When the pre-rack m.d.f. was in its prime, the terminating cable was ES & WCQ which was basically in multiples of 100 pairs and termination of these cables would automatically leave the 11th position spare. It was not the accepted practice to split the core of subsequent cables to use the 11th position on one vertical with the remainder of the core going to the tip of the next vertical. Once this had happened all subsequent cables had to be split because the vertical capacity was not compatible with the cable make-up. The lower positions would be taken up by a terminating cable which would run horizontally between the verticals.

This point is mentioned in an earlier issue of the educational pamphlet quoted, i.e. P.O. Educational Pamphlet, Draft Series, General 3/8, Issue 2/8/60, Page 7. The article intends to convey how the pre-rack m.d.f. was used.

It is agreed that on re-termination to install 40-pair fuse mountings No. 8064A, all 11 positions may be used although this does mean that the vertical capacity is not compatible with the terminating cable make-up, i.e. multiples of 400-pairs. This makes sub-division of the larger cables more difficult but some Areas, notably in the L.T.R., are prepared to forego this incompatibility.

The reference to pre-rack m.d.f.s. on page 46 is incorrect; it should indeed read rack type, this was a typographical error.

I do not quite appreciate the point concerning the "cables" paragraph, I can only answer it by stating facts. The standard cable between the m.d.f. and the "E" side of the cabinet is Cable P.C.U.T., i.e. Paper Core Unit Twin, with the exception of the terminating length which is Cable P.U.T., i.e. Polyethylene Unit Twin. The reason for this is, that although cheaper, paper-covered conductors are unsuitable for terminating on the m.d.f.

The cables on the "D" side of the cabinet are Cable Polyethylene Twin, i.e. all polyethylene, and do not exceed 100 pairs. The main difference between rural and metropolitan areas is one of scale, i.e. cable size.

The next point mentioned is in regard to random terminated cables. It is not unknown for considerable time to be spent collecting the cable pairs before terminating and then an electrical "tap-out" after terminating to verify the "straightness" of the terminations. This work is very costly, especially so with the introduction of cables up to 4,800 pairs. If the "tap out" after termination is an accepted fact, why bother to terminate in numerical sequence, why not use the "tap-out" to give the pair a number? It must be accepted that terminations will only be random within a unit of 100 pairs.

This pre-supposes that there is a quick and reliable method of pair identification. We hope that the Tester No. 176A with Indicator No. 1A and their successors will provide this. The thoughts on random terminating are in their infancy and it would be wrong to suppose that we have reached any conclusions. It is fully appreciated that records are of paramount importance and pair identification is essential to accurate records and a purpose-designed tester such as the one mentioned could improve this accuracy.

With a random terminated m.d.f., identification would be needed before any multiple joint or "E" cabinet joint was made to enable the cable pair layout, decided by the planning

engineer, to be followed. An example of this is that identification would take place before the "E" side cabinet joint was made so that the sequence of pairs on the "E" side of the cabinet was a mirror image of the terminations on the m.d.f., again appreciating that we are dealing with a 100-pair unit.

The auxiliary joint was superseded by the cabinet in the late 1940s and although specimens still exist, surely this should not be allowed to stifle development.

The writers seem to infer that pair identification equipment is proposed solely to overcome the problems with petroleum jelly-filled cables. This is not so. Pair identification is an essential aid to random jointing and, if it is adopted, random terminating. If the cable is petroleum jelly filled, the added advantage is that there is less need to handle the core to select a particular pair for a particular terminating position.

I hope the foregoing has gone some way to clear up the points raised by Messrs. Long and Woodward.

Yours faithfully,

K. B. KILSBY

Telecommunications Headquarters,  
Telecommunications Development Department,  
Civil and Mechanical Engineering Branch,  
Carlton House, Carlton Avenue East,  
Wembley, Middx. HA9 8QH

Dear Sir,

The article on engineering cost study methods in the July 1972 issue has stimulated me to make these comments.

I believe the Post Office should be selecting more projects on a revenue earning basis and not purely on minimum cost as in the past. At the beginning of the article the authors stress, correctly in my view, the importance of revenue but state, equally correctly, that revenue is often unknown and comparison is carried out purely on a cost basis. I do not accept, for all cases, the statement that appears on page 77: "the project having the lowest present value (in terms of cost) is then usually accepted as it should achieve the highest return". This can only be said to be true if the revenue, or perhaps more accurately the opportunity for obtaining revenue, is identical in each case. If a particular alternative, by costing slightly more, makes possible more revenue than this may well show a better overall return. If we, as a Corporation are to obtain our return on capital by adjustment of tariffs after investment rather than by selecting investments on their revenue earning capability, we might not detect investments with a low return until after the money has been spent. We need tariff adjustments to allow for the effects of inflation and, hopefully, we might eventually use them as a marketing tool, but they should not be used to prop up the return from poor investment.

We do, of course, have a need to invest capital for "social" reasons where we do not expect a full return but, with knowledge of the revenue expected, it might be possible to take local stimulating action to increase the return nearer to the required level. I believe the Post Office could control the return on its capital more if projects were fully appraised on both revenue and cost. There are very real difficulties in changing over completely to this system but we should be thinking of moving in this direction—or should we?

Yours faithfully,

B. CROSS

Wales and the Marches Telecommunications Board

Dear Sir,

With the increase of qualifications amongst telecommunication engineers, the time must surely have arrived when an Institution of Telecommunications Engineers should be formed. This institution would enhance the standing of telecommunications engineers, as do the other institutions for their members, by providing examinations for entry and

requiring, as the years pass, a higher standard for the various grades of membership. This institution could, of course, be open to all engineers involved with telecommunications—not only Post Office engineers.

I write this letter as I feel that though the I.P.O.E.E. fulfills an excellent function and publishes a most interesting Journal, its scope is necessarily restricted, and entrance to its senior section is gained by rank more than any other consideration.

Yours faithfully,

D. A. HEATH

3 Spring Cottages,  
Quarrey Road,  
Redlynch, Salisbury, Wilts.

### Publication of Correspondence

The Board of Editors would like to publish correspondence on engineering, technical or other aspects of articles published in the *Journal*.

Letters of sufficient interest will be published under "Notes and Comments". Correspondents should note that, as it is necessary to send copy to the printer well before publication date, it will only be possible to consider letters for publication in the January issue if they are received before 20 November 1972.

Letters intended for publication should be sent to the Managing Editor, *P.O.E.E. Journal*, Post Office Factories Headquarters, Bovay Place, London, N7 6PX.

### Model Answer Books

Books of model answers to certain of the City and Guilds of London Institute examinations in telecommunications are published by the Board of Editors. Details of the books available are always given at the end of the Supplement to the *Journal*. The Board of Editors has reduced the price of Line Plant Practice A to 37½p (42½p post paid).

The reprint of Telecommunications Principles B Answer Book is now available. The Board of Editors wishes to

apologize to readers for any inconvenience caused by the long delay to this reprint.

### Articles on Current Topics

The Board of Editors would like to publish more short articles dealing with topical subjects. Authors who have contributions of this nature are invited to contact the Managing Editor.

### Syllabuses and Copies of Question Papers for the Telecommunication Technicians' Course

The syllabuses and copies of question papers set for examinations of the Telecommunication Technicians' Course of the City and Guilds of London Institute are not sold by *The Post Office Electrical Engineers' Journal*. They should be purchased from the Department of Technology, City and Guilds of London Institute, 76 Portland Place, London, W1N 4AA.

### Notes for Authors

Authors are reminded that some notes are available to help them prepare the manuscripts of the *Journal* articles in a way that will assist in securing uniformity of presentation, simplify the work of the *Journal's* printer and draughtsmen, and help ensure that authors' wishes are easily interpreted. Any author preparing an article for the *Journal* who is not already in possession of the notes is asked to write to the Managing Editor to obtain a copy.

It is emphasized that all contributions to the *Journal*, including those for Regional Notes and Associate Section Notes, must be typed, with double spacing between lines, on one side only of each sheet of paper.

Each circuit diagram or sketch should be drawn on a separate sheet of paper; neat sketches are all that are required. Photographs should be clear and sharply focused. Prints should preferably be glossy and should be unmounted, any notes or captions being written on a separate sheet of paper. Negatives or plates are not needed and should not be supplied.

---

## Institution of Post Office Electrical Engineers

### Essay Competition 1972-73

To further interest in the performance of engineering duties and to encourage the expression of thought given to day-to-day departmental activities, the Council of the Institution of Post Office Electrical Engineers offers prizes totalling £40 for the five most meritorious essays submitted by Post Office engineering staff below the rank of Inspector. In addition to the five prizes, the Council awards five certificates of merit. Awards of prizes and certificates made by the Institution are recorded on the staff docketts of the recipients.

An essay submitted for consideration of an award in the essay competition and also submitted in connexion with the Associate Section I.P.O.E.E. prizes will not be eligible to receive both awards.

In judging the merits of an essay, consideration will be given to clearness of expression, correct use of words, neatness and arrangement and, although technical accuracy is essential, a high technical standard is not absolutely necessary to qualify for an award. The Council hopes that this assurance will encourage a larger number to enter. Marks will be awarded for originality of essays submitted.

Copies of previous prize-winning essays have been bound and placed in the Institution Central Library. Members of the Associate Section can borrow these copies from the Librarian I.P.O.E.E., 2-12 Gresham Street, London, EC2V 7AG.

Competitors may choose any subject relevant to engineering activities in the Post Office. A4 paper should be used, and the essay should be between 2,000 and 5,000 words. An inch margin should be left on each page. A certificate

is required to be given by each competitor, at the end of the essay, in the following terms:

*"In forwarding the foregoing essay of . . . . words, I certify that the work is my own unaided effort both in regard to composition and drawing"*

Name (in Block Capitals) .....

Signature .....

Official Address .....

The essays must reach:

The Secretary,  
The Institution of Post Office Electrical Engineers,  
2-12 Gresham Street,  
London, EC2V 7AG

by 15 January, 1973

The Council reserves the right to refrain from awarding the full numbers of prizes and certificates if in its opinion the essays submitted do not attain a sufficiently high standard.

### Institution Field Medal Awards—1970-71 Session

Detail of the medals awarded for the best papers read at meetings of the Institution in field subjects primarily of

regional interest were published in the July 1972 issue of the *Journal*.

The Council of the Institution is indebted to Mr. H. T. McGrath, Chairman of the Papers Selection Committee of Council, for the following précis of the medal winning papers:

*"An Insight into Transmission"*, by R. D. Cull

This paper provides a concise history of transmission techniques employed by the British Post Office from the early 1920s to the present day and reviews possible lines of development in the immediate future, viewed against a background of the ever-increasing growth in demand for over 25 mile trunk circuits.

The author briefly describes how the heavy open-wire trunk lines of the pre-1920 era were superseded during the 1920s by underground lines by the introduction of paper-core twin cables, and how the heavy conductor weights initially employed were reduced during the same decade by development of amplifying repeaters.

The fundamental change in technique on introduction of carrier systems during the early 1930s is described, the author indicating how improvements in amplifier design facilitated the evolution of the standard frequency division multiplex f.d.m. 12-channel system on a network of 40 lb Zone-centre cables by the end of the decade. Conversion of the 12-channel systems to 24-channel was achieved by reduction in repeater spacing during the early 1940s.

The first co-axial systems also appeared during the 1930s and the history of coaxial development is described in some detail, the paper emphasizing the following significant landmarks:

- (a) standardization of coaxial frequency spectrum during 1939,
- (b) introduction of automatic gain control on line amplifiers leading to development of the C.E.L. 6A coaxial system—(1955),
- (c) introduction of transistors in line amplifiers and location of repeaters in joint boxes. Development of small-bore coaxial systems—(1960-63).

The current standard 4 MHz and 12 MHz systems (C.E.L. 1,006 and C.E.L. 1,007) are described, followed by a review of frequency translating and generating equipment at terminal stations. The continuous efforts to miniaturize components and reduce power dissipation on this equipment are emphasized.

This development aim is stressed further by a dissertation on economics. A major proportion of the total cost of line systems is seen to be concentrated in channel equipment costs and the author considers that in order to reduce repeater station costs, further miniaturization is inevitable, although some practical problems with heat dissipation have still to be solved.

The paper then proceeds to a short review of techniques employed for television transmission, indicating how the development of u.h.f. devices, notably the klystron valve and travelling wave tubes, facilitated the evolution of the current microwave radio network. The establishment of television network switching centres is outlined and notable events such as the introduction of the independent authority and system upgrading to 625-line standards are mentioned.

Utilization of the micro-wave network for telephony is discussed, the author emphasizing that there is a finite bandwidth available with this transmission mode.

A short description of pulse-code-modulation principles is followed by a brief outline of current digital systems which serves as a convenient introduction to a description of the wideband distribution network experiment at Washington New Town. The long term objective of this pilot scheme is to provide each customer with a coaxial network feed in addition to his conventional telephone pair in order that the local network will be capable of supplying possible demands for broadcast sound and television services, viewphone and miscellaneous data services.

The author then reviews probable system development during the next decade, explaining that with trunk circuit demand remaining at approximately 14 per cent per annum it has been essential to develop a new back-bone coaxial system in the bandwidth 4-60 MHz, which, when used in conjunction with a new 18-tube cable, could provide up to

97,200 speech channels between major centres. It is anticipated that this system will be in service by 1975.

There will be important developments in long distance digital system techniques and the paper provides a short description of current experiments in connexion with the new digital data network; whilst it is intended that the system will ultimately employ an overlay transmission network, the present f.d.m. cable systems will have to serve in the short term.

The paper concludes with a description of the Martlesham waveguide experiments which will probably be the next generation main-highway transmission-mode.

The text of the paper is adequately supported by diagrams, graphs and additional detailed information on appropriate subjects.

*"The Practical Aspects of Telephone Traffic Engineering"*, by W. Kirkby

The paper examines the current techniques employed in obtaining and utilizing data for dimensioning Strowger exchanges and considers their effectiveness in a dynamic system.

The primary object of traffic engineering is carefully defined, the author emphasizing its importance by providing a short review of the current system size in terms of capital investment in telecommunications plant. Approximate costs per added internal and external circuit are derived and quoted.

The main sources of traffic data for the traffic engineer are traffic recording and information derived from reading various types of traffic meter. The paper stresses the importance of their accuracy by explaining how forecasts based on the data are used for determining the rate and extent of British Post Office capital expenditure in the communications field.

Traffic recording methods are described in some detail, the limitations of the traditional post-selective busy-hour method being examined and enumerated. The speed of system growth demanded a scheme which would provide more reliable and frequent traffic records, and an outline of the time consistent busy hour record (t.c.b.h.r.) method, which is superseding the traditional procedure, is provided. The advantages of t.c.b.h.r. are emphasized, the author suggesting that the additional and more presentative data obtained when the method is fully introduced will lead to better assessment of trends which should improve the accuracy of traffic forecasting.

The author considers that insufficient maintenance effort is directed towards traffic recorders despite constant exhortation, and some common sources of inaccuracy are quoted together with suggested methods of recorder check.

The basis of traffic theory is then outlined and A. K. Erlang's well known formulae are derived and quoted; recent practical tests compared with data based on his "lost calls" formula have indicated that, despite minor variations, the theory works in practice.

Dimensioning of Strowger systems is discussed in some detail, the extension of theoretical formulae to dimensioning tables described, and the concept of alternative equipment grades of service explained. The overall grade of service in a dynamic situation is outlined, and the general effects of congestion in the system are considered and evaluated.

Grading design is described in detail, the essential differences between full and limited availability conditions being stressed. After defining the traditional O'dell grading scheme the author explains that this well-tried inter-connexion method is excellent in a balanced situation but is susceptible to even minor unbalance at grading inputs. "Skipped" gradings are far more tolerant to grading imbalance and will be progressively introduced into the system.

The author suggests that insufficient training is devoted to the general subject of traffic engineering; both practical and academic instruction virtually excludes the subject from formal syllabuses and this fact tends to bias service effort towards maintaining equipment in 100 per cent condition rather than intelligent plant movement to avoid congestion. Training of service personnel should provide a real understanding of system behaviour under dynamic conditions which could achieve positive results in improving service to the customer.

The paper is lavishly supported by diagrams and appendices providing additional detailed information on specific subjects; the Appendix describing the effect of grading imbalance being particularly notable.

A. B. WHERRY

# Regional Notes

## London Telecommunication Region

### *Blackwall Tunnel fire, 20 April 1972*

At 08.20 hours on Thursday 20 April, while East London commuters were wondering where their trains had gone, our area fault control was informed that the Poplar-Woolwich No. 2 cable had been damaged by a fire in the Blackwall tunnel.

The fire was caused by faulty propane equipment being used by a working party of the London Transport Executive (L.T.E.). The fire caused severe damage to about 60 yards of the tunnel, and caused the breakdown of the L.T.E.'s power cables feeding sections of the East London underground railway.

Communication and power cables belonging to the tunnel authority were damaged, and four Post Office cables were put out of action.

The second tunnel at Blackwall, recently opened, has no cabling facilities, and it was found impossible to provide an alternative route for interruption cables. Work in the tunnel is hazardous and is only feasible at night when traffic flow is very light. Within three working nights, new lengths of cable were in position, and jointed at the ends remote from the scene of the fire. Work on the final joint was delayed by the prior needs of the L.T.E. until 7 May, and after six nights of work the cable was restored to service on 13 May.

Within two days of the fire it was obvious that restoration of service would be delayed, and there would be service difficulties in surrounding areas having circuits routed in this cable. Early choice traffic circuits were rerouted via tandem exchanges within a few hours of the fire, but emergency circuits, private wires, and telex circuits were liable to be out of service for several weeks.

The delay in restoration of this cable created problems in East area and adjoining areas, and in the regional circuit provision group who are responsible for the routing of circuits within the London Telecommunication Region.

T. A. HERBERT

## Midlands Postal Region

### *Leicester P.C.O.: Fire Damage to Vertical Riser*

On 1 March 1972 work was proceeding on the repair of one of the two vertical risers installed at the Leicester parcel concentration office (p.c.o.). The vertical risers elevate roadborne mail 96 ft to the top of the building. At approximately 16.10 hours a fire was discovered within the vertical riser being repaired, and by 17.30 hours the vertical riser had been gutted. The fire also damaged the vital system of electrical interlocks at the top of the building, and also the vertical riser's take-away conveyors. This damage prevented the second vertical riser from running and a critical situation developed with regard to mail despatches.

Emergency repairs to one of the damaged take-away conveyors were immediately put in hand and temporary electrical supplies were provided. The damaged electrical interlock system required cubicle wiring modifications to by-pass the damaged circuitry. The efforts of the local staff resulted in service being restored to all other mechanization routes by 22.45 hours; 5½ hours after the fire was extinguished.

Early examination was undertaken on components which were not readily available; these included the main chains and heat treated components. This examination by the Post Office Quality Assurance Branch (Birmingham Materials Section) revealed that these items did not need replacement. The main structure was also checked for dimensional distortion and found to be within acceptable limits. Had any major faults been found, a delay of up to six months in the rebuilding program was envisaged. This would have placed excessive demands on the remaining mechanization routes during the autumn and Christmas pressure periods.

The vertical riser is now being rebuilt and it is hoped that the efforts of all concerned will be rewarded by seeing the

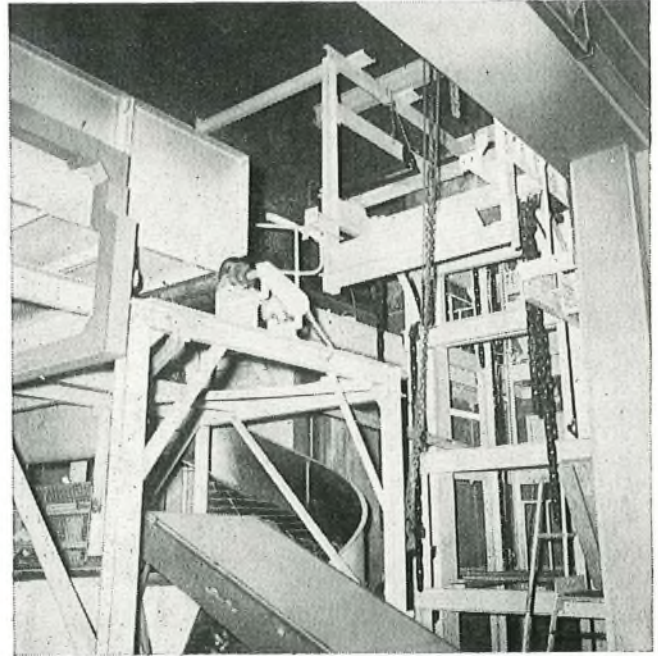

One of the vertical risers at Leicester P.C.O.

riser back in service to meet the autumn and Christmas parcel peaks.

The loss of one uplift system has caused some disruption to the working of this office. In spite of this, the parcel concentration program has not been modified, and further concentration of parcels into the office was introduced on 1 July 1972.

## South-Eastern Region

### *Rearrangement of Portsmouth-Southampton Coaxial Line System*

Motorway construction on the M27 at Portsdown Hill made necessary the diversion of several cables, including the Portsmouth-Southampton No. 2 coaxial cable system. The additional cable inserted for the diversion, lengthened the cable section between Fareham and the adjacent amplifying point No. 1 (A.P.1), making it necessary to split this section in two and install a new dependent repeater. The work was expected to take a full week-end, and the network co-ordination centre found alternative routings for the three hyper-groups concerned.

The insertion of a new repeater involved a change in the existing circuit arrangements at A.P.1, and the maintenance spare repeater was, therefore, prepared in advance for use at A.P.1, two outstanding modifications being included. This repeater, together with the new additional repeater, was tested on the bench, using a portable power-feed generator built by the regional commissioning group.

Cable diversion began at 14.00 hours on Saturday, after removal of traffic from the system, and by evening the two repeaters had been installed, the repeater originally at A.P.1 having been recovered for use as the new maintenance spare. The appropriate changes to the amplifier gain and the line building-out networks at Fareham were then made, and the three repeaters were left disconnected from the cable for the night, to allow high-voltage and interstice tests to be made.

On Sunday morning, the repeaters were re-connected in circuit, and the power-feed generators (adjusted to allow for the extra repeater) were switched on. The presence of pilots at each end of the system was checked, and re-alignment of the system was commenced. Each repeater was visited, and regulators were reset as necessary. Pilot measurements and

alarm locations were recorded, and finally the inter-super-group frequency-response was recorded and compared with results obtained prior to the cable diversion. The changes in response were minimal. The full frequency response showed a spread of 1.1 dB in one direction and 0.9 dB in the other.

Thanks to the help, and the accurate cable-length information, supplied by the internal and external works staff of the Portsmouth Telephone Area, the job was completed by 17.00 hours on the Sunday—28 hours after the release of the system.

S. R. BALDWIN

### South-Western Region

#### *New Microwave Radio Equipments Commissioned*

Two new designs of microwave radio equipments were accepted from the manufacturers during the first quarter of 1972.

A Pye 11 GHz system (Post Office radio system 10–25) is provided between Plymouth (Forder Battery Radio Station) and Caradon Hill television transmitter station. This is the first time the 11 GHz band has been used in the United Kingdom for a permanent microwave system. The system is intermediate frequency (i.f.) switched and has a capacity of six main and two protection channels or seven main and one protection channel. The equipment installed provides three main and one protection uni-directional channels to carry the British Broadcasting Corporation channels 1 and 2 and the Independent Television Authority channel traffic and a bothway auxiliary-channel to carry supervisory, control and engineers' order-wire services.

Incorporated in the design is a new solid-state modulator, a pre-focused travelling-wave tube, no adjustment being possible on site, and a new signalling system. Controls and indications are encoded using a six-digit binary-code giving a maximum of 64 possible combinations. A seven-bit word is completed by the addition of a condition pulse, which is used to initiate the desired operation once the required routing through the receive matrix has been selected by the first six bits. Commands are transmitted by a 13 kHz tone which is gated according to the word code. Synchronization of transmit and receive command signals is achieved by the transmission of an 11 kHz gated word divided to produce a clock frequency of 500 Hz.

An additional refinement is a routine automatic tester (r.a.t.) which automatically tests the i.f. switching system, at predetermined regular intervals, but which may also be operated by local command. All logic circuitry and switch elements are tested up to the final receive change-over switch, thus avoiding traffic interruption.

The other installation, by Ferranti (Post Office radio system 10–30), provides 300 bothway telephony channels between St Marys, Isles of Scilly and St Just. Each station is equipped with a single 7 ft 6 in 62-type rack which contains a main and standby transmitter, main and standby diversity receivers (a total of four), alarm and power supply units, and a five channel multiplex equipment which provides an engineers' order-wire and ancillary audio channels between the two radio terminals.

The equipment is all solid-state with a transmit output power of approximately 200 mW in the upper 6 GHz band.

Automatic space diversity with manual override is used to combat excessive fading which may occur over the water path.

R. HOPTON

#### *End of an Era*

On Wednesday 28 June 1972 the central battery (c.b.) manual exchange at Parkstone, Dorset was closed (see Fig.) and to replace it a new TXK1 exchange was brought into service. Parkstone was the last surviving manual exchange in South-West England and, hence, its demise was something of an



View of the Manual Exchange switch room during the last hours of its life

event. The exchange first opened in 1928 and, since about 1960, planning engineers have been continually faced with the problems of meeting the rapid growth in the district. Accommodation was a major problem because the combined postal and engineering building which housed the exchange equipment was very limited both in apparatus and welfare space. In fact, at the end, the main suite was a C.B. No. 1 while an island suite (with tie-circuits), installed mainly to cope with the growth of junction traffic, was a C.B. No. 10.

An attractive looking new building to house the crossbar exchange, was erected across the road from the existing exchange in the Parkstone main shopping centre which, with its cantilevered frontage and Portland stone panels, has proved to be an aesthetic addition to the neighbourhood. Building commenced in November 1967 with a ready for equipment date of February 1969. It became clear that the equipment contractor would be unable to meet his commencement date of September 1969 and expediency measures became necessary to cope with the heavy waiting list. It was decided to instal mobile non-director (m.n.d.) units in the garden of a house at the rear of the new building earmarked for main building extension in the future and to give these mobiles a separate identity. Thus, Castle Hill exchange was inaugurated with the first m.n.d. (400 lines) opening in March 1970 followed by two others (800 lines) and a tandem in July 1971 i.e. 1,200 additional lines became available. Installation of the crossbar equipment (9,000 line multiple) was commenced by the Plessey Company in June 1970 and, after a considerable amount of practical and technical difficulties, the exchange was handed over to the Post Office for flood testing in March 1972.

The Mayor of Poole finally opened the new TXK1 exchange on 28 June 1972 before approximately 120 guests who were linked to the main operational points by closed-circuit television so that they were able to watch the run-down of the old manual exchange, the control officer in the new exchange giving his instructions to staff in the building and in outlying exchanges, and finally the cut-out and cut-in operations on the change-over and main distribution frames. London Telecommunications Region provided the television coverage with great success and the event was reported on television by the British Broadcasting Corporation the evening before with an interview with the Telephone Manager. Many people may miss the personal service given by generations of operators to residents and industry in the Parkstone district, but it is hoped that the new modern exchange with its subscriber trunk dialling facilities will compensate for the loss of the personal touch. Incidentally, we are now awaiting the completion of extension 1 on the TXK1 equipment before we can shut Castle Hill mobile exchange.

R. E. BABIDGE

# Associate Section Notes

## Bournemouth Centre

The early part of 1972 was overshadowed by the death of our Telephone Manager, Mr. F. K. Radcliffe, M.I.E.E.

In March we welcomed the new Telephone Manager, Mr. B. H. Berresford, C.Eng., M.I.E.E., M.B.I.M. who has since agreed to become President of the Bournemouth Centre.

At the annual general meeting held on 6 April, the following officers were elected:

*Chairman:* Mr. R. H. Ough; *Vice-Chairman:* Mr. D. M. Woodley; *Secretary:* Mr. G. H. Seagroatt; *Assistant Secretary:* Mr. J. R. Dymott; *Treasurer:* Mr. L. F. A. G. Limburn; *Committee:* Messrs. M. B. Smithers, D. Fox, P. Dorey, P. A. Whitter, F. G. Kendrick, G. R. White, K. R. Neilson, J. Hancock, T. O. Pardy, and P. Dykes.

We have commenced a recruiting drive, aimed particularly at the younger members of the staff, and are already seeing some results, in an increase in membership of 14 per cent.

We started off the new season with attending, at the invitation of the Main Section, a lecture entitled, "The New Exchanges. Their Impact on a Telephone Area". Then in May another lecture on transit switching.

For the evening of 23 May, we arranged a visit to Strand Glass of Southampton, for a talk and demonstration of the uses and techniques of fibreglass. This was well supported, and most interesting.

Two trips in the pipeline are, a visit to the Police Driving School at Devizes, and a visit to the cable ship *Alert*.

G. H. SEAGROATT

## Aberdeen Centre

The Aberdeen centre visited Dial House, Glasgow on 19 April 1972, 14 members going on the trip. The visit was very interesting, the members being shown the repeater station, cable tunnel, cordless switchboard and various group switching centres.

At the annual general meeting, held in a local hotel on 5 May 1972, the following office bearers were elected:

*President:* Mr. J. W. H. Sharp; *Vice-President:* Mr. D. S. C. Buchan; *Chairman:* Mr. J. Davidson; *Vice-Chairman:* Mr. J. Stephen; *Secretary:* Mr. J. H. McDonald; *Assistant Secretary and Treasurer:* Mr. R. Mathewson; *Librarian:* Mr. B. G. Rae; *Auditors:* Messrs. D. Duncan and G. Milne.

After the meeting the members had a five-course meal and were entertained by a folk singer.

J. H. McDONALD

## Ayr Centre

The 1971/72 session opened with a talk in October on the subject "Service in the Seventies—A new look at exchange maintenance" given by Mr. Watters of Telecommunications Headquarters, Scotland. At this meeting, which was very well attended, in addition to the very interesting talk and discussion, a demonstration was given of the electronic test-call sender.

In January, a visit was made to the Mothers Pride bakery, Ayr, a new automated bakery where the numerous processes were seen in operation.

Our next meeting, planned for February but postponed until March, owing to the power situation, was a talk "Roads in Ayrshire" given by Mr. Clark, Ayr County Engineer. The speaker described fully the many road and other projects presently taking place.

In April, Mr. Davies of Telecommunications Headquarters, Scotland gave a very worthwhile talk on "Long Term Planning" and also took the opportunity of renewing many friendships in this district.

The session closed with the annual general meeting in May.

A. BAGNALL

## Bedford Centre

A lot of hard work has been done by the officers and committee of Bedford Centre during recent months and the results are encouraging.

We now have a centre library containing approximately £150 worth of books on various subjects but with the majority dealing with technical matters. It is run on exactly the same lines as a public library and is proving very popular.

On 23 February we hired the Bedford Civic Theatre and invited racing driver John Jordan to give us a talk and film show about his experiences in motor racing. He even offered to bring his McLaren M7B with him, but the theatre doors were not wide enough to get the car in.

On 31 May, members visited the local fire station and whilst we were in the control room a 999 Fire Emergency call came in and within 90 seconds the first appliance rushed out of the station.

About 30 people visited the gigantic airship hangars at Cardington, near Bedford on 21 June to see the Goodyear airship *Europa* which was ready for flight tests before touring Europe on goodwill flights and then being based in Rome.

Our next event was a visit to the Royal School of Artillery at Larkhill, Wiltshire where an Open Day was held on Saturday 15 July. This visit took the form of a family outing by coach.

E. W. H. PHILCOX

## Cambridge Centre

The Cambridge Centre has had a full program of meetings since our last report. Starting the session was a lecture on Hi-Fi, given by Mr. A. G. Watling of Cambridge. A very well attended meeting heard Mr. Watling's excellent collection of recordings both old and new. This was followed by a lively discussion on techniques and equipment.

In March, 15 members attended an evening visit to the Cambridgeshire Fire Brigade headquarters. They were shown the area control-room and had a chance to inspect the various appliances in the station.

The centre was unfortunately knocked out of its qualifying round of the "Land-Line Quiz" on 28 March. We only managed to score 20 points against Colchester's 21 points and Ipswich's 40 points. Our best wishes go to Ipswich in their forthcoming rounds.

A party of 12 visited Whitefriars Glass Works in London during May. Following a very interesting tour of the factory, members were able to purchase items of glassware at reduced prices from the company's shop.

Generally regarded as one of the most interesting visits, was a day out in June, to Rolls Royce Motors Ltd. at Crewe. The 19 members who took part, were very impressed with the care and attention which goes into making the Rolls Royce, the world's most luxurious car.

The autumn session opened with the annual general meeting in September.

P. J. YOUNG

## Dundee Centre

At the annual general meeting held on 8 May 1972 the following appointments were made:

*Chairman:* Mr. R. L. Topping; *Vice-Chairman:* Mr. R. C. Smith; *Secretary:* Mr. R. T. Lumsden; *Assistant-Secretary:* Mr. J. M. Low; *Treasurer:* Mr. A. Vaughan; *Committee:* Messrs. A. Dowie, J. Duncan, J. C. Howe, D. Moore, A. W. Smart, G. Stephen, and M. Williamson.

The meeting, which was well attended, dealt fully with domestic matters including a rather interesting list of suggestions for next season's program.

A slide show, postponed from January, closed the evening's proceedings and the "Best Slide" competition was won by Mr. J. M. Low.

R. T. LUMSDEN

### Edinburgh Centre

The annual general meeting and dinner was held in the Iona Hotel on Wednesday 12 April. The following Office-bearers and Committee were elected:

*Chairman:* Mr. M. K. Finland; *Secretary:* Mr. M. I. Collins; *Assistant Secretary:* Mr. R. Cunningham; *Treasurer:* Mr. R. W. Elder; *Librarian:* Mr. J. King; *Committee:* Messrs. J. Samson, I. D. Hoseason, S. Barr, R. S. Elder, J. Edwardson, R. R. Thompson, J. L. M. Alexander, T. Woolard and R. Bailey; *Auditors:* Messrs. A. Clachers and A. Johnstone.

M. I. COLLINS

### Exeter Centre

Another session has ended and we can look in retrospect through a term of activity which has been rewarded by good attendances—let us hope it continues. To some extent a new look on programs and its makeup was no doubt responsible in that highlighting the session with a popular speaker, started the trend. It is as well to point out, that such speakers, although at a premium regarding suitable dates, are not necessarily expensive, in fact fees I have been quoted are quite modest and probably well within the means of most centres. We plan to continue on these lines, but I hasten to add that this will only be worth while if support is forthcoming, thereby, preventing any embarrassment to both the speaker and the associate centre.

Hi-fi and loudspeakers by Mr. A. C. Field, Executive Engineer, Bournemouth, was presented in January and attracted the keen and interested members to a program which took much planning and expertise, demonstrated to an audience who wished to know more, but who were defeated by time. It was very evident that Mr. Field and his team would have continued on this popular subject.

In February, Mr. A. M. Hardie (who many of you must already know) of the Telecommunications Training School, Stone, presented a paper on the transit network. This topical subject was presented with the ease of an expert, to a delighted audience who were greatly indebted to him in travelling those 200 miles. A presentation by Mr. K. F. Jalland, Controller Planning, South Western Telecommunications Region to Colin Knapman for his paper "Voice-Frequency Remote Control System A" took place earlier that evening; this was a well deserved reward which does credit to Colin and the associate centre at Exeter. Although the miners' dispute was in full swing that evening, temporary lighting was kindly arranged by Mr. M. Wheeler, of the area power group.

At a members' meeting in March, Norman West and Don Craig presented their papers "The Post Office Radio Service—Past, Present and Future" and "The Wells of Mersa" respectively; Norman, giving his experiences throughout 23 years, supported his talk with exhibits of suppressors in many forms. Don, returning to 1935 with his adventures in locating the Wells at Mersamatrué, which dated from the Dynastys of Egypt, was descriptively related. Both these papers were enjoyed with admiration, and proved that talent can be found within the membership.

At the annual general meeting in April, votes of thanks were expressed by the Chairman and Secretary to the retiring President, Mr. O. P. Moss, for his dedication to the centre during his term of office, especially in the formation of winter program which had brought greater attraction to the members. The following Officers were then elected:

*President:* Mr. B. L. E. Yeates; *Chairman:* Mr. G. S. Steer; *Assistant-Chairman:* Mr. C. K. Sanders; *Secretary:* Mr. E. Soper; *Assistant-Secretary:* Mr. J. J. F. Anning; *Treasurer:* Mr. W. F. Lambert; *Librarian:* Mr. N. H. B. West; *Committee:* Messrs. T. F. Kinnaird, D. N. Miller, J. L. Petherick, S. G. Page, C. W. Paterson, J. Brown, G. W. W. Abbott and J. Scanes.

In his opening address, the President spoke of our identity within the field of telecommunications, endeavouring to maintain a professional status—to this goal our aim is directed.

A visit to Hinks and Sons, builders of "The Golden Hind" was arranged in April. This replica, constructed by using traditional methods, was a fascinating sight, showing the skills of boat building which had continued for over a century in the area of Appledore. We continued our tour through one of the most modern shipyards in Europe, fully automated and totally under cover, employing the latest in shipbuilding machinery.

It was with deep sadness to learn of the tragic death of our former Chairman, Mr. Roy Powlesland, who I am sure will be remembered by many for his contribution to the success of our Centre.

E. SOPER

### Salisbury Centre

A talk on the developments of the Ford Comuta car arranged by the Southampton Branch of the Institution of Electrical Engineers was the only event of note during the last quarter.

The lecture, which covered packaging problems, mechanical design and electrical design and suggested basic design procedures for electrical vehicles, was delivered by T. J. Dodedoe of the Ford Motor Company.

A. W. PATTERSON

### Southampton Centre

The Southampton centre finished its winter session with the best-attended annual general meeting in the centre's history, being held at the Civil Service Club with a free supper provided afterwards. The officers were re-elected *en bloc* and, after a ballot, a new committee was formed.

The first task of the committee was the design of a new application form which would be more suitable for our requirements. We are contemplating a locally organized reprint of an updated National Library Catalogue. Would any areas wishing to join us in this project please contact Mr. K. Mann, Southampton 71711.

The summer program started very well with a car mystery tour, but unfortunately our trip to the musical "Hair" in London was not well supported.

This year's program started in September with an Open Forum. Mr. W. Luff and Mr. P. Wiltshire, Area Engineers and Vice-Presidents, kindly consented to be members of the panel.

G. HOLYOAKE

### Sheffield Centre

At the final meeting of the 1971/72 session on 25 April 1972, Mr. W. Kirkby of Telecommunications Headquarters presented his paper "Practical Aspects of Telephone Traffic Engineering".

The annual general meeting was held on 17 May 1972 when the following officers were elected to serve for the 1972/73 session:

*Chairman:* Mr. D. J. Sturdy; *Vice-Chairman:* Mr. C. B. Grey; *Secretary:* Mr. F. Turner; *Assistant-Secretary:* Mr. K. H. Barker; *Treasurer:* Mr. A. E. Jewitt; *Committee:* Messrs. J. Steggle, J. P. Cooney, W. Wilks, R. Newbould, L. Venables, S. Mitchell, P. Weston, B. Harlow, D. Ashton, P. Pashley, C. Wragg and M. Rabbitt.

The Area Liaison Officer is Mr. H. S. Beddus.

K. H. BARKER



# Our electronics are a signal success



Our manufacturing resources could contribute to *your* success, too! We've chalked up many years of service to ministries, government departments, armed forces, and a formidable list of significant names in industry. They all come to Whiteley for the specialist knowhow and resources we have developed. Can we help you? We can build to your drawings and specification, or put our design departments at your service, as needed. From a small component to a complete system, in audio work, relay switching circuits, control systems, and many other spheres—our facilities are ready. The Whiteley organisation is self-contained. The manufacturing resources are backed by our own toolroom, sheet metal working and press shops, plating and finishing lines, coil and transformer winding shop, plastics moulding shop and a modern new cabinet factory. Capitalise on all these Whiteley facilities—call us in for a look at your next electronics need. You'll be in good company!

## Whiteley *versatility...*

ELECTRONIC & ELECTRICAL DESIGN

PRODUCTION CAPABILITY

CABINET MAKING

SHEET METAL FORMING/FINISHING

PLASTICS MOULDING

ENCAPSULATION

WHITELEY ELECTRICAL RADIO CO. LTD.  
Mansfield, Notts, England. Tel. Mansfield 24762  
London Office: 109 Kingsway, W.C.2. Tel. 01-405 3074

# you asked Aerialite for it!

# Do you know what else Herman Smith can do?

"62" type equipment is the aspect of our output you probably already know about. It's worth remembering however, that we produce many other types of presswork and sheet metal assemblies which may be of use to you.

We are acutely aware of the needs of the electrical and electronics industries and our experience in these spheres is comprehensive.

We are prepared for any challenge, complex or simple, large or small. Try us.

We produce the range of "62" type equipment, including the racks themselves, shelf assemblies, card locks, card guides, slide brackets, dummy front plates, etc. We also undertake electrical and electronic assemblies.



Contact Peter Bowen  
Herman Smith Limited Cinderbank Works Netherton Dudley  
Worcestershire Telephone Dudley 52791

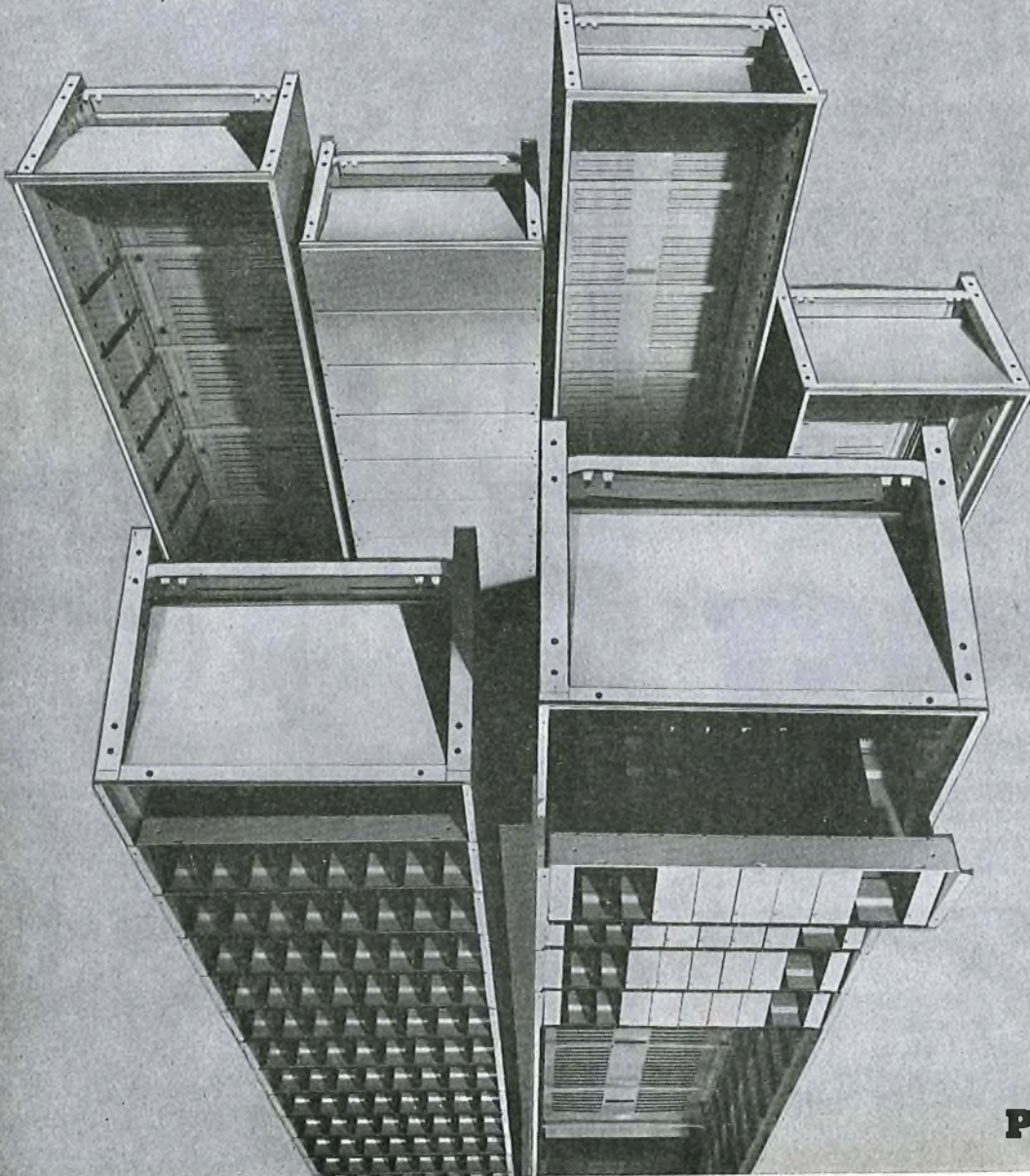

**PO approved**

# HOW TO BECOME A QUALIFIED ENGINEER



Send for your copy of this helpful **FREE** Book

Many first-class appointments in the Telecommunications industries are going begging for lack of qualified men to fill them. Yet, by means of a B.I.E.T. Home Study Course, you could give yourself the technical know-how to achieve rapid advancement in these great industries. We have a wide range of instruction in all aspects of Telecommunications including examinations for City & Guilds Telecommunications Examinations, Radio and T.V. Servicing, PMG Radio Operators Certificate, Radio Amateurs Exam and many other valuable and important Engineering subjects including Constructional, Mechanical, Draughtsmanship, Electrical and Electronic, Automobile and Aeronautical, Computers, Management and Production.

You have no books to buy. Fees are moderate and payable monthly. B.I.E.T. has achieved thousands of professional examination successes. Post coupon today for a FREE copy of our fully-illustrated guide **New Opportunities**. No obligation—but it could open your eyes to opportunities you are now missing.

Accredited by the Council for the Accreditation of Correspondence Colleges.

## POST COUPON NOW

**BRITISH INSTITUTE OF ENGINEERING TECHNOLOGY** B45  
(Dept. B45), Aldermaston Court, Reading RG7 4PF.

Please send me a FREE copy of **New Opportunities**.

Name .....

BLOCK CAPITALS PLEASE

Address .....

Subject ..... Age .....

**BRITISH INSTITUTE OF  
ENGINEERING TECHNOLOGY**

### STOCKISTS OF BPO COMPONENTS

Adaptors, Recall Switches  
Arrestors, Lightning

Blocks, Terminal MDF  
Boxes, Distribution  
Boxes, Junction

Carbons, Protector  
Capacitors, Telephone  
Coils, Induction  
Coils, Repeating  
Coils, Retardation  
Cords, Handset  
Cords, Instrument  
Cords, Switchboard

Dials, Automatic

Earpieces  
Electrodes

Fuses  
Fuse Mountings  
Fuse Panels

Generators, Hand

Handsets

Jacks, Battery  
Jacks, Instrument  
Jacks, Lamp 10 & 20 way  
Jacks, Lamp Single  
Jacks, Shelf  
Jacks, Strips 10 & 20 way  
Jacks, Test Relay Set  
Jacks, Switchboard

Keys, Lever, Standard  
Keys, Miniature  
Keys, Strip, Digital  
Keys, Plunger  
P.O. 228, 279 etc.

Lamp, Sockets  
Lamp, Caps  
Lamp, Strips  
Links

Meters, Subscriber  
Mouthpieces

Plugs, Instrument  
Plugs, Selector  
Plugs, Switchboard  
Plugs, Test

Receivers, Inset  
Rectifiers, Telephone  
Relays  
Relays, Miniature  
Relay Coils  
Ringers, Telephone

Transformers, Line 48A, 48H,  
3/215A, 3/216A, etc.  
Transmitter, Insets  
Telephone Instruments  
Telephone Cases

Uniselectors  
Uniselectors, Miniature  
Etc.

We also stock unit assemblies for  
PAX, PABX, PUBLIC EXCHANGE,  
MULTIPHONER EQUIPMENT.  
TWO MOTION SELECTORS BPO.  
2000 & 4000 TYPE GROUP SELEC-  
TORS & FINAL SELECTORS.  
TRANSISTOR RINGING GENER-  
ATORS, ETC.

PO Lever Keys Standard; many types ex-stock, others made to specification at short notice.

Manufacturers and Trade Enquiries only, quoting  
BPO and/or Manufacturers' Reference numbers

**TWC TELEPHONE & WIRELESS  
COMPONENTS LTD.**

147 The Broadway, London, NW9 7EA  
TEL. 01-203 2814 CABLES; Telwirco NW9

# Aerialite made it!

# Stored Program Control. Plessey System 250

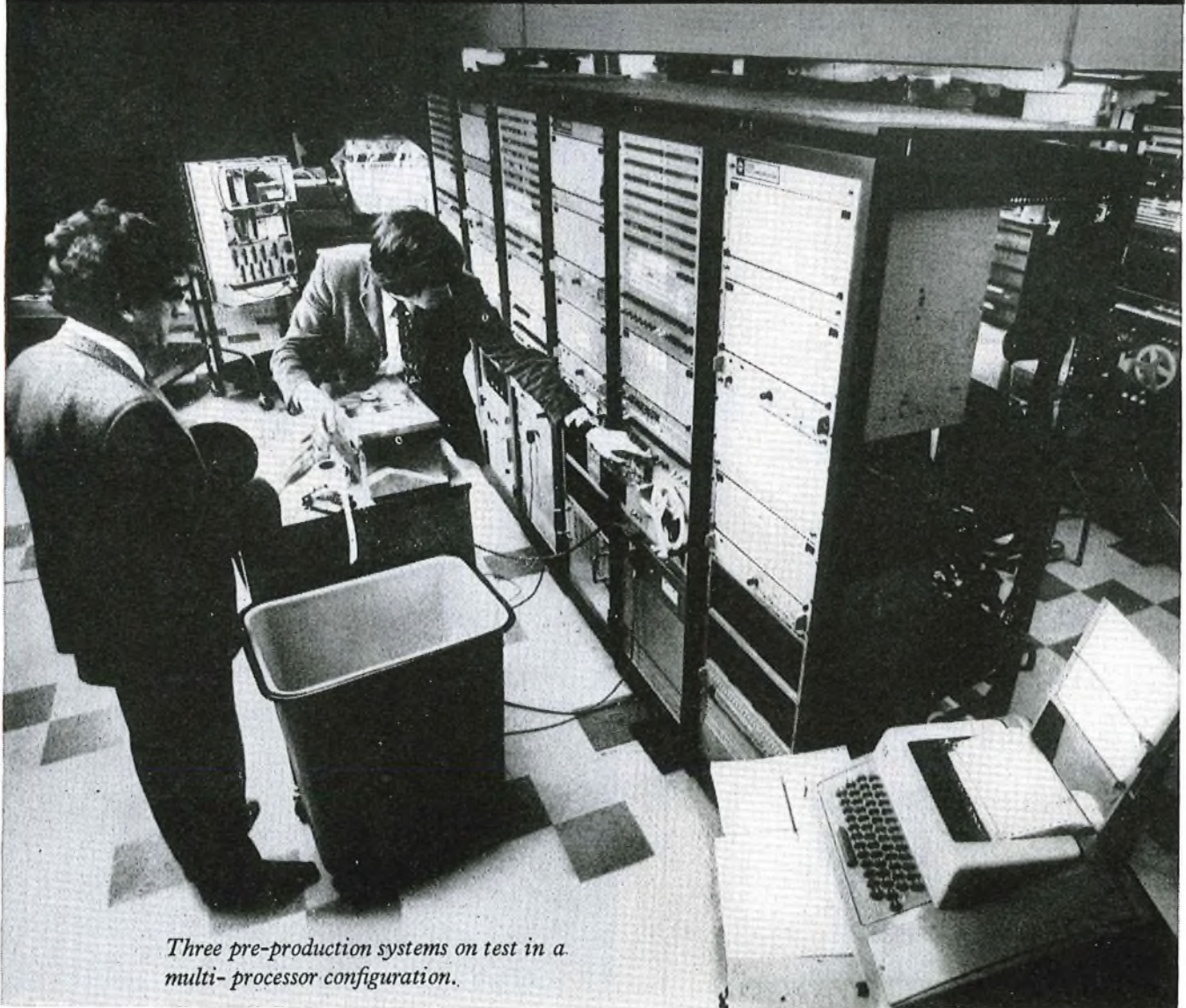

*Three pre-production systems on test in a multi-processor configuration.*

System 250 is unique. It has been designed specifically for controlling telephone and data exchanges and similar reliability-conscious real-time applications. It is modular in design in order to be flexible and easily extensible in operation and to provide economy in use.

A particular feature is that it can provide the system reliability required in these types of application. Not only are faults in both software and hardware quickly detected and the relevant module isolated, but the system automatically reconfigures in order to

ensure continuity of service. Basic checks built into the system permit time-sharing of programs without errors corrupting good program modules.



**PLESSEY**  
TELECOMMUNICATIONS

Edge Lane, Liverpool L7 9NW, England.

Telephone: Liverpool (051) 228 4830 Telex: 62267

581 PTG

# Here it is!

**Our two new ranges of 75 ohm TV distribution cables are now made on an extrusion line unique in Western Europe.**

We're one of the most technologically advanced cable manufacturers, using new techniques to produce TV distribution cables at a consistently high standard to tolerances much closer than previously possible. At very competitive prices.

**The two ranges:**

**Aeraxial Semi Air Spaced Polyethylene** dielectric copper taped braided and polythene sheathed television distribution cables. Five cables in the range, with inner conductor sizes from 1.27 mm to 3.05 mm.

**Solid Polyethylene** dielectric copper taped and polyethylene sheathed television distribution cables. Five cables in the range, with inner conductor sizes from 0.73 mm to 3.65 mm.

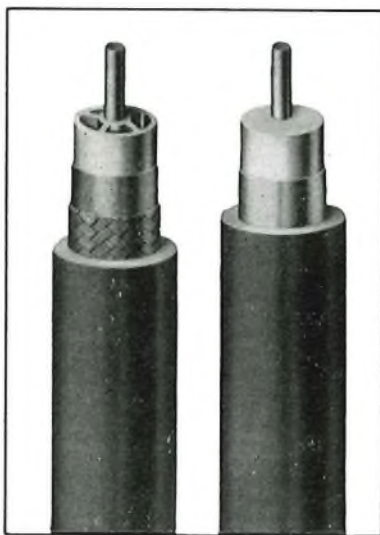

**Aerialite will specially manufacture TV distribution cables for any special TV application—also, you can make use of the Aerialite free technical advisory service to help you in the selection and application of distribution cables.**

For further information, send for Aerialite's new publication giving full technical specifications of the latest range of TV Distribution Cables.

# Aerialite

**Aerialite Cables Limited,**  
Castle Works,  
Stalybridge, Cheshire SK15 2BS.  
Telephone: 061-338 2223  
Cables: Aercables, Stalybridge.  
Telex: 669902

To Aerialite Cables Limited: Please send me your brochure entitled Aerialite Television Distribution Cables.

NAME \_\_\_\_\_

POSITION \_\_\_\_\_

COMPANY \_\_\_\_\_

ADDRESS \_\_\_\_\_  
\_\_\_\_\_  
\_\_\_\_\_

# TYPE 62

## FULL RANGE

7 TO 14 DAY DELIVERY

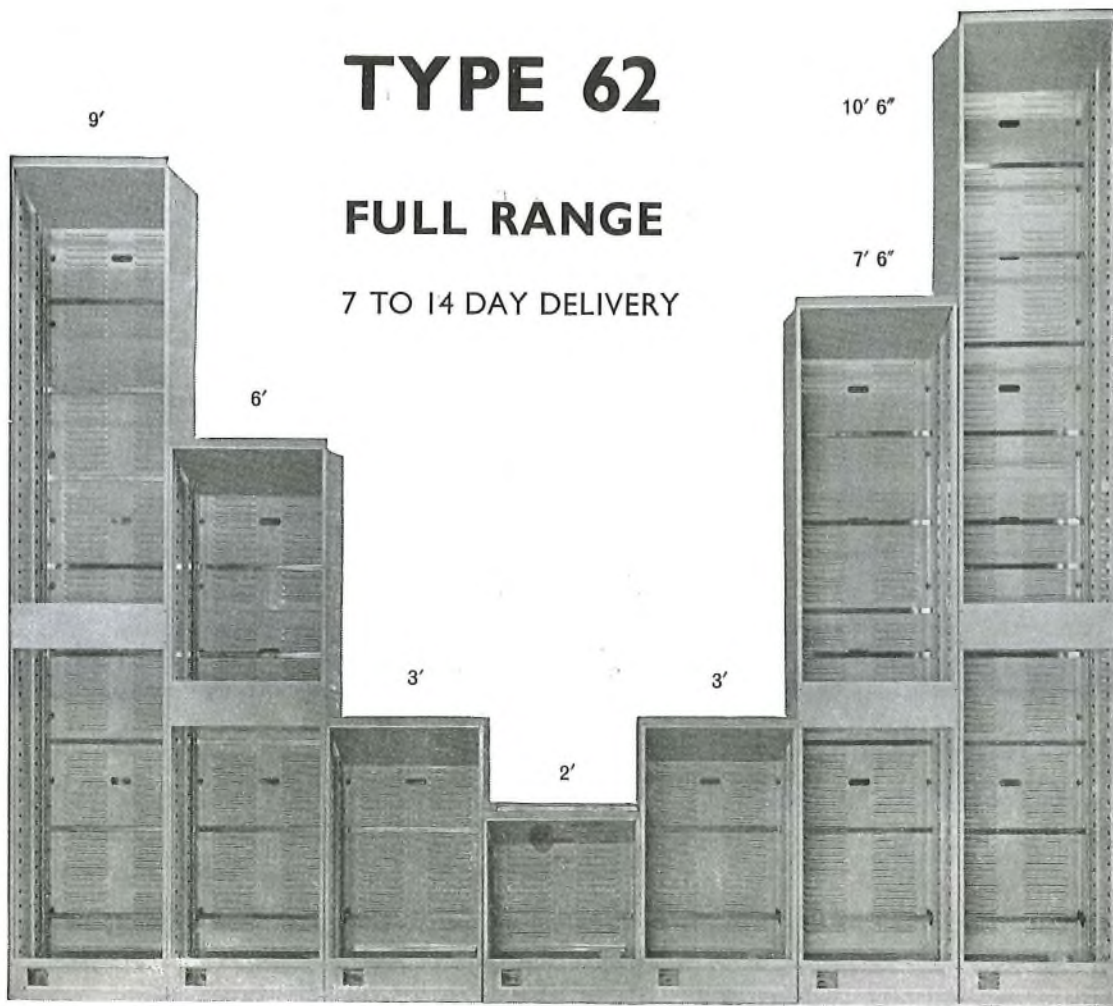

### HIGH PRECISION MECHANICS

FOR INSTRUMENT ELECTRONIC AND AUTOMATION INDUSTRIES

TELECOMMUNICATIONS  
MECHANICS

**P.O. APPROVED**

IMMEDIATE QUOTATIONS AND  
TECHNICAL SERVICE

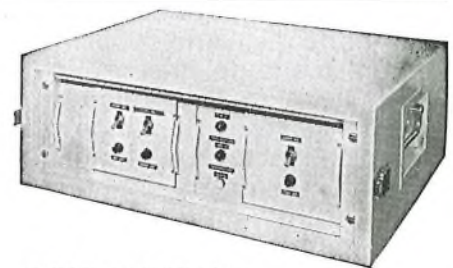

SHELF ASSEMBLIES

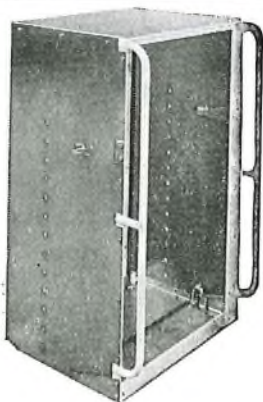

P.C.M. TRANSIT JIG



DATEL MODEM

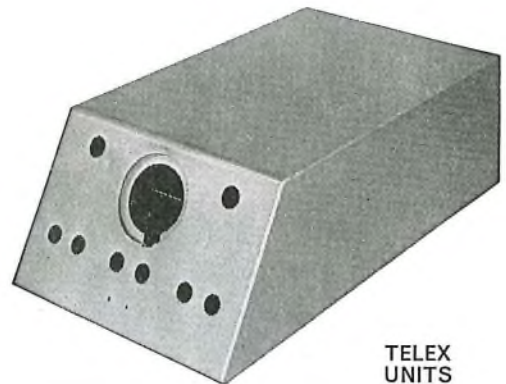

TELEX  
UNITS

# CRAY ELECTRONICS LTD

THAMES ROAD, CRAYFORD, KENT  
TELEPHONE: CRAYFORD 29251

# Profit from Access-ability\*

with the full range of **ACCESS EQUIPMENT** to get men overhead in greater safety, speed & economy

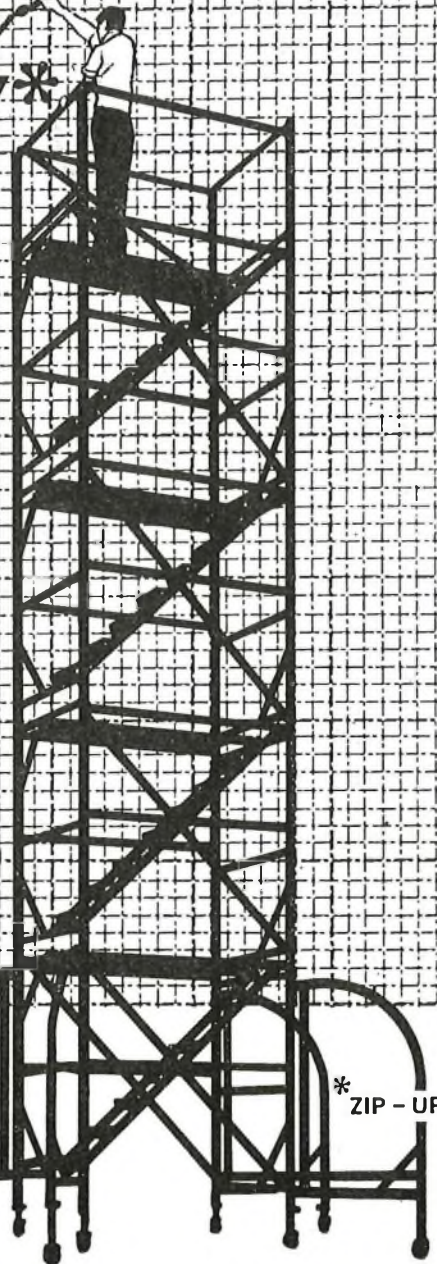

\* TALLESCOPE

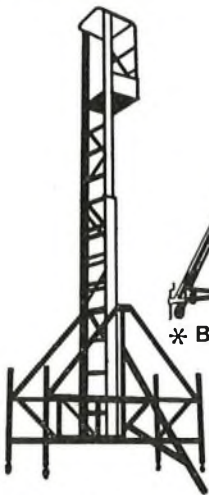

\* BEANSTALK



\* MOUNTIE



Lightweight Mobile Aluminium Staging, Mobile Aluminium Working Platforms, Mobile Powered Work Platforms, Mobile Safety Steps.

The full range of "ACCESS" Equipment is designed to cope with every installation and maintenance requirement.

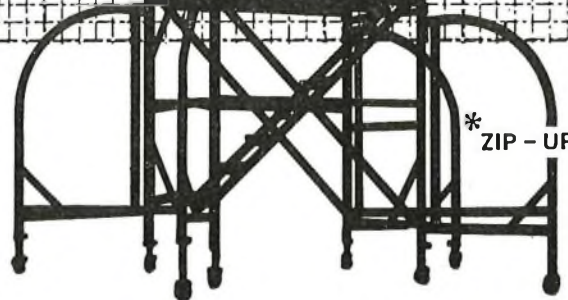

\* ZIP - UP

**\* SEND FOR YOUR BROCHURES NOW!**

FOEE 1072	ZIP - UP
NAME .....	TALLESCOPE
POSITION IN FIRM .....	BEANSTALK
COMPANY NAME .....	MOUNTIE
ADDRESS .....	
TEL. No. ....	

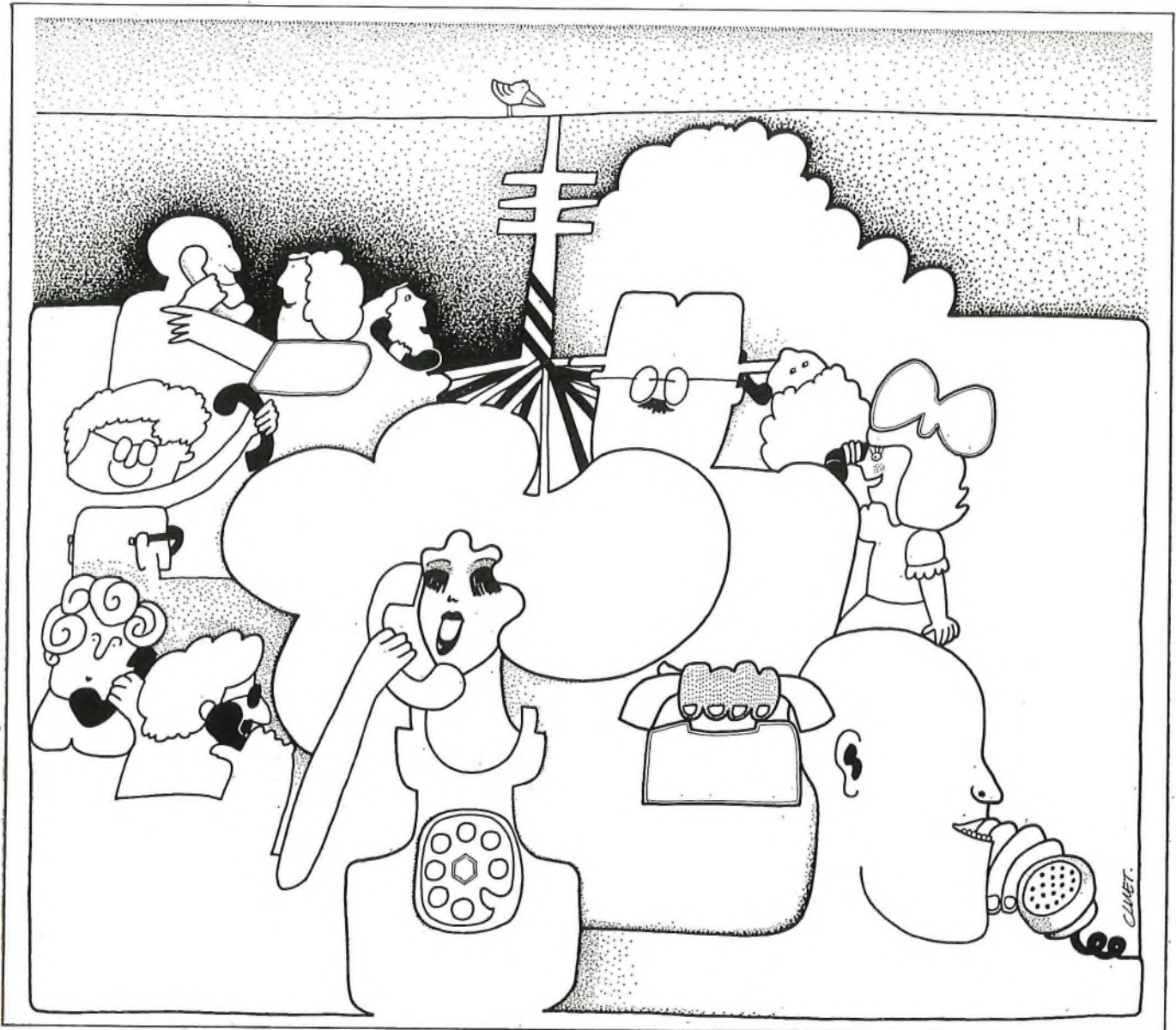

## 12-CIRCUIT CARRIER TELEPHONE SYSTEM FOR OPEN-WIRE LINES PST-L12

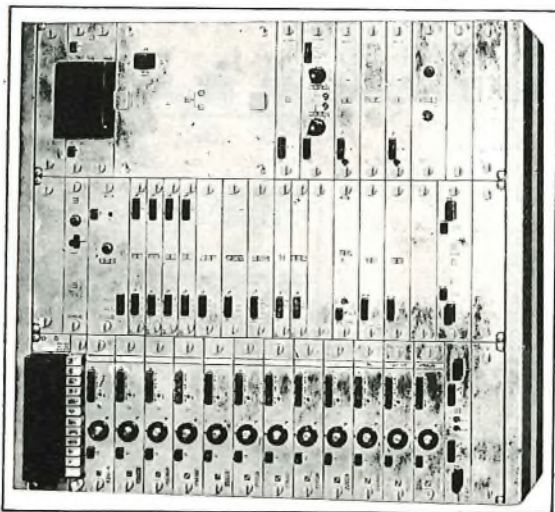

- \* TERMINAL, REPEATER AND LINE EQUIPMENT
- \* C.C.I.T.T. STANDARD PERFORMANCE
- \* INSTALLATION IS NO PROBLEM
- \* **OFF THE SHELF DELIVERY**

*Telettra*

LABORATORI DI TELEFONIA ELETTRONICA E RADIO  
20059 Vimercate-Milano (Italy) via Trento,30 - tel.(039) 63301-63551 - telex 31158



# ATR 20 solid-state relays match up to modern data interface requirements

Need a ready-made solution to interfacing problems between telegraph or data system lines?

Fairey Electronics ATR20 series relays are currently being used in full duplex, half duplex and differential duplex telegraph systems. Sensitivity is adequate for CCITT Recommendation V24 inputs, for example as an interface with Tariff J circuits. Very considerable improvements in performance, reliability and equipment bulk are being achieved.

Abridged Specification	ATR20 series polarised relays
Isolation	Meets BPO safety requirements
Mode	Single-pole changeover as each-side stable, one-side stable (+ or - side stable) or centre stable. Or, single-pole on/off (inverting or non-inverting action)
Speed	Typically 1,000 bauds at 100V output increasing to 5,000 bauds at 30V
Maintenance	None (no moving parts)
M.T. B.F.	4½ years (calculated) under typical conditions
Input impedance	15kΩ/30kΩ depending on mode
Input level	3.0V to 100V single or double current
Output voltage	6.0V to 100V single or 6-0-6V to 100-0-100V double
Output current	1.0mA – 250mA
Power supply	No external supplies are required other than the output signalling battery

Fairey Electronics ATR20 polarised electronic relays are offered (1) as plug-in replacements for existing e.m. types, (2) on p.c. boards for new equipment, or (3) as a complete interface package in a 19in rack containing up to 10 relays, filters and barretter lamps.

## You ought to know more about ATR20 relays

Fairey Electronics Limited,  
Pottington Industrial Estate, Barnstaple, Devon.  
Tel : Barnstaple 5911

I'd like to inquire further into Fairey solid-state telegraph relays and associated equipments.

Please send me :

- Literature  
 Application note. My application is \_\_\_\_\_

Please get in touch with me personally.

Name \_\_\_\_\_

Department \_\_\_\_\_

Address \_\_\_\_\_

 **Fairey  
Electronics**

# NO COMPRESSOR NEEDED



Send now for details of the powerful, portable Pionjar petrol driven drill and breaker to

**ITT Flygt Pumps Limited,**  
Colwick, Nottingham.

Please send details of the Pionjar Rock Drill/Breaker to

NAME \_\_\_\_\_

ADDRESS \_\_\_\_\_

## INDEX TO ADVERTISERS

	PAGE
Access Equipment Ltd. . . . .	21
Aerialite Cables Ltd. . . . .	15-19
British Institute of Engineering Technology . . . . .	17
Cray Electronics Ltd. . . . .	20
Fairey Electronics Ltd. . . . .	23
GEC Telecommunications Ltd. . . . .	8-11
Hallam Sleigh & Cheston Ltd. . . . .	14
Herman Smith Ltd. . . . .	16
ITT Components Ltd. . . . .	24
ITT Flygt Pumps Ltd . . . . .	24
Marconi Communication Systems Ltd. . . . .	13
Pirelli General Cable Works Ltd. . . . .	12
Plessey Telecommunications Ltd. . . . .	18
Record Electrical Ltd. . . . .	1
Rolls-Royce Motors Ltd . . . . .	25
Standard Telephones & Cables Ltd. . . . .	2-7
Telephone & Wireless Components Ltd. . . . .	17
Telephone Cables Ltd. . . . .	26
Telettra Spa, Milan. . . . .	22
Whiteley Electrical Radio Co. Ltd. . . . .	7, 15

# Powercard—the stabilised power supply you designed.

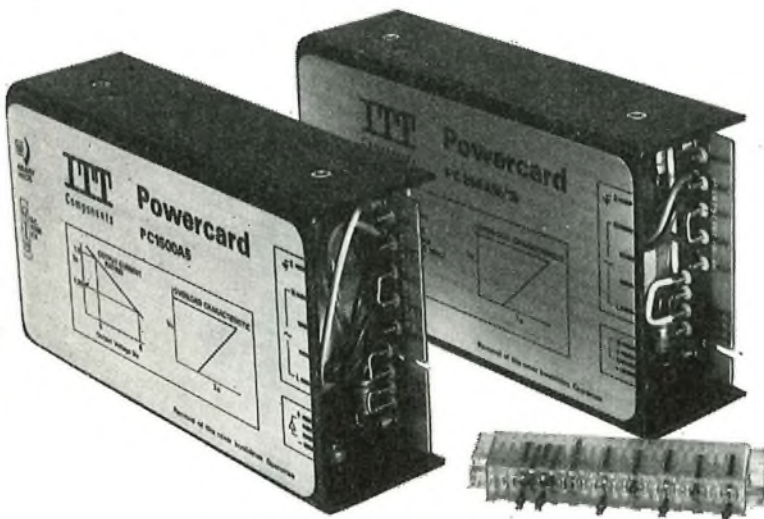

Small quantities available  
from ITT Electronic Services.  
Tel: Harlow 26777.

After a European survey we discovered what you really wanted in power supplies with current ratings of 250mA to 1.5A.

And we came up with ITT Powercards. Take a look at all these features.

Flexibility – there are five types with outputs from 0-5V to 15-0-15V.

Also they can be plug-in or chassis mounted.

Another important feature is that they're designed with a toroidal transformer to minimise leakage and reduce radiation.

This also makes each unit very compact, with an unbeatable power/size ratio.

Find out more about ITT Powercards and all their exciting new features. Like, for instance, their three modes of protection and 4 mm spacing.

Send away today for full technical data. Then you'll see how ITT put the finishing touches to your design.

ITT Components Group Europe Rectifier Division, Edinburgh Way, Harlow, Essex.  
Tel: Harlow 26811. Telex: 81146.

COMPONENTS **ITT**

# This winter we'd like to put the workers in power.



PHOTOGRAPH REPRODUCED BY KIND PERMISSION OF THE POST OFFICE

We've had power cuts for the last two winters. And it's an optimistic person who assumes this one will be any different.

The answer to the problem is of course, standby power.

But simply having a generator on hand for emergencies isn't enough. You have to be sure that it won't let you down just when you need it most.

And the answer to that problem is to have a generator powered by a Rolls-Royce diesel.

Our diesels for generating sets are simply designed and meticulously built to give continuous reliability. And even though we believe that's what they will give, we still test every engine, just to make absolutely sure.

Ten engines are available for producing from 80 to 450kW. (507kW with emergency generating sets). They can be naturally aspirated or turbo-charged. And of course, every one is backed by a comprehensive spares and service network.

Perhaps the nicest thing about our diesels is that for all this reliability and performance, you don't have to pay any more than for competitive engines.

That then, is our answer to power cuts. We can't stop them happening and you can't know when they'll happen.

But at least when they do, you won't be kept in the dark.



**You get all that it stands for.**

ROLLS-ROYCE MOTORS LIMITED DIESEL DIVISION  
SHREWSBURY SY1 4DP TEL: SHREWSBURY (0743) 52262 TELEX: 35171



## The world's first 18-Tube Coaxial Cable for 60MHz systems.



An innovation in telecommunication cable, this 18-tube coaxial was developed by TCL in co-operation with the British Post Office.

Well established frequency division multiplex techniques enable each pair of tubes to carry 10,800 conversations making possible a total of 97,200 simultaneous conversations between centres on the one cable.

The techniques of laying and jointing the new cable are currently being proved in the Marlborough area, Wiltshire.

For details of this and any other of our comprehensive range of coaxial, plastic and dry core cables, contact us.

# TCL