

The Post Office Electrical Engineers' Journal

VOL 64 PART 4/JANUARY 1972



THE POST OFFICE ELECTRICAL ENGINEERS' JOURNAL

VOL 64 PART 4 JANUARY 1972

Contents

	<i>page</i>
Editorial	207
Development of Cables for the Changing Network—J. Pritchett	208
A Subscribers' Carrier System for the Local Network—L. W. Kingswell and G. C. Toussaint	213
Confravision—J. E. Howarth	220
Air-Conditioning for Confravision in Glasgow—A. Ness	225
The Measurement of Telephone Traffic—H. M. Golesworthy, R. C. Kyme and J. A. T. Rowe	227
A Computer-Controlled Traffic Recorder—C. D. Vigar and J. T. Brookfield	234
Mobile Radio Systems—I. H. Beck	238
Pseudo-Random-Sequence Binary-Digit Generators and Error Detectors— D. J. Dieckmann and F. A. Graves	245
Private Automatic Telegraph Exchange—P.A.T.X.—No. 1A—B. Sheekey and C. A. R. Turbin	250
Some Aspects of Digital Microwave Radio Relay Systems—M. C. Davies and J. B. Hicks	256
Computer-Aided Drawing Equipment for Integrated Circuit Manufacture— G. S. Walker	260
Notes and Comments	266
Regional Notes	267
Associate Section Notes	270
Institution of Post Office Electrical Engineers	272
Post Office Press Notices	273
Book Reviews	212, 259

Published in April, July, October and January by the *Post Office Electrical Engineers' Journal*,
2-12 Gresham Street, London EC2V 7AG

Price 21p 31p (Including Postage and Packaging). Orders by post only.

Annual Subscription (post paid): Home and Overseas £1.24. (Canada and U.S.A., 3 dollars)

GEC Multiplex equipments are designed first and foremost to meet both CCITT and North American standards. Beyond that, GEC go out of their way to ensure that their Multiplex equipment incorporates the flexibility necessary to serve any administration.

For example, the patching unit illustrated below, with a specially built-in pilot meter, meets the specific requirements of the Canadian market. The 3,000-mile overland section of the Commonwealth Cable scheme between Montreal and Vancouver is equipped with GEC Multiplex. Similarly, GEC Multiplex equipment will meet your requirements.

With over 40 years' experience in the design and manufacture of Multiplex equipment to meet the needs of the world's markets, GEC continue to maintain their position in this field.

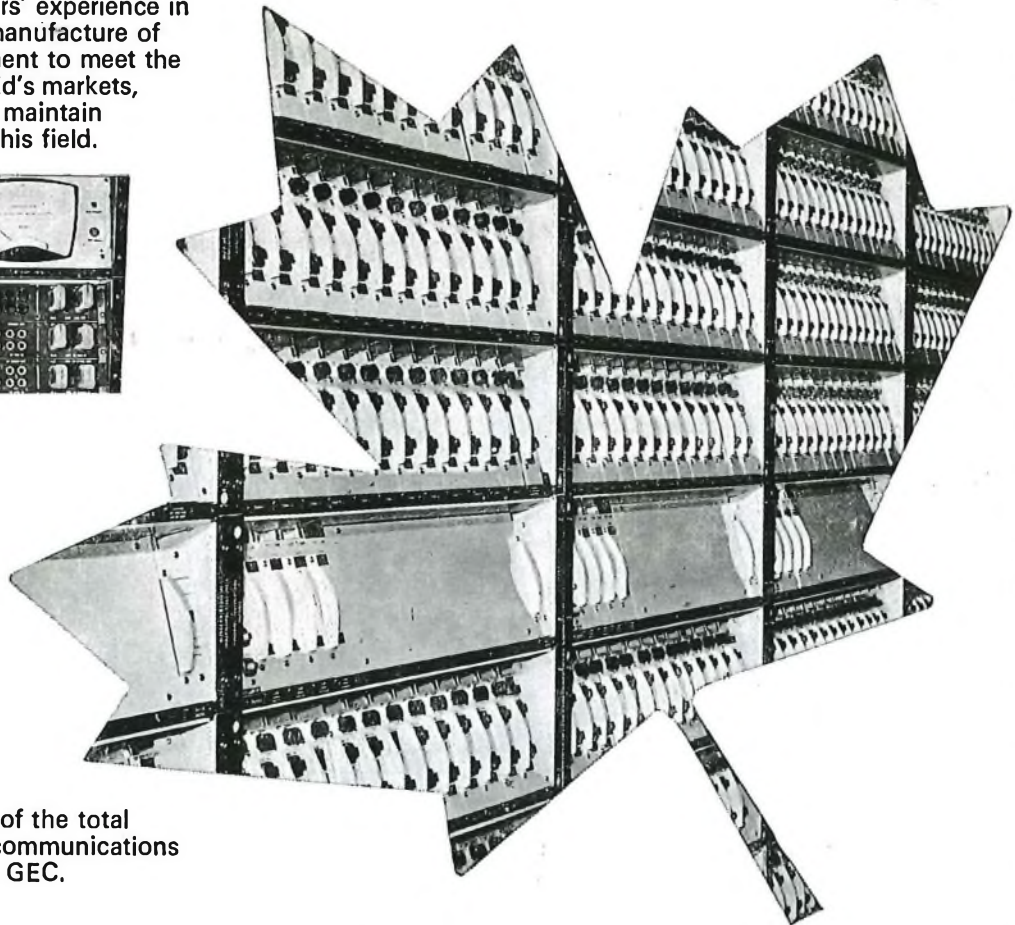
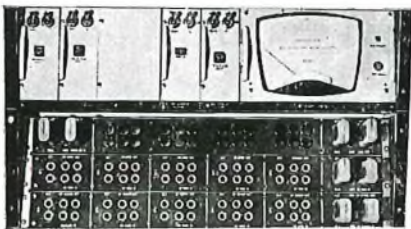

This is one facet of the total capability in telecommunications that is offered by GEC.

Takes telecommunications into tomorrow

GEC-AEI TELECOMMUNICATIONS LTD, OF COVENTRY, ENGLAND.

A Management Company of The General Electric Co. Ltd. of England.

ID/39A

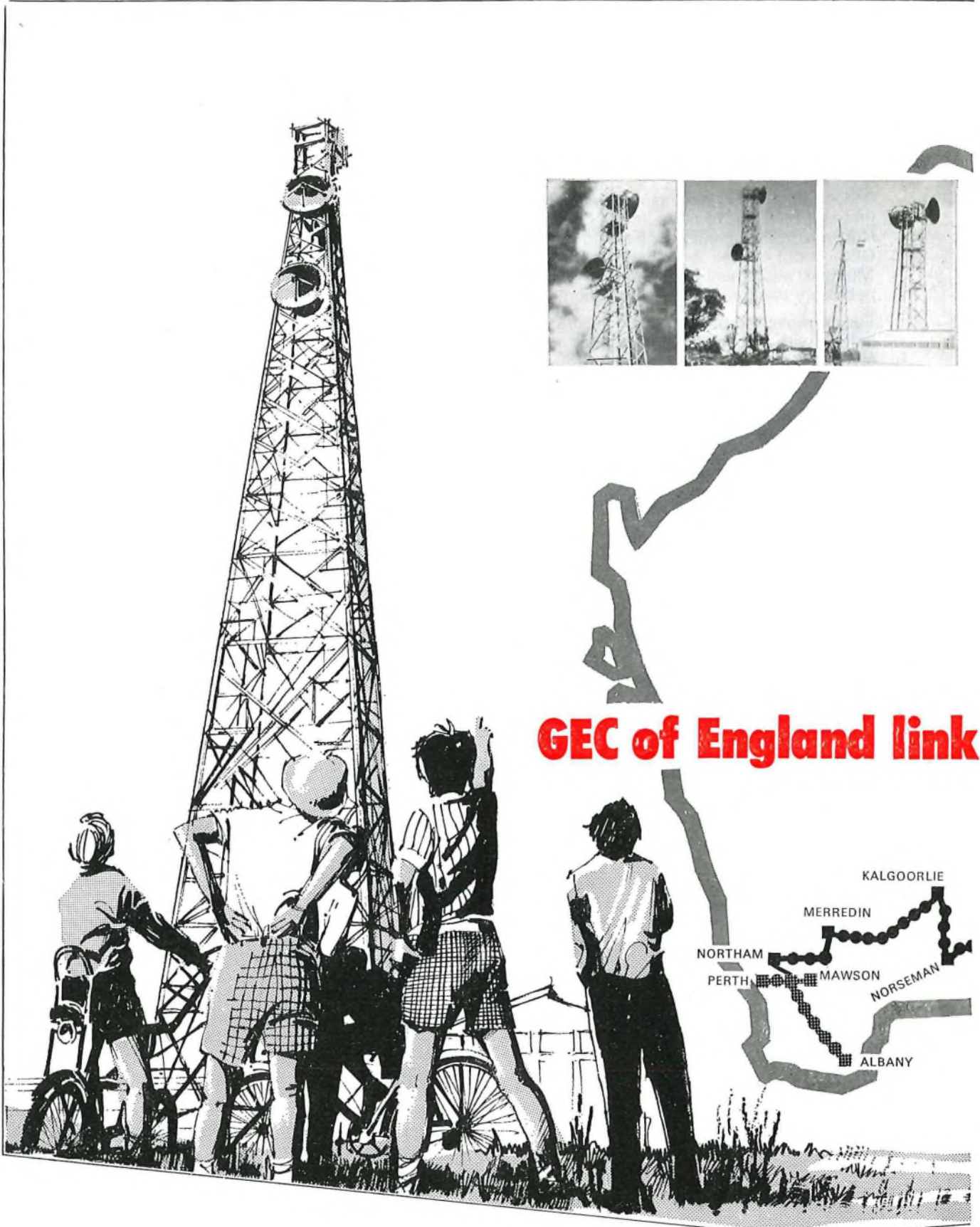

GEC of England link



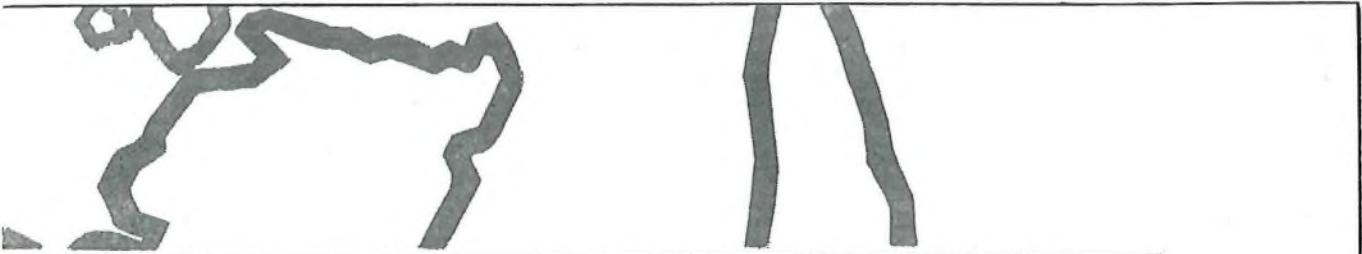

GEC of England is proud to have acted as main contractor for the East-West 2GHz microwave radio system now in service, which brings Western Australia into the national broadband trunk telephone and television relay network. The largest single telecommunications project carried out in Australia, and one of the longest systems in the world, it carries trunk telephone calls, at the present rate of 1.3 million per year, over 1500 miles between Western Australia and the Eastern States, and provides circuits to all centres en route. Working in close collaboration with the Australian Post Office, GEC was responsible for the engineering, manufacture, installation and commissioning of the radio equipment, and the design parameters for antennas and feeders, power plant equipment shelters and towers, and overall project management—an A\$8,000,000 responsibility.

The 2GHz system is part of the GEC total systems capability which includes 2GHz, 4GHz, 6GHz and 6.8 GHz systems for speech or colour television on long-haul main routes, and 7.5 GHz for speech on medium-haul and spur routes, all in accord with CCIR requirements, together with associated equipments including frequency division Multiplex, for up to 1800 circuits, supervisory alarm indication and remote control systems, I.F. and baseband switching, narrowband auxiliary radio for serviceband and antenna systems.

East and West with one of the longest civil microwave systems in the world!

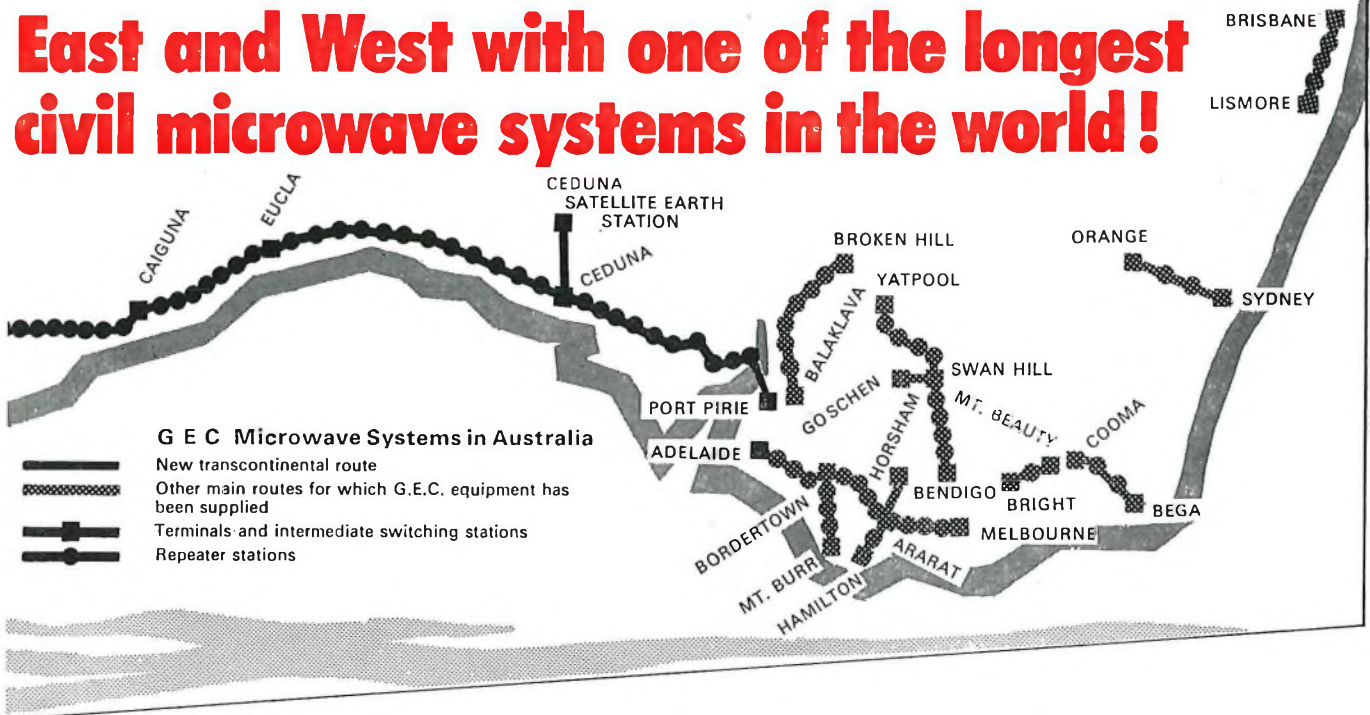

Takes telecommunications into tomorrow

GEC-AEI TELECOMMUNICATIONS LIMITED OF COVENTRY, ENGLAND
 A management Company of The General Electric Co. Ltd. of England

The Data Modem that's proved in service

Many thousands of GEC 600/1200 baud Type TED 0138 Data Modems are already in service. This is a practical demonstration of the reliability and versatility of this equipment, for converting data pulse information into voice-frequency signals for transmission over a switched public — telephone connexion or via a private circuit, and re-converting received signals into data format. Features include:

- Two switch-selected speeds of operation: up to 600 bauds and up to 1200 bauds, the latter being generally possible over modern public switched telephone networks.
- Modulator and/or demodulator may be used for 600 or 1200 baud operation.
- 75 baud operation for return supervisory and control data.
- Complies with CCITT recommendations.
- Power supply: 190 to 260V 50Hz single phase, 18W.
- Dimensions: 178 mm (7 in) high, 345 mm (13.5 in) wide, 452 mm (18 in) deep.
- More data required? Write Transmission Division, GEC-AEI Telecommunications Limited, P.O. Box 53, Coventry, England.

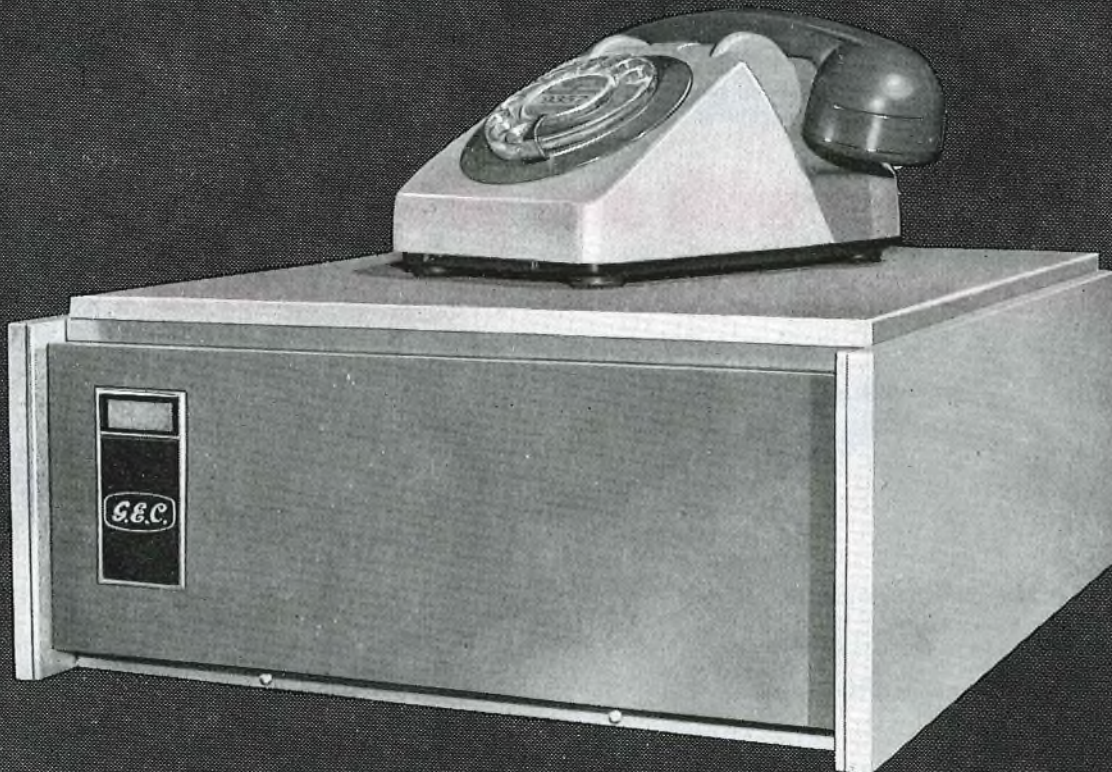

Takes telecommunications into tomorrow

GEC-AEI TELECOMMUNICATIONS LTD, OF COVENTRY, ENGLAND.

A Management Company of The General Electric Co. Ltd. of England.

FACTS ABOUT INSURANCE

to prove that your own Society offers a much better deal

Your own Society was formed to deal only with Civil Servants and their families. Your premiums can be deducted from your pay, thus avoiding the extra collecting costs, and you get the benefits of this saving.

Every policy indirectly benefits the Civil Servants Widows and Orphans Fund which exists to help dependants of deceased policyholders. An average of £3,000 per year has been paid by this Fund in grants for the past 20 years.

In 80 years associated companies of the Civil Service Insurance Society have issued 163,342 life insurance policies, and paid out over £42 million in claims.

Your own Society exists to serve people like you. We invite your enquiries.

New!

Car insurance by instalments! You can insure your car by instalments throughout the year and get better rates!

IMMEDIATE COVER For Car and Holiday Insurance

We'll give you an immediate quote and you're covered from the moment your first premium is received, simply 'phone: 01-688 3537.

CIVIL SERVICE INSURANCE SOCIETY

for Better Terms on EVERY type of Insurance



Post coupon to:

Civil Service Insurance Society,
33 Birdhurst Rise, South Croydon, CR2 7YH

Please send me details of Insurance for

Name

Address

PO11

STC Telecommunications

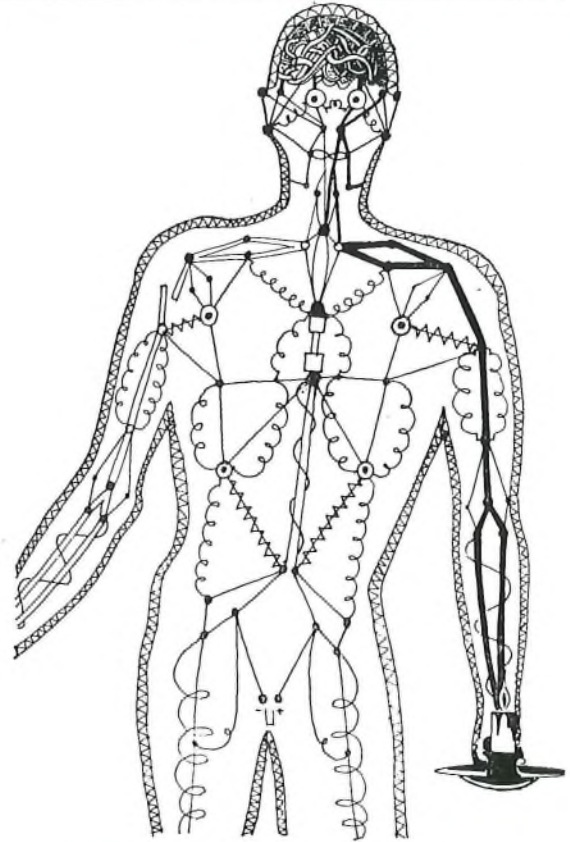

Where would we be without internal communication?

We take the intricate workings of our nervous systems very much for granted. Can't imagine them to be anything but reliable and smooth running.

The same goes for our INTERPHONE office communication—and think what a big hang-up life would be without that. STC, one of the largest manufacturers of cable for PABX and PBX installations, think so too.

STC cables are of the highest quality and have tinned copper wire conductors, insulated with PVC. Cables are sheathed overall with PVC and can be supplied in various conductor sizes and pairages, either as armoured or unarmoured cable.

These cables are designed primarily for use indoors. They are also satisfactory for outdoor use (but installation should not be attempted at temperatures below 0°C.)

They are part of a comprehensive range of STC cables and wires. Designed and manufactured for every application in the telecommunications and electronics field—with cables for particular applications made specially to order.

You only have to pick up the phone for more details.



STC Plastic Telephone Cable Division,
Corporation Rd., Newport, Monmouthshire.
Telephone: Newport 72281
Telex: 49368

an associate of

ITT

Communications Cables

STC

ENGINEERS!



Send for your **FREE** copy of 'ENGINEERING OPPORTUNITIES'

WHAT THIS BOOK WILL TELL YOU!
How to get rapid promotion or a better-paid job. How to put some valuable letters after your name. How to make use of our free Appointments & Advisory Service. How to gain the technical knowledge employers readily pay for. How you can succeed in any branch of Engineering you like—whatever your education or experience.
74 PAGES FULL OF EXPERT ADVICE.

Now ready a brand new edition of this famous book which we would like every ambitious engineer to have—free. We anticipate a tremendous demand so send for your free copy now.

'ENGINEERING OPPORTUNITIES' outlines our magnificent range of modern Home Study Courses and is packed with interesting and useful information. Don't miss this enlightening booklet.

ENSURE YOUR COPY BY POSTING COUPON NOW

To: BIET Dept. B3 Aldermaston Court, Reading RG7 4PF.

Tick subject that interests you. Aero Eng. Automobile Building
 Computers D'manship Electrical Electronics Management
 Mechanical Plastics Production Surveying TV & Radio
 Telecomms. Work Study AMIED AMIMI AMSE
 C.ENG. CITY AND GUILDS GENERAL CERTIFICATE OF EDUCATION

Other subjects _____

Please send 'ENGINEERING OPPORTUNITIES' without cost or obligation.

Name _____ Age _____

Address _____

Occupation _____



BRITISH INSTITUTE OF ENGINEERING TECHNOLOGY

STC Telecommunications

Stick-a-strip. The flat cable with instant impact that sticks anywhere.

Stick-a-Strip will stick to plaster, paint, tiles, glass and brickwork. So it'll go neatly along walls and skirting boards and lie flat under carpets. In the home or the office. Even in awkward corners where you can't swing a hammer, a special corner cover will take care of that.

It has a wide range of terminations for installing 'phones or low-voltage equipment such as radio or hi-fi speakers. And it saves you time, too. No stapling or sore thumbs. You just press it

gently into place and it stays put.

Stick-a-Strip's easy to store. Because it sticks to itself in a tidy roll when not in use. And it comes in 50 metre packs in grey or cream, to complement any colour scheme.

If you'd like to know more about Stick-a-Strip write, 'phone or telex : Standard Telephones and Cables Limited, Plastic Telephone Cable Division, Corporation Road, Newport, Monmouthshire, NPT OWS. Tel: 0633 72281 Telex: 49368

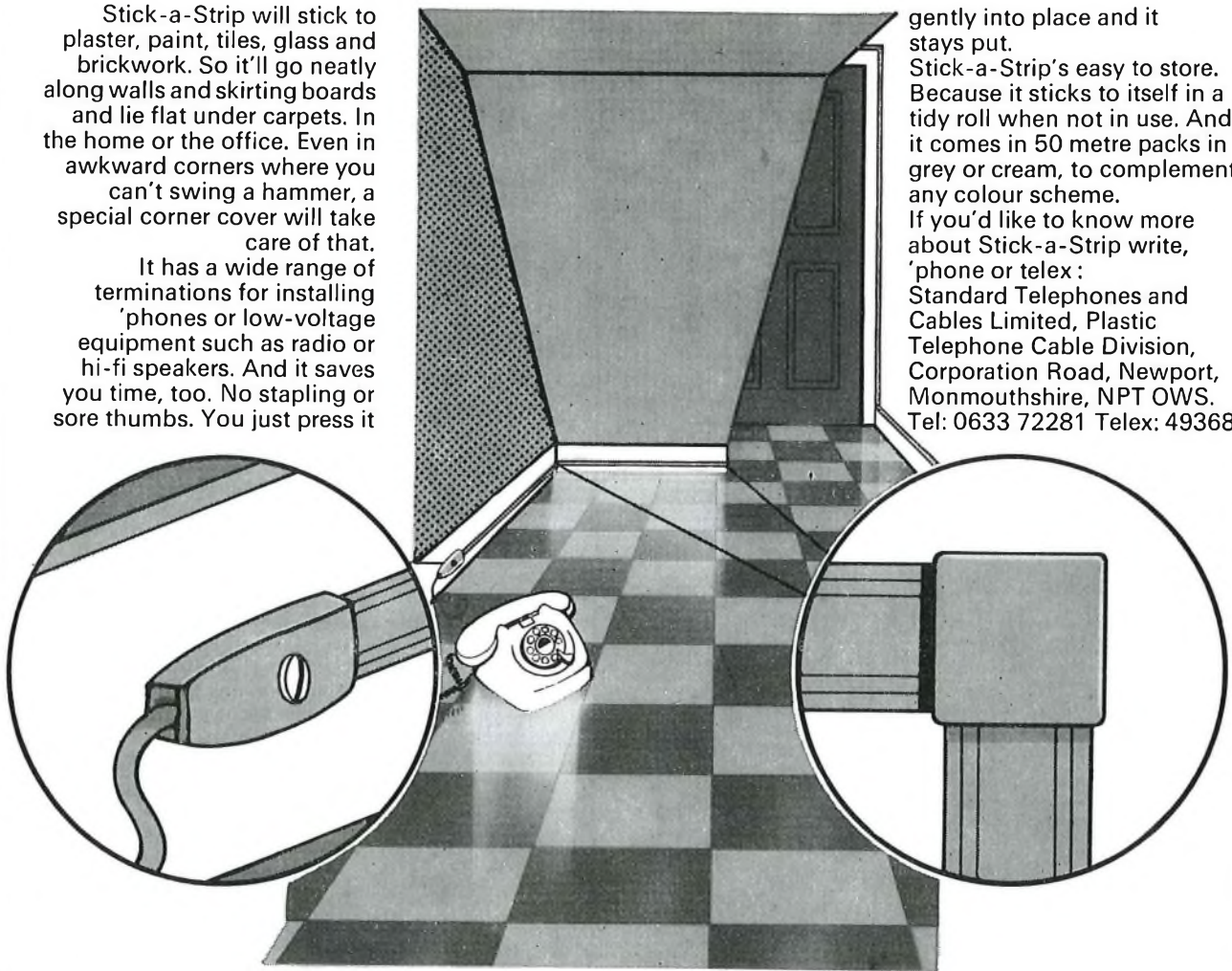

an associate of
ITT

Plastic Telephone Cable Division

STC

STC Telecommunications

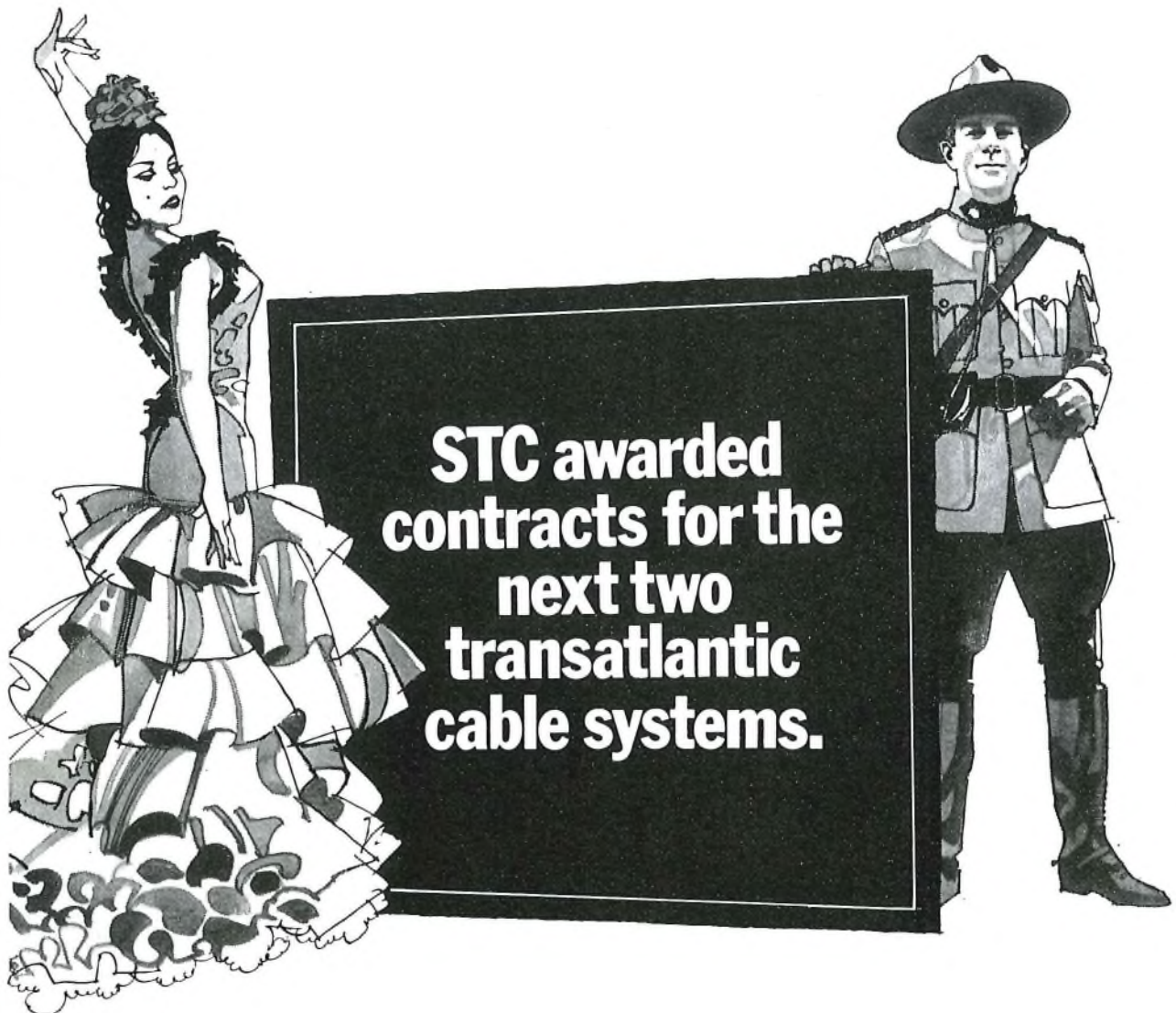

The two cables, CANTAT-2 and BRACAN-1, will give 2,000 additional circuits across the Atlantic. 1,840 between the UK and Canada (the largest capacity system anywhere in the world) and 160 circuits between Brazil and the Canary Isles, (the first submarine system to link South America with Europe). The value of these orders is £32 million and STC will be supplying the complete systems — terminals, cables and repeaters.

The award of these contracts reflects the immense confidence that the communications agencies have in STC's continuing ability to

produce the highest quality submarine cable systems.

It also evidences the belief in the future of submarine cables at a time when communications have become increasingly important.

We are proud to be meeting these twin challenges and proud too that our leadership in this field has been endorsed so conclusively and on such an immense scale.

Standard Telephones and Cables Limited
Submarine Systems Marketing,
North Woolwich, LONDON E.16.

an associate of
ITT

Submarine Systems Group

STC

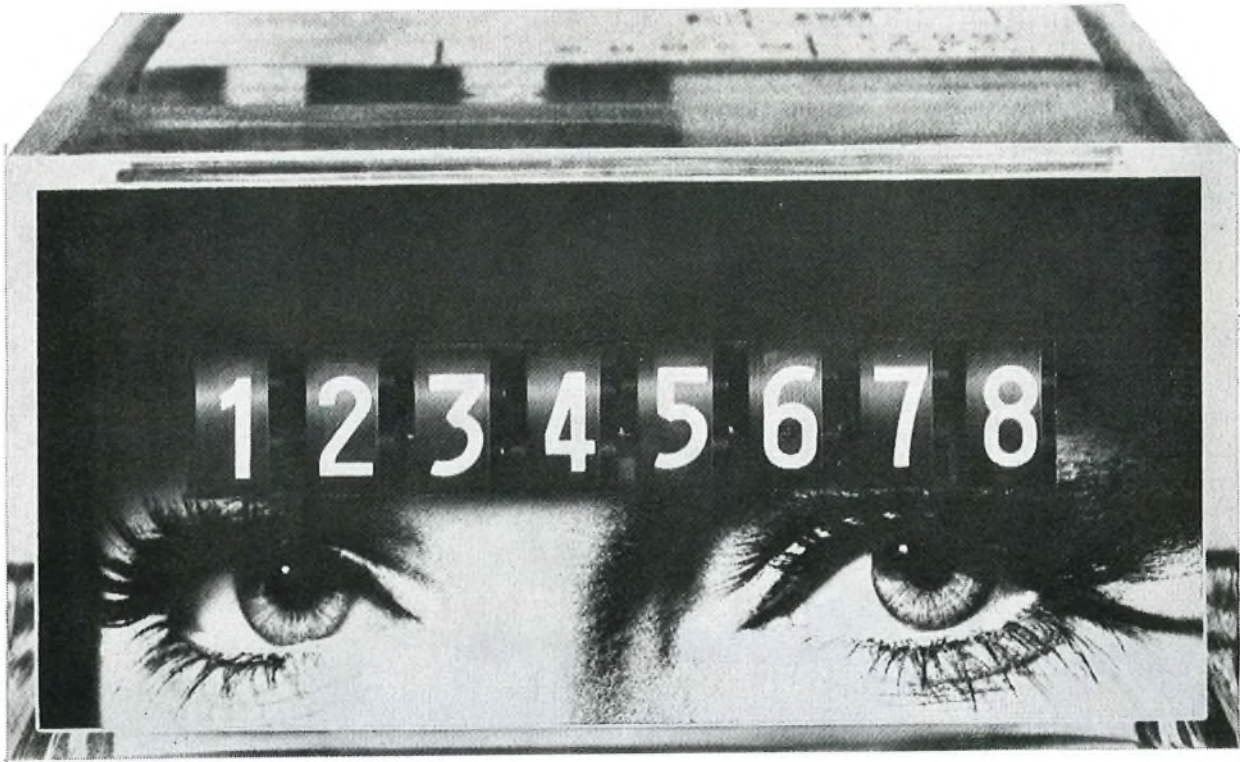

Easy on the eye

The extended range of Sodeco RG impulse counters from Landis & Gyr

Introducing the Sodeco RG range – the only impulse counters designed for the seventies. Compact and well proportioned, they blend perfectly with new instrument fascias. And the clearly presented figures allow fast, accurate reading – even from wide angles.

There's more to Sodeco RG counters than just a pretty face. Keen prices plus exceptional reliability and long life give unrivalled value for money.

Performance is outstanding. Sodeco RG counters are quieter in operation and have a life in excess of 200 million impulses, with up to 60 impulses per second for DC models, up to 25 impulses per second for AC models. Power requirements are low and the range allows wide voltage tolerances.

The range is comprehensive: counters with 3, 4, 5, 6 and 8 digits suitable for all popular mountings, with manual or electrical reset facilities in most versions.

SODECO
Impulse counters

Please write for full technical details to

Landis & Gyr
Limited

Victoria Road, North Acton, London W.3. Telephone: 01-992 5311 Telex: 21486



Actual size

The Post Office Electrical Engineers' Journal

BOARD OF EDITORS

N. C. C. de JONG, B.Sc.(Eng.), C.Eng., M.I.C.E., F.I.Mech.E.,
F.I.E.E., Chairman

E. W. AYERS, B.Sc.(Eng.), C.Eng., F.I.E.E.

D. R. BEARHAM, B.Sc.(Eng.), C.Eng., M.I.E.E.

S. H. SHEPPARD

A. J. BARNARD, C.Eng., M.I.E.E.

A. C. CROISDALE, M.B.E., B.Sc.(Eng.), M.I.E.E.

J. MARTIN, B.Sc.(Eng.), C.Eng., M.I.E.E.

Managing Editor

N. J. H. NINNIM, M.Sc., B.Eng.

Deputy Managing Editor

D. MILLINGTON, C.Eng., M.I.E.E.

Assistant Editors

P. G. STEELE, M.Sc., B.Sc.(Eng.)

T. R. K. RAITT

N. G. CRUMP, M.I.T.E.

Secretary-Treasurer

B. FARR, A.B.I.

Advertisement Manager

R. G. ROTHERY

EDITORIAL

One of the most valuable assets of the British Post Office is the vast network of cables lying under the ground throughout the United Kingdom. An important article in this issue discusses the philosophy of cable design and outlines the problems that the cable design engineer faces in matching new cables to changing network requirements. A related article, on the subject of subscribers' carrier equipment, deals with the rebirth of an old idea for making better use of the local cable network.

In its plans to meet increasing demand for telephone service and improve existing services, the British Post Office has placed a three-year contract for final development, supply and installation of large (up to 40,000 lines) electronic exchanges of the TXE4 design. This £15M contract dovetails into the Post Office's far-reaching studies for an extensive plan to make Britain's telecommunication system capable of meeting the operational demands of the future. Standard installation for new or replacement exchanges in the small-to-medium range (400 to 2,000 lines) is now the TXE2. This was first installed at Ambergate, Derbyshire, in 1966 and, with TXE2 exchanges coming into service at the rate of more than two a week, there are now nearly 150 in operation. The first TXE4 exchange is expected to come into service in Birmingham at the beginning of 1975; it will be followed shortly afterwards by others in London and Manchester. The *Journal* hopes to be able to publish an article on this subject in a later issue.

Development of Cables for the Changing Network

J. PRITCHETT, E.R.D., B.SC.(ENG.), M.I.E.E., C.ENG.†

U.D.C. 621.315.2.001.6

The British Post Office cable network is in a state of continuous but gradual change and it is the task of the cable development engineer to control its progressive growth. An appropriate development philosophy is postulated and the importance of reliability is emphasized. Some recent advances in local cable design are described.

INTRODUCTION

The telecommunications cable network which extends over the length and breadth of the United Kingdom is one of the most valuable assets of the British Post Office (B.P.O.), representing as it does, an investment of some £400 million in local lines alone. Parts of the network are probably 50 years old and the work of augmentation and gradual renewal has been going on ever since the first cable was laid. The present level of expenditure on new cables is about £40 million a year.

The network is, thus, an ever-changing but corporate thing and the task of the development engineer is to ensure that any new cable—while showing some technical or economic advantage over the old—nevertheless remains compatible with those already in use.

Demand for more circuits and new facilities grows apace, and the capabilities of existing plant are being called upon to an ever-increasing extent. The task of the engineer is to ensure that development progresses on sound lines because it would be folly to degrade the performance of the network by the use of inferior products or unsatisfactory installation techniques. This is why every new cable design is assessed in the laboratory and subjected to an extended field trial before being adopted as a standard item for B.P.O. use.

CABLE DEVELOPMENT PHILOSOPHY

There are many factors which the development engineer must consider before deciding upon the line of progression he should take. For example, the planners rightly demand value for money so as to ensure the best return on capital invested and this involves a critical appraisal of any new project. The purchasers understandably require supply by competitive tender so as to obtain the greatest advantage from the market. The works practices people naturally want to streamline installation methods so as to economize in manpower. The service organization insists, quite justifiably, on a high degree of reliability so as to minimize maintenance expenditure whilst giving the maximum of satisfaction to the customer. All these very laudable attitudes have to be reconciled by the development engineer.

It has often been said that anyone can design a bridge which will not fall down but it takes an engineer to design one which will be just sufficient to carry the traffic. He is, thus, credited with the ability to relate effectiveness and cost. Such ability is of no less importance in telecommunications than in bridge building. Many years ago, when electrical power transmission was in its infancy, Lord Kelvin studied the economic aspect and he showed how the optimum size of a power-feeder cable could be derived. So we have, to this day, Kelvin's Economy Law which has far wider implications than were at first thought. Its basis is illustrated in Fig. 1. Kelvin reasoned

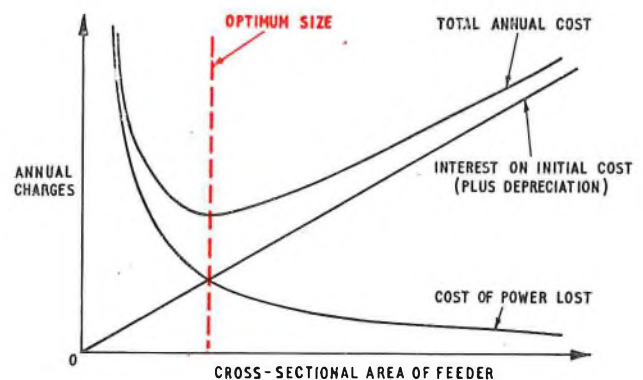

FIG. 1—Kelvin's Economy Law

that the two main components of the annual charges for a feeder were the interest on initial cost and the continuing cost of power lost due to voltage drop in the feeder itself. The former is directly proportional to the cross-sectional area of the conductors in the feeder while the latter is directly proportional to their resistance and, thus, inversely proportional to their cross-sectional area.

For telecommunications cables the detailed situation is somewhat different but Kelvin's principle remains the same. The B.P.O. is, of course, concerned with the initial cost of its cables and the consequent annual payment of interest, but its continuing annual expenditure is attributable to the cost of maintenance rather than to the cost of lost power. A new version of Kelvin's law for telecommunications cables can, thus, be postulated and the basis for it is shown in Fig. 2. In this diagram it has been assumed that the reliability of a cable is directly related to the initial cost, that the annual maintenance charge is inversely proportional to the reliability and that good reliability leads to customer satisfaction. A diagram of this kind provides a useful guide to cable-design philosophy but it must be treated with caution. Kelvin himself realized that feeders could not always be designed to his optimum economic size and still carry the load current in safety. Similarly, Fig. 2 can only be a guide because the optimum reliability on economic grounds may well be unacceptable from the viewpoint of the customer simply because it is well-nigh impossible to quantify customer satisfaction (or dissatisfaction) in terms of money.

Fig. 2 does, however, emphasize one very important point. Any design which is less costly than the optimum—the cable of poor quality—involves a lot of maintenance expenditure and little or no customer satisfaction; one which is dearer does, at least, give value for money. The meaning is clear; reliability and customer satisfaction have to be paid for and it is better to make a wise initial investment rather than to make

† Telecommunications Development Department, Telecommunications Headquarters.

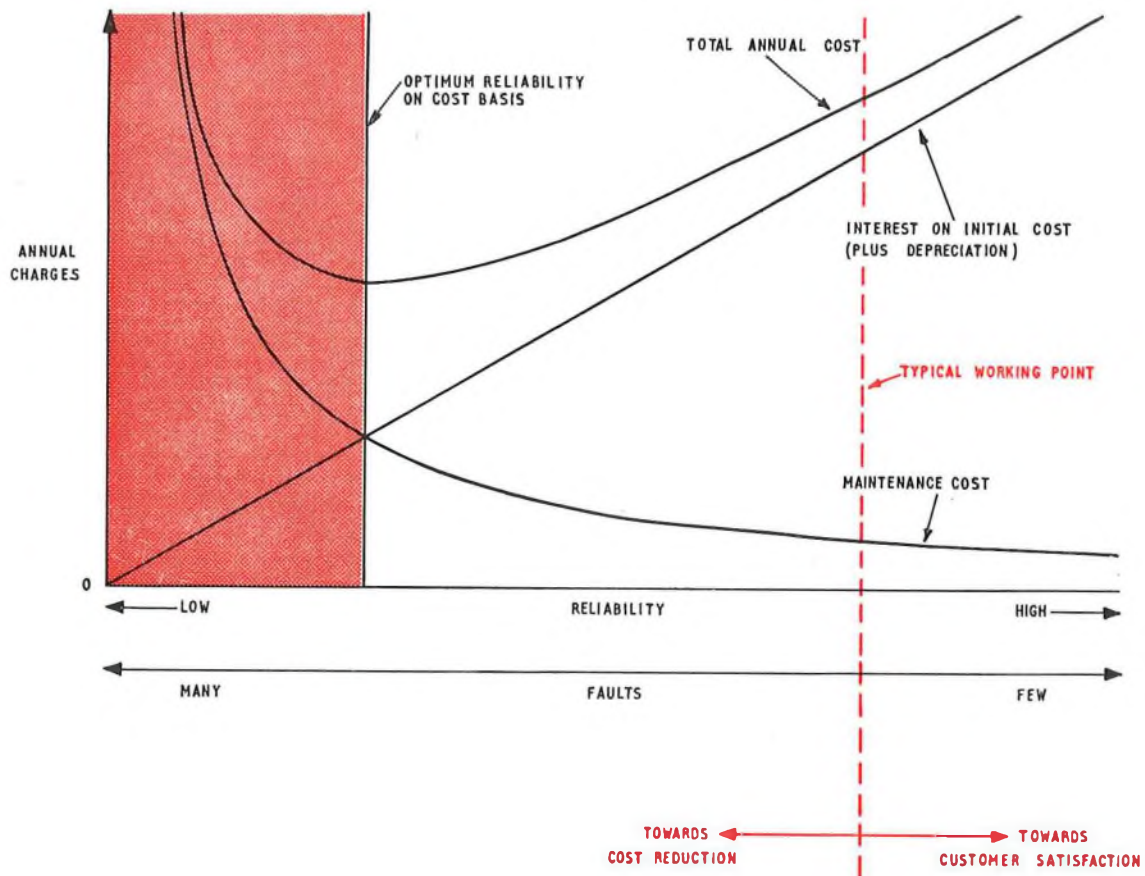

FIG. 2—Application of Kelvin's Economy Law to cable design philosophy

a cheap purchase which involves a heavy continuing maintenance commitment.

The diagram serves to illustrate the way in which the various parts of Telecommunications Headquarters have to co-operate in producing an end result which accords with current policy, whether this be the maximum of customer satisfaction, the minimum of new investment or a combination of the two. With the present drive to reduce costs by the use of new cable designs or by improved productivity methods, there is a grave risk that the reliability of the network, and the extent to which it can be exploited for new systems, will suffer in consequence. For this reason, the merits of any proposed change have to be examined very closely in relation to their effect upon the cable network as it exists at the time a change is contemplated, because, whatever its valuation for accounting purposes, the real worth of the present plant is beyond computation. This is why the growing network must be nurtured like a child to ensure that it develops along sound lines. This, no more and no less, is the plain duty of the development engineer.

SOME RECENT DEVELOPMENTS IN LOCAL CABLES

The principles of cable manufacture¹ were established many years ago and the combination of copper conductors, paper insulation and lead sheathing reigned supreme for a long time. But manufacturing methods are continuously improving, new materials are becoming available and new ways of utilizing those already available are being developed. The fundamental design parameters for pair-type cables have recently been revised^{2,3,4} in order to allow the planners the full economic benefits of the new forms of construction now coming into production.

Polythene

One new material—polythene—is of particular interest to the cable engineer because of its good mechanical and electrical properties and the ease with which it can be extruded. It has already superseded lead for the sheaths of audio cables, making them easier to handle and avoiding the corrosion problem. The reduced weight, together with the lessening of sliding friction in duct, has led to the adoption of long-length cabling techniques with consequent savings in joints. Polythene can be extruded over a thin wire to form a solid or a cellular coating of uniform thickness and, in parts of the network, this method of insulation has now been adopted in place of the traditional lapped paper. The material itself is more costly than paper but this disadvantage is offset, to a large extent, by the increased speed of the insulating process.

An early use for solid-polythene-insulated cables was to replace the very expensive enamel, silk and wool covered cables terminating on the main distribution frame (m.d.f.). It was found economic to extend this new terminating cable into the network for a whole cable length thus avoiding the need for a joint in the cable chamber. Fig. 3 shows a 4,800 pair cable⁵ with 0.32 mm diameter conductors.* This is the largest of the many solid-polythene-insulated cables used for terminations in the B.P.O. network.

Fully-filled Cables

The fully-filled cables now in widespread use in the distribution network were developed progressively as a result of earlier experience with solid-polythene insulation as a replacement for paper. Field usage of solid-polythene-insulated

* Designed and produced by Standard Telephones and Cables Ltd.

cables soon showed that maintenance was difficult because rupture of the sheath in a wet situation did not necessarily cause an earth fault at the point of damage as it did with the earlier paper-cored cables. Furthermore, there was nothing inside the sheath to swell up in the presence of water and restrict its flow as paper does. Thus, any electrical test



FIG. 3—A 4,800-pair cable with 0.32 mm copper conductors and solid-polythene insulation

designed to locate a damaged sheath was likely to give a false result because water entering the cable passed along the core and produced a low-insulation fault at a nearby joint, leaving the position of the sheath damage undiscovered.

In an effort to ease the fault-location problem, discrete blocks of waterproof material at 20-yard intervals were introduced into the cable during the manufacturing process to restrict the flow of any water which might enter. Such blocks were very inconvenient to the cable maker and their presence increased the wire-to-wire capacitance of all the pairs in the cable. Thus the blocking method, although having merit from the maintenance point of view, was disliked by the manufacturer and frowned upon by the transmission engineer. The obvious solution would have been a continuous block rather than a number of them placed at 20-yard intervals but the expense would have been prohibitive as the overall diameter of the cable would have had to be increased to allow for the wider spacing between the wires of each pair necessary to avoid an increase in wire-to-wire capacitance.

In the early 1960s, some manufacturers were experimenting with various techniques of applying polythene to a wire in a cellular form rather than as a solid coating because they realized that such a process would reduce the amount of polythene required and lead to a cheaper cable. By 1964, an extrusion technique had been perfected by British Insulated Callender's Cables Limited (B.I.C.C.), and a combination of cellular polythene and petroleum jelly was proposed⁶ as a

method of producing a continuous block without increasing the wire-to-wire capacitance and without making any significant change in the overall diameter of the cable. So appeared the concept of the jelly-filled cable as it is known today.^{7,8}

Cellular polythene contains a very large number of minute air pockets sealed under a thin surface skin so that the dielectric between a pair of wires in a fully-filled cable is really a combination of air, polythene and jelly. By suitable design this was made equivalent to the dielectric of polythene and air in the solid-polythene-insulated cable.

Petroleum jelly is used for the filling and the exact composition must be such as to be compatible with the polythene used both for the wire insulation and for the sheath. Other cable manufacturers adopted the technique and each uses his own choice of jelly and polythene. Fig. 4 shows part of the filling process during the course of manufacture.

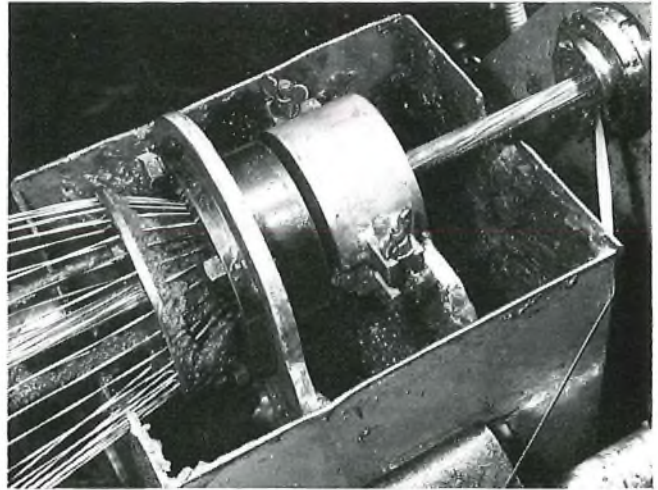

FIG. 4—Manufacture of a fully-filled cable

Fully-filled cables with copper conductors soon became standard for the B.P.O. distribution network and were a great success, their use being more than justified by the saving in maintenance expenditure.

Aluminium as a Conductor

Establishment of the general concept of fully-filled cables set the stage perfectly for the change from copper to aluminium as a conductor. It was realized that, although aluminium is somewhat more susceptible to corrosion than copper, the jelly filling would give very good protection against the effect of moisture.

The change to aluminium⁹ was prompted by the steep rise in the market price of copper in 1966 coupled with the great uncertainty about future trends in the metal market. For example, in October 1971, copper had fallen to a very low figure indeed—£420 per ton as compared with £610 in 1966. The copper market is quite unpredictable because the sources of its ore in the world are few and most copper mines are subject to strike action and political pressure. In contrast, aluminium occurs fairly generally over the surface of the earth, thus, local conditions can have little effect on the supply and the price is likely to remain comparatively stable. Demand for both metals for telecommunications purposes is so small in comparison with the requirements of other industries that it has no effect at all upon the copper and aluminium markets.

Fully-filled aluminium-conductor cables have given the benefit of savings on capital outlay as compared with copper although, in the initial stages of their introduction, this has been somewhat offset by teething troubles caused by unfamiliarity with the field use of aluminium as a conductor.

The possibility of using an aluminium alloy having mechanical characteristics more akin to those of copper is being investigated.

It was realized that similar savings could be made by extending the use of aluminium to the exchange-area network as well as to the distribution network and the prospect of avoiding pressurization by using a fully-filled cable was an added attraction. At this very moment it may be argued that the copper price is too low to justify such a step but the cable-development engineer must explore all possibilities so as to be prepared for the effect of future fluctuations in the metal market. This development shows promise and, therefore, a number of fully-filled aluminium-conductor cables in sizes up to 1,600 pairs have been installed for field trial. Some difficulties exist, particularly the problem of stripping down and terminating a large jelly-filled cable on the main distribution frame (m.d.f.). These are being investigated and, meantime, there is no reason why the terminating length should not be unfilled and pressurized. A reliable method of terminating aluminium wires is under development.

In order to allow full flexibility for maintenance replacement it is intended to include a small-bore pipe in the make-up of these fully-filled cables thus allowing them to be incorporated in pressurized systems without interfering with their normal operation.

Thin-Wall Cellular-Polythene Insulation

It has already been noted that the introduction of cellular polythene made the concept of a fully-filled cable a realizable proposition. In 1967 the B.P.O. suggested that further development of the extrusion technique might allow a very thin coating of cellular polythene to be produced so as to give a cable smaller in overall diameter than its equivalent with solid-polythene insulation while retaining the same wire-to-wire capacitance. Such cables have now been developed and they are in general production both for the B.P.O. and for overseas.* This type of cable is gradually superseding the solid-polythene-insulated cables used for terminating in the pressurized part of the network. Fig. 5 shows how 800 pairs

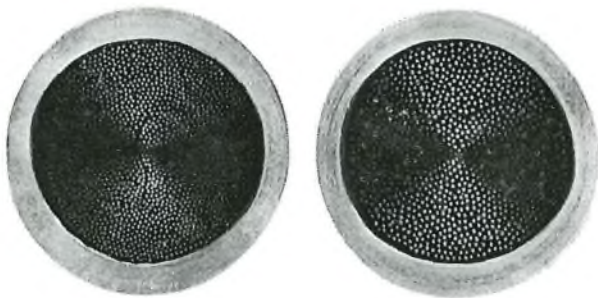

FIG. 5—Comparison of 800-pair cable with thin-wall cellular-polythene insulation and 600-pair cable with solid-polythene insulation, both with 0.4 mm copper conductors

of 0.4 mm diameter copper conductors with thin-wall cellular-polythene insulation can be contained within a sheath of the same diameter as 600 pairs with solid-polythene insulation. Apart from the consequent saving in duct occupancy there is little to choose between the two types on engineering grounds.

Longitudinal-Paper Insulation

Recently, a method of insulating wires with a longitudinal wrapping of paper has been developed by Standard Tele-

phones and Cables Limited (S.T. & C.) and the speed of application is much greater than that for lapped paper. The concept of longitudinal insulation is not new; it was used in the very earliest days but abandoned because of handling troubles in the field. Unwrapping occurred during jointing and wire-to-wire contacts in cable lengths were not uncommon. In consequence, the helical lapping technique became generally accepted in the United Kingdom† as the only practicable method of insulating wires with paper.

This new development* involves the continuous application of a single strip of paper with an adhesive under the outer edge so as to form a sealed paper tube of double thickness. Undoubtedly this use of paper provides a more rugged construction than helical lapping and the possibility of unwrapping is avoided. Laboratory assessment has shown cables of this kind to be suitable for use with the Jointing Machine No. 4,¹⁰ while the ruggedness of the sealed-tube construction prevents exposure of the wires as they are handled. For twist joints, it has been found preferable to strip the paper from each wire individually rather than to strip both at once as is the present practice with lapped paper. However, this slight drawback is more than offset by the handling advantage. A field trial of cables having longitudinal-paper insulation is now in progress and Fig. 6 shows some of the insulating

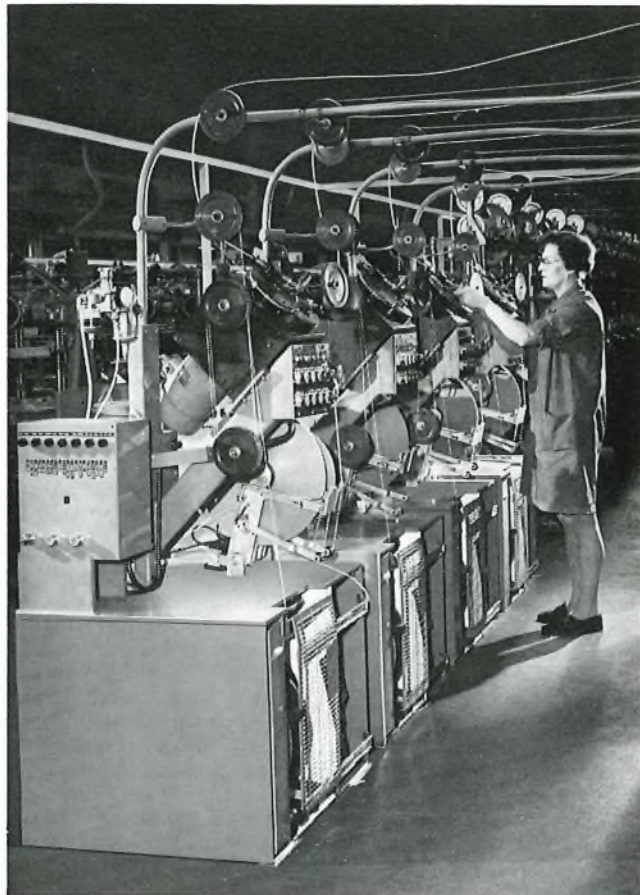

FIG. 6—A bank of machines for applying longitudinal-paper insulation to cable conductors

machines on which the conductors for these trial cables were prepared.

PURCHASING POLICY

The continuing development of new materials and processes has broadened the scope of the cable engineer and he now has

* First marketed by British Insulated Callender's Cables Ltd. (B.I.C.C.) as the "HYPERDEN" cable.

† For many years pulped paper has been used in the U.S.A.
* S.T. & C. Ltd. Sealed-Paper-Tube (S.P.T.) Cable

a wider choice than ever before in providing for the needs of the network. Some advocate a policy of standardization in order to simplify installation and replacement, but others prefer to allow the purchase of a multiplicity of types so as to make the best use of the new manufacturing techniques which are being developed.

The purchase price of a cable depends partly upon the cost of materials and partly upon the cost of the manufacturing processes involved in converting them into a finished cable. These costs may change for reasons beyond the control of the user and rigid adherence to a particular type, as implied by a policy of standardization, could well turn out to be uneconomic in the long run.

CONCLUSIONS

The cable network is in a state of continuous but gradual change as a result of progressive development in materials and manufacturing methods. It is for the cable development engineer to guide and control the network as it grows and there are many factors which he must take into account. Of these, the most important are reliability and technical performance because failure to give these sufficient weight could well lead to eventual degradation of the cable network with consequent reduction in its value as a vital part of the present system and an essential base on which to build the new by further exploitation of its latent capabilities.

Rigid adherence to a policy of standardization is of doubtful merit because it could well discourage the exploitation of new materials and the introduction of new processes upon which sound progression on the basis of wise investment mainly depends.

ACKNOWLEDGEMENTS

The British cable makers allot considerable effort to the development of cables both for the B.P.O. and for the export market and in many aspects they lead the world. In the preparation of this article their assistance, together with that of the author's colleagues, is gratefully acknowledged.

Figs. 3 and 6 are reproduced by permission of S.T. & C. and Figs. 4 and 5 by permission of B.I.C.C.

References

- ¹ BUCKLAND, E. H., and FRANKLIN, R. H. Some Notes on the Design and Manufacture of Telephone Cables. *I.P.O.E.E.* Printed Paper No. 144, Feb. 1932.
- ² SPENCER, H. J. C. Optimum Design of Local Twin Telephone Cables with Aluminium Conductors. *Proceedings I.E.E.*, Vol. 116, No. 4, p. 481, Apr. 1969.
- ³ SPENCER, H. J. C. Some Principles of Local Telephone Cable Design. *P.O.E.E.J.*, Vol. 63, p. 164, Oct. 1970.
- ⁴ BLACKWELL, J. F., and GENT, A. W. Optimal Design of Local Twin Telephone Cable with Paper Insulation. *Electrical Communication*, Vol. 46, No. 2, p. 157, 1971.
- ⁵ KOTTRITSCH, L. D. W. A World Cable Record. *P.O.Telecomms. J.*, Vol. 19, No. 4, p. 2, Winter 1967.
- ⁶ DODD, G. A. The Trends in Telephone Subscriber Cables. Conference on Transmission Aspects of Communications Networks. *I.E.E.*, 1964.
- ⁷ DEAN, N. S. Development of Fully-Filled Telephone Cables. Seventeenth Annual Wire and Cable Symposium, Atlantic City, N.J., Dec. 1968.
- ⁸ WINTERBORN, E. E. L. This New Cable is Really Waterproof. *P.O. Telecomms. J.*, Vol. 19, No. 3, p. 2, Autumn 1967.
- ⁹ WINTERBORN, E. E. L. Aluminium Conductor Cables in the Telephone Distribution Network. *P.O.E.E.J.*, Vol. 64, p. 146, Oct. 1971.
- ¹⁰ HARDING, J. P. A Wire-Jointing Machine for Subscribers' Cables. *P.O.E.E.J.*, Vol. 62, p. 31, Apr. 1969.

Book Reviews

"Active and Nonlinear Propagation in Electronics." Alwyn Scott. John Wiley and Sons Ltd. xiv + 326 pp. 150 ill. £7.00.

Science and engineering have many problems which are basically those of propagation in a nonlinear and possibly active medium. Related problems may be found in plasma physics and physiology, microwave engineering and oceanography. Solutions of these problems have often been derived by way of special or limiting cases or by making considerable (and sometimes quite unjustifiable) approximations in order to reduce the mathematical complexity of the problem and enable existing and more familiar mathematical techniques to be used.

What makes this book so refreshing is the physical insight behind the mathematics. For instance, after deriving the expression for the plasma frequency of an electron beam the author writes: "It (the plasma frequency) is the frequency at which the inertia of the electrons resonates with the dielectric constant of vacuum". Even the Manley-Rowe relations seem a good deal less formidable when given the treatment.

To an extent the book, dealing predominantly with coupled mode theory, both supplements and complements Louisell's "Coupled Modes and Parametric Electronics". It covers the applications of nonlinear active transmission-line theory from the travelling-wave tube through lasers and magneto-hydrodynamics to nerve axons. There are problems for the enthusiast to do at the end of each chapter (the book is based

on a series of lectures to students of electrical engineering), and an extensive bibliography is enhanced by an excellent cross-referencing system.

H. N. D. and R. B. D.

"Telecommunications (S.I. Unit Edition)." W. Fraser, M.Sc.(Eng.), F.I.E.E. Macdonald and Co. Ltd. xii + 803 pp. 438 ill. £4.40.

A further printing of this well-known book has been used to change the units employed throughout the text.

Originally published in 1957 as a textbook for HNC and University of London engineering-degree students, it was revised in 1967 and subsequently reviewed in the July 1969 issue of the *P.O.E.E.J.* Apart from those changes necessary for the conversion to S.I. units, few alterations have been made to the text since that review, although some more recent examination questions have been included as exercises for the student. The book deals with a wide range of topics: network and transmission theory, devices, circuitry and telecommunications systems all being covered. This has necessarily led to some subjects being treated in breadth rather than depth, but references for further reading can be found at the end of each chapter.

It can be thoroughly recommended to students of telecommunications at second year degree or similar level.

J. O. W.

A Subscribers' Carrier System for the Local Network

L. W. KINGSWELL and G. C. TOUSSAINT†

U.D.C. 621.395.743: 621.3.052.7

A subscribers' carrier system offers a means for providing extra exchange connexions using existing line plant. However, the introduction of such a system into the British Post Office local-line network will pose a number of problems in addition to those associated with transmission and signalling performance. This article concentrates on technical factors and suitable design parameters are proposed.

INTRODUCTION

Subscribers' carrier systems offer a method for increasing the number of exchange connexions that can be provided over standard unloaded local cable pairs. Each carrier connexion requires two electronic interface units, one located at a customer's premises and the other at the exchange. These interface units are connected to the line and convert normal speech and signalling frequencies into modulated carrier signals suitable for transmission over the line. In order to permit independent use of the pair at voice frequencies, the audio circuit is connected to the line through low-pass filters (Fig. 1).

Several commercially-available systems have been studied during the past few years and systems of British Post Office (B.P.O.) design have also been the subject of various field trials and feasibility studies. As long ago as 1938 a research report describing a "Carrier System for Subscribers' Lines"

mentioned a carrier system which was developed in 1938 and installed at St. Albans, in order to determine whether any insurmountable difficulties would occur in practice. Difficulties were encountered; some were overcome; others, however remained intractable until the advent of the improved techniques and components of recent years. Not all subscribers' carrier problems are of a technical nature; there are related economic and administrative aspects. In this article some of the technical factors affecting subscribers' carrier are identified, a suitable system described and system design parameters proposed.

THE LOCAL DISTRIBUTION NETWORK

Although the local line networks of this country have, in the main, been designed to provide certain standards of transmission as determined by d.c. and audio-frequency characteristics,¹ the majority of the network is capable of operation at frequencies above the audio range.

The network comprises underground and aerial cable, open wires and twin drop-wire. Conductors are either copper or

† Telecommunications Development Department, Telecommunications Headquarters.

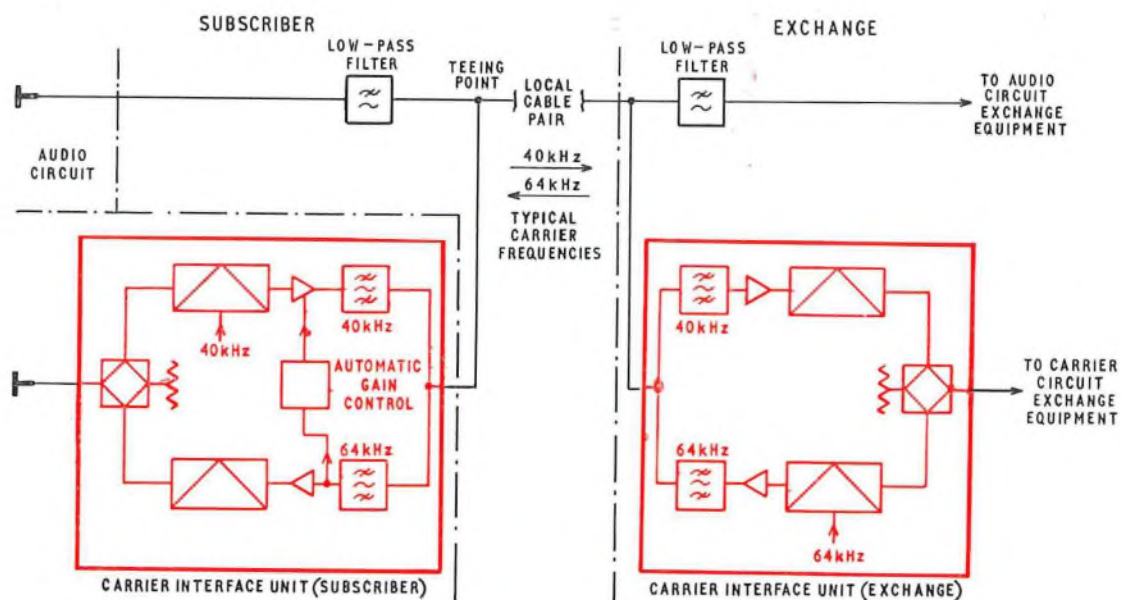

Notes: (1) Subscriber send and receive levels determined by line length
 (2) Exchange send level 0 dBm
 Exchange receive level $-37 \text{ dBm} \pm 5 \text{ dB}$

FIG. 1—Simplified block diagram of a 1 + 1 subscribers' carrier system

TABLE 1

Typical Line Limits for Cables using Common Copper-Conductor Gauges

Conductor Gauge mm (lb/mile)	Limiting Length km (miles)			Attenuation at 1,600 Hz		Attenuation at 70 kHz		Attenuation at 140 kHz	
	1,000 ohms d.c.	Transmission limit at 1,600 Hz	Overriding limit	dB/km	dB at limiting length	dB/km	dB at limiting length	dB/km	dB at limiting length
0.32 (2½)	2.3	3.5	2.3 (1.43)	2.8	6.45	11.4	26.0	13.6	31.2
0.4 (4)	3.6	4.5	3.6 (2.23)	2.2	7.94	8.6	31.0	10.51	38.0
0.5 (6½)	5.95	5.8	5.8 (3.6)	1.7	9.87	5.9	34.2	7.85	45.5
0.63 (10)	9.2	7.2	7.2 (4.5)	1.38	9.95	4.91	35.4	6.65	47.9

aluminium and can occur in a wide variety of gauges. Wires are either in pair formation or, in older cables, in star-quad formation. In all, about 100 different combinations are currently available. Table 1 shows typical limits for some of the more usual copper conductor gauges.

An exchange line can be composed of a number of sections of cable each having differing characteristics and length. The limiting length is determined by d.c. signalling requirements and the transmission performance at 1,600 Hz. The percentage of exchange connexions as a function of radial distance is shown in Fig. 2. This is an average curve and individual exchange networks will vary from this.

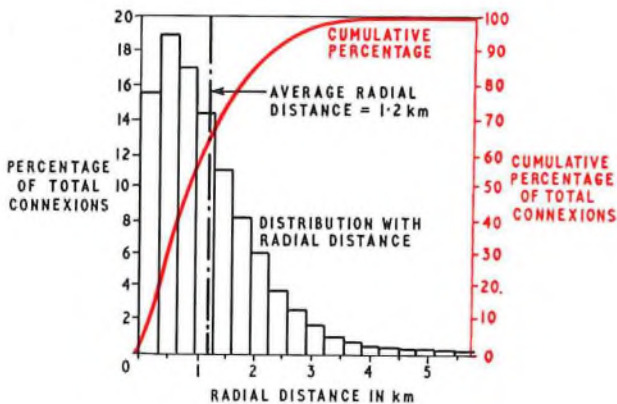

FIG. 2—Distribution of radial distances of exchange connexions

Crosstalk

Local cables are not much inferior to those used on main lines in respect of crosstalk but the jointing technique used for reducing the effect of unbalance is not utilized on the local network.

The curves for far-end signal-to-crosstalk ratios and line loss for a limiting length of line, estimated from measurements made on pairs in the local distribution networks, are shown in Fig. 3. The nominal value of the characteristic impedance of local cables at frequencies selected for carrier working (19–150 kHz) is 140 ohms.

Cables of recent manufacture tend to have higher wire-to-wire capacitance which leads to higher attenuation but they are found to have improved cross-talk performance. Cable pairs extended by parallel open wires frequently give poor crosstalk, probably no better than 18.5 dB/km at 100 kHz.

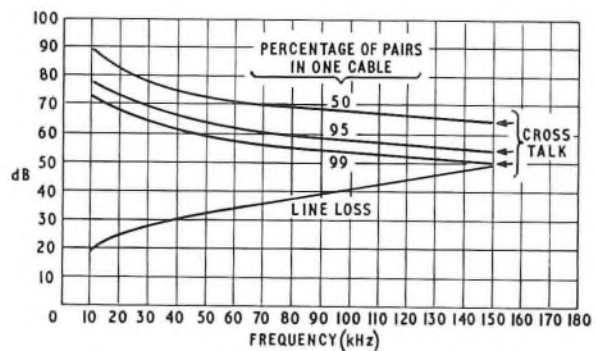

FIG. 3—Estimated line loss and far-end signal-to-crosstalk ratios for a limiting line (underground)

Radio interference can also cause serious problems on open wire routes and it is probable that exchange lines containing more than two or three spans of open wire may be unsuitable for connexion to a subscribers' carrier system. Fig. 3 shows that for an underground line of limiting length, the signal-to-crosstalk ratio at 150 kHz is approximately 50 dB, whereas, at 19 kHz, a 20 dB improvement can be expected. In order to take full advantage of the improved signal-to-crosstalk ratio at the lower carrier frequencies, analogue speech systems will use the band between 19 and 96 kHz and higher frequencies will be allocated for general-purpose signalling systems. If the upper frequency limit is set at about 150 kHz, system frequencies will be allocated in accordance with Fig. 4.

The bandwidth between 19 and 96 kHz can be used as dictated by system requirements. A single channel (1 + 1) system can, if necessary, occupy this entire band. Channel frequencies as shown in Fig. 4 are typical, the choice of frequencies generally being influenced by the need to achieve maximum economy in filter design. In practice, multiples of 4 kHz would be used in order to minimize the risk of mutual interference with main-line carrier systems. Fig. 5 shows the proposed filter characteristics.

THE CARRIER SYSTEM

Transmission

The overall transmission performance of a telephone connexion depends on the transmission characteristics of the following:

- (a) the subscriber's instrument,

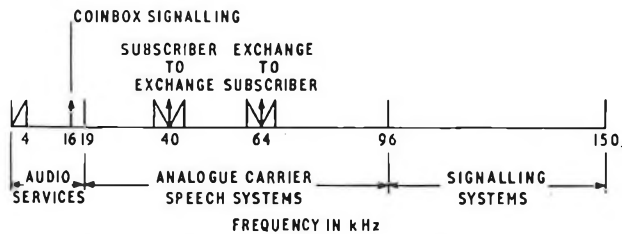

FIG. 4—Frequency allocations for pair-type local-lines

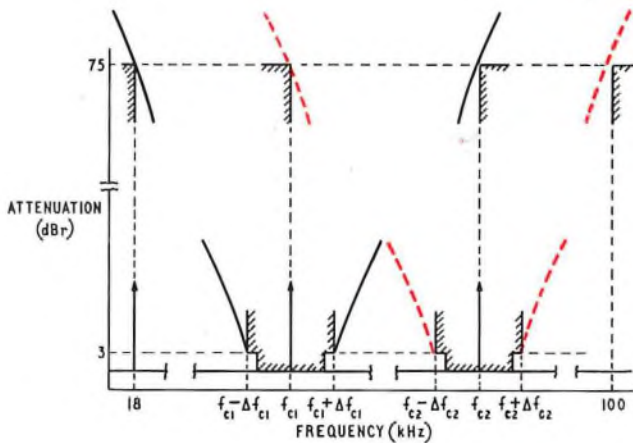

FIG. 5—Receive-channel filter-response showing stop and pass-band limits

- (b) the local line connecting the subscriber's instrument to the respective local exchange,
- (c) the equipment in the local exchanges,
- (d) each link in the connecting chain of circuits, i.e. trunk and junction networks, and
- (e) each intermediate switching point.

These factors are taken into account in national and international transmission plans^{2, 3} which ensure that, in general, whatever combination of plant is used in the connexions, the average levels of speech power arriving at receivers will be adequate and there will be voice recognition, i.e. there should be sufficient audio band-width and reasonable freedom from distortion. Side-tone levels need to be controlled since excessive side-tone causes talkers to reduce their mean speech-power output and insufficient side-tone has the opposite effect.

A wide range of power levels can be expected at the output of the 706-type telephone. Mean speech-power levels for 99.7 per cent of all 706-type telephones lie within the range +3 dBm to -27 dBm. However, peaks occur 10 dB above the mean bringing the maximum power output from the telephone up to +13 dBm. For network planning purposes the mean speech-power while the circuit is active is taken as -12 dBm with a standard deviation of 5 dB. To ensure that any telephone connexion which includes a subscriber carrier system should fit in with the overall transmission plan, it is proposed that the performance of the carrier channel should be made equivalent to that of an average local line which has a loss of approximately 4.0 dB at 1,600 Hz. The means of the national sending and receiving equivalents for local lines fitted with 706-type telephones are +7 dB and -4 dB respectively. (In each case this value is relative to NOSFER.)*⁴

Tables 2 and 3 show the percentage of local-line connexions related to particular values of sending and receiving reference equivalents.

With a 706-type telephone terminating the carrier channel and connected to any line up to the limiting length, the required sending and receiving equivalents are obtained when:

* New European Reference System for Telephone Transmission.

TABLE 2
Percentage of Local-Line Connexions with Stated Sending Reference Equivalents

Sending Reference Equivalent (dB)	+3 to +4	+4 to +5	+5 to +6	+6 to +7	+7 to +8	+8 to +9	+9 to +10	+10 to +11	+11 to +12
National percentage 1964/1965	—	—	14	78	5	2	1	—	—
London Telecommunications Region percentage 1964/1965	—	—	9	86	4	1	—	—	—
Provincial percentage 1964/1965	—	—	16	76	5	2	1	—	—

TABLE 3
Percentage of Local-Line Connexions with Stated Receiving Reference Equivalents

Receiving Reference Equivalent (dB)	-6 to -5	-5 to -4	-4 to -3	-3 to -2	-2 to -1	-1 to 0	0 to +1	+1 to +2
National percentage 1964/1965	11	79	6	3	1	—	—	—
London Telecommunications Region percentage 1964/1965	7	85	6	2	—	—	—	—
Provincial percentage 1964/1965	12	77	6	4	1	—	—	—

(a) the insertion loss of the carrier system in the direction of subscriber-to-exchange and exchange-to-subscriber is respectively, 2 dB and 4 dB, measured between 600-ohm non-reactive impedances at the two-wire points,

(b) the telephone transmitter has a feeding current of 25 mA. (At this value of current the regulator is inoperative. A fixed transmitter current also has the merit of reducing the range of speech power levels which are normally experienced where the transmitter current is determined by line length), and

(c) the audio-frequency response of the derived circuit has nominal 3 dB points at 300 Hz and 3,400 Hz.

These conditions will provide an adequate transmission performance and a reasonable margin of stability. In practice, the attenuation of limiting lines at 64 kHz could be as high as 40 dB in worst cases. However, the maximum gain of a carrier channel will be 45 dB to allow for impedance mismatch owing to the possible presence of an unterminated spur. Fig. 6 shows typical attenuations for various lengths of unterminated spur.

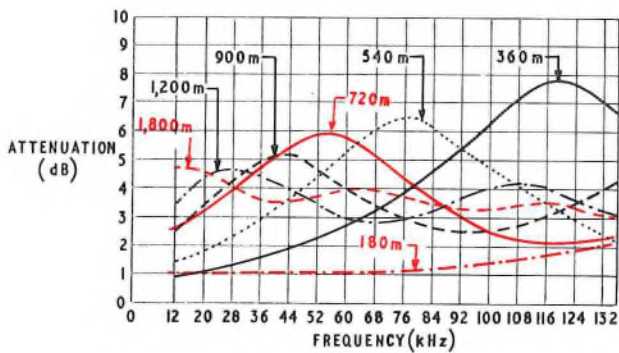

FIG. 6—Typical attenuations for various lengths of unterminated spur

From the exchange, the maximum transmitted carrier level will be 0 dBm. The level of the unmodulated carrier signal transmitted from the subscriber's terminal will be determined automatically by reference to the level of incoming carrier signal from the exchange (Fig. 7(a)) and will reach 0 dBm only on a line of maximum length. The automatic gain control is arranged in this manner so that the incoming carrier signal level at the exchange will be maintained at $-37 \text{ dBm} \pm 5 \text{ dBm}$ for a nominal carrier-signal frequency of 40 kHz. Signal-to-cross-talk ratio will, therefore, be improved at a point where a large number of carrier systems could converge and where, otherwise, a much wider range of carrier signal levels could be expected. The subscriber carrier system uses a different carrier-signal frequency for each direction of transmission (Fig. 4), the lower frequency being transmitted from the subscriber's terminal. Carrier-signal frequencies are not transmitted when the circuit is in the idle condition.

The need for cheap terminal equipment can, as yet, be met only by using an amplitude-modulated double side-band transmitted carrier system as opposed to the single side-band suppressed carrier system used on main lines. Recent feasibility studies have shown that, because of its improved signal-to-noise performance, and its inherent resistance to amplitude-modulated interference, a frequency-modulated system could give some advantage. However, to take full advantage of frequency modulation, complex filters of wider bandwidth are required which would increase on system costs.

Signalling

Outgoing Calls

When the telephone handset is lifted, a d.c. loop is established between the telephone and the subscriber's carrier unit which switches on the local 40 kHz oscillator. Carrier-signal frequency is then transmitted to the exchange where it is detected and made to operate a relay. Relay contacts re-establish the d.c. signalling loop between the exchange carrier-unit and the exchange calling equipment. At the same time, the exchange carrier-signal oscillator (64 kHz) is switched on, and a signal modulated with dialling tone is transmitted back to the subscriber, where it is detected and the audio output applied to the telephone (Figs. 7(a) and 7(b)).

Dialling can now commence and loop disconnect pulses from the subscriber's dial contacts interrupt the outgoing carrier signal, thereby causing the relay contacts in the exchange unit to pulse and re-establish the loop-disconnect dialling conditions.

Incoming Calls

Ringing tone is detected at the audio input to the exchange carrier unit and causes the carrier-signal oscillator (64 kHz) to be switched on and then interrupted at the ringing cadence. The incoming carrier-signal is detected at the subscriber's unit where a d.c. output voltage is connected into a ringing tone amplifier. The output of the amplifier is connected to the telephone bell. As soon as the telephone handset is lifted the ringing-tone amplifier is inhibited and carrier signal (40 kHz) is transmitted to the exchange to provide the ring-trip (loop) condition.

Facilities

Some limitation to the facilities available on the carrier channel can be expected, for example signalling conditions requiring one wire and earth return or a reversal of the line polarity might not be possible in a low-cost system. Such limitations might affect provision of facilities such as shared service, pay-on-answer coin boxes, subscriber-controlled transfer and trunk barring. Again, for reasons of economy, it may be necessary to restrict the number of extension bells which may be rung by the carrier-channel equipment.

Power Supplies

Exchange Carrier-Unit

This can conveniently be powered from the exchange battery. If only a small number of carrier units are involved (about 10) it is proposed to derive the supply voltage (12 volts d.c.) from the exchange battery by using a simple arrangement of voltage-dropping resistor and zener diode. For larger numbers, a d.c.-d.c. converter would be more efficient, avoiding the excessive power losses incurred by voltage-dropping resistors. Each channel requires about 200 milliwatts when active.

Subscriber's Carrier-Unit

Typical power requirements for carrier units in subscribers' premises are 16 milliwatts when the handset is on the rest, 320 milliwatts when the handset is off the rest and, depending on the number of bells, up to two watts for ringing.

Several methods for providing this power have been considered, each having some limitations. Methods can be classified under two main headings, namely line power and local power.

Line Power

Power fed directly over the line from the exchange battery will be limited to the source of impedance of the longer lines. To operate effectively from the available power, non-standard

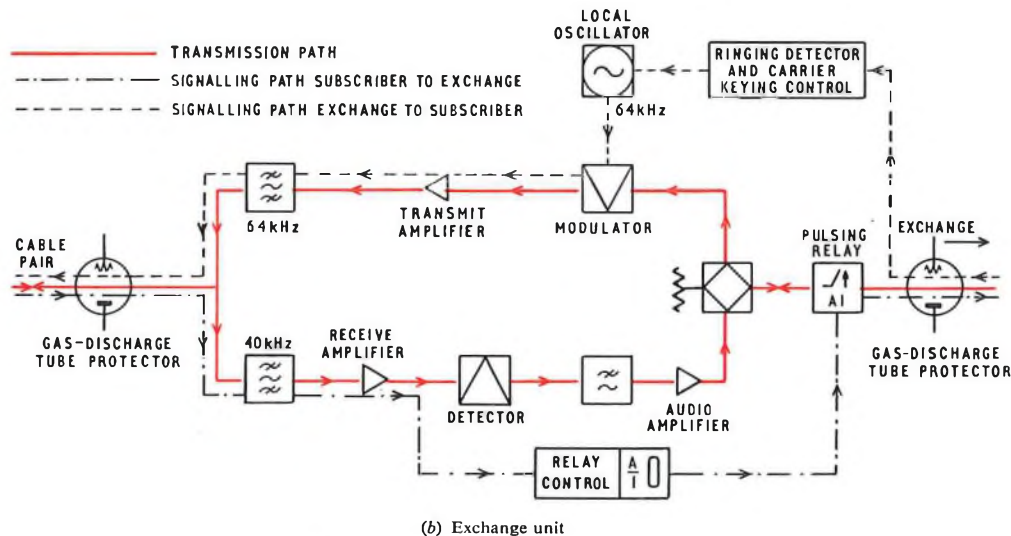
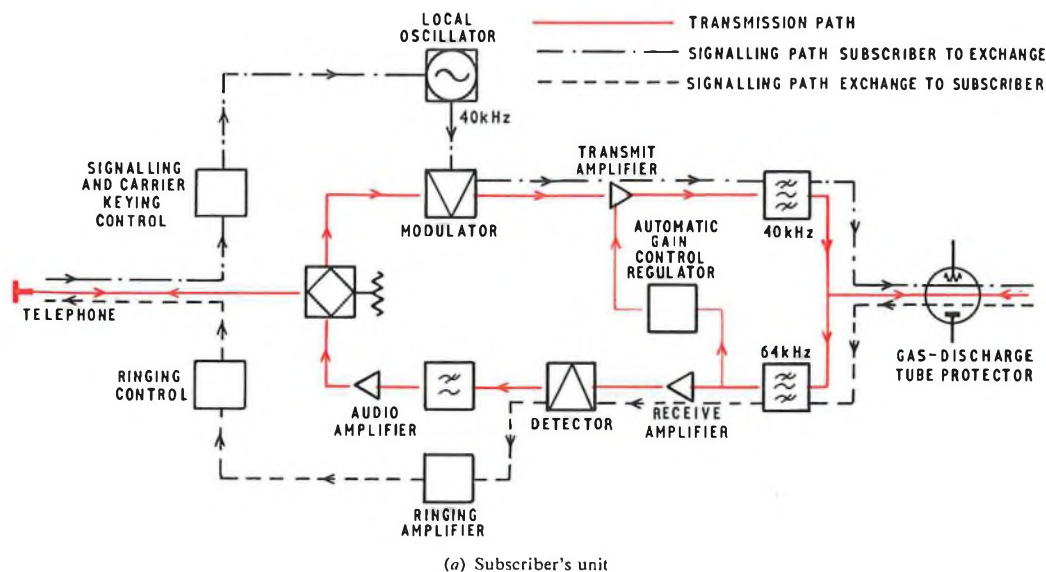

FIG. 7—Block diagrams of subscribers' carrier-units

telephones equipped with dynamic receivers and transmitters and tone callers would be needed. The audio circuit would require to be similarly equipped and, in addition, the loop-signalling condition would need to be replaced by its carrier-frequency analogue. Alternatively, power for the carrier unit could be derived from a local secondary nickel-cadmium battery, trickle charged over the line from the exchange battery. Existing methods are, however, limited to a charging current of a few milliamperes only. The continuous presence of the charging circuit across the cable pair has a number of operational disadvantages. It can, for example, cause dial-pulse distortion on the audio circuit. It will appear as a leakage across the pair, rendering the circuit more liable to insulation faults, whilst at the same time presenting non-standard line conditions which require different testing methods. The charging current flows through the line relay and will adversely affect its release performance. Because charging can take place only whilst the audio circuit is idle, a further difficulty could arise if both channels had a high calling rate. Recently-developed equipment enables a relatively high current to be drawn from the line when it is not in use by the audio subscriber. Incoming or outgoing calls or testing activities cause the battery charging circuit to be disconnected automatically from the line. The small quiescent

current required by the carrier unit in the idle condition can, in effect, now be drawn from the line during charging periods, thus enabling the total capacity of a fully-charged battery to be available for calls made to or from the carrier circuit.

Local Power

A local primary battery, replaced at regular intervals, could provide a satisfactory power source. Calling rates affect battery life and, therefore, an accurate assessment of its service life is not possible. Laboratory tests have been carried out simulating a variety of calling rates using two types of commercially available primary battery. The PP10-type battery was shown to be capable of providing up to one year's service for an installation having an average calling rate whilst the smaller PP9-type battery, similarly connected, lasted up to eight weeks. In arriving at the service life of batteries the average subscriber was assumed to make and receive, on average a total of four four-minute calls each day (1968 national calling-rate statistics).

The question of detecting a failing battery must also be considered. Subjective tests have shown that, on the carrier channel, the reducing terminal voltage of the battery causes a gradual ringing failure of the telephone bell well before any

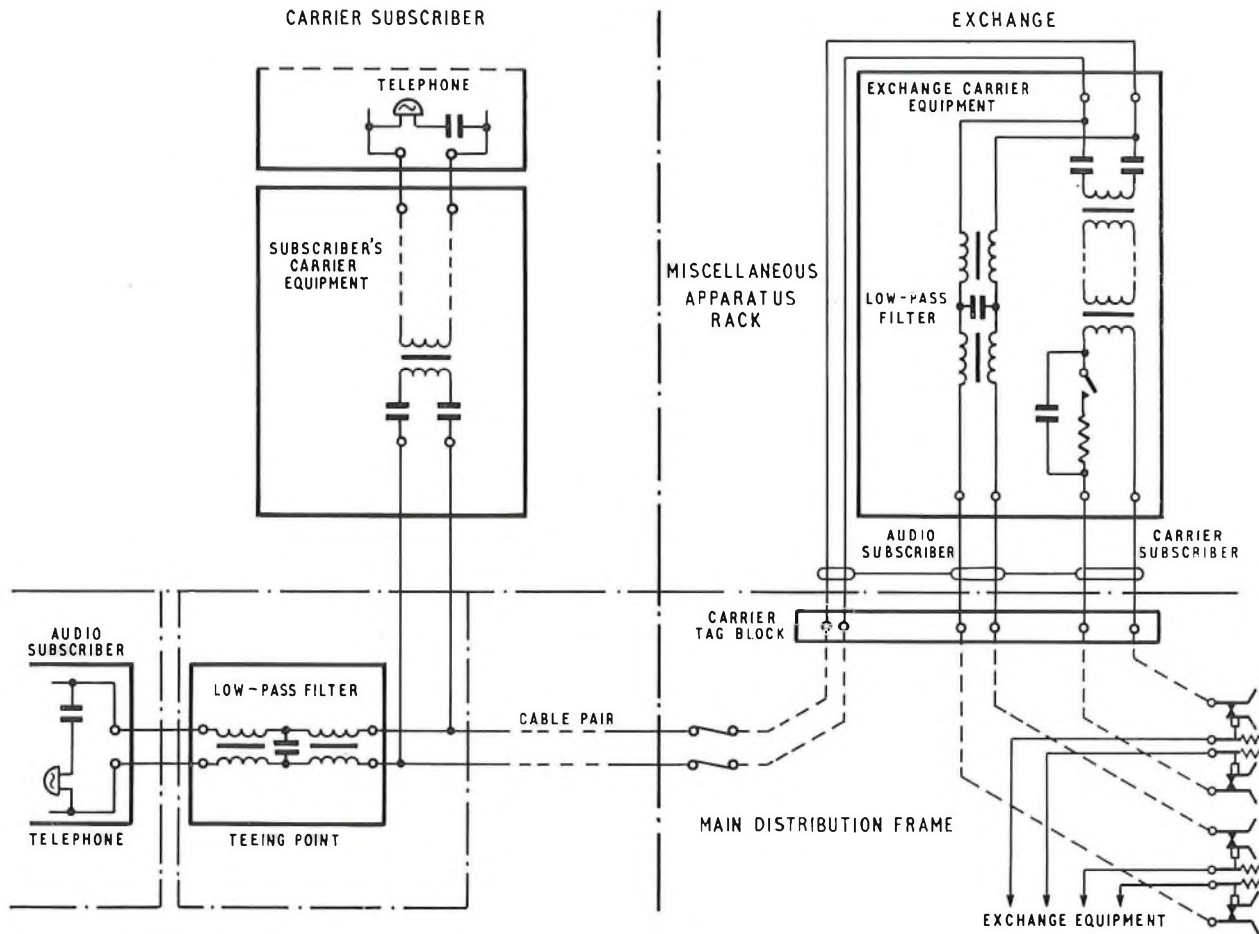

FIG. 8—Connexion of the line at the exchange

dial-pulse distortion arises. At first the loudness of the bell diminishes, followed by a distortion of the ringing cadence and, finally, complete failure. As this will occur over a period of several days, customers would have some indication of the state of the battery and should be able to anticipate replacement requirements. Often battery changing could be carried out during a normal maintenance visit which is, on average, once every three years, thereby minimizing additional maintenance costs.

A carrier unit, powered locally from the mains, would overcome the limitations imposed by previous methods. However, loss of telephone service during an electricity supply failure must be guarded against. Either a small primary battery or a rechargeable nickel-cadmium battery could be provided as a standby. Primary batteries are cheap and readily available but have comparatively short service lives. Rechargeable batteries, whilst having longer lives, are more costly and require additional circuitry for the control of charging currents.

On balance, the use of a primary battery as a standby would be preferred. The PP9-type battery offers suitable life expectancy for standby duty and has the merit of being currently in use by the B.P.O. Shelf life is estimated as upwards of two years, i.e. the battery would be still capable of supplying sufficient power to make an outgoing call after that time.

The choice of power supply must be influenced not only by engineering preferences but also by service and installation requirements. The improved form of line-powered trickle charging offers the most satisfactory general solution and is, therefore, chosen as the standard method for powering the 1 + 1 carrier system. Future developments or local requirements could necessitate some alteration to power-supply

methods. Mechanical design of the subscriber unit needs to be such as to allow their inclusion without the need for major modification.

SERVICE ASPECTS

General Requirements

Ideally a local-line subscriber-carrier system should be unobtrusive to the customer and to the sales, installation and maintenance staff. No special transmission skills should be required for installation and the system should operate for long periods without attention. Additional maintenance demands should be minimal and should not require significant departure from established methods. The estimated time between failures, based on reliability assessments of the individual components comprising a complete channel equipment, is approximately 20 years. This, at worst, would increase the annual number of maintenance visits for an exchange connexion (based on 1968-69 statistics of reported faults) from 0.3 to approximately 0.35 per carrier-derived connexion.

Installation and Maintenance

The automatic-gain-control feature will render the system self-aligning and self-compensating for changes in line attenuations owing to climatic variations, re-routing or connexion of interruption cable. Unless shared service is required on the audio circuit, no special attention will be necessary regarding line polarity.

Local maintenance of both the exchange and subscribers' carrier equipment will be limited to replacement of complete faulty units. Servicing at a central repair depot may be employed and, depending on the circuit lay-out and the final



(a) Subscriber's unit

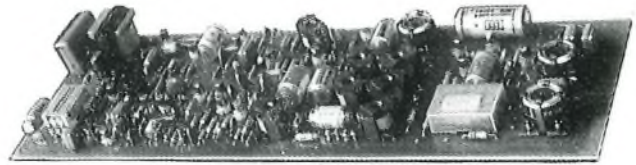

(b) Exchange unit

FIG. 9—Typical subscribers' 1 + 1 carrier equipment

cost of the system, this could be limited to isolating a particular faulty circuit board and replacing it on a throw-away basis.

Exchange cards will probably be mounted on the miscellaneous apparatus rack (m.a.r.). Each 1 + 1 carrier system will require three jumpers on the main distribution frame (m.d.f.). Permanent wiring will connect the m.d.f. carrier connexion block to the carrier equipment mounted on the m.a.r. (Fig. 8).

Testing

The cable pair is common to both audio and carrier circuits. Therefore, a test carried out from the exchange on the physical circuit will indicate any line-fault conditions common to both circuits. There will be a small increase in capacitance owing to the low-pass and band-pass filters which are teed across the line but this will be masked by the $1.8 \mu\text{F}$ capacitor in the bell circuit of the audio subscriber's telephone. Direct current tests for exchange conditions on the carrier circuit can be made only as far as the two-wire input to the exchange carrier equipment which will have the appearance of a small capacitance. To perform functional tests of the carrier circuit from the test desk it will be necessary to include carrier equipment in the testing circuit.

MECHANICAL DESIGN

Initially, carrier equipment will be designed to work with any standard telephone, the subscriber's carrier unit being regarded as a black box connected between the line and the telephone instrument (Fig. 9(a)).

The carrier equipment case will probably be injection moulded in a suitable plastic such as a.b.s. (acrylo-nitrile-butadienestyrene) and could be made available in a range of colours to match telephone instruments. The carrier equipment case will be proportioned so that it can be mounted unobtrusively for example, under a curtain where the telephone lead wire comes through the window frame. The standard unit will contain all the components necessary for the carrier circuit and power supply. Exchange equipment comprises a single plug-in printed-circuit card containing components for the carrier circuit plus the low-pass filter for the exchange end of the physical circuit. Fig. 9(b) shows a suitable arrangement.

To avoid the need for work to be carried out in the audio subscriber's premises, the low-pass filter is designed for pole or external mounting. Filter components will be encapsulated in a suitable epoxy resin, the assembly being provided with a wire tail suitable for connexion at the teeing point.

FIELD STUDIES

Following extensive laboratory tests, several sets of a commercially-available 1 + 1 carrier system (modified as far as possible to B.P.O. requirements) are being tested under field conditions. In addition to the assessment of technical feasibility these studies are intended to bring to light any problem associated with installation and maintenance.

The overall performance to date has been encouraging. Installation has proved straightforward and such maintenance as arose was adequately resolved by normal maintenance procedures. Two of the studies each involved 10 carrier systems working in the same main cable and, up to the present, there has been no conclusive evidence of crosstalk between individual systems.

CONCLUSIONS

If it is proved economic, the introduction of subscribers' carrier into the local network will influence an area in which radical changes seldom occur. Although it may be expected that some accepted practices will have to be modified to accommodate the new development, design proposals for the 1 + 1 carrier system are such that these changes should be kept to a minimum.

ACKNOWLEDGEMENTS

The authors wish to acknowledge the assistance and advice received from many colleagues within the B.P.O. and telephone industry with whom they worked in close co-operation for some time.

Thanks are due to G.E.C./A.E.I. for permission to publish the picture of a typical carrier equipment shown in Fig. 9 and to General Telephone and Electronics International for permission to publish the graphs shown in Fig. 6.

References

- ¹ FUDGE, G. A. E. Introduction and application of transmission performance ratings to subscribers' networks, I.P.O.E.E. Printed Paper No. 198.
- ² SPENCER, H. J. A new method of Local Transmission Planning. *P.O.E.E.J.*, Vol. 63, p. 84, July 1970.
- ³ BOAG, J. F., and SEWTER, J. B. The Design and Planning of the Main Transmission Network. *P.O.E.E.J.*, Vol. 64, p. 6, Apr. 1971.
- ⁴ C.C.I.T.T. Local Telephone Networks—July 1968, Chap. 5—New European Reference System for Telephone Transmission.

Confravision

J. E. HAWORTH, M.B.E., C.ENG., M.I.E.E.†

U.D.C. 621.397: 621.395.49

Confravision is a new service which enables business conferences to be conducted over long distances.

For some years now there has been an experimental link between the British Post Office (B.P.O.) Research Department at Dollis Hill and Telecommunications Headquarters at Gresham Street. A great deal of interest has been shown in these experimental links and the Marketing Department of the B.P.O. have, therefore, decided to set up a trial network. If successful, the network will be extended.



FIG. 1—Inside the Confravision studio

INTRODUCTION

Business conferences often involve top executives in a great deal of travelling, and in spite of the benefits of making personal contact with other executives, most of the time away from the office is ineffective. By means of Confravision, face-to-face meetings can be held without the waste of time, inconvenience and expense involved in long-distance travelling. To enable such conferences to take place, new studios have been built in London, Birmingham, Manchester, Glasgow and Bristol, these centres being chosen partly because they are business centres and partly because they are on the B.P.O. network of microwave radio links and can easily be interconnected.

The experimental Confravision links in this country and in the U.S.A. have indicated that the number of people taking

† Network Planning Department, Telecommunications Headquarters.

part in a conference will be small. Consequently, the studio has been designed to seat five people in camera with two additional seats out of camera. One of the objects of the trial is to decide if this is the best arrangement or if changes should be made.

The trial service will be restricted to monochrome only because colour would add little to the realism, the additional cost involved would far outweigh any benefits gained, and full-time engineering attendance would be required.

CONFRAVISION SUITE

A photograph of the inside of the Glasgow studio is shown in Fig. 1 and a plan of the Glasgow suite is shown in Fig. 2. All the suites are not identical in plan as they depend on the accommodation offered but, in general, the facilities are the same. The suite is composed of the studio, equipment room,

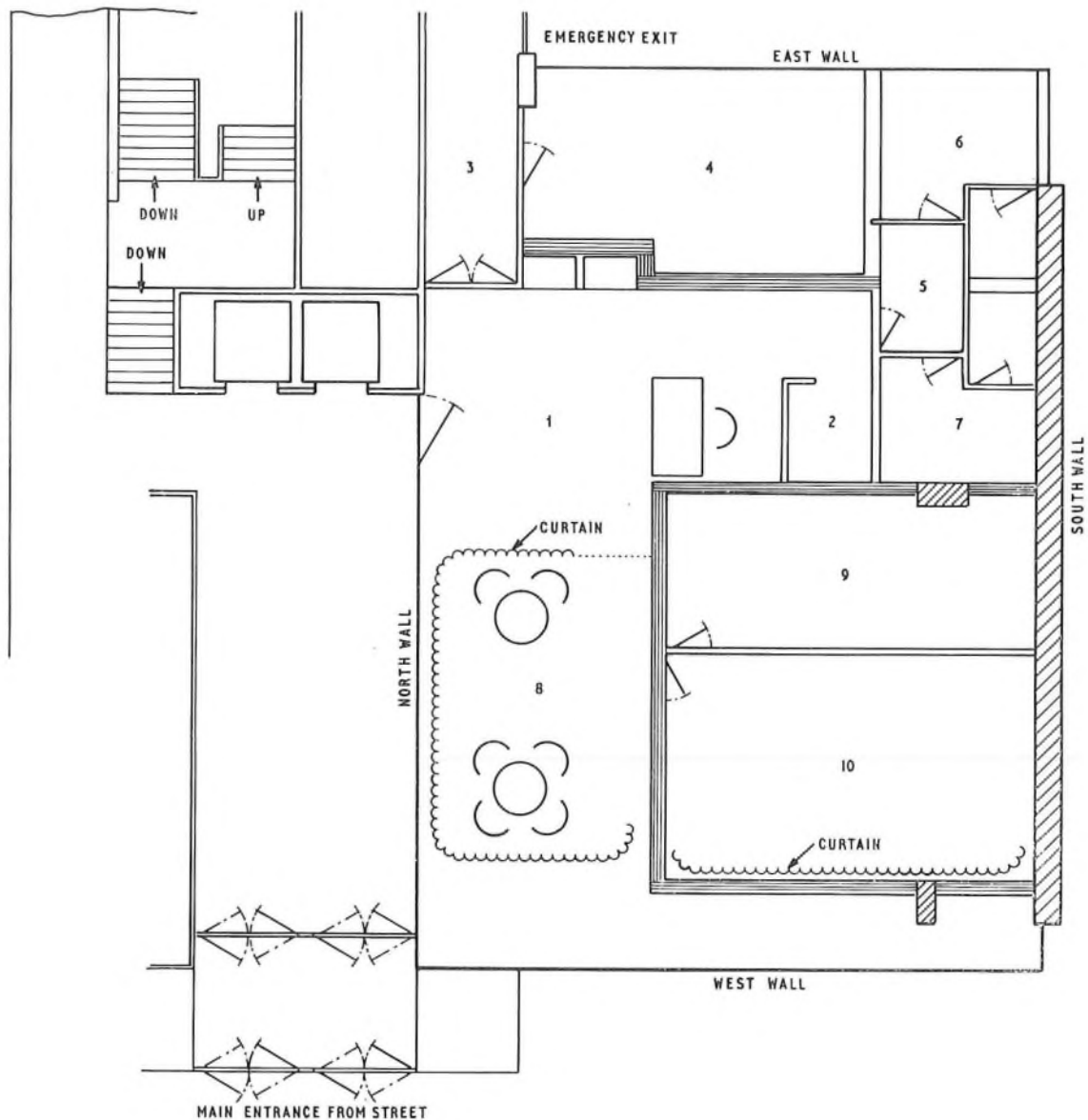

1. Reception 2. Galley 3. Emergency exit passage 4. Air-conditioning plant and switchgear 5. Toilet lobby 6. Ladies' toilet
7. Gentlemen's toilet 8. Display/waiting area 9. Confravision equipment room 10. Confravision production area

FIG. 2—Plan of Glasgow Confravision suite

reception area, a waiting room where conferees can assemble, a small kitchen for the use of the attendant, cloaks cupboard, air-conditioning plant and toilets. The air-conditioning plant is described in another article in this issue.

The suites have been designed with some degree of luxury to give an attractive setting and to present a first-class image of this new British Post Office service. For these reasons, a Consultant Designer, Kenneth Grange, Hampstead, was employed to design and furnish the suites.

Conference Studio

A plan of the conference studio and the equipment room is shown in Fig. 3. These are completely enclosed and sound-proofed to attenuate outside noise by at least 50 dB.

The conference table will seat five conferees, each position having a swivel chair and directional microphone. Facing the table and mounted behind the partition in the equipment room, is a camera with remotely-controlled two-turret lens. In one position, all five conferees are in view of the camera, but if there are only three or less conferees taking part, or if the chairman wishes to address the distant end, then the

second lens can be used to give a close-up of the three central positions. Also facing the table, but physically mounted to the rear of the partition, are two monitors having 24 in screens with 4 × 3 aspect ratio. One is used to display the incoming signal and the other to display the outgoing signal. This is useful when sending pictures of a document or model, as both studios see the same image.

A loudspeaker is mounted on the partition and although adequate power is available, the positioning of the loudspeaker and microphones and the choice of sound absorbing materials have been arranged to give a margin against howling of about 9 dB per studio.

A second camera, with remotely-controlled zoom lens, is mounted in the ceiling above the display table so that maps, documents, manuscripts or models can be displayed. This permits items as large as 36 in by 27 in to be examined, or the monitor screen to be filled with an item only 6 in by 4½ in. About 30 lines of typescript, each line having up to 78 characters, can be displayed and read over the system.

A table is provided for a secretary and mounted on the partition to the left of this table is an audio tape recorder which enables pre-recorded messages to be sent out over the circuit or the sound content of the conference to be recorded.

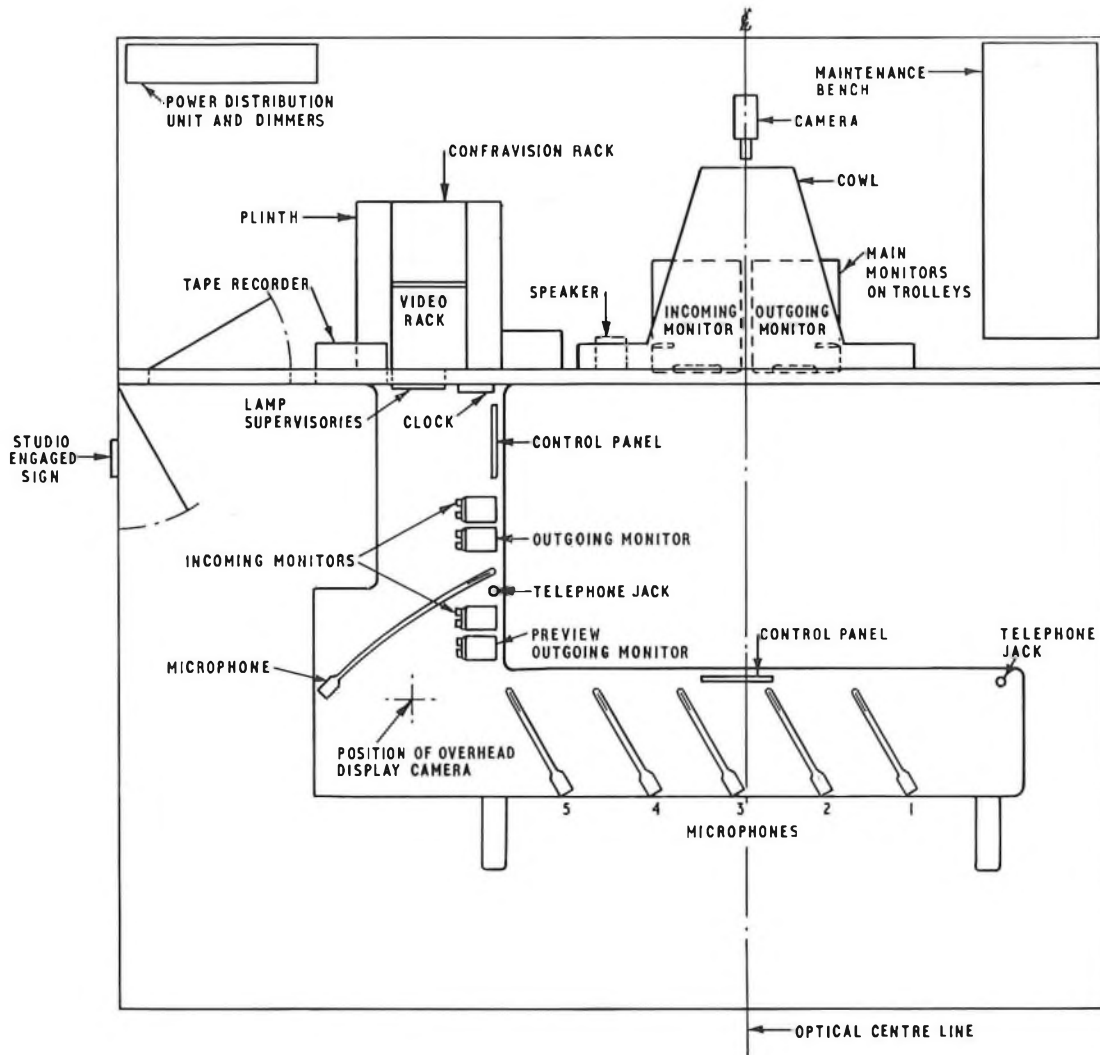

FIG. 3—Plan of conference studio and equipment room

Two small monitors mounted on the secretary's table (see Fig. 4) enable him to see what is displayed on the main monitors and a preview button enables him to view the display material before the signals are connected to the outgoing circuit.

A clock, which is in view of all the conferees, shows real time and light signals indicate five minutes and three minutes from the end of the booked conference period and also the end of the booked period. The circuits will not be cut automatically at this stage but the chairman will be expected to wind up the meeting when the light indications appear. Both the chairman and the secretary have identical control panels so that either one may operate the controls. Control is effected by illuminated push-buttons as shown in Fig. 5.

The design requirements of a Confravision studio are considerably different from those of any other type of television studio. In some ways, because cameras, seating and lighting are fixed, the problems are easier but, in other ways, because unrestricted bothway speech and vision are required, the technical problems are much greater. In addition, it is essential that the system be simple to operate, since Confravision studios will mostly be used by non-technical people.

The display monitors and loudspeaker circuits have been extended to outlet sockets in the reception area, so that extra viewers can see and hear the conference if this is requested by the chairman in advance.

Equipment Room

In addition to the camera, monitors and loudspeaker, the equipment room also houses the two equipment racks, a work bench, power controls and test equipment. One equipment rack holds the video- and sound-circuit terminal equipment and the other, all the equipment associated with the studio facilities, such as microphone amplifiers. A block diagram of the communications system is given in Fig. 6.

Three rack-mounted telephone handsets have been provided and space allocated for the provision of *sound-in-sync* equipment which will be installed early in 1972. Because of the unusual design requirements and the short time-scale available, all the design work and the construction of the equipment was done by B.P.O. staff.

CIRCUITS

Vision Circuits

For the trial period, the vision signal will be carried on second-choice radio protection channels. Protection channels are provided on most microwave radio routes to improve the circuit reliability, and if one of the working radio channels fails, the protection channel is automatically switched into service. On some routes, two protection channels are provided and the second protection channel is only taken on

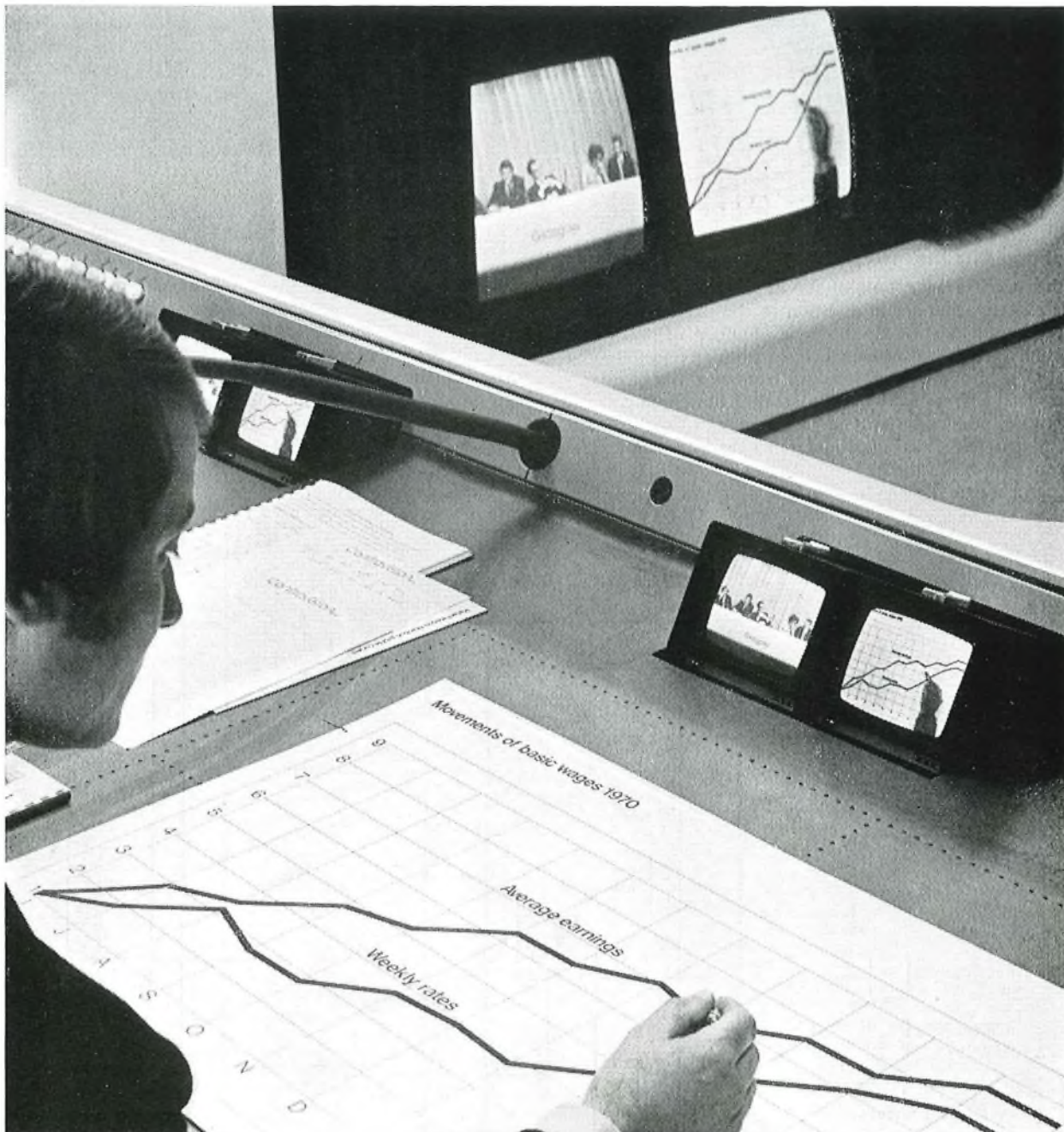

FIG. 4—Display facilities on secretary's table

those rare occasions when there are two simultaneous failures. For Confravision purposes, the second-choice protection channels have been connected via the automatic switches to video extensions which terminate in the Network Switching Centres (N.S.C.). Hence, when the automatic switches are in the normal position, there is a vision circuit through from N.S.C. to N.S.C. and all the setting-up required for conferences can be done in the N.S.C.s. This reduces the number of points to which instructions have to be sent to set up calls and also the risk of errors.

These arrangements do not affect the normal operation of the protection channels which will be automatically switched from Confravision to a working channel if the need arises. It might be argued that this will give an unreliable service and be a source of complaint if communications are broken during a conference. However, this is unlikely because the second protection channel is rarely switched so the loss of service during a Confravision call is highly improbable.

Sound Circuits

The sound circuits must be capable of giving high-quality speech and so program circuits have been provided. The circuits link the N.S.C.s and can be switched in tandem in the N.S.C.s as required except in Scotland where the circuits are routed into Glasgow direct and not via the N.S.C. at Kirk O'Shotts. Arrangements are being made to replace these sound circuits with *sound-in-sync* equipment. This is a system developed by the B.B.C., capable of handling frequencies up to 14 kHz. The sound signal is converted into a form of pulse-code modulation which is injected into the line synchronizing pulses of the vision waveform. The reliability of the system as a whole is improved because separate sound circuits and the associated sound-switching equipment are not required. The obvious disadvantage is that when a fault occurs both sound and vision are lost simultaneously. The effect of this, and the customers' reactions, must be evaluated during the trial period.

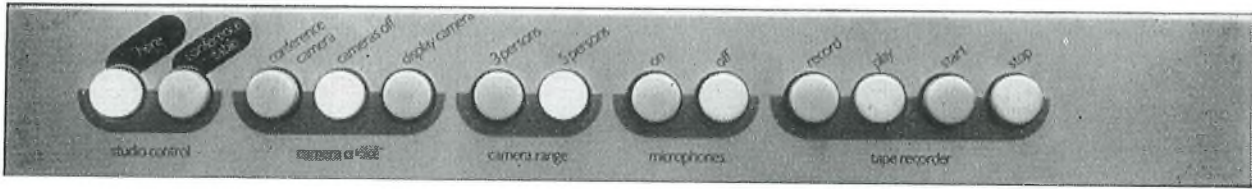

FIG. 5—Control panel

Telephone Circuits

With a Confravision type of service, reliable communication is essential and so, in addition to the main sound and vision circuits mentioned above, a number of telephone circuits have also been provided. For incoming and outgoing calls, the studio attendant has an exchange line with an extension telephone in the studio so that the conferees can speak to the attendant or, if required, they can make a call from the studio whilst the conference is in session. The attendant also has a direct line to the N.S.C. so that immediate contact can be made with the staff responsible for

switching and maintenance. A second telephone mounted on the rack in the equipment room is connected in parallel so that the maintenance staff, working in the equipment room, can also have direct contact with the N.S.C. Two other telephones have been provided in the equipment room for the use of the maintenance staff. Their main function is to give an alternative means of communication if a Confravision sound circuit fails. In such an emergency, the staff can set up calls to the distant studio and, thereby, restore the sound circuit to enable the conference to continue, although the quality will be degraded.

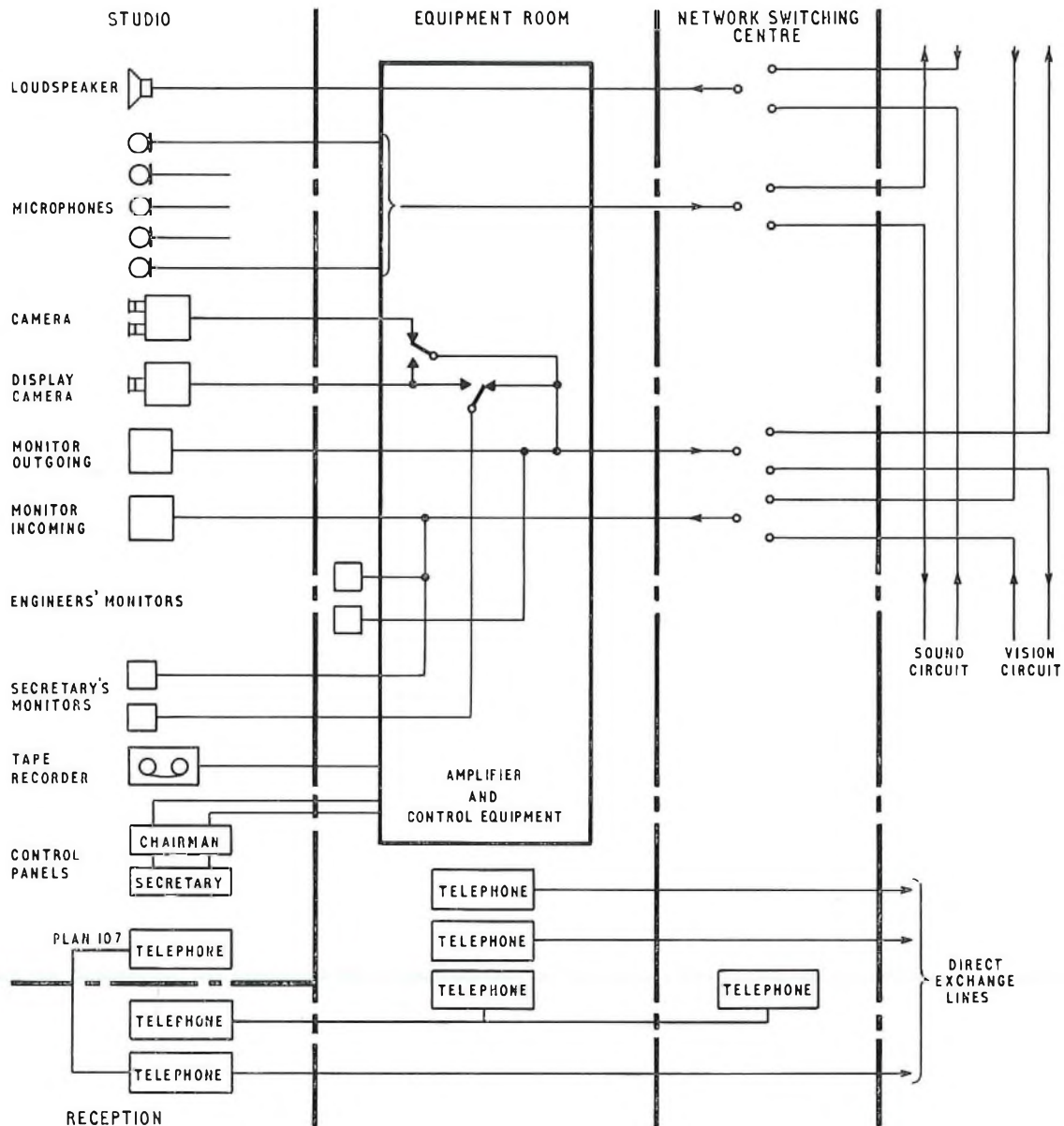

FIG. 6—Block diagram of communications system

PROCEDURE

It is essential that the conference facilities are available for the required periods and to ensure that this is so, all conference facilities must be booked in advance. A centralized booking duty has been established in Telecommunications Headquarters, Gresham Street, London, which will deal with all circuit and studio bookings on a first-come first-served basis. B.P.O. staff, wishing to use the circuits or studios for maintenance or conferences, must also book time to ensure that the facilities are available to them when required.

The booking duty will telex details to the regional Confravision marketing managers, so that they can arrange for the studios to be attended when the conferees arrive, and to the N.S.C.s giving the times when the circuits must be switched.

On entering the suite, the conferees will be met by the attendant who will give them what information they require on the use of the studio and instruct the chairman (and secretary if there is one) on the operation of the simple controls which have been provided. The attendant will stay outside the studio and maintenance staff will not be allowed into the equipment room during the conference sessions.

THE FUTURE

The market trial will be conducted until late 1972 in order to assess the commercial prospects of the service, and establish whether changes in the service offered should be made. Factors to be considered will include the difficulties created from simultaneous loss of sound and vision transmission, the serviceability of protection channels, and the effectiveness

of the booking and switching procedures. If the market trial is successful, permanent circuits will be provided and extension of the service to other centres will be considered. Although the emphasis during the trial period will be on Confravision between B.P.O. studios, other forms of utilization may have to be considered. Private firms who foresee a large use for this service may prefer to have a studio on their headquarters premises, and if a similar studio is not warranted at the outstations, then the outstation staff will be able to attend at a B.P.O. studio and hold a conference with their headquarters. The studios might also be of occasional use to the broadcasting authorities. News reporters could use them and be linked directly into the television network or they could be utilized for the interview type of program, the interviewer being in the main television studio and the interviewees in any B.P.O. studio.

International Confravision is no pipe dream. There is at present a regular world-wide exchange of television programs by microwave and satellite and the same circuits, with standard conversion equipment if necessary, can be utilized for Confravision. It is, therefore, feasible for any studio which may have been designed for broadcast television or Confravision to be directly connected to a B.P.O. studio in this country.

ACKNOWLEDGEMENTS

The author wishes to thank Kenneth Grange for permission to reproduce Fig. 2 and colleagues in Telecommunications Headquarters for their assistance in preparing this article.

Air Conditioning for Confravision in Glasgow

A. NESS, C.ENG., M.I.E.E. †

U.D.C. 697.19: 621.397.13

The introduction of the British Post Office Confravision service required the provision of small television studios in each of the cities from which the service is to operate. This article describes the air-conditioning system installed at Glasgow where the first of the uniformly-designed studio suites has been completed.

INTRODUCTION

The Confravision studio suite in Glasgow comprises the studio with its associated equipment room, a reception room and waiting area, male and female toilets, and a plant room for air-conditioning equipment. Although the suite is not large, the total floor area being about 1,500 ft², the enclosed nature of the accommodation and the stringent environmental requirements mean that air conditioning is the major accommodation service.

DESIGN REQUIREMENTS

The design conditions for the Confravision studio and equipment room are:

- temperature – 68°F ± 3°F dry bulb,
- humidity – not to exceed 60 per cent relative humidity,
- noise level – not to exceed Noise Criterion No. 20.¹

† Planning Division, Telecommunication Headquarters, Scotland.

In addition to these requirements, the system must allow for an occupancy of 10 persons, with smoking permitted, and there must be no transfer of speech sound from within the studio area. Conditions for the reception areas and toilets are based on the studio space conditions but need not necessarily be held to the same limits. As the suite is constructed within an existing building and as the construction is massive to achieve acoustic isolation, the heat losses are negligible. The plant must, therefore, handle all 15 kW of heat dissipated by equipment, lighting and people.

AIR DISTRIBUTION

Input air distribution is at high level with ducts above false ceilings. Ceiling-mounted diffusers are used in all rooms except the studio, which requires an air change rate of 22.5 air changes per hour. This is too high for conventional diffusers, bearing in mind the low permissible noise level, so a ventilated ceiling is utilized in the studio. Air is fed into the space above the ceiling, the surface of which is a perforated material

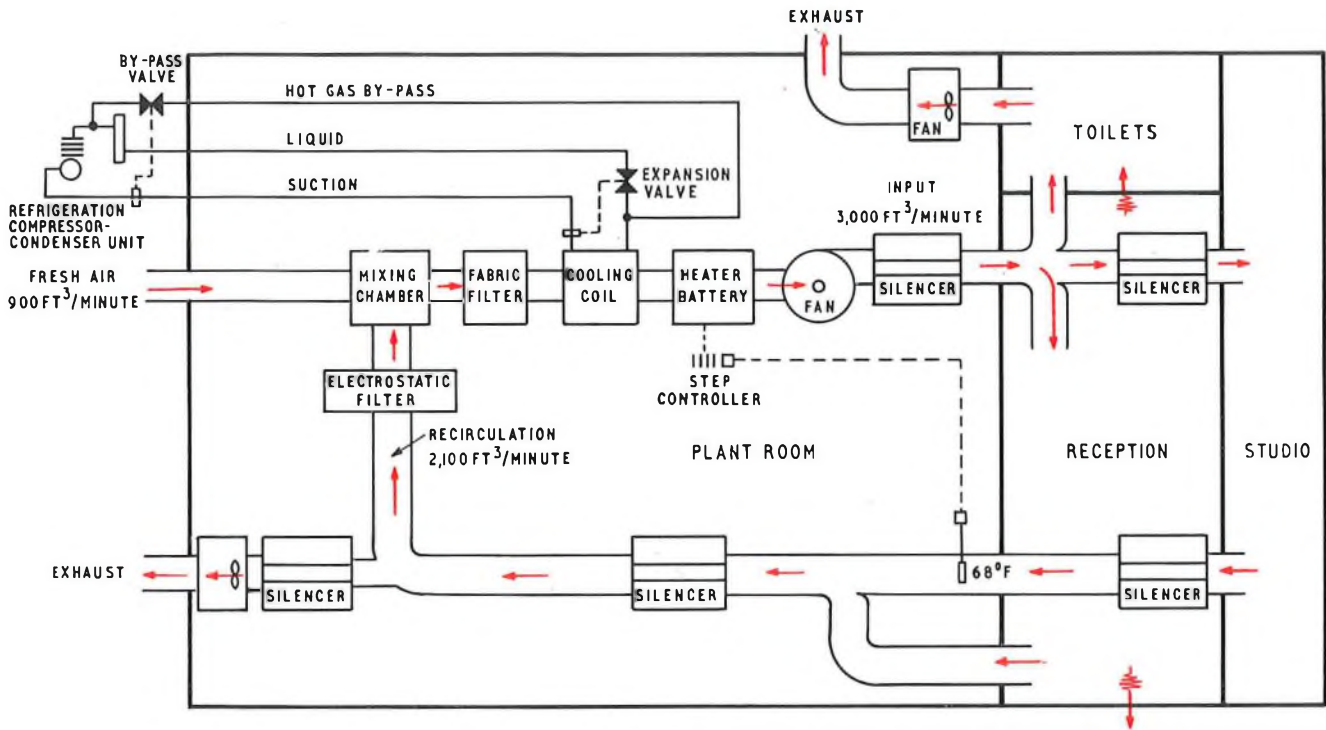

FIG. 1—Glasgow Confravision air-conditioning System

allowing an even distribution of air from its whole area. To operate successfully there must be a uniform pressure above this ceiling. In the Glasgow studio, the total space above the ceiling is too great to ensure an adequate pressure build up and, therefore, a functional ceiling has had to be installed between the decorative ceiling and the structural slab above.

As the studio area is well sealed, the air extract must equal the input so that there is no pressure differential. The reception and waiting areas are kept at a positive pressure to prevent infiltration from the entrance and the toilets, a negative pressure being maintained in the latter.

THE PLANT

The requirements of the system, related to its size, indicate that closeness of control is more important than economy of operation and, as the heat load is fairly constant, a system was designed using fixed air quantities with maximum recirculation. The capacity of the air-handling plant is 3,000 ft³/min. Fig. 1 is a block diagram of the system. Allowing for a possible maximum of 10 people in the studio, and also 10 in the waiting area, the fresh-air requirement is 900 ft³/min which is 30 per cent of the input quantity. Recirculated air is filtered by an electrostatic air-cleaner to remove tobacco smoke before mixing with the incoming fresh air. From the mixing chamber, the input air passes through a fabric filter before reaching the cooling coil and heater battery.

Operation of the system, having high internal heat-gains and 70 per cent recirculation, requires cooling at all times irrespective of the outside ambient conditions. Direct expansion cooling is used, evaporation of the refrigerant liquid taking place in the cooling coil. Heating is required for final adjustment of the room air condition and this is provided by an electric heater battery. The refrigeration compressor and air-cooled condenser unit has a capacity of 7 tons refrigeration² (84,000 B.t.u./h). It is installed outside the building in a suitable open-air location to ease condenser cooling and to isolate compressor noise from the studio suite.

CONTROL

The refrigerated cooling is controlled by the evaporator suction-pressure being maintained constant in the cooling coil. A hot gas by-pass is used in addition to the normal expansion valve on the cooling-coil liquid inlet. A by-pass valve, modulating in response to a rise or fall in suction pressure, injects compressor discharge-gas back to the evaporator inlet. Air leaving the coil is thereby kept at a steady condition of 50·5°F dry-bulb, the wet-bulb temperature being 49°F at maximum summer ambient load. Subsequent control of the air condition is effected by the heater battery which is operated by a step controller in response to a potentiometric thermostat in the return air-duct. This maintains the room temperature within the design limits and inherently provides the re-heat facility to keep the relative humidity below the required 60 per cent.

NOISE

Silencers are installed in the main supply and return air-ducts in the plant room and again in the supply and return air-ducts to the studio and equipment-room area. A small silencer is also fitted to the exhaust air fan. In addition to the silencers, the main ducts are lined internally with 1 in thick acoustic lining. The fans have the normal anti-vibration mountings and flexible duct connexions.

CONCLUSION

The concept of Confravision required the design, decor and finish of the whole studio suite, and its associated engineering services, to be of a very high standard. This, coupled with the special technical requirements produced many unusual problems in planning and installation which were solved by close co-operation between all concerned with the project.

References

- ¹ *Institution of Heating and Ventilating Engineers (I.H.V.E.). Guide 1965, Section 15G1.1.*
- ² *I.H.V.E. Guide 1965, Section 13.2.3.*

The Measurement of Telephone Traffic

H. M. G. GOLESWORTHY, R. C. KYME, C.ENG., M.I.E.E., and J. A. T. ROWE†

U.D.C. 621.395.31

For the proper administration and economic control of any telephone system, an accurate knowledge of the traffic flowing in the network is vital. The existing traffic-recording equipment used by British Post Office was designed for Strowger exchanges. This article describes, firstly the modifications to these traffic-recorders to enable them to produce more records per year, and secondly the more modern traffic-recorders used in crossbar and electronic exchanges. The traffic-recording aspect of the computer-aided maintenance project is also mentioned.

INTRODUCTION

The existing automatic traffic-recorder for Strowger exchanges was designed in the early 1930s, and the basic design has survived, virtually unchanged, until the present day. In pre-war years, automatic equipment was provided on a more generous basis than it is today, growth was slower and additional equipment was obtainable virtually on demand. It was usual to take a traffic record every three months, until in 1942, the number of records was cut to two a year as a war-time emergency measure. The problem of traffic recording was, to a large extent, ignored when the British Post Office (B.P.O.) faced the task of post-war reconstruction. However, increased demand, coupled with manufacturing and financial problems, soon led to the imposition of more stringent equipment-provisioning standards. The consequent need to improve forecasting techniques focused attention on the traffic-recording problem.

It is now generally realized that an accurate knowledge of the traffic flowing in the network is vital for the proper administration and economic control of any telephone system. This article describes the principles and practice of recording telephone traffic used in the B.P.O., and the steps now being taken to improve traffic-recording procedure.

THE IMPORTANCE OF TRAFFIC RECORDS

In the field of planning, traffic records are used extensively in the preparation of data for exchange design and also for forecasting the growth of every individual trunk and junction route. They are also used for more general forecasts concerning national and regional growth rates within the system and thus have an influence on the future level of capital expenditure.

From the service point of view, traffic records are an essential part of the machinery of maintaining the quality-of-service. Only by traffic recording is it possible to isolate and confirm suspected areas of congestion and, thus, to ensure that individual subscribers can enjoy the standard of service to which they are entitled.

Essentially, records must be both frequent and accurate. Levels of capital expenditure are now so high that a 1 per cent reduction in, for example, the annual expenditure on external trunk and junction plant could mean a saving of nearly £1M per year. If improvements in both the quality and quantity of traffic records can lead to better forecasting and thus achieve such a saving, the additional expenditure will be amply justified.

† Operational Programming Department, Telecommunications Headquarters.

THE PRINCIPLES OF TRAFFIC RECORDING

Traffic recording usually makes use of the principle that the average traffic flow in any circuit group over a period is equal to the average number of simultaneous calls in progress during that period. It is possible to determine this manually, for example, by actually counting, at intervals, the switches in use in a Strowger exchange and the method can be used quite successfully at very small exchanges. However, it is obviously more satisfactory to use some type of automatic recorder.

If the record is automatic, the sampling can be done continuously or at intervals. Continuous sampling (the analogue method) can be carried out, for example, by means of a pen-recorder, to determine and record the traffic flow. It is more difficult to use such a technique to determine average traffic, since the actual traffic-flow may vary considerably over short periods of time and it is more usual to record the number of simultaneous calls at intervals. This is often referred to as the computational method and is the standard technique at present in use by the B.P.O. Each circuit in a group is scanned sequentially and a meter associated with the group is operated every time a busy circuit is encountered. The total recorded for each group is then divided by the number of scans to obtain the average traffic flow, in Erlangs, over the recording period. Although theoretically, scanning may be carried out at random, it is more convenient, in practice, to test at regular intervals; the accuracy being greater the shorter the interval between scans. In general, however, sufficiently accurate results can be obtained with any periodicity less than twice the average call holding time providing sufficient samples are taken.

With the aid of traffic-recorders, extensive traffic measurement could be made to obtain estimates of the traffic carried by each group of circuits in an exchange, say for every hour of the day throughout the year. Although it might be instructive to carry out an intensive traffic-recording program, such a large amount of data would be an embarrassment to those concerned with the management of the system. Efficient management requires that information need only be supplied to provide and maintain equipment to the standard laid down by the controlling administration. It is, therefore, common practice throughout the world to restrict traffic measurements and their application of equipment and circuits to busy periods of the day. This is because:

- (a) it is more satisfactory to set minimum service standards for the worst conditions to be met,
- (b) the assumption of statistical equilibrium is more closely realised in the busy period, so enabling the main principles of generally accepted traffic-theory to be used.

Traffic records are, therefore, normally taken during what is generally known as the busy-hour.

The Busy-Hour

The busy-hour is the uninterrupted period of 60 minutes of the day for which the traffic is the maximum, and this definition can apply to an individual group of circuits or to a whole exchange or group of exchanges. The busy-hours of individual circuit groups, even within the same exchange, vary widely and do not necessarily correspond in any way with the observed busy period for the exchange as a whole. The time of individual and exchange busy-hours will also alter from day to day as will the level of the traffic. Conditions will also depend on the location and time of the year, for example, traffic on junction routes from certain seaside resorts may be highest in the evenings in the summer holiday period.

Although equipment provision is normally related to the busy-hour, this is by no means a simple exercise, since a great deal depends on just which busy-hour or hours are considered to indicate a reasonably representative traffic level. For example, traffic may be highest at a certain exchange on one particular day of the week which could be market day. If the exchange is provisioned to meet the market-day busy-hour traffic, some equipment will lie idle for the rest of the week. Conversely, if a lower standard of provision is used the equipment is liable to become congested on the busiest day. This conflict between economics and service to the customer needs to be taken into account when determining provisioning levels in relation to traffic measurements, as does tariff policy. Efforts are made to persuade telephone subscribers to originate more traffic at times when equipment is expected to lie idle, but it is also wise to ensure that equipment provisioning is, in general, tied to the busy-hour corresponding to the period of maximum revenue so that plant provision is not governed by traffic originating in cheap-rate periods.

TYPES OF TRAFFIC RECORD

It is evident from the previous paragraph that there are various ways of estimating busy-hour traffic from individual traffic-records and the method adopted may significantly affect the standard of service ultimately given to the subscriber. Two methods are described namely, the post-selected busy-hour method and the time-consistent busy-hour method.

Post-Selected Busy-Hour Traffic Recording

This method, which has been used for many years by the B.P.O., requires recording to take place over a period (say two hours) which is expected to include the exchange busy-hour or, if a special record is being taken on a particular route or routes, the busy hour peculiar to such routes. Separate records of traffic flowing during this period (say one for every separate half hour) are taken and a number of overlapping hourly measurements obtained for each day (e.g. 0900-1000 hrs, 0930-1030 hrs, etc.). The highest record is taken as the busy-hour traffic and it is usual to take the mean of a number of daily totals for the final record; the B.P.O. takes records over three representative days in each week. The method has the advantage of encompassing the true busy-hour even if this varies somewhat from day to day but has the following disadvantages:

- (a) the error is likely to be positive and the traffic level to be overestimated because the figure chosen for each day might be high owing to random variations,
- (b) a large amount of meter reading is required in the exchange and the subsequent processing is lengthy.

Time-Consistent Busy-Hour Traffic Recording

When consideration was being given to the need to improve the frequency of traffic records from the post-war standard of

two a year for most exchanges, a new method of recording was adopted since the post-selected busy-hour system then in use was too complex. The system adopted was the time-consistent busy-hour method.

Time-consistent records are taken during the same hour each day, the recording hour being determined in advance. The C.C.I.T.T.* recommend that, to determine the mean (or time-consistent) busy-hour, observations should be made at quarter-hourly intervals during the busy period, over 10 days. The values observed for the same quarter-hour each day are then added together and the time-consistent busy-hour is determined as being the four consecutive quarters which give the largest sum of observed values.

Since time-consistent busy-hour recording occupies a fixed hour each day the level of recorded traffic is generally lower than when using the post-selected busy-hour system. The fixed hour has the advantage that the recorder can be started and stopped automatically, and it is only necessary to record the totals registered on the meters at the beginning and end of the record. Subsequent calculation is reduced to a minimum and can be eliminated altogether by using a suitable scanning rate and resettable meters. Time-consistent busy-hour recording, therefore, assists in the production of more frequent traffic records since much less labour is required in the exchange and processing is greatly simplified. Recording over five days also avoids the need to select representative days, which was a feature of the post-selected busy-hour system. Time-consistent busy-hour recording was first introduced at some trunk exchanges in 1966 and at all remaining exchanges in 1969.

THE STROWGER-TYPE TRAFFIC-RECORDER

The original Strowger traffic-recorder operates on the following principles. The recorder may be divided into three sections, the access switches, the control switches and the control and recording equipment. In practice, uniselectors are used for the access and control switches, and recording leads from each item of equipment are connected to the banks of the access switches. Normally, access switches are mounted on a separate rack, which for economy in cabling can be placed as near as possible to the exchange apparatus which it serves. The control switches, however, are usually mounted on a control-rack together with the recording meters.

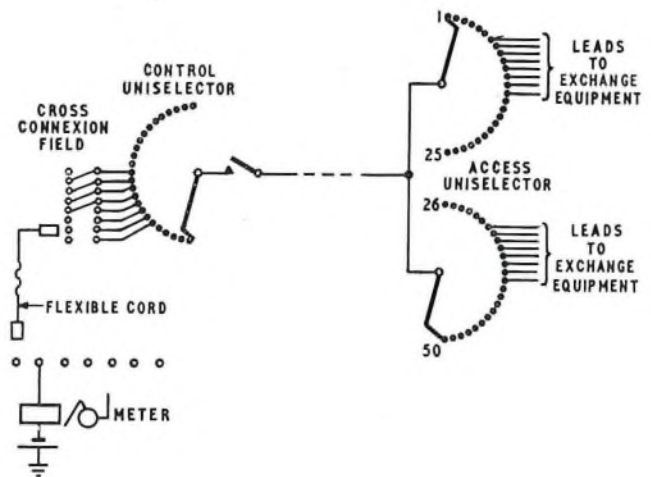

Fig. 1—The basic circuit diagram of the Strowger traffic-recorder.

An outline of the circuit shown in Fig. 1 and Fig. 2 is a photograph of a control rack. The operation of the recorder is, in essence, very simple. Each individual item of equipment on which traffic needs to be recorded is connected by a separate wire to the banks of an access switch and an earth

* C.C.I.T.T.—International Telephone and Telegraph Consultative Committee.

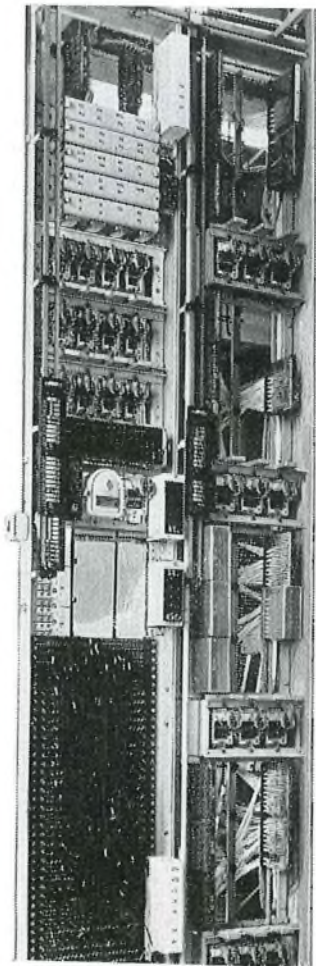

FIG. 2—Photograph of the Strowger traffic-recorder control-rack.

condition on the wire indicates that the item is busy. As the wipers of the access switches rotate, they scan each item sequentially and each time an earth, indicating a busy condition, is encountered, it is connected, via the wiper and bank of a control switch, to register on a meter. The control switches thus act as meter connectors.

The access switches step at the rate of approximately five pulses per second and for each four steps the control switches step once. A minimum of four access points can, therefore, be associated with a single meter. The entire scanning operation is repeated every 30 seconds. By means of links and cords on the control-rack, a meter may be associated with a larger number of circuits—for example, all the trunks in a particular grading—but one disadvantage of the original design is that a maximum of only 98 circuits can be so connected.

A more serious disadvantage is that the original recorder can normally only be connected to one-third of the exchange equipment at a time. This is accomplished simply by connecting three separate sets of access switches to each control-switch, and arranging that only one set can be in use at any one time. This achieves economy in control switches but a full traffic-record for an exchange may take up to three weeks, with perhaps an additional week for short-holding-time (s.h.t.) equipment, and to achieve a total of 12 records a year, the recorder would have to be in operation on almost every working day. Between each week of a complete traffic record, it is necessary to rearrange the cross-connexion field between the banks of the control switches and the meters. This time-consuming occupation requires considerable manpower and is a constant source of recording errors. Irrespective of the method of recording adopted, the requirements of an improved recording program require that this particular feature should be eliminated.

MODIFICATIONS TO EXISTING TRAFFIC-RECORDERS

One object of introducing time-consistent busy-hour recording is to obtain more frequent traffic records and the aim is to produce a minimum of 12 complete records a year at all exchanges. This can generally be achieved at crossbar and electronic exchanges which use recorders of more modern, if not altogether satisfactory design, but the Strowger traffic-recorder was designed for a more leisurely age.

A program of major modifications is, therefore, being undertaken for Strowger recorders which are found in the majority of director and non-director exchanges. The modifications are designed to:

(a) change the scanning time of the recorder from 30 seconds to three minutes for long-holding-time (l.h.t.) equipment and from 12 seconds to 18 seconds for s.h.t. equipment. This, combined with automatic control of the recorder to give a fixed number of scans (20 or 200) for one hour each day, means that the total number of weekly scans is 100 or 1,000 and the average busy-hour traffic is the total number of engagements recorded, with the decimal point inserted as appropriate,

(b) allow simultaneous recording of all l.h.t. and s.h.t. equipment, so that a complete traffic-record for the whole exchange can be taken in a single week. The advantages of this system are: accurate traffic balances can be obtained, recording time is substantially reduced and the meter connexion-field on the traffic-recorder no longer needs frequent alteration.

In addition to these modifications, the opportunity has been taken to improve the design of certain traffic-recorder circuit elements. All these changes, together with the savings in labour achievable with the use of time-consistent busy-hour recording should open the way to a more frequent and more reliable records at Strowger exchanges.

TRAFFIC-RECORDING AT ELECTRONIC AND CROSSBAR EXCHANGES

The policy at these exchanges is to use, as far as possible, traffic measuring principles and practices similar to those used in existing Strowger exchanges. This permits a uniform procedure and will ease the changeover to a computer-controlled scheme.

The following facilities have been included, from the start where possible:

- (a) resettable-meters,
- (b) electrically-driven time-switches,
- (c) recording leads which do not indicate busy when tested by the traffic-recorder if the circuits are artificially busied or undergoing routine testing,
- (d) call-count meters which can be switched on and off with the traffic-recorder to facilitate measurement of average holding-times.

In general there are two differences from the Strowger traffic-recorders. Neither originating, nor terminating calling-rates determined from traffic records on the common-control exchanges are directly comparable with those for Strowger exchanges. For originating calls, this is because in a Strowger exchange a large amount of false-traffic arises which is normally reduced or eliminated in common-control exchanges. To make Strowger originating calling-rates comparable with calling-rates from common-control exchanges, an originating efficiency factor (e.g. 95 per cent depending on the exchange concerned) is applied to the originating traffic.

Subscribers' incoming calling-rates are also lower in common-control exchanges since terminating calls are not set up if the called subscriber is busy or the particular number dialled is unobtainable. An efficiency factor is not used, however, because the difference in calling rates is less.

This inequality of traffic at various stages causes problems in achieving a traffic-balance between different sections of the exchanges and average factors have to be used to enable the traffic at one stage, to be equated with the traffic at another.

The traditional method of identifying the exchange busy-hour is to examine the trace from a recording ammeter. However, this is ineffective in electronic exchanges, since the battery discharge is more constant. One solution is to record the busy-hour of the registers using a recording decibel meter at a point where the current is proportional to the instantaneous traffic.

Some of the traffic-recording arrangements for particular common-control systems are described in the following paragraphs although only outstanding features, or differences from current practice, are mentioned.

TXK1 Crossbar Exchanges

The TXK1 system^{1, 2} is an electromechanical common-control crossbar system based on a 10-vertical-magnet switch with a variety of outlets depending on the construction and use. The system is used for local non-director exchanges and for group switching centres and sector switching centres (s.s.c.s.).

The original Automatic Telephone and Electric Company 5005A system, subsequently adopted as TXK1, was not designed specifically to B.P.O. requirements and, consequently, the traffic-recorder contains some features not required by the B.P.O., and lacks others. Each recorder consists basically of two five-bridge crossbar switches, control and pulsing relays and meters. Access to the traffic-recording leads is via the crossbar switches which cater for a maximum of 1,200 leads to l.h.t. equipment. A maximum of 60 leads, of which only 40 can be used at any time, are provided to s.h.t. equipment and 10 leads to very-short-holding-time (v.s.h.t.) equipment. L.H.T. and s.h.t. equipment, refer to equipment held throughout a call and to such equipment as registers respectively. V.S.H.T. equipment includes markers, coders and router controls. The full capacity of the recorder is, however, reduced because the physical construction and method of operation of the crossbar switches is arranged so that one recording-meter can only be associated with a certain fixed number of access points. In the case of l.h.t. equipment, for instance, these are in groups of 20 and 40 so that a junction route of, say, 21 circuits would monopolize a group of 40 access points.

At least two recorders are needed in even the smallest exchange, and each recorder is self-contained, except for the time switch which controls the start of recording. Whilst, therefore, all recorders will start a record together, completion of the records may not occur simultaneously unless each pulsing-circuit is operating at identical speed.

This traffic recorder was originally designed to complete 100 scanning cycles on l.h.t. equipment in 40 minutes taking 24 seconds to complete a scan, but this period is insufficient to provide a reliable record using the time-consistent busy-hour method. Since it is impossible, without considerable modification to provide for a one-hour record, a double period totalling 80 minutes is used. S.H.T. and v.s.h.t. equipment measured at 2 second and 200 ms intervals is scanned 10 and 100 times respectively for each single scan of l.h.t. equipment.

A feature of the TXK1 recorder, not previously included in traffic recorders used by the B.P.O., is the ability to measure delay in receiving dialling tone. This facility is used in some countries where exchanges are deliberately designed to handle a given quantity of traffic with a specified delay. The need for an equipment extension is then judged on the delay in receiving dialling tone. The method has the merit that it measures conditions actually experienced by subscribers, but suffers from the fact that only a small sample can be taken.

Another unusual feature of the existing recorder is the

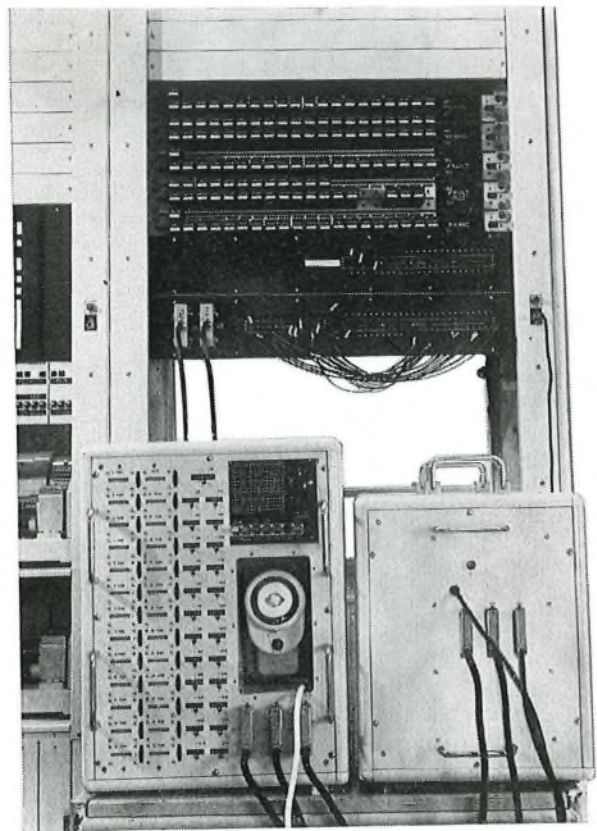

FIG. 3—The traffic-recorder for TXE-2 type exchanges

measurement of the traffic on v.s.h.t. equipment. Such equipment usually has a constant holding-time and it is simpler, and more convenient to provide a call-counting meter and record calls, rather than traffic in Erlangs. In the TXK1 exchange, however, the holding time of the v.s.h.t. equipment is not necessarily constant and may be held for a varying length of time depending on the number of switching stages through which a particular call passes.

Because of the size of the installations, the use of TXK1 type equipment for s.s.c.s. made it desirable to design a new traffic-recorder with full flexibility, standard scanning-rates and resettable meters. This new recorder will also be used at group switching centres and, eventually, at local exchanges. It consists of a control rack and up to a maximum of 20 access-shelves, each of which provides access to 720 access-points. The control rack consists of relays and a series of ring-counters which derive the required scanning rates from a basic one-second pulse. The pulses are used to operate l.h.t. access-relays each of which has 20 make contacts. A maximum of 180 access-points may be connected in a number of combinations to any meter. Access to s.h.t. equipment is provided in a similar manner. A very useful routine facility, not available on any previous recorder, permits a check on the number of circuits connected to each meter. This is achieved by arranging for each meter to step a number of times to indicate the number of circuits to which it is connected under recording conditions and these readings can be compared with the jumpering schedule for the recorder.

TXK3 and TXK4 Crossbar Exchanges

Both the TXK3 system and the TXK4³ system are somewhat similar systems to the TXK1 system but are based on a larger crossbar switch with a maximum of 22 vertical magnets. The TXK3 system is used for both director and non-director applications and the TXK4 system is a four-wire switching variant for use in the transit network.

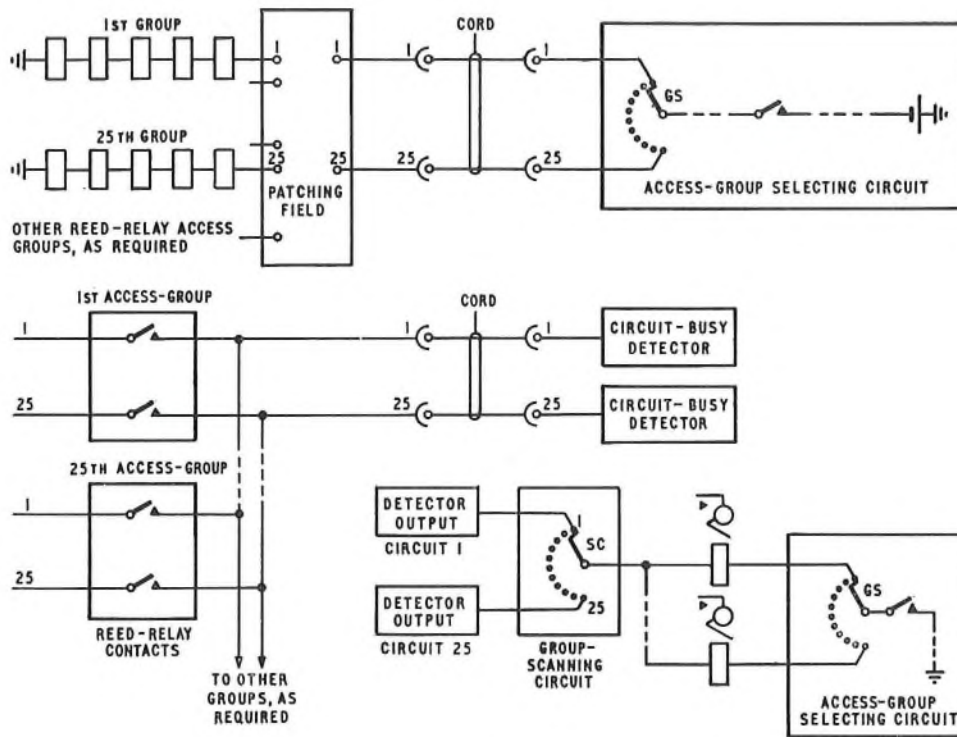

FIG. 4—A block diagram of the traffic-recorder for TXE2- type exchanges

Although the traffic-recorder in these exchanges is basically similar in construction to that provided at TXK1 s.s.c.s., it was provided with the needs of the TXK4 exchange in mind and for this reason is not entirely satisfactory for TXK3 exchanges. For instance, access is via 45 relays, each with 22 make-contacts which provide 22 groups each with a maximum of 45 circuits per traffic-recording group. This is adequate for transit routes where TXK4 exchanges are used, but is inadequate for many junction routes from director exchanges. The maximum capacity of a s.h.t. group is also limited to 45 circuits, which again, is adequate for transit exchanges where register-holding times are short, and registers correspondingly fewer, but not adequate for director exchanges. A more flexible traffic-recorder is, therefore, being designed.

Electronic Exchanges TXE2

The TXE2 exchange⁴ is a joint British Post Office and industry developed common-control electronic system using reed-relays and designed for small local non-director exchange application.

The traffic-recorder at these exchanges differs from all others so far described in that the control equipment and meters are transportable. However, now that traffic records are taken every month, a separate recorder is provided for each exchange. Fig. 3 shows this recorder, which, for convenience is now contained in two units. Access to recording points is via blocks of reed-relays which form part of the permanent equipment.

The traffic-recorder has a fixed capacity of 25 groups of 25 circuits, the first group of which can be used for s.h.t. equipment. Scanning rates are six seconds for s.h.t. equipment and three minutes for l.h.t. equipment, the number of busy circuits being recorded on resettable meters. In addition, the traffic-recorder has a further group of 25 resettable meters for analysing the traffic carried by the individual trunks in a group of 25. These analysis meters may be connected to any one of the 25 groups of circuits by means of keys and switches.

Two multi-way cords enable the traffic-recorder, which is

usually trolley mounted, to be connected easily to the access equipment, which is permanently installed. One of these cords operates the appropriate group of access reed-relays, and the other records the conditions (busy or free) of the 25 trunk circuits in a group.

Fig. 4 shows a block diagram of the traffic-recorder and the access reed-relays. The reed-relays are connected to three arcs of a uniselector, GS, and the appropriate meters are connected to corresponding contacts of three other arcs of the same uniselector, so that when the first group of access reed-relays is operated, the first meter is connected in the circuit. At this stage, the first group of reed-relays is momentarily operated and the 25 detector-circuits are simultaneously connected to the 25 recording-leads in this group. Those which are busy cause the reed-relay in the appropriate detector circuit to operate. While uniselector GS remains on this outlet, uniselector SC scans the outputs of the detector circuits and those which are busy cause the appropriate meter to operate. The other groups are measured in a similar manner. In practice, to achieve the required scanning rates, the first group in the 25 is multiplied around the arcs of uniselector GS so that it appears 30 times while the l.h.t. groups appear once.

A characteristic of this type of access is that each group of circuits is scanned in succession but the circuits within each group are scanned simultaneously, the conditions being momentarily stored before being transferred to the meter. This method is equally as satisfactory as the more usual method of scanning circuits within a group sequentially and enables the number of detector circuits, which are relatively expensive, to be restricted to 25 instead of one per recording-lead. A further saving in cabling cost is achieved by mounting the access-relays on, or near, the racks they serve.

At TXE2 exchanges records are taken of the traffic carried by A switch-B switch links, own exchange and outgoing supervisory, coin and fee checking equipment and registers. There are also four groups of 25 circuits extended to the intermediate distribution frame which can be used either for recording on incoming junctions or for measuring class calling rates. This is more necessary with common control systems

where, unlike Strowger exchanges, it is not possible to distinguish between residential and business subscribers on the basis of the type of calling equipment used.

Since the traffic-recorder was developed before the principle of monthly traffic-records was accepted, and before the simultaneous recording of all equipment was required, it is inevitable that some exchanges will not be able to record the traffic on all equipment at the same time and some modification will be necessary. It is hoped that some other improvements such as a routine facility, which is very desirable with portable equipment, can be included at the same time.

TXE4 Electronic Exchanges

The TXE4 system is a common-control electronic system designed for larger local director and non-director switching units and was developed from the TXE3 system.⁵

The traffic-recorder for the TXE4 system represents a different approach to the problem of recording-traffic, in that punched paper-tape is used as the output instead of meters. This departure from the long-established method of recording traffic on meters provides a solution to the problem of calculating certain traffic quantities, such as originating traffic, which, because of the method of trunking, it is not possible to measure directly. A disadvantage of the paper-tape punch is that it is a rather slow method of storing information. For example, with a tape speed of 2.5 inches per second and 10 characters to the inch, only 25 characters per second can be stored and with the large exchanges proposed for the TXE4 system more than one traffic-recorder will frequently be required. To enable the punch to be used more efficiently, and to reduce the number of points which need to be scanned, some addition of traffic is carried out within the traffic-recorder. This enables a single character to be punched to represent the traffic carried by a group of 10 trunks. While there are obvious advantages in this, it makes it difficult to check the traffic carried by an individual circuit.

A further reduction in traffic recording access has occurred because it has been proposed that the A switch-B switch link traffic on one odd and one even plane only should be recorded; the total A switch-B switch link traffic being obtained by multiplying by three in a six plane exchange and by four in an eight plane exchange. Provided the exchange is working correctly this should be satisfactory, and any malfunctioning should be indicated by means other than traffic recording. An attempt is being made to substantiate this theory by wiring one or two of the earlier exchanges for full recording.

A valuable facility with this recorder, especially where circuits need to be added frequently, is that they do not need to be connected to the traffic-recorder access physically in any particular pattern provided they are kept in groups of 10. The total traffic for a circuit group is obtained by summation within the computer without the need for all the circuits to follow in sequence. By using the traffic-recorder access progressively, with no need to leave space for growth within each group, the amount of spare access can be reduced. An even greater advantage is the avoidance of the frequent rejumping which is required with existing traffic-recorders.

One factor which makes for greater complexity is the need to punch on the tape a date, time and exchange identifier as well as to make provision for breakage or run out of the paper-tape and to detect a failure of synchronism.

LATER DEVELOPMENTS

Further development in traffic measurement is required because of the need to:

- (a) reduce to a minimum the labour involved in taking, processing and scrutinizing the records,
- (b) increase the accuracy with which records are taken and processed,

- (c) increase still further the frequency at which records are taken,
- (d) increase the number of hours each day for which records are taken so that, for instance, a permanent shift of the busiest hour from morning to afternoon could be detected.

It may be necessary to have continuous traffic measurement in the future for purposes of network-control, but it seems unlikely that such measurements need to be permanently recorded. If a continuous day-record is used for planning and design purposes, it is likely that the bulk of the record could be erased after selecting the busiest period.

Several methods have been, or are being, examined aimed at satisfying some or all of the above requirements.

Partially Mechanized Recorders

A method of producing, by computer, a traffic-record from manually taken traffic-recorder meter-readings was first tested in the Birmingham director area, and an improved version is now undergoing field trial at Leicester. In this latest form, readings of traffic-recorder meters are taken and entered on to special documents from which punched cards are prepared to input to a computer at telecommunications headquarters. The completed forms are sent back to the area, and copies can also be sent to interested headquarters departments and to regional headquarters. As the record remains on a computer file, various analyses are possible; for example, a list of routes carrying more traffic than they were designed to carry.

Another advantage of this system is that, the accumulation of records in a central file could provide the basic information for regression analysis as a means of forecasting subscribers' calling-rate trends and forecasts of traffic between centres of population throughout the country.

Fully Computerized Traffic Recording

One task to be carried out by the computer-aided maintenance-project (c.a.m.p.) is traffic-recording. This is the most advanced system under active consideration. The advantages of using a computer to record telephone-traffic, and to process the records, has long been recognised and a specification of requirements was first compiled in 1966. The opportunity to test such a scheme was offered by a proposal to use a computer for various maintenance tasks, a proportion of which would not require the full capacity of the computer at night. This would permit batch processing of traffic recorded during the day. Outline arrangements of the field trial at Leicester, insofar as they apply to traffic recording, are as follows. A more detailed description is given elsewhere in this issue of the journal.

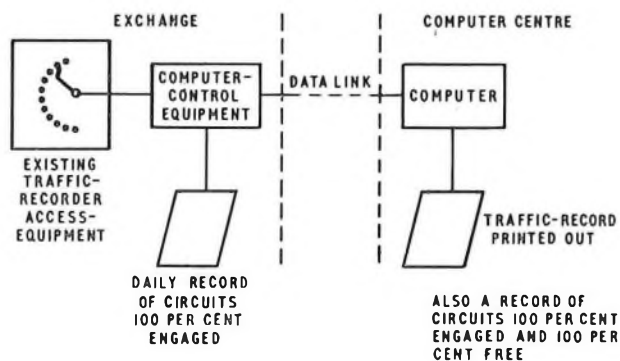

FIG. 5—Block diagram showing the the general arrangements of the fully computerized traffic-recording system

Fig. 5 shows the general arrangements. To reduce expense for the field trial, existing traffic-recorder access-arrangements were used, but it was necessary to replace completely the

control equipment. For two-way communication, 200-baud data-channels connect each individual traffic-recorder control-equipment to a multiplexor at the computer installation. The multiplexor forms the interface between the computer and the data network, so that data can be fed from each exchange into the computer and signals can pass from the computer, a Ferranti Argus 500, to various devices in the exchange.

Computing is performed in the central-processor, which is served by a core-store where data and programs currently in use are stored. Programs and data not immediately in use are stored on disk, whilst data for longer term use is put on to magnetic tape.

Initially, traffic-recorders at four exchanges around Leicester will be controlled by the remotely-situated computer which receives and processes the recorded information. A further 12 exchanges can be added, without additional computer-capacity, but the ultimate arrangement envisages control of up to about 40 traffic-recorders although this would involve an extension to the present computer.

The rate at which the recorders scan the equipment, on which traffic is being measured, and the number of scanning cycles in each hour, is similar to the existing Strowger recorder, but the facility for varying these times exists. The time-consistent busy-hour principle is used, but up to three separate hours recording may be carried out by each recorder during the day. This would normally be used to produce records for morning, afternoon and evening, but three consecutive hours may be used if required.

Recorders are switched on and off under control of the computer over the data-link, and the condition of each access point i.e. free or busy, is signalled to the computer over the same link. This information is stored and each successive day's totals is added to the total to obtain a grand total for the week. Separate totals are necessary if recordings are made of traffic during three separate hours during each day.

The computer tests for a balance within 5 per cent of incoming and outgoing traffic, produces compensated traffic figures for any circuit group which is carrying more traffic than it was intended to carry, and indicates access points on which no traffic at all was detected. The last facility is a useful check that the circuit has in fact been connected to the traffic-recorder; a common source of faulty records with existing recorders. A further useful extract is made of all access points which tested busy throughout an hour's record. This information is relayed to the exchange in question immediately after the record, where it is received on a teleprinter. The maintenance staff are thus able to check on such switches or external lines to make sure that they are not busied without good reason.

Since the condition of each access point is recorded separately, it is possible to analyse gradings in Strowger exchanges to check the balance of traffic and the facility for this has been provided.

CONCLUSION

The B.P.O. sells the facilities for carrying telephone traffic. To do this successfully, it must provide enough plant, both in exchanges and externally, to cope with the business offered to it. If it provides too much plant, profits are lowered or tariffs will be unduly high, but if it fails to provide enough plant, the customers suffer a poorer service than it is intended to give for the price charged. Much of the capital plant takes a long time to plan, manufacture and install so that all plant provision is based on a forecast of future requirements.

Existing traffic-levels must be monitored to check that equipment is adequate to provide intended grade-of-service. A history of past traffic-levels is the only reliable indication of how traffic is increasing (or, in rare cases, decreasing).

Traffic measurement is the major factor which must guide a telephone administration in the amount of plant it provides and the time at which it must provide it.

This article has shown that there are weaknesses in the existing traffic-recorders. The current series of modifications to recorders in Strowger exchanges, comprehensive though they are, will, even now, not ensure the frequency and accuracy of recording which will be required to design the networks of the future.

In the next decade, the deficiencies in existing traffic-recorders will be eliminated and computers will be used to record and process the results. In the field of junction forecasting, traffic measured by the computer-controlled recorder in the c.a.m.p. project is already being considered as an input to a separate computer-forecasting project, so eliminating human intervention in this process. However, recording accuracy will always depend on the care and attention paid to the recording program to ensure that records are taken on the right equipment, at the right time, and are processed correctly.

Reference

- ¹ CORNER, A. C. The 5005—Crossbar Telephone-Exchange Switching System, Part 1—Trunking and Facilities. *P.O.E.E.J.*, Vol. 59, p. 170, Oct. 1966.
- ² BANHAM, H. The 5005—Crossbar Telephone-Exchange Switching System, Part 2—Application and Maintenance. *P.O.E.E.J.*, Vol. 59, p. 271, Jan. 1967.
- ³ WALKER, W., STALLWORTHY, F. A., and McLUSKY, R. F.—Transit Switching Centres using BXB 1121 Crossbar Equipment. *P.O.E.E.J.*, Vol. 60, p. 302, Jan. 1968 and Vol. 61, p. 20, Apr. 1968.
- ⁴ LONG, R. C., and GORRINGE, G. E. Electronic Telephone Exchanges: TXE2—A small Electronic Exchange System. *P.O.E.E.J.*, Vol. 62, p. 12, Apr. 1968.
- ⁵ VOGAN, D. H., and PRICE, C. D. E. The TXE3 Experimental Electronic Exchange System. *P.O.E.E.J.*, Vol. 62, p. 142, Oct. 1969.
- ⁶ VIGAR, C. D., and BROOKFIELD, J. T. A Computer-Controlled Traffic Recorder. *P.O.E.E.J.*, Vol. 64, p. 234, Jan. 1972.

A Computer-Controlled Traffic Recorder

C. D. VIGAR, C.ENG., M.I.E.E., and J. T. BROOKFIELD, D.F.H.†

U.D.C. 621.395.31:654.153:681.31

The increasing complexity in the growth of the telephone network has created a need for more comprehensive telephone-traffic data. The high cost of manual recording and calculating has led to the use of computers to provide this data. By controlling many traffic recorders on-line, over data links, from a central computer it is planned to obtain comprehensive data of traffic by remote automatic-control.

THE NEED FOR RELIABLE TRAFFIC RECORDING

Traffic recorders measure the traffic carried at nearly all stages in the telephone network. From predictions based on these measurements, provisioning plans are made for the future annual expenditure on trunks, junctions and switching plant. The junction routes and exchanges where plant needs to be provided and any local short-term adjustment in provisioning to obviate serious congestion is also derived from this data.

During the next five years the Post Office plans to spend £540 million per year on capital plant, about two-thirds of which will be on traffic-carrying plant whose locality and quantity will be determined by predictions based on traffic records. When the investment of such large sums is being decided, small errors can be very costly. Although some of the assumptions used in predicting the future may not turn out to be perfectly true, errors must be avoided wherever possible. The starting point for the prediction is the traffic record, and there is thus a need for reliable traffic-records.

THE PRESENT METHOD OF RECORDING

The time-consistent busy-hour method of recording¹ has recently been introduced in which the traffic recorder makes 20 scans at three minute intervals for the same hour each day. Readings are taken once a week, from which the traffic flow in Erlangs is calculated. Although this is an improvement on the post-selected busy-hour method which it replaces, it still uses manual methods of collecting data, involving manual meter-reading and manual calculations.

POSSIBLE NEW METHODS OF TRAFFIC RECORDING

Traffic-record data is in digital form in the prime stage and is produced in large quantities (about 10^5 bits per hour of recording for a medium-sized traffic-recorder). Collecting and processing this data by manual methods is costly and the complete job is an obvious task for a computer. The data needs to be automatically extracted from the telephone system and presented to a computer and the following methods were considered;

- (a) a traffic recorder with its own processor to provide a print out,
- (b) a traffic recorder giving a punched-tape or magnetic-tape output, for processing on a computer,
- (c) a traffic recorder sending data over a link to a central magnetic-drum store, which would be shared by other recorders,
- (d) sending data from a traffic recorder over a link to a dedicated computer with each computer dealing with all the traffic recorders in one area,
- (e) control of the traffic recorder over a data link by a dedicated computer with one computer controlling all the recorders in an area.

† Telecommunications Development Department, Telecommunications Headquarters.

Of these, option (e), the control of the traffic recorder by computer gave the most useful facilities. All the others contained at least one serious management problem, for instance, if paper tape were used it would arrive at the computer centre in unmanageably large quantities.

Rough calculations estimated that the country could be served on a computer-per-telephone area basis for about £4 million capital cost and a running cost of about £100,000 per year. However, while the development work was in progress the computer-aided maintenance project (c.a.m.p.) was launched and there were many advantages in including the traffic recording in this project.

PRINCIPLES OF THE NEW TRAFFIC RECORDING SYSTEM

The principles adopted for the design are;

- (a) that the sampling frequencies will comply with the recently-accepted standards of one sample during the average holding-time of the trunks being sampled,
- (b) that the operation of the system will be under computer control,
- (c) that the system will be fault tolerant.

Sampling Rates

The basic cycle of the operation of scanning the whole of a telephone exchange takes three minutes. This enables all the trunks carrying conversation traffic to be sampled once per cycle (the average holding-time being three minutes). Short holding-time equipment is sampled once every 18 seconds and this is interlaced with the long holding-time sampling so that each short holding-time trunk is sampled 10 times during a cycle. The very-short holding-time equipment of common-control exchanges will use a greater frequency of interlacing to achieve the higher sampling-frequency.

Computer Control

The computer program, in conjunction with the computer's calendar and clock, initiates all processes, the operation of the recorder being by data-link signals. This enables all adjustments to recording requirements for any telephone exchange to be made at the computer. The data is assembled in the computer as it is received and all data manipulations are performed in the computer. Assessment studies showed that it is more economic to perform all data-sorting operations in the computer than in the traffic-recorder.

Fault Tolerance

The new traffic-recorder for Strowger exchanges has been designed to eliminate most of the presently known difficulties associated with traffic recording. The new recorder rack Fig 1(a) is the same size as the present control-rack (the left-hand rack in Fig 1(b)) and can be delivered to the site fully wired as a direct replacement. The existing uniselectors

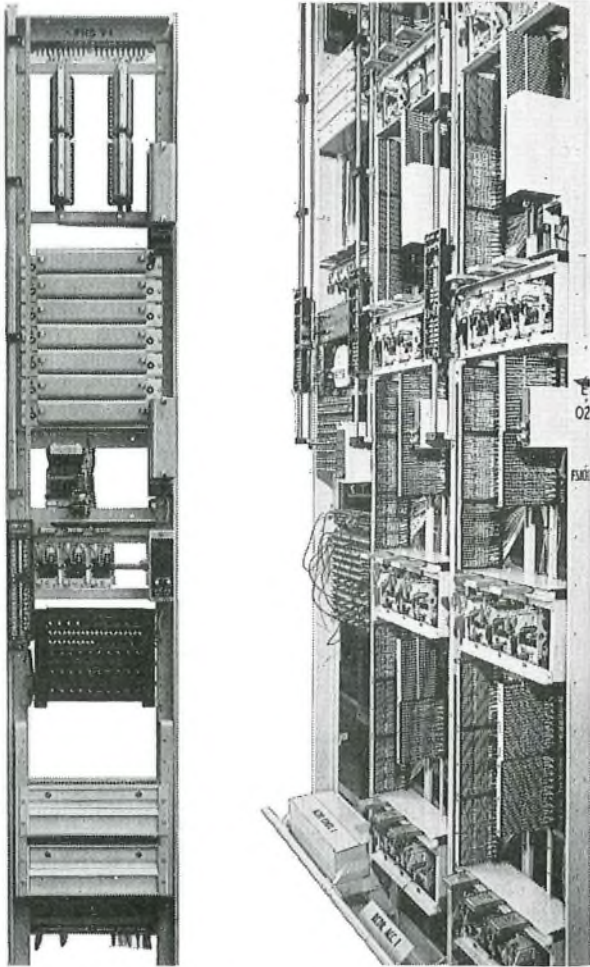

FIG. 1—The old and the new Strowger traffic-recorders

access is retained (the two right-hand racks in Fig 1(b)) because the major part of the cost of a traffic-recorder is in the access system and, furthermore, it is an integral part of the exchange wiring. The access system is made more reliable by the following features:

- (a) a check is made that all uniselectors are resting at the home position before recording commences and any unselector that is off-normal is automatically homed,
- (b) the access system is divided into independent blocks each of three uniselectors. A misoperation or fault on a block cannot interfere with recording on other blocks,
- (c) the recorder operates one block at a time through a fixed sequence of operations, during which it scans all its outlets and returns to its home position. A check is made that the uniselectors are correctly at the home positions at the end of the sequence. If any unselector is off normal, the recording for that block is marked invalid and the recorder attempts to home the unselector before moving to the next block.

REQUIREMENTS OF THE COMPUTER

The recorder has been designed to be compatible with the majority of process-control computers. It is not dependent upon a particular computer language. The computer needs to perform the following functions;

- (a) store several programs to meet the local needs of traffic recording and have a means of selecting a particular program,
- (b) store a look-up table of access points and gradings,
- (c) the look-up table must be capable of change when new equipment is added,
- (d) receive and store data from the recorder,
- (e) send control signals and receive the response signals in the sequence-of-operation required by the recorder,

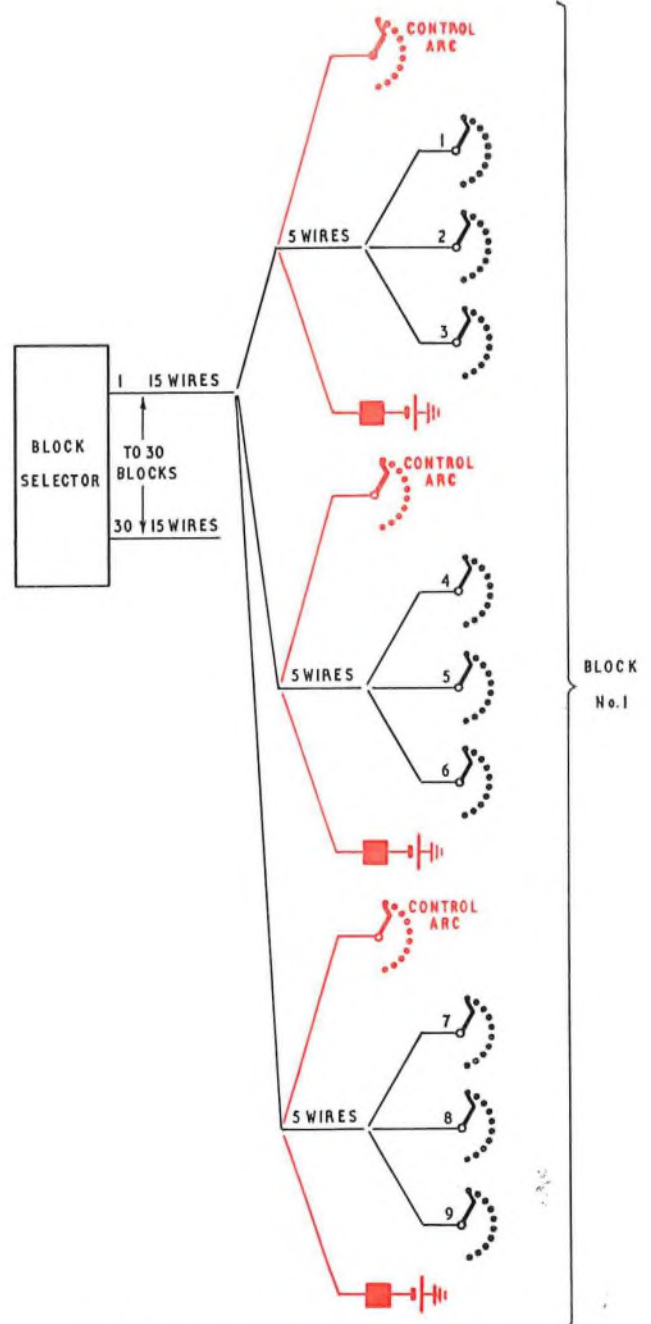

FIG. 2—Access uniselectors for computer control

- (f) check for errors of received data by the method used by the recorder,
- (g) keep a tally of the change-of-state of each switch, and give an output of those which fail to change state during a period of recording.

DESIGN OF THE RECORDER

All traffic recorders working on a scanning principle consist basically of two parts; the control section and the access equipment. When a conventional traffic-recorder is to be converted into a computer-controlled traffic-recorder, the original control section must be completely replaced. The access equipment, however, usually requires little modification, not even re-jumpering. Only the Strowger-type of traffic-recorder has been modified for computer control so far, but the recording system has been designed to accept data from electronic and crossbar, as well as Strowger, exchanges. The new control-equipment will be very similar for all types of exchange.

In the present Strowger traffic-recorder, access uniselectors

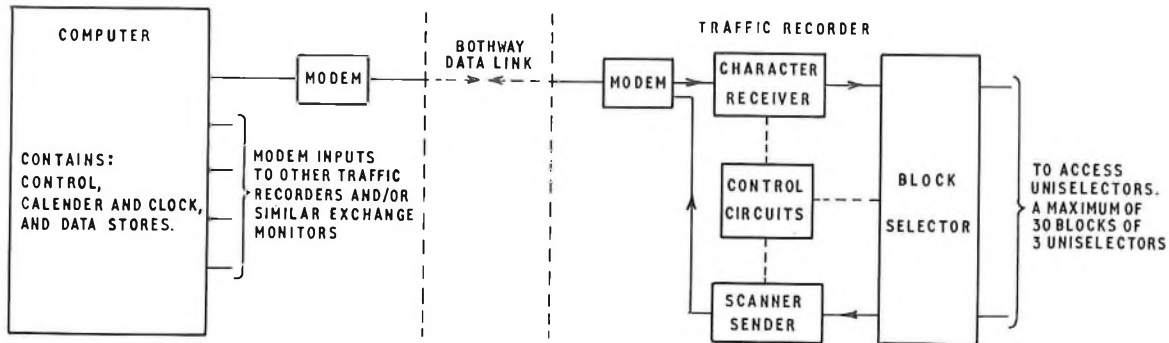

FIG. 3—Control equipment of the computer-controlled traffic-recorder

scan traffic-recorder leads, usually private wires, which normally assume an earth condition only when busy. Each access uniselector can scan 147 access points with three sets of staggered wipers. There are 50 outlets per uniselector but only 49 of these are used for access purposes. The fiftieth contact is the home contact and here access contacts are not connected.

When a Strowger traffic-recorder is to be converted for computer control, access uniselectors are split into blocks of three. Each block is assigned its own particular block identifying code or character. This character is wired on to the home contacts of the access uniselectors comprising the block, as a series of earths on some of the previously unconnected contacts. In any one block there are 441 access points which are scanned by nine sets of staggered wipers (Fig. 2).

The control equipment of the computer-controlled traffic-recorder consists of a character receiver, block selector, scanner-sender and associated control circuits (Fig. 3). The traffic recorder is connected to the computer by a bothway, 200 bit/s data link.

Operation

The sequence of operation (Fig. 4) is that the computer sends a block-identifier character (Fig. 5) to the recorder. This is received by the character receiver and the block selector starts to select the appropriate block. The scanner-sender sends two characters to the computer. The first character is a traffic-recorder code which identifies the particular traffic-recorder. The second character is a data-link

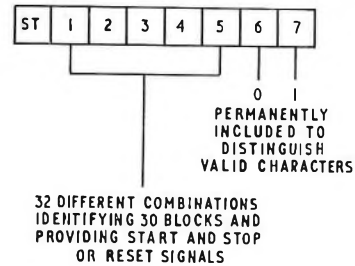

Sent from the computer to the traffic-recorder

FIG. 5—Control character

escape-code, which is required by certain types of computer, and is included to tell the computer that subsequent characters are data. When these two characters have been sent, and the block selector has selected the required block, nine access, and magnet and control wires from the block uniselectors are extended to the scanner sender and control circuits of the recorder. The scanner-sender simultaneously reads the states of the nine access leads into its store (i.e. logical 1 for busy or earth and logical 0 for free). Also read into the store are a start bit and bits 10 and 11, all of logical 0 polarity, together with an appropriate parity end-bit. Although only nine bits are used for recording on Strowger exchanges, a 10-bit word will be required for use on electronic exchanges. An eleventh bit is provided, partly to be a spare for unforeseen problems, and partly to facilitate scanning of crossbar systems. Thus a character is assembled (Fig. 6) and this is then sent out to the computer at 200 bit/s.

The first character to be derived from the access uniselectors of the required block is the block code, as this is wired on to the home contacts. The next 49 characters contain traffic data. The last character should again be the block code, as the uniselectors return to the home position. If one uniselector comes out of step, the sending of the block code is inhibited. As the block code is derived from the same place as the data is captured, it provides an overall system-check of each block of data.

Reception by the recorder of spurious characters is largely prevented by arranging that all valid characters contain a 0 and 1 in bit places six and seven, respectively. Blocks can be busied out for maintenance if required. If such a block is requested by the computer, the recorder sends back a *block not available* code to it.

The time taken for request and complete transmission of one block of data is six seconds. Thus, 30 blocks of long holding-time equipment may be scanned in three minutes, or less when short holding-time equipment is involved.

In a normal traffic-recording, over the whole exchange, the computer would request each recording block in order. The computer has, in its store, a map or look-up table identifying data bits of a character with particular pieces of exchange equipment. Thus the computer can arrange and process all received data into traffic records.

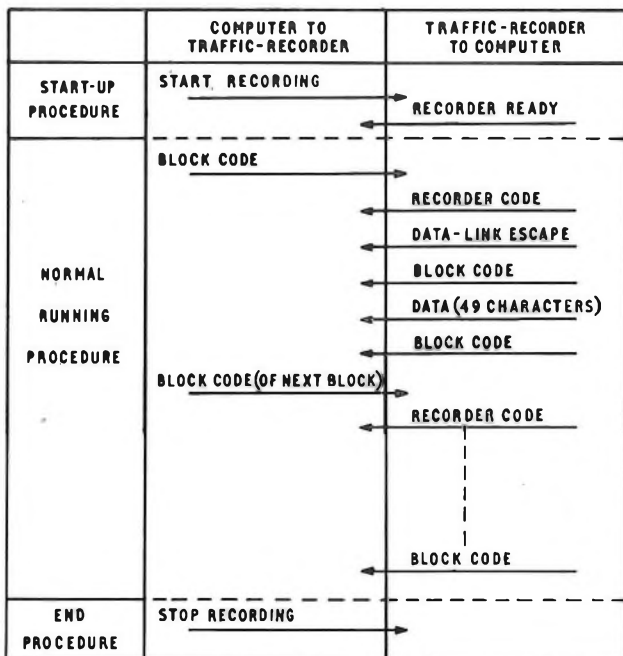
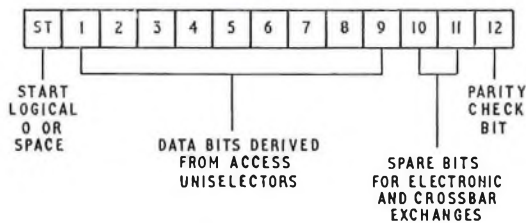

FIG. 4—Signalling sequence between the computer and the traffic recorder



Sent from the traffic-recorder to the computer
FIG. 6—Data character

Start-up Procedure

The traffic recorder is designed to operate in either an active mode or a passive mode. The computer can send the recorder into the passive mode by transmitting a stop or reset character to it. In the passive mode, the traffic recorder will not respond to any character except the *start* code. When the *start* code is received the traffic recorder initiates a pre-recording start routine. All access uniselectors are then automatically checked to determine that they are at their home position. If the recorder detects one, or more, access uniselectors off normal in any block, it attempts to home them. Should this fail, it brings up a prompt alarm so that the fault may be rectified manually. If all access switches are originally at their home positions, or when they are eventually restored, the recorder sends a *ready* code to the computer. Recording may then be commenced. This procedure may be programmed in or out as required.

MAINTENANCE ASPECTS

In this traffic-recording system, a fault can occur at the exchange traffic-recorder, the computer, the transmission line or the modems. It is, therefore, very important to be able to identify where such a fault occurs quickly and simply.

A tester and three access uniselectors with known patterns on their outlets are provided. With the aid of these it is possible to deduce whether a recorder has a fault and to help in its diagnosis.

The tester is incorporated in its own card frame. There are no common circuits shared between recorder and tester and possible masking of a fault is thus avoided. The function of the tester is to simulate the computer by sending a seven-bit character to the recorder. The contents of this character can be manually set and any particular character received from the recorder can be displayed. Facilities are provided to freeze both recorder and tester at any part of the operating sequence. The tester also contains circuits to compare the characters received from the three test uniselectors, with the characters actually wired on to them.

ADVANTAGES OF THE NEW RECORDING SYSTEM

The recorder has several novel features including the following:

(a) the data is assembled in the computer. This is possible because the system is on line. This feature eliminates the costly, time consuming, process of preparing, checking and error searching punched paper-tape. It also eliminates the use of input peripherals,

(b) the daily traffic-record is automatically run, read and processed without any attention from the maintenance staff.

(c) record can be taken at any predetermined time. The record may be of all blocks or of a few selected blocks. For example, the traffic originated by call offices during the evening rush-hour may be recorded or the traffic from a few exchanges on a particular Sunday when there is a local special event,

(d) the recording system has the ability to check on faulty switches. During the normal traffic-record an additional record is kept of the identity of switches which do not change state (busy or free) during the course of the recording. Thus, any switches which are either permanently busy or permanently free will be printed out on the exception report. An adjust-

ment can be made to the traffic record to allow for permanently busied-out switches (because although recorded busy they were not carrying traffic),

(e) the record is self checking in that when a scan is completed, the block number is sent to be compared with the block number in the computer store. Should these numbers differ, the record of the traffic for that block is known to be in error. The program can either arrange to scan the block again or just to mark the record as erroneous,

(f) a check for grading unbalance can be made by the computer,

(g) it provides the potential for supplying trunking and grading staff with reports showing only those traffic groups where attention is required.

DESIGN FEATURES

Transistor-transistor logic (t.t.l.) mounted in dual-in-line packages has been used for the recorder.

Effects of electrical and magnetic interference (noise) have been minimized. All the susceptible electronic components are mounted on cards in a frame, isolated as far as possible from the external electrical environment. A power pack in the frame supplies noise-free power to drive integrated circuits from supply and return rails isolated from outside the circuits. All conditions entering from the Strowger environment are transmitted to the electronic logic by driving relays and operate the logic by noise-free physical contacts. Also, all conditions from the electronic logic to the Strowger equipment are transmitted in the same way.

STATE OF DEVELOPMENT

Four models of the computer-controlled traffic-recorder have been built and installed in the Leicester Telephone Area where they are undergoing tests in preparation for inclusion in the computer-aided maintenance project² which will commence in 1972. The purpose of these models is to gain experience of the principles of computer-control of traffic-recorders. For this reason the design utilizes known techniques, wherever possible, as it is undesirable to include more unknowns than necessary to establish the new principle.

Once the principle is established, new traffic-recorders will include more electronic logic to perform functions now done by relays; other forms of logic, such as metal oxide semiconductor transistor logic, will be considered with the aim of improving the immunity from interference.

Future standard equipment for Strowger exchanges will probably retain the existing uniselectors for access as their maintenance costs will not be high enough to justify the cost of replacing them with a more reliable component. Furthermore, the inbuilt corrective actions of the recorder enable it to function correctly with access uniselectors that occasionally misoperate.

Only small changes are required in the design to develop computer-controlled traffic-recorders for crossbar and electronic exchanges. Different designs of access control are required to manipulate either a crossbar or a reed-relay access system. These access systems will need to be divided into independent blocks each of which can be scanned in six seconds at 200 bit/s. Each access control-circuit will probably be designed with the components of like kind to those of the exchange, i.e. the crossbar-exchange recorder would use crossbar switches and the electronic-exchange recorder would use reed-relays. Other than the access system, and the access control, the remainder of the recorder would be identical to the standard design using the same signalling system and the same computer program.

References

- GOLESWORTHY, H. M. G., KYME, R. C., and ROWE, J. A. T. The Measurement of Telephone Traffic. *P.O.E.E.J.*, Vol. 64, p. 227, Jan. 1972.
- BUTTERWORTH, D. C. A New Maintenance Aid—the Computer. *P.O.T.J.*, Vol. 23, Spring 1971.

Mobile-Radio Systems

I. H. BECK, C.ENG., M.I.E.E.,† and P. R. WILKINSON, GRAD. I.E.R.E.*

U.D.C. 621.396 : 621.395·4

The use of mobile-radio systems as an aid to vehicle and staff control has assumed greater importance in recent years, and has led to a considerable increase in the number of such systems in use. In the United Kingdom only a few frequency bands are available for such services and these are controlled by the Ministry of Posts and Telecommunications, who also specify the performance requirements of equipment for use on these bands. Standards have been established for both private systems and for systems which form an integral part of the public telephone network.

INTRODUCTION

Communication with people on the move has only become practicable during recent years. Reliable mobile-radio equipment which operates in the very high frequency (v.h.f.) bands, and produced at a price which permits large-scale application, only emerged after the end of the last war. The stimulus of war resulted in technical advances which were applied to peacetime uses. Modern equipment has displaced the early bulky, heavy and high-power-consuming valve equipment, and the effective cost has fallen.

Industry and commerce have long recognized the benefits of good communications, and this, together with the availability of equipment at the right price, has resulted in a considerable number of mobile-radio networks being established. There are now some 10,000 privately-operated base stations in the United Kingdom (U.K.). These are used in many ways to improve the efficiency of organizations. Sometimes this improvement cannot easily be measured in monetary terms; for example, the redirection of an ambulance to the scene of a road accident.

Many systems are, however, used for more easily quantifiable purposes; to re-direct transport in response to changing demands, to pass up-to-date information so that the time of personnel is not wasted, to permit the location and load of a workforce to be known and hence, to enable that workforce to be utilized more efficiently. An overall increase of 20 per cent in the utilization of vehicle-driver units has been quoted.¹

The British Post Office (B.P.O.) provides some mobile-radio services as part of the general communication service provided for the public. In addition, it also operates its own private services which are used to improve efficiency, security and safety of its operations. For example, outside working parties, laying and repairing cables, often would have no direct contact with their headquarters or with other teams with whom they need to work, except by mobile radio.

It is intended to publish a later article on the planning of a specific radio-relay system.

ADMINISTRATION OF THE FREQUENCY SPECTRUM

In the U.K., control of the civil use of radio frequencies is vested in the Ministry of Posts and Telecommunications under various acts which include the Wireless Telegraphy Act (1949). The object of this control is to ensure efficient use

† Telecommunications Development Department, Telecommunications Headquarters.

* Chester Telephone Area, Wales and the Marches Telecommunications Region.

TABLE 1
Frequency Bands Allotted to Private Land Mobile-Radio Service

Frequency (MHz)	Channel Separation (kHz)	
71·5 - 72·8 76·95 - 78·0 85·0 - 86·7 86·95 - 88·0	12·5	
105·0 - 108·0 138·0 - 141·0		12·5
165·05 - 168·25 168·95 - 173·05		
453·0 - 454·0 456·0 - 457·0 459·5 - 460·5 461·5 - 462·5		25·0

of the radio-frequency spectrum in the face of many competing demands, and to ensure that frequency assignment and technical conditions of use do not result in excessive mutual interference between radio users. General utilization of the frequency spectrum is regulated by international agreements, usually known as the international *Radio Regulations* of the International Telecommunications Union (I.T.U.). In these regulations, certain frequency bands are allocated for mobile radio use, and in the U.K. these are subdivided by a committee of representatives of government departments.

Several frequency bands have been allotted for private land mobile-radio services (Table 1). The manner in which these bands are used is decided by the Ministry from recommendations made by the Mobile-Radio Committee, a body which represents the Ministry, manufacturers and users.

There are now over 100,000 mobile radio-telephones in the U.K. and their use is expanding at a rate of about 17 per cent a year. The demand for more channels in the limited frequency bands allocated has led to the introduction of progressively narrower channel separations, i.e. the frequency spacing between carrier frequencies. New equipment operating in the v.h.f. bands must conform to the requirements of a channel separation of 12·5 kHz. Existing equipment, having mainly 25 kHz spacing, will be required to conform to the new standards by January 1973, or be replaced. Channel separation in the ultra-high-frequency (u.h.f.) bands is currently 25 kHz.



FIG. 1—Vehicle-mounted mobile-radio equipment

Administrative control of mobile radio extends to specifying technical characteristics of equipment and, subsequently, to testing and approving such equipment against the specifications prior to permitting its use. Before any radio equipment may be put into use, a licence, issued by the Ministry, is necessary. For B.P.O. systems, the licence authorizes the B.P.O. to use certain stations, working on specified frequencies, for the provision of public communication services. For private mobile-radio systems, however, including the private systems of the B.P.O., application has to be made to the Ministry for each proposed installation. Details have to be provided in a prescribed form of the proposals for the equipment, the fixed sites and the method of control, before a frequency is assigned.² Once a frequency has been assigned, planning and provisioning may then proceed. However, the equipment may be used only after an appropriate fee has been paid and a licence obtained from the Ministry.

A few frequency bands are available for the exclusive use of the B.P.O. for its own private mobile-radio networks. For these frequencies to be used effectively it is necessary to co-ordinate all requirements, and within the B.P.O. this function is carried out by Telecommunications Headquarters which has a specialist group dealing with mobile-radio matters. In addition to co-ordination and assignment of frequencies, technical advice is provided to prospective users. The group also deals with the development of public mobile-radio services, and provides technical support in the provision and installation of equipment for the public services.

PRIVATE SYSTEMS

The operational needs of many users are adequately met by private mobile-radio networks. These usually comprise a fixed-base radio station controlled by land line from a suitable control point, together with a number of mobile units. On private mobile systems, speech communication is permitted only between members of the same organization and the circuit may not be extended over the public telephone network. Messages tend to be short and stereotyped, and often pass between people who know each other and who are engaged in the same type of activity. Thus, a relatively poor grade of communication may be acceptable, and messages are often repeated. A large number of mobile units, frequently 70 to 100, depending on the nature and frequency of the traffic, may work to one base station on a single radio-frequency channel.

B.P.O. PUBLIC SYSTEMS

B.P.O. systems are used by telephone subscribers who are unfamiliar with mobile radio, and thus the service provided must be similar to the normal telephone service. Telephone calls are extended over lines of different lengths and hence the speech levels can vary widely. Also, since talkers could be unknown to each other, and could have widely differing speech characteristics, e.g. accents, levels, it is important that the radio circuits should afford good communication quality.

These systems therefore employ more complex equipment

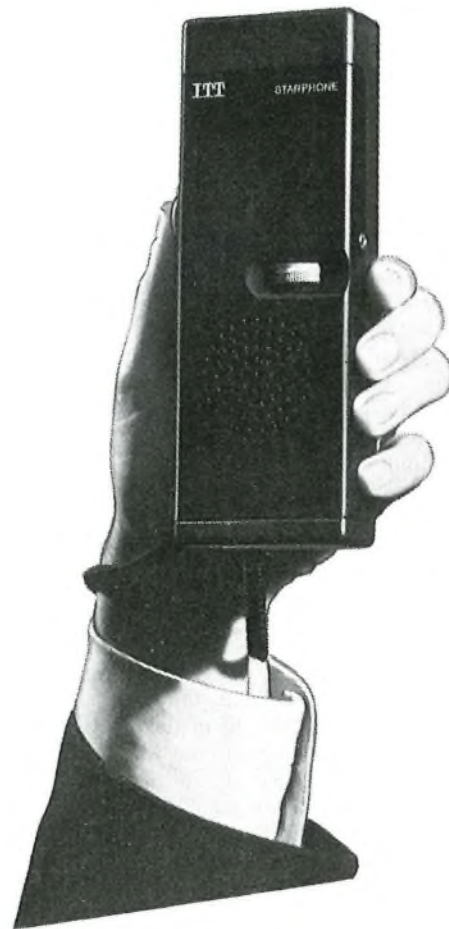

FIG. 2—Hand-held mobile-radio equipment

than private systems and usually provide more facilities, to simplify operating procedure and to make the system compatible with the telephone network.^{3,4} Because the messages are similar in content, duration and calling rate to those passed over the telephone network, the number of mobile units in each radio-frequency channel is limited. The customers are usually key personnel in frequent need of two-way communication, even when travelling in a vehicle.

EQUIPMENT DEVELOPMENT

In recent years, impressive improvements have been made in equipment design. Early mobile units weighed about 45 kg and occupied much valuable vehicle space. The current taken from a 12-volt supply by the receiver was about 4 amps, and it increased to about 20 amps when the transmitter was switched on. A modern unit uses semiconductors, often weighs less than 4.5 kg and is little larger than a car broadcast radio-receiver. Figs. 1 and 2 show examples of typical modern equipment. Consumption has been reduced to less than 200 mA

in the receive mode and a mobile receiver may therefore be left switched-on all day without unduly discharging the vehicle battery. The transmitter requires on warm-up period, and draws about 1.5 amps from a 12-volt battery for a 5-watt transmitter.

Modern circuit techniques have brought with them an improvement in reliability. The mean time between failures is now about 10,000 hours. Thus, the user can now expect less than one fault per equipment per year. Maintenance costs are correspondingly small and almost solely associated with a six-monthly frequency check, and when necessary, retuning to the assigned frequency. Although developments in the manufacture of quartz-crystal units have enabled closer standards of frequency tolerance to be achieved, aging still necessitates such checks.⁵ Nevertheless, long-term stabilities of 5 parts in 10⁶ are consistently achieved without recourse to temperature-stabilized crystal ovens, even with equipment subjected to extremes of temperature.

MODULATION METHODS

A number of methods of modulation have been considered for mobile-radio application. Complex methods, which result in increased cost and complexity of equipment, are usually unacceptable unless they offer a substantial benefit. The choice, therefore, is restricted to only a few modulation methods, and for the narrow channel-spacings employed in most mobile-radio services (12.5 kHz or 25 kHz), the choice is mainly confined to amplitude or angle modulation. Angle modulation includes both phase and frequency modulation and is commonly known as f.m.

Amplitude modulation (a.m.) has been selected by about 90 per cent of U.K. mobile-radio users, including the B.P.O. for its private services, whilst angle modulation is generally used by the B.P.O. for its public services.

Arguments about the relative merits of a.m. and f.m. have continued for many years. Both methods of modulation can be satisfactory, provided that the system is engineered correctly. In areas of medium field-strength, amplitude modulation does not provide as good a signal-to-noise ratio as an f.m. system, but where the field strength is higher, there is little difference between a.m. and f.m. unless very heavy interference is experienced.

The effect of an interfering signal is generally reduced in a f.m. receiver output, provided the amplitude of the desired signal exceeds that of any disturbing signals. If the amplitude of the desired f.m. signal is reduced until it is comparable with a disturbing signal, a sharp threshold is reached when the disturbing signal suppresses the desired signal. Therefore, an f.m. transmitter has a well-defined service-area, which in some applications is a desirable characteristic, however, when the average value of prevailing noise is only slightly below the desired signal, occasional noise bursts suppress the signal, and this can make f.m. reception impossible.

Angle-modulated systems tend to be subjectively worse when the field strength is low and interference levels are high, but reduce the effects of co-channel interference, that is, the interference from distant stations on the same frequency. With a.m., this type of interference usually results in an audible beat note between the carriers of the two transmissions. On the other hand, with angle modulation, there is a lower limit to the level of signal which results in an acceptable and intelligible speech quality. With f.m. systems all equipment must be tuned accurately and the frequency stability must be good if acceptable speech quality is to be maintained. It is significant that the majority of private systems in the U.K. use a.m., since contact is of paramount importance even at extreme range. On the other hand, most public systems employ angle modulation because of the more clearly defined service area, the improved quality within that area and the reduction of co-channel interference.

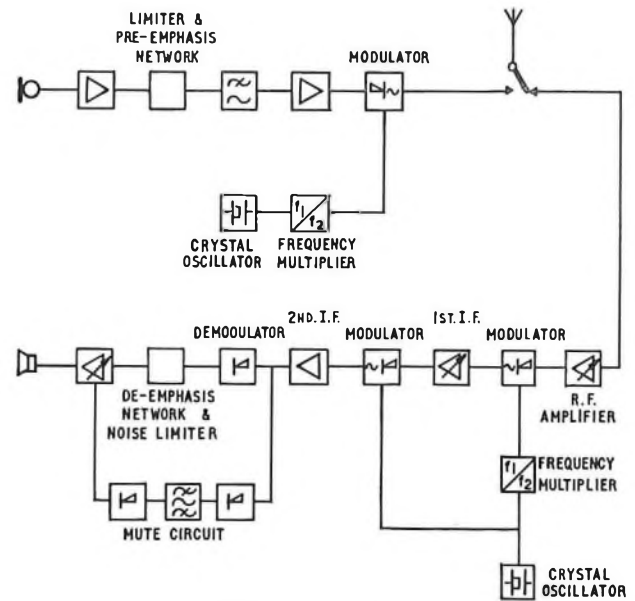

(a) Amplitude modulated

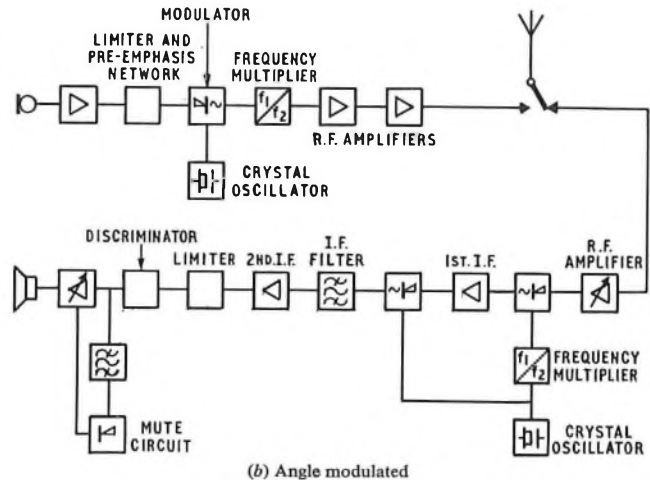

(b) Angle modulated

FIG. 3—Block diagrams of typical mobile-radio equipment.

EQUIPMENT DESIGN

The performance requirements for mobile equipment set by the Ministry and by overseas administrations are stringent, and taken in conjunction with the user's needs, require the manufacturers to apply the most modern techniques. A measure of uniformity has resulted and equipment now varies most in respect of modulation method, physical design and ancillary facilities. Those characteristics which concern transmission performance, transmitter power and receiver sensitivity and selectivity vary only between narrow limits.

Table 2 shows in a concise form the performance characteristics of a typical mobile equipment.

The circuits of typical amplitude- and angle-modulated equipment are shown in Fig. 3. In both cases the transmitter carrier is derived from a crystal-controlled oscillator operating at a low frequency, which is then multiplied up to the final frequency, and amplified at the same time.

The modulating signal from the microphone is amplified, applied to a pre-emphasis network, peak limited and then filtered to remove the higher-frequency components, particularly the distortion products caused by the limiting process, and then applied to the modulator at a high level for a.m.

For angle modulation, the modulating signal is applied at a low-level point, usually to modulate the frequency of the crystal oscillator. The resultant deviation is small, but is increased by the action of the frequency-multiplying stages,

TABLE 2
Characteristics of a Typical Mobile Equipment

General	Power supply	6, 12 or 24 volt, positive or negative earth
	Power consumption	Receive 200 mA (12 volt) Transmit 1.5 amp
	Operating temperature Weight	-25°C to +55°C 2.5 kg
Receiver	Sensitivity	1 μ V (e.m.f.) input for 500 mW output, 10 dB signal-to-noise ratio
	Spurious response attenuation	Better than 70 dB
	Adjacent-channel selectivity	Better than 70 dB
	Intermodulation Audio output	Better than -70 dB 2 watts, with less than 10 per cent distortion
Transmitter	Power output Spurious outputs	8 watts Less than 2.5 μ W at the aerial terminals
	Frequency stability	\pm 2 kHz from -25°C to +55°C
Controls	On/off switch Volume control Mute-level control Channel selector Transmit switch	

which convert or multiply the frequencies from the crystal oscillator up to the final operating frequency.

The receiver is of conventional superhetrodyne form, but generally employs double frequency-conversion. The local oscillators are, however, crystal controlled, and highly selective filters are employed in the intermediate-frequency amplifiers. These filters usually employ a number of quartz elements to obtain the required selectivity.

One circuit which is almost unique to mobile-radio application is the mute or squelch circuit. This circuit quietens, or mutes, the audio-frequency amplifier when no wanted signal is present. In the absence of a wanted signal, the noise in a frequency band above the speech band, e.g. 4-5 kHz, is high, and this noise signal, when rectified, provides a signal to cut-off the audio amplifier. When a carrier is present, the noise level falls and the control voltage is removed, thus allowing the output signal to pass to the loudspeaker.

LIMITATIONS IMPOSED BY TRANSMITTER AND RECEIVER

The radiated power is usually restricted to reduce interference to other radio services. For private mobile-radio services in the U.K., the limit is an effective radiated power* of 25 watts, although different limits often apply in other countries. Whilst the useful range may be increased by increasing the power, an approximately 16-fold increase is necessary to double the service range, but this would increase the probability of interference being caused, at great distances, to other services.

Modern receivers often have a better input-signal sensitivity than required by the performance specification. At frequencies up to 500 MHz, and in the absence of interference, a usable signal will normally be obtained if the wanted radio-frequency potential difference at the input terminals of the receiver is 2 μ V (equivalent to a power of 0.08 pW in a 50-ohm impedance). If noise is present, as in most built-up areas, a larger input signal may be required to achieve adequate performance. Thus, noise can limit the useful range of the system, and in severe cases, can cause a 20 dB reduction in useful sensitivity.

* Effective radiated power—the output power of the transmitter, less feeder losses, multiplied by the aerial gain, in the horizontal direction, relative to a half-wave dipole.

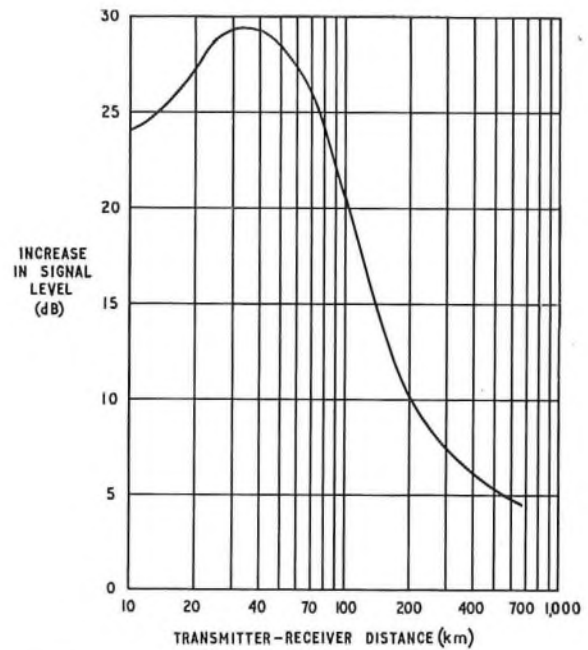

FIG. 4—Increase of received signal level due to increase of base-station aerial height from 37.5 m to 600 m

The source of the most predominant noise is the ignition systems of road vehicles.

Mobile stations are almost always exposed to a higher level of noise than base stations, largely due to the electrical equipment of the vehicles in which they are installed. Because of this, a mobile receiver often requires signals 6-10 dB higher than a base-station receiver, for the same communication quality. The mobile transmitter, therefore, can have a lower power rating than the base-station transmitter, and still provide a comparable range. Thus, although base stations usually radiate about 25 watts from a dipole aerial, it is usually satisfactory to employ 5-10-watt mobile transmitters with quarter-wave whip aerials. As a result, current drain from the vehicle battery is reduced, and more important, the probability of the mobile transmitter causing interference to other services is reduced.

Although most mobile equipment makes use of a combined transmitter and receiver working into a common aerial, the base-station transmitter and receiver are usually separate units. Therefore, it is possible to use two aerials, and for the receiver aerial, to make this provide gain relative to a simple dipole. However, for planning purposes, it is usually sufficient to consider the transmission path from the base-station transmitter to the mobile receiver.

TECHNICAL BASIS OF SYSTEM PLANNING

Any mobile-radio system needs careful planning if it is to meet the operational needs, and at the same time make economic use of the available radio-frequency spectrum. The desired coverage area is normally dictated by the operational needs and seldom coincides with the service area from the most convenient base-station site. Therefore, some compromise has to be accepted.

The signal received at the output of a mobile-radio receiver is dependent upon:

- the power radiated from the base station, which as explained, is limited by the terms of the licence,
- the useable sensitivity of the mobile receiver, which is influenced by the man-made noise in its immediate environment,
- the heights of both transmit and receive aerials above the surrounding ground, and
- the attenuation of the signal during propagation from the transmitter to the receiver.

The useable range is greatly influenced by the heights of the transmitting and receiving aerials, but these have only a slight effect on the signal received at locations separated from the base station by 100 km or more.

Fig. 4 shows the effect of a large increase in base-station aerial height, from 37.5 m to 600 m above ground. If the height gain were a linear function of height, a gain of 24 dB would be expected, and it is seen that at least this figure is obtained up to about 80 km. At greater distances, beyond the horizon, the gain is less, falling to less than 10 dB at distances beyond 200 km.

To produce the same signal levels from an aerial at 37.5 m as from one at 600 m, the transmitter power would need to be increased by 24 dB, that is 250 times, which would require an expensive 6 kW transmitter in place of one of 25 watts.

Between transmitter and receiver the signal is attenuated by dispersion and by the influence of the earth. The field strength E over a smooth good-conducting earth is given by:

$$E = \frac{3\sqrt{5P}}{d} \frac{4h_1h_2}{\lambda d} \mu\text{V/m},$$

where P = equivalent radiated power in watts,
 d = distance from transmitter in km,
 λ = wavelength in m,
 h_1 = effective height of the transmit aerial in m, and
 h_2 = effective height of the receive aerial in m.

The first part of the equation represents the effect of signal dispersion in free space, and the second part represents the influence of the earth. The field strength required to produce a received signal level of $1 \mu\text{V}$ is shown, for a range of frequencies, in Fig. 5.

The actual signal received at a location will usually differ from the value given by this formula, due to reflections and refractions from buildings, attenuation by obstructions such as hills, woods and buildings and by scattering at the edges of obstructions. The signal incident on the receive aerial therefore consists of an indeterminate number of components of varying amplitude and phase relationships. Such signals can only be described in statistical terms, and over small areas of the order of 1 km^2 , follow an approximately log-normal distribution law, given by:

$$P(F) = \frac{1}{\sigma\sqrt{2\pi}} \int_f^\infty \exp \frac{(-f - F_m)^2}{2\sigma^2} df.$$

$P(F)$ is the probability, percentage of time or locations, that the field strength, expressed in dB relative to $1 \mu\text{V/m}$, exceeds the level F . The median value F_m is that exceeded for 50 per cent of the time or locations and σ is the standard deviation of the distribution of values. Fig. 6 shows a normalized log-normal distribution curve. Given the value of the standard deviation, such curves can be used in calculating service and interference field strengths.

From Fig. 6 it can be seen that the signal (in dB) exceeded at 90 per cent of the locations, for example, is lower than the median value by 1.286 times the standard deviation. The median value of field strength must be, therefore, 10 dB greater (if $\sigma = 8 \text{ dB}$, the value applicable for frequencies up to 200 MHz) than the minimum useable value to ensure an adequate signal for 90 per cent of the time.

To predict the service range of a transmitter, i.e. the distance from the transmitter at which the median field strength is to be expected, it is necessary to use propagation data.

As an approximate guide, the formula given previously may be used for smooth unobstructed ground, but where buildings, hills and valleys intrude into the propagation path, the results may be too inaccurate. Curves published by the International Radio Consultative Committee (C.C.I.R.) have been prepared from many measurements made over a considerable period of time and give results which are more accurate. These curves

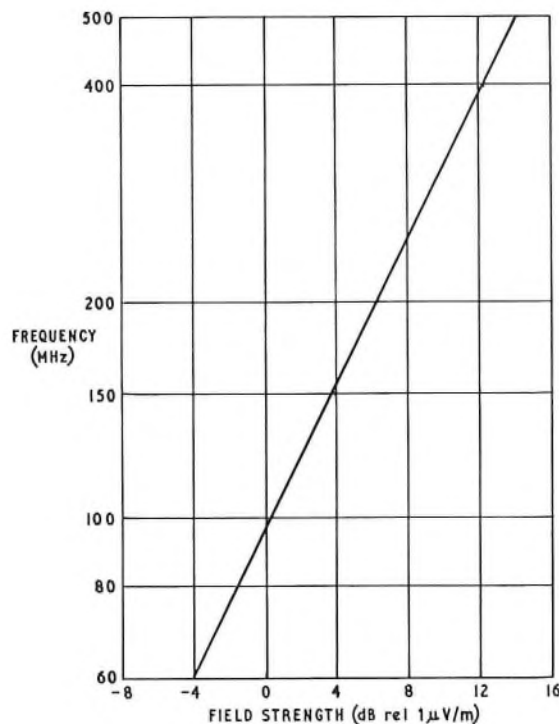

FIG. 5—Field strength necessary to produce $1 \mu\text{V}$ e.m.f. when incident on a half-wave dipole

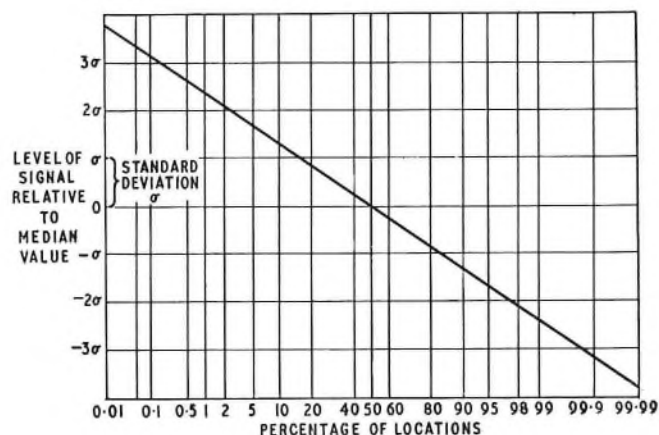
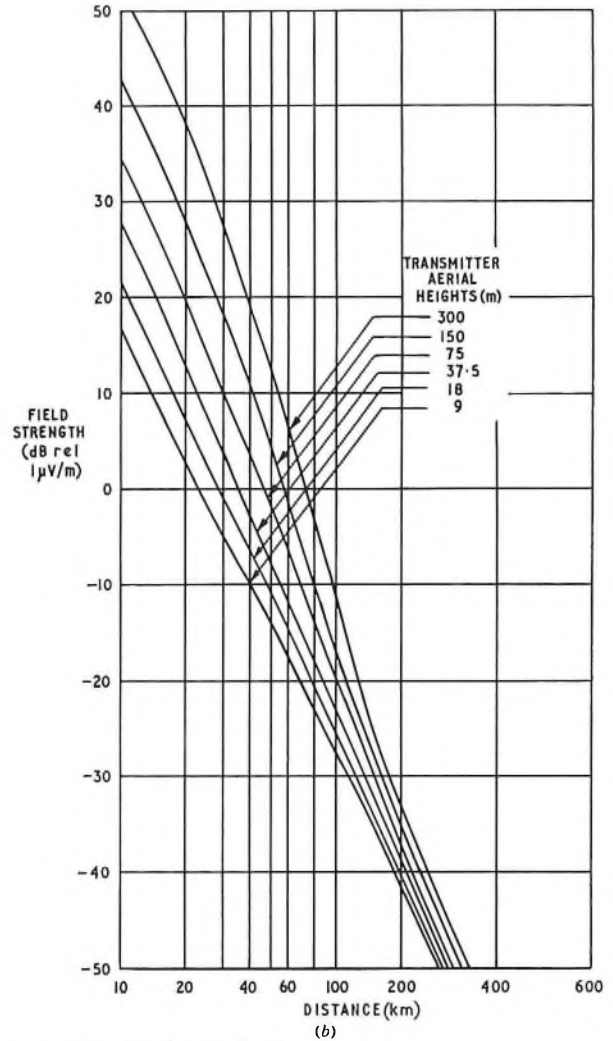
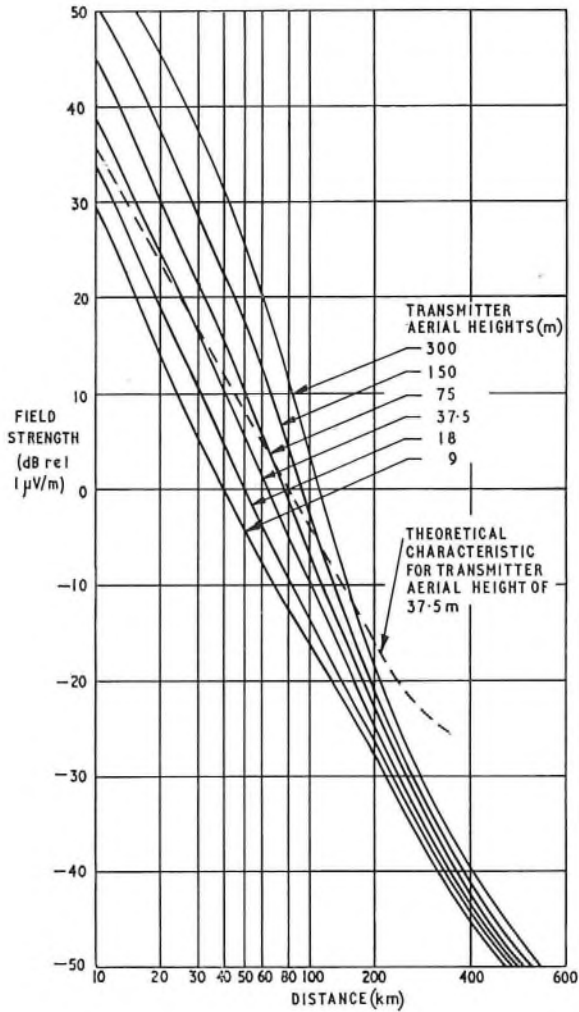

FIG. 6—Level of received signal relative to median value

are applicable to 50 per cent of locations for 50 per cent, 10 per cent and 1 per cent of the time. Significant differences between the curves are only apparent for distances beyond the horizon and the 10 per cent and 1 per cent curves are of most use in estimating interference between widely separated systems. Fig. 7 shows median curves extrapolated from C.C.I.R. Recommendation 370-1, for typical values of mobile-radio aerial heights. From Fig. 7(a) it may be deduced that a field strength of 15 dB (relative to $1 \mu\text{V/m}$), adequate for a service operating at about 80 MHz, can be expected at about 19 km if the transmitting aerial is 9 m high, but at about 70 km if the transmitting aerial is 300 m high.

The effective value of the aerial height can often be increased by placing the base station on a hill, as shown in Fig. 8.

In a built-up area the effective height can be taken as the height above the plane which represents the average building height within a distance of about 1-3 km. The value thus obtained is generally valid for calculating the field strength at greater distances, but is not necessarily of use in estimating at closer range. For close ranges, the angle at which the signal is propagated, together with the type, density and height of the buildings, needs to be known.



The curves represent 50 per cent time and 50 per cent locations for a radiated power of 25 watt, a receiver aerial height of 1.5 m and various transmitter aerial heights

Fig. 7—Propagation characteristics for (a) frequencies up to 200 MHz, and (b) frequencies between 400 and 470 MHz

From these propagation curves, accurate prediction of signal levels, and hence of service areas, is not possible when hills or large built-up areas intervene between base station and mobile station, although the general trend will be indicated. A more detailed study of the topography is then required, and a number of authorities are investigating methods of improving the accuracy of predictions. Computer methods have been described⁸ but these necessitate the acquisition of a store containing all relevant data including contour heights, building density and degree of wooding. Provided with such information, the computer may be programmed to calculate the path loss between the base station and any location and to give the data in the form of a suitable display.

A similar but less accurate method can be employed, even in the absence of a computer, which makes use of path profiles constructed from maps. Fig. 9 shows a typical example. The hill at about 8 km distance places the mobile station at 11.5 km in a shadow, and the signal reaching it is that due to diffraction by the surface of the hill top. Optical theory can be applied to calculate the shadow loss, which is the decrease in signal strength caused by the obstruction. The simplest approach is to regard the hill as a single knife edge.

More sophisticated prediction methods are possible but the simpler approach outlined usually indicates areas in which some uncertainty exists as to whether an adequate signal will be received. Practical tests, using a temporary base-station and a mobile receiver, can then provide a clearer picture of the actual grade of service which may be expected.

INTERFERENCE

Avoidance of interference is of particular importance in planning systems and in assigning frequencies. Interfering signals can arise from co-channelled systems employing the same frequencies, and also, occasionally, from systems on other frequencies. To avoid co-channel interference, base stations sharing the same frequency need to be geographically separated by up to 5 times the service radius,^{6,7} since an interfering signal should have a field strength of 17 dB or more below that of the wanted signal if it is to be incapable of causing unacceptable interference.

Interference from systems on other frequencies is generally confined to situations where the distance between a receiver and an interfering transmitter is short in comparison to the service range. It can arise from receiver desensitization (or blocking) caused when strong unwanted signals reach the receiver input, from cross-modulation, or intermodulation. Cross-modulation occurs in the presence of strong interfering signals because of non-linearities in the receiver, and results in the transference of the modulation from the interfering signal to the wanted one.

The cause of intermodulation interference is similar, but it can result from non-linear, or rectifying, characteristics of transmitters, receivers or even of metal work in the vicinity (known as the rusty-bolt effect). In the presence of strong signals, significant levels of signals at the second, third, fourth and higher harmonics of the original are produced. These can be reduced by suitable filters, but in addition, sum

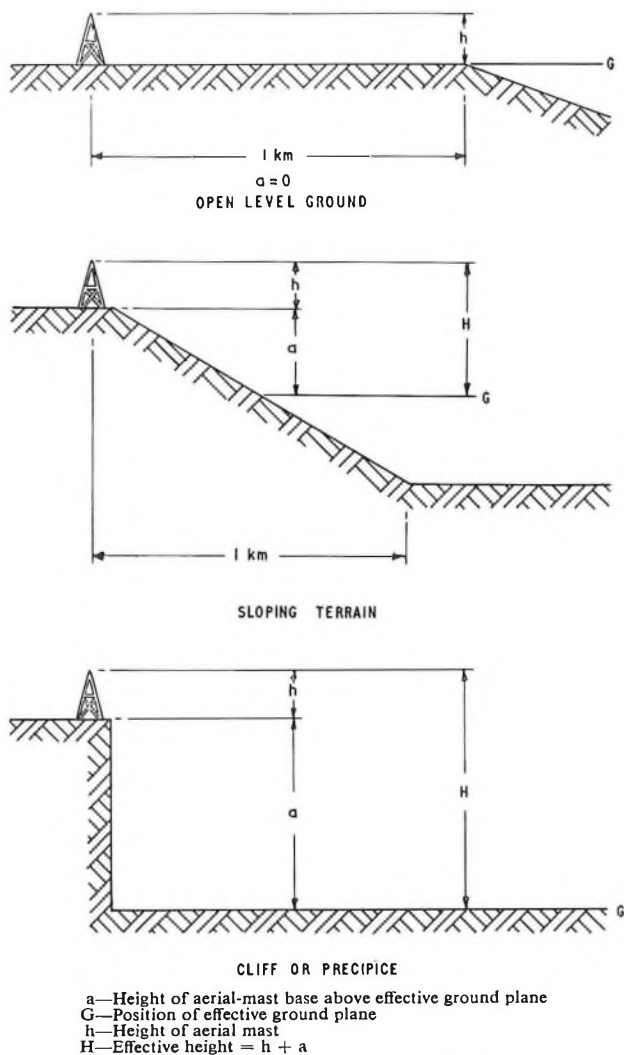
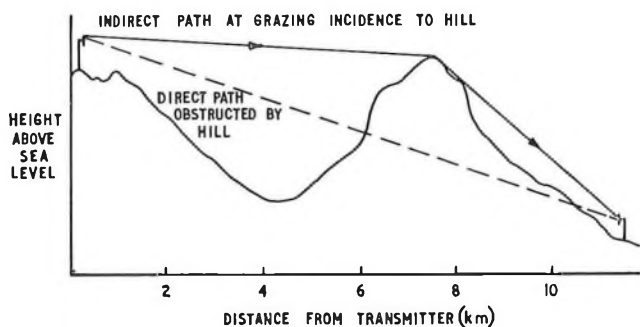

FIG. 8—Calculation of base-station effective aerial height



The vertical scale has been exaggerated and hence the radio path lengths appear distorted. In practice they are very nearly equal to the equivalent horizontal distances.

FIG. 9—Typical path profile

and difference products of the various frequencies can also result, the most serious of these being the third and fifth-order products having the following frequency relationships:

$$2f_a - f_b = f_d, \quad f_a + f_b - f_c = f_d,$$

$$3f_a - 2f_b = f_d, \quad 2f_a + f_b - 2f_c = f_d.$$

The frequency f_d falls in the same band as the originating frequencies f_a , f_b and f_c , and hence can cause interference to any receiver tuned to this frequency. Whilst the licensing requirements call for a high degree of linearity in the receiver circuits, intermodulation is very difficult to eliminate, except by careful choice of frequency, taking into account all other frequencies in use within a short distance of the proposed

transmitter, together with the power and location of existing base stations. The problem is most severe at base stations shared by a number of services, where particular care has to be taken to prevent frequency combinations which might result in unacceptable interference.⁹ Even if particular care is taken to reduce the risk by using filters, or circulators, which have little attenuation to signals from the transmitter to the aerial but high attenuation in the opposite direction, and by arranging the aeriels and feeders for minimum coupling, these measures may be rendered ineffective unless neighbouring metal-work, including structural reinforcement, is well bonded.

It can be seen that the choice of frequencies has to be made carefully if interference is to be avoided and that this requires knowledge of the frequencies and power employed by other users. In addition, the installations need to be carefully engineered in order to achieve the desired aims, whilst complying with the licence regulations.

ADDITIONAL FACILITIES

Although simple systems can provide speech facilities enabling a work force to be controlled, there are limitations. For example, a vehicle which is unattended can be called for a long time without reply, and this call will be listened to by other personnel who are not involved.

The introduction of selective calling enables the control operator to call any mobile individually without disturbing others, and also permits a signal to be permanently displayed in the vehicle until the call is answered.

By providing suitable voice-frequency code generators at the mobile station, with decoders at the control point, routine messages can be transmitted in a coded form in less time than is required for speech communication. Alarm and emergency calls can be similarly treated, thus ensuring instant attention.

Base stations can be controlled from more than one point, and hence be made to conform more to the operational needs. Suitable equipment already exists for this purpose, and in a subsequent article, a mobile-radio system will be described in which there is flexible control of a number of radio base-stations from a larger number of control points.

CONCLUSION

It has only been possible to indicate briefly the general characteristics of current mobile-radio equipment and to indicate the basis for planning systems. The need to apply good planning methods is becoming more pressing as the number of mobile-radio users increases.

References

- BRINKLEY, J. R. British Car Men Tune into the Great Mobile Radio Boom. *The Times Business News*, Dec. 1968.
- Ministry of Posts & Telecommunications (Radio Regulatory Division). *Memo BR1*. Conditions Governing the Licensing and Operation of Private Mobile Radio Services. (Undated.)
- ARMAN, L. T., and MELLOR, V. C. The South Lancashire Radiophone Service. *P.O.E.E.J.*, Vol. 52, p. 22, Jan. 1960.
- HYATT, J. L. The London Radiophone Service. *P.O.E.E.J.*, Vol. 59, p. 98, July 1966.
- ROLFE, N. C., and KENTLEY, E. W. Recent Developments in Quartz Crystals. *I.E.E. Conference Publication No. 18*, p. 10, Jan. 1966.
- EDWARDS, R., and DURKIN, J. Computer Prediction of Service Areas for VHF Mobile Radio Networks. *Proceedings I.E.E.*, Vol. 116, No. 9, Sept. 1968.
- FREYTAG, H. H., and HAAS, R. A Contribution to the Planning of Two-Way Speech Networks for Private Land Mobile Radio Services. *Nachrichtentechnische Zeitschrift*, Vol. 18, p. 561, Oct. 1965. (In German.)
- RUE, O. On the Planning of Communication Radio Networks for the Routing of Transports. *T.E.L.E. (English Edition)*. Vol. xx, p. 1, 1968.
- EDWARDS, R., DURKIN, J., and GREEN, D. H. Selection of Intermodulation-Free Frequencies for Multiple-Channel Mobile Radio Systems. *Proceedings I.E.E.*, Vol. 116, Aug. 1969.

Pseudo-Random-Sequence Binary-Digit Generators and Error Detectors

D. J. DIECKMANN and F. A. GRAVES†

U.D.C. 681.32:621.373:621.394.14.001.04

A pseudo-random sequence of binary digits may be used to simulate the traffic signal in a digital transmission system and, since the sequence is predictable and repeatable, errors introduced in transmission may easily be detected and counted. This article describes how such sequences may be generated and gives a brief account of the design and development of equipment required for assessing the performance of digital transmission systems.

INTRODUCTION

Binary notation is a system of counting in which the only two digits used are 0 and 1. Information may be transmitted from point to point by coding it in binary (or digital) form, using two discrete voltage levels to represent the 0 and 1 states, and transmitting the resulting stream of binary digits over any convenient medium. An outline system is shown in Fig. 1 and comprises a digital information source, modulator,

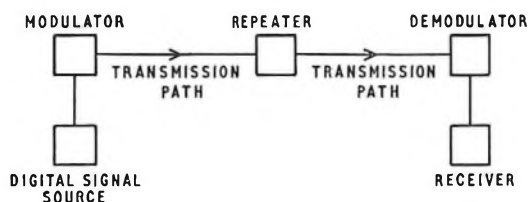

FIG. 1—Outline digital transmission system

transmission medium, demodulator and receiver. If the length of the transmission path is such that the binary signals would become badly distorted, one or more regenerative repeaters must be inserted to ensure that the signals are correctly received at their destination.

The criterion of performance of a digital transmission system is the number of errors received for a given number of digits transmitted. Errors occur in transmission due to noise, interference, distortion and jitter. The signal is regenerated at each repeater and again at the receive terminal; noise or interference on any part of the system, if serious enough, will cause error decisions to be made. These errors accumulate over a system when error decisions are made at any regenerator.

One method of measuring the errors received at the remote terminal or intermediate point is to transmit a test signal and compare, bit-by-bit (bit = binary digit), the signal received with the signal sent, assuming that an error-free channel is available for comparison. A further method makes use of the comparison of the received test pattern with a locally-generated pattern (identical to the transmitted pattern). The locally-generated pattern must be aligned with the received pattern before error measurements commence.

PSEUDO-RANDOM SEQUENCES

A test pattern consisting of a random sequence of binary digits may be generated by using, for example, a noise source and decision device, and timing pulses. The noise source is

sampled at intervals by the timing pulses and the output is set to 0 or 1 depending on whether the amplitude of the noise voltage is greater or less than a predetermined value. If the noise source is truly random, the order in which the decision device selects 0 and 1 states will be unpredictable. If a long succession of signals is analyzed, it will be found to contain an equal number of 0 and 1 states; also, the proportion of pairs and triplets (of 0 or 1) will be one-quarter and one-eighth respectively, and so on. The timing pulses ensure that each digit in the sequence occupies the same period of time.

A sequence that has a distribution of 1 and 0 states similar to the distribution from a random generator, but in which the pattern is predictable and repeatable, is termed a pseudo (false)-random sequence. The main advantage of using a pseudo-random sequence for testing digital systems is that the pattern sequence is predictable and easily generated, and errors in the received pattern can be detected by logic circuitry. The sequence, if long enough, has a similar distribution of 1 and 0 states to that in a random sequence. Longer sequences may be obtained from a shift register with more stages; the length of the pattern sequence is equal to $(2^n - 1)$ where n is the number of stages in the shift register.

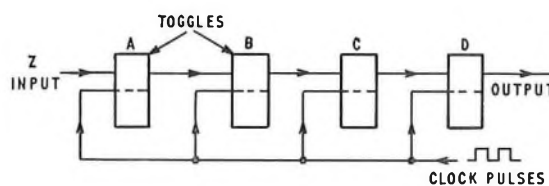

FIG. 2—Shift register

A pseudo-random sequence may be produced by a shift register and a logic feedback circuit operated by timing pulses. A shift register consists of a chain of bistable binary storage stages called toggles.* Clock or timing pulses are applied simultaneously to each toggle in the chain and cause the binary digit stored in each toggle to be transferred to the next toggle. Suitable circuitry is provided at each toggle to ensure that each binary digit is "shifted" only one stage at each clock pulse. In Fig. 2, the shift is assumed to be to the right. Thus, if the binary pattern stored in the four-stage shift register shown is

A	B	C	D
1	1	1	1

* Toggle—a trigger circuit which has two stable states and which requires an appropriate excitation in each state to cause a transition to the other.

† Research Department, Telecommunications Headquarters.

and the binary input at the input Z is 0, then the next clock pulse will cause one bit shift to the right and the A stage of the shift register will store the zero digit. The new state of the register will be

A	B	C	D
0	1	1	1

If the next digit applied is a 1, then the state after the next clock pulse will be

A	B	C	D
1	0	1	1

and so on.

By coupling the output to the input as shown in Fig. 3, the pattern can be made self-generating. Design procedures

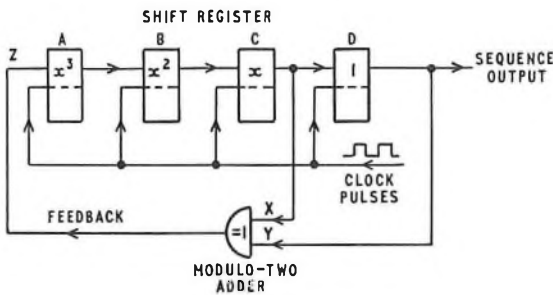

FIG. 3—Binary-pattern generator

are concerned with the production of the logic feedback signal, Z; this is accomplished by the use of a logic circuit called a modulo-two adder (also called a half adder or exclusive-or gate). The function of this circuit is illustrated by the truth table shown in Table 1.

TABLE 1
Truth Table for Modulo-two Adder

Inputs X Y	Output
0 0	0
0 1	1
1 1	0
1 0	1

The logic output from this circuit is 0 if the two inputs X and Y are the same and 1 if they are different. Thus the circuit may also be used as a comparator or parity-check device to detect agreement or disagreement between two binary digits. It may also be considered as a gate which transmits X unchanged if Y is 0, but inverts X if Y is 1.

Fig. 3 shows the connexions from the last two stages C and D of the four-stage shift register to the modulo-two adder, and the connexion from the modulo-two adder to the input Z of the shift register. The legend (=1) inside the gate symbol indicates that the output of the gate is logic 1 when one, and only one, of the input logic states is 1.

Table 2 shows the effect of successive clock pulses on each shift register stage, transferring the stored digit in one stage to the next stage, and it also shows the new resultant digit Z from the modulo-two adder to be transferred into the first stage of the shift register.

The output sequence obtained from stage D of the shift register is 100010011010111 and this forms a recurrent pattern sequence, frame or block of fifteen ($2^4 - 1$) binary digits.

The output sequence may be obtained from any of the four stages of the shift register, as may be seen on comparing columns A, B, C and D.

This sequence is called a maximum-length linear shift-register sequence (*m*-sequence for short) and it contains all combinations of 1 and 0 in the register except for the 0000 condition. If this condition is present in the register (say, initially) the modulo-two addition of two 0 states in the feedback loop would produce a further 0 at the input to stage A and the generator would not function. This difficulty is overcome by using a pulse to modify the state of the register (to, say, 0001) after which the pattern is continuously generated. The output waveform derived from any stage of the shift register is shown in Fig. 4, and the repetitive pattern is quickly recognized on an oscilloscope display.

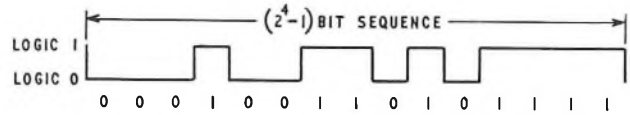

FIG. 4—Output waveform from pattern generator

PATTERN GENERATOR

In order that a pseudo-random test pattern may approximate closely to a random type of signal, the length of the sequence should be fairly large. (This, of course, has the disadvantage that it is not then possible to see the complete sequence on an oscilloscope display.) One design of such a generator will now be described in detail.

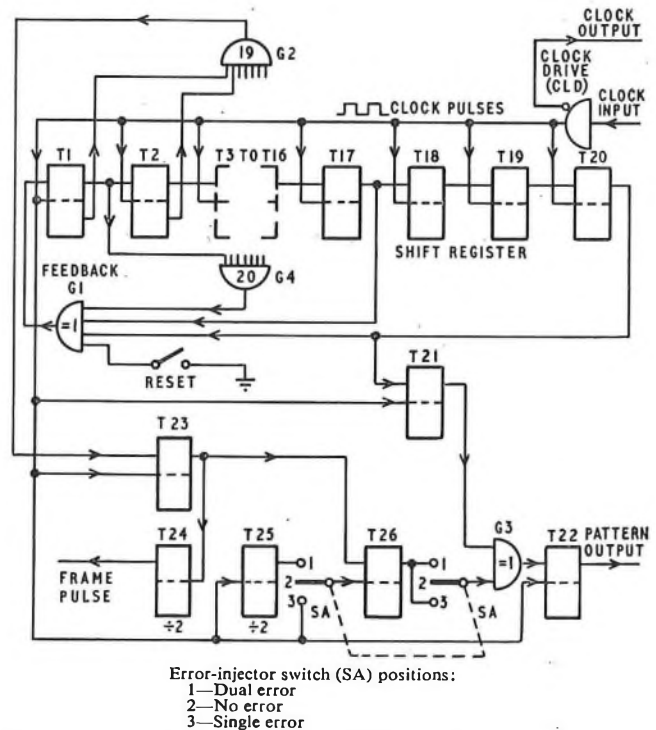

FIG. 5—Logic diagram of $(2^{20} - 1)$ -bit pseudo-random-sequence generator

Design Features and Circuit Description

Referring to Fig. 5, the generator consists of a 20-stage shift register with feedback. A pattern frame of $2^{20} - 1$ (1,048,575) bits long is thus produced, and within this pattern all combinations of ones and zeros are produced in the register except for the pattern of twenty zeros. In normal operation, the feedback logic precludes this condition but it could occur when the generator is switched on and a switch is required to change the state of one of the stages to start the sequence.

TABLE 2
Pattern sequence for (2⁴ - 1)-bit pseudo-random-sequence generator

The output sequence from column D is 100010011010111

Clock Pulse	Binary Digit at the Output of each Shift Register Stage with each Clock Pulse				Binary Digit Z (modulo-two addition of C and D)
	A	B	C	D	
1	0	0	0	1	1
2	1	0	0	0	0
3	0	1	0	0	0
4	0	0	1	0	1
5	1	0	0	1	1
6	1	1	0	0	0
7	0	1	1	0	1
8	1	0	1	1	0
9	0	1	0	1	1
10	1	0	1	0	1
11	1	1	0	1	1
12	1	1	1	0	1
13	1	1	1	1	0
14	0	1	1	1	0
15	0	0	1	1	0

To check whether the generator and an associated error-detector are functioning correctly, means are included in the design of the generator for changing known binary digits in the pattern at will; by operating a manual switch, the output pattern can be either the pseudo-random pattern or the pseudo-random pattern with two single errors per frame or two sets of two adjacent errors in alternate frames. The same bits in the pattern are changed in every frame.

A synchronization pulse is available as an output for oscilloscope triggering and to indicate frame timing. The generator operates satisfactorily with a clock pulse which is either a square wave or a sine wave at a level of about 0.3 volt peak to peak, and this signal is available as an output for synchronizing external equipment such as the regenerator and error detector used in laboratory tests on transmission systems. Integrated-circuit toggles of 70 and 120 MHz speed, and integrated-circuit positive-logic NOR gates (each circuit being mounted in a dual-in-line fourteen-lead pack) are used throughout. The logic level 1 is -0.7 volt and logic level 0 is -1.7 volts. The shift register (toggles T1-20) has the feedback modulo-two adder G1, specified by the polynomial $x^{20} + x^3 + 1$ (see Appendix 1 and Ref. 2.) The inputs to the gate G1 are taken from the outputs of stages 17 and 20 and the output from G1 is fed back to T1. The pseudo-random pattern is taken from T20 via the retiming element T21 and error gate G2 and a further retiming element T22. The gate G3 transmits the pattern unchanged providing the line from the error injector is at logic 0. The highest speed of operation using this design is about 30 Mbit/s.

The clock required to operate the shift register must run at double the required pattern speed. The clock is supplied from an external variable oscillator or a crystal-controlled oscillator with divider circuits to provide various preset

speeds. The clock signal is fed via a logic-level converter, monostable* and clock line drive stage CLD. The clock pulses driving the shift register T1-20 are also fed to an output logic gate with simultaneous OR and NOR outputs capable of driving external 50-ohm transmission lines.

The seven models that have been made included a non-locking manual switch to reset the pattern and a twenty-input AND gate G4 has been added to detect the twenty zeros condition, should this occur on switching on, and provide a pulse to set the feedback to the 1 state.

A nineteen-input AND gate G2 is used to detect nineteen ones. These inputs are derived from the output of each stage of the shift register with the exception of the nineteenth stage. The AND gate output provides a pulse when stages 1 to 18 inclusive and stage 20 are in the 1 state. This occurs twice in each frame, when the penultimate stage is in the 0 state and again when this stage is in the 1 state.

The two AND-gate pulses per frame are retimed in toggle T23 and fed to the error injector (toggle T26). The error injector is controlled by either clock pulses or clock-divided-by-two pulses from T25. Hence, the logic 1 pulses are of either one bit or two bits width which will either invert a single digit or a pair of digits at the error gate G3. The switch SA in the NO ERROR position inhibits these error pulses; in the SINGLE ERROR position, the clock signal is fed to the error injector and in the DUAL ERROR position, clock-divided-by-two pulses are fed to the error injector. Because there is an odd number of pulses per frame, the clock-divided-by-two condition has a phase inversion every frame, so that dual errors

* Monostable—a trigger circuit which has one stable and one unstable state, and which undergoes a complete cycle of change in response to a single triggering excitation.

occur every alternate frame only. The two AND-gate pulses per frame are also used via a divide-by-two stage, T24, to provide a frame pulse for oscilloscope synchronization.

ERROR DETECTOR

An error detector is required to detect errors in the repetitive pattern frame of 1,048,575 bits from the generator. One design of such a detector³ is as follows.

Design Features and Circuit Description

The integrated circuits used in the error detector are identical in type to those used in the associated generator described in the previous section. The shift register, formed by toggles T1-20 inclusive (Fig. 6), has an exclusive-OR

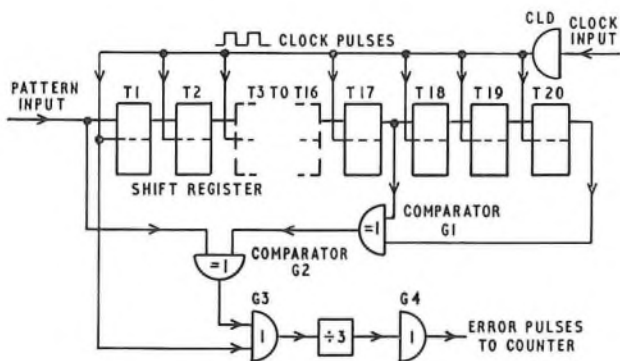

FIG. 6— $(2^{20} - 1)$ -bit pseudo-random-sequence error detector

comparator G1 comparing the outputs from stage T17 and T20. The output from the comparator G1 is compared with the input to stage T1 in the exclusive-OR comparator G2.

The clock signal required to operate the shift register runs at double the speed of the incoming pattern. The clock signal used on the error detector is derived from the same source as that supplying the generator.

The error detector (Fig. 6) is essentially identical to the generator (Fig. 5) except that instead of returning the feedback connexion from G1 (Fig. 6) to the input of toggle T1, a gate G2 is used to compare each digit from gate G1 with the digit about to be fed into the shift-register toggle stage T1. Provided that there are no errors in the received signal, the digits being compared in gate G2 will always be identical, because the digits being compared are produced in the same logical manner in both the generator and the error detector. The comparator G2 works on the same principle as the modulo-two adder where the logical output of this circuit is zero if the two inputs are the same. Hence, with error-free received signals, the output of G2 is logic zero. The output from comparator G2 is 1 whenever there is a single error at either the input to stage T1, the output from stage T17 or the output from stage T20. A single error being shifted through the register will, thus, produce three pulses at the output of comparator G2. To indicate the true number of errors detected, the three pulses are fed into a divide-by-three circuit and the resultant pulse is recorded on a counter via output drive circuit G4. To resolve adjacent errors into two pulses, the output from comparator G2 is fed through a clocked AND-gate G3.

OVERALL TEST OF GENERATOR AND ERROR DETECTOR

Clock Synchronization

The clock pulses operating the error detector must have the same speed as the clock pulses supplied to the generator.

For remote operation in a digital transmission system, the clock pulses operating the error detector would be derived from the bit-timing recovery circuits in the demodulation equipment. The clock pulses, ideally, should be phased so that the pulse edge appears in the centre of the pattern bits. A test at 6 Mbit/s showed that, when the pattern was fed directly from the generator to the detector, no errors were obtained for a 350° swing of the clock pulse relative to a pattern bit, i.e. $\pm 175^\circ$ where 360° represents one bit.

Accuracy of Error Counting

In the description of the error detector, a single error was shown to produce three pulses at the output of comparator G2 (Fig. 6). When the errors are spaced three, seventeen or twenty bits apart, four pulses are counted at the output of comparator G2 instead of six. If there are errors spaced three, seventeen and twenty bits apart, seven pulses are counted instead of nine at the output of comparator G2. The probability of this occurring is small. The worse case is a generator and detector with feedback functions fed from adjacent stages of the shift register (e.g. primitive polynomial $x^6 + x + 1$) used in a system employing differential-bit decoding in the demodulator where errors occur in pairs. For every pair of errors, four pulses are counted at comparator G2 instead of six pulses. If the probability of bit error of the received pseudo-random sequence is as large as 10^{-2} , the indicated errors recorded are false by less than 2 per cent, as shown in Appendix 2.

The frequency or rate of errors N from the $(2^{20} - 1)$ error detector fed from the $(2^{20} - 1)$ generator with two single bits changed per frame is $N = \frac{f}{b} q$ errors per second,

where f = bit rate in bits/s,
 $b = 2^{20} - 1 = 1,048,575$ bits/frame,
 q = number of single errors/frame.

The rate of errors N for the dual errors every alternate frame yields the same figure as for single errors.

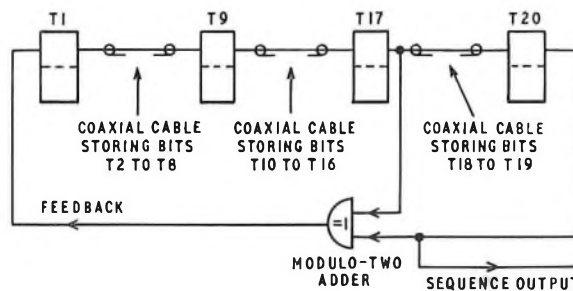

FIG. 7—Use of delay-line cables in place of shift-register stages

FURTHER DEVELOPMENTS

Higher-speed operation using a new range of logic units capable of toggle speeds of greater than 300 Mbit/s is now possible. For a $(2^{10} - 1)$ -bit pseudo-random-sequence generator with a ten-stage shift register, the highest speed of operation using items from the new range is about 260 Mbit/s. An error detector, of similar design and associated with the generator, functions at a similar speed.

A circuit (Fig. 7) using delay-line cables to store parts of the pseudo-random pattern in place of parts of the shift register is possible, but with a restricted speed range (e.g. 270-280 Mbit/s). A choice of the length of pseudo-random patterns may be achieved by switching in delay elements such as lengths of coaxial cable.

CONCLUSIONS

A pseudo-random sequence generator has been built for the speed range 500 kbit/s to 30 Mbit/s. To check whether the generator and an associated error detector are functioning correctly, means are included in the design of the generator for changing known binary digits in the pattern at will. The generator and error detector together form a test set for evaluating the error performance of digital transmission systems, and associated sub-systems, and represent an intermediate stage in the continuing development of high-speed pseudo-random pattern generators.

References

- 1 DAVIES, M. C., and HICKS, J. B. Some aspects of Digital Microwave Radio Relay Systems. *P.O.E.E.J.*, Vol. 64 (in this issue).
- 2 WATSON, E. J. Primitive Polynomials (Mod 2). *Mathematics of Computation*, Vol. 16, No. 79, p. 368, July 1962.
- 3 Patent No. 60314/69. Error detection in Pseudo-random Sequences.

APPENDIX 1

Polynomial Representation of Binary Information

It is convenient to consider the binary digits in a sequence as the coefficients of a dummy variable x . Thus, a sequence 101101 can be represented by the polynomial $x^5 + x^3 + x^2 + 1$, which is a special case of a general polynomial for a sequence of $n + 1$ bits,

$$a_n x^n + a_{n-1} x^{n-1} + \dots + a_2 x^2 + a_1 x^1 + a_0$$

where

$$a_j = 1 \text{ or zero, } j = 0, 1, 2 \dots n.$$

These polynomials are treated according to the laws of ordinary algebra except that any addition is always performed modulo-two. Thus, in addition to the usual distributive, associative and commutative properties associated with polynomials under this kind of algebra, every polynomial can be uniquely factorized into primitive (or irreducible) factors in only one way.

The feedback connexions required to generate a pseudo-random sequence can be specified by primitive polynomials. Thus, by definition, a primitive polynomial cannot be factorized and a primitive polynomial of degree n will not exactly divide $x^p + 1$ for values of p less than $2^n - 1$.

For example, $x^4 + x + 1$ is a primitive polynomial (no factors) of degree $n = 4$.

Also $\frac{x^p + 1}{x^4 + x + 1}$ is not exact for $p < 15$, bearing in mind that when division is carried out, modulo-two addition must be used.

But, under the same modulo-two addition conditions,

$$x^{15} + 1 = (x^4 + x + 1)(x^{11} + x^8 + x^7 + x^5 + x^3 + x^2 + x + 1)$$

Thus $(x^4 + x + 1)$ can be used to specify the feedback function of a four-stage shift register (see, for example, Fig. 3). Feedback to a modulo-two sum is applied where the coefficient of the corresponding term in the polynomial is unity, i.e. where $a_j = 1$. Invariably, there must be a connexion from the right-hand (unit) stage. (In the article quoted in Reference 2, a table is given of primitive polynomials for maximal-length sequences for n up to 100.)

APPENDIX

Probability of Bit Error at the Output of the Comparator

Consider the comparator shown in Fig. 8. Let the input be a direct binary (as distinct from differential binary) pseudo-random

bit-stream where it is assumed that the bit errors are statistically independent.

If p is the probability of bit error in the received sequence, then the probability q of a bit being correct is given by

$$q = 1 - p.$$

The output of comparator A will indicate *correct* (q_1) if the input signals to it are both *correct* or both *in error*. Thus

$$q_1 = q^2 + p^2.$$

Similarly the indication *correct*, q_0 , from comparator B is given by

$$q_0 = qq_1 + pp_1.$$

Now because

$$p_1 = 1 - q_1,$$

and

$$p_0 = 1 - q_0,$$

it follows that the indicated error

$$p_0 = 3p \left(1 - 2p + \frac{4}{3}p^2 \right).$$

In practice, only values of p smaller than about 10^{-2} are likely to be of interest, so it is evident that the indicated error p_0 is sensibly $3p$ (to within 2 per cent for $p = 10^{-2}$). It follows, therefore, that the probability of bit error p is obtained by dividing the indicated error p_0 by three, as indicated in Fig. 8.

Now consider a differentially-coded binary pseudo-random bit-stream. Because of the action of the differential decoder in the demodulator, the errors in the received pseudo-random sequence are not statistically independent; where errors occur in the coded bit-stream, they will appear in pairs in the decoded stream and, for a particular type of shift-register generator/comparator, each case will have to be assessed separately. Thus, in a comparator where the connexions are taken from adjacent stages in the shift register (as, for example, the $(2^4 - 1)$ -bit pseudo-random error detector), the output of the comparator B will have to be divided by two (not three as above) to indicate the true bit error rate.

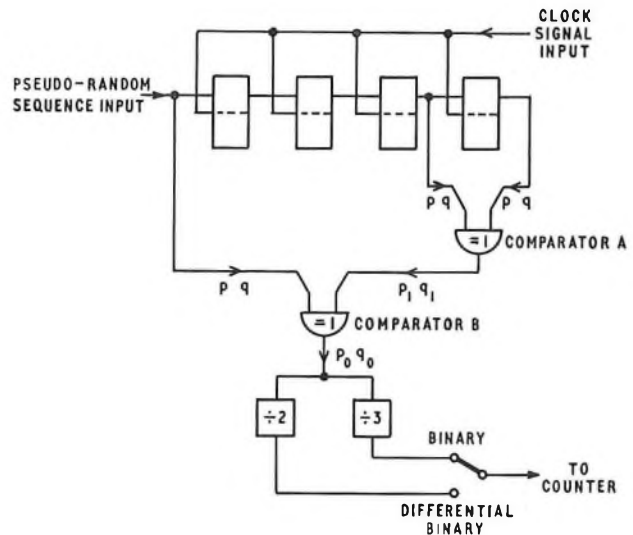

FIG. 8—Pseudo-random-sequence error counter

Private Automatic Telegraph Exchange— P.A.T.X. No. 1A

B. SHEEKEY and C. A. R. TURBIN†

U.D.C. 621.394.763

This article describes the private automatic telegraph exchange No. 1A which is designed to provide a small self-contained dial-selection 50-baud telegraph network with printed service signals and automatic request-of-answer back. Broadcast facilities can be provided if required. To simplify maintenance and minimize the amount of development required, existing well-proven circuits have been used as far as possible and the line signalling conditions arranged to allow the outstations to be provided with the same type of equipment as used by telex subscribers.

INTRODUCTION

For many years, networks of private telegraph circuits have utilized manual switching. Because the manual switching of telegraph circuits is cumbersome, the operational and cost advantages of automatic switching are probably greater than for telephone switching. Exceptionally, to meet the demands of one or two customers requiring 20 or fewer teleprinter stations in a 50-baud automatically-switched network, switching equipment, made surplus on the introduction of the automatic telex service, was adapted for the purpose.

The facilities thus provided, met the immediate requirements but were, in some respects, restrictive. The customers, however, were willing to forgo some operational facilities in order to obtain a quick solution to a then urgent problem. No printed-service signals or automatic broadcast facilities were provided.

Subsequently, further approaches were made to the British Post Office (B.P.O.), which suggested that a demand existed for a private automatic telegraph exchange (p.a.t.x.) to serve up to 20 teleprinter stations, with facilities for interconnecting more than one p.a.t.x. to form larger networks, and for any one station to be capable of broadcasting to a number of stations on the same unit, or to stations on another unit in the same network. No proprietary equipment was available at the time which provided all the facilities called for.

PHYSICAL FEATURES

The p.a.t.x. designed (P.A.T.X. No. 1A) uses type-2 and type-4 uniselectors and (B.P.O.) standard relays assembled within a metal cabinet on two double-sided racks. The overall dimensions of the cabinet are height 6 ft 1 in, width 5 ft 8 in and depth 2 ft. The cabinet assembly consists of two cubicles bolted together (Fig. 1), the necessary inter-cubicle circuit connexions being made by means of a preformed cable connected on site. The total weight of a fully-equipped cabinet is approximately 2,000 lb [180 lbs per ft²]. For transportation purposes, the cubicles are packed separately. Each cubicle is completely wired, the various plug-in type relay-sets being provided as required.

† Telecommunications Development Department, Telecommunications Headquarters.

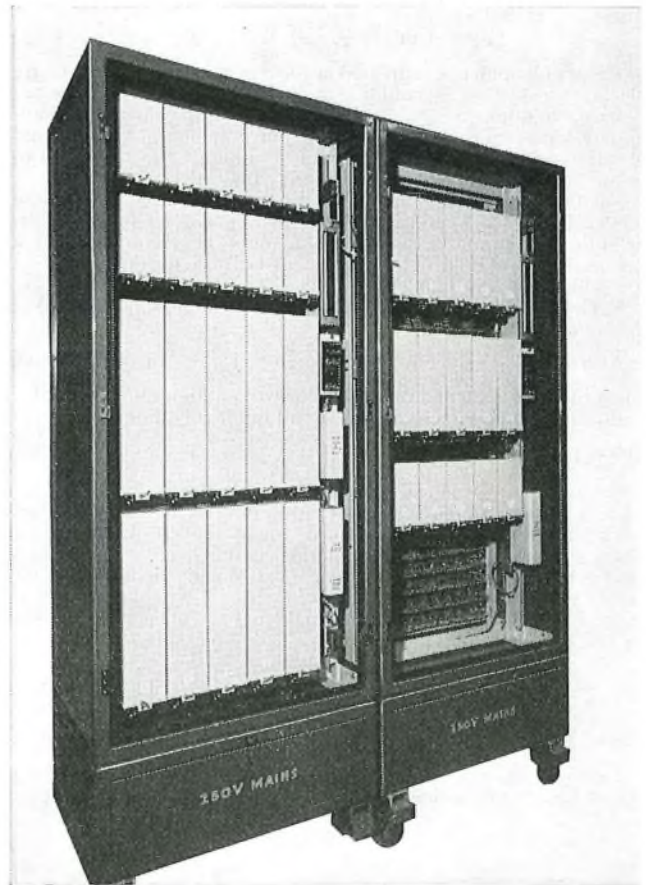

Fig. 1—View of the P.A.T.X. No. 1A in position

TRUNKING ARRANGEMENTS

The trunking arrangements of a P.A.T.X. No. 1A, is shown in Fig. 2. Each p.a.t.x. has capacity for 20 station-lines and 10 bothway trunk-circuits. The stations are equipped with teleprinters and control-units of the type used for the B.P.O. automatic telex service (e.g. teleprinter No. 15 and Unit-Telex No. 6). A two-digit numbering scheme is used for connexions between stations on the same unit in the

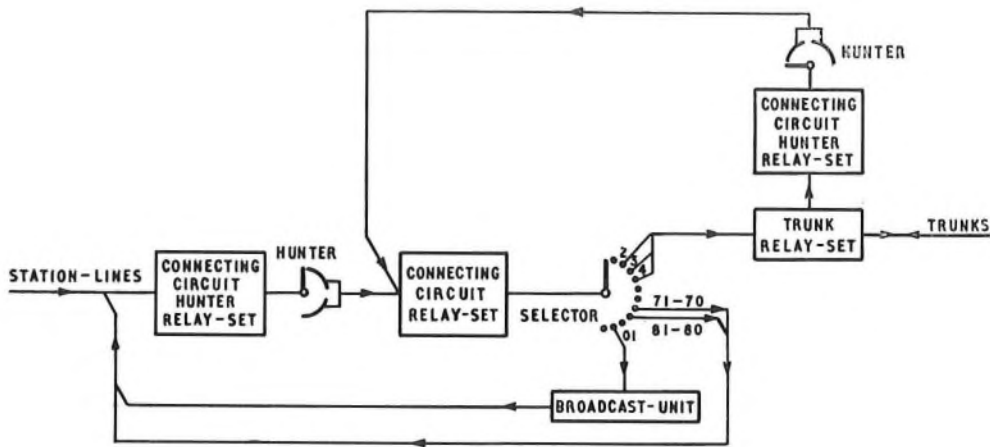
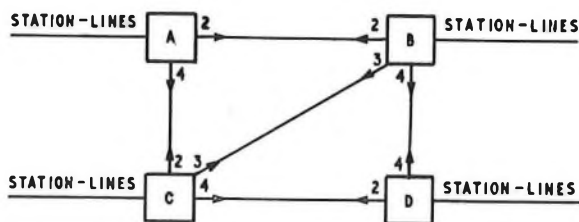

FIG. 2—Trunking diagram of the P.A.T.X. No. 1A

numbering ranges 71-70 and 81-80. Stations can be arranged as auxiliary groups, up to a maximum of five, by using consecutive numbers in each range. Digits 2, 3 and 4 have been allocated for trunk routes and the two-digit code 01 for access to the broadcast-unit. The two-digit codes 51, 52, 53, 54 and 55 are used within the broadcast-unit to indicate special pre-selected groups or patterns of stations to which a broadcast is to be made; code 55 being reserved for *All Stations* broadcast. Digit 0 is used in the broadcast-unit to indicate the end-of-selection of stations to which the broadcast is to be made.

For calls to stations connected to other p.a.t.x.s in the same network (Fig. 3), the two-digit code of the required station is preceded by a digit or digits necessary to select the trunk route to the required p.a.t.x.



Note: Connexions between stations on different p.a.t.x.s are set up by prefixing the station code by the appropriate routing code.

e.g. From a station on p.a.t.x. A to one on p.a.t.x. C, station A dials 4XX.
From a station on p.a.t.x. A to one on p.a.t.x. D, station A dials 24XX or 44 XX.

FIG. 3—Typical network configuration

SERVICE SIGNALS

A busy station, trunk, connecting circuit or broadcast-unit is indicated to the caller by the printing of occ followed by the automatic release of the connexion. Unavailable first digit codes 1, 5, 6 and 9 and codes corresponding to unallocated trunk routes are also indicated by the printing of occ followed by the automatic release of the connexion.

A station in the ABSENT condition, e.g. power off, or a spare station line-number, is indicated by the printing of ABS followed by the automatic release of the connexion. A caller switching to a faulty trunk-circuit will receive the signal occ followed by the automatic release of the connexion.

ENGINEERING TESTING AND MAINTENANCE

All lines and trunks are routed via a jack field mounted in the cabinet, and a small tester is provided to enable functional tests to be made on site. The tester simulates calling and

clearing conditions and gives an indication of receipt of the proceed-to-select, call-connected and answer-back signals. (Table 1). A key-and-lamp unit is provided to indicate alarms on the equipment, and power supply failure.

TABLE 1

Line-Signalling Conditions Used by the P.A.T.X. No. 1A

Calling condition	Continuous negative 80 volts
Clearing condition	Continuous positive 80 volts
Proceed-to-select	Pulse of negative 80 volts returned to calling station to indicate that dialling may proceed.
Call-connected	Change from positive 80 volts to negative 80 volts to indicate that called station is ready to receive telegraph signals.
Answer-back	A discrete 20-character code mechanically transmitted by a teleprinter.
Who are you (WRU)	A two-character code transmitted to a teleprinter to trigger its answer-back mechanism

CONNECTING-CIRCUIT HUNTER

Each station-line and trunk relay-set is terminated on a connecting-circuit hunter. A disengaged station, when in service, connects a positive potential to the RC-wire which holds relay LS operated (see Fig. 4).

When a station makes an outgoing call the positive potential on the RC-wire is replaced by a negative potential, causing relay LS to release, and the unselector to hunt for a disengaged connecting circuit. When a disengaged connecting circuit is reached, the station-line is switched through by relay H, which is held by an earth potential passed over the P1-wire.

Relay H also operates a guard-relay, G, to guard the circuit during the call. The incoming PC wire from the connecting circuit multiple, is busied when the line-relay releases. On release of the connexion, a busy condition is maintained on the incoming multiple until the station is ready to receive another call. This is indicated by a positive potential from the station which re-operates the line-relay LS.

On an incoming call, the switching relay, H, is operated and held by an earth potential passed over the PC-wire, disconnecting the line-relay LS from the station line. The guard-relay, G, also operates and, during the release of the

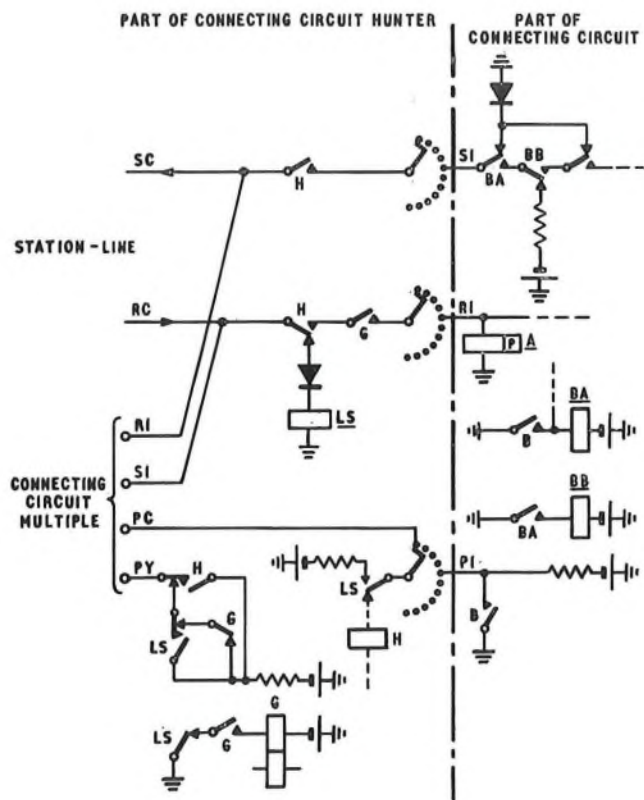

FIG. 4—Part of the circuit for calls to and from stations

call, prevents re-seizure of the circuit until the station equipment is normal.

If, for any reason, the station-line is disconnected, the line-relay LS releases. The unselector drives and hunts as in the case of a normal outgoing call, but does not hold to the connecting circuit seized owing to the absence of a calling negative-potential on the RC-wire. The failure of the switching-relay to hold results in the unselector driving to its home contact. The guard-relay, G, remains operated because the line-relay is released.

So long as no positive potential is connected to the RC-wire, the station remains in this out-of-service condition. Callers to this station receive the ABS signal, owing to the disconnection of the PY-wire by relay G.

CONNECTING CIRCUIT

The connecting circuit provides guarding and holding conditions for the apparatus used in setting up and maintaining a connexion, and also discriminates between a call to a station-line and one to a trunk route or broadcast-unit.

When the calling hunter switches to the connecting circuit, a negative potential is connected to the incoming R1-wire (Fig. 4) and relays A, B, and BA operate. The calling hunter is held by an earth potential from a B-relay contact over the P1-wire which is guarded. Relay BA changes the potential of the S1-wire from earth to negative; thus constituting the start of the proceed-to-select signal. The end of the proceed-to-select signal is indicated by the operation of relay BB, a slow-to-operate relay, which restores the earth potential to the S1 wire. The pulse, thus generated, indicates to the calling station that dialling may proceed.

When relay A responds to the dial pulses, the unselector is stepped to a position corresponding to the digit dialled. If dial pulses are not received within approximately 30 seconds of the circuit being seized, the circuit is forcibly released.

Unselector RS (Fig. 5) is stepped under the control of the first digit received by the connecting circuit. The position of its wipers at the end of this digit determines which of the RSA wipers will be used for the connexion being set up.

If the call is to a station-line or broadcast-unit on the same p.a.t.x., the relays operated, i.e. W and Z, X and Z or BR and Z cause unselector RSA (Fig. 6) to self drive to contact 14 passing over the outlets corresponding to the trunk routes. When the second digit is received, the RSA wipers are stepped to the contact corresponding to the required station or broadcast-unit.

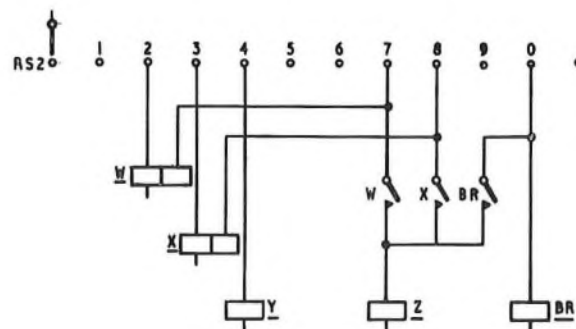

FIG. 5—Part of the circuit of discriminating selector unselector (RS)

For calls via trunk routes, the wipers of unselector RS (Fig. 5) are positioned on contact 2, 3 or 4 according to the trunk routing-digit dialled and only one relay W, X or Y operates. The particular relay operated not only determines which of the RSA unselector wipers will be used, but also causes unselector RSA to self-drive and hunt for a disengaged circuit in the particular group of trunks. The trunk circuits are connected to the first 10 contact positions of the unselector RSA bank (Fig. 6). The circuit arrangements are straightforward and result in the hunting and switching time being kept to a minimum.

If the called station is disengaged, there is a negative potential connected to the PC-wire of the station-line multiple. The connecting circuit switches to this, and connects the calling condition on the SC-wire. The called station returns a negative potential on the RC-wire as a call-connected signal. This causes the connecting circuit to transmit the WRU signal to the called station which then returns its ANSWER BACK code to the calling station.

A connexion is released when a positive potential is connected to the R1- or S1-wire for at least 400 ms.

If the called station is engaged, there is not a negative potential on its PC-wire but there is a negative potential on the PY-wire. This results in the occ signal being returned to the caller. If the called station is in the absent condition, the PC- and PY-wires are disconnected. This results in the ABS signal being returned to the caller.

When the call is to a station in an auxiliary group, the second digit dialled corresponds to the first line in the group. The hunting for, and testing of, a line in such a group depends upon the conditions connected to the PX-wire (Fig. 7). The PX-wires of the first and intermediate lines in the group are connected to a positive potential which indicates that they form an auxiliary group. The PX-wire of the last line in the group is connected to the parallel-connected PY-leads of the hunters forming the group. A negative potential, therefore, exists so long as there is one station in the group in service irrespective of whether it is engaged or not. Only if all the lines in the group are in the absent condition will the PX-wire of the last line in the group be disconnected.

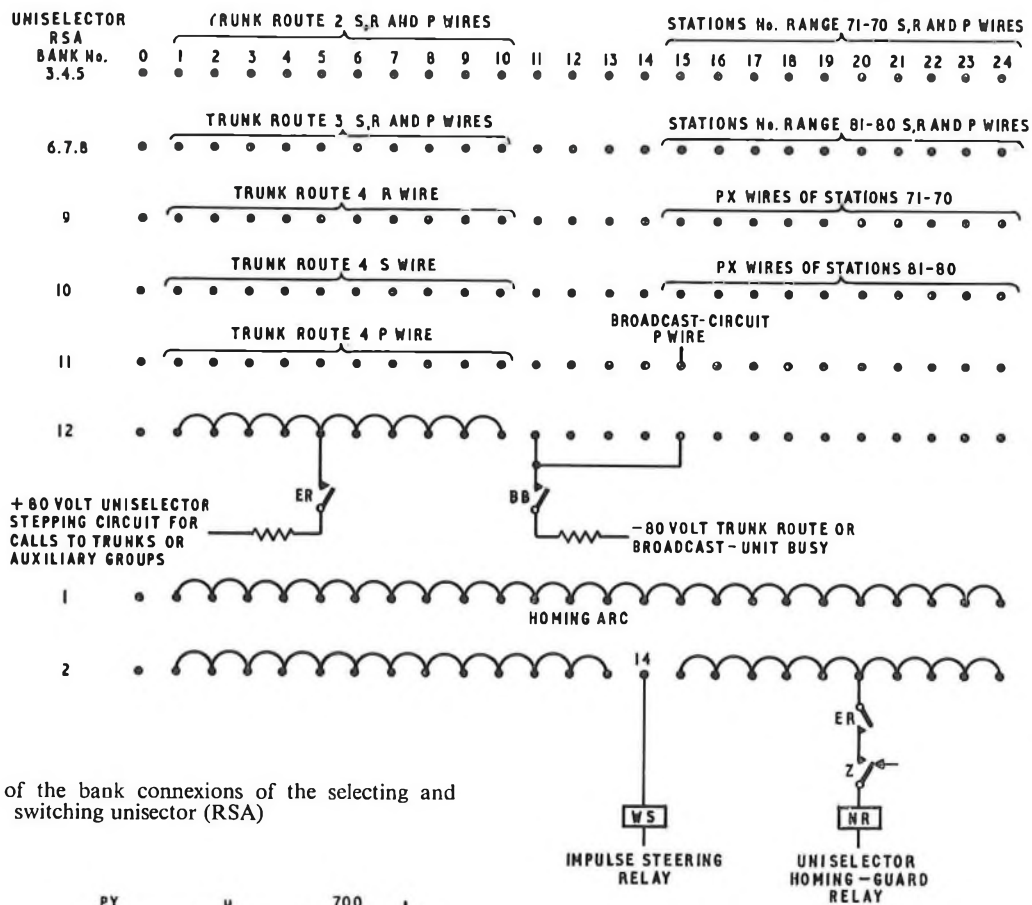

FIG. 6—Diagram of the bank connexions of the selecting and switching unselector (RSA)

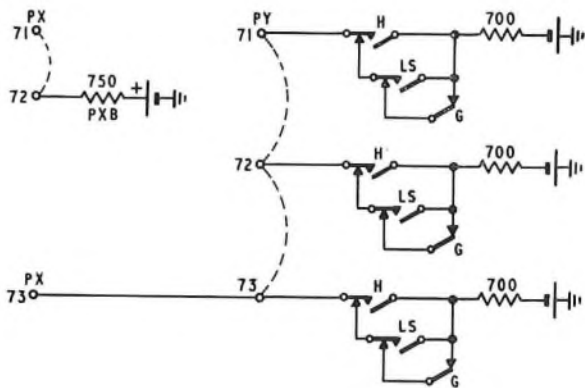

FIG. 7—Diagram showing part of the circuit of the connecting-circuit hunters

When the two digits appropriate for the call to be connected to the broadcast-unit (01) are received, digit 0 causes unselector RS to step to contact 10 and relays BR and Z to operate. Unselector RSA self-drives to contact 14 and the digit 1 causes unselector RSA to step to contact 15 and extends the caller to the broadcast-unit. The service signal occ is returned to the caller if the broadcast-unit is engaged when 01 is dialled.

BROADCAST-UNIT

When the broadcast-unit is seized, subsequent digits dialled are registered in the unit and indicate the broadcast requirement. The stations required for the broadcast can be indicated to the unit by dialling into it the appropriate two-digit station codes. Each two-digit code received, results in the operation of the corresponding storage relay. When all

the necessary two-digits codes have been dialled, digit 0 is dialled to indicate the end of selection. This results in the operation of relay BSA and the testing of the nominated stations as shown in outline in Fig. 8. The operation of relay BSA connects the calling station through to the broadcast-unit. The broadcast-unit transmits the call-connected signal to the calling station which changes from the dial condition to the teleprinter condition.

Unselector SL, in the broadcast-unit, steps and tests the P-wire conditions at arc SL4. If the station is free; the WRU signal is extended to the called station via arc SL2 and the answer-back code is returned via arc SL3. At the end of the answer-back code, the relay associated with the line, GAA to GAK, or GBA to GBK, is operated. This applies a busy condition to the P-wire and connects the S-wire to the broadcast-relay output. The unselector steps on to test the subsequent outlets. If a marked station is busy, the occ signal is returned to the calling station and the unselector steps to the next outlet.

The stations are tested in numerical order and the answer-back code of each free selected station, and a service signal for each busy selected station is returned to the calling station. When all the stations have been tested, relay BC is operated, connecting the originating station to the broadcast relays, the outputs of which feed the connected stations. Once connected for a broadcast, the called stations cannot clear the connexion. The release of the connexion is controlled by the originating station only. To avoid the necessity of repeatedly dialling the same combination of station codes, five pattern codes have been allocated. If a pattern code is dialled into the broadcast-unit, the stations associated with that pattern are automatically marked for selection. Four of these two-digit codes give station patterns arranged on site to the customers specific requirements, the fifth code marks all the stations.

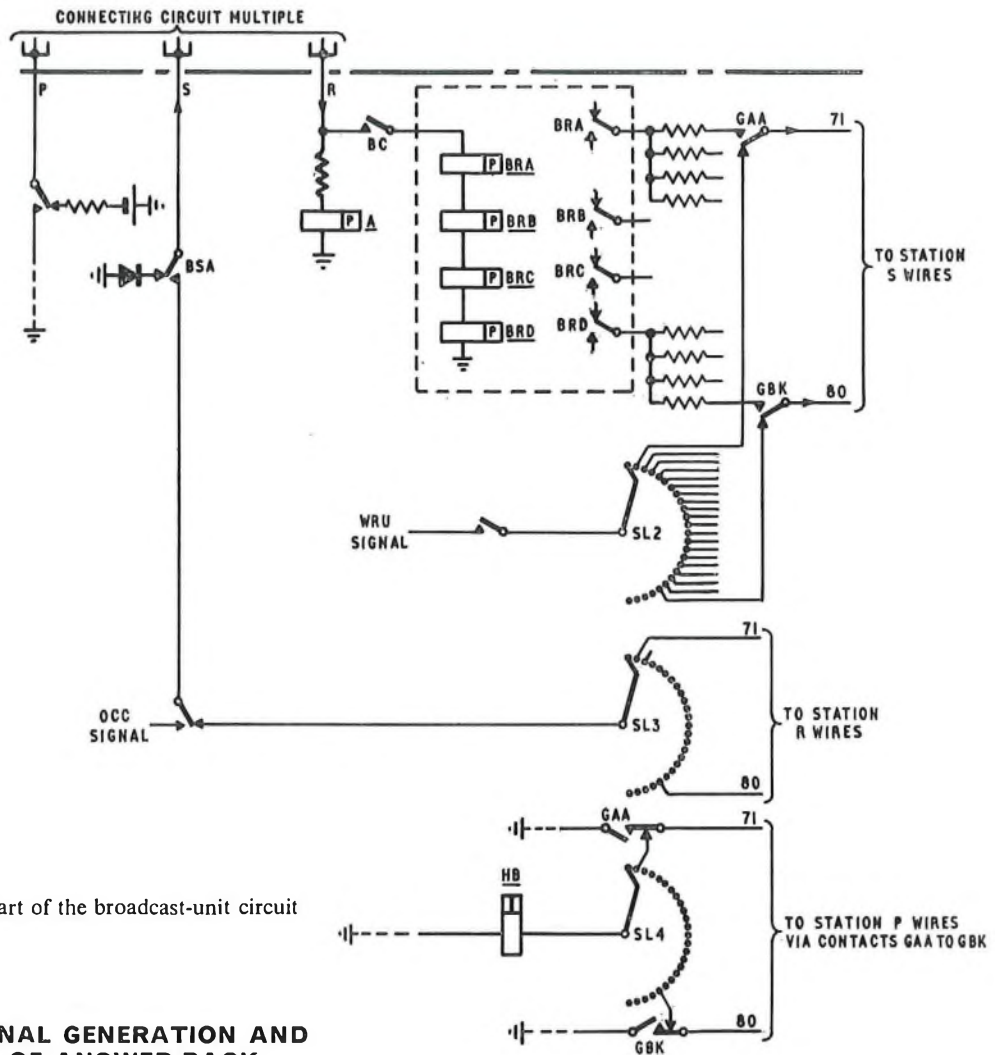

FIG. 8—Diagram showing part of the broadcast-unit circuit

PRINTED-SERVICE SIGNAL GENERATION AND AUTOMATIC REQUEST OF ANSWER-BACK CODE

To indicate to a calling station, the nature of the condition that has caused a call to fail, a printed signal formed by characters of the five-unit telegraph alphabet (International Alphabet No. 2), is returned by the equipment.

If a called station is to return its answer-back code automatically, the WRU signal must be produced by the equipment and transmitted to the called station when the call is connected. The method of producing the service signals and WRU code is shown in outline in Fig. 9. A relay-set requiring to connect the OCC signal, for example, applies a start condition which operates relay ST. This prepares the uniselector circuit, stepping it off normal and extending earth to the read-out unit to switch the input bi-stable circuit and start the multivibrator. The multivibrator operates at 50 Hz, giving a pulse-repetition rate of 20 ms. The first pulse from the multivibrator switches the three-stage binary counter from the $a b c$ condition to the $\bar{a} b c$ condition which results in the bi-stable circuit-controlling relay TR switching, and the output from relay TR changing to the start polarity (positive 80 volts). At subsequent intervals of 20 ms, the counter is stepped, giving the output conditions shown in the Table 2.

Thus, the voltage at each of the five arcs controls, for 20 ms, the operation of relay TR. Negative voltage logic is used and, therefore, if the outlet is connected to earth potential, the AND condition is not met and relay TR gives a positive 80-volt potential output.

Coincident with element 3 of a character, relay F is operated. This relay operates relay X which holds over its own contact and at the same time, energizes the uniselector magnet.

TABLE 2

Output Condition	Counter Output 1 Condition	Binary Equivalent
Idle	$a b c$	000
Start element	$\bar{a} b c$	001
1st element	$a \bar{b} c$	010
2nd element	$\bar{a} \bar{b} c$	011
3rd element	$a b \bar{c}$	100
4th element	$\bar{a} b \bar{c}$	101
5th element	$a \bar{b} \bar{c}$	110
Stop	$\bar{a} \bar{b} \bar{c}$	111

At the start of the STOP element, the mono-stable circuit which controls the relay KR is operated. The relaxation time is adjusted to give a 30 ms pulse operation of relay KR. When relay KR operates, it releases relay X and resets the input bi-stable circuit. The release of relay X allows the

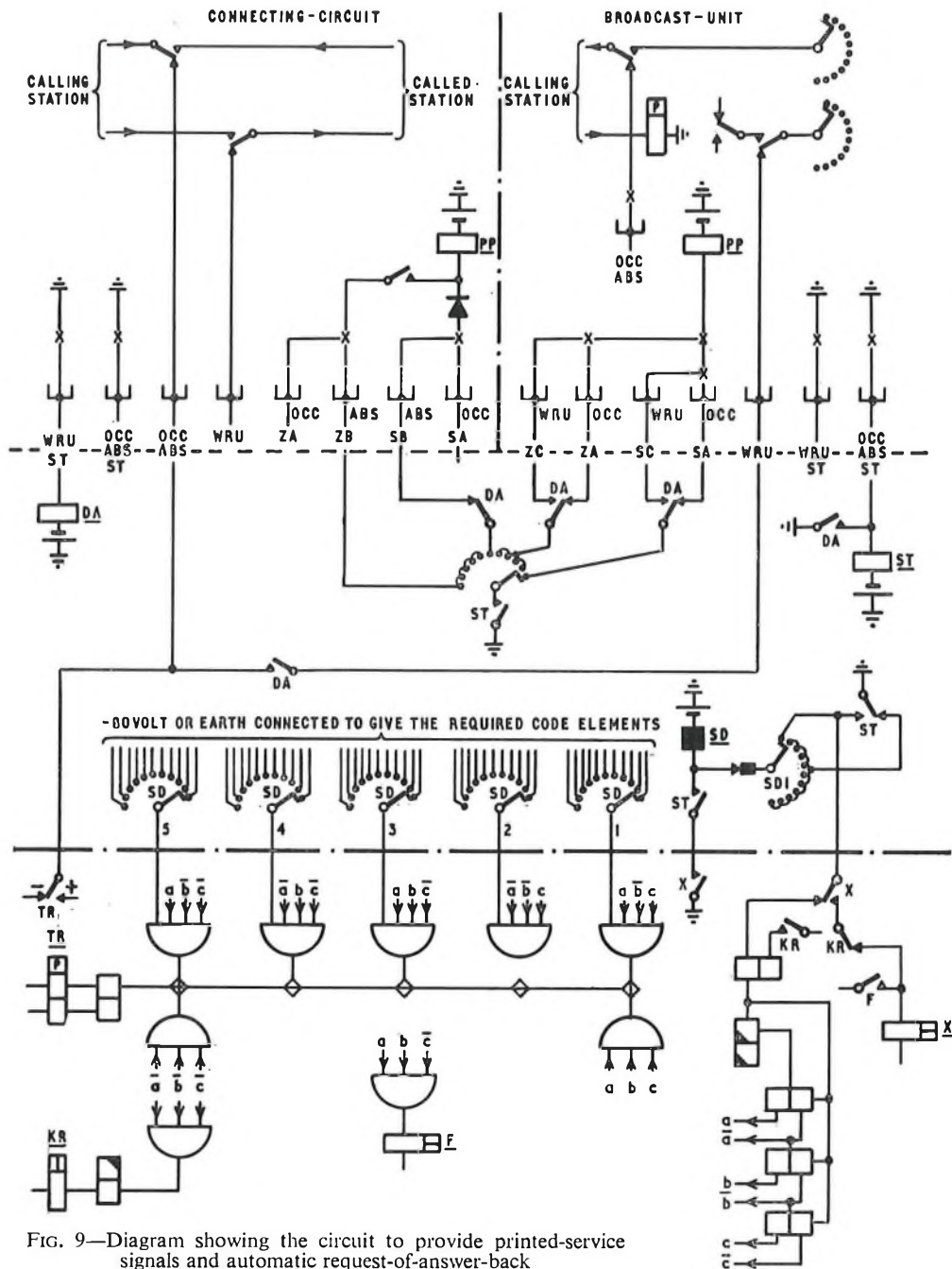

FIG. 9—Diagram showing the circuit to provide printed-service signals and automatic request-of-answer-back

uniselector to step to the next contact. The reset of the input bi-stable circuit resets the multivibrator and holds the three-stage counter.

After 30 ms, relay KR is released setting the input bi-stable circuit and allowing the multivibrator to restart for the next character. The uniselector is, thus stepped, every 150 ms and telegraph characters are produced dependent on the conditions connected to the bank contacts.

The S- and Z-pulses associated with the signal ensure that the complete code required is transmitted to line by the relay-set. These pulses are produced via another arc of the same uniselector. The S-pulse occurring at the start of a signal operates a phasing relay in the relay-set, and the Z-pulse holds the phasing relay during the signal transmission.

CONCLUSION

There is evidence of growing interest by large industrial organizations and Government departments in this form of telegraph network. Some firm orders have already been

received for service in early 1972. Wherever possible, well-tried circuit elements and components have been used. Further saving in development cost and time has been achieved by using station equipment already designed for, and in use on, the United Kingdom Telex network.

The digital nature of telegraph signals, the small number of lines involved, and the advent of cheap, readily-available, electronic circuits make a time-division highway system attractive for any future p.a.t.x. development.

ACKNOWLEDGMENT

Acknowledgment is due to Standard Telephones and Cables Ltd who manufactured the initial units.

Reference

¹ FORSTER, A. E. T., and TURBIN, C. A. R. Automatic Sub-Centres for the New Telex Service. *P.O.E.E.J.*, Vol. 48, p. 17, Apr. 1955.

Some Aspects of Digital Microwave Radio Relay Systems

M. C. DAVIES, PH.D., M.I.E.E., A.INST.P., and J. B. HICKS, GRAD.I.E.R.E.†

U.D.C. 621.371:621.37.029.6:621:376.4

Digital microwave line-of-sight radio links will provide some of the junction circuits in the digital network planned by the British Post Office (B.P.O.) In this article, the effect of interchannel interference, noise and filter bandwidth on the performance of radio links employing phase-shift-keyed modulation is considered. Testing of the validity of various computed results by a versatile test-bench constructed at the B.P.O. Research Department is also described.

INTRODUCTION

An extensive integrated high-speed digital network, employing pulse-code modulation¹ (p.c.m.) for the transmission of any digitally-coded analogue signals, would have many advantages when used to satisfy the rapid growth in demand for a wide range of telecommunication services. The channel requirements of any given signal, once converted to digital form, can be specified by two parameters only, namely, the maximum digit speed and the number of errors produced. A number of low-speed digital signals can be multiplexed into one high-speed digital channel by interleaving the digits. Thus, a digital network with one set of specifications can be used to carry a wide range of telecommunication traffic, such as telephony, data (teleprinter, computer terminal and computer inter-connection traffic), viewphone and television. Also, as digital signals can be regenerated at repeater stations, distortion contributed by the transmission system is not cumulative. This feature is particularly important because a large number of repeaters will be required to overcome the propagation attenuation or propagation distortion of some of the new transmission systems under development, such as, line-of-sight radio links using frequencies above about 10 GHz, optical waveguides and trunk waveguides.

Microwave links will probably form an essential part of the planned digital network. In this article, the effects of noise and interchannel interference on phase-shift-keyed (p.s.k.) modulated microwave digital systems are described. Before describing the microwave system, a brief description of the digital signal is given.

DIGITAL SIGNALS

A digital signal is made up of a sequence of elementary signals normally occurring at equally-spaced intervals. Each elementary signal, or digit, can represent any one of a finite number of messages. These messages could be numbers, but here, they are referred to as logical states. In a 2-level digital signal, there are only two possible states, logic 0 or logic 1. In a 4-level digital signal, there are four possible states, logic 0, 1, 2 and 3. A pair of 2-level digits, that is binary digits or bits, can be combined to form one 4-level digit. In the baseband section of a system, the various logic states may be represented by various discrete voltage levels.

The specifications for microwave digital circuits cannot be determined until the results of various studies are available, but digital rates in excess of 480 Mbit/s may be used in some sections. A capacity of 120 Mbit/s is sufficient to carry one p.c.m. 625-line colour-television channel or, approximately, 1,800 p.c.m. telephone channels. On each route, there may be

several radio channels operating on different carrier frequencies and using two polarizations. Interference amongst these channels can adversely affect the performance of the system.

PROPAGATION EFFECTS

One problem affecting line-of-sight microwave systems is fading.³ Rain and wet snow cause attenuation in the propagation path, and the severity increases with frequency. Allowance can be made for the resulting loss of signal at the receiver by using a transmitter of greater power. During very heavy showers, particular sections of the link may be unusable and some form of switched-path diversity may be desirable for systems operating in the higher microwave frequency range at about 30 GHz. Even in the absence of precipitation, fading can occur under certain meteorological conditions, because temperature inversions in the atmosphere cause waves to be reflected and so produce additional propagation paths for the signal. The received signal is then distorted in phase and amplitude. The effect of this distortion can be evaluated in a multi-path fading simulator being developed for the 10–12 GHz frequency band.

MODULATION METHODS

According to simple theory,² the most efficient type of modulation is phase modulation (known as phase-shift keying or p.s.k.).

In the simplest form of 2-level p.s.k. microwave link, one carrier phase represents a logic 1, and a phase at 180° to this represents a logic 0. At the receiver, the carrier is demodulated in a phase-comparison circuit having an output voltage dependant on the relative phase of two input signals. One of these signals is the modulated carrier and the other, the phase-comparison signal, must be of constant and correct phase, which can be obtained from an oscillator locked to one of the phases of the demodulated carrier. However, the phase-comparison generator may lock on to the wrong phase of the carrier with the result that the logic 1 and 0 states are interchanged.

This difficulty may be overcome by encoding the signal before transmission. In one such code, a change in carrier phase is produced every time a logic 1 is to be transmitted, but not when a logic 0 is to be transmitted. Then, only phase changes have meaning and the absolute phase is unimportant. The original signal is obtained by decoding the received signal. At the receiver, it is possible to dispense with the decoder by arranging that the demodulator compares the phase of one digit with that of the previous digit. This can be achieved by using the modulated carrier, delayed by the

† Research Department, Telecommunications Headquarters.

duration of one digit, as the phase-comparison signal. This method, although simple to implement, has the disadvantage that any noise or interference on the modulated carrier also reaches the phase-comparison signal.

An alternative method of determining the correct phase at the receiver is to introduce a recognizable sequence of digits into the signal before transmission. A monitor at the receiver then looks for this signal and interchanges the logic 1 and 0 states, if necessary.

There are, therefore, at least three modulation-demodulation methods to consider and these are:

- (a) coherent phase-shift keying (c.p.s.k.) with extra digits to indicate the correct absolute phase,
- (b) differential coherent phase-shift keying (d.c.p.s.k.) with a digital encoder in the transmitter and the phase changes compared in the phase comparator, and
- (c) c.p.s.k. with a digital encoder at the transmitter and a digital decoder at the receiver.

The third system produces about twice as many errors for the same carrier-to-noise-power ratio as the first system. The results presented here apply to the first two systems only.

An alternative method of transmitting a digital signal is to feed it through a conventional frequency-modulated analogue microwave radio link normally used for trunk telephone circuits or television. The existence of a network of analogue stations makes this method particularly convenient until a network of digital stations is established. The problems associated with using analogue frequency-modulated links to transmit digital signals are being investigated at the B.P.O. Research Department.

REGENERATION

The demodulated signal representing the digits is distorted by noise, interference from other systems, bandwidth limitations and other imperfections. To remove this distortion, a new digital signal is produced from the distorted signal by a regenerating circuit which contains a decision circuit that decides on the interpretation to be given to each of the distorted digits. If it makes a false decision, an error occurs.

In one type of decision circuit, the centre-decision circuit, the decision is based on the signal amplitude at a time corresponding to the mid-point of the digit interval. In the second type, the integrate-and-dump decision circuit, the decision is based on the integral of the signal amplitude taken over the duration of one digit. Both types of decision circuit require timing information, which can be derived from the demodulated signal.

THE EFFECT OF NOISE

The most general definition of noise is that it is any unwanted disturbance in the wanted signal. However, in the present context, the definition is limited to noise whose instantaneous voltage has a Gaussian (Normal) distribution and, in the absence of filters, has a flat frequency spectrum over the band of interest. Interference from other digital channels is treated later.

Noise arriving at the demodulator can affect the signal in such a way as to induce errors. Fig. 1 shows a graph of the error probability plotted against carrier-to-noise-power ratio (C/N) for a wideband c.p.s.k. system using a centre-decision circuit in which C is the carrier power measured at the demodulator with no modulation and N is the corresponding noise power. Since the bandwidth of the system is large compared with the digit speed of the channel, the signal is not distorted appreciably by the filters. The continuous curve was derived from a simple theory,² whereas the circles show experimental results derived from a versatile test-bench to be described later.

When designing a microwave link, it is important to know what transmitter power is required to keep the number of

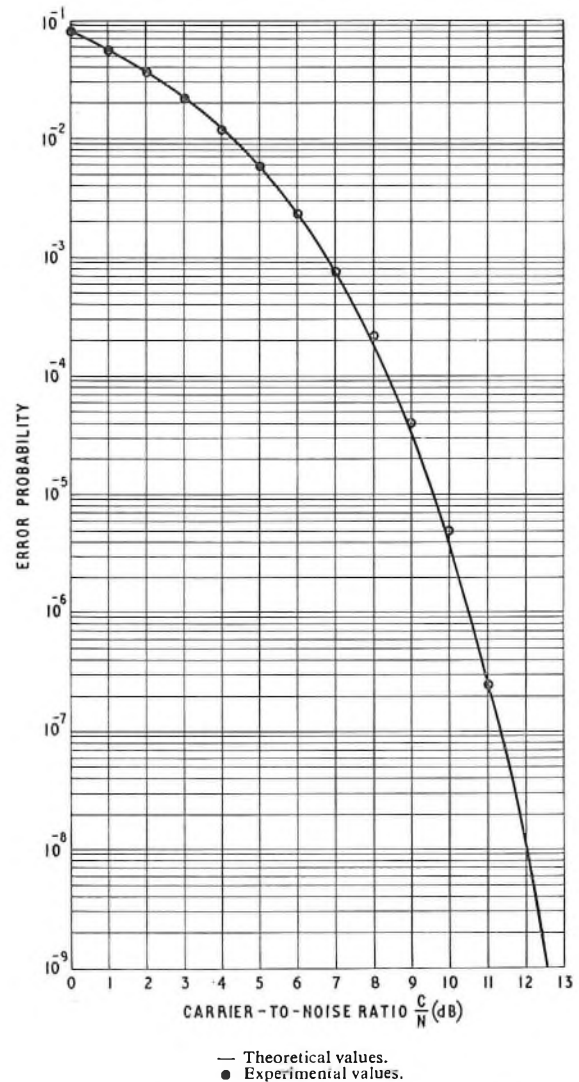

FIG. 1—Error probability/carrier-to-noise ratio characteristic for a wideband c.p.s.k. system employing a centre-decision circuit

errors sufficiently low under the worst propagation conditions³ for which the link is expected to be serviceable. This can be determined by considering the carrier-to-noise ratio required for a fixed error probability. Ideally, as shown in Fig. 1, a carrier-to-noise ratio of 6.8 dB is required to produce an error probability of 10^{-3} . In a practical system, a filter is required in the transmitter to limit interference to other radio channels and another is required in the receiver to limit interference from other radio channels and to limit the noise reaching the demodulator. Fig. 2 shows the effect of filter bandwidth on the value of carrier-to-noise ratio required to produce an error probability of 10^{-3} . The channel filter used possessed an amplitude/frequency characteristic which was found to be suitable according to computational studies, that is:

$$\text{transmission coefficient} = 20 \log_{10} \{ \exp [-k(f - f_0)^2] \} \text{ dB},$$

where f is the frequency, and f_0 and k are constants. This is known as a Gaussian filter.

It is seen from Fig. 2 that, for small filter bandwidths, the carrier power required for a fixed error probability of 10^{-3} using the centre-decision circuit is less than that required for the integrate-and-dump decision circuit.

The filter at the receiver affects the magnitude of the noise at the input of the demodulator and further distorts the demodulated signal. If the bandwidth is too narrow, the signal distortion increases the chances of errors whereas, if the bandwidth is too wide, excessive noise reaches the demodu-

lator. If Gaussian filters are used in the transmitter and receiver and the noise originates in the path between the filters, the optimum 3 dB bandwidth of each filter is 1.27 times the digit rate. For an error probability of 10^{-3} , the carrier-to-noise ratio required at the demodulator is then increased from 6.8 dB to 7.8 dB. However, the system performance is improved by the filters, because the receiver filter reduces the amount of noise reaching the demodulator.

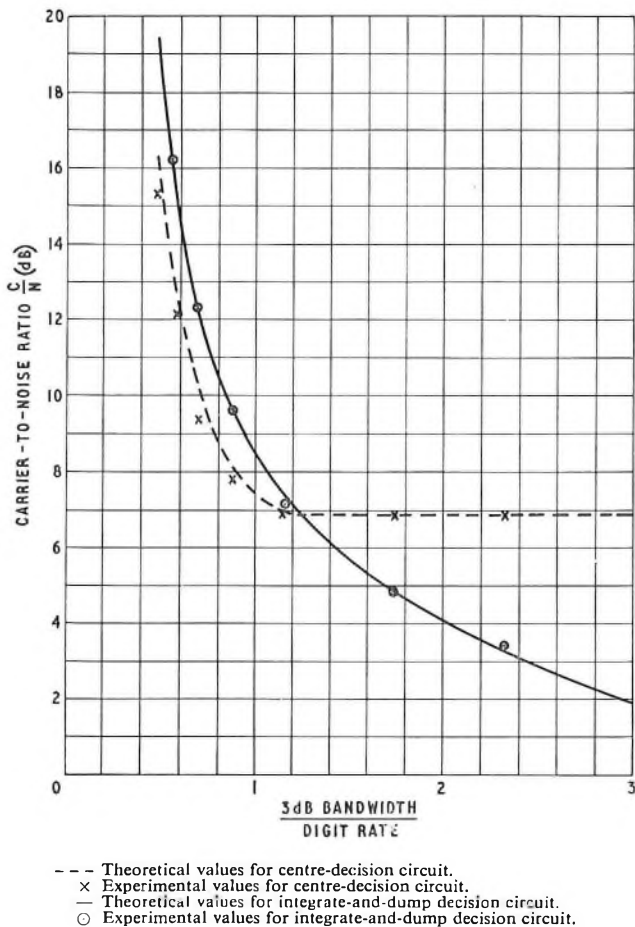

FIG. 2—Carrier-to-noise ratio for an error probability of 10^{-3} as a function of normalized filter bandwidth considering a c.p.s.k. system with a receiver filter only

THE EFFECT OF INTERCHANNEL INTERFERENCE

A digital microwave system would normally have several digital channels using separate carrier frequencies. To conserve radio spectrum these frequencies should be as close as possible. However, owing to the imperfections of practical filters and to possible overlapping of the frequency spectra, which will be dependent on the modulations, channels may interfere with each other. Transmission errors result from the combined effect of interference and random noise. Increasing the carrier powers increases the interference in proportion, but the random noise power in each channel remains constant. The effect of the interference is, therefore, to increase the value of the carrier-to-noise-power ratio required in each channel to maintain a given error probability. However, even with no noise, errors occur when the interference is above a certain value.

Some preliminary computations showing the magnitude of the effect of interchannel interference are shown in Table 1.

TABLE 1
The Effect of Interchannel Interference

Channel Separation Digit-Rate	Carrier-to-Noise Ratio (dB) for an Error Probability of 10^{-3}
∞	7.8
2.0	8.0
1.5	9.6

This gives the required value of carrier-to-noise ratio for an error probability of 10^{-3} in the middle channel of three 2-level c.p.s.k. channels having equally-spaced frequencies and equal transmitter powers. For this purpose, it is assumed that Gaussian filters are fitted at the transmitter and receiver having a 3 dB bandwidth-to-digit-rate ratio of 1.27, and that a centre-decision circuit is used. Further calculations showed that the effect is even greater for 4-level systems, particularly if d.c.p.s.k. is employed and it is suggested that filters, which cut-off more sharply than Gaussian filters outside the 3 dB bandwidth, may be more suitable than pure Gaussian filters.

EXPERIMENTAL PROGRAM

A versatile test-bench was developed to test the validity of

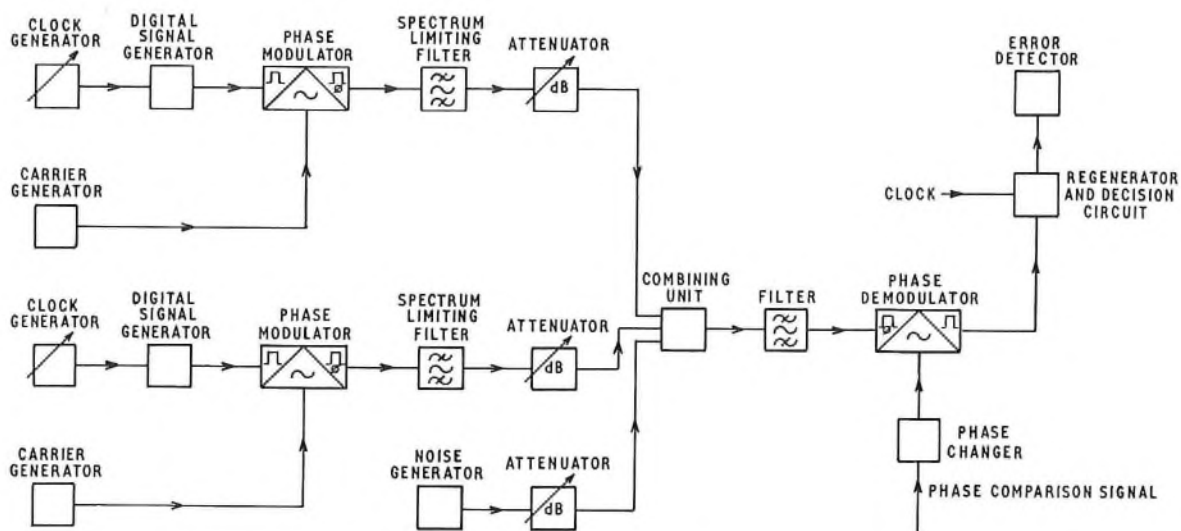

FIG. 3—Block diagram of test-bench connected for investigating 2-level c.p.s.k.

the theoretical ideas. Each unit was built in a separate box allowing many different arrangements to be investigated (see Fig. 3). The phase-comparison signal and clock were derived from the input end of the system. Various digital signals could be used, but the error-rate measurements were taken using a 1,048,575-bit pseudo-random digital pattern, that is, one having $(2^{20} - 1)$ possible combinations and many properties similar to those of a truly random signal, but one that is repetitive.⁴

The carrier frequency was 70 MHz and the digit rate normally of the order of 5 Mbit/s. Although this signalling speed is rather low, the results can be scaled in various ways. For example, the optimum bandwidth in each channel and the optimum channel carrier-frequency spacing are proportional to the signalling speed. Hence, the results can be applied to a low-capacity narrow-band system or to a high-capacity wideband system.

FUTURE WORK

The theoretical and experimental work is being extended to include the effects of interference and noise in 2- and 4-level c.p.s.k. and d.c.p.s.k. systems. It is also planned to use the multipath-fading simulator to study the effects of multipath fading on the transmission of digital signals. A propagation measurement program being carried out in the Mendlesham area by the Post Office Research Department in collaboration

with the Radio and Space Research Station⁵ should provide realistic data for the multi-path fading simulation machine.

CONCLUSIONS

The results presented here indicate that, if Gaussian filters are used and the channels are considered independently and a centre-decision circuit is employed, there is an optimum 3 dB bandwidth of each filter of 1.27 times the digit-rate. At this bandwidth, the centre-decision circuit is better than the integrate-and-dump decision circuit.

The effect of interchannel interference has been considered, and preliminary computations show that 4-level d.c.p.s.k. is much more sensitive to this interference than either 4-level c.p.s.k., or 2-level p.s.k.

References

- ¹ HARTLEY, G. C., MORNET, P., RALPH, F., and TARRAN, D. J. *Techniques of Pulse-Code Modulation in Communication Networks*. Cambridge University Press, 1967.
- ² SCHWARTZ, M., BENNETT, W. R., and STEIN, S. *Communication Systems and Techniques*. McGraw-Hill, 1966.
- ³ BAKER, A. E., and BRICE, P. J. Radio-Wave Propagation as a Factor in the Design of Microwave Relay Links. *P.O.E.E.J.*, Vol. 62, p. 239, Jan. 1970.
- ⁴ DIECKMANN, D. J., and GRAVES, F. A. Development of Pseudo-Random-Sequence Binary-Digit Generators and Error Detectors. *P.O.E.E.J.* (in this issue).
- ⁵ TURNER, D. Radio Trunk Communications and the Weather. *Post Office Telecommunications Journal*, Winter, 1970.

Book Reviews

"Television Engineering," Vol. 3. S. W. Amos., B.Sc., C. Eng., M.I.E.E., D. C. Birkinshaw, M.B.E., M.A., C. Eng., F.I.E.E., and K. H. Green, C. Eng., M.I.E.E. London: Iliffe Books, Ltd. 268 pp. 156 ill. £3.50.

This, the second edition of the third volume in a series of four books by members of the B.B.C. Engineering Department, takes account of the increasing application of transistor circuits to television waveform generation. The original text has been rationalized and expanded, whilst the most out-dated parts, such as those referring to gas-diode and gas-triode sawtooth generators, have been omitted. O. S. Puckle still receives honourable mention, and Schmitt has, somewhat belatedly, been introduced. A most useful addition to the first chapter takes the form of two complete families of *CR* and *LR* differentiating and integrating circuits. In the chapter on amplifier pulse-forming circuits, much worthwhile material has been added, particularly that referring to the use of transistors in pulse-narrowing and pulse-delay circuits. It is unfortunate that no mention is made of integrated-circuits, unijunction or field-effect transistors, and that the introduction to design techniques is mainly limited to valve circuits. As in the previous edition the text is well illustrated with clear diagrams and the volume is now adequately indexed. Whilst a decimal notation has been adopted for both text and figures, this does not apply to the index.

Although this volume is immediately recognized as a considerable improvement on the earlier edition, which itself was an invaluable source of information, there are three things which must be said of it. Firstly, it is unfortunately marred by a number of minor errors, most of which will

cause the reader no great difficulty. In one case, however, an early error in a numerical example leads to the need for a considerable number of consequential amendments. Secondly, as the authors are well aware, and as acceptable as this new edition is, the time has come for a completely new look at this subject; Amos *et al.* with their wealth of experience are well qualified to produce such a new treatise and it is hoped that, in the not too distant future, they will find the time to do so. Thirdly, in recommending this worthwhile textbook both to students and engineers, it is to be hoped that too many will not be deterred from acquiring a copy for their own bookshelves by the inordinate increase in price.

L. R. L.

"Radio Valve and Transistor Data", compiled by A. M. Ball. The Butterworth Group. vii + 232pp. 75p.

This ninth edition gives the characteristics of about 3,000 valves (and cathode-ray tubes), and approximately 4,500 transistors, diodes, rectifiers and integrated circuits. It also provides diagram information on all the commonly used bases for valves and active devices. The data are given on types commonly available in this country from about 20 companies.

A complete index is given at the back of the book, which gives the page number for the entry, or alternatively, the information can be found by referring to the family grouping for the component.

At £0.75 this is excellent value for over 200 pages of information.

W. T. L.

Computer-Aided Drawing Equipment for Integrated-Circuit Manufacture

G. S. WALKER†

U.D.C. 621.38.049.7: 681.3: 621.71

A fundamental part of the manufacture of integrated circuits is the preparation of high-precision photographic masks used to define areas for etching into various layers grown or deposited on to a silicon chip. The patterns required are complex and have to be accommodated on a very small surface, precise registration being required between individual masks forming a set. The automatic computer-controlled drawing equipment described enables the high-level of accuracy required to be achieved with the maximum economy of drawing-office effort.

INTRODUCTION

Research into the optimum design parameters of transistors and integrated circuits is being pursued at the British Post Office (B.P.O.) Research Department, involving the full manufacturing processes for progressive designs of these devices. Monolithic integrated circuits and transistors are prepared on silicon slices by a succession of operations each consisting of forming a layer, by deposition or growth, and then etching the layer to its own particular selective pattern determined by a photographic mask. The high-level of detail of the masks is indicated by the fact that a typical monolithic circuit of average complexity contained on a 1–3 mm square silicon chip could consist of up to 2,000 transistor-, resistor- or capacitor-elements requiring, for manufacturing purposes, the use of 8–20 photographic masks. It is normal to produce approximately 600 of these chips from a 25 mm diameter silicon slice.

The patterns required are evolved by the circuit designer and recorded as large-scale drawings on grid-lined paper. This information is then used in the drawing office to prepare very-precisely-dimensioned drawings, again on a large scale, which are then reduced photographically to final size for the production of the masks. The drawing-office work determines the accuracy of the final etched patterns and their position relative to each other. Since the spacing between shapes can be as little as $1\ \mu\text{m}$, exact registration of the masks is essential and, therefore, the highest obtainable drawing accuracy is required. To avoid human errors, achieve the specified accuracy and, because of the large amount of detail, to economize on drawing-office time, automatic computer-controlled drawing equipment has been brought into use.

† Telecommunications Development Department (formerly Research Department), Telecommunications Headquarters.

DESCRIPTION OF EQUIPMENT

The equipment consists of a large flat-bed plotter controlled by computer-prepared punched-paper tape, a digitizing system, a manually-operated co-ordinatograph and certain peripheral machines, such as tape readers and teletype-writers. A flow diagram for the operation of the plotter is shown in Fig. 1.

Master Plotter

The plotter (Fig. 2), which was manufactured by Ferranti Limited, is a flat-bed automatic drawing machine having a working area of $1.52\ \text{m} \times 1.22\ \text{m}$ and is capable of producing drawings of extreme accuracy at high speed. It has a maximum drawing speed of 100 mm/s and is accurate over the whole drawing surface to $\pm 60\ \mu\text{m}$ with a repeatability tolerance of $\pm 40\ \mu\text{m}$. This repeatability tolerance is of special importance as it ensures that common alignment details on a particular set of masks are accurately registered. The tolerance figures quoted were checked thoroughly during acceptance tests and the drawing squareness of the plotter was established as being better than four seconds of arc.

The input is in the form of a computer-prepared paper tape, read into the plotter at speeds of 500 or 1,000 characters per second. The drawing surface, which is constructed of hollow-formed aluminium for lightness, travels in the X-axis direction, and a gantry across the plotter carries a drawing carriage movable in the direction of the Y axis. Z-axis movements are used for raising or lowering the drawing instrument.

A variety of drawing devices can be attached to the drawing carriage. For example, it may be fitted with pens for drawing lines in a selection of colours with thicknesses in the range 0.18–1.0 mm, or an eight-station turret with automatic selection can be used. Other options include ball-point pens, scribing tools and a servo-driven cutting knife.

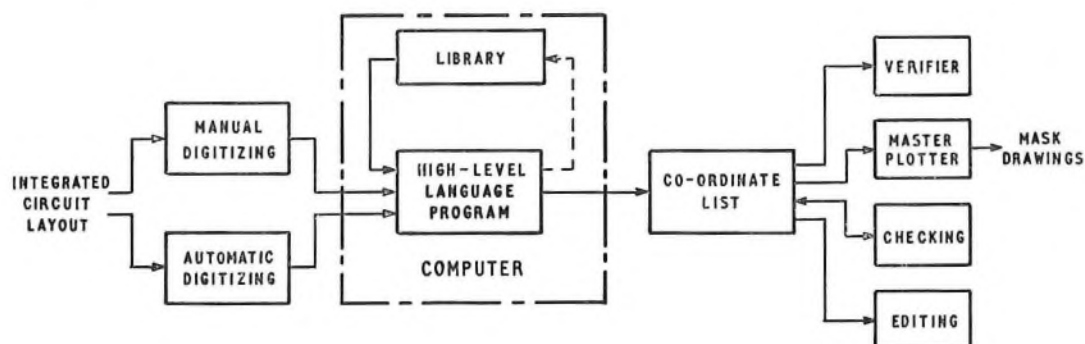

FIG. 1—System arrangement

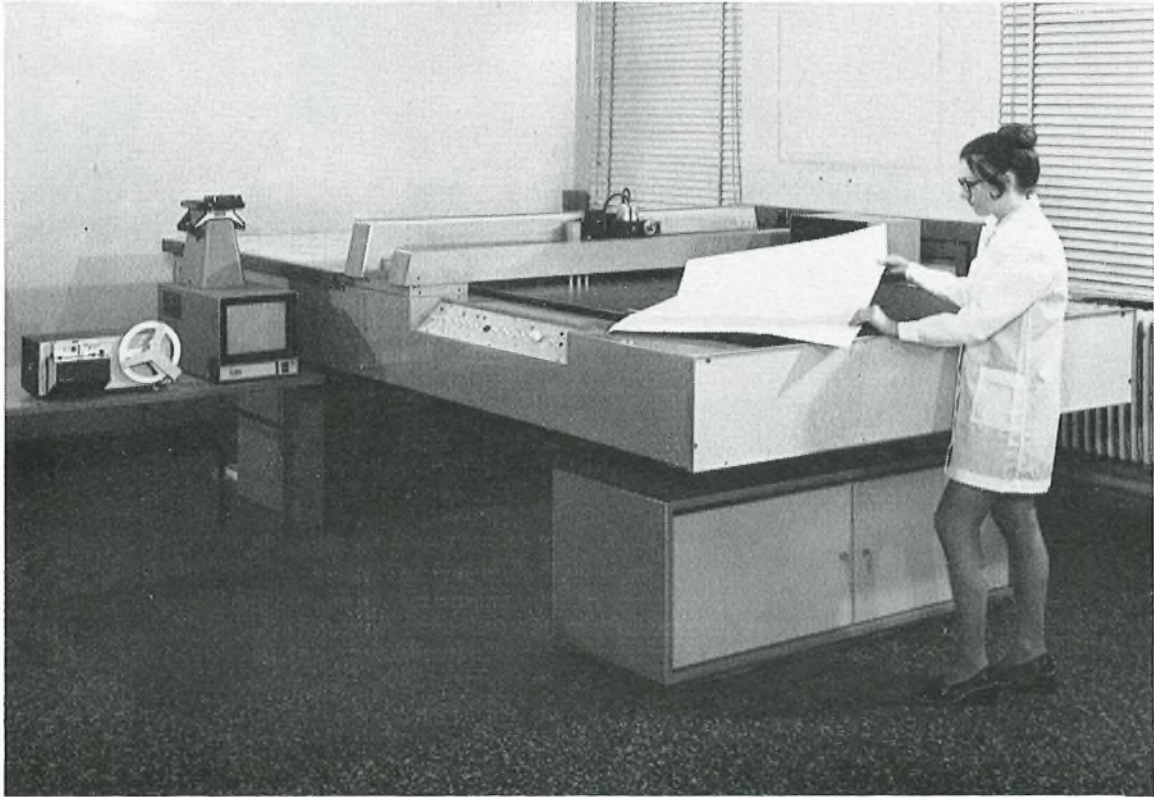

FIG. 2—Master plotter, tape reader and high-speed monitor and verifier

A light-spot optical projector can also be fitted for exposing photo-sensitive film in a controlled manner for the production of printed-circuit masters and circuit diagrams. This projector carries a disk fitted with apertures containing up to 64 pictorial symbols which can be projected on to the film. Alternative disks, completely loaded, may be inserted in a few seconds. Each symbol may be projected at 1:1 or 2:1 magnification by change of position of the objective lens under program control. Use of this optical projector for printed-circuit-board masters will eliminate the usual photographic reduction processes because a final-size film master can be produced.

Stepping motors, with reduction gear boxes and pinions, drive precision racks to attain movements in both X- and Y-axis directions. Accurate positioning is achieved by applying the *Moiré Fringe* technique using a diffraction measuring grating to provide a feedback to the servo control. This is a system of automatic control of the relative movement between parts of a machine in order to eliminate manufacturing errors introduced during construction. For example, difficulties may arise due to inaccuracies in the pitch of screws, gears and racks causing backlash errors. Racks and lead screws often introduce progressive and cyclic errors over their length due to manufacturing defects.

For both X and Y axes, two identical glass diffraction gratings are arranged face to face, one being held stationary fixed to the bed and the other moving with the draughting table (X axis) or drawing carriage (Y axis). The gratings are illuminated and inspected by photocells. The scribed lines on one grating are arranged to be at a very slight angle to the lines on the other. The interference to the light produced by the two sets of lines gives rise to a series of horizontal dark bands with a spacing much larger than the spacing between the lines, depending on the angle between the two gratings. When the travelling grating is moved, the bands move in a vertical direction up or down, according to the direction of movement, and at a speed such that the number of bands and the number of lines passing an inspection point is the same. Due to their wide spacing, the bands can readily be inspected

and counted using the photocells and thus, the movement measured in units of the line spacing of the diffraction gratings.

The movement required is fed into the plotter by the punched-paper input tape as a discrete number of pulses which cause the stepping motors to move the draughting table or drawing carriage until, when an equal number of pulses has been generated by the gratings and associated circuitry, the designated position has been reached. The stepping motors produce movement in the direction of the X and Y axis in steps of $12.7 \mu\text{m}$ and Z-axis input commands raise or lower the drawing instrument or operate a light-shutter mechanism when the optical projector is being used.

Other facilities include a vacuum hold-down device fitted to the draughting table to restrain the drawing material, a visual digital read-out display of X- and Y-axis co-ordinates of the drawing head, and a verifier-monitoring unit, which is fed by the plotter driving tapes and produces a display of the drawing on a storage tube at a very high speed. This display is used for a quick verification of the tapes before they are fed to the plotter as a separate operation. If the verifier-monitor unit is switched to MONITOR, the drawing is traced on the display tube in synchronism with the production of the drawing by the plotter.

The plotter electronic package contains an interpolator which is capable of generating straight lines, complete circles or circular arcs compatible with the working area of the drawing table.

Digitizing Equipment

The Ferranti *free-scan* digitizing system (Fig. 3) has no mechanical moving parts and requires no adjustment or recalibration. It consists, basically, of two main parts detailed below.

Working board and cursor

The working board has an active area of $1.5 \text{ m} \times 1.05 \text{ m}$ and contains within its surface an array of electrical conductors, which interact with a coil in the cursor and generate

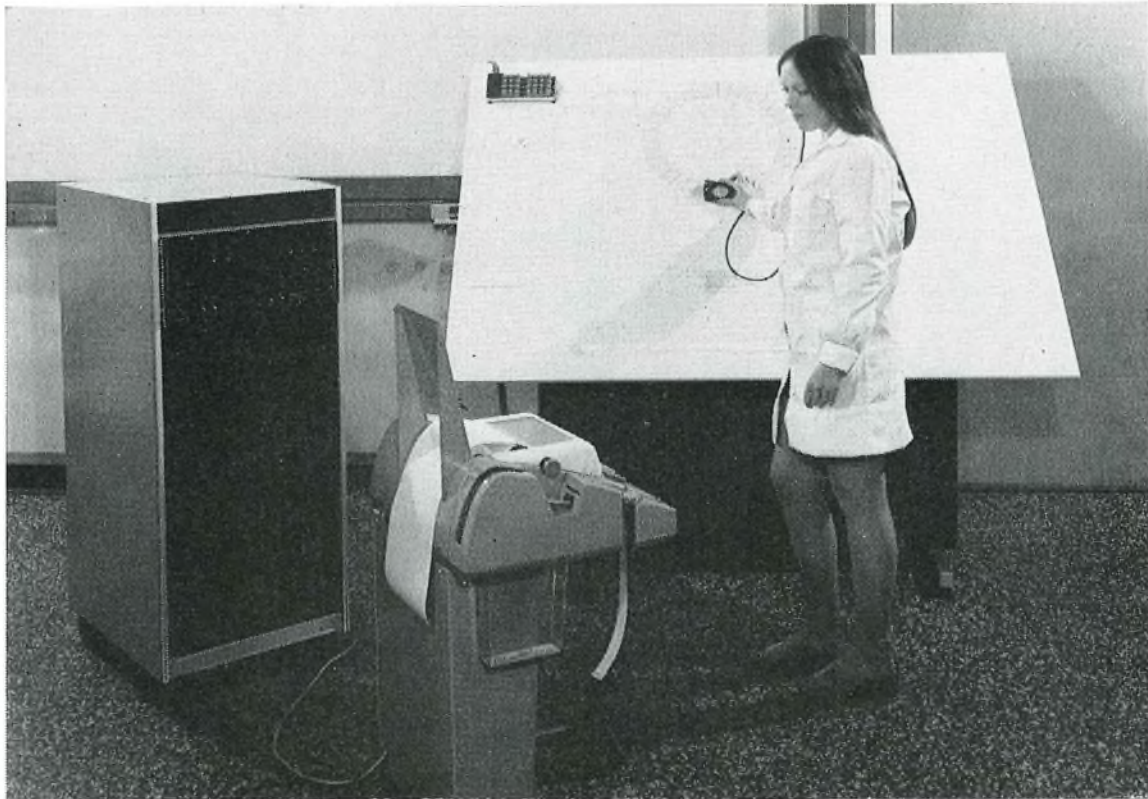

FIG. 3—Digitizing equipment

signals to record the co-ordinates of the cursor position. The cursor (Fig. 4) contains a cross-wire target within the viewing area. In use, when the cursor is positioned at a desired point, the operation of a push-button on the cursor records the co-ordinates of that point. Other push-buttons on the cursor provide facilities for clearing down before setting up a datum position and for locking on to the co-ordinates of a particular point, for example, at a pause in the work. A 28-character keyboard is connected to the electronics cabinet by a flexible ribbon cable and can be placed anywhere on the working board for operator convenience. It provides the operator with a quick method of entering machine-language codes into the recording format.

The positional accuracy of the board is $\pm 127 \mu\text{m}$ with a repeatability tolerance of $\pm 25 \mu\text{m}$.

Electronics cabinet with teletypewriter output

The electronics cabinet provides the circuitry for converting the signals from the working board and cursor into digital information and the interface circuitry between the digitizer and its associated teletypewriter. Data output from the teletypewriter is on punched-paper tape and the format selected for print-out is readily obtained by the manipulation of a patch panel in the cabinet.

Other facilities provided by the electronics cabinet include,

- (i) visual X- and Y-co-ordinate display of the cursor position,
- (ii) an event counter to count points digitized, characters recorded or other items related to recording commands,
- (iii) choice of absolute or incremental co-ordinate measurement,
- (iv) a variable scale-factor selection providing scaling in each axis independently, and
- (v) grid recognition device which allows for successful digitizing of a drawing produced on a dimensionally unstable material. Initially, the four corners of any rectangle which wholly encloses the drawing are examined and the digitizer instructed that these X- and Y-axis co-ordinates are a

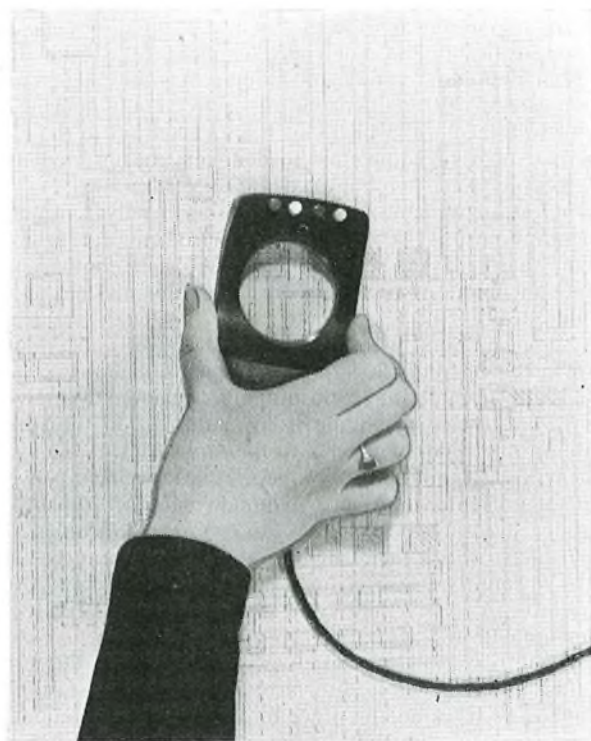

FIG. 4—Digitizing

selected number of units in length. Further digitizing uses this scale, and finally, the selected unit can be allocated any metric or imperial linear base element.

Manual Co-ordinatograph

The drawing equipment also includes a manually-controlled co-ordinatograph (Fig. 5) fitted with a visual digital display for reading X- and Y-axis co-ordinates. This machine has a drawing area of $850 \text{ mm} \times 850 \text{ mm}$ and includes a controlled rotating table adjustable to 10 seconds of arc. Posi-

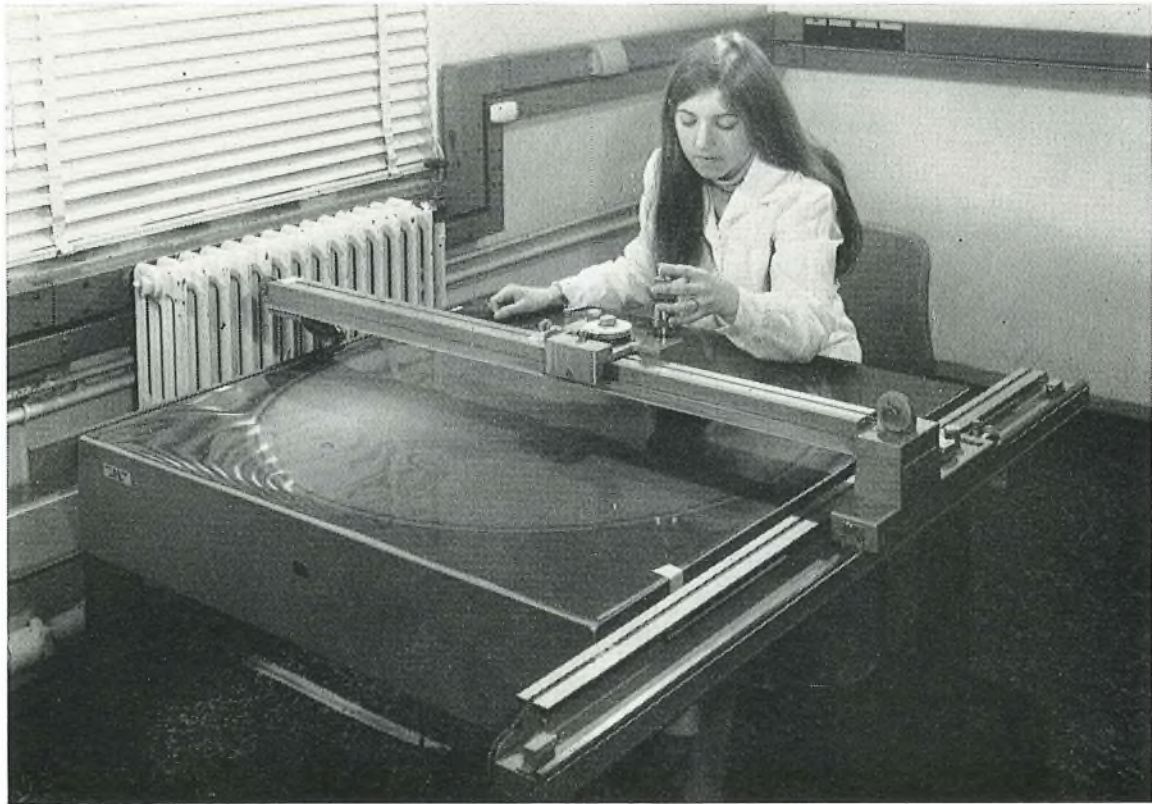

FIG. 5—Manual co-ordinatograph

tional accuracy is to $\pm 0.20 \mu\text{m}$ and the resolution is $0.10 \mu\text{m}$. This unit is used for drawings which require extreme accuracy but which are not sufficiently complex to necessitate the use of computer-aided equipment. Such drawings include photolithographic masks for microwave circuits, magnetic bubble travel patterns and pattern disks for impulse generators.

PREPARATION OF INTEGRATED-CIRCUIT ART-WORK

The circuit designer produces a composite drawing (Fig. 6) on 1 mm grid film, showing the circuit geometry, with various individual masks defined by coloured lines or cross-hatch shading. This drawing is usually prepared 250, 500 or 1,000 times the final integrated-circuit pattern size and lines only appear on the grid lines or centrally displaced between them. It is, therefore, possible to specify clearances of $0.5 \times 1/250 \text{ mm} = 2 \mu\text{m}$, if the sketch is 250 times final size. In order to ensure an efficient layout, the designer gives special consideration to spacing, tolerances and optimum inter-connexion routes. Drawing co-ordinate information is then extracted, manually or by the use of digitizing equipment, and recorded on tape. This data tape is processed by a computer which produces a tape for instructing the numerically-controlled master plotter to generate the necessary art-work. The art-work consists of a series of drawings (Fig. 7), one for each individual mask, which are reduced photographically to final size. Subsequently, up to 600 identical integrated circuits can be produced on a 25 mm diameter silicon slice.

In order to maintain accuracy, art-work is drawn on dimensionally-stable polyester film, known as Cut-N-Strip, at 250 or up to 2,000 times final size in a room where the environmental conditions will be eventually controlled to $20 \pm 1^\circ\text{C}$ ambient temperature, 50 ± 5 per cent relative humidity and $5 \mu\text{m}$ air filtration. Cut-N-Strip material consists of two transparent polyester-base film layers sandwiched together, the base being clear and the top layer coloured red. The red layer is cut with a knife located in the drawing carriage of the master plotter and unwanted sections of the layer are then peeled off to form a red and clear pattern

of the circuit geometry. Cut-N-Strip material has a dimensional stability such that a 1 per cent change in relative humidity produces a change of 1 in 10^3 and a 1°C change in temperature produces a change of 5.5 in 10^4 . The driving tapes for the drawing machine are produced on a Burrough's B5500 computer using software, prepared by the Mathematics Branch at the B.P.O. Research Station, and data tapes containing co-ordinate and final-size information of the required art-work.

Input to the plotter requires the co-ordinates of all the shapes appearing on each drawing. This mass of data is difficult to produce correctly and is also very time absorbing. However, a high-level language is available to specify these shapes and to cut the input data to a minimum consistent with ease of use. This language takes advantage of a great deal of redundancy that is present in the list of co-ordinates and reduces the input data by an order of magnitude or more. The redundancy arises for three main reasons.

(a) A great majority of shapes have sides parallel to the X and Y axes and where this is so, the data to describe the shape can be reduced by a factor of two.

(b) Patterns of shapes are often repeated in several positions, and perhaps, rotated or reflected. These patterns have only to be described once, and thereafter, allotted a name. They are then positioned by using only one pair of X- and Y-axis co-ordinates.

(c) Patterns appear which are common to a whole range of circuits. These may be held in a library or backing store and can be referred to by name when required.

Fig. 8 displays some very simple shapes which may be requested by the circuit designers. In order to produce two masks from this drawing by manual digitizing, the co-ordinate particulars of the shapes are extracted from the drawing and then combined with instructions specified in the high-level language program as shown in Fig. 9. This information is then used to produce a tape for driving the master plotter.

Other software packages used with the computer are for checking minimum clearances, minimum width of shapes,

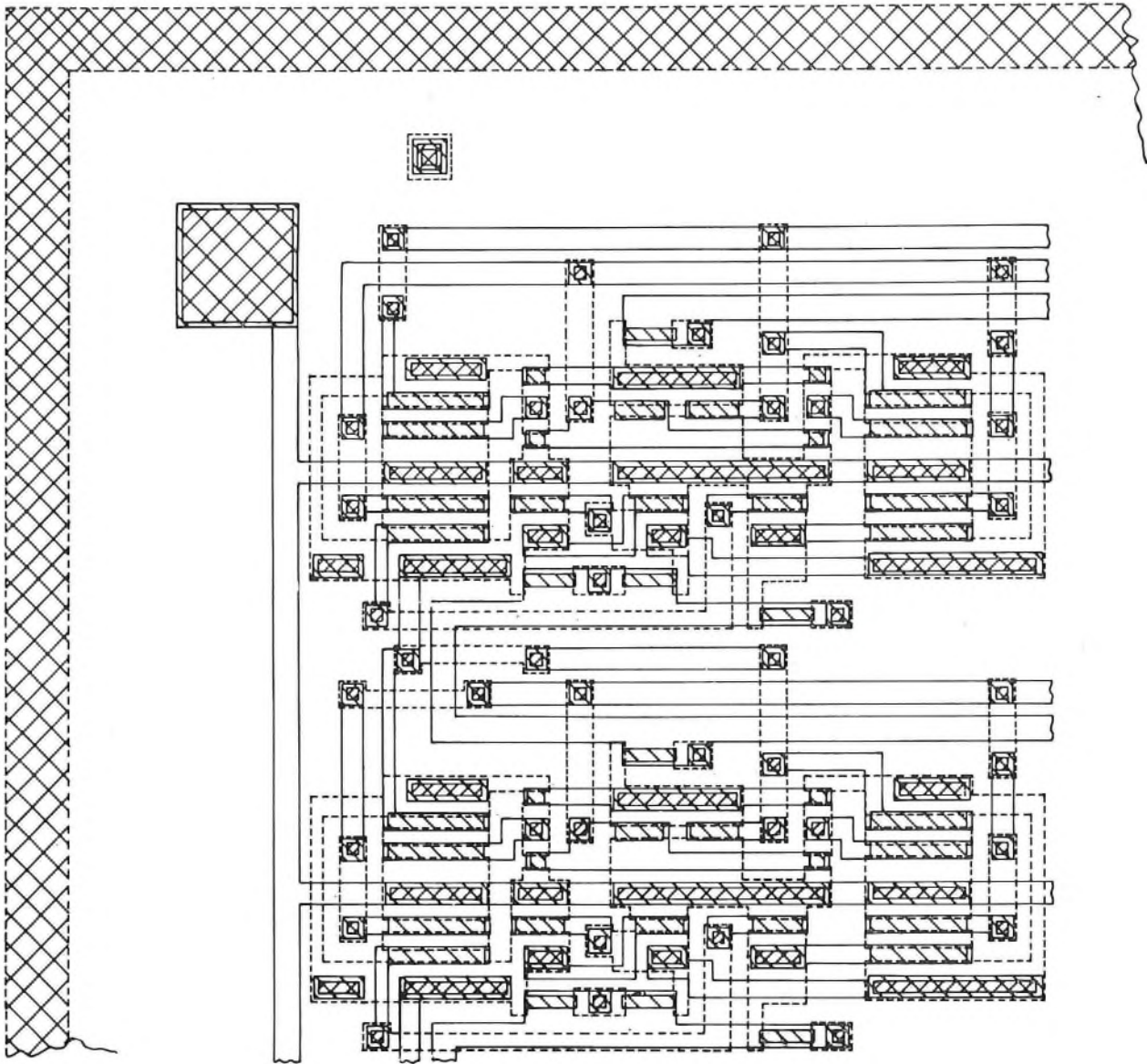

FIG. 6—Designer's composite layout

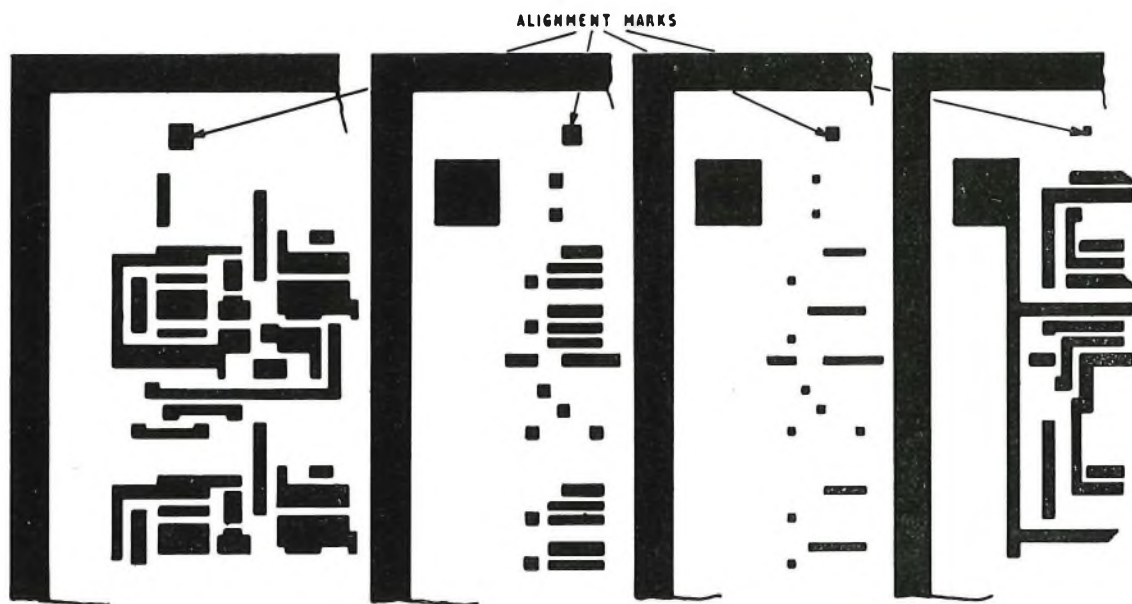

FIG. 7—Cut-N-Strip masks

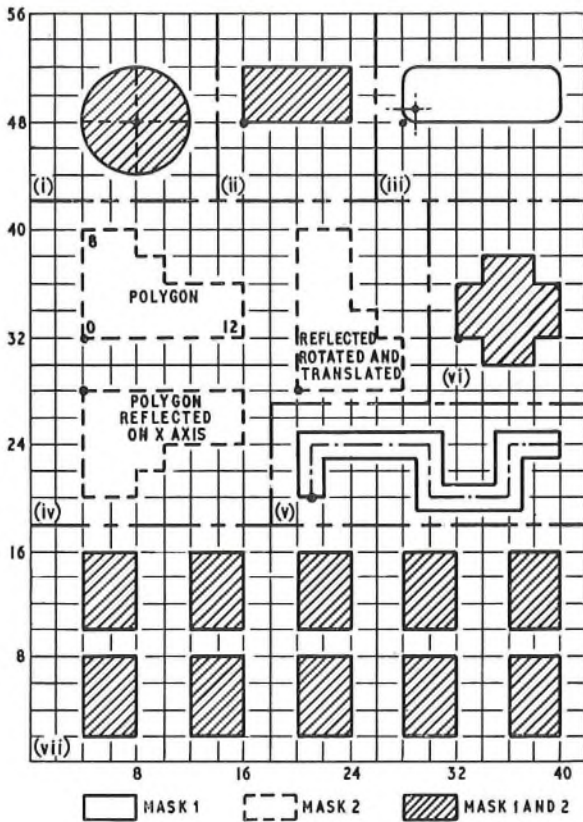

FIG. 8—Digitizing example

ensuring one shape lies completely within a particular shape on another mask by a defined clearance, editing the co-ordinate file, merging and demerging shapes and reporting back errors in the original data tape.

OTHER USES

The computer-aided drawing equipment described has been used for drawings having a large number of repetitive shapes such as accommodation layouts showing standard furniture. It is also used for any drawing requirement where the graphics demand an accuracy better than the conventional drawing methods can produce, that is, approximately ± 0.5 mm. Drawing information of details can be extracted from certain sub-assemblies of engineering parts resulting in a considerable saving in detail draughting time. The preferred method of detailing is to digitize shapes and enter important dimensions by use of the teletypewriter. Standard repetitive shapes and hole layouts are stored in the computer backing store on disk or magnetic tape and called for when required.

CONCLUSION

Automatic computer-aided drawing equipment has been introduced successfully in the B.P.O. Research Department to meet the accuracy required in the preparation of artwork for the production of etching masks used for the manufacture of integrated circuits and transistors. It is also used for other drawing work requiring better than conventional accuracy and for drawings having a large number of repetitive shapes. In the future, it is expected that the use of computer facilities and digitizing equipment will extend the use of the automatic drawing machine into a fair proportion of the conventional drawing-office work, especially in the production of printed-circuit-board masters, circuit diagrams and special shapes following a mathematical law. Research Department's future program will aim at producing driving tapes for constructing engineering drawings on a micro-film format, for inspection and record purposes which will also be capable of driving numerically-controlled machine tools. Interactive graphics equipment is also being considered to enable an operator to communicate direct to a

```

"JOB TEST" 1;
  job name
(i) ... "CIRCLE" (1, 2) 8, 48, 4;
      mask specifier    x and y co-ordinates of centre    radius
(ii) ... "RECT" (1,2) 16,48: 8, 4;
      x and y co-ordinates of datum    length of sides x and y
(iii) ... "RECT" (1) ARC, 1, 28, 48; 12, 4;
      radius on corners    x and y co-ordinates of datum    length of sides x and y
(iv) ... "NEW GROUP" ABC 1;
      shape name
      "POLY" (2) 0,0; 12,4, -6, 2, -2, 2, -4, -8;
      polygon    x and y co-ordinates of datum    length of sides x and y
      "END GROUP";
      "GROUP" ABC 1, 4, 32;
      shape name    datum
      "GROUP" ABC 1, 4, 28 100;
      datum    reflected on x axis
      "GROUP" ABC 1, 20, 28, 101;
      datum    reflected and rotated
(v) ... "LINE" (1) 2, 21, 20; 4, 9, -4, 6, 4, 4;
      line width    datum of centre line    length x and y
(vi) ... ["GROUP" ALIGN, 32, 32;
          shape name    datum
          "USE LIB" (1, 2) GH2;
          library file name
(vii) ... "REPEAT" X, 5, 8;
          repeat in x direction    number of shapes    spacing
          "REPEAT" Y, 2, 8;
          repeat in y direction    number of shapes    spacing
          "RECT" (1, 2) 4, 2:4, 6;
          shape to be repeated
          "ENDREPEAT"
          "ENDREPEAT"
          "PLOT" (1, 2) ALL, XYZ1, 0, 0;
          file name of complete drawing    security numbers if required
          "COMP" (1, 2) XYZ1, 0.001, 250, 1;
          1 μm = unit on drawing    scale
          "STOP";
  
```

FIG. 9—Example of high-level language

computer, and by using a visual display and light pen, modify his layouts for optimum positioning and error correction.

ACKNOWLEDGEMENTS

The successful introduction of computer-aided automatic drawing equipment has been due to the enthusiasm of the author's colleagues and the help readily given by Mr. G. Haley at Dollis Hill and Mr. Ian Blackie of Ferranti Limited.

Notes and Comments

J. A. Povey, B.Sc.(Econ), F.S.S., M.B.C.S., C.Eng, M.I.E.E.

The recent formation of a Teletraffic Branch in the Telecommunications Development Department underlines the increasing importance attached to traffic engineering in the Post Office. John Povey, who was appointed Staff Engineer in August to lead the new branch, is well equipped to tackle the numerous current problems in this field that have resulted largely from the introduction of new types of exchange system.



He started as a Youth-in-Training in 1946 in the Tunbridge Wells Area, moving to S Branch, Engineering Department, in 1953 on appointment as Assistant Engineer. In 1956 he moved to E Branch as an E.E. on exchange design and installation standards, contributing particularly to the development of over-ceiling cabling and introduction of the time-consistent busy-hour method of traffic recording. From 1963 to 1966 he was the S.E.E. in charge of the Traffic Theory and Engineering Group in TPD Branch; during this period he completed the investigation of the time-consistent busy hour and published tables for dimensioning an automatic-alternative-routing trunk network. He represented the Post Office at C.C.I.T.T. meetings and contributed to international conferences.

In January 1968, on promotion to A.S.E., he joined the newly formed Works Contract Control Branch of Purchasing and Supply Department, making a notable contribution to the development of procedures and computer-compiled statistics for the control and progressing of works contracts. In 1970 he was a member of the Post Office team that visited Australia to study switching policy and exchange equipment procurement.

John's penetrating mind, inexhaustible energy and initiative, coupled with his ability to get on with people, will ensure success in the exacting task that lies ahead in his new job. E.D.

Publication of Correspondence

The Board of Editors would like to publish correspondence on engineering, technical or other aspects of articles published in the *Journal*.

Letters of sufficient interest will be published under "Notes and Comments". Correspondents should note that, as it is necessary to send copy to the printer well before publication date, it will only be possible to consider letters for publication in the April issue if they are received before 23 February 1972.

Letters intended for publication should be sent to the Managing Editor, *P.O.E.E. Journal*, Post Office Factories Headquarters, Bovay Place, London, N7 6PX.

Notes for Authors

Authors are reminded that some notes are available to help them prepare the manuscripts of the *Journal* articles in a way that will assist in securing uniformity of presentation, simplify the work of the *Journal's* printer and draughtsmen, and help ensure that authors' wishes are easily interpreted. Any author preparing an article for the *Journal* who is not already in possession of the notes is asked to write to the Managing Editor to obtain a copy.

It is emphasized that all contributions to the *Journal*, including those for Regional Notes and Associate Section Notes, must be typed, with double spacing between lines, on one side only of each sheet of paper.

Each circuit diagram or sketch should be drawn on a separate sheet of paper; neat sketches are all that are required. Photographs should be clear and sharply focused. Prints should preferably be glossy and should be unmounted, any notes or captions being written on a separate sheet of paper. Negatives or plates are not needed and should not be supplied.

Model Answer Books

Books of model answers to certain of the City and Guilds of London Institute examinations in telecommunications are published by the Board of Editors. Details of the books available are always given at the end of the Supplement to the *Journal*. The Board of Editors has reduced the price of Line Plant Practice A to 37½p (42½p post paid).

The Telecommunication Principles B Answer Book is out of print at the moment but a revised issue is in preparation and an announcement will be made in the *Journal* when it becomes available.

Articles on Current Topics

The Board of Editors would like to publish more short articles dealing with topical subjects. Authors who have contributions of this nature are invited to contact the Managing Editor.

Supplement

Students studying for City and Guilds of London Institute examinations in telecommunications are reminded that the Supplement to the *Journal* includes model answers to examination questions set in all the subjects of the Telecommunication Technicians' Course. Back numbers of the *Journal* are available in limited quantities only, and students are urged to place a regular order to ensure that they keep informed of current developments in telecommunications and receive all copies of the Supplement.

Syllabuses and Copies of Question Papers for the Telecommunication Technicians' Course

The syllabuses and copies of question papers set for examinations of the Telecommunication Technicians' Course of the City and Guilds of London Institute are not sold by *The Post Office Electrical Engineers' Journal*. They should be purchased from the Department of Technology, City and Guilds of London Institute, 76 Portland Place, London, WIN 4AA.

Regional Notes

Eastern Region

A Double Decker U.A.X.

The present Offley Unit Automatic Exchange (U.A.X.) No. 13 replaced a U.A.X. No. 5 in September 1956 for which the A-type building was extended to the rear to the maximum, giving a floor area of 232 ft². This gave a capacity of 300 multiple connexions without subscriber trunk dialling (s.t.d.) and a forecast date of December 1971 for the exchange to be full.

A forward extension was possible, but so small that it would have given only a fractional improvement in multiple size, still not providing for s.t.d. Thus replacement by a non-director exchange was scheduled for 1973.

The search for a site proved extremely difficult. The one acceptable site was very expensive, and the vendor was making stipulations that were not acceptable.

The available time was running out and it was evident that a non-director exchange would not be ready to replace the U.A.X. No. 13 by 1973. It was, therefore, decided to explore the possibility of adding a second storey to the existing U.A.X. No. 13.

The main problems were as follows:

(a) the plan had to give both an adequate and economic increase in the exchange life,

(b) the building and site work had to be possible without interference to existing service and maintenance,

(c) the equipment needed on the first floor had to have an easy and ready access, and safety while the equipment was being handled had to be guaranteed,

(d) the first floor loading had to be such that normal standard layout of equipment was possible,

(e) the installation of equipment had to be possible by normal construction methods,

(f) the additions of equipment on a first floor had not to complicate the maintenance of the exchange as a whole.

After exhaustive examination of the problems, foundations were inspected and floor strengths calculated, and it was decided that the proposition was practicable.

Planning permission was the next problem since the exchange is situated in a conservation area. But encouraging comment and very helpful suggestions were received from the local authorities.

The final design consisted of a small forward extension which increased the width of the building to incorporate the stairs.

During construction, care and maintenance of the existing apparatus was the first priority, the building contractor agreeing that if further protection of plant in excess of the specification was called for he would provide it.

The co-operation was excellent. The main sequence of building operations was to build the new outer-walls up to existing plate height, then build all the walls to new roof height, roof the new structure, and glaze. The roof of the existing building was then removed before placing first floor joists for which the walls had been prepared by pre-fixing joist hangers.

The building is now completed, and the area has an exchange with over 10 years of life and a multiple in excess of 600 connexions with s.t.d. and pay-on-answer coin box facilities.

The cost of this expedient was £4,900 which compares very favourably with what it would have cost to erect a temporary B.1-type timber building on the non-director exchange site if the site could have been obtained in time.

H. E. WESTON

London Telecommunications Region

Installation of East (Ilford) Sector Switching Centre

Equipment installation at Ilford sector switching centre (s.s.c.) commenced on the 1 June 1971, this being the first of the s.s.c.s in the London Telecommunications Region.

The new s.s.c. building, known as Mill House (Fig. 1), consists of a tower block of 11 floors with 9,000 ft² per floor and a low-block of five floors with 12,000 ft² per floor. Floors 7, 8, and 9, are for the auto-manual centre (a.m.c.) switch rooms which will be soundproofed and carpeted for maximum operator efficiency and comfort. The top floor is designed for welfare and canteen facilities. There are four passenger lifts, one equipment lift and a deep-level tunnel lift to a cable tunnel. This cable tunnel, approximately one mile in length at nominal 30 ft depth, provides cable entry for the majority of the external cables.



FIG. 1

Partial occupation of the low-block and adjoining tower-block has permitted commencement of the installation on the incoming unit, outgoing unit, and repeater station. Dust prevention during partial occupation has been a problem requiring special precautions, whilst building operations are still in progress on the upper floors. Temporary catering facilities have been provided on an ultimate equipment floor, as the permanent canteen is not yet available. This has been overcome by the use of vending machines providing all types of drinks and hot meals. With no lifts working in the building under partial occupation, the handling of all equipment into the building has been via an apparatus hoist at the end of the podium block, including all the food for the temporary canteen on the fourth floor.

The equipment of each unit is of the crossbar 5005-type with stored program control (s.p.c.). The incoming-unit is now well under way with the majority of racks erected, cabling and forming is in progress and bench-testing of the crossbar switches has commenced. Construction on the outgoing-unit and repeater station has reached the cabling stage. Some of the s.p.c. equipment is now on site and testing was scheduled to commence in late September, 1971. The s.p.c. racks are the first of their type, and are to some extent to be proven at this s.s.c. Training of the British Post Office staff on the s.p.c. equipment is being carried out at the G.E.C. works, Coventry, since the Technical Training School (Stone) has not as yet the facilities available to do so. The course lasts for 13 weeks taken in three sessions of 3 weeks, 6 weeks, and 4 weeks respectively. The main units (Fig. 2) consist of:

(a) an incoming-unit to serve incoming trunk traffic to the East Area director exchanges from other group switching centres,

- (b) an outgoing-unit to control the East Area outgoing subscriber trunk dialled traffic,
- (c) a tandem-unit to relieve the existing London tandem-units,
- (d) an a.m.c.-unit, using cordless switchboards, which will replace most of the existing auto-manual boards in the East Area by 1974,
- (e) a telephone repeater station with coaxial and audio equipment.

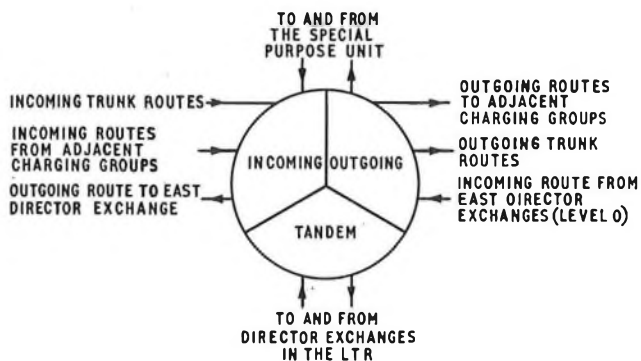

FIG. 2

The s.s.c. is scheduled to be brought into service finally by the end of 1974, the incoming-unit being first in late 1973. Each unit will be brought into service separately. Coupled with the work involved at the s.s.c., out-station work has commenced at the director exchanges.

J. D. WARREN

Providing a Main Duct Route Across Kingston Bridge

Some main underground trunk and junction duct routes to the west from London and the Kingston telephone exchange cross the river Thames in the footways of Kingston bridge. Additional duct routes were required for new cables to the new sector switching centre being built at Kingston because the existing route was inadequate.

Reference to records of the bridge indicated that, where the bridge was widened on the up-stream side in 1914, two 18 in steel pipes were installed by the Metropolitan Water Board (M.W.B.) in the footway and they had remained unused. Their position and depth of cover was verified by trial excavations and permission obtained to survey the interior of one pipe by closed circuit television. The survey showed no defects or obstructions, and negotiations were put in hand to purchase the pipe at scrap metal rates from the M.W.B.

Proposals to use the pipe as a cover for a circular formation of ducts were discussed with the bridge authority and local councils controlling the bridge approaches, and finally authorized.

Direct labour was to be used for all the operations, and after consultation with the area major-works group and the regional headquarters works branch, the following method of construction was agreed.

Each end of the pipe was excavated to the existing approach manholes. At the bridge centre an excavation was made and longitudinal half-section cuts made along the exposed pipe. The ducts were formed into 117 m and 86 m lengths in trefoil formation, tied with tape, and laid along the footway at each side of the centre excavation. Each section was then pulled in from the centre to each end of the pipe and the sections joined at the centre with short lengths of duct.

The area power-section workshop prepared special wooden dowels of lignum vitae for lightness and strength of coupling and the area mechanical-aids depot fitted the leading dowels with modified "stay swivels". The end dowels of varying length ensured that the duct spigots were staggered along the section length to maintain a uniform diameter of the ducts when taped together. A wire hawser secured to each leading dowel-swivel was passed through each duct-line and end dowel, tensioned, and held tensioned by a stay-clamp bolted against the face of the end dowel and the hawser.

To reduce the friction as the duct-lines were pulled along the footway, cable skates were modified and provided with a

bolt-on rack to support the ducts. The weight of the ducts secured the skates to the formation allowing each skate to be removed as it reached the centre excavation without interrupting the movement of ducts.

In three pulls, nine ducts were placed into position and the remaining space in the pipe filled with single duct lengths completing a duct capacity of 13 lengths end-to-end, and when dressed into the manholes provided a formation of 12 ducts (6 high by 2 wide).

Draw ropes were fitted to the hawser-shackles as they were withdrawn after each pull, and to assist with duct numbering and dressing a drop-wire was pulled into the last duct to provide a telephone communicating link between the pipe ends. At the centre, a weak mix of concrete was placed between and over the ducts which were finally protected by replacing the cut sections of pipe at this point.

The work and reinstatement was complete within the five weeks time limit allowed by the bridge authority and the success of the operation was due in no small measure to the enthusiasm and efficiency of the area major-works staff assisted by the team work of the area planning and regional headquarters works-groups. An 8-mm cine film camera was used during the operations to record various aspects of the excavations, progress, and techniques used to instal the ducts in the pipe. The overall cost of the work was £3,800 which affected an estimated saving of at least £4,000 had the work been contracted out.

E. H. CURTIS

North Eastern Region

Town Redevelopment: Plant Diversion

A request was received for the removal of a Post Office pipe from a site to be developed for a new supermarket at Gateshead in the Newcastle-upon-Tyne Telephone Area. The existence of the pipe prevented preliminary site works. The pipe was a six-way multiple duct, full to capacity with junction cables serving the telephone exchange on the adjacent site.

Preliminary estimates, prepared by the area planning-group, indicated costs of approximately £5,000, 20 weeks being required to divert the duct, and cable from the site. Because of the costs and labour involved, the feasibility of leaving the duct on site was reconsidered.

With the aid of duct diaries, dated 1927, giving the depth and course of the duct-line in relation to ground levels existing at that time, and the use of a track locator and surveying techniques, the area drawing-office built up a plan and profile drawing (Fig. 1). This drawing, together with the architect's building plans, indicated that the duct route, on solid rock, would require slewing approximately 4 ft and lowering a maximum of 6 ft to clear the building foundations, and it appeared to be just possible to do this.

Work commenced at the beginning of April 1971 and was completed within six weeks. The first stage of the work was to make pilot holes at intervals, along the existing duct-route and to mark the position of the duct on the surface. It was reassuring to find the depth and position of the duct was as indicated by the track locator. Knowledge of the duct position enabled the new trench to be dug-out by mechanical means, the excavator travelling over the top of the existing duct-line. As the new trench was excavated, the soil over the existing duct was turned into the new trench and removed.

Strongbacks (lengths of scaffold-tube) were lashed to the exposed duct, the lashings being tightened by driving wedges between the duct and the strongback. Additional rope ties were provided to give greater rigidity and to avoid the tendency of the duct to slide down the incline during movement. A support-framework to span the 14 ft wide trench was built up using scaffold-tubing. Three vertical supports were used across the trench and cross members were provided at 6 ft intervals together with various strengthening members throughout.

Ropes were fitted to the ducts and tied to scaffold-tubing running parallel with the trench and resting on top of the cross members for lifting and lowering the ducts (Fig. 2). The duct nest was raised 4 in by use of chain pullers, then the ropes adjusted to take the weight of the duct nest prior to slewing.

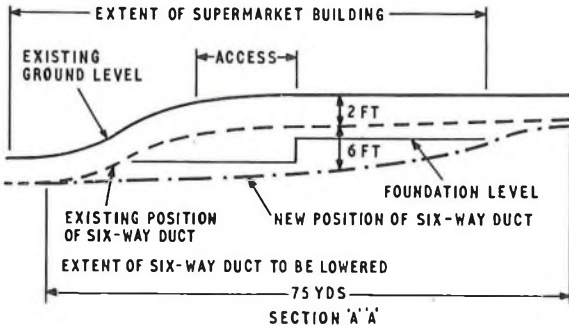
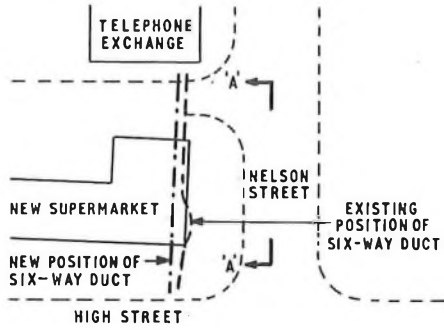

FIG. 1

To assist the slewing, alternate cross-tubes were greased. The slewing of the duct was completed in three stages, each stage consisting of moving the duct a little towards the new position, starting at the bottom of the incline and moving to the top. Between the first and second stage of slewing the duct was lowered slightly over a part of the route. This lowering prevented pressure being imposed on the duct collars as the duct was slewed from the curved section to the straight section.

The duct was lowered in easy stages using every third rope



FIG. 3

tie, the intermediate ties having been slacked off to give approximately 1 in of slack. These ties were used as safety stops if the weight of the duct was too great to hold. The duct was lowered to within 6 in of the trench floor, then manoeuvred over to its correct position, before being finally lowered onto a prepared bed of sand and soft soil (Fig. 3).

Although the duct route had been moved a considerable distance, not one of the 100 individual ducts were broken and a 5 in gap resulting at the manhole end of the duct route was easily taken up by moving a few ducts.

It has been estimated that direct savings of over £4,000 were achieved by slewing and lowering as against a complete diversion. In addition, considerable savings will result from the earlier start of the building operations. The successful conclusion to the work was achieved by close co-operation between all the parties concerned and shows that this method can be used in adverse conditions to obtain a satisfactory job.

J. ROBSON
W. T. WILLIAMS

South Eastern Region

Tonbridge By-pass

The £5½ M Tonbridge by-pass presented a complicated cable job which was one of the most difficult tackled by the area for some time. The biggest alteration was at Quarry Hill, Tonbridge, where the by-pass cut through the A26 road between Tunbridge and Tunbridge Wells in a 50 ft deep cutting. All the cables in this section had to be re-routed into ducts laid in a new bridge (shown in the Fig.) and extended on both sides of the bridge to link up with the existing duct routes. The duct work was co-ordinated with the road works over a period of more than two years, but it was not until February 1971 that the work became a critical part of the whole by-pass scheme. The ducts in the bridge were available early in March but the bridge had to be stressed, and cabling had to await the completion of this operation. All cables had been provided on both sides of the bridge, jointed, and pairs

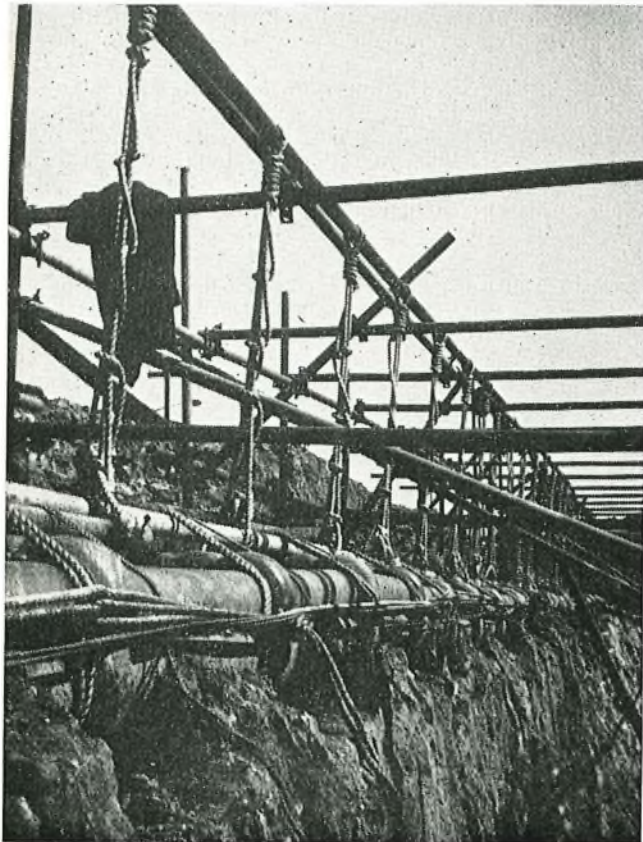
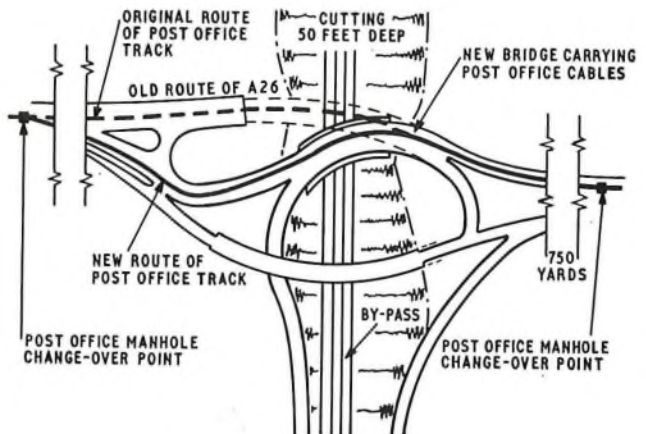

FIG. 2

identified and numbered at the changeover points. The final duct link-up on the Tunbridge Wells side of the bridge, which required a complicated change of formation, was completed by the end of March. Cabling was immediately put in hand and jointing of the final lengths proceeded. As soon as one cable had been jointed through to the changeover points, the cable was changed over. Cable recovery was done immediately the cables were changed over. The changeover involved some 3,800 audio pairs and 48 coaxial pairs with an additional 14,000 audio pairs and 180 coaxial pairs jointed. The job had another complication in that some of the cables had loading coils in the new section which had to be rebalanced into the new cables.

The final changeover was completed in the early hours of Saturday, May 1. The cabling gang had already been detailed

for the final recovery operation and by 1100 hours the last cable was recovered in the old duct-line where the old road was to be dug out to form the cutting for the by-pass. Earth movers and lorries were on site, and by midday the old duct-line was in a load of earth and rock some miles away down the by-pass. Cable recovery and re-pressurizing cables proceeded for some weeks, and all work was completed by the end of May. During the whole of the change-over, no circuits were reported faulty owing to working parties.

The co-operation of the other areas, the London Telecommunication Region and the regional network control-centre, enabled a difficult job to be completed ahead of schedule and resulted in a complimentary letter from the Kent County Council for our efforts.

F. PALIN

Associate Section Notes

Aberdeen Centre

The session this year started with a presentation dinner, held in a local hotel, in honour of Mr. R. T. Ross. Mr. Ross was chairman of this centre for 18 years and a presentation was made to him by our President Mr. J. H. W. Sharpe.

The first outing of the centre was to the British Aluminium smelter-plant at Invergordon where we had a comprehensive tour of the site accompanied by a very good description of the processes seen. This outing was thoroughly enjoyed by the party of 24 who attended.

J. H. McDONALD

Bristol Centre

The Bristol centre, which had been dormant for a couple of years, has come back to life with a full program. During 1971 the following talks and visits have been arranged.

- January: Crossbar Transit switching.
- February: A Talk on Old Bristol.
- March: Crossbar private automatic branch exchanges
- April: Annual general meeting and film show.
- May: Visit to the Post Office factory at Cwmcarn.
- June: Visit to the Police driving school at Devizes.
- July: Visit to the Royal Air Force station at Lyneham.
- September: A talk and demonstration of Hi-Fi.
- October: The work of the Bristol City museum by the museum's Director.
- November: The works of Brunel by the chairman of the Brunel Society.

A full program is in the course of preparation for 1972, and it is hoped that the membership of the Bristol centre can be increased beyond its present 150 mark.

The Bristol centre has adopted a policy which might be worth consideration by other centres with membership problems. Technician Trainee Apprentices (T.T.A.s) are offered honorary membership from the time they join the Post Office for their three years of training, after this time they will be given the opportunity to become full members.

H. PUNCHARD

Canterbury Centre

The 1971-72 session opened with a visit to Chislet Colliery on 11 September 1971. Since this visit was restricted to 11 members we are arranging a further visit in 1972. Our second event on 15 September 1971 was a talk entitled "Science and Archeology", a most interesting lecture delivered by our local expert Mr. F. Jenkins, Hon. M.A., F.S.A. who is in the Sales Division of the Canterbury area.

Two items that have given us cause for concern have occurred in recent months, firstly the resignation, owing to ill health, of our secretary, Mr. P. Godden. We would like to extend to Mr. Godden our sincere thanks for his hard work

on our behalf and to wish him a swift return to full health. Mr. P. Mould-Waller has stepped into the breach and his job as social and visits secretary has been filled by Mr. M. Wadey of Ashford. The second item was the fact that we had to withdraw from the technical quiz because we were not able to muster a team.

The annual general meeting was held on 1 October.

We are arranging an open forum meeting with the Telephone Manager and members of the Area Board. We urge members to watch the notice boards for date and venue.

It has given us much pleasure to see the forming of a National Committee and would extend to them our best wishes for a successful future.

J. MUSTON

Derby Centre

This centre has been active for some time and has enjoyed successful programs every year. However, no contribution has previously been made to the Associate Section Notes of the *Journal*.

Our current records go back to 1943 and, but for a short break between 1946 and 1954, a program has been produced every year, and our activities have been well supported. Below is a list of some visits and lectures which have been arranged during the years up to 1970-71. Perhaps it may help other centres when they come to formulate their programs.

Visits

Derby Cables; Pelapone Engines; Rugby radio station; Special Care and Treatment unit (Derbyshire Royal Infirmary); Toton marshalling yards, British Rail; Post Office Tower; Kodak Ltd, Wealdstone; Steel Peach and Tozer, Steel Works; British Rail Research Centre; A.E.I. Electronics Division; East Midlands airport; Brush Electrical Engineering; Pirelli Tyres, Burton-on-Trent; Ericsson Telephones, Beeston; M.G. cars; J. C. B. Excavators; Rolls-Royce, Ltd.; B.A.C. Weybridge; Farnborough air show; Marstons Brewery; Rolls-Royce cars; Pilkington Glass.

Talks

"The Traffic Aspect of Subscriber Trunk Dialling" by Mr. D. J. Brown, "Recent Developments on External Construction" by Mr. J. H. Saxby, "Appraisal and Promotion Procedure" by Mr. J. E. Porter, "Electronics in Telecommunications" by Mr. J. R. Pollard, "Explosives" by Dr. B. Shaw, "Radio Interference" by Mr. F. C. Ward, "The Work of the C.I.D." by Inspector W. Worth, "Making an Astronomical Telescope" by Mr. E. Phillips, "The Telephone Service and You" by Mr. N. Bagshaw, "Training-school Organization" by Mr. R. Eaton, "Metrication" by Mr. W. Wignall.

If any secretaries would like further information regarding the above visits or talks, please contact the Derby section.

We have held the annual general meeting, and the following officers have been elected for another year:

President: Mr. W. S. Morley; *Chairman:* Mr. G. Waywell; *Vice-Chairman:* Mr. P. Moreton; *Secretary:* Mr. J. A. Rice; *Treasurer:* Mr. M. Eaton; *Librarian:* Mr. M. Gregory; *General committee:* Messrs. P. Crossland, D. Sheldon, A. Hounsell, E. Hollands, D. Pratt, and P. Giles.

So far this session visits have been made to Johnson and Nephew, Wire Works; Derby Corporation Incinerator plant, and to the Radio Derby studios. We have also had the following talks, "Why Metals Break", by Mr. V. Wise, and "History and Preservation of Railways" by Mr. C. Rawlins.

The annual social was held at Belper at the beginning of January. The program for the rest of the session is as follows:

- 19 January: Visit to Ambergate Gas Works.
- 15 February: "Submarine Cables". A talk by Dr. P. R. Bray.
- 15 March: Visit to Post Office Factories, Birmingham.
- 13 April: Visit to English Electric-A.E.I. Machines Ltd. Rugby.
- 9 May: Visit to B.O.A.C. Aircraft and installations at Heathrow.
- 14 April: Annual general meeting

The Derby section would like to wish every success to the newly formed Nottingham centre and offer support and help if they require it.

J. A. RICE

Dundee Centre

The annual general meeting of this Centre took place in the Civil Service Club, Dundee on 20 March 1971, the guests of honour being the Associate Section President, Dr. P. R. Bray, the Telephone Manager of the Dundee area, Mr. A. F. Dollman and our Liaison Officer Mr. E. A. W. Page. This most successful event took the form of a dinner, followed by the meeting and included a presentation to Mr. A. W. Smart for his recent prize-winning paper entitled "A Look at a P.A.B.X. No. 6."

The Office bearers and committee were elected as follows:

Chairman: Mr. R. L. Topping; *Vice-Chairman:* Mr. R. C. Smith; *Secretary:* Mr. R. T. Lumsden; *Treasurer:* Mr. A. H. Vaughan; *Assistant Secretary:* Mr. A. W. Smart; *Committee:* Messrs. W. Bell, A. Dowie, G. K. Duncan, W. Hennessey, J. M. Low, G. Stephen, and M. Williamson.

Tribute was paid to Mr. D. L. Millar who has resigned from the post as Treasurer of the Associate Section.

The program for this session includes the following visits and talks:

Visits: Weights and Measures, Dundee; City Museum (old Dundee); N.E.L. East Kilbride.

Talks: "Preparation for An Interview" by Mr. H. C. Stevenson, Telecommunications Headquarters Scotland; "Island Communications" by Messrs. J. I. Murray and C. J. Macpherson, Telecommunications Headquarters Scotland; "The Growth of Dundee and its History" by Mr. W. Blain, and a members' slide night when it is hoped that members will show a selection of interesting slides and enter a best-slide competition.

We feel that this program, varied and with great potential, should appeal to members from all departments.

R. T. LUMSDEN

Glasgow Centre

At the annual general meeting, held on 7 May 1971, the following were elected to office.

President: Mr. J. Somerville; *Chairman:* Mr. J. McCallum; *Vice-Chairman:* Mr. W. Fotheringham; *Secretary:* Mr. R. I. Tomlinson; *Assistant Secretary:* Mr. R. W. Stevenson; *Treasurer:* Mr. K. Gordon; *Librarian:* Mr. N. Cochrane.

What should prove to be an exciting and varied 1971-72 program opened on 16 September 1971 with a lecture by Mr. W. Chatwin, the Deputy Telephone Manager of the Glasgow area, entitled "This is our Business". Mr. Chatwin explained in some detail the financial set-up within the British Post Office and brought home to all those present, the fact

that we are a business and must function as such. The lecture, which proved to be most interesting and informative, ended with a lively question and answer session.

In addition we have had the following program:

- 21 October: "Diamonds". A talk by Mr. H. J. Whitehead.
 - 18 November: A visit to National Engineering Laboratories, East Kilbride.
 - 16 December: "Power and Accommodation Services in a Large Telecommunications Complex". A talk by Mr. R. J. Morrison.
- We look forward to the remainder of the 1971-72 syllabus which includes one visit.
- 20 January: "Communications in the Army" by a Royal Signals Representative.
 - 17 February: "Preparation for Interview". A lecture by Mr. H. C. Stevenson.
 - 16 March: Visit to Dial House.
 - 20 April: "Crime Detection". Talk by a Detective Officer from the City of Glasgow Police.
 - 18 May: Annual general meeting.

R. W. STEVENSON

Guildford Centre

Tower Trophy Quiz

In the first round of the Tower Trophy Quiz against Ryde, the Guildford centre won by 46 points to 39.

Prior to the quiz, the team and supporters visited Britton Norman, and toured the Island. These arrangements were made for us by the Ryde Associate Section to which we would like to express our thanks.

A visit was made on the 26 August, to the Park Royal Guinness brewery by 36 members. We were given an excellent reception by Guinness and the visit was much appreciated and enjoyed by all who went.

On 16 September, there was an all day visit to the Nuclear Power station at Dungeness, which can supply up to 600 M watts. This was again a very interesting and informative visit.

A family film show was held in October.

Sheffield Centre

The annual general meeting was held on 19 May 1971 when the following officers were elected to serve for the 1971-72 session.

Chairman: Mr. C. B. Gray; *Vice-Chairman:* Mr. D. J. Sturdy; *Secretary:* Mr. J. Steggle; *Assistant Secretary:* Mr. K. H. Barker; *Treasurer:* Mr. A. E. Jewitt; *Committee:* Messrs. R. Newbould, P. Weston, S. Mitchell, W. Wilks, J. P. Cooney, C. W. Wragg, R. Pashley, F. R. Turner, F. Bough, D. Bowles, D. Ashton, and R. Heeley.

Following his recent success on a promotion board the retiring secretary Mr. D. Ashton did not seek re-election. We thank him for his efforts as secretary during the past 10 years and offer him good wishes for the future.

The following papers will be presented during the 1971-72 session: "Pulse Code Modulation," by Mr. J. F. S. Forster, of Telecommunications Headquarters; "Valves and Transistors, a Practical Outlook," by Mr. J. Hornsby; "Microwave Fundamentals," by Mr. M. Bennett; "The future of the Sheffield Telephone Area," by Mr. S. B. Watkins; Practical Aspects of "Traffic Engineering," by Mr. W. Kirkby, of Telecommunications Headquarters.

Film shows are also being arranged, but details are not yet available.

Visits are being arranged to the Post Office Factories Division, British Leyland Motor Corporation, B.O.A.C. and a local brewery. There will also be a coach outing to London.

D. J. STURDY

Southampton Centre

The centre's closing feature of the 1970-71 session was a visit to the British Broadcasting Corporation Television Centre at the White City. It was a most informative visit. We were shown into the studios, the technical rooms, watched a producer and staff at work and saw scenery being made.

During this quite speedy visit, to a very large centre, we were treated to a marvellous dialogue linking all that we saw to producing, staffing and financing a program.

Our year finished with the annual general meeting in late April supported by technical and other films. The centre wishes to thank Mr. Collins, the President, Mr. Luff and Mr. Wiltshire, Vice Presidents, for their support in the last year, and are pleased they have all accepted our invitation to stand next year.

The centre's committee for next year is:

Chairman: Mr. R. Genge; *Vice-Chairman:* Mr. A. Hutchings; *Secretary:* Mr. M. Short; *Publicity Officer:* Mr. G. Holyoake; *Treasurer:* Mr. E. Green; *Librarian:* Mr. K. Mann; *Committee:* Messrs. K. Hamerton, S. Parker, B. Roberts and D. Stephenson.

The new committee, during the summer months, set to work on a recruitment campaign and have increased the membership by 12 per cent. A questionnaire was sent to each member so that problems of various members could be considered when planning the new program. The first event of the year which was a contrast to the usual format, consisted of a mystery tour and social evening. This was enjoyed by 64 members and it is hoped other events of a social nature can be included in our program. Items already planned

for this year are visits to I.B.M. Hursley, Thorneycrofts Southampton, and a lecture "An Introduction to subscriber trunk dialling".

G. HOLYOAKE

Stirling Centre

The following program has been arranged for the 1971-72 session:

- 12 October: A visit to Bedlay Colliery, Glenboig.
- 4 November: A talk on Island Communications by Messrs. J. I. Murray and C. J. Macpherson.
- 7 December: Visit to the British Petroleum refinery, Grangemouth.
- 11 January 1972: A talk entitled "Radio-controlled Models" by Mr. G. B. Marshall.
- 10 February: A visit to the Linlithgow Distillery.
- 16 March: A visit to Dial House Glasgow.
- April: Annual general meeting.

When this item appears in print, part of the above syllabus will have been completed and I hope supported and enjoyed by members.

J. HANNAH

Post Office Press Notices

Laces Fully Operational this Week-end

The switch to computerised clearance and control that is speeding-up the throughput of incoming air cargo at London Airport was in September.

Then, the last of the 18 airlines involved in the scheme will begin to use the computers of LACES—the London Airport Cargo EDP Scheme, operated by the Post Office's National Data Processing Service (NDPS).

Britain is the first nation in the world to control incoming air cargo by computer: the LACES system puts Heathrow at least two years ahead of any other international airport.

The system began live running on August 23 and since then the airlines freighting through Heathrow have been connected on a progressive schedule. By September 26 LACES was in full operation, serving 18 airlines and HM Customs, and with connections to more than 60 freight-forwarding agents.

The LACES system was developed to meet a critical schedule—the contracts for hardware and software were placed only two years ago. It involved about 500 man-years of specialist effort by all concerned—PODPS who with H.M. Customs and the airlines designed the system requirements, International Computers Ltd, main contractors for hardware and software, Computer Sciences International who were responsible for the software system, and Cossor Electronics who supplied the visual display units. It is operated by PODPS on behalf of the airlines, forwarding agents, and H.M. Customs. Other countries are planning similar systems and the LACES scheme at Heathrow could well be the basis for an international airfreight data-processing network.

LACES drastically reduces paperwork and virtually eliminates manual calculation of complex sums. It makes goods available to customers faster, reducing the need for storage space. All users have instant information on the stages reached by every consignment passing through and it is easier to deal with discrepancies at once.

In terms of value landed Heathrow is the world's largest international air terminal and cargo arrivals are expected to rise considerably. The LACES real-time computer system makes the most efficient use of the new £23m cargo terminal facilities at Heathrow by transforming documentation and control of the swelling tide of cargo. It keeps constant check on imports, calculates Customs duty and other taxes, selects documents and goods for inspection and provides daily accounts and updated statistics for all its users.

Heart of the system is the PODPS centre at Harmonds-

worth, where the LACES computers are on duty day and night seven days a week, linked to the airport, three miles away, by Post Office lines. To communicate with them, there are more than 200 visual display units (v.d.u.) with keyboards, giving information on television-type screens in agents', airlines' and Customs offices and cargo sheds.

Using these v.d.u.s, airlines key into the computer information from the air waybill about expected consignments. The computer acknowledges each input within a few seconds. When consignments arrive at the cargo sheds v.d.u. operators read the air waybill number from each package and key the number into the computer. The storage location of each consignment is also keyed-in. Any difference between the packages expected and those received is noted by the computer, which automatically prints-out the information, enabling a swift check to be made by the airline.

Using records created from this inventory information the computer checks that each consignment is declared to H.M. Customs; these declarations are known as Customs Entries. It is the responsibility of each importer or his agent—either airline or shipping agent—to make Customs Entries for his consignments. For this, too, the v.d.u.s are used. On receipt of a Customs Entry the computer will check each item of information for credibility and clerical errors. Within seconds, any errors found will be sent back to the terminal for correction.

Once the information has been accepted the computer calculates all Customs duty, purchase tax and other revenue due and display the result on the screen. It gives provisional Customs clearance to some consignments and notification of this clearance is sent back to display screens. Then, after a specified time during which Customs officers are able to check the documents, the computer prints-out a suitable delivery authority to the airline.

The computer selects other consignments for Customs examination of documents or goods; selection criteria are determined by H.M. Customs and vary from time to time. When a consignment is selected for examination, the agent is notified on his display screen and H.M. Customs by computer print-out. After inspection the Customs officer keys-in the result, and advice of the result in the form of delivery authority or other disposal instructions is printed out for the airlines.

The system produces daily statements of importing agents' revenue accounts with H.M. Customs, and various statistical outputs.

Institution of Post Office Electrical Engineers

Annual Awards for Associate Papers, Session 1970-71

The Judging Committee having adjudicated on the papers submitted by the Local Centre Committees, prizes and Institution Certificates have been awarded to the following in respect of the papers named.

First Prize of £25:

G. D. Rudram, Technical Officer, South Eastern Centre. "The Small Electronic Exchange TXE-No. 2"

Second Prize of £10:

C. P. J. Knapman, Technical Officer, South West Centre, "Voice Frequency Remote Control System A."

Third Prize of £5:

W. J. McKittrick, Technical Officer, Northern Ireland Centre, "Craigavon Broadband System."

The Council of the Institution is indebted to Messrs. R. H. Adams, S. T. E. Kent and M. T. Turnbull for kindly undertaking the adjudication of the papers submitted for consideration.

Local Centre Secretaries

The following is a list of Local Centre Secretaries to whom inquiries about the Institution may be addressed. It would be particularly useful if members would notify any change in their addresses to the appropriate Secretary.

Centre	Local Secretary	Address
London	Mr. J. S. Gilroy	Telecommunications Headquarters, TD2.4, Procter House, 100-110 High Holborn, London WC1V 6LD
Stone-Stoke	Mr. R. V. Walters	Technical Training College, Stone, Staffs ST15 ONQ.
Eastern	Mr. R. A. Spanner	Planning Division (Plg D 3.2.2), Eastern Telecommunications Region, St. Peter's Street, Colchester, Essex.
South Eastern	Mr. J. M. Smith	Planning Division (PL/LT1.2), South Eastern Telecommunications Region, Greenville House, 52 Churchill Square, Brighton BN1 2ER.
North Eastern	Mr. H. Teale	Planning Division (PLE2.1.2), North Eastern Telecommunications Region, 36/37 Park Row, Leeds LS1 1EA
Northern	Mr. B. O. Slater	Telephone Manager's Office, Swan House, Pilgrim Street, Newcastle-on-Tyne NE1 1BA.
Birmingham	Mr. D. M. Clement	Planning Division (PL/CPA 1), Midlands Telecommunications Region, 95 Newhall Street, Birmingham B3 1EA.
East Midland	Mr. D. W. Sharman	Post Office Telephones, Essoldo House, 87 Granby Street, Leicester LE1 6FD.
North Western (Manchester and Liverpool)	Mr. S. Hart	Planning Division (Plg 1.2.1), North Western Telecommunications Region, Bridgewater House, 60 Whitworth Street, Manchester M60 1DP.
North Western (Preston)	Mr. J. W. Allison	Post Office Telephones, Clifton Road Depot, Marton, Blackpool FY4 4QD.
Wales and the Marches	Mr. R. J. Jones	Planning and Works Division, Telecommunications Headquarters, Wales and The Marches, 2 Plymouth Street, Cardiff CF1 4XZ.
Scotland East.. .. .	Mr. D. L. Stevenson	Service Division (S1.1.4), Telecommunications Headquarters, Scotland, Canning House, Canning Street, Edinburgh EH3 8TH.
Scotland West	Mr. D. M. Dickson	Telephone House, Room 316, Pitt Street, Glasgow C2.
South Western	Mr. C. W. Read	Planning Division (PL 1.5.1), South Western Telecommunications Region, Mercury House, Bond Street, Bristol BS1 3TD.
Northern Ireland	Mr. W. J. Gawley	Telephone Manager's Office, Churchill House, Victoria Square, Belfast BT1 4BA.

A. B. WHERRY
General Secretary

Post Office Press Notices

Cheaper Data by the Dozen

The new Dataplex Service 110, designed to multiplex up to 12 terminals operating at up to 110 bits per second into a private long-distance circuit, was launched commercially by Post Office Telecommunications on September 1.

Each circuit of a Dataplex Service 110 installation can, at any one time, connect to a remote time-sharing bureau up to a dozen calls from customers in one telephone area who use the Datel 200 data-transmission service on the public telephone network. The customer is connected to a bureau many miles away for two-way transmission of digital data at local telephone call charges instead of at trunk rates, so that Dataplex Service 110 provides a computer bureau with an economical means for extending its catchment areas.

Three sets of Dataplex Service 110 equipment have been on trial in preparation for the service becoming generally available. The Post Office already has about 40 orders from bureaux for the new service.

Annual rentals payable by a bureau for a 12-channel system range from £5,600 to cover a radial distance of up to 35 miles between bureau and customer's local call exchange, to £7,350 to cover distances over 300 miles. The connection charge is £750. Lower charges apply for a six-channel system.

Manual Telephone Exchanges—only 80 left

Only one in 75 of Britain's telephone exchanges is now manually operated.

At the end of August 1971 there were 6,119 public telephone exchanges in the U.K. telecommunication network. During the previous twelve months the Post Office had converted 21 exchanges to automatic working, leaving only 80 operated manually.

Automatic telephone service is now available to 98.8 per cent of all exchange connections in the U.K.

First Equipment Order for Mondial House International Telephone Exchange

A substantial order for switching equipment to be installed at Mondial House—the new International telephone exchange now being built in the centre of London—has been placed by the Post Office.

Costing over £10 million, the equipment will be of British crossbar design with register control and will be housed in the new £8 million building, due to be completed in 1972. When the exchange comes into operation during 1974 about a quarter of the equipment now on order should be in service.

The contract for this initial equipment has been placed with the Plessey Telecommunications. It is the largest single contract ever awarded by the Post Office for exchange equipment.

The equipment will form the initial stage of a switching unit which will ultimately handle about 8,000 international telephone circuits.

Mondial House will connect United Kingdom customers to numbers in all parts of the world and the great majority of calls will be dialled direct. The exchange will also connect calls from abroad to telephones in this country and will route some calls between countries in Europe and the rest of the world. Ultimately the exchange will connect up to 180,000 calls an hour using about 18,000 international circuits over cables and satellites. By 1975 it will be connecting about 20 million calls a year, about one-third of the total of U.K.-International calls.

Mondial House—one of Europe's largest international telephone exchanges—will be the third international automatic telephone exchange to be built in the U.K. The other two, also in the City of London, are the existing exchange in Faraday Building, Queen Victoria Street, and a new exchange now coming into operation in the Wood Street Building, London Wall.

Construction work on Mondial House has now reached first floor level at the 2½-acre site on the bank of the river Thames close to Cannon Street railway station. When complete it will stand 150 ft high.

The Mondial House International Telephone Service Centre (ITSC) now under construction will complement and greatly extend the international dialling facilities currently provided by Faraday Building and Wood Street in London. Before 1963 all overseas telephone calls were handled by operators, who recorded the call details for subscriber charging and international account clearing. In 1963 Faraday Building, with 1,050 incoming and 1,200 outgoing circuits, inaugurated International Subscriber Dialling in the U.K. Subscriber charges were registered direct on the subscriber's meter and magnetic drum storage was provided for international accounting.

To meet the spiralling demand for international calls the Wood Street international exchange was then put in hand and is being progressively brought into service with an ultimate total of 8,400 inland and international circuits. Now Mondial House with an ultimate 20,000 circuits—of which 7,500 will be provided under this contract—will begin to be available in about two years. Calls requiring operator completion or assistance will be handled by the existing Faraday Building and Wood Street manual boards.

Mondial House ITSC will be in many respects similar to Wood Street ITSC, which is also a Plessey Telecommunications project. There will be an International Switching Centre (ISC), International Accounting and Traffic Analysis Equipment (IATAE) and an International Transmission Maintenance Centre (ITMC).

The ISC, on the fourth floor, will consist of some 830 enclosed racks mounting 16,000 shelves of "5005" Crossbar System equipment. The 10,000 circuits in and 10,000 out will be accessed via five switching stages on a 4-wire basis. While centralised control applies generally, the 5005 principle of "self-steering" of calls through the switching stages provides a measure of control decentralisation. As the circuits work into many different national and international systems and transmission media, ancillary equipment has to be appropriately associated for each call to cover the differing signalling and checking requirements.

The IATAE, on the third floor of Mondial House, will be rather more advanced than that for the smaller Wood Street installation. Its duplicated computer complex interlinked with the switching complex will allow supervision of all calls for accounting, traffic analysis and performance checking purposes. The functioning of the IATAE will be controlled by software programs which incorporate many routine and self-checking facilities. Data are stored on magnetic and paper tape, with print-out of records automatically or on demand as required.

The ITMC on the third floor is an essential part of the set-up in ensuring that the high revenue-earning and prestige international circuits have maximum availability and efficiency. A series of maintenance consoles will allow technical staff to keep a close watch on live or test calls with regard to switching, transmission and signalling performance. From the consoles, the staff have access to the exchange circuits via a special 5-stage network, with a range of testing devices at their disposal.

Installation will proceed on a carefully planned schedule to ensure prompt and progressive service availability of the equipment. Cabling will be run-in on suspended ironwork in advance of the equipment racks which will be shipped to site fully equipped and wired. The exchange installation will proceed in steps so that functional groups of equipment can be progressively tested and cleared, using advanced test gear of the computer-controlled type.

Second Giant North Sea Cable—Laying Begins

Laying of the second of four giant cables that will more than double the number of the U.K.-Europe telephone circuits in use started with work on the shore end in September 1971. This new cable will carry 1,260 telephone circuits 64 nautical miles to Ostend. It has two-way transistorized repeaters at intervals of just over seven miles.

First of the four North Sea cables (all of the same capacity) was the Winterton (Norfolk) to Fedderwarden link with the Federal Republic of Germany, laying of which has now

finished. This cable runs under the sea for 285 n/miles and has 45 repeaters.

The Broadstairs-Ostend cable is expected to be ready for service soon. It will be followed by another between Aldeburgh (Suffolk) and Domburg in the Netherlands (92 n/miles, 13 repeaters) and a fourth from Scarborough to Thisted in Denmark (381 n/miles, 60 repeaters). The overall cost—in the region of £7 million—is being borne by the British, Belgian, Dutch, Danish and German administrations. The cables and repeaters are being supplied and laid by Standard Telephones and Cables Ltd.

The project stems from a decision of a seven-nation London conference in May 1967, held on the initiative of the British Post Office. At the end of that year there were just over 1,900 cable circuits in operation between Britain and the Continent; cables completed since then have brought the total to 2,880 circuits, which will rise to 7,920 when these four new cables come into use. Together with 2,160 microwave circuits now available and others planned, this is expected to meet telecommunication needs between the U.K. and the Continent for the next five years: traffic—including telephone calls, Telex messages and computer data transmissions—grows at about 14 per cent per year.

The cables are coaxial with a centre conductor consisting of a stranded steel core lapped with copper tape, surrounded by a polythene dielectric 1.47 in (37 mm) in diameter and carrying a wrapped-round aluminium-strip outer conductor. This is enclosed in an outer polythene sheath with a waterproof serving and wire armouring for mechanical protection.

Multiple-circuits operation is achieved by frequency division multiplexing at 4kHz intervals. Outgoing circuits from the U.K. occupy the base band of 312 to 6,016 kHz in each cable; return circuits (carried on a principal carrier of 14,012 kHz) occupy the upper band of 7,996 to 13,700 kHz the carrier and upper sidebands being suppressed.

The repeaters, which have an amplification of 43.15 dB, are powered in series from a constant current source at each end, feeding a direct current of 495 mA into the cable, establishes a potential drop of 20 V across each repeater.

The terminal equipment, also supplied by Standard Telephones and Cables, consists of high-frequency transmitters, super group translators (the multiplexing equipment), circuit monitors, repeater monitors and the power feeder.

Face to Face Hundreds of Miles apart. Post Office Launches Confravision

Confravision, the world's first purpose-built system of conferences-by-TV, was launched by Mr. Edward Fennessy, Managing Director, Post Office Telecommunications, and is now available to the business world.

This time-and-cost-saving service, unique to Britain, will enable conferences to be held in purpose-built studios between two groups of people in complete privacy over Post Office video circuits.

At the inaugural ceremony, Mr. Fennessy opened studios in London, Birmingham, Bristol and Glasgow simultaneously. A fifth studio in Manchester is to be opened later. Cities which are key centres in Britain's telecommunication network were chosen to provide the foundation of the system.

"The Post Office is quite rightly proud of a world first in Confravision," Mr. Fennessy declared. "It will prove a real aid to business. The nature of business executives' responsibilities requires that they spend much time in travel. Confravision provides the facility for bringing together people, hundreds of miles apart, face to face in working situations."

Turning to the charges for Confravision—£120 per hour up to and including 125 miles; £180 per hour over that distance—Mr. Fennessy pointed out: "This is a luxury service when we compare the charges with other Post Office telecommunication facilities but when these are measured against the cost of executives' time, travel and expenses, the comparison is attractive. We are in an era when we are closing the time separation of communicators, when business demands a decision today rather than tomorrow and equally a decision without leaving town."

From today, for the first three months, the Post Office is offering users a trial of the service for a nominal fee of £20.

On the basis of operating experience the Post Office will be deciding whether to extend Confravision to other cities.

End of Historic Herts Radio Station

The lease on the Post Office radio station at Slip End, Herts, ended in September, marking the end of 42 years' service during which the station took part in many historic events. It opened the first public telephone service with the U.S.A., took part in the big broadcasts that preceded the King's Christmas message in the 'thirties, monitored radio transmissions from the first Sputnik, and maintained communication with lone yachtsman Robin Knox-Johnston, winner of the round-the-world race.

Slip End radio station went out of service in May and most of the staff have already moved to other Post Office jobs; a four-man recovery team remains on the site, three miles from Baldock on the Royston road, to clear external plant.

The station came into operation in 1929 when the radio-telephone service to New York was opened, receiving high-frequency signals from Lawrenceville, U.S.A.: outward transmission was from Rugby to Netcong, N.J.

In the years that followed, the use of short-wave radio-telephony increased rapidly to other countries and to ships at sea. This service was started for the great liners of the era including the *Ile de France*, *Empress of Britain*, and later, the *Queen Mary*.

One of the station's first jobs was to listen for any reply to a telegram transmitted to the Moon from G-BR Rugby, handed in and paid-for by an eccentric.

Since 1938 Slip End has acted as a frequency checking station, monitoring domestic radio transmissions for accurate maintenance of frequencies and co-operating with other countries in tracing interference and maintaining trouble-free operation of international radio-communication. This work has now been taken over by the Ministry of Posts and Telecommunications.

Radiotelephone traffic at Slip End reached its peak in the 'fifties, when the station was working to 40 different countries and 100 ships a day. Traffic with other countries declined with the laying of the first transatlantic telephone cable and fell off sharply as other transoceanic cables, and then communication satellites, were brought into service. Meanwhile, ship-to-shore traffic continues to increase.

Traffic with other countries formerly handled at Slip End now passes through Post Office radio stations at Bearley (Warwickshire) and Somerton (Somerset) while the traffic with ships at sea is handled at the Burnham (Somerset) station, bringing the long-range maritime services under one roof.

Laying Begins of Channel Cable—Britain's Largest

Laying of the shore end of a 1,380 circuit telephone cable 100 nautical miles to Guernsey, C.I., started at Bournemouth in October. This will be the largest capacity submarine telephone cable in home waters. The shore end at Guernsey was laid earlier. When the Bournemouth shore end is completed, further work will be deferred until the end of February, to avoid working during the winter storm period.

The new cable is identical in construction to the four giant North Sea cables being laid between the U.K. and Belgium, Holland, Germany and Denmark. Terminal equipment for the Bournemouth-Guernsey route, which, like the cable, is supplied by Standard Telephones and Cables Ltd, will exploit the cable's maximum capacity. The link is due to come into service on June 1, 1972.

The main sea cable is coaxial with a centre conductor consisting of a stranded steel core lapped with copper tape, surrounded by a polythene dielectric 1.47 in (37 mm) in diameter and carrying a wrapped-round aluminium-strip outer conductor. This is enclosed in an outer polythene sheath with a waterproof serving and wire armouring for mechanical protection.

Multiple-circuit operation is achieved by frequency division multiplexing at 4kHz intervals. Southwards circuits occupy the base band of 312 to 6,016 kHz in the cable; return circuits (carried on a principal carrier of 14,012 kHz) occupy the upper band of 7,996 to 13,700 kHz, the carrier and upper sidebands being suppressed.

The 14 repeaters, which have an amplification of 43.15 dB, are powered in series from a constant current source at each end, feeding a direct current of 495 mA into the cable, to establish a potential drop of 20 volt across each repeater.

The terminal equipment consists of high-frequency transmitters, supergroup translators (the multiplexing equipment), circuit monitors, repeater monitors and the power feeder.

Ongar Radio Station gets 'Heart Transplant' at 50—Ready for next Half-century

After 50 years' service, the Post Office radio station at Ongar, Essex, has now been re-equipped with £¼ million worth of the latest transmitting equipment. By installing the new equipment in phases, the Post Office has ensured that the station's services—telephone, telegraph and facsimile transmissions to more than 25 administrations in eastern Europe, the Middle East, Africa, and South-East Asia—have not been disrupted during the re-equipment programme.

Mr. Keith Hannant, Director of Post Office International and Maritime Telecommunications, who formally reopened Ongar radio station, said: "This ceremony is almost a combined birthday party and heart transplant." Pointing to the station's long tradition of providing radio-communication links to many parts of the world he added: "Fifty years have passed since the first transmitters with their primitive circuitry were built at Ongar, when the chief safeguards against failure were the senses of smell, hearing and sight of the engineer."

The new equipment—a total of 23 self-tuning high-frequency radio transmitters—has increased the capacity of the station to 30 modern high-power units capable of world-wide operation. "This," Mr. Hannant declared, "will make Ongar one of the most up-to-date of radio stations of its kind in the world. The efficiency of the new equipment can be demonstrated by the ease and speed with which a change of frequency and re-selection of aerial can be made at the press of a button"—a declaration which he underlined by pressing a button on the central control panel. In less than 20 seconds, the transmitter had tuned itself, loaded itself to the correct output power, and begun broadcasting a greetings message to the world.

In the development of the Station over 50 years, high-frequency transmitters have been installed in unattended buildings and operated remotely. This allows the aerials to be distributed uniformly over the 730-acre site. The new arrangement provides fully unattended operation of four groups of transmitters in three buildings, with central control in the building with two transmitter groups. Transmitter outputs are connected to appropriate aerials through automatic crossbar exchanges.

There are 23 self-tuning transmitters: 16 of 10 kW, type QT8A/1, covering 2.5 to 28 MHz; seven of 30 kW, type QT3A/3, covering 4 to 28 MHz. A further seven 30-kW units are type DS1 3D, with remote wave changing between six preselected frequencies. Transmitters can be interchanged between the two groups in the main building.

All the transmitters act as linear amplifiers with negative feedback and automatic gain control and operate only when driven by an input signal. This consists of the carrier at the appropriate frequency, modulated according to the transmission mode needed—double side-band, single side-band, independent side-band or frequency shift keying. The self-tuning transmitters lock on to the carrier frequency in two stages—coarse tuning and fine tuning—using discriminating circuits and servo motors to drive the tuning components. The overall gain of the transmitter is adjusted automatically to develop the rated output power on receipt of an input signal of 0.030 watts.

The carrier frequency is generated by frequency synthesisers which produce an output from 1.6 to 30 MHz in 100-Hz steps. The synthesisers operate from one of three 100-kHz oscillators which provide a base frequency, stable to better than 1 part in 10⁹, and this is then modulated by the message signal.

There are 34 directional aerial arrays. Aerials for telephone and telegraph services are usually two-tier rhombics on 150-ft masts. The upper tier gives the low-angle radiation essential for frequencies below 13 MHz, while the lower tier covers the higher frequencies. Log-periodic aerials, with their characteristic wide horizontal angles and high back-to-front ratios, are used for facsimile transmission because this is often made to several countries simultaneously.

European Data Communication—Agreement signed for Market Study

Following discussions within the CEPT (Conférence Européenne des Administrations des Postes et des Télécommunications) the telecommunication administrations of 15 European countries meeting in Stockholm have signed an agreement to commission a European study of data-communications requirements over the next 15 years. Fourteen of these countries have contracted PA International Management Consultants of London to carry out the study, and the fifteenth—Italy—has signed a separate but related contract with an Italian company, Italsiel.

This project is unique in the history of European telecommunication administrations and is probably the largest and most comprehensive telecommunication market-research study ever carried out.

The administrations sponsoring this study, which will take about a year and cost 7M Swedish crowns, said in a joint statement that they fully recognise their obligation to forecast and provide for the future data-communication demands of their customers. "This study is evidence of a common purpose between the European telecommunication administrations, and a recognition that the demand for data services is growing rapidly, is international in character, and is closely integrated with the development of automatic data processing. In this respect, computers and communications are becoming more closely associated and the suppliers of each must co-ordinate their activities if the customer is to benefit. Since the operations of both manufacturers and customers are spreading across national boundaries, it is essential for the telecommunications administrations to think more and more in international terms. This study marks an important beginning in respect of data communications."

The prime objectives of the study, the statement said, are to establish:

"The volume, nature and future characteristics of activities giving rise to the need for data communications, and forecasts for up to 15 years ahead of data terminal characteristics and numbers.

"These objectives have been set in order to provide basic future planning information for the various administrations.

"The study will relate information and expert opinion from a wide variety of sources. One of the important inputs to the work will be a very large market research programme among the current and imminent users of data communications. Other inputs will come from the experience and past work of Quantum Science Corporation Inc. in America, a subcontractor to PA Management Consultants for this study.

"The major outputs from the work will be:

future customer requirements;
future data traffic flow (both within and between the sponsoring countries, to North America and to other main centres of the world);
future developments in data processing systems.

"These will be brought together in a concise way to form a summary of the European data communications market. Results are expected in 1973."

The 15 countries meeting in Stockholm are: Belgium, Denmark, Finland, Federal Republic of Germany, Iceland, Ireland, Italy, Luxemburg, Netherlands, Norway, Portugal, Spain, Sweden, Switzerland and the United Kingdom.

Overhauling Time

After eight years' solid day-and-night service answering millions of calls for the right time every week, the Post Office Speaking Clocks are being overhauled. Work on the two clocks of the London installation, which provides service for southern Britain and standby service for northern Britain, started in September and should be completed early this year. Similar operations then begin on the two Liverpool clocks which serve northern Britain and provide standby service for the South.

At present, the two clocks of the Liverpool installation are providing the main service for the whole country, with a new single clock temporarily installed in London as standby. This

clock will provide standby service from Liverpool when the two London clocks return to service and the Liverpool clocks are being overhauled. This ensures that the Speaking Clock service—oldest and most popular of all Britain's telephone information services and currently attracting calls at the rate of nearly 300 million a year—continues without interruption.

The announcements to be heard after the overhaul will be fresh recordings from the master tape made in 1963 by the Post Office's "Golden Voice" girl, Miss Pat Simmons, when the new-design clocks—using magnetic drum recordings instead of glass discs—were installed.

Direct Telex Dialling to USA

Subscriber dialling to all telex numbers in the U.S.A.—except 90 in New York—is now available to U.K. customers with the opening of automatic service to 41,000 lines on Western Union's TWX network.

About 10,000 calls a month are made to TWX lines from the United Kingdom. Call charges are 75p a minute or part of a minute, and there is a one-minute minimum.

Subscriber-dialled telex between Britain and the U.S.A. was first introduced in 1964, and U.K. customers now make 140,000 telex calls to the U.S.A. a month.

To make an automatic telex call overseas the customer dials a code for a London exchange and then types on the teleprinter the code and digits of the number he requires.

A Million more 'Phones— now nearly 15½M

There were nearly 15½ million telephones in use at the end of September 1971—over a million more than at the same time last year. The total of live telephones in the homes and workplaces of Britain showed a 3½ per cent increase in the six months to September 30, rising by 518,695 to a national total of 15,497,446. This compares with 14,448,076 telephones in use a year earlier.

Multi-purpose Telecommunications Centre for South London—most comprehensive in the country

A £7.5 million multi-purpose telecommunications centre is to be built on a three acre site in Vauxhall, South London, between South Lambeth Road and the main Waterloo-South railway line. It will house:

- An international telex exchange which will be capable of handling about 65,000 calls in the busiest hour of the day to some 110 countries within the first three years of operation;
- an inland telex exchange to serve 36,000 London customers and function as a trunk centre for many thousands of telex customers in the South-East of England;
- telephone switchrooms employing up to 500 telephonists handling more than 30,000 calls a day;
- a telecommunications service centre operating as a base for 350 engineering staff and 100 vehicles employed on installation and maintenance.

These four projects, each of major importance, will be combined within two linked buildings—a five-storey podium block and a 15-storey tower block—to form the largest and most comprehensive telecommunications centre in the country.

It will be built by Taylor Woodrow Ltd and will occupy the site of the former Brands Essence factory (well known to Southern Region rail travellers). The old buildings have been demolished. Construction work has just begun and will be completed in 1974 when the installation of equipment will begin with the expectation of becoming operational early in 1976. The centre will be called Keybridge House (embodying reference to the teleprinter key and the telecommunications "bridge" provided by the centre) and the development will provide a floor area of over 770,000 square feet gross.

Because the site is within a few hundred yards of the River Thames, the basements (descending to 40 feet below ground level) will be constructed with a diaphragm wall system to provide the external retaining support and act as a water-proof barrier. A reinforced concrete flat slab and column construction will be used throughout with two feet square "soft-infill" between reinforced concrete ribs to allow maximum flexibility in obtaining holes for future cabling.

The buildings will have external concrete surfaces finished in exposed spar-aggregate. All windows will be double glazed to provide thermal insulation and reduce sound from road and railway.

A controlled system of cooled air ventilation will deal with the heat generated by apparatus to be installed. Ventilation air will be taken from central air units on the podium and tower roofs and distributed through vertical ducts around the building. As some apparatus gives off great heat, additional air handling units will be housed in the vertical ducts to provide cooling and increase the ventilation locally. These ducts, with their metal cladding together with concrete ducts for electrical services, will provide dominant external features.

Solar gain from large glazed areas will be dealt with by directing cooled air down window faces during warm weather. These air streams will be warmed in cold weather, and controlled automatically.

Heating of both the podium and tower blocks will be provided by a common oil-fired plant. Lighting throughout will be fluorescent. There will be 12 lifts of various kinds for passengers and heavy goods.

The additional international telex exchange capacity to be provided initially in Keybridge House, together with the existing international telex exchanges located at Fleet Building (in the City), and St. Botolph's House (Houndsditch), will cater for the expected massive growth of international telex calls up to the late 1970's.

On current forecasts, the total volume of international telex calls from United Kingdom customers is expected to rise from the current level of 25 million calls a year to 81 million calls a year by 1978 and that at the same date incoming telex calls will rise from 22 million to 73 million a year.

Practically all these calls will be switched automatically—already 95 per cent of all telex calls from this country are dialled by the customer.

Keybridge House will be the switching centre for international telex calls to and from the majority of provincial customers and those in the western and southern parts of London. It will also provide automatic transit connection for telex calls to and from other countries via London. By 1978 Keybridge House will be connected by about 9,500 international telex circuits routed over long distance submarine cables, over high frequency radio channels and by satellite to some 110 countries, and will be handling international telex calls at the rate of about 65,000 calls during the busiest hour of the day.

Later development of the switching facilities at Keybridge House will cater for the further growth of the international telex service expected during the 1980's.

The new inland telex exchange in Keybridge House will cater for customers in South Central, South, South-West, West and North-West Telephone Areas of London. Initial equipment will serve some 10,000 subscribers and will be augmented as required to serve 36,000 customers eventually.

Existing telex installations in London are connected to the exchanges in Fleet Building and St. Botolph's House. The number of London telex users is growing rapidly and over the next 10 years the Post Office expects the number to increase fourfold to 48,000.

Some 5,000 subscribers' installations on the western side of London that will have been connected to Fleet Building by 1976 will be transferred to Keybridge House leaving equipment at Fleet Building free to be used to meet growing demands for telex service from Central and North London. Equipment will also be installed for connecting telex calls from customers in most of the South-East of England. This through-routing equipment will handle 15,000 calls an hour to start with, rising ultimately to 40,000 calls an hour.

Within the tower block there will be two telephone exchange switchrooms where operators will handle calls from Battersea, Pimlico, Nini Elms, Brixton and Vauxhall districts in the South Central Telephone Area. Telephonists here will work at modern design switchboards that look like office desks and are equipped with key switches and push buttons instead of with plugs and cords. Up to 500 telephonists will be employed to handle more than 30,000 calls every 24 hours when the switchrooms are fully operational.

Opening these switchrooms will permit the Post Office to

close switchrooms in the exchange at Greencoat Place, S.W.1, which are approaching the end of their useful life. The space vacated there will later house automatic equipment to serve customers in the locality.

Housed within the Keybridge House complex will be a telephone service centre—a depot from which more than 300 engineering staff will go out to lay or repair underground cables, to install telephones, switchboards and other telephone equipment in customers' premises, and to repair faults. A garage below ground level will house nearly 100 engineering vehicles and there will be storage space for cable drums, manhole frames and covers, ducts and other equipment.

At ground and first-floor level there will be storage space for hundreds of items in daily issue to field staff and a workshop where up to 10,000 telephones a year can be overhauled. The yard outside will have fuel pumps and a vehicle washing bay.

Exchange Power Goes Modular

A new power system which could save the Post Office £1½ million a year is under working trial at Chessington (Surrey) telephone exchange.

Developed entirely by Post Office engineers, the unique new system of low-voltage D.C. supply uses modular power units which can be linked together. This means that instead of having to equip new exchanges with power plant large enough to provide for the forecast load of the next 20 years, the Post Office can install plant in stages to match exchange growth.

The new modular plant also keeps standby batteries continuously charged. Eliminating periodic recharging cuts down on labour for maintenance and lengthens battery life.

At present, most exchange power plants cannot be extended. Plant installed in a new exchange has to cover the load foreseen for twenty years later, so that at first too much capital is tied up and there is the possibility that the plant could either be outgrown by the exchange or remain underloaded. Telephone exchanges are powered from the public mains supply, transformed and rectified to provide direct current at various voltages—to switching equipment at 50

volts positive or negative to earth, electronic register-translators at 30-volts negative, line transmission systems 24-volts negative, signalling systems 18-volts positive and negative, and telegraph 80-volts positive and negative. Lead-acid batteries in parallel with the rectifiers provide an immediate standby if the mains fail.

Up to 1960, batteries were installed to give a 24-hour reserve. Then the Post Office decided to provide a five-day standby by installing diesel alternators in all telecommunication buildings except the smallest exchanges, and reduce battery capacity to a one-hour reserve at peak load.

This policy change paved the way for modular plant, together with another P.O. decision—that all telecommunication systems installed after January 1975 would operate on a single D.C. supply of 50 volts negative to earth, regulated at source between 46 and 52 volts, with other voltages derived from built-in regulators or inverters. This makes it possible for the modular concept to embrace the whole system—public supply, standby sets, D.C. power plants and distribution.

Heart of the concept is a direct-current system based on fully automatic, self-contained supply modules, each with rectifier cubicle and 25-cell battery. A new exchange would go into business with one module and a standby rectifier in its own cubicle, and usually up to three modules would be added as the exchange load grew. The modules are planned in 10 ratings, from 30 amps to 2,000 amps, for use in multiples up to 8,000 amp total load.

In the exchange of the future, modules would be solidly connected to a fully insulated busbar, feeding load-unit groups of exchange equipment by cables from fused take-off points. Racks of equipment would also be fused.

The plant in operation at Chessington—a local exchange with Strowger equipment—consists of two 200 amp modules and a 200 amp standby. Early next year similar plant is to be installed on trial at the Redhill group switching centre to establish whether it is practicable to supply two completely different kinds of telecommunication equipment—in this case Crossbar switchgear and frequency division multiplexers operating on the new 50V standard—from a common power plant.

Copyright

The entire contents of this Journal are covered by general copyright, and special permission is necessary for reprinting long extracts, but editors are welcome to use not more than one-third of any article, provided that credit is given at the beginning or end, thus: "From *The Post Office Electrical Engineers' Journal*."

The Board of Editors is not responsible for the statements made or the opinions expressed in any of the articles or the correspondence in this Journal, unless such statement is made specifically by the Board.

Subscriptions and Back Numbers

The Journal is published quarterly, in April, July, October and January, at 21p per copy: 31p per copy including post and packing (£1.24 per year) (3 dollars Canada and U.S.A., per year). Back numbers will be supplied, if available, price 24p (34p post paid) per copy. January and April 1969, October 1968, and all Journals earlier than July 1967 (except January and October 1966) are no longer available. Orders, by post only, to *The Post Office Electrical Engineers' Journal*, 2-12 Gresham Street, London, EC2V 7AG.

Employees of the British Post Office can obtain the Journal through local agents.

Binding

Readers can have their copies bound at a cost of £1.87½p plus 24p (40p overseas) return postage, by sending the complete set of

parts, with a remittance to Press Binders Ltd., 4 Iliffe Yard, London, S.E.17.

Remittances

Remittances should be made payable to "*The P.O.E.E. Journal*" and should be crossed "& Co."

Advertisements

All correspondence relating to advertisement space reservations, copy, proofs, etc., should be addressed to the Advertisement Manager, *The Post Office Electrical Engineers' Journal*, 2-12 Gresham Street, London, EC2V 7AG.

Communications

With the exceptions indicated above, all communications should be addressed to the Managing Editor, *The Post Office Electrical Engineers' Journal*, 2-12 Gresham Street, London, EC2V 7AG.

Model Answer Books

Books of model answers to certain of the City and Guilds of London Institute examinations in telecommunications are published by the Board of Editors. Details of the books available are given at the end of the Supplement to the Journal.

Free for all



This offer applies to Post Office Design Engineers and Technicians only.

To RCA Solid State—Europe, Sunbury-on-Thames, Middx.

Please send me—entirely free of charge—a copy of:

- Linear Integrated Circuits Manual (400 pages) : design and application principles (formerly £1.30)
- RCA COS/MOS Integrated Circuits Manual (150 pages) : complementary symmetry/ metal oxide semiconductors (formerly £1.00)
- Transistor, Thyristor and Diode Manual (650 pages) : newly revised edition, SC-15 (formerly £1.30)
- Power Transistor Manual (100 pages) : for high speeds, voltages and currents (formerly £1.05)
- RCA Power Transistors :
- 8-page guide, RFT-700G
- 24-page directory, PTD-187B

RCA Digital and Linear Integrated Circuits :

- 8-page summary, DCT-177
- 40-page guide, CDL-820C
- RCA Solid State Product Guide : 48 pages, SPG 201G
- Solid State Power Circuit Modules and High-Power Arrays.

NAME _____

ADDRESS _____

Offer closes 29th February, 1972.

RCA
Solid State—Europe

**the GPO
are proud to serve
55 million people**

**WHITELEY
are proud to serve
the GPO**

The development and manufacture of telecommunications equipment requires forethought, research, technical expertise and a great deal of co-operation. Whiteley of Mansfield have been providing these services to the G.P.O. and Industry for many years, producing anything from a control knob to complete electronic and telecommunications equipment.



**WHITELEY ELECTRICAL RADIO CO. LTD., Mansfield, Notts, England. Tel. Mansfield 24762
London Office: 109 Kingsway, W.C.2 Tel. 01-405 3074**

Don't plan your cable network to meet the next 20 months. Plan it to meet the next 20 years.

Better still, let us plan it.

Planning a successful cable network is rather like planning a successful party. You cater not only for who you've invited, not only for who's bringing a friend, but for whose friend is bringing a friend.

No one's made us more aware of this than our customers.

That's why we produce one of the most comprehen-

sive ranges of modern telephone cables anywhere in the world. Dry core, plastic and coaxial.

That's why we're always experimenting to find new



cable compositions with even greater capacities.

And that's why the service we offer is not restricted to the manufacture of cable. We also plan complete cable networks and install them. Offer technological advice about them.

Now why should you do three times over—in 5, 12 and 20 years' time—what we can do for you now?

Marconi Tropospheric Scatter Systems

Marconi is a world leader in the provision of complete tropospheric scatter systems.

Marconi designed tropospheric scatter systems are in operation in the Caribbean, Malaysia, Persian Gulf, Mediterranean, E. Africa, Middle East, South America, Europe and Philippines.

BROADBAND SYSTEMS

Complete 'turnkey' projects, including provision of radio and antenna equipment, integration with s.h.f., u.h.f., v.h.f., and cable links, multiplexing and power generating equipment and civil engineering works.

LOW CAPACITY SYSTEMS

Marconi 'Thin Line' equipment gives up to 8 reliable speech channels over distances up to 175 miles. Economic installation and low running costs with high-grade performance and long-term reliability.

MILITARY SYSTEMS

Permanent strategic networks or transportable networks.

System performance studies ; Radio propagation surveys ; Installation and commissioning ; Training of personnel.

Marconi Radio Communications Division, designers and suppliers of h.f. point-to-point systems, microwave and tropospheric scatter microwave systems, part of the total system capability of Marconi Communication Systems.

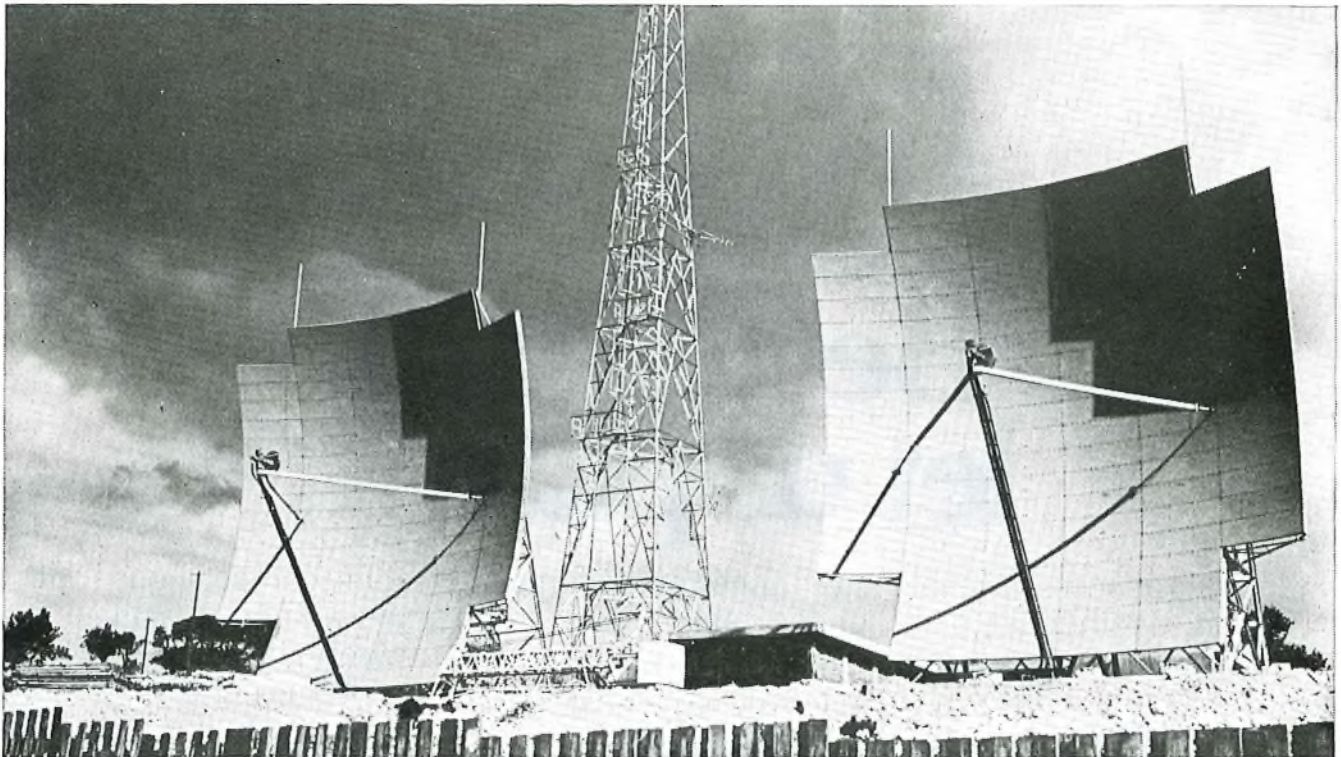

Marconi Communication Systems

Complete civil and military static and mobile communication systems

Message switching
Digital and data systems
Microwave and tropo systems
Mobile radio telephones
Specialized components

Satellite communications earth stations
H.F. and l.f. point-to-point systems
Television and broadcasting stations
Maritime and naval systems
Surveys, planning and commissioning

Marconi Communication
Systems Limited,
Chelmsford, Essex, England

A GEC-Marconi Electronics Company

Marconi PCM systems

Marconi is the foremost manufacturer and exporter of pulse code systems in the United Kingdom, and is a major supplier to the British Post Office.

Marconi cost-effective systems have also been chosen under competitive tender by many other authorities and public utilities, such as Eire P & T and Malta P & T and British Rail and London Electricity Board, because of their technical quality, economy and prompt delivery, coupled with the most experienced planning, installation and commissioning service.

- More than 100,000 Marconi PCM channel ends sold
- Signalling interfaces for most modern automatic exchange systems
- Suitable for future integrated switching systems
- Operates in adverse environments
- Optional teleprinter channels and suitable for data transmission
- Tolerates low-quality audio cable
- Can be expanded economically and flexibly
- Proved cost effectiveness

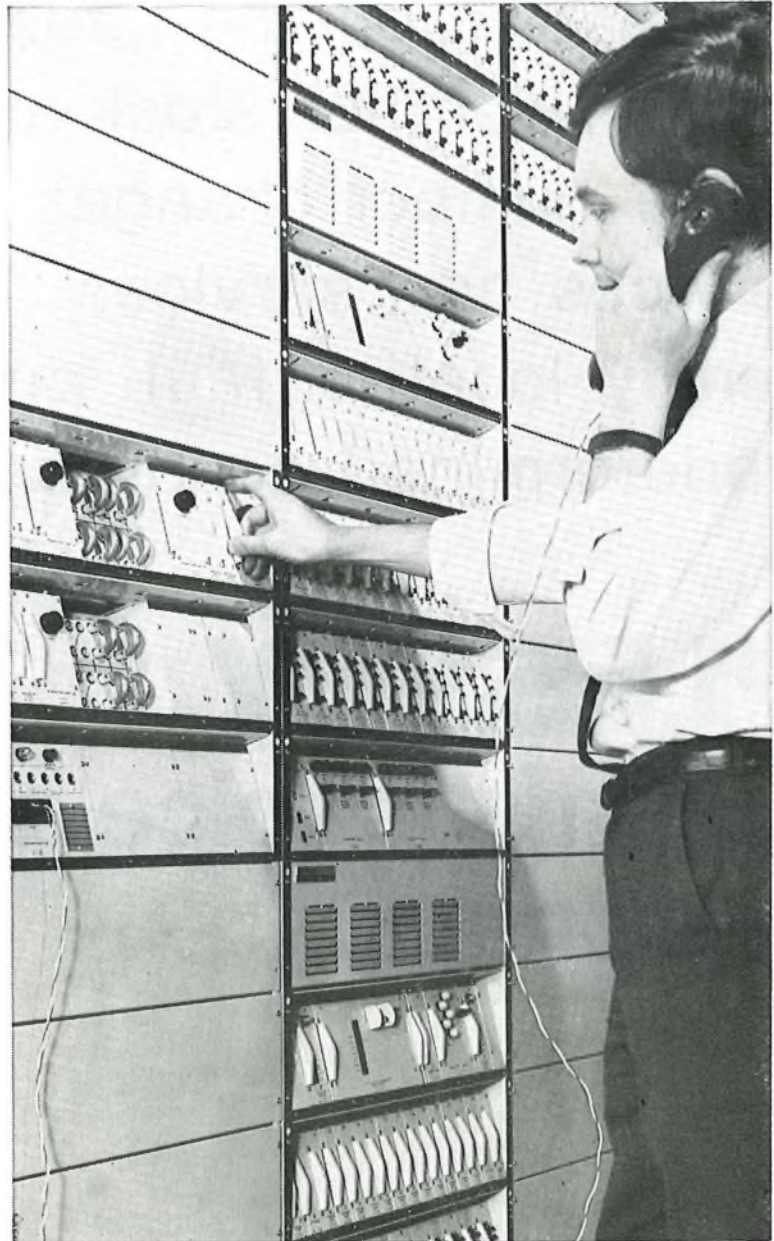

Marconi PCM installed in Hull Corporation Telephone Exchange

Marconi Line Communications Division, specialists in digital communications, including message switching, data transmission and error correcting equipment, part of the total systems capability of Marconi Communication Systems.

Marconi Communication Systems

Complete civil and military static and mobile communication systems

Message switching
Digital and data systems
Microwave and tropo systems
Mobile radio telephones
Specialized components

Satellite communications earth stations
H.F. and I.f. point-to-point systems
Television and broadcasting stations
Maritime and naval systems
Surveys, planning and commissioning

Marconi Communication
Systems Limited,
Chelmsford, Essex, England

A GEC-Marconi Electronics Company

Service telephone subscribers with information on the latest news, sporting details, weather, stock exchange news, **advise** number changes, discontinued services, new services, **identify** location, fault and other predetermined conditions with

PLESSEY

Automatic voice announcement equipment

auto announcer

The extremely reliable and economical Auto Announcer is ideal for announcing area identification, fault conditions and other short messages. Readily interchangeable recording drums allow the use of one record unit for many replay units.



multi channel AVAE

Engineered to the highest standards, the AVAE provides up to 12 separate 15 second channels each capable of feeding 200 telephone lines. Suitable to advise telephone subscribers of number changes, discontinued services and other service information.

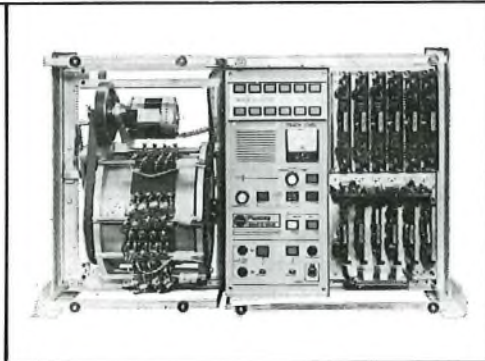

variable message repeater

The heavy duty VMR provides announcements of up to 3 minutes duration with immediate recycling at the end of the message. News, weather, sporting and other information services can be recorded by unskilled operators quickly and easily.

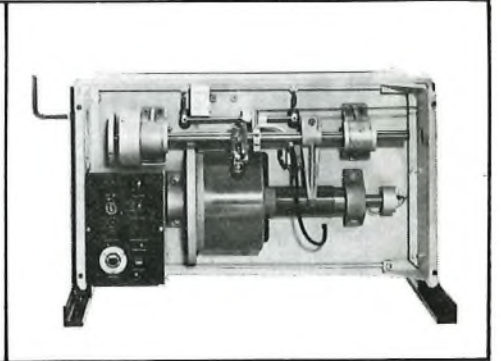

PLESSEY
Electronics



SALES PLESSEY RADIO Martin Rd West Leigh Havant Hampshire England
Telephone 0701 216391

Manufacturer PLESSEY ELECTRONICS PTY LTD 91 Murphy St Richmond Australia 3121
Telex 30383 Cables PLESSELEC Melbourne

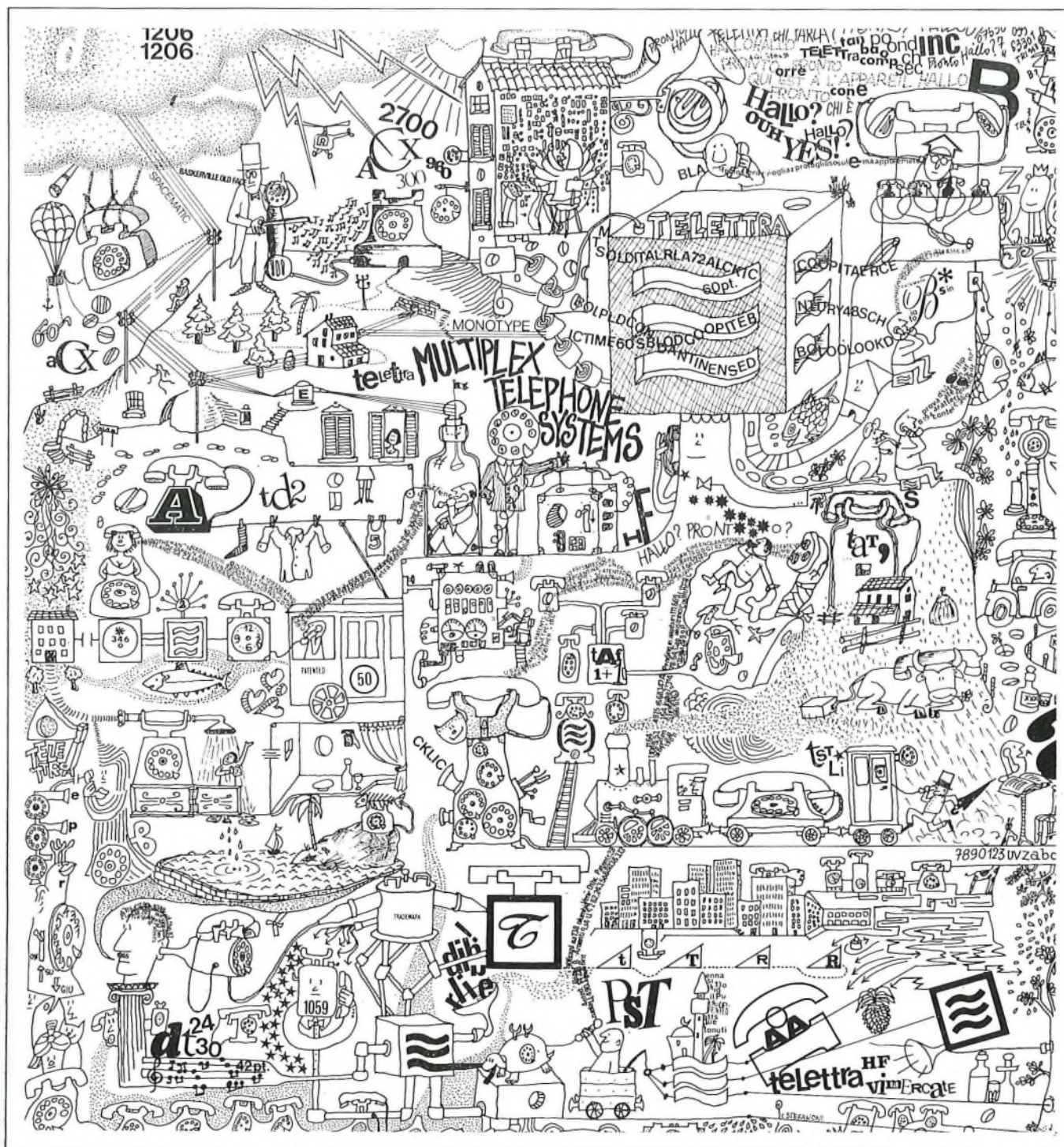

Telettra

MULTIPLEX TELEPHONE SYSTEMS

- LONG-DISTANCE, FREQUENCY DIVISION MULTIPLEX
- SHORT-DISTANCE, FREQUENCY DIVISION MULTIPLEX
- TIME-DIVISION MULTIPLEX FOR LOCAL NETWORKS (PCM)
- SINGLE-CHANNELS ON CABLE OR OPEN WIRE LINE

INDEX TO ADVERTISERS

	<i>Page</i>		<i>Page</i>
British Institute of Engineering Technology	5	Marconi Communications Systems Ltd	12, 13
Civil Service Insurance Society	5	Plessey Electronics Pty Ltd.	14
Cray Electronics Ltd.	17	R.C.A. Ltd.	9
Ferranti Ltd.	16	Standard Telephones & Cables, Ltd.	5-7
GEC-AEI Telecommunications, Ltd.	1-4	Telephone Cables Ltd.	11
Herman Smith Ltd.	18	Telletra S.p.A.	15
Landis & Gyr Ltd.	8	Whiteley Electrical Radio Co. Ltd.	10

Ferranti deliver system two months ahead of contract.

"Third on-line computer contract from the Post Office."

Two months ahead of time, Ferranti have delivered to the Post Office Corporation at Leicester an Argus 500 system designed to improve telephone network maintenance and help to give a better service to subscribers.

Previous Post Office Argus systems for Dollis Hill and Goonhilly Down were also delivered ahead of time—a year and two years ago respectively.

This new scheme is called 'CAMP'—Computer Assisted Maintenance Project—and this is the first time a process control type computer has been used in Post Office maintenance operations. The Ferranti CAMP System will receive and analyse data transmitted over telephone wires from 22 exchanges in the area. This will enable it to locate and draw

attention to faults before they significantly affect the grade of service, warn of impending breakdowns and identify fault-prone equipment.

The System will also log and print out the results of automatic nocturnal routine testing, analyse the pattern of telephone traffic and calculate new equipment needs.

It's a pilot scheme and may well be extended to other areas.

It's also one more example of how Ferranti are serving the communications business.

Ferranti Limited, Automation Systems Division,
Simonsway, Wythenshawe,
Manchester, M22 5LA.
Telephone: 061-428 3644

FERRANTI

FAS 49 

TYPE 62

FULL RANGE

7 TO 14 DAY DELIVERY

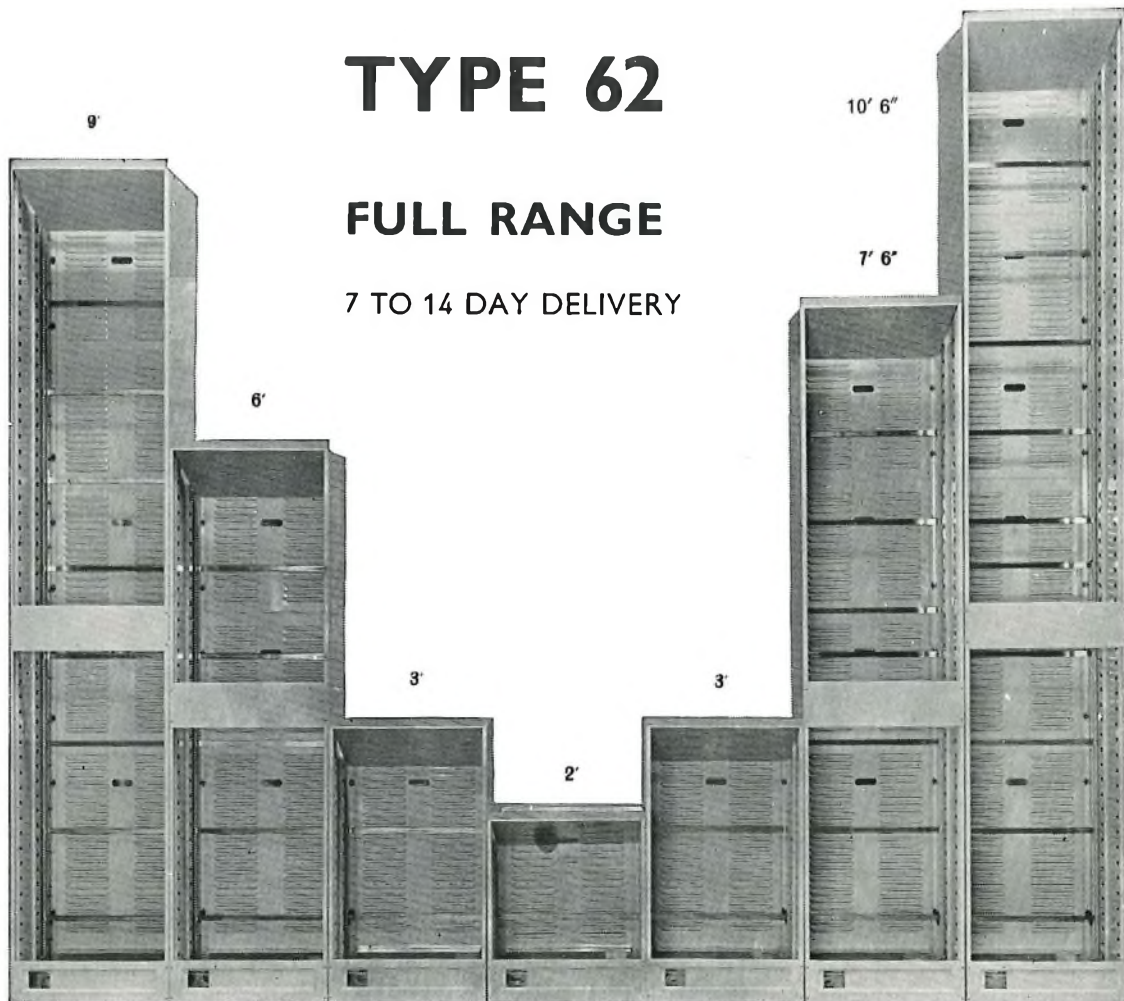

HIGH PRECISION MECHANICS

FOR INSTRUMENT ELECTRONIC AND AUTOMATION INDUSTRIES

TELECOMMUNICATIONS
MECHANICS

P.O. APPROVED

IMMEDIATE QUOTATIONS AND
TECHNICAL SERVICE

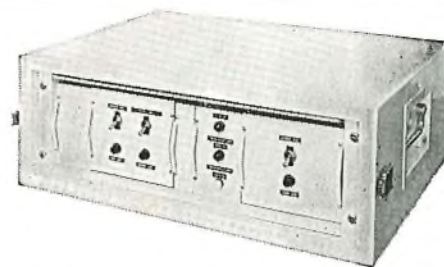

SHELF ASSEMBLIES



P.C.M. TRANSIT JIG



DATTEL MODEM

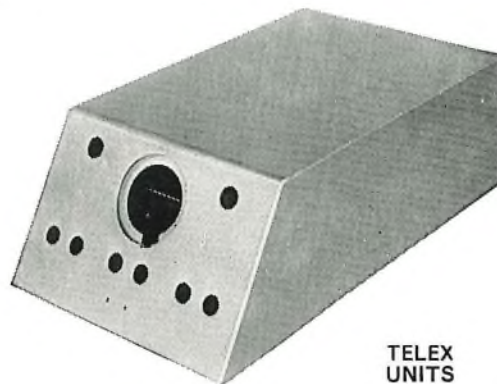

TELEX
UNITS

CRAY ELECTRONICS LTD

THAMES ROAD, CRAYFORD, KENT
TELEPHONE: CRAYFORD 29251

Do you know what else Herman Smith can do?

"62" type equipment is the aspect of our output you probably already know about. It's worth remembering however, that we produce many other types of presswork and sheet metal assemblies which may be of use to you.

We are acutely aware of the needs of the electrical and electronics industries and our experience in these spheres is comprehensive.

We are prepared for any challenge, complex or simple, large or small. Try us.

We produce the range of "62" type equipment, including the racks themselves, shelf assemblies, card locks, card guides, slide brackets, dummy front plates, etc. We also undertake electrical and electronic assemblies.



Contact Peter Bowen
Herman Smith Limited Cinderbank Works Netherton Dudley
Worcestershire Telephone Dudley 52791

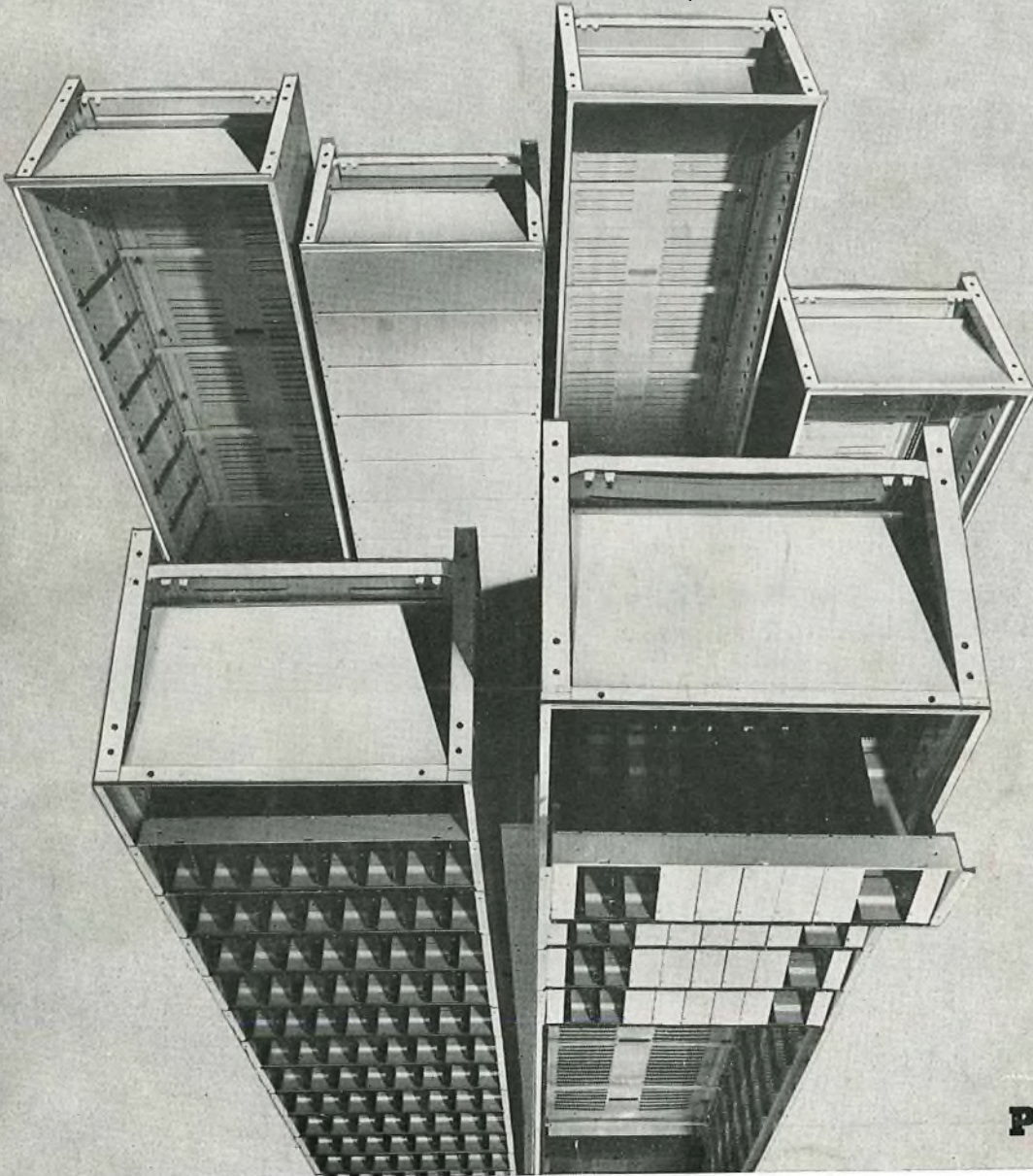

PO approved