

# The Post Office Electrical Engineers' Journal

---

**VOL 64 PART 1 / APRIL 1971**



# THE POST OFFICE ELECTRICAL ENGINEERS' JOURNAL

VOL 64 PART 1 APRIL 1971

## Contents

|  | <i>page</i>    |
|--|----------------|
| <b>Editorial</b>   | 1              |
| <b>Telecommunications Power Supplies—The Next Decade—<br/>Part 1—Introduction—R. Pine</b>                        | 2              |
| <b>Group Delay in the Audio Data Network—I. O. Jones and R. C. Adcock</b>  | 9              |
| <b>The Design and Planning of the Main Transmission Network—J. F. Boag and<br/>J. B. Sewter</b>                  | 16             |
| <b>A Rodding and Light-Cabling Vehicle—R. W. Martin</b>  | 22             |
| <b>Recent Developments in Datal-Testers—R. E. Quinney</b>  | 27             |
| <b>Post Office Wideband Local Distribution Networks—S. H. Granger</b>  | 33             |
| <b>A New Stamp-Selling Machine—D. B. Das</b>   | 40             |
| <b>Introduction to International Dialling from Non-Director Areas—J. W. Gibbs and<br/>F. G. Jackson</b>          | 44             |
| <b>An Experimental Manually-Switched 48 kbit/s Data-Transmission Network—<br/>M. E. Gibson and D. R. Millard</b> | 52             |
| <b>Notes and Comments</b>  | 59             |
| <b>Regional Notes</b>  | 62             |
| <b>Associate Section Notes</b>   | 64             |
| <b>Institution of Post Office Electrical Engineers</b>   | 64             |
| <b>Sir Gordon Radley</b>   | 66             |
| <b>Press Notices</b>   | 66             |
| <b>Book Reviews</b>  | 26, 39, 43, 51 |

Published in April, July, October and January by *The Post Office Electrical Engineers' Journal*,  
2-12 Gresham Street, London. EC2V 7AG

Price 21p 31p. (Including Postage and Packaging). Orders by post only.

Annual Subscription (post paid): Home and Overseas £1·24. (Canada and U.S.A., 3 dollars)



# STC Telecommunications

**Last year the Post Office told us  
exactly where to put our switching systems.**



Into their new transit switching network. To make more 'phones available all over the country and give an even faster more efficient telephone service.

The British Post Office knows STC produces all three kinds of telephone exchanges: step-by-step, crossbar and electronic. All available for director, non-director or transit switching. And as we're one of their major suppliers all our systems are designed to integrate with the

British network. We have a specialised installation team to supply complete working exchanges, too.

So it's hardly surprising that people keep telling us where to put our systems.

For further information contact:  
Standard Telephones and Cables Limited,  
Telephone Switching Group,  
Oakleigh Road, New Southgate,  
London N.11.  
Telephone: 01-368-1234.

an associate of  
**ITT**

worldwide telecommunications and electronics

**STC**

# STC Telecommunications

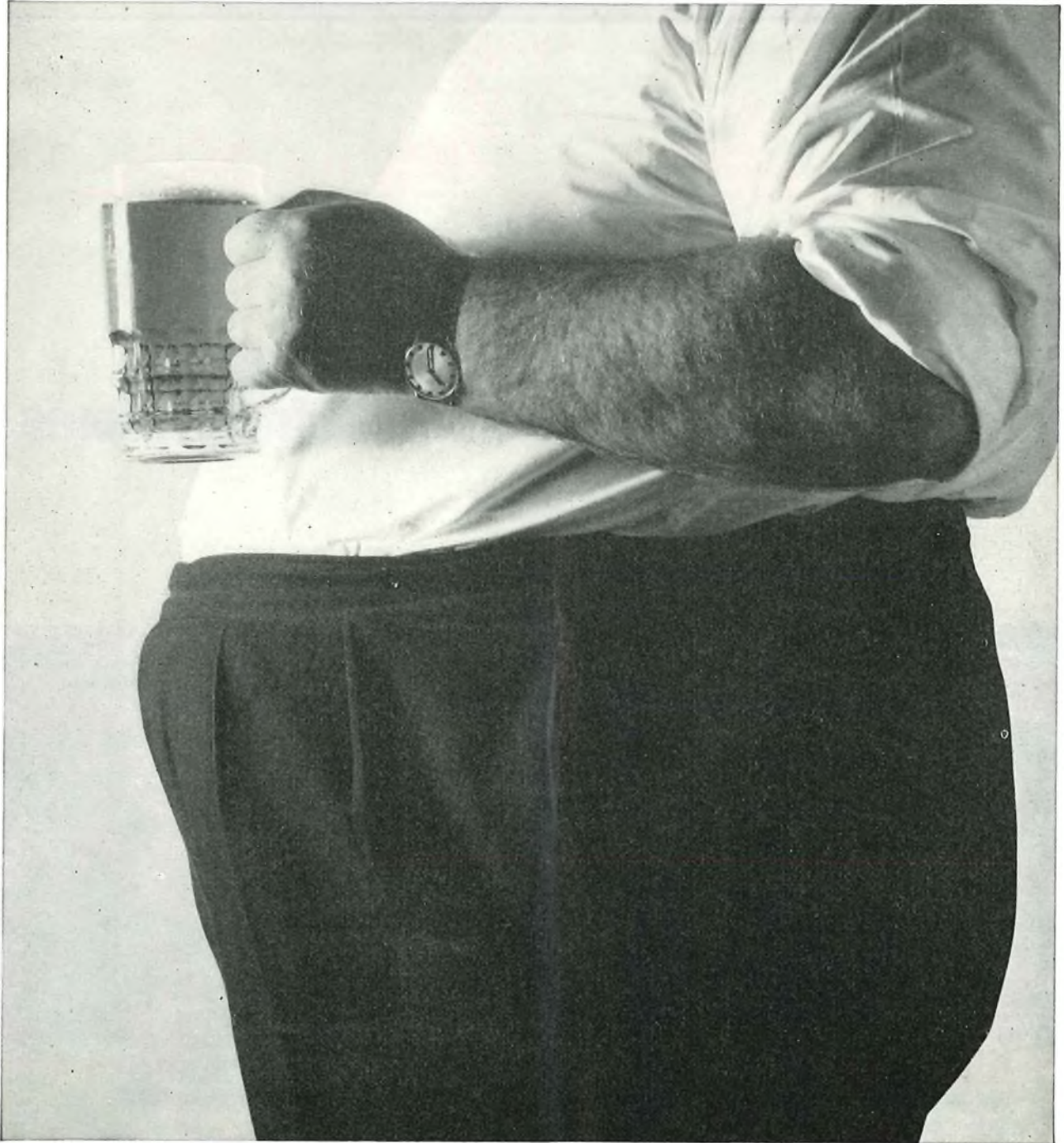

## Still room for more.

STC 4 MHz and 12 MHz Coaxial Cable Systems enable you to increase the circuit capacity of your existing routes providing up to 960 or 2700 circuits on each pair of coaxial tubes, whether small diameter (4.4 mm) or standard diameter (9.5 mm).

STC has been designing and manufacturing coaxial cable systems for nearly 40 years, having supplied the first 12 MHz coaxial cable system and the first small diameter coaxial cable system in the world.

STC also specialises in Frequency Division Multiplex, Pulse Code Modulation and Microwave Systems, offering installation, commissioning, training and maintenance services. STC is backed by the global resources and experience of ITT.

For more information write to: Standard Telephones and Cables Limited, Microwave and Line Division Basildon, Essex, England.  
Telex: 99101 (STC Basildon)

an associate of  
**ITT**

world-wide telecommunication and electronics

# STC



STC Telecommunications

# Joining Europe...

By new undersea telephone cables linking Britain with Belgium, with Denmark, with Germany, with the Netherlands and with the Channel Islands. And new cables from the Spanish mainland to the Canary Islands and the Balearics.

Each cable can handle 1,840 simultaneous conversations. More than double the capacity of any existing system in the world and ten times the capacity of any in use only five years ago!

So when these new cables are laid they'll be the most advanced undersea telecommunications systems anywhere. Under any sea.

Then, making advances of this sort on the sea bed is something STC is used to. First with 160-circuit, with 360-circuit and with 640-circuit deep water systems.

And by constantly coming up with new ideas incorporated in systems of advanced design STC intends to maintain

its leadership in the field of repeated submarine cable systems.

Not only providing submarine cables, repeaters, equalisers and terminal equipment, STC also offers an overall capability for systems planning, for project management and for systems implementation anywhere in the world.

Standard Telephones and Cables Limited, Submarine Systems Marketing and Projects Division, North Woolwich, London, E.16. England.

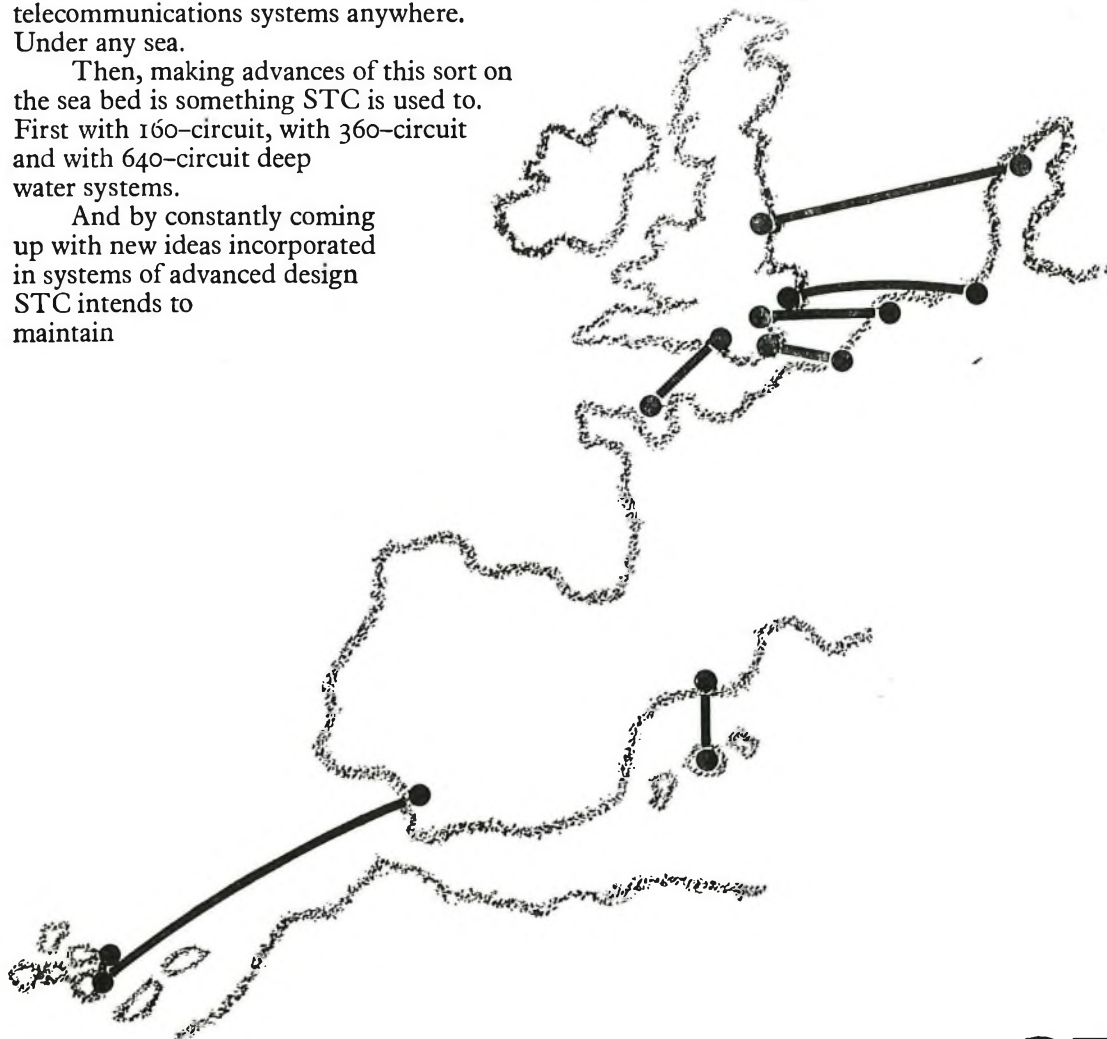

an associate of  
**ITT**

Submarine Systems Group

**STC**



# Our phone is your fortune.

Every Deltaphone your subscribers rent means more profit for you. And Deltaphone has a modern shape and comes in colours to blend with any colour-scheme.

That's why so many people want one.

There is no extra outside plant investment and maintenance is easy.

Let us help you make your fortune.

STC Subscriber Apparatus & Acoustic Division,  
Standard Telephones and Cables Limited,

Oakleigh Road, New Southgate, London, N.11.

Tel No: 01-368 1234. Telex: 21917

an associate of  
**ITT**

world wide communications & electronics

# STC



## STC Telecommunications

# PTFE wires and cables have a most responsible job.

### Order them from the most responsible company.

PTFE, an advanced high performance insulant for wire and cable, has to withstand a very wide range of temperatures. Inside a very wide range of highly advanced equipment. Such as commercial aircraft, spaceships, computers and special types of electronic equipment. That's quite a responsibility.

So is manufacturing such a product quite a responsibility. Especially to a company with as wide a reputation as STC's. A reputation for consistent quality and competitive prices. When you order PTFE cable from STC, you are assured of quick delivery and the most comprehensive after-sales service.

And if it's just advice or further details you want, STC are the most qualified people to give it to you. Just write, phone or telex: STC Plastic Telephone Cable Division, Corporation Road, Newport, Monmouthshire. Telephone: Newport 72281 Telex: 49368.

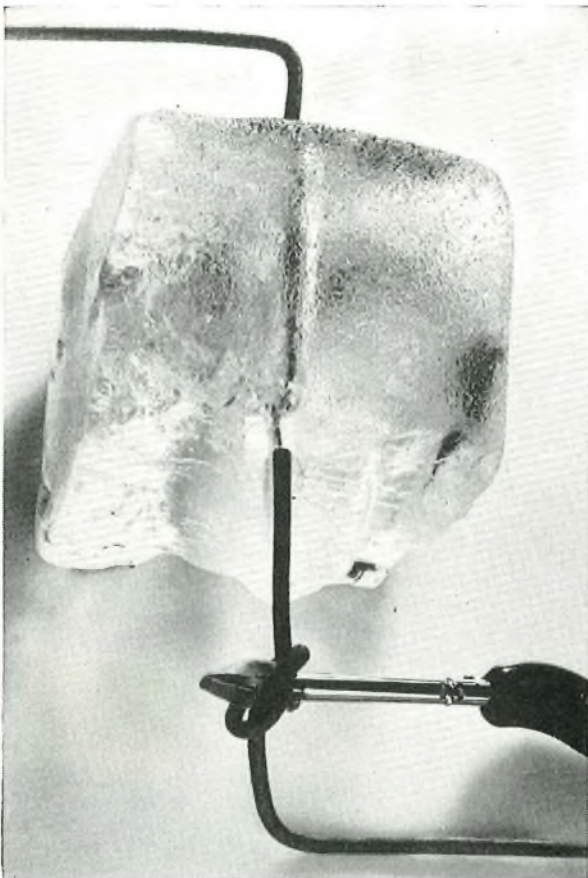

an associate of  
**ITT**

Communications Cables

# STC

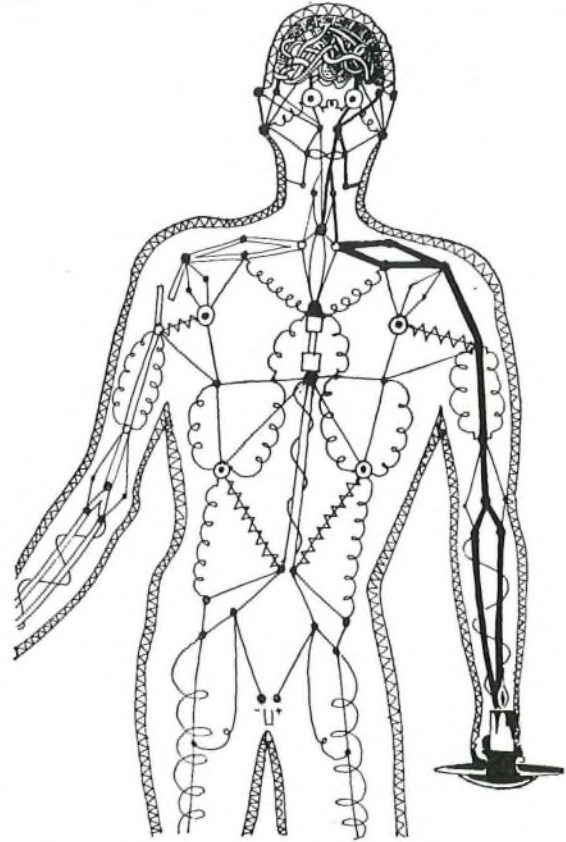

## Where would we be without internal communication?

We take the intricate workings of our nervous systems very much for granted. Can't imagine them to be anything but reliable and smooth running.

The same goes for our INTERPHONE office communication—and think what a big hang-up life would be without that. STC, one of the largest manufacturers of cable for PABX and PBX installations, think so too.

STC cables are of the highest quality and have tinned copper wire conductors, insulated with PVC. Cables are sheathed overall with PVC and can be supplied in various conductor sizes and pairages, either as armoured or unarmoured cable.

These cables are designed primarily for use indoors. They are also satisfactory for outdoor use (but installation should not be attempted at temperatures below 0°C.)

They are part of a comprehensive range of STC cables and wires. Designed and manufactured for every application in the telecommunications and electronics field—with cables for particular applications made specially to order.

You only have to pick up the phone for more details.



STC Plastic Telephone Cable Division,  
Corporation Rd., Newport,  
Monmouthshire.  
Telephone: Newport 72281  
Telex: 49368

an associate of  
**ITT**

Communications Cables

# STC





## Listen.

STC headsets are light as a feather. And beautifully comfortable to wear. Hardwearing to the point of being indestructible.

Yet inexpensive.

So it's not surprising that PTT's the world over are using them.

When you want headsets, use ours. You'll be glad you listened to us.

STC Subscriber Apparatus and Acoustic Division,  
Standard Telephones and Cables Ltd,  
Oakleigh Road, New Southgate,  
London N.11.

Tel. No: 01-368 1234. Telex: 21917

an associate of  
**ITT**

# STC

# CAMBION®

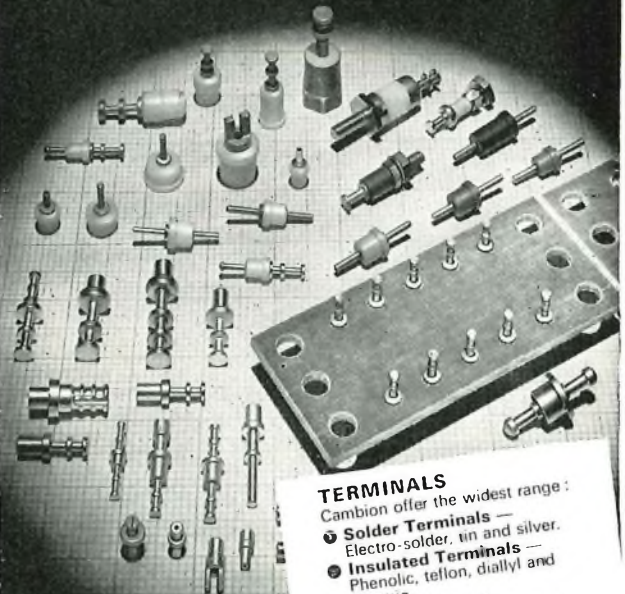

### TERMINALS

Cambion offer the widest range:

- Solder Terminals — Electro-solder, tin and silver.
- Insulated Terminals — Phenolic, teflon, diallyl and ceramic.
- Terminal Boards
- Hand and Power Swagers
- Insertion Tooling

Photographed on centimetre graph paper

## Top-Quality Components

Cambion design and manufacture the world's most reliable professional electronic components.

- SOLDER TERMINALS, INSULATED TERMINALS, TERMINAL BOARDS, ASSEMBLY TOOLING
- CAGE JACK CONNECTORS, PATCH CORDS, PLUGS
- I.C. ACCESSORIES, BREADBOARDS, SOCKETS ETC.
- WIRE WRAP TERMINALS, SOCKETS, CARDS
- R.F. COMPONENTS, CHOKES, COIL FORMS, COILS, MICROINDUCTORS, CAPACITORS
- THERMOELECTRIC DEVICES
- I.C. LOGIC ASSEMBLIES
- PANEL HARDWARE

Write now for illustrated literature on over 22,000 Cambion guaranteed Catalogue items.

Cambion Electronic Products Ltd.,  
Cambion Works, Castleton,  
Nr. Sheffield, S30 2WR  
Tel: 0433 2 831 (Hope 831)  
Telex: 54444





think of GEC-AEI and you think of...



Research  
Development  
Design



Surveying,  
Planning,  
Systems Design,  
Installation  
Commissioning



Transmission by  
Radio, Cable and  
Open-Wire Line



Frequency Division  
and Digital  
Multiplex



Audio, Programme,  
Signalling  
Telegraph and Data  
Equipment



Public Exchanges  
Trunk Switching  
RAX-UAX  
Mobile Exchanges

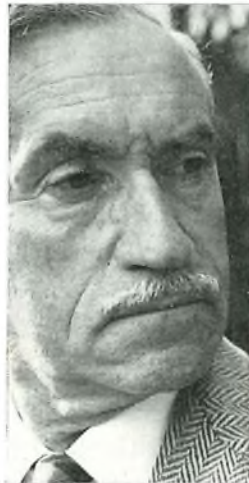

PABX-PAX  
Private Telephone  
Systems



Telephones  
Table, Wall,  
Secretarial,  
Loudspeaking



Maintenance  
Training



International  
Representation

## ... a complete telecommunications service

GEC-AEI Telecommunications Limited is a management company responsible for the telecommunications interests of The General Electric Co. Ltd. of England and Associated Electrical Industries Ltd.

The largest company in this field in England, and one of the largest in the world, GEC-AEI combines a vast research, development and manufacturing capability to provide a complete telecommunications service.

**Takes telecommunications into tomorrow**

GEC-AEI TELECOMMUNICATIONS LTD, OF COVENTRY, ENGLAND.

A Management Company of The General Electric Co. Ltd. of England.



IB/35A





**ever  
wanted** to cope with up to eight  
at a time in each direction?



**with the GEC  
upper 6  
microwave system  
you can!**

For high density routes, the GEC 6.8GHz semiconductored microwave radio equipment can accommodate up to eight radio bearers in each direction of transmission, using a single antenna.

The highly economical frequency usage provides up to 16 x 960 high-quality speech channels in the same frequency spectrum

**GEC MICROWAVE TYPE 68R9A**

**G.E.C.**

**Takes telecommunications into tomorrow**

GEC-AEI TELECOMMUNICATIONS LTD, OF COVENTRY, ENGLAND.

A Management Company of The General Electric Co. Ltd. of England.

IB/50



# the GEC co-axial cable system 4K9B is going places

- \* Proven in operation with over 230 systems covering 6000 route miles being supplied in the U.K. alone.
- \* 960 telephone circuits.
- \* 4.4 mm (0.174 in.) or 9.5 mm (0.375 in.) coaxial-cables.
- \* Power-fed repeaters at a maximum spacing of 4010 m. (4,400 yd.) for 4.4 mm. cable and 9250 m. (10120 yd.) for 9.5 mm. cable.
- \* Performance to CCITT recommendations.
- \* Underground repeater boxes to house up to six systems.

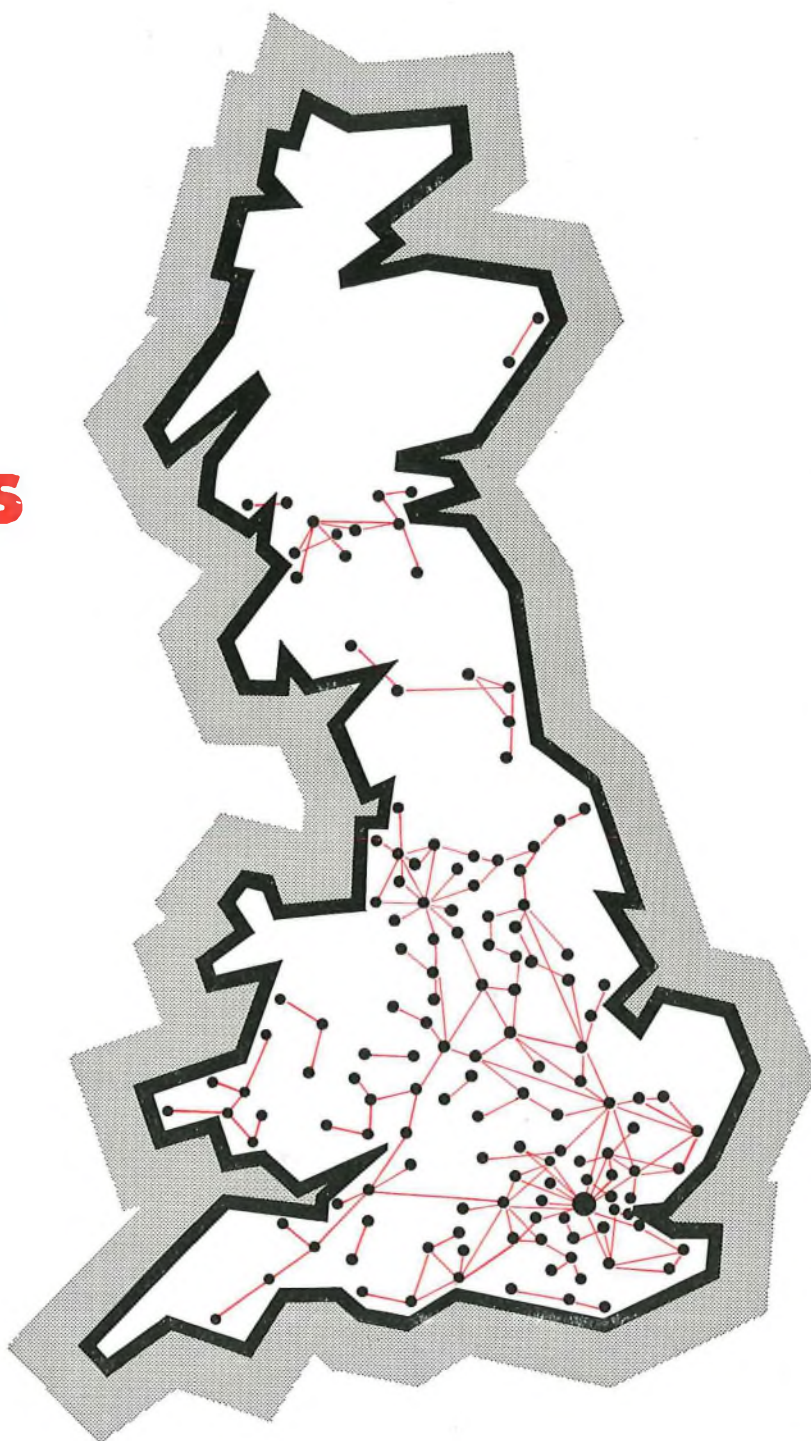

**Takes telecommunications into tomorrow**

GEC-AEI TELECOMMUNICATIONS LTD, OF COVENTRY, ENGLAND.

A Management Company of The General Electric Co. Ltd. of England.



# GEC links the world with microwave progress

AUSTRALIA • BAHREIN • CANADA • CHILE  
COSTA RICA • EL SALVADOR • FIJI • GHANA  
GREECE • GUYANA • HONG KONG • IRAN  
KENYA • LIBYA • MALAYA • MALAWI  
MALTA • NIGERIA • NORWAY • PERU  
PORTUGAL • SABAH • SWITZERLAND  
THAILAND • UNITED KINGDOM  
WEST INDIES • ZAMBIA

Broadband radio systems incorporating GEC microwave links are in operation in every continent in the world. The range of GEC microwave radio systems is impressive. It includes :-

- 2GHz, 4GHz, 6GHz and 6.8GHz equipments for speech or television on long haul main routes.
- 7.5GHz equipment for speech on medium haul spur routes.
- Associated equipments include F. D. Multiplex for up to 1800 circuits, supervisory alarm indication and remote control systems, I.F. and baseband switching equipments, narrowband auxiliary radio for serviceband antenna systems.

The achievement of GEC in the provision of microwave radio communication networks in so many countries of the world typifies their overall capability in telecommunications.



**G.E.C.**

**Takes telecommunications into tomorrow**

GEC-AEI TELECOMMUNICATIONS LTD, OF COVENTRY, ENGLAND.

A Management Company of The General Electric Co. Ltd. of England.



# The Post Office Electrical Engineers' Journal

---

## EDITORIAL

### BOARD OF EDITORS

N. C. C. de JONG, B.Sc.(Eng.), C.Eng., M.I.C.E., F.I.Mech.E.,  
F.I.E.E., Chairman  
E. W. AYERS, B.Sc.(Eng.), C.Eng., F.I.E.E.  
D. R. BEARHAM, B.Sc.(Eng.), C.Eng., M.I.E.E.  
S. H. SHEPPARD  
A. J. BARNARD, C.Eng., M.I.E.E.  
A. C. CROSDALE, M.B.E., B.Sc.(Eng.), M.I.E.E.  
J. MARTIN, B.Sc.(Eng.), C.Eng., M.I.E.E.

### Managing Editor

N. J. H. NINNIM, M.Sc., B.Eng.

### Deputy Managing Editor

R. A. SUDELL

### Assistant Editors

P. G. STEELE, M.Sc., B.Sc.(Eng.)  
D. MILLINGTON, C.Eng., M.I.E.E.  
T. R. K. RAITT

### Secretary-Treasurer

B. FARR, A.B.I.

### Advertisement Manager

N. G. CRUMP, A.M.I.T.E.

The inclusion of editorial comment in these columns is nothing new, years ago it formed a regular and important feature of the *Journal*. Reading those early issues enables one to capture some of the enthusiasm our predecessors had for the challenging new technology of communications. Since that time the Post Office has grown enormously and undergone many changes. The most recent of these have resulted in engineering staff throughout the organization losing, in some part, their corporate identity. They have been absorbed into the multidisciplinary structure needed to operate the massive new Post Office corporation.

Such changes are inevitable, but it would be tragic if they were to lead to the loss of the camaraderie of the engineering world that has contributed so much to the birth and application of so many new ideas. The function of the Institution of Post Office Electrical Engineers now assumes an even greater importance. By providing a forum for the presentation and exchange of such ideas it can be instrumental in preserving the essential spirit of that engineering fraternity.

The *Journal*, of course, has a most important part to play in this task of the Institution and the Board of Editors is aware that changes may be needed in order to fulfil the role. We have published a number of articles giving the broad picture of important current developments and hope to do more. We think that more short topical articles and more notes from the Regions would help, and the Managing Editor would be delighted to receive contributions of this nature. But what we do not know is what you, our readers, think the *Journal* should be like. The recently introduced correspondence column (another revival of an earlier practice) gives you all the opportunity to tell us what you think of the *Journal* and to suggest ways of improving it. We hope you will make good use of it.



# Telecommunications Power Supplies— The Next Decade

## Part 1—Introduction

R. PINE, B.SC., C.ENG., M.I.E.E.†

U.D.C. 621.39:621.3.031:621.311

*This article, in four parts, gives an account of new policies and developments in telecommunications power supplies. Part 1 contains a review of the present situation, an assessment of future requirements and the outline description of a new modular power system. Part 2 will describe new developments to improve and rationalize a.c. stand-by plant, Part 3 will contain a detailed description of a new, universal, modular d.c. power plant, and Part 4 will outline new proposals for power-distribution systems in telecommunications buildings.*

### INTRODUCTION

The British Post Office telecommunications network has developed over a period of nearly 60 years during which time power-supply systems have grown and evolved to keep pace with the ever-increasing demands. Not only has power consumption increased but the number of voltage standards has proliferated as new technologies have changed the basis of equipment design. As a result, the network now contains a large number of system voltages supplied by a wide range of plants, the performance standards of which vary considerably.

Future communications circuitry employing solid-state techniques may require power to be supplied at voltages lower than those used at present. If new central power plants are used to provide these supplies, the proliferation of voltages and plants will continue. This can only result in increased costs for plant, accommodation and maintenance, increased complexity and reduced system reliability.

These prospects, when considered in the light of the conflicting demands for improved manpower productivity, greater system reliability and reduced costs necessary for the explosive program of expansion that lies ahead, have stimulated a search for a new approach resulting in the production of a simple rational power-feeding policy supported by a program of system development.

### THE EXISTING SITUATION

Telecommunications equipment may be divided into two classes as regards power requirements. These are:

(a) equipment requiring a regulated a.c. supply at mains voltage, which includes a large proportion of existing line and radio transmission systems, and

(b) equipment requiring a d.c. supply maintained within specified limits about a nominal voltage, which includes exchange switching equipment and recent line and radio systems.

The variety of power supplies at present in use is illustrated by the distribution plan of Fig. 1. This shows the possible array of voltage standards and separate central power plants that could exist in a multi-functional centre. Each supply employs one or more rectifier sets, one or more batteries and a separate distribution system. The failure of any one of these supplies could result in the isolation of the centre.

Most a.c. operated systems require a continuous (no-break) supply unaffected by variations of the public mains. These power plants employ rotating machines (continuity sets) with

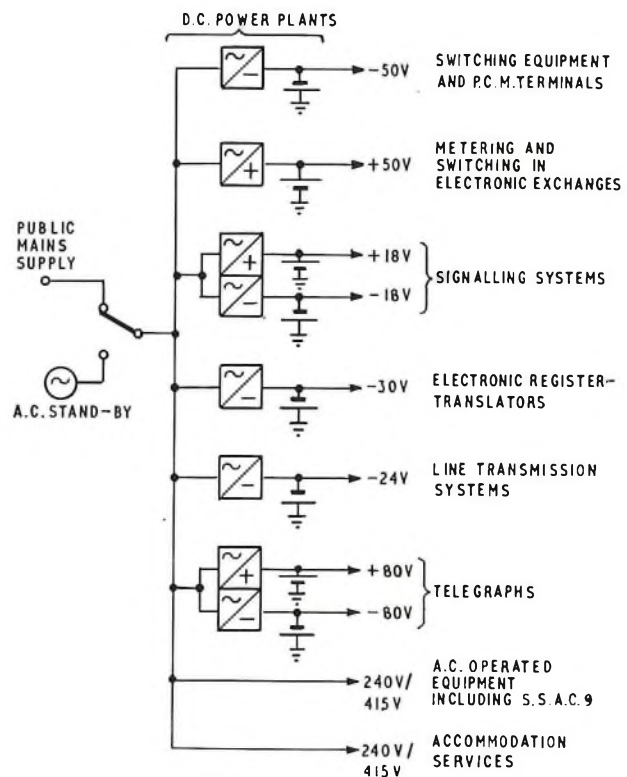

Fig. 1—A distribution diagram showing the possible supply standards that could be provided in a large communications centre.

associated batteries, rectifier sets and complex control systems. They are expensive to produce, install and accommodate; they require considerable maintenance attention and have a high failure rate in service.<sup>4</sup>

D.C. systems mostly comprise rectifier sets as a main source of d.c. power, with batteries connected in parallel with the load. These plants have proved to have a reliability at least 20 times better than that of no-break a.c. plants. With modern design, they can be made simple, very much cheaper to produce, install and accommodate, and they require substantially less maintenance manpower than an equivalent a.c. system.

Many telephone exchanges are equipped with batteries large enough to give a 24-hour reserve on failure of the mains supply. Since about 1960, the British Post Office policy has been to provide sufficient reserve to maintain service for five days in the event of a prolonged and widespread failure of the

† Telecommunications Development Department, Telecommunications Headquarters.



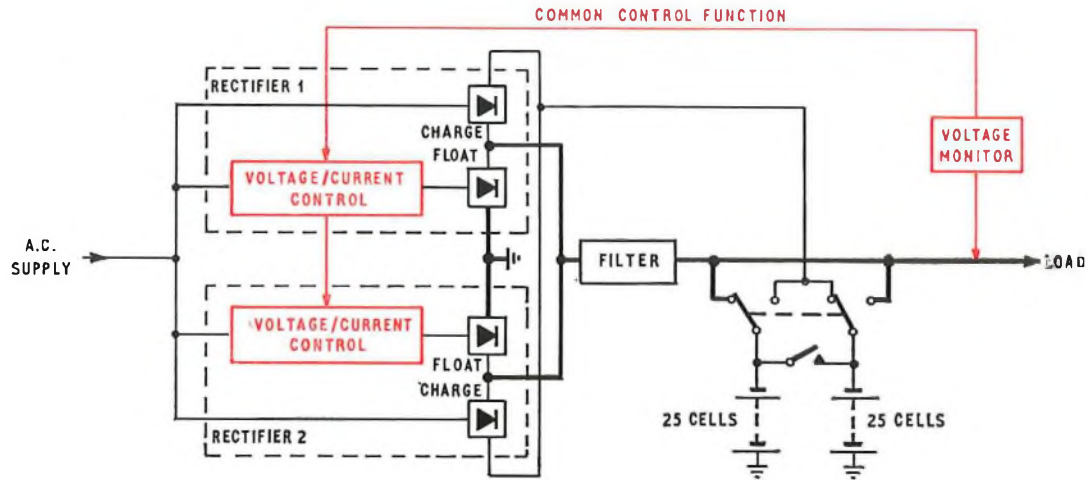

FIG. 2—Power Plant No. 210, simplified block diagram.

mains supply. To meet this requirement, a.c. stand-by plants are being installed in all telecommunications equipment buildings other than exchanges of less than 600 lines ultimate capacity. Where these are provided, the capacity of the batteries is reduced to that sufficient to ensure a one-hour reserve at peak load. A.C. stand-by is provided by means of diesel engine-alternator sets. These employ a control system that senses a failure in the public mains supply, starts the engine, switches the load from the mains supply to the alternator output and then monitors the performance of the system. During the short period between mains failure and full power being available from the alternator, the load is supplied from the battery. On restoration of the mains supply, the system reverts to the stand-by condition. Part 2 of this article will describe stand-by plants in greater detail.

### THE PRESENT STANDARD —50-VOLT POWER PLANTS

Since early 1968, studies have been made of the structure and performance of the present power-supply standards and of the needs of the future. These studies have been concerned with overall power-feeding policy and, in particular, with the —50-volt d.c. plants.

Since the bulk of the power consumed in the network is at —50 volts, it was clear that any study of power plants should be concentrated on this area.

There are three designs of power plant which cover the whole range of —50-volt power requirements and these will be described briefly.

#### The Power Plant No. 227

This is a single-battery-float system and is the smallest of the —50-volt plants. It comprises a single rectifier-unit, operating from a single-phase a.c. mains supply, a control cubicle and a battery. It is produced in sizes from 10 amp to 100 amp and is used to power u.a.x.s and some p.b.x.s. It is of modern design employing end-cell switching and static rectifier control to maintain the output voltage within the limits of 46 and 52 volts. The battery, which provides 24 hours reserve, is maintained fully charged at 2.3 volts per cell without the need for routine refresher charging.

#### The Power Plants No. 210 and 225

These plants serve the needs of all exchanges other than u.a.x.s. Both plants work on the double-battery-float principle by which rectifier-sets float batteries of 25 cells at 2.06 volts per cell. At this voltage, the cells lose about 1 per cent of their capacity each day so facilities are provided for routine refresher charges. These plants employ a common electro-mechanical voltage-control system with sequential switching of the rectifier

units to meet changes in load demand and to maintain the output voltage between 46 and 52 volts.

*Power Plant No. 210.*<sup>1,2</sup> This plant is produced in a range of sizes from 50 amp to 800 amp. Fig. 2 shows a simplified block diagram of the plant which comprises two rectifier-units, a smoothing filter and two batteries, each of 25 cells. Each rectifier has a float section, normally connected in parallel with the batteries, which supplies the load. In addition, there is a charge section which, when connected in series with the float section, provides additional voltage for battery charging. With this system, the float section has to supply the charging current as well as the load current. Thus the charging, which is under manual control, has to be carried out during periods of light load demand.

*Power Plant No. 225.*<sup>3,4</sup> This plant, a block diagram of which is shown in Fig. 3, is produced in a range of sizes from 1,000 amp to 20,000 amp. The smaller plants are equipped with two or three rectifiers and two batteries; the largest plant requires up to 10 rectifiers and five batteries. All the rectifiers in a given plant are similar and may be used for load supply or, by manual control, for charging. As with the Power Plant No. 210, the use of a rectifier for charging limits the capacity available for supplying the load and charging has to be performed during periods of light load.

### CHANGES IN REQUIREMENTS

#### Patterns of Load Demand

The power demand in a telephone exchange varies over a 24-hour period, the maximum demand usually occurring during the morning, in the busy-hour, with secondary peaks in the

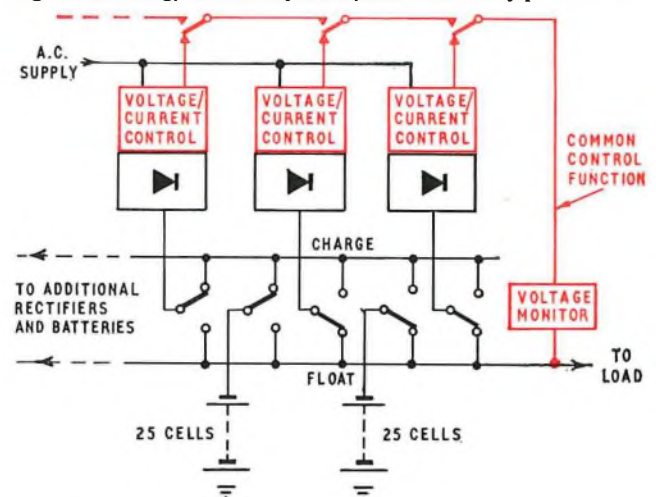

FIG. 3—Power Plant No. 225, simplified block diagram.

afternoon and evening. In a Strowger exchange, the load usually drops during the night to about 5 per cent of the peak morning load. The Power Plants No. 210 and 225 were designed at a time when, in most Strowger exchanges, distinct peaks of power with intervals of significantly lower demand could be recognized. These plants have rectifier capacity just adequate to meet the peak load. The relatively long periods of light loading, combined with the 24 hours of battery reserve that was provided, ensured that even if one rectifier failed, the small loss of charge from the batteries could easily be replaced during the 24-hour period. Under normal conditions, there were sufficiently long periods of low loading to enable refresher charging to be carried out during the day.

The following factors have, over the years, contributed towards a change in the situation:

(a) The pattern of loading, as described above, has changed. In most telephone exchanges, there are now long periods of high power demand during most of the daytime with only minor reductions in between.

(b) New electronic exchange systems have a high constant load level in addition to the varying component of power demand.

(c) In other telecommunications systems, such as p.c.m., the terminal equipment presents a wholly constant load demand. This form of demand will grow as the penetration of digital techniques increases.

(d) The present British Post Office policy, in all but the smallest exchanges, is to install engine-alternator sets for a.c. stand-by supply and to reduce the battery reserve period to one hour.

As a result of these changes, it has become increasingly difficult to perform routine refresher charges in many telephone exchanges during normal staffing hours. Also, as the load grows in these exchanges, the lack of spare rectifier capacity, over and above that needed to supply the load, puts the security of the power supply at considerable risk if a rectifier should fail.

### Reliability and Power Security

During the studies of power-system performance it became necessary to have some measure of reliability and the following definitions were adopted. They are not necessarily adequate for use out of the context of this article.

*Power System.* The overall power system embraces all equipment interposing between the a.c. input from the public mains supply and the telecommunications equipment. The function of the power system is to accept a.c. power, convert and distribute it at the supply standards and with the security required for the proper functioning of the telecommunications equipment.

*Defect.* A defect is defined as any occurrence which reduces the standard of performance of the power system, or any part of it, below the specified level.

*Isolation.* The isolation (of an exchange) is defined as the loss of service to half the subscribers or half the trunks or junctions in the exchange, or loss of half the traffic capacity.

*Failure.* A failure of the power system results in an isolation.

*Defect Rate.* A defect rate ( $D$ ) is expressed in defects per year and may be applied to individual components, sub-systems or the overall power system.

*Reliability.* Reliability =  $\frac{1}{D}$  and is expressed as the mean time in years between defects (m.t.b.d.).

*Failure Rate.* Failure rate ( $F$ ) is expressed in failures per year and applies to the overall power system only.

*Security.* Security =  $\frac{1}{F}$  and is expressed as the mean time in years between power system failures (m.t.b.f.).

In practice, the values of defect rate and failure rate are assessed from annual statistics as follows:

$$\text{Defect Rate} = \frac{\text{number of defects occurring in one year}}{\text{total number of items in service}}$$

$$\text{Failure Rate} = \frac{\text{number of failures occurring in one year}}{\text{total number of systems in service}}$$

The only source of this statistical information was the fault reports submitted by the Areas and Regions. It was realized that all faults and failures were not reported and statistics derived from this information could be considerably in error especially for types of plant where the numbers in service are small. However, the new awareness of the importance of performance statistics, the introduction of the National Network Co-ordinating Centre to monitor and control the performance of the telecommunications network, and the use of a new-style fault-reporting docket have together resulted in more complete reporting of defects and failures. From the information obtained from these improved returns, performance statistics have been derived, some of which are reproduced below.

In deriving these statistics, certain assumptions have been made, among them being that of a constant failure rate. The results obtained are estimates based on a limited amount of data but they are judged to be sufficient for the purpose of comparing one system with another, for which they were intended.

(a) 32 per cent of exchange isolations were caused by power-system failure.

(b) 10 per cent of exchange out-of-service time was the result of power-system failure.

(c) 26 per cent of power-system failures resulted from the activities of working parties.

(d) 84 per cent of power failures were caused by defects in the -50-volt plant and distribution. All other exchange power failures were caused by failure of the public mains supply or defects in a.c. stand-by plant; of these, 33 per cent resulted in loss of power to d.c. fed equipment and 67 per cent in loss of power to a.c. fed signalling equipment, e.g. S.S.A.C.9.

(e) The overall average m.t.b.f., due to all power causes, in telephone exchanges, is 30 years. There is very little variation in this figure with class of exchange.

The most important detail results are included in Tables 1 and 2.

**TABLE 1**  
**Analysis of Power-System Failures**

| Cause  | Number of Failures per Year | Failure Rate Exchanges/Year | M.T.B.F. Years/Exchange |
|--|-----------------------------|-----------------------------|-------------------------|
| -50-volt plant and distribution                                      | 152                         | 0.0247                      | 40.5                    |
| +50-volt plant and distribution                                      | Nil                         | Zero                        | —                       |
| Other essential d.c. supplies  | Nil                         | Zero                        | —                       |
| A.C. plant feeding d.c. plant  | 10                          | 0.0016                      | 625                     |
| A.C. plant feeding a.c. powered signalling equipment e.g. S.S.A.C. 9 | 20                          | 0.0032                      | 313                     |



**TABLE 2**  
**Service Performance of -50-volt D.C. Plant**

| Type of Plant                          | Design                                  | Defects per Plant-Year | Failures per Plant-Year | Mean time between Defects (Years) | Mean time between Failures (Years) | Maintenance Manhours/Plant/Year |
|--|---|------------------------|-------------------------|-----------------------------------|------------------------------------|---------------------------------|
| Small plants<br>(Less than 40 amp)     | Obsolete designs                        | 0.25                   | 0.035                   | 4                                 | 28                                 | 25                              |
|  | Modern designs<br>(Power Plant No. 227) | 0.4                    | 0.02                    | 2.5                               | 48                                 | 19                              |
| Medium plants<br>(40-800 amp)          | Obsolete designs                        | 0.7                    | 0.026                   | 1.4                               | 38                                 | 110                             |
|  | Modern designs<br>(Power Plant No. 210) | 0.46                   | 0.016                   | 2.2                               | 62                                 | 110                             |
| Large plants<br>(Greater than 800 amp) | Obsolete designs                        | 0.4                    | 0.034                   | 2.5                               | 29                                 | 500                             |
|  | Modern designs<br>(Power Plant No. 225) | 0.75                   | 0.016                   | 1.5                               | 60                                 | 300                             |

These results were analysed and compared with the new targets of power supply security set by the British Post Office Service Department for all communications centres. These targets are as shown in Table 3.

**TABLE 3**  
**Targets for Power-Supply Security**

| Type of Telecommunications Centre                                    | Mean Time between Failures (Years) |
|--|------------------------------------|
| Telephone exchanges  | 100                                |
| Group switching centres of less than 500 erlangs traffic capacity    | 100                                |
| Telephone repeater stations (line & radio)                           | 100                                |
| Group switching centres of greater than 500 erlangs traffic capacity | 200                                |
| Line & radio broadband switching equipments                          | 200                                |
| Key centres  | 500                                |

The study of the power system performance in the light of these security requirements has led to the following conclusions. The overall security of exchange power systems is well below the new service targets. The major causes are defects, including those resulting from working party activities, leading to failures of the -50-volt d.c. plants and their associated distribution systems. More detailed investigation has disclosed the following facts.

*The smallest exchanges (u.a.x.s).* Of these, 3,100 are powered by obsolete plants with a known high defect rate attributable to unreliable control components such as ampere-hour meters and mercury switches. These plants work on the partial charge/discharge system with its inherently short battery life. The remainder, about 1,000, are equipped with the Power Plant No. 227. Although this plant is of simple modern design the defect rate is higher than expected. More detailed investigation has shown these defects to be largely due to some minor design deficiencies which can readily be corrected.

*Medium and large exchanges.* At the present time, only about 50 per cent of the medium and large exchanges are provided with a.c. stand-by equipment and a one-hour battery reserve. The remainder have a nominal 24-hour battery capacity. Nevertheless, the overall power security is below an acceptable standard even though a high proportion of these plants are underloaded and thus possess an effective battery reserve well in excess of the nominal. In future, as the penetration of a.c. stand-by and one-hour battery reserves increases, as the plants become more fully loaded and as the pattern of loading becomes more constant, a higher proportion of the

defects will result in supply failure. Thus, the failure rate of the power systems in these exchanges can be expected to increase. The failures in the medium-sized exchanges are due equally to normal component defects and to working-party activities. Failures in the larger exchanges are almost entirely attributable to working parties.

About 50 per cent of the component defects occur in the electro-mechanical control circuits and in particular, result from the use of the moving-coil relay in a continuous voltage-control function. A high proportion of the failures caused by working parties occur during the extension of working d.c. distribution systems and the replacement of outgrown plants, where the present designs involve work on live conductors with risk of accidental short circuits.

#### **Flexibility of Planning and Provision**

Except in the largest sizes, the -50-volt d.c. plants installed in the medium and large telephone exchanges cannot be extended. The Power Plant No. 210 is installed at the outset with the full complement of two rectifiers, a separate smoothing filter and a power switchboard. The capacity of the plant is chosen to be adequate to meet the forecast 20-year life of the exchange. The batteries are normally installed for a 10-year life and are replaced with larger batteries when they become unserviceable or outgrown by load demand. The rating of the plant is limited by the common current-carrying components such as knife-switches, shunts and connecting bars on the power switchboard. The same conditions basically apply to the smaller sizes of the Power Plant No. 225 except that the provision of some of the rectifier capacity can be deferred. The largest sizes of Power Plant No. 225 can, however, be extended to a considerable extent.

Because the majority of -50-volt plants cannot be extended, it is necessary to forecast with some accuracy the load demand at least 20 years ahead to determine the size of the plant to be installed. This has proved to be an almost impossible task. The inevitable errors in long-term forecasting frequently result in one of the following two situations:

*Underprovisioning.* The installed plant becomes outgrown long before the end of its economic life. It then becomes necessary to replace the original plant with one of larger capacity. During the replacement operation, the power supply to the working exchange must remain intact. This is an inconvenient and costly exercise and the need to make connexions to live conductors puts the safety of personnel and the security of the power supply at risk.

*Overprovisioning.* This may be the result of genuine error or of a tendency to avoid the consequences of possible underestimation. In either case, a high-cost, high-capacity installation remains grossly under-loaded throughout its life.

Where the long-term forecast is correct, the non-extendible plant, of capacity large enough to supply the 20-year load demand, will be substantially underloaded for a high proportion of its life. In general, non-extendible plants require high initial capital investment, with little opportunity for deferment of costs, and result in wasteful investment. Errors in forecasting, in particular over-forecasting, increase the waste still further.

Most of the above remarks concerning extendibility of plant also apply to the provision of a.c. stand-by systems. The capacity of the a.c. stand-by provided is largely determined by the power to be drawn by the -50-volt d.c. plant. Hence, errors in long-term load forecasting will result in the provision of stand-by plant that is either too large or too small. The operation of replacing an outgrown a.c. stand-by installation, whilst not presenting so great a hazard to the security of the power supply as replacing a d.c. plant, is nevertheless costly and inconvenient.

The problems of inflexibility could be largely overcome if the capacity of power systems could be increased to keep pace with the growth of the loads that they serve. This would enable less reliance to be placed on long-term load forecasts and would facilitate the deferment of capital expenditure.

### Productivity

The manpower required for the maintenance of present power systems is at a high level for the following reasons:

(a) The double-battery-float principle, which is the design basis of the Power Plants No. 210 and 225, requires that the batteries be given refresher charges at intervals of two weeks. The alternate charging of the batteries under manual control involves the attendance of maintenance staff for at least one day a week.

(b) The use of electro-mechanical control requires considerable manpower both for routine maintenance and for the correction of the many defects that occur.

Table 2 shows the average annual maintenance requirements of the present d.c. power plants. It will be seen that the Power Plant No. 210 requires, on average, 110 manhours per year. An a.c. stand-by installation requires about 120 manhours per year. Therefore, the total power-system maintenance demand in a medium-sized exchange would amount to 230 manhours per year. In a large exchange, this figure can rise to 800 or 900 hours where a larger d.c. plant and two or more engine sets are installed.

In order that the expansion program of the Post Office network can proceed over the next decade without an escalation in manpower requirements, it will be necessary to increase productivity proportionately. In the power field, progress could be made in this direction if the need for routine battery charging were eliminated and the relatively unreliable electro-mechanical voltage control of rectifiers were replaced by a modern static control system. It is also possible that a reduction in the frequency of routine start-testing of engine sets and a general improvement in quality control during the manufacture of plant could contribute towards a productivity increase.

### Recommendations

The study of the existing power systems has led to the following recommendations being made:

(a) All future communication systems should be designed to operate directly from direct-current supplies.

(b) The number of different supply standards and voltages should be minimal; ideally, there should be one universal standard for all purposes.

(c) Since the majority of the power consumed in the network is at -50 volts d.c., the greatest benefits to the Post Office, in the next decade, would result from development work

directed towards overcoming the shortcomings of the present -50-volt power systems.

(d) This development work should take full account of the following factors:

- (i) the need to provide and sustain a high level of service security in a network subject to growth and change,
- (ii) the need for economy in manpower and investment,
- (iii) the need for simplicity and convenience in all aspects of planning, manufacture, installation and maintenance,
- (iv) the effect on power supply of the increasing use of electronic circuitry and digital techniques in all types of telecommunications equipment.

## THE MODULAR POWER SYSTEM

### The New Policy

A decision has now been made that from January 1975 all new British Post Office telecommunications installations will operate from a single central power supply at -50 volts d.c. The voltage of this supply will be regulated at source to within 46 to 52 volts. Such subsidiary voltages, d.c. or a.c., as may be required by the communications equipment, will, where practicable, be derived from regulators or convertors forming part of that equipment. The number and rating of such convertors will be chosen so that the failure of any one convertor will not result in a significant loss of service. This policy means that after the due date, all new installations including switching, transmission, radio and telegraph equipment and any other system subsequently developed, will, as far as is practicable, operate from a single -50-volt source. This will reduce the probability of power-supply failure and limit the variety and quantity of power equipment installed which, in turn, will reduce overall power plant costs. It will then be possible to conceive a single power-feeding system for all purposes. It should also be possible, in principle, to progress towards the elimination of special accommodation for power plant.

This policy decision has emphasized the importance of ensuring that there is a suitable -50-volt power system available.

### The New System Philosophy

To meet the -50-volt power needs of the future, a new system philosophy has been developed. This is based on a power source that is capable of extension in modular increments as the power demand of the load grows. This will enable the capacity of the power-supply system to keep pace with the growth of the communications centre that it serves. The modular power concept embraces the whole system from the public mains supply through the a.c. stand-by equipment, the d.c. power plant and the d.c. distribution system to the equipment racks. Fig. 4 shows a block diagram of the system.

The heart of the system is a d.c. plant which will employ fully-automatic, self-contained supply modules and a stand-by rectifier. Each module will comprise a rectifier cubicle and a 25-cell battery. The normal initial installation will be one module and the stand-by rectifier, additional modules being added, up to the normal maximum of four modules, as the load demand grows. Exceptionally, a fifth or sixth module may be added.

A.C. stand-by will be provided by one or two engine sets. One set, rated to supply four modules, will be provided in small centres except where an exceptionally high level of power-supply security can be justified. In larger centres, two engine sets will generally be installed, one at the outset followed by another at the appropriate stage of growth. This will facilitate the deferment of capital expenditure and allow a high level of power-supply security to be achieved. When two engine sets are provided, each will have the capacity to supply two d.c. modules. The aggregate capacity of the module batteries will be sufficient to sustain the supply to full constant load for one hour if all a.c. supplies fail. Where



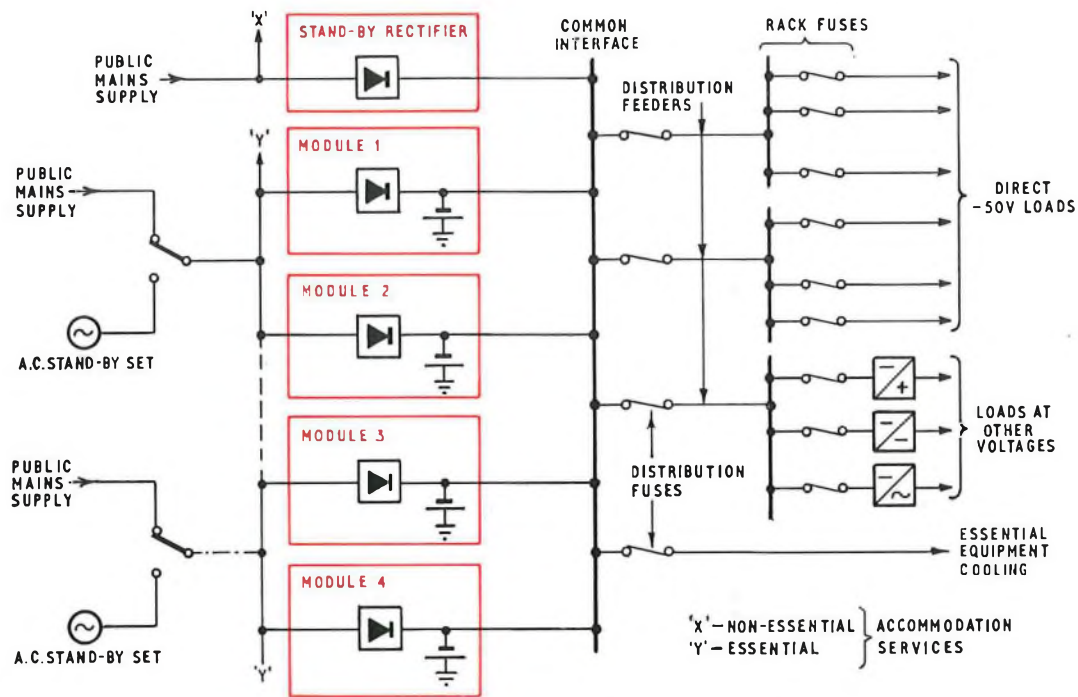

Note —When a single reserve is provided, insert connexions — — — and delete connexions ····· to the second a.c. stand-by set.

FIG. 4—Modular Power System with single and dual a.c. reserves.

two engine sets are installed, the same batteries will provide five hours reserve, at full constant load, in the event of the combined failure of the public mains and one stand-by a.c. supply. It is expected that five hours will be sufficient time for maintenance staff to attend any building and correct all but the most serious defects.

### The Modular D.C. Plant

The d.c. plant used in the Modular Power System will be known as the Power Plant No. 233 and Fig. 5 shows the main components of it. The module rectifier cubicle will contain a 51.5-volt and a 5-volt section, each employing static voltage and overcurrent control, which together will maintain the 25-cell battery fully charged, at 2.25 to 2.28 volts per cell, without need for routine refresher charges. A form of end-cell switching will ensure that the output voltage remains within the limits of 46 to 52 volts in the event of an a.c. supply or rectifier failure. The stand-by rectifier provides redundant capacity in the event of a module failure and spare capacity for charging after a battery discharge. The use of common control and of electro-mechanical devices will be kept to a minimum.

The modules will be produced in a rational range of sizes from 30 amp to 2,000 amp. The complete plant will be capable of supplying loads in the range 30 amp to 8,000 amp. Development of the Power Plant No. 233 is now well advanced and a detailed description of the plant and its development will form the subject of Part 3 of this article.

### Freedom for Design Innovation

An ideal approach to power-plant design requires the creation of a standard power-system framework within which the manufacturing industry would develop and provide controlled rectifier systems to specifications which are largely performance-based. Sufficient constraint and detailed interface requirements must, however, be included to ensure standardization of the overall system framework. This is necessary to ensure that reliability and security standards are maintained and that design changes have a minimal effect on installation,

operation and maintenance standards. This approach would allow the Post Office to control the cost of change, reap the benefits of advances in technology as they arise and give the industry freedom for innovation.

### The D.C. Distribution System

The system for the distribution of power to the communications equipment will be designed so that it can be extended safely as the load demand grows. It will take the form of a split-feeder system in which units of load will be connected by cables to distribution fuses. These fuses will be supplied by a safely-extensible, fully-insulated, unfused busbar to which the d.c. modules will be connected.

The design is based on the principle that it must not be necessary for personnel to work on unprotected live distribution conductors at any time during the life of the centre. Other advantages of this system are:

(a) It will be possible to allocate particular equipment racks or parts of racks to a single fuse irrespective of the location of these racks in the apparatus area. The fusing can then be arranged in a pattern best suited to the security needs of the supply. This is of particular importance in common-control systems where it may be necessary to supply the two halves of one rack from separate distribution fuses so that the rupture of one fuse may not cause isolation of the exchange.

(b) The cabling of equipment blocks back to a fuse electrically near to a low-impedance power source will be possible where it can be shown that this will reduce the effects of transient over-voltages and psophometric noise on equipment sensitive to these forms of interference.

### A.C. Stand-by

It will not normally be possible to provide a.c. stand-by sets with the same modular flexibility as the d.c. plants. However, development work is well advanced on a project to produce engine-alternator sets as packaged units to include all the auxiliary components with the exception of the control cubicle. This will facilitate quick and simple installa-



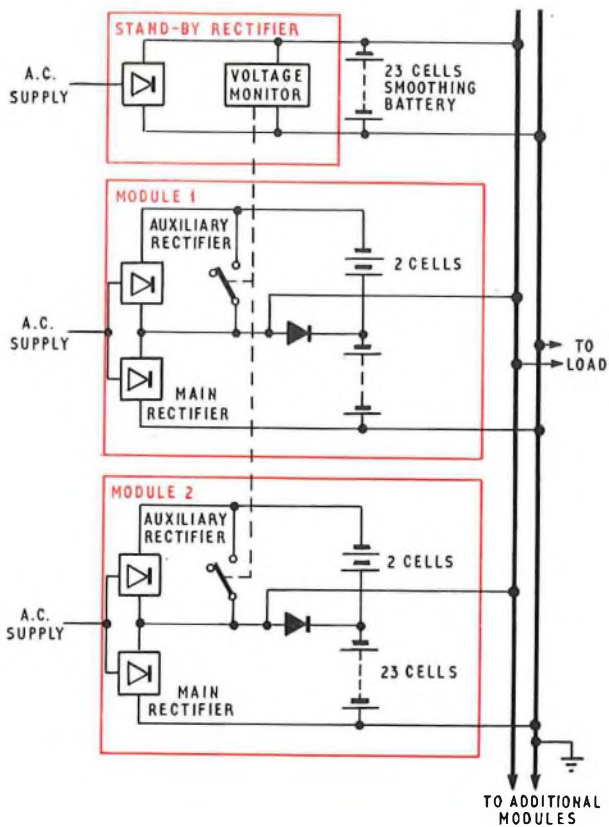

FIG. 5—Power Plant No. 233, simplified block diagram.

tion and replacement, enable production costs to be reduced and quality control to be improved. An account of the work in this field will be included in Part 2.

### PERFORMANCE AND ADVANTAGES OF THE MODULAR SYSTEM

The advantages of the modular system over the present power-supply arrangements may be summarized as follows:

(a) It will provide a fully-automatic power-feeding system for all telecommunications equipment irrespective of the patterns of loading. There will be one simple design of d.c. plant to serve all but the largest centres and the smallest exchanges.

(b) The system will provide far greater flexibility of planning and provision without the need for accurate long-term load forecasts. The power system will be capable of extension, in step with the growth of the centre that it serves, without risk to the security of supply.

(c) Simple design, the minimum use of common control, the elimination of unreliable electro-mechanical components and the provision of redundant rectifier capacity will result in greater reliability and enable the new service targets of power-supply security to be achieved.

(d) The exclusion of special plants for subsidiary voltage supplies, the elimination of routine battery charging and the use of modern simple design could enable the maintenance manpower to be reduced by 60 to 70 per cent.

(e) The system will allow significant cost savings to be achieved by the optimum deferment of capital expenditure, by rational purchasing methods and by the avoidance of wasteful investment.

(f) The system will promote greater flexibility in the utilization of accommodation and enable progress to be made towards the abandonment of special power areas.

(g) The system is designed as a standard framework within which maximum advantage may be gained from advances in technology and innovation in industry.

### Power Supply Security

The reliability of the modular d.c. plant will be governed by the availability of redundant rectifier capacity which will permit the failure of one module without battery discharge. Past experience indicates that the reliability of a modern rectifier set can be taken as 20 years m.t.b.d. The probability of a second rectifier failing during the repair time of the first failed unit is very low, of the order of  $2 \times 10^4$  years m.t.b.d. Thus, the overall reliability of the d.c. plant will be of that same order so long as the a.c. supply remains intact. Therefore, with the modular power system, the probability of failure of the d.c. plant, as an isolated unit, may be assumed negligible. The security of the whole system then becomes solely a function of the reliability of the a.c. supply.

The reliability of the a.c. supply may be estimated as follows:

(a) The best statistics available indicate that, except under conditions of national emergency, an average electricity consumer can expect 30 interruptions of supply in any one year. Only one of these will last longer than one hour.

(b) Experience shows that the failure rate of modern a.c. stand-by engine sets is of the order of one failure in 200 demands to start.

Thus, the average stand-by set will be called upon to start 30 times per year, but only in one of these cases will a failure to start be of consequence, that is, when the public mains supply does not restore within the one-hour battery reserve period. This fact, in combination with the fail-to-start probability of one in 200, results in an overall system security of 200 years m.t.b.f., when only one engine set is provided. If two engine sets are installed, the same batteries will sustain the load for at least five hours in the event of coincident failures of the public mains supply and one of the engine sets. The power security then becomes a function of the low probability of the public mains not restoring within five hours and the even lower probability of a failure of the second engine set within the same period. Under these conditions, the estimated overall power security would be equivalent to at least 1,000 years m.t.b.f.

### CONCLUSIONS

Studies have been made of the performance of existing telecommunications power systems and of the predicted needs of the future. An account of the most important considerations and proposals has been given. There are, of course, many other problems and other developments designed to solve them; space limitations have necessitated their omission from this account.

Development of the modular power system is now well advanced. Prototypes of the first Power Plant No. 233 have now been delivered by the manufacturer, and are undergoing laboratory evaluation. This will be followed by field trials in selected exchanges in the London Telecommunications Region.

In addition to the service and manpower benefits already stated, considerable cost savings should result from the use of modular power plants. The British Post Office at present spends about £5 million a year on telephone exchange power supplies. Under present conditions, this would rise, at today's prices, to £8 million a year by 1980. The modular power system is expected to reduce this expenditure by annually-increasing amounts up to an annual saving of 20 per cent by 1978. This is a conservative estimate which does not take into account the expected reduction in the present wasteful investment due



to over-provision of installed capacity and in premature replacement of outgrown plants, resulting from errors in load forecasting, which the modular system should achieve. To achieve this, the total research and development expenditure will have been £0.33 million.

Finally, it should be noted that although the existing power plant designs display shortcomings when compared with the requirements of the future, this must not be taken as a criticism of these designs or of those responsible for their development. At the time they were conceived, these designs employed the most modern proven techniques of the day and their performance was adequate to meet the predicted future requirements as seen at that time. It is a considerable credit

to those who designed and developed them that these same designs perform as well as they do under the radically changed conditions which now exist.

(to be continued)

## References

- <sup>1</sup> CATT, L. H. A New Standard Power Plant for Medium-Sized 50-Volt Telephone Exchanges. *P.O.E.E.J.*, Vol. 49, p. 93, July 1956.
- <sup>2</sup> CATT, L. H. Power Plant for British Post Office Telephone Exchanges. I.P.O.E.E. Printed Paper No. 221 (1961).
- <sup>3</sup> ROBINSON, J. Saving Space in Telephone Exchanges by using Modern Power Plants. *P.O.E.E.J.*, Vol. 56, p. 23, Apr. 1963.
- <sup>4</sup> SPURGIN, D. A. Power Supplies for Telecommunication Services. I.P.O.E.E. Printed Paper No. 230. (To be published.)

# Group Delay in the Audio Data Network

I. O. JONES and R. C. ADCOCK†

U.D.C. 621.372.553:621.395.74

*Group delay has only been of significance for audio-band telecommunication channels since the advent of data transmission and, in this context, is a relatively new subject. This article is intended to give a basic understanding of the meaning and cause of group delay/frequency distortion on an audio-frequency-band circuit and to explain the principles and procedures for group-delay equalizer design and utilization.*

## INTRODUCTION

The telephone network of today has been planned and developed to satisfy requirements for good commercial-quality speech communication. Limits have been specified for circuit parameters such as overall circuit loss, attenuation/frequency distortion, crosstalk attenuation, and background noise. The human ear is relatively insensitive to phase distortions of an audio signal and, for speech circuits, it has only been necessary to define broad limits relating to the phase/frequency characteristic for international circuits.<sup>1</sup> However, now that audio-band telecommunication channels are being used for non-speech purposes such as data transmission, the response of the phase/frequency characteristic is becoming increasingly important.

An information-bearing signal, which is, therefore, not a pure sinusoid but may be in the form of a pulse train, must not be distorted to the extent that the signal cannot be recognized without error at the receive end of a circuit. Non-linearity in both the phase/frequency and the attenuation/frequency characteristic causes pulse distortion which, if serious, gives rise to such error. The non-linearity of the phase/frequency

characteristic is assessed in practice by measuring the group delay/frequency distortion of the circuit.

## THE NATURE OF GROUP DELAY

Delay results from, and is inversely proportional to, a finite propagation velocity. It is important to distinguish between phase delay and group delay of propagation of a modulated (information-bearing) signal.

Phase delay,  $\tau_p$ , applies to a steady sinusoidal signal only and is given by the ratio of the total phase shift  $\beta$  divided by the angular frequency  $\omega$ .

Thus, 
$$\tau_p = \frac{\beta}{\omega}.$$

If  $\beta$  is in radians and  $\omega$  in radians/second, then  $\tau_p$  is in seconds.

To transmit information, a change in the sinusoidal signal must be made, and group delay is a measure of the transmission time of this change through a system.

This can be demonstrated by considering a simple case of the transmission of a complex wave composed of two equal-amplitude cosine waves  $A$  and  $B$  having frequencies  $\omega$  and  $\omega + \delta\omega$  which are phase shifted through the transmission system by  $\beta$  and  $\beta + \delta\beta$ . The resultant waveform envelope

† Telecommunications Development Department, Telecommunications Headquarters.

of the two cosine waves can be considered as the information in the waveform.

At the input to the system, the resultant is given by:

$$\begin{aligned} V_{in} &= \cos \omega t + \cos (\omega + \delta\omega)t, \\ &= 2 \cos \left( \omega + \frac{\delta\omega}{2} \right) t \cos \frac{\delta\omega}{2} t, \end{aligned}$$

where  $\omega + \frac{\delta\omega}{2}$  is the frequency of the resultant and  $\frac{\delta\omega}{2}$  is the frequency of the envelope.

At the output of the system, the resultant is given by:

$$\begin{aligned} V_{out} &= \cos (\omega t - \beta) + \cos [(\omega + \delta\omega)t - (\beta + \delta\beta)], \\ &= 2 \cos \left[ \left( \omega + \frac{\delta\omega}{2} \right) t - \left( \beta + \frac{\delta\beta}{2} \right) \right] \cos \left( \frac{\delta\omega}{2} t - \frac{\delta\beta}{2} \right), \end{aligned}$$

where  $\omega + \frac{\delta\omega}{2}$  is the frequency of the resultant,

$\beta + \frac{\delta\beta}{2}$  is the phase shift of the resultant,

$\frac{\delta\omega}{2}$  is the frequency of the envelope, and

$\frac{\delta\beta}{2}$  is the phase shift of the envelope.

It can be seen that the phase of the envelope of the output signal at frequency  $\frac{\delta\omega}{2}$  is lagging on that at the input by  $\frac{\delta\beta}{2}$ .

Delay of a wave is given by the ratio of phase shift to angular velocity. Therefore, the group delay  $\tau_g$ , which is the propagation delay to the envelope, is given by:

$$\tau_g = \frac{\delta\beta}{\delta\omega}, \text{ which in the limit } \delta\omega \rightarrow 0 \text{ becomes}$$

$$\tau_g = \frac{d\beta}{d\omega}.$$

As for phase delay, if  $\beta$  is in radians and  $\omega$  in radians/second, then  $\tau_g$  is in seconds.

Because group delay affects a modulated envelope, it is sometimes referred to as envelope delay.

In an ideal communication channel, where phase shift is linearly related to frequency and is also zero at zero frequency, all frequencies in a complex signal are delayed by the same propagation time and group delay  $\tau_g$  has a constant value. In this situation,  $\tau_g = \tau_p$ .

However, in a practical communication channel, the phase/frequency characteristic always possesses some degree of non-linearity and, consequently, propagation time varies with frequency and  $\tau_g > \tau_p$ .

Fig. 1 shows the effect of phase delay and group delay for the example considered above, in a transmission system with a non-linear phase/frequency characteristic. The two cosine waves *A* and *B* and the resultant of their addition are shown. At the input, the point *K* on cosine waves *A* and *B* occurs simultaneously with the point *L* on the resultant envelope at time equal to zero. In transmission through the system, cosine wave *A* suffers a propagation delay of  $T$  and cosine wave *B* a delay of  $T + \Delta T_1$  to points *K1* and *K2*, respectively. The envelope of the resultant suffers additional phase shift to its two constituent waves and this is apparent as additional

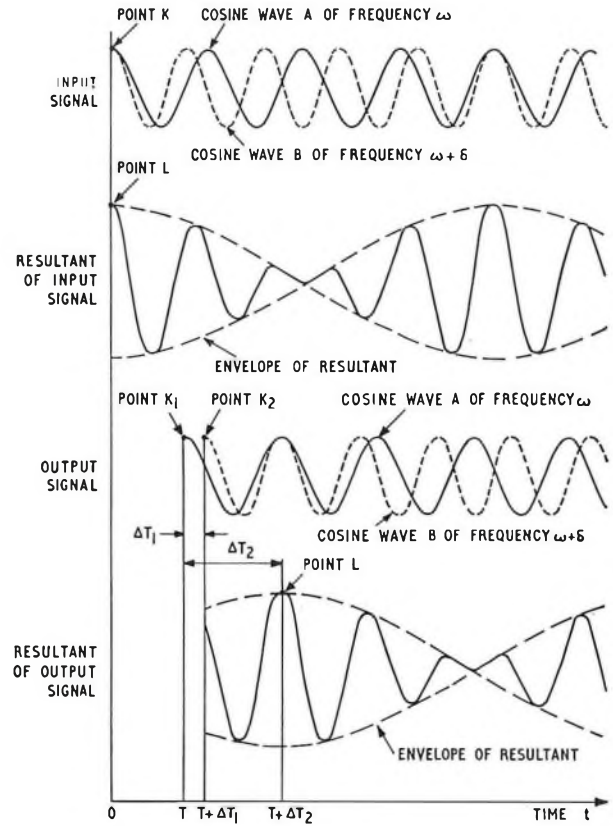

FIG. 1—Effect of phase delay and group delay.

propagation delay of the envelope, resulting in a total delay of  $T + \Delta T_2$ . In summary, therefore:

phase delay of cosine wave *A* is  $T$ ,

phase delay of cosine wave *B* is  $T + \Delta T_1$ , and

group delay of the resultant envelope of *A* + *B* is  $T + \Delta T_2$ .

Distortion of a pulse occurs when group delay is not constant within the frequency band of that pulse, so that group delay/frequency distortion exists through the transmission medium. The effect of group delay/frequency distortion depends upon the modulation system used, but whenever a sinusoidal carrier frequency is modulated by more than one sinusoidal frequency, group delay/frequency distortion causes distortion of the information-carrying signal.

To demonstrate this, consider the approximation to one cycle of a square wave made up from a fundamental frequency component to which is added a third-harmonic component having one-third the amplitude of the fundamental as shown in Fig. 2(a). Suppose that on transmission, when modulated on a carrier wave, the fundamental frequency component suffers a group delay of  $\tau_g$  and the third harmonic component suffers a group delay of  $\tau_g + \Delta\tau_g$ . The group delay/frequency distortion is

$$(\tau_g + \Delta\tau_g) - \tau_g = \Delta\tau_g,$$

that is, the change in group delay over the frequency band transmitted. Suppose that  $\Delta\tau_g$  were equal to a quarter of a cycle of the third harmonic, then the result would be as shown in Fig. 2(b). Considerable distortion of the waveform is now apparent. In more extreme cases, group delay/frequency distortion may reduce the amplitude of a transmitted pulse to such an extent that it is not reliably detectable as a pulse after



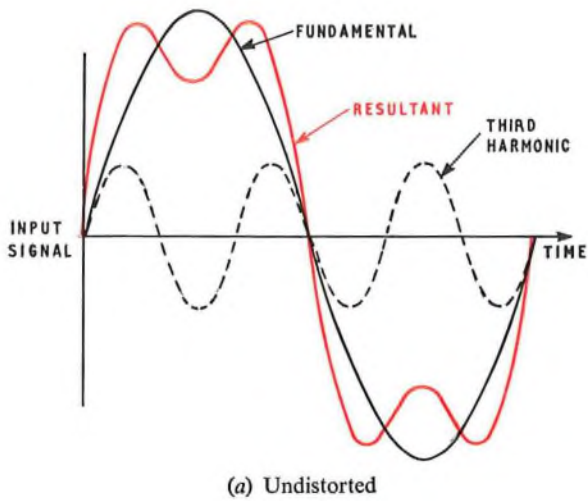

(a) Undistorted

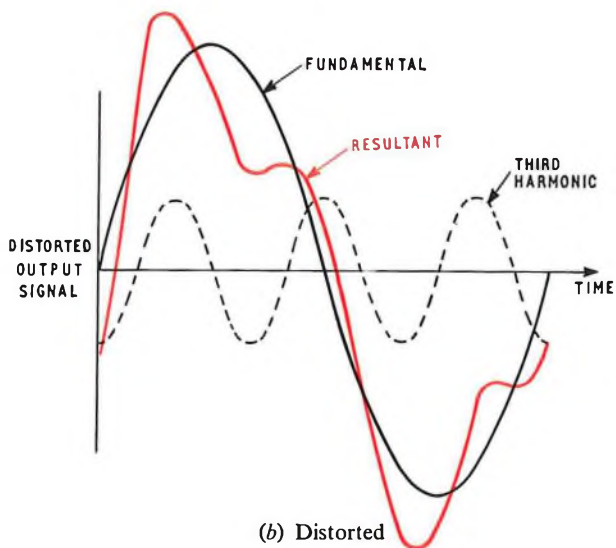

(b) Distorted

FIG. 2—Example of waveform distortion due to group delay/frequency distortion

transmission. Alternatively, components of one pulse may be so shifted in time as to interfere with the detection of preceding or following pulses.

### SOURCES OF GROUP DELAY

Group delay/frequency distortion arises from non-linear phase/frequency characteristics which, in turn, result from filters in the transmission path. On an audio circuit, there are two important sources of filtration which give rise to significant group delay/frequency distortion. Inductively-loaded audio cable acts as a low-pass filter with a cut-off frequency of about 4 kHz for standard loading of 88 mH coils at 1.136-mile spacing and group delay increases with frequency within the audio band. Channel translating equipments (c.t.e.) include bandpass filters which contribute increasing group delay towards both the upper and the lower frequencies of the audio band. Through-group filters (t.g.f.) contribute additional distortion in channels 1 and 12 as do 24-channel filters. Figs. 3 and 4 show the phase, and group delay/frequency characteristics for standard-loaded audio cable and a typical c.t.e., respectively. Fig. 5 shows group delay/frequency distortion (group delay values relative to minimum value) for the same standard-loaded audio cable,

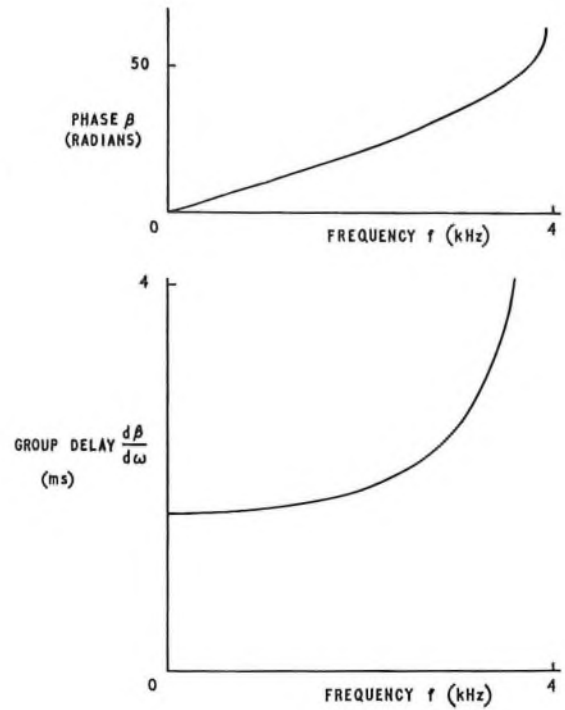

Note: Group-delay scale is 1,000 times phase scale in terms of fundamental units.

FIG. 3—Phase and group delay/frequency characteristics for 20 sections of standard-loaded audio cable

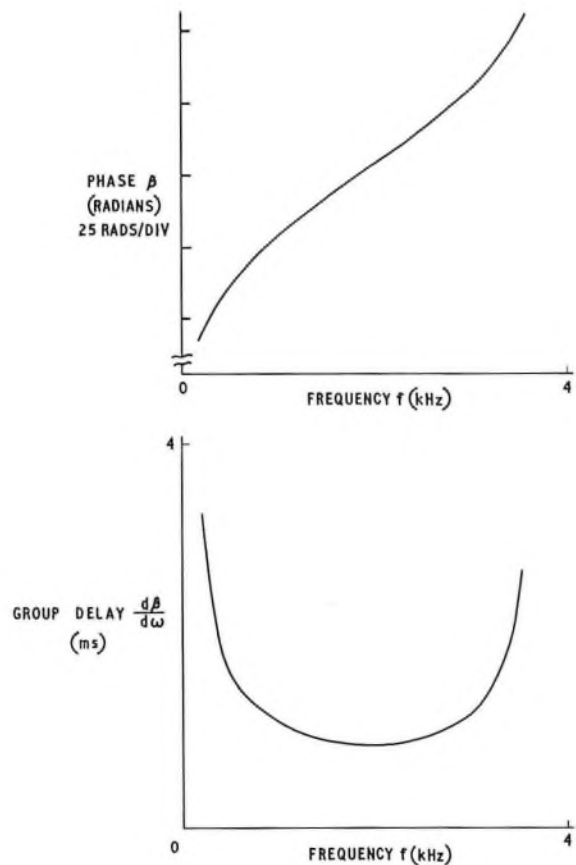

Note: Group-delay scale is 1,000 times phase scale in terms of fundamental units.

FIG. 4—Phase and group delay/frequency characteristics for a typical carrier channel

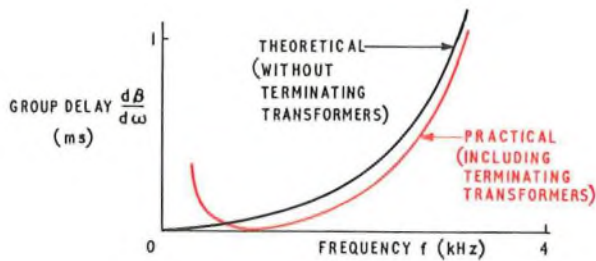

FIG. 5—Theoretical and practical group delay/frequency distortion characteristics for 20 sections of standard-loaded audio cable

comparing the calculated characteristic based on low-pass-filter theory for the cable alone with a measured characteristic with terminating transformers. Unloaded audio cable does not present a group-delay problem because the departure from linearity of the phase/frequency characteristic is small enough for the group delay/frequency distortion to be ignored on short lengths of cable. The curvature of the phase/frequency characteristic is such as to introduce increasing group delay with reducing frequency. Significant group delay/frequency distortion is also introduced by the low-pass filters in pulse-code-modulation (p.c.m.) channels.

### A DESIGN METHOD FOR AUDIO GROUP-DELAY EQUALIZERS

Some administrations provide group-delay equalization with the aid of variable equalizers which cannot be set up until the circuit has been engineered. In the British Post Office, the group delay/frequency characteristics encountered in setting up a circuit are known when line plant is selected. In these circumstances, it is advantageous to provide equalizers having group delay/frequency characteristics designed to meet all known requirements. The required equalizers can then be prescribed together with the line equipment at an early stage in the design of a circuit. The decision to adopt a prescriptive method of group-delay equalization for audio circuits was also largely governed by the availability of a design technique,<sup>2</sup> which offered clear advantages over other methods. These advantages are summarized below.

(a) Design procedures, which are mainly arithmetical, can be handled without difficulty either manually or with the aid of a small computer.

(b) Designs are easily realizable in practicable form to the required high degree of accuracy.

(c) Expensive specialized measuring equipment is not required for manufacture, nor is it strictly necessary for circuit provision, although it is desirable to measure the overall group delay/frequency characteristic of a circuit where this parameter is specified.

(d) Circuit design is greatly simplified, and circuit provision is not delayed by lengthy equalization procedures.

The design technique and factors involved in the realization of designs are described in the following sections.

### DESIGN PROCEDURE

The basic group-delay equalizer section is illustrated in Fig. 6(a), with alternative configurations in Figs. 6(b) and 6(c). All three configurations are constant-resistance, second-order, all-pass networks,\* which are completely defined by two frequency parameters  $f_1$  and  $f_2$  and by the design impedance

\* In theory, these networks have zero loss at all frequencies and exhibit a single peak of group delay of a value and at a frequency determined by the frequency parameters  $f_1$  and  $f_2$ .

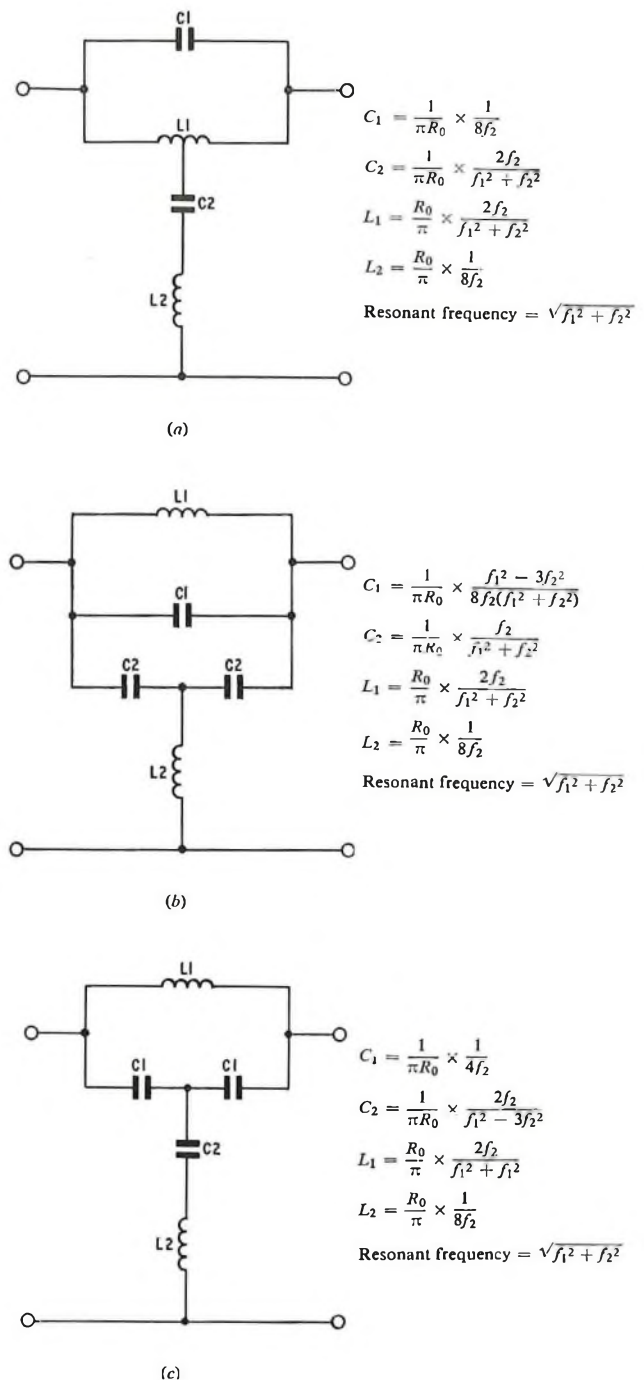

Note: Configuration (a) used when  $f_1 < \sqrt{3}f_2$ , configuration (b) used when  $f_1 \geq \sqrt{3}f_2$ , and configuration (c) used as alternative to (b) when capacitor values are more convenient.

FIG. 6—Group-delay equalizer networks

$R_0$ . The frequency parameters  $f_1$  and  $f_2$  are in fact the coordinates of the pole-zero quad in the complex frequency plane and a complete description of their significance is given in reference 4. However, understanding their derivation is not necessary for a designer wishing to use the design procedure.

It is convenient, for the audio-frequency band, to give  $f_1$  and  $f_2$  in kilohertz and group delay is then in milliseconds. The group delay of a section at frequency  $F$  is evaluated in terms of the two design parameters as

$$F = \frac{1}{\pi} \left[ \frac{f_2}{(F - f_1)^2 + f_2^2} + \frac{f_2}{(F + f_1)^2 + f_2^2} \right]$$



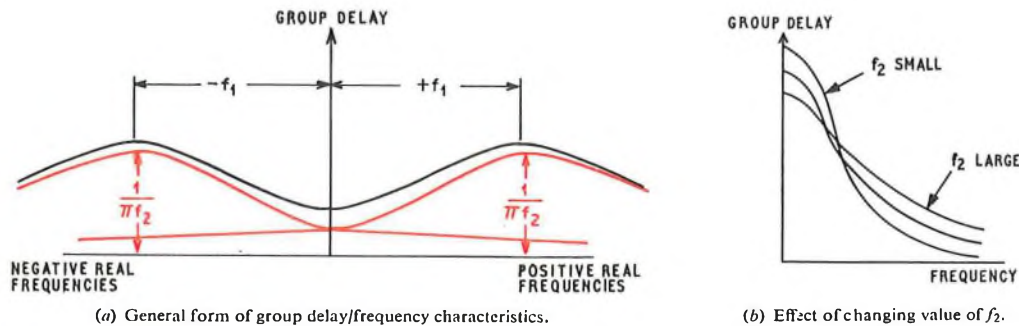

FIG. 7—Group delay/frequency characteristics of equalizer networks

If the two fractional parts of this expression are evaluated separately, it is apparent that they have identical values at  $F = +f_1$  and  $-f_1$ . Furthermore, as illustrated in Fig. 7(a), the two parts (shown in red) are identical and symmetrical about  $+f_1$  and  $-f_1$ , respectively. Therefore, the group delay/frequency characteristic of a section can be obtained from the addition of a symmetrical curve centred on  $+f_1$  and the tail of an identical curve centred at  $-f_1$ . Consequently, the resulting curve (shown in black) is not symmetrical about  $+f_1$ , and the degree of asymmetry depends on the value of  $f_1$ .

The  $f_2$  value relates to the peak value of the symmetrical curves at  $\pm f_1$ , a small value of this parameter resulting in a high peak value with a consequently narrower spread of group delay with frequency. This is illustrated in Fig. 7(b). The  $f_2$  value obviously also affects the degree of asymmetry about  $+f_1$ .

As indicated, this situation is easily resolved by a simple process of addition. Tables which generate standard symmetrical curves, sometimes referred to as templates, are required, covering a range of values of  $f_2$ . Values of  $f_1$  and  $f_2$  are chosen and the template for the chosen value of  $f_2$  is positioned symmetrically about both  $+f_1$  and  $-f_1$ . The values obtained from the two templates are then added together at each frequency to give the actual values of group delay for the section. The result of this addition is shown in Fig. 7(a) for both positive and negative frequencies to illustrate the symmetry about zero frequency, although negative frequencies have no reality in practice. The addition would normally only be carried out over the frequency band of interest.

The group delay/frequency characteristic required for all equalizers is achieved by the addition in tandem of a number of such constant-resistance networks. Choice of section parameters is facilitated by calculation of templates at small frequency intervals over a large range of typical values. This is most suitably done with the aid of a computer, both in terms of accuracy and manhours required. A computer was also used, under the control of a program which contained systematic design procedures, to select section parameters against an unequalized characteristic. This program gave the

most economic design in terms of the number of sections required to meet stated equalized performance limits.

In some circumstances, the systematic design procedures written into the program are inadequate and it fails to achieve the design. In this event, the best available design is produced. Suitable variations of this design may then be made with the aid of the template tables, and these designs entered as data for calculation only.

When large values of group delay are required, it is difficult in the normal way to avoid incurring a troublesome sharp ripple in the equalized characteristic. A two-step design procedure is used to overcome this difficulty. This takes advantage of the fact that there is no interaction between constant-resistance sections, even when they have identical design parameters. Thus, a given delay can be achieved by two or more identical sections which have the same  $f_1$  parameter value and a large, instead of a small,  $f_2$  parameter value. If a number of sections is chosen to achieve partial equalization, the resulting broad ripples can be balanced out by adding sections of appropriate  $f_1$  values to complete the equalization. This method is used extensively and greatly eases the choice of section parameters and achievement of smooth characteristics.

### PRACTICAL REALIZATION OF EQUALIZER DESIGNS

Practical coils have unavoidable imperfections, some of which are easily absorbed in the configurations illustrated in Fig. 6. Self-capacitance of inductor L1 may be allowed for in the value of capacitor C1. Leakage inductance between the two halves of inductor L1 in Fig. 6(a) appears in series with inductor L2 and so, if significant, may also be allowed for.

The effect of winding resistance was investigated with the aid of a computer program. This investigation had a very important outcome relating to the physical size, and cost, of a complete equalizer. It was found that winding resistance has negligible effect on group delay, but has a significant effect

TABLE 1

| Capacitor                 | Maximum Capacitor Voltage<br>Input voltage                  | $\frac{ V_c _{\max}}{V_{in}}$ | Frequency of Maximum<br>Capacitor Voltage |
|---------------------------|---|-------------------------------|---|
| C1 in Figs. 6(a) and 6(b) | 2   |                               | $\sqrt{f_1^2 + f_2^2}$                    |
| C2 in Fig. 6(a)           | 1 where $x = \frac{f_1}{f_2} \leq 1$                        |                               | 0   |
|                           | $1 + x^2$ where $x = \frac{f_1}{f_2} > 1$                   |                               | $\sqrt{f_1^2 - f_2^2}$                    |
| C2 in Fig. 6(c)           | $\frac{x^2 - 3}{2x}$ where $x = \frac{f_1}{f_2} > \sqrt{3}$ |                               | $\sqrt{f_1^2 - f_2^2}$                    |

on insertion loss and on the return loss of a section against its design resistance. Therefore, coil sizes, and hence winding losses, may be chosen without reference to any effect on group-delay values, so that a smooth insertion loss/frequency characteristic is obtained for a complete equalizer, and attenuation equalization is greatly simplified. Return losses of at least 40 dB against the design impedance can be obtained even when coils are wound on pot cores of 18 mm size.

Another factor affecting physical size and cost of equalizers is the maximum signal voltage which can be developed across the capacitors in a resonant circuit. Contrary to expectation, this voltage is remarkably small due to the circuit configuration and in the designs achieved, capacitors with a working voltage of 30 volts were more than adequate. General expressions for the maximum voltage were derived for all configurations for those capacitors from which a centre tap is not derived. These are given in Table 1 in the form of the ratio of the modulus of the voltage across the capacitor to the section input voltage. General solutions for capacitor pairs from which centre taps are derived are not available, but calculation gives results which are, for practical purposes, the same as in Table 1.

The physical size of an equalizer also depends on the design impedance chosen for the group-delay sections, since this is a scaling factor for the component values. A value of characteristic impedance is required which gives values of capacitance in a commercially available range of 1 per cent tolerance capacitors without making coil values unduly large. At the same time, matching of this impedance to the circuit impedance is necessary, and in audio circuits, masking from external impedances on both sides of the group-delay sections is also essential. For ease of maintenance, it is desirable to incorporate attenuation equalization and gain, so that each equalizer has zero loss and zero spread over the pass-band of any line plant with which it is to be used. Masking of the unbalanced equalizer circuit from balanced line plant is also necessary.

A design impedance of 2,100 ohms satisfies all requirements for the range of equalizers designed, in which a well-tried design for a 30 dB amplifier is used. This amplifier provides isolation for the unbalanced equalizer at the output. A standard line transformer is used at the input for this purpose, but it is necessary to ensure that this transformer has a primary inductance of at least 1 henry so that an adequate return loss is obtained at the equalizer input. Minimum-loss matching and masking attenuators of 11 dB loss are used at the input and output of the group-delay and attenuation-equalizer sections. This leaves at least 2 dB of spare gain to cater for manufacturing tolerances and maintenance adjustment.

## UTILIZATION AND MAINTENANCE

With one exception, all of the equalizers can be strapped to give more than one group delay/frequency characteristic. Appropriate attenuation equalizers are included in each strapping arrangement. All equalizers can be patched out of circuit by moving link-plugs on the front panels and provided that the equalizers are connected at a 600-ohm point in a circuit, no adjustment to the circuit gain or attenuation equalization is required. The circuit is then immediately available with degraded group-delay performance only, and fully satisfactory for speech or a lower-speed data transmission. At the same time, the equalizer input and output terminals are accessible for testing.

If transmission through an equalizer is possible, a test of attenuation/frequency response shows whether or not an equalizer is faulty. A component or wiring fault in a group-delay equalizer section produces a large loss over a narrow frequency band, since the constant-impedance configuration of a section is disturbed. Similar faults in attenuation equalizer sections introduce a small spread over a wide frequency band.

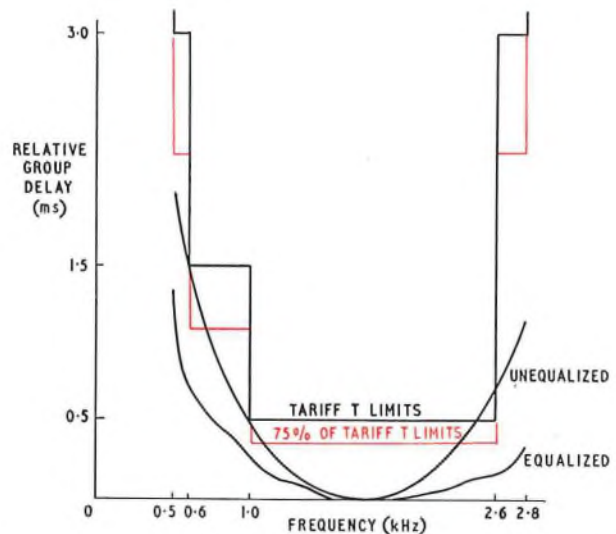

FIG. 8—Tariff T group delay/frequency distortion limits and typical equalized and unequalized circuit characteristics

Faulty matching attenuators are likely to result in a large spread over the whole frequency band.

## Positioning of Equalizers

Group delay/frequency equalization differs from attenuation/frequency equalization in that the absolute value is not normally important. For attenuation equalization, signal-to-noise ratio considerations make it necessary to limit the level to which a signal is allowed to fall, and this places restrictions on the positioning of equalizers along a circuit. In some circumstances, the end-to-end group delay is of concern, for example, where propagation time has an effect on error control and correction systems in which a transmitter must receive confirmation that a block of data has been received correctly before transmitting the next block of data. In general, however, on inland circuits, group-delay equalizers can be placed at any convenient point along a circuit.

## Equalization Procedure

In the British Post Office, the amount of equalization required is decided on a prescriptive basis, as investigations have shown that the group delay/frequency distortion introduced is fully reproducible for specific items of plant. Group delay is additive and the distortion introduced by several items of plant can be found by adding up the distortions at spot frequencies through the audio band of each individual item of plant and making the results relative to the minimum value. Tables give group delay/frequency distortion for incremental lengths of standard-loaded audio cable and for c.t.e. Equalizers are chosen appropriate to the circuit plant with the objective of meeting 75 per cent of the Tariff T group delay/frequency distortion limits. The equalized distortion is assessed by adding the equalizer characteristics to that of the unequalized circuit and making the result relative to the minimum value before comparing with the target objective. Post Office Tariff T group delay/frequency distortion limits are based on the C.C.I.T.T.\* Recommendation M102. These are shown in graphical form in Fig. 8 together with unequalized and equalized characteristics for a typical circuit comprising three c.t.e. and 20 miles of standard-loaded audio cable.

The Post Office range of prescriptive group-delay equalizers covers fixed lengths of standard-loaded audio cable of 12–100 miles and variable channel equalizers. The distortion

\* C.C.I.T.T.—International Telegraph and Telephone Consultative Committee.



introduced by c.t.e. of different type and manufacture varies significantly, and the variable channel equalizer is adjusted by strapping in equalizer sections appropriate to a particular c.t.e. combination of transmit and receive apparatus. This arrangement satisfies all but one 4 kHz c.t.e. for which a special fixed equalizer has been designed. Another variable channel equalizer has been designed for 3 kHz c.t.e. Cable equalizers have been designed for standard loading only, but they can be used when loading is not standard by applying a correction factor to the cable length. When measured characteristics are not available for non-standard loading of audio cable, the group delay can be calculated using low-pass filter theory, as shown in the appendix from which,

$$\tau_g = \frac{1}{\pi\sqrt{f_c^2 - f^2}},$$

where  $f_c$  is cut-off frequency, and  $f$  is frequency required. Also, group-delay distortion is given by:

$$\Delta\tau_g = \frac{1}{\pi\sqrt{f_c^2 - f^2}} - \frac{1}{\pi f_c}.$$

One further use for the cable equalizers is on p.c.m. channels. Compromise group-delay equalization is achieved by treating the group delay/frequency distortion introduced by one p.c.m. channel as equivalent to six miles of standard-loaded audio cable.

Prescriptive group delay/frequency distortion equalization has been found to operate very satisfactorily without group delay being measured on a circuit either before or after equalization. It has indeed been impossible to undertake group-delay measurements on all circuits for which this parameter is defined due to scarcity of suitable measuring equipment. A margin of tolerance has been allowed by attempting to equalize to 75 per cent of the required limit. Now that a Post Office group-delay measuring set is becoming available, it is intended that group delay should be measured after equalization, if required, to confirm the correctness of a prescription. However, this is not expected to change the basic method of group-delay equalizer utilization.

## CONCLUSIONS

Group delay/frequency distortion is now accepted as a necessary specified parameter for audio-frequency-band data circuits and group-delay equalizers have become familiar items of apparatus to circuit-provision and maintenance engineers in the field. The Post Office private-wire circuit specifications give a guarantee of group delay/frequency distortion performance where this is necessary for higher speeds of data transmission. The British Post Office has developed its own method of prescriptive block equalization which has many features to commend it, and which has attracted world-wide interest. It is simple to operate, and expensive group-delay measuring equipment is not required

except to confirm a correct prescription. The group-delay equalizers are virtually independent of the circuit they correct and can be patched in or out without affecting anything other than the group-delay performance. They have been designed to a high degree of precision which has only been possible by making full use of computing techniques.

## References

- <sup>1</sup> C.C.I.T.T. Recommendations G114 and G133.
- <sup>2</sup> Post Office Research Report No. 14314.
- <sup>3</sup> Delay Distortion, *The Lenkurt Demodulator*, Vol. 14, No. 6, June 1965.
- <sup>4</sup> MERTZ, P. The effect of Delay Distortion on data transmission. *Communications and Electronics*, No. 49, p. 228, July 1960.
- <sup>5</sup> BROWN, J., and GLAZIER, E. V. D. *Telecommunications*, Vol. 1 (Chapman and Hall), p. 97.
- <sup>6</sup> WILLIAMS, M. B. The Characteristics of Telephone Circuits in Relation to Data Transmission. *P.O.E.E.J.*, Vol. 59, p. 151, Oct. 1966.

## APPENDIX

### Group delay of loaded audio cable considered as a low-pass filter

For a prototype low-pass filter, the following relationship can be derived from the propagation constant for a  $\pi$  or T section:

$$\cos \beta = 1 - \frac{\omega^2 LC}{2} \quad (1)$$

Neglecting the effect of resistance, which can be proved to be insignificant, this can be related to one section length of loaded audio cable by the following identities:

- $L$  = inductance of section loading coil, henries,
- $C$  = capacitance of one loading section of cable, farads,
- $\omega$  = frequency, radians/second, and
- $\beta$  = phase coefficient, radians/loading section of cable.

From (1),

$$2 \sin^2 \frac{\beta}{2} = \frac{\omega^2 LC}{2}.$$

$$\therefore \sin \frac{\beta}{2} = \frac{\omega\sqrt{LC}}{2}.$$

If  $f$  is the required frequency and  $f_c$  is the cut-off frequency of the loaded audio cable ( $f_c = \frac{1}{\pi\sqrt{LC}}$ ), then phase  $\beta$  is given by:

$$\beta = 2 \sin^{-1} \left( \frac{f}{f_c} \right) \text{ radians/section.} \quad (2)$$

The units for  $f$  and  $f_c$  should be the same.

Now, group delay is given by  $\tau_g = \frac{d\beta}{d\omega} = \frac{1}{2\pi} \frac{d\beta}{df}$  and differentiating

(2) with respect to  $f$  gives:

$$\tau_g = \frac{1}{\pi\sqrt{f_c^2 - f^2}} \text{ time/section}$$

The units of time depend upon the units of  $f$  and  $f_c$ . When these are in hertz, group delay  $\tau_g$  is in seconds. If in kilohertz, then group delay is in milliseconds.

# The Design and Planning of the Main Transmission Network

J. F. BOAG, C.ENG., M.I.E.E. and J. B. SEWTER, C.ENG., M.I.E.E.\*

U.D.C. 621.395.741.001.6: 621.395.4: 621.315.2

*Planning the United Kingdom main-line transmission network is carried out at Telecommunications Headquarters. The layout and growth of the network are reviewed together with the steps taken to augment it. The types of transmission systems used are also discussed and the procedures adopted for selecting a particular system explained. The factors to be considered in route planning are then examined and the article ends with a brief review of future network plans.*

## INTRODUCTION

The main (trunk) transmission network provided by the British Post Office is a fundamental part of the long-distance telecommunications system of the United Kingdom, and has some of the heaviest traffic-carrying trunk routes in the world. This extensive nationwide transmission network uses audio, pulse-code modulation, carrier and coaxial systems on cables together with microwave radio-relay links. The network has to meet the ever-growing requirements of many services. These include the public trunk telephony service, which is the largest user, the public telegraph service, the telex service, private circuits including data transmission, radio and television broadcast services, closed-circuit television and international communications.

In determining the optimum design of the transmission network, account is taken of existing and possible future services, of performance requirements and of the comparative costs of switching, signalling and transmission plant.

A plan is prepared each year to augment the transmission network, where necessary, to meet the forecast growth. Each year's plan details the requirements for such items as duct, cable, line and multiplex equipment, radio plant and associated accommodation, power supplies and radio towers.

The present transmission network has involved an investment of £200 million, and in recent years each annual plan for increasing the capacity of the network has cost over £20 million. Additionally, a Service Protection Network of spare coaxial-cable systems has recently been designed and planned to achieve an improved re-routing capability on the more important trunk routes.

## GROWTH OF THE INLAND TRANSMISSION NETWORK

There has been a very large growth in the demand for trunk services during the last 25 years (Fig. 1) and the number of public trunk circuits over 25 miles in length has increased nearly nine-fold during this period (Fig. 2). In March 1970, the number of over 25-mile circuits in use was 87,500. There has also been a considerable expansion in the requirements of other services, particularly of wideband private circuits. As an example, the vision-link mileage provided for the broadcast authorities has increased since 1945 from about 10 miles to about 7,500 miles, most of this now being capable of carrying 625-line colour signals. Figure 3 shows the remarkable decrease in the cost of providing the line element of a trunk circuit since 1945. The costs from 1970 onwards have been estimated.

## NATIONAL TRANSMISSION PLAN

The two-wire switched trunk and junction network is used for the majority of subscriber trunk dialled (s.t.d.) calls.

\* Mr. Boag is, and Mr. Sewter was, in the Network Planning Department of Telecommunications Headquarters. Mr. Sewter is now with the Independent Television Authority.

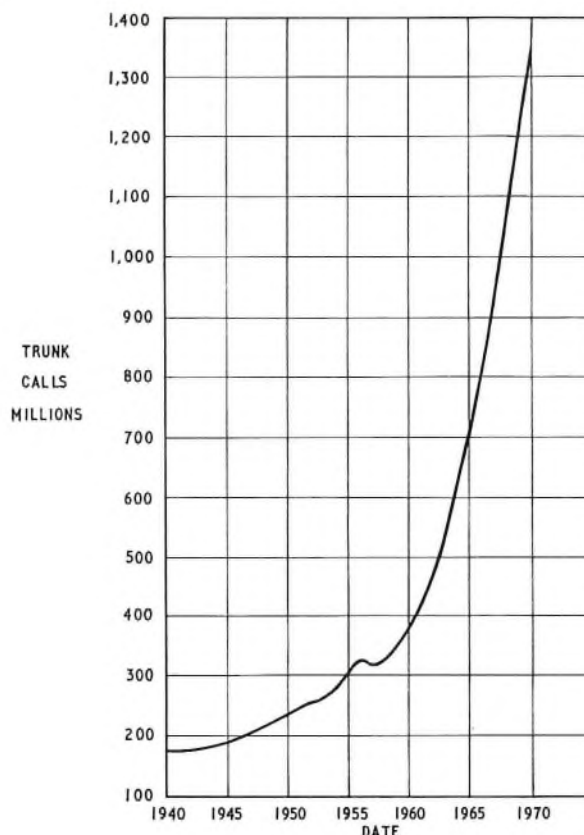

FIG. 1—Growth of inland trunk calls

Subscribers are connected to a local exchange and gain access to the trunk network through a group switching centre (g.s.c.). Calls are routed direct to the objective g.s.c. serving the subscriber being called or via not more than one g.s.c. The transmission and switching losses should not exceed those given in Fig. 4.

A further network, the *transit network*, is an overlay network used for trunk calls which would otherwise require more than two inter g.s.c. lines in tandem. It is switched four-wire and its transmission and switching losses should not exceed those given in Fig. 5. The network will be introduced gradually during the first half of the 1970s and will carry about 6 per cent of all s.t.d. calls by 1975.

There are approximately 360 g.s.c.s and 37 transit switching centres (t.s.c.s) in the trunk network. The t.s.c.s are divided into main switching centres (m.s.c.s) which are fully interconnected and district switching centres (d.s.c.s) which are the remainder.



## Direct and Indirect Routes

In both the 2-wire and 4-wire switched networks, there are possible auxiliary routes which provide direct connexions when the traffic justifies their provision.

The decision to connect two g.s.c.s directly instead of employing an intermediate switching point is based on an economic study which takes into account the volume and type of traffic and the relative costs of switching, signalling and transmission (translating and line) plant. Fig. 6 shows the component capital cost of a 100-mile circuit and a 40-mile circuit routed on modern coaxial plant. The translating and line plant account for approximately 30 per cent of the cost including apportioned costs for accommodation and power. An indirect route would involve additional switching and signalling equipment.

## ESTIMATE OF CIRCUIT REQUIREMENTS

Using a formula to assist in the direct/indirect route decision, Telephone Managers each autumn publish an Annual Schedule of Circuit Estimates which contains information on the routes and circuits required for the main network over a period of five years following publication. To these requirements are added the requirements of other users such as overseas services, broadcasting authorities, telegraph and data.

Circuits may be routed wholly on high frequency (h.f.) plant or wholly on audio plant or partly on each. Where the number of circuits on a traffic route exceeds twelve, two or more engineering routes are normally provided. The choice of whether to adopt an audio routing or h.f. routing is determined by economic considerations. Broadly speaking, the position at the present time is that, for distances up to 8-10 miles, the cheapest method of circuit provision is by audio cables with 0.635 mm conductors and negative-impedance repeaters. For distances greater than 10 miles, it is generally more economic to use h.f. plant either frequency-division multiplex (f.d.m.) or time-division multiplex (t.d.m.) depending on growth rates. By the end of 1974, some 330,000 circuits are planned to be carried by the h.f./f.d.m. network of which 327,000 circuits are for the main network. The corresponding

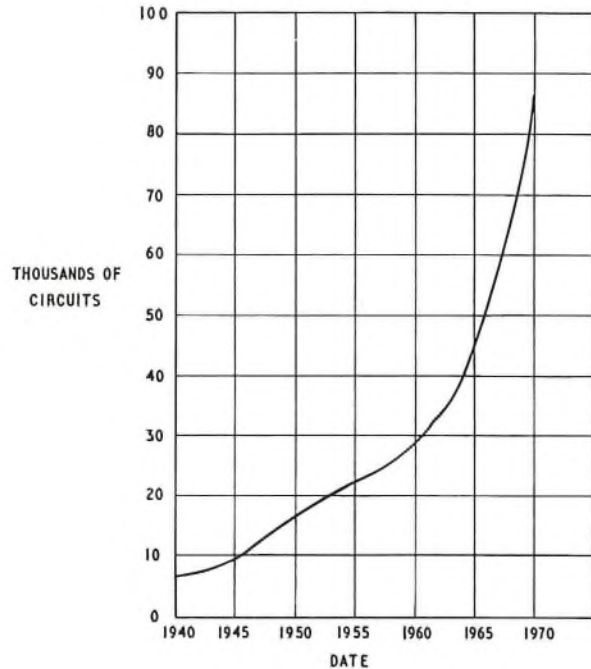

FIG. 2—Growth of trunk circuits greater than 25-miles long

figures for the audio network are 1,039,000 circuits and 52,000 circuits.

Having determined the quantity of circuits to be carried on h.f. or audio plant, the planning of the audio and h.f. networks can proceed. In the British Post Office, audio-plant planning is done at regional level, whilst h.f. planning is done at headquarters level.

## H.F. NETWORK PLANNING

Planning of the h.f. network is carried out with the assistance of an Elliot 503 computer. One program maintains the

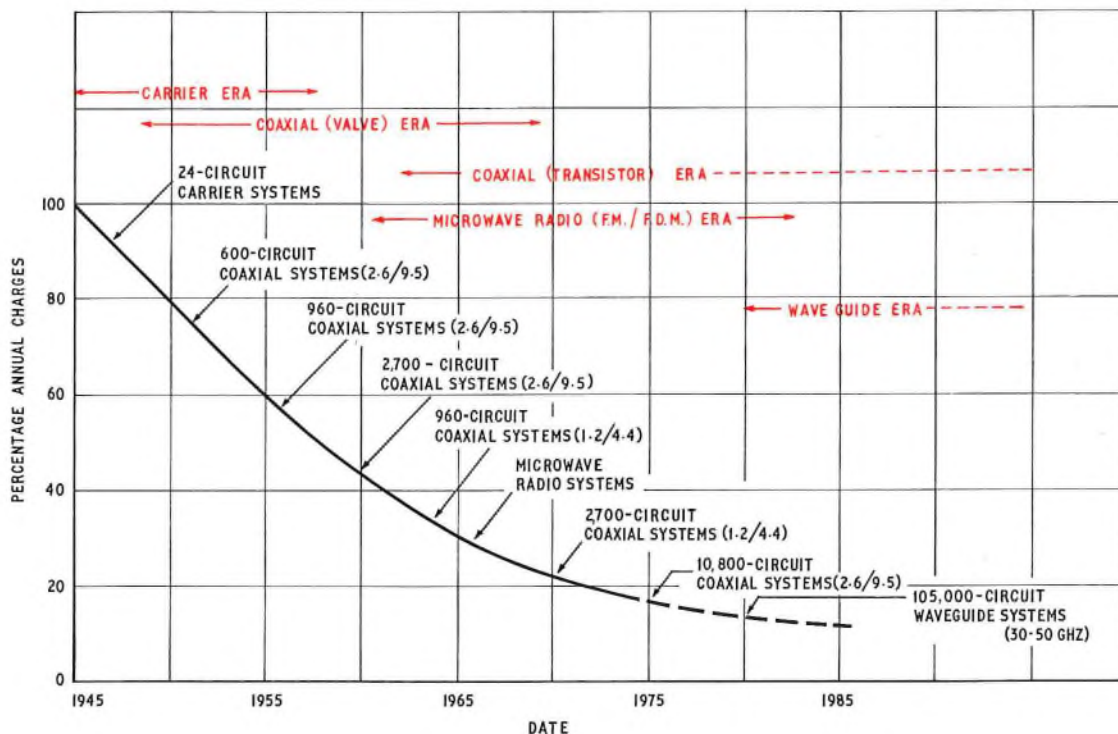
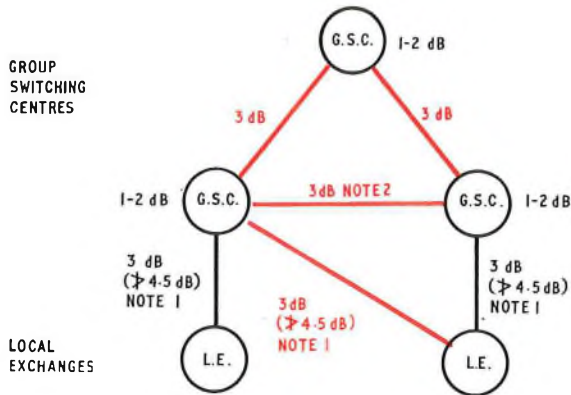

FIG. 3—Relative line-plant costs of a 100-mile trunk circuit at 1968 values



Note 1: Limits in brackets refer to unamplified circuits.  
 Note 2: This limit may rise to 7.5 dB on circuits carrying terminal traffic only.  
 Note 3: Switching loss at terminal local exchange is included in allowance for subscriber's line and instrument.

FIG. 4—S.T.D. routing and transmission plan (2-wire switched)

routing library which lists in alphabetical order the traffic routes, the number of h.f. circuits for each traffic route, the number of circuits on each of the engineering routes serving each traffic route, and the number of circuits on each of the engineering routes.

A second program compares the required circuit capacity with the existing capacity of each h.f. section and detects any exhaustion. It is also possible to apply multiplying factors to the required circuit capacity to determine the capacity required for later years. When plant exhaustion is indicated, the network in the vicinity of the exhausted section is examined for possible rearrangement of hypergroups\* and plant to overcome the blockage. If this is not practicable, new plant is added. The requirement for new plant is, with some exceptions, stated in terms of 15-supergroup hypergroups (900-circuit blocks) between h.f. nodes, together with a broad indication of the routing to be followed.

Some idea of the size of the h.f. network can be gauged from the following figures, which have been taken from the 1974 planning data:

|                                      |       |        |
|--------------------------------------|-------|--------|
| number of traffic routes             | .. .. | 7,200  |
| number of h.f. sections              | .. .. | 1,000  |
| number of h.f. nodes                 | .. .. | 570    |
| capacity of largest section (groups) | .. .. | 470    |
| number of hypergroups                | .. .. | 930    |
| hypergroup kilometres                | .. .. | 99,600 |
| average length of hypergroup (km)    | .. .. | 107    |

The next stage is to determine how much additional plant must be added to the h.f. network to enable the hypergroups to be set up.

### CHOICE OF TRANSMISSION SYSTEMS

The choice of transmission system is determined by the economics, transmission performance requirements and practical constraints of the route involved. In addition, speed of provision can sometimes be a factor affecting the decision.

General economic studies are carried out to determine, in broad terms, the economic operating conditions for different types of transmission systems. Average plant costs are used, and various rates of growth are assumed. Other studies have indicated that the economic provisioning period is of the order of 20 years for a duct, and 7–10 years for cables. The information obtained from general economic studies is used by the planning engineer as a guide to the type of transmission systems that could be used to augment the network.

To determine the most suitable transmission system to

\* A hypergroup is an assembly of two or more supergroups.

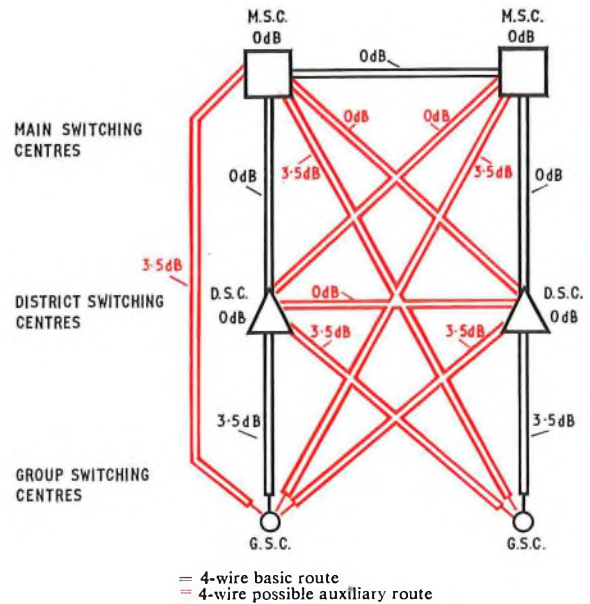

FIG. 5—Routing and transmission plan for the 4-wire switched Transit Network

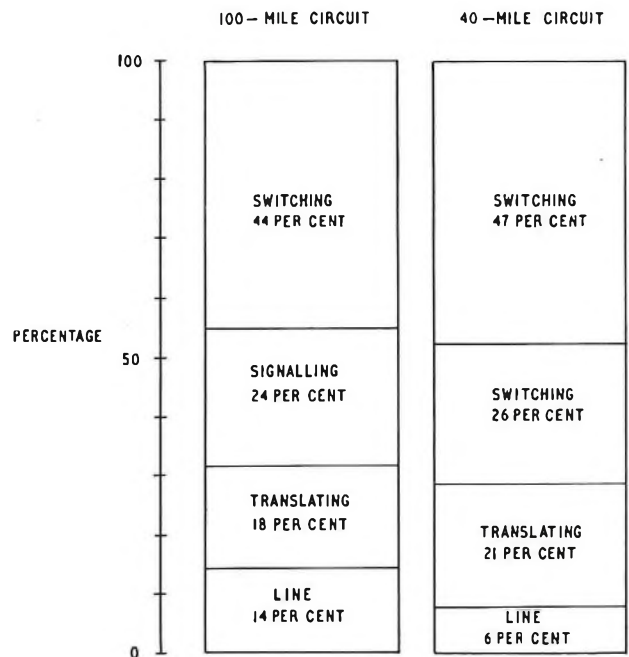

FIG. 6—Component capital cost of a telephone circuit based on transistorized terminal and 12 MHz line equipment and 2.6/9.5 mm coaxial cable

augment a section of the network, the circuit growth for the section for 10–20 years ahead is first calculated. The traffic calculation is based on calculating the circuit growth of a number of selected h.f. sections which are to be routed over the new system. The selection of h.f. sections to be carried by the new system is made in such a way that a fault in any one transmission system does not cause a total circuit failure between any two h.f. nodes.

Having determined the long-term traffic growth for the section of the network under investigation, a number of transmission systems may then appear to be suitable. The final choice of a system is determined by rejecting those which are not technically acceptable for the situation and then carrying out an economic study on a basis of the present value of annual charges of the other possible solutions. In the majority of cases, the most economical solution is selected.

At the present time, the choice of h.f. transmission systems



for distances greater than 15 miles is largely determined by the rate of growth as shown in Table 1.

**TABLE 1**

| Growth Rate (circuits per annum) | Transmission System Provided                            |
|----------------------------------|---|
| 20-100                           | 4 MHz coaxial systems                                   |
| 100-500                          | 12 MHz coaxial systems or microwave radio-relay systems |
| above 500                        | 60 MHz coaxial systems                                  |

For low growth-rate routes, pulse-code-modulation (p.c.m.) systems normally prove to be economic in the range 10-30 miles.

**TRANSMISSION SYSTEMS**

The main types of transmission systems being provided today to augment the trunk communications network in the United Kingdom are:

- (a) audio and p.c.m. systems on multi-pair cables, usually of paper-insulated star-quad construction,
- (b) carrier systems on coaxial-pair cables, and
- (c) microwave radio-relay systems.

**Audio Systems**

The principal characteristics of audio plant for the main network are given in Table 2 in which the distances quoted for amplified circuits assume the use of 2-wire negative-impedance amplifiers. Hybrid-type amplifiers permit somewhat longer 2-wire circuits to be provided and 4-wire amplified circuits can be used where audio circuits beyond the range of 2-wire amplifiers are required.

Present-day economics have led to most new audio cables having 0.635 mm conductors and it is hoped to rationalize and reduce the number of sizes of existing audio trunk cables in the near future.

Four-wire audio amplification is becoming obsolescent due to the introduction of stable 2-wire amplifiers, but not more than one 2-wire amplifier is used per circuit. Two types of 2-wire amplifier are in use, the hybrid type for longer routes and the negative-impedance type for shorter distances.<sup>1</sup> In addition to being considerably cheaper, the latter amplifier has the advantage that, under power-failure conditions, circuits amplified by it remain usable, although degraded to 6 dB below their unamplified condition.

**P.C.M. Systems**

Deloaded audio quads in existing cables are used to provide 24-circuit p.c.m. groups<sup>2</sup> and underground regenerators are provided, normally at 2,000-yard intervals at loading-coil positions, power at 75-0-75 volts being fed over the quad phantoms. Crosstalk considerations limit the number of systems which may be used in a cable, and the p.c.m. capacity is related to the number of cable-balancing groups available. New audio cables will be designed to take into account p.c.m. capabilities and are likely to be smaller.

**Coaxial Line Systems**

Table 3 lists the carrier systems employing f.d.m. on coaxial pairs which are now being used in the planning of the main network. All these systems employ transistor amplifiers, the intermediate repeaters normally being installed underground in footway boxes, and are suitable for routes up to about 150 miles.<sup>3</sup>

**TABLE 3**

| Number of Circuits per Pair of Tubes | Nominal Bandwidth (MHz) | Typical Frequency Band (kHz) | Repeater Spacing (km/miles) | Coaxial Pair Diameter (mm)* |
|--------------------------------------|-------------------------|------------------------------|-----------------------------|-----------------------------|
| 960                                  | 4                       | 60-4,000                     | 4.0/2.5                     | 1.2/4.4                     |
| 960                                  | 4                       | 60-4,000                     | 9.3/5.75                    | 2.6/9.5                     |
| 2,700                                | 12                      | 300-12,500                   | 2.0/1.25                    | 1.2/4.4                     |
| 2,700                                | 12                      | 300-12,500                   | 4.5/2.8                     | 2.6/9.5                     |
| 10,800                               | 60                      | 4,200-61,000                 | 1.5/0.93                    | 2.6/9.5                     |

\* 1.2/4.4 (previously termed 0.174) coaxial cable has an inner conductor having an outer diameter of 1.2 mm and an outer conductor of inner diameter 4.4 mm.

Similarly, 2.6/9.5 (previously 0.375) coaxial cable has inner and outer conductors having diameters of 2.6 mm and 9.5 mm respectively.

The standard sizes of coaxial cable are: 2.6/9.5 mm having 2, 4, 6 and 8 coaxial pairs, and 1.2/4.4 mm with 4, 8 and 12 coaxial pairs. In addition, a new 2.6/9.5 mm, 18 coaxial-pair cable is being developed for the 60 MHz line systems.

At present, all these coaxial cables are manufactured with a lead sheath, protected by a thin layer of polythene and to reduce construction and maintenance difficulties, audio layer pairs are not normally included.

**Microwave Radio-Relay Systems**

Microwave radio-relay links are used on inter-city routes where the trunk traffic makes them an economic method of provision. They are also used on routes where there is a television-transmission requirement,<sup>4</sup> but where a video-on-coaxial-cable system is not economic and practical.

The main u.h.f. and s.h.f. frequency bands allocated to the British Post Office are detailed in Table 4.

The 4 GHz band (3,790-4,200 MHz) and the lower 6 GHz band (5,925-6,425 MHz) are mainly used for general trunk traffic. Part of the upper 6 GHz band (6,425-7,100) MHz and parts of the 2 GHz band and 11 GHz bands are used for television as well as trunk traffic. Proposals are being considered to divide the 1,700-1,900 MHz band to give a larger number of small-capacity channels.

At present, f.d.m. is used on all microwave systems, and intermediate stations used for amplifying and re-transmitting the signals are usually spaced at intervals of about 25 miles, depending on such factors as the availability of sites and the

**TABLE 2**

| Type of Cable (Paper-insulated star quad)             | Number of Pairs in Cable | Distance for a 3 dB circuit (km/miles) |  |  |
|---|--------------------------|--|--|--|
|   |                          | Unamplified                            | One 2-wire amplifier at end of circuit | One 2-wire amplifier at mid-third of circuit |
| 0.635 mm (10 lb/mile) unloaded                        | 14-1,040                 | 2.2/1.4                                | —                                      | —  |
| 0.9 mm (20 lb/mile) unloaded                          | 14-542                   | 3.3/2.08                               | —                                      | —  |
| 0.635 mm (10 lb/mile) loaded at 88 mH per 1.136 miles | 14-1,040                 | 6.6/4.1                                | 16/10                                  | —  |
| 0.9 mm (20 lb/mile) loaded at 88 mH per 1.136 miles   | 14-542                   | 13/8.1                                 | 29/18                                  | 50/31  |

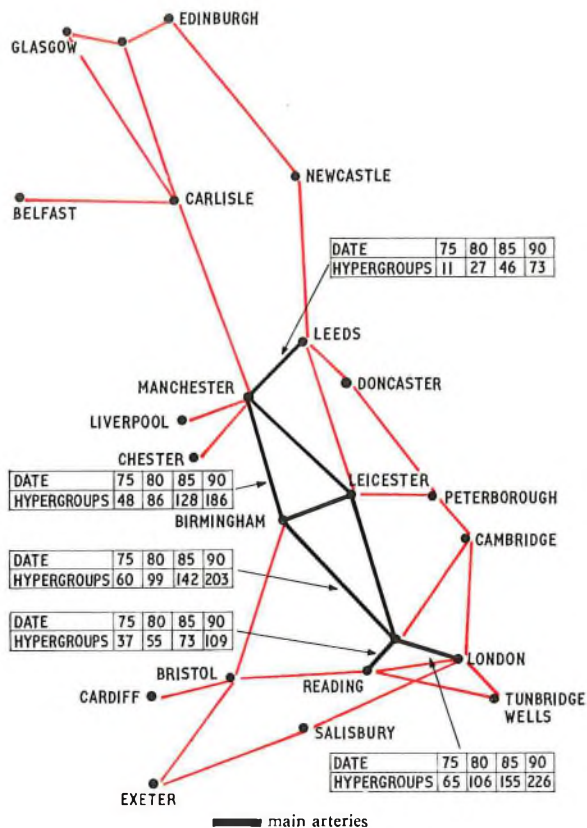

FIG. 7—Main inter-city transmission network

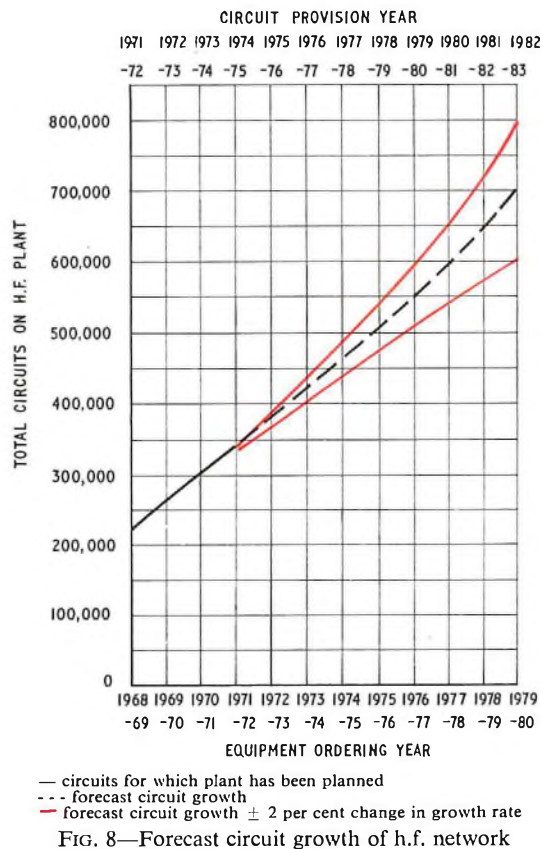

FIG. 8—Forecast circuit growth of h.f. network

nature of the terrain. New types of radio towers and radio equipments are planned and are being brought into service. The radio equipment is of solid-state construction, except for the output stage which employs a travelling-wave tube having an output power of, typically, 10 watts.

TABLE 4

| Frequency Band (MHz) | Number of Radio Channels | Traffic per Channel | Normal Usage Working Channels | Protection Channels |
|----------------------|--------------------------|---------------------|-------------------------------|---------------------|
| 1,700–1,900          | 2                        | 960                 | 1                             | 1                   |
| 1,900–2,300          | 6                        | 960                 | 4                             | 2                   |
| 3,790–4,200          | 6                        | 1,800               | 4                             | 2                   |
| 5,925–6,425          | 8                        | 1,800               | 6                             | 2                   |
| 6,425–7,110          | 16                       | 960                 | 12                            | 4                   |
| 10,700–11,700        | 12                       | 960                 | 10                            | 2                   |

### ROUTE PLANNING

The plans for augmenting an existing route, or establishing a new route, have been timed to enable the plant to be planned and provided to meet the circuit requirements. Establishment of a new coaxial or microwave route, or augmentation of an existing cable route where a considerable amount of duct work is required, has to be started at the planning stage 6 years in advance of the circuit requirements. The various stages of planning and provision, such as duct, cable, coaxial-line system and translating equipment, are phased during this period to enable the work to proceed in the most economic and practical way. On normal augmentation projects, planning 5 years ahead, instead of six, is normally adequate.

In order to establish the optimum routing for coaxial-cable systems, it is necessary to carry out surveys in which consideration is given to such factors as cost, security, siting of buried repeaters to meet system-spacing requirements, power feeders, if any, and maintenance access.

On radio-system surveys, suitable sites have to be found for masts and buildings. Line-of-sight microwave radio-relay

links are planned to achieve free-space propagation for all but a small percentage of the time. To meet this criterion, it is necessary to arrange that there is a certain minimum clearance between the direct transmission path of the microwave energy and any obstructions in, or near, that path, such as the surface of the earth, trees, or buildings. This minimum clearance is normally expressed in terms of the Fresnel Zone radius.<sup>5</sup> In site selection, consideration has also to be given to such factors as proximity to roads and mains power, access during winter, type of ground, possible amenity measures and possible building obstructions. Obtaining planning permission can often be a difficult problem.

The advantages of the wideband horn aerials covering both the 4 GHz and 6 GHz bands has been used on some of the main routes. However, there are serious disadvantages with their alignment and all provision is now planned using paraboloid aerials. The number of microwave routes that can be used into one terminal using the same frequency bands is limited to 4–5 by the discrimination between aerials.

### NETWORK PLANS

The main inter-city transmission network is shown in Fig. 7. The black lines represent the existing and planned main arteries of the network and some examples of the number of 900-circuit hypergroups estimated to be carried by routes over the period 1975–1990 are also given. The hypergroup figures clearly indicate that London is the centre for trunk traffic and, in fact, some 20 per cent of all trunk calls originate in the London director area and a similar number of calls terminate there. The present growth rate of the London–Birmingham–Manchester route is some 6–7 hypergroups per year.

No through routes are planned via London because of the problem of finding accommodation for plant in London, a problem already aggravated by the need to accommodate a vast amount of equipment for London terminal trunk traffic. It is planned to maintain at least two repeater stations at each node of the inter-city network in order to achieve a high degree of security.



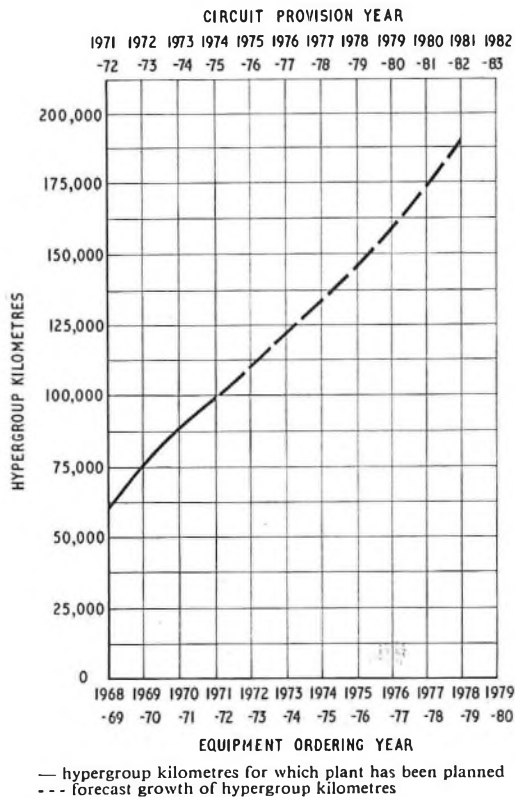

Fig. 9—Forecast growth of hypergroup kilometres

The h.f. plant planned to be in service by 1975 will include 119,000 tube-kilometres of 1·2/4·4 coaxial cable, 37,500 tube-kilometres of 2·6/9·5 coaxial cable, 80,000 microwave channel kilometres, 1,020 4 MHz coaxial systems and 300 12 MHz coaxial systems. The security of the system is being improved by the provision of a protection network which will be one-tenth the size of the traffic network.

By 1977, it is planned to have the London-Birmingham-Manchester-Leeds-Reading routes equipped with 60 MHz line systems on 8 or 18-pair, 2·6/9·5 coaxial cable. The security of this very high capacity system is very important and special construction techniques will be used.

The forecast growth of the h.f. network and the types of plant likely to be used during the 1970s is illustrated in Figs. 8, 9 and 10.

### FUTURE NETWORK

The present coaxial and radio network employs f.d.m. transmission, although it is carrying an increasing amount of digital information. The first steps are now being taken to plan a digital network, using low-capacity digital radio links and special modems to transmit digital bit-streams over the f.d.m. network.

In the second half of the 1970s, digital coaxial systems capable of transmitting digital bit-streams up to 120 Mbit/s should become available, and 500 Mbit/s coaxial systems will follow. Consideration is also being given to the introduction of waveguides operating in the band 30-50 GHz to give approximately 100,000 telephony or 1,200 viewphone circuits by the early 1980's. All these new facilities will help to meet the need to transmit an ever-increasing amount of information in digital form and to provide new services such as viewphone and confravision.

### CONCLUSIONS

The transmission main-line network is growing at a rate of approximately 12 per cent per annum and as its size increases so does its complexity. The procedures outlined in this article indicate how the British Post Office plans the development of the network to meet the annual circuit forecast. Some measure of the size of this task can be gauged

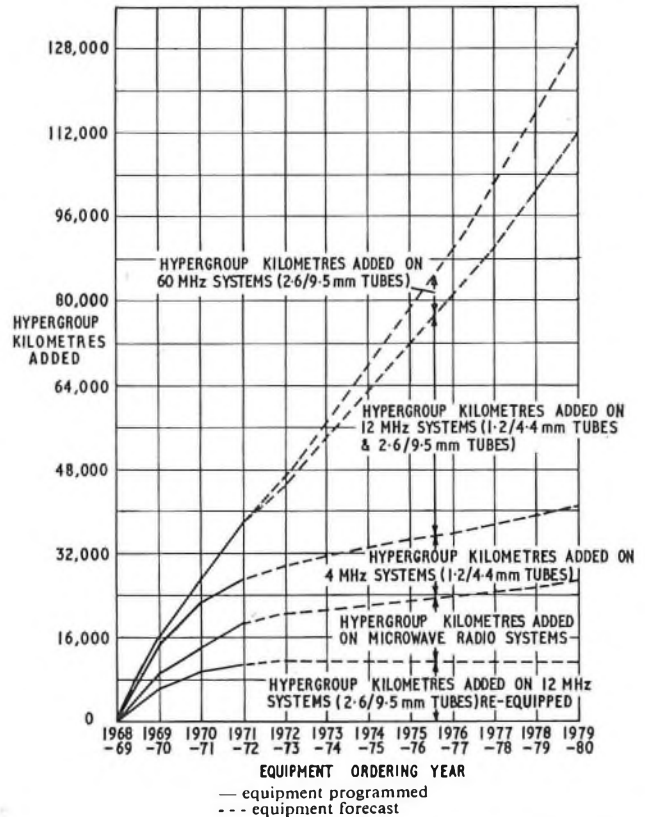

Fig. 10—Growth of hypergroup kilometres forecast for the various transmission systems

from the fact that an annual program costing typically £23 million for plant additions to the network to carry 300,000 additional circuits has to be prepared within a time scale of eight months.

The choice of transmission systems available for augmenting the network increases with time and it is, therefore, necessary to continually review the most economic methods of providing circuit capacity. In the second half of the 1970s, digital communication links will become an increasingly important consideration in network planning, and could have a profound effect on reducing the cost of providing circuits between exchanges. However, the effect on the costs of providing a transmission path for the circuit is not likely to be significant.

In order to cope with the ever-increasing amount of data presented to the planning engineer, further computer assistance is being considered. It is hoped to have available in 1972 the circuit forecasts on magnetic tape. This tape will be used to input data necessary for carrying out a large number of calculations which are at present carried out manually. In this way, further effort can be directed to ensuring that the network is continuing to be expanded in the most economic manner. Further stages in the computerization program envisages a greater measure of planning by computer in order that planning efficiency can be maintained in an ever-expanding and complex network.

### References

- 1 NEILL, T. B. M., and TURNER, D. The Principles of Negative-Impedance Converters and the Development of a Negative-Impedance Amplifier. *P.O.E.E.J.*, Vol. 51, p. 206, Oct. 1958.
- 2 BOLTON, L. J., and BENNETT, G. H. Design Features and Applications of the B.P.O. 24-Channel P.C.M. System. *P.O.E.E.J.*, Vol. 61, p. 95, July 1968.
- 3 MILLER, J. R., and GIPP, J. A. L. Recent Developments in F.D.M. Transistor Line Systems. *P.O.E.E.J.*, Vol. 63, p. 234, Jan. 1971.
- 4 SEWTER, J. B., and EDWARDS, P. J. The British Post Office Television Networks Present and Future. I.P.O.E.E. Printed Paper No. 224.
- 5 JONES, D. G., and EDWARDS, P. J. The Post Office Network of Radio Relay Stations. *P.O.E.E.J.*, Vol. 57, p. 147, Oct. 1964.

# Rodding and Light-Cabling Vehicle

R. W. MARTIN†

U.D.C. 621.315.232

*The Rodding and Light-Cabling Vehicle has been designed to enable a two-man crew to undertake rodding and the installation in duct of cables up to 45 mm diameter. It is anticipated that the crews of these vehicles will do nearly all the rodding and approximately 70 per cent of the light-cabbling work of an average Telephone Area. The first vehicle of this class was introduced in February 1969. Since then, six more have been on field trial, and during 1971, 266 vehicles will be provided for use nationally.*

## INTRODUCTION

To date, specialist rodding parties have been equipped with 1.5-ton or 2-ton vehicles modified to carry the tools, stores and mechanical aids necessary to carry out rodding operations. In this context, rodding may be defined as the installation in a duct of a drawline which is used to draw in a light cable or a heavier cabling rope.

General rodding practice requires the use of one or more of the following main mechanical aids:

- (a) an air compressor which is used typically for operating a ductmotor,
- (b) a mangle-type machine for pushing continuous steel rods and which also incorporates a small winch,
- (c) an electric generator having an output of 2 kW at 110 volts which is used to power electric road-breaking tools, and
- (d) a portable self-priming centrifugal pump-set for removing water from jointing chambers.

These machines are all self-contained and self-powered units which must be removed from the vehicle and set up near the jointing chamber before use. Thus, a considerable amount of time can be spent in off-loading, setting up, dismantling and reloading equipment.

## EARLY DEVELOPMENT

A general examination of the problems involved in rodding duct showed that:

- (a) for much of the work, a cable could be pulled in as easily as a drawline,
- (b) higher efficiency could be achieved by using a vehicle specially equipped to do both rodding and light cabling,
- (c) mechanical aids should be built into, and work from, the vehicle to minimize or eliminate off-loading and reloading of heavy plant,
- (d) the vehicle should be equipped with suitable guiding devices to enable it to work from the roadside, and
- (e) mechanical aids should operate from a common power source, which could be the vehicle engine, but a method of power distribution would be required.

At the time, a commercially-produced vehicle known as the AIRVAN (Fig. 1) came to the notice of the Post Office. The AIRVAN was a 2-ton payload vehicle fitted with an air compressor driven by the vehicle engine. The vehicle had several attractive features, namely that the compressed-air output of the compressor was a readily distributed means of power transmission and the compressor was mounted mainly below the vehicle floor so as not to intrude excessively into the body space.

One AIRVAN was purchased and equipped with a 1,000 lbf line-pull capstan winch, ductmotors, a 2-inch water pump

† Telecommunications Development Department, Telecommunications Headquarters.

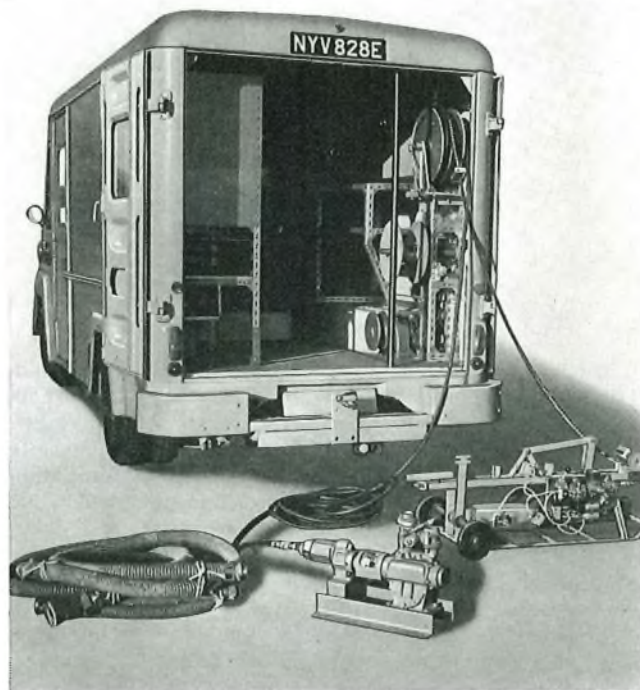

FIG. 1—Two-ton AIRVAN

driven by an air motor and a pneumatically-operated rod-pushing machine modified to use 15/16-inch diameter semi-rigid polyvinylchloride (p.v.c.) tube instead of the usual steel rod. The winch was mounted in the vehicle and served by fixed piping. The other devices still required to be unloaded for use and were driven by air from the compressor via a live-centre hose reel containing 30 ft of hose. At a later date, the modified pneumatic rodding machine was superseded by the prototype of a new type of rod-pushing machine (Fig. 2) which was fixed in the vehicle and connected to the compressed-air supply by permanent piping. The rod from the reel passed through the machine and was guided from the vehicle to the duct by a flexible tubular guide. This rod-pushing machine could propel the rod backwards or forwards at a maximum speed of 130 ft/min with a maximum force of 900 lb. Thus, after the rod has been pushed through a duct, cable can be attached and drawn in as the rod is retracted.

## INITIAL FIELD TRIAL

The field trial of the AIRVAN showed that the basic concept of in-built mechanical aids driven from a single power source could offer distinct advantages. It also demonstrated two major disadvantages of the particular installation, namely, lack of storage space due to the small vehicle size and limited



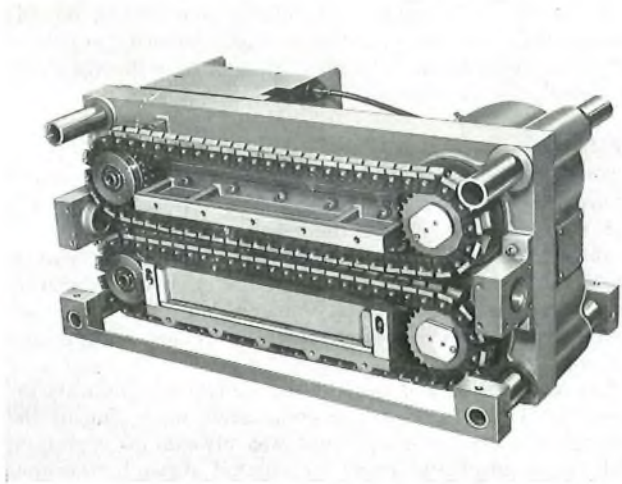

FIG. 2—Rod-pushing machine

power available for driving mechanical aids due to the poor efficiency of compressed air as a power-transmission medium.

Lack of space could easily be overcome by using a larger vehicle and it was decided to continue and extend the trial using a 5-ton payload chassis powered by a six-cylinder diesel engine, fitted with a three-man cab and a box body. Six chassis were purchased. One was reserved for future alternative development and the other five fitted with air compressors driven by the vehicle engine. The compressor installation used on the 2-ton AIRVAN was readily adapted to the larger chassis and mounted wholly below the vehicle floor (Fig. 3). In addition, equipment similar to that fitted on the earlier vehicle was provided. Thus, the minimum of additional development time was required to equip the five vehicles and the trial was able to continue with the least possible delay.

#### Compressor Installation

The compressor used on all vehicles was a single-stage oil-cooled rotary type driven at 2,300 rev/min and rated to deliver 100 ft<sup>3</sup> of air free air delivered (FAD) at a pressure of 100 lbf/in<sup>2</sup>. It was driven by the vehicle engine via a drive-line power take-off with a 1/1 transfer gear ratio. This ratio was later changed to 1/1.33 to enable the engine speed to be reduced to about 1,750 rev/min to diminish noise levels. Engagement of the power take-off automatically increased engine revolutions to the speed required to drive the compressor. This was effected by a solenoid connected to the engine throttle linkage and energized by the operation of a micro-switch when the power take-off engaged.

Secondary control of engine speed was effected by a bellows mechanism inserted in the engine throttle control linkage and operated by air pressure feed back from a suction unloader assembly on the compressor. This mechanism operated to reduce engine speed to approximately 1,000 rev/min when pressure in the air receiver rose to 100 lbf/in<sup>2</sup> and automatically increased engine revolutions to normal working speed when pressure in the air receiver fell.

#### Alternative Power Transmission System

To overcome the major disadvantage of poor efficiency of the compressed-air system, possible alternative systems were investigated and the obvious choice seemed to be an oil hydraulic system. Such a system offered a number of advantages including:

(a) high efficiency, which for individual hydraulic components can be better than 90 per cent and with reasonably careful design, a system efficiency of 60–70 per cent can be achieved,

(b) easy power distribution as pipes could be run to any part of the vehicle,

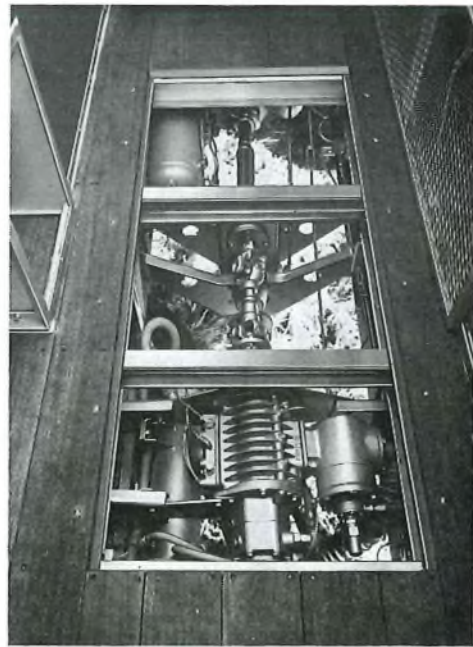

FIG. 3—Compressor installation on pneumatic Rodding and Light-Cabing vehicles

(c) a wide choice of hydraulic equipment is readily available,

(d) hydraulic pumps and motors are compact units with a high power-to-weight ratio, and

(e) hydraulic systems, when properly set up and commissioned, are generally reliable in operation.

A decision was, therefore, made to proceed with the design of a Rodding and Light-Cabing vehicle on which all the in-built mechanical aids would be hydraulically driven.

An experimental hydraulic system was designed and fitted to a standard British Post Office 4-ton vehicle. Full advantage was taken of the increased power available from the hydraulic system to equip the vehicle with all necessary mechanical aids which could be built into, and operate from, it. When complete, the vehicle was subjected to a short intensive field trial for the purpose of gaining operational experience with the hydraulic system and assessing the usefulness of the mechanical aids fitted.

#### PROTOTYPE HYDRAULIC RODDING AND LIGHT-CABLING VEHICLE

From experience with the experimental vehicle it was decided that a prototype should be equipped with:

(a) a low-pressure (100 lbf/in<sup>2</sup>) air compressor to operate a road breaker and other pneumatic tools,

(b) a high-pressure (200 lbf/in<sup>2</sup>) air compressor to operate ductmotors,

(c) a hydraulically-powered version of the new rod-pushing machine,

(d) a 2 kW, 110-volt, 50 Hz electric alternator,

(e) a 2,000 lbf line pull variable-speed capstan winch, with power-driven rope take-up reel, and

(f) a 3-inch self-priming centrifugal pump.

Each appliance had its own motor and the hydraulic system was designed to allow any one item to be powered by an hydraulic pump driven via a power take-off fitted to the off-side of the vehicle gear box. Maximum system pressure was 2,000 lbf/in<sup>2</sup>.



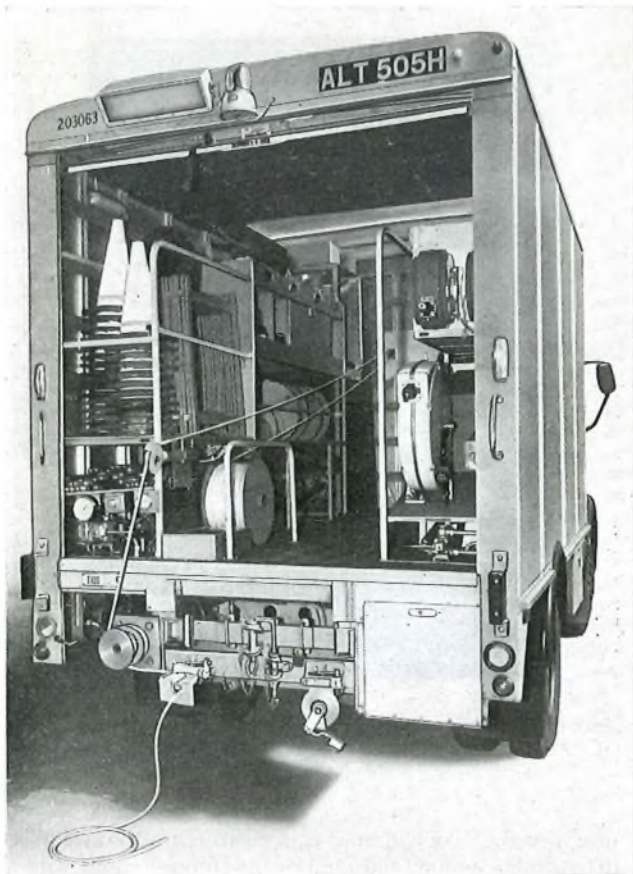

FIG. 4—Prototype hydraulic vehicle showing left-hand racking and winch with rope arranged

A pump rated to deliver 10.5 gal/min at a vehicle engine speed of 1,000 rev/min was chosen. This output closely matches the requirements of items (c) and (e). Items (b), (d) and (f) each require less than 10.5 gal/min so the flow was restricted by a pressure-compensated flow-control valve in series with each of these appliances. The low-pressure compressor, required a flow of 15 gal/min and this was provided by increasing the vehicle engine speed to approximately 1,400 rev/min while the compressor was in use.

The system of automatic selection of engine speed when the power take-off is engaged was adapted to the hydraulic vehicle and extended so that, when the low-pressure compressor control valve was operated, a second solenoid increased the engine speed to 1,400 rev/min.

Control valves were mounted at operationally convenient points and, where possible, so that they could be operated without entering the vehicle. To guard against more than one appliance being operated at any one time, open-centre valves were used and connected in series so that with all valves in neutral, the full pump output passed through each one in turn and then to the reservoir. When a valve was operated, the pump output was directed to the appliance controlled by that valve and if two appliances were selected, only the one nearest in the circuit to the pump would operate.

The winch consisted of a capstan unit mounted externally below floor level at the rear of the vehicle (Fig. 4) and a rope take-up reel drive unit fitted inside the vehicle. Each part was driven by a separate motor but the motors were connected in series and controlled by a single valve. Rope sheaves were provided to guide the rope from the capstan to the take-up reel and to regulate the layering of the rope on the reel.

Instruments were provided to indicate system pressure, output pressure of the two air compressors, alternator output voltage and system pressure at the winch capstan motor. The

latter gauge was calibrated to indicate line pull in pounds force at the winch capstan. A tachometer fitted in the vehicle cab, and driven from the engine camshaft by a flexible shaft, provided a visual indication of engine speed.

## TESTING

When the prototype was complete, the unit was subjected to intensive testing designed to assess the reliability of the system and the particular installation. No attempt was made to establish the probable service life of particular components or mechanical aids which were proprietary items operating within the manufacturer's recommended limits. A separate life test had already been undertaken on the new rod-pushing machine.

The test consisted of running the vehicle continuously for a period of 12 hours on five consecutive days. During the test period, one mechanical aid was always in operation, each one in turn being driven for a period of two hours either at maximum rated output or with repeated change from full-load to no-load condition. For example, when operating the low-pressure compressor, a simulated road-breaker rig was used to give alternately a 30-second full-load condition followed by 20 seconds at no load. Operating pressures, temperature and speed were continuously monitored at

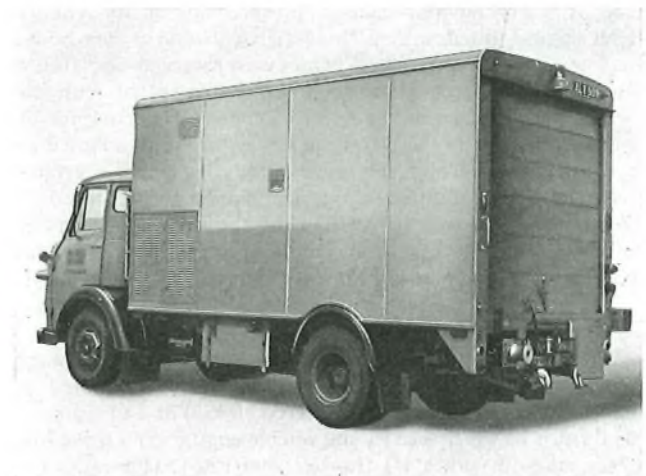

FIG. 5—Prototype hydraulic vehicle, general 3/4 rear view of whole vehicle

critical points. Noise levels were measured and readings of 61 dB were obtained in the working area immediately behind the vehicle. This is comfortably within the Burns & Littler Damage Risk Criteria, permits normal speech communication, and compares favourably with levels experienced with the pneumatic vehicles.

During the test period, none of the proprietary equipment developed any fault or failed to produce the rated performance. The vehicle engine temperature did not rise above the normal working condition, the temperature of the hydraulic oil remained comfortably within permitted limits and no faults developed on the hydraulic system.

Following the period of testing, the vehicle (Fig. 5) entered field service in the Sheffield Telephone Area in January 1970.

## PLANT AND TOOL STORAGE

All the experimental vehicles, except for the original AIRVAN, are fitted with racking designed to provide accommodation for all the required tools and stores and incorporate some of the mechanical aids.

The racking is made in two parts, fitted on each side within the body of the vehicle, and constructed as individual free-standing units each of which can be fitted to the vehicle as a complete section requiring only to be secured to a few built-in attachment points.



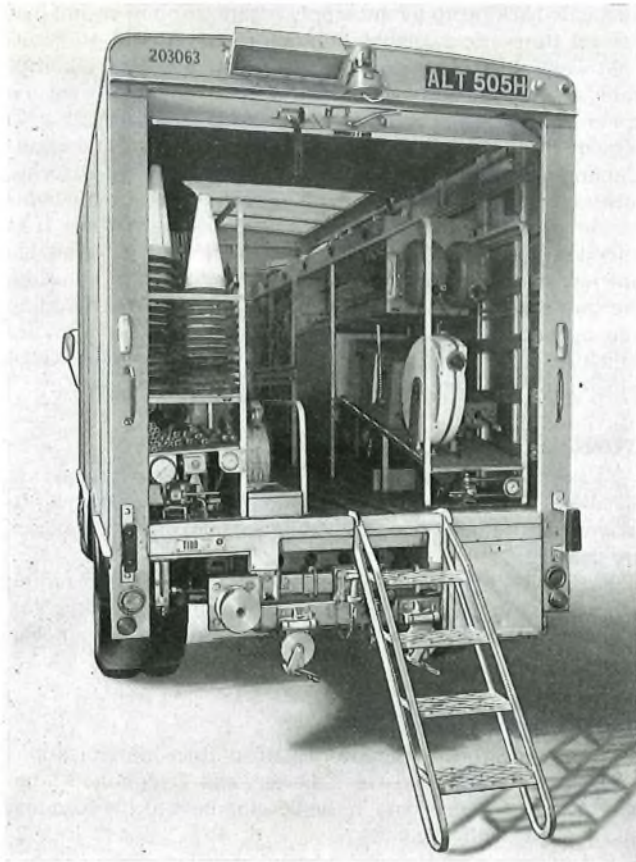

FIG. 6—Prototype hydraulic vehicle showing right-hand racking

The right-hand (off-side) racking (Fig. 6) incorporates the reel for the 200 yd of p.v.c. duct rod and, on the pneumatic vehicles, the winch. It also provides accommodation for four duct motors and split ducts and incorporates the mounting for the rod-pushing machine. On the hydraulic vehicles, the winch was moved, and the space in the right-hand racking used to accommodate the high-pressure compressor.

The left-hand (near-side) rack (Fig. 4) contains a welfare unit and has accommodation for tools, guards, road signs, sectional duct rods, reels of drawrope and small stores. It also provides writing facilities and storage for such items as drawings, diagrams and works instructions.

The vehicle has three external lockers, one for reinstatement materials, one for gas cylinders and one to accommodate a pneumatic road breaker and a pneumatic submersible pump.

### FINAL CHOICE

The pneumatic and hydraulic versions of the vehicle perform the same function and works procedures are the same. Thus, the major factors influencing the final choice were the relative efficiency and reliability of the two power systems.

The higher mechanical efficiency of the hydraulic system makes more power available at lower vehicle engine speed. This makes it possible to provide more and higher-powered aids and produces better working conditions.

The compressors on the pneumatic vehicles did not produce their full rated output and, in consequence, the mechanical aids fitted did not operate at full capacity. The compressed-air power available from the compressor was approximately 4 horsepower and was used to the full by the appliances fitted.

The hydraulic system has operated very reliably on trial and with the vehicle engine running at 1,000 rev/min produces about 14.5 usable horsepower or about 21 horsepower when running at the higher speed. The winch and the rod-pushing machine have already been upgraded to produce

a higher output than the pneumatic versions and this enables a wider range of work to be undertaken and larger or longer cables to be installed. The hydraulic system, therefore, has the development potential to cater for any new aids which might be introduced during the service life of the vehicles. One development expected to be introduced during the next two years is a redesigned ductmotor which will operate from the high-pressure compressor on the hydraulic vehicle but cannot easily be catered for on the pneumatic vehicles.

A hydraulic system was, therefore, chosen as it offered most advantages.

In the field trial, virtually no use was found for the alternator which had been used mainly to operate an electric road breaker. When given a suitable compressed-air supply however, the more powerful pneumatic road breaker is preferred. Therefore, this item was eliminated from the vehicle equipment.

The type of water pump fitted has not been found entirely suitable. The handling of 3-inch bore suction hoses, the necessity to prime the pump casing each time before use, and the disposal of the large volume of water pumped out were sources of difficulty and so this item was replaced by a pneumatic submersible pump. The latter is a compact, easily-handled item with adequate pumping capacity for general use. Also, it can be driven by the low-pressure compressor and it is cheaper than the 3-inch centrifugal unit.

Removing the pump and alternator has simplified the hydraulic system and reduced costs.

### FINAL DESIGN

The Rodding and Light-Cabling Vehicle, to be introduced nationally, will be a 5-ton payload vehicle with hydraulically-operated mechanical aids and unit-construction racking.

The vehicle will have a coach-built body comprising a light-alloy framework with aluminium exterior panels. A translucent resin-bonded glass-fibre roof will ensure adequate illumination of the interior during daylight hours and four 15-watt fluorescent lamps provide artificial illumination. Exterior illumination, apart from normal vehicle lighting, will consist of flashing orange beacons front and rear and a floodlight arranged to illuminate the working area in the immediate vicinity of the rear of the vehicle.

The vehicle will have four built-in mechanical aids driven by the hydraulic system, two air compressors, one low-pressure and one high-pressure, a winch and a rod-pushing machine. These items will all be of the same design as those fitted to the prototype hydraulic vehicle.

The output of the low-pressure compressor will be piped to a live-centre retractable hose reel and the high-pressure compressor output to two smaller hose reels which will enable two ductmotors to be operated simultaneously.

An air-blast oil cooler will be fitted to enable the capacity of the hydraulic reservoir to be reduced to 22 gallon compared with the 45-gallon reservoir fitted to the prototype. In addition to savings in cost, the smaller reservoir allows greater flexibility in siting it on the vehicle.

Instrumentation will be similar to that provided on the prototype vehicle except that no gauge is fitted to indicate system pressure. Instead, plug-in type pressure test points will be provided at each relief valve. Gauges to fit the test points will be held at maintenance workshops.

Careful attention has been paid to the layout of the system to provide good access to all components for maintenance purposes and all hydraulic pipes will be colour coded to indicate their function.

### PRODUCTIVITY ASPECTS

The field trial of the Rodding and Light-Cabling Vehicle has shown that it offers a means of obtaining a substantial increase in productivity. Rates of work of 40 yd per man-hour of duct rodded or cabled have been readily achieved

and this compares favourably with the current national average performance of 13 yd per manhour for rodding parties and 25 yd per manhour for light-cablings.

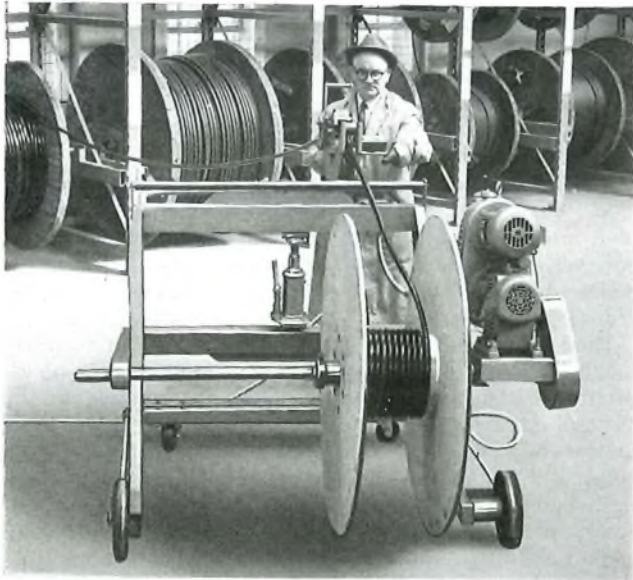

FIG. 7—Cable-dispensing equipment

The improved performance offers the promise of a very satisfactory return on the capital invested in the vehicles. The use of a rodding machine with the combined capability of rodding and drawing-in cable has removed much of the hard labour and has brought the work to within the capacity of a two-man party. The use of appliances designed to operate *in situ* within the vehicle has eliminated much loading and unloading and considerably reduced the setting-up and closing-down time at work points.

However, not all the features contributing to increased productivity derive directly from the vehicle and its equipment. Of prime importance is the careful programming of work and

adequate backing up by the supply organization to ensure that correct stores are available in time for carrying out programmed work. In this respect, a major factor is the provision of cable of the right size in the right length at the right time. To enable this to be achieved cable-dispensing equipment (Fig. 7) is being provided at section stocks serving Rodding and Light-Cablings Vehicles. The equipment will be used to dispense measured lengths of cable from supply drums on to lightweight cable drums for issue to light-cablings parties. It is intended that cable for programmed work shall be available not less than 24 hours before it is required thus minimizing the time spent by working parties collecting stores. Rodding and light-cablings parties will carry their cable on a trailer which will carry up to three lightweight cable-drums each of which can, if required, contain a different type of cable.

### CONCLUSIONS

The vehicles are being introduced into service over a period of about twelve months and training is programmed to ensure that trained crews are available in areas when vehicles are delivered.

The new system involves changes in local-line planning procedures for rodding and light-cablings work and the full effect of these will not be apparent until work in the pipeline is cleared.

### ACKNOWLEDGEMENTS

Acknowledgement is made to staff in Telecommunications Headquarters, Regional Headquarters and Telephone Managers' Offices for their part in the development of the Rodding and Light-Cablings Vehicles.

### References

- <sup>1</sup> DEADMAN, D. J., and SLIGHT, J. R. A New Approach to the Duct-Rodding Problem—Ductmotor No. 1. *P.O.E.E.J.*, Vol. 58, p. 91, July 1965.
- <sup>2</sup> SULLIVAN, E. Polyvinylchloride (P.V.C.) Rods. *P.O.E.E.J.*, Vol. 62, p. 124, July 1969.
- <sup>3</sup> CHARLTON, E. W. Two New Cable-Drum Trailers. *P.O.E.E.J.*, Vol. 61, p. 222, Jan. 1969.
- <sup>4</sup> PRESS NOTICE. New Rod-Pushing Machine for Underground Cables. *P.O.E.E.J.*, Vol. 62, p. 195, Oct. 1969.

## Book Reviews

"Mathematics for Electrical and Telecommunications Technicians." J. L. Smithson. McGraw-Hill Publishing Co., Ltd. Vol. 1: 212 pp. 135 ill., Vol. 2: 251 pp. 189 ill., Vol. 3: 244 pp. 111 ill., Vol. 1 £1·20, Vol. 2, £1·25, Vol. 3, £1·40.

These volumes cover the mathematics syllabus of the City and Guilds Telecommunications Technicians course, the Electrical Technicians course and the recently introduced Electrical Installation Technicians course.

SI Units are used throughout, although in his preface the author points out that the decision to do so was taken at a late stage in the preparation of the books. The necessary changes have undoubtedly resulted in some wrong answers in the worked examples and the set questions.

Starting with the basic processes of mathematics, Volume 1 develops the elementary concepts of algebra, geometry and trigonometry to cover the Practical Mathematics syllabus of the C.G.L.I. Telecommunications Technicians course.

Volume 2 covers the Mathematics A syllabus and Volume 3 both Mathematics B and C.

The books are well produced, with clear diagrams and a good layout, whilst steps in the calculations are for the most part clearly explained. Each topic is developed assuming little previous knowledge. Many worked examples are included in the text and the set problems are arranged in order of increasing difficulty so that the student may gain confidence before proceeding to more difficult questions.

It is a pity that the decimal coinage system has not been introduced where problems involve money, and it certainly should be possible to find the force in newtons due to grams weight without going via pounds and poundsforce as volume 2, page 203 suggests.

In spite of these minor criticisms and the inevitable misprints, the books can be recommended to Telecommunications Technician students.

J. O. W.



# Recent Developments in Datel-Testers

R. E. QUINNEY†

U.D.C. 621.394.4.001.42: 681.31: 621.317.34

*New developments in semiconductor technology, additional maintenance requirements and the introduction of new British Post Office data transmission services, have brought about new designs of test equipment. Various datel-testers are described briefly, giving the facilities afforded. The article also contains a summary of the different types of telegraph distortion encountered on data-transmission systems and an outline of the methods by which the more recent datel-testers measure and display such quantities.*

## INTRODUCTION

During the last five years, several thousand datel-modems have been installed, all of which required the use of one or more datel-testers for setting-up and initial system performance testing. The tester is used as the main diagnostic tool should a customer subsequently report a faulty installation.

In the period 1967 to 1969 many of the installations were subjected to special testing at the time of commissioning to enable a statistical analysis of Datel Service performance to be made. Apart from the application at customers' premises, there are many uses for datel-testers by datel test centres (d.t.c.s) and electronic repair centres (e.r.c.s), and for the assessment of new modem designs in the laboratory.

D.T.C.s, located in Birmingham, Brighton, Bristol, Edinburgh, Leeds, London, Norwich and Manchester, are provided as remote-testing facilities for use by Post Office staff from the customer's modem. The officer at the d.t.c. controls the testing procedure and maintains records of all the modems installed in that part of the country. E.R.C.s are at present provided at seven locations. Those e.r.c.s responsible for maintaining and repairing datel-modems are equipped with datel-testers.

A previous article<sup>1</sup> described Datel-Testers No 1A, 2A and 2B, but since then other factors, including the introduction of new Datel services<sup>2,3</sup> have brought about new designs of test equipment.

## DESCRIPTION OF DATEL-TESTERS

A datel-tester is a portable instrument for testing data-transmission equipment and the performance of telecommunications links used to convey data. The tester is provided with a connecting cord which couples to the customer's modem and acts as a data terminal equipment simulator. Among the facilities generally provided are interchange control and status indication circuits, data test signal generation and, when acting as a receiver, measurement and display of certain types of telegraph distortion and errors in the received test signal.

### Datel-Tester No 1A

Testers of this type, were brought into service during 1966 enabling the initial demand for the Datel 600 Service<sup>4</sup> to be met. Experience gained with the use of this instrument, coupled with the increasing availability and consequential cost reduction of semiconductor integrated circuits (s.i.c.s) led to some changes in the design requirements for the next generation of test equipment.

### Datel-Tester No 1B

This tester was brought into service in 1967 and became the main test facility of the d.t.c.s. By basing the design upon

† Telecommunications Development Department, Telecommunications Headquarters.



FIG. 1—Datel-Tester No 1C

digital techniques, the use of s.i.c.s was exploited to the full with 130 packages being incorporated. Whilst this tester was under development, the opportunity was taken to include facilities for testing the Datel-Modem No 7A<sup>2</sup> and, in anticipation of the time when unattended testing and analysis of system performance could be undertaken, a multi-way socket was located on the front panel for connexion of a data-logger.

The tester operates from a.c. mains supplies between 190-volt and 250-volt, without the need to change the tapping on the mains input transformer. The tester may be rack mounted, but the normal mode of use is as a portable instrument held in a grey stoved-epoxy aluminium carrying case. The tester measures 20 in by 11 in by 9 in and weighs 36 lb.

Other factors, including the desire of the Post Office to standardize the range of s.i.c.s in new designs, led to the adoption of modified logic for the next supply contract.

### Datel-Tester No 1C

Deliveries of this equipment (Fig. 1) were commenced in 1969. As a result of the recommendations<sup>5</sup> published by the C.C.I.T.T.\* some additional facilities were included, notably that of detection and counting of element and block errors simultaneously. An element error is defined as a data bit which has obtained the wrong polarity whereas a block error occurs when at least one such element error exists within a defined number of data bits.

At that time several of the interchange circuit definitions<sup>6</sup> were subjected to changes. Proposals<sup>7</sup> were also made by

\* International Telegraph and Telephone Consultative Committee.

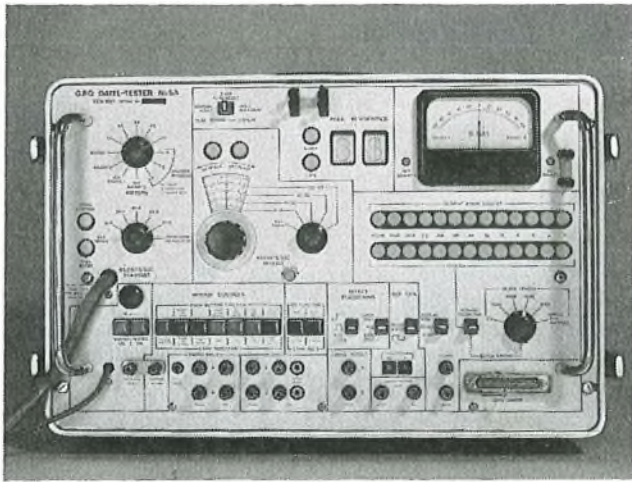

FIG. 2—Datel-Tester No 5A

the I.S.O.† that certain of the pin allocations previously used by the United Kingdom should be changed to facilitate international standardization. These factors led to some re-arrangement and re-titling of the modem control keys on the front panel of the tester.

The Post Office also took the opportunity of obtaining certain mechanical design changes, and incorporating other features to improve electrical performance.

Although 2,400 bit/second is the maximum Datel Service rate over audio-bandwidth circuits offered to customers at present, the tester will enable performance testing to be accomplished on any future systems up to 9,600 bit/second. (The Datel-Tester No 1C requires an external timing source to enable the transmission of data at rates greater than 4,800 bit/second, but it is likely that later models of the Datel-Tester No 1 will include rates of 7,200 bit/second and 9,600 bit/second.) The layout of controls is similar to the Datel-tester No 1B and outwardly it has the same general appearance. The Datel-tester No 1C is now standard equipment for the British Post Office, but does not render the earlier testers redundant in the majority of applications.

#### Datel-Tester No 2C

This tester, which supersedes No 2B, was brought into service during 1969. The basic design and construction were improved to take account of new electronic component developments and, as with the Datel-Tester No 1C, the changes in interface-pin allocation were incorporated. This tester is designed to transmit simple test patterns at 50, 75, 200, 600 or 1,200 bit/second. The only measuring facility provided is that of received signal bias. Testers of this type, therefore, have application only to modems installed for the Datel 200<sup>8</sup> and Datel 600<sup>9</sup> Services.

#### Datel-Tester No 5A

This tester (Fig. 2) was developed specially for approval testing, installation and maintenance of the Post Office Datel-Modems 8 and 9 designed for the Datel 48 kbit/second Service.<sup>3, 10</sup> This service provides transmission of serial binary data synchronously at 48 kbit/second or, alternatively, the equivalent non-synchronous data (i.e. as from newspaper page facsimile equipment). In principle, the facilities offered by this tester are similar to the Datel-Tester No 1C except that it operates at higher speeds. The C.C.I.T.T. Recommendation<sup>11, 12</sup> covering the requirements for systems operating above 20 kbit/second details a balanced interchange circuit for the data and timing circuits. This, necessarily, entails using a different type of interchange cable and plug, for connexion

† International Organization for Standardization.

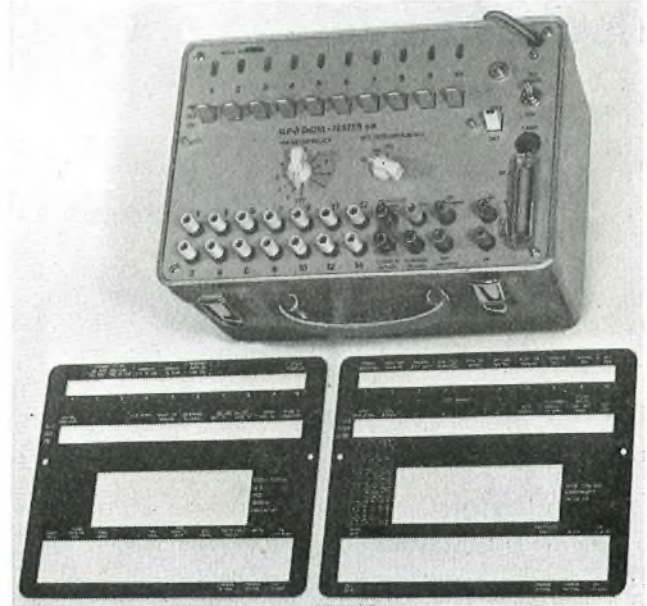

FIG. 3—Datel-Tester No 6A

to the Datel-modem No 8, incorporating balanced twisted-pair conductors.

To assist in the initial lining-up of a Datel 48 kbit/second baseband-circuit, the tester generates a signal known as a pulse-and-bar waveform<sup>13</sup> similar to that used for many years in television video-link performance testing. This waveform is injected into the line-driving stage of the sending modem and, when the received pulse-and-bar signal is monitored with an oscilloscope, provides a convenient means of assessing equalizer adjustment. A low frequency rectangular waveform is also provided for certain initial setting-up tests.

The tester is mounted in a dark grey plastic case from which it can be removed and rack mounted if desired. Its dimensions are 20 in by 13 in by 12 in and it weighs 45 lb.

#### Datel-Tester No 6A

This tester (Fig. 3) which has no self-contained measuring facilities, was designed and first manufactured by the Post Office to provide modem control and test facilities for interchange circuits included in any new data communication equipment for which specialized test equipment has not been developed. The tester consists of ten generating control interchange circuits and ten receiving (i.e. load) circuits. The generator voltages are applied to the output circuits by means of three-position lever keys, whereas the loads, which can be either infinite resistance (open-circuit), 3,000 ohms or 7,000 ohms, terminate in miniature indicator tubes. These glow when positive levels greater than 3-volts are present on the input circuits. An array of screw terminals is provided as test points, monitoring points, or for connexion of external signals or other test equipment. A useful feature of this tester is that the generator, load circuits and terminals can be made to connect to any specified interchange circuit of the data communication equipment under test, simply by using a corresponding dedicated test cord. Associated with each test cord is a label-plate placed over the normal front panel of the tester which indicates the titles of the functions and facilities of the keys, indicator tubes and terminals appropriate to the particular interchange circuits under test.

These testers have been manufactured and are used in conjunction with other equipment to commission Data Control Equipments No 1A, 2A<sup>14</sup> and 3A.

With the exception of the Datel-Tester No 6A, Table 1 summarizes the facilities and differences between the testers mentioned in this article.



**TABLE 1**  
**Comparison of Facilities**

| Function   | Datel-Tester No   |   |  |  |   |
|--|---|---|--|--|---|
|  | 1A  | 1B  | 1C   | 2C   | 5A  |
| Mains input  | Switched ranges covering 180 volt to 264 volt                             | 190 volts to 250 volt   | As 1B  | As 1B  | As 1B   |
| Transmitter bit-rates (bit/second) (switch selected) | 50<br>75<br>200<br>600<br>1,200<br>1,800<br>2,000<br>2,400<br>3,000       | 50<br>75<br>200<br>600<br>1,200<br>1,800<br>2,000<br>2,400<br>3,600<br>4,800                  | As 1B up to 9.6 k using an external timing source.                                   | 50<br>75<br>200<br>600<br>1,200  | 20.4 k<br>24.0 k<br>40.8 k<br>48.0 k<br>50.0 k<br>up to 1.6 M using an external timing source.  |
| Transmitter patterns (switch selected)               | Mark (binary 1)<br>1: 1<br>1: 3<br>1: 7<br>511-bit pseudo-random pattern  | Binary 1<br>Binary 0<br>1: 1<br>1: 3<br>3: 1<br>1: 7<br>7: 1<br>511-bit pseudo-random pattern | As 1B  | Mark (binary 1)<br>Space (binary 0)<br>1: 1<br>1: 3<br>3: 1                          | As 1B plus Pseudo-random Pattern A—511 bits Pattern B—1,048,575 bits Pattern C—33,554,432 bits  |
| Receiver bit-rate (bit/second tuning range)          | 45-160<br>150-500<br>450-1,600<br>1,500-5,000                             | 27-90<br>85-280<br>270-900<br>850-2,800<br>2,700-9,000  | 24-96<br>80-320<br>240-960<br>800-3,200<br>2,400-9,600                               | not applicable   | 8 k-16 k<br>16 k-23 k<br>32 k-64 k<br>64 k-128 k  |
| Method of indicating telegraph distortion            | Moving-coil meter for peak individual and bias distortion (0-50 per cent) | (a) Digital for peak individual distortion<br>(b) Taut-band meter for bias distortion         | As 1B  | Bias only using moving coil meter  | As 1B   |
| Error counting                                       | Only element errors up to 512   | Element or block error up to 2,047  | Up to 2,047 element errors and 10 <sup>6</sup> block errors simultaneously. (Note 1) | None   | Simultaneous element and block errors up to 4,095 at data rates and up to 1.6 Mbit/second (using external timing source)                                |
| Other facilities                                     | None  | Data-logger output  | As 1B, plus error sampling point selection. Interchange circuit option (Note 2)      | Bias meter may be used as a 10 volt meter, plus Interchange circuit option. (Note 2) | Data-logger output. Pulse-and-bar-output. Received block length may be subdivided into 512, 1,024, 2,048, 4,096 or 8,192 bits for block error counting. |

Note 1: The block-errors are often more important to a data-terminal manufacturer than element (bit) errors. Although the capacity of the electro-mechanical block-error counter is primarily a function of its design, it can be used on long tests when the bit error count may well be meaningless.

Note 2: Two front-panel keys permit the receiving and transmitting interchange circuits (control and data) to be connected to specified alternative connector pins if required, conforming to the I.S.O. recommendation that separate pins be used for forward channel and backward (i.e. return) channel.

### TELEGRAPH DISTORTION

For the non-specialist, the term telegraph distortion<sup>15</sup> is often perplexing and the causes and analysis of the effects of telegraph distortion are complex and beyond the scope of this article. However, a short summary is given of the classes of distortion capable of being measured by currently available datel-testers so that the description of the receiver can be understood more easily.

A sketch illustrating telegraph distortion is shown in Fig. 4.

### Bias Distortion

Bias distortion<sup>16</sup> is a shortening (or lengthening) of the duration of all of the positive elements in a two-condition (binary) signal, together with an equivalent lengthening (or shortening) of the negative elements, the mean data signalling

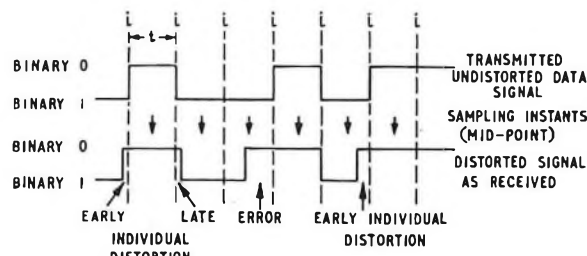

$t$  = theoretical elemental duration  
 $i$  = ideal instants

Note: The degree of individual distortion is expressed as a percentage of  $t$ . If mid-point sampling is used at the data receiver an error will result each time a distortion greater than fifty per cent from ideal instant is encountered.

FIG. 4—Sketch illustrating telegraph distortion

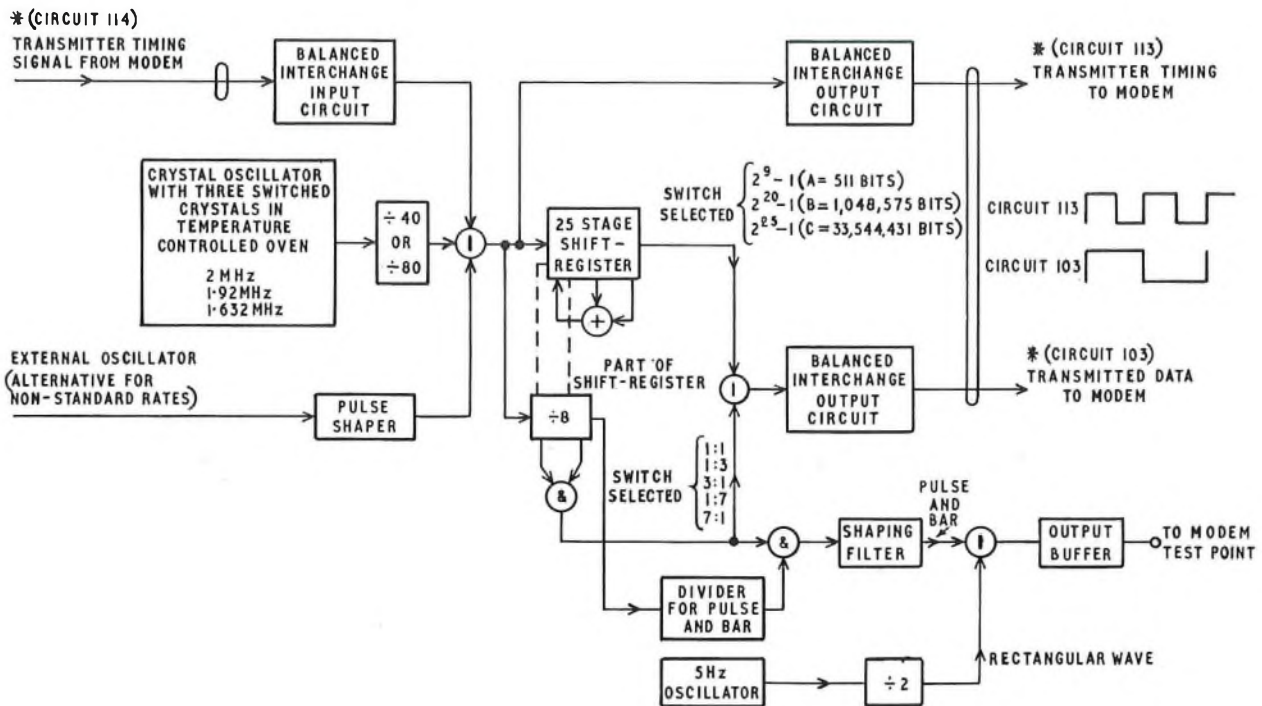

\* The circuit number is that of the function stated in C.C.I.T.T. Recommendation V24. The balanced circuit is specified in C.C.I.T.T. Recommendation V35

FIG. 5—Block diagram of the transmitter (Datel-Tester No 5A)

rate remaining unchanged. Datel-testers measure and display this quantity on a heavily damped centre-zero meter of the taut-band suspension type. The meter scale is linearly graduated, in percentage bias, and the pointer reaches equilibrium at a position proportional to the difference between the durations of the positive-going (binary 0) and negative-going (binary 1) signal elements.

### Peak Individual Distortion

Individual distortion<sup>17</sup> is the degree of displacement of an individual transition from the instant at which it should ideally have occurred. (A transition is the instant at which a change-over occurs between discrete signal elements. A positive transition occurs when a binary 1 state changes to a binary 0 state and a negative transition when a binary 0 state changes to a binary 1 state.) Such distortion can be caused by fluctuating disturbances of the transmission path. Peak individual distortion is the maximum displacement noted in a series of individual distortion measurements. The Datel-Testers 1B, 1C and 5A measure the degree of peak individual distortion by a digital process using a timing source derived from an oscillator which is maintained in synchronism with the mean speed of the received data. An indication of whether the detected transition arrived earlier or later than the reference time is also provided.

### Isochronous Distortion

Isochronous distortion<sup>18</sup> expresses the ratio of the maximum measured difference to the theoretical elemental duration of a data signal element (expressed as a percentage).

Generally it is assumed that isochronous distortion can be determined by adding the results from the early and late peak individual measurements. As the measurements are, necessarily, taken during different time intervals, the assumption is that the result of the early measurement remains valid during the late measurement. Facilities are provided on the datel-testers to take separate measurements of early or late individual distortion as required.

## PRINCIPLES OF OPERATION

This section concentrates on the basic circuit design of the Datel-Tester 5A which uses the principles established in the designs of the Datel-Testers 1B and 1C, but uses faster integrated circuits to cope with the higher operating rates.

### THE TRANSMITTER

A block diagram of the transmitter is given in Fig. 5. A temperature-controlled oven maintains the required stability of three crystal oscillators which provide timing, or clock, pulses to operate the integrated circuits in the subsequent stages. A divider, having selectable ratios, reduces the fundamental clock rate from the selected crystal to the required data rate; alternatively, external timing signals control the rate. A shift-register, driven by the output pulses from the divider, generates specified test patterns (listed in Table 1) according to the setting of the selection switch on the front panel. The output from the shift-register is converted to a balanced signal conforming to C.C.I.T.T. Recommendation V35,<sup>10</sup> and sent to the equipment being tested via an interchange cable, terminated in a special multi-way plug, which mates with a corresponding socket on the equipment.

### THE RECEIVER

The main function of the receiver is to measure the telegraph distortion and information errors in a received signal by establishing a high-fidelity reference with which the incoming data signal can be compared.

### Measurement of Peak Individual Distortion

The arrangement for peak individual distortion measurement using the digital process is shown in Fig. 6. A synchronized oscillator produces one-hundred clock pulses in the period of one signal element and enters them into a binary-coded-decimal (b.c.d.) counter. This counter is arranged to propagate its count in a forward direction for half the element period (i.e. a count of 50) after which a



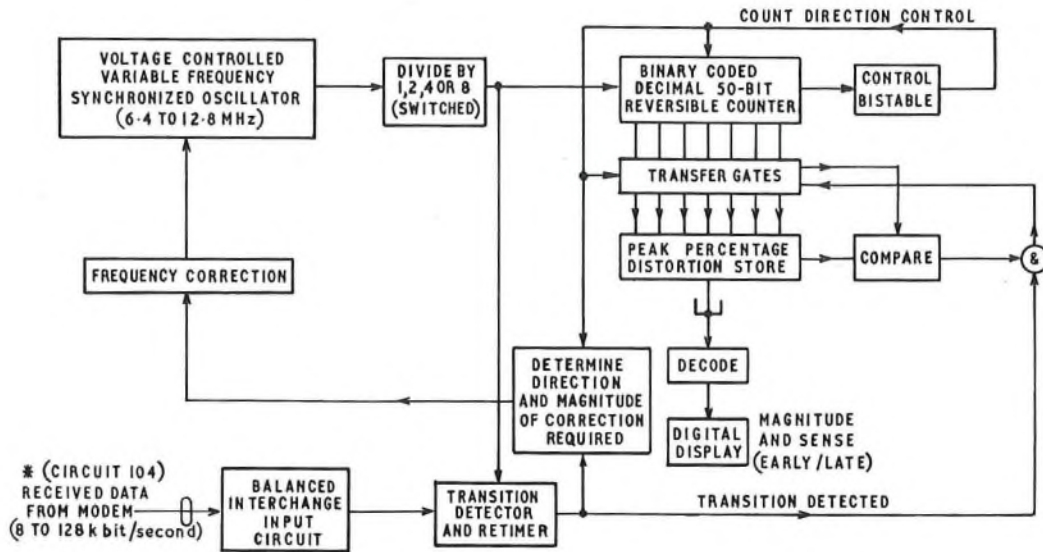

FIG. 6—System for measuring Peak Individual Distortion (Datel-Tester No 5A)

bistable circuit operates, reversing the direction of propagation. When the zero state is reached the controlling bistable circuit again changes state causing forward counting as before. This forward and reverse action is a continuous process and, because the synchronized oscillator produces the driving pulses, the zero-state of the counter coincides with the *ideal* instant of transition in the received data and the count-of-50, the *ideal* mid-point. A transition detector produces a pulse coincident with the *actual* instant of each received transition and is used to determine the degree of distortion *early* or *late* compared with the ideal reference generated by the reversing counter and its controlling bistable circuit. Because of the relationship established between received and reference signals it can be seen that the count held in the counter at the instant of transition detection is the degree of individual distortion of that transition measured as a percentage of a signal element at the bit-rate concerned. Transfer gates are arranged to update the peak individual distortion store only if the new distortion is greater than that previously stored.

### Detection of Errors

It has been mentioned that the count-of-50 state of the reversible counter gives the theoretical mid-point of the signal element. A pulse is extracted from the counter at this point and used to sample the state of a comparator. This compares the polarity of the received data test signal with a locally generated version of the expected signal (Fig. 7) at the instant when there is the greatest probability of them being identical (i.e. at mid-point). Any difference produces an error pulse which is used to operate a counter and display. The locally-generated version of the received signal is produced in a cyclic pattern generator (shift-register) similar to that in the transmitter.

Two error counters are provided (only one with the Datel-Tester 1B); one for element error detection and the other for block-error detection. A block error is counted when at least one element error occurs in a defined number of signal elements (a block). In the Datel-Testers No 1A, No 1B and No 1C the number of elements in a (pseudo-random pattern) block is 511; in the Datel-Tester No 5A three pseudo-random patterns are available (see Table 1) as well as the facility of dividing received data into arbitrary pattern blocks of 512, 1,024, 2,048, 4,096 and 8,192 signal elements (bits). The purpose of this is to be able to approach more closely the block lengths likely to be used by customers of the higher-speed service, Datel 48 k.

### Margin

The margin<sup>19</sup> of any receiver is the maximum degree of distortion up to which value all signals will be correctly received. Datel-testers are designed to have an effective margin against individual distortion of between 48.5 per cent and 49.0 per cent; it being impractical to achieve 50 per cent without undue additional cost. The difference between the theoretical and practical margins is usually due to jitter, or instability, in the synchronized receiver oscillator, and tends to be pattern-dependent. The actual error-rate experienced by a data-terminal equipment is a function both of telegraph distortion and the practical margin of the receiver.

The Datel-Tester No 1C has an additional facility, operated by a rotary switch on the front-panel, of selecting the margin of the error-counting arrangements in the receiver in five

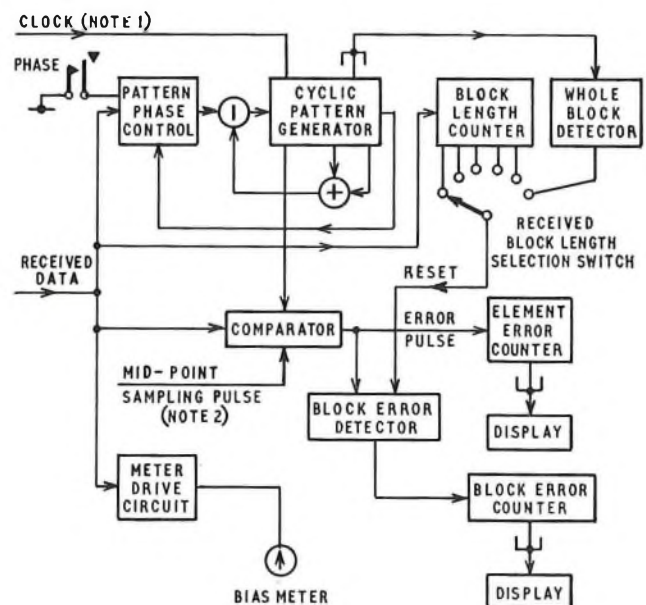

Note 1: The clock pulse may be derived from either the synchronized receiver oscillator or from timing signals on interchange circuit 115  
 Note 2: The mid-point sampling pulse is derived from the timing signal providing the clock pulse

FIG. 7—Circuit arrangement for error detection and bias distortion indication (Datel-Tester No 5A)

per cent increments from five to fifty per cent. This permits a closer analysis to be made of the distribution of the individual distortions.

### Element (bit) Synchronization and Pattern Phasing

So far, the high fidelity reference signal has been assumed. However, before any measurement of distortion can take place the receiver must be in bit synchronism and, before error detection is possible, correct pattern phase must be obtained so as to establish the reference.

The frequency of the synchronized oscillator which drives the reversible counter, used in the individual distortion measurement, is voltage controlled. The voltage is initially set by manually adjusting a tuning dial which is coupled to a precision potentiometer. Automatic control is superimposed upon the manual setting by means of a voltage derived from an integrating capacitor system which continuously sums the results of the individual distortion measurements. Early distortions are counted as positive and late ones as negative. The magnitude of charge put into the integrator system is proportional to the degree of distortion up to 10 per cent, but thereafter is constant. By this means both the receiving rate and the ideal transition positions are automatically adjusted accurately, unless the received signal contains so much bias distortion that no individual distortion is less than 10 per cent, in which case the *ideal* transition position may not be correct.

Having established bit synchronism, the receiver pattern generator is phased by first resetting the pattern generating shift-register to zero by means of a push-button control, then allowing the received data pattern to flow into it. When the last stage of the shift-register changes state (i.e. from zero to one) the input flow is disconnected and the shift-register feedback paths are connected. The process is extremely rapid, but occasionally fails when an erroneous reception happens to occur whilst the shift-register is being filled, in which case the operation should be repeated.

### Data-Logging

The term data-logging applies to fully-automatic or semi-automatic systems used for recording experimental results; direct outputs from the measuring or monitoring apparatus often being used. A connector for coupling equipment is included with Datel-testers No 1B, No 1C and No 5A for the purpose of automating certain tests. For example, by connecting a printing mechanism and suitably-designed electronics, permanent records could be made of error-rate, trends in peak individual distortion (using short measurement periods) with time, numbers and incidence of circuit interruptions. Studies are currently in progress to enable a specification for a data-logger to be drafted.

### CONCLUSIONS

The comprehensive range of datel-testers currently in use by the Post Office, and described in this article, enables

testing to be achieved over the range of datel services covering 50 bit/second to 48 kbit/second and is suitable for higher rate services which might be introduced later. The Datel-Testers No 1B and No 1C have been used satisfactorily for testing the quality of data transmission over many international communications links, as well as the day-to-day modem installation and maintenance tests within the United Kingdom.

Datel-Testers No 5A have provided valuable assistance during the initial commissioning trials of the Datel 48 k system and, more recently, for evaluating systems for the transmission of data up to 512 kbit/second over pulse-code-modulation digital links.

As a future development it is hoped that by using data-logging apparatus much of the long-term testing will be achieved with a minimum of manual supervision.

### ACKNOWLEDGEMENTS

The Datel-Tester No 1A was developed to British Post Office specification by the M.E.L. Equipment Company Ltd. The Datel-Testers No 1B, No 1C, No 2C and No 5A were developed to British Post Office specifications by Trend Electronics Ltd.

### References

- 1 SKINGLE, G. D., and SPANTON, J. C. Test Equipment for the Datel Services—Datel Testers No 1A, 2A and 2B. *P.O.E.E.J.* Vol. 59, p. 262, Jan. 1967.
- 2 ADAMS, G. W., A Modem for the Datel 2400 Service—Datel Modem No 7A. *P.O.E.E.J.* Vol. 62, p. 156, Oct. 1969.
- 3 Press Notices. *P.O.E.E.J.* Vol. 62, p. 196, Oct. 1969.
- 4 SMITH, N. G., An Introduction to the Post Office Datel Services. *P.O.E.E.J.* Vol. 59, p. 1, Apr. 1966.
- 5 C.C.I.T.T. *White Book*, Vol. VIII. Recommendations V52 and V53.
- 6 C.C.I.T.T. *White Book*, Vol. VIII. Recommendation V24.
- 7 I.S.O. Document ISO/TC 97/SC6 No 315, Nov. 1969.
- 8 SPANTON, J. C., and CONNELLAN, P. L. Modems for the Datel 200 Service—Datel Modems No 2A and 2B. *P.O.E.E.J.* Vol. 62, p. 1, Apr. 1969.
- 9 ROBERTS, L. W., and SMITH, N. G. A Modem for the Datel 600 Service—Datel Modem No 1A. *P.O.E.E.J.* Vol. 59, p. 108, July 1966.
- 10 GIBSON, M. A., and MILLARD, D. R. An Experimental manually switched 48 kbit/second Data-Transmission Network, *P.O.E.E.J.* Vol. 64, p. 52, April 1971.
- 11 C.C.I.T.T. *White Book*, Vol. VIII. Recommendation V35.
- 12 BOTT, A. J. Interfaces for Digital Data Transmission. *P.O.E.E.J.* Vol. 63, p. 113, July 1970.
- 13 MACDIARMID, I. F. Waveform Distortion in Television Links. *P.O.E.E.J.* Vol. 52, p. 108, July 1959.
- 14 BOTT, A. J., and CASTLE, W. C. Automatic Calling and Automatic Answering for Datel Services. *P.O.E.E.J.* Vol. 63, p. 253, Jan. 1971.
- 15 International Telecommunications Union. (I.T.U.) List of Definitions of Essential Telecommunication Terms No. 33.04.
- 16 I.T.U. List of Definitions of Essential Telecommunication Terms No. 33.17.
- 17 I.T.U. List of Definitions of Essential Telecommunication Terms No. 33.06.
- 18 I.T.U. List of Definitions of Essential Telecommunication Terms No. 33.07.
- 19 I.T.U. List of Definitions of Essential Telecommunication Terms No. 34.03.



# Post Office Wideband Local Distribution Networks

S. H. GRANGER, C.ENG., M.I.E.E.†

U.D.C. 621.395.743:621.395.97:621.315.212

*To gain experience of wideband transmission in the local network environment, dual-cable schemes have been installed in three new towns. The wideband element distributes television and sound-radio programs to dwellings in the broadcast bands I, II, and III. Broadcast signals are received at the telephone exchange and applied to a distribution system based on a single-tube coaxial cable equipped to transmit in the frequency band 40–240 MHz. The general design principles of the central station and line system are described and an account is given of system performance objectives and methods of alignment.*

## INTRODUCTION

An article in an earlier issue of this Journal,<sup>1</sup> introduced the revolutionary prospect of the ultimate displacement of the present type of local-line network, consisting of multi-pair cables with individual connexions to each customer, by a new wideband distribution network suitable in the long term for all telecommunications needs. Ideally, this will lead to a sophisticated system in which a single communication pipe into each dwelling will serve television and sound radio, telephones, viewphones and other forms of visual display, data services, telemetering and alarms.

In communications, efficiency in the transmission of information is generally most effectively achieved by aggregation. For example, inter-city trunk circuits, provided on coaxial cables, are aggregated to the extent that one transmission system carries 2,700 speech channels, and a system designed to carry 10,800 speech channels is in course of development. Similar aggregation is achieved with microwave radio systems. In the junction network linking local exchanges, the new pulse-code-modulation systems make possible the aggregation of 24 speech channels on plant which previously carried only two.

Extending the principle to the local network, it is reasonable to suggest that efficiency and economies will be similarly achieved, not only by aggregating channels, but also by combining a number of services. A flexible concept in system design and topology\* is needed so that integration of the various services can evolve as the technology develops, and so that customers of the future may seek access to all, or a proportion of, the services offered, according to their preferences and willingness to pay.

First it is necessary to gain experience on a large scale of the technique of distributing wideband information to the customer. The installation at Washington New Town is providing a valuable background of experience in the design, planning and servicing of wideband transmission systems, operating under local-network conditions. Similar installations at Irvine, Ayrshire and Craigavon, Northern Ireland have widened this field of experience. In these three towns, two cable networks have been laid together, one of conventional multi-pair cable to supply the telephone service, and the other of coaxial cable which, for the time being, is providing a straightforward distribution of entertainment television and sound-radio programs.

## INTEGRATION OF SERVICES

The integrated local-distribution network in its ultimate form is likely to exploit digital techniques of transmission and switching, in conjunction with similar digital systems operating in the junction and trunk networks. The first pilot systems, however, rely on analogue techniques for the multiplexing of television and sound-radio signals. As the degree of integration increases, it is probable that switched-speech and view-phone services will be multiplexed digitally and combined in frequency division with the multiplexed analogue signals of television and sound radio.

To deal with this very large amount of information, the new local network needs to be capable of transmitting a wide band of frequencies. Coaxial cable meets this requirement and the technical decision to adopt it as the transmission medium was supported by cost studies carried out during the early stages of development. Its bandwidth is limited chiefly by the performance of the associated electronic equipment, which is constantly and rapidly improving. It is adequate for use at v.h.f. and it offers maximum scope for extension into the u.h.f. band as technology develops. The first transmission systems have been designed to operate between 40 and 240 MHz, which embraces the whole of television broadcast bands I and III. This enables television programs to be distributed at frequencies to which the standard domestic television receiver can be tuned.

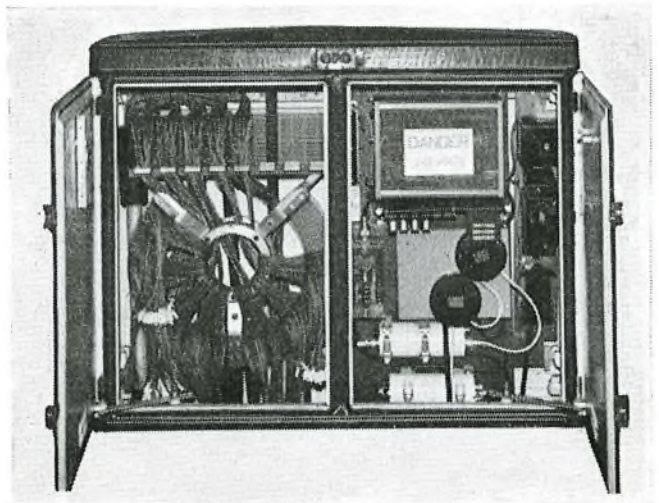

FIG. 1—Local-line cabinet with telephone pairs and coaxial-cable equipment installed

† Telecommunications Development Department, Telecommunications Headquarters

\* Topology—The branch of geometry concerned with the way in which figures are connected rather than their shape and size.



## NETWORK TOPOLOGY

The networks under provision at Washington, Irvine and Craigavon are known as dual-cable networks, since each dwelling is connected through two lead-in cables to two electrically-separate networks. The first is a two-pair lead-in for the telephone service, when required, and the second is a single-tube coaxial cable. The two networks share common plant, such as ducts, joint-boxes, trenches and cabinets.

As with all existing forms of local network, the coaxial-cable network needs a planned system of access and flexibility points, which may also be required to accommodate electronic equipment and power supplies. The access point at the cabinet, on which main v.h.f. highways from the exchange are terminated, is usually shared with the multi-pair telephone cables in the manner shown in Fig. 1. Beyond the cabinet in the distribution network, a further point of flexibility is provided for the distribution amplifier (see Fig. 2), and any other electronic equipment which may be required as further services are added. The main and distribution highways of the present system are connected throughout in tree configuration to provide outgoing transmission of television and sound radio and any other non-switched vision signals, such as schools television. Wherever possible, the wideband network is planned and designed so that it can evolve by stages and with the minimum of disturbance in the distribution highways towards a more complex arrangement, such as that proposed by Hare,<sup>2</sup> which, by means of a ring topology, will provide 2-way transmission channels for both digital and analogue signals.

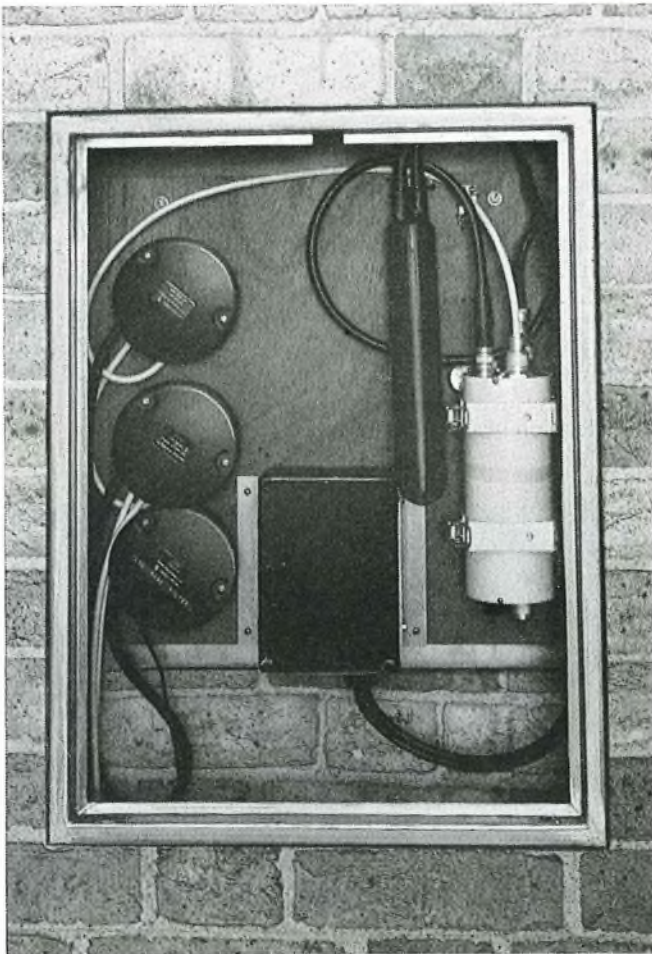

FIG. 2—Distribution amplifier mounted in a wall-box

## CENTRAL STATION

The central station is sited at the focal point of the local network, the telephone exchange, and contains the television head-end equipment. If the building is suitably placed, aerials may be erected on the roof; alternatively, as at Washington, they may be mounted on a mast erected alongside.

A typical head-end equipment, shown in Fig. 3, includes aerial pre-amplifiers and wide-range automatic-level-control units for all channels to reduce the effects of fading, especially flutter due to the passage of aircraft. Frequency translators are used to shift certain signals, such as those received "off-air" in the u.h.f. band, to other suitable channels in broadcast bands I or III which lie within the line-transmission band. It may sometimes be necessary to shift a v.h.f. signal from its off-air channel to another channel in the line system, for the following reason. The chassis screening of some receivers is not good enough to prevent them picking up some off-air signal, even with no aerial connected. Such a receiver, if operated in an area of high signal strength, might pick up an off-air signal through its chassis and, if the same signal were received on the same frequency from the line system, it might cause a double image to be seen due to different propagation times. Since all u.h.f. signals of necessity undergo translation, this problem is diminishing as the older 405-line receivers wear out.

However, considerable care has still to be exercised in the allocation of channel frequencies for transmission to the line system. It is the usual practice to choose channel frequencies so that any local-oscillator harmonics from domestic television receivers and any single-frequency intermodulation products fall either between channels or at points of minimum visibility on the television picture. In addition, it is necessary to recognize that the selectivity of the average television receiver is not good enough to permit the use of adjacent 8 MHz channels. Fig. 4 is an example of frequency allocations for Washington, where four 625-line channels, three 405-line channels and five f.m. sound-radio channels are made available in broadcast bands I, II and III. All television channels may include colour information and f.m. sound channels may include stereo information.

Signals are brought together at the output of the head-end equipment in a combining network consisting of filters and hybrid transformers. A pilot signal is generated to serve as a system test-signal and to control the operation of automatic-gain-control amplifiers along the system. The pilot is also used to initiate alarm indications of the more urgent failure conditions on the transmission network.

The performance of the central-station equipment is specified in terms of the frequency stability of its carriers and of its pilot ( $5$  parts in  $10^6$ ), the generation of spurious frequencies, its gain/frequency responses and its noise contribution from thermal and non-linear sources. Under average off-air reception conditions, the central station can be expected to contribute about 3 per cent of the total noise at a customer's receiver.

## V.H.F. LINE-TRANSMISSION SYSTEM

The main highways of the three existing systems are currently designed around the use of a coaxial cable having a core diameter of 0.345 in and a solid polythene dielectric. This cable, chosen for its low cost, ruggedness, and resistance to moisture, has been fully described in previous articles in this Journal.<sup>3,4</sup> It is possible to use the same cable in the primary distribution network but in the secondary distribution (see Fig. 5), a more flexible cable is needed to negotiate the sharp bends found in house-to-house cabling. Flexibility is achieved by using an outer conductor of corrugated copper tape. The dielectric consists of cellular polythene and the cable is



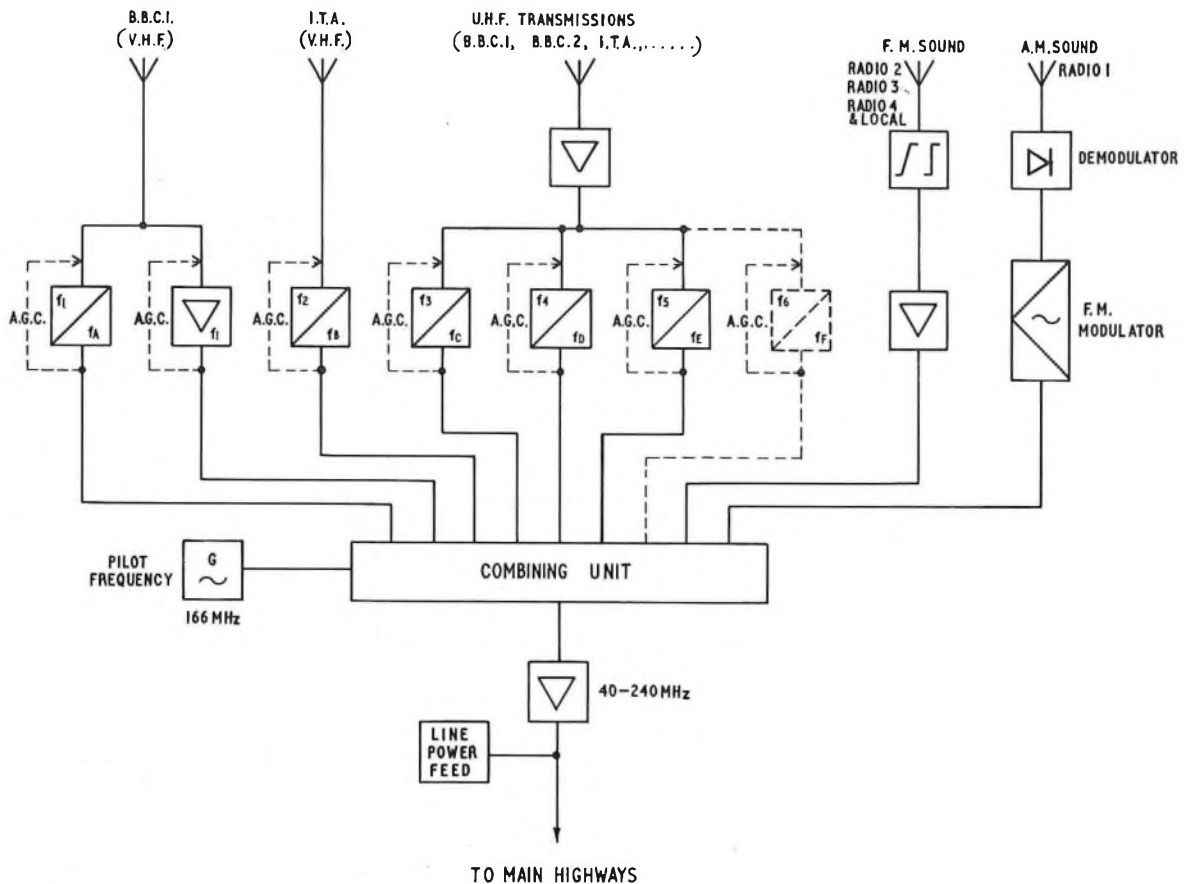

FIG. 3—Block diagram of television head-end equipment

covered by a polythene sheath containing an aluminium moisture barrier. The transmission properties of the two cables are similar.

Still more flexibility is required for customers' lead-in cable. A smaller-diameter coaxial cable is used, which has an outer conductor consisting of longitudinally-lapped copper tape covered by a wave-wound copper-wire outer screen. The dielectric is of solid polythene.

Using 0.345 in coaxial cable, line amplifiers are required at intervals of about 350 yards. In order to evaluate different methods of equalization and alignment, several types of amplifier are on trial in the three new towns. Certain of their characteristics are similar; for instance, each has a nominally-flat gain of 20–23 dB, the cross-modulation ratio with two applied carriers at the working level of 30 mV is about 95 dB and their input and output impedances, compared with a 75-ohm resistor, produce return losses approaching 20 dB over the line-transmission band. The last characteristic is much dependent on the accuracy of the manufacturer's alignment of the input and output coupling circuits.

Most of the equalization is supplied by means of 4-terminal iterative networks connected in front of the amplifiers. System residual equalizers, consisting of 2-terminal shunt-resonant networks, are inserted at every fourth amplifier or when the system gain/frequency spread exceeds 3 dB.

Amplifiers may be mounted in joint-boxes below ground, in cabinets or in wall-boxes. The mounting inside a cylindrical polythene case at Washington (see Fig. 6) is functionally satisfactory but does not permit easy access when assembled. A new design will probably be based on the use of a cylindrical polythene case, with all cables entering at one end, a principle already adopted successfully in the amplifier for schools television.<sup>3</sup>

Power at 40 volts d.c., for the operation of intermediate wideband amplifiers installed in underground joint-boxes, is fed along the cable from the telephone exchange. However, owing to voltage drop, further sources of power have to be established and generally these will be at cabinets (see Fig. 1). The power equipment includes terminal appliances for 50 Hz a.c. mains, equipment to generate the cable-feed voltage and a float-charged secondary battery to guard against loss of transmission due to power failure at the cabinet. Present designs of amplifier take their power in the range 12–20 volts, excess voltage at each amplifier being dissipated through a power transistor controlled from a zener diode. Although this method creates a problem of heat

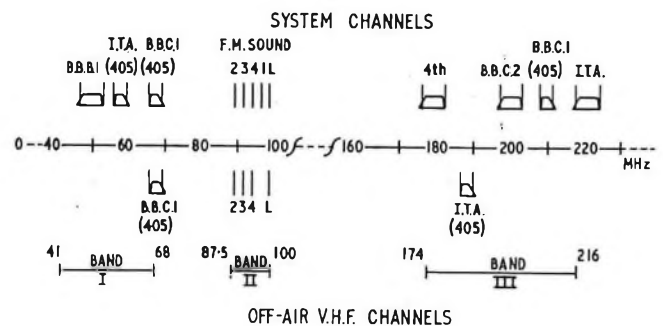

FIG. 4—Channel frequency allocations for Washington New Town

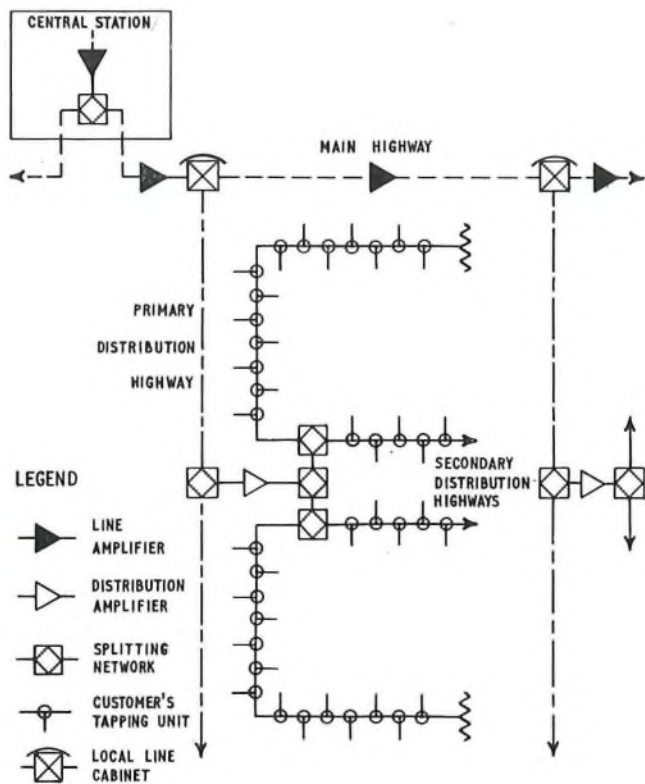

FIG. 5—Block diagram of the wideband highways

extraction, it has the advantage of being completely self-aligning, a very useful feature in a network likely to evolve or to undergo change during its service life.

The maximum permissible current fed into any cable served from a power source is limited by the current rating of the power-feed chokes. At present this is 2 amp but on future designs it will be increased to 4 amp. The loop resistance of an amplifier section on the main highway is approximately 4.5 ohms. With a main-amplifier loading of 250 mA and using shunt power feed because of the tree configuration of the network, it is possible to supply a maximum of six amplifiers in any one of several directions from the source. In later designs, the power-source voltage will be increased to 100 volts which, coupled with an improved regulator, should increase the range by some 75 per cent. In the planning of the system, allowance has to be made for the increased loading of the distribution amplifiers (300 mA) and bridging amplifiers (450 mA), if used.

The present supervisory system strikes a balance between the high cost of a fully comprehensive arrangement and the need to give instant warning of any major service breakdown. The continuity of the wideband channel is monitored by the system pilot. At each cabinet, the pilot is tapped off and fed through a tuned amplifier/detector to hold an alarm relay in the operated condition. Beyond the cabinet, similar pilot detectors are fitted in a few selected distribution amplifiers, chosen to provide surveillance of a maximum amount of the primary and secondary distribution networks.

The power equipment at cabinets is also monitored. Total failure causes loss of the pilot, which returns an urgent alarm. Non-urgent alarms are returned if the mains-unit fails to drive the equipment or charge the battery, or if the battery fails. At the central station, the supervisory-circuit logic combines the power and pilot indications from the television head-end equipment with the supervisory conditions from the network.

In the distribution highways, dwellings are served by means of branching devices in the form of transformers and resistive

taps of various values depending on their siting in the transmission plan. Accommodation and cabling for these networks will be influenced by the style of building construction. A unit serving a pair of houses of traditional brick construction can conveniently be installed in a small steel box built into the wall cavity. Larger boxes of steel or fibre-glass may be used to accommodate distribution amplifiers serving groups of about 40 dwellings. Houses built from pre-fabricated sections have to be treated differently; a number of customers' tapping units are concentrated in a pillar or wall box which, as shown in Fig. 2, may also contain the distribution amplifier. In this area, much is dependent on the resourcefulness of the planner to achieve an economic and flexible network.

## DESIGN OBJECTIVES

The design of the coaxial-cable distribution system is determined by the quality objectives set for television and sound signals as received at any point of the network.

Signals are delivered to subscribers at levels within the range acceptable to domestic receivers. These are 450  $\mu$ V to 3 mV (or -7 to +10 dBmV\*) for all television channels and 100 microvolts monophonic or 300 stereophonic for sound channels. In practice, to increase the design margin of the line

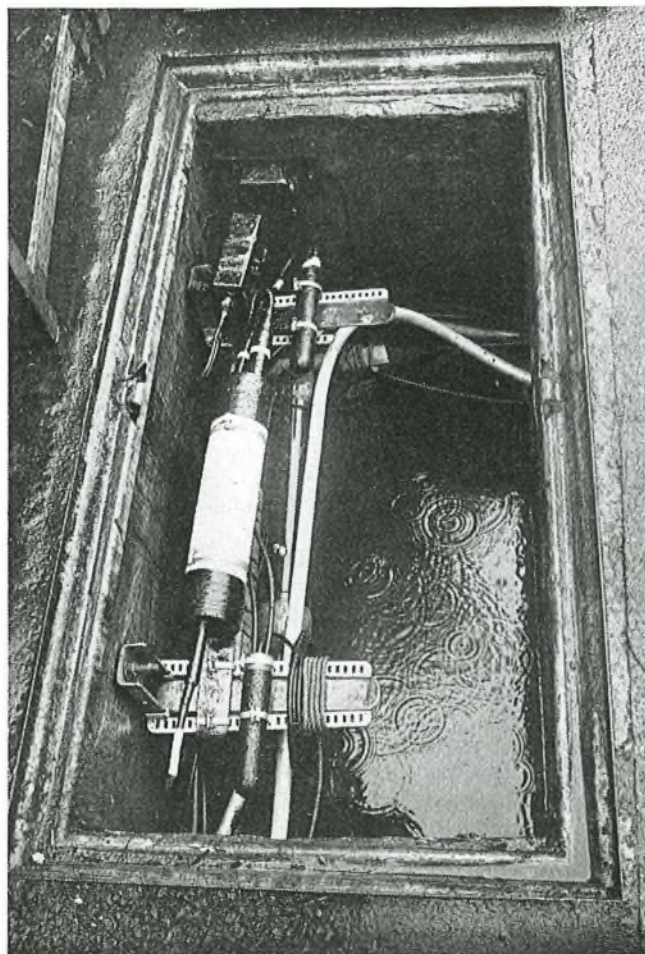

FIG. 6—V.H.F. line amplifier mounted in a joint-box at Washington New Town

\* dBmV—decibels relative to 1 millivolt.



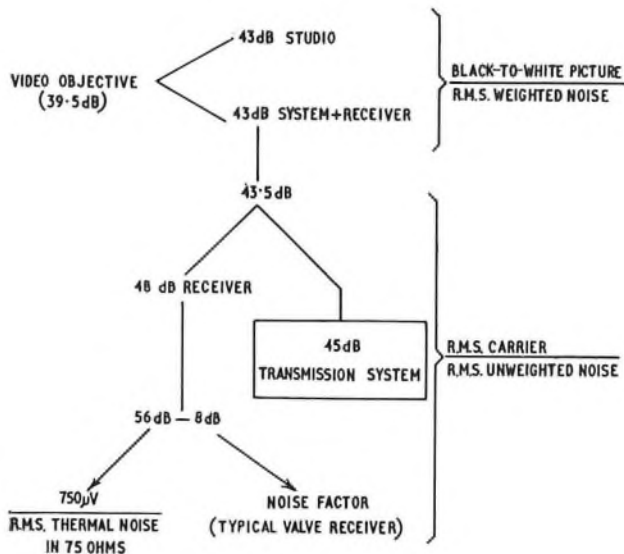

FIG. 7—Logic diagram showing steps in the derivation of system signal-to-noise ratio

system, the lowest permissible receiver input level is restricted to  $750 \mu\text{V}$  or  $-2.5 \text{ dBmV}$ .

The design objective of signal-to-noise ratio is set to achieve a performance which will gain a favourable rating from 95 per cent of observers using an average valve-operated receiver at the worst location. Subjective tests have shown that this rating is achieved when the ratio of black-to-white-picture to r.m.s. weighted noise is  $39.5 \text{ dB}$ . Generally, it is assumed that the program source, cameras, mixers, etc., will contribute 50 per cent of this noise. The signal-to-noise ratio of the system and receiver should therefore be not less than  $43 \text{ dB}$ .

This ratio has to be converted to noise per carrier channel in the wideband spectrum. It is expressed as the ratio of the r.m.s. maximum carrier level to r.m.s. unweighted random noise. With due allowance for removing the weighting ( $8 \text{ dB}$ ) and for carrier to sideband ratios ( $7.5 \text{ dB}$ ), this results in a system and receiver objective of  $43.5 \text{ dB}$  per carrier channel. If the signal arrives at its lowest permitted level of  $750 \mu\text{V}$ , the contribution of the receiver to signal-to-noise ratio will be  $48 \text{ dB}$ , and the resultant performance target for carrier channels in the wideband system is  $45 \text{ dB}$ . This reasoning is illustrated in Fig. 7.

An important distortion product in the line-transmission system is generated by the third-order term in the power series representing the system-transfer characteristic. It appears in the form of undistorted vision crosstalk from other channels in the system and is usually described as cross-modulation. The system-design objective for cross-modulation is defined in terms of the ratio of the percentage modulation of a disturbing carrier to that induced on an unmodulated disturbed carrier. The British Post Office is aiming to achieve  $52 \text{ dB}$ , although the present proposed international limit is  $46 \text{ dB}$ . When several channels are multiplexed, this figure has to be increased by  $10 \log_{10}(C - 1)$ , where  $C$  is the number of channels, assuming random addition of cross-modulation products from all other channels.

Another important design objective is the setting of a limit for intermodulation between the several vision and sound carriers of a multiplexed system. These products of all significant orders of non-linearity result in periodic noise, the visibility of which is dependent on its frequency. Fig. 8 shows the relative sensitivity to impairment caused by periodic noise at any part of the wideband spectrum relative to the frequencies of the vision carriers, the colour subcarriers and the sound carriers. The grading numbers refer to the subjective rating of picture grading used by the European Broadcasting

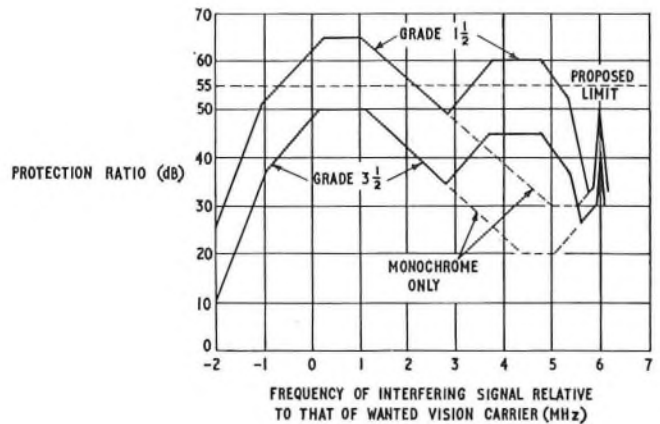

FIG. 8—Periodic-noise-protection ratios in a television channel frequency slot

Union. The proposed international limit is  $55 \text{ dB}$  carrier-to-periodic-noise ratio, but the British Post Office system is designed to achieve  $65 \text{ dB}$  at the most critical frequencies.

All amplifiers in the main and distribution highways will contribute random noise which adds according to the expression  $10 \log N$ , where  $N$  is the number of amplifiers. Products of non-linearity add directly, but the more important cross-modulation ratio, being a third-order product, is decreased by  $6 \text{ dB}$  for a  $3 \text{ dB}$  reduction in output level. Thus, when amplifiers are connected in tandem, the permissible output operating level is reduced by  $10 \log_{10} N$ , where  $N$  is the number of amplifiers. The length of transmission system in terms of the permissible number of tandem amplifiers for any chosen value of amplifier gain can be determined from Fig. 9 which relates signal-to-noise ratio, minimum input-signal level, gain and output-signal level. The practical operating output level per channel of the present type of transistor amplifier for the main highway, having a gain of  $20 \text{ dB}$  and a noise figure of  $10 \text{ dB}$ , is shown to be  $+30 \text{ dBmV}$ .

In the distribution highways, signals from the distribution amplifiers are transmitted at levels of  $+46 \text{ dBmV}$ . It is economic to permit these amplifiers to contribute 50 per cent of the cross-modulation impairment. Thus, to the system objective of  $52 \text{ dB}$  cross-modulation ratio, this amplifier may contribute up to  $58 \text{ dB}$ .

Leads-in to dwellings are taken from passive tapping devices designed for minimum through loss but providing isolation between receivers. Isolation is important in masking any impedance change caused by the disconnecting of customers' receivers from the system or by the short-circuiting of an outlet in customers' premises. Isolation also ensures that energy fed back into the system from the local oscillators of television receivers is reduced to harmless levels. The design objective for isolation loss between any two television receivers is  $40 \text{ dB}$ .

Equalization along the main highways is adjusted so that the spread in the gain/frequency response does not exceed  $3 \text{ dB}$ . The corresponding spread at least favourable locations in the secondary distribution could amount to  $8 \text{ dB}$  which is equivalent to about  $0.5 \text{ dB}$  across one television channel. However, when distortion due to the head-end equipment is added, the channel spread is increased towards  $2 \text{ dB}$ .

## ALIGNMENT

System alignment consists chiefly of the setting of correct channel-operating levels and the adjustment of equalizers to give the required gain/frequency response. Provided these conditions are properly set, other parameters such as linearity

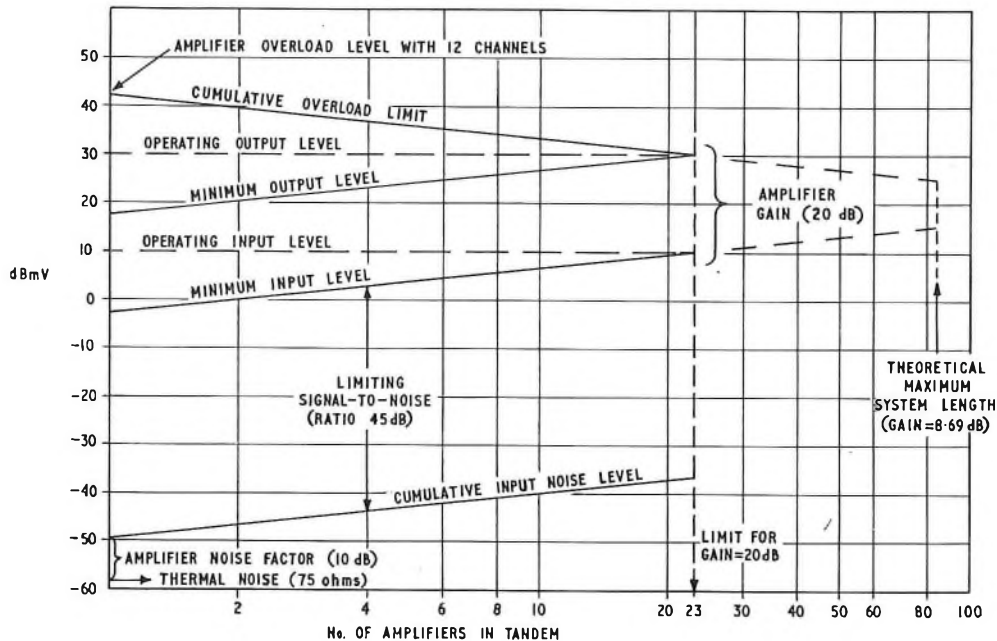

FIG. 9—Inter-relation of v.h.f. line amplifier gain, overload, signal-to-noise ratio, and noise figure

and waveform responses are determined by the basic design and will automatically meet the required limits. The present power-feed equipment is self-aligning but there is a possibility that on some future systems a coarse power line-up may be needed.

The principle parameter requiring skilled adjustment is the gain/frequency response. A method using a sweep-frequency generator, wideband detector, and oscilloscope is used and can be applied without difficulty when aligning any new highway starting at the central station. However, in a growing network based on the tree configuration, it will at times be necessary to align new main highways which may branch off from a system already carrying traffic. Separate alignment of each new section would be inconvenient as it would involve setting up the sweep-frequency generator at the branching points, which could be out in the open. In addition, the overall response from the central station could only be obtained by summation and it would be impossible to record it photographically.

To measure the overall response over part of a working system without interrupting television traffic, or working outside program hours, a method has been devised which is completely effective and which enables a photographic record to be obtained. It relies on customers being tolerant of a relatively small amount of interference to their pictures while the measurement is being made. The equipment shown in Fig. 10 is connected permanently in circuit at the central station while work is in progress. The sweep-frequency generator scans the line spectrum in 10 ms and a single scan is sufficient for the purpose of obtaining a photographic record. This can, if necessary, be remotely operated from the measuring point. If residual equalizers have to be adjusted, repetitive scans of 10 ms duration are generated at intervals of approximately 3 seconds and, at the measuring point, the result is viewed on a long-persistence oscilloscope.

While the 10 ms scan is activated, the television traffic is interrupted by the gating amplifier. The effect on television receivers of the loss of approximately one half of a field scan is generally not noticed, since there is no loss of synchronization.

Sweep techniques have been devised to deal with the present generation of line amplifiers and other networks in the system.

As better amplifiers are developed, it is expected that the task of equalization will become simpler and consequently, checks at a few fixed frequencies may be sufficient for system alignment. The use of sweep techniques may then be limited to special inspections or fault investigations and the recording of responses. If these are carried out at off-peak viewing times, they are unlikely to be the cause of complaint from customers.

If a visual display of the gain/frequency response is not required, it is possible to inject a signal from a sweep-frequency generator at the head-end at a low level, typically 20 dB below channel-test level, and to measure the network

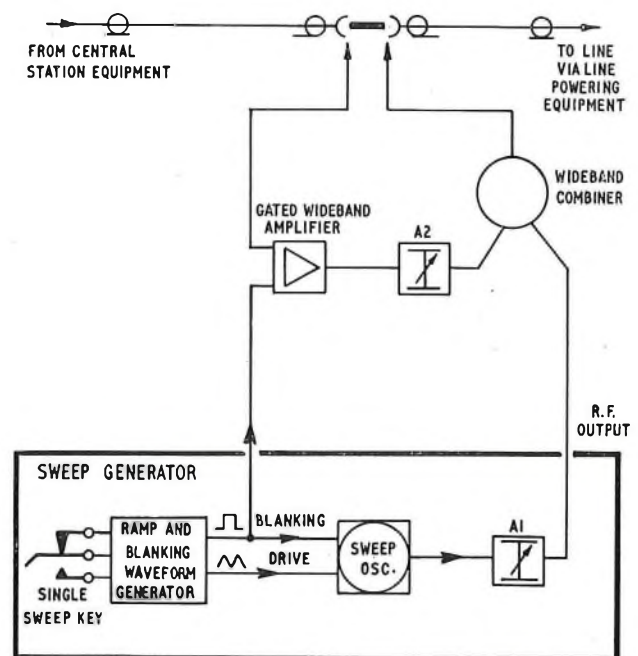

FIG. 10—Block diagram of sweep-frequency test equipment at central station



response at spot frequencies using selective measuring equipment. The advantage of this method is that the system is not interrupted and the effect on traffic of the low-level sweep frequency is negligible. However, the method is slower and could fail to reveal any sharp variations in response such as the narrow loss-crevasses typical of periodic cable irregularities.

## CONCLUSIONS

Wideband systems are now giving service to approximately 1,000 dwellings in three new towns. All are reported to be working well and there have been no major failures of electronic equipment. In the immediate future, considerable improvement in transmission technique can be expected. The use of higher-performance amplifiers, lower-loss coaxial cables and improved power-feeding methods will extend the capacity and reach of systems.

The spare bandwidth between the broadcast bands may be exploited by gradually bringing additional services into the network. Signals from a schools television studio centre could,

for example, be inserted at the central station at the expense of only minor changes to the head-end equipment. The remote reading of domestic meters could also be effectively realized on the wideband network, assuming that the service itself could be economically justified. Mutual economic gains would follow to all services and, by use of modular technique and staged extensions, an evolving network could be designed to handle most of the foreseeable long-term developments in telecommunications.

## References

- <sup>1</sup> GRANGER, S. H. Post Office Wideband Distribution Network at Washington New Town. *P.O.E.E.J.*, Vol. 61, p. 1, Apr. 1968.
- <sup>2</sup> HARE, A. G. Telecommunications of the Future. *Post Office Telecommunications Journal*, Vol. 21, p. 16, Summer, 1969.
- <sup>3</sup> HAWORTH, J. E. The Schools-Television Distribution Network. *P.O.E.E.J.*, Vol. 61, p. 250, Jan. 1969.
- <sup>4</sup> LINES, P. W. A 9-Channel V.H.F. Coaxial-Cable Closed-Circuit Television Distribution System. *P.O.E.E.J.*, Vol. 62, p. 93, July 1969.

## Book Reviews

“Communication Systems Engineering Theory.” Erling D. Sunde. John Wiley and Sons, Ltd. xv+512 pp. 148 ill. £9.50.

Much of the published literature on Communication Theory is principally concerned with the theoretical transmission performance of highly-idealized channels, when perturbed by Gaussian noise. Though such a mathematical communication theory is fundamentally important, it has not made much impact on the design of analogue and digital communication systems where, in practice, the performance is generally limited by other forms of transmission impairments. The objective of this book is to provide a unified, comprehensive and realistic transmission performance theory, using channel models that are a reasonable simulation of the physical conditions applying, the necessary approximations, based on sound engineering assumptions, being made in the mathematical derivations rather than to the channel model.

The author, E. D. Sunde, is a well-known authority on communication systems theory, and much of the material in the book is based on, and influenced by, his work in this field at Bell Telephone Laboratories during the last two decades. The book assumes a prior knowledge of conventional modulation principles, and familiarity with Fourier, Hilbert and Laplace transforms, etc., though for convenient reference, the analytical methods are reviewed briefly in the appendices.

The organization of the book is based on the various forms of transmission impairments rather than the types of communication systems. The emphasis is on basic analytical methods and theoretical relationships, each chapter dealing with a particular transmission impairment and its effect on the different communication systems. The first five chapters of the book provide the basic transmission and modulation theory that is necessary for the determination of transmission impairment by random noise. This includes such topics as the distortion of band-limited signals with particular emphasis on the Hilbert transform relationship between the amplitude and phase characteristics of physical minimum-phase-shift networks, the statistical properties of a Gaussian random process, and the optimum shapes of receiving and transmitting filters for both analogue and digital transmission systems. Chapter 5 deals with digital-pulse transmission, and considers such

points as the probability of error due to additive Gaussian noise, and the extraction of a coherent carrier and clock timing from a noisy signal.

The remaining chapters are concerned with the analytical methods necessary for the study of other forms of transmission impairments. The performance of analogue and digital systems in the presence of linear, parabolic and fine-structure variations in the amplitude and phase characteristics is discussed in some detail. Methods for determining intermodulation noise due to amplitude non-linearity and a.m-p.m. conversion are given; a topic that has aroused much interest in the satellite-communication field in recent years. The properties of random time-varying multi-path channels and the effect on transmission performance for the various fading modes of time-flat, frequency-flat, time-selective and frequency-selective are considered. The book concludes with a chapter on interference between systems.

This is an excellent book and is recommended reading for anyone who is seriously interested in communication systems. Though a reasonable level of mathematical ability is required for a full appreciation of the subject, this is somewhat alleviated by the easy tutorial style of the author.

R. J. W.

“Microwave Electronics.” John C. Slater, Ph.D. Constable & Co., Ltd., 204 + xiv pp. 91 ill. £1.67½.

Originally published in 1950 by Van Nostrand, this old friend to designers of microwave valves now appears as a paperback. In twenty years the approach to microwave electronics has changed, mostly with the application of the theory of space-charge waves on electron beams. Certain chapters therefore, notably the one on klystrons, where the theory is entirely ballistic, are out of date. Nevertheless, the large part of the book that deals with waveguides, cavities and periodic structures has a much wider application than to microwave electronics alone. The lucid style makes for easy reading, and the book is strongly recommended to anyone studying microwaves.

R. B. D.

# A New Stamp-Selling Machine

D. B. DAS†

U.D.C. 681.13: 656.835

*This article gives a description of the latest addition to the range of machines used by the Post Office for selling postage stamps, a machine designed to bridge the changeover to decimal currency and provide the facilities to enable them to maintain their usefulness for the next 20 years.*

## INTRODUCTION

The considerations which led to the development of the Stamp-Selling Machine Type G were mainly the changeover to decimal coinage, and possible frequent changes in postal tariffs. To provide continuous service during the change to decimal currency it was necessary to adopt a design that used a coin size available both before and after the changeover. It was decided that the machine should be operated by a 5p piece, or, with a change of coin tester and coin-slot plate, a 10p piece. This led to the need to issue more than one stamp for one coin; the changes in postal rates could then be met by altering the number and the individual values of the stamps sold.

## DESIGN FEATURES

In common with all vending-machine designs, adequate safeguards against fraudulent operation were required. The greatest difficulty is not to make a machine that will sell stamps but the prevention of fraudulent operation. The machine needed to be reliable, robust, completely mechanical, and capable of fitting existing mountings for the stamp-selling machines which have been described in earlier articles.<sup>1,2,3</sup> This latter requirement, although simplifying the installation problems, caused considerable difficulty with the design, since it meant that a fairly complex mechanism had to be packaged into a small volume.

The life of these machines is expected to be more than 20 years and within that time-span, the possibility of the introduction of coins of light weight was envisaged. Future coins might not be heavy enough to provide sufficient driving force for the mechanism. A draw-bar technique was tried experimentally but was abandoned in favour of using the lifting of a flap, covering the stamp-exit and coin-refund apertures, to provide the mechanical force to operate the machine.

In the final design, all coins or disks other than the one acceptable for operation of the machine are automatically rejected. There is a shutter which closes the coin-refund aperture when the flap is lifted to prevent the refund chute being deliberately blocked, and there is the usual device which blanks off the coin-accept slot and displays a *not in use* notice when the stamp roll is exhausted.

The dimensions of the stamp of the definitive series, commonly referred to as the definitive stamp, are at present 0.95 in by 0.80 in. The new machine has a capacity of 3,000 definitive stamps spooled sideways and, by a simple adjustment, can be set to issue from one to five such stamps. The width of a commemorative stamp is at present also 0.95 in but its length is 1.60 in, twice the 0.80 in dimension of the definitive stamp. By a change of parts connected with the stamp path, the machine can be adapted to issue either one or two commemoratives, two commemoratives and a definitive, or a commemorative and either one, two or three definitive stamps. A feed wheel with pins around its periphery drives the stamps by their perforations to the stamp-exit slot.

As explained above, the machine is operated by lifting the cover flap but this action is not direct. The flap lifts a weight which is allowed to fall to provide the motive power, and the flap needs to be in its lowered position at the time of coin insertion. However, once a cycle of operations has commenced, it must be completed before the machine can be operated again. This design feature in itself provides an effective safeguard against some fraudulent operations.

Zinc-plated mild steel, aluminium-alloy die-castings and stainless steel are the main materials used and a British Standard is specified wherever possible for all materials and finishes. I.S.O.\* metric screw threads are used throughout. Figs. 1 and 2 show right and left-hand views of the machine.

## DESCRIPTION

The upper end of the die-cast, tough-plastic-coated, flap (1) is keyed to a shaft (2) which couples it through a gear sector (3) and cam to the swinging half of the coin tester (4) and to the mechanism. The flap covers a recess in the lower half of the front plate (5) which contains the coin-refund slot to the left and, to the right, an opening for the stamp-exit-slot block of the stamp-feed-wheel assembly (6). A plate at the top of the front casting provides a hooded (7) coin-entry slot and below it is a window (8) with toughened glass for the *not in use* flag. The coin tester, which was designed to be more easily adjusted than those previously used, is mounted behind the front plate and above the accepted-coin (9) and the rejected-coin (10) chutes.

The stamp compartment is in the lower right half of the machine and it comprises a vertical base plate (11), a jockey pulley (12) around which the stamps traverse, a stamp-roll drum (13) which supports the stamp roll (14), and a stamp-feed-wheel assembly (6). The jockey pulley senses the tension in the stamp strip and, by its movement, controls in sympathy a band-brake on the stamp-roll drum. A spring on the stamp-roll drum ensures transmission of the braking force to the core of the stamp roll and thus prevents the stamp strip from looping and possibly misfeeding. When the roll comes to an end, or if the stamp-strip breaks, the release of the jockey pulley from the stamp strip actuates the trip mechanism for the *not in use* device. A removable, transparent, plastic cover (15) fits over the stamp compartment to assist in keeping the stamp roll dry and is secured to the vertical base plate by a captive knurled screw.

A coin which passes the preliminary over-diameter and over-thickness test imposed by the front coin-slot and which is accepted by the coin tester, enters the accepted-coin chute (9) and comes to rest on the end of a lever (16). The coin is now temporarily a part of the mechanism. A pawl (17) just above the stamp compartment and at the lower end of the accepted-coin chute (9) is actuated by the coin to divert to the refund aperture, through a side entrance in the rejected-coin chute (10), all other coins which may now be inserted and which may

† Planning and Mechanization Department, Postal Headquarters.

\* International Standards Organizations.



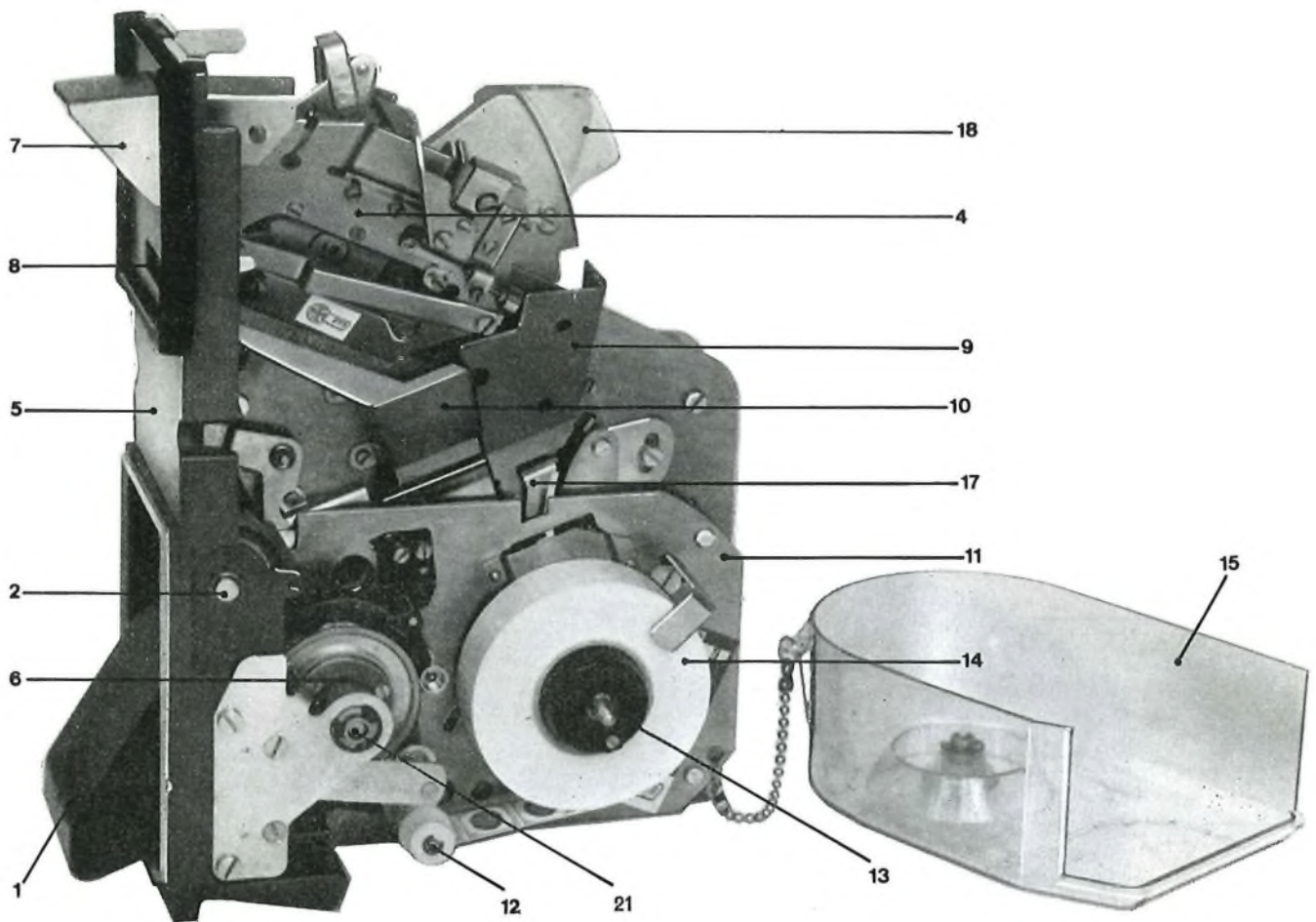

FIG. 1—The Stamp-Selling Machine Type G, right-hand view

pass the tester (4). Another pawl behind this coin-reject pawl prevents a coin or disk attached to a piece of string or wire from being withdrawn. A coin which fails the tester either falls directly into the reject chute (10) and is sent to the refund aperture or it is held trapped in the coin tester to be released later into the reject-chute by a subsequent operation of the flap (1).

A cast-iron weight (18), supported by arms rotating about a bearing behind the front plate, is in the upper left half of the mechanism. A rack (19) to the right of the weight (in Fig. 2) rotates about the same centre and a toe in its lower portion can engage with the arms of the weight. An arm pivoted on the rack hangs downwards and rests on a cam coupled to the flap. In the lower right corner of the left half of the machine are two toothed wheels of a detent assembly (20) which is designed to transmit the stored energy in the weight, unidirectionally rotating the stamp feed. The front wheel is pinned to a shaft (21) the other end of which is splined to the stamp-feed wheel. An assembly of cams and levers rotating about this shaft forms the detent drive (22) which is coupled directly to the weight through a pinion and rack. Behind all this is a disk (23) with five notches in its periphery, to which is fitted a detent locking pawl and a disk cam (24). This notched disk assembly can be rotated and is locked in place by a lever (25), one end of which

fits into one of the five notches; the other end is held against a knurled screw (26). The setting determines the number of stamps issued.

Below the weight are two vertical levers pivoted at the same point. The lower end of one acts upon a latch which engages with a stop on the detent drive assembly. The action of this lever and the latch is interlocked with that of the lever on the end of which an accepted coin first comes to rest. A pivoted pin is fitted to the upper end of this vertical lever (27) and is acted upon by the weight as it falls. The bottom end of the other vertical lever can also engage with the stop on the detent drive assembly; its upper end is acted upon by a pin on a horizontal link (28) running across the mechanism. The right-hand end of this horizontal link is coupled to the flap; the other end operates a lever which is brought to bear during operation on the accepted coin resting on the end of the lever already mentioned. The flap is also coupled through a vertical link (29) to the swinging half of the coin tester and through another link extending downwards to a shutter across the exit of the coin-refund chute.

The initial movement of the flap as it is raised rotates this shutter to close the exit of the refund-chute. Further movement of the flap opens the tester thus enabling a trapped coin to be released into the rejected-coin chute.

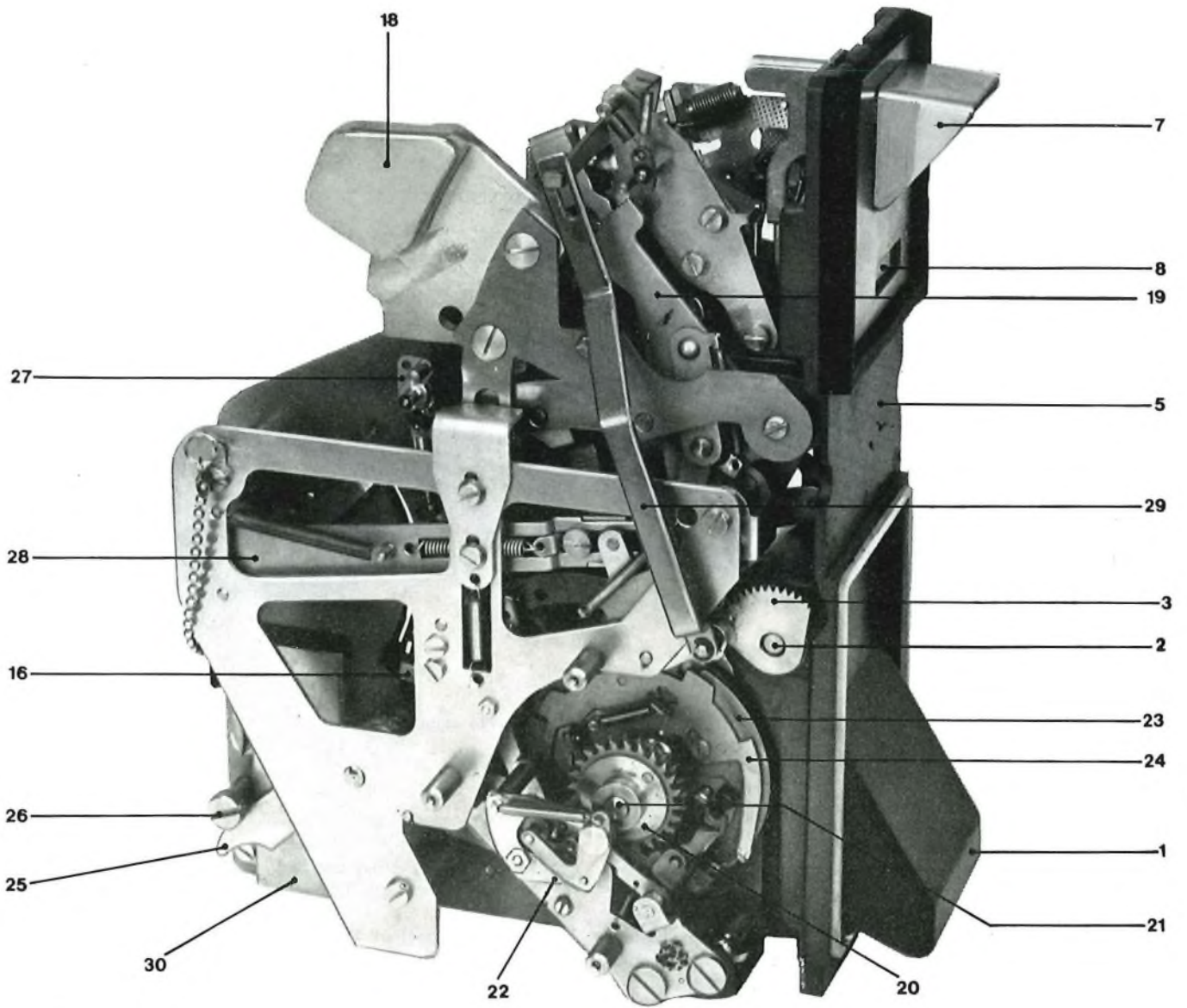

FIG. 2—The Stamp-Selling Machine Type G, left-hand view



The rack, and with it the weight, are also raised. The detent drive assembly (22) is rotated anticlockwise and the lever operated by the horizontal link is brought to bear on the accepted coin.

The rack is raised by the cam and arm mentioned earlier. Before the cam reaches top-dead-centre, the coin is forced past the end of the lever on which it had been resting. This lever is consequently depressed and this causes the vertical lever and latch combination with which it is interlocked to trip against a toggle action. The latch is removed from the stop on the detent drive assembly. The other vertical lever has also been rotated clockwise by the pin on the horizontal lever and its lower end is also brought free of the stop on the detent drive assembly. As the cam goes over top-dead-centre, the arm, the rack and the weight are all released. The weight falls as all latches are out of engagement and as it does so, it rotates the detent drive assembly clockwise. A pin on the detent drive assembly is brought into engagement with the detent and, since the detent locking pawl is tripped out of engagement, the detent rotates, the stamp-wheel rotates and the machine issues stamps.

The action would be almost the same if the flap had been raised before the machine had accepted a coin. The lever on the end of which an accepted coin first comes to rest would not, however, be depressed; the link which does this, the coin, not being present. The detent drive assembly would still have been rotated anticlockwise but the stop on it would have engaged with the latch. The fall of the weight would thus be arrested, and the machine would be in a primed condition with the flap free to fall and rise. Acceptance by the machine of a coin would cause the lever on which the coin comes to rest to be depressed on the raising of the flap and the action described briefly above would be repeated. The coin, having done its work, is fed into a separate cash container through a chute (30) at the lower left rear of the left half of the machine.

The machine automatically resets itself at the end of the operation and the detent locking pawl is actuated to lock the detent and thus the stamp feed wheel.

## CONCLUSIONS

The main purpose of a stamp-selling machine is to provide a service outside counter hours or where Post Office counter services do not exist; a secondary role is to supplement a counter service. To fulfil these roles, a machine must of necessity be robust and reliable, easily maintained and capable of operating under adverse conditions. Every effort has been made to ensure that the stamp-selling machine type G fulfils these requirements. There have been extensive laboratory tests; field trials with 25 pre-production machines provided an invaluable step in producing a reliable machine and about 10,000 are now being manufactured.

## ACKNOWLEDGEMENTS

Thanks are due to the Director of the Planning and Mechanization Department, Postal Headquarters, for permission to publish this article, and to Mr. R. J. Bath of Associated Automation Limited, the manufacturers of this machine, for information on design, construction and operation. Mr. Bath and Mr. M. Taylor, also of Associated Automation Ltd., have recently published an interesting article on this subject.<sup>4</sup>

## References

- <sup>1</sup> LONEY, H. J. Automatic Stamp-Vending Machines. *P.O.E.E.J.*, Vol. 54, p. 122, July 1961.
- <sup>2</sup> COMBRIDGE, J. H. The Development of Stamp-Selling Machines in the British Post Office. *P.O.E.E.J.*, Vol. 30, p. 18, Apr. 1937.
- <sup>3</sup> THOMPSON, S. Development of Postal Self-Service Machines. *P.O.E.E.J.*, Vol. 52, p. 272, Jan. 1960.
- <sup>4</sup> BATH, R. J., and TAYLOR, M. G-Type Stamp Vending Machine. I.Mech.E. Conference on British Postal Engineering, May, 1970, Paper No. 1.

## Book Reviews

Urolec United Kingdom. "Electronic Components, Materials and Sub-Systems, No. 14." 1970, "Companies and Contacts." David Rayner Associates. 432 pp. £1.75.

This self-styled pocket guide is one of a series. It may best be described as a ready reference to the companies engaged in electronic-component manufacture, sales and distribution. It gives details of nearly 1,000 companies, giving name, address, telephone number, location of factories, if any, associated companies, activities, number of employees and names of directors and chief executives.

It is compact, approximately 8 in × 4 in ×  $\frac{3}{4}$  in, and the print is rather small but acceptable for a pocket reference book. The arrangement adopted provides for reasonable convenience in use.

W. S. A.

"The Practical Aerial Handbook." Gordon J. King. Butterworth and Co. Ltd., 232 pp. 187 ill. £2.70.

The author, Gordon J. King, requires no introduction in the field of radio and television. Following his traditional style this second, much improved edition of *The Practical Aerial Handbook* provides an up-to-date comprehensive survey of practical aerial systems.

The opening chapters, which cover propagation and the principles of aerials and feeders are fairly detailed, but together with the rest of the book should be within the scope of the non-technical reader. The major part of the book considers most practical aerial systems, from l.f. longwires to complex yagis for u.h.f. television reception. The author's

guide to choosing an aerial for a particular situation is a particular welcome source of information. Other chapters give detailed consideration to signal combining, booster amplifiers, and shared-aerial systems, again in much detail. Radio and television interference is dealt with extensively in the final chapter. Eight informative appendices include articles on aerials for colour television and for stereophonic radio reception.

In conclusion, a very well written informative book on the practical aspect of receiving aerials.

M. G.

"Questions and Answers on Electricity." K. G. Jackson. Butterworth and Co., Ltd. 112 pp. 62 ill. 50p.

This little book sets out in question-and-answer form many interesting facts about the generation, distribution, heating, lighting and machine aspects of electrical engineering. Sections are also included on the basic principles of electricity and electrolytic action.

It is aimed at the school leaver or man experienced in another discipline who requires background information, but the answers vary a great deal in the amount of knowledge they assume the reader to have already. Also, the briefness of the answers occasionally leads to a false impression being left with the reader.

Although few people will read it without learning something, 50 pence seems rather a lot to pay for a book of this size. Perhaps a paperback edition is the answer.

J. W.

# Introduction of International Subscriber Dialling from Non-Director Areas

J. W. GIBBS, C.ENG., M.I.E.E., and F. G. JACKSON†

U.D.C. 621.395.374: 621.395.4: 621.395.74

*International subscriber dialling (i.s.d.) facilities were introduced, for London subscribers, in 1963. Facilities are now being introduced for i.s.d. from non-director areas; this necessitates the provision of i.s.d. register translators and call timers at non-director group switching centres. The article outlines the facilities of this additional equipment and describes some of the main circuit-elements.*

## INTRODUCTION

International subscriber dialling (i.s.d.) from the British Post Office network was introduced in 1963 when access was given from London to Paris.<sup>1</sup> Since then outgoing access has been extended to include the majority of European countries<sup>2</sup> and also New York. The service has also been given to subscribers in the other director exchange areas—Birmingham, Edinburgh, Glasgow, Liverpool and Manchester. It is now being extended progressively to non-director exchange areas commencing with the group switching centres (g.s.c.) originating the largest amounts of international traffic.

The magnetic-drum register-translator for director areas<sup>3</sup> included, in the original design, sufficient digit storage, code expansion, translation and metering facilities for i.s.d. purposes. These facilities were not included in the non-director-area register-translators;<sup>4,5</sup> instead, provision was made for the addition of i.s.d. register-translators and call timers when required. These items have now been developed.

## GENERAL DESCRIPTION OF I.S.D. EQUIPMENT PROVIDED AT NON-DIRECTOR G.S.C.s.

### Register Translator

The trunking arrangements are shown in Fig. 1. A caller dialling the subscriber trunk dialling (s.t.d.) access digit 0 seizes a register-access relay-set, which in turn seizes a free s.t.d. register. If the s.t.d. register then receives the digits 10 it diverts the call to an i.s.d. register-translator. A combined register-translator is used because this is more economic than separate registers and translators for the small amounts of i.s.d. traffic involved at the majority of non-director g.s.c.s. The i.s.d. register-translator caters for access from a maximum of 300 s.t.d. registers by using up to three motor-uniselector finders each with access to a group of up to 100 registers. In practice, a maximum of 96 s.t.d. registers per group is used, 96 being a multiple of 24, the number of s.t.d. registers in an access group from register-access relay-sets.

The i.s.d. register-translator is provided initially with storage capacity for 13 digits following the i.s.d. prefix digits 010; the capacity can be increased to 15 digits if required. The country destination can be established from an inspection of the first one, two or three digits. Having recognized the destination the translator provides the following information:

#### (a) Choice of route

A choice of up to four routes is available, each being reached by a maximum of three Strowger routing-digits. All

† Mr. Gibbs and Mr. Jackson are both in the Telecommunications Development Department, Telecommunications Headquarters.

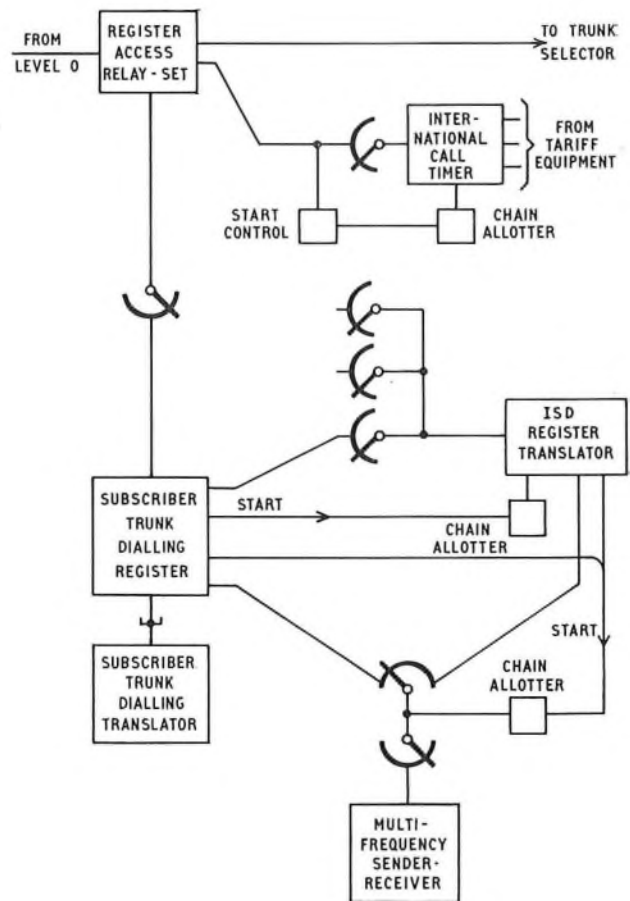

FIG. 1—Trunking diagram for i.s.d. calls at non-director g.s.c.s.

routes must use multi-frequency (m.f.) inter-register signalling as used on the transit network.<sup>6</sup> The routes will normally be part of the transit network, but direct routes to international switching centres (i.s.c.s) may be provided from g.s.c.s having sufficient i.s.d. traffic. Alternative routing from a high-usage route to a fully-provided route can be given on three of the routes; one of the four routes will always be a fully-provided route, usually the basic transit route.

#### (b) Choice of i.s.c.

A choice of up to ten i.s.c.s. is available on calls routed via the transit network. On such calls, in response to a m.f. transit proceed-to-send signal, the digits 10X are forwarded



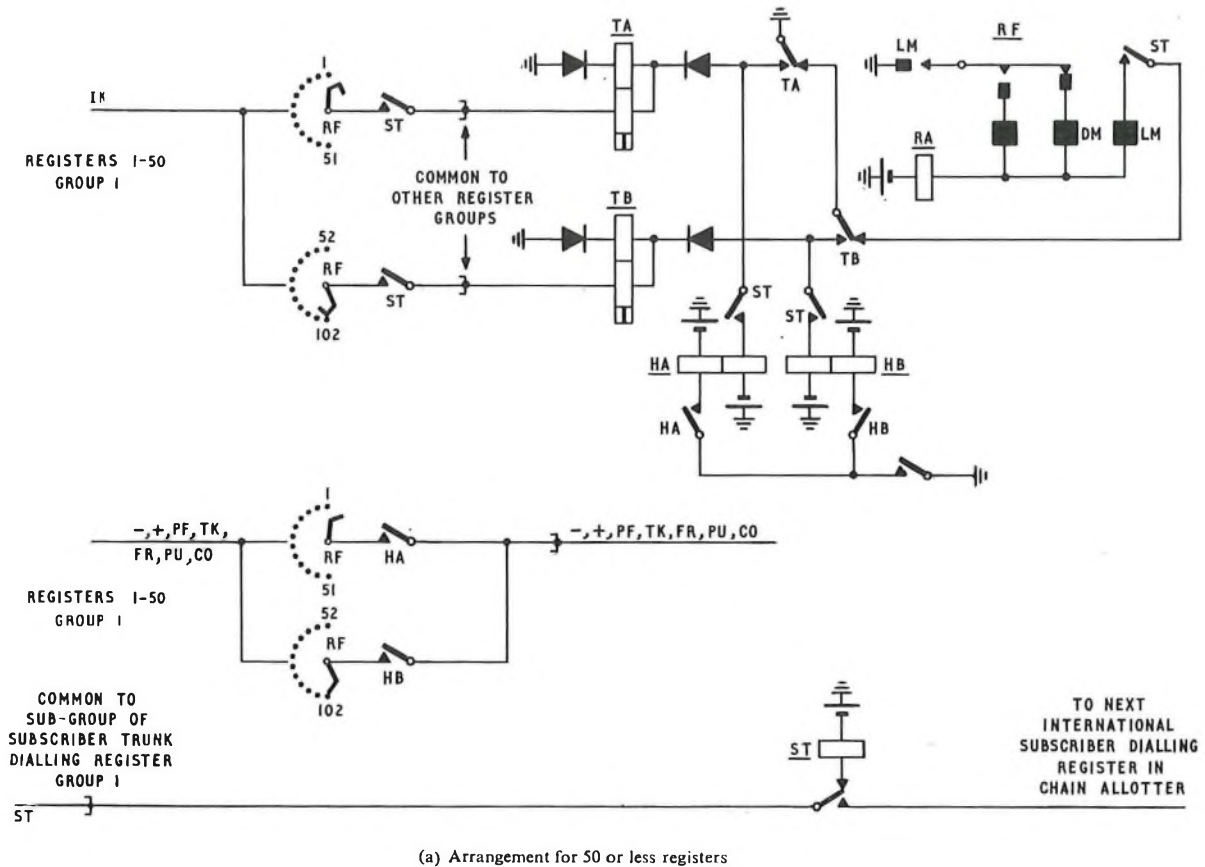

in m.f. form. The digits 10, part of the international prefix, have to be reconstituted, as they have been absorbed in the s.t.d. register. The digit, X, is provided by the translation to enable the transit network to route the call to the i.s.c. handling calls for the country concerned.

*(c) Choice of metering rate*

A choice of ten charge steps is available. When the charge step information is available a start/mark signal is sent via the s.t.d. register to the register-access relay-set to call in an international call timer (i.c.t.). When the i.c.t. is connected a digit indicating the charge step is pulsed to the i.c.t. via the s.t.d. register and the register-access relay-set.

**Multi-Frequency Sender-Receiver**

The m.f. sender-receiver used to establish the call is one of a common pool serving s.t.d. registers and i.s.d. register-translators. When it is required, it is associated with the register by using either a uniselector register-finder or a link circuit. The link circuit consists of two similar uniselectors connected back to back, one acting as a register finder and one as a m.f. sender-receiver hunter. The latter arrangement is normally used where the number of registers to be served exceeds 25 since it avoids the provision of one or more additional groups of m.f. sender-receivers.

The m.f. sender-receiver, in conjunction with the register, responds to m.f. transit proceed-to-send signals by forwarding the digits 10X. In response to terminal proceed-to-send signals it forwards the stored digits. When the incoming register at the i.s.c. recognizes that a complete number has been received it returns a m.f. number-received signal. On receipt of this signal the m.f. sender-receiver initiates the release of the s.t.d. register and the i.s.d. register-translator which, in turn, releases the m.f. sender-receiver.

Dependence on the i.s.c. for the determination of number length avoids the need for this feature in non-director i.s.d. register-translators, thereby simplifying their design.

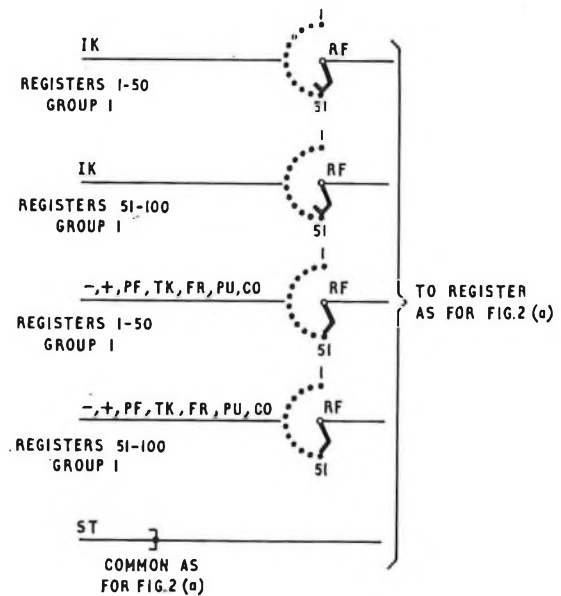

FIG. 2—Circuit diagram of the register-finder

**International Call Timer**

Each i.c.t. has a motor-uniselector-type finder serving a maximum of 200 register-access relay-sets. The receipt by the control circuit of a start/mark condition causes a finder to search for, and switch to, a marked register-access relay-set; the register-access relay-set extends a coin box discrimination condition if this is appropriate to the call. The i.c.t. then receives a train of pulses to select the charge rate applicable. On each of the ten charge rates there is a choice of a meter-pulse supply for ordinary callers or a meter-pulse supply for coin

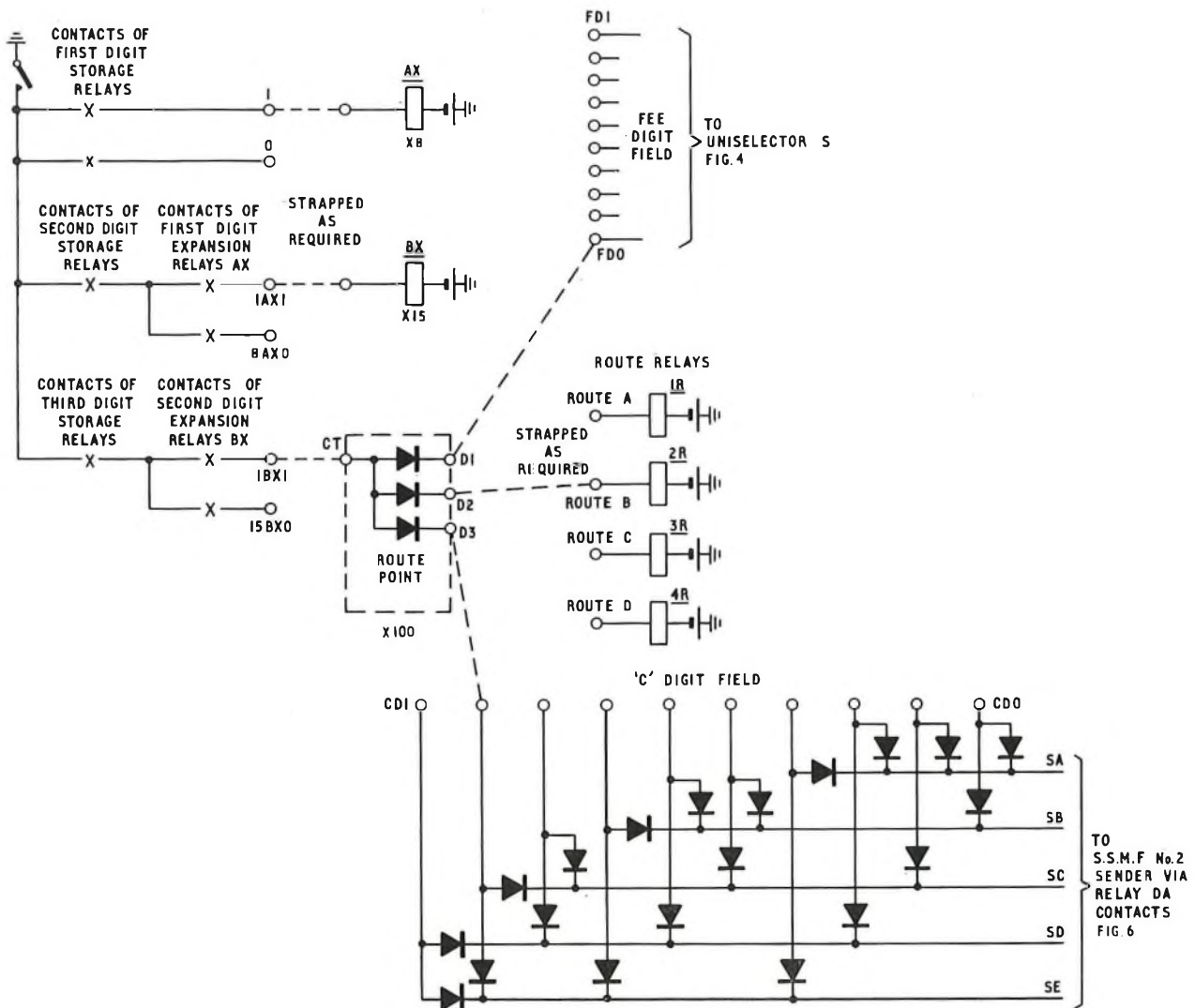

FIG. 3—Circuit diagram of the translator

boxes; alternatively any rate can be barred to coin boxes. On each charge rate there is also an option of either using the meter-supply pulses directly or introducing a divide-by-six circuit whereby metering is only applied on receipt of every sixth pulse. The meter pulses are fed to the register-access relay-set where they are repeated in the appropriate form for the duration of the call.

**CIRCUIT DESCRIPTION OF THE I.S.D. REGISTER-TRANSLATOR**

The description covers only new circuit elements and those which already exist but have been used in a novel way in this equipment.

**Register-Finder**

The method of bank wiring and the type of wiper assembly used for the motor-uniselector register-finder are determined firstly by the need to keep the searching time for a calling condition to a minimum, and secondly to contain wiper blade and contact-assembly wear within acceptable limits. The number of s.t.d. controlling registers in a main group served by the finder is another factor to consider. To meet these requirements, two schemes have been adopted and are shown in Fig. 2.

Fig. 2(a) is the scheme used if 50 or less registers form the main group. Every register in the group has two appearances on the finder, one in each bank, occupying similar outlet

positions on the two banks. In order to reduce maintenance liability, the wipers relative to each bank are positioned to perform consecutive group searches on alternate banks and non-homing circuit techniques are used.

If the finder is associated with a main group of more than 50 and up to 100 registers, the circuit shown in Fig. 2(b) is used. In this case the registers are divided equally between the two banks and each register has only one outlet appearance. The wiper arrangement keeps the register association time to a minimum by performing the group search function simultaneously over both banks.

Since the non-director controlling register-translators have no provision to store and forward any digits of the international number, association of an i.s.d. register must occur during the normal inter-digital pause (i.d.p.) following receipt of the prefix digits 010, and the i.s.d. register must be ready to receive subsequent digits of the international number immediately following association. For these reasons, the ST relay in the i.s.d. register chain-allotter, being the first relay in the circuit to operate, is also used to pre-flux relay A, the pulse-repeating relay, and, by the time pulsing begins, this relay is fully fluxed and the possibility of a mutilated first digit is eliminated.

**Translation**

The main elements of the translator are shown in Fig. 3. The single outputs from the digit expansion relays, or the





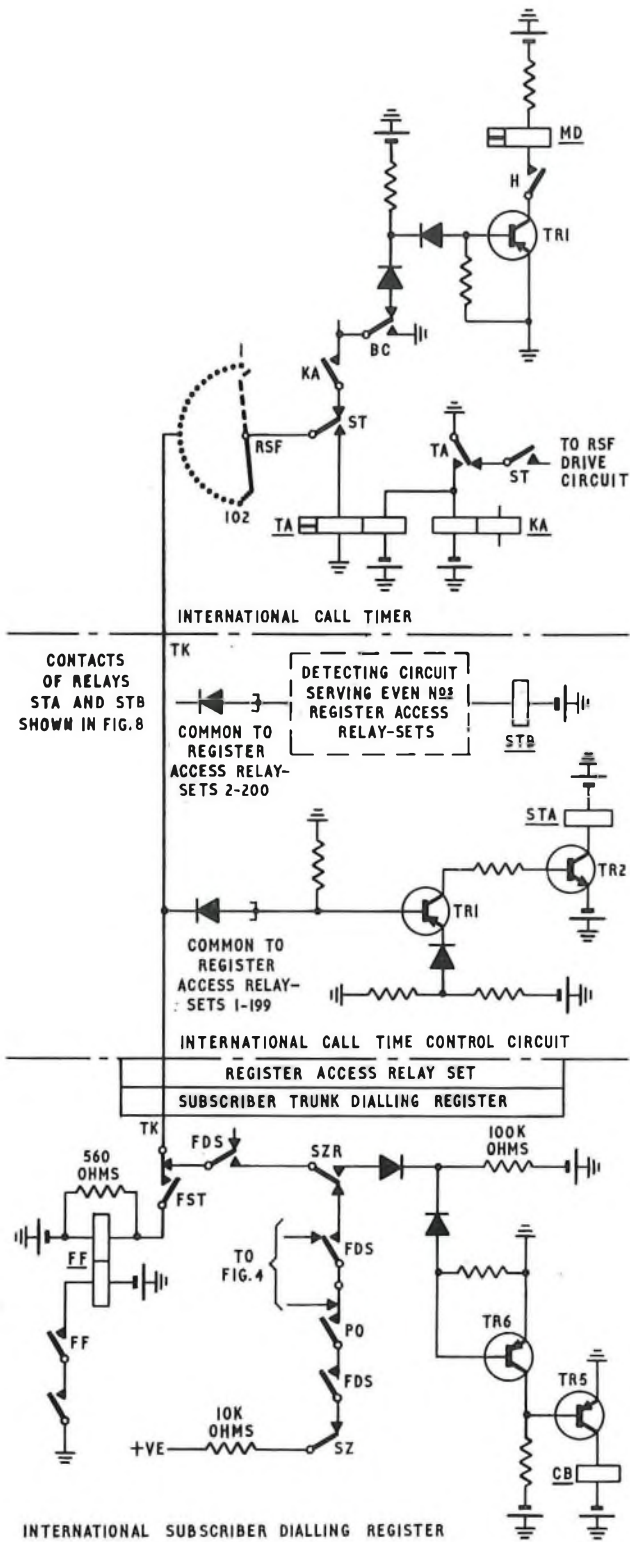

FIG. 5—Circuit diagram of the TK lead signalling elements

unselector S to outlet 13 in preparation for the second routing-digit.

When the 600 ms timer matures, relay PT operates and releases relays SZR and SZ. Relay SZR has a release lag of 150 ms, therefore giving a total normal i.d.p. of 750 ms. This is shortened if selector switching is detected, and relay HSD momentarily releases when the switching relay in the trunk selector operates to seize the next trunk selector, or an outgoing relay-set. In this case a contact of relay HSD removes the short circuit from relay SDA which operates. Relay SDA

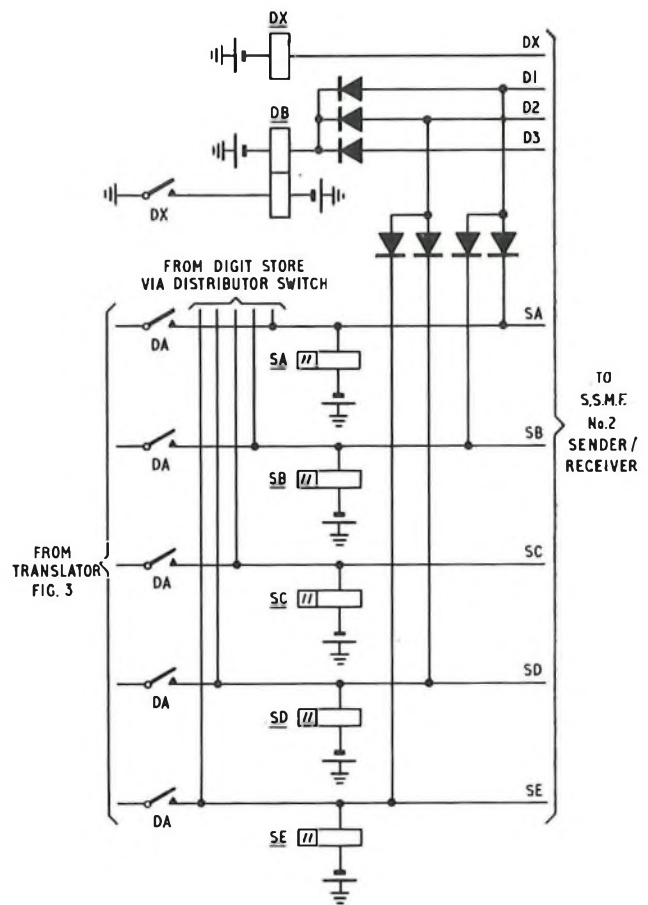

FIG. 6—Circuit diagram of the transit-network routing-digit element

operates relay PT, and, as for the normal i.d.p. case, relay PT releases SZR and SZ. The interacting circuit for relay PO and unselector S is restored and the sending sequence is repeated for the second routing-digit.

The third routing digit is transmitted in the same manner, but with unselector S starting its pulsing sequence from outlet 25. During the i.d.p. following the third routing-digit, unselector S drives to outlet 39 and relays FST and SMF operate. The drive later continues on to outlet 50 following the operation of relays MFC and MFD when the sender-receiver is associated.

On routes where access is achieved with less than the maximum of three routing-digits, relays FST and SMF operate at the end of the last routing digit sent, and this will occur before unselector S reaches outlet 39. In these cases the DCO tags are strapped to provide the alternative operate path for the relays. If only one routing digit is required, one of the terminals 1R1 to 4R1 and one of the terminals 1R2 to 4R2 are connected to their associated DCO terminals and the relays operate to the earth via arc S when the unselector drives to outlet 13 during the i.d.p. If two routing digits are used, one of the terminals 1R2 to 4R2 only is strapped to its associated DCO terminal and the relays operate when the unselector drives to outlet 25 during the last i.d.p.

### Signalling Elements for Control

The TK lead is used for the passage of all signals between the register and the i.c.t. and the i.c.t. control circuit.

The various signalling elements associated with the TK lead are shown in Fig. 5. I.C.T. association begins when relay FST in the register operates and connects negative battery to the TK lead. The negative potential appears on an outlet of the i.c.t. finder as a marking signal and at an input to the i.c.t. control-circuit-detecting element as a calling condition.



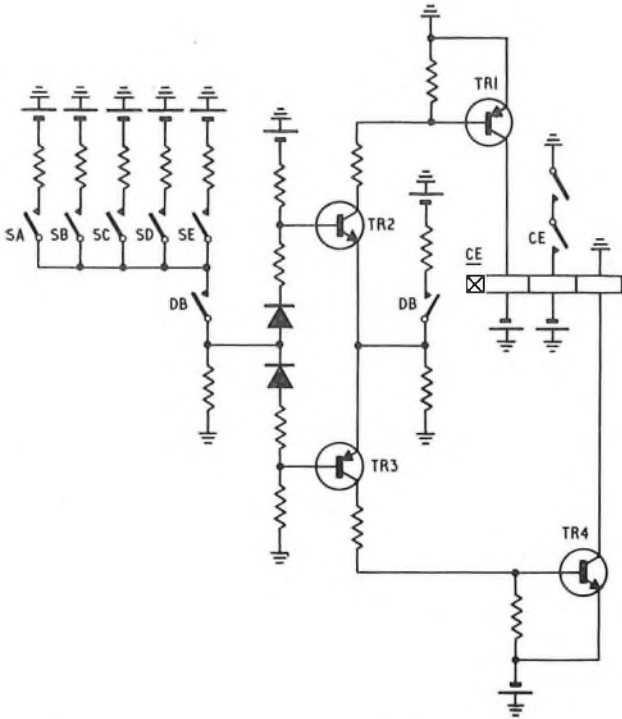

FIG. 7—Circuit diagram of the two-out-of-five digit-check element

The high input impedance of this element prevents premature operation of relay FF and also lessens the shunting effect on relay TA when the i.c.t. is finally associated. Transistors TR1 and TR2 conduct to the negative potential and relay STA operates and applies a start condition to the i.c.t. chain allotter. The finder of the selected i.c.t. hunts for the marked outlet on the TK arc. When the outlet is reached, relays TA and FF operate in series and reduce the TK lead potential to a level sufficient to cut-off the i.c.t. control circuit detecting element. Relay STA releases and removes the start condition from the chain allotter and relay ST in the i.c.t. releases. Relay TA operates relay KA to connect the i.c.t. fee-digit receiving element to the TK lead. Relay FF in the register releases relay FST and the calling and marking conditions are disconnected from the TK lead.

Relay FDS operates (Fig. 4) via outlet 50 and a contact of relay FF, and homes uniselector S to the first outlet ready to send the fee-digit. The fee-digit pulses are generated by the interaction of relay PO and uniselector S in a manner similar to that described for strowger sending. The pulsing-off contact of relay PO transmits positive-battery disconnect-pulses to the TK lead. The fee-digit receiving element trans-

sistor TR1 in the i.c.t. is normally conducting and is cut-off for the duration of each positive pulse received. Relay H operates prior to the first pulse and operates relay MD which then responds to the received fee-digit signals.

The last pulse of the fee-digit signal is followed by a delay period of 600 ms after which relay SZR re-operates. One contact of relay SZR completes a circuit for uniselector S to drive on to outlet 25 where it remains until the register releases. A further contact of this relay disconnects the pulsing element from the TK lead and connects the call-barred signal-detecting element. Transistor TR6 is normally conducting and transistor TR5 is held cut-off. The i.c.t. indicates a barred call by a full earth signal on the TK lead applied by relay BC. This signal cuts-off transistor TR6. Transistor TR5 now conducts and relay CB operates. The register releases the call and number-unobtainable tone is returned to the calling subscriber.

### Signalling the Transit-Network Digits to the Sender

Relay SMF (Fig. 4) applies start and marking conditions to the register-finder, or link circuit, to associate a S.S.M.F. No. 2 sender-receiver.

The transit-network routing digits 10X are signalled to the sender in two-out-of-five code over the SA to SE leads in response to earth signals received from the sender on the D1, D2 and D3 leads.

The signal received on the D1 lead (Fig. 6) is coded using diodes connected to the SA and SB signalling leads to send the digit "1". Diodes similarly used on the D2 lead are connected to signalling leads SD and SE to send the digit "0". The signal on lead D3 operates relay DA and this relay extends the two-out-of-five coded output from the "C" digit diode matrix in the translator to the sender for the third digit (or X digit) of the transit routing code.

### Two-out-of-Five Digit Check Circuit

A single-contact reed relay (relays SA to SE in Fig. 6) is connected to each of the sender signalling leads and operates, as appropriate, in the presence of a digit signal. A correctly coded digit will operate two relays, and, to ensure that two and only two have operated, the contacts are connected to the digit-check circuit (Fig. 7).

Relay DB is operated whenever the sender applies to the register for a digit signal. Contacts of relay DB enable the check circuit to compare the voltage at its input, with a reference voltage derived at the mid-point of two series resistors connected between battery and earth. A correctly-coded digit signal operates two of the relays and the resulting input voltage is very nearly equal to the reference voltage. Transistors TR1 to TR4 remain in their cut-off state and relay CE is normal.

If the code is incorrect and fewer than two relays operate, the input voltage is less negative than the reference voltage

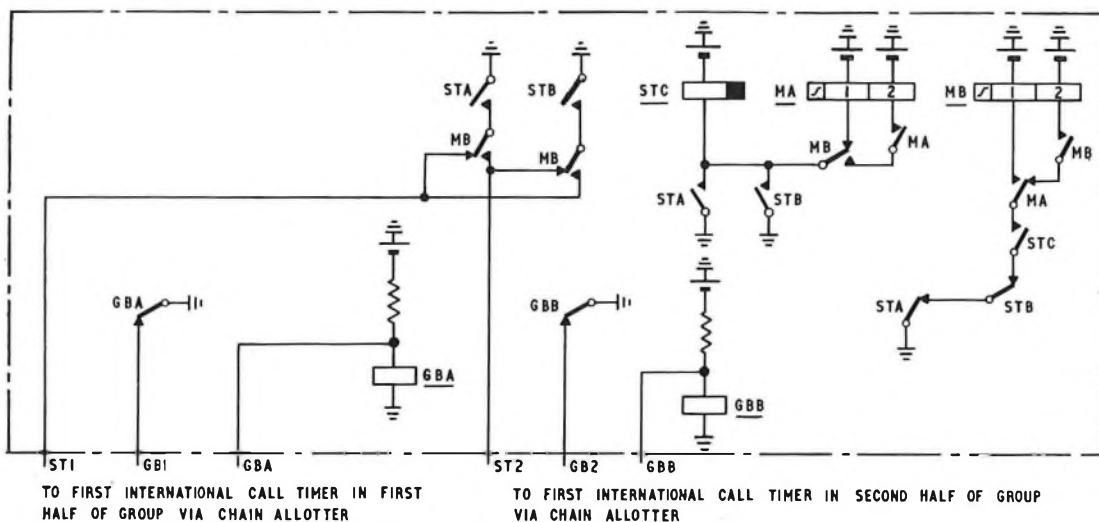

FIG. 8—Circuit diagram of the international-call-timer control circuit

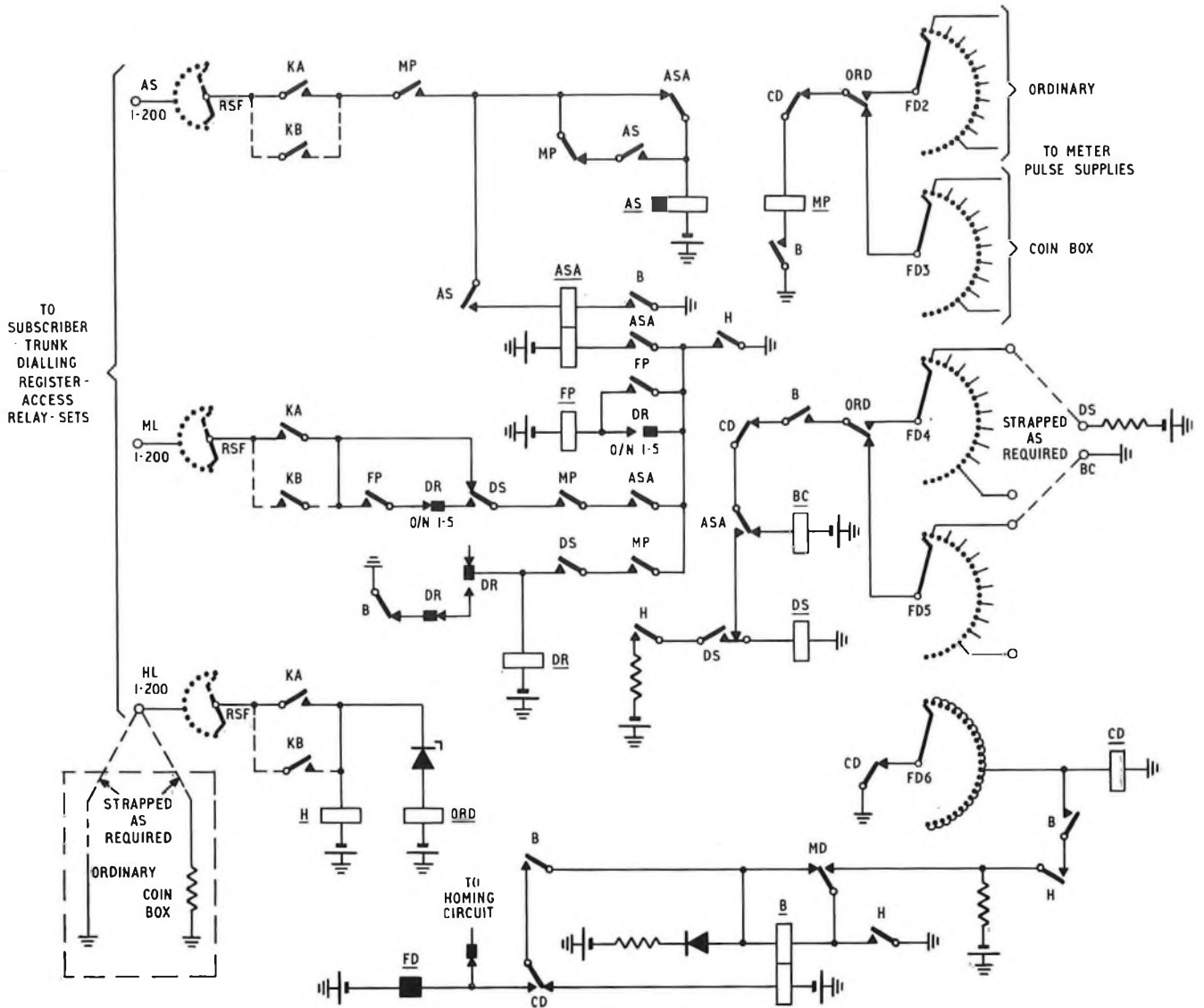

FIG. 9—Circuit diagram of the international call timer

and transistors TR1 and TR2 conduct and operate relay CE on one of its windings. An incorrect code operating more than two relays produces a voltage more negative than the reference voltage. Transistors TR3 and TR4 then conduct and operate relay CE on its other operate winding.

In either case, the operation of relay CE stops further sending and locks the register out of service. Number unobtainable tone is returned to the calling subscriber and the register retains its state of operation to assist fault location.

#### CIRCUIT DESCRIPTION OF THE I.C.T. CONTROL CIRCUIT

A feature of the i.c.t. control circuit is the remanent relay divide-by-two element (Fig. 8). The circuit is used to alternate consecutive start conditions between the start leads ST1 and ST2, each of which serves a different section of the i.c.t. chain allotter. Winding 1 acts as the operate winding on both relays, and winding 2 is differentially connected and is used as the release winding. Relay MA operates when relay STA (or relay STB) operates at the start of i.c.t. association. On completion of i.c.t. association, relay STA releases and is followed by slow-releasing relay STC, relay MB operating during the release lag of relay STC. Relay MA releases when relay STA operates at the beginning of the next

calling condition. Relay MB remains operated until the end of the calling condition and then releases during the release lag of relay STC. The circuit is then back to normal having completed one operating cycle.

#### CIRCUIT DESCRIPTION OF THE INTERNATIONAL CALL TIMER

Fig. 9 shows the circuit arrangement used to convert the fee-digit signal pulses received on the TK lead into a metering rate appropriate to the call. The drive circuit for unselector FD is controlled by relay MD responding to the fee-digit signal pulses. The outlets of arc FD2 are wired to the ordinary call group of meter-pulse-supply rates, and the outlets of arc FD3 are wired to the meter-pulse-supply group allocated to coin-box originated calls. The selected pulse supply is connected to relay MP following the release of relay CD at the end of the last fee-digit pulse, and relay MP responds to the received pulses.

The strapping field associated with arcs FD4 and FD5 and the DS and BC terminals enables either the divide-by-six or the barred-call facility, respectively, to be introduced into any of the selected meter pulse rates. In the case of the divide-by-six facility, the negative battery at terminal DS energizes relay DS when relay ASA operates following an answer



signal. One contact of relay DS completes a circuit for ratchet relay DR to step under the control of relay MP, and a further contact in the ML lead diverts the metering signals repeated by relay MP through the divide-by-six contacts of ratchet relay DR.

If the selected rate relates to a barred call, the earth at terminal BC energizes relay BC and a contact of this relay extends the barred call condition to the i.s.d. register where the barred-call element functions as previously described.

Wiper switching of ordinary and coin-box supplies is effected by means of a voltage-level detecting relay ORD connected to the HL lead. This relay identifies the earth discrimination condition on the HL lead, and if a full earth is present, as for ordinary calls, the relay operates.

A coin-box call is indicated by a resistance earth, which limits the potential at relay ORD to prevent its operation.

An answer signal on the AS lead from the access relay-set, followed by the operation of relay MP, operates relay AS and short circuits relay ASA. This ensures the first meter pulse on answer, connected by the access relay-set, is not distorted by the simultaneous operation of relay MP. Subsequent meter pulses are transmitted to the register access relay-set over the ML lead by a contact of relay MP, either directly, or via the divide-by six contact of ratchet relay DR.

At the finish of a call, a relay in the chain allotter (relay CN) remains operated to the earth on the GB lead (Fig. 8) and busies the circuit to the chain allotter until all other circuits, except the last, in the allotter group have been taken into use. When the last circuit is seized, its CN relay disconnects the final earth from the GBA (or GBB) lead and relay GBA (or relay GBB) in the control circuit operates. Contacts of relay GBA disconnected the earth on the GB lead, and all circuits except the last, release. The last circuit releases when the call with which it is associated ends. This arrangement

ensures an even spread of traffic over all the timers and lessens the risk of late choice circuits developing faults through long periods of idleness.

## CONCLUSION

I.S.D. facilities are being introduced for subscribers in non-director areas commencing with those areas originating the largest amounts of international traffic. The items of auxiliary equipment are electro-mechanical and consist of the i.s.d. register-translator, the i.c.t. control circuit and the i.c.t. They can be added conveniently as the original design of non-director register-translators made provision for their subsequent addition. All i.s.d. traffic from non-director areas will be carried over routes, using S.S.M.F. No. 2 signalling, to the appropriate i.s.c.

## References

- <sup>1</sup> MILES, J. V. Introduction of International Subscriber Dialling from the London Director Area to Paris. *P.O.E.E.J.*, Vol. 56, p. 33, April 1963.
- <sup>2</sup> MILES, J. V., and TURNBULL, M. G. Switching Arrangements for International Subscriber Dialling of Calls to Europe. *P.O.E.E.J.*, Vol. 57, p. 75, July 1964.
- <sup>3</sup> BENSON, D. L., and VOGAN, D. H. Controlling Register-Translators, Pt. 4—Magnetic Drum Register-Translators, *P.O.E.E.J.*, Vol. 51, p. 29, Jan. 1959.
- <sup>4</sup> BARNARD, A. J., BENSON, D. L., and WOOD, R. A. Controlling Register-Translators, Pt. 2—Electro-mechanical Register-Translators. *P.O.E.E.J.*, Vol. 51, p. 272, Jan. 1959.
- <sup>5</sup> KEARSLEY-BROWN, R. H. G., and CUMMING, W. S. Trunk-Transit-Network: Access from Controlling Register-Translators at Group Switching Centres. *P.O.E.E.J.*, Vol. 61, p. 120, July 1968.
- <sup>6</sup> MILLER, C. B., and MURRAY, W. J. Transit-Trunk-Network Signalling Systems—Part 1—Multi-Frequency Inter-Register Signalling. *P.O.E.E.J.*, Vol. 63, p. 43, April 1970.

## Book Review

"Information Theory." Prof. S. Goldman. Dover. xiii+385 pp. 75 ill. £1.68.

This book is an unaltered, unabridged republication of the first (1953) edition, and it is interesting to note that only in a few instances does the presentation appear at all dated. Information theory is not one of the easiest topics to absorb, but Professor Goldman gives a very clear exposition of the underlying principles, well suited to the student or lay reader new to this field and who has a fair knowledge of calculus and some engineering background. The author does, however, make frequent reference to one of his other publications, "Frequency Analysis, Modulation and Noise," and the reader would be well advised to have this available even though there is a trivial inconsistency in the author's use of  $\pi$  in Fourier's series.

Before one can begin to understand a new subject there is a certain amount of introductory material, definitions and ideas which must be correctly absorbed. By clear presentation of reasoned arguments, simple mathematics, and liberal use of diagrams and worked examples the author succeeds in making this initial task surprisingly enjoyable, covering such topics as information theory of discrete systems, properties of continuous signals, ergodic ensembles and random noise and the entropy of continuous distributions. This groundwork is

followed by treatment in some depth of band-limited systems having a continuous range of values, an introduction to the use of signal space, information theory aspects of modulation and noise reduction, linear correlation, filtering and prediction and various other aspects of information theory. A detailed treatment is given of the transformation of both information and constraints from the time to the frequency domain; various sampling theorems are developed and aspects of random noise, language and semantics are developed thoroughly. Thirteen very useful Appendices contain the necessary formal proofs, theorems and derivations which may have distracted the reader if they had appeared in the main body of the book. A table of logarithms to base 2, of numbers from 1 to 10,000, is included.

The presentation of the subject-matter is based on the classical works of Shannon and Wiener, but the author does not hesitate to comment critically upon their opinions or points of view or to redefine certain terms such as "random noise," "white noise," and "ergodic ensemble," and introduce new terms such as "liniva," "quadriva" and "ergodic range." This is not as confusing as it may appear at first sight.

The book is one of the Dover permanent paperback editions designed for ease of reading and hard use, and will provide stimulating reading and good value for money.

D. M.

# An Experimental Manually-Switched 48 kbit/s Data-Transmission Network

M. E. GIBSON, C.ENG., M.I.E.R.E., and D. R. MILLARD†

U.D.C. 621.394.4: 681.31: 621.395.74.001.5

*A manually-switched 48 kbit/s data-transmission network has been established on an experimental basis. The network is, however, expected to be relatively short-lived, and it has, therefore, been necessary to expend only the minimum development and production effort on it. The network is based upon the use of the newly-developed Datal Modems No. 8 and 9, and this article describes how the modems are used, the planning criteria necessary for the selection of suitable line plant, and the manual switchboards that have been specifically developed for the system.*

## INTRODUCTION

In July 1970 the British Post Office introduced an experimental 48 kbit/s manually-switched data-transmission network with switching centres at London, Birmingham and Manchester. A point-to-point 48 kbit/s data-transmission service was also introduced at the same time. Both the point-to-point service and the experimental switched network use Datal Modems No. 8 and 9, but this article describes their particular application to the switched network.

Unlike most telephone and telegraph services, for its data-transmission (datel) services the Post Office does not supply the whole means of communication between terminal points. At its source, data passes from the customer-owned processing equipment to a Post Office data-transmission link and thence from the link to customer-owned processing equipment at the destination. The Post Office, as the data-communication authority must, therefore, work closely with the manufacturers and users of the data-processing equipment to ensure that compatibility is achieved. Indeed, the commercial success of 48 kbit/s data transmission will depend not only upon the Post Office demonstrating that it is capable of successfully providing the transmission facilities but also upon the manufacturers being able to produce the data-processing equipment to exploit them to meet the users' needs. It is against this background that the experimental 48 kbit/s manually-switched network has been established.

To encourage the development of the necessary data-processing systems, computer manufacturers and related organizations have been invited to use the network free of charge for the first 6 months after connexion, provided that this period falls within the first year of the 2-year planned life of the experiment.

If the switched-network experiment is successful, the Post Office will gain useful experience in the field of 48 kbit/s data transmission, and the network may be retained beyond the 2-year trial period, to offer a limited manually-switched 48 kbit/s service. In addition, demand for the point-to-point service may also be stimulated.

## DATA TRANSMISSION AT 48 KBIT/S

Data transmission at 48 kbit/s typically requires a bandwidth of the order of 40 kHz. This is not difficult to obtain in the main network, using a 60–108 kHz group-link, but the extension of such a group-link from the h.f. terminal (repeater station) to the customer's premises would require specially provided plant, and this could be uneconomic.

It is planned to avoid high local-line costs by using different transmission techniques for the local and main sections of a circuit so that, as far as possible, existing types of line plant in each section may be used. For this reason, two complementary synchronous modems—Modems No. 8 and 9—have been developed.

## Modem No. 8

The Modem No. 8 is installed at the customer's premises and provides the interface between the data-processing equipment and the communications plant. The line signal produced by this modem, so that it may be transmitted over physical cable pairs, is in the baseband form and has a frequency range from low frequencies to approximately 40 kHz, with the d.c. component suppressed (a signal of this type is known as suppressed d.c. binary, abbreviated s.d.c.b.).

Where line attenuation limits permit, the s.d.c.b. signal can be transmitted to the h.f. terminal on normal unscreened local-cable or junction-cable pairs. The use of specially-provided cable is thus unnecessary. Another feature is that the modem incorporates a scrambler to break-up repetitive data patterns that would otherwise result in persistent single-frequency components being transmitted in the group-link; these could cause intermodulation in wideband line plant. An equalizer to correct the attenuation/frequency distortion introduced by the local circuit is also included. The receive portion of the modem recovers the original data by restoring the d.c. component and unscrambling the signal.

## Modem No. 9

The second modem of the pair—the Modem No. 9—is installed at the h.f. terminal. Its basic function is to convert the baseband signal received from the Modem No. 8 to a form suitable for transmission on a 60–108 kHz group-link.

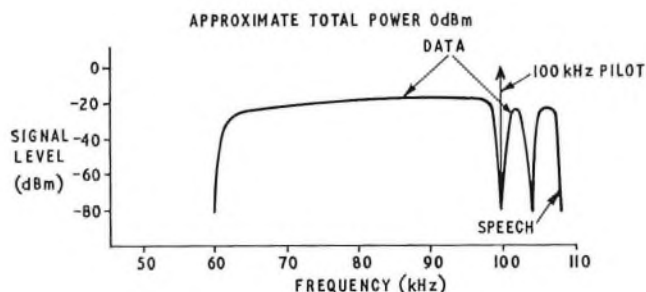

Fig. 1—Frequency spectrum of random data signal at "group-out" terminals of Datal Modem No. 9

† Network Planning Department, Telecommunications Headquarters.



This is achieved by modulating a 100 kHz carrier with the baseband signal, after equalization. The modulator output, which is arranged to contain a component of the carrier, to facilitate detection at the receive Modem No. 9, is filtered to reject all but the lower sideband and a vestige of the upper sideband. A telephone circuit, which is provided between the Modems No. 8 and 9 on separate cable pairs, is combined in the Modem No. 9 with the data circuit and occupies the nominal frequency band 104–108 kHz. The spectrum of the output signal on the group-band side is shown in Fig. 1 and the interconnexion of Modems No. 8 and 9 is shown in the block diagram in Fig. 2.

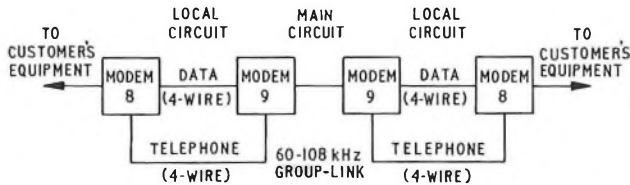

FIG. 2—Basic 48 kbit/s transmission circuit using Datal Modems No. 8 and 9

Both modems are constructed in 62-type module form and may either be housed in a case for installation in customers' premises, or mounted on a 62-type rack in Post Office premises.

#### Application to Network

The application of Modems No. 8 and 9 to the experimental network is shown in Fig. 3, the basic facilities offered being as follows.

(a) A 48 kbit/s isochronous duplex circuit can be switched to any other terminal of the experimental service, the connexion being established on a booked basis.

(b) A simultaneous telephone co-ordination circuit is available on an optional basis.

In Fig. 3, the three switching centres are shown, together

with a datel test centre (d.t.c.) and a Modem No. 8 at a customer's premises. The output of the Modem No. 9 is connected to the manual switchboard, where it is switched, using coaxial patching cords, to a group-link for onward transmission to another switching centre or to a Modem No. 9 associated with another local terminal. To avoid the need in an overall connexion for more than two switching centres in tandem, the latter are fully interconnected by group-links as well as by private telephone circuits that are used as order-wires in setting-up a data call.

The d.t.c. is connected to a switching centre in a similar manner to a customer's terminal, and may therefore call any customer for test purposes. In addition d.t.c.s may call each other to test the inter-switching centre group-links.

#### TRANSMISSION BETWEEN DATA TERMINAL AND SWITCHING CENTRE

The local data-transmission circuit interconnects the Modem No. 8 at the customers' premises and the Modem No. 9 at the h.f. terminal of the switching centre. It includes line plant in the local telephone distribution network and the circuit can be extended by junction line plant if transmission limits permit.

The transmission problems encountered arise from the use of plant that has been provided to give satisfactory commercial-quality speech communication, and for which the primary considerations are those of attenuation/frequency distortion, intelligible crosstalk and psophometric noise.<sup>1</sup> For data transmission the effects of group-delay/frequency distortion and high-energy impulsive noise become more significant as the rate of signalling is increased, although, in the present distribution network, group-delay/frequency distortion is not a serious problem. A further requirement is the need for compatibility between newly introduced services and existing transmission systems, such as subscribers' carrier systems.

In addition, the high utilization of the distribution or junction networks during 48 kbit/s data transmission can mean that faults that might go unnoticed on low traffic intensity telephone circuits become apparent much more

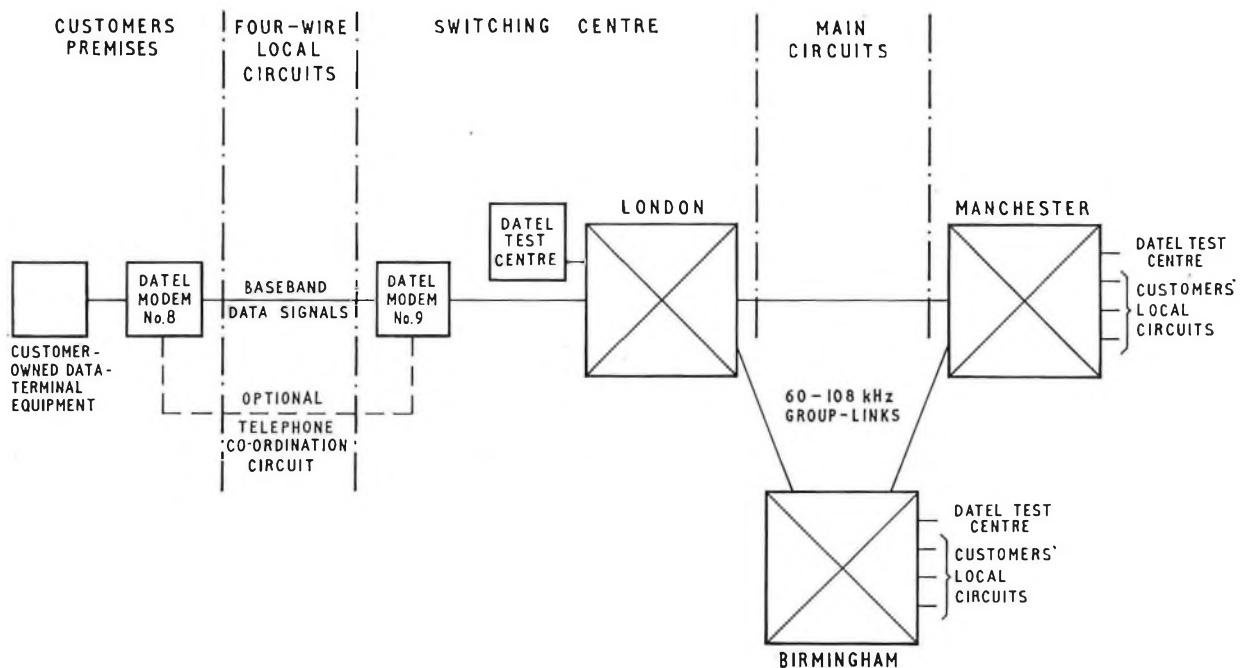

FIG. 3—An outline of the 3-centre manually-switched experimental network

quickly in this type of service. Furthermore, faults caused by vibration at flexibility points such as cabinets and pillars or by loose or corroded joints in shallow buried cable (particularly in built-up areas) can present serious problems. Also, transmission impairments such as momentary short-circuits, short-duration breaks, A-B reversals and accidental contacts by construction or maintenance staff are likely to be more serious for high-speed data transmission. A number of electrical and transmission tests have, therefore, been carried-out and basic planning rules devised, in order to ensure the provision of a suitable circuit.

### Planning Rules

The basic planning rules applied to a local circuit are that its insertion loss should not exceed 40 dB between 140 ohms at a frequency of 40 kHz, and that the near-end crosstalk attenuation should exceed 30 dB. These rules generally limit the location of customers' terminals to within a few miles of the switching centres. Longer circuits may be possible by specially selecting line plant, but special selection needs to be avoided if it is likely to give rise to difficulty in subsequent re-routing during overhauls or repairs.

### Tests

Tests carried-out on local circuits provided to date have included measurement of d.c. loop resistance, resistance unbalance, insulation resistance, echo-meter checks for split cable pairs, psophometric and impulsive noise and far-end crosstalk attenuation. The tests are concluded by a transmission level recording run for a minimum period of 24 hours at a selected test-frequency between 20 and 100 kHz. The need in future to apply all the tests specified is currently being reviewed.

### TRANSMISSION BETWEEN SWITCHING CENTRES

As already mentioned, main circuits are provided between switching centres by means of 60–108 kHz group-links. In an overall connexion established over the switched network the main circuit, therefore, forms that section which effectively interconnects the Modems No. 9.

A basic requirement of data transmission is that the shape of the data waveform should be retained with sufficient accuracy to permit, in the presence of circuit noise, detection at the receiver with low error-probability. To meet this objective it is necessary to control the amount of distortion, including group-delay/frequency distortion, present in the group-link. Group-delay/frequency distortion is of particular significance because of its relative unimportance to the transmission performance of the 12 speech channels that the group-link is designed to transmit.

Group-delay/frequency distortion is introduced typically by filters that sharply define the bandwidth of the transmission path, and is shown in Table 1 for items of apparatus commonly encountered in a group-link. The significance of the distortion quoted is seen when this is compared to the 20  $\mu$ s nominal duration of an element at 48 kbit/s.

The planning of the network commenced some time before prototype modems were available, and, in order to build in the maximum operating margin, the inter-switching centre routes were arranged not to include through-group filters (t.g.f.s), the object being to provide a group-link having parameters based upon C.C.I.T.T.\* recommendation H 14,<sup>2</sup> (Fig. 4).

Subsequent tests have indicated that the initial plans tended to be pessimistic, but even so the composition of group-links must be controlled to avoid excessive group-delay/

**TABLE 1**  
**Group-Delay/Frequency Distortion**

| Equipment                        | Nominal Distortion ( $\mu$ s referred to frequency band 64–104 kHz) | Remarks           |
|----------------------------------|---|-------------------|
| Through group filter             | 100   | } Typical values  |
| Equalized through group filter   | 18  |                   |
| Group translating equipment      | 12–29   | Dependent on type |
| Through supergroup filter        | 4   | Groups 2, 4       |
| Supergroup translating equipment | 2   | Groups 2, 3, 4    |

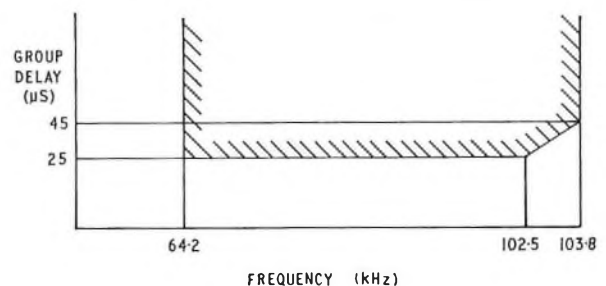

(a) Group-Delay/Frequency Distortion

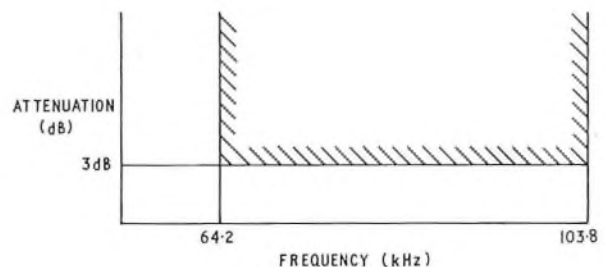

(b) Attenuation/Frequency Distortion

FIG. 4—Initial objectives for attenuation/frequency and group-delay/frequency distortion for inter-switching centre group-links

frequency distortion. General information on the composition of a group-link likely to have an acceptable performance is given in Fig. 5 and Table 2.

**Table 2**  
**Permissible Composition of a Group-Link used for 48 kbit/s Transmission**

| Component Section | Limitation  |
|-------------------|---|
| Group Number      | Group 2 or 4 in supergroup  |
| Supergroup Number | Supergroups 4–16, supergroup 2 (group 4 only) and supergroup 3 (group 2 only)   |
| Group-Link        | Not more than two group sections with equalized through-group filters but three group sections with intermediate equalized through-group filters can be used if low-distortion group translating equipment can be selected (see Table 1). |

Despite the fact that the switching centres are fully interconnected, in exceptional circumstances there could be a requirement for connecting two switching centres via the

\* C.C.I.T.T.—International Telegraph and Telephone Consultative Committee.



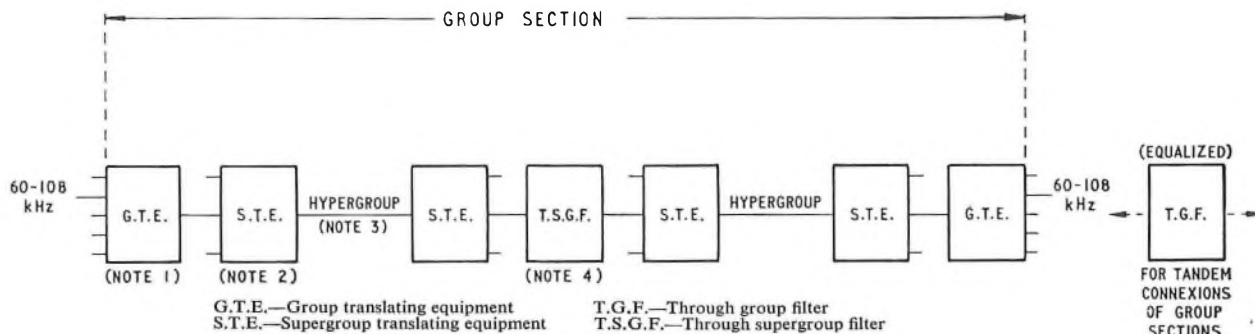

- Notes: 1. Distortion in group 3 excessive due to supergroup reference-pilot-stop filter.  
 2. Supergroup 1, supergroup 2, group 2, and supergroup 3, group 4, should not be used due to excessive distortion.  
 3. An edge supergroup in a derived hypergroup should not be used.  
 4. Excessive distortion in edge groups 1 and 5.

Fig. 5—General guidance on planning rules

third, so involving tandem links. At the planning stage there was some doubt whether modems would perform satisfactorily on such an overall connexion, and a back-to-back arrangement of Modems No. 8 and 9, as shown in Fig. 6, has been provided for such a contingency. The overall connexion may now be considered as two separate data links in tandem, or a single data link with an intermediate regenerator.

### OVERALL TRANSMISSION

A block diagram of the overall transmission arrangement is shown in Fig. 6. At the switching centre the Modem No. 9 associated with a customer's circuit is cabled via the group distribution frame (g.d.f.) through auxiliary amplifying and attenuating equipment to the switchboard, which is a 0 dBr point. This level is a compromise between that required for adequate margin against switchroom noise and that which can be obtained without risk of overload from relatively inexpensive amplifiers. The inter-switching centre group-links are also cabled to the switchboard via the g.d.f. and auxiliary amplifying and attenuating equipment. Another feature shown is the method of connexion of 104·08 kHz group reference-pilots. These pilots, which will be available later in the experiment, are required because the 48 kbit/s signal interferes with the standard 84·08 kHz pilot. It has been arranged that the a.g.c. equipment associated with the 104·08 kHz group reference-pilot will give a lamp indication at the switchboard should the group path fail.

As a safeguard against service failure, two alternatively-routed group-links have been provided on each inter-switching centre route, one being used as a main and the other its standby. However, until pilots are available these routes are being used on alternate days in order to monitor their performance. Furthermore, of the two routes, one is provided over coaxial-cable plant and the other over a microwave radiorelay system. In Fig. 6 the arrangements are also shown for cabling to the d.t.c. and for the back-to-back Modems No. 8 and 9 for regeneration if tandem connexion of inter-switching centre group-links is necessary.

The power transmitted to line at the customer's premises by the Modem No. 8 is 0 dBm. The Modem No. 9 in the repeater station is arranged to present the correct loading to the group-link, so that there is no risk of overloading in the main network due to the data signal. The basis for the group power loading is that the 48 kbit/s data system, including the in-band telephone circuit, should not present to the group-link an average power greater than that normally presented by a 12-channel telephone translating equipment.

### MANUAL SWITCHBOARD

The design and manufacture of low-cost 60-108 kHz manual switchboards in a timescale of about 9 months presented some novel problems. A rapid assessment of the

possibility of modifying a standard p.m.b.x. or special-purpose (trunk test or directory enquiry) switchboard indicated that the quickest and cheapest solution would be a new design (Fig. 7). The switchboards have been constructed to conform as far as possible to agreed design standards, but the most significant departure from standard practice is that the 60-108 kHz combined data and speech-coordination channels and operator-control (speech and signalling) circuits are entirely separate. Efforts have been made within the physical size limitations to provide maximum access for both construction and maintenance work. For this reason auxiliary equipment has been mounted on a special hinged rack which is fitted within the board (Fig. 8).

Interconnection between a Modem No. 9 and the group translating equipment (g.t.e.) necessitates the use of 75-ohm impedance coaxial cords and terminations. To effect bothway switching in one operation an arrangement of paired coaxial plugs and sockets, although suitable from an engineering point of view, would, if used, have presented manipulation difficulties for the operating staff. The design has, therefore, been based on the use of separate double-ended coaxial cords for the go and return channels. The face of the switchboard has been divided vertically into two halves, the incoming customer and outgoing group-link appearances on the left-hand side of the board and the outgoing customer and incoming group-link appearances on the right-hand side, and all circuits are terminated on strip-mounted coaxial sockets. The switchboard has a maximum capacity of 30 customer circuits and 10 group-links, but during the trial it has only been wired for the termination of 10 customer circuits, four group-links (two working and two standby) and a circuit to the d.t.c. A miscellaneous-facility strip situated at the bottom of the switchboard face includes incoming and outgoing d.t.c. appearances, regenerating Modems No. 8 and 9 and a cord-test circuit. Ten group reference-pilot fail-alarm lamps are associated with the group-link terminations, these having been fitted pending the future provision of 104·08 kHz group reference-pilot equipment.

The switchboards are equipped with 20 double-ended coaxial cords. These cords, which are fastened mid-way along their length, are terminated at each end by nylon-sleeved coaxial plugs. A large-diameter pulley weight has been provided for each half of the cords. Special arrangements incorporated in the cord-weight chamber ensure that the cord-weight bottoms just before the terminating coaxial plug comes to rest in the recessed socket on the switchboard desk; this prevents undue strain on the coaxial termination. The speech and signalling facilities between operators, and operator and customer, are provided by two built-in key-and-lamp units with modified associated auxiliary equipment. The associated auxiliary equipment permits termination of up to 10 direct exchange lines, four private circuits and one direct telephone circuit to the d.t.c. Provision has also been made

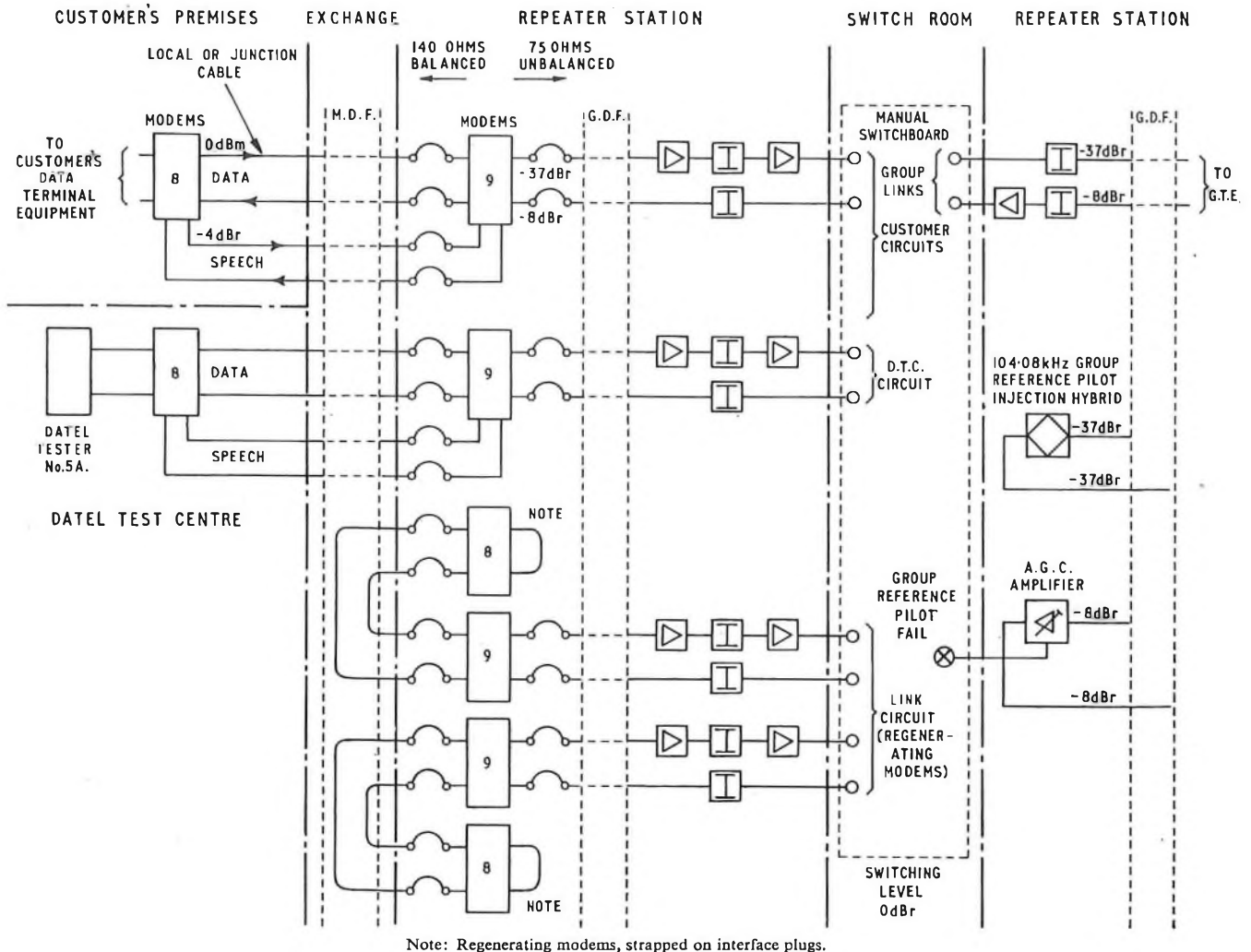

FIG. 6—Details of interconnexion of main items of plant

for the subsequent addition of apparatus to equip five spare key-and-lamp positions for further exchange lines or private circuits, if required. For the trial, the boards have been cabled for three outgoing and three incoming exchange lines, two order wires (one to each distant switchboard) and the telephone circuit to the d.t.c. A double jack is fitted at the front of the desk for the operator's headset and for supervisory assistance when necessary.

A telephone dial is brought into circuit when an outgoing DEL (exchange line) calling key is placed in the CALL position. A common alarm lamp is provided in addition to the calling lamps associated with each incoming telephone circuit. A 3-position key enables an audible alarm to be brought into use, or an earth potential to be extended to operate a remote alarm, according to local requirements.

Two clocks are provided for call-timing purposes, a mains-driven synchronous clock with digital display and a Clock No. 72A, driven by 6-second exchange-clock pulses, the latter being used in the event of a mains clock failure.

The switchboard is provided with a cord-tester for engineers' use. This includes a d.c. meter for checking short-circuits and disconnexions, and an amplifier and loudspeaker for detecting intermittent high-resistance faults. A visible-index file, ticket clips and ticket boxes for blank, booked and completed tickets are also provided.<sup>3</sup>

### OPERATION AND CALL BOOKING

The switchboards, which are operated by telephonists, have been installed in auto-manual centres, and a 24-hour service is provided for calls between any two customers, either over

the main network or between terminals served by the same switching centre.

Calls are normally pre-booked for connexion at specified times and for specified durations. The bookings may be made either for individual calls or on a batch basis. Individual bookings are accepted up to 10 days in advance, but 3 days notice is required for the batch bookings, which may be made for periods of up to 7 days at a time. During the trial period each customer is restricted to a maximum of two 45-minute periods (or the equivalent time) per day. These arrangements will no doubt have to be varied when the actual traffic patterns (calling rate, call durations and maximum-demand periods) have been established. As it is not possible for the operator to speak over the telephone circuit associated with the data circuit, communication between operators and customers is via the public telephone network. Communication between operators in connexion with bookings, setting-up and clearance of calls is effected over the inter-switchboard order-wire circuits.

### Operating Procedure

The local operator is responsible for both call-control and the notification of call-booking information to the distant switching centres. Shortly before a call is due to commence, the controlling operator sets up the connexions on the switchboard between go and return paths of the calling customer's local circuit and the appropriate group-link appearances, using two double-ended coaxial cords. She then requests the distant operator to connect the group-link appearances through to the called customer, using the same



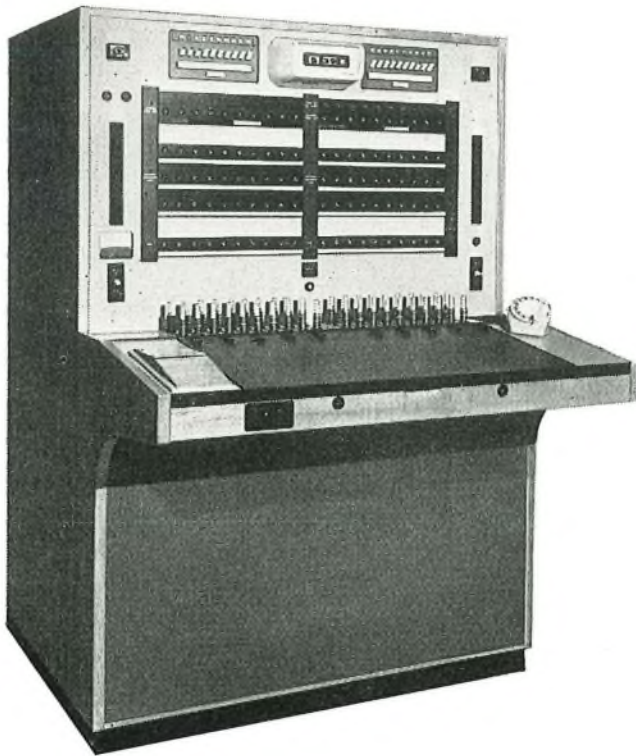

FIG. 7—Switchboard for 48 kbit/s service

operating procedure. The controlling operator then contacts the calling customer via the public telephone network to advise that the connexion has been established and also to verify that transmission is satisfactory before timing the call ON. The latter procedure is necessary because no monitoring or supervisory facilities have been provided on the switchboard for the 60–108 kHz data channels. Calls of less than 5 minutes duration are cleared down by the operators at the appropriate time without further reference to the customer. For bookings of over 5 minutes, the controlling operator recalls the customer just before his transmission is due to finish, to inform him that the call will be disconnected at the scheduled time. The call period may, however, be extended if requested by the customer, provided that the main network circuits are available. Having cleared the call at the end of the booked or extended period, the controlling operator times the call OFF and advises the distant operator to clear her connexions.

In the unlikely event of a failure of both the main and standby group-links between any two centres a tandem connexion can be set up by the operator at the third centre, using four coaxial cords to interconnect via the switchboard link (regenerative) circuit.

#### Fault Procedure

If transmission is unsatisfactory, the customer is required to contact the switchboard operator who will, in the first instance, change the switchboard cords and if necessary connect from main to standby group-link. If the trouble persists, the operator will ask the customer to verify that his equipment at both ends of the circuit is fault-free before she reports the fault to the d.t.c.<sup>3</sup>

#### COMMISSIONING AND OTHER TESTS

The Post Office had little experience of data transmission at 48 kbit/s until field tests of the prototype modems were able to commence in the autumn of 1969. At that time, the effects of various signal impairments, particularly those due to impulsive-noise interference and group-delay/frequency

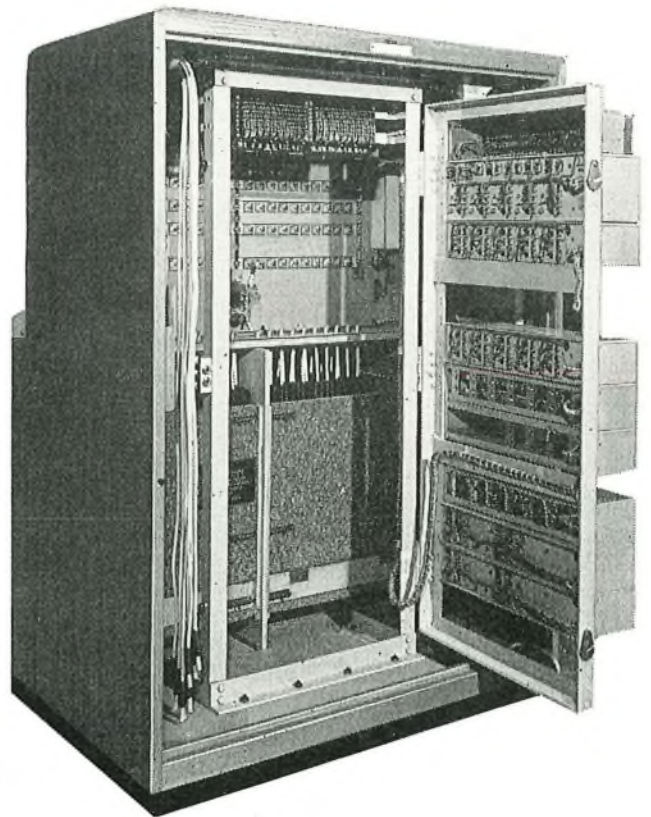

FIG. 8—Rear view of switchboard showing hinged rack

distortion produced in various types of transmission equipment had yet to be assessed. When the prototype modems became available, an intensive series of data-transmission tests was carried out over the group-links between the switching centres and also over the customers' local circuits as they were set up. Routine tests using the full network facilities were not possible until early in June 1970 when the d.t.c.s were equipped.

Before measuring the digital performance of the inter-switching centre group-links they were terminated by channel translating equipment and assessed on a telephone channel basis to determine their performance in respect of gain stability, psophometrically-weighted noise, impulsive noise and freedom from short-term interruptions. The tests were made via a channel translating equipment because no suitable test equipment was available for direct measurement in the 60–108 kHz band.

Following the line-up of a customer's local circuit between the terminal Modem No. 8 and the switchboard, its digital performance is measured by connexion to the local d.t.c. In addition, the digital performance of the inter-switching centre group-links is kept under scrutiny throughout the experiment as routine error tests are being carried out on a weekly basis by the d.t.c.s. As a block error-rate in conjunction with the bit error-rate gives some idea of error distribution, the tests include block as well as bit error measurements. A standard block length for 48 kbit/s transmission has not yet been defined, but initial Post Office tests have used a 512-bit block. The tests consist of two 15-minute data runs for each direction of transmission; the actual time of transmission is varied to obtain a representative sample of conditions between the hours of 8 a.m. and 5 p.m.

At the sending d.t.c. a Datel Tester No. 5A<sup>4</sup> is used as a data-terminal equipment to transmit a repetitive 512-bit pseudo-random pattern. At the receiving d.t.c. a similar tester is used to compare the incoming data signal with a corresponding internally-generated synchronized 512-bit

pattern and to record both the total number of element errors and block errors occurring during the transmission. The tester also simultaneously records peak telegraph distortion. A summary of results for the first two months of the tests is shown in Table 3.

**TABLE 3**  
**Error-Rate Performance of the Main Network**

| Inter-Switchboard Links           | Element Error-Rate (in $10^7$ ) | Block Error-Rate (512-bit blocks) (in $10^3$ ) |
|-----------------------------------|---------------------------------|--|
| Whole network                     | 2.7                             | 3.1  |
| London-Manchester group-links     | 2.1                             | 2.5  |
| London-Birmingham group-links     | 4.3                             | 5.1  |
| Birmingham-Manchester group-links | 2.3                             | 2.2  |
| All radio group-links             | 1.7                             | 2.0  |
| All cable group-links             | 3.7                             | 4.3  |

The inter-d.t.c. test results quoted in Table 3 are measurements of the digital performance of the main links. Tests including customer local circuits were made when these circuits were lined-up, but no significant source of error was found. It can, therefore, be concluded, within the limits of experience gained to date, that selection of plant in accordance with the rules and tests outlined for local circuits is a reasonable indication of suitability. Furthermore, one customer has indicated that it is not unusual in calls of  $\frac{1}{2}$ -hour duration to have no errors attributable to transmission facilities. However, it is pointed out that these conclusions are drawn from a very small sample, and greater penetration of 48 kbit/s into local networks must be awaited before more general conclusions can be given. The freedom from errors in the local network noted to date tends to lead to the initial view that in normal circumstances little trouble should be experienced, but should an error source arise it is likely to be dominant and result from a fault.

A series of tests has also been carried out to determine the degree of possible interference between certain neighbouring channels in adjacent telephone groups and the data group, and vice versa. It was thought that the most likely source of interference from the adjacent telephone groups would be telephone signalling systems. The results of the tests made to date have indicated (a) that in some cases a very slight increase in the data error-rate occurs during signalling on channels 1, 2 and 3 of the next higher telephone group in frequency, but that this should not cause serious problems for the 48 kbit/s services, and (b) that there should be no discernible interference with telephone services in adjacent groups caused by data transmission at 48 kbit/s.

### INITIAL OBSERVATIONS AND FUTURE PLANS

Although the experimental network has been in operation only about 8 months, the initial technical performance has been encouraging. This has been true for the main network,

as the early inter-d.t.c. tests have indicated, and for the local network in as much as testing of the limited number of customer installations has not revealed any intractable difficulties.

Plans for the future of the 48 kbit/s switched network are continuously under review. One problem common to most data-transmission planning is that it has to be based on assumptions that need to be continually revised, and what was true when the plans were initially drawn-up, may not be true when they come to fruition. This is particularly true of the 48 kbit/s.

Originally it was planned that the 48 kbit/s network would become the first phase experiment of a dedicated 48 kbit/s network that would eventually develop into an automatic system. Since then, plans for a more comprehensive data network have been made and, as such a network would include 48 kbit/s transmission, there should be no need for a separate 48 kbit/s network as initially envisaged. If the 48 kbit/s manual network experiment is successful and becomes a service, its main role will be to bridge the gap for 5 years or so until the comprehensive network becomes available.

In fulfilling such an interim role, the shortcomings of the network, such as a limited number of switching centres (due to difficulties in operating a booked service with more than four switching centres) and a limited number of customers per switching centre, need to be faced. These shortcomings could be overcome, but would absorb development effort, and this in all probability would not be worthwhile on a system expected to have a fairly short life. One area of development currently being studied and which should prove attractive, however, is the extension of the switching-centre catchment area. Growth of the system is inhibited by the need, for economic reasons, to use existing local or junction line plant for customer connexions to the switchboard, and restriction of the serving area is a consequence. At the moment customers outside the serving area could be connected using specially laid cables but the high cost of this is likely to be a deterrent. The study referred to is concerned with identifying less-expensive alternatives to specially laid cable, and could utilize one or more of the following:

(a) 48 kbit/s multiplexing equipment in conjunction with 1.536 Mbit/s (or 2.048 Mbit/s) digital links of the type developed for p.c.m. telephony,

(b) 48 kbit/s data baseband repeaters to extend the present coverage by local or junction cable plant, or

(c) optional use of speech time-slots in p.c.m. systems.

Development of such techniques is likely to be justified, because similar techniques will probably be required in the comprehensive data network.

### References

- 1 WILLIAMS, M. B. The Characteristics of Telephone Circuits in Relation to Data Transmission. *P.O.E.E.J.*, Vol. 59, p. 151, Oct. 1966.
- 2 C.C.I.T.T. White Book Vol. III\* Line Transmission, Mar del Plata 1968, International Telecommunications Union, Geneva.
- 3 ADCOCK, R. C., and BURGESS, M. J. Purpose-built Switchboards for New Data Service. *Post Office Telecommunications Journal*, Vol. 22, p. 20, Summer 1970.
- 4 QUINNEY, R. E. Recent Developments in Datel Testers. In this issue of the *P.O.E.E.J.*



# Notes and Comments

## New Year Honours

The Board of Editors offers congratulations to the following engineers honoured by Her Majesty the Queen in the New Year Honours List:

|  |         |                  |       |  |       |  |
|--|---------|------------------|-------|--|-------|--|
| Northern Ireland                           | .. .. . | F. C. Haliburton | ..    | Telephone Controller<br>(retired)      | ..    | Officer of the most Excellent<br>Order of the British Empire |
| North Eastern Telecommunications<br>Region |         | G. E. Winterburn | ..    | Senior Executive Engineer<br>(retired) |       | Member of the most Excellent<br>Order of the British Empire  |
| Scottish Telecommunications Region         |         | J. D. Heslin     | .. .. | Technician 2A                          | .. .. | British Empire Medal   |

### G. Haley, B.Sc.(Eng.), C.Eng., M.I.E.E.

Geoff Haley succeeds G. N. Davison as Staff Engineer in charge of Research Department's largest branch, that dealing with external plant and research services; he brings to the post a wealth of experience, both technical and in the handling of a wide range of staff. Though he began his Post Office career



while still in his teens, in a telephone area, he soon had his first taste of Dollis Hill, spending six years in the old WE branch, working on coaxial and u.h.f. systems. He then had a short stay in the Long Distance Area of London Telecommunications Region—still on coaxial systems. Back at Dollis Hill, in 1948, he joined the team that was to do so much to give us a world-wide reputation in submarine telephony, being a pioneer in some of the first deep-sea work. But, on becoming an S.E.E. his services were needed in the Factories Department where he spent five years helping with very considerable reorganization. Once more, however, he returned to Dollis Hill, again on submarine telephony, taking part in several big advances, notably on laying procedures and cable ship facilities. In 1965 he became A.S.E. in R1, with responsibilities for the drawing office and model shop. While still encouraging good craftsmanship, he has introduced several new techniques, notably numerically-controlled machines, which have greatly speeded some projects; he is now busy with the changeover to metric units.

With the transfer to Research Department to Martlesham already under way, R1 faces problems of re-equipping and re-staffing itself. Geoff is undoubtedly the man to solve these problems, with drive and a proper understanding of the human problems involved.

J.R.T.

### D. V. Davey, C.Eng., M.I.E.E., M.I.Mech.E., M.B.C.S.

David (Dave) Davey, recently appointed Controller in the Program and Projects Division, joined Postal Headquarters barely three years ago having faced the dilemma of choosing between an attractive computer job in America, appointment as Principal and in-line promotion to A.S.E. The Planning and



Mechanization Department were fortunate when he chose the last, taking responsibility for commissioning letter code-sorting projects and evolving new performance measurements. His enthusiasm, energy and friendly manner have been contagious, leading colleagues to pool their efforts in this multi-disciplined field.

He served his apprenticeship at Devonport Dockyard, joining the Post Office in 1953 as an A.E.E. He was vitally involved in designing large-output silicon and germanium rectifiers for the new range of automatic power plants to replace telephone exchange motor-generator systems, before moving on to problems of ventilation and air conditioning. This opened the way, on promotion to S.E.E. in 1964, to work on computer environmental and power-supply problems in the Technical Support Unit of the Ministry of Technology. This was quickly followed by responsibility for the selection of computer peripheral equipment, involving visits to evaluate equipment in the United States.

In his new job, David will lead a branch engaged on the operational planning of new mechanized letter offices and devising the program to implement the fundamentally new letter-post plan. His youthful zest, clarity of vision and a certain determination will ensure success and his friends wish him well at this challenging stage of his career.

I.G.W.

**W. G. Simpson, B.Sc., C.Eng., M.I.E.E.**

The recent promotion of Mr. W. G. Simpson to Staff Engineer in the Network Planning Department will be welcomed by his many friends in the Post Office and industry. His appointment to NP2 with the responsibility for planning the main transmission network comes at a time when the demands for the transmission of new services in the network are greater than ever before. Geoff Simpson brings to his new



task a comprehensive experience of transmission systems and an intimate knowledge of the new systems now being developed, particularly those for digital transmission. With this background and his flair for reaching well-balanced conclusions, the planning of the network will be in good hands.

Starting in the Post Office in 1941, he had seven years basic experience in the field and his first insight into transmission. He came to Headquarters in 1948 and, including three years at the Research Station Dollis Hill, has been engaged on the design and development of all types of transmission systems. Since 1965, he has been much concerned with the international aspects of transmissions systems and has represented the Post Office at numerous C.C.I.T.T. and C.E.P.T. meetings, and as Vice-Chairman of C.M.T.T. His work on sound program transmission and on digital systems has deservedly earned him the respect of transmission engineers in many countries. His cheerful outlook on life and boundless enthusiasm will undoubtedly be a constant inspiration to his colleagues, who will, none the less, be hard pressed to keep pace with an astonishing capacity for hard work. He leaves the Development Department with all our good wishes for the success he deserves in his new responsibilities.

J.C.B.

**D. M. Gambier, C.Eng., M.I.E.E.**

Dennis Gambier's Post Office career started at Youth-in-Training in 1942, in the Bournemouth Area. He joined the old LM Branch as an Assistant Engineer in 1950, following a number of years in the transmission group of the Central Training School.

From 1956 to 1963, he was engaged on submarine-cable systems work, including the first trans-Atlantic telephone cable and the string of cables forming the trans-Pacific COMPAC system.

He resumed ordinary transmission development work in 1963, as S.E.E. of a group concerned with setting-up a new structure of specifications for f.d.m. terminal equipments at the beginning of competitive purchase of transmission equip-

ment, and the successful introduction of competition owes much to the technical knowledge and insight which he applied to this task.



Promotion to A.S.E. in 1968 to the Network Planning Division represented a challenge outside his dominantly development experience, and his success in this field, marked by his recent promotion to Staff Engineer of NP1, reflects the organizing ability and cheerful vigour with which all who have had the pleasure of working with him are familiar—characteristics which augur well for his continuing success in the new post.

A.W.W.

**A. C. Eley, B.Sc., C.Eng., M.I.E.E.**

In December, Alan Eley was appointed Staff Engineer in Network Planning Department and assumed responsibility for a branch dealing with future plans for the trunk switching network.

His experience suits him admirably for his task for since has seen service at all organizational levels: in the old North Wales District, in the Midland Region on exchange planning

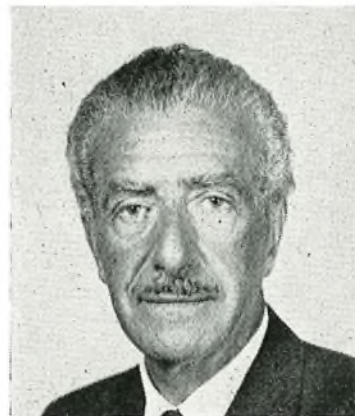

and efficiency engineer duties, and at Headquarters with the joint MPBW/PO building research group. Since 1961, he has been concerned with all aspects of the development of modern electronic and crossbar switching systems.

Alan's quiet and somewhat shy exterior hides a core of considerable determination. These qualities with his high personal integrity will ensure his success. His many friends in the Post Office and Industry are delighted to see his appointment.

J.M.



## Letter to the Editor

Dear Sir,

I am sure that I am not alone in feeling that the official organ of the Institution could fulfil an extended function if reshaped and restyled to meet present-day needs and conditions.

Whilst not wishing in any way to criticize the high standard and literary excellence of the *Journal* in its present form it is still largely a collection of specialist technical articles, many of which are of limited interest to large sections of the membership. Observing the behaviour of most members on receipt of their copy I find that they turn to the end:— departures, promotions, Notes and Comments, Regional Notes etc. This seems to suggest that the more human, down-to-earth section has the first appeal and that besides purely technical subjects, articles on topics of general interest should be included, such as:—training and education of engineers, management, the place of the engineer in society, comments on Post Office policy, practices of overseas administrations, human relations, readers letters etc; each edition could be prefaced by a short editorial.

The *Journal* could become a lively organ for the exchange of views and discussion aimed at widening the sometimes constricted views of telecommunications engineers and could help to weld the Institution into a living organism, ready to play its part in shaping the future of telecommunications.

It would be interesting to hear the reactions of members to the possibility of a new look to the *Journal*.

Yours faithfully,

J. C. ENDERSBY

70 Bradbourne Road,  
Sevenoaks,  
Kent.

## Supplement

Students studying for City and Guilds of London Institute examinations in telecommunications are reminded that the Supplement to the *Journal* includes model answers to examination questions set in all the subjects of the Telecommunication Technicians' Course. Back numbers of the *Journal* are available in limited quantities only, and students are urged to place a regular order to ensure that they keep informed of current developments in telecommunications and receive all copies of the Supplement.

## Syllabuses and Copies of Question Papers for the Telecommunication Technicians' Course

The syllabuses and copies of question papers set for examinations of the Telecommunication Technicians' Course of the City and Guilds of London Institute are not sold by *The Post Office Electrical Engineers' Journal*. They should be purchased from the Department of Technology, City and Guilds of London Institute, 76 Portland Place, London, W1N 4AA.

## Postal Strike

The Board of Editors wishes to apologize to those readers whose copy of the January 1971 issue of the *Journal* was delayed as a result of the Postal Strike. It is regretted that some delay to the April issue may also result.

## Publication of Correspondence

The Board of Editors would like to publish correspondence on engineering, technical or other aspects of articles published in the *Journal*.

Letters of sufficient interest will be published under "Notes and Comments". Correspondents should note that, as it is necessary to send copy to the printer well before publication date, it will only be possible to consider letters for publication in the July issue if they are received before 18 May 1971.

Letters intended for publication should be sent to the Managing Editor, *P.O.E.E. Journal*, Post Office Factories Headquarters, Bovay Place, London, N7 6PX.

## Notes for Authors

Authors are reminded that some notes are available to help them prepare the manuscripts of the *Journal* articles in a way that will assist in securing uniformity of presentation, simplify the work of the *Journal's* printer and draughtsmen, and help ensure that authors' wishes are easily interpreted. Any author preparing an article for the *Journal* who is not already in possession of the notes is asked to write to the Managing Editor to obtain a copy.

It is emphasized that all contributions to the *Journal*, including those for Regional Notes and Associate Section Notes, must be typed, with double spacing between lines, on one side only of each sheet of paper.

Each circuit diagram or sketch should be drawn on a separate sheet of paper; neat sketches are all that are required. Photographs should be clear and sharply focused. Prints should preferably be glossy and should be unmounted, any notes or captions being written on a separate sheet of paper. Negatives or plates are not needed and should not be supplied.

## Model Answer Books

Books of model answers to certain of the City and Guilds of London Institute examinations in telecommunications are published by the Board of Editors. Details of the books available are always given at the end of the Supplement to the *Journal*. The Board of Editors has reduced the price of Line Plant Practice A to 37½p (42½p post paid).

The Telecommunication Principles B Answer Book is out of print at the moment but a revised issue is in preparation and an announcement will be made in the *Journal* when it becomes available.

## Articles on Current Topics

The Board of Editors would like to publish more short articles dealing with topical subjects. Authors who have contributions of this nature are invited to contact the Managing Editor.

## Circulation of the Post Office Electrical Engineers' Journal

| Journal Issue              | Number of Copies Printed |
|----------------------------|--------------------------|
| Vol. 63, Part 1, Apr. 1970 | 37,500                   |
| Vol. 63, Part 2, July 1970 | 38,000                   |
| Vol. 63, Part 3, Oct. 1970 | 38,200                   |
| Vol. 63, Part 4, Jan. 1971 | 38,200                   |

Approximately 10 per cent of the *Journals* are sold to overseas readers in more than 50 countries.

# Regional Notes

## London Telecommunications Region

### *Bastion Trunk Unit*

With the completion of the Post Office call-through tests on 9 November 1970, the final stage of the £2.5M G.E.C./A.E.I. Bastion trunk unit contract was accepted. This brought to a close a project which has provided London subscribers with the largest trunk unit yet, and ultimately an additional 7,200 outgoing trunk lines to all parts of the United Kingdom, with a capacity of 8 million calls per month.

The exchange, with its associated repeater station, was originally designed to open as a complete unit: but owing to the dramatic increase in s.t.d. traffic, it had to be rescheduled into three stages, each stage bringing approximately 2,000 junctions into service. Stage 1 was brought into service on 23 September 1968 when the Postmaster General, the Rt. Hon. John Stonehouse, M.P., made the inaugural call to the Lord Provost of Aberdeen. Stage 2 followed on 23 March 1970 and finally Stage 3 on 30 November 1970.

There have been many problems during the installation. The initial delivery of the equipment was made with the building work still incomplete, with the subsequent hazard of dust and dirt. New equipment and techniques were involved, the Trunk Call Sampling Equipment had not, at that date, been tested on live equipment. Labour was a headache both for the Post Office and Contractor, in that the lack of skilled men necessitated a large number of men on loan from the outer London Areas, and not least, the formation of a new area, North Central, was in progress.

Facts and figures for the installation are impressive, especially when compared with a 1,000-line-multiple extension of 12 to 20 racks for a director exchange. Eight hundred and forty racks were installed with 18,850 selectors, 12,309 relay-sets, 30 magnetic-drum register-translators, 7,000 incoming junctions, three hyper-groups, 100 super-groups, and 732 groups. The wiring required 200 miles of cable and 150 miles of jumper wire, the whole job requiring 142,159 man-hours of Post Office work.

Numerous departments of the Post Office and the Ministry of Public Building and Works were involved in one way or another, from its concept, perhaps ten years ago, to its final stage. For the last four years the project has revolved round the Clerk-of-Works who, with his staff of 31, has completed a job which many an outside contractor would hesitate to take on.

For the future we have programmed increases to switching stages, relay-sets and trunk lines (1970/72), and an m.f. installation (1971) in readiness for transit working scheduled to be introduced in conjunction with sectorization; yet another new technique, one of many which we will see developed and brought into service with the assistance of North Central Area personnel.

G. A. ALDRICH  
C. H. S. MOORE

### *The End of an Era*

At precisely 1.15 p.m. on Thursday 3 December 1970 the end of an era was reached when the plugs were withdrawn from the last connexion in Upminster Manual Telephone Exchange, the last manual exchange in the London Telecommunications Region (L.T.R.), and the changeover to the new Upminster Crossbar Automatic Exchange, the first Crossbar Automatic Exchange in the L.T.R., was completed.

The old C.B.1 manual exchange, which was initially installed in April 1929, when it had only a handful of subscribers, had been continually extended in order to cater for the growth in demand which had been contained, however, until just prior to the changeover.

The new automatic exchange, manufactured and installed by the Plessey Telecommunications Group, is a non-director

5005 crossbar type and forms part of the Romford group switching centre (g.s.c.) complex and has full s.t.d. facilities. The exchange has a present capacity of 11,500 exchange connexions and the 7,517 subscribers given automatic service at changeover will now receive any necessary operator assistance from the manual board at the Romford g.s.c. Watching the whole operation over closed-circuit television from a local hall was a distinguished gathering including Mr. E. W. Weaver, Director L.T.R., Mr. W. G. Lillicrap, Senior Director of Customer Services, Telecommunications Headquarters, Mr. D. R. Bearham, Telephone Manager, East Area, L.T.R., Mr. M. Clarke, Managing Director of Plessey Co. Ltd., Councillor A. James, Mayor of the London Borough of Havering, and various local dignitaries, including staff association representatives.

The culmination of the opening ceremony came when Councillor James officially opened the new exchange by making an inaugural call to Sleaford, Lincolnshire, whose telephone exchange had been converted to a 5005 crossbar type only one week previously.

Truly a notable end to the last manual exchange in the L.T.R. and it is fitting that it has been recorded for posterity both on film and video tape.

L. F. POOLE

## Northern Ireland Directorate

### *Explosion at Newcastle (County Down) U.A.X. No. 14*

In the early hours of Sunday 2 August 1970 the tranquillity of the holiday resort of Newcastle (County Down), nestling at the foot of the Mountains of Mourne, was rocked by the sound of an explosion. The local telephone exchange, a U.A.X. No. 14 with 800 lines, had been completely shattered by a terrorist bomb attack.

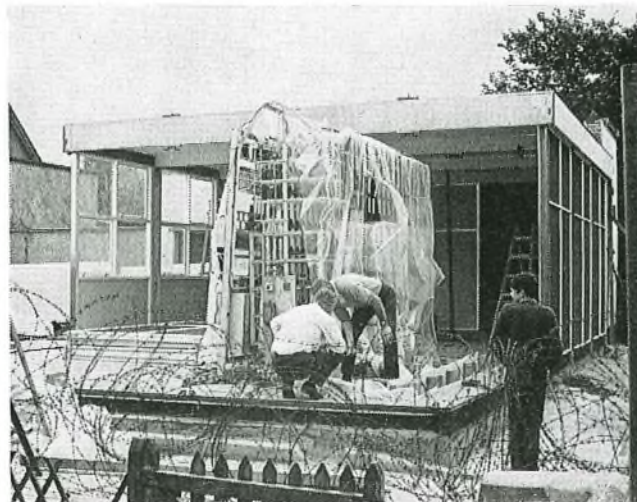

Newcastle (County Down) telephone exchange

An early inspection by the two local maintenance officers, who live nearby and were quickly on the scene, revealed that the damage was indeed severe and that exchange service had ceased completely. An explosive device had been placed in a gangway between racks in the centre of the apparatus room and all of the equipment, with the exception of the combined main and intermediate distribution frame, was badly damaged. A measure of the severity of the blast can be gauged from the fact that the equipment racks located near the seat of the explosion were displaced at floor level by approximately 6 ft.

The exchange equipment was housed in a non-standard building of 14 in brick walls with a reinforced concrete roof



and the force of the explosion had severely damaged both walls and roof. With the assistance of a structural engineer of the Northern Ireland Ministry of Finance and a local contractor, the building was buttressed so that Post Office engineers could safely make a detailed assessment of the damage and decide how best to restore service.

It soon became clear that both building and equipment would have to be replaced but, as this would mean a lengthy delay, immediate action was taken to have an emergency mobile U.A.X. No. 13 towed to the site. Concurrently with the task of linking emergency subscribers from the main distribution frame (m.d.f.) to the mobile exchange, hurried consultations with Telecommunications Headquarters resulted in the allocation of two mobile non-director exchanges (m.n.d.x.s) to Northern Ireland and these enabled restoration of service for all existing subscribers. Since these mobile exchanges would only be available for a limited period of time, insufficient to allow for the erection and equipping of a permanent non-director exchange on a new site, it was decided to purchase a prefabricated wooden building and install small automatic exchange (s.a.x.) type equipment already held in Northern Ireland for other work. This wooden building, manufactured by Terrapin Ltd, was of a convenient size to be erected on the existing apparatus room floor area following demolition of the damaged building, which on more detailed examination by the structural engineers was found to be beyond repair. Before demolition of the building, arrangements were made to enclose the m.d.f. in a box-like structure of sufficient strength to withstand the weight of falling roof concrete. Access to the m.d.f. allowed engineering work for the restoration of service to proceed.

The exchange clock stopped at 2.40 a.m. on 2 August and by 5.0 p.m. on the same day all emergency lines had been given service and by the time business premises opened on Monday morning 3 August they too had been reconnected. The arrival of the m.n.d.x.s. over the next few days allowed complete restoration to be achieved by Sunday 9 August. Some difficulty was experienced initially when the emergency lines were connected to the U.A.X. No. 13 which had a three-digit numbering scheme but lists of the revised numbers were circulated locally and this helped to relieve the problem. The s.a.x., being installed to provide service until the new non-director exchange is built and equipped, has been trunked to non-director standards so that subscribers will not be involved in a number change when the m.n.d.x.s are recovered.

The recovery of the U.A.X. No 14 equipment, demolition of the damaged structure, erection of the Terrapin building, repair of the bomb damaged apparatus room floor and cable trench covers were all accomplished in 26 days to allow installation work to commence.

A site had already been acquired and planning proceeding for the erection of the new building. Work on this project was immediately accelerated and the ready-for-equipment date has now been advanced from 1974 to December 1971.

L. R. GRIFFITH  
J. J. MCLACHLAN

## North Western Region

### *Moleploughing across the River Douglas*

The provision of service to an isolated farm in the Longton district presented the Preston Area with a problem.

To provide a line from Longton Exchange would have involved the Post Office not only in wayleave difficulties, but in a considerable expense, and it was decided, therefore, to give service from the nearer exchange at Hesketh Bank.

The Longton-Hesketh Bank exchange boundary is the River Douglas, which is a tidal river about 40 yd wide and used by yachts with masts up to 60 ft high. After a survey of the banks and a check of the sub-soil of the river bed, it was decided to attempt moleploughing an armoured cable across the river to avoid having to erect 60 ft poles.

Two local men were hired to assist with the operation using a skin-diving suit and a boat. The tractor was set up on the west bank, the moleplough on the east bank, a line was taken across the river by boat and the winch-cable drawn over the river. This was then taken through a block attached to the nose of the moleplough and the free end secured, near the water line, to an upright of a boat jetty on the west bank.

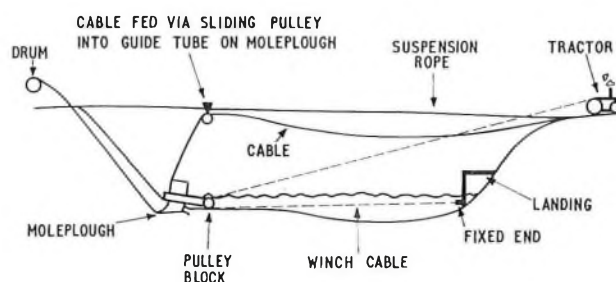

Diagram of cable arrangement across the river Douglas

The Post Office support gang guided the moleplough down the east bank to the river edge, the hired man in the diving suit took over and guided the moleplough across the river to the west bank where it was again taken by the Post Office gang and ploughed up the bank.

The cable was laid at a depth of 18 in and the operation carried out during low tide when the depth of the river was approximately 5 ft. The work was completed by seven men in one day, and it was found that the work had been done at less than half the cost of traditional methods. From the experience gained we consider, given the circumstances, the laying of duct and cable by this method can be both practical and cheap.

A. Y. O. SMITH

# Associate Section Notes

## Aberdeen Centre

The 1970/71 session started for this centre with a day visit to the Chrysler car factory, Linwood, on 30 September. Twenty-one members took part and all considered the trip highly successful. Our first talk of the session was on 4 November entitled "Gold Medal Communications" by Mr. A. V. Knight. This was an illustrated talk describing the Post Office undertakings at the Commonwealth Games in Edinburgh. The third item on our program was an evening visit on 19 November to Dow and Nicholson Ltd., a local electrical contracting and armature-winding firm.

R. MATHEWSON

## Ayr Centre

In November of last session, a talk was given by Mr. Scott of the South of Scotland Electricity Board entitled "The National Grid". This talk, following some weeks after the serious power failure in the West of Scotland in October 1969, gave us some insight into the problems encountered.

A visit was made to Dalry TXE 2 telephone exchange in January. The many novel features of this new and exceedingly reliable system were capably explained by local staff. Of special interest was the print-out equipment for monitoring the exchange performance.

A talk was given in March by Mr. A. S. Kerr, Area Engineer, Scotland West, entitled "The Changing Pattern of External Construction". With the aid of an excellent collection of slides, Mr. Kerr explored the many aspects of the subject and his talk was much appreciated.

The annual general meeting was held in May, at which items for our future program were discussed, and some changes in the membership of the committee were approved.

A. BAGNALL

## Dundee Centre

Our first visit of the session, to the new fire station, included a demonstration of the Snorkel hydraulic ladder and an intensive look at all aspects of the latest equipment to combat any fire.

Mr. R. Burns, Telecommunications Headquarters, Scotland paid us a visit in November to talk on Datel Services. This illustrated lecture was most informative and delivered in an expert manner.

The December meeting was spent on a visit to the Scottish Occupational Health Laboratory Service Ltd., Dundee and the subject was health hazards in industry. This hygiene unit is one of only four in Britain and it caters for the needs of industry in the whole of Scotland. Noise, dust and toxic hazards are tackled with very sophisticated equipment and, working closely with the medical profession, provides a service which has the health of the individual as its main concern.

We now look forward to the 1971 part of our syllabus.

R. T. LUMSDEN

## Edinburgh Centre

The first meeting of the 1970/71 session was held on 16 September when Mr. A. G. Tarbet of Postal Headquarters, Scotland gave a talk on Postal Mechanization. The subject of the talk was the movement of letter mail from its collection to its automatic sorting. Slides were shown to illustrate the various mechanical devices utilized in the process. The meeting ended with a 20-minute film showing the complete operation in service.

The second meeting of our session was held on 1 October when 13 members made an all-day visit to Hunterston Power Station, Largs. After an introductory talk illustrated with a scale model of the reactor, the party was taken on a tour of the plant, seeing the control rooms and reactor. Unfortunately, there wasn't much taking place the day of our visit.

On Tuesday 10 November a talk entitled "Long-Term Planning" was presented by Mr. C. G. Davis of Telecommunications Headquarters, Scotland. The speaker gave a first class talk on general long-term planning and then a lively discussion took place on future planning for the Edinburgh Area.

M. K. FINLAND

## Exeter Centre

The 1970/71 Winter program which, at the time of going to press, is well under way, is as follows:

- 11 November: "Engine Oils for Modern Motor Cars", by Mr. R. Fry.
- 9 December: "Pulse Code Modulation", by Mr. G. H. Bennett.
- 14 January: "Bacteriology and Public Health", by Dr. R. V. Cartwright.
- 17 February: "Propane Explosion Hazards", by Messrs. J. O. Colyer, R. C. Senior and R. Tharby.
- 24 March: Members evening  
"Firemans Remote Call Out Voice Frequency System A", by C. P. J. Knapman.  
"Driving", by D. Craig.
- 20 April: Annual general meeting.

Attendance at the first two meetings averaged 92, a very encouraging start to the session. In view of power cuts, the December meeting was particularly well attended. The beginning of the paper was given in candlelight but fortunately power was restored early in the evening so that the excellent paper was not spoiled by the lack of slides. We are indebted to the speakers for these events, particularly to Mr. Bennett who visited the Area during the difficult period of the power dispute. It was very pleasing to see so many visitors at the pulse code modulation paper, especially those members of the Barnstaple Associate Centre, who make quite regular visits to our meetings.

Members will wish to note that the Centre's autonomy now extends to subscription rates, and in accordance with verbal instructions from the Secretary of the Council the Committee have decided that the following subscription rates will apply with effect from 15 February 1971.

|   |              |
|---|--------------|
| Weekly paid members up to and including Technician I rank .. .. . | 1p per week  |
| Salaried members .. .. .  | 5p per month |

This is the nearest equivalent to the old rate, albeit a slight increase.

In the 1971 summer program it is hoped to arrange visits to two of the following:

Mid-April—Westland Aircraft and R.N.A.S. Museum (H.M.S. *Heron*)

Mid-September—Avon Tyres.  
Bovington Tank Museum and Portland Stone Co.  
National Smelting Co.

It is also hoped to arrange an evening visit during May to the Decca School of Navigation at Brixham.

As usual, there will be a limit on the number of members attending any of these events but, if interest demands, a second trip will be arranged to take place a week or two after the first, and not the following year as we have done in the past.

T. F. KINNAIRD



### Guildford Centre

This section continues to flourish with a membership of over 480.

So far this year we have had trips to Arun Shipyard, Littlehampton, Vauxhall Motors, Luton; B.O.A.C., Heathrow Airport; London Fire Brigade Headquarters, Lambeth; Whitefriar Glassworks and Firestone Tyres.

The family film show held on 12 November was attended by approximately 70 people. There was a lecture on closed circuit television on 3 December, with a further film show on 14 January of a semi-technical nature.

We have also arranged an evening visit to a London theatre on 28 January, which was tried for the first time last year and was extremely successful.

The Chairman, Secretaries and Committee would like to express their thanks and appreciation to Mr. R. C. Terry for all the work he has done as Secretary, and then Chairman, over the past four years, now that he has had to retire owing to promotion to Assistant Executive Engineer.

D. C. HEATHER  
R. STONE

### Hereford Centre

The annual general meeting was held at the Spread Eagle Hotel, on 30 November 1970 and was followed by a steak supper.

The following officers were elected:

*Chairman:* Mr. E. W. Ballinger, *Vice Chairman:* Mr. S. J. Cound; *Secretary:* Mr. L. Evans; *Assistant Secretary/Librarian:* Mr. R. M. Fairclough; *Treasurer:* Mr. L. J. Knight; *Auditors:* Messrs W. J. Merrick and M. Powell; *Committee:* Messrs. J. Bethell, F. Dykes, L. Higgins, M. G. Frost, N. A. W. Innes, H. W. R. Holt, P. A. Williams, A. J. Charles, G. K. Vanston, K. J. Manning, M. J. Parry, P. A. Sykes, C. J. T. Brace and F. Neate.

Membership of the section now totals 128 and in 1970 one, well supported, successful visit was undertaken to B.O.A.C. Heathrow and the following talks were given; "The Affluent Society and Your Food" and "Principles of Crossbar Exchanges".

Visits for 1971 so far arranged are to the Special Air Service Headquarters, Hereford and to Smiths Industries Ltd., London. Details have to be finalized on three official papers and it is hoped these will be read in the first quarter of 1971.

L. EVANS

### Motherwell Centre

The 1970/71 session opened on 26 October with a talk entitled "Mexico World Cup" given by Mr. R. H. Davidson, the well known F.I.F.A. referee. Mr. Davidson not only described the actual event, but also the organization leading to it, and the world-wide communication network set up to report it. Twenty-seven members attended this meeting.

The meeting on 17 November, took the form of a visit to the Air-Traffic Control-Tower, Glasgow Airport, where the various communication aids used in the running of a large airport were ably explained by the Board-of-Trade staff. Owing to the size of the tower, the number of visitors was restricted to 22 members.

The National Cash Register Company provided our next guest speaker on 15 December, the subject being "Decimalization". Mr. Symington, the representative, explained the difficulties which would be encountered on and after D-Day, illustrating the talk with slides, and discussing how the difficulties could be easily overcome. Nineteen members attended this meeting.

D. K. RAINEY

### Plymouth Centre

The 1970/71 session started with the annual general meeting in October, when the Officers and Committee were re-elected en-bloc.

In November a visit was made to Hurley (Marine) Ltd. at Plympton. Hurleys make yachts of varying sizes using moulds of fibre glass. An interesting evening was spent in touring their workshops.

December's meeting was a paper entitled "Transit Crossbar Switching" read by Mr. A. E. Manley, the Clerk of Works at the new Bristol Transit Exchange.

A meeting a month has been arranged for the winter period and we are looking forward to a successful session.

J. B. LAFFORD

---

## Institution of Post Office Electrical Engineers

### Retired Members

The following members, who retired during 1970, have retained their membership of the Institution under Rule 11(a):

H. Alcock, 10 Penrhus Avenue, Gately, Cheadle, Cheshire.  
E. W. Anderson, 96 York Way, Banstead, Surrey.  
W. D. Brown, 19 Regent Terrace, Parkers Piece, Cambridge.  
R. O. Carter, 8 Grange Avenue, Woodford Green, Essex.  
R. Clark, 4 The Rise, Kenton, Newcastle-on-Tyne, NE3 4LT.  
W. L. A. Coleman, Middle Noor Cottage, Kingsbridge, Devon.  
W. D. Cranston, 8 Meadows Close, Portishead, Bristol, BS20 83H.

B. F. Marsh, SvD 6.3.3, 2-12 Gresham Street, London, EC2V 7AG.

L. W. W. Raynor, 74 Dukes Avenue, London, N.10.

E. Sharples, 503 Newchurch Road, Rawtenstall, Lancashire.

### Printed Papers

Council has approved for printing the following papers which will be distributed in accordance with Rule 35.

"Power Supplies for Telecommunications Services" by D. A. Spurgin.

"The Metal-Foil Polythene Cable Sheath and its use in the Post Office" by Dr. J. C. Harrison.

A. B. WHERRY  
General Secretary

# Sir Gordon Radley

Sir Gordon Radley died on 17th December, 1970. The span of Sir Gordon's career in the Post Office, from a junior Research Engineer to Director General is a measure of his characteristics and ability. In each phase of his career he left an enduring influence. His early engineering work on interfering reactions between high-voltage power transmission and telecommunications systems stands as a basis for much of today's work. His contributions over a wide range of telecommunication techniques to air, sea and land warfare enabled forces to be kept under control. His leadership of teams developing national and international telecommunications in the immediate post-war period paved the way for the national and global networks of today.

But in a very real sense, his period as Director General in the late fifties enabled his comprehensive grasp of the possibilities of science and engineering, his uncanny clarity of mind, together with an instinctive flair for decision taking, to be brought to bear on the basic problems of the role of the Post Office for the future. For, under his guidance, the White Paper on Post Office development and Finance of 1955 was prepared. It was this that presented the dilemma of a Government Department operating commercial services. It recaptured the spirit of Bridgeman and ended the role of the Post Office as a mere revenue department capable of being used as an instrument of general taxation. This delicately negotiated principle paved the way for a train of events, foreseen by Sir Gordon, encompassing the 1961 Act, which separated the Post Office financially from the Exchequer and culminated

in the setting up of the Post Office as a Corporation in 1969.

Though he steered the administration and business of the Post Office with freshness, energy and incisiveness he remained at heart an engineer. Facts first, problem second; not to be magnified out of proportion, but to be simplified so that an elegant, uncomplicated, straightforward solution could emerge, that decisions could be taken and courses set.

In his role as an outstanding engineer, he was elected President of the Institution of Electrical Engineers having served its council and committees over two decades. His counsel was sought by industry and government on the role of the engineer and scientist in administration and government. His advice and his actions pre-dated Fulton. Indeed, if he erred, it was that in many of his decisions he was ahead of his time having failed to give full weight to inertia of organisation or to the relative slowness of major technological innovations.

His kindness and, sometimes enigmatic, twinkle made staff feel wanted, evoked loyalty and response, and made them stretch themselves willingly in trying to match up to his seemingly endless energy.

Typical of his Christian faith and compassion was his service for the British Council of Churches, his work as a vice-president of the Crusaders Union for a decade and in his later years, his fine work for the housing of old people; he was at one time Chairman of the National Council of the Abbeyfield Societies and at the time of his death a Regional Chairman.

J.H.H.M.

---

## Press Notices

### Gas-Powered Mailvan

The first gas-powered mailvan to be tried by the Post Office is being introduced on an experimental basis. At a cost of £80 an Austin Morris 6 cwt van has been converted to run on petroleum gas instead of petrol and may pave the way for a large-scale conversion to gas power.

For many years the Post Office has used gas to drive equipment such as forklift trucks and small tractors. Many advantages are claimed for gas-powered vehicles and the Post Office now intends to test these claims. The gas is clean, odourless and burns efficiently, producing an invisible and non-toxic exhaust vapour. Instead of petrol being drawn from the tank through the carburettor, gas is drawn from a cylinder through a gas mixer, which replaces the carburettor. At normal temperatures and atmospheric pressures it is a true gas, but may be readily liquefied and stored at comparatively low pressures.

Direct savings on fuel alone could be £70 a year on an average of 12,000 miles. Liquid petroleum gas, which carries no duty, can be bought in bulk at about one-quarter the cost of petrol.

Early tests show that when using gas, vehicles start instantly and run quietly and smoothly with no loss of performance, even in cold weather. Other claims not yet tested are that gas reduces mechanical wear, cuts down corrosion of silencers, increases mileage intervals between oil changes, and prolongs the life of sparking plugs.

Although the cost of conversion on a one-off basis is £80, the cost of a new van equipped for gas would be only about £50 more than a standard van.

### An Argus for the Telephones

An aptly-named Argus computer system to watch over the reliability of the telephone service has been ordered by the Post Office from Ferranti Ltd. The Argus 500 configuration is to be installed in Leicester about the end of 1971 for trials that could lead country-wide to the faster detection of faults, further improvements of service for customers, and cost savings.

Acting as a round-the-clock trouble shooter, the £180,000 on-line computer system will monitor performance, draw instant attention to faults and impending breakdowns and alert maintenance engineers, enabling them to start repair work much sooner. Repairs will often be completed without the customer being aware that a fault has ever developed.

The computer will help network development staff to provide additional plant where it is needed by tracing the pattern of calls and identifying the most commonly-used routes, and by keeping a constant check on the volume of calls being made. It will also analyse signals from the equipment-testing devices already used to provide engineers with information on fault-prone equipment. The computer's analysis of these tests of individual pieces of exchange equipment will show where overhaul is needed and provide an additional safeguard against breakdown.

In the Leicester Computer-Aided Maintenance Project (CAMP), the computer will be task-programmed by the Post Office's Data Processing Service. Ferranti will provide the general-purpose programs.

Housed in the West Wigston telephone exchange building, the Leicester computer will gather information from 13



exchanges serving 48,000 Leicester numbers and from nine exchanges at Burton-on-Trent, Coalville, Hinckley, Kettering, Loughborough, Market Harborough, Melton Mowbray, Oakham, and Tamworth, serving 31,000 numbers.

Leicester area was picked for its representative spread of exchanges of the kind that could benefit most from computer-controlled maintenance, and for its even pattern of calls without high concentrations.

If the trial with the Argus 500 proves successful, about 2,000 exchanges up and down the country—all the larger electro-mechanical exchanges—could be similarly served by about 60 computers.

At present the Post Office spends £39 million a year on maintenance of telecommunications plant—a large part of it on servicing exchange equipment. Maintaining exchange equipment and customers' lines accounts for 45 million man-hours a year.

The Post Office is considering other possible uses for computers in exchanges, including analysis of fault patterns in electronic systems and testing subscribers' lines to see that they are kept in good working order.

At Leicester, solid-state electronic scanners installed alongside test equipment will keep constant check, registering pulses from the equipment and converting them to digital signals for direct input to the computer. They will monitor between 10,000 and 15,000 calls a day from 14 exchanges looking for any sign of trouble.

The computer cannot, of course, listen-in—it cannot be programmed to identify which subscriber is making the call—but it will pick up the dialling signals as they go out from the originating exchange.

When it detects a fault, the computer will print out the information about it over a permanent teleprinter link to the telephone exchange affected so that engineers can act on it immediately. At the same time, if there have been any similar faults, the computer will print out a case history giving engineers additional help.

Although individual items of telephone exchange equipment are tested systematically, the sheer quantity of plant means that it is sometimes possible for an equipment fault to remain undetected for several days until discovered by routine tests or reported by a customer. The computer will analyse the results of these tests in 22 exchanges to improve the knowledge of types of plant that are fault-prone and which need overhaul or even replacement.

From its monitoring input and other data on the volume of calls, the computer will build up the pattern of calls made in the area, including the proportion of local and trunk calls and identity of exchanges called. This will help the Post Office

to provide sufficient circuits to meet demands over heavily-used routes and, where necessary, order additional exchange equipment.

### **C.C.I.T.T. No. 6 to improve International Dialling**

The possibility of bringing a new long-distance signalling system into international use, giving telephone users improved international dialling, was brought a step nearer by a 12-nation conference in London.

Meeting under the auspices of the International Telegraphs and Telephones Consultative Committee (C.C.I.T.T.), a technical organ of the International Telecommunications Union, 55 telecommunications engineers from 12 countries planned international trials of the C.C.I.T.T. No. 6 separate channel signalling system which, they hope, will prove more flexible, reliable and economical than systems now in use.

Following previous meetings in Geneva, the conference met for two weeks in Fleet Building, one of the Post Office's headquarters, with Mr. J. J. Bernard of the Netherlands in the Chair. Leader of the U.K. delegation was Mr. D. J. Harding, a Staff Engineer with the Post Office.

The new signalling system's specification was drawn up after four years' joint study preceding the 1968 plenary meeting, when a working party to organize field trials was set up. Systems 4 and 5, already in use on international circuits, transmit control information over the circuit to be used for speech, whereas System 6 employs a separate data link which has a processor at each end and can control up to about 1,000 speech circuits on each route. An advantage is the elimination of individual signalling equipments; the greater the number of circuits controlled, the greater the economy.

The program of tests being organized includes both submarine cable and satellite circuits to establish the practical feasibility of the system. Tests have already started between London, Munich and Antwerp and will shortly take place in co-operation with partners in Australia and Japan.

Field trials are expected to be concluded during 1973 and, subject to satisfactory results, the system could be in operational use by 1975.

Much of the field-trial program of tests is dedicated to establishing that a very high quality of service can be achieved even under adverse conditions.

The data link itself is provided with at least one stand-by link with controlled changeover arrangements, so that traffic is not lost. An error-detecting code, with provision for acknowledgement and retransmission when required, ensures a high degree of accuracy in the transmission of the data messages.

### **Copyright**

The entire contents of this Journal are covered by general copyright, and special permission is necessary for reprinting long extracts, but editors are welcome to use not more than one-third of any article, provided that credit is given at the beginning or end, thus: "From *The Post Office Electrical Engineers' Journal*."

The Board of Editors is not responsible for the statements made or the opinions expressed in any of the articles in this Journal, unless such statement is made specifically by the Board.

### **Subscriptions and Back Numbers**

The Journal is published quarterly, in April, July, October and January, at 21p per copy: 31p per copy including post and packing (£1.24 per year) (3 dollars Canada and U.S.A., per year). Back numbers will be supplied, if available, price 24p (34p post paid) per copy. January and April 1969, October 1968, and all Journals earlier than July 1967 (except January and October 1966) are no longer available. Orders, by post only, to *The Post Office Electrical Engineers' Journal*, 2-12 Gresham Street, London, EC2V 7AG.

Employees of the British Post Office can obtain the Journal through local agents.

### **Binding**

Readers can have their copies bound at a cost of £1.87½p plus 24p (40p overseas) return postage, by sending the complete set of

parts, with a remittance to Press Binders Ltd., 4 Iliffe Yard, London, S.E.17.

### **Remittances**

Remittances should be made payable to "*The P.O.E.E. Journal*" and should be crossed "& Co."

### **Advertisements**

All correspondence relating to advertisement space reservations, copy, proofs, etc., should be addressed to the Advertisement Manager, *The Post Office Electrical Engineers' Journal*, 2-12 Gresham Street, London, EC2V 7AG.

### **Communications**

With the exceptions indicated above, all communications should be addressed to the Managing Editor, *The Post Office Electrical Engineers' Journal*, 2-12 Gresham Street, London, EC2V 7AG.

### **Model Answer Books**

Books of model answers to certain of the City and Guilds of London Institute examinations in telecommunications are published by the Board of Editors. Details of the books available are given at the end of the Supplement to the Journal.

# A rose by any other name...

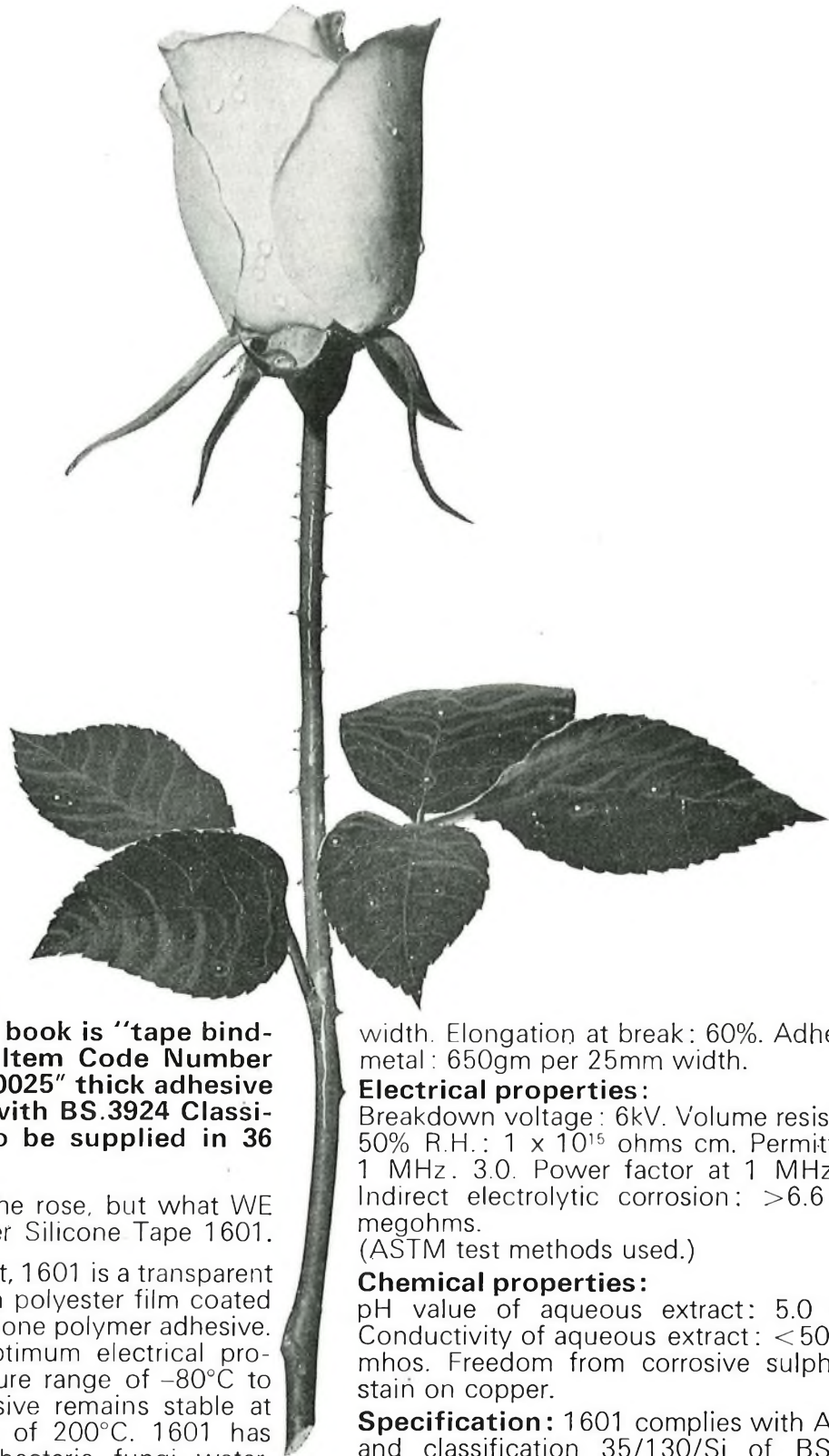

Its name in your rate book is "tape binding adhesive 12mm. Item Code Number 071763 transparent .0025" thick adhesive tape in accordance with BS.3924 Classification 35/130/Si, to be supplied in 36 yard reels."

No – we don't mean the rose, but what WE call 'Sellotape' Polyester Silicone Tape 1601.

But whatever YOU call it, 1601 is a transparent tape manufactured from polyester film coated with a thermostable silicone polymer adhesive. The tape retains its optimum electrical properties over a temperature range of  $-80^{\circ}\text{C}$  to  $+140^{\circ}\text{C}$  and the adhesive remains stable at temperatures in excess of  $200^{\circ}\text{C}$ . 1601 has excellent resistance to bacteria, fungi, water, salt water, acids and alkalis and good resistance to most alcohols, esters, ketones and oils.

#### Physical properties:

Base thickness: 0.025mm. Total thickness: 0.065mm. Tensile strength: 10kg per 25mm

width. Elongation at break: 60%. Adhesion to metal: 650gm per 25mm width.

#### Electrical properties:

Breakdown voltage: 6kV. Volume resistivity at 50% R.H.:  $1 \times 10^{15}$  ohms cm. Permittivity at 1 MHz: 3.0. Power factor at 1 MHz: 0.01. Indirect electrolytic corrosion:  $>6.6 \times 10^4$  megohms.

(ASTM test methods used.)

#### Chemical properties:

pH value of aqueous extract: 5.0 to 7.5. Conductivity of aqueous extract:  $<50$  micro-mhos. Freedom from corrosive sulphur: No stain on copper.

**Specification:** 1601 complies with AFS 292 and classification 35/130/Si of BS 3924.

Write for technical data sheets describing the full range of 'Sellotape' electrical products, or ask for our specialist representative to call.



Sellotape Products Ltd., Industrial Sales,  
Sellotape House, 54-58 High St, Edgware, Middx, HA8 7ER  
Telephone: 01-952 2345 Telex No. 262462

'Sellotape' is the Registered Trade Mark of Adhesive Tapes Limited.

a (DRC) company



# Some strange ingredients make up a telephone cable

## No stranger: TCL know-how

Some strange bedfellows get together in a first-class telephone cable. Like the plastic buttons shown — 146,595 go into every tube mile of TCL 1.2/4.4A coaxial cable to space and insulate. Or the vast quantities of bitumen, paper string and petroleum jelly that are also vital in their contribution.

No stranger to first-class cable, however, is TCL expertise. Into every mile of TCL cable — dry core and plastic — go 135 years of specialist knowledge.

It is this background — along with top professional planning — that has enabled us to install entire telecommunication systems the world over. Today, TCL cable is serving the British Post Office and similar organisations in more than 75 countries.



Telephone Cables Ltd., Dagenham, Essex, England. Tel: 01-592 6611. Cables: Drycore Dagenham. Telex: 896216.

*The organisation with 135 years experience*

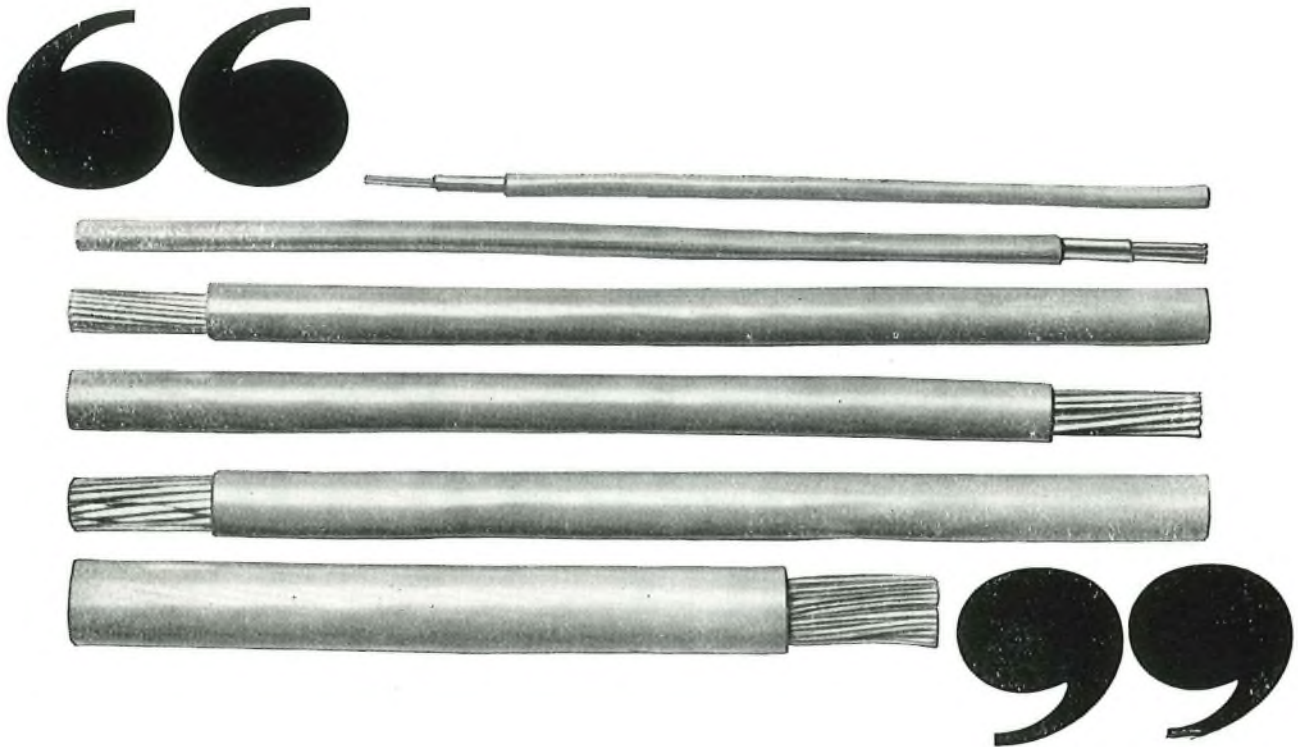

“**PIRELLI**”  
**GENERAL**

**and the power  
of speech**

Internal telephone communication systems call for the same degree of reliability as for national networks. Pirelli General manufactures a range of multipair and multiway internal telephone cables which are stocked for immediate delivery.

To reduce cross-talk in the multipair construction the pairs are twisted and laid-up with varying lays. Each cable has a distinct colour identification scheme for the cores or pairs which facilitates quick termination, and a Terylene ripper cord assists in quick removal of the pvc sheath. For further details ask for Publication MC3:1970.

PIRELLI GENERAL CABLE WORKS LIMITED · SOUTHAMPTON · TELEPHONE: SOUTHAMPTON 20381



# Racal bridges a gap in communications

with this new radiotelephone terminal  
type LA 1005

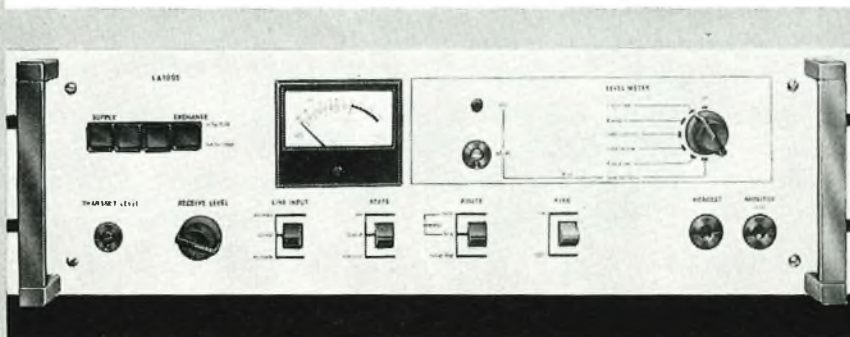

In quantity production after successful world-wide acceptance trials, the Racal LA 1005 provides exceptional system flexibility and operational facilities at low cost. Extremely compact, it is suitable for Post and Telegraph Administrations' circuits and ideal for military or civil operation.

- 4 wire radiotelephone to 2 wire or 4 wire telephone circuit.
- Automatic voice operated switching. ● Fully transistorised.
- Visual and aural calling indicators.
- Access for speech privacy. ● Built-in test oscillator.

Obtain full details NOW about this essential communication link

## **RACAL**

**RACAL-BCC LIMITED**

**Western Road, Bracknell, Berkshire RG12 1RG  
Tel: Bracknell 3244, Telex: 84166**

# WHITELEY

**Telephone Mansfield 24762**

It makes sound sense to talk to Whiteley. Not only for audio but all signals from d.c. to r.f. Firstly we generate or transduce signals as you require. Then we make them louder, softer, squarer, pulsed, smoother or whatever to send down your wire or co-ax. We can ease the signals into the line. Boost them when they are weak, filter or re-shape. If they get lost we provide equipment to find them. At the other end we can reproduce them in quantity and quality. From packages that are attractive or rugged, attractively rugged, or, ruggedly attractive. The facilities and know-how are at Mansfield — come and sound us out.

## **FOR SOUND & SIGNAL CONTROL & MONITORING**

Field and Exchange test equipment, low frequency and high frequency cable location equipment, line repeaters, transmitter and receiver insets, attenuators, filters and rheostats.

**WHITELEY ELECTRICAL RADIO CO. LTD.**, Mansfield, Notts, England. Tel. Mansfield 24762  
London Office: 109 Kingsway, W.C.2. Tel. 01-405 3074





Plugs, Sockets, Jacks—in all sizes and for every purpose—are made by the Special Products Division of Astralux Dynamics Ltd. They're chosen by the British Government and approved by the Post Office and Aircraft Industry. The special Astralux design service for prototype models is used by these organisations and by private industry. You can rely on Astralux efficiency and technical accuracy to produce equipment strictly to specification—and quickly. Plugs, Sockets and Jacks are just some of the products of a company streamlined to serve world-wide industry today. Learn more about what Astralux can offer you. Write to us for descriptive literature.

**ASTRALUX** dynamics limited

Relay Division, Brightlingsea, Colchester,  
Essex, England. Tel. Brightlingsea 2571/5

## ALKEN

**ALKEN PRECISION ENGINEERS LIMITED**

PALACE OF ENGINEERING OLYMPIC WAY  
WEMBLEY MIDDLESEX TEL. 01-902 8381

An open letter to all our PO friends inviting them to use our new and extended workshop facilities for the production of mechanical and electrical telecommunication jointing aids.

We should be very happy to introduce our one-off and short production run manufacturing services to an even wider circle of PO engineers and trust that this letter will serve as our introduction to those with no previous knowledge of the firm: let us help if we can—it's our business.

ALF WESTWOOD,  
*Director*

**You've got 6 gossips gossiping,  
5 chatterers chattering, 2 whiners whining,  
1 moaner moaning,  
5 prattlers prattling, 4 jabberers jabbering**

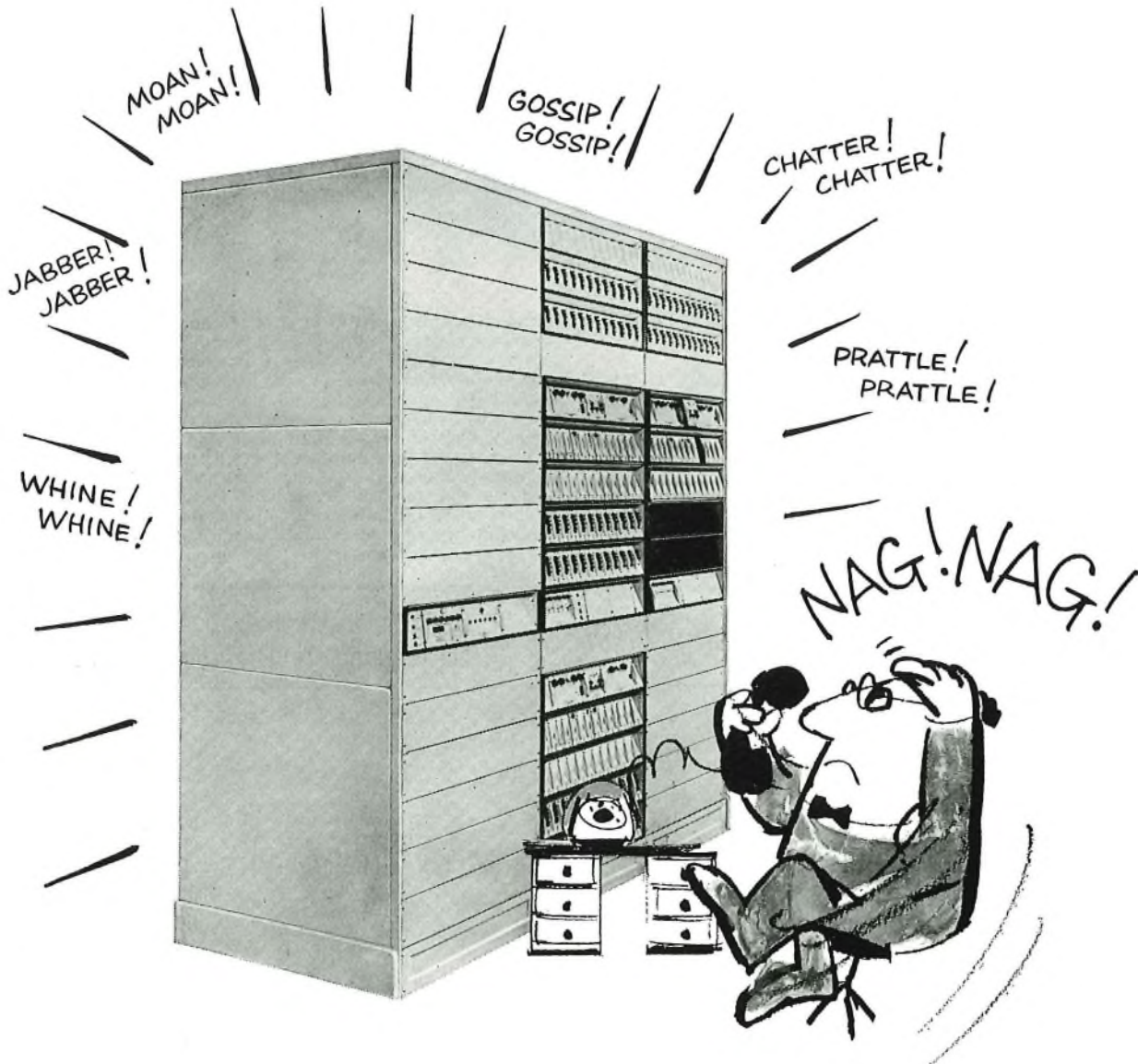

**and you can still call your wife on the same line!**

The Plessey 24 Channel Pulse Code Modulation Equipment provides 24 2-way telephone channels—over two pairs in audio cables. The system has been produced from designs developed to cater for the British Post Office. It is arranged for complete flexibility and allows the use of rackside shelfspace to meet the particular demands of any location.

The system provides additional low loss circuits on existing or new cable pairs, and is of particular use in conditions where induced noise and crosstalk are prevalent. It is possible to use the

equipment on cables where other carrier equipment does not operate satisfactorily. The speech channels have an effective bandwidth of 300—3,400Hz, and each channel is provided with signalling facilities via a wide range of units. Give us a call and find out more about Plessey PCM.



**Plessey Electronics**

Transmission Division,  
Beeston, Nottingham NG9 1LA, England.  
Tel: Nottingham (0602) 254831 Telex 37201



# FACTS ABOUT INSURANCE

to prove that your own Society offers a much better deal

Your own Society was formed to deal only with Civil Servants and their families.

Your premiums can be deducted from your pay, thus avoiding the extra collecting costs, and you get the benefits of this saving.

Every policy indirectly benefits the Civil Servants Widows and Orphans Fund which exists to help dependants of deceased policyholders. An average of £3,000 per year has been paid to this Fund in grants for the past 20 years.

In 80 years associated companies of the Civil Service Insurance Society have issued 163,242 life insurance policies, and paid out over £42 million in claims.

Your own Society exists to serve people like you. We invite your enquiries.

**New!**

Car insurance by instalments. You can insure your car by instalments throughout the year and get better rates!

**New!**

Immediate Cover available *just by phoning* for car—travel and holiday insurance! 01-688 3537.

## CIVIL SERVICE INSURANCE SOCIETY

for better terms on EVERY type of Insurance



Post this coupon to:

Civil Service Insurance Society, Dept. TX12, 33 Birdhurst Rise, South Croydon, CR2 7YH.

Please send me details of Insurance for

Name.....

Address.....

POJ4

# ENGINEERS!



Send for your **FREE** copy of 'ENGINEERING OPPORTUNITIES'

**WHAT THIS BOOK WILL TELL YOU!**

How to get rapid promotion or a better-paid job. How to put some valuable letters after your name. How to make use of our free Appointments & Advisory Service. How to gain the technical knowledge employers readily pay for. How you can succeed in any branch of Engineering you like—whatever your education or experience. 74 PAGES FULL OF EXPERT ADVICE.

Now ready a brand new edition of this famous book which we would like every ambitious engineer to have—free. We anticipate a tremendous demand so send for your free copy now.

'ENGINEERING OPPORTUNITIES' outlines our magnificent range of modern Home Study Courses and is packed with interesting and useful information. Don't miss this enlightening booklet.

**ENSURE YOUR COPY BY POSTING COUPON NOW**

To: BIET Dept. 727D Aldermaston Court, Reading RG7 4PF.

Tick subject that interests you. Aero Eng.  Automobile  Building   
 Computers  D'manship  Electrical  Electronics  Management   
 Mechanical  Plastics  Production  Surveying  TV & Radio   
 Telecomms.  Work Study  AMIED  AMIMI  AMSE   
 C.ENG.  CITY AND GUILDS  GENERAL CERTIFICATE OF EDUCATION

Other subjects \_\_\_\_\_

Please send 'ENGINEERING OPPORTUNITIES' without cost or obligation.

Name \_\_\_\_\_ Age \_\_\_\_\_

Address \_\_\_\_\_

Occupation \_\_\_\_\_

**BRITISH INSTITUTE OF ENGINEERING TECHNOLOGY**

## A match made by Hatfield



An extensive range of High Power impedance matching transformers is available on quick delivery from Hatfield Instruments. The range of H.F. Transformers covers P.E.P. ratings of 400W, 1.5KW, 3KW and 5KW.

The 6000 Series offers the most efficient means of coupling transmission systems of dissimilar characteristic impedances operating within the H.F. communications band. They are suitable for exterior mounting or in a transmission hall. All types are waterproof, can be pressurised, and are completely corrosion-resistant.

Send for full details of Hatfield High Power Transformers and a copy of our Short Form Catalogue.

**HATFIELD**  
forward thinking  
in electronics

HATFIELD INSTRUMENTS LIMITED  
 Burrington Way, Plymouth PL5 3LZ, Devon.  
 Tel. Plymouth (0752) 72773/4 Grams: Sigjen, Plymouth. Telex: 45592  
 South-East Asia: for prompt service and deliveries, contact:  
 Hatfield Instruments (NZ) Ltd., P.O. Box 561, Napier, New Zealand.

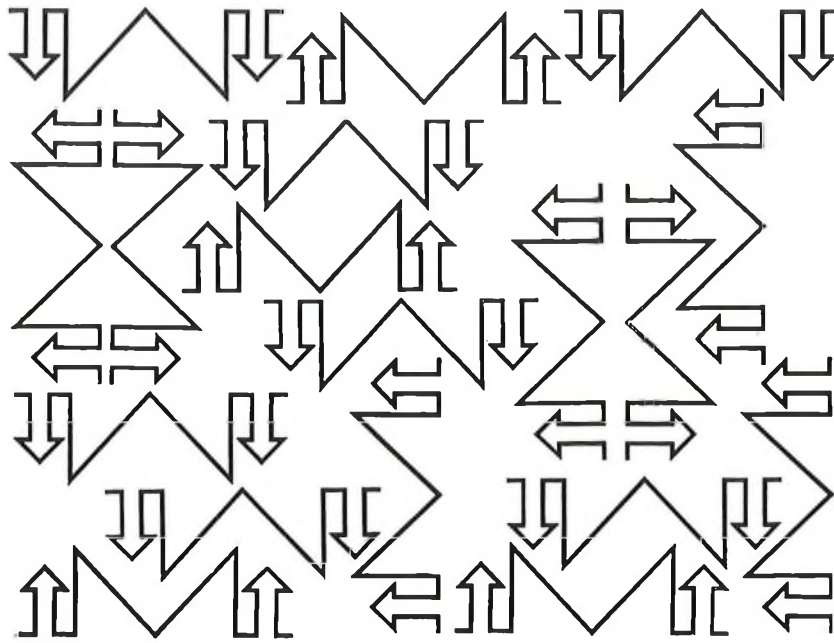

# 18 programme channels per rack

## CM-18A1 PROGRAMME MULTIPLEX

18 high-quality programme channels compatible with 60 telephone channels over the same bearer circuit. Any channel pair in a group of channels may be chosen for stereophonic programme transmission without need for pre-settings. Frequency shift eliminated by carrier regeneration at the receiving end. Non-oven oscillators are used.

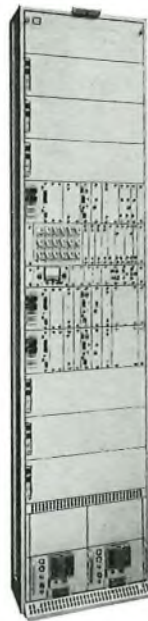

Independent channels. Economic installation even with a small number of programme channels. Performance complying with CMTT\* recommendations in a 2500 km circuit with three cascaded audio modulations. No need for compandor. Automatic level control. Emphasis network complying with CCITT standards.  
\* Doc. CMTT/119 - September 17, 1968.

- |                                |  |   |  |
|--------------------------------|--|---|--|
| RADIO RELAY SYSTEMS            |  | DATA TRANSMISSION SYSTEMS               |  |
| MULTIPLEX TELEPHONE SYSTEMS    |  | TRAFFIC CONTROL SYSTEMS                 |  |
| TV AND FM BROADCASTING SYSTEMS |  | TELECOMMUNICATION EQUIPMENT AND SYSTEMS |  |

*Telettra*



# Every day is a farad day with us!

Why? Because every day we can meet your every need for capacitors. We can supply everything from a 10pF tubular ceramic to a 15,000  $\mu$ F electrolytic, from stock.

It's the same with all our capacitors (we've shown some of them below). And all the other components we can supply—everything from Adhesives to Zener diodes. Order today and they'll be in the post today.

So what do you want by tomorrow at the latest?

## ***Radiospares***

P.O. Box 427, 13-17 Epworth  
Street, London EC2P 2HA  
Tel: 01-253 7501  
Telex: 262341





# ask **ASTRALUX** about Relays *today!*

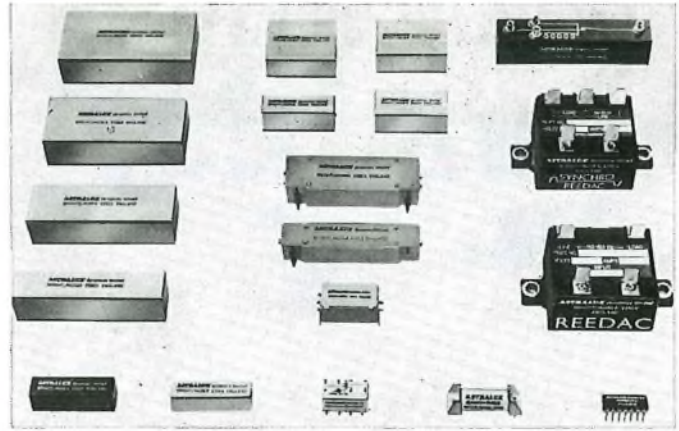

## Because we offer:

- The widest range and latest developments.
- 'Economy' versions when price is all important.
- Models to meet stringent environmental specifications.
- A prototype design service for your special requirements.

Why not find out about the Astralux range of Reed Relays and Solid-State Controllers? We would be pleased to advise on your application and quote for your specific requirement. With our comprehensive range coupled to our experience in Reed Relay and Solid-State Switching Technology we offer a service second to none in this field.

## New from Astralux: The GB811 Series

The first 'family' of 14 pin Dual-In-line Relays. They are completely compatible with all DIP-IC Devices and have the option of electrostatic screens and/or internal diodes.

Plus a revolutionary Mercury-Wetted, latching Form C Relay. The GB813C is a bistable, latching Mercury Film Relay. It is a distinct high-reliability device—with a life expectancy of a billion operations. But, of even more importance, it is completely position insensitive. Another unusual feature is its inherent contact memory. The contact always remains in its last position until again activated—without the need of any external assistance, such as a magnet or an energised coil!

Actual Size

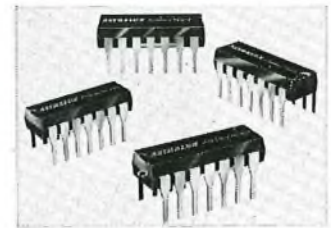
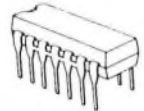

Ask for our Catalogue illustrating the wide range of Circuit-Ready Reed Relays and 'Reedac' Solid-State Switches and Controllers.

**ASTRALUX** *dynamics limited* Relay Division, Brightlingsea, Colchester, Essex, England. Tel. Brightlingsea 2571/5

## INDEX TO ADVERTISERS

|   |        |  |        |
|---|--------|--|--------|
| Alken Precision Engineers Ltd. . . . .                | 16     | Plessey Co. Ltd., The . . . . .            | 17, 22 |
| Astralux Dynamics Ltd. . . . .                        | 16, 21 | Racal-BCC Ltd. . . . .                     | 14     |
| British Institute of Engineering Technology . . . . . | 18     | Radiospares . . . . .                      | 20     |
| Cambion Electronic Products Ltd. . . . .              | 6      | Sellotape Ltd. . . . .                     | 11     |
| Civil Service Insurance Society . . . . .             | 18     | Standard Telephones & Cables, Ltd. . . . . | 1-6    |
| Cray Electronics Ltd. . . . .                         | 23     | Telephone Cables Ltd. . . . .              | 12     |
| GEC-AEI Telecommunications, Ltd. . . . .              | 7-10   | Telettra S.p.A., . . . . .                 | 19     |
| Hatfield Instruments Ltd. . . . .                     | 18     | Whiteley Electrical Radio Co. Ltd. . . . . | 15     |
| Pirelli General Cable Works Ltd. . . . .              | 13     |  |        |



# 1912

-the day your number  
came up!



In 1912 Plessey installed the first automatic exchange for the British Post Office at Epsom. That was the day you said Goodbye to the Hello girls. The day your number came up. Automatically.

## So what else has come up?

Since then Plessey has clocked up a great many other firsts - particularly in TXE2 (Pentex in the world markets).

A Plessey TXE2 was the first production electronic exchange to be installed in Europe. There are now over 75 Plessey electronic exchanges in operation in Britain alone - not to mention those overseas.

Plessey equipment is in great demand all over the world, so we can't promise delivery overnight. But what we can promise is the care we take to meet our obligations to you. Care in the opening of new factories, training of new staff and the availability of our engineers to advise on your telecommunications problems.

Whether you want an electronic, crossbar or Strowger system - whether you want to replace existing equipment piece by piece, do a direct conversion or provide an entirely new system - Plessey will ensure that everything is ready and waiting to go. The very day you want your number to come up.



## Plessey Telecommunications

Plessey Telecommunications Group, Edge Lane, Liverpool L7 9NW, England

PT383/1



R.A. Roe PE. 1.2

# TYPE 62

## FULL RANGE

7 TO 14 DAY DELIVERY

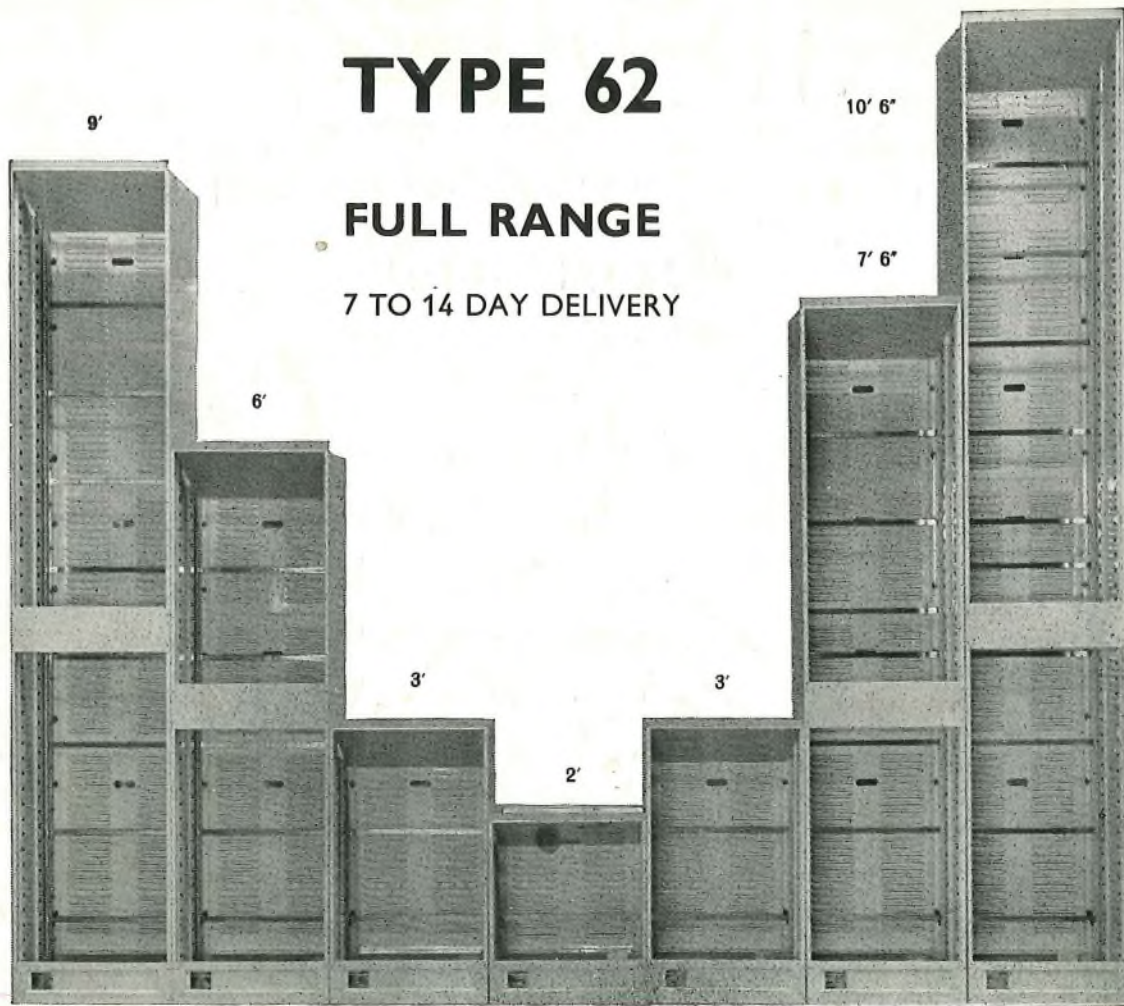

### HIGH PRECISION MECHANICS

FOR INSTRUMENT ELECTRONIC AND AUTOMATION INDUSTRIES

TELECOMMUNICATIONS  
MECHANICS

**P.O. APPROVED**

IMMEDIATE QUOTATIONS AND  
TECHNICAL SERVICE

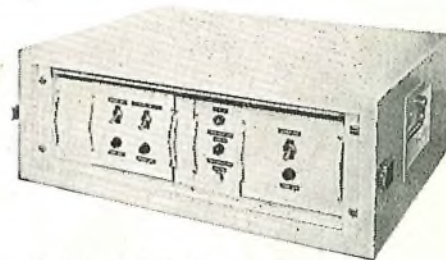

SHELF ASSEMBLIES

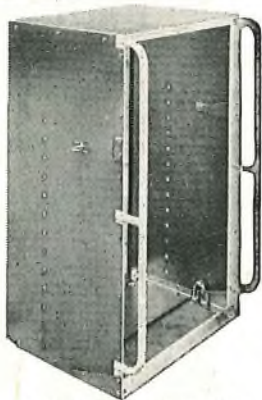

P.C.M. TRANSIT JIG



DAtEL MODEM

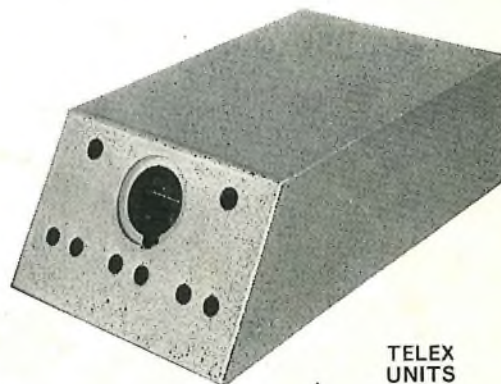

TELEX  
UNITS

## CRAY ELECTRONICS LTD

THAMES ROAD, CRAYFORD, KENT  
TELEPHONE: CRAYFORD 26526