

# The Post Office Electrical Engineers' Journal

---

VOL 63 PART 3 / OCTOBER 1970



# THE POST OFFICE ELECTRICAL ENGINEERS' JOURNAL

Vol. 63 PART 3 OCTOBER 1970

## Contents

	<i>page</i>
<b>Progress in Postal Engineering—Part 2—Packets and Parcels—N. C. C. de Jong</b>	131
<b>A New Concrete Tower for Purdown Radio Station—G. Birchby and R. L. Moxon</b>	138
<b>Gas Turbines for Telecommunications Power Plant—H. E. Pearson</b>	143
<b>Post Office Standard Video Transmission Equipment—J. Sixsmith</b>	147
<b>Call-Failure Detection Equipment—Standard Equipment for Director and Non-Director Strowger Exchanges—K. W. Hix, R. A. Francois and J. D. Pyrah</b>	152
<b>Monitoring the Speed of Stand-by Engine Generator Sets—J. S. True</b>	157
<b>Transit-Trunk-Network Signalling Systems—Part 3—Line-Signalling-Systems—C. B. Miller and W. J. Murray</b>	159
<b>Some Principles of Local Telephone Cable Design—H. J. C. Spencer</b>	164
<b>Remote Control and Supervisory Systems for Microwave Radio-Relay Links—R. D. Martin-Royle and J. M. Heather</b>	169
<b>Identification of New Cable Pairs—J. F. Craggs</b>	177
<b>Electrical Contacts in Telephone Exchanges: Contact Opening and Closing Phenomena and Quenching Techniques—Part 2—The Design of Contact Switching Circuits—W. L. Scott</b>	179
<b>An Anti-Jamming Device for Conveyor-Belt Systems—A. Ioannides and C. G. MacMillan</b>	189
<b>Notes and Comments</b>	191
<b>Institution of Post Office Electrical Engineers</b>	193
<b>Regional Notes</b>	195
<b>Associate Section Notes</b>	196
<b>Press Notices</b>	198
<b>Book Reviews</b>	137, 163

Published in April, July, October and January by *The Post Office Electrical Engineers' Journal*,  
2-12 Gresham Street, London, E.C.2V 7AG

Price 4s. 3d. 6s. (Including Postage and Packing). Orders by post only.

Annual Subscription (post paid): Home and Overseas 24s. (Canada and U.S.A., 3 dollars)

# THE INSTITUTION OF ELECTRICAL ENGINEERS

## Individual Study Service

The Individual Study Service is an extension of the activities of the Institution of Electrical Engineers intended to contribute to the continuing education of members of the electrical-engineering profession.

Its aim is to provide an engineer who qualified between, say, 5 and 20 years ago, with continuing opportunities to bring himself up to date.

## Field-effect transistors

by Robert King, MA, CEng, MIEE  
(Imperial College of Science & Technology)

## Pulse-code modulation

by Prof. K. W. Cattermole, BSc, CEng, MIEE  
(University of Essex)

### General arrangements

Courses run continuously, and a student having registered may start at any time after the initial commencement date for that course.

Each student will be associated with an individual tutor who, through the medium of correspondence, will advise and comment on his progress. Each course is divided into 15 lesson units comprising a written text covering a particular part of the syllabus illustrated by diagrams and worked examples where applicable, together with graded test questions.

At the commencement of a course each student will be sent lesson units 1 and 2. After studying lesson 1 a student is required to return his written answers to the test questions and continue with lesson 2. The corrected scripts, together with any comments by his tutor, will then be forwarded with lesson 3, and so on. In this way the whole of the 15 lesson units can be covered (by UK students) without any long delays while awaiting the return of corrected material. Airmail will be used for students overseas. In their case, to guard against possible delays, the first three lessons will be despatched together at the start of the course.

Although the time a student can devote each week to his studies will vary, the course has been designed with the intention that each lesson and its test questions should occupy, for an average student, about six hours and should be completed within two weeks. In this way the normal duration of a course will be of the order of 30 weeks.

At the end of the course the IEE will issue a certificate to each student who has satisfactorily completed all the written work.

For courses which attract a sufficient number of students, the material will be up-dated at intervals and students who have completed such a course will be provided with copies of the up-dated sections for a small extra fee.

### Fees per subject

Members of the Institution of Electrical Engineers:	
Resident in the United Kingdom	£25
Overseas	£30
Non-members:	
Resident in the United Kingdom	£35
Overseas	£40

The appropriate fee must be paid in full before an applicant can be registered.

### Important

The courses commence at a level appropriate to the final year of a modern 3-year degree course in electrical/electronic engineering. Intending participants should prepare themselves in advance by studying the reading matter recommended for the selected course and by refreshing their background mathematical knowledge at the standard indicated.

### Enrolments

Applications from P.O. staff for these courses must be made via local Training Officers, who will have details of the official assistance available, and who will obtain the necessary registration forms from The Education Officer, IEE, Savoy Place, London WC2.



**GEC Lincompex**  
 Already proved in practice  
 in over 35 countries ...  
**can increase  
 revenue from your  
 long-distance  
 HF radio  
 circuits, too!**

Over 35 countries already rely on GEC Lincompex to bring the quality of HF radio telephone circuits up to line transmission standards. Now, you, too, can increase your revenue from long-distance HF radio circuits with GEC Lincompex. Developed from a British Post Office design, it provides:

- Improved signal-to-noise ratio
- Substantial reduction in fading
- Constant loading of radio transmitter
- Quiet 'no-signal' periods to ease the flow of conversation
- Higher traffic handling capability
- Elimination of singing suppressor

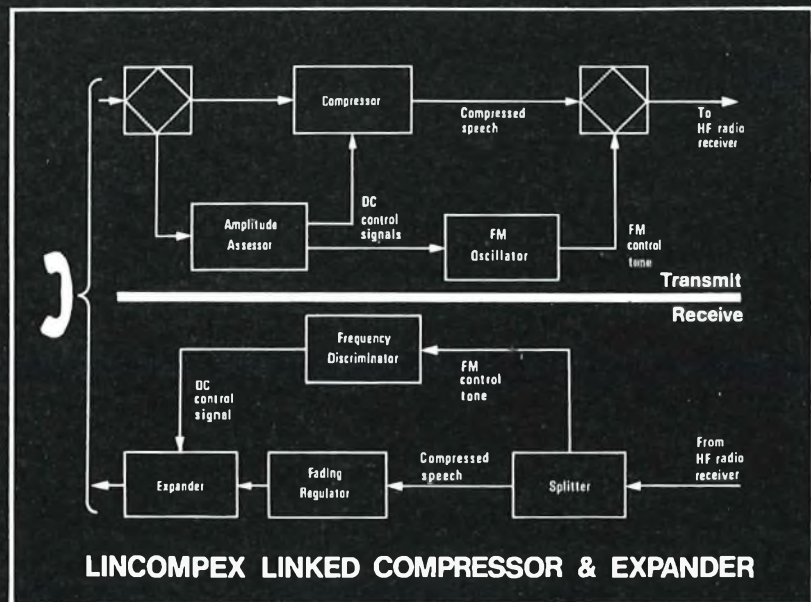
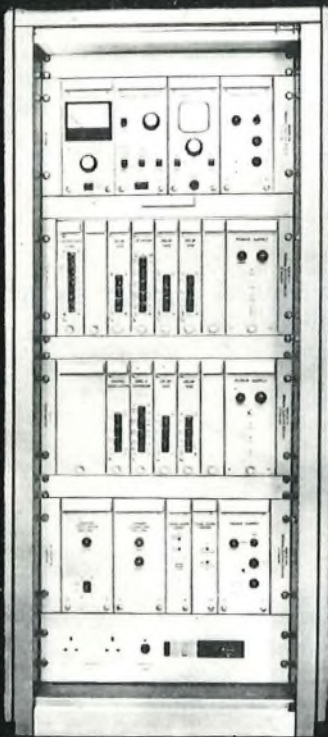

◀ A single-channel '1T' terminal. It comprises: monitor unit; Lincompex transmit unit; Lincompex receive unit; and ringer/signalling & echo-suppressor equipment.



**Takes telecommunications into tomorrow**

GEC-AEI TELECOMMUNICATIONS LTD. OF COVENTRY, ENGLAND.

A Management Company of The General Electric Co. Ltd. of England.



**“put me through  
to the manager...  
room service...  
theatre bookings...”**

Our new low line Cord Switchboard is at home wherever personal service is still important....

Even in the pace of today's modern world, personal service is expected and often necessary. The GEC low line Cord-type telephone switchboard combines elegance with efficiency and boasts adaptability to suit its surroundings, wherever they may be ... whether in luxury hotels, hospitals, or even cruise liners. It's the ideal PABX private telephone system for situations where personal service counts.



Registered Design  
No. 940229



**Takes telecommunications into tomorrow**

GEC-AEI TELECOMMUNICATIONS LTD, OF COVENTRY, ENGLAND.

A Management Company of The General Electric Co. Ltd. of England.

18|48



# GEC links the world with microwave progress

AUSTRALIA • BAHREIN • CANADA • CHILE  
COSTA RICA • EL SALVADOR • FIJI • GHANA  
GREECE • GUYANA • HONG KONG • IRAN  
KENYA • LIBYA • MALAYA • MALAWI  
MALTA • NIGERIA • NORWAY • PERU  
PORTUGAL • SABAH • SWITZERLAND  
THAILAND • UNITED KINGDOM  
WEST INDIES • ZAMBIA

Broadband radio systems incorporating GEC microwave links are in operation in every continent in the world. The range of GEC microwave radio systems is impressive. It includes:-

- 2GHz, 4GHz, 6GHz and 6.8GHz equipments for speech or television on long haul main routes.

- 7.5GHz equipment for speech on medium haul spur routes.

- Associated equipments include F. D. Multiplex for up to 1800 circuits, supervisory alarm indication and remote control systems, I.F. and baseband switching equipments, narrowband auxiliary radio for serviceband antenna systems.

The achievement of GEC in the provision of microwave radio communication networks in so many countries of the world typifies their overall capability in telecommunications.



**G.E.C.**

**Takes telecommunications into tomorrow**

GEC-AEI TELECOMMUNICATIONS LTD, OF COVENTRY, ENGLAND.

A Management Company of The General Electric Co. Ltd. of England.



# GEC of England can be very small-minded about Multiplex



The coil on the left is the type we used to use in the Supergroup Harmonic Generator of GEC Multiplex Equipment. We took a close and critical look at it and set about designing and producing the smaller coil to replace it.

Why? Not for the sake of miniaturisation but because this particular reduction in size of coil enabled us to make a substantial reduction in the a.c. power required to drive the harmonic generator with a corresponding improvement in reliability.

With over 40 years' experience in the design and manufacture of Multiplex Equipment to meet the needs of the world's markets, GEC continues to maintain its position in this field.

This is one facet of the total capability in telecommunications that is offered by GEC.

**Takes telecommunications into tomorrow**

GEC-AEI TELECOMMUNICATIONS LTD, OF COVENTRY, ENGLAND.

A Management Company of The General Electric Co. Ltd. of England.

IB/36A

6

# STC Telecommunications

## *Our flexible construction plan*

STC multiplex equipment enables you to build up a system channel by channel, group by group, or supergroup by supergroup, in any order you wish. In fact, it sorts out your channels whether you use coaxial cables or microwave radio as the trunk bearer.

STC manufactures a wide range of solid state multiplex equipment conforming to CCITT recommendations and suitable for all applications.

Constructed in STC Mark 6 (BPO 62 EP) form you can have a single channel card or a fully wired shelf containing a dozen, with in-band or out of band signalling.

A fully equipped 2.74 m (9ft) high rack can contain 15 shelves giving 180 channels.

STC's experience, based on over 40 years of design and manufacture of multiplex equipment, plus the global resources of ITT, enables us to provide your complete requirements in telecommunications terminal equipment.

For more information, write to:- Standard Telephones and Cables Limited, Microwave and Line Division, Basildon, Essex, England, Telex: 99101 (STC Basildon)

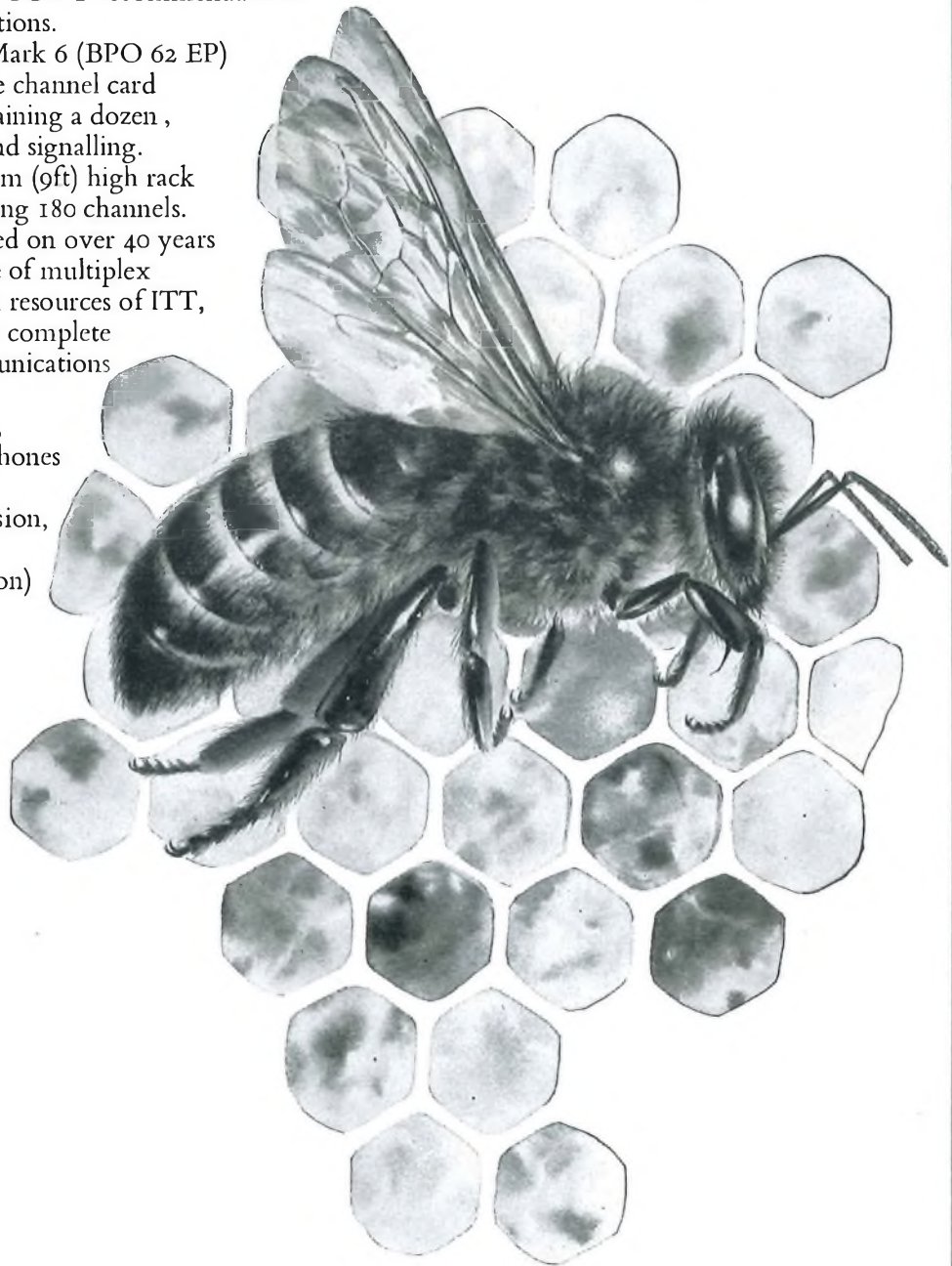

an associate of  
**ITT**

world-wide telecommunications and electronics **STC**



## STC Telecommunications



### 47,704 are better than one

If you want a light, inexpensive headset, you can't do better than the British Post Office Corporation. For 47,704 of their girls, they chose STC sets. So should you.

Our sets are light as a feather, strong as a whip, and offer incredible value for money. They weigh a mere 4 ozs, and when your girls wear them, they won't notice a thing. The headset leaves their hands free to plug in lines or do their make-up, and however violently they shake or shrug, the headset stays put.

Better still, these sets are quite indestructible. Black or grey, take your pick.

So next time you're thinking of buying headsets, use your head. Buy STC.

Write, phone or telex for leaflet D/104 to:— Standard Telephones and Cables Limited, Subscriber Apparatus and Acoustic Division, New Southgate, London, N.11, England. Telephone: 01-368 1234. Telex 21917.

an associate of  
**ITT**

# STC



### Easy money

For every Deltaphone your subscribers hire, you get a few shillings/schillings/krona/dollars extra every year.

With a lot of subscribers, you naturally get a lot more shillings/schillings/krona/dollars etc. every year.

And your subscribers get a very beautiful instrument (this gem of a telephone comes in several fashionable colours, to blend with the decor). With a few rather nice things other telephones don't have, like a gentle warbling tone (the volume is adjustable) instead of a loud insistent ring.

And an optional luminescent dial that glows in the dark.

And the fact that it weighs only a few ounces. And that it's only 4.3 inches (105 mm) wide, means it can be held comfortably in the hand.

Best of all, with all this extra money rolling in, very little rolls out. Because the Deltaphone is of modular construction and needs only a screwdriver for any repair job.

So why not stock up with the STC Deltaphone? It's so slim and elegant, your subscribers are sure to ask for it.

So write to: Standard Telephones and Cables Limited, Subscriber Apparatus and Acoustic Division, Oakleigh Road, New Southgate, London N.11, England. Telephone: 01-368 1234. Telex: 21917.

an associate of  
**ITT**

# STC





# It's twins!

4,800 pairs of them

This  $2\frac{3}{4}$ " diameter cable is made up of 4,800 pairs of conductors. More than you'll find in any other cable of the same diameter.

It's the largest in the range of STC unit twin exchange cables used in standard Post Office ducts.

Each conductor is insulated with polythene and paired. These pairs are assembled into units, sub units or multiple units of 25. Then the application of a polythene/aluminium sheath overall provides a very effective barrier against moisture and water vapour.

Unit Twin cables are suitable for duct installation and steel wire armoured versions can be supplied in some sizes where direct burial is required. STC cables are widely used by the British Post Office for telephone distribution applications, and by large industrial concerns throughout the world.

For further information, write, 'phone or telex:

Standard Telephones and Cables Limited, Plastic Telephone Cable Division, Corporation Road, Newport, Monmouthshire.  
Telephone: Newport 72281. Telex: 49368.

an associate of  
**ITT**

world-wide telecommunications and electronics

# STC



**STC** Telecommunications

# STARPHONE by STC

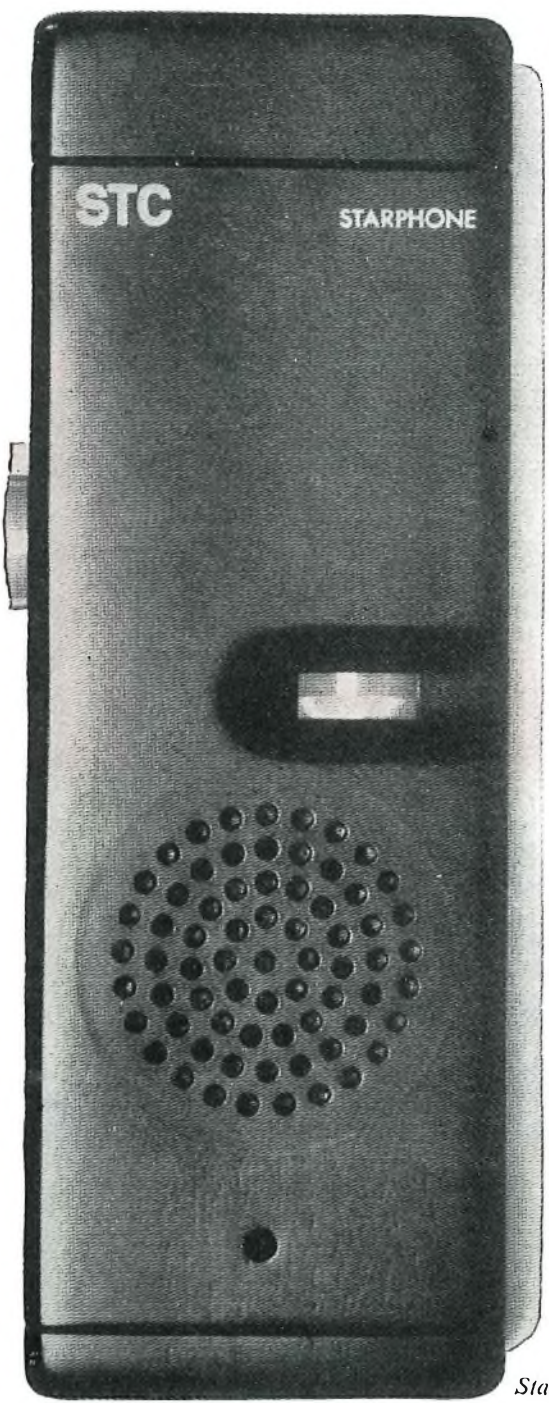

## The World's Smallest UHF Radiotelephone

The Starphone is unique. It's the first radiotelephone designed to go in the pocket without external wires or rods. Operating on UHF, STC Starphone has an astonishing penetration of buildings and steel structures, and can give you instant two-way communication with your staff over a wide area.

Write for details to  
STC Mobile Radiotelephones Limited,  
New Southgate, London N.11. England.  
Telephone: 01-368 1200.  
Telex: 261912.



*Starphone—actual size*

an associate of  
**ITT**

Attach your letterheading to this panel.  
Please send me full details of your  
STARPHONE

Name.....  
Position.....

**STC**  
Mobile Radiotelephones



## STC Telecommunications

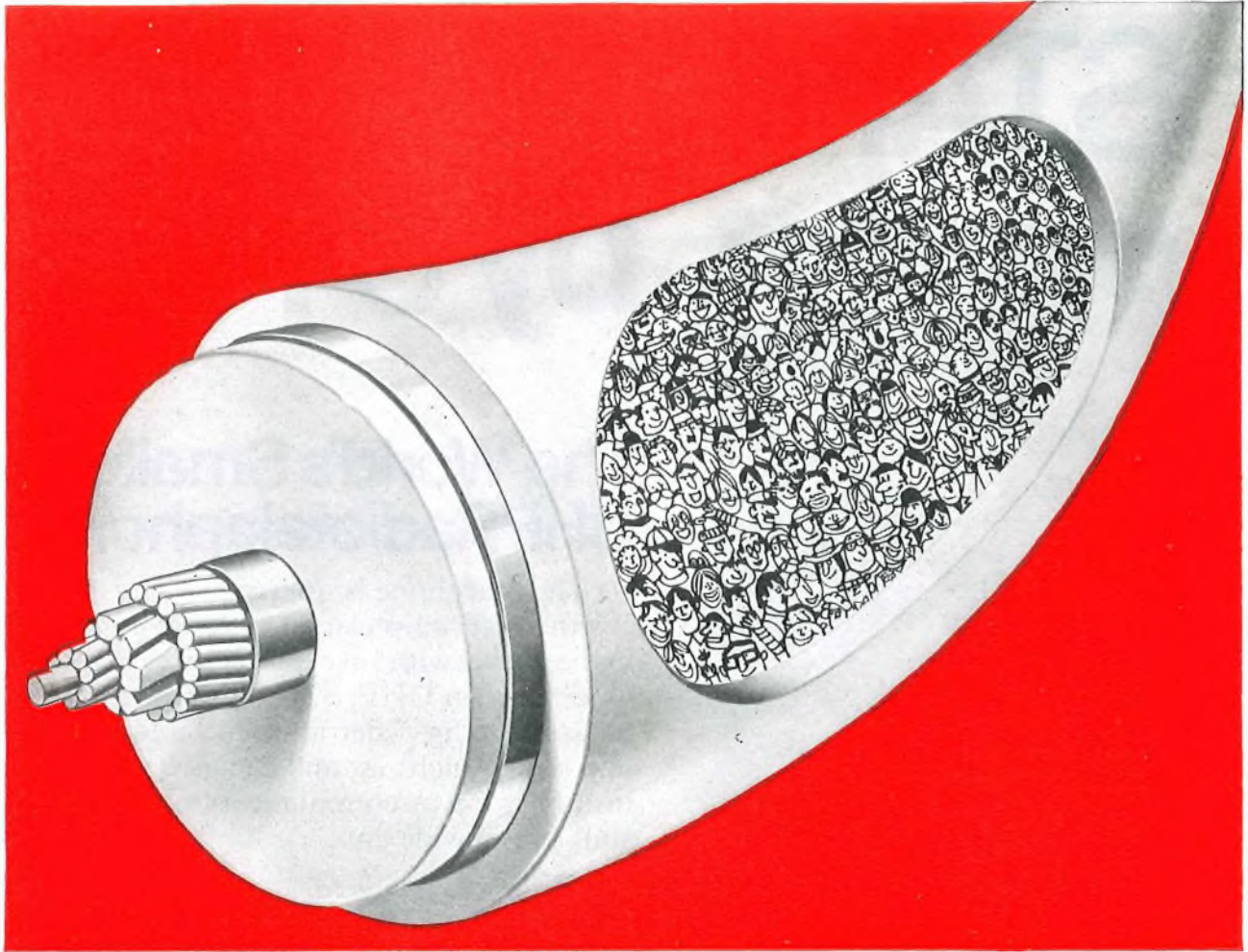

# Soon 1840 people will reach the Canaries by tube—simultaneously!

The tube is the new undersea cable system made by STC. With an overall diameter of 1.75 inches, it has the astonishing capacity of 1840 separate telephone circuits each of full 3 kHz capacity. The world's largest to date. STC's first system in the Canaries had only 160 channels. But now that they have Subscriber Trunk Dialling (STD) the Compañía Telefonica Nacional de España needs another cable.

And again STC has been asked to provide this. Naturally. Because 1840-channels is only one of a succession of STC firsts in this field. First with 160- and 360-circuit deep-water systems. First with the master/slave power feeding system. First with the equaliser test lead making cable laying that much easier. But submarine cables, repeaters, equalisers and terminal equipment

are not all that we offer. Add an overall capability for systems planning, project management, installation of complete systems, including civil engineering works and services—and you have a **unique organisation** able to meet any requirement, anywhere. Standard Telephones and Cables, Submarine Systems Marketing Division, North Woolwich, London, E.16, England.

an associate of  
**ITT**

world-wide telecommunications and electronics

# STC



# STC Telecommunications



## Some of the books that have been written about us.

It's rather gratifying to see the results of our work in print. But not unusual for STC. A lot more volumes will adorn desks and kiosks around the country by the time we're through. At the moment, we're the only company involved in all 3 types of telephone exchange: Director, Non-Director, and Transit Switching. Transit Switching will eventually provide a new telephone network for the United Kingdom. In a year or so thirty Transit Switching centres all made and installed by us will be in operation for the Post Office Corporation.

Each will have its Group Switching Centres. Which in turn will be responsible for their own smaller, area exchanges.

The very fast signalling provided by Transit Switching will allow more calls through per minute. Fewer delays. Less time wasted, which will be greatly appreciated, because the telephone is the bread and butter of a lot of businesses.

Including ours.

Standard Telephones and Cables Limited, Telephone Switching Group, Oakleigh Road, New Southgate, London N.11, England.

Telephone 01-368 1234. Telex 21917.

an associate of  
**ITT**

worldwide telecommunications and electronics

# STC



# **INDUSTRIAL COMMUNICATIONS**

## **2 SYSTEMS FOR INDUSTRIAL SITES**

### **INDUSTRIAL HELMET TRANSDUCER ASSEMBLY** for use with pocket transmitter receivers

- Rugged dependable construction
- Versatile operation
- Semi-flexible tubes and adjustable earcups to suit individual requirements
  - Covered by an Intrinsic Safe Certificate

### **ALL PURPOSE FIELD TELEPHONE HANDSETS**

- Versatile—operates under all climatic conditions
- Lightweight and robust construction
- Shock resistant and water proof
- Effective over 20 miles using standard telephone wiring
- Up to 12 handsets may be inter-connected on average building site



**HAWKER SIDDELEY**

**COMMUNICATIONS**

S. G. BROWN LTD., KING GEORGE'S AVENUE, WATFORD, HERTFORDSHIRE  
TEL: WATFORD 23301 TELEX 23412 TELEGRAMS RADIOLINK WATFORD

Hawker Siddeley Group supplies mechanical, electrical and aerospace equipment with world-wide sales and service.



**Now...  
you can find  
trouble  
in your sleep.**



Or while you're on another job, in another part of the building, or fishing over the weekend. The Amprobe Recorder keeps watch over trouble spots and makes a printed, permanent, accurate record to show what happens when it happens and how long it lasts while you're away.

And there's an Amprobe Recorder for virtually any job. For example, the LAVA models have up to three expanded scale AC voltage ranges for greater accuracy, and four current ranges (up to 500 amps AC). Literally two instruments in one.

The chart is pressure-sensitive, with no ink to spill, no pen to clog. It loads easier than film in a camera. Without the chart, you can still take direct meter readings. So altogether, you have four instruments in one.

See your Amprobe Distributor for the full line and the full story.

**CANADIAN INSTRUMENTS AND ELECTRONICS LTD.**  
35 WAVERLEY STREET  
NOTTINGHAM  
062 71157/8

**For people looking for trouble...  
AMPROBE\* INSTRUMENT**  
\*REGISTERED TRADEMARK OF AMPROBE INSTRUMENT,  
DIVISION OF SOSS MANUFACTURING COMPANY



# VALUABLE FREE BOOK

**Tells You How to Pass Your C. & G. Examination at First Attempt!**

All Post Office personnel who are anxious to obtain early promotion should at once send for a copy of our handbook "ENGINEERING OPPORTUNITIES" which, among other intensely interesting matter, describes our unique methods of preparation for the CITY AND GUILDS EXAMINATIONS for the Telecommunication Technicians' Certificate and for individual subjects—Mathematics, Engineering Science, Engineering Drawing, Elementary Telecommunication Practice, Telecommunication Principles, Radio and Line Transmission, Telegraphy and Telephony, Line Plant Practice. It also contains details of our courses covering the G.C.E. subjects required for promotion to Assistant Engineer, Telecommunication Traffic Superintendent and other grades; and the City and Guilds examinations in Electrical Engineering Practice, the A.M.I.E.R.E. and A.M.S.E. Examinations, in addition to a wide range of non-examination courses in all branches of engineering—Radio and Electronics, Electrical Mechanical, etc.



**We also provide tuition for the Radio Amateurs' Examination and the P.M.G. Certificates for Radio Operators, with or without Morse training. Details are given in the handbook.**

**On "SATISFACTION OR REFUND OF FEE" terms**

If you intend to make the most of today's opportunities, you cannot afford to miss reading "ENGINEERING OPPORTUNITIES." It tells you everything you want to know to secure advancement, and describes many opportunities you may now be missing through lack of information. Send for your copy today—FREE and without obligation.

**BRITISH INSTITUTE  
OF ENGINEERING TECHNOLOGY**  
727D ALDERMASTON COURT,  
ALDERMASTON, BERKSHIRE

# BIET

# MODEL ANSWER BOOKS

CITY AND GUILDS OF LONDON INSTITUTE  
TELECOMMUNICATION TECHNICIANS' COURSE

Model answer books are available, each covering one of the following subjects:

**TELECOMMUNICATION PRINCIPLES A**

**TELECOMMUNICATION PRINCIPLES B**

**ELEMENTARY TELECOMMUNICATION PRACTICE**

**RADIO AND LINE TRANSMISSION A**

**TELEPHONY AND TELEGRAPHY A**

**LINE PLANT PRACTICE A**

PRICE 7/6 each (Post Paid 8/-)

Orders may be sent to the *Journal* Local Agents or to  
*The Post Office Electrical Engineers' Journal*,  
2-12 Gresham Street, London, E.C.2.

ask  
**ASTRALUX**  
about  
Relays  
*today!*

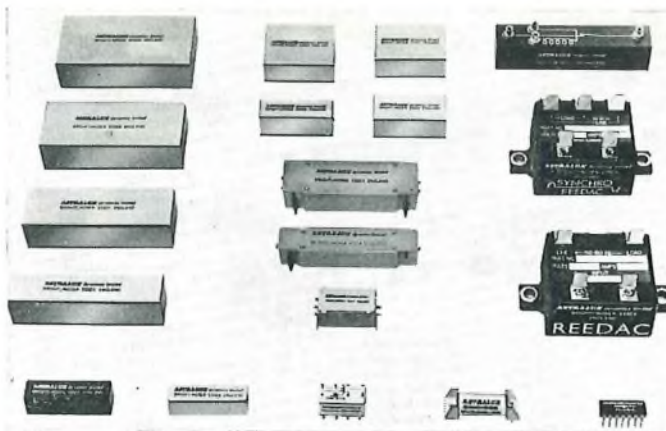

**Because we offer:**

- The widest range and latest developments.
- 'Economy' versions when price is all important.
- Models to meet stringent environmental specifications.
- A prototype design service for your special requirements.

Why not find out about the Astralux range of Reed Relays and Solid-State Controllers? We would be pleased to advise on your application and quote for your specific requirement. With our comprehensive range coupled to our experience in Reed Relay and Solid-State Switching Technology we offer a service second to none in this field.

**New from Astralux: The GB811 Series**

The first 'family' of 14 pin Dual-Inline Relays. They are completely compatible with all DIP-IC Devices and have the option of electrostatic screens and/or internal diodes.

**Plus** a revolutionary Mercury-Wetted, latching Form C Relay. The GB813C is a bistable, latching Mercury Film Relay. It is a distinct high-reliability device—with a life expectancy of a billion operations. But, of even more importance, it is completely position insensitive. Another unusual feature is its inherent contact memory. The contact always remains in its last position until again activated—without the need of any external assistance, such as a magnet or an energised coil!

Actual Size



Ask for our Catalogue illustrating the wide range of Circuit-Ready Reed Relays and 'Reedac' Solid-State Switches and Controllers.

**ASTRALUX** *dynamics limited*

Relay Division, Brightlingsea, Colchester,  
Essex, England. Tel. Brightlingsea 2571/5

# ALKEN

**ALKEN PRECISION ENGINEERS LIMITED**

PALACE OF ENGINEERING OLYMPIC WAY  
WEMBLEY MIDDLESEX TEL. 01-902 8381

An open letter to all our PO friends inviting them to use our new and extended workshop facilities for the production of mechanical and electrical telecommunication jointing aids.

We should be very happy to introduce our one-off and short production run manufacturing services to an even wider circle of PO engineers and trust that this letter will serve as our introduction to those with no previous knowledge of the firm: let us help if we can—it's our business.

ALF WESTWOOD,  
*Director*



**POST OFFICE  
APPROVED**

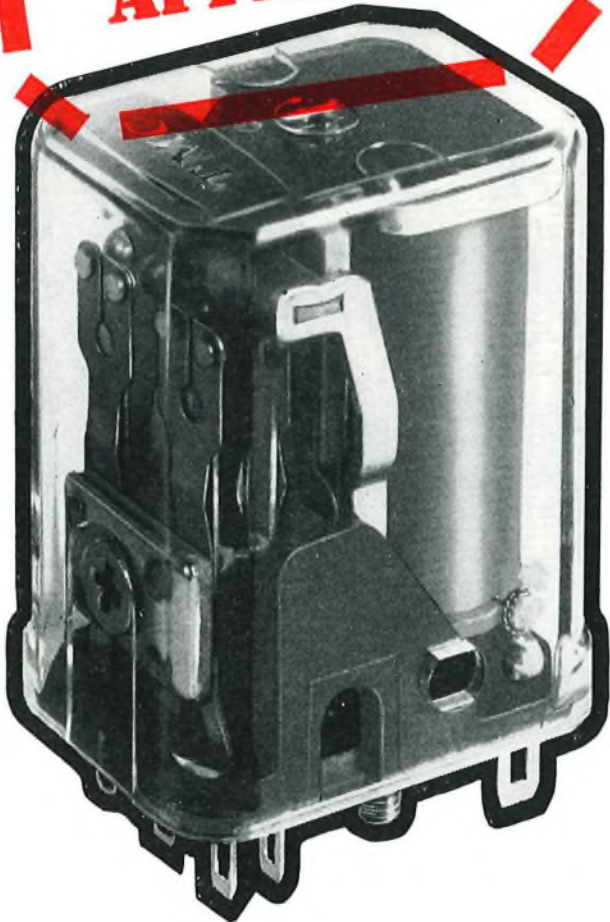

# RELIABILITY WINS APPROVAL FOR TMC RELAYS.

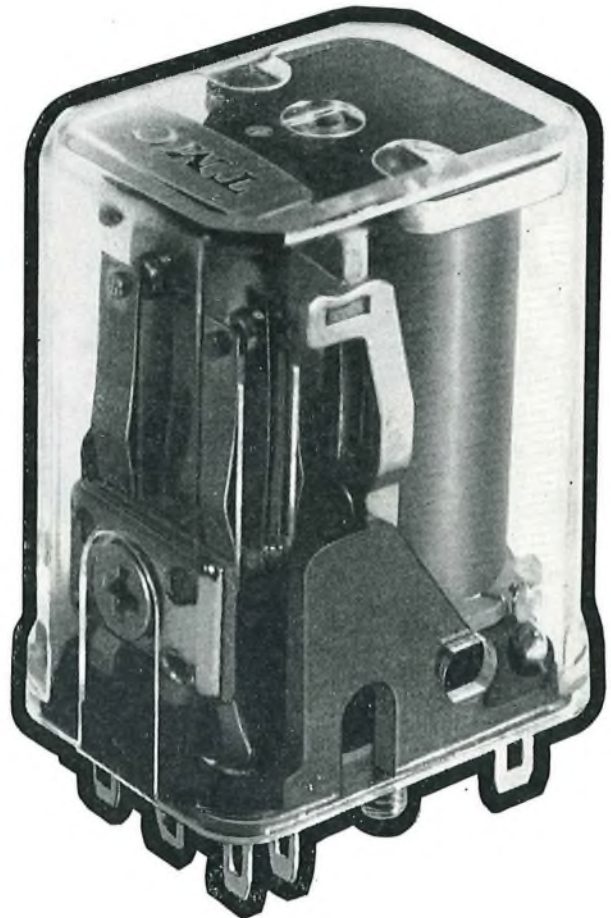

Built-in reliability. That's what you get with TMC Relays.

A reliable, fully bridged mounting base—it's specially designed to prevent base distortion and fracture around the fixing screw.

A reliable, positive location for the cover at the end of the yoke, so the cover can be simply and quickly removed. Or refitted.

Large contacts (bifurcated for the twin contact relay), with reliable, high contact forces and extremely long, trouble-free life.

TMC Relays are available now for quick delivery. For full details and free leaflets, write to:

**PYE TMC Ltd., Components Division,**  
Roper Road, Canterbury, Kent.  
Telephone: Canterbury (0227) 66041.

rely on **PE TMC**

# WHITELEY

**Telephone Mansfield 24762**

It makes sound sense to talk to Whiteley. Not only for audio but all signals from d.c. to r.f. Firstly we generate or transduce signals as you require. Then we make them louder, softer, squarer, pulsed, smoother or whatever to send down your wire or co-ax. We can ease the signals into the line. Boost them when they are weak, filter or re-shape. If they get lost we provide equipment to find them. At the other end we can reproduce them in quantity and quality. From packages that are attractive or rugged, attractively rugged, or, ruggedly attractive. The facilities and know-how are at Mansfield — come and sound us out.

## **FOR SOUND & SIGNAL CONTROL & MONITORING**

Field and Exchange test equipment, low frequency and high frequency cable location equipment, line repeaters, transmitter and receiver insets, attenuators, filters and rheostats.

**WHITELEY ELECTRICAL RADIO CO. LTD.**, Mansfield, Notts, England. Tel. Mansfield 24762  
London Office: 109 Kingsway, W.C.2. Tel. 01-405 3074



# Progress in Postal Engineering

## Part 2—Packets and Parcels

N. C. C. de JONG, B.SC.(ENG.), C.ENG., M.I.C.E., F.I.MECH.E., F.I.E.E.†

U.D.C. 656.88

*This is the second part of a three-part article on Postal Engineering which includes extracts from the author's opening address to the British Postal Engineering Conference of May, 1970. It surveys the development in organization and mechanization of the packet and parcel post services and the machinery used for handling mail in bulk.*

### PACKET AND PARCEL MAIL

The provision of economical and reliable packet and parcel services is of considerable importance to the national economy. In this market the Post Office competes with other businesses engaged primarily in the transport and distribution of goods. The organization of collection, sorting, despatching and delivery follows broadly similar lines for letters, packets and parcels. There is, indeed, a continuum of size and shape of items to be transmitted from one point to another and the subdivision into the three categories is a postal invention adopted for economic and practical reasons. For the purpose of mechanization, letters are defined as Post Office Preferred (POP) size envelopes (or postcards).<sup>1</sup> Packets are any other items for which letter postage rates are paid, including envelopes other than of POP size. Parcels (limited to 10 kg) are generally larger, heavier items than packets. Because of their size, they must be handed in over a Post Office counter or collected in bulk. The postage is less because delivery usually takes longer.

Thus there is a complication that packets are charged at letter rates and have to be integrated with the letter traffic; whereas for handling purposes most are similar to parcels. Numerically, parcels (200 million items per annum) constitute less than 2 per cent of the other mail posted (11,500 million letters and packets per annum). The total weights are, however, the same, namely 450,000 tons per annum each. Packets (that is items which cannot be handled on the letter-sorting machines) are about 17 per cent of the "letter" mail. The physical variety of packet and parcel mail makes complete mechanization uneconomical and would, in any case, be difficult to achieve. The appendix shows some of the parameters measured in a sample survey. A wide variety of materials is indicated but the proportions and materials are continually changing as technology develops.

### HISTORY

In the earliest stage of mechanization, manual parcel-sorting was assisted by the use of chutes or conveyor belts for the distribution of mail around the office. This was followed by the invention of sorting machines. The first successful machine comprised a series of moving, openable buckets; it was developed by Sovex, and installed for a trial at Paddington in 1936. Other such installations have been operating in Leeds since 1959 and in London Western District Office since 1965. Another type of parcel-sorting machine, known as the Tray-

Operated Parcel Sorting Installation (T.O.P.S.I.) was designed by the Post Office and operated at Bristol. These machines were not accepted for general use and were overtaken by the Australian concept of the tilted-belt parcel-sorting machine. This has been extensively developed in this country and is now our present standard. Over 70 are in use or are currently being installed. It will be described in a later paragraph.

Whilst code marks could be put on to packets and parcels, automatic facing and reading, and therefore subsequent automatic sorting, is not yet feasible. Mechanization is consequently limited by the need for a man to read the address at each sorting stage but can provide mechanical distribution of the item to the despatching point. The lighter items, i.e. the packets, are manually sorted into selection boxes which are emptied automatically. The sorting of parcels, however, is effected mechanically after the sorter has pressed a key to signal the destination to the machine control system.

At the same time as packet and parcel handling machines were being developed, other changes were taking place in associated fields; the shipping lines were introducing their network of ISO container services; the railways started their Freightliner services, and pallet handling became fashionable. With these new techniques it became obvious that service advantages of reliability and reduced handling costs could be obtained by concentration of traffic on to fewer, and hence larger, offices. The larger scale of operation results in economies. This concentration leads naturally to a new system based on the use of containers and the design of purpose-built offices having a multiple of sorting machines with combined outputs.

The most recent example has been the building and equipping of the Peterborough office which, under a single "package" contract, has been completed in record time. Fig. 6 shows, diagrammatically, the mechanized equipment installed there.

### PARCEL POST PLAN

At the present time, parcel sorting is performed in about 1,200 offices. These offices are not fully interconnected by mail transport routes but considerable numbers do arrange direct connexion. It is not unusual for a large office such as Birmingham to have around 500 direct dispatches, some carrying only a few parcels. A systems plan is being implemented to concentrate the work of sorting parcels on to 30 offices. This network of offices will be fully interconnected and the majority of routes will carry many tens of thousands of parcels daily. Each Parcel Concentration Office (P.C.O.) will sort once only, whereas under the present scheme more than one sort is required in each office. (No one sorter could

† Director of Planning and Mechanization, Postal Headquarters.



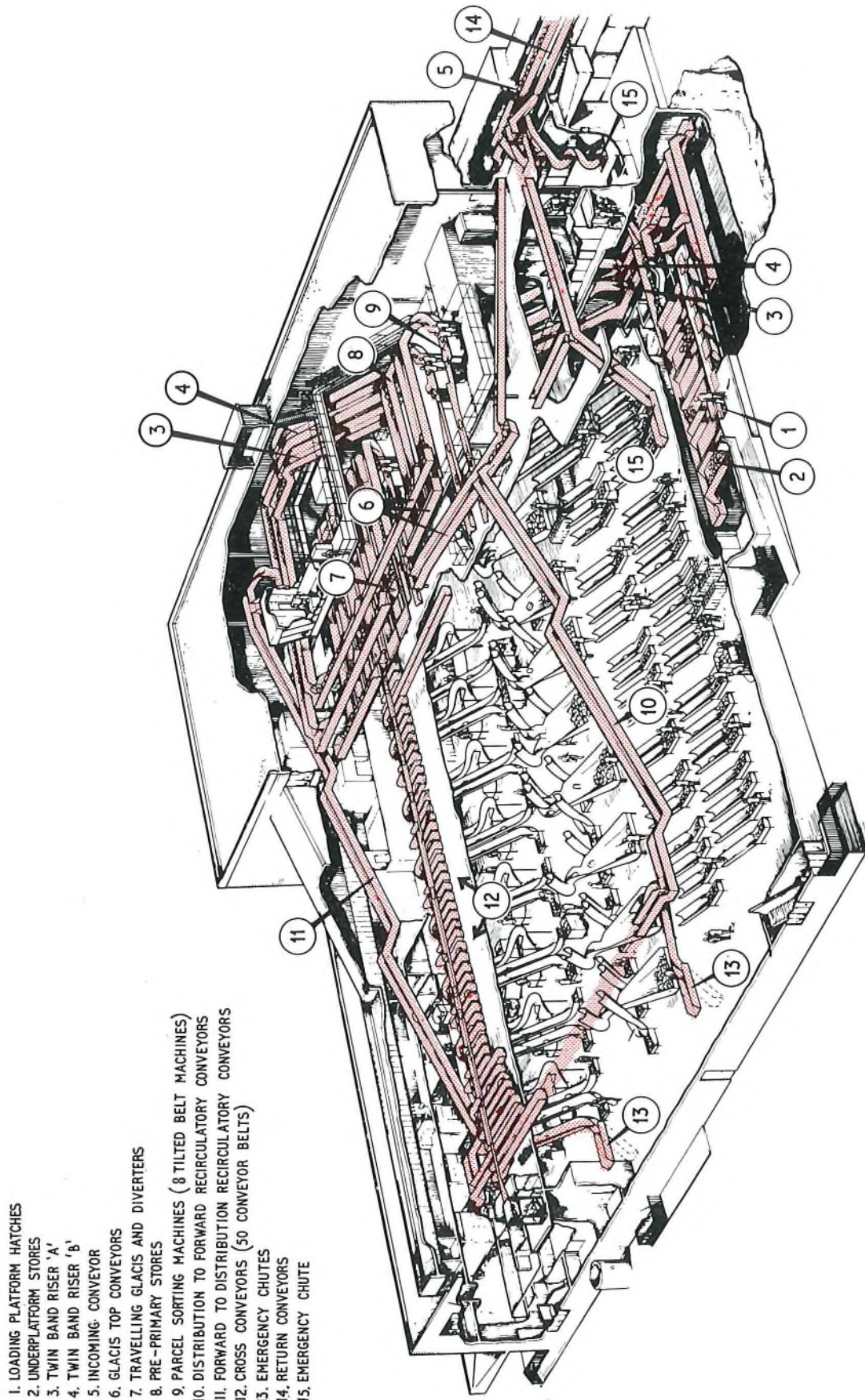

- 1. LOADING PLATFORM HATCHES
- 2. UNDERPLATFORM STORES
- 3. TWIN BAND RISER 'A'
- 4. TWIN BAND RISER 'B'
- 5. INCOMING CONVEYOR
- 6. GLACIS TOP CONVEYORS
- 7. TRAVELLING GLACIS AND DIVERTERS
- 8. PRE-PRIMARY STORES
- 9. PARCEL SORTING MACHINES (8 TILTED BELT MACHINES)
- 10. DISTRIBUTION TO FORWARD RECIRCULATORY CONVEYORS
- 11. FORWARD TO DISTRIBUTION RECIRCULATORY CONVEYORS
- 12. CROSS CONVEYORS (50 CONVEYOR BELTS)
- 13. EMERGENCY CHUTES
- 14. RETURN CONVEYORS
- 15. EMERGENCY CHUTE

FIG. 6—Peterborough Parcel-Sorting Office (cut-away view)



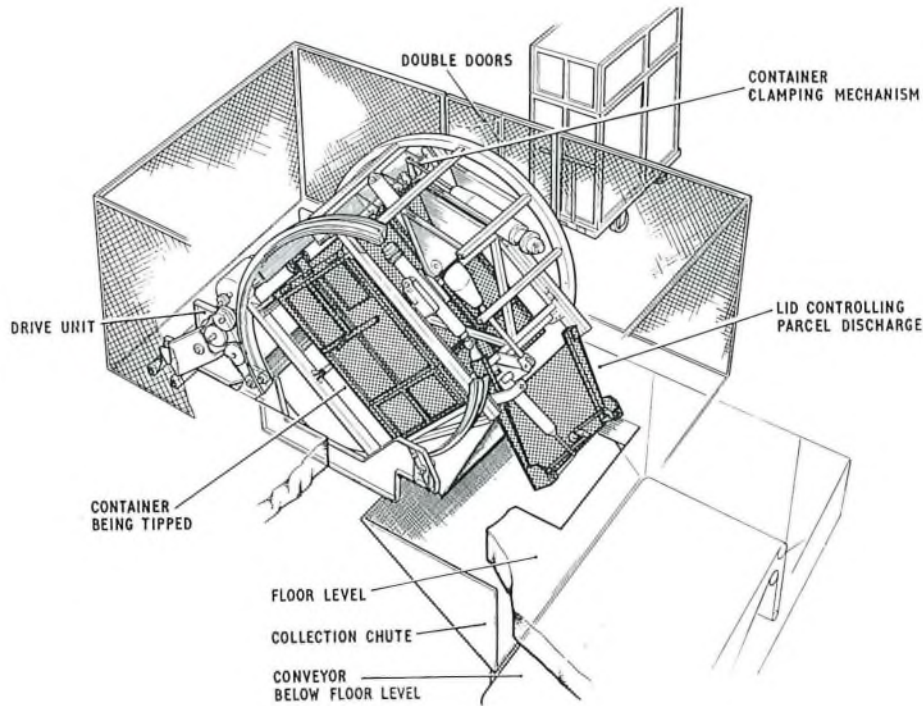

FIG. 7—Container Tipper

remember, or reach without walking long distances, all the high number of selections required to be made in the present system.) The degree of concentration can be judged by consideration of the mid-Thames areas, where parcel sorting was carried out in 22 offices and the work is now all concentrated at the Reading P.C.O. The new plan was proposed at a time when many buildings were to be replaced and the complete program should be implemented by 1980, capital resources permitting.

### CONTAINERIZATION

The cost of transportation, including loading and unloading, is a major part of the expenditure on the parcel service. The use of mailbags which contain, on average, only about five parcels each, contributes greatly to the cost. A research investigation of parcel handling indicated:

- (a) that for transport between P.C.O.s, the best container should be as large as possible, providing it was modular with the Freightliner and railcoach sizes,
- (b) that for distribution of parcels within the P.C.O. areas, there exists an optimum size of container at about 70 ft<sup>3</sup>,
- (c) that the moving of containers within sorting offices is most economically achieved by towing them in trains,
- (d) that containers should be emptied automatically,
- (e) that each container should be filled with the maximum number of parcels. This entails loading by hand at present as no machine can yet achieve a high enough packing efficiency.

The Post Office Universal Trailer Mk III<sup>2,3</sup> which has been developed, nearly meets the optimum requirements, and has been adopted as an interim standard. A new design, using new materials and carrying 15 per cent more parcels within the same external dimensions, is under development.

Two tipping devices for emptying the containers have been designed, one for emptying the parcels on to an underfloor conveyor, and the other to lift and tip the contents on to a conveyor 4 to 10 feet above floor level. It is necessary to control the discharge from the container if parcels are not to be damaged by excessive falls. Fig. 7 is a sketch of the tipper for emptying on to an underfloor conveyor and it shows the lid that controls the parcel discharge.

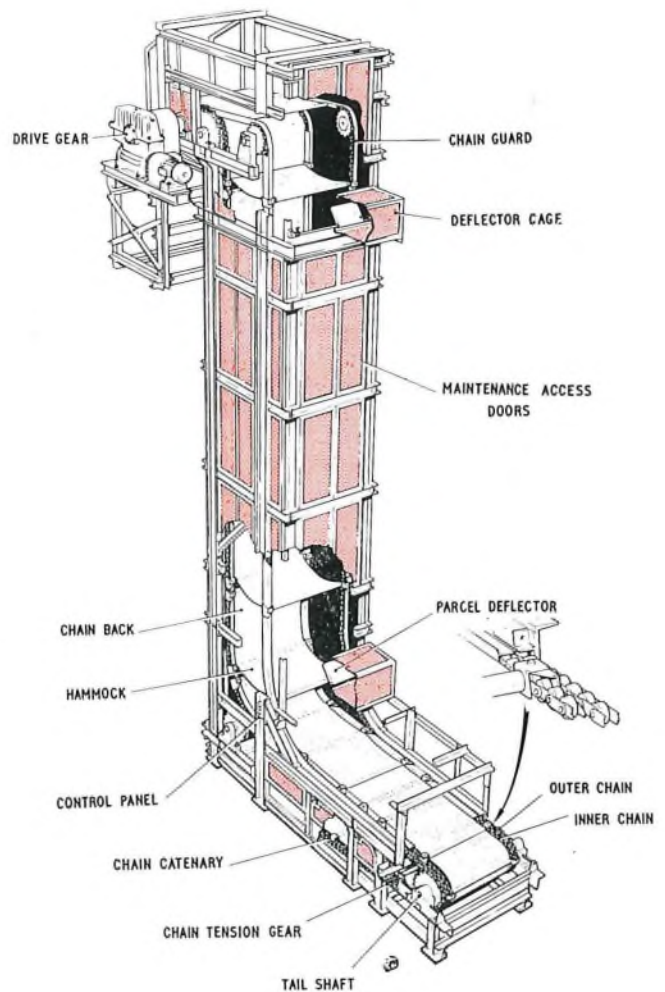

FIG. 8—Langton Elevator Conveyor



FIG 9—Tilted-belt Parcel-Sorting Machines at Worcester

#### PARCEL AND PACKET HANDLING MACHINES

Although containers will be used for large traffic flows, there will be areas of work in which there is only a small number of items to be handled (less than 100 parcels a day). Bags will continue to be used in these circumstances. Therefore, machines are required for moving either loose parcels, parcels in containers, or parcels in bags.

Loose packets and parcels or bagged mail can readily be moved on conventional belt conveyors, either horizontally or up an angle of  $15^\circ$ . If they need to be lifted between floors in a building, either a "Twin-Band Riser" or "Langton Riser" can be used. Machines used for handling packets are similar in principle to those designed for parcels, but narrower belts are satisfactory for the smaller items. The Twin-Band Riser<sup>4</sup> operates in the same way as a normal belt conveyor, but the mail is held against the carrying belt by a band, weighted with iron bars or cups, which passes over the top of the items. The maximum angle of lift is about  $60^\circ$  and this machine consequently sterilizes a larger floor area than is necessary for vertical uplift. The Langton Riser<sup>5</sup> permits the vertical lifting of loose or bagged items. This machine comprises a flat belt made up of over-lapping sections which are converted automatically into a number of hammocks to lift the parcels (see Fig. 8). Langton Risers giving an uplift of as high as 90 feet with a throughput of about 10,800 parcels per hour have been provided.

Although bags may be moved on machines similar to those used for loose parcels, it is more usual to hang the bags from a chain conveyor.<sup>6,7,8</sup> The Post Office operates these chains at up to 60 ft/min, about four times faster than the majority of factory chain-conveyor systems. Coding techniques are used to provide selective discharge of bags from the chains. There are locations when greater speeds are desirable, for example, where a long tunnel connects the sorting offices to the railway station. Experimental work is in hand on chain conveyors designed to run at 240 ft/min, a speed not yet achieved in any country. At this speed, chains cannot be loaded by hand and automatic pick-up devices have to be designed.

Where containers are needed on upper floors, conventional goods lifts can be used but more efficient specialized automatic

elevators are also used where justified. One such machine, based on an American design, is the "Vertiflow". This machine will handle 40 containers per hour, i.e. about 4,000 parcels per hour. This modified pallet elevator operates on the pater-noster principle, but the platform of the lift which carries the containers is moved into the vertical plane for the return path, to save space. The machine drive is reversed for lowering containers.

#### PARCEL SORTING MACHINES

The standard parcel sorting machine operates on the tilted-belt<sup>9</sup> principle. A photograph of the machine at Worcester is shown in Fig. 9. The parcels are carried on a belt moving at 180 ft/min; the belt is twisted so that at about 10 feet from the input it is running with its width at an angle of  $37^\circ$  to the horizontal. A side wall at right-angles to the belt prevents the parcels sliding off. This wall is sectionalized into a number of doors which may be opened on the command of the sorter. The sorter reads the address, decides the road into which the parcel should be despatched and presses a key to indicate his selection. When the parcel cuts a light beam at the input, the selected code is written into a memory store and the parcel is tracked along the belt so that the appropriate door is opened to release the parcel into the desired selection. The discharge may be into individual storage hoppers or the outputs from a number of parcel sorting machines can be accumulated on to cross conveyors. Although the regulations allow parcels up to three feet in length, a small percentage are found to be a few inches longer. A system of doors opening in three sections, allows the discharge of even these parcels on to cross conveyors that are spaced at only 2 ft 8 in pitch. Machines catering for up to 50 selections, requiring a conveyor length of 250 ft, are to be installed to handle the traffic under the Parcel Post Plan.

A belt speed of 180 ft/min gives a potential throughput of 2,700 to 3,600 parcels per hour depending on parcel size. Each sorter can average about 900 parcels per hour and, even if assisted by other men, their combined output will not



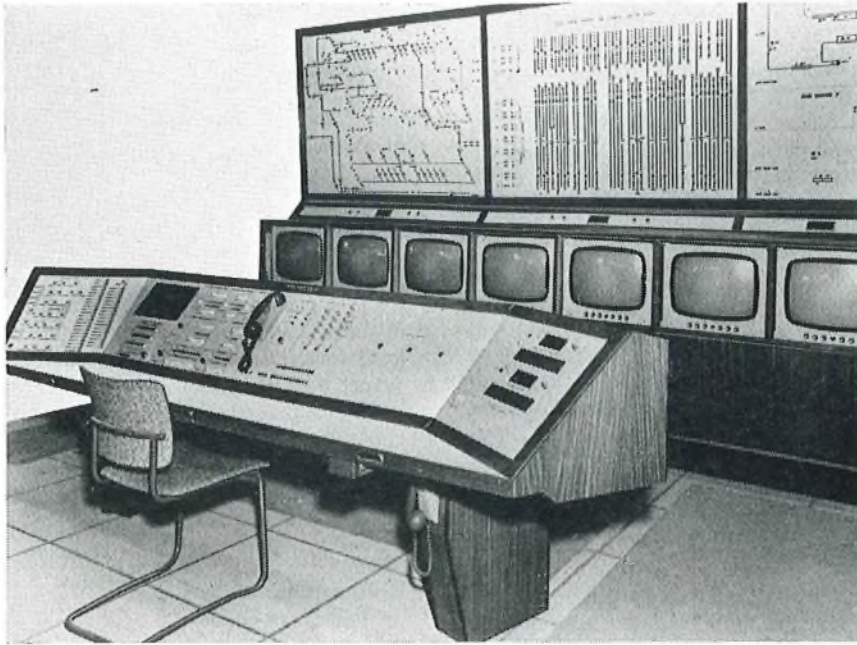

FIG. 10—Sorting Office Central Control at Birmingham



FIG. 11—Packet Sorting Machine at London Western District Office

fully load the machine. Experiments are being made with machinery to permit the work of two or three sorters to be fed to one parcel-sorting machine with the minimum of interaction between them. In this way, machine utilization can be increased. However, the economic advantage is offset by the high cost of the combining and additional control equipment.

Many installations have sorting machines controlled by a pinwheel memory system. A drum carrying rings of pins is rotated in synchronism with the movement of the sorting-machine belt. When the parcel cuts the light beam at the machine input, a pin is displaced to indicate the distance along the belt to the discharge door. A micro-switch detects the displaced pin and operates door actuators to open them at the correct time. Where there are many machines in one sorting office, it is

economical to control all the machines from one central electronic control unit.

#### Electronic Control of Machines

Computer technology will be used to form the basis of the control of future sorting machines. The installation of a number of machines in one building will permit time sharing of the control unit. Additionally, since the destination of each parcel is registered electronically as each parcel is sorted on the machine, it is easy to record any statistics needed. The numbers of parcels despatched on each route will be known; ultimately the machine could print the waybill for each train or van load.

## OFFICE CONTROL

In addition to control of the sorting process on the machines, a central control point in each office needs to be kept informed as to which machines are operating and how the work is flowing. Mimic diagrams indicate which conveyors and sorting machines are operating and closed-circuit television displays show the various parcel-storage points in the sorting office (see Fig. 10). Mobile radio equipment is used to inform controlling staff of vehicle arrivals and to advise them of the need to prepare despatches.

## PACKET SORTING

For mechanical handling, packets can be considered in two categories, the large flat letters (flats) and items of all other shapes. This has resulted in two lines of development because these different shapes pose different problems. The flats can be faced with their address a given way up and their facing retained for subsequent handling. However, light-weight flat items tend to float if thrown, making it difficult to toss them accurately into boxes. The reverse is true of the more chunky-shaped packet.

For sorting large letters, a machine called a slit sorter has been developed in Australia. A trial machine is in use in London at Mount Pleasant. The letters to be sorted are inserted into vertical slits and are carried along on edge by narrow belts at the bottom of the slits. The ends of the slits are fanned out to discharge the items into 24 stacks.

The packet-sorting machine at London Western District Office, which can be used for the sorting of packets of any shape, is shown in Fig. 11. The sorters have the packets delivered to them from a tilted distribution-belt. They read the address and toss the item into one of the 36 boxes. The pattern of 4 by 9 boxes is repeated along the length of the machine. The boxes are cleared automatically, in sequence, on to conveyors under the boxes. The machine shown has mechanically-linked clearing-mechanisms, but later machines have pneumatic control which permits more complex clearing-sequences, giving a more efficient use of the clearing conveyors.

## CONCLUSION

The mechanization of the letter post (to be described in part 3) will result in much heavier concentration of packets. This justifies reconsideration of the problem of mechanizing their handling and sorting processes. An operational research program is in progress and will deal with these and all other aspects of the packet service.

The design of mechanized parcel-handling equipment is well advanced and the new equipment will take over much of the heavy labouring work. There will be a continuing increase in the use of electronic devices (computers, television etc.) in the P.C.O.s of the future. The reliability of the machines, both in terms of failure to operate and errors in sorting, will at least match that of the manual operating standards. The Parcel Post Plan will simplify the system and should result in reduced operating costs from 1975 onwards. The use of containers in the simplified system will reduce parcel damage. Thus, from the point of view of our customers, mechanization of the parcel post should mean that the costs, in real terms, will be reduced and a more consistent level of service maintained.

(to be continued)

## References

- 1 Post Office Guide.
- 2 CLINCH, C. E. E. Containers for Transporting Mail, *P.O.E.E.J.*, Vol. 62, p. 20, Apr. 1968.
- 3 SLATFORD, J. M. Containerization for parcel and bulk mails in the Post Office *I.Mech.E. British Postal Engineering Conference*, May 1970, Paper No. 5.
- 4 WILKINSON, A. J. Twin-band rising conveyor. *I.Mech.E. British Postal Engineering Conference*, May 1970, Paper No. 10.
- 5 WHITTINGTON, K. W. H. The Langton Riser. *I.Mech.E. British Postal Engineering Conference*, May 1970, Paper No. 25.
- 6 SMITH, W. J., and ROGERS, J. D. Chain Conveyors in Postal Engineering, *P.O.E.E.J.*, Vol. 51 p. 53, Apr. 1958.
- 7 SMITH, W. J. Chain conveyors for the transport of mail in bags. *I.Mech.E. British Postal Engineering Conference*, May 1970, Paper No. 43.
- 8 BRACKSTONE, R. L. Coding for selective discharge from overhead chain conveyors. *I.Mech.E. British Postal Engineering Conference*, May 1970, Paper No. 19.
- 9 CASTELLANO, E. J. Tilted Belt parcel-sorting machine. *I.Mech.E. British Postal Engineering Conference*, May 1970, Paper No. 6.

## APPENDIX

TABLE 1  
PACKETS

Summary of characteristics from Sample Survey

Shape	per cent	Wrapping	per cent	Binding	per cent
Rectangular .. ..	63.92	Paper .. ..	82.44	Paper tape .. ..	60.62
Soft rectangular ..	26.20	Card .. ..	16.60	Sellotape .. ..	26.20
Cylindrical .. ..	6.31	Sacking .. ..	0.55	String .. ..	10.14
Flat (<0.1 in thick) ..	1.92	Waxed paper ..	0.27	Plastic string ..	2.05
Soft cylindrical ..	1.65	Plastics .. ..	0.14	Polythene tape ..	0.41
				Wire .. ..	0.28
				Canvas tape ..	0.28
				Other .. ..	0.02

Size	Minimum	Mean	Maximum
Length (in)	2.75	10.02	24.5
Breadth (in)	0.5	5.77	12.75
Thickness (in)	0.1	1.47	4.5
Weight (lb)	0.1	0.688	2.75



TABLE 2

## PARCELS

Summary of characteristics from Sample Survey

Shape	per cent	Wrapping	per cent	Binding	per cent
Rectangular .. ..	80.78	Paper .. ..	62.85	Paper tape .. ..	38.77
Soft rectangular ..	14.86	Card .. ..	36.34	String .. ..	29.60
Cylindrical .. ..	3.55	Sacking .. ..	0.32	Sellotape .. ..	13.40
Soft cylindrical ..	0.81	Plastics .. ..	0.32	Plastic string ..	9.85
		Wood .. ..	0.16	Wire .. ..	6.78
		Other .. ..	0.01	Polythene tape ..	0.80
				Canvas tape .. ..	0.6

Size	Minimum	Mean	Maximum
Length (in)	5	15.19	40
Breadth (in)	2.5	9.54	20
Thickness (in)	0.25	4.85	13
Weight (lb)	0.5	5.649	22

## Book Review

"Electrical Engineers and Workers." P. W. Kingsford. Edward Arnold (Publishers) Ltd. pp 268. 20 ill. 30s. (paperback 18s).

Authors of early text-books of electrical technology frequently approached their subjects in a leisurely fashion along historical lines. Rapid technological progress, however, soon made it essential to devote the whole of the available space to the exposition of current principles and techniques. Vestiges of history remained only in the eponymous terms adopted for various units and items of equipment, and historical studies became mainly the concern of specialists.

The desirability, however, of providing students of science and engineering with information on the historical background to their studies is now recognized. Dr. P. W. Kingsford's "Electrical Engineers and Workers" is intended for students taking courses for Electrical Technicians and for National Certificates in Electrical Engineering, but a wider readership is also envisaged, ranging from school to degree students. It is concerned with "the contribution which scientists, electrical technologists and workers of all sorts have made to the present industrial society of Britain". Separate chapters are devoted to the work of the bearers of some of the more familiar names associated with early electrical science, the telegraph, the first Atlantic cables, the telephone, light and generation, radio, broadcasting, television and radar. To this Dr Kingsford adds a description of early working conditions, and the rise and development of trades unions within the electrical industry.

The difficulty of covering such a large field in the space of 250 or so pages of text will be apparent; the problems of selection and organization of material alone are considerable. Dr Kingsford's method is to describe some of the principal developments in electrical technology in a series of biographical accounts of the personalities concerned. The choice of names is, in the circumstances, bound to be a little

arbitrary. Whilst, for example, William Gilbert, Luigi Galvani, Alessandro Volta, George Simon Ohm and Michael Faraday receive the full biographical treatment (with dates), Coulomb, Ampère and Oersted get only passing references: we look in vain for any mention of Gauss, Henry, Weber *et al.* Inevitably also, not everyone will agree with the relative amounts of space accorded to the chosen few. Thus, in this respect, the importance of Claude Chappe's semaphore in the development of "the present industrial society of Britain" seems somewhat exaggerated. Similarly, although no doubt, as a promoter of the first Atlantic cables, Cyrus W. Field is entitled to his niche, the successful conclusions of these enterprises were largely the result of the engineering skill of Sir Charles Tilston Bright, who is not mentioned.

Another problem in a book of this kind is at what point in time to stop, and here one feels that Dr. Kingsford has sometimes drawn the line a little prematurely. The chapter devoted to the telephone, for example, more or less begins and ends with Alexander Graham Bell. But perhaps the intention is to whet the appetite for the additional reading matter thoughtfully listed at the end of each chapter.

One of the few references to modern equipment, the description of the teleprinter at the end of Chapter Two, needs clarification. What is a "Band code employing five digits"? It should also be noted that the Telex service is not confined to Europe.

The lives of the pioneers of electrical engineering were marked by a uniform tenacity of purpose in the face of many daunting difficulties and discouragements. With the help of extracts from correspondence and personal accounts, Dr. Kingsford ably conveys their spirit of dedication. His readers will find his account an interesting and enlightening adjunct to their formal studies.

D. A. J.

# A New Concrete Tower for Purdown Radio Station

G. BIRCHBY, C. ENG., M.I.STRUCT.E.† and R. L. MOXON‡

U.D.C. 624.97: 621.396.67

*The new Purdown radio tower caters exclusively for aerials of the parabolic-dish type rather than for a mixture of horn and dish aerials, and this has permitted considerable reduction in the tower core diameter as well as the incorporation of more aerial galleries that closely match aerial heights to the optimum value for propagation. The operational facilities of the new tower are described; some account is also given of the need to safeguard services on the existing steel tower during the construction and changeover period. Main features of the structural design are outlined and the method of construction of the tower is described.*

## INTRODUCTION

Since it was established in 1961, the radio site at Purdown, in Bristol, has become an important terminal and repeater station in the microwave radio-relay network, carrying telephony and television circuits from Bristol to London, South Wales, Goonhilly and Plymouth. Work will start shortly on a new radio link from Bristol to Birmingham, and the channel capacity of the Bristol-London link is being increased for the third time.

It is planned that, by 1972, the Purdown station will be carrying about 18 television and 20,000 telephony channels. This rate of growth is in excess of the original forecast to the extent that the lattice-steel tower at present used to support aerials has already reached the limit of its capacity, although it has been heightened and strengthened as far as practicable. To meet the scheduled expansion and to cater for future growth, a new tower is needed.

Purdown is a prominent hill about 280 ft above mean sea level, within 3 miles of Bristol centre, and is visible from many parts of the city; it was thus important to choose carefully the form of the new structure to be added to the skyline. Of the designs submitted, the ferro-concrete tower described in this article was preferred by the Bristol City Council; it was also approved by the Royal Fine Arts Commission.

## COMPARISON WITH EARLIER FERRO-CONCRETE TOWERS

### Accommodation of Radio Equipment

The microwave network already incorporates some ferro-concrete towers, notably the London Post Office Tower<sup>1</sup> and the Birmingham Tower.<sup>2</sup> These particular examples are unusual in being designed to accommodate radio equipment at a high level within the tower itself, an arrangement made necessary by the great aerial heights needed to achieve radio paths unobstructed by tall buildings in the conurbations. A cheaper and more adaptable arrangement, used almost everywhere else in the network, houses the radio equipment in an extendable standard building at ground level, with the aerials supported at more modest heights on an adjacent steel or concrete tower. The aerials are connected to the radio equipment by waveguide feeders of acceptable length and loss. Wotton-under-Edge and Stokenchurch are examples of radio stations of this type having ferro-concrete towers<sup>3</sup> with separate equipment buildings.

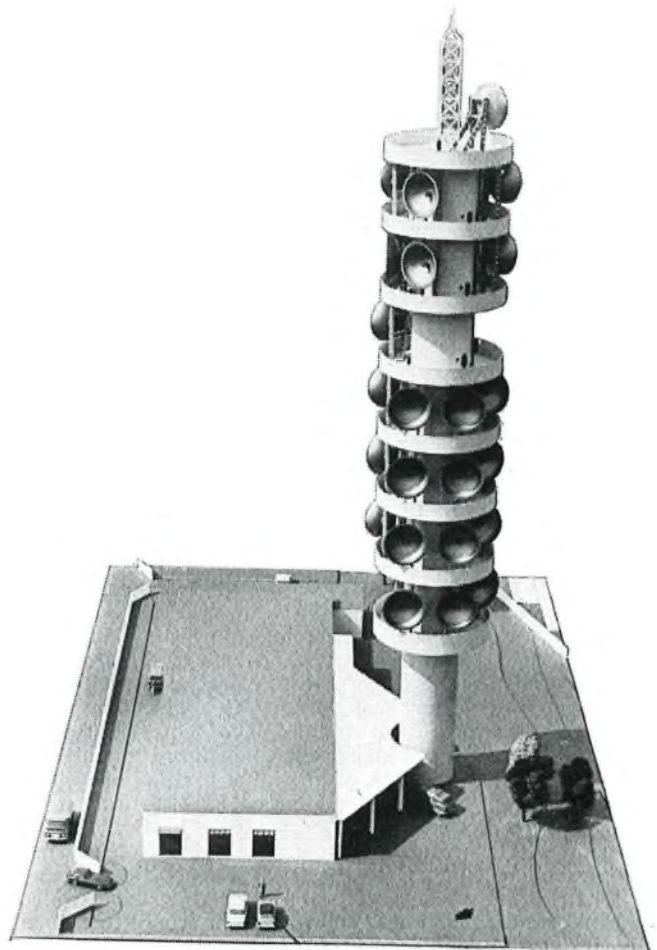

Fig. 1—Model of the new Purdown tower showing waveguide canopy and ultimate aerial development

For the new tower at Purdown (Fig. 1), a compromise solution has been adopted. The majority of the radio equipment will continue to be housed at ground level, and for this purpose the floor area of the existing apparatus building has been doubled. At the same time, the tower has been designed so that, without increasing its initial cost, it could in future house some radio equipment within the core, adjacent to the aerial galleries. This facility may be advantageous in exploiting the 11 GHz frequency band, for which losses per unit length of feeder are several times greater than, for example, at 6 GHz.

† South West Regional Headquarters, Ministry of Public Building and Works.

‡ Network Planning Department, Telecommunications Headquarters.



## Supersession of Horns by Dish Aerials

Earlier concrete towers such as those at Wotton-under-Edge (Fig. 2) and Stokenchurch radio stations were designed primarily to accommodate horn aerials and their associated circular waveguides, a requirement which largely dictated the



Fig. 2—An earlier type of ferro-concrete tower at Wotton-under-Edge radio station

physical form of the towers. At that time (circa 1960) the performance of horn aerials was greatly superior to that of dish aerials in respect of gain, angular discrimination and the ability to carry orthogonally-polarized signals on one device simultaneously in two or more frequency bands (e.g. 4 GHz and 6 GHz).<sup>4,5</sup> A circular waveguide was necessary to make best use of the horn-aerial performance, with the guide having to be run in a straight line vertically downwards from the base of the horn. Thus, guides from horns on the higher aerial galleries had to pass among aerials on lower galleries, limiting the number of usable galleries and requiring critical layout planning to fit the ultimate complement of aerials and feeders into the available space. This arrangement had the disadvantage that the aerials were grouped at the top of the tower at a height fixed by the requirements of only one propagation path; transmission in all other directions was thus subjected to unnecessary loss.

Below gallery level, the tower core-diameter was increased to encompass the circular waveguides, not only to protect the guides but also to give safe access to them and, not least, to improve the appearance of the structure. However, this feature resulted in a tower-core diameter of 32 ft, widening at the base to 45 ft and giving a generally heavy appearance to those towers having only moderate height.

Dish aerials have now been developed to the point where some designs approach the performance of horn aerials in

all respects except effective frequency range. Two dish aerials are usually needed to replace one horn and, for bi-polar operation, two rectangular or elliptical waveguide feeders per dish are normally required, such feeders having greater loss than circular guides. The excellent electrical performance of the horn has, however, been found in practice to be offset by the high cost, in time as well as money. Installation and alignment of a horn system with circular guide and branching filters, and the potentially large loss of traffic capacity in the event of failure of, or damage to, a single device are the main factors. Dish aerials have advantages of economy and reliability together with much greater ease of replacement in the event of fault or damage, and for these reasons it was decided to use them exclusively on the new Purdown tower.

## Provision for Waveguide Runs

At or near the base of the earlier towers, inside the core, each circular waveguide was connected to up to four rectangular guides at the band branching unit. These rectangular guides, together with guides from any dish aerials, were routed horizontally into the apparatus building through ports in the tower wall. The concentration of a large number of guides in the ports, coupled with the need to leave adequate access for maintenance has led to difficulty in layout and, in some instances, has resulted in an undesirably large number of bends and some unavoidable increase in the length of the horizontal waveguide runs.

On the new tower, waveguides are run from the aerial galleries, down the outside of the tower core through slots in the aerial galleries. Placing the guides in this manner has avoided problems of structural design that would otherwise have arisen in making provision for guides to enter the slender core at gallery level and leave again near ground level. At the same time, the space inside the core has been left available for other use. The guides are arranged in a single layer close to the core, thus giving good access and having minimal effect on the appearance of the tower whilst also achieving short runs with the least number of bends.

## FACILITIES PROVIDED BY THE NEW TOWER

### General

Removal of the constraints imposed on tower shape by the need to carry horn aerials afforded the opportunity to design a structure most suited to dish aerials; the result was the tower shown in model form in Fig. 1. The concrete core, or shaft, of the actual tower is parallel-sided, the external diameter being 18 ft. There are eight aerial galleries, spaced at 20 ft intervals at heights from 50–190 ft above ground level; this permits aerials to be mounted close to the optimum height for propagation on each line of shoot.

The model is equipped with the ultimate forecast complement of 31 dishes. Each dish is 12 ft 6 in in diameter in practice, and there is contingency space for a further 17 dishes, i.e. up to six on each gallery. The gallery diameter is 36 ft and is the minimum necessary to accommodate two dishes side-by-side on the same line of shoot with minimum permissible horizontal spacing of 15 ft between dish centres. Fig. 1 shows four such co-planar pairs of aerials on the four lowest galleries. It will be seen from the model that the dishes protrude only slightly outside the gallery diameter, and this was considered to be desirable so that the tower silhouette should not be greatly changed in appearance by addition to, or modification of, the aerial complement.

The tower has a finial consisting of a lattice-steel mast, 5 ft square and 30 ft high, giving an overall height of 220 ft to the bottom of the lightning spike; this mast has functions, other than aesthetic, which are described later. Towards the left of the base of the tower can be seen the reinforced-concrete canopy which serves to integrate visually the tower



and the apparatus building. This canopy carries, in a single layer on its underside, the waveguides, which leave the building through windows at about 11 ft above ground level.

### Aerial Mountings

It was desired to have a standard arrangement for mounting aerials on the galleries. As vertically-running waveguides could occupy an arc of up to  $180^\circ$  on the surface of the core, core bands could not be tolerated; tripods or other floor mountings would unnecessarily clutter the limited gallery floor-space and generate high overturning moments. The solution adopted was to mount each aerial on a pair of castellar beams, each approximately 12 in  $\times$  5 $\frac{1}{4}$  in  $\times$  20 ft, fixed vertically between galleries. Installed beams and aerials are visible on galleries 1 and 6 in Fig. 3. The beams are fixed to the floor and ceiling by expanding bolts placed in holes drilled when needed into the concrete, sufficient redundancy of reinforcement being incorporated in the gallery concrete decking to permit random drilling.

Each gallery deck is supported by 12 reinforced-concrete ribs radiating from the core; the ribs have cast-in holes for use where aerial mountings must be fixed to them. The presence of the radial ribs has given a particularly simple method of marking the fixing-hole positions for a given line of shoot; as the orientation of the ribs is accurately known, the floor may be marked for drilling by ordinates drawn from the rib centre-lines.



Fig. 3—Tower almost complete, with aerials mounted on first and sixth galleries

It was essential to avoid the generation of excessive stresses that could arise in the galleries, because of the presence of the castellar beams, when the tower sways; this was achieved by including a simple hinged link in the upper beam attachments; the link also conveniently absorbs dimensional tolerances in gallery spacing and beam length.

### Accommodation of Waveguides

Accommodation has been provided for flexible elliptical waveguides, coaxial cables and rigid rectangular guides. For the horizontal portion of the run, from the apparatus building window to the bottom of the tower, each suite of equipment racks has a pre-determined position for its waveguides, which fan, in a single horizontal layer, on the underside of the ferro-concrete waveguide-canopy. Space between canopy and tower core allows flexible guides and coaxial cables to turn, with bending radii greater than their permissible minima, on to the outside of the tower core, where they run vertically in a single layer, again in a pre-determined position for each suite, to the required aerial gallery level; rigid rectangular guides may be run in the same way. Thus, crossing of guides and changes of level or position are not needed on the horizontal or vertical runs where guides are most concentrated. Under the canopy, the guides are clamped to bearers attached, as required, to a pattern of cast-in sockets. On the tower core, guides are fed through the most appropriate of a set of six slots in each gallery floor; the slots are about 4 ft wide and 15 in deep, and occupy altogether an arc of  $180^\circ$  round the core.

When it has risen to the required aerial-gallery level, each guide is run from the slot to the aerial, being supported *en route* by floor-mounted tubular-steel supports, made up on site as needed, care being taken to fix the supports clear of future aerial-mounting positions.

Up to six dishes may be mounted on any one gallery and these may be fed by up to twelve waveguides; there is ample space to route this number of guides from slots to dishes.

The arrangements described above will facilitate the installation of waveguides having the shortest possible length of run and with fewer bends than in former practice. Upwards of 60 guides can be installed in a single layer on the canopy and tower core. This should suffice for the ultimate forecast aerial complement, though the number of guides could be doubled, with some sacrifice of easy access, by utilizing a second layer.

### Lifting Facilities for Aerials and Feeders

Once services have been transferred from the old to the new tower, lifting facilities will be required only infrequently, perhaps once or twice per year. A simple form of derrick with hoisting by means of a trailer winch at ground level was therefore provided. Post Office rigging gangs are already equipped with such winches.

The derrick takes the form of an "A" frame which is stored on the top gallery and which can be erected on any required bearing by means of built-in floor mountings permanently bonded to the tower earth-system. Slewing facilities have not been provided, but luffing is accomplished by means of a Tirfor cable-puller using the lattice mast as a convenient king post, the luffing operator standing on a small platform inside the lattice mast. Maximum reach is 6 ft outside of the gallery edge.

The derrick has a maximum lifting capacity of 25 cwt. The normal maximum load would be a dish aerial complete with its panning frame, weighing about 15 cwt. The derrick may also be used to suspend a man requiring access to the front of an aerial.

Waveguide slots in the gallery floors have a radial depth of 15 in and thus give adequate space for hoisting Flexwell guides and cables. A pulley sheave for lifting guides has been provided, which clamps simply to any of the reinforced concrete "toe-board" upstands surrounding the slots in the gallery floors.



## Access Facilities

It is intended that access to the aerial galleries should be restricted to trained rigging staff and, for this reason, vertical scaling ladders have been provided inside and outside the tower core. For security, only an internal ladder has been provided from ground level to the first gallery at 50 ft, this ladder having two intermediate rest platforms for ease of climbing. The lockable door into the core at ground level is of sufficient size to permit the passage of personnel or an equipment cabinet or rack.

At each gallery level, access doors through the concrete shaft have been constructed similar to those used for ships' bulkhead doors, with neoprene seals and shoot bolts operated from both sides by means of a wheel and rack-and-pinion gearing. Adjacent to the doors, circular apertures are provided; these are conveniently closed by means of ships' port lights. These apertures may be used for cables to operate power tools on the aerial galleries or for the passage of cables for outside-broadcast equipment. At the same time, they provide sufficient natural light to the inside of the core to give safety in the event of a failure of the electric lighting.

## Provision for Elevated Apparatus Rooms

There is no initial requirement for elevated apparatus rooms, but the eventual need has been catered for, and the internal floors at gallery levels are each adequate to support a room containing about eight apparatus cabinets. A lift would be essential for installation of equipment and for the use of maintenance staff; a self-climbing type would be suitable, eliminating the need for a motor room. Normal access to such an apparatus room would be by means of the lift, though in an emergency the scaling ladders could be used; however, riggers could use the internal and external scaling ladders without having to enter the apparatus rooms.

Care has been taken to make the tower core weather-tight. Experience with earlier ferro-concrete towers has shown that the atmosphere inside the core has a relative humidity approaching 100 per cent; this is attributed to condensation and ingress of water vapour through the concrete walls and is aggravated by imperfect ventilation. Positive ventilation is being provided for the new tower by means of an air-drying plant of 10,000 ft<sup>3</sup>/h capacity, installed at ground level and controlled by a humidistat. A slight air-pressure and temperature rise will be generated by this machine within the core, thus assisting natural convection and causing air to vent from a scuttle ventilator installed in the tower roof.

The walls of the elevated apparatus rooms would be formed of fireproof insulation-board, leaving space at the sides adjacent to the core for circulation of dry air. In this way it is expected that problems of humidity and heat dissipation would be minimal.

Ducts have been provided in the tower foundations for a.c. and d.c. power and for transmission cables, these ducts terminating in a chamber in the floor of the apparatus building.

## LIGHTNING PROTECTION

It was decided that the tower, regarded as a structure, should have its own earthing protection, independent of existing arrangements at the radio station. For this purpose, four earth-rods were driven beneath the foundation block and are connected to the steel reinforcement at approximately the four cardinal points. Just below ground level, the tower earth-system is connected to the radio station earth-system and to a peripheral buried tape, by conductors of heavy gauge to ensure that the entire installation maintains a common potential in the event of a heavy current-surge from a lightning strike.

The tower reinforcement-steel has ample cross-sectional area and has therefore been used as the lightning conductor, by suitably welding the reinforcing bars, welded-on screwed

studs being provided at gallery levels for earthing aerial-mounting steelwork and waveguides. The lattice-steel mast surmounting the tower carries a lightning spike and itself constitutes a means of providing a "cone of protection" for equipment mounted on the top gallery.

## MAINTAINING SERVICE DURING CHANGEVER FROM OLD TOWER

One of the advantages of a slender-cored ferro-concrete tower is the small area occupied by the core at ground level compared with the area needed for a lattice steel tower of similar aerial-supporting capacity. Because of the compact plan of the new tower at Purdown, it has been possible to avoid serious obstruction of existing lines of shoot while simultaneously placing the new tower in a position giving short waveguide runs to apparatus in the original and extended parts of the apparatus room. With a less favourable site layout or with a new tower having a greater spread in plan, it would be necessary to erect a temporary aerial tower, clear of obstruction, to maintain service during the construction period.

The site layout at Purdown was also favourable in that it permitted the construction of a new access track remote from the original one, thus obviating risk of damage to services from construction works; the construction area was, in fact, fenced off from the existing tower and station.

The greatest risk to services occurred during excavation for the new tower foundations. The edge of this excavation encroached upon the foundation blocks of one existing waveguide gantry, but this was safeguarded by welding its stanchions to heavy steel joists, cantilevered from the old tower foundations, to provide an alternative support.

## STRUCTURAL DESIGN

The overall diameter of the tower was conditioned by the need to accommodate a stated number of microwave dish aerials on the external galleries; these galleries were required to provide a 9 ft usable space beyond the tower-shaft core to the external edge. Structural considerations necessitated a shaft core with an external diameter of 18 ft, this resulting in overall diameter of 36 ft. Foundation considerations were based on a safe bearing pressure at excavated level at 2 tons/ft<sup>2</sup>, and the proximity of a recently-extended station building.

The design wind velocity was ascertained from the Meteorological Office as being 120 m/h for a 3-second gust, this being the highest wind velocity expected in a period of 100 years.

In addition to the site and user restrictions, the tower had to satisfy the normal stability requirements: these were dead loads from tower and equipment, overturning moments due to wind loading on projected faces and oscillation due to sequential vortex shedding. The resulting base diameter, taking into account vertical and horizontal forces, was required to be 56 ft. It was decided to make the base of cellular form, with the object of utilizing the fin walls to dissipate the forces occurring in the tower shaft at ground level into the base slab and to form, incidentally, a series of compartments into which would subsequently be placed compacted material of known density.

With a shaft diameter of 18 ft, it was found that wind-excited oscillations of the shaft would occur at a steady wind speed of approximately 78 m/h, i.e. lower than the maximum forecast by the Meteorological Office for this area. This being so, provision would have had to be made for a damping system to be incorporated during building, should the shaft be constructed without galleries.

However, the obvious choice of material for the galleries was concrete so that, as far as possible, it would be maintenance-free. The galleries could, therefore, be constructed concurrently with the shaft, thereby obviating the oscillation problem by utilizing them as an integral damping system. The

galleries were provided with a 1 in fall from the tower core face to facilitate rapid drainage of rainwater. Drainage holes were provided at the perimeter of the galleries. Internally, at levels adjacent to the external concrete galleries, an open steel-decked 'Flow Forge' system of flooring has been provided; the steel decks, supported on a beam system, are designed to carry future apparatus loading with an area allocated for a future lift.

## CONSTRUCTION

### Foundations

Immediately prior to the commencement of the tower construction, an extension to the existing radio station took place. Allowance was made in the structural foundation to the station for subsequent excavation for the tower foundation by designing a wall section to act as a propped cantilever (Fig. 4).

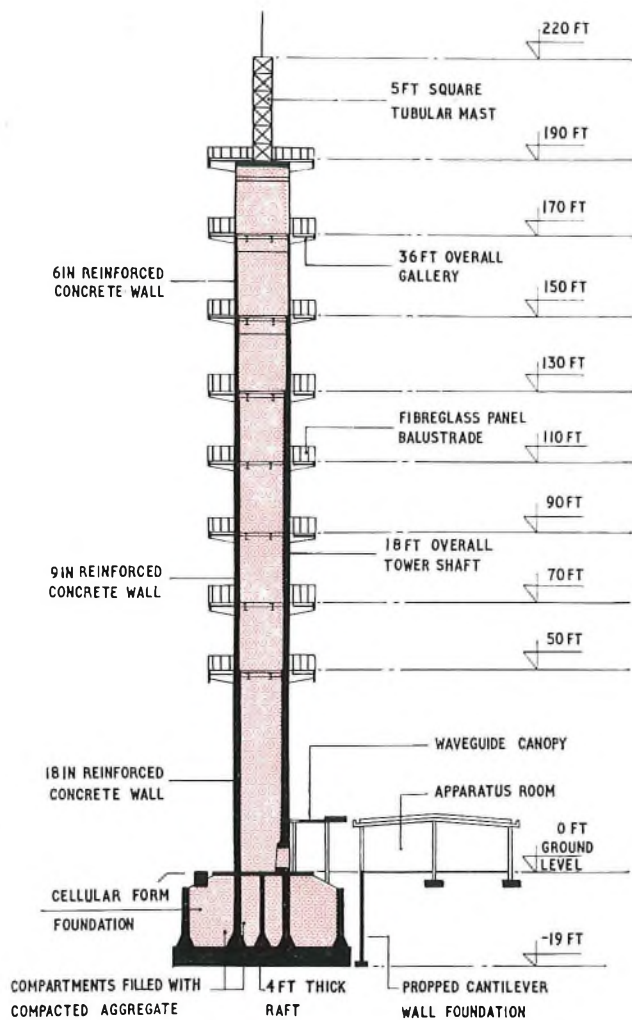

Fig. 4—Section through tower

This was constructed within a deep-trench excavation, the propping being provided by three steel-joint sections concreted-in against the toe, which had been designed to span horizontally between the props.

Excavation of the trench for the wall revealed ground water some 12 ft below ground level. As a result, it was decided that, for the excavations for the tower base, drainage would probably have to be provided and the open-cut method of excavation was adopted. No propping or shuttering of excavated sides was provided but a battered slope was formed consistent with the natural angle of repose of the ground. At formation level, it was found that the carbonized-shale stratum dipped

towards the north at approximately 10°–15°. In order to maintain a sound horizontal bearing in the strata, the mass concrete under the base was stepped to a maximum thickness of 18 in.

A 10-month building period was allowed for the tower and ancillaries, excavation work being timed to commence in fair-weather conditions in early summer while the upper levels of the tower were planned to be constructed in the winter. In the event, even with the favourable weather conditions encountered, it was necessary to protect the exposed shale from weathering immediately after excavation to formation level, by mass concrete blinding. It was found possible to cope with the ground water which issued from a limestone band at some 6 ft above trial excavated level by channelling to a sump and adopting normal pumping methods.

To expedite construction of the 4 ft thick base-slab and to preclude the use of complicated "stop-ends" for construction joints, the slab was constructed in one stage by utilizing the total output of a ready-mixed concrete plant, situated about 7 miles from the site, during the course of one Sunday. The volume of concrete poured was 365 yd<sup>3</sup>, using strict quality-control measures. The concrete was a mix designed to have a mean strength of 5,500 lb/in<sup>2</sup>, and a 10 per cent substitution of pulverized fuel ash (p.f.a.), for cement was used with the object of reducing heat development and assisting in workability. The maximum temperature reached after pouring was 29°C.

### Tower Core and Galleries

It was important to maintain a constant concrete strength throughout the construction of the shaft in order to ensure a reasonably close approximation to the calculated performance. The strength of concrete used was that adopted for the base construction, without the addition of p.f.a. It was mixed on site under strict quality control, cube and beam test results being satisfactory throughout.

The casting of the concrete walls of the tower was arranged to be in 5 ft 8 in lifts, three of which were sufficient to make up the distance between gallery floors, with due allowance for gallery-supporting formwork. The shutters used were of resin-bonded plywood on wrought timbers constructed to the tower-shaft radius, three sets of shutters being sufficient for the whole of the concreting work to the tower walls. It was found possible to concrete the 1 ft 6 in and 12 in thick reinforced concrete walls in a double lift of 11 ft 4 in, satisfactorily incorporating all door openings, portlight and built-in socket fixings to accommodate Post Office apparatus. Each lift was plumbed optically, the maximum deviation from the true position being 5/16 in, a deviation which was well within tolerable limits.

As all galleries were identical, they were cast from the same shutters. All plywood was treated with an epoxy-based release agent, giving an acceptable finish without further treatment.

The major difficulty during erection was the high wind speeds, which became more onerous with height. Due to the small compass of the working area, i.e. a small circle of 18 ft or 36 ft diameter, the successive operations of different trades had to be closely integrated. The construction team consisted of 12 men augmented from time to time as necessary. All materials were elevated by an external hoist; the final operation of concreting the roof and top gallery, however, was carried out by pumping concrete from ground level to a height of 200 ft.

## CONCLUSIONS

The type of ferro-concrete tower developed for Purdown radio station offers adaptable and convenient facilities for terminal or crossing-route stations needing a large number of dish aerials. Such towers are economically comparable with steel towers of similar capacity, but may have an advantage in readier acceptance in the landscape.



A tower of similar shape and giving equivalent facilities is under construction at Morborne Hill radio station, though this example will be 320 ft high. Planning permission is also being sought for other structures of a form derived from the Purdown design, which has thus already become a useful pattern for future rural towers, especially where replacement is needed for an existing steel tower which has reached the limit of its capacity.

#### ACKNOWLEDGEMENTS

Thanks are due to the authors' colleagues in the South Western Regional Office of the Ministry of Public Building and Works and in the Network Planning Department of the

Post Office for assistance in the preparation of this article.

It is deeply regretted that, since this article was written, Mr Birchby has died.

#### References

- <sup>1</sup> KNEE, H. J., and BALCOMBE, F. G. Museum Radio Tower. *P.O.E.E.J.* Vol. 55, p. 73, July 1962.
- <sup>2</sup> HANMAN, B. L. G., and SMITH, N. D. Birmingham Radio Tower. *P.O.E.E.J.* Vol. 58, p. 182, Oct. 1965.
- <sup>3</sup> MILLAR, J. B. Reinforced-Concrete Radio Towers. *P.O.E.E.J.* Vol. 58, p. 178, Oct. 1965.
- <sup>4</sup> JONES, D. G., and EDWARDS, P. J. Post Office Tower, London, and the United Kingdom Network of Microwave Links. *P.O.E.E.J.* Vol. 58, p. 149, Oct. 1965.
- <sup>5</sup> GAUNTLETT, R. D. Dual-Frequency-Band Horn-Aerial Systems. *P.O.E.E.J.* Vol. 60, p. 217, Oct. 1967.

---

## Gas Turbines for Telecommunications Power Plant

H. E. PEARSON, B.SC.(ENG.), C.ENG., M.I.MECH.E.†

U.D.C. 621.438:621.39:621.311

*There are applications in telecommunications for gas turbines in place of diesel engines as prime movers in a.c. stand-by generating plant. These occur principally where the advantages of smaller size and weight per horsepower outweigh the disadvantages of increased initial cost and fuel consumption.*

#### INTRODUCTION

A turbine may be defined as a wheel which rotates when pressure is applied to blades attached to it. A simple example is the water-wheel, in which rotary motion is produced by the pressure of a head of water. The principle is easy to understand and may be applied to the modern hydro-electric generator, which operates in exactly the same way. When steam replaces water as the working fluid, as in the turbo-electric generator, the principle of operation may still be readily appreciated. It may be less apparent how the gas turbine can be made to work, by the internal combustion of fuel, to produce shaft power and exhaust heat in economically acceptable proportions. Engineers took some two thousand years to solve this problem, for Hero of Alexandria built hot-air engines and Leonardo da Vinci wrote of such devices. British Patent Specification 1833 taken out by John Barber of Nuneaton in 1791 described the thermodynamic cycle of the modern gas turbine some 30 years before Kelvin, Carnot, Otto, and Stirling produced their classic works which led to the development of the reciprocating internal-combustion

engine. Now, in 1970, gas turbines are available in sizes which can drive generators having outputs appropriate to Post Office needs in stand-by a.c. power installations.

#### THE SIMPLE GAS TURBINE

In the familiar four-stroke cycle of a reciprocating engine, a mixture of fuel and air is admitted, compressed, expanded, and exhausted as successive operations, each taking place in the same part of the engine, the cylinder. In a simple open-cycle gas turbine, the same four operations happen together and continuously in different parts of the engine. The working medium, air, is drawn into a rotary compressor where its pressure is raised several times, then it is heated by contact with burning fuel in a combustion chamber and expanded through rows of fixed and moving blades in a turbine casing, to exhaust at approximately atmospheric pressure. The compressor is driven by the turbine on the same shaft, excess power being available at the end of the shaft for external use. The rotor is well-balanced and runs at high speed, thus permitting a large continuous flow of the working medium to pass through a comparatively small machine. This results in a high power output for a given weight of engine, although a gearbox

† Power and Ancillary Systems Branch, Telecommunications Development Department, Telecommunications Headquarters.

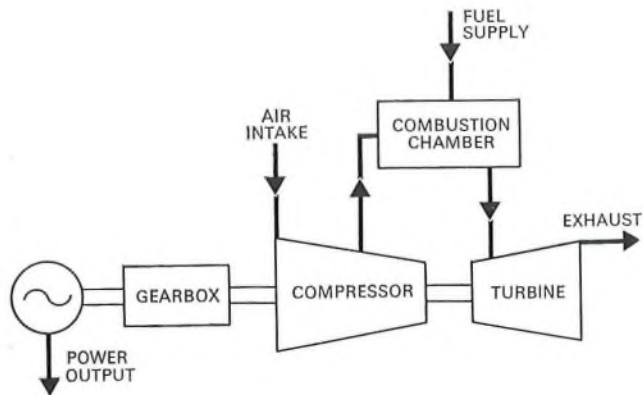

FIG. 1—Open-cycle single-shaft gas turbine

may have to be included to reduce the output-shaft speed to a usable value.

The arrangement for driving an alternator is shown diagrammatically in Fig. 1. Such a rotary turbine will not start up in the first few turns of the shaft, as does the reciprocating internal combustion engine, because the rotary compressor must be run up to speed before it can deliver air at the right pressure. Ignition is delayed until the system has been purged of residual gas, then, when the main flame has been established, the fuel supply is increased up to the working level. Other operations in the starting cycle to do with lubricating-oil distribution, clutch operation and other items, also lengthen the starting time, which might total from one to three minutes according to the output power of the turbine. This should be compared with less than half a minute for a diesel engine of the same power output. Once started, however, the gas turbine is capable of running for very long periods with little or no attention, since the basic engine has only one moving part, the ignition is self-sustaining and needs no complex electrical system, the air cooling is built-in, rendering a water jacket unnecessary, and only one fuel injector is required. A cross-section of a gas turbine of the open-cycle single-shaft type is shown in Fig. 2.

When a gas turbine is running, the continuous expansion of gas through the blades imparts a smooth, regular motion to the shaft and when this shaft drives an a.c. generator, the waveform of the output voltage will be as good as the generator design permits. When the complete engine-generator set is balanced for rotary motion, it is virtually vibrationless in relation to its environment, though some vibration will occur on run-up as the speed passes through the critical values for the shaft.

## TYPE VARIATIONS

There are several variants of the basic design. In one of these, the turbine is divided into two sections, the high-pressure end driving the compressor on one shaft, and the low-pressure end driving the load on a separate shaft. This increases the flexibility of the machine but delays its response to changes of load. Another employs a heat exchanger to raise the temperature of the air between the compressor and the combustion chamber by recuperation of some exhaust heat energy. This saves the appreciable amount of fuel which would otherwise be used in causing that rise in temperature. It increases the thermal efficiency but carries the penalty of also increasing the cost, size, and weight by the addition of the heat exchanger.

Intercooling the air between two or more stages of the compressor is sometimes employed to reduce the size of the turbine. This necessitates the provision of an intercooler and does little to improve efficiency. Re-heating the air by the introduction of a second combustion chamber to raise the

temperature between two stages of the turbine is also practised, as are other complex variants aimed at improving efficiency in particular applications.

## COMPARISON WITH DIESEL

A gas turbine weighs only one-sixth as much as the equivalent diesel and occupies only one-quarter the space, but this relates to the power unit alone. The user, in a fully-automatic stand-by a.c. generating application, must find accommodation for the alternator and the control switchgear (which are the same size irrespective of the engine) and must allow also for an air intake and filtering system to handle about ten times as much air as a diesel uses, a larger exhaust system, and double the bulk fuel storage, since the fuel consumption per kilowatt-hour of a turbine is twice that of a diesel. Nevertheless, the advantages of smaller size and reduced weight can be very great where space or floor strength is limited and where the burdens of air and fuel handling are acceptable. The actual cost of using twice as much fuel during operation of a stand-by set is not itself a significant factor.

Two subjects of great interest at the present time are the reduction of noise and air-pollution. These factors must be brought into any comparison of gas turbines and diesel engines. Because of the great amount of air passing through the turbine, combustion of fuel is more complete, residual products of combustion are greatly diluted and they may be regarded as non-toxic. Noise in both cases can be reduced by established methods of treatment in engine mounting, housing, and inlet and exhaust silencing but, because it is very unusual in character, the turbine noise, especially on starting, may prove more objectionable. The level of noise from the diesel may be just as high but it is more acceptable to ears accustomed to that type of noise. Turbine noise is more like aircraft noise, with its bad reputation for annoyance. Fortunately, adequate noise-reducing methods are available. Routine runs of a stand-by set can be carried out when ambient noise is high, and, if the engine runs during a power failure, hearers may be more tolerant of the noise it makes at that time.

The prime cost of a gas-turbine-driven a.c. stand-by installation in the U.K. is likely to be 50 to 100 per cent higher than one with a diesel engine. This is because the turbine contains costly heat-resistant, high-strength materials expensively machined, fitted, and tested. Further, there is a bigger demand for diesels and consequently more scope for price reduction by quantity production. To offset the high cost, therefore, the advantages of the turbine must outweigh the disadvantages by a large amount. If space or floor-loading capacity is sufficient for a turbine installation but not for a diesel installation, then the turbine wins. It may also be possible to locate it on an upper floor nearer to a power-load centre and where air-intake and exhaust problems might be simpler, though this does involve pumping fuel up the building and the manner of doing so must meet fire regulations. Turbines are most likely to prove acceptable for those installations where each engine-generator unit has an output of 300 kW or more.

It was said earlier that the gas turbine used fuel twice as fast as the equivalent diesel. Their efficiencies as heat engines are of the order of 20 per cent and 40 per cent respectively. Recently, a great deal of interest has been shown in how to recover some of the lost heat by using the hot exhaust gases either directly in some drying process or to heat water for other useful purposes. Schemes have been devised for both turbines and diesels and have been put into operation with overall efficiencies in the region of 70–80 per cent. For such purposes, the gas turbine offers more waste heat and delivers it at a higher temperature. This may be ideal in some applications but is less attractive where a surplus of heat already exists from the way in which the shaft-power-generated electricity is used. Integrated schemes of this nature require the prime movers to be running continuously and are not suitable for stand-by installations.



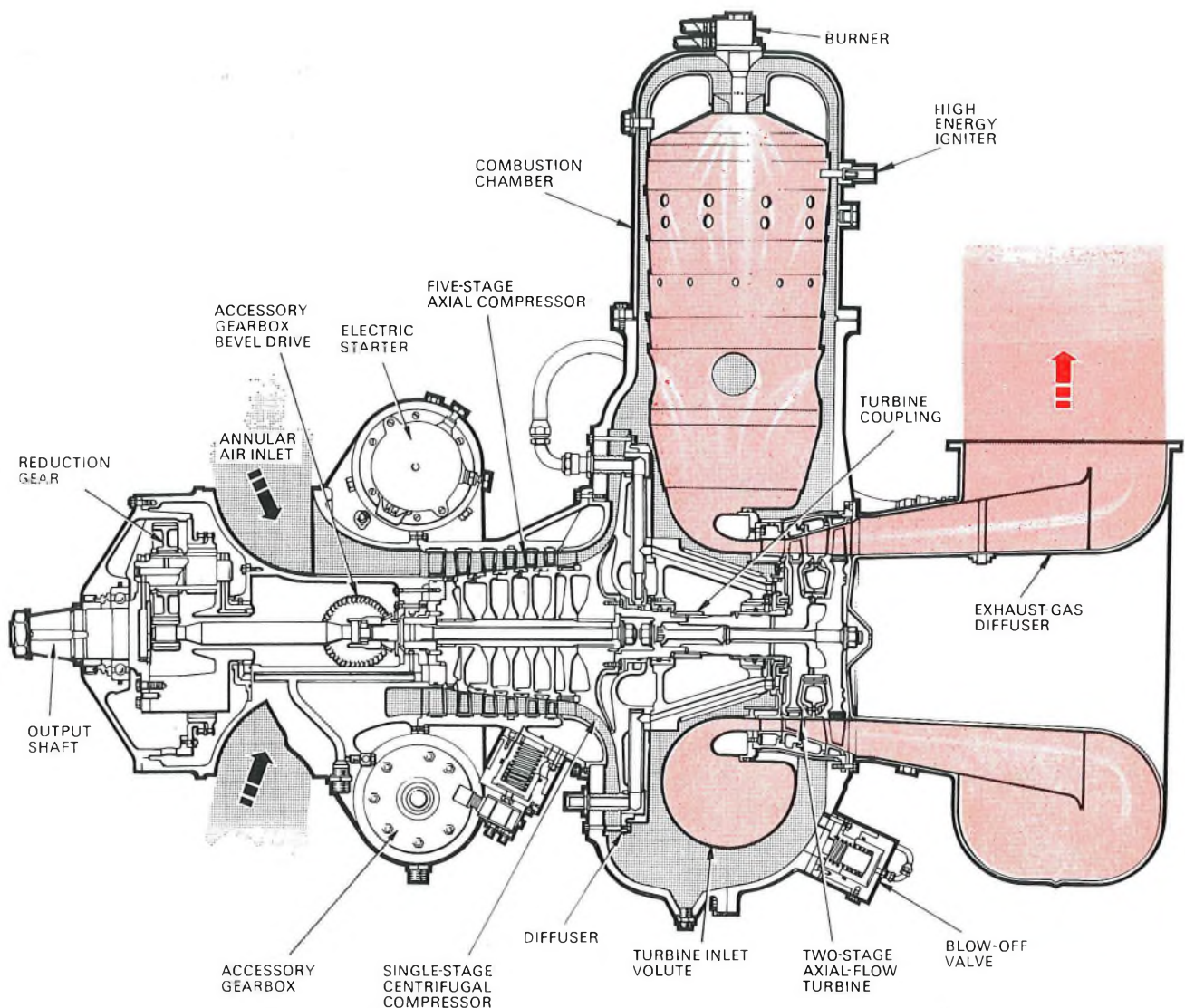

FIG. 2—Cross-section of Centrax C.S. 600 gas turbine

### TELECOMMUNICATIONS APPLICATIONS

Post Office telecommunications services are currently employing gas turbines for stand-by generating duty in three separate ways. At Faraday House in London there is a permanent installation of three Centrax turbines; these, running at 22,000 rev/min and driving 1,500 rev/min McFarlane Transicon alternators, provide a total of 1,240 kW continuously (1,395 kW peak) with automatic changeover on mains failure. One of these turbines is of the simple form shown in Fig. 1 and 2 and its overload capacity provides the short-term peak load. The others are fitted with heat-exchangers to improve fuel consumption and may not be overloaded. Turbines were installed because the space and floor restrictions would not permit a diesel installation to yield the power required additional to that available from installations elsewhere in the building.

The same type of turbine has been provided in mobile form, Fig. 3, and a smaller mobile version uses an Austin 250 gas turbine which drives a 160 kW Houchin alternator. These mobiles are intended to be used as temporary replacements for fixed sets which are being overhauled in accordance with a maintenance plan, and such units may be moved several times a year.

The third type of application is for a transportable, though not necessarily mobile, unit to be used whilst a power room is being stripped during a rebuilding operation. Current examples, again using the Centrax turbine, occur at Liverpool and Bristol. At both locations, the power unit is on wheels, but for this sort of application, which may last for one or two years and where site space is restricted, a skid-mounted unit placed in position by a crane is more attractive. In these mobile and transportable units, the advantages of the turbine over the diesel are that more power can be packed into a smaller, lighter unit and no water is required. Additional absorbent curtain-wall silencing of the turbine may be necessary, however, in certain locations.

The fully-automatic mobile stand-by unit now in use at Liverpool was used earlier at Criggion Radio Station whilst a permanent engine was being replaced. As the Criggion site is flat, open country with tall aerial-supporting structures available, the opportunity was taken to measure the pattern of noise distribution through the audible spectrum at all angles of emergence from the source. These data were later used for guidance in placing the unit in an environment close to a hospital.

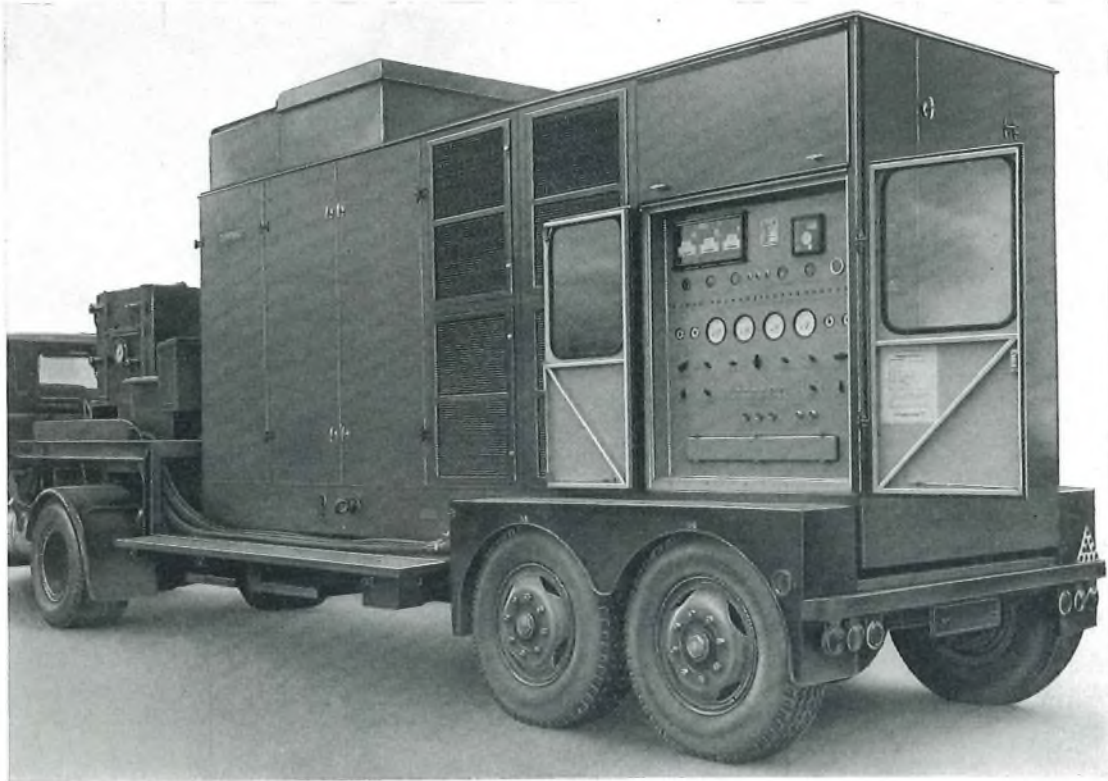

FIG. 3—Centrax mobile gas-turbine generating-unit

#### **CONCLUSION**

With half-a-dozen gas turbines in Post Office use, experience is being obtained on two makes, two sizes, two types, and three methods of usage. Smaller sizes are not readily available and are unlikely to find much application where cheaper diesels are acceptable. Larger sizes are available within the Post Office range of interest and, as space for switching and

transmission equipment becomes more valuable, the extra prime cost of gas turbines occupying less space may be justified.

#### **Acknowledgements**

The author wishes to thank Messrs. Centrax Limited for permission to reproduce Fig. 2 from their original drawing.



# Post Office Standard Video Transmission Equipment

J. SIXSMITH†

U.D.C. 621.397.743

*The Post Office provides an extensive network of television links for the United Kingdom broadcasting authorities. Video circuits up to 25 miles in length are commonly provided using coaxial cables, and the present standard type of line transmission equipment is described. The system design parameters that have to be considered are briefly reviewed.*

## INTRODUCTION

The Post Office operates an extensive network of television links for the broadcasting authorities. Currently, some 75 main links, with a total length of 6,000 miles, are provided over microwave-radio systems. In addition, about 300 local video links, totalling over 2,000 miles in length, are provided on coaxial cable.

Television signals have been transmitted over coaxial cables by the Post Office since 1954, and it is now common practice to provide circuits up to 25 miles long, using video-on-coaxial-cable techniques. The early circuits employed a 20 dB valve-type amplifier designed at the Post Office Research Station. With the advent of 625-line monochrome transmission and, in addition, the need for a colour service, it was necessary to design a new video line amplifier. The opportunity was taken to design a transistor amplifier and to re-engineer associated items in Post Office 62-type construction.

The technique of video transmission on unbalanced cables has been described previously,<sup>1</sup> and the waveform correction of video circuits has been the subject of an earlier article.<sup>2</sup>

## SYSTEM PLANNING

To effect the design changes outlined above it was necessary to review the basis of video-system design and planning.

The recommended performance of international television circuits is based on a 2,500 km hypothetical reference circuit. For planning purposes the British Post Office adapted this concept of a reference circuit to give a United Kingdom hypothetical reference chain that is more convenient, in length and composition, for application to circuits in this country. This hypothetical reference chain comprises four main links (totalling 500 miles), two major local links and six minor local links. Main links to 625-line colour standards, which are at present provided by radio, have been described earlier in this Journal.<sup>3</sup>

Major local links are less than 25 miles in length; minor local links are links without intermediate stations. Local links, although short, form by far the greater number of circuits. They provide connexions between transmitters and Post Office network-switching centres, and between network-switching centres and program-switching centres, studios, and monitoring centres. The methods of measuring the distortions and impairments on vision circuits and the target performance requirements for a United Kingdom reference chain have already been described.<sup>4</sup> The relevant allowances for a major local link are shown in Appendix 1.

## MILAGES AND CIRCUIT LEVELS

The new equipments can provide a major local link of eight repeater sections, each of 3·2 miles, to 625-line colour standards over Post Office 375E-type coaxial cable. Two sections up to 3·6 miles may, however, be included. A system layout is given in Fig. 1. The system input level\* is -4 dB and the system output level is +4 dB. The level to line is +5 dB. System input and output levels allow for the corrected loss of up to 75 yards of internal cabling connecting the line equipments to circuit terminations on the video distribution rack, where the level is 0 dB.

## LINE TERMINAL EQUIPMENT

The transmit terminal employs a single shelf containing an amplifier, waveform correctors for the internal ties to the video distribution rack, and supervisory units. The equipment used at receiving terminals and intermediate stations has two video line amplifiers. It can, however, accommodate a third amplifier for repeater sections longer than the standard. A block schematic diagram of an intermediate repeater is shown in Fig. 2.

## AMPLIFIERS

The amplifiers have been described elsewhere,<sup>5</sup> but an outline description is given here, as they are the major design contribution to the new system.

The nature of the video signal presents special difficulties to the amplifier designer. It is necessary to cover the large number of octaves in the nominal video spectrum from 50 Hz (field frequency) to 5·5 MHz, but, in practice, the response must be extended well below and above this frequency range to ensure that the phase characteristics are satisfactory.

The amplifier cannot be d.c. coupled at its input because of the large non-useful d.c. component that might accompany the video signal. One result of the a.c. coupling employed is that a voltage step applied to the amplifier input produces quasi-oscillatory overshoots at the output. This condition occurs in practice when there is a rapid change in picture content from, say, black to white. It has been calculated that, at best, the first overshoot from a voltage-step waveform applied to a chain of non-interacting single time-constants associated with a.c. couplings approaches a little over 40 per cent of the step as the number of a.c. coupled stages is increased. This ideal condition is very difficult to achieve in practice, and, unless the amplifier behaves as a close approximation to a single time-constant, the build up of overshoots

† Telecommunications Development Department, Telecommunications Headquarters.

\* Levels are quoted as the ratio in decibels of peak-to-peak picture plus synchronizing pulses, to 1 volt peak-to-peak across a resistance of 75 ohms.

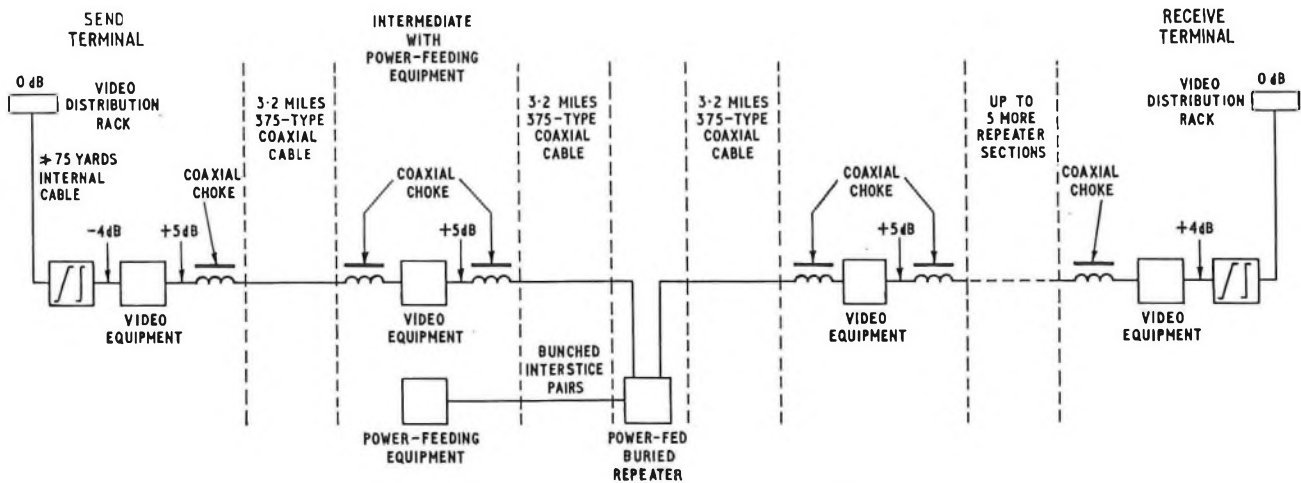

Note: levels are relative to 1 volt peak-to-peak in 75 ohms

FIG. 1—Block schematic diagram of video system

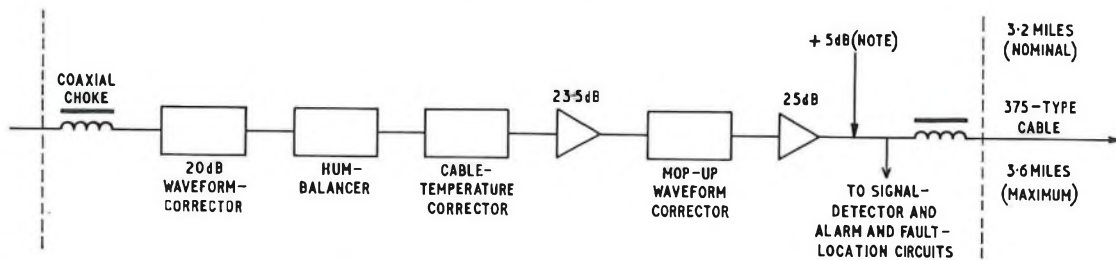

Note: levels are relative to 1 volt peak-to-peak in 75 ohms

FIG. 2—Block schematic diagram of intermediate repeater

on a few repeated sections could render the system unusable.

The gain of the amplifier extends down to less than 1 Hertz, but any rise in gain in this region, caused, for example, by the addition of conventional low-frequency-lift components, can be detrimental to the step response. The overshoots must be accommodated within the power-handling capacity of the amplifiers; they are eliminated by the broadcasting authorities, before transmission, by the use of black-level clamps.

Colour information is transmitted within the same frequency band as the monochrome or luminance signal, thus meeting one of the requirements for compatibility between monochrome and colour receivers. The nature of the colour signal, coupled with the increased amount of information carried, compared with monochrome transmissions, calls for a very stringent control of linearity in the line amplifiers. In practice, the amplifier needs substantial negative feedback extending beyond colour sub-carrier frequencies, and, to achieve this, the response has to be controlled well beyond the working frequency range. A good margin of stability is, of course, essential. The measured feedback response of the amplifier is given in Table 1 and it will be seen that at 23 MHz, where the loop gain is 0 dB, there is still a phase margin of 30° and at the critical zero phase-shift point (53 MHz) there is a gain margin of 7 dB.

Two amplifiers were designed: a send amplifier with 25 dB gain and a receive amplifier with 23.5 dB. In the following description, reference is made only to the send amplifier. Repeater-section lengths and output levels to line were optimized by a study of signal-to-noise ratios, and linear and non-linear distortions anticipated from amplifiers using the best available transistors.

A simplified schematic diagram of the line amplifier is given in Fig. 3 and its construction is shown in Fig. 4. The output stage operates in series push-pull, this being the most efficient class-A stage, giving good linearity and taking constant power. The driver stage handles large voltage swings, and the common-base configuration was chosen. It is compounded with a common-emitter stage of opposite polarity, to reduce the current swing in the supply line. The input stage is in common-emitter configuration to give high voltage-gain, hence it largely determines the amplifier noise factor. It is followed by a common emitter to give impedance matching into the next stage. Nyquist criteria for stability in the feedback loop are observed, and an approximation to a Bode step<sup>6</sup> is produced in the feedback-loop response. Loop feedback is controlled by network N, capacitor C3 in the output drive circuit, and capacitors C1 and C2 in the feedback path.

The closed-loop response is sensibly flat to 10 MHz, and

TABLE 1  
Feedback-Loop Response of Amplifier

Parameter	Frequency (MHz)									
	1	2	5	10	20	23	40	50	53	100
Gain (dB)	30	28.5	24	14.5	1.5	0	-5	-6.5	-7	-9
Phase (degrees)	160	134	84	44	30	29	30	8	0	—



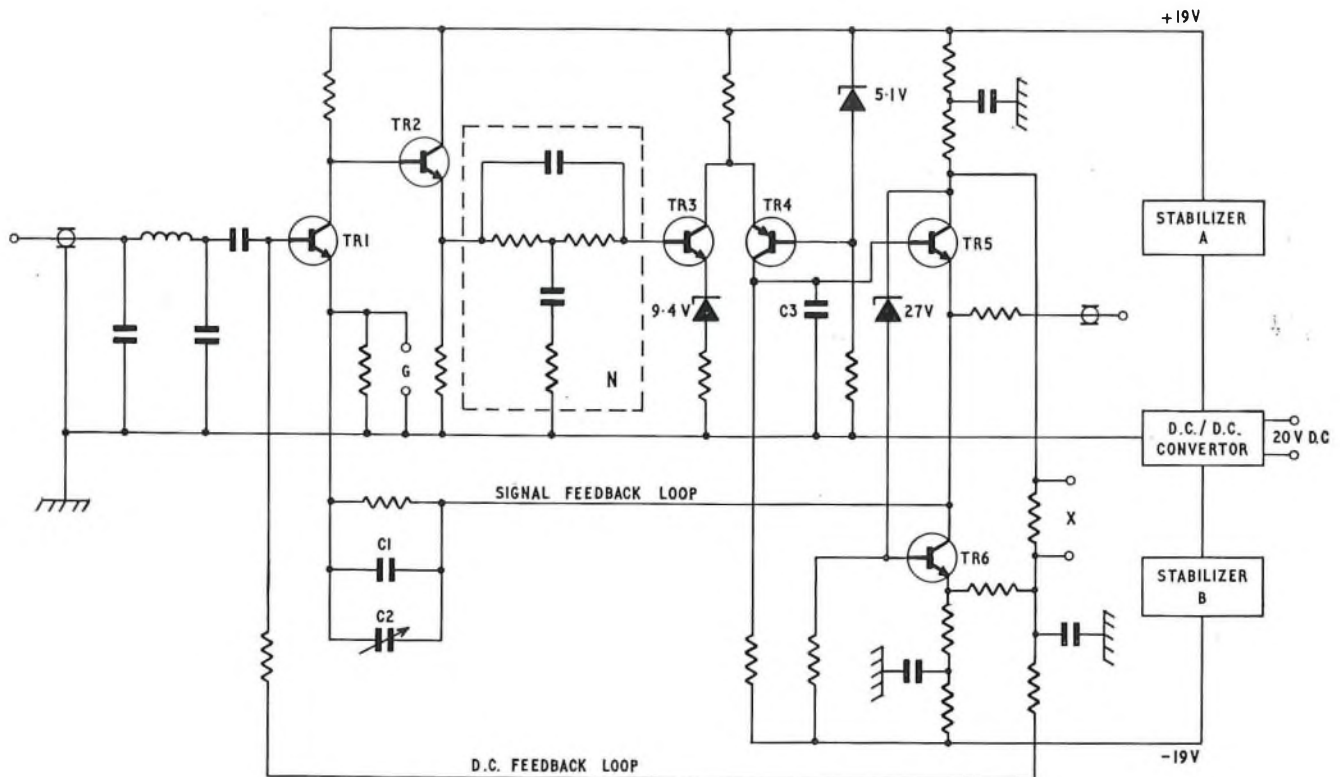

FIG. 3—Simplified schematic diagram of video line-amplifier

the 3 dB points occur at 0.1 Hz and 25 MHz. Temperature stability is achieved by a second feedback loop (d.c.) with a very low cut-off frequency, in place of the more commonly used temperature-compensating elements, and a reduction of 26 dB in output drift is obtained. The output potential is constant within  $\pm 0.25$  volts between  $0^{\circ}\text{C}$  and  $40^{\circ}\text{C}$  ambient temperature, and the adjustment of the output potential is substantially independent of the feedback factor.

#### Power Supplies

The amplifier operates from stabilized  $-24$ -volt and  $+24$ -volt rails from a power inverter which is part of the amplifier unit. The inverter is driven from standard rack power supplies. It is self-starting and also self-protecting when overloaded.

#### Performance

The performance of the send amplifier in terms of non-linear distortions is given in Appendix 2.

#### POWER FEEDING

The reduced power consumption of the transistor amplifiers has made it possible to power feed a single repeater over bunched interstice or other pairs. Using three bunched 20 lb/mile cable pairs it is possible to supply power at safe voltages to one intermediate repeater over a distance of 3.6 miles. The power-fed repeater may be a standard surface-station equipment (with minor modification) or a unit engineered to fit in a standard case used for accommodating repeaters in manholes or joint boxes. A maximum spacing of surface stations of approximately 10 miles may be obtained.

#### UNDERGROUND REPEATER

If the amplifier is used in a buried repeater, coaxial chokes and hum-balancers, described later, are not used at the underground point; this is to economize in space. Adequate immunity to low-frequency interference is obtained by iso-

lating the repeater electrically from earth. The signal-current excursions in the  $\pm 24$ -volt supply rails cancel in the inverter transformer and do not reflect into the 20-volt supply. There is, therefore, no common-supply coupling: it is thus possible to feed power in series to the send and the receive amplifier without mutual interference at low frequencies. The current fed is 0.45 amp, and the voltage across the two amplifier inverters in series is 40 volts.

#### LIGHTNING PROTECTION

The protection of the amplifier and other units from damage by lightning discharges presented a difficult problem, as the spectrum of energy in a lightning discharge is almost completely contained within the video-transmission band. A transistor can be destroyed by a pulse of energy a fraction of a microsecond in duration, so the protective device must be fast acting.

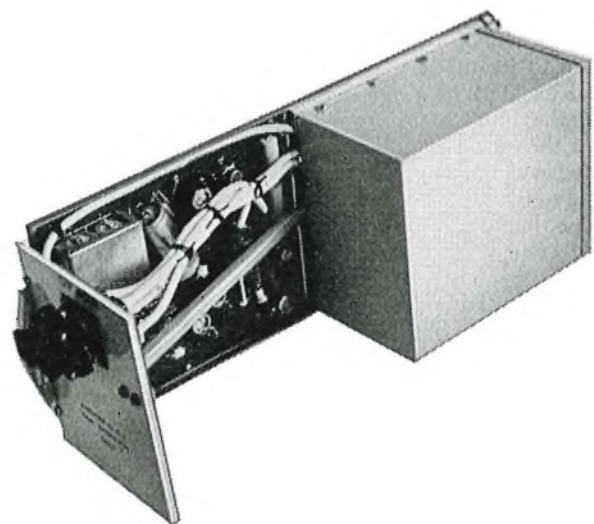

FIG. 4—Video line-amplifier

Protection is applied in two stages. The first of these consists of two low-voltage gas-discharge tubes connected, respectively, between the inner conductor of the external cable and the sheath, and the outer conductor of the external cable and the sheath. These tubes are fitted at both ends of the external cable, at the sealing ends. The second stage is a very-fast-acting low-slope resistance limiter in the form of a diode bridge, and this is fitted across the receive-amplifier input. This element takes advantage of the high forward resistance of diodes at low voltages, such as signal voltages, and their low resistance at higher voltages. The turn-on time is less than 10 ns, and the terminal voltage-drop during a 1  $\mu$ s pulse of 8 amp is 12 to 14 volts. Between the two stages of protection is a coaxial choke, the impedance of which delays longitudinal surges sufficiently to allow the slower-acting discharge tubes to conduct and dissipate the main energy to

requirements of differential phase and gain, necessitating lower sending levels, make the suppression of low-frequency interference a more difficult problem. The use of hum-balancers in addition to chokes at each end of a cable section is now standard. The hum-balancer forms a bridge circuit with respect to longitudinal currents, and, when it is correctly balanced, the circuit termination appears across the null points.

The problem of low-frequency interference has recently become more serious with the extension of railway electrification and the increasing use of high-efficiency semiconductor power inverters, which have caused induced hum-voltages to have a wider frequency spectrum than hitherto. The original passive hum-balancer is rapidly being superseded by a transistor unit which is much more effective over the wider range of interference frequencies now encountered.

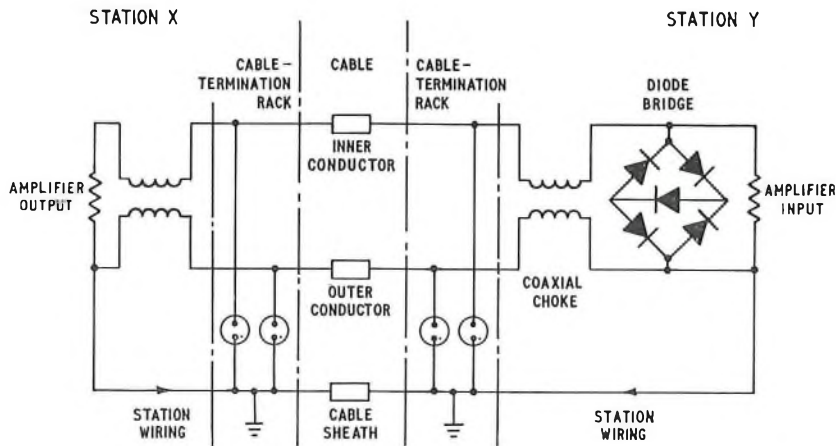

FIG. 5—Lightning protection on video circuits

cable sheath and earth. The second stage of protection then protects the amplifier from residual surges. An outline schematic diagram of the arrangement is given in Fig. 5.

### COAXIAL CHOKES AND HUM-BALANCERS

The screening property of a coaxial outer conductor becomes less effective as frequency is reduced, and at 50 Hz there is a little difference between induced currents along the inner and outer conductors of a coaxial pair. The cable is therefore susceptible to mains-frequency and harmonic interference due to differences in earth potential between the ends of the cable and also to directly-induced voltages. Low-frequency crosstalk from adjacent circuits can also be troublesome.

Coaxial chokes, made by winding small-diameter flexible coaxial cable on mu-metal laminations, present a high impedance to longitudinal interference and can reduce it by as much as 20 dB on a repeater section. The chokes also reduce sporadic interference from impulsive circuits. The chokes have their own built-in waveform-correctors and a simple impedance-matching network to match one end of the choke-cable to line.

The time delays of echoes within the chokes are approximately equal, and, without matching, echoes on long circuits employing many chokes would be additive. The addition of a second choke at the other end of the circuit improves hum suppression by less than 6 dB, but is useful in improving low-frequency crosstalk attenuation and in reducing sporadic interference.

On monochrome circuits, the use of chokes at each end of a repeater section often proved sufficient to reduce mains hum to acceptable levels. Where this was not so, a second method of suppression, in the form of a hum-balancer at the receiving end of each repeater section, was added. The introduction of 625-line colour standards and the stringent

### WAVEFORM-CORRECTORS

Waveform correction is a process analogous to equalization. It is a technique of correcting the attenuation/frequency and delay/frequency characteristics of a circuit by observing and systematically reducing the distortions suffered by specified waveforms transmitted over the circuit.<sup>2</sup>

Two block, or fixed, waveform-correctors are available, designed to correct the distortion introduced by 2 miles or 1.16 miles of 375-type coaxial cable. On a standard colour circuit one block-corrector is fitted, and this precedes the hum-balancer and the first amplifier. The equivalent of this corrector in cable length is always less than the length to be corrected, so that a substantial amount of correction, say 8 dB or more at 5.5 MHz, is left for mop-up correction. This results in correctors with more easily realizable components, and the mop-up correctors are designed on site.

Correctors for overall cable attenuation change due to seasonal variation of cable temperature are fitted at approximately 6-mile intervals, designed to maintain the *k*-rating\* of a circuit within  $\pm 0.25$  per cent for temperature changes of  $\pm 8^\circ\text{C}$  relative to the mid-seasonal average temperature.

### SUPERVISORY CIRCUITS

Duplicate input-signal detectors monitor the input to a vision channel. Cessation of the input signal is sensed by the detectors, and associated circuits apply the output of a local synchronizing-pulse generator to line. The vision signal or the locally-generated synchronizing pulses are monitored by line-signal detectors at the output of every repeater on the link. Release of a line-signal detector circuit applies earth potential to a channel alarm wire, causing alarms to operate at the control terminal. The fault is located from the control terminal by measuring the resistance of the alarm wire to the

\* *k*-rating—linear waveform-distortion assessment.



marking earth, using a d.c. bridge. The bridge controls are calibrated in station numbers.

Input-signal detectors are duplicated to guard against application of synchronizing pulses to line by misoperation of a faulty input-signal detector. If the input-detector circuits operate or release, out of step, beyond a small tolerance, the circuits connecting synchronizing pulses to line are inhibited and alarms operate. When the control terminal is also the receive terminal, a second supervisory wire is used to operate by-pass circuits on the channel alarm wire at stations between the faulty one and the control terminal which, without this facility, would register as faulty.

Main and standby power-stabilizer units are fitted at all stations, and failure of a power unit (including the standby unit) operates an alarm at the control terminal over a power alarm wire. The fault can then be located on the bridge.

## MEASURED RESULTS ON A LINK

The results of measurements taken recently on a link of 17 miles length are given in Appendix 3.

## CONCLUSION

The majority of the 300 local television links in the United Kingdom are now equipped with apparatus of the type described above. These links are giving satisfactory service for colour television. The continuous monitoring of transmission by synchronizing-pulse and line-signal detectors at the output of every repeater has proved a valuable maintenance aid, while use of power-feeding for buried repeaters leads to substantial economies where no existing accommodation is conveniently located for a normal-type repeater installation.

## References

- <sup>1</sup> HALE, H. S., and MACDIARMID, I. F. Video Transmission System for Use with Coaxial Cable, and Video-Waveform Correctors for Use with Coaxial Cable. *Proceedings I.E.E.*, Vol. 110, No. 8, Aug. 1963.
- <sup>2</sup> MACDIARMID, I. F. Waveform Distortion in Television Links. *P.O.E.E.J.* Vol. 52, pp. 108 and 188, July and Oct. 1959
- <sup>3</sup> JONES, D. G., and EDWARDS, P. J. The Post Office Network of Radio-Relay Stations. *P.O.E.E.J.* Vol. 47, pp. 147 and 238, Oct. 1964 and Jan. 1959.
- <sup>4</sup> TANNER, R. K. R. Testing 625-Line Monochrome and Colour Television Transmission Systems. *P.O.E.E.J.*, Vol. 58, p. 126, July 1965
- <sup>5</sup> COMBER, G. A. Transistorized Video Line System International Broadcasting Convention, 1968. No. 46, Part 1, 6.4.1.
- <sup>6</sup> BODE, H. K. Network Analysis and Feedback Amplifier Design. Van Nostrand, 1945.

## APPENDIX 1

### Allowances for a Major Local Link

#### Insertion Gain Variations

Short term (1 second)	$\pm 0.1$ dB
Medium term (1 hour)	$\pm 0.1$ dB

#### Random Noise

Luminance channel, weighted, 10 kHz–5 MHz	62 dB
Chrominance channel, weighted, 3.5–5.5 MHz	56 dB

#### Periodic Noise:

Mains frequency and lower harmonics (hum)	35 dB
---	-------

#### Linear Waveform Distortion:

<i>k</i> -rating	1 per cent
------------------	------------

#### Luminance-Chrominance Inequalities:

Gain inequality	2 per cent
Delay inequality	20 ns

#### Non-Linearity Distortions:

Luminance channel	2 per cent
Chrominance channel:	
Differential gain	2 per cent
Differential phase	1°

The non-linearity distortions allowed are increased by a factor of two for a signal 3 dB above normal level.

A minor local link has lower impairment allowances.

## APPENDIX 2

### Performance of Send Amplifier (Non-Linearity)

Signal	Output Level (dB)	Non-Linear Distortion
Luminance	+5	0.1 per cent
Luminance	+8	0.2 per cent
Synchronizing pulse	+5	0.1 per cent
Synchronizing pulse	+8	0.2 per cent

#### Parameter (measured at 4.43 MHz)

Differential gain	+5	0.12 dB
Differential gain	+8	0.24 dB
Differential phase	+5	0.08°
Differential phase	+8	0.16°

## APPENDIX 3

### Measured Performance of 17-mile Link

#### Random Noise

Luminance channel, weighted	70 dB
Chrominance channel, weighted	67 dB

#### Periodic Noise

Mains frequency and lower harmonics (hum)	40 dB
Linear waveform distortion ( <i>k</i> -rating)	0.9 per cent

#### Luminance-chrominance inequalities

Gain inequality	2 per cent
Delay inequality	<5 ns

#### Non-linearity distortions

Luminance channel	1 per cent
Chrominance channel:	
Differential gain	1.25 per cent
Differential phase	0.45°

These measured results are within the allowances quoted previously for a major local link (see Appendix 1).

# Call-Failure-Detection Equipment—Standard Equipment for Director and Non-Director Strowger Exchanges

K. W. HIX, M.I.E.E., R. A. FRANÇOIS and J. D. PYRAH†

U.D.C. 621.395.63: 658.562

*An earlier article on call-failure-detection equipment (c.f.d.e.) described the interim arrangements made to provide facilities for observing live traffic in order to detect and locate call failures and thereby improve the quality of service. This article reviews development in this field and describes the standard equipments which will supersede the interim arrangements in the larger director and non-director Strowger exchanges.*

## INTRODUCTION

In an ideal telephone service, faults in the switching and signalling equipment are detected and removed before service to customers is adversely affected. This ideal can be achieved largely by carrying out preventive maintenance, involving the use of specially designed test equipment, with sufficient regularity to ensure that faults are detected soon after their occurrence. The early detection of faults can also be facilitated by the provision of inbuilt fault-detection devices or externally connected fault print-out equipment. Capital cost and design complexity have prevented the widespread adaptation of such devices to Strowger equipment, and despite the considerable variety of test equipments which have been provided in exchanges, it has rarely been possible to carry out manual testing with sufficient regularity to ensure a fault-free service. The automation of testing equipment, such as the association of fault recorders with automatic routiners is beneficial, but the catastrophic failures that can occur between test cycles can

Test-call sending of this type has been widely used, but is open to various objections. The possibility of using automatic fault-detection methods to find faults on subscriber-dialled traffic is attractive, and various systems have been tried and numerous equipments developed by the Post Office since the first experiments were conducted on no-tone detection equipment in the West Area of the London Telecommunications Region in 1945. This article describes equipment which has been developed and standardized for use in Strowger exchanges to detect certain types of failure conditions on subscriber-dialled traffic, to provide automatic service measurements for engineering control purposes and facilitate the location and tracing of faults.

## TYPES OF EQUIPMENT

Equipment to perform fault detection and call holding has been developed in several regions for association with com-

TABLE 1

Code	Exchange Type	Mode of Access	Application
C.F.D.E. No. 1	Non-director and director	Common use of c.s.o. access equipment	Non-director and some director exchanges Ultimately on smaller units only
C.F.D.E. No. 2	Director	Connected to individual modified directors	Fault investigation in director exchanges
C.F.D.E. No. 3	Non-director and tandem	Jumpered-in access to 96 or 192 selectors in groups of 24 with call-splitting facilities	Large non-director and director tandem exchanges; outgoing and incoming equipment
C.F.D.E. No. 4	Director	As above	Large director exchanges; outgoing and incoming equipment
C.F.D.E. No. 5	Group switching centres	100 or 200 selectors/relay-sets in groups of 25 with call-splitting facilities	Major group switching centre exchanges; outgoing, and incoming (non-transit), equipment

affect service over a considerable period before detection. Inevitably, some parts of the system such as connexions on frames and racks cannot be covered by automatic routine testing of individual equipments and alternative methods of overall checking exchange connexions to locate faults have been found necessary. One method consists of the continuous generation of test calls made from spare exchange calling equipments or other access points, with a stage-by-stage check of progress.

† Mr. Hix is in the Service Division, London Telecommunications Regional Headquarters, but was formerly in the Service Department, Telecommunications Headquarters. Messrs François and Pyrah are in the Telecommunications Development Department, Telecommunications Headquarters.

mon equipment (i.e. directors) or at early stages of calls (1st numerical selectors). These equipments have been valuable in improving service, and particular mention should be made of the automatic traffic-monitoring equipment (SCOTS MON) developed in Scotland and now in use at many group switching centres. The majority of these equipments have the disability of access to limited portions of the exchange with a requirement for immediate call-tracing activity when a fault is found. The equipments have been variously known as no tone detectors, call-trap units and monitoring equipments. With the rationalization and standardization of these equipments the generic name of call-failure-detection equipment (c.f.d.e.) has been adopted and applied to a range of items listed in Table 1.



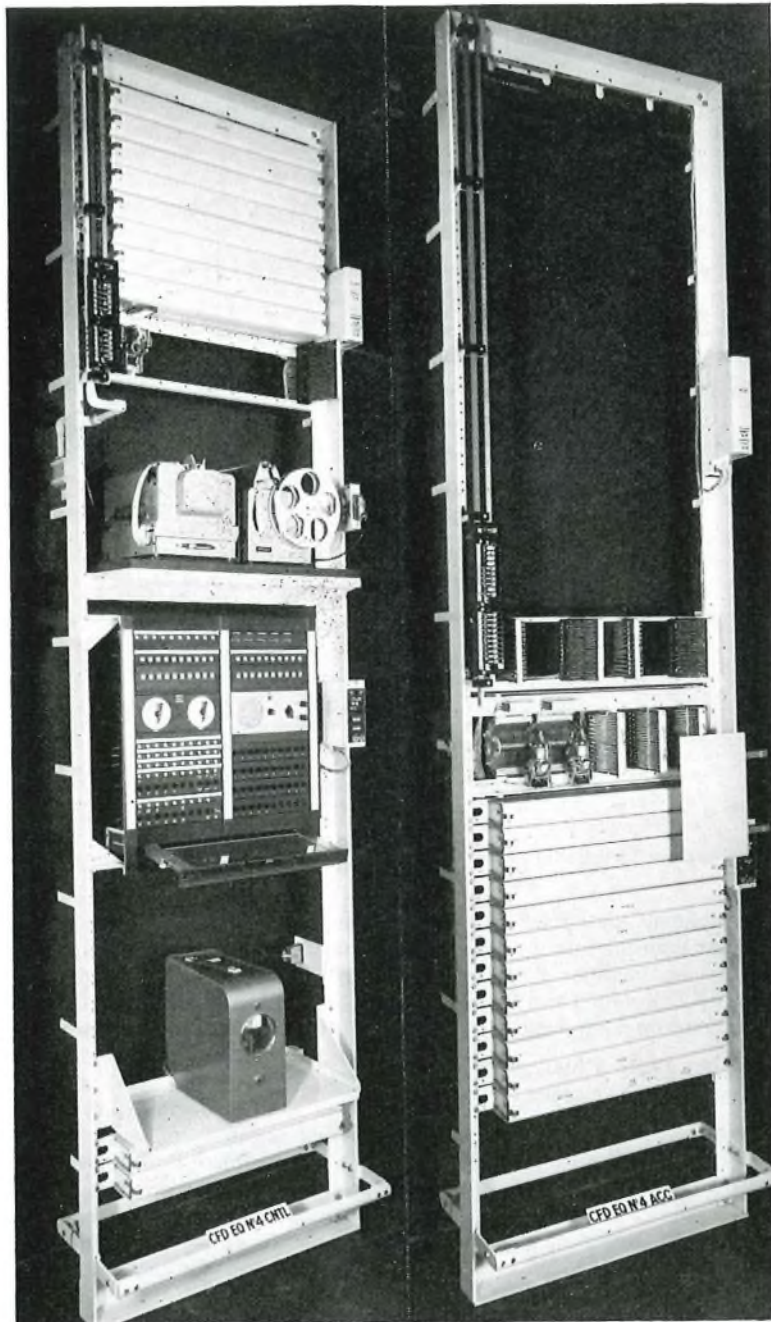

FIG. 1—Call-Failure-Detection Equipment No. 4

*CFD E3 similar*

### INTERIM EQUIPMENT

To supplement the equipments of Regional and Area design and provide simple equipment which could be readily manufactured and installed, two interim designs were introduced (C.F.D.E. No. 1 and No. 2). These have been described elsewhere.<sup>1</sup> The C.F.D.E. No. 1 and No. 2, whilst performing satisfactorily in their prime function as no-tone detectors on subscriber-originated calls within the local telephone network, have certain disadvantages from design and operational points of view. A major disability is that when used in the fault-tracing mode the calling party on a faulty call is prevented from releasing the connexion and making a second attempt until the call has been at least partially traced by the maintenance staff. Safeguards introduced to limit the period over which a call may be held, and to afford discrimination on the types of call monitored, have reduced the subscriber inconvenience to acceptable proportions.

From an operational viewpoint the absence of segregation of failed-call particulars from the printed-out record of all

calls monitored by the associated meter-check printer equipment is disadvantageous. The limitation in access and restrictions arising from the common use of access equipment with central service observation (c.s.o.) equipment reduce the value of the C.F.D.E. No. 1. A high sampling rate cannot be achieved when associated with c.s.o. equipment that waits for calls to arise on a limited number of selectors (i.e. "camp-on" type equipment) and neither can observations be made on circuits incoming to the exchange.

### STANDARD EQUIPMENT

The three standard equipments, C.F.D.E. No. 3, 4 and 5 have basic similarities of facilities but have been tailored to the needs of non-director, director and trunk exchanges respectively. Prototypes of the first two equipments have been evaluated on field trials, and standard equipments incorporating modifications tested during the trials are now being manufactured and installed. A prototype C.F.D.E. No. 5 for trunk exchanges is under development and will be the subject

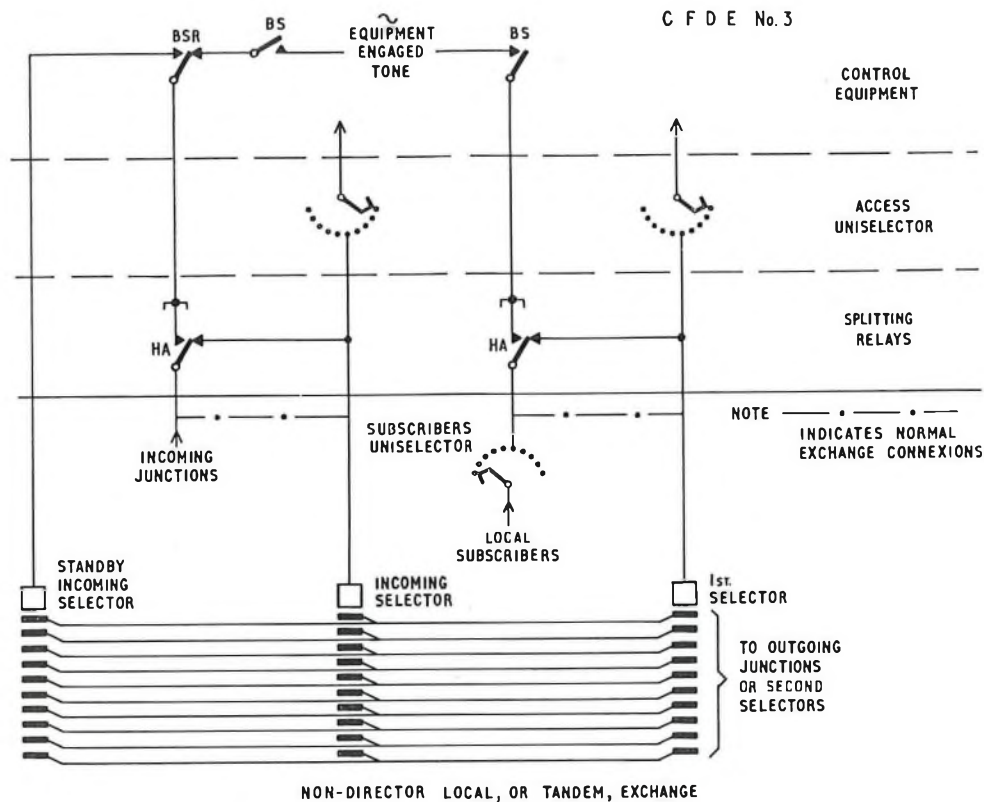

Note: At tandem exchanges access connected to incoming selectors only.

FIG. 2—Call-Failure-Detection Equipment No. 3: access trunking

of a later article. The two equipments described in this article are larger and more complex than the interim designs which they supersede. The following facilities have been incorporated in the design of the C.F.D.E. No. 3 and No. 4 to overcome the shortcomings of the interim equipment:

- (a) exclusive finder-type access affording a high sampling rate to a maximum of 192 local or incoming circuits,
- (b) line-splitting to permit a calling party to clear and make a second attempt when a faulty call is held; equipment engaged tone is returned to the caller in these circumstances,
- (c) standby selector switching on incoming junction circuits to maintain service when a faulty call is held,
- (d) storage of observed-call particulars, with visual displays of received and transmitted digits,
- (e) print-out of particulars of failed calls using a meter-check printer,
- (f) punched-tape record of all originating calls monitored.

The equipment, which is mounted on two 10 ft 6 in by 2 ft 9 in racks, is illustrated in Fig. 1 and consists of an access rack (shown right), and a control rack. A C.F.D.E. No. 4 is shown, the C.F.D.E. No. 3 being similar in general appearance.

### ACCESS ARRANGEMENTS

Access equipment for either 96 or 192 circuits is provided on a separate rack to the control equipment. Motor unselector finder-type, equipment is used to obtain access to an individual circuit on which a call has originated within a group of 24 in a manner similar to that used on the c.s.o. equipment described in an earlier article.<sup>2</sup> Early-choice local or incoming selectors are normally chosen to give maximum coverage of succeeding ranks of equipment, and these are jumpered on the distribution frame to cabling from the circuit-splitting relays which are provided on the access rack. Normally four groups of 24 circuits, forming one access unit,

are provided, but facilities exist for accommodating a second unit, thereby doubling the quantity to 192 circuits, where the size of exchange justifies. In those exchanges where a second access unit is not required, the space may be used for mounting miscellaneous apparatus. The access groups on which it is desired to observe may be selected by means of keys.

On the C.F.D.E. No. 3, any group may be associated with either local-call originating equipment, normally connected to first selectors, or with incoming junctions connected to incoming numerical or tandem selectors. It will be possible on all except prototype equipments to carry out combined observations over all selected groups, whether associated with originating or incoming traffic, separate meter indications being provided for each type of traffic.

On the C.F.D.E. No. 4, the first two groups of an access unit are always associated with originating equipment, i.e. first-code selectors and the fourth group with incoming equipment. On early equipment the third group can be associated only with originating equipment, but in due course optional use for originating or incoming traffic will be possible. Initially, use on either access groups associated with originating traffic, or the incoming access group, will be possible, but it is intended to provide combined observation facilities with registration on separate meters in the near future. The C.F.D.E. No. 4 includes a second motor unselector giving access to the A-digit hunter to permit monitoring of the setting-up of the call whilst observing originating traffic. The trunking arrangements of the access equipment are shown in Fig. 2 and 3 for C.F.D.E. No. 3 and No. 4 respectively. The association of an individual access circuit with the control connects the incoming line to the control equipment and enables all dialled digits to be monitored. In the event of fault conditions being detected, the circuit-splitting facility is brought into action to return equipment-engaged tone to the caller and permit the release of the calling equipment whilst the faulty connexion is being held forward. On an originating call an engaged condition is retained on the outlet to the first selector after the calling party is released, but on an incoming



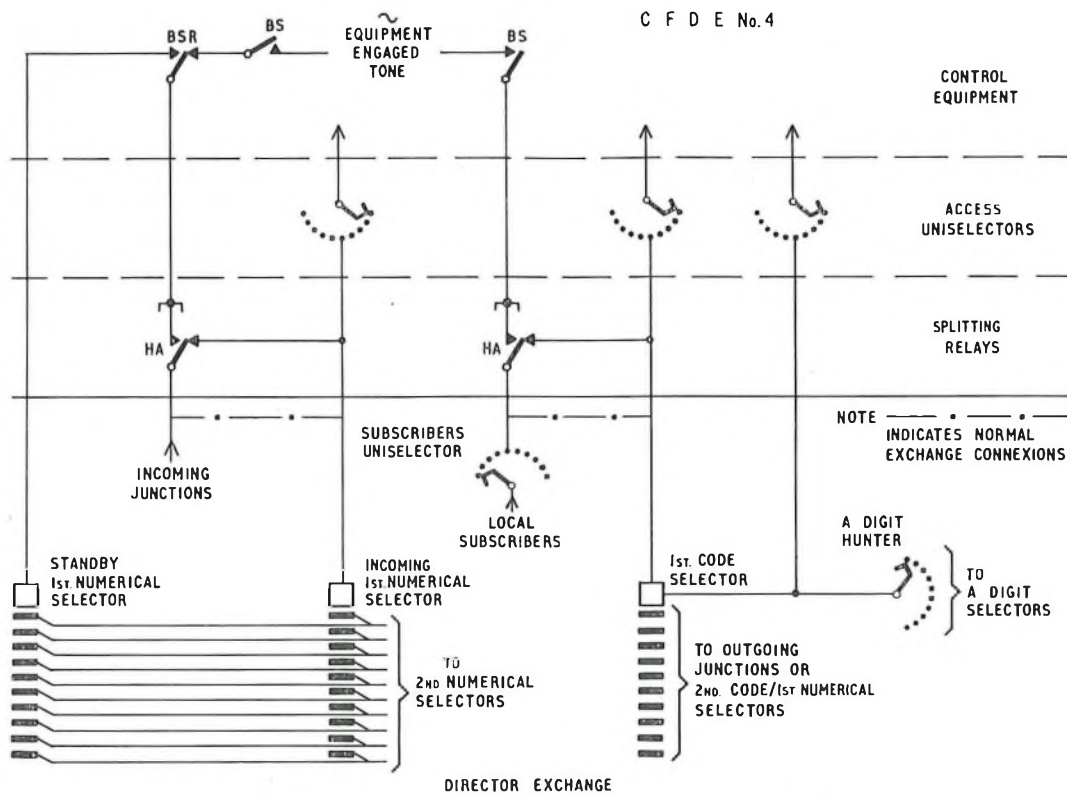

FIG. 3—Call-Failure-Detection-Equipment No. 4: access trunking

circuit it is necessary to prevent the loss of subsequent calls and so the control circuit transfers the junction to an appropriate alternative selector to avoid service interruption.

### CONTROL EQUIPMENT

The control rack includes a control panel, control relays, monitoring and tone-detection units, meter-check printer<sup>3</sup> and punched-tape control equipment. The control panel of a C.F.D.E. No. 4, shown in Fig. 4, includes a set of 10 single-digit display meters which indicate the digits dialled by the originating subscriber. A second set displays those received

over a junction (incoming groups) or transmitted by the director or local register (originating groups).

On the C.F.D.E. No. 3 only one set is provided to display the received digits. The display units also act as temporary stores of digital information to enable details of call failures to be printed out.

Four groups of discriminatory keys are provided. Two of these groups permit originating or incoming calls commencing with any selected initial digit to be excluded from observation, thus providing some degree of selection of the traffic to be observed. The remaining two groups, again associated with originating or incoming traffic, allow rejection of calls not

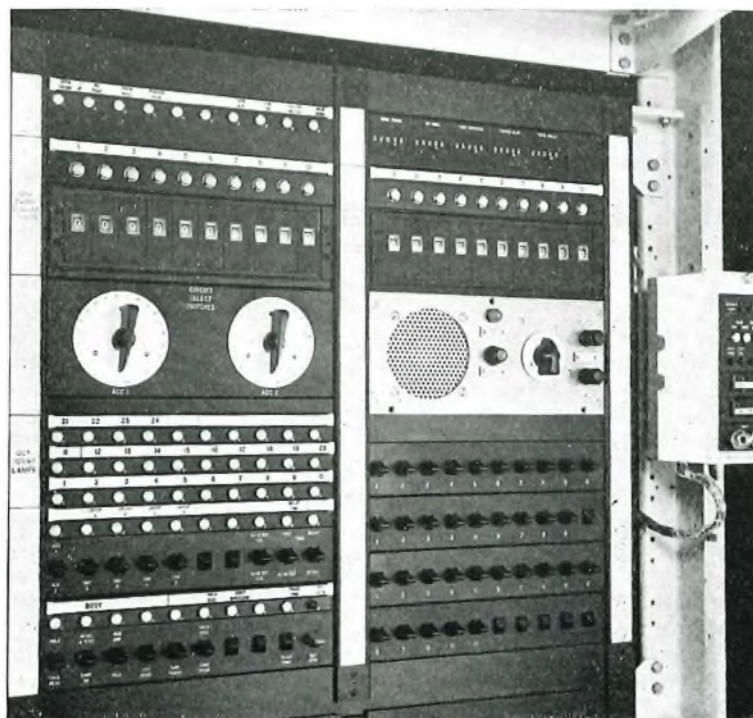

FIG. 4—Call Failure Detection Equipment No. 4: control panel

reaching the number of digits appropriate to the shortest valid code under observation. This permits some degree of rejection of subscribers' errors and can in some circumstances provide additional selectivity of traffic observed. The C.F.D.E. No. 3 includes second digit discrimination facilities necessary for the more complex code conditions met in non-director networks, but in this case control is exercised by wire strapping.

The 5-digit meters, on which a manual reset is provided, indicate the total calls observed, the no-tone, premature reversal and open trunk failures. For originating traffic observed on the C.F.D.E. No. 4 an additional meter indicates forced-release failures, but open trunks are not detected or indicated, mainly because of the masking effect of the forward holding earth from the first code selector. Lamps are provided, the most important of which indicate the access group and outlet on which an observation is being made, the particular fault condition encountered on faulty calls, and the last digit received on the digit display. A standard type of equipment monitor amplifier is provided to facilitate call supervision. A hand telephone jack is also provided for this purpose. Other keys and lamps control the c.f.d.e. under junction diversion and camp-on conditions, and permit connexion of trace tone, or disconnexion of hold conditions, when locating faults.

The monitoring units are high-impedance transistorized circuits used to detect pulsing, reversal of line potential, timing of open-trunk disconnexions, and, where appropriate, meter pulses. The 400 Hz tone receiver is similar in design to that described in an earlier article,<sup>4</sup> as is the pulse detector.<sup>5</sup> A standard meter-check printer is used to record details of all faulty calls in both the SERVICE MEASURE and HOLD AND TRACE mode of operation. The record consists of the date and time information normally provided, the digits dialled, or received at the incoming selector, where appropriate, the digits transmitted by a director or local register; and a code using the M and F characters to indicate the particular fault condition encountered and the stage at which it occurred. In addition the I/C symbol is printed to indicate those call failures occurring on access groups dedicated to incoming observations.

## TAPE PUNCH EQUIPMENT

The access equipment chooses calls initiated from the 96 (or 192) circuits in a chance manner and therefore affords information on the distribution of traffic over routes outgoing from the exchange, as well as to the constituent parts of the exchange. This information is of value for planning purposes and a facility is included for giving an output suitable for computer processing by means of a standard tape punch and winder. This equipment will not be provided on all installations, but, while connected, the call particulars are punched in 8-unit code form.

## OUTLINE OF OPERATIONS

Facilities for operation of the equipment in the SERVICE MEASURE or HOLD AND TRACE modes are provided under key control. In the latter mode, faulty calls are held and an alarm given in addition to the normal call and fault recording activity which takes place in both modes of operation. Access having been established to a call, the digits detected are stored on the digital display meters previously described. The tone receiver is connected on receipt of the preselected minimum number of digits dialled by a caller or received over an incoming junction. For originating calls in director exchanges, the end of sending signal from the director or local register is detected. Receipt of this signal permits the splitting of the circuit at this stage, thus preventing speech by the calling party causing false operation of the receiver. Where the number of digits expected is not known, e.g. in non-director networks, this is not possible. The tone

detector in this case is disconnected if another digit is received and then reconnected. The tone detector remains connected for a period of 4 to 10 seconds for local calls, or 12 to 18 seconds for s.t.d. calls, from receipt of the last digit or end of sending signal. It is possible to select these time periods at 2-second steps within the ranges, thus permitting some flexibility to meet the requirements of particular environments, e.g. routes from the exchange may include one or more regenerators and require a longer delay period. The selection of the period must be a compromise between allowing for the most onerous routing in this respect, and abandonment by the calling party of a failed call.

Receipt of any 400 Hz supervisory tone, or alternatively of a supervisory reversal or a meter pulse, is accepted as indication of a successful call and recorded as such on the total-calls meter. The connexion to the circuit is released and the access is immediately restored to normal to await the connexion of a call on the next selected access group. Acceptance of the alternative conditions as satisfactory ensures that a call where no tone is received owing to a rapid answer by the called party is not registered as a failure. Failure to receive an appropriate tone or supervisory condition within the prescribed period results in the operation of a no-tone meter as well as the total-calls meter. For incoming calls, and for originating calls in non-director areas, as far as the routing permits, the p-wire earth is monitored for indications of open-trunk conditions. Where an open trunk is detected, an earth is immediately connected to hold selectors up to the point of failure, and the open-trunk meter is operated in addition to the total-calls meter.

The line potential is also monitored during the process of setting up the call, reversals are detected, and once it is established that it is an abnormal condition, a premature reversal-meter is operated in addition to the total-calls meter. When the equipment is being operated in the HOLD AND TRACE mode, if any of the failures referred to above occurs, the circuit is split (or the split is maintained) and equipment engaged tone is returned to the calling party. Only one fault condition is registered for any one call, this being the first to be detected. For originating calls in director exchanges a forced-release condition from a director or local register under spare-code or faulty-equipment conditions is detected. The tone receiver is used to check the presence of number unobtainable (n.u.) tone; if tone is not present the condition is regarded as no-tone and treated as such. If n.u. tone is present, a forced-release meter is operated in addition to the total-calls meter.

## CONCLUSION

Call-failure-detection equipments have been adopted as standard maintenance items for the supervision of the quality of service and the location of faults in Strowger exchange networks. C.F.D.E. No. 3 and 4 will gradually supersede the simpler forms of interim equipment, which are now in widespread use. A new equipment for trunk exchanges (C.F.D.E. No. 5) will be introduced at a later date. These types of equipment give improved facilities, function with greater reliability and reduce the risk of prolonged interference with service compared with the interim designs of equipment. This type of equipment is intended to supplement rather than supplant other methods of fault location such as automatic routining and test-call sending. The method has the dual advantages that equipment need not be taken out of service until it is proved to be faulty, and that the equipment is operating under normal conditions as evidenced to the subscriber. It has the disadvantages that it is dependent upon the reliability of the supervisory tones throughout the network and can be affected by subscribers' misoperations, whilst the total circuit access is limited by physical and economic considerations. Nevertheless, the results to date justify the introduction of this equipment as an essential step in the



policy of improving the service to existing subscribers. It provides information for engineering management on the quality of the automatic service and provides a means of detecting network faults which are difficult to find by other methods of fault location.

#### ACKNOWLEDGEMENTS

Acknowledgement is made to Messrs Plessey Telecommunications Limited, Nottingham, and in particular Mr. M. V. Dunn, for their part in the development of C.F.D.E. No. 3 and No. 4.

#### References

- <sup>1</sup> PYRAH, J. D. Call-Failure-Detection Equipment: Interim Equipment for Director and Non-Director Exchanges. *P.O.E.E.J.*, Vol. 60, p. 202, Oct. 1967.
- <sup>2</sup> VIGAR, C. D. Central Service Observation Equipment using a Transistor-Controlled Motor Uniselector. *P.O.E.E.J.*, Vol. 54, p. 9, Apr. 1961.
- <sup>3</sup> GREEN, B. A., and BLAKEY, H. A. Printing Recorder for use with Observation Equipment. *P.O.E.E.J.*, Vol. 53, p. 118, July 1960.
- <sup>4</sup> FRANÇOIS, R. A., and HOLLIGON, E. R. Measuring Quality of Service on Trunk Routes. *P.O.E.E.J.*, Vol. 60, p. 227, Oct. 1967.
- <sup>5</sup> SANDS, M. J. E. A New Dial-Pulse Detector. *P.O.E.E.J.*, Vol. 60, p. 300, Jan. 1968.

---

## Monitoring the Speed of Standby Engine-Generator Sets

J. S. TRUE†

U.D.C. 621.313.322-84

*This article indicates the past system used for speed monitoring and gives reasons for the frequency detector being chosen as the current method of speed monitoring. A brief description of the introduction and operation of the static frequency-detector is also given.*

#### INTRODUCTION

Diesel-engine generator sets used by the Post Office as standby to the public electricity supply are required to deliver power at a frequency which is compatible with the equipment that is to be fed. To achieve this, the engine sets are governed to operate the generator at  $50 \pm 2$  Hz, which is well within the limits laid down by the telecommunications equipment designers (45 to 55 Hz). The engines are under complete automatic control, and monitoring of speed is therefore essential both to detect successful completion of the starting sequence and to initiate shut-down of the engine should the governor fail to maintain the engine speed within acceptable limits during running. As engine generators operating at 50 Hz can run at 750, 1,000 or 1,500 rev/min., depending on size and design (the larger sets usually being the slower), the monitoring of engine speed may be either by mechanical or electronic devices suitable for the speed range of the engine or, by monitoring the frequency of the generator output.

In the past, speed detection has been mainly by means of centrifugal switches, either direct or belt driven from the engine crankshaft. The available mechanical items have an inherently poor reliability record resulting from mechanical failure and the need for constant readjustment.

#### METHODS OF SPEED DETECTION

When considering the design of current standard engine generators, centrifugal switches were eliminated from the design of the control system. A survey of possible methods of speed monitoring revealed that solid-state frequency detectors

and direct-driven tachogenerators were the only acceptable alternatives. A detailed study resulted in the selection of the frequency detector, since the addition of a tachogenerator to an engine is expensive, its mounting sometimes costing more than the tachogenerator. Also, if a tachogenerator is used, a voltage-detector has to be incorporated to change the voltage output signal into a form suitable for control purposes. This detector could be comparable in cost to a frequency detector. In addition, tachogenerators are susceptible to mechanical and magnetic failure. Conversely, frequency detectors can be a standard unit not related to engine speed or type.

Frequency detectors may also be sited at any convenient point away from the effects of vibration. This is usually the power-plant control cubicle.

#### FREQUENCY-DETECTOR SPEED MONITOR

Suitable frequency detectors were not commercially available, and special items were developed by several firms in conjunction with the Post Office. All the units that have been tested and approved to date have used well-proven circuit elements. A block diagram of a typical unit is shown in Fig. 1.

The a.c. input is taken from the engine generator output and used to produce a constant-amplitude d.c. pulsed at the same frequency as the a.c. input.

#### Diode Pump Circuit

The pulsed d.c. is fed into a diode pump circuit; this comprises diodes, capacitors and a resistor as shown in Fig. 2. The output of the pump circuit is dependent on the charge and discharge of capacitor C2. When a signal is applied to the input, capacitors C1 and C2 charge until the signal is

† Service Department, Telecommunications Headquarters, formerly Telecommunications Development Department.

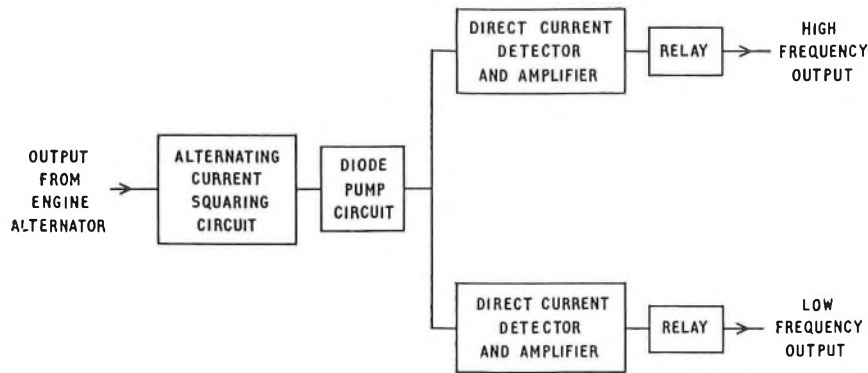

Note: High Frequency Output (60 Hz Engine Overspeed)  
Low Frequency Output (45 Hz Engine Speed Minimum Acceptable)

FIG. 1—Block schematic diagram of frequency monitor

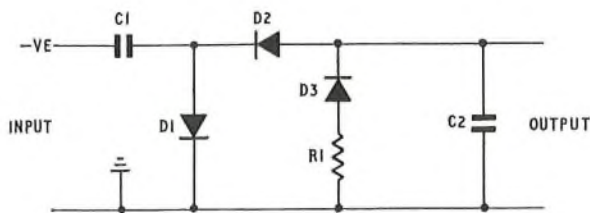

FIG. 2—Diode pump circuit

removed. When the signal is removed, capacitor C1 discharges through diode D1, diode D2, being back-biased, restricts the discharge of capacitor C2 to the path, diode D3 and resistor R1. A train of pulses at the input results in the mean voltage across capacitor C2 reaching a stable state when the charge and discharge are equal. This mean voltage is dependent on the duration of the pulses and hence the frequency. The voltage is given by the following formula:

$$V = E \frac{fCR}{1 + fCR},$$

where  $V$  = voltage across capacitor C2,  
 $E$  = amplitude in volts of each input pulse,  
 $f$  = frequency of input signal in Hz,  
 $R$  = value of shunt resistance across capacitor C2, in ohms,  
 $C$  = value of capacitor C1 in farads.

As all components in this formula with the exception of frequency are constant, the output voltage is dependent on frequency. In practice the output is not a steady d.c. voltage but one having a ripple as shown in Fig. 3. By use of a suitable d.c. voltage detector and amplifier, a relay can be made to operate at any given frequency.

### Temperature Variations

During acceptance testing of the prototype units, several problems were encountered following temperature cycling and high-voltage surge testing.

At the time of development a temperature range  $-10^{\circ}\text{C}$  to  $+40^{\circ}\text{C}$  was considered to be possible in engine rooms. Cycling between these temperatures caused certain potentiometers (used for adjusting the operate frequencies) to fail and soldering on printed circuits boards to become high resistance. As a result, special attention was given to the choice of components and the assembly techniques used.

### Voltage Surges

Previous investigation into voltage spikes on a.c. and d.c. supplies had showed that, for reliability, electronic units should be capable of absorbing 2 kvolt surges of 1 ms duration. Some components in the prototype units were in fact destroyed when subjected to such voltages and additional surge-suppression circuits were required. The most effective suppression circuit was found to be a capacitor and resistor in series across the supply.

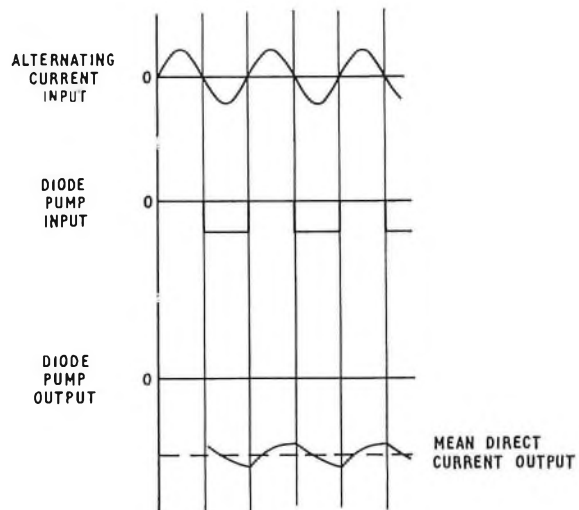

FIG. 3—Output of the diode pump

### CONCLUSIONS

Frequency detectors have now been incorporated in the latest standard engine generator control-cubicles and up to five years operational experience has been obtained. Few service faults have occurred up to the present time, making a detailed analysis of faulty components difficult. However, sufficient data are available to show that the mean time between failures of the frequency detectors is about four times that for centrifugal switches. This increase in reliability, in addition to the cost saving, more than justifies the change-over in monitoring from mechanical to electronic devices.

Electronic replacements for other items having a high failure rate, such as moving-coil relays, are now being developed and will be subject to a field trial shortly. These efforts will significantly increase the reliability of all power plant.



# Transit-Trunk-Network Signalling Systems

## Part 3—Line-Signalling Systems

C. B. MILLER and W. J. MURRAY†

U.D.C. 621.395.37:621.395.38

*Parts 1 and 2 of this article outlined the signalling arrangements adopted for the trunk-transit network and described the facilities and operation of the multi-frequency senders and receivers at the switching centres. Part 3 deals with the three line-signalling systems used, and describes the facilities and method of operation of each.*

### LINE SIGNALLING

Each circuit of the transit network is equipped with an exclusive line-signalling system. Whereas the register signalling system, S.S.M.F.2, is used only during the setting-up of a connexion, all the line-signalling systems associated with the individual links of a transit-network connexion are in use for the duration of that connexion.<sup>1</sup> Three line-signalling systems are available, namely S.S.A.C.11, S.S.A.C.12 and S.S.D.C.3, each providing the same basic facilities and the same interfaces with exchange register and switching equipments, but individually catering for different line-transmission media.

A transit-network line-signalling system provides for seizing, holding and releasing the circuit with which it is associated and for relaying supervisory conditions from incoming to outgoing ends. Line signalling is effected on a link-by-link basis and, at a transit exchange, backward-supervisory conditions are relayed from an outgoing-line relay-set to the incoming-line relay-set associated with the preceding link in the connexion. For this, d.c. signalling is used through the transit-exchange switch block. The line relay-sets terminate 4-wire line-transmission circuits and include a 7 dB attenuator, which is connected into the 4-wire receive path to adjust speech-transmission levels at transit points and to provide an overall 2-wire-to-2-wire nominal transmission loss of 7 dB at terminal g.s.c.s.

At terminal g.s.c.s, access to and from the transit network is on a 2-wire basis, and the required 2-wire terminating equipment is conveniently accommodated in the outgoing and incoming g.s.c. line relay-sets. At transit exchanges, an incoming relay-set first extends the 4-wire line circuit to register and S.S.M.F.2 equipment via a register-finder. Subsequently, when register signalling has been completed and the connexion through the transit exchange established, it extends the 4-wire line circuit via the transit switches to the line relay-set associated with the selected outgoing transit-circuit.<sup>3</sup>

An incoming line relay-set at a terminal g.s.c. provides the 4-wire line circuit with access to incoming register and S.S.M.F.2 equipment during the setting-up of the connexion, and subsequently extends a derived 2-wire circuit to the subsequent exchange equipment.

### SEQUENCED RELEASE OF LINE CIRCUITS

All the line-signalling systems provide for sequenced release of the circuit and associated exchange equipment. Following the start of the release of a circuit, a release-guard signal is transmitted by the incoming relay-set. The outgoing equip-

ment is maintained in a busy condition until all the incoming equipment has restored to normal, when the release-guard signal is disconnected.

If, due to a line or equipment fault, the outgoing relay-set does not receive a release-guard signal at the due time, it transmits a signal to re-seize the incoming relay-set which, for a both-way circuit, will maintain circuit-busy conditions on the outgoing multiple in the distant exchange. Subsequently, the outgoing relay-set transmits a release signal, which, if effective, will cause the incoming equipment to release and return another release-guard signal. This sequence is repeated at nominally 50-second intervals until such time as the fault is cleared and correct signalling conditions are established, or until maintenance attention is given. Circuit arrangements in the incoming relay-sets ensure that incoming register equipment is not periodically taken into use during this repeated seize and release re-test sequence.

### BACKWARD BUSYING

All the line systems provide a facility for busying the circuit from the incoming end. The insertion of a busying link into an incoming relay-set, or routine testing of associated incoming switching equipment, will cause a continuous backward-busy signal to be transmitted to the outgoing relay-set; this causes the circuit to be busied at the outgoing exchange.

### SIGNALLING SYSTEM A.C. 11

Signalling system A.C. 11 is a 1 v.f. within-speech-band system designed for general use and, in particular, to terminate circuits routed via standard frequency-division-multiplex

TABLE 4  
S.S.A.C.11 Signal Code

Signal	Transmitted Signal Duration (ms)	Recognition Time of Signal (ms)
<i>Forward Signals</i>		
Seize .. .. .	50-80	20-35
Clear .. .. .	650 (minimum)	400-600
<i>Backward Signals</i>		
Answer .. .. .	200-300	100-150
Clear .. .. .	200-300	100-150
Release Guard .. .. .	650 (minimum)	400-600
Blocking (unidirectional)	Continuous	35 maximum
Blocking (Bothway) ..	Continuous (1,650 (minimum))	120-180 (note)

Note: Bothway equipment recognizes a signal of duration less than 150 ms as a seizure signal and a signal of 150 ms duration or more as a blocking signal.

† Mr. Miller is in the Telecommunications Development Department, Telecommunications Headquarters, and Mr. Murray is in the Network Planning Department, Telecommunications Headquarters.

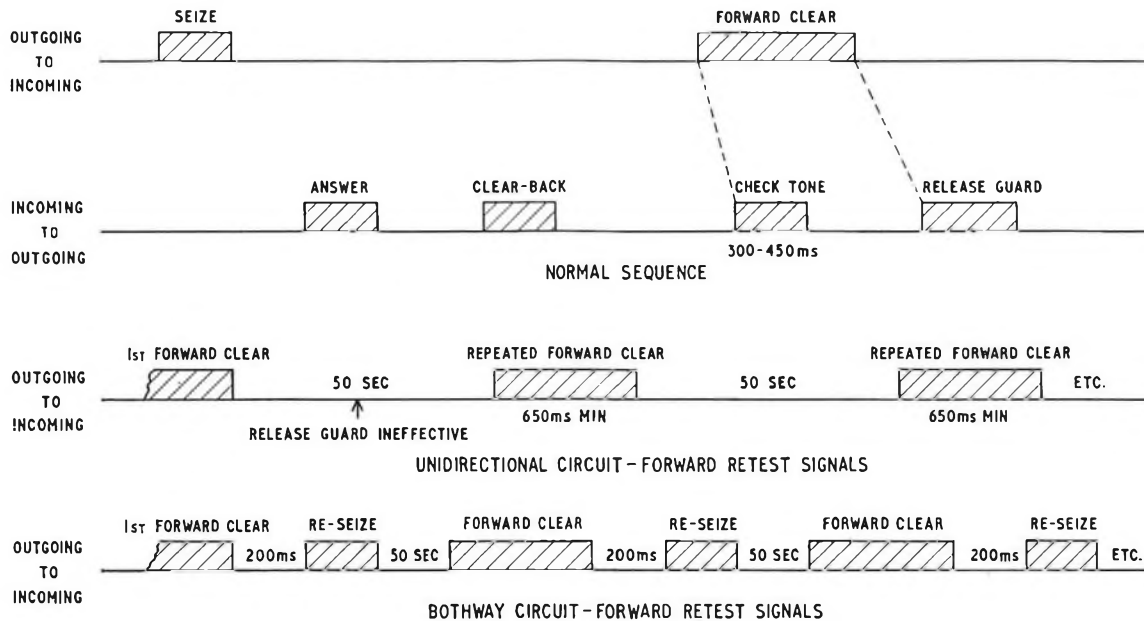

Hatching indicates 2,280 Hz signal.  
 FIG. 6—S.S.A.C.11 sequence of signals

transmission equipment. It employs a signalling frequency of 2,280 Hz and is similar in this and other respects to the trunk system S.S.A.C.9.<sup>6</sup> Table 4 gives the signal code and signal-recognition times. The signalling sequence is shown in Fig. 6.

The v.f. signalling equipment is connected to the 4-wire transit-network line circuits as illustrated by Fig. 1. The transmitted level of the signals is  $-6 \pm 1$  dBm0. The receiver is connected to the exchange side of the 7 dB attenuator in the 4-wire receive path, and, as this is a  $-3$  dBm0 point, the nominal level of the received signal at the receiver is  $-9$  dBm.

### V.F. Line Receiver and Buffer Amplifier

Protection of the v.f. receiver from near-end interference is achieved by the use of a zero-gain buffer amplifier in the 4-wire receive path following the receiver. A control lead to this amplifier is used during signalling to switch it off and effectively split the receive path, so limiting the spill-over of signals to subsequent links. Line spill-over is directly controlled by the v.f. receiver, and hence spill-over signals are of short duration. The design of the v.f. receiver is basically the same as that of the transistor receivers used for S.S.A.C.9 and international signalling equipment, the circuit operation of which has been described elsewhere.<sup>7</sup> The difference between this and the other receivers is that it is operated from a 12-volt power supply derived from the central 18-volt + 18-volt supply for the S.S.M.F.2 equipment. The 50-volt version, as developed for S.S.A.C.9, is being used in S.S.A.C.11 equipment for the later transit-exchange installations. The receiver will not operate to signals of  $-28$  dBm or less, and has a response time of 8 ms over an input range of  $-9 \pm 9$  dBm and over a frequency range of  $\pm 25$  Hz with respect to the nominal 2,280 Hz signalling frequency.

### Check-Tone Feature

A signal-check feature is provided so that, once a call has been established, the receipt, by the incoming relay-set, of a line signal exceeding 80 ms in duration prompts the return of a check tone to the outgoing relay-set. This check tone causes the 4-wire circuit to be split in the outgoing relay-set. If the signal on the outgoing path prompting this check tone is transmitted by the outgoing relay-set, it will not be affected by the line split. However, a false signal arriving from preceding equipment will be disconnected by the split before it can be

fully effective in the incoming relay-set. Spill-over signals, being of short duration, do not cause check tone to be transmitted.

### Release Sequence

A unidirectional outgoing relay-set that fails to receive a release-guard signal during the release sequence, repeats forward-clear signals at 50-second intervals, alternate signals prompting the seizure and release of the incoming relay-set. In the same circumstances, the outgoing relay-set of a bothway circuit transmits a forward-seize signal, following the forward-clear signal, before the transmission of a release-guard signal is terminated at the incoming end. This seizure signal effects the seizure of the incoming relay-set at the other end of the circuit, and, consequently, busying conditions are connected to the distant outgoing multiple. The sequence of a forward-clear signal followed after a short interval of approximately 200 ms by a forward-seize signal is repeated until a release-guard signal is received. These release sequences are shown in Fig. 6.

### Backward Busying

The backward-busying signal is continuous. The incoming relay-set of a bothway circuit applies recognition timing to a backward-busy signal, and, when this time has elapsed, it causes the partner outgoing relay-set to apply a busying condition to the outgoing multiple and releases without having initiated register association.

Where a number of S.S.A.C.11 circuits are terminated on one incoming switching equipment, such as a crossbar switch, it is not possible to apply backward busying on the S.S.A.C.11 circuits if this switching equipment goes faulty or is taken out of service. The transmission of a number of continuous in-band signals at the same time would overload transmission systems. Consequently, it is arranged that, should the incoming selector be faulty, the incoming S.S.A.C.11 circuits associated with the selector are inhibited from sending a release-guard signal, and hence the circuits will ultimately be busied out after being seized and subsequently released.

### SIGNALLING SYSTEM D.C. 3

Signalling System D.C. 3 is for general use to terminate transit-network circuits that provide a continuous metallic



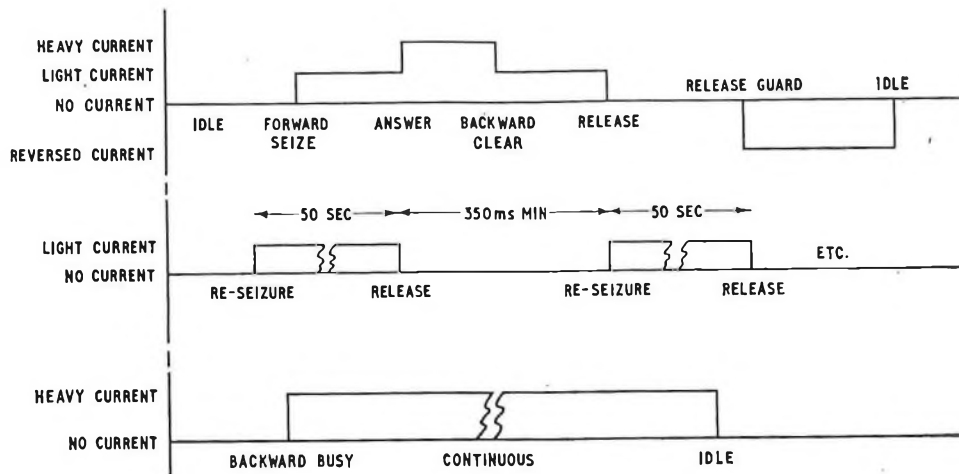

FIG. 7—S.S.D.C.3 signalling sequence

path for d.c. signalling. It employs loop signalling over the phantom circuit derived from the 4-wire line circuit and is designed to cater for circuits having not more than 5,000 ohms total signalling-path resistance. Immunity from interference by longitudinal currents induced into the circuit by external sources and from any earth-potential differences existing between the two ends of the circuit is obtained by connecting both the battery and earth at one end of the circuit. The signal code is shown in Fig. 7. Seizure, release guard and backward busying are signalled by the connexion of earth and battery potentials to the circuit, to cause loop current to flow. Supervisory conditions are signalled by increase and decrease in the loop current caused by changing the signalled resistance of an incoming relay-set. Polarized line relays are used, and, in the no-signal condition, the relay contacts are held over by current flowing through bias windings of the relays. Fig. 8 shows the basic line-signalling elements.

When the outgoing relay-set is seized, B relay contacts connect battery and earth potentials to the line via relay D. Loop current flows via the A relay in the incoming relay-set of such magnitude as to operate this relay and effect the seizure

of the incoming equipment, but is insufficient to overcome the bias flux in relay D in the outgoing relay-set. Subsequently, when the called party answers, relay DD in the incoming relay-set operates to reduce the loop resistance of the signalling path by approximately 17 kohms. The resultant increase in loop current causes relay D in the outgoing relay-set to operate and repeat supervisory conditions to preceding equipment, relay A in the incoming relay-set remaining in the seized condition. When the circuit is released, the B relay contacts in the outgoing relay-set restore to disconnect the line current and so effect the release of the incoming A relay and the incoming exchange equipment. The B relay contacts also connect relay BG across the line.

When the incoming equipment has restored to normal, a release guard is signalled in the form of battery and earth potentials connected via RG and DD relay contacts to line in the incoming relay-set. Relay BG in the outgoing relay-set operates and is subsequently released to free the circuit when the incoming equipment has fully restored and the battery and earth potentials are disconnected. The direction of the release-guard signal current, connected via DD relay contacts, is opposite to that of a seizure signal. This arrangement

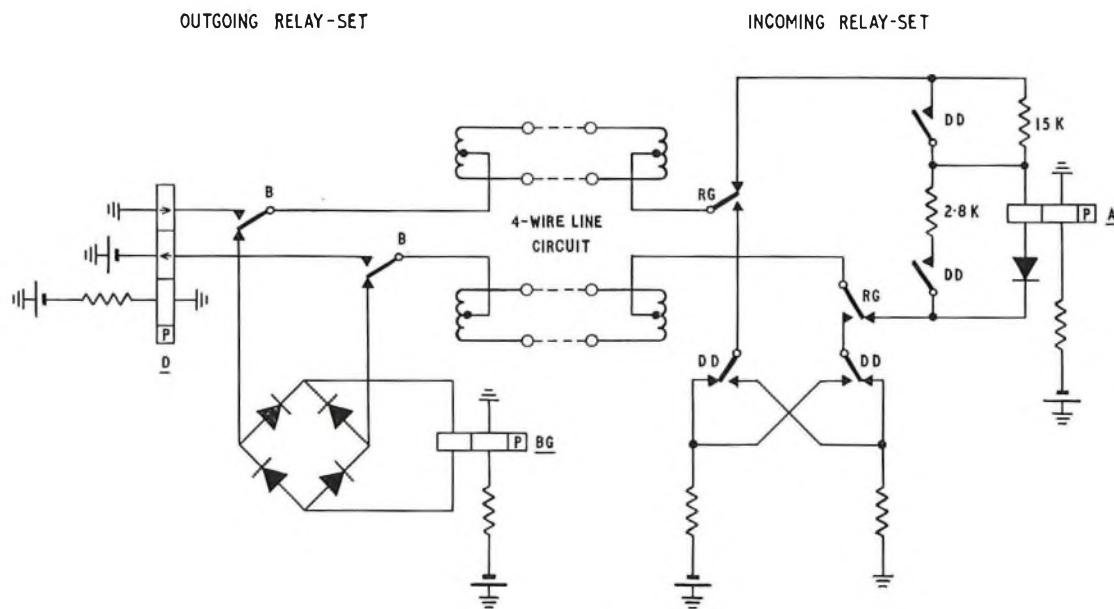

Note: When no current flows in the line coils of the relays the position of the relay contacts is controlled by the current in the bias winding. However, when sufficient current flows in the direction indicated by the arrows, the relay contacts change position.

FIG. 8—Signalling-circuit elements S.S.D.C.3

ensures that a spurious release guard occurring on a bothway circuit does not effect the seizure of incoming equipment and so cause a circuit interaction. When a bothway circuit is seized from both ends simultaneously, it is necessary for the outgoing relay-sets to accept a seizure signal as a release-guard condition, and hence relay BG is connected to line via a bridge rectifier which enables it to be operated by line current

in both directions. Backward-busy conditions are signalled by the operation of RG relay contacts and by RT (routine) relay contacts in the incoming relay-set.

### SIGNALLING SYSTEM A.C. 12

Signalling System A.C.12 is similar to the trunk system S.S.A.C.8,<sup>8,9</sup> and is used in association with transmission

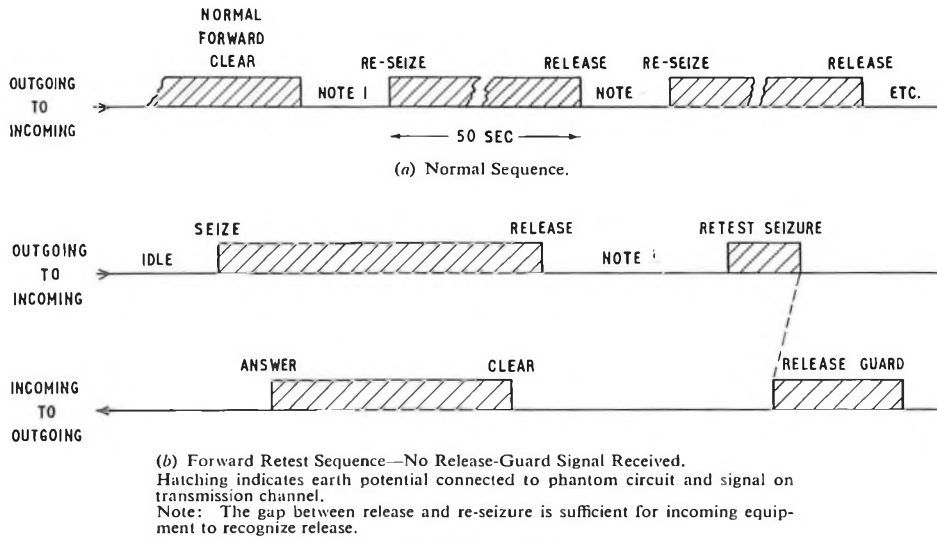

FIG. 9—S.S.A.C.12 signalling sequence

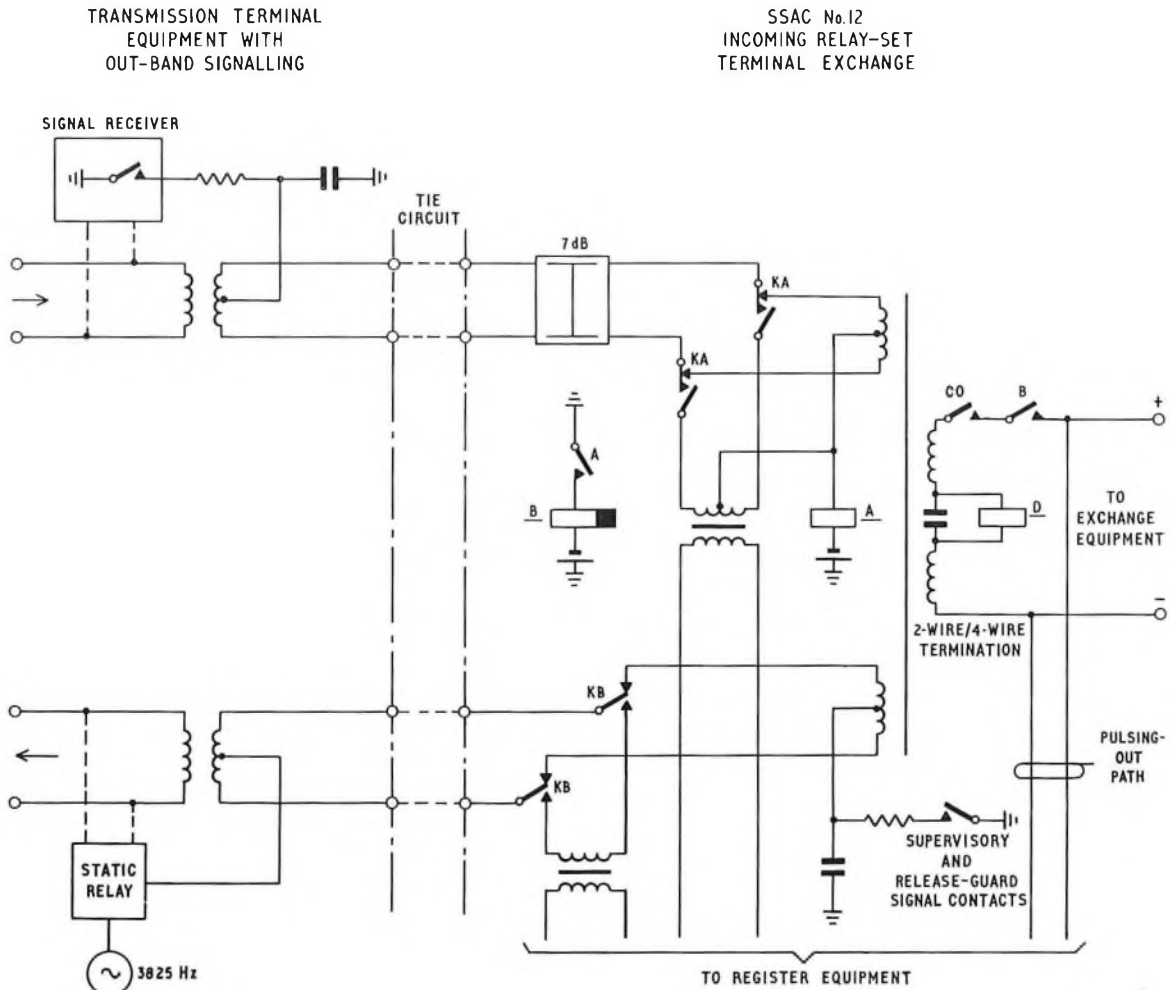

FIG. 10—Typical connexions of S.S.A.C.12 equipment



equipment which provides separate forward and backward signalling paths for each circuit which are independent of speech. A typical transmission equipment of this type employs a frequency of 3,825 Hz in both directions of transmission for signalling purposes. It is not for general use but for special circumstances as dictated by line-plant considerations. The signal code is shown in Fig. 9.

The connexion of typical S.S.A.C.12 equipment to transmission equipment providing outband-signalling facilities is shown in Fig. 10.

The signalling equipment required to transmit and detect the outband line signals over the two directions of transmission is integrated with the transmission equipment. The S.S.A.C.12 relay-set in the exchange controls, and is controlled by, earth signals over the two phantom circuits derived from the 4-wire tie circuit between the exchange and the transmission equipment. This tie circuit can be up to 10 miles in length using 20 lb/mile cable. The contacts in the S.S.A.C.12 equipment and in the transmission terminal which connect earth to the phantom circuits, do so via a simple resistor-capacitor network which limits the noise injected into adjacent pairs in the tie cable when these contacts make and break.

Forward seizure and backward answer are signalled by steady-state tone-on, earth-on conditions. Relays A and B operate when the relay-set is seized. A register is associated, and relays KA and KB are operated to extend the 4-wire transmission path to the register so that inter-register signalling can commence. At the end of the inter-register signalling sequence, and when pulsing-out by the register has been completed, relay CO is operated and relays KA and KB are released to extend the transmission path and a holding loop to the exchange equipment. The register is then released.

When the calling party clears, relays A, B and CO restore to release the exchange equipment and the relay-set. Sequenced release is provided by a backward-release guard signal. This signal is timed to be between 50 and 75 ms. and a recognition time of 100–150 ms for an answer signal ensures that, should a premature release guard be transmitted to an outgoing relay-

set in the unanswered condition due to a fault, e.g. a transmission failure of the forward transmission path, this signal will not cause the call to be falsely metered. A "re-seize" signal is continuously maintained during the retest sequence between successive forward clear signals in order to ensure that a bothway circuit is busied by virtue of the incoming relay-set being in a seized condition.

## ARRANGEMENT OF LINE EQUIPMENT

Unidirectional or bothway working can be employed. In the case of S.S.A.C.11, both unidirectional and bothway equipments are available. Bothway S.S.A.C.12 circuits are catered for by associating unidirectional outgoing and incoming relay-sets with a separate bothway switching equipment. All outgoing S.S.D.C.3 relay-sets incorporate a bothway switching element as a standard feature and can be associated with an incoming relay-set to provide a bothway line termination.

## CONCLUSION

The development of three line-signalling systems and a multi-frequency inter-register signalling system has enabled the transit network to be provided over the different types of line plant currently available and permits the advantages in switching and transmission offered by the transit network to be realized.

## References

- <sup>6</sup> MILES, J. V., and KELSON, D., Signalling System A.C. No. 9 *P.O.E.E.J.*, Vol. 55, p. 51, Apr. 1962.
- <sup>7</sup> WELCH, S., Line and Register Signalling Systems for Dialling over Transoceanic Telephone Cables. *P.O.E.E.J.*, Vol. 56, p. 111, July 1963.
- <sup>8</sup> HORSFIELD, B. R. and GIBSON, R. W., Signalling over Carrier Channels that Provide a Built-in Out-of-Speech-Band Signalling Path. *P.O.E.E.J.*, Vol. 50, p. 76, July 1957.
- <sup>9</sup> GIBSON, R. W., and MILLER, C. B. Signalling over carrier channels that provide a Built-in Out-of-Speech-Band Signalling Path. *P.O.E.E.J.*, Vol 50, p. 165, Oct. 1957.

## Book Review

"Fading Dispersive Communication Channels." Dr. Robert S. Kennedy. John Wiley and Sons, Ltd., xii+282 pp. 53 ill. 150s.

This book provides a detailed exposition of the theoretical performance of a random linear time-varying channel. The analysis, based on certain constraints, combines the concepts of communication, detection and information theory to determine the performance bounds of such a channel. The important constraints in the analysis are (a) the received signal is assumed to be a Gaussian process, (b) digital transmission is considered rather than analogue, (c) the signal is a large alphabet of equal-energy orthogonal waveforms that retain their orthogonality after transmission through the channel, this being obtained in the system considered by a combination of encoding and modulation techniques, and (d) in the sequential transmission of waveforms it is assumed that there is no intersymbol interference or memory. In general terms, the book provides a comprehensive treatment of the performance that can be attained when the information rate is small compared with the available system bandwidth, and is not much greater than the reciprocal of the "multi-path spread."

The mathematical model of the fading dispersive channel is discussed in terms of the scattering function  $\sigma(r, f)$ , and the Fourier related time-frequency correlation function. The scattering function defines the energy spectrum density for a range delay  $r$  and Doppler shift  $f$ . It is shown that the time-varying channel may be regarded as a classical diversity system, such that the optimum receiver consists of a number of parallel-branch demodulators detecting each of the paths separately. In Shannon terms, the capacity of the optimum system is

shown to be the same as an additive white Gaussian noise channel with the same average power-to-noise ratio. In addition, the performance of the optimum receiver in terms of probability of bit error is such that the fading dispersive channel requires about 5dB more power than the equivalent additive Gaussian noise channel at large values of energy-to-noise ratio per information bit  $E/N_0$ , reducing to a negligible power difference at low values of  $E/N_0$ .

Due to certain constraints assumed in the analysis much of the material on optimum performance in the later chapters of the book is only relevant to tropospheric scatter systems. It would have been helpful in stimulating further thought on the subject if the author had outlined some of the problems associated with dispersive mediums such as line-of-sight optical and microwave systems. Also, as much of the material in the book is based on the experience of the author in this field in the past decade (the West Ford Project is briefly mentioned), some practical results of actual receivers used and measured performance would provide a more balanced presentation of the subject.

The presentation of system performance in terms of system reliability per information bit rather than probability of bit error, and a definition of signal bandwidth based on the integral of the square of its power spectrum may be regarded as unconventional if not confusing by some communication engineers. However, in general this is an excellent book for those interested in fading communication channels, and who have the necessary level of mathematics and ability to reason about a subject that is conceptually difficult.

R. J. W.

# Some Principles of Local Telephone Cable Design

H. J. C. SPENCER, C.ENG., M.I.E.E.†

U.D.C. 621.395.73:621.315.211.2

*This article discusses the various electrical characteristics of a telephone cable and in particular the capacitance. The optimum cable capacitance is investigated both for minimum cable size and minimum material cost, taking into account changing prices. The way in which cable design is dependent on price changes is discussed as is the matching of cables to system transmission and signalling limits. Finally, present designs of cables are reviewed.*

## INTRODUCTION

The design of telephone cables is a many-sided activity in which the skills of the cable maker are allied to those of the system designer to produce cables which allow the operational requirements to be met in the most economic way. This article is confined to one facet of design, albeit an important one which can be lost sight of, namely, the determination of the preferred electrical characteristics for cables taking into account the costs of the materials from which they are made, and of the space they occupy in ducts. The system requirement considered is the connexion of telephones to a local telephone exchange and the arguments are confined to twin, rather than star quad, cables because the British Post Office now uses twin exclusively for local lines. The principles discussed are, however, applicable to telephone cables of other types used for other purposes.

## SYSTEM REQUIREMENTS

In a conventional telephone system each subscriber is connected to the local exchange by an individual pair of wires in multi-pair cables. The function of the pair of wires is twofold. Firstly, it provides a path for the currents, largely d.c., used for setting up and supervising calls, and for feeding power to the telephone transmitter. Secondly, it provides a path for alternating currents at speech frequencies. For the first function, the main requirement is a path of sufficiently low resistance with adequate insulation between wires. For the second function, however, as well as the wires being insulated from each other, the effect of the capacitance between the wires on the transmission of voice-frequency currents must be considered. Since, at the relatively low voltages used in telephony, adequate insulation can be achieved with very thin wire-coatings, the second function is the dominant one for telephone cables.

## FACTORS AFFECTING ATTENUATION

Inductance and insulation resistance have little effect on the transmission of voice-frequency currents. The attenuation,  $\alpha$ , of a cable pair is given approximately by:

$$\alpha = \sqrt{\left(\frac{R\omega C}{2}\right)} \text{ neper/km,} \quad \dots\dots(1)$$

where:  $R$  is the loop resistance in ohm/km and,  
 $C$  is the wire-to-wire capacitance in farad/km.

For a given attenuation, therefore, the product of  $R$  and  $C$  is fixed but there is freedom to vary their ratio between

limits set by practical considerations. Cables can be made with a low value of resistance and a high value of capacitance, or vice versa; that is, they can have thick conductors and thin insulation, or thin conductors and thick insulation. It is necessary to decide how, within this freedom, to design cables to provide a path of the required attenuation at the lowest material cost, or to best satisfy some other criteria.

## Dimensional Factors

The effect on cable size of varying the ratio of  $R$  to  $C$  while keeping the product constant can be evaluated using relationships between the electrical characteristics of a cable and the dimensions and physical properties of the conductor and insulation.

The loop resistance of a cable pair is given by:

$$R = \frac{8\rho}{\pi d^2} \times 10^7 \text{ ohm/km} \quad \dots\dots(2)$$

where:  $d$  is the diameter of the wire in mm and,  
 $\rho$  is the resistivity of the conductor in ohm cm.

The capacitance between the wires of a pair in a multi-pair twin cable<sup>1</sup> is given approximately by:

$$C = \frac{k}{\log [1.346(2x - 1)]} \text{ nF/km} \quad \dots\dots(3)$$

where:  $x$  is the ratio of the diameters of the insulated and uninsulated wires and,

$k$  is a constant depending upon the effective permittivity of the insulation.

Typical values for  $k$  are given in Table 1.

TABLE 1

Insulation	$k$
Paper and air .. .. .	55
Polythene (solid) and air .. .. .	66
Polythene (cellular) and air .. .. .	59
Polythene (cellular) and petroleum jelly	66

The significance of equation (3) is that, for a given insulating material, the capacitance depends only on the proportions of conductor and insulation, and is not affected by absolute size. Thus, in Fig. 1, pairs (a) and (b), although of very different size, have the same capacitance because they have the same value of  $x$ , whereas pair (c), although smaller in

† Operational Programming Department, Telecommunications Headquarters.



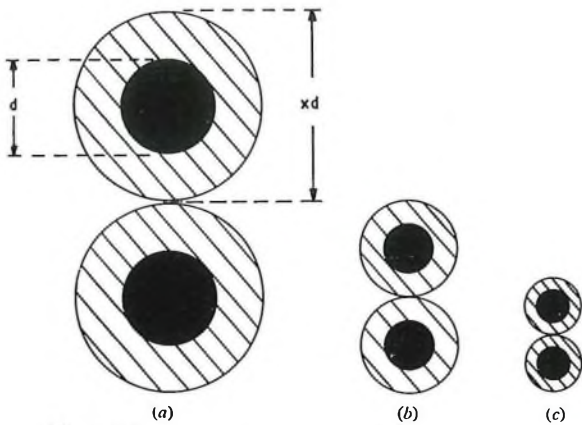

(a)  $x = 2$   
 (b)  $x = 2$   
 (c)  $x = 1.5$  } cable pairs with equal capacitances  
 (c)  $x = 1.5$  cable pair with higher capacitance than (a) and (b)

FIG. 1—Cable-pair cross-sections

size than (a) and (b), has a higher capacitance because of its smaller value of  $x$ .

The effect of varying  $x$ , and thereby the ratio of  $R$  to  $C$ , on the overall size of cable pairs is illustrated by Fig. 2. The

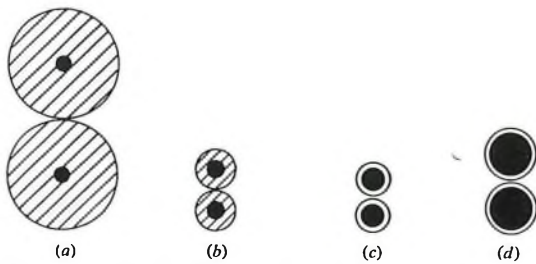

(a)  $x = 9$   $C = 20$  nF/km  
 (b)  $x = 2.5$   $C = 36$  nF/km  
 (c)  $x = 1.33$   $C = 83$  nF/km  
 (d)  $x = 1.1$   $C = 310$  nF/km  
 (Capacitances are for polythene insulation)

FIG. 2—Cable-pair cross-sections for equal attenuation

cable pairs, shown to scale in cross section, all have the same attenuation. It can be seen that extreme values of  $x$  result in significant increases in size, and that one value will result in minimum size.

### Design for Minimum Size

The overall diameter of an insulated wire of a pair is given by  $xd$ .

From equations (1), (2) and (3),

$$xd = \frac{x}{\alpha} \sqrt{\left\{ \frac{8\rho f k 10^{-2}}{\log [1.346(2x - 1)]} \right\}} \text{ mm} \dots\dots(4)$$

where  $f$  is the frequency at which the attenuation is measured.

This expression has a minimum, with respect to  $x$ , for an  $x$  of about 1.33. A multi-pair twin telephone cable will, therefore, be of minimum size, for a given attenuation, when the ratio of the diameters of the insulated and uninsulated wires is 1.33. This is true whatever the materials from which the conductors and insulation are made. Cable (c) in Fig. 2 has the minimum size proportions of conductor to insulation. The capacitance which results from this value of  $x$  depends

TABLE 2

Insulation	Capacitance, nF/km
Paper and air .. .. .	69
Polythene (solid) and air .. .. .	83
Polythene (cellular) and air .. .. .	74
Polythene (cellular) and petroleum jelly	83

upon the permittivity of the insulation and once this is specified then the capacitance for minimum size is also fixed.

Typical values of capacitance are given in Table 2.

### Design for Minimum Material Cost

If conductor and insulation materials cost the same by volume, and therefore by cross section, then the cable with the minimum cross section as determined above, would also have the lowest material cost. Conductor materials are, however, much more expensive. To evaluate the effect on costs of changing the proportions of conductor to insulation, the relative cross-sections must be appropriately weighted. This is done in Fig. 3 for the cable pair cross-sections of

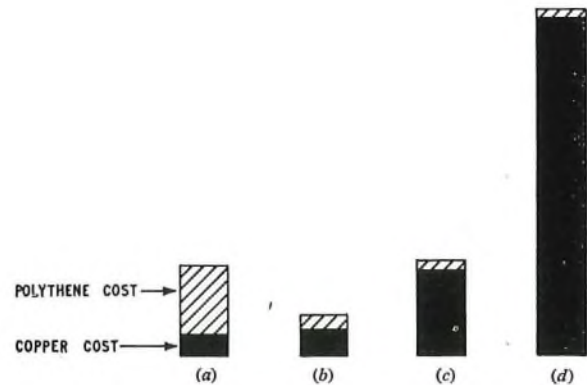

(a)  $x = 9$   $C = 20$  nF/km  
 (b)  $x = 2.5$   $C = 36$  nF/km  
 (c)  $x = 1.33$   $C = 83$  nF/km  
 (d)  $x = 1.1$   $C = 310$  nF/km

FIG. 3—Relative material costs for equal attenuation

Fig. 2 using the current prices for copper and polythene. (taken in this article at £450/tonne, and £165/tonne (1s 6d/lb.)) The figure shows that there will be an  $x$  which will result in minimum cost, and that this will not be the same as the  $x$  which gives minimum size.

The material costs per pair per unit length are proportional to:

$$\frac{\pi}{2} d^2 p_1 + \frac{\pi}{2} d^2 (x^2 - 1) p_2 + 8\sqrt{3} d^2 x^2 t_s p_3 \dots\dots(5)$$

where the first, second and third terms correspond to the material costs of conductor, insulation and sheath respectively, and  $p_1$ ,  $p_2$ , and  $p_3$  are the prices per unit volume of the materials from which they are made. The sheath term is derived from an empirical relationship between pair size and complete cable diameter, and  $t_s$  is the ratio of sheath thickness to the diameter of the cable core before it is sheathed. From equations (1), (2) and (3) and expression (5) the material costs of a cable pair are proportional to:

$$\frac{8\rho f k \left[ \frac{\pi}{2} p_1 + \frac{\pi}{2} (x^2 - 1) p_2 + 8\sqrt{3} x^2 t_s p_3 \right]}{\alpha^2 \log [1.346(2x - 1)]} \dots\dots(6)$$

This expression can be shown to have a minimum when:

$$x[(2x - 1) \log \{1.346(2x - 1)\} - x] = \frac{p_1 - p_2}{p_2 + 8.82 t_s p_3} \dots\dots(7)$$

From equation (7),  $x$  for minimum material cost can be evaluated once the prices of the materials are known. Note that the prices are the only factors which affect the value of  $x$ . The solution is independent of the resistivity of the conductor, the permittivity of the insulation, and of the design attenuation and frequency. Once  $k$  for the insulation is known the capacitance is also fixed. Typical values of capacitance are given in Table 3.

TABLE 3

Insulation	Capacitance, nF/km
Paper and air	28
Polythene (solid) and air	38
Polythene (cellular) and air	34
Polythene (cellular) and petroleum jelly	38

**THE IMPORTANCE OF CAPACITANCE**

The fact that design for minimum size and design for minimum material cost both result in the determination of a fixed capacitance, once the materials are specified, shows that this is the fundamental electrical characteristic. Once the capacitance has been fixed to satisfy a particular criterion the resistance, for a given design attenuation, can be determined from equation (1). The resistance is proportional to  $\alpha^2$  and since, from equation (2), it is also inversely proportional to  $d^2$ , it follows that the conductor diameter is inversely proportional to attenuation.

To summarize, the proportions of conductor to insulation should be fixed by material cost or cable size considerations, and the scale by the attenuation required.

The characteristic impedance,  $|Z_0|$ , of a cable pair is given by:

$$|Z_0| = \sqrt{\left(\frac{R}{\omega C}\right)} \dots\dots(8)$$

If  $C$  is fixed and  $R$  is a variable depending upon the design attenuation it follows that  $|Z_0|$  will also be a variable. Variation of impedance with conductor gauge is a situation which has long been tolerated in local-line networks. Cables could, in theory, be designed to have a particular  $|Z_0|$  regardless of conductor gauge but all freedom to design for maximum economy of materials, or for minimum cable size, would then be lost.

**Penalty for Departure from Optimum Capacitance**

The penalty for departing from the capacitance giving minimum material costs can be evaluated by comparing the costs for non-optimum design cables with the cost for the optimum design cable with the same attenuation. The results for copper/polythene cables are shown by Fig. 4. For this

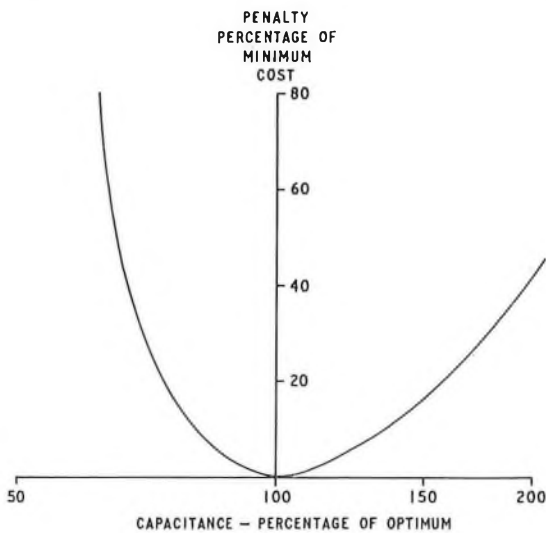

FIG. 4—Material-cost penalty for departure from minimum material-cost capacitance [copper conductors—polythene insulation]

combination of materials, gross departures involve significant penalties. Design is less critical when the difference between the conductor and insulation prices is smaller.

**COMPROMISE BETWEEN CABLE SIZE AND MATERIAL COSTS**

Because the minimum material cost and the minimum cable-size designs differ, a decision must be made as to which, if either, to adopt. The problem is illustrated by Fig. 5 in which

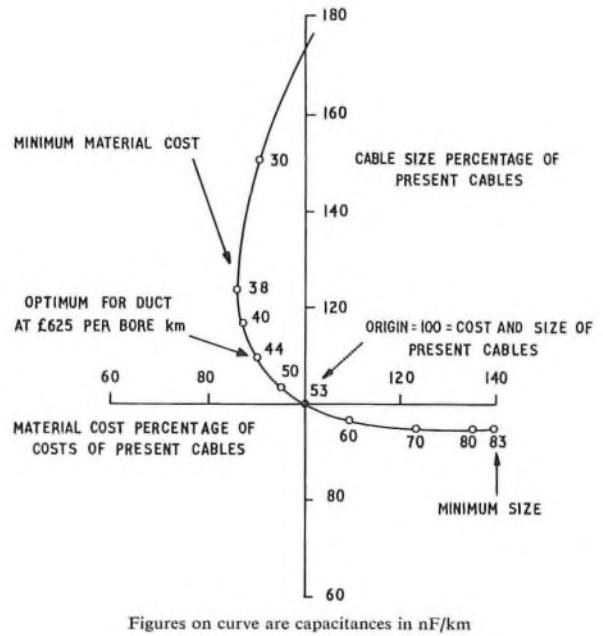

FIG. 5—Relationship between cable size and material cost (constant attenuation, copper conductors—polythene insulation)

the relationship between capacitance, material costs, and cable size is shown using the properties of existing cables as a datum. One approach to a compromise would be to select the point of greatest curvature as a working point. For the curve illustrated this is rather indeterminate but for some other materials and prices it is more clear cut. An alternative approach is to assign a value to duct space and to add this as a further component of the material cost in expression (5). Equation (7) then becomes:

$$x[(2x - 1) \log \{1.346(2x - 1)\} - x] = \frac{p_1 - p_2}{p_2 + 8.82t_s p_3 + 2.2(1 + 4t_s)p_4} \dots\dots(9)$$

where  $p_4$  is the cost per unit volume assigned to space in duct.

Assuming the cost per bore/km of 900 mm diameter duct to be £625, this gives a compromise  $x$  of 2.5. Corresponding capacitances are given in Table 4.

TABLE 4

Insulation	Capacitance, nF/km
Paper and air	34
Polythene (solid) and air	44
Polythene (cellular) and air	39
Polythene (cellular) and petroleum jelly	44

**DUCT COSTS**

The determination of the value to assign to space in duct is difficult. At one extreme duct costs are negligible, either because the cable is buried directly in the ground or because the space already available is sufficient for all future needs however prodigally it is used. At the other extreme, the value of duct space can be very high because only a little is left and



providing more would involve major civil engineering work. The value chosen avoids these extremes and is the marginal cost of providing extra bores at a time when excavation would already be necessary. It will be shown later that the actual value used is not very critical.

### SENSITIVITY OF DESIGN TO PRICE CHANGES

Equations (7) and (9) show that it is only the relative prices of materials and duct which are important. The changing value of money has no effect, therefore, but disproportionate changes in the price of one material must be considered. Fig. 6 shows the effect of variation in the price of

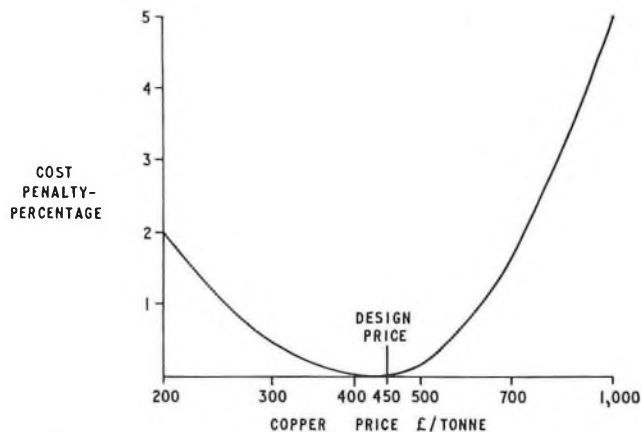

Note: The cost penalty is the material cost increase for using the design price shown instead of the true price. The penalty is expressed as the percentage of the cost of a cable designed for the true price

FIG. 6—Cost penalty for designing to the wrong conductor price

copper. The penalty has been calculated by comparing the material costs, for constant attenuation, of cables designed for copper at £450/tonne when the true price differs from this. A difference by a factor of 2 between the true and the design price only increases material costs by a few per cent so that it is clearly not worth while following normal price fluctuations by design changes. It would also be impracticable. Similarly, design is not critically dependent on the exact value assigned to duct space as shown by Fig. 7.

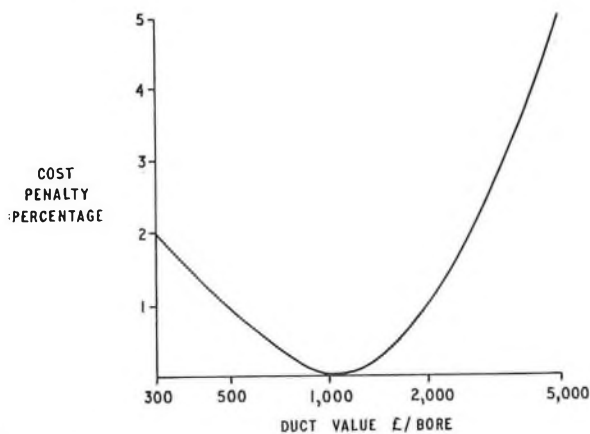

Note: The cost penalty is the material and direct cost increase for using the design duct value shown instead of the true value. The penalty is expressed as the percentage of the cost, including the duct cost, of a cable designed for the true value

FIG. 7—Cost penalty for designing to an incorrect duct value

### Manufacturing Costs

Manufacturing costs tend to be independent of conductor gauge and insulation thickness. As a constant added to the material costs they will, therefore, mask differences in them and minimize the advantage of following the principles of minimum cost design. In some circumstances, manufacturing

costs could have a component proportional to the volume of material used. For example, applying a thick insulation could slow extrusion speeds, or could involve an additional process. In this case it would be right to add the proportional component of the manufacturing cost to the material cost for design purposes. The manufacturing cost component could be negative. For example, wire-drawing costs increase as the diameter of the finished wire is reduced.

### MATCHING CABLES TO SYSTEM TRANSMISSION AND SIGNALLING LIMITS

To ensure satisfactory operation of a local telephone system, the lines must be planned to meet both an attenuation and a signalling limit. For most of the British Post Office system these are respectively 10 dB (at 1,600 Hz) and 1,000 ohm.<sup>2</sup> For maximum economy, it is desirable that cables should have electrical characteristics which result in these limits being met at the same line length. This is illustrated by Fig. 8 in which attenuation is shown as a function of

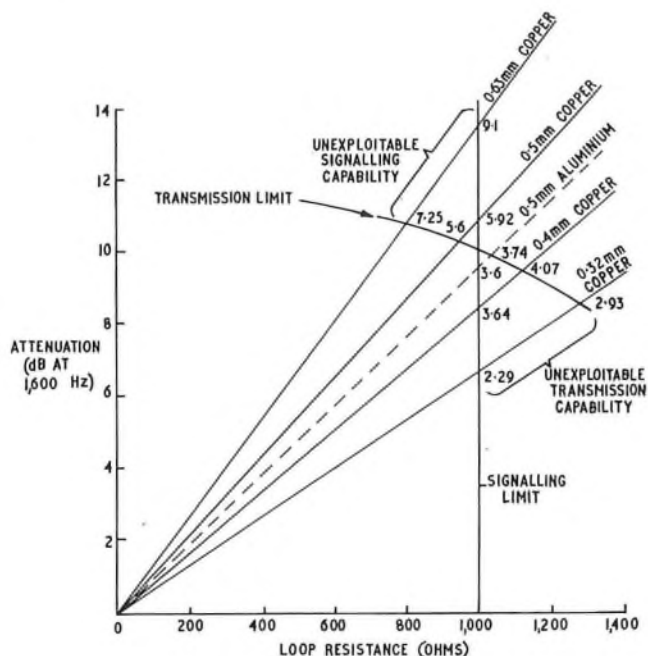

Note: All cables have polythene insulation. Cables with copper conductors have nominal capacitances of 53 nF/km. Figures on curves are the lengths in km

FIG. 8—Cable characteristics related to transmission and signalling limits

resistance for four common types of copper-conductor cable with polythene insulation. The transmission and signalling limits are also indicated on the figure. The 0.5 mm\* cable nearly satisfies the requirement of meeting both limits at about the same line length (0.5 mm cable with paper insulation meets it exactly).

The 0.32 mm and 0.4 mm cables, however, reach the signalling limit first and have unexploitable transmission capability, and the reverse is true of the 0.63 mm cable. Unfortunately, the electrical characteristics which give the best value in terms of attenuation versus material costs, often conflict with those necessary to meet the transmission and signalling limits at the same line length. It has been shown, for example, that the optimum capacitance for the cables shown in Fig. 8 is about 44 nF/km, but if the capacitance of the 0.5 mm and 0.32 mm cables were reduced to this from the present 53 nF/km the result would be merely to rotate the curves for these cables in Fig. 8 clockwise about the origin. The maximum usable line lengths, set by resistance, would remain unchanged and no economic advantage could be

\* The new metric conductor measurements are used. These are referenced to Imperial weight measurements in the appendix.

gained to set against the additional cost and size of cable. For the 0.63 mm cable, however, a change to a lower capacitance would be beneficial because at present it is limited by the transmission maximum.

From the foregoing it can be seen that in the short term the relationship between the transmission and signalling limits may sometimes make it unprofitable to follow the principles of minimum material cost design. In the long term, however, the only fundamental barrier to overcome is the attenuation. If a circuit is satisfactory for transmission then signalling is always possible. The signalling performance of exchange equipment has in general followed the transmission capabilities of telephones. The possibility of being able to exploit the transmission properties in the future is a reason for following the principles of economic design even though there is nothing to be gained immediately.

Another reason is provided by the nature of the transmission limit. It is not an attenuation which, if exceeded, results in calls being impossible, but one which results in the vast majority of calls being satisfactory. It is affected, therefore, by the transmission performance of every telephone and line in the system, and a general reduction in attenuation can indirectly allow an increase in the maximum permitted.

### PRESENT CABLE DESIGNS REVIEWED

Local telephone cables at present have capacitances of about 53 nF/km, considerably higher than those shown to be desirable. It is not surprising that this is so because the designs were fixed at a time when cable materials and prices were very different from those now current.<sup>3</sup> Sheaths were of lead, which, since it is much more expensive than polythene, is a strong incentive for designing compact cables, and the conductors were insulated almost exclusively with paper.

Because of the present relationship between transmission and signalling limits there is nothing to be gained in the short term by optimizing the design of cables with copper conductors of 0.5 mm diameter and less. Indeed a case could be made for moving even further from the optimum for cables with 0.4 mm and 0.32 mm conductors. Change would be beneficial for cables with 0.9 mm and 0.63 mm conductors but these are not now widely used. The position is very different for cables with aluminium conductors, however.

### Optimum Design Principles Applied to Cables with Aluminium Conductors

The continuing high price of copper has driven many telephone administrations to consider the use of aluminium as an alternative. In trials started as long ago as 1956<sup>4</sup> the British Post Office has overcome the practical difficulties and is now using this metal exclusively for the jelly-filled cables in the non-pressurized part of the network beyond the cabinets.<sup>5</sup> For convenience, the cables used in trials have the same electrical characteristics as the cables with copper conductors they replace but the complete change-over has now given opportunity to review the design.

Aluminium is about half the cost by weight of copper, and about one fifth the cost for equal resistance, but the significant fact in the light of equations (7) and (9) is that it is only about one eighth of the cost per unit volume. As a result the optimum capacitance, taking into account duct costs, is about 67 nF/km. This leads to the paradox that cables with aluminium conductors should have lower resistances than their copper conductor counterparts, despite the higher resistivity of aluminium.

Although the change to the optimum capacitance for cables with aluminium conductors both reduces their size and the cost of materials, the most important effect of change to a higher capacitance is that, for the higher attenuation cables now commonly used, the matching of the electrical characteristics to the British Post Office transmission and signalling limits is much improved. This is illustrated by the curve for cables with 0.5 mm aluminium conductors shown

in dotted line in Fig. 8. These cables are particularly suited for use in the British Post Office system as shown by the comparison with the commonly-used cables with 0.4 mm copper conductors and polythene insulation (Table 5).

TABLE 5

Characteristic	0.4 mm copper	0.5 mm aluminium
Resistance, ohm/km ..	275	278
Capacitance, nF/km ..	53	67
Attenuation, dB/km ..	2.3	2.6
Z <sub>0</sub>  , ohm at 1,600 Hz ..	720	645
Limiting line length, km	3.64	3.6
Relative size ..	100	100
Relative material cost ..	100	27
Relative total cost ..	100	64

Note: Assuming a constant manufacturing cost equal to the material cost of 0.4 mm copper cable.

Broadly, the aluminium conductor cables have very nearly the same limiting length of line and take up no more space in duct. They are about 36 per cent cheaper, however. Compared with cables with 0.32 mm copper conductors, the optimum design 0.5 mm aluminium conductor cables are superior in everything except size, and they are 20 per cent cheaper.

### CONCLUSIONS

The principles which should govern the choice of electrical characteristics for local telephone cables have been discussed. The optimum properties are found to be a compromise taking account of the need to minimize material costs, to minimize cable size, and to match system transmission and signalling limits. It is not possible to follow all the principles all the time and it is impractical to change established designs frequently. Where a change is to be made for other reasons, however, there may be significant economic advantages in following the principles. Such a change was the standardization of aluminium conductors for the distribution part of the local-line network and the cables with 0.5 mm aluminium conductors now being introduced into service are an example of the application of the principles of optimum design.

### References

- 1 SPENCER, H. J. C. Optimum design of local twin telephone cables with aluminium conductors. *Proceedings I.E.E.*, Vol. 116, No. 4, pp. 481-488, Apr. 1969.
- 2 SPENCER, H. J. C. A New Method of Local Line Transmission Planning, *P.O.E.E.J.*, Vol. 63, p. 84, July 1970.
- 3 BUCKLAND, E. H., and FRANKLIN, R. H. Some Notes on the Design and Manufacture of Telephone Cables. I.P.O.E.E. printed paper 144, Feb. 1932.
- 4 HAYES, H. C. S. The Dover-Deal Experimental Cable. *P.O.E.E.J.*, Vol. 48, p. 224, Jan. 1956.
- 5 WINTERBORN, E. E. L. This New Cable is Really Waterproof. *P.O. Telecommunications Journal*, Vol. 19, No. 3, p. 2, Autumn 1967.

### APPENDIX

#### Metric and Imperial Equivalents for Copper Conductors

Metric (wire diameter) mm	Imperial conductor weight lb/mile
0.32	2½
0.4	4
0.5	6½
0.63	10
0.9	20



# Remote Control and Supervisory Systems for Microwave Radio-Relay Links

R. D. MARTIN-ROYLE, C.ENG., M.I.E.E., M.I.E.R.E., and J. M. HEATHER †

U.D.C. 621.37.029.6: 621.39: 621.371: 621.394.347

*Automatic switching equipment for protection arrangements on broadband radio systems has created a need for remote control and supervisory indicating equipment for operational and maintenance reasons. This article describes the requirements of such equipment and the principles adopted to meet them.*

## INTRODUCTION

Earlier articles in this Journal have described the details of the U.K. microwave network<sup>1</sup> and the automatic protection systems<sup>2</sup> employed to ensure high reliability<sup>3</sup> when such large concentrations of traffic are being transmitted. In this article, a peripheral, but none-the-less vital, equipment which is now always associated with automatically-switched radio-relay systems, namely the remote control and supervisory equipment, is described.

As an introduction to the subject it is useful to review briefly the make-up of a typical multi-broadband channel link.

### Typical Multi-Broadband Channel Link

In a broadband microwave channel, the baseband signal consists of either a 625-line colour television signal or 1,800 frequency-division-multiplexed audio channels. This signal is applied to a modulator and frequency modulates the carrier frequency of 70 MHz.

aerial and feeder system and applied to a mixer together with a u.h.f. or s.h.f. signal offset 70 MHz from the receive signal. The output of the mixer is thus the original 70 MHz frequency-modulated signal. After any necessary amplification, this signal is applied to a frequency demodulator and the original baseband signal is recovered.

If, as is usual, the distance between the two terminals is too large for direct operation, intermediate repeater stations are necessary. A repeater is simply the u.h.f. or s.h.f. to 70 MHz part of a terminal receiver connected back-to-back with the 70 MHz to u.h.f. or s.h.f. section of a terminal transmitter. Thus, no demodulation is carried out at a repeater and all the necessary amplification is at i.f.

Repeaters are usually spaced at 25–35 mile intervals and on routes in the U.K. there are typically three or four such repeaters.

### Protection Arrangement

In order to avoid loss of traffic resulting from the failure

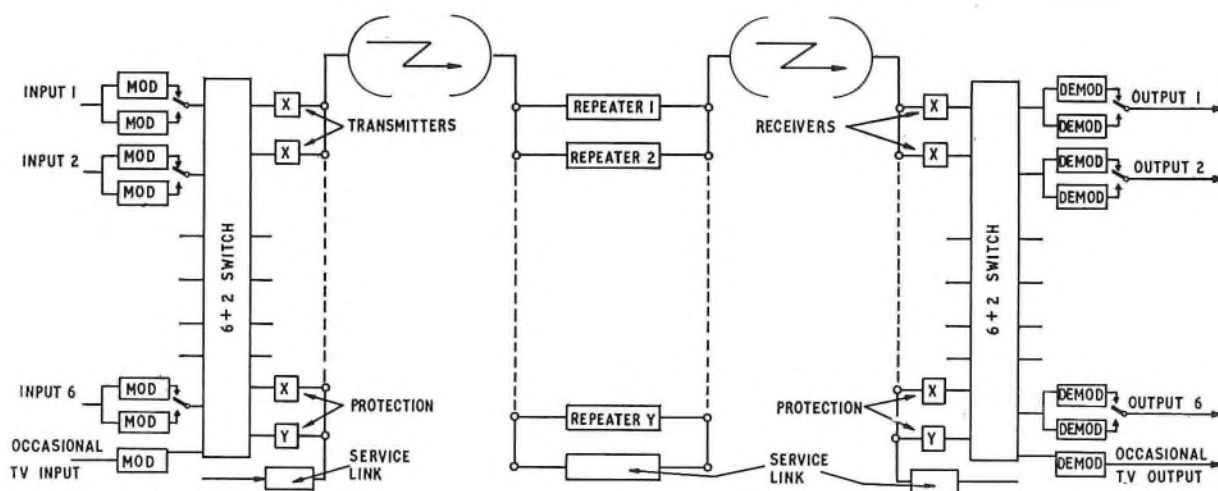

FIG. 1—Protection arrangement for radio-relay link

A transmitter is basically a frequency changer which converts the 70 MHz intermediate frequency (i.f.) signal into the required u.h.f. or s.h.f. range, the most common frequencies being 2 GHz, 4 GHz, 6 GHz, 7 GHz or 11 GHz. A travelling-wave-tube amplifier raises the level of the u.h.f. or s.h.f. signal to, typically, 10 watts and the output is fed to a parabolic-dish or hog-horn aerial using a waveguide feeder.

At a terminal station, the signal is received on a similar

of a broadband transmission path, the arrangement most commonly used in the U.K. is to provide additional broadband channels, with automatic switching at i.f. as shown in Fig. 1 and previously described in this Journal.<sup>2</sup>

The switching is carried out automatically by monitoring continuity pilots and noise on each of the working and protection channels. The detected outputs from these monitors are taken to logic circuits which determine any switching action that may be necessary. An auxiliary link is used to convey the automatic switching instructions between the two terminal stations.

† Network Planning Department, Telecommunications Headquarters.

## SUPERVISION AND CONTROL OF SWITCHING SYSTEM

For an automatically-switched system of, say, six working and two protection channels (6 + 2), it is necessary to monitor the state of each traffic path to ensure its fitness to carry traffic and to be able to override the automatic-switching equipment by manual control. The principle used in the P.O. network is receive-end control and a radio link is normally controlled from a point which is staffed 24 hours per day and situated at a station associated with the receive terminal of the radio link. Since most radio links are bi-directional, there will usually be two control points, one for each direction of transmission. If there is no suitably-staffed point geographically near the receive terminal, the control point may need to be located near the transmit terminal, probably at the same station as the control point for the reverse direction of transmission.

As the control point is normally remote from the radio terminal station, it is necessary to extend the indications and controls over land lines or a combination of land lines and

(c) *A modulator.* This is determined by the pilot detectors on the modulator outputs.

### Remote Manual Controls

Facilities are required to permit manual control of the switching system to effect one or more of the following operations:

(a) transfer of traffic from any working i.f. to i.f. channel to either of the protection channels,

(b) transfer of traffic to the second-choice modulator on each path,

(c) transfer of traffic to the second-choice demodulator on each path,

(d) exclusion of any i.f. to i.f. channel from the automatic switching facility. Any channel so locked out retains all its normal transmission and alarm facilities except the ability to participate in the automatic-switching action.

Each of the above actions must override any previous or subsequent automatic action until the system is restored to automatic operation.

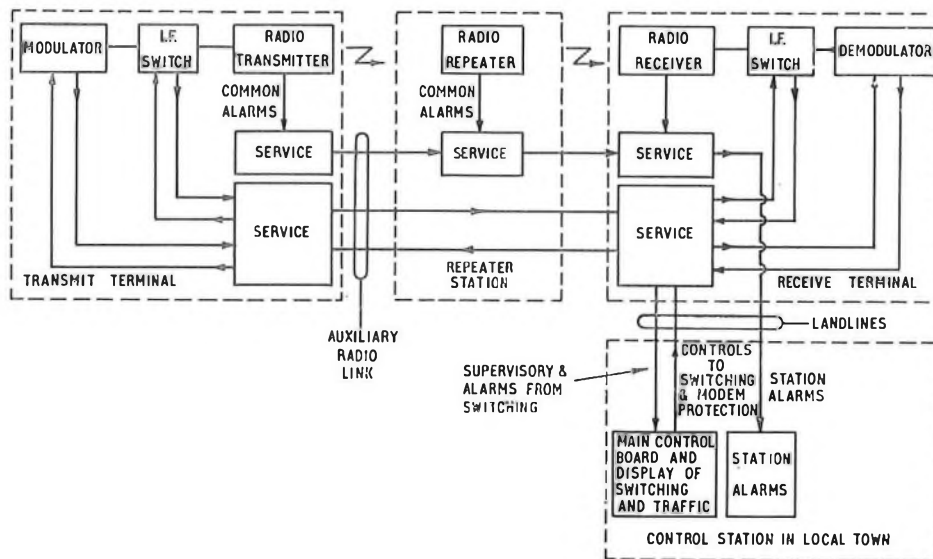

FIG. 2—Auxiliary radio and land line arrangements for control and supervisory purposes

auxiliary-radio-link audio channels. The arrangement shown in Fig. 2 is typical.

Thus, control-point equipment must be designed to provide a number of facilities and, in addition, it must cater for varying route capacities up to a normal maximum of six working and two protection channels.

### DETAILED REQUIREMENTS OF THE CONTROL AND SUPERVISORY EQUIPMENT

The requirements of a control and supervisory equipment to relay such indications and effect control operations for one direction of transmission are detailed below.

#### Alarm Indications for the Switching System

Alarm indications must be given to indicate the failure of the following:

(a) *A traffic path.* This is determined by the pilot detectors associated with the demodulator equipment. This alarm will only be given when both the normal traffic path and the protection arrangements have failed and the ability to carry traffic has, therefore, been lost.

(b) *A radio channel.* This is determined by the continuity-pilot and noise detectors associated with the i.f. switching equipment. In this case, traffic is not necessarily lost as a protection channel may have been taken into use.

### Supervisory Indications

Supervisory indications are needed showing:

(a) the routing of traffic on its regular or either of the protection channels,

(b) that a second-choice modulator is in use,

(c) that a second-choice demodulator is in use,

(d) that a channel is excluded from the automatic-switching process.

### Other Alarms and Supervisory Indications

The above alarms and indications are concerned solely with the switching systems at the terminal stations. However, an indication is also required at the control point of any failure or change of status in the radio equipment at an intermediate repeater station or the terminal radio station.

These local alarms are grouped together at terminal and intermediate repeater-stations to give one common alarm per station which is sent to the distant control point. These alarms are referred to as the remote-station alarms at the control point.

### Speed of Operation

In order to give confidence in the performance of the manual control, and to ensure that an up-dated supervisory display is given, the time between the operation of a control, and display of an indication confirming the control has been



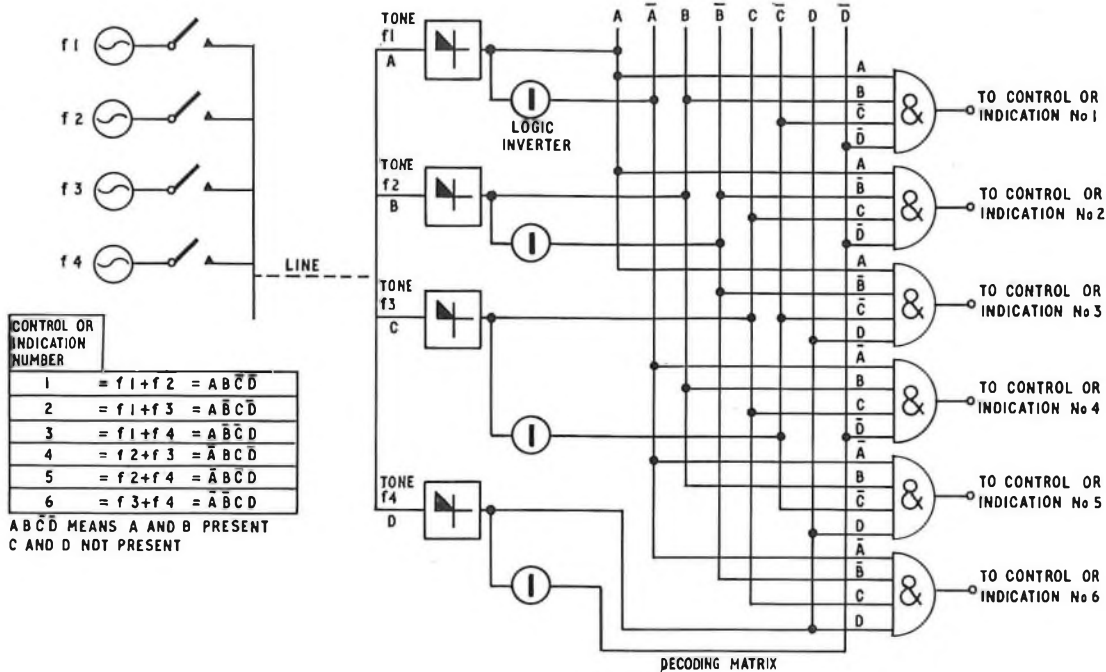

FIG. 3—Principle of decoding

successful, must be relatively short. In practice, a delay of up to one second is found to be acceptable.

### Control Systems for Export

The above summary states the requirements of a control system for a typical U.K. unidirectional link having six working channels plus two protection channels and automatic i.f. switching. Manufacturers of microwave equipment, however, take into account in their design the requirements of the export market as well as the home market.

As an example of the different requirements for overseas microwave links, which tend to be much longer but with fewer broadband channels, it is quite common for control signals to be sent to intermediate repeater stations to start up emergency power plant and there may well be a need for more comprehensive supervisory information from these stations. This arises since repeater stations are often isolated in mountain and jungle situations and lack the easy access of most U.K. stations. For these reasons, the facilities offered by an equipment design are not always fully exploited when the equipment is used for Post Office applications.

### DESIGN CONSIDERATIONS

In designing the equipment to meet the requirements outlined above, provision must, therefore, be made for a relatively large number of controls and indications to be relayed over land lines or auxiliary radio systems at an acceptable speed of operation. The equipment must be easy to apply to various radio systems and be of reasonable cost. Different manufacturers have designed their own systems taking into account the requirements of the home and export market. Three such systems are now being supplied to the Post Office and the principles of operation are described in this article.

### COMBINATION V.F. TONE SIGNALLING

An existing system used for transmitting a large number of indications or controls over an audio circuit is by the simultaneous selection of a number of v.f. tones from a larger number. For example, by selecting, say, five tones out of a possible ten, then the number of unique combinations possible is 252. Each combination can be sent for a short period in a sequence to effect each indication or control in turn.

### Principle of Coding and Decoding

For a system where two tones are selected out of a possible four, giving a total of six combinations, the allocation of tones for each control or indication may be as given in Fig. 3. To transmit the required indication or control, the appropriate two tones are connected to line. At the receive end of the system, v.f. tone receivers are provided each giving, say, a d.c. negative output or logic 1 when the corres-

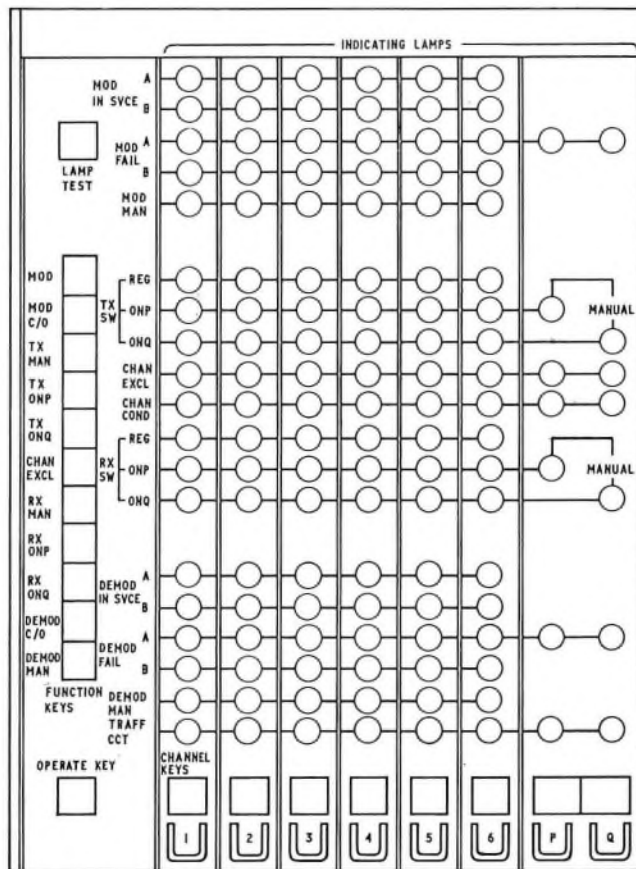

FIG. 4—Display-lamp and key layout

ponding tone is present, and a positive or logic 0 output when the tone is absent. Inverted outputs are also provided from each receiver which give the reverse conditions to those of the direct outputs. These direct and inverted outputs are connected via a decoding matrix to gating circuits, so arranged that when two tones appropriate to a control or indication are present and the remaining tones absent, four outputs are applied to the appropriate gate. Only under this condition will the output of the gate be a logic 0 and the control or indication be accepted. For all other conditions, the output will be logic 1.

### Control System

The system, which uses this principle for remotely-controlling a unidirectional 6 + 2 i.f. switching system, groups the controls and channels into function codes and address codes, respectively. In this way, a simplified control-key layout is achieved, and a minimum number of logic frequencies is used. A 6 + 2 unidirectional system requires a group of six tones for the functions and a group of five tones for the addresses. The selection of three tones out of each group enables up to twelve control operations to be carried out at up to ten addresses.

A typical control and display panel of a system using this method is shown in Fig. 4. To perform a remote control operation, the function required is selected by operating the appropriate function key. This action will set up (but not send) three tones out of the group of six. The channel key (the address) is then selected and prepares the three tones out of the second group of five. These pre-selected tones are not sent until a third common operate-key is pressed, when the pre-selected tones are sent for 100 ms.

At the receiving point of the system, the logic outputs of the v.f. receivers are taken, via a decoding matrix, to the control gating-circuits. For a control to be operated effectively, not only must the six tones received be proper to that control, but also, the remaining tones must not have been received. If the wrong number of tones are present, then the control action will be rejected. Each control is in the form of a bi-stable trigger, and to restore a condition to its original state it is necessary to operate the same control a second time.

### Indicating System

For an i.f. switching system where up to 120 indications are to be relayed, each indication having a normal as well as an abnormal state, the number of codes required is 240. This can be covered by the selection of five tones out of ten which gives 252 possible combinations.

For sending indications, it is normal to transmit only those conditions that have changed. At each radio switching-terminal, electronic counters independently scan all the conditions that are to be indicated. At the beginning of each scan, a CHECK Z tone-combination signal is sent to the control station for 25 ms followed by a 25 ms rest. The time taken to scan the 120 indicative conditions is about 2.5 ms and, provided no conditions have changed since the previous scan, a CHECK A signal is sent. After a further rest period of 25 ms, the cycle is restarted with a CHECK Z signal. By this means, the system is constantly checked and is able to transmit any single changed condition within 100 ms of its occurrence.

Should any one of the conditions to be indicated change, say, from a normal to abnormal condition, the point of the scan appropriate to that indication is marked with a logic condition and the scan stopped at this point. The tone combination appropriate to the abnormal condition to be indicated is transmitted for 25 ms. After a further rest period of 25 ms, the scan counter is restarted and logic mark condition restored. Subsequent scans will not stop at the same point until the indicated condition restores to its original state, when the operation will be repeated except that the tones sent will be appro-

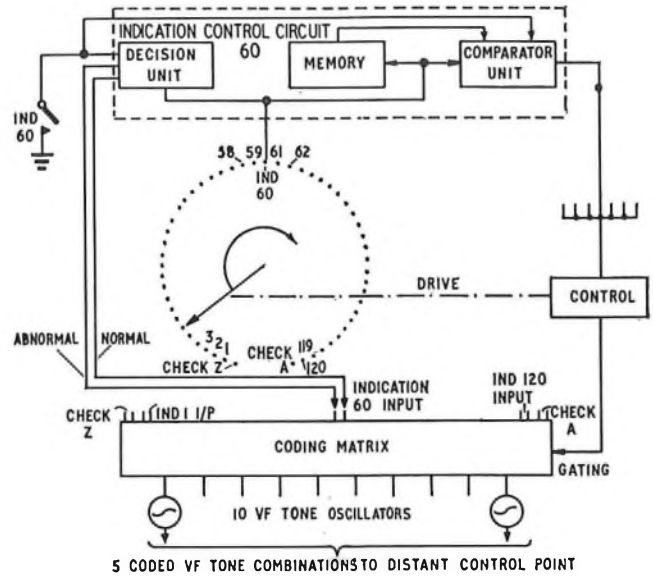

FIG. 5—Indication transmit principle

priate to a normal condition. An explanatory block schematic diagram of the sender is shown in Fig. 5 and a typical timing cycle for a check and single indication sequence is shown in Fig. 6.

The decoding of the indication is similar to that already described. The outputs of the decoding gates are taken to memory gates and lamp amplifier circuits. The display-indicating lamps and control keys are arranged in the sequence shown in Fig. 4.

### Check Operation

If it is required to check all indications, for example after a break in the transmission path, then by operating the CHECK EXPRESS INDICATIONS key, a signal is transmitted to the counter which causes each of the 120 conditions to be transmitted in turn for one scan. This process takes about six seconds and, after completion, the counter will restore to normal operation.

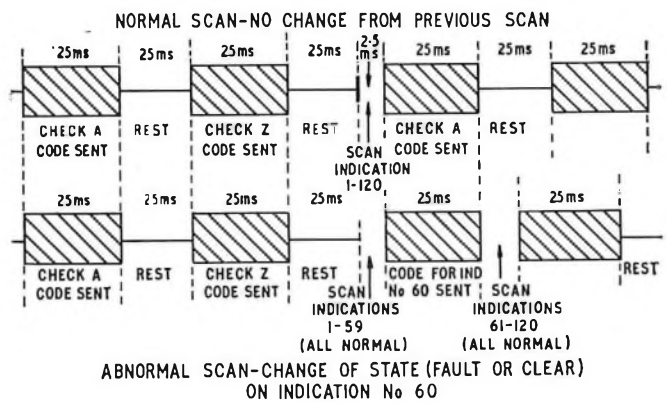

FIG. 6—Scan timing sequence

### False Code Detection

To prevent incorrect displays arising from transmission breaks, noise or equipment faults, it is necessary to determine that the indications can be received at all times. The system is functioning correctly when all following conditions are met:

- each code received is a correct indication code or check code,
- each consecutive CHECK A code is within 12 seconds of the previous one,
- each CHECK Z follows a CHECK A within 73.5 ms.



If all of these conditions are not met, an alarm is given, and all the indication lamps flash until the fault is cleared.

### Remote-Station Alarms

The alarm conditions are grouped at each intermediate repeater and terminal station into those applicable to each direction of transmission. At each station, normally two v.f. tones are sent to the appropriate control points. If a fault condition applicable to one direction of transmission exists at a station, the tone appropriate to that station and direction of transmission is removed causing the appropriate alarm indication to be given at the control point.

### FREQUENCY-SHIFT V.F. TONE SIGNALLING

A new system, which will be introduced during 1970-71, attempts to achieve a compromise between economy of frequency spectrum, large information-handling capacity and speed of operation.

#### Principle of Signalling

Taking one audio channel, the maximum number of standard-spaced v.f. tones is 24. The new system increases the information capacity of these 24 tones by arranging to frequency-shift key each v.f. tone.

A number of indications having a binary state are scanned in turn, and a v.f. tone-frequency is shifted to represent the condition of each indication. The actual method is to send a frequency  $f_0 + 30$  Hz when the indication is normal, and frequency  $f_0 - 30$  Hz when off-normal. Up to 48 indications are checked in this way in the system described. If now a v.f. tone receiver is located at some point in the system and connected to the audio circuit carrying the transmitted digital stream, then a mark for frequency  $f_0 + 30$  Hz or a space for frequency  $f_0 - 30$  Hz, may be detected.

The v.f. tone is arranged to return to frequency  $f_0$  for 16 milliseconds between each indication check and an end-of-scan synchronizing pulse of frequency  $f_0$  is sent for 48 milliseconds. Thus, a complete scan of 48 points, plus the synchronizing pulse, occupies approximately 1.6 seconds. In practice, the number of indications can be any number from 8 to 48 in multiples of eight and, consequently, the scan time can be reduced, if required.

Although the above refers to indications, it could equally refer to control information and 48 bits of information, indication or control, can be carried by one v.f. tone. Thus,

one audio channel having a capacity of 24 v.f. tones can handle 1,152 indications or controls.

### Encoder

At each point where indications are checked or control information is originated, an encoder unit is required. The encoder unit consists of the v.f. tone oscillator, which is to be frequency-shifted, and a counter unit. The indications are connected to the encoder as parallel inputs and the electronic counter steps round to each input in turn. The input indication is then converted to the appropriate shift of the v.f. tone, the principle being that shown in Fig. 7. An input card can handle up to eight inputs and one encoder caters for six such cards. The inputs are logic 0 or 1 which are gated in turn to shift the oscillator frequency to  $f_0 - 30$  or  $f_0 + 30$ .

### Decoder

A decoder unit consisting of the corresponding v.f. tone-receiver and register unit is required at the point in the system where the information is to be monitored, this being the control point for alarms and the switching terminals for controls.

Referring to Fig. 8, the input to the decoder is a stream of tones of frequencies  $f_0 + 30$ ,  $f_0$  or  $f_0 - 30$  followed by an end-of-scan signal of 48 ms of frequency  $f_0$ . The detector has three outputs, a normal line, an abnormal line and a carrier-fail output. A logic 1 is given on the normal line for frequency  $f_0 + 30$  and on the abnormal line for frequency  $f_0 - 30$ . Frequency  $f_0$  gives a logic 0 on both lines.

The pulse trains from the normal and abnormal lines are fed into a 48-position register. The incoming logic is also used to generate a clock pulse which steps the received information into the register. When all 48 indications or controls are received, the end-of-scan signal generates a transfer pulse which causes the information held in the register to be read out and fed to an associated display unit for alarms or to the switching equipment for controls. The register is then reset ready to receive the next scan.

### Safeguards

To avoid displaying incorrect information, certain safeguards are included in the decoding arrangement. The principle is to prevent the display of an incorrect scan by blocking the transfer pulse from reaching the read-out unit.

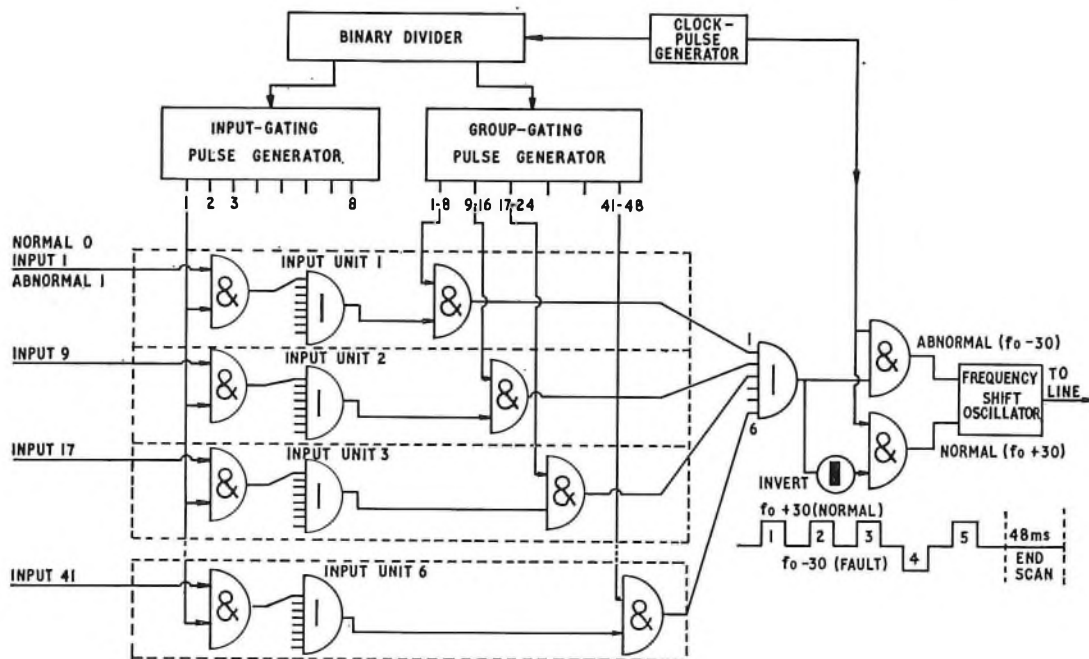

FIG. 7—Block schematic diagram of encoder unit

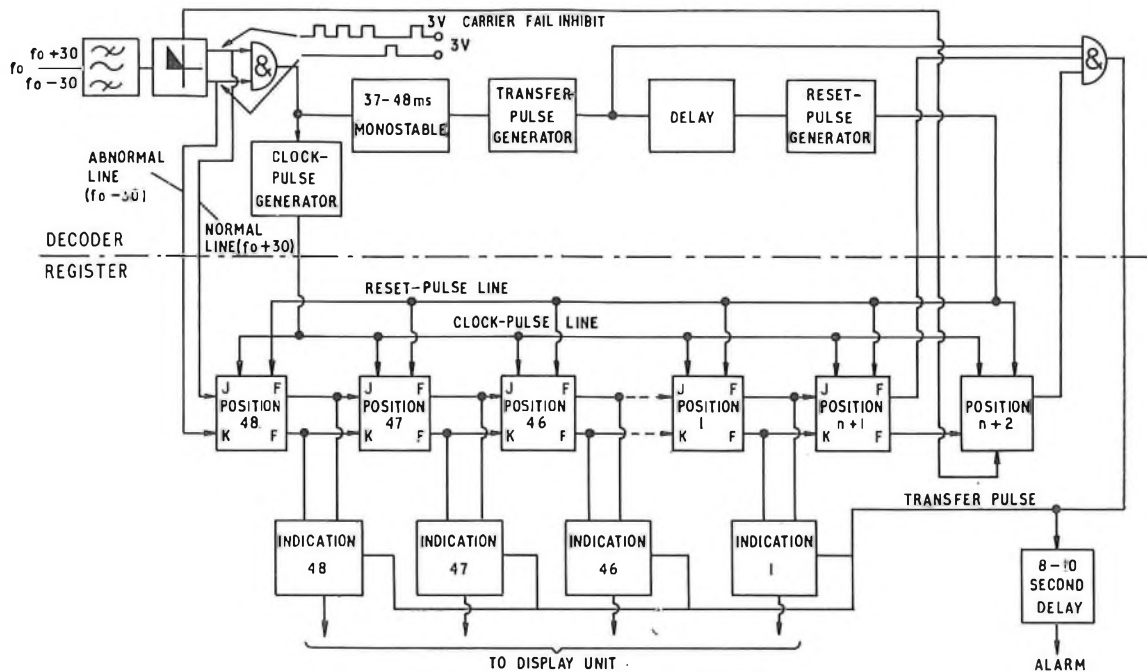

FIG. 8—Block schematic diagram of decoder unit

This is achieved by the use of two additional register positions  $N + 1$  and  $N + 2$ . When a correct scan is received, all positions of the register contain information except  $N + 1$  and  $N + 2$ . The  $N + 1$  register contains a validity marker which is inserted into the register number 48 prior to the start of the scan. This marker is, therefore, shifted along the register stages until, at the end of a scan having the correct number of clock pulses, it appears in the  $N + 1$  register but not in the  $N + 2$  register. If either of these registers is not in its correct state at the end of the scan, it is likely that some interference on the line or auxiliary system has simulated or broken-up the signal pulses. Alternatively, the link may be either broken or interrupted. By arranging the transfer pulse to be routed through a gate which is only open when  $N + 1$  and  $N + 2$  and the main register positions are in their correct conditions, false displays or controls are avoided. Similarly, if the v.f. tone falls below a predetermined level, the carrier-fail output of the detector is also arranged to inhibit the transfer pulse.

If, after approximately 8–10 seconds, no transfer pulse is successfully gated, an alarm is given.

### Key-and-Display Units

For control purposes, a key unit is employed to give the required input information to the associated encoder. A single-key action is used in place of the 3-key action used in the code-combination system, and for indications, a display unit is associated with each decoder.

### Remote-Station Alarms

In the Post Office network, remote control instructions are not sent to intermediate repeater stations, although the system could cater for this if required. Alarms are required, however, and the following two facilities are provided:

- (a) a local display of the condition of each rack of equipment,
- (b) combination of these local alarms into one station alarm to be sent to the control point.

The alarm contacts from each rack at each station bring up a local alarm as required. In addition, all the contacts are fed into a combiner unit which in turn operates a frequency-shift oscillator. The scan technique is not required since only one abnormal condition can arise and, when this occurs, the

combiner unit shifts the oscillator frequency to  $f_0 + 30$  Hz. At the control point, a decoder unit is fitted to detect this condition and bring up the appropriate station alarm.

If further identification were required, urgent alarms could be arranged to shift the frequency to  $f_0 + 30$  Hz whilst a second combiner could extend non-urgent alarms by shifting the frequency to  $f_0 - 30$  Hz.

### PULSE-CODE SYSTEM

A third system is currently under development in which the principle is again based on scanning, in sequence, a number of indication or control inputs. This system, however, differs somewhat from the others in its method of transmitting the controls or indications and in its method of synchronizing the system and guarding against false information. The basis of the system is pulse-code modulation (p.c.m.).

### H.F. Tones

One of the restricting features in any end-to-end switching system using standard v.f. tones spaced at 120 Hz in an audio channel of 300–3,400 Hz is the response time of the narrow-bandwidth v.f. tone receivers. This is particularly important in the operation time of the i.f. channel-switching sequence and one way of overcoming the problem is to use wider bandwidths and high-frequency tones. The i.f. switching system to be associated with this control and supervisory system uses tones in the range 10–30 kHz, transmitted over wideband auxiliary systems (sub-baseband or auxiliary radio channels). The use of directly-modulated h.f. signalling also avoids the use of audio-channel multiplexing-equipment and results in a simplified system.

For convenience, therefore, the design uses h.f. tones for both the control and supervisory system. The system is based on the use of two tones which are pulse-code modulated. Each tone receive-bandwidth is 1 kHz.

The use of h.f. tones is, of course, only convenient when an auxiliary system having adequate bandwidth is available. As explained earlier, the connexion between the terminal receive station and the control point is invariably by means of four-wire audio circuits which require, as for previous cases, the use of v.f. tones. At the receive terminal, the indications or control signals are decoded from h.f. tones and recoded into v.f. tones.



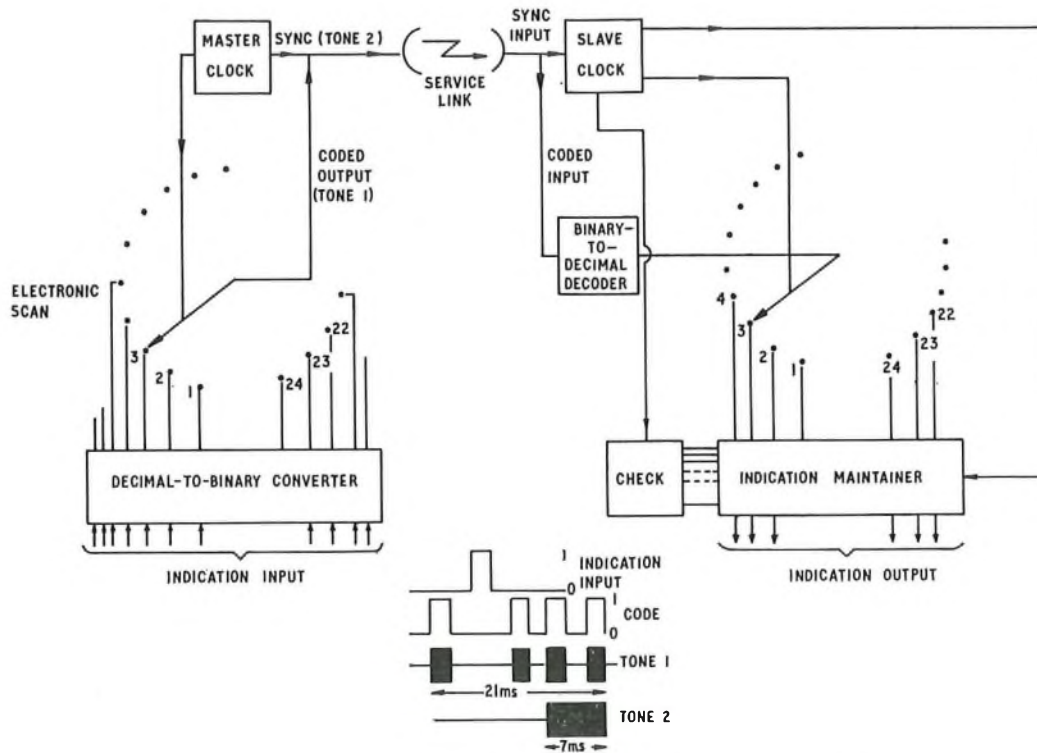

FIG. 9—Basic principle of pulse-code system

### System Principle

Fig. 9 shows a simple unidirectional system. The indications are fed into the encoder as binary logic inputs, the two states being normal, which may be represented by an earth potential, and abnormal, by +5 volts relative to earth.

### Indications

The inputs are electronically scanned by a master clock and the binary inputs checked in sequence. If all inputs are normal, no effective output is given, but if any input registers an abnormal condition, a pulse-coded output is sent to the control point as described below.

A 5-bit pulse-coded word is used with an additional blank pulse inserted between each word. With five information bits, 32 combinations are possible. One combination is used for synchronizing the two clocks at each end and another is used to indicate a normal condition. The remaining 30 combinations are available for various abnormal indications.

Each indication at the transmit end, therefore, is allocated a pulse code and this code is used to 100 per cent modulate one of the h.f. tones. At the end of each code, a clock pulse modulates the second tone, which is used to step the distant receive slave clock to the next position.

Each word bit lasts 3.5 milliseconds, and therefore, each indication word lasts 21 milliseconds on tone 1. The step-on synchronizing bit lasts 7 milliseconds on tone 2 and is sent during the last 7 milliseconds of each word.

Position 1 on each scan is not used for indications, but is used as a reset position. This is necessary since it is possible that the master and slave clocks could get out of step. The master clock sends a word on position 1 which causes the slave clock to jump into synchronism and ensures that each scan commences in synchronism. Further clock pulses will then continue to keep it in step with the master clock.

At the receive terminal, the pulse-coded inputs are decoded into the single binary state (0 or 1) and fed into a counter to ensure that it is in its correct position. It is then added to the receive-end indications.

The combined inputs are then recoded in an identical manner on a second master clock. Two v.f. tones are then pulse-code modulated by this signal and sent to the control-

point slave clock. Again, the pulse code is demodulated into binary states (0 or 1) and used to operate the alarm and display equipment.

### Safeguards

Each word is associated only with one particular indication and, since these are scanned sequentially, the words must be received in a specific order. Thus, if a word is sent in the wrong position, it will not be recognized by the receive supervisory equipment. Each indication, therefore, must have its correct code and be in its correct position in time, giving a guard against spurious responses.

### Timing

In practice, only 26 of the 32 possible words are used and as each word lasts for 21 milliseconds, the total time per scan is 436 milliseconds.

If a receive-end indication is just missed on one scan, it would take just under 500 milliseconds for that indication to be detected. A transmit-end indication, being encoded and decoded twice, would take just over 1 second to be detected. It is thus necessary to hold an indication on at the decoder register for at least one scan-period.

### Control signals

The previous description relates to indications, but exactly the same principle is applied to control signals emanating from the control point. The control key injects a binary change of state into a control-point encoder. The encoder is now the master clock and the appropriate p.c.m. signal is transmitted on v.f. tones over the 4-wire audio circuit to the receive-end terminal, where it is decoded. If it is destined for the distant transmit terminal, it is re-coded in p.c.m. form on h.f. tones.

If the link is two-directional, these control signals from the receive-end terminal can be combined, on the same clock, with indications from the transmit-terminal equipment for the return direction.

Similarly, control signals for this return direction from the second control point can be combined with the indications for the go direction described in detail above.

For intermediate-station alarms, single tones are injected into the auxiliary channel and detected at the receive terminal. They are then combined with the indications which are fed to the control point.

If required for other applications, the system capacity can be extended by the use of six, seven or eight-unit codes.

### CONCLUSIONS

As a result of the use of automatic switching on microwave radio-relay system channels, a need arises for a comprehensive supervisory system and a means of manually overriding the automatic switch.

For operational reasons, this supervisory and control equipment is normally located remotely from the automatic switching system.

Due to the variety of arrangements that can occur on the U.K. trunk microwave radio-relay network and the differing needs of overseas systems, a flexible control and supervisory

system is needed. This article has described three different system principles aimed at meeting these requirements.

Although the systems described were developed for use with microwave radio-relay systems, they could, of course, be easily used for other applications.

### ACKNOWLEDGEMENTS

The authors would like to thank the Transmission Division of GEC-AEI Telecommunications Ltd., the Microwave and Line Division of S.T. & C. Ltd. and Pye Telecommunications Ltd. for help given in the preparation of this article.

### References

<sup>1</sup> JONES, D. G., and EDWARDS, P. J. The Post Office Network of Radio-Relay Stations. *P.O.E.E.J.*, Vol. 57, p. 147, Oct. 1964.

<sup>2</sup> MARTIN-ROYLE, R. D. Intermediate-Frequency Switching Systems for Microwave Radio-Relay Links. *P.O.E.E.J.*, Vol. 61, p. 110, July 1968.

<sup>3</sup> ELKINS, N. A. The Reliability of Microwave Radio-Relay Systems. *P.O.E.E.J.*, Vol. 61, p. 143, Oct. 1968.

---

## MODEL ANSWER BOOKS

CITY AND GUILDS OF LONDON INSTITUTE EXAMINATIONS  
FOR THE  
TELECOMMUNICATION TECHNICIANS' COURSE

---

LINE PLANT PRACTICE A  
REDUCED TO 7/6; 8/- (post paid)

---

Orders may be sent to the *Journal* Local Agents or, by post only, to

*The Post Office Electrical Engineers' Journal*, 2-12 Gresham Street, London, E.C.2



# Identification of New Cable Pairs

J. F. CRAGGS†

U.D.C. 621.315.212.4: 621.315.687.1

*In order to employ the new cable jointing machines to the greatest advantage it is necessary to pick the cable pairs to be jointed at random. A quick method of subsequently identifying the individual cable pairs is needed and the equipment described requires only one operator for the job.*

## INTRODUCTION

One of the most time and labour consuming operations in cable installation is the identification and numbering of cable pairs in local distribution cables. The current practice is for an identifying tone to be applied to a cable pair at the exchange, and a search made for this tone by a jointer using a probe and amplifier at the point where identification is required. On identification a signal is sent to the exchange either via a speaker circuit, or by short-circuiting the pair being identified. The tone is then transferred to the next pair to be found. Thus two men are required for the duration of the tests.

Investigation into the introduction of jointing machines has indicated that a substantial saving in jointing time can be effected if the joints are made at random within a unit (a unit is usually 100 cable pairs, but it may be 25 or 50 pairs) and the jointing completed throughout the cable and the cable pairs identified prior to connexion at another numbered point, say cabinet or pillar. Time saved in jointing in this manner will be offset because of the inordinate time that would be required to identify these pairs using the present methods. If, however, a system of pair identification could be introduced where the jointer was automatically given the identify of any pair picked at random, the time required for identification would be reduced to the time taken to select the pair. Further, if the apparatus at the exchange was under the control of the jointer, the work could be done by one man.

## CABLE-PAIR IDENTIFICATION EQUIPMENT

Development is proceeding on equipment for use by a jointer at a point remote from an exchange which will indicate on any pair its terminating position on the main distribution frame (m.d.f.). The equipment at present undergoing trial is intended to be used on new cables terminated on type 8064 Fuse Mountings (Fig. 1). The apparatus enables a complete unit of 100 pairs to be identified. This figure has been chosen for the prototype models since:

- (a) the random jointing referred to above is confined to individual units of 100 pairs, and
- (b) only two digits are required for identification purposes.

The apparatus is portable and in two parts, firstly the exchange equipment (Fig. 2), which operates from the exchange 50-volt battery. This is connected to the fuse mountings on the cable to be identified by means of ten special connecting cords. Secondly, jointer's equipment (Fig. 3) which operates from the jointer's 24-volt lighting battery and includes an illuminated digital display.

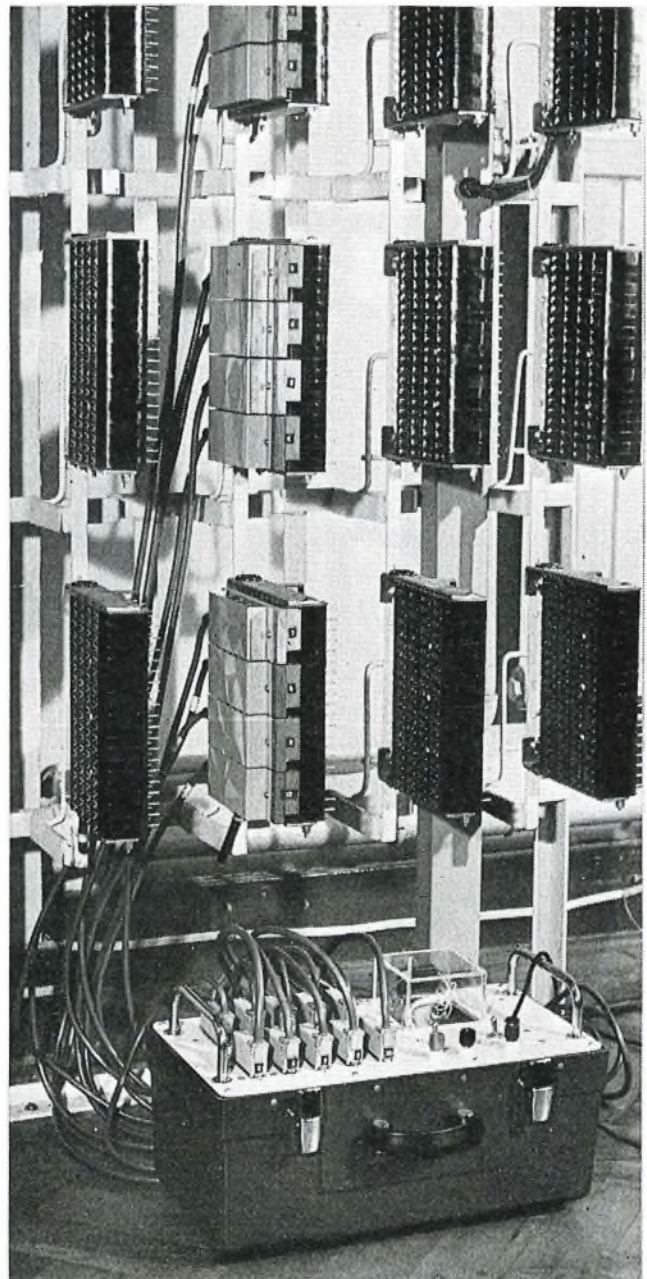

FIG. 1—Exchange equipment connected to type 8064 Fuse Mounting

† Mr. Craggs is in the Civil and Mechanical Engineering Branch, Telecommunications Development Department, Telecommunications Headquarters.



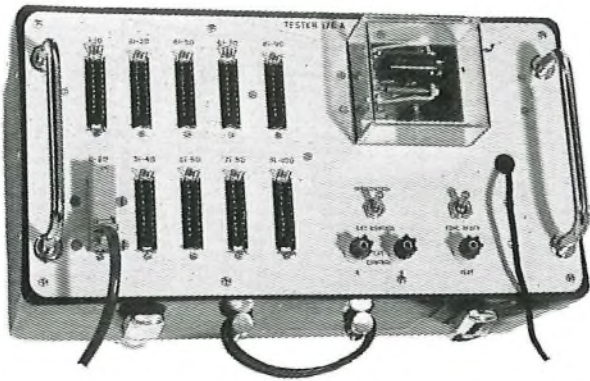

FIG. 2—Exchange equipment

cator will not restore and the pair is put aside for investigation. The equipment is then restored to normal by means of a reset key ready for identification of the next pair.

### DESIGN FEATURES

The exchange equipment consists of a uniselector connected as a 100-point linefinder. When the probe is touched on the "A" wire of the pair to be identified, a start signal causes the linefinder to step until the required wire is found. The uniselector is locked in this position and can only be restored to its home position by a signal on the appropriate "B" wire.

The steps taken by the uniselector are repeated over the control pair and operate the counter in the indicator unit at the jointer's equipment. Each complete operation, i.e. counting the pulses to the required position and subsequent restoration to the home position, takes 100 pulses. Since the counter starts

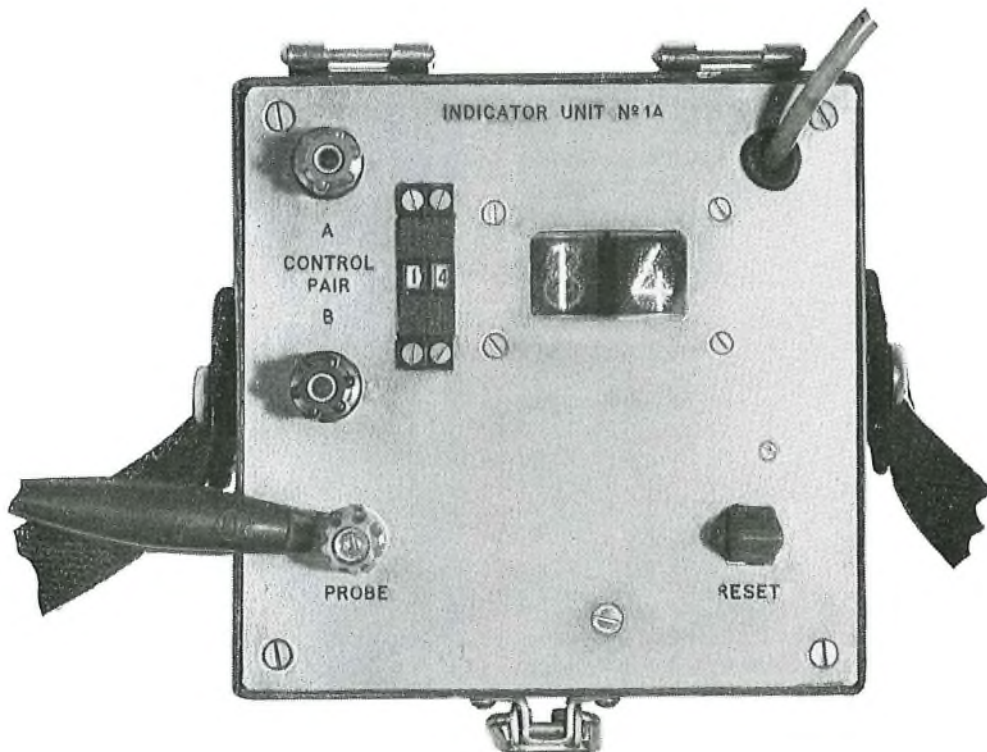

FIG. 3—Jointer's equipment

### METHOD OF USE

The cords are designed for exchanges with standard numbering on the m.d.f., i.e. numbering from top to bottom. Where, exceptionally, non-standard numbering, i.e. numbering from bottom to top is encountered, conversion cords are required which are connected in series with the standard cords.

A control-pair is required, which may be pair No. 100 of the unit being tested, or a separate pair in another cable. Initially, the test pair has a 1 kHz tone applied to it immediately the tester is plugged into a 50-volt battery jack. When the jointer has found this pair using normal pair identification methods with an amplifier and probe, it is connected to the indicator unit. A reset key is then operated which removes the identification tone from the test pair and prepares the exchange equipment for operation.

A random pair is then chosen from the cable to be identified and one of the wires touched with a probe connected to the indicator unit. If the wire selected is an "A" wire, the equipment will show on the digital indicator the number of the pair. The probe is then transferred to the other wire of the pair which, if it is the correct "B" wire, will restore the indicator to zero. If the correct "B" wire has not been chosen, the indi-

and finishes on zero this provides a check on the operation of the equipment.

The indicator unit consists of an electromechanical counter with associated drive circuits and an illuminated digital read-out for use in dimly-lit situations. The stepping speed of the uniselector is approximately 45 steps per second, hence the machine is capable of indicating a pair in  $2\frac{1}{4}$  secs. Under normal operation most of the time will be taken in selecting the pairs to be identified and collecting the pair. It has been found that the time taken to identify and collect 100 pairs can be as low as 20 minutes.

### FUTURE DEVELOPMENT

Development is continuing on a solid state counter, but this will, of course, mean that an illuminated display only will be available without electromechanical counter. This might cause difficulty when the counter is operating in bright sunlight. It is also hoped to develop a unit which will enable a complete m.d.f. vertical to be connected, thus eliminating the need to frequently change the position of the plugs.

The equipment should be in service by the end of 1970 on the basis of one item per area.



# Electrical Contacts in Telephone Exchanges: Contact Opening and Closing Phenomena and Quenching Techniques

## Part 2—The Design of Contact Switching Circuits

W. L. SCOTT, C.ENG., M.I.E.E.†

U.D.C. 621.395.34: 621.395.121: 621.3.067: 621.784

*Part 1 of this article discussed general principles of contact-switching phenomena and quenching. Part 2 deals with the practical approach to the design of contact-switching circuits for Post Office equipment. Part 3 will cover quenching techniques, laboratory tests and service investigations.*

### INTRODUCTION

Part 1 of this article<sup>1</sup> described some of the diverse fundamental physical factors involved in contact switching. This part discusses contact switching in more practical terms and gives some idea of the attention paid at the circuit-design stage to eliminate potential difficulties. The practices described relate to Post Office standard Strowger selectors and the relays which carry out the ancillary switching functions in a telephone exchange. The contacts in these systems are exposed to the effects of the surrounding atmosphere. Dry-reed, sealed relays are now coming into service in Post Office electronic-switching exchanges.<sup>2</sup> Experience is still being gained on the large-scale use of these forms of contact and it is too early to attempt a comprehensive survey. The information given may, however, be extended beyond open-type contacts by analogy, and by appropriate weighting of the factors described.

### AIMS OF CONTACT SWITCHING

The basic aims of all contact-switching functions are;

- (a) to establish conduction of current at some pre-determined value in a contact-circuit load,
- (b) to maintain the current,
- (c) to interrupt the current, when required.

Attention tends to be concentrated on the current-interrupting function of opening contacts, as the hazards are easily appreciated and are well-known. The penalties of bad design are often of a spectacular nature, as the examples given in Part 1 testify. For these, and other reasons, the design approach for switching circuits is, to a large extent, based on considerations of the maximum permissible current loading and the maximum interrupt-capability of the contacts. This article follows the same lines, but covers the more subtle, but vital, aspects of contact characteristics in establishing and maintaining current conduction.

### CHARACTERISTICS OF ELECTRICAL CONTACT LOADS IN EXCHANGE EQUIPMENT

A high proportion of the loads controlled by switching contacts in exchange equipment are inductive, but resistive and capacitive loads are common.

† Telecommunications Development Department, Telecommunications Headquarters.

### Inductive loads

These are mainly electro-magnets or relay-coils. Magnets are used principally in uniselectors and two-motion selectors and, although a high degree of standardization has resulted in only a small number of different types, each is used in very large quantities. Magnet-coils, controlling-contacts and quench circuits have, therefore, to be very carefully designed. In contrast, the number of possible relay-coil designs is large, although the range has been reduced recently by rationalization. Discussion will be based on the well-known Post Office 3,000-type relay, in view of its extensive coil range and widespread use.

A relay-coil may have one or more windings, of from a few hundred to more than 97,000 turns and with resistance of less than an ohm to over 40,000 ohms. A non-inductive shunt winding may be included which, acting as a resistor quench, limits the induced voltage and increases the armature release-time. The core may be of soft-iron, of soft-iron with nickel-iron sleeves, or entirely of nickel-iron. Magnetic flux decays rapidly in nickel-iron, causing a high induced voltage in the winding and more noticeable sparking, arcing or glow discharge at the contacts. Glow predominates, indicating a relatively high voltage, but contact damage is usually less severe than the visual effects suggest. A copper slug may be fitted at the armature end of the core for slow operation and slow release, or at the heel end for slow release only. Slugs reduce the rate of flux decay and thus the induced voltage, but this is offset by the need for high energizing ampere-turns to ensure consistent release-time. With a slugged relay, the effective inductance of the coil is reduced; on operation, the current rises relatively rapidly and conditions are more onerous should bounce or chatter occur.

Paralleled coils, controlled from a single contact, are common. When all the coils have identical characteristics, the common induced voltage corresponding to a single coil appears across the opening contacts. Due to the higher load-current, however, contact-opening conditions are more onerous than with a single coil, being roughly proportional to the square of the current. Paralleled coils of differing design, in particular of differing numbers of turns, develop unequal induced voltages and circulating currents pass between the windings. A resultant voltage appears across the contacts and conditions tend to be less onerous than with identical coils. Depending on the relative directions of the currents in the windings, flux decay in the individual cores may be accelerated or retarded, with corresponding effects on armature release.

## Resistive Loads

Purely resistive loads present only the simple problem of making and breaking the current. Lamp loads are usually included in this category and as the lamps are generally metal filament type, with a positive temperature coefficient, there is a high initial surge, or inrush current, on closure of the contacts. After heating of the filaments, the current is reduced and subsequent opening conditions are notably less severe.

## Capacitive Loads

These are mainly long, or multiplied leads, with large distributed capacitance, capacitor-resistor quenches, capacitor resistor time-delay circuit elements, or external line circuits. The charge or discharge surges associated with capacitive loads may damage contacts, causing erosion, material transfer and adherence.

## WIRING AND CABLING BETWEEN CONTACTS AND LOAD

Contact-switching phenomena are affected by the associated wiring and cabling, and by other factors individual to the circuit elements concerned, but the possibilities are not easy to analyse theoretically at the design stage. Very high-frequency currents can be involved.

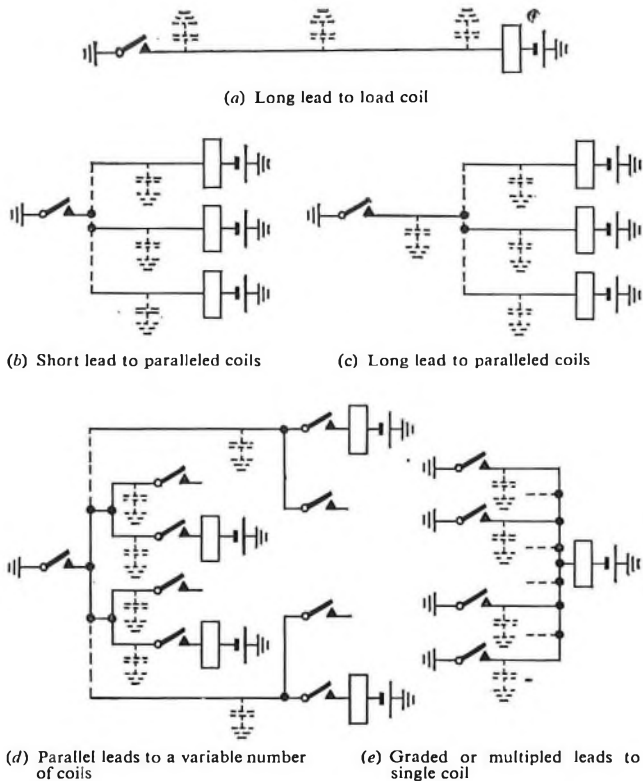

FIG. 1—Wiring and cabling between contacts and load

## Methods of Interconnexion

Contacts and loads may be interconnected in many ways a number of which are shown in Fig. 1. Important aspects are the length of the connecting leads and distributed capacitance. The examples given all result in increased total capacitance.

## Preclosure Effects

At closing contacts, high distributed capacitance increases preclosure discharges. Where a number of leads are connected in parallel and extended to the controlling contact via a common lead, Fig. 1(c), the effects are less severe than if they are paralleled at the contact, Fig. 1(b), due to the attenuating effects of the wiring.

Increasing the circuit voltage above the 50-volt supply, in common use for switching contacts, results in a disproportionate increase in preclosure discharges. Fig. 2 shows an example in which a lead voltage of 150 volts, in conjunction with distributed capacitance, resulted in the stored energy being sufficient to curtail the life of the A relay contact.

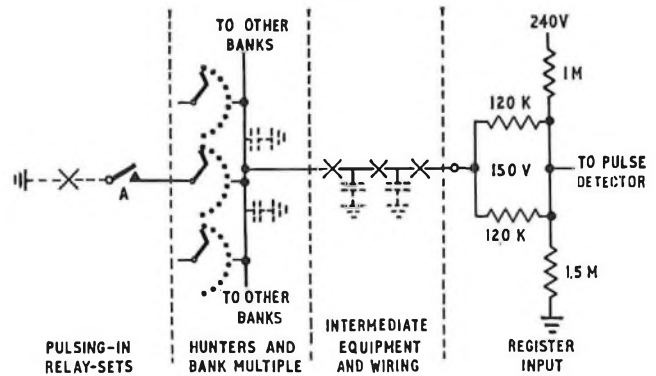

FIG. 2—Contact damage due to distributed capacitance and high lead voltage

## Polarity Reversals

Conditions are severe where leads are subjected to polarity reversals for signalling purposes, as the voltage swing due to charge and discharge of the distributed capacitance is relatively large. Fig. 3 shows an example in which the voltage swing of 160 volts is more than three times the typical exchange voltage of 50 volts and the stored energy is consequently ten times greater.

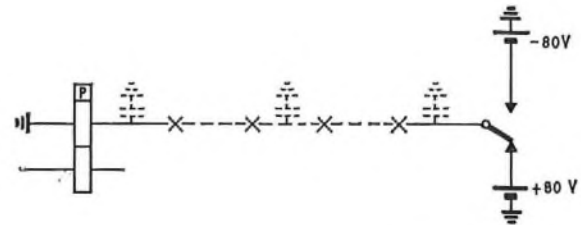

FIG. 3—Contacts subjected to polarity reversals

## Discharges at Opening Contacts

Sparking and arcing at opening contacts is more pronounced with leads of intermediate lengths of, say, 15 to 50 ft, than with short local wiring of an inch or so, or with long leads of several hundred feet. With short leads, the high initial rate of energy dissipation and heating at the contacts is followed by a tendency for glow discharge. With long leads, the distributed capacitance acts as a quench and limits the surge voltage. Increase of voltage or current accentuates discharges at opening contacts.

## Effect of Lead Length on Interference

The length of the lead between contacts and load affects the form of interference produced during switching and also the extent to which it is propagated within the exchange. With short leads, the discharges are of relatively high frequency, causing radiated interference. With longer leads, the frequencies are lower, radiated interference is less likely but the possibility of wire-to-wire coupled interference is greater. (See Part 1, Fig. 7.)

## PHYSICAL CHARACTERISTICS OF CONTACTS TO MEET LOAD CONDITIONS

The physical characteristics of the contacts in any circuit should ensure that the load can be controlled reliably and economically throughout the life of the equipment. The load should not exceed the capacity of the contacts and, conversely,



the contacts should be capable of satisfactorily switching the load. Loads may obviously be varied to meet contact limits, but variation of contacts to meet load conditions is much restricted. Devices usually cater for a range of load conditions, and some offer alternative contact materials to extend their switching capability.

### Contact Ratings

For many years, contact rating and related information for switching devices were quoted in a generalized and abbreviated form, making it difficult to predict the performance where there was wide variation in the circuit applications. Over the last decade, great improvements have been made in the data provided for the applications engineer by the manufacturers. This is particularly so with relays and the presentation of comprehensive information on performance characteristics has become an art in itself. Committees of the International Electrotechnical Commission and the British Standards Institution have provided background information and guide-lines for much of this work. Arrangements are well advanced to include relays in the B.S. 9,000 scheme for the establishment of common standards for electronic parts.<sup>3</sup> This should establish comprehensive unified procedures for the specification of relay characteristics, performance and testing. Post Office practices have evolved from many years of practical experience, and are compatible with the form in which information is likely to be disseminated in the future.

Ideally, a complete specification of contact ratings should cover not only voltage, current and power, but also other factors such as the characteristics of suitable loads, the estimated life of the contacts under various load conditions, and, as far as they are known, any limitations due to operating features of the device itself. Some aspects of performance are not known or covered until after considerable experience of field use.

### Contact Life

This is expressed as the maximum number of switching operations which can be carried out satisfactorily under specified load conditions. It is affected by load and mode of operation; as the load increases, the rate at which the contact life is reduced becomes progressively greater, until a point is reached where there is a very great reduction in life for only a small increase in load. The effect of a particular load depends on whether the controlled circuit is opened or closed at the contacts and on any unusual operating features.

### Voltage, Current and Power Ratings

*Opening contacts.* The relationship between the minimum arcing-current referred to in Part 1 and the voltage, may be determined experimentally with resistive loads and shown in graphical form. These curves are known as limiting arcing-current and voltage curves and Fig. 4 shows these for silver, platinum and tungsten. It is not the practice to show such a curve for palladium, as its performance varies greatly with factors such as surface deposits and occluded gases, which normally are not under control. The minimum arcing-current is, instead, quoted with reference to a voltage range and a particular field of use.<sup>4</sup>

These curves are asymptotic to minimum voltages below which, theoretically, a current of any magnitude may be interrupted without arcing. They are also asymptotic to minimum current values, below which the load may be interrupted at any voltage, subject to the insulant and air-gap breakdown values not being exceeded.

Load ratings for opening contacts are usually quoted with reference to resistive loads, as maximum current loadings for specified voltages, or as maximum permissible wattage loadings. Inductive loads are much more onerous than equivalent

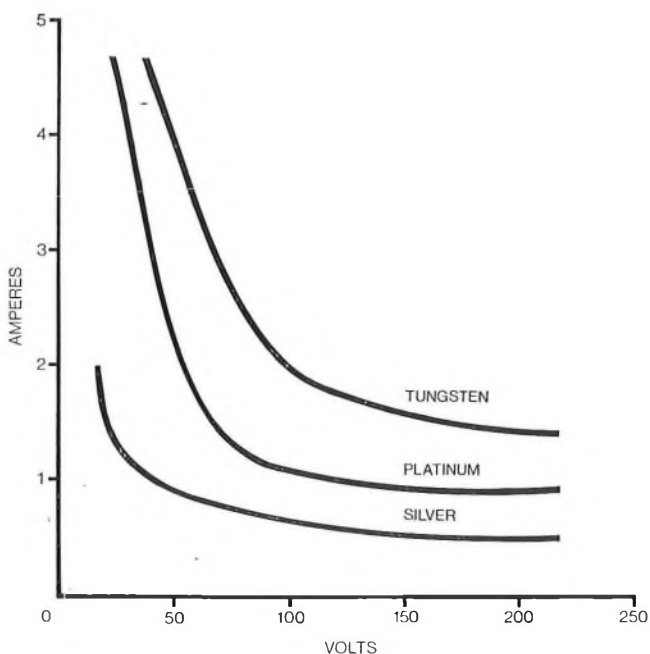

FIG. 4—Limiting arcing-current/voltage characteristics

resistive loads carrying the same current, and to obtain the same contact life, derating is necessary. A suitable quench may also be recommended to extend the contact life.

*Closing Contacts.* Load ratings may be quoted for closing, or closed contacts, usually in the form of maximum permissible surge currents at closure, and maximum steady currents after closure. The surge rating is intended to prevent excessive transient current at close of lamp loads, capacitive loads and similar circuit conditions, which might cause momentary overheating or welding. The object of the steady rating is to eliminate the possibility of overheating such parts as contacts, springs and lifting pins, especially as the use of thermoplastics parts is now widespread and increasing.

When bounce is present at closure, conditions may be less onerous with inductive loads as, due to slow build-up, a smaller current is interrupted at the contacts.

### DESIGN OF SWITCHING CIRCUITS

The engineering of a switching circuit involves four different activities: design of circuit configurations, selection of relays, other switching devices and components, determination of quench requirements and finally, the drafting of the specification.

#### Circuit Configuration and Switching Devices

For reasons of economy in time and effort, the designer employs well-proved circuit elements and devices, adapting them to his purposes. Requirements vary widely and existing devices often have to be employed in new circuit elements and new circuits have to be devised to utilize new devices. Design defects can involve the subtle interplay of obscure electrical and mechanical features and, as will be seen, the designer needs to use all available information on performance characteristics and modes of behaviour of the switching devices with great skill, and some intuition.

#### Establishment of Current Conduction

When contacts close, the probability of successfully passing current can be increased if a number of factors are made favourable.

(a) The voltage across the contacts should be relatively high, aiding electrical breakdown of surface films. The total source impedance of the voltage should be sufficiently low

to permit the desired value of current to flow. Some investigators favour a 20-volt minimum, but, owing to practical limitations, values of a few volts are not uncommon. Furthermore, in some speech or tone circuits, the voltage, and the current are so small that there are negligible electrical or thermal effects during switching and the interface is changed only by the mechanical forces.

These conditions apply at voltages less than the softening voltage of the contact material.<sup>5,6</sup> Gold has the lowest softening voltage, 80 mV; the value for silver is 90 mV and for platinum 250 mV. The softening voltage of palladium is critically dependent on the variable factors described earlier in connexion with its minimum arcing-current value; in view of this variability, no figure is quoted in the literature. For practical design work, it is assumed that the softening voltage lies between 90 mV and 250 mV, the values for silver and platinum respectively.

(b) The contact force should be high, aiding mechanical and electrical breakdown of surface films. A compromise minimum is 10 grams, as reliability rises rapidly above this value, but forces less than 10 grams are common. Increasing the number of contact units on a relay may incur the penalty of lower contact force, due to the use of thinner springs to prevent excessive load on the armature. For example, on a 3,000-type relay, 12 mil springs with contact forces of 10 to 16 grams may have to be used instead of 14 mil springs with 15 to 21 grams. The 14 mil springs are preferred choice for 3,000-type relays on Post Office equipment because they give greater reliability.

Twin contact points are employed on the 3,000-type relay and the contact force divides approximately equally between them.<sup>7,8</sup> This provides greater reliability than if the same total force were exerted on a single contact point.

(c) There should be no critical time-limit on the build-up of current to the required value. During investigations into the coherer effect,<sup>9</sup> it was observed that the time for conduction to commence depended upon the magnitude of the voltage and the contact force. This delay in the build-up of current is not infrequently a hidden factor in circuit failures; practical values may be of the order of a few milliseconds.

(d) The contact material should be of appropriate quality. Of the four contact materials in common use, platinum is the best and tungsten the worst. This assumes that conditions are not conducive to the formation of polymerization products, as described in Part 1.

(e) The contacts should be closed vigorously with appreciable relative tangential motion, i.e. wipe, and appreciable follow after closure. Relay contacts in counting and pulsing applications are usually actuated quickly and vigorously and the coils and other parts of the relays are designed accordingly. Unless the design is good, the penalty of vigorous actuation may be contact bounce, damage and malfunctioning.

Contacts on relays designed to provide a time delay are generally less vigorously actuated, for example, relays having slugs or released by short-circuiting the winding. Slow actuation is particularly marked with relays having an armature-end slug to provide both slow operation and slow release. However, contact chatter may occur during slow actuation and this may improve contact conduction, but with a penalty of surface damage.

(f) The contact voltage should be present before closure or should be applied before the contacts come to rest. Specification clauses for checking relay contact interface-resistance and conduction performance require the test potentials to be withheld until the contacts come to rest, in order to avoid the results being favourably influenced.

(g) The environment should not be abnormally conducive to the deposition of dust or the formation of poor-conductivity

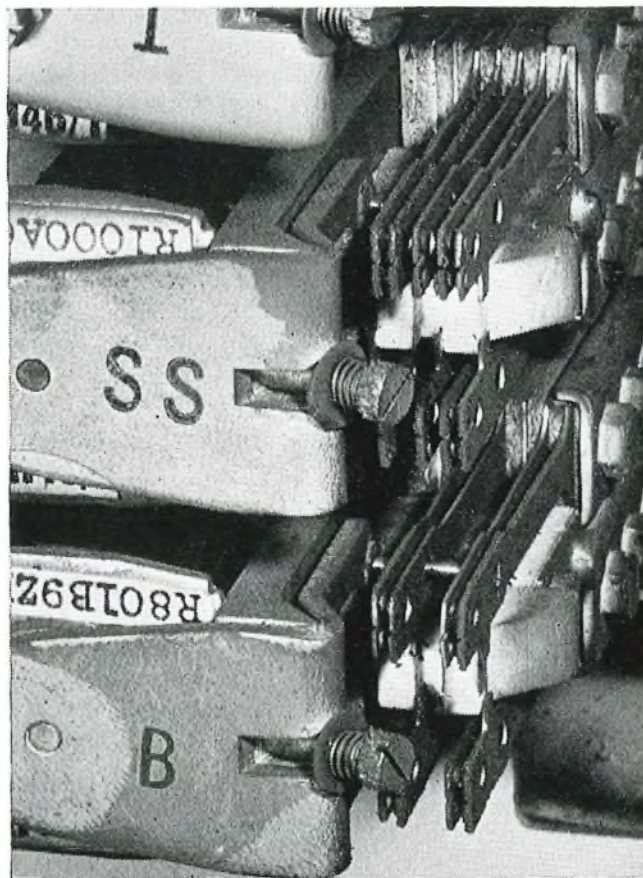

FIG. 5—Dust on telephone exchange relay contacts

films on the contact surfaces. A constant stream of air is drawn through apparatus mountings by convection action and, apart from general dust deposition, fine particles are attracted to any contacts and bearer-springs maintained at an electrical potential. Fig. 5 shows an example.

(h) Some minor degree of arcing when the contacts open disturbs films and particles and improves conduction at subsequent closure.

(i) Preclosure discharges aid conduction to a limited degree but with a possibility of surface damage and adherence. The discharge from capacitor-resistor (CR) quenches or time-delay circuit elements are also known to improve initial conduction.<sup>10</sup>

(j) The number of contact units in series in the electrical circuits should not be unduly large. Factors such as the distribution of the circuit voltage across the individual contacts do not appear to have been investigated, but experience has shown that this is a prudent precaution, particularly with long chains of infrequently-disturbed contacts.

Since a highly-reliable performance at low maintenance cost is needed, the designer aims at making as many as possible of the factors described favourable to conduction, but must pay due regard to initial cost. The choice is a compromise. Examples 1-5 in Appendix 1 illustrate some of the principal points.

These examples arise from experience of the behaviour of contacts in switching equipment. Potential sources of trouble that now appear obvious were less so when design practices were still in the evolutionary stage. The introduction some years ago of palladium as an alternative to platinum for the Post Office 3,000-type relay and for other devices, has provided the designer with a reasonably economic means of improving reliability, which was previously not available.



## Maintenance of Current Conduction

The factors involved in the establishment of current conduction also influence its maintenance, except that, as the contacts are at rest, contact movement is not normally involved. The effect of voltage variations predominates and other factors may be assumed constant.

Voltage variations may cause conduction to cease or to become intermittent. This can occur with full circuit voltage, but becomes more likely as the voltage is reduced. The most common and troublesome example of this occurs when speech and tone currents, varying in magnitude with time, cause corresponding variations in voltage across contacts in transmission paths. Under unfavourable conditions, conduction may cease as the voltage falls, and subsequently fail to be re-established even when the voltage rises to its maximum, a phenomenon referred to as speech-fading. Alternatively, and more commonly, conduction may be intermittent, affecting speech transmission and exasperating and annoying the customer. Tones are widely used in signalling systems and conduction failures in such circuits cause traffic to be mis-routed. Movement of any of the contacts in a connexion, particularly selector base-metal wiper-to-bank contacts, can cause similar troubles, by affecting most of the factors involved in establishing conduction. Mechanical vibrations transmitted from nearby switching mechanisms are the principal source of unwanted contact movement.

The most commonly-observed results are microphonic, or "frying" noises, and noises in the form of pulses corresponding to the magnet operations. A less-well-known effect of variable contact resistance is the unbalance it can cause between the wires of a transmission pair; this introduces distortion when the pair forms part of a long-distance circuit.

The possibility of failure is notably reduced by using high-quality contacts or by arranging for the speech or tone currents to be superimposed on a separate current which maintains conduction even when the speech or signal voltage is zero. This current, termed a wetting-current, is maintained by a wetting-voltage, applied at a suitable point in the chain of contacts. The term "dry circuit" is used for circuit paths in which the current is too small for reliable conduction. Modern definitions of these terms are given in Appendix 2.

The wetting voltage may be unidirectional or alternating, and may be applied to the contacts periodically as a pulse or applied continuously at constant amplitude. Post Office practice is to aim for a wetting voltage of 50 volts and wetting current minima of 1 mA d.c. for precious-metal contacts, such as those on relays and 5 mA d.c. for base metal contacts, of which selector wiper-to-bank contacts are the most important and best-known example. Other administrations have used periodic capacitor discharges for wetting, sometimes superimposed on small direct currents of less than a milliampere. Keeping the wetting current small is intended to reduce noise. The periodic discharges, which are applied symmetrically to the circuit, are intended to maintain high wetting efficiency. Wetting systems employing pure tones of 20 kHz, either continuously applied, or interrupted, or rectangular voltage pulses at 25 p.p.s. have also been investigated in detail.<sup>11</sup>

It is fortunate that many speech transmission paths, particularly in short-distance connexions, are required to pass relatively high direct currents and these more than suffice for wetting. It is less fortunate that the switching configurations in some important long-distance circuits do not have the advantage of wetting from direct-current signalling.

The essentially simple nature of the precautions for dry circuits is illustrated in Fig. 6, but contacts requiring wetting may form part of complex configurations, and different conditions may apply at various stages in the sequence of switching operations. Some of the practical difficulties which can arise are as follows.

(a) The wetting current minima may be unacceptably high

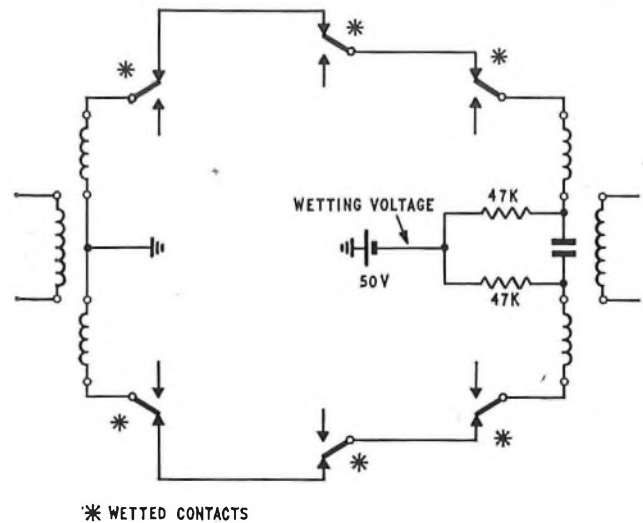

FIG. 6—Circuit paths with wetted contacts

because of detrimental effects of current flow on items, such as relays and transformers, in the wetted-circuit path.

(b) The path required to be wetted may be shunted by other branches during switching and unless excessively high source-currents are used, the minimum wetting current cannot be maintained.

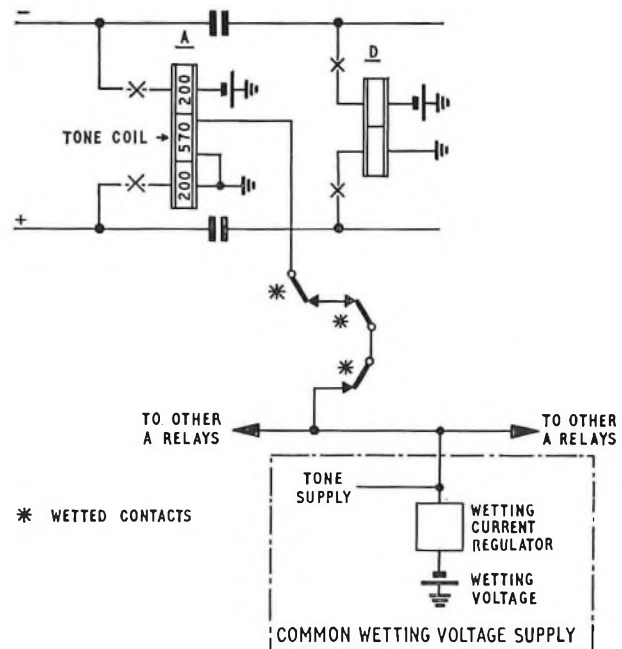

FIG. 7—Wetting of tone-supply contacts

(c) Wetting of tones may only be economical if done on a common-supply basis as illustrated in Fig. 7. Good regulation under variable-load conditions is essential, but is not easy to achieve in a simple manner. With poor regulation, the high current affects items in the wetted path; the low current reduces wetting efficiency.

(d) Switching of wetted contacts gives rise to electrical transients which cause spurious responses in tone-signalling systems. Arrangements may have to be made to connect and disconnect the wetting currents at certain stages in the setting-up and clearing-down of the connexion.

### Interruption of Current

The harmful effects which can occur when contacts open and interrupt a current, i.e. contact damage, surge voltages and interference, were described in Part I. The design approach is first to prepare circuit configurations which avoid, or minimize, contact damage and then to examine them critically for surge-voltage and interference hazards which are dealt with either by modification or by providing a quench.

**Contact Damage.** Circuit elements are analysed for unsound features such as excessive demands on the capability of the contacts and the characteristics of the switching devices. In particular, load-currents and the ampere-turns of inductive components are minimized. Information is available of potential causes of failure but the skill and experience of the designers plays a major part in ensuring good circuits. Examples 6 and 7 in Appendix 1 illustrate typical situations which are avoided in modern design.

Load switching with slowly-actuated contacts increases hesitation chatter and contact damage. As slow actuation is commonly an essential requirement, these effects are minimized by the following measures;

- (a) keeping the contact load-current small,
- (b) keeping the actuation delay short,
- (c) switching heavy loads by a quick-acting device controlled by the slow-acting contacts,
- (d) applying a suitable quench.

**Surge Voltage Hazards.** If any lead, component or switching device is likely to be subjected to an excessive voltage during the functioning of a circuit, the arrangement is either modified or a quench is provided. Troublesome conditions are not always easy to recognize. Any highly-inductive load is a

potential source of trouble to itself, or to wiring or associated equipment. Multi-winding relay coils, particularly those in which nickel-iron cores are used to reduce release-time, present severe hazards and are examined to see whether the following measures can be taken;

- (a) eliminating the need for the nickel-iron core,
- (b) reducing the turns-ratio between windings,
- (c) rearranging the winding connexions to reduce voltage stress between adjacent sections of windings,
- (d) providing a quench.

Fig. 8 illustrates these coil hazards and remedial measures. In Fig. 8(a), a non-linear resistor quench was fitted to prevent the high induced voltage breakdown of the 2,000-ohm winding. This necessitated a mechanical adjustment change, as the relay performance requirements were critical.

In the circuit shown in Fig. 8(b), an abnormal number of service failures due to breakdown of the 1,500-ohm winding was virtually eliminated by reducing the turns ratio and changing the core material from nickel-iron to soft-iron. This also appreciably reduced the initial coil cost and saved nickel, an important strategic material.

Coils connected as in Fig. 8(c) have a high failure rate. One winding is energized by switching an earth, the other by switching a battery, with the windings connected in the aiding directions. Flux collapse induces voltages of opposite polarity across the windings, i.e. at tags *b* and *d*. As these voltages are additive, there is a high peak voltage between the lead-out wires to tags *b* and *d*, and also between the outer layer of winding *a-b* and the inner layer of winding *d-e*, which are contiguous. The more common method of connexion, shown in Fig. 8(d), limits the induced voltages between the windings or lead-out wires to that generated by one winding only, i.e. between tags *a* and *e* or *d* and *b*. Also, the induced voltages at tags *a* and *d* are of the same polarity and the resultant voltage is generally small. Where circuit conditions permit, rearrangement as in Fig. 8(e) substantially

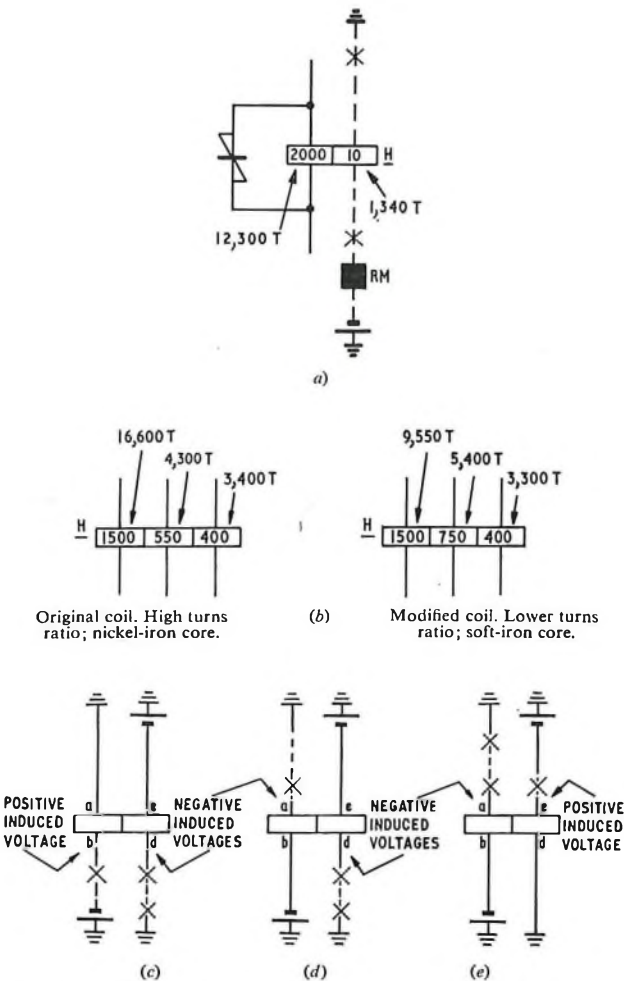

FIG. 8—Surge-voltage breakdown of multi-winding relay coils



FIG. 9—Electrical tracking damage on unsuitable moulding material



reduces breakdown hazards. The voltage between the outer layer of winding *a-b* and the inner of *d-e* is limited to that of the supply.

Voltage-limiting quenches applied to switchboard plugs not only protect the insulant against breakdown but also avoid the risk of electric shock to the user. Some idea of the severity of the conditions to which plug insulants are subjected is given by Fig. 9, which shows tracking damage suffered by unsuitable moulding material during evaluation tests.

**Interference Hazards.** As with surge-voltages, recognition of interference hazards is not easy at the design stage. It is necessary to consider not only the circuit itself, but associated circuits to which it will be connected by wiring and cabling, and also any adjacent equipment. The term *critical wiring* is used to describe situations in which connecting leads sensitive to interference have to be routed in a particular way for the equipment to work satisfactorily, and Post Office specifications draw special attention to these requirements. Interference sources and modes of propagation in exchange equipment were described in Part 1 (Fig. 7) and this is used as a guide in checking for the following:

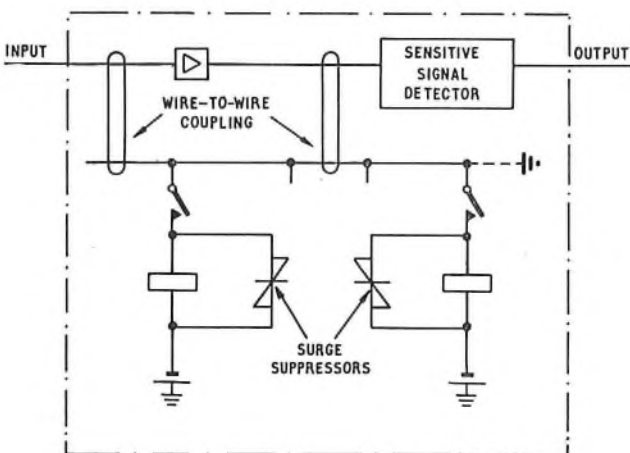

FIG. 10—Relay surges affecting sensitive signal detector

(a) elements likely to be affected by interference, e.g. amplifiers, electronic toggles, and sensitive signal-detecting circuits, Fig. 10,

(b) elements likely to cause interference by contact discharges or electrical transients, e.g. heavily-loaded and slowly-actuated contacts and selector-stepping and drive circuits,

(c) possibility of interference with, or from, associated circuits connected by wiring or cabling,

(d) possibility of interference with, or from, adjacent equipment.

Depending on conditions, one or more of the following measures may be applied:

(e) circuit elements likely to be affected by interference may be modified to reduce sensitivity,

(f) separate battery, earth, and pulse, common-supply leads may be provided for the sensitive elements, Fig. 11(a). Decoupling of the main "noisy" battery lead may be used to reduce surges to an acceptable level, Fig. 11(b),

(g) sensitive input leads may be segregated and protected by earthed screening,

(h) quenches may be applied to elements likely to cause interference.

## FINAL ASSESSMENT OF CONTACT REQUIREMENTS

When all circuit configurations have been completed and the types of components, relays and other switching devices

decided, together with resistance values, the designer can make a final assessment of contact requirements.

## Contact Loading and Life

Estimation of loadings is fairly easy, as the requirements are primarily determined by the functions and design of the circuit elements, with which the designer is well acquainted. Few circuits are self-contained, however, and care is necessary where external loadings in other circuits are involved. Contact-life requirements are estimated in terms of the number of switching operations the contacts are required to perform in the lifetime of the equipment. Conditions vary widely. Some contacts only prepare circuit paths and never close or open under load; some are used infrequently, a few operations a day; others are very heavily-worked indeed, more than 20 million operations a year.

Details of the number of operations likely to be performed by various equipment items are available for reference. As described earlier, rating information available to the designer consists largely of maximum permissible currents for unquenched resistive loads at various voltages. When the working resistive currents are less than the rated maxima, the contact life is extended, the increase depending on the device and conditions. Relaxation of the load limit is at the discretion of the designer, subject to there being no risk of switching troubles and that a reduced contact life is acceptable. For example, lamp loads of 0.8 amp at 50 volts may be switched with silver contacts for which the normal maximum current is 0.3 amp. With metal-filament lamp loads, there is a high inrush current, around 20 amp, for the steady load of 0.8 amp mentioned and it is interesting to note that the relatively-high thermal conductivity of silver gives it some advantage over platinum or palladium by more efficiently conducting the heat from the contact interface during the initial surge. With inductive loads, the currents are normally kept

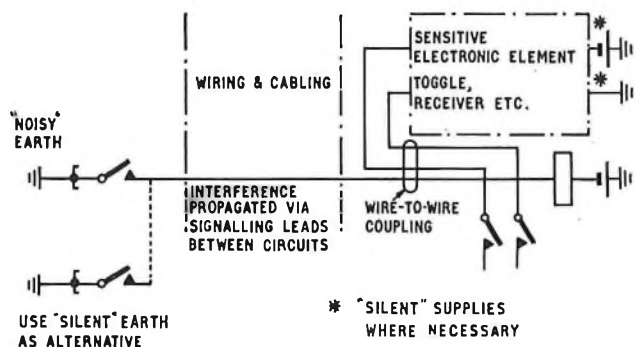

(a) Segregation of common supplies for electronic equipment

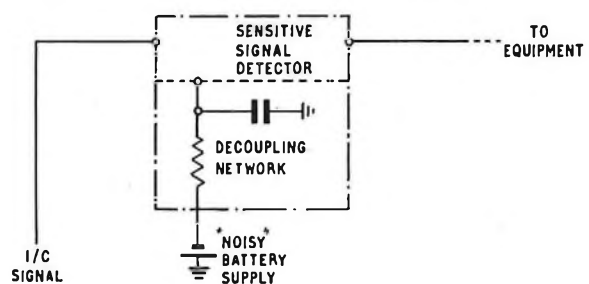

(b) Decoupling "noisy" battery supply

FIG. 11—Elimination of interference from battery and earth supplies

TABLE 1

Relay	Design Features	Circuit application	Contact material
Type 10	Long mechanical life	Heavily-worked circuits e.g. pulse distribution	<i>Silver</i> —general application, current maximum 0.3 amp <i>Platinum</i> —heavier loads, increased reliability, current maximum 1 amp
Type 12	Small size, common yoke, low cost	Subscribers' line circuits	<i>Silver</i> —current maximum 0.3 amp <i>Palladium</i> —heavier loads, increased reliability, current maximum 1 amp
Type 16	Small size and weight	Portable equipment	<i>Silver-palladium</i> —general applications, current maximum 0.6 amp <i>Palladium</i> —heavier loads, increased reliability, current maximum 0.7 amp
Type 17	Large contacts, 43 mil armature travel, non-conducting lifting-pins	Heavy loads at up to 250 volts	<i>Silver-nickel</i> —current maximum 2.5 amp d.c., 5 amp a.c.
Type 3,000	Designed for general-purpose use	Wide range of loads	<i>Silver</i> —general applications, current maximum 0.3 amp <i>Palladium</i> —heavier loads not heavily worked, increased reliability, current maximum 1 amp
Type 3/400	High-speed, critical timing	Selector cut-drive and pulsing circuits	<i>Platinum</i> —increased reliability, current maximum 0.75 amp due to small contact gap

well below the rated resistive maxima, but a decision is required on whether or not to provide a quench. This will be covered in Part 3 of this article.

**Choice of Contact Material**

Switching devices may employ only one type of contact material or may offer a choice, to meet different load or environmental conditions. Where there is a choice, the general-purpose cheaper material is used as far as possible, the alternative higher-quality material being employed only where it is essential for heavy currents, or where extra reliability is required as in important equipment, or in unvetted speech and tone transmission paths. Examples of the use of contact materials for various relays are given in Table 1. Current values quoted are for a 50-volt supply.

(To be continued)

**References**

- SCOTT, W. L. Electrical Contacts in Telephone Exchanges: Contact Opening and Closing Phenomena and Quenching Techniques. Part 1, Contact Switching Phenomena and Quenching Techniques. *P.O.E.E.J.*, Vol. 61, p. 263, Jan. 1969.
- ELEY, A. C., and LOWE, W. T. Electronic Telephone Exchanges: Reed Relays for Exchange Systems. *P.O.E.E.J.*, Vol. 60, p. 140, July 1967.
- BRITISH STANDARD 9000: 1967. Specification for General Requirements for Electronic Parts of Assessed Quality.
- ELECTRICAL CONTACTS. December 1960. Johnson, Matthey and Co. Ltd.
- HOLM, R. Electrical Contacts Handbook. Springer-Verlag, Berlin, 1958.
- ENGINEERS' RELAY HANDBOOK. Sponsored by The National Association of Relay Manufacturers of America. Hayden Book Company, Inc., New York, 1966.
- BARKER, R. Design of Relays for Automatic Telephone Equipment Circuits, with Special Reference to Relay Type 3,000. *P.O.E.E.J.*, Vol. 26, p. 15, Apr. 1933.
- PALMER, R. W. The Introduction of the Standard Telephone Relay. *P.O.E.E.J.*, Vol. 27, p. 46, Apr. 1934.
- WINDRED, G. Electrical Contacts. MacMillan & Co. Ltd.
- TRUSKALOV, N. P. The effect of Spark Suppression Circuits on Contact Resistance. *Vestnik Svyazi*, Vol. 26, No. 5, May 1966.
- BORCHERT, L., and RAU, K. L. Different Methods of Contact Wetting and a Basis for their Evaluation. *Nachrichtentechnische Zeitschrift (N.T.Z.)* No. 11, 1961.

**APPENDIX 1**

**Examples of Contact Failure and Remedial Action**

*Example 1* (Fig. 12). The line finder fails to switch to the line-circuit marked by battery via contact LR2 operated. Cleaning of contact ST4 alleviated the trouble. The time for relay KA to operate and

cut the line-finder drive circuit at KA1, when the marked contact is reached, is critically short. ST relay has an armature-end slug, an operate time of 100 ms, and, therefore, operation is not vigorous. Contact ST4 has 12 mil bearer springs, low contact force, and is at rest when the P-wire testing circuit is completed via the rotating wiper. The contact material was silver; a change to palladium

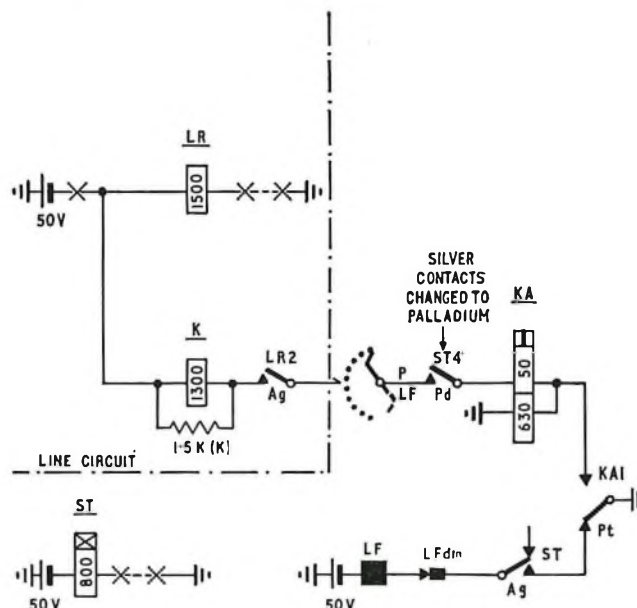

FIG. 12—Failure of line finder to switch to marked line circuit

eliminated the trouble. This type of fault occurs intermittently, and at random, affecting the grade of service until the occasional continuous hunting of the line finder is noticed.

Contact LR2, in the same circuit path as ST4, and of silver, has higher contact force, is operated vigorously and does not cause failures.

*Example 2* (Fig. 13). The selector fails to switch to a free outlet marked by battery via contact BA2 normal. (This is a cut-drive failure similar to the previous example but illustrates other important points.) The selector either switches to a later-choice outlet or rotates to the 11th position, returns equipment-engaged tone and registers congestion when free outlets are available. Routine functional checks at test-point 2 are likely to give "correct" indications unless the test equipment incorporates a critical time-feature corresponding to the dynamic circuit conditions. Likewise, a voltmeter applied to test-point 2 will probably show full circuit voltage, even though a faulty BA2 contact makes the total series impedance extremely high.

Failures were eliminated by changing BA2 to palladium. Rectifier MR2, provided to reduce the possibility of switching to engaged outlets, probably contributes towards failure. It acts as a series high-impedance in the AH relay path when engaged outlets are tested by the selector, and the P-wire potential and current via MR2 are small.



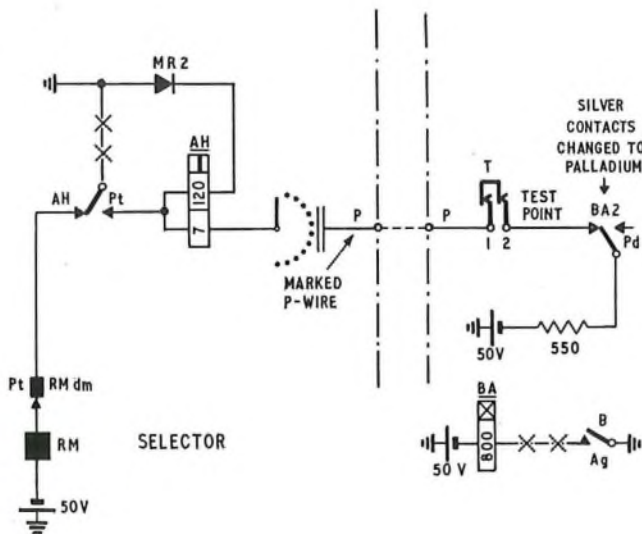

FIG. 13—Selector fails to switch to marked P-wire

*Example 3.* Fig. 14 illustrates improvements to the conduction-reliability of unselector circuits. Post Office type 2 uniselectors are often employed under onerous conditions and the preferred material for the interrupter contacts is tungsten, because of its durability. Tungsten has the disadvantage of rapidly forming a

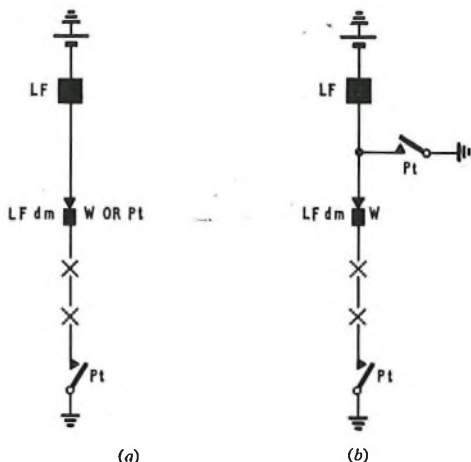

FIG. 14—Improvements to reliability of unselector circuit

surface layer of tungsten oxide, and after a short period at rest, the contact reliability is notably reduced, even though other factors such as contact force, wipe, voltage and CR-quench discharges are favourable. The alternative material, platinum, was introduced for use in carefully-selected circuits where contact life could be traded for reliability (Fig. 14(a)). The alternative configuration of Fig. 14(b) ensures that the surface films are disturbed by directly operating the magnet and interrupter contacts before the latter are required to pass current.

*Example 4.* Fig. 15 shows circuit elements in which unreliable conduction results in contacts failing to carry out short-circuiting functions. In Fig. 15(a), relay CD is energized initially via the 700-ohm winding and contact B2 operated. During pulsing of the selector vertical magnet, this winding is short-circuited via contacts HA6 and HB3, operated, but the 5-ohm winding is pulse-energized at each restoration of contact A1. At the end of the train of pulses, contact A1 remains operated, pulses via the 5-ohm winding cease, but CD releases slowly because of the short-circuited 700-ohm winding. The release delay is provided to ensure that rotary hunting of the selector is not started prematurely. Excessive release-delay of CD introduces a risk of a further train of pulses being received before rotary hunting and switching to a free outlet has been completed. The time-margin for correct release of relay CD is rather small, as the static release lag is increased under dynamic circuit conditions by a small current via its 5-ohm winding. Contacts HA6 and HB3 are of silver and have low contact force. The voltage across the contacts is less than the 50-volt supply. Even a small value of resistance in the short-circuit relay-contact path has a pronounced effect on the release time of relay CD, for example, 5 ohms

increases the release time by 40 per cent. This failure is corrected by cleaning and burnishing of the contacts and in recurrent cases, by periodic lubrication, as will be described in Part 3.

*Example 5.* In Fig. 15(b), the function of contact F1x is to maintain a short-circuit across the 400-ohm winding of relay F until the called party lifts the receiver and completes a d.c. path to partially-operate relay F via its 300-ohm winding. This opens contact F1x. (An x contact is one which operates in advance of the other contacts on the same relay.) Relay F is then fully operated by the 400-ohm

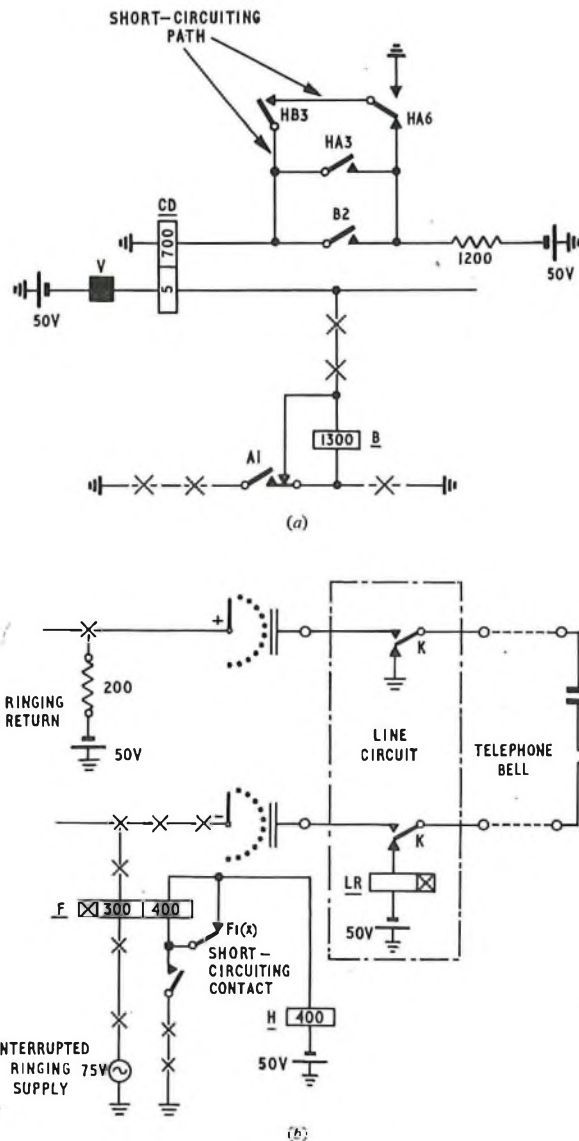

FIG. 15—Failures of short-circuiting function

winding. Conditions are exacting; to meet long-line ring-trip conditions, relay F must be sufficiently sensitive to open contact F1x with only a small ampere-turns energization of the 300-ohm winding. The transient current via the winding when ringing is applied to line is of considerable magnitude, due to the alternating ringing superimposed on a steady "return" voltage and the charge retained by the bell-circuit capacitor from the line-circuit potentials. Contact restoration is not vigorous and the contact force is low. If contact F1x is not a fully-effective short-circuit, a small current through the 400-ohm winding, aided by the ringing transient, reduces the contact force. The contact resistance increases and premature operation of relay F occurs. This fault is dealt with by contact cleaning and burnishing and, in bad cases, by lubrication. Some very early selector circuits employed an x make contact for F1x instead of an x break, in a slightly different circuit element and it is possible that this arrangement provides a larger reliability margin.

*Example 6.* Fig. 16 shows how an apparently-attractive circuit can be troublesome. High-speed relay PA self-interacts at 14 p.p.s. to step uniselectors DM1 and DM2. A high-speed relay seems very suitable, having platinum contacts, speedy actuation and small pulse distortion. In service, spikes formed on the contacts, causing inter-

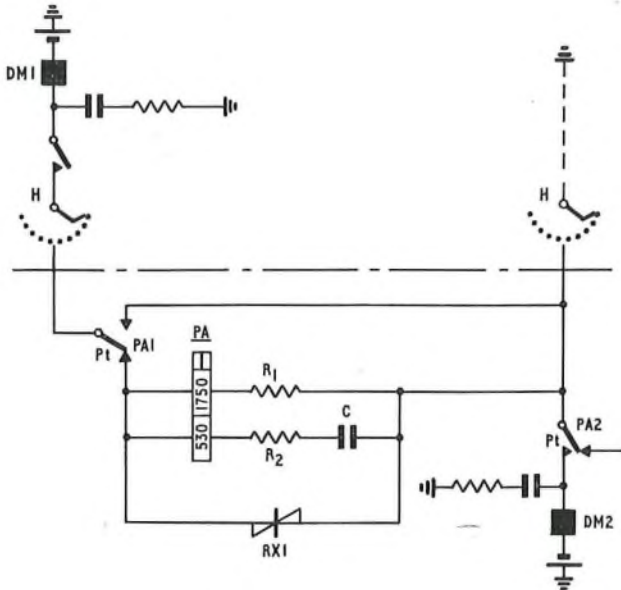

FIG. 16—Incorrect use of high-speed relay

locking, due primarily to the circuit conditions being too onerous. The load is inductive, the rate of use is high, bounce is usually present on restoration of high-speed relay break contacts, the contact clearance is small (4 mils) and platinum develops hard spike formations. The non-linear resistor quench RX1, added retrospectively, alleviated the trouble.

*Example 7.* Fig. 17 illustrates a situation in which a load, well within the capability of an opening relay contact, may cause severe damage when disconnected at a bank contact by a moving wiper. Both wiper and contact are of base metal and contact erosion is increased by wiper bounce, abrasive carbon particles and other debris. This method of load switching needs to be examined very carefully indeed.

Repeated failures occurred due to wiper and bank-contact damage, even though analysis of the relay timings, at the design stage, indicated that there was sufficient margin to ensure that the heavy magnet-load current was never disconnected at the wiper. Investigation revealed that, with the high rate of use, wear of the spring-lifting studs and contacts was affecting the operating sequences and more than offsetting the margin. An additional Y-relay contact had to be provided to eliminate the possibility of the magnet being disconnected by the wiper.

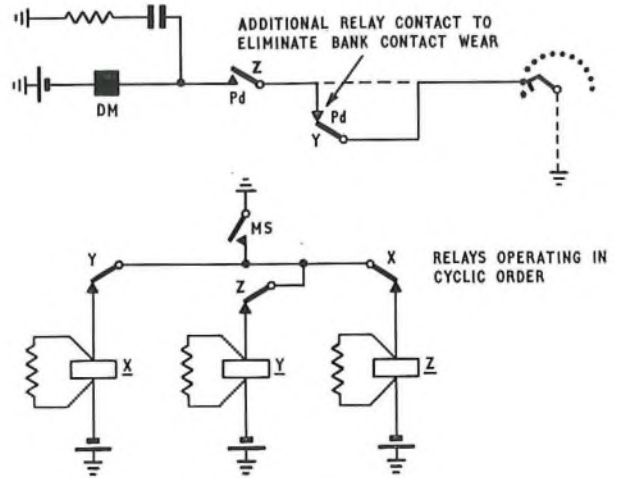

FIG. 17—Elimination of bank-contact damage

## APPENDIX 2

### Definitions of Terms

#### Wetting Voltage

A voltage whose magnitude is dependent on the type of contact-point material and whose source impedance is sufficiently low, which, when connected to a contact circuit, ensures that the closed-circuit current flowing is not less than a specified value. This value is also dependent on the type of contact-point material.

NOTE. The voltage may be unidirectional or alternating; it may be applied to the contact points periodically as a pulse, or applied continuously at constant amplitude.

#### Wetting Current

Current flowing through contact points as the result of the application of a wetting voltage.

#### Electrically-Wetted Contact points

The electrical state of contact points in a contact circuit when its open-circuit voltage and closed-circuit current always exceed specified values which depend on the type of contact-point material.

#### Wetted Circuit

A closed circuit which is completed through contact units all of which are electrically wetted.

#### Electrically-Dry Contact Points

The electrical state of contact points in a contact circuit when its open-circuit voltage and closed-circuit current do not exceed specified values which depend on the type of contact-point material.

#### Dry Circuit

A closed circuit that is completed through contact units, any one of which is electrically dry.



# An Anti-Jamming Device for Conveyor-Belt Systems

A. IOANNIDES, B.SC., C.ENG., M.I.E.E. and C. G. MACMILLAN\*

U.D.C. 621.867: 656.85

*The employment of a high-speed roller as an anti-jamming device at critical transition points in bulk-mail conveyor systems has proved very successful. A description is given of some of the background work that was done in eliminating a source of discontinuities in the steady transit of parcels along the conveyor belts of the main sorting offices.*

## INTRODUCTION

In sorting offices, there have been many instances where parcels and mailbags have failed to pass smoothly from one conveyor to the next at right-angle turns in the belt-conveyor systems. A temporary build-up of mail at these transfer points, although quite normal, and usually self-correcting by the continuous movement of the belts, sometimes causes a parcel to dwell at the transition point between one conveyor and the next. This can allow an appendage, such as a tied-on label, or D-ring on a bag, to be carried round by the first conveyor, and to become jammed in the narrow gap between the moving belt and the static plate below the conveyor end-roller which forms part of the structure (Fig. 1). This

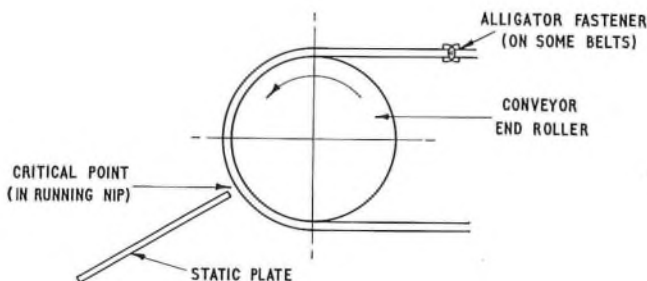

FIG. 1—Original configuration of conveyor end-roller and static plate

and wedge-shaped parcels have also become trapped. The offending parcel or mailbag, being now firmly held, causes a rapid build-up of the mail following on, leading to a total jam, which has to be freed manually. Even worse, labels sometimes become completely detached, and further identification may be lost.

## SOME ALTERNATIVE SOLUTIONS

It was evident that one solution, if practicable, would be to close up the gap between conveyor belt and static plate. However, the gap had to be large enough to allow the thickest part of the belt, usually the metal "alligator" joint between the two ends of the belt, to pass through without touching the static plate. Such a gap would still allow labels to enter the gap and clearly would be no solution. On the other hand, increasing the gap would permit even more wedge-shaped parcels to become jammed.

A further possibility was that of making the right-angle turn in stages. One method would be to make the turn through quarter-turn chutes. Such arrangements, however, demand a loss of height of at least four feet and this is not practicable at many locations.

A means was therefore sought of positively repelling any parcel or appendage as it approached the critical area, and the employment of an intermediate high-speed roller, set between conveyor belt and static plate, and moving in the same direction of rotation as the conveyor end-roller, was provisionally decided upon. Such an arrangement, if successful, would not involve costly large-scale modifications to existing equipment or layouts.

## THE NEW CONFIGURATION

The arrangement is illustrated in Fig. 2. With the high-speed roller rotating in the same direction as the

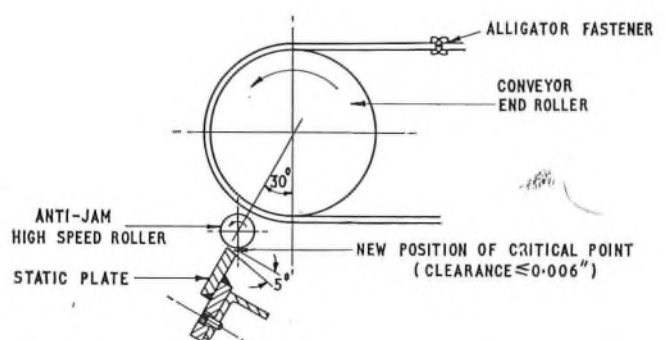

FIG. 2—Proposed configuration incorporating anti-jam high-speed roller

conveyor end-roller, it automatically tends to counter the drawing-in effect of the latter, and further, by giving it a velocity at the circumference greater than that of the belt, its effect predominates at the critical point. In addition, contact alone with the top side of the roller repels any unwanted object back towards the required direction of flow.

An important advantage of the intermediate high-speed roller is that the critical point is, in effect, moved from the direct vicinity of the conveyor belt to a position below the high-speed roller where the gap between it and the static plate can be reduced below the minimum thickness of any potential obstruction.

## WORKS TRIALS OF THE ANTI-JAMMING DEVICE

Trials were carried out in October 1968 with the first device which incorporated a 2-inch diameter high-speed roller.

The choice of 2 inches as roller diameter was governed by a number of factors. These were that the roller must be large enough to have adequate strength and rigidity, while it must not be so large that it obstructs the normal flow of mail, and it should not require a high-power motor to drive it.

\* Parcel and Bulk Mail Branch, Planning and Mechanization Department, Postal Headquarters.

Two types of roller were manufactured and tested, a rubber-faced mild-steel roller and an all-steel roller. With these fitted in turn, a large number of thin envelopes, labels and pieces of paper were discharged from the conveyor with complete success. Further, pieces of paper and envelopes which were placed between the conveyor belt and high-speed roller, with the system at rest, were immediately ejected as soon as the system was switched on. The rubber-faced roller was marginally more effective in this test.

### ON-SITE TRIALS AT THE WESTERN DISTRICT OFFICE

Following the successful works trials outlined above, early in 1969, two devices incorporating high-speed rollers were installed at the Western District Office at one of a number of transfer points which had been particularly prone to jamming.

Motive power for each roller was supplied by a half-horsepower motor, this being considered the smallest size which would produce sufficient torque to over-ride any tendency for the roller to be retarded by the direct pressure of parcels during a temporary build-up of mail.

The installation is shown in Fig. 3, the conveyor numbers being those used at the Western District Office.

For a preliminary test, an all-steel roller was fitted at the end of conveyor 3/1 and a rubber-faced roller fitted at the end of conveyor 3/2A. The gap between rollers and static plates was set to 0.001 inch. On switching on, both rollers were marked due to contact with the static plates, and the rubber-faced roller quickly generated sufficient heat to burn badly.

As a result of this test, a number of changes were made and these are listed below.

(a) The gaps were opened to 0.004 inch.

(b) The rubber-faced roller was replaced by an all-steel roller treated with a 0.001-inch sprayed matt finish of tungsten carbide, the surface being ground flat but not smooth, retaining a high coefficient of friction.

(c) The method of adjusting each static plate was modified to that shown in Fig. 2, the securing bolts being made more accessible. A vitreous-enamel-finished notice plate, mounted at a point where it is obvious to the maintenance staff, specifies a maximum clearance of 0.006 inch.

(d) A rake angle of 5° was incorporated at the upper edge of the static plates, thus ensuring line and not surface contact.

Three tests were then carried out using 100 dummy parcels specially prepared for machine testing. This test parcel selection ensured that a high percentage of awkward parcels were included. The parcels were loaded on to conveyor 3/1 for a length of 10 ft and to an average depth of 2 ft 3 in. The speeds of the roller and belts listed below were maintained constant throughout the three tests at the values shown below: surface speed of high-speed roller—380 ft/min, speed of conveyor 3/1—85 ft/min, speed of conveyor 3/2—110 ft/min. Conveyor 3/2A was adjusted in turn to speeds of 130 ft/min,

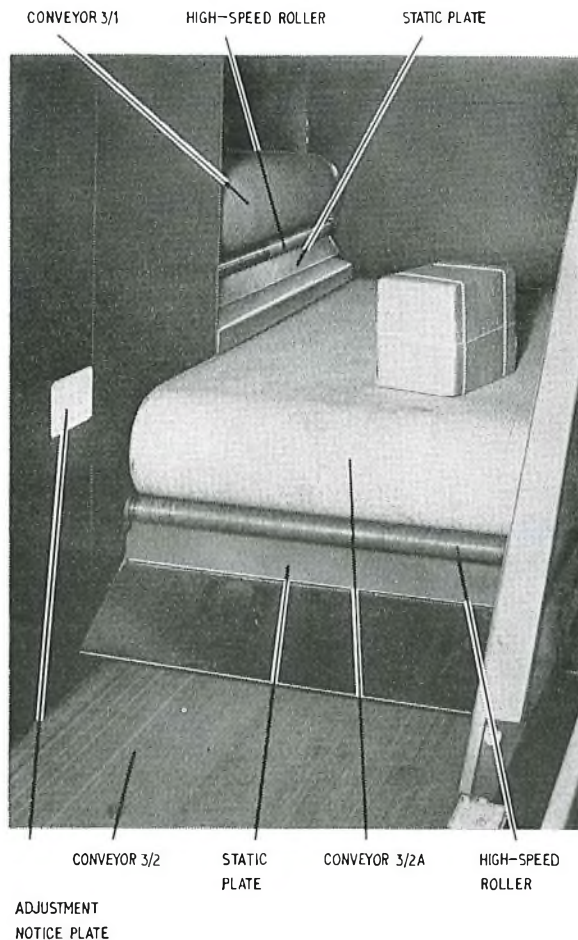

Fig. 3—Installation at the Western District Office

185 ft/min and 160 ft/min and the performance assessed at each speed.

The flow of parcels was marginally better in the third test than in the first and second and 160 ft/min was adopted as the correct speed for conveyor 3/2A.

### CONCLUSIONS

The tests clearly demonstrated the effectiveness of the high-speed rollers as an anti-jamming device. There were no cases of jamming at the rollers. The only instances of parcel build-up either quickly cleared themselves, or were the result of parcels longer than the 3 ft 6 in width of conveyor 3/2A being included in the test batches. These were outside the limits laid down by Post Office Regulations, and the cause of jamming was unconnected with the function of the device under test.

The equipment has been left in service and the devices have continued to function to the date of writing. No cases of jamming under the head rollers have been reported.



# Notes and Comments

## Birthday Honours

The Board of Editors offers congratulations to the following engineers honoured by Her Majesty the Queen in the Birthday Honours List:

Telecommunications Headquarters	J. B. Holt	..	..	Assistant Staff Engineer	..	Officer of the Most Excellent Order of the British Empire
External Telecommunications Services	..	M. Johnston	..	..	..	Executive Engineer
Scotland	..	..	..	..	..	Member of the Most Excellent Order of the British Empire
	..	A. B. Jones	..	..	..	British Empire Medal

## S. T. E. Kent, M.I.E.E.

S. T. E. (Sid) Kent's very many friends will not be surprised to learn of his appointment as Service Controller in E.T.R.

He started his P.O. Service in 1928 as a youth-in-training at North West Area L.T.R., was successful in the Probationary Inspectors' Examination in 1934 and subsequently served as an Inspector on installation, external construction and maintenance duties in the old L.E.D. and in South West Area L.T.R.



In 1943 he was commissioned in the Royal Signals and gained extensive experience in the provision and maintenance of communications in the difficult and sometimes hazardous conditions of the Italian Campaign. He left the service with the rank of Captain, and returned to the P.O. in 1946 as a Chief Inspector on external planning.

His promotion to E.E. in 1948 introduced him to a longish period of association with efficiency and organization work, first in L.T.R. and subsequently as an S.E.E. in O.E. Branch of the former engineering department. He has the distinction of being one of the first of that small but select band who introduced serious work study into P.O. activities with the now well-known results in terms of productivity achievements.

He transferred to Canterbury Area in 1962 and was then R.E. in E.T.R., first on line planning and works in 1966, later on service and maintenance.

His down-to-earth approach, drive, and wide experience ensure his success in his new post and we all wish him well.

R.H.A.

## I. F. Macdiarmid, C.Eng., M.I.E.E.

Ian Macdiarmid's reputation and background of experience made it easy to predict his promotion to Senior Principal Scientific Officer heading the Visual Telecommunications Branch in Research Department.

Since entering the Post Office as a Youth-in-Training in 1935, he has been concerned almost exclusively with one aspect or another of transmission, both cable and radio. It was doubtless inevitable that his inclination and abilities would sooner or later lead him to research work, and this happened when he was transferred to Dollis Hill in 1947. Soon afterwards, he became a founder-member of the first team there to be wholly concerned with the problems of waveform transmission, especially of television signals. Continuing in this field, his achievements brought him recognition

as a specialist, particularly in television measurement methodology, and his many published papers and lectures have made his name well known outside the Post Office, both nationally and internationally.



He takes up his appointment at a time of transition. The demands of broadcast television are giving place to wider studies of visual telecommunication systems, covering close circuit television, data display and facsimile transmission. Visual systems are clearly destined to form an important part of future Post Office business, and it is certain that "Mac" will not be short of challenging opportunities for exercising his talents.

N.W.L.

## G. D. Allery, B.Sc.(Eng.), C.Eng., M.I.E.E., F.B.C.S.

The appointment of George Allery as Staff Engineer of the new TDD Branch set up to co-ordinate development aspects of the Digital Data Network will be welcomed by his many friends in THQ, the telecommunication and computer industries, and in overseas telecommunication administrations.



His involvement in C.C.I.T.T., C.E.P.T. and I.S.O. activities, and in particular his chairmanship of the C.C.I.T.T. Working Party on Data Transmission Interfaces, has brought him into contact with engineers around the world.

George's eight years' experience of telegraph transmission development work, followed by six years in the original

computer group of O Branch, where he helped to plan the first P.O. computer (LEAPS), and a further six years in the Telegraph and Data Systems Branch, where he was concerned with the development of the datel services, made him a natural choice to head the project team set up in 1968 to study data networks.

In addition to a wealth of relevant official experience, George brings to his new responsibilities a lively interest in the arts and an active churchman's concern for people. These qualities and the good wishes of his many friends should ensure his continuing success.

May he still find time to pursue his keen interest in church architecture and oecumenical progress.

R.W.B.

### **B. B. Gould**

Many people attending engineering promotion boards will soon face across the table one of the best-known telephone engineers in the business. B. B. Gould—almost universally known as “Ben”—has been promoted to Staff Engineer in the Telecommunications Personnel Department.

Indubitably a Yorkshireman, Ben started his career in York Area in 1933. After six years he came south to take up a post in the training school—then at Dollis Hill. In 1944, on promotion to inspector, he started his career in the then telephone branch. Five years later he passed the Limited Competition for Executive Engineer and became a Senior Executive Engineer in 1957.



Throughout those vital days of post-war development, Ben was involved in almost all aspects of circuit design for Strouger exchanges. Even so, the future needs of the telecommunications business were always at hand: he formed part of the late Harold Francis's study team on s.t.d. and he was also deeply involved in the early studies of the first electronic telephone exchange.

In 1963 he was promoted to Assistant Staff Engineer in the Telephone Development Branch, under Bill Tobin, and remained with him in TD1 after the 1968 reorganization. Until his recent promotion he still controlled much of the conventional telephone exchange development work, but was also responsible for cordless switchboards, including the new Cordless Switchboard No. 2.

Although most of his career has been spent on so-called inanimate technical problems, Ben has never lost his essential interest in people; he was, until recently, the secretary of the Association of Staff and Regional Engineers. Always urbane, he brings to his new post essential qualities of patience and compassion; he is ideally suited for it, and we all wish him well.

C.A.M.

### **Supplement**

Students studying for City and Guilds of London Institute examinations in telecommunications are reminded that the Supplement to the *Journal* includes model answers to examination questions set in all the subjects of the Telecom-

munication Technicians' Course. Back numbers of the *Journal* are available in limited quantities only, and students are urged to place a regular order to ensure that they keep informed of current developments in telecommunications and receive all copies of the Supplement.

### **Syllabuses and Copies of Question Papers for the Telecommunication Technicians' Course**

The syllabuses and copies of question papers set for examinations of the Telecommunication Technicians' Course of the City and Guilds of London Institute are not sold by *The Post Office Electrical Engineers' Journal*. They should be purchased from the Department of Technology, City and Guilds of London Institute, 76 Portland Place, London, W1N 4AA.

### **Publication of Correspondence**

The Board of Editors would like to publish correspondence on engineering or technical aspects of articles published in the *Journal*.

Letters of sufficient interest will be published under “Notes and Comments”. Correspondents should note that, as it is necessary to send copy to the printer well before publication date, it will only be possible to consider letters for publication in the January issue if they are received before 15 November 1970.

Letters intended for publication should be sent to the Managing Editor, *P.O.E.E. Journal*, Room 506, Lutyens House, London, EC2.

### **Notes for Authors**

Authors are reminded that some notes are available to help them prepare the manuscripts of the *Journal* articles in a way that will assist in securing uniformity of presentation, simplify the work of the *Journal*'s printer and draughtsmen, and help ensure that authors' wishes are easily interpreted. Any author preparing an article for the *Journal* who is not already in possession of the notes is asked to write to the Managing Editor to obtain a copy.

It is emphasized that all contributions to the *Journal*, including those for Regional Notes and Associate Section Notes, must be typed, with double spacing between lines, on one side only of each sheet of paper.

Each circuit diagram or sketch should be drawn on a separate sheet of paper; neat sketches are all that are required. Photographs should be clear and sharply focused. Prints should preferably be glossy and should be unmounted, any notes or captions being written on a separate sheet of paper. Negatives or plates are not needed and should not be supplied.

### **Model Answer Books**

Books of model answers to certain of the City and Guilds of London Institute examinations in telecommunications are published by the Board of Editors. Details of the books available are always given at the end of the Supplement to the *Journal*. The Board of Editors has reduced the price of Line Plant Practice A to 7/6 (8/- post paid).

### **Articles on Current Topics**

The Board of Editors would like to publish more short articles dealing with topical subjects. Authors who have contributions of this nature are invited to contact the Managing Editor.

### **Journal Back Numbers**

A reader has the following issues of the *Journal* for disposal:  
Bound volumes 4–9 (1912–1916).  
Bound volumes 24–57 (1931–1965)  
Unbound volumes 58–62.

Any reader interested in purchasing these items should contact Mr. H. Jeffs, 1 Kimbolton Avenue, Bedford.



# Institution of Post Office Electrical Engineers

## Essay Competition 1970-71

To further interest in the performance of engineering duties and to encourage the expression of thought given to day-to-day departmental activities, the Council of the Institution of Post Office Electrical Engineers offers five prizes, a first prize of six guineas and four prizes of three guineas, for the five most meritorious essays submitted by Post Office engineering staff below the rank of Inspector. In addition to the five prizes, the Council awards five certificates of merit. Awards of prizes and certificates made by the Institution are recorded on the staff docketts of the recipients.

An essay submitted for consideration of an award in the essay competition and also submitted in connexion with the Associate Section I.P.O.E.E. prizes will not be eligible to receive both awards.

In judging the merits of an essay, consideration will be given to clearness of expression, correct use of words, neatness and arrangement, and although technical accuracy is essential, a high technical standard is not absolutely necessary to qualify for an award. The Council hopes that this assurance will encourage a larger number to enter. Marks will be awarded for originality of essays submitted.

Copies of previous prize-winning essays have been bound and placed in the Institution Central Library. Members of the Associate Section can borrow these copies from the Librarian I.P.O.E.E., 2-12 Gresham Street, London, EC2V 7AG.

Competitors may choose any subject relevant to engineering activities in the Post Office. Foolscap or quarto paper should be used, and the essay should be between 2,000 and 5,000 words. An inch margin should be left on each page. A certificate is required to be given by each competitor, at the end of the essay, in the following terms:

*"In forwarding the foregoing essay of . . . words, I certify that the work is my own unaided effort both in regard to composition and drawing"*

Name (in Block Capitals) . . . . .

Signature . . . . .

Official Address . . . . .

The essays must reach:

The Secretary,  
The Institution of Post Office Electrical Engineers,  
2-12 Gresham Street,  
London, EC2V 7AG

by 15 January, 1971

The Council reserves the right to refrain from awarding the full number of prizes and certificates if in its opinion the essays submitted do not attain a sufficiently high standard.

## Institution Field Medal Awards—1968-69 Session

Details of the medals awarded for the best papers read at meetings of the Institution in field subjects primarily of regional interest were published in the July 1970 issue of the *Journal*.

The Council of the Institution is indebted to Mr. E. C. Swain, Chairman of the Papers Selection Committee of Council, for the following précis of the medal winning papers:

*"A Critical look at Telephone Engineering Centres. Do we get Value for Money?"* by D. H. Anderson and A. P. Parsons

This paper explains the problems of providing a complex of telephone engineering centres (t.e.c.) within a telephone area and discusses the spatial relationships of the components of a t.e.c. as they affect operational efficiency. Examples are drawn from t.e.c.s being planned in the Midland Telecommunications Region. Following a brief history of the development of t.e.c.s the authors explain that the basic function of a t.e.c. is to provide not only a headquarters for field staff but also a range of services that will enable the staff

to spend a minimum of time at the t.e.c. and a maximum of productive time at their places of work. Reference is also made to the problem of reconciling the demands of the various user groups within a t.e.c.

In discussing the principles to be observed in the overall lay-out the authors stress the importance of allowing adequate parking and circulation arrangements for both private and official vehicles and to this end they advocate locating buildings towards the centre of a site; one way traffic flow; separate IN and OUT gates linked by peripheral roads; parking round the perimeter; adequate provision for separate private car parking and, desirably, the complete segregation of private cars from official vehicles both in terms of parking and circulation. A collection road for obtaining all forms of stores ensures that the vehicles involved do not block the main circulation areas. Plans illustrate how the authors' basic principles have been applied to a variety of sites.

The paper describes the preparation of area fundamental plans and the determination of areas to be served by t.e.c.s. It includes a description of the computer techniques which are available for deciding t.e.c. locations. Graphs illustrate the optimum sizes of t.e.c.s based on the telephone density of the areas being served and the cost of sites. The planning sequence having been outlined, the authors stress the need to critically examine t.e.c. sites that might be made available and they describe how simple feasibility studies may be conducted.

The paper concludes with a discussion of t.e.c. costings; the temporary use of t.e.c. sites in the period between site acquisition and provision of permanent buildings; the problems of supervision, security and maintaining operational efficiency: studies of staff movements at t.e.c.s and some, still to be solved, problems of stores provisioning and handling.

*"Long-Term Planning Aspects of Craigavon New Town"*, by W. J. Gawley

In this paper the author reviews and describes a number of the aspects involved in planning for the provision of telephone service for Craigavon New Town in Northern Ireland.

At the outset, he emphasises the need to be continuously aware of maintaining an "on demand" service to meet the current rate of growth in the new development area while concentrating on the basic problem of planning and providing for the forecast long-term requirements. He outlines the evolution of Craigavon, a unique concept designed to link two existing towns into an urban linear core by the creation of a new town centre between them.

The paper examines the new town against the background of the growth and potential development of the telephone system in Northern Ireland. Then follows a general description of the procedures involved in planning for a new telephone system and the problems of forecasting the telephone demand.

The author proceeds to a detailed analysis of the Craigavon complex and evaluates the significant factors to be considered in formulating proposals for a viable telephone system to meet the long term forecasts. Consideration is given to the effect on existing exchange-area boundaries, the new exchange site and building, extensions to existing buildings and the necessity for accurate programming. The complex poses some novel and interesting problems which are brought out in assessing alternative schemes to provide interim or temporary means of giving service until the permanent Craigavon exchange is ready for opening.

Consideration is also given to the effect on the numbering scheme, group switching centre, auto manual centre, telephone repeater station and a number of other related factors, e.g. telephone engineering centres, co-ordination of underground services and the need for close liaison with the development authority.

In reference to future developments in communications in new towns, the author compares the Washington scheme with proposals for a similar project at Craigavon. The provision of a network offering fully-integrated facilities, could, he says, open the way for many futuristic ideas which are technologically possible but might never become economically viable.

New houses in new towns of the future, however, could conceivably be linked by means of a single communication pipe to a general-purpose communication main at the building stage as they are now linked to the electricity and water supply.

In conclusion, the author emphasises the importance of recognizing that no plan is immutable; the new town plans may change during implementation. The planner must, therefore, constantly review his methods, ideas and attitudes to ensure that they are adequately geared to exploit current techniques.

Economic and technological trends shape the future and flexibility must always be a basic factor in planning.

#### **Election of Members of Council 1970-71**

The results of the recent elections of members of Council are as shown below, the names being shown in order of votes counted.

Honorary Treasurer

Mr. H. T. MacGrath (THQ/TD1) (returned unopposed)

#### *Grade Representation*

Regional Engineers of the Provincial Regions

Mr. S. H. Shephard (ETR) (returned unopposed)

Senior Executive Engineers, Motor Transport Officers Class II, Senior Experimental Officers, Senior Scientific Officers, Chief Officers, Chief Engineers and Senior Technical Costs Officers of the Post Office Headquarters Departments and Assistant Factory Managers of the Factories Division (London).

Mr. A. H. Elkins (THQ/TD3)

Mr. S. J. Rawlinson (THQ/TP)

Senior Executive Engineers and Regional Motor Transport Officers of the London Regions.

Mr. F. K. Marshall (LTR/Trunk Planning)

Mr. K. D. Busby (LTR/S)

Mr. H. J. S. Mason (LTR/W)

Assistant Executive Engineers, Technical Assistants, Senior Scientific Assistants, Assistant Experimental Officers, Third Officers, Fourth Officers, Third Engineers, Fourth Engineers, Electrical Engineers, and Assistant Technical Costs Officers of the Post Office Headquarters Departments and Factory Foremen and Assistant Factory Foreman of the Factories Division (London).

Mr. J. M. MacKirdy (THQ/TD3)

Mr. R. V. Walters (THQ/TP7)

Mr. M. G. Grace (THQ/MK1)

Assistant Executive Engineers and Technical Assistants of the London Regions.

Mr. G. F. Morley (LTR/RETS) (returned unopposed)

Assistant Executive Engineers, Technical Assistants, Senior Scientific Assistants and Assistant Experimental Officers of the Provincial Regions. Factory Foremen and Assistant Factory Foremen of the Factories Division (Provinces).

Mr. R. C. Maltby (Cambridge)

Mr. D. W. Sharman (Leicester)

Mr. T. J. L. Painter (Swansea)

Mr. E. A. Wallis (Wolverhampton)

Mr. R. B. Duncan (Edinburgh)

Mr. G. Dryburgh (Edinburgh)

Mr. D. B. McMillan (Edinburgh)

Corporate Members holding non-engineering posts in the Post Office (Rule 11a).

Mr. D. R. Bearham (LTR/E)

The constitution of the Council for the year 1970-71 will therefore be as follows:

Mr. N. C. C. de JONG—Chairman.

Mr. D. WRAY—Vice-Chairman.

Mr. H. T. MacGrath—Honorary Treasurer.

Mr. M. MITCHELL, M.B.E., E.R.D.—Representing the Staff Engineers, Chief Motor Transport Officers, Submarine

Superintendent, Senior Principal Scientific Officers, Assistant Staff Engineers, Motor Transport Officers Class I, Deputy Submarine Superintendent, Principal Scientific Officers, Chief Experimental Officers, Commanders (Cable Ships), Chief Factories Engineer and Principal Technical Costs Officers of the Post Office Headquarters Departments and Regional Engineers of the London Regions.

Mr. S. H. SHEPHARD—Representing the Regional Engineers of the Provincial Regions.

Mr. A. H. ELKINS—Representing the Senior Executive Engineers, Motor Transport Officers Class II, Senior Experimental Officers, Senior Scientific Officers, Chief Officers, Chief Engineers and Senior Technical Costs Officers of the Post Office Headquarters Departments and Assistant Factory Managers of the Factories Division (London).

Mr. F. K. MARSHALL—Representing the Senior Executive Engineers and Regional Motor Transport Officers of the London Regions.

Mr. C. T. LAMPING—Representing the Senior Executive Engineers and Regional Motor Transport Officers of the Provincial Regions. Factory Senior Executive Engineers and Assistant Factory Managers of the Factories Division (Provinces).

Mr. J. F. WALLINGFORD—Representing the Executive Engineers, Motor Transport Officers Class III, Experimental Officers, Scientific Officers, Second Officers, Second Engineers and Technical Costs Officers of the Post Office Headquarters Departments and Factory Overseers of the Factories Division (London).

Mr. F. W. G. REDMAN—Representing the Executive Engineers and Assistant Regional Motor Transport Officers of the London Regions.

Mr. J. FARRAND—Representing the Executive Engineers, Assistant Regional Motor Transport Officers, Experimental Officers and Scientific Officers of the Provincial Regions. Factory Executive Engineers and Factory Overseers of the Factories Division (Provinces).

Mr. J. M. MacKIRDY—Representing the Assistant Executive Engineers, Technical Assistants, Senior Scientific Assistants, Assistant Experimental Officers, Third Officers, Fourth Officers, Third Engineers, Fourth Engineers, Electrical Engineers and Assistant Technical Costs Officers of the Post Office Headquarters Departments and Factory Foremen and Assistant Factory Foremen of the Factories Division (London).

Mr. G. F. MORLEY—Representing the Assistant Executive Engineers and Technical Assistants of the London Regions.

Mr. R. C. MALTBY—Representing the Assistant Executive Engineers, Technical Assistants, Senior Scientific Assistants and Assistant Experimental Officers of the Provincial Regions and Factory Foremen and Assistant Factory Foremen of the Factories Division (Provinces).

Mr. L. J. LASSETER—Representing the Inspectors of the Post Office Headquarters Departments and of the London Regions.

Mr. J. MACKAY—Representing the Inspectors of the Provincial Regions.

Mr. G. H. E. COLLINS—Representing the Draughtsmen and above and Illustrators and above of the Post Office Headquarters Departments and of the London Regions.

Mr. L. C. WHARMBY—Representing the Draughtsmen and above of the Provincial Regions and of the Factories Division (Provinces).

Mr. D. R. BEARHAM—Representing the Corporate Members holding non-engineering posts in the Post Office (Rule 11(a)).

Mr. L. A. WHITE—Representing the Clerical and Photographic Staff of the Post Office Headquarters Departments and of the London Regions.

A. B. WHERRY  
*General Secretary*



# Regional Notes

## Midland Region

### Birmingham Area—All-Figure Numbers

At 0800 hours 25 April 1970, all the tees between letter and figure codes were cut at all Birmingham director exchanges and those trunk register-translator units serving incoming traffic to Birmingham Director Area. Letter codes were connected to an announcement advising customers of the change. At the end of four weeks, the number of callers still dialling letter codes was less than 0.8 per cent and the announcement was ceased at 1700 hours 22 May 1970 and number unobtainable (n.u.) tone connected, thus completing the operation.

When the method of carrying out the work was considered in October 1969, it was decided that to cut all the tees in one operation would result in less confusion for customers, operating staff and engineering staff. At that time, approximately 35 per cent of customers were still dialling letter codes and it was not thought feasible to route such large quantities of calls over the network to a central announcement. Therefore, it was decided that each exchange should contain its intercepted traffic within itself. This would require provision of a distribution amplifier at each exchange with only a junction feed from the central announcement.

Choice of an appropriate announcement made it possible to feed it over the existing distribution of n.u. tone (forced release) to 1st code selectors and register-access relay-sets. Thus, the letter codes could be made spare code in the first instance and obviate the necessity for further translation changes, thereby saving engineering labour. The announcement chosen was—"Have you dialled correctly? Birmingham now has all-figure numbers. Please consult your dialling instructions."

Having taken the basic decisions, the Factories Division Laboratory, Birmingham, were asked to design and manufacture a distribution amplifier with an announcement-fail detection facility to give changeover to n.u. tone. It was to be based on a cheap proprietary printed-circuit transistor amplifier and to be mounted on a standard relay-set base. A prototype was tested in the Area at the beginning of March 1970 and after various modifications, 65 amplifiers were manufactured and delivered during the first three weeks of April 1970.

The amplifiers were fitted by Area maintenance staff in a spare relay-set position on the auxiliary equipment rack and connected to the n.u. tone (forced release) distribution. To provide the central announcement, two Equipments Announcer No 9A were fitted at Midland tandem exchange and connected to a distribution network each junction of which could serve up to six exchanges. Each announcer normally served half the distribution network but changeover facilities permitted it to serve the whole network in the event of failure.

G. C. CROCKETT

## Northern Ireland Directorate

### Computer Record for Belfast (City) Exchange Conversion

Due to the magnitude of the records required to control the conversion of subscribers from Central to City Exchange Belfast (TXK3), it was decided to use the Burroughs Computer situated at Gresham Street, London, to hold the complete subscribers' record for the transfer. The program for the computer was prepared by Telecommunications Headquarters Management Services Department, and its operation controlled by Telecommunications Headquarters Operational Programming Department. The input information is controlled by details inserted on a record card, Fig. 1, and it is anticipated that more than 20,000 cards will be filed.

The record is originated by the External Planning Groups who insert the circuit number, main distribution frame (m. d. f.) records and cabinet details. The Traffic Division add the name, address, category and type of installation. The maintenance control check the accuracy and add information regarding shared service and tie-circuit routing.

## EXCHANGE TRANSFER

2 2 1 8 3										SUBSCRIBERS NEW NUMBER of P.W. NUMBER	
2 2 1 8 3					SUBSCRIBERS OLD NUMBER					C B SPECIAL INSTRUCTIONS	
P.W. IDENTIFIER AorB											
C D		I S 3		B D		2		2			
VERTICAL NEW MDF PAIR		VERTICAL OLD MDF PAIR									
CABINET No. EorD		PILLAR No. EorD		D.P. NUMBER		PAIR NUMBER		A 3			
3		D E L		LINE SELECTOR UNIT							
CAT. EQPT.		TYPE									
S O R T I N G O F F I C E											
SUBSCRIBERS NAME (Including Christian Name INITIALS and Status ie Mr, Mrs/Miss)											
H P O 2 8 / 3 2 R O Y A L A V E											
SUBSCRIBERS HOUSE NUMBER AND STREET NAME											
										TOWN OR VILLAGE	
										S V *	
										PLANNING	
										TRAFFIC SALES	
										CHECK 1	
										CHECK 2	
										CHECK 3	

Fig. 1—Record card

The central records office forward the completed cards to the Telecommunications Headquarters computer centre for the production of punched tape. The information is then transferred from the punched tape to a magnetic tape and the card is returned to the central record office for filing as shown in Fig. 2.

The card has been designed to act as an individual card record for both traffic and engineering staff during the installation of the exchange. This avoids having to obtain a complete up-to-date computer print-out of the record to keep the

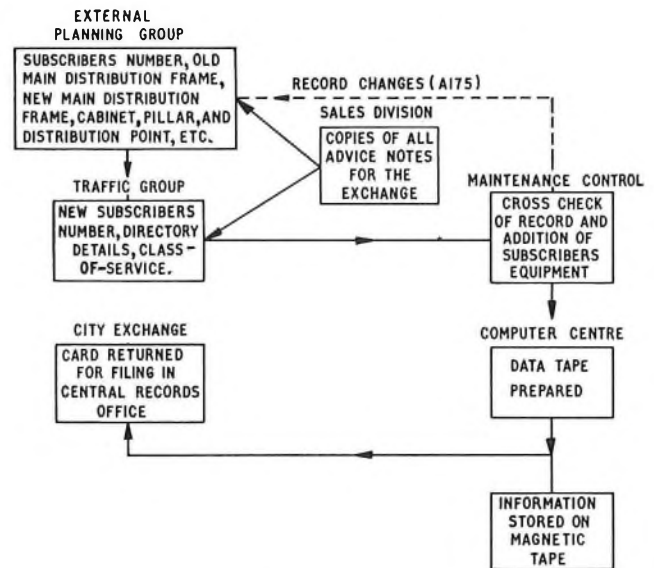

Fig. 2—Document flow chart

master file up to date. The record includes all types of subscribers' circuits, telex, private wires, extension, power leads, ringers, etc. All changes due to advice notes and faults are collected by maintenance control and forwarded for updating of the record.

The computer in this case is acting as a large memory store and will be able to supply any portion of the record in various orders to the working parties as required.

The cables are at present being terminated on the m.d.f. and the accuracy will be checked at this stage.

Jumpering of the lines on the m.d.f. will be in accordance with the computer print-out as the work proceeds.

The advantages of this method of holding the record is the speed and accuracy of obtaining any part of the information required for use by the operational groups involved in the transfer and all divisions are using one central source of information.

G. F. ALTON

## London Region

### *General Election 1970 London Television Outside Broadcasts*

The extensive television coverage given by the B.B.C. and I.T.V. to a general election has always strained to the limit the resources of the Post Office groups concerned. This election was no exception.

It was the first election to be transmitted in colour and to add to the difficulties it was held during the period of the World Cup coverage. In order to provide this coverage of the World Cup in Mexico a main and standby temporary three-hop radio link was provided between Goonhilly and Forder Battery (Plymouth). This meant that six radio links and eight staff were not available for the election coverage.

With the help of telecommunications headquarters and regional headquarters, who provided equipment and four members of staff, the coverage provided by the London staff was more extensive than on any previous election. To provide the vision circuits a total of 21 send amplifiers, 43 outside-broadcast type repeaters, together with seven radio links were provided and manned by 40 staff, almost all of whom worked a period of 36 hours during 18 and 19 June.

Of all the venues covered by television for the election, Trafalgar Square provided the most interest and biggest challenge to the Post Office. Both I.T.V. and B.B.C. required a vision circuit out from Trafalgar Square to their respective studios in order to show the reactions of the crowd. Both companies required a vision circuit in the other direction to enable the colour pictures, which were being transmitted to the viewers at home, to be seen on two cinema-sized screens using Colour Eidophor Projectors. This presented quite a problem to the Post Office as colour vision signals transmitted on telephone pairs within the same or adjacent cables are susceptible to crosstalk, but by careful choice of pairs and use of separate cables by the external staff no interaction between circuits was experienced.

By lunchtime on 19 June, the staff were already recovering the equipment used for the election and installing it elsewhere for use on 20 June, for the coverage of the first Test Match at Lords, Ascot, the Royal Festival Hall, the Garrick Theatre, Elstree Studios and the London World Cup venues.

R. G. WARD

## Eastern Region

### *Uni-Diameter Repair on a 1,400-Pair Cable*

During the late evening of 26 May 1970, Corporation workmen excavating a trench across Gentleman's Walk, Norwich, for the installation of a Pelican crossing, punctured four out of five cast-iron pipes laid in horizontal formation at a shallow depth and embedded in concrete. One pipe contained a 1,400-pair 0.5 mm diameter cable which had been pierced several times by the pneumatic drill and in an adjacent pipe a 400-pair 0.5 mm diameter cable was similarly damaged. After an examination of the situation, and as slack cable existed in the adjoining manholes, two jointers working throughout the night effected temporary repairs to the 400-pair cable by the following morning.

The 1,400-pair cable, however, presented a very different problem. Since a further layer of pipes, also embedded in concrete, existed under the damaged one it was impossible to examine the cable from underneath and as no slack cable existed the core could not be examined either. It was decided that the most speedy and effective repair would be to uni-diameter joint the cable, although no cable of similar size had been repaired in the area by this method before. Six feet of lead sheath was removed and the wires lengthened by piecing layer by layer to enable the cable core to be examined. The damage was worse than feared, and it was necessary to piece some 1,300 of the 1,400 pairs. The wires were then shortened, and the cable restored to its original formation, each wire twist being soldered as a precaution against any subsequent failure. Lead sheet was used to effect a uni-diameter joint some six-feet long. The work was achieved by two pairs of jointers working alternate twelve-hourly shifts and the quality of the workmanship was such that to bury it under concrete seemed an injustice.

The incident was not without humour, however. The extensive use of tarpaulins to protect the excavation and its resemblance to a Bedouin encampment in the centre of Norwich became a common association. The practice of hosing down the adjoining market-place at 0700 hours on a Sunday morning needed the intervention of an Inspector to restore peace on a Sabbath morning.

D. D. LAMMING

# Associate Section Notes

## Aberdeen Centre

On 29 May, the Aberdeen Associate Section held their 1970 annual general meeting. This was held in the Caledonian Hotel and attended by 20 members. After normal business, the following office bearers were elected: *President*: Mr. J. W. H. Sharp; *Vice President*: Mr. H. A. McFarlane; *Chairman*: Mr. R. T. Ross; *Vice Chairman*: Mr. J. Davidson; *Secretary* and *Treasurer*: Mr. R. Mathewson; *Assistant Secretary*: Mr. J. Stephen; and *Librarian*: Mr. W. Williamson.

After the meeting, the company had dinner and were then entertained by a conjuror and folk singers.

R. MATHEWSON

## Cambridge Centre

The annual general meeting was held in the North Lounge, Government Offices, Brooklands Avenue, on Thursday, 14 May 1970. The following officers were elected to serve for the 1970-71 session:

*President*: Mr. A. E. Paterson; *Chairman*: Mr. C. F. Nunn; *Vice-Chairman*: Mr. L. A. Salmon; *Secretary*: Mr. R. S. King; *Assistant Secretary*: Mr. J. W. Tookey; *Treasurer*: Mr. J. H. Acker; *Committee*: Mr. S. L. Hurt and Mr. R. J. Stewart; *Auditors*: Messrs. P. R. Howlett and J. E. Clark.

The meeting wished to express its gratitude to three officers, Mr. E. A. Bury, Mr. R. J. Farrington, and Mr. R. F. Halls for their much appreciated work on the Committee. All three officers, being recently promoted, resigned from the Section.

In the last session, 1969-70, members enjoyed very informa-

tive visits to a North Sea oil rig, a coal mine in the Nailstone colliery, the Corby steel works, and London Airport. Lectures were also given on Transit Switching and Signalling and Mechanical Aids.

Visits arranged so far for the 1970-71 session are to the Atomic Power Station at Sizewell; the Post Office sorting office, Mount Pleasant; and possibly Tracked Hovercraft at Erith. Lectures include a follow-up talk to the oil-rig visit by Shell Oils Ltd; talks on I.B.M. computers, space communications, postal mechanization and pulse-code modulation.

J. W. TOOKEY

## Exeter Centre

The 1970 summer program started with a visit to Wills of Bristol where our party of 40 were shown over the cigar and cigarette factories. Like all the summer trips, arranged by the Assistant Secretary, it was very much appreciated by all those fortunate enough to attend. A follow-up trip will be arranged for the autumn in addition to the programmed visit to Holmans of Cambourne which will take place in September.

For some years now the Centre has been asked to hold an annual dinner and dance. In order to gauge the interest, a sub-committee was formed to examine all aspects of such an event. Extensive enquiries were made throughout the area but interest was very limited and dependent upon the type of function anticipated. Because of the response, the committee have decided not to embark on social events.



At the annual general meeting held in April, the following officers were elected: *President*: Mr. O. P. Moss; *Chairman*: Mr. G. S. Steer; *Vice-Chairman*: Mr. D. E. Elford; *Secretary*: Mr. T. F. Kinnaid; *Assistant Secretary*: Mr. J. J. F. Anning; *Treasurer*: Mr. W. F. Lambert; *Librarian*: Mr. N. H. B. West; *Committee*: Messrs M. W. Durrant, S. G. Page, J. L. Petherick, L. E. Hines and D. N. Miller; *Auditors*: Messrs B. Adams and B. Turner.

Members who did not attend the annual general meeting should note that rule 8 was changed and in future priority in the allotment of places on summer visits, for which there are a limited number of seats, will be given to persons who have attended at least one meeting of the previous winter's program. The new rule will affect allocation of seats on the September trip to Cambourne.

Recruitment is hardly keeping pace with losses at the moment, and any effort that members could make to reverse this position would be appreciated.

A date to remember in the forthcoming winter program is 24 March when two of our own members, Mr. D. Craig and Mr. C. Knapman, will be giving papers on diving and "Fireman's call-out v.f. remote control system A." The remainder of the program is not yet formulated but it is hoped to arrange papers on the following subjects: p.c.m., line transmission, engineering finance, oil technology and television production.

The Committee are currently involved with the revision of the Centre Rules which will be placed before the next annual general meeting for ratification.

T. F. KINNAID

### Glasgow Centre

The 1969-70 session, which is now behind us, finished with the annual general meeting held in the Ca'Doro restaurant on 1 May 1970.

Our members now total 615, an increase of 23 over last year, and interest and activity continue to grow within the section.

The past session began in October with a most interesting and informative talk from Mr. W. Sheldon, Deputy Telephone Manager, Edinburgh Telephone Area, on "The Transit Network", and the following question time gave rise to some very lively discussion.

Our November talk was given by Mr. J. C. Graham, Assistant Executive Engineer, Glasgow Telephone Area, his subject being "Dial House Equipment" and was a natural follow-on from the previous month's talk. The members and friends present gave an indication of their appreciation by the questions that followed the talk.

The December meeting was a film show, "Satellite Communication", "The Post Office Tower", and "Ship-to-Shore Communication".

The first meeting of the new year was held in January, and Mr. D. C. Paterson, a senior meteorological officer from the Glasgow Weather Centre, gave a most interesting talk on "How the Meteorological Office Works".

The first visit of the session was to the Glasgow University Observatory, where the 22 members present were given a most enjoyable tour of the various workshops, laboratories, and the planetarium, finishing with a visit to the main telescope. Inclement weather that evening, however, would not allow viewing through the telescope, but a comprehensive explanation of the workings of the telescope was given by Mr. Keddie, our guide for that evening.

Our second visit was a most interesting and fascinating one to Strathclyde University, Glasgow, where Professor R. M. Kennedy gave an introductory talk on "Engineering of the Human Body", and continued with a conducted tour of exhibits, showing the variety of work done by the Bio-Engineering division of this University.

The guest speaker at our last meeting of the session in April was Mr. Marsh of Mullard Ltd, who presented an excellent film, and taped speech by a Mr. Nicolson, also of Mullard Ltd, on "Integrated Circuits".

Arrangements for the 1970-71 session are now underway and we look forward to our opening meeting on 15 October 1970. The guest speaker that evening will be Mr. Revell, Director, Post Office Headquarters Scotland.

R. I. TOMLINSON

### Middlesbrough Centre

Last season's events started with a week-end trip to London to visit the equipment sections of the Post Office Tower. An overnight stay allowed plenty of time for sightseeing as well.

Other visits were a trip down Horden Colliery and a visit to Vaux's Brewery.

We had two talks and film shows by visiting speakers, one on Tyres by Messrs Dunlop and one on tobacco by Messrs Wills. We also had a talk on the Fireman's v.f. System given by one of our members.

The attendance at meetings is still very poor for the membership we have and we must look into ways of improving things. The officers elected for the coming season are as follows:

*Chairman*: Mr. R. G. Inns; *Vice-Chairman*: Mr. W. Outhwaite; *Secretary*: Mr. K. Whalley; *Assistant Secretary*: Mr. R. D. Purvis; *Treasurer*: Mr. P. K. Harrison; *Librarian*: Mr. T. Beckett; *Auditors*: Messrs K. Roe, and R. Oliver; *Committee*: Messrs K. Roe, R. Oliver, C. Carr, I. Tyreman.

K. WHALLEY

### Norwich Centre

After a lapse of activity, the Norwich Centre has made an effort to start again.

The annual general meeting was held on 17 June and the following officers were elected: *President*: Mr. J. C. Saunders (Telephone Manager); *Chairman*: Mr. J. Bird (Area Engineer); *Vice-Chairman*: Mr. A. T. Sandall; *Secretary*: Mr. H. G. Way; *Treasurer*: Mr. M. H. Bishop.

Before the annual general meeting the members spent two successful evenings at Beccles crossbar exchange, the lecture and demonstrations being given by the installer and members of his staff.

H. G. WAY

### Southampton Centre

Our 1969-70 Session started with a lecture, "The Long Term Plan", by Mr. W. C. Taylor, Assistant Executive Engineer in this area. He gave an interesting insight into the new numbering scheme, its introduction to the area and some history leading up to the plan itself.

The *Southern Evening Echo* printing works helped the members visiting them to obtain an increasing knowledge of modern printing techniques. Accident photography, crime recording, finger printing, training and the police organization of Hampshire and the Isle of Wight were thoroughly explained, and some illustrated, during our visit to the police Headquarters at Winchester.

The new Pirelli Factory at Bishopstoke manufactures coaxial cable of many sizes. These were seen in various stages of manufacture when the section visited the factory. A well-informed guide answered many questions during the tour, in spite of the noise, which made some of his observations inaudible to the large party.

The visit to Mullard's semi-conductor production plant at Millbrook, Southampton was well worth the time spent. Design drawings are reduced to micro-size by photographic means for the production of integrated circuits. A large percentage of the manufacturing techniques are performed inside dust-proof machines, the completed components often being tested by computer-controlled machines. Tea and a chat concluded a pleasant afternoon.

We were fortunate this year to have another Assistant Executive Engineer from our own area to talk about "An Outline of Transit Switching in g.s.c.s." Mr. Grace went to much trouble to familiarize those attending with many aspects of the expensive transit network, including S.S.M.F. No. 2 signalling and logic circuits. Visual and audio aids, in the form of slides and recordings assisted listeners during a very informative lecture.

We have had two other lectures this year. "Satellite Communications in the 1970's" by Mr. D. J. Withers, United Kingdom representative to the Intelsat Satellite Program, was very enlightening both in the telecommunications field and satellite launching problems. Mr. C. G. Clow, the Development Manager of Energy Conversion Ltd., Basingstoke, was

good enough to open up a new subject for us in his talk on "Fuel Cells". These cells, specimens of which were shown, are the subject of chemical and mechanical technology. The larger Bacon cell is used in Apollo craft, and is built under licence from this firm.

Messrs Dimplex Ltd., Millbrook Road, showed us their production techniques associated with their various radiators, after which an informal discussion took place with the sales manager.

The 1969-70 session closed with a high speed lecture on a high speed subject, "Planning of Data Networks." Messrs R. C. Barker and W. J. Murray from the Network Design and

Planning departments of Telecommunications Headquarters gave a very full account of data now and in the future.

We are indebted to all of these devoted men for giving their time and energy to talk to us.

The following officers were elected to serve the Centre for the 1970-1971 session. *Chairman:* Mr. R. G. Genge; *Vice Chairman:* Mr. A. A. Hutchings; *Hon. Secretary:* Mr. B. G. Roberts; *Assistant Secretary:* Mr. M. Short; *Treasurer:* Mr. E. J. Green; *Librarian:* Mr. K. Hammerton; *Committee:* Messrs M. S. Blake, D. G. Rolfe, J. Holyoake and D. Stephenson.

R. G. GENGE

## Press Notices

### Heavy Overseas Interest in Britain's Postal Mechanization

At the first British Postal Engineering Conference (at the Institution of Mechanical Engineers, May 19-21) 300 delegates from many postal administrations, from industry and the engineering professions discussed advanced technical developments made by engineers of the Post Office and British industry. The conference, sponsored by the Post Office and the Institutions of Mechanical and Electrical Engineers, was opened by Ewen G. M'Ewen (Director and Chief Engineer of Joseph Lucas Ltd) representing the President of the I.Mech.E. The opening address was given by Prof. J. H. H. Merriman, Post Office Board Member for Technology and this year's Faraday Lecturer.

Although Britain's postal service is already the world's best, the Post Office is investing heavily in mechanization and reshaping its postal network to improve service to the customer, even further increase productivity, and hold down costs. Throughout the conference, specialists from the Post Office described major machine developments which will lead to the plan to concentrate parcels sorting in the mid-70s on a network of 30 highly-mechanized centres and to the possibilities now being discussed between management and the unions of reducing 1,600 manual letter-sorting offices to about 120 fully-mechanized centres by the 1980s; and the postcoding scheme due to cover Britain by mid-1972—in which major countries are showing keen interest.

With leading representatives of British manufacturers, they also described technical applications of the machines used in Britain's mechanized sorting offices to handle, segregate, face, sort and code the mail automatically at speed, and research into further advances. Members of the conference visited the most modern sorting office in the world—brought into operation at Croydon only last year—to see this equipment at work.

The introductory and final addresses of the Conference were given by Mr. N. C. C. de Jong, the Post Office's Director of Planning and Mechanization, Postal Headquarters.

### Advanced Keying System replaces Dials in Telephone Exchanges

Following successful trials, the Post Office has placed an order for 20,000 keysenders with the Telephone Manufacturing Company to equip all exchange switchboards in the country. Installation will start in mid-1971.

With the keysender, operators will press buttons instead of turning a dial to call telephone numbers. Keysenders will be more reliable than dial mechanisms and will save time for operators.

This is one of the world's first commercial applications of a unique system of custom-designed metal-oxide-silicon-transistor circuits developed by the Telephone Manufacturing Company, using micro techniques employed originally in space exploration communications.

When a key or button on a keysender is pressed, the number is translated into binary form and is put into an MOS shift-register-type store. At the same time, the fact that a store now has information causes the first number in the store to be transferred to the output pulsing circuit. Thus, further numbers can be keyed into store without affecting the output operation. Sending ceases when all the keyed digits have been transferred from the store.

Two MOS chips perform all the functions of storage, sequencing of input and output information, and timing, for both the pulses and the inter-digital pause. These two chips each contain about 700 transistors and measure 2mm square. The pulsing to line is performed by a mercury-wetted reed relay.

### Supercable planned for London-Birmingham-Manchester Telephone Links

Europe's biggest trunk telephone cable is planned by the Post Office to link London, Birmingham and Manchester by the middle 1970s. The cable will contain nearly 100,000 telephone channels—six times as many as the largest-capacity coaxial cables at present in use.

To protect it from physical damage, and to overcome the risk of radio and electrical interference, this supercable will be laid at twice the depth at which telephone cables are normally buried now, and it will run in specially-constructed ducts or be buried in a steel sheath.

A new route is being worked out that is completely separate from existing cable routes so that there will be no possibility of people working on older cables interfering with the new one.

The North-South route will link those parts of the country that have the highest growth rate for trunk telephone circuits, currently rising at 12,000 circuits a year. It conforms to a pattern in national communications that has existed since the Industrial Revolution. The supercable will help cope with the demand for more and more telephone circuits in a national trunk system that is growing currently by 15 per cent a year as the size of the public telephone service expands and people make greater use of it.

The supercable will contain 18 large coaxial tubes within a single armoured sheath. Its development represents a bold extension of the coaxial system to the limits of current technology. Field trials are being carried out to overcome technical problems still to be resolved. The scheme accords with Post Office policy to take advantage of both cable and microwave radio systems in telecommunications development.

### All North-East Telephones now Automatic

A fully automatic telephone service for every telephone customer in the United Kingdom came a step nearer when the North-East Region became the first region in the country to have all its telephones working through automatic exchanges.



This milestone was reached with the opening of a new electronic telephone exchange at Corbridge, Northumberland. It was the last manually-operated exchange in the region to be converted to automatic working. About 99 per cent of the country's 8,342,300 exchange connexions are now on automatic service. The Post Office expects to provide automatic exchanges for the remaining one per cent within four years. In the next few months two other Post Office regions will bid farewell to their last manually-operated telephone exchanges—London region, when Upminster exchange is converted to automatic working, and Midland region, when Sleaford, Lincs, exchange goes automatic.

### Keen Interest in Datapost

The first contract was signed for Datapost—the new hand-to-hand overnight delivery service—only six weeks after the service was announced.

Within hours of the announcement, the Post Office received dozens of enquiries from businessmen interested in using Datapost. The first firm order was placed by Rolls-Royce Ltd, for a two-way service to carry punched cards between Shrewsbury and Derby, three nights a week. The original target for Datapost earnings was £200,000 within the year, but one contract currently under discussion could be worth £500,000 a year.

Large concerns that have shown an interest include I.C.I., the Central Electricity Generating Board, Wilkinson Sword, some of the major clearing banks, Singer Sewing Machine Co. Ltd., the Science Research Council, Heinz, and several Government Departments.

Datapost offers collection and delivery of material such as computer data, medicines, machine parts and important documents door-to-door at times and places agreed between the sender and the Post Office. It is not available on a casual basis, only as a regular contractual service for a minimum of three months. Charges will vary according to each individual agreement but can be about £2 for a package weighing up to 10 lb.

### New Post Office Regional Boards

The Post Office is setting up Regional Boards on an experimental basis. One will be for the telecommunications business in Wales and Border Counties and the other for the postal business in the North-West. The two new boards began in April and their work will be reviewed at the end of this year. Each Regional Board will consist of a chairman and up to eight members, of whom not more than four will be part-time members from outside the Post Office.

The new arrangements will allow maximum freedom for Regional initiative, compatible with the requirements of a coherent national policy. There will be wide devolution of powers to the new Boards and the Boards will also give maximum freedom to local managers. The members of the newly-styled Telecommunications Board for Wales and the Marches have been appointed and an announcement about the North-Western Postal Board will be made shortly.

### Discussions on Mechanized Mail Sorting

A plan which could revolutionize mail-handling methods based on a mail sorting and circulation concept is to be discussed by management and unions.

The new plan envisages the reduction of some 1,600 manual mail sorting offices to about 120 fully-mechanized centres by the 1980s. By taking full advantage of the automatic-letter sorting machinery now coming into increasing use the Post Office expects to reduce costs and increase the reliability of the service.

The sorting system in use at the moment relies on the dispersal of work between hundreds of offices, most of them too small to justify future mechanization. A letter may have to be manually sorted between three and six times before delivery.

Under the proposals about to be discussed, all mail sorting could eventually be done within the mechanized system. After posting, mail would be taken into a mechanized office where it would be automatically segregated into letters and packets, and postmarked. Letters would then be passed to a coding console where an operator would read the postcode and copy it on a keyboard. This would translate the letters in

the address and cause a pattern of almost invisible phosphorescent dots to be printed on the envelope. Automatic sorting machines can read this dot pattern and sort the letters at high speed during all stages of its journey until it reaches the postman who is to deliver it.

Mail would be transported between the mechanized offices by road, rail or air.

The introduction of the proposed changes, if agreement is reached, would be phased over a number of years and normal staff wastage is expected to offset any reduction of staff numbers due to automation and concentration, thus avoiding any redundancy problem. At the moment the Post Office have not decided on the offices to be mechanized, but a short list of 133, from which the final choice could be made, has been drawn up.

### Programming for the Data Explosion

Plans for an advanced network to cater for Britain's soaring needs for data-transmission facilities into the 1980s are now being drawn up by the Post Office.

They are based on surveys of likely markets and studies of completely new techniques, including a survey among industrial and commercial customers to assess likely future demand and technical studies into data network requirements that are nearing completion.

Results of the technical studies, which have been in progress over the past 18 months, are expected to be ready within the next three months. They have included investigations into store-and-forward working, control principles and digital transmission and switching techniques.

When the final, collated reports of these studies are available and further market surveys are completed, the Post Office will be able to decide how and when to go ahead with providing the nation with new data-transmission services.

The SciCon market survey report foresaw that the 6,000 data terminals then operating in Britain could rocket to about 250,000 by 1978 and over 400,000 by 1983.

Lord Hall, Chairman of the Post Office, commented "The door to the computer age is now wide open and we face an explosive demand for ancillary computer services. Post Office growth forecasts have been confirmed by independent specialists who also agree that Post Office Telecommunications are ideally placed to co-ordinate all possible services competitively for data transmission."

Lord Hall stressed that the Post Office could place Britain in a unique position in data transmission. This would enhance the use of computing equipment and set an international lead.

### Battery Mailvan for Belfast

After a week's showing at the Electrical Engineers exhibition at Earl's Court the last of 10 battery-electric mailvans recently purchased by the Post Office now goes into service in Belfast.

The other nine vans are already in service at Aldershot, Gloucester, Cardiff, Newcastle, Edinburgh, High Wycombe, Liverpool and at two London offices. An additional prototype van has been in use at Leicester since 1967.

With a top speed of about 20 m.p.h., each van carries 240 cubic feet, or about 30 cwt, of mail. Initially, they are being used mainly to carry parcels, but they will be put to other uses.

With a full load, each van weighs 4½ tons. Existing diesel vans of the same capacity weigh just under 3½ tons with a full load. Much of the weight difference is accounted for by the heavy set of batteries needed. Although first cost is higher than for diesel vans of comparable capacity, they are expected to be cheaper to run and maintain and to last longer.

Nearly 20,000 postal vans are at present in use throughout Britain. Just over 1,900 of these vans have the same load capacity as the new battery-electric vehicles.

### New-style training for apprentices

Technical instruction completely "off the job" for Post Office telecommunication apprentice technicians in their first year is to be adopted for the first time in an experimental scheme to be launched in Brighton in September.

The Brighton scheme will find the Post Office and Brighton Education Committee working very closely together to provide a fully-equipped and staffed telecommunications

centre where apprentices will spend three days of each week under instruction. Apprentices will also spend two days a week at Brighton Technical College and will visit telephone exchanges, transmission stations and so on. They will be introduced to field work in the second year.

The present training scheme provides separate courses at Post Office regional engineering training schools and block or day release courses at local technical colleges with field training during the first two years.

This scheme has reduced previous difficulties in arranging apprentices' attendances at both technical college courses and regional training school courses, but the Post Office will watch the Brighton scheme closely to see if these difficulties can be reduced even further.

Setting an example in co-operation between a public corporation and a local education authority, the Brighton scheme will serve the whole of the Brighton Telephone Area and will cater for an intake of 48 young men between the ages of 16 and 18 each year.

In its first year, the Brighton telecommunications training centre will have a staff of five lecturers. Two more lecturers will join them in September 1971 when the second year's apprentice intake is due. These lecturers will be appointed by the education authority after recommendation from the Post Office.

Brighton Telephone Area is considered suitable for this experiment because it is comparatively compact and apprentices will be able to travel from all parts to the training centre each day. There will be no need for residential hostel accommodation.

Training will follow the present national syllabus which includes instruction and practice in installing and maintaining underground and overhead plant and equipment; fitting and maintaining customers' rented equipment; installing and maintaining exchange and transmission equipment.

As with the present training scheme, the Brighton centre will keep a close control over correct working methods.

### **Industrial Relations in the Post Office**

Mr. W. Pounder, formerly Deputy Director of the London Postal Region, has been appointed a director at Post Office Headquarters, with responsibility for industrial relations. He will work under Sir Richard Hayward, board member for industrial relations.

The appointment is in accordance with the corporation's statement of intent, made in October 1969. In this they sought to "create a spirit of mutual understanding . . . a free and uninhibited exchange of views which will recognise both the interests of the staff and the problems of management".

Mr. Pounder's immediate task is to build up and run an organisation advising on industrial-relations problems generally, with a view to establishing and maintaining conditions favourable to constructive industrial relations.

### **Decimalising the Post Office—Plans Going Smoothly**

Plans for changing telephone coinbox mechanisms and for producing telephone bills with amounts shown in £sd and £p conversions are going ahead smoothly in the Post Office in readiness for decimalisation of the currency on February 15, 1971.

As already announced, telephone coinboxes are to take the 2p and 10p coins. Conversion of mechanism in Britain's 75,000 public coinboxes and 150,000 privately-rented coinbox telephones will start on D-Day plus one, February 16, 1971, and should be completed within six weeks. Cost to the Post Office will be about £3 million.

Telephone bills made out in the three months preceding D-Day will have details in £sd with totals shown in both £sd and the decimal equivalent. All telephone bills produced after D-Day will be in decimal currency. Before D-Day, subscribers will receive literature giving general information and guidance on decimal tariffs and bills. Customers will not be paying more as a result of decimalisation. Some charges that cannot be converted exactly will be rounded-up marginally but others will be rounded-down.

Britain's first decimal stamps were on sale on June 17 this year. They are the high-value stamps at 10p, 20p and 50p. The £1 stamp remain unchanged. To-pay labels, high-value

equivalent of postage-due labels, will also be in use at the same four values as the stamps. The stamps and labels are being introduced prior to decimalisation to ease pressure on stamp printing and distribution caused by the need for a completely new series of stamps and labels. Low-value decimal stamps and postage-due labels will not be introduced before February 1971.

More than 21,000 Post Office counter staff, plus wages and accounts staff, are to train for decimalisation with the aid of special courses.

National Giro goes decimal on D-Day and will ignore the ½p in transactions. There are now 200,000 Giro accounts, totalling £35 million—an increase of 40,000 accounts and £12 million in just over three months.

Most of the Post Office's accounting is now carried out on large computer systems operated by the National Data Processing Service; modifications needed for a swift change-over to decimal processing are already well under way.

### **New Channel Islands Telephone Link planned**

The Post Office, in conjunction with the Channel Islands telecommunications administrations, intends to lay a new submarine cable between Guernsey and the mainland.

The new cable, due to be in operation in time to carry the heavy summer traffic in 1972, will replace two existing cables which run from Dartmouth to Guernsey, and from Guernsey to Jersey, which were laid in 1938. It will provide 1,380 circuits, compared with the present 720, which will remain in operation for the time being.

The cable will be laid between Bournemouth and L'Ancrese Bay, Guernsey, using the most advanced transistorized submersible repeaters—one every seven miles or so. The cable-laying will be carried out around December 1971 or January 1972.

To accommodate the onward link to the island of Jersey, there will be a micro-wave radio link through the new radio-tower at St. Peter Port.

The volume of telephone calls from the Channel Islands to the mainland greatly increases in the busy summer months, and at the height of the summer there can be as many as 271,000 calls a month.

### **New Transmitter for Criggion**

Improved communications with shipping are provided by means of a new transmitter at the Post Office's Very Low Frequency Radio Station at Criggion, Welshpool, Montgomeryshire.

The new transmitter, designed by Post Office engineers, has been manufactured and installed under contract by Redifon Ltd. With it the station is capable of increasing its radiated power by four times—from 7.5 kW to 30 kW at 19.6 kHz, at which frequency it normally operates.

To carry the greatly enlarged aerials, three new masts 700 ft high have been constructed in addition to three 600 ft towers that have served since the station first started operating in 1943.

With the other Post Office v.l.f. transmitter at Rugby, Criggion is among the most modern installations of its kind in the world. It has always been available as a reserve for Rugby and is therefore equipped to radiate international time signals when required. For this, the station uses an electronic program clock that will not vary more than one second in 300 years.

### **Post Office in forefront with CCTV**

Development and exploitation of closed-circuit television techniques finds Post Office Telecommunications in the forefront, providing vision, sound and control lines for many CCTV requirements including point-to-point links and networks on temporary and permanent arrangement. Types of system provided vary from single-channel video links to multi-channel v.h.f. networks.

The high quality CCTV achieved over Post Office circuits is to be seen at NAVEX (National Audio Video Exhibition) at Olympia, London, July 20-23, where the Post Office is demonstrating the quality of reception over its own lines of the Inner London Education Authority schools CCTV network.



The final phase of the Inner London Education Authority's system was completed at Easter this year and about 1,200 schools are now connected to the seven-channel v.h.f. system.

In addition to the transmission of material produced by the I.L.E.A., the network is used to relay B.B.C. and I.T.A. programmes and this eliminates the need for separate aerials at each school.

Already the largest CCTV network in Europe, this Post Office-provided system is to be extended further to include the University of London and other educational establishments in the London area.

Educational CCTV systems provided by the Post Office in other areas include a seven-channel v.h.f. network at Plymouth linking about 100 schools; and v.h.f. and video networks at several universities. A single-channel video network linking six schools was installed recently at Dover.

A 20-channel v.h.f. network set up by the Post Office is now in use by the Stock Exchange who operate a price display service to many offices in the City of London. This service is being extended to some other parts of London.

The flow of traffic through London's crowded streets will be eased when an extensive CCTV system, now being installed, comes into operation early in 1972. Over this system, television cameras will monitor 40 important road junctions for the Greater London Council; and a complex network of data circuits—also being provided by the Post Office—will link traffic signals to a central computer control.

### Field Trial for Waveguide—Super-Highway of Communications

Plans for full-scale field trial of a new system which could speed telecommunications, reduce cost and offer unlimited scope for future expansion have been completed by the Post Office.

Laboratory experiments have confirmed that up to 400,000 conversations can be transmitted at the same time in a 50-mm waveguide. Now, in collaboration with the British telecommunication industry, the Post Office is to install and equip a 30-km experimental system in Suffolk, linking the new Post Office Research Station at Martlesham Heath near Ipswich to Mendlesham, nearest station in the Post Office microwave network.

This trial is a further step in the Post Office's long-term programme of research and development to meet growing demands for existing services and prepare for new services.

Plans for Europe's biggest trunk telephone cable, a 100,000-circuit coaxial system to link London, Birmingham and Manchester by the mid-1970s were announced on July 1.

Systems of even greater capacity will be needed in the 1980s for, just as the growth of road traffic has made a national motorway network essential, so the rapid expansion of telephony, television and data communications means that new 'super-highways' will soon be needed to handle telecommunications traffic.

One possible 'super-highway' is the waveguide—hollow circular tube laid underground from city to city. The principle of waveguides transmitting signals of extremely short wavelength has been known for many years and various organisations including the British Post Office carried out research on them in the 1950s: then, their enormous traffic potential was ahead of demand and the electronic devices needed especially valves—were barely adequate.

During the sixties, however, both factors were changed. Developments in transistor-like devices have greatly improved equipment reliability and lowered costs until it should now be possible to set up a satisfactory and economic waveguide system.

Over the past two years the Post Office Research Department has been working on a 50 mm diameter waveguide system capable of carrying a third of a million two-way telephone conversations, or 200 television circuits, or other forms of traffic. Now, in the full-scale trial, the waveguide system will be tested by loading it with traffic of all kinds, including high speed data, viewphone (picture telephone) and conference television.

For the 50 mm waveguide, the useful range of wavelengths is about 3–10 mm. Although loss of signal strength is very low, repeater stations are needed at intervals. If the route is fairly straight and level these repeaters may be 20 km or more apart. In built-up areas where the waveguide must bend to avoid pipes and cables already in the ground, there are additional losses and repeater spacing may be 10 km or less.

Contracts have been placed with The Marconi Company (Research Division) for the development of terminal and repeater equipment, and with Plessey Telecommunications Research Limited for waveguide studies. A number of other firms and University College London, will also be providing support. It is expected that most of the installation work will be completed by the end of 1972, and that full-scale tests will take place during 1973–4.

### BOARD OF EDITORS

N. C. C. de JONG, B.Sc.(Eng.), C.Eng., M.I.C.E., F.I.Mech.E., F.I.E.E., Chairman  
E. W. AYERS, B.Sc.(Eng.), C.Eng., F.I.E.E.  
A. J. BARNARD, C.Eng., M.I.E.E.  
D. R. BEARHAM, B.Sc.(Eng.), C.Eng., M.I.E.E.  
S. H. SHEPPARD  
A. C. CROISDALE, M.B.E., B.Sc.(Eng.), C.Eng., M.I.E.E.  
J. MARTIN, B.Sc.(Eng.), C.Eng., M.I.E.E.  
N. J. H. NINNIM, M.Sc., B.Eng., Managing Editor  
R. A. SUDELL, Deputy Managing Editor  
P. G. STEELE, M.Sc., B.Sc.(Eng.)  
D. MILLINGTON, C.Eng., M.I.E.E. } Assistant Editors  
T. R. K. RAITT }  
B. FARR, A.B.I., Secretary-Treasurer  
N. G. CRUMP, A.M.I.T.E., Advertisement Manager

### Copyright

The entire contents of this Journal are covered by general copyright, and special permission is necessary for reprinting long extracts, but editors are welcome to use not more than one-third of any article, provided that credit is given at the beginning or end, thus: "From *The Post Office Electrical Engineers' Journal*."

The Board of Editors is not responsible for the statements made or the opinions expressed in any of the articles in this Journal, unless such statement is made specifically by the Board.

### Subscriptions and Back Numbers

The Journal is published quarterly, in April, July, October and January, at 4s. 3d. per copy: 6s. per copy including post and packing (24s. per year) via inland mail, (3 dollars Canada and U.S.A., per year) Back numbers will be supplied, if available, price 3s. 6d. (5s. 6d. inland mail, 5s. 3d. overseas mail) per copy. With the excep-

tion of January and October 1966 Journals, copies of the April 1967 and all earlier Journals are no longer available. Orders, by post only, to *The Post Office Electrical Engineers' Journal*, 2–12 Gresham Street, London, E.C.2.

Employees of the British Post Office can obtain the Journal through local agents.

### Binding

Readers can have their copies bound at a cost of £1 12s. 6d. plus 4s. 6d. return postage, by sending the complete set of parts, with a remittance to Press Binders Ltd., 4 Iliffe Yard, London, S.E.17.

### Remittances

Remittances should be made payable to "*The P.O.E.E. Journal*" and should be crossed "& Co."

### Advertisements

All correspondence relating to advertisement space reservations, copy, proofs, etc., should be addressed to the Advertisement Manager, *The Post Office Electrical Engineers' Journal*, 2–12 Gresham Street, London, E.C.2.

### Communications

With the exceptions indicated above, all communications should be addressed to the Managing Editor, *The Post Office Electrical Engineers' Journal*, 2–12 Gresham Street, London, E.C.2.

### Model Answer Books

Books of model answers to certain of the City and Guilds of London Institute examinations in telecommunications are published by the Board of Editors. Details of the books available are given at the end of the Supplement to the Journal.

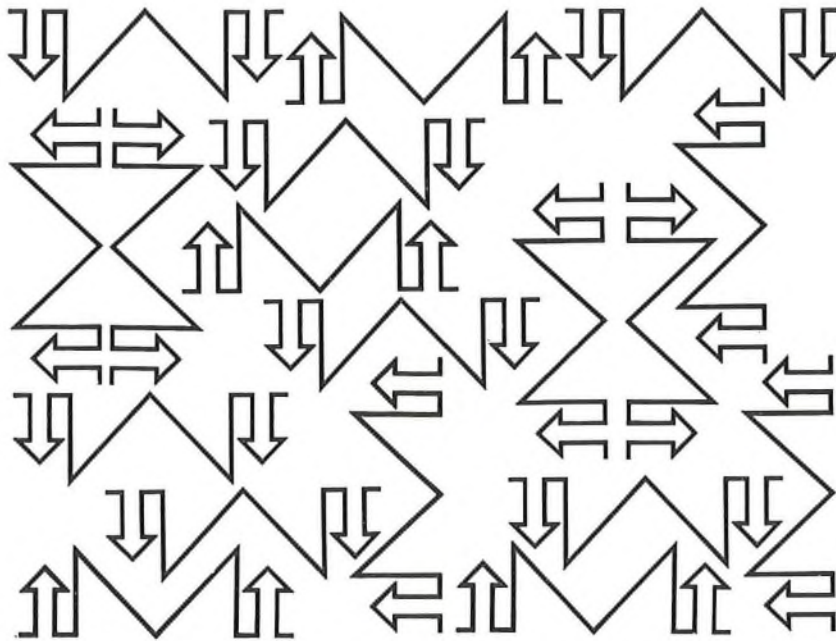

# 18 programme channels per rack



## CM-18A1 PROGRAMME MULTIPLEX



18 high-quality programme channels compatible with 60 telephone channels over the same bearer circuit. Any channel pair in a group of channels may be chosen for stereophonic programme transmission without need for pre-settings. Frequency shift eliminated by carrier regeneration at the receiving end. Non-oven oscillators are used.



Independent channels. Economic installation even with a small number of programme channels. Performance complying with CMTT\* recommendations in a 2500 km circuit with three cascaded audio modulations. No need for compandor. Automatic level control. Emphasis network complying with CCITT standards.

\* Doc. CMTT/119 - September 17, 1968.

RADIO RELAY SYSTEMS   
 MULTIPLEX TELEPHONE SYSTEMS   
 TV AND FM BROADCASTING SYSTEMS 

 DATA TRANSMISSION SYSTEMS  
 TRAFFIC CONTROL SYSTEMS  
 TELECOMMUNICATION EQUIPMENT AND SYSTEMS

*Telettra*



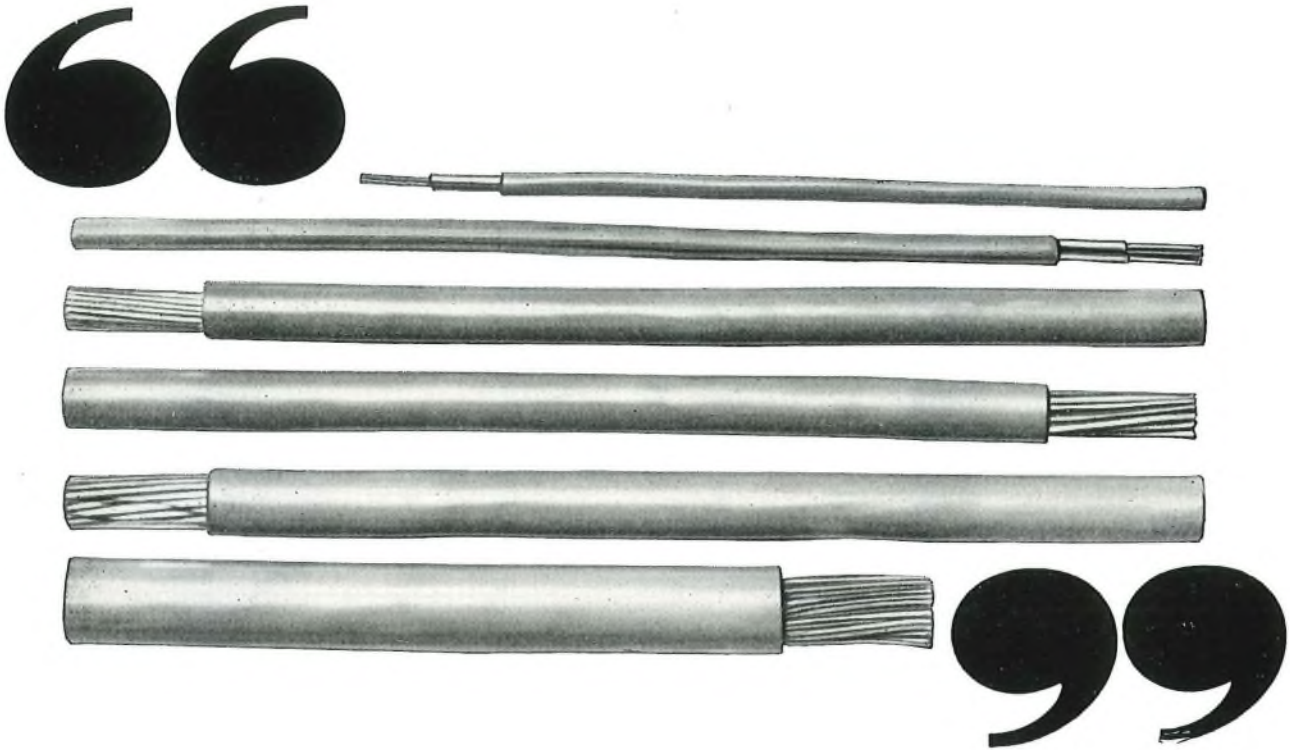

“**PIRELLI  
GENERAL**”  
and the power  
of speech

Internal telephone communication systems call for the same degree of reliability as for national networks. Pirelli General manufactures a range of multipair and multi-way internal telephone cables which are stocked for immediate delivery.

To reduce cross-talk in the multipair construction the pairs are twisted and laid-up with varying lays. Each cable has a distinct colour identification scheme for the cores or pairs which facilitates quick termination, and a Terylene ripper cord assists in quick removal of the PVC sheath. For further details ask for Publication C3:1968.

PIRELLI GENERAL CABLE WORKS LIMITED · SOUTHAMPTON · TELEPHONE: SOUTHAMPTON 20381

# Marconi Space Communications



**Marconi is Europe's largest supplier of satellite communication earth stations.**

**Seven Marconi earth terminals are operating or are on order for the INTELSAT global system.**

**The Marconi earth terminals at Hong Kong and Bahrain have proved to have the best performance of all 90ft or smaller stations in the world.**

## **Marconi 97ft diameter Kingpost Antenna**

- High G/T (figure of merit) performance, in excess of 40.7dB
- New non-metallic azimuth bearing virtually eliminates interruption to operation
- Versatile modular design
- High overall reliability

*Marconi Space Communications Division, world leaders in the design and construction of complete civil and military earth terminals, part of the total system capability of Marconi Communication Systems.*

## **Marconi Communication Systems**

**Complete civil and military static and mobile communication systems**

Message switching  
Digital and data systems  
Microwave and tropo systems  
Mobile radio telephones  
Specialized components

Satellite communications earth stations  
H.F. and l.f. point-to-point systems  
Television and broadcasting stations  
Maritime and naval systems  
Surveys, planning and commissioning

Marconi Communication  
Systems Limited,  
Chelmsford, Essex, England

*A GEC-Marconi Electronics Company*



# Marconi PCM systems

Marconi is the foremost manufacturer and exporter of PCM systems in the United Kingdom.

Marconi is a major supplier of PCM to the British Post Office, with equipment in operation in the London Region and many provincial regions. Marconi PCM systems are in use improving the communications efficiency of public utilities and telephone undertakings both in the United Kingdom and overseas.

Marconi has the widest experience in planning and installing complete PCM systems, adaptable to widely ranging requirements.

Marconi 24 channel PCM equipment Series U1310 is an advanced multiplexing system employing the latest microcircuit techniques.

- Low cost.
- Pulse system permits the use of regenerative repeaters to prevent noise and distortion build-up along the line.
- Deeper penetration of advanced micrologic circuits gives greater reliability.
- Advanced manufacturing processes and testing techniques increase equipment reliability.
- Suitable for future integrated switching systems.
- A range of signalling sets for different exchange conditions.

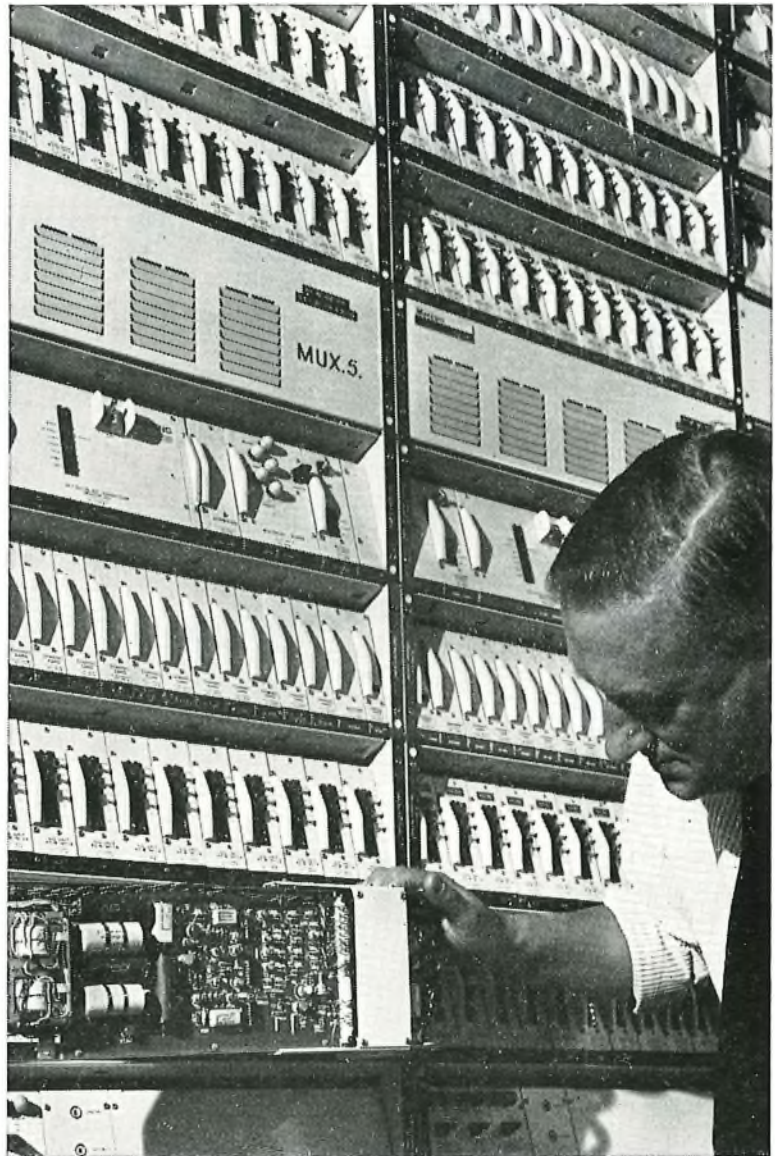

- Suitable for data transmission, and optional teleprinter facility.
- Accurate fault location and comprehensive fault alarm facility.

*Marconi Line Communications Division, specialists in digital transmission, including message switching and error correcting equipment, part of the total systems capability of Marconi Communication Systems.*

## Marconi Communication Systems

Complete civil and military static and mobile communication systems

Message switching  
Digital and data systems  
Microwave and tropo systems  
Mobile radio telephones  
Specialized components

Satellite communications earth stations  
H.F. and I.f. point-to-point systems  
Television and broadcasting stations  
Maritime and naval systems  
Surveys, planning and commissioning

Marconi Communication  
Systems Limited,  
Chelmsford, Essex, England

*A GEC-Marconi Electronics Company*



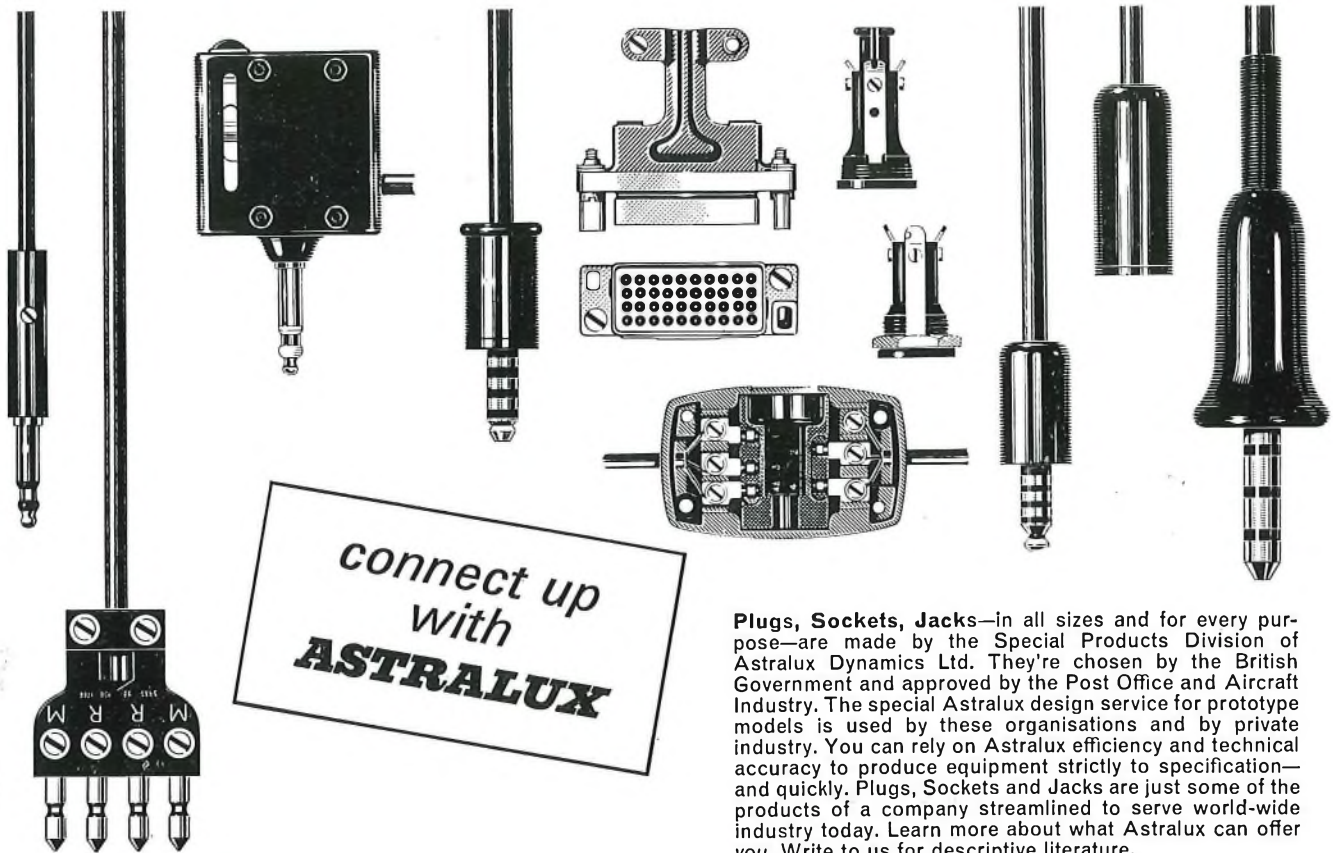

**Plugs, Sockets, Jacks**—in all sizes and for every purpose—are made by the Special Products Division of Astralux Dynamics Ltd. They're chosen by the British Government and approved by the Post Office and Aircraft Industry. The special Astralux design service for prototype models is used by these organisations and by private industry. You can rely on Astralux efficiency and technical accuracy to produce equipment strictly to specification—and quickly. Plugs, Sockets and Jacks are just some of the products of a company streamlined to serve world-wide industry today. Learn more about what Astralux can offer you. Write to us for descriptive literature.

**ASTRALUX** *dynamics limited*

Relay Division, Brightlingsea, Colchester,  
Essex, England. Tel. Brightlingsea 2571/5

## Wrap up your troubles.....

With the new Ostby and Barton system from UECL. Designed to provide a rational and high-speed solution to the problems of wrapping multi-terminations in the production shop. The AUTO WRAP includes closed-loop numerical control to eliminate wiring errors, speed production and minimise turn-round time.

AUTO WRAP systems can be programmed for point-to-point, dressed or twisted pair terminations. Bits, sleeves and accessories for all wire gauges and terminal configurations are quickly interchanged to tailor the system to alternative applications. For full details contact Ultra Electronics (Components) Limited, Fassetts Road, Loudwater, Bucks. Tel: High Wycombe (0494) 26233

**UECL**





# C & S Antennas

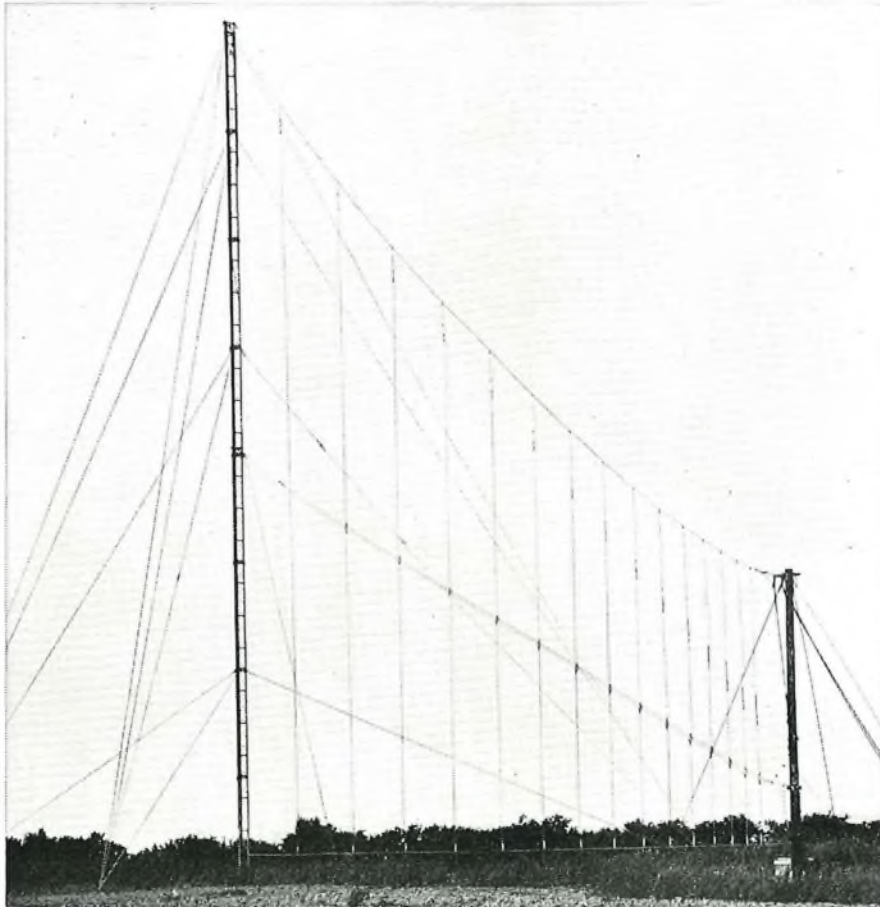

*C & S Vertical log Antenna*

for the complete aerial service—LF to Microwave

**Point to Point  
Broadcasting**

**Radio Relay  
Ground to Air**

**Navigational Aids**

**Business Radio**

**Design**

Site layouts, Antenna System Design.

**Antennas**

LF, 'T' and 'L' Antennas, Mast Radiators,  
HF Dipoles, Quadrants, Rhombics,  
Log Periodics, Conicals, Biconicals,  
Vertical Incidence Arrays,  
VHF & UHF Yagis, Helices, Ground Planes,  
Colinears, Whips, Marine Antennas.  
TELEVISION Arrays to 100 kW e.r.p.  
SHF Passive Reflectors, Dishes 3in. to 60ft dia.

**Supporting Structures**

Self-supporting Towers,  
Tubular and Lattice Masts,  
Telescopic Masts

**Accessories**

Coaxial and open wire Feeders, Filters,  
Antenna Switches, Lead-in panels,  
Earth Systems, Termination Networks,  
Air-cooled Transmitter Loads.

**Installation**

World Wide Service



## C & S Antennas Ltd

Wentworth House, Eastern Avenue, Ilford, Essex, England.

Telephone: 01-554 0102 Telex: 25850 Cables: Antennas Ilford (England)



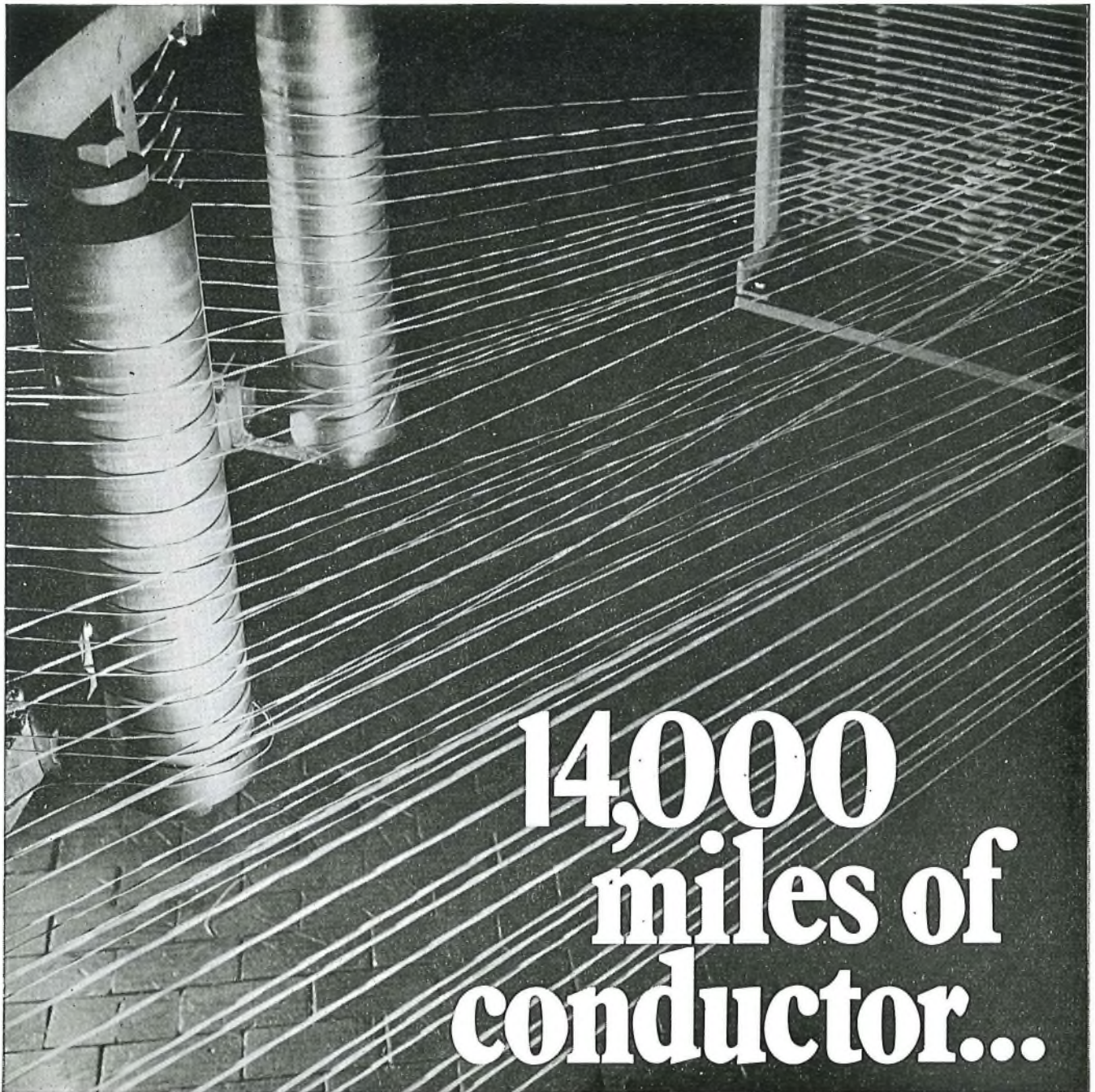

# 14,000 miles of conductor...

## ...and that's only one day's output!



TCL's daily output of insulated conductor would stretch over half way around the equator – yet after the raw material and laboratory tests, it is subjected to quality checks at every stage, from the wire insulation to the formation of the final cable core. Before final sheathing, all paper insulated cables are dried in giant ovens which extract moisture from the insulating paper – particular care being taken to avoid its becoming brittle and so impairing the jointing operation.

**Telephone Cables Limited** Dagenham, Essex. Tel: 01-592 6611 Cables: Drycore Dagenham Telex: 896216  
*The organisation with 135 years' experience.*

Both paper and plastics insulated cables are then finally tested after sheathing and prepared for despatch to the customer.

TCL – the largest company in Europe exclusively concerned with the manufacture of telecommunications cable – makes *all* types of dry core and plastic cables as well as being a major supplier to the British Post Office also exports to over 70 countries throughout the world. A world-wide technical advisory service is provided.



# For electronic components fast...

For semi-conductors, transistors and integrated circuits and all other components from anti-surge fuses to zener diodes, the name to remember is

Radiospares, P.O. Box 427,  
13-17 Epworth Street,  
London E.C.2  
Telephone: 01-253 7501  
Telex: 262341  
Telegrams: Radosperes London

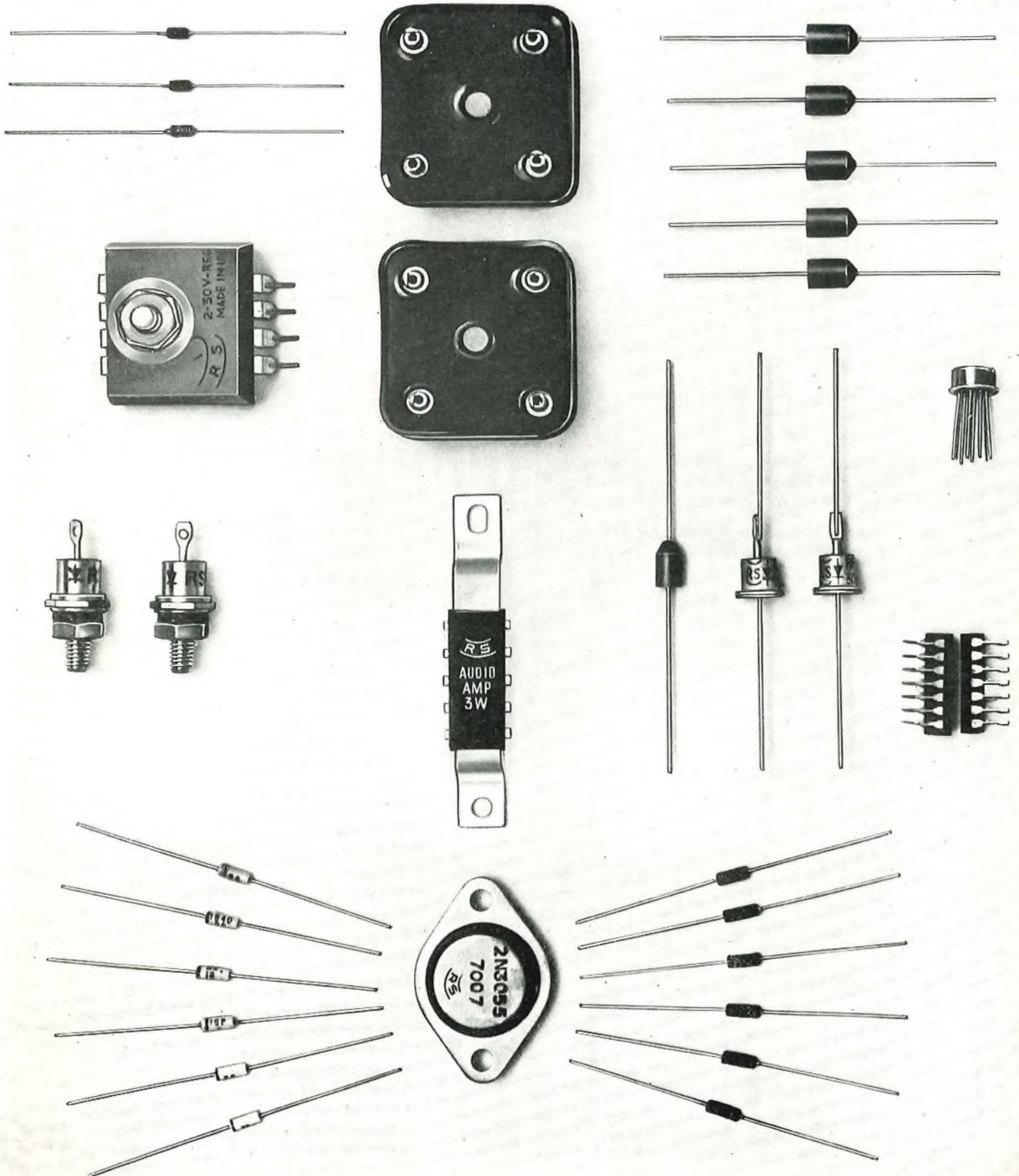

# Taking an interest in your retirement is as logical as taking an interest in your very own Insurance Society

With a view to retirement and death you cannot cover yourself better than with the capital cover offered by the **Civil Servants' Annuities Assurance Society**. For example:

- 1 **Survivorship Annuity.** Up to £208 a year bonus payable on your death to your dependants when for life or for a specified term of years.
- 2 **Deferred Annuity.** A similar income payable from a specified age for the rest of your life or that of a beneficiary.
- 3 **Combined Survivorship and Deferred Annuity.** A combination of the two for any dependant on your death or from age 60 for the remainder of their life.
- 4 **Joint Life and Survivorship Annuity.** An immediate income up to £312 a year payable throughout any two lives, reducing by one third for the survivor.
- 5 **Immediate Annuity.** Up to £208 p.a. immediately for yourself and/or your wife.

It is in your own interest to post this coupon today to:

## THE CIVIL SERVANTS ANNUITIES ASSURANCE SOCIETY

33 Birdhurst Rise, South Croydon, Surrey, CR2 7YH

Name .....

Dept. ....

Address .....

Date of Birth .....

Wife's Date of Birth .....

I am interested in .....

..... POJ10

and wish to receive details without obligation.

## INDEX TO ADVERTISERS

Alken Precision Engineers Ltd. . . . .	14
Astralux Dynamics Ltd. . . . .	..14, 21
British Institute of Engineering Technology . . . .	13
Borg Warner Control, Ltd. . . . .	26
S. G. Brown Ltd. . . . .	12
Canadian Instruments Ltd. . . . .	13
Civil Service Annuities Assurance Society . . . .	25
Cray Electronics Ltd. . . . .	27
C & S Antennas Ltd. . . . .	22
GEC-AEI Telecommunications, Ltd. . . . .	2-5
Institution of Electrical Engineers . . . . .	1
Marconi Communication Systems Ltd. . . . .	..19, 20
Pirelli General Cable Works, Ltd. . . . .	18
Radiospares . . . . .	24
Standard Telephones & Cables, Ltd. . . . .	6-11
Telephone Cables Ltd. . . . .	23
Telephone Manufacturing Co. Ltd. . . . .	15
Telettra S.p.A. . . . .	17
Ultra Electronics Ltd. . . . .	21
Whiteley Electrical Radio Co., Ltd. . . . .	16



The best comes from Borg-Warner. It never sets, it's called Accupower and it provides 'no-break' a.c. power to the load the moment the mains fail. Instantly. Stored d.c. is automatically fed through an inverter to give continuous a.c. for the period of the outage.

The next time your power supply sets below the horizon, and while you're waiting for

the sunrise, think about Borg-Warner Accupower. 50 to 360 kVA in standard units – systems up to 2 mVA.

Any time now, you could be in trouble. A phone call or letter to us today could avert it.

Write or phone: BORG-WARNER CONTROLS Division of Borg-Warner Limited, Elgin Drive, Swindon, Wiltshire, England. Tel: 0793 24121 Telex: 449101

Accupower is a registered trade mark.



the next best source of  
uninterruptible a.c. power



R. A. Roe

# TYPE 62

## FULL RANGE

7 TO 14 DAY DELIVERY

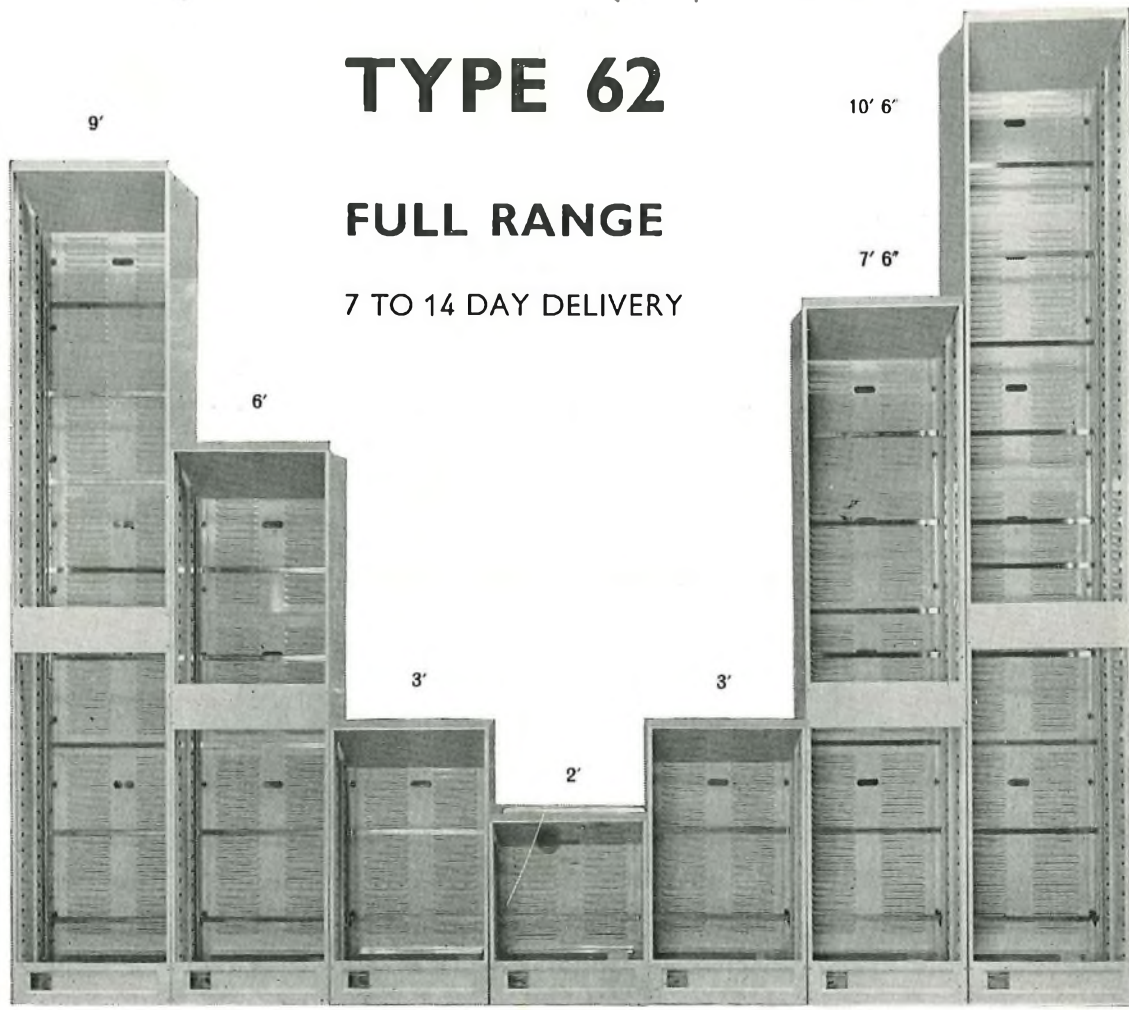

### HIGH PRECISION MECHANICS

FOR INSTRUMENT ELECTRONIC AND AUTOMATION INDUSTRIES

TELECOMMUNICATIONS  
MECHANICS

**P.O. APPROVED**

IMMEDIATE QUOTATIONS AND  
TECHNICAL SERVICE

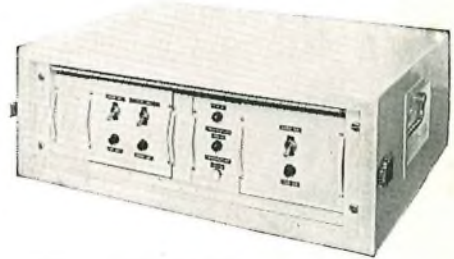

SHELF ASSEMBLIES



P.C.M. TRANSIT JIG



DAtEL MODEM

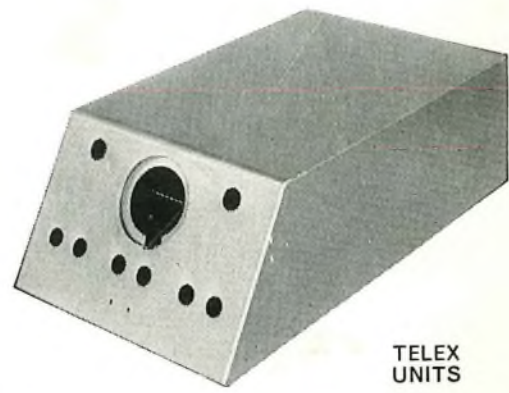

TELEX  
UNITS

## CRAY ELECTRONICS LTD

THAMES ROAD, CRAYFORD, KENT  
TELEPHONE: CRAYFORD 26526