

The Post Office Electrical Engineers' Journal

VOL 63 PART 2 / JULY 1970



THE POST OFFICE ELECTRICAL ENGINEERS' JOURNAL

Vol. 63 PART 2 JULY 1970

Contents

	<i>page</i>
Progress in Postal Engineering—Part 1— A General Survey—N. C. C. de Jong	65
Developments in Medium-Range Ship-to-Shore Radio Services—E. G. Bronsden	71
The Post Office Technical Training College—N. Fox	77
A New Method of Local Transmission Planning—H. J. Spencer	84
The Echo Suppressor No. 7A—A. G. Modsoll	86
Transit-Trunk-Network Signalling Systems—Part 2—Multi-frequency Signalling Equipment—C. B. Miller and W. J. Murray	91
Lives of Plant and Depreciation—R. C. Kyme	96
Transmission Measurements of Connexions in the Switched Telephone Network—P. N. Ridout and P. Rolfe	97
Metal-Oxide-Semiconductor (MoS) Integrated Circuits—Part 2—Simple Logic Circuits—F.H. Reynolds	105
Interfaces for Digital Data Transmission—A. J. Bott	113
A Line-Transmission Simulator for Testing Data Transmission Systems—K. Groves and P. Mackerill	117
Notes and Comments	123
Regional Notes	125
Associate Section Notes	126
Institution of Post Office Electrical Engineers	128
Speech by Chairman of Council	129
Press Notices	130
Book Reviews	70, 95

Published in April, July, October and January by *The Post Office Electrical Engineers' Journal*, 2-12 Gresham Street, London, E.C.2

Price 3s. 5s. (Including Postage and Packing). Orders by post only.

Annual Subscription (post paid): Home, 20s.; Overseas, 19s. (Canada and U.S.A., 2 dollars 50 cents).

For electronic components fast...

For Cables, Connectors and all other components from Anti-Surge Fuses to Zener Diodes, the name to remember is

Radiospares

P.O. Box 427,
13-17 Epworth Street, London, E.C.2.
Telephone: 01-253 9561. Telex: 262341.
Telegrams: Radosperes London.

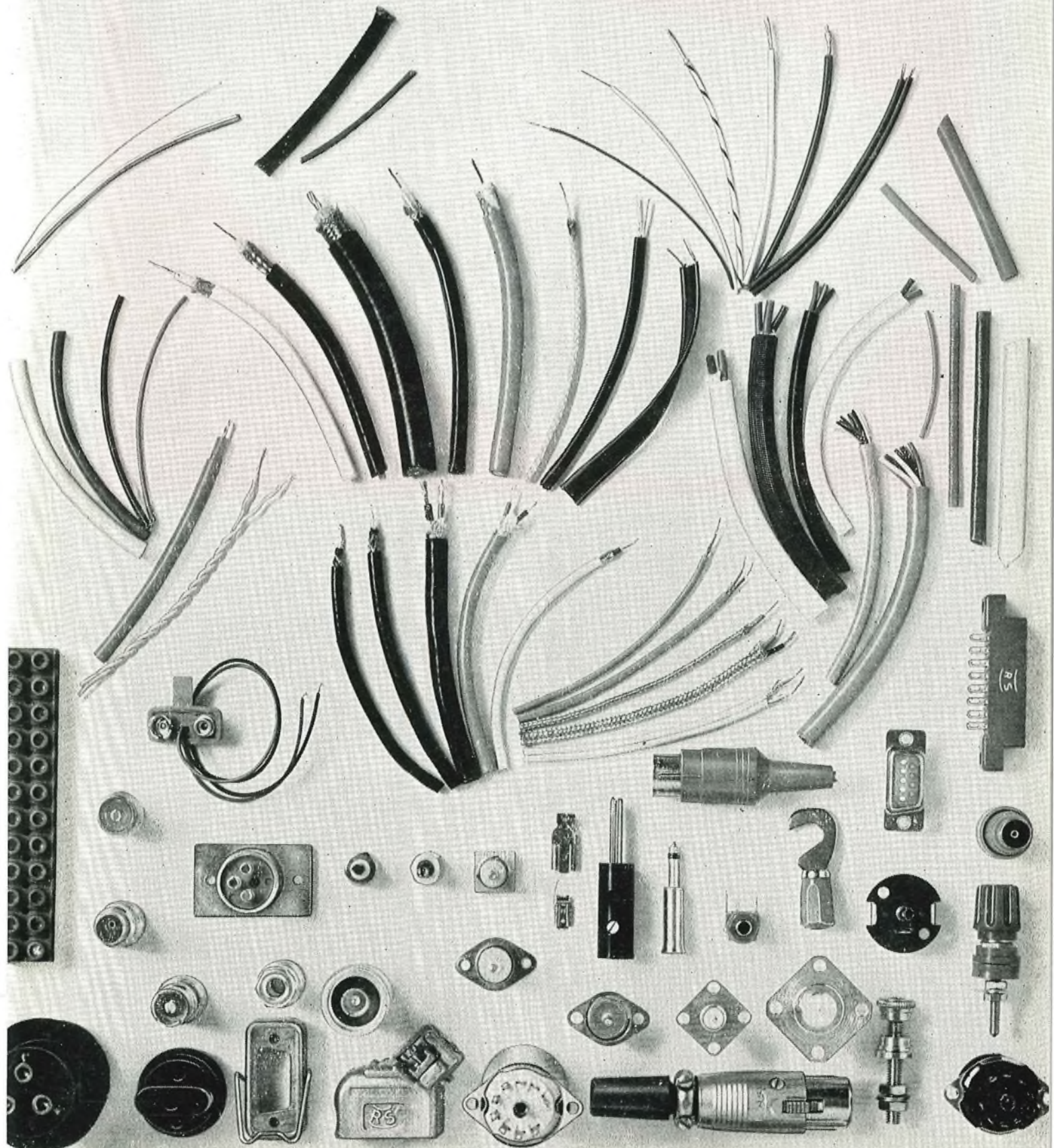

STC Telecommunications

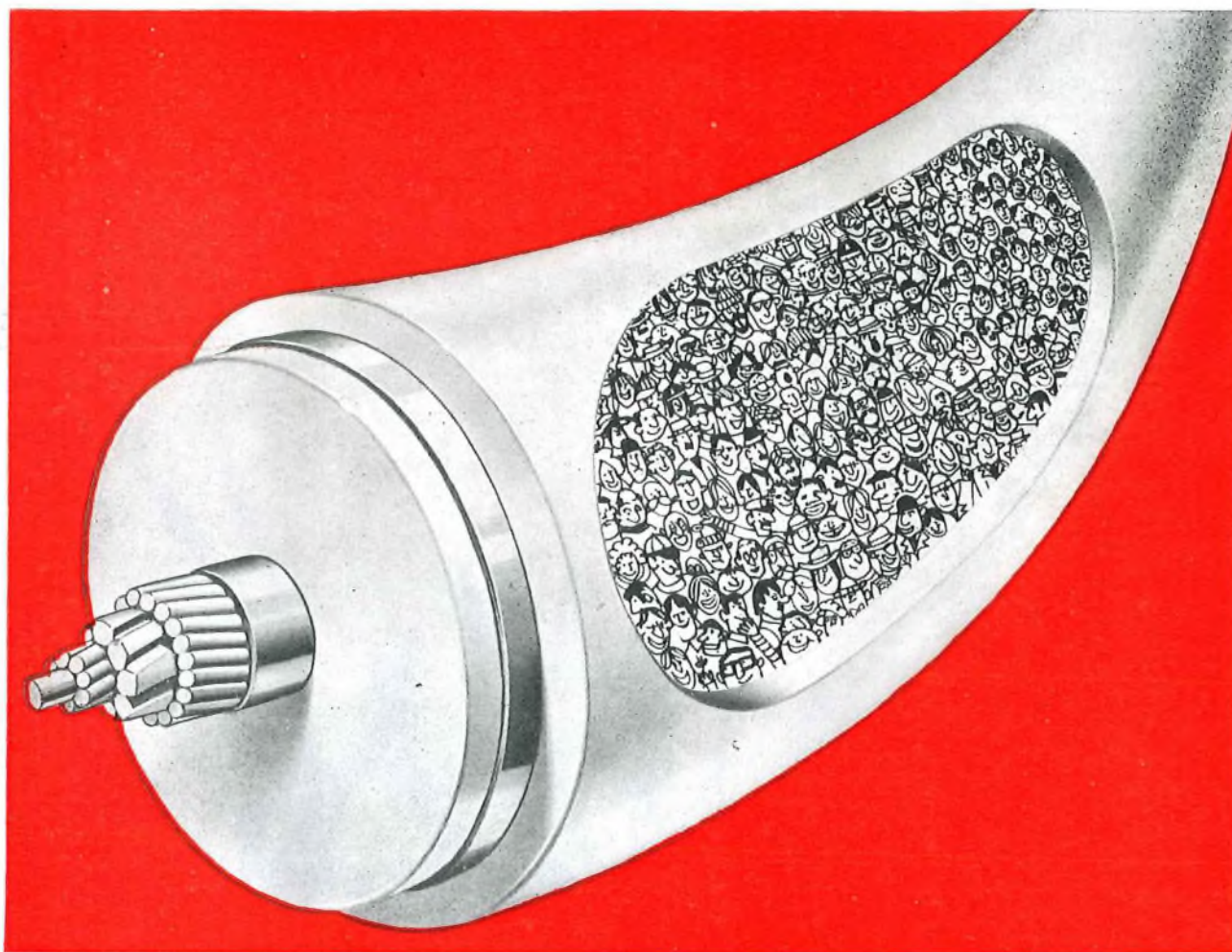

Soon 1840 people will reach the Canaries by tube—simultaneously!

The tube is the new undersea cable system made by STC. With an overall diameter of 1.75 inches, it has the astonishing capacity of 1840 separate telephone circuits each of full 3 kHz capacity. The world's largest to date. STC's first system in the Canaries had only 160 channels. But now that they have Subscriber Trunk Dialling (STD) the Compañía Telefonica Nacional de España needs another cable.

And again STC has been asked to provide this. Naturally. Because 1840-channels is only one of a succession of STC firsts in this field. First with 160- and 360-circuit deep-water systems. First with the master/slave power feeding system. First with the equaliser test lead making cable laying that much easier. But submarine cables, repeaters, equalisers and terminal equipment

are not all that we offer. Add an overall capability for systems planning, project management, installation of complete systems, including civil engineering works and services—and you have a unique organisation able to meet any requirement, anywhere. Standard Telephones and Cables, Submarine Systems Marketing Division, North Woolwich, London, E.16, England.

an associate of
ITT

world-wide telecommunications and electronics

STC

STC Telecommunications



47,704 are better than one

If you want a light, inexpensive headset, you can't do better than the British Post Office Corporation. For 47,704 of their girls, they chose STC sets. So should you.

Our sets are light as a feather, strong as a whip, and offer incredible value for money. They weigh a mere 4 ozs, and when your girls wear them, they won't notice a thing. The headset leaves their hands free to plug in lines or do their make-up, and however violently they shake or shrug, the headset stays put.

Better still, these sets are quite indestructible. Black or grey, take your pick.

So next time you're thinking of buying headsets, use your head. Buy STC.

Write, phone or telex for leaflet D/104 to:—
Standard Telephones and Cables Limited,
Subscriber Apparatus and Acoustic Division,
New Southgate, London, N.11, England.
Telephone: 01-368 1234. Telex 21917.

an associate of
ITT

STC



Easy money

For every Deltaphone your subscribers hire, you get a few shillings/schillings/krona/dollars extra every year.

With a lot of subscribers, you naturally get a lot more shillings/schillings/krona/dollars etc. every year.

And your subscribers get a very beautiful instrument (this gem of a telephone comes in several fashionable colours, to blend with the decor). With a few rather nice things other telephones don't have, like a gentle warbling tone (the volume is adjustable) instead of a loud insistent ring.

And an optional luminescent dial that glows in the dark.

And the fact that it weighs only a few ounces. And that it's only 4.3 inches (105 mm) wide, means it can be held comfortably in the hand.

Best of all, with all this extra money rolling in, very little rolls out. Because the Deltaphone is of modular construction and needs only a screwdriver for any repair job.

So why not stock up with the STC Deltaphone? It's so slim and elegant, your subscribers are sure to ask for it.

So write to: Standard Telephones and Cables Limited, Subscriber Apparatus and Acoustic Division, Oakleigh Road, New Southgate, London N.11, England. Telephone: 01-368 1234. Telex: 21917.

an associate of
ITT

STC

STC Telecommunications

★ **Star products
star award**



STC is proud to announce that its entire range of Star equipment has received the award of the British Council of Industrial Design. Elegant and functional in design the Star Mobile Radiotelephone and Starphone Pocket Radiotelephone are milestones in the design of Radiotelephone products.

The rapid acceptance of Star Mobile Radiotelephones in the UK and in over 30 countries throughout the world is a forceful reminder of the importance of design in worldwide marketing success.

For further information :
STC Mobile Radiotelephones Limited,
New Southgate, London N.11.
Telephone : 01-368 1200.
Telex : 261912.

an associate of
ITT

Mobile Radiotelephones **STC**

STC Telecommunications

Introducing Stick-a-Strip

Self adhesive impact cable A new product from STC

In modern office planning Stick-A-Strip makes obsolete those ungainly telephone wires, the sort you see stapled around skirting boards.

Stick-A-Strip is a flat cable—4 conductors in a plastic cover with impact adhesive on one side. Stick-A-Strip lays flat against walls, skirting boards, or under carpets. No mess. Neat and smooth instead.

Stick-A-Strip cable isn't just for telephones, either. It can be used for a great variety of low voltage applications.

And Stick-A-Strip can be moved and repositioned. It'll still stick and look smart. Stick-A-Strip can even make skirting boards beautiful.

Just how low can you get.

Deliveries available ex stock in 50 metre packs. In colours Grey or Cream.



For further information—write, 'phone or telex.
Standard Telephones and Cables Limited,
Plastic Telephone Cable Division, Corporation Road,
Newport, Monmouthshire, NPT OWS.
Tel: 0633 72281. Telex: 49368.

an associate of
ITT

world-wide telecommunications and electronics

STC

STC Telecommunications

STC Pulse Code Modulation makes network planning more flexible

The advanced PSC-24B system provides up to 24 telephone circuits over two existing unloaded audio cable pairs.

Advanced circuit design, including silicon monolithic integrated circuits, means a compact, highly reliable system. Repeaters are conveniently buried below ground at approximately 1800m (2000yds) intervals and are power fed over the cable.

With PCM equipment, unexpected changes in circuit growth can be easily met. Equipment can be transferred from one route to another, or added to high growth routes as required.

For more details, write:—

Standard Telephones and Cables Limited,

Microwave and Line Division,

Basildon, Essex, England.

Telex: 99101 (STC Basildon)



an associate of

ITT

world-wide telecommunications and electronics

STC

STC Telecommunications



Some of the books that have been written about us.

It's rather gratifying to see the results of our work in print. But not unusual for STC. A lot more volumes will adorn desks and kiosks around the country by the time we're through. At the moment, we're the only company involved in all 3 types of telephone exchange: Director, Non-Director, and Transit Switching. Transit Switching will eventually provide a new telephone network for the United Kingdom. In a year or so thirty Transit Switching centres all made and installed by us will be in operation for the Post Office Corporation.

Each will have its Group Switching Centres. Which in turn will be responsible for their own smaller, area exchanges.

The very fast signalling provided by Transit Switching will allow more calls through per minute. Fewer delays. Less time wasted, which will be greatly appreciated, because the telephone is the bread and butter of a lot of businesses.

Including ours.

Standard Telephones and Cables Limited, Telephone Switching Group, Oakleigh Road, New Southgate, London N.11, England.

Telephone 01-368 1234. Telex 21917.

an associate of
ITT

worldwide telecommunications and electronics

STC

GEC links the world with microwave progress

AUSTRALIA • BAHREIN • CANADA • CHILE
COSTA RICA • EL SALVADOR • FIJI • GHANA
GREECE • GUYANA • HONG KONG • IRAN
KENYA • LIBYA • MALAYA • MALAWI
MALTA • NIGERIA • NORWAY • PERU
PORTUGAL • SABAH • SWITZERLAND
THAILAND • UNITED KINGDOM
WEST INDIES • ZAMBIA

Broadband radio systems incorporating GEC microwave links are in operation in every continent in the world. The range of GEC microwave radio systems is impressive. It includes:-

- 2GHz, 4GHz, 6GHz and 6.8GHz equipments for speech or television on long haul main routes.
- 7.5GHz equipment for speech on medium haul spur routes.
- Associated equipments include F. D. Multiplex for up to 1800 circuits, supervisory alarm indication and remote control systems, I.F. and baseband switching equipments, narrowband auxiliary radio for serviceband antenna systems.

The achievement of GEC in the provision of microwave radio communication networks in so many countries of the world typifies their overall capability in telecommunications.

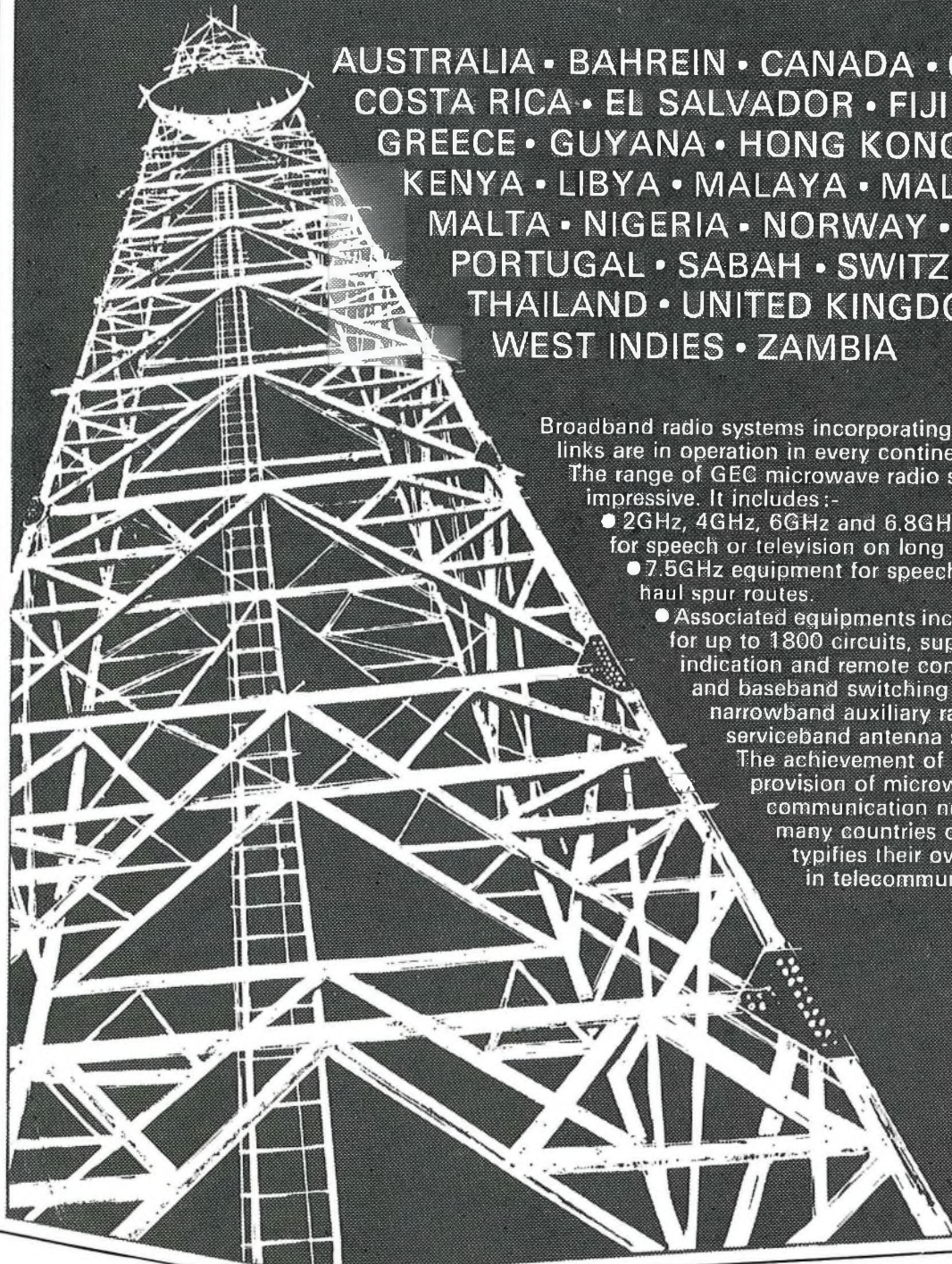

G.E.C.

Takes telecommunications into tomorrow

GEC-AEI TELECOMMUNICATIONS LTD. OF COVENTRY, ENGLAND.

A Management Company of The General Electric Co. Ltd. of England.

The Data Modem that's proved in service

Many thousands of GEC 600/1200 baud Type TED 0136 Data Modems are already in service. This is a practical demonstration of the reliability and versatility of this equipment, for converting data pulse information into voice-frequency signals for transmission over a switched public — telephone connexion or via a private circuit, and re-converting received signals into data format. Features include:

- Two switch-selected speeds of operation: up to 600 bauds and up to 1200 bauds, the latter being generally possible over modern public switched telephone networks.
- Modulator and/or demodulator may be used for 600 or 1200 baud operation.
- 75 baud operation for return supervisory and control data.
- Complies with CCITT recommendations.
- Power supply: 190 to 260V 50Hz single phase, 18W.
- Dimensions: 178 mm (7 in) high, 345 mm (13.5 in) wide, 452 mm (18 in) deep.
- More data required? Write Transmission Division, GEC-AEI Telecommunications Limited, P.O. Box 53, Coventry, England.

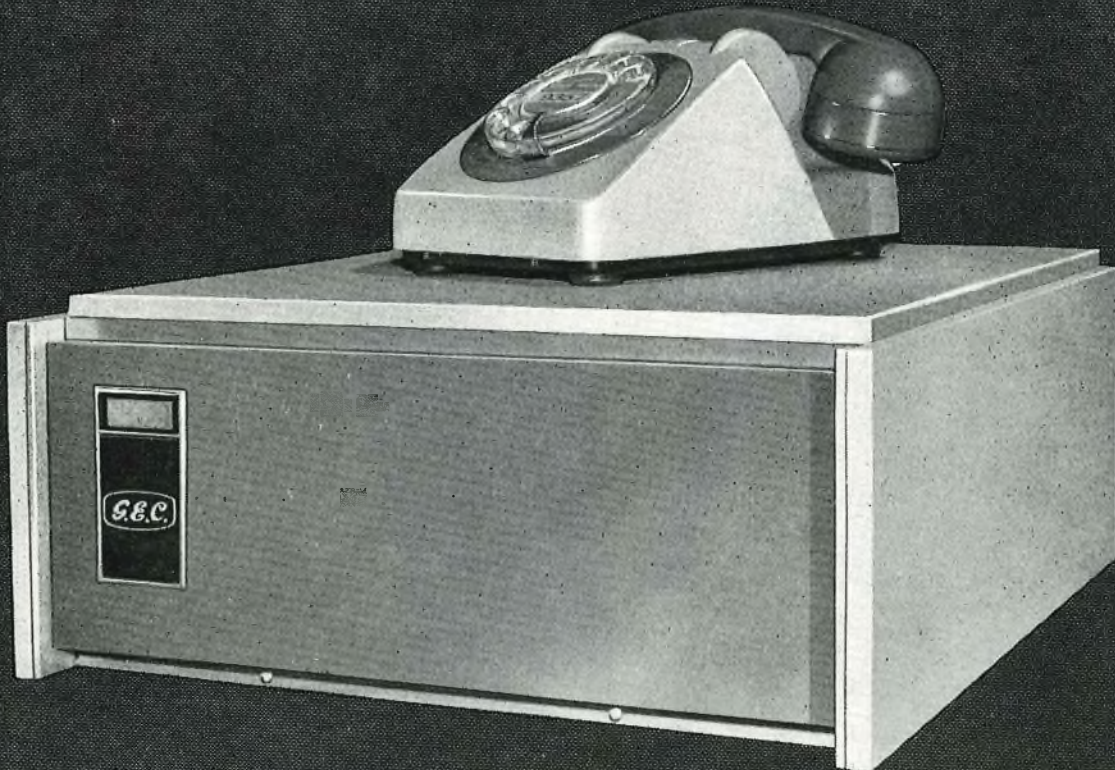

Takes telecommunications into tomorrow

GEC-AEI TELECOMMUNICATIONS LTD, OF COVENTRY, ENGLAND.

A Management Company of The General Electric Co. Ltd. of England.

ever wanted

to match your
load bearing capacity to
your own rate of growth?

with GEC multiplex you can!

GEC Multiplex equipment is easily built up from a few circuits to the maximum capacity you require. Groups, supergroups, and hypergroups can be assembled economically in line with CCITT, North American, or other requirements. The equipment construction is compact but flexible, with plug-in units mounted in standard 'CASE' rack frameworks easily adaptable in height to meet individual requirements. These features of design *and* construction enable you to match the development of GEC Multiplex equipment to your own developing requirements, large or small.

GEC MULTIPLEX TYPE 4M EQUIPMENT



Takes telecommunications into tomorrow

GEC-AEI TELECOMMUNICATIONS LTD, OF COVENTRY, ENGLAND.

A Management Company of The General Electric Co. Ltd. of England.

the GEC co-axial cable system 4K9B is going places

- * Proven in operation with over 230 systems covering 6000 route miles being supplied in the U.K. alone.
- * 960 telephone circuits.
- * 4.4 mm (0.174 in.) or 9.5 mm (0.375 in.) coaxial-cables.
- * Power-fed repeaters at a maximum spacing of 4010 m. (4,400 yd.) for 4.4 mm. cable and 9250 m. (10120 yd.) for 9.5 mm. cable.
- * Performance to CCITT recommendations.
- * Underground repeater boxes to house up to six systems.

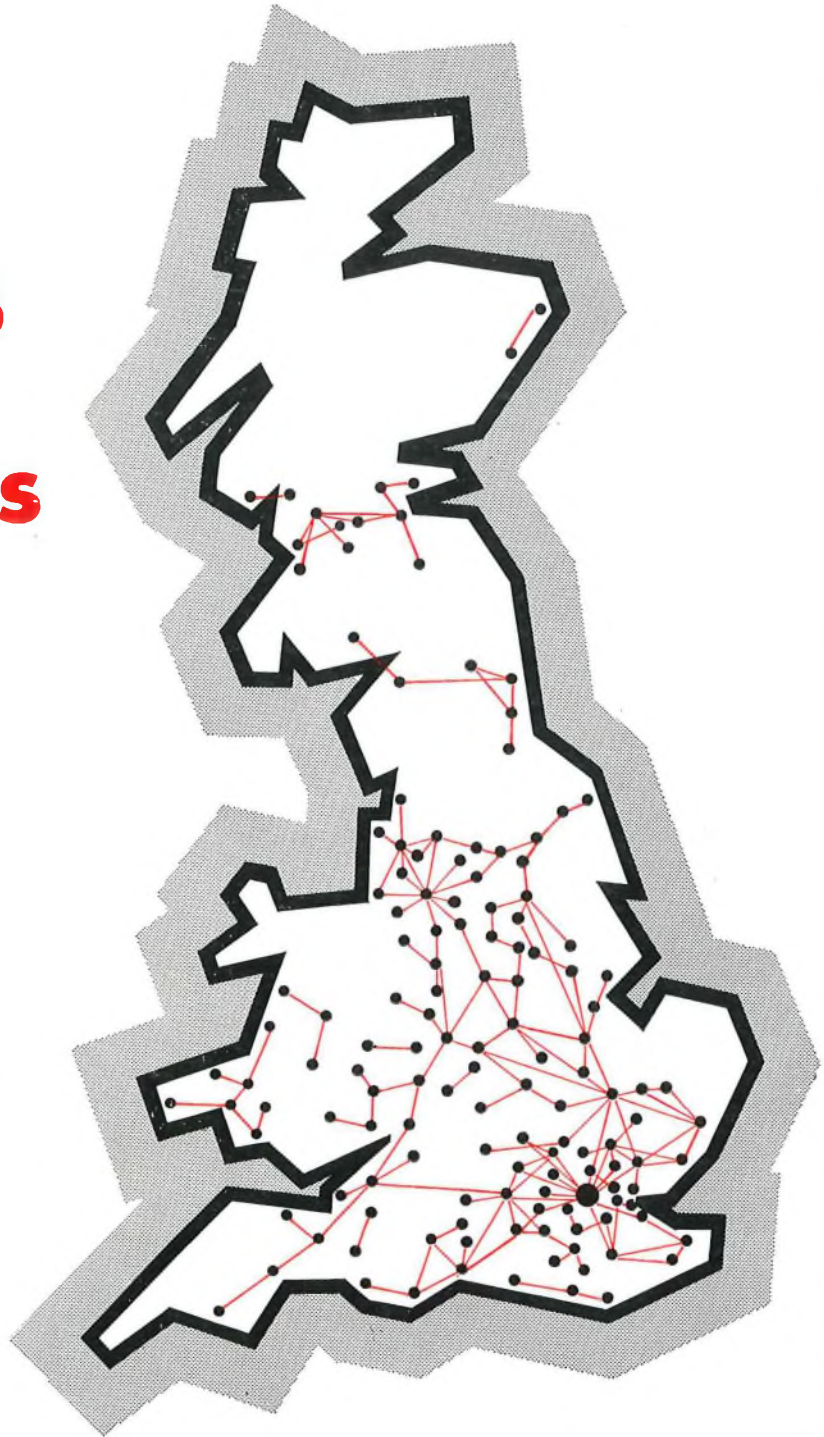

Takes telecommunications into tomorrow

GEC-AEI TELECOMMUNICATIONS LTD. OF COVENTRY, ENGLAND.

A Management Company of The General Electric Co. Ltd. of England.

New Grey Scale Generator...

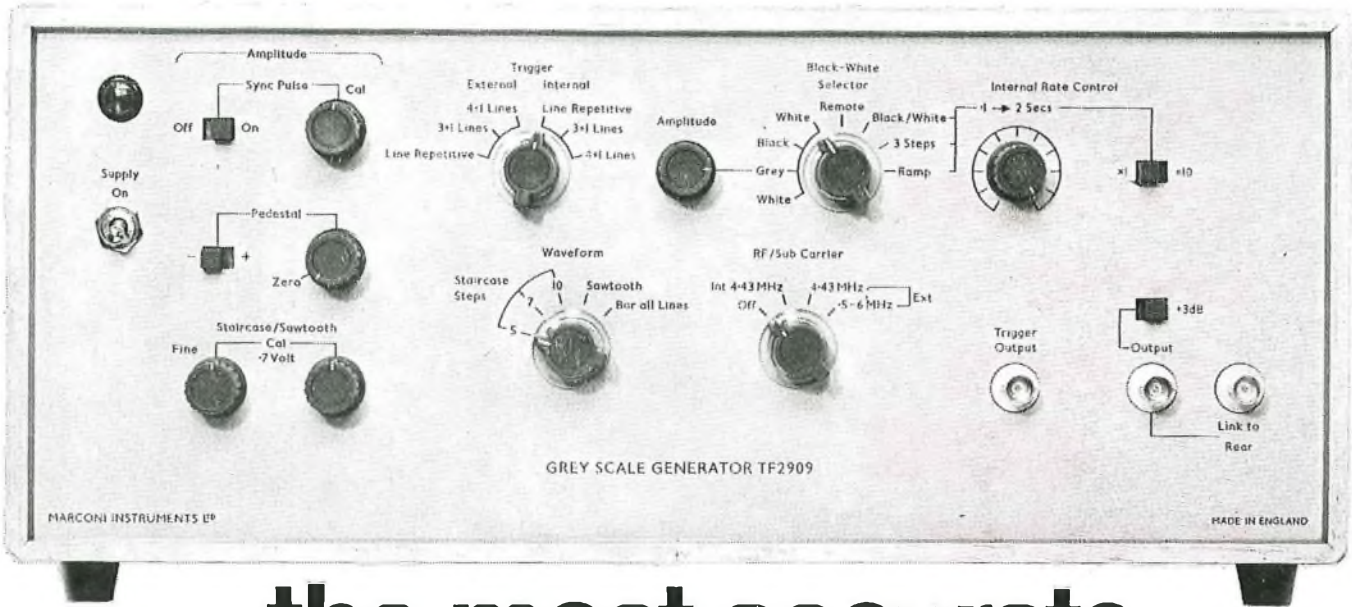

...the most accurate linearity-measuring waveforms yet.

Grey Scale Generator TF 2909 is the latest addition to the wide range of MI television transmission test equipment. Specially designed to meet the recommendations of the British Post Office and the C.C.I.R., the TF 2909 produces the most accurate linearity-measuring waveforms at present obtainable.

- Switch-selected grey scale waveform: linear sawtooth or 5, 7, or 10 step staircase, with manually variable amplitude.
- Switch-selected test-line sequence: grey scale waveform on every line, every fourth line, or every fifth line, with bar on intermediate lines: or bar on every line.
- Colour sub-carrier: internally or externally generated sub-carrier may be added to the sawtooth or staircase, with a ten-cycle reference burst at the start of each line.
- R.F. input: an externally generated sinewave between

0.5 and 6 MHz can be added to the sawtooth or staircase for differential gain measurements over the video band.

- White-level reference (optional): with sub-carrier or r.f. added to the staircase, the top step may be extended beyond the sinewave to give a white-level reference.
- Adjustable pedestal: with standard 1-volt p-p waveform amplitude, the pedestal level is variable to 0.6 volts above or 0.3 volts below black level.
- Adjustable sync pulse amplitude: the sync pulse may be set to calibrated or continuously variable level, and may be switched on or off.
- Excellent signal-to-noise ratio: negligible error is introduced due to internally generated noise.
- Accuracy: differential gain – accurate to 0.1%, differential phase – accurate to 0.1°.
- Price £845 f.o.b. U.K.

Plus Sine-Squared-Pulse and Bar Generator for precise measurement of response characteristic.



The Grey Scale Generator complements the well established TF 2905/8 Sine-Squared-Pulse and Bar Generator. Together they provide all necessary test waveforms for comprehensive video-to-video testing of any television transmission system. The TF 2905/8 generates four test waveforms: 50Hz squarewave on

line sync pulses; \sin^2 pulses; \sin^2 pulse and bar (T and 2T) on sync pulses with an inverted \sin^2 pulse during the bar period; chrominance \sin^2 pulse and bar (5T, 10T and 20T), with 10 cycle sub-carrier reference burst, available as a chrominance or a chrominance + luminance waveform.

For full details, please write to:



MARCONI INSTRUMENTS LIMITED

A GEC-Marconi Electronics Company

Longacres, St. Albans, Hertfordshire, England. Telephone: St. Albans 59292 Telex: 23350

Of special concern to all P O Employees

You qualify for special discounts on all forms of insurance through your own society

THE CIVIL SERVICE INSURANCE SOCIETY

Every policy indirectly benefits the Civil Service Widows' and Orphans' Fund which exists to help dependants of policy holders

Fill in the coupon now for further details.

1. Life 2. Endowment 3. Group Life Excellent cover for very modest premiums deducted from official pay 4. Family Protection 5. Educational 6. Mortgage Protection 7. Annuities 8. Household Comprehensive 9. All risks to valuables 10. Car 11. Sickness 12. Accident 13. Holiday 14. Travel 15. Unit Trust with Life Insurance 16. NEW: Income Replacement Scheme: Sickness Income and/or Widows' Income and/or Dependants' Income 17. Immediate Annuities —new and improved rates (partly tax free) A profitable form of investment for part of one's gratuity on retirement to increase one's income

NEW. For immediate cover and favourable terms for car, travel, personal accident and holiday insurances, telephone: 01-688 3537

Post this coupon to:

THE CIVIL SERVICE INSURANCE SOCIETY

33 Birdhurst Rise, South Croydon,
Surrey CR2 7YH

Name

Address

POJ

Dept..... Date of Birth.....

Please send details of Insurance No.....

For Annuities

Wife's date of Birth

Own date of Birth.....

Amount and Type of Annuity.....

In favour of.....

Radio and Line Transmission (A)

D. C. GREEN

This book covers the specific requirements of the first year of the Radio and Line Transmission paper of the Telecommunication Technicians' Course No. 49. Just issued is the paperback of this well established textbook.

45s (£2.25) net

Paperback 30s (£1.50) net

Introduction to Telephony and Telegraphy

E. H. JOLLY

Covering the joint paper 'Telephony and Telegraphy A' in the City and Guilds Telecommunications Technicians' Course No. 49 this book brings out how transmission and switching in both telephony and telegraphy have become increasingly similar. This being caused by the adoption of electronic methods and pulse code modulations and data transmission.

75s (£3.75) net

The Protective Gear Handbook

F. E. WELLMAN

Second Edition

A critical survey of modern protective systems, with notes on their operation, maintenance and testing. Intended primarily for operating engineers and maintenance staff, the book will also be of help to students and lecturers concerned with the generation and application of electrical energy.

85s (£4.25) net

Solution of Problems in Electronics and Telecommunication

C. S. HENSON

Third Edition

A valuable work for University and Technical College students. It contains more than 250 problems in telecommunications and electronics. The problems are classified under 20 headings, numerous fully worked out examples are provided and answers given to the others.

55s (£2.75) net

Paperback 38s (£1.90) net



PITMAN PUBLISHING
39 PARKER STREET LONDON WC2

**POST OFFICE
APPROVED**

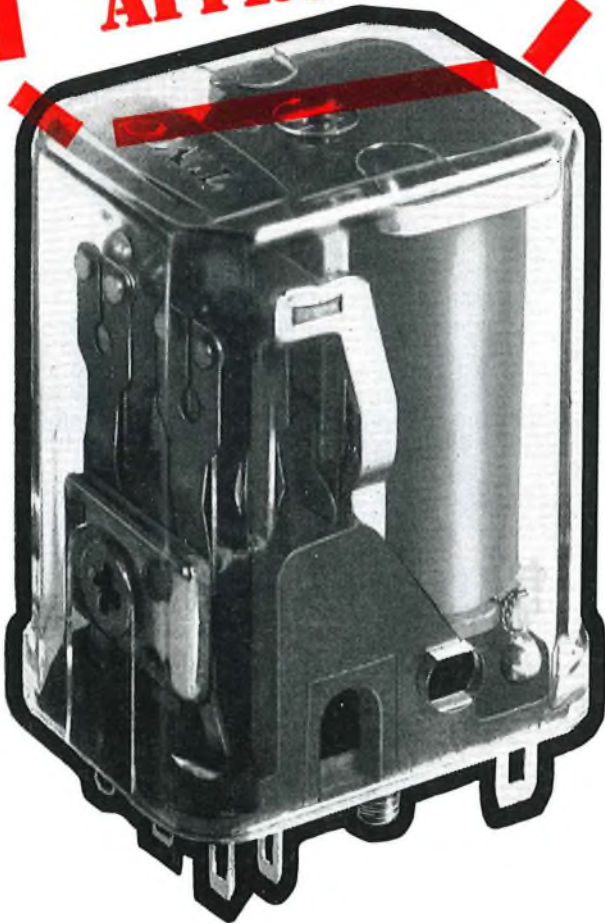

RELIABILITY WINS APPROVAL FOR TMC RELAYS.

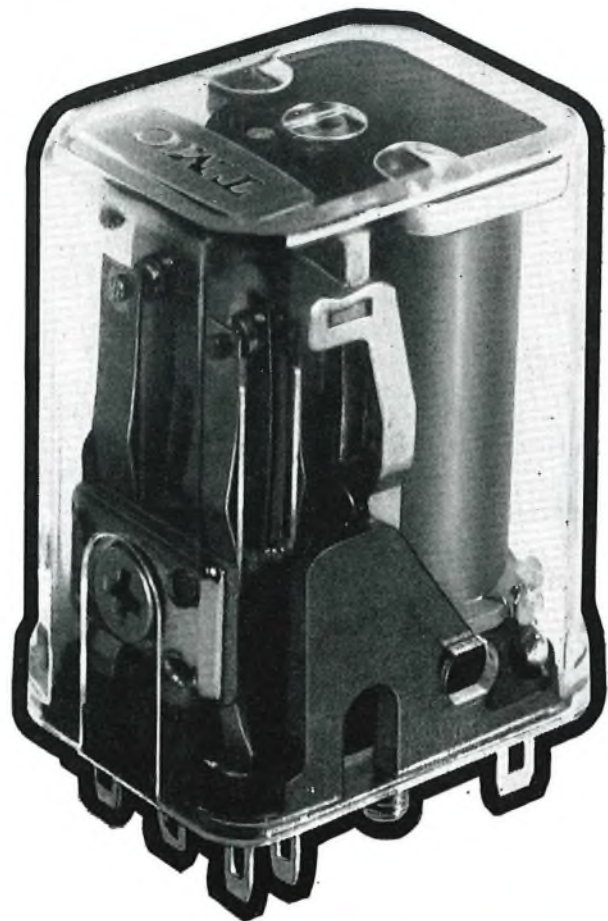

Built-in reliability. That's what you get with TMC Relays.

A reliable, fully bridged mounting base—it's specially designed to prevent base distortion and fracture around the fixing screw.

A reliable, positive location for the cover at the end of the yoke, so the cover can be simply and quickly removed. Or refitted.

Large contacts (bifurcated for the twin contact relay), with reliable, high contact forces and extremely long, trouble-free life.

TMC Relays are available now for quick delivery. For full details and free leaflets, write to:

Telephone Manufacturing Company Ltd.
Components Division,
Roper Road, Canterbury, Kent
Telephone: Canterbury 66041

TMC

a member of the  Group of Companies

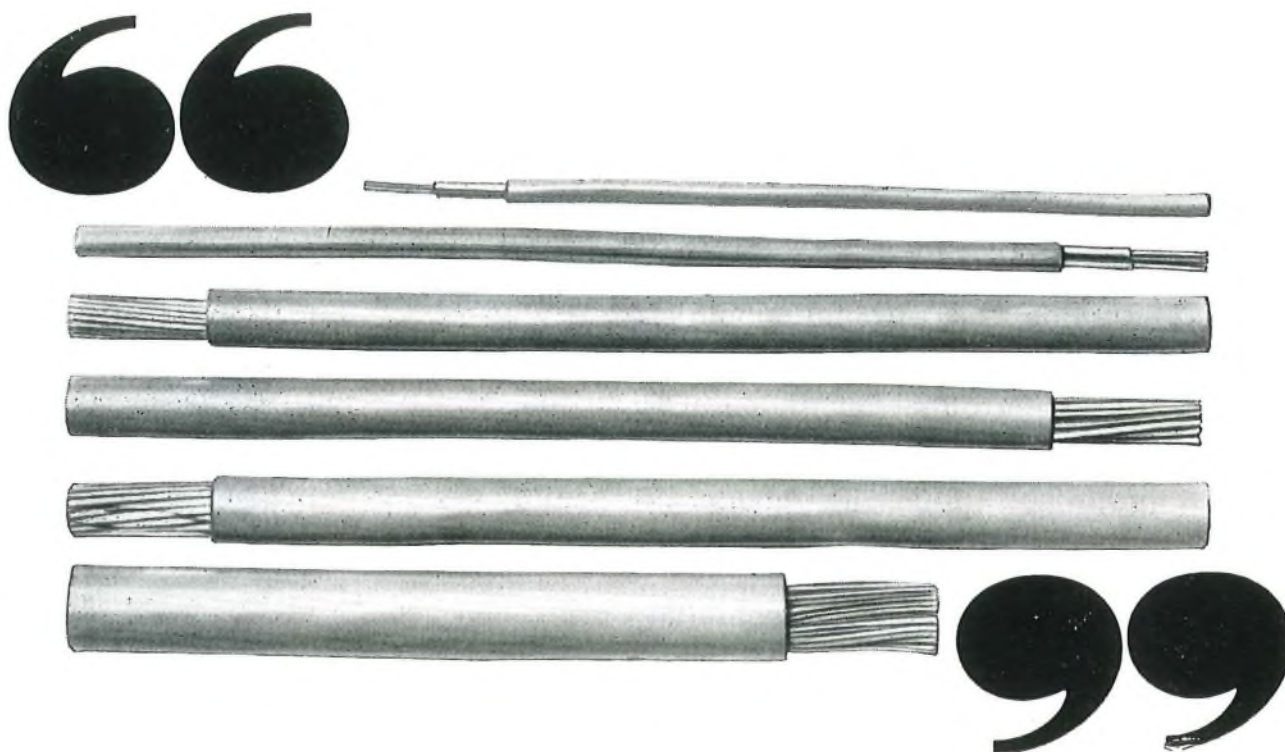

“**PIRELLI**”
GENERAL

**and the power
of speech**

Internal telephone communication systems call for the same degree of reliability as for national networks. Pirelli General manufactures a range of multipair and multiway internal telephone cables which are stocked for immediate delivery.

To reduce cross-talk in the multipair construction the pairs are twisted and laid-up with varying lays. Each cable has a distinct colour identification scheme for the cores or pairs which facilitates quick termination, and a Terylene ripper cord assists in quick removal of the PVC sheath. For further details ask for Publication C3:1968.

PIRELLI GENERAL CABLE WORKS LIMITED · SOUTHAMPTON · TELEPHONE: SOUTHAMPTON 20381

P8577

**the GPO
are proud to serve
55 million people**

**WHITELEY
are proud to serve
the GPO**

The development and manufacture of telecommunications equipment requires forethought, research, technical expertise and a great deal of co-operation. Whiteley of Mansfield have been providing these services to the G.P.O. and Industry for many years, producing anything from a control knob to complete electronic and telecommunications equipment.



WHITELEY ELECTRICAL RADIO CO. LTD., Mansfield, Notts, England. Tel. Mansfield 24762
London Office: 109 Kingsway, W.C.2 Tel. 01-405 3074

Progress in Postal Engineering

Part 1—A General Survey

N. C. C. de JONG, B.S.(ENG.), C.ENG., M.I.C.E., F.I.MECH.E., F.I.E.E.†

U.D.C. 656.88

This article, which will appear in three parts, outlines the past, present and future of postal engineering. It is based on the author's paper which prefaced the first British Postal Engineering Conference, held at the Institution of Mechanical Engineers, London, in May 1970. Part 2 will cover in more detail the mechanization of the Parcel Post and the handling of mail in bulk. Part 3 will deal with the Letter Post and the complex problems met in the automation of some of its activities.

INTRODUCTION

Postal Engineering is now a rapidly-developing branch of technology. Evidence of the first machines specially designed for postal use dates back 100 years, but as yet there are no text books on the subject. Earlier this year the first British Postal Engineering Conference took place under the auspices of three professional Institutions (I.Mech.E., I.E.E. and I.P.O.E.E.). The Conference papers,¹ nearly 50 in number, in the main written and presented by members of the I.P.O.E.E., provide a major contribution to the literature of the subject.

THE POSTAL BUSINESS

The Postal business offers a wide variety of services but its main purpose is to deal with the great bulk of the country's letters, packets and parcels. There has been steady growth in the numerical size of the letter traffic since its inception, but the level of parcel traffic has been reasonably constant over the last few decades. In addition to the long established letter and parcel posts there are new services arising from modern technological developments, for example, "phonopost"² and the recently introduced "datapost" (in effect, a courier service for packets). No doubt further diversification will follow, but as compared with telecommunications there is far less scope for the creation of such new ventures.

The parcel service, unlike that for letters, is not a monopoly. The Post Office share of the business during the last two decades has varied between 200 and 250 million items per year. Parcels can be posted at the 25,000 public counters; in addition direct collection from firms is arranged. The Freight Integration Council, appointed by the Government to study rationalization of the four nationalized parcel services, will be reporting this year. It is possible that its recommendations will have a stimulating effect for the Post Office, which already handles the bulk of the parcel traffic under 10 kg (22 lb) in weight. Modern handling techniques are being introduced and these will be fully described in Part 2 of the article. The scale of parcel movement can be appreciated from the amounts involved on the London to Birmingham and London to Manchester routes; the traffic on each route would fill a Freightliner train of over ten 40 ft containers daily.

The 11 thousand million items of letter mail handled every year arrive through 100,000 posting boxes and over the 25,000 public counters. Attempts to alter the pattern of service required by the customer—such as requests to "post early in the day"—have generally failed. This means that 80 per cent

of the 35 million daily letters enter the system during 10 per cent of the 24-hour postal working-cycle. The above traffic figure is a weekday average; Friday's post usually peaks to over 40 million items and there are massive additions even to this volume in the postings before Easter and Christmas. It is difficult to visualize what these vast quantities mean, but in numerical terms the problem is equivalent to shifting our adult population daily, each person being routed to any address of his choice.

The first "Master of Posts" of the U.K. was appointed well over 400 years ago. Many generations of Postmasters since then have influenced the evolution of the present system which has served so well, but until recently technology has had no startling effect on its *modus operandi*. In essence this remains unchanged from its character of a century ago. At that time Rowland Hill, the most renowned leader of the Post Office and a man of many parts (including engineering talents), initiated the use of postage stamps and launched the universal system we know today. This system is labour intensive. It will remain so, although the present proportion of annual expenditure, 75 per cent, which goes in personnel charges, can be reduced. Automation may also affect the work of the public counters and self-service facilities may well be increased.

The methods of collection, sorting and delivery have been modernized but are still basically manual tasks. The first and last of these will always maintain the personal nature of the service in the form of the postman. In between these terminal activities is a whole range of processes, centring on the handling and sorting requirements which are now amenable to mechanization, ultimately perhaps to complete automation. The man-hours employed in repetitive processes and in mail movement within sorting offices are equivalent to some 50,000 men. This is the one area in which the postal business can match the technological advances in other large industries. The extent to which it does, and so becomes less dependent on man-power, depends on the inventiveness of postal engineers and the successful application of their ideas.

COMPARISONS: POSTS AND TELECOMMUNICATIONS

Postal and telecommunication systems have significant interests in common which help to explain their long association at home and abroad within the Post Office organizations. The main purpose of both is to provide means for communication between persons not in direct aural contact. The one does so by a written message, physically transported in the original form; the other by a spoken message, converted to electrical form which can be modified for transmission. The one is universal in application, the other more selective; the

† Director of Planning and Mechanization, Postal Headquarters

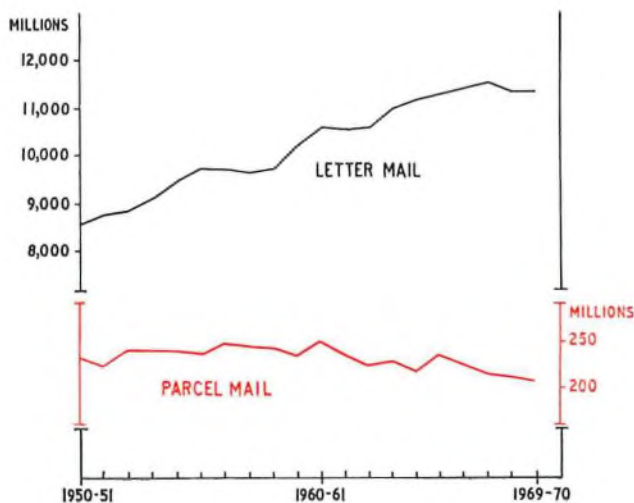

FIG. 1—Numbers of items handled annually

one is delayed, the other is instantaneous. These contrasts reveal the true difference between the services if compared in terms of social-benefit costing. For the price of a stamp one can send a secure message anywhere, but for this price one must accept a delay of a day or more. The cost of the immediate telephone call ranges from an amount, for a local call, of the same order as that of the stamp, to many times its value if the other party is far distant. The difference in unit costs can exceed an order of magnitude. This gap may remain indefinitely. It is reflections such as these which lead the author to believe that the form of communication by letter (and the friendly postman) will be with us indefinitely and is not, as some visionaries would have us believe, on the way out.

Besides speed and economy, transmission error-rate is another factor to be considered. Because any error (missort) in postal transmission takes a relatively long time to correct there has been a long tradition of high accuracy. Such levels are notoriously difficult to measure but over 99 per cent has been the aim. This is a grade-of-service to be envied in a manual system. Machines are potentially even more accurate, but public and operator errors have to be engineered out of the system by careful organization.

A further analogy which can be made between Posts and Telecommunications lies in the system elements. In telephony these are recognized as signalling, switching and transmission functions. Although not recognized as such for postal traffic, there are in fact equivalent functions. Thus *signalling* is derived from the stamp (which indicates the class of service) and the address postcode (a shortened form of the address which is the equivalent of the telephone user's national

dialling code); *switching* is comparable to the sorting process; *transmission* to the transportation of mail.

We can carry this comparison further. Both services distribute their traffic over complex trunk and local networks, the one transporting it physically, the other transmitting it electrically. Both started with large numbers of switching centres manually operated to control the routing of the messages to the right one of a multitude of destinations. Over 50 years ago the telephone business started its program to convert the manual exchanges to automatic ones. It is completing this process this year and, by strange coincidence, the postal business is in the same year opening its first completely automatic letter-sorting offices and announcing its total systems plan based on some 120 mechanized centres. Although there is a difference in scale it is a measure of the speeding up of change which we accept in the modern world that the last manual sorting office conversion could be effected in a quarter of the time it has taken in the telephone system. But there is another and more intriguing comparison. The gap of 50 years shortens in one very important respect. For the first 30 years of automatic telephony, the trunk and assistance traffic continued to be handled by manual operators. Then came subscriber trunk dialling (s.t.d.) and the system is well on the way to its second stage of conversion to an integrated national automatic network. But complete automation still cannot be envisaged. At a critical number of centres the human operator must remain to connect those long-distance calls which the customers cannot obtain by using dialling codes, and (for the part which will always remain as a personal service) to give the public other assistance when required. While the conversion of the individual sorting office from manual to automatic working is comparable with its automatic telephone exchange equivalent, it is in the network theory that the similarity really occurs. Ultimately, when a viable automatic reading-system can cope with all the variables in postcodes and addresses, the analogy will be complete, as it is conceivable that, like telephone messages, most letters will be routed (without operator assistance) to a trunking network connecting automated centres.

BRIEF HISTORICAL SURVEY

At the commencement of this century, the only specialist equipment available was a stamp-cancelling machine. The first of these machines was made in England in 1857. It was designed to be steam operated as was the fashion in those days, but it had an output of only 50 letters per minute. The steam power idea unfortunately failed, as did the foot-treadle version which followed. The latter cost £173 to construct, equivalent to £2,500 at the present day! The machine eventually had to be hand-operated.

From the start of the 20th century engineers became increasingly involved in postal work. On the completion of King Edward Building in the City of London in 1910 the first mechanized mail-handling plant was installed in a British

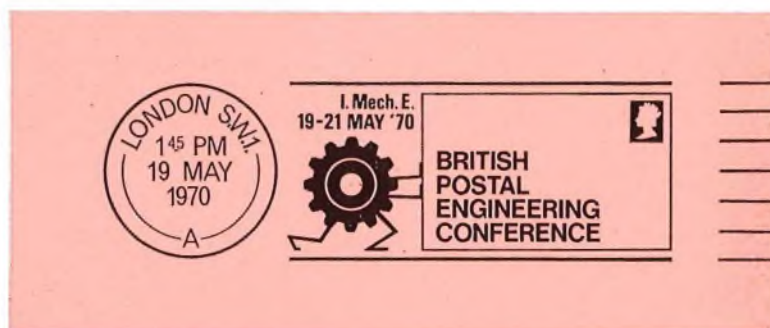

FIG. 2—Modern stamp-cancellation mark

Post Office.³ It included three belt conveyors for bags, a double-track rope-way with carriers (the fore-runner of modern chain conveyors?), belt conveyors and elevators for letter trays. Automatic means for clearing the letter boxes in the front of the office were also provided. The outstanding achievement of this period was the Post Office London Railway⁴ still running 22 hours in every 24 after over 40 years of uninterrupted service. It remains the only fully-automatic railway in the world.

Another milestone was the opening of Mount Pleasant in London in 1933, which at that date was one of the most highly mechanized offices in the world. Development ceased between 1939 and 1945 but later there was need to plan new offices in Britain and throughout the world employing the latest methods. The Executive and Liaison Commission of the Universal Postal Union (U.P.U.) therefore arranged for the British, Netherlands and Swiss postal administrations to publish a brochure giving information about the current state of technical development.⁵ This brochure was published in 1951. It is significant to note that no letter-process machine is described, although reference is made to the Transorma sorting machine installed at The Hague. (Similar machines installed at Brighton⁶ in 1935 have only recently been recovered; although they were never considered economically viable, 15 additional men were needed on reversion to manual sorting.) There is no mention of specialized parcel-sorting machinery although a prototype of the "hopper" or "bucket" machine had first been constructed in this country in 1937. The use of belt conveyors of various types for moving parcels and mail bags had, by this date, become commonplace, but machinery for facing, sorting and office processes was still in the minds of inventors. A study of the patent office records clearly proves this. There is a rash of patented ideas but only a small fraction of those described were able to stand up to the harsh reality of postal service requirements. Parcel sorting methods described in the U.P.U. publication are all manual—that is each parcel is directed into the appropriate channel by muscle power, whether it be into an array of baskets, bags, chutes or conveyors. All letters are manually sorted into boxes but letter bundles are transported in trays on conveyors.

PHILOSOPHY OF DEVELOPMENT

How have the problems of applying technology to the postal service been tackled? For reasons which follow, most of the original research and development work has been carried out within the Post Office. Conveyors, elevators and similar standard forms of mechanical-handling aids used in industry generally have been applied to the movement of bagged mail and installations have been extended steadily. Much of the basic design has been on parallel lines to that in other spheres. Commercial equipment cannot be used (when loose mail has to be handled in bulk) without design changes found necessary to avoid jamming and damage in transit. There are basic reasons for this. In all other organizations using large-scale mechanical handling plants the goods handled are either in the form of unpacked materials such as coal, grain and cement where relatively rough treatment can be tolerated, or their goods are packed in standardized sizes of sacks, cartons, tins or bottles (and the design engineer can influence the specification of these packs). When mail pieces have to be handled by machine, one item at a time, highly specialized equipment is essential; there is no commercial equivalent upon which to draw. Progress has been extremely difficult because the relatively few postal scientists and engineers have been faced with rapid handling of material of an exceptional and heterogeneous nature.

In its passage through the system, not a single item should be delayed, damaged, or lost and this has demanded great ingenuity in design. These problems are compounded by the customer's natural resistance to change and by the established service which historically carries items restricted by a minimum of regulation.

A detailed study of the 1970 Conference papers shows clearly the very great influence of these characteristics not only on the rate but on the direction of developments in postal machinery. Theoretical studies and analyses are essential as it would be uneconomic to make a large range of machines from which to select the best one. But it is equally impracticable to finalize the design on theory. The great variety of items flowing through any machine defies mathematical expression. We know what "mail" is only in broad terms and forecasting results is hazardous. Even the

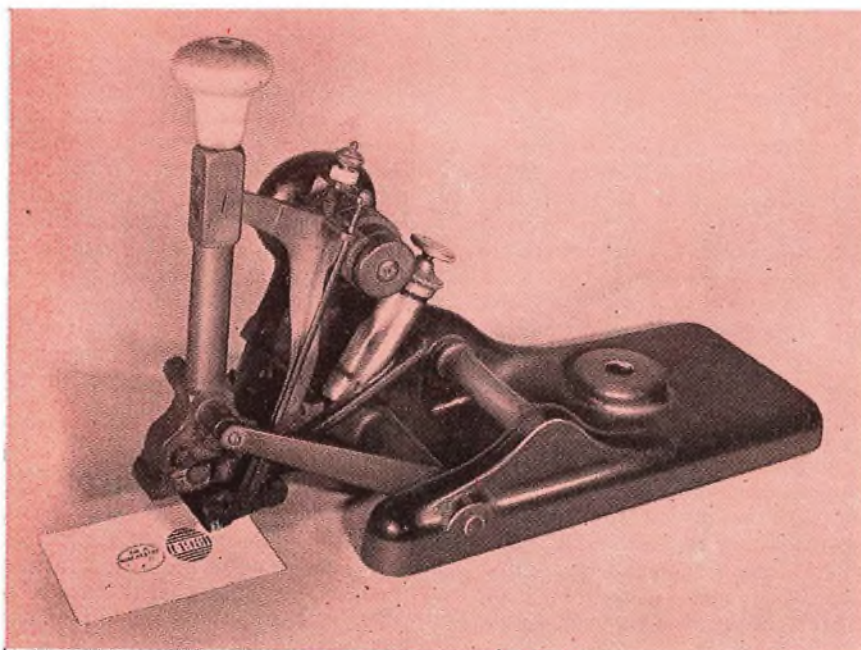

FIG. 3—Pearson Hill Date-Stamp Machine 1859 (first successful stamp-cancelling machine)

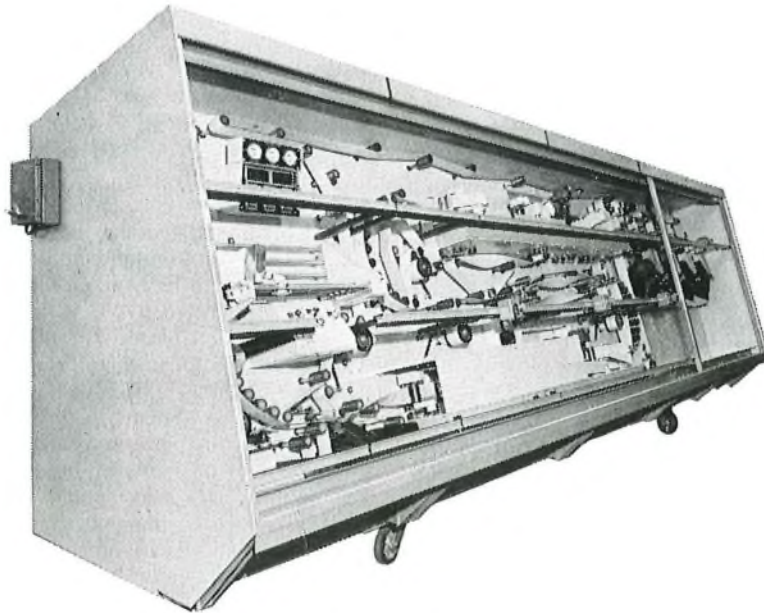

FIG. 4—Automatic Letter-Facing Machine, 1970 (turns letters to face all the same way, cancels stamps and separates into first and second class)

weather has an effect on the physical characteristics of items in pillar boxes due to humidity changes and some of the mechanical characteristics of parcels are continuously altering as new packing materials become available. In addition to the many and obvious external differences between the items in an ordinary collection of mail, coefficients of friction, centres of gravity, moments of inertia, stiffness and other mechanical features including, e.g. abrasive resistance, have random variations between individual items. Further, the differing liability to generate and hold static electrical charges is ever present to complicate the designer's problems.

At Christmas the daily flood of mail becomes a torrent. Commercial, domestic, foreign—the full complex of human activity is reflected in some way or another in parcel and letter traffic; even when the items are bundled or bagged for transit, standardization has only been marginally achieved. Thus there are variations from hour-to-hour, day-to-day and week-to-week in the type of mail arriving at a sorting office for treatment.

Because there are so many interacting factors involved in the performance of machinery handling mail, it is very difficult to repeat tests with exactly the same result. Practical trials with "live mail" (as the jargon has it) are therefore followed by necessary design changes and slowly but steadily we are able to build up a new engineering expertise.

Postmen apparently carry out a series of simple operations in their sorting office duties. However, on thorough analysis these actions are found to be extremely complicated. The human machine is incredibly flexible and is able to make use of that utterly unmatched combination—man's eye/brain/muscle system.

The processing of vast numbers of items in short periods of time is not conducive to economic use of capital equipment. Hence, postal equipment must be of low first cost, an additional burden to the pioneering engineer. The use of machines in flow lines usually demands more floor space than manual operation; postal accommodation tends to be at the centre of service areas where building costs are high and the designer must also bear this in mind.

It has not yet proved possible to mechanize all the manual tasks and some further standardization of mail may indeed be

required before economic solutions are found. More theory is sure to evolve as time goes on and it is possible that future postal engineers will look back on the 1970 Conference as recording the early days of this difficult marriage between mail and machine in which both inventive art and engineering science can be found. Throughout the development stages of the more complex machines, an immense amount of courage and persistence has been required by engineers, and by management. The reward is the array of equipment which is now being put into service at an increasing pace and which will be described in the second and third parts to this article.

The effective use of machinery can require co-operation from the public, and the philosophy behind our development policy takes this into account. The changes and problems created for the staff by the introduction of mechanization are of major importance; our research and development programs include work in physiology and psychology and in the modern sciences of ergonomics and cybernetics. The requirements of man, machine and their environment must all be taken into account to ensure maximum overall efficiency. The rapid transformation of long-standing manual tasks to mechanized operations, before the advent of full automation, depends wholly on its acceptance by the personnel involved and their acquisition of new skills. The process of change must be gradual but carefully phased. This requires negotiation, reorganization and retraining on a national scale yet the special needs of individual offices must be fully met. These issues have become a major challenge now that the initial technical development of the first generation systems have been completed.

FULL IMPACT OF POSTAL ENGINEERING

The influence of technology has extended beyond the direct substitution of manual processes by their automatic equivalent to affect the basic structure of the postal service itself. It is fortunate that this has become possible at a time when there is need to contain running costs and when many buildings require replacement. The potential of mechanized operation has, therefore, been seized and a radical reshaping of mail circulation is in hand. For this to be done most



FIG. 5—The New Sorting Office at Birmingham
(to be opened for service in 1970)

effectively it is necessary for the various tasks of systems research, planning and engineering to be fully integrated and this has been the case since 1968 in a new Department (Planning and Mechanization Department) of the Post Office. The harnessing under a single direction of the main activities of the postal experts, mechanical and electrical engineers (including those who work in environmental engineering) and the transport and building planners, has consolidated the work of the past and set the pattern for the future.

The circulation of parcel traffic is being reorganized under the Parcel Post Plan. This plan will be described in Part 2 together with the machines used for parcel handling. It is based on the maximum use of machinery at 30 major centres linked by direct transport routes, whereas sorting is at present carried out in some 1,200 offices of which only 17 have mechanical sorting equipment. For parcel operations, machinery is used for storage, conveyance and sorting. After manual separation from the mass an individual parcel can be placed into a sorting machine and routing instructions simultaneously impressed on a mechanical or electrical memory system to control the correct routing within the machine. So far, in this country, mechanized packet sorting has been limited to automatic distribution from manually-loaded boxes. No economic solution beyond this has yet been found. Further development will be considered when operational research study of the packet service and its future in the two-tier situation has been completed.

The biggest challenge lies in the extensive mechanization of the letter post which is also planned. The new machinery (already in use at several offices) allied with the use of post-codes should make possible, within the time scale previously mentioned, the concentration of all the traffic on to about 120 fully-mechanized letter-sorting offices. A plan to achieve this will be described in Part 3 together with the letter handling equipment.

In the end, the best economic use of modern postal equipment will depend upon the co-operation of the public. Parcels will need to be reasonably well packed and clearly addressed; letters, wherever practicable, will need to be inserted in sealed POP-sized envelopes and accurately addressed with the full postcode.

Some of the individual schemes to implement the above plans are very large indeed. The new Birmingham project provides what is believed to be the largest single industrial-process floor area in Europe—20 acres. Extensive mechanization capable of handling 2 million items daily is included and commissioning will begin later this year. As another example the Mount Pleasant sorting offices are to be rebuilt in stages on the present site. Work has commenced on the first stage and the complete operation will take up to 10 years. This project has severe managerial and organizational problems. The 4,250 men who handle and sort the 4½ million items of mail every day will have to be found working accommodation within the site boundary whilst rebuilding takes place and mechanization systems are installed. Civil engineering works are also involved including resiting part of the Post Office London Railway.

In the near future, the code-sorting system for letters will be extended to offices other than Norwich, Croydon, E.C.D.O. London, Southampton, Newport (Mon.), Preston and Stoke where equipments are already working or being installed.

It will be evident that industry is playing an increasing part in postal mechanization. In this connexion reference must be made to the British Postal Equipment Engineering Association (B.P.E.E.A.). This was formed in 1966 by the major suppliers to stimulate export orders and has since provided a channel for technical dialogue and co-operation in our own expanding program.

RESEARCH

As already indicated, full automation of sorting processes is our long-term objective. Optical character-recognition for the automatic reading of postcodes is therefore the most important research project in hand. Recognition is not the sole problem, for it is necessary to scan the envelope and locate the code and to extract the relevant information before processing it into a form suitable for the final recognition process. The problem, both technical and economic, could be resolved by already-proven technology if location and character form were controlled by standards. Such regulation is accepted in some countries and we may see a few instances

of rapid advance in this decade. In the U.K. the political and social environment make such measures less likely within the same time scale.

Research into a wide range of other postal engineering problems is also being undertaken. For example, voice-command recognition for machine control has been investigated but the technique is too expensive and inaccurate at present. Investigations of new techniques for coding and sorting mail, ergonomic and human factor-studies especially related to keyboard designs, are included in current plans. Advanced electronic control techniques will be studied as well as the application of computers for such purposes as the training of keyboard operators and the monitoring of machine performance. A further study is being carried out on the problems and economic factors involved in the use of standard computers instead of the code translators and control equipment of the present design.

INTERNATIONAL CO-OPERATION

The U.K. Post Office has pioneered many of the developments which have revolutionized the mechanical handling of mail and has played a major role in international co-operation which is so essential in an activity which spans all continents and crosses all boundaries. To save unnecessary duplication of research and development effort a close contact is main-

tained with comparable work overseas. Solutions to problems accepted in one country are seldom directly applicable in the environment of another. However, to see and exchange ideas is always stimulating and can lead to closer collaboration. The British Postal Consultative Service (B.P.C.S.) was formed in 1965, to provide professional advice in all postal matters. Its postal experts are currently engaged in projects for more than ten countries. This Post Office service is independent of manufacturing interests, even though commercial contracts may result, and this independence is valued by potential clients and enhances its reputation.

(to be continued)

References

- 1 British Postal Engineering Conference 1970, Papers published by and available from the Institution of Mechanical Engineers, 1 Birdcage Walk, London, S.W.1.
- 2 P.O. Guide, July 1969 issue, p. 20.
- 3 PETTIT, E. W. The New General Post Office (K.E.B.). *P.O.E.E.J.* Vol. 1, p. 165 et seq. Oct. 1908.
- 4 CARTER, M.C., MAJ. W. G. Post Office (London) Railway. Post Office Green Paper No. 36.
- 5 Mechanical Handling of Mails in Large Sorting Offices. U.P.U. Publication.
- 6 GEMMELL, W. T. The Transorma Letter Sorting Machine. *P.O.E.E.J.*, Vol. 29, p. 16, April 1936.

Book Reviews

“Printed Wiring and Printed Circuit Techniques.” Prepared by The Electronic Engineering Association. Published by Design Electronics. pp. 50. 40s.

This handbook replaces the smaller book of the same title published in 1963 and also the E.E.A. “Guide to the Repair of Printed Board Assemblies” published in 1961. It covers materials, design and production methods for single-sided, double-sided and multilayer printed wiring boards and also flexible wiring. There are sections on selection and mounting of components, soldering and solderability, and on protection of printed-wiring board assemblies. The final section is concerned with the repair of assemblies.

In the space of 50 pages there is a large amount of information which would be of interest to electronic engineers concerned with the design and use of printed-wiring boards, although the aim has also been to provide recommendations for the printed-wiring manufacturer. The handbook does not set out to lay down standards, but extensive references are made to British, American, German and International Electro-technical Commission specifications and documents, and advice and information is given on subjects not generally covered by specifications.

The layout is systematic and clear, but in such a comparatively small space the treatment of some aspects is necessarily brief. The section on production methods makes no reference to the die-stamping process, and the coverage of repair techniques is very conservative, being restricted almost entirely to component changes by the methods given in the earlier 1961 edition.

E. J. Y.

“Jahrbuch des Elektrischen Fernmeldewesens, 1968” (Telecommunications yearbook). Helmut Bornemann. 428 pp. 51 ill.

The book covers seven separate topics, two being of general interest, the rest relating to technical developments in the West German telecommunications network, mainly in the transmission field. The whole forms a good guide to recent German thinking on particular subjects, which are fully explained and well illustrated, and contains many novel ideas.

The longest chapter is a comprehensive description of “International aid for the advancement of telecommunications” in developing countries. It outlines the relevant U.N. organizations, traces the course of aid from its basic planning, through offers of technical knowledge, to the supply of money and equipment and includes details of many projects recently carried out by the U.S.A., Great Britain, France and Germany.

The second general topic is “Data processing systems and their central processing units”. The fundamental similarity of many data processing applications is demonstrated and is used to lead to a concept of stored-program-controlled central processors which can be assembled with a selection from a range of auxiliary items, e.g. memory units, to fulfil any desired function.

Other subjects covered include: new transistorized carrier systems (300, 960, 2,700 channels f.d.m.), advances in radio relay systems (standard, transistorized, interchangeable units), p.c.m. applications to telecommunications (transmission only), new developments in line construction (underground, overhead lines and terminations), and telecommunications in the German Meteorological Service (includes world linkage).

H. B.

Developments in Medium-Range Ship-to-Shore Radio Services

E. G. BRONSDON†

U.D.C. 654.16.001.6: 621.371: 656.6.052

For many years the Post Office has operated radiotelegraph and radiotelephone services for ships in and around U.K. coastal waters through a number of small coast stations. Recent international agreements will result in significant changes in technique and equipment for these services within the next decade. The present services and impending obligatory changes are described, as well as possibilities for further improvements in efficiency.

INTRODUCTION

Ionospheric propagation with high frequencies (h.f.) above about 4 MHz cannot generally be used to provide medium-range radio services because the skip-distance of the first ionospheric reflexion is often 1,000 km or more. Reliable communication up to about 1,000 km is only economically practicable with frequencies below about 4 MHz and with ground waves following the earth's curvature. For a given transmitter power, the effective ground-wave communication range is largely determined by ground conductivity and by the transmission frequency used.¹ Fig. 1 shows that for a given field-strength at 2 MHz, the overseas range is generally at least three times greater than the overland range and that the 2 MHz overseas range is typically some 30 per cent greater than the 5 MHz overseas range. Therefore, for communicating with ships within about 1,000 km from the coast, it is important to site radio stations close to the sea and to use frequencies below about 4 MHz.

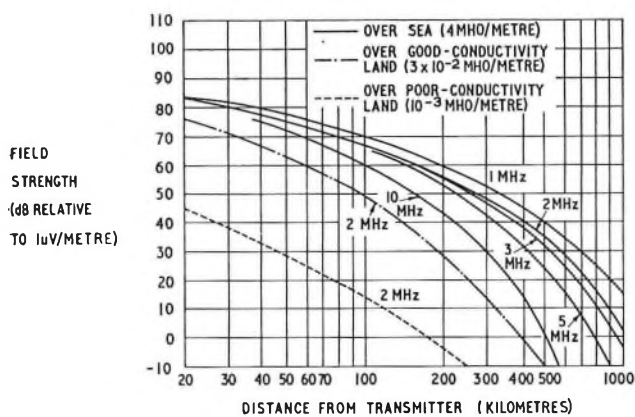

FIG. 1—Ground-wave propagation curves for 1 kW radiated power

Fig. 2 shows the system of eleven U.K. medium-range coast radio stations which are all situated within about a mile of the sea and which operate with frequencies between 400 kHz and 4 MHz. Very high frequencies (v.h.f.), at about 160 MHz, are also used for the radiotelephone service up to about 80 km range.

Because of the international character of ship-to-shore radio services, it is necessary to maintain operational compatibility between coast stations and ships of all nationalities. For this reason the International Telecommunications Union (I.T.U.) lays down certain principles and operating procedures in the *Radio Regulations* which are binding on member countries. The I.T.U. also publishes the *List of Coast Stations*, and the corresponding *List of Ship Stations*, giving details of

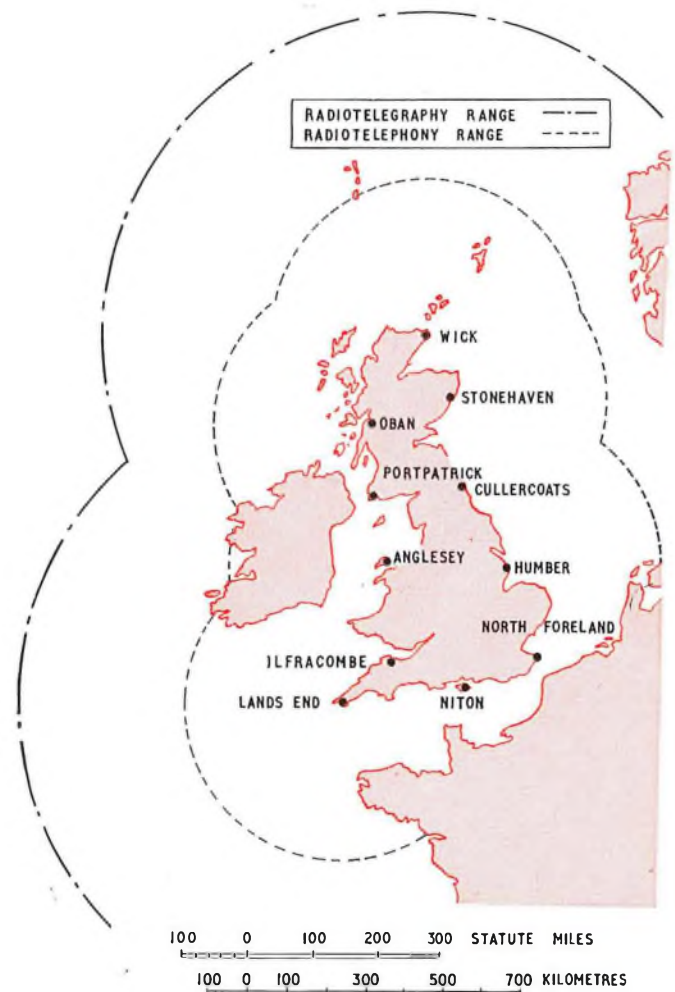

FIG. 2—The United Kingdom medium-range coast radio stations

† Radio Engineering Section, External Telecommunications Services.

each member-country's maritime radio services. These publications are normally held by all coast and ship stations.

Every few years the I.T.U. convenes a World Administrative Radio Conference (W.A.R.C.) to review the radio regulations and the 1967 conference at Geneva dealt exclusively with maritime mobile services. It promulgated important changes aimed at improving the quality and efficiency of existing services and at more economic use of the available radio spectrum to permit the introduction of new services.

PRESENT MEDIUM-RANGE SERVICES

Each of the coast stations shown in Fig. 2 has a nominal service range of about 800 km for telegraphy and about 400 km for telephony. The effective range is dependent upon the prevailing levels of radio noise and interference, both of which increase very considerably at night, and upon the efficiency of the ship's installation. Within its effective service range, each coast station provides a public correspondence service and also operates the Distress Service in which a continuous watch is kept on the international calling and distress frequencies of 500 kHz* (telegraphy) and 2,182 kHz (telephony). In addition, weather bulletins, navigation and other warnings are broadcast at regular intervals.

Public Correspondence Service

Full details of the U.K. maritime services are given both in I.T.U. and national† publications but a brief summary of the procedures used for medium-range public services may be of interest.

All U.K. coast stations broadcast telephone and telegraph traffic lists at regular intervals to advise ships of waiting traffic and these roll-calls are made at slightly different times from adjacent stations so that ships can listen to both stations. Ships first call the appropriate coast station, either in response to a roll-call or to originate traffic, on a common calling-frequency and the coast station replies on the corresponding answering-frequency. After contact has been established, the circuit is transferred, in turn with other calls, to agreed traffic channels which are normally those allocated for use through that particular coast station. However, if a ship is not equipped to transmit on a preferred channel, the coast station can receive any other U.K. ship-to-shore channel.

For the medium-range telephone service in the 1.6 MHz to 3.8 MHz frequency band, British ships use a common calling-channel of 2,381 kHz to contact U.K. coast stations between 0900 and 1700 hours on weekdays only, using the international calling/distress frequency of 2,182 kHz outside normal business hours. The corresponding answering-frequency used by U.K. coast stations is normally 1,792 kHz at all times, although 2,182 kHz is used to call British ships between roll-calls, if necessary, and for contacts with foreign ships. This calling procedure relieves the international distress frequency considerably and has the effect of improving the efficiency of the distress watch and of reducing delays to traffic.

For the short-range service in the 156 MHz to 174 MHz band, contact is first established on a simplex basis using the same calling-frequency (156.8 MHz) for both directions but traffic frequencies are assigned in duplex pairs for public service. For both frequency bands, the extension of radio-telephone circuits into the inland network is controlled by the coast-station operators.

The telegraph service is operated with the Morse code, mainly in the 405 kHz to 525 kHz frequency band, though trawlers in more distant northern waters also use telegraph channels in the 1.6 MHz to 3.8 MHz band for working with certain Scottish coast stations. Radiotelegrams (phonograms) can also be passed over radiotelephone circuits in the latter

frequency band. The common calling-frequency in the main telegraph band is 500 kHz for both directions, thereafter specified traffic channels between 405 kHz and 525 kHz are used. Radiotelegrams are relayed over the inland telegram and telex networks, but letter telegrams from ships are posted to inland destinations from the coast station.

Distress Service

If the present international regulations pertaining to safety of life at sea had been in force in 1912, the sinking of the liner *Titanic* might well have had less tragic consequences. It was not until 1916 that the first of a series of safety regulations was introduced which required all passenger ships and ocean-going cargo vessels of over 1,600 gross tons to carry qualified radio officers and to have 500 kHz radiotelegraph facilities for safety and distress purposes.² Also, cargo vessels of between 300 and 1,600 gross tons, and fishing vessels of more than 140 ft in length, must now have radiotelephone installations for operating in the 1.6 MHz to 3.8 MHz band, at least, and must also carry qualified radiotelephone operators.

The U.K. coast stations operate the Distress Service on behalf of the Board of Trade which is responsible in this country for administering the safety regulations. The service is part of the U.K. Search and Rescue Organization. On hearing a distress call, a coast station is responsible for reporting the emergency to the coastguards and for advising other authorities (e.g. rescue co-ordination centres, naval authorities and Lloyd's agents) according to circumstances. The coast station is also responsible for co-ordinating radio working with ships and lifeboats and restricts commercial operations during the emergency if necessary. The responsibility for controlling actual rescue operations, however, remains with the coastguards.

A distress call may either be a Morse sos on 500 kHz or a radiotelephone MAYDAY call on 2,182 kHz and may be preceded by an automatic alarm-signal to alert any stations within range. Ship and coast stations alike suspend other transmissions on both frequencies for three minutes every half-hour to give weak distress calls the best possible chance of being heard.

Special Services

A special communication service is available for drilling-rigs exploring for natural gas in the North Sea.³ This service is operated through the Humber, Cullercoats and Stonehaven stations and provides up to 15 private radioteleprinter circuits between individual rigs and their mainland base offices. In addition, three radiotelephone circuits are available to the rigs on a party-line basis.

Typical Coast Station Installations

Present-day coast-station radio installations vary with traffic loading from two to about eight transmitters, with a similar number of receivers and radiotelephone terminal equipments. Although individual stations are relatively small, there is a total of some 50 transmitters and 50 receivers in the 11-station U.K. system. The majority of existing transmitters and receivers are suitable for Morse telegraph circuits in the 405 kHz to 525 kHz band and for double-sideband (d.s.b.) radio-telephone circuits in the 1.6 MHz to 3.8 MHz band. These equipments will require to be replaced within the next few years because they are unsuitable for single-sideband (s.s.b.) operation which becomes mandatory for coast stations by 1975. Most stations already have some newer radiotelephone transmitters and receivers which can be operated in the s.s.b. mode. Present transmitter powers are generally of the order of 2 kW peak-envelope-power (p.e.p.).*

* Except at Oban.

† Post Office Notices to Ship Wireless Stations.

* The average power during one radio-frequency cycle at the highest crest of the modulation envelope.

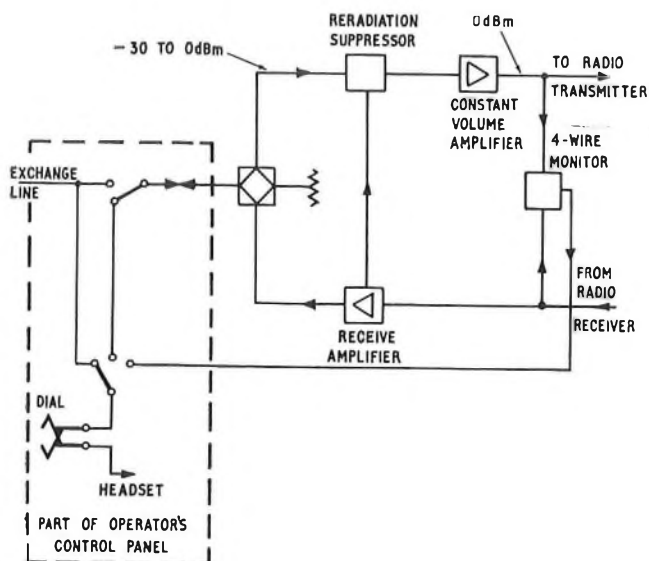

FIG. 3—Coast station radiotelephone terminal (schematic)

Fig. 3 shows a simplified diagram of a radiotelephone terminal equipment which is used for connecting a radio circuit to the public telephone network. It provides means for maintaining full modulation of the coast-station transmitter irrespective of talker-level or exchange-line loss, and for suppressing echoes which would otherwise arise from re-radiation of the ship-to-shore transmission due to leakage across the hybrid transformer. Fig 4 is a photograph of a coast-station operator's console.

Directional aerials are neither practicable nor operationally suitable at medium-range coast stations operating with frequencies below 4 MHz. A typical transmitting aerial consists of a T or inverted-L wire aerial for the 405 kHz to 525 kHz band and a number of tuned vertical radiators (either supported wire cages or mast-radiators) for frequencies in the 1.6 MHz to 3.8 MHz band. For the latter band, more use will be made in future of the broadband monopole aerial⁴ which can serve several transmitters simultaneously through suitable coupling equipments. The broadband aerial is more economic, both in capital cost and in the use of site-space, than several single-frequency aerials and, because some coast stations are in areas of considerable natural beauty, the minimization of high structures is also desirable on amenity grounds.

Receiving aerials are situated about a mile from the main site because the high electromagnetic fields in the immediate

vicinity of the transmitting aerials would otherwise cause severe degradation of receiver performance. Underground coaxial-feeders connect the receiving aerials to the station where comb-filter networks further reduce the effects of the local transmissions. Distribution amplifiers enable about eight receivers to be fed from one aerial. The v.h.f. transmitting and receiving aerials are supported by a single 180 ft mast, usually on the main site. This mast may also partially support the 500 kHz transmitting aerial.

SHIP INSTALLATIONS

There are about 40,000 merchant ships in the world of over 100 gross tons and most of these use some form of radio communication. The radio spectrum available internationally to maritime mobile services is very small in relation to this number of ships, and it is evident that without some discipline, maritime communications would be seriously imperilled by interference. To minimize interference problems, the radio regulations define the parts of the maritime mobile frequency bands to be used respectively by coast stations and ship stations and also require all ships' radio installations to meet certain performance standards especially with regard to the frequency-accuracy of transmissions and the reduction of harmonic and spurious radiations. Additionally, a ship's installation must comply with the relevant clauses of the Final Acts of the International Conference for the Safety of Life at Sea, 1960, which stipulates certain minimum limits for the range of transmission on the distress frequencies according to the size and category of the vessel.

In the U.K. the Ministry of Posts and Telecommunications is now responsible for administering the radio regulations and the issue of a ship's radio licence is dependent, amongst other things, upon all the installed radio equipments being type-approved to nationally-agreed performance specifications.⁵ The specifications embody the relevant international regulations and are approved by the Ships' Wireless Working Party, a committee which includes representatives of the Board of Trade, the Post Office, the Ministry of Defence, the principal shipping interests, the marine operating and equipment manufacturers and the Radio and Electronics Officers' Union. As agents of the Board of Trade, Post Office ship-radio surveyors examine all new compulsorily-fitted ship-radio installations and carry out annual inspections.

The efficiency of aerials on modern ships is a present cause for concern. Reasonably efficient mast-supported aerials have been used for many years but the modern trend is for ships to have no masts and for aerials to be supported from other available structures or for self-supporting aerials of various types to be used. There is also a tendency to relegate accommodation for radio equipment to parts of the ship which are

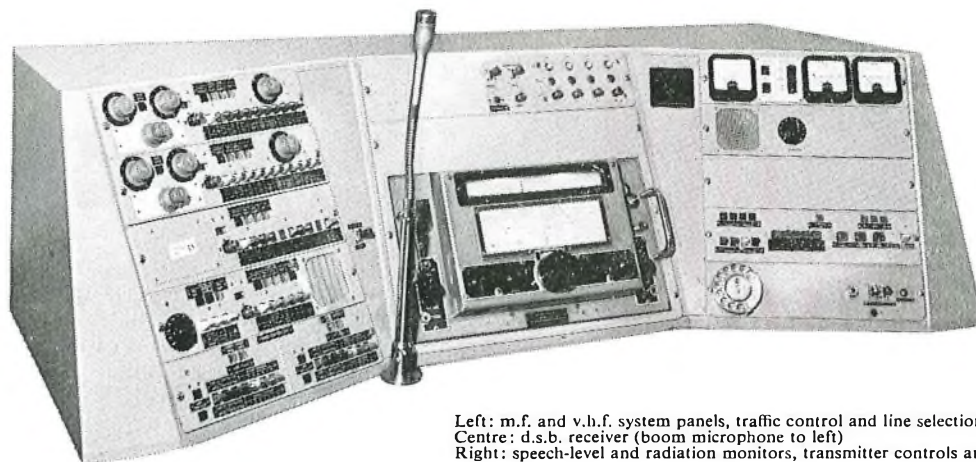

Left: m.f. and v.h.f. system panels, traffic control and line selection pane
Centre: d.s.b. receiver (boom microphone to left)
Right: speech-level and radiation monitors, transmitter controls and dial

FIG. 4—Coast-station operator's console

remote from the aerials and the longer feeder-runs required have tended to reduce radiation efficiency, particularly at the 500 kHz distress frequency. The problems are currently under consideration both nationally and internationally.

TRAFFIC STATISTICS

The U.K. medium-range ship-to-shore telegraph traffic has declined fairly sharply from the 1960 peak, as shown in Fig. 5,

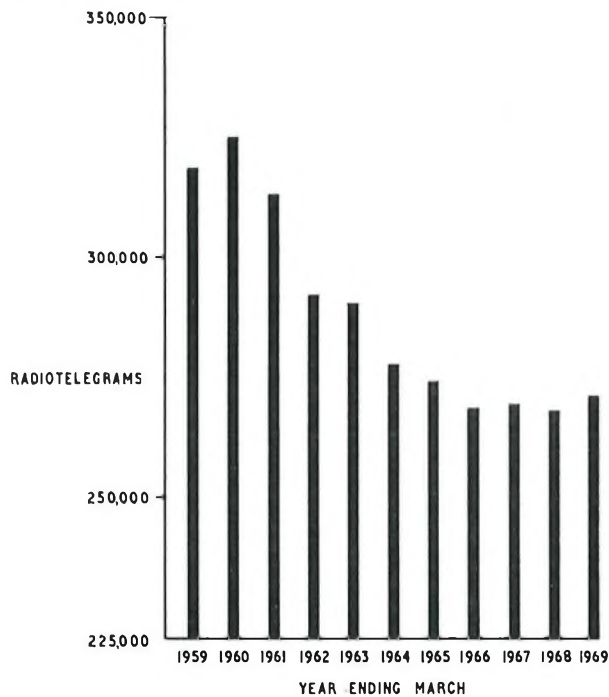

Fig. 5—Medium-range radiotelegraph traffic (all U.K. coast stations)

but has remained fairly steady at about 270,000 messages per year recently. The initial decline coincided with a shipping recession in the early 1960s and it is also probable that some telegraph traffic has been replaced by radiotelephone calls. However, there will be a continuing demand for the telegraph

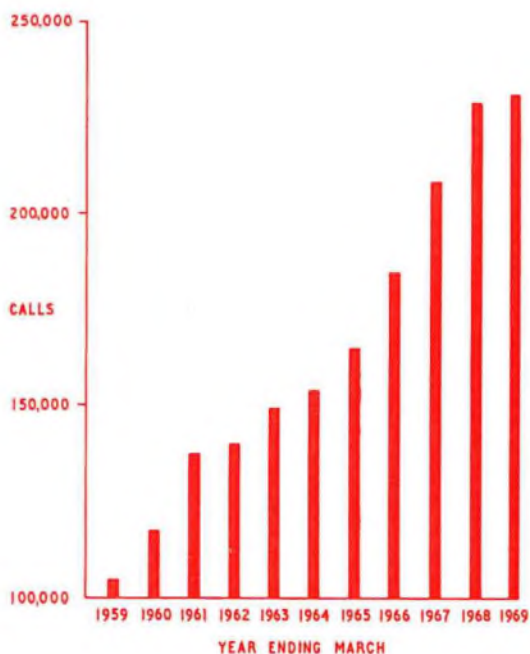

Fig. 6—Medium-range radiotelephone traffic (all U.K. coast stations)

service so long as there is a mandatory requirement for ships to have 500 kHz distress facilities. Also, telegraphy enables an appreciably greater range to be achieved, compared with telephony, for the same transmitter power.

Fig. 6 shows that medium-range telephone traffic rose sharply between 1965 and 1968 and this was partly due to traffic with oil rigs. Without oil-rig traffic, the present level is about 200,000 calls per year, which represents an average of 50 calls per coast station per day. A busy station such as Niton may handle over 80 calls per day and over 15 calls per hour at peak periods, whereas a lightly-loaded station like Oban may only handle about 20 calls per day.

FUTURE DEVELOPMENTS

Important developments in medium-range maritime radio services will result from the acts of the 1967 World Administrative Radio Conference⁶ and, in addition, further technical improvements are likely to be adopted as time goes on.

Introduction of Single-Sideband Working

The agreement to adopt s.s.b working for telephony was perhaps the most important decision of the conference. This system has been in use for many years on fixed point-to-point radiotelephone routes mainly because, power for power, it confers a signal-to-noise-ratio advantage of some 9 dB over d.s.b. and also because the circuit capacity of the available radio spectrum is effectively doubled. On a point-to-point route, agreement to use any particular technique, or system, is only necessary between the two administrations concerned, but world-wide agreement is required to achieve international compatibility in the maritime mobile service. It is, therefore, generally necessary to implement major changes by stages and the Conference drew up a timetable for the phased introduction of s.s.b. operation. This is shown in Table 1 in relation

TABLE 1

Introduction of Single Sideband Radiotelephone Operation in the 1.6 to 3.8 MHz Frequency Band

Coast Stations	Starting Date	Completion Date
(i) Cease use of d.s.b. and be capable of s.s.b. operation (A3H, A3A and A3J)	At earliest possible date	1.1.75
(ii) Cease use of A3H	1.1.82	1.1.82
(iii) Use A3A and A3J only } (see note)		
Ship stations	Starting Date	Completion Date
(i) Be capable of s.s.b. operation (A3H, A3A, A3J)	As soon as possible after 1.4.69	
(ii) Cease new installations of d.s.b. equipment	1.1.82	1.1.73
(iii) Cease use of A3H		1.1.82
(iv) Use A3A and A3J only } (see note)		

NOTE—The use of A3H emissions will continue after 1.1.82 on the calling and distress frequency of 2,182 kHz.

to the 1.6 MHz to 3.8 MHz frequency band. The A3H mode, which is permissible during the transitional period up to 1982, is sometimes known as compatible s.s.b. because, although only one sideband is radiated, the carrier component is transmitted at the same power as with d.s.b. and the transmission can be received with d.s.b. receivers. A transmitter which is capable of A3H emissions is normally also capable of A3A and A3J emissions so that a transmitting station can use the same equipment to work with other stations, whether or not these are equipped with s.s.b. receivers.

With A3A, a pilot carrier is radiated (16 dB or more below the p.e.p. of the transmission) and can be used in receivers to provide a precise tuning facility which is important for minimizing degradation of speech quality in s.s.b. circuits. The pilot carrier can also be used to derive continuous automatic gain control (a.g.c.) on duplex circuits, thus preventing receiver noise from rising during intervals between speech periods and in this respect, carrier-derived a.g.c. is much superior to a.g.c. derived from the sideband components. For these reasons, A3A is much to be preferred to the suppressed-carrier (A3J) mode, especially for public services.

Selective Calling

It has long been recognized that a selective calling system would be of great value in the maritime mobile service. For example, it would enable a coast station to call any ship within range instantly, without the need for the ship to maintain a listening watch. This would reduce the traffic delays which are inherent with the present practice of broadcasting traffic lists at intervals. Various selective calling systems have been proposed, but for immediate needs the conference recommended the adoption of one developed by the Federal Republic of Germany. This system, the sequential single frequency code (s.s.f.c.), essentially comprises ten digits, each digit being represented by a unique audio-frequency tone. The code address of a ship consists of five digits, the remaining digits being available to indicate the identity of the calling station. Recent tests with this system between North Foreland Radio and a cross-channel vessel indicated that a very high degree of reliability can be achieved. The tests were made at about 2 MHz and about 160 MHz, and some 700 calls were sent from North Foreland with 100 per cent success when using normal transmitter powers. This confirmed successful trials carried out by the C.C.I.R.* Plans are already in hand to equip all eleven U.K. coast radio stations with the s.s.f.c. facility.

The Lincompex Radiotelephone System

A conventional radiotelephone terminal equipment employs a singing suppressor to block the go or return path, according to the direction of speech, to prevent oscillation when the loop-circuit gain exceeds unity. In addition to causing some syllable-clipping, and making break-in very difficult, the sing-

ing suppressor may be falsely operated by high noise peaks or interference, and can cause a partial or total circuit lock-out. These effects can cause considerable frustration to telephone users.

The Lincompex system⁷, developed by the Post Office, is rapidly replacing conventional radiotelephone terminal techniques on fixed international h.f. routes. This system operates with a small constant overall transmission loss and because a singing suppressor is then unnecessary, conversation flows freely. The system also confers other advantages such as improved transmitter loading, high resistance to noise and interference and the virtual elimination of frequency-selective fading effects. Fig. 7 shows the standard Lincompex terminal which is identical at both ends of a circuit.

The Cunard Company was quick to realize the advantages of Lincompex and has fitted the *Queen Elizabeth II* and two other liners with the system. However, it was realized that to encourage the spread of the system, it would be necessary to develop a special ship-terminal at the minimum possible cost, especially for the smaller ships operating at shorter ranges. This has been done by omitting the expensive delay-units and by reducing the speech compression range, though the delay has to be restored in the shore terminal to maintain the correct time-relationship between the speech and control paths. The simplified ship Lincompex terminal is expected to be available at about half the cost of a standard terminal. Other shipping companies are showing interest in Lincompex, and the P. & O. Company recently co-operated with the Post Office in extended trials between the U.K. and the *Orcades* during a voyage of this vessel to Australia. Although the results have not yet been fully evaluated they have shown that the ground-wave range at about 2 MHz can be more than doubled with Lincompex. As a result, the Niton and Lands End stations will shortly be equipped to serve Lincompex-fitted ships throughout the English channel and well beyond. It seems probable that most of the busier U.K. coast stations will need to be similarly equipped within the next few years.

* C.C.I.R.—International Radio Consultative Committee.

Direct-Printing Telegraphy

Direct-printing, e.g. teleprinter, techniques are beginning to be used instead of the Morse code for some long-range h.f. ship-to-shore telegraph services and it is highly probable that ships which are fitted with direct-printing equipment will also expect to be able to use this for medium-range communica-

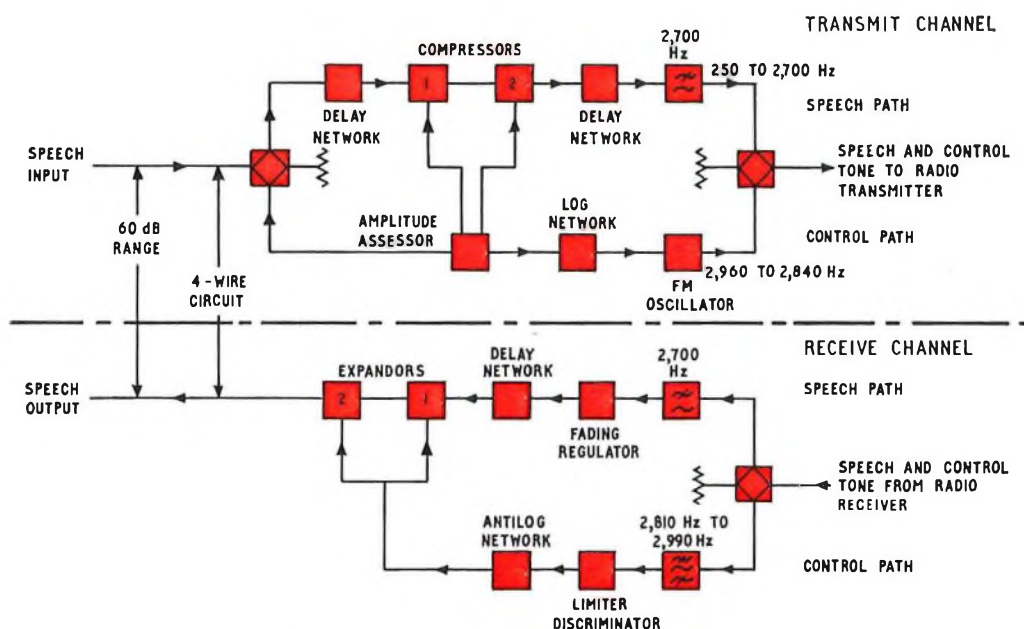

Fig. 7—Standard Lincompex terminal (schematic)

tions in due course. It can thus be foreseen that a need will arise for a public direct-printing service at frequencies below 4 MHz and there would be no great technical problems in providing such a service as has been demonstrated by the success of the private radioteletypewriter service for North Sea drilling rigs.

Improvements to U.K. Coast Stations

Each of the eleven coast stations at present has transmitters and receivers in the same building and reliance is placed on remote siting of the receiving aerials, and suitable filtering in their feeders, to protect the receivers from transmitter radiation fields. The combined station is economic of building accommodation and is convenient for operation and maintenance, but difficulties arise from transmitter induction fields and earth currents adversely affecting receiver performance. This becomes increasingly troublesome as more transmitters are brought into service and as modern transistor receivers, often using wideband techniques, are introduced. Also, a one-mile separation between transmitting and receiving aerials is not sufficient to prevent local spurious radiations (even though these may be well below the specified maximum power levels) from producing significant interfering signals in the ship-to-shore frequency bands. To achieve a satisfactory degree of protection for the receivers they should be situated some hundreds of yards from the transmitters and the transmitting and receiving aerials should be well separated, ideally by at least five miles. It would be economically impracticable to have receiving aerials five miles away from the receivers and the best technical solution would be for each coast station to comprise adequately-separated transmitting and receiving stations each with its own aerial system. The principle is being applied to new stations which are now being planned to replace the existing Niton and Cullercoats stations, which cannot safely be maintained in their present locations because of coastal erosion. However, the acquisition of a suitable additional site for each of the other nine stations would involve prolonged investigations and negotiations, and each case would have to be treated on its merits, according to the extent to which co-siting difficulties affect the efficiency of the services.

FUTURE SHIP INSTALLATIONS

Aerial Efficiency

The present concern with the inefficiency of ships' aerials has led to consideration being given to a national code of practice for ships' aerial installations. Other countries are considering this problem, which is also being actively studied by the C.C.I.R., especially in view of the need for ships' installations to satisfy the minimum requirements of the safety convention. It is possible, therefore, that certain installation standards will be agreed internationally in due course.

Single-Sideband Receivers

The present national type-approval specification for a ship's s.s.b. receiver does not require the pilot carrier of an A3A emission to be processed to facilitate precise tuning. Such a facility is considered desirable in any case and especially for Lincompex where the end-to-end frequency error in the control tone should be as small as possible if the full advantages of the system are to be realized. The U.K. radio industry is

generally appreciative of the merits of Lincompex and of the desirability of providing the precise tuning facility, perhaps as an optional extra, in new designs of ships' receivers. Some existing approved types of s.s.b. receiver could be modified fairly cheaply to provide this facility.

Direct-Printing Telegraphy

It might be thought that direct-printing services could be satisfactorily operated without error-protection equipment on substantially non-fading medium-range circuits below 4 MHz. However, there is a definite advantage in using synchronous working which requires considerably less transmitter power than start-stop working for a given grade-of-service. This is an important consideration for services with ships, where transmitter powers are necessarily limited.

CONCLUSION

Although communication via satellites is technically possible for long-distance ship-to-shore telecommunication services, there would appear to be no economic alternative to direct radio links for short and medium-range maritime mobile services within the foreseeable future. There is, therefore, a continuing need for development to improve the efficiency and reliability of such services and the recent international conference agreements will contribute significantly towards this objective. In addition, the exploitation of recent developments in technology will make available reliable and efficient communications, extending from the national networks for several hundred miles around our coast, at a price within the range of a high proportion of potential users.

This article was written within the context of long-standing Post Office regulatory responsibilities which are now vested in the Ministry of Posts and Telecommunications. No account has been taken of policy changes that may result from the new status of the Post Office.

ACKNOWLEDGEMENTS

The material for this article was very largely drawn from a paper on maritime radio services which was read at various centres of the Institution of Post Office Electrical Engineers during the 1968/69 session. Acknowledgement is therefore due to the co-author of that paper, Mr J. L. Hyatt, and also to other colleagues in the Wireless Telegraph Section of the External Telecommunications Services, for information relating to operational and regulatory procedures contained in the article.

References

- ¹ International Radio Consultative Committee (C.C.I.R.) Documents of the XIth Plenary Assembly, Oslo, 1966. Vol. II. Propagation.
- ² *H.M. Stationery Office*. Final Acts of the International Conference on Safety of Life at Sea, 1960.
- ³ BRONSDON, E. G. Communications for the North Sea Oil-Exploration Project. *P.O.E.E.J.*, Vol. 58, p. 160, Oct. 1965.
- ⁴ MASON, H. P. Some Factors influencing the Design of Broad Band Monopole Aerials. *I.E.E. Convention on H.F. Communication*, p. 114, March 1963.
- ⁵ *H.M. Stationery Office*. Performance Specifications in the Series "Radio for Merchant Ships."
- ⁶ International Telecommunications Union. Final Acts of the World Administrative Radio Conference, Geneva, 1967.
- ⁷ WATT-CARTER, D. E., and WHEELER, L. K. The Lincompex System for Improvement of H.F. Telephone Circuits. *P.O.E.E.J.*, Vol. 59, p. 163, Oct. 1966.

The Post Office Technical Training College

N. FOX, C.ENG., M.I.E.E.†

U.D.C. 378.962: 354.42

The primary function of the Post Office Technical Training College at Stone, Staffordshire, is to provide vocational training for up to 750 engineering students, who are drawn mainly from the Technician and Technical Officer grades. This article gives a brief survey of the object, training organization, accommodation, teaching techniques, training methods and working policy of the College.

INTRODUCTION

"Learning is a continuous process"—this was the opening sentence of an article¹ by C. E. Calvey on The Central Training School, Stone, published in April 1947, and the college which exists today is such living proof of the truth of these words that they are worthy of restatement. Since they were written, the telephone network has grown in size and complexity but the older telecommunication techniques are still with us and exist side by side with new systems and technologies. In consequence, the problems of training the staff to maintain the network have also become more complex as each new system has created its own peculiar demands.

Formal training for engineering grades in the Post Office can be traced from its inception in 1924 at the King Edward Building, London, through the 1930s at both the Post Office Research Station, Dollis Hill and the newly-appointed Regional Training Schools, to the establishment of the Central Training School at Stone which, in September 1969, changed its title to the Post Office Technical Training College. Fig. 1 shows the growth in the number of students trained per year since 1947.

PHILOSOPHY OF TRAINING

A Technical Training College (T.T.C.) course is a period of concentrated objective learning about the job, without involvement with day-to-day work and its attendant diversions. Its object is to produce a practising technician by imparting accelerated experience in progressive steps, which, when reinforced by field experience, develops a working knowledge and manual and diagnostic skill of a very high order. To be fully effective, each technician must have the ability to use and communicate information, to measure or make use of measurements involving tools and instruments, to organize his work and the work of others, and finally, he must have diagnostic ability. It is towards the development of these abilities that Post Office training at Stone is aimed.

TRAINING ORGANIZATION

The main purpose of the T.T.C. is to train Technicians and Technical Officers in the maintenance of telecommunications and postal equipment, but additionally, short-duration technical appreciation courses are held regularly for supervising officers and specialized courses are occasionally organized for Headquarters and Regional groups.

The College is of the residential hostel type with accommodation for 750 students. Currently, it offers some 145

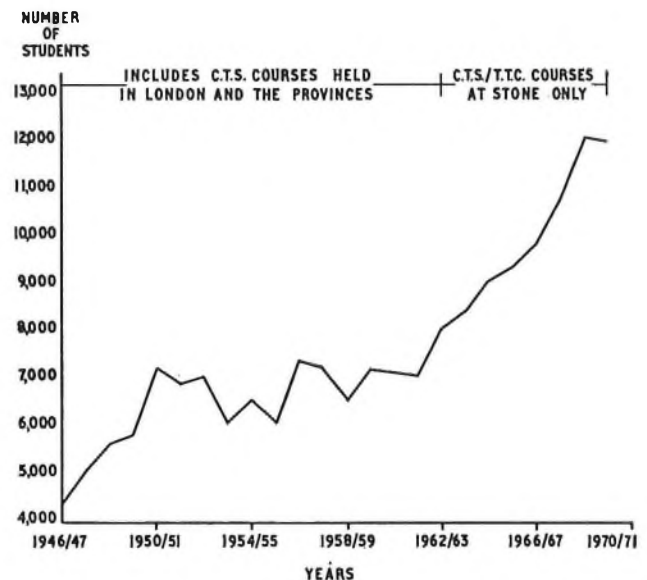

FIG. 1—Growth in the number of students trained per year

courses varying in duration from one to six weeks with an average length of three weeks. The optimum duration for a course, however, is four weeks. Shorter courses suffer from excessive overheads in the form of travelling expenses; longer courses incur the expense of a mid-course break and there is a danger that they may become tedious to students who are unaccustomed to prolonged spells of classroom work.

The sequence and content of all courses is under constant review. This avoids duplication of basic training, permits adjustment of course material to line up with modern maintenance techniques, facilitates the incorporation of new techniques where necessary and minimizes the number of courses in a main stream. Fig. 2 shows a typical example of the progressive sequence of training to be followed by an officer employed in a non-director (n.d.) exchange or a trunk exchange, who will attend three or four courses in his early years. In the example given he will qualify for promotion to Technical Officer on Course 150 (Non-director A) or Course 181 (Trunk N.D.) and proceed to specialist equipment training on subsequent occasions as the need for additional skill arises. The aim is for course attendance at the earliest date commensurate with experience and individual capacity. Courses which in the early days of training were quite lengthy are now appreciably shorter, allowing much greater flexibility and catering for the unusual case which does not call for slavish adherence to the normal sequence of training.

† Engineering Training Division, Telecommunications Personnel Department, Telecommunications Headquarters.

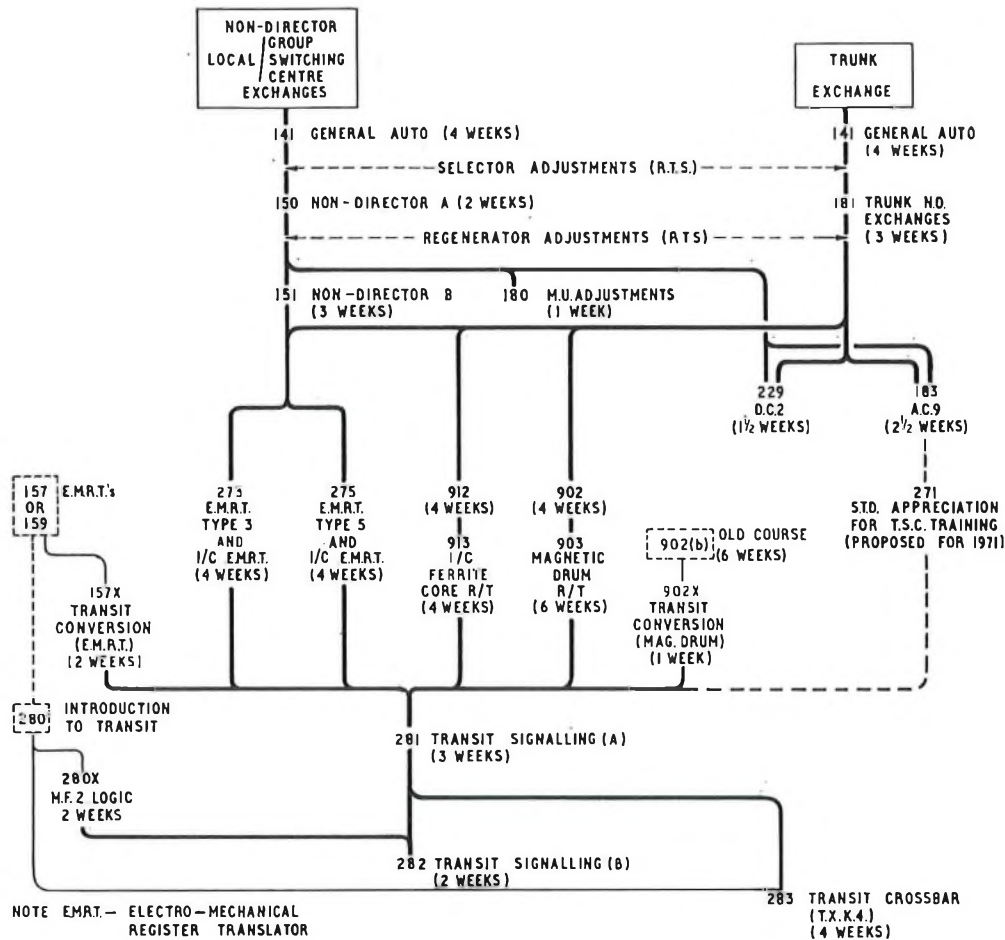

FIG. 2—Example of sequential training program for non-director or trunk-exchange staff

For working purposes the T.T.C. is divided into eight roughly equal groups as shown in Table 1. Each group is controlled by an Executive Engineer who has eight Assistant Executive Engineers for lecturing duties and from seven to thirteen Instructors (Engineering) for demonstration duties. Because of the varying demands of course preparation work and other duties, it is often impossible for a lecturer to devote more than 80 per cent of his working time to actual teaching. The current average student-contact time for all lecturers is 63 per cent, but for those on lecturing duty the work can be particularly arduous and demanding.

A further engineering group, numbering about 30, provides

the supporting services of workshops, stores, transport, planning, construction and drawing office. In addition, considerable labour forces for maintenance purposes are made available by the Telephone Manager, Stoke-on-Trent and the Ministry of Public Building and Works. A clerical and ancillary staff of nearly 100 look after cash, staff, records and statistics, accommodation, stores and student services (tea bars, shop and students' club), and a hostel staff, some 135 strong, maintains the domestic services such as house-keeping, sick bay, reception, and catering. In all, the Principal has the ultimate responsibility for over 1,300 people working and studying on the College site.

TABLE 1

Group	Title	Course Subjects
A	Automatic Switching	Director, Non-director, Routiners, Clerk of Works, and Cordless Switch-board Systems
B	Automatic Switching	Trunk Switching and Signalling Systems, Crossbar Systems TXK3 and 4 and International Subscriber Dialling
C	Automatic Switching	Preliminary and General Auto, UAX, PABX, Repair Control Officer
D	Automatic Switching	Electronics, Electronic Register Translators, Crossbar System TXK1, Electronic Exchange Systems TXE2 and 4
E	Power and Postal Engineering	Power Plants, Postal Engineering, Lifts, Heating, Lighting and Ventilation
F	Transmission	Audio, Coaxial, Submarine Cable and P.C.M. Systems, Visual Aids, Closed-circuit Television.
G	Telegraphs, Data and Radio	Telegraph machines, Datel equipment, Telex exchange and subscribers rented equipment, Microwave Radio Systems, V.F. Telegraph equipment
H	External Plant	External Planning, Precision Testing, Cable Balancing, Works Supervision

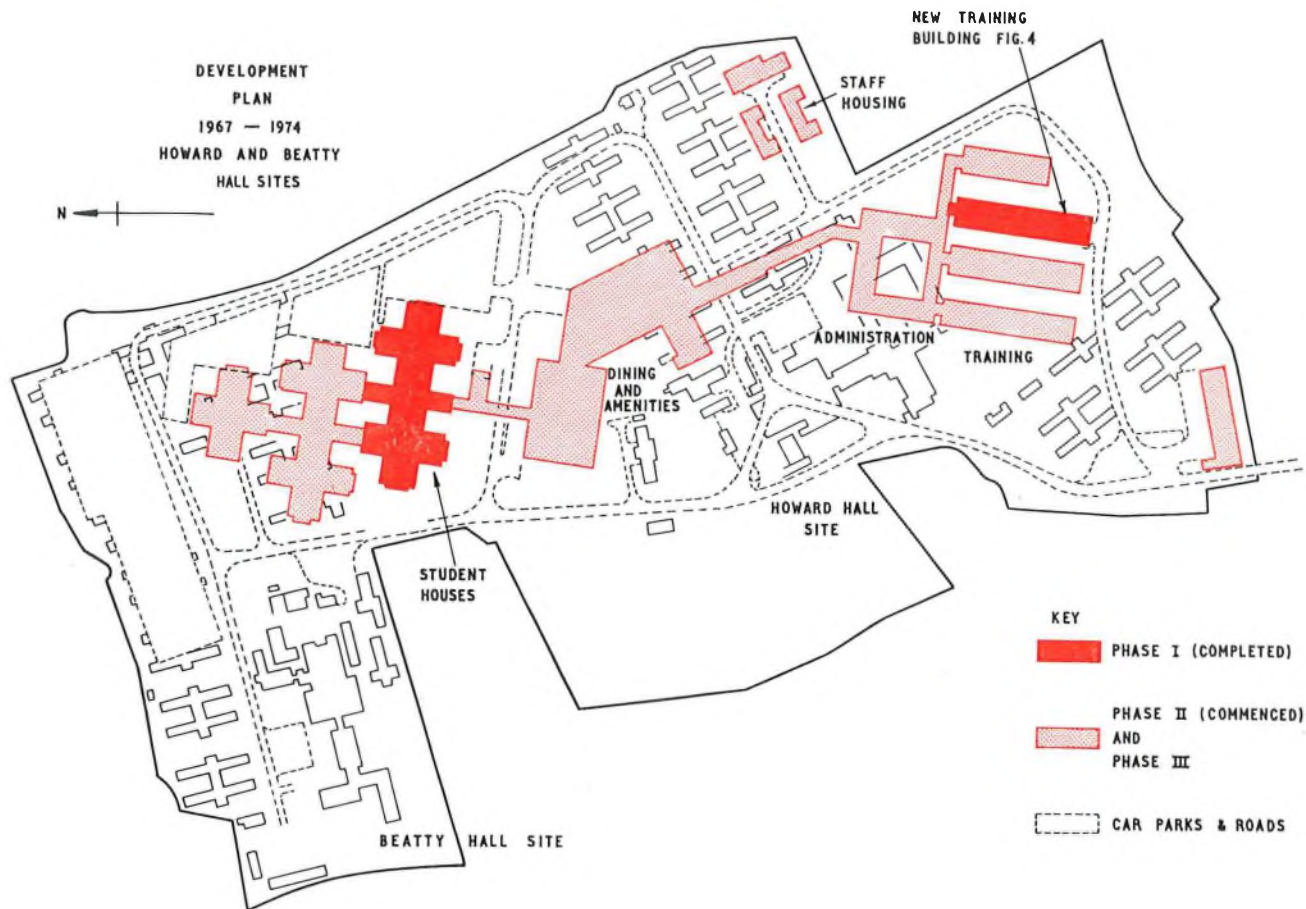

FIG. 3—T.T.C. rebuilding development plan 1967–1974, superimposed on an outline plan of the existing Howard Hall and Beatty Hall sites

ACCOMMODATION

In order to overcome the arrears of training at the end of the last war, the Post Office acquired four sites on which temporary buildings had been used as hostels by a nearby Royal Ordnance Factory. These buildings were adapted to form a school and living accommodation for staff and students.

In the early 1960s, with guidance from a special Joint Working Party, permanent buildings for a school of 600 students were planned for erection on a site at Harlow, Essex. It soon became evident, however, that the proposed site was not large enough to cope with the foreseeable training demands and, as many of the staff were reluctant to move to the South-East, the decision was made to continue at Stone using the Harlow design for buildings. The rebuilding development plan is shown in Fig. 3. By 1974 the College will be completely re-equipped and will cater for a student population of about 850 with a capability for expansion well beyond 1,000 places. To date, Phase I, which provides new training accommodation and 432 study-bedrooms, has been completed and Phase II, which will provide a similar number of study-bedrooms, is now in progress. Fig. 4 illustrates the new training building.

ADVANCES IN TEACHING TECHNIQUES

Considerable effort has been directed over a period of many years into studying the circumstances and methods by which people learn, and in consequence the college is now far removed from the days of "chalk and talk." Moreover, training techniques have to be more carefully studied when mature students are involved in that they are critical of

training methods and require different motivation from that needed by younger students. Some of the more recent introductions to improve the training techniques are described below.

Whiteboards

These boards are covered in a light grey-blue vinyl material, and measure 15 ft by 5 ft. Felt pens charged with dense water-based colours give a much-improved pictorial presentation, easily seen from the back of a classroom. The absence of chalk dust from the chalkboard is a major advantage, but board cleaning is more difficult in that a two-stage wet-and-dry method is required. The centre section of the board is capable of forward movement through an arc of about 20° to provide a distortionless screen for an overhead projector. The vinyl surface has good reflective properties, and 8 mm film and 35 mm slides can be projected in a darkened room with a minimum of fuss. The boards are metal-backed so that magnetic display techniques can be utilized.

Overhead Projectors

The overhead projector is an illuminated horizontal transparent writing-surface about 10 in square coupled to an optical system capable of projecting on to a vertical surface, and hence enlarging, any writing or prepared transparent material placed on its writing plane. It is used in a variety of ways. As a replacement of the chalkboard, the lecturer writes with a fine felt pen on a thin acetate roll which can be wound on as the lecture proceeds. Alternatively, prepared transparency frames may be projected in sequential order, or as a series of overlays showing the steps in the build-up of an

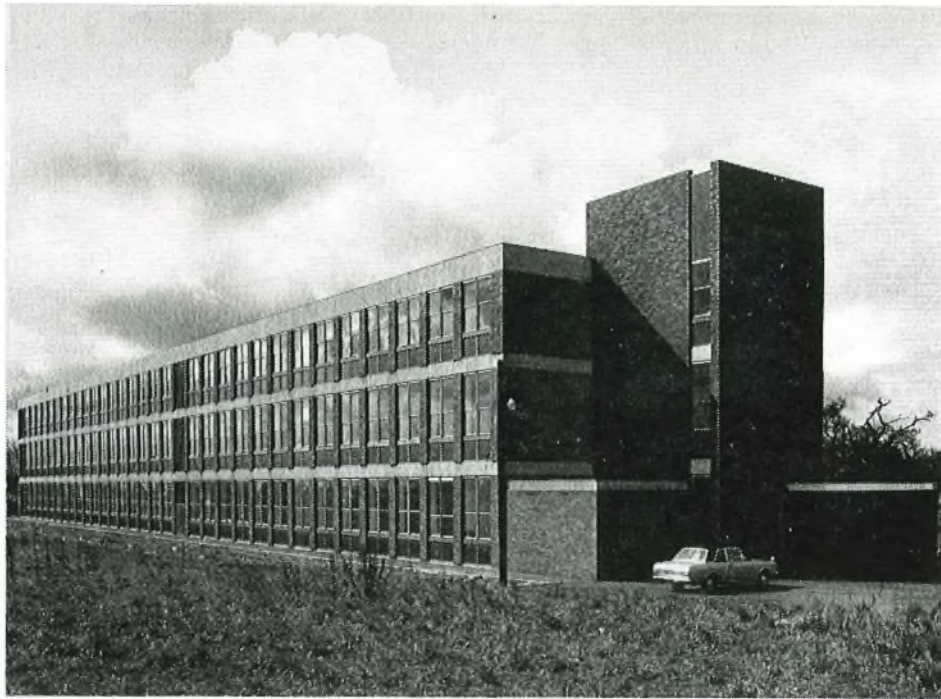

FIG. 4—The new training building opened in April 1969

operation. In addition, small mechanical models may be reproduced in Perspex and projected as shadowgraphs or silhouettes.

An advantage of the overhead projector is that the lecturer sits facing his students and therefore has direct address and more effective class control. Lecturers are encouraged to use it whenever possible, and preparation work for new courses includes the production of a series of transparencies to ensure that each similar course has the same logical development and presentation of information.

The introduction of this technique has effected significant savings in lecture time, thereby allowing the college to include in its courses extra material or additional practical or tutorial sessions.

Film Projectors

Use is made of 8 mm and 16 mm cine-projectors and 35 mm slide-projectors to provide backing-up lecture material. Closed-loop 8 mm films have been introduced for certain aspects of training and these are available for students to operate by themselves during tutorial lessons in order that lecture material may be reinforced.

Closed-Circuit Television

Closed-circuit television has been in use for some time to provide live demonstrations of oscilloscope displays of waveforms taken from remote working equipment, and for transmitting enlarged pictures of mechanically-operated equipment. By the appropriate use of monitors in the lecture room, instruction can be given to a whole course instead of dividing the students into small parties with each party in turn gathering around the working face for similar instruction. The saving in time for both tuition and group faulting can be quite considerable.

Video-Tape Recorder (V.T.R.)

Video-tape recording is a logical development of cine film and closed-circuit television training techniques. It requires as much detailed scripting and planning as a cine film, and although appearing to have a similar end-result, v.t.r. has many production advantages. The recording cameraman has an immediate picture on his monitor of the field of view, depth of focus and illumination levels (Fig. 5). The producer has the advantage of immediate playback, and this alone is a major advance on any previous film techniques. In the classroom as many monitors as are necessary for comfortable viewing can be operated under normal lighting conditions, enabling note-taking and tabulation of experimental results to continue unimpeded.

To date, two distinct classes of work have been undertaken. The first is the conventional demonstration and experiment subject. So far, four have been recorded, and these, by the employment of careful production techniques, have attained a high standard of instruction, free from the weaknesses associated with conventional demonstrations. They feature student participation in experimental work and have proved to be popular and completely successful. In addition they save some 50 per cent of the time previously needed for demonstrations by eliminating movement between lecture room and laboratory and by simultaneous demonstration to a whole course rather than repeated deliveries to a number of smaller parties.

Recordings of equipments or techniques which for economic or practical reasons cannot be presented at the College fall into the second classification. The v.t.r. is reasonably mobile and may be used externally. Indeed, equipment existing only at Goonhilly has been put on record there and the tape subsequently used to explain to students the operation of similar equipment which is to be installed in Italy and Spain.

It is proposed for the future that all lecture rooms will be connected to the system by coaxial cable so that recordings can be called for and transmitted as required.

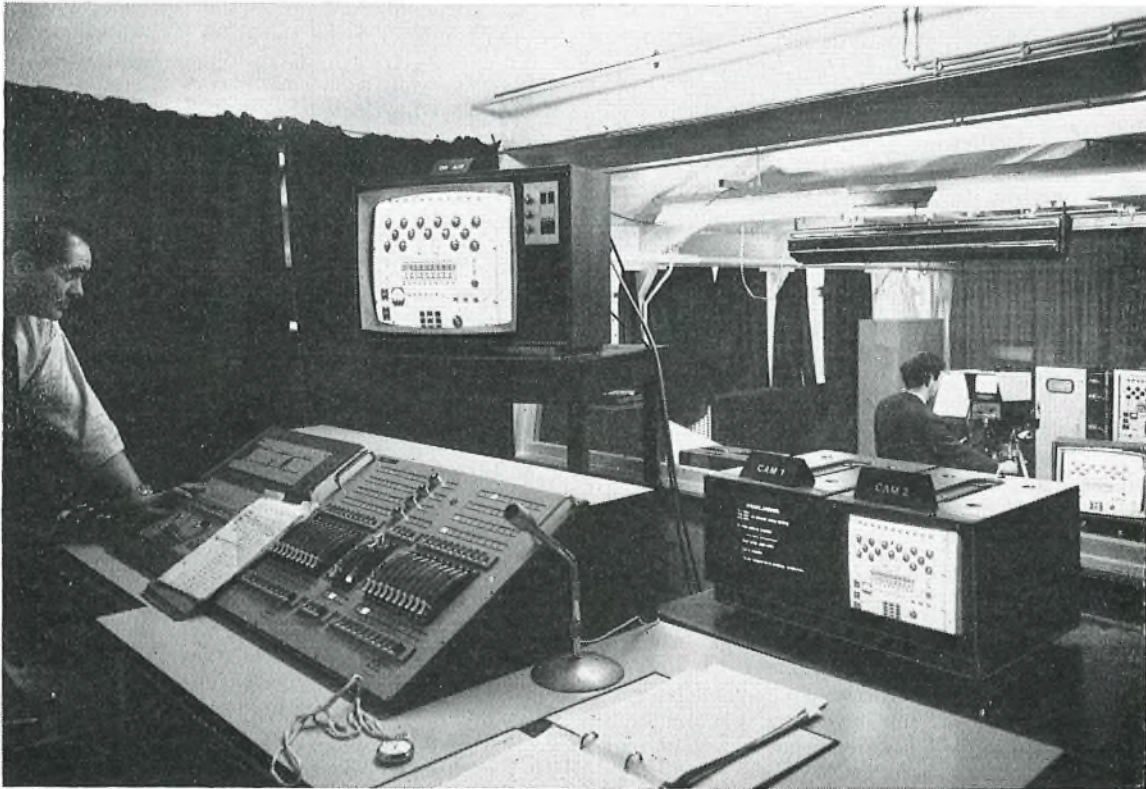

FIG. 5—Television studio and control room for video tape-recording production

Programmed Learning

Between 1965 and 1967 two groups were established at the College to determine whether programmed learning could be used successfully on T.T.C. courses. The development work was concentrated upon the non-director course and the basic transmission course. In the non-director field it was found that although students learned at least as much from the program as from a lecture, most students took longer. In the transmission field, with a different approach, it was found that although the programs were reasonably effective, they also took longer to work through than the lecture form and met considerable opposition from students against their application for prolonged periods.

It is now generally accepted that students should have a maximum exposure to programs of two periods of 45 minutes per day. This is clearly unworkable at the College, where the time required for lectures exceeds that for practical work, and it is therefore unlikely that programmed learning will feature in future training schemes. However, the discipline acquired from the exercise has led to numerous changes in the pattern of instruction and to the introduction of other forms of idea-communication.

Examinations, Testing and Assessment

Successful attendance on certain courses is a formal requirement for promotion, and an assessment of performance is often required. Examinations are usually considered to play a part in the learning process by helping to consolidate information derived throughout the course, or conversely, by forcing a realization of the gaps in his knowledge on to the individual student. Examinations and tests are also part of the teaching process in that they provide feedback information on the effectiveness of tuition and highlight any short-

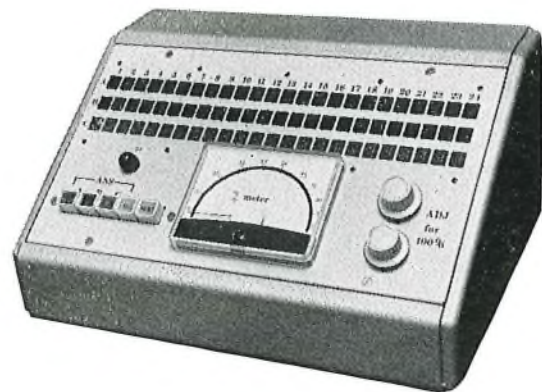

FIG. 6—Lecturer's desk-unit for student response in the feedback classroom

comings. For this reason, it is illogical to defer them to the end of a course. Ideally, testing should be a continuous process so that weakness of comprehension may be noticed at an early stage, but as this is not practicable, the College endeavours to give a series of short tests at frequent intervals. The essay-type examination is now a thing of the past and the examination atmosphere is discouraged. All course material is made available to the student, thereby examining his application skill rather than his powers of memory. Wherever possible, practical tests are given, but if written tests are necessary they are usually of the multiple-choice answer or short-answer type.

In the multiple-choice-answer technique, a question is presented to the student together with a number of alternative answers, only one of which is correct. To prevent the student deducing the correct answer by eliminating those that are

blatantly incorrect, all answers should appear to be reasonably valid. The student indicates the correct answer by inserting a tick in the appropriate box in the answer sheet and the lecturer marks the paper with the aid of a scoring template. Experience has shown that this type of test is well received by the students, and the time taken by the lecturer in marking the answer paper is greatly reduced.

Students' Response Unit—The Feedback Classroom

In a feedback classroom, the lecturer is provided with an overhead projector with which he projects a question, together with multiple choice answers, on to a screen. The T.T.C. has decided on a maximum of three answers to each question. Each student has a desk-unit fitted with push-buttons marked A, B and C and he presses the button appropriate to the answer he considers to be correct. The lecturer has a desk-unit (Fig. 6) which is provided with three lamps per student corresponding to the push-buttons, a PERCENTAGE CORRECT meter, CORRECT ANSWER keys, a RECORD key and a RESET key. A separate console contains a meter for each student and a TOTAL QUESTIONS meter.

When the students depress their buttons, the lecturer is given a lamp indication of each student's choice of answer. When each student has answered (and up to a point the student is free to change his mind), the lecturer may register the correct answers on each individual student's meter and also add to the total questions meter, by operating the RECORD key. The RESET key will restore the circuitry to normal in readiness for the next question.

All students must participate, and the lecturer therefore has their attention and an immediate feedback of the effectiveness of his teaching, enabling him to take remedial action if required. Students are tested on their technical knowledge only, since poor command of language does not affect their marks and any cumulative incorrect response quickly indicates the weak student who may need extra tutorial attention.

Pictorial Presentation

For many years, hand-out material at the T.T.C. has followed a familiar pattern of duplicated information sheets and block diagrams. More recently, however, it has been considered that time spent on the improvement of graphic reproductions and printing quality could have significant savings in teaching effort. Imaginative presentation enables students to see things for themselves, focuses attention and stimulates interest, giving the student a desire to learn often in advance of instruction from a lecturer.

ADVANCES IN TRAINING METHODS

Automatic Switching

In the Strowger field, continuous development over a period of 20 years has culminated in the present design of faulting racks for training on director and non-director equipment. These racks (24 of each) are equipped to represent an exchange system rather than the previous collection of typical equipment items. Faulting problems may now be posed which encourage the student to think logically about the facilities and the trunking of the whole system, until eventually the fault is localized, by a more detailed analysis, to a single piece of equipment. For example, the director faulting-rack contains two calling-line circuits, full director equipment including local register, manual board relay-set and manual board simulator, coin-and-fee check circuit, auto-to-auto relay-set and distant-exchange selector train which includes an 11-and-over final selector. As an additional training aid, the digits sent from the outgoing levels of the 1st-code selector by the director or the local register are displayed on number-display tubes. A switch panel controls up to 200 separate fault conditions on each rack.

Systems-faulting racks, similar in concept to the above, are in course of development for signalling systems, register translators, private automatic branch exchanges and the small electronic exchange.

In laboratory work, it has been usual in the past for students on electronic switching courses to build their own circuits on small breadboards using standard components and soldering all connexions. Development work is in progress on the provision for each student of a plug-in board with components mounted on removable plugs. Circuits may then be set up and broken down more quickly, the cleaning of tags obviated, and more time made available for investigation into circuit performance.

Transmission

Considerable changes have taken place in the way in which line transmission has been taught, and also in the rate of presentation of information. In the 1930s, a single course of three months duration was provided but this was diversified in 1941 to a basic course of six weeks duration followed by specialized courses as required. Training was system orientated and each new system required a new course. A further revision in 1958 reduced the basic course to four weeks and specialized courses were also changed to enable the training to be equipment orientated.

In 1965 the basic course was split into Elementary Principles followed by either an Audio Equipment course or a further, but more advanced, Principles course. This was seen as the first step to rationalize training, avoiding the need to provide new courses when either the system or the equipment changed.

The present objective is to teach an understanding of the behaviour of the building-blocks likely to be found in the newer systems together with an understanding of the principles of f.d.m. systems. Generating and translation courses subsequent to this training will be short and will teach only typical examples.

External

One of the more interesting teaching aids used for external training is the model town (Fig. 7) which was designed to form the basis of practical exercises for students on the Local Line Planning course. It simulates field surveys that are part of design work and gives to students a wide variety of planning problems such as overloaded distribution poles, power crossings, replanning underground distribution of a small commercial area involving building demolition and redevelopment, and phasing of cable-laying for a new housing estate.

SOME OF THE PROBLEMS OF TRAINING

The Older Man and Technological Expansion

Updating and retraining is necessary in the industrial field to keep pace with the tremendous expansion rate of newer technologies. College updating and retraining ensures that the technician is fully effective in his own field when new equipment is introduced and old equipment is modified for operational compatibility, or when he is transferred to new duties from older and dying technologies. The most difficult training task in this respect is that of retraining the older man who in the past was an expert in his own field but who now finds himself in competition with younger men at a time when his own ability to absorb information has slowed down. Much thought has been devoted to devising presentation methods suitable for men who are overtaken by events in this way.

The Organization of Training Courses

Ideally, courses should be available on demand, for they are most effective when a student can return at the end of

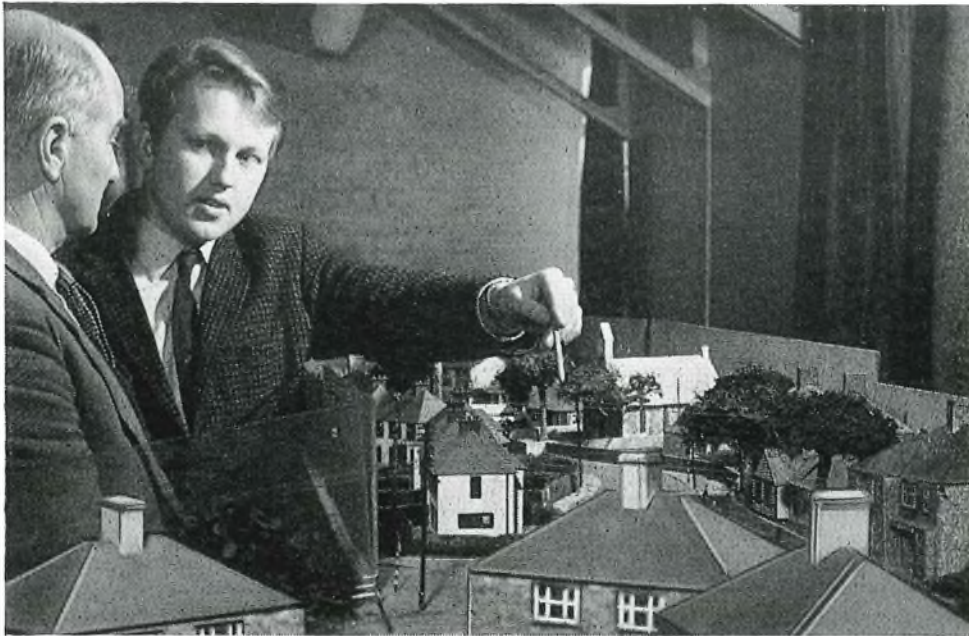

FIG. 7—Part view of the 1/76 scale-model town

his course to a situation where he puts into practice his newly-acquired skills. However, having regard to the economics of training, it has been found preferable to ask Regions to make forecast estimates of demands and then for the T.T.C. to convert them into a realistic six-monthly training program. Regions are therefore asked to bid for seats which they intend to take up between six and twelve months later and in this period many changes in their requirements can occur, such as redeployment of manpower, delays in installation, unforeseen promotions and so on. In consequence, although the T.T.C. program may have been planned to cater for 820 students in some weeks, the actual population rarely exceeds 750. Indeed the dropped-seat percentage has been as high as 17 per cent although the average is around 5 per cent. Much training effort and money can be wasted by the cumulative effect of declining seats demanded at earlier forecasts.

The Cost Effectiveness of Training Courses

The characteristics of the job of any telecommunications engineer are well known and courses and training methods are adopted and adapted in the light of experience. Despite much attention to detail, difficulty is still encountered in assessing the impact of training on work in the field, particularly in maintenance activities. The effectiveness of a College course can readily be measured in an artificial situation by means of special analyses involving pre-course and post-course diagnostic skill and knowledge. The ability to

out-perform fellow students is not necessarily confirmation of ability to perform an allotted task under normal working conditions. It is only from an assessment of how well students fit into their appointed roles in the field that the quality of service given to Regions by the College can be measured. Much more feedback on the success or failure of student training is required from Regions.

CONCLUSION

This article has touched only briefly on the function, aims, the changing techniques and the problems of training at the Technical Training College. The usefulness of formal course-training cannot be determined by precise measurement but must be largely a matter of subjective assessment; nevertheless, the formal course plays an important part in the adult life of the Post Office engineer and it is essential that it should be given at the right time—that finely balanced interval between the acquisition of background experience and the future need for knowledge. Without early application, much of what has been learnt on a course is rapidly forgotten, and the effort of training, and the expenditure on it, are virtually wasted. The objective, therefore, must be to give training of the right type to the right man at the right time.

Reference

¹ CALVELEY, C. E. The Central Training School, Stone. *P.O.E.E.J.* Vol. 40, p. 19, April 1947.

A New Method of Local Transmission Planning

H. J. SPENCER, C.ENG., M.I.E.E.†

U.D.C. 621.317.34: 621.395.743

The difficulties of the assessment of the transmission efficiency of local lines is discussed. The limitations of the concept of transmission equivalent resistance are indicated and the new method of local transmission planning adopted by the British Post Office is explained.

THE BRITISH POST OFFICE TRANSMISSION STANDARD

The measurement of the transmission efficiency of the line connecting a telephone subscriber to the local exchange presents special difficulties. On the one hand there is a subtle relationship between the subscriber and the telephone instrument, the man-machine interface. On the other hand there is a complicated inter-action between the telephone, the line and the exchange termination. To overcome the difficulties the British Post Office (B.P.O.) defines the limiting transmission efficiency, upon which planning of the local network is based, as that of a specified combination of telephone, line and transmission bridge. From time to time, the physical embodiment of this limiting standard has been changed to keep abreast of technical developments and it is now defined as the performance of a Telephone 706 connected by 3.7 miles of $6\frac{1}{2}$ lb/mile cable (copper conductors with paper insulation) to a 50-volt 200 + 200 ohm Stone transmission-bridge. The d.c. resistance of this line is 1,000 ohm.

The Transmission Equivalent Resistance Concept

A transmission limit of the above form can only be used directly in planning a local-line network if all the telephones and transmission bridges and all the cables in the network are of the same kind as those of the standard. In practice this rarely happens and means have to be devised to relate other combinations of telephone, line and transmission bridge to the limit. In 1946 the B.P.O. adopted the *transmission equivalent resistance* (t.e.r.) concept for this purpose. In this method of planning, hypothetical resistances, known as t.e.r., were ascribed to the different cable gauges. For the standard gauge of $6\frac{1}{2}$ lb/mile, the t.e.r. was the same as the d.c. resistance. For other gauges, however, the t.e.r. values were obtained by multiplying the d.c. resistances by factors. These factors were so chosen that lines having the same transmission performance as the standard limiting line, but made up from cables of different gauge, had the same t.e.r. as the standard. The t.e.r. multipliers for the different gauges were based on transmission performance ratings. These took into account the sensitivities of the telephone in both the sending and receiving directions, its frequency response, and its sidetone characteristics. The rating for a given telephone, line and transmission bridge combination was computed using the image attenuation of the cable at 1,600 Hz, together with allowances for the effect of the line resistance on the transmitter feed current, and of the line impedance on sidetone levels and mis-match losses.

The t.e.r. concept was a valuable planning method when telephones had, by present standards, poor frequency res-

ponses and rather wide ranges of sidetone levels. In particular, it dealt quite well with the problem of lines made up from sections of different gauge, straight addition of the t.e.r. values of the separate sections giving results which were satisfactory in practice. Values of t.e.r. cannot be measured, however, and because of their artificiality, the concept has proved difficult to comprehend. Also, this method of assessing local transmission efficiency does not line up with measurement by power ratios, expressed in dB, used in other links in the transmission chain, and it is not suitable for use with terminal apparatus other than telephones, e.g. data modems.

A Possible Alternative to T.E.R.

An alternative method of presenting transmission limits is illustrated by Fig. 1. The image attenuation at 1,600 Hz is shown as a function of line resistance for a number of different gauges, and the transmission limits as determined by the t.e.r. method are indicated on the curves. A further curve, A-B, has been drawn linking the limits for the individual gauges. The shape of A-B is due largely to the fall in transmitter output as the line resistance increases. It is also affected by changes in sidetone and in mis-match losses because the impedances of lines are implicit in the relationships between attenuations and resistances. A curve such as A-B effectively defines the transmission limit and a family of such curves, one for each telephone-transmission-bridge combination, could be used to replace the t.e.r. method of local-line planning and would give very similar results. The attenuations and resistances of lines would be found by adding the values for different sections, and conformity with the limit would be established if the plot of total attenuation and total resistance for a line fell below the appropriate limiting curve.

A NEW SIMPLIFIED PLANNING METHOD

Transmission performance is not the only limiting factor in planning local lines. Resistance limits must also be met to ensure satisfactory operation of signalling devices. The highest line resistance permitted in the B.P.O. system is 1,000 ohm and when a limiting line, C-D, at this resistance is added to Fig. 1 the possibility of a further simplification becomes apparent. With modern telephones the working part of the attenuation limit curve, A-O, is sensibly flat and little error is introduced by taking a fixed limit of 10 dB. Compared with the t.e.r. limit, a 10 dB limit slightly reduces the maximum length of line for gauges greater than $6\frac{1}{2}$ lb/mile but this is relatively unimportant because these are not now widely used. Where there is a difference, it is in favour of the subscriber.

From the reasoning given above it has been decided that, in future, local lines will be planned to a limiting attenuation of 10 dB at 1,600 Hz, and to the appropriate resistance limit for the exchange. The change in planning method has

† Operational Programming Department, Telecommunications Headquarters.

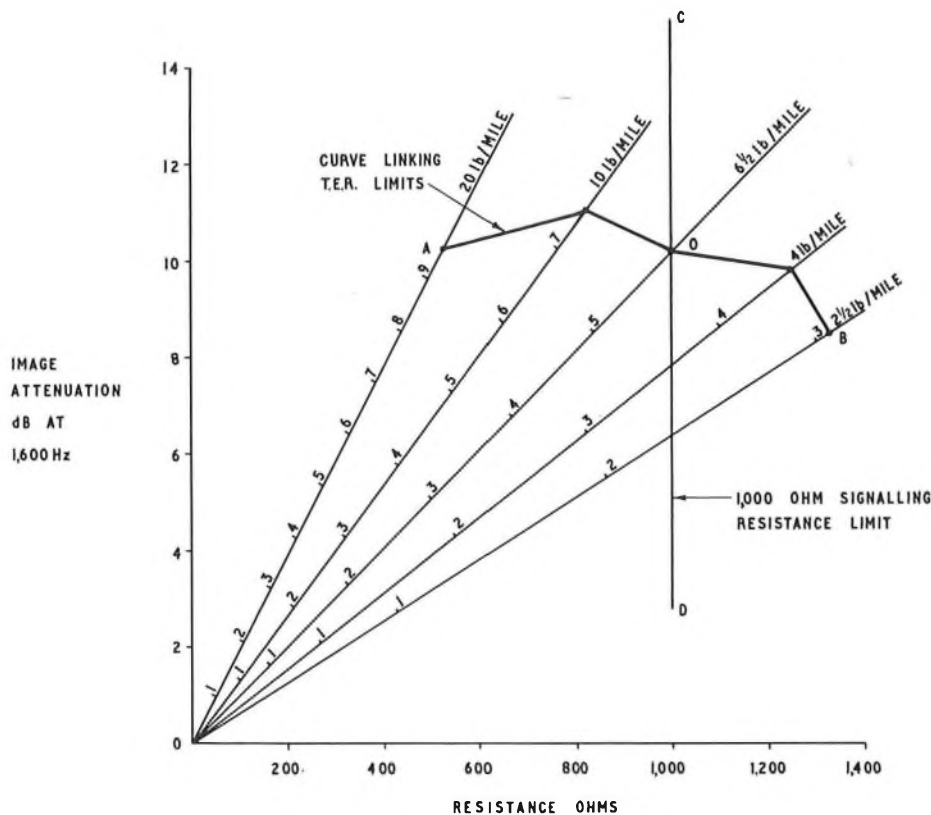

Note: Cable lengths are indicated on curves in kilometres

FIG. 1—T.E.R. limits presented in attenuation/resistance form

been timed to coincide with the change to metric dimensions for cables. Attenuations and resistances, in dB and ohm per kilometre have been published for local line cables; typical values are shown in Table 1. Small differences in attenuation

TABLE 1
Local Line Cables
Planning Attenuation and Resistance Constants

Conductor			Attenuation dB/km	Resistance ohm/km
Material	Weight lb/mile	Diameter mm		
Copper	2½	0.32	2.8	434
	4	0.4	2.2	275
	6½	0.5	1.7	168
	10	0.63	1.38	109
	20	0.9	1.04	55
Aluminium	—	0.5	2.7	287
	—	0.8	1.7	112

between cables of different type, such as those between cables with polythene and paper insulation, have been ignored and compromise values used. The 10 dB transmission limit will be universal, assuming that 700-type telephones will always be used on critical lines and taking no account of differences in transmission bridges.

TRANSMISSION BRIDGE CONSIDERATIONS

Only 50-volt non-ballast transmission bridges are considered because the change from manual to automatic exchanges is now almost complete in the B.P.O. system and new local networks will be planned to anticipate completion. The use of ballast resistors is being discontinued because the improvement they give in sending efficiency on long lines is now

slight, due to the dominant effect of line resistance, and because when used with regulated telephones they degrade the performance of the many subscribers on medium-length lines.

INTERNATIONAL STANDARDS

Transmission performance is regulated internationally by reference to a laboratory reference system known as NOSFER (New fundamental system for the determination of reference equivalents). National local ends (the connexions between the international exchange and the subscriber) are compared with this on a subjective loudness basis and should not be more than 20.8 dB quieter in the send direction and 12.2 dB in the receive direction. In the U.K., the national reference equivalent has been apportioned to allow limiting reference equivalents for the local telephone circuit of 12 dB in the send and 1 dB in the receive directions.

A standard based on transmission performance ratings is not strictly comparable with one based on reference equivalents, because it takes into account other factors besides loudness. It would theoretically be possible, for example, for circuits with equal transmission performance ratings to have different reference equivalents. In practice, however, the use of different bases does not lead to anomalies and the possibility of them will not be increased by the new method of planning. It can be assumed, therefore, that a limiting local telephone circuit consisting of a 700-type telephone connected to an exchange by a line with an image attenuation of 10 dB, at 1,600 Hz, will allow the international standard to be met by calls from the U.K.

CONCLUSIONS

A simple attenuation limit has been introduced to take the place of the t.e.r. method of transmission planning in the local line network. The new method of planning will not involve any significant change in the B.P.O. transmission standard.

The Echo Suppressor No. 7A

A. G. HODSOLL†

U.D.C. 621.395.664.12

A new half-echo suppressor has been designed for use on international telephone circuits with one way propagation times of up to 300 ms. This article describes the design objectives and the performance achievements of the echo suppressor. Included in the echo suppressor is a tone disabler which is the first such device used in the British Post Office telephone network.

INTRODUCTION

The long propagation times of international telephone circuits routed via synchronous satellites aggravate the problem of echoes. To provide satisfactory echo suppression on such circuits a new echo suppressor was required. The new Echo Suppressor No. 7A has been designed for circuits having one-way propagation times of up to 300ms. A tone disabler is included in the circuit which inhibits echo-suppressor action when speech circuits are used part time for the transmission of data. The basic performance requirements for this type of echo suppressor have been described in a previous article.¹ This article describes how the theoretical design was achieved in practice with particular emphasis on the design of the tone disabler.

paths under various speech conditions. The suppressor is inserted in the 4-wire audio portion of the connexion and in the unoperated condition, the transmission paths should be degraded by only a negligible amount, specified in terms of input and output impedances, insertion-loss/frequency response, harmonic distortion and noise. The transmission paths through the suppressor must be adjustable so that it can be connected at any nominal level point in the 4-wire audio section of the circuit. When the suppressor operates, the attenuation switched into the transmission paths should not degrade the input and output impedances and should not vary appreciably with frequency or signal level. The level of clicks produced on the transmission paths during operations of the suppressor should be inaudible and also of a form which will

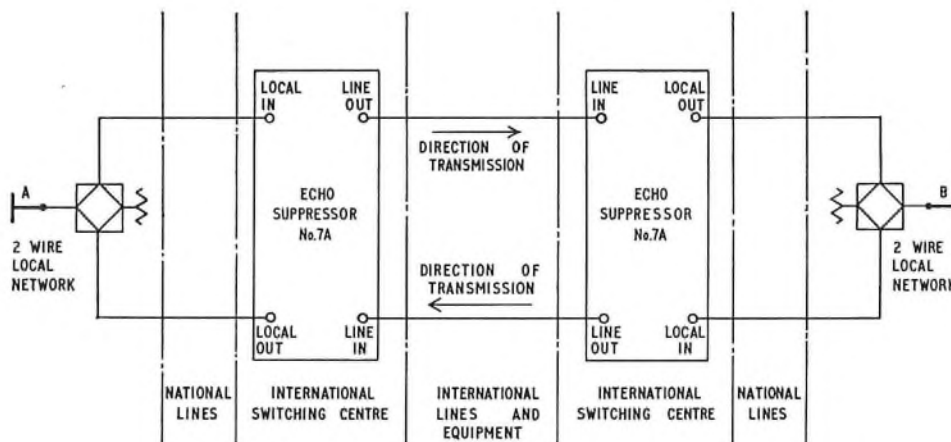

FIG. 1—Positions of half-echo suppressors in an international telephone connexion

DESIGN OBJECTIVES

The device is a half-echo suppressor since two similar devices are provided, one at each end of the circuit. Fig. 1 shows the position of the two half-echo suppressors in an international connexion. The two half-echo suppressors in any one circuit may be designed and manufactured by different administrations. To ensure compatibility in performance each half must be designed to meet a common specification² of certain essential parameters agreed internationally by the C.C.I.T.T*. These parameters concern operate and hangover times, the sensitivities of the speech detectors and the amount of attenuation switched into the transmission

not interfere with any signalling systems connected to the circuit.

International telephone circuits are sometimes used as part-time private circuits, when the full duplex capability of the connexion is required to send data simultaneously in both directions of transmission. Provision must therefore be made for the echo suppressor action to be inhibited by means of a conditioning tone sent in advance of the data signals. Echoes cannot occur under these conditions because the circuit is 4-wire terminated in the data modem. Once the disabler has been conditioned, it must be held operated by the data signals. It must release and restore the echo suppressor to normal at the end of the data signals.

Echo-suppressor action must also be removed from the circuit for normal telephony signalling during the setting up and clearing down of the circuit by the application of an earth signal from the adjacent signalling relay-set.

In addition to the requirements for long propagation-time circuits a replacement echo suppressor is required for circuits routed through the transatlantic cables, having

† Formerly Line and Radio Branch, Telecommunication Development Department, Telecommunications Headquarters, now with Organisation and Methods Assignment Division, Management Services Department, Telecommunication Headquarters.

* C.C.I.T.T.—International Telegraph and Telephone Consultative Committee.

London to New York one-way propagation times of about 35 ms. The one-way propagation time of a telephone circuit between London and New York via a synchronous satellite is about 270 ms. Using an echo suppressor capable of operation on circuits having both long and short propagation times facilitates the making good of cable routes by means of synchronous satellites in the event of a cable breakdown. The converse also applies.

PRINCIPLES OF THE ECHO SUPPRESSOR

The block schematic diagram of the Echo Suppressor No. 7A is shown in Fig. 2. For descriptive purposes the local to line transmission path is referred to as the *send path* and similarly the line to local path is referred to as the *receive path*.

The echo suppressor is a voice-operated device which uses a small part of the speech signals in the receive path to operate an electronic logic circuit which switches a high value of attenuation (approximately 60 dB) into the send path. This high value of attenuation suppresses the echoes which would otherwise have been returned to the distant talker's ear. Further logic circuitry permits the listener to interrupt the talker or to make interjections so that the talker knows that the listener is still hearing his speech. This break-in logic distinguishes between echoes and speech from the former listener and, if it detects speech, the 60 dB suppression is quickly removed to allow the break-in speech to be transmitted to the talker. As well as removing the suppression from

the send path, the break-in logic circuit also switches a fixed attenuation of 6 dB into the receive path to provide partial suppression of echoes when speech is present in both directions simultaneously.

CIRCUIT OPERATION

For the purpose of the following description Fig. 2 is taken to be the echo suppressor at the A end of the circuit. Under no-signal conditions, both transmission paths through the suppressor give an insertion loss of 0 dB. Attenuators AU 1 to AU 4 are used to adjust the transmission paths to suit the level point in the circuit at which the suppressor is inserted.

Suppression

Speech from talker B enters the suppressor at the *line in* terminals, passes through attenuator AU 3, the 10 dB and buffer amplifiers, attenuator AU 4 and the 20 dB amplifier, then leaves, unattenuated, at the *local out* terminals to be heard by listener A.

Part of the signal at the output of the 10 dB amplifier is fed via the bandpass filter through the 22 dB amplifier, a weighting network and the 34 dB amplifier to a half-wave rectifier circuit. The output of the rectifier is smoothed by a capacitor-resistor circuit TC1. When the output voltage exceeds a value set by the suppression threshold detector, a signal is forwarded via the suppression hangover stage and main logic (I/P1 to O/P1) which switches a 60 dB attenuator into the send transmission path. This 60 dB attenuation prevents echoes of

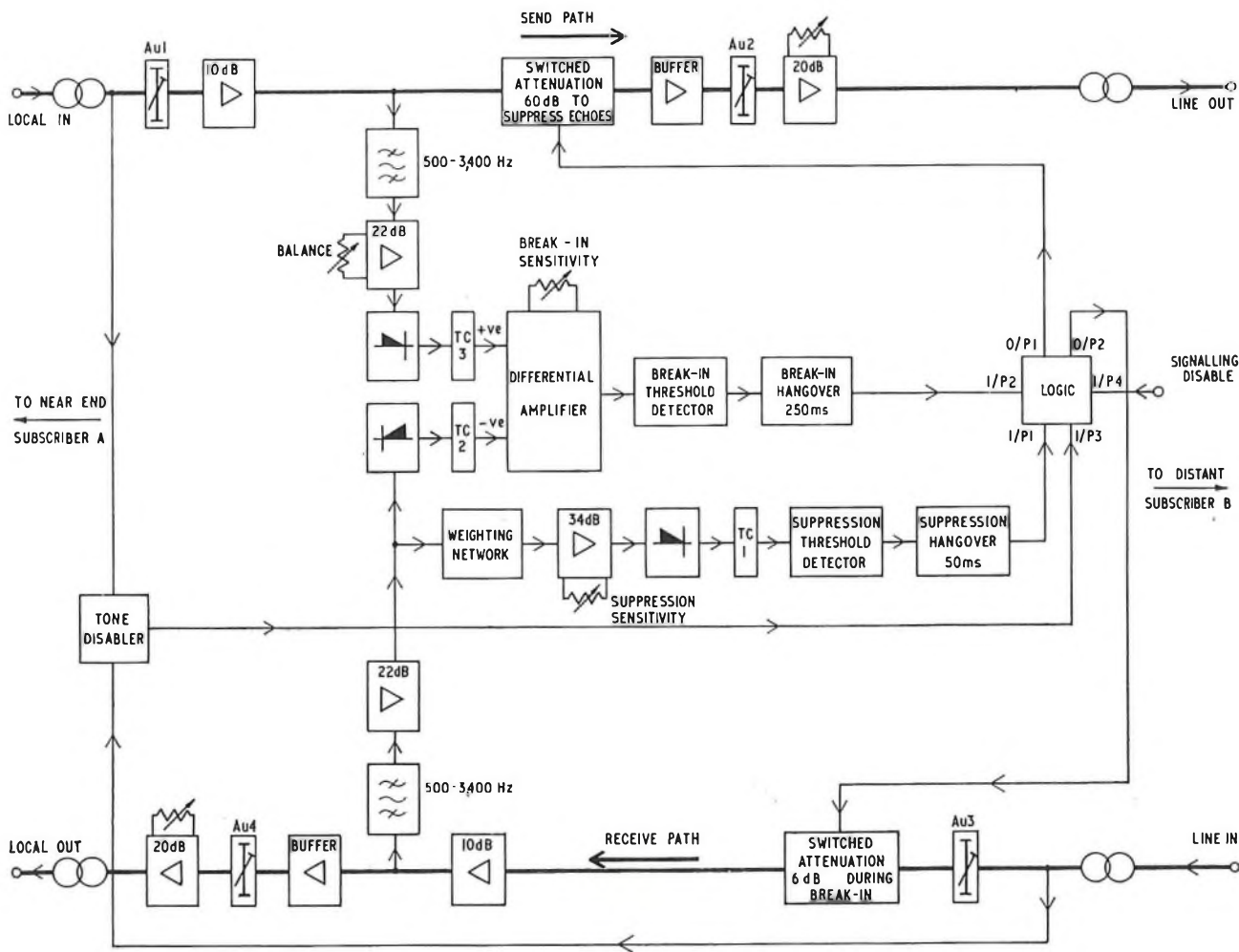

FIG. 2—Block schematic diagram of the Echo Suppressor No. 7A

subscriber B's speech from returning to end B. The charging time-constant of the capacitor-resistor circuit, TC1, is a compromise value, which is long enough to prevent false operation by short duration spiky noise, without preventing fast operation (about 1 ms) to normal level speech signals. The suppression sensitivity is -31 dBm0 which is sufficiently above normal circuit noise levels to prevent false operations by noise. When the level of the speech from end B falls below the level set by the threshold detector, the 60 dB suppression is maintained for 50 ms by the suppression hangover circuit. The hangover is necessary for two reasons:

(a) Speech signals may not terminate abruptly and word or syllable endings often contain low-level energy. These endings may be below the sensitivity of the suppressor but their echoes must still be suppressed.

(b) Echoes may arrive at the send side of the echo suppressor after speech signals have ceased at the receive side, due to the end delay in the circuit on the local side of the echo suppressor. End delay is twice the one-way propagation time of the near-end circuit between the local side of the echo suppressor and the point of mismatch where the reflexion (echo) occurs.

The bandpass filter (500 to 3,400 Hz) prevents interference from inaudible signals such as induction from a.c. mains. The weighting network increases the sensitivity of the suppression detector, with increase of frequency, at the rate of 6 dB per octave to assist in the detection of sibilants. These hissing sounds, although easily audible, tend to contain insufficient energy to operate the suppressor unless the circuit is weighted in their favour.

Break-in

Whenever speech is present in the receive path, a second output from the 22 dB amplifier is fed to a full-wave rectifier circuit producing a negative d.c. output which is smoothed by a capacitor-resistor circuit TC2. The d.c. output is fed to one input of the differential amplifier. Assuming that subscriber B is talking and subscriber A listening, then the 60 dB suppression will be switched into the send path as previously described. At the same time any signals in the send path, which can be echoes of subscriber B's speech or break-in speech from subscriber A or both, will enter the echo suppressor at the *local in* terminals. The signals pass through attenuator AUI and the 10 dB amplifier. Part of the output of the 10 dB amplifier is fed via the bandpass filter, the 22 dB amplifier, a full-wave rectifier circuit and a smoothing circuit, TC3, to give a positive d.c. output which provides the second input to the differential amplifier. The magnitudes of the negative and positive d.c. outputs of the smoothing circuits TC2 and TC3 are directly proportional to the levels of the signals in the receive and send transmission paths respectively. The input circuit of the differential amplifier adds the negative and positive inputs algebraically and the resultant voltage is directly proportional to the difference in levels between the send path and receive path signals. The amplifier only responds to and amplifies a positive resultant, i.e. when the level of the signal in the send path is higher than that in the receive path. When the output of the differential amplifier exceeds the value set by the break-in threshold detector the decision is made that the former listener, A, has started talking and a signal is fed via the break-in hangover circuit to the main logic circuitry (I/P2). Input I/P2 overrides the suppression control signal (I/P1 to O/P1) which immediately removes the 60 dB switched attenuation from the send path thus permitting subscriber A's break-in speech to be transmitted to subscriber B. Subscriber A's speech passes unattenuated via the buffer amplifier, attenuator AU 2 and the 20 dB amplifier to leave the suppressor at the *line out* terminals. At the same time, output O/P2 from the logic circuitry switches an attenuation of 6 dB into the receive path. This additional loss serves two purposes:

(a) When both subscribers A and B are speaking simultaneously speech is present in both transmission paths and the echo suppressors at each end of the circuit will have both switched to the break-in state. This means that each direction of transmission between subscribers A and B will be attenuated by 6 dB, but the echo paths will be attenuated by 6 dB in each transmission path to give partial suppression of echoes, during the "double talk," of 12 dB. The 6 dB drop in received speech level during break-in is not noticed by either talker because when speaking, particularly during controversy, one does not wish to hear what the other party is saying.

(b) The 6 dB loss also attenuates the signal which is fed into the receive side of the differential amplifier, thus giving a 6 dB advantage to the send-side signals. This bias helps to maintain the echo suppressor in the break-in state until the conversation has settled down to the normal disciplined state of one talker only.

The break-in hangover is provided to prevent the echo suppressor from switching rapidly between the break-in, suppression and non-operated states as the instantaneous level of the speech in the transmission paths changes. The hangover time, which is about 250 ms, is long enough to smooth out this erratic operation which in older type echo suppressors caused considerable mutilation of speech during double talk.

The break-in circuit operation also facilitates the transmission of short interjections by the listener.

The two circuits from the *local in* and *line in* terminals to the inputs of the differential amplifier are accurately matched (to within ± 0.5 dB) so that the send and receive path signals have equal control over the differential action up to the time of break-in. The balance control provides an adjustment to compensate for manufacturing tolerances in the gains of the two circuits but careful circuit design was necessary to ensure adequate matching of the rectifier circuits over the range of speech levels from -40 dBm0 to $+6$ dBm0. This range represents a minimum to maximum voltage ratio of 200 at the output of the rectifiers. The time constants of TC2 and TC3 are different. The value of TC3 is chosen so that the d.c. output voltage approximately follows the shape of the speech envelope waveform. The amount of smoothing is also sufficient to prevent false operation of the break-in circuit by spiky interference signals, such as noise from subscriber A's end of the circuit and echoes of sharply rising signals in the receive path when the end delay is small. The maximum value for the time constant of TC3 is limited because it directly affects the break-in operate time. The operate time for normal speech levels is about 5ms.

The time constant of TC2 is greater than that of TC3 so that the d.c. output voltage will not have decayed by more than 6 dB (half voltage) 25 ms after the cessation of a signal in the receive transmission path. This value of TC2 guards against false operation of the break-in circuit by echoes of receive path signals which appear at the send path input after being delayed by end delays of up to 25 ms.

Transmitted Speech

When only subscriber A is talking, his speech passes unattenuated through the send path to subscriber B. The logic circuit of the echo suppressor at subscriber A's end of the circuit interprets this as break-in speech and an attenuation of 6 dB will be switched into the receive path. Under this condition, the 6 dB loss plays no significant part in the performance of the circuit; it is only switched in under this condition for simplicity in design of the logic circuit.

PRINCIPLES OF THE TONE DISABLER

The connexions of the tone disabler into the circuit of the echo suppressor are shown in Fig. 2. The tone disabler continually monitors the inputs of the two transmission paths through the echo suppressor so that it can be operated by a

conditioning tone from a data modem at either end of the circuit. It will recognize and operate to a conditioning tone signal of any single frequency which is above a threshold level of -31 dBm0 within the band 2,000 Hz to 2,250 Hz and which persists for at least 300 ms; it cannot be operated by continuous tones at frequencies outside of the conditioning band or by speech signals. When it operates, as well as inhibiting all echo suppressor action, the tone disabler switches itself to the broadband holding state. It can then be held operated by data signals at any frequency within the band 300 Hz to 4,000 Hz provided that the level of the signal is above -31 dBm0. The tone disabler will release and restore the echo suppressor to normal, after there has been a break of greater than 125 ms in the holding signals.

Tone Disabler Circuit Operation

The block schematic diagram of the tone disabler is shown in Fig. 3. The signals in the send and receive transmission paths are sampled by means of attenuators and 26 dB amplifiers having high input impedances to keep the tapping loss small. The outputs of the amplifiers are fed as parallel inputs into a combining circuit which includes the sensitivity control. The amplifiers, as well as amplifying the input signals, act as buffers between the send and receive transmission paths so that the crosstalk attenuation between the two paths will be high. The attenuators are adjusted to suit the nominal levels of the respective transmission paths. The combined output passes through a bandpass filter and 21 dB amplifier. The filter restricts the bandwidth accepted by the tone disabler to 300 to 4,000 Hz, to prevent it being falsely held by noise when in the broadband holding condition. Up to the output of the 21 dB amplifier, conditioning tone and speech signals are treated in the same manner. The output of the 21 dB amplifier is connected to two paths. Signals at all frequencies can pass through path 1 to a rectifier circuit which produces a positive d.c. output voltage which is proportional to the level of the a.c. input signal. Path 2 includes a band-stop filter which blocks frequencies within the conditioning tone band (2,000 Hz to 2,250 Hz) but frequencies within the guard bands, 700 Hz to 1,775 Hz and 2,475 Hz to 3,000 Hz will pass through the filter, the normally-closed switch and the 11 dB amplifier to a rectifier circuit which produces a negative d.c. output. The negative d.c. voltage is proportional to the level

of the guard band frequency component of the a.c. signal at the output of the 21 dB amplifier. The 11 dB amplifier gives the guard-band frequencies in path 2 a level advantage of about 5 dB over the signals in path 1. The negative and positive d.c. outputs are compared in the difference detector. This gives a d.c. output which is proportional to the difference in levels between the a.c. signals at frequencies within the guard-bands and the a.c. signals within the conditioning band. The combined output is fed to a d.c. amplifier which only amplifies when its input signal is positive.

Paths 1 and 2 are matched over the range of speech levels to ensure that the d.c. output of the difference circuit truly represents the signals in the transmission paths. All parts of the tone disabler through which a.c. signals pass are designed to prevent excessive production of harmonics which could be falsely detected as conditioning or guard-band signals.

Operation by Conditioning Tone

A conditioning tone applied to either transmission path of the echo suppressor will pass through path 1 to produce a positive d.c. output from the difference detector. This d.c. voltage is amplified and applied to the threshold detector which will operate when the d.c. voltage represents an a.c. signal level of -31 dBm0 or above in either transmission path. When the threshold detector first operates, its output is applied to the operate timing circuit where the signal must persist for at least 300 ms before an output is passed via the hangerover stage to the two inverters. The output from one inverter is taken to the echo suppressor main logic circuit, I/P 3 (Fig. 2). This signal inhibits all echo-suppressor action by overriding I/P 1 and I/P 2 and if the echo suppressor is already operated it is immediately restored to the unoperated state. The output of the second inverter performs two functions both of which are concerned with keeping the tone disabler operated during the transmission of data signals:

- (a) it operates a switch to disconnect path 2,
- (b) it prepares the operate-time canceller circuit against the time when subsequent short breaks occur in the holding signal.

If conditioning tone is applied on the circuit whilst speech is present, the conditioning tone level must exceed the speech

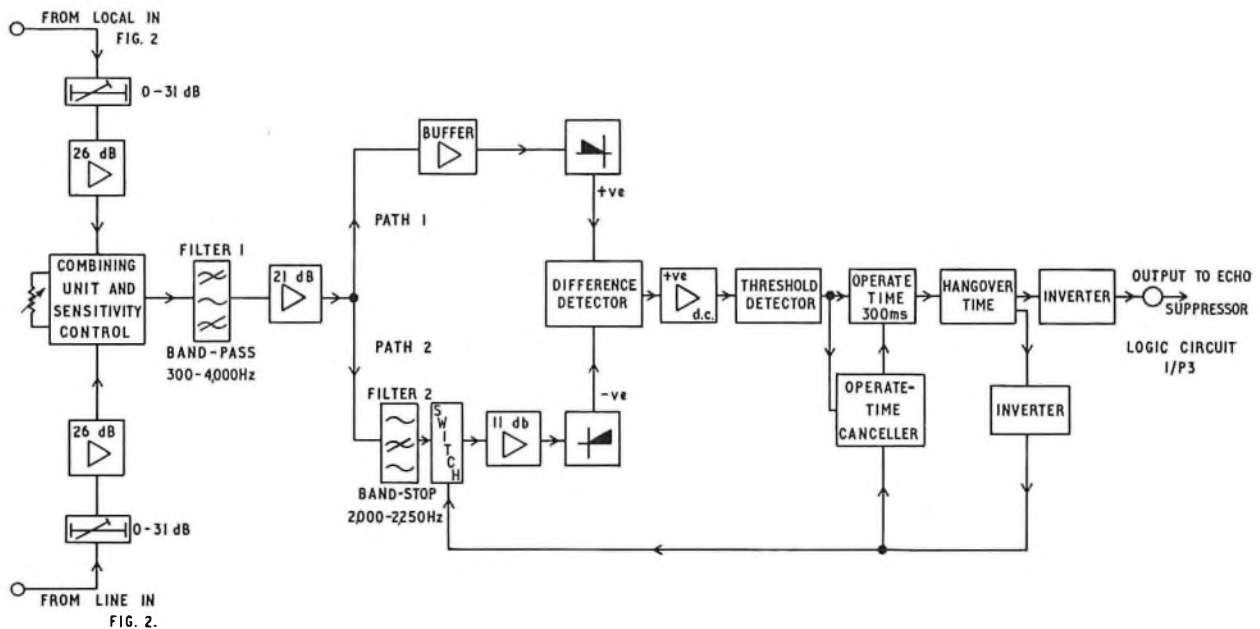

FIG. 3—Block schematic diagram of the tone disabler

signal level by about 5 dB for 300 ms before the tone disabler will operate. Path 2 is designed only to pass signals at levels above -39 dBm0 to ensure that the presence of circuit noise will not prevent correct operation of the tone disabler by a conditioning tone.

Immunity from Voice Operation

The arrangement of paths 1 and 2 to produce opposing d.c. outputs is one of two means used to prevent false operation of the tone disabler by speech signals. Speech signals will contain, simultaneously, energy at frequencies both within the conditioning-band and the guards-bands. Because path 2 has more gain than path 1, the output of the difference detector when speech is present will be a negative voltage which will not operate the tone disabler.

Further protection against voice operation is provided by the long operate time. Even when there is a large component of speech which falls within the conditioning band, it is very unlikely to persist for 300 ms at a level above that set by the threshold detector. The operate timing circuit is also designed to prevent cumulative operation by a number of short bursts of signals, having frequencies within the conditioning band and occurring at syllabic rate, by having a relatively short reset time. The timing circuit will completely restore to normal for a loss of conditioning signal exceeding 60 ms. This means that, after recycling, the duration of the conditioning tone required to disable is equal to the operate time. For breaks of a few milliseconds the timing circuit will not completely recycle. Thus after a short signal loss, the duration of conditioning signal required to operate the disabler is less than the operate time.

Broadband Holding and Release

When the tone disabler operates, path 2 is disconnected by the switch so that all signals at frequencies within the bandwidth of filter 1 (300 Hz to 4,000 Hz) will pass via path 1 to develop a positive output from the difference detector. Provided that the data signals which follow the conditioning tone are of sufficient level to hold the threshold detector, (i.e. above -31 dBm0) then the tone disabler will remain operated. When the data signals cease the threshold detector will restore to normal but the tone disabler will remain operated under the control of the hangover circuit for at least 125 ms. The tone disabler will release within 250 ms after cessation of the holding signal.

When breaks occur in the holding tone which are shorter than the hangover time, the tone disabler will remain operated

but the hangover time will start to elapse. On re-connexion of the holding signal the output of the threshold detector is immediately forwarded to recharge the hangover-time stage, without the delay of the 300 ms operate time. This is achieved by means of the operate-time canceller which short circuits the operate timing element when it receives simultaneous operate signals from the inverter and the threshold detector. Without this arrangement any short break which occurs in the holding signal would falsely release the tone disabler because the operate time (300 ms) is greater than the hangover time (125 ms to 250 ms).

Signalling Disabling

During the setting up and clearing down of telephone calls, the signalling relay-sets at each end of the circuit need to send audio-tone signals in both directions of transmission simultaneously. Under signalling conditions the international circuit is 4-wire terminated, therefore no echoes can occur. An earth connected to the *signalling disable* terminal of the echo suppressor by the adjacent signalling relay-set, during signalling, is applied to the main logic circuit input I/P 4 which inhibits all echo suppressor action by overriding inputs I/P 1 and I/P 2 in the same manner as the output of the tone disabler. The operate and release times of the signalling disabler are both less than 10 ms.

DESIGN ACHIEVEMENTS

Three of the new echo suppressors including tone disablers can be accommodated on each shelf of the 9 ft 62-type rack (Fig. 4). Each rack contains 42 Echo Suppressors compared with only 14 of the superseded echo suppressors in the same floor space.

All of the design objectives mentioned were achieved using a circuit which contains 67 transistors laid out on three printed wiring cards (Fig. 5) no electro-mechanical relays being used. The echo suppressor functions are contained on two of the cards and the third card is the tone disabler. The power consumption is 4 watts at 20 volts d.c. All setting up adjustments can be made by means of a screwdriver without removing the cards from the shelf.

CONCLUSIONS

The prototypes were tested in the Line and Radio Branch Laboratory followed by subjective testing at the Post Office Research Station. The results showed that the Echo Suppressor No. 7A met its performance requirements and proved that it was compatible with, and at least as efficient in

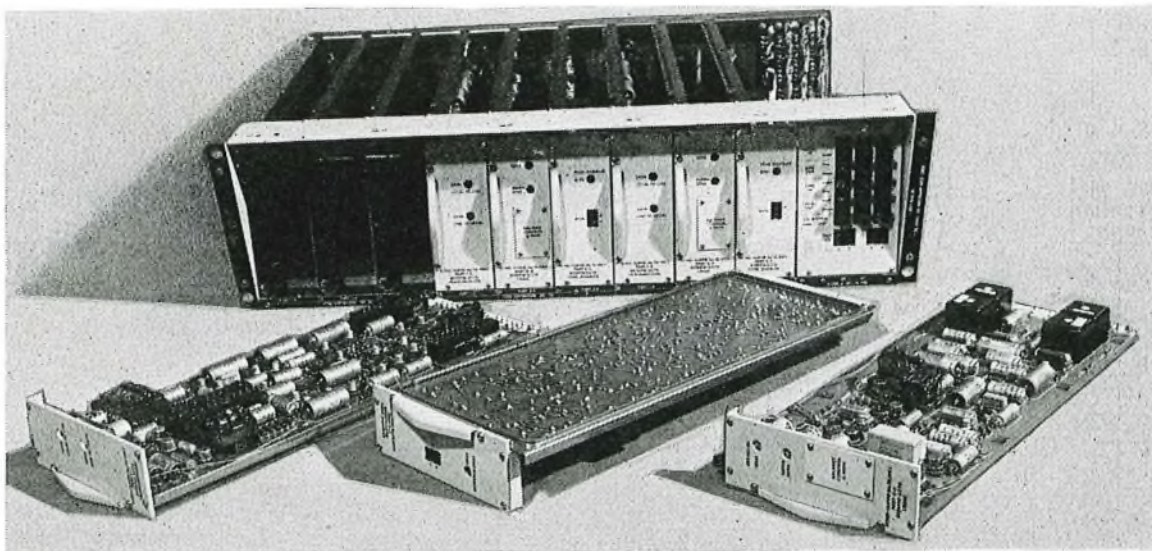

FIG.4—Shelf layout of Echo Suppressor No. 7A

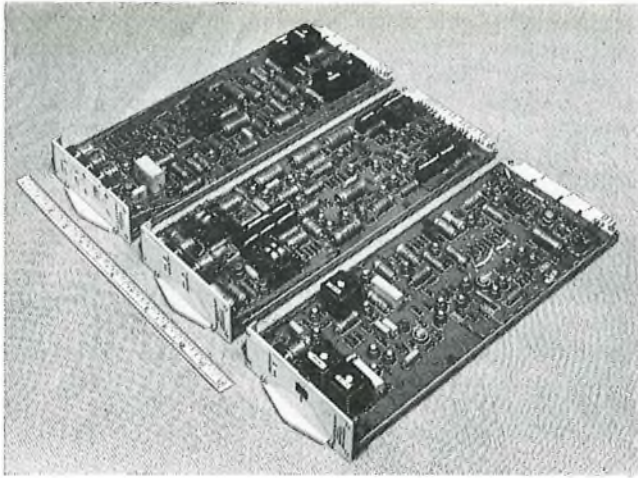

Fig. 5—Physical layout of Echo Suppressor No. 7A

performance as, similar echo suppressors developed by overseas administrations. The tests also proved that the new

echo suppressors would give the public improved international telephone calls.

The first 120 Echo Suppressors No. 7A were installed in the International Repeater Station at Faraday Building, London, during 1968 for use on transatlantic telephone circuits routed by way of the Intelsat I (Early Bird) and Intelsat III satellites. A further installation of 250 echo suppressors at Faraday is being used to replace the echo suppressors used on cable circuits. Three hundred Echo Suppressors No. 7A are also being installed at the new International Switching Centre at Wood Street, London.

A considerable number of Echo Suppressors No. 7A are being supplied to overseas administrations by British manufacturers.

ACKNOWLEDGEMENT

The Echo Suppressor No. 7A was designed and developed in conjunction with Associated Electrical Industries Ltd.

References

- ¹ SHANKS, P. H. A New Echo Suppressor for Long Distance Communications. *P.O.E.E.J.* Vol. 60, p. 288, Jan. 1968.
- ² C.C.I.T.T. Report to Study Group XV, Document AP IV/47-E, June 1968.

Transit-Trunk-Network Signalling Systems

Part 2—Multi-Frequency Signalling Equipment

C. B. MILLER and W. J. MURRAY†

U.D.C. 621.395.37; 621.395.38; 621.395.74

Part 1 of this article outlined the signalling arrangements adopted for the trunk transit network. Part 2 describes the facilities and operation of the multi-frequency senders and receivers at group switching centres, transit switching centres and at the incoming-terminal switching centres.

FACILITIES OF OUTGOING M.F. SENDER AND RECEIVER AT G.S.C.

The outgoing m.f. sender and receiver for the g.s.c. has been designed for operation in conjunction with electromechanical or magnetic-drum type controlling-register equipment.³ Access to the common pool of m.f. equipment is obtained from the registers by a finder circuit through which are extended the 2-wire transmission path, the signal leads and the control leads. The 2-wire transmission path is terminated on a line transformer: the primary winding provides a loop to hold the A relay in the outgoing-line signalling relay-set, and the secondary winding is connected to a directional filter. Avalanche diodes are connected across the secondary winding to limit the surge voltages arising from d.c. switching conditions on the transmission paths.

A 4-wire transmission path is derived from the 2-wire transmission path by the directional filter which comprises a high-pass and a low-pass section presenting 600-ohm input and output impedances. The low-pass filter prevents transmitted signals in the 1,380–1,980 Hz range from entering the m.f. receiver input stages, and the high-pass filter prevents

received signals in the 540–1,140 Hz range from appearing in the output stage of the signal-sending elements. To give adequate suppression of unwanted frequency components, the high-pass filter has been designed to have a nominal loss of 1 dB in the passband, which extends down to 1,360 Hz, and a loss in excess of 30 dB at 1,160 Hz. The low-pass filter also has a nominal loss of 1 dB in the passband and a loss in excess of 30 dB at 1,360 Hz.

The m.f. signals to be transmitted are applied to the input side of the high-pass filter from transistor sending-gates that function in a similar manner to the conventional diode-type static relay. The sending-gates are activated on the application of marking-in conditions, either on the 2-out-of-5 signalling leads from the register, or from control signals extended from the logic elements associated with the m.f. receiver output stages. The m.f. sender is equipped to forward any of the frequency combinations listed in Table 1 (Part 1).

The low-pass filter output is connected via a 4 dB attenuator to the m.f. receiver, which is designed to give a separate d.c. output corresponding to each of the signalling frequencies 660, 780, 900, 1,020 and 1,140 Hz. The receiver has a bandwidth of ± 20 Hz centred on each signalling frequency, and an operate range of -8 dBm to -26 dBm, provided that the frequencies comprising any signal lie within 8 dB of one another and their relative displacement with time does not exceed 5 ms. The receiver is also designed to reject any

† Mr. Miller is in the Telecommunications Development Department, Telecommunications Headquarters, and Mr. Murray is in the Network Planning Department, Telecommunications Headquarters.

frequency component in the signal arriving at the receiver at a level 15 dB or more below that of the frequency having the highest level.

The logic circuits incorporated in the receiver arrange that the prefix signal (660 Hz + 900 Hz) must persist for a nominal 20 ms period before a forward prefix is sent in acknowledgment. The recognition of the other backward signals detailed in Table 2 is made conditional on the prior receipt of a prefix signal. The logic elements also arrange for the d.c. channel outputs in 2-out-of-5 form to be checked for validity and conversion to a 1-out-of-10 discrete signalling condition for operation of the logic stages and extension of the signals to the register.

In the event of a condition other than a 2-out-of-5 combination being staticized in the receiver output, or the non-appearance of a d.c. channel output within a nominal 135 ms period following the cessation of the backward prefix, a d.c. signal is passed to the register to indicate that an error has occurred. Logic elements also check for any out-of-sequence signal condition, e.g. the detection of a number-received signal before a terminal proceed-to-send signal, and give an error signal to the register.

A timing element detects a failure to obtain a backward signal within 5 or 2.5 seconds of initial seizure or of the end of a forward signal. The 5-second time-out applies until the first terminal proceed-to-send signal has been received, after which the 2.5-second time-out applies. On recognition of an error condition, the controlling register immediately releases the m.f. sender and receiver and is programmed to make a second attempt to establish the transit-network call.

FACILITIES PROVIDED BY THE T.S.C. M.F. SENDER AND RECEIVER

At the t.s.c., a m.f. sender and receiver is directly connected on a 4-wire basis to each register equipment.⁴ On association of the register with an incoming line-signalling relay-set, following a line-seizure signal, the transmit and receive transmission paths are extended through the register to the m.f. sender and receiver.

The transmit path is connected in the m.f. sender to the combined output of the static modulators that control the sending of the backward-direction signals. The m.f. sender is equipped to send the frequencies 660, 780, 900 and 1,020 Hz, and these provide the frequency combinations corresponding to the backward prefix, transit proceed-to-send, and congestion signals, which are transmitted, as required, from t.s.c.s under the control of d.c. signals from the register. The receive transmission path is extended via a high-pass filter located in the m.f. receiver, which detects the forward signalling frequencies 1,380, 1,500, 1,620, 1,740, 1,860 and 1,980 Hz. The design characteristics of the high-pass filter and the m.f. receiver stages are identical to those employed in the outgoing g.s.c. equipment, with the exception of the receiver sensitivity and the frequencies of the tuned circuits in the channel-detector stages.

The m.f. receiver at the t.s.c. is required to provide d.c. outputs from each channel-detector stage over an input level range of -4 dBm to -22 dBm. This reduced sensitivity is obtained by increasing the value of the attenuator in the input stage to the receiver from 4 dB to 8 dB. The d.c. logic elements are arranged to detect a d.c. seizure signal extended from the associated register marker and to control the application of a continuous backward-prefix signal, the transmission of which continues until the m.f. receiver has detected a forward acknowledging prefix (1,740 Hz + 1,980 Hz) as a 2-frequency-only condition persisting for a nominal 20 ms period. The backward signal is then replaced by an 80 ms pulse of the transit proceed-to-send signal.

Each of the received m.f. pulses corresponding to the ABC digit sequence is passed forward, on detection, to the register as d.c. signals of fixed duration. In the event of a con-

gestion signal being marked-in by the register, a continuous backward-prefix signal is first transmitted and then replaced by an 80 ms pulse of the congestion signal after a forward acknowledging prefix signal has been received and recognized. On completion of sending the congestion signal, a d.c. signal is forwarded to the register, which resets the m.f. sender and receiver before clear-down.

FACILITIES PROVIDED BY INCOMING TERMINAL M.F. SENDER AND RECEIVER

The incoming terminal sender and receiver is connected on a 4-wire basis to the register⁵ from which the 4-wire transmission path is extended to the incoming trunk circuit on the association of the register with the incoming line-signalling relay-set. The same design of equipment is used as in the t.s.c. application, with a number of additional facilities to provide the different types of backward signal to be sent from an incoming terminal centre. For the present application, the m.f. sender is equipped to send the frequencies 660, 780, 900 and 1,140 Hz, which cover the requirements of existing designs of incoming terminal centres, to send the backward prefix, terminal proceed-to-send, number received (n.r.) and spare code signals. For future designs of incoming terminal centres all the signals listed in Table 3 with the exception of the transit proceed-to-send signal are required and will be incorporated in a different design of m.f. equipment.

On seizure by the associated register, a continuous prefix signal is transmitted by the m.f. equipment. At the same time, a terminal proceed-to-send signal is marked-in for transmission on detection of the forward acknowledging-prefix signal. The signal-sending control includes additional logic elements to enable all backward signals following the initial terminal proceed-to-send signal to be preceded by a pulse of the prefix signal of nominally 80 ms duration. On completion of sending each signal sequence, a d.c. signal is passed to the register to permit any following signal to be processed immediately or, following a n.r. or spare-code signal, to permit the register to reset the m.f. equipment and after the completion of sending Strowger digits into the local network, to clear-down.

SIGNAL SENDING ARRANGEMENTS

Operation to a Transit Switching Centre

The basic logic elements of the outgoing g.s.c. m.f. sender are shown in Fig. 4. On detecting the backward-prefix signal, the m.f. receiver extends a condition on the prefix lead to set the toggle TBP. The toggle output operates gate G7, which in turn enables the linear gates G4 and G6 to send, continuously, the forward-prefix frequencies 1,740 Hz and 1,980 Hz via the high-pass filter to the 2-wire line. A subsequent marking on the transit proceed-to-send lead operates gate G8, which has already been primed by a signal from the digit distributor. The output from gate G8 operates relay DA, and the DA1 contact extends a marking signal on the D1 lead to the controlling register equipment. In response, the A digit is marked-in as a 2-out-of-5 condition on the SA-SE leads to operate the appropriate two relays in the group A-E. The contacts of the operated relays extend signals to the corresponding AND gates in the group G12-G16 and also operate gate G9. The output from gate G9 primes the 6 ms delayed-start element T1. The function of this element is to prevent any discontinuity resulting from contact bounce from the register or m.f. equipment interface relays. The delayed-output element T1 resets toggle TBP via gates 21 and 24. Gate G7 is thus closed, so stopping the prefix frequencies being sent at gates G4 and G6. The output from element T1 also removes the enabling condition from gate G10, so closing gate G11 and removing the input signal condition from the end element T2, which operates and gives

an output signal for an 80 ms period. The output from element T2 is passed to gates G12–G16 and, in conjunction with the marking from the contacts of the operated relays in the group A–E, permits the two frequencies corresponding to the A digit to be transmitted to line from the appropriate linear gates in the group G1–G6. The output from element T2 also operates gate G17, previously primed by the signal condition on the transit proceed-to-send lead. The output from gate G17 operates gate G18, which applies a signal input to the end element T3.

At the end of the 80 ms period, the T2 element output is restored, the transmission of the A digit ceases, the pulse-unit PU1 is operated and the digit distributor steps. The digit distributor releases relay DA and operates relay DB, so removing the marking from the D1 lead, permitting the operated relays in the group SA–SE to release and, subsequently, gate G9 and element T1 to restore. Contact DB1 marks the D2 lead to the register equipment. The restoration of element T2 also removes the signal from gate G17, and the subsequent closure of gate G18 ends the signal input to element T3, which then gives an output for an 80 ms period. This operates gates G4 and G6 to send an 80 ms pulse of the forward prefix signal.

During the sending of the prefix signal, the B digit is marked-in by the register equipment on the SA–SE leads and the appropriate relays in the group A–E are operated. The sequence of operation of the logic elements that ensues is similar to that already described for the A digit, except that during the operation of element T2, the frequencies sent to line correspond to the B digit. At the end of the 80 ms digit-signal period, a further 80 ms prefix signal is sent, and the digit distributor is stepped. The marking signal is removed from the D2 lead and applied to the D3 lead to the register.

The output from the digit distributor also sends a pulse signal to reset the m.f. receiver logic, and the signal condition is then removed from the transit proceed-to-send lead, thus preventing the sending of a further prefix signal on the restoration of element T2.

During the sending of the second pulse-prefix signal, the C digit is marked in on the SA–SE leads, and the circuit operation is similar to that described for the B digit except that the two frequencies corresponding to the C digit are transmitted to line for 80 ms. At the end of the 80 ms period, the pulse unit PU1 is operated and resets the digit distributor preparatory to the sending of a further digit sequence.

Operation to the Incoming Terminal

On the recognition of the prefix signal from an incoming terminal, toggle TBP operates, permitting the forward prefix frequencies to be transmitted as already described. The marking on the terminal proceed-to-send lead operates toggle TM. This operates relay DX and inhibits the operation of the digit distributor at gate G19. Contact DX1 extends a marking condition to the register equipment, which responds by marking-in the digit to be sent on the SA–SE leads, the corresponding relays in the group A–E. The logic circuits then operate in a similar manner to that already described for operation to a transit switching centre, so that the prefix signal is cut off and the two frequencies corresponding to the marked-in digit are transmitted to line for 80 ms. In this instance, however, the output of element T2 also operates gate G22 to set the toggle TL, which remains operated until the m.f. equipment is released. At the end of the 80 ms period, element T2 restores and operates pulse-unit PU1. This resets toggle TM, which releases relay DX, so

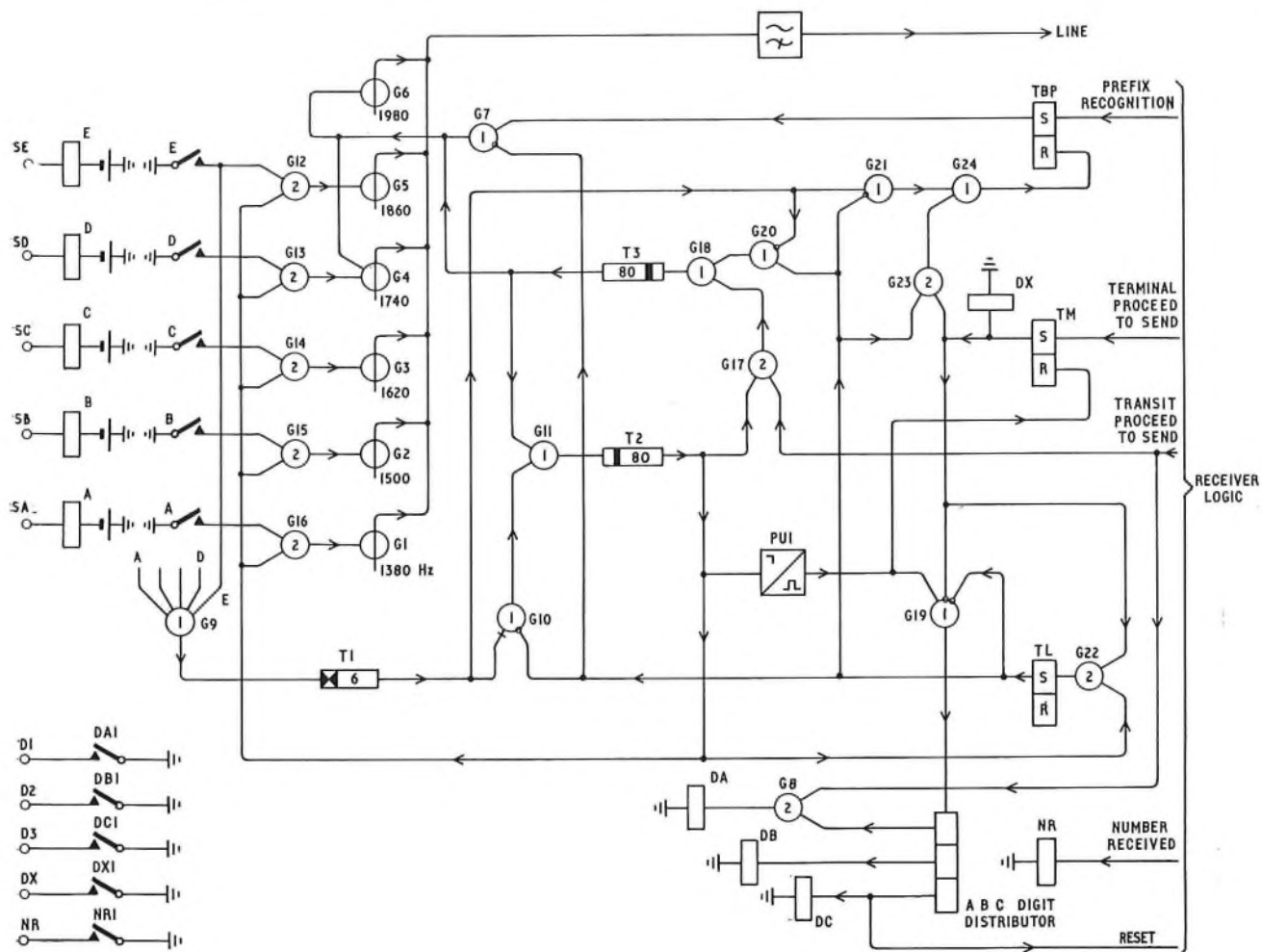

FIG. 4—Outgoing g.s.c. m.f. sender logic

restoring the operated relays in the group A-E. Toggle TL functions to control the change-over of the logic elements to enable all signals to be sent forward as 2-element pulse signals.

The subsequent terminal proceed-to-send signals are in the form of 2-element pulse signals. On recognition of the prefix pulse in the m.f. receiver, toggle TBP is set, preparing for the recognition and storage, on the toggle TM, of the following pulse of the terminal proceed-to-send signal. The setting of toggle TM operates relay DX. The output from toggle TM also operates gate G23, previously primed by the output from toggle TL. Gate G23 operates gate G24, which resets toggle TBP. The DX1 contact extends a marking condition to the register and the next digit to be sent is marked-in on the SA-SE leads operating the corresponding relays in the group A-E and, subsequently, gate G9 and element T1, as described previously. In this instance, the output of element T1 restores gate G20, previously operated when toggle TL was set. The removal of the output from gate G20 restores gate G18, and its closure ends the signal input to element T3, which then operates for 80 ms. The output signal of element T3 also operates gate G11, which applies a signal to the input of element T2. On restoration of element T3, the sending of the prefix signal ceases and gate G11 restores. The removal of the input signal from element T2 permits it to operate for 80 ms to send out the marked-in digit as previously described. Pulse-unit PU1 operates on the restoration of element T2 and the output resets toggle TM and releases relay DX, so releasing the operated relays, gate G9 and timer T1.

The remaining numerical digits are sent forward in a similar manner, in response to further terminal proceed-to-send signals. If such a signal arrives before the next digit has been dialled by the subscriber, the system awaits the storage of this digit, which is then sent forward immediately. On recognition of a state-of-connexion signal, e.g. n.r., a discrete output signal is forwarded to the register, which then releases the m.f. equipment. The method of operation after the first terminal proceed-to-send signal also permits a signal from the incoming terminal to be sent immediately following the

sending of a terminal proceed-to-send signal without waiting for a response to it. This override facility enables the terminal proceed-to-send signal to be cancelled and the new signal to take over the control and initiate further action at the outgoing controlling register.

M.F. RECEIVER ARRANGEMENTS

The circuit logic and the receiver arrangements used at a t.s.c. for the reception and detection of m.f. signals in the band 1,380-1,980 Hz and the conversion into 2-out-of-6 code are shown in outline in Fig. 5.

A limiter device comprising avalanche diodes, which restricts the magnitude of high-voltage surges on the network, is incorporated in the secondary side of the transformer coupling the incoming receive transmission path to the high-pass filter. The filter prevents backward-direction signals in the 660-1,140 Hz range, returned via the outgoing g.s.c. 2-wire/4-wire termination, from entering the receiver circuits. The filter output is connected to a common amplifier that provides a 9 dB gain for incoming signalling frequencies and matches the impedance of the 600-ohm filter output to the 110-ohm common input to the six channel filters.

Each channel filter is tuned to the appropriate signalling frequency and has band-pass characteristics over the required ± 20 Hz range. The output of each filter drives a detector stage, which gives a d.c. output when the a.c. input signal level exceeds a predetermined threshold value controlled, in the first instance, by a common sensitivity-control connected to each channel detector. As the applied signal builds up, the cross-bias control, comprising diode networks coupling each channel sensitivity circuit, becomes operative. The sensitivity of each signal-detection stage is reduced and becomes a function of the cross-bias voltage developed in the channel with the highest power level at its input. The cross-bias voltage is applied by this channel to all other channels, and is arranged so that with a level difference between frequencies in excess of approximately 12 dB the lower-level frequency will not be detected. This arrangement satisfies the requirement that the signal frequency should be

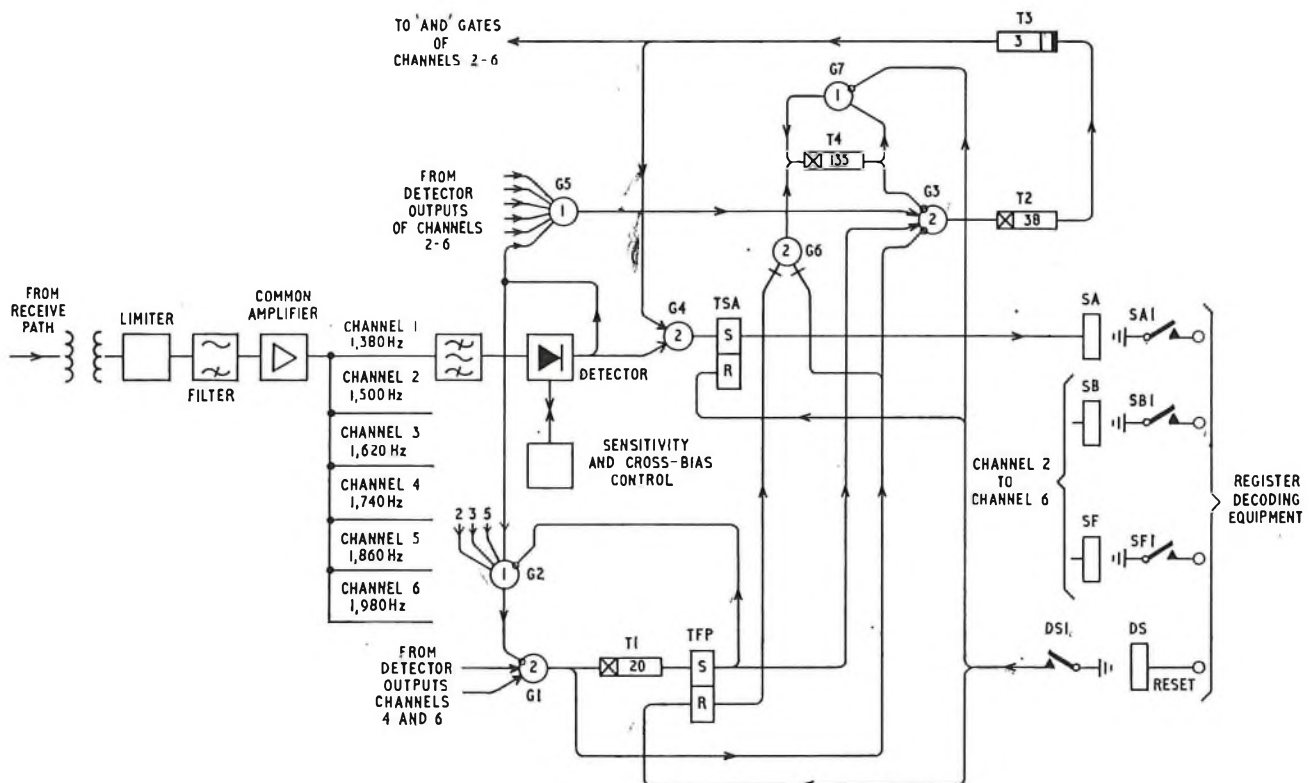

FIG. 5—S.S.M.F.2: receiver and logic for t.s.c.

rejected if its level is 15 dB or more below that of another simultaneously-received signal frequency and provides improved immunity against error conditions arising from the effects of transient voltages occurring during the transmission of signals.

On the application of a prefix signal from the distant end and following the cessation of the ringing of the channel filters, the two-only d.c. conditions corresponding to the prefix-signal channel outputs (channels 4 and 6 in this case) operates gate G1. The output from gate G1 primes the persistence-check delay-start timing element T1 and inhibits gate G3. Should any other channel filter subsequently give an output of sufficient magnitude to overcome the threshold of the channel detector, this other channel will give an output from gate G2 to inhibit gate G1. The prefix condition is then removed from the timing element T1, which restores.

After the two-only condition corresponding to the prefix frequencies has persisted for a nominal period of 20 ms, an output is given from the delayed-start timing element to set toggle TFP. The operation of toggle TFP primes gate G3 in preparation for the response to the information or digital signal applied via gate G5 following the cessation of the prefix signal. The output of toggle TFP also inhibits gate G2 to prevent a response to any frequency other than the prefix frequencies.

On cessation of the two-only prefix condition, the inhibit on gate G3 is removed and the 38 ms delayed-start element T2 is primed on the appearance of a channel output from gate G5.

After a signal-recognition time of nominally 38 ms, an output from the T2 element operates the pulse-timer element producing a 3 ms pulse. The output from element T3 primes gate G4 of channel 1 and the corresponding gates of all other channels, permitting any output from channels 1 to 6 which is present during the operation of element T3 to be stored on the associated channel toggles TSA-TSF, respectively. The continuous outputs of toggles TSA-TSF operate corresponding reed relays, the contacts of which connect earth signals to the register decoding equipment. After processing the signals, the register resets the receiver toggles to permit a response to a further incoming prefix signal. In this particular case, the detection of an error condition in the signal observed as a 1-out-of-6 condition, or more likely a 3-out-of-6 condition, is detected in the associated register.

The delayed-output element T4 provides for a nominal 135 ms period for the acceptance of any signal following the cessation of the prefix signal. In the event of a signal not being stored within the 135 ms period, element T4 inhibits gate G3 on each channel detector stage and remains operative until reset by the register equipment.

POWER SUPPLIES

The 12-volt positive and the 12-volt negative d.c. power supplies for the operation of the semiconductor devices and the reed relays incorporated in the m.f. sender and receiver equipment are derived from d.c. regulators operating from an 18-volt positive and an 18-volt negative exchange battery. The regulators have been designed to provide a stable voltage output of 12 volts \pm 2 per cent with load variations from 0 to 1.5 amp over the battery supply-voltage range of 14 to 18.8 volts. To protect the semiconductor devices in the m.f. equipment, each regulator is designed to disconnect the power supply input within 100 ms of the output voltage exceeding 14 volts. Each regulator unit comprises a 12-volt positive and a 12-volt negative regulator mounted together on one mounting board and coupled together to provide a total of 24 volts for operation of the transistor stages. The 0-volt common provided by the coupling between the regulators is distributed throughout the m.f. equipment units on each shelf and connected to the "electronic" earth at the regulators. The term electronic earth is used to define the central feed of the +18-volt and -18-volt supply, which is earthed at the battery and distributed separately to the electronic power-supply equipment. The racks housing the electronic equipment are connected to the common exchange earth.

(To be concluded)

References

- ³ KEARSLEY-BROWN, R. H. G., and CUMMING, W. S. Trunk Transit Network: Access from Controlling Register-Translators at Group Switching Centres. *P.O.E.E.J.*, Vol. 61, p. 120, July 1968.
- ⁴ WALKER, N., STALLWORTHY, F. A., and MCLUSKY, R. F. Transit Switching Centres using B/B1121 Crossbar Equipment. *P.O.E.E.J.*, Vol. 60, p. 302, Jan. 1968 and Vol. 61, p. 20, Apr. 1968.
- ⁵ BLANCHARD, D. T., and RYAN, W. A. Trunk Transit Network: Incoming Register-Translators for Director and Non-Director Areas. *P.O.E.E.J.*, Vol. 61, p. 176, Oct. 1968.

Book Reviews

"The Principles of Mechanical Engineering Science in SI Units." M. G. Page, B.Sc.(Eng.)(Hons.), C.Eng., F.I.Mech.E., F.I.Prod.E., M.B.I.M., F.S.C. The English Universities Press, Ltd. x+196 pp. 100 ill. 20s (boards) 13s (paperback).

Although written primarily as an introduction to the concept of the International System of Units (SI Units), an objective which it achieves very well, this book is a useful conversion course for those more familiar with earlier systems. It is very readable, and, in addition to discussing the principles upon which the new system is based, shows, with the aid of many examples, how SI Units may be used to solve problems in the fields of dynamics, machines, statics, strength of materials and thermodynamics. Study of these examples, followed by solution of typical problems, of which many, with their answers, are included, enable the reader to rapidly gain confidence in, and a clear understanding of, the new system.

The book is also a useful compendium of physical laws governing the fields covered and can be recommended not only to those commencing their studies of mechanical engineering science but also to practising engineers seeking to bring their knowledge up to date.

S. J. L.

"Luminescent Screens: Photometry and Colorimetry." J. Kamler, M.Sc. London. Iliffe Books, Ltd. 204 pp. 146 ill. 60s.

The main topic of the book is the measurement of brightness and colour of phosphors in the screens of cathode-ray tubes used for monochrome or colour television (phosphors for postal uses are not mentioned at all). It is concerned entirely with measurement, not at all with the physics of luminescence and very little with the choice of the substances used. It gives an adequate theoretical background, and develops the experimental methods from it, describing both visual and instrumental techniques in good detail. On the measurement of colour in general the book offers nothing new, but the detail relating to cathode-ray-tube screens may prove useful. It is a translation from Polish, reading well in English, but the C.I.E. has become the I.C.I., which may be confusing. The references naturally tend to be more to Polish and Russian sources than those of an English book. The index is good and the diagrams are clear.

A. C. L.

Lives of Plant and Depreciation

R. C. KYME, C.ENG., M.I.E.E.†

U.D.C. 620.169: 657.372.3

Lives of plant and depreciation is a subject which engages the attention of numerous members of Headquarters staff of the British Post Office. This article describes the work of the Committee on Lives of Plant and Depreciation which is more commonly referred to as the Lives of Plant Committee.

INTRODUCTION

The largest single operating expense of Post Office Telecommunications Business is depreciation provision which, at present for the Post Office as a whole, is well over £100 M a year. The work of the Lives of Plant Committee forms a basis for depreciation provision and, in addition, provides information for cost studies.

PROCEDURE

In order to provide the information for depreciation provision and cost studies the committee:

(a) examines at regular intervals, normally every five years, the lives expected from the various items of plant which make up most of the fixed assets of the Post Office,

(b) examines the average net recovery value which items may be expected to realize after allowing for any costs resulting from the recovery operations,

(c) assesses the capital value of the items in a particular category for which lives and net recovery values have been assigned,

(d) advises what records should be kept, with the object of supplying data to enable the committee to frame its recommendations.

PLANT GROUPS

For accounting purposes, Post Office telecommunication and postal engineering plant, including motor transport, is arranged in groups of which, at present, there are 56. Some groups consist of more than a single class of items, a typical example being the exchange equipment group which is broken down into the following seven sub-groups:

- Main automatic exchange equipment,
- Main batteries,
- Small automatic exchanges,
- Mobile non-director and mobile tandem exchanges,
- Unit Automatic Exchanges No. 12,
- Unit Automatic Exchanges No. 13,
- Unit Automatic Exchanges No. 14.

The Lives of Plant Committee considers a number of plant groups and sub-groups each year. Review of the sub-groups is programmed so that the work of assessment by the division or branch concerned is not excessive in any one year. All

plant groups are reviewed at least once every five years, but more frequent review of an item may be justified if conditions are changing, or are likely to change, particularly rapidly. The need for reassessments usually ceases with advancing obsolescence, manual telephone exchanges being a case in point.

PLANT LIFE

The life which is the concern of the committee is the average life in one position. To take exchange equipment as an example, this means taking into account, not only the equipment first installed when an exchange is opened, but the extensions carried out throughout its life. When an exchange is finally recovered, much of the equipment may be relatively new and will be re-installed elsewhere. This explains why there are exchanges still working which were installed in the early 1930s, although the current life assessment for main exchanges is only 30 years and for UAXs only 15 years.

The statistical methods used to investigate past lives are complex and have been described adequately elsewhere.¹ An increasingly important factor, which must always be considered in the final assessment, is the possibility of premature retirement due to obsolescence, inadequacy, changes in policy, and changes in demand and requirements. It is perhaps not generally realized that much of Post Office plant is retired for these reasons rather than for wear and tear, decay, or action of the elements.

RECOMMENDATIONS AND REPORT

Committee papers prepared by experts co-opted to deal with particular plant items form the basis of the committee's recommendations. If the recommendations for any plant item involve a change in depreciation provision for that group of more than £100,000, they must be ratified by the appropriate Managing Director's Committee.

The work of the Lives of Plant Committee for any one year must be completed by October of that year. This permits the effects of the committee's findings to be taken into account in the financial forecasts for both the current year and also the following year.

Finally, a report is published. This report summarizes the authorized assessments of the committee for those items of plant reviewed during the year. This assessment will apply until the items are next reviewed by the Lives of Plant Committee.

References

- ¹ I.P.O.E.E. Paper No. 209. Depreciation and Service Life of Telecommunications Plant. KNIGHT, N. V.

† Operational Programming Department, Telecommunications Headquarters.

Transmission Measurements of Connexions in the Switched Telephone Network

P. N. RIDOUT, C.ENG., M.I.E.E., and P. ROLFE, B.SC.(ENG.), C.ENG., M.I.E.E.†

U.D.C. 621.317.34:621.395.74:621.394.4

A series of transmission measurements has been made over the United Kingdom switched telephone network to ascertain its suitability for data transmission at rates higher than at present offered. Measurements were made of insertion loss/frequency, group delay/frequency, signal/echo ratio, echo delay time and signal/basic noise ratio. Statistical distributions of these measurements were weighted according to the class of connexion and used to estimate the behaviour of the national network. A later article will interpret the results of this investigation in terms of the effect on various methods of data transmission.

INTRODUCTION

The Datel 600 service enables customers to transmit data over most routes in the switched telephone network at speeds up to 600 bit/s and, under favourable conditions, operation up to 1,200 bit/s is possible. The method of transmission used, binary frequency-modulation of a carrier near the centre of the audio-frequency band, is simple and flexible and the tolerance to noise is good. It is very suitable as a general-purpose system and parameters for its use in this type of service have been agreed internationally.

However, it is desirable to provide faster data-transmission services, and a number of transmission methods have been studied to determine the quality of service that could be offered at higher speeds. The principal factors which influence the maximum speed of transmission are the insertion loss/frequency and phase/frequency characteristics of the transmission path, the received signal/noise ratio, and the actual method of transmission used. Customers' lines, loaded junctions of various types, and carrier systems make their differing contributions to the overall transmission characteristic of a connexion. In addition, the situation is complicated by the occurrence of echo signals as a result of multiple reflections. Some aspects of these problems have been described in an earlier article.¹

Data transmission methods differ in their tolerance to imperfect transmission and in their signal/noise ratio requirements. Thus, an optimum system may be selected to suit a particular combination of transmission characteristics and signal/noise ratio. However, no single characteristic is representative of the telephone network as a whole. Therefore, statistical information about the transmission characteristics and signal/noise ratios encountered in the network is required to choose the best system to use or to estimate the quality of service to be expected from a given system. Consequently, a joint program of field measurements was undertaken by Research Department, Line and Radio Branch and three Telephone Regions.

It was impracticable to operate from subscribers' premises, and all measurements were made from telephone exchanges using simulated local lines. A prearranged program of tests, normally lasting two days, was carried out between four exchanges at a time. Four test teams were used to enable six routes to be tested without change in location. The actual exchanges were selected by a random process but the method of selection ensured that satisfactory proportions of short, intermediate and long connexions were tested.

DESIGN OF EXPERIMENT

Line Parameters

The transmission properties of the network were of primary concern, although some measurements of noise were included. Time-domain measurement techniques were considered but it was concluded that frequency-domain measurements met the more general requirements of the investigation.

The parameters of interest were:

- (a) insertion loss/frequency characteristics,
- (b) group delay/frequency characteristics,
- (c) magnitude of listener echo and its delay time,
- (d) rating of circuit using a Peak-to-Average Ratio (P.A.R.) meter,*
- (e) frequency-offset,
- (f) noise measured in the relevant bandwidth with no signal.

Selection of Exchanges and Routes

With the exception of tests made in the London Telecommunications Region (L.T.R.), the zone-group-minor routing structure of the telephone network was used as a basis for selection of different types of connexion.

Approximately 35 per cent of United Kingdom telephone traffic originates in the L.T.R., so that measurements in this Region were considered essential and a random selection of eight exchanges from each of the eight telephone areas was made.

Two other Regions were chosen: these were the North-West Region (N.W.R.) which is mainly industrial and the South-West Region (S.W.R.) which is largely rural. A selection of most types of regional and inter-regional routings was made and, although these exchanges were not chosen in a completely random manner, there is no reason to suppose that their choice has unfairly biased the experiment. Five telephone numbers, distributed throughout the equipment, were allocated at each exchange, four of which were used for tests and one for communication purposes.

Local-Line Simulation

The local-line network consists, in the main, of four different types of cable, namely 4, 6½, 10 and 20 lb/mile, together with overhead open-wire line. Laboratory tests indicated that it was possible to simulate, with sufficient accuracy over the frequency range of interest, any combinations of lengths of these cables by one single length of

† Research Department, Telecommunications Headquarters.

* A form of measurement of circuit distortion by means of a series of band-limited pulses.

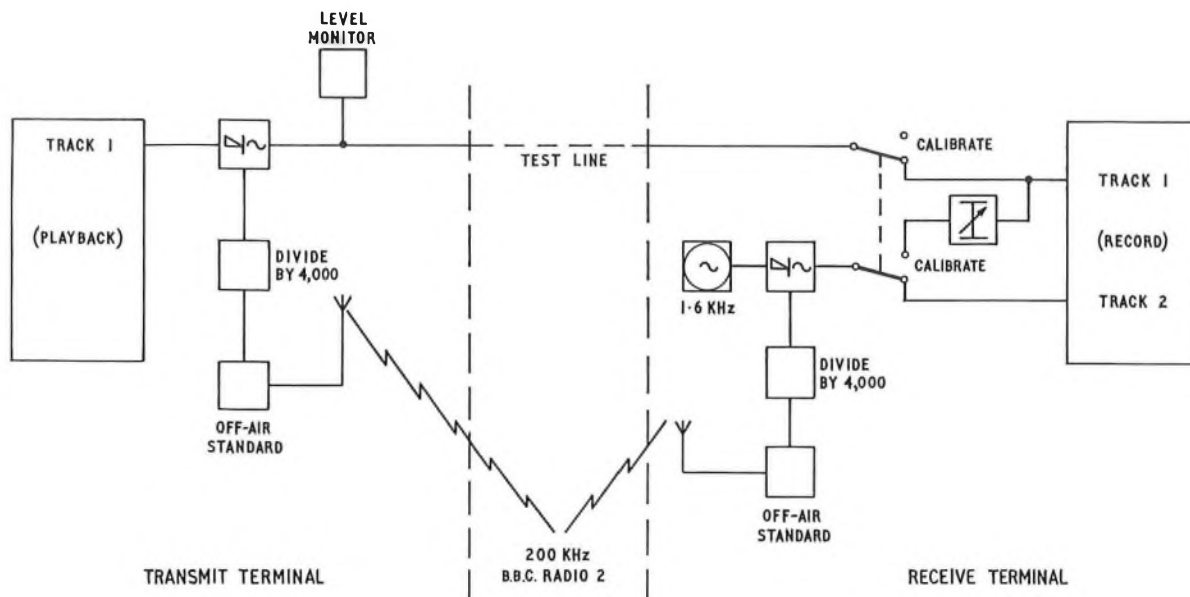

FIG. 1—Block schematic diagram of recording technique for measuring insertion loss and group delay

6½ lb/mile cable. Overhead open-wire line had virtually no effect on insertion loss and group delay over the frequency range of interest and was ignored.

Therefore, a local-line simulator was made covering the range of local lines encountered in the United Kingdom in six ranges of 6½ lb/mile cable. When choosing one of the six ranges of local line for a test, it was necessary to weight the choice according to the percentage of customers covered by that particular range. The weightings employed for lines in the L.T.R. were different from those used elsewhere in the United Kingdom.

MEASURING EQUIPMENT

It was considered that individual measurement of the required parameters in the field would require unwieldy equipment and complex operating procedures giving rise to a high possibility of equipment faults and misoperation. In addition, it would be difficult to keep to an acceptable timetable. A technique using magnetic tape recorders to generate and control the transmitted test signal, and to record it at the receiving end was therefore developed in order to streamline the measuring procedure. The recorded tapes were subsequently replayed in the laboratory to extract the required information. Advantages of this technique were:

- (a) the test procedure was standardized and reasonably quick,
- (b) the equipment could be operated efficiently by area staff after very little training,
- (c) transmit/receive roles were easily interchanged,
- (d) all the results were processed in the laboratory on a single semi-automatic equipment by a two-man team,
- (e) the magnetic tapes provided a permanent record of each test which could be re-examined in cases of doubt.

The measuring equipments used in the field were arranged to operate in either a transmitting or receiving mode and, after initial calibration, it was necessary only to play a master tape at the transmitting terminal and to record the resulting signal at the receiving terminal.

Four complete field equipments were used in the tests. The main items in each were a dual-track tape recorder, an off-air frequency standard and a specially-made control unit

which contained the amplitude modulators, calibrating oscillator, the local-line simulator and various function switches and relays used to control the test program.

The master tapes used to generate the test transmission carried the actual test signals on track 1. The various parts of the test program were controlled by a sequence of tones on track 2 which operated relays in the control unit.

PRINCIPLES OF OPERATION

Insertion Loss and Group-Delay Variation

A block schematic diagram of the technique used when making the tape records of insertion loss and group-delay variation is shown in Fig. 1. At the transmitting terminal, the master tape generated the program of 16 test frequencies in the range 200–3,500 Hz in an unmodulated form. The output of the tape recorder was then amplitude-modulated to a depth of 33 per cent by a 25 Hz square wave derived from the off-air standard receiver tuned to the B.B.C. 200 kHz transmission. The modulated test signal was sent to line via the local-line simulator at a level of –3 dBm into 600 ohms.

At the receiving terminal, the incoming signal was recorded on one track of the tape recorder, which had previously been calibrated for level by recording a short period of a local tone. A reference signal, modulated with 25 Hz derived from the off-air standard, was recorded simultaneously on the second track to provide a timing reference.

Listener Echo

To measure listener echo, a tone, gliding from 200–3,500 Hz, was transmitted via the test connexion from the master tape so that the received tone represented a continuous insertion loss/frequency characteristic of the line. Listener echo causes cyclic amplitude variations of the insertion loss/frequency characteristic from which the echo magnitude, delay time and phase can be determined.

No attempt was made to avoid the operation of v.f. signalling receivers. When the gliding tone operated a receiver, the connexion was broken but reconnected immediately the tone ceased to affect the receiver. As a result, a gap occurred in the received gliding tone centred about the appropriate signalling frequency, thus identifying the type of system.

P.A.R. Meter Pulses

The P.A.R. meter is a commercial instrument^{2,3} designed to provide a quick method of checking the quality of a telephone circuit for data transmission. In principle, a series of pulses having a spectrum approximating to that of the data system under consideration is transmitted over the circuit. The ratio of the peak value to the full-wave-rectified average value of the pulses is defined as 100 per cent and distortion encountered during transmission will reduce this ratio, the extent of the reduction providing a measure of the distortion. The meter is sensitive mainly to insertion loss and group-delay distortions and, since different data systems are affected differently by these two quantities, the relationship between P.A.R. rating and data-set performance varies with the modulation method and speed of transmission.

acteristic of the line could then be deduced from the settings of the attenuator. To derive the group-delay characteristic, the reference and test signals were demodulated and filtered to minimize the effects of line noise. The resulting 25 Hz sine waves were limited to form square waves which were applied to a phase comparator to enable the variation of group delay with frequency to be determined. This equipment is semi-automatic, requires a minimum of operator assistance and provides a page-type and paper-tape output. The information relating to echo, P.A.R. rating, frequency shift and noise was determined on the individual equipments and entered manually into the output using the teleprinter keyboard. A code number was included in the print-out to indicate the particular combination of tape recorders and control units used in a test, so that allowance could be made during computer pro-

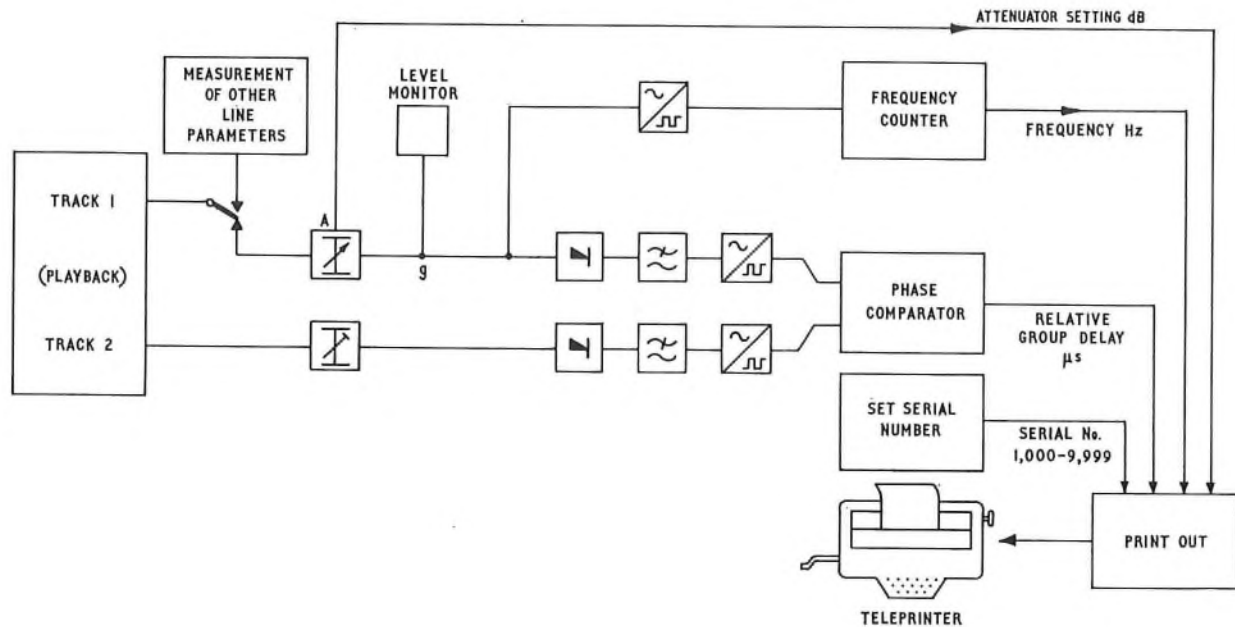

FIG. 2—Block schematic diagram of analysis technique for measuring insertion loss and group delay

Frequency Offset

To detect and measure any frequency offset suffered during transmission, a series of pulses, each containing two cycles of carrier and having a repetition rate which is a simple fraction of the carrier frequency, are transmitted over each connexion. Any frequency displacement alters the frequency of the carrier content of each pulse but not the repetition rate. When observed on an oscilloscope, the received pulses appear to rotate and by timing the rate of rotation the frequency offset can be deduced.

Additive Noise

The sending end of the line was terminated with 600 ohms, and with no transmitted signal, the noise reaching the receiving terminal was recorded in the full tape-recorder bandwidth. When the signal was replayed into the noise measuring circuit, a filter enabled a particular part of the spectrum to be analysed.

PROCESSING THE DATA

The insertion loss and group-delay characteristics were retrieved using the equipment illustrated in Fig. 2. After initial calibration, the attenuator A in the signal path was adjusted at each test frequency to restore the indicated level at point "g" to the standard value. The insertion loss char-

acteristics of the equipment.

The results were analysed by means of two main computer programs. These were:

(a) A program to find the mean, standard deviation, probability density and cumulative probability distributions of any measured parameter. The results shown in this article were obtained with this program.

(b) A curve-fitting program which read the insertion loss, delay and echo characteristics of each line in turn and determined equivalent control settings on a telephone line transmission simulator described in another article.*

DESCRIPTION OF TESTS

During February and March 1967, 480 test recordings were made over 60 routes within the L.T.R. In both the S.W.R. and N.W.R., 224 test recordings were made and, in addition, 144 recordings were made of connexions between these Regions during May and June 1967. Eight recordings (four bothway tests) were made over each route in one continuous period of approximately 3 hours. Most test series required three recording sessions, each of three-hours duration, to be completed in two days, including setting up and dismantling

* GROVES, K., and MACKRILL, P. A Line-Transmission Simulator for Testing Data-Transmission Systems. In this issue of the P.O.E.E.J.

the test equipment, and this normally allowed time for any contingencies. Some test series were only one day in duration and required a total recording time of six hours.

Test Procedure

When setting up the test connexion, it was necessary to ensure that the selection of equipment was not biased by connexions set up for communication purposes. Therefore, all other outgoing lines associated with the tests were cleared while the test line was being set up.

After one recording had finished, the connexion was held and a test made in the opposite direction. At the end of one bothway test, the test and communication circuits were released and set up again to the instructions of the test schedule. One bothway test took about 45 minutes.

RESULTS

Examples of the insertion loss/frequency and group delay/frequency characteristics measured in each Region have been included to illustrate the nature and range of the characteristics encountered. Only a small proportion of the results could be shown in this way but summaries of all the results are presented in the form of statistical frequency distributions of the various measured parameters. These distributions have been adjusted, by appropriately weighting the results, so that they are representative of the transmission characteristics encountered by telephone traffic in each Region in February 1968. From the results, corresponding traffic-weighted national distributions have been estimated.

Weighting of Results

The routes selected for test included sufficient of each class of connexion to ensure adequate representation of each class. The measurements were then weighted to produce results representative of a particular traffic pattern. However, no information regarding the pattern of data traffic in the United Kingdom was available. Therefore the traffic pattern for business telephone calls, as far as possible, was used instead and traffic details for February 1968 are shown in Table 1.

TABLE 1
Telephone Calls (Millions) for February 1968

Class of Connexion	Calls Originating Within:		
	L.T.R.	S.W.R.	N.W.R.
Director area to director area ..	208	—	—
Director area to adjacent charge group and vice versa	12·1	—	—
Calls within adjacent charge area ..	12·1	—	—
Trunk calls originating in L.T.R. ..	19	—	—
Local non-s.t.d. calls ..	—	49·2	73·6
Calls passing through two g.s.c.s ..	—	4·8	6·4
Calls passing through three g.s.c.s ..	—	2·1	2·8
Calls passing through more than three g.s.c.s	—	0·76	1·0

In most cases, the effect of weighting was small with some parameters affected more than others. All the results given in this article have been traffic-weighted.

The results are displayed for L.T.R., S.W.R., N.W.R., and S.W.R.—N.W.R. together with the estimated characteristics of the national network.

The longer-distance trunk circuits tested between the S.W.R. and N.W.R. used only one main route and so were not very representative of trunk circuits as a whole. However, the calls originated in several different parts of each Region and will, therefore, have included a variety of junction circuits. The ratio of local to trunk calls for the United Kingdom is about 7 to 1 and so the limited nature of that sample does not significantly affect the national picture.

For echo delay time and signal/echo ratio, information was available on longer trunk circuits from another source⁴ and this was used, in conjunction with a simple weighting method, to obtain a more accurate national picture.

Insertion Loss/Frequency Characteristics

Fig. 3 illustrates samples of the insertion loss/frequency characteristics measured in the different Regions with each characteristic plotted relative to its estimated loss at 1,700 Hz had there been no echo.

Figs. 4 and 5 show the Regional, inter-regional and national traffic-weighted cumulative distributions of insertion loss at frequencies of 400, 1,100, 1,700, 2,400 and 2,700 Hz.

Group Delay/Frequency Characteristics

Fig. 6 shows samples of group delay/frequency characteristics measured in the different Regions. No additional information with respect to the ripples due to echo was available, and so it was not possible to plot the group-delay characteristics in full detail. Consequently, all group-delay samples were plotted as the mean of the measured points and show no echo component.

Figs. 7 and 8 show the traffic-weighted regional, inter-regional and national cumulative distributions of group delay relative to that at 1,700 Hz at frequencies of 400, 675, 1,100, 2,400 and 2,700 Hz.

Listener Echo

(a) *Signal/Echo Ratio.* Traffic-weighted cumulative distributions of the worst signal/echo ratio observed on each connexion in the frequency band 900–2,400 Hz are shown in Fig. 9. The signal/echo ratio represents the ratio of the main signal amplitude to that of the first echo component. It is also the ratio between successive echo-component amplitudes.

The sample of trunk connexions measured in these tests was rather small and limited in scope. The results have been supplemented, however, by about 150 independent measurements⁴ made for facsimile test purposes. These independent results shown in Fig. 9 indicate that even lower signal/echo ratios were observed confirming the severity of the listener echo problem on trunk connexions.

(b) *Echo Delay Time.* Fig. 10 shows the cumulative distributions of echo delay time.

The estimated national distribution indicates that long trunk connexions only affect the distribution to any extent in about 10 per cent of connexions.

Delay times of up to 12 ms were observed in the independent measurements⁴ and the lower values of signal/echo ratio tended to be associated with long echo delays.

P.A.R. Rating

The distribution of P.A.R. rating measurements are shown in Fig. 11 together with an estimated distribution for the national network. The P.A.R. ratings of the trunk connexions are noticeably worse than those for the within-region and national connexions. This may be due to the more severe group-delay distortion and lower signal/echo ratio observed on the trunk connexions.

Frequency Offset

Frequency offset was detected on about 60 per cent of the inter-regional calls but never exceeded 0·5 Hz. Very little importance can be attached to these results, however, because of the small size of the sample (70 connexions) and the fact that only one main route was involved.

Line Noise

The distributions of received line noise-power are shown in Fig. 12. These were measured with a thermal meter via a filter centred on 1,700 Hz having 3 dB points at approximately

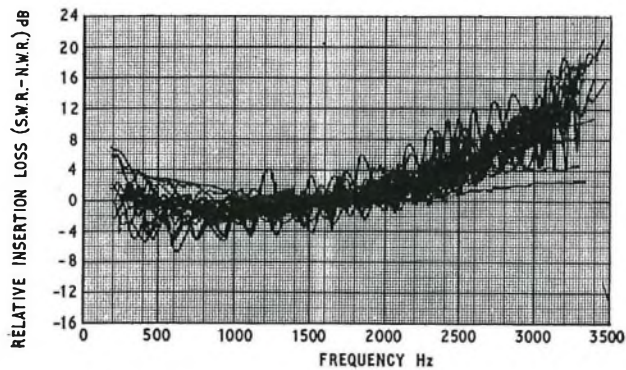
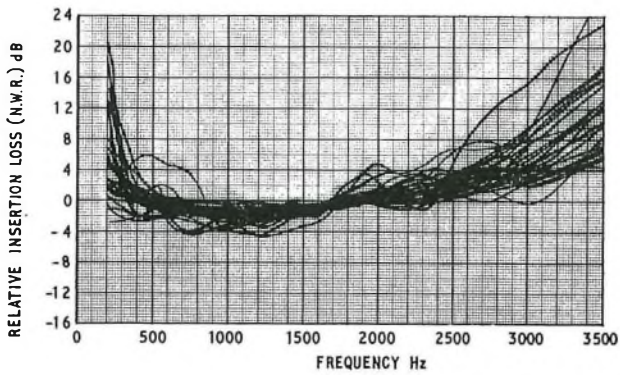
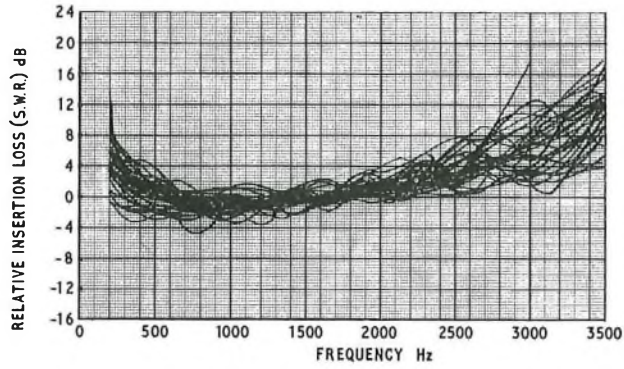
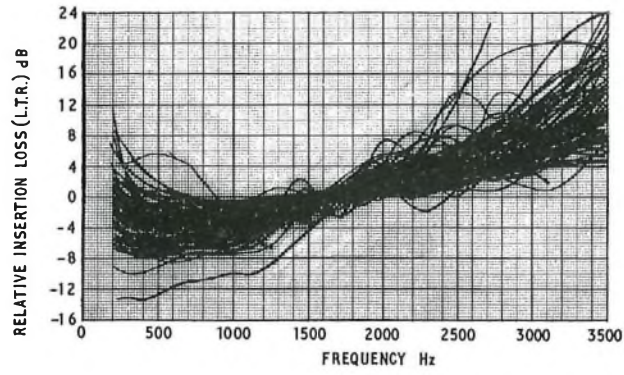
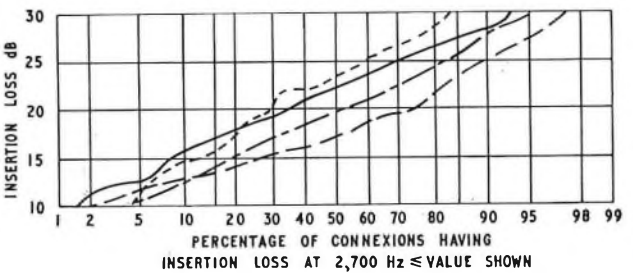
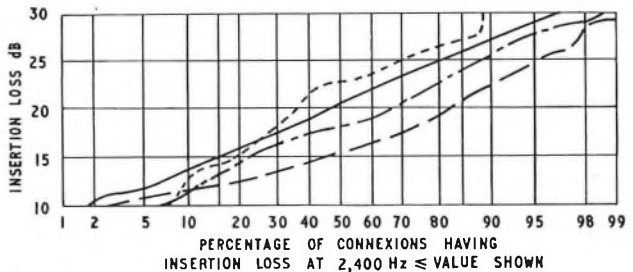
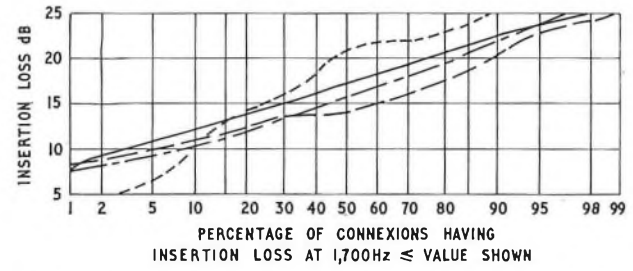
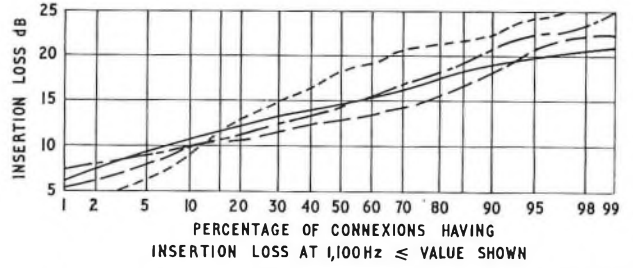
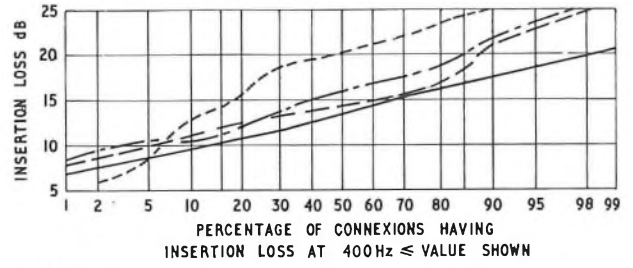

FIG. 3—Samples of insertion loss/frequency characteristics



— L.T.R. - - - S.W.R. — — — N.W.R. - - - S.W.R. — — — N.W.R.

FIG. 4—Regional and inter-regional traffic-weighted cumulative distributions of insertion loss

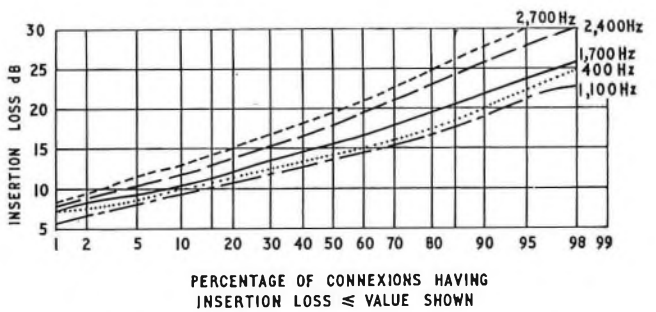

FIG. 5—National traffic-weighted cumulative distributions of insertion loss

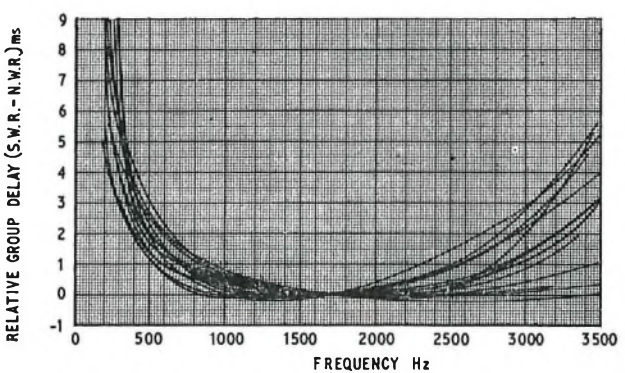
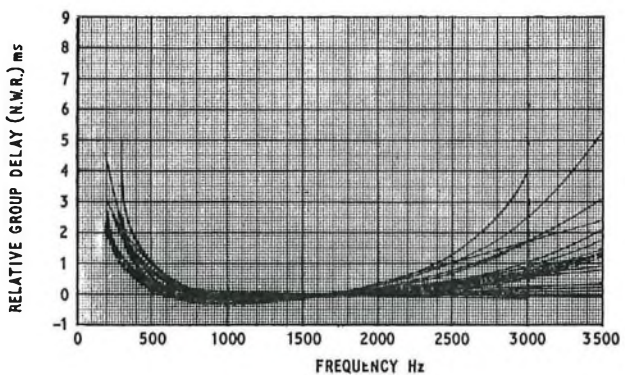
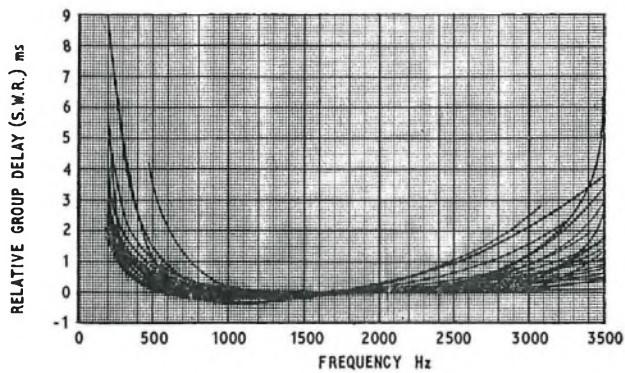
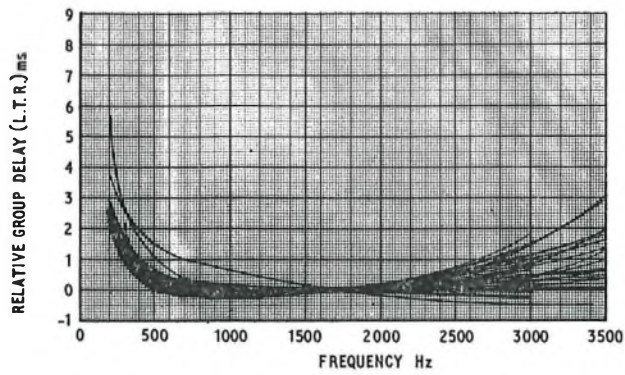
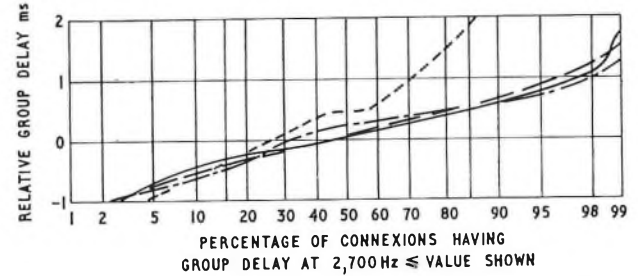
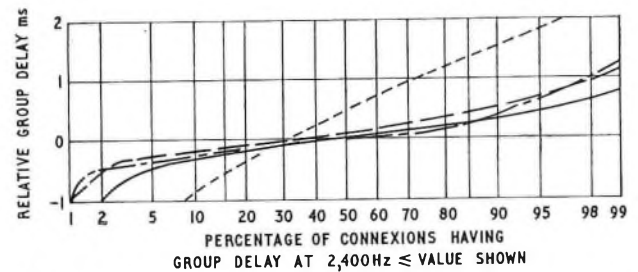
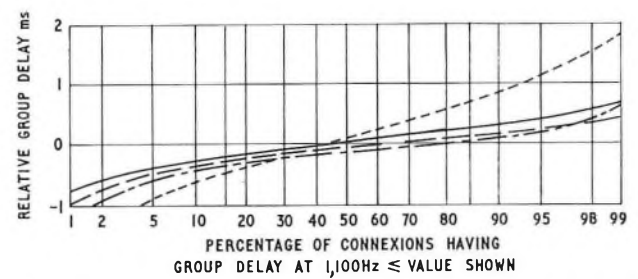
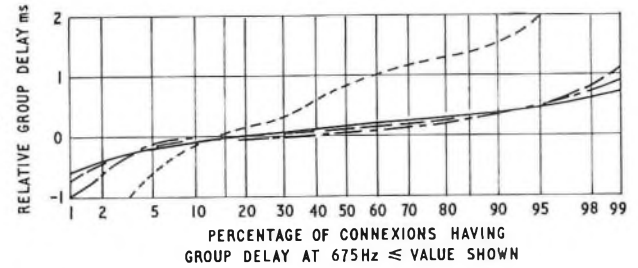
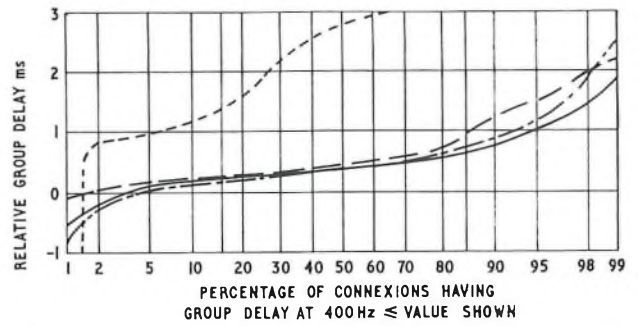

Fig. 6—Samples of group delay/frequency characteristics



— L.T.R. - - - S.W.R. - - - N.W.R. - - - S.W.R.-N.W.R.

Fig. 7—Regional and inter-regional traffic-weighted cumulative distributions of group delay relative to that at 1,700 Hz

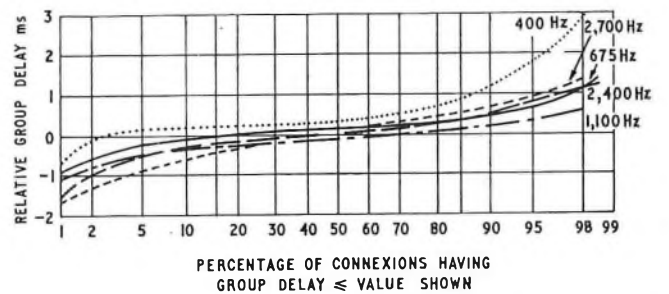

Fig. 8—National traffic-weighted cumulative distributions of group delay relative to that at 1,700 Hz

1,100 and 2,300 Hz and giving an equivalent noise bandwidth of 1,142 Hz.

Signal/Noise Ratio

The distributions of received signal/noise ratio are shown in Fig. 13. These were measured in the same frequency band as the line noise, with a transmitted level of -6 dBm into 600 ohms and a signal frequency of 1,700 Hz.

DISCUSSION OF RESULTS

The connexions tested were selected so that variations in the transmission characteristics of the national network could be estimated. Consequently, any one subscriber who generally only uses a small prescribed portion of the network, will not experience the whole range of characteristics observed in the tests.

Comparing the within-region results, the most noticeable differences arise in the insertion loss/frequency characteristics. The L.T.R. measurements showed a generally larger increase in insertion loss with frequency than in the other two Regions, an effect consistent with the use of loaded junctions in the N.W.R. and S.W.R., while much unloaded cable is used in the L.T.R. Unloaded cable introduces a small negative group-delay slope with increasing frequency, while loaded cable causes a generally positive slope. Again, characteristics consistent with the use of unloaded cable in the L.T.R. and loaded cable in the S.W.R. and N.W.R. were obtained.

Although the results have not been analysed separately for the various classes of connexion, their influence on the transmission characteristic can be deduced from the effect of the weighting of the measured results. In the S.W.R. and N.W.R., this indicated that local calls had a low insertion loss; a not unexpected result. In the L.T.R. weighting had little effect, suggesting that the insertion loss/frequency characteristic is largely independent of the class of call.

Weighting did not affect the within-region group delay/frequency distributions significantly indicating that connexion class has little influence on this characteristic.

The inter-regional characteristics differ from the within-region ones in the following respects:

(a) the insertion loss was generally several decibels greater and exhibited a greater spread

(b) the group-delay distortion was appreciably greater and displayed the dish shape associated with carrier-system channel filters, the increased delay at low frequencies being particularly apparent.

The most interesting and surprising results relate to the occurrence of listener echo. These results indicated that perceptible echoes (signal/echo ratio less than 30 dB) may be expected on about 75 per cent of all within-region connexions, that 50 per cent will experience ratios less than 20 dB and that 5-10 per cent may have values lower than 14 dB. Echo delay times on within-region calls ranged up to 4 ms and the median value was just below 2 ms indicating that most echoes traversed the whole length of the route, but in some cases two echo paths were present. Echoes were observed on both 2-wire and 4-wire circuits.

Signal/echo ratios on inter-regional connexions were appreciably lower than on those within-region, being below 10 dB in more than 10 per cent of connexions. Again, results indicated that echoes traversed the length of the route. Therefore, first listener echo delay times up to 15 ms may be experienced on extreme connexions within the United Kingdom. Echoes with delays less than 30 ms are not usually of great importance to speech transmission,⁵ but echoes with delays greater than about 0.5 ms may affect data transmission, particularly when the signal/echo ratio is low.

An example of measured characteristics, with severe echoes,

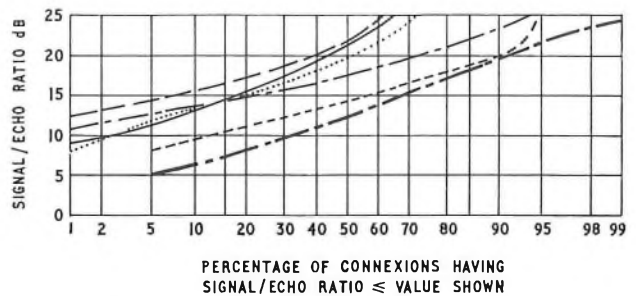

Fig. 9—Traffic-weighted cumulative distributions of signal/echo ratio

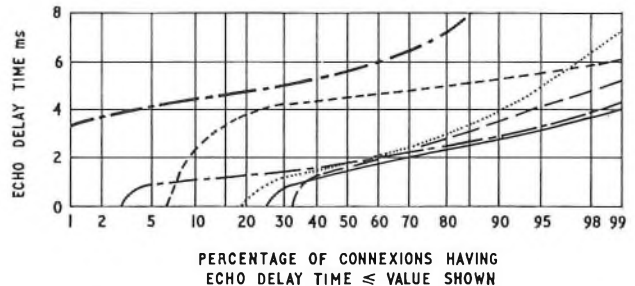

Fig. 10—Traffic-weighted cumulative distributions of echo delay-time

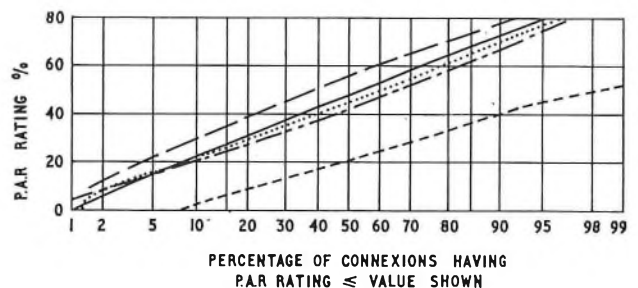

Fig. 11—Traffic-weighted cumulative distributions of P.A.R. rating

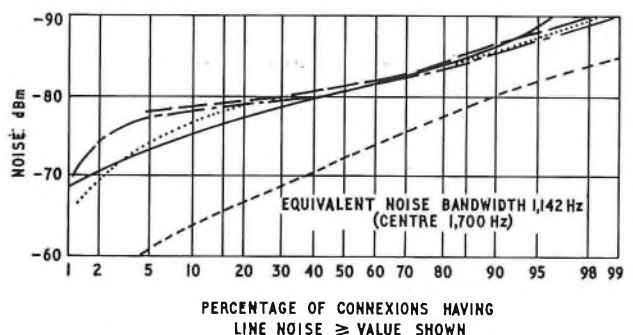

Fig. 12—Traffic-weighted cumulative distributions of line noise

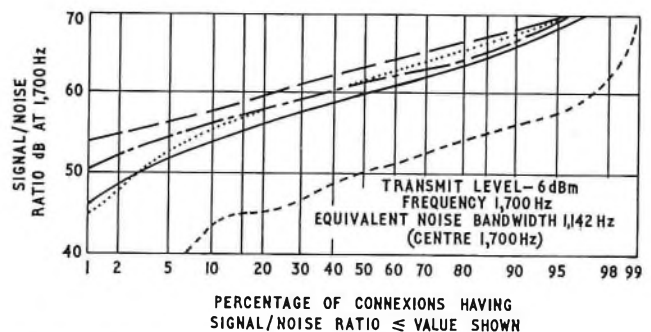

Fig. 13—Traffic-weighted cumulative distributions of signal/noise ratio

Legend for Figs. 9-13

— L.T.R. - - - S.W.R. - - - N.W.R. - - - S.W.R.-N.W.R.
 ··· National weighted - - - - Other trunk circuit measurements

shown in both the frequency and time domains, is given in Fig. 14.

As the signal/echo ratio is composed of two transmission losses plus two return losses, the very low values observed in some cases seem at first sight to be very difficult to explain. The balance return losses of 4-wire transmission systems should rarely fall below 5 dB and therefore, with circuits adjusted to 3 dB transmission loss, signal/echo ratios less than 16 dB should seldom occur. However, two factors which may have given rise to the lower values observed are:

(a) adjustment of these circuits to "best possible" loss which may lead to zero transmission loss at some frequencies. The signal/echo ratio could then fall to 10 dB,

(b) the presence of multiple echoes in some connexions measured.

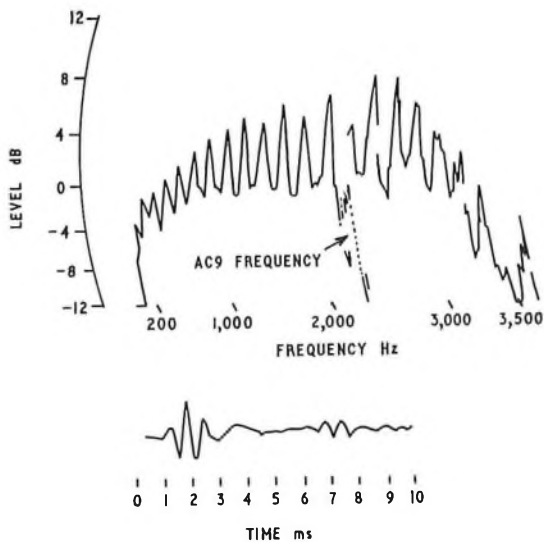

FIG. 14—Measured characteristics with severe echo shown in both frequency and time domain

Recently, a study of the method of alignment of amplified circuits has been started by Line and Radio Branch. Initial tests on the same trunk route (Bristol-Manchester) confirm that the majority of circuits had 2-wire to 2-wire losses of less than 3 dB. It is estimated that if all circuits were aligned to 3 dB loss instead of "best possible", improvements in signal/echo ratio of at least 3 dB at the median value and about 6 dB at the 5 per cent point would be obtained.

The measurements of line noise refer only to the continuous background noise in the frequency band of interest to data transmission. No measurements of impulsive disturbances were made in the tests since their effect can best be assessed by direct error-occurrence measurements with particular data-transmission methods. The signal/continuous-background-noise ratio together with the bandwidth determine the ultimate capacity of the channel and so the distributions of signal/noise ratio are of particular interest. These show that signal/noise ratios in excess of 50 dB were observed on most within-region connexions, but that the values on the trunk connexions were generally some 10 dB lower and values below 40 dB occurred in 5 per cent of cases. None of these was sufficiently low to affect existing data-transmission services but they approach the area of significance to higher-speed, multi-condition transmission systems.

The Federal Republic of Germany P.T.T. has carried out a similar experiment.⁶ Comparison of results shows that the basic shapes of the sample insertion loss and group-delay characteristics (ignoring echo effects) are the same, but the signal/echo ratio was, in general, 10 dB higher in the German tests. However, the German tests were divided into three series, each one having a central test point to which tests were made from ordinary telephone stations and the routes were chosen beforehand to conform with expected data traffic.

CONCLUSIONS

Measurements on randomly-selected routes in the switched telephone network have been made, and from these an overall transmission picture of the network in the United Kingdom has been obtained.

The semi-automatic measuring equipment allowed large amounts of information to be measured relatively quickly and easily by telephone area staff having no prior knowledge of the parameters to be measured. Research Department laboratory staff processed the magnetic tapes and transferred the information to paper tape used for computer analysis of the results.

The basic insertion loss and group delay/frequency characteristics measured were consistent with those expected from the component parts of the network. The spread of characteristics in the L.T.R. was rather greater than in the other two Regions measured but otherwise the differences were small. The presence of carrier transmission in the trunk connexions noticeably affected the characteristics.

Listener echo was observed on about 80 per cent of all connexions and had a major influence on the transmission characteristics. Some surprisingly low values of signal/echo ratio were measured, especially on trunk connexions, and subsequent tests have indicated that substantial improvements in signal/echo ratio may be obtained by a revised alignment procedure on amplified circuits.

Echo delay times up to 4 ms were observed on within-region calls and values up to 15 ms may be expected on trunk connexions in the United Kingdom.

ACKNOWLEDGEMENTS

The authors wish to thank their colleagues in the three telephone Regions concerned in the tests, Line and Radio Branch and Telegraph and Data Systems Branch. Thanks are also due to A. C. Frost and other colleagues in Research Department.

References

- 1 WILLIAMS, M. B. The Characteristics of Telephone Circuits in Relation to Data Transmission, *P.O.E.E.J.*, Vol. 59, p. 151, Oct. 1966.
- 2 ANDERSON, T. C. The P.A.R. Meter. *I.E.E.E. International Convention Record* 1964, Part 5, p. 155.
- 3 COCHRAN, W. T. Measuring Waveform Distortion with a P.A.R. Meter. *Bell Laboratories Record*, Vol. 43, No. 9, p. 369, Oct. 1965.
- 4 Unpublished measurements made by Telegraph and Data Systems Branch, Telecommunications Headquarters and Rank-Xerox.
- 5 RICHARDS, D. L. Theoretical Study of the Functioning of Echo Suppressors, *Teletechnik* (English Edition), Vol. 7, p. 71, 1963.
- 6 C.C.I.T.T. Comp. Sp.A-Doc. No. 95-E Federal Republic of Germany, Study of the General Switched Telephone Network with a view to its suitability for Data Transmission. Feb. 1967.

Metal-Oxide-Semiconductor (MOS) Integrated Circuits

Part 2—Simple Logic Circuits

F. H. REYNOLDS, PH.D., B.SC.(ENG.), C.ENG., F.I.E.E., A.INST.P., and W. D. MORTON, B.SC., C.ENG., M.I.E.E.†

U.D.C. 621.38.049.7: 537.311.33: 621.374.32

The basic circuit unit of nearly all metal-oxide-semiconductor (MOS) integrated circuits is the logic inverter. Of the many possible inverter configurations, some of the more useful types are described and compared and it is shown how they may be adapted to provide desired logic functions. The performance of the circuits is then discussed, concentrating on noise immunity, switching speed and power consumption. It is finally shown how the transistor technology outlined in Part 1 can be utilized for the fabrication of circuits, showing also the essential design features of the necessary photographic masks.

INTRODUCTION

In Part 1 of this article the metal-oxide-semiconductor (MOS) transistor was considered as a discrete device and its construction, mode of operation and salient characteristics were described concluding with the essential steps involved in its manufacture. Attention was drawn particularly to the attractively simple features of the device, notably to the proportionate dependence of many of its parameters on the width/length ratio of the channel. Of the possible forms of the MOS transistor, the p-channel enhancement type was seen to combine the advantages of manufacturing simplicity and ready circuit utilization, and it is, therefore, used almost exclusively in MOS integrated logic circuits.

The present article describes and compares some of the basic circuit configurations used and shows how the technology of the MOS transistor is applied to cover the additional requirements of integrated circuits.

LOGIC CIRCUITS

Integrated logic circuits of considerable complexity have now been made in MOS form, but on examination it is found that nearly all have been developed from simple inverter configurations which provide a logic "1" output when the input is a logic "0," and vice versa. Many different types of inverter have been proposed, and examples of the more distinctive configurations will be described. It will be assumed throughout that one supply rail is at earth potential and is connected to the substrate whilst all the other supplies are negative, thereby ensuring that the source-substrate and drain-substrate junctions are always reverse-biased. Negative logic is generally used for MOS circuits, meaning that an earth, or near-earth, signal identifies the logic "0" state, whilst a negative signal voltage indicates a logic "1."

To aid description, some simple operating rules can be deduced from the text of Part 1. The transistor will be considered as a switch which can be either ON or OFF depending on whether the channel is conducting or not. For the transistor to be ON, the gate must be more negative than either the source or the drain by at least the magnitude of the threshold voltage and it will then be operating over the saturated region of its characteristics. If the gate is more negative than both the source and drain by at least the magnitude of the threshold voltage, the transistor will still be ON but will be operating in the unsaturated region. It follows that if earth is the most

positive potential in a circuit, a transistor will be OFF if the gate is at earth or near-earth potential, regardless of the potential of the source and drain.

It is not usual on circuit diagrams to draw the complex pattern of capacitances associated with an integrated circuit. Capacitances which have a significant role in circuit operation will, however, be shown (in broken lines) as will load capacitances, recognizing that the output of a practical inverter will normally be connected to the gate input of a following stage.

Finally, it will be assumed that all the transistors in a circuit have a common substrate and, unless the contrary is indicated, it is to be understood that they have all been uniformly processed.

Static Resistor-Load Inverter

An MOS transistor with a resistor load is shown in Fig. 1. If the input is in the logic "0" state, implying a voltage not sufficiently negative to reach the threshold voltage of the transistor T1, the transistor will be OFF and the load capacitance, C, will charge up through the resistor R until the output potential is approximately that of the (negative) supply rail indicating a logic "1."

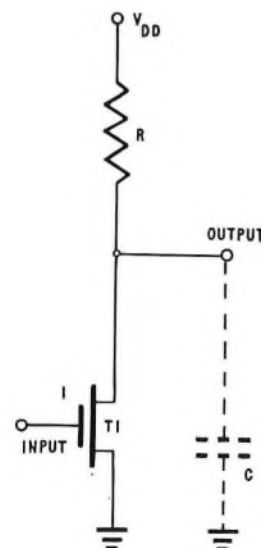

Note: In this and later diagrams the number placed by a transistor shows its aspect ratio. V_{DD} is negative

FIG. 1—Static resistor-load inverter

† Research Department, Telecommunications Headquarters.

If the input is a logic "1," the gate of transistor T1 will be sufficiently negative to turn the transistor ON causing current to flow through transistor T1 and resistor R so that the output voltage will depend on their relative resistances. To ensure that the output voltage is close enough to earth potential to be recognized as a logic "0" by any subsequent stage, the value of resistor R must clearly be large in comparison with the ON-resistance of transistor T1, the minimum ratio being about 10. In practice, the ratio may range up to 30 to allow for tolerances on components and supplies and, as will be seen in a later section, resistors are very expensive in circuit area in comparison with the requirements of MOS transistors. This circuit is not, therefore, widely used.

Static Transistor-Load Inverter

An alternative form of static inverter, shown in Fig. 2, is obtained by replacing the load resistor with a MOS transistor operating as a resistor, its gate and drain being strapped as described in Part 1 of this article. As in the previous circuit, an input logic "0" holds the transistor T1 OFF but the load capacitance, C, now charges through the load transistor T2.

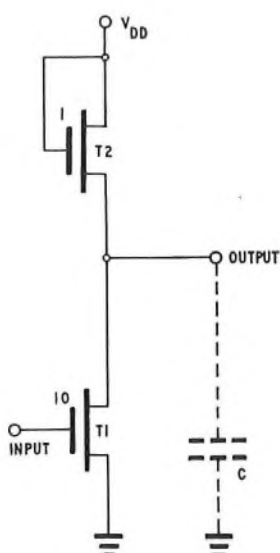

FIG. 2—Static transistor-load inverter

In this circuit the output voltage will stabilize at a value more positive than the supply rail potential by the magnitude of the threshold voltage of transistor T2 because at that point, the load transistor turns OFF. A degraded logic "1" level is thus obtained which must not prejudice the operation of any subsequent stage which the inverter might drive. It should also be noted that because the two transistors share a common, earthed, substrate, the load transistor will effectively have its substrate positively biased with respect to its source thereby increasing its threshold voltage.

If the input is now changed to the logic "1" state, turning the transistor T1 ON, the load capacitance will discharge bringing the output voltage towards earth potential. The stable output voltage will be determined by the ratio of the ON-resistances of the two transistors which, from Part 1 of this article, is seen to depend solely on their channel aspect ratios. If, for example, the transistor T1 had an aspect ratio of 10 : 1, a unit MOS transistor could be used for the load MOST as marked on Fig. 2.

Given no constraints on the design of this circuit, other than the conservation of area, and assuming that the technology imposes minimum values on the width and length of a transistor channel, it can be shown that the aspect ratios of the driver transistor (T1) and load transistor (T2) should have a reciprocal relationship. If, for example, the resistance ratio were 16 : 1, transistor T1 should be of minimum

channel length with an aspect ratio of 4 whilst transistor T2 should be of minimum channel width with aspect ratio of 0.25. Load transistors in this type of inverter circuit will often be long and narrow and driver transistors short and wide.

Quite often, the degraded output level in the logic "1" state obtained with the inverter of Fig. 2 is avoided by the use of an extra supply rail for the gate of the load transistor. If the additional supply is more negative than the drain supply by the magnitude of the threshold voltage of transistor T2, the output capacitance can charge up to the full drain-supply voltage.

DYNAMIC INVERTERS

It was noted in Part 1 of this article that the MOS transistor is endowed with the property of storing charge on the capacitance associated with its gate electrode so that a voltage applied through a switch which is subsequently opened will decay only slowly with time. It is this property which makes dynamic inverter configurations possible. The switches, themselves MOS transistors, can be operated by regularly repeated clock pulses in such a way that the circuits can perform logic operations whilst drawing current from the supply rail for only a small fraction of time. The clock pulses are all negative-going from earth, their potential being more negative than the supply rail by at least the magnitude of the largest threshold voltage in the circuit.

As will be seen later, dynamic inverters are pre-eminently suited to one particular application, namely shift registers, for which they are connected in tandem pairs and require multi-phase clock pulses. Although not necessarily required for an explanation of inverter operation, the full clock-pulse pattern is shown on the diagrams which follow.

Dynamic 2-Phase Transfer Inverter

In this circuit, Fig. 3, the driver and load transistors have the same geometrical relationship as in the previous static inverter but the load transistor, along with an extra transfer device is driven by the clock pulse ϕ_1 .

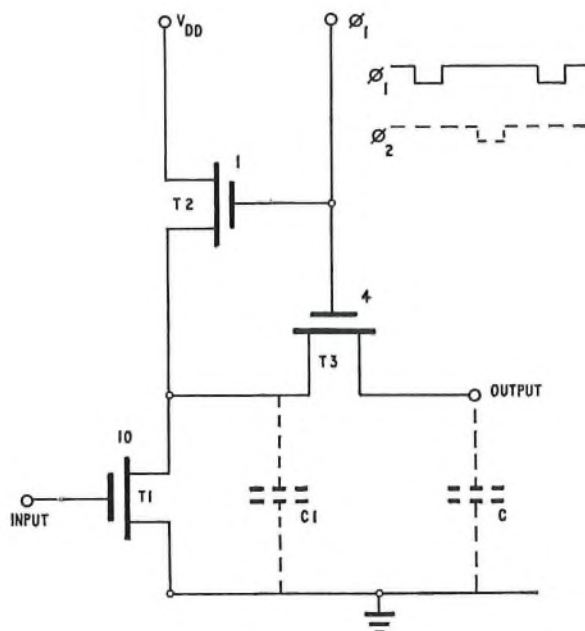

FIG. 3—Dynamic 2-phase transfer inverter

If a logic "0" is applied to the input, then transistor T1 will be OFF and when the clock pulse goes negative, both the transistors T2 and T3 will turn ON. The node and load capacitances, C1 and C, will then charge to the supply voltage through transistor T2 to give an output logic "1"

which remains there when, by the return of the clock pulse to earth, transistor T3 is turned off.

If the input is now changed to the logic "1" state, the input transistor turns ON, discharging capacitor C1 to earth. When the clock pulse goes negative again, the transistors T1 and T2 function as in the static inverter of Fig. 2, determining the near-earth potential taken up by capacitor C1. As transistor T3 is ON, the capacitance C discharges to this potential to give an output "0", which is again preserved when the clock pulse goes back to earth.

It can be seen that current may flow in either direction through the transfer transistor T3, thereby exploiting the bilateral property of the MOS transistor. The geometry of this device must be such that it has an aspect ratio large enough to ensure that it does not add significantly to the series resistance (of transistor T2) through which the output capacitance charges, and yet does not add appreciably to the load capacitance which would also impair the switching speed. An aspect ratio of 4 is often a suitable compromise.

Dynamic 4-Phase Clock-Drive Inverter

The inverters already described are often known as ratio-types because the output voltage in the logic "0" state depends on resistance ratios. There is, however, another class of inverter where the operation has no such dependence; these types are described as ratioless. At no time is there a resistance chain across a voltage source and unit MOS transistors can be used throughout.

Both 2-phase and 4-phase ratioless inverters exist; the particular 4-phase design of Fig. 4 has the additional feature of requiring neither earth nor supply rails but the clock pulses, which thus provide power for the circuit, must overlap as shown.

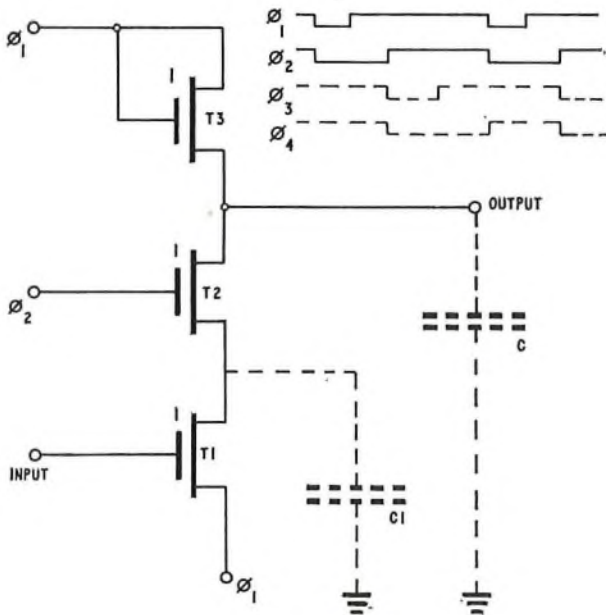

FIG. 4—Dynamic 4-phase clock-drive inverter

During the time when both the clock pulses ϕ_1 and ϕ_2 are negative, transistors T2 and T3 are both turned ON charging the node and load capacitances C1 and C, regardless of the state of the input. The output potential will stabilize at a value more positive than the negative clock-pulse level by the magnitude of the threshold voltage of transistor T3. When clock pulse ϕ_1 returns to earth, transistor T3 is turned OFF. Therefore, if the input is a logic "0," transistor T1 is OFF and the output capacitance will remain charged negatively indicating a logic "1." If, however, the input is a logic "1," transistor T1 will be ON and the output capacitance will discharge to earth through transistors T2 and T1 to give an

output logic "0." At the end of clock pulse ϕ_2 , the output is isolated leaving the acquired signal on the load capacitance.

In this circuit, the output logic "1" level is degraded in a way similar to that occurring in the static transistor-load inverter, but in contrast to all the previous circuits, the output logic "0" is a true earth. Due to the spurious output logic "1" signal, the output is only valid when clock pulse ϕ_2 is at earth potential.

BASIC CIRCUITS

The inversion function is often required in logic circuits, but by modifying the foregoing configurations or connecting them in tandem, other basic arrangements can be obtained which also recur frequently in complex systems.

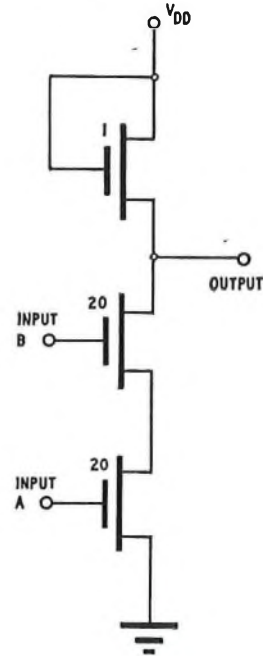

FIG. 5—Static 2-input NAND gate

All the inverters described may be modified to form gates by replacing the driver transistor with an appropriate group of devices as shown in the examples of Figs. 5 and 6. In the NAND circuit (Fig. 5), only when both inputs A and B

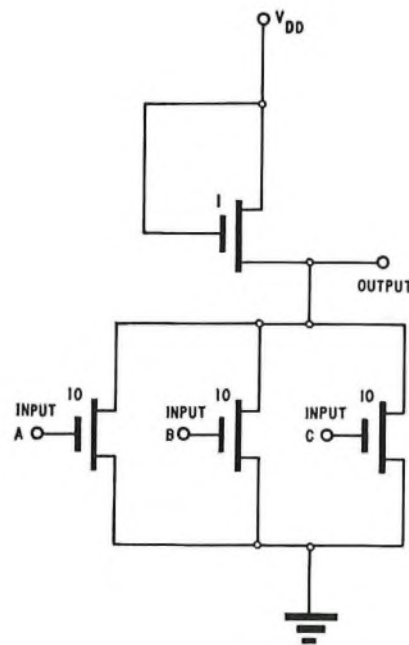

FIG. 6—Static 3-input NOR gate

are logic "1" is a logic "0" obtained at the output, whilst for the NOR circuit (Fig. 6), a logic "1" on any input A, B or C ensures an output logic "0." When logic transistors are placed in series in ratio-type circuits as required for the NAND function, the output logic "0" level will be degraded unless the aspect ratios of the transistors are increased to make their combined ON resistance equal to the replaced driver transistor. In Fig. 5 the series devices are accordingly shown with a 20:1 aspect ratio compared to the 10:1 ratio needed for all the paralleled transistors in the NOR-type gate of Fig. 6. To avoid the excessive usage of area, NAND gates are limited to about 2 inputs but for NOR gates the maximum may be as high as 10. The number of inputs is limited only by the drain-source leakage current and by the enlargement of the load capacitance due to the paralleled drain-substrate capacitances which would impair the switching speed. In the circuits of Fig. 5 and Fig. 6, the gate of the load transistor could, if desired, be taken to a separate supply. In ratioless circuits, as many as 15 inputs have been used for both NOR and NAND gates based on the 4-phase circuit of Fig. 4, and even higher numbers would appear possible.

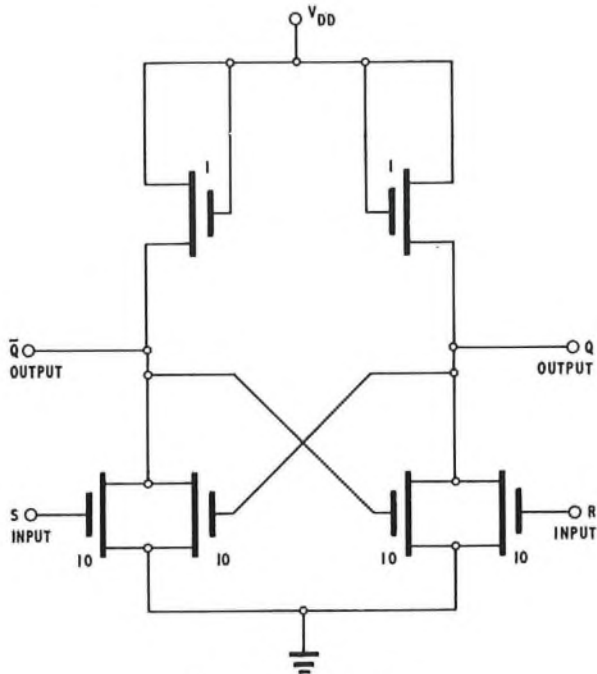

FIG. 7—Static bistable

A second, frequently used, development is the bistable circuit obtained by cross-coupling a pair of NOR gates (Fig. 7). The inputs S and R are normally in the logic "0" state. If a logic "1" signal is applied at input S, the Q-bar output will go nearly to earth potential causing output Q to exhibit a logic "1" which will in turn maintain the logic "0" state at output Q-bar even after the input signal is restored to logic "0." The circuit will stay in this condition until a logic "1" signal is applied at input R causing output Q to change to logic "0" and output Q-bar to logic "1" which again remains stable when the input to R is restored to logic "0."

A third important building unit is the dynamic shift-register, already mentioned. A shift-register comprises a linear array of storage cells such that a logic signal applied at the input advances to the next cell under the control of an external stimulus. This control is provided by the clock-pulse supply so that an input subsequently appears at the output delayed by the product of the clock period and the number of cells in the array. The transfer inverter of Fig. 3 has been used for the 2-bit shift register of Fig. 8. A logic "1" signal sustained at the input for the duration of the ϕ_1 clock pulse will reappear as a logic "1" at P after the occurrence of clock pulse ϕ_2 . After another clock period, the logic

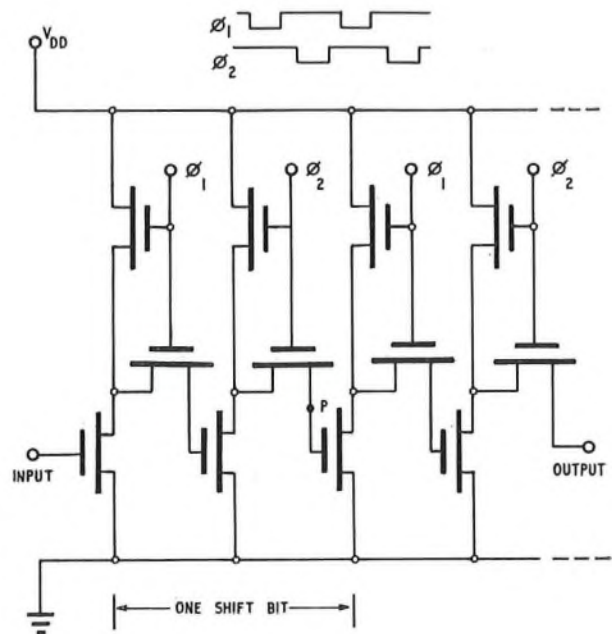

FIG. 8—Dynamic 2-phase transfer type 2-bit shift register

"1" signal will appear at the output. The number of integrated serial shift-register stages is limited only by technological considerations; registers able to hold as many as 512 bits have been developed.

As a simple illustration of the flexibility of MOS circuits, a one-bit 4-phase shift register with an AND-OR input is shown in Fig. 9. Because this configuration is based on a ratioless inverter circuit, unit MOS transistors are used throughout.

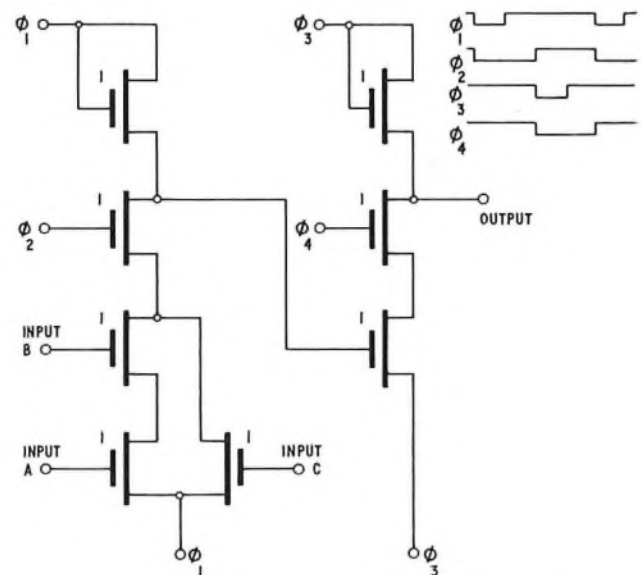

FIG. 9—Dynamic 4-phase clock-drive type 1-bit shift register with AND-OR-NOT input

PERFORMANCE

Supplies

The supply voltage and logic levels of MOS integrated circuits are dominated by the transistor threshold voltages. In the static inverter of Fig. 2, for example, the output logic "1" level must be more negative than the threshold voltage of the driver device (so that it can drive a subsequent stage) and the supply rail will necessarily be more negative than the output logic "1" level by the magnitude of the load transistor threshold voltage. In practice, to meet tolerances and allow

safety margins, larger voltages are used with a limit imposed by the risk of parasitic transistor action as will be discussed later.

From the above considerations, transistor threshold voltages in the range -4 to -6 volts (with the source earthed) lead to supply voltages of about -20 volts for static circuits or, if the gates of the load transistors are separately fed at say -20 to -24 volts, the drain supply may be reduced to -12 volts. In dynamic circuits, drain supply voltages, where used, may again be -12 volts with clock pulses having a 24-volt excursion from earth in the negative direction.

The clock pulses required for the dynamic circuits have previously been shown in idealized form with infinitely steep edges, but practical generating circuits can only provide non-zero rise and fall times. Moreover, the circuits based on a particular inverter type will normally require a fairly detailed specification of their clock pulse timing especially at the higher frequencies where the rise and fall times are of the same order of magnitude as the clock period. Typically, clock pulses may be several hundred nanoseconds fully negative with a minimum of about 100 ns. Rise and fall intervals are often of similar duration, although the highest repetition frequencies may require the transitions to be complete in under 50 ns. As a general rule, intervals between clock pulses are allowable; the essential requirement is that they must never overlap unless specifically required to do so as in the 4-phase circuit of Fig. 4. The load presented to the clock-pulse supply is almost wholly capacitive and may easily require the delivery of comparatively large currents. A supply used to drive a group of six 100-bit dynamic shift registers, for example, could be loaded with a capacitance of 150 pF which for 24-volt pulses of 40 ns rise and fall times requires average transient currents of about 100 mA.

Like logic circuits in general, MOS circuits are characterized by their noise immunity, speed and power consumption.

Noise Immunity

Although the foregoing circuits have been described in terms of their response to fixed logic levels, an input signal will in practice be subject to steady and transient excursions from its nominal value, both describable as noise. Estimates of the sensitivity of circuits to noise are complicated by the range and possible combinations of disturbances, by temperature variations, and by the effect of manufacturing tolerances.

A determination of the steady or d.c. noise immunity of a

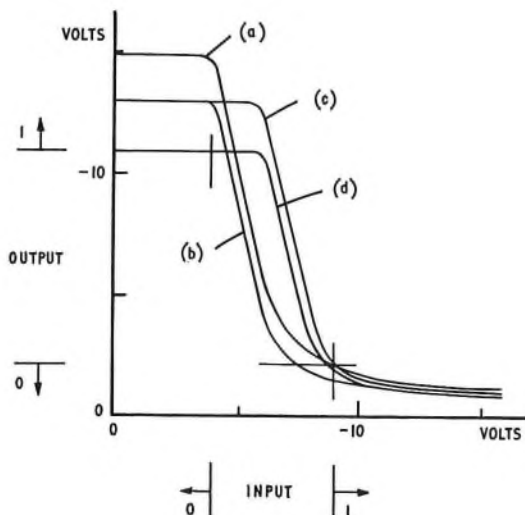

(a) $V_{DD} = -20$ volts $V_t = -4$ volts (c) $V_{DD} = -20$ volts $V_t = -6$ volts
 (b) $V_{DD} = -18$ volts $V_t = -4$ volts (d) $V_{DD} = -18$ volts $V_t = -6$ volts

FIG. 10—Transfer characteristics: static inverter noise immunity for circuit of Fig. 2

static inverter is obtainable by plotting its output voltage as a function of the input voltage. If it is then assumed that in practice the threshold voltage is subject to manufacturing variations from say -4 to -6 volts, and if the supply rail can vary from -18 to -20 volts, a limiting group of transfer characteristics can be drawn as shown by Fig. 10. The length of the horizontal upper segment of each curve indicates the threshold voltage of the driver transistor, whilst the output voltage level over this region has a value more positive than the supply rail by the magnitude of the threshold voltage of the load device. The latter threshold voltage is, of course, the greater in magnitude due to the effective substrate bias of the load transistor. The slope of the inclined regions of these characteristics increases in proportion to the square root of the ratio of the aspect ratio of the driver to that of the load transistor.

If the output logic levels are guaranteed as not more negative than -2 volts for a logic "0" and not more positive than -11 volts for a logic "1," then the input logic "1" can be as positive as -9 volts whilst the input logic "0" level can go as far negative as -4 volts. Remembering that an output is normally fed to another input, the inverter thus accommodates the superposition of 2 volts of noise at each logic level so determining the steady noise immunity. In practical systems, the specified logic levels may differ by a few volts from those quoted above and the noise immunity can range from 1 to 3 volts.

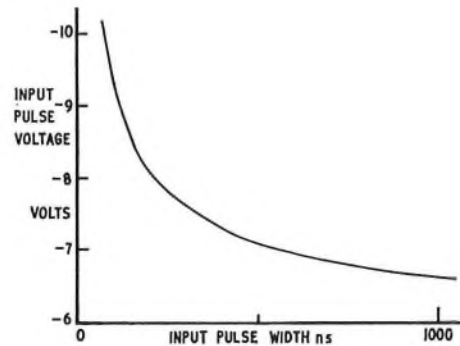

Relationship between pulse width and amplitude applied to one input of 3-input static NOR gate for output level -5 volts. $V_{DD} = -20$ volts

FIG. 11—Transient noise-immunity of logic gate

The foregoing arguments hold even if the noise signals are of long duration, but because all circuits have a definite response time (whilst capacitances are being charged or discharged) it is to be expected that they will tolerate higher noise voltages if the spurious signal is only present for a short time. Thus, Fig. 11 shows the effect of applying a negative-going pulse to one of the inputs of a 3-input static NOR gate (the other inputs being at logic "0") and measuring the dependence of the pulse amplitude on its width for a given output voltage level. If the maximum allowable excursion from the output logic "1" level (towards zero) is specified, then the region below the curve defines acceptable pulses. In the particular circuit used for Fig. 11, input noise pulses of say 100 ns width are thus rejected even if their amplitude is as high as 10 volts.

Problems of specifying noise immunity are even greater in dynamic circuits and preclude generalization, although the value of the threshold voltage continues to have a dominant effect. Allowance should really be made for noise on the clock-pulse lines as well as on the logic levels, whilst the timing of noise pulses is significant because dynamic circuits have a natural tendency to reject noise occurring outside the appropriate clock-pulse period. In practice, it is also more useful to consider the overall noise immunity of a complete circuit such as a shift register rather than that of an individual stage using, as before, the appropriate transfer characteristic. A typical overall characteristic for 24 stages of the 2-phase

transfer shift register of Fig. 8, when fed with steady input signals, is shown in Fig. 12. The register shows a fairly large tolerance to input level variations.

When comparing the noise immunity of MOS circuits with that of other types of integrated circuits, it should be remembered that external noise sources may generate higher voltages in MOS circuits due to the high input resistance of the MOS transistor.

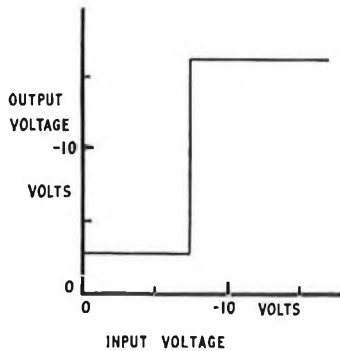

$V_{DD} = -16$ volts, clock pulses = -25 volts (circuit of Fig. 8)

FIG. 12—Overall transfer characteristic of 2-phase transfer type shift register

Speed and Power

During the discussion of the simple static inverter of Fig. 2, it was noted that logic "0" to logic "1" and logic "1" to logic "0" voltage steps at the input caused the output capacitances to be discharged through transistor T1 giving, therefore, output signals which are delayed. To illustrate these effects quantitatively, Fig. 13 shows the response of the inverter of Fig. 2 to an ideal input pulse having zero rise and fall times assuming the load capacitance to be 1 pF and the supply rail -20 volts. If the input logic levels are the worst case values used on Fig. 10 (i.e. -4 volts and -9 volts) and an average transfer characteristic is assumed, then the times necessary to reach the guaranteed output levels are 90 ns for the output "0" to "1" transition and 25 ns for the return to logic "0." The disparity in transition times is due to the 10 : 1 resistance ratio of the inverting and load transistors.

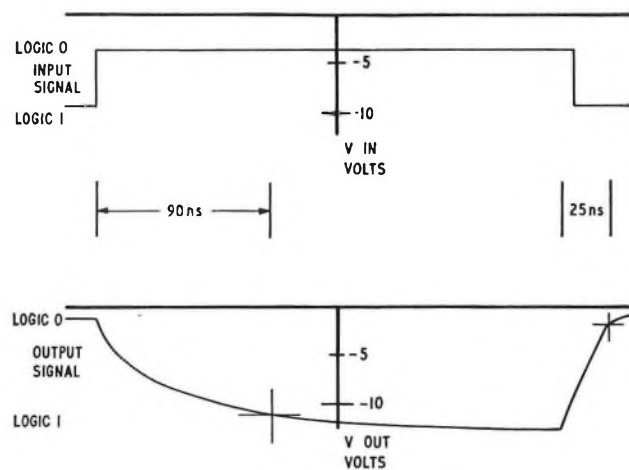

Circuit of Fig. 2 with $C = 1$ pF and $V_{DD} = -20$ volts

FIG. 13—Propagation delay through static inverter with MOST load

The load capacitance of an inverter is compounded from the contributions of diffused areas and the gate input capacitance of the succeeding stage and can vary appreciably, according to the circuit layout, from the value used above. However, the propagation delays shown by Fig. 13 are typical of the performance of many circuits within the silicon die. In practice, speed performance is often compromised by the relatively large load capacitances of the

output stages of a circuit, which can be 10 pF or more, arising from the bonding pad (shown in a later section) and other components making connexion to the external circuit. Larger transistors are thus used in output stages for the advantage of their lower ON resistance, but the improvement is partially offset by their proportionately larger gate input capacitances.

The power taken by the static inverter of Fig. 2 is virtually zero when the output is a logic "1" but, with a -20 volt supply, the power approximates to 8 mW for an output logic "0." If the gate supply is maintained at -20 volts, but the drain is taken to a separate rail at -12 volts, the power falls to about 5 mW for a marginal loss of speed. Lower power consumptions can be achieved by reducing the aspect ratios of the driver and load transistors but only with a proportionate increase in propagation delay.

In the dynamic circuits, the capacitances associated with the gate electrodes cannot hold charge indefinitely, so the clock-pulse frequency has a minimum allowable value determined by the time-constants of the gate capacitances and their leakage resistances. The effective leakage resistance is generally that of a reverse-biased p-n junction between a diffused region and the substrate having a value of the order of 10^{10} ohms, so for capacitances of about a picofarad, the lowest frequency will be a few hundred hertz. Due to the strong temperature-dependence of a p-n junction leakage current, specifications often quote higher minimum frequencies, say 1 kHz, to cover the whole range of specified operating temperatures.

Due to the use of external clock pulses and the extensive application to shift registers, it is generally more useful to specify the speed performance of dynamic circuits by the maximum usable clock frequency rather than by propagation delay. For ratio-type circuits the speed depends essentially on the same charge and discharge time-constants as applied to the static inverter so that, after allowing for the rise and fall times of clock pulses, the upper limit is constrained to 1 or 2 MHz. The power consumption approaches that of static logic if the clock pulses are just not overlapping but decreases in proportion to the clock duty-cycle. A 2-phase shift register operated from short duration pulses may thus

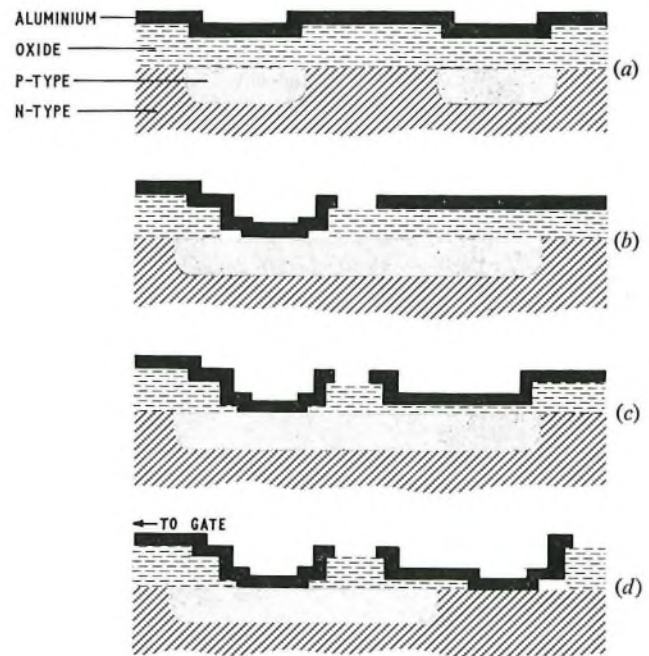

(a) Crossovers. Metal conductor crossing two parallel diffused conductors and illustrating the "parasitic MOST"
(b) "Thick-oxide" capacitor
(c) "Thin-oxide" capacitor
(d) Gate protection diode

FIG. 14—Additional components

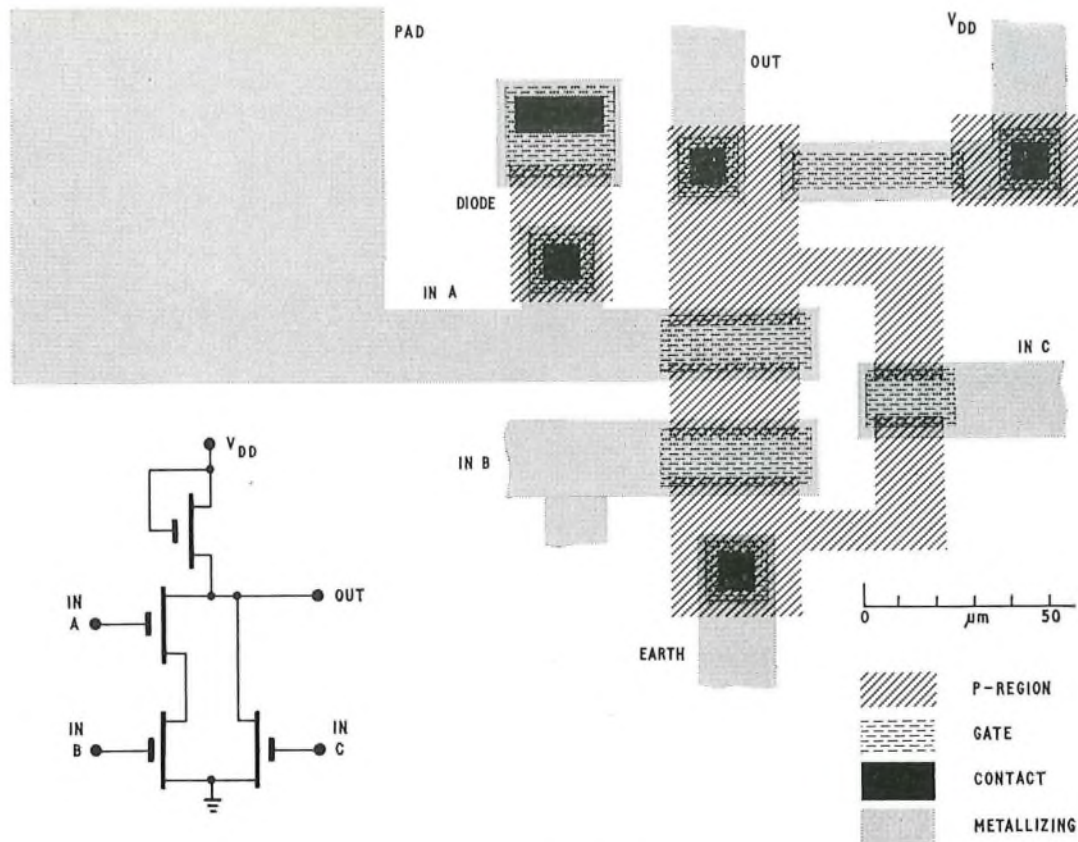

FIG. 15—Mask design for AND-OR-NOT circuit fragment

consume 3 to 5 mW/bit at 1 MHz falling to a few microwatts/bit at 1 kHz.

In ratioless circuits, power is saved by the absence of a resistor chain across the supply, whilst the exclusive use of unit area devices leads to an improvement in speed. These circuits only dissipate power at each transition of the clock pulses, therefore the power consumption is proportional to the clock pulse frequency. They can operate at clock-pulse frequencies up to about 5 MHz and for shift registers at this frequency the power consumption is typically 0.5 mW/bit.

CIRCUIT TECHNOLOGY

The technology described in Part 1 for the fabrication of MOS transistors is immediately applicable to integrated circuits. Provided the masks are suitably designed, the same process steps will yield any extra components required, such as resistors, capacitors and diodes together with the means to interconnect them.

Interconnexions may be made using diffused p-type areas or metallization, the latter providing superior conductivity, of typically 0.05 ohms per square, compared with 100 ohms per square for diffused areas. Normally both types of interconnection are used as they together provide a valuable cross-over facility as shown by the section of Fig. 14(a). In many circuits the drain, say, of one transistor is connected to the source of another and hence a single diffused area suffices for both electrodes and their interconnection.

Diffused area can also be used for resistors, but as mentioned earlier they tend to be expensive in silicon area. A 25 kohm resistor, for example, suitable for the inverter of Fig. 1 (assuming a 10 : 1 aspect ratio for the transistor), would require a strip of diffused area of length 250 times its width. As the minimum practical width of diffused area is about 10 μm, the resistor would require over 100 times more area than a unit MOST which, when turned on, has a similar resistance. The advantage of using load MOSTs is now apparent.

Every diffused area provides, of course, a capacitor of the p-n junction type to substrate, but isolated voltage-independent capacitors can also be realized having diffused area for one electrode, the other being metallization. The dielectric can be either thick or thin oxide, as shown in Figs. 14(b) and 14(c) with capacitances respectively of 30 pF/mm² and 300 pF/mm².

Diodes are normally only required in MOS circuits for protection purposes. If left isolated, the gate of an MOS transistor may, due to its high insulation and low capacitance, acquire sufficient stray charge to raise the magnitude of its potential until the gate insulation breaks down, typically at -100 to -120 volts, destroying the device. In an integrated circuit, the gate of one device is often connected to a p-type diffused area which can break down to the n-type substrate reversibly, and at a lower voltage (say -75 volts), so providing protection. As seen from the earlier circuit diagrams, however, input transistors are not usually so connected and at the same time, by their position in the circuit, they are especially vulnerable. It is, therefore, normal practice to connect a protective diode to each input gate, designed to have a breakdown voltage lower than that of the simple p-n diode. In the design shown by Fig. 14(d), the conductor from the gate is connected to a diffused region part of which is overlain with thin oxide and earthed metal resembling half an MOS transistor. The earthed gate of this device lowers the breakdown voltage of the junction, typically to -40 to -50 volts. With this arrangement, an inadvertent voltage applied to the input could produce a large current through the protective diode which might fuse the metallization. Thus, a limiting resistor is sometimes included between the diode and the metal pad to which connexion is made to the external circuit.

In Fig. 14(a) a problem in MOS circuits is revealed which calls for particular process control. It can be seen that the metal crossing over a pair of diffused regions resembles the gate of an MOS transistor albeit with a very thick gate oxide. This device will accordingly have a threshold voltage propor-

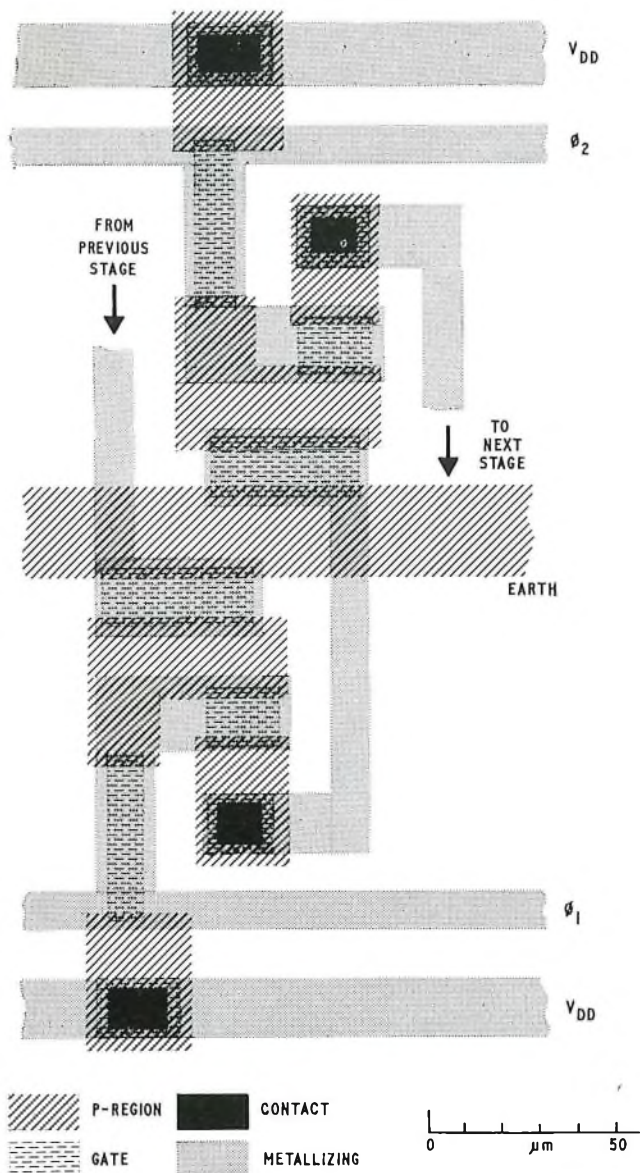

FIG. 16—Mask design for 1-bit fragment of 2-phase transfer type shift register

tionately dependent on the oxide thickness and, if this voltage is exceeded, an unwanted conducting path will exist between the diffused regions. As the thick oxide is generally about 10 times thicker than the gate oxide, parasitic threshold voltages down to about -40 volts can be anticipated, providing a reasonable margin of safety.

The superimposed photographic mask designs for two fragments of integrated circuit are shown in Fig. 15 and 16.

In Fig. 15, the layout is easily compared with the circuit diagram, showing the double-width devices needed for the NAND function and the long channel of the load MOST to give an effective resistance ratio (load/driver) of 10 : 1. A simple gate-protection diode is included. The bonding pad shown on input A for connexion to the circuit is clearly expensive in silicon area relative to the circuit itself and has a large capacitance to the substrate. A complete stage of the shift register of Fig. 8 is shown by Fig. 16, illustrating the efficient device packing attainable and showing how a shift register can be extended in length. In this design both aluminium and p-type regions are used for bus-bars.

The diffused areas of an integrated circuit are not normally visible by inspection with an optical microscope. Many of the features of the superimposed set of masks are nevertheless identifiable on a fully processed die due to the outlines of steps in the oxide and the pattern of the metallization.

CONCLUSION

The logic gates, shift registers and more complex circuit configurations which can now be realized in MOS integrated-circuit form are mainly based on logic inverter configurations, the operation of which can be explained in simple qualitative terms. Inverters are classifiable as static or dynamic, the latter exploiting the charge-storage property of the MOS transistor. Static circuits are characterized by their simplicity whereas dynamic circuits require clock-pulse supplies and have low-frequency limitations, but they combine higher speed with lower power consumption. Some inverters depend on the voltage-divider action of series devices but others do not, providing an alternative classification as ratio or ratioless, the latter type being faster and more economical of power. In all the circuits the speed of operation depends on the rates of charge and discharge of capacitance whilst the effective gain of an inverter stage and the threshold voltage of the driver transistor provide a degree of built-in noise immunity to spurious input voltages.

Although MOS integrated circuits are almost wholly compounded of transistors, interconnexions and some additional components are required, but they are all realizable by the transistor technology described in Part 1 of this article. The translation of a logic-circuit diagram into the corresponding set of photographic masks is a simple and efficient process.

It is already possible to draw some preliminary comparisons between the characteristics of MOS integrated circuits and those based on the conventional (bipolar) transistor. On the credit side, the number of process steps is smaller whilst a higher device packing density can be achieved and, although higher supply voltages are generally required, the power consumption can be very much less. The switching speed of MOS circuits is, however, appreciably slower and is very sensitive to capacitive loading. The economy of area, processing, and the advantages of minimizing the number of connexions to the external circuit, all point to the development of large circuit arrays.

Interfaces for Digital Data Transmission

A. J. BOTT, B.SC.(ENG), C.ENG., M.I.E.E.†

U.D.C.681.32: 621.394.4

The use of telecommunications for data-transmission purposes is increasing rapidly. To provide an essential link between the customers' data-terminal equipment and the telecommunication transmission path, data-communication equipment, e.g. a modem, is required. This article describes both the electrical and functional characteristics of interfaces which have been standardized for use between data-communication and data-terminal equipment.

INTRODUCTION

Three distinct classes of plant are involved in the transmission of data using telecommunication circuits. Firstly, there is the line itself which, in the present state of the art, is usually designed primarily for telephone or telegraph use and provided by the telecommunications authority. Secondly, there is a class of equipment, commonly known as data-communication equipment (d.c.e.), which includes signal converters, timing generators, pulse generators and control circuits, together with equipment to provide functions such as automatic calling and automatic answering. This group of equipment is usually provided by the telecommunications authority when associated with a public telephone or telegraph switched-network. Where leased circuits are concerned, it is often similarly provided, but most authorities also permit the connexion of privately-owned equipment. The third class is known as data-terminal equipment (d.t.e.), which will comprise a data source or a data sink, or both. Typically, this could be a data processor or some remote peripheral equipment. In most cases, data-terminal equipment is privately owned.

In order to avoid lengthy discussion between parties designing and installing individual items of equipment in the classes described in the previous paragraph, and to ensure compatibility, it is highly desirable that, wherever possible, standards should exist for the signals passed via the interfaces. Recognising this need, the C.C.I.T.T.* has made a number of recommendations regarding the line signals to be transmitted and received by data-communication equipment. It has also made recommendations regarding the signals to pass via the interface between the data-communication equipment and the data-terminal equipment. A recommendation¹ for this interface was first published in 1964; it has subsequently been revised and extended², but not fundamentally changed. This recommendation has been of particular importance to the Post Office because the interface to which it relates is, in most instances, the point of interconnexion between Post Office and privately-owned equipment. Moreover, there is now such a large and ever-increasing range of data-terminal equipment available that it is apparent that its introduction would have been hindered had there not been a recognized international standard for the interface. The purpose of this article is to discuss this interface.

INTERFACE FOR SIGNALLING RATES UP TO 20 KBIT/S

C.C.I.T.T. recommendation V24 applies to interconnecting circuits, called interchange circuits, between data-terminal equipment and data-communication equipment for the trans-

fer of binary data, control, and timing signals. The recommendation also applies to both sides of separate intermediate equipment which may be inserted between these two classes of equipment, as illustrated in Fig. 1. Such intermediate equipment could be classified as data-communication equipment or data-terminal equipment, depending on its function.

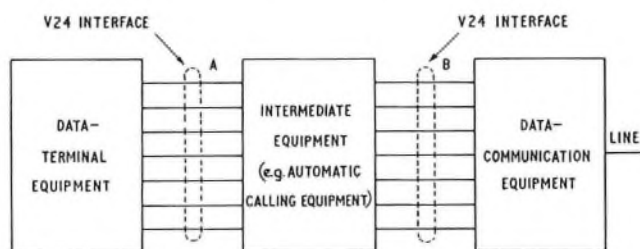

Note: Without intermediate equipment the selection of circuits at A and B would be identical

FIG. 1—Interconnexion of equipment

Recommendation V24 includes a section which defines the electrical characteristics of interchange circuits; another section defines the functions of a range of interchange circuits from which a selection is made for each type of equipment. When there is a C.C.I.T.T. recommendation for a particular item, it includes a list of the actual interchange circuits which shall be provided. At present, the selection of interchange circuits for equipment not currently covered by a C.C.I.T.T. recommendation is left to the equipment designer, but the C.C.I.T.T. intends, at some future time, to formulate operational guide-lines for the selection of interchange circuits.

The interface between data-terminal equipment and data-communication equipment is located at a connector which interconnects the two classes of equipment. Separate connectors may be provided for the interchange circuits associated with signal-conversion (e.g. modem) or similar equipment and those associated with automatic-calling equipment. The connectors are normally on or near the data-communication equipment, and interconnecting cables are normally provided with the data-terminal equipment. The length of these cables is limited solely by the permissible capacitance and other electrical characteristics.

It is not a C.C.I.T.T. responsibility to standardize the type of connector to be used at the interface or the connector-pin assignment. These are within the jurisdiction of the I.E.C.‡ and the I.S.O.,* and the latter has prepared and agreed upon a draft³ which will shortly be published as a recommendation of connector-pin assignment. The type of connector has still to be agreed, but it is generally accepted that it should be a 25-way D-type connector with the female part (socket) associated with the data-communication equipment.

† Telecommunications Development Department, Telecommunications Headquarters.

* C.C.I.T.T.—International Telegraph and Telephone Consultative Committee.

‡ International Electrotechnical Commission.

* International Standards Organization.

ELECTRICAL SPECIFICATION

Fig. 2 shows the equivalent circuit of an interchange circuit with the electrical parameters that are specified. The equivalent circuit is independent of whether the generator is located in the data-communication equipment and the load in the data

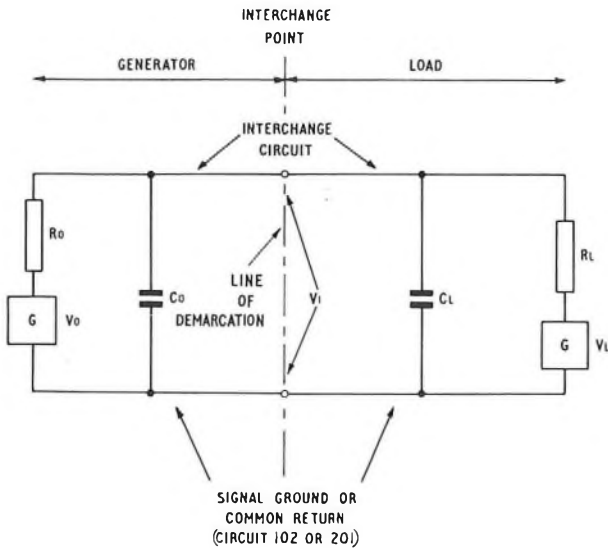

FIG. 2—Interchange equivalent circuit for signalling rates not exceeding 20 kbit/s

terminal or vice versa, and the common return-path is shared by other circuits in the interface.

It is specified that the load impedance of an interchange circuit shall have a d.c. resistance (R_L) of not less than 3,000 ohms nor more than 7,000 ohms measured with an applied voltage, positive or negative, of 3 to 15 volts. The effective shunt capacitance shall not exceed 2,500 pF, and the open-circuit load voltage shall not be more than 2 volts. No inductive component is permitted as part of the load. The load shall interpret a signal as binary 1 when V_1 is more negative than -3 volts and as binary 0 when more positive than $+3$ volts. The binary conditions 1 and 0 are referred to as OFF and ON, respectively, if the circuit is used for control purposes. Table 1 gives the equivalence with other symbols and conditions which may be encountered in other parts of a system.

TABLE 1
Table of Equivalence

$V_1 > +3$ volts	$V_1 < -3$ volts
Digit 0 ON Space Start A	Digit 1 OFF Mark Stop Z

The generator provides, at the interchange point of the circuit, signals in which the two binary states are indicated by positive and negative polarity with respect to common return. The values of R_0 and C_0 are not specified except for the requirement that V_0 and R_0 should be selected so that, in the event of a short-circuit between any two interchange circuits, the current should not exceed one-half ampere. A practical limit for the maximum value of C_0 is set by the rate at which the voltage across it can be changed with chosen values of V_0 and R_0 and any load in the specified range. It rests with the circuit designer to determine this limit and to make sure it is acceptable, bearing in mind that it includes any cabling from equipment to interchange point. V_0 , the open-circuit voltage

of the generator, is specified to be not more than 25 volts in magnitude. Additionally, when the open-circuit voltage (E_L) of the load is zero, the voltage (V_1) at the interchange point should be not less than 5 volts nor more than 15 volts in a steady binary state for any load resistance (R_C) in the range 3,000 ohms to 7,000 ohms. The generator should be capable of driving the maximum permitted value of load capacitance (C_L), 2,500 pF, so that, for data and timing circuits, the time taken for the signal to pass through the transition region between $+3$ volts and -3 volts is not more than one millisecond or 3 per cent of a signal element, whichever is less on the interchange circuit being considered. For control circuits the time should not exceed one millisecond.

INTERCHANGE-CIRCUIT FUNCTIONS

Tables 2 and 3 list the recommended interchange circuits and indicate the direction in which they operate. It is not proposed to discuss the functions of all these circuits in detail. For many, the function will be obvious. However, the following are selected as being of particular interest.

Timing Circuits

Timing circuits are used to provide timing information either to control the instants at which data elements are presented at the interface or to mark the mid-points of data elements so that a receiving equipment can interpret the data with the maximum possible margin against error. The signals on timing circuits take the form of square waves with the periods of ON and OFF present for nominally equal periods of time. Transitions from OFF to ON are used to indicate the instants at which the next data element should be presented, and transitions from ON to OFF are used to indicate the mid-point of each data element.

Circuit 108

Circuit 108 is really a single circuit that can operate in either of two ways. In some data-communication equipment the method of operation may be selected by a wiring option to meet a user's requirements. In the CONNECT DATA SET TO LINE (108/1) method of operation, an ON condition causes the data-communication equipment to be connected to line regardless of the condition on any other interchange circuit. Similarly, an OFF condition causes disconnection. For example, where a modem is associated with a telephone exchange line the modem may be connected and the line looped at any time by turning ON circuit 108/1. The DATA TERMINAL READY (108/2) method of working differs from the foregoing in that the circuit may be turned on at any time without causing the modem to connect until it is given some other stimulus. This may be the detection of ringing current, if calls are to be answered automatically, by a detector in the modem itself or elsewhere. Alternatively, the stimulus may be provided by momentary operation of a key on the associated telephone, if a call is originated or answered manually. In either case, the modem will remain connected until the DATA TERMINAL READY circuit is turned OFF momentarily.

Request to Send (Circuit 105)

The ON condition on the REQUEST TO SEND circuit causes the data-communication equipment to assume the data-channel transmit mode, which may include the transmission of line signals for the purpose of equalization, synchronization, etc. In modems, it causes carrier to be transmitted to line. Users of modems are encouraged to turn the circuit OFF whenever they are not transmitting or about to transmit data, in order to minimize the length of time during which a tone is transmitted. This is of importance in minimizing the power loading of, and hence the noise generated in, carrier systems.

In systems operating in a simplex mode, that is to say in which transmission may take place only in one direction at a

TABLE 2
100-Series Interchange Circuits by Category

Interchange-Circuit No.	Interchange-Circuit Name	Ground	Data		Control		Timing	
			From D.C.E.	To D.C.E.	From D.C.E.	To D.C.E.	From D.C.E.	To D.C.E.
101	Protective ground or earth	×						
102	Signal ground or common return .. .	×						
103	Transmitted data			×				
104	Received data		×					
105	Request to send					×		
106	Ready for sending				×			
107	Data set ready				×			
108/1	Connect data set to line					×		
108/2	Data terminal ready					×		
109	Data-channel received line-signal detector				×			
110	Signal-quality detector				×			
111	Data-signalling-rate selector (D.T.E.)					×		
112	Data-signalling-rate selector (D.C.E.)				×			
113	Transmitter signal-element timing (D.T.E.)							×
114	Transmitter signal-element timing (D.C.E.)						×	
115	Receiver signal-element timing (D.C.E.)						×	
116	Select stand-by					×		
117	Stand-by indicator				×			
118	Transmitted backward-channel data ..			×				
119	Received backward-channel data ..		×					
120	Transmit backward-channel line-signal					×		
121	Backward channel ready				×			
122	Backward-channel received-line signal detector				×			
123	Backward-channel signal quality detector				×			
124	Data-channel receiver cut-off					×		
125	Calling indicator				×			
126	Select transmit frequency					×		
127	Select receive frequency					×		
128	Receiver signal-element timing (D.T.E.)							×
129	Backward-channel receiver cut-off ..					×		
130	Transmit backward tone					×		
131	Received-character timing						×	
132	Return to non-data mode					×		
133	Ready for receiving					×		
134	Received data present				×			

D.T.E.—Data-terminal equipment.
D.C.E.—Data-communication equipment.

TABLE 3
200-Series Interchange Circuits by Category

Interchange Circuit No.	Interchange Circuit Name	Ground	Data		Control	
			From D.C.E.	To D.C.E.	From D.C.E.	To D.C.E.
201	Signal ground or common return	×				
202	Call request					×
203	Data line occupied				×	
204	Distant station connected				×	
205	Abandon call				×	
206	Digit signal (2 ⁰)			×		
207	Digit signal (2 ¹)			×		
208	Digit signal (2 ²)			×		
209	Digit signal (2 ³)			×		
210	Present next digit				×	
211	Digit present					×
212	Protective ground or earth	×				
213	Power indication				×	

D.C.E.—Data-communication equipment

time, an ON condition on this circuit causes the RECEIVED DATA circuit (104) to be clamped to the binary 1 state and the RECEIVED LINE-SIGNAL DETECTOR circuit (109) to be clamped to the OFF condition. This renders the receiving section of the modem inoperative, as far as the data-terminal equipment is concerned, whenever the transmit section is in use. This prevents the transmitted signal affecting the receiver.

Data Set Ready (Circuit 107)

The ON condition on the DATA SET READY circuit indicates that the signal-conversion or similar equipment is connected to line and that the data-communication equipment is ready to exchange further control signals with the data-terminal equipment to initiate the exchange of data. The conditioning of a data channel, such as equalization and clamp removal, will not take place until this circuit is ON. The OFF condition indicates that the data-communication equipment is not ready to operate, although this condition does not impair the operation of the CALLING INDICATOR (Circuit 125).

Backward Channel

Some interchange circuits are designed for use in connexion with a backward channel. This is a channel operating at a slower rate than the associated data channel and in the reverse direction. It is primarily intended to be used for error-control purposes, typically carrying back to the transmitter requests for repetition of data received containing errors. In some systems in which data may be transmitted in both directions, it is possible also to have backward channels in both directions. The modems used in the Post Office Datel 600 Service⁴ enable a 75 bit/s backward channel to be provided.

Circuit Failures

The following interchange circuits, where implemented, may be used to detect a power-off condition in the equipment on the generator side of the interface or a disconnection of the interconnecting cable:

- Circuit 105 (request to send)
- Circuit 107 (data set ready)
- Circuit 108/1 or 108/2 (connect data set to line/data terminal ready)
- Circuit 120 (transmit backward channel line signal)
- Circuit 202 (call request)
- Circuit 213 (power indication)

In the power-off condition, it is specified that the generator side of these circuits should generate no e.m.f. and that the impedance to common return should be at least 300 ohms when measured using an applied voltage of not more than 2 volts.

INTERCHANGE CIRCUITS FOR USE ABOVE 20 KBIT/S

The electrical specification for interchange circuits described earlier is not suitable for high bit-rates. The C.C.I.T.T. has, therefore, specified in recommendation V35⁵ the electrical characteristics for a balanced-pair type of interchange circuit and recommended its use above 20 kbit/s. No upper limit has been specified and, as far as is known, the practical upper limit has not been determined, but it is understood that one organization plans to use it at 6 Mbit/s.

Balanced-pair interchange circuits need to be used only where the signalling rate exceeds 20 kbit/s. Other circuits in the same interface, e.g. control circuits, should conform to the V24 specification.

Electrical Specification

Fig. 3 shows the essential features of the V35 interchange circuit. Tolerances permitted on the values of circuit para-

eters are not fully discussed here, since they will, in general, be of interest only to circuit designers, who are recommended to consult the relevant C.C.I.T.T. document. The circuit is drawn with both the generator and load as star networks each presenting a nominal impedance of 100 ohms to a balanced-

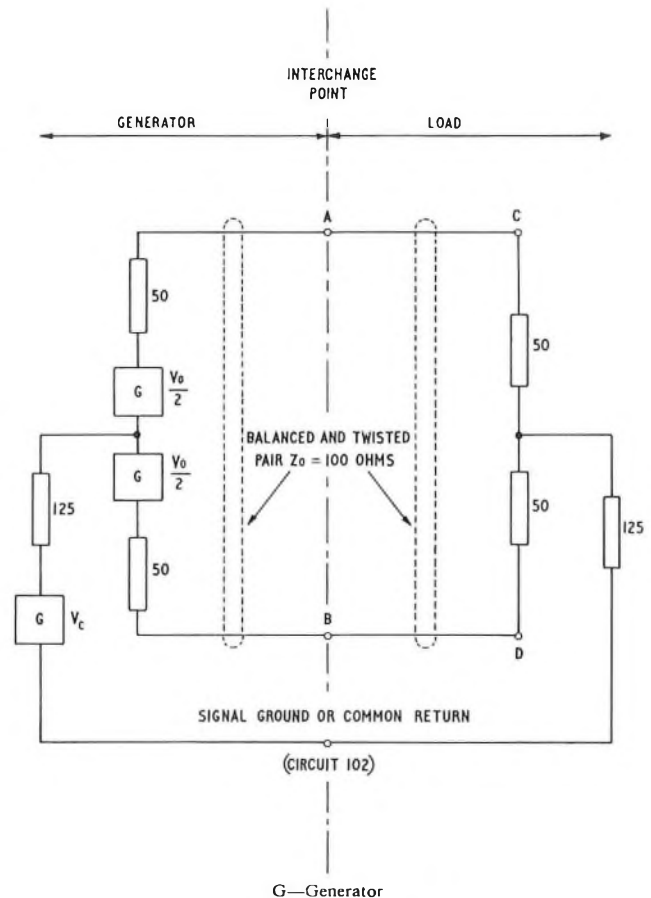

FIG. 3—Interchange equivalent circuit for signalling rates exceeding 20 kbit/s

and-twisted pair interconnecting cable. This cable has a nominal characteristic impedance of 100 ohms at the fundamental frequency of the timing signal, i.e. twice the fundamental frequency of a data signal composed of alternate binary noughts and ones. A connexion is made so that the resistance between common return and the generator terminals, when disconnected from the load and short-circuited, is 150 ohms. The load has a similar connexion to common return. The two nominally equal sources of e.m.f., $V_0/2$, in the generator are such that if the load is replaced by a 100-ohm resistive load at point AB the voltage will be 0.55 volts \pm 20 per cent. Terminal A will be positive to terminal B when a binary 0 is transmitted, and the conditions will be reversed when binary 1 is transmitted. The methods commonly used to generate the signal voltages can result in the arithmetic mean of the voltages of terminal A to common return and terminal B to common return being significant. This is known as the d.c. offset of the generator and it is shown as V_c in Fig. 3. The maximum value of V_c permitted is 0.6 volt.

Performance in the Presence of Noise

The superiority of a balanced-interchange circuit over the unbalanced type lies in its ability to resist the effects of noise induced longitudinally in the conductors of the interconnecting cable. Since virtually equal noise voltages will be induced in the two wires of a twisted pair, the detection circuits of the load should be designed to respond only to voltages appearing between C and D (Fig. 3) and to be insensitive to voltages

between these points and common return. The C.C.I.T.T. recommendation V35 specifies that design should be such as to ensure error-free operation under the following conditions:

- (a) with ± 2 volts (peak) noise present longitudinally, or
- (b) with ± 4 volts common-return offset (in addition to $V_c = 0.6$ volts in the generator), or
- (c) if common return offset and longitudinal noise are present simultaneously, (common return offset)/2 + longitudinal noise (peak) = 2 volts or less.

CONCLUSION

The use of internationally-standardized interfaces wherever possible on equipment developed for the Post Office datel services has kept to a minimum the amount of negotiation

necessary to secure satisfactory operation of commercially-produced data-terminal equipment. A large range of commercial terminal equipment is now available for use with the Post Office datel services, and the current rate of growth is such that the demand for these services is increasing by about 100 per cent per annum.

References

- ¹ C.C.I.T.T. Blue Book, Vol. VIII, Recommendation V24.
- ² C.C.I.T.T. White Book, Vol. VIII, Recommendation V24.
- ³ I.S.O./TC97/SC6 Document 315.
- ⁴ ROBERTS, L. W., and SMITH, N. G. A Modem for the Datel 600 Service—Datel Modem No. 1A. *P.O.E.E.J.*, Vol. 59, p. 2, July 1966.
- ⁵ C.C.I.T.T. White Book, Vol. VIII, Recommendation V35, Appendix 4.

A Line-Transmission Simulator for Testing Data-Transmission Systems

K. GROVES, C.ENG., M.I.E.E., and P. MACKRILL†

U.D.C. 621.394.4.001.57: 621.317.34

A line-transmission simulator for testing data-transmission systems is described. The majority of transmission conditions likely to be encountered in the switched telephone network can be set up, enabling data sets to be tested in the laboratory over a wide range of simulated lines. The effect of various types of distortion upon each transmission method can be determined independently. The results of tests carried out on a number of data systems using the line simulator will be discussed in a later article.

INTRODUCTION

The telephone network was designed for satisfactory and economical transmission of speech. As a result, it was based chiefly on the attenuation/frequency characteristic, crosstalk and noise, with little account being taken of the phase/frequency characteristic which has a negligible effect on the intelligibility of speech.¹ The transmission of data signals, however, is not only dependent on those parameters affecting the transmission of speech but also upon the phase/frequency characteristic. Departure from the ideal linear phase/frequency characteristic impairs the waveform and reduces the margins of detection which are required to resist the effects of noise and interference. The higher the data-signalling rate, the more stringent the line specification if satisfactory transmission is to be achieved. To assist in the study of the performance of data-transmission systems over telephone circuits, equipment has been built which simulates the majority of conditions found in a wide range of telephone circuits and enables the performance of data sets to be assessed in the laboratory.

DESCRIPTION

A block schematic diagram of the line-transmission simulator is shown in Fig. 1. The equipment has a balanced input having an impedance of 600 ohms and is capable of accepting signals in the frequency range 0.1–4 kHz at levels of between –30 dBm and 0 dBm. A variable attenuator and a level meter, not shown in the diagram, are provided at the input

to set the signal level within the equipment. The input circuit is followed by a range of attenuation/frequency networks and a range of group delay/frequency networks. The signal path is then divided and one path passes through an amplifier and a variable attenuator to a balanced output having an impedance of 600 ohms. The signal level at the output can be set in 1 dB steps within the range 0 dBm to –100 dBm. An amplitude modulator and a non-linear circuit may be switched into circuit either following the amplifier as shown, or preceding the two sets of networks. The second signal path, which is used to simulate echo, phase discontinuities and frequency offsets, passes through a variable-delay circuit to a frequency changer where it is translated by a 10 kHz oscillator into the frequency band 10.1–14 kHz. The band-pass filter which follows selects the upper sideband and has been equalized for group delay to better than ± 0.1 ms within the passband. The translated signal is then re-translated to the 0.1–4 kHz band using either the same 10 kHz oscillator output after passing through a variable phase shifter, or a signal obtained from an independent oscillator whose frequency can be varied ± 20 Hz about 10 kHz. The second frequency changer is followed by a low-pass filter and variable attenuator before the signal paths are combined at the output of the amplifier in the direct path. A 20 Hz multivibrator may be used to switch a preset phase-shift in and out of circuit and also to control the amplitude modulator. Alternatively, a single phase-displacement of preset duration or a single unidirectional shift may be introduced manually.

A white gaussian noise generator or a simple pulse generator may be switched into circuit via switch S1, a low-pass filter,

† Research Department, Telecommunications Headquarters.

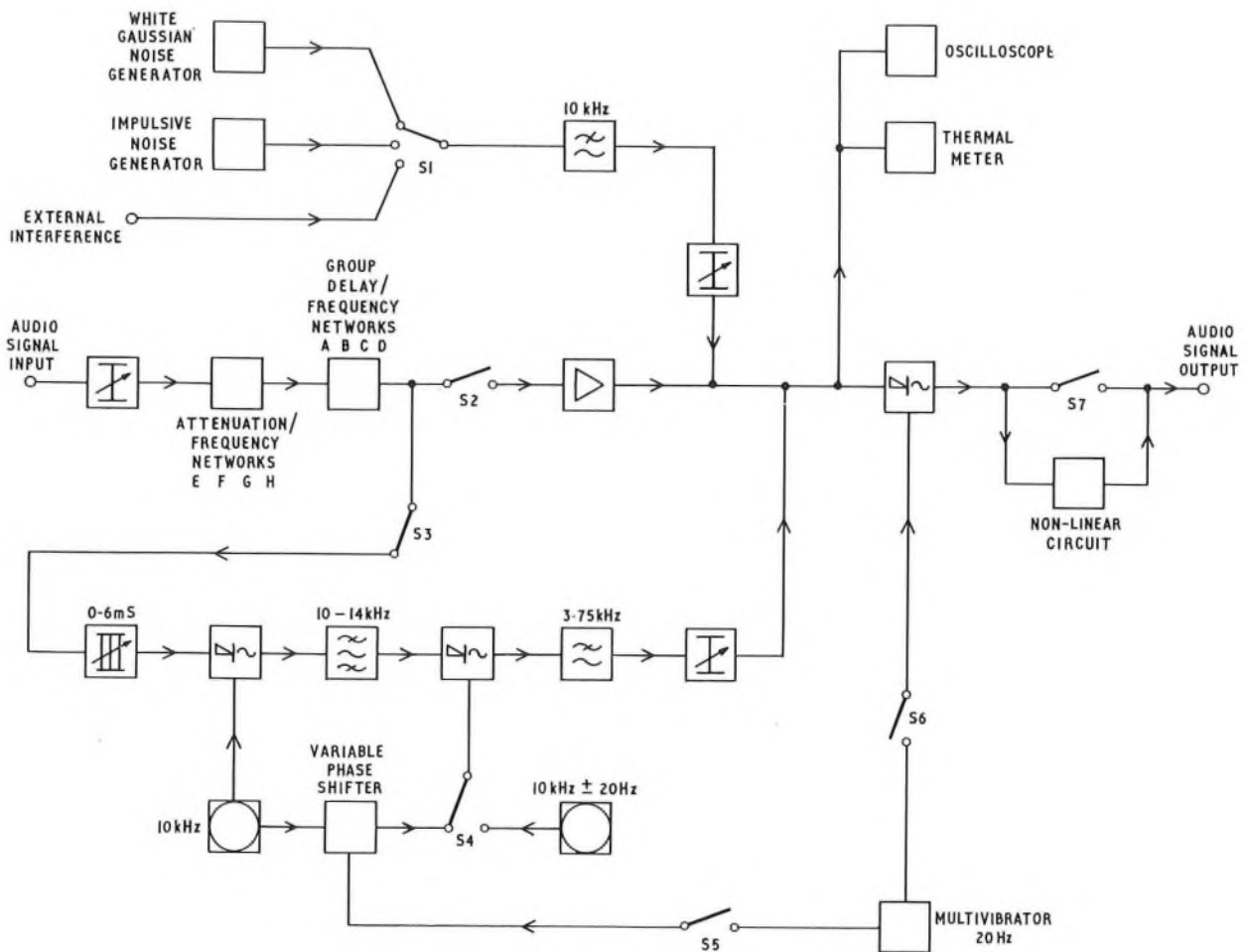

FIG. 1—Block schematic diagram of the Line-Transmission Simulator

and variable attenuator. Signal and interference levels may be measured either on a thermal meter or an auxiliary oscilloscope.

All the equipment, apart from the auxiliary oscilloscope, is mounted on a 7 ft 6 in rack and 51-type equipment practice has been used extensively in the construction as shown in Fig. 2.

FACILITIES

The equipment is capable of providing the facilities detailed below.

Attenuation/Frequency Characteristics

Twenty attenuation/frequency characteristics (E-5 to E + 15) can be introduced and some examples are shown in Fig. 3. Characteristics +1 to +15 simulate unloaded local lines with each step corresponding to approximately one mile of unloaded $6\frac{1}{2}$ lb/mile cable pair. The negative slope curves (-1 to -5) are largely for experimental purposes, although such characteristics may occasionally arise in practice due to short-delay echo (less than 0.2 ms) or to over-equalization on leased circuits. The variation in group delay of these characteristics is less than ± 0.1 ms in the frequency range 0.1-4 kHz.

A further five attenuation/frequency characteristics, shown in Fig. 4, are provided by three high-pass filters (G1-3) and two low-pass filters (H1-2). Filter G1 simulates the low-frequency cut-off associated with transmission bridges. It was felt when the equipment was designed, that the effect of the attenuation characteristic of transmission bridges in the fre-

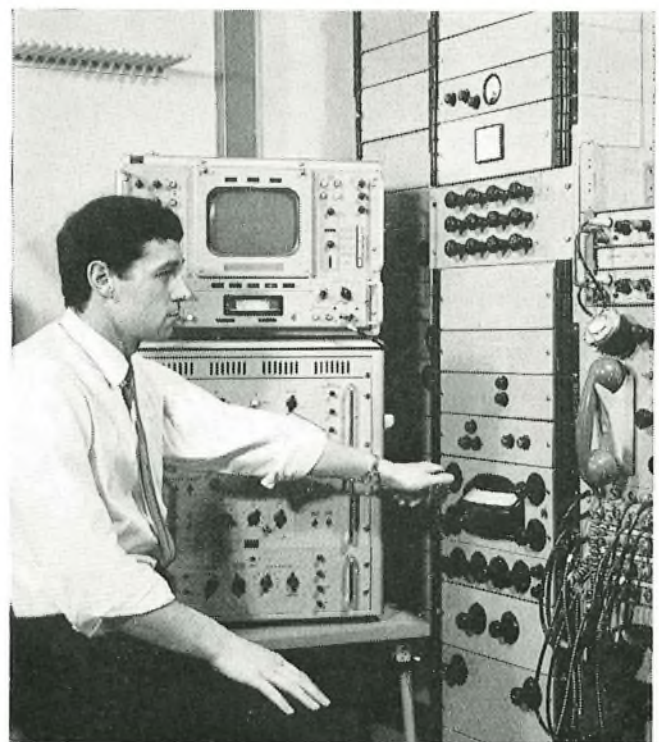

FIG. 2—Adjusting the signal/noise ratio on the line-transmission simulator

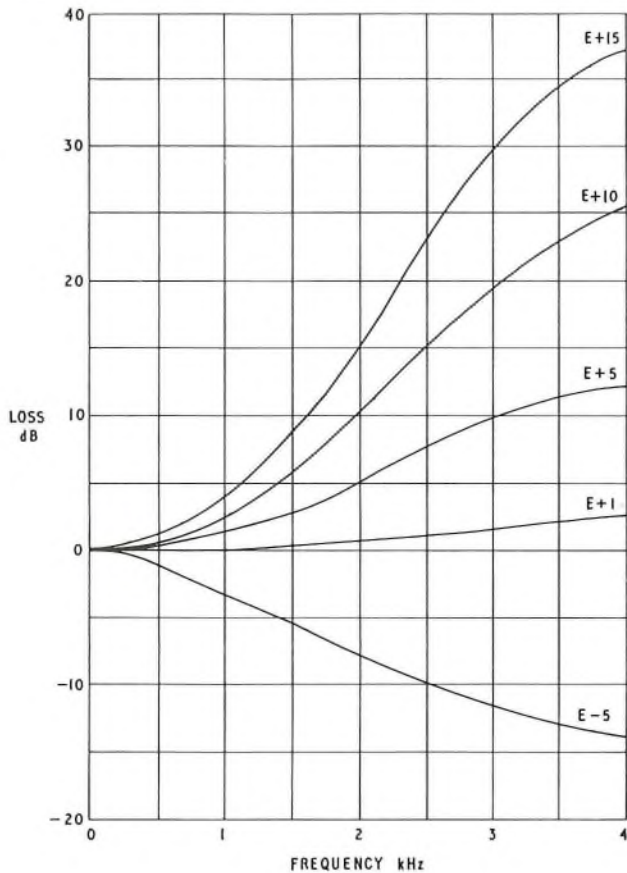

FIG. 3—Attenuation/frequency characteristics

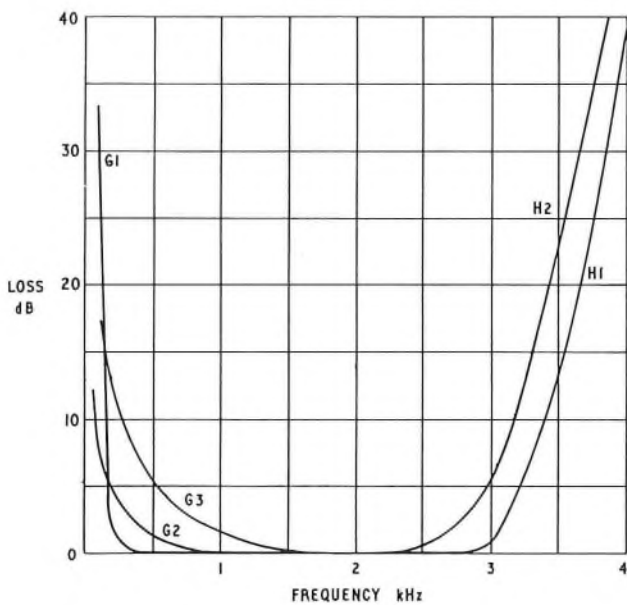

FIG. 4—Attenuation/frequency characteristics

quency band of interest for data transmission would be small. Consequently, only one condition, corresponding to about four transmission bridges connected in tandem, has been provided. Filter G2 simulates the low-frequency characteristics of a single typical carrier system and filter G3 that of five such systems in tandem. These three filters have not been equalized for group delay.

The low-pass filter H1 simulates the upper-frequency cut-off due to one typical carrier system and filter H2 that of five such systems in tandem. Both filters are equalized for group delay to less than ± 0.1 ms within the pass band.

A third range of 15 band-pass type characteristics (F1–15), of which samples are shown in Fig. 5, were included to assess the effect of symmetrical attenuation but have been found to be of little value in simulating characteristics encountered in the switched telephone network. The variation in group delay of this range of characteristics is always less than ± 0.1 ms in the frequency range 0.1–4 kHz.

Group Delay/Frequency Characteristics

Four families of group-delay characteristics are provided. The A and C families each consist of 15 curves some of which are shown in Fig. 6. The A family simulates the steep rise in group delay at low frequencies associated with transmission bridges. The C family simulates loaded lines, with each step corresponding to approximately 25 miles of 20/88/1.36 cable. The B and D families, shown in Fig. 7, consist of 7 and 15 individual characteristics, respectively, and are used for simulating up to five carrier systems in tandem. The attenuation characteristics of all these networks are equalized to better than ± 0.25 dB over the frequency range 0.1–4 kHz.

Echo

When two or more impedance mismatches are present in a transmission path with a finite propagation time between them, the resulting multiple reflections give rise to listener echo. A single listener echo due to one pair of mismatches separated by a propagation time $t/2$ causes a succession of signal components to be received at intervals of time t .

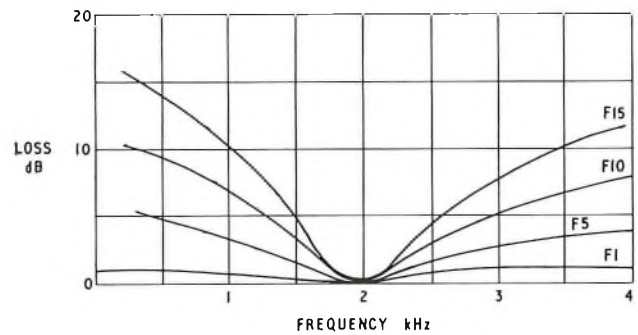

FIG. 5—Attenuation/frequency characteristics

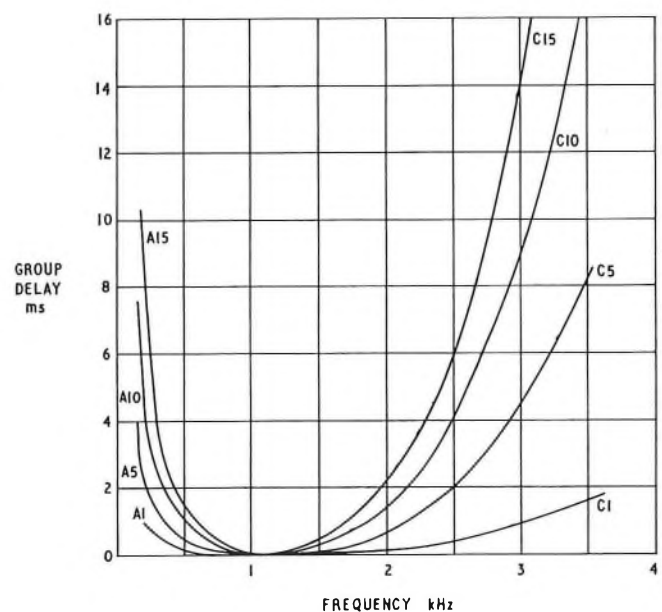

FIG. 6—Group-delay/frequency characteristics

Provided no other distortion is present, then each received component is a replica of the direct component but is successively lower in amplitude by an amount equal to the loss in the echo path. In the majority of cases encountered in practice, the loss of the echo path is in excess of 10 dB and so the effect of the second and higher order reflections may be neglected. Listener echoes generated by the line simulator in its present form are subject to this approximation. A single listener echo in which only the first echo component is present may be simulated by closing both the direct and delayed path switches S2 and S3 and by connecting the second frequency changer to the output of the variable phase-shifter following the first 10 kHz oscillator by using switch S4. The required delay time of the echo may then be set on the variable-delay network (0–6 ms in steps of 0·1 ms), the relative level (0–60 dB) set on the variable attenuator and the relative phase (0–360°) set on the variable phase-shifter. Interference between the direct and delayed signals gives rise to a combined transmission characteristic in which the attenuation and group delay vary cyclically with frequency. Expressions for the attenuation and group delay/frequency characteristics in terms of the ratio of the amplitudes of the direct to the delayed component and the echo delay-time and phase are derived in the Appendix. Figs. 10 and 11 show these characteristics, normalized with respect to echo delay-time, for a range of direct/delayed signal-amplitude ratios between 0·1 dB and 20 dB.

It must be stressed that these curves show the transmission characteristics provided by the line simulator and take into account the presence of only the first echo component. They represent the effect of true listener echo with reasonable accuracy only when the signal/echo amplitude ratio is greater than 10 dB.

Phase Discontinuities

Unidirectional phase discontinuities, such as may occur when carrier-system translating oscillators change to standby equipment, are particularly detrimental to some data-transmission methods and must be distinguished from random variations of phase about a fixed mean value. The effect may be simulated by closing the delayed-path switch S3, and breaking the direct-path switch S2, so that the signal traverses the double frequency-translation stages. The required phase shift, in the range 0–180°, is set on the variable phase-shifter which may be gated in and out of circuit under the control of the 20 Hz multivibrator when switch S5 is operated, or alternatively, under manual control as described earlier.

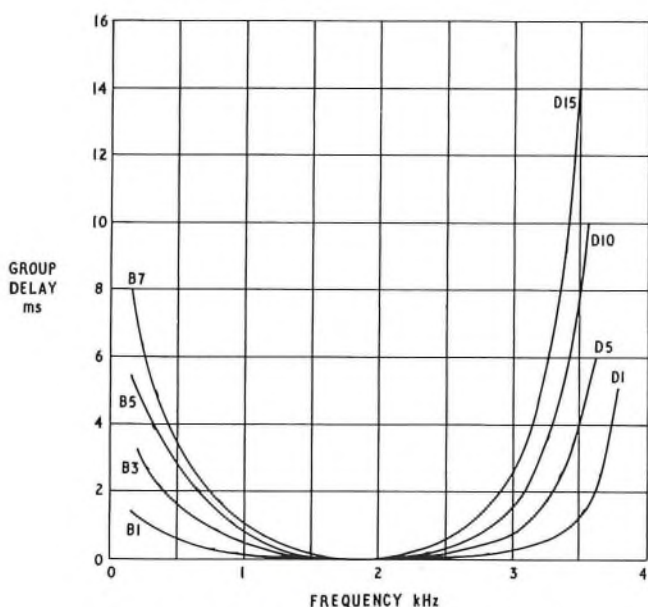

FIG. 7—Group-delay/frequency characteristics

Frequency Offset

Frequency offset may occur in carrier systems when there is a difference between the frequencies of the modulating and demodulating oscillators. The effect may be simulated by using only the delayed path and connecting the second frequency changer to an independent 10 kHz oscillator, whose frequency can be shifted ± 20 Hz. The effect of frequency offset and echo cannot be simulated simultaneously.

Additive White Gaussian Noise

The noise generator in the equipment provides a uniform spectrum of gaussian noise up to approximately 20 kHz at a level of 1 mW measured in a 3 kHz bandwidth. This is followed by a 10 kHz low-pass filter to define the bandwidth, a preset attenuator and the variable attenuator used for setting the signal-to-interference ratio, before the noise is combined with the signal. The noise level may be adjusted using the preset attenuator and the thermal meter.

Non-Linear Distortion

A simple resistive network incorporating biased diodes may be switched into the signal path. This attenuates the positive half-cycles of the signal relative to the negative half-cycles and introduces a predetermined degree of distortion. The circuit has been adjusted, using two test tones, to give second-order intermodulation products at -20 dB relative to the level of each tone. The signal-to-distortion ratio is substantially constant for all signal levels in the range $+5$ dBm to -10 dBm.

Additive Impulse Interference

A simple pulse generator is incorporated in the equipment. The output of a trigger circuit, designed to be driven by an external random-telegraph-signal generator, is differentiated to give positive and negative pulses 100 microseconds wide, either or both of which may be selected.

Combined Additive and Multiplicative Interference

This type of interference, sometimes known as amplitude hits, may arise in the switched telephone network at a dry joint or faulty switch contact. The signal level is affected (multiplicative interference) and, when this occurs in a circuit such as the line between a subscriber and the local exchange, where a direct current is also flowing, additive impulsive interference is introduced simultaneously. An output from the 20 Hz multivibrator via switch S6 is used as the modulating signal applied to a simple amplitude modulator to provide the multiplicative interference. A bridge circuit enables simultaneous additive interference up to ± 5 times the peak signal amplitude, to be introduced, if required. A switch on the modulator provides a choice of seven modulation factors between 12 and 100 per cent.

CONCLUSIONS

Although equipment with many of these facilities has been described elsewhere,² the inclusion in the present equipment of the ability to simulate echoes greatly increases its versatility. Each parameter can be varied independently of the others so that, for example, the effect of different group-delay characteristics may be determined whilst retaining any selected attenuation characteristic constant.

The range of characteristics available has been found to be satisfactory apart from the group-delay family C which simulates standard 20/88/1·136 loaded lines. The unit steps in this family correspond to 25 miles of cable and have been found rather coarse for the work in hand. The equivalent of 10-mile steps would have been a better choice. The simulator

has been used extensively for testing the performance of experimental data sets and the results will be given in a later article.

References

- ¹ WILLIAMS, M. B. The Characteristics of Telephone Circuits in Relation to Data Transmission. *P.O.E.E.J.*, Vol. 59, p. 151, Oct. 1966.
- ² ANDREWS, JR., F. T. Data System Tests using Simulating Transmission Impairments. Part I of *Trans Amer. Inst. Elect. Engrs Commun and Electronics (U.S.A.)*, Jan. 1962, No. 58, 590.

APPENDIX

Insertion Loss and Group Delay/Frequency Characteristics with Single Echo Component

When a single echo component is present, the received signal is the resultant of this and the direct component. Assuming otherwise ideal transmission, the distortion due to the presence of the echo signal may be determined by comparing the resultant signal in amplitude and phase with the direct signal. The phasor diagram of the received signal is shown in Fig. 8 where:

- A = amplitude of the direct signal,
- B = amplitude of the delayed signal,
- S = amplitude of the resultant signal,
- $p = 2\pi f$ = frequency of signal in radians/second,
- t = delay time of echo in seconds,
- θ = phase angle of the echo signal relative to the direct signal at $p = 0$.

Since the echo signal is delayed by a constant time, the phase of the delayed signal relative to the direct signal will be proportional to both p and t . If the delayed signal B' is assumed to have a phase angle θ relative to the direct signal at $p = 0$, the phase angle at any other frequency p is $pt + \theta$ radians

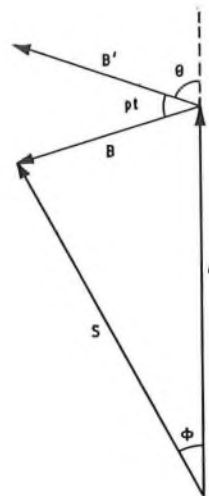

FIG. 8—Phasor diagram of signal and single echo component

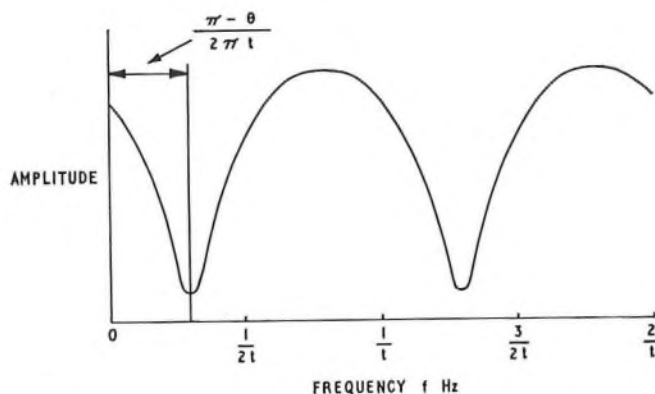

FIG. 9—Resultant signal amplitude/frequency characteristic with single echo component

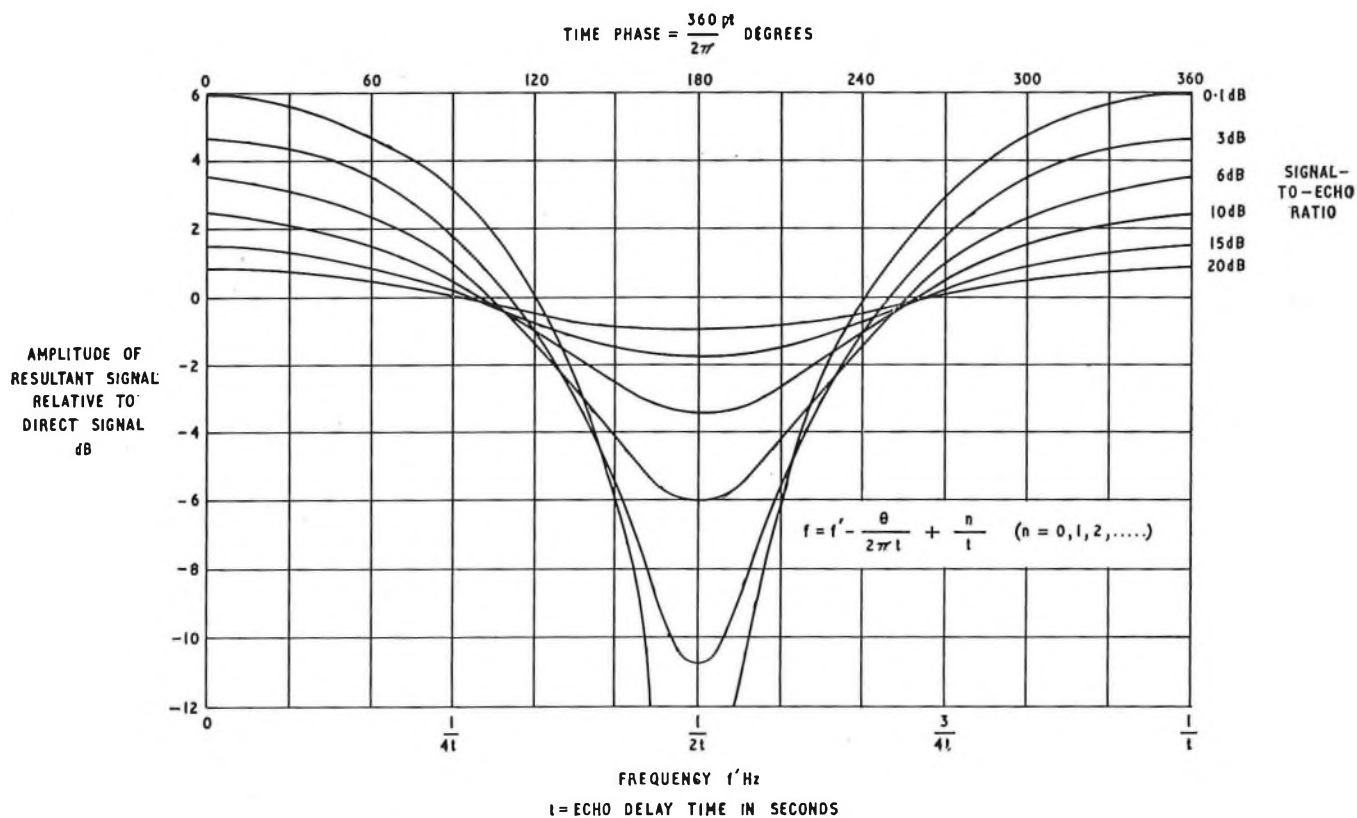

FIG. 10—Resultant signal amplitude/generalized frequency-characteristic with single echo component

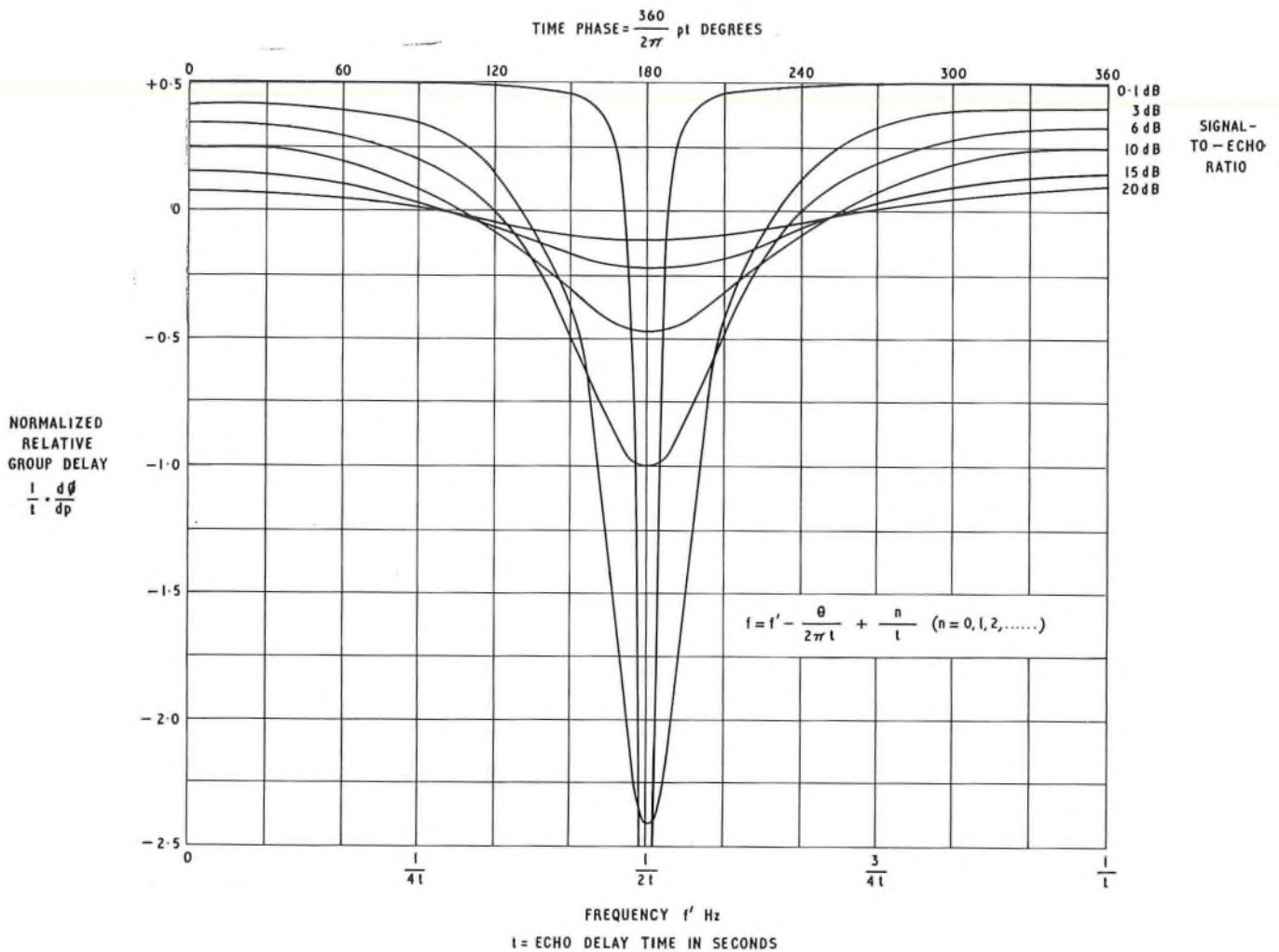

FIG. 11—Normalized group delay/generalized frequency characteristic with single echo component

and the frequency of the first amplitude minimum is $\frac{\pi - \theta}{2\pi t}$ Hz as shown in Fig. 9. Successive amplitude minima occur at intervals of $\frac{1}{t}$ Hz.

Let $R = B/A$
 and $L = 20 \log_{10} 1/R$.

Then, referring to Fig. 8,

$S = [A^2 + B^2 + 2AB \cos(pt + \theta)]^{1/2}$
 and $S/A = [1 + R^2 + 2R \cos(pt + \theta)]^{1/2}$.

The level of the resultant signal relative to the direct signal is given by $20 \log_{10} S/A$ and this result is plotted with a generalized frequency scale in Fig. 10 for several values of L .

Referring again to Fig. 8, the phase of the resultant signal relative to the direct signal is given by the angle ϕ , where:

$$\phi = \tan^{-1} \frac{B \sin(pt + \theta)}{A + B \cos(pt + \theta)}$$

$$= \tan^{-1} \frac{R \sin(pt + \theta)}{1 + R \cos(pt + \theta)}$$

The group delay relative to the direct signal is given by:

$$\frac{d\phi}{dp} = \frac{tR[R + \cos(pt + \theta)]}{1 + R^2 + 2R \cos(pt + \theta)}$$

or normalizing with respect to t :

$$\frac{d\phi}{dp} \left(\frac{1}{t}\right) = \frac{R[R + \cos(pt + \theta)]}{1 + R^2 + 2R \cos(pt + \theta)}$$

This result is shown plotted in Fig. 11 for several relative levels of listener echo.

The normalization may be removed from the group-delay scale by multiplying by t .

Notes and Comments

C. A. May, M.A., C.Eng., M.I.E.E.

A little over three years since his appointment as Staff Engineer in charge of the OMC Branch of the then Engineering Department, Charles May has been appointed Deputy Director of Engineering and head of the Exchange Systems Division in the Telecommunications Development Department. His early history was described in a Journal notice in January 1967.



After reorganization, and until June 1969, he was head of Computer Systems Engineering Branch (TD9) in the Telecommunications Development Department where his responsibilities included close liaison with user and manufacturer in the commissioning and proving of Post Office computers, studies in the application of computers to control of the telecommunications systems, and a general interest in the development and application of computing resources for research and development.

In June 1969 he made a significant move back to the conventional telephone switching field when he took charge of TD1, Established Telephone Exchange Systems Development Branch. However, none of his colleagues was surprised earlier this year to learn that he had been named to succeed John Lawrence with responsibility for the whole field of telephone exchange system development.

He brings to his new post a high reputation for significant contributions in fields of importance for the future development of telecommunications, coupled with concern for individual members of his staff and their careers. Exchange Systems Division can look forward with confidence to a challenging future under its new head; his colleagues look forward to stimulating, fruitful, and friendly collaboration.

M. B. W.

A. G. Hare, B.Sc.(Eng), C.Eng, M.I.E.E.

A. G. Hare ("Bert" to all his friends), now promoted to Staff Engineer in Research Department, spent the most formative years of his career in the army. He had only just joined the Post Office as a Youth-in-Training in the L.T.R. when war broke out, and, as a member of the Territorial Army, he was immediately mobilized. Active service in the Middle East intensified his interest in telecommunications, and he was subsequently transferred to the School of Signals at Catterick, where he became a Foreman of Signals. In retrospect, he considers these seven years of army life to have been invaluable, both in training and experience.



He returned to civilian life and the Post Office in 1946, and was then granted four years special leave to take his degree at Northampton Engineering College, after which he was appointed to Research Branch as an Executive Engineer. For twenty years now he has been actively engaged at Dollis Hill in the design of electronic communication equipment, and on the production and assessment of long-life, high-reliability transistors.

In 1968, he was appointed A.S.E. in the newly-created R13 Branch to study the application of digital-transmission techniques to the local-distribution network, and it is a mark of recognition of his personal contribution to these studies that he has now been promoted to Staff Engineer. With his wide experience of digital techniques, and the energetic and inspiring leadership which he has brought to this work, it will go ahead with new impetus. His many friends will wish him every success.

Away from the job, his consuming passion is to travel and see the world, and he spends his leave in exploring far-off places, preferably off the beaten track.

F. E. W.

J. B. Holt, C.Eng., M.I.E.E.

The well-merited promotion of Mr. Holt to Staff Engineer in charge of the Cable & Radio Systems Planning & Provision Branch of Network Planning Department will be welcomed by his many friends in the Post Office and in the telecommunications industry.

Joining the Post Office in 1934 at Shrewsbury, his work in the field provided a sound foundation for his subsequent career at headquarters. Work in War Group from 1941,



including the restoration of telecommunications services to the continent led, in 1945, to submarine cable systems work with which Mr. Holt has been associated for many years. On promotion to E.E. in 1955 he spent a few years on the maintenance of the inland coaxial and television network. Returning in 1961 to submarine cable systems, he was engaged on planning and laying sections of the COMPAC and SEACOM systems. With reorganization in 1968, Mr. Holt, at A.S.E. level, became head of a branch of Network Planning Department responsible for submarine cable systems. He led the Branch with competence and distinction during a period of exceptional activity when submerged repeaters with long-life transistors were introduced in large numbers into submarine cable systems. He saw to completion the cable to Portugal and launched a program for new high-capacity systems to the continent.

His success in negotiating with people at all levels in other administrations and in industry has earned him a world reputation as a systems engineer skilled in the art of diplomacy. This experience and his many contacts in the telecommunications industry, together with a keen sense of how to spend Post Office money wisely, will stand him in good stead in his new responsibilities. He undoubtedly has the good wishes of all his colleagues for success in his new venture.

J. C. B.

Supplement

Students studying for City and Guilds of London Institute examinations in telecommunications are reminded that the Supplement to the Journal includes model answers to examination questions set in all the subjects of the Telecommunication Technicians' Course. Back numbers of the *Journal* are available in limited quantities only, and students are urged to place a regular order for the Journal to ensure that they keep informed of current developments in telecommunications and receive all copies of the Supplement.

Syllabuses and Copies of Question Papers for the Telecommunication Technicians' Course

The syllabuses and copies of question papers set for examinations of the Telecommunication Technicians' Course of the City and Guilds of London Institute are not sold by *The Post Office Electrical Engineers' Journal*. They should be purchased from the Department of Technology, City and Guilds of London Institute, 76 Portland Place, London, W1N 4AA.

Publication of Correspondence

The Board of Editors would like to publish correspondence on engineering or technical aspects of articles published in the *Journal*.

Letters of sufficient interest will be published under "Notes and Comments". Correspondents should note that, as it is necessary to send copy to the printer well before publication date, it will only be possible to consider letters for publication in the October issue if they are received before 15 August 1970.

Letters intended for publication should be sent to the Managing Editor, *P.O.E.E. Journal*, Room 264, 207 Old St, London, EC1V 9PS.

Correction

It is regretted that an error occurred in the letter from Mr. A. F. G. Allan published in the July issue of the *Journal*. In the third line of the last paragraph of column one, "0·2" should read "0·02".

Increase in Journal Price

The Board of Editors regrets that increases in paper and labour costs have made it necessary to raise the price of the *Journal* to 4s 3d (6s including postage and packing). Subscription rates will be 24s. per year inland and overseas (3 dollars Canada and U.S.A. per year). This increase will take effect from the October 1970 issue.

From April 1971 the price will be 21p per copy or £1.2 per year.

Notes for Authors

Authors are reminded that some notes are available to help them prepare the manuscripts of the *Journal* articles in a way that will assist in securing uniformity of presentation, simplify the work of the *Journal's* printer and draughtsmen, and help ensure that authors' wishes are easily interpreted. Any author preparing an article for the *Journal* who is not already in possession of the notes is asked to write to the Managing Editor to obtain a copy.

It is emphasized that all contributions to the *Journal*, including those for Regional Notes and Associate Section Notes, must be typed, with double spacing between lines, on one side only of each sheet of paper.

Each circuit diagram or sketch should be drawn on a separate sheet of paper; neat sketches are all that are required. Photographs should be clear and sharply focused. Prints should preferably be glossy and should be unmounted, any notes or captions being written on a separate sheet of paper. Negatives or plates are not needed and should not be supplied.

Model Answer Books

Books of model answers to certain of the City and Guilds of London Institute examinations in telecommunications are published by the Board of Editors. Details of the books available are always given at the end of the Supplement to the *Journal*.

Regional Notes

London Telecommunications Region

Internal Maintenance Section

The London Telecommunications Region Internal Maintenance *Bulletin* which originated as an experimental venture in 1949 on the initiative of the late W. S. Procter (of Herbert and Procter fame) attained its majority in April of this year. The *Bulletin*, a pioneer in the field of what may be termed amateur technical journalism is used, among other things, for the interchange of information relating to internal maintenance problems. The *Bulletin*, which is published by the Engineering Service Division at Regional Headquarters, normally appears at 4-monthly intervals. Three thousand copies are required to cover its circulation to other Regions, Telecommunications Headquarters and overseas as well as every part of the London Telecommunications Region.

F. J. CURLE

Cabling on London Bridge

The new London Bridge is being built in four separate stages and, as the first upstream stage has now been erected, the London Telecommunications Region has been able to go ahead with the alteration of the Post Office plant.

Across the old London Bridge there were 32 steel pipes containing 17 cables. This track was situated in the centre of the old bridge.

Unfortunately, due to both the construction of the new bridge and the erection sequence, the new ductwork had to be sited within two of the boxes on the upstream side (see Fig. 1).

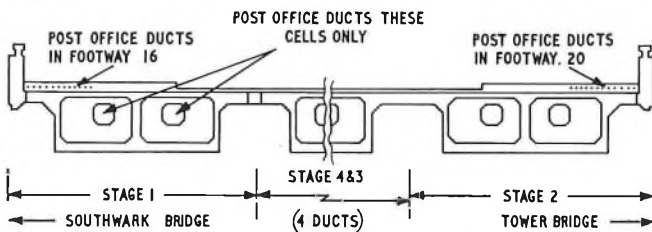

FIG. 1—Cross section of London Bridge

It was decided to run 18 thick-wall p.v.c. ducts (duct 54) through each of the two boxes and suspend them by means of steel hangers. This ensured that although the height of the boxes varied from 5 ft 6 in at the abutments to 17 ft 3 in at the piers, the track would remain virtually level throughout. The spacers were manufactured from Burmese Teak which is practically impervious to atmospheric conditions and parasitical attack.



FIG. 2—Cable box

In order to intercept the existing cables, two large chambers have been built at both ends of the bridge where specially designed standard cable bearers are being erected.

Supplementing the 36-way ducts being laid in the two upstream boxes will be a further 36-way duct laid in the two footways but this, of course, will be at a later stage.

Fig. 2 shows one of the boxes with the p.v.c. ducts in position on steelwork hangers.

J. L. LEONARD

London Postal Region

Move of Letter Code-Sorting-Installation

During the weekend of 21-22 February a working unit of 12 Coding Desks and four medium-speed Letter-Sorting machines was transferred from Bird Street (London W1) to the East Central District Office at King Edward Building.

A novel feature was the use of hoverpallets to transport the machines over a light-load-bearing floor thus obviating the need to strengthen the floor and also reducing shock damage to the delicate equipment. Minor difficulties were soon overcome and the method showed many advantages over conventional handling.

The installation was re-assembled, tested and operational within one week of the move thanks mainly to the enthusiasm and co-operation of the engineering staff concerned.

R. F. POULTER

Scotland

The Flying Manhole

During a recent road improvement at Linlithgow, the local authority decided to lay a new sewer and to cut out the stream which ran under the road. This work involved the demolition of the road, excavations to a depth of some 20 to 30 ft, and the provision of a temporary Bailey bridge.

Unfortunately for the Post Office, a loading-coil manhole was in the middle of the excavations. A two-way duct line, junction and local cables were involved. Owing to the local

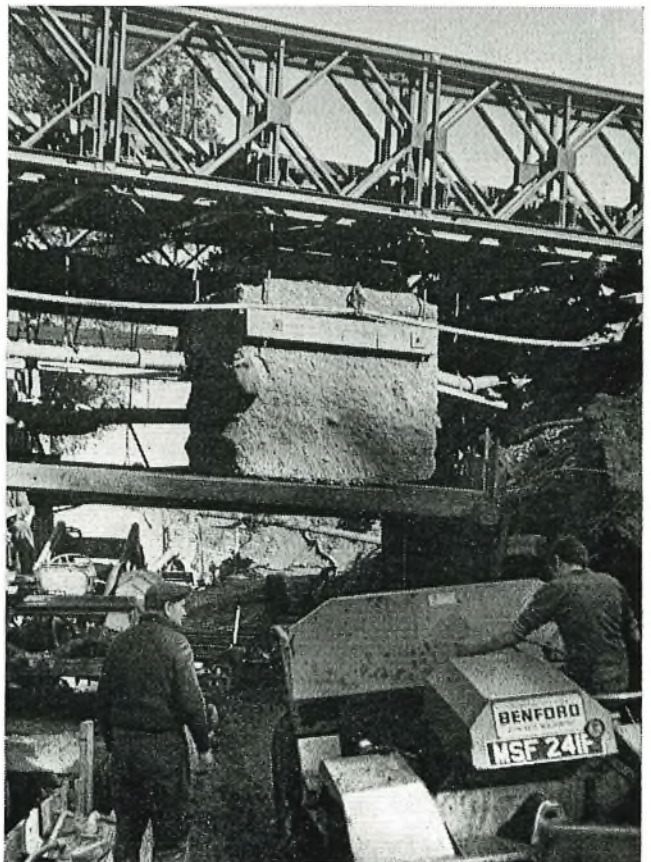

Manhole at Linlithgow

conditions it would have been difficult to have provided an interception route and it was decided to suspend the manhole and cables from the Bailey bridge (see Fig.). This was done by boring through the opposite walls of the manhole and bolting 12 in by 3 in joists to the walls and suspending 1 in steel rods from the joists to the Bailey bridge. As an added precaution, two steel ropes were also suspended from the Bailey bridge round and underneath the manhole. Most of

the ducts were broken as the cables were tied at frequent intervals along the length of the Bailey bridge.

In spite of an accident when a water main burst and dislodged one side of the Bailey bridge, the manhole and cables survived and after nearly four months the road has now been re-instated and the duct line and manhole are once again "back to earth"—none the worse for their experiences.

H. I. BURCHELL

Associate Section Notes

Aberdeen Centre

On 21 January the company were entertained by a film show which included the films "The Post Office Tower of London", "Thinking about Golf" and "Early Bird". The show lasted two and a half hours and was thoroughly enjoyed by all present.

The subject for the month of February was a talk by Mr. R. Mathewson entitled "Automatic Busing of Trunk Circuits". The talk covered automatic gain control devices used on h.f. groups and the busing facilities derived from them.

On 25 March our visiting speaker was Mr. D. Cruickshank from the Meteorological Office who gave a very interesting and revealing talk on the subject of weather and the Meteorological Office.

R. MATHEWSON

Belfast Centre

After a long absence from these pages the Belfast Centre returns with the news that, notwithstanding our silence, we are still going strong and are as active as ever. Our membership still hovers about the 200 mark.

We held our annual general meeting for the 1969/70 season on 18 November, later than usual due to the civil strife in our area. At this meeting, the following committee was elected:

Chairman: Mr. T. T. Dearden; *Vice-Chairman:* Mr. A. McWhinney; *Hon. Secretary:* Mr. D. McLaughlin; *Treasurer:* Mr. C. C. Smith; *Committee:* Messrs. G. Gettingby, H. Gabbie, P. Hedgecock, N. Geddes and A. Birrell.

The program for the season was arranged and covered some very interesting and fashionable subjects:

- 11 December: "Tropical Fish Keeping", by Mr. B. F. McClean, one of our members.
- 15 January: "Car Rallying", by Mr. V. G. Morrison and Mr. M. Maguire, Belfast Telephone Area.
- 18 February: "Satellite Communication in the Seventies", by Mr. D. I. Dalgleish, Telecommunications Headquarters.
- 11 March: "Maintenance Techniques in the Crossbar and Electronic Age", by Mr. A. R. Redhouse and Mr. E. Davis, Telecommunications Headquarters.
- 25 March: "Datel Services—Present and Future", by Mr. G. W. Adams, Telecommunications Headquarters.

Attendances at these lectures ranged between 10 and 60. Our average attendance for the program was 25.

The Faraday Lecture, "People, Communications and Engineering", by Prof. J. H. H. Merriman was held in Belfast on 17 April.

Our Summer program will consist of a visit to the local S.T. & C. factory where Crossbar equipment is manufactured, and a "Stereo and Hi-Fi" demonstration and lecture at a retailer's premises.

D. McLAUGHLIN

Colchester Centre

Our 1969/70 Winter Session started in October with a talk on "Skin Diving" illustrated by films; this was followed in November by a very interesting talk on "Pulse Code

Modulation" given by Mr. C. T. J. Tooke from Eastern Region Headquarters.

The December meeting was about the "Festiniog Railway", the speaker for the evening being a member of the Festiniog Railway Society.

Our most popular meeting for some time was held in January; it was in the form of a photographic competition for colour prints, black and white prints and colour transparencies. The entries, which were of a high standard, were judged by members of the Colchester Camera Club and small prizes were awarded to the winners. The meeting was attended by approximately 75 members and guests.

Unfortunately, our March meeting had to be cancelled, but the annual general meeting was held in April, and this was followed by a talk on brass bands by Mr. Dave Cawdell who ended the evening with a practical demonstration, assisted by some of his musical Post Office colleagues.

K. H.

Dundee Centre

A varied and interesting program has come to a close—the annual general meeting was on 7 April and our annual day outing on 10 April, to Barr and Stroud, Glasgow. An extra item this year was a visit to the Usher Hall, Edinburgh, to attend the Faraday Lecture.

The success of any program depends on the support given by members and once again we have witnessed an increasing interest in our meetings and visits.

If any of our former members, who are now overseas, read our notes, we would be pleased to hear from them.

R. T. LUMSDEN

Edinburgh Centre

On Wednesday 14 January a talk entitled "1912 and all that" was given by Mr. R. B. Munro, Telephone Manager, Edinburgh. This was a review of the organizational development of the telephone system in the United Kingdom from the days of the National Telephone Company up to the present.

Twenty-one members visited Bilston Glen Colliery on Tuesday 10 February. The party descended two thousand feet in a cage, were driven in an electric train for two miles, then walked approximately one mile to the coal face. On arrival at the face an automatic chain cutter was seen in operation, and the coal was seen leaving on a conveyor for the surface. This was a very worthwhile visit.

On Thursday 5 March one of our members, Mr. Stuart Barr, presented a talk "Mountaineering and Skiing". Mr. Barr displayed various pieces of equipment and illustrated his talk with slides taken in Scotland and on the Continent. This meeting was attended by 14 members.

M. K. FINLAND

Exeter Centre

The Centre's activities continue on the basis of visits to places of interest during the summer months, arranged mid-week involving annual leave, and formal meetings during the winter evenings.

The 1969 summer program was concluded with a visit to British Steel Corporation's Spencer Works at Newport, Monmouthshire. Our party were able to see the whole of the "hot finished" and "cold reduced" steel sheet production

lines, with the exception of the blast furnaces, one of which was being re-lined, from the raw material handling to packaging and despatch. We also enjoyed excellent hospitality and are indebted to the British Steel Corporation for this very interesting visit.

The 1969/70 winter program has proved to be a popular one, attendances averaging 99. For the last five years the Centre has been addressed by Mr. G. Cload. This year, to mark the occasion, our President, Mr. W. J. Foster, presented him with a power jig-saw in appreciation of the very pleasant and interesting evenings he has given us.

The evening of importance to the Centre this session proved to be Wednesday 11 February. A local speaker, Mr. G. W. Harris, presented an excellent paper on "Datel"; the paper was very well supported even though it had been presented on previous occasions to maintenance and installation staff.

The Centre was also honoured by the presence of Mr. K. F. Jalland, C.Eng., M.I.E.E., M.B.I.M., Controller Planning, South Western Region, who attended the evening to present prizes to Centre members for their success in the 1968/69 Associate Centre Papers Award. Certificates and cheques were presented to Messrs. G. S. Steer, F. J. Brown and N. H. B. West, who between them had gained three of the six prizes awarded by the Institution. Mr. Jalland said the awards were indicative of the interest members had in the activities of the Centre. Also presented at the meeting was the award of which the Exeter Associate Centre is particularly proud—"The Trainee Technician Apprentice of the Year Award" which this year was won by Mr. P. A. Tiley.

The Centre sincerely appreciated the attention of its speaker and guest in its affairs.

The winter program ended in April with the annual general meeting, which this year was followed by films.

The first of the 1970 summer events was held in April when a party of members visited Wills of Bristol.

The Hon. Secretary would be pleased to receive any suggestions for the 1970/71 winter program.

T. F. KINNAIRD

Glasgow Centre

The year began under a new chairman, Mr. S. T. Marsh, who has so ably chaired our meetings for so long, has had to retire due to promotion. He was succeeded by Mr. J. McCallum, and Mr. J. L. Somerville accepted the appointment of President.

The 1969/70 program opened with a talk on Transit Switching by Mr. W. Sheldon, Deputy Telephone Manager, Edinburgh, who presented this very topical subject in a manner which was both informative and entertaining. Talks were also given by Mr. J. C. Graham on Dial House equipment and a Senior Meteorological Officer who spoke on the organization and functions of the Meteorological Office.

The December meeting took the form of a film show. Three films: "Transmission Systems", "The Post Office Cable Ship" and "The Post Office Tower" were shown and provided an opportunity to see how the other half lives.

Two visits have been made. The first to Glasgow University Observatory was unfortunately marred by bad weather which prevented use of the telescope. The second visit, which was of exceptional and unusual interest, was to Strathclyde University Bio-engineering department under Prof. Kennedy. The visit coincided with an exhibition of the work of the department which covers such widely divergent subjects as the design of kidney machines, artificial limbs, properties of human skin and the mechanical aspects of childbirth.

At the last meeting of the year Mr. Marsh of Mullard spoke on Integrated Circuits aided by a film.

The annual general meeting was held in May and concluded what we hope has been a successful year.

J. S. MITCHELL

Gloucester Centre

During the winter months we have welcomed a variety of speakers to our Centre, all experts in their own field, who presented to us papers on their particular subject.

Stroud was our first venue when a representative of the

Consumers' Association explained to us "The How and Why of *Which?*" The Technical Sales Manager of Smiths, Aviation Division talked on the operation of "Automatic Landing Systems" at our Cheltenham meeting. We returned to Stroud again for "The Transit Network" kindly presented by Mr. W. Sheldon, who rearranged his tour of the main Centres to address us. A pleasant evening was spent at Gloucester in the company of Mr. F. W. Rowbotham (the District Engineer of The Severn River Board), whose subject was "The Severn and its Bridges".

The joint meeting this year with the Swindon Associate Section was the paper on "Satellite Communications in the 70's". The meeting was held as usual at Cirencester and given by Mr. D. I. Dalgleish.

Besides our various indoor meetings, we have had two very successful outings. The first, during February, was to the British Aircraft Corporation Works at Filton, Bristol, where the program included a film of the first flights of Concorde 001 and 002, a visit to the mock-up and finally a tour of the Assembly Halls to view the first pre-production Concorde 001, in an advanced state of construction. In March we spent a day as guests of the General Electric Company at Coventry. Here, we were shown the latest development in microwave systems and testing, p.c.m., t.d.m., multiplex and generating equipment and the Crossbar system of exchange switching.

At the time of going to press, we have reached a mile-stone in the history of our local centre, having just enrolled our three-hundredth member, and, by the time you read this report, I hope we will be progressing towards our fourth century.

Finally, arrangements are under way for the annual general meeting which we hope to combine with a demonstration of hi-fi equipment. Arrangements are also well advanced regarding our visits for the summer.

P. G. WHITE

Kingston-upon-Hull Joint Centre

The opening event of the 1969/70 session in September was a visit to a new stern-fishing trawler. Members enjoyed a very comprehensive tour of the vessel, conducted by Mr. J. Fox of Boston Deep Sea Fisheries Ltd.

During October, some 30 members attended the North Eastern Regional Associate Section lecture at Leeds University. The subject was "The Use of Computers in Telecommunications".

In November Mr. P. H. Wade, North East Telecommunications Region, presented his paper "S.T.D.—the next step". This proved to be most informative as regards the future of s.t.d. and the development of the transit switching system.

During December, two separate evening visits were made to Keyingham TXE2 electronic reed-relay exchange. The principles of the system were explained by Mr. D. Magee who used to good effect a TXE2 simulator loaned by its designer, Mr. D. Monaghan, Executive Engineer, York Area.

In January a joint meeting was held with members of the Hull Electronic Engineering Society, the paper on Communication Satellites being given by Mr. W. P. Robins of G.E.C.—A.E.I. This was an extremely interesting lecture, covering amongst other things, some of the problems of the design and construction of the satellites themselves, and of their launch and control, and also the complex test procedures and systems at ground stations.

A dinner attended by both past and present members was held in February 1970. Guests included Mr. D. A. Evans, Hull Corporation's new Telephone Manager, and Mr. W. P. Abbott, Telephone Manager, York Area. The guest of honour was Mr. H. V. J. Harris, the retiring Telephone Manager, Hull. At the end of a very pleasant evening, the hon. secretary presented to Mr. Harris an illuminated address thanking him on behalf of our members for his assistance to the centre since its re-opening in April 1952.

Our final meeting was a film show and annual general meeting and was held on 12 March. The programme included a film entitled "The Seeing Eye" which dealt with the use of monochrome and colour cine techniques. The range of information given in this film is outstanding and fully justified its loan. Officers and the committee were also elected for the 1970/71 session.

L. JOHNSON

Sheffield Centre

A party of 29 members from the Sheffield Centre visited the Prescott works of Messrs. B.I.C.C. Ltd. on 9 February. In addition to the facilities offered to the party to tour the cable manufacturing works, the Company provided a most enjoyable lunch for the visitors.

On 19 February Messrs. Redhouse and Davis, of Telecommunications Headquarters, presented their paper entitled "Maintenance Techniques for Crossbar and Electronic Exchanges" to an audience of some 30 members. Also at this meeting Mr. J. Knox, the Service Controller, presented to Mr. D. Ashton the first prize in the National Associate Section Papers Award for his paper entitled "Motorway Emergency Telephones". At a further meeting, Mr. K. Grainger presented a paper dealing with "The Application of Works Study in the Post Office". The wealth of questions raised at the conclusion of the paper amply compensated for the relatively small audience and the meeting ended later than usual.

Arrangements are complete for a third party from Sheffield to visit the Post Office tower. Previous visitors have found much that is of interest in this unique building and once again all seats on the coach are reserved.

T. DUNCUM

Leeds Centre

At the annual general meeting held in April 1969, the following appointments were made

Chairman: Mr. J. Middleton; *Vice-Chairman:* Mr. J. Brooks; *Secretary:* Mr. K. Field; *Visit Secretary:* Mr. D. N. Kirk; *Treasurer:* Mr. R. Kirk; *Committee:* Messrs. L. Greenwell, J. Coyle, J. Smith, J. Brownless, P. W. Midgley,

W. McLoughlin, E. O. Clarke, J. Duggan, B. Stockwell and J. Longbottom.

The activities of the past year and the financial position were reviewed and agreed to be satisfactory. The former included visits to Messrs. Mullards at Blackburn, Messrs. Appleyards Repair Garage at Leeds, Messrs. Pilkington Glass Producers, Messrs. Plessey Cables, two visits to Yorkshire Television Studios, and one of our main events, the annual dinner and dance at Ringway's Restaurant.

During the 1970/71 session it is hoped that parties from the centre will visit Messrs. British Leyland, Messrs. B.I.C.C. Yeadon Airport, and Messrs. Rocol Oil Manufacturers.

K. FIELD

Oxford Centre

The first quarter of this year has been an interesting one for the Oxford Centre. Hi-Fi equipment was appraised and scrutinized in January, and to aid members with their persuasive manoeuvres, wives were also invited.

Space Research was the subject for February and Mr. M. F. Ingham from the Oxford Department of Astrophysics described experiments with space probes and satellites, their uses, findings and justification.

Later in February, in a land-line quiz between Ipswich, Southend and Oxford, Ipswich avenged their narrow defeat of the previous year with an easy win.

Mr. Eric Tolliday spoke on the development, problems and future for exchange switching equipment; providing a historical background that many know little about.

The final meeting before the annual general meeting is an Any Questions evening, allowing members to question the Area management.

D. A. COTTERILL

Institution of Post Office Electrical Engineers

Institution Field Medal Awards, 1968-69 Session

In addition to the Institution Senior and Junior silver and bronze medals, the Field Medals are awarded annually for the best papers read at meetings of the Institution on field subjects primarily of Regional interest.

Field Medals were awarded to the following authors for papers read during the 1968-69 session:

D. H. Anderson and A. P. Parsons, Birmingham Centre. "A Critical Look at Telephone Engineering Centres—Do we get value for money".

W. J. Gawley, Belfast Centre. "Long Term Planning Aspects of Craigavon New Town".

Result of Essay Competition, 1969-70

A prize of £6 6s. and an Institution Certificate have been awarded to the following competitor:

J. W. Henderson, Technical Officer, Doncaster Centre. "Precision Testing—Past and Present".

Prizes of £3 3s. each and Institution Certificates have been awarded to the following four competitors:

C. F. Newton, Instructor, Otley Centre. "Tailor-Made Training Films".

D. E. G. Coles, Technical Officer, Birmingham Centre. "Hastening the Understanding of Circuit Provision Procedure with the aid of Flow Diagrams".

A. Buttrees, Technical Officer, Wakefield Centre. "Telephones and Televisions in New York City, U.S.A.".

S. E. Crowder, Mechanic A, Birmingham Centre. "The Post Office Mechanic".

Institution Certificates of Merit have been awarded to the following three competitors:

P. English, Technician 2A, Edinburgh Centre. "Reliability of Electronic Equipment".

D. C. Ferguson, Technical Officer, Old Meldrum Centre. "Overhaul Centres".

F. J. Crampton, Technical Officer, Aylesbury Centre. "Datel Services".

The Council of the Institution records its appreciation to Messrs. T. J. Morgan, S. Rata and R. Holden, who kindly undertook to adjudicate upon the essays entered for the Competition; it is also indebted to them for the following report on the prize-winning essays. The prize-winning essays will be kept in the Institution Central Library and will be available to borrowers.

Review of Essay Competition, 1969-70

Although the number of entries for this year's essay competition was smaller than last year, the variety of subjects chosen was wide and interesting. The subjects ranged over, A Visit to the Telephone and Television Centres in New York, Circuit Provision Procedure, Overhaul Centres, Datel Services, The Post Office Motor Mechanic, and The Local Production of Training Films using amateur cine equipment.

The winning essay by Mr. J. W. Henderson of Doncaster "Precision Testing—Past and Present", although at first glance dealing with a "dry as dust" subject, was well presented and admirably illustrated. The author gave some early history of the telecommunications art and showed how the Varley, Murray and Double-ended Varley tests use the basic principles of the resistance bridge invented by Wheatstone in 1843. Mention is made of the operation of the Cable Fault Indicator and the principle part of the essay deals with developments in the precision testing field since 1960. The gas pressurization of cables is described and the pneumatic fault location methods are discussed with actual examples given from the field. The location of faults by means of probing with Arcton Gas using the H.A. Leak Detector is

described. It is quite clear from the discussion on the subject that the author has some practical experience of the techniques he describes. The essay concludes with a short note on the application of pulse techniques using the Echometer TO 3/2.

N.B.—Particulars of the next competition, entry for which closes on 15 January 1971 will be published later.

Retired Members

The following members, who retired during 1968, have retained their membership of the Institution under Rule 11(a):

T. J. V. Alton, 1 Pine Road, Didsbury, Manchester.

R. O. Boocock, 100 Glebe Road, Cambridge.

C. E. Calveley, O.B.E., E.R.D., Fiveways, Warninglid, Haywards Heath, Sussex.

W. Davies, 39 South Parade, Bramhall, Cheshire.

J. M. Fleming, 17 Graham Park Road, Gosforth, Newcastle-on-Tyne.

G. C. Greenwood, 148 Perne Road, Cambridge.

J. B. Harnden, C.B., 108 Friern Park, North Finchley, N.12.

H. Leigh, 36 Stanbourne Way, West Wickham, Kent.

F. N. Lucas, E.R.D., 18 Warwick Road, Hale, Altrincham, Cheshire.

C. A. L. Nicholls, O.B.E., 12 Justice Avenue, Saltford, Bristol.

R. E. Ratcliffe, 18 Angel Hill Drive, Sutton, Surrey.

S. M. E. Rousell, 60 St. Augustines Avenue, Wembley, Middlesex.

R. Taylor, Sartoria, Breuisyard Road, Rendham, Saxmundham, Suffolk.

H. Todkill, 16 Halton Road, Boldmeer, Sutton Coldfield, Warwickshire.

W. C. Ward, Cockfields, Cock Green, Felstead, Dunmow, Essex.

A. B. WHERRY

General Secretary

Speech by the Chairman of Council

The following is extracted from a speech given by the Chairman of Council, Mr. N. C. C. de Jong, at an I.P.O.E.E. Dinner on 29 April, 1970 in Shrewsbury.

"I have a very good reason to appreciate your invitation for this evening and to have this opportunity to respond to a toast to the I.P.O.E.E. The Institution is now 65 years old, and some of you, like myself, will have taken part in its affairs for well over half that period. The reasons for my accepting your invitation with such pleasure is that my first attendances were at Cardiff and I recall with some nostalgia the trips via the delightful mid-Wales Railway to those first joint meetings at Shrewsbury. In those far-off days I had no idea that eventually I would have the privilege of becoming Chairman of the Council and be invited here to enjoy your company.

"From its beginnings in 1906 the Institution has always been a powerful influence in the general advancement of electrical and communications science. In this lies its prime purpose, although our archives tell us that the original idea was for a Society for the improvement in status of engineers and the promotion of their material interests. If this proposal had been adopted, it is a moot point whether the status of engineers would have been advanced more than it has been by the creation of our learned Society, but I for one am in no doubt that the right choice was made. From the start the Post Office has encouraged the I.P.O.E.E. by a small annual grant, and more so by the facilities provided. It has never intervened in the running of our affairs. Your Council is determined to maintain this relationship, and so preserve the independence of the Institution in the Corporation era though it is equally anxious not to emulate an ostrich in a quickly changing environment. We have, therefore, kept our rules up to date and carried through reforms, but without pursuing any radical change for which the membership is not yet ready. However, in the Corporation, engineers as such are less recognizable and are more and more taking on wider responsibilities. Much thought has therefore been given to the difficult problem of whether the Institution should be reorganized to encompass all the professional skills needed to run the Post

Office as a Corporation. Not unnaturally, there is still much reluctance from the membership at large against moving in this direction, but in accepting this I am bound to point out that if the Post Office were to drop the title of engineer in its description of grades, then Council would find itself in a difficult and embarrassing position because of the present constitution and rules.

"Meanwhile, I am glad to say that the Institution has gone from strength to strength though, as for other bodies, rising prices cause a constant headache to your management. For the first time there are now over 10,000 senior members and the Associate Section continues to flourish. Our journal sales have steadily increased to 140,000 copies, many of these going to 53 overseas countries. I hope you will agree that the journal, also without losing its character, has enhanced its prestige and I also hope to see you make good use of our most recent innovation, the Correspondence Column.

"Incidentally, we also have in mind to design a new seal, the present one with its Wimshurst machine and other ancient parts could be described as a Victorian Whimsy—perhaps we shall see another competition with a compulsory transfer to Wales and the Marches as the first prize.

"The Institution is grateful for the assistance given by the Post Office in defraying certain expenses, such as travel and subsistence costs when attending local centre meetings. Once a year Council avails itself of this generosity by holding its meeting in a local centre in the morning and then attending the paper presented locally in the afternoon. By tradition, Council visits each local centre in turn. A ten-year cycle will be completed next year when Council visits the newly-established Eastern Regions.

I put these thoughts to you, gentlemen, hoping that they will encourage you to think of the advantages of the Institution going forward and changing its shape, so that it can continue to play an important role in the dissemination of our technological and other advances and exert a cohesive and educational effect on the various professional engineering disciplines in the telecommunications and postal business, which together form the biggest industry in the United Kingdom."

Press Notices

New Target for Telecommunications

The Government plans to raise the Post Office's telecommunications financial target of an 8½ per cent return on net assets to 10 per cent from July 1, 1970. To help meet the 10 per cent target during the 2½ years from July 1, 1970, to March 31, 1973, the Post Office must raise prices for telecommunications to produce additional revenue of £65m. in a full year, an increase of about 8 per cent on current revenue. The telecommunications business will also meet the 10 per cent target by stimulating profitable business and cutting costs through higher productivity. The Post Office has embarked on a five-year £2,700m. capital investment program designed to correct the deficiencies of under-investment in the 1940s, 1950s and 1960s and to meet the needs of the 1970s. Main objectives of the Corporation's telecommunications business are to maintain and improve its services; put itself on a sound commercial footing; meet its social responsibilities; and meet the financial target set by the Government.

If prices remain at present levels, the amount of capital available from within the Post Office would drop from half the total required to less than a third between now and 1975: outside borrowing would increase from £190m. a year to £400m. Capital spending between July 1, 1970, and March 31, 1973 will amount to £1,400m. The new tariffs will enable the Post Office to find an additional £200m., or £750m. in all, (54 per cent of the capital needed) from its own resources and borrow only £650m. (46 per cent) thus significantly reducing future interest payments. The need for a massive investment programme can be seen from the fact that the present total of 8 million telephone lines in Britain will at least double by 1980, with the number of calls double the present 27 million a day. Today, one home in three has a telephone. Post Office telecommunications must be prepared to cater for a five-fold growth in Telex, a 50-fold growth in the number of data transmission terminals, and to provide an expanded and more flexible system during the seventies if it is to remain among the world's leaders. In terms of productivity, the telecommuni-

cations business is ahead of most other industries. Productivity is such that the number of telephone connexions will grow by a quarter in the next 2½ years without any increase in staff: the output per head will have been increased by more than 8 per cent a year in the period 1965-71 compared with a national average 2½ per cent. The investment program gives priority to maintaining and improving the quality of service for both commercial and private customers. If the proposals put to the Post Office Users' Council are agreed and implemented, the British telecommunications services will still be inexpensive by international standards. An efficient telecommunications service in Britain can only be achieved by prudent investment now.

New Transatlantic Telephone Route

Britain will have a new alternative route for telephone calls across the Atlantic Ocean through a submarine cable between Spain and the U.S.A., formally inaugurated on April 9, 1970. This new cable has a direct connection with the cable constructed for the Post Office between Britain and Portugal last year.

Several northern European countries will be making use of the service through London to this new cable. Named TAT 5, the cable is the sixth submarine telephone cable to be laid across the Atlantic. Part of the cable was manufactured in Britain. Transatlantic telephone cables already carrying calls between this country and North America are Cantat (Britain-Canada), TAT 1 and TAT 3 (UK-USA). Cables TAT 2 and TAT 4 run between France and the U.S.A.

Communication satellites are carrying an increasing number of telephone calls between Britain and the U.S.A. and elsewhere in North and South America, but the Post Office believes that use of both cable and satellite will continue to be valuable in providing complementary transatlantic communications. On a normal business day about 5,000 telephone calls are made from the U.K. to North America.

BOARD OF EDITORS

N. C. C. de JONG, B.Sc.(Eng.), C.Eng., M.I.C.E., F.I.Mech.E., F.I.E.E., Chairman
E. W. AYERS, B.Sc.(Eng.), C.Eng., F.I.E.E.
A. J. BARKER, C.Eng., F.I.E.E.
A. J. BARNARD, C.Eng., M.I.E.E.
G. E. BRETT, E.R.D., B.Sc.(Eng.), M.I.E.E.
A. C. CROISDALE, M.B.E., B.Sc.(Eng.), C.Eng., M.I.E.E.
J. MARTIN, B.Sc.(Eng.), C.Eng., M.I.E.E.
N. J. H. NINNIM, M.Sc., B.Eng., Managing Editor
R. A. SUDELL, Deputy Managing Editor
P. G. STEELE, M.Sc., B.Sc.(Eng.)
D. MILLINGTON, C.Eng., M.I.E.E. } Assistant Editors
T. R. K. RAITT
B. FARR, A.B.I., Secretary-Treasurer
N. G. Crump, A.M.I.T.E., Advertisement Manager

Copyright

The entire contents of this Journal are covered by general copyright, and special permission is necessary for reprinting long extracts, but editors are welcome to use not more than one-third of any article, provided that credit is given at the beginning or end, thus: "From *The Post Office Electrical Engineers' Journal*."

The Board of Editors is not responsible for the statements made or the opinions expressed in any of the articles in this Journal, unless such statement is made specifically by the Board.

Subscriptions and Back Numbers

The Journal is published quarterly, in April, July, October and January, at 3s. per copy: 5s. per copy including post and packing (20s. per year) via inland mail, and 4s. 9d. (19s. or 2 dollars 50 cents Canada and U.S.A., per year) via overseas mail. Back numbers will be supplied, if available, price 3s. 6d. (5s. 6d. inland mail, 5s. 3d.

overseas mail) per copy. With the exception of January and October 1966 Journals, copies of the April 1967 and all earlier Journals are no longer available. Orders, by post only, to *The Post Office Electrical Engineers' Journal*, 2-12 Gresham Street, London, E.C.2.

Employees of the British Post Office can obtain the Journal through local agents.

Binding

Readers can have their copies bound at a cost of £1 12s. 6d. plus 4s. 6d. return postage, by sending the complete set of parts, with a remittance to Press Binders Ltd., 4 Iliffe Yard, London, S.E.17.

Remittances

Remittances should be made payable to "*The P.O.E.E. Journal*" and should be crossed "& Co."

Advertisements

All correspondence relating to advertisement space reservations, copy, proofs, etc., should be addressed to the Advertisement Manager, *The Post Office Electrical Engineers' Journal*, 2-12 Gresham Street, London, E.C.2.

Communications

With the exceptions indicated above, all communications should be addressed to the Managing Editor, *The Post Office Electrical Engineers' Journal*, 2-12 Gresham Street, London, E.C.2.

Model Answer Books

Books of model answers to certain of the City and Guilds of London Institute examinations in telecommunications are published by the Board of Editors. Details of the books available are given at the end of the Supplement to the Journal.



14,000 miles of conductor...

...and that's only one day's output!

TCL
put **more** into
telephone cables

TCL's daily output of insulated conductor would stretch over half way around the equator – yet after the raw material and laboratory tests, it is subjected to quality checks at every stage, from the wire insulation to the formation of the final cable core. Before final sheathing, all paper insulated cables are dried in giant ovens which extract moisture from the insulating paper – particular care being taken to avoid its becoming brittle and so impairing the jointing operation.

Telephone Cables Limited Dagenham, Essex. Tel: 01-592 6611 Cables: Drycore Dagenham Telex: 896216
The organisation with 135 years' experience.

Both paper and plastics insulated cables are then finally tested after sheathing and prepared for despatch to the customer.

TCL – the largest company in Europe exclusively concerned with the manufacture of telecommunications cable – makes *all* types of dry core and plastic cables as well as being a major supplier to the British Post Office also exports to over 70 countries throughout the world. A world-wide technical advisory service is provided.

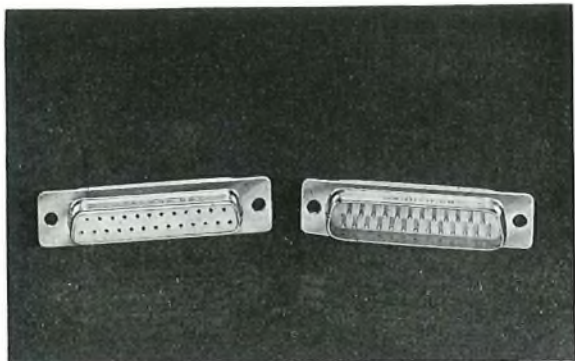

P.O. APPROVED 'D' CONNECTORS

Cannon offer the popular D*M connector in 9, 15, 25, 37 and 50 ways fully approved to G.P.O. specification D2399 for Code 217 series connector. Also available are combination layouts using coaxial high voltage and heavy duty contacts.

Cannon Electric (G.B.) Ltd.,
Lister Road,
Basingstoke, Hants.
Tel: Basingstoke 3171.



VALUABLE FREE BOOK



Tells You How to Pass Your C. & G. Examination at *First Attempt!*

All Post Office personnel who are anxious to obtain early promotion should at once send for a copy of our handbook "ENGINEERING OPPORTUNITIES" which, among other intensely interesting matter, describes our unique methods of preparation for the CITY AND GUILDS EXAMINATIONS for the Telecommunication Technicians' Certificate and for individual subjects—Mathematics, Engineering Science, Engineering Drawing, Elementary Telecommunication Practice, Telecommunication Principles, Radio and Line Transmission, Telegraphy and Telephony, Line Plant Practice. It also contains details of our courses covering the G.C.E. subjects required for promotion to Assistant Engineer, Telecommunication Traffic Superintendent and other grades; and the City and Guilds examinations in Electrical Engineering Practice, the A.M.I.E.R.E. and A.M.S.E. Examinations, in addition to a wide range of non-examination courses in all branches of engineering—Radio and Electronics, Electrical Mechanical, etc.

We also provide tuition for the Radio Amateurs' Examination and the P.M.G. Certificates for Radio Operators, with or without Morse training. Details are given in the handbook.

On "SATISFACTION OR REFUND OF FEE" terms

If you intend to make the most of today's opportunities, you cannot afford to miss reading "ENGINEERING OPPORTUNITIES." It tells you everything you want to know to secure advancement, and describes many opportunities you may now be missing through lack of information. Send for your copy today—FREE and without obligation.

BRITISH INSTITUTE
OF ENGINEERING TECHNOLOGY
727D ALDERMASTON COURT,
ALDERMASTON, BERKSHIRE

BIET

Now... you can find trouble in your sleep.



Or while you're on another job, in another part of the building, or fishing over the weekend. The Amprobe Recorder keeps watch over trouble spots and makes a printed, permanent, accurate record to show what happens when it happens and how long it lasts while you're away.

And there's an Amprobe Recorder for virtually any job. For example, the LAVA models have up to three expanded scale AC voltage ranges for greater accuracy, and four current ranges (up to 500 amps AC). Literally two instruments in one.

The chart is pressure-sensitive, with no ink to spill, no pen to clog. It loads easier than film in a camera. Without the chart, you can still take direct meter readings. So altogether, you have four instruments in one.

See your Amprobe Distributor for the full line and the full story.

CANADIAN INSTRUMENTS AND ELECTRONICS LTD.
35 WAYERLEY STREET
NOTTINGHAM
062 71157/8

For people looking for trouble...

AMPROBE* INSTRUMENT

*REGISTERED TRADEMARK OF AMPROBE INSTRUMENT,
DIVISION OF SOSS MANUFACTURING COMPANY



C & S Antennas

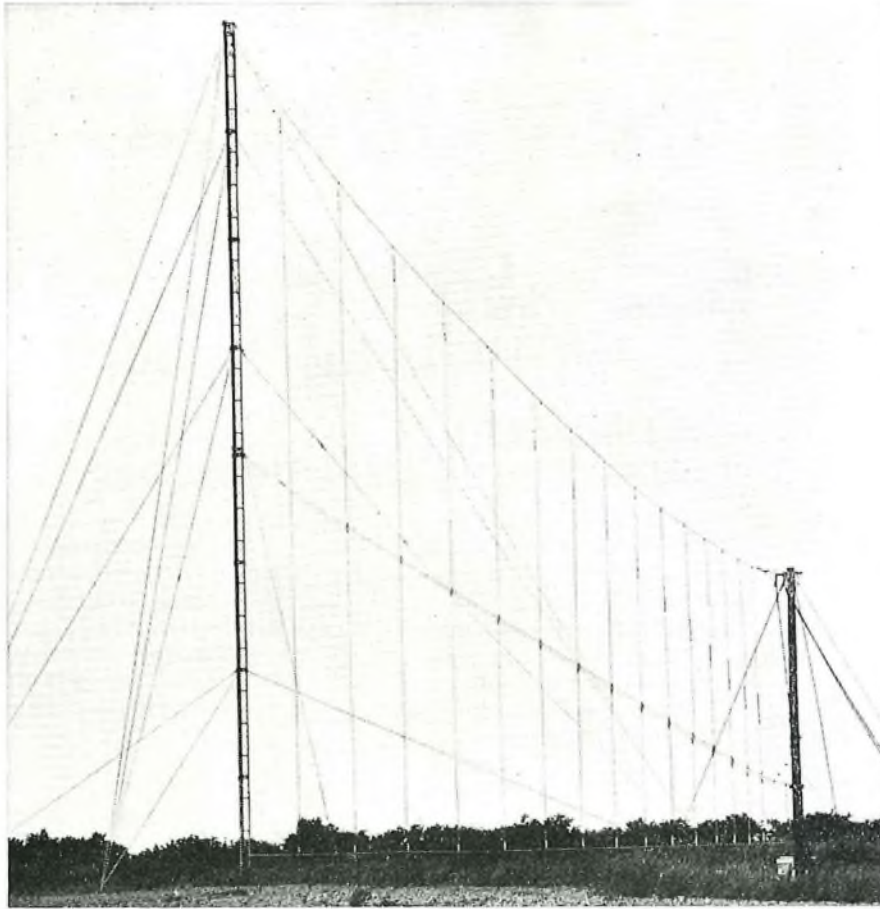

C & S Vertical log Antenna

for the complete aerial service—LF to Microwave

Point to Point
Broadcasting
Radio Relay
Ground to Air
Navigational Aids
Business Radio

Design

Site layouts. Antenna System Design.

Antennas

LF, 'T' and 'L' Antennas, Mast Radiators,
 HF Dipoles, Quadrants, Rhombics,
 Log Periodics, Conicals, Biconicals,
 Vertical Incidence Arrays,
 VHF & UHF Yagis, Helices, Ground Planes,
 Colinears, Whips, Marine Antennas.
 TELEVISION Arrays to 100 kW e.r.p.
 SHF Passive Reflectors, Dishes 3in. to 60ft dia.

Supporting Structures

Self-supporting Towers,
 Tubular and Lattice Masts,
 Telescopic Masts

Accessories

Coaxial and open wire Feeders, Filters,
 Antenna Switches, Lead-in panels,
 Earth Systems, Termination Networks,
 Air-cooled Transmitter Loads.

Installation

World Wide Service



C & S Antennas Ltd

Wentworth House, Eastern Avenue, Ilford, Essex, England.

Telephone: 01-554 0102 Telex: 25850 Cables: Antennas Ilford (England)

INDUSTRIAL COMMUNICATIONS

2 SYSTEMS

FOR INDUSTRIAL SITES



INDUSTRIAL HELMET TRANSDUCER ASSEMBLY

for use with pocket
transmitter receivers

- Rugged dependable construction
- Versatile operation
- Semi-flexible tubes and adjustable earcups to suit individual requirements
 - Covered by an Intrinsic Safe Certificate

ALL PURPOSE FIELD TELEPHONE HANDSETS

- Versatile—operates under all climatic conditions
- Lightweight and robust construction
- Shock resistant and water proof
- Effective over 20 miles using standard telephone wiring
- Up to 12 handsets may be interconnected on average building site



HAWKER SIDDELEY

COMMUNICATIONS

S. G. BROWN LTD., KING GEORGE'S AVENUE, WATFORD, HERTFORDSHIRE
TEL: WATFORD 23301 TELEX 23412 TELEGRAMS RADIOLINK WATFORD

Hawker Siddeley Group supplies mechanical, electrical and aerospace equipment with world-wide sales and service.

this new Ferranti edge connector has G.P.O. approval..



and a lot more!

The new Ferranti EPP Edge Connector has been designed for electronic telephone exchange equipment, and has Post Office Approval to Specification D2343, Type 206D

And a lot more.

EPP is a new generation of Edge Connectors—offering many new features designed to improve efficiency and reliability.

Such as the one-piece construction of the wrapping post and spring contact. This form of construction removes the possible source of unreliability in two part welded constructions.

Such as the brand new design which allows each wrapping post/contact unit to be removed from behind the equipment. This operation can be carried out in seconds using a simple extraction tool, without even disturbing the printed-circuit board.

Such as the remarkably low insertion force required—only 6 oz maximum per pair of non-bridging contacts.

In addition to these new features, Ferranti EPP Edge Connectors retain many of the successful characteristics of earlier types—including the unique Ferranti 'rolling-leaf' spring contact, with inherent stress-limiting properties and the non-porous hard-gold plating 5 microns thick on the contact area.

12 and 18 pole single-sided 12+12 and 18+18 pole double-sided contacts are available. Pole spacing 0.200 in (5.08mm).

The advanced design of Ferranti EPP Edge Connectors, together with many proved-in-service features, offers equipment manufacturers a connector which is versatile, easy to use and extremely reliable.

Full details available from
FERRANTI LTD.,
Connector Sales, Dunsinane Avenue,
Dundee DD2 3PN, Scotland.
Tel: 0382 89311 Telex: 76166

FERRANTI

INDEX TO ADVERTISERS

	PAGE		PAGE
British Institute of Engineering Technology	18	Marconi Instruments Ltd.	12
S. G. Brown Ltd.	20	Pirelli General Cable Works, Ltd.	15
Canadian Instruments and Electronics Ltd.	18	Pitman, Sir Isaac, & Sons Ltd.	13
Cannon Electric (GB) Ltd.	18	Radiospares	1
Civil Service Insurance Society	13	Standard Telephones & Cables, Ltd.	2-7
Cray Electronics Ltd.	23	Telephone Cables Ltd.	17
C & S Antennas Ltd.	19	Telephone Manufacturing Co. Ltd.	14
Ferranti Ltd.	21	Telettra S.p.A.	24
GEC-AEI Telecommunications, Ltd.	8-11	Ultra Electronics Ltd.	22
		Whiteley Electrical Radio Co., Ltd.	16

Wrap up your troubles.....

With the new Ostby and Barton system from UECL. Designed to provide a rational and high-speed solution to the problems of wrapping multi-terminations in the production shop. The AUTO WRAP includes closed-loop numerical control to eliminate wiring errors, speed production and minimise turn-round time.

AUTO WRAP systems can be programmed for point-to-point, dressed or twisted pair terminations. Bits, sleeves and accessories for all wire gauges and terminal configurations are quickly interchanged to tailor the system to alternative applications. For full details contact

Ultra Electronics (Components) Limited,
Fassetts Road, Loudwater, Bucks.
Tel: High Wycombe (0494) 26233

UECL



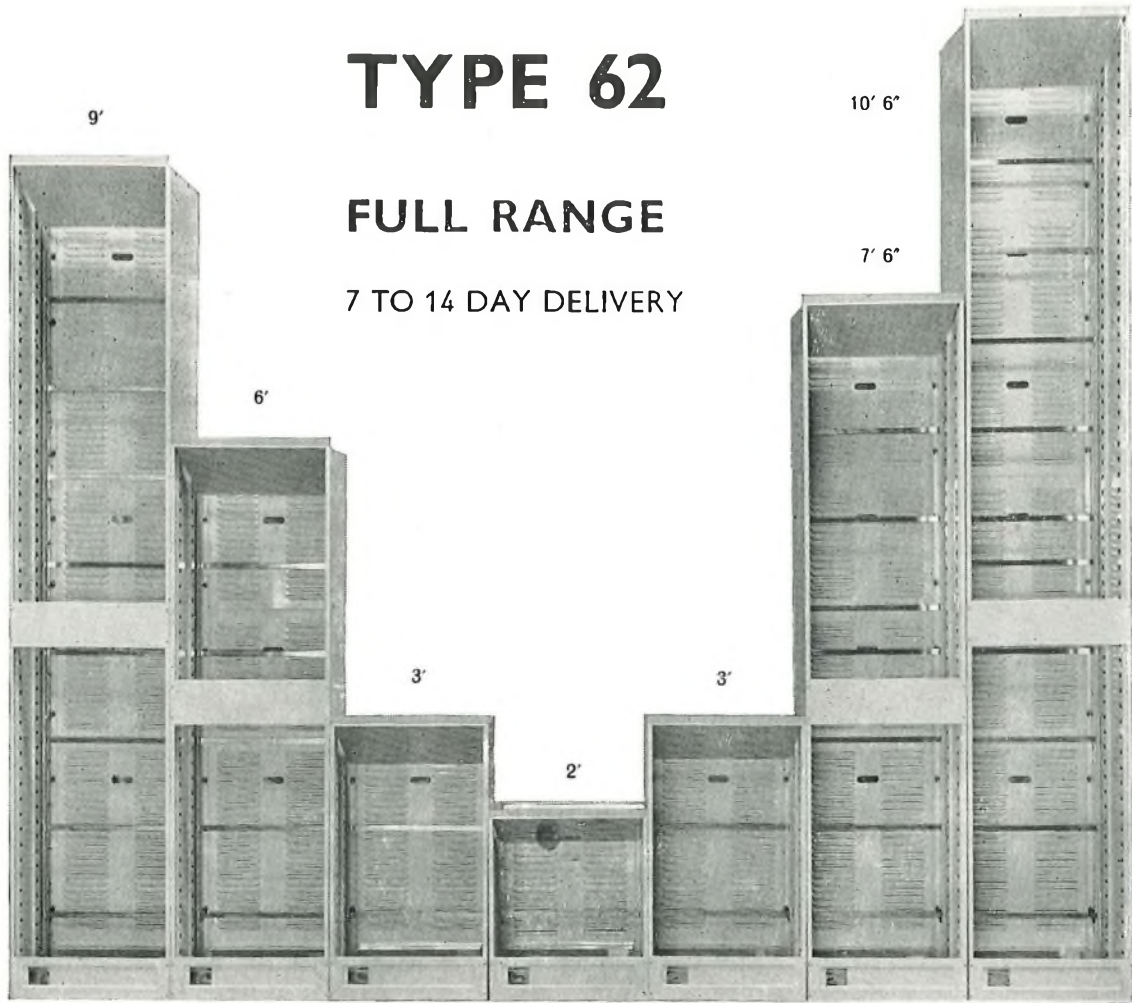

TYPE 62

FULL RANGE

7 TO 14 DAY DELIVERY

HIGH PRECISION MECHANICS

FOR INSTRUMENT ELECTRONIC AND AUTOMATION INDUSTRIES

TELECOMMUNICATIONS
MECHANICS

G.P.O. APPROVED

IMMEDIATE QUOTATIONS AND
TECHNICAL SERVICE



SHELF ASSEMBLIES

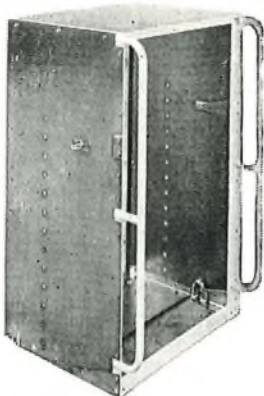

P.C.M. TRANSIT JIG



DATA MODEM

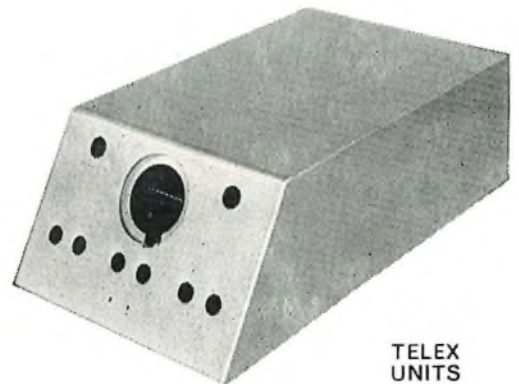

TELEX
UNITS

CRAY ELECTRONICS LTD

THAMES ROAD, CRAYFORD, KENT
TELEPHONE: CRAYFORD 26526

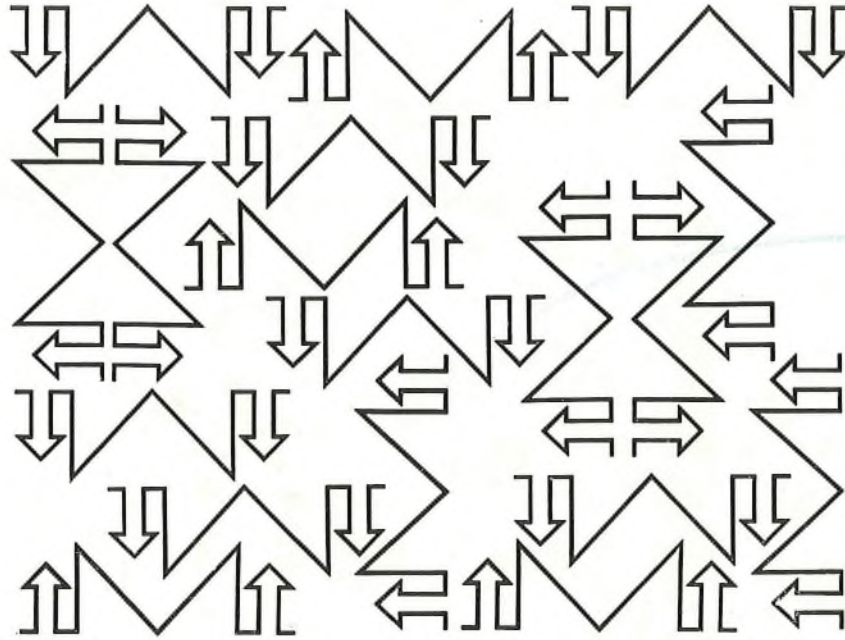







18 programme channels per rack

CM-18A1 PROGRAMME MULTIPLEX

18 high-quality programme channels compatible with 60 telephone channels over the same bearer circuit. Any channel pair in a group of channels may be chosen for stereophonic programme transmission without need for pre-settings. Frequency shift eliminated by carrier regeneration at the receiving end. Non-oven oscillators are used.



Independent channels. Economic installation even with a small number of programme channels. Performance complying with CMTT* recommendations in a 2500 km circuit with three cascaded audio modulations. No need for compandor. Automatic level control. Emphasis network complying with CCITT standards.
* Doc. CMTT/119 - September 17, 1968.

- | | | | |
|--------------------------------|-------------------------------------------------------------------------------------|-------------------------------------------------------------------------------------|-----------------------------------------|
| RADIO RELAY SYSTEMS |  |  | DATA TRANSMISSION SYSTEMS |
| MULTIPLEX TELEPHONE SYSTEMS |  |  | TRAFFIC CONTROL SYSTEMS |
| TV AND FM BROADCASTING SYSTEMS |  |  | TELECOMMUNICATION EQUIPMENT AND SYSTEMS |

Telettra

TELETTRA S.p.A. - 20059 VIMERCATE - MILANO - ITALY

RA 10