

RA Roe

© Pol.

THE POST OFFICE ELECTRICAL ENGINEERS' JOURNAL



C O N T E N T S

	Page
THE ANGLO-CANADIAN TRANSATLANTIC TELEPHONE CABLE SYSTEM (CANTAT) R. J. Halsey, C.M.G., B.Sc.(Eng.), F.C.G.I., D.I.C., M.I.E.E.	73
ANGLO-CANADIAN TRANSATLANTIC TELEPHONE CABLE (CANTAT): Submerged Repeaters, Equalizers and Associated Terminal Equipment—F. Scowen, B.Sc., A.M.I.E.E., A.Inst.P., S. A. Taylor, B.Sc.(Tech.), A.M.I.E.E., J. F. P. Thomas, B.Sc.(Eng.), A.M.I.E.E., and D. C. Walker, M.B.E., B.Sc.(Eng.), D.I.C., A.C.G.I., A.M.I.E.E.	76
* ANGLO-CANADIAN TRANSATLANTIC TELEPHONE CABLE (CANTAT): Cable Development, Design and Manufacture—R. A. Brockbank, O.B.E., Ph.D., B.Sc.(Eng.), M.I.E.E., E. F. S. Clarke, B.Sc.(Eng.), A.M.I.E.E., and F. Jones, B.Sc.(Eng.), A.M.I.E.E.	82
* ANGLO-CANADIAN TRANSATLANTIC TELEPHONE CABLE (CANTAT): Cable-Laying Gear E. F. S. Clarke, B.Sc.(Eng.), A.M.I.E.E., and K. J. Chapman, B.Sc., A.M.I.E.E.	91
* ANGLO-CANADIAN TRANSATLANTIC TELEPHONE CABLE (CANTAT): Laying the North Atlantic Link—Capt. O. R. Bates and R. A. Brockbank, O.B.E., Ph.D., B.Sc.(Eng.), M.I.E.E.	99
SWITCHING ARRANGEMENTS FOR SEMI-AUTOMATIC OPERATION OF TRANSOCEANIC TELEPHONE-CABLE CIRCUITS—D. L. Heptinstall and P. F. Jones.	105
LINE AND REGISTER SIGNALLING SYSTEMS FOR DIALLING OVER TRANSOCEANIC TELEPHONE CABLES—S. Welch, M.Eng., A.M.I.E.E.	111
TAPE-RECORDING MACHINE FOR TICKING-IN MAILS AT SORTING OFFICES.	118
FREQUENCY-GENERATING EQUIPMENT FOR THE TRANSOCEANIC LINE-SIGNALLING SYSTEM—J. H. Gee.	119
OUTLINE OF TRANSISTOR CHARACTERISTICS AND APPLICATIONS, Part 1—Transistor Parameters and Stabilization of Characteristics—J. A. T. French, B.Sc.(Eng.), A.M.I.E.E., D. J. Harding, B.Sc.(Eng.), A.M.I.E.E., and J. R. Jarvis, B.Sc.(Eng.), A.M.I.E.E.	122
PRESSURIZATION OF TELECOMMUNICATION CABLES, Part 3—Miscellaneous Pressurization Equipment—J. R. Walters, J. F. Keep and J. F. Craggs.	129
THE POST OFFICE ENGINEERING DEPARTMENT'S COMPUTER—ITS USE IN RESEARCH W. E. Thomson, M.A.	133
NOTES AND COMMENTS.	136
INSTITUTION OF POST OFFICE ELECTRICAL ENGINEERS.	136
REGIONAL NOTES.	138
ASSOCIATE SECTION NOTES.	141
STAFF CHANGES.	145
BOOK REVIEWS.	75, 81, 98, 104, 110, 121, 128, 144

* Reproduced by permission of The Institution of Electrical Engineers

Price 2s. 6d. (Post Paid 3s. 6d.)

Published in April, July, October and January by *The Post Office Electrical Engineers' Journal*,
G.P.O., 2-12 Gresham Street, London, E.C.2.

Annual Subscription (post paid): Home and Overseas, 14s. (Canada and U.S.A., 2 dollars 25 cents).

THE POST OFFICE ELECTRICAL ENGINEERS' JOURNAL

Vol. 56 Part 2

JULY 1963

The Anglo-Canadian Transatlantic Telephone Cable System (CANTAT)

R. J. HALSEY, C.M.G., B.Sc.(Eng.), F.C.G.I., D.I.C., M.I.E.E.†

U.D.C. 621.395.45:621.315.28

The design objectives and the performance of the overall system are briefly reviewed. The progress so far achieved in the construction of the Commonwealth telephone cable system of which CANTAT is the first link is also noted.

INTRODUCTION

SERVICE on the Anglo-Canadian transatlantic cable system (CANTAT) was inaugurated by Her Majesty the Queen¹ on 19 December 1961, and a broad outline of the arrangements has already been given in the Journal.² The system links London (International A) with Montreal and consists of four sections:

CANTAT A, the ocean crossing between Oban and Corner Brook, Newfoundland, 2,076 n.m., owned jointly by Cable and Wireless, Ltd., (C. & W., Ltd.), and Canadian Overseas Telecommunication Corporation (C.O.T.C.).

CANTAT B, a submarine cable system from Corner Brook, up the Gulf of St. Lawrence to Grosses Roches, 400 n.m., owned by C.O.T.C.

CANTAT C, the overland section between Grosses Roches and Montreal, 426 miles, on microwave relay systems.

CANTAT D, the overland section between London and Oban.

The main technical interest resides, of course, in CANTAT A, the ocean crossing, and a series of four articles relating to this section follow the present one which, itself, has a twofold object:

(a) to set out briefly the design objectives, performance³ and experience with the overall system, and

(b) to note the present position in the construction of the Commonwealth system⁴ of which CANTAT forms the first link.

PERFORMANCE OBJECTIVES

The overall performance objectives adopted for CANTAT were, with the exception of noise, the same as for TAT-1.⁵ The overall loss in terminal and through service was to be 6 dB and 0.5 dB, respectively, with an expected maximum standard deviation, without automatic gain control (a.g.c.), of 1.5 dB. These conditions

†Director of Research, Post Office Research Station.

*C.C.I.T.T.—International Telegraph and Telephone Consultative Committee.

ensure that service can be extended at London to the inland network (zone centres) and to the Continent (têtes des lignes) without increasing the overall loss. At Montreal they can be similarly extended with such insertion loss as is inherent in the North American switching plan. The target overall-loss/frequency characteristic was one-half of the limits set by the C.C.I.T.T.* for its hypothetical reference circuit of 2,500 km.⁶

The C.C.I.T.T. noise requirement for the same reference circuit is 10,000 picowatts (pW) in the busy-hour, 3 pW/km being allocated to the line and 2,500 pW to terminal equipment; the repeaters for CANTAT A were designed, with some margin for deterioration, to meet this C.C.I.T.T. requirement. In 1959, however, after the Commonwealth Governments had agreed to provide a "round-the-world" telephone cable system and to include CANTAT as its first link, the requirement was reconsidered on the basis of a potential 25,000 km connexion to Australia, and a preferred noise objective was adopted without modifying the repeater design. This new objective was based on 1 pW/km in the busy hour, averaged over all channels in each direction separately, the minimum objective corresponding to the C.C.I.T.T. overall allowance of 4 pW/km.

It was agreed by the Partners and by the Post Office, which operates the circuits, that half echo-suppressors would be fitted at each end of the circuits, that overall a.g.c. would be applied to each 48 kc/s group and that generator signalling would be used initially. Plans already in hand to introduce semi-automatic operation of all transatlantic circuits early in 1963, and now in effect, would automatically include CANTAT.

The original plan was for five through-groups between London and Montreal with standard 4 kc/s-spaced channel equipments at the terminal stations to provide 60 telephone circuits. Any of these could be used, alternatively, for 24-channel voice-frequency telegraphy, increased to 48 channels by the incorporation of synchronous operation and a time-division multiplex system. Program circuits would be provided in place of two or three telephone circuits and a full range of telecommunication services, with the exception of real-time television, would be possible.

While planning for CANTAT was proceeding, agreement was reached between the British, Canadian, Ameri-

can, French and German authorities to re-equip all major submarine cable systems, including TAT-1 and TAT-2, with new high-efficiency, 3 kc/s-spaced channel equipment which had been developed by the British Post Office.⁷ This would increase the number of channels in each group from 12 to 16 at the expense of reducing the upper cut-off frequency of each channel from 3,400 c/s to 3,150 c/s, and would be compatible with the Time Assignment Speech Interpolation (T.A.S.I.) system developed by the American Telephone and Telegraph Company.^{8, 9}

There are difficulties in operating 16-channel groups over inland systems, and for TAT-1 and TAT-2 it had been agreed to apply the 3 kc/s-spaced system to the submarine cable sections only. For CANTAT it was decided to use 4 kc/s-spaced channels in the first instance and to explore means for the most effective use of 3 kc/s-spaced channels at a later date.

For maintenance purposes, telephone and telegraph circuits additional to the five groups are provided; there are also two pilots on each group:

(i) A group-reference pilot transmitted end-to-end and used at the receiving terminal to control the group a.g.c.

(ii) A group-section pilot confined to each individual group-section and used to ensure that the transmission performance of that group-section is properly adjusted and maintained.

On each submarine cable system there are special pilots for monitoring the transmission performance of the cable link and also an elaborate system for measuring the transmission and noise performance of each submerged repeater.

OVERALL PERFORMANCE AT COMMENCEMENT OF SERVICE

The mean and extreme gain/frequency characteristics of the London-Montreal circuits (4 kc/s-spaced) are shown in the figure; it will be seen that the objective, half C.C.I.T.T. limits, has been met. On modern long-distance systems there is no very great difficulty in meeting the straightforward transmission requirements and it is in respect of gain stability and noise that the success of such systems must be judged.

During the period March-June 1962, the mean loss of the circuits at 800 c/s was 0.1 dB less than the nominal loss, with a standard deviation of 0.6 dB. The mean

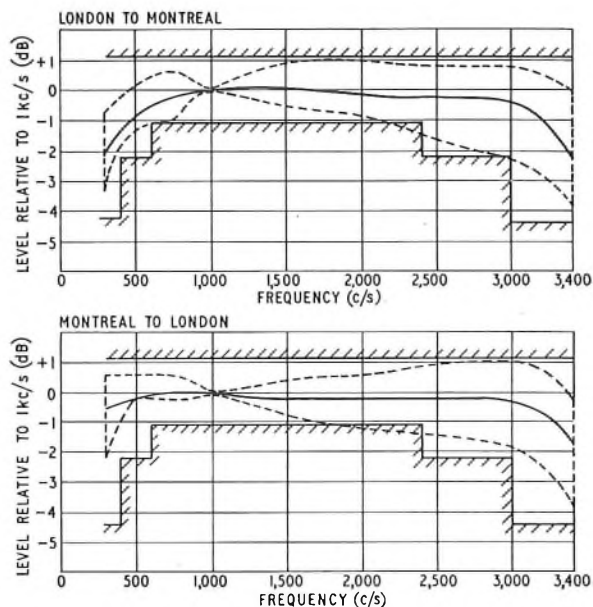

LONDON-MONTREAL CIRCUITS—ATTENUATION/FREQUENCY CHARACTERISTICS RELATIVE TO 1,000 c/s (4 kc/s-SPACED CHANNELS)

frequency shift over the channels was about 0.1 c/s, the highest recorded value being 0.6 c/s. The noise contributions from the four sections are given in the table.

It will be seen that the preferred objective was met on both submarine cable sections but on neither of the inland sections. The London-Oban section, which is engineered to normal C.C.I.T.T. standards, falls short of the preferred objective by only a small margin, and it is essentially because of the Grosses Roches-Montreal microwave system that the preferred overall noise objective is not quite met.

CANTAT IN SERVICE

In December 1961 when CANTAT was opened, telephone traffic to Canada had increased by a factor of 3.6 since September 1956, when TAT-1 came into ser-

Overall Circuit Noise—4 kc/s-Spaced Channels

	Montreal (MTL) 689 km		Grosses Roches 742 km		Corner Brook 3,844 km		Oban 962 km		London (LON)		CANTAT Overall 6,237 km		
	pW	pW/km	pW	pW/km	pW	pW/km	pW	pW/km	pW	pW/km	pW	dBm0	pW/km
Preferred Objective	689	1.0	742	1.0	3,844	1.0	962	1.0			6,237	-52	1.0
Minimum Objective	2,765	4.0	2,968	4.0	15,376	4.0	3,848	4.0			24,948	-46	4.0
MTL-LON Best Group	3,060	4.4			410	0.11	1,940	1.98			5,430	-52.7	0.87
Worst Group	4,350	6.3			4,760	1.24	1,780	1.82			10,910	-49.8	1.75
Average	3,570	5.2	20	0.03	1,950	0.51	1,720	1.76			7,240	-52.0	1.16
LON-MTL Best Group	4,530	6.6			1,300	0.47	1,330	1.36			8,210	-50.8	1.31
Worst Group	11,020	16.0			1,270	0.45	1,390	1.42			14,230	-48.7	2.27
Average	7,500	10.6	55	0.74	2,130	0.60	1,150	1.18			11,330	-49.0	1.79

vice; since the opening there has been a further 40 per cent increase to 5 times and, with leased circuits, the cable is nearly full. Two groups are extended to New York until TAT-3 is completed in the autumn of 1963, when they will be required for extension across the Pacific in the COMPAC system.

To meet growing demands, conversion to 3 kc/s channel spacing soon became urgent. Canada was reluctant to install 3 kc/s-spaced equipment on the submarine cables only and the problems associated with 3 kc/s spacing on inland networks have not yet been fully overcome. In December 1962, therefore, 3 kc/s spacing was introduced on all groups between Oban and Montreal, those circuits which were subject to interference tones from 4 kc/s generating equipment between Grosses Roches and Montreal being allocated for multi-channel voice-frequency telegraphy. The principal effect of the change is to reduce the upper cut-off frequency of the channels by about 250 c/s. The circuit noise is little affected, the mean values being 1.7 and 1.6 pW/km in the Montreal-London and London-Montreal directions, respectively.

The submarine cable sections have performed well; there have, unfortunately, been two cable faults in shallow water off Oban, one definitely due to a trawler and one due to a faulty joint which had been pulled either during laying or subsequently.

CANTAT AND THE COMMONWEALTH TELEPHONE CABLE NETWORK

CANTAT is the first link in the cable system planned to connect all the major countries of the British Commonwealth. The general agreement between Governments, in 1959, to provide such a system was followed the same year by a conference in Sydney, Australia, at which it was agreed to proceed at all speed with a trans-Pacific cable from Canada to New Zealand and Australia.⁴ This, the Commonwealth Pacific Cable (COMPAC), is now under construction to the CANTAT pattern and will connect Vancouver, Canada, via Honolulu, Hawaiian Islands, and Suva, Fiji, to Auckland, New Zealand, and thence to Sydney, Australia. Progress has been rapid; the Australia-New Zealand link, 1,200 n.m., was opened for service in July 1962; the New Zealand-Fiji link, 1,200 n.m., in December 1962. H.M.T.S. *Monarch* is now engaged in laying the most northerly ocean section from Port Alberni, Vancouver Island, to Honolulu (2,390 n.m.). C.S. *Mercury* (C. & W.,

Ltd.) is laying the Fiji-Honolulu section (3,047 n.m.); this section, with 118 repeaters and terminal voltages 6.3 + 6.3 kV, is the most ambitious so far planned and will eclipse the CANTAT system itself. Laying operations for the entire system (8,100 n.m.) are due for completion in October and service is planned for December 1963.

CONCLUSION

The Anglo-Canadian transatlantic cable system was completed in December 1961, within the scheduled time agreed at the Ottawa Conference which conceived it in 1957. This achievement reflects great credit on everyone concerned. Within four years lightweight cable was brought from experiment to full production; repeaters were transformed from units suitable only for distances of a few hundred miles in comparatively shallow water to be suitable for ocean depths and for distances in excess of 3,000 n.m.; ship's gear was designed, tested and built to allow the project to proceed; over 1,500 n.m. of lightweight cable, over 550 n.m. of armoured cable, 90 repeaters and 9 equalizers were constructed and tested to meticulous standards, and placed at the bottom of the Atlantic in full confidence that there will be no more than a few deep-water failures in a life of at least 20 years.

References

- ¹Inauguration by Her Majesty the Queen of the New Cable to Canada. *P.O.E.E.J.*, Vol. 54, p. 219, Jan. 1962.
- ²HALSEY, R. J. CANTAT—A New Submarine Telephone Cable System to Canada. *P.O.E.E.J.*, Vol. 54, p. 220, Jan. 1962.
- ³BAMPTON, J. F., GRIFFITH, R. G. and HALSEY, R. J. Anglo-Canadian Transatlantic Telephone Cable (CANTAT): Planning and Overall Performance. *Proceedings I.E.E.*, Paper No. 4244E, July 1963 (Vol. 110, p. 1,115).
- ⁴Proposed Commonwealth Pacific Telephone Cable System. *P.O.E.E.J.*, Vol. 53, p. 42, Apr. 1960.
- ⁵MOTTRAM, E. T., HALSEY, R. J., EMLING, J. W., and GRIFFITH, R. G. Transatlantic Telephone Cable System: Planning and Overall Performance. *Proceedings I.E.E.*, Paper No. 2274R, Jan. 1957 (Vol. 104, Part B, Supplement 4, p. 3). (Reproduced in the *P.O.E.E.J.*, Vol. 49, p. 384, Jan. 1957)
- ⁶C.C.I.T.T., 2nd Plenary Assembly (New Delhi, 1960). Red Book, Vol. III, p. 23.
- ⁷LAW, H. B., REYNOLDS, J., and SIMPSON, W. G. Channel Equipment Design for Economy of Band-Width. *P.O.E.E.J.*, Vol. 53, p. 112, July 1960.
- ⁸BULLINGTON, K., and FRAZER, J. M. Engineering Aspects of TASI. *Bell System Technical Journal*, Vol. 38, p. 353, Mar. 1959.
- ⁹CLINCH, C. E. E. Time Assignment Speech Interpolation (T.A.S.I.). *P.O.E.E.J.*, Vol. 53, p. 197, Oct. 1960.

Book Review

"Electron Transport in Metals" (Interscience Tracts on Physics and Astronomy, No. 12). J. L. Olsen. John Wiley and Sons. viii + 121 pp. 61 ill. Cloth 34s. Paper 19s.

The author of this short book seeks mainly to describe the theoretical background to electronic conduction in metals in a way he thinks will appeal to experimental physicists, and his clear presentation will appeal also to electrical and electronic engineers with any interest in the subject. The ability of metals to conduct electricity relatively so well—though by no means equally, the temperature dependence of conductivity, and the effects of alloying are some of the things the author shows need no longer be accepted empirically.

The book deals also with thermal conductivity, the effect of magnetic fields (e.g. magnetoresistance) and size effects (as displayed in thin films); superconductivity is excluded because it is a subject of another book in the series. The text and mathematics are supported by quantitative data in the form of tables and graphs and the bibliography is extensive. No newcomer should pick up this book with the expectation of a few hours of easy reading; nor can he expect that the devotion of many hours to it will enable him to apply what he has absorbed to specific problems—only recourse to much fuller works will do that. But he can expect an acceptable insight of the models built up by mathematical physicists which take account of or predict a wide range of what might otherwise seem disconnected experimental observations.

J.R.T.

Anglo-Canadian Transatlantic Telephone Cable (CANTAT): Submerged Repeaters, Equalizers and Associated Terminal Equipment

F. SCOWEN, B.Sc., A.M.I.E.E., A.Inst.P., S. A. TAYLOR, B.Sc.(Tech.), A.M.I.E.E.,
J. F. P. THOMAS, B.Sc.(Eng.), A.M.I.E.E., and
D. C. WALKER, M.B.E., B.Sc.(Eng.), D.I.C., A.C.G.I., A.M.I.E.E.†

U.D.C. 621.395.46:621.315.28

The repeaters and equalization methods on the North Atlantic section of the CANTAT submarine telephone system, and the repeater power-feeding and supervisory terminal equipments, are described. Although the d.c. voltage across each repeater is only 70 volts owing to the use of a new valve, with the large number of repeaters involved the total system voltage is 10 kV. A new continuous-tone supervisory system was designed to measure the loop gain to each repeater and also to locate noise faults. Repeater distortion is measured by an improved version of the pulse monitoring equipment used on previous schemes. The submerged equalizers, besides having basic networks, allow mop-up equalization to be introduced on board ship as the laying operation proceeds.

INTRODUCTION

THE North Atlantic section of the CANTAT system^{1,2,3,4} contains 86 repeaters in the Oban (Scotland) to Hampden (Newfoundland) submarine cable and 4 repeaters in the landward extension from Hampden to Corner Brook. These repeaters, which are similar to those used in the Newfoundland to Nova Scotia section of TAT-1⁵ were first used in the Anglo-Swedish cable⁶ laid in 1960, and are being used in the COMPAC system.⁷ The repeated cable provides two-way transmission of a 240 kc/s band, giving 60 4 kc/s-spaced telephone circuits of C.C.I.T.T.* quality.

Because of the length of the CANTAT system the accumulative misalignment is large, and submerged equalizers are required at intervals along the route. These equalizers, unlike the TAT-1 type, were designed so that "mop-up" networks could be inserted during the laying operation.

For the deep-water sections of the route, the new Lightweight 0.99 in. diameter polythene cable^{8,9} has been used, and this allows the repeater spacing to be increased to 26.3 nautical miles (n.m.). The shallow-water sections use conventional armoured 0.62 in. diameter cable with a repeater spacing of 18 n.m. This cable, however, has a modified construction of centre conductor to make the impedance and the shape of the attenuation/frequency characteristic similar to that for the Lightweight cable, enabling the same design of repeater to be used throughout the system.

FREQUENCY SPECTRUM

Fig. 1 shows the frequency spectrum of the repeated cable. The Corner Brook-Oban direction of transmission, A-B, uses the frequency band 60-300 kc/s, and the opposite direction of transmission, B-A, uses the bands 360-552 kc/s and 560-608 kc/s. Each repeater provides gain to neutralize cable loss over a slightly wider band than that which is required by the speech groups,

†Post Office Research Station.

*C.C.I.T.T.—International Telegraph and Telephone Consultative Committee.

and the additional band is utilized primarily by the supervisory equipment, which uses a receive band centred on 56 kc/s and send bands centred on 556 kc/s

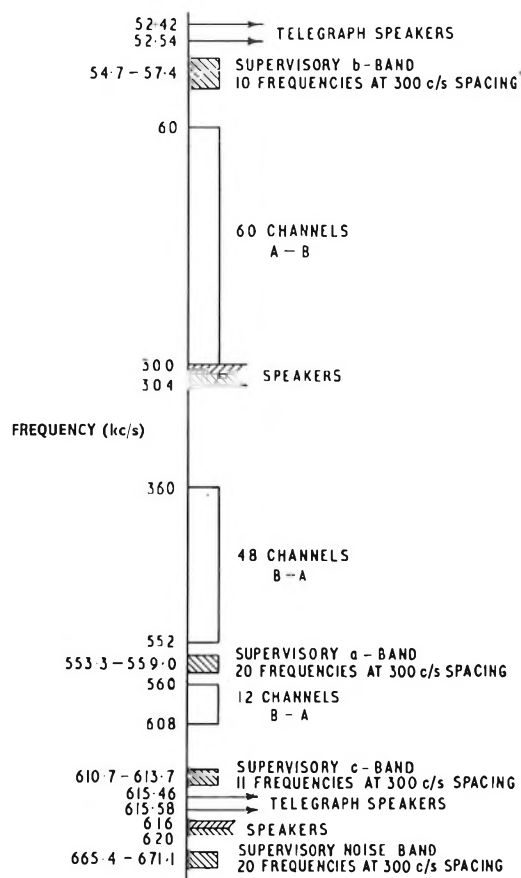

FIG. 1—FREQUENCY SPECTRUM OF REPEATED CABLE

and 612 kc/s. At 608 kc/s the repeater has a gain of 55 dB, and the gain at 360, 300 and 60 kc/s is 42, 38 and 18.5 dB, respectively.

EQUALIZATION

Seasonal variations in temperature can be compensated by adjustments of the send and receive equalizers at the terminal stations and at Hampden—the normal send level allows sufficient margin on overload and noise for this to be done. At Hampden pre-set equalizers were also provided to enable the land and sea sections (under mean-temperature conditions) to be balanced for optimum performance. In order to prevent the accumulative mismatch from becoming excessively large, even

under mean-temperature conditions, it was necessary to insert submerged equalizers in the sea section; it was decided to insert these after every twelfth repeater.

Cable and repeaters were jointed before laying to form ocean blocks of six repeater sections. The equalizers were connected to the ends of the even numbered blocks and each block, other than the first, had an extra length of cable added to its starting end for adjustment. Two types of submerged equalizer, E and F, were provided. The type-E equalizer was normally used, and it included a basic equalizer correcting for the known deviations from the target of the production repeaters and cable; it also allowed for further trimming-equalizer networks to be designed, constructed and inserted on board ship just before the equalizer was laid. The type-F equalizer did not contain the basic equalizer and was intended for cable simulation or mop-up purposes only at the end of a lay or at the final splice. The addition of an equalizer, of course, requires the repeater-section length to be reduced, e.g. by an amount corresponding to 2.5 n.m. of Lightweight cable for the basic type-E equalizer.

Each equalizer was supplied with an associated hermetically-sealed kit-box containing approximately 100 trimming-equalizer components from which a wide range of equalizer characteristic shapes was reproducible. The procedure used on the ship for the selection of the components was, briefly, as follows.¹⁰ Whilst the system was being laid the gain response between ship and shore was monitored, and changes in this gain, owing to the effect of (a) temperature differences between the ship's tanks and the sea bed on the cable and repeaters, and (b) the pressure change and other laying effects on the cable, were plotted. About 12 hours before the end of a block was reached, the results were extrapolated to predict the result expected at the end of the block, and hence the equalization required. Suitable networks (usually two-terminal) were designed, checked with a switched equalizer unit capable of giving all the combination of components possible from the kit-box, and wired up in an air-conditioned room provided on the ship. The equalizer unit was sealed and assembled into the submerged-equalizer housing, which was then jointed to the next ocean block. Speed of operation was essential to ensure that the laying operation would not be halted, and accuracy was important in order to keep level misalignment to a minimum.

SUPERVISORY SYSTEMS

The principle of the continuous-tone supervisory system^{11,12} is illustrated by the repeater circuit in Fig. 2. Briefly, the repeater contains a modulator which, when fed with a carrier frequency f_c (about 612 kc/s), can convert a frequency of $f_c - f_b$ (about 556 kc/s) or $f_c + f_b$ (about 668 kc/s) into the frequency f_b (about 56 kc/s). Each repeater is allocated a unique combination of frequencies f_c and f_b (see Fig. 1). Thus, if the appropriate f_c and $f_c - f_b$ frequencies are sent in the h.f. band from the B-station (Oban), an l.f.-band signal, f_b , is returned from the repeater concerned. Hence, a loop-gain measurement can be made to each repeater in turn, and a transmission fault can thereby be located.

If the carrier frequency f_c is sent, noise centred on frequencies $f_c - f_b$ and $f_c + f_b$ will be converted into noise around frequency f_b . However, all repeaters operating on a particular frequency f_c produce noise centred on a different f_b frequency, but these can be identified by a

selective receiver. To prevent the converted noise from being the accumulation of noise from all repeaters up to the repeater being measured, it has been arranged that the $f_c + f_b$ sideband noise predominates, and the noise from all preceding repeaters is blocked by a noise-stop filter. Thus the noise from a single repeater can be measured, and a noisy repeater is readily discernible. The terminal supervisory equipment¹² generates the frequencies f_c and $f_c - f_b$ when required and selectively receives frequency f_b as described later.

Distortion in repeaters, and hence the detection of a faulty amplifier, is measured by the pulse-supervisory system used on previous submerged-repeater systems.^{6,13,14} With this system no equipment is required in the repeaters. Either terminal station can send pulses, of 200 μ s duration and of the frequencies shown in the table, at a repetition rate of 23 pulses per second. The second-order and third-order distortion products from the amplifier in each repeater are returned to the sending station where they are measured on the special terminal equipment described later; the time delay of the received pulse identifies the repeater.

Test Station	Distortion-Product Measured	Send Frequency (kc/s)	Receive Frequency (kc/s)
A (Corner Brook)	Second order Third order	240 160	480 480
B (Oban)	Second order Third order	472 + 612 376 + 612	140 140

SUBMERGED REPEATERS

A block-schematic diagram of the repeater is shown in Fig. 2. The repeater contains two sets of directional

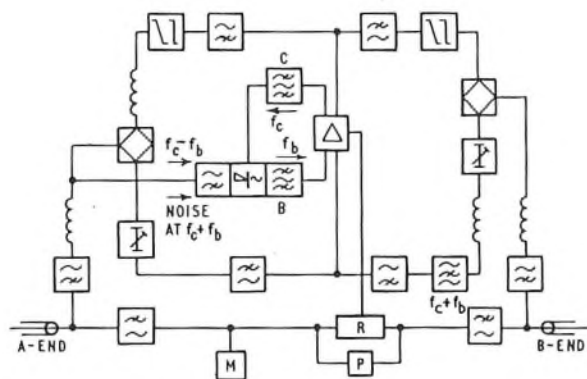

R—H.T. resistance box and valve heaters
M—Moisture detector for housing
P—Amplifier protection unit

FIG. 2—BLOCK SCHEMATIC DIAGRAM OF SUBMERGED REPEATER

filters which separate the two directions of transmission and pass them through the common amplifier. Supervisory equipment is connected across the amplifier and near to the A-end of the repeater. Power-separating filters at the terminals of the repeater separate the direct current from the transmission signals as in previous designs. The amplifier, directional filters, power filters and equalizers are similar to those used in the TAT-1 repeaters,⁵ except that they are designed for different frequency bands and for a circuit impedance of 43 ohms in order to match the new Lightweight cable.

Amplifier

The amplifier unit comprises two 3-stage amplifiers connected together at the input-valve grids and at the output-valve anodes, and has a common feedback network. Mixed feedback is taken from the output and fed back in series with the input signal. The input and output transformers of the amplifier are skew hybrids which have a low loss, of the order of 0.5 dB, in the paths connected to the directional filters, and a loss of about 10 dB in the paths connected to the supervisory network. The amplifier has a transmission-path gain of 60 dB at 608 kc/s, dropping smoothly to 59, 55 and 42.5 dB at 360, 300 and 60 kc/s, respectively.

With the two paralleled amplifiers operating, the amplifier has a single-tone overload point of +20 dBm (dB above 1 mW); if one amplifier fails, the single-tone overload point is reduced to +18 dBm, but the non-linearity at output powers of the order of 1mW is increased by 12 dB (from -88 dBm) for second-order distortion and by 18 dB (from -113 dBm) for third-order distortion. The valves¹³ have similar characteristics to those of the previous designs except that they operate from a 70-volt h.t. supply. The output valves work at a 10 mA anode current, and the voltage amplifiers at 3 mA. The heater consumption per valve is 3 watts at 10 volts.

Power Path

The repeaters are energized by 430 mA d.c. through the centre conductor of the cable and the six valve heaters are connected in series. As the new valve may operate with heater-cathode voltage of either polarity the voltage drop across the heater chain can be used for the 70-volt h.t. supply; thus, the voltage drop across the whole repeater is only 73 volts. In the event of a heater failure the d.c. path is maintained by a shunt circuit, and the excess current through this path operates a thermal short-circuiting fuse which connects resistances to restore normal working conditions on the remaining amplifier.

Supervisory Units

The supervisory units are shown in Fig. 2. The balanced-ring modulator is fed with a carrier supply from the amplifier output through a crystal filter, C (approximately 612 kc/s with 60 c/s bandwidth), and an input signal from the A-end of the repeater through a high-pass filter which gives approximately 16 dB discrimination between 668 kc/s and 556 kc/s band signals. The modulator output signal (difference frequency of approximately 56 kc/s) passes through another crystal filter, B (with about 40 c/s bandwidth), and back to the amplifier input.

It has been arranged that there is a loop conversion gain of about 27 dB from 668 kc/s to 56 kc/s measured at the amplifier input. This ensures that converted noise predominates over basic noise. The noise-stop filter near the A-terminal of the repeater attenuates noise from previous repeaters in the 668 kc/s band by at least 10 dB, but it has negligible effect on normal working frequencies. The relatively high conversion loss of the test-tone frequency of 556 kc/s to 56 kc/s for repeater loop-gain measurements (12 dB measured at the amplifier output) is not very important as there is ample margin over noise.

Surge Protection

Trawler damage is probably the most likely hazard against which the system must be protected. Trawlers operate only on the Continental shelves, and therefore trawler damage must be expected near the two terminal stations where the normal working voltage is about 5 kV. When the cable is cut by a trawl the centre conductor will be earthed, and the resulting high-voltage surge may be sufficient to cause breakdown of transmission components. Quick-operating gas-discharge tubes are therefore connected across the transmission paths and across the amplifier d.c. supply path, and these are robustly made so that they cannot short-circuit the circuit they are called upon to protect.

Construction

The repeater components¹⁶ (which are at the voltage of the centre conductor) are assembled in cylindrical gold-plated copper cans mounted between four perspex bars as in the TAT-1 repeaters.⁵ This assembly, together with a desiccator, is hermetically sealed in a brass cylinder which is lined with a 0.25 in. thick polythene tube. There is an air space between the unit cans and end castings of sufficient length to withstand 20 kV; the h.t. terminals of the power-filter capacitors protrude into this space. These capacitors are the only components which have to withstand the centre-conductor-to-earth voltage, and they have been designed to withstand 5 kV for at least 20 years and 10 kV for testing periods of a few hours.

The pressure housing is a high-tensile steel cylinder 9 ft 11 in. long, with a 10.5 in. external diameter and 8 in. internal diameter, sealed (after the insertion of the internal repeater unit) by two brazed-in bulkheads. The coaxial cable passes through each bulkhead via a pressure-resistant moulded gland of the type used in the TAT-1 repeater. After the repeater has been sealed, it is subjected to water pressure of 5 tons/in² for at least five days and the relative humidity of the inside of the housing is monitored (by means of a humidity-sensitive resistor) to confirm the quality of the seals.

SUBMERGED EQUALIZERS

Circuit

Fig. 3 shows the type-E submerged-equalizer circuit. Power-separating filters are fitted so that all the equalizer

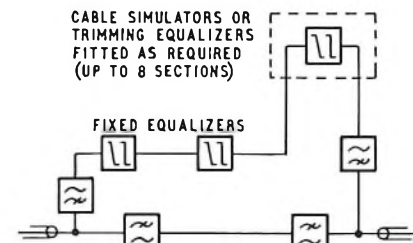

FIG. 3--BLOCK SCHEMATIC DIAGRAM OF SUBMERGED EQUALIZER

units are earthed, as the variable equalizer unit in a working cable might be adjusted on board ship. The fixed equalizer units, which cater for known differences over 12 repeater sections between repeater and cable characteristics, are mostly four-terminal networks similar to repeater equalizer units. The variable equalizers (built from the kit-box) are normally two-terminal series or shunt networks which can be damped

resonant circuits. The inductance, capacitance or resistance values can be obtained from series or parallel combinations of two components selected from six values of each parameter, so a wide range of resonant frequencies and shape factors is possible. In the type-F submerged equalizer the fixed equalizer units are omitted.

Construction

The internal unit comprises two can assemblies; the one containing the power filters and fixed equalizers is a sealed unit similar to a repeater but shorter, and the other, with provision for the variable equalizer, is a rectangular box whose lid is sealed on board ship. Both units contain a desiccator. The fixed unit is connected to a bulkhead by a tube with a ball joint for flexibility, and the variable-unit box is mounted on this tube. The demountable equalizer housing is generally similar in external appearance and dimensions to that of a repeater, but the design of the bulkhead and the means of sealing it against hydrostatic pressure are radically different since it is not possible to carry out brazing operations on the ship. The main seal consists of two Neoprene "O" rings carried in grooves on the bulkhead, and, in order to eliminate water-vapour diffusion, a lead ring is inserted between the bulkhead and its seating.

The assembly on board ship was a new operation, and no pressure test was possible. The sealing had to take place in a horizontal plane, and this called for a special assembly rig which had to be made with great precision owing to the very small clearance between bulkhead and housing.

POWER TERMINAL EQUIPMENT

As in previous submerged repeater systems^{13,17,18} power for the CANTAT repeaters is supplied by a constant direct current (430 mA \pm 0.2 per cent) over the centre conductor from power equipments at the terminals; the earth return is through the sea. The voltage required is 10 kV, but the voltage to earth is halved by the adoption of double-end feeding (+5 kV from Corner Brook and -5 kV from Oban) for all normal operations including the initial energization. Each terminal, therefore, has alternative equipment available which automatically maintains double-end feeding in the event of terminal-equipment faults. Emergency single-end feeding arrangements are provided to energize repeaters for locating faults when normal power-feeding is not possible.

Each equipment consists of:

- (a) three high-voltage constant-current rectifier cubicles,
- (b) two control cubicles containing the common monitoring and alarm equipment, and
- (c) one cable-terminating cubicle containing the commoning equipment for the simultaneous connexion of power and transmission to the cable.

The provision of three rectifier cubicles permits one to be out of service for routine maintenance or fault clearance while the remaining two provide mutual protection against failure. The equipment employs magnetic amplifiers for all control and alarm purposes. The constant-current reference is a permanent magnet.¹⁹

Voltage Sharing

At each terminal the rectifier cubicles are connected in series and must each provide a sufficient contribution to the total terminal voltage to ensure rapid automatic take-over in the event of one cubicle becoming faulty.

The two terminal equipments must also share approximately equally the 10 kV required for the system and absorb potential differences due to magnetic-storm activity. The current/voltage characteristics are therefore shaped to obtain the required sharing both between the terminals and between the units within a terminal.

Voltage Sharing at Each Terminal. Constant-current units in series will share the output voltage only if the currents they produce are precisely equal. In practice, it is necessary to shape the characteristics to produce a stability point where the current/voltage characteristics of the units intersect. The rectifier units are therefore designed with a rising current characteristic at low voltages to ensure that each unit provides a minimum of 10 per cent of the terminal voltage.

Voltage Sharing Between the Terminals. Each terminal equipment is fitted with a voltage-limiting unit operating on all the rectifier cubicles at that terminal; this unit changes the characteristic from constant current to constant voltage at a pre-selected output voltage. Referring to Fig. 4, terminal A has voltage limiting set to 5 kV

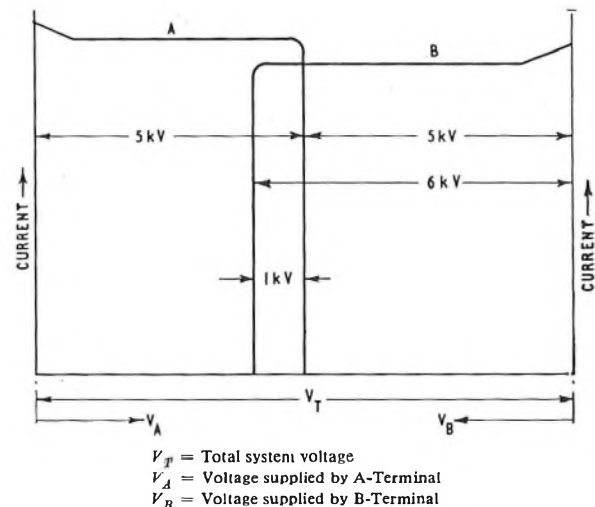

FIG. 4—VOLTAGE SHARING BETWEEN TERMINALS

and terminal B to 6 kV. The current setting for A, however, is intentionally set high (1 per cent) while that for B is correct for the system. The voltages stabilise at the point of intersection of the two characteristics and each terminal provides approximately half the total voltage at the correct line current. When the system voltage varies due to a magnetic storm the output voltage of B varies to cancel this change, and the system current remains constant.

Switch-On Procedure

The system current must be either the normal 430 mA or below 130 mA. The current must not remain between these values for more than a few seconds or the repeater valves may be permanently damaged. These current limitations and approximate equality between the voltages supplied by the terminals during the initial energization are met by the use of a synchronizing current of 80 mA to ensure that the terminals switch on at the same time.

The rectifier control circuits are designed to provide either the normal 430 mA or 80 mA, the value generated depending upon the double-wound relay X for terminal

A and relay Y for terminal B (see Fig 5). Winding 1 of each relay carries the cable current; winding 2 carries

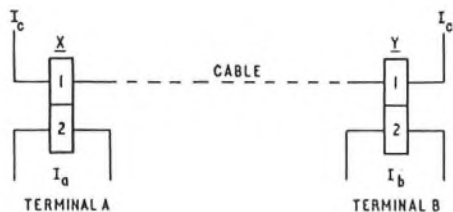

FIG. 5—DOUBLE-END SWITCH-ON CIRCUIT

the current produced by the local rectifier cubicles. When either relay is operated (currents in windings unbalanced) it locks until the associated rectifier cubicles are switched off, and the local rectifier current is controlled to 430 mA. When either relay is normal the local rectifier current is controlled to 80 mA.

Assuming terminal A switches on first, relay X will have the same current in both windings and will remain normal. The current from A will rise to 80 mA and operate relay Y, which then locks. When terminal B switches on, relay Y having operated, the current from B will rise to 430 mA. When the current from B flows through winding 1 of relay X, this relay will operate and the current from A will rise to 430 mA. The time interval between the initiation of the current rise to 430 mA at the two ends will, therefore, be small.

SUPERVISORY TERMINAL EQUIPMENTS

Submerged-Repeater Pulse Monitoring Equipment

On short cable schemes, the uniform misalignment between repeater gain and cable loss caused by seasonal temperature variations permits the transmitted pulse level from at least one of the terminals to be raised to a point where the repeaters are near overload. The returned non-linearity products are, therefore, at a relatively high level and the pulses can be measured on a visual display.^{13,14} With the CANTAT link, even at the mean temperature, the steps in the misalignment owing to the use of submerged equalizers do not permit all the repeaters to be tested near their overload point, and the returned pulses from low-signal-level repeaters are too near the noise level to be measured visually.

In the new equipment¹² one gate separates the pulses received from the repeater to be tested and another gate the pulses from a reference signal injected at the equipment input. The timing of the received-pulse gate can be varied to coincide with the pulses from any one of the repeaters. Two separate, but identical, receive paths determine the mean amplitude of a large number of successive pulses from the two sources; their mean amplitudes are then compared in a null detector. This technique enables fluctuations due to noise to be reduced to any required degree, the only limitation to the reduction being set by the stability of the equipment and by the time considered reasonable to make a measurement. The present equipment is designed for integration times from $\frac{1}{2}$ to 32 seconds.

With the large number of repeaters on the CANTAT system and the long integration times required for their measurement the manual measurement of all the repeaters is tedious. Automatic measuring and recording facilities have been provided, permitting all the repeaters in the system to be measured sequentially without manual adjustment of the controls. A motor-

driven control sweeps the time position of the received-pulse gate so that it accepts pulses from each repeater in turn. The difference between the mean amplitude of the received pulses from each repeater and the mean amplitude of the reference pulse is traced on a recorder. Sweep times of $\frac{1}{2}$ to 4 hours are available.

Submerged-Repeater Continuous-Tone Monitoring Equipment

For loop-gain tests the equipment¹² provides generators to transmit 11 carrier frequencies in the c-band and 20 test-tone frequencies in the a-band (see Fig. 1). The difference between the carrier frequency and the test-tone frequency for the repeater under test is the received frequency (in the b-band) for that repeater.

For noise tests the same 11 carrier frequencies are used but in this case the 10 received frequencies will be simultaneously produced. It is therefore necessary to provide a tuned detector.

The transmit and receive equipment can be operated manually, but to minimize the tedium of measuring a large number of repeaters it can be arranged that the carrier generator steps automatically to each of the 11 carrier frequencies and, during each step, the test-tone generator sweeps through the test-tone frequencies. Furthermore, the difference frequency, which is the same as the received frequency, is used to automatically track the tuned detector, the output of which is connected to a recorder.

ACKNOWLEDGEMENTS

The authors are grateful to all those who assisted with this project, and to the following main contractors: Standard Telephones and Cables, Ltd., Submarine Cables, Ltd., Westinghouse Brake and Signal Company, Sykes Interlocking Signal Company, and Airmec, Ltd.

References

- ¹CANTAT—A New Submarine Telephone Cable System to Canada. *P.O.E.E.J.*, Vol. 54, p. 220, Jan. 1962.
- ²BAMPTON, J. F., GRIFFITHS, R. G., and HALSEY, R. J. Anglo-Canadian Transatlantic Telephone Cable (CANTAT): Planning and Overall Performance. *Proceedings I.E.E.*, Paper No. 4244E, July 1963 (Vol. 110, p. 1,115).
- ³CLARKE, E. F.S., and CHAPMAN, K. J. Anglo-Canadian Transatlantic Telephone Cable (CANTAT): Cable-Laying Gear. *Proceedings I.E.E.*, Paper No. 4240E, July 1963 (Vol. 110, p. 1,151). (In this issue of the *P.O.E.E.J.*)
- ⁴BATES, O. R., and BROCKBANK, R. A. Anglo-Canadian Transatlantic Telephone Cable (CANTAT): Laying the North Atlantic Link. *Proceedings I.E.E.*, Paper No. 4241E, July 1963 (Vol. 110, p. 1,159). (In this issue of the *P.O.E.E.J.*)
- ⁵BROCKBANK, R. A., WALKER, D. C., and WELSBY, V. G. Repeater Design for the Newfoundland-Nova Scotia Link. *Proceedings I.E.E.*, Paper No. 2249R, Jan. 1957 (Vol. 104, Part B, Supplement 4, p. 91).
- ⁶The Anglo-Swedish Submarine Telephone Cable. *P.O.E.E.J.*, Vol. 53, p. 165, Oct. 1960.
- ⁷Proposed Commonwealth Pacific Telephone Cable System. *P.O.E.E.J.*, Vol. 53, p. 42, Apr. 1960.
- ⁸BROCKBANK, R. A., and MEYERS, A. L. A New Deep-Sea Coaxial Cable. *P.O.E.E.J.*, Vol. 50, p. 7, Apr. 1957.
- ⁹BROCKBANK, R. A., CLARKE, E. F. S., and JONES, F. Anglo-Canadian Transatlantic Telephone Cable (CANTAT): Cable Development, Design and Manufacture. *Proceedings I.E.E.*, Paper No. 4239E, July 1963 (Vol. 110, p. 1,124). (In this issue of the *P.O.E.E.J.*)
- ¹⁰SCOWEN, F. The Equalization During Laying of the Anglo-Swedish Submarine Telephone Cable. *P.O.E.E.J.*, Vol. 54, p. 48, Apr. 1961.
- ¹¹SCOWEN, F. Location of Repeater Faults on Submarine Telephone Cables. *P.O.E.E.J.*, Vol. 54, p. 252, Jan. 1962.

¹²SCOWEN, F., and POOLE, P. H. Anglo-Canadian Transatlantic Telephone Cable (CANTAT): Repeater Fault-Locating Equipment. *Proceedings I.E.E.*, Paper No. 4242E, July 1963 (Vol. 110, p. 1,140).

¹³WALKER, D. C., and THOMAS, J. F. P. The British Post Office Standard Submerged-Repeater System for Shallow-Water Cables, with Special Mention of the England-Netherlands System. *Proceedings I.E.E.*, Paper No.1634, Feb. 1954 (Vol. 101, Part 1, p. 190).

¹⁴HALSEY, R. J., and BAMPTON, J. F. System Design for the Newfoundland-Nova Scotia Link. *Proceedings I.E.E.*, Paper No. 2243R, Jan. 1957 (Vol. 104, Part B, Supplement 4, p. 80).

¹⁵HOLMES, M. F., and REYNOLDS, F. H. Post Office Valves for Deep-Water Submarine Telephone Repeaters. *Proceedings I.E.E.*, Paper No. 3163E, Mar. 1960 (Vol. 107, Part B, p. 165).

¹⁶THOMAS, J. F. P., ALVA, J. G., GLOVER, W. F., and LILLEY, V. T. Design and Construction of Reliable Components for Submerged Repeaters. *Proceedings I.E.E.*, Paper No. 3269, June 1962 (Vol. 109, Part B, Supplement 22, p. 592).

¹⁷THOMAS, J. F. P., and JEYNES, E. J. Anglo-Canadian Transatlantic Telephone Cable (CANTAT): Power-Feeding Equipment. *Proceedings I.E.E.*, Paper No. 4243E, July 1963 (Vol. 110, p. 1,146).

¹⁸THOMAS, J. F. P., and KELLY, R. Power-Feed System for the Newfoundland-Nova Scotia Link. *Proceedings I.E.E.*, Paper No. 2243R, Jan. 1957 (Vol. 104, Part B, Supplement 4, p. 103).

¹⁹Improvements in or relating to Electrical Control Apparatus British Patent No. 731,080 (17 July 1953), and Improvements relating to Control Apparatus for Alternating Electric Current Circuits, British Patent No. 623,661 (8 May 1947).

Book Reviews

"Static Fields in Electricity and Magnetism." D. H. Trevena, B.Sc., Ph.D.(Wales), Ph.D.(Cantab.) Butterworth and Co. (Publications), Ltd. xi + 255 pp. 137 ill. 35s.

This book is based on a course of lectures given by the author in the University of Wales. It is stated to be aimed at pass degree standard in physics at that University. The scope is that part of the syllabus which is concerned with electrostatics, magnetostatics and the magnetic fields due to currents (including galvanometry).

The author seems to be firmly convinced that the natural development of the subject based on the conceptions of isolated charges and isolated magnetic poles provides the only sound logical approach to this subject and accordingly his early treatment follows the traditional lines, with the usual accompaniment of c.g.s. units. Bearing this in mind, the first part of the book is, on the whole, clear and explicit but rather uninspiring and old-fashioned. Modern thought has, however, had sufficient impact upon the author for him to state emphatically that magnetic poles cannot exist in isolation and that the fundamental magnetic entity is the magnetic dipole. Consequently, the fundamental magnetic property is regarded as magnetic moment. Following this line of thought logically, he introduces the conception of intensity of magnetization as magnetic moment per unit volume, and the development of his system of magnetostatics proceeds on this basis, rather than on the alternative basis of magnetic flux arising from magnetomotive force. An unfortunate consequence of this seems to be a good deal of unnecessary confusion for the student when, later on, dealing with the magnetization curve of a magnetic material. The closed curve showing the relation between intensity of magnetization (rather than flux density) and the applied magnetic force is referred to as the "hysteresis loop," and a seeming distinction is drawn between the value of the intensity of magnetization when the magnetizing field is reduced to zero (which the author defines as residual magnetism) and the corresponding ordinate on the B/H loop (which the author defines as remanence). Of course, these two ordinates have precisely the same value for the same specimen, but the author fails to point out that the remanence is, in fact, the residual magnetization after magnetic saturation.

In dealing with the magnetic effects of currents, the whole treatment is based on the classic fiction of magnetic shells, but here the author wisely keeps to the traditional development and no anomalies were noticed.

The book closes with a criticism of the teaching sequence, which is necessitated by the use of the m.k.s. system of units. Two of his most pertinent objections are:

(a) the replacement of the concept of magnetic poles by the concept of current elements is of doubtful value.

Current elements are just as fictitious as magnetic poles and more difficult for the student to grasp.

(b) The magnetic field intensity H , and the electric field intensity E , are not defined as the force on anything, and, as a result the student finds them more difficult to grasp.

A good feature of the book is the large number of examples taken from past examination questions, some of which are answered fully in the text as illustrations of the standard of answer expected at this stage of University studies. Although it is stated in the preface that some questions from examinations of the University of Cambridge are included no such questions appear to have been included. All seem to have originated in the University of Wales and presumably set by the author. This is a pity and gives the book an atmosphere of "in-breeding" which might have been avoided.

To sum up, the author's treatment is reasonably sound and self-consistent, but is neither a particularly inspiring version of the old traditional treatment, which might have an educational value, particularly to the student of physics, nor is it useful to the engineering student who wants a modern treatment based on m.k.s. units. In fact, the treatment of magnetization might be very confusing to engineering students.

F.C.M.

"Landesfernwahl (Nationwide Dialling) Vol. II., Technical Solutions." 2nd Edition. Dr.Ing., F. Fuhrer. R. Oldenbourg. 330 pp. 208 ill. D.M. 36.

This is the second edition of Vol. II of Dr. Fuhrer's well known Vols. I and II on the subject which were first published in 1959 and reviewed previously (*P.O.E.E. Journal*, Vol. 53, p. 166, Oct. 1960). While the book follows closely the plan of the first edition, Dr. Fuhrer has revised all the sections to bring them up to date with the present subscriber-trunk-dialling technique in Germany.

Section 3, components and equipment, has been expanded and includes details of an interesting magnetic pulse regenerator, pulses being stored by incremental magnetization of rectangular-loop ferrite. The main additions are to Section 4, subscriber-trunk-dialling techniques, which has been expanded to include modern register design, dry-reed-relay translators and cordless boards. An excellent and extremely comprehensive bibliography is included.

The book, published in German, forms an excellent treatment of up-to-date German telephone switching and signalling practices and will be of considerable interest to telephone engineers dealing with the problems arising from the application of subscriber trunk dialling to existing networks. It continues the high standard set by the first edition.

The production of the text and of the diagrams is of high standard.

S.W.

Anglo-Canadian Transatlantic Telephone Cable (CANTAT): Cable Development, Design and Manufacture*

R. A. BROCKBANK, O.B.E., Ph.D., B.Sc.(Eng.), M.I.E.E., E. F. S. CLARKE, B.Sc.(Eng.), A.M.I.E.E.,
and F. JONES, B.Sc.(Eng.), A.M.I.E.E.†

U.D.C. 621.395.45:621.315.28

In 1951, the British Post Office evolved an entirely new type of deep-sea submarine telephone cable which was intended to overcome many of the serious disadvantages inherent in conventional wire-armoured cable. This new cable, known as the Lightweight cable because of its very light weight in water, was under exhaustive development for seven years before it could be accepted with confidence for a transoceanic system. 1,600 miles of this cable has now been laid on the Anglo-Canadian (CANTAT) system, and in all respects it has met the highest performance expectations. It has also proved to be much cheaper than a comparable conventional cable. Its electrical stability is noteworthy as it has exhibited a much smaller attenuation laying change than that experienced with previous cables, and, during the first year, there has been no significant indication of aging. This type of cable is expected to be employed on all new deep-sea systems.

INTRODUCTION

SINCE the first successful submarine cable was laid across the English Channel in 1851, over a quarter of a million miles of submarine cables have been laid, mainly in ocean depths. All those cables, with the exception of a short but interesting telegraph experiment,¹ had an external covering of iron or steel armouring wires. These wires served the dual purpose of providing the necessary longitudinal cable strength and of protecting the relatively fragile core.

Charles Bright,² in 1898, described various forms of unsuccessful cables, and wrote: "There can, however, be no question that, if some form of light cable were devised which, while obviating the various objections—especially that of decay—applying to the ordinary iron and hemp combinations, really possessed the required strength, it would have a great future." Such a lightweight cable has at last been devised, though not primarily for the reasons that Bright envisaged, and it is around this revolutionary new design that the CANTAT cable system has been engineered.

CANTAT marks the first laying of the new cable. It has so far proved successful in every respect, and has eliminated almost all the disadvantages inherent in the conventional design. The wire-armoured cable has well served its purpose for 110 years, but with the completion of CANTAT it undoubtedly became obsolescent for deep-sea cable routes.

EARLY EVENTS

In 1948, the Post Office began to study seriously the problems associated with laying a repeatered system in deep water. Apart from the question of whether an economic degree of electrical reliability could be realized in the repeaters, there was the overriding problem of whether the Post Office type of rigid housing could, in fact, be recovered in order to repair a fault. Great care has always had to be exercised in handling cables at sea, in order to prevent the formation of kinks or twists

which can damage or break the cable.³ The most common cause of kink formation is the untwisting of the armour layer under tension near the ship: this results in a twisting-up of the armour at the lowest tension point, i.e. the sea bottom. Several thousand twists may readily be stored in the cable under practical conditions. If, for any reason, the tension near the bottom is relaxed—even momentarily—the cable will spring into loops which, under subsequent tension, will be drawn into kinks. The actual laying operation of cable and repeaters in general presents no serious difficulties if carried out uniformly without stopping. During recovery, however, the twist-up torque in the armour can usually expend itself satisfactorily along the tensioned cable on the sea bottom. Such transmission will stop when it meets a heavy repeater, which is almost incapable of being twisted. When this happens the turns build up, and ultimately twist the cable to a complete break at the weakest point in the cable near the repeater. Fig. 1



FIG. 1—FAILURE OF ARMoured CABLE CAUSED BY ROTATION DURING A REPEATER RECOVERY OPERATION

shows such a twist break that occurred when the repeater was lost during a trial. Experiences like this led to the conclusion that deep-sea repair in a system with conventional cable and heavy housings would be a hazardous, if not an impossible, operation. It is possible to lessen the hazard by skilfully "rolling" the cable on the sheave with a cable lead, but this cannot be considered a reliable or adequate technique with repeatered cables.

A double-wire armoured cable with reverse lays could,

*Reproduced by permission of The Institution of Electrical Engineers.

†Post Office Research Station.

theoretically, eliminate twisting and thereby provide a satisfactory solution, but there would be serious disadvantages with respect to cable size, because the cable tensions would be too great for existing cable ship's gear to handle. Smaller armour wires would greatly increase the existing corrosion liability. The cable would also be unfavourable because of cost, inflexibility and stowage limitations.

In 1950, the A.T. & T. Co. laid a two-cable system⁴ between Key West and Havana in which the repeaters were long flexible structures with a diameter only a little greater than the main cable. Such repeaters would undoubtedly transmit the turns fairly readily. The Post Office, however, has always considered it desirable to provide one-cable systems, and the greater amount of equipment required for such repeaters could not be contained in such a limited space.

This, in brief, was the very unhopeful position which faced the Post Office in early 1951 in its contemplation of a deep-sea system. What has since proved to be the break-through was initiated later in 1951, when one of the authors, seeking a means of eliminating the twisting in a submarine cable, worked out a design⁵ for a coaxial submarine telephone cable which completely eliminated this effect. It was also immediately evident that the design resulted in a true lightweight cable which should possess many other important advantages over conventional cable. The new cable has been called the Lightweight cable because, in water, it has only about one-fifth of the weight of a comparable wire-armoured cable having the same attenuation coefficient.

It was clear, however, that such a revolutionary design would have to be carefully studied, developed and tested with respect to its mechanical, electrical and corrosion properties, in order to check with complete confidence that it would have a long and stable life on the sea bed, and that it could be laid and recovered satisfactorily with repeaters.

PRINCIPLE OF THE LIGHTWEIGHT CABLE

The basic principle of the new cable is that the strength member of the conventional cable, i.e. the layer of steel armour wires, is removed from the outside of the cable, and replaced by a torsionally balanced steel strand

located at the centre of the cable. By using high-tensile steel wires the cross-section of steel required is greatly reduced, and economically fills the centre of the inner conductor. At carrier frequencies, the centre of the inner conductor serves no useful purpose, and steel wires are, in any case, about the cheapest method of providing an incompressible but flexible filling. The removal of the outer protection afforded by the armour wires was considered to be permissible if the cable were laid in water sufficiently deep to be undisturbed by trawls, anchors, waves and strong tidal currents. The corrosion of armour wires has always been a problem, because

their strength can deteriorate to such an extent that subsequent recovery is impossible. In the Lightweight cable the original strength should remain unimpaired indefinitely.

It was envisaged that the inner conductor would consist of a thin longitudinal copper tape folded round the steel strand. Polythene insulation would be applied over this conductor, and the outer conductor, a layer of aluminium or copper tapes, laid over the core. The cable would be completed with a non-metallic covering, such as a polythene sheath or an impregnated textile covering.

The new cable structure immediately posed several fundamental queries for which satisfactory solutions had to be forthcoming if the cable were to be developed successfully. There were, for example, questions as to whether (a) the steel strand would "knife" through the polythene when the cable was under tension on a sheave, (b) the steel strand would introduce intermodulation, or (c) there could be sufficient adhesion in the cable layers to transfer the tension from the steel strand to the cable engine. A preliminary appraisal of these points proved heartening. A brief consideration of other points suggested that some method of jointing the steel strand could be devised, and that the tension could be transferred from the steel strand to a repeater housing by armouring a sufficient length of the end of the cable. Aluminium was tentatively proposed for the outer conductor as it is cheaper than copper and capable of yielding a much higher cable modulus, i.e. length of cable in water which can be supported by its own strength. Although these conclusions seemed promising, it was obvious that much protracted work, both on land and in sea trials, would have to be undertaken before a final design could be developed and accepted with complete confidence in its performance.

DEVELOPMENT OF THE LIGHTWEIGHT CABLE

It was at this early stage that the assistance of a cable manufacturer was sought, and agreement was rapidly reached on the details for an early experimental sample. The first length of Lightweight cable was produced by the end of 1951: this is shown in Fig. 2. The centre copper tape was folded round to butt, and copper was



FIG. 2—FIRST EXPERIMENTAL LENGTH OF LIGHTWEIGHT CABLE

also used for the outer conductor tapes as it was more readily available than aluminium. The copper binding tape was primarily used to minimize environmental cracking of the core owing to the compound used on the serving. This compound was too fluid on the first sample, and was sticky to handle. It was improved on the next sample, which employed 18 mil aluminium tapes with no metallic binder. Both these cables had a strength of about 5 tons. Tests on these experimental lengths showed that (a) no decentralization of the centre conductor occurred at 4.5 tons round a 3 ft 6 in. diameter sheave, (b) third-harmonic production in the centre con-

located at the centre of the cable. By using high-tensile steel wires the cross-section of steel required is greatly reduced, and economically fills the centre of the inner conductor. At carrier frequencies, the centre of the inner conductor serves no useful purpose, and steel wires are, in any case, about the cheapest method of providing an incompressible but flexible filling. The removal of the outer protection afforded by the armour wires was considered to be permissible if the cable were laid in water sufficiently deep to be undisturbed by trawls, anchors, waves and strong tidal currents. The corrosion of armour wires has always been a problem, because

ductor was extremely low, (c) preliminary bending and gripping tests were satisfactory, (d) the butted centre conductor was responsible for about 30 per cent increase in attenuation, but this was expected with this simple construction, and (e) there was an appreciable unbalance in the steel strand.

These tests were very encouraging, and it seemed probable that no fundamental obstacles would be encountered. There followed a period of consolidation on many aspects of the cable which led to a more mature design. Unfortunately, owing to Post Office and contractors' commitments on TAT-1, progress was slow until 1956. During this period, however, a comparatively advanced design for an 0.8 in. (diameter of core)⁶ cable was completed. Advantage was taken of an ocean trial⁷ in October 1956 to test 5 n.m. of this cable by laying and recovering with a repeater. Tests were made in 600, 1,500 and 2,600 fathoms (without a repeater), and results were very promising. Efforts made to damage the cable, e.g. by kinks and twists, were quite fruitless; it came inboard on each occasion clean and coiled like new cable. This was the first Lightweight cable ever to be laid.

In 1955, an economic study suggested that a cable of about 1 in. diameter over the core would be the best size for frequencies of 0.5–1 Mc/s. Design and production were therefore initiated for 55 n.m. of 0.99 in. cable for a full-scale deep-sea trial. This took place in February 1958 in 2,700 fathoms of water. Two repeaters were used, and every cable ship operation was carried out; i.e. laying, recovery, buoying-off, grappling and repairing. Parachutes were used successfully for reducing the sinking velocity of the repeaters to that of the cable, and so retaining a straight cable line to the sea bottom. Attenuation measurements were carried out by sending a series of stabilized tones from a bank of oscillators housed in a special repeater at the distant end of the cable. The mechanical performance of the cable was, in general, excellent, and the operations were carried out with much more confidence and fewer difficulties than on a conventional cable trial. It was noted, however, that in certain circumstances, e.g. with the cable under tension over the bow sheave for several hours, breaks could occur in some of the outer aluminium tapes. Electrical measurements were very satisfactory, except that on occasions there were small unexplained discrepancies. However, the temperature and pressure coefficients were not known very accurately, and, in addition, a new and unexpected factor came to light. Serious crosstalk was found to exist between adjacent cable sections in the same tank. The near-end crosstalk, at 700 kc/s, was as low as 50 dB, and 3 per cent rolls were produced in the attenuation/frequency characteristic making it difficult to determine the mean value accurately. By recoiling, so as to stagger flake lengths into a rough pyramidal construction, this was greatly improved, but it was not considered to be a final solution. A considerable improvement in crosstalk was essential, because, during laying, accurate measurements have to be made through repeater-section lengths on the ship.

Because the results of the trial were so satisfactory, a decision was taken to employ the Lightweight cable on CANTAT, though some modifications were necessary to improve both the robustness of the aluminium tapes and the cable crosstalk. With the following changes the cable assumed the final structure, as laid on CANTAT.

The aluminium tapes were made of soft metal, and were increased from 15 to 18 mils thick: there has never since been any indication of broken tapes. A thin insulated aluminium screen was inserted over the return tapes. This initially gave a great improvement in crosstalk, but this was not fully maintained in production, so that a slightly more complicated cable loading plan was found to be necessary. With the agreed standardization of this cable for CANTAT, it was essential to obtain a more detailed knowledge of its electrical and mechanical performance, and to finalize the cable-ship techniques to be employed. This led to a further series of laying trials as follows:

August 1958. Aging check on a 22 n.m. length of cable relaid in February 1958 in 1,000 fathoms.

February 1959. Measurements on laying effect, etc., on 12 n.m. in 1,700 fathoms. Interlayer slip and water penetration tests. Repeat of the August 1958 aging check.

September 1959. Repeat measurements on August 1958 test and on 12 n.m. laid in February 1959.

May 1960. Measurements on crosstalk, interlayer slip and cable handling methods. Aging effect check on 12 n.m. laid in February 1959. Laying effect, etc., on 20 n.m. in 1,700 fathoms. Check on repeater, bight stowage and use of parachutes.

January 1961. Check on shear-limiting laying gear, interlayer slip. Check on aging on 20 n.m. laid in May 1960.

Nearly all these trials were also used to carry out various corrosion and water-penetration studies. At the conclusion of a trial, special laboratory-prepared samples would be attached to the cable end and lowered to the sea bottom. At a subsequent trial they would be recovered and examined. A gratifying result of these trials was that no laying effect or aging could be determined within the accuracy of measurement (0.15 per cent over most of the frequency band). The cable appeared to be completely stable electrically. It was also noted that slight interlayer slip could occur during laying or recovery at high tensions, but it was not detectable externally, nor was it possible to associate it with any mechanical or electrical degradation. It was concluded at the end of these trials that the laying of CANTAT could be begun with confidence.

DESCRIPTION OF 0.99 IN. LIGHTWEIGHT CABLE

General Construction

The general construction and dimensions of the cable are shown in Fig. 3.

Steel Strand. The primary requirements of the steel strand are strength and torsional balance. The centre-swaged heart has wires of 110–125 tons/in² tensile strength and the outer layer 115–130 tons/in². Histograms of strand strength with and without a joint are shown in Fig. 4. The contribution of the rest of the cable amounts to about 0.5 ton, so that the cable strength varies from a minimum of about 7.0 tons (with joint) to a maximum of 7.9 tons (without joint). Since the cable weight in water is 0.6 ton/n.m. there will be a minimum excess strength in 3,000 fathoms of 5.2 tons during recovery. This will cover acceleration forces produced by bow-sheave movement and the drag-resistance force of the water at recovery speed. For those cable-ship operations which are virtually static, and many of them are, the cable modulus of about 12 is of

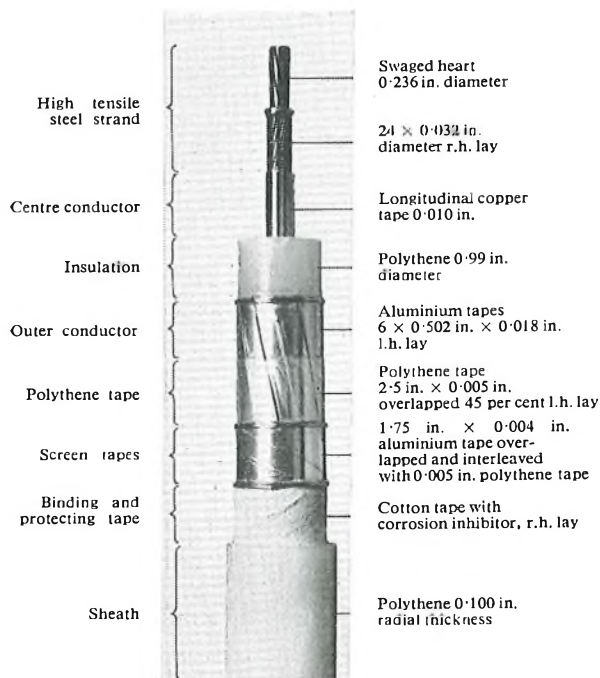
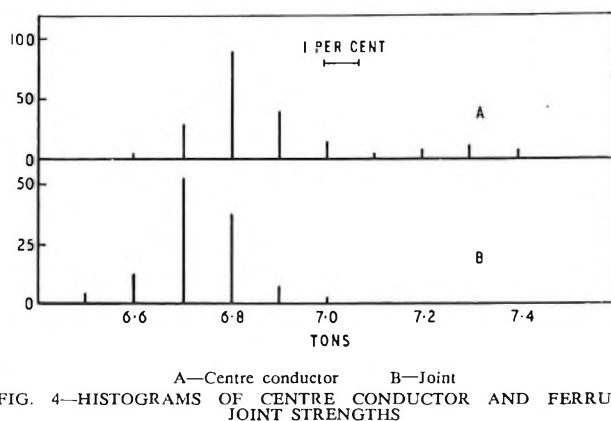

FIG. 3—LIGHTWEIGHT CABLE FOR THE CANTAT SYSTEM



considerable advantage compared with about 7 for conventional cable. The torsional unbalance of the complete cable is hardly measurable (less than 0.01 turn per fathom) up to 80 per cent of the breaking strength.

Inner conductor. The 10 mil longitudinal copper tape used for the inner conductor has been found capable of standing up to the severest handling. Its thickness, however, has to be controlled to ± 0.25 mil. as the shape of the attenuation characteristic is considerably influenced by tape thickness at frequencies below about 300 kc/s. The box-seam principle is simple and works well, but it does increase the attenuation by about 1 per cent. The finished conductor cannot be degreased as the solvent would be trapped in the seam and could produce flaws in the core extrusion. Minimum values of inter-layer friction are specified for the cable, but it is the steel/copper interface at which there has been most difficulty in meeting the requirements without serious

indentation of the copper by the steel strand. Acceptable results have been obtained by including a thin smear of an epoxy resin between steel and copper.

Insulation. Polythene with a maximum melt-flow index of 0.3 is specified for the insulating material, with an anti-oxidant additive of 0.1 per cent (maximum). Permittivity and power-factor limits are imposed, but the value of the latter during production was fairly constant at about 0.00012. Extrusion is primarily by diameter control, but capacitance and eccentricity are monitored.

Outer Conductor. The six soft aluminium tapes of the outer conductor are specified in thickness to ± 0.5 mil, and are applied with a 16 in. lay.

Screen. Fig. 3 is self-explanatory. The layers in the screen are tightly wound and the intention is to eliminate any metallic contact which might lead to instability during the cable life.

Chromate Cotton Tape. The chromate cotton tape is impregnated with a mixture of zinc and barium chromates (see later section on Chemical Requirements). The former is highly soluble, and the latter has a long-term action because it is not readily leached away. A 1 mil Melinex tape wound over the chromated tape prevents the dissemination of these toxic powders in the factory.

Oversheath. The oversheath is a tightly fitting sheath of the same grade of polythene as is used on the core.

Joining

The major problem in cable jointing has been that of jointing the steel strand. The strength of the joint should not be much less than that of the strand. The joint should be capable of being enclosed within the normal core diameter, and it should not be inflexible for more than a few inches, or it would give trouble when bent around a sheave. Welding, brazing and soft soldering methods were all dismissed for various reasons, and the successful method finally adopted is as follows.

The joint uses a cylindrical ferrule of EN 32 steel, 0.650 in. in diameter and 4.5 in. long, drilled to give a sliding fit on the strand. To prepare the steel strand for jointing, the centre-conductor end is clamped in two electrodes 1 in. apart. When a high current is passed through the strand it is burned through, and the constituent wires are welded together at their extremities, so retaining their normal lay-up. This accomplishes a very important operation in a very simple manner. After trimming the end, removing sufficient copper tape to clear the ferrule, and sprinkling with powdered silicon carbide, the ends are inserted in the ferrule to meet at the centre. The ferrule is then pressed on to the strand in three operations by means of a 200-ton press. The die is a four-section radially-closing die giving a cylindrical finished joint.

The joint is arranged so that a bridging wire connects the copper conductors. A square-section slot is milled in the ferrule and filled with a hard-drawn copper wire during the pressing operation. This is afterwards replaced by a square-section annealed copper wire which is connected to the copper conductors by soft soldering. The core joint is completed by normal injection-moulding procedure. The outer-tape jointing technique needed considerable study in order to meet the bending requirements, and a cold-pressure-welding method was finally adopted. Fig. 5 shows the completed joints after a severe bending test. The sheath can be restored by any one of several established methods.

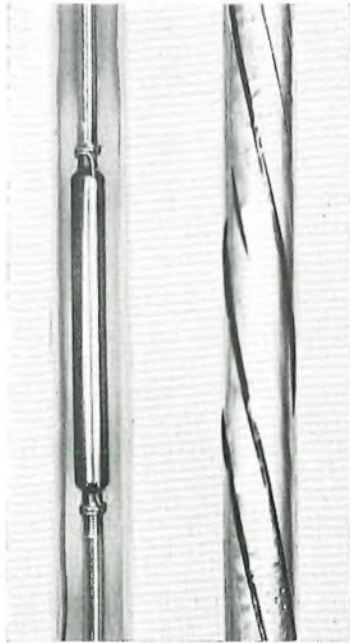

FIG. 5—INNER AND OUTER CONDUCTOR JOINTS FOR CANTAT LIGHTWEIGHT CABLE AFTER BENDING TEST

MECHANICAL REQUIREMENTS

Resistance to Sea-Bottom Conditions

Sea-bottom conditions include any type of mechanical damage which the cable could suffer on the sea bottom. In deep water it would seem that the only damage that could be inflicted would be by subterranean movement, not necessarily in the vicinity of the cable, or by the effect of suspensions over cliffs, rocks or wrecks. These suspensions would be aggravated if the support were sharp or localized, or if the catenary span oscillated in a bottom current. Samples of cable have been subjected to (a) very acute bending, (b) compression by objects varying from a large round bar to a knife edge, and (c) types of abrasion from sand blast to rough stone. In most cases comparisons were made with armoured cable. The cable was found to be electrically sound after surprisingly severe deformations. In general, the Lightweight cable was inferior to the conventional cable only when the damaging method was severe; e.g. tearing or penetration by a knife edge. Even on an armoured cable, however, the life would be comparatively short under such conditions. The X-radiograph in Fig. 6 shows deformation by a steel angle on a Lightweight cable after four



FIG. 6—RADIOGRAPH SHOWING DEFORMATION OF LIGHTWEIGHT CABLE BY A STEEL ANGLE AT A LOADING OF 0.75 TON

days with a load of 0.75 ton. The cable is still electrically satisfactory; i.e. no contacts between the steel angle, aluminium tapes and centre conductor. With 0.5-ton loading, extrapolated movements indicate that the cable should survive 20 years. Fig. 7 shows comparative results with an armoured cable of the effects of similar high-pressure sand blasts under water. It was concluded that the Lightweight cable should stand up well to most foreseeable hazards on the ocean bottom.

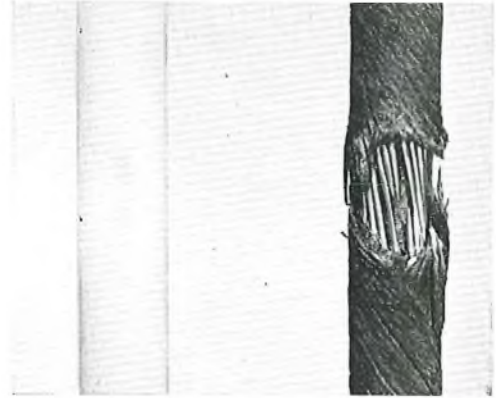

FIG. 7—DAMAGE SUFFERED BY LIGHTWEIGHT CABLE AND ARMOURED CABLE BY SIMILAR SAND-BLASTING UNDER WATER

Bending Performance

It is obviously desirable to limit, as far as possible, the amount of bending which the cable must suffer before being laid. Work-hardening can alter the electrical characteristics, and severe bending can “cockle” or even crack the conductors. In the factory the bending radius is kept large, and is never decreased below 3 ft. The most severe bending is probably imposed by the laying gear, in which the cable passes round a train of V-sheaves of 6 ft diameter. The cable suffers about three and a half “reverse” bends during the laying operation. A reverse bend comprises the following sequence—bend, straighten, bend in opposite direction, and straighten. The cable had to be designed to undergo this laying treatment without noticeable change, and the CANTAT cable and its joints can, in fact, meet this requirement after 30 reverse bends.

The Properties of Cable Interlayers

Transfer of the cable tension from the steel strand to sheaves, drum, repeater and stoppers has been a major problem. Shear forces set up have to be contained by adhesion and friction forces. The former exist owing to the normal hoop stresses residing in the cable, and these are augmented by friction forces when external radial pressure is applied to the cable. Difficulties are complicated by the fact that the cable is extensible, and the effective coefficients of friction vary considerably with radial pressure. Since there was not much margin, initially, between friction forces obtainable on the cable and what was considered desirable, many tests at sea under practical conditions were required to determine the minimum values which could be accepted with confidence. It was appreciated that serious damage might occur if the friction decreased considerably over even a few yards of cable. One successful method of measuring slip was to drill small radial holes through to the steel strand, and, after the operation, to measure the misalignments produced. Minimum frictional and ad-

hesion forces were specified to ensure that excessive slip would not be encountered.

Cable Terminations

The termination of the cable at a repeater required (a) means for transferring the cable tension from the steel strand to the repeater housing, and (b) a transition from the cable with its insulated outer to a small-diameter tail cable with an outer-braided conductor for connexion to a similar flexible tail from the repeater. The first requirement was realized by armouring a length of about 10 fathoms of the end of the cable with a layer of 30 No. 12 s.w.g. p.v.c.-covered steel wires. The ends of these wires were bent back round a steel cone which was clamped to the housing using a method well established with conventional cable. The taper for reducing the 0.99 in. cable to a 0.31 in. tail cable required special mouldings, so that a connexion to the outer aluminium conductor could be brought outside the cable without allowing the entry of water. The terminations had also to be capable of withstanding severe bending and small longitudinal movements of the conductors.

Cable Stoppers

Cable-ship operations often require a bight or cable end to be held up to tensions approaching the cable strength. When damage to the cable is permissible, chain stoppers are simple and effective up to about 5 tons. In the more usual case, however, the cable must not be damaged, and an ordinary seaman's stopper is satisfactory up to about 4 tons if the cable under the stopper is first wound with a close helix of No. 16 s.w.g. soft-iron wire. Two such stoppers can be worked in tandem, the tensions being equalized by a pulley block. This is a comparatively lengthy procedure, and, after further investigations, the following method has been adopted. A pre-formed grip is used, comprising eight high-tensile steel wires pre-formed into a 1 in. diameter helix and bent to form two tails. Each tail is separately wrapped on to the cable, and this results in the cable being substantially covered with a tightly applied short-lay layer of armour wires for about 8 ft. One grip can be loaded up to about 4 tons, and, with two grips in tandem, the cable can be held up to its breaking load. The stopper can be applied in a few minutes.

CHEMICAL REQUIREMENTS

Long-term attenuation stability of a very high order, e.g. 0.1 per cent, is of great importance, since re-equalization of the system after laying is extremely difficult unless suitable devices are built into the system initially. In general, two distinct types of degradation can be envisaged. The first is a long-term change in the cable occurring uniformly along the whole route owing to small aging changes in the constituents of the cable, aggravated, perhaps, by environmental conditions; e.g. hydrostatic pressure or water diffusion. Such changes must be kept small, because they are effective over the whole cable length. The second is owing to a localized condition; e.g. a flaw or gash in the oversheath which results in broken tapes. Such occurrences are likely to be infrequent, and they must be assessed on the actual loss or noise change incurred. It has been found by tests that the system is not noticeably degraded if (a) the oversheath is intact and all but one of the aluminium tapes are broken, or (b) the oversheath is bared to the

aluminium tapes, all tapes are disconnected and a sea path exists across the gap.

Aluminium can be more liable to corrosion than copper, and so chemical and galvanic corrosion tests on a large scale have been carried out, both in the laboratory and at sea, during the last ten years to establish confidence in aluminium as used in the cable. Some of these tests have already been recorded.⁷ As an additional inhibitor against chemical corrosion, the chromate-impregnated tape referred to earlier has been incorporated over the screen tapes, and, as a further safeguard against galvanic action, each repeater is fitted with a sacrificial anode of non-passivating zinc to nullify the cell existing between aluminium and steel. The conclusions drawn from the results of all these tests indicate a long and stable cable life.

ELECTRICAL PERFORMANCE

The most important electrical parameter of the cable is the insertion-loss/frequency characteristic. In the laid condition, the loss of each repeater-length section should be accurately counter-balanced by the repeater gain. Variations in the cable loss during manufacture were taken up by a length-adjustment procedure in which each repeater-section length was adjusted to give a loss of 55 dB at 608 kc/s under the particular sea-bottom condition.

Insertion Loss

The average loss/frequency characteristic measured on CANTAT cable is shown in Fig. 8 in dB/n.m., and, for a more accurate appraisal of the shape, as $\frac{\text{dB/n.m.}}{\sqrt{f}}$

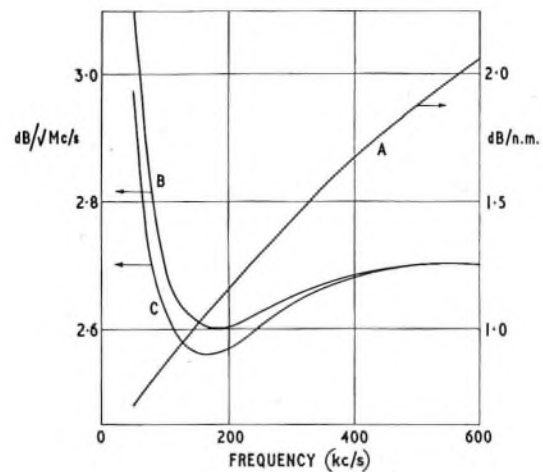

Curve A—dB/n.m. for Lightweight cable
 Curve B—dB/n.m./√Mc/s for Lightweight cable
 Curve C—dB/0.67 n.m./√Mc/s for shallow water simulator cable
 FIG. 8—ATTENUATION OF LIGHTWEIGHT AND SHALLOW-WATER SIMULATOR CABLES AT 60°F

Temperature and Pressure Coefficients of Attenuation

The temperature and pressure coefficients are shown in Fig. 9 and 10, respectively. They were determined by laboratory measurements on 30 ft samples in pressure tanks with accurately controlled temperature. A confirmatory check was obtained during a sea trial. The temperature coefficient is cyclical, but, as the pressure coefficient is not, the correct values to be used are those obtained on the first application of pressure. The

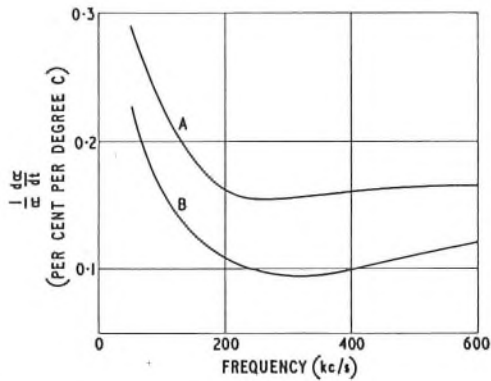

Curve A—Lightweight cable
Curve B—Shallow-water simulator cable
FIG. 9—TEMPERATURE COEFFICIENTS OF ATTENUATION

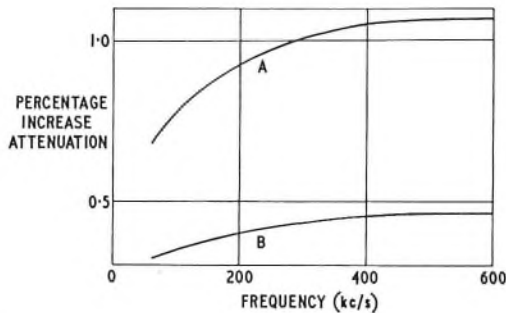

Curve A—2,000 fathoms
Curve B—500 fathoms
FIG. 10—CHANGE OF ATTENUATION OF LIGHTWEIGHT CABLE WITH DEPTH

measured results do not agree precisely with those expected by theory.

Characteristic Impedance and Pulse Response

The average value of the characteristic impedance, measured on all sections of the CANTAT cable, varied from 44.1 ohms at 600 kc/s to 44.5 ohms at 60 kc/s, with a maximum deviation of ± 1.6 per cent.

The measured response of the cable to a "raised-cosine" pulse with a half-amplitude duration of $0.33 \mu\text{s}$ showed a general level of echo of the order of 65 dB at the point of reflection, with a minimum value of 50 dB. In general, the echoes from ferrule-joint positions could not be readily distinguished from the cable response.

D.C. Resistance

The average d.c. resistance of the centre conductor was 2.92 ohms/n.m. ± 2 per cent. The comparatively large spread is explained by variations in the steel strand, and so is not reflected in the attenuation characteristic, which is substantially determined only by the copper conductor.

Cable Capacitance

The measured capacitance on all CANTAT cable was $0.2135 \mu\text{F/n.m.} \pm 0.7$ per cent. As the deviations affect the attenuation of the cable, but not the shape of the loss/frequency characteristic, they are readily tolerated.

GENERAL LAYING PERFORMANCE OF LIGHTWEIGHT CABLE

Considerable experience of the laying behaviour of the Lightweight cable has now been obtained from sea trials and by the laying of 1,600 n.m. on CANTAT. Mechanically the cable has performed excellently in all

respects; it is quite incapable of kinking, and at no time has there been any doubt that it was not in perfect condition.

At a laying speed of 8 knots, the cable streams out at an angle to the horizontal of about 6° , so that in 2,000 fathoms it touches bottom 20 n.m. behind the ship. This gives ample time to slow up the ship or make slack adjustments if the echo sounder reveals unexpected bottom conditions. The tangential drag force of this cable is so small that it is not practicable to determine or adjust slack percentage by dynamometer tension readings. The cable (specific gravity 1.37) rests only lightly on the bottom (1.25 lb/fathom run) so that, in conjunction with the low coefficient of friction (about 0.2) of the smooth polythene surface, it is evident that even relatively low tensions in the cable at the sea bottom will pull out the slack for many miles; e.g. a pull of 1 ton might be felt for 18 n.m. Any cable tension at the ship in excess of depth-of-water weight of cable will also exist in the cable at the sea bottom. Since, in practice, any repair operation is bound to produce several tons excess tension, it follows that slack will be drawn out of the whole repeater section and probably beyond. There is no simple means whereby slack can be restored uniformly.

It is readily possible to picture conditions existing during various ship's operations with Lightweight cable. Fig. 11 shows conditions for the picking-up of a bight

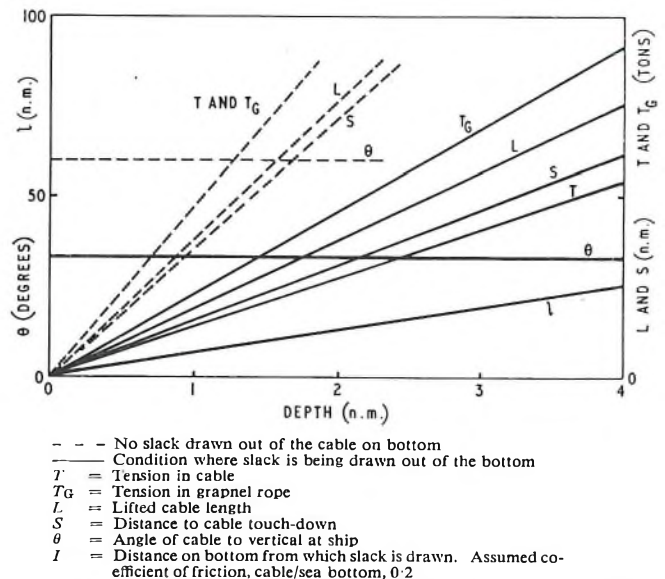

FIG. 11—CONDITIONS EXISTING IN THE PICKING-UP OF A BIGHT IN A LIGHTWEIGHT CABLE LAID WITH 5 PER CENT SLACK

in still water in a cable laid with 5 per cent slack assuming (a) a coefficient of friction between the cable and the sea bottom of 0.2, or (b) a limiting condition where no slack can be drawn out of the cable whilst it is on the sea bottom. If the cable is laid on ooze, viscosity has a greater effect than friction and results would probably be lower than (a). It is interesting to note that in (a) a bight could be recovered in 3,000 fathoms with a maximum cable tension of 4 tons.

The electrical performance of the cable has been excellent. Since CANTAT, three further Lightweight cable systems have already been laid. On these systems, the average difference between measured and predicted seabottom attenuation on a 26.3 n.m. repeater section is

0.18 per cent (0.1 dB) gain at 608 kc/s, decreasing almost linearly to 0.4 per cent (0.07 dB) loss at 60 kc/s. It is probable that pressure-coefficient variations may account largely for these differences.

With respect to aging, supervisory level measurements are now available over a length of 50 repeater sections in deep water on CANTAT during the first year. If there is any aging trend it is less than 0.2 dB (0.1 per cent). Such extremely small changes could equally well be due to the repeaters or to small changes in temperature, e.g. 0.05°C. The stability of the cable is therefore much greater than that of any previous cable, and its behaviour can be predicted more precisely.

THE SHALLOW-WATER SIMULATOR CABLE

The Lightweight cable described in the previous sections was intended to be used in depths where the cable would not be disturbed. On the CANTAT route, nearly 500 n.m. of cable lie in depths of less than 400 fathoms, where the cable is liable to trawler damage. For these sections it was proposed to use an armoured, and therefore heavier, cable, which would be less vulnerable. The normal armoured-cable design is sufficiently different in impedance, and in the shape of the loss/frequency characteristic, to require a differently designed repeater. It appeared preferable to standardize the repeater, and produce a new shallow-water cable. A theoretical study led to the design shown in Fig. 12, and it is a sufficiently

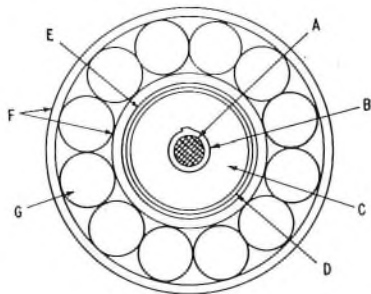

- A—19 × 0.036 in. mild-steel strand
- B—Copper tape 0.010 in. thick
- C—Polythene core 0.620 in. diameter
- D—6 × 0.012 in. thick copper tapes plus 0.003 in. binder tape
- E—Impregnated cotton tape
- F—Jute serving
- G—12 × 2 s.w.g. armour wires

FIG. 12—SHALLOW-WATER SIMULATOR CABLE

accurate simulator of Lightweight cable characteristics as indicated in Fig. 8 and 9. Since the ultimate strength of this cable is intended to reside in the armour, and not in the centre strand, the latter is made of mild steel and has a shorter lay than the centre strand in the Lightweight cable. The loss characteristic of the manufactured cable is shown in Fig. 8. Tests appeared to indicate that this cable would have a laying effect of 0.7 per cent and an aging effect of 0.6 per cent: this is similar to that which is experienced in normal armoured cable, both effects being a reduction in loss.

The jointing of this cable is conventional except that the strand is electrically welded, the copper being kept well clear of the weld area. Conductor continuity is obtained by a soldered copper sleeve. The repeater-section ends were tapered to 0.31 in. tail cable as for the Lightweight cable. The cable behaved, and could be handled, like a normal armoured cable. Transitions between Lightweight and shallow-water cable are

arranged to occur at a repeater when possible. If this is impracticable, e.g. because of depth changes, a joint housing is used which is similar in external appearance to a repeater, but consists only of a shell with an armour clamp at each end.

THE 1.5 IN. LIGHTWEIGHT REPAIR CABLE

The final splice of a repair operation requires the insertion of an extra length of cable equal to about twice the depth of water. Except possibly during a shallow-water repair, provision has to be made to neutralize this extra cable loss, and previous practice has been to insert a low-gain repair repeater. This method has several disadvantages, including inflexibility to deal economically with a range of depths from 400 to 4,000 fathoms. A new method has been adopted for CANTAT, in which a length of recovered cable is replaced by a cable having a lower attenuation coefficient. For example, the replacement of 8 n.m. of 0.99 in. Lightweight cable by 12 n.m. of 1.5 in. Lightweight cable would not affect the attenuation, but it would provide an "up and down" bight for a final splice in 2,000, and it could be used in 3,000 fathoms with a 22° angle between the two cables. The 1.5 in. repair cable which has been adopted is shown in Fig. 13. It was considered

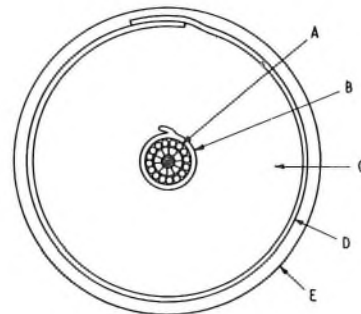

- A—Steel strand 0.300 in. diameter
- B—Copper tape 0.010 in. thick
- C—Polythene core 1.50 in. diameter
- D—Aluminium tape 0.018 in. thick
- E—Polythene sheath 0.120 in. thick

FIG. 13—REPAIR-CABLE CROSS-SECTION

preferable to retain the 0.99 in. core and build it up to 1.5 in. at the expense of introducing a slight mismatch loss and rolls owing to a change from 44 to 61-ohm impedances. The outer conductor has been simplified by employing a single overlapping tape: this results in a very good bending performance. The chromated tape has been abandoned, because the oversheath is now in continuous intimate contact with the conductor surface. The cable is being supplied in 6 and 12 n.m. lengths, all ends being tapered down in the factory to 0.99 in. cable, terminated with 0.31 in. tails, and armoured as for a normal repeater-section end. Lengths can, if desired, be jointed together on the cable ship at the 0.99 in. diameter points. The weight of this cable in air and water is 3.6 and 0.46 tons/n.m., respectively, and the modulus is about 17 n.m. It is expected that this method of repair will be cheaper and quicker than the insertion of a low-gain repeater, and it will also leave the system unchanged electrically, as seen from the terminals.

MANUFACTURE OF CANTAT CABLES

The manufacture of Lightweight cable is very different from that of conventional cable, and so the factory had to be reorganized and re-equipped. CANTAT cable

production began in November 1959 and was completed in August 1961. The steel heart was supplied to the cable manufacturer in lengths of 4-14 n.m. In one operation the outer layer of steel wires was applied and the copper conductor folded round and box-seamed. To improve the adhesion, a smear of epoxy resin was inserted by applying the resin and hardener separately to the strand and copper tape just before the folding operation. The main requirements during the core extrusion were (a) to maintain a good vacuum on the conductor to prevent the possibility of gas bubbles forming on the conductor, (b) to obtain uniform diameter and concentricity, and (c) to obtain good adhesion to the conductor. The addition of the outer conductor, screen and tape followed conventional practice, the aluminium tapes being preformed before application. A longitudinal black tape of carbon paper inserted under the oversheath was clearly visible externally, and was useful in checking that the cable had not been twisted. Teething troubles, which largely disappeared as production proceeded, were met involving repairs to the centre conductor, low adhesion, jointing of the copper and aluminium tapes before application, and in the use of polythene from different sources.

FUTURE DEVELOPMENTS

It has been apparent for several years that the 0.99 in. cable used on CANTAT could be considerably improved both in cost and electrical efficiency, and work has been proceeding to this end. Crosstalk attenuation would also have to be considerably improved if greater bandwidths are envisaged. The chief modifications proposed consist of (a) replacing the box seam with a butt weld to give a perfectly cylindrical surface, (b) the use of a single longitudinal overlapping aluminium tape for the outer conductor, and (c) the elimination of the chromated tape. The last two modifications have already been adopted in the 1.5 in. repair cable. Expectations are being realized on sample lengths of this cable. There would also be advantages in using the same type of cable, suitably armoured or protected, for the shallow-water sections of the route, and this is being investigated. If a satisfactory method of entrenching the cable in the sea bottom in shallow water were to be found, this would also have a bearing on the cable design.

CONCLUSIONS

It has been amply demonstrated by results to date that the lengthy and exhaustive development work on the Lightweight cable has been fully justified. The more important advantages which this cable has been found to possess over the conventional cable can be summed up as follows:

(a) The torsion balance confers freedom on the cable ship to carry out any operation, with confidence that the cable cannot be damaged by kinks or twists. Its considerably greater modulus is advantageous in quasi-static cable operations.

(b) For the same electrical performance it is much cheaper.

(c) It can be manufactured and laid in the large sizes which system economics require, particularly with increasing bandwidths.

(d) As the strength of the cable is at its centre it cannot be adversely affected by the passage of time.

(e) It is much favoured on a cable ship because of its light weight, cleanliness, flexibility and the absence of

broken armour wires which can cause personal injury. It coils equally well in either direction, and, in the tanks, adjacent coils cannot stick together.

(f) It possesses a much higher order of electrical predictability and stability than any previous cable.

The only apparent disadvantages are:

(a) The application of stoppers is a slightly more lengthy and complicated procedure if the cable is not to be damaged.

(b) Although the cable is superior in withstanding mild abrasion, the polythene oversheath is more vulnerable to tearing and cutting. Improved plastics can minimize this effect.

A comparison of the main characteristics of the CANTAT cables described in the paper and the type of deep-sea armoured cable used on the previous transatlantic systems is given in the table.

CHARACTERISTICS OF CANTAT AND TAT-TYPE CABLES

	0.99 in. Lightweight cable	0.62 in. simulated Lightweight cable type A	1.5 in. Lightweight repair cable	0.62 in. armoured cable type D
Overall diameter (in.)	1.30	1.9	1.82	1.27
Weight in air (tons/n.m.)	2.2	9.1	3.18	3.1
Weight in water (tons/n.m.)	0.6	5.7	0.54	1.8
Tensile strength (tons)	7.7	22.0	8.0	12.0
Modulus (n.m.)	12.8	4.0	14.8	6.7
Attenuation at 608 kc/s (dB/n.m.) (60°F, zero fathoms)	2.11	3.12	1.38	3.18
Impedance (ohms)	44	44	61	55

It is concluded that the laying of Lightweight cable on CANTAT marks the obsolescence of deep-sea armoured cable for submarine cable systems.

ACKNOWLEDGEMENTS

The authors wish to thank Submarine Cables, Ltd., for their very helpful and active co-operation in the development of the Lightweight cable and in their successful manufacture of it for CANTAT. The work of British Ropes, Ltd., in developing the steel heart, and their assistance in jointing the steel strand, is also greatly appreciated. Success would not have been possible without the assistance and advice of many colleagues in the Post Office Engineering Department.

References

¹LAWTON, C. S., and HUTCHINS, L. H. A Non-Armoured Submarine Telegraph Cable. *Transactions of the American I.E.E.*, Vol. 72, Part 1, p. 153, May 1953.

²BRIGHT, C. Submarine Telegraphs (Crosby, Lockwood & Sons, 1898).

³BESLEY, J. C., and HIGGITT, H. V. The Recovery of Deep-Sea Cable. *Journal I.E.E.*, Vol. 72, p. 160, 1933.

⁴GILBERT, J. J. The New Key West-Havana Telephone Cable. *Bell Laboratories Record*, No. 29, p. 149, 1951.

⁵BROCKBANK, R. A. Improvements in or relating to Submarine Cables. British Patent No. 703,782 (1 Aug. 1952).

⁶BROCKBANK, R. A., and MEYERS, A. L. A New Deep-Sea Coaxial Cable. *Journal I.E.E.*, Vol. 2, p. 572, 1956. (Reproduced in the *P.O.E.E.J.*, Vol. 50, p. 7, Apr. 1957.)

⁷BROCKBANK, R. A. Deep-Sea Trials with Light-Weight Cable. *P.O.E.E.J.*, Vol. 50, p. 9, Apr. 1957.

Anglo-Canadian Transatlantic Telephone Cable (CANTAT): Cable-Laying Gear*

E. F. S. CLARKE, B.Sc.(Eng.), A.M.I.E.E., and K. J. CHAPMAN, B.Sc., A.M.I.E.E.†

U.D.C. 621.395.45:621.315.284

The paper describes the stern cable-laying gear and associated equipment developed for cable and repeater stowage, handling and laying on H.M.T.S. *Monarch*. The techniques and equipment described were used throughout the laying of the CANTAT cable and operated very satisfactorily under widely differing operational conditions.

INTRODUCTION

CANTAT is the third transatlantic telephone system in which H.M.T.S. *Monarch* has played a major part. It is, however, the first system in which Lightweight cable has been used, and the first in which rigid repeaters have been laid in deep water. Both facts have had a considerable bearing on the equipment and technique employed for laying. With the exception of three repeaters and one equalizer, which were laid over the bows in shallow water, all sea repeaters, equalizers and joint housings, i.e. 92 in all, were laid over the stern using the Post Office multiple V-sheave cable engine.¹ Although this machine was first used in its basic form in 1958 (for Lightweight cable trials) and has since laid several other systems (TAT-2, Newfoundland-Nova Scotia in 1959, Anglo-Swedish in 1960, CANTAT B, Newfoundland-Canada, SCOTICE, Iceland-Faroes, New York-Bermuda, in 1961, Sydney-Auckland and Fiji-Auckland in 1962), no description of it has yet been published.

The development of a new cable engine was only one of several steps necessary to make the laying of cable systems containing large numbers of rigid repeaters a practical proposition. Of paramount importance was the need to devise methods of stowing cable and repeaters in the restricted space of *Monarch's* centre castle, originally designed for the laying of unrepeatered telegraph cables, so that bights would straighten without risk of damage and repeaters move off without manhandling.

Although developed specifically for *Monarch*, the equipment and methods devised have since been adopted on several new cable ships, both British and Continental.

STERN LAYING GEAR: HISTORY AND DEVELOPMENT

The Post Office deep-sea submerged repeater is designed for laying over the stern in line with the cable. Concurrently with the development of the repeater, attention was given to the design of a simple and easily operated cable engine which would accept either cable or repeater, thus making possible the laying of repeaters without slowing the ship to such a speed and for such a time that navigation would be seriously affected, or the risk of damaging the cable by kinking would be incurred.

Many interesting and ingenious ideas were put forward. Perhaps the most obvious was the caterpillar type of engine in which the path of the cable and repeater was always a straight line. The cable was led between gripper blocks attached to two endless roller chains, the necessary gripping force being applied to the blocks via rollers. As originally conceived, two such machines were to be used for laying repeaters, the gripper blocks

of each being parted in turn to allow a repeater to pass. Another design employed two pairs of V-sheaves, each pair being capable of rotation about a common axis situated between them. Under normal laying conditions, the path of the cable round a pair of sheaves was in the form of a letter S. At the approach of a repeater the first pair of sheaves was rotated about their common axis, so that the cable was unwound, permitting the repeater to pass between them in a straight line. The first pair of sheaves was rotated back again and the second pair opened to allow the repeater to pass. A third type of machine used a pair of cylindrical drums also capable of rotating about a common axis.

The development of the new type of repeater outstripped the development of a satisfactory method of laying it. The first two systems in which the new type of repeater was used, the Aberdeen-Bergen cable in 1954, and the Terreaceville-Sydney Mines section of the TAT-1 cable in 1956, had to be laid over the bows with conventional cable gear using the turns-off-the-drum method.

This method involves attaching a rope to the cable ahead of the repeater; transferring the outboard cable tension via this rope to another cable engine; manually removing the turns of cable from the drum of the first engine; paying out rope on the second engine and simultaneously manhandling the repeater up to the bow sheaves; replacing cable turns on the drum of the first engine; lifting the repeater over the sheaves; transferring tension to the repeater and cutting the rope. The whole operation resulted in the ship being held without forward movement for some 20-30 minutes, thus presenting conditions ideal for the formation of kinks. In the case of TAT-1, when 14 repeaters and one equalizer were laid at intervals of about four hours, this laying method also resulted in a considerable degree of crew exhaustion. It was clear that the method was not suited to the laying of a system comprising a large number of repeaters.

The autumn of 1956 had seen the successful trial laying of a short length of experimental 0.8 in. diameter Lightweight cable, and the less successful trial of a caterpillar type of cable engine. During the same year it was decided to concentrate on the specific task of devising suitable modifications to the existing cable gear on *Monarch* to enable rigid repeaters in Lightweight cable to be laid experimentally over the stern, these modifications to be carried out in time for trials in early 1958. The gear would be required to handle a maximum tension of 4 tons, or 3.5 tons at the time of laying a repeater, and the existing stern sheave was to be used. It was envisaged then that heavy armoured cable would be laid over the bows.

A review of all the existing and some new ideas was carried out. Amongst the new ideas was the redesign of the repeater in an articulated form which would enable it to pass round a conventional drum; another

*Reproduced by permission of The Institution of Electrical Engineers.

†Post Office Research Station.

was the redesign of the cable which would enable the tension-carrying and transmission components of the cable to be separated. Several ideas were carried out in model form in the laboratory. During the review it became apparent that the complexity of all the machines proposed was a direct result of attempting to make cable and repeater take the same path. Since the machine would be laying cable for well over 99 per cent of the time it seemed unfortunate that it should be necessary to depart radically from the simplest design which would lay cable efficiently. Clearly a machine with one or more drums or sheaves with fixed axes was the simplest. The question was whether it was possible to devise a method of using it, similar to the turns-off-the-drum method, but in which tension was transferred automatically from the cable to a rope and back again whilst the repeater moved past it on a trolley. This was obviously not possible in the case of a drum with complete turns on it, but it might be possible if the cable engine comprised a number of coupled sheaves round each of which the cable took less than a complete turn. With this approach, which was believed to be novel, a simpler solution became apparent. Fig. 1 shows the general arrangement of a machine of this type, which it appeared, could be accommodated on *Monarch* without major structural changes.

E is a sheave of 6 ft diameter and with a 45° V-groove which replaces the conventional drum on the after paying-out gear on the cable ship. C and D are two similar sheaves directly coupled to E by means of a roller chain and large-diameter sprockets. A is a sheave with a flat rim against which the cable is pressed by the two jockey rollers J_1 and J_2 on the arm K, which is pivoted on the end of lever L, loaded by the weight M. B is a V-sheave similar to C, D and E. In the final model, A and B were each fitted with an independent brake and torque indicator calibrated in terms of the increase in tension in the cable round the sheave. A is termed the first back-tension sheave and B the second back-tension sheave. N is the splaying stool at which the rope replaces the cable in the gear, and vice versa, and O is a gate which is opened to allow this operation to take place. F is the dynamometer sheave, and G_1 , G_2 and H are the small pulleys of the shortening gear, the function of which will be described later. P is the diverter ball.

The repeater is mounted on a light trolley and is

bridged by a flexible steel rope, spliced to the cable about 4 fathoms ahead of and behind the repeater. Shortly after the leading splice has entered the splaying stool, the cable is guided to one side of the diverter ball, and the rope takes its place in the grooves of the sheaves. The repeater trolley is also guided to one side by a wooden trough, and moves parallel to the normal cable line, towed by the cable ahead of it. As the rope enters the sheaves, tension is transferred smoothly and automatically to it from the cable, and, simultaneously, the increasing difference between the path length of rope and cable creates slack cable behind the repeater, allowing the trailing splice to re-enter sheaves A and B without difficulty. As the rope emerges from the sheaves, the tension is progressively transferred back to the cable and the slack behind the repeater disappears. Provided the rope, termed the by-pass rope, is made shorter than the length of the cable and repeater it by-passes, no further equipment is necessary. The shorter rope would, however, entail the repeater being suspended in a bight of cable: this would tend to prevent free rotation of cable and repeater on its way to the sea bottom. This was considered undesirable, especially if the gear should be required to lay conventional armoured cable. The rope is therefore made about a foot longer than cable and repeater, so that it is quite slack when the latter is laid. This slackness introduces a difficulty. It is important that the cable shall not be allowed to re-enter sheave F when the repeater is under laying tension, to avoid risk of damage to the cable by the rim of the sheave. Arrangements are therefore made to shorten, temporarily, the effective length of the by-pass rope by means of the shortening gear previously referred to. Pulley H is made to slide vertically between G_1 and G_2 under hydraulic control, is brought down on the rope—a process that effectively shortens its length by roughly twice the length of its travel—and is lifted as soon as the cable is wholly in the last sheave.

The first stage in development consisted of making a 1 in. to 1 ft scale model of the after deck of *Monarch*. To this was fitted a scale model of the gear shown in Fig. 1. The model included a ramp to the stern sheave, which was fitted with enlarged conical "whiskers" to

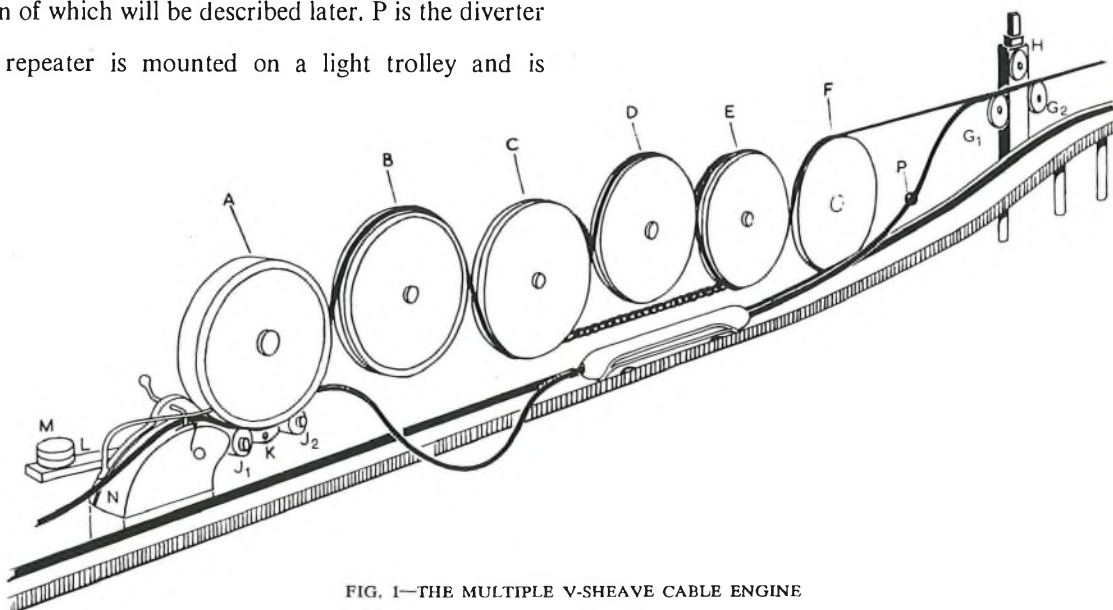

FIG. 1—THE MULTIPLE V-SHEAVE CABLE ENGINE

allow for the ship being slightly out of line with the cable when launching a repeater. The shortening gear was electrically driven and arranged to be operated by the repeater trolley so that the laying operation was fully automatic. The ship's cable engine was simulated by a simple friction brake, the tension in the "cable" (stranded steel wire) being derived from a motor driving a drum via a clutch. The model provided a great deal of valuable information on the optimum disposition of the various components, such as length of rope and methods of attachment, speed of operation, and behaviour of the repeater under various conditions of laying.

The next step was to make up a full-scale model with three 6 ft wooden V-sheaves and a single flat-rim back-tension sheave. This was used to lay a full-size repeater housing spliced into Lightweight cable so many times that the cable started to show signs of wear. This model also provided valuable information, assisted in preparing a final design for the splaying stool and in drawing up a crew drill, and gave confidence in the practicability of the scheme.

In November 1956, a contractor was approached with a view to the manufacture to a general specification. Within 14 months the equipment was engineered, drawn, manufactured, factory-tested and installed, during a refit, in *Monarch*.

As engineered and installed the machine follows the models closely, the only important difference being that the shortening gear is hydraulically operated. Since the installation was regarded as experimental, no attempt was made to make the laying operation wholly automatic, the control of the shortening gear being manual. The roller chain drive for the three main sheaves is retained, this being the simplest and cheapest method of coupling to the existing cable engine. The maximum laying tension had been specified at 4 tons, this being regarded as allowing an ample margin of safety when laying Lightweight cable in any depth likely to be encountered. The angle of lap round each sheave is approximately 130° , giving a total for the three coupled sheaves of 390° or 6.8 rad. The use of the V-grooved sheave instead of a plain drum improves the effective coefficient of friction by a factor of about 2.6, so that the coupled sheaves alone are the equivalent of nearly three turns on a plain drum.

The maximum tension which can be applied, without slip, to a rope or cable held by a V-sheave is given by the well-known equation

$$T_1/T_2 = e^{\mu\theta\csc\alpha/2}$$

where T_1 = maximum applied tension,
 T_2 = back tension,
 μ = effective coefficient of limiting friction,
between cable and sheave,
 α = included angle of the V-groove = 45° ,
 θ = angle of lap of the cable on the sheave,
rad.

It will be seen that the maximum tension which can be held is directly proportional to the back tension, and is highly dependent upon effective friction. Unfortunately, the coefficient of limiting friction between the polythene oversheath of Lightweight cable and the sheave is not constant, but varies with radial pressure and, therefore, applied tension. The holding power of the sheaves and the back tension required were thus determined by direct experiment. With a total back

tension of 750 lb, the cable can be held without slipping at a tension of at least 6.5 tons. This is approaching the breaking load of the cable (7-8 tons), and is more than four times the maximum laying tension expected for CANTAT. Higher tensions can be held on conventional cables and ropes.

The shortening gear is designed for a maximum load on the ram of 7 tons with an oil pressure of 1,000 lb/in², corresponding to a cable tension just before laying a repeater of 3.5 tons. Oil is applied to the ram via a pilot valve which is itself hydraulically operated by a remote-lever-operated valve. In the original design, hydraulic pressure was obtained from a continuously-operating motor-driven rotary pump. This was used successfully in the laying of TAT-2 and the Anglo-Swedish systems, but suffered from the disadvantage that the capacity of the pump unit was the factor which ultimately decided the maximum speed at which a repeater could be laid. When redesigning the gear for equipping H.M.T.S. *Alert* in 1960 this problem was overcome by the use of a high-pressure gas-accumulator system in which the oil pressure is much less dependent upon the rate of movement of the ram. The shortening gear on *Monarch* was modified to work on the same principle in time for CANTAT. Before modification the speed of laying a repeater was limited to a little over 1 knot. With the accumulator, it would be possible to lay at over 3 knots should conditions make it practicable and desirable.

The new cable engine, now christened the five-sheave gear, was first used during the Lightweight cable trial in February 1958, during which 110 miles of the new 0.99 in. cable, 4 live repeaters, and 5 dummies were laid, mostly in a depth of 2,700 fathoms. Fears had been expressed that the reverse bends described by the cable in its passage through the gear might adversely affect its transmission characteristics. In fact, the first repeater-section length was laid over the stern and recovered over the bows using the conventional drum and fleeting knife, and after recovery showed negligible change in attenuation. During this trial, the gear was equipped with solid cast steel sheaves. The resilient or shear-limiting sheaves (to be referred to later) had not been developed at this stage.

Although the gear had been designed specifically for laying Lightweight cable, its performance during the trials was considered to merit its use to lay the rigid repeater section of TAT-2 in 1959 and the Anglo-Swedish cable in 1960. These two schemes involved the laying of heavy armoured cable and a total of 45 repeaters and equalizers. During the laying of the Anglo-Swedish cable a peak tension of over 10 tons was recorded in heavy weather with no sign of the cable slipping on the sheaves. The experience gained on these projects was invaluable in establishing confidence in the machine, indicating where improvements could be made, and developing a repeater laying routine.

SHEAR-LIMITING SHEAVES

When an extensible cable is held by gripper blocks attached to a far less extensible member, such as the chain of a caterpillar cable engine, and is then subjected to increasing tension, the cable will slip at each of the blocks in turn, until the sum of the forces due to the limiting friction at each block is equal to the applied tension. If the cable is of Lightweight type in which the extensible strength member is in the centre, and

assuming (a) similar coefficients of limiting friction between the cable and the blocks and between the various components of the cable itself, and (b) the absence of any bond or adhesion between them, slip will occur at the interface having the smallest diameter, i.e. between the strength member and the centre conductor. Similar conditions apply, but in a lesser degree, to a cable held in a V-sheave. In practice, so-called adhesion forces are automatically built into the cable during manufacture, and minimum figures for these were laid down in the Post Office specification for the cable used in the 1958 trials. The results of these trials showed that, if any internal slip had occurred, it was insufficient to produce any significant change in transmission. It was found when entering upon large-scale production of the cable that it was very difficult to ensure that the required adhesion figures would always be met, and as a precautionary measure, steps were taken to develop a design of resilient or shear-limiting sheave² to replace the three coupled sheaves of the five-sheave gear.

Part of one of these sheaves is shown in Fig. 2. The periphery of the sheave containing the V-groove is divided into 24 segments, each of which is linked to the boss of the sheave by two pairs of radial flat steel springs. They are designed to carry the full radial load imparted by the cable, and provide a frictionless mounting for the V-segments. The use of two sets of springs ensures that, when deflected, the segments move in a line which approximates closely to the arc of the cable on the sheave. These springs are preformed so that when strained so as to be straight, as they are when assembled in a sheave, the segments press against a backstop with a predetermined pressure. The backstop takes the form of a square rubber-covered block mounted eccentrically on a stud attached to the side plates of the sheave, and can be set in either of four positions to give alternative preload pressures. The

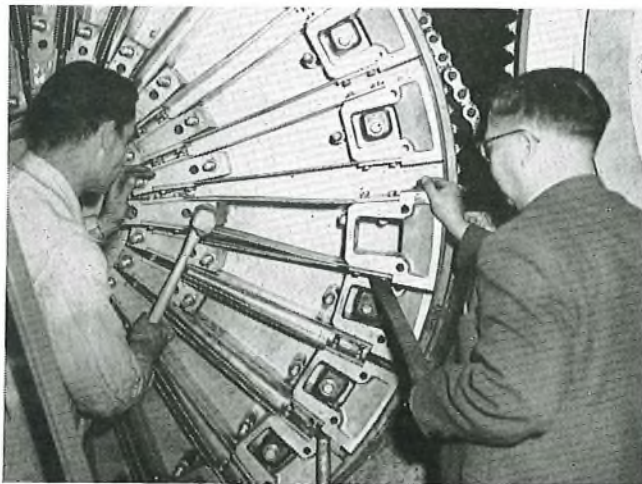

FIG. 2—ASSEMBLING ONE OF THE SHEAR-LIMITING SHEAVES OF THE CABLE ENGINE

springs for each of the three sheaves are preformed to different contours, giving preload pressures chosen so as to be related to the radial pressure produced by cable tension on the low-tension side of each sheave.

In operation, as soon as the load due to cable tension on any one segment reaches the preload figure, the segment tends to leave the backstop and thus increase the load on the next segment, the overall effect being to make the rate of decay of tension in the cable around the periphery of each sheave nearly linear. The amount of travel of each segment is just over 0.8 in., and when this limit is reached the sheave ceases to be resilient. Curve A₁ of Fig. 3 shows how tension would decay

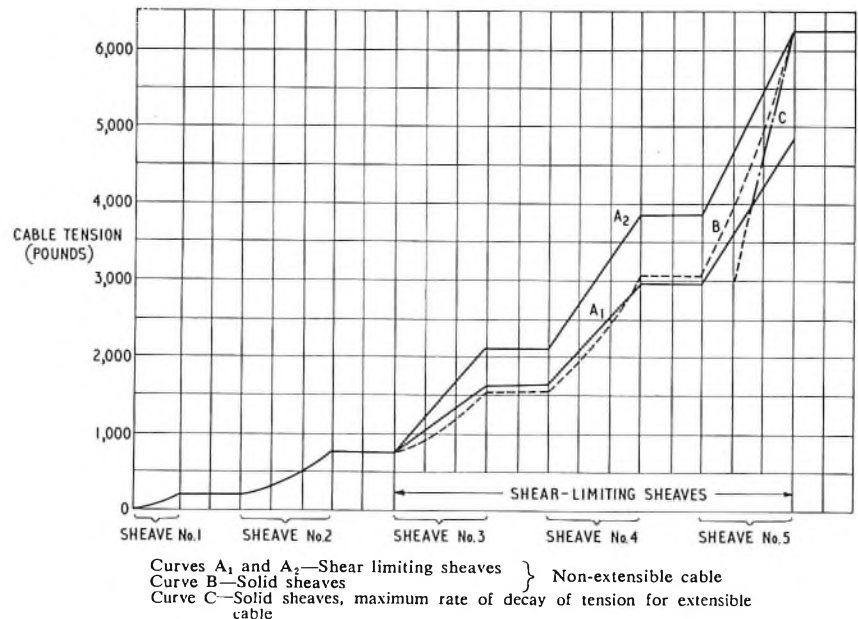

FIG. 3—DECAY OF CABLE TENSION ON MULTIPLE V-SHEAVE CABLE ENGINE

through the gear with the nominal settings used for CANTAT, all segments being on the point of starting to move, and curve A₂ gives the picture when all segments reach the end of their travel—conditions which, strictly, could only arise with a static load and a hypothetical non-extensible, non-deforming cable. Curve B shows the exponential form of decay which would be expected with solid sheaves for the same tension as for curve A₂ assuming a uniform coefficient of friction. Curve C shows the rate of decay of tension at which slip would occur between the polythene oversheath of Lightweight cable and the sheave at the high-tension end, assuming a coefficient of limiting friction of only 0.15 at this point. It is a measure of the shear forces which the inter-layers of an extensible cable would need to withstand in order to avoid internal slip. Comparison with curve A₂ gives some indication of the improvement offered by shear-limiting sheaves.

In practice, owing to the extension of the cable and its bedding down into the V-groove, the last segment of the last sheave will always reach the end of its travel a little earlier than those before it, so that actual dynamic operating conditions lie between curves A₁ and A₂; the maximum outboard tension for shear-limiting action being about 50 cwt.

Apart from the property of reducing the tendency towards internal slip in Lightweight cable, shear-limiting

sheaves also reduce the risk of straining or even breaking the cable or rope in which there is a sudden decrease in diameter. Since the three coupled sheaves must each have the same angular velocity, the linear velocity of the neutral axis of a thick cable moving with them will be greater than that of a thin one. As a transition between two such cables passes through the gear, the thin one tends to lag behind and may increase the tension at the junction to many times that of the outboard tension. It is for this reason that the leading half of the by-pass rope is always served up to cable diameter. During an experimental laying operation with solid sheaves when this precaution was not observed, the by-pass rope coupling (designed to withstand a tension of 10 tons) fractured, although the outboard tension was less than a ton.

When a transition in the opposite sense (thin to thick) passes through the gear, the tendency is for the trailing cable to loosen on the sheaves and allow the leading cable to slip. This state of affairs exists to some extent with uniform-diameter cable, since at the high tension end of the gear the cable will sink a little deeper into the V-groove than on the earlier sheaves. Shear-limiting sheaves tend to eliminate this effect.

Before embarking on the manufacture of the new sheaves for *Monarch*, extensive static and dynamic life tests were carried out in the laboratory. Prototype segments and spring sets were subjected to tests simulating steady tensions of up to 10 tons and the laying of over 10,000 miles of cable at a tension of 3 tons. After manufacture and installation, the gear was given a short sea trial in February 1961 during which cable was paid out at tensions of up to 6.5 tons.

Fig. 4 shows the gear fitted with the new sheaves used for laying CANTAT.

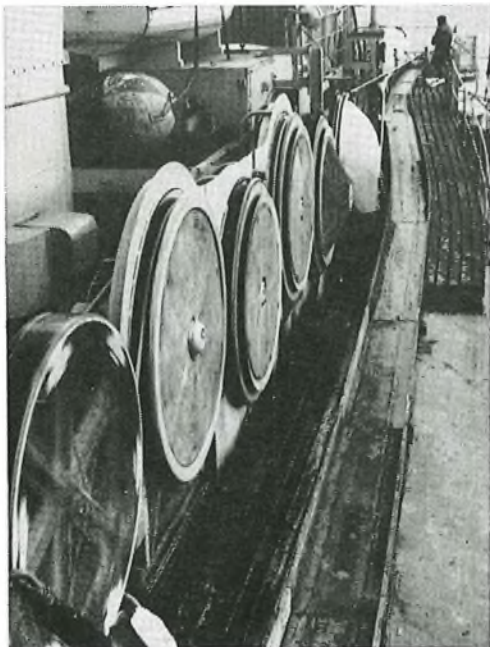

FIG. 4—5-SHEAVE CABLE ENGINE ON *MONARCH* FITTED WITH SHEAR-LIMITING SHEAVES

OVERBOARDING ARRANGEMENTS

The V-section stern sheave on *Monarch* was 10 in. wide, i.e. slightly less than that of a repeater, and in

order to use it, the design of new conical whiskers having a greater included angle than that of the sheave was necessary. These allowed the repeater to roll over the sheave without rubbing, but suffered from the disadvantage of allowing cable to climb up the sides when there was a strong port or starboard lead. Horizontal control bars were fitted to prevent the cable reaching a dangerously high level.

THE STONKER

This somewhat arresting title, of uncertain origin, has been given to devices designed to regain control of runaway cable. Under normal laying conditions the splaying stool and gate provide a positive guide for the cable entering the gear. When laying a repeater it is possible, in the event of serious mishandling of cable or the breakage of the by-pass rope, for a runaway to occur. Unless quickly arrested, the cable would attain a high speed endangering the safety of the men in the cable tank. It was considered prudent to develop some such device to prevent this mishap. Various ideas were examined and tried, but none were found which were simple, small and light, and which would stop the cable quickly without damaging it. The device adopted is based on the well-tried chain stopper. A framework of four horizontal tubes was fitted above the repeater trough just forward of the stern sheave, permitting the cable to be surrounded by three half hitches of chain. The forward end of the chain is shackled permanently to a strong eye-bolt and the after end attached to a 200 lb sinker suspended by lashings over the stern. In the event of a runaway, the sinker is cut loose and drags the chain off the frame so that it grips the cable. The degree of damage caused to shallow-water armoured cable may not be serious, but if used on Lightweight cable a repair operation would be necessary. It is fortunate that, in the course of the laying of nearly 300 rigid repeaters by *Monarch*, the "stonker" has never had to be used.

BY-PASS ROPES

The by-pass ropes are very flexible, being made of many strands of high-tensile steel wire with opposing lays giving a neutral, or non-twisting, characteristic under tension. They have a breaking load of over 20 tons and are served with mill waste up to cable diameter at the leading end. They are terminated in ball-and-socket type connectors swaged to the steel wire, and are coupled, on the ship, to woven wire stockings or cable grips, previously assembled in the cable factory on the repeater tails. The low-tension end of each stocking is brazed to a cylindrical swivel, the inner member of which is attached to the repeater tail by means of a four-tail stopper. This ensures accurate longitudinal positioning of the stocking but allows it to be rotated, after compression, on the ship so that the by-pass rope can be arranged to lie wholly on the correct side of the cable before the repeater moves out of the centre castle.

PARACHUTES

The sinking velocity of Lightweight cable, in a direction perpendicular to its axis, is about 0.8 knot, whereas that of a repeater may be very much higher. If no preventive action is taken the repeater will reach the sea bottom well in advance of cable laid ahead of it, creating an undesirable loop of slack cable. On a rocky bottom it may also receive an undesirable mechanical

shock. Parachutes were fitted to each repeater in Lightweight cable to equalize the sinking velocities. A viscose rayon canopy, 28 ft in diameter, was used, and has been proved in trials to give the correct rate of descent. It was assembled in a special pack, some 8 ft long, designed to lie on top of a repeater housing, together with a device which uncoupled the parachute after use. This was provided in order to reduce recovery tensions in the event of a repair operation. The device was primed by hydrostatic pressure, disconnexion occurring on release of load when the repeater reached the ocean bottom.



FIG. 5—LAUNCHING A REPEATER WITH PARACHUTE

The parachute was attached to the repeater by means of two wire slings shackled to two rotatable rings, one at

each end of the repeater. The pack was lightly taped to the repeater before it was placed in the trolley prior to laying. Deployment was effected by clipping a nylon line to the pack just before overboarding and pulling it off after the repeater has entered the water. These operations are shown in Fig. 5 of this paper and in Fig. 4 on page 101.

CABLE AND REPEATER STOWAGE AND BIGHT HANDLING

The problem of devising a pattern for the stowage of cable and repeaters, with their associated bights, so that laying operations can proceed smoothly without stopping payout or risking the formation of kinks has been given much attention by the Post Office and the Bell Telephone Laboratories in America, the latter in connexion with the design of a new cable ship. Between 1957 and 1959 a mutual and beneficial exchange of ideas and visits took place. It was found that both parties had been covering similar ground in their investigations, including alternative means of stowing repeaters in cable tanks and on deck, and alternative designs of slotted crinolines. The name "crinoline" is given to a closed ring of steel tube suspended two or three feet above the top flange of cable in a ship's cable tank to ensure that the cable moves radially inwards before lifting during payout, thus reducing the danger of sticking turns. A second, smaller, ring suspended higher in the tank is often used to control the bellying out of cable when paying out inside (small-diameter) turns at high speed. Early cable ships including the *Great Eastern* had more than two such rings, and the resemblance of the complete structure to a then familiar article of feminine apparel led inevitably to its name. The passage of a cable bight either to another cable tank or to a repeater involves the provision of a slot or gate in the ring, and for the Lightweight cable trials in 1958 a form

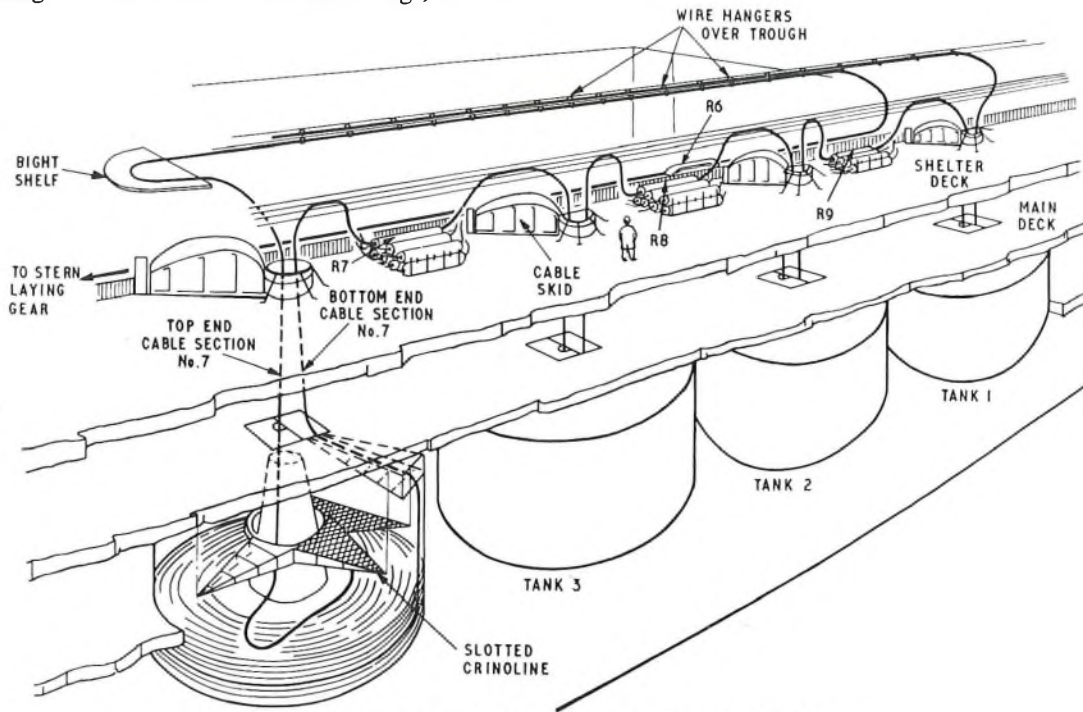

FIG. 6—SKETCH OF CABLE TANKS AND CENTRE CASTLE OF MONARCH, SHOWING CABLE AND REPEATER STOWAGE ARRANGEMENTS

of rotary gate which maintained the continuity of the ring was developed and used successfully. The Bell Laboratories were more advanced with the design of an open slotted crinoline, and this was subsequently adopted, with only slight modifications, for the *Monarch*. It became clear, however, that a scheme involving deck stowage of repeaters, which promised to be very satisfactory for a new ship, had serious disadvantages if applied to an existing ship such as the *Monarch* where space in the centre castle is limited.

Looking ahead, beyond CANTAT, to systems with a wider frequency band and more repeaters, it was decided that the best stowage scheme for *Monarch* was on a tank-to-tank basis, i.e. one in which cable sections before and after a repeater are stowed in different tanks, and in which the necessary long bights following every third repeater are cleared in a vertical plane in the line of payout when passing down the centre castle. This allows more repeaters to be stowed across the available width of the ship. It also has other advantages, the most important from the point of view of laying procedure being that the top end of the repeater section following a repeater can be prepared in advance, the length of cable out of the tank being adjusted, if desirable, and being in a ready-to-run position in the tank when the

repeater moves off. Another advantage of the tank-to-tank system, when laying imperfectly screened cable,³ is that it makes possible the production of a stowage pattern which overcomes difficulties due to crosstalk between cable repeater sections. This was very valuable in the Lightweight cable section of CANTAT, and will be referred to later.

A simplified diagram of the scheme is shown in Fig. 6. Repeaters are clamped in stacks between tank hatches, and arranged so that each repeater is forward of the cable section which precedes it. There are three stacks only, since there is insufficient room to provide a repeater stack forward of tank 1. In the figure, repeater R6, previously mounted in a stack between tanks 1 and 2, is shown moving off aft, pulling cable out of its stowed position on the deckhead. It is held in position between numerous wire hangers designed to facilitate rapid stowage, the actual support being provided by rubber bands for Lightweight and thin twine for armoured cable. These supports break away readily during the peeling-out process. Aft of tank 4 the cable lies in an arc on a horizontal sector-shaped shelf, from which it falls on to the cable skid when straightened by light tension. The top end of section 7 has been released from its stowed position on the tank ceiling and passed through the slot

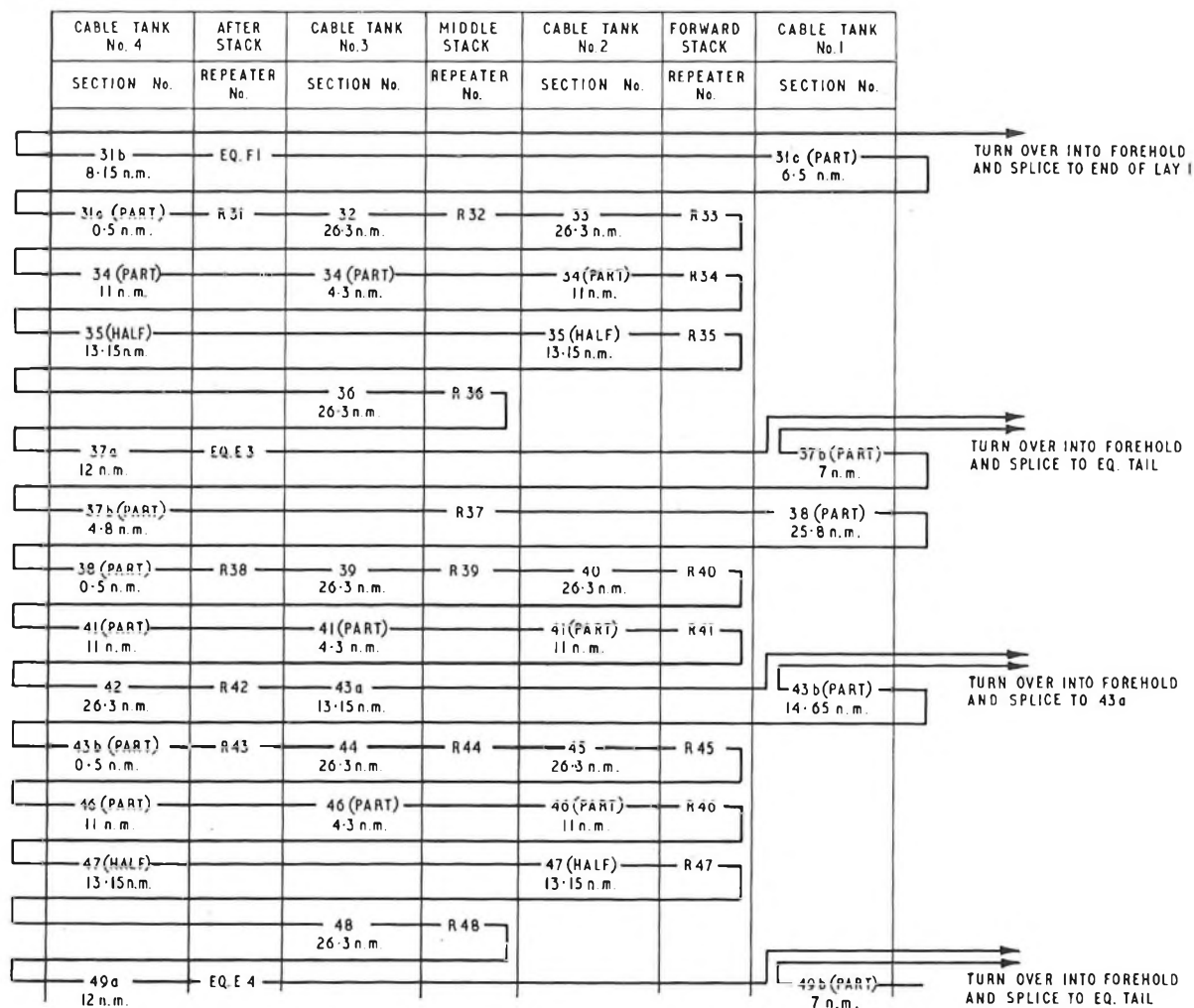

FIG. 7—PART OF STOWAGE PLAN ON *MONARCH* FOR CANTAT SECOND LAY

in the bellmouth and crinoline in a ready-to-run position.

The bottom end of section 7 is shown in its stowed position, secured to a grid fixed to the tank ceiling, and to stout mesh panels on the centre castle deckhead. When preparing repeater R7 for launching, the cable at each end is released from the deckhead, the repeater lifted from the stack by a powered hoist, traversed to the trough, and lowered on to the trolley. The trolley is then hauled forward to straighten the bight from tank 4, and the cable forming the top end of section 8 is placed in a ready-to-run position. The same basic drill is carried out for each repeater, with minor variations at ocean block ends (every six repeaters) where an equalizer or a cable-length adjustment is involved. In order to develop the scheme, a one-twelfth size scale model of *Monarch's* centre castle and shelter deck, between the forward cable engines and the after end of the port alleyway, together with cable tanks, crinolines, etc., was built in the laboratory. Fig. 7 is part of the stowage plan adopted for the second lay of CANTAT, and shows the general pattern adopted on all lays to reduce the effect of crosstalk between sections, and to provide for adjustment of cable lengths at ocean block ends during laying. By dividing up certain repeater sections between tanks it was possible to arrange that, at an early stage in the laying of each ocean block, the maximum level difference between adjacent flakes of cable did not greatly exceed half the repeater gain. This reduced crosstalk rolls sufficiently to ensure ample accuracy of the transmission measurements required during laying operations for equalizer network design. The plan also ensured that the cable sections detailed for length adjustment, always stowed in tank 1, were uncovered in ample time for turnover and jointing operations to take place, without slowing the ship.

POSITION-INDICATING EQUIPMENT

Laying a repeatered system requires continual co-operation between those responsible for navigation, cable laying, handling repeaters and cable bights, testing, equalization, and jointing. To facilitate this, position indicators were provided throughout *Monarch*. Controlled by the cable-laying engineer, these clearly showed the progress of the laying operation in terms of miles of cable after the last repeater laid.

At the stern laying gear a mileage indicator was set in motion three miles before laying each repeater, so

that an automatic count down was provided for this operation. A warning system was also provided to relay the progress of each repeater and by-pass rope assembly through the centre castle and entry to the laying gear.

LOADING AND TESTING

Cable loading was performed with a single loading line, the repeaters being loaded separately and jointed on the ship at a rate sufficient to keep pace with the cable. Adjacent repeater sections came aboard linked by a bridging rope which was never removed until the repeater was jointed in. Approximately twice in each repeater section portable resistance thermometers were positioned between flakes in the cable tank, the measuring leads being carefully placed so that the thermometers would be readily recovered during cable laying. These thermometers were thus in intimate contact with the cable mass and proved invaluable in assessing the temperature of the cable remaining in the tanks while testing during laying operations. The placing of terminations and bights followed a strict routine, the position of each being shown on a detailed plan and marked at key points on the cable tank hatch coamings and deckhead.

ACKNOWLEDGEMENTS

The authors wish to express their thanks to the personnel of H.M.T.S. *Monarch* for their patience and co-operation in proving the new equipment under widely differing operational conditions and to Messrs. Submarine Cables, Ltd., who were responsible for the engineering and manufacture of the laying gear. The assistance of many colleagues at the Post Office Research Station is also gratefully acknowledged.

References

¹CLARKE, E. F. S. Improvements in or relating to Apparatus for Laying Submarine Cables. British Patents No. 825,138 (30 Sept. 1957) and No. 826,974 (30 Sept. 1957).

²BROCKBANK, R. A., PIGGOTT, J., CLARKE, E. F. S., JURY, R. J., and TAYLOR, E. W. E. Improvements in or relating to Submarine-Cable Laying Apparatus. British Patent No. 916,541 (16 Aug. 1961).

³BROCKBANK, R. A., CLARKE, E. F. S., and JONES, F. Anglo-Canadian Transatlantic Cable (CANTAT): Cable Development, Design and Manufacture. *Proceedings I.E.E.*, Paper No. 4239E, July 1963 (Vol. 110, p. 1,124). (In this issue of the *P.O.E.E.J.*)

Book Review

"Progress in Dielectrics." Vol. 4. Edited by J. B. Birks, B.A., Ph.D., D.Sc., F.Inst.P., A.M.I.E.E., and J. Hart, Ph.D. Heywood & Co., Ltd. vii+312 pp. 97 ill. 63s.

How much prior knowledge of the subject should authors assume in a book of this type? Some, certainly, but there are differences of outlook in this volume. The articles on microwave spectra of gases, and on the theory of gas breakdown, will serve as general introductions to their subjects, but, nevertheless, appear to give the specialist a useful collection of references to recent work. The rest of the articles enter so quickly into detail that the uninitiated reader will probably get no general picture from them. In the article on breakdown in liquids this is excusable, since it is concerned only to bring up to date the good article on the same subject in Volume 1 of the series. Sub-

ject to this criticism, the articles on microwave absorption in gases and liquids, and on ferroelectricity, are informative and—so far as the reviewer can judge—complete.

The article on static electrification is a wasted opportunity of giving a broad picture of an interesting subject. Unsystematic grouping of subject-matter combines with carelessness in units and mistakes in simple formulae to undermine the reader's confidence and discourage attempts to penetrate the obscurity of the text.

The book gives an impression of painstaking thoroughness, and, in comparison with previous volumes, the lists of references have grown longer, but it contains less of immediate practical application than its predecessors. The series would be more widely useful if more of the articles illustrated applications of the theoretical concepts and if the standard of assumed prior knowledge were lowered a little.

A.C.L.

Anglo-Canadian Transatlantic Telephone Cable (CANTAT): Laying the North Atlantic Link*

Capt. O. R. BATES and R. A. BROCKBANK, O.B.E., Ph.D., B.Sc.(Eng.), M.I.E.E.†

U.D.C. 621.315.285: 621.395.45

CANTAT was the third telephone system to be laid across the Atlantic, but it was of a very different type from its predecessors and was unique in many ways. It was the first system to use the new Lightweight cable. A new equalization technique had to be introduced whereby system transmission misalignments encountered during the lay were corrected by suitable networks built and housed on the ship, without stopping the laying operation. Every effort was made to anticipate all possible eventualities, since the laying of any long ocean system is hazardous. The complete laying operation was spread over seven months, and although many incidents occurred none was abnormal, and no weaknesses were apparent in the equipment or the techniques.

INTRODUCTION

DURING the last 18 years the British Post Office has accumulated a fund of experience in the laying of rigid repeater housings in shallow water. The number of repeaters in a system has steadily increased with growing confidence in their reliability. The laying, testing and equalizing methods have had to be steadily improved to meet the more stringent requirements. For TAT-2 (16 repeaters) laid in 1959, the earlier practice of laying over the bows was changed to aft laying with a newly developed V-sheave gear, and a factory-made equalizer was inserted at the centre of the route. On the Anglo-Swedish system (30 repeaters) laid in 1960 the electrical testing arrangements on the ship were greatly improved, and, based on transmission measurements made as the lay progressed, a mid-route equalizer was designed, built and housed on the ship without stopping the operation.

Compared with all previous systems CANTAT presented a more formidable problem. Over 90 rigid repeaters and equalizers had to be laid with an entirely new type of cable¹ in depths of up to 2,300 fathoms, in the bad weather and sea conditions which prevail in the northern North Atlantic. Sea trials in sunny latitudes had proved, as far as was possible, the mechanical capabilities of the Lightweight cable and checked the electrical performance in respect of laying effect, aging, and temperature and pressure coefficients of attenuation. It was realized, however, that only a complete system lay could definitely confirm that all factors were under control.

All operations concerned with stowage and splicing-in of repeaters, and laying, testing and equalizing methods, were carefully worked out^{2,3} in advance and rehearsed with skilled staff. Forethought was also given to courses of action which should be pursued if the laying operations failed to proceed as expected. Therefore we started the lay confident that we could cope satisfactorily with all foreseeable contingencies.

THE ROUTE

The requirement was for London-Montreal circuits.⁴ There were certain factors to be considered in choosing

*Reproduced by permission of The Institution of Electrical Engineers.

†Capt. Bates is in the Submarine Branch, E.-in-C.'s Office, and Dr. Brockbank is at the Post Office Research Station.

the cable route across the Atlantic: the crossing should be as short as possible; the shallow-water ends should be situated in a location of minimum trawler activity; and crossings of other cables should also be obviated where practicable. Sea-bottom conditions did not vary greatly over the range of latitudes likely to be considered. The final choice was from Oban (Scotland), where the TAT-1 cables terminate, to Hampden at the head of White Bay (Newfoundland). The sea cable was then to be extended over four land repeater sections to Corner Brook, which would be the western terminal of the system. Another shallow-water system would link Corner Brook to Grosses Roches on the mainland. Over the main crossing the cable would run some 15-50 miles north of the TAT-1 No. 1 cable, and no cable crossings would be involved over the whole route.

The only disadvantage which had to be accepted was the unpleasant weather likely to be encountered so far north. About 350 miles west of Oban the Rockall Bank had to be crossed in relatively shallow water, requiring about 45 miles of armoured cable. The worst sea-bottom conditions would be met over the mid-Atlantic ridge, which is very bumpy with frequent large changes in depth. The route was carefully surveyed by H.M.T.S. *Iris* in June 1958, and is shown in Fig. 1.

The lay was to be from Oban towards Hampden, which was the direction of transmission of the higher-frequency band. From considerations of cable weight imposed chiefly by the heavily armoured cable required in the shallow waters off Newfoundland and Oban, it was evident that the system would have to be laid in three separate operations. The laying was planned to take place in the summer months when White Bay would be free of ice and storms would be less frequent.

LAYING METHOD

Loading

Each laying operation commenced with the loading of the cable into the four tanks of H.M.T.S. *Monarch* in accordance with a carefully prearranged schedule.² This schedule was governed by the need to reduce crosstalk between repeater sections so that satisfactory electrical measurements could be made in the ship. A tank change was necessary at every repeater, and sometimes a repeater section would have to be distributed over three tanks. Only a single-cable line loading could be employed under these conditions. It was also desirable to minimize the number of changes from a forward to an aft tank, as this tended to be a more complicated operation. In order to prevent a knot being formed in the complicated bight assembly, repeater-section ends were joined by a rope which was not removed until the repeater was jointed in. Nominal repeater-section lengths were 26.3 n.m. and 18.0 n.m. for Lightweight and shallow-water simulator cables, respectively.

Each repeater was given a full electrical test after it came aboard. The repeaters were connected into the cable by jointing the 0.31 in. tail cables on the repeater-

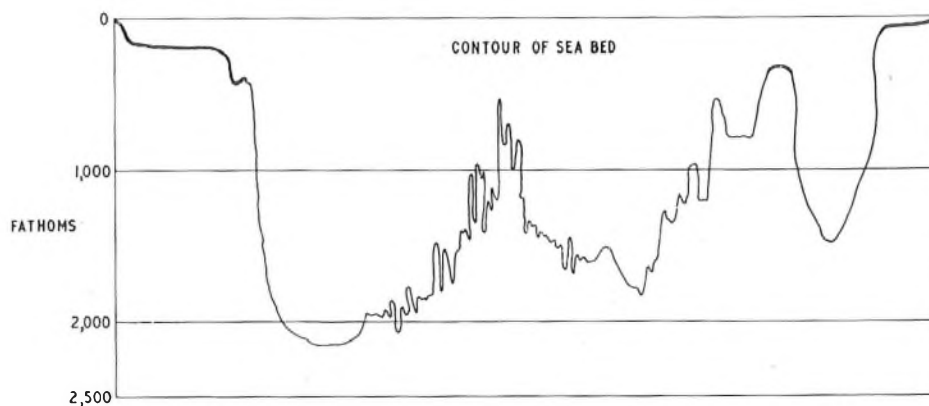
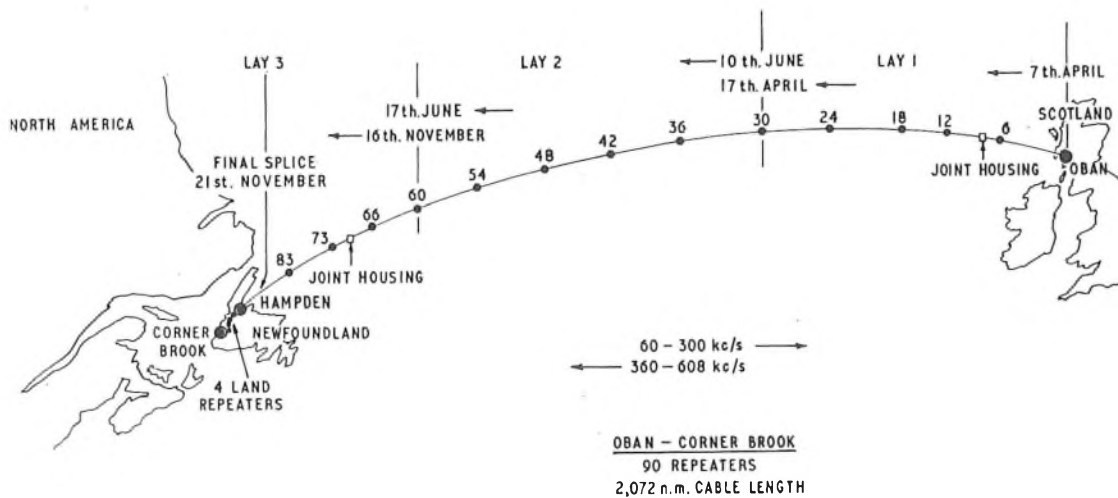

FIG. 1—NORTH ATLANTIC LAYING OPERATIONS

section ends to similar tails on the repeater. The final assembly of the repeater ends included clamping the armour wires and fitting the rubber cones and zinc anodes¹—for Lightweight cable. Three repeaters were completed in a day, and this just maintained pace with continuous cable loading.

The repeaters were jointed into the cable to form ocean blocks of six repeaters, each ocean block terminating in about half a repeater section of cable. High-voltage test leads were moulded to the ends of every ocean block and run to the test room, so that, by suitable switching, any ocean block or sequence of blocks could be energized and tested. After every odd ocean block there was the facility,³ during laying, of improving the equalization by adjustment of the cable length before jointing on the next ocean block. At every even block end a submerged equalizer was provided, within which, if necessary, quite complex equalization networks could be inserted.

Laying of Repeaters

The laying of repeaters was normally carried out by using the V-sheave machine² mounted aft, and feeding the cable over a dynamometer sheave, and then out-boarding over a stern sheave. The cable passed round three linked and braked V-sheaves of 6 ft diameter, thereby reducing the cable tension. The required back tension was provided by adjustable braking on two fur-

ther 6 ft sheaves. A repeater or equalizer was by-passed using a rope which passed through the gear and allowed the repeater to move aft in a trough to the stern sheave. Full cable tension was applied to the repeater just before it reached the stern sheave.

The distribution of tension around each V-sheave can be made uniform by dividing the periphery of the sheave into a number of separate segments, each of which, after a minimum pre-determined tension, can move within limits round the circumference. This shear-limiting arrangement² was adopted on CANTAT as it reduced mechanical stresses in the Lightweight cable.

The laying of the cable and repeaters with the V-sheaves was very satisfactory, but at each repeater the cable speed had to be reduced to about 1 knot, and the cable ship slowed down. In some sea and weather conditions this introduced problems in seamanship. Cable laying was found to proceed very satisfactorily at 7 knots (Fig. 2), so that in Lightweight cable a repeater was laid about every 4 hours. Parachutes² were attached to every housing connected to the Lightweight cable. Their operation presented no difficulties and they appeared to function correctly. Fig. 3 shows the transference of a repeater with parachute attached from a repeater stack to the trolley (lower, right). In Fig. 4 a repeater is about to enter the water. The by-pass rope is slack and the parachute is about to be pulled out of its cover.

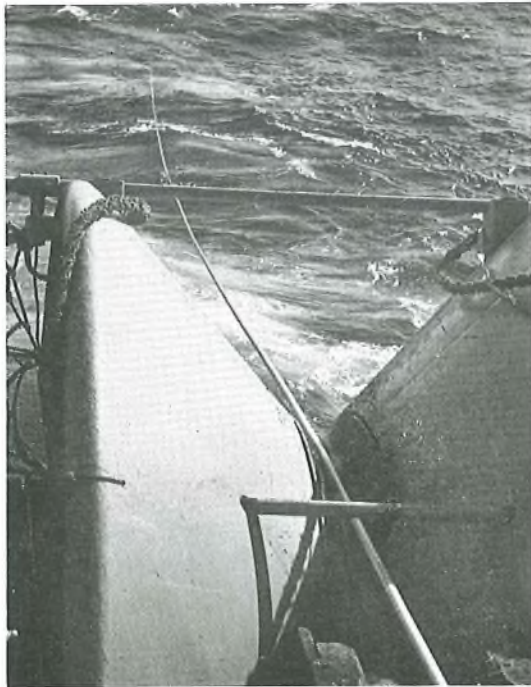

Cable angle to the horizontal is about 7°
 FIG. 2—LAYING LIGHTWEIGHT CABLE AT 7 KNOTS

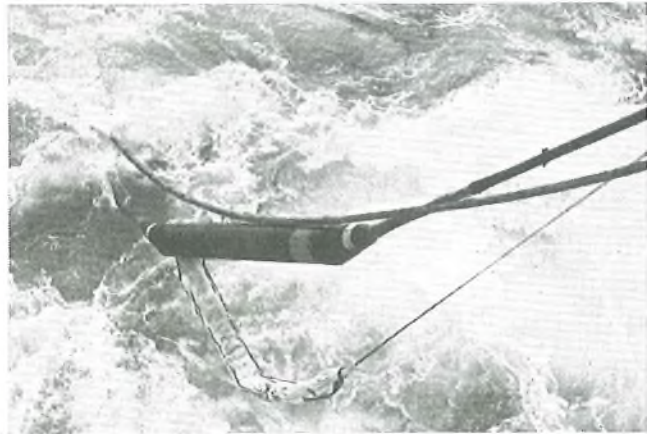

FIG. 3—LOADING THE NEXT REPEATER TO BE LAID ON TO A TROLLEY IN THE CENTRE CASTLE OF MONARCH

Electrical Testing

Since CANTAT was a single-cable scheme it was possible to maintain continuous two-way speech contact with the terminal, provided the system was energized. The primary function of the test-room team was the progressive collection of transmission data on the system as it was laid, so that the best equalization could be introduced at the block ends. The test-room team also carried out frequent checks on the supervisory responses of the repeaters, system noise and distortion. Whenever possible a check was made on each repeater during the mechanical handling it received when being launched, by confirming that a test tone remained perfectly steady.

The system was kept energized except when power had to be removed for equalizing and jointing purposes. In general, power was fed through both the block being



The rope used to enable repeater to by-pass the V-sheaves is slack.
 FIG. 4—REPEATER ENTERING THE SEA AT ABOUT 1 KNOT. PARACHUTE ABOUT TO PULL OUT OF COVER WHICH IS RECOVERED BY ROPE

laid and the next block to be laid. This enabled the latter to be check-tested well in advance.

For the first half of the route the system was energized by the power cubicles on *Monarch* feeding into a short-circuit at Oban. *Monarch* was thus free to energize the cable, when required, with complete safety. After midway the increasing voltage made it necessary for *Monarch* and Oban to supply power, and this required special safety measures to prevent Oban energizing when jointing, etc., was in progress on *Monarch*. A device was installed at Oban whereby the Oban power switch was made inoperative until an uninterrupted line current of $80 \text{ mA} \pm 2 \text{ mA}$ had been received over the cable for four minutes. This eliminated the potential danger of false signals being received by Oban owing to earth currents. *Monarch's* power equipment provided this stabilized 80 mA signal when Oban was required to energize the cable.

A very slight change occurs in the gain characteristic of a repeater during the warming-up period. Fig. 5

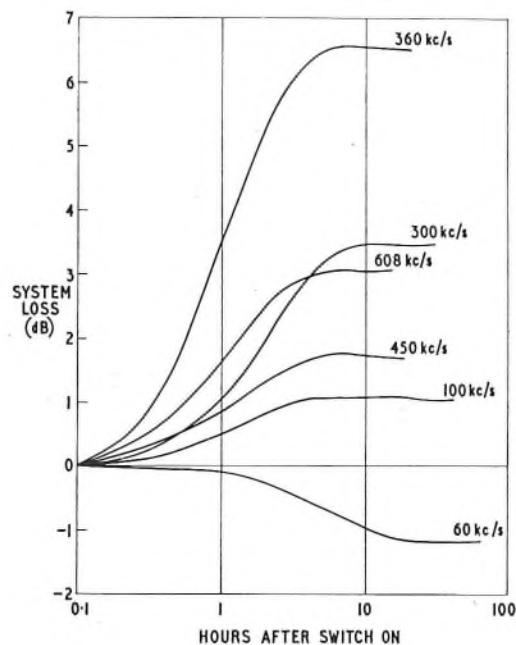

FIG. 5—CHANGE IN LOSS OF 90 REPEATER SECTIONS AFTER SWITCHING ON POWER

shows the warming-up changes on a chain of 90 repeaters, and this indicates that, on a very long route, precise measurements require a warming-up period of about 15 hours. For normal measurements however, a four-hour period was considered to be adequate. This time allowance was necessary after re-energizing at each block end unless corrections were applied.

Testing was carried out continuously during the lay, and for this, a rota of six trained officers was required.

Equalization

Equalization methods had been worked out³ in some detail prior to the lay, and these were found to work very successfully in practice. After each re-energization, following the splicing in of a new block, measurements were taken until the third repeater in the block was launched. The end of the block equalization could then be obtained by either (a) extrapolating the readings obtained up to the third repeater, or (b) correcting the last measurement at the third repeater by the theoretical change which the remaining cable in the block would experience when transferred from the ship's tank to the sea-bottom. In general, there proved to be a greater difference between these results than expected, but the misalignment was not seriously affected.

At odd block ends, equalization consisted in correcting the 608 kc/s level by cutting off a suitable amount from the extra cable provided at the block end and jointing. Allowing for contingencies (e.g. a re-mould), this required about 9 hours. At even block ends more time (12-14 hours) was required in order to design, construct, and test appropriate equalizing networks and to seal them up in the housing. Fig. 6 shows the selection



FIG. 6—SELECTING COMPONENTS ON THE SHIP FOR THE EQUALIZING NETWORK TO BE INSERTED IN A SUBMERGED EQUALIZER

of components in the clean room preparatory to constructing a network. Splices in 0.31 in. tail cable and in 0.99 in. Lightweight cable had also to be completed.

Cable Slack

The intention was to lay the armoured cable with just enough slack (about 1 per cent) to let the cable follow the contour of the sea-bed. Too much slack would make the cable much easier to bring to the surface if caught by a trawl, whereas a bar-tight cable could introduce suspensions off the sea bottom which could readily be hooked by trawls. It was planned to lay the

Lightweight cable at an average slack of 6 per cent over the route, reducing this slightly over a good bottom and increasing it over certain sections of the mid-Atlantic ridge. Theoretically, under reasonable weather conditions, the Lightweight cable should be recoverable in a bight, for repair purposes, anywhere on the route.

The only existing method of adjusting slack percentage continuously is by running a taut wire—0.028 in. diameter high-tensile steel—and comparing wire and cable speed. The taut-wire method worked very satisfactorily, but if the wire breaks, a distance of up to ten times the depth of water may have to be covered before acceptable accuracy is re-established. The Decca Navigator system can be used to compute slack over a repeater-section length, but on CANTAT its coverage was restricted to the two continental shelves. Loran, Dectra and Astro-sights can only give an accurate average over a number of repeater sections.

LAYING OPERATIONS

A general picture of the laying operations is given in Fig. 1.

Lay 1 Operation

With loading, jointing, and testing completed, *Monarch* sailed from Greenwich on 4 April 1961 with five ocean blocks comprising some 700 n.m. of cable, three-quarters of which was Lightweight, 30 repeaters, two equalizers and a joint housing.

On arrival at Oban the joint and splice to the shore end were completed early on the morning of 8 April and the system energized. Two-way communication with Oban was established over the first ocean block and check transmission tests were carried out. After a bow to stern transfer, payout commenced at 10.30 a.m. at a speed of 6 knots, the ship slowing to about 1 knot, 300 fathoms before each repeater. The weather, which had been fine and clear, started to deteriorate soon after the lay commenced. Three miles beyond the fifth repeater the wind had risen to gale force with rough seas and a rising swell, and it was decided to cut and buoy the cable in order to avoid the risk of damaging the cable or the repeaters. *Monarch* stood by the buoy for two days until the weather improved, then the end was recovered and spliced, and laying operations were resumed on the morning of 11 April. Meanwhile, electrical tests had shown that the best equalization between blocks 1 and 2 would be obtained by adding 0.6 n.m. of cable. The adjustment length of 1.75 n.m. provided at the beginning of block 2 for this purpose was therefore cut back to give the increased length, and then jointed to the end of block 1. The edge of the Continental Shelf, with the transition to Lightweight cable at the joint housing, was reached in the afternoon, and the first laying of Lightweight cable on a telephone system commenced. Repeater No. 8, the first to be laid with a parachute, was launched at 6.25 p.m. in a depth of 825 fathoms.

After the laying of repeater No. 10 the amount of equalization required at the end of ocean block 2 was predicted, and the design of the electrical network commenced. Power was removed from the system to enable the jointing and splicing of the equalizer tail cables to proceed after a cable length adjustment. As a precautionary measure the ship's speed was reduced to about 4 knots during the early stages of this operation, but a

normal payout speed of 6.5 knots was resumed after the joints had been X-rayed and passed inspection. The equalizer was laid on the evening of 12 April. Laying and equalization proceeded satisfactorily and 0.6 n.m. of cable was added between blocks 3 and 4. The weather, which had again deteriorated, improved, and the lay was completed without interruption, the last repeater, No. 30, being laid at 7.33 a.m. on 16 April in a depth of 1,600 fathoms. After a short period of transmission testing, the cable end was fitted with a special short-circuited termination to permit the system to be energized and tested from Oban, and then buoyed off.

Monarch then returned to Greenwich to load cable and repeaters for the second lay.

Examination of the final electrical tests confirmed what had been noticed during the progress of the lay. There was a slight increase in gain at high frequencies, and a more serious decrease in gain at low frequencies than what had been expected. To correct this, an additional equalizer was constructed to be inserted at the beginning of lay 2.

Lay 2 Operation

Shortly before loading was completed a fault in the nature of a full earth on the laid section was reported by Oban. The location made by shore-end tests put the fault near the edge of the Continental Shelf, and it appeared that one or more repeaters had been damaged.

It was decided that repair operations should be carried out by *Monarch* en-route to lay 2. On completion of the loading of 790 miles of Lightweight cable, 30 repeaters and 3 equalizers, together with spare cable and repeaters for the repair, the ship sailed from Greenwich on 31 May.

The repair proved to be a complicated operation, with little assistance from the weather. The "B" armoured cable had been badly mauled by a trawl at a point some five miles beyond repeater No. 7, and cut at a point a quarter of a mile from where it had been mauled. The marks of the axe used for the cutting were clearly visible, and since the potential to earth of the centre conductor was over 2 kV, the operation was not without hazard to the welder of the axe. In addition, repeaters No. 6 and 7 had suffered electrical damage necessitating their replacement. In the course of the repair a complete repeater section of cable was relaid.

It was subsequently confirmed that the repeater damage was due to surge voltages set up by the cable fault. This was unexpected as gas tubes were fitted in each repeater to prevent the build-up of dangerous voltages if the cable was suddenly short-circuited. It is probable that the cutting introduced a more serious condition, consisting of a series of open-circuits and short-circuits.

Repairs were completed on 8 June and *Monarch* proceeded to the buoyed end to commence lay 2. It was a welcome sight on the morning of 11 June to find that the buoy laid two months earlier, 700 miles out in the Atlantic, was still in position. The cable end was recovered, and, after testing and splicing, payout commenced the same evening. In spite of periods of bad weather the lay proceeded smoothly and without incident apart from the detection on board of a minor fault in a repeater termination which involved a repeater replacement. Since the available spare repeaters had been used in the repair operation only 29 repeater sections could be laid. Payout was completed at mid-day on 17 June, and the end was buoyed off the same night.

Electrical results on this lay, which consisted wholly of Lightweight cable, were again satisfactory but confirmed the unexpected differences which had been noted on lay 1. This again necessitated the provision of additional networks, this time in the equalizer to be laid at the beginning of lay 3.

Lay 3 Operation

The plans for lay 3 had to be amended at a late stage in order to fit in with the cable manufacturing arrangements. After loading some 250 miles each of Lightweight and armoured cable at Greenwich, *Monarch* sailed for Southampton to load 50 miles of armoured cable (three repeater sections) for the Hampden, Newfoundland, shore end. Owing to this cable's position in the cable tanks it had to be laid first, before *Monarch* could continue the main lay from the buoyed end of lay 2.

The shore end, with its three repeaters, was laid on 12 September with a short-circuited termination so that it could be energized from Corner Brook. On returning to the buoyed end of lay 2, weather conditions were too bad for cabling operations, and the recovery of the buoy was delayed for two days. When the buoy was recovered, the tail of scrap armoured cable attached to the Lightweight cable parted. Grappling operations were started, the depth being 2,120 fathoms, but were halted when receiving storm warnings of Esther, described as a large and dangerous hurricane, approaching the area. In anticipation of a further long period at sea *Monarch* put in to St. John's, Newfoundland, for fresh water and stores. She returned to the cable ground on 18 September, but before operations could be resumed there was a labour dispute, originating in London, affecting working hours of all Post Office cable staff, which made further work impossible. *Monarch* returned to London bearing many disappointed engineers and ship's personnel.

Owing to the deteriorating weather situation in the North Atlantic and the onset of icing conditions as winter approached, the completion of CANTAT in 1961 seemed very doubtful at this stage. A postponement would have delayed completion until favourable weather conditions were restored in the following May. The labour difficulties were resolved; and on 7 November *Monarch* sailed in a last determined effort to complete the operation.

Just before *Monarch* sailed, another trawler fault was reported coinciding in location with the previous fault. Since the system was not energized only a cable fault was envisaged. H.M.T.S. *Alert* left Glasgow on 7 November to carry out repairs; these were completed on 9 November.

Meanwhile Corner Brook reported a noise fault in the shore end with its three repeaters. Localization placed it in the most seaward repeater or in the short-circuited tail. The cause was not finally resolved until the whole operation was almost complete, when it was found that the temporary short-circuit provided had become faulty.

In order to save *Monarch* valuable time C.S. *Lord Kelvin* had grappled for, and buoyed off, the lost end of lay 2, so that *Monarch* was able to recover the end on 15 November. The cable had, however, been damaged by the grappling operation, and 3 n.m. had to be picked up before a sound cable to Oban was obtained. Unfortunately, since time was an important factor it was not possible to allow a long warming-up period, but measure-

ments agreed very well with those taken on the cable end five months earlier. Payout commenced on 16 November and continued satisfactorily through to the joint housing transition in 385 fathoms. Rough seas on 18 November almost involved cutting the cable. The shore end was reached on 20 November and recovered. The final splice was slipped at 11.35 p.m. G.M.T. on 21 November. At midnight a message was received that Oban and Corner Brook were in satisfactory communication over the cable and that preliminary tests were commencing. The race against the weather had been won.

CONCLUSIONS

The first deep-sea project by the British Post Office in the turbulent weather of the North Atlantic was an ambitious and adventurous one. It differed in many ways from the previous transatlantic lays.

Much had to be learned before the event, and much experience was gained during the operations. A fair share of hazards and difficulties was encountered, but very little that reflected on the cable and repeaters and on the laying and equalizing methods, which were performed most satisfactorily.

The Lightweight cable, as expected, handled extremely well throughout, and its electrical performance and stability were better than those obtained on any previous submarine cable. The repeaters, except for one minor incident, gave no cause for worry at any time. The method of building in the required equalization on the ship worked excellently and was very flexible. It imparted a quiet confidence that practically any kind of equalization misalignment that arose could be dealt with on the ship. The laying gear, not for the first time, operated very satisfactorily, and although not ideal, there is no better method available for handling heavy rigid

repeaters of the Post Office type.

About 12 technical staff were required on each lay, and most of these were trained to carry out several duties, so that sickness would not jeopardize any operation. It was noted that, by the third lay, techniques were becoming established, and the various duties and responsibilities were working smoothly on an almost routine basis.

No modifications appear to be necessary to the CANTAT techniques, so that, except for the occasional emergency which may have to be faced in any laying operation, it is believed that future similar systems can now be undertaken and laid with confidence even in still greater ocean depths.

ACKNOWLEDGEMENTS

The authors are well aware that this successful laying of CANTAT was primarily due to the efforts of their many colleagues in the Post Office Engineering Department.

References

¹BROCKBANK, R. A., CLARKE, E. F. S., and JONES, F. Anglo-Canadian Transatlantic Cable (CANTAT): Cable Development, Design and Manufacture. *Proceedings I.E.E.*, Paper No. 4239E, July 1963 (Vol. 110, p. 1,124). (In this issue of the *P.O.E.E.J.*)

²CLARKE, E. F. S., and CHAPMAN, K. J. Anglo-Canadian Transatlantic Cable (CANTAT): Cable-Laying Gear. *Proceedings I.E.E.*, Paper No. 4240E, July 1963 (Vol. 110, p. 1,151). (In this issue of the *P.O.E.E.J.*)

³SCOWEN, F., WALKER, D. C., and TAYLOR, S. A. Anglo-Canadian Transatlantic Cable (CANTAT): Repeaters and Equalization. *Proceedings I.E.E.*, Paper No. 4249E, July 1963 (Vol. 110, p. 1,134).

⁴BAMPTON, J. F., GRIFFITH, R. G., and HALSEY, R. J. Anglo-Canadian Transatlantic Cable (CANTAT): Planning and Overall Performance. *Proceedings I.E.E.*, Paper No. 4244E, July 1963 (Vol. 110, p. 1,115).

Book Reviews

"Television Engineering. Principles and Practice." Vol. 4: General Circuit Techniques. Second Edition. S. W. Amos, B.Sc. (Hons), A.M.I.E.E. and D. C. Birkinshaw, M.B.E., M.A., M.I.E.E. Iliffe Books, Ltd. 278 pp. 175 ill. 35s.

This is the last of a series of four volumes making up a comprehensive survey of modern television principles. It has been prepared primarily for the training of B.B.C. engineering staff but contains much material of interest to engineers in other fields.

The first two chapters covering counting and frequency-dividing circuits are fully illustrated with waveform and outline-circuit diagrams. The following three chapters deal in similar detail with d.c. clamping and d.c. restoring circuits. Chapter 6 considers the need for gamma correction, the amplifier characteristics required and the circuit design necessary to achieve this performance. A chapter on delay cables and networks is followed by two comprehensive chapters on fixed and variable equalizers. Three up-to-date chapters cover the problems of scanning and the development of circuit designs used in modern television equipment. The final pages of the book deal with the problem of high-power video amplifiers of the shunt-regulated type, and the shunt-regulated cathode follower.

The mathematical detail in the text is simple and practical, and that contained in the appendices does not demand a high mathematical standard. As with other volumes in this series based on B.B.C. Engineering Training Manuals, the text is clear, concise, adequately illustrated and indexed.

R. A. D.

I.P.O.E.E. Library No. 2511.

"Newnes Concise Encyclopaedia of Electrical Engineering." Edited by Prof. M. G. Say, Ph.D., M.Sc., A.C.G.I., D.I.C., M.I.E.E., F.R.S.E., M.Brit.I.R.E. George Newnes, Ltd. xii + 906 pp. Fully illustrated with line drawings. 140s.

This book is intended to cover power production and utilization, but related matters which are now becoming important to the power engineer have been included. In these circumstances it is obviously difficult to decide how much space should be given to such subjects as piezoelectricity and transistors. Space given to these must be taken from other subjects with which the reader may be expected to be more familiar. On the whole a fair balance has been struck. Comparison with the same publisher's *Electrical Engineers' Reference Book* shows that there is a large amount of common ground between the two books but the treatments and the arrangement are quite different. Whereas the reference book provides much more detail than the encyclopaedia on such subjects as electrification of mines, the encyclopaedia is more detailed on skin effect and the quantum theory. The reference book gives a good deal of information on installation and operating practice, whereas the encyclopaedia deals more with the basic principles. The two pages on the Schrage motor are a good example.

The book should be very useful to editors and others who have to deal with reports and articles on specialized subjects and who need a work of reference to give them a reasonable amount of background information in easily assimilated form.

H. D. B.

Switching Arrangements for Semi-Automatic Operation of Transoceanic Telephone-Cable Circuits

D. L. HEPTINSTALL and P. F. JONES†

U.D.C. 621.395.65:621.395.35

The rapid increase in the number of long-distance submarine-cable circuits has led to the introduction of semi-automatic operation. Operator access to the transatlantic telephone circuits is indirect and new register-controlled 4-wire link circuits have been provided for outgoing calls, while for incoming calls a new incoming international register-translator has been installed.

INTRODUCTION

THE rapid increase in the number of long-distance submarine-cable circuits due to the introduction of T.A.S.I.¹ on the transatlantic cables,² the provision of the Canadian transatlantic cable³ and the plans for the future Commonwealth cables⁴ make it desirable to introduce semi-automatic operation of the transoceanic cables. This facility enables operators to complete calls to subscribers in a distant country without the assistance of operators in that country. Concurrently with the replacement of generator signalling by automatic signalling on the transatlantic cables,⁵ a new international 4-wire switching unit was brought into service in March, 1963. Whereas direct operator access is provided on Continental circuits,⁶ operator access to the transatlantic telephone circuits is indirect, and a newly-designed register-controlled marker system is used to connect the operator's manual-board relay-set to a line relay-set via a link circuit, providing 4-wire switching facilities. In addition, to permit incoming calls to the United Kingdom to be directly dialled, a new incoming international register-translator has been installed.

OUTLINE OF THE 4-WIRE SWITCHING UNIT

The function of the 4-wire switching unit is to provide initially the requisite 4-wire connexions between any outgoing manual-board relay-set and any outgoing line relay-set, but eventually it will also provide 4-wire switching for outgoing international subscriber dialled calls to the Continent, and for automatic transit switching of both continental and transatlantic (and other transoceanic) circuits. The switching unit utilizes a link system in which each link consists of two 100-outlet motor-uniselectors, one a finder and the other a selector, connected wiper-to-wiper as shown in Fig. 1. The unit caters for a maximum of 1,500 incoming and 1,500 outgoing circuits arranged in 15 incoming and 15 outgoing sections, each having a capacity of 100 circuits.

To allow for the connexion of any incoming circuit to any outgoing circuit, the link circuits are arranged in groups, each group being capable of effecting connexions between designated incoming and outgoing sections. Thus, link-circuit group 2/1 provides connexions between incoming section 2 and outgoing section 1. At the instant a 4-wire connexion is to be made, marking conditions are applied via the manual-board relay-set to the incoming-section multiple and via the selected group of circuits of the outgoing-section multiple. A free link circuit in the appropriate link-circuit group is allocated and its two motor-uniselectors simultaneously

†Telephone Exchange Systems Developments Branch, E.-in-C.'s Office.

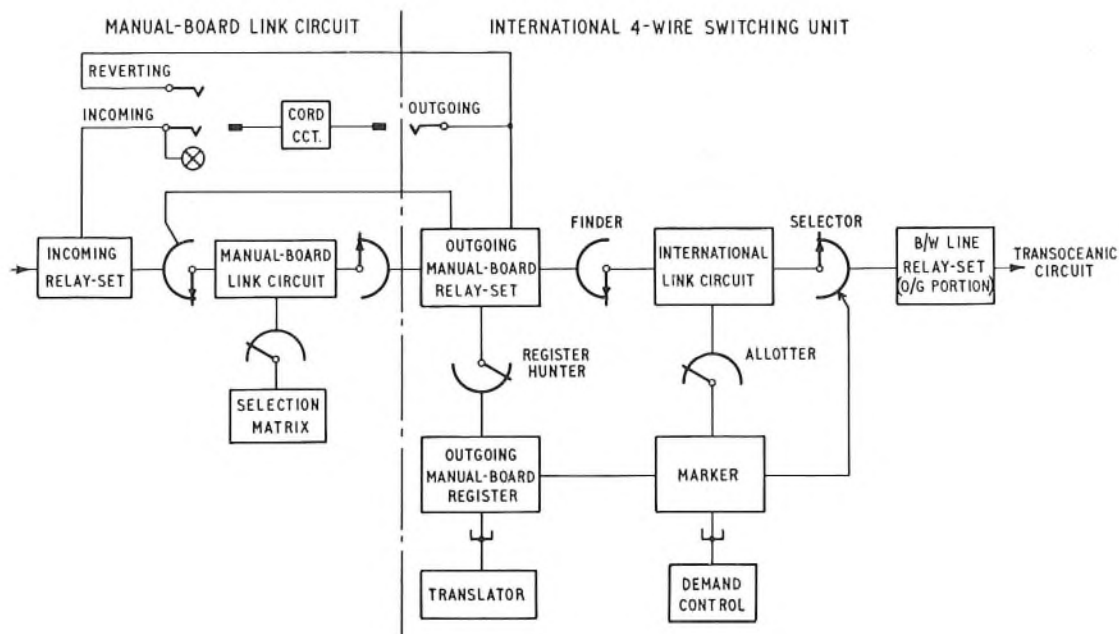

FIG. 1—TRUNKING DIAGRAM OF MANUAL BOARD AND INTERNATIONAL 4-WIRE SWITCHING UNIT

search for the marked outlets. When both have been found, the wipers of each unselector are connected together and link association takes place. To ensure that only one marking condition can occur on any incoming or outgoing section, it has been arranged that the above operation is controlled on a one-at-a-time basis. More than one call may be dealt with at a time, and a maximum of 15 calls (one in each outgoing section) can be set up at the same time provided they originate in 15 different incoming sections.

OUTGOING CALL THROUGH THE 4-WIRE SWITCHING UNIT

Register

When a plug is inserted into the outgoing-multiple appearance of the common-access manual-board relay-set, a register is associated via a register-hunter. The association of the register with the manual-board relay-set is indicated by the darkening of the cord-circuit supervisory lamp. The operator then keys into the register:

- (i) a "start" signal,
- (ii) the country code,
- (iii) the subscriber's national number, and
- (iv) a "keying-finished" signal.

The register digit store can be reset at any time before the keying-finished signal is keyed, by the re-operation of the start/cancel key. The keyed information is passed over the tip and ring wires as coded positive and negative signals and is stored in binary form. The register uses relay stores with a capacity for 16 digits. When the keying-finished signal is received, the outgoing register knows that the complete number has been stored and the call can now be set up. First, it is necessary to determine the outgoing section containing a free circuit to the required destination. This information is obtained from the translator, and the first four digits held in the register stores are converted into two-out-of-six code and stored on four groups of code relays (the register carry-stores) in readiness for transfer to the translator.

Translator

The register now seizes a free translator and transfers to it the first four digits in two-out-of-six code. The received digits are checked as valid two-out-of-six codes, and are then expanded to decimal form, and the appropriate route relay operated; there is a route relay for every different outgoing route. Operation of the route relay causes a reset signal to be applied to the register, and on receipt of a return signal indicating that the register carry-stores are reset, the routing information is extended to the register as four digits in two-out-of-six code. These four digits give the following information:

- (a) The outgoing section required and, therefore, the marker to be used.
- (b) The portion of the outgoing-section multiple giving access to the outgoing route.
- (c) Whether a language digit is to be inserted, and whether a terminal or transit prefix is to be transmitted.
- (d) The number of digits to be omitted when sending (the country code will be suppressed on terminal calls).

On receipt of the four digits the register releases the translator.

Each route is monitored and, when the last circuit is taken into use, the corresponding route-busy relay in

the translator is operated. On operation of the associated route relay the route-busy condition is used either to return a busy signal to the register or to give access to an alternative route.

Section Marking

A marker is associated with each outgoing section and the marking is, therefore, carried out with respect to the outgoing section. It is possible to connect 100 outgoing circuits to each outgoing-section multiple, which is divided into 15 different groups of outlets. All of the groups may or may not be used for outgoing routes. Within these limits, there is complete flexibility in the number of circuits in any route and the location of the individual circuits in the multiple. The trunking diagram of the unit is shown in Fig. 2.

The manual-board relay-set indicates to the register on seizure the incoming section to which it is connected. The register, on receipt of the routing information from the translator, applies for the marker associated with the required outgoing section. The marker contains a demand-control element ensuring that one and only one register can seize it, even if two or more registers apply simultaneously for the same marker. The register extends to the marker the routing information, giving the required incoming section and the required portion of the outgoing multiple on the link-circuit selector.

To ensure that only one marking condition is applied to any one incoming section at the same time, the marker makes an application to a demand-control relay-set associated with the required incoming section. The first marker to obtain the demand-control relay-set is permitted to extend a signal to the link-circuit allotter serving the incoming section concerned, the allotter having pre-allotted a free link circuit. The markers are connected in pairs, each pair having two allotters per link-circuit group. Each marker and allotter of a pair is normally used alternately, except in the case of faulty operation or manual busying.

Link-Circuit Allotter

A maximum of 50 link circuits is provided in each group, and a link-circuit allotter chooses the particular link circuit that will be used to associate the two relay-sets in the incoming and outgoing sections, respectively. Normally the allotter will be standing on a free link circuit, and when the start signal is received from the marker this is extended to the pre-allotted free link circuit. Should all link-circuits be engaged, the manual-board relay-set releases the common equipment, and busy tone and a supervisory signal are extended to the operator. In the absence of a link-circuit busy condition, should a link circuit fail to become associated within 2.5-5 seconds, the link-circuit allotter is locked out of service, a prompt alarm is given, and the partner allotter handles all further demands. A repeat attempt is then made by the register.

Link-Circuit Association

Having seized a free link circuit in the required link group, marking conditions are extended by the marker to the selected group of circuits on the selector side of the link circuit. At the same time the marker extends a marking condition, via the register and the manual-board relay-set, to the finder side of the link circuit. The selector of the link circuit now hunts for a free outgoing-line relay-set whilst the finder searches for the marked

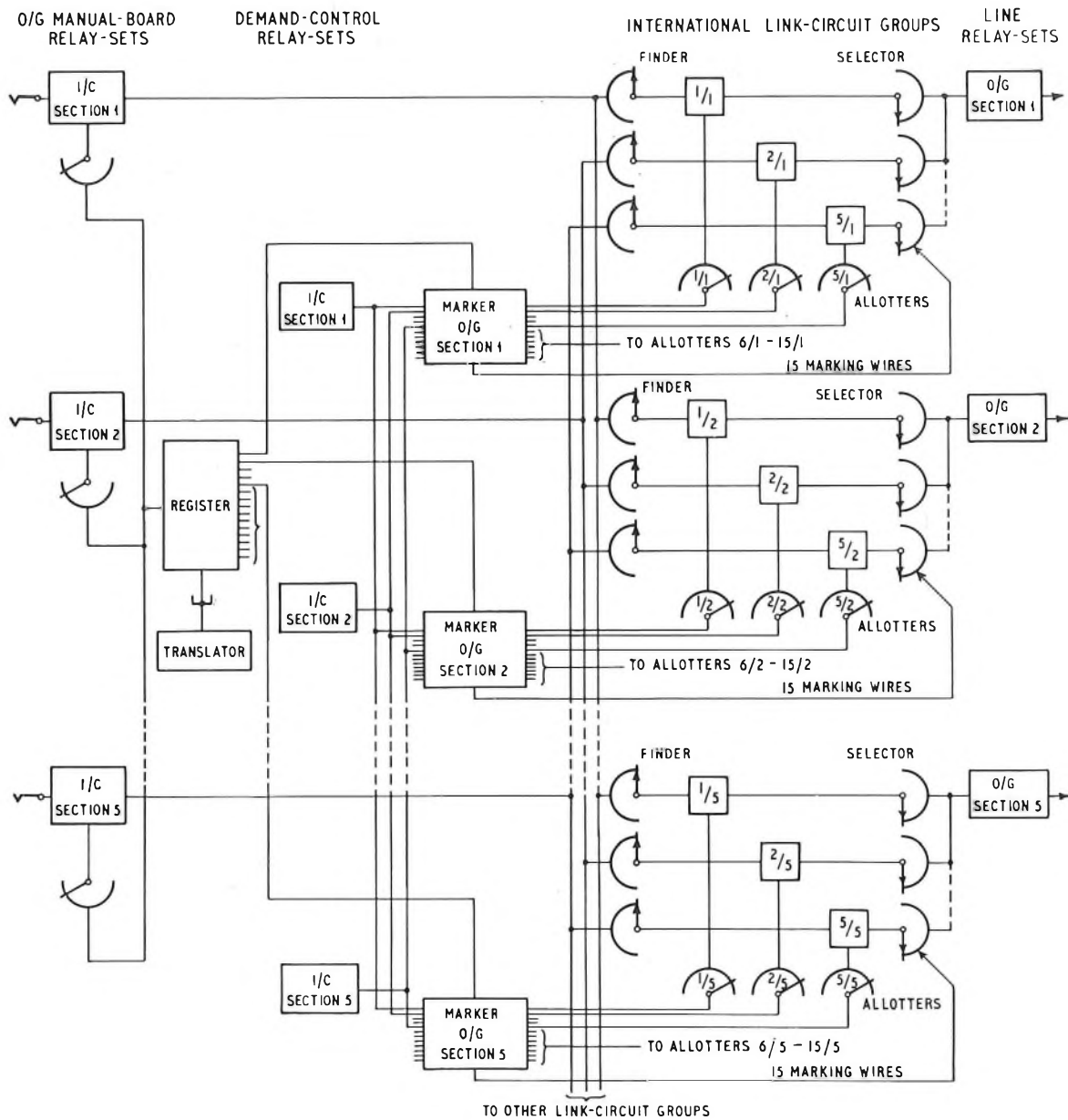

FIG. 2—BLOCK SCHEMATIC DIAGRAM OF 4-WIRE SWITCHING UNIT

manual-board relay-set. When the finder and selector have found their respective outlets the manual-board relay-set is extended via the line relay-set to the required outgoing route, and a "switched-through" signal is given to the manual-board relay-set and is repeated to the register. On receipt of this signal the register releases the marker, which then releases the allotter and demand-control relay-set. A further link-circuit association can now take place.

Sending M.F. Pulses to Line

At this stage the manual-board relay-set is extended to the line relay-set and the outgoing register awaits the receipt of a "proceed-to-send" signal from the distant incoming equipment. The register transmits all its stored information in a continuous sequence of two-out-of-six multi-frequency (m.f.) pulses in response to the proceed-to-send signal, the digital signals being preceded by a

terminal or transit (KP1 or KP2) discriminating signal and followed by an "end-of-pulsing" (ST) signal. When the ST signal has been transmitted a "send-finished" signal is extended by the register to the manual-board relay-set.

Four-Wire Switching

When the manual-board relay-set receives the send-finished signal it releases the register and indicates to the operator, by causing the cord-circuit supervisory lamp to glow, that the register has been released. The send-finished signal is repeated by the manual-board relay-set to the line relay-set, and this is used to prepare the line relay-set to receive a signal indicating whether it is connected to a 4-wire circuit. Receipt of the send-finished signal by the manual-board relay-set also causes the association of this relay-set with the incoming relay-set connected to the operator's answering cord, via the

4-wire manual-board link circuit' (see Fig. 1). At this stage the relay-sets are associated, but the speech connexion remains 2-wire through the operator's cord circuit until the operator's speak key has been restored. When the called subscriber answers, the cord-circuit supervisory lamp darkens and, after ascertaining that the call has been correctly set up, the operator restores her speak key. This is detected by the manual-board relay-set and the speech connexion is now diverted from the cord-circuit to the 4-wire manual-board link-circuit.

Reverting Operation

As it may be necessary for an operator to set up a call in two directions, e.g. a booked call, the manual-board relay-set is associated with the incoming as well as the outgoing multiple of the manual-board link circuit. The reverting appearance in the multiple permits the relay-set to perform the outgoing function with respect to the line and an incoming function with respect to the manual-board 4-wire switching unit (see Fig. 1).

Dual Seizure

The transatlantic telephone circuits are arranged to operate on a bothway basis with the risk of a dual seizure occurring. In the event of a dual seizure being detected by the line relay-set a signal is given to the outgoing register. The register repeats the signal to the manual-board relay-set, which releases the international link circuit and the bothway line relay-set. A second demand is then automatically made to the translator so that another attempt may be made to set up the call. The repeat attempt follows the same sequence as previously described, but should a second failure occur the register is released, busy tone being returned to the operator.

INCOMING INTERNATIONAL CALLS

The trunking arrangements for incoming international calls are shown in Fig. 3. The incoming portions of the line relay-sets have access to a common group of incoming registers whose function is to receive digital information from the distant international switching centre and, on the basis of this information, to route the call partly or wholly to its destination.

Incoming registers will have access to two groups of translators, one group to deal with calls terminating within the United Kingdom and the other for calls in transit via the United Kingdom. Only the terminal translators have so far been installed and international transit calls are at present routed via an operator.

Receipt and Storage of Digits

When the incoming portion of a line relay-set receives a seizure signal, its associated register-hunter searches for a free incoming register. When the register has been seized the line relay-set returns a proceed-to-send signal to the distant international switching centre, which then transmits, in a two-out-of-six m.f. code, the digital information required to set up the call. The signals are received by a m.f. receiver associated with the incoming register and are stored on relays in the same two-out-of-six code. The digit store is capable of holding the KP (KP1 or KP2) discriminating signal and up to 17 digits, of which the last is always the ST signal.

Terminal and Transit Calls

Except for calls to an operator, it is necessary to associate the register with a translator to complete the routing of a call and, since two types of translator are available, the register has to distinguish between terminal

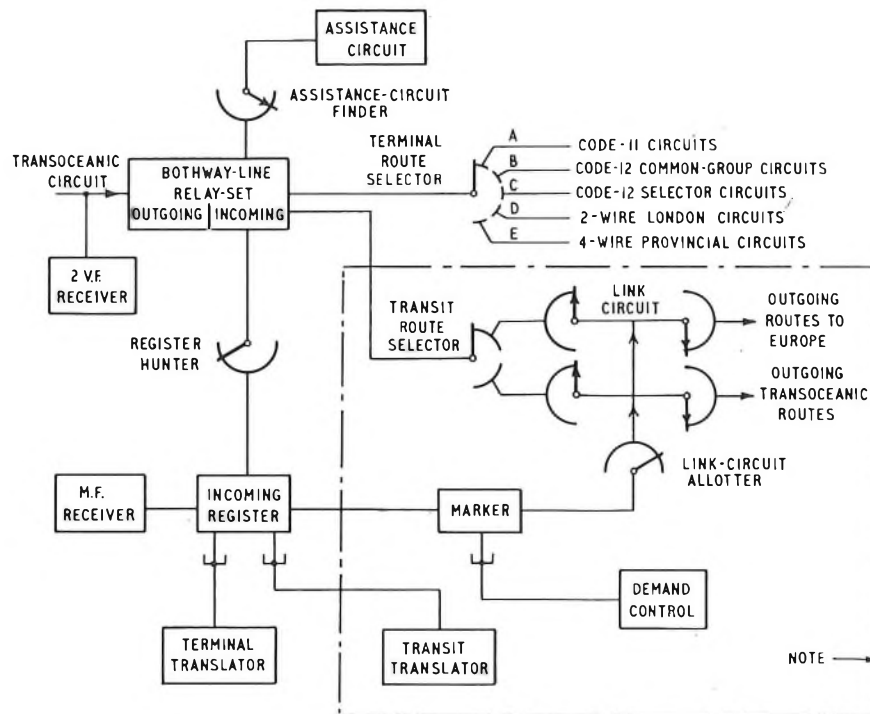

NOTE: The equipment enclosed within this boundary will be provided when automatic international transit is required.

FIG. 3—TRUNKING DIAGRAM FOR INCOMING TRANSOCEANIC ROUTES

and transit calls. This it may do in one of two ways: either by noting which of the two KP signals is received, i.e. KP1 (terminal) or KP2 (transit), or by examining the three digits (the country code) following the KP signal; some incoming routes may use one method and some the other. On seizing an incoming register, a line relay-set indicates to the register which method is to be used. When the digit discrimination method is used, KP1 is received but this has no discriminating function and a call is identified as a terminal call by the three digits following the KP1 signal.

On calls identified as terminal, the register makes a further selection between calls destined for the London director area, those to charging groups outside London, and calls to operators. The register makes this selection by examination of the first significant digit of the United Kingdom national number or the digit occupying that position. This is the second or fifth digit following the KP signal according to the type of terminal discrimination in use: if the digit is 1 the call is for London; if the digit is in the range 2-0, the call is to an exchange outside the London director area; a code-11 or code-12 signal received in this position will route the call to an operator.

Route Selectors

Associated with the incoming portion of each line relay-set are two route selectors, one for terminal and the other for transit calls. These route selectors are motor-uniselectors arranged to search a particular section of the unselector bank, according to signals supplied by the incoming register. The terminal route selector has five sections, allocated as shown in Fig. 3, and the register derives the marking signals to control this selector by examination of the digits received, as described above for London and provincial calls. For the transit route selector, which has two sections, the register derives its marking information from the transit translator.

Access to Translators

Incoming registers gain access to terminal or transit translators via translator-hunters. These are Post Office Type-4 uniselectors^a arranged to search cyclically for translators in each group. Due to the number of wires needed to associate a register with a translator, the translator-hunters search only the testing-in wires. On switching to a free translator, a group of connecting relays in the register, corresponding to the selected translator, is operated, and contacts of these relays connect the remaining wires between the register and translator.

Search for a translator begins as soon as the requisite number of digits have been received. For a London call, the translator is given the first three letters of the London exchange name; for a provincial call, the first three significant digits of the United Kingdom national number are given; for a transit call, the first four digits after the KP signal are sent into the transit translator, though they are not all necessarily used by the translator to determine a routing.

Digits are presented to a translator in a two-out-of-five code which is identical with the 10 frequency combinations denoting the digital signals of the inter-register two-out-of-six code. The same two-out-of-five code is used by the translator to signal routing digits back to the register. This code is adopted for interworking between the register and the translator as the additional

signals given by the two-out-of-six inter-register code are not required.

Terminal Translator

The three digits received by the translator in two-out-of-five code are converted to decimal code and are then combined to give a discrete marking on one of a number of code tags. The 900 London tags correspond to all the possible letter-code combinations of a director area with the additional expansion of initial digit 1 so that test codes of the form IXX may be used; the initial digit 0 is treated as a spare code. The 1,000 provincial tags correspond to all the possible numbering group codes.

Separate tag cross-connexion fields are provided for London and the provinces, and each code tag is cross-connected either to a route relay, a spare-code tag or a code-11 tag. Cross connexion to a code-11 tag is used where the amount of traffic does not justify an automatic routing or where, for any other reason, a call is to be completed by an operator. A separate route relay is allocated for each London exchange and for each provincial numbering group to which automatic access is to be given. There are 520 route relays in all: 299 are for London, 216 for the provinces and five for routine-test purposes. Cross-connexions on a second tag-field relate the routing information for each exchange or numbering group to the allocated route relay.

Translators supply only one routing digit at a time. The registers therefore make separate demands to a translator for each of the routing digits needed to set up a call, indicating each time to the translator seized which of the routing digits (first, second, third, and so on) it requires. The digits used on any particular call are not, therefore, all necessarily obtained from the same translator. Up to four demands may be made for calls to the London director area and up to six for calls to the provinces, but when a translator signals a final routing digit to a register it simultaneously gives a "last-demand" signal, and the register makes no further demands for a translator while completing the setting up of the call.

Routing digits are transmitted by the register using loop-disconnect pulsing. Each register is capable of storing two routing digits, so that a demand to a translator for a routing digit may be made whilst the previous one is being sent, thus reducing the setting-up time of calls. The routing digits take a call as far as the first numerical selector in a London exchange or in a provincial non-director exchange but, for calls to provincial director areas, the routing digits take the call as far as a provincial incoming register-translator.

Transmission of Stored Digits

When all routing digits have been sent, the incoming register transmits those stored digits which are required to complete the call. For London calls these digits are the numerical part of the London number, i.e. excluding the three-letter exchange code, whereas for calls to provincial exchanges, both director and non-director, the register pulses out the complete local number. At present, all calls are completed by loop-disconnect pulsing. Provision is made, however, for access to the inland trunk transit network⁹ when this is brought into service, and calls routed over this network will be completed by inter-register m.f. signalling.

On completion of pulsing-out, a register gives a

"sending-complete" signal to the incoming section of the line relay-set, the register releases and a transmission path is established through the line relay-set.

International Transit Calls

As previously mentioned, provision has been made for the automatic routing of international calls in transit via the United Kingdom, although the complete equipment to enable this to be done has not yet been installed.

For transit calls, a single demand to a transit translocator is all that will be necessary to obtain complete routing information to switch the call through 4-wire link circuits similar to those described for outgoing calls. On completion of link association, some or all of the received digits will be retransmitted, either in the same two-out-of-six m.f. code by which they were received or, for calls to European countries, using the standard 2 v.f. binary code of the C.C.I.T.T.* international 2 v.f. signalling system.⁶

*C.C.I.T.T.—International Telephone and Telegraph Consultative Committee.

References

- ¹CLINCH, C. E. E. Time Assignment Speech Interpolation (T.A.S.I.). *P.O.E.E.J.*, Vol. 53, p. 197, Oct. 1960.
- ²The Transatlantic Telephone Cable. *F.O.E.E.J.*, Vol. 49, Part 4, Jan. 1957.
- ³HAISEY, R. J. The Anglo-Canadian Transatlantic Telephone Cable System (CANTAT). (In this issue of the *P.O.E.E.J.*)
- ⁴Proposed Commonwealth Pacific Telephone Cable System. *P.O.E.E.J.*, Vol. 53, p. 42, Apr. 1960.
- ⁵WELCH, S. Line and Register Signalling Systems for Dialling Over Transoceanic Telephone Cables. (In this issue of the *P.O.E.E.J.*)
- ⁶TURNBULL, M. G. Introduction of Semi-Automatic Operation of Continental Telephone Services. *P.O.E.E.J.*, Vol. 52, p. 89, July 1959.
- ⁷MAURER, C. J., and NEWELL, E. Integration of the International and Continental Telephone Services. *P.O.E.E.J.*, Vol. 55, p. 22, Apr. 1962.
- ⁸MANNING, D. J. The Post Office Type 4 Uniselectors. *P.O.E.E.J.*, Vol. 52, p. 215, Oct. 1959.
- ⁹TOBIN, W. J. E., and STRATTON, J. A New Switching and Transmission Plan for the Inland Trunk Network. *P.O.E.E.J.*, Vol. 53, p. 75, July 1960.

Book Reviews

"Elementary Telecommunications Examination Guide"
3rd Edition. W. T. Perkins, M.Inst.B.E., A.M.
Brit.I.R.E. George Newnes, Ltd. viii+324 pp. 182 ill.
17s. 6d.

This book aims to be an examination guide covering the Elementary Telecommunications Practice and Telecommunications Principles A syllabuses of the City and Guilds of London Institute Telecommunication Technicians' Course. It is intended for students as an addition to the more usual text books on the subjects. The book is thus not a text book in the usually accepted sense. It consists of a collection of questions and answers, divided into subjects, with the claim that the questions are typical of those set in the City and Guilds examinations.

Inevitably in a book of this type, the subject matter covered is limited by the questions selected and, perhaps due to limitation of size, the book far from covers the syllabuses intended. Principles A is superficially covered as the book tends to concentrate more on Elementary Telecommunications Practice. While the up-to-date syllabuses are printed in the book, the subject matter covered is not in accordance with these syllabuses, but is based in the main on the original 1947 versions. The 1951 and 1960 syllabus revisions make about half of Section IX, the whole of Section XI and about half of Section XIII of the book unnecessary. As the book is a third edition produced in 1961, this is a particularly unfortunate matter for student purposes and greater care should have been taken in subject-matter selection. The space saved by omitting the unnecessary material would have permitted other rather weak sections to be strengthened and the inclusion of additional material required by the syllabus revisions. For example, Section VII is weak on carbon resistors, Section IX could have included the polarized bell, Section X could have included cables and a more adequate treatment of electrolytic corrosion, and Section XII could have covered the principle of receiver polarization and a more adequate treatment of inductors.

Most of the questions set and answered consist of selected parts of City and Guilds examination questions. They are far too brief and simple and not up to City and Guilds standard for whole questions. This is unfortunate in an

examination guide as a student would be misled as to the standard to aim at. Used very carefully by discriminating students the book could be a very general guide. For the majority of students, however, more faithful guidance than this book presents is called for.

S.W.

"Telecommunications Principles and Practice." Second Edition. W. T. Perkins, M.Inst.B.E., A.M.Brit.I.R.E. George Newnes, Ltd. 384 pp. 293 ill. 21s.

This book aims to suit the needs of students studying for the City and Guilds of London Institute examinations in Elementary Telecommunications Practice and Telecommunications Principles A.

The justification of producing one book covering the two syllabuses was presumably based on the reasoning that, in broad concept, certain subject matters are common to the two syllabuses although the required treatment differs. In the result, probably due to limitation of size of the book, coverage of both syllabuses suffers. The coverage of the Elementary Telecommunications Practice syllabus treats fundamental principles inadequately, for instance, in the self-capacitance of resistors, electrolytic corrosion, cable conductor identification, testing, power ratings, etc. The need to give basic theory in the Telecommunications Principles scheme suffers due to insufficiency of worked examples to illustrate the basic conclusions. Such examples are important as the students concerned would be in an early year of study. The combination of the material presented could also be confusing to students wishing to discriminate between Practice and Principles.

Although an attempt has been made to bring this second edition into line with current syllabuses, some unnecessary material of the out-of-date syllabus, e.g. telegraph equipment, moving coil microphone and loudspeaker, is still included. Further material required by the current syllabus, e.g. polarized and non-polarized bells, and internal cables, is not covered.

Used carefully by discriminating students the book could be of use in regard to the main sections of the respective syllabuses, but owing to the superficial treatment in many areas of the text it would not meet the requirements of the majority of students aiming at thorough understanding of the subjects.

S.W.

Line and Register Signalling Systems for Dialling Over Transoceanic Telephone Cables

S. WELCH, M.Eng., A.M.I.E.E.†

U.D.C. 621.395.636.1:621.395.45:621.315.28

Line and register signalling systems have been developed for dialling over transoceanic cables. The systems are compatible with T.A.S.I. equipment and with both 3 kc/s-spaced and 4 kc/s-spaced circuits. This article describes the circuit principles of both signalling systems.

INTRODUCTION

SEMI-automatic operation over transatlantic telephone cable circuits was introduced between the United Kingdom and U.S.A. in March 1963, a 4-wire intercontinental switching unit¹ being installed in London for the purpose. Using the same unit, dialling between the United Kingdom and Canada and Australia will be applied in the near future, with further intercontinental dialling at a later stage. A previous article² described the signalling philosophy of the proposed arrangements and the present article describes the design features based on that signalling philosophy.

The signalling is compatible with the use of Time Assignment Speech Interpolation (T.A.S.I.)³ equipment on the transoceanic cables and with both 3 kc/s-spaced and 4 kc/s-spaced circuits. For outgoing calls automatic access to the bothway circuits applies at the originating point, the automatic search being from outlets 1 to n at one end and from n to 1 at the other to minimize dual seizures.

The signalling equipment is in two parts:

(a) line signalling to control the seizure, supervision and release, and

(b) inter-register signalling for the transmission of the digital information and other signals convenient to pass between registers.

Both the line and register systems are 4-wire, link-by-link signalling.

LINE SIGNALLING

Table 1 shows the line-signalling code together with

TABLE 1
Line-Signalling Code

Signal	Transmitted Signal		Recognition Time (ms)
	Frequency	Duration (ms)	
Forward Signals			
Seize	f_1	continuous	40 ± 10
Forward Transfer	f_2	850 ± 200	125 ± 25
Clear forward	$f_1 + f_2$ (compound)	continuous	125 ± 25
Backward Signals			
Proceed-to-Send	f_2	continuous	40 ± 10
Answer	f_1	850 ± 200	125 ± 25
Busy Flash (and Error Detected)	f_2	850 ± 200	125 ± 25
Clear Back	f_2	850 ± 200	125 ± 25
Release Guard	$f_1 + f_2$ (compound)	continuous	125 ± 25

$f_1 = 2,400\text{c/s}$

$f_2 = 2,600\text{c/s}$

the transmitted-signal durations and the received-signal recognition times. The transmitted level is -9 ± 1 dbm0 per frequency. Frequency generation is described in another article in this Journal.⁴

Line-Signalling Relay-Sets

The 4-wire bothway relay-sets are in two parts, (a) outgoing and (b) incoming, at each end of the circuit. The v.f. line receiver and buffer amplifier are associated with the incoming relay-set, and static relays for the transmission of the v.f. signals with the outgoing relay-set.

On outgoing calls, access is obtained via a link circuit either from the auto-manual board or, on transit, from a preceding incoming relay-set. The relay-sets incorporate a 2-wire/4-wire terminating set to permit the 4-wire circuit to be extended to the 2-wire position circuit.

To avoid interference with signalling, the relay-sets extend a d.c. condition to make an echo-suppressor at the signal transmit point ineffective for the duration of the transmitted signal. The ineffective condition applied on the seize signal is not removed until the outgoing register has completed the sending of the digital information and other inter-register signals, i.e. until register "pulse out" is complete. Discriminating arrangements are included to enable incoming and outgoing half echo-suppressors to be switched out on transit connexions. Any v.f. signal transmitted for longer than 9–18 seconds due to a fault is timed out and an alarm is given.

The following description is for an operator-originated call.

Seizure. The outgoing intercontinental register controls the link circuit and the selection of the route to be used. The outgoing relay-set is taken into use when all the keyed call is stored in the register and the ST (end-of-pulsing) signal has been received. While this so-called *en bloc* arrangement delays the setting up of the call, which is perhaps of greater significance with subscriber-dialled than with operator-dialled traffic, it has the merit that the seizure of the expensive transoceanic circuit is delayed until it is necessary to take the circuit, and it also avoids T.A.S.I. association problems which would otherwise arise on register pulse out.

Fig. 1 shows the essential arrangements associated with outgoing seizure. The link-circuit hunter switches to the 550-ohm testing-in battery on the P-wire. Relay P operates to the link circuit. Relays XS, BA, FW, AS, EA, TA, DX and TS operate. Contacts DX2, DX3, XS2 and XS3 connect the three static relays to line. Contacts FW1 to FW4 extend the 4-wire line and switch out the terminating set. Contacts P4 and TS1 bias the 2,400 c/s static relay to transmit the continuous seize signal. To minimize signal interference, the line is split on the exchange side 30–50 ms before the v.f. signal is transmitted. When the link circuit has associated the preceding equipment, relay B operates and contacts B1

†Telephone Exchange Systems Development Branch, E.-in-C.'s Office.

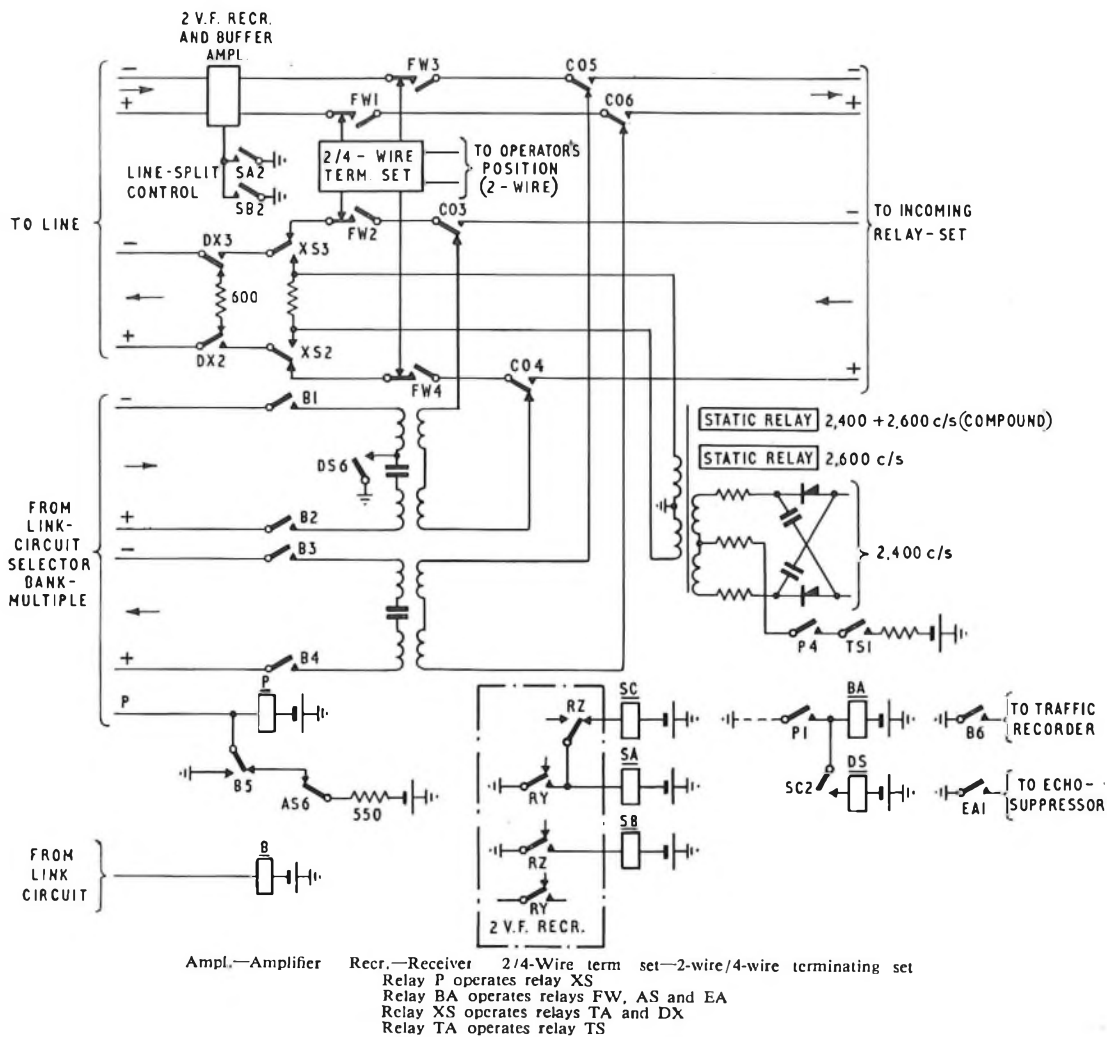

FIG. 1—CIRCUIT ELEMENT FOR SEIZURE AND DUAL SEIZURE

to B4 extend the 4-wire path from the link circuit to line. Contact B5 busies the P-wire and holds relay P. Contact B6 applies earth to the traffic recorder and contact EA1 extends a signal to render the echo-suppressor ineffective.

Proceed-to-Send. On seize-signal received, the incoming relay-set at the incoming end causes an incoming register to be associated and busies the partner outgoing relay-set. The static relays of the partner outgoing relay-set are switched into circuit and a continuous proceed-to-send signal is transmitted back from the 2,600 c/s static relay.

At the outgoing end, the seize signal is ceased when both the conditions (a) proceed-to-send received, and (b) the outgoing register is ready to pulse out, are met. The proceed-to-send condition is extended on a d.c. basis to the outgoing register which returns a d.c. signal to the outgoing relay-set to indicate that the register is ready to pulse out, that the seize signal can be ceased, and that the transmission path can be switched to the register for the pulse out. This arrangement avoids a T.A.S.I.-prefixed register pulse out, the "Go"-channel T.A.S.I. association on the seize signal being available for the register pulse out. The first register signal (a KP signal, see Table 2) follows the termination of the seize signal within 80 ± 20 ms, which is within the 240 ms hang-over

of the T.A.S.I. speech detector. At the incoming end, cessation of the received signal ceases the transmission of the proceed-to-send signal.

Register Pulse Out. The durations of the pulses and gaps of the register pulse out assure maintained T.A.S.I. association (see Table 2).

When the register pulse out is complete (indicated by the transmission of the ST signal) at the outgoing end:

- (a) the outgoing register releases, and
- (b) the 2-wire/4-wire terminating set is connected and the 4-wire circuit is extended to the operator on a 2-wire basis.

At the incoming end:

(a) The incoming relay-set receives a signal from the incoming register indicating terminal or transit routing. In preparation for the forward routing, a terminal or a transit route selector is controlled on a group-marking basis from the incoming register. When a free outlet is found, a pulse-out circuit to the forward equipment is provided from the register.

(b) The incoming register releases when it has pulsed out forward (indicated when the ST signal has been transmitted).

Answer. The incoming relay-set at the incoming end transmits a 2,400 c/s 850 ms pulse via the 2,400 c/s

static relay. When the operator goes out of circuit, the 2-wire/4-wire terminating set is switched out and the transmission path is completed 4-wire.

Clear Back. The incoming relay-set at the incoming end transmits a 2,600 c/s 850 ms pulse via the 2,600 c/s static relay.

Called-Party Flashing. A signal, once started, is always carried to completion. A silent interval of at least 100 ms separates any two successive v.f. signals sent in the same direction. Thus, should the called party flash his receiver rest at a faster rate than the equipment can transmit a succession of clear-back and answer signals, the succession of signals will not be given, but the correct indication of the final position of the receiver rest will always be given by the appropriate 850 ms pulse signal.

Clear Forward and Release Guard. On clear down, a continuous 2,400 + 2,600 c/s compound signal is transmitted from the outgoing end via the 2,400 + 2,600 c/s static relay. On receipt of the clear-forward signal the incoming end initiates the release of the incoming equipment and sends back a continuous 2,400 + 2,600 c/s release-guard signal. The receipt of this signal at the outgoing end ceases the clear-forward signal. The release-guard signal persists until acknowledged by the cessation of the clear-forward signal, or until the incoming equipment has released, whichever is the later. The release guard thus maintains the outgoing end engaged while the incoming equipment is releasing. The outgoing access at the incoming end is maintained busy for 200–300 ms after the termination of the release-guard signal.

A clear-forward signal, which must be acknowledged by a release-guard signal under all conditions of the equipment including the idle condition, may be sent from the originating end at any time to initiate the release of the circuit at any stage.

Busy Flash. The incoming end transmits a busy flash (2,600 c/s for 850 ms) signal if the call cannot be completed for any of the following reasons:

(a) Congestion at the incoming intercontinental exchange, terminal or transit.

(b) Error detected in the receipt of the register signals.

(c) Busy flash (if given) from the incoming international or national network.

(d) Time out of an incoming intercontinental register.

Receipt of the busy flash at the outgoing exchange causes:

(a) a clear-forward signal to be transmitted and the transoceanic circuit released by the clear-forward/release-guard sequence, thus releasing the expensive intercontinental circuit early, and

(b) busy tone to be transmitted to the operator.

Forward Transfer. On an automatically established connexion the forward transfer is sent by the outgoing operator to connect the call to an operator at the incoming intercontinental exchange. On connexions completed via an operator at the incoming intercontinental exchange, the forward-transfer signal causes this same operator to be recalled, which operator can speak to either the called or calling party to give assistance. An 850 ms 2,600 c/s signal is transmitted from the outgoing relay-set for the forward transfer.

Dual Seizure. Considering the transmitted-signal line-split (50 ms), the clipping of the seize signal by T.A.S.I. equipment (occasionally 500 ms), the circuit propagation time (35 ms for a transatlantic circuit) and the seize-signal recognition-time (50 ms), it is apparent

that the unguarded interval relative to dual seizure on bothway operation of the circuits approaches 635 ms in the extreme case. In view of this, the signalling system is designed to detect dual seizure and to make an automatic repeat-attempt to set up the call.

The whole sequence is such that the outgoing seize is received as being transmitted at each terminal. This condition is detected. Relay P (Fig. 1) is operated on outgoing seizure as described previously. Relay SC is operated by the v.f. receiver (relay RY) on the incoming seizure. Relay SC operated while relay P is operated is the dual-seizure detection. Relay DS operates over contacts SC2 and P1. Contact DS6 indicates the dual seizure to the preceding equipment, which releases from the call it attempted to set up and, when released, releases relay B, which initiates the release of the outgoing relay-set and the cessation of the outgoing seize signal.

The whole sequence is such that the outgoing seize signal is transmitted for at least 850 ± 200 ms. Each outgoing seize signal, maintained for at least 850 ± 200 ms to achieve T.A.S.I. association, ensures that both ends of the circuit detect the dual seizure.

The outgoing relay-set releases on the termination of both the outgoing (release of relay TS) and incoming (release of relay SC) seize signals. A clear-forward signal is not sent and the clear-forward/release-guard sequence does not apply on dual-seizure release, which saves time. The call is still stored in the outgoing register and an automatic repeat-attempt is made to set it up. The repeat-attempt is not limited to the circuit used for the first attempt, but should the first circuit be re-seized on the re-search over the circuits for the second attempt, a minimum interval of 100 ms occurs between the termination of the first-attempt outgoing seize or the recognition of the cessation of the incoming seize signal, whichever is the later, and the commencement of the second-attempt seize signal. This interval allows time for the initiation of the release of the equipment which was used at the distant end for the first attempt.

Dual seizure on the second attempt results in busy tone to the operator. A third attempt is not made.

2 V.F. Line Receiver

The link-by-link and non-digital signalling arrangements ease the design requirement of the line-signal v.f. receiver because a wide operate-level range and small pulse distortion, respectively, are not necessary. In view of the important nature of the transoceanic traffic, a high order of immunity against signal imitation by speech is desirable.

A 50-volt 1 v.f. transistor-type receiver, designed for application to a decimal-pulsing line-signalling national system, was adapted for the purpose. While the small pulse distortion of this receiver was not essential, the high order of speech immunity of the design made the receiver attractive.

Two 1 v.f. receivers, one tuned to 2,400 c/s and the other to 2,600 c/s, are combined as a 2 v.f. receiver. As the guard circuit of the 1 v.f. receivers is responsive close to the respective signalling frequencies, in the combination a 2,400 c/s band-stop filter precedes the 2,600 c/s receiver and a 2,600 c/s band-stop filter the 2,400 c/s receiver to allow for the compound operation of the 2 v.f. receiver. The consequential removal of some 200 c/s from the guard bandwidths of both 1 v.f.

receivers made negligible difference to their signal-imitation performances.

The general arrangement of the 2 v.f. line receiver is shown in Fig. 2. The input impedance of the input

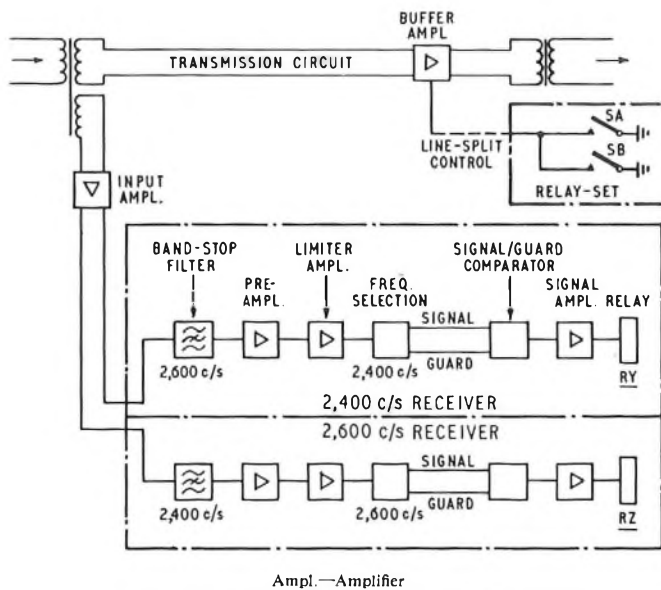

FIG. 2—GENERAL ARRANGEMENT OF 2 V.F. LINE RECEIVER

amplifier is high to give a small bridging loss across the speech transmission path. A series LC circuit in the frequency-selection circuit, tuned to the signalling frequency (f_s) provides a tuned-guard characteristic.⁵ A parallel LC circuit in the pre-amplifier is tuned to f_s , reducing the gain at f_s by some 12 db, to obtain the desired overall guard ratio.⁵ The comparator compares the signal and guard potentials and its output drives the signal-detector stage, the relay of which operates in single-current manner.

Buffer Amplifier

A zero-gain amplifier in series with the receive point of the transmission path protects the v.f. receiver from near-end interference. The received v.f.-signal line-split, necessary to limit the duration of the incoming v.f.-signal spill-over to subsequent links, is effected on the buffer amplifier.

Fig. 3 shows the essentials of the circuit, transistors in common-base configuration being used to obtain high

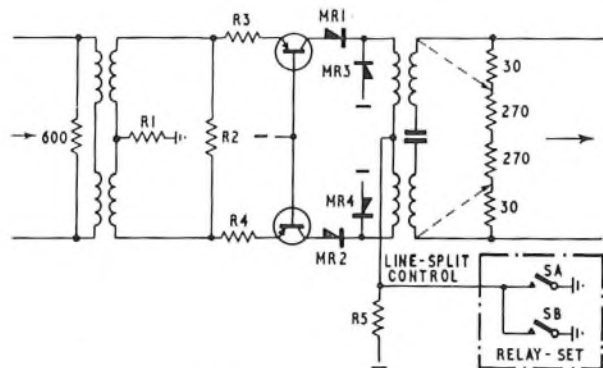

FIG. 3—BUFFER AMPLIFIER

linearity without negative feedback. The Class A push-pull arrangement provides a symmetrical circuit to aid noiseless line splitting.

The gain, nominally 0 db over the range 200–3,400 c/s, is adjusted by strapping on the 30-ohm resistors which are part of the 600-ohm terminating resistor. This gain adjustment is mainly required to compensate for the sample-to-sample variation of the transformer losses. The line split, controlled by relay SA (2,400 c/s signal) or relay SB (2,600 c/s signal) in the relay-set (see Fig. 1), occurs 35 ms after receiver operation. The applied earth reverse biases rectifiers MR1 and MR2, introducing a forward loss of some 70 db which gives the line split. Rectifiers MR3 and MR4 limit the negative-voltage excursions to 50 volts to protect the transistors. The reverse loss, which gives the protection against near-end interference, is some 70 db during normal and line-split conditions.

Operation of Line Receiver

Fig. 4 shows the essential circuit elements of the 2,400 c/s 1 v.f. receiver, the 2,600 c/s receiver being the same except for the tuning. The parallel $L1, C1$ circuit, tuned to f_s , across resistor R1 in the emitter feedback circuit of the pre-amplifier provides a de-emphasis of some 12 db at f_s relative to the guard frequencies, f_g . While the guard response falls off below 500 c/s, network $C2, R2$ ensures a considerable reduction below 200 c/s to prevent excessive guarding if 50 c/s interference is present.

The output of transistor VT1, a linear amplifier over the working-level range, is fed to a limiter. If transistor VT1 collector current increases by more than, say, i , rectifier MR1 is reverse biased and a current i flows into capacitor C3 and the base of transistor VT2. Similarly, if the collector current of transistor VT1 falls by i , rectifier MR2 will be cut off and a current i will flow from capacitor C3 and the base of transistor VT2. A sensibly constant input to transistor VT2 over the working range is thus obtained by clipping the collector current of transistor VT1.

The output of transistor VT2, a current amplifier the gain of which is stabilized by shunt negative feedback provided by resistors R6 and R7, is fed to the frequency-selection stage L3, C5, tuned to f_s , and in parallel with the guard resistor R8. Capacitor C4, functioning as a simple low-pass filter, reduces the harmonics of the signal that would otherwise result in guard response. At f_s , the signal voltage, v_s , developed across the secondary of transformer T3 is high and the guard voltage, v_g , developed across resistor R8 is low. At guard frequencies f_g , v_s is low and v_g high. When v_s exceeds the bias provided by resistor R11 in the comparator circuit, transistor VT3 is turned on. Transistor VT4 (with v_g applied to the base) acts as a rectifier and charges capacitor C6 to the peak of the guard voltage, applying a bias to transistor VT3 to oppose the turn on of this transistor by v_s applied to its base. Resistor R11 provides a guard bias to transistor VT3 to prevent receiver operation below -27 dbm0. The time constant of network R13, C6 provides a 4 ms hang-over on the guard circuit.

Transistor VT3 thus functions as the signal/guard comparator and as the driving transistor for the relay-detector stage. When transistor VT3 is turned on to a signal, the rise of collector current produces a secondary voltage on transformer T4 in a direction such as to hold transistor VT5 off. Capacitors C7 and C8 in the relay

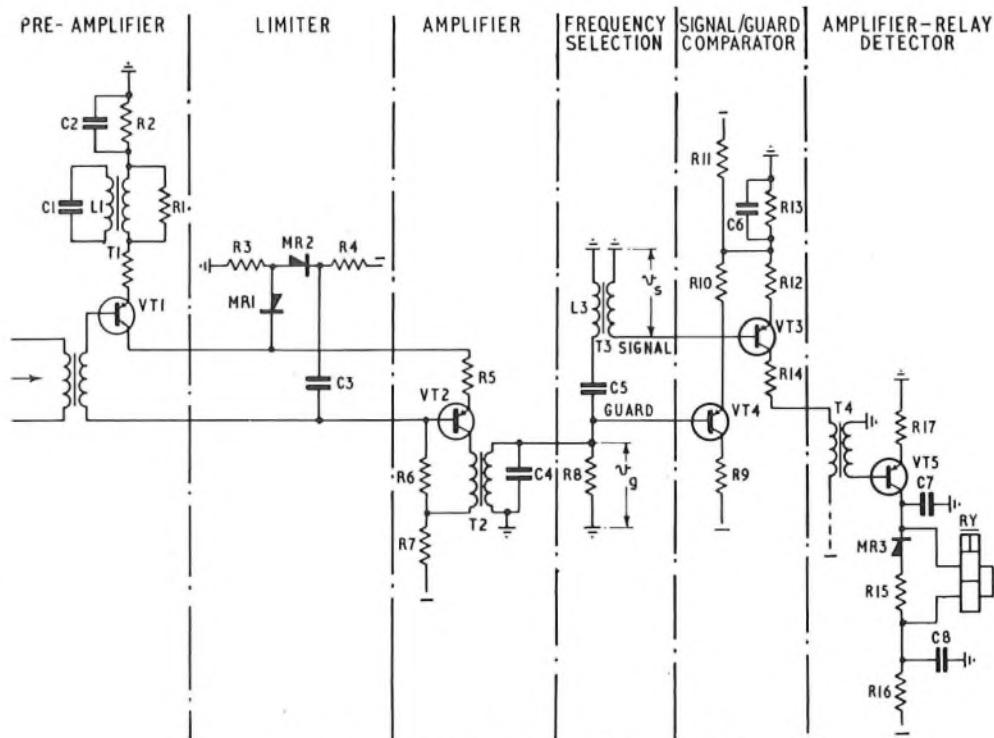

FIG. 4-1 V.F. SECTION OF 2 V.F. LINE RECEIVER

stage are normally charged to the transistor VT5 collector potential. When transistor VT3 is turned off after the first negative peak signal, the energy stored in transformer T4 discharges into the base of transistor VT5 and collector current flows through relay RY. At the same time capacitors C7 and C8 discharge to the transistor VT5 emitter circuit, C8 discharging through the relay in a direction such as to aid the transistor VT5 collector current flowing through the relay. Relay RY thus operates quickly.

The discharge of energy from transformer T4 tends to maintain transistor VT5 turned on during the intervals when transistor VT3 is turned on to the negative peaks of the signal. Should transistor VT5 turn off, capacitors C7 and C8 charge to the transistor VT5 collector potential. Capacitor C7, charging through the relay in a direction to hold it operated, effectively smooths the input half cycles. When transistor VT5 turns on again, capacitors C7 and C8 again discharge as previously described. At the end of the signal, capacitor C7, discharging through the relay, increases the release lag to contribute to equal operate and release times. This minimizes the pulse distortion on the relay signal repetition. The network R15, MR3 shunt the relay, preventing excessive negative spikes which would otherwise damage transistor VT5 when it is turned off. The shunt also contributes to increasing the relay release-lag.

The performance of the receiver may be summarized as follows:

(a) It has an operate bandwidth of 100 c/s for either signal frequency.

(b) It has a required operate level range of +2 dbm0 to -13 dbm0.

(c) It will not operate to a signal below -27 dbm0.

(d) Its pulse distortion is within 5 ms. Small pulse distortion on line signals is not a requirement for trans-oceanic signalling, the specification requirement being

15 ms for simple signals and 25 ms for compound signals.

(e) It will operate with up to 6 db difference in received level between the two signal frequencies.

(f) Its speech immunity performance (1 v.f. section) is 3 imitations of 12.5 ms and 0.5 of 25 ms duration per speech hour. The compound performance is better. As the line-split delay is 35 ms and the minimum recognition time of signals subject to imitation is 100 ms, it is clear that the receiver has high speech immunity against both line-split and signal imitation.

REGISTER SIGNALLING

The inter-register signalling system employs a two-out-of-six multifrequency (m.f.) code giving 15 signals (see Table 2). The transmitted signal level is -6 ± 1 dbm0

TABLE 2
Inter-Register Signalling Code

Signal	Frequencies (c/s) (Compounded)
Digit value 1	700 + 900
2	700 + 1,100
3	900 + 1,100
4	700 + 1,300
5	900 + 1,300
6	1,100 + 1,300
7	700 + 1,500
8	900 + 1,500
9	1,100 + 1,500
0	1,300 + 1,500
Code 11	700 + 1,700
Code 12	900 + 1,700
KP1 (terminal)	1,100 ± 1,700
KP2 (transit)	1,300 + 1,700
ST (end-of-pulsing)	1,500 + 1,700

Signal Durations: KP1 and KP2, 100 ± 10 ms.
All other signals, 55 ± 5 ms.

Interval between all signals: 55 ± 5 ms.

per frequency. Frequency generation is by a rotary machine similar to that described previously in this Journal.⁶

The frequency combinations differ in regard to the KP2 and code-12 signals from that agreed initially,² the revised arrangement being regarded as a more logical combination.

The KP signal, which gives the terminal/transit discrimination, is the first signal of the register output. The ST signal is the last. The information is transmitted in a continuous sequence between the registers, the T.A.S.I. association being maintained by the m.f. pulses during the register pulse out.

M.F. Transmitter

The outgoing register transmits the two-out-of-six m.f. signals via a static relay controlled by a transistor-type multivibrator time base.

M.F. Receiver

Fig. 5 shows the arrangement of the transistor-type

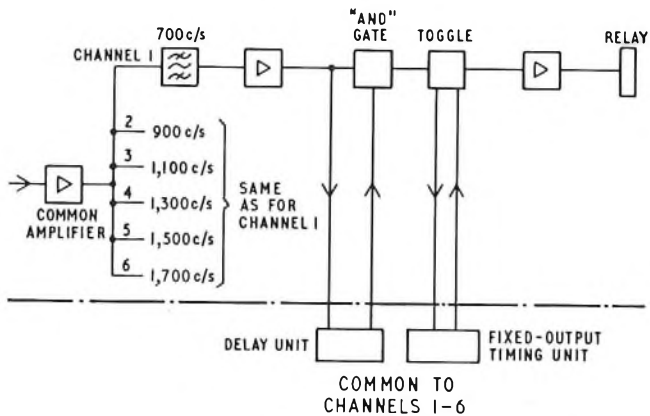

FIG. 5—GENERAL ARRANGEMENT OF M.F. RECEIVER

24-volt m.f. receiver. The input common amplifier is connected to six parallel channels, each tuned to the relevant signal frequency. The delay unit (15 ms delay) operates on all six channels to mask the initial 15 ms of the signal. After 15 ms the delay unit extends a condition to the channel AND gates and if the signal is present at the other input, the gate opens to pass the signal to the channel toggle to operate the channel relay (dry-reed type).

The delay masks the transient output from all other channels when a steeply rising signal is applied to one. The duration of the transient is a function of the filter design and is some 10 ms. The delay unit, by controlling the AND gates, ensures that a signal is passed forward only when it has persisted for at least 15 ms, a longer period than the transient output, and is thus regarded as being a true signal.

The release of the channel relay is dependent upon a fixed-time output unit common to all six channel toggles, and not on the input signal. The channel relay thus provides a fixed-duration signal to the register, pre-adjusted as required in the timing unit. This avoids a small pulse-distortion requirement on the m.f. receiver and, within limits, permits flexibility in the speed of the register-reception device.

A true m.f. signal operates two channels of the receiver and the incoming register incorporates a two-and-two-only check of a signal. Busy flash (a line signal) is returned when an error is detected in the number of frequencies received, and the intercontinental circuit is released.

Operation of the M.F. Receiver

Fig. 6 shows the basic circuit of one channel of the m.f. receiver, the other five being the same except for the filter. The input is applied from the common amplifier through the channel filter.

The rectified output of the transistor VT1 stage is

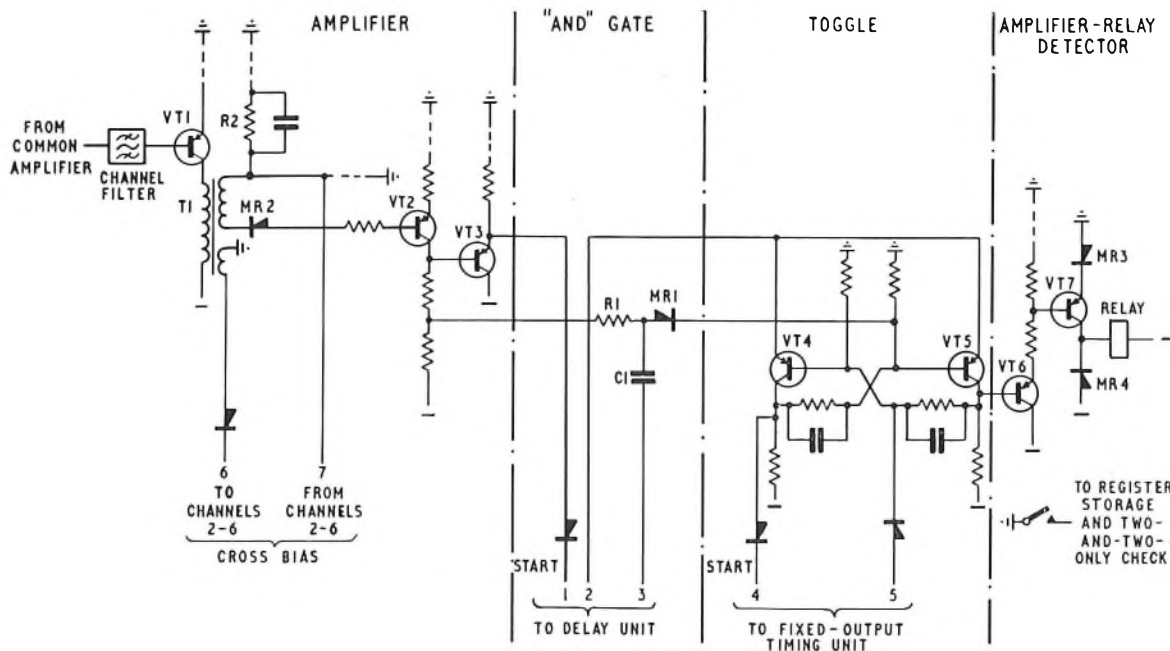

FIG. 6—BASIC CIRCUIT OF ONE CHANNEL OF M.F. RECEIVER

applied to the base of transistor VT2, the potential of which is also determined by the coupling to other channels provided by a cross-bias network. Transistor VT2 turns on, turning off transistor VT3. Transistor VT2 turning on also applies a negative potential as the signal input to R1 of the AND gate and VT3 extends a start signal to the delay unit. After some 15 ms, the delay unit extends a condition on lead 3 as the second input to the AND gate R1,C1,MR1. The signal input, if present at this time, is applied to the toggle via rectifier MR1, turning on transistor VT4 and turning off transistor VT5. Transistor VT5 turning off drives the detector stage, which consists of a d.c. amplifier and the channel relay. When transistor VT5 is turned off the base potential of transistor VT7 is such that rectifier MR3 conducts turning on transistor VT7, the collector current of which operates the channel relay.

A second output from the toggle is applied as a start signal (lead 4) to the timing unit. After a time delay, which can be pre-adjusted as required in the timing unit (set at 45 ms for the initial transatlantic application of the system), a condition on lead 5 from the timing unit resets the toggle. Transistor VT4 turns off and transistor VT5 turns on, and the reset causes the channel relay to release.

The other channels of the m.f. receiver operate similarly.

Cross Bias. To prevent the possibility of modulation products of two signal frequencies operating unwanted channels, part of the output of a channel receiving a signal frequency is rectified and applied (lead 6, Fig. 6) to all the other channels to desensitize the channel amplifiers. This condition is received by all the other channels on lead 7 and a potential is developed across resistor R2 to bias the base potential of transistor VT2.

Delay Unit. Fig. 7 shows the basic circuit of the delay unit. The start condition sets the toggle circuit of transistors VT8 and VT9, and an input is applied to the AND gate C2,R2,MR5 at capacitor C2. With the flip-flop circuit of transistors VT10 and VT11 normal, a second input is applied at resistor R2 and the flip-flop is triggered by the output of the gate via rectifier MR5. After some 15 ms, during which capacitor C3 is charged with the rate of charge being conditioned by capacitor C3 and resistors R3 and R4, the flip-flop triggers back. An output is applied on lead 3 to all the channel AND gates to allow any signal present

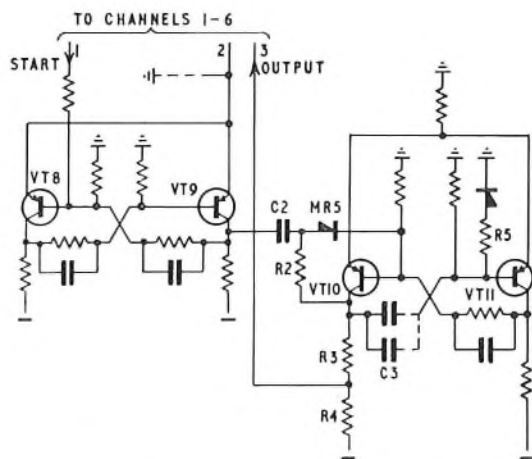

FIG. 7—DELAY UNIT OF THE M.F. RECEIVER

to be passed through to the appropriate channel relay. Capacitor C3 discharges via resistor R5. A strapping arrangement on capacitor C3 enables the delay to be pre-adjusted as required.

Fixed-Output Timing Unit. Fig. 8 shows the basic circuit of the fixed-output timing unit. The start condition from the channel toggles (lead 4) turns off transistor VT12. Capacitor C4 discharges via resistor R6 to turn on transistor VT13 and turn off transistor VT14 after a time set at 45 ms. Transistor VT14 applies an output on lead 5, common to all the channel toggles, which resets any toggles that have been set, the toggles in turn releasing any channel relays operated. When the last toggle has reset, a condition on the start lead changes to reset the timing circuit to normal. The delay can be varied as required by a strapping arrangement on resistor R6.

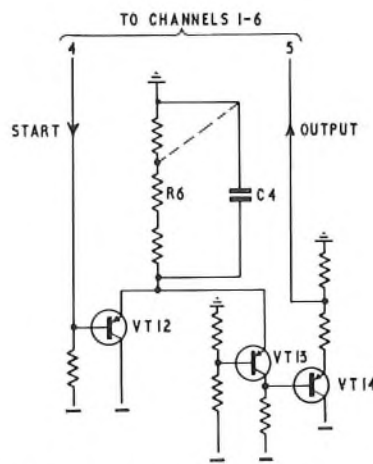

FIG. 8—FIXED-OUTPUT TIMING UNIT OF THE M.F. RECEIVER

Performance of the M.F. Receiver

The performance of the m.f. receiver may be summarized as follows:

- It is required to operate over the range -1.5 dbm0 to -18.5 dbm0.
- It will not operate to a signal below -28 dbm0.
- It will operate with up to 7 ms difference between the start of any two signal frequencies.
- It will operate with up to 6 db difference in received level between any two frequencies.
- It will operate to a minimum signal of 16 ms and will extend a minimum signal to the register of 22 ms.

CONCLUSIONS

Line and register signalling systems have been designed for dialling over T.A.S.I.-equipped transoceanic telephone cables. T.A.S.I. has complicated the design of the systems relative to that which could have been used on circuits not associated with T.A.S.I. equipment, but as the signalling facilities have been kept to a minimum consistent with international requirements, a robust design has been achieved. The systems have operated successfully on the TAT-1 transatlantic cable since March 1963 and will be applied on the other transatlantic cables and on the COMPAC (Pacific) cable in the near future. The design principles of the equipment will be adopted for all the dialling units associated with the Commonwealth round-the-world cable scheme.

ACKNOWLEDGEMENTS

As with all major developments, many colleagues were engaged on the project and the author gratefully acknowledges their work and assistance. Grateful acknowledgement is also made to Standard Telephones and Cables, Ltd., for technical assistance and for their ready cooperation in the production of the equipment for the London installation.

References

¹HEPTINSTALL, D. L., and JONES, P. F. Switching Arrange-

ments for Semi-Automatic Operation of Transoceanic Telephone-Cable Circuits. (In this issue of the *P.O.E.E.J.*)

²WELCH, S. Signalling Arrangements for Dialling over the Transatlantic Telephone Cables. *P.O.E.E.J.*, Vol. 53, p. 201, Oct. 1960.

³CLINCH, C. E. E. Time Assignment Speech Interpolation (T.A.S.I.). *P.O.E.E.J.*, Vol. 53, p. 197, Oct. 1960.

⁴GEE, J. H. Frequency-Generating Equipment for the Transoceanic Line-Signalling System. (In this issue of the *P.O.E.E.J.*)

⁵WELCH, S. The Influence of Signal Imitation on the Design of Voice Frequency Signalling Systems. *I.P.O.E.E.* Printed Paper No. 206, 1953.

⁶GEE, J. H. A Motor Alternator for A.C. Signalling Supplies. *P.O.E.E.J.*, Vol. 54, p. 268, Jan. 1962.

Tape-Recording Machine for Ticking-In Mails at Sorting Offices

U.D.C. 681.846:656.853

THE arrival of mails at a sorting office is checked by a simple process known as "ticking-in." Forms called tick sheets are prepared, listing the mails due and their scheduled time of arrival. At a non-mechanized sorting office mail bags are manhandled from the arrival point outside the office to a position inside where a ticking-in officer sits at a desk; information recorded on the bag label is called out to him as each bag is brought into the office, and he "ticks-in" the appropriate entry. The ticking-in officer has to exercise control of the porters so that the rate of arrival of the mail bags does not exceed that at which he can record them. The information recorded on the tick sheet provides the supervising staff with up-to-date information on arrivals; and the delay to or non-arrival of a complete mail or an individual mail bag is readily detected.

The manual ticking-in process requires the services of at least two men at peak periods, one to read and call out the necessary information and the second to record it on the tick sheets. If, however, the ticking-in officer is provided with an oral recording device he can both read and record at the same time. Whilst the primary objective would be to spread the peak demand on manpower by transcribing from the oral recording to the tick sheets in off-peak periods, some slight economy may be shown in the overall manpower required for portage and tick-in operations.

If a chain conveyor* is used to transfer mail bags from the loading platform to the various processing points inside a sorting office, difficulty arises in regard to the ticking-in process; to utilize the full potential of the conveyor no avoidable delay should arise between the arrival of a van and the discharge of the mail bags in the office. Because labels are attached to the necks of mail bags, the bags are loaded on to the conveyor with their necks downwards. At a suitable point within the sorting office ticking-in facilities are provided by running the conveyor at a level which permits the labels to be read as the bags pass. However, if a conveyor is heavily loaded a bag may arrive at the ticking-in point every few seconds; it would be difficult for the ticking-in operator to work at this speed and it is therefore necessary to provide him with a machine by means of which he can record the label details orally.

*SMITH, W. J., and ROGERS, J. D. Chain Conveyors in Postal Engineering. *P.O.E.E.J.*, Vol. 51, p. 53, Apr. 1958.

General Description of Recorder and Facilities Provided

The recorder currently in use is a modified dictating machine using magnetic tape as the recording medium. The machine is used by non-engineering personnel and it is essential that the loading and unloading of the tape spools should be as simple as possible. This requirement restricted the choice of machine to one in which the tape spools are enclosed in a container or cassette and in which the action of loading the cassette on to the machine automatically locates the tape within the recording and tape-transport mechanism of the recorder. The arrival of mail bags at the ticking-in position will not be continuous and the ticking-in officer must be able to stop and start the machine at will. To avoid damage to the machine and provide a suitable environment for transcribing from the machine to the tick sheets, the recorder is installed in an enclosure away from the ticking-in position, and thus remote control of the machine from the ticking-in position is necessary.

Control of the remote machine is by foot switch, which enables the operator to start, stop and back-space the machine as necessary to enable him to search for a particular entry in the tick sheets. When recording, the machine is set manually to the recording position, and indications are given at the ticking-in position to show when the machine is available for recording and also when all the available tape has been used.

The number of commercially-available machines capable of fulfilling the foregoing requirements is limited, and when the problem was first considered only one type of machine was known that would give all the facilities required. This machine is expensive and is produced in limited quantities; subsequent service experience shows that it is also less reliable than expected and that the cassettes are easily damaged. Mass-produced dictating machines, with cassette loading, which can be readily modified to give the facilities required have since appeared as standard items of office machinery provided by Her Majesty's Stationery Office and will be used experimentally in the first installation at Dover sorting office.

A robust solenoid-controlled cassette-loading tape deck has been produced by one manufacturer. This item could form the basis of a future remotely-controlled dictating machine. Prolonged running tests have been carried out on a sample mechanism and it appears to be reliable.

E.C.P.

Frequency-Generating Equipment for the Transoceanic Line-Signalling System

J. H. GEE†

U.D.C. 621.313.3.029:45:621.395.636:621.395.45

The signalling frequencies used for the transoceanic line-signalling system are generated by motor alternators whose speed is controlled so that the frequencies produced are accurate to within ± 5 c/s. The speed-control and frequency-deviation-detector equipments associated with the motor alternators are described.

INTRODUCTION

THE signalling frequencies for the transoceanic line-signalling system¹ are generated by battery-driven motor alternators similar in design and construction to those described in an earlier article in this Jour-

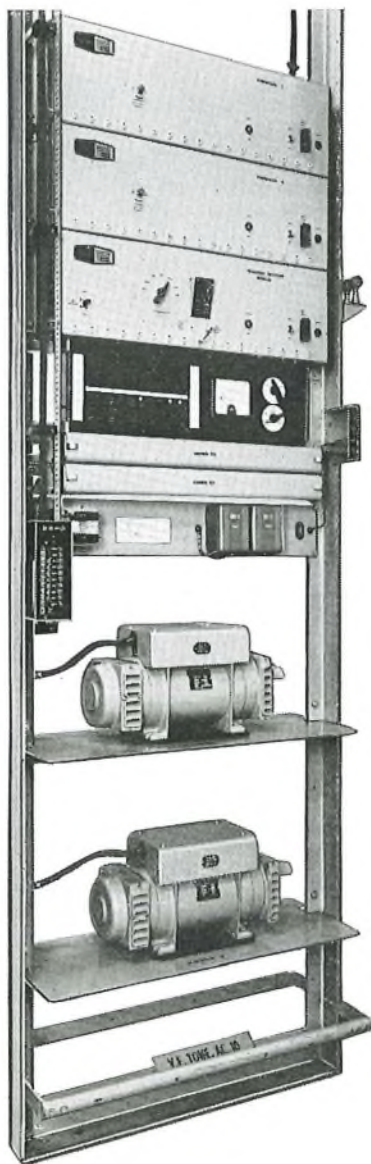

FIG. 1—FREQUENCY-GENERATING EQUIPMENT FOR TRANSOCEANIC LINE-SIGNALLING SYSTEM

nal.² It is necessary for the frequencies generated (2,400 c/s, 2,600 c/s and a compound 2,400 + 2,600 c/s) to be controlled to within ± 5 c/s of the nominal value. The installation comprises two machines, and a separate speed-controller is provided for each machine. One machine normally supplies the load while the other acts as standby, and the output of the working machine is continuously monitored by a frequency-deviation detector; automatic change-over to the standby machine takes place if the output fails or the frequency drift exceeds preset limits.

The speed-control and frequency-deviation-detector equipments are of electronic design using semiconductors. A complete equipment is shown in Fig. 1.

The alternators provide a maximum output of 4 watts at 20 volts, with a regulation of ± 0.5 volt and a harmonic content of less than 5 per cent. As already stated, they are similar to an earlier design, but excitation is by a field winding instead of by permanent magnets. A transistor regulator maintains the field current to within 1 per cent of its preset value irrespective of normal supply-voltage and field-resistance variations.

Distribution of the signalling frequencies to the racks of senders and receivers is by 2-wire screened feeds; distribution transformers and resistive networks provide for the correct sending voltage for a group of circuits.

MOTOR SPEED CONTROL

The basis of the speed-control system is the phase-angle comparison of two signals: one is a reference signal provided by frequency division from a crystal-controlled oscillator in the speed-control circuit (Fig. 2), and the other is generated by a small alternator driven from the motor shaft.

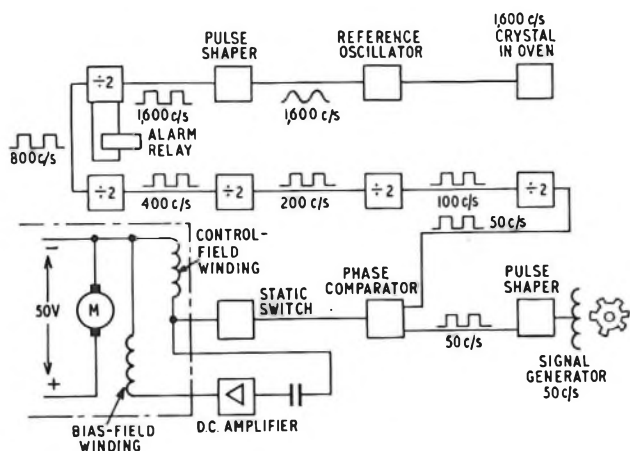

FIG. 2—BLOCK SCHEMATIC DIAGRAM OF SPEED-CONTROL EQUIPMENT

†Telephone Exchange Standards and Maintenance Branch, E.-in-C.'s Office.

Referring to Fig. 2, the output of the 1,600 c/s reference oscillator, a sine wave of approximately 0.5 volt amplitude r.m.s., is passed via a pulse shaper to obtain the square-wave pulse required to operate the subsequent divide-by-two circuits to produce the 50 c/s reference for the phase comparator. The output of the signal generator on the machine is also passed via a pulse shaper to obtain a square-wave pulse before connexion to the phase comparator.

The two waveforms are shown as A and B in Fig. 3.

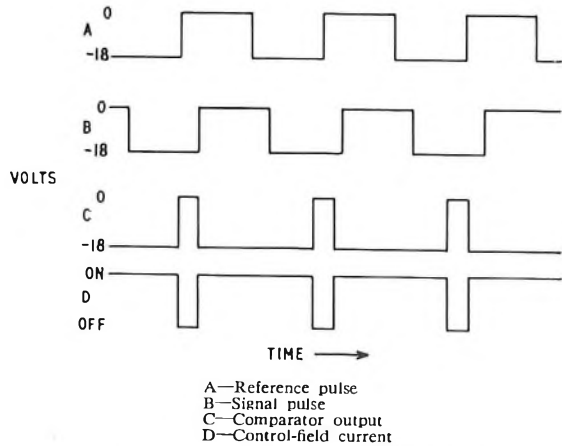

FIG. 3—WAVEFORMS IN SPEED-CONTROL CIRCUIT

They are displaced in time by a period depending on the adjustment of the d.c. amplifier and, therefore, on the current flowing in the bias-field winding. If the machine is in synchronism with the reference, i.e. the signal generated is 50 c/s, there will be no phase difference between the two signals and the output of the phase comparator will be as shown in waveform C. The phase comparator is arranged to switch when these signals change from negative to positive. The output waveform is used to control transistors in the static switch so that in the "on" condition the controlling transistor draws its current via the control-field winding of the motor. The current flowing in this winding will therefore have a mark:space* ratio as shown in D. With a small increase in signal frequency the square waves of trace B will occur slightly closer together and the control field will be switched-off earlier in each successive cycle. This will result in an increase in the mean field current, a reduction in machine speed and a corresponding change in the signal frequency so that the frequency error is corrected. Likewise, a small decrease in signal frequency will also produce the appropriate restoring effect.

The mark : space ratio for the synchronous condition, and hence the current in the bias field, can be varied by adjustment of the d.c. amplifier. The effect upon the mark : space ratio is such that the mark period decreases and the space period increases for a reduc-

tion in voltage, and vice versa. The mark : space ratio is set to take these changes into account so that the equipment will perform satisfactorily over the range 47–51 volts. This initial adjustment of the d.c. amplifier also caters for small differences between machines due to tolerances in motor windings, etc.

To provide an alarm should the controller of the standby alternator fail, an additional output is taken from the divide-by-two circuits at 800 c/s and applied via a transistor drive circuit to hold the alarm relay operated. If for any reason this supply fails an alarm is given.

FREQUENCY-DEVIATION DETECTOR

Fig. 4 is a block schematic diagram of the frequency-deviation detector. The frequency of the reference oscillator, 2,600 c/s, is controlled by a crystal similar to those used in the speed controllers. The output of this oscillator and one output from the 2,600 c/s alternator are connected to a resistive network; any difference in frequency produces a beat, which is detected, amplified, and rectified. The signal so obtained is then shaped to obtain a square-wave output and fed into a counter circuit arranged to count the beats over a period of a second and thus indicate the alternator frequency error.

A display panel of eight indicator tubes is arranged to indicate percentage errors of 0, 0.02, 0.06, 0.1, 0.13, 0.17, 0.21 and 0.25. If, for example, four beats are received in 1 second, the maximum count will be indicated visually by the tube marked 0.13 glowing at the end of the 1-second period. The counter then resets to zero and, if the error persists, the same tube glows again at the end of the next second.

To obtain an alarm pulse, the input to the display tubes is also connected to the contacts of a selector switch set according to the appropriate percentage error, in this instance 0.17, which corresponds to the specified limit of ± 5 c/s. A signal appearing at this point will be passed via a pulse shaper to re-form the signal into a square pulse, and this pulse is now used to effect change-over. To ensure that this does not occur unnecessarily (e.g. due to a transient disturbance registering an error of 0.17 per cent in less than

*The mark condition is that in which current flows through the control-field winding; in the space condition there is no current in the control-field winding.

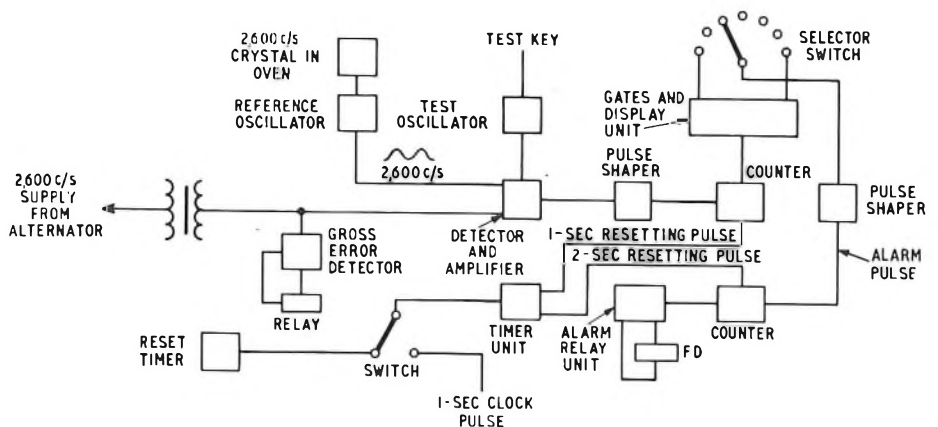

FIG. 4—BLOCK SCHEMATIC DIAGRAM OF FREQUENCY-DEVIATION-DETECTOR EQUIPMENT

a second) the alarm pulse is fed into a counter circuit arranged so that only if an alarm pulse is received in two consecutive 1-second periods will an output be obtained to switch off the relay drive circuit and cause relay FD to release. A single alarm pulse received during the 2-second period will set the counter, but it will perform no further function before the 2-second reset pulse arrives and the counter will then be cleared. A time-constant is included in this circuit to allow a period of 5 seconds to elapse before relay FD is reset; this provides an additional guard and prevents hunting.

Other facilities provided by the display panel include a test key which disconnects the detector from the machine output and change-over circuit and provides routine-test conditions from a test oscillator. This facility enables faults in the panel to be located and cleared without affecting service.

The type of beat-counter circuit described above is suitable for detecting frequency drift up to approximately ± 0.25 per cent, i.e. 7 c/s. It would be possible, however, to have a fault condition that would allow the motor speed to deviate outside the 0.25 per cent range within a 2-second period and be undetected. To detect this type of error and to change over the machines, a gross-frequency error-detector is provided. This is broadly tuned to 2,600 c/s. Should the motor speed deviate by more than 0.25 per cent, the error is detected in a transistor drive circuit that is used to operate a relay that causes the machines to change over.

Timing pulses for the counters may be derived from an external 1-second clock pulse or from the internal reset timer.

During the starting period of the standby machine under failure conditions the change-over circuit is

arranged to hold off the action of the frequency-detector circuits for a period of approximately 25 seconds: this allows sufficient time for the standby machine to reach its synchronous speed and produce a stable output frequency.

CONCLUSIONS

The equipment has now been in service during testing periods, etc., for approximately 10 months during which time a frequency stability better than 0.06 per cent has been maintained, and the regulation of the alternator outputs has been well within limits.

Little attention to the control equipment other than routine inspection of waveforms should be required. To assist in the latter, test points are provided on the fronts of the control panels and the frequency-deviation-detector panel which enable inspection of the waveform to be made and measurements of the voltage to be taken while the equipment is in service. A chart has been prepared giving limits and showing the types of waveform that can be expected; this chart can also be used as a guide to faulting the equipment.

ACKNOWLEDGEMENTS

The author wishes to acknowledge the assistance and information given by the designers and manufacturers of the equipment, Walter Jones & Co., Ltd.

References

- ¹WELCH, S. Line and Register Signalling Systems for Dialling Over Transoceanic Telephone Cables. (In this issue of the *P.O.E.E.J.*)
- ²GEE, J. H. A Motor Alternator for A.C. Signalling Supplies. *P.O.E.E.J.*, Vol. 54, p. 268, Jan. 1962.

Book Review

"Taschenbuch der Nachrichtenverarbeitung (Information-Processing Handbook)" Dr.-Ing. K. Steinbuch. Springer-Verlag, 1,521 pp. 1,295 ill. 98 DM.

The title of this book has been translated as "handbook" rather than the literal "pocketbook" since a book of this size would undoubtedly be described as a handbook in English; its dimensions are 8 in. by 5 in. by 2 $\frac{1}{4}$ in.

The book is divided into 13 sections, which are listed below with a further indication of the subdivision of the sections; the pairs of numbers associated with each section give, respectively, the number of pages and number of references.

1. General Foundations (historical development, definitions, information theory and coding, logical algebra and switching theory, electrical transients) 181, 366.

2. Components and Hardware (valves, semiconductor diodes, transistors, magnetic components, transducers, power supplies) 245, 404.

3. Switching Circuits (relay, diode, transistor, valve, magnetic, parametron) 95, 130.

4. Storage (electronic, magnetic, cathode-ray tube, optical, delay line, cryotron) 133, 217.

5. Input and Output (keyboards, digital display, teleprinters and punched-tape equipment, punched cards, high-speed printers, analogue/digital and digital/analogue converters, curve and point plotters) 145, 192.

6. Special Transducers (automatic character and speech recognition, speech synthesis) 57, 188.

7. Data Transmission (telegraphy, high-speed digital transmission, telemetry and remote control) 78, 121.

8. Control Systems (continuous and sampled-data) 47, 43.

9. Document Conveyor Systems (pneumatic tubes, direct belt conveyors, belt and roller conveyors for document trays) 27, 40.

10. Information-Processing Systems (digital computers, data-processing, analogue computers and simulators, digital integrators, automatic machine control, information retrieval, automatic letter sorting) 321, 697.

11. Programming (digital and analogue computers) 88, 125.

12. Learning Machines (including teaching machines) 63, 155.

13. Information-Processing in Man, 21, 66.

Index: about 4,000 entries.

This book covers an extraordinarily wide field, from highly abstract concepts such as the Turing-machine to highly concrete objects such as the mechanical details of a teleprinter. The references, some 2,700 in number, are by no means confined to German literature. In well-established subjects, most of the references are to German papers, but in currently developing fields the references reflect the geographical distribution of workers; thus in section 12 (on learning machines) about 120 out of 150 references are to papers in English.

Any worker with a knowledge of German would find this an invaluable work of reference and introduction; those without such knowledge would still find it useful as a guide to the literature.

W.E.T.

Outline of Transistor Characteristics and Applications

Part 1—Transistor Parameters and Stabilization of Characteristics

J. A. T. FRENCH, B.Sc.(Eng.), A.M.I.E.E., D. J. HARDING, B.Sc.(Eng.), A.M.I.E.E.,
and J. R. JARVIS, B.Sc.(Eng.), A.M.I.E.E.†

U.D.C. 621.382.3.012.7

This is the first of a series of three articles which it is hoped will be useful to the many readers of the *Journal* who have the need for a general understanding of the construction and application of transistors but not the time or opportunity to study the extensive literature on the subject. Part 1 describes the various types used, their essential parameters, and the stabilization of their characteristics. The subsequent articles will deal more fully with amplifying and switching applications.

INTRODUCTION

DURING the last decade there has been a steady improvement in the quantity and quality of transistors produced and at the same time a steady reduction in price. Because of their small size, low power wastage, and reliability they have become very attractive for use in many Post Office applications, and for some years transistors have been used to replace valves wherever possible and in new developments.

In some of the early equipment using small numbers of active devices it was found that two transistors were required to replace each valve (e.g. in the standard line amplifier). In spite of this apparent disadvantage the use of transistors was economically justified in many applications and provided, at the same time, an increase in flexibility and performance.

One of the first large-scale applications was the Post Office development of the Medresco hearing aid which commenced in 1955.¹ Transistors are now widely used for line amplifiers,² carrier terminals, and a host of miscellaneous applications including letter-sorting machines,³ v.f. receivers, electronic directors using ferrite cores,⁴ and experimental electronic telephone exchanges.

In some of these applications, the number of transistors needed is no greater than the number of valves displaced, and some modern transistors are superior to the conventional valve in bandwidth and speed of operation.

TYPES OF TRANSISTOR

In the process of evolution numerous methods of manufacture have developed. One type, the simple alloy structure, has, however, predominated among the devices produced in this country and in spite of its shortcomings is still by far the most numerous and cheapest unit available. More recently the planar transistor has become notable for its performance and reliability. It is proposed to confine description and discussion to these two types.

The basic materials used in the manufacture of transistors are extremely pure germanium or silicon which have been doped, or made impure, by the addition of very small and carefully controlled amounts of such elements as indium or boron (p-type), antimony or phosphorus (n-type), depending upon the required function. Material doped with p-type impurities has a

preponderance of positive-charge carriers (holes) and, conversely, the n-type has a preponderance of negative-charge carriers (electrons). A junction transistor is made up as a sandwich of these two types of materials either in the form p-n-p or n-p-n.

The Alloy Type

Fig. 1 shows the cross-section of a typical germanium p-n-p audio-frequency alloy transistor. During manu-

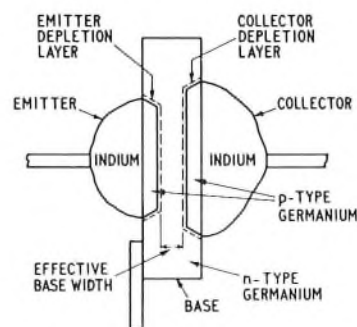

FIG. 1—GERMANIUM ALLOY TRANSISTOR

facture the germanium is formed into a single crystal and doped with antimony to make it n-type. It is then sawn and lapped to form the basic dice (about 0.16 in. × 0.08 in. and 0.005 in. thick), and is placed in a jig with two pellets of indium (p-type), and is placed in a jig with two pellets of indium (p-type) in contact with areas which, after heating in the alloying furnace, subsequently become the collector and emitter of the transistor. Briefly, the action is that at 155°C the indium melts and at 550°C dissolves the germanium, forming a liquid alloy which penetrates into the dice. On cooling, the alloy recrystallizes leaving a small but sufficient amount of p-type impurity in the germanium. In the example shown the effective base width remaining is about 0.002 in. and it is this dimension which largely determines the frequency response and, for some devices, also the voltage rating of the unit. After suitable etching and washing to remove surface impurities the transistor is mounted on a header and hermetically sealed.

The Planar Type

The planar construction differs in many respects from that just outlined and at present is restricted to silicon transistors. All but the final steps in the process are performed on up to a thousand transistors at once on a single slice of material which is subsequently divided: the transistor is protected by a glass-like layer of silicon dioxide, and the junctions are formed beneath this surface.

A section of a silicon n-p-n planar transistor is shown

†Post Office Research Station.

in Fig. 2, and since the manufacture involves 15 or more steps it is not proposed to describe the process in detail.

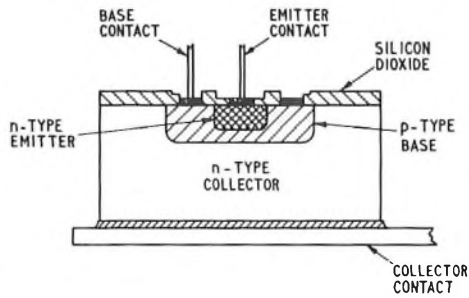

FIG. 2—SILICON PLANAR TRANSISTOR

However, it is interesting to note that the effective areas of the many transistors are defined by photographic exposure through a mask, followed by etching and diffusion of impurities. This process is performed on the n-type slice, first with boron (p-type) to form the base region, and subsequently with phosphorus (n-type) to form the emitter. Because the diffusion takes place through a hole in the silicon dioxide and the impurity penetrates both at right angles and parallel to the surface, the actual p-n junction is located beneath the protective layer and is protected from the effects of the immediate atmosphere. It is usual to test the transistors electrically, by using tiny probes positioned under a microscope, before dicing the slice; after this they are attached to the header and encapsulated.

Choice of Material

The transistors described above are germanium-alloy and silicon-diffused types, respectively, but it is possible also to have silicon-alloy and germanium-diffused versions. The choice of material and technique as far as the manufacturer is concerned is dominated by the user's specification for electrical performance. At the present time germanium transistors are on the whole cheaper than silicon devices but the price gap is narrowing and parity may soon be reached in many performance ranges. The performance of the two types differs mainly in temperature limitations, germanium having a maximum junction temperature limit of about 85°C and silicon one of approximately 170°C. Coupled with this temperature sensitivity is the magnitude of the leakage currents that will be defined later. There is also some difference in the voltage required to "turn on" the device when it is used as a switch and in the voltage remaining across the transistor when it is fully switched on (known as the bottoming voltage); in this respect germanium forms a more efficient switch than silicon. Finally, there is undoubted advantage in using the silicon-planar type from a life and reliability viewpoint.

Epitaxy

To reduce the bottoming voltage on diffused transistors a technique has been developed where a thin layer is grown on the slice as part of the same crystal structure (epitaxial layer). This layer is of relatively high-resistivity material and diffused impurities penetrate into the layer. The bulk of the collector material can then be of lower resistivity so that the series collector resistance is much reduced. This treatment can be applied to both

germanium and silicon diffused transistors, but it is most advantageous when silicon devices are used at fairly high currents, say, greater than 20 mA, in switching applications.

BASIC OPERATION

The p-n-p sandwich which has been described contains a p-n junction and an n-p junction forming two diodes having one electrode (the base) common. The method of construction makes these two diodes similar in nature and they differ mainly in physical dimensions. Because of this symmetry an alloy transistor will operate if emitter and collector are interchanged but the performance will be, in general, degraded in one direction. Fig. 3(a) shows that in normal operation one

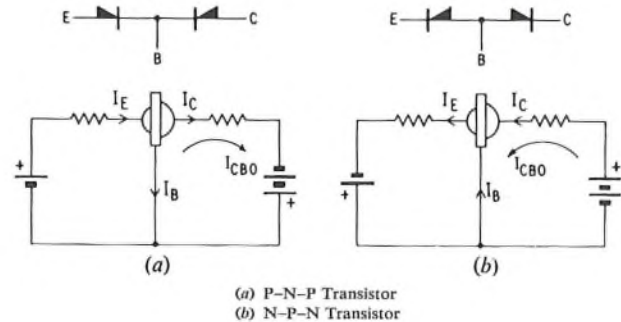

FIG. 3—TRANSISTOR CIRCUITS

diode (emitter-base) is forward biased and emits positive-charge carriers (holes) into the common base region while the other diode (base-collector) is reverse biased and has a small leakage current, I_{CBO} . However, since these diodes are made on the same very thin piece of material the negative field from the reverse-biased diode collects most of the positive charges in the base region and only a very small proportion (typically 2 per cent) flows in the base lead.

For an n-p-n transistor, Fig. 3(b) shows that the collector and emitter diodes are of opposite polarity to those of the p-n-p transistor and are low impedance to a current flowing away from the base. As before, the emitter diode is forward biased and the collector diode reverse biased so the required supply potentials are also reversed. The operation is the same if it is remembered that negative-charge carriers (electrons) are now emitted into the base region where most of them are collected by the positive field from the reverse-biased diode.

Transistors are said to be complementary when they are identical in all their parameters except polarity, and the use of mixed n-p-n and p-n-p types leads to important circuit simplifications.

BASIC PARAMETERS

Symbols

A brief explanation of the symbol nomenclature is given in Appendix I.

Current Ratios

The ratio of collector current flowing out of the collector (I_C) to the current flowing into the emitter (I_E) without regard to the leakage current (I_{CBO}) is known as the d.c. current gain or $-h_{FB}$. (The minus sign arises because the currents have been assigned as flowing in opposite directions with respect to the

transistor, i.e. one current flowing in and one current flowing out.)

$$\text{Thus, } \frac{I_c}{I_e} = -h_{FB}.$$

Because the collector current is always slightly less than the emitter current, h_{FB} is always less than unity in a junction transistor. However, in amplifier circuits, for example, the small-signal a.c. current gain, which is the change of collector current for a given small change of emitter current, is important. This is known as h_{ib} or α and the value is almost the same as the d.c. current gain unless the bias current is comparable with I_{CBO} .

$$\text{Thus, } \frac{I_c}{I_e} = -h_{ib} = \alpha.$$

The base current represents the difference between emitter and collector currents (see Fig. 3).

$$\therefore I_b = I_e - I_c = I_e(1 - \alpha).$$

The ratio of collector current to base current is known as h_{ie} or β .

$$\frac{I_c}{I_b} = \frac{\alpha}{1 - \alpha} = h_{ie} = \beta.$$

A typical value for α is 0.98, in which case

$$\beta = \frac{0.98}{1 - 0.98} = 49.$$

Frequency Dependence

The current gain of a transistor will fall as the operating frequency increases. The alpha cut-off frequency, f_α , is defined as the frequency at which the α has fallen to $1/\sqrt{2}$ (approximately 70 per cent) of its low-frequency value. In the example already taken, if α falls to, say, 0.7 then β falls to 2.3, and the frequency at which β has fallen to 70 per cent of its low-frequency value f_β is very much less than f_α .

It can be shown that, approximately,

$$f_\beta = f_\alpha/\beta.$$

It is not always convenient to specify the frequency response in this way and other parameters are often used, namely:

f_{max} , the maximum frequency of oscillation,

f_i , the frequency at which β is unity, and

f_T , the product of β and the frequency at which it is measured, provided β has there fallen to a low value.

Voltage Limitations

Maximum voltage ratings under various conditions are usually specified by the transistor manufacturer after the characteristics of a large number of devices have been measured. As shown in Fig. 1, there is a region adjacent to the collector and to the emitter called the depletion layer and the effective base width is the region left between these limits. As the collector voltage is increased the collector depletion layer increases in width and the effective base width decreases until eventually "punch-through" occurs which effectively joins emitter to collector. Under these conditions a very heavy current may flow and the transistor may be permanently damaged.

Two other mechanisms which cause breakdown are the Zener and avalanche effects. With the Zener effect the large potential gradient in the junction itself liberates charge carriers, and, with the avalanche effect, carriers liberated by heat are accelerated and in turn liberate

further carriers by impact. The effect of both these mechanisms is similar, resulting in the collector current rapidly increasing at a given collector-emitter voltage. This does not damage the transistor provided the collector dissipation is controlled and some devices are deliberately operated in this mode to achieve speedy operation.

These three effects occur at different voltages which vary for different types of transistor and it is not possible to specify which will occur first. The voltage at which the effects occur are known as:

$V_{(BR)CBO}$, which is the breakdown voltage between collector and base with the emitter open-circuit,

$V_{(BR)CEO}$, which is the breakdown voltage between collector and emitter with the base open-circuit, and

$V_{(BR)CER}$, which is the breakdown voltage between collector and emitter with a resistance R between the base and emitter, e.g. 10 ohms or 1,000 ohms.

In addition to these collector-voltage limitations there is a limit on the emitter to base voltage when that junction is reverse-biased, known as $V_{(BR)EBO}$. This may be some 10–20 volts for an alloy transistor but is usually 3–6 volts for a diffused device and in some applications it is necessary to adopt circuit techniques to prevent the transistor rating being exceeded.

Current Limitations

In general, for alloy transistors there is no limit to the magnitude of collector or emitter current provided that the permissible power dissipation is not exceeded. In practice, however, the current gain (β) falls at high currents until eventually circuit design becomes impossible, and for this reason manufacturers usually indicate a maximum value of collector current for each type of transistor. For the highest-frequency planar transistors there may also be a current limit set by the fusing of the internal connexions.

Power Limitations

A maximum junction temperature is usually specified and this must not be exceeded if the transistor is to have a long useful life. In operation the junction temperature is higher than the ambient temperature due to dissipation within the device. Most of the dissipation usually occurs at the collector (it is the product of the collector current, I_c , and collector-emitter voltage, V_{CE}) but in addition there is some dissipation at the base, $I_B V_{EB}$. A constant known as the thermal resistance, R_T , is specified for these devices, usually in terms of $^{\circ}\text{C}/\text{mW}$. Consequently, the rise of junction temperature above ambient is readily calculated for a given dissipation. The transistor, and its case and mounting have a typical thermal time constant of a millisecond or more and consequently very high dissipation may be tolerated for short periods (microseconds). Depending upon the on-off duty ratio it may be possible for the average power handled by the transistor to approach the maximum rated dissipation of the transistor. The thermal resistance may be decreased in manufacture by physically mounting the collector on a large copper case and may be further reduced by bolting this case to an external heat sink.

Leakage Currents

The leakage current I_{CBO} is the collector-base reverse current with the emitter open-circuit. Similarly, I_{EBO} is the emitter-base reverse current with collector open-circuit. Finally, I_{CBO} is the collector current which flows

from the emitter when the base is open-circuit. It can be shown that

$$I_{CE0} = (1 + \beta)I_{CB0} \text{ (see Appendix 2).}$$

Other leakage currents are defined with particular junctions reverse-biased. Thus, I_{CBX} is the collector-base reverse current with the emitter-base junction reverse-biased but for practical purposes in this article

$$I_{CB0} = I_{CBX}.$$

It is possible in practice to obtain a collector leakage current between I_{CE0} and I_{CB0} when the base circuit has a finite resistance or is suitably biased.

The leakage current in a well-made transistor is almost independent of collector voltage until the breakdown region is approached. It is, however, very temperature sensitive and, theoretically, for a germanium transistor doubles for about each 8°C increase and for a silicon transistor doubles for about each 5°C rise. In practice transistors often have leakage currents greater than the theoretical minimum but they double for each rise of about 12°C for germanium types and up to 16°C for silicon types. The room temperature leakage current for germanium transistors may be about 1,000 times that of a silicon device (say 10^{-6} amp and 10^{-9} amp, respectively).

CIRCUIT CONFIGURATIONS

There are three possible ways in which transistors can be connected in a circuit and in each instance one electrode is common to input and output. The circuit configuration is then described by the electrode which is common, e.g. common-base configuration. The common electrode is sometimes earthed and because of this the term grounded, instead of common, is used to define the arrangement, e.g. grounded-base configuration.

Fig. 4(a) shows the common-base arrangement with the input connected between emitter and base. This

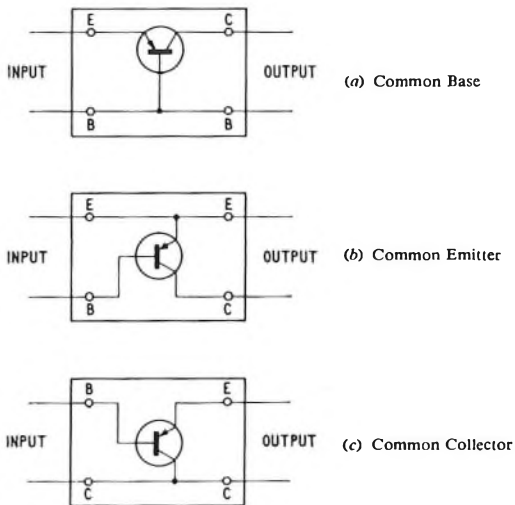

FIG. 4—CIRCUIT CONFIGURATIONS

configuration gives the highest frequency response (f_α), a current gain (α) of almost unity, and a low input impedance and a high output impedance. As an amplifier it does not produce current gain, but because of the ratio of the input and output impedances it can have considerable voltage and hence power gain.

Fig. 4(b) shows the common-emitter arrangement. This is the most frequently used and can produce current

gain (β) as well as voltage gain. It has the lowest cut-off frequency (f_β) and inverts the output.

Fig. 4(c) shows the third arrangement with a common collector. This is sometimes called the emitter-follower by analogy with the valve cathode-follower. It has a voltage gain of almost unity, a possible current gain of approximately β and is particularly characterized by having high input and low output impedances. Its frequency response lies between those of the other two arrangements.

CHARACTERISTIC CURVES

A great deal of useful design information may be obtained from a family of static characteristics. The most commonly used is the output family of curves: collector voltage V_C against collector current I_C with either base current (for a common-emitter arrangement), or emitter current (for a common-base arrangement), as the independent variable.

Output Characteristic

The common-emitter static output characteristic is shown in Fig. 5(a); this has a resemblance to a pentode-

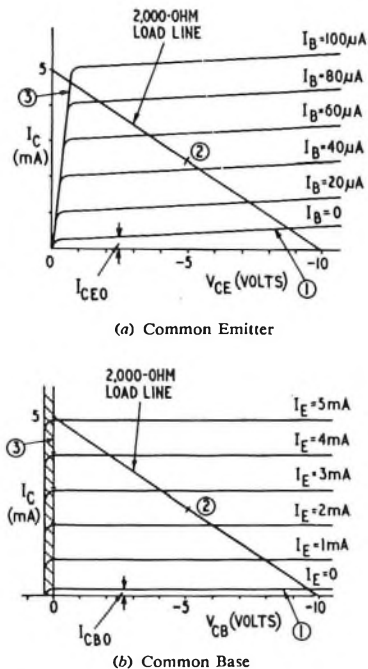

FIG. 5—STATIC OUTPUT CHARACTERISTICS

valve anode characteristic but with important differences. The input is the base current (instead of grid volts) and consequently the input impedance is much less. In addition, voltage V_{CB} at which all the curves coalesce (the bottoming potential) is a very small fraction of the supply voltage so that the transistor forms a very efficient switch. Further, a collector current I_{CB0} flows when the base current is zero but it is possible to reduce this to I_{CB0} by reverse bias.

The common-base static output characteristic is shown in Fig. 5(b) and here the input is emitter current. These curves are nearer to the horizontal, representing a higher output impedance. The curves are also more linearly spaced which means that amplification can be

achieved with less distortion. In addition, when the transistor is bottomed the collector potential rises above the base potential, as indicated by the shaded region, and again the transistor forms a very efficient switch.

Load Line. Superimposed on both sets of curves is a load line, equivalent to a collector load resistor R , and the operating point must always lie upon this line. There are three possible states shown in Fig. 5.

1 Off, i.e. with emitter-base reverse biased;

$$I_C = I_{CBO} \text{ (strictly } I_{CBX}).$$

2 Normal active; $I_C = \beta I_B = \alpha I_E$.

3 Saturated or bottomed, i.e. $I_B > \frac{I_C}{\beta}$; $I_C = \frac{V_{CC}}{R}$.

State 2 is used for linear amplifier and oscillator applications and any excursion to the saturated or cut-off states will produce distortion. When used as a switch the transistor's state is quickly changed from state 1 to state 3 and the output voltage change is almost equal to the voltage of the collector supply.

Input Characteristic

The input characteristic of a common-emitter stage is shown in Fig. 6(a) for a constant collector voltage. The curve is approximately exponential in shape as for a

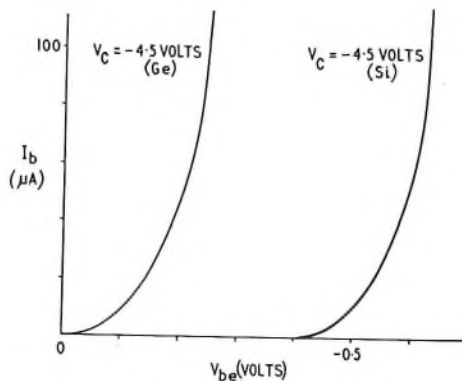

(a) Common Emitter

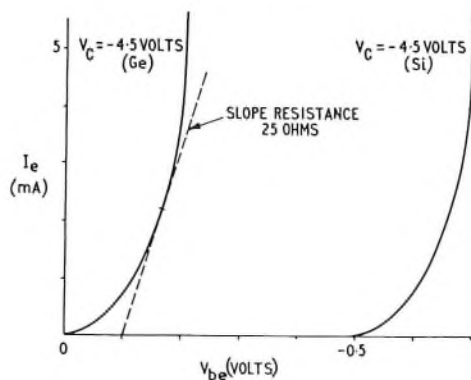

(b) Common Base

FIG. 6—INPUT CHARACTERISTICS

simple diode and emphasizes the fact that the emitter-base junction behaves as a diode. It is convenient to show on this curve one of the differences between silicon and germanium, i.e. the base-emitter voltage has to be increased by about 0.4 volts to produce the same base

current. It should be noted, however, that the slope (a.c. impedance) of the curves is almost the same at the same current.

The common-base input characteristic is shown in Fig. 6(b) for the same constant collector voltage. It is of the same general shape as before but the vertical current scale is different as the input impedance is much less in this arrangement.

The emitter-base voltage is temperature sensitive and for a given current falls by about $2mV/^\circ C$ increase in temperature for both germanium and silicon devices. This factor must be taken into consideration when stabilizing circuits are designed.

From these two sets of curves all the information for static design purposes under given conditions may be obtained. It is usual, however, for many more curves, derived from the same information, to be published for a particular device and some of these may be more convenient for design purposes.

D.C. STABILIZATION

The stabilization of the operating point is very important with transistors due to the variation of leakage current with temperature and the wide spread of leakage current and current gain (β) from sample to sample. A typical specification has, for example, a minimum β of 30 and a maximum of 150 under the same specified test conditions. The amount of stabilization required depends upon the application and is most critical in output stages where a large collector-current swing is expected and movement of the operating point would cause distortion due to clipping of the signal waveform. The operating efficiency is also important and can be almost 50 per cent in a class A amplifier if the operating point is carefully defined. In low-level applications, such as the early stages of radio receivers or hearing aids, clipping is not a problem and stabilization is required largely to control the leakage currents.

Common-Base Amplifier

Fig. 7(a) shows a simple common-base amplifier using a transistor which has the output characteristic already described in Fig. 5(b) and the input characteristic

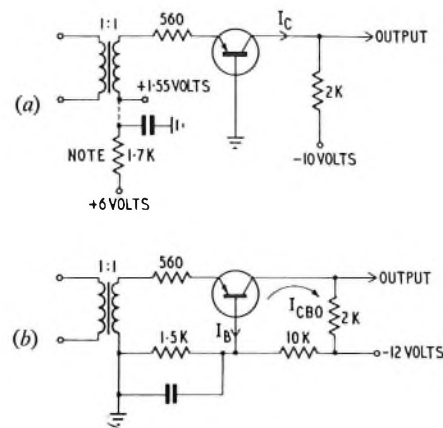

Note: Alternative Bias Supply

(a) Simple Amplifier

(b) Amplifier with Base Potentiometer

FIG. 7—COMMON-BASE AMPLIFIER

of Fig. 6(b). A line representing a 2,000-ohm load is drawn across the output curves, and for a maximum

output without distortion the operating point should be with the collector voltage at half the supply voltage, i.e. 5 volts, and the collector current at 2.5 mA. From the input curve the emitter potential V_{BE} is approximately +0.15 volts and the a.c. input impedance is about 25 ohms. If some allowance is made for the resistance of the transformer input winding a series emitter resistance of 560 ohms will give an input impedance to the amplifier of about 600 ohms. In order that the emitter current should be 2.5 mA the positive bias potential required is $(560 \times 2.5 \times 10^{-3}) + 0.15 = 1.55$ volts.

This circuit is relatively insensitive to temperature changes due to the low base impedance but since the emitter-base junction voltage for a given emitter current falls by approximately 2 mV/°C then for 50°C rise in junction temperature the junction voltage decreases by about 0.1 volts and the voltage drop across the 600-ohm input increases by the same amount. Thus, the emitter current will increase by about 0.2 mA. In addition, the leakage current I_{CBO} will increase from, say, 10 μA to 300 μA for a germanium transistor. The total change in collector current is thus 0.5 mA and the operating point on the output characteristic will change by 1 volt to -4 volts instead of -5 volts. Some improvement can be made by reducing the effect of the emitter-current variation and at the same time using a more convenient positive-bias supply by adding a further emitter resistance (decoupled to prevent signal-frequency feedback) of 1,700 ohms and connecting it to +6 volts as shown.

It is usually more convenient to arrange an amplifier to work from a single supply voltage, if at all possible, and then the base potential may be derived from a potentiometer, as shown in Fig. 7(b). There are two disadvantages with this method: firstly, the worsened temperature stability and, secondly, the decrease in efficiency due to power wastage in the potentiometer. In the example shown the potentiometer current is approximately 1 mA and allowance is made for the d.c. base current I_B . If the temperature is now increased by 50°C the leakage current I_{CBO} increases to 300 μA as above and the collector leakage current is approximately $3I_{CBO}$ (see Appendix 2) or 900 μA. Together with the change of base-emitter voltage the combined effect is to produce a change in the collector operating point of about 2 volts.

Common-Emitter Amplifier

The simplest possible arrangement is shown in Fig. 8(a) but this is not a practical circuit for most linear applica-

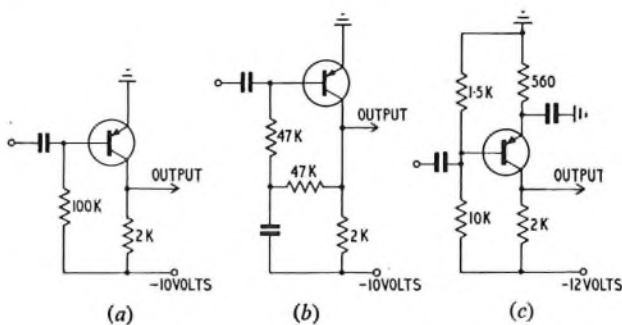

(a) Simple Amplifier
(b) Amplifier with D.C. Feedback
(c) Amplifier with Base Potentiometer

FIG. 8—COMMON-EMITTER AMPLIFIER

tions, due largely to the variation of β from one transistor to another. At high temperatures the leakage current is also very large, tending to $(1 + \beta)I_{CBO}$ which causes the transistor to bottom. This circuit may be used for non-linear pulse applications, however, as here the transistor is normally in the bottomed state and is switched off by a positive pulse applied to the base.

Some improvement may be made by arranging for the base resistor to be connected to the collector (Fig. 8(b)) instead of the negative supply and this provides d.c. feedback (and also a.c. feedback if the decoupling capacitor is omitted) which compensates to some extent for changes in β . However, the stage is still temperature sensitive and with germanium transistors its use would be limited to small-signal low-temperature applications but with silicon transistors it could be used at higher temperatures.

The most commonly-used stabilizing circuit employs an emitter resistor and base potential divider as shown in Fig. 8(c). This has a single supply voltage and any required degree of stabilization can be achieved. From a d.c. viewpoint the operation is identical to that of the circuit in Fig. 7(b) but from an a.c. point of view the potentiometer forms a shunt on the input signal and hence cannot be made of very low impedance.

Thermal Runaway

When an increase in junction temperature causes an increase in leakage current, which in turn increases the collector dissipation causing a further increase in junction temperature, the eventual destruction of the transistor may occur; this series of events is called thermal runaway. Thermal instability depends upon the magnitude of the increases and these may be limited by the same techniques as those used for d.c. stabilization of the operating point. In the examples already given there is no risk of thermal runaway since, although a rise in temperature increases the collector current, the collector voltage decreases due to the high resistive load and overall the dissipation is reduced.

The risk of thermal runaway is most pronounced in circuits having transformer-coupled loads as shown in Fig. 9(a) for a switching circuit with a pulse transformer and in Fig. 9(b) for a linear amplifier. Both of these

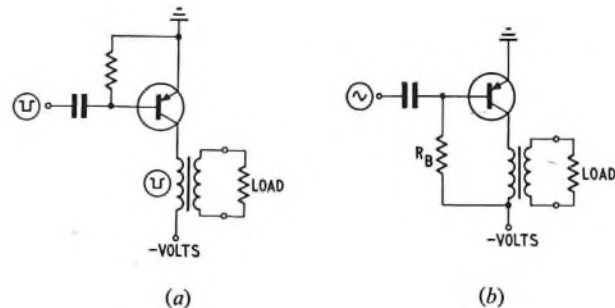

(a) Pulse Amplifier
(b) Linear Amplifier

FIG. 9—AMPLIFIERS WITH RISK OF THERMAL RUNAWAY

circuits must be regarded as examples of bad practice. In the circuit of Fig. 9(b) an emitter resistor and base potentiometer can provide stabilization and, in the circuit

of Fig. 9(a), it is usual to reverse bias the base-emitter junction so that the collector leakage current is limited to I_{CBO} (see Appendix 2).

Fig. 10 shows a circuit very commonly used for pulse work. This maintains a reverse-bias potential on the

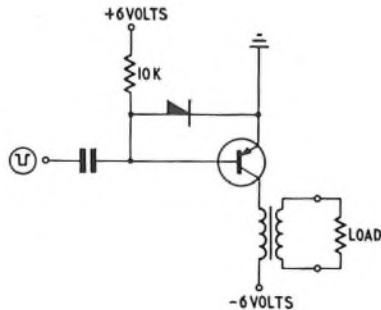

FIG. 10—SATISFACTORY PULSE AMPLIFIER

transistor equal to the forward voltage drop across the clamping diode and has several advantages. Among these are the almost constant input impedance, the base-emitter junction is protected against high reverse voltages which could cause breakdown, and the switching speed is increased since the input capacitance does not require a large charge to change its potential.

(To be continued)

References

- ¹THWAITE, H., and ASPINALL, E. A. Transistor Hearing Aid. *P.O.E.E.J.*, Vol. 52, p. 163, Oct. 1959.
- ²THOMSON, D. Transistor Line Amplifiers for Speech and Program Circuits. *P.O.E.E.J.*, Vol. 54, p. 238, Jan. 1962.
- ³ANDREWS, J. D. A Code Translator for Letter Sorting Machines. *P.O.E.E.J.*, Vol. 52, p. 199, Oct. 1959.
- ⁴LOUGHHEAD, W. A. E. A Three-digit Electronic Director. *Ericsson Bulletin* No. 42, p. 10, Jan. 1961.

APPENDIX 1

In general the symbols used throughout this series of articles conform to the rules specified in British Standard 3363:1961, "Schedule of Letter Symbols for Light-Current Semiconductor Devices." The significance of the basic symbols is that i , v or p relate to instantaneous quantities whereas I , V or P , relate to r.m.s., d.c., average, or peak values. Subscripts e, b or c are then used to describe components of current, voltage, or power, and subscripts E, B or C relate to the total quantity at the emitter, base or collector terminals, respectively. Additional subscripts O, X or S are used as a third subscript to indicate that the terminal not indicated is open-circuit, reverse-biased or short-circuit, respectively.

- Thus, I_E = Total direct-current at emitter.
 I_e = R.M.S. value of varying component of emitter current.
 i_e = Instantaneous value of total emitter current.

- i_e = Instantaneous value of varying component of emitter current.
 I_{CEO} = The collector current when the collector is biased in the reverse direction with respect to the emitter and the base is open-circuit.
 I_{CEx} = The collector current when the collector and base are biased in the reverse direction with respect to the emitter.
 I_{CExS} = The collector current when the collector is biased in the reverse direction with respect to the emitter and the base is short-circuited to the emitter.

APPENDIX 2

By analysing Fig. 11 it is possible, as shown below, to determine the effects of various biasing arrangements on the stabilization of collector leakage current.

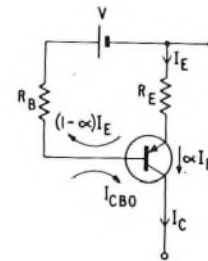

FIG. 11—STABILIZATION-CIRCUIT ANALYSIS

Fig. 11 shows the resistor connexions and currents in a transistor circuit. It is assumed that the external resistors R_E and R_B are large compared with the internal resistance of the transistor emitter and base.

$$\begin{aligned} \text{Then, } I_E R_E &= R_B(I_{CBO} - I_E(1 - \alpha)) - V, \\ I_E(R_E + R_B(1 - \alpha)) &= R_B I_{CBO} - V, \\ \text{and } I_E &= \frac{R_B I_{CBO} - V}{R_E + R_B(1 - \alpha)} \dots\dots\dots(1) \end{aligned}$$

$$\begin{aligned} \text{But } I_o &= \alpha I_E + I_{CBO} \\ &= \frac{\alpha R_B I_{CBO} - V}{R_E + R_B(1 - \alpha)} + I_{CBO} \\ &= \frac{I_{CBO}(R_E + R_B)}{R_E + R_B(1 - \alpha)} - \frac{V}{R_E + R_B(1 - \alpha)} \dots\dots\dots(2) \end{aligned}$$

The following deductions can now be made.

(a) If $V = 0$, the collector leakage current is increased by a factor

$$\begin{aligned} \frac{R_E + R_B}{R_E + R_B(1 - \alpha)} &\simeq \frac{R_B}{R_E}, \text{ as } \alpha \rightarrow 1, \text{ and } R_B > R_E. \\ \text{Thus, } I_o &\simeq \frac{R_B}{R_E} I_{CBO}. \end{aligned}$$

(b) If in Eqn. (2) R_B also $\rightarrow \infty$, $I_o \rightarrow \frac{I_{CBO}}{(1 - \alpha)}$
 $= (1 + \beta) I_{CBO} = I_{CEO}$.

(c) If the collector leakage current is to be limited when an external base resistor is fitted the emitter-base junction must be reverse biased so that $I_E = 0$. Then, from Eqn. (1), the bias voltage must be $V = R_B I_{CBO}$ and $I_o = I_{CBO}$.

Book Review

"Loudspeakers". N. W. McLachlan, D.Sc. Constable & Co., Ltd. xii + 399 pp. 165 ill. 18s.

Since its first publication in 1934, this work has become a classic reference, the present paperback edition is an unabridged and corrected version retaining the original pagination in a sewn binding.

The book is divided into two nearly equal parts, the first

giving an excellent mathematical treatment of sound waves and a wide range of radiating surfaces, the second is concerned with the practical aspects of design and testing. It is the latter section which unfortunately leaves something to be desired, for although the principles are fundamentally based, the practical aspects are somewhat dated today.

Although at variance with modern teachings of M.K.S. units, the C.G.S. system is used leading to more tractable solution to practical problems.

A.H.I.

Pressurization of Telecommunication Cables

Part 3—Miscellaneous Pressurization Equipment

J. R. WALTERS, J. F. KEEP and J. F. CRAGGS†

U.D.C. 621.315.211.4

The principles of gas pressurization of telecommunication cables and the methods of supplying dry compressed air to the cables were discussed in Parts 1 and 2 of this article. Part 3 describes the supervisory equipment, provided at telephone exchanges and repeater stations, as well as other items such as contactors, valves, air lines and cable seals.

INTRODUCTION

WITH the development of cable pressurization the telecommunication engineer has found it necessary to become familiar with some of the equipment and techniques of applied pneumatics. Various types of pressurization equipment installed in telephone exchanges, repeater stations, cable jointing chambers and distribution cabinets are described in the following paragraphs. During the experimental and development period (from about 1957 to 1962) some changes in design were evolved, and it was also found practicable to reduce the size of certain items so that pressurization equipment for a large number of cables can now be accommodated on one equipment rack. Brief descriptions are also given of some items of superseded designs, because large numbers of these items are in use and are expected to remain in service for a considerable period.

PRESSURE AND FLOW MONITORING EQUIPMENT

Pressure Gauges

In telephone exchanges and repeater stations pressure gauges are used, and special care has been taken to ensure that the mechanical linkage between the gauge and its pointer is able to withstand wear due to vibration that may be transmitted from the compressor and desiccator via the air line. The gauges have a range of 0–10 lb/in² above atmospheric pressure, a scale diameter of 3 in., and are fitted with alarm contacts actuated by the gauge pointer. One of the contacts is pivoted on the gauge glass and acts as an adjustable index. To enable the gauge to be easily connected to any of the compression couplings in current use by the Post Office the entry connexion consists of a short section of $\frac{1}{4}$ in. diameter brass tube in place of the screwed unions usually provided on pressure gauges.

An example of the use to which this type of gauge is put is illustrated in Fig. 13. The item shown (Panel, Pressure-Indicating, No. 1) incorporates two selector

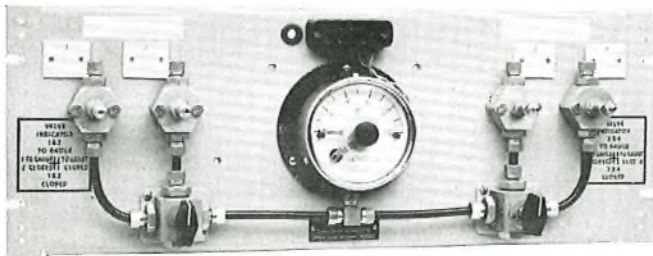

FIG. 13—PRESSURE-INDICATING PANEL

valves that permit a maximum of four cables to be connected individually or in groups to a single gauge. Panels of this type with various selector-valve arrangements and having one or two gauges were used during the development period to connect coaxial cables together at intermediate repeater stations, in order to provide a common reservoir of air in the event of a leakage occurring on one of the cables, or to connect the gauge to a cable for maintenance purposes. This type of panel has now been superseded by a simpler arrangement in which a pressure gauge is connected to a cable through a compound compression coupling, a tee-junction and a Schrader valve that also makes provision for the connexion of an air line for supplying dry air when required. This arrangement of valve and gauge is intended for use in exchanges where only a small number of trunk and junction cables are to be pressurized, and several different types of plate are available on which the equipment may be mounted.

Flowmeters

The type of flowmeter used at exchanges to measure the rate of flow of air to each cable is shown diagrammatically in Fig. 14. The tube, which may be of glass

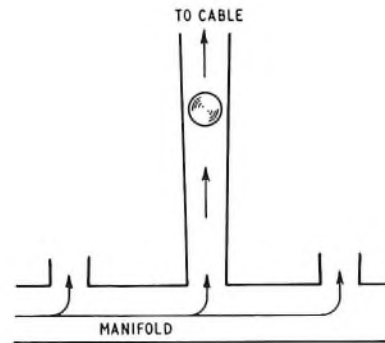

FIG. 14—PRINCIPLE OF FLOWMETER

or Perspex, has a tapered bore. The float may be conical or spherical in shape, and the action of the flowmeter is as follows. Air passes upwards through the bore causing the float to rise and the area of the annular orifice round the float to increase. Because the float is free to rise it will assume a position of equilibrium in the stream of air at a point (depending on the rate of flow) where the pressure drop at the annular orifice is equal to the resistance offered by the float to the upward flow of air.

The flowmeters used at present are calibrated to indicate flows from 0.1–1 ft³/hour, and a cursor is provided to indicate the normal rate of flow to the cable. In existing installations single flowmeters are commoned together by means of a manifold in groups of six to form distribution panels. In new installations, units of five

†External Plant and Protection Branch, E.-in-C.'s Office.

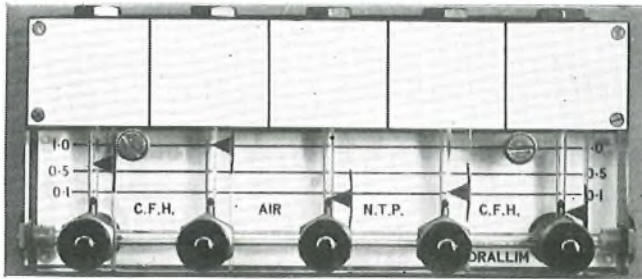

FIG. 15—FLOWMETER UNIT

flowmeters will be used, and four such units (Fig. 15) can be fitted on a smaller mounting plate (19 in. × 7 in.) than that previously used for six flowmeters. A control valve, associated with the inlet to each tube, can be used to stop or to reduce the air flow to any particular cable. This facility is useful when a large leakage on one cable tends to reduce the pressure of the whole of the air supply system to a dangerously low level. All flowmeters are now provided with two outlets to facilitate the connexion of a pressure gauge when this is required for trunk and junction cables. Local cables, operated on a continuous-flow basis, do not require individual pressure gauges at the supply end and so the second air outlet of a flowmeter used for these types of cable is plugged.

Cable-Pressurizing Equipment

A diagram showing the layout of the individual components associated with the distribution of air in a telephone exchange or repeater station is given in Fig. 16.

The compressor, desiccator and humidity-detecting equipment referred to is that described in Part 2 of this article. The equipment is known under the general title of "Equipment, Cable-Pressurizing" and there are four variants, the basic differences being shown in the table.

Equipments, Cable-Pressurizing, No. 1, 2 and 3 are each fitted on racks 2 ft 9 in. wide by 10 ft 6½ in. high (Racks, Apparatus, No. 51) and are intended to be used in telephone exchanges. The No. 2 and No. 3 type equipments are illustrated in Fig. 17. At a few ex-

changes there is not sufficient head-room for 10 ft 6½ in. racks and a shorter rack can be used; minor rearrangement of the equipment is then necessary. Equipment, Cable-Pressurizing, No. 4 is fitted on a rack 1 ft 8½ in. wide by 10 ft 6 in. high (Rack, Apparatus, No. 42A) for use in repeater stations.

Equipment mounted on 9 ft high racks is being developed for use in repeater stations without battery-derived d.c. power supplies. A rack of this type will be provided with mains-operated equipment and will cater for up to 20 trunk and junction cables. For repeater stations with more than 20 cables a supplementary rack will be provided beside the main rack to accommodate the necessary additional distribution panels, gauges, etc.

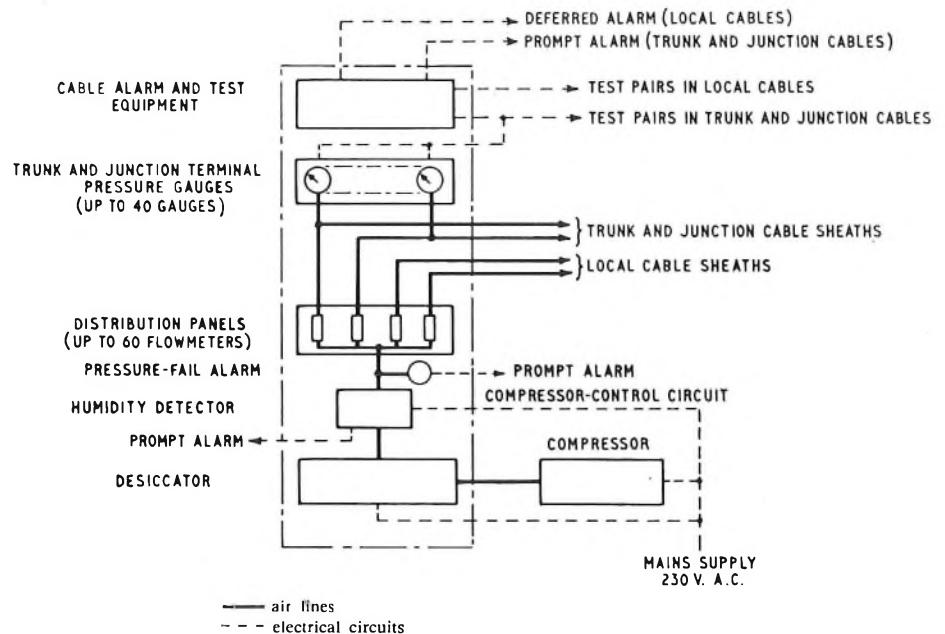
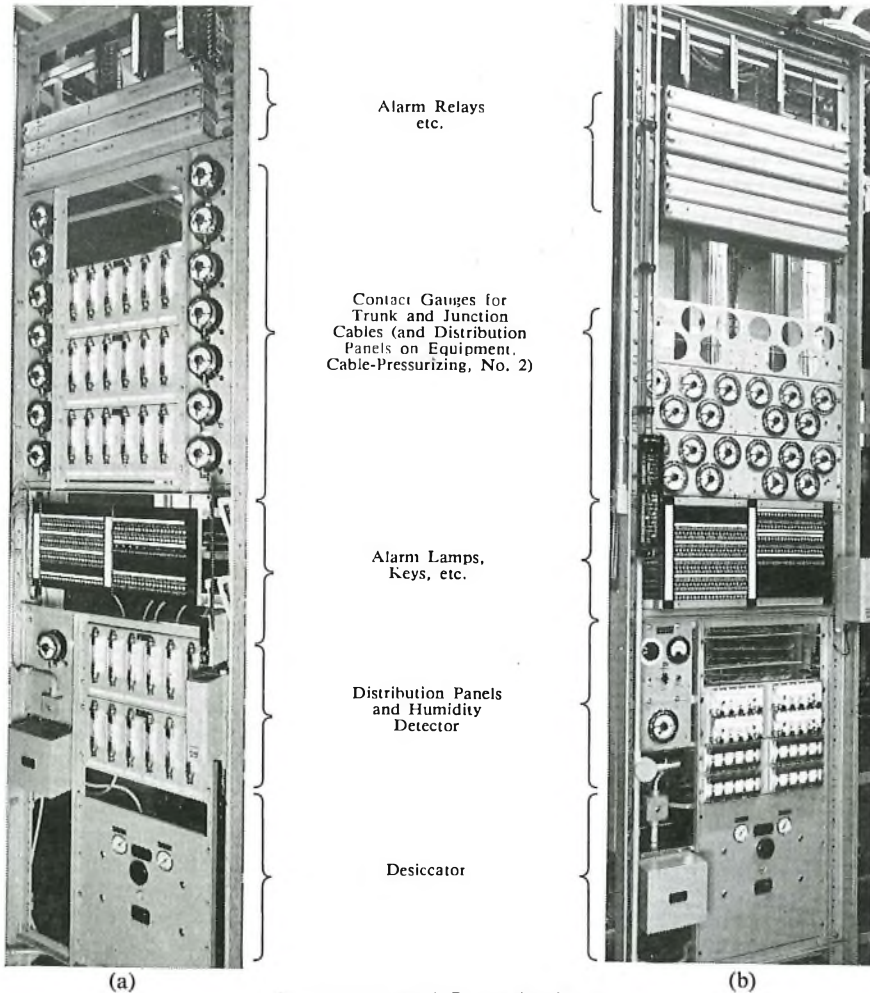

FIG. 16—ARRANGEMENT OF AIR-DISTRIBUTION EQUIPMENT IN TELEPHONE EXCHANGE OR REPEATER STATION

Equipments, Cable-Pressurizing, No. 1 and 2 incorporate the larger type of flowmeter in blocks of six, and in consequence only a small number of cables may be connected to them. The use of smaller flowmeters on the No. 3 type equipment permits a maximum of 60 cables to be connected, although the maximum number of either local cables or trunk and junction cables is limited to 40. With local cables this limitation is imposed by the amount of alarm equipment required, and for trunk and junction cables space is available for up to 40 pressure gauges and associated alarm equipment.

Numbers and Types of Cable Served by Cable-Pressurizing Equipments

Type of Equipment, Cable-Pressurizing	No. 1		No. 2		No. 3		No. 4	
Type of Cable	Local	Trunk and Junction	Local	Trunk and Junction	Local	Trunk and Junction	Local	Trunk and Junction
Maximum Number of Cables	12	6	25	14	40 30 20	20 30 40	Nil	40
Total	18		39		60		40	



Alarm Relays etc.

Contact Gauges for Trunk and Junction Cables (and Distribution Panels on Equipment Cable-Pressurizing, No. 2)

Alarm Lamps, Keys, etc.

Distribution Panels and Humidity Detector

Desiccator

(a) Equipment, Cable-Pressurizing, No. 2.
 (b) Equipment, Cable-Pressurizing, No. 3.
 FIG. 17—CABLE-PRESSURIZING EQUIPMENT FOR USE IN TELEPHONE EXCHANGES

In future, one of the three arrangements of the No. 3 type equipment referred to in the table will be used at all exchanges where space is available to instal the rack and compressor. Wiring for maximum capacity will be provided, but alarm equipment will be supplied for multiples of 10 cables (local or trunk and junction) as required. Flowmeters will be supplied in blocks of five as necessary and pressure gauges will be fitted for each trunk and junction cable as needed.

A feature of the No. 3 type equipment is the provision of a sub-frame on which is mounted the alarm apparatus (test jacks, test keys, alarm lamps, relays, etc.) and panels on which the pressure gauges can subsequently be fitted. The sub-frame may be fitted as a single wired unit, and this method has been adopted to give flexibility and because the demand for pressurizing equipment has outstripped the rate at which the fully-equipped and wired exchange-type racks can be supplied. The use of this type of assembly enables the pressurizing equipment to be fitted and brought into service in advance of the supply of alarm equipment.

Alarm Equipment

Local Cables. The alarm circuits for local cables make use of the test pairs normally available at cross-

connexion cabinets, and should a pair be required for test purposes the alarm equipment may be temporarily disconnected at the exchange main distribution frame and at the cabinet. The basic alarm circuit is shown in Fig. 18. The earth connexion at the cabinet is

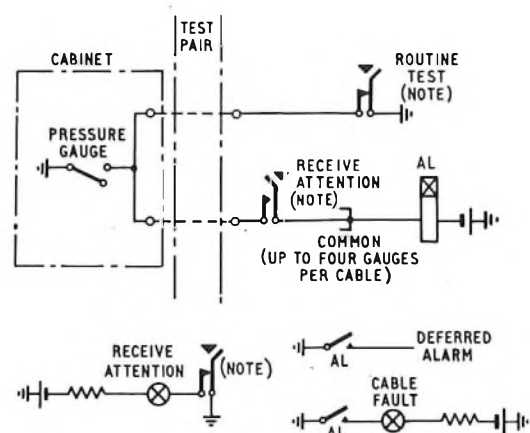

Note: Keys normally operated.

FIG. 18—ALARM CIRCUIT FOR PRESSURIZED LOCAL CABLES

obtained by making contact with the metal structure of the cabinet. When the pressure in a cable falls below the value to which the pressure gauge has been set (see Part 1 of this article) the closing of the pressure-gauge contacts causes relay AL to operate. Up to four cabinet pressure gauges associated with a cable may be connected to any one AL relay. The operation of this relay causes the alarm lamp associated with the cable to glow and, following this, the group of four RECEIVE ATTENTION keys are momentarily restored in turn until the cable-fault alarm lamp is extinguished. The cabinet at which the pressure is low is thereby identified. In this equipment the plunger-type receive-attention and routine-test keys are normally operated. Because attention to local cable faults is not regarded as a matter of urgency, the exchange deferred alarm is brought into operation when relay AL operates. The electrical continuity of the circuit may be checked by operating the ROUTINE TEST key.

Trunk and Junction Cables. If a spare pair is available in a trunk or junction cable, it is allocated for an alarm circuit. However, the high value of pairs in such cables makes it essential to utilize alarm circuits common to a number of cables, the alarm-point exchange or contactor (to be described later) being identified by a Murray test on the alarm circuit. Further details of these arrangements will be given in Part 4 of this article.

CABLE EQUIPMENT

Cable Seals

To prevent loss of air and to extend the effective range of the air supply over as great a distance as possible, the cables must be sealed at all terminations. Cable seals are therefore made on all cables in telephone-exchange and repeater-station cable chambers and at cabinets, pillars and distribution points associated with the cables to be pressurized. Lead-covered paper-core cables are sealed by impregnating the cable core with a special hot wax compound consisting of petroleum-based wax and natural pine-resin. In large-diameter cables a short lead sleeve is plumbed over a section of the cable from which an annular section of sheath has been removed. Fig. 19 (a) shows this type of seal. The wax

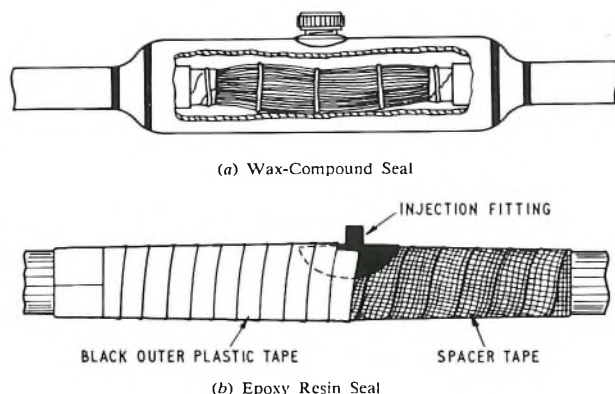

FIG. 19—GAS SEALS FOR PRESSURIZED CABLES

compound is forced into the seal under pressure at a temperature of 150°–160°C. Small-diameter cables are sealed by injecting the hot compound directly into the core through a slot cut in the sheath.

The wax seal is unsuitable for polythene-sheathed cables or for cables with polythene-insulated conductors

because the wax will not bond to polythene and the temperature required is above the melting point of polythene. Synthetic resins are therefore used, and the resin is injected under pressure through an open-weave tape wrapped round an annular gap in the cable sheath. An outer p.v.c. tape restricts the resin to the locality of the gap during the injection process. Fig. 19 (b) shows this type of seal applied to a polythene-sheathed cable. When a suitable resin can be obtained at substantially less than the present price it is expected that all cables will be sealed with synthetic resin.

Contactor

It is sometimes desirable to site a pressure-indicating device at a point along the length of a cable where it would be impracticable to use a contact pressure-gauge. In the past, bellows-type contactors have been installed in selected joints of a number of cables.¹ These contactors were set to operate with a fall of cable pressure to a predetermined value and it was hoped that it would be possible to locate accurately a leakage in a cable from a knowledge of the recorded times at which the various contactors operated. Experience has shown that the operate pressure of this type of contactor varies with time and this appears to be primarily due to aging of the metallic bellows.

A contactor has now been designed which can be plumbed into a jointing sleeve and the device is so constructed that adjustments may be made to the pressure at which the contacts operate, without removing the switch from the cable or losing air pressure. Alteration of the operate characteristics of the contactors may therefore be checked by routine tests at joints and suitable re-adjustment can be made if necessary. The contactor (Fig. 20) consists of a cylindrical brass case, a

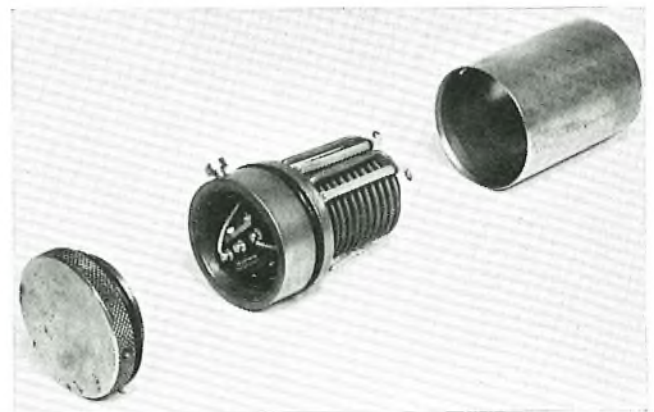

FIG. 20—CONTACTOR THAT CAN BE PLUMBED INTO A CABLE JOINTING SLEEVE

bellows unit, a switch unit and a sealing cap. The outer case, which has a diameter of $1\frac{9}{16}$ in., is plumbed into a circular hole cut into one end of a cable jointing sleeve, and this operation is carried out with the bellows and switch unit removed to avoid damage due to heat. The unit is then re-assembled and connexion made to test wires inside the cable. Two neoprene ring seals are provided which render the unit leakproof and waterproof. The contactor can be set to operate at a selected pressure between 2 and 10 lb/in², and the contacts are

¹KEEP, J. F. Field Trial of Pressurized Cable System. *P.O.E.E.J.*, Vol. 48, p. 7, Apr. 1955.

accessible through the sealing cap so that the adjustments can be checked in the jointing chamber.

Air Lines

Plastic tubing has been standardized for all air lines at telephone exchanges and repeater stations, using $\frac{3}{8}$ in. outside diameter nylon tubing for the main air line between compressor, desiccator and distribution panels, and $\frac{1}{4}$ in. outside diameter nylon tubing from distribution panels to the individual cables at a point on the cable sheath on the street side of the cable seal. The tubing, being fairly flexible, is easy to instal, and can be laced to racking in a similar manner to switchboard cables, or fixed by means of suitable plastic buckles. Metal channelling of rectangular cross-section with a clip-on lid has been found suitable for large numbers of these plastic tubes. For use in jointing chambers and for connexions between cables and contact gauges in cabinets $\frac{1}{4}$ in. outside diameter polythene tubing is used because it has better moisture-absorption characteristics than nylon tube. In the past, polythene with a melt flow index of 2 has been used, but the opportunity will be taken to change to a better quality polythene (melt flow index 0.3) now that tubing of this quality is becoming available. Copper tubing is used at the output of compressors and to link items of equipment together in desiccating units where high temperatures occur.

Tube and Cable Fittings

Compression-type fittings are used with plastic tubing, and sealing is obtained by means of a neoprene ring

contained in a threaded nut.² The fittings may be used repeatedly and do not require special preparation other than trimming the ends of tubes. Outlets from distribution panels, air valves, etc., may be sealed by inserting a short length of solid rod into the compression coupling.

The standard valve used when a pressure-test point is required on a jointing sleeve or cable sheath is a specially-adapted small Schrader air check having a domed protective cap and a ring seal. A combined pressure-test valve and through compression-coupling as described earlier in this article is used for connecting a pressure gauge to a cable. The Schrader tubeless-type valve can be used as a pressure-test valve in a polythene jointing sleeve.

It may be necessary to instal pressure-test points on the cable jointing sleeves in jointing chambers liable to flooding. The time and labour required to pump flood-water from the chamber to gain access to cables can be avoided by mounting the pressure-test valves at the entrance to the jointing chamber. The valves are mounted on a pre-drilled brass bar that can be cut to any desired length. A compression coupling is machined into the stem of each valve for connecting the polythene tube. The tubes are connected to the cable by means of a compression connector soldered to the jointing sleeve or cable bath. *(to be continued)*

²Improvements in or relating to Pipe Couplings and Spring Locking Clips for use therewith. British Patent No. 859598 (25 June, 1961).

The Post Office Engineering Department's Computer —Its Use in Research

W. E. THOMSON, M.A.†

U.D.C. 681.142:354.42.001.5

Examples are given of the use made by the Research Branch of the Post Office Engineering Department of the Department's electronic computer in the first 18 months since its installation.

INTRODUCTION

Pre-Computer Arrangements

ALTHOUGH this article is primarily concerned with the use of the Post Office Engineering Department's computer¹ by the Research Branch of the Engineering Department, it will be useful to begin with a brief review of computing in the Research Branch prior to the acquisition of the electronic computer.

The individual engineer or scientist has, of course, been accustomed to do occasional computing for many years. The slide-rule and the book of four-figure logarithm tables have formed part of almost every officer's equipment and they will probably continue to do so in spite of the existence of electronic computers. Some projects, however, involve enough computing to warrant special computing machines and, possibly, special staff to operate them. By 1948, the Mathematics Group of Research Branch provided a computing service that involved about half-a-dozen staff equipped

with a variety of hand or electromechanical desk calculating machines, and several more such machines were used by various other groups, such as the network design group, whose work justified the special facilities.

The advent of electronic computers in the decade 1945–55 was naturally of immense interest to mathematicians in Research Branch. The opportunity to do something came when Ferranti, Ltd., opened a computing centre in London in the spring of 1956, with a Pegasus electronic computer available for hire; the first Research Branch program was run on this machine in April of that year. In the 5 years that followed, more and more use was made of electronic computers, but this use was restricted by two things: the inevitable limitations of hiring computer time, and the fact that programs had to be written in machine code.² This meant that it was worth while writing programs only for jobs in which it was expected that the program would be used many times. Two examples of such programs are (a) testing the randomness of digit sequences, used regularly as a routine test for ERNIE,³ and (b) calculating the transmission parameters of a coaxial cable, given its dimensions and the properties of the materials used—a program produced primarily for application to submarine cables.

†Post Office Research Station.

Post-Computer Arrangements

Since the Engineering Department's computer was installed at the Post Office Research Station, Dollis Hill, in March 1961, approximately half its time has been spent on work for Research Branch. The work previously done by the Mathematics Group's computing service is now almost entirely done on the electronic computer. The jobs are mostly non-repetitive and may take anything from half a day to a few weeks, occasionally longer; these times are for the complete work, i.e. programming time and computing time. Many jobs of the type that would previously have been passed to the computing service are now done by the originators, i.e. the programming is done by the originators, the tape punching and computer running being done by the computer staff. An essential feature for this type of work is the facility to write programs in Autocode;² without this, many of the smaller non-repetitive jobs would not be worth putting on the computer, since the programming would take too long.

There is also a growing use of the computer in research projects that would have been quite impracticable without it.

TYPICAL COMPUTER PROGRAMS

An attempt was made to classify the computer work that has been carried out by the Research Branch; this has been, however, abandoned, partly because of the wide field of work covered by Research Branch, and partly because of the great variety of work in computing itself.

The following is, therefore, a selection of computer programs that have been run in the period March 1961 to September 1962, chosen to illustrate different applications and different computing techniques. Some comments are given in the individual sections and some general comments follow.

Tables of Functions

It is often a great help to a designer to have special tables available; a typical example is a table of

$$L = \frac{v}{\sqrt{\{(f+x)^2 - (bv/2\pi a)^2\}}}$$

where f , b , v , and a are constant for these particular calculations and x takes on 500 values from 0 to 0.499 in steps of 0.001.

The computing, and consequently the programming, is trivial. The computer is being used to carry out automatically the sheer grind of calculation and also, and this is quite important, to print the results in tabular form, complete with textual headings, arranged in a manner convenient to the user.

Problem in Waveguide Design

Given sets of values of k , t , and z , find the corresponding values of B to satisfy the equation

$$\frac{-4B^2t(1+t^2)\arctant + t^4 + 2(z-1)t^2\sqrt{(B^2t^2 - 2Bt - t^2)}}{4B^2(2B+t-B^2t)\sqrt{(1+t^2)}} = k$$

Test Schedules

It was intended that the results of a series of observer-opinion tests of television distortion should be analysed on the computer. It is inherent in such tests that they are carried out, and the results recorded, in a random order, whereas the computation required for the analysis

is enormously complicated unless the results can be rearranged in a systematic order. The more obvious ways of overcoming this difficulty add considerably to the work involved in preparing the data tapes recording the test results.

The method used was to use a computer program to decide the "random" order in which the tests were carried out. This made use of a method of generation of pseudo-random numbers, in which a fairly simple calculation produces a deterministic series of numbers that can be used as if they were random. This program recorded its results in the form of printed schedules for use by the test controllers. The results of the tests were then punched on data tapes in the order in which they were recorded, and the computer program which analysed them began by regenerating the same sequence of pseudo-random numbers in order to control the storing of the results in systematic order as a prelude to the analysis proper.

Frequency Characteristics of a Ladder Network

A program calculates the insertion loss, phase-shift and delay, the input impedance and admittance, and the return loss, of a given ladder network at a given set of frequencies. One of the most interesting features of such a program is the problem of specifying the network in a form acceptable by a computer program, i.e. as a series of numbers, in distinction to the normal way of specifying the construction of the network by a pictorial circuit diagram and the component values by numbers.

With a ladder network, the problem is not too difficult, since the alternate series and shunt arms of the network can be dealt with in the obvious sequence, and it is reasonable to assume that all series arms have the same configuration and all shunt arms have the same configuration. Practical networks can be forced into the standard form, although this may involve tricks such as introducing dummy short-circuit or open-circuit arms.

With more general forms of network, the problem of defining the network is much more complicated.

Design of a Low-Pass Filter

A program for designing a certain type of low-pass filter is interesting in that it shows that the programming of a problem previously tackled by desk machines often calls for a reconsideration of the numerical methods to be used.

The design of filters has, over the last 30 years or so, been progressing in the direction of synthesis, i.e. given a suitable specification of the filter, a definite sequence of steps leads to the determination of component values. Formal solutions to this problem are available, but they are not entirely satisfactory from the computing point of view, since subtraction of nearly equal quantities occurs, and consequently, even though four-figure precision may be enough for the component values, a very much greater precision is required for intermediate values.

The program in question adopts a different approach, which is in a sense a return to the cut-and-try methods in vogue 30 years ago. It is possible to derive a set of non-linear equations that must be satisfied by the component values and to solve this set by trial-and-error. This approach requires, of course, some initial set of

approximate component values. This is a separate problem; it can be handled in various ways.

Analysis of Large-Scale Measurements

The computer has been used for the statistical analyses of the results of large-scale measurements, such as are required, for example, for life-tests. The main point of interest here is not so much the computer work as the possibility of carrying out the measurements and punching the results on paper tape automatically, ready for input to the computer. The planning of this, and in particular the coding arrangements for the data punching, depends on the numerical analysis to be subsequently carried out.

Several schemes of this kind have been successfully tried out, but there are many aspects that require further experience to enable the best way of dealing with them to be decided.

Transistor Equivalent Circuit

The design of equipment using transistors is made easier by finding an "equivalent circuit", i.e. a combination of resistors, capacitors, inductors, and generators, whose input, output, and transfer characteristics are near enough the same as those of a particular type of transistor, as determined experimentally.

Given a particular circuit configuration, the problem of finding the best component values reduces itself, in mathematical terms, to a minimization problem involving a set of non-linear simultaneous equations; these can be solved by trial-and-error methods. It is, however, a very lengthy process. On a medium-speed machine such as the Engineering Department's computer, many hours of computer time are needed for any one set of bias conditions for any one transistor.

A Valve-Construction Problem

A problem arises in winding grids for thermionic valves because the lack of rigidity of the frame on which the winding is put leads to a variation in tension after winding. The frame could, of course, be made rigid, but only at the expense of increased size, which would have the undesirable effect of increasing the inter-electrode capacitance.

An approximate mathematical analysis reduces the problem to that of solving linear simultaneous equations, about 50 in number, which is a quite straightforward problem on electronic computers.

Design of Thermionic Valves

The performance of thermionic valves can, in principle, be predicted by using electromagnetic field theory to analyse a particular physical structure. In practice, however, the problem is very difficult. Only fairly simple structures can be analysed theoretically and such structures are, perforce, only crude approximations to actual valves. Numerical methods can be applied to more complicated structures, but these require very lengthy calculations.

A fair amount of work has been done on the Engineering Department's computer, both in evaluating formulae that have been deduced theoretically and in direct numerical analysis.

GENERAL COMMENTS

The programs described in the previous section include examples of two extremes: on the one hand, there is fairly straightforward computing of the kind that has been done for many years, but can now be done faster and with the additional facility of printing the results in a form suitable for use and, if required, publication; on the other hand, the high speed of the electronic computer makes it possible to do things that are quite impracticable without it and thus opens up new fields for research.

It is customary in electronic computing to distinguish between "scientific computing" and "data-processing". There is no hard-and-fast distinction, but a typical scientific computing job would be finding the roots of a polynomial equation. A typical data-processing job would be the calculation of a weekly payroll, the results being payslips and "updated" pay records; serious work of this type requires the facility for storing extensive records, say on magnetic tape, and the use of high-speed printers.

Not unnaturally, most of the computing work in Research Branch is "scientific computing," but some of the work, e.g. that for life-tests, might well be classed as data-processing.

References

¹ALLERY, G. D. The Post Office Engineering Department's Computer. *P.O.E.E.J.*, Vol. 55, p. 199, Oct. 1962.

²LAVER, F. J. M. On Programming Computers. *P.O.E.E.J.*, Vol. 55, p. 125, July 1962.

³THOMSON, W. E. ERNIE—A Mathematical and Statistical Analysis. *Journal of the Royal Statistical Society, Series A*, Vol. 122, p. 301, 1959.

Notes and Comments

Birthday Honours

The Board of Editors offers congratulations to the following engineers honoured by Her Majesty the Queen in the Birthday Honours List:

Dundee Telephone Area..	..	W. A. White	..	Technical Officer	..	British Empire Medal
Engineering Department..	..	S. W. Broadhurst	..	Assistant Staff Engineer..	..	Companion of the Imperial Service Order
Engineering Department..	..	A. H. Mumford	..	Engineer-in-Chief	..	Knight Commander of the Most Excellent Order of the British Empire
Liverpool Telephone Area	..	A. G. H. Armour	..	Assistant Engineer	..	Member of the Most Excellent Order of the British Empire
Northern Ireland Directorate	..	T. S. Wylie..	..	Senior Executive Engineer	..	Member of the Most Excellent Order of the British Empire
Factories Department	..	S. Griffiths	..	Technical Works Group I	..	Member of the Most Excellent Order of the British Empire

Sir Albert Mumford, K.B.E., B.Sc.(Eng.), M.I.E.E.

It is with great pleasure that we record the Knighthood



conferred upon Mr. A. H. Mumford, Engineer-in-Chief, in the recent Birthday Honours List. His election earlier this year to the Presidency of The Institution of Electrical Engineers, 1963-64, gave great satisfaction to all members of the Post Office engineering staff, and the signal honour which has now been awarded to him truly makes this a most memorable year for him, and for all his Post Office colleagues.

Since he commenced his Post Office career in 1924, Sir Albert has achieved world-wide reputation, notably in the radio field. His energy, enthusiasm, and buoyancy, have made him a most successful and inspiring leader, and it is a tribute to his capacity for work that, in addition to his widespread Post Office responsibilities, he has also managed to play such a considerable part in the activities of The Institution of Electrical Engineers. Members of the Institution of Post Office Electrical Engineers will remember with pride that he has been our own President since 1960.

This latest honour is a great tribute to his outstanding contributions, both nationally and internationally, in the field of telecommunications, and we feel sure that his many friends at home and abroad will join us in offering him the warmest congratulations.

Institution of Post Office Electrical Engineers

Institution Field Medal Awards, 1961-62 Session

In addition to the Institution Senior and Junior silver and bronze medals, up to three bronze medals, the Field Medals, are awarded annually for the best papers read at meetings of the Institution on field subjects primarily of Regional interest.

Field Medals were awarded to the following authors for papers read during the 1961-62 session:

A. A. George, Leeds (Northern Eastern Region). "Subscribers' Maintenance Problems with Reference to the Application of Certain Transmission Testing Techniques."

H. Thomas, Chester (Wales and Border Counties). "Local Lines Development Schemes—A Critical Review."

P. A. Benefield, Engineering Branch, and J. T. Crocker, Tunbridge Wells (Home Counties Region). "Two New Coaxial Line Systems—Comments on Installation and Acceptance Testing."

The Council of the Institution is indebted to Mr. J. Stratton, Chairman of the Papers Selection Committee of Council, for the following précis of the medal-winning papers:

Subscribers' Maintenance Problems with Reference to the Application of Certain Transmission Testing Techniques

This paper directs the spotlight on to one of the least publicized areas in the maintenance field, the subscribers' local network. The problems which arise here are those that affect the public directly. It is from the quality and efficiency of the subscribers' network and local installation that the public largely form their opinion of the Post Office communication system, and too much attention cannot be given to this subject.

Noise, intermittent disconnexions and overhearing troubles are by no means uncommon, yet it is none too

simple to trace the causes and to rectify them. The author of this paper, however, was employed for many years in main-lines transmission maintenance practices before moving into subscribers' maintenance. He has been able to suggest, and put to use most successfully, in dealing with the more awkward local-network faults, some of the techniques and equipment used by the transmission engineers. The greater cost of the more sophisticated equipment—recording decibel meters, vibration testers, etc.—is offset by a very real saving in the time required to pin-point trouble sources.

If any criticism may be made of this paper it is in the lack of reference to one of the more fruitful sources of bad overhearing troubles, i.e. "split" pairs and "rectified splits," in the cable network. Such splits are exceedingly difficult to locate by conventional means and can consume so much time and cause so much trouble that the inevitable result is that these faults remain uncleared. Experiments with a relatively inexpensive pulse echo test set are proving most successful in this field and it may be that the author will see, in the not too distant future, this item joining his suggested maintenance-control pool of higher-class test gear.

Local Lines Development Schemes—A Critical Review

As the author of this paper so rightly stresses, many millions of pounds are invested in underground and overhead plant and "there is an obvious need, therefore, for skill, care and economy in the preparation of development schemes." Each stage of the process, from the initiation of a development scheme to those points in time when actual duct or cable works may commence, is explained clearly and in logical sequence. Even for those to whom the field of local-cable networks is an alien world there would be no difficulty in understanding the present modes of operation.

It is the very clarity of this explanation of present methods which helps to impress the reader with the force of the author's arguments for improvements in various directions. The plea (from a planning engineer) to restrict alterations to existing plant and to lay the new networks over the old must gladden the hearts of maintenance engineers, for nothing is so conducive to the production of a crop of major troubles as rearrangement of an old network.

The author will find support for his opinion that development-scheme projects tend to become submerged in too much paper-work—diagrams, plans, forms, etc.—yet this is a matter which cannot be disposed of without very careful consideration, for the "skill, care and economy" so desirable in planning often has a sound basis in the paper-work.

Two New Coaxial Line Systems—Comments on Installation and Acceptance Testing

Whilst this paper gives a very good and comprehensive account of the design details of various coaxial line systems, and of the modifications and adjustments found necessary during acceptance testing and commissioning, it is, unfortunately, somewhat excessive in length.

The over-long introductory description of the basic principles of older coaxial line systems, C.E.L.2 and C.E.L.6A, may have been thought necessary to provide a basis on which to build the real story of the two new coaxial line systems mentioned in the title of the paper and thus may be excused. However, this is followed by descriptions of not two, but three new systems, C.E.L.8A, 11A and 12A, and the total mass of information becomes rather a lot to absorb. But this is a criticism which should not be allowed to obscure the overall high standard of treatment of the subject.

The authors have been closely connected with the instal-

lation, acceptance testing and commissioning of many different types of coaxial line systems for a considerable time, and, in these circumstances, there is always the possibility of failure in that the expert will assume that readers of, or listeners to, his paper know the background history. As mentioned, this pitfall has been avoided, but in the avoidance just that little too much information has been supplied.

This paper, with some judicious pruning, is recommended as very good reading for anyone who wishes to gain a sound working knowledge of general features of a wide range of coaxial line systems.

Result of Essay Competition, 1962-63

A prize of £6 6s. and an Institution Certificate have been awarded to the following competitor in respect of the essay named:

W. Mercer, Technical Officer, Port Patrick. "Brief Encounter with a Nuclear Explosion."

Prizes of £3 3s. each and Institution Certificates have been awarded to the following four competitors:

J. C. Hines, Technical Officer, Inverness. "Some Aspects of Human Relationship in the Engineering Department."

D. J. G. Corin, Technical Officer, Portscatho. "A Non-Director Man Goes Out."

A. G. Hickson, Technical Officer, Northampton. "Training of Maintenance Staff (Microwave Radio Equipment)."

H. R. Merry, Technical Officer, Reading. "Housing Estates and the Telephone Service."

Institution Certificates of Merit have been awarded to: D. M. Rennolds, Technical Officer, Bristol. "Maintenance and Installation—Unified Command."

A. A. Simpson, Technical Officer, Glenrothes. "Transmission by Waveguides."

R. Hare, Technical Officer, Middle Wallop. "Submarine Cables."

D. W. J. Smith, Technician I, Bletchley. "Applied Human Kinetics for Manual Handling and Lifting."

A. J. Christie, Technical Officer, Thurso. "On Designing a Circuit."

The Council of the Institution records its appreciation to Messrs. R. O. Boocock, C. G. Grant and E. Hoare, who kindly undertook to adjudicate upon the essays entered for the competition.

N.B.—Particulars of the next competition, entry for which closes on the 31 December 1963, will be published later.

S. WELCH,
General Secretary.

Additions to the Library

Library requisition forms are available from Honorary Local Secretaries, from Associate Section Centre Secretaries and representatives, and from the Librarian, I.P.O.E.E., G.P.O., 2-12 Gresham Street, London, E.C.2.

2701 *How to Read Statistics*. I. R. Vessels (Brit.1962).

For the layman; presents the elements of statistical method in such a manner as to induce a critical attitude towards the conclusion drawn from numerical and graphical data.

2702 *Bromoil and Transfer*. G. E. Whalley (Brit.1961).

A practical handbook for those who have had little success in the medium, and for new workers.

2703 *The Use of English for Technical Students*. R. A. Kelly (Brit. 1962).

Written to help the technologist to use language functionally, and to express himself clearly and lucidly within his specialized subject and in subjects closely allied with it.

W. D. FLORENCE,
Librarian.

Regional Notes

London Telecommunications Region A HOLE IN THE ROAD

It was 6.30 a.m. on 1 April, 1963, when the driver of a lorry arriving at the junction of Invermore Terrace and Plumstead Road, Woolwich, realized that the earth was opening beneath him. The driver managed to make a hurried exit before the lorry came to rest partially suspended on a cradle of telephone, electricity and London Transport cables, nose down in a crater approximately 30 ft deep and 60 ft across. Broken sewers, and water and gas mains were all contributing to an incident similar to some encountered during the war years.

Eleven telephone cables, including three junction cables, existed at this point. Advice was received that, in view of the importance of the thoroughfare, which takes all the riverside traffic south of the Thames, the Borough Engineer was calling a site meeting of all interested parties at 11.30 a.m., at which he required the various undertakers to have their emergency proposals available.

An immediate inspection was made of the routes on either side of the crater to ascertain the amount of visible damage. Access to the crater itself was prohibited, as apart from gas, earth falls were still occurring.

It was apparent that all cables except one had pulled from the London direction. It was considered advisable to provide interruption cable between two manholes which gave access to all the routes, rather than at any intermediate points. The interruption cables (1,600 pairs were required) had to be taken to the north side of Plumstead Road because of the crater, and mechanical protection was therefore required for the two road crossings and also across the main gate of Woolwich Arsenal.

At Woolwich Exchange, director retranslation to route calls via Toll exchange was necessary to maintain the Woolwich to Erith traffic and although several hundred short-circuited lines had been dealt with, at least an equal number of circuits were disconnected at the crater.

At the meeting it was stressed that all immediate work would have to be carried out away from the crater, as the lorry was lying on live electricity cables which would



VIEW OF THE CRATER

have to be disconnected before the lorry could be moved. Also water, sewage and gas, as well as the undermining of the remaining road surface near the crater, were additional hazards. It was thought that it would take over a month to restore the road. A view of the crater is shown in the photograph.

It was hoped to use polythene-sheathed experimental

cables for the interruption work, two 225 yd lengths of 800 pr., 6½ lb/mile were required for the main diversion, but ultimately lead-sheathed cable was obtained. Shallow trenching, sufficient to accommodate two 4 in. steel pipes for each crossing, was commenced in the early afternoon. The cables were drawn in and laid along in the angle of the pavement and the wall outside the Arsenal and jointing commenced the next day. Several interruptions, due to Gas Board operations, were necessary in the early stages. All connexions to subscribers in the immediate area had to be proved back to the exchange as all the conductors had been pulled out of the distribution-block joints at Invermore Terrace.

A small tarmacadam fillet was put on the two interruption cables in the wall angle, where they were not covered by a temporary 8 in. polythene gas main, partly for mechanical protection but also to discourage would-be scrap-metal collectors. It was not possible or practicable to obtain timber or split steels for this purpose. Protection probably would not have been necessary if polythene-sheathed cable had been available.

Conductors were damaged in two cables outside the interruption area. This may have been caused during the recovery of the lorry, or by large baulks of timber (20 ft × 1 ft × 1 ft) which were dropped by crane into the crater, followed by 150 bales of straw, as protection for the main 11 ft sewer lying at the bottom of the crater.

An office in an empty building within a few yards of the crater was taken over by Woolwich Borough Council as liaison headquarters and telephone service was given to this office by noon on the day of the incident. L.J.I.

CLOSING DOWN OF THE CENTRAL TELEGRAPH OFFICE (C.T.O.) PNEUMATIC SYSTEM

With the fall in telegraph traffic, coupled with the advance in teleprinter automatic switching, the C.T.O. pneumatic-tube system has now become obsolete. This linked the Central Telegraph Office with acceptance and delivery points for telegrams for distances of up to four miles.

The present installation, described in an article in the *P.O.E.E.J.*, Vol. 40, p. 164, Jan. 1948, comprised the new pneumatic plant commissioned in 1947 to replace that destroyed by enemy action in 1941 (*P.O.E.E.J.*, Vol. 38, p. 11, Apr. 1945) and the automatic carrier switchgear which did not suffer much damage and which was described in an early article (*P.O.E.E.J.*, Vol. 27, p. 173, Oct. 1934).

Most of the street tubes are, however, very much older, the oldest having been laid in the 1860s. The street tubes are being abandoned save for a few lengths used for point-to-point tubes since, being laid in the concrete foundations of the roadways and with no manholes, the cost of recovery would be greater than the value of metal recovered.

S.I.B.

Wales and Border Counties CARDIFF-PENARTH ROAD TOLL-BRIDGE REPLACEMENT

The demolition of the old Toll Bridge over the River Ely at Cardiff and its replacement by a more modern and substantial bridge is now under way and the job presented its own peculiar design problems as is usual with many works of this nature.

The old bridge marked the boundary between Cardiff and Penarth, and carried five important junction cables, serving Penarth and neighbouring exchanges such as Barry, which needed to be diverted to the new bridge.

The more usual method of diverting the cables to new duct-track in stages might have been adopted but, to

prevent delay to the road works, it was agreed that the Post Office would divert the cables at the outset to a temporary route well clear of the operations. New cables will later be installed in the new bridge without interference with the bridge work.

Of the different methods available it was decided to support the cable across the river on a temporary overhead span. The span is approximately 100 yd long with four 7-strand, 12 s.w.g., steels terminating at each end on two extra-stout poles in H formation. Because of the weight of the suspension wire and cables carried, each H-pole has six backstays. The soil, which is wet mud, has low shear strength so that reinforced-concrete footings below the poles and a pair of lateral stays were provided at each end. All stays were given ample "spread."

Of the 928 pairs in the existing cables, 800 will be sufficient to carry the service for the period of the work, and these were temporarily diverted into eight 100 pr., 10 lb/mile polythene cables carried in pairs on the four suspension wires. All the cables were gas pressurized.

W.G.S.

MORPETH FLOOD

As a consequence of the rapid thaw which followed the recent severe winter, the river Wansbeck overflowed its banks and inundated the main A1 road through Morpeth.

Some 170 circuits were rendered faulty, primarily in underground plant, due to the almost complete submersion of a cabinet which unfortunately was not watertight.

Twenty telephones and a 3 + 9 switchboard, which were the victims of the flood, were all scheduled to be changed as part of the impending transfer of Morpeth C.B.S.2. exchange to non-director working. The exchange fitters were already in the vicinity and all the equipment was changed in a very short time.

The underground cable faults proved to be more difficult as it was necessary to cut the cabinet out of the network. Service was, however, restored to the majority of circuits within three days.

The Post Office garage in Dark Lane, situated close to the flood point, also felt the full impact; within a short time the garage floor was under more than 3 ft of water (8 ft in a sub-area boiler room), but with commendable foresight the boiler fire had been drawn and slow flooding through a drain pipe slowly cooled the boiler so that apart from the lagging there was no other damage. A Morris van, without engine, was quickly immersed and despite the best efforts of the motor transport staff, four engines, two of which were new, suffered similarly. A tank containing some 200 gallons of lubricating oil was turned over by the flood and materially added to the chaos. Prompt action did, however, prevent any floodwater from entering the petrol tank. The staff rose to the occasion splendidly and there was no loss of service, at any time. Electrical services did not go unscathed and the inspection-pit lighting and a hoist needed re-wiring.

It will be many a long day before the citizens of Morpeth and those even more concerned with the aftermath forget that the departure of winter often brings in its wake events vastly more unpleasant than those normally associated with it.

F.A.N.

North Western Region

REPOSITIONING OF CROSS-CONNEXION CABINET AT BROMBOROUGH VILLAGE

Due to a building extension at the Midland Bank in Bromborough Village, it became necessary to reposition a cross-connexion cabinet, which completely obstructed the proposed rear entrance to the bank, as shown in the sketch. This cabinet contained seven enclosed-type assemblies served by one 4/400 and three 1/100 tails, and provided

service to 250 subscribers by means of 350 E-side and 700 D-side pairs.

On account of the estimated high cost of moving the cabinet by conventional methods, it was agreed to move the cabinet and cable feed as one unit by means of a hydraulic crane.

The electricity authority co-operated by removing an obstructing power cable at their own expense. Due to a 90°

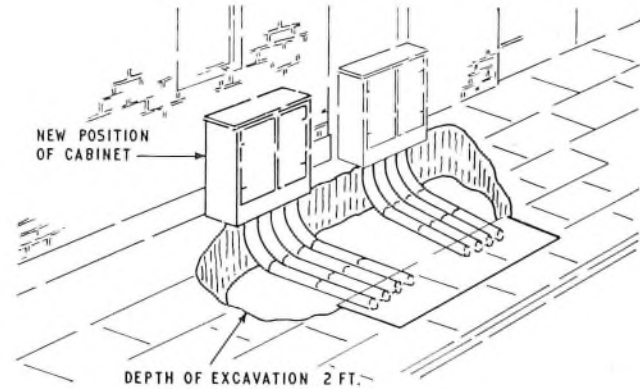

SKETCH SHOWING THE CHANGE IN POSITION OF THE CROSS-CONNEXION CABINET

change in the direction of feed and the cabinet base having been keyed to old foundation work, the base, bends and ducts had to be broken away before the cabinet could be removed.

Complete restoration was effected by the use of split bends and ducts, and a new cabinet-base was provided in situ.

Although the work was time consuming a considerable saving was achieved by using this method and interruption to the telephone service of the subscribers concerned was avoided.

E.S.

Scotland

MOSSFENNAN REPEATER STATION FAILURE

At noon on Thursday, 7 February, 1963, Uddingston repeater station received a prompt alarm from Mossfennan. Normally this alarm would get attention within an hour or so but on this occasion the A701 road from Broughton to Moffat was blocked by snow. The station is about 3½ miles south of Broughton and about 20 miles north of Moffat. Selected customers along the route were called by telephone and asked about the condition of the road. All confirmed that movement by road was difficult and in some parts impossible. Road authorities could not say when the snow ploughs would get to work. At 4.20 p.m. all circuits routed through Mossfennan repeater station failed.

Relief parties were then organized from Moffat, Dumfries, Biggar, Jedburgh and Stobo. At 1 p.m. on Friday the Stobo lineman reached the station just behind the snow plough working south on the A701 and ten minutes later, as the Assistant Engineer at Dumfries was preparing to direct his efforts to restore service, the party from Dumfries arrived. The station was restored to service at 1.25 p.m. and the party from Jedburgh was recalled. It was not possible to get in touch with the Biggar party and this party did manage to reach the station about two hours later after having travelled across country between Biggar and Broughton.

It is assumed that a mains-supply failure caused the standby charging set to start up but the engine failed on low speed. Subsequently this was found to be due to mechanical failure of the timing relay in the power-plant control equipment.

W.F.G.S.

South Western Region

COLLAPSE OF STEEL POLES AT ROPLEY

The recent bad weather caused the collapse of three steel poles in an exposed part of the Ropley (Winchester) exchange area. Freezing rain resulted in an ice formation



ONE OF THE COLLAPSED POLES

of up to 1 in. diameter on the wires, and with a freshening wind a section of the route collapsed. As illustrated in the photograph, each pole buckled at a joint and pulled apart. W.S.

Midland Region

A NEW CABLE AND WIRELESS OFFICE AT BIRMINGHAM

The increase in Cable and Wireless traffic at Birmingham over the last few years has resulted in the rather limited accommodation at Lombard House proving insufficient even for normal development. Following the proposed decentralization of overseas telegraphs and the opening in 1963 of the Birmingham Office as an Overseas Telegraph Area Office, new accommodation to cater for a much larger office had to be provided. Accordingly, the first floor of Canterbury House, a new office block close to Telephone House, was leased for the new office and the opportunity was taken by the Telecommunications Branch to plan a layout of the position equipment to suit



POSITION EQUIPMENTS AT THE NEW CABLE AND WIRELESS OFFICE AT BIRMINGHAM

the special operating procedures for provincial overseas traffic area offices. A general view of position equipments is shown in the photograph.

The layout consists essentially of two continuous double-sided suites, each divided by a conveyor belt running down the entire length of the suite. The conveyor-belt systems were made up locally by the Telephone Manager's Engineering Division, and they largely eliminate the need for manual transfer of traffic within the office. One suite, designated "A", deals with traffic originated within the Region and forwarded overseas, whilst the other suite, designated "C", caters for homeward traffic received from overseas to be delivered within the Region. Phonogram facilities have been provided temporarily on both suites by the use of key and lamp units as at the moment this service is conducted over ordinary exchange lines. However, in the near future when the supervision of pay-on-answer calls is required, it is proposed to replace these units with a later design of equipment. Twelve phonogram positions were provided on the A suite and eight on the C suite. Eighteen telex positions, two inland T.A.S. positions and three outgoing gentex positions were provided on the A suite. In addition, there are two duplex private-circuit (P.C.) positions working to Electra House, each equipped with a Teleprinter No. 11, an Auto-Transmitter No. 2F and a Perforator No. 45. Two outgoing circuits will also be provided on the A suite for connexion to the torn-tape relay centre at Electra House when this becomes operational. The C suite was equipped with five outgoing inland T.A.S. positions, three incoming gentex positions, and a further two P.C. positions connected to Electra House using Teleprinters No. 11 and Printing Reperforators No. 2. In addition, two incoming-circuit positions, each equipped with a Teleprinter No. 7 and a Printing Reperforator No. 2, will be provided on the C suite to be connected to the torn-tape centre at Electra House.

The suites were provided by the Ministry of Public Building and Works, and consist of a continuous wooden table top, 4 ft wide, covered with linoleum and supported at approximately 4 ft intervals on cast-iron legs that were also designed to carry wooden cable-ducting to facilitate the wiring of the teleprinter and phonogram positions. The two suites are, respectively, 88 ft and 66 ft in length, and to provide for flexibility each position has been cabled back to distribution frames housed in Type 52 apparatus racks. Due to the shallowness of the floor screeding, channelling to carry the necessary cables to the suites could not be provided and the use of surface capping, which would impede movement of trolleys, etc., was not desirable. To avoid unsightly overhead racking, etc., and as the offices immediately below the new office were not completed at the time, agreement was reached with the developer of the building for metal trunking to be fixed to the ceiling of the offices below. This trunking was concealed by a false ceiling provided by the developer who also arranged for the necessary cable holes to be cut through the floor of the instrument room. This method of running cables and the use of the Type 52 cabinets to house the distribution frames and patching jack fields made a very tidy layout. An engineering enclosure on the instrument-room floor houses a patching jack field so that any teleprinter position can be monitored or tested. Repair facilities are also provided to cover the normal maintenance and repair of the instrument-room teleprinters. A separate battery room situated on a lower floor houses the five Rectifiers No. 56A used to provide the teleprinter motor supplies and the signalling 80+80-volt supplies and a spare rectifier is also fitted. A temporary 24-volt battery which feeds the phonogram positions has been installed but this battery will be replaced by a 50-volt battery when the phonogram circuits are modified.

The office was opened for traffic on Monday, 4 March, 1963. E.H.

Associate Section Notes

Middlesbrough Section

The first visit of the 1962-63 session took place in December when a party of 24 of our members visited the anhydrite mine owned by I.C.I., Billingham. The party made the 4-mile journey from the shaft bottom to one of the working faces by means of a lorry, to see how the anhydrite was drilled, blasted and transported to the surface.

At the first meeting of 1963, Mr. W. Outhwaite gave a talk entitled "Bee Keeping as a Hobby." The talk was supplemented by two short films, and the break before question time included sampling some of the honey brought by the speaker. Although not well attended, those present agreed that it had been an interesting and lively meeting.

The subject of the lecture at the February meeting was "The Earth's Natural Satellite," by Mr. C. Cox, a Technical Officer from Darlington. Mr. Cox fully explained the different theories of the origin of the moon, and the position of the satellite in our own solar system, finally dealing with the structure, surface and atmosphere of the moon itself. During the talk he referred to some 36 slides, all of which he had prepared himself for the lecture. Question time proved very interesting. The members present really appreciated the lecture and voted the whole evening most interesting.

The final meeting of the 1962-63 session was to have been a visit to the early warning station at Fylingdales. Unfortunately, due to weather conditions, and to the introduction of security precautions, this had to be cancelled. Instead of the visit some members attended a film show given by Mullard, Ltd., at the Cleveland Scientific Institute, Middlesbrough.

N.W.

Bradford Section

The second part of the 1962-63 session opened with a talk entitled "Transistors, Simple Theory and Some Applications," by Mr. L. Burkitt. Transistors are appearing in more and more types of equipment, and members were shown their use in a range of subscribers' apparatus. Attendance at this meeting was the highest for some time and we are grateful to Mr. Burkitt for a most interesting evening.

We continued the session with another of our "Open Nights" at the Bradford Telephone Exchange. These evenings are always very popular and we were able to show 200 relatives and friends round the exchange.

In conclusion we are to visit the works of British Insulated Callender's Cables, Ltd., Prescot, and look forward to an instructive day.

R.C.S.

Lancaster Centre

The Lancaster Centre was successfully reopened on 9 July 1962, after a break of 3½ years.

The first meeting of the Centre was held in July in order to arrange a program of events. To complete the evening we had an excellent lecture on "Telecommunications for the Space Age," given by Mr. S. J. Rawlinson, Assistant Engineer.

In October, 18 members had a very interesting visit to the local power station.

December proved to be an active month with two trips to B.I.C.C., Ltd., at Prescot, and a lecture on "Some Aspects of Supervision" given by Mr. J. E. Dadswell.

In January an excellent lecture was given by Mr. A. F. G. Allan, Main Lines Development and Maintenance Branch, Engineering Department, entitled "Small-Diameter Coaxial Cables—A Survey of Developments." Over 30 members attended the meeting and everyone was impressed with the exhibits, and the practical nature of the lecture.

Our February event was a lecture on the "P.O. T.V. Network" and a demonstration of colour television given by Mr. J. B. Sewter and Mr. P. J. Edwards, Main Lines Development and Maintenance Branch, and Inland Radio Planning and Provision Branch, Engineering Department, respectively. The lecture was held in the new exchange at Preston and was attended by approximately 140 members and visitors.

In March a lecture was given by Mr. C. F. Davidson, Research Branch, Engineering Department, on "Space Communication." A working model of the aerial at Goonhilly Down was demonstrated and a half-size replica of TELSTAR was also on view.

The meetings held so far have been quite well attended and have given the committee great encouragement. The centre, which started with 30 members, has now increased to 60 but there is still room for expansion. It is hoped that the present enthusiasm and support of all members will continue in the following season.

C.W.

Cornwall Centre

For the January meeting Mr. H. E. Pearson of the Space Communication Systems Branch, Engineering Department, gave a talk tracing the use of microwaves from their introduction commercially to their present use in the satellite communications field. In February, members were fortunate in having an invitation to attend a lecture by Professor Andrade on "Sir Isaac Newton."

For the March meeting Mr. Uren offered a prize of one guinea and Mr. Stevens offered a second prize of half a guinea for the best paper of approximately 15 minutes duration. Some seven papers were entered, the winning one being "The Quantum Theory" by Mr. D. L. Shenton (Youth in Training). The second prize was given to Mr. C. H. Gardner for his paper on "Positive-Battery Failure-Alarm Systems."

The annual general meeting will be held in April followed by a paper on "Microwaves for the Layman" by Mr. Lawson of the experimental satellite ground station, Goonhilly Down.

A.R.B.

Sheffield Centre

On 27 March, a lecture entitled "Domestic Hi-Fi" brought to an end another successful winter session. We are indebted to our energetic secretary and the committee for organizing an interesting program, to the Telephone Manager and Area Engineers for their encouragement and co-operation, and, not least, to the members who supported us at our visits and lectures.

During the session we have visited Tennant's Brewery in Sheffield, British Insulated Callender's Cables, Ltd., at Prescot, Pioneer Exchange at Manchester, British Railways' signalling installations at York, and the Sheffield trunk exchange. This last visit drew a record attendance of 107 members and friends, who were shown the trunk automatic exchange and switchboard, junction-tandem exchange, instrument room, telex automatic exchange, repeater station, m.c.v.f. terminal and the power room. Refreshments served during the visit were particularly appreciated by the guides, for such was the interest shown that four hours had lapsed before the last of the visitors departed.

At York we visited the main station signal box, and an experimental installation in the goods-yard box. Originally it needed a team of 30 or 40 signalmen to set the signals and points manually. Now the pressing of two appropriate buttons will set up a route from point A to point B across the station or goods yard. All sections are checked automatically for obstructions before points and signals are set pneumatically. Four men operate the

whole installation. Our thanks are due to British Railways staff who made the visit so interesting that we kept them talking well after their normal finishing time.

Lectures have included "S.T.D. as it Affects the Non-Director Exchange" by Messrs. B. B. Gould and B. G. Woods, Telephone Exchange Systems Development Branch and Telephone Exchange Standards and Maintenance Branch, Engineering Department, respectively, "Colour T.V." by Mr. Carnt of G.E.C., and "Domestic Sound Reproduction" by Messrs. Russell and Jamieson of Wharfedale Loudspeakers, Ltd. Not unnaturally, the last lecture dealt mainly with loudspeakers and pointed out that improvements have been due to better magnetic materials, improved methods of suspending moving parts, and better matching of loudspeakers to air loads, i.e. the technique of cabinet and enclosure construction. Points were convincingly demonstrated by the use of loudspeakers ranging from a horn of 1927 vintage, and the firm's first moving-coil model (1933), to an assortment of current models.

On 3 January we were invited by the Sheffield centre of the Institution of Electrical Engineers to assist as stewards at the lecture by Capt. Booth, Deputy Engineer-in-Chief, on "TELSTAR and Satellite Communications."

The annual social on 19 January was highly successful. There was a film show before supper, and games and dancing afterwards. Our guests were the Telephone Manager and the Area Engineers. Thanks again to the usual team of hard workers and, in particular, to Arthur and Mrs. Knowles who organized the entertainments.

J.E.S.

Tunbridge Wells Centre

The Annual Event, which was held in the Telephones Club, Tunbridge Wells, on 17 April, marked the end of another season. Mr. L. W. Barratt, Area Engineer, acted as quiz-master in the contest between the Tunbridge Wells and Hastings Associate Sections—the Hastings team won as usual, but only by three points! The subjects covered a wide field and included the identification of objects photographed from unusual angles and odd pieces of metal which had been gleaned from junk boxes at home and at work.

During the 1962-63 session visits were made to the Radio Show, Messrs. Allen West and Co., Ltd., Brighton, and Stone Chance, Ltd., Crawley. Three members read papers: Mr. P. Gorrett on "Taped Sound," Mr. J. Mitchell "Design of Yesterday," a follow-up to his award-winning paper of last year, and Mr. T. Wells, "British Railways Telegraphs and Signals."

Of talks by non-members there was "Advanced Driving" by Inspector Loughlin of the Kent County Constabulary, and "The History of Tunbridge Wells" by Mrs. Edith Bradley, curator of the Municipal Museum. Mr. R. Nevett gave the talk, which was postponed from the 1961-62 program, on "Mechanical Aids." One meeting was held at East Grinstead when Mr. F. Hicks gave a talk on "Campanology." When the meeting closed a visit was made to the belfry of the parish church where the local team of bellringers were practising. It has been suggested that we should hold more of these meetings at our out-stations. Mr. P. Crombet-Beolens, an amateur geologist from the Telephone Manager's office, gave a talk, illustrated by colour transparencies, entitled "From Shore to Mountain."

The attendance at meetings has continued to be disappointing but we hope to present another interesting and varied program for the 1963-64 session.

L.S.H.

Reading Centre

The 1962-63 session of meetings has proved to be the best session so far in the Reading Centre's brief history.

The session started with a talk, "The Thames Conservancy," and, by a happy chance, the last meeting of the session turned out to be complementary to the first—"The Hydraulic Research Station at Wallingford." One meeting was cancelled through bad weather, but during the session we have heard about "Budgetary Control and Post Office Finances," "Metal Fatigue and its Problems," "The Electrical Research Station at Shinfield" and "Housing Estates and the Telephone Service," this last one by the Centre Secretary, Mr. H. R. Merry.

We have visited Huntley & Palmers biscuit factory and the Meteorological Office at Bracknell, but visits to the Pan American communications centre at London Airport were postponed at the last minute as fog suddenly blanked out the area. A further postponement was the cables visit, this time due to a tight schedule in port, but we have been promised facilities when she next calls in for a refit.

During the summer, one visit a month has been programmed, the first visits being to the Hydraulic Research Centre at Wallingford and to the Television Centre.

The awards gained in the Associate Section Papers Awards by Messrs. C. H. Collins and H. R. Merry were presented by Mr. A. H. C. Knox, at the annual general meeting on 24 April. The committee hope that this will encourage other members to prepare papers to be read before the Centre, and as a further encouragement the Centre is to offer a prize for each paper presented.

The committee feel well satisfied with last year's work and are already working on the future program, which they hope will be even more successful.

H.R.M.

Guildford Centre

During the past year the Guildford Centre has lost a number of active members due to promotion. One of these was the Secretary, Mr. J. F. T. White, who during his term of office contributed a considerable amount of time and energy to keeping the section active.

In September of last year the centres in the Home Counties Region held a conference at Bletchley Park where a number of resolutions of mutual interest were discussed. It was the general feeling that this conference proved a good means of advancing the activities of the centres by an exchange of ideas, and it was hoped that these meetings may continue.

The centre has just completed a year of instructive and interesting visits, lectures and films, commencing with a visit to the B.P. oil refinery on the Isle of Grain. Here members were shown the refining process from crude oil to petrol.

Early this year members visited the Courages brewery at Alton.

Lectures this session have included "New Coaxial Systems" given by Mr. Benefield and Mr. Crocker of Engineering Branch, Reading; the lecture was followed by a lively discussion on the problems involved when connecting new systems.

Dr. Byford of the R.A.F. Institute of Aviation Medicine, Farnborough, delivered an instructive illustrated lecture on the work of the institute; members were shown film of various experiments carried out to simulate supersonic high-altitude flying.

Two film shows have been held in the last session and have been well supported with average attendances of 90 members. Films shown included "Production of Tyres," "Motor Racing," a nature film "Serengeti Shall Not Die," and "Gowns and Gears," a cartoon film about women drivers.

Future activities already arranged include a visit to the National Coal Board's Snowden colliery in Kent and a lecture on "Cable Pressurization." It is also hoped to have a lecture on the work of the Thames Conservancy.

The section is still expanding and the membership to date stands at 184. Purchases this year include a trans-

parency projector and screen which is available for hire to members.

R.W.

Edinburgh Centre

At our January meeting Mr. D. M. Plenderleith, one of our members, presented a program of films, the main feature being a film entitled "Captive River" which dealt with the Kariba dam project.

In February, Mr. J. W. Sime from the Regional Training School, Edinburgh, gave a most interesting talk on "Recent Underground Developments," dealing in particular with polythene cables, cable pressurization and small-diameter coaxial cables. Added interest was given by the use of models and demonstration sets.

The final talk of the present session was given in March by another of our members, Mr. J. M. Dixon, who gave a talk on "Telex"; this was followed by a lively question session in which the audience took an active part.

Over the past session, attendances at meetings have shown a small but encouraging increase. The committee are actively engaged in seeking ways and means to increase these attendances.

J.M.D.

Bletchley Centre

It is regretted that the severe weather conditions earlier in the year hampered not only the organization of visits but also, due to the unexpected blizzard, caused our January talk on S.T.D. by Mr. Hitchin to be postponed until May. We apologize to members for the rather short notice given for that meeting.

In March, Mr. Evans of the Midland Region of British Railways gave members a very interesting review of the "A.C. Electrification of the Crewe to Euston Line" with a detailed account of work being performed in the Bletchley area. The talk was rounded off by travelling on film from Sheffield to Manchester by electric train service in 60 minutes.

April brought a very enlightening talk on the growth of telecommunications in the Bedford area. Mr. F. M. Facer introduced the talk by revealing how the engineering organization of the Post Office developed into its present-day shape, with particular reference to the Bedford area. Mr. Coles then talked about the growth of line plant and the problems created by changing practices and costs. He was followed by Mr. Brown who spoke about internal plant and planning in the area, giving many interesting facts of how the Bedford area has developed particularly since 1939.

Only one visit has been organized in this last quarter. This was to Texas Instruments at Bedford in February, where members viewed with interest how semiconductors are produced on an assembly-line basis. A brief coverage of the firm's activities and production methods was given by Mr. P. Robinson before the tour of the factory commenced. Members were very impressed with the excellent working layout of the factory and its production facilities.

Our winter program for 1963-64 is as follows:

September: not yet arranged.

21 October: "The Work of the Port of London Authority," by Mr. A. G. Endicott.

2 December: "The History and Evolution of the Teleprinter," by Creed & Co., Ltd.

20 January: "The Planning and Construction of Goonhilly Down," by Mr. H. E. Pearson.

24 February: "Motorway Projects," by Mr. Parr of the Ministry of Transport.

April: not yet arranged.

June: Annual general meeting—date not yet fixed.

A.J.H.

Aberdeen Centre

This year we had two meetings in Aberdeen, one in Inverness and one in Kirkwall.

At the February meeting in Aberdeen, Mr. G. D. Adams

read his paper "An Introduction to Computers and Programming." This was followed by the films "In Two Dimensions" and "Introduction to Feedback."

At the March meeting, the Regional President, Mr. R. J. Hines, presented Institution Certificates to Messrs. J. McColl and James Davison, awarded to them for their respective papers "The Television Network Switching Centre" and "An Introduction to the Slide Rule," read at meetings of the Centre last session. Mr. A. M. Duff then read his paper "Music Circuits." Afterwards there was a showing of the film "The First Transatlantic Telephone Cable."

The Inverness section also had a meeting in February and were taken on a conducted tour of Glen Albyn Distillery, Inverness.

The Kirkwall section had a meeting in March during which a large attendance saw the film "The First Transatlantic Telephone Cable."

Further honours have come the way of our members. Mr. J. C. Hines, Inverness, has been awarded a prize in the Institution essay competition for 1962-63 for his essay "Some Aspects of Human Relationships in the Engineering Department."

Mr. A. J. Christie, Thurso, has been awarded an Institution Certificate for his essay "On Designing a Circuit."

D.W.

Salisbury Centre

When the activities of the Centre were last reported it was mentioned that we were looking forward to a visit to H.M.T.S. *Monarch* and to a paper on space communications. Both of these events have now taken place. On the evening of 5 December, 1962, 270 people gathered at the N.A.A.F.I. services club, Salisbury, to hear Mr. D. Wray, Space Communication Systems Branch, Engineering Department, give a paper on "Satellite Communications" and particularly the TELSTAR project. The audience was drawn from a large area and Senior and Associate Section members attended from Southampton and Bournemouth. Other Government Establishments were also represented together with staff and students from the local technical college. The meeting was a great success and it is the first time that such a large gathering has attended a technical lecture of this nature in Salisbury. The Centre President, Mr. C. S. Hale, was in the Chair and the Mayor of Salisbury, Councillor S. A. Vokes, himself an ex-Post Office Engineer and Senior Section member, welcomed Mr. Wray to Salisbury.

In February this year 20 members of the Centre visited Southampton and H.M.T.S. *Monarch* which had taken on 1,000 miles of Lightweight submarine cable and was about to set sail for the Pacific Ocean to lay the cable as a further link in the "round-the-world" cable now being engineered. Members of the Submarine Branch, Engineering Department, and the staff of Standard Telephones and Cables, Ltd., showed the party over the ship. It proved to be a most interesting and instructive visit and the Centre museum now proudly shows a section of COMPAC submarine cable.

In April, the annual general meeting was held. The following officers and committee members were elected. *Chairman:* Mr. F. Beaver; *Secretary:* Mr. R. Hare; *Assistant Secretary and Treasurer:* Mr. K. W. S. Scamell; *Librarian:* Mr. K. Hatcher; *Committee:* Messrs. R. Hawkins, P. Keel, J. Beeson, D. Harris and F. Keyes. The membership figures for the year show an increase of 61 and we all look forward to another busy and successful year.

R.H.

Swindon Centre

The 1962-63 session has been concluded with the following visits.

In January several of our members visited a semiconductor factory at Swindon where the intricate problems involved in the construction of semiconductors were explained and illustrated.

During February a visit was made to the Deloro-Stellite factory where the hard alloy stellite is manufactured.

Finally in March members visited the Garrard factory to see the construction of the firm's products and to hear an absorbing exhibition of stereophonic sound reproduction.

The membership of the Centre has now reached 62 and with several interesting visits planned to stimulate interest we are hopeful of increasing this number further.

A.J.B.

Ipswich Centre

The 1962-63 winter program was concluded with our annual general meeting held in April. This included the presentation of the Chairman's cup to the member producing the best mechanical aid of his own design. Many ingenious and strange devices were on display, all of a very high standard. The cup was awarded to Mr. Harris of our motor-transport section for his device for facilitating the insertion of cotter pins when assembling the valves of side-valve engines. After a sausage supper the meeting ended with a photographic competition including a showing of members' colour transparencies.

The winter program included two papers by local members, "Precision Testing" by Mr. P. E. L. Roffe and "New Subscribers' Apparatus" by Mr. T. J. F. Wells. Both papers were presented with large diagrams and displays of equipment and our thanks are due to the authors for the large amount of time and effort put in on our behalf. Other papers given in this session were "Corrosion" by Mr. A. G. Spencer of Regional Headquarters, and "The Traffic Division" by Mr. T. L. Bentley of our own area. Both papers proved to be of a most interesting and topical nature.

On the social side, our annual dinner and dance was held at Felixstowe in November. Guests of honour included the Regional Liaison Officer, Mr. Saunders, Tele-

phone Manager, Mr. R. N. Hamilton and Mrs. Hamilton, Area Engineer, Mr. F. K. Radcliffe and Mrs. Radcliffe. The Regal Restaurant having provided their usual excellent dinner, a most enjoyable evening of dancing and competition followed.

In March our Chairman and six members accompanied the Bletchley Centre in their visit to our opposite numbers in Dusseldorf, Germany. We should like to thank our colleagues at Bletchley for their invitation to take part and for the wonderful organization which provided our members with a memorable weekend.

T.A.B.

Bournemouth Centre

On 13 February, 10 members visited the B.B.C. Television Centre, London. On the way to the Centre we visited the trunk automatic exchanges and manual boards in Faraday building, and this visit gave us a useful insight into the problems encountered in the big exchanges.

By permission of the Submarine Superintendent a party of 22 visited H.M.T.S. *Monarch* on 24 February. This visit too was most instructive.

The annual general meeting was held on 8 April, but only 20 of our 80 members attended. The following officers were elected:

Chairman: Mr. L. J. Taylor; *Secretary:* Mr. A. E. A. Barwell; *Financial Secretary:* Mr. W. G. Limburn; *Vice-Chairman and Asst. Secretary:* Mr. D. P. Cosh; *Committee:* Messrs. H. J. Goodwin, H. E. Haddon, G. Mouat and T. Williams.

The retiring Chairman, Mr. F. G. Williams, was thanked for his help during his tour of office. The meeting continued with a discussion of the forthcoming year's program, and closed with the showing of two excellent coloured films on transistors by Mullard, Ltd.

A.E.A.B.

Book Reviews

"Taschenbuch der Hochfrequenztechnik." H. Meinke and F. W. Gundlach. Springer-Verlag, Berlin. xxxi + 1,641 pp. 2,300 ill. 97.50DM.

This is the second and much enlarged edition, and the contributors, 48 in number, have been drawn from the leading commercial laboratories. The first edition having sold out, the opportunity was taken to bring the book up to date, especially in the rapidly expanding fields of semiconductor and microwave techniques.

If it were necessary to find a single adjective to describe the book, it would be "comprehensive." Each topic is treated in great detail and is followed by a long list of references. As an example, the first chapter, on passive components, covers 150 pages and ends with a list of 179 references, 47 of which are in English. In this chapter the treatment of inductors begins with a detailed discussion of the magnetic field, skin effect, proximity effect and eddy currents. Then the inductances of single wires, single-layer coils, toroids, flat-spirals and multi-layer coils are considered. Practical details of construction of low-loss coils and variometers follow. Information on core materials and core forms (solid and laminated) occupies the next 33 pages, with much graphical and tabulated data. The treatment of capacitors is similarly detailed, beginning with a general treatment of the electric field. This is typical of the kind of coverage in the rest of the book.

In relation to prices now ruling for technical books, this book represents very good value. It would of course be more useful to English readers, and would doubtless enjoy much greater sales, if an English edition were available.

H.D.B.

"Ferromagnetismus." E. Kneller. Springer-Verlag. 795 pp. 603 ill. 126DM.

The usefulness of a German book to an English reader can be either in its coverage of subjects less fully dealt with in English books or in providing references to German original papers. In both respects this book has something to offer.

It is a full treatment of the theory of magnetic phenomena: not of magnetic materials, nor to any great extent of underlying physical theory. If we take Bozorth's "Ferromagnetism" as a starting-point, omit the half of it which discusses particular materials, and expand the rest to include three times as much detail, we shall have something like Kneller's book. Its point of view should be of interest to both engineers and applied physicists.

The book is well up to date, including references as recent as 1962, and discussing such modern topics as superparamagnetism, evaporated films, and e.s.d. permanent magnets.

The long lists of references are well balanced: mainly German in the earlier, more theoretical, chapters, but also listing many American, French, and British papers where appropriate. Hardly any Russian papers are quoted, however; this is disappointing, because for some years Russian work has been better known in Germany than in Britain. Indexes are provided in both German and English: the indexing often gives many references without showing which is the main one, but is otherwise good. If on some particular point the English books give too little detail, it would be well worth trying this one. The only regret is that the author could not find room for some treatment of the properties of the magnetic materials that are met with in technical use.

A.C.L.

Staff Changes

Promotions

Name	Region, etc.	Date	Name	Region, etc.	Date
<i>Senior Executive Engineer to Assistant Staff Engineer</i>			<i>Assistant Engineer (Open Competition)—continued</i>		
Balcombe, F. G.	E.-in-C.O.	21.1.63	Head, K.	E.-in-C.O.	22.1.62
Haworth, J. E.	E.-in-C.O.	19.2.63	Rodger, W. H.	E.-in-C.O.	16.1.62
Balchin, D. B.	E.-in-C.O.	5.3.63	Johnson, R. L.	E.-in-C.O.	16.1.62
<i>Area Engineer to Regional Engineer</i>			Forsyth, C. D.	E.-in-C.O.	16.1.62
Bryden, J. E. Z.	L.T. Reg.	15.1.63	Clarke, P. G.	E.-in-C.O.	16.1.62
<i>Executive Engineer to Area Engineer</i>			<i>Inspector to Assistant Engineer</i>		
McLeod, J.	Scot.	10.1.63	Simpson, W.	N.E. Reg.	13.1.63
Mainwaring, G.	Mid. Reg.	1.1.63	Jowitt, C.	N.E. Reg.	4.1.63
Chisnall, W. E.	L.T. Reg.	15.2.63	Wallace, W. V.	Scot.	7.1.63
<i>Executive Engineer to Senior Executive Engineer</i>			Edwards, R. L.	H.C. Reg.	4.3.63
Kyme, R. C.	E.-in-C.O. to S.W. Reg.	7.1.63	Bass, N. G.	H.C. Reg.	4.3.63
Holt, J. B.	E.-in-C.O.	18.1.63	Peacey-Nash, J. T.	S.W. Reg.	1.3.63
Thurlow, H. J.	E.-in-C.O.	30.1.63	<i>Technical Officer to Assistant Engineer</i>		
Martin, J.	E.-in-C.O.	15.2.63	Hurst, W. N.	N.W. Reg.	17.1.63
Kelson, D.	E.-in-C.O.	15.2.63	Nash, R. A.	L.T. Reg.	7.1.63
Collier, E. G.	Foreign Office	15.2.63	Henderson, J.	Scot.	21.1.63
(in absentia)			Saint, W. A. S.	Scot.	26.12.62
Looser, R. C.	E.-in-C.O.	22.2.63	Robinson, J. A.	Mid. Reg.	2.1.63
Hunt, A. H.	E.-in-C.O.	21.2.63	Tytherleigh, W. A.	Mid. Reg.	2.1.63
Hughes, C. J.	Sudan	14.3.63	Prichard, R. W.	H.C. Reg.	28.1.63
(in absentia)			Miles, J. D.	N.W. Reg.	14.1.63
Dalgleish, D. I.	E.-in-C.O.	14.3.63	Hannah, C.	N.W. Reg.	21.1.63
Blakely, R.	Iran	29.3.63	Little, W. H. F.	L.T. Reg.	7.1.63
(in absentia)			Wright, J. E.	L.T. Reg.	7.1.63
<i>Executive Engineer (Open Competition)</i>			Rebeck, L. J.	L.T. Reg.	7.1.63
Kershaw, G. D. W.	E.-in-C.O.	1.1.63	Rees, T. G.	L.T. Reg.	7.1.63
<i>Assistant Engineer to Executive Engineer</i>			Etherington, G.	L.T. Reg.	7.1.63
Foulkes, S. A.	E.-in-C.O.	7.12.62	Baker, D. J.	L.T. Reg.	7.1.63
Clatworthy, J. F.	E.-in-C.O.	7.12.62	Jones, M. H.	S.W. Reg.	17.1.63
Harris, R. H.	E.-in-C.O.	7.12.62	Bigg, R. W.	H.C. Reg. to E.-in-C.O.	31.1.63
McLachlin, A. S.	E.-in-C.O.	7.12.62	Long, P.	L.T. Reg. to E.-in-C.O.	31.1.63
Cooling, J. O.	E.-in-C.O.	7.12.62	Mayes, F. W. L.	L.T. Reg. to E.-in-C.O.	31.1.63
Tucker, E. P.	E.-in-C.O.	7.12.62	Strachan, W. G.	E.-in-C.O.	31.1.63
Lodge, J. B.	E.-in-C.O.	7.12.62	Stabbing, L. K.	L.T. Reg. to E.-in-C.O.	31.1.63
Levett, F. D. W.	E.-in-C.O.	7.12.62	Lush, W. F.	L.T. Reg. to E.-in-C.O.	31.1.63
Hyatt, J. L.	E.-in-C.O.	7.12.62	Allen, A. V.	L.T. Reg. to E.-in-C.O.	31.1.63
Pollock, I. G.	E.-in-C.O.	7.12.62	Behan, T. C.	L.T. Reg. to E.-in-C.O.	31.1.63
Tharby, R.	E.-in-C.O.	7.12.62	Beattie, E. M.	E.T.E. to E.-in-C.O.	31.1.63
Needham, F.	N.W. Reg. to N.E. Reg.	1.1.63	Howell, J. R. C.	L.T. Reg. to E.-in-C.O.	31.1.63
Creigh, J. W.	L.P. Reg. to Factories Department	14.1.63	Lemos, B. R.	L.T. Reg. to E.-in-C.O.	31.1.63
Lewis, R. C. G.	E.T.E.	1.1.63	Kingett, D. C.	L.T. Reg. to E.-in-C.O.	31.1.63
Powell, R.	N.E.R.	14.1.63	Coomber, A. H.	E.-in-C.O.	31.1.63
Davis, C. G.	Scot.	28.1.63	Morecock, W. H.	L.T. Reg. to E.-in-C.O.	31.1.63
Simpkins, S.	E.-in-C.O.	16.1.63	Bowers, D.	E.-in-C.O.	31.1.63
Hoyle, J. H.	E.-in-C.O.	16.1.63	Stevens, L. R. J.	L.T. Reg. to E.-in-C.O.	31.1.63
Matthews, S. F.	L.T. Reg.	21.1.63	Gay, S.	L.T. Reg. to E.-in-C.O.	31.1.63
Lewis, G. E.	L.T. Reg.	14.1.63	Myhill, R. P.	H.C. Reg. to E.-in-C.O.	31.1.63
Templeton, R.	Scot.	31.1.63	Wells, D. R.	L.T. Reg. to E.-in-C.O.	31.1.63
Higson, W.	Mid. Reg.	17.1.63	Buist, A. S.	E.-in-C.O.	31.1.63
White, A. H.	L.T. Reg.	23.1.63	Lenton, P. J.	N.E. Reg. to E.-in-C.O.	31.1.63
Rawlinson, S. J. R.	N.W. Reg.	30.1.63	Franks, F. A.	L.T. Reg. to E.-in-C.O.	31.1.63
Donaldson, J.	L.T. Reg.	30.1.63	Jenkins, J. G.	L.T. Reg. to E.-in-C.O.	31.1.63
Crawford, A.	Cairo	29.11.62	Clark, D.	E.-in-C.O.	31.1.63
(in absentia)			Game, R. S.	H.C. Reg.	18.3.63
Fuller, J. A.	H.C. Reg. to E.-in-C.O.	4.3.63	Wells, T. F. G.	H.C. Reg.	18.3.63
Ray, M. A.	E.-in-C.O.	4.3.63	McGeorge, P. J.	H.C. Reg.	1.3.63
McNab, A. M.	Scot.	28.2.63	Harwood, D. A.	H.C. Reg.	4.3.63
Kingswell, L. W.	E.-in-C.O.	12.3.63	Richards, X. C.	H.C. Reg.	1.3.63
Housley, G. J. T. P.	E.-in-C.O.	19.3.63	Edis, D. J.	L.T. Reg.	13.3.63
Gross, F. G.	E.-in-C.O.	19.3.63	Warren, D. J.	E.-in-C.O.	6.3.63
Burwell, H. E. R.	E.-in-C.O.	19.3.63	Cowley, R. J.	H.C. Reg.	20.3.63
<i>Assistant Engineer (Open Competition)</i>			Oliver, L. G.	S.W. Reg.	1.3.63
Bramwell, R. M.	N.W. Reg.	22.1.62	Marshall, J.	E.T.E. to E.-in-C.O.	20.3.63
Johnson, P. L.	E.-in-C.O.	22.1.62	Pummell, R. A.	L.T. Reg. to E.-in-C.O.	20.3.63
Eyre, J.	E.-in-C.O.	16.1.62	Tuxhill, P. M.	L.T. Reg. to E.-in-C.O.	20.3.63
			Battams, D. S.	H.C. Reg.	22.3.63
			Saturley, K. F.	S.W. Reg.	5.3.63
			Millard, R.	H.C. Reg.	22.3.63
			Chandler, F. J.	H.C. Reg.	22.3.63
			Hurren, J. H.	L.T. Reg.	6.3.63
			King, A. A.	L.T. Reg.	6.3.63

Promotions—continued

Name	Region, etc.	Date	Name	Region, etc.	Date
<i>Technical Officer to Assistant Engineer—continued</i>			<i>Senior Scientific Officer (Open Competition)</i>		
Sacker, A. E. ..	L.T. Reg. ..	6.3.63	Rollet, J. M. ..	E.-in-C.O. ..	1.3.63
Buckland, R. G. ..	L.T. Reg. ..	6.3.63	<i>Assistant Experimental Officer (Open Competition)</i>		
Hogg, H. A. ..	L.T. Reg. ..	28.3.63	Stroyan, A. P. ..	E.-in-C.O. ..	20.3.63
Scarborough, H. W. ..	L.T. Reg. ..	6.3.63	Dean, D. J. ..	E.-in-C.O. ..	28.3.63
Buer, S. G. ..	L.T. Reg. ..	6.3.63	<i>Assistant Regional Motor Transport Officer, to Regional Motor Transport Officer</i>		
Vincent, D. W. ..	L.T. Reg. ..	6.3.63	Byatt, H. A. ..	N.I. to Mid. Reg. ..	8.1.63
Bedford, A. F. ..	L.T. Reg. ..	6.3.63	<i>Workshop Supervisor II to Technical Assistant</i>		
Flueter, G. D. ..	L.T. Reg. ..	6.3.63	Margison, A. ..	E.-in-C.O. ..	2.1.63
Jones, E. ..	L.T. Reg. ..	6.3.63	Kelly, W. J. ..	E.-in-C.O. to London Reg.	21.1.63
Briar, R. W. ..	L.T. Reg. ..	6.3.63	<i>Workshop Supervisor III to Technical Assistant</i>		
Pratt, V. H. ..	L.T. Reg. ..	25.3.63	Wood, B. V. S. H. ..	N.E. Reg. to Mid. Reg. ..	21.1.63
Simmons, B. P. ..	L.T. Reg. ..	25.3.63	Leach, E. J. ..	E.-in-C.O. ..	2.1.63
Hale, B. E. R. ..	L.T. Reg. ..	25.3.63	<i>Mechanic A to Technical Assistant</i>		
<i>Draughtsman to Assistant Engineer</i>			Birks, J. ..	N.I. to Scot. ..	21.1.63
Saunders, E. J. W. ..	S.W. Reg. ..	17.1.63	Crombie, D. B. ..	Scot. to W.B.C. ..	21.1.63
<i>Technical Officer to Inspector</i>			<i>Leading Draughtsman to Senior Draughtsman</i>		
Munday, A. R. ..	L.T. Reg. ..	30.3.63	Bates, C. E. ..	N.W. Reg. ..	1.1.63
Smith, A. E. ..	L.T. Reg. ..	27.3.63	Challenger, G. ..	W.B.C. to Mid. Reg. ..	14.1.63
Holmes, R. F. ..	L.T. Reg. ..	1.3.63	<i>Executive Officer to Higher Executive Officer</i>		
Wirdnam, E. F. ..	H.C. Reg. ..	22.3.63	Baillie, C. C. ..	E.-in-C.O. ..	4.3.63
<i>Technician I to Inspector</i>			Newton, B. J. ..	E.-in-C.O. ..	5.3.63
Ferguson, D. ..	Scot. ..	26.12.62	<i>Clerical Officer to Executive Officer</i>		
Little, C. ..	N.E. Reg. ..	4.1.63	Philbrick, G. E. ..	E.-in-C.O. ..	14.1.63
Home, J. ..	N.E. Reg. ..	4.1.63	Wood, L. F. ..	E.-in-C.O. ..	21.1.63
Makin, J. ..	N.W. Reg. ..	21.1.63	Comber, B. D. (Mrs.) ..	E.-in-C.O. ..	28.1.63
Fisher, A. ..	N.W. Reg. ..	28.1.63	Davis, J. H. ..	Savings Bank to E.-in-C.O.	21.1.63
Hankinson, G. D. ..	N.W. Reg. ..	21.1.63	<i>Inspector</i>		
Playfoot, L. R. ..	N.W. Reg. ..	26.3.63	Turner, A. ..	N.W. Reg. ..	16.1.63
Reed, B. W. ..	Mid. Reg. ..	28.2.63	Burton, J. R. ..	L.T. Reg. ..	18.1.63
Cockbill, E. W. ..	Mid. Reg. ..	28.2.63	Wicks, C. L. ..	S.W. Reg. ..	8.2.63
Sparrey, R. H. ..	Mid. Reg. ..	28.2.63	Dykes, H. E. C. ..	Scot. ..	6.3.63
Rogers, R. J. ..	Mid. Reg. ..	28.2.63	Evans, W. S. ..	N.W. Reg. ..	16.3.63
Mills, A. C. ..	Mid. Reg. ..	28.2.63	Rowland, J. ..	W.B.C. ..	19.3.63
Thompson, N. H. ..	Mid. Reg. ..	28.2.63	Evans, F. W. ..	L.T. Reg. ..	20.3.63
Wilkins, F. ..	N.W. Reg. ..	4.3.63	Goodson, J. H. ..	L.T. Reg. ..	29.3.63
Batley, K. W. A. ..	Mid. Reg. ..	1.3.63	Hickman, E. E. ..	L.T. Reg. ..	31.3.63

Retirements and Resignations

Name	Region, etc.	Date	Name	Region, etc.	Date
<i>Staff Engineer</i>			<i>Assistant Engineer—continued</i>		
Beer, H. G. ..	E.-in-C.O. ..	3.1.63	Short, W. H. D. ..	L.T. Reg. ..	31.1.63
<i>Regional Engineer</i>			Edmonds, I. R. G. ..	E.-in-C.O. ..	31.1.63
Palmer, W. T. ..	L.T. Reg. ..	14.1.63	<i>(Resigned)</i>		
<i>Area Engineer</i>			Hyman, H. L. ..	Mid. Reg. ..	1.3.63
Clarke, T. M. ..	S.W. Reg. ..	31.1.63	Sutcliffe, H. ..	N.E. Reg. ..	13.3.63
<i>Senior Executive Engineer</i>			McGaw, P. ..	Scot. ..	18.3.63
Smith, R. C. ..	S.W. Reg. ..	5.1.63	Evison, P. W. ..	L.T. Reg. ..	27.3.63
Gearing, A. ..	E.-in-C.O. ..	29.1.63	Coster, F. A. J. ..	E.-in-C.O. ..	29.3.63
Pyrah, F. ..	E.-in-C.O. ..	31.1.63	Drewson, A. V. C. ..	L.T. Reg. ..	31.3.63
<i>Executive Engineer</i>			<i>Inspector</i>		
Richards, E. L. ..	E.T.E. ..	4.1.63	Turner, A. ..	N.W. Reg. ..	16.1.63
Bulfin, A. ..	N.E. Reg. ..	31.12.62	Burton, J. R. ..	L.T. Reg. ..	18.1.63
Bennett, L. A. M. ..	E.-in-C.O. ..	7.12.62	Wicks, C. L. ..	S.W. Reg. ..	8.2.63
<i>(Resigned)</i>			Dykes, H. E. C. ..	Scot. ..	6.3.63
Mills, G. L. (Resigned)	E.-in-C.O. ..	31.1.63	Evans, W. S. ..	N.W. Reg. ..	16.3.63
<i>Assistant Engineer</i>			Rowland, J. ..	W.B.C. ..	19.3.63
O'Brien, A. ..	N.W. Reg. ..	2.1.63	Evans, F. W. ..	L.T. Reg. ..	20.3.63
Simmons, A. C. ..	L.T. Reg. ..	5.1.63	Goodson, J. H. ..	L.T. Reg. ..	29.3.63
Baines, W. ..	N.E. Reg. ..	13.1.63	Hickman, E. E. ..	L.T. Reg. ..	31.3.63
Green, E. S. ..	N.E. Reg. ..	17.1.63	<i>Experimental Officer</i>		
Cummins, A. ..	N.W. Reg. ..	17.1.63	Woodgate, E., (Mrs.) ..	E.-in-C.O. ..	31.3.63
Edwards, A. ..	H.C. Reg. ..	31.1.63	<i>(Resigned)</i>		
Morton, A. R. ..	L.T. Reg. ..	31.1.63	<i>Assistant Experimental Officer</i>		
Baker, K. J. L. ..	L.T. Reg. ..	31.1.63	Wills, W. G. (Resigned)	E.-in-C.O. ..	17.3.63
			Eccleston, M. D. ..	E.-in-C.O. ..	29.3.63
			<i>(Resigned)</i>		

Retirements and Resignations—continued

Name	Region, etc.	Date	Name	Region, etc.	Date
<i>Senior Draughtsman</i>			<i>Executive Officer</i>		
Bailey, C.	N.W. Reg.	31.12.62	Bozzett, G. M. (Miss)	E.-in-C.O.	30.9.62
Stormont, W. J. ..	Mid. Reg.	31.1.63	Garner, J.	E.-in-C.O.	30.9.62
Cooke, F. O.	H.C. Reg.	31.3.63			

Transfers

Name	Region, etc.	Date	Name	Region, etc.	Date
<i>Assistant Staff Engineer</i>			<i>Executive Engineer</i>		
Knight, N. V. ..	Joint PO/MOW R. and D.G. to Nigeria. ..	4.1.63	Cootes, E. J. ..	E.-in-C.O. to S.H.A.P.E.	2.1.63
Jago, W. B. ..	E.-in-C.O. to Philippines ..	30.1.63	Archer, E. W. ..	E.-in-C.O. to L.T. Reg. ..	28.1.63
<i>Area Engineer</i>			<i>Assistant Engineer</i>		
Thirsk, R. D. ..	Scot. to E.-in-C.O. ..	7.1.63	Hood, J. W. ..	E.-in-C.O. to L.T. Reg. ..	7.1.63
<i>Senior Executive Engineer</i>			Warburton, J. E. ..	E.-in-C.O. to H.C. Reg. ..	7.1.63
Dobbie, A. K. ..	E.-in-C.O. to Ministry of Health	1.1.63	Draper, G. T. ..	E.-in-C.O. to L.T. Reg. ..	14.1.63
Partington, E. V. ..	L.T. Reg. to Sudan ..	6.3.63	Bates, G. W. ..	E.-in-C.O. to New Hebrides	4.3.63
			<i>Higher Executive Officer</i>		
			Diamond, W. B. ..	E.-in-C.O. to Treasury ..	31.12.62

Deaths

Name	Region, etc.	Date	Name	Region, etc.	Date
<i>Area Engineer</i>			<i>Assistant Engineer—continued</i>		
Hayman, H. W. S. ..	S.W. Reg.	26.7.62	Huke, G. A. ..	H.C. Reg.	22.1.63
<i>Executive Engineer</i>			Kimber, R. H. ..	Mid. Reg.	11.2.63
Quellin, A. A. ..	N.W. Reg.	13.11.62	Hart, J. N. ..	L.T. Reg.	9.3.63
Lawrie, A. P. ..	Scot.	2.3.63	Nichols, J. L. ..	N.W. Reg.	10.3.63
<i>Assistant Engineer</i>			Deaville, J. C. ..	E.-in-C.O.	27.3.63
Lord, G. W. R. ..	L.T. Reg.	11.1.63	<i>Inspector</i>		
Gale, B. G. ..	L.T. Reg.	14.1.63	Warren, J. W. ..	Mid. Reg.	31.12.62
			Johnson, H. ..	Mid. Reg.	3.3.63
			Gower, E. E. ..	N.E. Reg.	23.3.63

BOARD OF EDITORS

D. A. BARRON, C.B.E., M.Sc., M.I.E.E., Chairman.
 L. F. SCANTLEBURY, Whit.Sch., A.C.G.I., D.I.C., M.I.E.E.
 T. H. FLOWERS, M.B.E., B.Sc.(Eng.), M.I.E.E.
 W. J. E. TOBIN, B.Sc.(Eng.), A.C.G.I., D.I.C., M.I.E.E.
 E. J. MARKBY, A.M.I.E.E.
 D. J. HARRIS, B.Sc.(Eng.), A.M.I.E.E.
 R. F. WALDEGRAVE.
 A. G. LEIGHTON, B.Sc.(Eng.), A.M.I.E.E., Managing Editor.
 J. MARTIN, B.Sc.(Eng.), A.M.I.E.E., Deputy Managing Editor.
 J. A. POVEY, A.M.I.E.E. } Assistant Editors.
 R. A. SUDELL. }
 B. FARR, A.B.I., Secretary-Treasurer.
 B. CROSS, Advertisement Manager.

Copyright

The entire contents of this Journal are covered by general copyright, and special permission is necessary for reprinting long extracts, but editors are welcome to use not more than one-third of any article, provided that credit is given at the beginning or end thus: "From *The Post Office Electrical Engineers' Journal*."

The Board of Editors is not responsible for the statements made or the opinions expressed in any of the articles in this Journal, unless such statement is made specifically by the Board.

Subscriptions and Back Numbers

The Journal is published quarterly, in April, July, October and January, price 2s. 6d. (3s. 6d. post paid) per copy or 14s. per year post paid (2 dollars 25 cents, Canada and U.S.A.). Back numbers will be supplied, if available, price 2s. 6d. (3s. 6d. post paid) per copy. Copies of the April 1959 and all

earlier Journals are no longer available. Orders should be sent to *The Post Office Electrical Engineers' Journal*, G.P.O., 2-12 Gresham Street, London, E.C.2.

Employees of the British Post Office can obtain the Journal through local agents.

Binding

Readers can have their copies of volumes bound at a cost of 15s. by sending the complete set of parts to the local Post Office distribution agent or to *The Post Office Electrical Engineers' Journal*, G.P.O., 2-12 Gresham Street, London, E.C.2.

Remittances

Remittances should be made payable to "*The P.O.E.E. Journal*" and should be crossed "& Co."

Advertisements

All correspondence relating to advertisement space reservations, copy, proofs, etc., should be addressed to the Advertisement Manager, *The Post Office Electrical Engineers' Journal*, G.P.O., 2-12 Gresham Street, London, E.C.2.

Communications

With the exceptions indicated above, all communications should be addressed to the Managing Editor, *The Post Office Electrical Engineers' Journal*, G.P.O., 2-12 Gresham Street, London, E.C.2. Telephone: HEADquarters 1234.

Model Answer Books

Books of model answers to certain of the City and Guilds of London Institute examinations in telecommunications are published by the Board of Editors. Details of the books available are given at the end of the Supplement to the Journal.

**STILL
FIRST
CHOICE**

*-Both sides
of the
Atlantic*

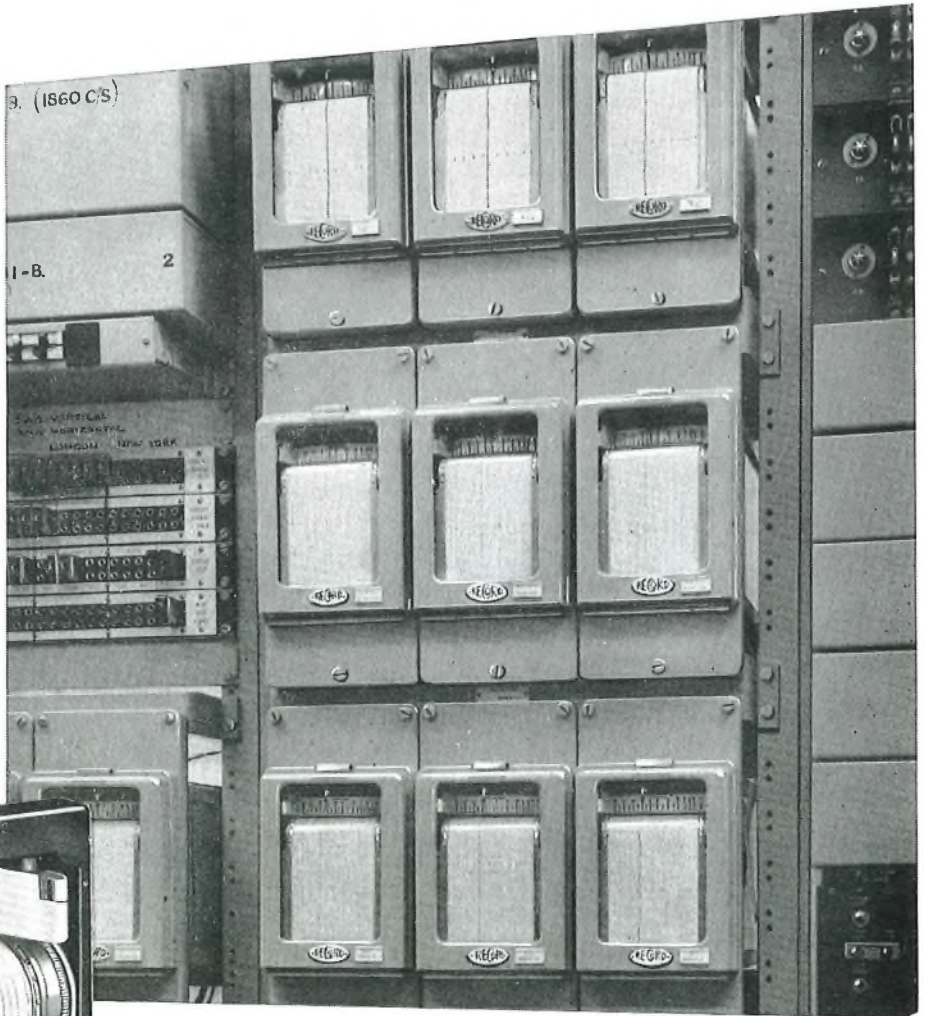
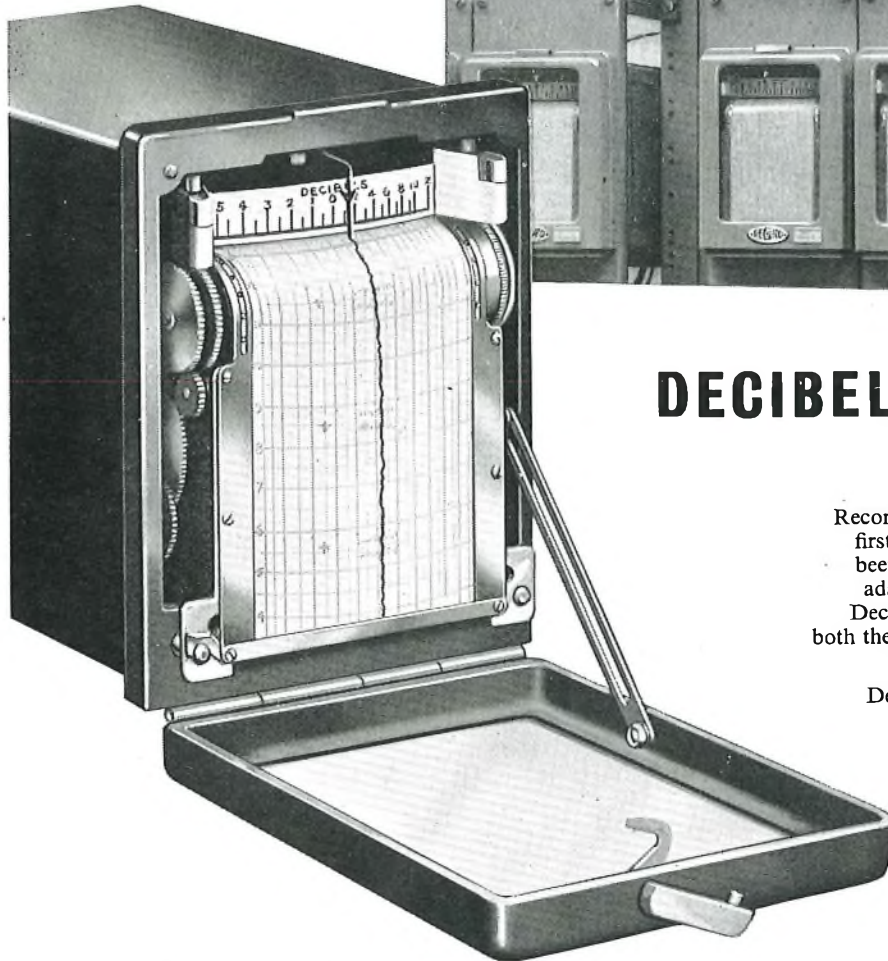

By courtesy of H.M. Postmaster General

DECIBEL RECORDERS

Record Decibel Recorders were installed on the first Transatlantic Telephone Cable, and have been used on all subsequent Cables. Specially adapted for this important monitoring work, Decibel Recorders have again been chosen for both the U.K. and American terminals of the new TAT 3. Transatlantic Cable.

Decibel Recorders are just one version of an extensive range of RECORD switchboard and portable recording instruments suitable for a wide variety of applications.

Write for leaflets.



THE RECORD ELECTRICAL CO LTD
"CIRSCALE WORKS," BROADHEATH, ALTRINCHAM, CHESHIRE.



The first two volumes in an important new series

RADIO and LINE TRANSMISSION Vols 1 & 2

G. L. Danielson, M.Sc.(Tech.), B.Sc., A.M.I.E.E., Head of the Telecommunications and Electronics Department, Norwood Technical College.

R. S. Walker, Grad.I.E.E., Grad.Brit.I.R.E., Lecturer, Norwood Technical College.

RADIO and LINE TRANSMISSION

Volumes 1 and 2 are part of a series primarily intended to cover the Telecommunications Technicians' Course of the City and Guilds of London Institute—selected volumes later in the series will also cover examinations for O.N.C., H.N.C. and some professional bodies. These first two volumes cover the second and third year syllabi of the City and Guilds Course.

For the first volume a knowledge of only elementary physics and mathematics is assumed; it deals in the main with practical

and mechanical features of communications systems whether by radio, land line or Post Office apparatus.

The second volume introduces more advanced concepts, basing much of the text on the principles expounded in the first. Each book is lavishly illustrated with line and circuit diagrams, and throughout there are numerous worked examples and exercises. These volumes will be of the utmost assistance to students, whether attending a full-time course or doing part-time study.

Vol. I. 21s net

by post 21s 10d 8 $\frac{3}{4}$ " \times 5 $\frac{1}{2}$ "
252pp. Illustrated

Vol. II. 22s 6d net

by post 23s 5d 8 $\frac{3}{4}$ " \times 5 $\frac{1}{2}$ "
304pp Illustrated

obtainable from leading booksellers

Published by ILIFFE Books Ltd.

DORSET HOUSE STAMFORD STREET LONDON S.E.1.



G.N.T. 5-Unit Transmitter Model 20



G.N.T. Undulator Model 311



INSTRUMENTS

- Complete range of Wheatstone equipment
- Complete range of special Morse training equipment
- G.N.T. 5-unit Transmitters with one or two sensing heads
- G.N.T. Converters for Morse or Cable Code to 5-Unit or 5-Unit to Morse or Cable Code
- G.N.T. Tape Readers for 5, 6, 7 or 8 Unit Tape

GREAT NORTHERN TELEGRAPH WORKS

4 SYDHAVN PLADS
COPENHAGEN DENMARK

LONDON OFFICE:
5 ST HELENS PLACE EC3

a tradition of progress...

Long before the 'automation' era, the telephone engineer was quietly supplanting manually performed tasks with automatic machines of considerable refinement.

The progressive approach of AEI designers has become traditional by their participation at every stage in the steady development of the electro-mechanical telephone switching systems of today.

Typical of their latest developments is a system of Automatic Number Identification which swiftly and surely locates a calling line and conveys the number to automatic trunk ticketing equipment at a distant centre.

Adaptable for several purposes, this equipment takes every advantage of electronic components and compact construction, and provides a foretaste of the suitability of these techniques for the needs of tomorrow.

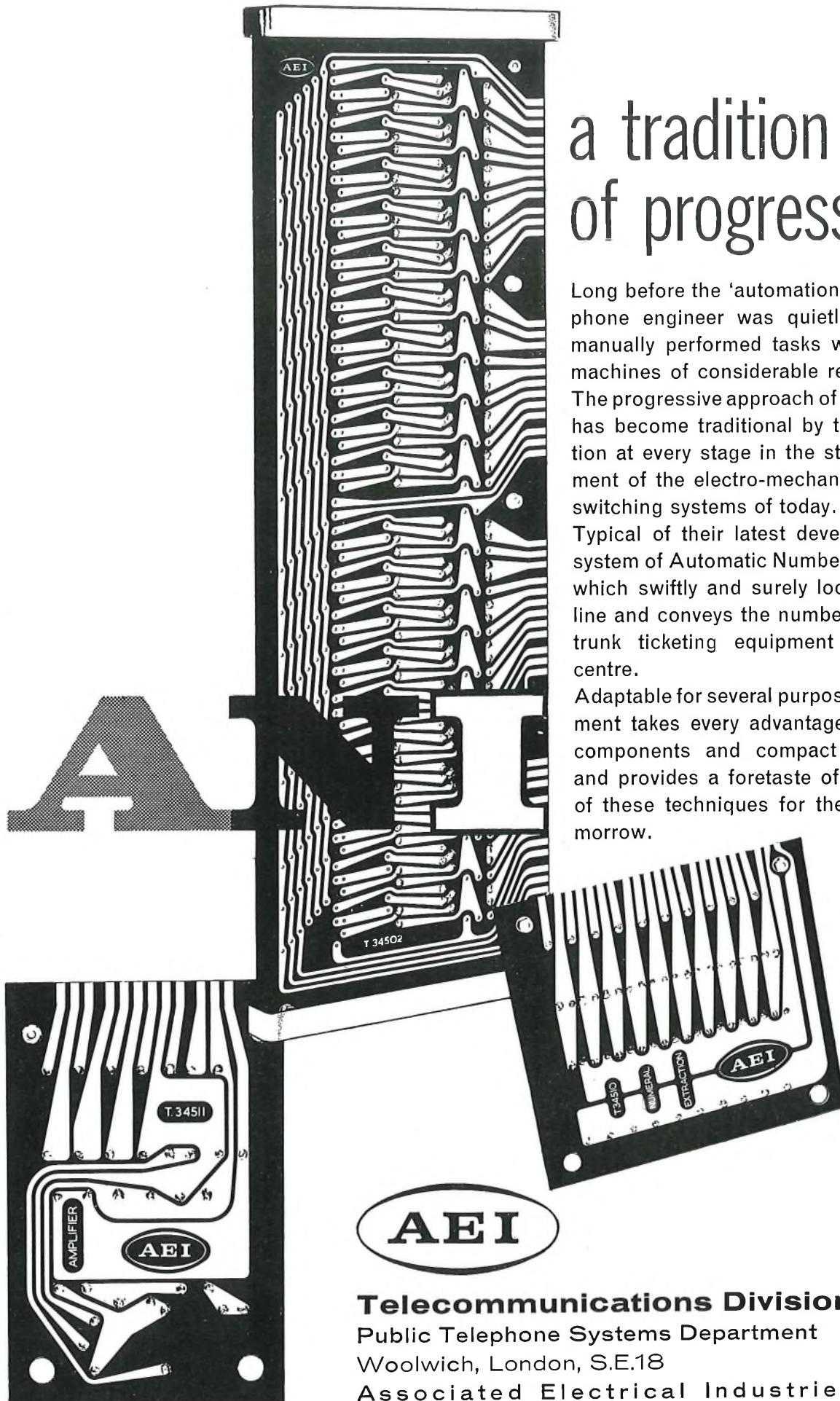

Telecommunications Division

Public Telephone Systems Department

Woolwich, London, S.E.18

Associated Electrical Industries Limited

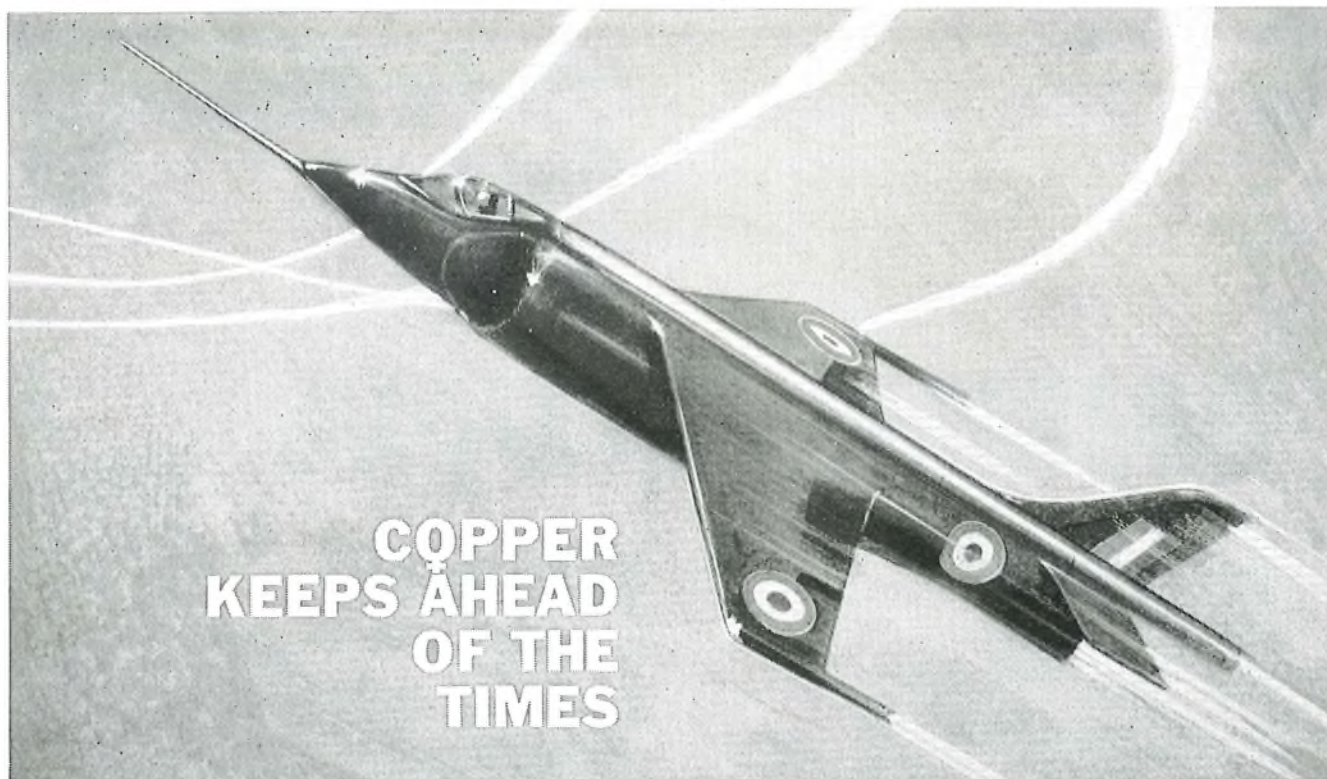

Whenever an idea is born technology calls more and more for improved materials. Copper and its alloys are playing an increasingly large part in bringing these ideas to fruition. In supersonic aircraft for instance, the commutators at the heart of their electrical systems get hotter as conditions become more exacting. Here Zirconium copper (0.12% zirconium) gives efficient electrical conductivity at temperatures that would break down other conductors. Back on the ground Chromium copper (1% chromium) is used in resistance welding electrodes and for electrical switchgear. Electric trains, too, have power supplied through cadmium copper (1% cadmium) catenary and contact rails.

Why can copper alloys be used so effectively? Because copper itself is still the most efficient and economical conductor of electricity. Alloyed with minute quantities of other metals, copper gains additional properties. Zirconium, for instance, raises the safe operating temperature of copper. Tellurium copper (1% tellurium) and sulphur copper (0.3% sulphur) both improve copper's machinability. So often the demands of modern technology for improved materials are satisfied by a new copper base material. The versatility of copper is unchallenged.

Zirconium copper is used in the construction of commutators in the latest electrical generators.

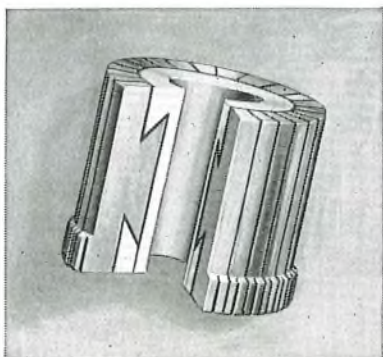

10,000 tons of Cadmium copper are used in the most recent railway electrification scheme.



COPPER

THE FIRST CHOICE METAL OF THE MODERN AGE



CAPACITORS FOR ELECTRONIC SWITCHING

Britain's first electronic telephone exchange at Highgate Wood, London, incorporates many hundreds of STC miniature capacitors. Among the ranges of STC capacitors for the space-saving circuit designer are Tantalum, Stantelac, Mica and Polystyrene types.

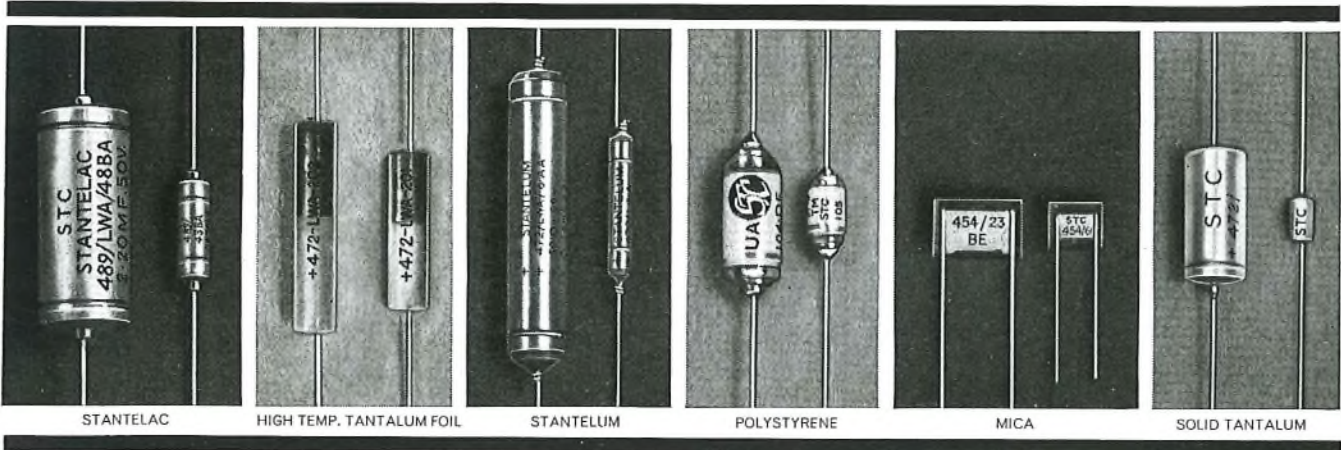

STANTELAC

HIGH TEMP. TANTALUM FOIL

STANTELUM

POLYSTYRENE

MICA

SOLID TANTALUM

Write, phone or Telex for Data Sheets



Standard Telephones and Cables Limited

COMPONENTS GROUP · **CAPACITOR DIVISION**
 BRIXHAM ROAD · PAIGNTON · DEVON · Telex 4251

London Sales Office: FOOTSCRAY · SIDCUP · KENT · Tel FOOTscray 3333

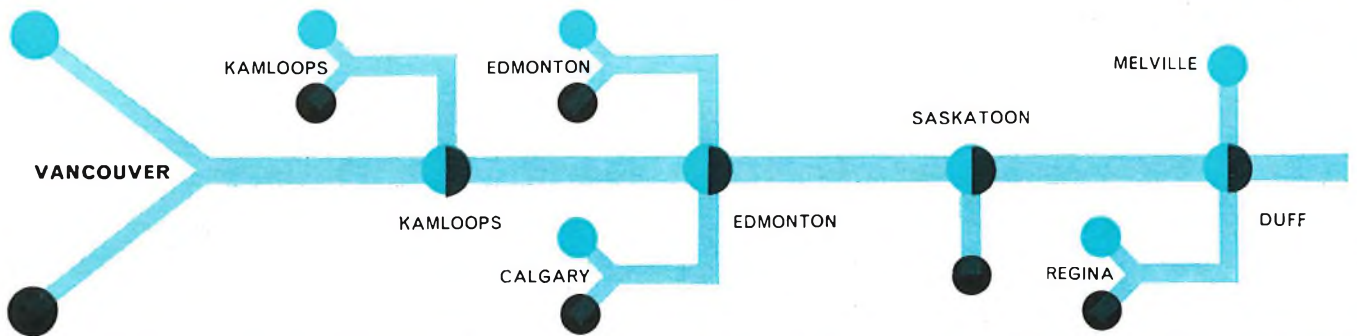
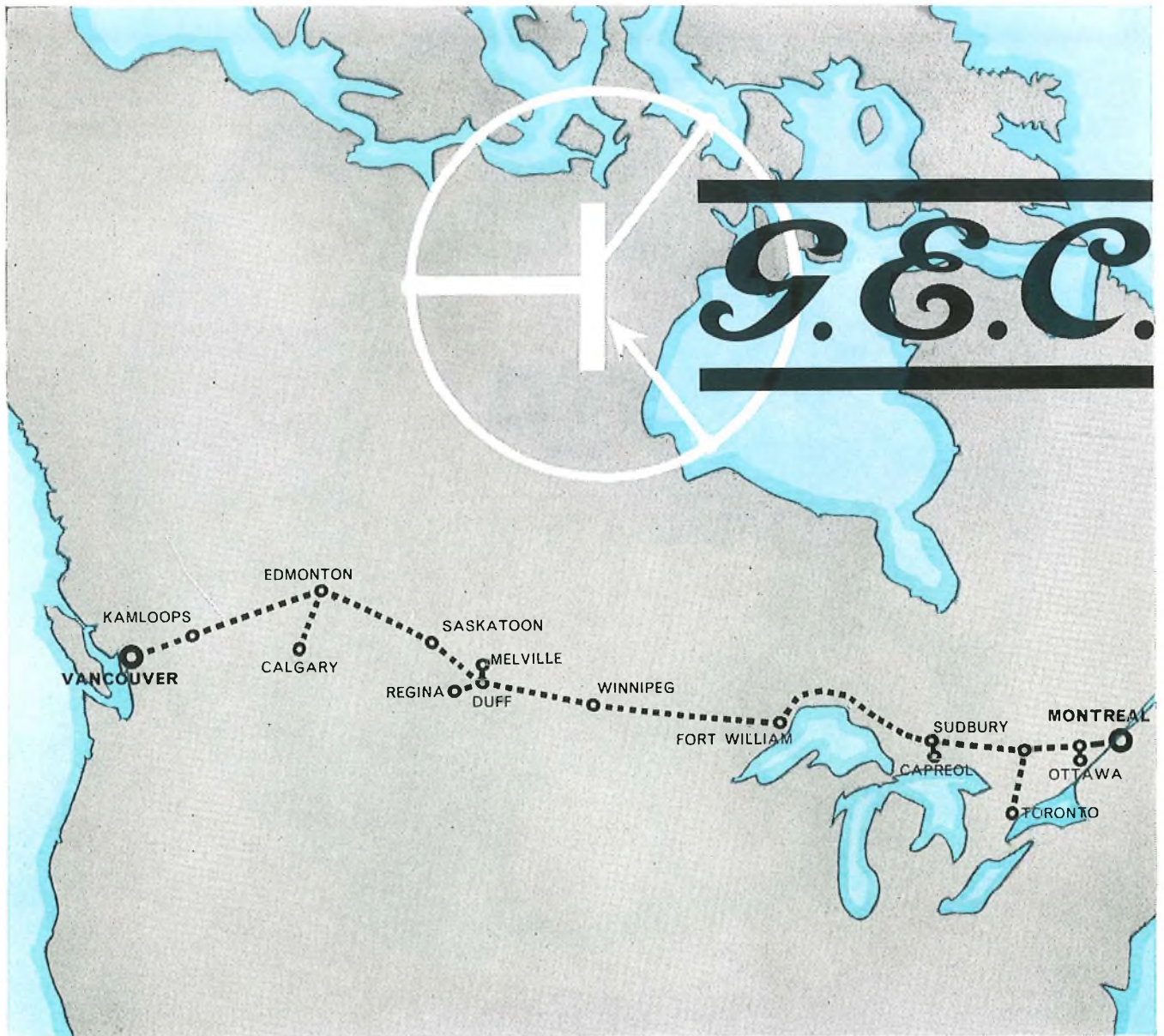

TRANSISTORED MULTIPLEX

G.E.C. have secured the order for all the multiplex equipment at the 32 terminal locations on the new Montreal-Vancouver Microwave route which is being constructed jointly by Canadian National Telecommunications and Canadian Pacific Telecommunications.

All multiplex equipment of this system is completely transistorized and extensive use is made of supergroup derivation filters at intermediate terminals to avoid demodulation of the supergroups directly connecting Montreal and Vancouver. These supergroups are equipped with automatic gain regulating equipment.

Each group and supergroup in the system is provided with a reference pilot which is monitored by electronic scanning equipment and an alarm is given if the level of the pilot deviates by more than a fixed amount.

for the MONTREAL- VANCOUVER route

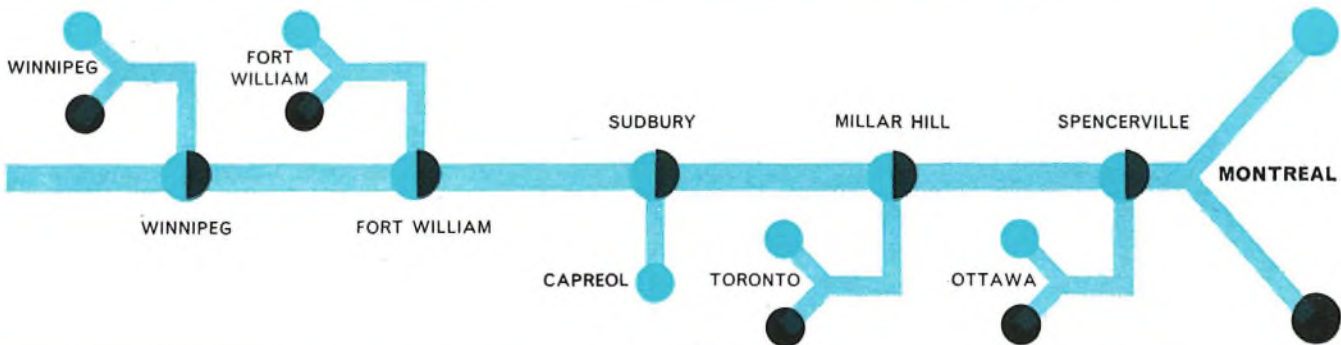

The multiplexing equipment used throughout this new system was designed and manufactured by The General Electric Company Limited of England, and supplied by Canadian General Electric—Toronto, Canada.

EVERYTHING FOR TELECOMMUNICATIONS



TRANSMISSION DIVISION
G.E.C. (TELECOMMUNICATIONS) LIMITED
 Telephone Works · Coventry · England
 Works at Coventry · Middlesbrough

TMC

Transistorised 12-Circuit Carrier Telephone System for 2-wire cable working C12H

Equipped on one 9 ft. rackside — ready for immediate delivery the TMC's type C12H is self-contained with 'E and M' signalling, and its own power supply panels, for energisation from battery or a.c. mains.

A terminal may be sub-equipped initially and later extended as required. It embodies transistor circuits giving low power consumption, and is suitable for use in tropical climates. The equipment is grouped in functional units, and mechanical design allows maximum accessibility with minimum disruption of working circuits. Engineers will recognise in the performance specification of this equipment the high standards which characterise TMC products.

Can you benefit by the immediate availability of this economical high quality unit, or do your projects and problems involve other types of modern terminal equipment for multi-channel working? Write to us giving an outline of your immediate or long-term plans for telephone services. Experienced transmission engineers of TMC's Advisory Service will study your problems and give detailed recommendations without delay.

TMC
TELEPHONE MANUFACTURING COMPANY LIMITED

Transmission Division

Sevenoaks Way • St. Mary Cray • Orpington • Kent • Telephone: Orpington 27020

 A MEMBER OF THE  GROUP OF COMPANIES

Typical constant voltage float charger type PO.91B incorporating the TRINISTAT circuit. Output 15 amperes at 27 volts smoothed to 1mV weighted to 800 cycles when operating with a battery.

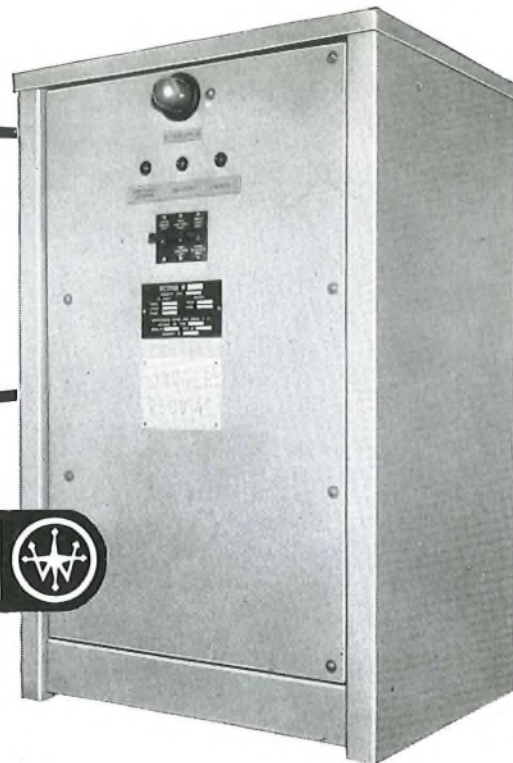

TRINISTAT CONSTANT VOLTAGE RECTIFIER SETS

Salient features of the new Westinghouse TRINISTAT silicon controlled rectifier regulated circuit are:—

- CLOSE LIMITS of voltage regulation irrespective of wide input VOLTAGE and FREQUENCY changes.
- Regulation achieved over ENTIRE LOAD RANGE without use of heavy bleed resistances.
- LOW WEIGHT and REDUCED DIMENSIONS.

TRINISTAT constant voltage equipment type 6113 designed to achieve a similar technical performance to the PO.91 range of sets but having a greater output. Contained within the lower half of the cubicle only are two independent circuits each having an output of 75 amperes at 50 volts, smoothed to 2mV weighted to 800 cycles when operating with a battery.

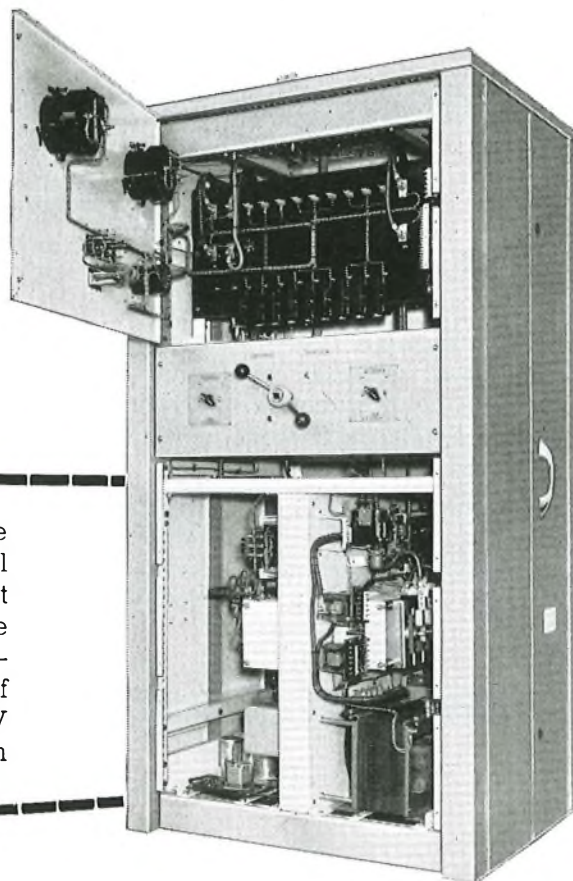

*For further information please write to Dept.
POEEJ 7/63 Rectifier Division (Equipments).*

WESTINGHOUSE BRAKE AND SIGNAL CO. LTD · 82 YORK WAY · KING'S CROSS · LONDON N1

Tel: TERminus 6432

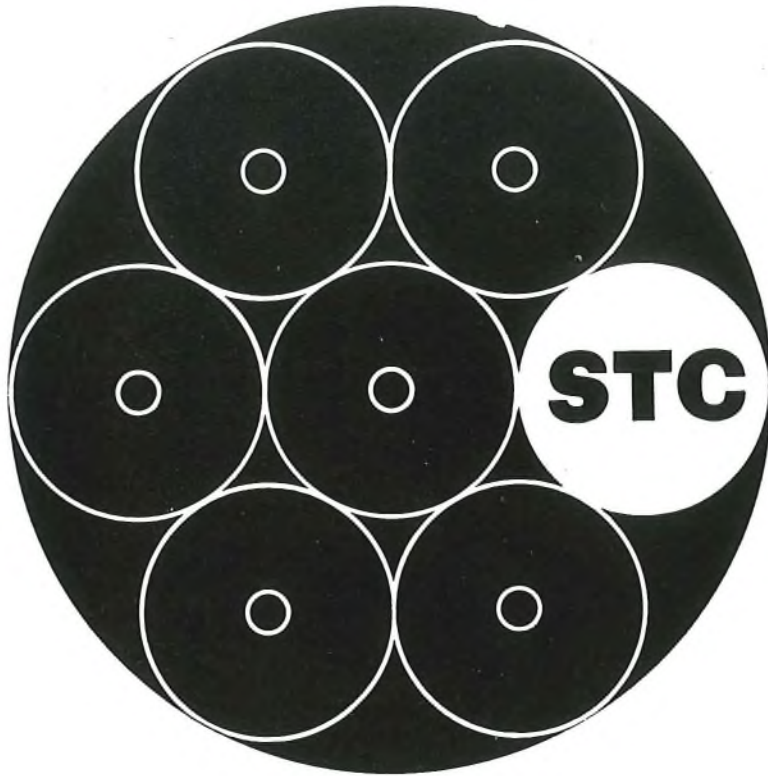

SMALL DIAMETER

**COAXIAL
CABLE
SYSTEMS**

**WITH LOW
INSTALLATION AND
RUNNING COSTS**

STC system type LE1A, designed to comply with proposals currently before the C.C.I.T.T., carries up to 300 two-way speech channels at 4 kc/s spacing over one pair of coaxial tubes. The use of transistorized repeaters specially designed for manholes, footway boxes and underground containers means that the construction of repeater station buildings is reduced. Attenuation changes are regulated automatically by gain control units fitted to alternate amplifiers. Main repeaters facilitate the dropping and insertion of super groups.

Brief technical data: Coaxial core diameter 0.174 in. (4.4mm); Characteristic impedance 75 ohms; Line frequency spectrum 60-1300 kc/s; Nominal repeater gain (at 1300 kc/s) 35 db; Corresponding spacing 5.8 km (3.6 miles).



Dependent repeater housing with lid removed showing repeater units fitted for two systems.

Write, 'phone or Telex for leaflet C/AE38



Standard Telephones and Cables Limited

63/1C

TRANSMISSION SYSTEMS GROUP: NORTH WOOLWICH · LONDON, E.16 · Telephone ALBert Dock 1401 · Telex 21646

ITT

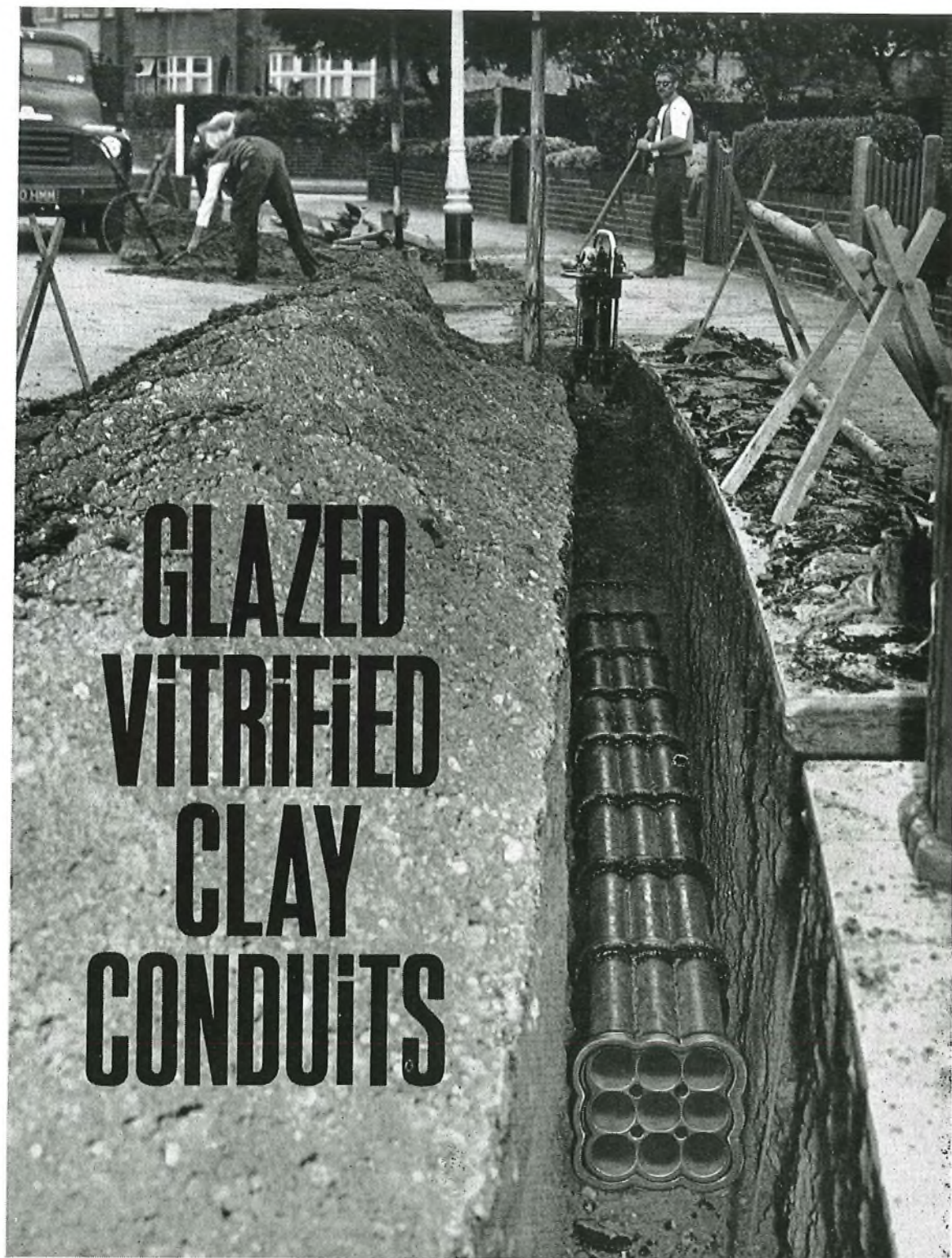

GLAZED VITRIFIED CLAY CONDUITS

... for underground security

Our telecommunications, lighting systems and power lines are vital.
For permanence, how right to use **glazed vitrified clay conduits**
... there is no adequate substitute.

write for further information to the Engineer

NATIONAL SALT GLAZED PIPE MANUFACTURERS' ASSOCIATION
Hanover Court, Hanover Square, London W.1
Telephone: Mayfair 0364

*Photograph by courtesy of
H.M. Postmaster General.*



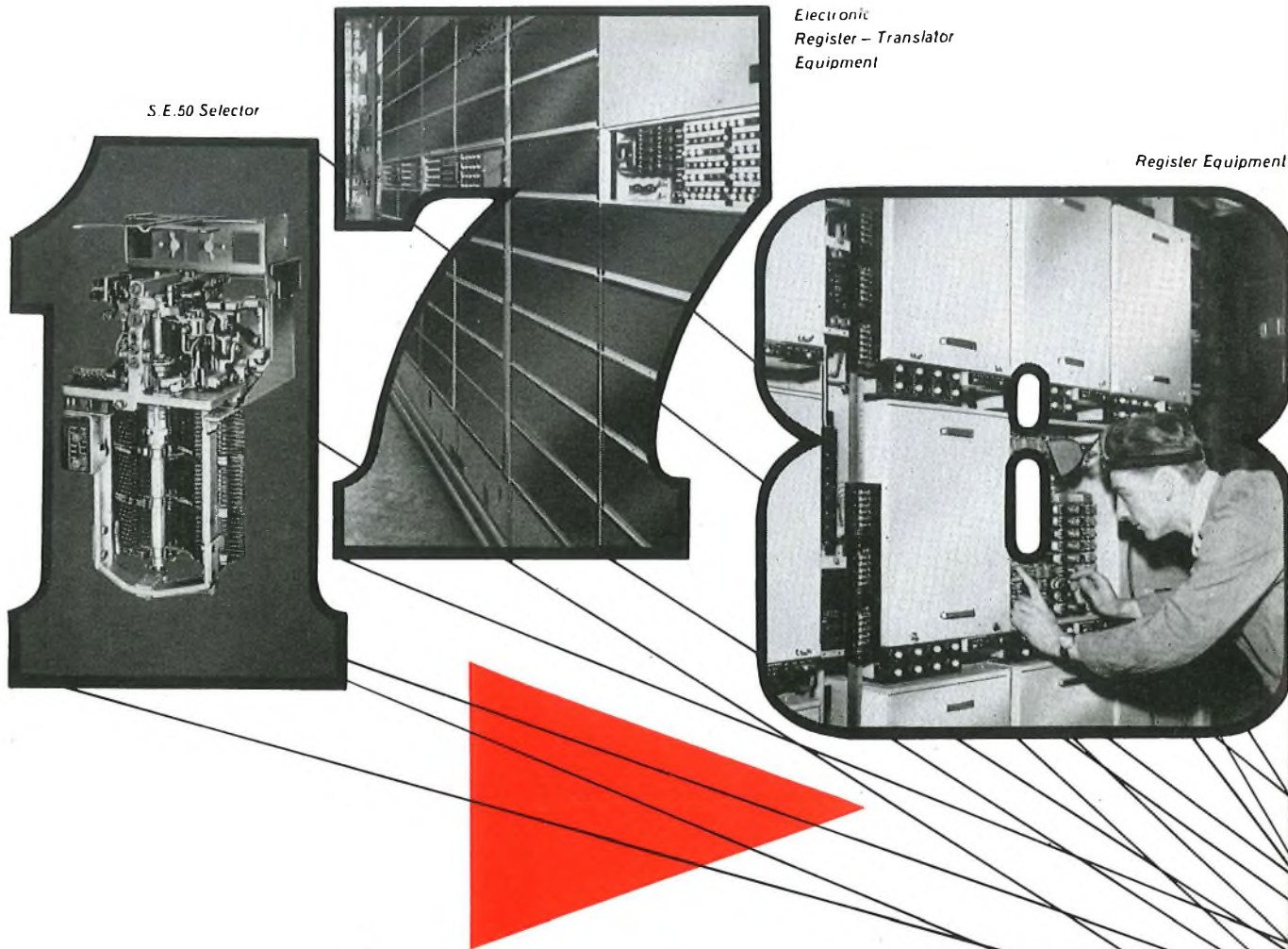

Since supplying equipment for the first subscriber trunk dialling exchange in the United Kingdom at Bristol, G.E.C. has received orders for STD equipment for 178 exchanges—another example of the vital role played by G.E.C. telephone exchange equipment in the essential field of telecommunications. In addition, countries as far from the United Kingdom as Malaya and Nigeria have opened STD services using G.E.C. equipment. G.E.C. Telephone Exchange Systems are complete, compatible, comprehensive, fully flexible, reliable and simple to service . . . 'as modern as tomorrow', thanks to constant research and development.

The majority of the world's telephone exchanges use step-by-step systems.

AS MOD

Exchange Division

G.E.C. (TELECOMMUNICATIONS) LTD · TELEPHONE WORKS · C

Works at Coventry and Middlesbrough



**TELEPHONE EXCHANGES
USING
SUBSCRIBER
TRUNK
DIALLING
EQUIPMENT**

BY



IN AS TOMORROW

ENTRY • ENGLAND

POWER IN HAND... WITH ONAN ELECTRIC PLANT



*By Courtesy of
Messrs Kango
Electric Hammers
Ltd.*

Onan Model 205AJ-3P provides ample power (120/240 volts AC) for three or four man teams operating electric concrete breakers or similar equipment.

Easily transportable, no trouble to maintain, Onan power plants are eminently suitable for running spraying equipment, grass cutters, hedge trimmers and electric tools. Powered by a rugged single cylinder four stroke air cooled petrol engine, the 205AJ-3P may be fitted with 'Idlematic' control which cuts fuel costs by half, by automatically reducing the engine to idling speed, when there is no load on the generator.

There is an Onan power plant to suit any voltage and D.C. models are available for operating temporary traffic lights, radio equipment or for battery charging.

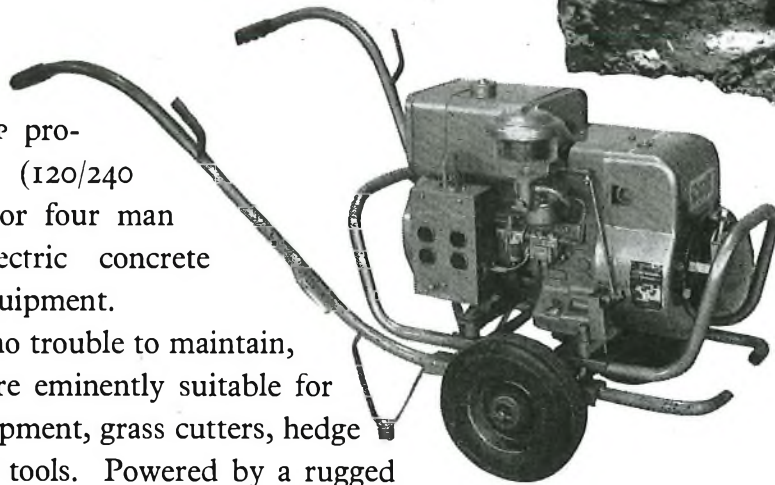

For further information about Onan Electric Plant, write to:

G.M. POWER PLANT CO. LTD.

MAGNET WORKS, WHITEHOUSE ROAD, IPSWICH, SUFFOLK.
TELEPHONE: IPSWICH 41795



is one speech channel enough?

If your H.F. radiotelephone circuits are pushed to the limit or if you find new planning difficult—you need **Rediplex** for maximum utilisation and lower operating costs. Now for the first time, at low capital cost, Redifon introduce a compact ISB multi-channel system for short and medium distance communication. Four speech channels simultaneously using one carrier. The cost of the transmitting and receiving terminals, including the channelling, is far less than you would pay for regular channelling and displacement equipment—a quickly installed packaged deal. It will pay you to find out more about Rediplex. Write now for full specifications.

The Rediplex system gives you

Four simultaneous speech channels, or any combination of speech, teleprinter, facsimile or tone intelligence signals.

Four crystal controlled spot frequencies, 2 to 16 Mc/s.
100 watts p.e.p output, continuous rating (or 750 watts with the GA.406 amplifier).

Compatible with Standard International ISB systems.

Completely transistorised receiving terminal and transmitter drive unit.

Modular construction and printed circuits.

Alternative power supply units for a.c. mains or **24 volts battery supplies**.

Redifon

REDIFON LIMITED Communications Sales Division
Broomhill Road, London, S.W.18. Telephone: VANdyke7281
A Manufacturing Company in the Rediffusion Group.  Rx2

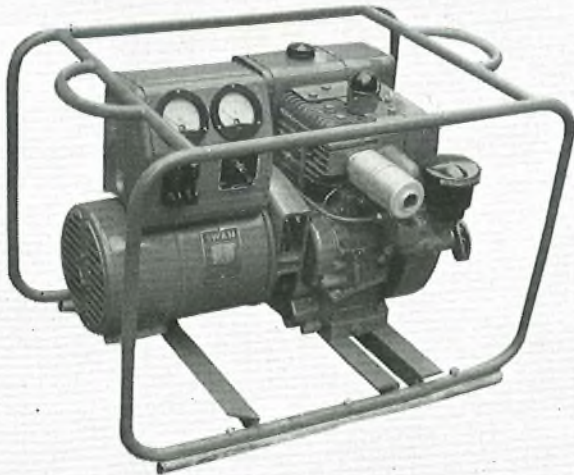

generates everywhere

SWAN

generates everywhere

Swan Generating sets are designed for service throughout the world to provide an electricity supply for domestic lighting and for industrial applications particularly where close frequency and voltage regulation requirements are essential.

The Swan range includes for sets up to 50 kw as standard and up to 150 kw against specific enquiries to customers individual requirements. These include remote control units, portable units, including road towing trailers, and mains failure standby units. All single and three phase voltages are standard in addition to special dual voltage machines, D.C. output machines and sets designed for marine use.

ILLUSTRATED ABOVE
A 600 watt-direct-current generating set, with compound-wound generator, designed to a British General Post Office Specification to provide a supply for lighting and battery charging.

SWAN



SWAN

generates everywhere

SWAN

generates everywhere

ILLUSTRATED RIGHT
A 15 kilo volt-amp fully-automatic standby generating set as supplied to the Syrian Post Office.

Write now for a copy of a catalogue showing the complete Swan range of petrol or diesel engined generating sets.

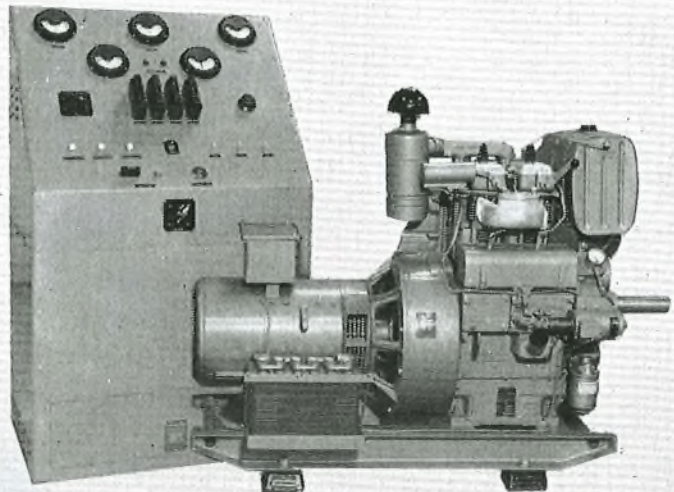

ENGINE APPLICATIONS LIMITED
 Swan Close Road, Banbury, Oxon. Tel. Banbury 3783

Export Office, Martin House, 84-86 Grays Inn Road, London, W.C.1

NEW MARCONI 'SOLID STATE' AUTOPLEX

The most advanced error correcting
telegraph equipment in existence

ERROR PROOF HF TRAFFIC

WITH 40% less capital cost per channel
75% reduction in size
75% reduction in weight
90% reduction in power consumption

PLUS Considerable savings in manpower,
spares and maintenance

- * One cabinet houses equipment for two 2-channel circuits which may be operated as one 4-channel circuit
- * Modular construction means greater reliability and greatly simplified maintenance
- * *Built-in* character storage for 4 or 8 character repetition cycle
- * Fully automatic phasing including rephasing in traffic with no loss or duplication of characters
- * Average rephasing time in traffic 4 seconds
- * Mis-routing of sub-channels is impossible even with sub-division on all channels
- * Error rate improvement factor of 100-10,000

* **FERRITRANSISTORIZED** code converters and stores surpass fully transistorized designs by significant reduction in power and saving in space.

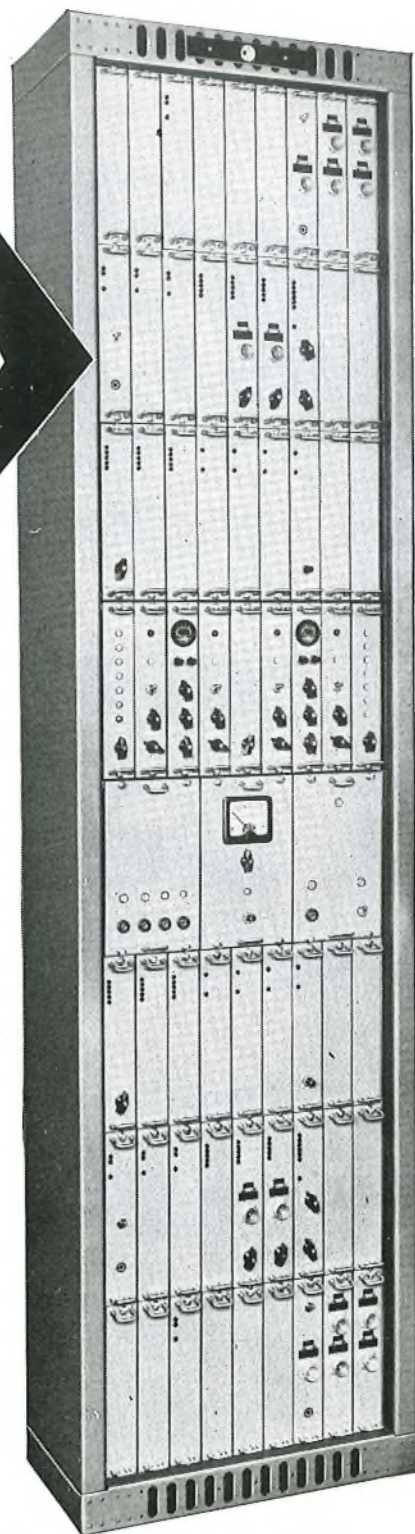

MARCONI SOLID STATE AUTOPLEX

accurate ERROR CORRECTION MULTIPLEX TELEGRAPH SYSTEMS

MARCONI'S WIRELESS TELEGRAPH COMPANY LIMITED · CHELMSFORD · ESSEX · ENGLAND

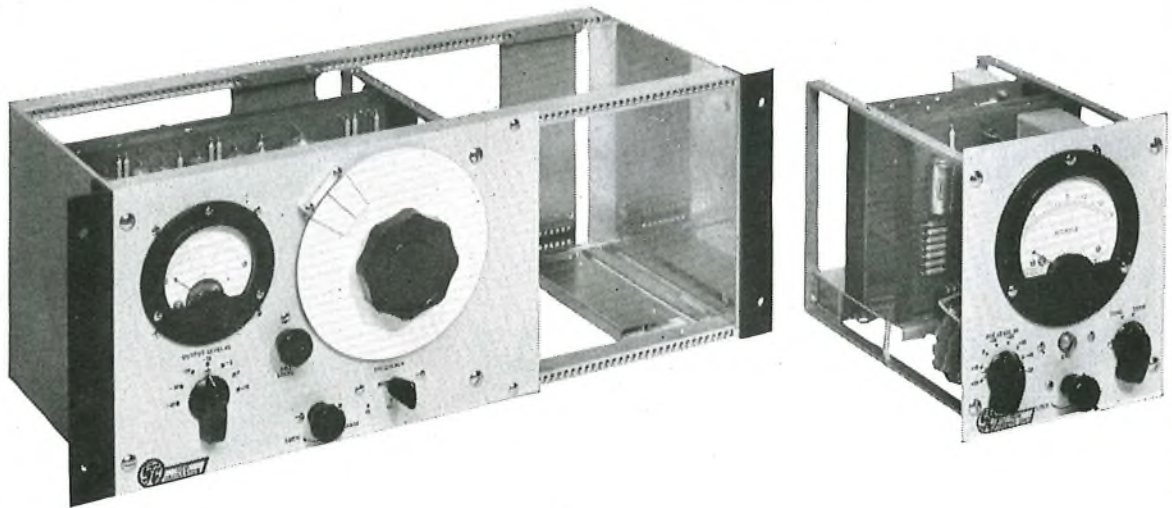

FROM THE STC RANGE OF TRANSISTORIZED TESTING APPARATUS

New compact modular construction

- * PLUG-IN CONNECTION
- * PRINTED BOARD MOUNTING

74233 Variable Oscillator
Frequency range 20 c/s to 20 kc/s. +10 to -40 dbm.

74234 Receiving Unit
Frequency range 20 c/s to 20 kc/s. +26 to -56 dbm.

74235 Fixed Frequency Oscillator
Frequency range 200 c/s to 3400 c/s. +10 to -40 dbm.

74232 Power Unit
Operates from 115V or 230V a.c. supplies. Output 20 \pm 1 volts 300mA.

These sets can be placed side by side on 19 inch 51/56 type rack sides or singly on Telephone Trunk test desks.

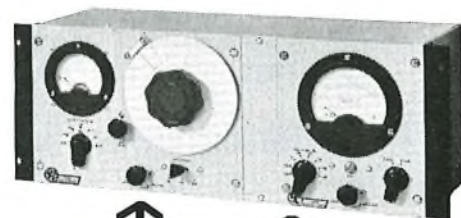

74233 74234

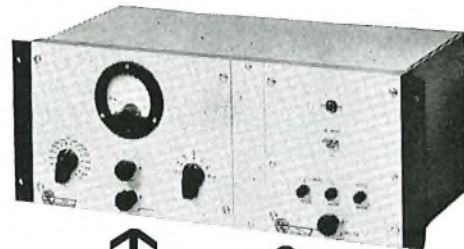

74235 74232

Write, Telephone or Telex for data sheets



Standard Telephones and Cables Limited

TRANSMISSION SYSTEMS GROUP

NORTH WOOLWICH · LONDON, E.16 · Telephone ALBert Dock 1401 · Telex 21645

637CT

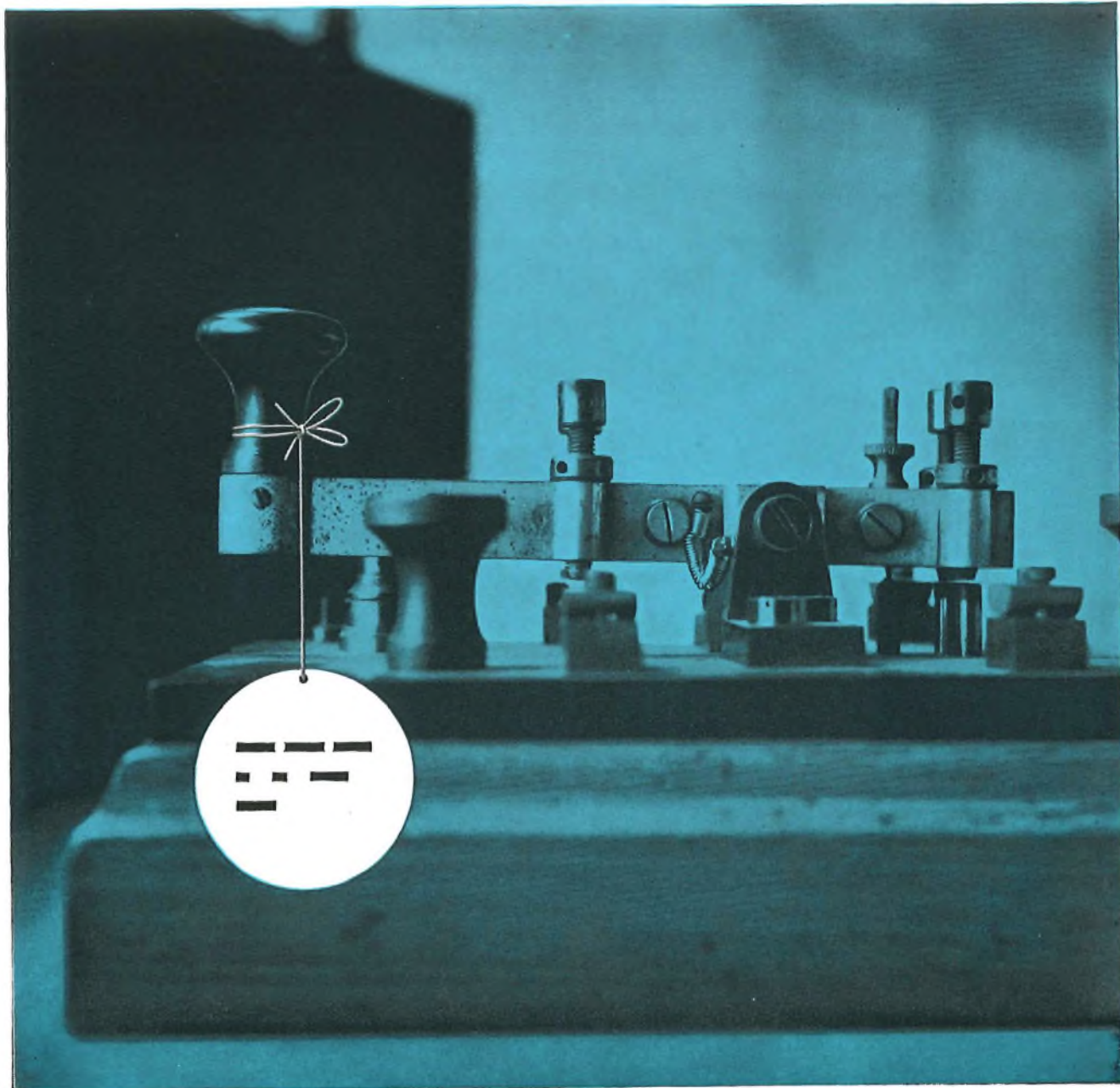

Dots and dashes . . . too slow. They're going o-u-t. FORMICA* industrial laminates play an important part in today's fast talking telecommunications, telephone exchanges and communications satellites. Formica Limited make over 50 industrial laminate grades for industry, including specialised grades famous for their electrical properties for printed circuitry, selector bank insulation and terminal strips. With FORMICA industrial laminates goes a complete Technical Service which includes consultation, investigation, advice. Just write or ring.



Industrial laminates

**FORMICA is a registered trade mark*

Formica Ltd., De La Rue House, 84-86 Regent Street, London, W.1

REGent 8020



**How would you provide
the multiplex equipment for
a microwave radio system?**



**By
using
TMC**

**R 60 N — R 120 B
60/120**

**circuit Telephone Channelling
FOR MICROWAVE RADIO LINKS**

FULL MARKS FOR THE RIGHT ANSWER!

—plus a bonus mark for economy

The requirements of a station planned for an ultimate capacity of a 120-circuit terminal are fully met by TMC Channelling Equipment Types R60N and R120B. They provide up to 120 high quality telephone circuits, with low level "E & M" signalling, and operate in the bands 60-552 kc/s or 12-552 kc/s, conforming to the latest CCITT recommendations for international circuits.

These two equipments meet requirements in the most economical way. Type R60N has in-

built carrier-generating equipment. A 60-circuit terminal occupies two rack sides and is extensible to 120 circuits by two additional rack sides. R120B, for larger stations, occupies three rack sides, and a separate carrier-generating rack side capable of feeding up to three 120-circuit terminals.

Are you planning high quality multiplex radio links? If so, write to us about it, and our Advisory Service will study your needs and make suitable recommendations.

TMC

TELEPHONE MANUFACTURING COMPANY LIMITED

Transmission Division:

Sevenoaks Way • St. Mary Cray • Orpington • Kent • Telephone: Orpington 27020

A MEMBER OF THE  GROUP OF COMPANIES

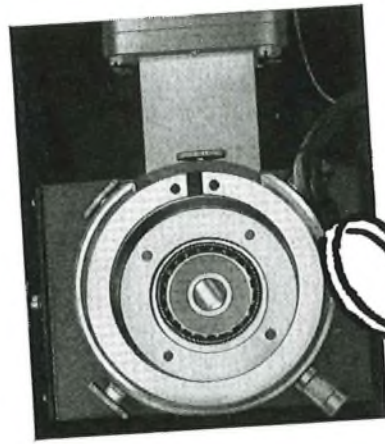
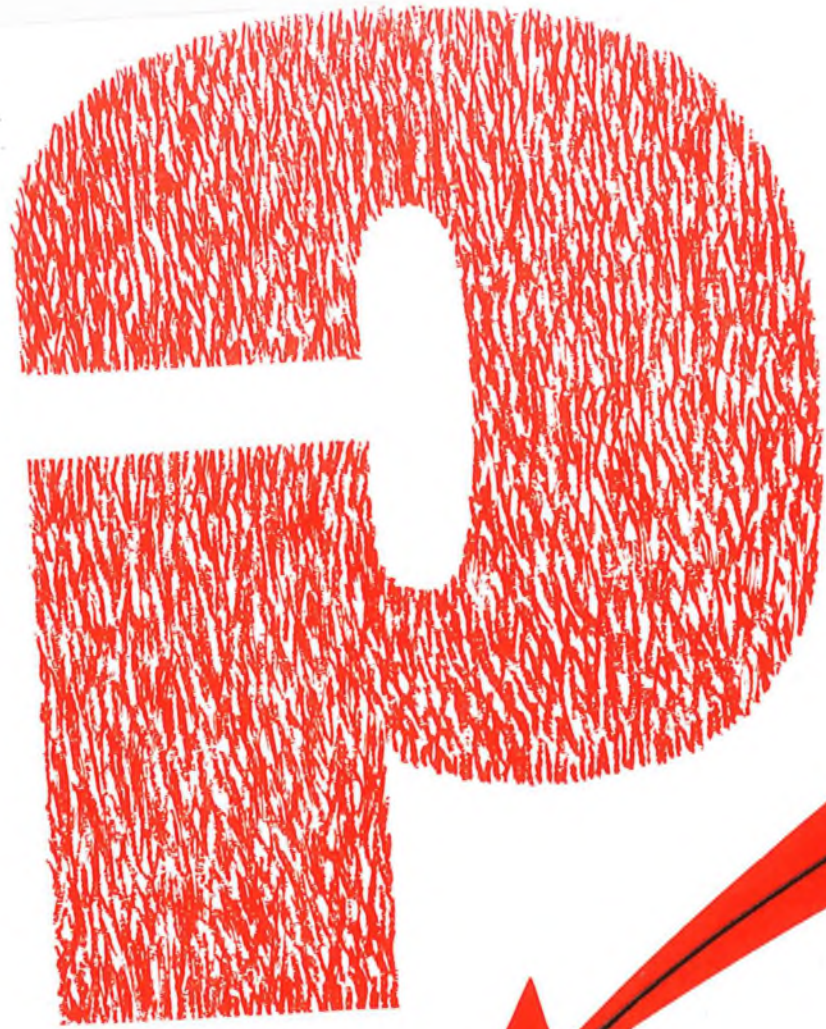

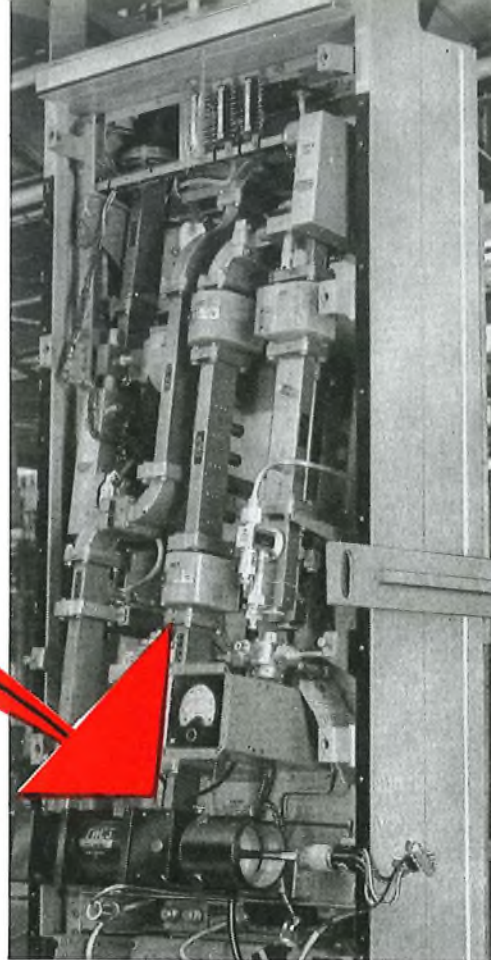

it's a **TRAVELLING**

used in the

G.E.C.

S.H.F. Transmitter/Receiver

(960 and 1800 channel versions)

WAVE TUBE MOUNT

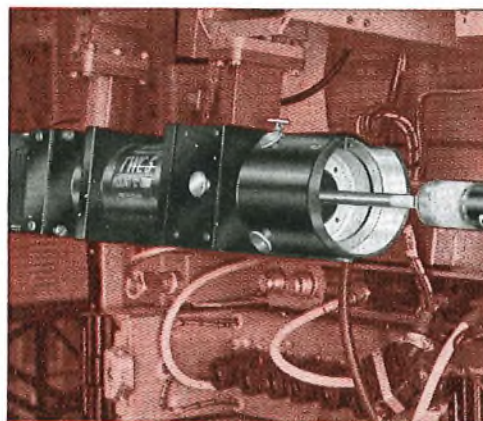

G.E.C.'s 960 channel and 1800 channel micro-wave equipment operating in the 6000Mc/s band employ periodic magnet focused travelling wave tubes. A tube can be replaced independently of the mount and the only adjustment is the mechanical re-alignment of the tube by means of thumbscrews.

Transmission Division

G.E.C. (TELECOMMUNICATIONS) LIMITED · TELEPHONE WORKS · COVENTRY · ENGLAND · Works at Coventry and Middlesbrough

it's the filling that matters...

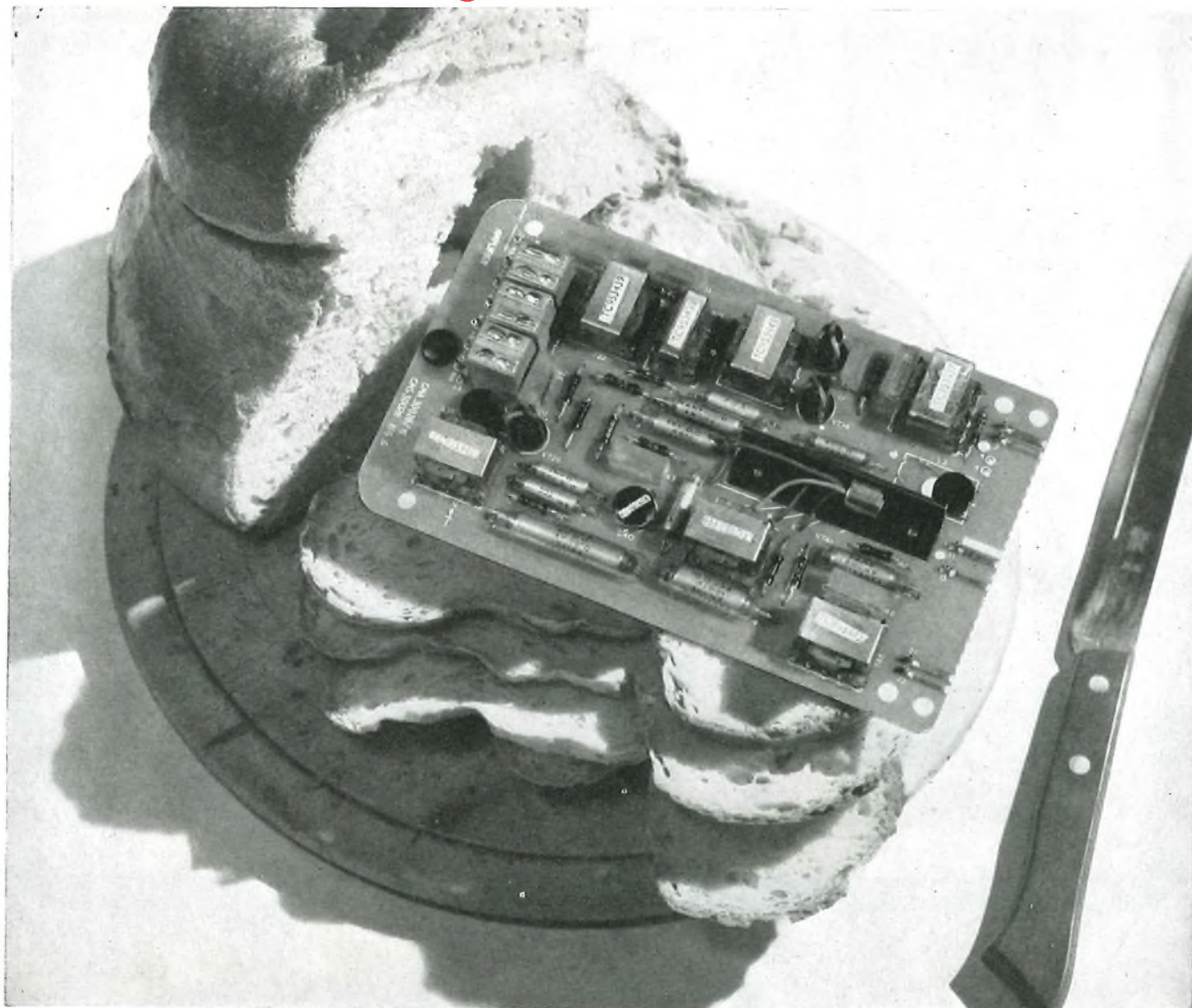

**TYPE
CM
CARRIER**

A T & E Type CM Carrier Equipment offers substantial saving in prime and operating costs whilst taking full advantage of the small size and proven reliability of modern components. Thus conventional methods have been discarded in favour of an advanced card mounting printed circuit technique. The result is a compact, reliable system with up to 90% power saving over equivalent valve equipment. A T & E Type CM Carrier Equipment has been chosen by British and overseas railways, and by other organisations, for microwave, open-wire and cable carrier communications.

*Fully transistorized *Plug-in printed circuit cards *Mains or battery operation *Optional in-built out-band 3825c/s low or high level signalling for ring down or dialling *Suitable for extension to existing valve equipment *Up to 96 channels per rackside *Easy accessibility *A third of the size of an equivalent valve equipment.



AUTOMATIC TELEPHONE & ELECTRIC COMPANY LIMITED
Strowger House · Arundel Street · London WC2. Telephone: Temple Bar 9262
Strowger Works · Liverpool 7

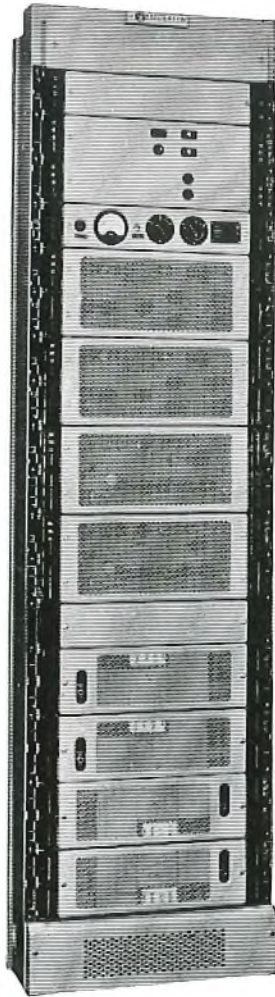

MUSIC ON TV MICROWAVE LINKS

TWO NEW F.M. SYSTEMS FOR THE TRANSMISSION,
OVER MICROWAVE LINKS, OF HIGH QUALITY 15 kc/s
SOUND CHANNELS FOR BROADCASTING SERVICES

ATTRACTIVE FEATURES OF THE SYSTEMS:

- Low noise on long routes due to double frequency modulation
- Channel dropping and insertion facilities at intermediate stations
- Routing is independent of telephone multiplex equipment

TYPE MV1

Provides one music channel for transmission on the same broadband radio channel as the TV picture signal. Equipment is rack mounted, or in portable form suitable for outside broadcasts.

TYPE MH4

Provides up to 4 music channels in 200 kc/s to 1 Mc/s baseband for transmission over auxiliary microwave links, such as STC type RA4, which use the antenna system of the main-line link.

Ideal for carrying multilingual commentaries on the same vision programme or for direct programme feeding to VHF broadcast transmitters adjacent to microwave stations.

Write, 'phone or Telex



Standard Telephones and Cables Limited

TRANSMISSION SYSTEMS GROUP

NORTH WOOLWICH · LONDON, E.16 · Telephone ALBert Dock 1401 · Telex 21645

CAYTEL

STABILISED POWER UNITS

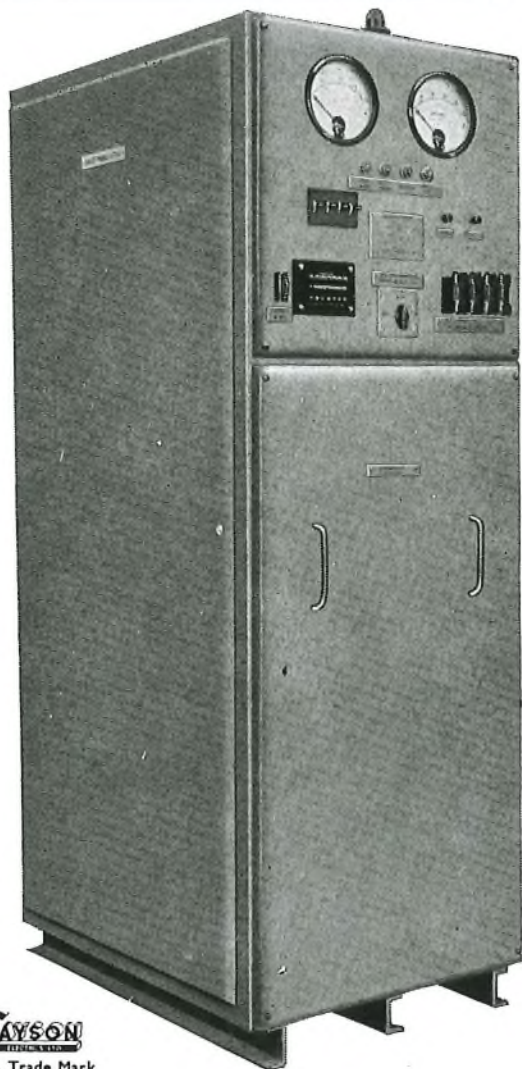

CAYSON
Regd. Trade Mark

CAYTEL STATIC RECTIFIER UNITS UP TO 100 KW., WITH CLOSE VOLTAGE LIMITS FOR VARYING LOADS FROM 0-100% AND COVERING A WIDE RANGE OF INPUT VOLTAGE AND FREQUENCY VARIATIONS

CAYSON ELECTRICS LTD.
HOLYWELL INDUSTRIAL ESTATE
WATFORD · ENGLAND
TEL: WATFORD 41272



WHITELEY
manufacture
a wide range
of



**electronic
equipment**

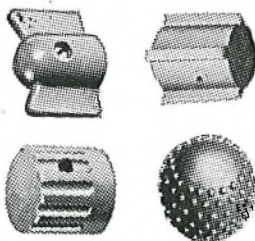

**plastic
mouldings**

**and
encapsulated
components**



*get
in touch* *with us
NOW!*

The items shown here are representative of the extensive variety of products manufactured by the Whiteley organization. Our technical resources are available for the development and production of specialized components for the electronic industry.

WHITELEY ELECTRICAL RADIO CO LTD
MANSFIELD · NOTTS · Telephone: Mansfield 1762-5

TELEPHONY

A Detailed Exposition of the Telephone Exchange Systems of the British Post Office

In Two Volumes

J. Atkinson, M.I.E.E.

Universally regarded as the standard work on the subject, this text, originally written by T. E. Herbert and W. S. Procter, has been completely revised and brought up to date with the most modern practice.

Vol. One—General Principles and Manual Exchange Systems—40s. net

Vol. Two—Automatic Exchange Systems—55s. net

DICTIONARY OF ELECTRICAL ENGINEERING

German/English/German

the late Professor H. F. Schwenkhagen

An essential reference book for use in industry, commerce, and the academic world where an interchange of electrical engineering information in the two languages is needed. 85s. net

METER ENGINEERING

J. L. Ferns, B.Sc.(Hons.), M.I.E.E., A.M.C.T.

Seventh Edition

This book deals with meter fundamentals, meter testing and meter maintenance. The latest information on methods and new models has been incorporated in this seventh edition, although many older models still in use are described. A book for all meter engineers, which is based on the C.E.G.B. regulations involved. 42s. net

FROM ALL BOOKSELLERS

PITMAN

PARKER ST., KINGSWAY, LONDON, WC2

SINGAPORE TELEPHONE BOARD

Applications are invited from suitably qualified nationals of Singapore and Malaya for employment as Telecommunications Engineers with the Board.

Commencing salary will be awarded according to experience in scales ranging from \$600 to \$1,456 a month which includes a Cost of Living Allowance of 25% of basic salary. Provident Fund is operated.

Candidates should be Graduates of the Institution of Electrical Engineers and preferably have had some experience of telephone communication engineering.

Candidates lacking practical experience but possessing Grad.I.E.E. membership or qualifications granting exemption from the Institution's examinations are still encouraged to apply as consideration will be given to arranging courses in the U.K. for those selected.

Apply to **CROWN AGENTS, 4 Millbank, London, S.W.1** for application form and further particulars, stating age, name, brief details of qualifications and experience and quoting reference M2/51946/DAB.



**Telephone
Answering Set No. 1
Overseas Enquiries Welcomed**

Developed by

SONTRONIC LIMITED Makers of Subscribers' Telephone Answering and Recording Equipment

For further information write to:

SONTRONIC LIMITED · FORUM WAY · EDGWARE · MIDDLESEX · ENGLAND

Telephone: EDGware 6666/7/8

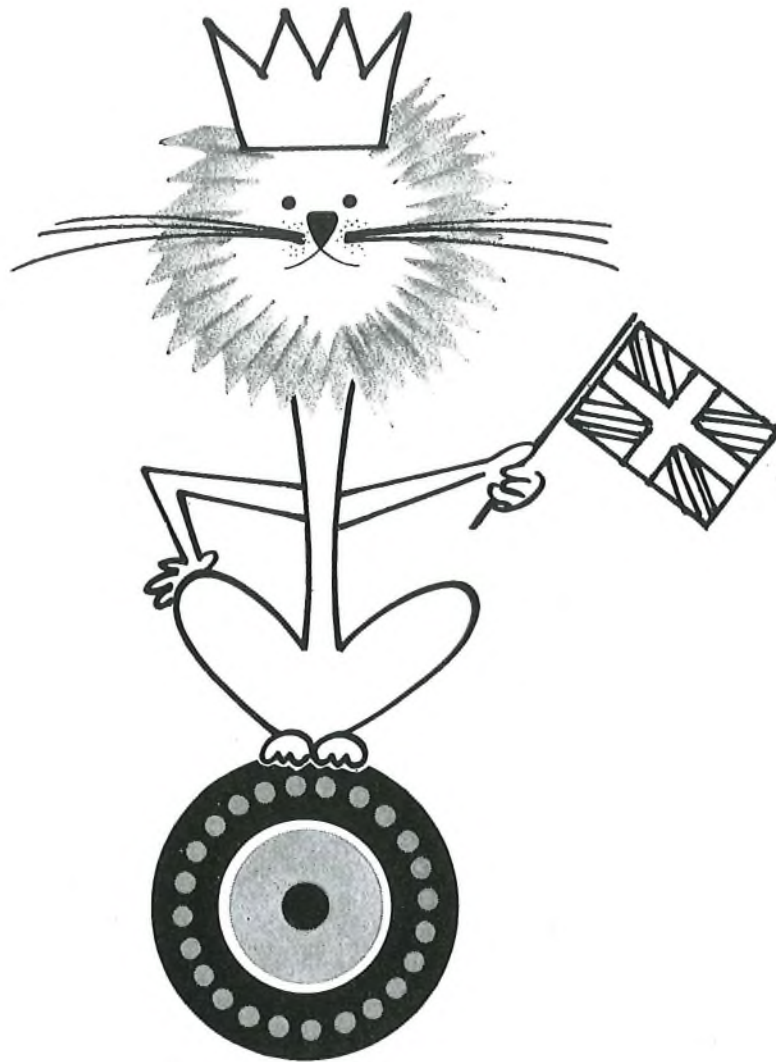

THE LION'S SHARE

Submarine Cables Ltd., England, and its predecessors have pioneered and supplied far the largest proportion of the world's submarine telecommunication cable—90% of the telegraph cable between 1850 and 1950 and the largest share of telephone cable since 1950—also the main cable-laying gear for Cable Ships, MONARCH, ALERT, MARCEL BAYARD, MERCURY, INGUL and JANA. For submarine telecommunication cable, repeaters and—through AEI—terminal equipment; for cable handling gear and also for deck auxiliaries, consult:

HERE ARE SOME OF THE COMPANY'S MILESTONES:

- 1850** *First ever submarine telegraph cable—
from England to France.*
- 1866** *First successful transatlantic telegraph cable.*
- 1939** *First polythene-insulated submarine cable.*
- 1955/6** *First transatlantic telephone cable—
95% supplied by the Company.*
- 1961** *First armourless telephone cable—
2000 miles from Newfoundland to England.*
- 1961** *Longest repeatered 120-circuit telephone cable—
400 miles from Newfoundland to Canada.*
- 1961/3** *Supply over 5000 miles of armourless
cable and 90 repeaters for the 8000-mile
Commonwealth Pacific system.*
- 1962** *Contract for 420-circuit transistorised repeaters.*

SUBMARINE CABLES LIMITED

(OWNED JOINTLY BY AEI AND BICC) • MERCURY HOUSE • THEOBALD'S RD • LONDON WC1 • ENGLAND

'ONE SYSTEM' SURFACE

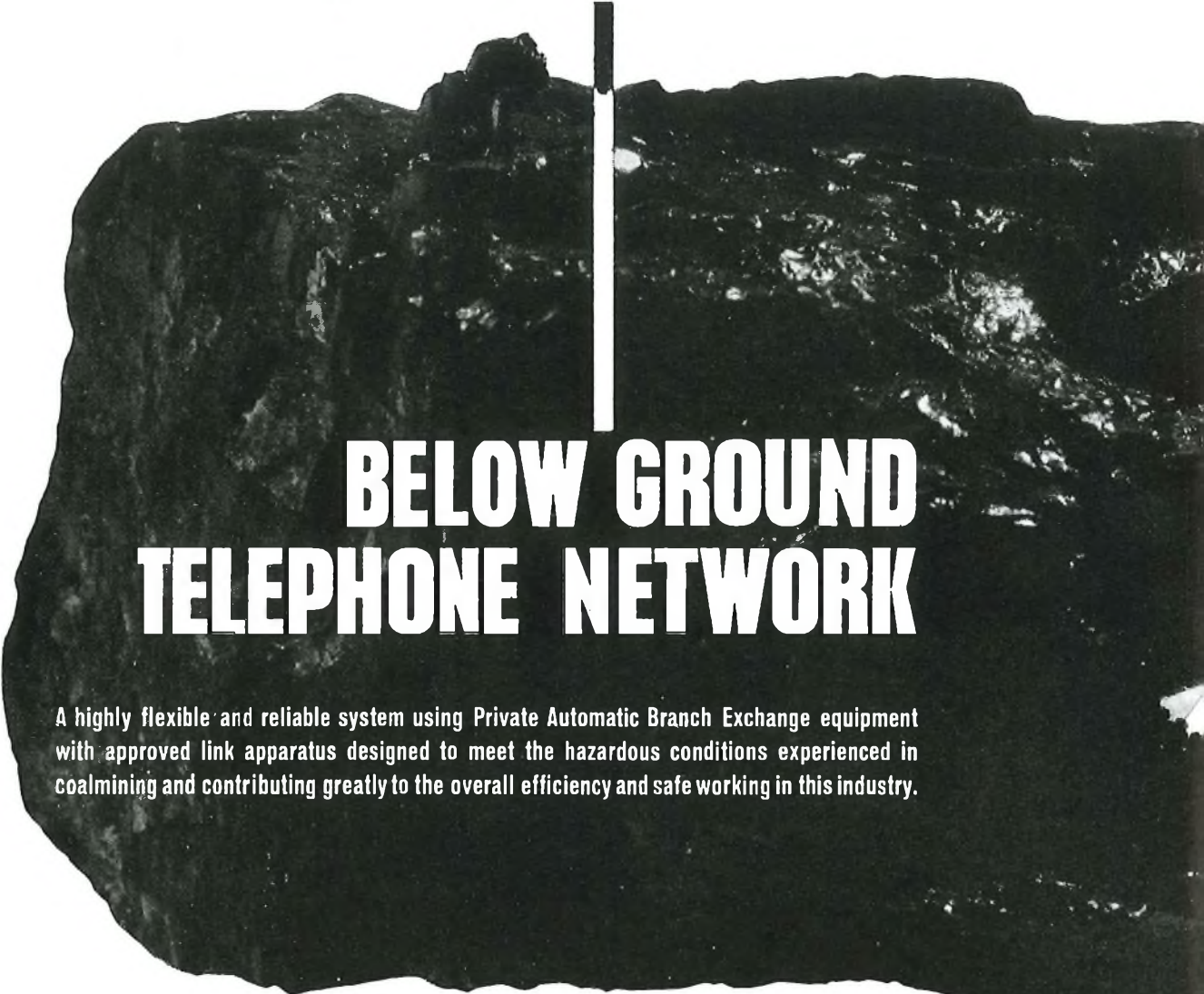

BELOW GROUND TELEPHONE NETWORK

A highly flexible and reliable system using Private Automatic Branch Exchange equipment with approved link apparatus designed to meet the hazardous conditions experienced in coalmining and contributing greatly to the overall efficiency and safe working in this industry.

This Ericsson equipment enables both surface and underground extensions (through a safe link) to be interconnected to form one integrated telecommunications system. All extensions have access to each other simply by dialling the appropriate number and access to the public system by interconnection through the manual board. Incoming calls can be switched to any extension. Operator recall facility is available on exclusive telephones if required.

Party-line working between underground extensions is established by coded ringing and does not interfere with the service provided by the automatic equipment. Callers on the party line however can be warned of an incoming call by a suitably coded tone.

Emergency control can be initiated by any underground caller dialling 777. This call is received at the alarm reporting telephone which is placed in a surface area which is manned continuously. In emergency circumstances any underground line can be placed under manual control on the emergency switchboard.

Private Automatic Branch Exchanges are available which meet the requirements of small, medium and large collieries.

More information about the Ericsson "one system" layout will be sent on request.

ERICSSON TELEPHONES LTD
ETELCO LTD

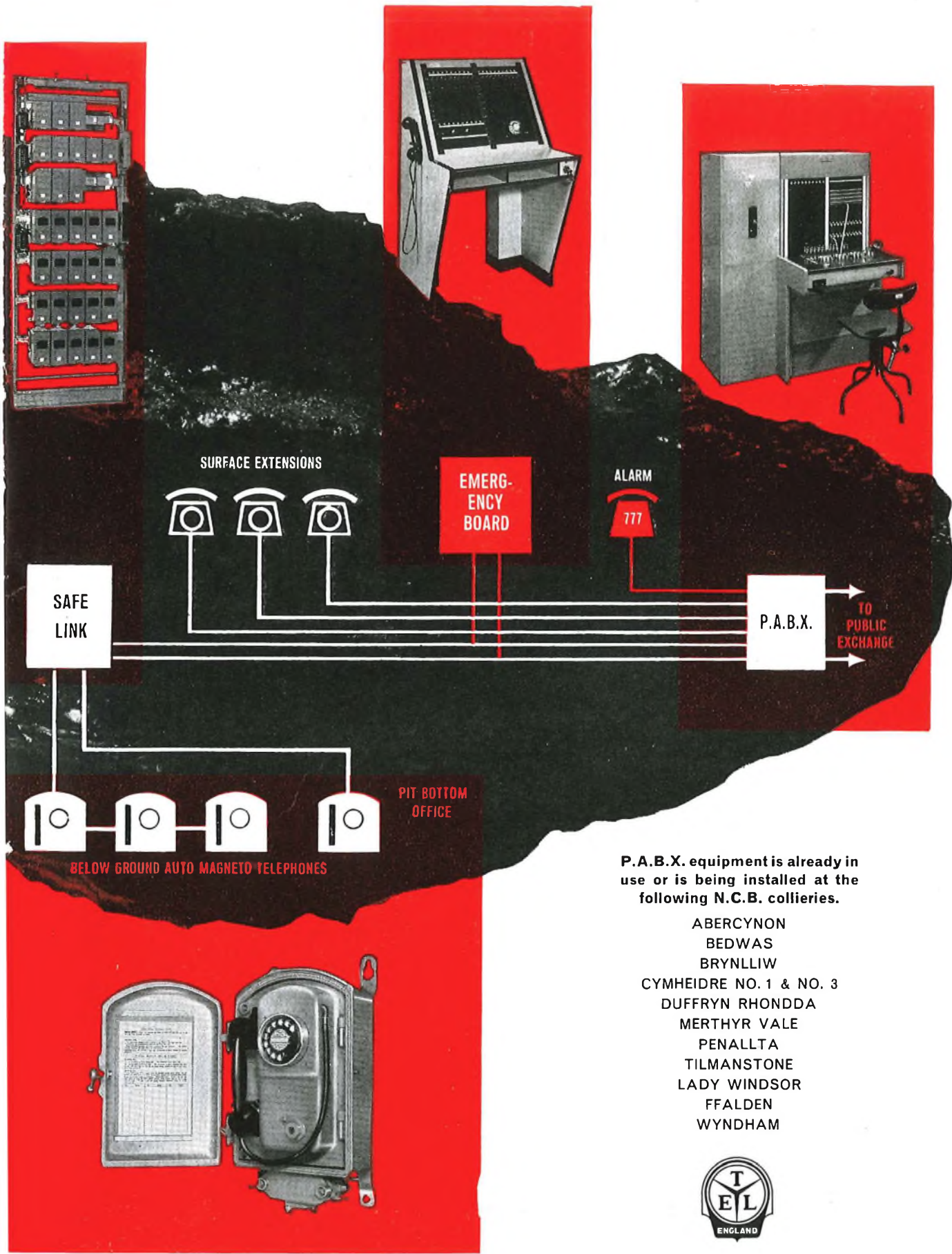

P.A.B.X. equipment is already in use or is being installed at the following N.C.B. collieries.

- ABERCYNON
- BEDWAS
- BRYNLLIW
- CYMHEIDRE NO. 1 & NO. 3
- DUFFRYN RHONDDA
- MERTHYR VALE
- PENALLTA
- TILMANSTONE
- LADY WINDSOR
- FFALDEN
- WYNDHAM



2 LINCOLN'S INN FIELDS, LONDON W.C.2 Telephone: HOLborn 6936

Transistorized Range of Transmission Testing Apparatus from **STC**



FREQUENCY RANGE 30 c/s to 16 kc/s

74186A Oscillator

The 74186A Oscillator is a general-purpose transistorized oscillator covering the frequency range 30 c/s - 16 kc/s in two overlapping bands, and capable of delivering signals at levels of 0 to -80 dbm into 600 ohm balanced and unbalanced circuits.

In conjunction with the 74187A Receiving Unit it forms an equipment for making general transmission measurements in the audio-frequency range.

74187A Receiving Unit

The 74187A Receiving Unit is a companion set to the 74186A Oscillator. It will make flat (non-selective) through and terminated level measurements on 600 ohm balanced and unbalanced circuits down to -71 dbm in the audio-frequency range. In addition, a high impedance (unbalanced) input circuit gives it a range of applications as a sensitive a.c. voltmeter. A circuit is also incorporated for feeding a recorder.

FREQUENCY RANGE 4 kc/s to 610 kc/s

74188A Oscillator

The 74188A Oscillator is a general-purpose heterodyne instrument covering the frequency range 4 - 610 kc/s in two bands. It will meet a wide range of requirements for testing multi-channel telephone systems. A feature of the oscillator is that it provides a signal for automatically tracking the associated 74189A Selective Level Measuring Set, thus ensuring that the selective circuit of the latter keeps in step with the oscillator output frequency throughout the frequency range.

74189A Selective Level Measuring Set

The 74189A Selective Level Measuring Set is intended for making selective measurements on multi-channel carrier telephone systems. It can be used for measuring tones in channels at group and supergroup frequencies and also line frequencies when adjacent channels are in traffic. It is a companion set to the 74188A Oscillator.

These sets are portable and housed in light-weight carrying cases with detachable lids. The sets contain their own power supplies in the form of six replaceable 1½ volt battery cells; alternatively an external 18 - 24 volt d.c. supply may be used.

63/4CT



Write, Telephone or Telex for leaflets:

Standard Telephones and Cables Limited

TRANSMISSION SYSTEMS GROUP
NORTH WOOLWICH · LONDON, E.16
Telephone ALBert Dock 1401 · Telex 21645



AEI

EXPERIENCE SPANS THE WORLD

For more than a century the Telecommunications Division of AEI has played a part in pioneering major telecommunications projects and has to its credit technical achievements of the highest order in this very specialised field. Since its formation in 1935, the Transmission Department has supplied and installed a wide range of multi-channel

telephone and telegraph systems to administrations throughout the world.

It is this background of experience, gained over the passage of a hundred years, that has enabled AEI and Submarine Cables Ltd to contribute towards the success of the round-the-world cable scheme, first with CANTAT and now with COMPAC.

When reliability matters, AEI equipment is used

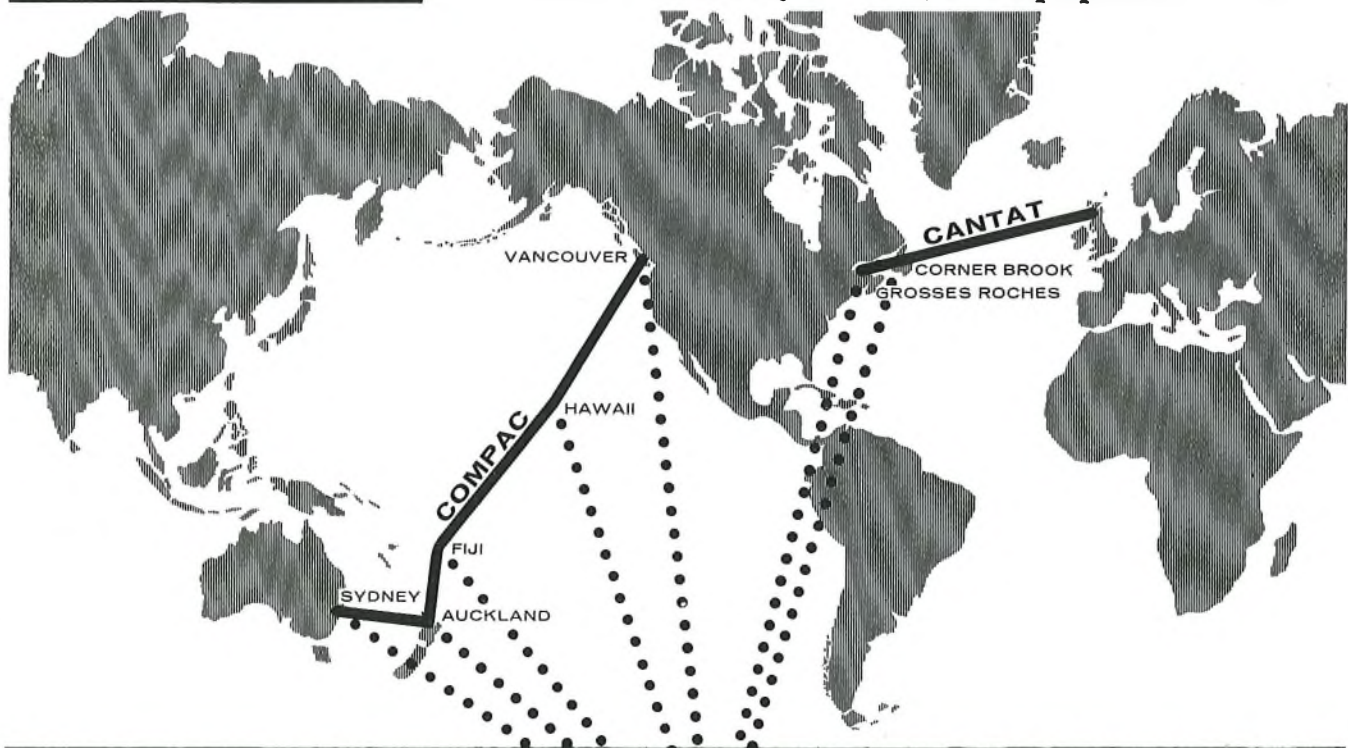

TRANSOCEANIC TELEPHONE CABLE SYSTEMS

CORNER BROOK
GROSSES ROCHES
VANCOUVER
HAWAII
FIJI
AUCKLAND
SYDNEY

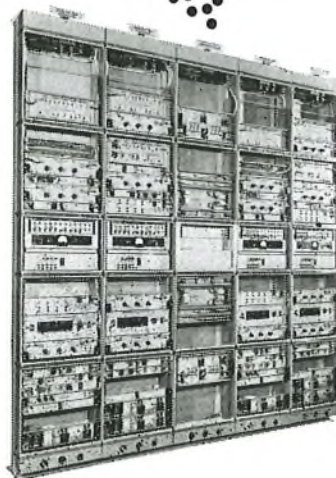

DIRECTIONAL FILTER AND
CABLE-FREQUENCY TRANSLATING
EQUIPMENT



Telecommunications Division

Transmission Department
Woolwich, London SE18

Associated Electrical Industries Limited

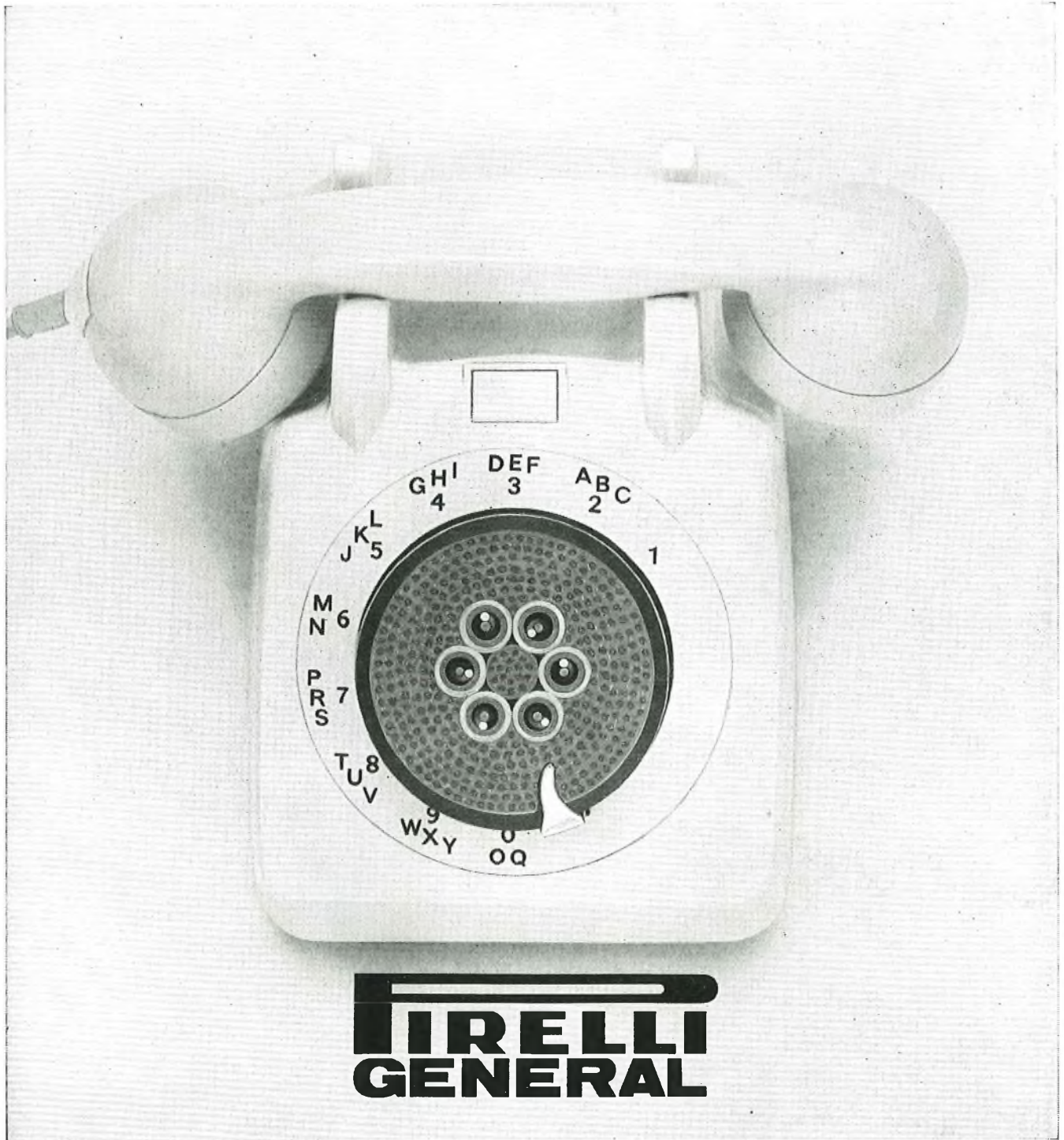

TELECOMMUNICATIONS CABLES

Pirelli General are in a position to advise on complete Telecommunications schemes and are organised to manufacture and install cables for distribution and trunk services; also carrier and all types of coaxial cables.

Pirelli General also manufacture cables to meet special requirements of Public Utilities or of industry.



S.E.C.

**manufactures
telephones
for all
applications**



S.E.C. 706 telephone
a general purpose table instrument.

S.E.C. also produces intercommunication sets, loudspeaking telephones and telephones for special applications for ships, railways, mines etc.

Telephone Division

S.E.C. (TELECOMMUNICATIONS) LTD · TELEPHONE WORKS · COVENTRY · ENGLAND
Works at Coventry and Middlesbrough



S.E.C. 711 telephone
a general purpose wall instrument.



S.E.C. 710 telephone
for plan and extension systems and special facilities.



S.E.C. switching telephone
for plan 105 and plan 107 operation.



Telecommunications is people talking . . .

... and A.T.E. have been talking communications for over half a century. In that time A.T.E. has grown from the small nucleus organisation that pioneered the Strowger system of automatic telephony in the United Kingdom to a world-wide network of companies — the largest manufacturers of telecommunications equipment in the British Commonwealth.

In the U.K. alone, the Company has one and a half million square feet of production space at its

AUTOMATIC TELEPHONE & ELECTRIC COMPANY LIMITED WORLD LEADERS IN COMMUNICATIONS



across the world

disposal whilst, overseas, there are associated factories in Australia, New Zealand, South Africa, Portugal and Brazil.

The whole of the Company's research and development programme is centrally co-ordinated and the resultant cross-fertilisation of ideas and information is one of the main reasons why A.T.E. telecommunications equipment is the most advanced in the world.



8 ARUNDEL STREET · LONDON WC2 · *A Principal Operating Company of the Plessey Group*



G.E.C.

TUBELESS

*Transistored
12-circuit
terminal rack*

It's not tyres we are talking of, but our new 12-circuit carrier telephone equipment for open-wire lines, which is completely transistored.

The Posts and Telegraphs Department of Finland has awarded a contract to G.E.C. for the supply of this new equipment which provides twelve circuits occupying the

TRANSMISSION DIVISION

frequency band 36 kc/s—143 kc/s on a single pair of an open-wire route. Each speech circuit has an effective bandwidth of 300c/s—3400c/s.

The contract includes the supply of 100 terminal and 90 repeater equipments. A complete terminal equipment is accommodated on one single-sided rack, 9 ft. high \times 1 ft. 8½ ins. wide \times 8½ ins. deep.

G.E.C.

(TELECOMMUNICATIONS) LTD · TELEPHONE WORKS · COVENTRY · ENGLAND

Works at Coventry and Middlesbrough

Smee's 140

ADCOLA

ESTABLISHED 1911
(Royal Trade Mark)

EQUIPMENT
FOR
PRODUCTION

Soldering Instruments for Vital and Exacting Work

SOLDER JOINTS OF THE HIGHEST DEPENDABILITY
ARE CALLED FOR WHEN CIRCUITS ARE TO OPERATE
UNATTENDED FOR YEARS ON OCEAN BEDS

Illustration shows

SOLDER JOINTING TERMINATIONS ON THE UNITS OF THE
SUBMARINE REPEATERS FOR **COMPAC** WHICH WILL LINK
AUSTRALIA, NEW ZEALAND, FIJI AND CANADA

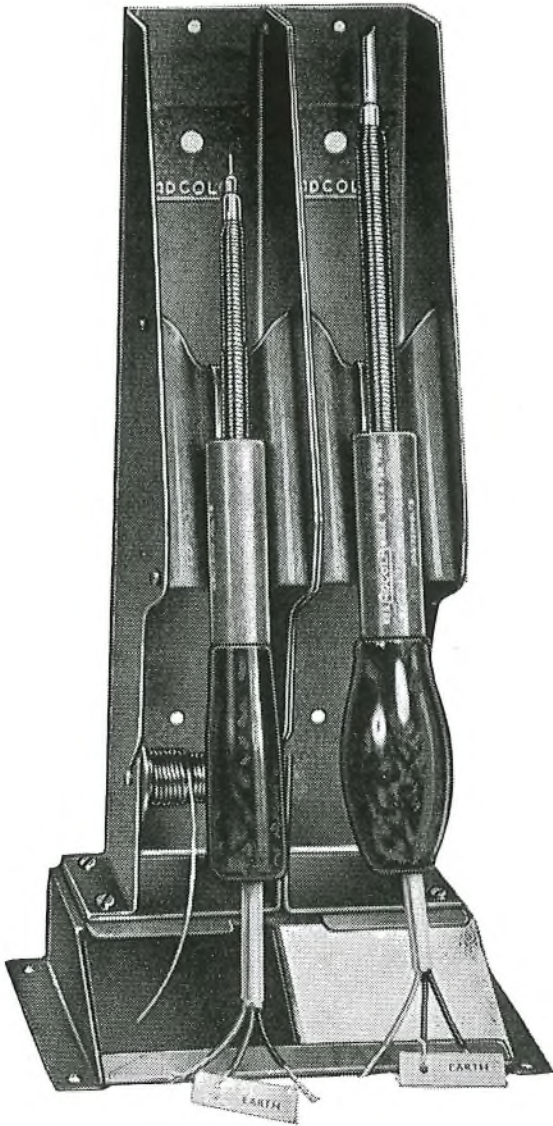

ADCOLA'S DOUBLE BANKED FOR JOINTING
CIRCUITS WITH LARGE AND SMALL
TERMINATIONS

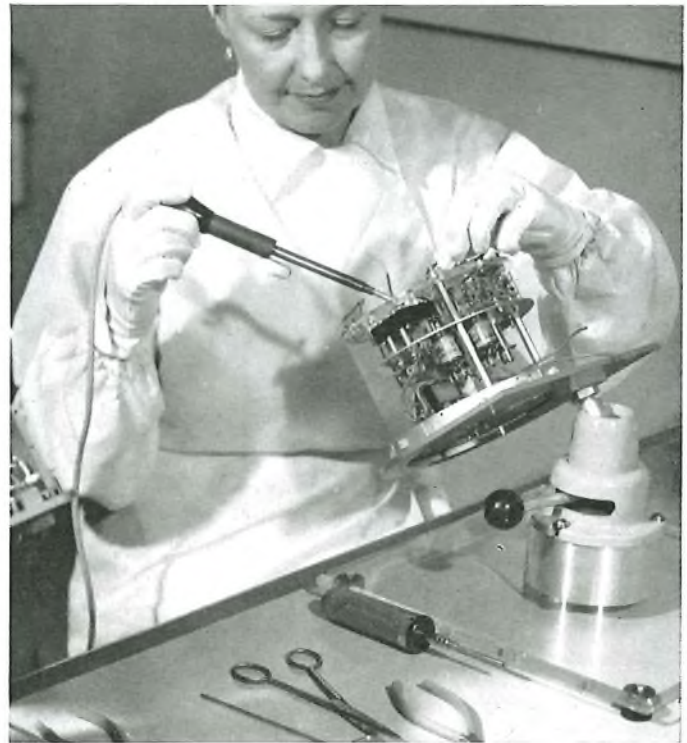

Photograph by the courtesy of Submarine Cables Ltd.

All communications to:

ADCOLA PRODUCTS LTD.

ADCOLA HOUSE

GAUDEN ROAD

LONDON, S.W.4

Telephones: MACaulay 4272 & 3101

Telegrams: SOLJOINT LONDON S.W.4

Forced Air Cooled TETRODES

Direct equivalents to USA types

ABRIDGED DATA

TYPE	CONSTRUCTION	AMPLIFIER CLASS	TYPICAL OUTPUT (W)	f. MAX. (FULL RATINGS) (Mc/s)
4CX250B	ceramic/metal	AB1 (SSB)	300	500
4X250B CV2487	ceramic/metal/glass base			
4X150A CV2519	glass/metal	C (FM)	370	500
4X150D CV3991	glass/metal			
		AB1 (SSB)	300	150
		C (FM)	370	150

All the above have oxide-coated unipotential cathode ($V_h=6V$, except 4X150D where $V_h=26.5V$)



Forced air cooled tetrode Type 4X250B

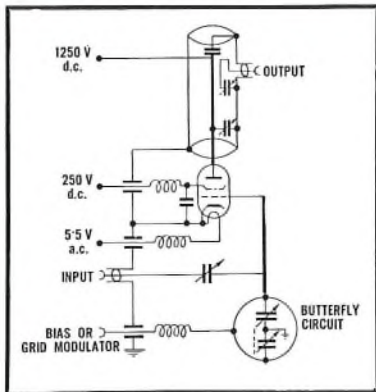

These valves are compact and require only moderate air cooling.

They are, therefore, ideal for mobile equipments (CW or pulse).

The construction of the valves is conducive to cavity mounting which is essential for operation at frequencies up to 500 Mc/s.

The diagram above illustrates a 400 Mc/s amplifier circuit using a coaxial line cavity.



3A/167M

5A/170K

5A/180M

Frame grid valves for wide band amplifiers

TYPE	3A/167M (CV5112)	5A/170K (CV3998)	5A/180M
Figure of Merit	370	185	180
g_m	47	16.5	32 mA/V
I_a	40	13	26 mA
$P_a \text{ max}$	6.5	3.3	6 W

The STC range comprises 3 valves, a triode and two beam tetrodes all of which are characterized by a high mutual conductance in ratio to capacitance yielding a high Figure of Merit.

Type 5A/170K is suitable for multistage, high gain amplifiers. Where a higher power level is desired Type 5A/180M may be used.

Triode 3A/167M is particularly suitable for cascode connexion and cathode follower applications. A combination of these two circuits is illustrated below.

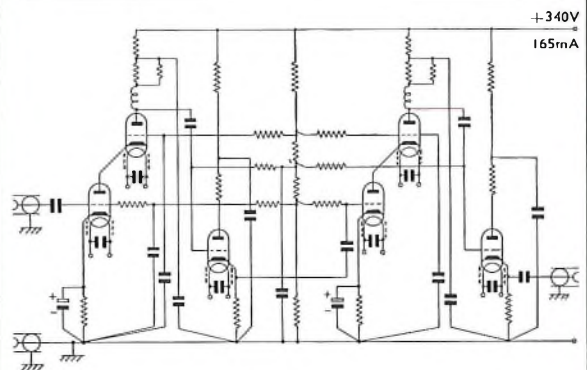

6 valves type 3A/167M in a wideband, low noise amplifier (5.5kc/s to 37.5 Mc/s). Voltage gain 200. Details on request.

Write, 'phone or Telex for full details

COMPONENTS GROUP VALVE DIVISION



Standard Telephones and Cables Limited

FOOTSCRAY · SIDCUP · KENT
Telephone FOOTscray 3333 Telex 21836

when
life
depends
on
toughness
cable
is
sheathed
in

RIGIDEX

the
polyethylene
plus

Rigidex sheathing is unequalled for providing undersea cable with every property it needs for survival—great strength, impermeability, tireless resistance to abrasion, corrosion and low temperatures. Cable Grades of Rigidex have been specially developed to meet the individual requirements of high performance cables. Find out more about them . . . contact B.R.P. and ask for our Leaflet (Ref. 328).

Rigidex is a reg'd trade mark of British Hydrocarbon Chemicals Ltd, and one of the products they manufacture at Grangemouth.

Sole Selling Agents

British Resin Products Ltd

A COMPANY IN DISTILLERS CHEMICALS AND PLASTICS GROUP



SALES AND TECHNICAL SERVICE DEVONSHIRE HOUSE PICCADILLY LONDON W1 HYDE PARK 8131

Distillers Plastics Serve Everyman

there's more in a

MALLORY MANGANESE BATTERY

than meets the eye!

- * More hours of dependable service
- * More energy for heavy duty operation
- * Full life after lengthy storage
- * Extra selling power for
battery operated products
- * More freedom to choose
the right battery for the job

MALLORY

Depolariser
Electrolyte Anode

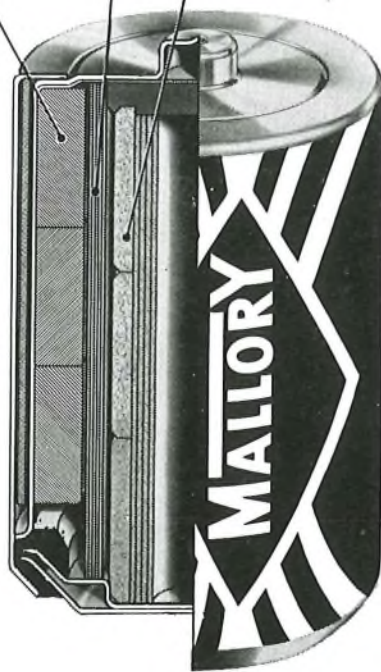

no cathode?

It's there, of course,
in the depolariser cylinder mix.
This is just one of the many
revolutionary features
that makes Mallory's
Manganese Alkaline system
so powerfully different.

MANGANESE ALKALINE BATTERIES IN STANDARD SIZES

A new combination of chemicals... the proven 'inside-out' construction of the Mallory Mercury system... ingenious venting arrangements... low internal impedance... these are just a few of the features that make Mallory Manganese Alkaline batteries so revolutionary, so powerfully different. They last *at least* three times longer than ordinary types — up to ten times on heavy loads, need no recuperation periods, and can be stored for two years or more without leaking, corroding or losing energy.

MINIATURISATION NEEDS MALLORY MERCURY

Where space is a premium or voltage stability an essential feature, Mallory Mercury batteries are indicated. A full range from aspirin size cells to multi-voltage stacks and packs — custom built if required — enables the needs of virtually any application from wrist watches to air/sea rescue homer radios to be met.

HORSES FOR COURSES

These two systems for the first time give designers the freedom to choose a battery that fully meets the requirements of their products, that enables them to enhance equipment specifications with improved battery performance.

**Mallory Batteries
are internationally available**

**Write NOW for literature
and details of consultancy service**

for new ideas in batteries

MALLORY BATTERIES LTD CRAWLEY SUSSEX *Crawley 26041*
Export Office: 33 Duke Street London W1

MARCONI MST

– the technological breakthrough that anticipates every foreseeable advance in HF communication for a generation



– MARCONI SELF TUNING HF SYSTEM

A decade of Marconi research and development has perfected and brought together into one completely integrated system —

SYNTHESIZER FREQUENCY SELECTION

WIDEBAND DISTRIBUTED AMPLIFIERS

NEW SELF-TUNING FREQUENCY FOLLOWING TECHNIQUES

AUTOMATIC AERIAL SELECTION

LOGARITHMIC AERIALS



– CUTS COSTS

Only one man is now required to control a complete station and the greater reliability of equipment has reduced the need for maintenance and maintenance personnel. Reliability is greatly increased by drastic design simplification which has reduced equipment size by 50%. New buildings can be smaller or existing buildings can carry more services with fewer ancillaries. Almost instantaneous frequency selection increases circuit efficiency and gives more time in service.



– **is fully compatible with existing equipment encouraging progressive modernization of existing HF systems at low cost.**



MST

MARCONI SELF TUNING HF SYSTEM

THE WORLD'S FIRST
'STATION PLANNED' SYSTEM
FROM INPUT
TO OUTPUT

STEPMASTER

by

STC



The new range of Stepmaster PABX's by STC provides efficient and fast telephone communication to meet modern business requirements. Operating procedure is so simple that the attendant can devote time to secretarial or receptionist duties in addition to handling calls.

- Push-button cordless type attendant's cabinet.
- Extension line capacity. 20, 50 or 100 units and 100/200 extensible.
- B.P.O. type "long life" components.
- 4000-type selectors.
- All "plug in" type equipment.
- Transistorized tone circuits.
- Switching equipment mounted in totally enclosed cubicle if required.
- Quick, easy expansion up to capacity.
- Simple installation and maintenance.
- Tropical finish.

Write, 'phone or Telex



Standard Telephones and Cables Limited

TELEPHONE SWITCHING DIVISION
OAKLEIGH ROAD · NEW SOUTHGATE · LONDON, N.11
Telephone ENTerprise 1234 · Telex 21612

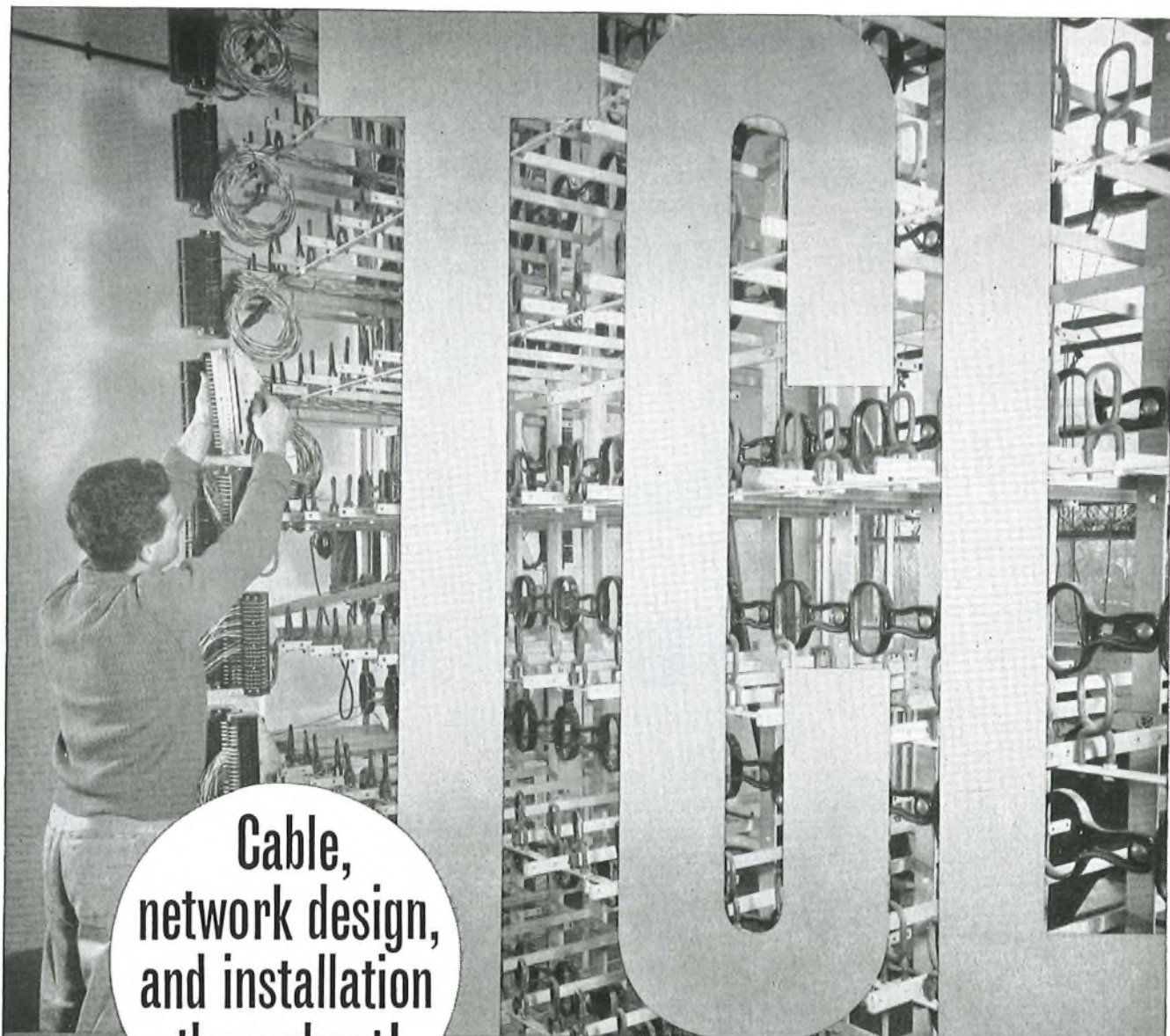

**Cable,
network design,
and installation
throughout!**

TELEPHONE CABLES LIMITED

not only manufacture telephone cables in an immense variety of types, sizes and different kinds of insulation, but also undertake the installation of complete systems and will supply highly experienced technicians to supervise the work throughout. Entrusting the whole project—its design, production and installation—to T.C.L. ensures the greatest speed, efficiency and economy ... and above all—long term reliability in operation.

TELEPHONE CABLES LIMITED, DAGENHAM, ENGLAND · TELEPHONE: DOMINION 6611 · CABLES: DRYCORE DAGENHAM

THE ORGANISATION WITH 125 YEARS' EXPERIENCE

IMPROVED

STANDARDS OF

ACCURACY AND RELIABILITY

Modern styling in light grey with legible black engraving.

Constructed to withstand adverse climatic conditions.

Ever ready case, including leads, prods and clips.

Improved internal assemblies.

Re-styled scale plate for easy rapid reading. 2 basic scales, each 2.5 inches in length.

New standards of accuracy, using an individually calibrated scale plate: d.c. ranges 2.25% of full scale deflection, a.c. ranges 2.75% of full scale deflection.

Available accessories include a 2500V d.c. multiplier and 5, 10 and 25A shunts for d.c. current measurement.



Mk4

MULTIMINOR



The Mk.4 MULTIMINOR is an entirely new version of this famous Avo instrument and supersedes all previous models. It is styled on modern lines, with new high standards of accuracy, improved internal assemblies, and incorporating pan-climatic properties.

The instrument is supplied in an attractive black carrying case, which also houses a pair of leads with interchangeable prods and clips, and an instruction booklet. It is packed in an attractive display carton. Robust real leather cases are available, if required, in two sizes, one to take the instrument with leads, clips and prods, and the other to house these and also a high voltage multiplier and a d.c. shunt.

Dimensions (including case):—
7½ × 4 × 1½ ins. (197 × 102 × 41 mm.) approx.
Weight (including case):—
1½ lbs. (0.675 kg.) approx.

D.C. Current: 100μA f.s.d.—1A f.s.d. in 5 ranges.
A.C. Voltage: 10V f.s.d.—1,000 f.s.d. in 5 ranges.
D.C. Voltage: 2.5V f.s.d.—1,000 f.s.d. in 6 ranges.
D.C. Millivolt range: 0—100mV f.s.d.

RESISTANCE: 0.2MΩ in ranges, using 1.5V cell.
SENSITIVITY: 10,000Ω/V on d.c. Voltage ranges.
1,000Ω/V on a.c. Voltage ranges.

● For full details of this great new pocket size instrument, write for descriptive leaflet.

AVO LTD

AVOCET HOUSE, 92-96 VAUXHALL BRIDGE ROAD, LONDON, S.W.1.

Telephone: VICTORIA 3404 (12 lines)



MM 17

VALUABLE FREE BOOK

Tells You How to Pass Your C. & G. Examination at First Attempt!

All Post Office personnel who are anxious to obtain early promotion should at once send for a copy of our handbook "ENGINEERING OPPORTUNITIES" which, among other intensely interesting matter, describes our unique methods of preparation for the CITY AND GUILDS EXAMINATIONS for the Telecommunication Technicians' Certificate and for individual subjects—Mathematics, Engineering Science, Engineering Drawing, Elementary Telecommunication Practice, Telecommunication Principles, Radio and Line Transmission, Telegraphy and Telephony, Line Plant Practice. It also contains details of our courses covering the G.C.E. subjects required for promotion to Assistant Engineer, Telecommunication Traffic Superintendent and other grades; and the City and Guilds examinations in Electrical Engineering Practice, the Grad.Brit.I.R.E. and A.M.S.E. Examinations, in addition to a wide range of non-examination courses in all branches of engineering—Radio and Electronics, Electrical, Mechanical, etc.

We also provide tuition for the Radio Amateurs' Examination and the P.M.G. Certificates for Radio Operators, with or without Morse training. Details are given in the handbook.

**We definitely guarantee
"NO PASS — NO FEE"**

If you intend to make the most of today's opportunities, you cannot afford to miss reading "ENGINEERING OPPORTUNITIES." It tells you everything you want to know to secure advancement, and describes many opportunities you may now be missing through lack of information. Send for your copy today—FREE and without obligation.

BRITISH INSTITUTE
OF ENGINEERING TECHNOLOGY
369 COLLEGE HOUSE,
29-31 WRIGHT'S LANE, LONDON, W.8

BIET

MODEL ANSWER BOOKS

CITY AND GUILDS OF LONDON INSTITUTE
TELECOMMUNICATION TECHNICIANS' COURSE

**TELECOMMUNICATION
PRINCIPLES A**

**TELECOMMUNICATION
PRINCIPLES B**

**ELEMENTARY
TELECOMMUNICATION
PRACTICE**

Price 7s. 6d. each. Post Paid 8s.

The following model answer book, although published for the old Telecommunications Engineering Course, is still useful and is offered at a considerably reduced price.

TELEPHONE EXCHANGE SYSTEMS I
(Telephony and Telegraphy A, Telephony B)

Price 2s. each. Post Paid 2s. 6d.

Orders to
The Post Office Electrical Engineers' Journal
G.P.O., 2-12 Gresham Street, London, E.C.2

STC contracts for North Sea projects

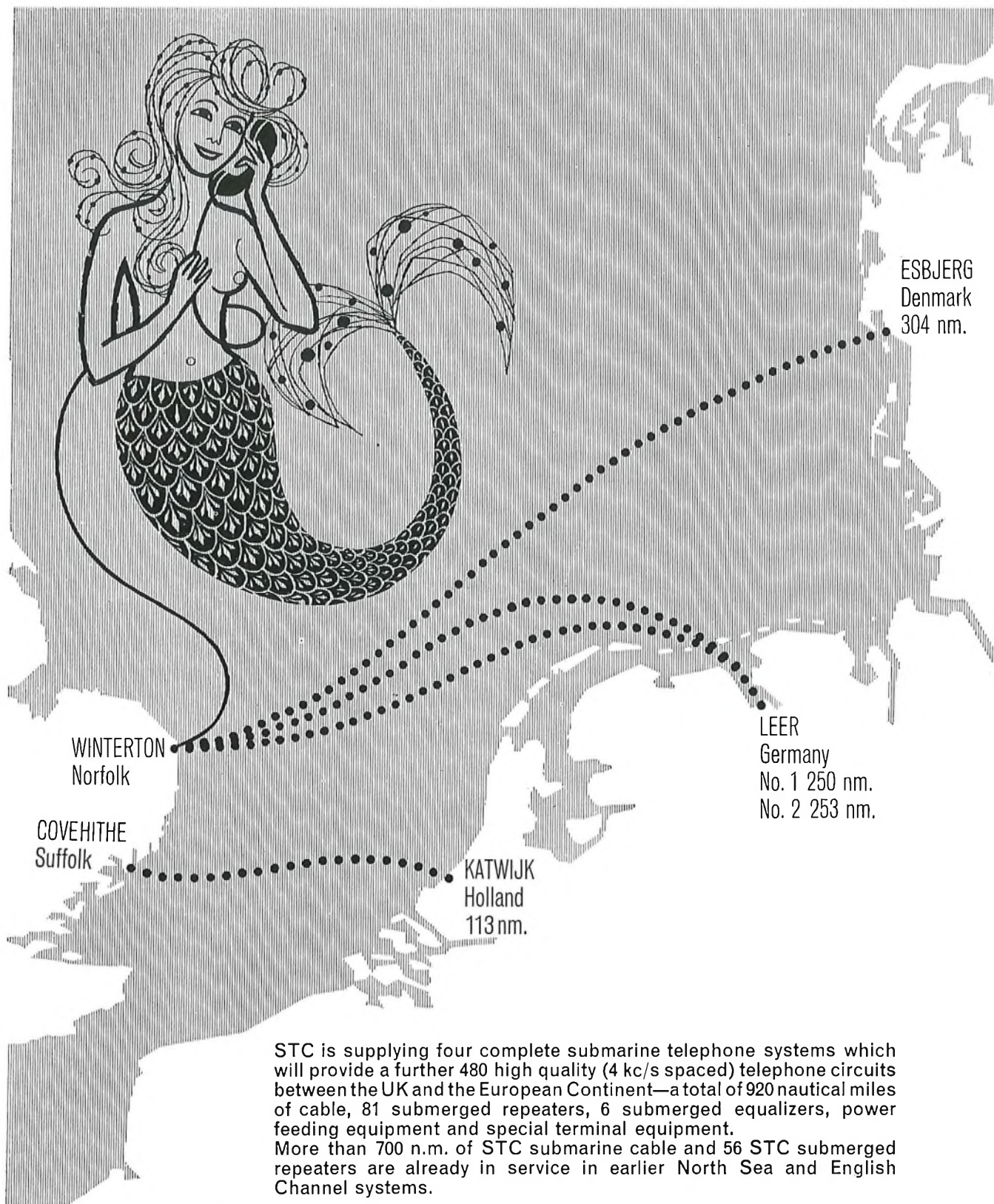

Standard Telephones and Cables Limited

SUBMARINE CABLE DIVISION: NEW DOCKS · SOUTHAMPTON · HANTS
TRANSMISSION SYSTEMS GROUP: NORTH WOOLWICH · LONDON, E.16

DENSO PROTECTION

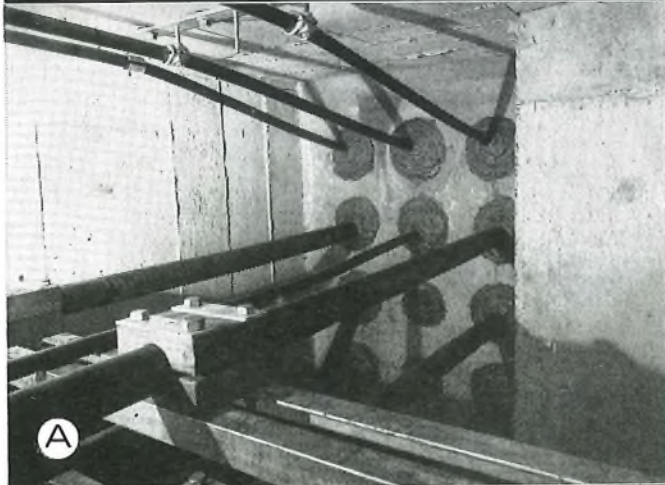

A

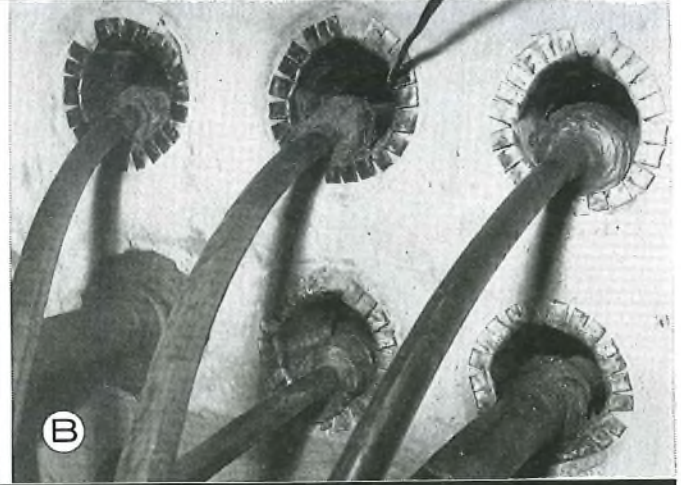

B

FOR CABLES AND PIPES

- A** Inside an inspection chamber — the cables are supported by steelwork and the ends of the duct sealed with Denso Mastic. Denso Mastic is the all-purpose cold applied sealing medium, and can be used for plugging, sealing and caulking duties below ground, above ground or underwater.
- B** Underground cables in ducts. Denso Tape is used to protect the cables where they pass over lead linings at the edge of the pipe in case the cable sinks onto the hard edges.

DENSO MASTIC and DENSO TAPE are used by the Central Electricity Generating Board, who also supplied the photographs.

WINN & COALES LTD

Denso House, Chapel Road, London, S.E.27.

Tel: GIPsy Hill 7511

Also at Manchester, Belfast and Dublin.

Agents throughout the Commonwealth.



“DRITAN” SOLID TANTALUM ELECTROLYTIC CAPACITORS

The range has been designed
in line with Spec. MIL. C-26655/2

T.C.C. offer hermetically sealed solid electrolyte “Dritan” capacitors made to the most stringent performance characteristics.

Previous low leakage current limits have been cut in half and surge voltage limits increased, while the miniaturisation of these capacitors makes them ideal for use in such transistorised equipment as R.F. timing, integrating and differentiating circuits, and servo systems where large value of capacitance in small physical size is an essential requirement.

In “Dritan” Electrolytics there is no sacrifice of quality or reliability, and these capacitors are rated for operation over the temperature range of -55°C . to $+85^{\circ}\text{C}$. With appropriate voltage derating, they may be operated at temperatures as high as $+125^{\circ}\text{C}$. All T.C.C. “Dritan” Electrolytics are fitted with ‘Melinex’ insulating sleeving.

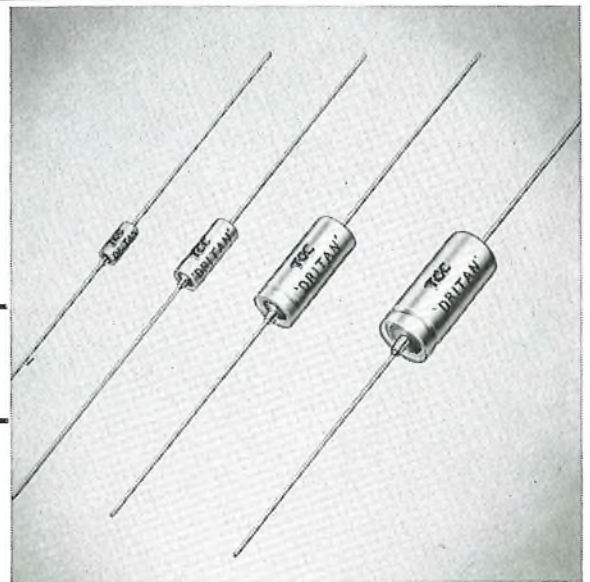

Temp. range: -55°C . to $+125^{\circ}\text{C}$ (with voltage derating)
Voltage: Up to 50 V.D.C.
Cap. range: 0.0047 μF to 350 μF .
Cap. Tolerance: $\pm 20\%$ standard
 $\pm 10\%$ $\pm 5\%$ to special order
Polarized types only: Sintered slug or wire anode and solid electrolyte construction.
Maximum leakage current: 1 (μA) = 0.02 C (μF).V (volts) at room temp.
 1 (μA) = 0.2 C (μF).V (volts) at $+85^{\circ}\text{C}$.

THE TELEGRAPH CONDENSER CO. LTD
 NORTH ACTON · LONDON · W.3

Telephone: ACOrn 0061



New improved reliability with the A T & E 'Country Set'

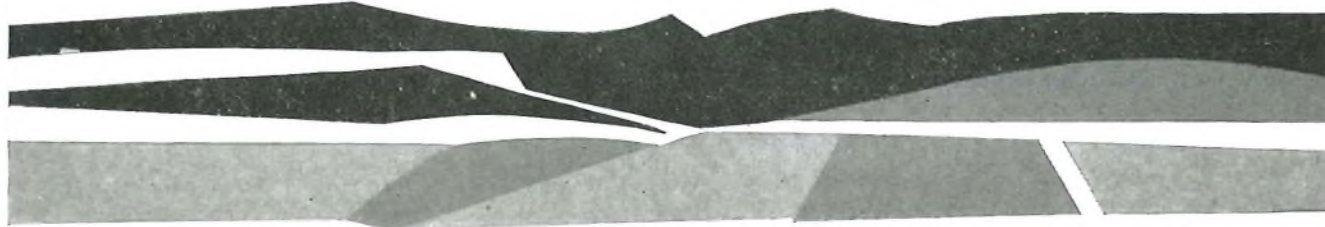

The 'Country Set' VHF frequency modulated radio-telephone has been specially designed to operate efficiently and with field-proven reliability in an extremely wide range of different environmental conditions. It provides isolated subscribers with a complete telephone service and by means of an in-built out-of-band tone relay set, it can work directly into an automatic or manual exchange with full signalling and supervisory facilities including dialing. Other versions provide for junction operation (auto or manual) between exchanges.

The improved 'Country Set' with its transistorized receiver is designed to run continuously from a 12 volt source (either primary or secondary batteries). Two versions of the equipment are available operating in the frequency range of 54-88 Mc/s and 156-184 Mc/s; units are also supplied to provide a variety of selective calling and party line facilities.

The 'Country Set' Rural Telephone is just one of a wide range of commercial equipments built by A T & E, who also offer a comprehensive planning, surveying and installation service.

If you would like more details, please write to:

AT&E (Bridgnorth) Ltd. Bridgnorth, Shropshire, England

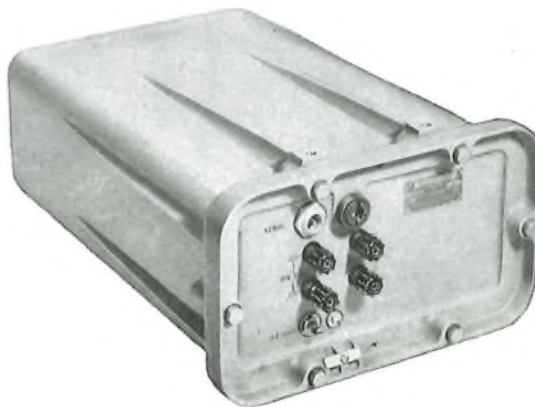

Ernest Turner

Electrical Measuring Instruments

Ideally matching contemporary panel design, the Ernest Turner Model 703, illustrated here, is enhanced by the flush-fitting surround. A high degree of accuracy is adequately supported by the easy-to-read scale and clean dial layout. Full details of the range of rectangular electrical measuring instruments and flush mountings are contained in Leaflets 85/G and 85/AF, available on request.

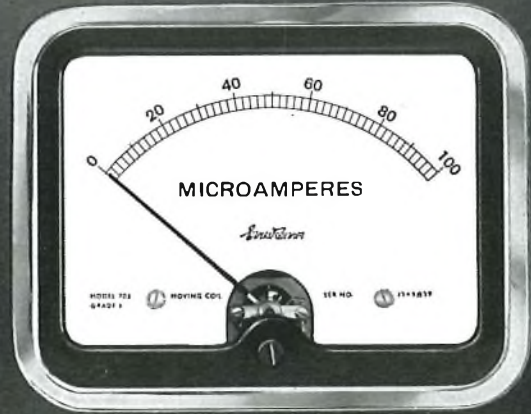

Ernest Turner Electrical Instruments Ltd

HIGH WYCOMBE · BUCKINGHAMSHIRE · ENGLAND

THRISSELL MARK 3 LETTER SORTING MACHINE

The Mark 3 is the latest and most advanced letter sorting machine, combining compactness, reliability and ease of operation.

Orders have already been received from Egypt, Pakistan, Spain and Switzerland.

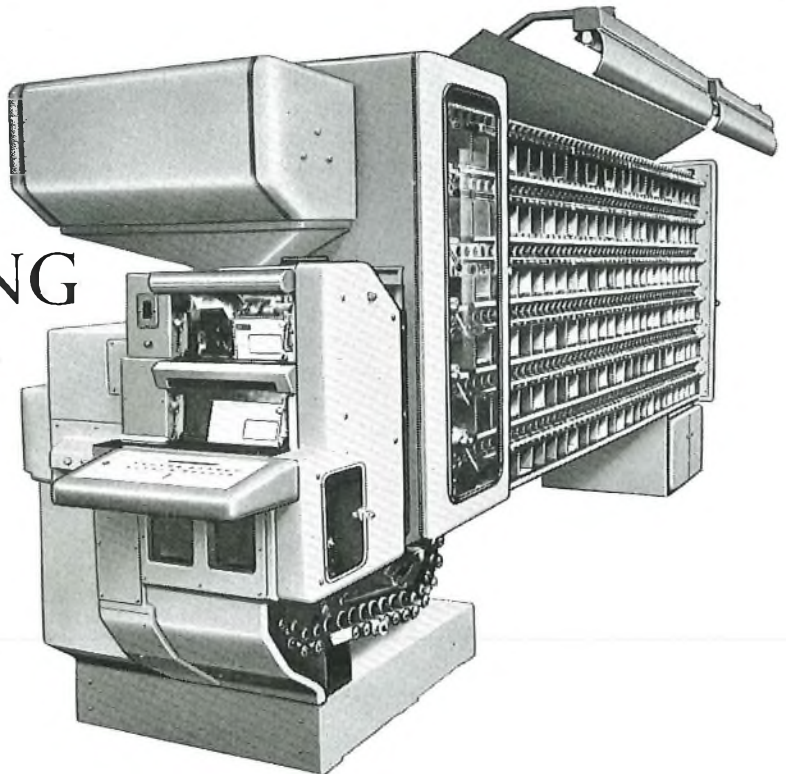

THE THRISSELL ENGINEERING COMPANY LTD · EASTON ROAD · BRISTOL 5 · ENGLAND

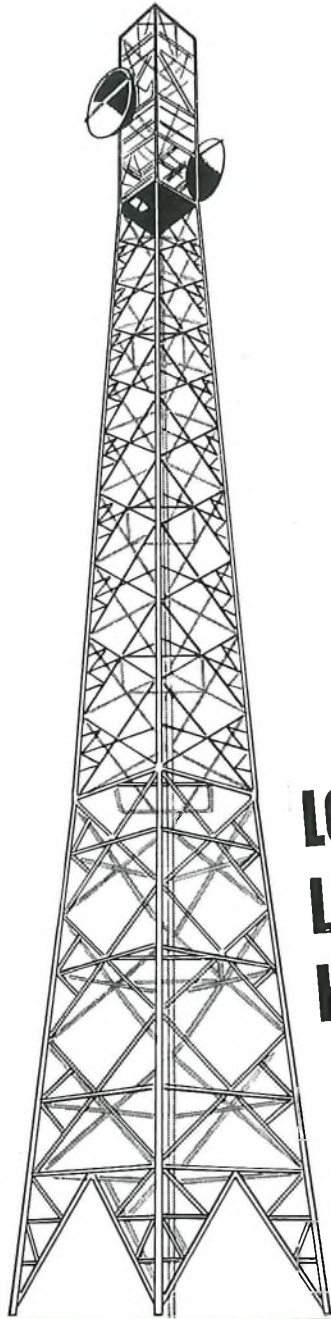

**LOW RUNNING COSTS
LOW INSTALLATION COSTS
HIGH PERFORMANCE**

with the new
STC
4 Gc/s system

The RL4-G high performance 960-circuit telephony/TV system is a development based on STC's wide experience with 4 Gc/s systems in both hemispheres of the world. The many new features of the system will commend it to all those interested in the installation of national and international telecommunications networks.

A full range of ancillary equipment is available, including remote supervisory and control systems.

STC provide an overall service from route planning and site survey to installation and maintenance.

- Terminal transmitter and receiver mount in one cubicle.
- Permanent magnet focused TWA with 38 db gain gives approx. 5W transmitter output.
- Natural cooling eliminates air blowers.
- Crystal local oscillator with multiplier reduces power and valve costs. Single TWT is only microwave valve in terminal or repeater.
- Direct i.f. modulator improves performance and reduces running costs.
- Compact baseband switching system using transistor circuits provides up to 5+1 protection channel operation.



Standard Telephones and Cables Limited

TRANSMISSION SYSTEMS GROUP · NORTH WOOLWICH

LONDON E.16 · Telephone ALBERT Dock 1401 · Telex 21645

INDEX TO ADVERTISERS

	PAGE		PAGE
Adcola Products, Ltd.	39	New Era Publishing Co., Ltd.	6
Associated Electrical Industries, Ltd.	4, 33	Oxley Developments Co., Ltd.	54
Associated Iliffe Press, Ltd.	3	Pirelli-General Cable Works, Ltd.	34
Automatic Telephone & Electric Co., Ltd.	25, 36-37, 51	Pitman, Sir Isaac, & Sons, Ltd.	28, 54
Avo, Ltd.	48	Pye Telecommunications, Ltd.	56
British Institute of Engineering Technology	48	Record Electrical Co., Ltd.	2
British Non-Ferrous Metals Federation	5	Redifon, Ltd.	17
British Resin Products, Ltd.	41	Sontronic, Ltd.	28
Cayson Electrics, Ltd.	27	Standard Telephones & Cables, Ltd.	7, 12, 20, 26, 32 40, 46, 49, 53, 55
Crown Agents	28	Submarine Cables, Ltd.	29
Engine Applications, Ltd.	18	Telephone Cables, Ltd.	47
Ericsson Telephones, Ltd.	30-31	Telegraph Condenser Co., Ltd.	50
Formica, Ltd.	21	Telephone Manufacturing Co., Ltd.	10, 22
G.E.C. (Telecommunications), Ltd.	8-9, 14-15, 23-24, 35, 38	Thrissell Engineering Co., Ltd.	52
G.M. Power Plant Co., Ltd.	16	Turner, Ernest, Electrical Instruments, Ltd.	52
Great Northern Telegraph Co., Ltd.	3	Westinghouse Brake & Signal Co., Ltd.	11
Mallory Batteries, Ltd.	42-43	Whiteley Electrical Radio Co., Ltd.	27
Marconi's Wireless Telegraph Co., Ltd.	19, 44-45	Winn & Coales, Ltd.	50
National Salt Glazed Pipe Manufacturers' Association	13		

**OXLEY
DEVELOPMENTS
CO. LTD.**



OXLEY

**SOLDERLESS
WRAPPED
JOINTS**

CHARACTERISTICS
Chassis thickness, 16-18 SWG—048/064"—
1.2/1.6 mm.
Capacity, less than 1.5 pF.
Operating temperature, —55°C to +200°C.
The Oxley "Barb" solderless wrapped con-
nector is a speedily assembled lead through,
of outstanding electrical and mechanical
characteristics.
The spill is nickel flashed and solder dipped
and spun to British P.O. Specification No
M38. Insert the bush in a .156 dia. plain hole in
the chassis, and press the barbed spill firmly
but slowly through the bush; the latter expands,
particularly on the far side of the chassis, and
results in the insulator becoming an integral
part of it. In addition to its excellent qualities,
a considerable saving of time is effected in
assembly. Supplied in sealed packets of 100
and 1,000.

ACTUAL SIZE



BRITISH
& FOREIGN
PATENTS

Write for technical details of these and other Oxley Products.
OXLEY DEVELOPMENTS CO. LTD., ULVERSTON, LANCASHIRE

Dictionary of Electrical Engineering

German/English/German

By the late Professor H. F. Schwenkhagen

An essential reference book for use in industry,
commerce, and the academic world, where an
interchange of electrical engineering information
in the two languages is needed

1058 pages — 85s. net

PITMAN

PARKER ST., KINGSWAY, LONDON, W.C.2

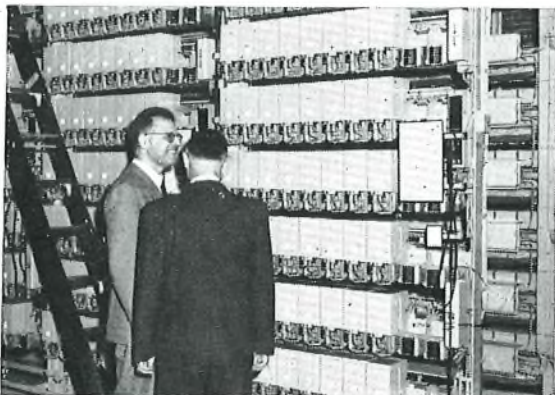
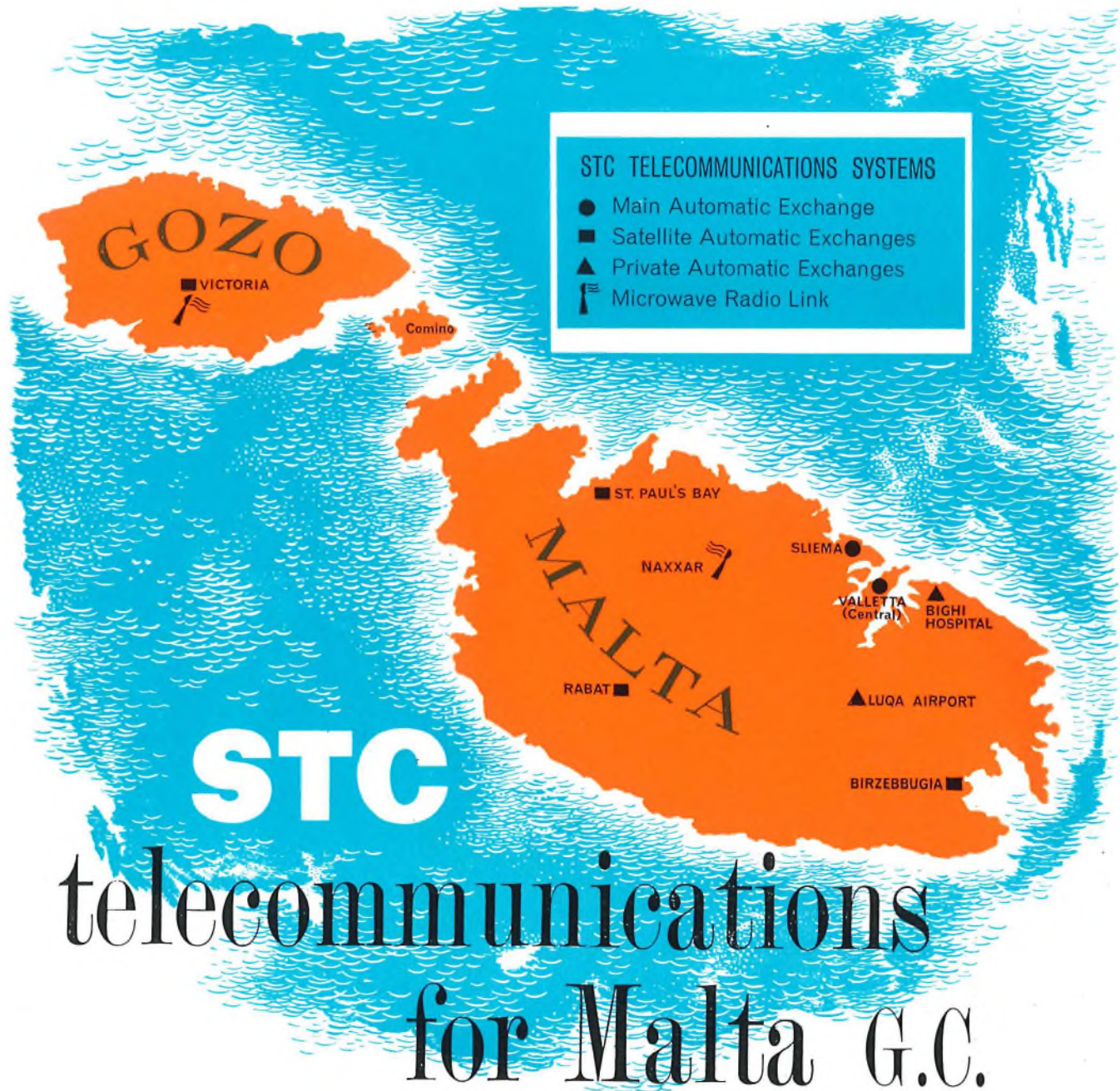

STC equipment in Valletta Central Automatic Exchange

Latest STC Public Telephone Exchange to go into service in Malta is the 5 000-line automatic exchange at Sliema. The Central Telephone Exchange at Valletta, with a 7 000 lines capacity, was installed by STC in 1957. STC are supplying a further four exchanges situated at Birzebbugia, Rabat, St. Paul's Bay and Gozo (Victoria). All these exchanges are fully automatic and subscribers will be able to dial direct between all the areas. An STC Microwave Radio Link, with a 240 circuit capacity, connects Malta with Gozo island. At Luqa Airport there is an STC 400 lines Private Automatic Exchange and, at Bighi Hospital, an STC 100 line Private Automatic Exchange.



Standard Telephones and Cables Limited

TELEPHONE SWITCHING DIVISION: OAKLEIGH ROAD, NEW SOUTHGATE, LONDON N.11
Represented in Malta by: Bartolo Parnis Co., 2 Windmills Street, P.O. Box 252, Valletta.



These Advanced Features give the Vanguard **EXTRA PERFORMANCE**
UNIT PRINTED BOARD CIRCUIT ELEMENTS

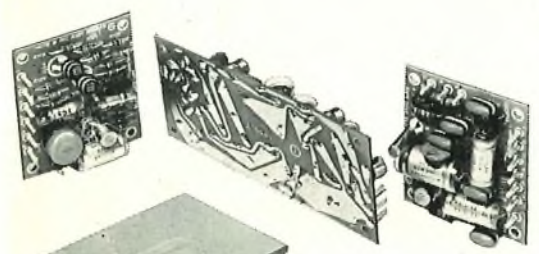

**SEALED
 BLOCK I.F. FILTERS**
 Need no tuning



INTRODUCE THE
VANGUARD
 A Magnificent
 25-Watt Transistorised
RADIOTELEPHONE

ONLY the VANGUARD has ALL these qualities

- 25/30 & 50/60Kc/s channels
- Extensively Transistorised
- Sealed Block I.F. Filters
- Printed Circuitry
- Very low Battery Drain
- All Aluminium Construction
- Dust-proof and splash-proof
- One—Six Channels
- 25 Watts Output
- Very low-noise Receiver
- High Stability Mute
- 4 Watts Audio Output

Meets British, American, Canadian and Continental Specifications

PYE TELECOMMUNICATIONS LIMITED . . . CAMBRIDGE

