

# SUPPLEMENT

## TO THE

# POST OFFICE ELECTRICAL ENGINEERS' JOURNAL

Vol. 54 No. 3

October 1961

## CONTENTS

City and Guilds of London Institute Examinations, 1960 and 1961		Page
TELEGRAPHY C, 1960 (Q. 7-10)	.. ..	33
LINE TRANSMISSION C, 1960	.. ..	34
TELECOMMUNICATION PRINCIPLES C, 1960	.. ..	37
ENGINEERING SCIENCE, 1961	.. ..	42
TELECOMMUNICATION PRINCIPLES A, 1961	.. ..	45
PRACTICAL MATHEMATICS, 1961	.. ..	48
ENGINEERING DRAWING, 1961	.. ..	51
ELEMENTARY TELECOMMUNICATION PRACTICE, 1961 (Q. 1-8)	.. ..	53

## CITY AND GUILDS OF LONDON INSTITUTE EXAMINATIONS, 1960 and 1961

### QUESTIONS AND ANSWERS

Answers are occasionally omitted or reference is made to earlier Supplements in which questions of substantially the same form, together with the answers, have been published. Some answers contain more detail than would be expected from candidates under examination conditions.

#### TELEGRAPHY C, 1960 (continued)

**Q. 7.** Describe briefly the equipment which would be required to provide simplex teleprinter communication over a telephone circuit (a) as an alternative to providing for speech over the circuit, and (b) to enable the circuit to be used simultaneously for speaking and teleprinting.

In each case what carrier frequency would you consider suitable for providing the teleprinter channel?

**A. 7.** (a) To provide teleprinter communication over a telephone circuit as an alternative to speech it is essential to use a method in which the teleprinter signals modulate a carrier current in the voice-frequency range. This ensures transmission through amplifiers and the transmission bridges in telephone exchange equipment.

At the sending end, as shown in sketch (a), an oscillator is required to generate the voice-frequency carrier. This could be amplitude modulated directly from the teleprinter contacts so that transmission of voice-frequency tone takes place only during the elements of start

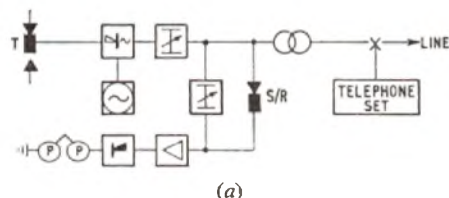

polarity. This is necessary if communication over a 2-wire circuit is to take place in alternate directions, and desirable to avoid loading the circuit during idle (prolonged stop-polarity) periods.

At the receiving end an amplifier stage is required to raise the power level of the incoming signals for demodulation by a detecting stage. The amplifier should be equipped with automatic gain-control or level-limiting. The amplitude of the signal-envelope passed to the detector is then reasonably constant for all line-connections and excessive telegraph-signal distortion is avoided. The detector restores the direct-current nature of the signals to operate the electromagnet. To provide for communication in either direction, each station would be equipped with an oscillator, amplifier-detector, and a suitable power unit to enable the equipment to operate from the electricity mains supply. A local record of transmitted signals is provided by feeding the modulated output through an attenuator to the local amplifier-detector. A telephone set would be provided for setting-up and clearing connections in accordance with normal procedure; a change-over switch would be fitted to enable the line to be switched to the voice-frequency telegraph equipment as required.

(b) For a circuit to be used simultaneously for speaking and teleprinting over a telephone circuit it would be necessary to use voice-frequency transmission for the teleprinter signals. In addition, it would be necessary to appropriate a portion of the speech frequency-spectrum for telegraph use and this bandwidth would be

denied to the speech circuit to avoid mutual interference between telegraph and telephone channels. The oscillator and amplifier-detector equipment described under (a) would be required for the service. In place of the change-over switch, each station would require a pair of filters (see sketch (b)):

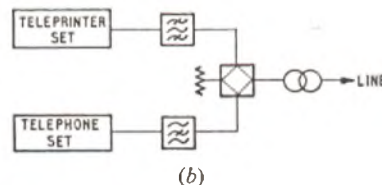

(i) A band-stop filter in series with the telephone set and the line, to offer a high attenuation to the frequency band allotted for teleprinter transmission.

(ii) A band-pass filter in the telegraph circuit to offer a high attenuation to frequencies outside those allotted for teleprinter transmission.

If ringer terminations are fitted, these should be in the telephone circuit and not in the common line circuit, otherwise both speech and teleprinter paths would be interrupted by ringing signals.

If a circuit is used for alternative speech and teleprinter operation the whole speech bandwidth is available for teleprinter transmission. However, it is necessary to avoid those frequency-regions which are used for supervisory voice-frequency signalling on long-distance telephone circuits. As a result, the choice of a carrier frequency is limited to the band between 900 c/s and 1,900 c/s. Between 1,200 c/s and 1,400 c/s the effects of crosstalk are more severe, while on older heavily-loaded line plant the attenuation tends to rise as the frequency approaches 1,900 c/s. A carrier frequency of 1,500 c/s has been found to be suitable.

For simultaneous speech and teleprinter transmission, similar considerations to those given for alternative working apply to the selection of a telegraph carrier frequency. In addition, the frequency-band used for telegraphy, and extracted from the speech path, should be made as narrow as possible yet commensurate with the required speed of working. Since the speech circuit will be deprived of a part of the frequency spectrum this should be selected in a region where the least degradation to speech will result. The main speech energy is concentrated towards the low-frequency end of the spectrum and for simplex teleprinter communication a telegraph carrier frequency of 1,500 c/s would be suitable.

**Q. 8.** Describe how the engaged signal in a teleprinter automatic exchange is (i) generated, (ii) distributed to the selectors, and (iii) connected to calling circuits requiring this facility.

Why is precise timing necessary for this signal and how is it ensured?

A. 8. The engaged signal from a teleprinter automatic exchange results in printing the letters OCC (the first three letters of the word "occupied"), but to ensure correct registration on the teleprinter page at a subscriber's station it is necessary to send a sequence of signals (see sketch (a)) which includes the characters line-feed (L/F), carriage-return (C/R) and letters-shift (L/S).

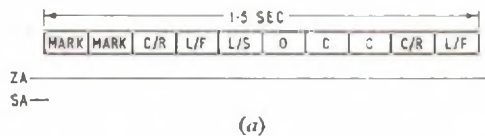

Since these signals are to be recorded on a remote teleprinter, the signals must be generated at constant speed and with low distortion comparable to the signals which would be transmitted from a standardized teleprinter.

A face-plate distributor (see sketch (b)) is driven from a motor at constant speed to generate basic 7.5-unit teleprinter signals,

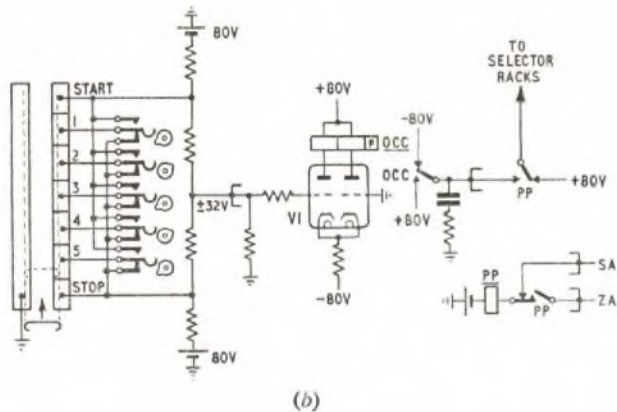

accurately timed for 50-baud transmission. From the same machine a set of cam-driven springsets determine the d.c. polarity to be applied for any of the five code-elements at any instant. The machine is driven at 3,000 rev/min and the speed is governed by a phase-comparator circuit. The controlling voltage for this circuit is derived from comparison of a nominal 50 c/s output from the signal generator with a standard 50 c/s output from a valve-maintained tuning fork.

To minimize wear on the distributor brushes and segments, the output from the distributor, for primary distribution, is applied to the high-impedance input circuits of a number of d.c. valve amplifiers. The secondary distribution is from polarized telegraph relays with suitable spark-quench circuits, since a number of circuits may be fed simultaneously with the engaged signals.

The complete engaged-signal cycle, comprising a sequence of ten characters each of 150 ms period, is indicated in the sketch (a). In order that the printing shall not be mutilated on the subscriber's teleprinter, the start and finish of the cycle are phased by the use of the relay PP whose contacts control the distribution. A contact of relay PP normally sends the +80V signal to the circuit until the SA pulse operates relay PP, which is then held for the duration of the signal cycle by the ZA pulse. The SA and ZA pulses are generated once every three seconds by the machine, in the desired phase relationship. The operated PP contact changes the distribution from +80V to the signal supply and a period of 300 ms mark polarity followed by the eight characters is transmitted. The end of the ZA pulse releases relay PP which restores the distribution circuit to the +80V space condition and so gives the clearing signal to break down any connexion after OCC has been printed once.

The OCC signal-distribution leads are cabled to the equipment

racks where they are fed to the 11th contact (S-wire) of group-selector levels for indicating congestion on inter-selector trunks or on trunk circuits and to final selectors for application when the selector finds a subscriber's line engaged.

Q. 9. State the characteristics and the relative advantages of (a) cable code, and (b) double-current cable code.

Describe with a simple sketch the main features of an automatic transmitter suitable for use with either one of these codes.

Q. 10. Explain briefly what you understand by the following:

- (i) space-diversity,
- (ii) frequency-diversity,
- (iii) error-detecting code,
- (iv) automatic error-correction (ARQ).

A. 10. In telegraphy the four terms have particular reference to radio-telegraph techniques.

(i) High-frequency radio links are subject to severe fading which varies from instant to instant. Moreover, the effects may be instantaneously of different degree at two receiving points which are relatively close to one another. Advantage is taken of this to equip a radio-receiving station with two or more aerial systems spaced several wavelengths apart so that a given signal is unlikely to fade simultaneously at each aerial. Each aerial has a separate receiving equipment and the strongest output signal at any instant is automatically selected. The term space-diversity refers to the physical separation of the two or more receiving aerials.

(ii) In radio-transmission it is found that when at any instant one frequency is subjected to fading, another frequency which differs by but a few hundred cycles per second may at that moment be free from the effects of fading. Advantage is taken of this selective fading to transmit a signal on two or more frequencies simultaneously. In the receiving equipment the higher-level signal at any instant is automatically selected. The difference between any two frequencies used for simultaneously transmitting the same information by frequency-diversity should be not less than 400 c/s, and in practice is usually of the order of 700 c/s. In diversity systems the automatic-gain controls of the receivers are linked so that noise will not be introduced from a path suffering from a deep fade. Frequency-diversity requires greater total power and also greater bandwidth. Space-diversity reception is therefore to be preferred if a sufficiently large aerial site is available.

(iii) An error-detecting code is used in printing telegraphy, particularly on radio-teleprinter circuits, to enable a receiving equipment to determine, automatically, whether a received-signal combination is acceptable or has been mutilated sufficiently during propagation to be in error. In an error-detecting code, redundant elements are added which do not carry telegraphic information but enable unused combinations to be identified.

In the Van Duuren error-detecting code, which is widely employed, a seven-unit code is adopted but only those arrangements are used which comprise four spacing elements with three marking elements. This 4/3 ratio is automatically examined in the receiving equipment and any received signal-character which does not conform to this ratio is rejected as faulty. From this seven-unit code 35 combinations having the 4/3 ratio are available, which adequately covers the requirement of the standardized telegraph alphabet for 32 combinations.

(iv) If a duplex telegraph circuit is available, the return channel can be used for automatically sending back, to the transmitting station, a special signal requesting a retransmission of any character which has suffered mutilation in transmission. At the receiving equipment the detection of an error inhibits printing on the teleprinter and initiates transmission of the automatic request-for-repetition signal to the sending station. At the sending station the equipment includes a means for keeping a cyclic store of a certain number of signal-characters, the number stored depending on the loop propagation time of the circuit. In automatic error-correction systems for radio-teleprinter working it is usual to re-transmit the last three characters on request together with a control signal. This retransmission can be repeated, if necessary, until acceptable reception has resulted.

LINE TRANSMISSION C, 1960

Students were required to attempt not more than any six questions.

Q. 1. Describe what happens to the voltage and current components of a signal applied to a uniform transmission line when it arrives at an open-circuit.

A uniform line has a characteristic impedance of 1,000 ohms and at a particular frequency it has a loss of 3 db and is one-half of a wavelength long. From a consideration of reflexions, calculate the input

impedance of the line when the far end is open-circuited. (Note:  $\log_{10} 2$  may be taken as 0.3).

A. 1. When a wave travelling along a uniform transmission line meets a discontinuity, some of the energy in the incident wave travels on through the discontinuity and the remainder is reflected

back along the line. If an open circuit is encountered by the travelling wave, however, no energy can be absorbed by the open-circuit so all the energy has to be reflected. The incident voltage is reflected with no change of sign or amplitude, and the incident current is reflected with no change of amplitude but with a change of sign. The voltage at the open circuit is the sum of the incident and reflected voltages and thus is twice the amplitude of the incident wave. The current at the open circuit is the sum of the incident and reflected currents and therefore is zero, as would be expected at an open-circuit.

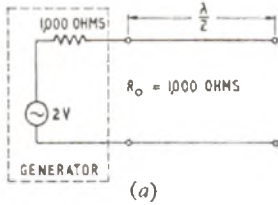

Sketch (a) shows a generator of 1,000 ohms internal impedance feeding the uniform transmission line. The incident voltage applied across the line will be 1 volt and the incident current applied to the line will be 1 milliampere. When the incident wave reaches the end of the line the voltage and current waves will have been attenuated by 3 db and, because the line is  $\frac{1}{2}$  wavelength long, will have changed

phase by  $180^\circ$ . When the reflected wave reaches the sending-end the voltage and current waves will have been attenuated by 6 db and will have suffered a further phase change of  $180^\circ$ . Thus, the reflected voltage wave when it reaches the sending-end will be reduced in amplitude by 6 db and have a phase of  $180^\circ + 180^\circ = 360^\circ = 0^\circ$  with respect to the incident voltage. The reflected current wave will be 1 mA reduced in amplitude by 6 db and have a phase of  $180^\circ + 180^\circ + 180^\circ = 540^\circ = 180^\circ$  with respect to the incident current. The vector diagrams for voltage and current are shown in sketch (b).

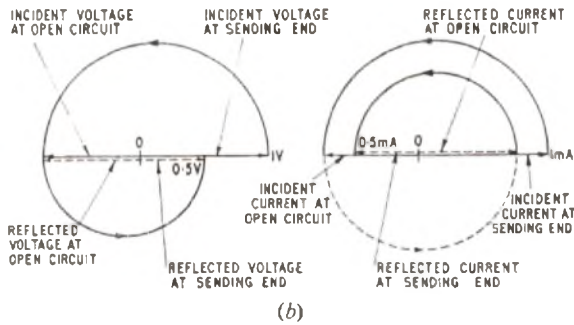

On arrival at the sending end the reflected wave is completely absorbed in the 1,000-ohm impedance of the generator and there is no further reflection.

$$\text{Now the attenuation in db} = 20 \log_{10} \frac{V_1}{V_2} = 6 \text{ db.}$$

$$\therefore \log_{10} \frac{V_1}{V_2} = 0.3, \text{ and } \frac{V_1}{V_2} = 2.$$

Thus, an attenuation of 6 db is equivalent to the voltage amplitude being reduced by a half.

The voltage at the beginning of the line is the sum of the incident and reflected voltages, and is  $1\text{V} + 0.5\text{V} = 1.5\text{V}$ .

The current at the beginning of the line is the sum of the incident and reflected currents and is  $1\text{ mA} + 0.5\text{ mA} \angle 180^\circ = 1\text{ mA} - 0.5\text{ mA} = 0.5\text{ mA}$ .

Thus, the input impedance of the line is:  
voltage/current =  $1.5\text{ V}/0.5\text{ mA} = 3,000\text{ ohms}$ .

**Q. 2.** Sketch graphs illustrating the changes in the primary coefficients of a cable or an open-wire pair over the frequency range 0 to 100 kc/s giving explanations for these changes.

**A. 2.** See A. 8, Line Transmission I, 1956, Supplement, Vol. 50, No. 2, p. 28, July 1957.

**Q. 3.** What are the causes of crosstalk between pairs in a cable? Describe the precautions taken in the design, manufacture and installation of a cable suitable for 12-channel carrier telephony.

**A. 3.** The main causes of crosstalk are capacitance unbalances and mutual inductance between pairs. The capacitance unbalances can be seen by reference to sketch (a), which shows two pairs AB and CD. These capacitance unbalances can be redrawn in the form of a capacitance bridge as in sketch (b). The complete solution of this bridge is outside the scope of this paper, but one solution which will give balance conditions is that  $(w-x)$ ,  $(w-z)$ ,  $(z-y)$ ,  $(x-y)$ ,  $(a-b)$  and  $(c-d)$  are all equal to zero.

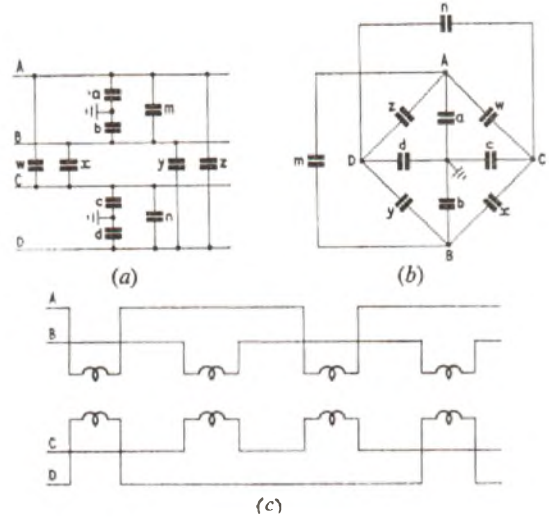

Inductive coupling is kept to a minimum by twisting the wires together into pairs or quads, and then twisting these together to form the cable. This is shown diagrammatically in sketch (c). This ensures that the magnetically-induced e.m.f.s in one pair, due to the current flowing in any other pair, will tend to cancel out over the whole cable. A further improvement can be obtained by arranging that the pairs do not all have the same length of lay. Two different lays are generally sufficient for an audio cable, the pairs in each layer being arranged so that any two adjacent ones have different lays. In a carrier cable, this may still not reduce the mutual inductances to the required level and it may then be necessary to give all the pairs different lays and space the metal sheath away from the wires to reduce mutual coupling via the sheath.

Capacitance unbalance is more serious and cannot generally be kept within required limits merely by ensuring uniformity of cable construction. On an audio cable, a sufficient degree of capacitance balance can be achieved by the use of "test-selected" joints. At such a joint, measurements of capacitance unbalance are first made on the cable sections on either side of the joint, and the pairs are then selectively jointed so that the unbalances of the portions of cable on either side of the joint tend to cancel out. The selected joints usually occur at about 1,000 yd intervals.

The balancing problem is more severe with a carrier cable because the crosstalk coupling increases with an increase in frequency. This necessitates a selected joint for each manufactured length of 176 yd. The cable is built up of unit "balancing sections" of eight lengths each. Each section is formed by first jointing the eight lengths in four pairs, in such a way that the unbalances tend to cancel out in each pair. The four pairs are then jointed to form two groups of four lengths, which in turn are selectively jointed together to form the unit section. These sections of about 1,400 yd are then selectively jointed in pairs, groups of four, and so on until a complete repeater-section length of cable has been formed.

This process is generally not sufficient and it is necessary to provide "balancing frames" at intervals along the cable (usually one per repeater section). Each frame contains a number of variable capacitors with a suitable cross-connexion field which enables a capacitor to be connected between every combination of two pairs in the cable. The capacitors are adjusted to reduce the residual unbalances to a satisfactory level.

See also A. 10, Line Transmission I, 1958, Supplement, Vol. 52, No. 2, p. 26, July 1959.

**Q. 4.** Draw a block schematic diagram of a 4-wire repeatered circuit with one intermediate repeater station, the trunk exchanges being adjacent to the terminal repeater stations.

Draw the level diagram of the circuit, if the 2-wire to 2-wire circuit has been lined-up to a zero loss, each cable section has a loss of 25 db at the highest transmitted frequency, the amplifiers have a fixed flat gain of 30 db, and the amplifier output relative level is to be +10 dbr.

**A. 4.** Sketch (a) shows a block schematic diagram of an audio, 4-wire, repeatered system. The 2-wire ends are split into a 4-wire circuit by means of hybrids as shown. The directions of transmission are as indicated by the arrows.

Sketch (b) shows the level diagram of the circuit. For clarity the levels in only one direction of transmission are illustrated, i.e. from A to B.

If a point in a circuit has a relative level of  $+X$  dbr, this implies that there is a gain of  $X$  db between the 2-wire point and the point in

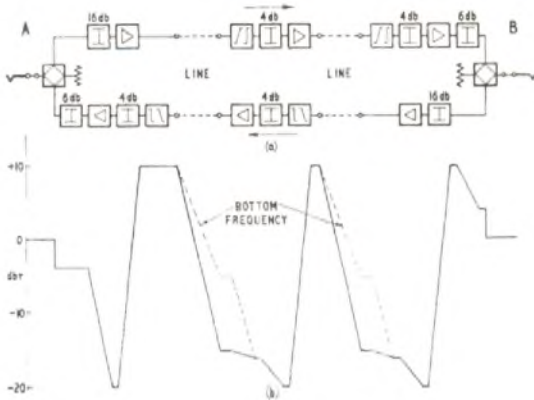

question; if the point has a relative level of  $-Y$  dbr there is a loss of  $Y$  db between the 2-wire point and the point in question. The loss in the hybrid, from the 2-wire point to either side of the 4-wire point and vice versa is  $3\frac{1}{2}$  to 4 db, of which 3 db arises from the hybrid action, the remainder being the transformer loss. Thus, in the A to B direction of transmission there is a loss of, say, 4 db between the 2-wire point and the transmit 4-wire point and the latter is thus a  $-4$  dbr point as shown on the level diagram. The relative level has to be reduced to  $-20$  dbr at the input of the 30 db amplifier if the output of the amplifier is to be  $+10$  dbr. This requires a 16 db attenuator to be fitted before the A station transmit amplifier. Between the 2-wire point and the input to this amplifier there is no attenuation/frequency distortion. The loss of the line between the A station and intermediate station is 25 db at the top frequency, and the relative level at that frequency at the cable head is thus  $-15$  dbr. The relative level at the lowest frequency is somewhat higher and is shown by the dotted line. The equalizer and pad shown at the intermediate station bring the relative level at all frequencies to  $-20$  dbr at the intermediate amplifier input.

The intermediate amplifier restores the relative level of all frequencies to  $+10$  dbr for transmission to line, where the frequencies again suffer the attenuation/frequency distortion described above for the first line section. Again at the receive station (B), the frequencies are equalized and reduced in level to  $-20$  dbr for amplification to give a  $+10$  dbr output. A further pad reduces the level to  $+4$  dbr and the level is again reduced to 0 dbr at the receive 2-wire point by the losses in the hybrid.

**Q. 5.** Describe with block schematic diagrams the operation of the channel equipment of a 12-channel C.C.I.T.T. carrier terminal utilizing the frequency band 60–108 kc/s. Explain with sketches the modulator and demodulator filter requirements if the effective transmitted band is 0.3 to 3.4 kc/s.

**A. 5.** See A. 7, Line Transmission I, 1958, Supplement, Vol. 52, No. 2, p. 25, July 1959.

**Q. 6.** Describe briefly the transmission tests that would be made on a new subscriber's telephone set to assess its suitability for use in an existing network.

**A. 6.** In order to assess the suitability of a new subscriber's telephone set for an existing network it is necessary to ensure that its performance is at least equal to existing sets. If it has been specifically designed to have a significant improvement under limiting conditions, it will also be necessary to check that the additional loudness on low-loss connexions is not too great to lead to overloading of wideband amplifiers or to complaints of speech being too loud from other subscribers.

Therefore subjective tests are made to assess:

(a) Loudness of the set

For national purposes, the loudness of the set is assessed when associated with various local lines and transmission bridges for sending, receiving and sidetone, relative to an existing well-proved standard local-telephone circuit. For international purposes, the assessment is made relative to a high-quality reference circuit. A trained speech-test team carry out these tests using artificially controlled conditions with the handset clamped in a modal position, at a fixed modal talking distance and vocal level. The amount of attenuation to be added to the circuit under test in order to give equality of loudness with the standard or reference circuit is used as a measure of the relative rating.

(b) Acceptability in the network

In the past, articulation tests using the trained team have often been used for this purpose. The artificialities introduced have,

however, led to anomalous results. Their place has been taken by free-conversation tests, where untrained talkers and listeners use the handset normally and are able to take account of all the factors which influence their opinion such as loudness, intelligibility and side-tone effect. In some of these tests, conversation is stimulated by providing puzzles which are solved over "test" and "standard" links. The opinions are then collected and graded on a scale such as excellent, good, fair, poor and bad. Scores can be given to these, and the amount of added attenuation in the "test" circuit to give equal acceptable performance, compared with the "standard," can be found.

In other tests, recorded sentences are played over "test" or "standard" circuits and listening comparisons are made on a better-or-worse than the "test" circuit basis, the test circuit having various values of loss included as compared with the "standard." Ratings may then be obtained after due allowance has been made for the fact that the speech voltage from the recordings will not in general correspond to the normal speech voltage.

For further information see SPENCER, H. J. C., and WILSON, F. A. The New 700-Type Telephone. P.O.E.E.J., Vol. 49, p. 69, July 1956.

**Q. 7.** What is balance return loss?

How is it:

- (a) measured directly,
- (b) calculated from impedance measurements?

**A. 7.** Balance return loss is a measure of the accuracy with which the impedance of a balancing network simulates that of the line it is to terminate. It is the attenuation suffered by a signal in the line on

reflexion at the balance network and is equal to  $20 \log_{10} \left| \frac{Z_0 + Z_B}{Z_0 - Z_B} \right|$  db,

where  $Z_0$  is the characteristic impedance of the line and  $Z_B$  is the impedance of the balancing network.

(a) It may be measured directly by means of a 4-wire terminating set or hybrid transformer (see the sketch). The impedance ratio of the transformer is chosen to match the impedance of the oscillator and voltmeter to the modulus of the line and balance impedances. With the line connected and the balance terminals either open or short-circuited the voltmeter reading ( $V_1$ ) is noted. The balance is then connected and the voltmeter reading ( $V_2$ ) is noted. The balance return loss is equal to  $20 \log_{10} (V_1/V_2)$  db. It would be usual to take these readings with a transmission measuring set (T.M.S.) when the readings  $V_1$  and  $V_2$  would be in db relative to 0.775 V, the oscillator and voltmeter impedances each being 600 ohms; the balance return loss would then be the difference between the two db readings.

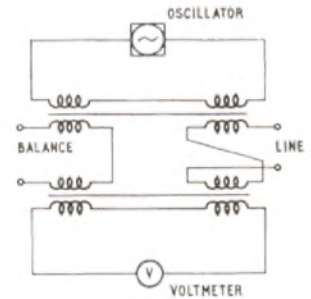

(b) To calculate the balance return loss would necessitate the measurement, by means of a suitable bridge, of the characteristic impedance of the line and the impedance of the balancing network  $Z_0$  and  $Z_B$ , respectively, over the required range of frequencies, and substitution of these values in the formula  $20 \log_{10} \left| \frac{Z_0 + Z_B}{Z_0 - Z_B} \right|$ .

**Q. 8.** Describe, with sketches, the construction of a single coaxial pair of a land trunk cable, giving reasons for the construction described.

**A. 8.** The sketch shows the construction of a coaxial pair in a typical 4-tube cable.

The centre conductor is a copper wire, 0.014 in. diameter of high conductivity and ductility, which is held centrally by low-loss polythene spacers every 1.3 in. along the cable. The dielectric is effectively air and therefore the insulation resistance is extremely high.

The internal diameter of the outer conductor is 0.375 in., making the ratio of outer diameter to the centre-conductor diameter equal to 3.6 : 1. This ratio gives the minimum attenuation of an air-spaced line with inner and outer conductors of the same material and gives a nominal characteristic impedance of 75 ohms.

In earlier designs of cable the outer conductor comprised a number of interlocking copper tapes having a long lay. In 1940, however, it was discovered that an appreciable increase of attenuation had occurred in some cables. It was shown that this was due to an increase of contact resistance between the tapes, brought about by oxidation of the copper. The sketch shows how this problem was overcome by using an outer conductor formed out of a single 10-mil

LINE TRANSMISSION C, 1960 (continued)

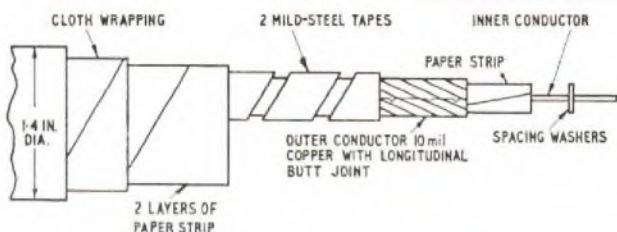

copper tape in such a way that the seam is nearly longitudinal.

In any transmission system crosstalk is a limiting factor in the design and, in general, with paper-core quad cables, this gets worse with an increase of frequency. In coaxial cables, however, the crosstalk at low frequencies is the limiting factor as the depth of penetration of the current in the outer conductor is greatest at the lowest frequency transmitted, i.e. some of the current in the outer conductor tends to flow on the outside instead of the inside. To overcome the crosstalk resulting from this, magnetic screening is provided in the form of two mild-steel tapes wound as shown in the sketch.

During manufacture the dimensions of the outer and centre conductors must be held as constant as possible to ensure a constant characteristic impedance.

**Q. 9.** What are the sources of noise and crosstalk in an intermediate repeater station on an audio frequency route?

What steps are taken to ensure that the noise and crosstalk are at a tolerably low level?

**A. 9.** In a route comprising a number of audio telephone circuits there will be mutual crosstalk between all circuits. The total of this interference in any one circuit will take the form of confused unintelligible sounds. This is called "babble" and is classified as noise. Noise, other than babble and inherent circuit noise, results from interference from circuits transmitting any form of electrical energy other than that of speech or music.

The chief place of interference is the repeater station and most of the noise enters via the power supplies. This is partly because the battery is a common impedance to all circuits and partly because of the noise produced by the generators when trickle charging the batteries.

The battery merely serves as a standby when changing over from one generator to another, or during a generator failure. The battery is, however, across the supply and is designed to have as low an impedance as possible to reduce the coupling.

The generator is the greater source of noise and can be considered as a number of alternating e.m.f.s of various frequencies and amplitudes. The predominant interfering frequency is the slot ripple voltage which is at a frequency of  $NX/60$  c/s, where  $N$  is the speed in rev/min and  $X$  is the number of armature teeth. This frequency has to be eliminated from the station transmission equipment and, consequently, a low-pass filter is placed between the generators and the station equipment.

Other sources of noise are crosstalk in the station wiring, panel-to-panel crosstalk and crosstalk due to unbalance of the station equipment.

The following precautions are taken to minimize these crosstalk paths:

- (a) The high and low levels of speech are kept separate as far as possible.

- (b) The lacings of the wiring forms are kept as loose as practical.
- (c) The components and panels are adequately screened.
- (d) The equipment is balanced as accurately as possible.

For further information see ROSSITER, G.E. Coaxial Cables—Some Practical Aspects of their Design and Maintenance. I.P.O.E.E. Printed Paper No. 205.

**Q. 10.** Describe the circuit of the equipment that you would use to measure the insertion loss of an audio-frequency line equalizer between generator and load impedances of 600 ohms and explain clearly how you would make the measurements.

**A. 10.** Sketch (a) shows a basic circuit that could be used to measure the insertion loss of a network such as an equalizer. The

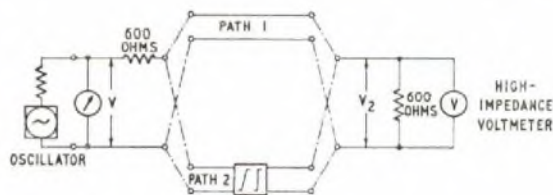

(a)

circuit shown enables  $V_2$  to be conveniently measured for the two paths (1) and (2). The insertion loss is given by  $20 \log_{10} V_{2(1)}/V_{2(2)}$ . It is imperative that the source voltage  $V$  be kept constant whilst  $V_2$  is read for the two paths, and that the voltmeter,  $V$ , has a very high input-impedance to avoid shunting the 600-ohm termination.

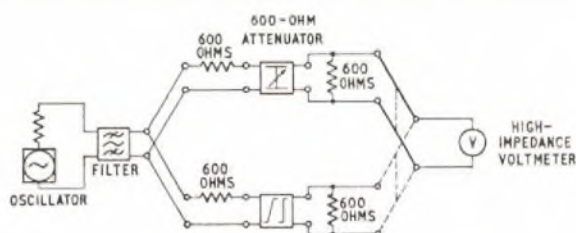

(b)

Sketch (b) shows a more practical arrangement using a comparison panel. In this method the two paths are made equal by the insertion of an attenuator in path 1 (see sketch (a)) and a slight re-arrangement of the circuit as shown.

The insertion loss of the equalizer is equal to the attenuation of the attenuator, for equal voltmeter readings on the voltmeter  $V$ .

The "cleaning-up" filter is necessary if measuring a network with a loss/frequency characteristic such that the loss at the harmonic frequencies of the fundamental is very much less than the loss at the fundamental frequency. The reason is that the voltmeter  $V$  is a wideband measuring instrument and will give an answer which is a function of the harmonic frequencies. The filter eliminates the harmonics from the test oscillator and a true answer at the fundamental frequency is obtained. Another way of overcoming this problem is to use a selective form of voltmeter.

This form of comparison panel ensures that the source voltage  $V$  is automatically kept constant.

TELECOMMUNICATION PRINCIPLES C, 1960

Students were required to attempt not more than any six questions.

**Q. 1.** Distinguish between the "loss angle" and "power factor" of a dielectric.

Why are the requirements in telecommunications such that these two quantities should be nearly equal?

Mention some modern materials which satisfy this condition.

**A. 1.** The loss angle of a capacitor or dielectric is the angle by which the angle of lead of the current falls short of  $90^\circ$ . This angle is only applicable when both the current and voltage supplied to the capacitor are sinusoidal.

The power factor is the ratio of the watts dissipated to the volt-amperes supplied in a single-phase system. It should be noted that the volt-amperes are the product of the r.m.s. values of the voltage and current. When both the current and voltage are sinusoidal the power factor is equal to  $\cos \phi$ , where  $\phi$  is the phase-angle between them.

Thus, for sinusoidal functions,  
 loss angle =  $\psi = 90 - \phi$ ,  
 and power factor =  $\cos \phi = \sin (90 - \phi) = \sin \psi$ .

When the power factor is small,  $\phi$  will be very nearly equal to  $90^\circ$  and, therefore,  $\psi = 90 - \phi$  will be small. When  $\psi$  is small,  $\sin \psi \approx 1.0$ , i.e. power factor  $\approx$  loss angle.

When this relationship applies to a capacitor or dielectric, the power loss in it will be very small so that it approaches an ideal capacitor, which has capacitance only. In telecommunications, particularly, when the amount of power is usually very small, it is important that power losses should be reduced as far as possible. Thus, where it is necessary to use a capacitor in a circuit, its loss angle should be nearly equal to its power factor. Some modern materials satisfying this condition are polythene, ceramics and mica.

**Q. 2.** Explain why, in an ideal transformer, the core flux does not change with load.

Show that the impedance measured across the primary winding of an ideal transformer is given by

$$Z_1 = \left\{ \frac{N_1}{N_2} \right\}^2 Z_2,$$

when  $N_1$  is the number of turns in the primary winding,  $N_2$  is the number of turns in the secondary winding, and  $Z_2$  is the load connected across the secondary winding.

A long transmission line having a characteristic impedance of  $2,400 \angle 30^\circ$  is connected to a termination by means of a step-down transformer which has a turns ratio of 2 : 1.

What must be the impedance of the termination if:

- (a) The line is to be correctly terminated,
- (b) maximum power is to be transferred from the line to the termination?

A. 2. Any two-winding transformer supplying a load  $Z_2$  can be represented by sketch (a) provided  $M$  is complex, i.e.  $M = a + jb$ , to allow for core losses due to hysteresis and eddy currents.

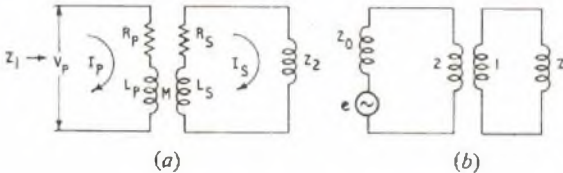

Now,  $\pm j\omega MI_p = (R_s + j\omega L_s + Z_2)I_s$ ,  
 and  $V_p = I_p(R_p + j\omega L_p) \pm j\omega MI_s$

$$= I_p \left\{ R_p + j\omega L_p \mp \frac{\omega^2 M^2}{R_s + j\omega L_s + Z_2} \right\}$$

$$\therefore Z_1 = \frac{V_p}{I_p} = R_p + j\omega L_p \mp \frac{\omega^2 M^2}{R_s + j\omega L_s + Z_2}$$

$$= \frac{(R_p + j\omega L_p)(R_s + j\omega L_s + Z_2) \mp \omega^2 M^2}{R_s + j\omega L_s + Z_2}$$

Now,  $L_p \propto N_p^2$ , and  $L_s \propto N_s^2$   
 or,  $L_p = k_1 N_p^2$ , and  $L_s = k_2 N_s^2$

Then,  $Z_1 = Z_2 \frac{R_p + j\omega k_1 N_p^2}{R_p + j\omega k_2 N_s^2} + \frac{(R_p + j\omega L_p)(R_s + j\omega L_p) \mp \omega^2 M^2}{R_s + j\omega L_s + Z_2}$

If  $Z_1 = \frac{N_p^2}{N_s^2} \times Z_2$ , it follows that:

- (i)  $R_p$  must be negligible in comparison with  $\omega L_p$ .
- (ii)  $R_s$  and  $Z_2$  must be negligible in comparison with  $\omega L_s$ .
- (iii)  $(R_p + j\omega L_p)(R_s + j\omega L_s) \mp \omega^2 M^2$  must be negligible.
- (iv)  $k_1$  must be equal to  $k_2$ .

Thus, in an ideal transformer:

(i) The resistance of the primary and secondary windings must be negligible, i.e. there should be negligible loss in the windings themselves.

(ii) The impedance of the load  $Z_2$  must be small in comparison with the reactance of the secondary winding, which should, therefore, be high without increasing the secondary winding loss.

(iii)  $(R_p + j\omega L_p)(R_s + j\omega L_s)$  will be very nearly equal to  $-\omega^2 L_p L_s$ , and this should be equal to  $-\omega^2 M^2 = -\omega^2 (a + jb)^2$ .

It follows, therefore, that  $b$  should be negligible in comparison with  $a$ , i.e. core losses should be negligible, and  $L_p L_s$  should equal  $M^2$ . This means that all the primary flux should link with all the secondary turns, and vice versa.

(iv) There should be no leakage flux from either the primary or the secondary winding, i.e. all the primary flux must link with all the primary turns, in addition to linking with all the secondary turns, and all the secondary flux must link with all the turns on the secondary winding. Furthermore, the path taken by the primary flux and the secondary flux should be identical.

From the above it will be realized that in an ideal transformer the winding and core losses must be negligible, i.e. the power delivered to the secondary load must be equal to the power supplied to the primary.

$$\therefore V_p I_p \cos \phi_p = V_s I_s \cos \phi_s.$$

$$\text{Also, } \left| \frac{V_p}{I_p} \right| \epsilon^{j\phi_p} = \frac{N_p^2}{N_s^2} \left| \frac{V_s}{I_s} \right| \epsilon^{j\phi_s}.$$

$$\text{Thus, } \phi_p = \phi_s$$

$$\text{and, } I_p^2 N_p^2 = I_s^2 N_s^2$$

$$\text{or } I_p N_p = I_s N_s.$$

Hence, when a load is connected across the secondary winding of an ideal transformer the source must supply an increased current to the primary winding so that the additional magnetizing ampere-turns will neutralize the demagnetizing ampere-turns imposed on the core by the load current flowing in the secondary winding, i.e. the core flux remains constant.

(a) Since the line is long, it can be regarded at the receiving end as an alternator having an internal impedance  $Z_0 = 2,400 \angle 30^\circ$  and an e.m.f. which can be assumed sinusoidal, as shown in sketch (b). If the line is to be correctly terminated, the impedance of the termination must be equal to the characteristic impedance of the line. If  $Z = |Z| \angle \phi$  is the impedance connected across the secondary winding of the step-down transformer, then, for correct termination,

$$Z_1 = 2,400 \angle 30^\circ = (2/1)^2 Z,$$

$$\text{or } Z = 600 \angle 30^\circ.$$

(b) The power delivered,  $W$ , to the termination, assuming no losses in the transformer, will be

$$W = \left( \frac{e}{2,400 \angle 30^\circ + 4|Z| \cos \phi} \right)^2 |Z| \cos \phi$$

$$= \frac{e^2 |Z| \cos \phi}{[2,400 \cos 30^\circ - j 2,400 \sin 30^\circ + 4|Z| \cos \phi + j 4|Z| \sin \phi]^2} \dots (1)$$

$$= \frac{e^2 \left\{ \frac{2,400 \cos 30^\circ}{\sqrt{|Z| \cos \phi}} + 4\sqrt{|Z| \cos \phi} \right\} + j \left\{ \frac{4|Z| \sin \phi}{\sqrt{|Z| \cos \phi}} - \frac{2,400 \sin 30^\circ}{\sqrt{|Z| \cos \phi}} \right\}}{e^2}$$

$W$  will be a maximum when the denominator is least, i.e.

$$\text{when } 2,400 \sin 30^\circ = 4|Z| \sin \phi, \dots (2)$$

$$\text{and } 2,400 \cos 30^\circ = 4|Z| \cos \phi \dots (3)$$

Thus,  $\phi = 30^\circ$  and  $|Z| = 600$ , i.e.  $Z = 600 \angle 30^\circ$ .

Therefore, the impedance of the termination and the characteristic impedance of the line must be equal in magnitude and opposite in phase, i.e. they should be conjugate, for maximum power transfer.

Note: An alternative method of obtaining equations (2) and (3) is as follows:

Rearranging equation (1)

$$W = \frac{e^2 |Z| \cos \phi}{[(2,400 \cos 30^\circ + 4|Z| \cos \phi) + j(4|Z| \sin \phi - 2,400 \sin 30^\circ)]^2}$$

$W$  will be a maximum when the denominator is least. Since  $\phi$  cannot exceed  $90^\circ$  the real part of the denominator will always be positive, therefore one condition for the denominator to be least is  $4|Z| \sin \phi - 2,400 \sin 30^\circ = 0$ ,

$$\text{i.e. } 2,400 \sin 30^\circ = 4|Z| \sin \phi \dots (4)$$

$$\text{Then } W = \frac{e^2 |Z| \cos \phi}{(2,400 \cos 30^\circ + 4|Z| \cos \phi)^2}$$

$$\text{and } W = \frac{e^2 R}{(2,400 \cos 30^\circ + 4R)^2}, \text{ where } R = |Z| \cos \phi.$$

$$\frac{dW}{dR} = e^2 \left\{ \frac{(2,400 \cos 30^\circ + 4R)^2 - 8R(2,400 \cos 30^\circ + 4R)}{(2,400 \cos 30^\circ + 4R)^4} \right\}$$

For maximum  $W$ ,  $\frac{dW}{dR} = 0$ , i.e. the numerator is zero.

$$\therefore (2,400 \cos 30^\circ + 4R)^2 = 8R(2,400 \cos 30^\circ + 4R)$$

$$\therefore 2,400 \cos 30^\circ = 8R - 4R = 4R$$

$$\text{and } 2,400 \cos 30^\circ = 4|Z| \cos \phi \dots (5)$$

Solving equations (4) and (5)

$$\phi = 30^\circ \text{ and } |Z| = 600$$

and, as before,  $Z = 600 \angle 30^\circ$ .

Q. 3. In some transmission systems, the following frequency ranges are employed:

(a) for speech 300–3,400 c/s,

(b) for music 50–6,000 c/s,

(c) for television 50 c/s–3 Mc/s.

Explain why the bandwidths are so limited and discuss the disadvantages which arise.

Q. 4. Sketch the circuit of a triode valve used as an anode modulator. Show that this depends for its operation on the non-linearity of the anode current/anode voltage characteristic.

Derive an expression for a sinusoidally modulated, sinusoidal carrier.

What would be the effect if the modulation factor were greater than 100 per cent?

A. 4. The simplified circuit of a triode valve used as an anode modulator is given in sketch (a). The high-frequency carrier is applied to the grid of the valve and the lower modulating frequency is transformer-coupled to the anode circuit. Alternatively, the valve could be arranged as an oscillator for generating the carrier frequency and the modulating frequency could be choke-coupled to its anode circuit, as shown in sketch (b).

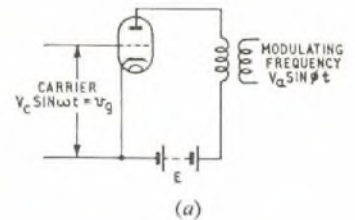

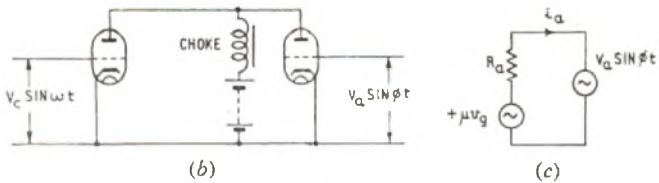

If  $R_a$  is constant, i.e. if the valve has linear characteristics, the equivalent anode circuit of the valve of sketch (a) is shown in sketch (c), and it will be realized that

$$i_a = \frac{\mu v_g + V_a \sin \phi t}{R_a}$$

No modulation will occur.

However, if the characteristics are not linear

$$i_a = (a + b v_g + c v_g^2)^n$$

which will include terms of the product of  $v_g$  and  $v_a$ .

For example, suppose  $n = 2$  then,

$$i_a = a^2 + b^2 v_g^2 + c^2 v_g^4 + 2abv_g + 2acv_a + 2bcv_g v_a$$

Now  $v_g v_a = V_c \sin \omega t \times V_a \sin \phi t$

$$= -\frac{V_c V_a}{2} \{ \cos(\omega + \phi)t - \cos(\omega - \phi)t \}$$

That is, the product term is equivalent to two combined frequencies, namely, the upper side frequency  $(\omega + \phi)$  and the lower side frequency  $(\omega - \phi)$ .

If  $V_c$ , the amplitude of the sinusoidal carrier  $V_c \sin \omega t$ , is sinusoidally modulated by  $V_a \sin \phi t$ , the carrier amplitude will vary sinusoidally from  $V_c$  between a maximum of  $V_c + V_a$  and a minimum of

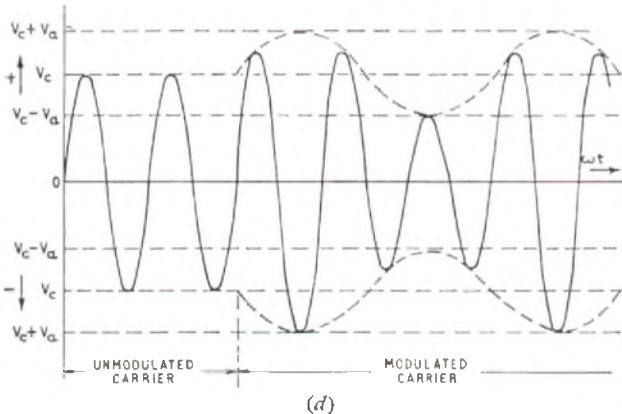

$V_c - V_a$ . As shown in sketch (d), at any instant the amplitude will be

$$V_c + V_a \sin \phi t = V_c \left( 1 + \frac{V_a}{V_c} \sin \phi t \right)$$

and the expression for the modulated wave is

$$v = \left( 1 + \frac{V_a}{V_c} \sin \phi t \right) V_c \sin \omega t$$

$V_a/V_c$  is the modulation factor. If this is greater than unity, i.e. when the amplitude of the modulating signal is greater than the amplitude of the carrier ( $V_a > V_c$ ), the modulated signal would only be produced for a part of the period of the modulating signal, as indicated in sketch (e).

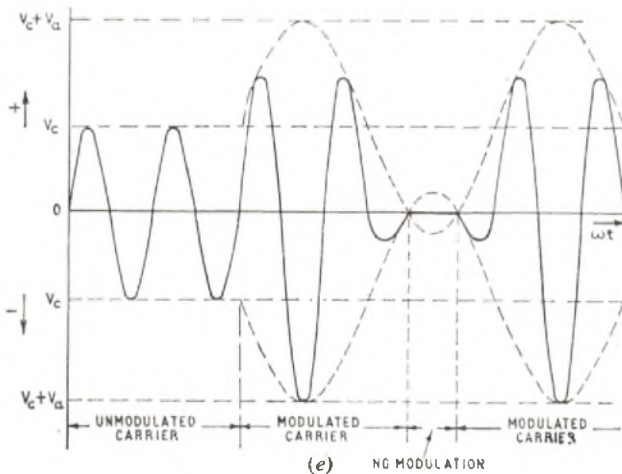

Q. 5. A very long, uniform, transmission line has an attenuation of 1 db/mile and a phase-change coefficient of  $\pi/6$  radians/mile.

By means of graphs show how the magnitude and phase of the current at any point varies along the first 24 miles of the line. At what distance from the sending end would the current be in phase with the sending end?

What would be the effect of disconnecting the line at a point 6 miles from the sending end?

A. 5. The variations of the magnitude and phase of the current along the uniform transmission line have been calculated and are included in the table below.

Distance from sending end (miles)	Phase Angle (degrees)	Attenuation (db)	$\log_{10} \frac{I_1}{I_2}$	$\frac{I_2}{I_1}$
0	0	0	0	1.0
1	30°	1	0.05	0.894
2	60°	2	0.1	0.79
3	90°	3	0.15	0.71
4	120°	4	0.2	0.635
5	150°	5	0.25	0.567
6	180°	6	0.3	0.5
7	210°	7	0.35	0.446
8	240°	8	0.4	0.398
9	270°	9	0.45	0.355
10	300°	10	0.5	0.317
11	330°	11	0.55	0.282
12	360°	12	0.6	0.25
13	390°	13	0.65	0.224
14	420°	14	0.7	0.199
15	450°	15	0.75	0.177
16	480°	16	0.8	0.158
17	510°	17	0.85	0.141
18	540°	18	0.9	0.125
19	570°	19	0.95	0.112
20	600°	20	1.0	0.1
21	630°	21	1.05	0.089
22	660°	22	1.1	0.08
23	690°	23	1.15	0.0708
24	720°	24	1.2	0.0625

From the table it will be apparent that the line current will be in phase with the current at the sending end, and at 12 miles, 24 miles, etc., from the sending end.

If the line is disconnected at a point 6 miles from the sending end there can be no current at that point. Thus, the current which existed there before the disconnection must be sent back (reflected) towards the sending end. In its progress in this direction it will be attenuated in precisely the same manner as the original current at that point was in its progress down the line before the disconnection was made. The current at any point will be the vector sum of the initial incident and resulting reflected current at that point.

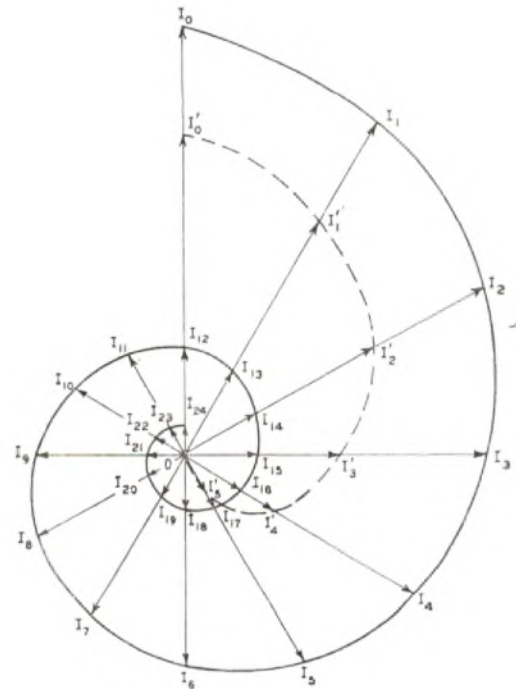

In the sketch a polar diagram has been constructed to indicate (by the full line) how the magnitude and phase of the current changes in its progress down the line. The broken-line curve shows how the current varies when the line is disconnected 6 miles from the sending end.

**Q. 6.** Determine the insertion loss introduced when the resistance network given in the accompanying sketch is connected between an a.c. source having an internal resistance of 50 Ω and a load of 200 Ω. Describe the essential features of any additional apparatus which could be used to reduce this loss.

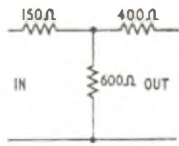

**A. 6.** Referring to sketch (a),  $I_a = e/250$  amp, where  $e$  volts is the e.m.f. of the a.c. source. From sketch (b)

$$I_{2b} = \frac{1}{2} \left( \frac{e}{200 + 300} \right) = \frac{e}{1,000} \text{ amp.}$$

$$\therefore \text{Insertion loss} = 20 \text{ Log}_{10} \frac{I_a}{I_{2b}} = 20 \text{ Log}_{10} \frac{1,000}{250} \approx 12 \text{ db.}$$

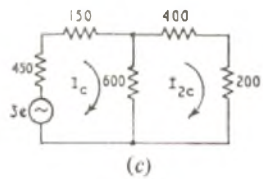
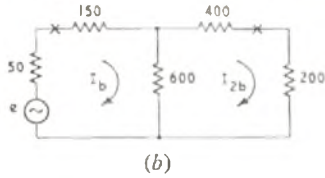
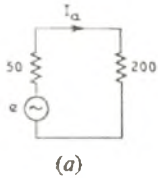

The resistance measured across the sending-end terminals when the 200-ohm load is connected across the output will be  $150 + 300 = 450$  ohms. The insertion loss would be reduced if a transformer having a step-up turns ratio of  $\sqrt{450/50} = 3$  were connected between the source and the network. Under this condition, as shown in

sketch (c), the source and transformer would appear as an e.m.f. of  $3e$  having an internal impedance of 450 ohms, as far as the network is concerned.

$$\text{Thus, } I_{2e} = \frac{1}{2} \left( \frac{3e}{450 + 150 + 300} \right) = \frac{e}{600} \text{ amp,}$$

which is larger than  $e/1,000$  amp. Hence, the insertion loss of the network is reduced by connecting a suitable ideal transformer between the source and the sending end. That is, the insertion loss with input matching transformer = 7.6 db.

Alternatively, the resistance measured across the output terminals when the source is connected directly to the input is

$$400 + \left( \frac{600 \times 200}{600 + 200} \right) = 400 + 150 = 550 \text{ ohms.}$$

If an ideal transformer having a step-down turns ratio of  $\sqrt{500/200} = 1.658$  were connected between the network and the 200-ohm load then the load would appear as 550 ohms as far as the network is concerned, as shown in sketch (d). Then

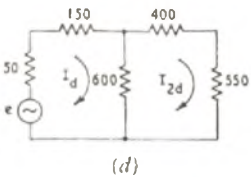

$$I_{2d} = \frac{600}{1,550} \left[ \frac{e}{200 + \left( \frac{600 \times 950}{600 + 950} \right)} \right]$$

$$= \frac{e}{1,550} \times \frac{1}{3 + 950} = \frac{e}{1,466.6} \text{ amp.}$$

The current in the actual load would, however, be

$$\frac{1.658 e}{1,466.6} = \frac{e}{885} \text{ amp,}$$

which is greater than the current without a transformer. Therefore the insertion loss of the network is again reduced and is, in this instance, 11.0 db.

Now the sending-end image impedance of the network is

$$Z_{ie} = \sqrt{Z_{oc} \times Z_{is}}$$

$$= \sqrt{(150 + 600) \left( 150 + \frac{600 \times 400}{600 + 400} \right)}$$

$$= \sqrt{750 \times 390} \approx 540 \text{ ohms,}$$

and the receiving-end image impedance of the network is

$$Z_{ir} = \sqrt{(400 + 600) \left( 400 + \frac{600 \times 150}{600 + 150} \right)}$$

$$= \sqrt{1,000 \times 520} \approx 720.$$

If matching transformers were connected at both ends of the network, the turns ratios would be:

$$(a) \text{ Sending-end (step-up)} = \sqrt{\frac{540}{50}} = \sqrt{10.8} = 3.3,$$

$$(b) \text{ Receiving-end (step-down)} = \sqrt{\frac{720}{200}} = \sqrt{3.6} = 1.9$$

As far as the network is concerned the source and load would now appear as indicated in sketch (e), and

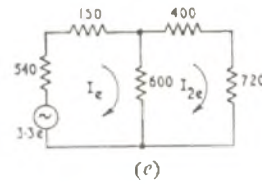

$$I_{2e} = \frac{600}{1,720} \left[ \frac{3.3e}{690 + \frac{600 \times 1,120}{600 + 1,120}} \right]$$

$$= \frac{3.3e}{1,978 + 1,120} = \frac{3.3e}{3,098}$$

The current in the actual load would, however, be

$$\frac{1.9 \times 3.3e}{3,098} = \frac{e}{500} \text{ amp,}$$

which is the largest current for any arrangement. Hence, with these conditions, the insertion loss of the network is least, and is 6 db.

**Q. 7.** Draw vector diagrams to indicate the current and voltage when a sinusoidal voltage of 1.0 volt r.m.s. and frequency  $f$  c/s is applied across,

- a non-reactive resistance,  $R$ , of 1,000 ohms,
- a pure inductance,  $L$ , of 0.2 henry,
- a pure capacitance,  $C$ , of 0.2 microfarads.

Thence, or otherwise, construct the vector diagram for a circuit in which the three components are connected in parallel.

What is the frequency of resonance of the combination?

Draw to scale a vector diagram of the currents and voltage at this frequency. Determine the impedance and  $Q$ -factor of the circuit at resonance.

How would the diagram and these characteristics be modified if the inductance,  $L$ , and parallel resistance,  $R$ , were replaced by an inductor having a resistance of 500 ohms in series with an inductance of 0.1 henry?

**A. 7.** The vector diagrams for (a), (b) and (c) are given in sketches (a), (b) and (c). The positive direction of rotation of the vectors is shown by the arrows.

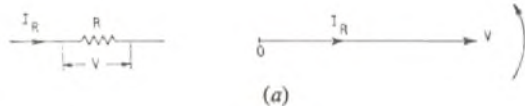

In sketch (a), the current and voltage are shown in phase and the r.m.s. value of the current is  $I_R = V/r = 1 \text{ mA}$ , which does not vary with frequency.

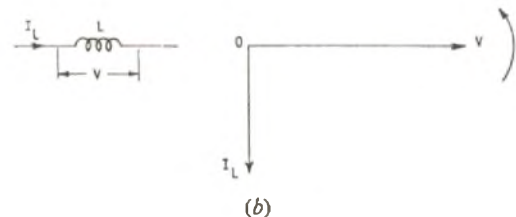

In sketch (b), the current lags 90° behind the voltage and its r.m.s. value is  $I_L = V/\omega L = 1/0.2\omega$  amp, which decreases with frequency.

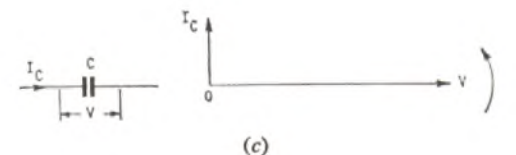

In sketch (c), the current leads the voltage by 90° and its r.m.s. value is  $I_C = \omega CV = 0.2 \times 10^{-6}\omega$  amp, which increases with frequency.

These three sketches have been combined in sketch (d), from which the magnitude,  $I$ , and phase angle,  $\phi$ , of the resultant current supplied to the parallel circuit can be determined.

When the circuit is at resonance the current supplied to it will be in phase with the applied voltage, i.e. the circuit will be purely



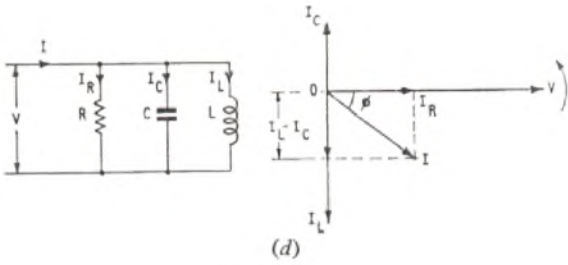

resistive. For this to occur it will be apparent from sketch (d) that

$$I_L - I_C = 0, \text{ or } I_L = I_C$$

$$\therefore V/\omega_0 L = \omega_0 C V$$

$$\text{or } \omega_0^2 = \frac{1}{LC} = \frac{1}{0.2 \times 0.2 \times 10^{-6}}$$

$$\therefore \omega_0 = 10^3 \sqrt{5} \text{ radians/second.}$$

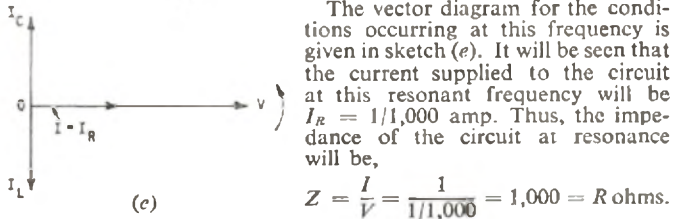

The vector diagram for the conditions occurring at this frequency is given in sketch (e). It will be seen that the current supplied to the circuit at this resonant frequency will be  $I_R = 1/1,000$  amp. Thus, the impedance of the circuit at resonance will be,

$$Z = \frac{V}{I} = \frac{1}{1/1,000} = 1,000 = R \text{ ohms.}$$

This would be expected, since by reference to the circuit in sketch (d) it will be appreciated that the impedance of the loss-less resonant circuit, LC, will be infinite when  $\omega = \omega_0 = 1/\sqrt{LC}$  radians/second. To find the Q-factor of the circuit at resonance, the energy dissipated in the circuit during half a cycle and the average value of the oscillating energy must be determined.

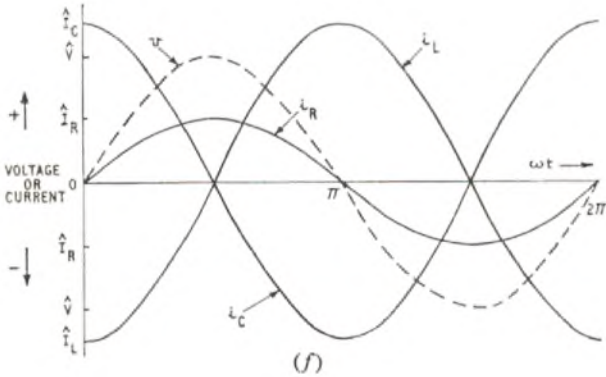

In sketch (f), the waveshapes of the current in the three parallel branches of the circuit have been plotted, together with that of the voltage applied across them, where  $i_R = \hat{I}_R \sin \omega t = \frac{\hat{V}}{R} \sin \omega t$ ,  $i_L = -\hat{I}_L \cos \omega t = -\frac{\hat{V}}{\omega L} \cos \omega t$ ,  $i_C = \hat{I}_C \cos \omega t = \omega C \hat{V} \cos \omega t$  and  $v = \hat{V} \sin \omega t$ .

By multiplying  $v$  and  $i_R$  the watts dissipated in the resistance can be plotted against time, as shown in sketch (g). It will be apparent from

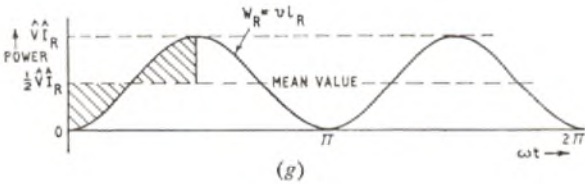

sketch (g) that the average value of the power dissipated in the circuit is

$$\frac{1}{2} \hat{V} \hat{I}_R = \frac{1}{2} \frac{(\hat{V})^2}{R} \text{ watts.}$$

The energy dissipated in one half-cycle is

$$\frac{1}{2} \frac{(\hat{V})^2}{R^2} \tau = \frac{1}{2} \frac{(\hat{V})^2}{R^2 f} \text{ joules,}$$

where  $\tau$  is the periodic time in seconds and  $f$  is the frequency in c/s.

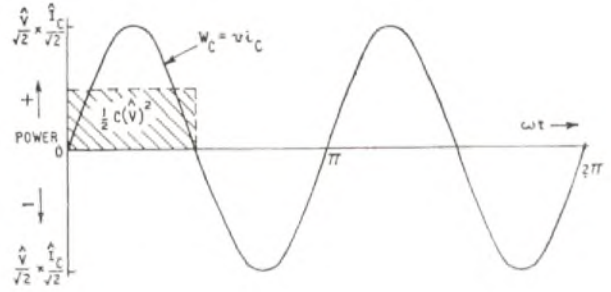

(h)

The power supplied to the capacitor will be  $v i_C$  watts. This product has been plotted in sketch (h), and it will be observed that during the first quarter-cycle, when the voltage is increasing, the product is positive, and during the second quarter-cycle, when the voltage across the capacitor is decreasing, the product is negative. Thus, the capacitor is receiving energy during the first quarter-cycle and delivering energy to the circuit during the next half-cycle, and so on.

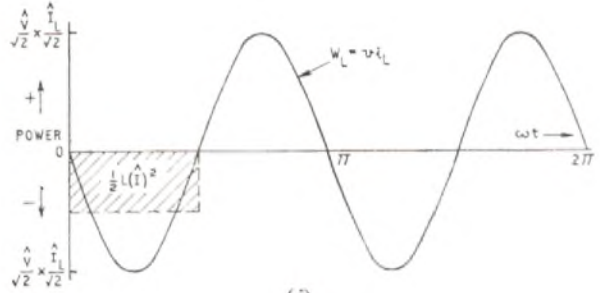

(j)

The power supplied to the inductor will be  $v i_L$  watts. This product is plotted in sketch (j) and it will be seen that, during the first quarter-cycle, when the current flowing in the inductor is decreasing (negatively) the product is negative, i.e. the energy previously stored in the magnetic field of the inductor is being returned to the circuit. During the next half-cycle, when the current flowing in the inductor is increasing (positively) the product is positive, i.e. energy is being taken from the remainder of the circuit to build-up the magnetic field associated with the inductor.

Thus, when the inductor is delivering energy to the circuit, the capacitor is receiving energy from it, and vice versa. Since the circuit is at resonance, i.e. externally it behaves as if it were purely resistive, all the energy supplied to it from the source is dissipated in it and none is oscillating between the source and the circuit. Hence, the energy stored in the magnetic field of the inductor is used to build up the electric field in the capacitor, and vice versa.

The maximum amount of energy stored in the capacitor (at the end of the first quarter, third quarter, etc., of a cycle) will be the area under the curve of  $w_C$  against time for a quarter of a period.

The average value of this area over a quarter of a period is

$$\frac{2 \hat{V} \hat{I}}{\pi \sqrt{2} \sqrt{2}} = \frac{1}{\pi} \hat{V} \hat{I} \text{ watts.}$$

Maximum stored energy

$$= \frac{1}{\pi} \hat{V} \hat{I} \times \frac{\tau_0}{4} = \frac{1}{2\pi f_0} \frac{1}{2} \hat{V} \hat{I}$$

$$= \frac{1}{\omega_0} \frac{1}{2} \hat{V} \omega_0 C \hat{V} = \frac{1}{2} C (\hat{V})^2 \text{ joules,}$$

where  $\tau_0$  is the periodic time in seconds and  $f_0$  is the frequency in c/s at resonance.

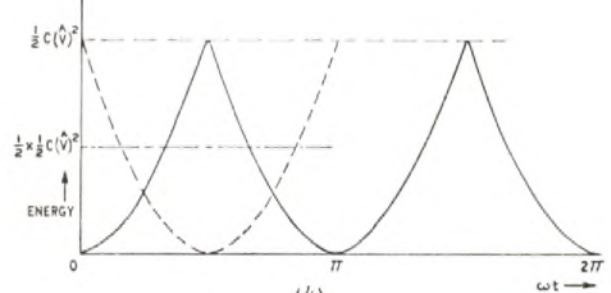

(k)

In sketch (k), the amount of energy stored in the capacitor at any instant has been indicated. Note:

$$\int_0^{\pi} \sin x \, dx = [-\cos x]_0^{\pi} = 1 - \cos \pi$$

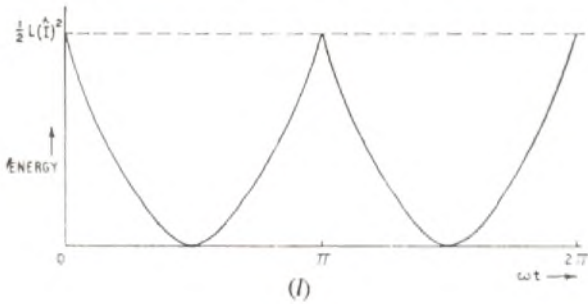

Sketch (l) shows the corresponding information for the inductor and this curve has also been included by a broken line in sketch (k). From this it can be seen that the average value of the energy oscillating between the magnetic field of the inductor and the electric field of the capacitor is

$$\frac{1}{2} \times \frac{1}{2} C(\hat{V})^2 = \frac{1}{2} C(\hat{V})^2 \text{ joules.}$$

Hence, the Q-factor of the circuit

$$\begin{aligned} &= 2\pi \left[ \frac{\text{Average value of the oscillating energy}}{\text{Energy dissipated during half a cycle}} \right] \\ &= 2\pi \frac{\frac{1}{2} C(\hat{V})^2}{\frac{1}{2} (\hat{V})^2 \frac{1}{R}} = 2\pi f_0 RC = R\omega_0 C = R \frac{C}{\sqrt{LC}} \\ &= R \sqrt{\frac{C}{L}} = 1,000 \sqrt{\frac{0.2 \times 10^{-8}}{0.2}} = 1.0 \end{aligned}$$

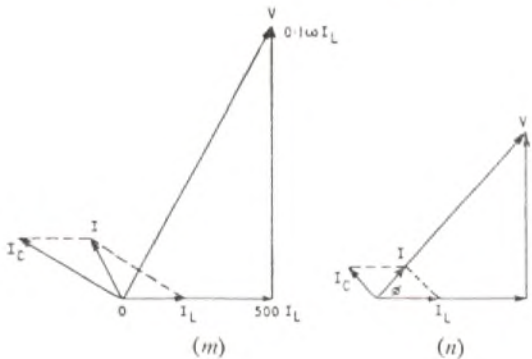

In sketch (m), the vector diagram of the modified tuned circuit is given. A current  $I_L$  is assumed to be flowing in the inductor. The voltage across its resistance will be  $RI_L = 500 I_L$ , in phase with  $I_L$ , and the voltage across the inductor will be  $0.1\omega I_L$ , leading the current  $I_L$  by  $90^\circ$ . The vector sum of  $RI_L$  and  $0.1\omega I_L$  gives the applied voltage

$V$ . The current supplied to the capacitor will lead  $V$  by  $90^\circ$  and its r.m.s. value will be  $I_C = V/(0.2\omega \times 10^{-6})$ . The current supplied to the circuit will be  $I$ , the vector sum of  $I_L$  and  $V/(0.2\omega \times 10^{-6})$ .

The circuit will resonate when  $I$  is in phase with  $V$ , as shown in sketch (n). If  $\phi$  is the phase angle of the inductor at this frequency then the phase difference between  $I_C$  and  $I_L$  will be  $(90 + \phi)$ .

$$\begin{aligned} \text{Then } \tan \phi &= \frac{\omega_0 L}{R} = \frac{I_C \sin(90 + \phi)}{I_L + I_C \cos(90 + \phi)} \\ &= \frac{I_C \cos \phi}{I_L - I_C \sin \phi} = \frac{I_L}{I_C \sqrt{R^2 + \omega_0^2 L^2} - \omega_0 L} \end{aligned}$$

$$\frac{\omega_0 L}{R} = \frac{R}{\omega_0 C V} - \omega_0 L = \frac{R}{\omega_0 C} - \omega_0 L$$

$$\therefore \frac{L}{C} - \omega_0^2 L^2 = R^2, \text{ and } \frac{L}{C} = R^2 + \omega_0^2 L^2$$

$$\text{i.e. } \omega_0^2 = \frac{1}{LC} - \frac{R^2}{L^2}$$

$$= \frac{1}{0.1 \times 0.2 \times 10^{-8}} - \frac{500^2}{0.01}$$

$$= 5 \times 10^7 - 2.5 \times 10^7$$

$$\text{and } \omega_0 = 5,000 \text{ radians/s} \approx 796 \text{ c/s.}$$

The impedance at resonance,

$$\begin{aligned} \frac{V}{I} &= \frac{V}{\sqrt{I_C^2 + I_L^2} + 2I_C I_L \cos(90 + \phi)} \\ &= \frac{1}{\sqrt{\omega_0^2 C^2 + \frac{1}{R^2 + \omega_0^2 L^2}} - 2\omega_0 C \frac{1}{\sqrt{R^2 + \omega_0^2 L^2}} \frac{\omega_0 L}{\sqrt{R^2 + \omega_0^2 L^2}}} \\ &= \sqrt{\frac{R^2 + \omega_0^2 L^2}{\omega_0^2 C^2 (R^2 + \omega_0^2 L^2) + 1} - 2\omega_0^2 LC} \\ &= \sqrt{\frac{L/C}{\omega_0^2 LC + 1} - 2\omega_0^2 LC} = \sqrt{\frac{L/C}{R^2 C/L}} \\ &= \frac{L}{CR} = \frac{0.1}{0.2 \times 10^{-8} \times 500} = 1,000 \text{ ohms.} \end{aligned}$$

Since the Q-factor of the capacitor is infinite, the Q-factor of the circuit will be the Q-factor of the inductor.

$$\text{At resonance, } Q = \frac{\omega_0 L}{R} = \frac{5,000 \times 0.1}{500} = 1.0.$$

**Q. 8.** Two vertical, transmitting dipoles, separated by a quarter of a wavelength, are fed in anti-phase.

Sketch the resulting polar diagram in the horizontal plane.

Suggest one method of connecting the aerials to the source in order to produce the  $180^\circ$  phase-difference between them.

**Q. 9.** Derive an expression for the force between two magnetized surfaces.

Using this, explain the functions of the permanent magnet in a telephone receiver.

On what other factors does the sensitivity of the receiver depend?

**Q. 10.** Describe, with the aid of sketches, the construction and operation of a cathode-ray tube employing magnetic focusing and deflexion.

Give a method of providing a linear horizontal scan.

ENGINEERING SCIENCE, 1961

Students were required to attempt not more than six questions including not more than two questions from questions 7-10.

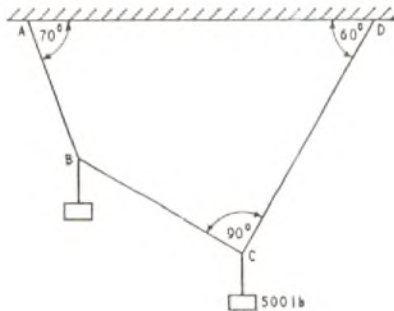

Fig. 1

**Q. 1.** Masses are suspended from two points B and C on a rope ABCD as shown in Fig. 1. The ends A and D are on the same horizontal level.

Find the tension in each section of the rope, and the mass suspended from the point B.

**A. 1.** The sum of the angles in a quadrilateral is  $360^\circ$ , hence the angle  $ABC = 360 - (70 + 60 + 90) = 140^\circ$ . If the weight suspended from B has a mass of  $W$  lb the figure can be redrawn as shown in sketch (a), where  $T_1$ ,  $T_2$  and  $T_3$  represent the tensions in AB, BC and CD, respectively.

The point C is in equilibrium under the action of tensions  $T_2$ ,  $T_3$  and the 500 lb load. A triangle of forces can, therefore, be drawn as shown in sketch (b). Line MN is drawn vertically down to some scale to represent the 500 lb load; a line parallel to BC is drawn through N to represent the direction of  $T_2$ ; a line parallel to CD is

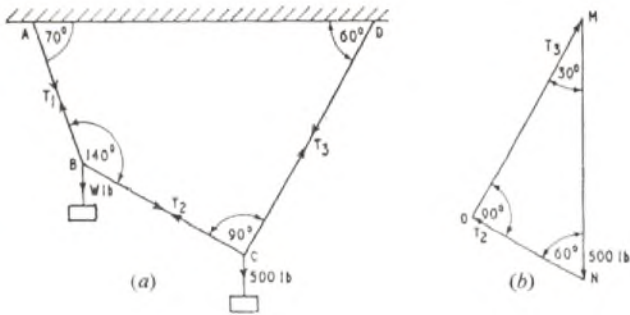

drawn through M to represent the direction of  $T_3$ . If the two lines through M and N intersect at O then NO represents  $T_2$  in magnitude and direction, and OM represents  $T_3$  in magnitude and direction.

Solving the triangle MNO:

$$T_2 = 500 \cos 60 = 250 \text{ lb wt.}$$

$$T_3 = 500 \sin 60 = 433 \text{ lb wt.}$$

Similarly, a triangle of forces can now be drawn for the point B. This is shown in sketch (c), where PQ represents  $T_2$ , QR represents  $T_1$ , and RP represents  $W$ .

Applying the sine rule to triangle PQR gives:

$$\frac{T_2}{\sin 20} = \frac{T_1}{\sin 120} = \frac{W}{\sin 40}$$

$$\therefore \frac{250}{0.3420} = \frac{T_1}{0.866} = \frac{W}{0.6428}$$

$$\text{Hence, } T_1 = 250 \times \frac{0.866}{0.3420} = 633 \text{ lb wt.}$$

$$W = 250 \times \frac{0.6428}{0.3420} = 470 \text{ lb wt.}$$

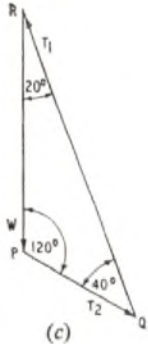

Q. 2. Explain what is meant by the terms moment and shear.

Two forces are applied to a horizontal beam which is built into a vertical wall as shown in Fig. 2. The beam has a mass of 100 pounds

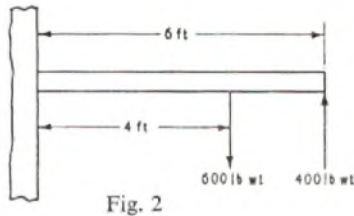

per foot. Find the magnitude and direction of the force and the couple exerted by the wall on the beam.

What is the value of the shear force at the centre of the beam?

A. 2. If a straight section is considered across any rigid structure the resultant force acting at the section can be expressed in terms of a moment and a shear, generally termed a bending moment and a shear force, respectively. The bending moment is the tendency for the structure to bend at the section and the shear force is the force tending to make the two parts of the structure slide over each other along the line of the section.

With a simple structure, such as a beam with a vertical section, the bending moment is calculated by taking the algebraic sum of the moments, about any point on the section, of all the forces applied to either the right or the left of the section.

The shear force is the algebraic sum of all the perpendicular components of forces applied to the beam either on the right or on the left of the section.

The system given in the question can be represented as shown

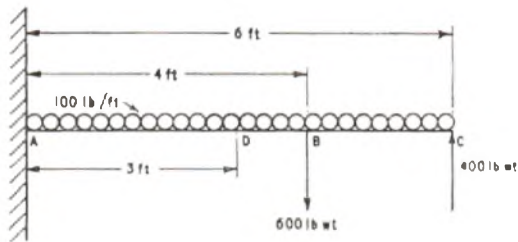

in the sketch. The total vertical component of forces acting to the right of A is given by

$$S_A = (6 \times 100) + 600 - 400 \text{ lb wt.}$$

(By convention, forces acting down to the right of a section are assumed to be positive.)

$$\therefore S_A = 800 \text{ lb.}$$

Hence, for equilibrium the wall must exert an upward force on the beam of 800 lb.

The moment at A due to the mass of the beam can be calculated by considering the total mass of the beam to be concentrated at its centre, i.e. at D. Hence, the moment at A is

$$M_A = (6 \times 100 \times 3) + (600 \times 4) - (400 \times 6) \text{ lb ft.}$$

(By convention, clockwise moments to the right of a section are assumed to be positive.)

$$\therefore M_A = 1,800 \text{ lb ft}$$

The wall must, therefore, exert a moment of 1,800 lb ft anticlockwise on the beam at A.

To calculate the shear force at the centre, consider all vertical components to the right of D:

$$S_D = (3 \times 100) + 600 - 400$$

$$= 500 \text{ lb wt.}$$

Q. 3. A force of 650 Newtons is applied to a mass of 200 kilograms for a period of 10 seconds. If the only other force acting on the mass is a constant friction force of 400 Newtons in opposition to its motion, find the velocity acquired and the distance travelled by the mass in this time.

How much work is done by the applied force, and what percentage of this work is done in overcoming friction?

If the applied force is removed at the end of the 10 seconds, find the time taken for the mass to come to rest.

A. 3. Referring to sketch (a), the total accelerating force is 650 - 400 = 250 Newtons.



(a)

$$\text{Acceleration} = \frac{\text{Force}}{\text{Mass}} = \frac{250}{200}$$

$$= 1.25 \text{ m/s}^2$$

The gradient of the velocity/time graph, shown in sketch (b), is 1.25 m/s<sup>2</sup>. The velocity after 10 seconds is 1.25 × 10 = 12.5 m/s.

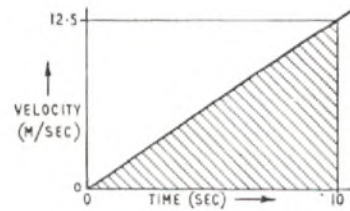

(b)

The distance travelled is given by the area under the velocity/time curve.

$$\therefore \text{Distance, } S = \frac{12.5 \times 10}{2} = 62.5 \text{ m.}$$

$$\text{Work done by force } P = 650 \times 62.5 \text{ joules.}$$

$$\text{Work done to overcome friction} = 400 \times 62.5 \text{ joules}$$

$$\therefore \text{Percentage of total work to overcome friction}$$

$$= \frac{400 \times 62.5}{650 \times 62.5} \times 100$$

$$= 61.5 \text{ per cent.}$$

$$\text{Rate of deceleration} = \frac{400}{200} = 2 \text{ m/s}^2$$

$$\therefore \text{Time to come to rest} = \frac{12.5}{2} = 6.25 \text{ seconds.}$$

Q. 4. A man wishes to raise a load of 300 pounds through a vertical distance of 3 ft. He is prepared to exert a force of not more than 70 pounds weight. Draw a diagram of a machine suitable for carrying out the lift. State the speed ratio of the machine you have chosen, and calculate the minimum efficiency it would require.

If the lifting process is carried out in 20 seconds, calculate the output power of the machine.

A. 4. The pulley system shown in the sketch could be used. For the theory of such a pulley system see A.5, Engineering Science, 1960, Supplement, Vol. 53, No. 4, p. 59, Jan. 1961.

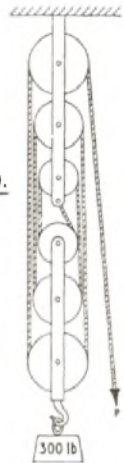

The velocity ratio is  $6 : 1$

The required mechanical advantage is at least  $300/70$ .

$$\therefore \text{Minimum efficiency} = \frac{\text{Mechanical advantage}}{\text{Velocity ratio}}$$

$$= \frac{300}{70} \times \frac{1}{6} = 71.4 \text{ per cent.}$$

$$\text{Output power} = \frac{300 \times 3}{20} \text{ ft lb/s.}$$

$$= 45 \text{ ft lb/s.}$$

Q. 5. Explain what is meant by the terms work, energy and power, defining one unit in which each of these quantities may be measured.

State the principle of conservation of energy, and describe an experiment suitable for the measurement of the mechanical equivalent of heat.

Q. 6. Explain what is meant by the terms tensile stress, tensile strain, Young's modulus.

A mass of one kilogram is suspended from a vertical steel wire of diameter 0.30 millimetre and length 300 centimetres. Calculate the extension of the wire. Young's modulus for steel may be taken as  $2 \times 10^{11}$  Newtons per square metre, and the acceleration due to gravity as 9.8 metres per second<sup>2</sup>.

How would you expect the tension to be affected if the wire were used to lift the mass with a constant acceleration?

A. 6. Tensile stress exists in a body when it is subjected to forces which tend to pull it apart. The stress at any section is defined as the quotient of the normal component of the force acting across the section and the area of the section.

If a body is extended as a result of a tensile stress then it is said to be strained. The tensile strain is defined as the quotient of the extension and the original length, both being measured in the same units.

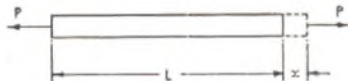

In the sketch a uniform bar of cross-sectional area  $A \text{ m}^2$  and length  $L \text{ m}$  is subjected to a tensile force  $P \text{ Newtons}$ , and is thereby extended by  $x \text{ m}$ .

The stress in the bar is  $P/A \text{ Newtons/m}^2$  and the strain is  $x/L$ .

It can be shown experimentally that within the elastic limit of a material the ratio stress/strain is a constant for the material. This constant is known as Young's Modulus of Elasticity for the material.

In the wire on which 1 kg is suspended,

$$\text{stress} = \frac{1 \times 9.8 \times 4}{\pi \times 0.3^2 \times 10^{-6}} \text{ Newtons/m}^2$$

and strain =  $\frac{x}{300}$  where  $x$  is the extension in centimetres.

$$\therefore 2 \times 10^{11} = \frac{9.8 \times 4}{\pi \times 0.3^2 \times 10^{-6}} \times \frac{300}{x}$$

$$\text{and } x = \frac{9.8 \times 4 \times 300}{2 \times 10^{11} \times \pi \times 0.3^2 \times 10^{-6}} = 0.208 \text{ cm} = 2.08 \text{ mm.}$$

If the mass were lifted with a constant acceleration of  $a \text{ m/s}^2$  then the tension would increase to a steady value of  $(1 \times 9.8) + (1 \times a) \text{ Newtons}$ .

Q. 7. A 12-volt lead-acid accumulator has a rated capacity of 40 ampere-hours at the 20-hour rate, its terminal voltage falling from 13.5 volts to 10.8 volts during discharge. While being charged with a current of 4 amperes, its terminal voltage rises from 12.6 volts to 16.2 volts.

It is proposed to charge the accumulator at 4 amperes from a source having a constant terminal voltage of 24 volts, then to check the capacity. Draw two suitable circuit diagrams, one for charge and one for discharge, calculating the extreme values of resistance required in each case.

Describe another test which could be used to give additional information as to the state of the accumulator.

A. 7. The circuit shown in sketch (a) could be used during charging.

At the commencement of the charge

$$R_1 = (24 - 12.6)/4 = 2.85 \text{ ohms.}$$

At the end of the charge

$$R_1 = (24 - 16.2)/4 = 1.95 \text{ ohms.}$$

Hence, the value of resistor  $R_1$  must be varied between 1.95 and 2.85 ohms.

The circuit shown in sketch (b) could be used to check the capacity (A.H. is an ampere-hour meter).

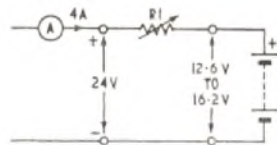

(a)

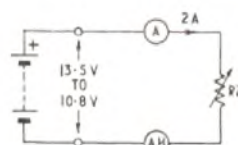

(b)

To discharge at the 20-hour rate  $I = 40/20 = 2 \text{ amp}$ .

At the commencement of the discharge

$$R_2 = 13.5/2 = 6.75 \text{ ohms.}$$

At the end of the discharge

$$R_2 = 10.8/2 = 5.4 \text{ ohms.}$$

Hence, the value of resistor  $R_2$  must be varied between 5.4 and 6.75 ohms.

The cadmium-electrode test is used to give additional information about the state of accumulators suspected of low capacity. The purpose of this test is to establish whether the prime cause of failure is due to the negative or positive plates.

The test is conducted by giving the accumulator an equalizing charge and then discharging the accumulator at the 9-hour rate; during the latter part of the discharge (i.e. when the voltage per cell falls from 1.9 to 1.5 volts) the potential difference between either the positive plate or the negative plate and a special cadmium electrode inserted in the electrolyte is noted at  $\frac{1}{2}$ -hourly intervals. If the voltage between either set of plates and the cadmium electrode varies appreciably then that particular set of plates is failing.

Q. 8. Two resistors of values 50,000 ohms and 100,000 ohms are connected in series across a source of constant voltage. Explain why a false reading is obtained if a moving-coil meter is used to measure the voltage across the 50,000-ohm resistor.

If the meter requires a current of 1 milliampere to give a full-scale deflexion of 50 volts, and gives a reading of 18.5 volts when used as above, calculate the source voltage and the true voltage across the 50,000-ohm resistor in the absence of the meter.

With the above circuit, what would be the meter reading if there were a break in (a) the 50,000-ohm resistor, (b) the 100,000-ohm resistor?

A. 8. The resistance of the meter would be shunted across the 50,000-ohm resistor as shown in sketch (a), and would cause an additional current to flow in the 100,000-ohm resistor. The additional current would produce a greater voltage drop in the 100,000-ohm resistor and thus produce an incorrect voltage measurement. (It should be noted that the error is in the method of measurement and not in the meter itself.) The meter resistance is  $50/(1 \times 10^{-3}) \text{ ohms}$ , i.e. 50,000 ohms.

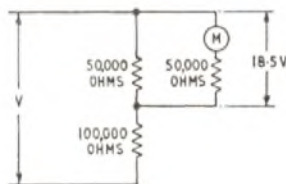

(a)

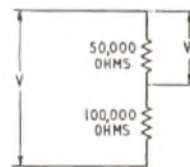

(b)

The combined equivalent resistance of the meter,  $M$ , and the 50,000-ohm resistor is 25,000 ohms. Thus, the current flowing in the 100,000-ohm resistor is  $18.5/(25 \times 10^3) = 0.74 \text{ mA}$ .

Hence, the potential difference across the 100,000-ohm resistor is  $0.74 \times 10^{-3} \times 100 \times 10^3 = 74 \text{ volts}$ .

The source voltage  $V$  is, therefore,  $74 + 18.5 = 92.5 \text{ volts}$ .

The voltage  $V_1$  (see sketch (b)) across the 50,000-ohm resistor is, therefore,  $92.5/3$ , i.e.  $V_1 = 30.83 \text{ volts}$ .

If the 50,000-ohm resistor shown in sketch (a) went open-circuit the meter would read  $\frac{92.5 \times 50}{(100 + 50)} = 30.83$  volts.

If the 100,000-ohm resistor went open-circuit the meter would read zero.

**Q. 9.** With the aid of a diagram, describe the construction and action of a moving-coil meter.

The coil of a moving-coil meter has two identical sections which may be connected either in series or in parallel. How would a change from the series connexion to the parallel connexion affect (a) the resistance, (b) the full-scale deflexion of the meter?

**A. 9.** See A.7, Engineering Science, 1959, Supplement, Vol. 52, No. 4, p. 54, Jan. 1960.

(a) If each of the sections of the meter coil has a resistance of  $R$  ohms then the series-connected meter would have a resistance

of  $2R$  ohms, and the parallel-connected meter would have a resistance of  $R/2$  ohms. That is, the meter resistance would decrease to one quarter of the series-connected value.

(b) The deflecting force is proportional to the product of the current and the number of turns. If the number of turns on each of the sections is  $N$  and the total input current is  $I$  amp, then for series connexion the deflecting force  $\propto I \times 2N = 2IN$ , and for parallel connexion deflecting force  $\propto \frac{IN}{2} + \frac{IN}{2} = IN$ , since  $I$  divides equally between the two halves of the winding.

Hence, the full-scale deflexion would be doubled.

**Q. 10.** Write short notes on three of the following topics, illustrating your answer by a suitable diagram in each case:

- (a) the hot-wire ammeter,
- (b) electroplating,
- (c) the filament lamp,
- (d) the electromagnet.

TELECOMMUNICATION PRINCIPLES A, 1961

Students were required to attempt not more than six questions, three from questions 1-4 and three from questions 5-10.

**Q. 1.** In the circuit shown in Fig. 1, when the switch  $S$  is closed, a battery of internal resistance 2 ohms maintains 12V between the terminals  $AB$ . Calculate:

- (a) the battery current,
- (b) the current in the 25-ohm resistor,
- (c) the e.m.f. of the battery.

When the switch is open, what is the voltage across the contacts?

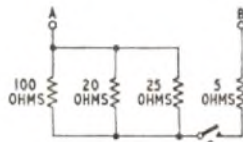

Fig. 1

**A. 1.** Three parallel-connected resistors,  $R_1, R_2, R_3$  can be reduced to a single equivalent resistor  $R$  by the relation:

$$\frac{1}{R_1} + \frac{1}{R_2} + \frac{1}{R_3} = \frac{1}{R}$$

Hence, the 100-ohm, 20-ohm and 25-ohm resistors are together equivalent to:

$$0.01 + 0.05 + 0.04 = 0.1 = \frac{1}{R}$$

Therefore,  $R = 10$  ohms.

Thus, the circuit between  $A$  and  $B$  is equivalent to two series resistors of 10 ohms and 5 ohms, as shown in the sketch. The total resistance between  $A$  and  $B$  is then 15 ohms.

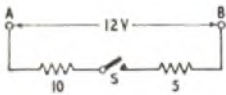

(a) By Ohm's Law, the current in a circuit is given by the ratio of the voltage across that circuit to the circuit resistance.

If then a p.d. of 12 volts is maintained across  $A$  and  $B$ , the current taken from the supply is:

$$I = \frac{12}{15} \text{ amp} = 0.8 \text{ amp.}$$

(b) The p.d. across the equivalent resistor of 10 ohms is given by:

$$0.8 \times 10 = 8 \text{ volts.}$$

This is, therefore, the p.d. across the 25-ohm resistor.

$\therefore$  current in the 25-ohm resistor =  $\frac{8}{25} = 0.32$  amp.

(c) The battery has an internal resistance of 2 ohms and can maintain a p.d. of 12 volts across its terminals when a current of 0.8 amp is flowing in it. Thus, the battery internal e.m.f. must be greater than its terminal p.d. by the voltage drop in its internal resistance, i.e. by the voltage  $2 \times 0.8 = 1.6$  volts, which is the internal voltage drop.

$$\therefore \text{Battery e.m.f.} = 12 + 1.6 \text{ volts} = 13.6 \text{ volts.}$$

When the switch is open, no current can flow in the circuit. Therefore, the full battery e.m.f. will appear across the switch contacts because there is no internal battery voltage drop. The voltage across the open switch contacts is 13.6 volts.

**Q. 2.** What factors determine the capacitance of a parallel-plate capacitor? Write down an expression for the capacitance.

A capacitor consisting of two air-spaced parallel plates each of effective area  $1,000 \text{ cm}^2$  spaced 0.1 cm apart, is connected across a constant voltage source of 500 volts. Calculate the charge on the capacitor.

The permittivity of free space in m.k.s. units is  $8.854 \times 10^{-12}$  farads per metre.

**A. 2.** The factors determining the capacitance of a parallel-plate capacitor are:

- (i) The effective area of the plates,  $A$  sq. metres.
- (ii) The perpendicular distance between them,  $d$  metres.
- (iii) The permittivity of the dielectric between them,  $\epsilon$ , which is assumed to fill entirely the interplate space.

These factors are related by:

$$C = \epsilon \frac{A}{d} \text{ farads} \dots \dots \dots (1)$$

$\epsilon$  is known as the absolute permittivity of the dielectric.

In m.k.s. units,  $\epsilon = \epsilon_0 \epsilon_r$ ,  
 where  $\epsilon_0$  = permittivity of free space  
 $= 8.85 \times 10^{-12}$  rationalized m.k.s. units,  
 and  $\epsilon_r$  = relative permittivity of the dielectric.

The charge  $Q$  coulombs held by a capacitance,  $C$  farads, maintained at  $V$  volts is given by:

$$C = Q/V, \text{ or } Q = CV \text{ coulombs} \dots \dots \dots (2)$$

The capacitance of the given capacitor, from relation (1), is:

$$A = 1,000 \times 10^{-4} = 0.1 \text{ sq. m.}$$

$$d = 0.1 \times 10^{-2} = 0.001 \text{ m.}$$

$$\epsilon_r = \text{relative permittivity of air} = 1$$

$$\epsilon_0 = 8.854 \times 10^{-12} \text{ f/m.}$$

$$\text{Hence, } C = \frac{1 \times 8.854 \times 10^{-12} \times 0.1}{0.001}$$

$$= 885.4 \times 10^{-12} \text{ farads} = 885.4 \mu\text{F.}$$

Using relation (2), the charge on this capacitor at 500 volts

$$= 885.4 \times 10^{-12} \times 500 \text{ coulombs.}$$

$$= 0.4427 \text{ microcoulombs.}$$

**Q. 3.** Describe the principle of operation of the moving-coil milliammeter.

Explain why an iron core is provided within the coil in this type of meter.

How is the movement "damped"? What effect has this damping on the accuracy of the meter reading? Give a reason for your answer.

Instrument makers frequently specify the "ohms per volt" for a voltmeter. Explain why this form of specification is of value to users of the meter.

**A. 3.** For a description of the operation of a moving-coil milliammeter see A.8, Telecommunication Principles A, 1959, Supplement, Vol. 52, No. 4, p. 58, Jan. 1960.

**Q. 4.** Characteristics of a junction transistor are given in the following table:

Collector volts ( $V_{ce}$ )	Collector current, ( $I_c$ mA)		
	$I_b = 0$	$I_b = 40 \mu\text{A}$	$I_b = 80 \mu\text{A}$
1.0	0.20	1.90	3.7
4.0	0.30	2.05	4.0
7.0	0.40	2.20	4.3

The transistor is connected in a common-emitter stage with a collector load of 1,500 ohms, a supply voltage of 6 volts and a d.c. bias of 40 microamperes.

Plot the characteristics and draw the appropriate load line. Calculate the power dissipated in the transistor.

What will be the total voltage swing at the collector for an a.c. input signal current of 40 microamperes peak in the base?

**A. 4.** The collector-current/collector-voltage characteristics are plotted in sketch (a).

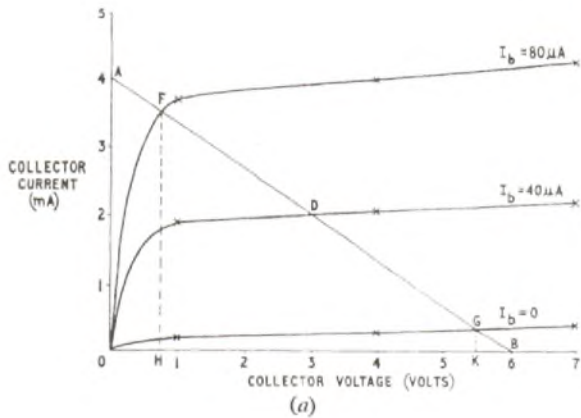

The basic circuit of a common, i.e. grounded, emitter transistor stage is shown in sketch (b), with a load resistance of 1,500 ohms. The value of resistor  $R_b$  would be chosen to give the desired bias current, and with this arrangement only one battery is needed to operate the circuit.

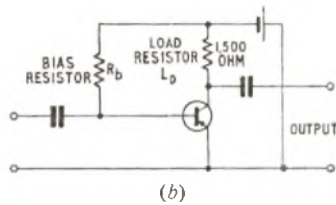

The load line is a straight line with a gradient which is the inverse of the collector-load resistance, and passes through points that represent the extreme working conditions. Thus, at the point B, where the potential of the collector with respect to the emitter is the same as the battery voltage, there can be no voltage drop in the collector load and, therefore, at this point the collector current is zero. The voltage and current co-ordinates of the point B are thus 6 volt, 0 mA. When the load current is the greatest possible, i.e. so that all the battery voltage is dropped across the collector load, the collector-emitter voltage is zero. The collector current is thus  $6/1,500 = 4$  mA. Hence, point A has the co-ordinates 0 volt, 4 mA. Then AB is the load line for a resistive collector load of 1,500 ohms, since its inverse slope is given by

$$6/(4 \times 10^{-3}) = 1,500 \text{ ohms.}$$

The quiescent working point is at D, where the load line cuts the  $40 \mu\text{A}$  characteristic. When an input signal of  $40 \mu\text{A}$  peak current is applied, the peak-to-peak input signal will be  $80 \mu\text{A}$  and the current in the base will vary between 0 and  $80 \mu\text{A}$ . The working condition is up-and-down the load line centred about D, and the extremes of the working range for a 1,500-ohm collector load will be at F and G, where F and G are the points at which the load line cuts the characteristic curves for base currents of  $80$  and  $0 \mu\text{A}$ , respectively. The limits of collector-emitter voltage swing will be the points H and K, the abscissae of F and G. The peak-to-peak collector-emitter voltage excursion, HK, is then 4.9 volts.

When the quiescent condition pertains the base current is  $40 \mu\text{A}$  and the power taken from the battery is dissipated in the 1,500-ohm load and the transistor. This corresponds to the steady state at point D in sketch (a). At D, the collector current is 2.05 mA, which is therefore the current drawn from the battery and also the current in the 1,500-ohm load.

The power supplied by the battery =  $I \times V = 2.05 \times 6$ ,  
= 12.3 milliwatts.

The power dissipated as heat in the 1,500 ohm load  
=  $(2.05)^2 \times 10^{-6} \times 1,500$  watts,  
= 6.3 milliwatts.

Therefore, the power dissipated in the transistor itself  
=  $12.3 - 6.3 = 6.0$  milliwatts.

**Q. 5.** Explain the meaning of the following terms used in connexion with alternating current:

(a) frequency, periodic time, amplitude.

What is meant by the phase difference between the voltage across a circuit and the current flowing in it?

(b) Draw diagrams to illustrate the following:

(i) a sinusoidal voltage having an amplitude of 1 volt and a frequency of 50 c/s,

- (ii) a sinusoidal current that leads the voltage in (i) by  $90^\circ$ ,
- (iii) a sinusoidal current in antiphase with the voltage,
- (iv) a voltage of double the frequency and amplitude of that in (i).

**A. 5.** (a) The frequency of an alternating current is the number of repetitions of the wave pattern per second, ( $f$ ).

The periodic time of an alternating current is the time in seconds occupied by one complete wave pattern. The periodic time is related to the frequency by:

$$\text{periodic time} = 1/\text{frequency, } (t = 1/f).$$

The amplitude of the wave form of an alternating current is the maximum excursion above (and below) the mean of a complete wave pattern. It can also be defined as half the peak-to-peak excursion of the waveform.

The phase difference between the voltage across a circuit and the current flowing in it is the angular difference between corresponding points in the two waveforms, taking  $2\pi$  radians as representing one complete cycle of either wave pattern.

These four quantities are illustrated in sketch (a) for two waves of the same frequency but different amplitudes.

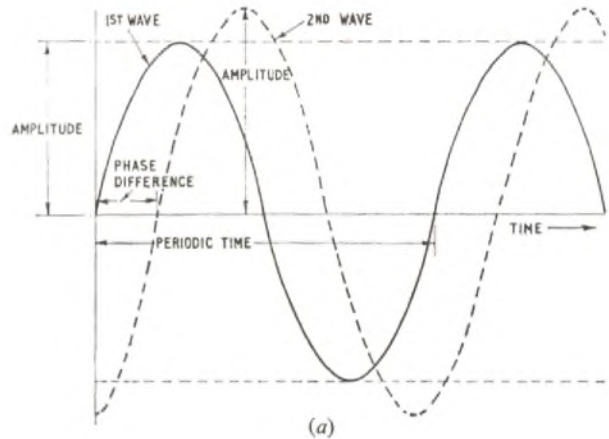

(b) In sketch (b) are shown:

(i) A sinusoidal voltage having an amplitude of 1 volt and a frequency of 50 c/s. One wave pattern of this voltage occupies  $1/50$  seconds, and has a peak-to-peak amplitude of 2 volts.

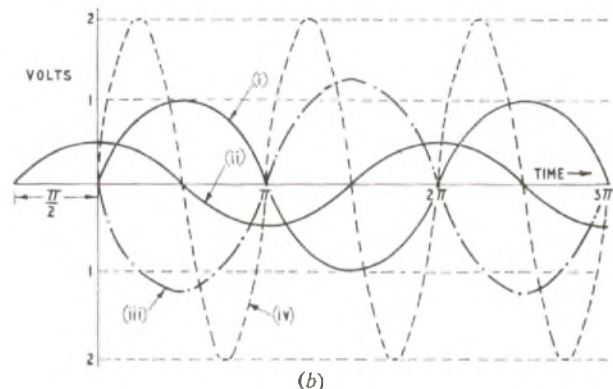

(ii) A sinusoidal current that leads the voltage in (i) by  $90^\circ$ . In determining the relative phase of two sine waves it should be noted that a point on the right-hand side of the time axis occurs after a point on the left-hand side. In moving from left to right on the time axis, therefore, a current zero occurs first; and  $90^\circ$  later in time, i.e.  $\pi/2$  radians further to the right, a voltage zero occurs.

(iii) A sinusoidal current in antiphase with the voltage. "Anti-phase" means  $180^\circ$  out-of-phase, and the same result is arrived at whether the phase difference is considered to be either leading or lagging by  $\pi$  radians (i.e.  $180^\circ$ ).

(iv) A voltage wave of double the frequency and amplitude of that in (i). There are two complete wave patterns of this wave in the time interval occupied by one wave pattern of the 50 c/s wave. It has a frequency of 100 c/s and a peak amplitude of 2 volts. The peak-to-peak value is therefore 4 volts.

**Q. 6.** Explain the principle of the Wheatstone bridge for measuring an unknown resistance.

A resistance thermometer takes the form of a Wheatstone bridge in which one arm is a coil of wire that changes in resistance in proportion to its temperature. The bridge circuit contains two 100-ohm resistors as ratio arms. A resistor, adjustable from 50 to 100 ohms makes the third arm and the coil provides the fourth arm of the bridge. The coil has a resistance of 60 ohms at 20°C. When the coil is heated, the adjustable resistor must be increased by 5 ohms to restore the balance of the bridge circuit.

If the temperature coefficient of resistance of the coil is 0.05 per cent per °C, what is the temperature of the coil?

**A. 6.** The Wheatstone bridge basically takes the form of the circuit shown in sketch (a). When four resistors, R<sub>1</sub>, R<sub>2</sub>, R<sub>3</sub> and R<sub>4</sub>, are connected in a ring and a source of voltage is connected across one pair of opposite terminals, then, if a centre-zero galvanometer is joined across the other opposite pair of terminals, the galvanometer will read zero if the resistances have the relation:

$$R_1/R_2 = R_3/R_4$$

This can be proved as follows:

Let  $i_1, i_2, i_3$  and  $i_4$  be the currents in the four resistances. Then the voltage drop across each resistance will be:

$$R_1 i_1, R_2 i_2, R_3 i_3 \text{ and } R_4 i_4.$$

The condition under which no current flows in the galvanometer is that there shall be no p.d. across it. Therefore, the voltage drop across R<sub>1</sub> must equal that across R<sub>3</sub>.

$$\text{Hence, } R_1 i_1 = R_3 i_3, \text{ and } R_2 i_2 = R_4 i_4 \dots \dots \dots (1)$$

Now,  $i_1 = i_2$  and  $i_3 = i_4$  because no current flows in the galvanometer. Thus, dividing equations (1) gives  $R_1/R_2 = R_3/R_4$ .

This bridge is used to measure an unknown resistance, R<sub>x</sub>, by

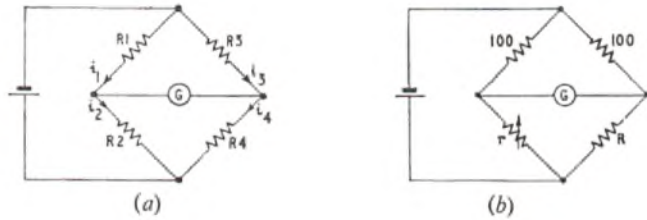

constructing a bridge circuit in which R<sub>x</sub> is one of the four arms, the other three being known resistances. One of these is adjustable over a known range; the other two, called the ratio arms, have known values, usually in powers of ten. A low-voltage battery supplies the voltage and a sensitive moving-coil centre-zero meter, with a safety resistor in series to avoid overload, gives an indication of balance.

The bridge is a "null" instrument in that a zero reading on the galvanometer indicates correct balance. This balance is independent of the voltage of the supply. However, a higher supply voltage may give greater sensitivity.

In using the bridge, care must be taken not to let the resistors get warm as their resistance is dependent on temperature. Obviously, high-grade resistors with low temperature-coefficient of resistance should be used for the known elements of the circuit.

The circuit of the measuring device is that of a Wheatstone bridge as shown in sketch (b), where r is the adjustable resistor and R is the resistance of the coil of the thermometer. As the ratio arms are fixed at 100 ohms, for balance

$$r/100 = R/100, \text{ i.e. } r = R.$$

At 20°C, R = r = 60 ohms.

At t°C, the unknown temperature of the coil, r is adjusted to 65 ohms. Therefore, R has also become 65 ohms, due to an increase of resistance with rise of temperature.

If α is the temperature coefficient of resistance of the coil of wire in the thermometer, then the resistance of the coil at t°C = (1 + αt) R<sub>0</sub>, where R<sub>0</sub> is the resistance at 0°C.

If T is the rise in coil temperature and R<sub>20</sub> is the resistance at 20°C, then the resistance at (T + 20)°C is given by:

$$R_{T+20} = R_{20} (1 + \alpha T).$$

Now, R<sub>T+20</sub> = 65 ohms, and R<sub>20</sub> = 60 ohms.

Therefore, because the temperature coefficient of resistance is

$$0.05 \text{ per cent, } 65 = 60(1 + \frac{0.05}{100} T).$$

$$\text{Hence, } T = \frac{(65 - 60) \times 100}{0.05 \times 60} = \frac{500}{0.3} = 166.7 \approx 167^\circ\text{C}.$$

This is the rise in temperature. The temperature of the coil is, therefore, 167 + 20 = 187°C.

**Q. 7.** Describe briefly how the conduction of electricity through an electrolyte differs from that through a metallic conductor.

How is this principle applied in copper plating?

A metal object with a total surface area of 64 cm<sup>2</sup> is to be copper-plated to a depth equivalent to a uniform deposit of 0.15 grammes per cm<sup>2</sup>. If a current of 0.8 A is to be used, how long would the plating process take?

The electrochemical equivalent of copper is 0.000329 grammes per coulomb.

**A. 7.** When an electric current flows in a common metal, no chemical change occurs as a result. The only effect will be the generation of some heat, due to energy losses in the metal as the electrons move from molecule to molecule. The moving of electrons from molecules where they are loosely held to others having an electron deficiency constitutes the passage of an electric current, and this can be stimulated by the application of a potential difference between adjacent molecules. This corresponds to applying a potential difference across a piece of metal.

When current flows in an electrolyte, chemical dissociation occurs, each molecule of the electrolyte breaks, under the potential gradient, into two ions with equal charges, one positive and the other negative. The complete molecule exhibits no resultant charge. Pure metal ions are positive and are attracted to the negative plate or cathode where they lose their charge. The acid radicle, e.g. the sulphate ion in the problem, is negative and so is attracted to the anode or positive plate.

In copper plating, the electrolyte is a solution of copper sulphate in water. Copper electrodes are used, with the article to be plated connected to the cathode. It may, in fact, form the complete cathode itself. A low-voltage d.c. supply is connected with its negative terminal at the article to be plated; an adjustable resistor, switch and ammeter are also included in the circuit in order to regulate the current to a suitable value. An excessive current can lead to irregular and loose deposition of the copper on the cathode. The sulphate ions, as they discharge on the anode, recombine with copper from the anode itself to give copper sulphate, which returns into solution. The electrolyte is thus replenished with copper sulphate at the expense of the anode.

The mass of copper deposited is proportional to the current and the time for which it flows, i.e. to the quantity of electricity passed through the electrolytic bath. It is also proportional to e, the electrochemical-equivalent of the metal being deposited. Hence, mass deposited = e × i × t grammes, where i amp is the constant current flowing for t seconds.

$$\text{Mass of copper to be deposited} = 0.15 \times 64 = 9.6 \text{ grammes.}$$

Using the above relation, we have, since the current is 0.8 amp,

$$9.6 = 0.000329 \times 0.8 \times t$$

$$\text{Hence, } t = \frac{9.6 \times 10^5}{26.32}$$

$$= 36,480 \text{ seconds} = \underline{10 \text{ hours } 8 \text{ minutes.}}$$

**Q. 8.** Define electrical power and electrical energy. State the units in which they are expressed.

The current in a circuit is measured by a shunted moving-coil milliammeter, having a 50-ohm coil. Full-scale deflexion is obtained when 10 mA flows in the coil.

Calculate the value of the shunt resistor if the milliammeter is to measure 5 A at full-scale deflexion.

What power does (a) the meter itself, (b) the complete shunted ammeter, dissipate when the shunted meter is showing its full-scale reading of 5 A?

**A. 8.** Electrical Power is the rate of using electrical energy. It is measured in joules per second, known as watts. Large quantities are given in kilowatts; 1 kilowatt = 1,000 watts.

Electrical Energy is the quantity of energy, given by power multiplied by time. It is measured in joules, or for large quantities in watt-hours or kilowatt-hours.

The circuit of the shunted meter is shown in the sketch. The value of the shunt resistor is calculated so that the voltage across the meter itself is just sufficient to give full-scale deflexion when the total current in the meter plus the shunt is 5 amp.

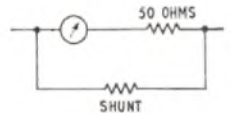

Since the meter-coil resistance is 50 ohms and full-scale deflexion is obtained when 10 mA flows in the coil, the voltage across the meter for full-scale deflexion = 50 × 0.01 = 0.5 volts.

If the combined meter plus shunt is to indicate 5 amp when the meter is fully deflected, then the meter will be taking 10 mA and the shunt 4.99 amp. When this current flows in the shunt the voltage across it must be 0.5 volts.

Then, by Ohm's Law, resistance of shunt =  $\frac{0.5}{4.99}$   
 = 0.1002 ohms.

(a) The power dissipated in the meter coil at full-scale deflection  
 =  $v^2/r = (0.5)^2/50 = 0.005$  watts  
 = 5 milliwatts.

(b) The complete shunted meter will pass 5 amp when the voltage across it is 0.5 volts.

Hence, its power consumption =  $v \times i = 0.5 \times 5$   
 = 2.5 watts.

Q. 9. Explain the operation of the thermionic diode valve as a rectifier of alternating currents. Sketch, and discuss the shape of, a typical  $I_a/V_a$  characteristic for such a valve over its full working range. What factors in the valve limit the current that can be passed through it?

A. 9. A thermionic diode valve consists essentially of an emissive surface, called the cathode, surrounded by a metal plate, the anode, the two being enclosed in an evacuated glass container, through which the connecting leads to the two electrodes pass. When the cathode is heated to a sufficiently high temperature electrons are "boiled off." An electron carries a negative charge so that, as an electron leaves the surface, the cathode becomes more positively charged. Thus, the emitted electrons experience a force of attraction towards the cathode and stability is reached when the number of electrons leaving the cathode is the same as the number returning. The cloud of electrons surrounding the cathode is called the "space charge," and it gives a negative potential to this immediate region. If the anode is maintained at a positive potential relative to the cathode, some of the electrons will be attracted to the anode and, if an external circuit connects the anode back to the cathode, they will flow round the circuit as a unidirectional current. Conversely, if the anode were maintained at a negative potential relative to the cathode, electrons would be repelled by the anode and no external current would flow.

When an alternating potential is connected between anode and cathode, current will only flow in the external circuit when the anode is positive with respect to the cathode. The basic circuit is shown in sketch (a). The transformer provides a means of connecting the alternating potential across the anode and cathode, and completes the circuit for the direct current that flows only during the positive half cycles.

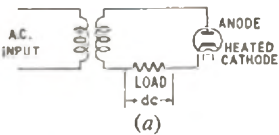

The anode current is the result of electrons being drawn from the

space charge by a positive anode. The current only flows in an external circuit when the anode has a positive potential. The curve in sketch (b) shows how the anode current will increase as the anode

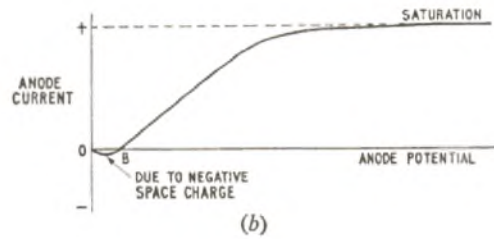

potential is gradually raised from zero. No current flows when it is at zero potential, point 0. As a small positive potential is applied, some of the negative space charge is overcome but not all, leaving the resultant potential on the anode slightly negative. The anode current at this stage tends to flow from anode to cathode. With rising anode potential this is overcome, until point B is reached at which there is equilibrium and no current flows despite the fact that the anode has a small positive potential applied to it. Further increase in anode potential attracts enough electrons to give a slight positive current which then increases in proportion to the increase in anode potential. This part of the characteristic is a straight line.

Saturation is reached when the anode potential is sufficient to draw off all the electrons in the space charge. This is the greatest anode current that can be drawn from the diode for the prevailing cathode temperature. If the cathode temperature is increased, more electrons boil off, the space charge rises, and the saturation point is also raised, giving a greater value of saturation current. The  $I_a/V_a$  characteristic is therefore asymptotic to a line of constant current, the saturation current, which is dependent upon cathode temperature. It is also governed by the resistance of the external circuit completing the anode-cathode path.

The nature of the cathode surface also affects the current that the diode can pass; a highly-emissive surface will give more electrons than one of less emissivity, for a given cathode temperature, i.e. for a given power consumption for heating the cathode.

Q. 10. Describe the principle of operation of a microphone for producing electric currents from sound waves.

What is the source of electrical energy in the microphone you describe?

PRACTICAL MATHEMATICS, 1961

Students were required to attempt not more than any six questions.

- Q. 1. (a) Simplify  $(10\frac{1}{2} - 6\frac{1}{3}) \div (\frac{6}{5} + 1\frac{2}{3})$ .  
 (b) Express 44 miles per hour in centimetres per second, assuming 400 metres is equivalent to  $437\frac{1}{2}$  yards.  
 (c) At the first inspection  $\frac{1}{8}$  of a batch of goods are rejected as faulty and  $\frac{2}{5}$  of the remainder the second inspection. Express the total number of rejected goods as a percentage of the number in the original batch.

A. 1. (a)  $(10\frac{1}{2} - 6\frac{1}{3}) \div (\frac{6}{5} + 1\frac{2}{3})$   
 =  $\frac{21/2 - 19/3}{5/2 + 5/3} = \frac{63/6 - 38/6}{5/12 + 20/12}$   
 =  $\frac{25/6}{25/12} = \frac{25}{6} \times \frac{12}{25} = 2$ .  
 (b) If  $437\frac{1}{2}$  yards is equivalent to 400 metres, 1,760 yd (1 mile) is equivalent to  $\frac{400}{437\frac{1}{2}} \times 1,760$  metres.

Hence, 44 mile/hr =  $\frac{44}{60 \times 60}$  miles per second  
 =  $\frac{44}{3,600} \times \frac{400}{437\frac{1}{2}} \times 1,760$  metres per second  
 =  $\frac{44 \times 400 \times 1,760 \times 100}{3,600 \times 437\frac{1}{2}}$  cm/s  
 =  $\frac{176 \times 1,760 \times 100 \times 2}{36 \times 875}$  cm/s

No.	Log.
88	1.9445
176	2.2455
8	0.9031
	5.0931
63	1.7993
	3.2938

(c) At the first inspection,  $\frac{1}{8}$  of the batch of goods are rejected and hence  $\frac{7}{8}$  are submitted to the second inspection.

As  $\frac{2}{5}$  of the remainder pass the second inspection,  $\frac{1}{5}$  must fail, i.e.  $\frac{1}{5} \times \frac{7}{8}$  of the original batch fail.

∴ Total number of failures, expressed as a fraction of the original batch,

=  $\frac{1}{8} + (\frac{7}{8} \times \frac{1}{5}) = \frac{6 + 7}{48}$

∴ Percentage of failures =  $\frac{13}{48} \times 100$  per cent

=  $\frac{325}{12} = 27\frac{1}{4}$  per cent.

Q. 2. (a) Use tables to evaluate:

(i)  $\sqrt{\frac{81.52 \times 0.5346}{66.82}}$  expressing your answer in standard form.  
 (ii)  $\sqrt{\frac{1}{5.26}} + \sqrt{\frac{1}{3.47}}$

(b) Evaluate z when  $\frac{1}{z} = (2.26)^2 + (1.54)^2$ .



A. 2. (a) (i)

$$\sqrt{\frac{81.52 \times 0.5346}{66.82}}$$

$$= \sqrt{0.6522} = 0.8076$$

$$= 8.076 \times 10^{-1}, \text{ expressed in standard form.}$$

(ii)  $\frac{1}{\sqrt{5.26}} + \frac{1}{\sqrt{3.47}}$

$$= \frac{1}{2.293} + \frac{1}{1.863}, \text{ from a table of square roots.}$$

$$= 0.4361 + 0.5367, \text{ from a table of reciprocals.}$$

$$= 0.9728.$$

(b)  $\frac{1}{z} = (2.26)^3 + (1.54)^2$

$$= 5.107 + 2.371$$

$$= 7.478$$

$$\therefore z = \frac{1}{7.478}$$

$$= 0.1338, \text{ from a table of reciprocals.}$$

No.	Log.
81.52	1.9113
0.5346	1.7280
66.82	1.6393
	1.8249
0.6522	1.8144
$\sqrt{0.6522}$	1.9072

A. 4. (a)

(i)  $(2^3)^2 = 64.$

(ii)  $(2pq^2)^4 = 16p^4q^8.$

(iii)  $\frac{(3ab)^2 \times 2ab}{12a^2b} = \frac{3ab^2}{2}.$

(b) The result is  $\frac{x+y+z}{x=3, y=2.5}.$

(c)

Q. 5. (a) Evaluate  $a^3 + 4ab - b^2 + a$  when  $a = -2, b = 1.$

(b) Factorise (i)  $x^2 + 4x$ , (ii)  $2x + 8$ . Hence or otherwise divide  $x^2 + 4x$  by  $2x + 8$ .

(c) Simplify  $\frac{2}{yz} - \frac{3}{zx} + \frac{4}{xy}$  giving your result with the lowest common denominator.

(d) Solve the equation  $\frac{1}{3}(3x - 1) + \frac{1}{4}(2x + 3) - 6 = 0.$

A. 5. (a)  $a^2 + 4ab - b^2 + a$   
 $= (-2)^2 + 4 \times (-2) \times 1 - 1^2 + (-2),$  substituting the values given.

$$= 4 - 8 - 1 - 2$$

$$= 4 - 11 = -7.$$

(b) (i)  $x^2 + 4x = \frac{x(x+4)}{2x+8}$

(ii)  $2x + 8 = \frac{2(x+4)}{2x+8}$

$$\therefore \frac{x^2 + 4x}{2x + 8} = \frac{x(x+4)}{2(x+4)}$$

$$= \frac{x}{2}.$$

(c)  $\frac{2}{yz} - \frac{3}{zx} + \frac{4}{xy} = \frac{2x - 3y + 4z}{xyz}.$

(d)  $\frac{1}{3}(3x - 1) + \frac{1}{4}(2x + 3) - 6 = 0$   
 Multiply throughout by 20 to clear the fractions.

$$\text{Then } 4(3x - 1) + 5(2x + 3) - 20 \times 6 = 0$$

$$12x - 4 + 10x + 15 - 120 = 0$$

$$\text{or } 22x = 120 - 11$$

$$\therefore x = 109/22.$$

Q. 6. (a) The speed  $n$  r.p.m. of a motor and the voltage  $V$  across the armature vary according to the law  $n = aV + b$ . When  $n$  is 710 and 1,070,  $V$  is respectively 80 and 120. Calculate the values of  $a$  and  $b$ .

(b) Use the formula  $\sqrt{\frac{1}{4}p^2 + q^2}$  to calculate  $f$  when  $p = 14.2$  and  $q = 8.6$ .

Make  $p$  the subject of the formula.

A. 6. (a)  $n = aV + b$   
 Substitute the given data:

$$710 = a \cdot 80 + b,$$

$$\text{and } 1,070 = a \cdot 120 + b$$

Subtract the first equation from the second:

$$360 = 40a,$$

$$\text{or } a = 9$$

Substitute for  $a$  in the first equation:

$$710 = (9 \times 80) + b,$$

$$\text{or } b = 710 - 720 = -10.$$

Thus,  $a = 9, b = -10,$

and the law is  $n = 9V - 10.$

(b)  $f = \sqrt{\frac{1}{4}p^2 + q^2}$   
 $= \sqrt{(\frac{1}{4} \times 14.2^2) + 8.6^2},$   
 when  $p = 14.2$  and  $q = 8.6$   
 $= \sqrt{50.41 + 73.96}$   
 $= \sqrt{124.37}$

$$\therefore f = 11.15.$$

$$f = \sqrt{\frac{1}{4}p^2 + q^2}$$

$$\therefore f^2 = \frac{1}{4}p^2 + q^2$$

$$\text{or } 4f^2 = p^2 + 4q^2$$

$$\text{and } p = \pm 2\sqrt{f^2 - q^2}.$$

No.	Log.
14.2	1.1523
14.2 <sup>2</sup>	2.3046
4	0.6021
	1.7025
8.6	0.9345
8.6 <sup>2</sup>	1.8690
124.37	2.0947
$\sqrt{124.37}$	1.0474

Q. 3. (a) Find the exact value of  $\frac{2.8 \times 0.05}{0.7 \times 0.4}.$

(b) Find the Lowest Common Multiple and Highest Common Factor of 44 and 112.

(c) A square is equal in area to a circle of radius 3 in. Calculate the radius of its inscribed circle. State the ratio of the areas of the inscribed and circumscribed circles of the square.

A. 3. (a)  $\frac{2.8 \times 0.05}{0.7 \times 0.4} = \frac{28}{7} \times \frac{0.5}{4}$   
 $= 0.5$

(b)  $44 = 4 \times 11 = 2 \times 2 \times 11$   
 $112 = 4 \times 28 = 2 \times 2 \times 2 \times 2 \times 7$   
 L.C.M. =  $2 \times 2 \times 11 \times 2 \times 2 \times 7$   
 $= 44 \times 4 \times 7 = 176 \times 7$   
 $= 1,232$

H.C.F. =  $2 \times 2 = 4$

(c) See the sketch. Suppose the square ABCD, of side  $a$  in., is

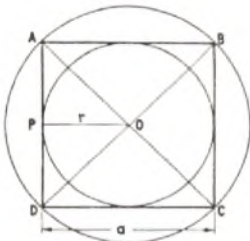

equal in area to a circle of radius 3 in.

$$\text{Then } a^2 = \pi \times 3^2 = 9\pi$$

$$= 9 \times 3.142 = 28.278$$

$$\therefore a = 5.317 \text{ in., from a table of square roots.}$$

From the sketch it will be seen that the radius,  $r$ , of the circle inscribed in the square is half the side of the square, or  $r = a/2$ .

$$\therefore r = 2.659 \text{ in.}$$

The inscribed and circumscribed circles of the square are both shown in the sketch. From this:

$$\frac{\text{Area of inscribed circle}}{\text{Area of circumscribed circle}} = \frac{\pi r^2}{\pi (AO)^2}$$

$$= \frac{r^2}{(AO)^2}$$

Now, from triangle APO, where OP is perpendicular to AD,

$$AP = OP = r = a/2$$

$$\therefore (AO)^2 = r^2 + r^2 = 2r^2$$

$$\therefore \frac{\text{Area of inscribed circle}}{\text{Area of circumscribed circle}} = \frac{r^2}{2r^2} = \frac{1}{2}$$

Q. 4. (a) Simplify: (i)  $(2^3)^2,$   
 (ii)  $(2pq^2)^4,$   
 (iii)  $\frac{(3ab)^2 \times 2ab}{12a^2b}$

(b) Add together  $(4x - 3y + 2z), (3x + y - z)$  and subtract  $(6x - 3y)$  from your result.

(c) The sides of an equilateral triangle are  $(3x - 1)$  in.,  $(x + 5)$  in. and  $(2y + 3)$  in. Calculate the values of  $x$  and  $y$ .

$x$	-1	1	3
$y$			

$$2x + y = 6$$

$x$	-1	1	3
$y$			

$$x - y = 1$$

PRACTICAL MATHEMATICS, 1961 (continued)

With the scales 1 in. = 1 unit for  $x$  and 1 in. = 2 units for  $y$  draw on the same axes, the graphs of  $2x + y = 6$  and  $x - y = 1$ .

Use these graphs to:

- (a) solve the two simultaneous equations,
- (b) find the slope of each line,
- (c) obtain the areas of the triangles between the lines and each axis in square inches.

A. 7.  $2x + y = 6$ ,  
or  $y = 6 - 2x$

$x - y = 1$ ,  
or  $y = x - 1$

x	-1	1	3
y	8	4	0

x	-1	1	3
y	-2	0	2

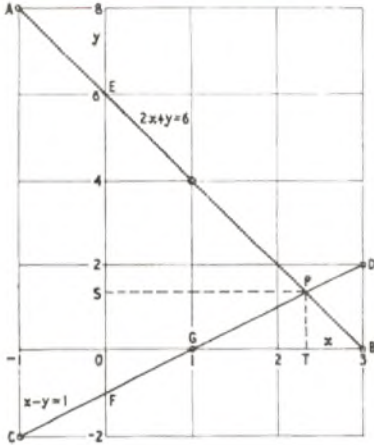

The graphs are shown in the sketch. For convenience in printing the sketch is reproduced at a reduced size from that asked for in the question.

(a) Where the graphs intersect, at point P, the coordinates of the point satisfy each equation and, hence, give the solution to the simultaneous equations.

From the graph,  $x \approx 2.33$  and  $y \approx 1.35$ .

Note: The solution can only be obtained approximately from the graph. The accurate solution is  $x = 2.3$  and  $y = 1.3$ .

(b) The slope (gradient) is conveniently found from the coordinates of two points widely separated on the graph. For the graph of  $2x + y = 6$  (points A and B),

$$\text{slope} = \frac{y_2 - y_1}{x_2 - x_1}$$

where  $x_1, y_1$  and  $x_2, y_2$  are the coordinates of the points A and B, respectively,

$$= \frac{0 - 8}{3 - (-1)} = \frac{-8}{4} = -2$$

For the graph of  $x - y = 1$  (points C and D),

$$\text{slope} = \frac{2 - (-2)}{3 - (-1)} = \frac{4}{4} = 1$$

(c) The triangle contained between the two lines and the y-axis is PEF. Area of triangle PEF =  $\frac{1}{2} \times EF \times PS$ , where PS is the perpendicular drawn from P to the y-axis,

$$= \frac{1}{2} \times 7 \times 2.3 \text{ in.}^2$$

$$= \frac{16.1}{4} \text{ in.}^2 = 4.025 \text{ in.}^2$$

The triangle contained between the two lines and the x-axis is PGB. Area of triangle PGB =  $\frac{1}{2} \times GB \times PT$ , where PT is the perpendicular drawn from P to the x-axis,

$$= \frac{1}{2} \times 2 \times 0.675 \text{ in.}^2$$

$$= 0.675 \text{ in.}^2$$

Q. 8. (a) Fig. 1 illustrates a part of a profile gauge form.

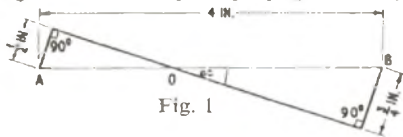

Calculate the lengths of AO, OB and the value of angle alpha to the nearest minute.

(b) Draw a triangle ABC, with the perpendicular BD from B to AC. Mark BC = a units and AC = b units.

Show that  $BD = a \sin C$  and that the area of the triangle is given by  $\frac{1}{2} ab \sin C$ .

Use this area formula to calculate the area of a regular hexagon of side 6 in.

A. 8. (a) With reference to Fig. 1 of the question, in the right-angled triangle with AO as its hypotenuse,

$$\sin \alpha = \frac{1}{AO}$$

In the right-angled triangle with OB as its hypotenuse,

$$\sin \alpha = \frac{1}{OB}$$

$$\therefore \frac{1}{AO} = \frac{1}{OB} \text{ or } OB = \frac{3}{2} AO$$

But  $AO + OB = 4$ , or  $AO = 4 - OB$ . Substituting for AO in the previous equation:

$$OB = \frac{3}{2}(4 - OB) = 6 - \frac{3}{2}OB$$

$$\therefore \frac{5}{2}OB = 6,$$

$$\text{or } OB = \frac{12}{5} = 2.4 \text{ in.}$$

$$\therefore AO = 4 - 2.4 = 1.6 \text{ in.}$$

$$\sin \alpha = \frac{1}{AO} = \frac{0.5}{1.6} = \frac{1}{3.2}$$

= 0.3125, from a table of reciprocals.

$$\therefore \alpha = 18^\circ 13', \text{ to the nearest minute.}$$

Thus,  $AO = 1.6 \text{ in.}$ ,  $OB = 2.4 \text{ in.}$ , and  $\alpha = 18^\circ 13'$ .

(b) The triangle is shown in sketch (a). Triangle BDC is right-angled at D and angle BCD is the same as angle BCA, i.e. angle C of triangle ABC.

$$\therefore \frac{BD}{BC} = \frac{BD}{a} = \sin C,$$

$$\text{or } BD = a \sin C.$$

Q.E.D.

$$\text{Area of triangle ABC} = \frac{1}{2} \times AC \times BD$$

$$= \frac{1}{2} \times b \times a \sin C$$

$$= \frac{1}{2} ab \sin C.$$

Q.E.D.

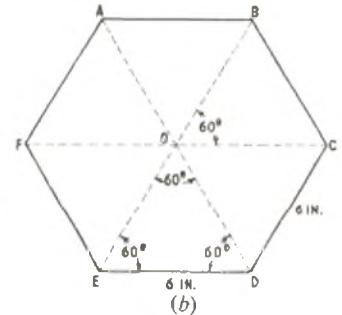
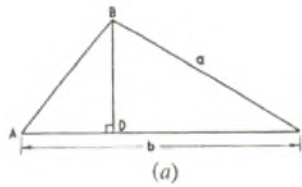

A regular hexagon with 6 in. sides is drawn to scale in sketch (b). Since it is regular, the hexagon comprises six equilateral triangles ABO, BCO, etc., having a common vertex O, which is the centre of the figure. It is clear that, in any one triangle, e.g. DEO, the internal angles are  $60^\circ$  and that  $ED = DO = OE = 6 \text{ in.}$

$$\therefore \text{Area of hexagon} = 6 \times \text{Area of triangle DEO}$$

$$= 6 \times \frac{1}{2} \times OE \times OD \times \sin \angle EOD$$

$$= 3 \times 6 \times 6 \times \sin 60^\circ$$

$$= 108 \times 0.8660$$

$$= 93.53 \text{ in.}^2$$

No.	Log
108	2.0334
0.866	1.9375
	1.9709

Q. 9. (a) Evaluate from tables:

$$\cos 35^\circ 26', \sin 72^\circ 41', \tan 45^\circ 07'.$$

(b) Fig. 2 shows a right pyramid on a rectangular base ABCD with vertical height VO.

$AB = 8 \text{ in.}$ ,  $BC = 6 \text{ in.}$ ,  $VO = 10 \text{ in.}$  Show that  $VA = 11.18 \text{ in.}$  and calculate the angles VAO and BYA correct to the nearest minute.

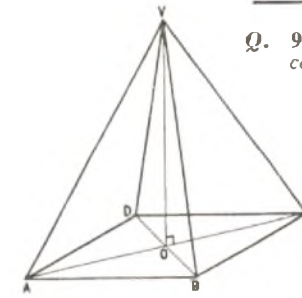

Fig. 2

A. 9. (a)  $\cos 35^\circ 26' = 0.8148$ .

$\sin 72^\circ 41' = 0.9546$ .

$\tan 45^\circ 07' = 1.0041$ .

(b) See sketches (a), (b), and (c).

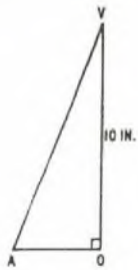

(a)

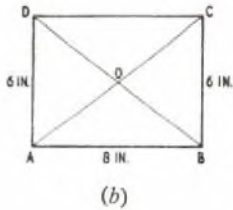

(b)



(c)

Sketch (c) shows the face BVA. Since  $AO = OB$ , triangles VAO and VBO are congruent and hence  $VA = VB$ . The perpendicular, VE, from V on to AB therefore bisects AB and angle BVA.

$$\therefore \sin \angle BVE = \frac{4}{11.18} \quad \left| \begin{array}{l} \text{No.} \\ 4 \\ 11.18 \end{array} \right. \begin{array}{l} \text{Log.} \\ 0.6021 \\ 1.0484 \\ \hline 1.5537 \end{array}$$

$$= 0.3579$$

$$\therefore \angle BVE = 20^\circ 58', \text{ to the nearest minute}$$

$$\therefore \angle BVA = 2 \times \angle BVE = 41^\circ 56'$$

Note: This answer is not necessarily correct to the nearest minute because of the doubling of  $20^\circ 58'$ , which was obtained within the limits of accuracy of the 4-figure tables. Greater accuracy would be obtained by the use of the cosine formula, but this is beyond the syllabus of Practical Mathematics.

Sketch (a) shows triangle VAO in which  $VO = \text{height of pyramid} = 10 \text{ in.}$  AO is half the diagonal of the rectangular base of the pyramid, as shown in the plan view of sketch (b).

From the right-angled triangle ACB (sketch (b)),  
 $AC^2 = AB^2 + BC^2$   
 $= 64 + 36 = 100$   
 $\therefore AC = 10 \text{ in.},$   
 and  $AO = 5 \text{ in.}$

Hence, from sketch (a),  
 $VA^2 = AO^2 + VO^2$   
 $= 25 + 100 = 125$   
 $\therefore VA = \sqrt{125} = 11.18, \text{ from a table of square roots.}$

Q.E.D.

$\tan \angle VAO \text{ (sketch (a))} = \frac{VO}{AO} = \frac{10}{5} = 2$   
 $\therefore \angle VAO = 63^\circ 26', \text{ to the nearest minute.}$

Q. 10. A cylinder (volume  $V_1$ , density  $\mu_1$ ) and a hemisphere (volume  $V_2$ , density  $\mu_2$ ) are joined together to form a solid, the plane end of the cylinder coinciding with the plane face of the hemisphere. If the centre of gravity of the solid lies in the common face then

$\frac{1}{2}hV_1\mu_1 = \frac{3}{8}rV_2\mu_2$   
 where  $h$  is the height and  $r$  the radius of the cylinder. When  $\mu_1 = 2\mu_2$  express  $r$  in terms of  $h$  and find an expression in terms of  $h$  and  $\pi$  for the total surface area of the solid.

A. 10.  $r = \frac{2}{3}h$   
 Total surface area of solid =  $16\pi h^2$ .

ENGINEERING DRAWING, 1961

Students were required to attempt question 1 and not more than any three questions from questions 2-7.

Q. 1. The elevation and plan of a terminal block, for the brush holders of a large electric motor, are shown in Fig. 1 on the attached plate, and these two views are in first angle projection.

Do not draw the views as given but draw, twice full size, two views as follows:

- (i) the given elevation,
- (ii) end elevation, looking in the direction of the arrow A.

These views are to be arranged in third angle projection. Show the hidden edges dotted. Print the title and scale neatly. Show eight principal dimensions.

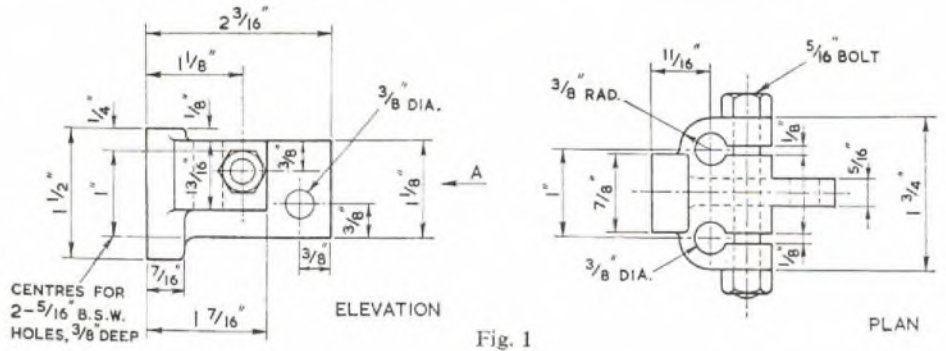
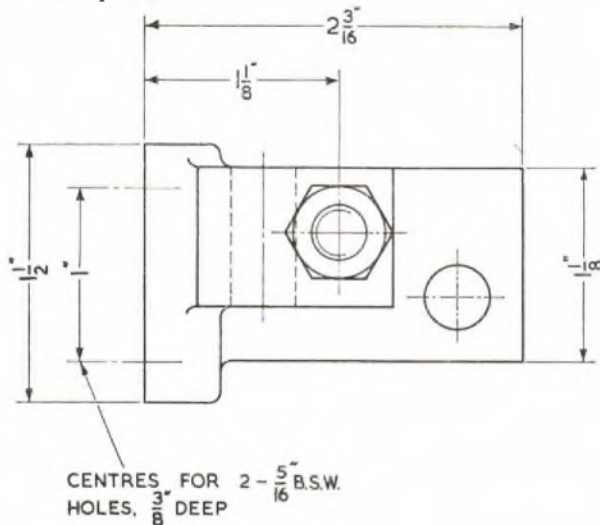

Fig. 1

A. 1. The required views are shown in the sketch. For convenience in printing, the sketch is reproduced at a reduced size from that asked for in the question.



CENTRES FOR 2 -  $\frac{5}{16}$  B.S.W. HOLES,  $\frac{3}{8}$  DEEP

TERMINAL BLOCK

SCALE:  $\frac{2}{1}$

Q. 2. Name three good conductors and three good insulating materials. Give one example, for each material, of where it could be used.

A. 2. Three Good Conductors

- (i) Copper. Copper is used for electrical conductors in all types of wires and cables.
- (ii) Silver. Silver is used for the electrical contacts of electro-magnetic relays.
- (iii) Gold. Gold plating is used for special switch contacts subject to exposed conditions.

Three Good Insulators

- (i) Glazed porcelain. Glazed porcelain is used for the insulators which support overhead power-transmission lines.
- (ii) Polyvinyl-chloride. Polyvinyl-chloride (p.v.c.) is used for the insulation in all types of wire and cables.
- (iii) Synthetic resins. Synthetic resins are used for connexion blocks and case mouldings.

Q. 3. Make a freehand drawing, showing the exterior of an automatic telephone for standing on a desk or table. Show clearly the dial for obtaining the numbers and the cradle for the handset. The handset is not to be included. The drawing may be pictorial or two views in orthographic projection.

A. 3. A freehand pictorial drawing of an automatic telephone for standing on a desk or table is shown in the sketch.



Q. 4. Make freehand drawings showing the shapes of the following steel sections: equal angle, unequal angle, Tee, channel, and rolled steel joist (1).

A. 4. The freehand drawings of the rolled steel section are shown in the sketch.

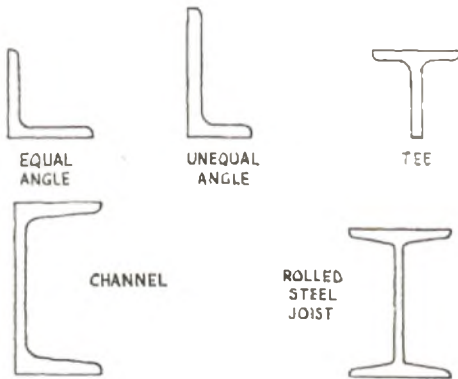

Q. 5. The form of a link of a large chain is shown in Fig. 2 on the attached plate. Draw this accurately, full size, showing all the construction lines for obtaining the centres of arcs and the points where they join.

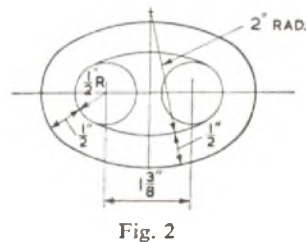
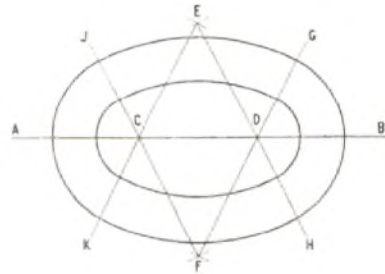

Fig. 2

A. 5. The construction of the chain link shown in the sketch,



although not required to answer the question, is as follows:  
 Draw the horizontal line AB, and locate two points, C and D, 1 3/8 in. apart on this line.

To locate points E and F  
 Describe two arcs with centre C and radius 1 1/2 in. and two arcs with centre D and radius 1 1/2 in. such that these arcs intersect at points E and F.

To draw lines EH, EK, FG and FJ  
 Draw lines through points E and C, E and D, F and C, and F and D, and produce to points K, H, J and G, respectively.

Completion of construction  
 Describe arcs with centre C and radii 1/2 in. and 1 in. between lines CJ and CK.

Describe arcs with centre D and radii 1/2 in. and 1 in. between lines DG and DH.

Describe arcs with centre E and radii 2 in. and 2 1/2 in. between lines EH and EK.

Describe arcs with centre F and radii 2 in. and 2 1/2 in. between lines FG and FJ.

For convenience in printing the sketch is reproduced at a reduced size from that asked for in the question.

Q. 6. Two cylindrical pieces are joined at PQ as shown in Fig. 3 on the attached plate. Determine the true shape of the joint marked PQ.

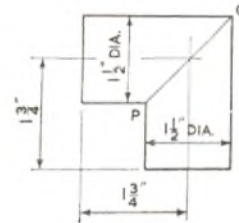
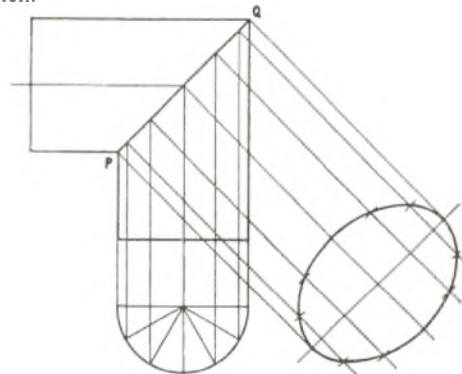

Fig. 3

A. 6. The true shape of the joint marked PQ in Fig. 3 is shown in the sketch.



Q. 7. Draw the two parts of the circuit diagram shown in Fig. 4 on the attached plate. Name the items denoted by the symbols R, K, HS, L, C, and S and state their functions.

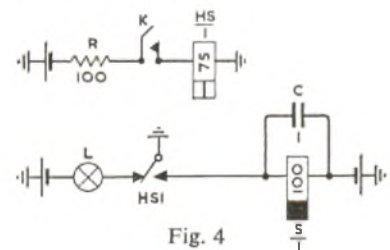
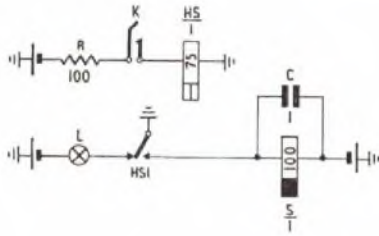

Fig. 4

A. 7. The circuit diagram of Fig. 4 is shown in the sketch.



The items denoted by the letter symbols, and their functions, are as follows:

(i) R is a 100-ohm resistor. It is provided to safeguard the key contacts under earth-fault conditions.

(ii) K is a manually-operated locking key, which when operated will complete the circuit for the operation of relay HS.

(iii)  $\frac{HS}{1}$  is a high-speed 75-ohm relay with one contact. When the relay is operated the single change-over contact will extinguish the signal lamp and complete the circuit for the operation of relay S.

(iv) L is a signal lamp which, when glowing, indicates that key K is unoperated.

(v) C is a 1  $\mu$ F capacitor. It will assist in delaying the release of relay S, but it will not affect the operating time of relay S which is connected directly between battery and earth.

(vi)  $\frac{S}{1}$  is a slow-to-release 100-ohm relay with one contact (not shown). The copper sleeve, or slug, fitted at the heel end of the core of a slow-to-release relay has little effect on the operating time of the relay but will produce a release lag, which is dependent on the size of slug used; in this circuit the release lag of the relay is assisted by capacitor C.

ELEMENTARY TELECOMMUNICATION PRACTICE, 1961

Students were required to attempt not more than any six questions.

Q. 1. Sketch and describe the construction of a foil-type capacitor having a relatively large capacitance and wide tolerances.

Give reasons for the choice of materials used and state the factors which influence the capacitance.

Would the capacitor you describe be regarded as being of high or low stability? Give reasons for your answer.

A. 1. See A.7, Elementary Telecommunications Practice, 1959. Supplement, Vol. 52, No. 4, p.65, Jan. 1960.

Q. 2. Explain why resistors are sometimes included in electrical circuits.

Sketch and describe the construction of two resistors, one having a relatively high, and the other a relatively low, power rating. Point out the features in the two constructions which contribute to the respective power ratings.

A. 2. The basic reason for the inclusion of resistors in electrical circuits is to cause a voltage drop across the resistor, the power being dissipated in the form of heat. In the functioning of a circuit, the result would depend upon how the resistor is connected relative to other components in the circuit and there would be many specific reasons for the inclusion of resistors. Typically, a resistor could be:

(a) Connected in series with another element to increase the total circuit resistance, reduce the total current, and thus reduce the volts dropped at other points in the circuit.

(b) Connected in parallel with another element to decrease the total circuit resistance, increase the total current, and increase the volts dropped at other points in the circuit.

Sketch (a) shows the construction of a typical wire-wound resistor

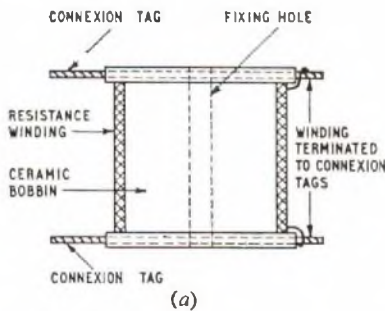

having a relatively high power rating. A cylindrical ceramic bobbin is wound with enamelled copper-nickel resistance wire which is spot-welded to phosphor-bronze connection tags. The winding may be single or multi-layer, but there is always an odd number of layers to facilitate the termination of the wire. The winding and welded connexions are finished with a coat of enamel or varnish. The power rating of the single-layer resistor of this type is 10 watts, and that of the multi-layer is 8 watts.

Sketch (b) shows the construction of a typical moulded carbon-composition resistor of the insulated type having a relatively low power rating of up to 2 watts. The raw material of the resistive

element—carbon black, resin binder, and refractory filling—are first graded, mixed in the required proportions, and sifted. The

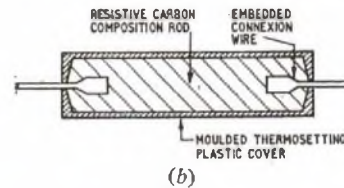

resultant black powder is compressed into shape and "cured" in a kiln which solidifies the unit. Tests are then made on the resistors, which are automatically sorted according to their resistance values before they are marked with the standard colour code, or resistance value, on the outer insulating cover. The end connexions are made by various methods, one of which consists of moulding the enlarged ends of tinned-copper connecting wires directly to the carbon rod. A thermosetting plastic insulation is moulded around the resistive element (hence the term insulated type) to prevent short-circuit to adjacent components or metal chassis, and to form protection against humidity.

When a current  $I$  flows through a resistor  $R$ , power in watts, given by  $I^2R$ , is generated and dissipated as heat. The heat raises the temperature of the resistor and an excessive temperature rise would cause damage such as fire, charred insulation, or in some forms of resistive element (e.g. carbon) permanent change in the resistance value.

The power rating, or the power-handling capacity, of a resistor is the maximum power in watts which can be dissipated by the resistor without raising the temperature above a certain critical value and, thus, without risk of damage to the resistor. A factor of safety is usually allowed. With a known resistor, the power rating thus sets a limit to the current which may be carried with safety.

In the wire-wound resistor described, a relatively high power rating is achieved by:

(a) The relatively large surface area in contact with free air which permits the heat to be transferred away from the resistor by convection air currents at a rapid rate.

(b) The lack of an outer cover which would prevent free air access to the resistive element.

(c) The large wire, and in particular the single-layer winding, permits rapid heat dissipation with negligible risk of hot spots.

(d) The good thermal-conductivity of the wire, of the large fixing screw to the mounting, and the reasonably good thermal conductivity of the bobbin, increase the rate at which heat is transferred away from the hot regions of the resistive element.

In the carbon resistor described, the features which contribute to the relatively low power rating are:

(a) The small physical size limits access to free air.

(b) The insulating outer case prevents air access to the resistive element.

(c) The solid and non-homogeneous nature of the resistive element tends to the formation of hot spots.

(d) There is little mass of good thermal conducting material to conduct the heat away from the hot regions.

ELEMENTARY TELECOMMUNICATION PRACTICE, 1961 (continued)

**Q. 3.** Describe THREE methods which may be used to obtain an indication of the state of charge or discharge of a lead-acid secondary cell. State, with reasons, which method you consider to be the best.

**A. 3.** Three methods are as follows:

**(a) Measurement of the Specific Gravity of the Electrolyte**

Chemical actions take place during the charge and discharge of a lead-acid secondary cell. During discharge, sulphuric acid of the electrolyte is converted to water. During charge, some of the water content of the electrolyte is converted into sulphuric acid. As water and sulphuric acid have different values of specific gravity, that of sulphuric acid being greater than that of water, the resultant specific gravity of the electrolyte, which is a mixture of water and sulphuric acid, is an indication of the strength of the electrolyte at any time during charge and discharge. As the chemical reactions are continuous processes, the specific gravity of the electrolyte decreases uniformly from 1.215 to 1.175 during the normal discharge period, and increases uniformly from 1.175 to 1.215 during the normal charge period up to the gassing condition. Sketch (a) shows how specific gravity changes during charge and discharge.

Thus, if the range of the specific gravity and the capacity of the cell are known, the residual capacity can be determined with reasonable accuracy at any time by measuring the specific gravity of the electrolyte with a hydrometer. As the specific gravity is dependent on temperature, allowance is made for temperatures above and below 60°F.

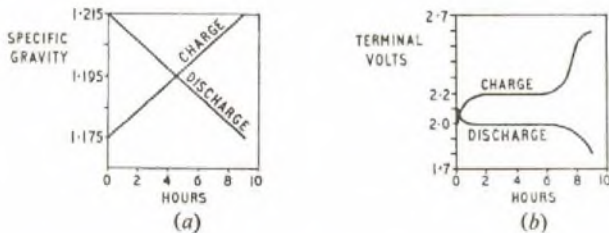

**(b) Measurement of Terminal Voltage**

During charge there is an initial rapid rise of the terminal voltage of the cell. Then there is a very gradual steady rise over the normal charge period due partly to the increase in density of the electrolyte and partly to the increase in potential of the positive plate. As the rise is so gradual, the terminal volts over the normal charge period can be regarded as being reasonably constant at about 2.2 volts, as shown in sketch (b). At a late stage in the charge, the terminal voltage rises rapidly, but falls rapidly to about the normal charged value when the charging current is ceased.

During discharge, the terminal voltage falls very gradually, due partly to the decrease in the potential of the plates as the active material is converted to lead sulphate and partly to an increase in the potential drop in the cell as the electrolyte becomes less dense and of higher resistivity. As the fall is so gradual over the normal discharge period, the terminal voltage can be regarded as being substantially constant at 2 volts, as shown in sketch (b). Beyond the normal discharge period, the terminal voltage decreases rapidly. It is clear that measurement of the terminal voltage gives a very general indication only of the charge or discharge condition of the cell.

**(c) Colour of the Positive Plate**

In the charged state, the positive plate is coated with lead peroxide which gives the plate a dark brown colour. The negative plate is pure spongy lead and is grey in colour. In the discharged state, the active material of both the plates is in a sulphated condition, consisting in the main of lead sulphate, and both the positive and negative plates are grey in colour. During charge, the colour of the positive plate changes slowly from grey to dark brown, and during discharge, from dark brown to grey. Thus, indication of the state of charge or discharge of the cell can be given by the colour of the positive plate.

The specific gravity method is the best method of assessing the condition of a cell as the variation is uniform over the charge and discharge periods and a reading relates directly to the charge or discharge condition of the cell.

In the voltage method, as the terminal volts are substantially constant during the normal charge and discharge periods, measurement of the voltage would not give a reliable indication of the state of charge or discharge of the cell.

The positive plate colour method is difficult to perform and is impossible with enclosed cells where the plates are not visible. Also, colour varies with cells from different manufacturers. Even with a skilled observer the method is arbitrary and unreliable as interpretation of the test depends upon the human element.

**Q. 4.** What advantages has a bridge-megger over a megger?

Describe, with simple sketches, the principle of tests, using either of these instruments, to measure:

- (a) the wire-to-wire insulation resistance of a pair of wires,
  - (b) the wire-to-earth resistance of a wire,
  - (c) the loop resistance of a pair of wires,
- and (d) the single-wire resistances of a pair of wires.

Point out the essential differences between tests (a) and (c).

**Q. 5.** Describe the arrangements adopted for conductor identification in the construction of (a) unit-twin, and (b) star-quad paper-covered underground cables. Point out the basic differences in the two arrangements.

Describe the constructional features adopted to minimize the capacitance of paper-covered underground cables.

**A. 5. (a) Unit-Twin Cable**

The paper insulation around the conductors is marked with one, two, three or four lines (the standard "spaced line" markings) for identification purposes. The A and B wires of one twisted pair are marked with one and two lines respectively, and the A and B wires of the adjacent twisted pair with three and four lines, respectively. The amount of ink on each paper is arranged to be the same in order to equalize capacitance and leakage effects.

Within a unit the colour of the lines differentiates between adjacent layers, and between the two marker pairs and the other pairs in each layer. There are no reference pairs. The numbering of the pairs in the centre and each layer commences with the first marker and follows clockwise with the second marker pair, and so on.

The marker pairs in the centre and even-numbered layers have the spaced-line markings coloured green (one and two green lines for the first marker pair, three and four green lines for the second marker pair), and the other pairs red (one and two red lines for one pair, three and four red lines for the adjacent pair). The marker pairs in the odd-numbered layers are coloured orange and the other pairs are blue.

Each unit in the unit-twin cable is lapped with white paper cotton-whipped, the paper having the unit number printed on it throughout its length to facilitate identification of a particular unit.

**(b) Star-Quad Cable**

The paper insulation around the conductors is marked with the one, two, three or four lines of the spaced-line markings. The A and B wires are marked with one and two lines, respectively, to form one pair (but not an individually twisted pair), and the C and D wires with three and four lines, respectively, to form the other pair of the quad.

The spaced lines of alternate quads in each layer are red or blue. The first quad (the marker) is marked red; the second, fourth, etc., are blue; the third, fifth, etc., are red; and the last quad (the reference) is blue. Cotton-whippings around the quads are coloured white for the centre and even layers, and black for the odd layers. The marker and reference quads in the centre and in each layer have an additional orange whipping.

The numbering of the quads in the centre and each layer commences with the marker, and follows clockwise to the reference, the last quad in the centre or layer.

The basic differences in the two conductor identification arrangements are:

(a) Unlike star-quad cables, identification in the unit-twin cable is complete without coloured-cotton-whippings around the basic (pair) element.

(b) The unit-twin cable has two marker pairs (the first two pairs), and no reference pairs. The star-quad cable has a marker (the first) and a reference quad (the last) in the centre or layer.

The relative permittivity (about 2) of the paper around the conductor is greater than that of air (unity). Thus, to reduce the capacitance of the cable, air space is desired around the conductors. This is achieved by loosely wrapping creased paper, helically, on the conductor. Alternatively, the air space can be obtained by lapping the conductor with a helix of paper string over which is a helical lapping of paper. Insulation with air and paper in the ratio of the order 1 to 1 gives the most satisfactory combination of electrical and mechanical properties, the capacitance being sufficiently low and the insulated conductor being neither too stiff nor too spongy.

Capacitance unbalance is reduced by the lay of a cable, i.e. the pairs, quads and layers being twisted relative to each other.

**Q. 6.** Describe the process of soldering a wire to a terminal to make an electrical connexion. Explain

- (a) the desired characteristics of the solder,
- (b) the desired characteristics, and the purpose of, the flux,
- and (c) why it is usually important to make a good mechanical joint before soldering.

A. 6. If necessary, the bit of the soldering iron is first tinned. The surface on one side of the bit is filed bright and clean for about  $\frac{1}{4}$  in. The bit is then heated and resin-cored solder applied until the surface is well tinned. The terminal is usually tinned in manufacture. Any insulation, including enamel, is removed from the wire for a distance to allow about one-and-a-half turns of bared wire to be twisted around the terminal. The wire should be in close contact with the terminal as the solder should function merely as an adhesive and not as a conductor. The bit, at the correct heat, is then placed against the terminal and the wire and the resin-cored solder is held against the terminal. This method allows the terminal and wire to heat up until both become hot enough to melt the solder, which then runs into the joint. The solder should not be melted direct by the bit, as it would not run correctly on the cold terminal and wire. When the solder has melted, the bit is moved over the wire and drawn off the terminal, carrying with it any surplus solder. The iron should be applied for a sufficient time to ensure complete melting of the solder, but must not be left on long enough to damage the surrounding insulation.

Immediately after use, the tinned surface of the bit is touched with solder as a precautionary measure to prevent the tinning from burning off when the iron is re-heated. Any excess solder is removed before the iron is used again.

(a) The desired characteristics of solder are:

(i) The melting point should be lower than that of the metals to be joined.

(ii) It should "wet" the surfaces to be joined. Insufficient "wetting" of the surfaces gives rise to poor "alloying" of the solder with the basis metal and causes high-resistance joints.

(iii) It must be free from brittleness and have reasonable mechanical strength.

(iv) The electrical conductivity should be as good as possible consistent with the mechanical requirements.

(v) The plastic range should be small to allow quick soldering. For soldering wires, solder having a tin-lead composition at or near the eutectic (62 per cent tin, 38 per cent lead) is usually adopted. This solder solidifies quickly, the plastic range being about 7°F.

(b) The adhesive strength of a joint depends upon intimate molecular contact between the solder and the metal. This is not possible unless the solder "wets" the surface of the metal and this cannot occur unless the surface of both the solder and metal are chemically clean. It is the flux used which performs this function. The desired characteristics of the flux are:

(i) It should clean the metal and remove oxide from the solder.

(ii) It should be stable under heat during the soldering process, to maintain continual freedom from oxide formation.

(iii) Any residue of flux should be neutral and hard to give protection of the joint against atmospheric conditions.

For soldering wires, the flux usually consists of resin, with the addition of a little activating agent such as alcohol, either ethyl or butyl, white spirit.

(c) The electrical conductivity of solder is relatively low and if the wire is not in close contact with the terminal the electrical resistance of the joint is increased. The wire should make a good mechanical joint with the terminal and the solder should function merely as an adhesive and not as a conductor. A dry joint may also occur when there is not a good mechanical contact between wire and terminal. Here the solder may hold the wire to the terminal, but may not have cohered to the terminal due to the presence of a layer of resin flux between the wire and the terminal.

It may not be always possible to ensure a good mechanical joint by wrapping (e.g. printed board wiring), but even here every effort should be made to achieve the best mechanical joint possible in the circumstances.

Q. 7. Describe, with a simple sketch, the construction of a polarized bell. Explain the principle of operation and the reason for the polarization.

What would be the probable effect on the working of the bell if, by some defect, the polarizing feature ceased to function?

A. 7. The construction of a polarized bell is shown in the sketch. The two operating coils, connected in series and so that their fields are aiding, consist of enamelled copper windings (500 ohms each) on soft-iron cores. The cores are clamped to a steel yoke. The cylindrical permanent magnet (tungsten steel or Alnico) is clamped at the yoke at one end and pivots the armature at the other. The armature is a light soft-iron stamping with a clearance hole at the centre for the permanent magnet. Brass residual studs are fitted to the armature to prevent closed magnetic circuits between the armature and cores and thus prevent the armature from sticking. The striker arm is attached, at its lower end, to an extension of the armature at the pivot point. The other end of the striker arm carries a small ball which strikes the gongs when the bell is energised.

In the idle condition, the permanent-magnet flux traverses two

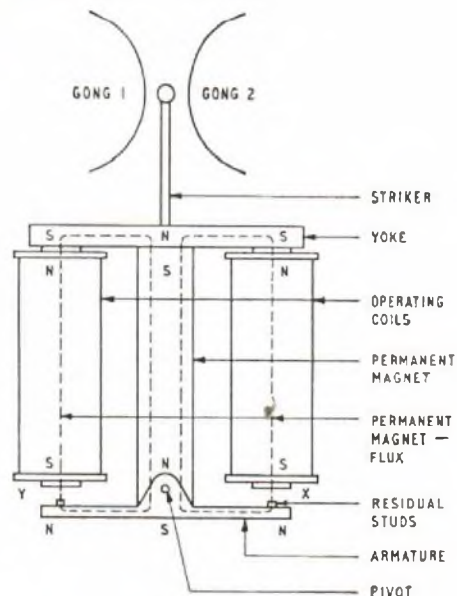

parallel paths, as shown in the sketch, and the various magnetic polarities are assumed as shown. It will be noted that like poles appear at the armature ends of the two coils, and, with the armature in the central position, the whole magnetic system is balanced and the armature will not be attracted to either pole. In practice, however, the armature is in a state of unstable equilibrium and any slight disturbance shortening one air-gap and lengthening the other, thus upsetting the magnetic balance, will cause it to move to one or other of the pole pieces. This condition is called "either-side stable" and is the practical condition.

When alternating current flows through the coils, the direction during the first half-cycle will cause, say, the pole piece at X to be S polarity, and that at Y to be N, due to the operating current. The standing permanent-magnet polarity S at X is thus strengthened, and S at Y is weakened. The flux in the air-gap X increases, that at Y is reduced, and the armature moves to pole piece X and gong 1 is struck.

When the current reverses during the second half-cycle, polarity N will appear at X, and S at Y due to the operating current. The flux in air-gap Y will be increased, that in X reduced, and the armature will move to pole piece Y causing gong 2 to be struck. Thus, each of the bell gongs is struck once per cycle of operating current.

The bell is polarized to give it directional operating characteristics to enable it to operate on a.c. The polarization also makes the bell sensitive, but this is not the primary reason for the polarization.

Let  $B$  be the flux in each coil core due to the permanent magnet, and  $b$  the flux in each core due to the operating current. Assuming that the armature is to move to X, then the total flux at X will be  $(B + b)$  and that at Y,  $(B - b)$ . Each air-gap flux will attract the armature, but the armature will move to X under the control of the stronger flux, the force on the armature being proportional to  $(B + b)^2 - (B - b)^2$ , which is proportional to  $4Bb$ . This includes the large factor  $B$  which gives the bell its sensitivity. On reversal of the operating current, the armature is attracted to Y under a force proportional to  $4Bb$ , and the directional operating properties of the bell are evident.

If the polarizing feature should cease to function, there would be no flux  $B$  in the above expressions. The force on the armature would be proportional to  $(+b)^2 - (-b)^2$ , which is zero, and the bell would not function. As, in practice, the armature rests on one pole piece or the other when idle, the armature would remain in this position of rest, attracted by the stronger flux but regardless of the direction of the operating current.

Q. 8. Explain why:

(a) a carbon-granule microphone requires a polarizing current, and (b) a telephone receiver requires a polarizing magnetic field.

Describe how the magnitude of the polarization affects the performances of the microphone and the receiver.

A. 8. (a) Microphones may be divided into two general types: (i) generator and (ii) modifier. The generator-type generates its own electrical power. The carbon-granule microphone is a modifier type. Here, the movement of the diaphragm due to the sound waves

striking it, deforms the carbon granules due to the varying pressure. Assuming no current flow through the granule path, no further effect would result, there would be no electrical power output and the acoustic power in the sound waves would not be converted into electrical power. When there is a standing current flow through the granules, the deformation of the granules varies the resistance of the granule path and the standing current is thus varied in magnitude. The microphone thus "modifies" the current flowing and the sound waves merely act to control an external source of power. For this it is necessary to pass an electric current through the carbon-granule type microphone.

Assume a simple microphone circuit.

Let  $I$  = steady d.c. polarizing current,

$R$  = total steady resistance of microphone circuit,

$E$  = applied volts,

$r$  = change in resistance of microphone during operation,

and  $i$  = resultant change in current.

Assume the resistance decreases in operation, then:

$$\begin{aligned} I + i &= \frac{E}{R - r} \\ i &= \frac{E}{R - r} - I \\ &= \frac{E - IR + Ir}{R - r} \\ &= \frac{E - E + Ir}{R - r} \\ &= \frac{Ir}{R - r} \end{aligned}$$

As  $r$  is small compared with  $R$ , the current  $i$  is approximately  $Ir/R$ . The term  $I$  is the steady component, and the term  $r/R$  is the changing component in the microphone circuit.

From this it is seen that the microphone output is directly proportional to the polarizing current. Also, if the changing component introduces distortion, increase in  $I$  will increase the distortion. There is a limit to the magnitude of the polarizing current as an excessively high value will produce intermittent arcing between granules (known as frying).

The internal resistance of the microphone depends on the magnitude of the polarizing current, the resistance decreasing with increased current, which again increases the output. A very small polarizing current  $E/R$ , where  $R$  is very high due to the current being small, would result in negligible microphone output.

(b) In the telephone receiver the polarizing field is produced by a permanent magnet. The operating magnetic flux varies in direct proportion to the current flowing in the coils of the receiver. The pull on the diaphragm is proportional to the square of the flux density.

Let  $B$  be the flux density due to the permanent magnet, and  $b$  the maximum flux density, in a positive or negative direction, due to the signal or speech.  $B$  is alternately assisted and opposed by  $b$ , and the variation of pull is (proportionally) from  $(B + b)^2$  to  $(B - b)^2$ , giving a maximum difference of pull proportional to  $4Bb$ .  $B$  is very large compared with  $b$ , and thus the sensitivity is greatly increased due to the permanent magnet. Without the permanent-magnet flux  $B$  the pull would be proportional to  $b^2$  and, as  $b$  is relatively small, the sensitivity would be low.

Without the permanent magnet, the diaphragm would be equally attracted in the same direction during each half cycle of the signal as  $(+b)^2$  and  $(-b)^2$  are both equal to  $b^2$ . The operation would then be unidirectional and the reproduced speech would have twice the frequency of the received speech currents. With the permanent magnet the respective half-cycle pulls are proportional to  $(B + b)^2$  and  $(B - b)^2$  and the addition of  $B$  thus ensures directional operation and thus correct response.

Consider the expression  $4Bb$ . Increase in the permanent-magnet flux,  $B$ , providing that it did not magnetically saturate the pole pieces, would increase the sensitivity further, and the sound output would increase under otherwise equal conditions. If  $B$  was very large, and sufficient to magnetically saturate the pole pieces under all conditions, the varying signal currents would cause little, if any, change of flux in the pole pieces. The sound output would be low and there would be the possibility of the receiver ceasing to function.

Decrease in  $B$  would reduce the sensitivity and the sound output would decrease. With  $B$  small relative to  $b$ , frequency doubling would occur and the sensitivity would be very low.

(To be continued)

## MODEL ANSWER BOOKS

CITY AND GUILDS OF LONDON INSTITUTE EXAMINATIONS FOR THE  
TELECOMMUNICATION TECHNICIANS' COURSE

TELECOMMUNICATION PRINCIPLES A TELECOMMUNICATION PRINCIPLES B

PRICE 7/6 each (Post Paid 8/-)

ELEMENTARY TELECOMMUNICATIONS PRACTICE PRICE 5/- each (Post Paid 5/6)

Model answer books for two of the subjects under the old Telecommunications Engineering Course are still available and are offered at a considerably reduced price.

### TELEPHONE EXCHANGE SYSTEMS I

Model answers published in this book come within the syllabuses for Telephony and Telegraphy A, and for Telephony B.

### TELEGRAPHY II

The model answers published in this book come within the syllabuses for Telegraphy B and for Telegraphy C.

PRICE 2/- each (Post Paid 2/6)

Orders may be sent to the *Journal* Local Agents or to  
*The Post Office Electrical Engineers' Journal*, G.P.O., 2-12 Gresham Street, London, E.C.2