

RA Roe

THE POST OFFICE *Granville P. d*  
ELECTRICAL ENGINEERS'  
JOURNAL



## CONTENTS

	Page
A NEW SWITCHING AND TRANSMISSION PLAN FOR THE INLAND TRUNK NETWORK W. J. E. Tobin, B.Sc.(Eng.), A.C.G.I., D.I.C., M.I.E.E., and J. Stratton, A.C.G.F.C., M.I.E.E. ....	75
MODIFICATIONS TO ALUMINIUM-ALLOY LADDERS E. J. Young, A.C.T.(Birm.), and R. J. Feasey, A.I.M. ....	80
MANUAL LIFTING AND HANDLING S. Rata, E.R.D., B.Sc.(Eng.), A.M.I.E.E. ....	82
A PULSING AND RINGING MACHINE FOR U.A.X.s N. H. Pendlebury. ....	87
LOCATING FAULTS BETWEEN JOINTING POINTS ON PRESSURIZED CABLES H. B. Cooper and R. A. M. Light. ....	89
THE ELECTRONIC SPEECH VOLTMETER TYPE 5A J. Hutter, B.Sc., A.M.I.E.E., and E. C. Archer. ....	92
THE LETTER-CARRYING CHAIN CONVEYOR AT LEEDS HEAD POST OFFICE J. H. Alderson, M.A., A.M.I.E.E. ....	95
NEW VALVES FOR DEEP-WATER SUBMERGED TELEPHONE-REPEATERS M. F. Holmes, B.Sc., and F. H. Reynolds, B.Sc.(Eng.), A.M.I.E.E. ....	98
THE SWITCHING OF TELEVISION CIRCUITS IN LONDON C. H. Blanchard, B.Sc.(Eng.), A.M.I.E.E., W. L. Newman, and W. M. Willett. ....	102
AN ELECTRONIC CLOCK FOR TELEVISION NETWORK SWITCHING A. C. Lander and L. A. Joyce. ....	108
CHANNEL EQUIPMENT DESIGN FOR ECONOMY OF BAND-WIDTH H. B. Law, B.Sc.Tech., A.M.I.E.E., J. Reynolds, B.Sc., A.C.G.I., and W. G. Simpson, B.Sc., A.M.I.E.E. ....	112
A PRINTING RECORDER FOR USE WITH OBSERVATION EQUIPMENT B. A. Green, M.I.Prod.E., M.I.E.I., and H. Blakey. ....	118
A LINE-SIGNAL MONITORING UNIT USING TRANSISTORS C. K. Price. ....	121
AN AUTOMATIC METER-OBSERVATION EQUIPMENT F. W. G. Redman and G. S. Donn. ....	124
EQUIPMENT FOR THE PROVISION OF STATISTICAL DATA CONCERNING SUBSCRIBER-DIALLED TRUNK CALLS—D. R. B. Ellis. ....	127
NOTES AND COMMENTS. ....	131
INSTITUTION OF POST OFFICE ELECTRICAL ENGINEERS. ....	132
REGIONAL NOTES. ....	134
ASSOCIATE SECTION NOTES. ....	140
STAFF CHANGES. ....	143
BOOK REVIEWS. ....	79, 86, 94, 117, 123, 126, 130, 131

Price 2s. 6d. (Post Paid 3s. 6d.)

Published in April, July, October and January by *The Post Office Electrical Engineers' Journal*,  
G.P.O., 2-12 Gresham Street, London, E.C.2.

Annual Subscription (post paid): Home and Overseas, 14s. (Canada and U.S.A., 2 dollars 25 cents).

# THE POST OFFICE ELECTRICAL ENGINEERS' JOURNAL

Vol. 53 Part 2

JULY 1960

## A New Switching and Transmission Plan for the Inland Trunk Network

W. J. E. TOBIN, B.Sc.(Eng.), A.C.G.I., D.I.C., M.I.E.E., and J. STRATTON, A.C.G.F.C., M.I.E.E.†

U.D.C. 621.395.74:621.395.37

The increasing proportion of telephone calls dialled by subscribers and the need to ensure satisfactory transmission on calls connected via several trunk circuits in tandem have made it necessary to plan changes to the inland trunk network. These include the provision of a separate transit trunk network to carry calls requiring the use of several circuits in tandem. The new network will have 4-wire switching at the transit switching centres and calls will be connected using rapid switching and signalling techniques. The reasons for formulating the new plan are discussed and its salient features are described.

### INTRODUCTION

THE need to ensure rapid connexion and satisfactory transmission on subscriber-dialled trunk calls has made it necessary to plan changes to the inland trunk network. Although the routing of the majority of trunk calls will not be altered radically and existing equipment and trunk circuits will be used, the longer-distance multi-link trunk calls will be routed over a new transit trunk network; these calls will be connected using rapid signalling and switching techniques, with 4-wire switching at the transit exchanges.

This introductory article discusses some of the reasons which have led to the formulation of the new plan and gives an outline description of the transit trunk network, including the methods of signalling and switching to be used and some of the transmission features.

### EXISTING TRUNK NETWORK

For the control and routing of trunk telephone traffic the United Kingdom is divided into zones and these are further divided into trunk groups, the trunk traffic originated at each exchange in a group being manually controlled from the trunk group centre exchange. There are 24 existing and authorized zone and sub-zone centres, approximately 250 group centres, and about 6,000 local telephone exchanges to which subscribers' lines are connected. The 6,000 local telephone exchanges are of two types: minor exchanges, which have direct circuits to their parent group centres; and dependent exchanges, each of which is connected to its group centre via a minor exchange.

† Mr. Tobin is head of the Telephone Exchange Systems Development Branch, and Mr. Stratton is head of the Main Lines Planning and Provision Branch, E.-in-C.'s Office.

Each zone centre exchange, except Belfast, is connected by trunk circuits of low transmission loss to all other zone centre exchanges. The function of a sub-zone centre is to relieve the zone centre of part of its through traffic by collecting traffic from part of the zone and routing it to any destination to which the sub-zone centre has direct trunk circuits. All group centre exchanges with circuits to a sub-zone centre should also be provided with circuits to a zone centre for the connexion of trunk traffic that cannot be routed through the sub-zone centre.

Trunk calls are at present normally set up under the control of a telephone operator at the trunk group centre exchange. Where possible, calls are connected using direct circuits to other group centres or via one intermediate group centre; the longer distance calls which cannot be connected in this way are routed via one or two zone centres.

In the past an operator would have been required to switch a call at each trunk exchange through which it passed. The mechanization of the trunk service<sup>1</sup>, involving the installation of automatic trunk exchanges at zone and group centres, is now well advanced and usually not more than one trunk operator, at the controlling group centre, is required for setting up a trunk call.

### *Subscriber Trunk Dialling and the Routing of Trunk Traffic*

Having reduced to one the number of operators concerned with each trunk call, the next logical step is to replace the operator by automatic equipment and allow telephone subscribers to dial their own trunk calls. Subscriber trunk dialling (S.T.D.), which has already been provided at several centres and is being rapidly extended, will achieve this objective. The system has been described in detail in a special issue of the Journal<sup>2</sup>.

To facilitate the introduction of S.T.D., the system of relating the charges for trunk and junction calls to the radial distances between exchanges has been replaced by a system under which the telephone exchanges in the United Kingdom are formed into 639 charging groups, with call charges common to all exchanges in a charging group. A charging group consists of one or more numbering groups, each of which will be identified by a code consisting of one, two or three digits.

The routing of S.T.D. calls to and from the exchanges in each numbering group will be via an exchange selected as the group switching centre (G.S.C.). A centre can, if necessary, deal with calls for more than one numbering group and, in the particular case of very large cities, there may be more than one G.S.C. handling the trunk traffic to and from a numbering group. G.S.C.s have not yet been selected for all numbering groups, but it seems likely that there will be about 400 of them, consisting of nearly all existing trunk group centres and some of the more important minor exchanges.

A subscriber wishing to make a trunk call will dial "0," which will connect his telephone to a controlling register-translator at the G.S.C. The register-translator will receive the digits dialled subsequently by the subscriber and determine the routing of the call and the call charge. For most calls it will be possible to use a direct route to the G.S.C. of the wanted subscriber or to route the call via one intermediate G.S.C. For the remaining calls, use of the present trunk network would result in undue delay occurring between the end of dialling and the receipt of a supervisory tone, and for the time being these calls will continue to be handled by an operator.

To enable these multi-link calls to be dialled by subscribers, a new trunk switching system, as described later, has therefore been planned.

#### *Transmission Features of the Existing Trunk Network*

The transmission features of the existing trunk network are, in general, in accordance with the transmission plan formulated in 1933<sup>3</sup>. It was then considered that the audibility should be not worse than that obtained from two standard telephones, with specified subscribers' lines and feeding bridges, and a nominal line loss of 15 db in the chain of trunk and junction circuits between terminal exchanges. To meet this standard it was intended that the various links in the trunk and junction network should comply with the following requirements.

<i>Type of Link</i>	<i>Transmission Loss (db)</i>
Zone centre to zone centre	0
Zone centre to group centre	3
Group centre to group centre	3 (Note 1)
Group centre to minor or dependent exchange	4.5 (Note 2)
Tandem exchange to minor exchange in a multi-exchange area (for traffic within the multi-exchange area)	6.5
Minor exchange to minor exchange for terminal traffic only	12

Note 1. A loss of 7.5 db was later allowed for circuits between group centres that carried terminal traffic only.

Note 2. For London, a loss of 6.5 db was later allowed between a minor exchange in the director area and a trunk exchange.

Note 3. The maximum nominal line loss (15 db) results on a call routed as follows: minor (or dependent)-group-zone-zone-group-minor (or dependent); i.e. 4.5 + 3 + 0 + 3 + 4.5 = 15 db.

The intention in the original plan that the permissible line losses would eventually include the transmission losses in the exchange equipment has not been realized. In practice a loss of the order of 1 to 2 db is introduced at each switching centre, and there may be additional loss in cables connecting different apparatus rooms in a building or group of buildings.

In 1933 most zone centres were linked by audio-frequency circuits in underground cable or on open-wire overhead routes. Speech signals were transmitted over the cable circuits at relatively low velocity and echoes caused serious difficulties which, on low-loss circuits,

made it necessary to fit echo suppressors. Zone centres are now linked by high-velocity carrier circuits which do not require the use of echo suppressors; the circuits are, however, adjusted to have a zero margin of stability (freedom from oscillation) when both ends are open-circuit, instead of the zero transmission loss originally visualized. This results in circuits connecting zone centres having a line loss of 1½ db or more at 800 c/s. In addition, it has proved too costly to provide routes from all group centres to fully interconnected zone centres and as a result a small proportion of calls have to be routed through three zone and sub-zone centres.

Although the points mentioned above have resulted in the transmission performance of the trunk network falling short of the standard set in 1933, the feature of the plan which has probably caused most difficulty is that of maintaining a line loss of 4.5 db from a dependent exchange, via a minor, to its group centre. The replacement of overhead routes by underground cables, with the economic desirability of avoiding the use of cables having 40 lb/mile or heavier conductors, has resulted in a worsening of transmission in some cases. With two independent circuits in tandem, amplifiers are of little help in obtaining a transmission loss of 4.5 db.

#### THE NEW PLAN

The new plan for the trunk network visualizes that local exchanges, to be known as "minor" exchanges, will each be directly connected to a G.S.C. via a single link. This is necessary for the following reasons.

(a) To allow periodic meter pulses to be relayed from the G.S.C. to the subscriber's meter at the minor exchange without the need for repetition at an intermediate exchange.

(b) To limit the number of digits needed to route a call to the objective exchange.

(c) To allow satisfactory transmission to be achieved without excessive expenditure on junction cables with heavy-gauge conductors.

It would be impracticable and unnecessary to convert the whole of the existing trunk network to a new system embodying fast setting-up of calls and improved transmission. Therefore G.S.C.s will continue to be interconnected by direct circuits wherever justified economically, and connexions may be set up with not more than two such circuits in tandem. The majority of trunk calls (possibly about three-quarters) will be routed in this way and will make full use of existing switching and signalling equipment. New equipment and a separate network of trunk circuits will be provided for the remaining calls to cater for the requirements of fast signalling and switching and to ensure satisfactory transmission.

#### *Transit Trunk Network for Multi-Link Trunk Calls*

The controlling register-translator at the originating G.S.C. will determine the routing of a call direct to the wanted G.S.C., via an intermediate G.S.C., or over the transit network. An outline trunking diagram of a G.S.C. is shown in Fig. 1.

This form of control will facilitate the provision of automatic alternative routing, which will permit traffic to be offered to a direct route and then, if all circuits are engaged, to overflow to the transit network. Direct circuits can then be economically provided for smaller quantities of traffic than would otherwise be possible; such direct routes could be economically justified on a

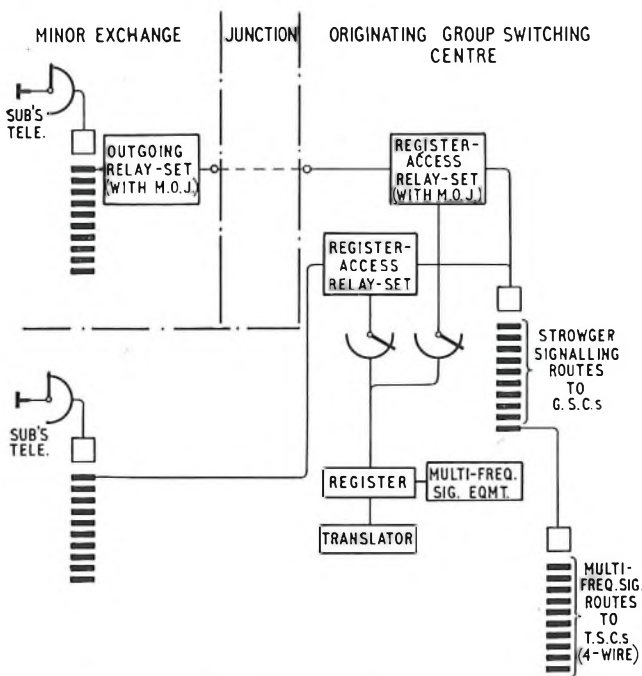

FIG. 1—OUTLINE TRUNKING DIAGRAM OF GROUP SWITCHING CENTRE

“high usage” principle, i.e. more traffic would be offered to the route than could be carried by the circuits in the route at the standard grade of service, overflow traffic being diverted to the transit network. It follows that the routes in the transit network to which calls may be alternatively routed must be “fully provided” to carry traffic normally routed in this way as well as the overflow traffic from the direct routes.

Automatic alternative routing will also be used at transit centres, but the extent to which this will be desirable has yet to be determined. A maximum of two alternatives per route is being considered.

#### Four-Wire Switching

The use of a separate relatively small transit trunk network, carrying only a small proportion of the trunk traffic, makes it practicable to use 4-wire switching techniques at transit centres without undue cost or complication. This will be advantageous for rapid signalling, it will ensure that transmission is satisfactory and will enable more transit trunk circuits to be connected in tandem than would be possible with simple 2-wire switching. At present the number of circuits in tandem between trunk group centres is normally limited to three, i.e. when connexion is made via two zone centres. Under the new plan, group switching centres may be connected via five transit trunk circuits in tandem; exceptionally, for some calls to the Scottish islands, six links may be connected in tandem.

#### Transit Switching Centres

There will be 42 transit switching centres (T.S.C.s), located in the following cities and towns.

Some of the T.S.C.s (possibly six, though this has yet to be decided) will be fully interconnected to enable the number of transit trunk circuits in tandem to be normally limited to five. Each T.S.C. will have a route to one or more of these fully-interconnected T.S.C.s

- |             |            |                |              |
|-------------|------------|----------------|--------------|
| ‡Aberdeen   | *Edinburgh | Lincoln        | Peterborough |
| §Belfast    | Exeter     | *London        | ‡Plymouth    |
| *Birmingham | *Glasgow   | *Manchester    | Preston      |
| *Bristol    | Hereford   | *Middlesbrough | *Reading     |
| *Cambridge  | Hull       | *Newcastle     | ‡Salisbury   |
| *Cardiff    | ‡Inverness | Norwich        | *Sheffield   |
| ‡Carlisle   | Kirkwall   | *Nottingham    | Shrewsbury   |
| *Chester    | Kyle       | Oban           | Stornoway    |
| Colchester  | *Leeds     | Oxford         | ‡Swansea     |
| Colwyn Bay  | *Leicester | Perth          | *Tunbridge   |
| Dumfries    | Lerwick    |                | Wells        |
- \*Existing or authorized zone centres.  
‡Existing or authorized sub-zone centres.  
§Partially-connected zone centre.

#### SWITCHING AND SIGNALLING

At G.S.C.s 2-wire switching will be used for access to and from the transit trunk network; full use will be made of existing equipment, level 1 of the 1st trunk selectors being used for access to 2nd trunk selectors serving transit routes. For the transit switching centre exchanges new switching and signalling systems are being designed, as described below.

#### Setting Up Multi-Link Trunk Calls

When setting up a call over the transit network a free circuit to the required T.S.C. will be selected at the originating G.S.C. At the T.S.C. a transit register-translator will be connected to the trunk circuit and a “transit-proceed-to-send” signal will be returned to the controlling register-translator at the originating G.S.C., which will then transmit the information needed by the transit register-translator to route the call through the T.S.C. If the call is to be routed through further T.S.C.s the process will be repeated until the terminal G.S.C. is reached. A “terminal-proceed-to-send” signal will then be returned to the controlling register-translator, which will transmit the “local” part of the required subscriber’s national number.

#### Rapid Switching at Transit Centres

The speed of switching required at T.S.C.s can be achieved with the type of motor-uniselector<sup>4</sup> that is already being used at trunk mechanization centres. The connexion through the exchange will be established via a link circuit consisting of two motor-uniselectors connected “wiper-to-wiper,” as shown in Fig. 2. One motor-uniselector will act as a “finder” to connect the incoming trunk-circuit line relay-set to the link circuit; the other motor-uniselector will select a free outgoing circuit to the next centre.

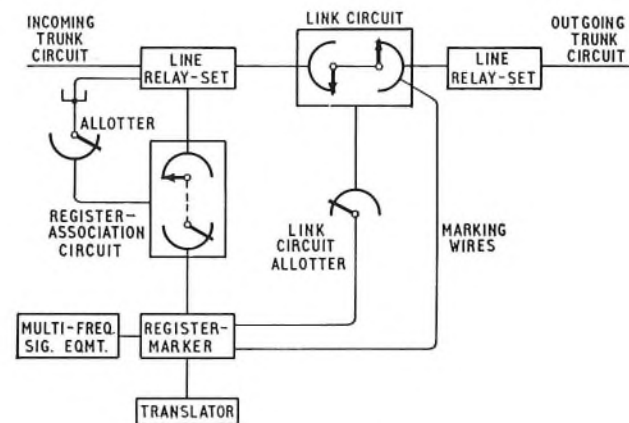

FIG. 2—BLOCK SCHEMATIC DIAGRAM OF TRANSIT SWITCHING CENTRE

### Inter-Register Signalling

A 2-out-of-5 code multi-frequency signalling system will be used to transmit the digital information in the forward direction. This signalling equipment will be associated with the registers and not directly with the trunk line circuits.

Two frequencies, different from those used in the forward direction, will be used for signals in the backward direction (proceed-to-send, etc.).

### Line Signalling

The seizure, release and supervisory functions will be effected by means of line signalling systems which will be individual to the circuits concerned. The majority of the circuits will employ a 1 v.f. in-band signalling system. Exceptionally, an out-of-speech-band voice-frequency signalling system (similar to Signalling System, A.C., No. 8<sup>b</sup>) may be used on some of the h.f. circuits and a d.c. signalling system on audio circuits.

there will be some error due to limited accuracy of adjustment, and subsequently there will be changes due to power supply variations, component changes (particularly valve aging and replacement) and temperature changes. Consequently, when several independent circuits are connected together to set up a call, the transmission loss between G.S.C.s is unlikely to be exactly 7 db and it may be appreciably more or less. It is, however, planned to provide automatic gain control of the longer-distance carrier groups to restrict the range of variation.

The nominal loss between G.S.C.s (7 db) is a compromise: it must be sufficiently high to ensure that there is little chance of instability (i.e. oscillation round the loop path formed by the separate go and return paths and the 4-wire/2-wire terminating sets) if some of the component circuits have a transmission loss less than the nominal; but on the other hand it must be as low as possible so that speech and signalling currents are not

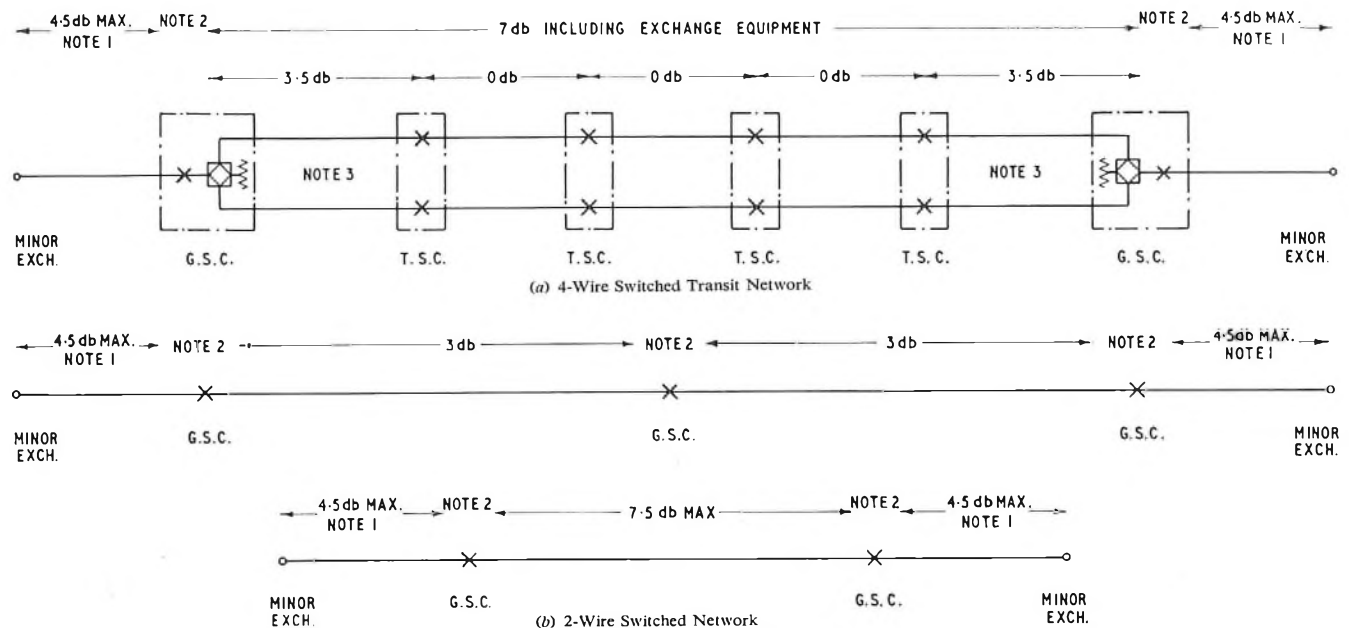

- Notes:
1. In London there may be a maximum loss of 6.5 db for minor to G.S.C. links.
  2. The switching-point loss at a G.S.C. will be approximately 1 to 2 db. At T.S.C.s the transmission loss of exchange equipment will be included with the line loss.
  3. It will be possible to use 2-wire circuits between a G.S.C. and its T.S.C. in

- special cases where the distance is short. Each such link will be provided with a 2-wire/4-wire terminating set at the T.S.C. to allow connexion to the 4-wire switching equipment.
4. X denotes 2-wire switching equipment; X denotes 4-wire switching equipment.

FIG. 3—NEW TRANSMISSION PLAN

### TRANSMISSION

The more important transmission features of the new plan are illustrated in Fig. 3. It will be seen that for the majority of calls, which make use of direct circuits between G.S.C.s, the arrangement is similar to that of the existing plan, except that there are no dependent exchanges, and group switching centres take the place of trunk group centres. The main change is for calls over the 4-wire switched transit network. The arrangement adopted will provide more uniform transmission for long-distance multi-link trunk calls than the present trunk network and will ensure that transmission is satisfactory between subscribers connected to exchanges on the fringe of the network.

Although the transmission loss of each trunk circuit between T.S.C.s will be adjusted to a nominal 0 db (measured between 4-wire switching points), initially

unduly attenuated when the component circuits have a greater than nominal loss (or so that the number of links that can be connected in tandem is not unduly restricted). Also, the transmission loss or gain of the 4-wire part of the connexion when added to the loss (go to return) of the 4-wire/2-wire terminating sets must not be such that there is likelihood of objectionable echoes being heard by the talker or listener.

Nearly all the longer-distance circuits of the transit network will be high-velocity circuits on carrier or coaxial cables and, with the loss chosen for the 4-wire part of the connexion, echo suppressors will not be needed.

As previously mentioned, avoiding the arrangement whereby two junctions in tandem are required to have a transmission loss not greater than 4.5 db will help ensure that the new plan can be followed without incur-

ring excessive expenditure on junction cables with heavy-gauge conductors, although some additional circuits will be necessary.

#### AUTOMANUAL CENTRES

Telephone switchboards are at present located at trunk group centres and at such other places as are necessary for the normal connexion of trunk traffic and for dealing with the queries and difficulties of subscribers. With the increasing proportion of calls being dialled by subscribers, due to the introduction of group charging and S.T.D. and the replacement of manual exchanges by automatic equipment, the amount of telephone traffic handled by operators will be progressively reduced and fewer automanual centres will be needed.

Consideration of transmission requirements leads to the conclusion that the automanual centre for a group of exchanges should generally be either at the G.S.C. serving the exchanges or at the T.S.C. Automanual switchboards at G.S.C.s will normally use conventional 2-wire switching, but at T.S.C.s the switchboard will control 4-wire switching equipment. Similar 4-wire switching equipment will be required for association with a switchboard at a G.S.C. to enable it to handle automanual traffic from another G.S.C. where this is the most economical way of giving automanual service.

#### CONCLUSIONS

The new trunk switching and transmission plan will enable multi-link trunk calls, particularly those dialled by subscribers, to be connected quickly and economically

and with satisfactory transmission performance. The principal features of the new plan have been decided and development work has been started, though it will be some time before the first transit switching centre is in use.

Further articles will describe in more detail the different features of the plan and the new equipment that is being developed.

#### ACKNOWLEDGEMENTS

The new plan has resulted from co-operation between several branches of the Engineering Department and the Inland Telecommunications Department. In particular, the Telephone Exchange Systems Development Branch is responsible for switching and signalling, the Main Lines Development and Maintenance Branch and the Main Lines Planning and Provision Branch for the transmission aspects of the new plan, and the Exchange Equipment and Accommodation Branch for trunking aspects and the implementation of the plan.

#### References

- <sup>1</sup> THOMPSON, A. J., and BROADHURST, J. H. Trunk Mechanization. *I.P.O.E.E. Printed Paper No. 201*, 1951.
- <sup>2</sup> Subscriber Trunk Dialling. *P.O.E.E.J.*, Vol. 51, Part 4, Jan. 1959.
- <sup>3</sup> STRATTON, J., and LUXTON, W. G. Modern Developments in Telephone Transmission Over Lines. *I.P.O.E.E. Printed Paper No. 153*, 1933.
- <sup>4</sup> MAY, C. A. The Post Office Standard Motor Uniselectors. *P.O.E.E.J.*, Vol. 46, p. 79, July 1953.
- <sup>5</sup> HORSFIELD, B. R., GIBSON, R. W., and MILLER, C. B. Signalling Over Carrier Channels that Provide a Built-in Out-of-Speech-Band Signalling Path. *P.O.E.E.J.*, Vol. 50, pp. 76 and 165, July and Oct. 1957.

## Book Review

"Theoretical Electromagnetism." W. R. Myers, M.Sc. Butterworths Scientific Publications. xii + 274 pp. 117 ill. 42s.

Some years ago we were delighted by a book from the pen of an engineer, Prof. E. G. Cullwick, about fundamental electromagnetism. Here is the complementary volume, written from an equally delightful standpoint, although the author does not claim to have attempted what in fact he has actually achieved.

Mr. Myers is a physicist writing for undergraduates who aspire to an honours degree in physics. However, unlike most of his colleagues in the academic world of physics the author, unashamedly and without any apologetic attitude, bases his treatment on the rationalized M.K.S. system of units. He assumes no previous knowledge of this system as he is presuming that most of his readers will have come straight from school where they will have studied physics up to G.C.E. advanced or scholarship level using only c.g.s. units.

His treatment starts traditionally with electrostatics based on Coulomb's inverse square law, and proceeds at once to the development of the conception of electric fields and field theory with due regard to, and emphasis upon, energy conditions. The concept of electric displacement and polarization is clearly developed and lucidly treated in his opening chapter.

The second chapter deals with magnetostatics, and in order to emphasize to the student the highly artificial nature of magnetic poles in contrast to electric charges, the author indicates the temptation to start with magnetic

poles because of the identity of the field equations of electrostatics and magnetostatics, but refuses to do so and bases his magnetostatics firmly on the more practical idea of electric currents and the mutual forces between conductors carrying currents. Having established his basis in this way, by means of Ampere's Theorem, he introduces, in this order, magnetic potential, magnetic moment, magnetic shells and, finally, magnetic poles.

Throughout his treatment of elementary field theory the author is most careful to point out to the student the distinction between scalar and vector parameters using the parameters themselves as illustrations. This is all too frequently omitted, students learning about scalars and vectors in their mathematics but failing to apply their mathematical knowledge correctly when studying its application to more advanced physics.

At the end of the chapter on magnetostatics, the author includes an elementary but rigid treatment of magnetization, the conception of the magnetic vectors  $B$  and  $H$  and their relation to the electric vectors  $D$  and  $E$ . There follows a short chapter on electromagnetic induction in which the application of magnetic vector potential is most clearly explained and the betatron is used as an illustration of the connexion of Faraday's Law with static field theory.

Alternative ways of defining inductance are next discussed and the conception of magnetic energy is explained.

The subject of alternating currents is introduced via Ampere's Law, the conception of displacement current and wave propagation. Low frequency alternating currents thus emerge as a special case where radiation effects are small. A reasonably complete treatment of resonance and

(Continued on p. 81)

# Modifications to Aluminium-Alloy Ladders

E. J. YOUNG, A.C.T.(Birm.), and R. J. FEASEY, A.I.M.†

U.D.C. 645.497:669.715

With the experience gained from the use of aluminium-alloy ladders a number of deficiencies became apparent. This article describes the developments in materials and design which were found to be necessary.

## INTRODUCTION

WHEN the Post Office first introduced aluminium-alloy ladders, the specification laid down no definite requirements for the stile and rung material, and the ladders were virtually standard commercial types modified by the provision of a flexible top rung. All the manufacturers used an aluminium alloy to Specification AW10C (B.S. STA7 Schedule)<sup>1</sup> for both stiles and rungs. Since their introduction, however, considerable changes have been found necessary in order to obtain ladders which will be satisfactory from the points of view of safety and Post Office conditions of service.

A brief description is given of the defects of earlier materials and designs, together with details of the correction of production faults and the modifications which have been developed by the Post Office.

## STILES

Stiles for the original ladders, either shaped drawn tubes or direct extrusions, were constructed from an aluminium-silicon-magnesium alloy in the fully heat-treated condition. Alloys of this type were recognized to have very good resistance to atmospheric attack, and consequently an adequate service life was to be expected. It was later found, however, that the stiles could develop a form of corrosion in which intercrystalline attack progressed inwards from the outer surface (Fig. 1), the



Magnification: 160 times

FIG. 1.—SURFACE PITTING AND CRACKS DUE TO INTERCRYSTALLINE CORROSION

penetration being dependent on the corrosive properties of the atmosphere. This corrosion resulted in a reduction of effective cross-section (leading to a loss of strength) and also in an increase in “notch sensitivity” (liability to

† Birmingham Materials Section, Test and Inspection Branch, E.-in-C.'s Office.

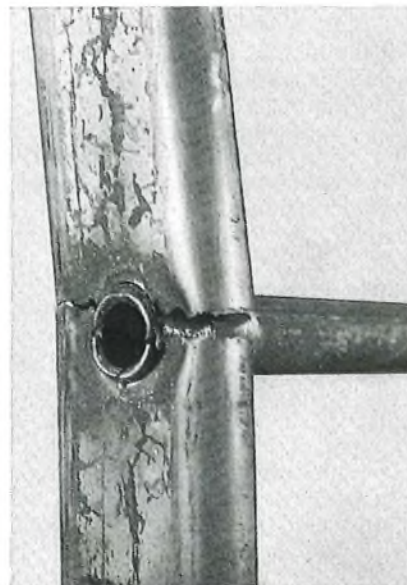

FIG. 2.—TYPICAL CRACK FORMATION IN A LADDER STILE AS A RESULT OF INTERCRYSTALLINE CORROSION ATTACK

cracking under stress), the crack starting in the corroded part of the surface and then progressing across the whole section (Fig. 2).

It became known to other users and manufacturers that fully heat-treated aluminium alloys containing magnesium and silicon could be prone to this form of attack. As a result of practical experience and research by industry the alloy formerly used for stiles is now more closely defined in British Standards. However, the Post Office decided to change the alloy, and stiles are now constructed from rectangular box section to B.S.1474 HV 30 WP<sup>2</sup> or shaped from tube to B.S.1471 HT 30 WP.<sup>3</sup> While the basic alloying constituents remain the same as before, the present alloy contains a definite proportion of manganese. The impact and “notch sensitivity” of this alloy is such that the effect of corrosion from a structural point of view is less serious than in the former alloy.

The desire to provide a very light ladder had resulted in the use of rather thin section for the stiles. When the change in alloy was made it was thought desirable to increase the factor of safety, and a minimum thickness of 0.080 in. is now required.

## RUNGS

Rungs were formerly constructed from fairly-thin serrated tubular section of the same alloy as the stiles, but in the solution-treated condition. This condition is necessary to allow ease of fixing into the stiles. A more robust rung of improved design was necessary to give longer life. The new alloy as used for the stiles is now specified, minimum wall thickness is required to be 0.080 in. and the rungs incorporate a raised non-slip surface rib. In addition, this form of rung, when fitted into the stiles, can be spun over on the ends, thereby



eliminating the possibility of "pinching in" or distorting stiles, a defect which has previously been not uncommon.

#### FITTINGS

When the ladders were first introduced, apart from the need for mild-steel fittings to be galvanized, no specific requirements were laid down for fittings. The first run-hooks were formed from mild-steel strip, and they were later required to be of aluminium alloy. The troubles first experienced with the latter type, gravity-cast in D.T.D.424 alloy, were bad design in the position of the fixing holes, and shrinkage porosity. After modification of the design and production technique, sound castings of adequate strength resulted. One manufacturer used aluminium-bronze castings, but again the design was not ideal. The castings were prone to shrinkage cavities, and the design had to be modified. Ultimately, hooks in

various designs were cast from B.S.1490 LM4 M<sup>4</sup> alloy, or forged from B.S.1472 HF 12W<sup>5</sup>, and these are now the specification requirements. Recently, hooks cut from extruded section in B.S.1476 HE 30<sup>6</sup> alloy have been investigated.

Defects have arisen with guide brackets, due to incorrect forming from mild-steel strip. It was found that when the strip was formed to a 90° bend over a tool with sharp corners there was deformation of grain flow on either side of the notch formed (Fig. 3). The grain flow was in line with the major direction of strain in the notch area, and this weakness could lead to cracking and ultimately to failure by fatigue. Brackets are now required to be formed so that the bends in the brackets have an internal radius of approximately  $\frac{1}{4}$  in. After bending, the brackets must not show any cracks, notches or indentations and, on preparing a micro-section at the bend of the bracket, the grain flow of the metal must follow the line of the bend with no signs of deformation.

B.S.1490 LM 4 alloy proved to be the most suitable material for the safety release catch, a fitting later introduced by the Post Office. A modification to the original pattern was necessary as there was a design weakness around the bearing insert.

#### CONCLUSION

The improvements in both roof and extension ladders will undoubtedly result in a longer service life and, from the safety aspect, field staff should acquire confidence in their use.

#### References

- <sup>1</sup> B.S. STA7 : 1945. Services Schedule of Non-ferrous Metals; Group 6, Aluminium and its Alloys (British Standards Institution).
- <sup>2</sup> B.S.1474 : 1955. Wrought Aluminium Alloys: Extruded Round Tube (British Standards Institution).
- <sup>3</sup> B.S.1471 : 1955. Wrought Aluminium Alloys: Drawn Tube (British Standards Institution).
- <sup>4</sup> B.S.1490 : 1949. Aluminium Alloys: Ingots and Castings (British Standards Institution).
- <sup>5</sup> B.S.1472 : 1955. Wrought Aluminium Alloys: Forgings (British Standards Institution).
- <sup>6</sup> B.S.1476 : 1949. Wrought Aluminium Alloys: Bars, Rods and Sections (British Standards Institution).

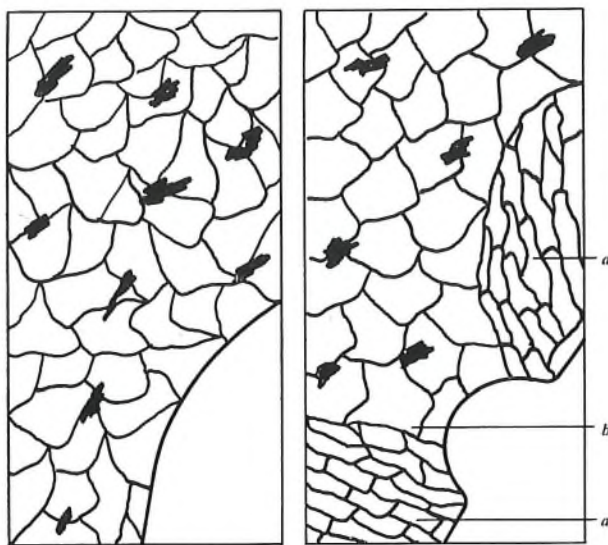

FIG. 3—EFFECT OF A NOTCHED BEND

## Book Review

"Theoretical Electromagnetism"—continued from p. 79

oscillation is included, and retardation and skin effects are discussed rigidly. The chapter on alternating currents concludes with a traditional (to the engineer) treatment of the transmission line, both in its ideal form and the form where losses are taken into account.

The author is now in a strong position to deal with electromagnetic radiation and this he does most thoroughly with a careful explanation of Poynting's Theorem, energy considerations being emphasized throughout. Wave motion in dielectrics and conductors is treated by means of the conception of complex permittivity and leads to a thorough elementary treatment of waveguide theory. The chapter on electromagnetic waves concludes with a study of the Clausius-Mossotti relation and the theory of dispersion.

The book concludes with a large section (40 pages) in which a series of problems in electrostatic field theory are analysed and discussed. These problems are mainly of

academic interest but they are typical of those with which the honours graduate in physics is expected to be familiar, but the author indicates that the corresponding electromagnetic problems—which in general have a more practical application to engineering work—are solved by precisely the same mathematical procedure. Thus, after careful study of the electrostatic cases, the student should be easily capable of developing the solutions for himself. This is sound teaching technique and provides the necessary incentive for the student to study the mathematical processes in sufficient depth to reinterpret their application to electromagnetic as well as electrostatic fields.

Viewed as a whole, this book is an inspiring and interesting volume. Although of primary interest to the student of academic physics, its treatment of alternating currents, radiation and waveguides in particular, will be found valuable to the telecommunications engineer who wants a sound grasp of the underlying theory from a modern standpoint.

F. C. M.

# Manual Lifting and Handling

S. RATA, E.R.D., B.Sc.(Eng.), A.M.I.E.E.†

U.D.C. 613.65

Notwithstanding the increase in mechanical aids available in the field, there are still many jobs which have to be carried out manually. Many injuries result from wrong methods of lifting, and this article describes how these injuries can occur and the best methods of avoiding them.

## INTRODUCTION

IN common with many industries the Post Office has become very much aware of the loss of time and money consequent upon accidents sustained whilst staff have been engaged on manual work of all kinds. Whilst it is true that mechanical aids have taken a lot of the heavy labour out of many tasks, there still is and always will be a considerable amount of manual lifting in industrial processes. This is borne out by the fact that accidents occurring while lifting manually are more numerous than any other type and during 1957 made up approximately 27 per cent of the total of industrial accidents. Accidents resulting from manual lifting are not always serious but they are of a nature which often involves long periods of rest, resulting in a great deal of lost time.

It is remarkable how many ways there appear to be of lifting and carrying various items, and it is probably true to say that in 95 per cent of cases the wrong methods are used. In view of this, it is not surprising that the accident rate is so high. Very often, injury does not occur at once but follows from the cumulative effect of repetitive movements carried out in the wrong way.

The majority of instances of cumulative strain occur very unexpectedly; for example, a man accustomed to heavy manual labour can suddenly become incapacitated while carrying out a simple task such as sweeping or picking up an article off the floor. Cumulative strain is one of the most common types found among manual workers.

## ANATOMICAL CONSIDERATIONS

When the structure of the human spine is examined, its shortcomings and inherent weaknesses become apparent. The fact that this is so has been explained by taking into account man's normal upright posture. The spinal columns of most vertebrates are very similar in design to those of man except that their carriage varies considerably, and in the majority of vertebrates the spine is supported at both ends. In the vertical position normally adopted by man it has, however, a degree of instability. It has been stated<sup>1</sup> that "when our remote ancestors assumed an erect posture a structure designed as a cross-bar was converted into a flexible tent pole with its guy ropes tethered so close to the pole that their mechanical advantage was reduced to a minimum. It is this poor structural arrangement that makes the human spine so vulnerable to injury and so prone to backache, resulting from failure of this supporting mechanism". This description explains why so much attention should be given to body position, and in particular to that of the spine, while exerting effort such as is required in a manual handling movement.

Fig. 1 shows a vertical section through the vertebrae.

† External Plant and Protection Branch, E.-in-C.'s Office.

<sup>1</sup> NICHOLL, E. A. Injuries to the Back. *British Medical Journal*, 18 April, 1953.

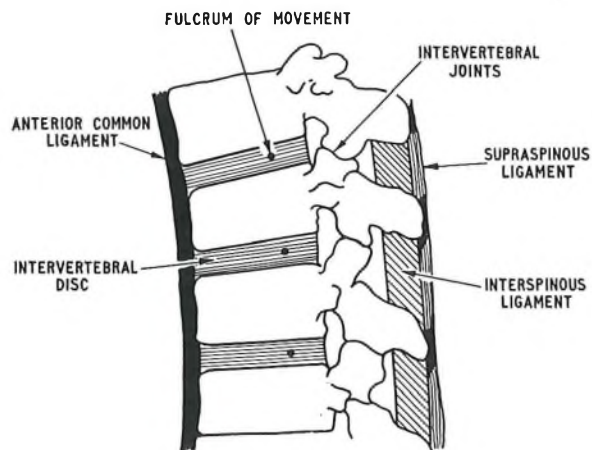

FIG. 1—VERTICAL SECTION THROUGH VERTEBRAE

The spinal column is composed of various types of segment which have their characteristic curvature, but for the purpose of showing the action of the spine a representative section has been taken. From this illustration it would at first sight appear that the individual vertebra pivots about the intervertebral joint, but this is not so, and the fulcrum lies in a position in the intervertebral disc. It is the fact that this pivotal position lies within the intervertebral disc that accounts for the disc injuries which are so prevalent. The results of pressure on a disc caused by bending the back are shown in Fig. 2 (a) and (b). If the upright position is regained slowly, the disc will resume its normal shape without injury, but if the spine is straightened too quickly, it is possible for a disc to become trapped, with very painful and often serious consequences. Fig. 2 (a) shows the disc being pressed on to the spinal cord, causing pain, but Fig. 2 (b) shows a more severe condition where the disc actually impinges on a nerve root, which can result in paralysis.

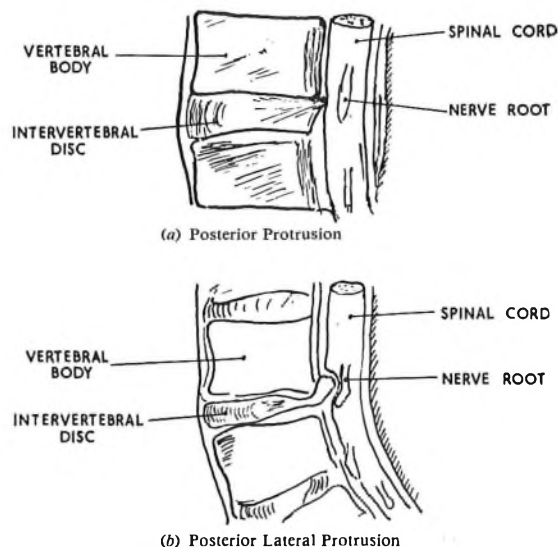

FIG. 2—RESULTS OF PRESSURE ON INTERVERTEBRAL DISC

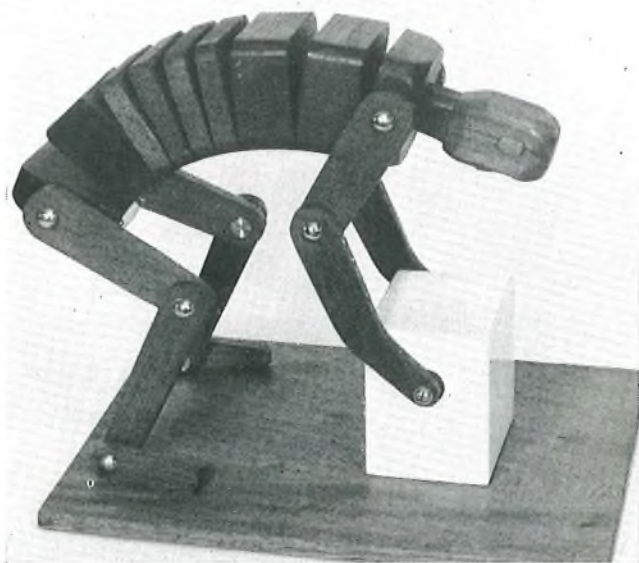

FIG. 3—STOOPING POSTURE DURING LIFTING

Some interesting facts have been assembled recently<sup>2</sup> concerning loads occurring on intervertebral discs when weights are lifted in various ways. It has been shown experimentally that normal lumbar vertebral bodies are crushed by loads equivalent to about 1,000 lb weight and that such a load may well result in permanent deformation of the intervertebral discs. Table 1 shows the theoretical loads sustained by the fourth lumbar vertebra during weight lifting using a stooping posture and also using the correct erect posture.

TABLE 1  
Theoretical Load on the Fourth Lumbar Vertebra During Lifts

Posture	Load (lb)		
	When holding 70 lb still against gravity	Induced by initial acceleration	Total during early stages of lift
Erect	140	80	220
Stooping	700	350	1050

These postures are illustrated in Fig. 3 and 4. It has been assumed that only the spinal mechanism is in action and the figures are based on that of a normal male of 5 ft 10 in. in height. From Table 1 it can be seen that in the stooping position loads are obtained in the range likely to injure the intervertebral discs. It appears that in the stooping position the contraction of the abdominal-wall muscles produces loads in the trunk which press upwards on the ribs and downwards on the pelvic floor in a manner which sustains a considerable portion of the flexing force induced by the weight. It has been calculated that about one-sixth of the weight is supported in this way, and Table 2 shows lumbar vertebra loads occurring during lifts similar to those of Table 1 but taking into account the loads induced in the chest and abdomen. It can also be seen that these subsidiary loads have no effect

<sup>2</sup> DAVIS, P. R. Posture of the Trunk During the Lifting of Weights. *British Medical Journal*, 10 Jan. 1959.

TABLE 2

Theoretical Load on the Fourth Lumbar Vertebra Taking into Account the Raised Intra-abdominal and Intra-thoracic Load

Posture	Load (lb)		
	When holding 70 lb still against gravity	Induced by initial acceleration	Total during early stages of lift
Erect	140	80	220
Stooping	580	220	800

when lifting in the correct manner with the back straight. The erect method of lifting is definitely the safest method, and at the same time approximately three times the weight can be handled safely compared with the more usual bent-back method. The opening up of the vertebrae may be clearly seen in Fig. 3.

#### COMPETITIVE WEIGHT-LIFTING

When the loads handled by weight-lifters are compared with the relatively small weights lifted by workmen and which cause frequent injury, it would appear obvious that the trained weight-lifter is using his body and skill to maximum advantage and in a manner least likely to cause injury. The weights used by the weight-lifter are shaped for ease of handling, whereas normal loads are often bulky and mis-shapen, but even taking this into account the principles involved in lifting them are basically the same. Fig. 5 and 6 show weight-lifters in two positions during a competitive lift. In both instances it can be clearly seen that the spine is kept perfectly straight, and any deviation from this position while handling heavy weights would most certainly result in serious injury. The weights being handled in the photographs are of the order of 3 cwt; an amount which most men would be unable to lift from the ground. Weight-lifters have been using effective methods of lifting for many years but it is only quite recently that some thought has been given to the application of these methods to

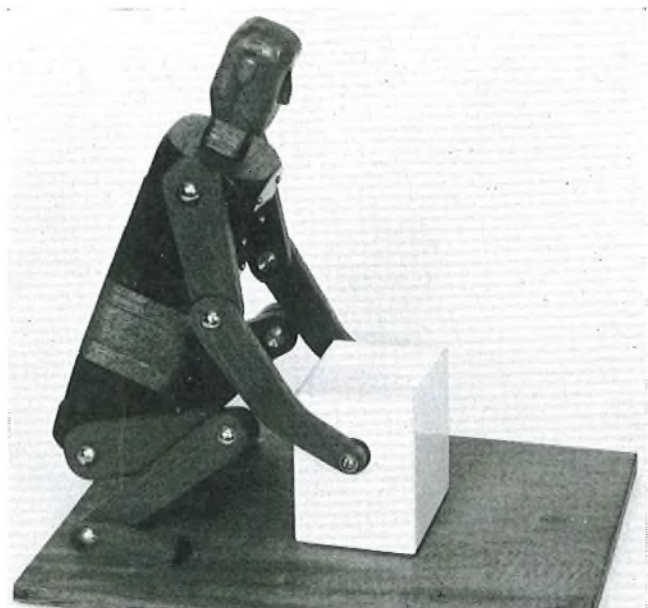

FIG. 4—CORRECT ERECT POSTURE FOR LIFTING

manual handling in industry. Weight-lifters have been looked upon in the past as a muscle-bound group of misguided individuals getting results only by the use of brute-force methods. Nothing could be further from the truth, and weight-lifting is now recognized as a sport calling for great skill and fitness from those taking part, and the methods of training are being adapted to assist those taking part in athletics generally. Ruptures and back injuries among weight-lifters are practically unknown, which is a sure indication of the correctness of the methods used, especially in view of the very heavy weights that are handled.

#### APPLICATION OF PRINCIPLES TO INDUSTRIAL HANDLING WORK

While competitive weight-lifting is concerned with lifting heavy weights designed specially to allow for ease of lifting, the principles involved can be applied in many ways to the lifting of items met with daily. The Central Council of Physical Recreation, in conjunction with the Industrial Welfare Society, have carried out a great deal of work in establishing methods of training in an effort to reduce the present very high accident rate.

Some of the more common mistakes made in lifting are as follows:

(a) Poor starting position resulting in unbalance while lifting. This particularly applies to the position of the feet.

(b) Insufficient grip. The fingers are used instead of the much more effective grip given by the palm of the hand.

(c) Lack of confidence in the ability to carry out the lift successfully.

(d) Over-confidence in attempting to lift weights and bulky objects far beyond the capacity of the individual. There are, of course, limits even when lifts are carried out in the correct manner.

The key factors which cover the correct methods of lifting and handling are as follows:

*Foot Position.* The feet should be comfortably placed and normally hip width apart.

*Grip.* A firm hold should be taken of the item in



FIG. 5—WEIGHT-LIFTER IN ACTION

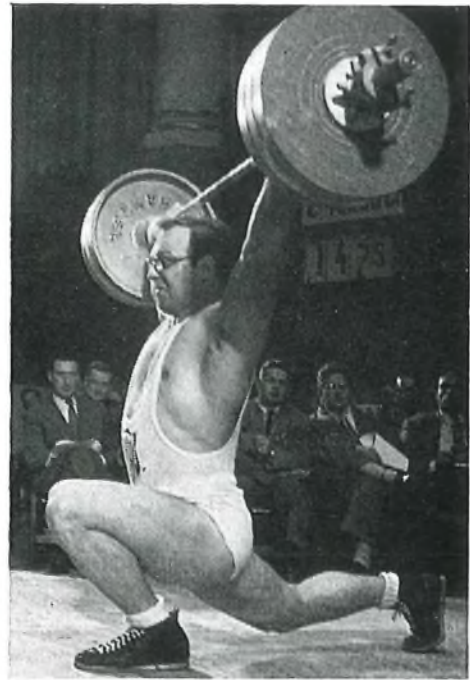

FIG. 6—WEIGHT-LIFTER IN ACTION

question. The grip should be made with the palm of the hand with the fingers assisting.

*Straight Back.* As already described, it is essential to keep the back straight during a lift because the back when bent is very weak and large pressures bear on the intervertebral discs. In order to assist the automatic straightening of the back the chin should be kept well tucked in; if the head is allowed to sag forward the spine becomes relaxed.

*Arm Position.* The arms should be kept close to the body during a lift. There is a tendency for the elbows to be bent away from the body, which places an excessive strain on the arms, shoulders, upper back and chest.

*Body Weight.* The body weight should be used as efficiently as possible when endeavouring to overcome the resistance of an object. The correct use of body weight will reduce the amount of muscular effort employed.

If all these factors are considered when carrying out lifting and handling movements, not only will the task seem easier but the possibility of strain will be very greatly reduced. The way in which these principles can be applied to work in the Post Office is shown in two examples. Fig. 7 shows the easing of a manhole cover using a crowbar. Note the straight back, secure grip with the hands close together, correct foot position and arms fully extended. The whole movement appears controlled and there is no possibility of injury or strain. Fig. 8 shows the commencement of the removal of a manhole cover. Here again can be seen the straight back, extended arms and firm hold. In fact, the principles of lifting described earlier can be applied to lifting and handling of all types of objects and the time will eventually come when these methods of lifting are accepted as normal rather than a departure from the haphazard and dangerous methods at present adopted.



FIG. 7—EASING A MANHOLE COVER USING A CROWBAR

#### MAXIMUM LIFTING CAPACITY

The problem of how much weight a person can be expected to lift is constantly arising. The Factories Act 1937 has two things to say about this question. Section 56 (1) says "A young person, i.e. a person under 18, shall not be employed to lift, carry or move any load so heavy as to be likely to cause injury to him". Section 56 (2) gives power to the Minister to make regulations prescribing maximum weights which may be lifted, carried or moved by persons employed in factories, but at present no such regulations have been made. It should be noted that Section 56 (1) previously applied to young persons only; the 1959 Act amends this to apply to all employees in factories and no special regulations are needed to make it effective for this purpose, but it applies only to factories as defined in the Act. The booklet "Precautions Against Accidents" (RG 41) issued by the Post Office Engineering Department gives the following maximum loads for individual lifting:

Men: 130 lb (compact load)

Young men, 16 to 18 years: 60 lb (intermittent work)  
45 lb (continuous work)

The lifting is regarded as continuous if a total of one ton or more is lifted each day.

The question as to what constitutes a load "so heavy as to be likely to cause injury" is extremely difficult to assess as there are so many contributory factors, including the physique, strength and health of the lifter, the shape and bulk of the load and generally the height to which the weight has to be raised. In order to relate physique of the lifter to the load, the maximum weights are often quoted as a percentage of the body weight, but for this there must be some qualification to protect young people.

When the question of loads is under consideration it is not only the weight of a single load that is of importance but the total weight lifted or carried daily that must be estimated. When lifting and carrying form a substantial part of a worker's daily task the total handled can often amount to several tons.

Having experienced the disparity of lifting ability among people of different ages and body weight, etc., it is the author's view that maximum weights should not be laid down. A table could be produced to give

maximum weights within the capacity of various types of person, but it would be far too large and complicated to be of any practical value. It has been found that the average person has very little idea of the amount of weight he is able to carry, and, unless a person is able to judge within reasonable accuracy the weight of the items he has to carry, a maximum-weight table has no value.

#### TRAINING AND PUBLICITY

The problem of training staff in the correct methods of lifting is difficult because it is hard to convince a worker used to traditional methods that the habits he has formed over the years are entirely wrong and that a new system should now be adopted. Also, there is a tendency on the part of younger men to show off their prowess at lifting by trying to get results by brute-force methods regardless of the extra effort required and the possibility of strain. However, once the initial prejudice has been broken down and the trainee realises that there is something in what is being taught, the response is quite remarkable and the tendency is to show surprise that such methods had not been taught many years earlier.

Attempts have been made in the past to carry out effective training, with varying degrees of success. During the war many women were called upon to carry out tasks to which they were physically unsuited and consequently there was an increase in back strains and injuries. To counter this increase in accidents the Ministry of Labour made special efforts and produced a training film to encourage workers to employ the correct methods while carrying out heavy manual tasks. This film is still of value for training purposes as the principles agreed upon then still obtain today. The standard of training facilities is extremely high at the present time as the subject is being given priority and publicity by the Industrial Welfare Society, the Faculty of Physiotherapists, The Royal Society for the Prevention of Accidents and many other interested bodies. The National Safety week for 1959 was devoted to manual handling and lifting.

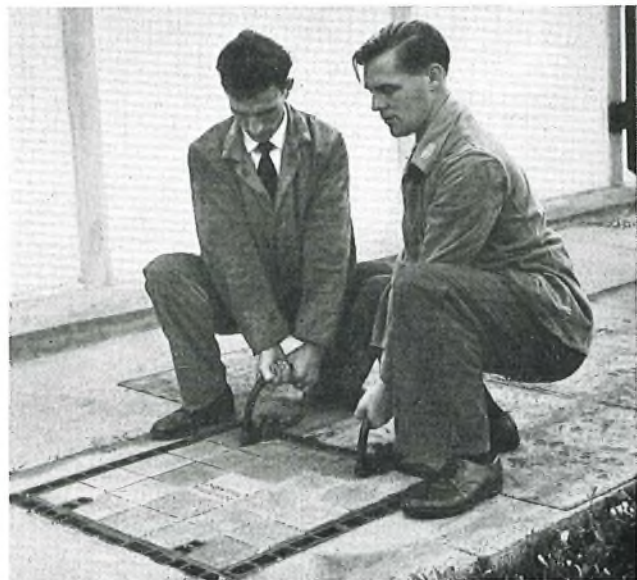

FIG. 8—COMMENCEMENT OF REMOVAL OF MANHOLE COVER

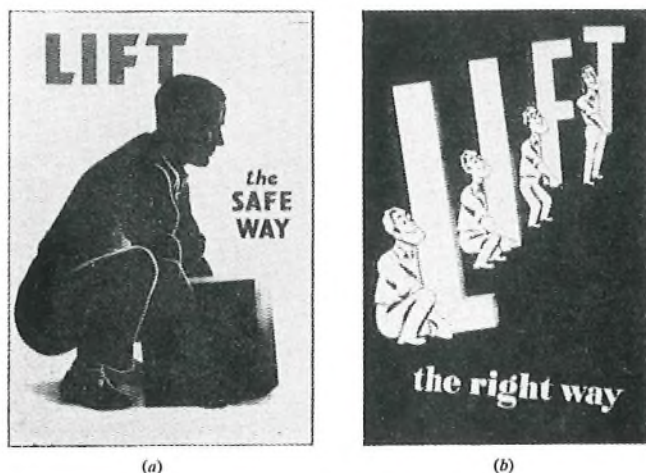

FIG. 9.—POSTERS ISSUED BY ROYAL SOCIETY FOR THE PREVENTION OF ACCIDENTS

A considerable amount of training has been carried out within the Post Office Engineering Department in an endeavour to reduce the accident rate due to manual handling, but up to the present time this training has been confined mainly to the external staff. Initially,

instructors from Regional Training Schools were trained by the manual lifting specialist from the Central Council of Physical Recreation. This was followed by courses for instructors from Telephone Areas run at the respective Regional Training Schools. Finally, instruction to external staff in the field was energetically followed up in Telephone Areas, resulting in the training of practically the whole of the external staff throughout the country. The subject has now been included in the majority of regional training courses and consideration is being given to the training of internal staff. Posters are issued from time to time to draw attention to the importance of the subject to those concerned. Two typical posters issued by the Royal Society for the Prevention of Accidents are shown in Fig. 9 (a) and (b).

#### ACKNOWLEDGEMENTS

The author wishes to acknowledge the assistance given by Mr. George E. Hickling of the Central Council of Physical Recreation in formulating methods of lifting particular to Post Office plant. These methods are being adopted as standard throughout the Post Office Engineering Department. Thanks are due to the Industrial Welfare Society for their co-operation with training and also to their Information Department for the loan of material.

## Book Review

“Semiconductors.” Edited by N. B. Hannay. Reinhold Publishing Corporation, N.Y., and Chapman & Hall, Ltd., London. xxiii + 767 pp. 360 ill. 120s.

Although semiconductors have long been the subject of studies by physicists, much of the work prior to 1940 was carried out on natural crystals without appreciation of the importance, for many purposes, of the residual impurities, and the two semiconductors which were industrially prepared, copper oxide and selenium, were equally poorly understood for scientific studies. The period 1939–48 saw greater activity on a few narrower fronts, culminating in the discovery of transistor action, and the realization of the importance of knowing the impurity content and the crystalline imperfections of the materials used if the subject was to go forward without contradictions between the findings of different experimenters doing nominally the same experiments. The concentration of effort on to germanium and silicon because of their merits as transistor materials at room temperature (high mobilities of charge carriers and sufficiently low intrinsic density of carriers) only temporarily slowed down progress with other materials, for once the newer ideas of preparing semiconductors, and measuring and accounting for their properties, had been well established for these two elements, better planned experiments could go ahead with many compounds.

Although few compounds have come to challenge germanium and silicon as materials for transistors and rectifiers in everyday use, there are many other uses to which some can be put, e.g. as photoconductors for infra-red detectors, as rectifiers at high ambient temperatures, as thermoelectric generators or refrigerators, as magnetoresistance elements, etc. Accordingly, very considerable effort has been devoted to the preparation of many compounds, particularly those between elements in Group III and Group V of the periodic table. This book tries to present a picture of the work on most semiconductors, preparation and properties being the major subjects for description. It was written primarily for

chemists, but metallurgists and physicists need shun no part, and engineers with some background to the subject will find few difficulties in following most of it.

The editor opens with a short review of some of the reasons for the properties of semiconductors and explains how the exact composition affects the properties. The chapter authors, all from the Bell Telephone Laboratories, then take up particular parts of the subject, though in an order which might well have been improved. First, some of the chemical side is analysed in terms of electron configurations, degree of ionic behaviour and the interaction of imperfections (anything other than a wanted atom at a proper site) in solids. Energy considerations are not stressed here as much as in a later chapter dealing specifically with defect interactions. The metallurgical problems of making crystals which are pure, homogeneously doped or non-homogeneously doped, according to requirements, and of diffusing impurities into crystals are given several chapters. Their solution, for germanium and silicon, which has made possible so many of the advances with transistors, is gone into fairly fully; it has, however, also been dealt with adequately in at least one other book recently. A chapter is devoted largely to the preparation of compounds between elements from Group II and Group VI (e.g. ZnO and CdS). It is followed by a return to the physical theories for the electrical properties of silicon and germanium, and to a survey of the properties of covalent compounds (in particular, the Group III–Group V range, some of which offer very high carrier mobilities).

The infra-red properties of semi-conductors are important in several respects to the physicist as well as to the user, and they receive good treatment. The recombination and trapping of mobile carriers sets a limit to the properties of semiconductors—a limit which has been pushed back sufficiently for germanium and silicon to permit of useful transistor action. An account is given of the investigation of these phenomena, which still bedevil much of the work on compounds. An excellent account of physical imperfections

(Continued on p. 88)

# A Pulsing and Ringing Machine for U.A.X.s

N. H. PENDLEBURY†

U.D.C. 621.395.38:621.395.722:621.395.34

A description is given of a compact, low-powered and inherently reliable pulsing and ringing machine. It will be used to replace the vibrator-type relay-sets in the larger existing U.A.X.s No. 13, and will be provided as the standard for all new U.A.X.s No. 13.

## INTRODUCTION

ONE of the main difficulties experienced in operating unit automatic exchanges (U.A.X.s) has been maintaining a satisfactory supply of ringing current, ring and supervisory tones and pulses. The adjustment of the vibrator relays used for the generation of ringing current, ring and supervisory tones is very critical and when the correct adjustment has been obtained the output voltage can be observed to vary considerably even with a small change of load. With the ringing vibrator this poor regulation is an embarrassment, especially in view of the increased ringing load resulting from the extension of exchanges beyond the capacity originally planned. Subscribers' installations having a number of extension bells demand a high standard of bell adjustment because narrow limits of satisfactory operation are imposed by the ringing current supplied by a vibrator relay. These limits are reduced still further on shared-service lines which have a thermistor included in the bell circuit.

Tone vibrators also suffer from poor regulation. This usually appears as a change in tone level and frequency, which can mislead a subscriber listening to the supervisory tone, and result in either mis-operation or confusion. Pulse generation and tone interruption by a uniselector is not completely satisfactory since the wear due to continuous operation makes necessary frequent renewal and readjustment of the component parts of the uniselector. An improvement is obtained by the use of a heavy-duty uniselector but the rate of wear is still considerable.

The requirements for a ringing and pulse machine for a U.A.X. to replace the vibrator relays and uniselectors demand that the machine should be able to run for long periods without attention and have a low power-consumption. Several machines have been tested in the past but none has given an entirely satisfactory performance, probably due to the fact that they were originally designed for other purposes.

The introduction of a satisfactory permanent-magnet-field tone-generator, which resulted from advances in magnet manufacturing technique, enabled the physical size and power input to be reduced to an acceptable figure and a small experimental machine, suitable for U.A.X.s No. 12 and 13, was produced. This type of machine, a rotary converter fitted with interrupter springs, was used to obtain information regarding the operation of machines in U.A.X.s. for long periods.

Twelve such machines were installed at selected exchanges throughout Great Britain and proved to be very reliable in service. Some trouble was experienced initially with the lubrication of the reduction gear that drove the interrupter camshaft, but the lubricant finally selected enabled the gear to run without attention for approximately a year. The experimental dynamotor did not generate a meter pulse as required for the U.A.X., and was not capable of further modification. A completely new design of machine, the Machine, Pulsing and Ringing, No. 1, was therefore produced.

## THE NEW MACHINE

The new machine (Fig. 1) is a conventional type of ringing machine designed to run with its baseplate and

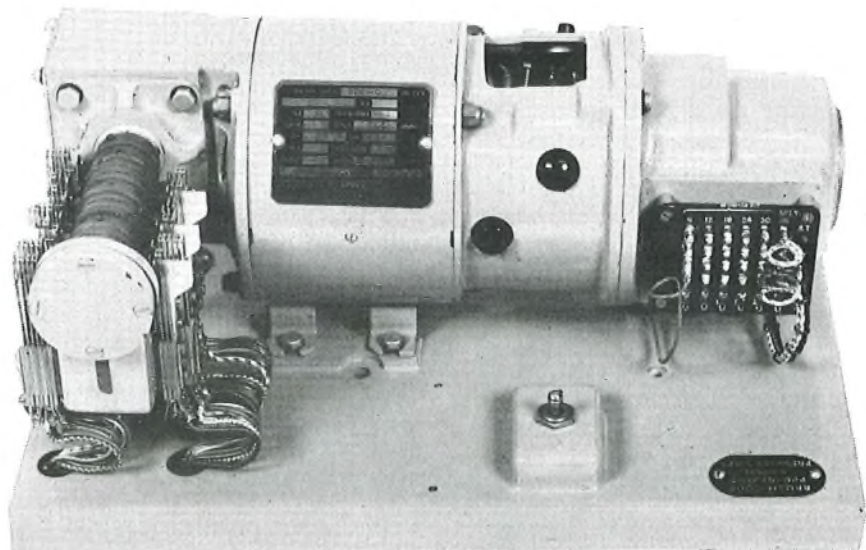

FIG. 1—MACHINE, PULSING AND RINGING, NO. 1

camshaft in the vertical plane. The machine is secured by lock-nuts in a specially designed mounting located in the U.A.X. "C" unit, and since the electrical connexions are made by normal relay-set-type plugs and jacks the machine can be readily removed and replaced if necessary. The machine camshaft is divided into two sections; one section, revolving at 20 rev/min, operates spring-sets which produce the interruptions of the supervisory tones, meter pulses and 3-second timing pulses, while the other section, revolving at 1 rev/min, is used to produce a 1-minute sequence of timing pulses.

The reduction gear between the main-shaft and the 20 rev/min camshaft consists of a steel worm meshing with a nylon worm-wheel and requires no lubrication in normal service. This arrangement dispenses with the oil-filled gear-box, and the oil-leakage difficulties experienced in earlier machines having camshafts in a

† Telephone Exchange Standards and Maintenance Branch, E.-in-C.'s Office.

vertical plane cannot arise. The absence of oil also eliminates the speed variations caused by the change of viscosity of gear lubricants over the wide range of temperatures experienced in unattended exchanges. The second stage of reduction gear is of the eccentric type in which the pinion of the slow-speed camshaft is advanced one tooth for every revolution of the 20 rev/min camshaft. The rotating parts of this gear are carried on needle roller bearings, which require no attention under normal operating conditions. The need for lubrication has been reduced to a minimum by the use of these types of reduction gear and by fitting pre-lubricated sealed bearings to the machine main-shaft.

The spring-sets and buffer blocks used on the machine are similar to those used on 600-type relays and adjustment methods are identical. Spring-sets are arranged alternately on either side of the camshaft to allow the necessary space for the fitting of buffer blocks and the adjustment of springs. The cams are arranged in assemblies of four and the grouping of the cams has been arranged so that intervals between timing pulses can be fixed during manufacture, which avoids subsequent faults due to the displacement of cam assemblies.

The machine is driven from the exchange 50-volt battery supply, a current of 0.85 ampere being required to maintain a full-load output. It is operated on a start-stop basis and controlled by a relay-set connected to the exchange "start" leads. The machine is continuously rated and overload protection is given by a thermal-overload trip built into the stator casting. This trip requires resetting by hand before the machine can be restored to service after a failure due to overheating. A switch is provided on the baseplate to disconnect the motor circuit for inspection and maintenance purposes, and in the "off" position an auxiliary contact operates an alarm circuit to prevent the disconnection being overlooked.

The continuous full-load output of the alternator is 5 volt-amperes at 75 volts, 25 c/s, but the machine is capable of supplying loads in excess of this figure for short periods. The tone generators are of the permanent-magnet rotating-field type with the output winding on the stator. Control of the tone output is achieved by tapped coils which allow the selection of 25 per cent, 50 per cent, 75 per cent, or 100 per cent of the available output. Dial, busy and number-unobtainable tone

inductor rotors are concentric with the stator but the ring tone inductor rotor is eccentric, which produces varying air-gaps during rotation of the armature and generates the characteristic modulated ring-tone waveform.

Two interrupted ringing-current supplies, a normal ring tone and an inverted ring tone are obtained from spring-sets operated by the interrupted-ringing cam. The 1-minute S and Z pulses are obtained by "gating" the 3-second S and Z pulses with spring-sets operated by the 1 rev/min camshaft. A continuous-ringing supply may also be taken from the machine.

#### CONCLUSION

The new machine is intended to replace the existing vibrator-type relay-sets in U.A.X.s No. 13 and it is capable of supplying the load requirements of the largest and busiest exchanges of this type. A single machine without standby arrangements will become part of all new U.A.X.s No. 13 while the larger existing exchanges will be modified and the vibrator-type relay-sets recovered. A new design of U.A.X. No. 13 "C" unit has been produced to accommodate the machine and arrangements have been made to modify existing "C" units when the relay-sets are recovered.

It is expected that the new machine will prove to be more reliable in service than the vibrator-type relay-set which it replaces. The attention required during normal service in an exchange should be limited to inspection and cleaning of the brush gear, commutator, slip-rings, cams and spring-sets.

Change of relay-sets is not contemplated at smaller U.A.X.s No. 13, but special consideration will be given to exchanges where local conditions have shown that ringing current from vibrator relays is not entirely satisfactory.

U.A.X.s No. 12 will retain the present arrangements for ringing-current and tone generation until the future policy regarding this type of exchange is determined, but the new machine could readily be installed at these exchanges if necessary.

#### ACKNOWLEDGEMENT

The author wishes to acknowledge the assistance and information given by the manufacturers of the machine, Walter Jones & Co. (Engineers), Ltd.

---

## Book Review "Semiconductors"—(continued from p. 86)

follows, with a little on their influence on electrical properties.

The book then returns to oxides and sulphides, describing their electrical behaviour and introducing some new concepts when polarization plays a role; it is clear that there is plenty of scope here for further work. A separate chapter is devoted to the oxides of the elements close to iron in atomic number, for here we meet incompletely filled shells in their electron structure. Spin enters as an important parameter, and magnetic and semi-conducting properties must be simultaneously explained by any model depicting the structure. There is a short account of some organic semiconductors, whose optical effects have long been studied. Here, again, is a huge field which may

one day yield a major advance. The next chapter reviews that very important subject, the physics and chemistry of semiconductor surfaces, on a more complete understanding of which may hang the reliability of many transistors and other semiconductor devices of present-day geometries and mechanisms; progress has certainly been made in the past five years in the work with germanium, and some basis found for describing the electrical properties of surfaces. A final, short, chapter deals with some problems involving semiconductor-electrolyte interfaces. There are excellent bibliographies with each chapter.

This book is not for the beginner, but it will find a home in many laboratories as the best single account of the preparation and properties of a wide range of semi-conducting materials.

J. R. T.



# Locating Faults Between Jointing Points on Pressurized Cables

H. B. COOPER and R. A. M. LIGHT†

U.D.C. 621.317.333.4: 621.315.211.4

The use of exact methods of locating faults between jointing positions in pressurized cables can result in a considerable financial saving. Various possible methods are described and particular reference is made to the use of a low-density-liquid manometer.

## INTRODUCTION

**P**RESSURIZATION of underground telephone cables is a technique designed to prevent the ingress of water when a fault occurs in the sheath of a cable. An internal air pressure of approximately 9 lb/in<sup>2</sup> is maintained in the cable and this is sufficient to withstand a head of 20 ft of water but does not produce any undesirable stresses in the lead sheath or sleeves.

If a cable is filled with air under pressure, the pressure along the cable will be constant if no leaks exist. If, however, a leak in the sheath should develop, air will flow from both directions towards the leak and, if pressure is plotted against distance along the cable, the position of the fault will be indicated by the intersection of the curves.

The factors influencing the shape of the pressure/distance gradient in a leaking cable have been discussed by R. G. Giese.<sup>1</sup> The increase in velocity as the gas expands towards the fault and, in particular, the turbulent gas flow in the immediate vicinity of the fault will, in general, produce a characteristic gradient of the type indicated in Fig. 1.

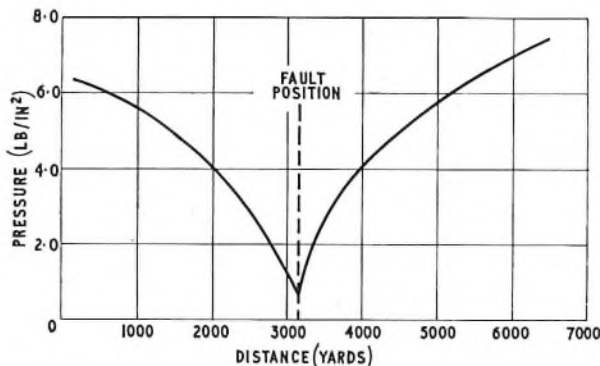

FIG. 1.—TYPICAL PRESSURE/DISTANCE CHARACTERISTIC OF FAULTY GAS-FILLED CABLE

Observation of the pressure gradient, using a conventional type of mercury manometer, will enable a fault to be located easily if it occurs in a jointing chamber. Occasionally, however, a fault may appear to be between jointing chambers and this is verified by a further test at each end of the suspected length, using a differential manometer consisting of an inclined gauge filled with a low-density spirit. The gauge is connected between two specially designed valves fitted to the cable sheath for the purpose of the test. The valves are so placed that the connexions span as great a length of the sheath as is accessible. The direction of the flow of air at the point of test is thus established.

† Mr. Cooper is in the Cambridge Telephone Area and Mr. Light is in the Engineering Branch, Home Counties Region.

\* Dichlorodifluoromethane.

The more extensive use of pressurization methods now being adopted has brought to light a number of faults of the above type and, particularly if large cables are involved, it is not always possible to decide whether it is economic to renew the faulty length without obtaining more information about the actual fault. If, therefore, the nature of the ground makes excavation of the track practicable, it is desirable to determine the exact position of the fault in the length.

Once the fault has been found, the permanent repair, by unidiameter jointing if necessary, will present no problem if the fault is due to mechanical damage, because the internal pressure of air will have prevented water entering and damaging the core of the cable. If, however, the fault is due to corrosion, such factors as the life of the cable, corrosion history in the vicinity of the fault and the condition of the duct track must all be taken into account in determining the appropriate method of repair. It will frequently be acceptable to make a repair without withdrawing the faulty length because, even if there should be further corrosion in the same length, the internal air pressure will prevent actual breakdown of the circuits.

## LOCATION BY RADON

For cables buried directly in the ground means have been described<sup>2,3</sup> by which a radio-active tracer-gas can be introduced into the cable and the leak point determined by observations at ground level with a radiation-intensity meter; such methods have been used with success in Sweden and Australia. Radon is the tracer employed because, unlike other radio-active transmutation products, it is gaseous and can be obtained in small quantities. The radon is introduced into the cable near the fault, and the gamma rays that are emitted can be detected on the surface of the ground, the intensity being greatest over the point where the radon has leaked from the cable and penetrated into the ground.

Although it is claimed that the hazard to health is extremely slight, the method is not suitable for general use by the British Post Office because the majority of cables in this country are provided in duct tracks and these would prevent a concentration of radon and gamma radiation being detected near the fault.

## LOCATION BY ARCTON GAS

Another possible means of locating sheath faults is to introduce into the cable a mixture of 2 per cent Arcton\* in air and to detect the point where it leaks from the cable. Arcton is an inert gas of the halogen group and its presence is indicated by the change in colour of the flame of a halide-lamp detector or by the use of a positive-ion detector. This sensitive electronic device, which is portable and suitable for field use, measures the increased rate of positive-ion formation which occurs when a halogen gas is drawn over a heated platinum surface.

The method suggested for this type of fault location is to introduce Arcton at one end of the faulty length and to test at each duct mouth to see from which point it first emerges. Once the Arcton has been proved to exist in the duct mouth, a draught is set up along the duct, and

a hose carried on flexible rods is introduced from the end at which the draught is applied. Air is then drawn from the hose by a small centrifugal pump and sampled by the Arcton detector. Working from the testing end, no Arcton will be withdrawn until the hose reaches the fault point, but once this point has been passed, both Arcton and air will be withdrawn through the hose and the fault point will thus be established. Allowance for the time of passage of air through the hose must, of course, be made.

The above method, although theoretically straightforward, has not been found to be particularly successful in practice. The objections are:

(a) when dealing with large cables, for which it is particularly desirable to obtain an accurate location, there is insufficient space to draw a hose into the duct track beside the cable;

(b) the method will fail entirely if the track is obstructed by silt or if it is flooded at any point, and

(c) if the leak is very small, the 2 per cent Arcton mixture is diluted by the draught of air to an extent which makes detection unreliable.

#### LOCATION BY LOW-DENSITY-LIQUID MANOMETER

The most successful technique so far adopted is a repetition of the pressure-gradient method using a manometer filled with water or a liquid of similar specific gravity. As, however, measurement of a pressure of 10 lb/in<sup>2</sup> using water would require an instrument some 23 ft in length, it is necessary to allow the cable pressure to drop (by leakage from the fault) to about 4-5 lb/in<sup>2</sup>. Measurements can then be made with a manometer of more reasonable length.

Fig. 2 shows a manometer the height of which can be increased from 10 ft to 15 ft by means of a hinged extension. The liquid is contained in a transparent constant-bore polythene tube formed into a U and half-filled with liquid. The cable is connected via an air line to the top of one vertical limb, and the depression of the level of liquid in that tube read to an accuracy of 0.01 in.

It has been found useful to be able to increase the height of the instrument to 15 ft on occasions when the cable pressure over the area of test has not dropped to the level expected. The liquid can also be changed if necessary for one of greater specific gravity, to increase further the range of pressure measurements that can be taken.

Methylated spirit (sp. gr. 0.8) has been found most suitable for use in a polythene tube. Water is not suitable, as its lack of wetting properties results in the formation of many air bubbles in the tube. Carbon tetrachloride (sp. gr. 1.5) is a suitable liquid of greater density. Table 1 shows the range of pressures that can be measured with a combination of different liquids and manometer heights.

TABLE 1

Range of Pressures Measurable with Different Liquids and Manometer Heights

Liquid	Manometer Height (ft)	Pressures Measurable (lb/in <sup>2</sup> )
Methylated spirit	10	0-3½
	15	0-5½
Carbon Tetrachloride	10	0-6½
	15	0-9½

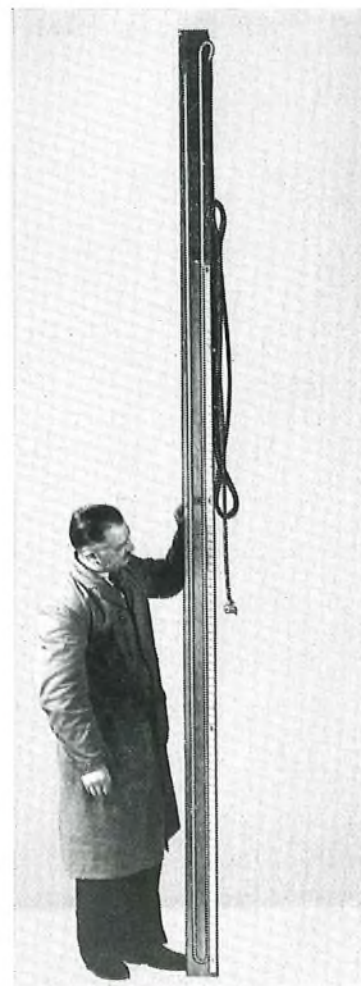

FIG. 2—LOW-DENSITY-LIQUID MANOMETER

It has been found satisfactory to fit test valves at the three jointing points immediately on each side of the suspected length and to make pressure measurements at each of these in turn. The following precautions are of particular importance:

(a) Readings should be taken commencing at one end and continuing at equal time intervals between test valves to the other end. Maintaining the same time interval, readings are then taken in the opposite direction, ending at first test point. If the average of the two readings at each point is then calculated, errors due to the fall in pressure that takes place while the test is being conducted will be eliminated. The resulting average will be equivalent to a set of simultaneous readings, as Table 2 indicates.

If the rate of fall in pressure is substantially constant for the duration of the test, the bottom row of figures will be equivalent to readings made at 0930 hours at all the points.

(b) At each point at least three minutes must be allowed to elapse after connexion of the manometer, to allow complete drainage of the liquid down the internal surfaces of the tube.

(c) If used on a sunny day, the instrument and air line connexions must, when connected to the cable, be shielded or turned away from the direct rays of the sun, to prevent errors due to temperature rise.

TABLE 2  
Pressure Readings Taken at Equal Time Intervals between Adjacent Test Valves

Test point	1		2		3		4		5		6
Time	0900	1000	0906	0954	0912	0948	0918	0942	0924	0936	0930
Pressure (inches of liquid)	33.15	32.70	32.32	32.01	31.91	31.73	32.87	32.73	34.43	34.34	39.38
Average pressure	32.92		32.16		31.82		32.80		34.39		39.38

The average pressures are then plotted against distance, using a scale of 10 or 20 yards to the inch. It is usually found that the three points on each side of the faulty length will very nearly lie on a straight line and, to a first approximation, the position of the fault is indicated by the intersection of the straight lines joining the pressures measured at the first two test-positions on each side of the faulty length. Subsequently, the actual curves can be sketched in to obtain a more accurate intersection. To determine the general shape of the curves, it is useful to plot them on a reduced-scale of perhaps 50 yards to the inch. Fig. 3 shows the graph of a fault location that has been obtained by these means.

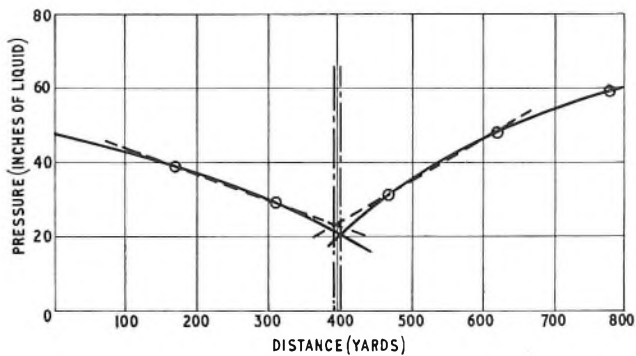

The intersection of the dotted lines gives an approximate location; the intersection of the full lines gives a more accurate location  
FIG. 3—LOCATION OF FAULT USING LOW-DENSITY-LIQUID MANOMETER

The sketching of the graphs requires practice, particularly if the test points available are not placed symmetrically on either side of the suspected length.

The duct track is broken down at the point indicated by the intersection of the curves and, if the fault is not visible, a flow test with a differential manometer is made across the exposed cable to determine the direction in which the fault lies. Arcton can be injected at this stage to obtain a final location. When fairly close to the fault it is normally possible to probe a few feet into the duct with a semi-flexible tube and to detect the Arcton without the difficulties mentioned previously.

#### FACTORS LIMITING THE ACCURACY OF LOCATIONS MADE BY MANOMETER

It should be appreciated that accuracies comparable with the standard Murray electrical test will not be achieved by the methods described here, because the internal construction of a cable is not as uniform throughout its length as is the resistance of a conductor. Accuracy will, moreover, be affected by the following factors:

(a) The accuracy of the manometer readings; all

pressures should be read by one observer. The manometer should be vertical when readings are taken and spirit levels are fitted to assist in achieving this.

(b) The assumption is made that the construction of the cable is uniform and that the pneumatic resistance does not change throughout the cable under test. This condition will be approached, provided each length of cable within the area of test is of the same size and type.

(c) The precision with which the pressure/distance curve can be drawn.

(d) The actual steepness of the pressure gradient near the fault. This will be a function of cable pneumatic resistance, the rate of leakage from the fault, and the existing cable pressure. In this connexion, E. J. Hooker<sup>4</sup> has deduced from theoretical considerations that the effective sensitivity will be improved by three times if water is substituted for mercury, and the pressure allowed to drop from 10 lb/in<sup>2</sup> to 2 lb/in<sup>2</sup> to avoid the necessity of using an excessively long manometer. Such a large pressure drop is not usually necessary however, and it would appear that if methylated spirit is used instead of mercury and the pressure allowed to drop to about 5 lb/in<sup>2</sup>, an improved accuracy of about 10 times is obtained.

#### CONCLUSIONS

Early experiments using glass tube for 10 ft manometers were satisfactory in many ways, but the instruments were rather fragile and easily broken. The polythene-tube instrument, however, is as easily transported as a ladder of similar length and has not been found in any way inconvenient to use. Table 3 gives some idea of the accuracy of recent fault locations.

TABLE 3  
Examples of Recent Fault Locations using Manometer

Cable size and type	Faulty length (yards)	Error in location (yards)
384/20 P.C.Q.T.	167	1½
38/40 P.C.Q.T.	204	1
14/40 P.C.Q.T. (Aerial)	120	3
254/20 P.C.Q.T.	164	1¾
150/20 P.C.Q.T.	205	2¾

#### References

- <sup>1</sup> GIESE, R. G. Gas Pressure for Telephone Cables. *Transactions of the American I.E.E.*, 1947. Vol. 66, p. 471.
- <sup>2</sup> Gas Control on Telephone Cables by Gas Flow Methods and Automatic Pressure Compensation. *Ericsson Review*, 1954, No. 2, p. 34.
- <sup>3</sup> BRETT, P. R. New Methods for Location of Leaks in Gas-Filled Cables. *Telecommunications Journal of Australia*, Oct. 1953, p. 241.
- <sup>4</sup> HOOKER, E. J. The Factors Influencing the Use of Pneumatic Methods for the Location of Sheath Faults in Pressurized Telephone Cables. *Proceedings I.E.E.*, Paper No. 2710R, Sept. 1958 (Vol. 105, Part B, p. 483).

# The Electronic Speech Voltmeter Type 5A

J. HUTTER, B.Sc., A.M.I.E.E., and E. C. ARCHER†

U.D.C. 621.317.725:534.78

The Speech Voltmeter Type 4A was developed to overcome the observer bias inherently associated with the Type 3, but although it is accurate, free from bias and suitable for continuously spoken, fragmentary, or conversational speech, it is, nevertheless, bulky and essentially laboratory equipment. The Speech Voltmeter Type 5A described here is reasonably portable, combines certain of the desirable features of both Types 3 and 4A, and under certain conditions can be used with advantage.

## INTRODUCTION

THE assessment of the performance of telephone circuits often necessitates the measurement of speech voltage at various points in a transmission path. Owing to its complex waveform, varying level and fragmentary nature, speech voltage is difficult both to define and measure with accuracy; complications arise due to varying form factor if simple linear measuring devices are used.

The Speech Voltmeter Type 3<sup>1</sup> at present used for speech-voltage measurement is a direct-reading instrument providing a square-law relationship between the input and the signal applied to its d.c. meter. This meter has a pointer integration time of 100 ms and is calibrated directly in decibels relative to 1 volt;

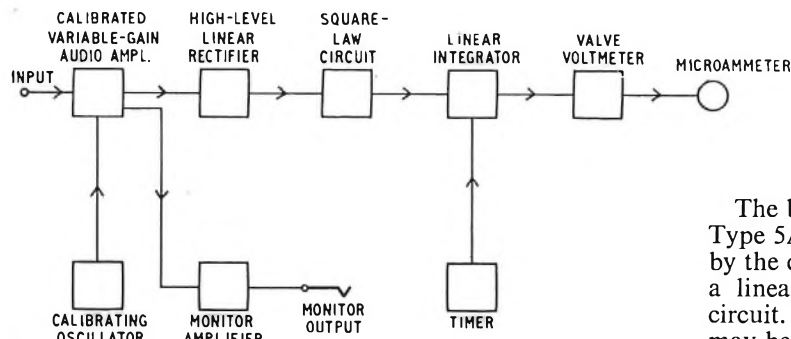

FIG. 1—BLOCK SCHEMATIC DIAGRAM OF SPEECH VOLTMETER TYPE 5A

its indications, however, when used with conversational speech, require interpreting and in practice it is desirable to employ a team of observers following a technique of reading laid down by the C.C.I.T.T.\*

In order to avoid the observer bias inherently associated with the Type 3 instrument, the Type 4A was subsequently developed. In this instrument the speech waveform, having been amplified and passed to a square-law rectifier, is applied to a 100 ms integrating circuit, followed by a group of trigger circuits each biased to operate only when successive uniform voltage-level steps are exceeded. The operations of the trigger circuits are counted by means of electromechanical counters and the readings thus obtained are a function of speech voltage.

This instrument, although accurate, free from observer bias and suitable for continuously spoken, fragmentary, or conversational speech, is essentially for laboratory use, being bulky and requiring appreciable time for setting-up.

The electronic Speech Voltmeter Type 5A, described below, does not in fact supersede either the Type 3 or the Type 4A instruments, but combines certain of the desirable features of both; under certain conditions it may be used with advantage. It is a direct-reading instrument, free from observer bias and suitable for measuring any form of audio signal, i.e. speech, music, or continuous tone. It is also reasonably portable.

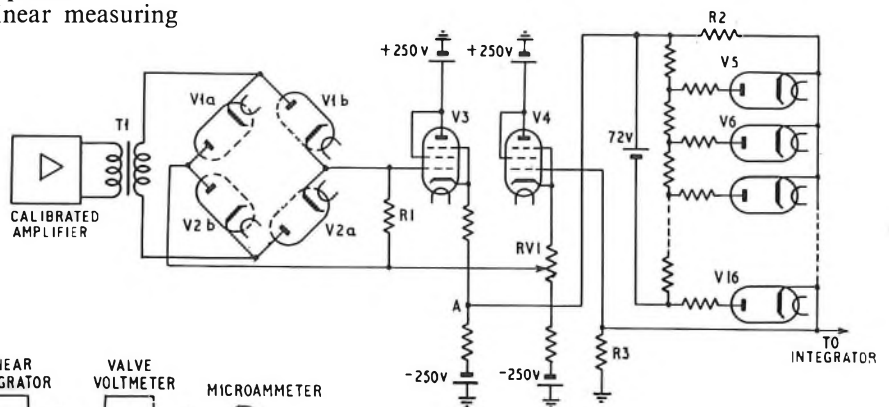

FIG. 2—SIMPLIFIED LINEAR-RECTIFIER AND SQUARE-LAW CIRCUITS

## PRINCIPLE OF OPERATION

The block schematic diagram of the Speech Voltmeter Type 5A is shown in Fig. 1. The input signal is amplified by the calibrated variable-gain amplifier and is passed to a linear full-wave rectifier, followed by a square-law circuit. The output voltage from the square-law circuit may be applied for a predetermined period of 1, 3 or 10 seconds to a linear integrator. A valve voltmeter, with a microammeter calibrated directly in decibels relative to 1 volt, is associated with the integrator. After completion of the timing period, the meter needle remains in its deflected position until reset by means of a key.

Facilities are provided for the day-to-day calibration of the instrument with the aid of a built-in oscillator, and an additional amplifier is included for monitoring the input signal.

The various units comprising the speech voltmeter will now be described in greater detail.

### Calibrated Variable-Gain Amplifier

The calibrated variable-gain amplifier is similar to that used in the Speech Voltmeter Type 3 and provides identical facilities, i.e. balanced or unbalanced input conditions and a total variation in gain of 80 db adjustable in 2 db steps.

### Linear Rectifier

The linear rectifier consists of a pair of bridge-connected double-diode valves V1, V2 (Fig. 2), fed from

† Post Office Research Station.

\* C.C.I.T.T.: International Telegraph and Telephone Consultative Committee.

the secondary winding of transformer T1, which is associated with the calibrated amplifier. The input voltage is of such a level that non-linear distortion is negligible, and the unsmoothed output voltage is developed across the load resistor R1. Provision is made, by means of potentiometer RV1, for applying a small standing bias to the diodes, so that no voltage appears across R1 in the absence of a signal. The voltage developed across R1 as a result of an input signal is applied to the square-law circuit.

#### Square-Law Circuit

The square-law circuit comprises a cathode-follower stage V3 (Fig. 2) fed from the signal voltage developed across R1. The point A, which is arranged to be at earth potential in the absence of an input signal, is connected to a potential divider comprising resistors R2 and R3. Twelve diodes V5 to V16, with their associated anode-load resistors, are effectively paralleled across R2, and are also connected to points on a potentiometer network energized by an independent 72 volts d.c. supply. The diodes are thereby biased successively more negative. On application of a signal, a positive potential varying in accordance with the input signal is developed between point A and earth. As this potential increases, the standing bias on the diodes is progressively overcome, their loads are shunted across R2, and the potential-divider ratio  $R_2:R_3$  is altered. The diode load values would normally be chosen so that the input/output characteristic would be of polygon form closely approximating to the relationship:

$$V_{out} = a(V_{in})^2,$$

as shown in Fig. 3.

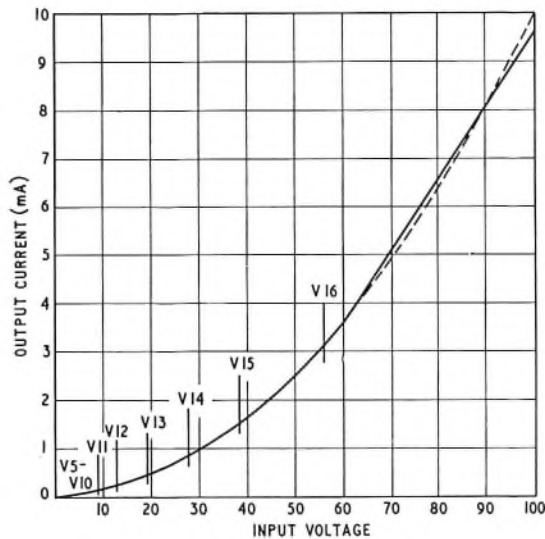

FIG. 3—CHARACTERISTIC OF SQUARE-LAW CIRCUIT

In practice, this cannot be achieved with the above simple arrangement since the diode loads cannot be reduced in value sufficiently to give the desired input/output relationship when the output voltage is comparable with the input voltage. This difficulty has, however, been overcome by applying the output voltage, via a cathode-follower stage, V4, in series with the input

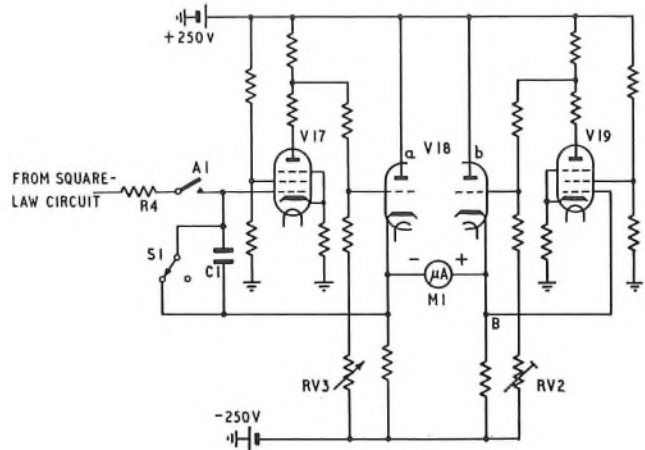

FIG. 4—SIMPLIFIED INTEGRATOR AND VALVE-VOLTMETER CIRCUITS

voltage so that the voltage across the diode network is nearly equal to the input under all conditions.

The signal, now modified by the square-law circuit and developed across R3, is applied to the linear integrator.

#### Linear Integrator and Valve Voltmeter

The Miller-type integrator (Fig. 4) consists of the resistor R4 and capacitor C1 in conjunction with valves V17 and V18a. In the 10-second position of the timing switch, the integrator has a time constant of about 680 seconds, thus ensuring linearity over the period required. The time constant for the 3-second and 1-second periods is made proportionally less by selection of appropriate values for R4, so that for a given charging voltage the potential acquired by the integrating capacitor, C1, and hence the final meter reading, remains the same for each timing period.

Valves V18b and V19 have been included to provide a balanced circuit for the operation of the meter, which would otherwise be susceptible to zero drift due to random heater-current variations. Point B is preset, by means of RV2, to be at earth potential during the initial setting-up of the instrument, whilst the "Set Zero" adjustment RV3 is used for day-to-day calibration.

The switch S1, which is opened at the commencement of a timing period, ensures the complete discharge of C1 prior to the timing period. Relay contact A1, which is associated with the timing circuit, closes for the duration of the timing period.

#### Timer

The purpose of the timer is to close relay contact A1 for periods of 1, 3 or 10 seconds, as desired. The phantastron<sup>2</sup> principle is employed, but the circuit will not be described in detail as no novel features are employed.

#### Calibrating Oscillator

A 1 kc/s oscillator is embodied in the speech voltmeter for calibration purposes. It enables a 1-volt r.m.s. sine wave to be applied to the input. The oscillator itself may be calibrated initially against a check point on the main meter scale by operation of a non-locking change-over key.

#### Monitor Amplifier

To enable the signal to be monitored while being measured, a buffer amplifier is associated with the output

of the calibrated variable-gain amplifier. This ensures that no shunt loss is caused by the monitoring equipment and also that the monitoring signal is of reasonably constant level, irrespective of the level of the input signal.

#### Power Unit

Supplies of  $\pm 250$  volts are obtained from mains-operated regulated power-supply units. Valve-heater supplies and the 72-volts d.c. supply for the square-law circuit are not regulated.

#### CONSTRUCTION

The Speech Voltmeter Type 5A is contained in two metal cabinets of identical dimensions. One of these,

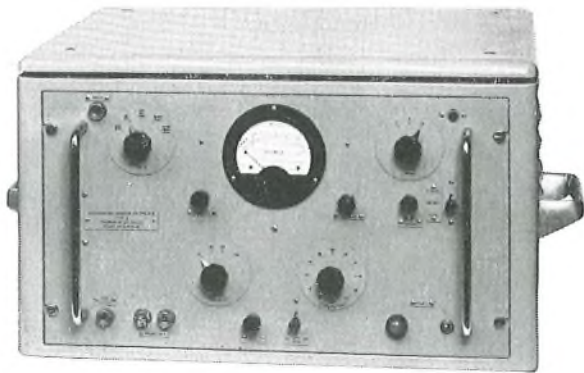

FIG. 5—MEASURING UNIT OF SPEECH VOLTMETER TYPE 5A

which contains all apparatus except power supplies, is illustrated in Fig. 5. The cabinets are inter-connected by means of three plug-ended flexible cables. The weight of the complete instrument is 144 lb.

#### CONCLUSION

This voltmeter has proved a reliable instrument in service and has been shown to fulfil a need. It was used successfully at Canterbury, during the field trial of the new Telephone No. 706,<sup>3</sup> to measure the speech voltage on outgoing calls from the P.B.X. extensions and, thus, to assess the relative speech levels between the Telephone No. 332 and the new telephone under normal conditions of use.

Used in conjunction with a specimen of conversational speech recorded on tape and a high-quality microphone, overall sensitivity tests on the receiving path of loud-speaking telephones have been made and conversely, using an artificial mouth, measurements on the overall sending path were also made.

The uses to which this instrument will be put will no doubt increase as its versatility becomes recognized.

#### References

<sup>1</sup> SHEARME, J. N. and RICHARDS, D. L. The Measurement of Speech Levels. *P.O.E.E.J.*, Vol. 47, p. 159, Oct. 1954.

<sup>2</sup> PUCKLE, O. S. Time Bases (Scanning Generators), (Chapman & Hall, Ltd., 1951), p. 172.

<sup>3</sup> SPENCER, H. J. C. and WILSON, F. A. The New 700-Type Table Telephone—Telephone No. 706. *P.O.E.E.J.*, Vol. 52, p. 1, Apr. 1959.

## Book Review

"The Services Textbook of Radio. Volume 5. Transmission and Propagation." E. V. D. Glazier, Ph.D.(Eng.), B.Sc., A.M.I.E.E., and H. R. L. Lamont, Ph.D., M.A., A.M.I.E.E. Her Majesty's Stationery Office. xi + 500 pp. 425 ill. 25s.

This volume of an already deservedly popular series is no less worthy than its predecessors, and it contains a good deal of material which the reviewer believes has been gathered together in a textbook for the first time.

The book opens with a most thorough fundamental treatment of the primary and secondary electrical parameters of transmission lines, including coaxial pairs. This treatment follows the traditional approach with the mathematical analysis very fully amplified by descriptive discussion. The distortionless condition, the effect of lumped loading, and the characteristics of artificial lines are among the subjects included. This is followed by a chapter on the transmission of audio-frequency and video-frequency signals, which includes a study of the variation of attenuation with frequency and other phenomena associated with distortion. A separate chapter is devoted to a most comprehensive treatment of reflection and related phenomena.

Succeeding chapters deal, in turn, with transmission at radio-frequencies, i.e. from about 1 Mc/s upwards, electromagnetic waves, guided waves, waveguide components and techniques, and cavity resonators. The treatment of the somewhat complex field considerations arising in waveguide theory is particularly thoroughly and lucidly treated, different colours being used, where necessary, in the numerous diagrams to distinguish between electric and magnetic components of the electromagnetic fields.

The remainder of the book (nearly one-half) is devoted to a most detailed and comprehensive (but thoroughly clear and readable) study of the theory of radiation from aerial systems. There is a full discussion of the different types of aerial suitable for radiation and reception of each characteristic range of frequencies from 3 kc/s to 30,000 Mc/s and above. As far as the reviewer is aware this is the first occasion on which such a comprehensive and thorough treatment of the theory of aerial systems has been included in a single textbook.

A final chapter deals with the practical problems associated with wave propagation in free space. These include effects due to terrestrial and other obstacles, the figure of earth, the atmosphere, ionosphere and troposphere. The theories underlying the structure of these extra-terrestrial zones and strata are amply explained and examples are included in which the theories are applied to practical data so as to predict effects which are confirmed by quoting experimental results.

Throughout the book the authors have clearly concentrated on producing a continuous and easily readable text amply illustrated by diagrams, sketches, tables and graphs. They have made very free and commendable use of appendices to include full discussions of any underlying mathematical theory which would break up the continuity of the text and interfere with its readability.

Only one or two errors were noticed and it is evident that special care has been taken in editing and proof-reading. The index seems to be sufficiently comprehensive without being unduly large. The book is recommended both to the student as a textbook and to the professional engineer as a work of reference.

*I.P.O.E.E. Library No. 2556.*

F. C. M.

# The Letter-Carrying Chain Conveyor at Leeds Head Post Office

J. H. ALDERSON, M.A., A.M.I.E.E.†

U.D.C. 621.867.3: 656.86

A new type of chain conveyor has been installed in the sorting office at Leeds Head Post Office to convey faced letters from the stamp-cancelling machines to the outward primary letter-sorting fittings. The chain conveyor incorporates features not previously used in the Post Office, including the automatic loading of trays of letters on to the chain-conveyor carriers and the automatic discharge of returned empty trays.

## INTRODUCTION

WHEN the need to extend the public counter at the Head Post Office, Leeds, arose some years ago, it was found necessary to encroach on much-needed space in the adjoining sorting office, but this loss of valuable working area has now been made good by extending the sorting office. The facing tables\* and stamp-cancelling machines have been retained in their previous positions convenient to the entry point of the incoming mails, but the outward primary letter-sorting fittings have been moved to the other side of the office to give a straight-line flow of traffic from the primary to the secondary roads.

The separation of the outward primary letter-sorting fittings from the facing and stamp-cancelling machine area of the office (see Fig. 1) made it desirable to provide some mechanical means of conveying the faced letters across the office, preferably at a high level to relieve the congestion on the floor of the office. The decision was, therefore, taken to install a chain conveyor as its flexibility, permitting the use of steeply rising and falling sections and sharp bends, would conserve headroom and floor space.

† Power Branch, E.-in-C.'s Office.

\* Facing tables are tables at which small packets and bulky envelopes are removed from among the mail and the remaining letters are arranged in bundles with the addresses all to the front and the stamps at the top right-hand corner, ready for passing through the stamp-cancelling machine.

## FUNCTIONS OF THE CHAIN CONVEYOR

The main functions to be performed by the chain conveyor are: (a) to automatically load trays of faced and stamped letters on to the chain-conveyor carriers, and transport them to the primary-sorting section where they will be unloaded by hand, and (b) to transport empty trays, placed on the carriers by hand, to the loading station and discharge them automatically on to a storage conveyor.

It was considered advantageous for the loaded carriers to be arranged to stop automatically at the unloading station and form a queue, without stopping the chain, until it was convenient for the trays to be unloaded and the letters distributed to the sorters. This would enable one postman, under all but the heaviest traffic conditions, to attend to the unloading of the carriers and the distribution of the letters to the sorters, whereas, if the carriers were moving continuously with the chain, constant attendance would be required for the removal of every loaded tray and this duty could not then be combined with the distribution of the letters.

It was, therefore, decided to install a proprietary type of chain conveyor known as the "Stanrun." The special features of this type of chain are:

(a) The carriers are not attached rigidly to the chain but are fixed to trolleys, which are capable of running on top of the chain and are normally driven by the friction between the trolley and the chain. Such a connexion between the chain and carriers makes it possible for the carriers to be held at any horizontal part of the chain track, and to form a queue without stopping the chain and interfering with the motion of other carriers and their loads.

(b) On rising and falling sections of the chain track, and at loading and unloading stations where it is necessary

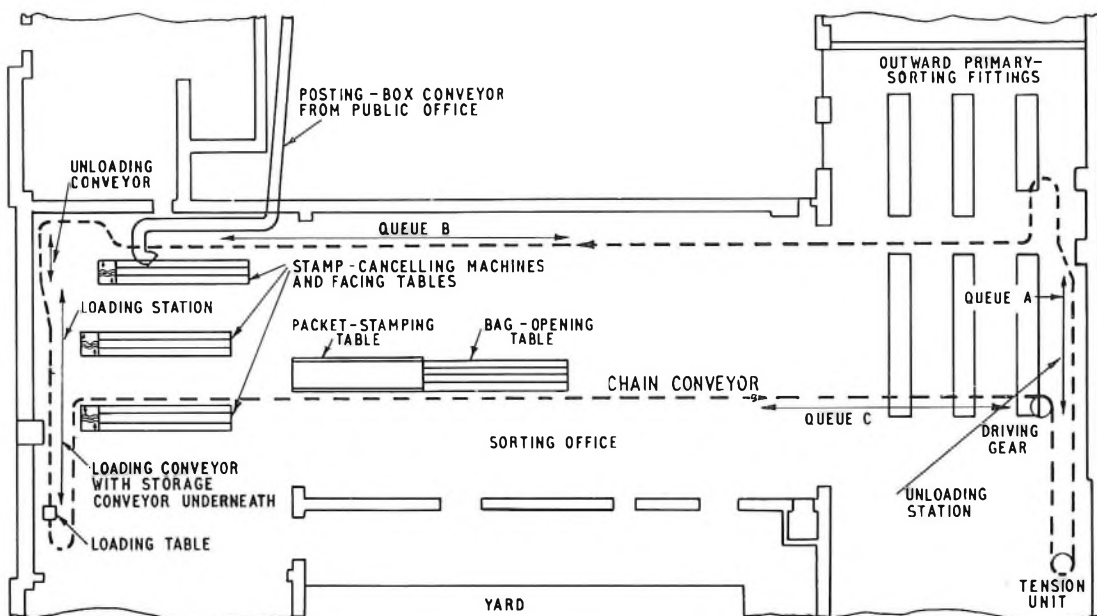

FIG. 1—PLAN OF SORTING OFFICE

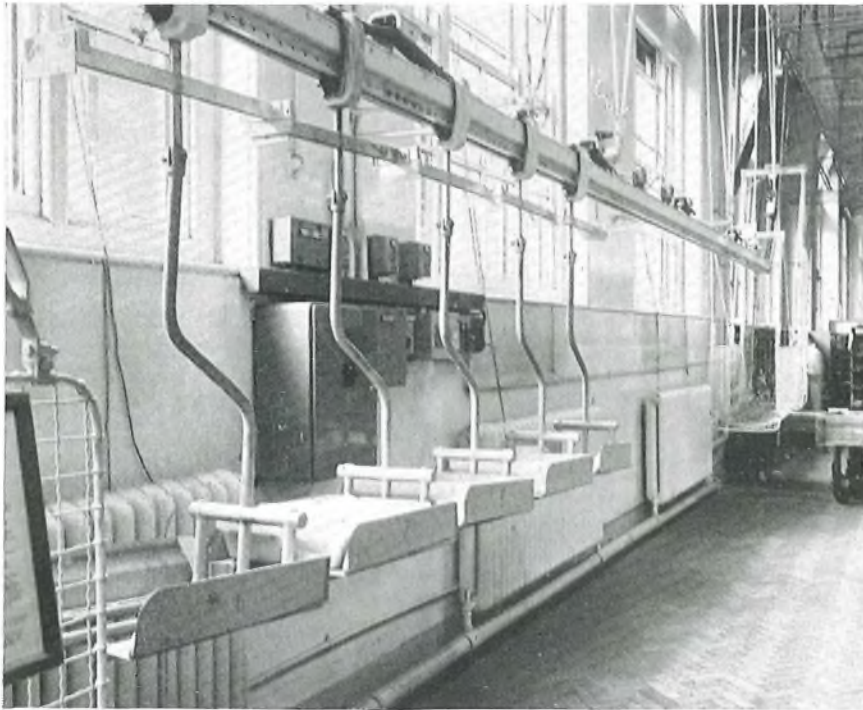

FIG. 2—CARRIERS IN QUEUE A AT THE UNLOADING STATION

to maintain a fixed relationship between the chain and the carriers, the trolley is attached to the chain by means of a pin or "dog" on the chain which engages with the trolley and drives the carrier positively over the desired section. The dogs are held in position by means of a ramp strip running along the chain track, and are removed when required by means of a dog ejector.

#### OPERATION OF CHAIN CONVEYOR

In order to ensure the efficient operation of the conveyor and a constant flow of trays, three queues of carriers have been incorporated in the chain circuit. The first queue (queue A, Fig. 1) is situated at the unloading station, Fig. 2, while the second is a queue (queue B, Fig. 1) of carriers just short of the loading station which ensures that empty carriers will always be available to pick up full trays of letters from the stamp-cancelling machines. The third is a queue (queue C, Fig. 1) of loaded carriers which forms in advance of the unloading station when the unloading section, which accommodates nine carriers, is full, and feeds the unloading station as the unloaded carriers move off.

#### *Control of Carriers in the Queues*

The movement of the carriers is controlled by a nine-position switch and a push-button at the unloading station, whereby pressure on the button will release from the unloading-station queue the number of carriers selected by the switch. The postman in charge of unloading and distribution of letters to the

sorters unloads and dispatches the carriers in batches as convenient to suit the density of traffic. As each carrier moves away from the unloading station, a carrier is released from each of the other two queues, towards the loading and unloading stations, respectively. Once a carrier has been released from a queue it travels continuously until it reaches the next queue.

This method of controlling the carriers from one point in the chain circuit ensures an even flow of carriers round the circuit, and prevents carriers accumulating at any point, which would thereby deprive the loading station of carriers when they were required.

When a carrier reaches a queuing position it is stopped by an arrestor switch and takes its place in the queue. Following carriers, driven by the chain running underneath the trolleys, queue up automatically behind the first carrier, and when the first carrier moves off all carriers in the queue move up one place. The dogs used to

obtain a positive drive from the chain are spaced along the chain at a pitch of 12 ft 8 in. and, after a carrier has been despatched from the unloading station, the first dogs to reach the carriers at the head of the B and C queues release the arrestors and engage the trolleys, thus causing one carrier to move off from the head of both queues.

#### *Loading Arrangements*

Full trays of faced letters are placed on the horizontal belt conveyor (Fig. 3) which delivers them on to a short length of gravity roller conveyor. This roller conveyor in turn delivers them on to a twin vee-belt conveyor,

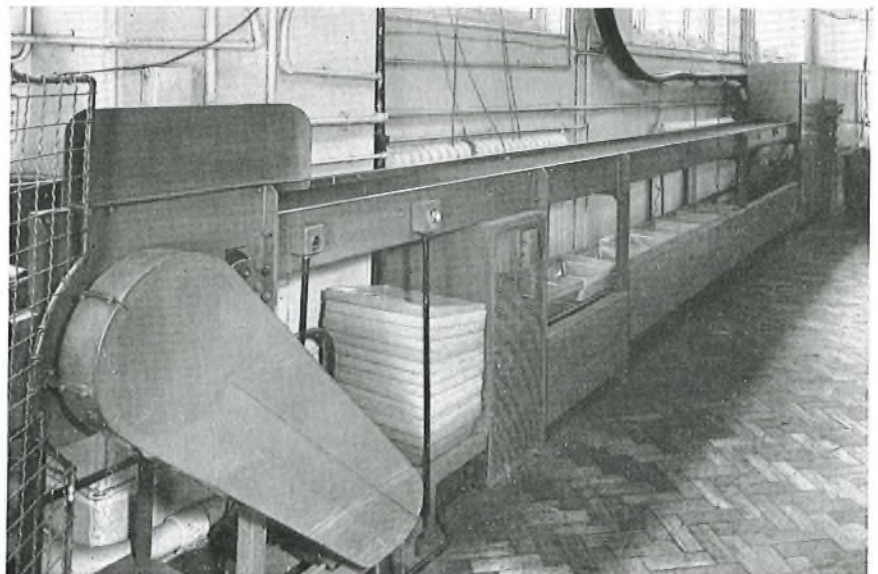

FIG. 3—THE LOADING CONVEYOR WITH STORAGE CONVEYOR UNDERNEATH



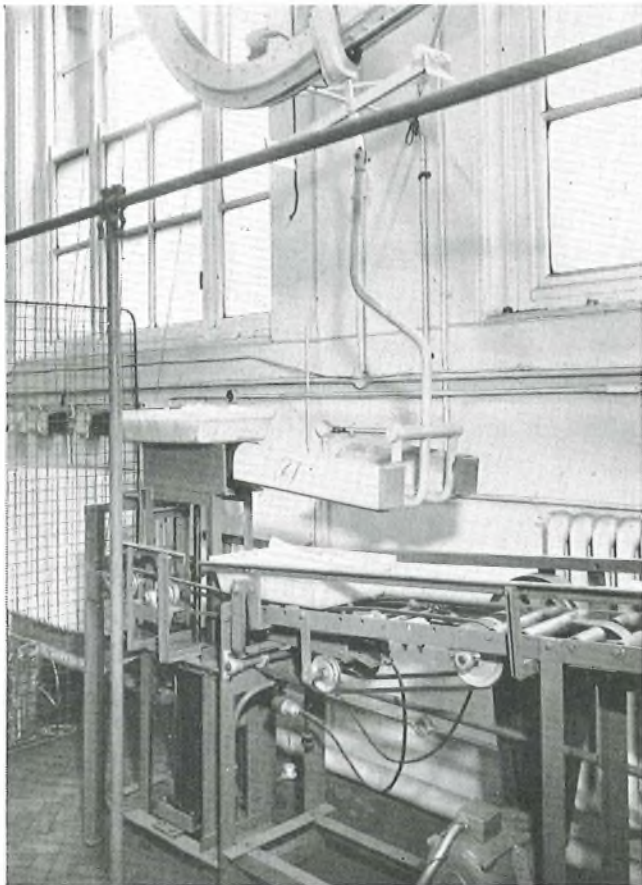

FIG. 4—VEE-BELT LOADING CONVEYOR AND LOADING TABLE

which places them in position over the loading table. An air cylinder, working in synchronism with the carriers via microswitches in the chain track, raises the tray on the loading table into the path of the approaching carrier (Fig. 4) and, after the tray has been deposited in the carrier, lowers the table ready for the next loading sequence. The movement of the trays up to the loading table is controlled by switches in the conveyor track which allow only one tray to move into position at a time.

The speed of the belt conveyor is 35 ft/min, and of the vee-belts 23 ft/min. The vee-belts are arranged to run continuously as the trays are held stationary on the belts for short periods only, but the belt conveyor is arranged to stop automatically as soon as five trays accumulate on the vee-belts and gravity rollers, and restart automatically when the number of trays is reduced to two. This safety device prevents the belt conveyor running under stationary loaded trays.

The vee-belt conveyor is employed in the final stage of loading to give a more positive movement of the trays than is possible using gravity rollers.

#### *Unloading Arrangements*

A twin vee-belt conveyor is used to unload the returned empty trays from the carriers by running the belts between the forks of the carriers and lifting the tray out of contact with the carrier. The belts run at 140 ft/min, approximately  $2\frac{1}{2}$  times the speed of the chain conveyor, and thus convey the tray out of the track of the carrier as it proceeds to the loading station. The empty

trays move via a short section of vee-belts running at 85 ft/min to the storage section, running at 20 ft/min. There is storage for ten trays in this section, which is underneath the loading conveyor (see Fig. 3), and safety devices are provided to prevent the number of stored trays accumulating and fouling the oncoming carriers in the high-speed sections of the belts. Audible warning is given first and, if the trays are still permitted to accumulate, the vee-belts are stopped, thereby preventing any further unloading.

#### CARRIERS

The carriers were designed as a result of extensive experiments with various types of carriers, and it was finally decided to use 3-pronged forks rather than 2-pronged forks to eliminate the possibility of a badly loaded tray slipping between the prongs and falling to the floor. Sloping sides are fitted to the outer prongs to ensure that each tray is loaded centrally on the carrier. Fifty carriers were manufactured for use at Leeds.

#### LETTER TRAYS

The letter trays are 12 in. wide by 17 in. long and have been designed to carry 700 short letters or 200 long letters, and to fit within one another when stacked awaiting use (Fig. 3). They have been moulded from  $\frac{3}{16}$  in. thick p.v.c. sheet and make very little noise when handled or in use on the conveyors. One hundred and eighty trays are used in the conveyance of a normal evening's mail.

#### CHAIN-CONVEYOR TRACK AND GUARDS

Except at the loading and unloading sections, the chain-conveyor track has been fixed at a height of 16 ft 7 in. to give a clearance of 12 ft from the floor level to the underside of the carriers or guards. The chain-conveyor track in the loading section has been fixed at a height to give a clearance of 12 in. above the loading conveyors to the underside of the carriers, permitting letters up to 12 in. in width to be carried in the trays.

Guards have been provided where the track of the chain conveyor passes over the primary-sorting fittings and where the carriers come down within 7 ft of the floor level, except at the unloading station where they would interfere with operational requirements. Elsewhere, guards have not been considered necessary underneath the chain on account of the special design of the carriers that prevents trays from falling out. The guards consist of wire-mesh panels supported from the chain track.

#### DRIVING EQUIPMENT

A motor-driven air compressor and an air receiver are installed to provide a supply of compressed air at 80 lb/in<sup>2</sup> to operate the air cylinder and loading table, arrestor units and lubricators. The chain, which has a total length of 525 ft, is driven at a speed of 60 ft/min by a  $1\frac{1}{2}$  h.p. motor. A spring-operated tension unit is used to maintain the chain tension.

#### ACKNOWLEDGEMENTS

The author wishes to acknowledge the design work of members of the Power Branch laboratory on the type of carrier to be used with this chain conveyor. Acknowledgements are also due to members of the Cornwallis Road workshop, London Telecommunications Region, who manufactured the carriers which are in use at Leeds.

# New Valves for Deep-Water Submerged Telephone-Repeaters\*

M. F. HOLMES, B.Sc., and F. H. REYNOLDS, B.Sc.(Eng.), A.M.I.E.E.†

U.D.C. 621.385.1:621.375.2:621.395.64:621.315.28

New valves have been developed and are now available for the first Post Office trans-ocean telephone cable. The problems of mechanical and electrical design of these valves are considered in some detail and a description of their construction and characteristics is included.

## INTRODUCTION

THE technique of using submerged telephone-repeaters in shallow-water telephone cables has been actively developed by the Post Office from the time the first repeater was laid in the Irish Sea in 1943. The design and production of the thermionic valves for these shallow-water repeaters culminated in the 6P12-type valve used in the Newfoundland–Nova Scotia section of the first transatlantic telephone cable.<sup>1</sup> It was, however, known that this valve would be quite unsuitable for a trans-ocean deep-water cable.

New valves, specially designed for deep-water repeaters, have been developed and are now available. They are being used for an intermediate-length cable between this country and Sweden, and also for the "CANTAT"

## LIFE STABILITY OF MUTUAL CONDUCTANCE, WORKING POINT AND GRID CURRENT

It will readily be appreciated that the stability of the repeater amplifier is closely linked with the stability of the mutual conductance, working point and control-grid current of the individual valves. It is proposed to consider each of these parameters in turn and to indicate how stability is achieved in the 10P-type valves.

### Mutual Conductance

If the mutual conductance is to remain stable, it is necessary to prevent growth of interface resistance and to prevent deactivation of the cathode by gas attack. In an earlier article in this Journal<sup>2</sup> it has been shown that the use of platinum as a core material effectively prevents interface-resistance growth. The 6P10-type and 6P12-type valves were protected in this way against deterioration of mutual conductance. More recent work has, however, shown that avoidance of interface-resistance growth and achievement of mutual-conductance stability

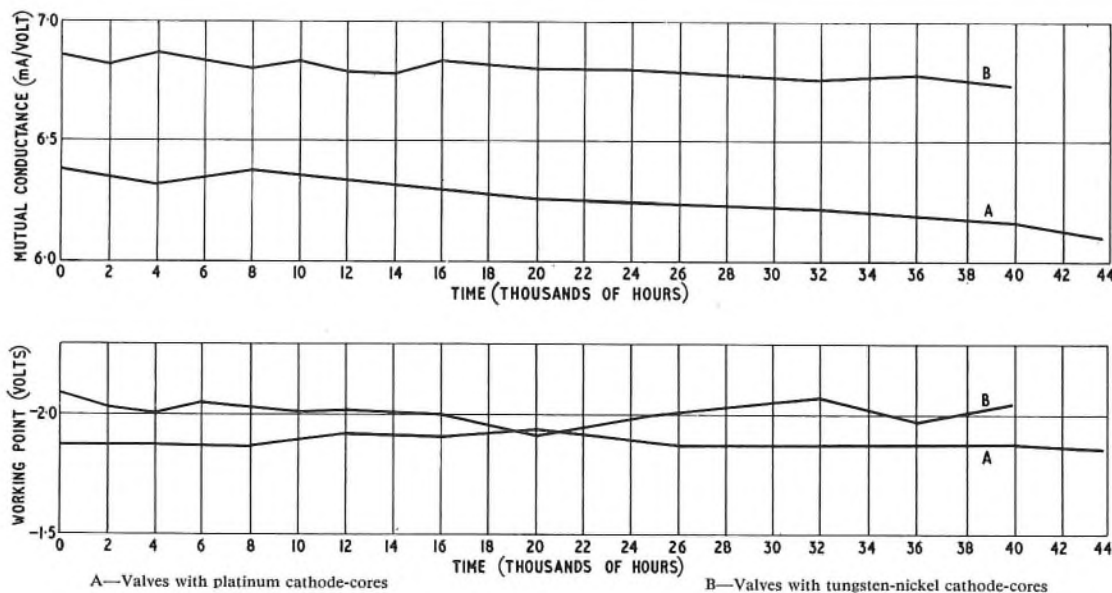

FIG. 1—LIFE STABILITY OF MUTUAL CONDUCTANCE AND WORKING POINT

cable between Canada and the United Kingdom. The valves are known as the 10P1-type and the 10P2-type, for output and input use respectively. In designing these valves use has been made of the experience gained on the 6P12-type valve and, in addition, there has been an improvement in long-term stability of some of the principal valve parameters and a reduction of h.t. voltage from 90 volts to 70 volts without loss of output power. Protection has also been provided against breakdown of heater-cathode insulation and against some of the disadvantageous effects associated with deposition of conducting films on the valve insulators.

\* This article is based on Paper No. 3163E of the Institution of Electrical Engineers (*Proceedings I.E.E.*, Vol. 107, Part B, March 1960).

† Post Office Research Station.

can be attained by using a cathode core of a low-impurity tungsten-nickel alloy containing 4 per cent tungsten. Typical life-test curves are shown in Fig. 1 comparing valves having platinum cathode-cores with valves having tungsten-nickel cores. On this basis there is little to choose between the two materials. Nevertheless the 10P-type valves use tungsten-nickel because of the additional advantages that this alloy affords in comparison with platinum. The alloy is not only stronger mechanically but the finished cathode is easier to activate and consequently the losses in production are substantially reduced, from perhaps 60 per cent in the case of platinum to about 30 per cent in the case of tungsten-nickel.

The prevention of deactivation of the cathode by gas attack is as important as the prevention of interface

resistance. A deactivated cathode has a higher resistance and a lower emission and both these factors reduce the mutual conductance. The problem of avoiding gas attack is a difficult one and is being solved by methods of attrition rather than by a single clear-cut procedure. It is not proposed here to list the many techniques that are being used but merely to mention one and then to direct attention to the success so far achieved. This may well be assessed from the results presented in Fig. 1.

In one instance the level of gas attack was reduced by making a change of material in the valve. It has been shown that if soda glass is used for the valve envelope then glass electrolysis may lead to the evolution of a gas, probably oxygen, into the valve atmosphere. This danger can be avoided by using lead glass, which has a much higher resistivity.

#### *Working Point*

The stability of the valve working point (defined as the voltage applied to the control grid to yield a given anode current at specified screen-grid and anode potentials) depends on cathode resistance and grid-cathode contact potential.† It will therefore be clear that the precautions outlined in the previous two paragraphs will contribute substantially towards attainment of a stable working point by keeping the cathode resistance low. Control of contact potential is more difficult, but the aging schedules used for the 10P-type valve at the time of manufacture, followed by a "long-aging" process of about 2,000 hours on the life-test racks, yield a stable value of contact potential of about 0.7 volts which varies little from valve to valve. The degree of stability of working point which has been attained may be seen in Fig. 1.

#### *Control-Grid Current*

Control-grid current may develop during life due to grid emission, gas current or leakage. The measures taken to prevent deactivation of the cathode by gas will, in themselves, keep any gas current within acceptable limits. Prevention of grid emission is helped by keeping the control-grid temperature as low as possible. Cooling fins, coated with graphite and fitted to the control-grid support rods, ensure that, for the 10P-type valve, grid emission need not be a cause for concern. Leakage current to the control-grid is one of several aspects of deposition of conducting films on insulating surfaces in the valve and will be considered in the next section. As a result of all the measures taken, it has been possible to achieve stable control-grid currents of less than  $0.01\mu\text{A}$  over life tests which have already lasted four years and are still continuing.

#### SECONDARY FORMS OF ELECTRICAL FAILURE

There are other ways in which a valve can fail electrically. The first of these is caused by the deposition of conducting films on the insulating surfaces inside the valve, particularly on the mica insulators. The effect of these films is to produce a marked increase in anode-grid capacitance<sup>3</sup> and they may also provide leakage paths which give rise to random bursts of noise.<sup>4</sup> The source of these films is probably the cathode, but recently it has been noticed that impurities in the anode may also contribute to their production.<sup>3</sup> In the 10P-type

† Contact potential is equal to the difference in surface work function of the electrodes.

valve, however, the anodes are made of the same low-impurity alloy as the cathode and can therefore be eliminated as a source of film growth. Evaporation from the barium-strontium-oxide matrix cannot be eliminated, but arrangements are made to shield vital areas of the mica insulators from direct evaporation. As a result there has been no growth of capacitance or incidence of noise bursts as far as life tests have proceeded.

Another cause of failure yet to be considered is breakdown of heater-cathode insulation. In the deep-water repeater, the valve heaters are arranged in series and the h.t. voltage is derived from the voltage drop across the heater chain. In this way the repeater voltage is kept as low as possible, but the heater-cathode potential difference may equal the h.t. voltage in the worst case, the heater operating at a positive potential relative to the cathode. This has been shown to be favourable to an insulation breakdown between heater and cathode.<sup>5</sup> In the 10P-type valve, breakdown is prevented by using an insulating heater sleeve of non-porous alumina between the heater and the cathode core.

#### VALVE DESIGN FOR LOW H.T. VOLTAGES

The design of submerged-repeater valves centres on the h.t. restrictions the valve must tolerate. It is proposed to consider the general problem first and this falls naturally into two parts, corresponding to the two divisions or sections within the valve. Attention will be directed to the triode section, from cathode to screen grid, and after that to the suppressor section from screen grid to anode.

#### *Design of Triode Section*

In the triode section, for a given current and screen-grid voltage, the grids can be designed to give the highest possible mutual conductance. In general, closing the electrode gaps increases the mutual conductance. There is however a limit, for, if the gaps are too small, local field variations will start to reduce the mutual conductance. Consequently a balance is required, but even when this balance has been achieved the design will still be subject to the overriding limitations which can be expressed by the symbolic equation:

$$\left[ \begin{array}{c} \text{Potential of} \\ \text{screen grid} \end{array} \right] + \left[ \begin{array}{c} 1 \\ \text{mechanical} \\ \text{quality} \end{array} \right] = \left[ \begin{array}{c} \text{mutual} \\ \text{conductance} \end{array} \right] + \left[ \begin{array}{c} \text{magnitude} \\ \text{of} \\ \text{working point} \end{array} \right] + \left[ \begin{array}{c} \text{steady} \\ \text{anode} \\ \text{current} \end{array} \right]$$

In this equation mechanical quality refers partly to the size of the gaps between electrodes and partly to the diameter of the grid helix wires. The mechanical quality is considered to increase as the gaps and diameter increase. The terms on the right-hand side taken together provide a measure of electrical performance. Thus for a given screen-grid voltage and mechanical quality, any one of the performance factors can only be improved at the expense of one or both of the other two. Alternatively, by transferring the "mechanical quality" term to the right-hand side, the screen-grid voltage can be regarded as a credit which must be equitably distributed between electrical performance and mechanical quality.

#### *Design of Suppressor Section*

It is the suppressor section of the output valve which determines to a large extent the maximum undistorted power output from the third stage of the amplifier.

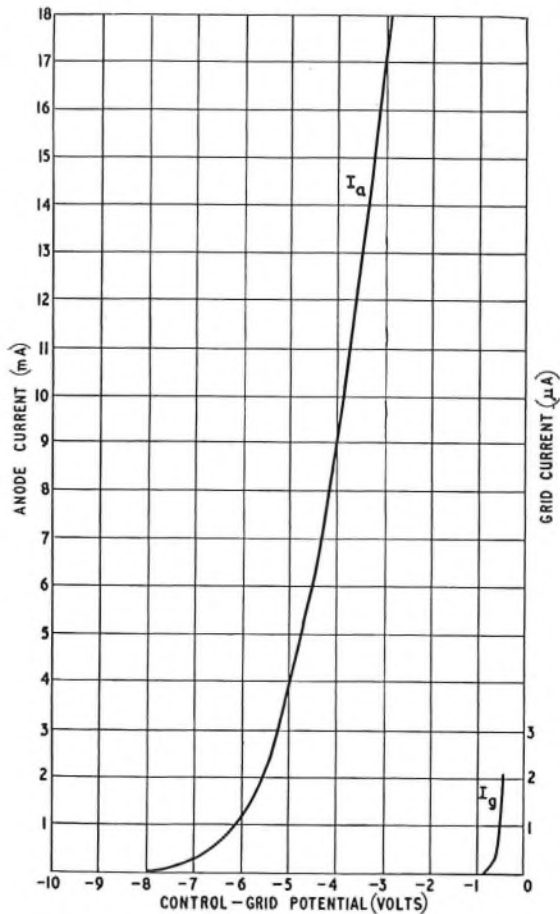

FIG. 2—TYPICAL MUTUAL AND GRID-CURRENT CHARACTERISTICS OF 10P1-TYPE VALVE

The “knee” of the anode characteristic should be sharply defined and should be located at as low an anode voltage as possible. In addition the anode impedance should be high, the anode-grid capacitance minimized and secondary emission avoided.

Two effects cause difficulty when designing the suppressor section of the output valve. First, there is inherent over-suppression due to low electron velocities and higher space currents and, secondly, the definition of the “knee” worsens as the screen-grid potential increases. In the context of the second difficulty it must be remembered that maximum screen-grid voltage is required to give the best performance in the triode section. The solution of the problem hinges on the provision of just enough secondary-electron suppression and no more. Consequently a very open-mesh suppressor-grid will be required and is in fact used.

#### DESIGN AND PERFORMANCE OF THE 10P-TYPE VALVES

The 10P-type valves are designed on the basis of the principles outlined in the previous section and make use of the features discussed in the second and third sections of this article.

A conventional lamp-coil heater

rated at 10 volts and 3 watts is used. The heater wire is 0.090 mm in diameter and is coated with alumina in the normal manner. The heater sleeve, of non-porous alumina, has a wall thickness of 0.15 mm and fits inside a cathode core fabricated from tungsten-nickel alloy. The alloy is produced to a specification and is coded L2. The heater operates at 1,370°K and the cathode at 1,020°K.

When designing the valves it was decided that adequate mechanical quality would be provided if the minimum diameter of the grid helix wires was placed at 32 microns. This minimum was actually used for the control-grid of the 10P2-type valve. It was, however, possible to use 38-micron wire for the same grid of the 10P1-type valve and 44-micron wire for the screen grids of both valves. In addition it was felt that the gap between the surface of the cathode and the control grid, which needed to be of the order of 0.11 mm to give satisfactory electrical performance, was in fact adequately large when considered from the aspect of mechanical safety.

The method proposed by Liebmann<sup>6</sup> and developed by the second author<sup>7</sup> was used for the design of the valves, and the resulting characteristics are given in Fig. 2, 3 and 4. It should be noted that the normal anode-dissipation of the 10P1-type valve is 0.7 watts. Tests have shown, however, that life stability is maintained when the dissipation is as high as 1.5 watts. This limit is shown in Fig. 4. The operating conditions for the 10P1-type valve in the repeater are:  $V_a = V_{g2} = 70$  volts,  $V_h = 10.2$  volts, and  $I_a = 10$  mA. The conditions for the 10P2-type valve are:  $V_a = 40$  volts,  $V_{g2} = 50$  volts,  $V_h = 10.3$  volts, and  $I_a = 3$  mA.

A photograph of the electrode structure is shown in Fig. 5. The anodes and mica shields as well as the cathode core are made of L2 alloy. In order to achieve a reliable structure, the number of joints has been minimized by making connectors in one piece as far as possible. In general, joints have been designed as mechanical joints with a weld or welds acting as reinforcement. The bulb is made of lead glass in order to reduce electrolytic effects.

Manufacture of the valve is carried out under the semi-clinical conditions now commonly used for production of submerged-repeater components. Careful visual examinations are made at various stages of

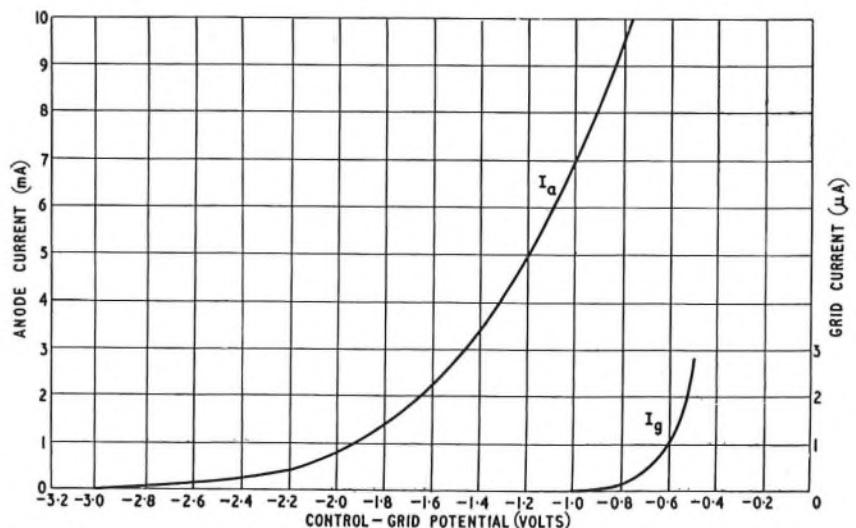

FIG. 3—TYPICAL MUTUAL AND GRID-CURRENT CHARACTERISTICS OF 10P2-TYPE VALVE

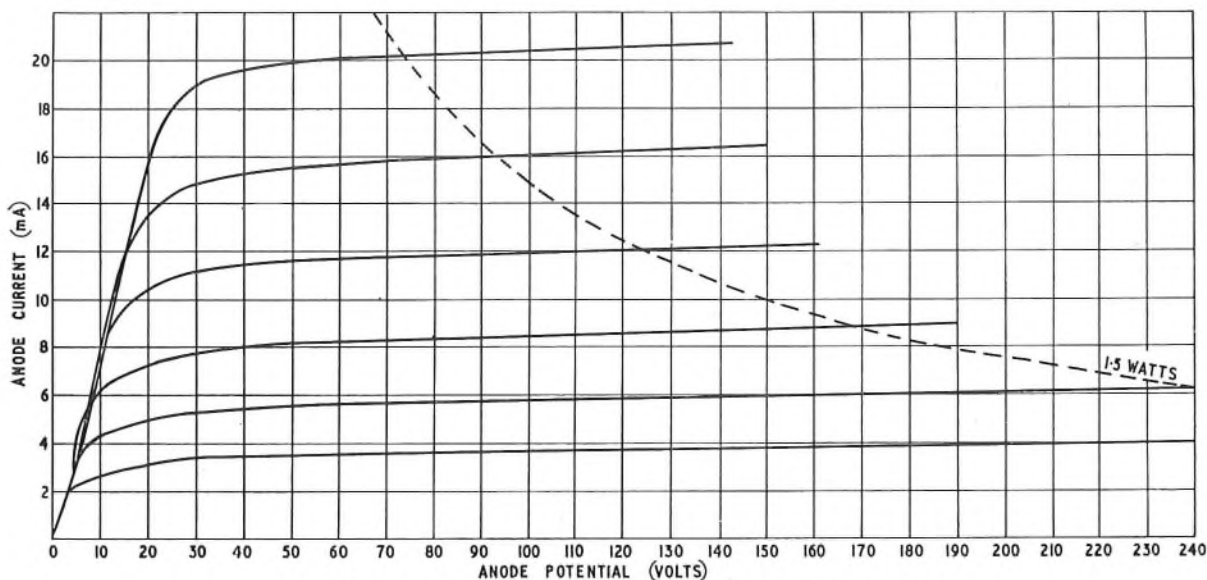

FIG. 4—TYPICAL ANODE CHARACTERISTICS OF 10P1-TYPE VALVE

manufacture followed by an intensive microscopic examination for every selected repeater valve.

#### CONCLUSIONS

The first valves made with tungsten-nickel cathodes have been on life test for over five years and the earliest

10P-type valves have entered their third year. So far the characteristics are entirely satisfactory but a complete assessment must await the passage of further time.

The new deep-sea repeater valves represent an advance on earlier techniques but finality has by no means been reached. Much of the progress reported here has resulted from examination of life trends in the context of the mechanical and production history of the valve. Continued vigilance and new concepts may well point the way to further developments which could permit corresponding advances in submerged-repeater design considered as a whole.

#### ACKNOWLEDGEMENTS

The authors would like to acknowledge the assistance given by their colleagues in the Thermionics Group and, in particular, that given by Dr. G. H. Metson, who has guided the development of submerged-repeater valves from the start. Thanks are also due to Mr. E. G. Rowe of Standard Telephones and Cables, Ltd., for valuable assistance given during the later stages of the project.

#### References

- 1 McNALLY, J. O., METSON, G. H., VEAZIE, E. A. and HOLMES, M. F. Electron Tubes for the Transatlantic Cable System. *Proceedings I.E.E.*, Paper No. 2279R, Jan. 1957 (Vol. 104 Part B, Supplement No. 4 p. 60), and *P.O.E.E.J.*, Vol. 49, p. 411, Jan. 1957.
- 2 METSON, G. H., and HOLMES, M. F. Deterioration of Valve Performance Due to Growth of Interface Resistance. *P.O.E.E.J.*, Vol. 46, p. 198, Jan. 1954.
- 3 REYNOLDS, F. H., JOHNSON, C. B., and ROGERS, M. W. Growth of Anode-to-Grid Capacitance in Low-Voltage Receiving Valves. *Proceedings I.E.E.*, Vol. 104, Part B, p. 487, Sept. 1957.
- 4 CHILD, M. R. Notes on a Source of Intermittent Noise in Oxide-Cathode Receiving Valves. *Proceedings I.E.E.*, Paper No. 2140R, Sept. 1956 (Vol. 103, Part B, p. 667).
- 5 METSON, G. H., RICKARD, E. F., and HEWLETT, F. M. Some Experiments on the Breakdown of Heater-Cathode Insulation in Oxide-Cathode Receiving Valves. *Proceedings I.E.E.*, Vol. 102, Part B, p. 678, Sept. 1955.
- 6 LIEBMANN, G. The Calculation of Amplifier Valve Characteristics. *Journal I.E.E.*, Vol. 93, Part III, p. 138, May 1946.
- 7 REYNOLDS, F. H. Design of Pentode Receiving-Type Valves. *Electronic Engineers' Reference Book* (Heywood, London, 1958), Sections 424-7.

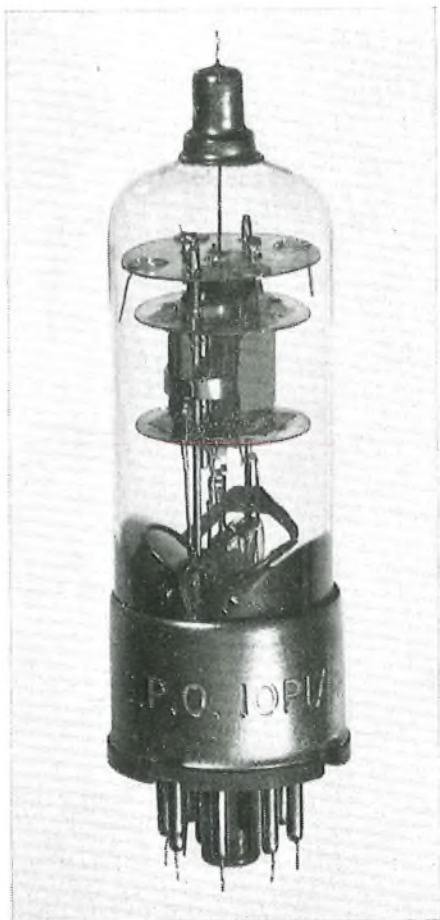

FIG. 5—10P1-TYPE VALVE

# The Switching of Television Circuits in London

C. H. BLANCHARD, B.Sc.(Eng.), A.M.I.E.E., W. L. NEWMAN and W. H. WILLETT†

U.D.C. 621.316.5:621.397.743

An extensive network of circuits for sound and vision transmission has been provided by the Post Office for the Independent Television Authority and its associated program contractors. To enable programs to be distributed and exchanged as required, the inter-connexions of the circuits forming the network have frequently to be rearranged. The switching operations required are complex and must be carried out instantaneously and at specific times. The apparatus installed at the London network switching centre for this purpose is described.

## INTRODUCTION

THE inauguration of an alternative television service under the control of the Independent Television Authority (I.T.A.)<sup>1</sup> in September 1955 resulted in the Post Office having to add an ever-increasing number of vision and sound circuits to the national network. The B.B.C. television service is essentially a national one and, except for such items as regional news bulletins, the majority of the transmitting stations radiate a centrally produced program. The I.T.A. service is much more flexible, and the individual transmitter with its associated program contractor is basically a regional unit producing its own program.

The division of responsibility between the I.T.A. and the program contractor results in the main inter-city and transmitter circuits, both vision and sound, being rented by the Authority, while the studio circuits are rented by the individual contractors. All these circuits terminate in Post Office control rooms located in the main cities. The program contractors are free to distribute and interchange programs between companies as they desire, thus allowing popular items to be seen by larger audiences and so reducing the cost of particular programs. Any rearrangements of the network necessary to achieve this exchange of program material are under the control of the Post Office. Such network switching, as it is now called, has normally to be done at specific times. The Post Office speaking clock<sup>2,3</sup> is, by agreement, used as the time standard for these switching operations and the instant of switching is determined by the third "pip" signal following the speaking-clock announcement of the appointed time. Owing to the complexity of the network it is quite a common occurrence for as many as six circuits to be switched simultaneously to cater for a program change.

As all large Post Office control rooms in which the Independent Television Network circuits terminate are required to undertake network rearrangements, they have been designated television Network Switching Centres (N.S.C.s). There will ultimately be 14 such centres and of these London, Birmingham, Manchester and Carlisle will be the more important. The studio circuits are extended from each N.S.C. to a similar centre established by the program contractor and known as a Program Switching Centre (P.S.C.). Fig. 1 shows how such centres are usually interconnected.

It was originally intended that the switching of programs should be performed by representatives of

† Mr. Blanchard is in the Main Lines Development and Maintenance Branch, E.-in-C.'s Office; Messrs. Newman and Willett are in the London Telecommunications Region.

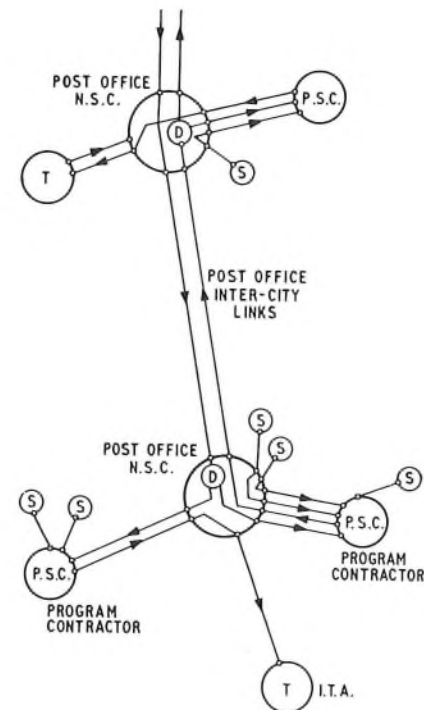

- |     |                         |        |                          |
|-----|-------------------------|--------|--------------------------|
| (S) | Studios                 | N.S.C. | Network Switching Centre |
| (T) | Transmitting stations   | P.S.C. | Program Switching Centre |
| (D) | Distribution amplifiers |        |                          |

FIG. 1—TYPICAL ARRANGEMENT OF NETWORK SWITCHING CENTRES, PROGRAM SWITCHING CENTRES, STUDIOS AND TRANSMITTERS

the program contractors, and arrangements were made in London to provide accommodation for this purpose. It was eventually decided, however, that this work should be carried out by Post Office staff, and an elementary switching equipment was constructed and fitted at the London N.S.C., which is situated in the Museum telephone exchange building.

The first switching of programs was scheduled for early 1956, the first I.T.A. transmitter in the provinces having opened for service at Lichfield on 17 February of that year. The first switching unit was made from three 2-position rotary switches, each capable of switching one of two incoming vision circuits to an outgoing circuit as well as switching the associated sound circuits. This equipment was brought into use in May 1956 and during that month a total of 231 switching operations took place. When originally introduced, the scheme called for the presence at the N.S.C. of an I.T.A. engineer whose function was to provide a liaison between the program contractor and the Post Office, but, as his duties were limited to checking that the circuits were satisfactory before and after a switching operation, it was quickly found that such duties were superfluous, and after four months these I.T.A. engineers were withdrawn. Since that time liaison between the Post Office and the program contractors has been direct.

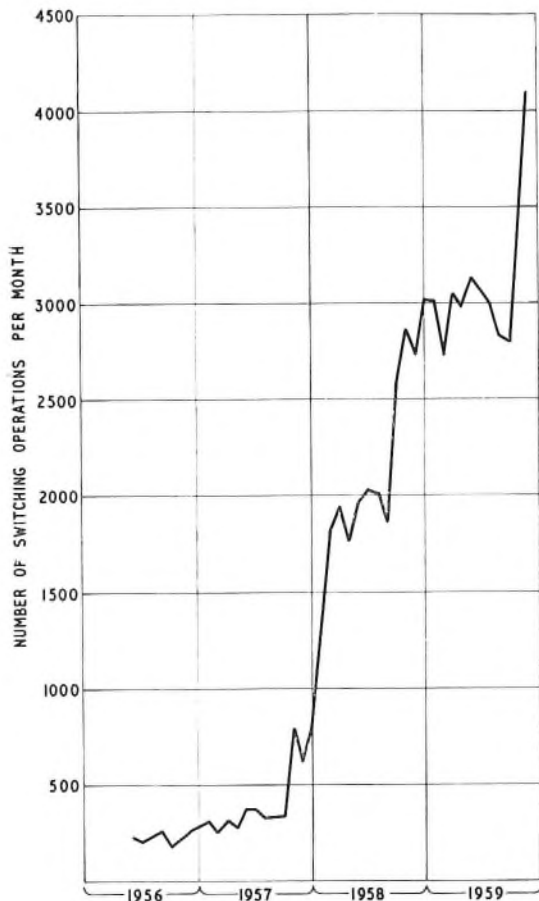

FIG. 2.—PROGRAM SWITCHING OPERATIONS AT LONDON N.S.C.

From the opening of the service in London until December 1957, there was only a gradual increase in the number of switching operations performed, as shown in Fig. 2. The opening of the St. Hilary transmitter, in South Wales, resulted in a 280 per cent increase. This increase occurred in a period of two months, the actual opening date being 14 January 1958. There followed a period of relative stability, the daily switching operations averaging 62. On 29 August 1958 the Chillerton Down transmitter in the Isle of Wight opened for service and this resulted in another sudden rise in the number of program circuits switched. This was due to the large number of items exchanged by the program contractors. Fig. 2 shows that on each occasion a provincial transmitter with a direct connexion from London opened there was a large instantaneous increase in the number of switching operations to be performed, and it is to be expected that this trend will continue in the future.

To carry out the ever-increasing number of switching operations, various improvised switching equipments were installed at the N.S.C.s. These were temporary expedients pending the completion and bringing into service of equipment specifically designed for the work. Such an equipment, the Automatic Network Distribution Equipment, was installed in the London N.S.C. and brought into use on 17 December 1958. The number of switching operations carried out by this equipment in November 1959 was 4091, compared with 219 in June 1956.

#### SWITCHING FACILITIES REQUIRED

As a result of the experience gained using very simple forms of switching apparatus, it was possible to appreciate the design requirements for a large switching equipment. It was apparent that any such equipment should provide the following facilities:

(a) A means of switching any program source to any destination in any possible combination from (i) a different source to every destination to (ii) one particular source to every destination, by means of relays or other suitable switching devices.

(b) The ability to accomplish (a) automatically at a specific time by means of a preset switching clock.

(c) A means of manually operating the switching apparatus in the event of a clock failure.

(d) A means of pre-selecting at least three switching operations together with the facility of presetting the corresponding switching times on the clock.

(e) Switching operations should not interfere with circuits passing through the equipment which are not being switched.

(f) Facilities for switching vision and sound circuits separately if required.

(g) Failure of a.c. mains or d.c. control voltages should not give rise to any condition other than that of a disconnected circuit.

(h) All component items using a.c. or d.c. power should be separately fused.

(i) Facilities for emergency patching to overcome a circuit failure and for rapid location of faults in the switching apparatus.

(j) A means of monitoring sources and destinations, both vision and sound (not to enable the quality of transmission to be checked but merely to ensure that what is received from a source is fed to the correct destination or destinations).

(k) Single-operator control of the equipment.

#### VISION-CIRCUIT SWITCHING

It was necessary to devise a method of switching which would enable any source to be connected to any single destination or to all the destinations simultaneously if required. Four possible schemes for achieving this were considered.

(a) The provision of a multi-outlet distribution amplifier associated with each source.

(b) The use of high-impedance-input destination-amplifiers which could be connected in parallel across the source as required.

(c) The provision of an amplifier, associated with each source, which would give an output of at least +20 db relative to a 1 volt peak-to-peak vision signal. This output would then be fed through a resistive branching network designed to give the requisite number of outlets.

(d) The use of a resistive branching network in each source and the restoration of the signal to 1 volt peak-to-peak by means of a vision-signal amplifier connected in the destination feed.

Of the four schemes that were considered method (d) was the one finally chosen. Method (a) appeared to be the most simple in application but, when the equipment was designed, no distribution amplifier with a sufficiently large number of independent outlets was available. Method (b), that of using high-impedance-input amplifiers, raised considerable problems due to the capacitance of the connecting cables. Method (c), requiring the use of a high-level send amplifier, was not favoured, because

the only amplifier available was bulky and expensive. Owing to the fact that the requirements were for more sources than destinations, the use of amplifiers permanently connected to sources was uneconomic. It was realised that with method (d) the actual switching would be done at a comparatively low signal level, but it was thought that this would not cause any insuperable difficulties.

The capacity of the switching console was agreed to be 15 sources and 10 destinations, these figures taking into account the future expansion likely to occur. Fig. 3 shows a simplified schematic diagram of the vision-signal transmission path. The maximum number of

### Waveform Correction

The amount of cabling has been kept to an absolute minimum in the switching console of the Automatic Network Distribution Equipment, but nevertheless the transmission loss introduced could not be neglected and a small waveform-corrector had to be designed and fitted in each source feed. These correctors were designed using the normal techniques<sup>4</sup> for unbalanced video circuits. The original design and final adjustments were carried out using a pulse-and-bar generator<sup>5</sup> as the source of test signal and observing the received waveform on an oscilloscope. When all the adjustments had been completed, the waveform distortion introduced by any path through the console was negligible.

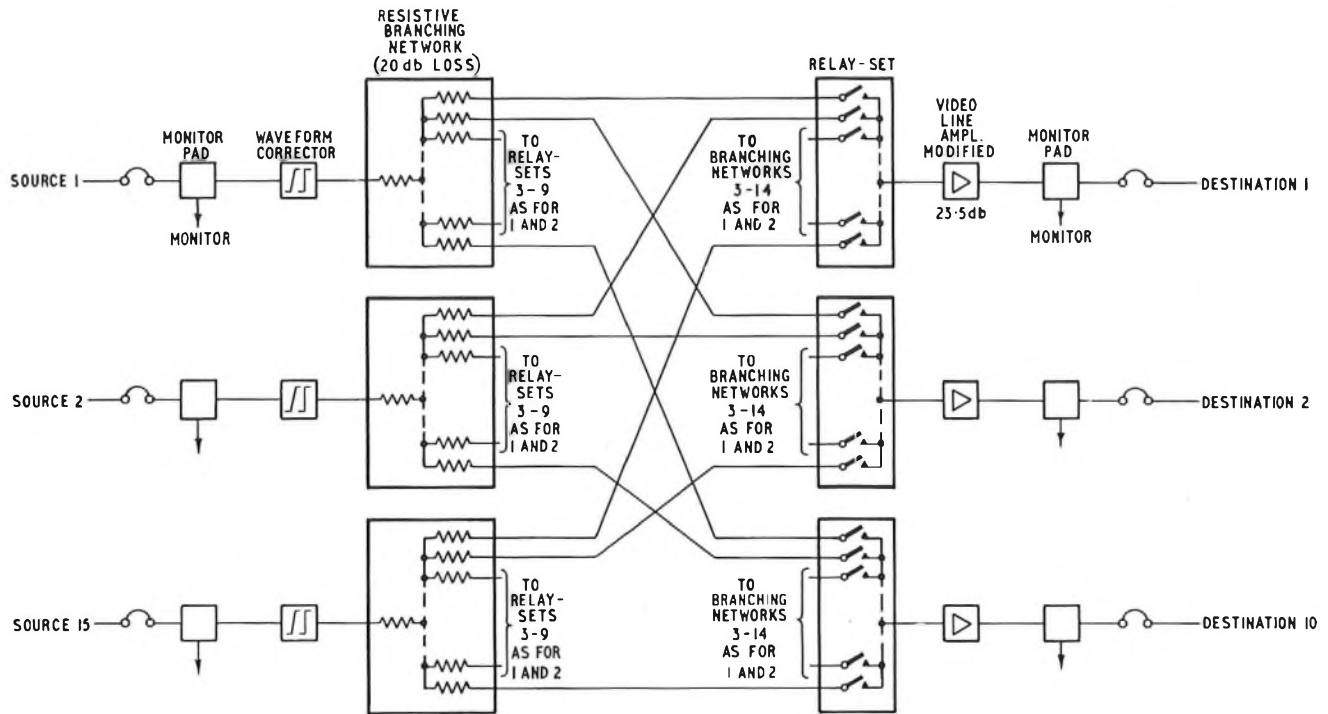

Notes:

1. Sources 3-14 are connected in the same way as sources 1 and 2
2. Destinations 3-9 are connected in the same way as destinations 1 and 2

FIG. 3—SIMPLIFIED SCHEMATIC OF TRANSMISSION PATH FOR VISION-CIRCUIT SWITCHING

sources available with the present arrangement is limited by the number of relays in the relay-set and also by the number of positions on the switches used in the switch panels. The maximum number of destinations that can be served is a function of the gain of the amplifier; in this instance a 10-way branching network in conjunction with the standard type of vision-signal amplifier was satisfactory.

As can be seen in Fig. 3, each source is split to give 10 outlets. Each outlet is fed to a separate relay-set which is permanently connected to a destination amplifier. The operation of a particular source relay in the relay-set connects the destination to that source.

### Branching Networks

The resistive branching network was designed to have both an input and output impedance of 75 ohms and the minimum transmission loss. The loss between the input and any one output when all the others are correctly terminated is 20 db.

### Relay-Set for Vision-Circuit Switching

A special relay-set was designed incorporating low-capacitance relays. The relay contacts are connected as shown in Fig. 4 so that crosstalk between the spring-sets is reduced to a minimum. At the rear of the relay-set, vision-circuit connexions are taken to the spring-sets from coaxial plugs mounted on bridge-pieces which each straddle three relays. An additional bridge across the two final relays carries the output plug. Coaxial connexions for the vision signals are made via sockets which are fitted to the ends of the coaxial cables from the branching networks and destination amplifier.

D.C. connexions from the switch panels on the console to the relays are made via a 24-way plug and socket, the plug being fixed to the relay-set.

### Destination Amplifier

The sum of the transmission losses due to the branching networks, monitor pads, cabling and waveform corrector amounts to 23.5 db. The standard type of video line



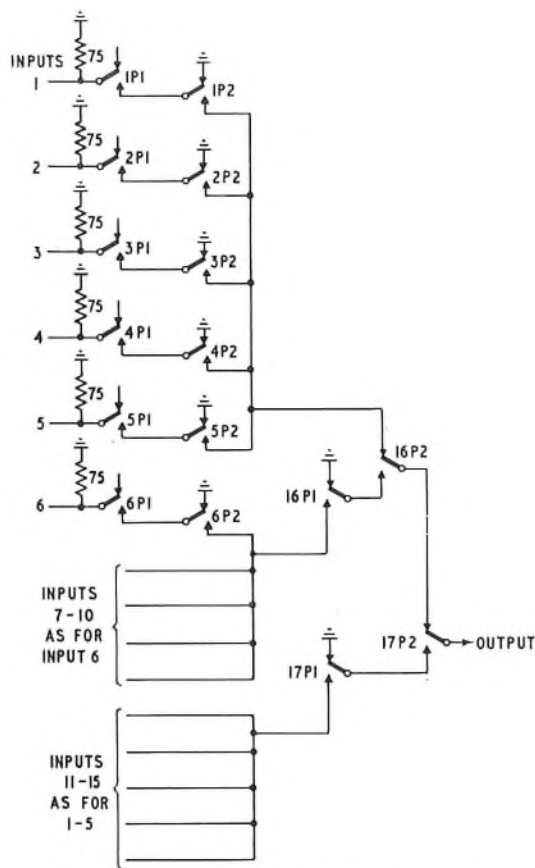

FIG. 4—VISION RELAY-SET CONTACT WIRING

amplifier has a nominal gain of 20 db and, rather than have two of these amplifiers in tandem, it was decided to modify the standard amplifier to have a gain of 23.5 db by reducing the amount of negative feedback. It was felt that this was justified in this instance, particularly as the amplifiers work from a regulated mains supply and because their normal band-width is in the region of 7 Mc/s. Experience has shown that, for the purpose for which these modified amplifiers are being used, no difficulty is caused by the increase in gain.

During the initial acceptance tests it was found that, owing to the transit time of the switching relays, interference with destinations already connected to a source occurred when additional destinations were connected. To overcome this difficulty, the branching-network outputs are always terminated in 75-ohm resistors permanently fitted in the relay-sets (see Fig. 4). The input resistor in each amplifier was removed, this being quite practicable as the cable length between relay-set and destination amplifier never exceeds 15 in. because the two items are fitted adjacent to one another in the rear of the console.

#### SOUND-CIRCUIT SWITCHING

The sound-circuit switching relays are arranged as shown in outline form in Fig. 5. This is similar to the vision scheme except that, instead of a resistive branching network, the feeds to the 15 relay-sets are obtained from each source by direct commencing. The input impedance of each destination amplifier is approximately 200,000 ohms so that even with all destinations connected

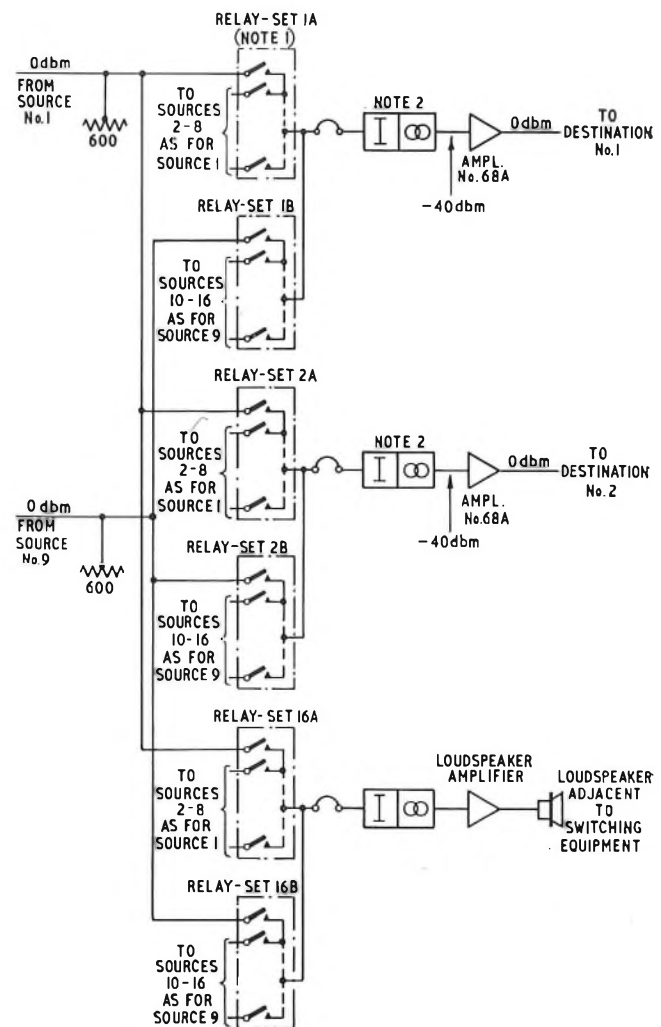

#### Notes:

1. Two relay-sets are required for each of 15 destinations plus an additional pair for monitoring
2. The loss of the pad is approximately 40 db. The input impedance of the transformer is 200,000 ohms and the output impedance is 600 ohms
3. dbm—decibels relative to a milliwatt

FIG. 5—SIMPLIFIED SCHEMATIC OF TRANSMISSION PATH FOR SOUND SWITCHING

to the same source there is no significant change from the output level obtained when only one destination is connected.

#### CONTROL AND MONITORING CIRCUITS

The principle of operation of the Automatic Network Distribution Equipment is that the desired changes in the interconnection of the links forming the independent television network are preselected manually and, at the appropriate time, the actual switching operations are carried out automatically under the control of an electronic clock.<sup>6</sup> This clock is in turn synchronized by signals from the Post Office speaking clock.

Three switching operations can be set up in advance on the console of the equipment, the three sets of selection switches having control knobs coloured red, blue and green to facilitate identification. The three switching times appropriate to the three switching operations are preset on the electronic clock, using similarly coloured controls. The electronic clock also gives an audible "pre-switching" alarm to warn the operator when any

one of the switching operations is imminent. The interval between this warning and the instant of switching may be varied to suit the operational requirements.

### Control Equipment

Each destination circuit has two switch panels, one for vision circuits and one for sound, on which the selection of sources can be made. Each panel has a row of three switches, the control knobs being red, blue and green. The switches are mounted on a plate approximately 3 in. × 12 in. together with two 15-way 51-type U-link strips, mounted one at each end. Each switch has 15 positions, one for each source, and engraving on the skirt of each switch knob indicates the source selected. Connexions from the switches to the relays and from the central master switching unit are made via the 51-type U-links so that the whole panel can be removed without disturbing the associated wiring. The vision-switch panels, together with the vision relay-set and associated destination amplifier, are considered as destination equipment and the branching networks as source equipment. The sound-switch panels and the relay-sets are the corresponding sound destination equipment.

The switch panels occupy the whole of the face of both left (sound) wing and right (vision) wing of the console, being mounted in two rows of eight with a supervisory panel in the centre of each row. Each wing gives the appearance of a single panel containing rows of red, green and blue knobs together with control supervisory lamps. In practice, the first switching operation required during the day's transmission is set up on the red switch-knobs. Any subsequent change in the connexions of sources to destinations is set up on the green knobs. A third rearrangement can be set up on the blue knobs.

### Master Switching Unit

The connexion of a source to a destination is achieved by operating the specific source relay in the destination relay-set. The relay is operated by means of an earth extended from the sound or vision motor-switch (see Fig. 6) via either the red, green or blue selector switches in the switch panel appropriate to that destination. As already mentioned, three selections may be made, one on each of the red, green and blue switches, but only one of these selections will be operative at any one

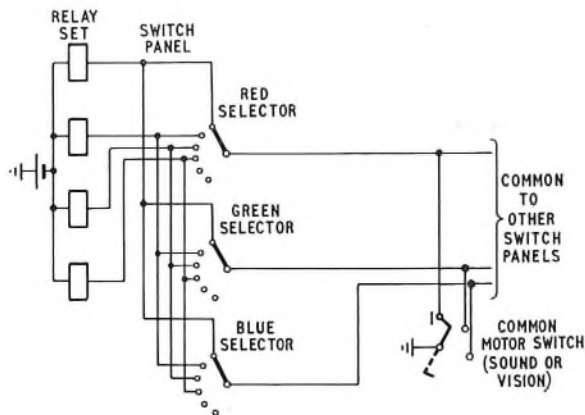

Sound and vision switching circuits are similar  
FIG. 6—SIMPLIFIED D.C. SWITCHING PATH APPROPRIATE TO ONE DESTINATION

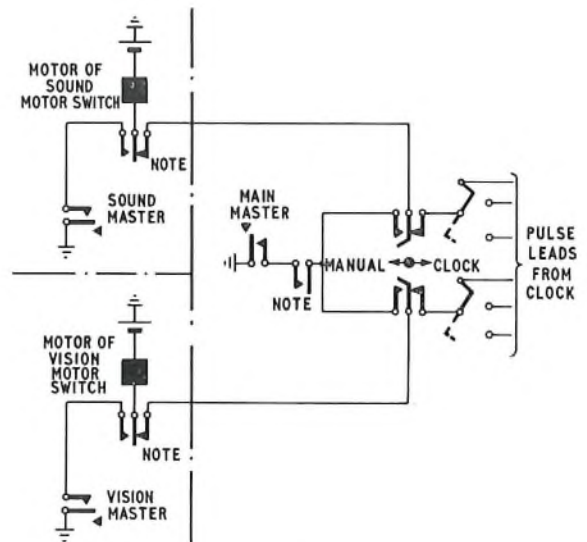

Note: For manual operation these keys are depressed simultaneously with the main master key  
FIG. 7—MASTER SWITCHING UNIT

time, since the motor switch, an electrically-operated wafer-switch contained in the master unit, controls the application of the operating earth to either the red, green or blue selections. There are two of these motor switches, one for vision relay switching and one for sound relay switching and they form the heart of the switching unit.

The master switching unit (Fig. 7) can be considered as three separate items, the sound master unit, the vision master unit and the main master unit. Under normal working conditions the keys on the main master unit are not used because the operating pulse controlling the motor switches is obtained from the electronic clock. The sound master unit and vision master unit each carry a "Clock/Manual" key. This key is of a non-locking type and connects the electronic clock to the motor switch when normal but connects a "Manual Operate" heavy-duty press-button to it when operated. This press-button requires considerable force to operate it and is used in conjunction with the non-locking key to connect an earth to the appropriate motor switch. The need for both a considerable force on the press-button and the operation of a second key safeguards against inadvertent operation.

The main master unit enables the sound and vision master units to be operated simultaneously. It contains a non-locking key and a press-button similar to those on the other two units and in addition a locking lever-key is provided so that the electronic clock can be disconnected during fault conditions. The sound and vision units are removable sub-units fitted into a frame above and below the main master unit. The complete assembly is fitted adjacent to the electronic clock in the console centre section.

When network changes are preselected on the red, green or blue knobs on the switch panels, the electronic-clock knobs of the same colour are set for the time the switching operation is due to take place and to give the requisite pre-switch alarm time. When the pre-switch alarm is given, the officer in attendance throws a "receive attention" key which, in cutting off the alarm, applies speaking-clock signals to a loudspeaker built into the equipment. After the appropriate interval,

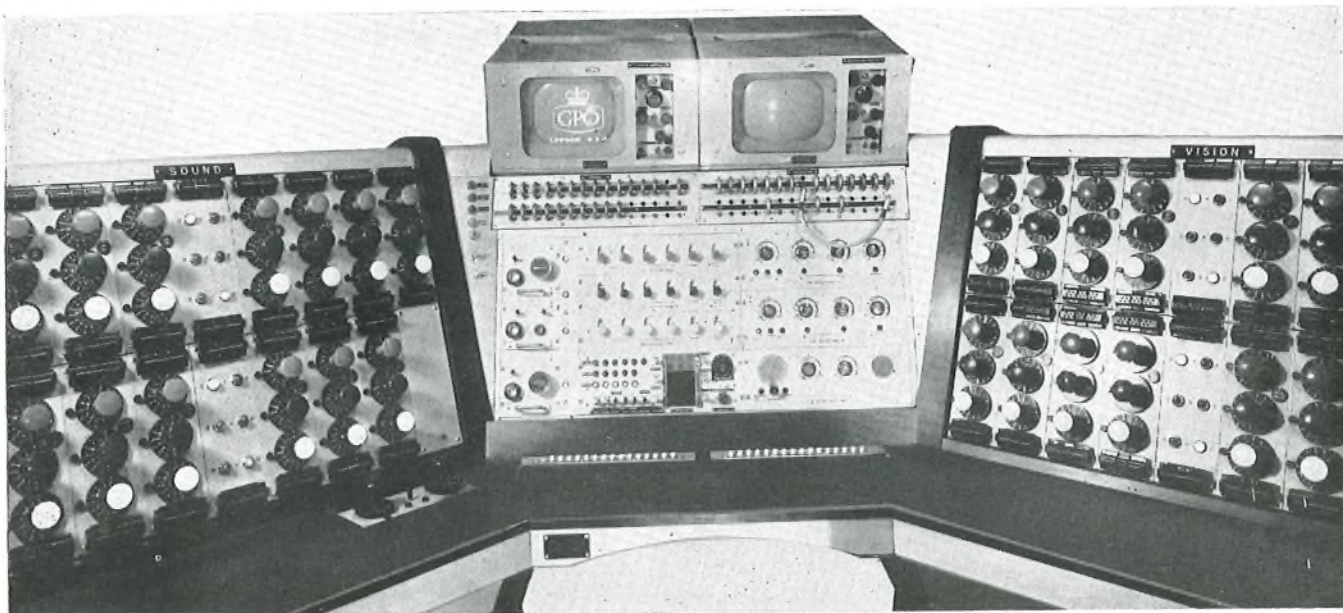

FIG. 8—SWITCHING CONSOLE

on the third pip of the desired speaking-clock signal a pulse from the electronic clock operates the two motor switches, so that the operating earth is transferred to the next row of switches on the switch panels, thus implementing the necessary network rearrangement. The set of selector switches so released can be used to set up a further network rearrangement.

#### Monitoring

Two vision monitors with associated amplifiers are provided for monitoring sources and destinations. These monitors are cabled via two push-button units to the monitor pads associated with the sources and destinations. Each monitor pad provides a monitor output at a level of  $-30$  db relative to the vision signal and introduces a loss of  $0.5$  db in the transmission path.

Similar arrangements are made for monitoring the sound programs.

For neither sound nor vision is it intended that a quality check should be made by use of the monitoring circuits; the purpose is merely to check the continuity of switched circuits.

#### CONSOLE

A photograph of the front of the console is shown in Fig. 8. The left-hand wing of the console provides space for the sound-circuit switch panels, the centre face houses the electronic clock and the master switching unit, while the right-hand wing is used to accommodate the vision-circuit switch panels. The rear of the console provides space for all the vision branching networks, relay-sets, amplifiers and, in addition, two  $30$  db vision-monitor amplifiers. Forced ventilation is used to keep the internal temperature of the amplifiers within reasonable limits. The sound relays and associated amplifiers are not fitted in the console. The console is assembled from commercially available slotted angle-sections and covered with laminated plastic. Fuse-alarm lamps are fitted on the centre face panel.

#### CONCLUSIONS

The London switching unit has been in service for 18 months and during that time has performed over 60,000 operations and only two faults have occurred in the console. No program time was lost as a result of these faults although occasional operating errors have resulted in short transmission breaks.

Automatic network distribution equipment is shortly to be provided in Birmingham, Manchester and Carlisle. Experience has already shown that the design of the London N.S.C. console is not ideally suitable for other centres, and development is proceeding along slightly different lines in an effort to reduce operating errors and to cater for more sources and destinations.

#### ACKNOWLEDGEMENTS

The authors wish to express their thanks to the London N.S.C. maintenance and construction staffs for their suggestions and willing co-operation and also to the London Telecommunications Region Power Section, for their assistance in the construction of the equipment.

#### References

- <sup>1</sup> GRANGER, S. H. The New Independent-Television Network. *P.O.E.E.J.*, Vol. 48, p. 191, Jan. 1956.
- <sup>2</sup> MAGNUSON, L. E., SPEIGHT, E. A., and GILL, O. W. The Speaking Clock. *P.O.E.E.J.*, Vol. 29, p. 261, Jan. 1937.
- <sup>3</sup> FORTY, A. J., and MILNE, F. A. The British Post Office Speaking Clock, Mark II. *P.O.E.E.J.*, Vol. 48, pp. 154 and 229, Oct. 1955 and Jan. 1956.
- <sup>4</sup> MACDIARMID, I. F. Waveform Distortion on Television Links. *P.O.E.E.J.*, Vol. 52, pp. 89 and 188, July and Oct. 1959.
- <sup>5</sup> MACDIARMID, I. F., and PHILLIPS, B. A Pulse-and-Bar Generator for Testing Television Links. *Proceedings I.E.E.*, Paper No. 2687R, Sept. 1958 (Vol. 105, Part B, p. 440).
- <sup>6</sup> LANDER, A. C., and JOYCE, L. A. An Electronic Clock for Television Network Switching (In this issue of the *P.O.E.E.J.*).
- <sup>7</sup> HARRIS, E. T. C., and SPRATT, C. J. An Improved Form of Mechanical Construction for Transmission Equipment—51-Type Construction. *P.O.E.E.J.*, Vol. 51, p. 197, Oct. 1958.

# An Electronic Clock for Television Network Switching

A. C. LANDER and L. A. JOYCE†

U.D.C. 529.781:621.318.57:621.397.743

To meet the requirements of the Independent Television Authority and its associated program contractors, the Post Office television network switching centres have frequently to rearrange the inter-connexions of the sound and vision circuits forming the independent television network. To enable these switching operations to be carried out automatically at precisely the times required an electronic clock is used.

## INTRODUCTION

THE number of sound and vision circuit switching operations required daily at the Post Office television network switching centres has greatly increased due to the growth of the television services and because of the operating methods of the Independent Television Authority and its associated program contractors. This increase has made it necessary to provide a method of controlling the switching operations which ensures accurate timing coupled with reliability and ease of operation. It was therefore decided to design a special clock for this purpose. The design and construction of a prototype was undertaken by the Main Lines Development and Maintenance Branch and the clock is now installed in the London Network Switching Centre at Museum telephone exchange.

It was clear that several different forms of time standard could be used for such a clock. For example, a standard 1 kc/s tone having an accuracy of better than 1 second/year is available from the Post Office Research Station at Dollis Hill. It was, however, decided that the Post Office speaking clock<sup>1,2</sup> is the most desirable standard for this purpose because its signals are available all over the country in a form which is sufficiently reliable and which requires no special means of interpretation. Since the equipment to be controlled by the clock is dependent upon the 50 c/s mains no loss of reliability would be occasioned by the use of the same mains for the clock itself. The clock consists of an electronic counter driven at mains frequency and corrected every 10 seconds by the speaking-clock signals.

## DESCRIPTION OF CLOCK

The clock is arranged so that any time, to an integral 10 seconds, can be preselected by the operator by means of time-selection switches. At the selected time the clock transmits a pulse which causes the program-switching equipment<sup>3</sup> to operate.

Three sets of time-selection switches are provided so that a sequence of three switching operations can be effected without the need for hurried (and therefore possibly inaccurate) resetting of the time-selection switches by the operating staff. Warning of an imminent program switching operation (a "pre-switch alarm") is given 3, 6, or 9 minutes before the effective switching time as required.

Except for the stage necessary to differentiate between the 0-11 and 12-23 hour periods, counting is performed by a series of Dekatron selector tubes. These have two great advantages over other methods, namely, direct display in a form which is easily read and electrical

outputs which can be selected easily by manually operated switches.

The electronic clock is corrected every 10 seconds by converting into d.c. pulses the three 1 kc/s "pip" signals which follow each speaking-clock announcement, the third "pip" being the actual time signal. The first of these d.c. pulses is used to generate a synchronizing pulse to reset the Dekatron selectors which divide the mains frequency by 500. The 10-second pulse derived from this divide-by-500 circuit is used to drive the seconds Dekatrons which in turn drive the minutes and hours Dekatrons of the time-display panels.

A comprehensive alarm system is provided to give the earliest possible warning of fault conditions. Up to the point in the counter circuit at which a pulse occurs every 10 seconds, a continuous verification of the presence of pulses is made; beyond this point verification of time intervals by resistance-capacitance circuits becomes impracticable and two independent time-display panels (T.D.P.s), designated A and B, are therefore provided and continuously cross-checked.

Each of the time-selection switches has two sets of contacts, one set being associated with T.D.P. A and the other with T.D.P. B. The corresponding switch wipers are connected to separate pre-switch alarm gates which operate two trigger tubes independently at the selected pre-switch-alarm time. The outputs of these tubes are arranged to give a fault alarm if either tube strikes without the other.

Fig. 1 is a simplified block-schematic diagram of the clock and Fig. 2 shows a front view of the clock.

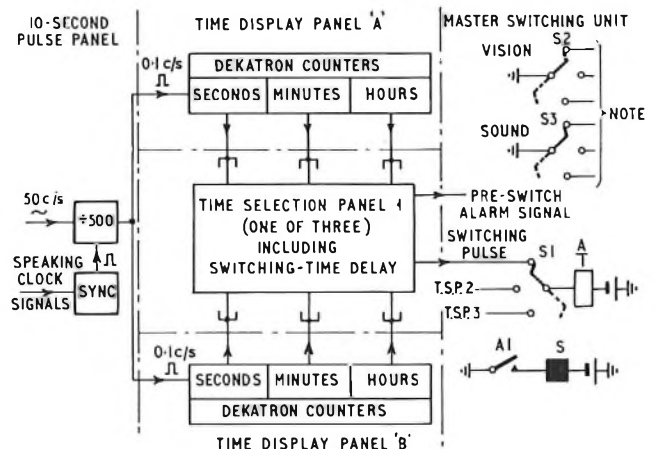

Note: The contacts of switch wafers S2 and S3 are connected to the network-switching relay-sets.

FIG. 1—SIMPLIFIED BLOCK-SCHEMATIC DIAGRAM OF CLOCK

## The 10-Second Pulse Panel

The 10-second pulse panel (Fig. 3 and 4) contains three Dekatron selectors arranged to divide the frequency of the mains supply (nominally 50 c/s) by 500, thus giving an output pulse once every 10 seconds. The speaking-clock signal is connected to a tuned selector circuit which responds to the nominal 1 kc/s of the

† Messrs. Lander and Joyce are in the Main Lines Development and Maintenance Branch, E.-in-C.'s Office.

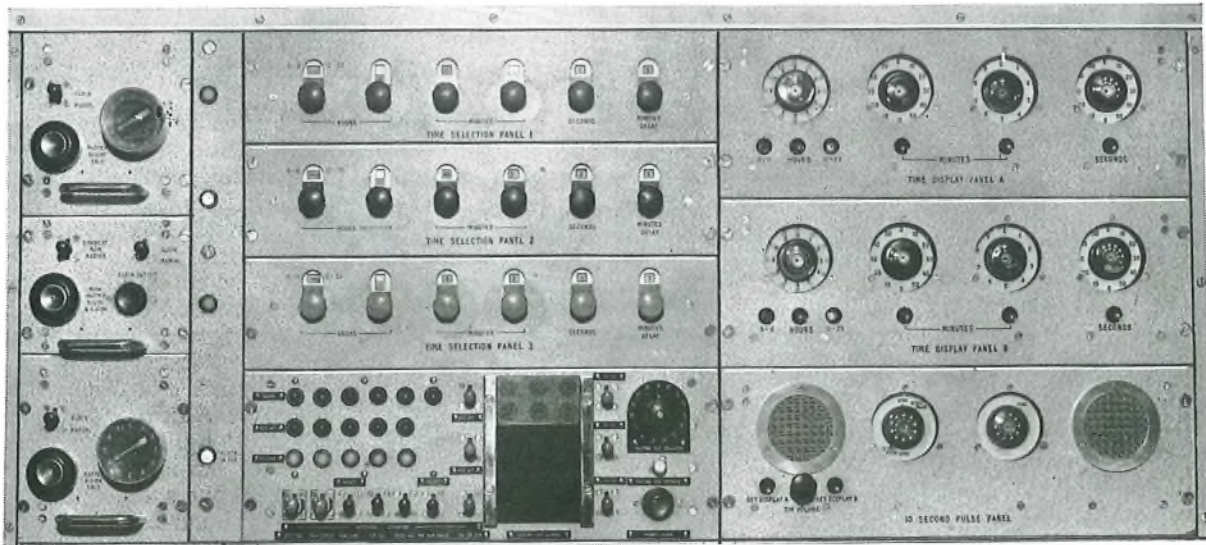

FIG. 2—FRONT OF ELECTRONIC CLOCK

speaking-clock pips. This circuit is in turn connected to a detector which is inhibited by the speech part of the speaking-clock signal. Reliable discrimination against speech interference requires a highly selective tuned circuit and this demands a high order of frequency stability of the speaking-clock pip signals. The output of the detector circuit consists of three d.c. pulses corresponding in time to the speaking-clock pip signals, which are transmitted every 10 seconds. The first of these d.c. pulses is used to trigger the synchronizing generator—a bi-stable pair of cold-cathode tubes—which simultaneously emits a negative-going pulse to set the Dekatron selectors of the 10-second pulse unit to the 8·2-second point. The second and third pip signals and any spurious signals allowed by imperfections of the inhibitor in the selector circuit are prevented from causing false synchronization by the synchronizing generator, which remains side-stable for 8·8 seconds. After this 8·8-second interval, the second and third Dekatron selectors will have advanced so that cathodes five and three respectively are registering and the synchronizing-generator restoring gate will emit a pulse to restore the synchronizing generator so that the synchronizing cycle can recommence.

If the synchronizing generator fails to respond to the first d.c. pulse, it can operate to either the second or

third. The clock would then be one or two seconds slow, but the timing of the synchronizing generator permits correction by subsequent speaking-clock signals. If no synchronizing signal is given, the clock continues to run with mains-frequency accuracy and a speaking-clock fail alarm is given. On restoration of the speaking-clock signals the electronic clock will re-synchronize to the correct time provided that the accumulated error does not exceed + 2 seconds or - 8 seconds.

The 10-second pulse unit delivers an output pulse 1·8 seconds after synchronization (200 ms before the third pip signal, i.e. 200 ms ahead of the true time), when the three Dekatron selectors are at their 0 positions. Approximately 200 ms later, the first Dekatron selector having advanced nine positions, the three elements of the delayed-pulse gate are primed and the delayed pulse is fed to the pre-switch alarm and program switching-time gates. The need for a 200 ms delayed pulse is explained in the next section.

It is possible under certain false synchronizing conditions, e.g. a short interruption of the speaking-clock signals, for the 10-second pulse unit to emit a double pulse. A double-pulse-preventer circuit (D.P.P.) is arranged to guard time-display panel A from such a condition, but the double pulse is permitted to reach panel B. The display panels thus become out-of-step and an alarm is given by a parity-check circuit.

#### Time-Display Panels

As already mentioned, two identical time-display panels are provided. One, designated time-display panel A, is the means of providing the pre-switch-alarm and program-switching-time pulses; the other, designated panel B, is used to check panel A continuously for coincidence and to provide for an alarm if both panels should fail to register the pre-switch-alarm time simultaneously.

The time-display Dekatrons (Fig. 5) are stepped forward every 10 seconds by pulses from the 10-second pulse unit, panel A being guarded by the double-pulse preventer. Each of these display panels consists of four Dekatron selectors showing tens of seconds, minutes, tens of minutes and hours respectively, and a pair of

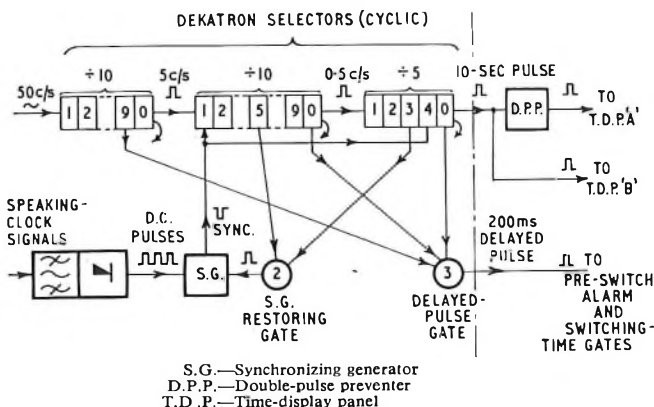

S.G.—Synchronizing generator  
D.P.P.—Double-pulse preventer  
T.D.P.—Time-display panel  
FIG. 3—THE 10-SECOND PULSE PANEL

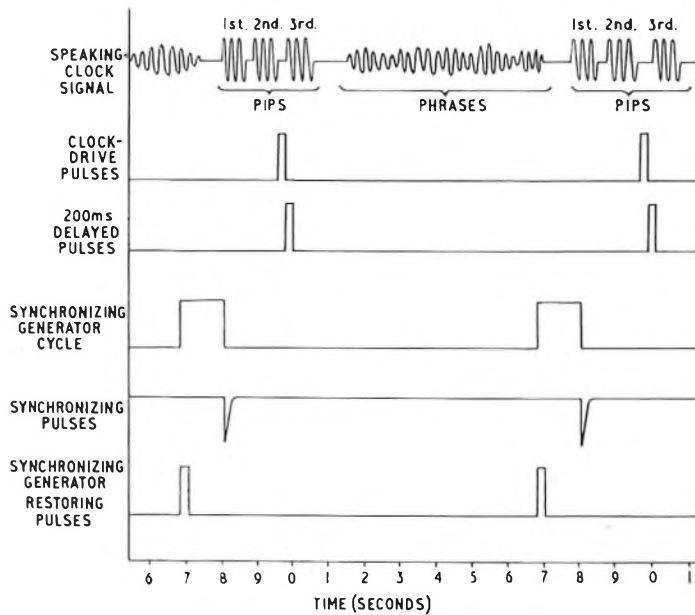

FIG. 4—DERIVATION OF SYNCHRONIZING PULSES

cold-cathode tubes indicating either the 0-11 or the 12-23 hour period. As mentioned earlier, the selector tubes in the time-display panels are stepped 200 ms ahead of true time. This is necessary to allow "carries"\* to be propagated along the counting-train. Consider, for example, the change from 8 hours, 59 minutes, 50 seconds to 9 hours 0 minutes 0 seconds. For a brief instant, when the "carry" has reached the minutes but not the hours Dekatron, the panels will display 8 hours 0 minutes 0 seconds and an operation set to take place at that time could occur falsely at 9 hours 0 minutes 0 seconds. An additional gate element in the trigger circuit inhibits operation of the trigger for 200ms and thus allows ample time for the "carries" to be propagated, when necessary, to the end of the counting train. It is, however, possible for the switching operation to take place up to 200 ms early on account of the random phase of the first Dekatron (50 c/s-5 c/s) in the 10-second pulse panel because this Dekatron is not synchronized by the speaking-clock signals. Allowing 100 ms for the operation of the relays, etc., between the clock and the switched circuits, it may therefore be said that switching occurs with an accuracy of  $\pm 100$  ms.

Under each Dekatron of the time-display panels is a push-button which may be used to advance the Dekatron under manual control, subject to a

\* The "0" cathode of each Dekatron stage is connected to the time-selection switches and to the trigger unit of the next stage. Thus, when the glow transfers to the "0" cathode, the corresponding time-selection-switch contact is marked and the next Dekatron stage is advanced one position by the "carry". This is analogous to adding 1 to 99. The units digit then returns to 0 and 1 is "carried" into the tens column, whereupon the tens digit returns to 0 and 1 is "carried" into the hundreds column.

"set-display" master button on the 10-second pulse panel being pressed. This master button also inhibits the switching triggers of time-display panel A, to prevent programs being switched incorrectly whilst the time indications are being set or corrected.

The parity-check circuit consists of a number of double-wound centre-stable polarized relays in the cathode circuits of the Dekatrons of the time-display panels. Each Dekatron has its cathode resistors divided into two groups corresponding to the odd-numbered and even-numbered cathodes. The odd-numbered cathodes of panel A are commoned to the even-numbered cathodes of panel B and taken to the negative-side of the high-tension supply via one coil of the relay, while the other coil carries the even-numbered cathodes of panel A and the odd-numbered cathodes of panel B. So long as both panels show either an even or an odd indication, the relay currents produce opposing fluxes, but a difference between the two panels causes both currents to flow in the same coil and the relay is operated giving a "display-error" alarm. An even discrepancy is unlikely and is not immediately detected but becomes apparent when the time-display panel having the leading display "carries" into the next stage before the other panel, causing an odd/even discrepancy in that stage.

The cathodes of the Dekatron selectors and cold-cathode tubes forming the time-display panels are extended to the switches in the time-selection panel. The time indications are thus available visually as glow-discharges and electronically as 50-volt positive marking potentials on the stators of the time-selection switches. The ring-of-two counters are necessary to distinguish the 0-11 or 12-23 hour period of each day. The hours Dekatrons have two concentric sets of numbers engraved on their dials. In conjunction with the glow from the 0-11 or 12-23 stage, this enables the time indicated to be read off on a 24-hour basis.

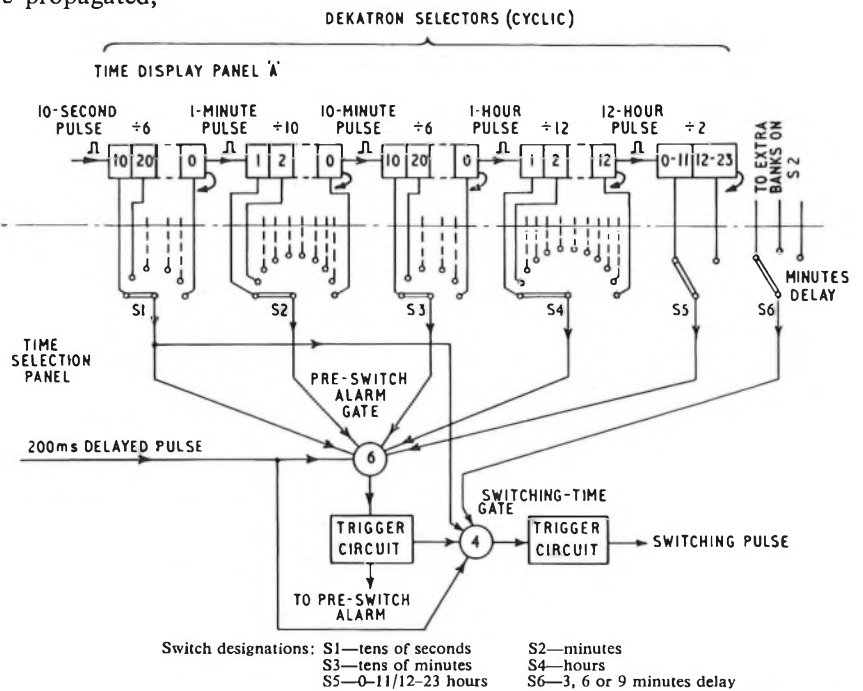

FIG. 5—ASSOCIATION OF TIME-DISPLAY PANEL A WITH TIME-SELECTION PANEL AND SWITCHING TRIGGERS

### *Time-Selection Panels and Switching Triggers*

Each of the three time-selection panels has six switches labelled, respectively, "0-11/12-23 hours," "hours," "tens of minutes," "minutes," "tens of seconds," and "minutes delay." Except for the last-mentioned, these switches correspond to the Dekatron selectors and cold-cathode tubes of the time-display panels. A pre-switch-alarm signal is given at the time corresponding to the settings of the first five switches, and the program switching operation takes place 3, 6, or 9 minutes later according to the setting of the minutes-delay switch. It might be considered that the program switching should take place at the time set on the first five switches with the "minutes-delay" replaced by a "minutes advance-warning" switch, but this would seriously complicate the contact arrangements and the wiring of the time-selection switches.

Two sets of contacts are provided on each of the first five time-selection switches, one set being wired to time-display panel A, as shown in Fig. 5, and the second set to time-display panel B. The sixth time-selection switch has only one set of contacts, which are associated with time-display panel A only. When the time-display panels show the pre-switch alarm time already pre-set on the time-selection switches, the first five rectifiers of each pre-switch-alarm gate are primed by the positive potentials on the corresponding cathode resistors, and the arrival of the delayed pulse on the sixth rectifier causes a cold-cathode trigger tube associated with each gate to strike. The trigger tube associated with the gate of time-display panel A provides the pre-switch-alarm signal, thus enabling checks of the clock and switching console settings to be made. A fault alarm is given if the trigger tubes associated with both time-display panels fail to strike simultaneously.

The minutes switch of each time-selection panel is provided with three additional sets of contacts (associated with time-display panel A only) whose wiring is "slipped" 3, 6, and 9 minutes behind the other sets. One of the additional sets is selected by the minutes-delay switch; a further 4-way gate, the switching-time gate, primed from the pre-switch-alarm trigger tube, causes the program switching operation to take place when the correct (delayed) minutes and tens of seconds are indicated and the 200 ms delayed pulse has arrived.

### *Master Switching Unit*

The electronic clock is linked to the switching equipment console by a master switching unit. This unit includes a motor-driven multi-wafer rotary switch. The operating coil of this switch is connected via a relay contact and one of the contact wafers to each of the time-selection panels in turn, while the remaining wafers control the operation of the program-switching relays in accordance with the requirements as set up on the console. Thus only one of the time-selection panels is

"live" at any one time, and this is indicated by a pilot lamp. The time-selection panels have distinctively coloured knobs—red, green or blue—and, at the time indicated on the "live" panel, the interconnexion of the program circuits is changed by the master switching unit to that indicated on the console knobs of similar colour. The clock checks the continuity of the control wire to the master switching unit and also checks that the motor switch in this unit does in fact step when energized. Failure to step causes a prompt alarm to be given and the master unit can be operated by hand if necessary: electrical interlocks and physical guards prevent accidental manual operation.

### POWER SUPPLIES AND MAINTENANCE FACILITIES

A mains-driven power unit housed behind the master unit provides 6.3 volts a.c., 250 volts regulated d.c. for the valves, and 500 volts unregulated d.c. for the Dekatrons, but a separate 50-volt supply is required for the operation of the relays and the master switching unit electromagnet. Appropriate power-fail alarms are provided, such alarms immediately disconnecting the clock from the master switch unit.

A comprehensive alarm and supervisory system with fault lamps, receive-attention keys and a routine-check switch is provided.

To facilitate maintenance each time-display panel is made as four units, each unit being interchangeable with its counterpart in the other panel. The trigger units between each of the counter stages are interchangeable and of a plug-in type. A long 25-way cord is provided so that connexion may be made to any unit for maintenance purposes, without necessarily withdrawing the clock from service. The valves forming part of both the miscellaneous panel and the time-selection panels are directly accessible from the rear of the equipment. The rear of each of these panels is hinged so that it may be turned into the horizontal plane to expose the components and wiring.

### CONCLUSION

The clock has been in use for more than a year and has given satisfactory service. The number of program failures connected with switching are known to have been considerably reduced since the clock was brought into service, and the local staff appear to place considerable reliance on the instrument. Consideration is being given to the provision of similar equipment at other network switching centres.

### *References*

- <sup>1</sup> MAGNUSSON, L. E., SPEIGHT, E. A., and GILL, O. W. The Speaking Clock. *P.O.E.E.J.*, Vol. 29, p. 261, Jan. 1937.
- <sup>2</sup> FORTY, A. J., and MILNE, F. A. The British Post Office Speaking Clock, Mark II. *P.O.E.E.J.*, Vol. 48, p. 154 and 229, Oct. 1955 and Jan. 1956.
- <sup>3</sup> BLANCHARD, C. H., NEWMAN, W. L., and WILLETT, W. H. The Switching of Television Circuits in London. (In this issue of the *P.O.E.E.J.*)

# Channel Equipment Design for Economy of Band-width

H. B. LAW, B.Sc.Tech., A.M.I.E.E., J. REYNOLDS, B.Sc., A.C.G.I., and W. G. SIMPSON, B.Sc., A.M.I.E.E.†

U.D.C. 621.395.664.2

The high cost of long submarine-cable telephone systems has encouraged investigations into methods by which the frequency band required for a telephone channel may be reduced. One successful step in this direction is described, in which channel equipment design results in the unused frequency band separating channels being only 5 per cent compared with 22½ per cent on conventional equipments, with a corresponding increase in the number of channels per carrier group.

## INTRODUCTION

LONG-DISTANCE submarine-cable telephone systems are very costly, and methods of increasing the number of telephone conversations and telegraph messages that they can carry have been studied in recent years. The greatest increase in telephone channels is likely to come eventually from work on the fundamental characteristics of speech sounds, leading to vocoder<sup>1</sup> techniques or formant analysis and synthesis; such techniques are, however, not yet considered suitable for use in a public telephone system.

The number of telephone channels carried by a high-frequency line can be increased very simply, at the expense of quality, by reducing the band-width of the channels; the number can also be increased, without significant loss of quality, by reducing the loss of transmission band-width in the inter-channel gaps. In conventional carrier equipment a channel has a nominal band-width of 3,100 c/s, the pass band extending from 300 to 3,400 c/s, and it occupies 4,000 c/s of line band-width; thus the loss of band-width amounts to 900 c/s in 4,000 c/s, or 22½ per cent. The large inter-channel gaps, which allow the use of comparatively simple channel filters, are acceptable in normal inland practice, where h.f. line costs represent only a small part of the cost of a channel. The gaps have, incidentally, proved useful in some systems by providing space for out-of-band signalling, for line and group reference pilots, and for through-group filters to develop their attenuation.

On long submarine-cable systems line costs are all-important, and complication of the channel equipment can be justified if it increases the number of channels. Study has shown that the loss of band-width in the inter-channel gaps can be reduced fairly simply to about 5 per cent by modern filter techniques. Several channel equipments have been designed during the last few years and development has now crystallized in a system transmitting audio frequencies from 200 c/s to 3,050 c/s and occupying 3,000 c/s of cable band-width.

The 3 kc/s channel equipment has been designed to suit the T.A.S.I. system of speech interpolation<sup>1,2,3</sup> developed in the Bell Telephone Laboratories. This system requires the transmission channels to meet close limits for attenuation and delay distortion in the band 565-2,550 c/s.

† Messrs. Law and Simpson are at the Post Office Research Station. Mr. Reynolds is in the Main Lines Development and Maintenance Branch, E.-in-C.'s Office, but was formerly at the Post Office Research Station.

In many ways the 3 kc/s channel equipment resembles the 4 kc/s equipment with which many readers will be familiar. There are, however, some important differences in selectivity requirements, and in the way that the filters combine to meet these requirements. It is to these unusual features that the present article directs attention.

## A CHANNEL EQUIPMENT FOR BAND-WIDTH ECONOMY

The main problem in reducing the inter-channel gaps of a carrier system is to get a sufficiently sharp transition from the pass band to the stop bands of the channel selecting filters. To obtain this solely by the use of channel band-pass filters, as in normal channel equipment, while maintaining a suitable but not excessive stop-band attenuation, would be difficult. There is a fundamental relation<sup>4</sup> connecting envelope-delay distortion with the attenuation/frequency characteristic of filter networks, and any appreciable excess of discrimination is to be avoided because of its inevitable by-product of extra delay distortion in the pass band. The solution lies in the use of audio-frequency high-pass and low-pass filters to define the steep edges of the channel selectivity characteristics and to provide a suitable loss in the stop bands where the channel band-pass filters have insufficient discrimination.

A typical frequency allocation and schematic diagram are shown in Fig. 1 and Fig. 2. Taking the transmit direction, the audio input signal is filtered to define its band-width, 200-3,050 c/s, and it then modulates one of four carrier waves for translation to the sub-group band 12-24 kc/s. The desired sideband is selected in a channel filter and combined with the outputs of three other channels to produce the complete sub-group. By further modulation and filtration four sub-groups are combined to produce a 16-channel group in the frequency band 60-108 kc/s. Corresponding processes occur in the reverse order in the receive direction.

The need for a band-stop filter in the channel panel arises from the very close frequency spacing of the

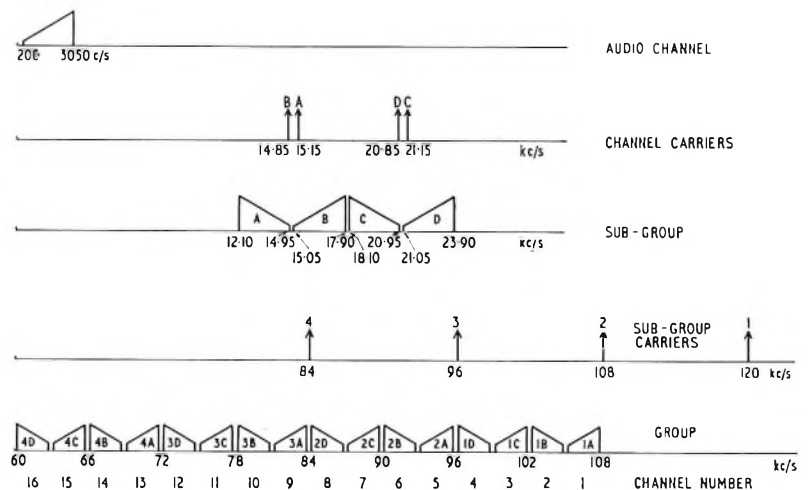

FIG. 1—FREQUENCY ALLOCATION



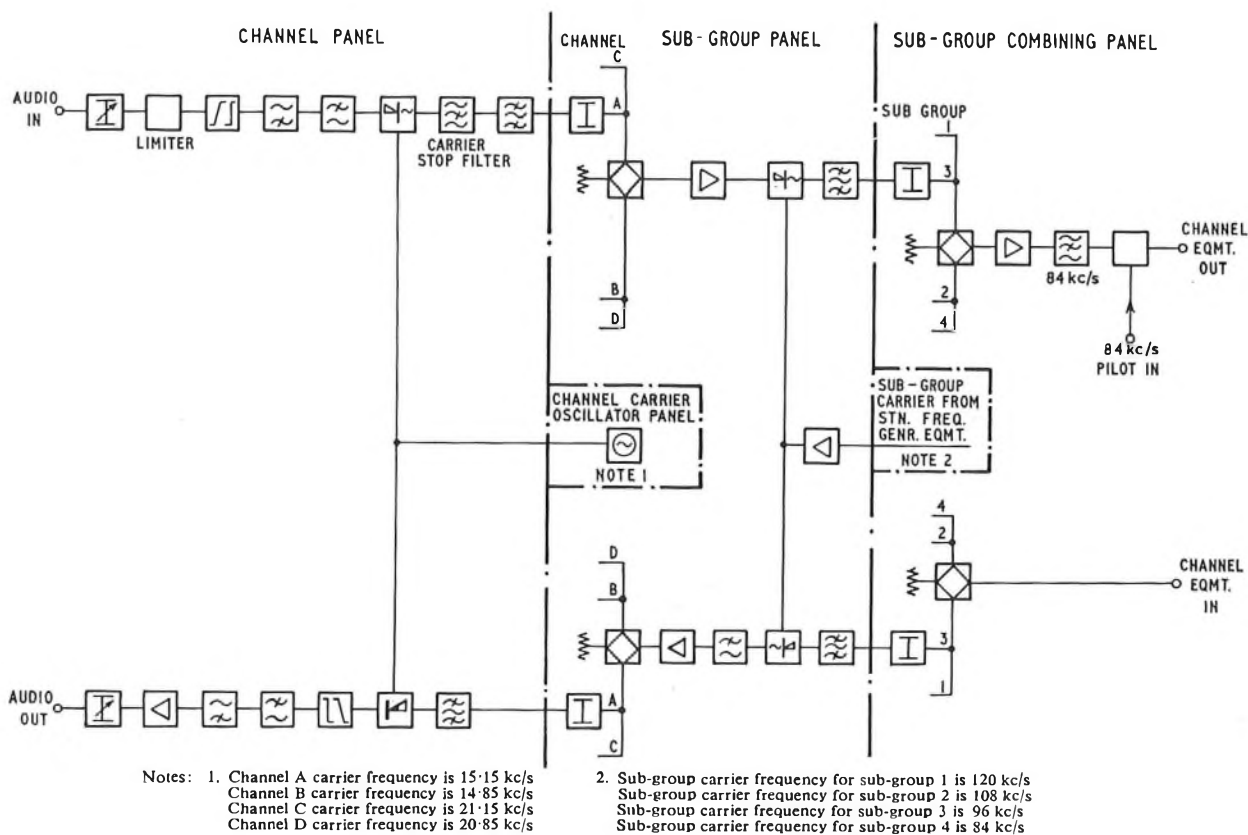

FIG. 2—BLOCK SCHEMATIC DIAGRAM

channels. The channel carrier frequency of, for example, channel A (15.15 kc/s) falls in the wanted sideband of channel B at a point corresponding to an audio frequency of 300 c/s, and any appreciable leakage of this carrier into the sub-group panel will produce an audible tone in channel B. The degree of carrier suppression provided by modulator balance and the channel band-stop filter is insufficient to control this effect in the transmit direction, so a narrow-band-stop filter is included; this provides a minimum of 30 db additional discrimination against the carrier leak, attenuating it to  $-70$  dbm0\* or lower.

Owing to dissipation in the inductors of filters there is a tendency for the attenuation of the channels to rise near the upper and lower edges of the pass band; audio-frequency attenuation equalizers are provided on the sending and receiving sides of the equipment to reduce this distortion. A typical equalized audio-audio attenuation/frequency characteristic is given in Fig. 3.

The pass bands of the channel filters of adjacent channels overlap and the filters are not suitable for operation directly in parallel. In the transmit direction, for example, the A and C channel filters are combined in a resistive network, and the output of this is then combined in a hybrid transformer with the output of a similar network for the B and D channels. There is a similar arrangement in the receive direction.

The maximum output signal that any one channel can transmit to line is controlled by a limiter at the audio input to the transmit side. It is not permissible to use overloading of the channel modulator to provide the limiting characteristic, as is commonly done in conven-

\* dbm0—decibels relative to 1 mW when measured at, or referred to, a point of zero relative level (usually the 2-wire point of the circuit).

tional equipments; with some of the channel selectivity provided by audio-frequency filters, higher-order products generated in the modulator could produce interference in adjacent channels. Consider, for example, an audio-frequency signal of 1,100 c/s applied to channel B. If this were allowed to overload the modulator, an unwanted product at  $14.85 + 3 \times 1.1 = 18.15$  kc/s would appear, and it would suffer little attenuation in the channel B filter. This frequency falls in the sub-group frequency band allocated to channel C, corresponding to an audio frequency of 3,000 c/s in that channel. Operating levels are therefore so arranged that, safeguarded by the limiter, the modulator is operated in its linear range at all times.

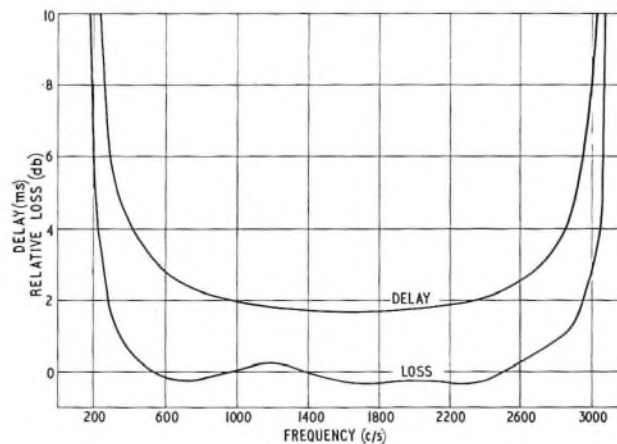

FIG. 3—TYPICAL CHANNEL AUDIO-AUDIO FREQUENCY CHARACTERISTICS

### CHOICE OF METHOD

Before going into more detail about the design, some account should perhaps be given of the reasons for adopting the particular arrangement described.

The 3 kc/s channel arrangement, giving 16 channels in a carrier group, was chosen as a reasonable compromise between quality and quantity. It permits a convenient method of assembly in two modulation stages, with sub-group carriers that are normally available in terminal repeater stations. The first equipments were made to pass the audio frequency band 300–3,150 c/s, but further work showed that, for ordinary telephone users, transmission of the band 200–3,050 c/s gave a small but definite improvement and this band was adopted for later equipments.

The use of two stages of modulation eases the carrier supply problem. The 16 virtual carrier frequencies, 62.85, 63.15, 65.85 . . . 105.15 kc/s, that arise in packing 16 channels closely into the normal basic carrier group band, 60–108 kc/s, have values that are not members of a harmonic series and are not related in any simple manner to the frequencies that are normally available in a terminal repeater station. Also, such frequencies must be accurately controlled. By using two stages of modulation, with initial assembly in a 4-channel sub-group of comparatively low frequency, the number of special frequencies required is reduced to four. Assuming that very stable sub-group carriers are available from normal station supplies, the proportional stability required for these special frequencies is eased. For example, the highest special frequency required in the system adopted is 21.15 kc/s, compared with 105.15 kc/s, which would be required if a single stage of modulation were used.

The frequency allocation shown in Fig. 1, with alternate upper and lower sidebands, was preferred to other arrangements because this ensures that any attenuation and delay distortion, due to such features of the h.f. line plant as through-group filters and pilot filters, is confined to the higher audio frequencies of the affected channels; thus through-group filters affect the higher frequencies of channels 1 and 16, and pilot filters at 84.00 kc/s affect those of channels 8 and 9. Speech and T.A.S.I. signalling, which are more sensitive to disturbance at the lower audio frequencies, are affected as little as possible.

The alternate upper-sideband and lower-sideband arrangement imposes a small penalty in that the channel filter discrimination required is increased by 3 db compared with the conventional lower-sideband arrangement. This is because the two sideband frequencies produced by a tone in the disturbing channel give, in the disturbed channel, two audio frequencies separated by not more than 600 c/s, whereas in the conventional arrangement the received audio frequencies are separated by twice the audio frequency applied to the disturbing channel. The higher frequency component then receives substantial psophometric weighting and can therefore be neglected.

### SELECTIVITY REQUIREMENTS

The performance required of the filters stems from the desire to have as wide as possible a channel pass band, extending from about 200 c/s to 3,050 c/s, and from the need to keep inter-channel interference down to an acceptably low level. The design objective for sideband interference is that a 0 dbm0 signal consisting of a band of noise uniformly distributed from 50 to 4,000 c/s, applied at the input to a channel, should not cause a disturbance exceeding  $-64$  dbm0, psophometrically weighted, in any other channel; the same level of disturbance is permitted from a 1,000 c/s signal at 0 dbm0. Specification of the requirements in this way is of some help to the designer for, subject to satisfying the requirements at 1,000 c/s, he can dispose his selectivity to secure a satisfactory result over the whole band without having to meet a fixed requirement at every point.

Consider the 0 dbm0 test signal to be applied to channel A. After band limiting by the audio filters and then modulation to sub-group frequencies, the signal will occupy the band 12–18 kc/s and have a total power of  $+1.7$  dbm0. Considering the interference produced in channel B, suppression over the band 15–18 kc/s is provided by the channel A transmit channel filter and over the band 12–15 kc/s by the channel B receive channel filter. Since the interference should not exceed  $-64$  dbm0, the sum of the filter discrimination and psophometric weighting should be 65.7 db at all frequencies in the band 12–18 kc/s. However, around the peaks of attenuation in the filter stop bands there is considerable margin over this figure and this enables a lower value of 64 db to be adopted for the minimum stop-band attenuation in the filter specifications.

With the exception of the band-stop filter, which is peculiar to the sending equipment, the sending and receiving filter requirements are broadly similar, so identical filters have been used for the two directions, to reduce design work and facilitate production and spares provision.

An indication of the way that the stop-band characteristics of the audio-frequency high-pass and channel band-pass and band-stop filters combine to meet an overall requirement is given in Fig. 4, which shows the

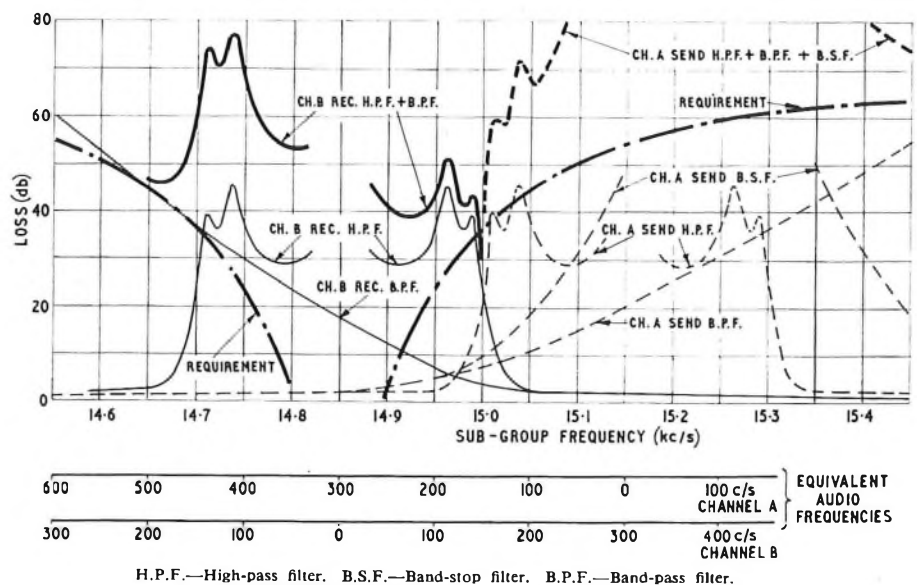

FIG. 4—ADDITION OF FILTER CHARACTERISTICS

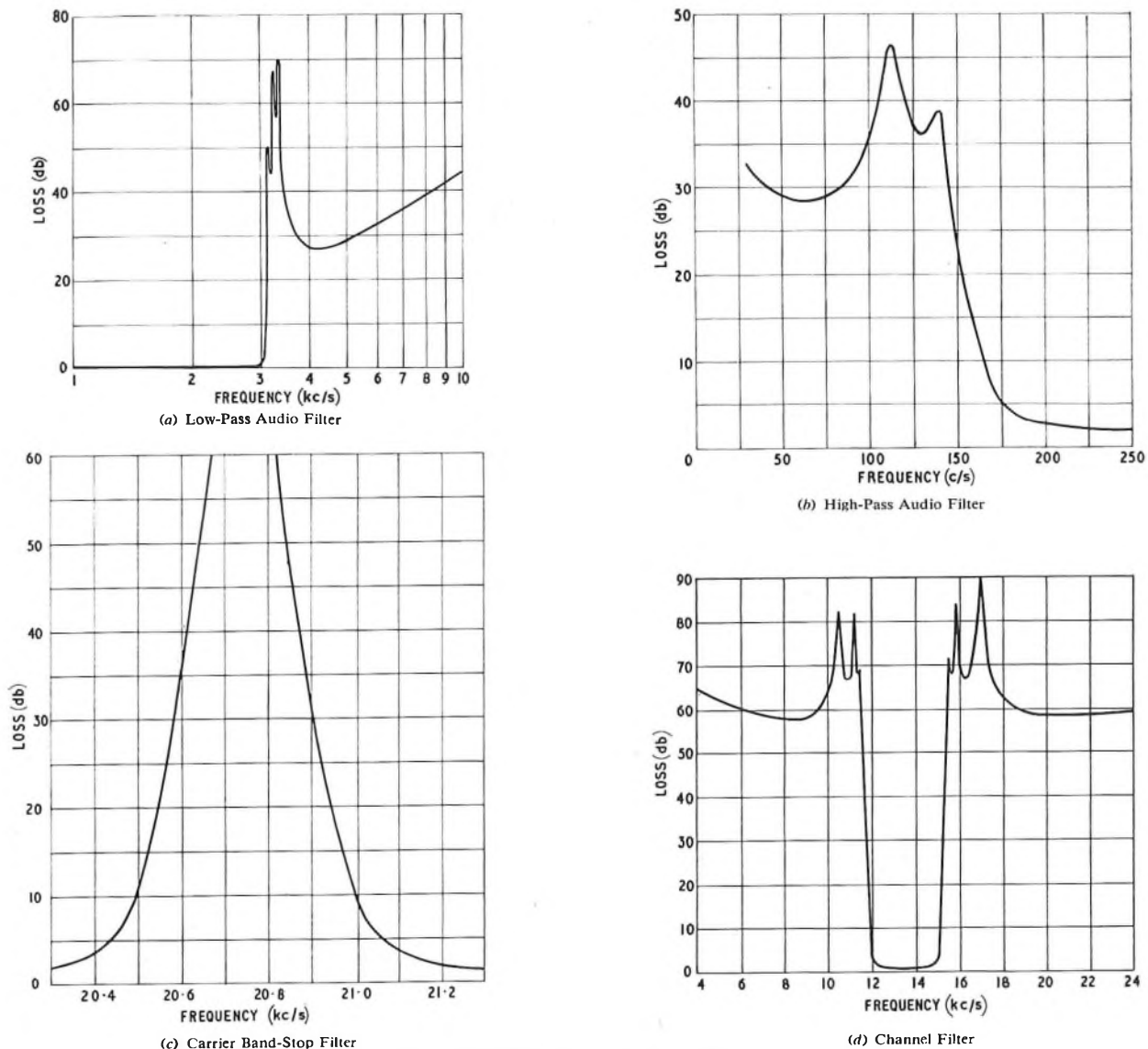

FIG. 5—TYPICAL FILTER CHARACTERISTICS

low-frequency cross-over region plotted on a sub-group frequency scale. The requirement curve corresponds to interference from channel A into channel B and takes account of psophometric weighting. The weakest point is around the sub-group frequency, 14.6 kc/s, where the channel B receive channel filter, acting alone, barely satisfies the requirement; this weakness is offset by the existence of a useful margin in the rest of the cross-over region. It will be noticed that the stop band of the band-stop filter has been extended upwards, beyond the region of the carrier frequency (15.15 kc/s), to fill in a gap that would otherwise exist around 15.4 kc/s.

#### FILTERS

With the exception of the sub-group filters, which are of image-parameter design, all the filters have been designed by insertion-parameter methods. Some typical characteristics are shown in Fig. 5. Ferrite-cored inductors and polystyrene-film capacitors are used in the filters, the positive temperature coefficient of the inductors being approximately compensated by the

negative coefficient of the capacitors. Fig. 6 shows a channel filter ready for sealing in its can.

Certain features of the filter characteristics call for comment. The channel low-pass filter (Fig. 5(a)) has a stop-band insertion loss rising from a minimum of 27 db at about 4 kc/s to 50–65 db in the sub-group band 12–24 kc/s, to prevent the transmit side from responding to sub-group frequencies applied at the audio input, or the receive side from delivering sub-group frequencies at the audio output, due to imperfect balance of channel modulators or demodulators. The use of double-balanced modulators and demodulators assists in suppressing these unwanted effects. A loss of over 70 db in the band 27–45 kc/s prevents response to inputs, or delivery of outputs, at frequencies corresponding to the sum of the channel carriers and the sub-group band. Such spurious inputs should not normally appear at the audio input to a carrier system, and the spurious h.f. components in the audio output could hardly cause trouble in purely audio plant. They could, however, be a cause of interference if channel equipments were operated "back-to-back," and

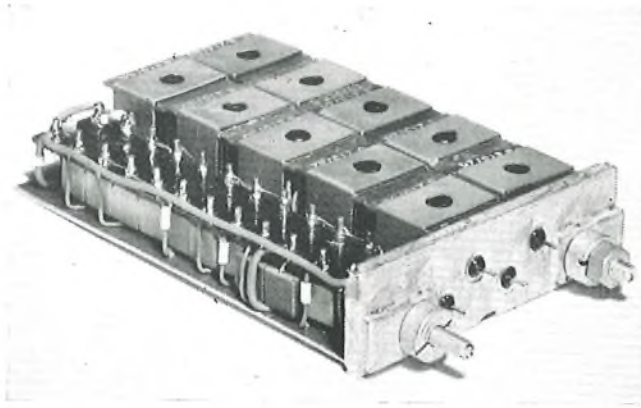

FIG. 6—CHANNEL FILTER

it seemed a wise precaution to provide protection in the equipment.

Another feature of the low-pass filter is the peak of attenuation at 3,150 c/s. This audio frequency corresponds to multiples of 6 kc/s in the group frequency band, and the attenuation, specified to exceed 43 db, permits the use of a  $-20$  dbm0 pilot at any multiple of 6 kc/s without the disturbance in the adjacent channels exceeding  $-69$  dbm0, psophometrically weighted.

The discrimination provided by the carrier band-stop filter (Fig. 5(c)) is excessive over the central part of its stop band, as will be apparent from an inspection of Fig. 4, and this causes some avoidable delay distortion. A re-design is in hand to make the filter performance match the requirements more accurately. This filter is the most sensitive to temperature effects, and a drift allowance of  $\pm 50$  c/s has been incorporated in its design and specification, to cater for operation over the temperature range 50–110°F.

#### CARRIER SUPPLIES

Each group terminal has its own channel carrier supplies derived from crystal oscillators utilizing NT-cut flexure-mode crystals. A simple thermostat controls the crystal temperature to about 55°C, and the frequency errors under normal conditions are less than  $\pm 0.5$  c/s.

Sub-group carrier supplies are taken from the station carrier-generating equipment. These have adequate frequency stability, but they may contain unwanted components 8 kc/s, 16 kc/s, etc., away from the wanted frequency. These unwanted components, innocuous in normal 4 kc/s channel equipment, can cause trouble in 3 kc/s equipment by leaking to line and producing 1,150 c/s tones in affected channels and by generating additional products which cause inter-channel interference. A 3 kc/s equipment therefore includes means for purifying the sub-group carriers.

Failure of a channel carrier oscillator, or of a sub-group carrier amplifier, affects only four channels, and the provision of duplicate carrier supplies is considered unnecessary.

#### MECHANICAL ARRANGEMENT

A 16-circuit 3 kc/s terminal equipment occupies one 9 ft rack-side. A typical installation for three carrier groups would consist of four rack-sides, three working and one spare. By modern standards the equipment is rather bulky, which is due to the amount of space occupied by the filters. Valve amplifiers are used in the present design; the use of transistors is planned but, although giving other benefits, it is not likely to reduce the bulk appreciably.

#### APPLICATIONS AND FUTURE DEVELOPMENTS

The 200–3,050 c/s channel equipment described is that currently in production. An earlier design, passing 300–3,150 c/s, was brought into use early in 1960 on the London–White Plains (New York) transatlantic telephone cable route and on a new cable linking Florida with Puerto Rico. The first application of the new technique was to a 2 kc/s system, which has been in use for over two years on the London–Montreal route; similar equipment was installed in October 1958 on the London–White Plains route. With the advent of 3 kc/s equipment and T.A.S.I., and of additional transatlantic cables, the use of 2 kc/s equipment for telephony is likely to be confined to emergencies.

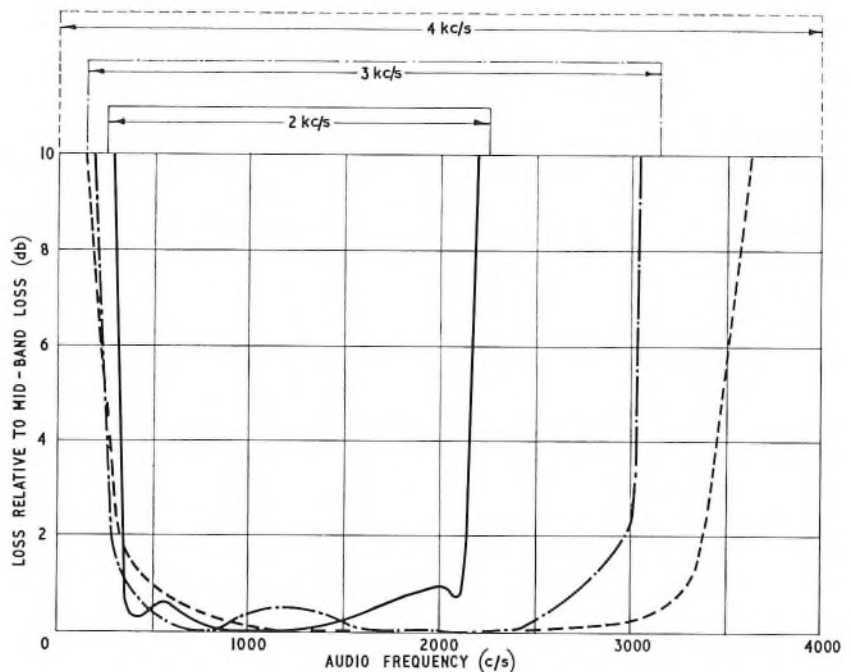

FIG. 7—2 KC/S, 3 KC/S AND 4 KC/S SPACED CARRIER CHANNELS

Typical overall response characteristics given by 2 kc/s, 3 kc/s and conventional 4 kc/s equipments are shown in Fig. 7.

In the 2 kc/s system, two 2 kc/s channels are placed in the position allocated to a single channel in 4 kc/s equipment. The channels, of band-width 300–2,200 c/s, are first translated to a sub-group, 8–12 kc/s, by locally generated carriers, 9.75 and 10.25 kc/s, and then to the group band by standard 4 kc/s spaced carriers. The system has the useful feature of being compatible with

normal carrier line plant designed for use with 4 kc/s systems. The 4 kc/s points 60, 64, 68 . . . kc/s in the basic 60–108 kc/s group fall into inter-channel gaps, so that carrier leaks or pilots at any of these frequencies are innocuous.

The existing 3 kc/s systems are not compatible with 4 kc/s systems in this way, and in current applications the 3 kc/s channel equipment is located at the submarine-system terminals, extension over inland systems being by means of normal 4 kc/s plant. Through h.f. working is very much to be preferred, and current developments for the Commonwealth network<sup>5</sup> should lead to a compatible 3 kc/s system. The proposal is to provide twelve 3 kc/s channels in the band 68–104 kc/s, and to have various 2 kc/s, 3 kc/s and 4 kc/s options for the 60–68 kc/s and 104–108 kc/s bands, the whole to be compatible with the 64 kc/s, 92 kc/s and 104 kc/s pilots which feature in North American line practice. It is further proposed to take the opportunity to convert the 3 kc/s design to transistor operation.

The use of transistors and rearrangement of the frequency allocation for compatibility with inland line plant should not of themselves affect the filter selectivity requirements, but these may be affected by changes in specification, as yet unsettled. In place of the test signal of uniformly distributed noise postulated in this article, a shaped characteristic is proposed, giving a spectral distribution approximately corresponding to that of telephone speech. The general effect would be to concentrate most of the energy in the 500–1000 c/s region, and this operates to the disadvantage of the present type of design, with alternate upper and lower sidebands. Since the compatible arrangement need not, and perhaps should not, place telephone channels right at the edges of the group band, questions of clipping at one or other end of the audio band due to through-group filters in the h.f. line

need not arise, and the main reason for the present type of allocation disappears.

#### CONCLUSION

The recent work has shown that, compared with normal practice, substantial economies in band-width can be obtained by suitable design of channel equipment. The particular channel spacings adopted suit present requirements. Future requirements may be different, but the need for economy of band-width on very expensive lines, and perhaps in very congested radio bands, is likely to remain. It is probable therefore that the methods described will continue to find useful application.

#### ACKNOWLEDGEMENTS

The authors owe thanks to many engineers, of several organizations, who have contributed to the development of the equipment described in this article. These include members of the Telephone Manufacturing Company, Ltd. and Standard Telephones & Cables, Ltd. and the authors' colleagues in Research Brand, particularly Mr. H. J. Orchard, who was responsible for the design of the filters. Acknowledgement is made to the Telephone Manufacturing Company, Ltd., for the use of the photograph in Fig. 6.

#### References

- <sup>1</sup> HALSEY, R. J. The Economic Usage of Broadband Transmission Systems. *P.O.E.E.J.*, Vol. 51, p. 212, Oct. 1958.
- <sup>2</sup> BULLINGTON, K., and FRASER, J. M. Engineering Aspects of T.A.S.I. *Bell System Technical Journal*, Vol. 38, p. 353, Mar. 1959.
- <sup>3</sup> Increasing the Traffic Capacity of Transatlantic and Other Submarine Telephone Cables. *P.O.E.E.J.*, Vol. 52, p. 140, July 1959.
- <sup>4</sup> BODE, H. W. Network Analysis and Feedback Amplifier Design (D. Van Nostrand & Co., 1945), p. 303.
- <sup>5</sup> Proposed Commonwealth Pacific Telephone Cable Systems. *P.O.E.E.J.*, Vol. 53, p. 42, Apr. 1960.

## Book Review

"Electric Circuit Theory." F. A. Benson, D.Eng., Ph.D., A.M.I.E.E., and D. Harrison, M.Eng., Ph.D., A.M.I.E.E. Edward Arnold (Publishers), Ltd. viii + 371 pp. 299 ill. 30s.

In the preface the authors state that this book "covers almost completely the electric-circuit theory given in the first two post-intermediate years of university engineering courses". Although written primarily for university students a survey of its contents shows that it would be equally suitable for use in the earlier parts of the relevant National Certificate course. It caters for students who will have no more knowledge of the subject than would be gained from an elementary study of electricity and magnetism and whose mathematical abilities extend only to the threshold of the differential and integral calculus.

Chapters one and two deal with d.c. circuits and are partly in the nature of revision and preparation for the main work which begins in chapter three, where the reader is first introduced to a.c. theory. Most of the remainder of the book is concerned with explaining the simpler concepts of the theory, and applying them to situations and problems taken from both power and communication systems. More advanced methods of analysing circuits by using mesh or nodal equations are certainly mentioned, but no great use is made of them as the main object at this stage is to give the reader a thorough understanding of the physical properties of

simple circuits. The description of a.c. circuits using vectors and the j-operator follow the traditional pattern, and here it is perhaps regrettable that the authors have not taken the opportunity of replacing the misleading word "vector" in this context by the much more appropriate word "phasor."

Although the majority of the book is concerned with sinusoidal or periodic excitation of circuits, one chapter is devoted to transients: it deals with simple circuits having one or two natural modes and being excited by step functions. The analysis is carried out by deriving the differential equations of the circuits and solving them in the classical fashion; the description is detailed and clear.

The circuit theory is supplemented by a consideration of some applications and the authors deal with such items as transformers, generators, motors, valves, transmission lines, filters, etc., in their simplest form. Polyphase systems are introduced and the theory of symmetrical components briefly touched upon.

The last few years have seen the publication of a great many books on circuit theory, mostly from America, but they have mainly been concerned with the higher flights of the subject and aimed at relatively advanced students. The present work is a welcome addition to the more scanty ranks of books for beginners, although the level of treatment suggests that it ought to be more appropriate at a technical college than to the university course at which it was primarily aimed.

H. J. O.

# A Printing Recorder for Use with Observation Equipment

B. A. GREEN, M.I.Prod.E., M.I.E.I., and H. BLAKEY†

U.D.C. 681.17:621.3.087.6:621.395.123

The printer described was developed primarily for use with meter-observation equipment. It is portable but requires an external control equipment and a 1-second clock pulse. It is intended to work without attention for long periods and has been designed to ensure ease of maintenance.

## INTRODUCTION

UNTIL recently most observation equipment, used either for verifying circuit operation or to collect statistical data, has involved the use of an operator. For some purposes automatic observation equipment would have given sufficient information, but the scope for such automatic equipment has not previously justified the design work involved. However, the introduction of subscriber trunk dialling and the consequent registering of trunk-call charges on the subscriber's meter has increased the need for automatic observation equipment with printing recorders. The largest application of the printing recorder described in this article will be for checking the accuracy of the metering of customers' calls,<sup>1</sup> and it is this use which has determined the basic facilities. There is, however, a degree of flexibility in the design which will permit other applications, the most obvious of which is for traffic analysis.<sup>2</sup>

The machine, a general view of which is shown in Fig. 1 and with the cover removed in Fig. 2, is designed to provide a printed record of all events on the circuit to which it is connected and the time at which each event occurs; for example, on an outgoing call the digits dialled and the meter pulses applied to the subscriber's meter are recorded, together with the week, day, and time of day, to the nearest second, at which each such event occurred. After printing, the paper tape moves upwards past the printing wheels and can, if required, be advanced manually by a knob on the outside of the case to enable the latest record to be viewed through the window at the front of the case. For special applications it is possible to pass the paper over a writing tablet positioned near the handle (Fig. 2). Manuscript entries can then be made on the tape before it passes back into the machine and on to the take-up spool.

All the printing operations are performed by electromagnets operated by an external control equipment, which must also supply the 1-second pulses for the timing mechanism. The machine is connected to its control equipment by a flexible cord.

A lamp (A, Fig. 2) indicates that the equipment is in use and also illuminates the printed record. A key in front of this lamp (B, Fig. 2) disconnects the time mechanism when it is operated in one direction, and in the other direction it provides a local pulsing circuit. This facility is for synchronizing the printer with the exchange clock. When the cover is in position this key is not accessible.

†Mr. Green is with Ericsson Telephones, Ltd. Mr. Blakey is in the Telephone Exchange Standards and Maintenance Branch, E.-in-C.'s Office.

<sup>1</sup>REDMAN, F. W. G., and DONN, G. S. An Automatic Meter-Observation Equipment. (In this issue of the *P.O.E.E.J.*)

<sup>2</sup>ELLIS, D. R. B. Equipment for the Provision of Statistical Data Concerning Subscriber-Dialled Trunk Calls. (In this issue of the *P.O.E.E.J.*)

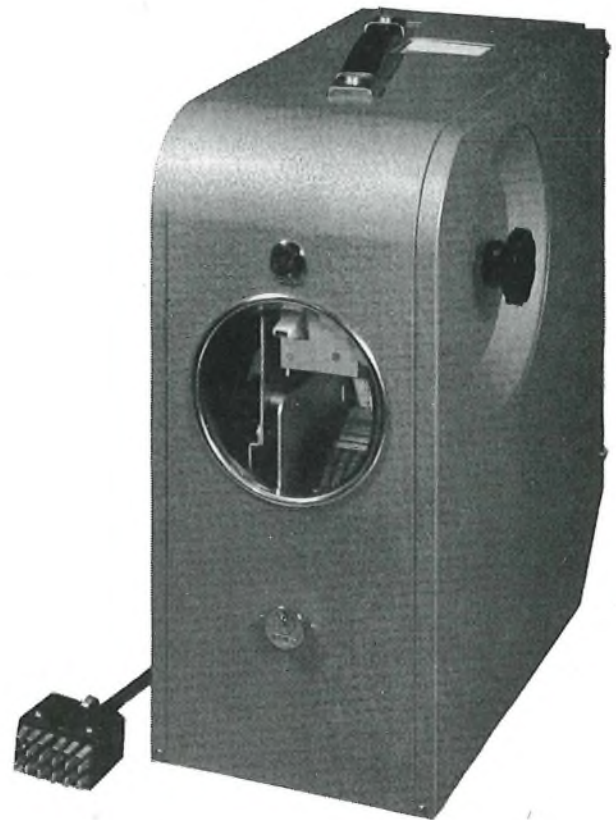

FIG. 1—THE PRINTING RECORDER

The printer is 14 in. high with a base 13 in. × 7 in., and weighs about 29 lb with a roll of paper fitted.

## DESIGN CONSIDERATIONS

The size and general proportions of the machine have been largely fixed by the requirement that it should be portable and capable of holding a roll of 2-inch wide paper tape which can be transferred to a take-up spool within the case. The cover can be locked to prevent interference.

To keep down tooling costs many components already in production have been used and, to simplify both assembly and subsequent maintenance, the machine has been designed as a number of sub-assemblies which are individually mounted either side of a central plate. This central plate is supported on an L-shaped frame forming the base and back of the recorder. The carrying handle is attached to the central plate enabling the unit to be easily moved with the cover removed, and avoiding the distortion which might occur if it were fixed to the cover.

## MECHANICAL DETAILS OF SUB-ASSEMBLIES

### *The Meter-Pulse and Digits-Dialled Storage Unit*

The meter-pulse and digits-dialled storage mechanisms are shown as C and D, respectively, in Fig. 2. They are mounted either side of a vertical plate and the combined unit is shown separately in Fig. 3. Each consists of

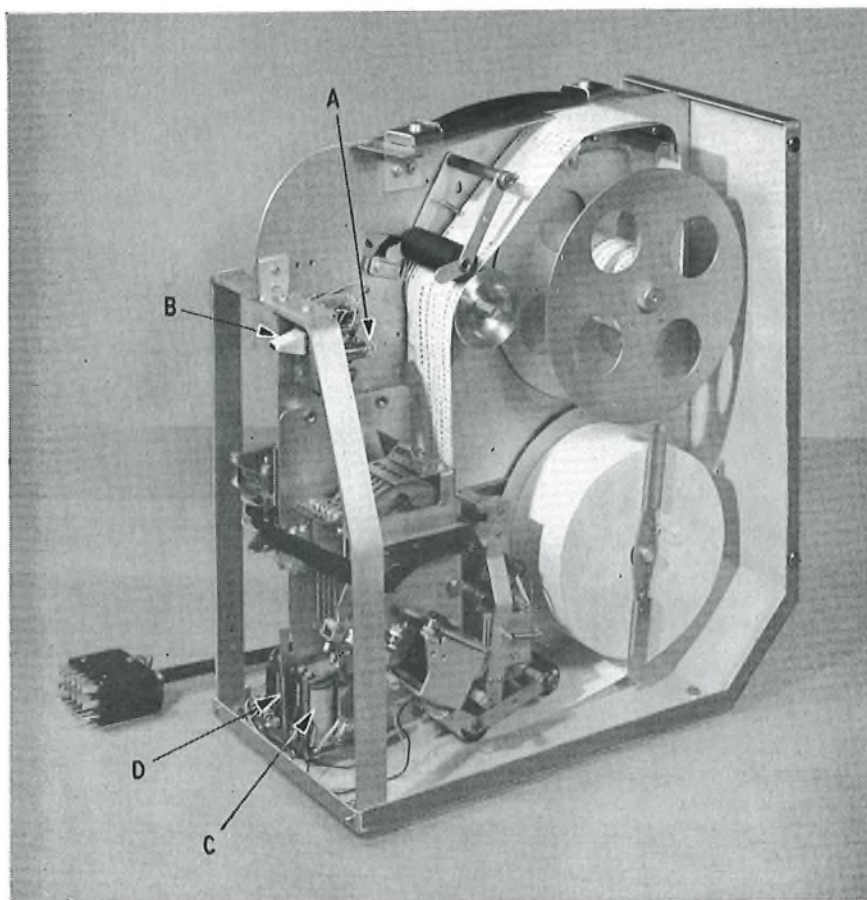

A = Equipment-busy lamp      C = Meter-pulse sub-assembly  
 B = Time-synchronizing key      D = Digits-dialled storage sub-assembly

FIG. 2.—PRINTING RECORDER WITH COVER REMOVED

a ratchet and pawl mechanism operated by magnets which are basically the release magnet of the 4,000-type two-motion selector. Type sectors are fixed to the ratchets, and restoration of the type sectors to their normal positions after printing has taken place is by gravity.

The digit sector will print the characters -, 1, 2, 3, 4, 5, 6, 7, 8, 9, 0 and the metering sector will print F, M, 2, 3, 4, 5, 6, 7, 8, 9, 0, 11. The dash in the home position of the digit sector is used to indicate the beginning and end of an outgoing call. The F on the meter sector indicates that a call has not been metered and a single meter pulse steps the sector into the M position. Subsequent positions on the meter sector are used to indicate that multi-fee metering has been correctly registered.

Mounted on the vertical plate carrying these storage mechanisms there is a type-block with the letters I/C positioned so that it lies between the digit and meter sectors. This is the abbreviation printed to indicate the beginning and end of incoming calls.

#### The Date and Time Unit

The date and time sub-assembly, complete with the 1-second magnet (which is basically a 4,000-type selector vertical-magnet assembly), is shown as A in Fig. 3. This sub-assembly is mounted on the plate carrying the storage mechanisms, an extension of the shaft carrying the type-wheels being located in a socket in the meter-pulse ratchet-wheel bearing to ensure correct alignment of all

the type. The 1-second magnet operates the seconds wheel by a conventional ratchet and pawl mechanism. A snail cam on the side of the seconds wheel gradually lifts the minutes pawl during a period of 59 seconds. On the next 1-second pulse the pawl is released and advances the minutes wheel one step. Similar transfers occur between the remaining type-wheels in the unit. This method of gradually storing the energy helps to overcome the considerable load which is imposed when all the wheels have to move together once each week; there are five type-wheels, which are used to indicate the week of the year, the day of the week, the hour, minute and second.

To facilitate the setting of the date and time wheels a stainless-steel mirror is fixed at an angle above the wheels so that the characters can be read from the front of the machine. To overcome the difficulty of seeing the type at the actual printing position the reading is made at a position 90° in advance of the printing position where one type position on each type-wheel can be seen through a slot in a metal plate. The correction required to establish the time printed is a constant for each type-wheel and the appropriate correction factors are marked on the metal plate adjacent to each type-wheel. Thus, for example, if the seconds wheel is

ready to print 25 the reading of the setting in the mirror shows "40 minus 15". This reflection of the correction factor enables the actual setting at the printing position to be established without reference to a translation chart.

Individual type-wheels may be set by manually operating the transfer pawl levers to the full extent and then rotating the particular wheel to the required position.

#### The Printing Hammers and Magnets

The printing hammers, which are plastic faced, carry the paper and ink tape on to the type. This gives a much more simple construction than the alternative method of holding the paper stationary against a platen and moving the type to make the impression.

The date and time printing hammer is a modified 4,000-type selector magnet with a special armature (B, Fig. 3). The hammer has considerable inertia to give a sharp impression over the full width of the type-wheels. The hammer is pivoted on the armature so that it hits the paper on overthrow and rebounds after printing. This results in the hammer being in contact with the paper for a minimum period and almost eliminates the possibility of a smudged impression due to the 1-second wheel moving during printing. The other three printing hammers do not have this overthrow feature and are of a simpler and lighter construction, and their magnets are standard 4,000-type selector vertical-magnet assemblies (E, Fig. 3).

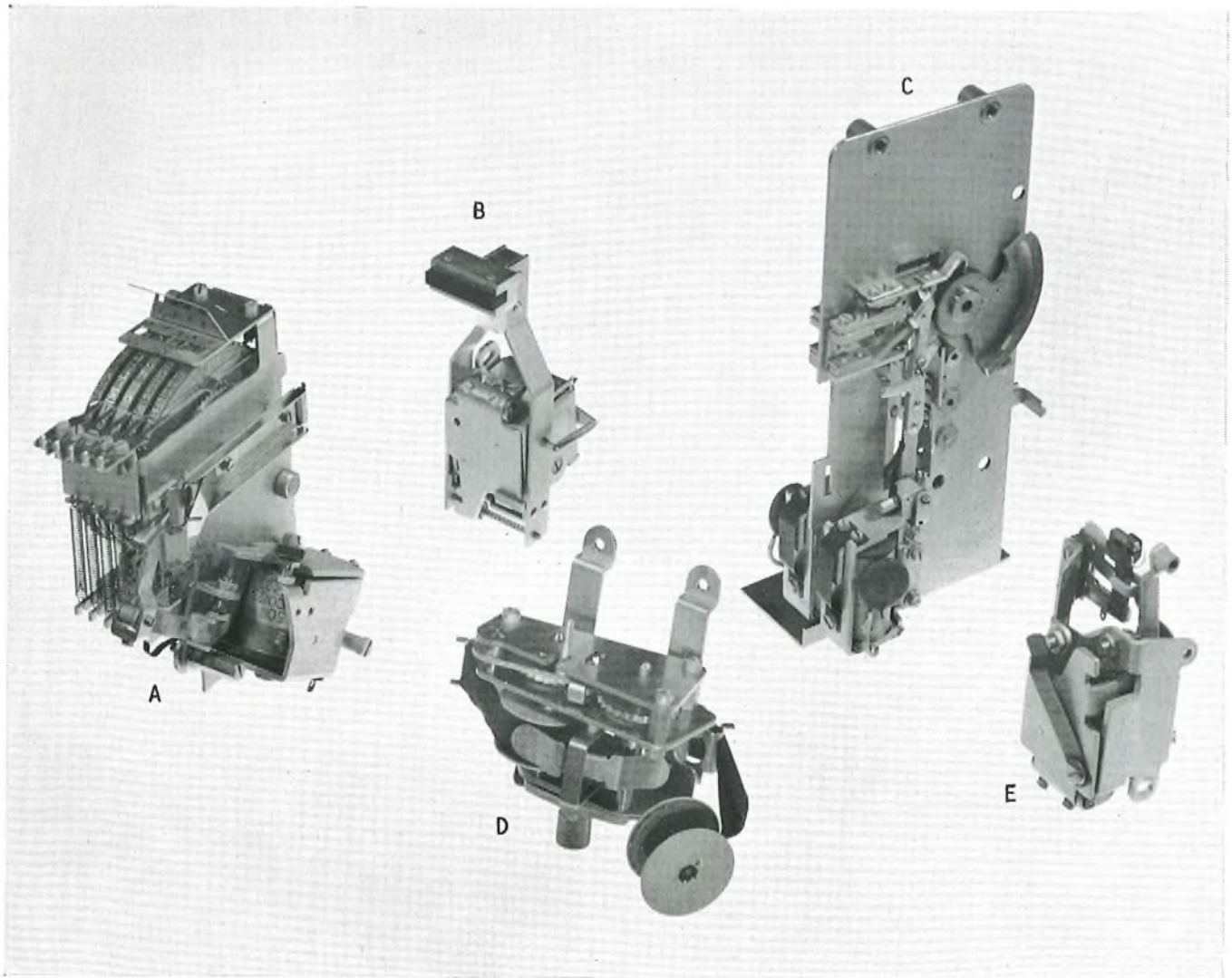

A = Date and time unit  
 B = Date and time printing-hammer unit  
 C = Meter-pulse and digits-dialled storage unit  
 D = Ribbon-drive unit  
 E = Individual track printing-hammer unit

FIG 3—MAIN SUB-ASSEMBLIES OF PRINTING RECORDER

#### *The Paper-Advance and Type-Ribbon-Advance Mechanisms*

Separate magnets are used for the paper-advance and type-ribbon-advance mechanisms. The ribbon-advance mechanism uses a 4,000-type selector magnet, but the paper-advance mechanism is basically that of the P.O. Type 2 Uniselect. Both mechanisms are reverse acting so that movement of the paper or ribbon takes place on release of the magnets.

The paper take-up spool is driven by a spring belt from the paper-advance mechanism. To counteract the effect of the gradually increasing diameter of the take-up roll, a slipping clutch is provided between the spindle and pulley wheel.

The ribbon drive (D, Fig. 3) is a compact unit which is

located on the opposite side of the machine to the printing wheels. The ribbon is self-reversing and is kept taut by a leaf spring which also acts as a ribbon guide. This unit is a well-tried one, which is already in wide use in time-recording clocks produced for other markets by the developing manufacturer.

#### MOUNTING

The printer has been designed for use either as a portable item or for rack mounting in exchanges. In the latter case the printers will stand on open trays mounted on a rack, and the cut-away bottom corner (shown in Fig. 2) provides a space for the cords to run behind the machines to the jacks.



# A Line-Signal Monitoring Unit Using Transistors

C. K. PRICE†

U.D.C. 621.395.361.1:621.373.52

The existing centralized service-observation equipment and similar equipment use a valve-type monitoring element. A new monitoring element has now been designed using transistors; this results in a very compact unit which does not require a special power-supply unit but operates from the exchange battery.

## INTRODUCTION

FUNDAMENTALLY, an observation circuit interprets the condition of the observed line by the measurement of the potential of one of the line wires with respect to earth potential. Only two conditions need be considered, namely, the line looped and the line not looped, and both are characterized by predictable potential ranges. In the adverse case the minimum value of the line-looped potential range may be very low. A valve-type line-signal monitoring unit was developed some five years ago for use in centralized service-observation equipment,<sup>1</sup> and subsequently used extensively in other applications. Unfortunately this unit requires a mains-operated power-supply unit, which is a disadvantage, particularly when the monitoring unit is to be incorporated in portable equipment such as the automatic meter-observation equipment.<sup>2</sup>

A most important feature is that the input impedance of the line-signal monitoring unit should be high. A valve circuit offers a ready means of achieving this objective. However, it was not found possible to design a valve circuit capable of the necessary degree of discrimination with only a 50-volt anode supply and attention turned to the possibility of using a transistor circuit. The requirement of high input impedance combined with high sensitivity was a difficulty which was overcome by using an oscillator as the detecting device.

An oscillator is a two-state device; it will oscillate or not according to whether its energizing condition is above or below some particular threshold value. Furthermore, a transistor oscillator can be a very sensitive device requiring only one or two volts for operation. By letting a sensitive oscillator derive its energization from the observed line it is possible to arrange for oscillation to occur when the line is looped but for the oscillator to remain quiescent when the line is not looped. The oscillator output, after conversion to d.c., can control a relay, the operation of which, therefore, will follow the line signals being observed.

In some monitoring applications it is also necessary to guard against the possibility of an incorrect response being produced by line transients, which arise from the group selectors switching as the call under observation is set up. An additional circuit element can be provided to prevent a false response from this cause.

The simplicity of the monitoring circuit element and the small size of the components used results in a very compact assembly.

## CIRCUIT DESCRIPTION

From a knowledge of the threshold current of the transistor oscillator and the line voltage which, with adequate margins, can be said to represent the line-looped condition under the most adverse circumstances, it is possible to determine a value of series resistance which

will ensure that the oscillator always oscillates ("turns on") when the line is looped but remains quiescent ("turned off") when the line is not looped. In a typical transistor oscillator circuit the threshold current is  $6-10\mu\text{A}$ , in the temperature range  $10^{\circ}\text{C}-55^{\circ}\text{C}$ , and with a line voltage representing the most adverse line-looped condition, say 2.5 volts, a series resistor of 150,000 ohms is a practical solution. This value of resistance then represents the input impedance of the monitoring element.

The line-signal monitoring element circuit is shown in Fig. 1 and resistor R1 is the input resistor. It will be

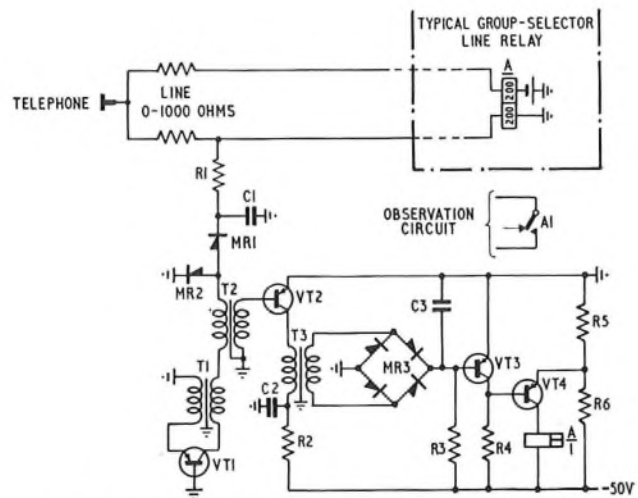

FIG. 1—CIRCUIT OF LINE-SIGNAL MONITORING ELEMENT

noted that the resistor also acts in conjunction with capacitor C1 to decouple the line and oscillator circuits so that speech signals will not interfere with the oscillator and, conversely, so that the oscillator output will not be heard on the line. The capacitor also provides the a.c. return path for the oscillator circuit.

The oscillator transistor is designated VT1 and the feedback transformer, a miniature hearing-aid type, is shown as T1. The oscillator output is coupled to transistor VT2 via another miniature transformer, T2. The collector of transistor VT2 is decoupled by resistor R2 and capacitor C2, the a.c. output being transferred to the bridge rectifier circuit via the third miniature transformer, T3.

The rest of the circuit is used to convert the oscillator output to d.c. signals. The transistors VT3 and VT4 are operated as switches, i.e. as two-state devices, either "on" or "off." While the oscillator is not oscillating, i.e. when the line is not looped, transistor VT3 is switched on by current supplied to its base via resistor R3, and the base and collector are virtually at earth potential; hence,

† Telephone Exchange Systems Development Branch, E.-in-C.'s Office.

<sup>1</sup> BARNARD, A. J., and BECK, E. H. A. The New Centralized Service-Observation System. *P.O.E.E.J.*, Vol. 49, p. 81, July 1956.

<sup>2</sup> REDMAN, F. W. G., and DONN, G. S. An Automatic Meter-Observation Equipment. (In this issue of the *P.O.E.E.J.*)

capacitor C3 is not charged and rectifiers MR3 are of relatively high resistance. With the collector of VT3 at earth potential the base-emitter junction of transistor VT4 is reverse-biased by virtue of the connexion of its emitter to  $-2$  volts at potential divider R5 and R6. Transistor VT4 is, therefore, switched off and relay A is unoperated. While the line is looped the amplified oscillator-output pulses are delivered to the bridge rectifiers MR3, which are arranged to provide a positive d.c. output. The rectified output pulses are integrated by capacitor C3 and the net positive voltage developed across the capacitor switches off transistor VT3. The base current now provided via resistor R4 causes transistor VT4 to switch on and operate relay A. The potential of the emitter of transistor VT4 falls to  $-10$  volts as the result of the increased current drawn by the relay from the potential divider. In spite of the consequent reduction of base current and of voltage across the relay, the operation of the circuit is not jeopardized and there is a saving of standing current by the use of a high-resistance potential divider.

When the oscillator pulses cease as the loop is removed from the line the net positive charge on capacitor C3 has to be dissipated as quickly as possible so that the make pulse period is not unduly extended. This is ensured by letting capacitor C3 charge from the  $-50$ -volt supply. Once a net negative voltage appears

across the capacitor, transistor VT3 conducts and relay A releases.

The output from the monitoring-circuit relay must be as nearly as possible a faithful reproduction of the dial signals. Unfortunately, the dial pulse-train waveform is modified by the line conditions, as indicated by the oscillograms shown in Fig. 2. The characteristic oscillatory waveform may lead to the generation of a spurious pulse when the negative overshoot, following the high positive swing, is of sufficient amplitude to turn on the oscillator. This effect on the oscillator is also shown in Fig. 2. The difficulty is overcome by storing some of the positive charge and using it to inhibit the oscillator for a period of time sufficient to cover the overshoot period. Without rectifier MR1 (Fig. 1) the voltage across capacitor C1 cannot follow the positive part of the waveform because of the clamping action of rectifier MR2, this rectifier being necessary to prevent a reversal of the transistor VT1 collector polarity. The inclusion of rectifier MR1, however, allows capacitor C1 to be charged by the positive swing to a degree determined by the values of C1, R1 and line voltage, and by the duration of the swing, the rectifier being connected in such a way as to be reverse-biased, and hence high resistance, during the positive excursion. After the positive voltage surge has decayed, the charge on capacitor C1 begins to fall but the process takes time because the discharge path is via resistor R1. The reverse-bias condition applied to rectifier MR1 is thus preserved for a period following the positive voltage surge, throughout the negative voltage overshoot period in fact, and the consequent high resistance of MR1 prevents the oscillator responding to the overshoot voltage. The addition of rectifier MR1 totally eliminates the spurious responses shown in Fig. 2.

It is necessary to ensure that a false pulse is not registered between pulse trains as the result of the oscillator being momentarily turned off by the line disturbance which occurs due to each successive group-selector switching as the observed call is being established. There are two conditions which can arise and stop oscillation during this time: (a) both wires disconnected simultaneously by the switching contacts, and (b) the operation of relay contacts so that the negative wire is disconnected first, thus extending a high positive back-e.m.f. to the line. The first difficulty is countered by connexion of a negative potential to the negative wire of the observed line, making the oscillator independent of the group-selector battery feed, but the second difficulty requires the addition of a special guard element to ensure proper operation of the oscillator. A transistor inverter, connected to the negative wire, converts the positive surge into a negative potential which is used to maintain oscillation for the duration of the line disturbance.

Fig. 3 shows the complete negative-wire circuit element which, in more detail, functions as follows. A negative potential is supplied to the negative wire of the line via resistor R8 to make the oscillator

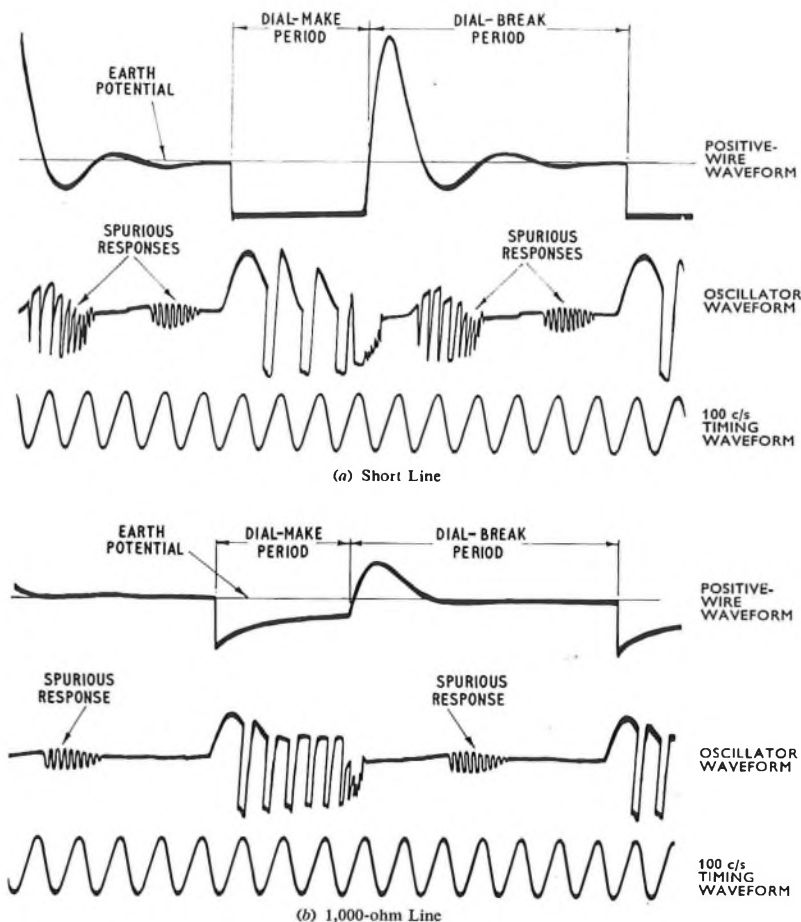

The spurious responses shown in (a) and (b) are totally eliminated by the addition of rectifier MR1

FIG. 2—OSCILLOGRAMS SHOWING LINE AND OSCILLATOR WAVEFORMS

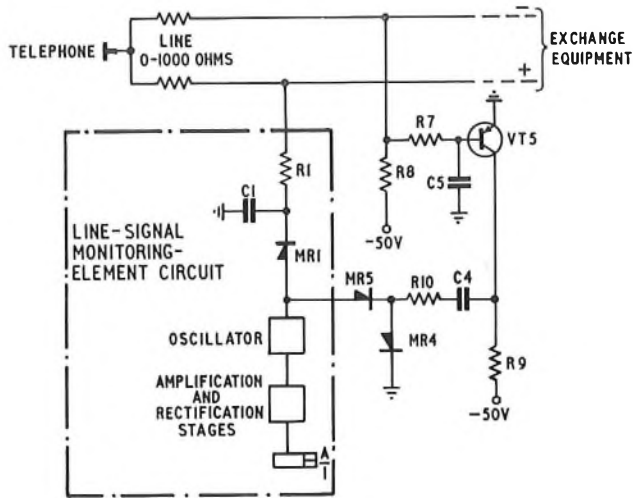

FIG. 3—GUARD CIRCUIT

battery supply independent of the group-selector switching contacts. Transistor VT5 is switched on by the negative state of the negative wire, the base current being determined by resistor R7. The collector is therefore at earth potential and capacitor C4 is uncharged.

When the line is looped the oscillator draws current

from the positive wire and rectifier MR5 is reverse-biased. When the operation of a group-selector contact gives rise to a positive voltage surge, transistor VT5 switches off because its base is driven positive with respect to the emitter. This allows capacitor C5 to charge and hold the transistor switched off after the surge has decayed. The collector of transistor VT5 falls immediately to -50 volts so that capacitor C4 charges via the oscillator, the rectifier MR5 being now forward-biased. The rate of charge depends upon the values of capacitor C4 and resistors R9 and R10. During the positive voltage surge on the line, rectifier MR1 is reverse-biased, and the oscillator draws current from the collector circuit of transistor VT5 as capacitor C4 charges. When the charge on capacitor C5 is dissipated, transistor VT5 switches on again, its collector rising to earth potential. Capacitor C4 is now discharged, at a rate controlled by resistor R10, via rectifier MR4 provided for this purpose. The guard element is capable of maintaining oscillation in the face of line disturbances for approximately 70 ms.

The unit is susceptible to transient peak voltages occurring in a battery-supply lead used in common with electro-mechanical apparatus. It is necessary to suppress such transient voltages, particularly those liable to occur while the oscillator is turned off, if spurious operation of the output relay is to be avoided.

## Book Review

"Handbook of Automation, Computation, and Control: Vol. I—Control Fundamentals." Edited by Eugene M. Grabbe, Simon Ramo and Dean E. Wooldridge. John Wiley & Sons, Inc., N.Y., and Chapman & Hall, Ltd., London. 986 + xx pp. 408 ill. 136s.

This is the first volume of an ambitious three-volume project; the second volume deals with Computers and Data Processing; the third with Systems and Components. Such a wide field is covered by this first volume that the only reasonable way of dealing with the contents seems to be to give the complete list of chapter headings, as follows (the pairs of numbers in parentheses give the number of pages and number of references respectively):

Sets and Relations (11, 7); Algebraic Equations (6, 7); Matrix Theory (17, 10); Finite Difference Equations (8, 3); Differential Equations (23, 11); Integral Equations (17, 10); Complex Variables (28, 12); Operational Mathematics (20, 12); Laplace Transforms (21, 13); Conformal Mapping (11, 12); Boolean Algebra (11, 6); Probability (12, 7); Statistics (21, 10); Numerical Analysis (90, 48); Operations Research (129, 118); Information Theory (48, 52); Smoothing and Filtering (34, 24); Data Transmission (32, 32); Methodology of Feedback Control (21, 3); Fundamentals of System Analysis (86, 54); Stability (83, 35); Relation Between Transient and Frequency Response (61, 11); Feedback System Compensation (56, 9); Noise, Random Inputs, and Extraneous Signals (56, 9); Non-linear Systems (68, 57); Sampled-data Systems and Periodic Controllers (32, 7).

A team of 29 writers have contributed to this volume: it would take several reviewers to make a full appraisal.

The following opinions are based largely on two samples, one of matter with which your reviewer considered himself familiar, and one with which he did not; for this handbook, like others, tries to present its material so as to act as an introduction for newcomers as well as a reference book for experts.

As a reference book, Vol. I of the Handbook appears to be, on the whole, excellent. The section on Waiting-line (*anglice* Queuing) Theory is an almost ideal example of what a handbook should provide. Among other things, it gives some reference to unsolved problems; too often, it is only the complete failure to find any reference to a problem in the literature that leads one to the conclusion that it is unsolved. As an introductory text, the volume is not quite so satisfactory; points are sometimes taken for granted that are not obvious to a beginner. The references are extensive and up-to-date and not confined to United States literature.

The editing could have been improved. Contributors to some of the sections on control have been allowed to restate material already covered in the general mathematical sections. For example there are two sets of tables of Laplace transforms. It would be easier for the user to have one comprehensive table; this, along with tables of mathematical functions, and possibly some other tables, might have formed a separate section. Cross-referencing is not as good as it might be. For example, under sampled-data systems, there is an illustration of the usual sectorially divided disc for converting shaft position to a binary number. The necessity for accurate alignment of the reading position is mentioned, but there is no reference to the advantages of the reflected binary code; this code is, however, discussed under data transmission.

Apart from these comparatively minor deficiencies, this volume does the job it sets out to do very well indeed.

W. E. T.

# An Automatic Meter-Observation Equipment

F. W. G. REDMAN and G. S. DONN†

U.D.C. 621.395.123:621.3.087.6

The meter-observation equipment described has been designed to produce automatically a record of both outgoing and incoming calls made on an individual subscriber's line, for the purpose of verifying the accuracy of the registration of meter pulses on the subscriber's meter.

## INTRODUCTION

WHILE telephone equipment is designed to ensure accurate metering of calls, some method of verifying the accuracy of the metering on individual lines is needed. Present arrangements require the attention of an operator and give only limited information. The advent of subscriber trunk dialling (S.T.D.) brought a need for a more detailed record without the use of an observation operator. A number of foreign administrations use special machines for the purpose of recording call details and meter registrations but, as none of these was entirely suitable for use by the British Post Office, it was decided to develop a British machine which would give all required facilities.

The main features required are as follows:

(i) The record should be in a form which can, if required, be presented to, and easily understood by, a subscriber.

(ii) The time of origination of each call, of each digit dialled, of each meter pulse, and of the clear-down of each call should be clearly shown.

(iii) The number dialled by the subscriber for each outgoing call should be recorded.

(iv) The occurrence of both outgoing and incoming calls should be recorded.

The equipment comprises three distinct parts: the printing recorder<sup>1</sup>, a line-signal monitoring unit<sup>2</sup>, and a connecting circuit which translates the line signals into signals to operate the electromagnets of the printing recorder. Details of the first two parts are described elsewhere in this issue of the Journal; this article describes the functioning of the whole equipment and the detailed operation of the connecting circuit. The line-signal monitoring circuit and the connecting circuit are assembled in the same relay-set and at larger exchanges will be rack-mounted. A fully-equipped rack will contain nine relay-sets and recorders, together with a routine-test circuit. For use in smaller exchanges a portable equipment has been designed, which incorporates its own routine-testing facilities, and 1-second and 24-hour timing mechanisms to provide the clock pulses for the date and time unit.

## TAPE RECORD

The paper tape used in the printing recorder is approximately 2 in. wide and provides eight parallel tracks for figures or symbols. Fig. 1 shows the records produced on various types of call; recording (a) is for an outgoing local call, recording (b) is for an outgoing S.T.D. call, recording (c) is for an unanswered incoming

† Telephone Exchange Systems Development Branch, E.-in-C.'s Office.

<sup>1</sup> GREEN, B. A., and BLAKEY, H. A Printing Recorder for Use with Observation Equipment. (In this issue of the *P.O.E.E.J.*)

<sup>2</sup> PRICE, C. K. A Line-Signal Monitoring Unit Using Transistors. (In this issue of the *P.O.E.E.J.*)

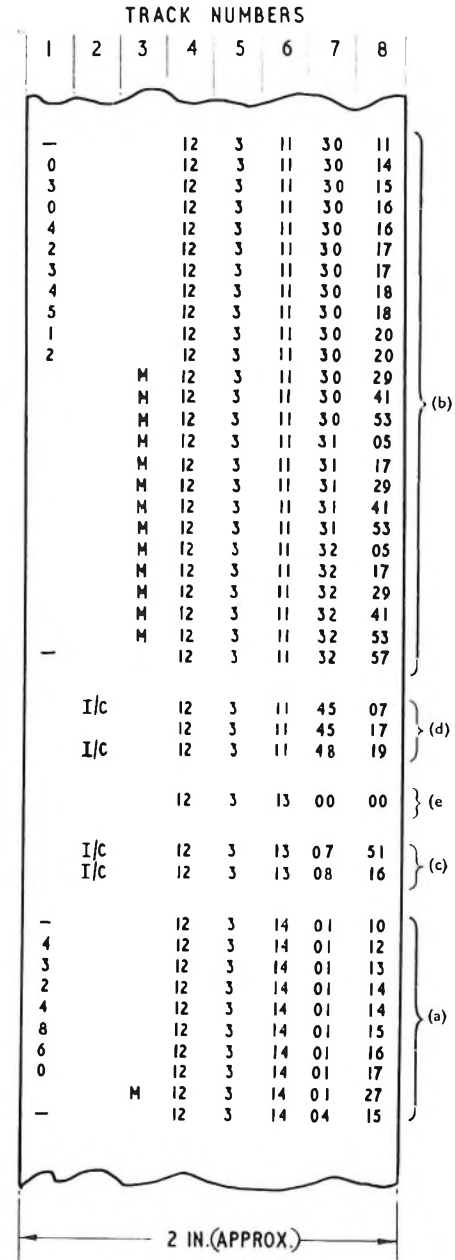
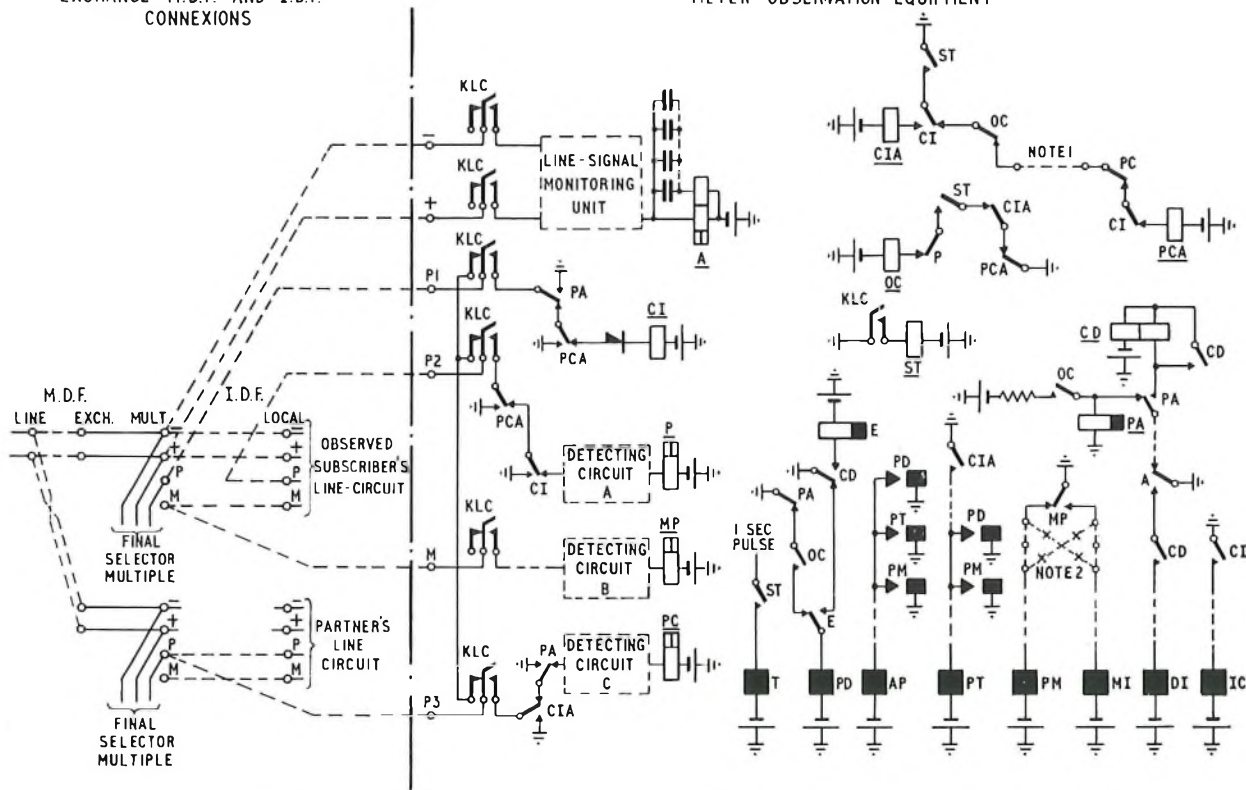

FIG. 1—TYPICAL SECTION OF RECORDINGS ON THE PAPER TAPE

call, and recording (d) is for an answered incoming call. It will be seen that a dash is printed in track 1 at the moment the subscriber lifts the receiver to originate a call, the time of the occurrence being printed in tracks 4, 5, 6, 7 and 8, as the week of the year, day of the week, hour, minute and second, respectively. Then, in track 1, the digits dialled follow consecutively and, upon answer by the called subscriber, receipt of the meter pulse is recorded by printing M in track 3. Finally, clear-down of the call is indicated by again printing a dash in track 1.

EXCHANGE M.D.F. AND I.D.F. CONNEXIONS

METER OBSERVATION EQUIPMENT



- Notes:  
 1. Strap inserted only when subscriber's line to be observed is one connected for shared service  
 2. Strap to suit exchange metering system

FIG. 2—SIMPLIFIED CIRCUIT OF METER-OBSERVATION EQUIPMENT

The times at which each digit is dialled, the called subscriber answers, and the meter pulse is received are recorded in tracks 4, 5, 6, 7 and 8. The record of an S.T.D. call is similar, but with repeated printing of the symbol M each time a meter pulse is received and with the appropriate time recorded alongside. An ineffective call would be indicated by the absence of the M symbol. To distinguish between an answered and an unanswered incoming call, it is arranged that the answer signal will cause the time only to be printed, whereas the seizure and clear-down signals for all incoming calls cause I/C to be printed on track 2, together with the time in the usual tracks.

OUTLINE OF CIRCUIT OPERATION

The method of connecting the relay-set to the line to be observed is shown in Fig. 2, and it will be seen that until the operation of key KLC the line is isolated from the detecting equipment. When the key KLC is operated the line-signal monitoring unit is connected to the negative and positive wires, and the detecting circuits A, B and C are connected to the observed subscriber's line-circuit private and meter wires and his partner's line-circuit private wire, respectively. In addition, the operation of key KLC operates relay ST, and those contacts of this relay not shown in Fig. 2 complete the potential-divider circuits for the transistors in the line-signal monitoring unit and the three detecting circuits.

With no call in progress the negative potential from relay K on the subscriber's line-circuit private wire,

acting upon a transistor in detecting circuit A, causes the operation of relay P. When there is a partner's line circuit for a shared-service connexion, relay PC is operated in a similar manner from detecting circuit C. Due to the high-speed operation of relays P and PC, relays OC and PCA remain unoperated.

When the subscriber whose line is being observed makes an outgoing call the change from negative potential to earth on the private wire makes the base of the transistor, in detecting circuit A, positive with respect to its emitter, and the subsequent release of relay P operates relay OC. A contact of this relay completes a circuit for the printing magnet PD, and the dash, which is on the home position of the DI type-sector, is printed. The auxiliary springs of the PD magnet operate the time-printing hammer (PT) and paper-advance (AP) magnets. Until a free first selector is found by the subscriber's uniselector the line-signal monitoring unit is isolated from the line, by a switching relay not shown in Fig. 2, in order to prevent premature operation of relay A. The operation of relay A allows relay PA to operate, releasing the printing magnet PD, and this in turn releases the paper-advance magnet AP causing the advance of the paper in readiness for the printing of the next symbol. The operation and release of relay A to the dialled pulses repeats the signals to the DI magnet, and the DI type-sector acts as a counting store. At the first release of relay A, relay CD operates and this in turn operates relay E. During the inter-digit pause relay CD releases and a contact of relay CD operates the printing magnet PD thus printing the number cor-

responding to the dialled pulses received; subsequently, magnet AP operates to prepare to advance the paper and the AP springs (not shown in Fig. 2) release relay E. This action is repeated for each digit dialled.

As the call progresses switching surges occur which are liable to cause registration of false pulses. Two particular transient conditions which can arise are (a) the disconnexion of the line-signal monitoring-unit oscillator power supply as relay change-over contacts move, and (b) sequencing of relay contacts, e.g. the negative-wire contact breaking first and causing a high positive back e.m.f. on the line. The action taken to counteract these conditions is described in the article on the monitoring circuit.<sup>2</sup>

Because of the different systems of metering employed, various arrangements of the transistor circuit in the detecting circuit B and of the contacts of the controlling relay MP are provided enabling the equipment to be used at all exchanges. Relay MP is normally operated when key KLC is operated at exchanges with booster, positive-battery or fourth-wire earth-metering systems, but unoperated at fourth-wire negative-battery metering exchanges. Relay MP is, therefore, released by each meter pulse in exchanges of the first three types and is operated by each meter pulse in exchanges of the fourth type. The contact of relay MP has to be connected to suit the type of exchange, as indicated in Fig. 2. Relay MP controls the operation of magnet MI to record the meter pulse, and, on cessation of the meter pulse, magnet PM causes the symbol M to be printed on track 3, while the PM springs cause the consequent operation of magnets PT and AP. It is possible for the machine to deal with multi-metering as meter pulses can be counted and stored on the MI type-sector and the total printed as a figure instead of the symbol M.

At the conclusion of the call, relay A releases, and relay P operates when earth is removed from the line-circuit private wire; a combination of relay contacts then causes magnet PD to operate and print the dash symbol, signifying clear-down of the call, together with time of occurrence.

It will be seen that, with the P-wire split by removing the normal intermediate-distribution-frame jumper, for

an outgoing call the release of relay P operates relay OC causing the printing of a dash on track 1 to indicate an outgoing call, whereas an incoming call connects earth to the multiple private wire and thus operates relay CI. By this means the magnet IC is operated and the symbol I/C printed on track 2. If the call is answered, arrangements are made for the PT magnet to operate and print the time, while the conclusion of the call is shown by reprinting the symbol I/C together with the time at which it occurred. If, however, the call is not answered only two items are shown: the time of arrival of the call together with the symbol I/C and the time of abandonment of the ineffective call together with the symbol I/C.

With shared-service lines the private wires of the two numbers are split and the busy condition is relayed to the partner's line by contacts in the connecting circuit. Only calls on the circuit under observation are recorded and calls on the other circuit of the pair are ignored.

A 1-second earth pulse is used to control the time magnet, T, which steps the seconds wheel, and from this the minutes, hours, days and weeks wheels are stepped mechanically.

At 1 p.m. each day a pulse is connected to the circuit to print the time (recording (e) of Fig. 1), provided that no call is in progress at the time, in order to provide a check should a subscriber not make a call during 24 hours. This confirms that the machine is in fact functioning correctly as far as the time indication is concerned, because the day indication on track 5 will have changed.

In the portable equipments, self-contained mains-driven timers are provided for both the 1-second and the 24-hour pulses so that the machines are independent of exchange pulse supplies.

#### ROUTINE TESTING

A test circuit is provided on each rack of meter-observation equipment and the functioning of any of the observation circuits and recorders can be proved by the operation of appropriate keys. By leaving unoperated the key KLC of the connecting circuit to be tested the routine tests may be made without interference with the subscriber's line.

---

## Book Review

"Progress In Dielectrics." Edited by J. B. Birks, B.A., Ph.D., D.Sc., F.Inst.P., A.M.I.E.E., and J. H. Schulman, Ph.D. Heywood & Co., Ltd. x + 312 pp. 139 ill. 70s.

Books or periodicals entitled "Progress in so-and-so" are becoming common, and they can be valuable in providing a considered and balanced review while keeping nearly up to date with new developments. The disadvantage is the need (or temptation) to include reference to work which is still in progress and awaiting interpretation.

"Progress in Dielectrics" is intended to be an annual volume; the first of the series has, however, taken so high a proportion of the obviously interesting subjects that it is difficult to see how the standard can be maintained in future. It contains seven articles; the one most likely to interest readers of this Journal is on breakdown of solid insulation, by Dr. J. M. Mason, of the Electrical Research Association, and his 25,000-word article would alone

justify the presence of the book in a reference library. Dr. Mason classifies various types of breakdown and deterioration of insulation, including tracking, in a way which not merely distinguishes between effects having different origins but which will help the engineer needing to choose an insulating material.

The article on non-oxide ceramics may serve to excite the imagination, but will appeal chiefly to those concerned with materials for high temperatures. The article on the ferroelectricity of barium titanate is sound, but much of the information in it is already accessible in review articles. Other articles cover breakdown in crystals and in liquids, the use of gases as dielectrics, and the deposition of insulants by electrophoresis. All are authoritative and well written and all give ample references to original papers. An index, or separate indexes for each article, would have been welcome. The book is well produced; diagrams are clear, and mathematical work well set out.

The book earns a welcome, coupled with some scepticism about whether its high standard can be maintained.

A. C. L.

# Equipment for the Provision of Statistical Data Concerning Subscriber-Dialled Trunk Calls

D. R. B. ELLIS†

U.D.C. 621.395.66 : 519.24 : 621.395.374

With the introduction of subscriber trunk-dialling facilities it has become necessary to provide a method of automatically obtaining the information formerly recorded by the operators who controlled the calls. A method of monitoring a "1-in- $n$ " sample of all calls routed to trunk-level relay-sets is described, and the access and control circuits are briefly outlined.

## INTRODUCTION

TRUNK-CALL statistics have in the past been obtained from information recorded on tickets prepared by the operators who controlled the calls. A form of "1-in- $n$ " sampling was achieved by printing a distinctive mark on the  $n$ th ticket of each pad, and on each of these tickets additional information, as required, was inserted by the operators. With the introduction of trunk-dialling facilities for subscribers, some alternative means of providing the information has now become necessary. An ideal analysis equipment would be one which extracted the required information from each call and recorded it in a form which could be directly processed by computing equipment. Until such an equipment has been developed, use will be made of a printing recorder<sup>1</sup> to provide a printed record on a paper tape. The recorded information will subsequently be processed manually.

## OUTLINE OF METHOD

The "1-in- $n$ " method of sampling is used, i.e. all calls routed to trunk-level relay-sets are counted and every  $n$ th call is monitored. Counting is effected by an electronic equipment on which the value of  $n$  can be varied between 1 and 1,000 by the setting of multi-position rotary switches. The value of  $n$  necessary to ensure an adequate sample of calls will depend upon the calling rate and average holding time for calls in the exchange concerned. When each  $(n - 1)$ th call is originated, the counter sends a signal to the access equipment, which is then made ready to associate the printer control equipment with the trunk-level relay-set on which the next, i.e. the  $n$ th, call originates. Each  $n$ th call is monitored and pulses dialled by the subscriber are repeated to the printer. Only the first six digits dialled into the trunk equipment are monitored, this number being sufficient to determine the terminal exchange to which the call is being routed. Meter pulses are recorded by monitoring the private wire (P-wire) for calls originated locally or the positive wire for calls originated via metering-over-junction circuits.<sup>2</sup>

At the conclusion of each call, a

clear-down signal is printed. If, when an  $(n - 1)$ th call is signalled by the counter, the previous  $n$ th call is still in progress, the analysis equipment is released and prepared for connexion to the next call to be originated. In these circumstances, an indication is given that the recorded information for the earlier  $n$ th call is incomplete. The printer incorporates a 24-hour clock driven by the exchange 1-second pulse, and the date and time to the nearest second are printed alongside all other characters.

## CIRCUIT DESCRIPTION

### Access Circuit

In a group of up to 200 trunk-level relay-sets each one is associated with an individual relay; these relays are designated 1A to 20K (Fig. 1). The group is arranged as a matrix of ten sub-groups, designated A to K, each of 20 circuits. To identify the position of a circuit in a sub-group, all the corresponding circuits in each sub-group, e.g. all the first or all the 20th circuits, are associated and operate "position-in-sub-group" relays, designated 1M to 20M. To connect any circuit in the group of 200 to the printer control equipment, the individual relay associated with the particular trunk-level relay-set marks the sub-group of 20 circuits in which that relay-set is connected. A signal from this sub-group is connected via a contact of the individual relay to mark its position in the sub-group. A high-speed-relay testing circuit is used for each sub-group and to ensure that only

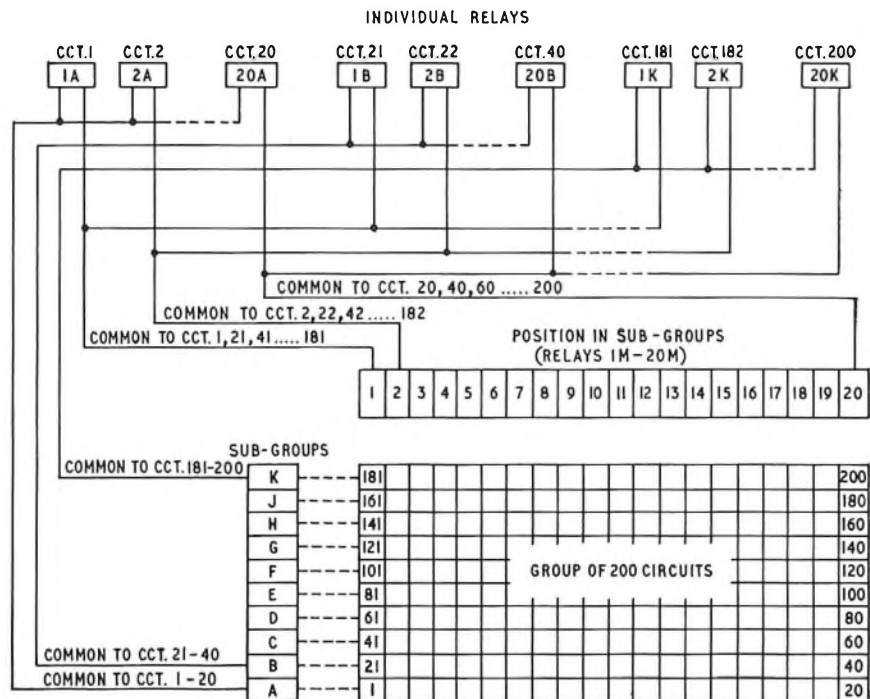

FIG. 1—BLOCK SCHEMATIC DIAGRAM SHOWING ACCESS TO A CIRCUIT IN A GROUP OF 200 CIRCUITS

† Telephone Exchange Systems Development Branch, E.-in-C.'s Office.

one of the sub-groups A to K can be operated at any one time, the testing battery is connected via a 560-ohm resistor to all the high-speed relays in groups A to K. A similar arrangement is used for relays 1M to 20M.

When the sub-group and the position in the sub-group have been marked, a switching relay associated with the group of 200 circuits is operated and the positive and private wires of one trunk-level relay-set are connected to the printer control equipment. If there are more than 200 trunk-level relay-sets in one exchange, additional access equipment is provided on a basis of 200-circuit groups, and the two 560-ohm testing resistors are used for marking all the A to K sub-groups and all the 1M to 20M positions in the sub-groups, respectively. Hence, in the whole exchange, only one sub-group circuit relay, one position-in-sub-group relay and one group-switching relay can be operated at any time.

The access equipment provided for a group of 200 circuits is shown in Fig. 2. It will be seen that when any one of contacts 1A2-20A2 closes, it operates relay AP. Contact AP1 short-circuits the 120-ohm coil of relay AP to connect a 7-ohm earth to the 560-ohm testing battery, effectively shunting any of the other high-speed relays associated with sub-groups of 20 circuits. Relay APR operates, and contact APR1 operates relays APW, APX, APY and APZ. The 40 contacts of these relays connect the positive and P-wires of the 20 circuits in sub-group A to their respective MM1 and MM2 contacts. Nine other similar circuits are provided, with B-K, indicating the other nine sub-groups, for the initial letters of the relay designations. A similar high-speed-relay testing circuit operates one of the relays 1M-20M and, in consequence, the corresponding relay in the group of relays 1MM-20MM marks the position in the sub-group. Contact MM3 operates relay H, and contacts MM1 and MM2 connect the P-wire and positive wire to the printer control circuit via contacts H1 and H2.

**Counting Circuit**

Each sub-group of 20 individual relays is associated

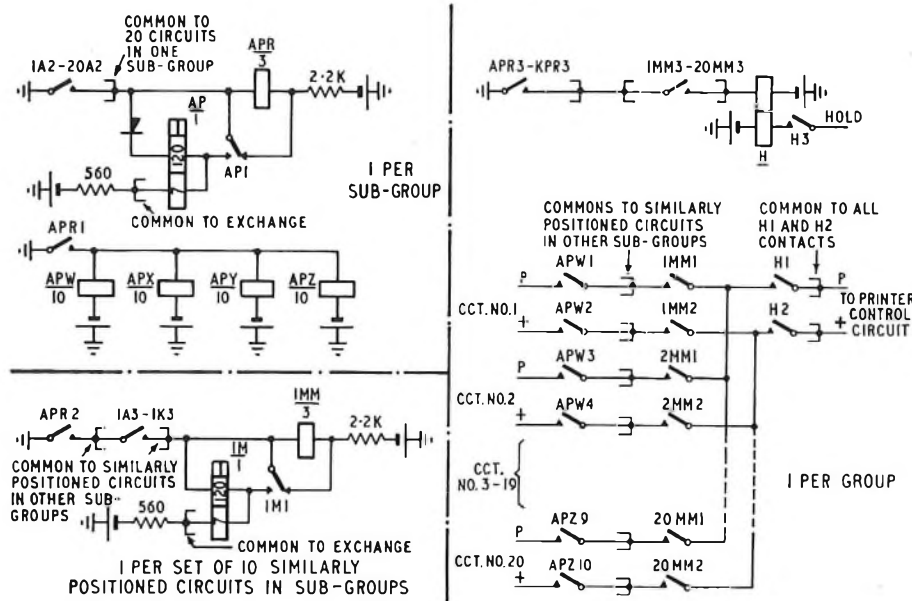

FIG. 2—ACCESS CIRCUIT

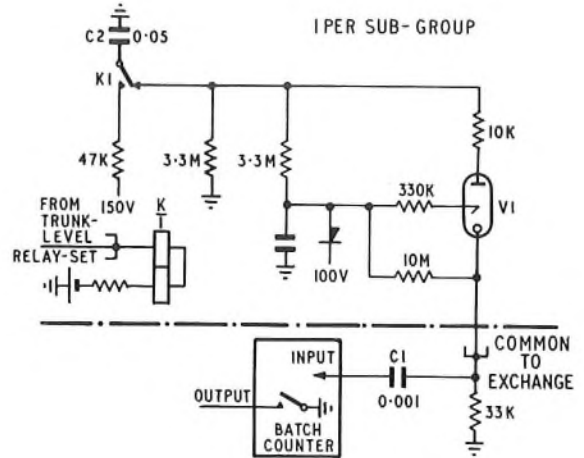

FIG. 3—COUNTING CIRCUIT

with a relay K (Fig. 3) and the origination of a call at a trunk-level relay-set is indicated by an earth pulse of approximately 30 ms duration, connected via the individual relay, which operates relay K. It is improbable that two or more calls will originate simultaneously, i.e. within approximately 30 ms, in any group of 20 circuits, but if that should happen only one call will be counted. It is more probable, however, that simultaneous calls will originate in two or more groups of 20 circuits and, to ensure that each of these calls is counted, a pulse-separating device (Fig. 3) is used. Capacitor C2, charged when K1 operates, discharges when relay K releases, allowing thyatron V1 to conduct. A pulse output via capacitor C1 operates the counter, which is an Ericsson Dekatron-operated Batch Counter, type 102C, and which can be preset to any value of *n* up to 1,000. In the event of two or more K1 contacts releasing simultaneously, due to calls originating at the same time in two or more sub-groups, the first thyatron to conduct increases the potential of the common cathode circuit to a value which prevents another thyatron from striking.

When the first C2 capacitor has discharged, its corresponding thyatron is extinguished and a second thyatron is allowed to conduct. In practice, this circuit gives a pulse separation of 2 to 3 ms, which is greater than the minimum time required for the operation of the batch counter.

Each time *n* calls have been counted a 50 ms earth pulse from the counter operates relay NA (Fig. 4), which in turn operates relay NB. Contact NB2 operates relay NC and NB4 prepares a circuit for the operation of relay SX. Relay NC has 10 contacts, each of which is connected in the circuit of a relay K, to give overall control to the 200 circuits in the group. When the *n*th call is connected, the high-resistance coil of relay K will be short-circuited by an NC contact, and relays A and K operate in series with each other. Contact A1 operates relay



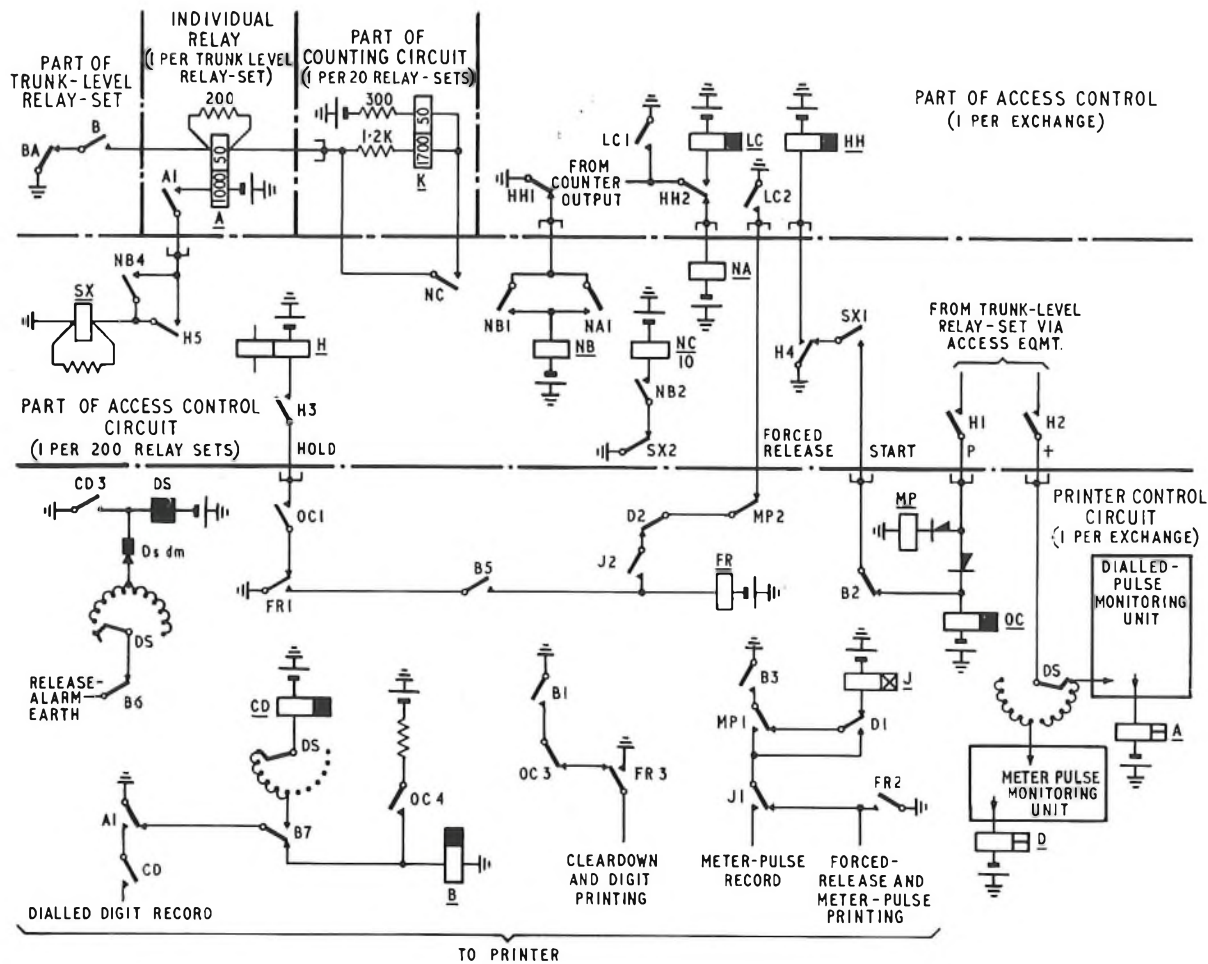

FIG. 4—ACCESS AND PRINTER CONTROL CIRCUITS

SX, and contact SX1 connects an earth start condition to the printer control circuit to prepare it for use. With relay OC operated, earth is returned via contact H3 to hold relay H, with contacts H1 and H2 connecting the trunk-level relay-set to the printer control circuit. Relay NC is released at contact SX2 and the analysis equipment is held under the control of the earth connected to the P-wire of the trunk-level relay-set.

#### Printer Control

Relay OC (Fig. 4) is operated by the start earth connected at SX1 in the access equipment. Relay A of the printer control circuit is operated, via the line-signal monitoring unit,<sup>3</sup> when the positive line is connected. This unit normally requires a connexion to the negative line when monitoring selector circuits, to provide a guard against spurious pulses being generated when the contacts of relays HA or HB operate in the signalling circuit. The signalling circuit of a trunk-level relay-set terminates on a transformer-type bridge and, because these spurious pulses cannot be generated, the connexion to the negative line is not required. The operation of contact A1 allows relay B to operate. Pulses dialled by the subscriber are repeated by relay A to the digits-dialled storage mechanism of the printing recorder and to relay CD, which operates on the first break pulse of each train and releases after each digit is dialled. Contact CD3 steps the Type-4 uniselector (DS),<sup>4</sup> which thus counts each pulse train.

The called-subscriber-answer condition is taken to be the first meter pulse, which may be the connexion of positive battery to the P-wire for a locally originated call, or a change of potential of the positive wire from positive to negative for a call originated via a metering-over-junction circuit. In the first case relay MP operates but in the second case relay D operates. Either of these relays connects an earth pulse to the meter-pulse storage mechanism of the printing recorder during the release lag of relay J. After the release of contact J1, the meter-pulse printing magnet is operated to print the metering character. Subsequent meter pulses are similarly recorded.

When the calling subscriber clears, earth is disconnected from the P-wire and relay OC releases. Contact OC1 releases relay H to clear down the access equipment, and contact OC3 operates the digits-dialled printing magnet. The digits-dialled type-sector of the printing recorder is in the home position, so that it records a "dash," used as the clear-down signal.

It may be that a call being monitored is still connected to the printer control circuit when the access equipment signals the counting of the next ( $n-1$ )th call. In these circumstances the printing recorder and access circuits are released and a character is printed to indicate that the data for that call is incomplete. This character is a letter F printed on the meter-pulse track of the tape from the home position of the meter-pulse type-sector. Relays H and HH are already operated when the counter signals the next ( $n-1$ )th call, and relay LC operates; contact

LC2 operates relay FR. If a metering character is at that time being printed, the operation of relay FR is delayed until relay J re-operates after metering has been completed. Contact FR1 releases the access equipment and contact FR2 operates the meter-pulse printing magnet to print the forced-release character. After all equipment has been restored, the next trunk call which originates is connected to the printer control circuit.

#### CONCLUSION

A prototype equipment has been installed for trial at Bristol and, as a result of its use, changes may result in the type of information recorded by a standard equipment which will be developed at a later date. Additional information which is already known to be desirable includes:

(a) The class of service of the originating circuit, e.g. coin-box or ordinary circuit.

(b) The originating charging group where trunk-

dialling equipment serves more than one charging group.

(c) The tariff rate appropriate to each call.

(d) The time of seizure of the trunk-level relay-set in addition to the time of receipt of the first digit.

#### ACKNOWLEDGEMENTS

The author wishes to acknowledge assistance given during the development of this equipment by the Automatic Telephone and Electric Company, Ltd., who manufactured the prototype, and by the Instrument Division of Ericsson Telephones, Ltd., who advised on and supplied the batch counter.

#### References

<sup>1</sup> GREEN, B. A., and BLAKEY, H. A Printing Recorder for Use with Observation Equipment. (In this issue of the *P.O.E.E.J.*)

<sup>2</sup> HEPTINSTALL, D. L., and RYAN, W. A. Metering over Junctions. *P.O.E.E.J.*, Vol. 51, p. 335, Jan. 1959.

<sup>3</sup> PRICE, C. K. A Line-Signal Monitoring Unit Using Transistors. (In this issue of the *P.O.E.E.J.*)

<sup>4</sup> MANNING, D. J. The Post Office Type 4 Uniselectors. *P.O.E.E.J.*, Vol. 52, p. 215, Oct. 1959.

## Book Reviews

"Electronics." Second Edition. A. T. Starr, M.A., Ph.D., M.I.E.E. Sir Isaac Pitman & Sons, Ltd. viii + 429 pp. 390 ill. 35s.

The first edition of this book was reviewed in the October 1954 issue of the *P.O.E.E. Journal* and the comments therein, by the previous reviewer, are equally applicable to the second edition now issued. The latter differs from its predecessor only by the addition of a little new material about semi-conductors and high-frequency valves, and of some more recent examination questions. In all, the additions amount to an extra 34 pages.

The book was expressly written to meet the requirements of students taking the subject of Electronics at London University and is remarkable for the very large amount of detailed information which has been included, ranging from the elements of wave mechanics to practical matters like winding data for delay lines. The explanations which accompany this array of information are brief, but to the point, and only occasionally do they appear inadequate. The general effect is to make it read more like a handbook than a textbook.

The material is divided into six chapters and seven appendices. The first chapter, entitled "Physical Fundamentals", attempts to describe the operation of modern electronic devices in a background of present-day theories of the atom; both intention and attempt are well made but the compression ratio proves just too high and it is to be feared that only students with the highest octane rating will make much out of it. Subsequent chapters deal with more-engineering topics and the treatment becomes easier to follow. The choice of subject matter has largely been prescribed for the author by the syllabus of the subject to which it is devoted and, therefore, cannot be criticized except in relation to this; if the many examination questions which are included are anything to judge by then the choice is satisfactory.

H.J.O.

"Radio Stations—Installation, Design and Practice." G. A. Chappel, A.M.(S.A.)I.E.E., A.M.Brit.I.R.E., A.M.Inst.E. Pergamon Press, Ltd. vii + 248 pp. 188 ill. 50s.

In his preface the author states that he has confined his

attention to the design of small radio stations, which are, as he remarks, in the majority throughout the world. Even so the problems are so extensive and widespread that to cover them adequately within a 250-page volume is well-nigh impossible. However, the book appears to be aimed at the technician with some manufacturing, or purely experimental, experience who finds himself faced with the wide problems involved in the construction of a station and in the setting up of operational and maintenance procedures. Thus it has been possible to omit any consideration of equipment design and circuit performance and to concentrate upon the multifarious ancillary matters.

One half of the book is devoted to external plant, and a quite detailed treatment is given to masts, transmission lines and aerials. A fair amount of design information is given, with some references on transmission lines and cables, but, to assist the engineer in construction, some discussion of measurements and adjustments would have been valuable. The chapter on masts and towers is confined to a description of typical structures, structural design being regarded as a specialist matter, but there is a wealth of practical detail that would assist the inexperienced in rigging aerials.

The remainder of the book is divided between accommodation, services, operation and maintenance. Some of the sections seem a little laboured; for instance on page 156, six practically identical drawings show how to run a power cable from wall switch to equipment. Yet the practical details will be invaluable to the inexperienced. A fuller discussion of testing and inspection of power equipment would have rounded off this section of the book. The chapter devoted to message handling seems rather out of scale with the rest of the work, for multiway conveyors, closed-circuit television, and facsimile are described. Two appendices deal with maintenance control and fault finding, and these are obviously, and probably wisely, aimed at relatively unskilled staff.

Despite its shortcomings, which are due to compression and the desire to produce an attractive and readable book rather than a handbook, it fills a gap in existing literature. The book is well produced and is written in simple English, which should encourage its use in under-developed countries. The problems are stated, and if the information for their solution is sometimes lacking, this is at least half-way to a solution. The inexperienced will find that it will supply a considerable amount of valuable background information.

S. G. Y.

## Notes and Comments

### Birthday Honours

The Board of Editors offers congratulations to the following engineers honoured by Her Majesty the Queen in the Birthday Honours List:

Bournemouth .. ..	F. R. Pettyfer .. ..	Technical Officer ..	British Empire Medal
Galashiels .. ..	M. Perkins .. ..	Technical Officer ..	British Empire Medal
Gloucester .. ..	W. E. Knowles .. ..	Technician, Class IIA	British Empire Medal
London Telecommunications Region	J. H. A. Pugh .. ..	Assistant Engineer ..	Member of the Most Excellent Order of the British Empire
Research Station .. ..	F. J. D. Taylor, M.B.E...	Staff Engineer ..	Officer of the Most Excellent Order of the British Empire
West Telephone Area, London Telecommunications Region	S. J. Pusey .. ..	Technician, Class I ..	British Empire Medal

### Special Commendation

The Board notes with pleasure that the Postmaster-General has personally commended Mr. J. A. Nichols, Technician Class I, South Western Region, to whom the Society for the Protection of Life from Fire has awarded its framed certificate for his prompt and gallant action in saving a woman's life when her clothes caught fire on 11 June 1959.

### Payment for the Journal by Deductions from Pay

Commencing with the October issue of the Journal, all Post Office readers may arrange to pay for the Journal by deductions from their salaries or wages. This arrangement will not affect members of the main section of the Institution of Post Office Electrical Engineers, whose membership subscription will continue to include the cost of the Journal. Associate Section members will be asked to complete two authorities for deduction from pay, one for their membership subscription and one for the Journal (see page 132 for further details). Journal local agents will have forms available for completion by Post Office readers who are not members of the Institution.

Deductions from pay will be made at the rate of 10d. per month for monthly-paid staff, and at 3d. per week for 40 weeks each year for weekly-paid staff.

### Model Answer Books

Books of model answers are available for some of the City and Guilds of London Institute examinations in telecommunications subjects, and details of these books are given on the last page of each issue of the Supplement to the Journal.

Two of the books (Telephone Exchange Systems I and Telegraphy II) were prepared for subjects of the old Telecommunications Engineering Course but students

will find them of considerable value when studying for the Telecommunication Technicians' Course. However, because these two books no longer apply to any one year of the new syllabus, they have been reduced in price from 5s. to 2s. (2s. 6d. post paid).

### 12-Year Index

All readers who placed advance orders for the index to Volumes 39-50 (1946-1958) should by now have received their indexes. Copies are still available at 2s. each (2s. 6d. post paid). Orders should be sent to the Managing Editor.

### Notes for Authors

Authors are reminded that some notes are available to help them prepare the manuscripts of their Journal articles in a way that will assist in securing uniformity of presentation, simplify the work of the Journal's printer and draughtsmen, and help ensure that authors' wishes are easily interpreted. Any author preparing an article for the Journal who is not already in possession of the notes is asked to write to the Managing Editor to obtain a copy.

It is emphasized that all contributions to the Journal, including those for Regional and Associate Section Notes, must be typed, with double spacing between lines, on one side only of each sheet of paper.

---

### Book Review

"Functions of a Complex Variable." James Pierpoint, LL.D. Dover Publications, Inc., N.Y., and Constable & Co., London. xiv + 583 pp. 132 ill. 20s.

This book was developed from a series of lectures given to students at Yale University by Prof. Pierpoint. It has long been known as one of the best of its kind in the world. This new paperbound Dover edition is an unabridged and unaltered republication of the first edition.

Students will find in this volume a rigorous and detailed

exposition of the fundamental concepts and theorems pertaining to the functions of a complex variable. Of particular value is Prof. Pierpoint's discussion of the theory of linear differential equations, especially in relation to the functions of Legendre, Laplace, Bessel, and Lamé. There are three chapters devoted to elliptic functions. All the chapters contain carefully selected problems worked out to illustrate the various topics.

Engineers and others interested in the applications of twentieth-century calculus will find this book interesting and valuable.

H. J. J.

# Institution of Post Office Electrical Engineers

## Associate Section

### *Subscriptions and Payment for The Post Office Electrical Engineers' Journal*

Commencing with the October 1960 issue of *The Post Office Electrical Engineers' Journal*, arrangements have been made for any Post Office reader, except members of the main section of the I.P.O.E.E., to purchase the Journal by deductions from salaries or wages.

The new scheme will thus apply to Associate Section members who purchase the Journal by deduction from pay as part of their I.P.O.E.E. subscription. Associate Section Centres should note that members will now be required to complete two forms of consent for deduction from pay, one for purchase of the Journal and the other for I.P.O.E.E. Associate Section subscription. Centres that have adopted the national scheme for deduction of Associate Section subscriptions from pay should also note that the Institution has adopted a standard Associate Section subscription rate of 1d. per week or 5d. per month in an effort to ensure that the new arrangements work satisfactorily.

Except for separate deductions from salaries or wages for the Journal and for I.P.O.E.E. subscriptions, it is not desired to disturb any arrangements particular Associate Section Centres may have for local deductions from pay, but such Centres may adopt the national scheme at the standard subscription deduction rate if they so wish.

The new scheme will commence in October 1960. Arrangements are being made for the new forms of consent to be sent to Associate Section members.

Associate Section members will be aware that the cost of the Journal was increased from 2s. to 2s. 6d. per copy commencing with the April 1960 issue. The new arrangements for purchasing the Journal by deductions from pay will take account of the new cost of the Journal. Separate arrangements are being made to recover the increased cost of those copies of the April and July 1960 issues of the Journal that have been supplied at 2s. per copy.

The above arrangements do not apply to members of the main section of the Institution. The supply of the Journal to such members is covered by their I.P.O.E.E. subscription, in accordance with the rules of the Institution.

## Results of Essay Competition, 1959-1960

A prize of £6 6s. and an Institution Certificate have been awarded to the following competitor in respect of the essay named:

W. F. Garrett, Technical Officer, Engineering Department (Telephone Exchange Standards and Maintenance Branch). "Copper Oxide and Selenium Rectifiers."

Prizes of £3 3s. each and Institution Certificates have been awarded to the following four competitors:

H. Bettridge, Technical Officer, Engineering Department (Test and Inspection Branch). "Roto-Finish—A Modern Engineering Finishing Process."

T. Clark, Technical Officer, Grimsby. "Atoms and Magnets."

J. G. Philip, Technical Officer, Aberdeen. "Step No. 3 and Works Study."

L. W. Burkitt, Technical Officer, Lincoln. "A Decade of Interference Investigation Duties."

Institution Certificates of Merit have been awarded to:

J. G. Mullett, Technical Officer, Southend. "Work Study and Exchange Construction."

A. W. Brighton, Technical Officer, Newport-on-Tay. "Fault Statistics—Their Aid to Efficiency and Productivity."

N. F. Wright, Technician IIA, Birmingham. "The Post Office 4,000-Type Selector and a Comparison with its Forerunners."

D. W. Everett, Technical Officer, Southend. "A Brief Synopsis of Exchange Maintenance and Faulting Problems."

R. L. Wood, Technical Officer, Reading. "The P.O. Carrier Type Public Address System."

The Council of the Institution is indebted to Mr. J. Stratton, Chairman of the Judging Panel, for the following review of the five prize-winning essays.

The first prize was awarded to Mr. W. F. Garrett, Technical Officer, Engineering Department, for his essay on "Copper Oxide and Selenium Rectifiers." The author introduces the subject with a brief history of the growth of contact rectification. He goes on to give a description of the manufacture of copper and selenium rectifiers, and gives some details of the construction of both forms of rectifier. He states that many involved theoretical explanations for the mode of action of contact rectifiers have been put forward but he goes on to give an electronic explanation of the phenomenon in a simple manner. The essay concludes with some examples of the use of copper and selenium rectifiers in the Post Office and forecasts possible future uses, mentioning the possible competition from other types of rectifiers, such as silicon and germanium rectifiers. The author could have improved an otherwise excellent essay by including some graphs.

The second prize was awarded to Mr. H. Bettridge, Technical Officer, Engineering Department, for his essay entitled "Roto-Finish—A Modern Engineering Finishing Process." As the title indicates, this essay describes a process used in some contractors' factories for the finishing of a number of Post Office equipment parts. The author explains that the process makes use of a rubber-lined octagonal barrel, which is loaded with equipment parts together with abrasive chips and compound and then rotated. He states the factors which affect the final finish, such as speed of rotation, duration of operation, ratio of chips to parts, type and size of chips, etc. He describes the various types of chips and compounds and their uses. The essay concludes with a description of some of the more recent developments.

The third prize was awarded to Mr. T. Clark, Technical Officer, Grimsby, for his essay on "Atoms and Magnets." He introduces his essay with a definition of three categories in which materials fall: namely, paramagnetic, diamagnetic and ferromagnetic. He goes on briefly to describe the different behaviour of these three categories as being due to atomic structure, but deals more fully with ferromagnetic materials, spontaneous magnetism and domains and the behaviour of materials in varying magnetic fields. The author concludes with a short description of the ferromagnetic group of the ferromagnetic category—these are usually known as ferrites.

The fourth prize was awarded to Mr. J. G. Philip, Technical Officer, Aberdeen, who submitted an essay entitled "Step No. 3 and Works Study." He begins his essay with the explanation that Step 3 is one of the steps referred to in a pamphlet published in 1959 dealing with efficiency within the Post Office organization. Step 3 actually dealt with efficiency and friendliness, and it is the efficiency part that the author concentrates on. He then turns to a definition of works study, saying that it is nothing more or less than common sense applied to the organization of work. He follows this with a brief account of the use to which works study is put in British industry and in other countries, and then suggests where the application of works study would be appropriate in the telephone service. He finishes with a section dealing with a matter not strictly works study; the problem of telephone engineers keeping abreast with the rapid developments that are taking place at the present time.

The fifth prize was awarded to Mr. L. W. Burkitt, Technical Officer, Lincoln, for an essay entitled "A Decade of Interference Investigation Duties." In this the author

describes the changes that have taken place in the causes and cures of interference within his experience during the last ten years. He says that the work of any one investigating officer could never be identical with the work of any other, but the broad outline should be similar, and the survey is a very interesting one.

The Council of the Institution records its appreciation to Messrs. J. Stratton, G. Spears and A. J. Leckenby, who kindly undertook to adjudicate upon the essays entered for the competition.

*N.B.—Particulars of the next competition, entry for which closes on the 31st December 1960, will be published later.*

#### Institution Field Medal Awards, 1958–59 Session

In addition to the Institution Senior and Junior silver and bronze medals, up to three bronze medals, the Field Medals, are awarded annually for the best papers read at meetings of the Institution on field subjects primarily of Regional interest.

Field Medals were awarded to the following authors for papers read during the 1958–59 session:

J. F. Chapman and T. H. Whitaker, Leeds (North Eastern Region). "Some Aspects of Exchange Maintenance."

R. A. Kibby and T. E. Day, Swansea (Wales and Border Counties). "The Use and Maintenance of Mechanical Aids."

F. W. Allan, Middlesbrough (North Eastern Region). "The New Automatic Telephone Exchange, Middlesbrough."

The Council of the Institution is indebted to Mr. J. J. Edwards, Chairman of the Paper Selection Committee of Council, for the following précis of the medal-winning papers.

#### *Some Aspects of Exchange Maintenance*

This paper reviews the methods used for exchange maintenance and the results achieved following a systematic inspection of every exchange of 2,000 lines or over, maintenance control, automanual exchange, and 2 v.f. signalling centre in the North Eastern Region. Comments are given on four aids to the supervision of exchange maintenance, i.e. (a) service observation, (b) fault reports, (c) regular inspection by supervising officers, and (d) the latest addition—the artificial traffic equipment. The authors reproduce a list of common defects that were found during the inspection and comment on the reasons for these defects. The delay in the provision of testers for the new types of equipment that are being installed is highlighted; this delay results in local staff designing and constructing their own testers and eventually interchanging ideas with other regions. Interesting details are given of tests conducted on routes from Bristol to four centres in the North Eastern Region prior to the opening of S.T.D., revealing a very high fault incidence, which resulted in special overhauls being necessary to reduce faults to a more reasonable level. The methods of staffing exchanges, the training of staff and the organization of testing with the object of giving good service to the customer are discussed.

#### *The Use and Maintenance of Mechanical Aids*

This paper is a comprehensive review of the mechanical aids used in the Post Office for engineering work. It explains, with some constructive criticisms, the procedures whereby Telephone Areas obtain their mechanical aids and then goes on to give helpful suggestions on the ways to use the aids, methods of control and the responsibilities of management for ensuring that maximum effective utilization is achieved. The latter point is emphasized by an analysis of costs with examples to illustrate that usage is a dominating factor in economically justifying expenditure on mechanical aids. Training of staff and maintenance is next discussed and a scheme for improved maintenance is described. Then follows an interesting account of the authors' experiences with a number of the more important aids. Finally there is

a section on materials handling and the effects of modern methods upon the design of stores accommodation.

#### *The New Automatic Telephone Exchange, Middlesbrough*

The paper surveys the major activities involved in the provision of a new telecommunications installation for Middlesbrough, which functions as the principal telephone switching centre on Tees-side. Starting with a description of the problems involved in site selection and building, the paper deals, in rather more detail, with the local and tandem automatic switching units, and with the associated cordless-type automanual board. The integration of the new centre with the existing line plant network presented special problems due to unusual features of the site and the rather large distance between the old and the new exchanges. The paper explains how these problems were overcome and, in addition, gives an indication of the quantities and types of other equipment housed in the building; in particular, the transmission equipment and the power and ventilating plant.

S. Welch,  
*General Secretary.*

#### Additions to the Library

Library requisition forms are available from Honorary Local Secretaries, from Associate Section Centre Secretaries and representatives, and from the Librarian, I.P.O.E.E., G.P.O., 2–12 Gresham Street, London, E.C.2.

2579 *Electrical Engineering for Ordinary National Certificate*,  
2580 *Vol. I and II*. G. N. Patchett (Brit. 1959).

The main purpose of this series is to supply a set of notes to supplement knowledge already acquired. Vol. I deals with the flow of electricity in electrical circuits, from simple consideration of Kirchhoff's Laws and transients. Vol. II deals with magnetism and electrostatics, from simple ideas of permanent magnets to composite magnetic circuits, and with the energy stored in magnetic and electric fields.

2581 *Sandwich Courses*. P. F. R. Venables (Brit. 1959).

A review of the working of the scheme for training technologists and technicians.

2582 *Servicing Transistor Receivers*. F. R. Pettitt (Brit. 1959).

A brief handbook indicating the new servicing techniques required.

2583 *Diesel Engine Manual*. Ed. E. Molloy (Brit. 1959).

For those concerned with installation, operation and maintenance of all types of diesel engine.

2584 *Introduction to Electronic Analog Computers*. J. N. Warfield (Amer. 1959).

Emphasizes topics, concepts, and a philosophy desirable for those who may engage in engineering research and design as related to analog computers. The electronic and mechanical design of the devices is not stressed.

2585 *Statistics*. A. R. Ilersic (Brit. 1959).

Covers the syllabuses of various professional bodies that set a paper in elementary statistical methods. Designed for the professional and business man as well as for the student.

2586 *Organization and Methods*. Ed. G. E. Milward (Brit. 1959).

Compiled by the staff of nine large companies comprising the Organization and Methods Training Council in co-operation with a business man turned Civil Servant, after some years practice of organization and methods by those companies.

2587 *Electronic Computers*. E. H. W. Hersee (Brit. 1959).

Presents the basic working principles of digital and analogue machines.

2588 *Science as History*. H. Gartman (German 1960).

The story of man's technological progress from steam engine to satellite.

W. D. FLORENCE,  
*Librarian.*

# Regional Notes

## London Telecommunications Region OUTSIDE-BROADCAST ARRANGEMENTS FOR THE ROYAL WEDDING, 6 MAY 1960

When the engagement of H.R.H. Princess Margaret was announced it was natural to assume that the wedding, or the procession to and from the ceremony, would be televised and broadcast. However, in the event, the requirements for the B.B.C. television and sound services, and the commercial television service, were considerably greater than anticipated.

The processional route from Buckingham Palace to Westminster Abbey is only one mile in length yet there were 27 broadcasting sites set up for the three broadcasting services, and just over 350 circuits were provided to cater for the two national television networks, for Eurovision, and for the domestic and overseas radio broadcasts. Although the total number of circuits provided did not reach the large quantity set up for the Coronation in 1953, the vision circuits required were considerably more. This was due to the demand for main and reserve vision circuits from the B.B.C. television sites and the demands of commercial television program contractors, who were not in operation in 1953. Fig. 1 shows the broadcasting sites along the route.

The exceptionally large demand for vision circuits made it necessary for all the Post Office outside-broadcast equipment rented by the B.B.C. to be brought to London from Manchester, Birmingham and Cardiff, and other Regional outside-broadcast teams were called in to assist the London Telecommunications Region in the work. It was also necessary for Associated Rediffusion, Ltd., who are the London program contractors (Monday-Friday) to borrow repeaters from other program contractors. Twenty-nine vision circuits were set up and 40 video repeaters were used.

The plans for the broadcasting arrangements of the wedding were delayed, first, by the visit of General De

Gaulle in early April, which had required 13 outside broadcasts during the 3-day visit and, later, while the broadcasting authorities obtained formal permission and decided the various sites. Some of the Post Office work had to be carried out in anticipation, and such sites as Westminster Abbey and outside Buckingham Palace were fairly obvious as essential to the requirements.

A large proportion of the route is skirted by Green Park and St. James's Park where cable plant in any quantity is not readily available. Fortunately, the Telephone Manager's staff of the Centre Area, L.T.R., are familiar with royal processions and the many and varied requirements such as broadcasting services, police control, Ministry of Works public-address systems, etc., and they were quick to offer suggestions and find solutions to the problems.

At Canada Gate, Green Park, which is a usual broadcasting point covering Buckingham Palace and the Victoria Memorial, a junction cable between Mayfair exchange and a distribution point in one of the government buildings in Parliament Street was opened and a number of spare cable pairs were extended to a small distribution frame fitted in the B.B.C. sound-control hut erected in Green Park. This gave two directions of routing for the large number of circuits required.

Some difficulty was expected in providing cable pairs to Westminster Abbey but here again the Centre Area staff

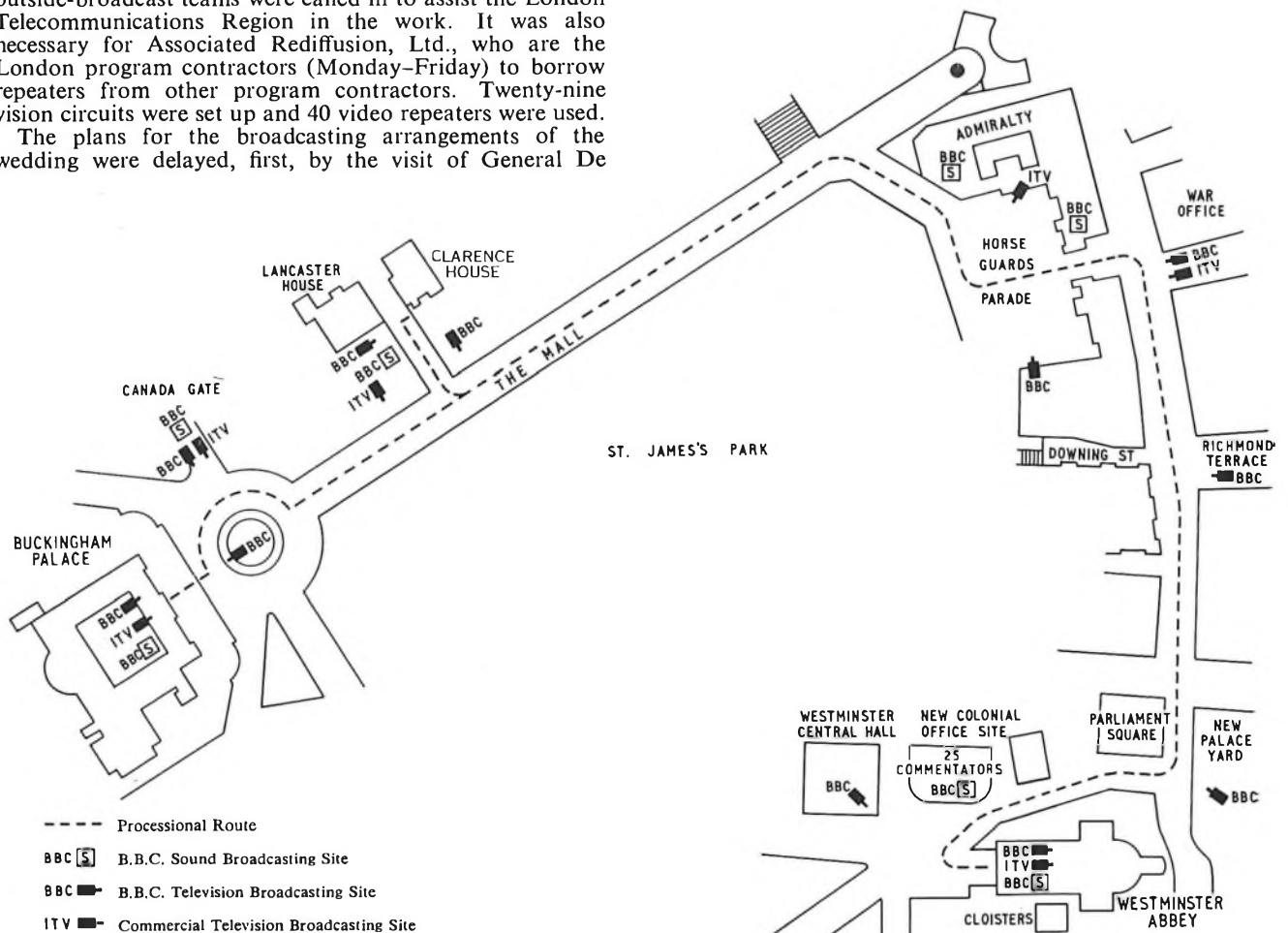
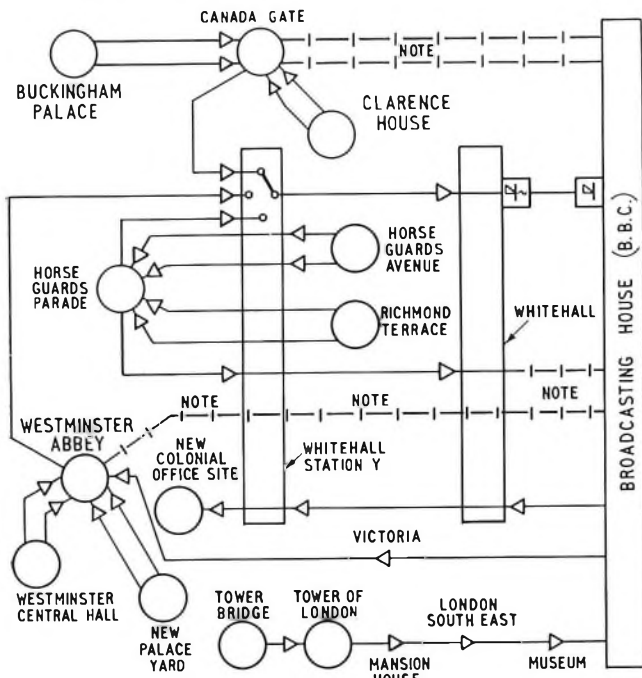

FIG. 1—PROCESSIONAL ROUTE FOR H.R.H. PRINCESS MARGARET'S WEDDING



Note: These circuits are over low-loss balanced pairs rented by the B.B.C.

FIG. 2—VISION CIRCUITS FOR B.B.C.

found a solution by opening a cable at the rear of the Abbey and extending the circuits up to and along the triforium level of the Abbey to the huts which had been specially erected in the cloisters to house the line and camera equipment.

Fig. 2 and 3 show the network of vision circuits provided, and it will be seen that the network of low-loss balanced-pair cables rented by the B.B.C. played an important part in making it possible to extend the links to Broadcasting House. The commercial television program contractors do not rent any network of special cables and, to avoid four vision circuits being routed simultaneously in one fairly small cable with a risk of crosstalk between them, two of the links were provided by radio from a building near Whitehall exchange.

Two circuits, to carry the nationally broadcast television program, were provided from Broadcasting House for the B.B.C., one to a position known as the new Colonial Office site opposite the West door of Westminster Abbey and the other to Westminster Abbey. The first circuit was used to feed television monitors used by 25 commentators, mostly of foreign broadcasting organizations, situated in a stand which had been specially erected. These commentators

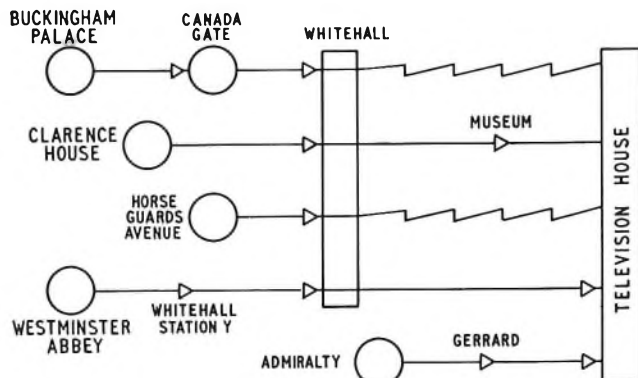

FIG. 3—VISION CIRCUITS FOR COMMERCIAL TELEVISION

were thus able to give commentaries of the whole of the procession and ceremony. The second circuit was used to feed television monitors inside Westminster Abbey for the guests who were unable to get a direct view of the ceremony.

In addition to the large number of circuits provided to link the various outside-broadcasting sites to the broadcasting authorities' premises, 367 microphone leads were installed at sites along the route and in Westminster Abbey. For those provided in the Abbey, three miles of cable were used to suspend the microphones along the centre aisle from the triforium level.

Skyport telephone exchange, although many miles from the processional route and Westminster Abbey, played an important part in the wedding broadcast communications. A vision circuit, to give 525-line definition and requiring a frequency band-width of 5 Mc/s, was set up with three video repeaters between the B.B.C. television centre at White City and Skyport exchange using a spare coaxial cable. The B.B.C. made video tape recordings of the whole vision broadcast, and these recordings were immediately placed on planes and flown to the U.S.A. and Canada for the various broadcasting companies in those countries.

To get the sound signal to the recording units, 12 high-grade sound circuits were provided from Broadcasting House to Skyport exchange. Alternative routing was required as a safeguard against breakdown, and some circuits were routed via Slough repeater station while others took more direct routes.

Two high-grade sound circuits were also set up for film companies to record the sound and effects. These circuits, one to Denham, Buckinghamshire, and the other to Wardour Street, were routed from Broadcasting House.

The success of the Post Office work for the broadcasting arrangements was due to the excellent co-operation given by the Main Lines Development and Maintenance Branch of the Engineering Department, the Birmingham, Manchester and Cardiff outside-broadcast teams, the London Telecommunication Region, and the very excellent work performed at such short notice by the external and installation staffs of Centre Telephone Area.

B. H. M.

#### ORGANIZATION AND SUPERVISION TRAINING COURSES FOR LEADING DRAUGHTSMEN

For more than 10 years the London Telecommunications Region has held organization and supervision courses at the Regional engineering training school for newly-promoted Assistant Engineers and Inspectors, to assist them in appreciating the duties and responsibilities of junior managerial positions. These courses, of three weeks' duration, have proved their value and have been a suitable preliminary to the Engineering Department's central training school course at Stone in the same subject.

In 1959 a Regional course on similar lines, but of two weeks' duration, was devised for Leading Draughtsmen in Area, Regional and Power Section Drawing Offices to assist these first-line supervising officers in the functions of management. The courses were attended by all Leading Draughtsmen in the London Telecommunications Region and an equal number of Draughtsmen who act as Leading Draughtsmen on a substitution basis. The total number attending the courses was 44, with 11 on each course. The scheme was enthusiastically received, and it is considered that it will prove to have been well worth while as an introduction to the subject.

The subject matter covered a wide field, and the method of presentation included lectures, demonstrations, discussions, role-playing, films and visits to Area and Regional offices and workshops. Visiting speakers dealt with such subjects as finance, staff matters, welfare, productivity and recruitment.

E. M. G.-R.

## ARMoured POLYTHENE CABLE

The advantages of plastics for cable manufacture have resulted in the development of cables for power distribution entirely insulated and sheathed with p.v.c. For adequate protection and continuity of the earth connexion these cables are made up with a layer of galvanized armour wires between an inner and outer p.v.c. sheath. The wires, with a long lay, give a lower earth impedance than could be given by the steel-tape armouring commonly used with lead-sheathed power cables. Special glands enable a sound mechanical and electrical connexion to be made to the armour wires.

Experience with such a p.v.c.-insulated power cable prompted the remedy to a recent telephone problem. Two circuits were placed underground near to a new power station to avoid numerous e.h.t. circuits. Within a few weeks the circuits were faulty. One section in which a fault was located showed the impression of small teeth, which had cut right through to the bare wire; clearly the work of moles.

A  $\frac{1}{2}$ -mile length of standard 2 pr. 20 lb/mile polythene cable was given a layer of galvanized armour wires and covered by a p.v.c. sheath, in a similar manner to the power cables already referred to, giving an overall diameter of about  $\frac{1}{2}$  in. This cable was mole-drained without damage, and it is confidently expected that the previous trouble will not recur.

This armoured cable is smooth, clean to handle and easily bent. Bearing in mind the troubles frequently experienced in estate development schemes, such methods of protection seem worthy of consideration in preference to expanded mesh, which appears to offer poor protection against damage. Removal of armouring for jointing purposes can be done by cutting almost through the armour wires with a small saw, after which a few bends and a pull will withdraw a few inches of armour complete with the outer sheath. The joint is then made in the ordinary way.

Costs would appear to be near enough to those of the standard method to justify further experiment.

A. F. T.

## INSTALLATION OF TIME ASSIGNMENT SPEECH INTERPOLATION EQUIPMENT AT FARADAY BUILDING

Time Assignment Speech Interpolation (T.A.S.I.) equipment has been developed by the Bell Telephone Laboratories to increase the overall traffic-carrying capacity of long cables. The first installation was required at Faraday Building, London, and White Plains, New York, for use on the TAT No. 1 cable, and it was desirable to have it ready for service as quickly as possible after manufacture had been completed.

Preparatory work, including conversion of American cabling and wiring schedules to British standards, erection of overhead iron-work, power distribution and cabling, was completed by the London Telecommunications Region Power Section and the Long Distance Area construction group prior to the arrival of the equipment from America.

The sixteen 11 ft 6 in. racks, weighing together approximately 6 tons, were flown across the Atlantic and arrived on 30 December 1959. With the customs check completed, uncrating and erection of the racks commenced immediately. Wiring followed and most of the terminations, approximately 11,000 connexions, were dry-wrapped using electric wrapping tools supplied by the equipment manufacturer, the Western Electric Company. Special miniature p.v.c. coaxial cable of approximately 0.1 in. external diameter was used for those inter-rack connexions carrying high-frequency pulses. It was found that the plastic insulation moulded over the centre conductor of this cable was unaffected by heat, which simplified the soldering of these terminations.

The Post Office staff worked under the guidance of an installation supervisor from the equipment manufacturer and readily accustomed themselves to the new terminating

techniques. With a concentrated effort by all concerned, during which there was at one time almost one wireman to each equipment rack, the installation was completed by 8 February 1960 and handed over for testing well ahead of the scheduled date.

R. J. G.

## South-Western Region

### HISTORICAL FIND AT LOSTWITHIEL

On 3 November 1959, the Western Underground cable, laid in its own 2 in. cast-iron pipe between London and Penzance, and originally carrying transatlantic telegraph circuits but now carrying mainly carrier circuits, was reported faulty at Lostwithiel.

At Lostwithiel the cast-iron pipe carrying the cable was not allowed to be laid on, or be attached to, the ancient bridge crossing the River Fowey, but instead it was dug into the bed of the river, alongside the bridge on the upstream side. During operations to deepen the river on one side of the bridge, the pipe carrying the cable had been bulldozed up, had cracked into irregular lengths and pierced the cable within, allowing ingress of the river water.

On arriving at the river, the jointers had first to dig up the 4 ft 6 in. split couplings at the top of the banks on each side of the river, in order to open up the Western Underground cable joints and divert the circuits by means of an interruption cable. This interruption cable was drawn into a much later (1926) nest of three steel pipes, similarly laid on the river bed and joining up to a 2-way multiple duct in manholes at the top of either bank, as there is no connexion between the Western Underground cast-iron pipe laid in 1908 and the 1926 multiple-way duct track.

Alongside the joint on the Western Underground cable on the eastern bank of the river was a sealed heavy lead sleeve, 11 in. in length and just over  $1\frac{1}{2}$  in. in diameter. On opening one end of the sleeve a tightly-rolled official envelope, bearing the frank of the South-Western Superintending Engineer's District, was discovered, held in place longitudinally by a roll of joiner's wrapping paper upon which the joiner had pencilled his name and the date, "L. J. Dales, 14 Sept., 09."

The O.H.M.S. white envelope was addressed "Lostwithiel East Side, Fowey River" and on being opened a parchment 13 in.  $\times$  9 in. was exposed. This bore an indian-ink diagram showing the "up" side pair numbering and colour code of the six pairs of 100 lb/mile copper, the four pairs of 100 lb/mile screened copper, and the four single 200 lb/mile screened copper conductors. A legend in clear script also recorded this information, together with a footnote: "Note. Fowey River West Side similarly numbered." The parchment was signed by "J. C. Jones, 13 Sept., 1909." It is assumed that J. C. Jones was the engineer-in-charge of the cable laying. It is proposed to put the parchment, shown in the photograph, in the Post Office Headquarters Museum.

The main cable joint was in perfect condition when opened, and the 4 ft 6 in. coupling had apparently been undisturbed since it was laid in September 1909, over 50 years ago.

This Western Underground cable was among the first telegraph cables that were laid, which included the London-Birmingham No. 1, laid between 1897 and 1898, the Liverpool-Manchester, laid 1902-04, and the London-Chatham, laid 1905-06. These early cables made use of conductors of gauges up to 200 lb/mile, were frequently of composite construction (i.e. contained pairs or single wires of different gauge) and were provided for telegraphy rather than for telephony. In modern times many of these cables have been re-conditioned and are now very successfully meeting certain high-grade circuit requirements, such as carrier working.

One interesting item about the 4 ft 6 in. split coupling, housing the joint and coupling the 2 in. cast-iron land-pipe to the 3 in. under-river pipe, was a long indentation in the half coupling into which the joint neatly fitted so that the joint lay supported along the indentation with the cable



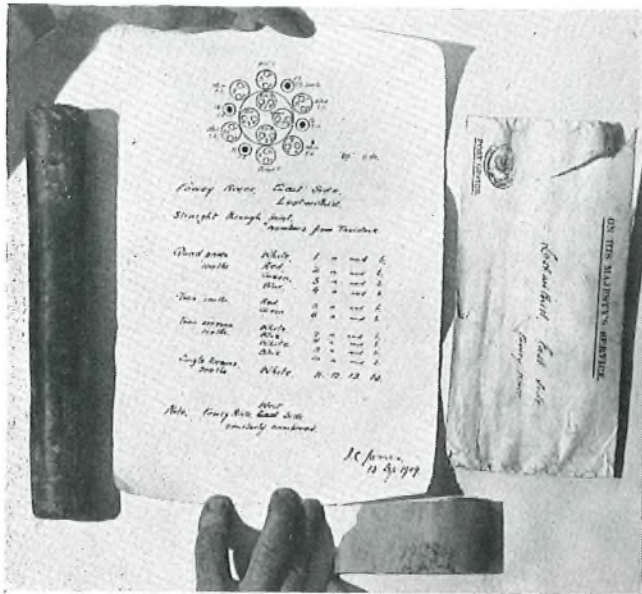

HISTORICAL DOCUMENT FROM CABLE JOINT AT LOSTWITHIEL

stubs supported by the plain ends of the coupling, this giving good mechanical support along the whole length of the cable. This principle of supporting joints and cable stubs is now being revived by lashing them to a suitably shaped flat iron bar supported between the cable bearers in manholes and boxes. It is thought that such longitudinal support will save many cracked joints in future.

S. T. S.

#### AN OOLITIC DUCT-BLOCKAGE

During cabling operations for a recent Bath, Somerset, local-development scheme, it proved impossible to rod a duct on the steep Wellsway which contained two cables. Upon exposing and opening the 3 3/8 in. earthenware duct a length of some 13 in. of solidified sediment was found, and although portions broke away on removal from the duct the remaining piece demonstrated how formidable was the blockage.

The whole of the surrounding locality is set on a limestone strata of varying hardness, ranging in commercial use, when quarried, from building blocks to abrasive powder. It seems likely that seepage water, after percolating through an area of the softer limestone, entered the Post Office track and, carrying grains of limestone, produced an oolitic deposit effectively blocking the duct bore. The last cable provided along the section concerned was drawn into the duct in 1946. Thus, in thirteen years 13 in. of limestone formed in the bore.

P. K. S. and E. G. R. H.

#### RECOVERY OF TELEPHONE POLES

The once familiar lines of telephone poles are rapidly disappearing and in the Bristol Telephone Area it is not often that fairly long stretches of route have to be recovered. The majority of the recovered poles stand in isolation or in small groups; this probably accounts for the fact that traditional methods of recovery are largely used. A "Hydra" crane is used wherever it is economical to do so. It is, however, a clumsy tool because the jib has no traverse; this often means positioning the vehicle across a road and disrupting traffic. A recent program involved the recovery of about 450 poles in a short period, and the following is a brief account of this operation.

Ninety-seven poles, which formed the biggest part of a 3-mile length of route carrying junction between Chippen-

ham and Malmesbury, were selected for recovery. Of these, 81 poles were on one side of the busy but narrow main road and were grouped in three sections, while the remainder were gallows poles spread out over the whole distance. The largest were two 55 ft stout poles; it was, therefore, necessary to have a crane which could raise these in one direct lift. A firm of crane-hire specialists at Bath suggested that this requirement could be met with a 5-ton lorry-mounted crane having a 30 ft jib. The hiring rate was 35s. an hour, which covered insurance risks of £5,000 for goods lifted and £500,000 for third party risks. A recovery rate of 10 poles per hour was anticipated.

All the normal operations necessary before a pole is recovered were carried out—arms and stays were removed and the struts unbolted. The poles were all 1907 vintage and it was assumed that only strutted poles were blocked. These, and their struts, were dug out to a depth of about 1 ft so that a portable mechanical saw could be used to cut them off below ground level if the crane failed to lift them.

A detailed plan was prepared to show the dumps for the recovered poles (which were to be sold on site under normal contract procedure), the positions of road caution signs at the various stages of the work, and the positions of the gang's vehicles which were used for transport to and from the site. Other arrangements included obtaining a load of soil for filling the empty holes, and the provision of additional stores lorries and mechanical saws. Finally, the staff were fully briefed so that each man knew the exact job that he had to perform throughout the day.

The estimate of 10 poles per hour proved to be very low as it was found possible to recover 80 poles in four hours. When working back over the route to recover the gallows poles the rate fell appreciably as the crane's jib had to be lowered when moving from pole to pole. In suitable circumstances a recovery rate (including the filling in of holes) of 20 poles per hour is possible, but this has to be lowered by 50 per cent when the route is crossed by trees, bridges, power wires, etc. The savings in time are considerable and easily offset the hire charges. Furthermore, inconvenience to the travelling public is avoided.

J. McC. and D. W. P.

#### Midland Region

##### BIRMINGHAM AUTOMATIC TELEX EXCHANGE

The opening, at mid-day on 5 March 1960, of Birmingham automatic telex exchange marked the successful completion of an operation which involved very close co-operation between traffic and engineering staff throughout the Region and in the Shrewsbury Area. The exchange is a zone centre and has an equipped capacity for 1,000 subscribers, including 100 each for the Peterborough, Shrewsbury and Stoke-on-Trent hypothetical exchanges. A total of 305 subscribers and 175 trunks and junctions were connected to the equipment at the opening date.

The new exchange is located in Telephone House, Birmingham, and is remote from the manual board at Birmingham Head Post Office. This manual board remains in use, to serve Coventry and Leicester subscribers, until the opening of area automatic telex exchanges in these cities later this year. The new exchange is also remote from the M.D.F. located in the basement of Telephone House, and this involved the provision of two 1,400-pair external tie cables between the M.D.F. and I.D.F. Because of this, the routing of circuits from the M.D.F. to the automatic equipment was somewhat unorthodox, as shown in the sketch, which also shows the main points within the City where the various lines were teed. The transfer was effected on the engineering control boards at the Head Post Office and at the new automatic telex exchange.

The engineering call-through test was completed on 23 January and the equipment was handed over for traffic testing on 24 January. Six teleprinters were provided in the apparatus room for the traffic staff and these were used

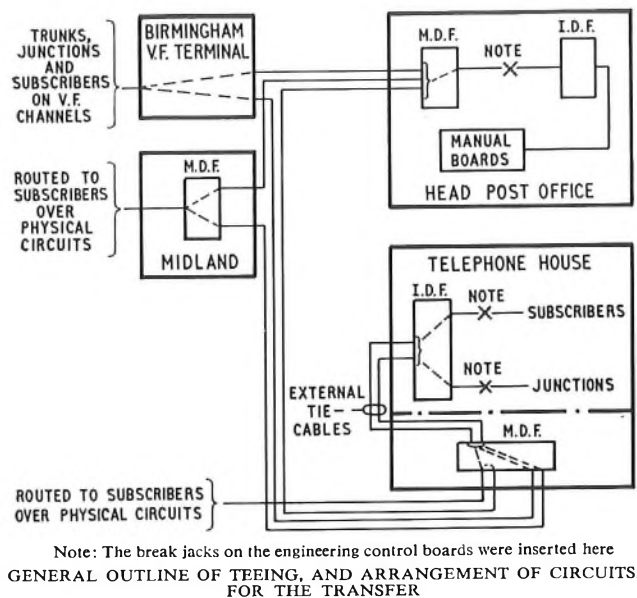

extensively during the pre-opening period for testing the exchange equipment, trunks, junctions and subscribers' lines. Two of these machines were equipped with automatic transmitters, and these were used for sending, immediately after the transfer, messages of welcome to all subscribers to the new service.

The conversion of subscribers' installations had started in July 1959 and, despite supply difficulties in the early stages, the work was completed in time for pre-transfer testing immediately after the call-through test. Two temporary subscribers' lines to Manchester automatic exchange were provided from the teleprinter workshop in Birmingham and were found to be invaluable in the testing of subscribers' equipment before installation.

Pre-transfer testing of the subscribers' installations in each area was carried out to an agreed program to avoid congestion on the test positions. The final slight modification of the new equipment for automatic working, and the insertion of relay-units in lines routed over v.f. channels, was carried out in conjunction with these visits; this obviated a further engineering visit to the subscribers at the time of transfer, but produced false signals on the manual board under certain conditions. It was agreed with the traffic staff that this could be tolerated for the short time involved before the transfer. Traffic pre-transfer testing by visiting telegraph service representatives followed, and test calls were made from each installation into the automatic exchange equipment.

At 6.0 p.m. on 4 March all traffic to Birmingham from existing automatic telex exchanges throughout the country was diverted via the manual board in London. This enabled the necessary conversion work on the Birmingham circuits to be carried out, and soon after midnight all junctions and trunks were connected to the new exchange. Traffic testing and meter reading commenced at 8.0 a.m. and was completed well before the actual transfer.

The inauguration of automatic telex service in the Midlands was made the occasion for civic ceremonies at Birmingham and Nottingham, where an area exchange was opened at the same time. On completion of the transfers, messages of greeting were exchanged, via the new exchanges, by the Lord Mayor of Birmingham, the Lord Mayor of Nottingham, the Deputy Lord Mayor of Stoke, and the Mayor of Peterborough.

Post-transfer testing was carried out by the test clerks and revealed an almost negligible number of faults. This showed the value of continuous routine testing of the exchange

equipment from the completion of the call-through test until the opening date. Major structural alterations in a room immediately adjacent to the apparatus room produced a large amount of dust, and it was feared that extensive dirty-contact troubles would arise. However, as the test results showed, this was not the case.

The combination of cream-painted racks, cream-plastic cabling and fluorescent lighting throughout gives the new apparatus room an extremely pleasing effect. A novel feature is the provision of trunking instead of conduit for the 240-volt lighting supply to the apparatus racks, with built-in fuses for each local-distribution circuit.

Because of a traffic overload on the manual board the connexion of new subscribers ceased in November 1959, and a waiting-list was established. The equipment for these new subscribers was installed prior to the transfer date and service given as soon as the automatic exchange was brought into use.

The automatic exchange equipment provides for the installation of subscribers' private meters but none of these has yet been fitted. Similarly, routing-translator equipment has been installed but will not be brought into use until later this year when Fleet exchange in London opens.

W. G. D.

#### EXPLOSION AT SELLY OAK REPEATER STATION

On the morning of 1 June, 1959, the leading technical officer at Selly Oak repeater station prepared to carry out routine tests on the standby diesel alternator set, which consists of a 168 h.p. six-cylinder Paxman diesel engine driving a 100 kVA, 400-volt, 3-phase alternator at 1,500 rev/min. The engine was started. As it reached full speed there was a violent explosion from the alternator, and pieces of metal were thrown across the engine room; the engine was immediately shut down. A workman in the room was struck on the leg by a piece of metal, fortunately without sustaining any injury; a further piece of metal was subsequently found in the leading technical officer's jacket pocket.

An examination of the alternator revealed that the fan at the engine end of the rotor had disintegrated, and parts of it had burst through the alternator end-bracket, forcing off the guards at the two sides, bending the guard at the bottom and punching a hole approximately 13 in.  $\times$  4 in. through the  $\frac{1}{2}$  in. thick cast-iron top. The outer windings at that end of both the stator and rotor were damaged, the insulation was cut through in several places, exposing the conductors, and the conductors were partially cut through in two places. As many parts of the fan, fan boss and end bracket as possible were collected and an attempt was made to fit them together.

The pattern of the fractures in the fan and the other evidence suggest that the sequence of the break-up was as follows:

(i) A centrifugal burst caused the outer part of the fan to break away from the central bell. The central bell at this stage broke up radially into a number of pieces and tore away from the boss. At the same time the outer portion broke up radially into three or four large segments.

(ii) The large segments struck the end-bracket and were shattered and, at the same time, forced off the guards and punched the hole in the top of the end-bracket.

Material from the fan was sent to the Test and Inspection Branch, Engineering Department, for metallurgical tests to be carried out. The reasons for the centrifugal burst are not known for certain but it is suggested that there had been aging of the broo-zinc casting, causing the formation of a large coarse-grained brittle structure and, although the fan was of ample strength when made, a point was reached when it was not able to withstand the normal centrifugal stresses. These stresses were probably increased by the addition of the balance weight and by the fan being skew on the shaft.

The fan has now been replaced by one of another aluminium alloy, the windings have been repaired, a new end-bracket has been fitted and the set has been returned to service.

R. F. D.

### NON-DIRECTOR AUTOMATIC EXCHANGE INSTALLED BY DIRECT LABOUR

"At 12.30 p.m. on 17 March 1960, the subscribers' lines connected to Dudley Hill exchange were converted to automatic working." This simple announcement was the outcome of an unusual undertaking by the Post Office Engineering Department, namely, the construction by direct labour of a public non-director exchange, using recovered apparatus obtained through the surplus equipment register.

The old manual exchange consisted of eight C.B. No. 10 (40-volt) positions with a 1,200-line multiple, and was due to be extended. As the exchange was accommodated in a converted dwelling house, the arrangement of apparatus rooms and the operators' and engineers' welfare and locker rooms had developed in a curious way. A scheme had been authorized to improve the welfare conditions at the same time as the floor of the switchroom was to be strengthened to carry additional positions.

Nevertheless, it seemed illogical to extend a manual exchange when the needs of S.T.D. demanded its conversion. Furthermore, Dudley Hill was not scheduled to become an automatic exchange until after S.T.D. is introduced at Bradford, although it was one of the remaining two manual exchanges in the Bradford linked-numbering scheme. Everything pointed to an early conversion on economic and operational grounds and, after careful consideration of all the known facts, engineering proposals for a non-contract conversion were submitted to Regional Headquarters for approval.

The reasons given for proposed conversion were:

(i) The all-in cost per annum, i.e. wages, overtime, welfare, superannuation, etc., for the supervisor, 10 telephonists, and four night telephonists was approximately £10,000, and, in addition, engineering maintenance costs were £350 per annum.

(ii) Engineering maintenance costs only, for an automatic exchange, were estimated as £400 per annum.

(iii) The existing building was of robust construction and adequate for the purpose. Additional building costs to meet automatic-exchange requirements would only be about £600 more than that required for an extension to the manual exchange.

(iv) External costs would be confined to the minimum required to bring the overhead line plant up to automatic-working standards. No major underground development would be needed at this stage, and the existing M.D.F. could be used.

(v) A simple trombone-type trunking scheme could be used, as shown in the sketch.

(vi) All the apparatus required for the construction of the automatic exchange was listed in the surplus equipment register.

(vii) Although shown at rate-book prices, most of the plant to be used had already rendered 18 years of service and the actual value must be very much less.

(viii) The subscribers' apparatus will not need to be replaced when the new exchange is provided in the years to come.

(ix) Subscribers with S.T.D. facilities will have access to Dudley Hill earlier, and Dudley Hill subscribers could have S.T.D. facilities at the same time as the Bradford exchange subscribers.

The Regional Director's approval was given accordingly, and with it considerable help and assistance from the

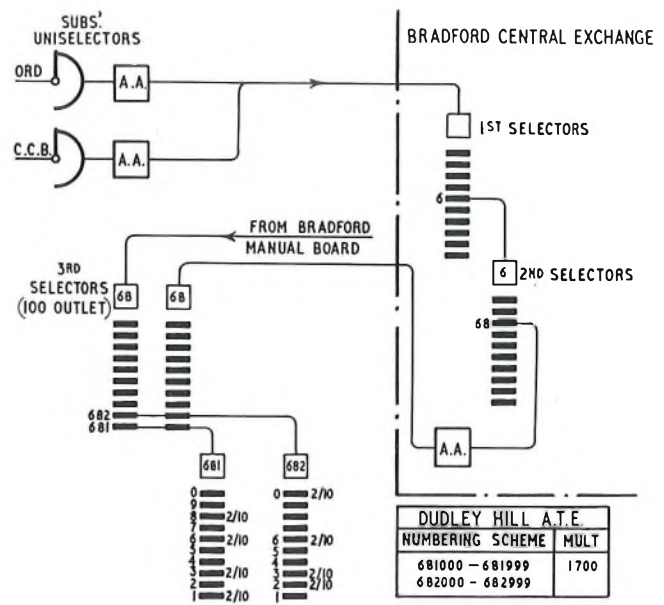

TRUNKING SCHEME OF DUDLEY HILL EXCHANGE

Engineering Branch. Equipment came from as far afield as Watford and Middlesbrough, and was transported to local exchanges where appropriate staff were available to overhaul it.

Many engineering difficulties were encountered during this project. Of these, perhaps the most difficult tasks were due to the turn-round having to be accomplished within existing cramped accommodation and with working equipment. Some of these problems of planning and execution are described below.

The old M.D.F., serving a manual-exchange multiple of 1,200 lines, consisted of 19 verticals each having 80 subscribers' protectors; these verticals had to be freed to accommodate the automatic multiple of 1,700 lines. This was done by adding two temporary verticals to each end of the frame and diverting the working lines to temporary protectors mounted on both the line and exchange sides of these temporary verticals. The freed verticals, modified to accommodate 100 protectors per vertical, were then equipped with new protectors.

Despite the smallness of the battery room, the power plant was successfully converted from a 40-volt charge-discharge system to a 50-volt parallel-battery automatic system (Power Plant No. 203). Use was made of five counter-e.m.f. cells to maintain the appropriate voltage to the manual exchange until the conversion took place. New cells were provided, but the remainder of the power plant had been recovered from other local exchanges.

The remainder of the work followed conventional lines, e.g. the conversion of the subscribers' apparatus, outstation arrangements, call-through testing, until 17 March 1960. On that date, the Lord Mayor of Bradford, himself a Dudley Hill subscriber, inaugurated the conversion to automatic working by changing over his own line.

The complete job of installing the 1,700-line multiple exchange and converting 1,160 subscribers' instruments took six months, whilst the total cost, including building alterations, power plant and fluorescent lighting, and installation and recovery of the old exchange, amounted to £33,800. On present trends, the automatic exchange should last until 1971, and the resultant savings on operating costs should repay this in a few years and show a profit to the Post Office of several thousands of pounds before it is finally replaced by a modern telephone exchange.

J. W. and E. H. W.

## Associate Section Notes

### Aberdeen Centre

Talks on the following subjects have been given at our meetings this session: "S.T.D.," "Visual Training Aids," "Optical Aids to Maintenance and Development," "The Wipe-Up Centre," "Major Works Control," "The Artificial Traffic Equipment," "West Indies Telephone Service," "Nuclear Fission" and "Electronic Switching." In addition we had a meeting entitled "Your Questions Answered" at which members of the Senior Section answered the questions of Associates on "Future Development" and "Control of the Repair of Storm Damage." Two films on transistors were also shown at this meeting.

To date we have tentatively arranged papers, to be read during the next session, on "Works Study" and "Hi-Fi."

J.G.P.

### Bangor Centre

The 1959-60 session commenced a little later than anticipated but, nevertheless, it has proved a successful one. The lecture program was as follows:

- 19 November: "Recent Developments in Automatic Telephony," by Mr. K. Gray, Area Engineer, Chester.
- 16 December: "Modern Astronomy," by Mr. J. A. Fielding, of the Friar's School, Bangor.
- 20 January: "Optical Aids to Development and Maintenance," by Messrs. Hubbard and Mack of the Telephone Exchange Standards and Maintenance Branch, Engineering Department.
- 23 February: "Gas Manufacture and Distribution," by Mr. J. Lomax, District Manager, of the Wales Gas Board.
- 10 March: "Pay-on-Answer Call-Office System," by Messrs. Collingwood and Newell of the Engineering Department.

We are indeed proud that one of our members gained the first award for the best lecture given during 1958-59, and preceding the January meeting a presentation of a certificate and cheque to Mr. Hari Williams for his paper on "Development of Carrier Telephony," was made by Mr. P. L. Barker, the Chief Regional Engineer.

On this occasion we were pleased to welcome a number of colleagues from our neighbouring centre of Colwyn Bay and also members of the Senior Section.

Our final meeting for this session was held at the end of April when a lecture was given on "Communications in the Royal Air Force."

O.E.J.

### Edinburgh Centre

At the first meeting of the new year, held in January, Mr. H. J. Whitehead of the Edinburgh Telephone Area gave a lecture entitled "Identification and Testing of Precious Stones." The structure and classification of precious stones comprised the first part of the lecture, and was followed by a demonstration of the methods used in their identification. The various instruments used include a direct-reading refractometer together with a chromatic light source (sodium lamp), and a prismatic spectroscope with a polarizing microscope. Demonstrations of fluorescence with the aid of a long-wave ultra-violet lamp and the determination of specific gravity by the use of heavy liquids were also given. A selection of rough and cut specimens was on display.

The February meeting consisted of a lecture on "Printed Circuits," given by one of our members, Mr. W. Morrison. The lecture opened with Mr. Morrison correcting a popular misconception, i.e. in many cases what is commonly termed a "printed circuit" is in reality printed wiring. The various materials used and the methods employed in producing printed circuits were then explained, with the emphasis on

those used in this country. Many examples were on view, including those used in computers, gyroscopes, guided missiles, television and radio receivers, and the 700-type telephone. Many questions were asked concerning, among other things, fault location and changing of components, and were followed by an extremely interesting discussion.

On 15 March Messrs. W. Johnston and C. Forbes presented their paper entitled "TV—Outside Broadcasts," which had previously been given to the Senior Section. Mr. Johnston began by explaining the function of the Post Office television outside-broadcast service, including a review of its growth. Details of how the vision circuits are provided were given, commencing with the survey of the outside-broadcast site. The general principles of television were then explained, followed by a fairly detailed discussion on waveform timing. Examples of waveform distortion showed the need for limits to be placed on waveform responses, and the methods of measuring these limits by means of the K-rating mask were shown. At the conclusion of the lecture, members were given the opportunity of raising questions relative to the lecture.

The Committee are pleased to record that at each of the above meetings more than 28 members were present.

D.M.P.

### Huddersfield Centre

A visit was made, on 26 January, to the new Wigan factory of H. J. Heinz, Ltd., when a party of 30 members enjoyed a really interesting and informative afternoon during which they were shown one of the largest and most modern food factories in Europe. It produces over 1½ million cans of food per day and, although it is not as yet in full production, it really is well worth a visit.

In February an extremely interesting paper was given by Mr. C. F. Stansfield of the Sales Division on "Sales and Service." Many varied questions were put by members and answered by our speaker in the question time that followed.

Our March visit was to Automatic Telephone & Electric Co., Ltd., Liverpool—a most fascinating tour of the factory, with excellent lunch and tea provided by our hosts. The highlight of the day, which included seeing most of the processes, was a visit to the firm's electronic exchange.

Following a visit on 6 April to Slazenger, Ltd., sports-goods manufacturers, Horbury Bridge, near Wakefield, the session ended with the annual general meeting and film show on 31 May.

B.S.

### Ipswich Centre

The Ipswich Centre's winter program opened on 15 October with a talk on the "Modern Motor Car," by our colleagues from the Motor Transport Division, Mr. Harris and Mr. Dyble. The talk was illustrated by a sectionalized engine, diagrams and engine parts. Members found this talk enjoyable and informative.

The November meeting again provided members with valuable information and help when Mr. F. Woodward gave a well illustrated talk on "Colour and the Home." With the aid of colour charts and film, Mr. Woodward gave us much food for thought about our surroundings at home; the intelligent use of colour can change the once dull room into something alive and exciting.

"Sales and A. N. Control" was the subject for the December meeting, when Mr. Cooper and Mr. Bloomfield gave us talks on the working of these departments. Mr. Cooper gave details of methods used in dealing with subscribers' requests for telephone services and the various aspects of charging. Mr. Bloomfield continued with a detailed account of the function of A. N. Control from the time an advice note is received until the work is completed. The evening ended with a talk by Mr. F. Ranson on

"Building Your Own Home." Mr. Ranson gave details of building by direct-labour methods and pointed out the pitfalls he met with during the building of his bungalow.

The Shell Mex and B.P. film library provided us with a film show in January. Members enjoyed a pleasant 3½ hours of films and we are indebted to Shell Mex and B.P. for the loan of these excellent films.

A well attended meeting in February heard a talk on "Postal Mechanization" given by our Head Postmaster, Mr. S. B. Wood. The talk was well illustrated by films and Mr. Wood, who has been very much concerned with this project from the beginning, gave an excellent and detailed talk on the machinery. Members thoroughly enjoyed this meeting and we are grateful to Mr. Wood for making it such a success.

At our March meeting we did "battle" with our Southend colleagues in a quiz. This provided a lively and enjoyable evening, resulting in even scoring. We now look forward to a return battle with Southend or a challenge from other Centres, since this quiz was such a success.

Our winter program ended on 7 April with the annual general meeting and an exhibition of members' work resulting from their hobbies.

E.W.C.

### Leeds Centre

During February a visit was paid to the Leeds Centre by Mr. J. Tweedley of the Industrial Supplies Division of Standard Telephones & Cables, Ltd. Mr. Tweedley presented a most interesting and instructive talk on private automatic branch exchanges with particular reference to the new cordless P.A.B.X. No. 4.

The talk was very well illustrated with technical literature and a prototype console of the new P.A.B.X. The general design and facilities were explained in great detail; one of the most intriguing features of the circuit design is the way in which calls are prevented from being lost in a busy period. The meeting was very well attended by 85 members and guests, and a very interesting period of questions and answers was conducted by Mr. Tweedley.

In conclusion the chairman thanked Mr. Tweedley and Standard Telephones and Cables, Ltd., for their excellent co-operation in making this very successful and interesting evening possible.

Following requests from our members of the electric light and power section, a visit was arranged for a party of 30 members to Chloride Batteries, Ltd., Swinton Works, Clifton Junction, Manchester, on 4 March. The party travelled by coach and were received at Manchester by Mr. Hawarth of the Sales and Service Division.

The tour of the works was most instructive, and each process was followed through until the finished product was ready for its final charge. The motor industry's demands for new batteries has created a large volume of business, and the company were working a 24-hour shift system to meet this demand.

To conclude the visit the party were entertained to tea, and each member was presented with a rubber-finished torch and a copy of the group photograph as mementoes of their visit.

Mr. Baker proposed a vote of thanks to Mr. Hawarth and Chloride Batteries, Ltd., for making this most instructive and entertaining visit possible. Mr. Hawarth said he hoped that he would have the opportunity of seeing further members from the Leeds Centre in the near future.

I.A. and C.B.

### London Centre

The first lecture of 1960, "Analysis-Synthesis Telephony," in spite of its somewhat awe-inspiring title, which may have been responsible for the small attendance, proved to be of great interest. The lecturers, Mr. J. N. Holmes and Mr.

J. N. Shearme, of the Joint Speech Research Unit at Ruislip, showed how speech could be analysed, the essential components for intelligibility transmitted and, at the incoming end, the reconstitution of speech controlled to form a signal similar to the original. A tape recording demonstrated the results which could be obtained.

The attendance at the February lecture given by Mr. H. E. Francis on "Subscriber Trunk Dialling" must have been a near record, some 270 members of both the Senior Section and the Associate Section being present. Mr. Francis dealt with the general plan for S.T.D. and used the demonstration equipment that has been shown at the Senior Section lectures on this subject throughout the country. So interested were the audience that the questioning continued until well into the evening.

The following lecture in March on the S.T.D. "Pay-on-Answer Coin-Box System" by Messrs J. D. Collingwood and E. Newell also proved a great draw with an attendance of 120. The new post-payment coin-box was shown and demonstrated together with the "pay-tone" and coin pulsing signals which are used in this system.

In January the President of the Associate Section, Mr. A. H. C. Knox, gave his talk on "Appraisements and Promotions" before members of North Area, L.T.R., at Bowes Park Exchange. The 40 or so members who came to listen were treated to a most enjoyable and informative evening and confirmed the ever-present interest in this subject.

Arrangements are now almost complete for the 1960-61 session. The opening lecture will be held at the London Planetarium and will follow up last session's inaugural lecture on space exploration by examining the heavens from the viewpoint of the space traveller. An added attraction will be a private viewing of Madame Tussaud's Waxworks.

The semi-finals of the inter-area technical quiz were held in February. City Area beat London Test Section at Shoreditch Exchange on 2 February, and West Area won their contest with East Area at the Circuit Laboratory on 16 February. The results, as during the previous session, were very close, West Area beating East Area by only 2½ points. It is a pity that the teams, who find these contests worth-while, instructive and entertaining, are not supported by their area colleagues.

The Centre Committee were pleased to learn that the first prize in the 1959-60 Institution Essay Competition was won by a London Centre Associate Section member from the Circuit Laboratory, Mr. W. F. Garrett, for his essay "Copper Oxide and Selenium Rectifiers." It is intended that this essay shall be printed in the London Centre's Quarterly Journal during the summer. Our congratulations also go to Mr. H. Bettridge of the London Test Section, another London Centre prize-winning member, for his essay "Roto-Finish—a Modern Engineering Finishing Process."

The Quarterly Journal of the Centre, with a circulation now of some 900 copies, included in its last issue articles on a newspaper facsimile process in use in Japan, the L.T.R. test-call sender, and a university student's impressions of his vacation work in the Circuit Laboratory.

Visits organized during the session by the Centre, in addition to those arranged by the Areas, have included the Central Telegraph Office, the Royal Small Arms factory at Enfield Lock, the Research Station at Dollis Hill, the B.B.C., Museum Television Terminal, and Ericsson's factory at Beeston.

D.W.W.

### London Power Centre

Membership continues to increase and current interest may be gauged by the innovations at general meetings, such as recorded talks and more elaborate demonstrations.

The sessional activities closed with the annual general meeting on 21 April, when Mr. W. Sutton presented his paper dealing with the engineering problems solved in building the new Western District Office (W.D.O.) railway station at Rathbone Place.

Intense interest in pulse techniques has been stimulated by Messrs. Towner and Jarvis in their exposition of the principles of the electronic letter-sorting machine (E.L.S.M.).

The 1959-60 lecture program was as follows:

October: "The Electronic Letter-Sorting Machine," by Mr. A. H. J. Towner.

November: "Maintaining the E.L.S.M.," by Mr. J. Jarvis.

December: "Thermionic Valve Amplifiers," by Mr. W. J. Titmarsh.

January: "The Post Office Railway in Action," by Mr. A. G. Weech.

February: "Planning a Domestic Hot-Water Supply," by Mr. T. Mitchell.

March: "Modifications to the E.L.S.M.," by Mr. A. H. J. Towner.

April: "Engineering Operations at W.D.O.," by Mr. W. Sutton.

Among the regular activities of the Power Centre, the visits program occupies a prominent place. The 1959-60 program included visits as follows:

October: The Evening News.

November: The Dewrance Engineering Co.

December: The Otis Elevator Co.

January: The Daily Mail.

February: The Chrisson Printing Co., Ltd.

March: The Electronic Instruments Co., Ltd.

The youth-in-training essay competition sponsored by the centre has again been successful in attracting the efforts of the "up and coming." Papers received include discussion of their training in the field, and the chairman has expressed the opinion that this subject could form the basis of a discussion at a general meeting in the 1960-61 session.

P.J.F.

#### Pontypridd Centre

The 1959-60 winter session of this centre began on the 23 September with a film demonstration, providing an interesting evening of an instructional nature. Amongst the films shown were "The Principles of the Transistor" and "Powered Flight."

In October three of our members gave us a lecture on "Photography."

November saw a party of 17 members enjoying a hearty lunch in Bristol, followed by a visit to the subscriber-trunk-dialling equipment. It is interesting to note that the hospitality received, and the preview of the type of equipment that many of us will eventually have to become familiar with, is still a subject of many a conversation in this area; our thanks to Mr. C. G. Newton and his colleagues of Bristol Central telephone exchange for being such generous hosts.

For the January meeting Mr. Davies, the librarian for the town of Pontypridd, gave an excellent talk on the "History of the Locality."

February found a group of 14 members being conducted around the B.B.C. television station at Wenvoe, which proved to be an interesting afternoon, thanks to Mr. Broadbent and his colleagues.

In March we had another film show with the films "The Atlantic Cable" and "Writing Wrongs," both provided by our P.R.O., and the film "This is the B.B.C." hired from the

Central Film Library. In our opinion this film is definitely worthy of the award it received recently.

The centre held its first annual general meeting in April, when the financial and annual report was given, and further activities discussed.

Our membership to date is 65 which represents a percentage increase of membership of 25 per cent. The average attendance for the 1959-60 session was 25 per cent of the membership, which may appear low. However, the section covers approximately 200 square miles, many members live in remote areas, and with bad weather conditions a high attendance cannot be expected. The committee wish to thank all members for their support in one form or another during this session and hope that future sessions will be at least as successful.

R.E.J.

#### Sheffield Centre

A full quarter's program started with a lecture by Mr. J. L. Garland of the L.T.R. Long Distance Area on "The Continental Semi-Automatic Switching Unit." After outlining the purpose of the unit, the speaker described the signalling methods used.

Visits to the Criminal Investigation Departments of the Sheffield City police and the West Riding police at Wakefield were made during February and March. At Wakefield we saw card files in which some 750,000 records are kept up to date by information taken from the national Police Gazette and circulars from other police forces. The Wakefield police record is printed on site and circulated daily. In the photographic section the importance of photographic evidence was stressed, although the working conditions under which it must sometimes be obtained are far from ideal. Equipment and darkrooms were on view and a typical assortment of photographs was shown. The fingerprint section has a collection of some six million prints. We were told something about the methods of classification which enable an identification to be made within a few seconds if a full set of 10 prints is available. It was unfortunate that our time limit for return to Sheffield cut short a most interesting evening at this centre, which ranks second only to Scotland Yard.

A show of amateur 8 mm films taken by members of the Chesterfield Cine Society was given on 30 March by Mr. C. Poulson, whose own Austrian holiday film was the main feature. It was accompanied by a tape-recorded commentary. Another colour film, of the Farnborough Air Show, was very impressive and showed to great advantage the merits of the telephoto lens.

On 6 April we again visited the Ericssons, Ltd., factory at Nottingham. We were particularly interested this time to see the manufacture of the 4,000-type selector and the 700-type telephone. Because almost all the components for their products are made within the factory, an enormous number of different processes can be seen and for this reason a visit to Ericssons is always extremely interesting and informative. We enjoyed the excellent hospitality of the Company, to whom we are greatly indebted.

The Radio Section is featuring a series of talks on "Radio and Television Servicing" given by our member Mr. F. S. Brasher of Chesterfield.

J.E.S.

# Staff Changes

## Promotions

Name	Region, etc.	Date	Name	Region, etc.	Date
<i>Executive Engineer to Senior Executive Engineer</i>			<i>Technical Officer to Assistant Engineer—continued</i>		
Troke, F. E. I.	E-in-C.O.	24.2.60	Griffiths, W. J. E.	E.T.E.	7.3.60
<i>Executive Engineer (Open Competition)</i>			Adams, R. L.	S. W. Reg.	15.3.60
Stenson, D. W.	E-in-C.O.	10.2.60	Miller, J. L.	L. T. Reg.	7.3.60
<i>Executive Engineer (Limited Competition)</i>			Poole, L. F.	L.T. Reg.	7.3.60
Ball, P. W.	E.T.E. to E-in-C.O.	28.3.60	Delroyd, J. A.	L.T. Reg.	7.3.60
Lisney, D. L.	E-in-C.O.	21.3.60	Reeves, S.	N.W. Reg.	2.3.60
Dell, F. R. E.	E-in-C.O.	21.3.60	Haslam, G.	N.W. Reg.	2.3.60
Hogben, C. W.	E-in-C.O.	28.3.60	Smith, A. P. J.	L.T. Reg.	28.3.60
Lelliott, S. R.	E-in-C.O.	14.3.60	Martindale, H.	N.W. Reg.	17.3.60
Burville, P. J.	H.C. Reg. to E-in-C.O.	28.3.60	Smith, J. K. R.	H.C. Reg.	30.3.60
Disley, C. G.	E-in-C.O.	11.4.60	Burch, C. G.	Mid. Reg.	8.4.60
<i>Assistant Engineer to Executive Engineer</i>			Edgson, P. M.	Mid. Reg.	19.4.60
Chuter, A. G.	S.W. Reg.	14.7.59	Harris, J. D.	Mid. Reg.	1.4.60
Beckley, D. J.	S.W. Reg. to Scot.	22.2.60	Briers, G. R.	E-in-C.O.	13.4.60
Wilshaw, G. W.	N.E. Reg.	15.2.60	Hearsey, R. R. L.	L.T. Reg. to E-in-C.O.	20.4.60
Bennett, T. A.	L.T. Reg. to E-in-C.O.	19.2.60	Davis, S.	Mid. Reg.	1.4.60
Dawes, O. K.	E-in-C.O.	19.2.60	Johnson, S.	N.E. Reg.	5.4.60
Bennet, G. C.	Scot.	7.3.60	Gilbank, C. K.	N.E. Reg.	5.4.60
Francis, B. J.	S.W. Reg.	22.2.60	Grainger, K.	N.E. Reg.	25.4.60
Davies, W. S.	W.B.C.	22.2.60	Cawthorne, A.	N.E. Reg.	5.4.60
Chippendale, B.	E-in-C.O.	26.2.60	Longhurst, B. H.	L.T. Reg.	22.4.60
Burrows, J. G.	L.T. Reg.	14.3.60	Shiell, A. McK.	L.T. Reg.	27.4.60
Cullis, A. D. S.	E-in-C.O.	1.4.60	Hodgson, C.V.	N.W. Reg.	7.4.60
Peters, A.	H.C. Reg. to E-in-C.O.	28.3.60	Saxby, J.	N.W. Reg.	25.4.60
<i>Assistant Engineer (Open Competition)</i>			<i>Draughtsman to Assistant Engineer</i>		
Duncan, S. J.	Scot.	20.1.60	Stringfellow, J.	Mid. Reg.	14.4.60
Rice, W. B.	E-in-C.O.	9.2.60	Halls, D. F.	Mid. Reg.	14.4.60
Charmer, F. W.	N.W. Reg.	11.1.60	<i>Technical Officer to Inspector</i>		
Henley, H. R.	E-in-C.O.	21.1.60	Richardson, A. W.	L.T. Reg.	19.2.60
Booth, D.	N.E. Reg.	11.1.60	Hamilton, G. W.	L.T. Reg.	19.2.60
Marlow, J. A.	L.T. Reg.	11.1.60	<i>Technician I to Inspector</i>		
Dawson, R.	E-in-C.O.	14.3.60	Elvin, C.	Scot.	1.2.60
Lough, J.	E-in-C.O.	15.3.60	Wickenden, C. D.	H.C. Reg.	29.2.60
Davies, M. J.	E-in-C.O.	12.2.60	Lambert, J. W.	N.E. Reg.	8.2.60
Turner, C. D.	E-in-C.O.	11.1.60	Harley, L. A.	L.T. Reg.	4.2.60
Deadman, D. J.	E-in-C.O.	13.1.60	Roberts, G. E.	W.B.C.	18.2.60
Emms, J.	E-in-C.O.	11.3.60	Hargan, J. M.	N.W. Reg.	11.3.60
<i>Inspector to Assistant Engineer</i>			Brown, R. W.	S.W. Reg.	8.3.60
Camm, F.	Mid. Reg.	1.2.60	Green, A. J.	H.C. Reg.	1.3.60
Maine, H. D.	N.W. Reg.	25.2.60	Moul, W. B.	N.E. Reg.	3.3.60
Wallace, W. P.	N.W. Reg.	29.2.60	Windass, E. S.	N.E. Reg.	2.3.60
Clifton, B. M.	N.E. Reg.	21.3.60	Hammond, E. G. R.	S.W. Reg.	14.3.60
Prentice, J. A.	L.T. Reg.	14.3.60	Drew, R. H. P.	S.W. Reg.	22.2.60
Pitt, J. J. S.	L.T. Reg.	28.3.60	McGill, D. R.	S.W. Reg.	21.3.60
Warren, J. L.	L.T. Reg.	28.3.60	King, B.	N.E. Reg.	2.3.60
Young, W. C.	L.T. Reg.	28.3.60	Grice, A.	N.E. Reg.	2.3.60
Hopkinson, R. R.	N.E. Reg.	5.4.60	Evans, D. R.	W.B.C.	28.3.60
<i>Technical Officer to Assistant Engineer</i>			Pimm, E.	L.T. Reg.	28.3.60
Leslie, H. F.	E.T.E.	16.8.56	Boyse, O. E.	L.T. Reg.	28.3.50
Laws, L. D.	N.E. Reg.	2.2.60	Steele, F. J.	L.T. Reg.	28.3.60
Tovey, W. H.	W.B.C.	27.1.60	Durdey, K. J.	L.T. Reg.	28.3.60
Griffiths, H. F.	W.B.C.	8.2.60	Rae, J. B.	L.T. Reg.	28.3.60
Mitchell, A.	N.E. Reg.	23.12.59	Harris, F. G.	L.T. Reg.	28.3.60
Copping, P. J.	E-in-C.O.	22.2.60	Davies, W. A.	W.B.C.	19.4.60
Thomas, R.	W.B.C.	22.2.60	Roberts, F.	W.B.C.	1.4.60
McCallum, J. C.	Scot.	2.2.60	Arrowsmith, R. J.	Mid. Reg.	16.3.60
Boyne, F. G.	Scot.	2.2.60	Shorter, H. G.	H.C. Reg.	30.3.60
McMullan, T. P.	N.I.	19.2.60	Figgins, M. H.	H.C. Reg.	30.3.60
Newton, C. A.	N.E. Reg.	2.3.60	Pannell, R. R.	H.C. Reg.	30.3.60
Morris, R. E. H. H.	S.W. Reg.	10.2.60	Clarke, R. J.	L.T. Reg.	4.4.60
Jenkins, D. S.	S. W. Reg.	22.2.60	Littlewood, A.	N.W. Reg.	25.3.60
Crosby, A. K.	E.T.E.	22.2.60	<i>Senior Scientific Officer to Principal Scientific Officer</i>		
McDougall, R. S.	Scot.	22.2.60	Ellis, J. H.	Admiralty to E-in-C.O.	26.2.60
Blake, P. B.	E.T.E.	16.2.60	<i>Senior Scientific Officer (Open Competition)</i>		
de Boise, F. P.	E.T.E.	1.3.60	Faktor, Dr. M. M.	E-in-C.O.	16.2.60
Padgham, D. A.	S.W. Reg.	22.2.60	<i>Experimental Officer (Open Competition)</i>		
Cooper, G. A.	S.W. Reg.	15.3.60	Hollingdale-Smith, P.A.	E-in-C.O.	22.1.60

Promotions—continued

Name	Region, etc.	Date	Name	Region, etc.	Date
<i>Assistant Experimental Officer (Open Competition)</i>			<i>Chief Executive Officer to Staff Controller</i>		
New, L. J.	E.-in-C.O.	2.12.59	Manning, W. J.	E.-in-C.O.	1.4.60
<i>Assistant (Scientific) (Open Competition)</i>			<i>Higher Executive Officer to Senior Executive Officer</i>		
McPherson, J. M.	E.-in-C.O.	24.3.60	Sturges, A. F. R.	E.-in-C.O.	1.4.60
<i>Workshop Supervisor II to Technical Assistant II</i>			<i>Welfare Officer Class I to Chief Welfare Officer</i>		
Baldwin, J.	N.W.Reg.	14.3.60	McEvoy, E. M.	E.-in-C.O. to L.T.Reg.	5.4.60

Retirements and Resignations

Name	Region, etc.	Date	Name	Region, etc.	Date
<i>Area Engineer</i>			<i>Inspector</i>		
Loveday, T. C.	L.T. Reg.	7.2.60	Boothman, F. R.	N.E. Reg.	8.2.60
<i>Senior Executive Engineer</i>			Dunn, J. E.	W.B.C.	12.2.60
Magnusson, L. E.	E.-in-C.O.	29.2.60	Foster, J. R.	N.W. Reg.	19.2.60
Langton, H. J. (Resigned)	E.-in-C.O.	29.2.60	Collins, G. W. T.	L.T. Reg.	27.2.60
Banks, W. R.	H.C. Reg.	10.4.60	Humphries, S. F.	Mid. Reg.	29.2.60
<i>Executive Engineer</i>			Willdern, A. R.	N.E. Reg.	29.2.60
Head, D. E.	E.-in-C.O.	19.2.60	Davidson, W. H. J.	S.W. Reg.	22.2.60
Tissington, R. S.	E.-in-C.O.	29.2.60	Taylor, H. T.	L.T. Reg.	7.3.60
(Resigned)			Burley, W. C.	L.T. Reg.	10.3.60
Dore, L. J.	Mid. Reg.	13.2.60	Collins, W. H. G.	W.B.C.	25.3.60
Durrant, H. L.	L.T. Reg.	26.2.60	Stanton, T.	W.B.C.	25.3.60
Goulden, C. J.	N.W. Reg.	20.3.60	Johnson, E.	Mid. Reg.	6.3.60
Smith, E. R.	L.T. Reg.	31.3.60	Spearey, F.	W.B.C.	15.4.60
<i>Assistant Engineer</i>			Landey, E. H.	L.T. Reg.	22.4.60
Finney, P.	N.W. Reg.	21.2.60	Taylor, A. F.	L.T. Reg.	29.4.60
Elvidge, J. E. H.	E.-in-C.O.	29.2.60	<i>Principal Scientific Officer</i>		
(Resigned)			Josephs, H. J.	E.-in-C.O.	14.4.60
Granger, E. H.	S.W. Reg.	1.2.60	<i>Experimental Officer</i>		
Galsworthy, J. R.	E.T.E.	29.2.60	Jones, D. H. (Resigned)	E.-in-C.O.	21.4.60
Malyon, J.	H.C. Reg.	10.3.60	<i>Assistant (Scientific)</i>		
Crossing, R. G.	S.W. Reg.	19.3.60	Somers, A. (Resigned)	E.-in-C.O.	22.4.60
Gregory, A.	N.E. Reg.	28.3.60	<i>Temporary Assistant (Scientific)</i>		
Field, A. H. G.	W.B.C.	31.3.60	Howard, A. M.	Birmingham Materials Section	26.2.60
Woolven, J. E.	L.T. Reg.	31.3.60	(Resigned)		
Bradshaw, W.	N.E. Reg.	31.3.60	<i>Technical Assistant I</i>		
Keats, A. B. (Resigned)	E.-in-C.O.	31.3.60	Coppin, W. L.	London Reg.	7.4.60
Thorpe, H. V.	H.C. Reg.	31.3.60	<i>Staff Controller</i>		
Shimmin, W. H.	N.W. Reg.	6.4.60	Daly, G.	E.-in-C.O.	31.3.60
Gore, F.	N.W. Reg.	13.4.60	<i>Executive Officer</i>		
Jackson, R.	N.E. Reg.	15.4.60	Peacock, C. O. G. G.*	E.-in-C.O.	25.4.60
Barrett, V. G.	H.C. Reg.	18.4.60	* Mr. C. O. G. G. Peacock is continuing as a disestablished officer with E.-in-C.O.		
Johnson, F. W. B.	N.W. Reg.	20.4.60			
Kelly, R. C.	N.W. Reg.	21.4.60			
Pierpoint, S. H.	L.T. Reg.	24.4.60			
Cobb, C. W.	L.T. Reg.	26.4.60			
Bolus, E. H.	L.T. Reg.	30.4.60			

Deaths

Name	Region, etc.	Date	Name	Region, etc.	Date
<i>Executive Engineer</i>			<i>Inspector</i>		
Morris, T. G.	E.-in-C.O.	21.11.59	Price, L. T.	L.T. Reg.	18.12.59
Harrold, E. J.	L.T. Reg.	12.1.60	Powell, F. E.	H.C. Reg.	1.1.60
Yates, G. A.	Mid. Reg.	31.3.60	Low, L. G.	H.C. Reg.	31.3.60
<i>Assistant Engineer</i>			Morris, W. H. F.	L.T. Reg.	2.4.60
Evans, A.	W.B.C.	21.12.59	Green, F.	N.E. Reg.	25.4.60
Hodges, R. R.	S.W. Reg.	2.1.60	<i>Senior Draughtsman</i>		
Cox, A. G.	S.W. Reg.	8.1.60	Porter, F. V.	E.-in-C.O.	25.3.60
Wood, R.	S.W. Reg.	25.1.60	<i>Leading Draughtsman</i>		
Kingston, T.	N.E. Reg.	13.2.60	Higgins, R. H.	E.-in-C.O.	16.4.60
Mackenzie, D.	Scot.	26.2.60			
Cooke, E. M.	S.W. Reg.	28.3.60			



### BOARD OF EDITORS

D. A. BARRON, M.Sc., M.I.E.E., Chairman.  
 L. F. SCANTLEBURY, Whit.Sch., A.C.G.I., D.I.C., M.I.E.E.  
 T. H. FLOWERS, M.B.E., B.Sc.(Eng.), M.I.E.E.  
 W. J. E. TOBIN, B.Sc.(Eng.), A.C.G.I., D.I.C., M.I.E.E.  
 A. J. LECKENBY, M.B.E.  
 G. J. MILLEN, A.M.I.E.E.  
 R. F. WALDEGRAVE.  
 E. DAVIS, A.M.I.E.E., Managing Editor.  
 A. G. LEIGHTON, B.Sc.(Eng.), A.M.I.E.E., Deputy Managing Editor.  
 J. MARTIN, B.Sc.(Eng.), A.M.I.E.E. } Assistant Editors.  
 R. A. SUDELL }  
 B. FARR, Secretary-Treasurer.  
 B. CROSS, Advertisement Manager.

### Copyright

The entire contents of this Journal are covered by general copyright, and special permission is necessary for reprinting long extracts, but editors are welcome to use not more than one-third of any article, provided credit is given at the beginning or end thus: "From *The Post Office Electrical Engineers' Journal*."

The Board of Editors is not responsible for the statements made or the opinions expressed in any of the articles in this Journal, unless such statement is made specifically by the Board.

### Subscriptions and Back Numbers

The Journal is published quarterly, in April, July, October and January, price 2s. 6d. (3s. 6d. post paid) per copy or 14s. per year post paid (2 dollars 25 cents, Canada and U.S.A.). Back numbers will be supplied, if available, price 2s. 6d. (3s. 6d. post paid) per copy. Orders should be sent to *The Post Office Electrical Engineers' Journal*, G.P.O., 2-12 Gresham Street, London, E.C.2.

Employees of the British Post Office can obtain the Journal through local agents.

### Binding Cases

Readers can have their copies of volumes bound at a cost of 10s. 6d. by sending the complete set of parts to the local Post Office distribution agent or to *The Post Office Electrical Engineers' Journal*, G.P.O., 2-12 Gresham Street, London, E.C.2. Alternatively, binding cases are available, price 3s., for those readers who wish to make their own arrangements for binding.

### Remittances

Remittances should be made payable to "*The P.O.E.E. Journal*" and should be crossed "& Co."

### Advertisements

All correspondence relating to advertisement space reservations, copy, proofs, etc., should be addressed to the Advertisement Manager, *The Post Office Electrical Engineers' Journal*, G.P.O., 2-12 Gresham Street, London, E.C.2.

### Communications

With the exceptions indicated above, all communications should be addressed to the Managing Editor, *The Post Office Electrical Engineers' Journal*, G.P.O., 2-12 Gresham Street, London, E.C.2. Telephone: HEADquarters 1234.

### Model Answer Books

Books of model answers to certain of the City and Guilds of London Institute examinations in telecommunications are published by the Board of Editors. Details of the books available are given at the end of the Supplement to the Journal.

# Ernest Turner

## Electrical Measuring Instruments

Ideally matching contemporary panel design, the Ernest Turner Model 703, illustrated here, is enhanced by the flush-fitting surround. A high degree of accuracy is adequately supported by the easy-to-read scale and clean dial layout. Full details of the range of rectangular electrical measuring instruments and flush mountings are contained in Leaflets 85/G and 85/AF, available on request.

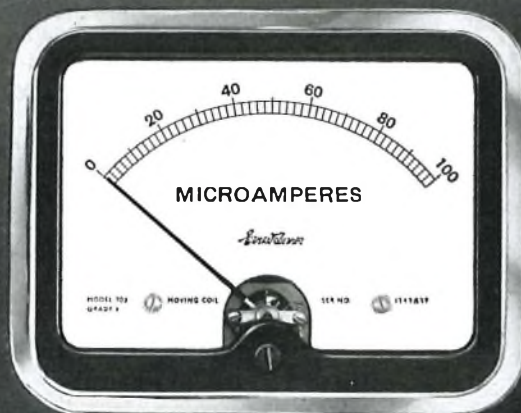

**Ernest Turner Electrical Instruments Ltd**

**HIGH WYCOMBE · BUCKINGHAMSHIRE · ENGLAND**

# BIRMINGHAM

via



to

# LONDON

This, the first long distance trunk television circuit in Britain to be built, installed and maintained by private enterprise, carries high quality vision and sound from the Alpha studios in Birmingham to ASSOCIATED TELEVISION LIMITED'S London headquarters.

It is the first link in the U.K. to operate in the new 7,000 megacycle band, the highest frequency yet to be used for television relays.



a new

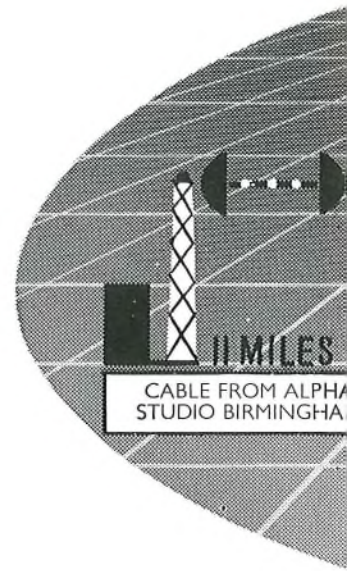

*The diagram sent by cable to Meriden cable company tower enclosure circuit is*



A PYE INSTALLATION FOR



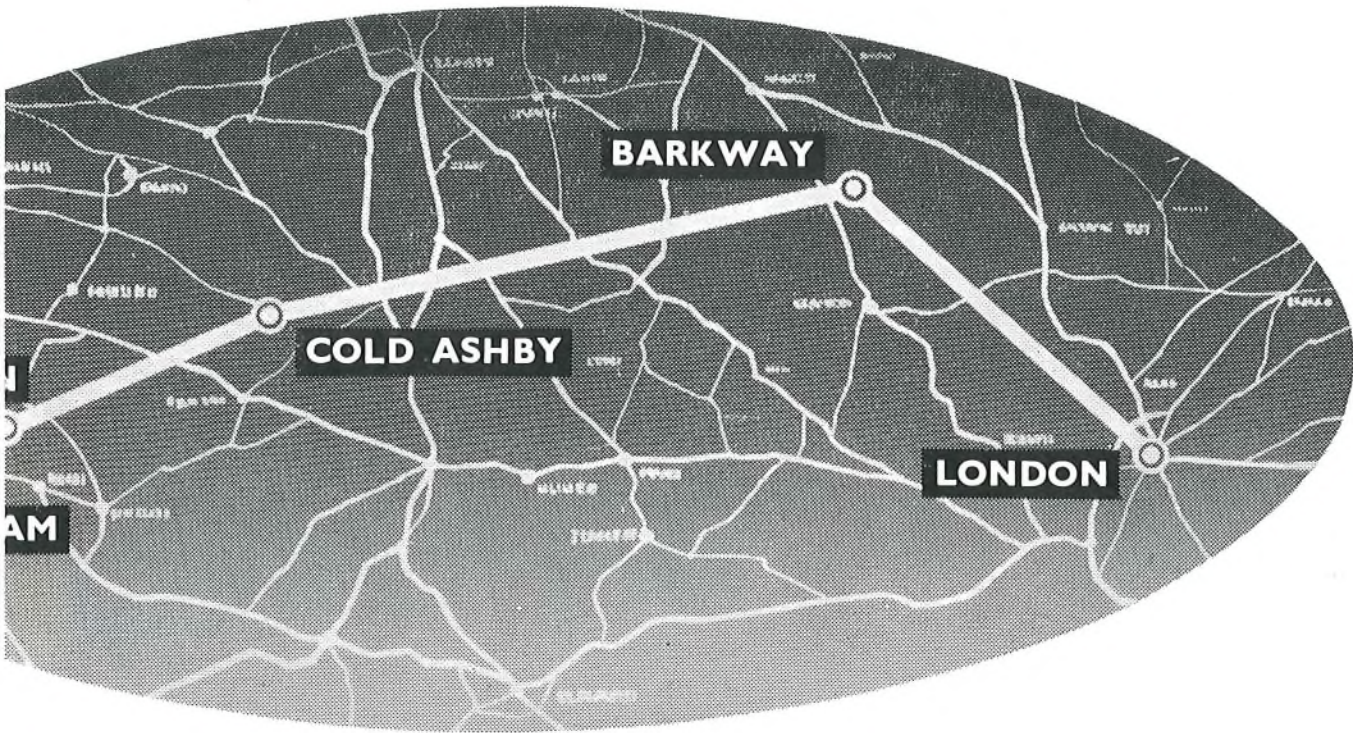

## tv highway of the air

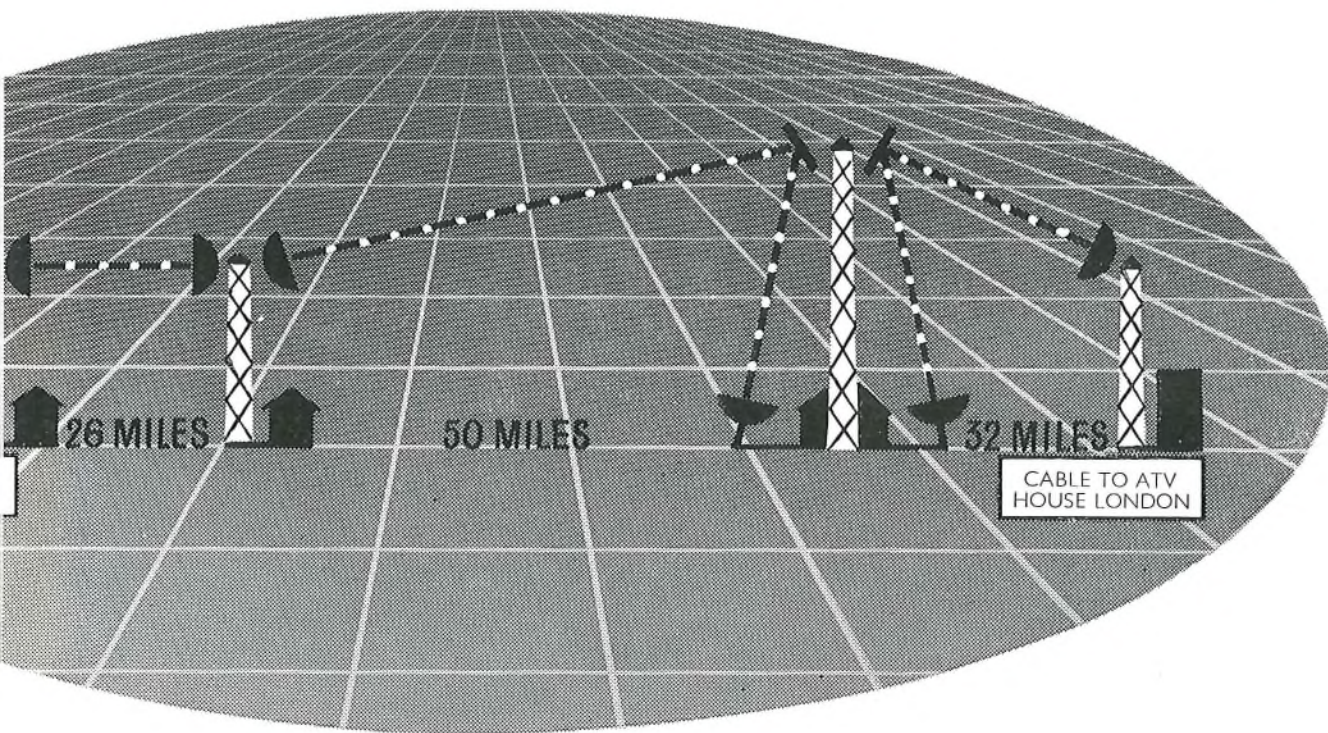

...n shows how the new television link works. The picture originating in Birmingham is ...xial cable to CML buildings in Birmingham. Here, the first microwave station beams ...en. Further stations at Cold Ashby and Barkway take it to Highgate where another ...ts it to A.T.V. House, London. At Barkway, microwave mirrors on top of a 200-foot ...e the beams to clear obstructions on the long hops to Cold Ashby and Highgate. The ...5 miles long and is entirely automatic and unattended.



**WESTINGHOUSE**

# Rectifiers

FOR

## ANGLO-SWEDISH SUBMERGED COAXIAL CABLE

CÖTEBORG

MIDDLESBROUGH

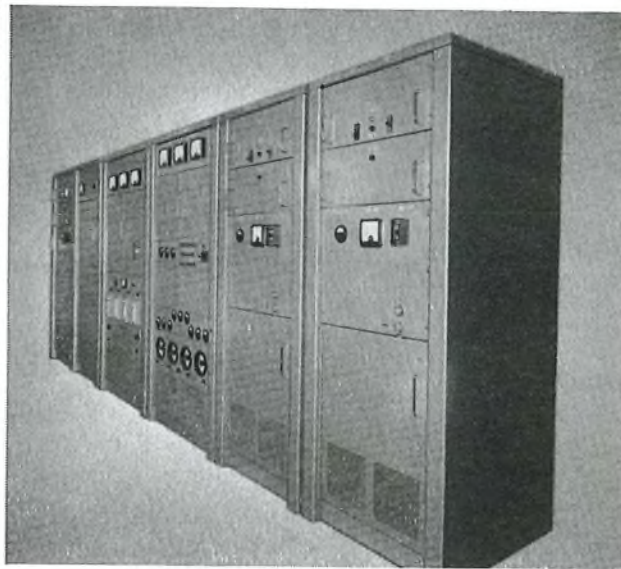

To meet the requirements of d.c. power supplies for submerged repeaters Westinghouse have developed a range of equipments which employ a transductor regulator, controlled by means of a magnetic discriminator.

The complete equipment illustrated above, which is being supplied for the Anglo-Swedish cable system, consists of a suite of six cubicles comprising three constant current units, two control cubicles, power separation filter and cable terminating cubicle. Complete indication, alarm, interlock and test facilities are built into the equipment.

Other equipments are at present in the course of being supplied for the Transatlantic Cable and System, H.M.T.S. Monarch, and the Bermuda Manahawkin Link.

For full details of Westinghouse rectifiers for telecommunications please write to Dept. P.O.7 Rectifier Division (Special Products)

WESTINGHOUSE BRAKE AND SIGNAL CO. LTD • 82 YORK WAY, KING'S CROSS • LONDON, N1.

Terminus 6432

# Telegraph distortion measurement

in the speed range 40-400 bauds

Rapidly increasing international use of high-speed synchronous telegraph systems has led to the urgent need for suitable distortion measuring equipment. M.S. Type TCA1219, manufactured by A.E.I. at their Woolwich factory to a British Post Office design, enables distortion measurements to be made within 1% accuracy. The method of indication is by bright spots on the circular time base of a cathode-ray tube. Screening and the fitting of radio interference suppressors have been given particular attention.

Size	17 in. high x 15 in. wide x 18 in. deep
Weight	110 lb.
Power supply	200/250 v. 50 c.p.s.
Power consumption	170 w.



•  
•  
1:1  
2:2  
6:1  
7:7  
Q9S  
•  
•  
or any  
single  
character

vast experience



in the science of telecommunications



**Telecommunications Division**

Transmission Department Woolwich London SE18

**Associated Electrical Industries Limited**



*“Twitterton!*

*Is this really*

**FORMICA\*?”**

Yes, this is a printed circuit made from a FORMICA copper-clad laminate. It is used in the newest type of telephone, beautifully made by The Plessey Company Limited to G.P.O. specifications. And it's just one of many Formica products.

Not so long ago, the name Formica was associated with decorative laminates, used mainly in kitchens and canteens. Today, among many other activities, Formica Ltd. with their industrial laminates make a valuable contribution to quick and reliable telecommunications. And in today's world you'll frequently come across most of the other Formica products listed below.

**FORMICA**  
make

CHAIR SETS  
DECORATIVE LAMINATES  
**INDUSTRIAL LAMINATES**  
EXTRUDED PLASTICS



For full information on any FORMICA product, please write to:

**FORMICA LIMITED, De La Rue House, 84-86 Regent Street, London, W.1 Tel: REGent 2901**

\* FORMICA is a registered trade mark.

**TUNGSTONE BATTERIES** have been designed to meet Post Office, British Standards and other national Post and Telegraph Specifications. They are being used in Power Stations, Telephone Exchanges, etc., all over the United Kingdom, Australia, India, South Africa, West Africa, West Indies, Portugal, Venezuela, etc.

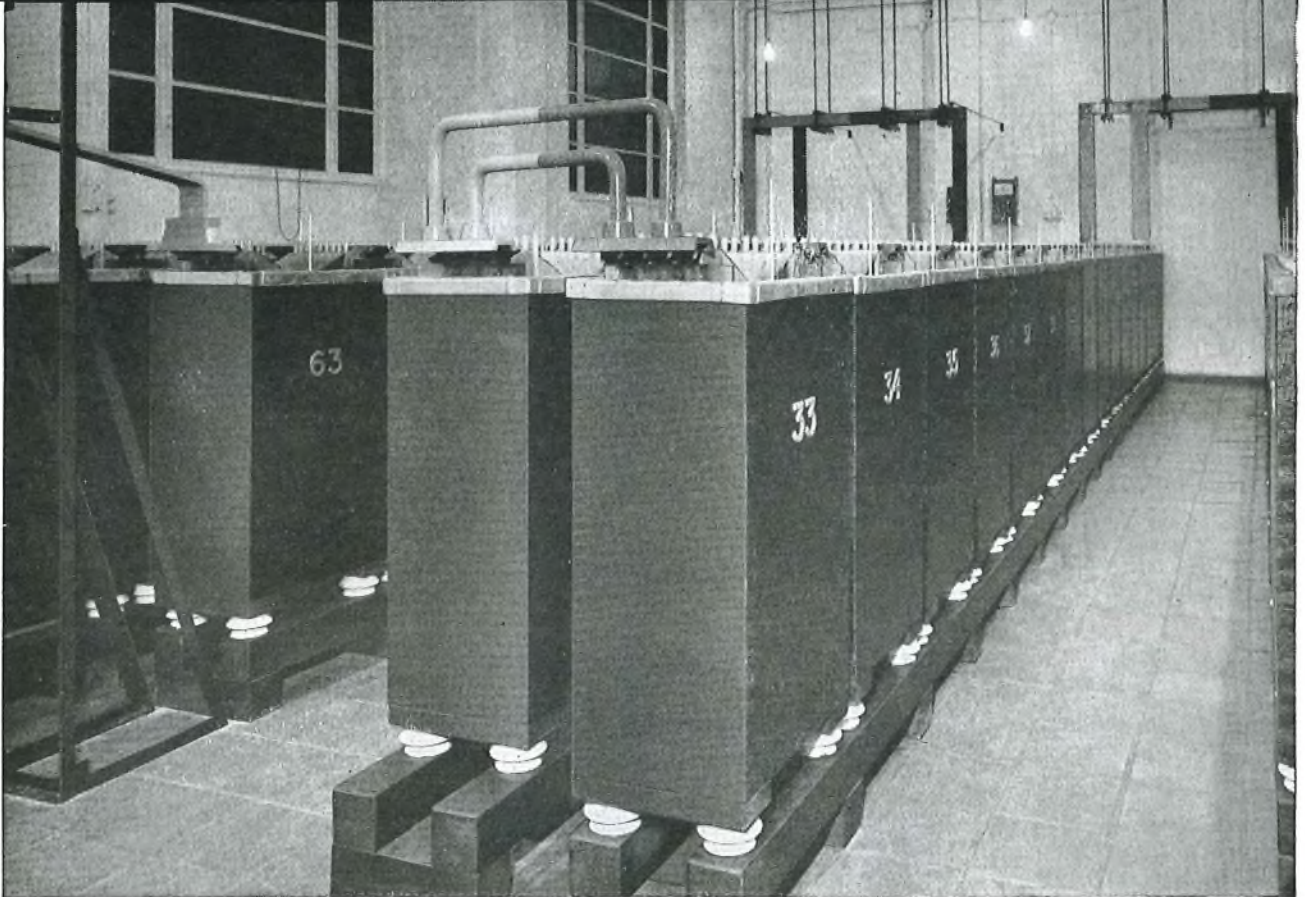

# TUNGSTONE

## BATTERIES

This illustration shows . . . the installation of a 126 cell TUNGSTONE Battery, Type BSSFW9 giving capacity of 800 a.h. at the 9 hr. rate.

### TUNGSTONE PRODUCTS LIMITED

Salisbury Square, London, E.C.4.

Telephone: LUDgate Circus 0342

WORKS: MARKET HARBOROUGH, LEICS.



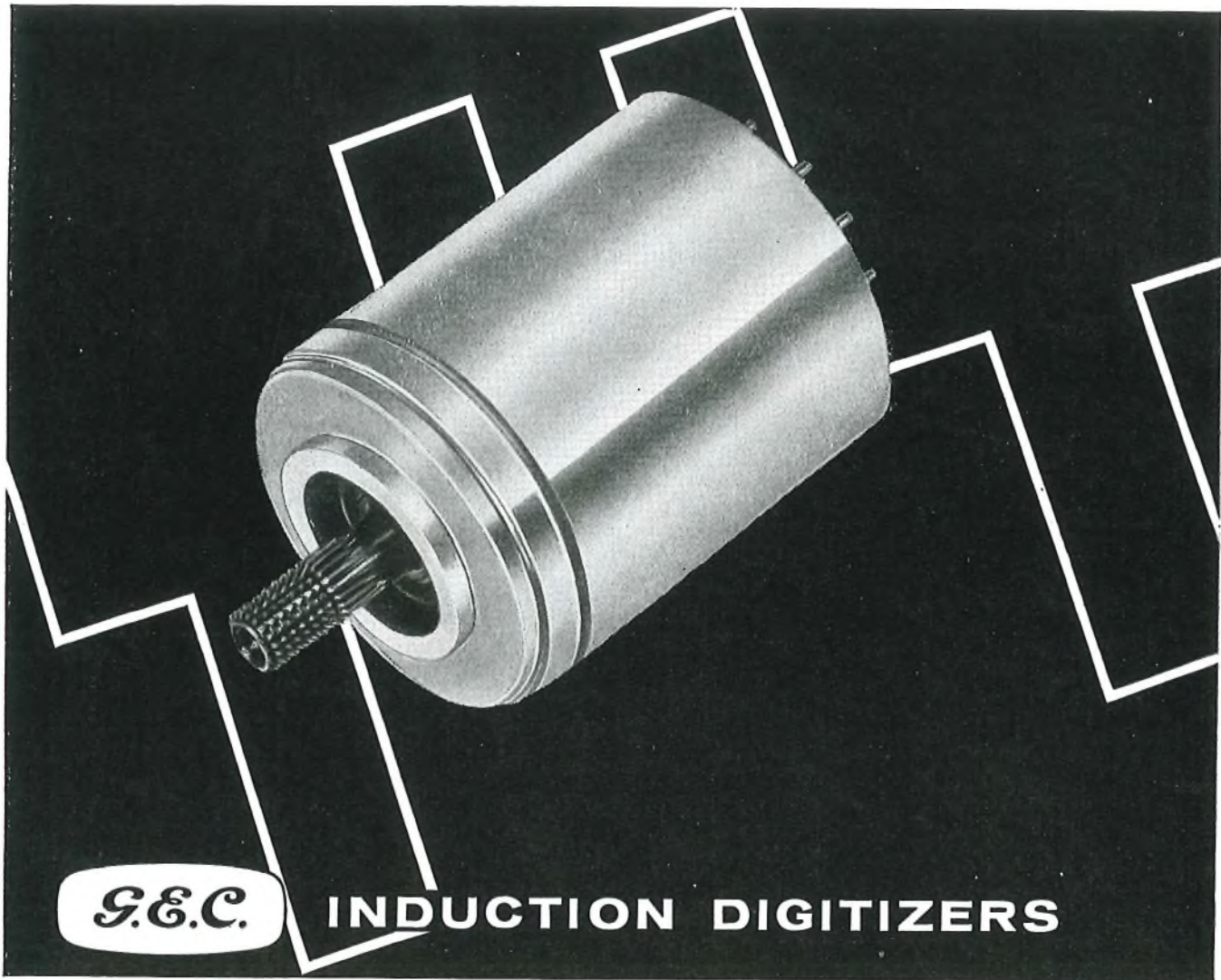

**no slip rings**

**no commutator**

**no photocells**

THIS ENTIRELY NEW type of transducer, for use in digital data handling and computer systems, gives a numerical representation of the position of a shaft or slide in the form of coded electrical signals without the use of slip rings, commutator or photocells.

Basically the digitizer is a transformer with a single exciting winding and a number of secondary windings corresponding to the number of digits. The position of a moving yoke determines the polarity of coupling between the exciting winding and the various digit windings, which are arranged to conform to the requirements of the code. Either pulse or sine wave excitation can be used.

Shaft digitizers can be operated in coarse/fine combinations, an additional winding preventing ambiguity between the digitizers. Instruments can be supplied for 5-digit read-out in a size 11 standard synchro housing. The coding may be either in a binary form (type LB5-3) or in decimal form (type LD5-2). Other types of digitizer, e.g. those having a 7-digit read-out in a size 23 housing, are in an advanced stage of development.

#### SPECIFICATIONS

	TYPE LD5-2	TYPE LB5-3
Mechanical Input	Shaft rotation	Shaft rotation
Code	5-digit cyclic binary coded decimal	5-digit cyclic binary
Resolution	1 in 20 for a single instrument	1 in 32 for a single instrument
Frame size	Similar to a size 11 synchro	Similar to a size 11 synchro
Typical excitation	10 volts r.m.s. at 20 kc/s	8 volts r.m.s. at 20 kc/s
Nominal output	1.5 volts r.m.s. maximum	800 millivolts r.m.s. maximum

*British patent applications Nos. 11280/57 1051/59 and 1052/59*

Please address specific enquiries and orders to:

ELECTRONICS DIVISION

**The General Electric Company Limited of England**

FORD STREET · COVENTRY · ENGLAND

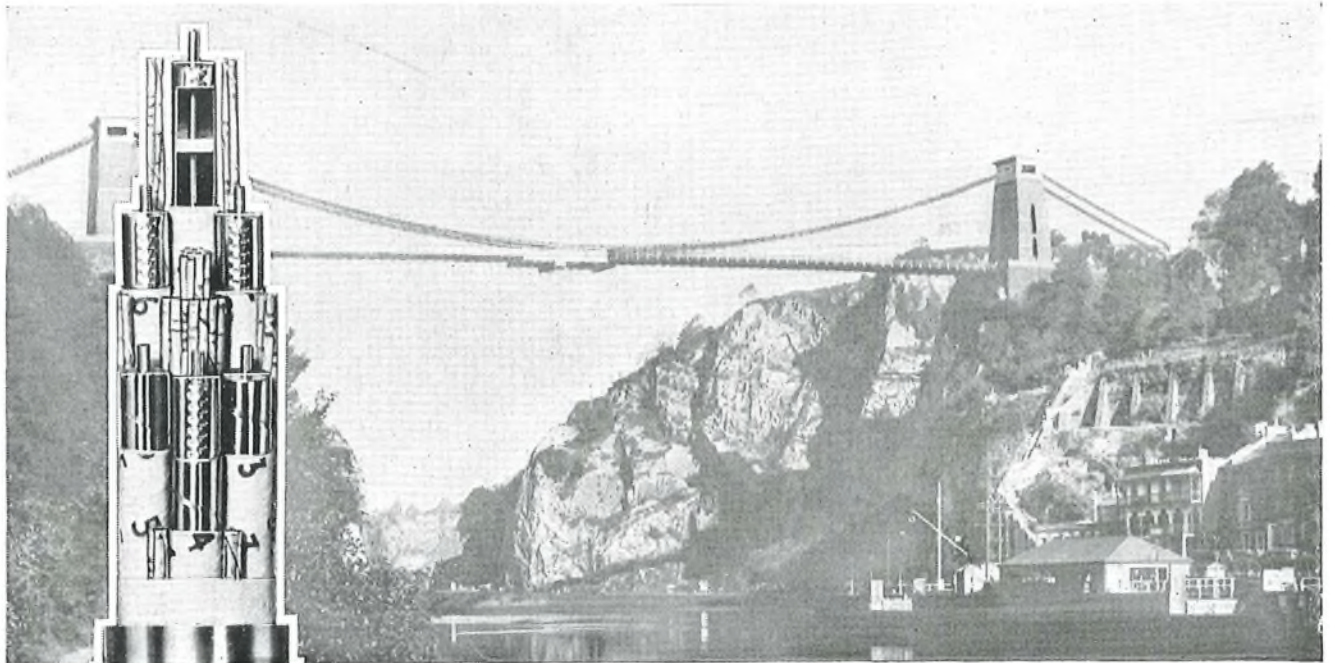

## S.T.C. coaxial cable for S.T.D.



A 6 tube, type 375 Coaxial Cable incorporating 32 pairs 20 lb/mile conductors has been manufactured and installed between Bristol and Oxford by Standard Telephones & Cables Limited for the British Post Office. The cable, necessitated by the introduction of the Subscriber Trunk Dialling (S.T.D.) system in Bristol, provides additional trunk circuits between Bristol, Oxford, Birmingham,

London and other principal cities. S.T.C. pioneered the introduction of the first coaxial cable and have been responsible for all subsequent developments. Already the company has manufactured and installed in the U.K. alone over 3000 route miles of cable incorporating over 10,000 miles of coaxial tube. This further contribution to the U.K. telephone system re-emphasises the leading position of S.T.C.

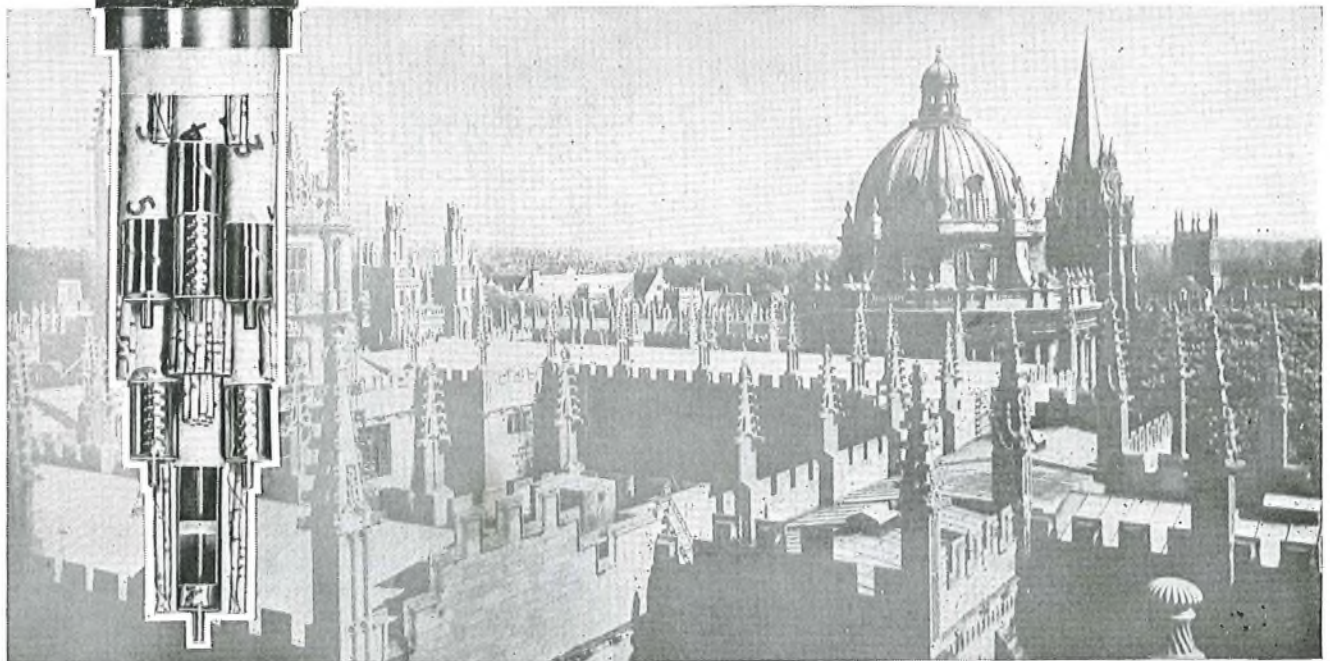

**Standard Telephones and Cables Limited**

Registered Office: Connaught House, Aldwych, London, W.C.2

TELEPHONE CABLE DIVISION: NORTH WOOLWICH · LONDON · E.16



## electronic components

Our long experience in the design and manufacture of electrical components enables us to offer a wide range of products designed to meet with the many requirements of the electronic industry today.



This fixed frequency oscillator is constructed on a standard octal base and encapsulated in epoxy resin. Slight tuning either side of the fundamental frequency is provided by means of an adjustable core. Output: 10mw into a 600 ohm load. Frequency: As required within the range 700-2000 c.p.s. sinusoidal.

This P.O. Transistor Amplifier Moulding is another example of potted components, the illustration is of a development of a miniature version of the amplifier 100A, this model utilising transistors to replace the miniature valves.

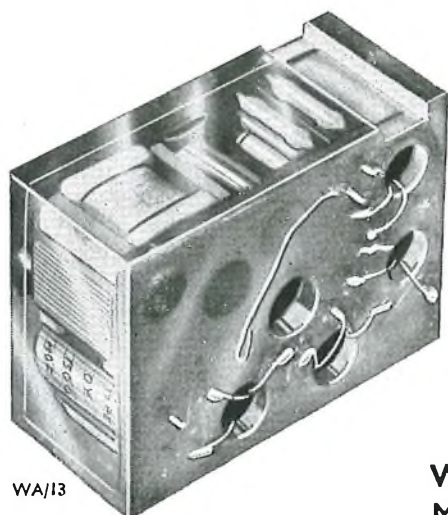

WA/13

**WHITELEY ELECTRICAL RADIO CO. LTD.**  
Mansfield, Notts

Telephone: Mansfield 1762/5

# ONAN-WORLD CHAMPION

## 2½ KW GENERATOR AT 140 LBS

### PORTABLE WINNER ON ALL POINTS

Outpointing all contenders for the lightweight title in the telecommunications field, ONAN was selected by the Post Office Telephone Engineering Department. A power-packed 140 lbs for lights, tools and equipment. Air-cooled 5.5-h.p. petrol engine, full pressure pump lubrication, rotating stellite-faced exhaust valve, solid stellite exhaust seat insert, radio suppressed, with recoil starter. Aluminium frame-mounted for easy carrying or dolly mounted. Also available for standby purposes, ONAN 500-watt to 200-KW petrol and diesel models and INSTAPAC no-break equipment, for telecommunications applications.

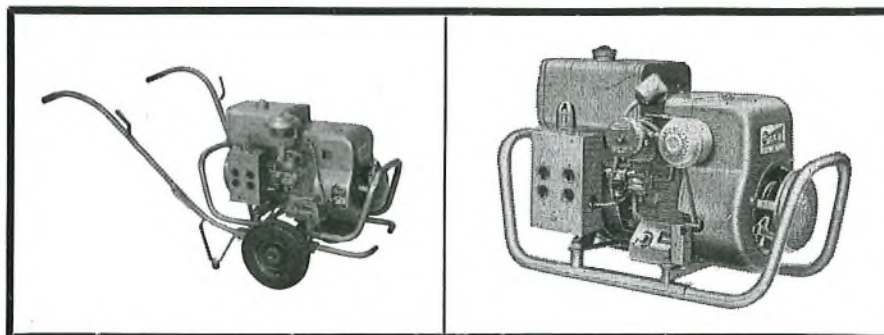

*Sole U.K.  
Distributors*

**G.M.  
POWER PLANT  
CO. LTD.**

Dept. L, 1-3 Richmond Road, Ipswich, Suffolk  
Tel: IPSWICH 81795/6

# NEW TRANSISTORIZED CARRIER

For Cable Systems · Radio Systems ·

## TECHNICAL FEATURES

- 300-3,400 c/s Channel Bandwidth.
- 4 kc/s spaced.
- Optional Inbuilt Out-band signalling (3825 c/s at -20 dbmO)
- Fully transistorized.
- 96 Circuits without signalling or 48 circuits with signalling per 9 ft. rackside (20½ in. x 8½ in. floor dimensions).
- Compact plug-in units with hinged, card-mounted components give maximum component accessibility.
- Can be supplied on rack-sides or a complete basic group on a sub-frame.
- Available in 60-108 kc/s basic channel groups or as systems for 12-circuit 2-wire cable operation or multi-circuit, for radio links.
- Conforms with CCITT and BPO requirements.

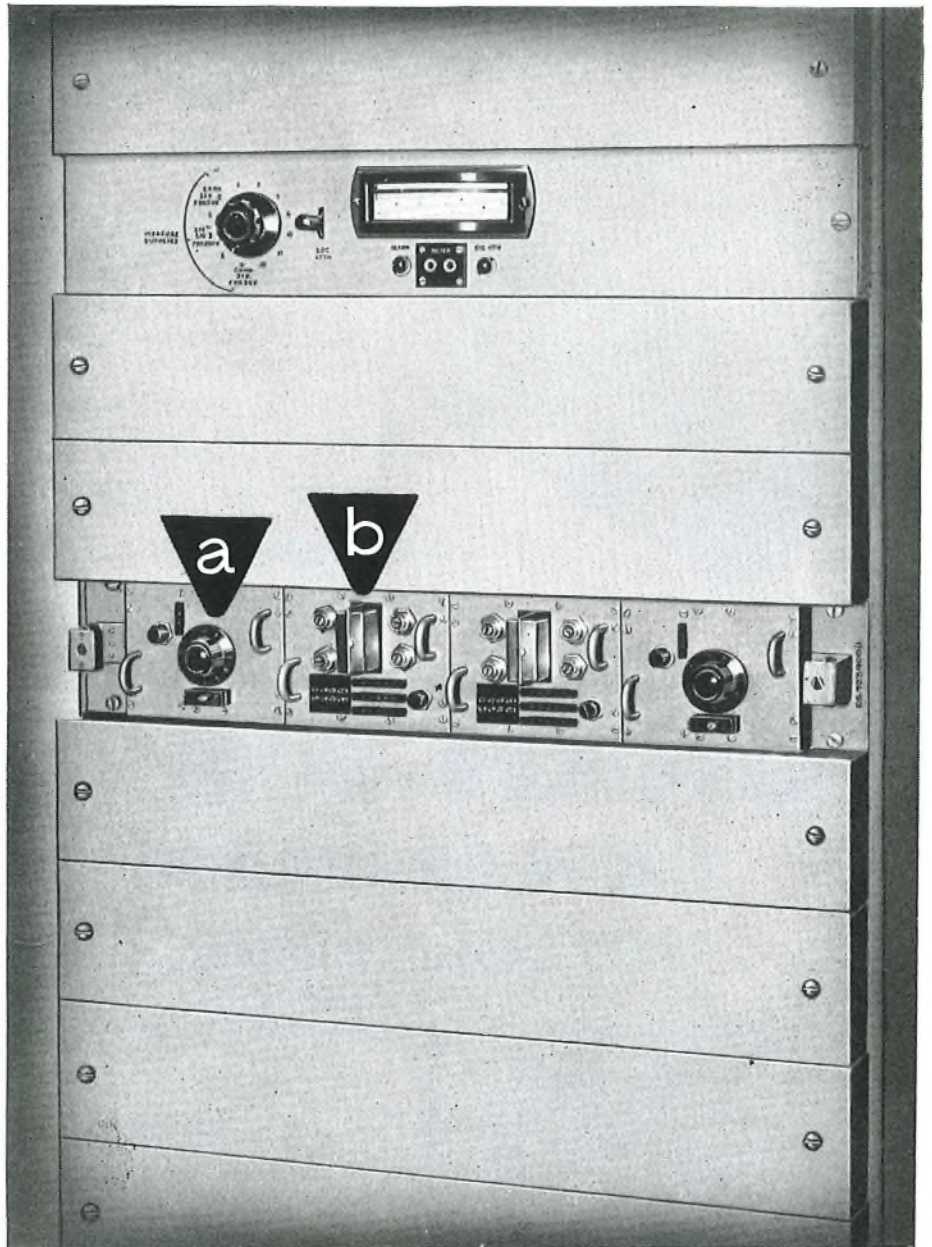

Cover removed to show panel with Channel and Signalling Units in position

# TMC

Further information from:

**TELEPHONE MANUFACTURING COMPANY LIMITED**

Transmission Division: Cray Works, Sevenoaks Way, Orpington, Kent

Telephone: Orpington 26611

SELLING AGENTS *Australia and New Zealand:* Telephone Manufacturing Co. (A'sia) Pty Ltd., Sydney, New South Wales.

*Canada and U.S.A.:* Telephone Manufacturing Co. Ltd., Toronto, Ontario.

*All other Countries (for transmission equipment only):* Automatic Telephone and Electric Co. Ltd., London.

# TELEPHONE EQUIPMENT BY T.M.C.

## Channelling Equipment

This is the latest addition to the T.M.C. range which includes: 2, 3, 4 and 6 kc/s spaced carrier telephone equipment for cable, radio and open-wire systems. 120, 170 and 240 c/s spaced FM telegraph equipment. Companders, negative impedance repeaters, VF amplifiers and privacy equipment.

a

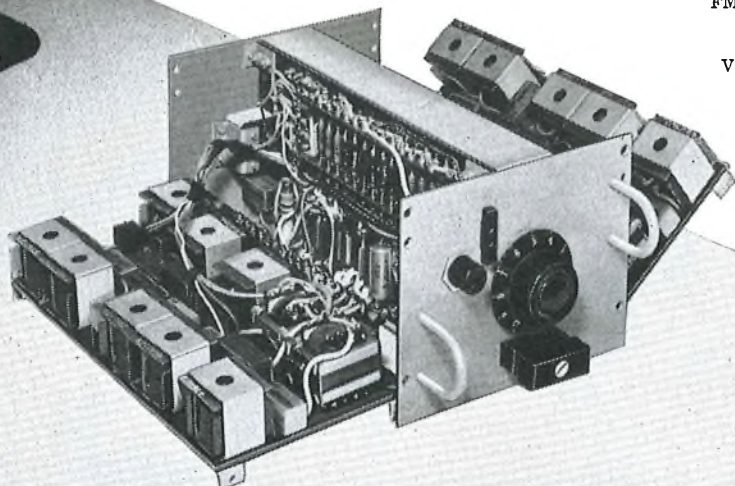

Channel Unit

b

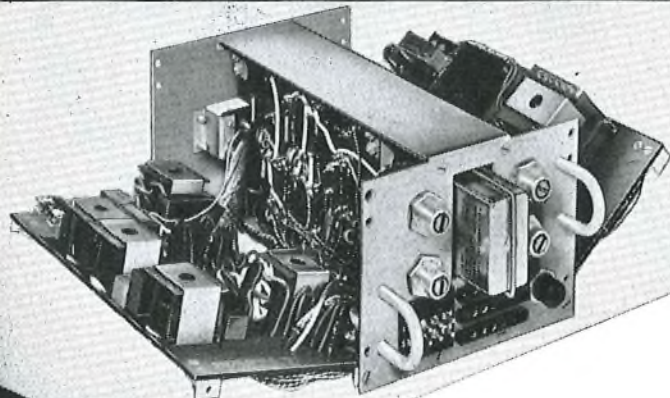

Signalling Unit

### GENERAL

- As multi-channel carrier telephone equipment, it is designed to provide high-quality wide-band telephone circuits.
- It can be energized from suitable batteries or a.c. mains.
- Plug-in units and panels make transport, installation and maintenance easier.
- Great care has been taken to simplify the problem of installation. With plug-in panels and units removed, the rackside is easily lifted into position. Rackside may be mounted side-by-side back-to-back or back to a wall. Cable entries are arranged for both overhead and floor-duct distribution.

This new equipment is a further T.M.C. contribution to the recent advances made by the electronics industry in the field of telecommunication. In comparison with similar equipment, it effects considerable economies in the reduction of space used and power consumed. And still more economies are brought about by its simplicity of installation and ease of maintenance.



# Over 1,000 multi-circuit VHF junction radio equipments in 28 countries

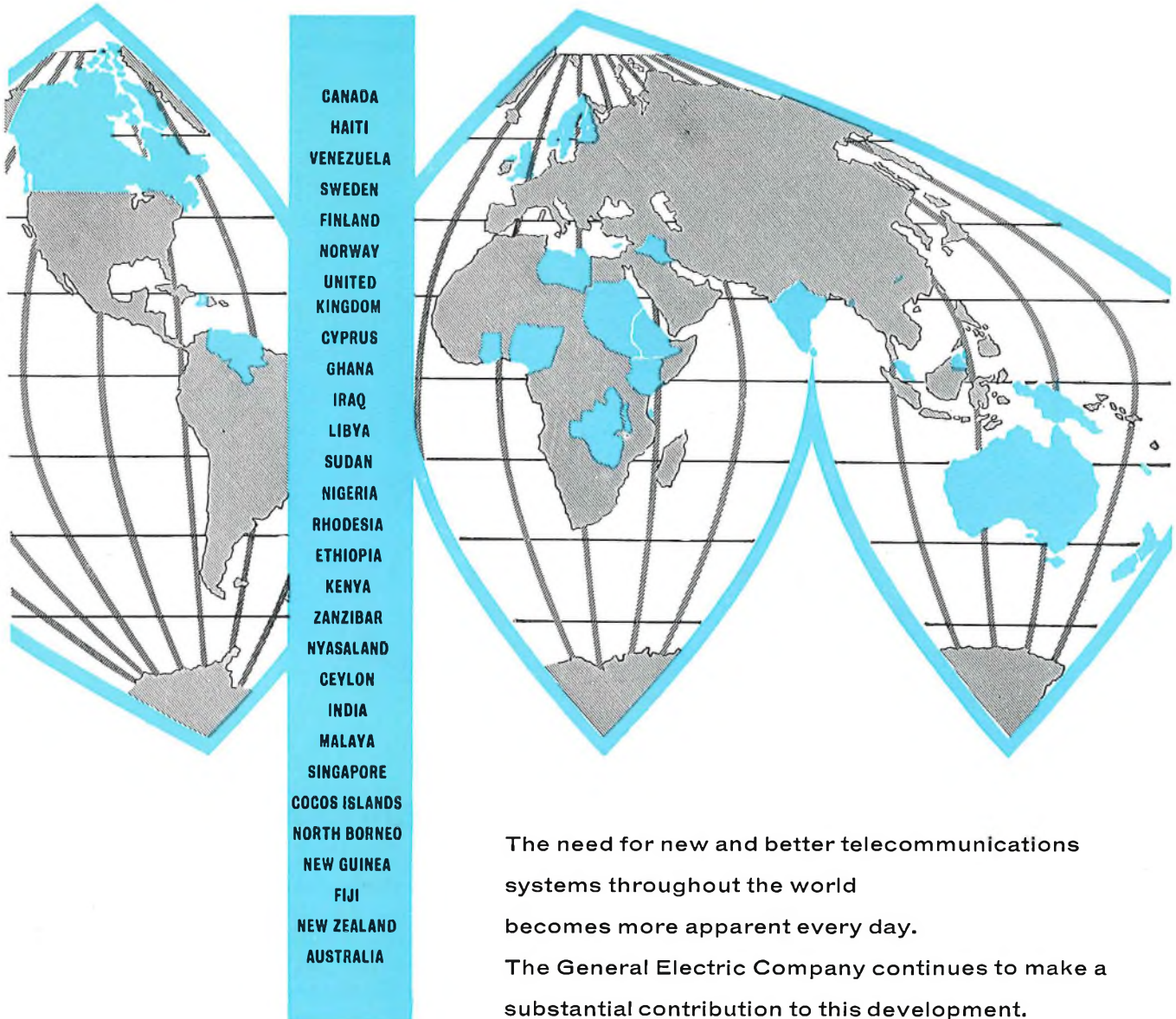

*EVERYTHING FOR TELECOMMUNICATIONS*

Please write for further information to  
**THE GENERAL ELECTRIC COMPANY LIMITED OF ENGLAND**  
 TELEPHONE WORKS · COVENTRY · ENGLAND  
 Works at Coventry · London · Middlesbrough · Portsmouth

# PROPAGAS

PROPANE

carries weight  
in the  
building industry

Propane and Butane are now available to industry from the great British refineries of the Shell, Eagle and BP Groups. They are petroleum gases delivered and stored as liquids under moderate pressure. The Chinook Heater operated on **Propane** is ideally suited for drying out of buildings, heating workshops, stores, repair sheds and working in open sites, also for preheating frozen plants and equipment.

*For full details of these and other products including Floodlighting and Space Heating equipment, apply now to :*



**SHELL-MEX AND B.P. GASES LIMITED**

(Regd. users of trade marks)

"The biggest distributors of Propane in the U.K."

CECIL CHAMBERS 76-86 STRAND LONDON WC2 Telephone: TEMple Bar 1234



# SUBSCRIBER TRUNK DIALLING METERS

Adopted for the new scheme for the United Kingdom and commencing at **BRISTOL**, these counters are part of a British-made range available for telephone and other systems. The designs are based on extensive Continental experience.

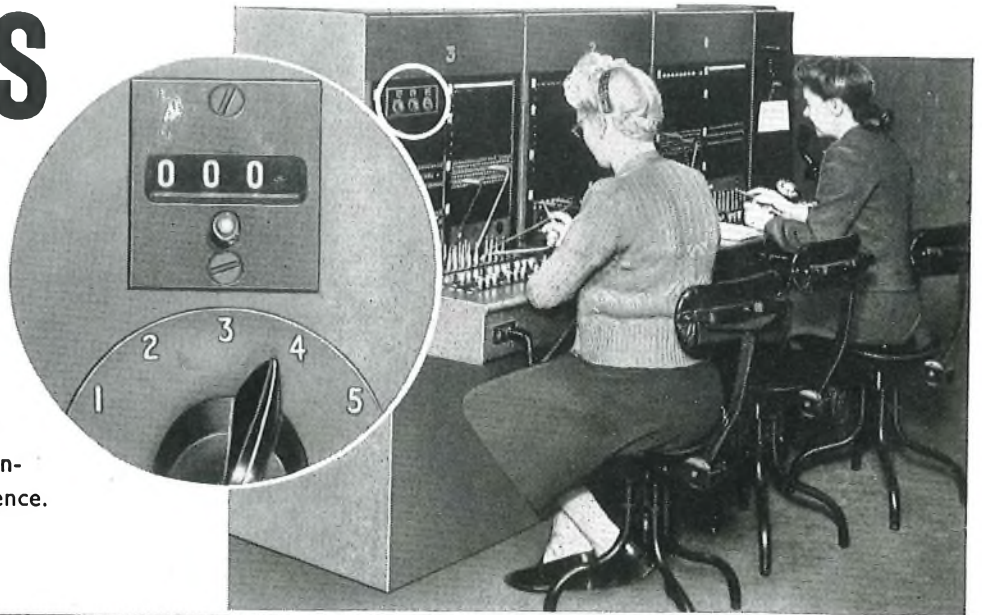

**STONEBRIDGE**  
CONTROLS & INSTRUMENTS

**THE STONEBRIDGE  
ELECTRICAL CO. LTD.**

6 Queen Anne's Gate · London · S.W.1  
Telephone: TRAfalgar 1444

Agents and Licensees in U.K. for 'SODECO' Geneva



**PIRELLI GENERAL**  
CABLE WORKS LTD.

PAPER INSULATED TRUNK CABLES  
TELEVISION CABLES  
RADIO FREQUENCY CABLES  
COAXIAL CABLES

PIRELLI-GENERAL CABLE WORKS LIMITED, SOUTHAMPTON



Designed, primarily for use by private and public telephone operators and approved by the G.P.O., STC Lightweight Headsets are now being widely used for other applications. Authorities and operators concerned with audio monitoring and control have quickly recognized the advantages in comfort and sensitivity provided by this new design.

## Wider use for **STC Lightweight Headsets**



*STC Lightweight Head Receiver in use at Broadcasting House. These instruments have been adopted by the B.B.C. for use in their London and provincial studios.*



*At London Airport, B.E.A. Apron Control have recently reorganised their communication facilities to cater for their 400 air movements a day peak load. The controllers use STC Lightweight transmitter/receiver headsets to assist them with strain-free operation.*

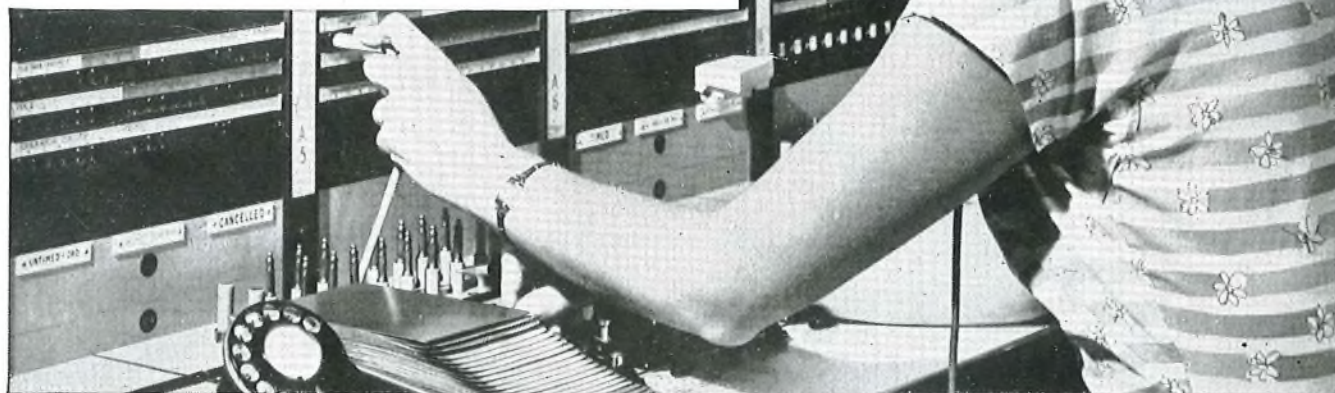

The "Rocking Armature" principle which gives improved sensitivity and frequency response—an important STC development in telephone receiver design—has been incorporated into these instruments.

The main advantages of this STC product are: extraordinary light weight, a high degree of comfort, stability and manoeuvrability and constant level of transmission regardless of head movement. Available in black or ivory nylon plastic which is virtually unbreakable.

*Write for Brochure D/104*



60/1D

# Standard Telephones and Cables Limited

Registered Office: Connaught House, Aldwych, London, W.C.2

TELEPHONE DIVISION: OAKLEIGH ROAD · NEW SOUTHGATE · LONDON N.11

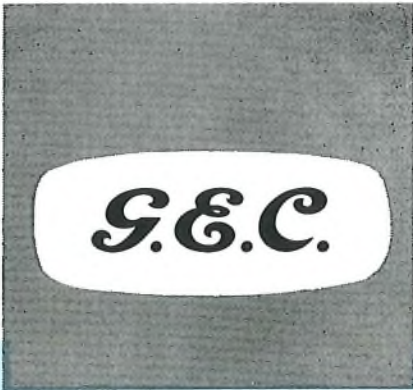

# Extension

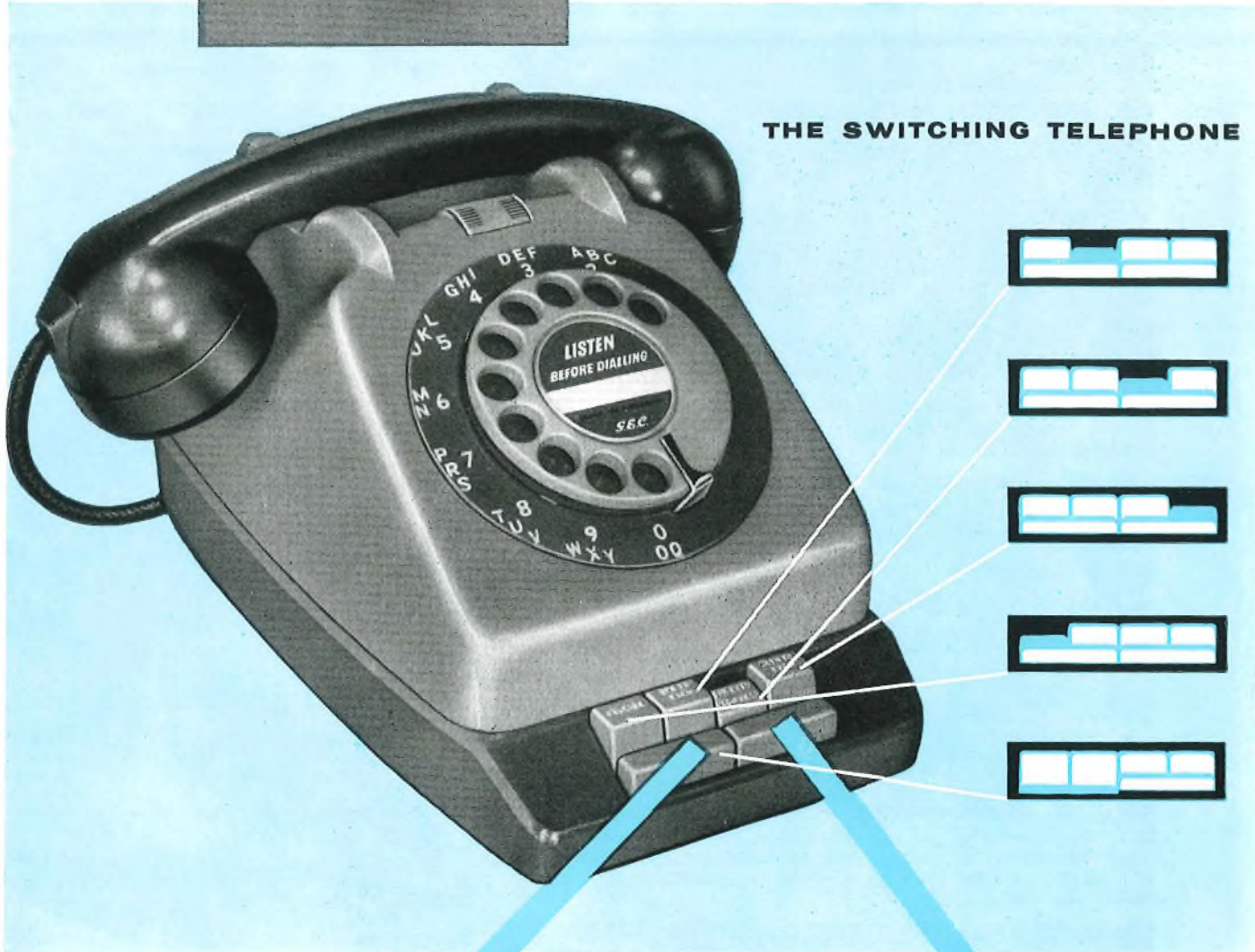

**THE SWITCHING TELEPHONE**



**THE EXTENSION TELEPHONES**



**THE GENERAL ELECTRIC COMPANY LIMITED OF ENGLAND**

WOR

# Telephone System

## **with 4-button operation**

### **Speak to Exchange**

Extension telephones cannot hear the conversation

### **Speak to Extension (Exchange held)**

Exchange line cannot hear conversation between main (switching) telephone and extension telephone.

### **Extension to Exchange**

The conversation can be secret or non-secret from the main telephone.

**Release** By depressing this button, the other buttons that have been engaged are released to their original positions.

**Twin keys** By depressing the appropriate key the required extension telephone is called.

This G.E.C. system permits two or three telephones to be associated on one exchange line using one switching telephone and one or two extension telephones. Exchange calls can be made or received by each telephone, as required. Alternatively, any of the telephones can converse independent of the exchange. The maximum line loop resistance between the main and an extension or between an extension and the exchange is 1000 ohms.

The system can easily be connected to any type of exchange, and is especially suitable for commercial organisations where a secretary can filter calls through the switching telephone to an executive and/or his assistant.

***These telephones were designed in conjunction with the British Post Office and are the only telephones accepted by the British Post Office giving full plan 5 and plan 7 facilities.***

*For further details please write to*

**AND • TELEPHONE WORKS • COVENTRY • ENGLAND  
AT COVENTRY • LONDON • MIDDLESBROUGH • PORTSMOUTH**

EVERYTHING FOR  
TELECOMMUNICATIONS

**G.E.C.**

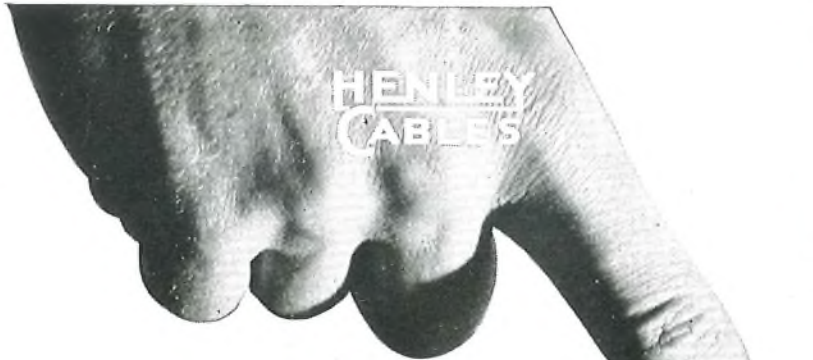

# A NEW SYMBOL FOR COMMUNICATION CABLES

In the communication cables field the new drum symbolises the combined resources of Henley, Liverpool Cables and Siemens Ediswan. For communication cables of all types—paper, plastic or textile insulated—small switchboard wires, local distribution and trunk type cables or composite co-axial cables—including loading coil accessories—A.E.I. leadership is unsurpassed. YOU CAN RELY ON A.E.I.

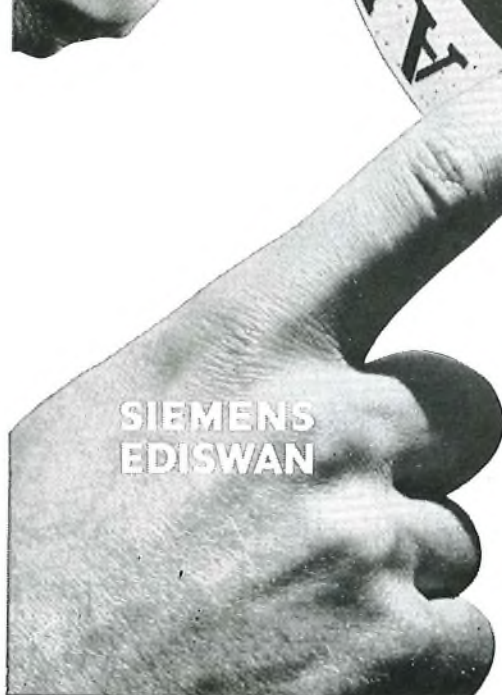

**AEI CABLE DIVISION**  
TELEPHONE CABLE DEPARTMENT  
Associated Electrical Industries Ltd.,  
Woolwich, London, S.E.18 Telephone: Woolwich 2020





*there's more than  
one form of protection . . .*

*A troop of Royal Horse Guards passing stacked G.V.C. Conduits ready for the diversion of the London G.P.O. cables, in preparation for the £5,000,000 Hyde Park improvement scheme.*

To protect vital electricity cables, telephone mains, television communications and the like from underground risks, **glazed vitrified clay conduits** do much more than provide the highest-known safety factors.

They ensure to the engineer responsible for the reliability of his project a peace of mind not past understanding. Today he has evidence—by tests in laboratory, by time and experience—there is no adequate substitute for

#### GLAZED VITRIFIED CLAY CONDUITS

*For information write to The Secretary,  
NATIONAL SALT GLAZED PIPE MANUFACTURERS' ASSOCIATION  
Hanover Court, Hanover Square, LONDON, W.1.  
Telephone MAYfair 0364.*

GLAZED VITRIFIED

CONDUITS

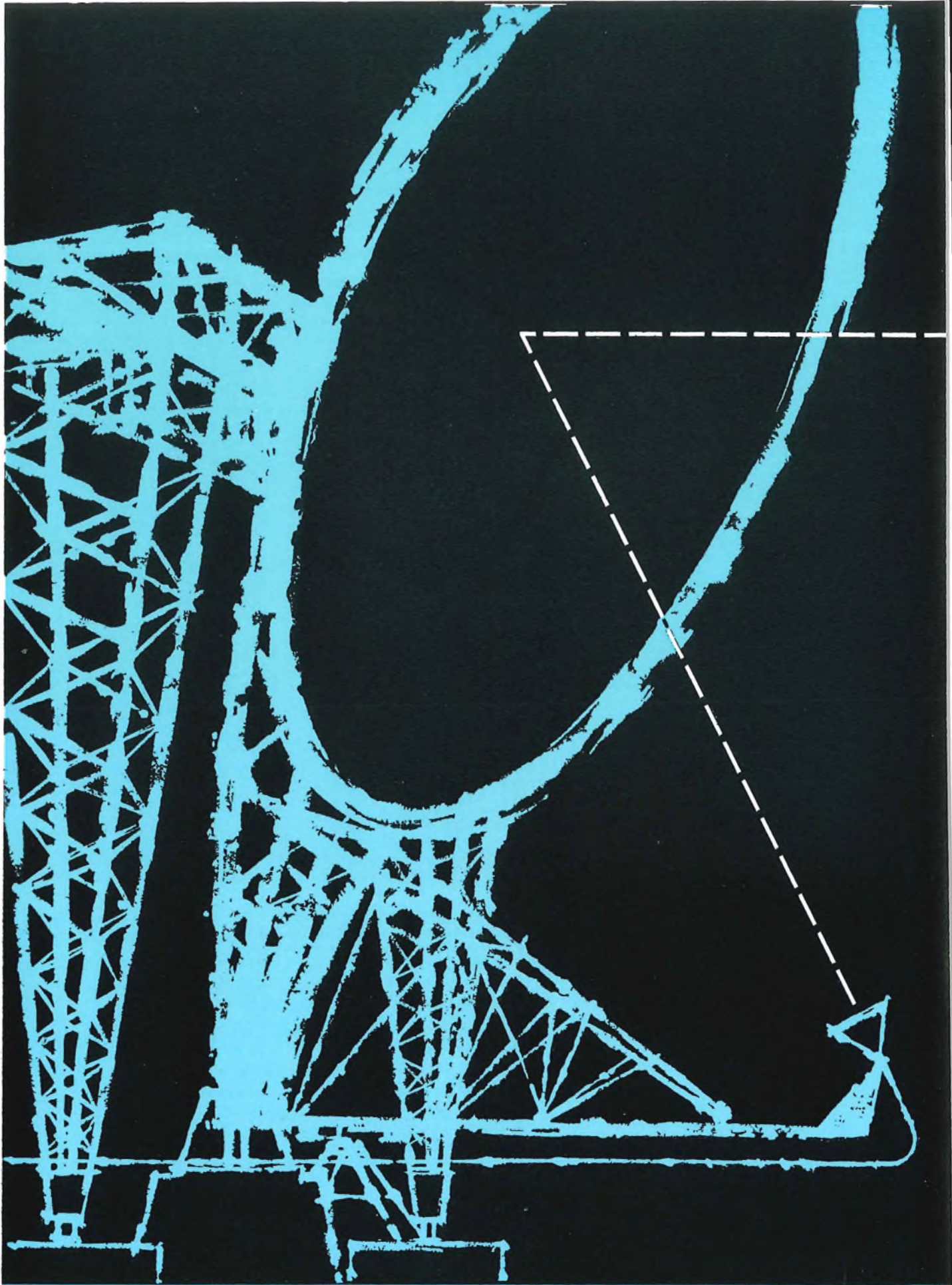

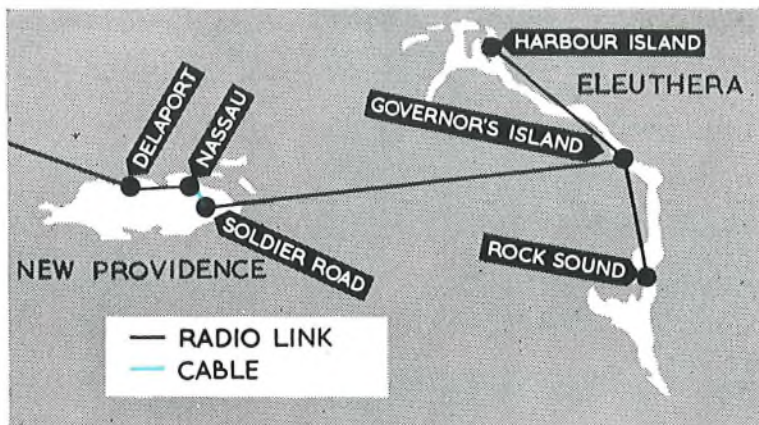

## STC O.T.H. in the Bahamas



STC high power, forward-scatter (O.T.H.) radio telephone equipment installed near Nassau is now operating as one end of a 72-circuit link which connects the Bahamas with the U.S.A. nation-wide telephone network. This STC equipment is working in conjunction with U.S. equipment installed in Florida. Signals are transmitted and received over a single 180 mile over-water path.

### *Coupled with Microwave and V.H.F. Radio Links*

The O.T.H. forward-scatter installation at Delaport is connected to the telephone exchange in Nassau City by a 7400 Mc/s line-of-sight microwave link. The flourishing tourist centres in the Eleuthera Islands are connected to Nassau City by a V.H.F. radio-telephone network comprising 3 links.

#### **STC have also supplied:**

- a 100 kVA diesel alternator standby power machine for the O.T.H. terminal;
- frequency multiplex channelling equipment;
- 4 telephone exchanges with a total of 22 switchboard positions.



60/4C

## *Standard Telephones and Cables Limited*

Registered Office: Connaught House, Aldwych, London, W.C.2

TRANSMISSION DIVISION: NORTH WOOLWICH . LONDON . E.16

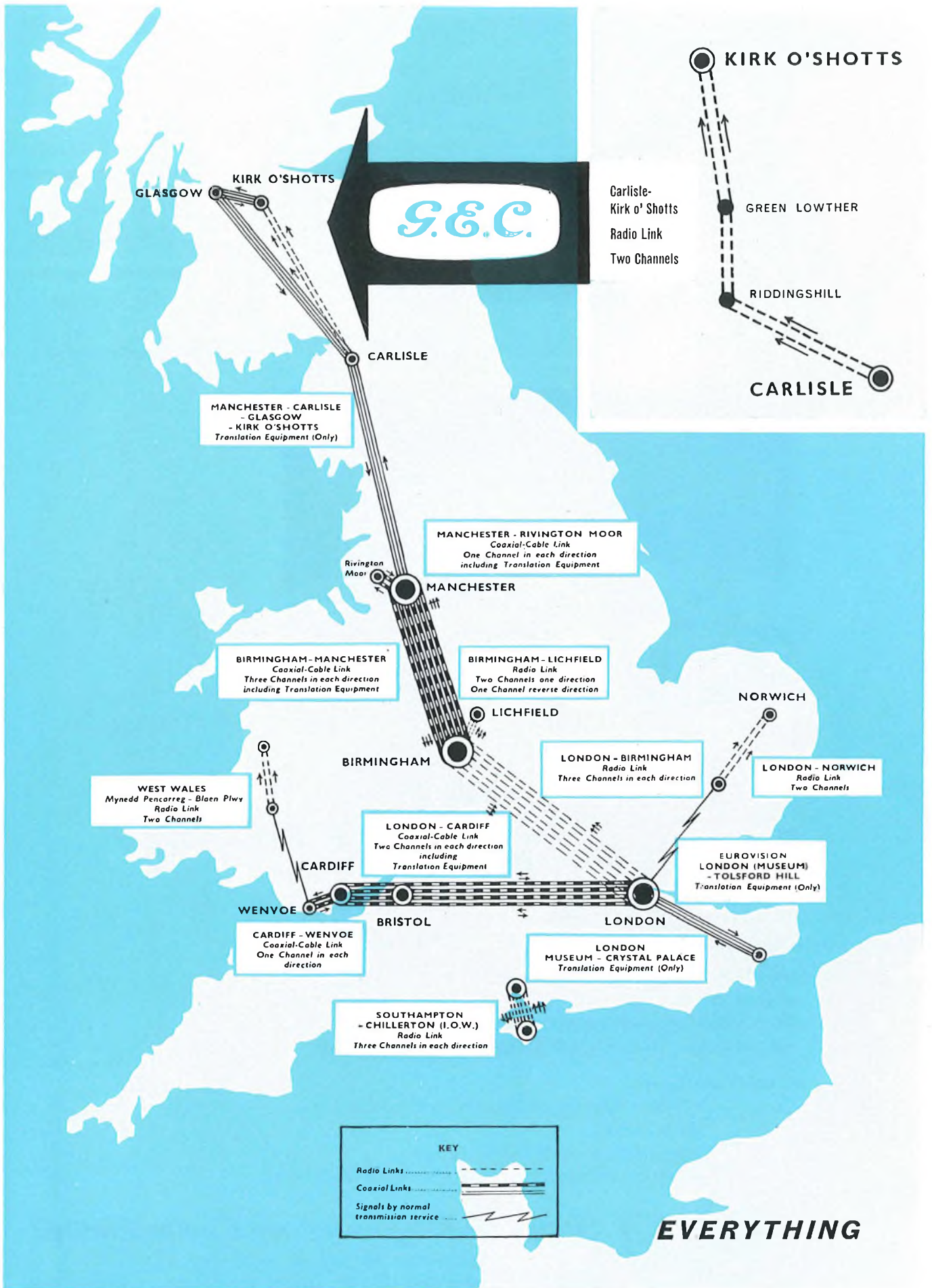





**SHF**

**Broadband  
Radio  
Equipment**

*selected by the*  
**BRITISH POST OFFICE for**  
**NEW TELEVISION LINKS**

GEC has been awarded the contract to supply and instal two television channels between Carlisle and Kirk o' Shotts. Operating in the 6000 Mc/s frequency band, the system will have repeater stations at Riddingshill and Green Lowther.

The equipment, which conforms to the latest CCIR recommendations, is capable of conveying either a television circuit or 960 speech circuits.

Ever since the introduction of its 2000 Mc/s radio equipment, the aim of GEC has been to develop a larger capacity equipment embodying the same high standards of performance and reliability, and the same ease of maintenance that have gained for the Company's UHF equipments so high a reputation with Telephone Administrations throughout the world.

Development of the new equipment began in 1954. It was found that our design objectives could not economically be achieved in the 2000 Mc/s band. Development was therefore transferred to the SHF bands, of which the 6000 Mc/s band was finally chosen because of our firm belief that within the next few years the 4000 Mc/s band would become increasingly congested. The present BPO contract has fully justified our earlier decision.

*For further information, please write for Standard Specification SPO 5555.*

**FOR TELECOMMUNICATIONS**

THE GENERAL ELECTRIC COMPANY LIMITED OF ENGLAND  
Telephone Works · Coventry · England  
Works at Coventry · London · Middlesbrough · Portsmouth



**G.E.C.**

**ERICSSON**  
presents the new

**MAGNETO-E TELPHONE**

● **CAN BE FULLY TROPICALIZED**

In this instrument, for use in Magneto Systems, the usual hand generator has been replaced by a static device — a Transistor Ringing Current Generator.

The MAGNETO-E TELPHONE, with carrying attachment, has the same attractive appearance and colour range as the new Etelphone.

A simplified method of signalling obviates the necessity for handle twirling. The ringing current generator is operated by means of a press button immediately in front of the handset and tone is heard in the receiver during ringing out. This feature greatly facilitates code ringing, essential when several telephones operate on a single line.

Of high over-all performance, this telephone incorporates the latest type induction coil and rocking-armature receiver, thus providing a transmission performance superior to that of other Magneto instruments. Side tone is maintained at a satisfactorily low level.

The instrument normally employs a 5000 ohm bell and under favourable working conditions, operation of 10 telephones per line is possible.

Advantage has been taken of the 6-volt source required for the generator, to supply the telephone transmitter via a resistor. This feature prevents damage to the transmitter during any circumstance of low transmitter resistance.

● **CONVERTIBLE TO WALL MOUNTING**

**IVORY**

**TWO-TONE GREEN**

**TWO-TONE GREY**

**CONCORD BLUE**

**TOPAZ YELLOW**

**LACQUER RED**

**BLACK**

FURTHER PARTICULARS ON REQUEST.

**ERICSSON TELEPHONES LIMITED — ETELCO LIMITED**

HEAD OFFICE:— 22 LINCOLNS INN FIELDS, LONDON, W.C.2. TEL. HOL. 6936.

WORKS:— BEESTON, NOTTINGHAM AND SUNDERLAND.



## Telecommunications Division

*Comprehensive Telecommunications Systems*

*Public Telephone Exchanges*

*Private Telephone Systems*

*Telephone Instruments and Apparatus*

*Marine Signalling Apparatus*

*Marine Radio Equipment*

*Carrier Telephone Systems*

*FMVF Telegraph Equipment*

*VHF Radio Telephone Terminals*

*Control and Indicating Apparatus*

### Associated Electrical Industries Limited

#### Telecommunications Division

WOOLWICH, LONDON, S.E.18



formerly the Telecommunications Division of  
SIEMENS EDISON SWAN LIMITED, WOOLWICH, LONDON, S.E.18





# Economy begins at the design stage



Free  
technical  
literature

## Eclipse

## permanent magnets



Made by the designers and manufacturers of Eclipse Permanent Magnet Chucks

JAMES NEILL & CO. (SHEFFIELD) LTD · SHEFFIELD · ENGLAND

M 25

# More

for less...

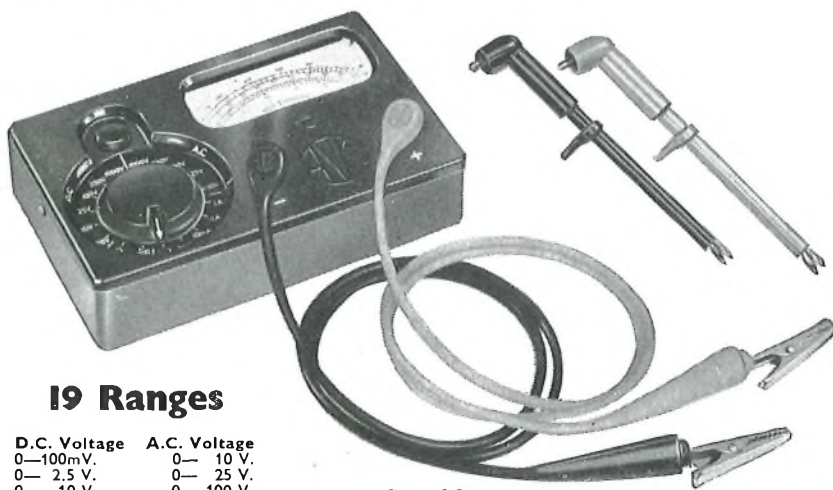

### 19 Ranges

<b>D.C. Voltage</b>	<b>A.C. Voltage</b>
0—100mV.	0— 10 V.
0— 2.5 V.	0— 25 V.
0— 10 V.	0— 100 V.
0— 25 V.	0— 250 V.
0— 100 V.	0—1000 V.
0— 250 V.	
0—1000 V.	
	<b>D.C. Current</b>
	0—100μA
	0— 1mA
	0— 10mA
	0—100mA
	0— 1 A
<b>Resistance</b>	
0—20,000Ω	
0—2MΩ	

List Price: **£9 : 10s.**

complete with test Leads  
and Crocodile Clips.

Leather case if required 39/-

Size 5½ × 3½ × 1½ in.  
Weight: 1 lb. approx.

**D**ESIGNED to offer the widest possible range of accurate and reliable measurements at the lowest possible price, the versatility and usefulness of the Multiminor are now further extended by specially designed leads. These new leads, available at no extra cost, will accept crocodile clips or PRODCLIPS.

The Multiminor takes full advantage of the possibilities of printed circuit techniques to achieve outstanding compactness and economy of weight. The scale is clear and open. The fine red coloured pointer and effectively damped movement facilitate easy and rapid reading.

For use in Radio, TV, Electronics, Motor Vehicles, domestic appliances, workshop equipment, you'll find the Multiminor a great little meter!

**Use PRODCLIPS with the Multiminor (Pat. No. 748811)**

These cleverly designed spring-loaded insulated prods are the complete answer to a long-standing problem. Press the trigger to open. release to grip. Keep your hands free no matter how difficult of access your test points may be! **15/- per pair**

...with the

# MULTIMINOR

Write now for illustrated literature to:

**AVO LTD**

AVOCET HOUSE · 92-96 VAUXHALL BRIDGE ROAD  
LONDON S.W.1

Victoria 3404 (12 lines)

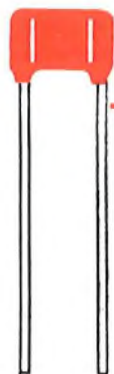

# NEW

# HIGH TEMPERATURE CAPACITORS

*efficient at* **250°C**

Type H precision silvered mica capacitors—the latest addition to the JMC range—are suitable for use from  $-70^{\circ}\text{C}$  to  $+250^{\circ}\text{C}$ . Silicone rubber protection safeguards their outstanding performance at very high operating temperatures.

- ★ Fired construction
- ★ Two standard sizes covering all values from  $5\mu\text{F}$  to  $50,000\mu\text{F}$
- ★ Minimum tolerance  $\pm\frac{1}{2}\%$  or  $\pm 1\mu\text{F}$  (whichever is greater)
- ★ Small physical size
- ★ Silver or silver-clad connecting leads

*Catalogue sheets describing the complete range of JMC precision capacitors are available on request*

**Johnson**  **Matthey**

**JOHNSON, MATTHEY & CO., LIMITED**  
73-83 HATTON GARDEN, LONDON, E.C.1 Telephone: Holborn 6989  
Vittoria Street, Birmingham, 1. Telephone: Central 8004  
75-79 Eyre Street, Sheffield, 1. Telephone: 29212



**SIEMENS**

## Faster and More Accurate Measurements

using

### Carrier-Frequency Level Measuring Equipment 3D 335/W518

10 kc/s to 15 Mc/s —100 dBm to +30 dBm

for co-axial and broad-band radio link systems.  
— multi-channel telephone and television programme exchange —

- \* Crystal-controlled electronic frequency lock-in system gives frequency accuracy of  $\leq 2 \times 10^{-5}$  on oscillator and detector
- \* **Coarse and fine** frequency control of level meter automatically tuned from the level oscillator
- \* Provision for electronic sweeping
- \* Noise-level measurements

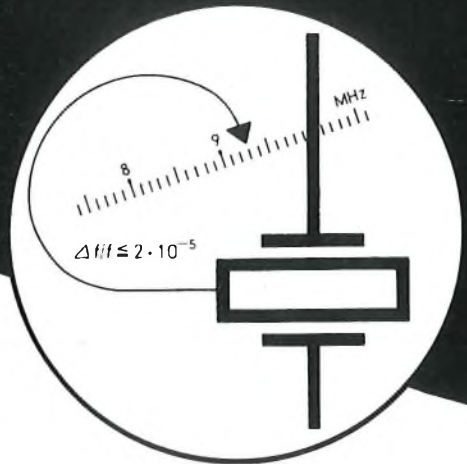

#### Level Oscillator 3W 518

Frequency range on one scale . . . . . 10 kc/s to 15 Mc/s  
continuously variable or in locked-in 100 kc/s steps  
Additional fine control . . . . . 0 to 100 kc/s  
Sending level continuously variable —60 dBm to +10 dBm



#### Selective Level Meter 3D 335

Tuning continuously variable or in locked-in steps, internally or externally . . . 10 kc/s to 16.8 Mc/s  
Additional fine tuning, internally or externally . . . . . 0 to 100 kc/s  
Measuring range . . . . . —100 dBm to +30 dBm  
Pass-band, switchable . . . ≙ channel width or  $\pm 100$  c/s



Test Gear combinations also available  
for other measurements and frequency ranges

SIEMENS & HALSKE AKTIENGESELLSCHAFT

MÜNCHEN · BERLIN

Authorised U. K. Agents

**R. H. COLE (OVERSEAS) LTD.**

2, Caxton Street, Westminster, London, S. W. 1 · Telephone: ABBey 3061 · Telex: 23864

# HIGH SPEED AUTOMATIC MORSE EQUIPMENT



## Keyboard Perforator Model 50

Provided with locking device which prevents the simultaneous depression of two keys. Max. operating speed 750 characters per minute.

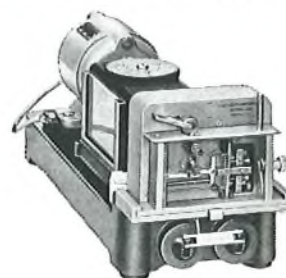

## Transmitter Model 112

Speed range 13-250 words per minute. For training schools model 113 having a speed range of 5-35 words per minute is recommended.

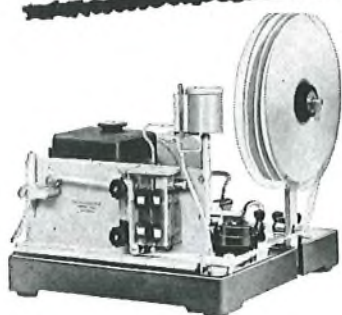

## Undulator Model 309

Max. operating speed 300 words per minute. Other models available with double recording part and with amplifier/rectifier for tone frequency signals.

# G.N.T.

## Reperforator Model 451

A truly synchronous receiver which produces a perforated tape similar to the one used for transmission. Normal speed range 40-200 words per minute.

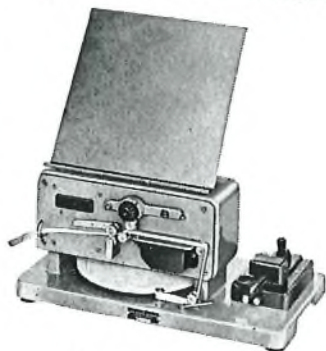

## Morseinker Model 1515

Used for training purposes. Motor-driven. Also available with built-in amplifier/rectifier for tone frequency signals. Spring-driven models also available.

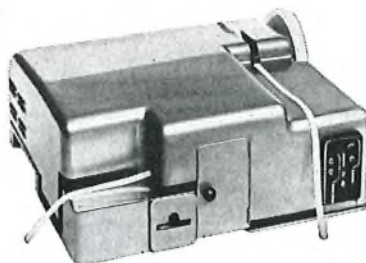

## Converter Model 2201

For the conversion of a perforated Morse Code, or Cable Code, tape into a perforated 5-unit Code tape or into 5-unit signals at standard teleprinter speed.

## Converter Model 2206

For the conversion of a perforated 5-unit Code tape into a perforated Morse Code, or Cable Code, tape.



# GREAT NORTHERN TELEGRAPH WORKS

DIVISION OF THE GREAT NORTHERN TELEGRAPH CO. LTD.

4, SYDHAVNS PLADS  
COPENHAGEN SV, DENMARK

LONDON OFFICE: 5, ST. HELEN'S PLACE  
LONDON E. C. 3.

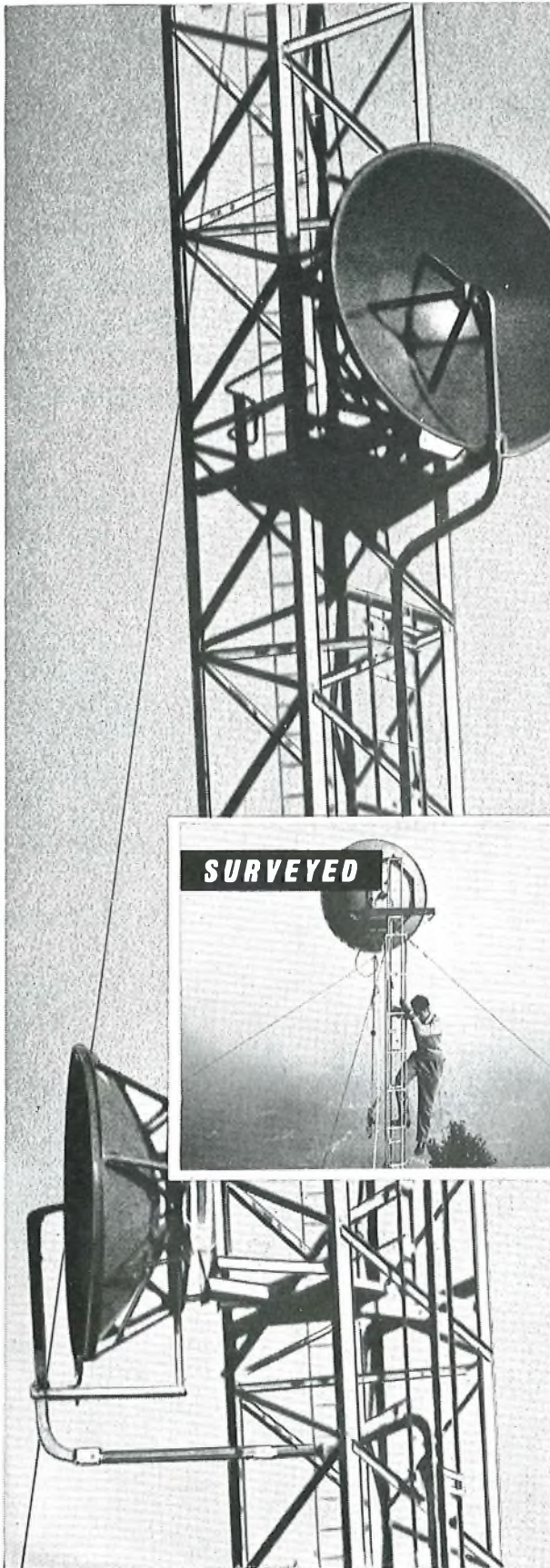

**MARCONI**  
microwave  
communication  
systems



**WORLD LEADERS IN  
ALL TRAVELLING WAVE TUBE  
MICROWAVE SYSTEMS**



## HIGH PERFORMANCE

Marconi microwave systems, with capacities from 60 to 960 channels and capable of carrying high quality television, are designed to meet exacting international standards of performance with margins in hand.

## EXTREME SIMPLICITY

Travelling wave tube techniques ensure extremely simple circuitry and make full use of high gain and great band width available. A unidirectional repeater consists of only three travelling wave tube amplifiers and one frequency change oscillator with their power supplies.

## GREAT RELIABILITY

The use of travelling wave tubes in the repeaters has allowed considerable reduction in the number of valves and components used. Thus the likelihood of unexpected failure has been considerably reduced.

## EASY MAINTENANCE

The design of the units ensures easy access to all parts of the equipment and the extensive use of printed circuitry allows speedy and accurate replacement of precision circuits by technician staff, without realignment of the equipment.

## EXTREME SAFETY

All high voltages are fully interlocked.

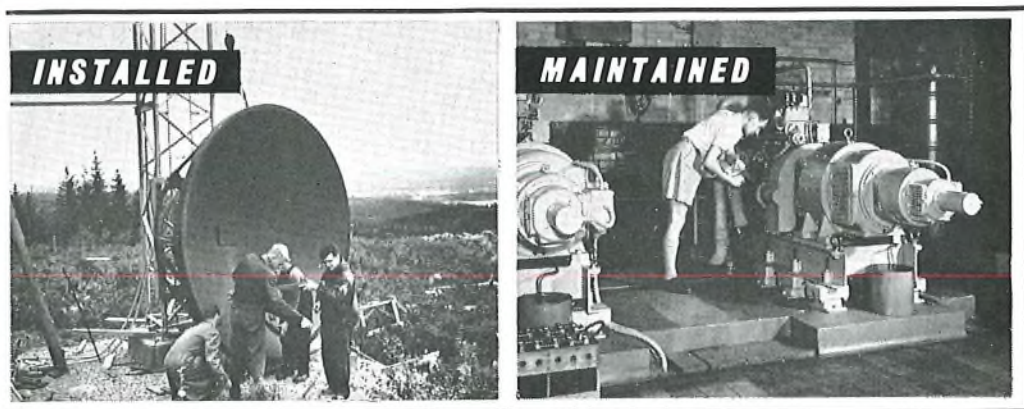

*The Post and Telegraph Authorities in  
more than 80 countries rely on*

**MARCONI**  
**COMMUNICATIONS SYSTEMS**

*High Capacity  
Mobile Microwave  
Systems*

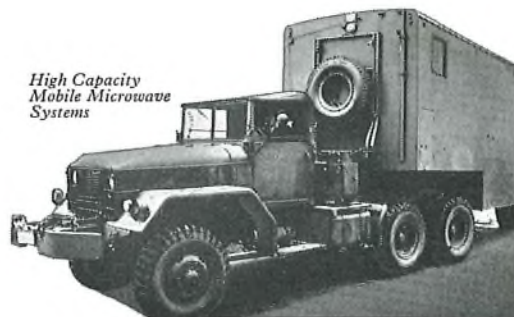

MARCONI'S WIRELESS TELEGRAPH COMPANY LIMITED · CHELMSFORD · ESSEX · ENGLAND

# SUCCESS linked with SUCCESS



The new microwave radio link in Canada between Saint John and Moncton was successfully opened for service, as scheduled, in December, 1959. This forms the first link of a new East coast microwave network undertaken jointly by The New Brunswick Telephone Company and the Maritime Telegraph and Telephone Company.

Already work is in progress on the next stage—the provision of similar microwave links between Moncton and Campbellton in the north and from Saint John to Halifax and Sydney in the east.

This extends the network to a total of 667 route miles, including a path of 49 miles over water, and comprises 30 terminal and 34 bothway repeater equipments. This provides an effective demonstration of confidence in G.E.C. microwave equipment.

The radio system operates in the 2000 Mc/s frequency band and provides a main and standby (protection) channel on all routes. In the event of failure or degradation of the working radio channel, changeover to standby is automatic. The capacity of each radio link is 300 speech circuits. When traffic increases and additional links are supplied, one standby will be used for several working channels. When required, the standby channel can be utilised to carry television signals.

The radio and multiplexing equipments used throughout the system were designed and manufactured by The General Electric Company Limited of England, and supplied and installed by Canadian General Electric Company.

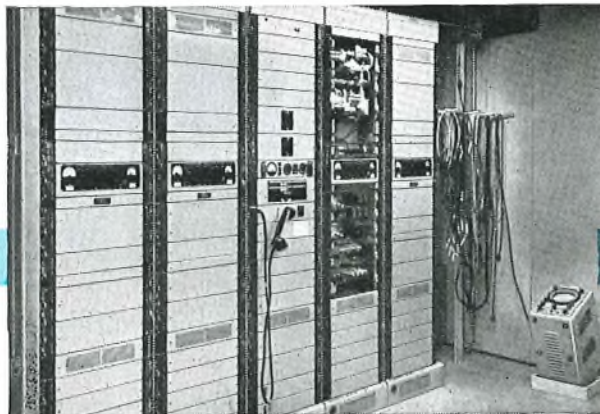

*For further information on the radio and multiplexing equipment, please write for Standard Specifications SPO.5502 and SPO.1370.*

*Everything for Telecommunications*

**THE GENERAL ELECTRIC**

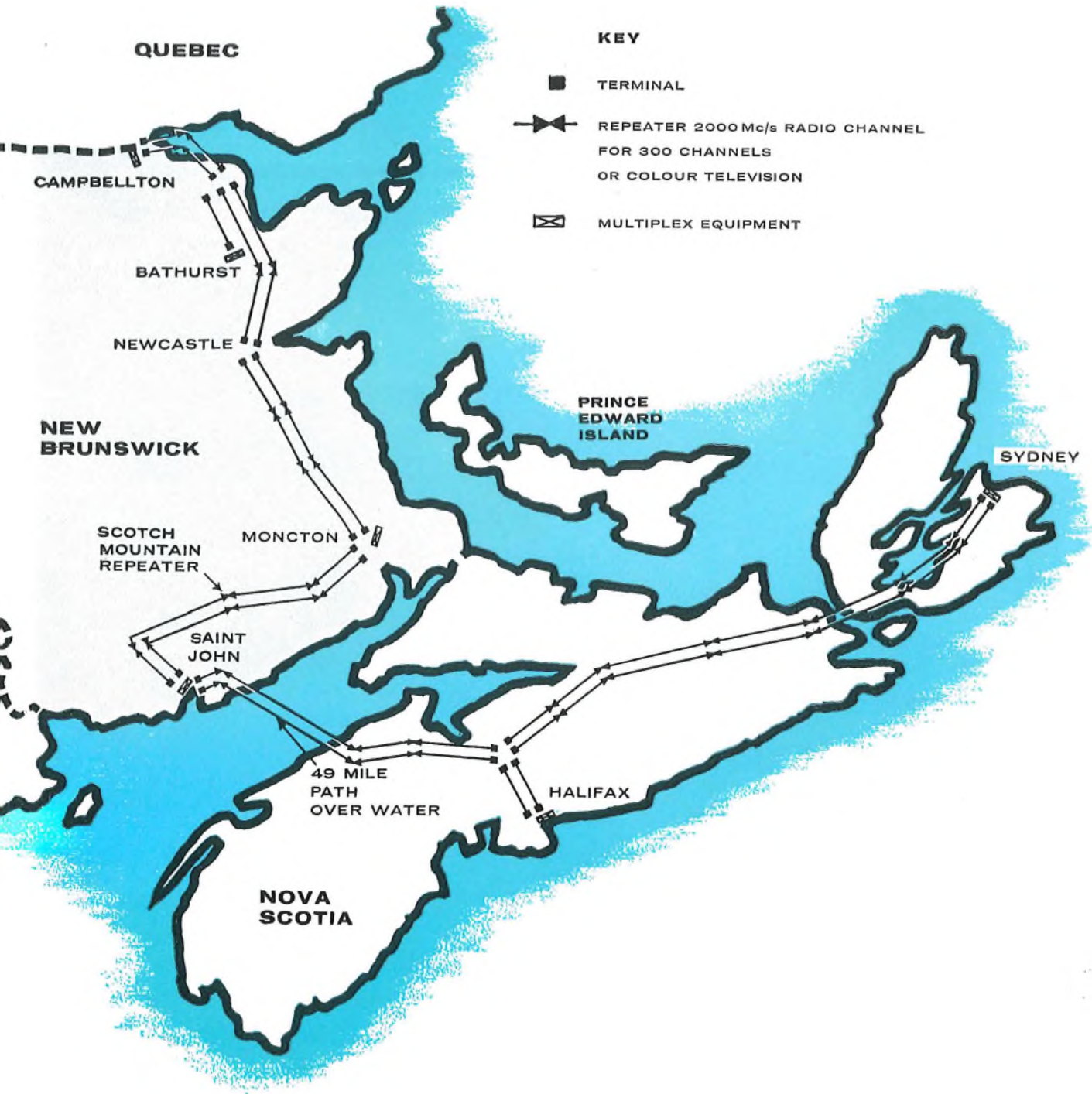

**COMPANY LIMITED OF ENGLAND**

TELEPHONE WORKS · COVENTRY · ENGLAND

*Works at Coventry · London · Middlesbrough · Portsmouth*



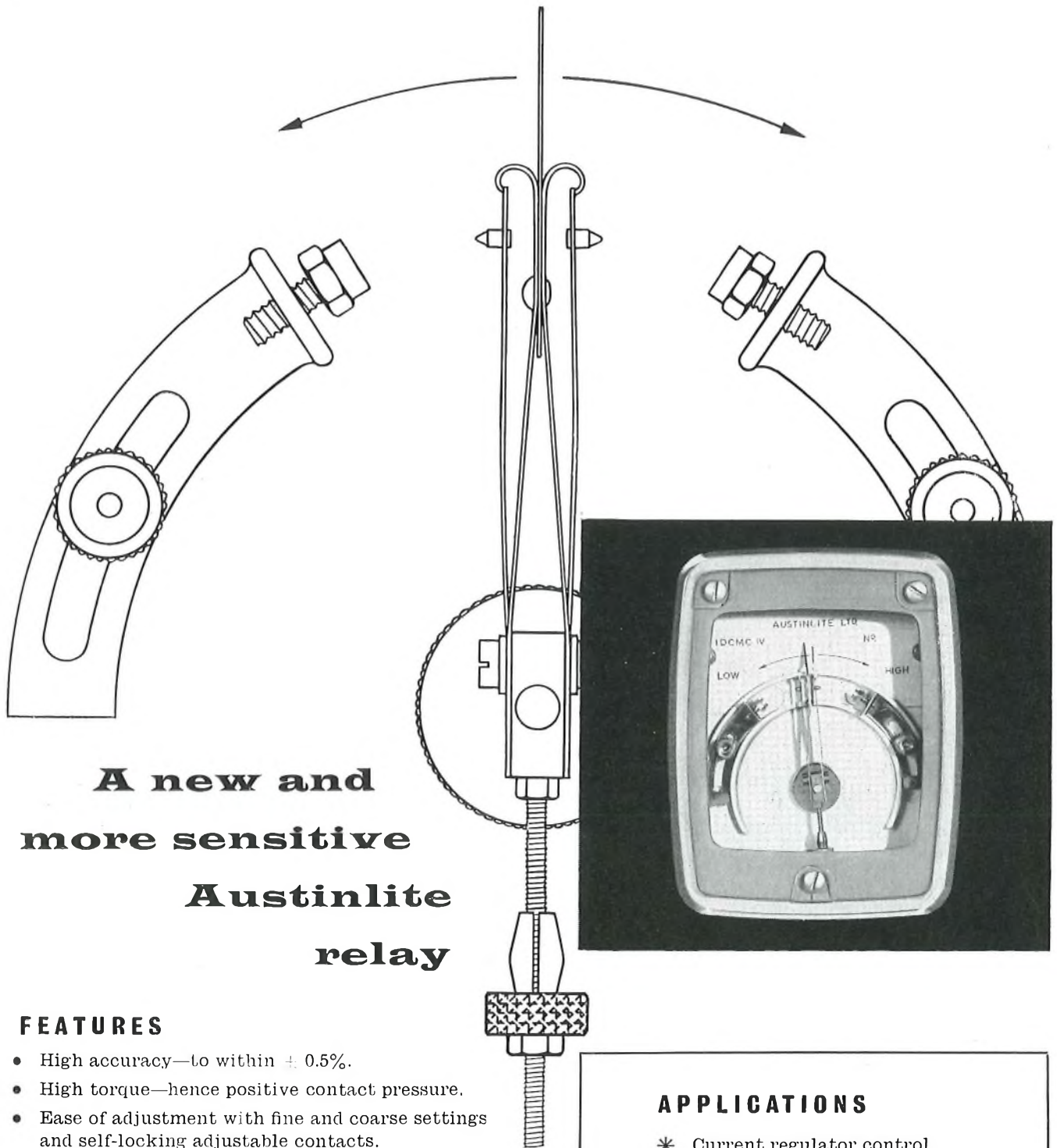

**A new and  
more sensitive  
Austinlite  
relay**

**FEATURES**

- High accuracy—to within  $\pm 0.5\%$ .
- High torque—hence positive contact pressure.
- Ease of adjustment with fine and coarse settings and self-locking adjustable contacts.
- Choice of either two or four adjustable contacts.
- Contemporary case design—projection or flush mounting.
- Dustproof and suitable for use in the tropics.
- Conforms to Post Office Specification P.T. 1025B.
- Suitable for current or voltage sensing on either D.C. or A.C.

**APPLICATIONS**

- \* Current regulator control.
- \* Voltage regulator control.
- \* Monitoring duties.
- \* Limiting duties.
- \* Equipment protection.

*Austinlite* ELECTRICAL EQUIPMENT  
Custom-built by **STONE-CHANCE LTD.**

(Makers of Sumo Pumps and  
Stone-Chance Lighthouses).  
CRAWLEY, SUSSEX.

These new STC complete packaged oscillator units represent a revolutionary step forward in crystal design. They are extremely small units for use as laboratory references or as the oscillator section of high performance equipment. The ruggedness of design together with the small size makes possible a degree of portability hitherto unknown in this type of unit. Standard frequency is 5 Mc/s.

*Write for Technical Data Sheets.*

**1 in  $10^9$  per day  
frequency  
standard for  
laboratories  
at £195**

*One of a new, low priced range of frequency standards from STC.*

- **Rugged**
- **Compact**
- **Light-weight**
- **Reliable**
- **Low Cost**



601MQ

***Standard Telephones and Cables Limited***

*Registered Office: Connaught House, Aldwych, W.C.2.*

**QUARTZ CRYSTAL DIVISION: HARLOW • ESSEX**

# A.T.E.

## Transistorised Transmission Equipment type C.M.

**FOR LINE, CABLE AND RADIO SYSTEMS**

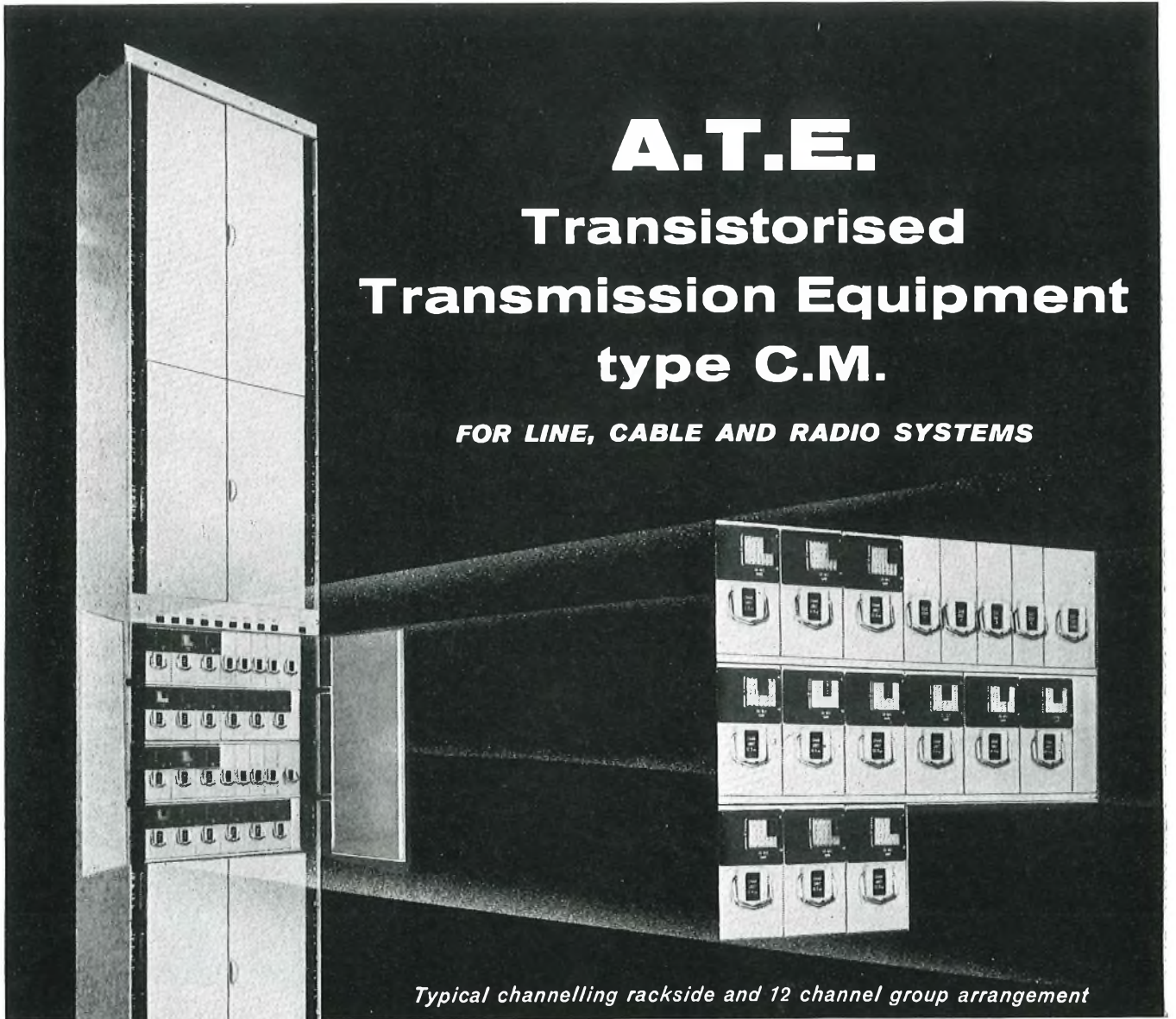

*Typical channelling rackside and 12 channel group arrangement*

- \* *Fully transistorised equipment, operation from mains or batteries.*
- \* *300-3400 c/s channel bandwidth, 4 kc/s spaced.*
- \* *60 channels per 9 ft. rackside complete with in-built outband signalling, 96 channels without signalling.*
- \* *Conforms to C.C.I.T.T. requirements in both transmission standards and mechanical dimensions.*
- \* *Straightforward installation and extension with minimum station cabling.*



**AUTOMATIC TELEPHONE & ELECTRIC CO. LTD.**

STROWGER HOUSE, ARUNDEL STREET, LONDON, W.C.2. 'PHONE: TEMPLE 9262

# VINKOR

Pot

Core

Assemblies

offer...

**adjustment of  $\pm 7\%$**

**with an accuracy of better than  $\pm 0.02\%$**

Any assembly in the Mullard Vinkor range can be easily adjusted to an accuracy of better than  $\pm 0.02\%$  by using a trimming screwdriver, whilst stability is ensured by the self-locking action of the adjuster core. The range of adjustment is approximately  $\pm 7\%$  about the nominal mid-position of the adjuster core. Over and above these advantages, for each size of core there is a choice of three permeabilities, which are controlled to close limits so that it is possible to calculate and wind an inductance to  $\pm 3\%$  of the value required before adjustment. These are just some of the reasons why leading equipment designers acclaim Vinkor as the world's most efficient pot core. If you have not received your copy of Vinkor data, write at once to the address below.



Mullard Ltd. Component Division, Mullard House, Torrington Place, W.C.1.

# The NEW Painton subminiature resistor type 70

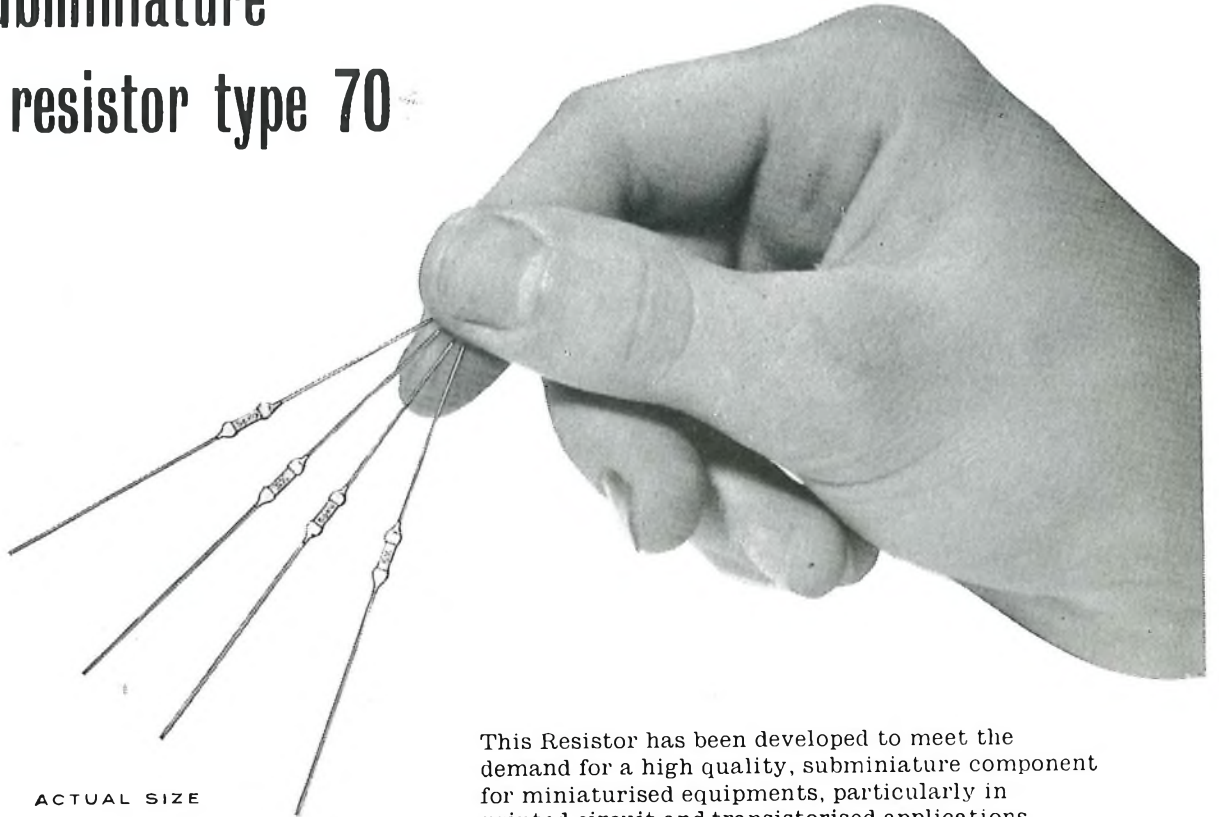

ACTUAL SIZE

This Resistor has been developed to meet the demand for a high quality, subminiature component for miniaturised equipments, particularly in printed circuit and transistorised applications where space is at a premium. The leads are pre-tinned to facilitate dip-soldering.

Resistance Range:	4.7 ohms to 330K ohms. (preferred values).
Tolerance:	5%, 2% and 1% (up to 100K ohms).
Rating:	$\frac{1}{8}$ W at 70° C.
Voltage Limitation:	AC: none within rated wattage. DC: 150 V.

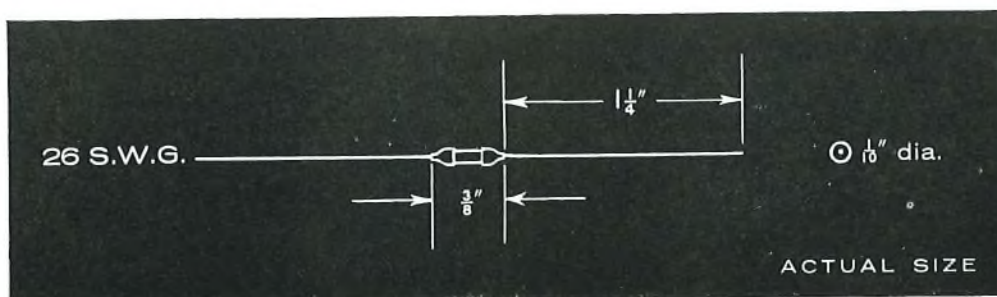

## Painton & Co. Ltd.

KINGSTHORPE · NORTHAMPTON

Tel: 34251 (10 lines) · Grams: 'Cell Northampton'



# ERICSSON MULTI-CHANNEL TELEGRAPH EQUIPMENT

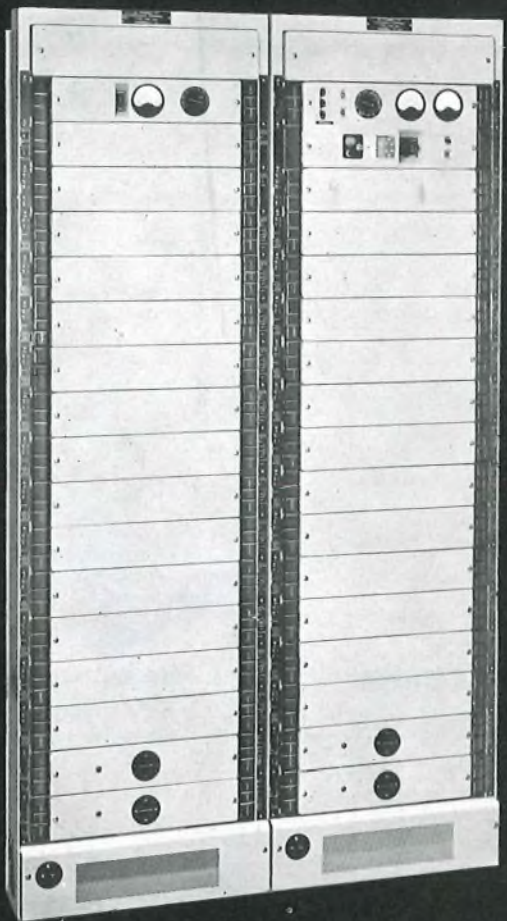

## FMT. 241

This FMT. 241 equipment provides 24 frequency modulated voice frequency telegraph channels to C.C.I.T.T. recommendations over any bearer having a bandwidth of 300-3400 c/s. It has considerable advantage over the equivalent amplitude modulated system under conditions of high noise and has a wider level range and lower distortion at higher signalling speeds. It is designed to work directly from double current (two path polar) telegraph signals but can be supplied with converters (loop control equipment) for use with single current (neutral) telegraph signals. Conversion to party line working is easy and suitable conversion equipment can be supplied for specific requirements.

The FMT. 241 equipment is mounted on plug-in panels carried on two 9 ft. racks equipped with full test facilities or two 6 ft. racks with reduced test facilities. Operation is from 90-260 V. 40-60 c/s. a.c. mains supply. Auxiliary equipment comprises a wall mounted 80-0-80 volt signalling supply furnishing up to 1.5 amps or alternatively a rack mounted supply of 700 mA. capacity.

A system using the FMT.241 equipment and giving party line facilities was recently developed and installed for International Aeradio (Caribbean) Ltd. This is the largest v.h.f. inter-island aeronautical system in the world, linking ten of the Caribbean group of islands from St. Kitts in the north to Trinidad in the south. Using only one telephone channel as a bearer circuit it serves some 25 telegraph offices or about 60 teleprinter installations.

VF Band	360-3240 c/s.
Basic channels	1140-2460 c/s.
Maximum Telegraph Speed	80 bauds
Telegraph Distortion (50 bauds)	3% (nominal)
Power Consumption	380 watts approx.
Rack Dimensions	2 bays 6' 0" x 1' 8½" x 8" or 2 bays 9' 0" x 1' 8½" x 8"



For further information please write to:

**ERICSSON TELEPHONES LIMITED — ETELCO LIMITED**

HEAD OFFICE:—22 LINCOLNS INN FIELDS, LONDON, W.C.2. TEL: HOL. 6936  
WORKS:—BEESTON, NOTTINGHAM AND SUNDERLAND

## INDEX TO ADVERTISERS

	PAGE
Adcola Products, Ltd. . . . .	4
Automatic Telephone & Electric Co., Ltd. . . . .	38
Associated Electrical Industries, Ltd. . . . .	6, 20, 27
Avo, Ltd. . . . .	28
British Institute of Engineering Technology . . . . .	4
Cathodeon Crystals, Ltd. . . . .	43
Cole, R. H., (Overseas), Ltd. . . . .	30
Ericsson Telephones, Ltd. . . . .	26, 41
Formica, Ltd. . . . .	7
General Electric Co., Ltd., The . . . . .	9, 14, 18-19, 24-25, 34-35
G. M. Power Plant Co., Ltd. . . . .	11
Great Northern Telegraph Co., Ltd. . . . .	31
Johnson, Matthey & Co., Ltd. . . . .	29
Marconi's Wireless Telegraph Co., Ltd. . . . .	32-33
Mullard, Ltd. . . . .	39
National Salt Glazed Pipe Manufacturers' Association . . . . .	21
Neill, James, & Co. (Sheffield), Ltd. . . . .	28
Painton & Co., Ltd. . . . .	40
Pirelli-General Cable Works, Ltd. . . . .	16
Pitman, Sir Isaac, & Sons, Ltd. . . . .	4
Pye Telecommunications, Ltd. . . . .	2-3
Shell-Mex and B.P. Gases, Ltd. . . . .	15
Smith, Frederick, & Co. . . . .	42
Standard Telephones & Cables, Ltd. . . . .	10, 17, 22-23, 37, 44
Stonebridge Electrical Co., Ltd., The . . . . .	16
Stone-Chance, Ltd. (Austinlite) . . . . .	36
Telephone Manufacturing Co., Ltd. . . . .	12-13
Tungstone Products, Ltd. . . . .	8
Turner, Ernest, Electrical Instruments, Ltd. . . . .	1
Westinghouse Brake & Signal Co., Ltd. . . . .	5
Whiteley Electrical Radio Co., Ltd. . . . .	11
Winn & Coales, Ltd. . . . .	42

for the right  
connection

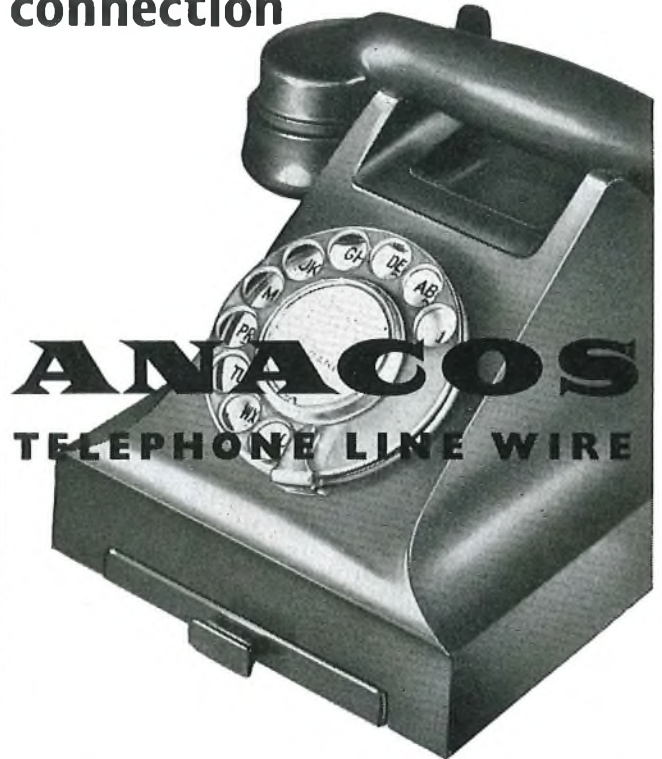

**FREDERICK SMITH AND COMPANY**  
ANACONDA WORKS · SALFORD 3 · LANC'S

# DENSO MASTIC H.D.

is essential for . . .

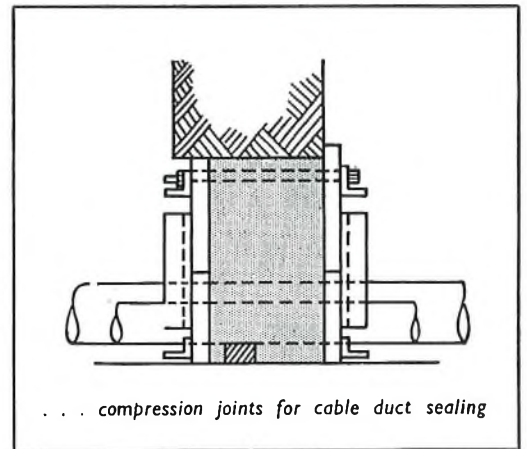
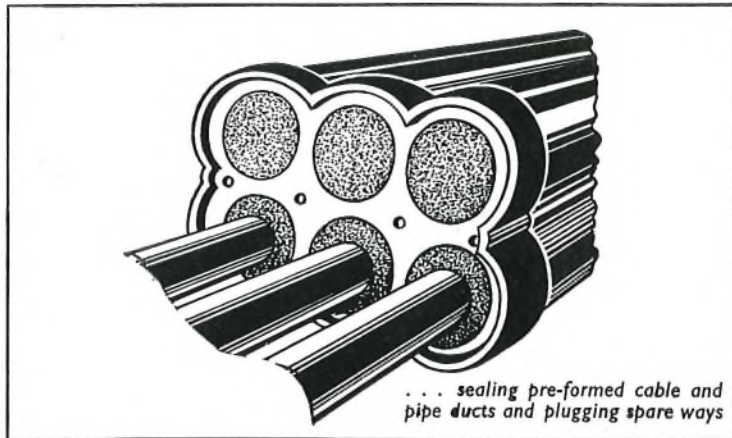

. . . plugging and sealing against air, gas and water. It meets the requirements of the several B.S. Codes of Practice and is adopted generally by Public Authority and Industry . . .

. . . and saves time, labour, money

**WINN & COALES LTD**

**LONDON**  
Tel.: GIPsy Hill 7511

**MANCHESTER**  
(also Contracting Dept.) Tel.: Sale 8271

**BELFAST**  
Tel.: 56623

**DUBLIN**  
Tel.: 61768

Agents throughout the Commonwealth

# PRECISE TEMPERATURE CONTROL

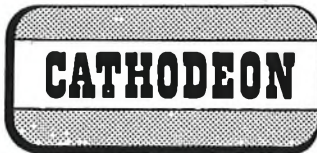

The latest addition to the range of thermostatically controlled ovens is this "plug-in" version, type B5. The Oven provides up to thirteen connections on an 18-way plug and is ideal for quartz crystals, diodes, transistors and other devices which are sensitive to ambient temperature changes.

Temperature Settings from 45°C to 85°C.  
Temperature differential better than  $\pm 1^\circ\text{C}$   
from  $-20^\circ\text{C}$  to the operating temperature  
less  $10^\circ\text{C}$ .

External diameter  $3\frac{1}{8}$ "  
Internal space  $1\frac{3}{4}$ " dia. x  $\frac{5}{8}$ "  
Power Supply 6v, 12v, or 24v.  
Weight 8 oz.

*Send for details of this unit or for any of our range of Ovens now available in production quantities.*

**CATHODEON CRYSTALS LIMITED**  
**LINTON CAMBRIDGESHIRE**

TELEPHONE LINTON 501 (4 lines)



# Conventional F.S.K. receivers outmoded by new

# STC

# RX5C

- The Standard RX5C represents probably the most notable advance in F.S.K. receiver design in the last decade.
- The whole concept centres round greatly increased "good-printing" time when compared to conventional limiter/discriminator techniques.
- Intensive study of field conditions has enabled some welcome technical features to be incorporated of particular interest to the discerning operator.
- The equipment is fully tropicalised to current governing user-specifications.
- A range of passband filters from 0.5 kc/s to 6 kc/s, variable frequency oscillator and Four-Frequency Duplex operation (F.6) are optionally available.
- Special attention has been paid to the use of "common valve" types and full self-checking circuit arrangements are incorporated to enable the operator to align and set up the receiver without external test apparatus.

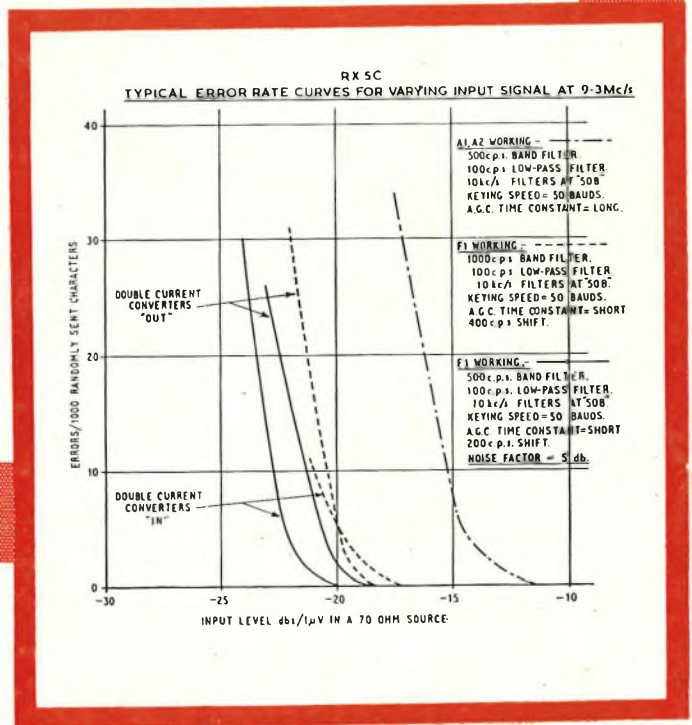

## Standard Telephones and Cables Limited

Registered Office: Connaught House, Aldwych, London, W.C.2

RADIO SYSTEMS DIVISION: OAKLEIGH ROAD · NEW SOUTHGATE · LONDON N.11