

THE POST OFFICE ELECTRICAL ENGINEERS' JOURNAL



Vol. 52 Part 4

JANUARY 1960

CONTENTS

	Page
SUBSCRIBERS' LINE CONNECTORS A. J. Barker, A.M.I.E.E., and E. Driver, A.M.I.E.E.	237
EMERGENCY TELEPHONES FOR THE LONDON-YORKSHIRE MOTORWAY G. Turner.....	243
AN ANALOGUE COMPUTER FOR INVESTIGATING THE DIRECTIVITY CHARACTERISTICS OF COMPLEX ARRAYS OF UNIT AERIALS—G. Mitchell, B.Sc.(Eng.), A.M.I.E.E.....	246
THE WORK OF THE JOINT POST OFFICE AND MINISTRY OF WORKS RESEARCH AND DEVELOPMENT GROUP—W. K. Mackenzie.....	251
THE SOUTH LANCASHIRE RADIOPHONE SERVICE L. T. Arman and V. C. Meller.....	253
MODEL ELECTRONIC EXCHANGE IN DOLLIS HILL LABORATORIES.....	260
WORKING ALOFT J. J. Moffatt, A.M.I.Mech.E., A.M.I.E.E., and E. W. Charlton, A.M.I.Mech.E.....	262
A NEW POWER PLANT FOR U.A.X.s No. 12 AND 13—POWER PLANT No. 214 D. H. Sander.....	265
THE LONDON-OXFORD-BIRMINGHAM 12 Mc/s COAXIAL LINE SYSTEM.....	270
DEVELOPMENT OF POSTAL SELF-SERVICE MACHINES S. Thompson, A.M.I.E.E.....	272
LABORATORY TEST EQUIPMENT FOR SYNCHRONOUS REGENERATIVE RADIO- TELEGRAPH SYSTEMS—R. P. Froom, B.Sc.(Eng.), A.M.I.E.E., F. J. Lee, B.Sc.(Eng.), A.M.I.E.E., C. G. Hilton and P. Mackrill.....	276
A SELF-TUNING INSERTION-LOSS MEASURING EQUIPMENT (10 kc/s–1.5 Mc/s) G. J. Crank, B.Sc.(Eng.), A.M.I.E.E., and H. A. Hathaway.....	280
MECHANIZATION OF THE INITIAL STAGES OF PROCESSING MAIL, Part 1—Segregation of the Various Classes of Mail—G. P. Copping, B.Sc.(Eng.), A.M.I.E.E., and T. R. Myers.....	286
REPEATER STATION TESTING METHODS AND EQUIPMENT C. E. E. Clinch, B.Sc.(Eng.), A.M.I.E.E., F.S.S.....	290
THE INSPECTION AND SUBSEQUENT TREATMENT OF RECOVERED STORES.....	295
NOTES AND COMMENTS.....	298
INSTITUTION OF POST OFFICE ELECTRICAL ENGINEERS.....	299
REGIONAL NOTES.....	300
ASSOCIATE SECTION NOTES.....	304
STAFF CHANGES.....	308
INDEX TO VOLUME 52.....	311
BOOK REVIEWS.....	242, 245, 250, 259, 261, 269, 271, 297

Price 2/6 net

THE POST OFFICE ELECTRICAL ENGINEERS' JOURNAL

Vol. 52 Part 4

JANUARY 1960

Subscribers' Line Connectors

A. J. BARKER, A.M.I.E.E., and E. DRIVER, A.M.I.E.E.†

U.D.C. 621.395.348

This article describes the more interesting features of the present designs of line connector; it deals with the economic considerations and explains how line connectors can help in providing telephone service. In particular, the article refers to the line connectors used by the British Post Office.

INTRODUCTION

IN a telephone system much of the plant is provided on a common-user basis, the scale of provision being dependent upon the busy-hour calling rate and the grade of service required. The local-line network, however, provides an individual pair of wires for each exclusive line, or pair of shared-service connexions. Generally, this plant is in use for only a small fraction of the day; indeed, many residential subscribers use their telephone only a few times a week.

Much of the growth of a telephone system can be expected to occur in the residential districts, which are often in the outer parts of exchange areas. The calling rates for many future subscribers will certainly be low and the revenue consequently small. Under these conditions, it will be increasingly difficult not to exceed the present costs of providing service and ways must be found of bringing about economies.

It would seem, therefore, that the line plant serving residential subscribers and other subscribers with low calling rates would lend itself to the application of common-user techniques. Such a proposal is made especially attractive when it is appreciated that local-line plant accounts for about 70 per cent of the cost of a subscriber's exchange connexion and involves a vast capital investment.

Various ways of using the local-line plant to better advantage have been tried but all have had their drawbacks. Line connectors are the latest attempt to make better use of the line plant by giving service to a number of subscribers via a common group of links.¹ The British Post Office, in common with other administrations, is installing line connectors.

OUTLINE OF SYSTEM

Ideally, all normal facilities should be available to subscribers served by a line connector and secrecy should be possible for exclusive connexions. The line connector

† Mr. Barker is a Senior Executive Engineer, Local Lines and Wire Broadcasting Branch, E.-in-C.'s Office, and Mr. Driver is an Assistant Engineer, Telephone Exchange Systems Development Branch, E.-in-C.'s Office.

should permit transmission of all normal tones and signalling conditions, including those required for subscriber trunk dialling (S.T.D.) and should be capable of working to any type of exchange. The permissible signalling and transmission limits appropriate to the exchange should not be reduced by the use of a line connector and the introduction of an additional switching stage should not introduce sufficient delay in setting up a connexion in either direction to cause unfavourable comment from the subscribers.

Present forms of line connector consist essentially of two switching units. One unit is mounted in the exchange and is termed the "exchange unit;" the other is installed at a suitable point in the local-line network and is termed the "subscribers' unit." The units are interconnected by pairs of wires called "links," which are switched to subscribers' lines when calls are made. Intercommunication between subscribers served by the same line connector is possible without special dialling procedure but utilizes two links. Subscribers connected to line connectors are given numbers on the exchange serving the area and use standard telephone instruments; individual metering for each subscriber is provided. Line connectors in certain circumstances are given distinctive exchange names.

DESIGN CONSIDERATIONS

Initiating a Call

The circuit operations which follow the initiation of a call fall, in existing types of line connector, into two basic categories. In the first, the subscribers' lines are joined to a single call-circuit associated with a link, and a loop connexion on any line causes a calling signal to be sent to the exchange unit. After the calling-subscriber's line has been identified, it is connected to the link; the other subscribers' lines being transferred to another call-circuit. In the second category, each subscriber's line has in the subscribers' unit a calling relay operated by a loop and which, when operated, extends a start signal to a control relay-set in the unit.

Selection Control

A number of methods are used to control the stepping of the selectors in the exchange and subscribers' units. An important consideration in deciding which method to adopt is whether or not there is a source of power at the subscribers' unit. If no power supply is provided, the equipment at the subscribers' unit must be capable of

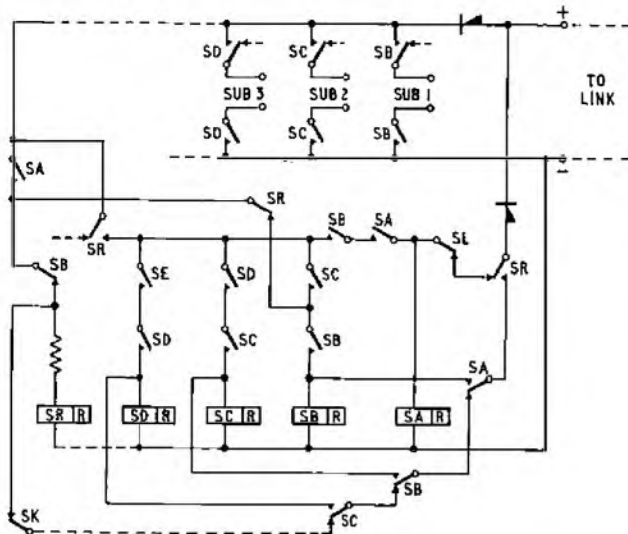

FIG. 1.—CIRCUIT ELEMENTS OF REMANENT-RELAY SELECTOR

being operated from the exchange battery and, unless a heavy-gauge power lead is to be employed, it must have low current consumption.

Remanent relays have been used satisfactorily in the subscribers' unit. These are like 3,000-type relays but have carbon-steel cores. When a remanent relay is energized by a pulse of current its armature is held operated by the residual magnetism in the core. It is released when a pulse of current is passed through its coil in a direction opposite to that of the energizing pulse. The elements of a remanent-relay selector are given in Fig. 1.

The calling condition is extended to the exchange unit (via a normal speech link if the subscriber served by the line connector is initiating the call) and causes current reversals to be transmitted in pulses of short duration over the link to the subscribers' unit. Rectifiers ensure that the reversed current pulses operate the remanent relays in cyclic order (SB, SC, SD, etc.) until the required line is found, when the two wires of the link are looped together and the selecting operation ceases. During the periods between the reversed current pulses, pulses of current in the normal direction release the remanent relays of subscribers' lines that have been found not to be the required one. The current reversals also operate a relay selecting device in the exchange unit, and the calling-subscriber's line, when found, is extended to his exchange calling equipment and he receives dial tone. It will be apparent that with this method the exchange calling equipment is not seized until the line connector has extended the calling-subscriber's line to it, and the operate time of the connector is thus added to the normal delay in receiving dial tone.

A similar method has also been proposed in which current pulses charge electrolytic capacitors which, between pulses, discharge into a light electromechanical device causing it to step.

Crossbar switches of low current consumption are also suitable for use in the subscribers' unit. In one design, the vertical switching bar associated with the pre-allotted link is held ready to receive a call. The origination of a call in either direction causes a combination of code relays to release and a combination of marker relays to operate. In conjunction with subscribers' control relays,

these marker relays operate the horizontal switching bar associated with the required subscriber's line. When the subscribers' and exchange units have been switched via a link, the code, marker and control relays release and are available for connecting the next call. Control of this line connector is not exercised over the speech links but over special control wires. Power for operating the relays is supplied via one of these wires but, to meet the additional load required by the crossbar-switch magnets, electrolytic capacitors are used as a power reservoir.

If a power supply is provided in the subscribers' unit, more-conventional selecting circuits are used. Uniselectors are employed in both subscribers' and exchange units, the banks being connected to the subscribers' calling relays and exchange calling equipment, respectively, while the wipers of both uniselectors are connected to a link circuit. Arrangements are then made to step both uniselectors in synchronism until a marked condition is found on the bank of one of them (dependent upon the direction of the call).

The control of stepping is exercised over special control wires or over the speech links. If the former method is employed, the saving in line plant is lessened, whereas if speech links are employed some unorthodox methods must be used to meet the desirable feature of having no equipment bridged across or in series with the line when the connexion has been made. With either method of control, it is possible to send a signal to the exchange calling equipment at the same time as the uniselectors in the line connector are stepping to the calling-subscriber's line. This obviates the additional delay in receiving dial tone mentioned earlier.

Clearing

With the remanent-relay selector, the removal of the calling loop causes current pulses to be applied again to the remanent relays until the cycle has been completed and the selector has returned to its original state.

Where separate control wires exist they can be used to transmit a clearing signal, but where control is effected over the links other methods must be used. An example is shown in Fig. 2. Two capacitors (C1 and C2)

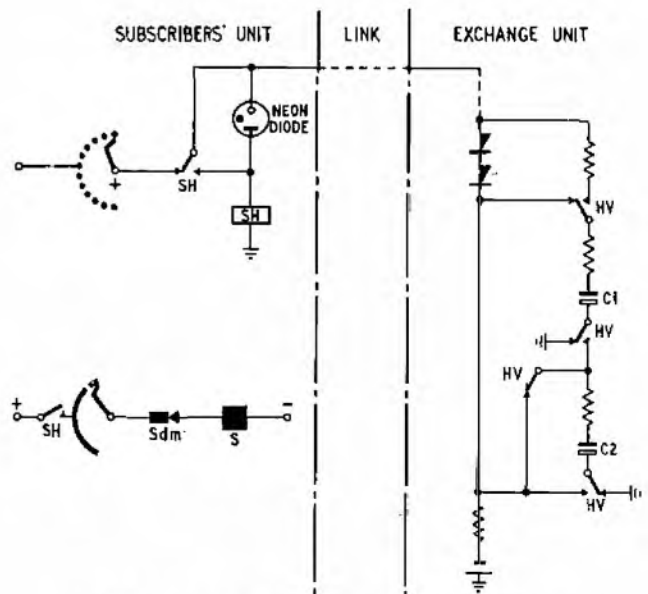

FIG. 2.—HIGH-VOLTAGE-PULSE CLEAR-DOWN CIRCUIT

are charged by the 50-volt supply. When a link circuit is being released, relay HV operates and the capacitors are connected in series to create a 100-volt potential which, when added to the 50-volt exchange battery, causes a 150-volt negative pulse to be sent over the positive wire of the link to strike a neon tube and operate relay SH in the subscribers' unit.

Exchange Calling Equipment

Some designs of line connector work on the principle of concentration only between the exchange and subscribers' units. Since, however, the number of connexions that can be made at one time is limited by the number of links, there is no need to provide more exchange calling equipments than there are links so long as suitable arrangements can be made to operate the appropriate subscriber's meter. This arrangement allows substantial saving in exchange calling equipment to be made in certain types of exchange. It may be required, however, to segregate certain subscribers from others on a line connector, e.g. coin-box lines. The facility has, therefore, to be available for giving any subscriber an individual exchange calling equipment.

Shared Service

It is inappropriate in principle to give shared-service facilities on a line connector as this offers little opportunity for further plant sharing and, indeed, the means of providing it may complicate the equipment. Nevertheless, it may be necessary for administrative convenience to provide means for shared service where line connectors are to be used in a system in which shared service is used extensively.

Power Supplies

Power at the subscribers' unit could be provided, if required, by a suitable unit operated from the mains or by batteries fitted in the unit. Mains supply may not necessarily be available at a site and may be costly to obtain. Primary batteries have a limited life and may be quickly exhausted under fault conditions. For secondary batteries there must be a means of charging them; this can be done over power-feeding lines but it reduces the line-plant saving. Alternatively, the speech links, when idle, can be used as charging leads. Traffic carried by the line connector has a compound effect on the charging arrangements in these circumstances because when a link is taken into use not only does it mean that current is consumed by a call in progress but also that the link cannot be used as a power lead. In the extreme, if all links are engaged either by genuine traffic or by a fault condition, no charging is possible and the whole load is taken from the battery. The charging rate over idle links should, therefore, be variable to compensate for the links being taken into use for traffic, and the battery should be of such capacity as to provide a reserve to cover the periods for which the load exceeds the charging current.

GRADE OF SERVICE

The line connector applies to line plant the basic principles of exchange switching. In fact, it can be considered as part of the pre-digital switching stage of the exchange, outstationed in the distribution network. Hence, just as the quantity of exchange equipment at all switching stages is adjusted to give a predetermined grade of service, so the subscriber/link ratio of the line

connector can be adjusted so that subscribers will receive virtually the same grade of service as that which would be given if they were connected to the exchange by an exclusive pair of wires.

The calling rate of the subscribers connected and the proportion of the traffic that is between two subscribers on the same connector (the "local" traffic) are the prime factors in determining the grade of service given. Fig. 3 (a) shows how calculated overall grades of service for line connectors of various sizes vary with traffic. The grades of service have been calculated assuming that the traffic is pure chance and that no local traffic occurs, and excluding switching losses in the exchange. Fig. 3 (b) shows similar curves assuming 10 per cent local traffic. It will be seen that to provide an acceptable grade of service, line connectors, especially those of the smaller sizes, should serve only subscribers with low calling rates.

ECONOMIC CONSIDERATIONS

When a line connector is used as an integral part of a cable network as a long-term measure, a new balance between line-plant costs and switching-plant costs is established. It is, therefore, necessary to compare the cost of a connector and its appropriate line plant with that of line plant provided by traditional methods. In other words, for each case considered, annual charges on a line connector should be less than the annual savings in line plant.

It is not possible to state precisely at what point line connectors will prove to be economic, and each proposal to use one or more line connectors requires individual study. Any case depends upon many factors, including the following:

- (a) The number of subscribers in the area or group considered.
- (b) The appropriate sales forecast.
- (c) The type of construction of line plant.
- (d) The distance from the exchange.
- (e) The existing plant.
- (f) Exchange equipment and accommodation considerations.

An examination of various telephone communities shows that line connectors are economic when about 2 route-miles of line plant to the exchange is involved. However, the amount and type of existing plant are important and obviously, if the need for augmenting the local-line network can be avoided by exploiting existing pairs by the use of line connectors, savings are possible even at distances much less than 2 miles. These values, of course, only apply to the British Post Office system and other telephone undertakings must examine proposals in the light of their relevant cost factors and policy.

The economics of an exchange-area layout can be affected by the provision of line connectors. As the distance from the exchange increases, so will greater economies in line plant be possible by the use of line connectors, resulting in a tendency to increase the size of the exchange area.

APPLICATION OF LINE CONNECTORS

There are three main fields in which the line connector is used. Firstly, the connector is of value as an expedient to overcome a temporary shortage of plant. Line connectors will often enable service to be given when provision by normal means cannot be undertaken for some considerable time. The criterion here is that the additional revenue from the subscribers should compen-

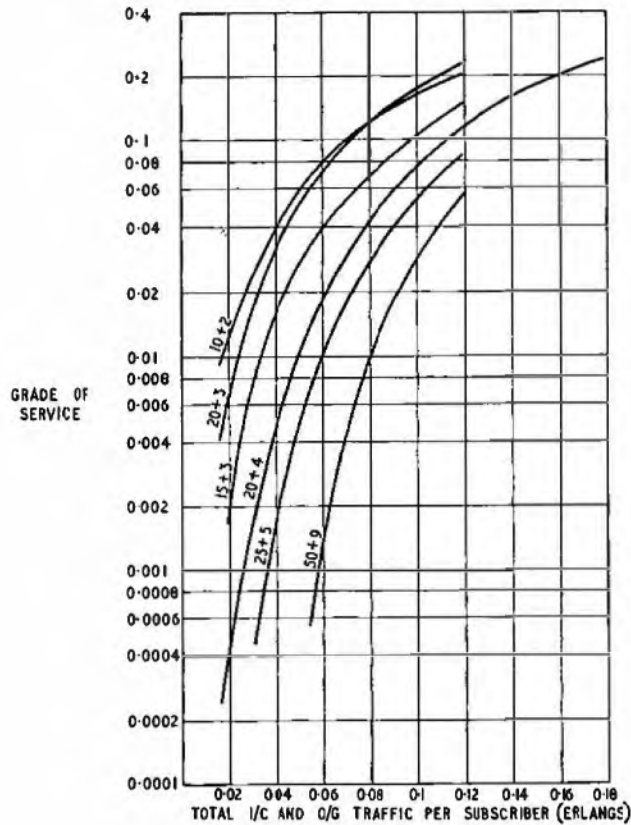

(a) No Local Traffic

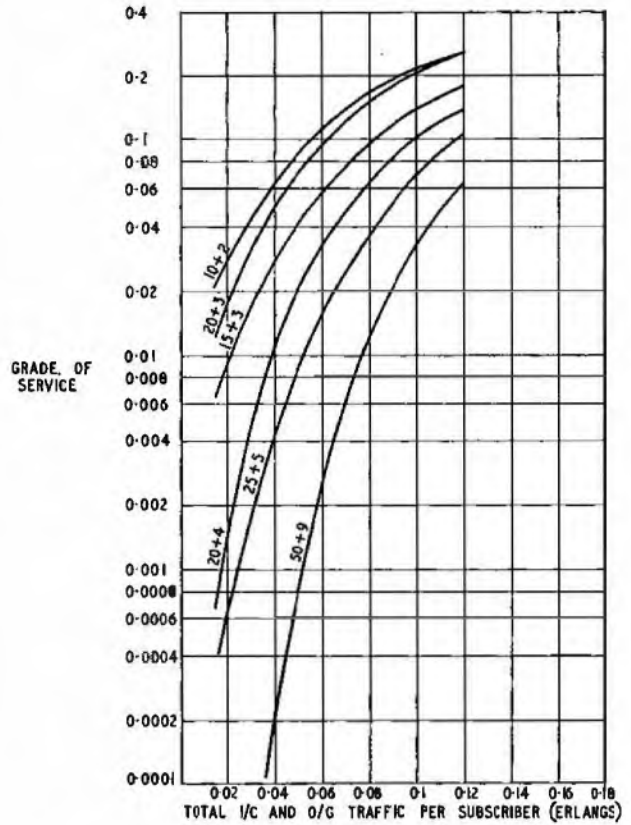

(b) Ten per cent Local Traffic

FIG. 3—GRADE OF SERVICE

sate for the cost of installation, the hire, and the ultimate recovery, of the line connector. Equally important is the good will which arises when delay is reduced. Secondly, line connectors can be incorporated as an integral and permanent feature of the local-line network, justified by normal costing. Thirdly, line connectors can be exploited as a means of replacing small manual and country-satellite exchanges, or as an alternative to a small unattended automatic exchange.

There are other uses, such as reducing maintenance charges on overloaded overhead routes by decreasing the number of wires, providing temporary service and, by the use of a suitable type of line connector, calling equipments can be saved in certain types of exchange.

Special conditions occur when a line connector is provided as an alternative to a small exchange. An important feature is the transmission limits. Links to a line connector from an existing exchange will form part of the local-line network and must conform with the local-line transmission standards of the exchange, whereas the same circuits, if converted to junctions serving a new exchange, must be made to conform with the standards applicable to junctions.

The planning officer is faced with an alternative method of providing plant and this he must consider on the basis of engineering requirements, economics or expediency. If a connector scheme is justified, its flexibility is important, i.e. its facility to allow for provision and cessation of telephone service within prescribed limits of a development forecast so as to make best use of individual pairs and connector connexions. Arrangements have been made to associate a cross-connexion assembly, as used

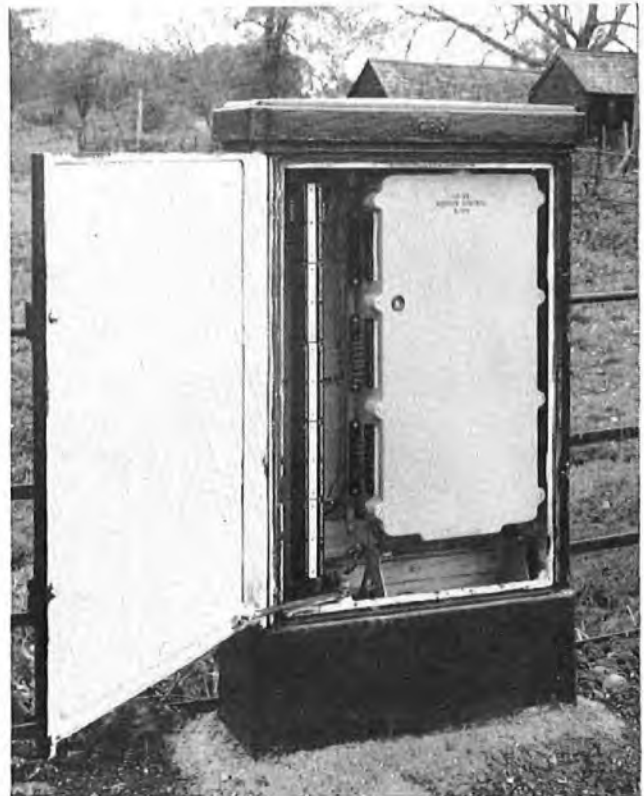

The subscribers' unit and cross-connexion assembly are shown mounted in a local-line distribution cabinet

FIG. 4—SUBSCRIBERS' UNIT

in local-line distribution pillars and cabinets, with the subscribers' unit. The present designs of line connector now in use in this country permit the installation of the subscribers' unit, with an assembly, in a cross-connexion cabinet of the smallest size (see Fig. 4).

Not all circuits in a given distribution area need to be connected through the line connector, and the assembly, if fitted, permits any subscriber's line to be served via the connector or over a direct pair of wires. Such an arrangement will facilitate a rearrangement of subscribers' lines, if the line connector should become overloaded.

Fig. 5 shows the alternative methods of providing service. It can be seen from the plans that by installing three Line Connectors No. 2 now and a further two in 1970 the existing network of aerial cable, with some small additions, can be made to meet the demand for the next 20 years, thus avoiding the expense of 1 mile of duct and cable, 2 miles of 50 pr., 10 lb/mile aerial cable and a pillar with its serving cable.

One of the difficulties that might be encountered in the widespread application of line connectors is the siting of the subscribers' unit. It would help matters if the physical dimensions of this unit could be reduced.

Line Connectors in Use in the British Post Office

The Post Office at present uses two types of line

connector. The Line Connector No. 1 serves 10 subscribers' lines, uses two links and employs the remanent-relay selection principle.² Its use is restricted by the transmission bridge in the speech circuit to areas without subscriber trunk dialling, although another version of this model has been developed in which the transformer has been dispensed with; remanent-relay selection has been retained only at the subscribers' unit, the exchange unit employing uniselectors. Savings in calling equipment are now possible with this later version.

The Line Connector No. 2 serves 22 subscribers over four links and uses standard uniselectors both at the subscribers' and exchange units.³ Power for the subscribers' unit is provided by a secondary battery which is charged over idle links. The charging is controlled by a resistance network which reduces the rate of charge as the battery voltage rises. Selection is by synchronized stepping of uniselectors and no separate control wires are required. The allocation of links is performed by a control circuit incorporating a un-selector, the wipers of which are arranged to be standing on a free link. The exchange calling equipment is seized as soon as the link is seized and the delay to the subscriber in receiving dialling tone is thus minimized. Savings in calling equipment are possible.

Both these types of line connector permit a 1,000-ohm

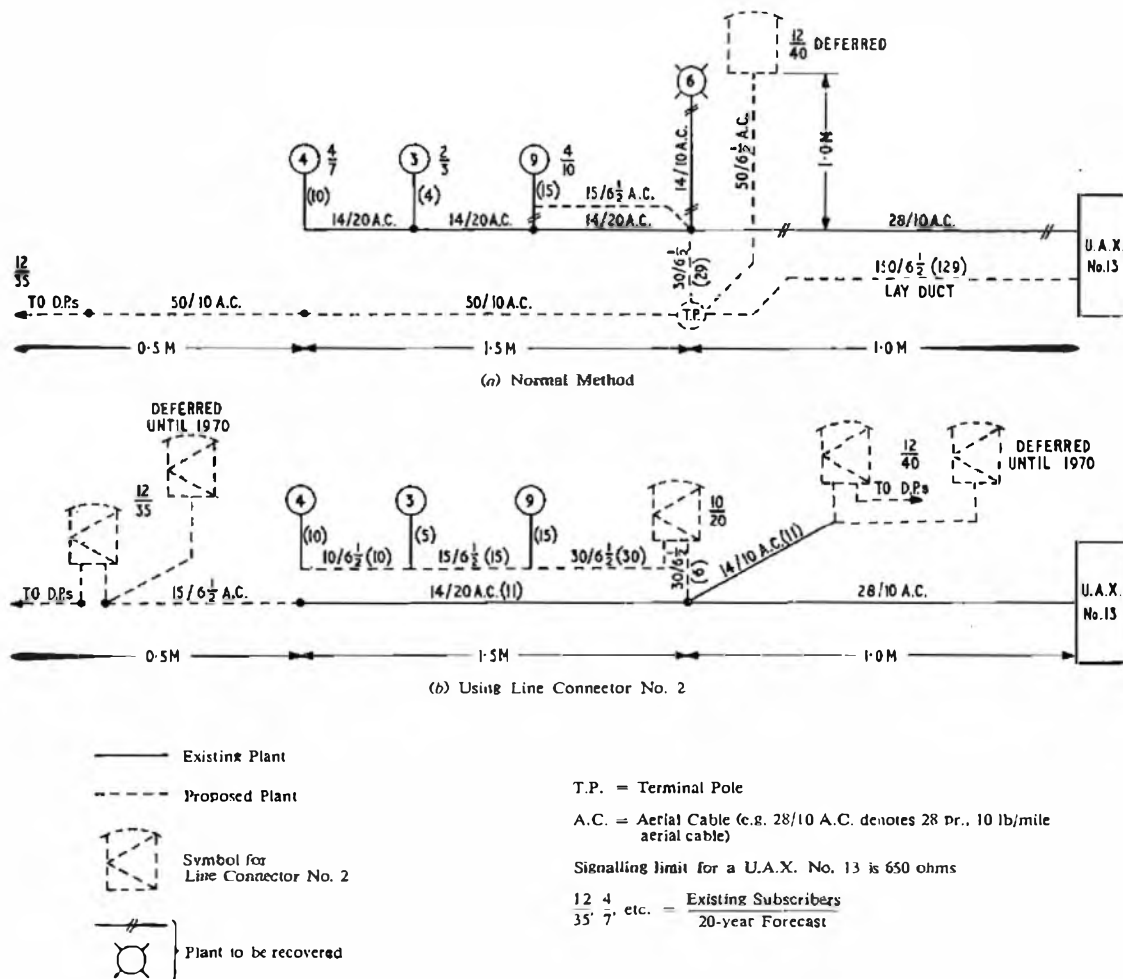

FIG. 5—ALTERNATIVE METHODS OF PROVIDING TELEPHONE SERVICE

signalling limit. The units are of an "add-on" type; that is to say, they can be added to any suitable automatic exchange system.

Numbers of Line Connectors No. 1 and No. 2 are already in service and proving satisfactory.

FUTURE TRENDS

Considering the long-term possibilities it would appear that electronic techniques could be applied to line connectors and this would most likely lead to a reduction in the physical size of the units.¹ It is also possible that the design of new local-line networks and new exchanges could incorporate line-connector techniques as an integral part of both the local-line network and of the exchange equipment. This development must, however, be conditioned by the economic demand.

CONCLUSIONS

With the present relative costs of line plant and line

connectors in this country, the discriminate use of line connectors is a valuable means of providing a telephone service either as an expedient or as a long-term economic measure. If line connectors become cheaper, or line plant becomes dearer, the field of use will be increased.

The actual value of line connectors to a telephone undertaking depends primarily upon the relative costs of stores and labour for line plant and equipment, but it is also related to the number of applicants waiting for telephones and the resources available.

References

¹ An Introduction to the Line Connector. *P.O.E.E.J.*, Vol. 50, p. 171, Oct. 1957.

² BROWN, C. W. T.M.C. 10-line Subsidiary Automatic System. Published by the Telephone Manufacturing Co., Ltd.

³ HARVEY, J. P. A New Line Connector. *Ericsson Bulletin*, No. 36, p. 40, Jan. 1958.

⁴ JOEL, A. E., Jr. An Experimental Remote-Controlled Line Connector. *Bell System Technical Journal*, Vol. 35, p. 249, Mar. 1956.

Book Reviews

"Classified Examples in Electrical Engineering." Vol. 1. S. Gordon Monk, B.Sc., M.Sc.(Eng.), M.I.E.E. Sir Isaac Pitman & Sons, Ltd. 147 pp. 9 ill. 15s.

The standing of a book can often be judged by the time it has been in existence and the demand that there has been for it. "Classified Examples in Electrical Engineering" has done well by these standards. It was first published in 1928 and since then there have been many new editions and reprints until now Vol. 1 of the eighth edition has been produced.

The new Vol. 1 differs from the old volume. It now contains examples in both d.c. and a.c. electrical engineering up to Ordinary National Certificate standard only whereas before it contained examples in d.c. electrical engineering only, up to Higher National Certificate standard. M.K.S. units have been introduced, and there are many new examples especially on the subject of a.c. circuits.

The book contains some 505 examples taken from examination papers set by London University, the Institution of Electrical Engineers and the City and Guilds Institute and classified in 43 sections. There are questions on resistances, Ohm's law, power, energy and costs, resistances in parallel, battery and resistance grouping, temperature coefficients and heating. Examples are given on supply lines, Kirchhoff's and Maxwell's Laws, magnetic fields and circuits, ballistic galvanometers, inductances, lifting magnets, hysteresis, electrostatics, electrochemistry, illumination and transients. Eleven sections are devoted to d.c. machinery including problems on characteristics, paralleling, field regulators, starters, battery charging and boosters. There are questions on series, parallel and combined a.c. circuits, resonance, circle locus diagrams, mutual coupling, three-phase circuits, transformer principles and alternator voltage calculations.

The questions in each section are preceded by short notes on the relevant theory and formulae. Numerical answers are provided at the back of the book and occasionally hints or complete solutions are included.

This book with its good choice of examples is well suited for the use of a class under the direction of a lecturer and would be very useful for class tutorial work and homework.

L. W. O.

"Principles of Noise." J. J. Freeman. John Wiley & Sons, N.Y., Chapman and Hall. x + 299 pp. 175 ill. 74s.

The practical problems considered in this book are: noise in thermionic valves, the effect of noise on the measurement of direct voltages and the detection of alternating voltages, and target noise in radar, in particular its effect on automatic tracking systems. This is a fairly restricted field, but the general background treatment, partly physical, partly mathematical, required to cover these problems is sufficient to provide a good foundation for an attack on almost any noise problem.

The three chapters dealing with thermionic valves begin by studying from first principles the motions of electrons in resistive media and in vacuo, leading to "thermal noise" and "shot noise." Both theoretical and experimental methods are discussed. The usual practical methods of handling noise in circuits, by means of equivalent noise generators and by noise factors, are extensively discussed.

The two chapters dealing with measurement of direct and alternating voltages discuss the effect of noise on the accuracy of measurement and the minimum detectable signal, and compare different types of detector. The chapter on target noise applies the general methods of the book to a particular automatic tracking system and to a simplified model of a target and discusses, for example, the optimum receiver band-width and its dependence on noise and signal spectra.

There are four mathematical chapters. The first two are on Fourier analysis and probability, respectively, and are necessarily of the nature of revision chapters which would be difficult going for someone completely unacquainted with the subjects. The particular needs of noise theory are covered by two chapters on stationary random processes and the Gaussian random process, respectively. The mathematical analysis in the practical chapters is carried out in great detail, perhaps in too much detail in places.

The practical problems dealt with in this book are already handled by many engineers using formulae which they take for granted. Anyone who wants to know how the formulae are derived, or to get a real understanding of the foundations of the subject, could do so from this book.

W. E. T.

Emergency Telephones for the London–Yorkshire Motorway

G. TURNER†

U.D.C. 621.395.9:625.711.3

The first section of the London–Yorkshire motorway to be constructed, between London and Birmingham, has been provided with emergency telephones at intervals of approximately one mile. The signalling system used, which is described in this article, was developed specially and was constructed and installed at short notice for the opening of the motorway.

INTRODUCTION

THE emergency telephones provided at the request of the Ministry of Transport along the first section of the London–Yorkshire motorway (Route M1) between London and Birmingham are housed in roadside pillars at intervals of approximately one mile along each carriageway of the road. By lifting the telephone handset a lamp-calling signal is given on a small telephone switchboard in the county police station that has control of the particular section of the road, and the police authorities then assume the responsibility for calling, using other communication channels, the appropriate assistance service required. The circuits are private wires and calls from the roadside pillars cannot be extended to the public network nor can calls be made from the police stations to the pillars.

PRINCIPLE OF OPERATION

To economize in line plant the telephones are arranged as party-line circuits, each having up to 10 stations, and to limit the extent of breakdown in the event of a fault the pillars on the north-bound carriageway are connected to a different party-line from the corresponding pillars on the south-bound carriageway. The facility which is of most interest technically is that each station of the group is given a distinctive calling signal. This was requested by the Ministry of Transport so that the police would know exactly where assistance was needed in the event of the caller being unable to express himself clearly, either because he was in a state of distress following an accident or because he was an alien with little knowledge of English. Also, to reduce operating instructions to the minimum the caller was not to be expected to do anything more than lift the receiver to make a call.

From a number of schemes which were considered there eventually evolved the system now described, which has the merit of

- (a) giving all the essential facilities at small cost,
- (b) requiring the minimum of equipment at the pillar, where maintenance is difficult,
- (c) requiring only standard components, and
- (d) being easy to construct locally.

For purposes of line identification each of the telephones on the circuit is fitted with a series "padding" resistor so that the line resistances of the

10 stations become 2,200, 3,300, 4,700, 6,800 ohms, etc., up to the highest value of 68,000 ohms (each step an increase of approximately 50 per cent). When a call is received a potentiometer device controlled by two transistors and a uniselector identifies the calling station by its resistance.

The principle of the circuit is shown in Fig. 1. The line loop resistance represented by the resistor R is connected in turn via uniselector arc $U1$ to a series of test resistors whose values correspond to the station resistances mentioned above. So long as the test resistor in circuit is less than or equal to the line resistance, R , the potential at point P is -25 volts or less and the base of transistor $VT1$ is negative with respect to the -24 volts of its emitter. A current of about 1 mA therefore flows in the collector circuit and a potential difference of 33 volts is developed across the $33,000$ -ohm resistor. The potential at point Q is therefore -17 volts and the base of transistor $VT2$ is positive with respect to the -28 volts of its emitter. The collector current is therefore cut off and the high-speed relay X remains inoperative, so allowing the uniselector drive to continue.

When the uniselector passes to the first test resistor that is greater than the value of the line resistance, R , the potential at P becomes approximately -20 volts* and the base of $VT1$ is then positive with respect to its emitter. The transistor thus cuts off and the potential at point Q becomes -50 volts. The base of $VT2$ now becomes negative with respect to its emitter and a collector current

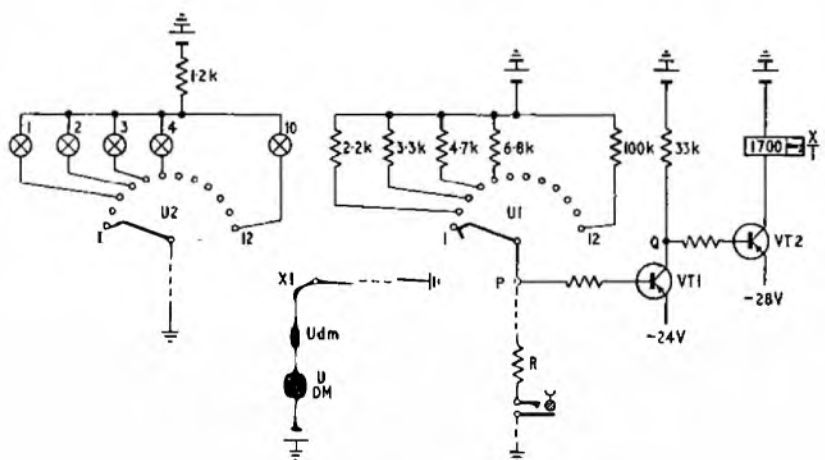

- Notes: 1. The battery supply voltage is 50 volts except where otherwise indicated.
 2. R denotes the resistance of the calling line.
 3. Loop resistances are as follows:
- | Station No. | 1 | 2 | 3 | 4 | 5 | 6 | 7 | 8 | 9 | 10 |
|-------------------------------|-----|-----|-----|-----|----|----|----|----|----|----|
| Loop resistance (k Ω) | 2.2 | 3.3 | 4.7 | 6.8 | 10 | 15 | 22 | 33 | 47 | 68 |

FIG. 1.—PRINCIPLE OF STATION-IDENTIFICATION CIRCUIT

† Executive Engineer, Subscribers' Apparatus and Miscellaneous Services Branch, E.in-C.'s Office.

$$\text{*Potential at } P = -50 \times \frac{3.3}{3.3 + 4.7} \approx -20 \text{ volts for station No. 2}$$

$$\text{or } -50 \times \frac{68}{68 + 100} \approx -20 \text{ volts for station No. 10}$$

of approximately 13 mA causes relay X to operate and stop the uniselector. The appropriate station identification lamp is lit via arc U2.

By placing a suitable rectifier in parallel with the padding resistor in each telephone, and arranging for the line polarity during testing to be the reverse of that during calling and speaking, the padding resistor is bypassed at all stages when it is not required.

In most cases the line resistance is small enough to be neglected and only when the lowest values of padding resistance are required at stations with relatively high loop resistances is it necessary to reduce the value of the padding resistor so that the total resistance approximates to the design value.

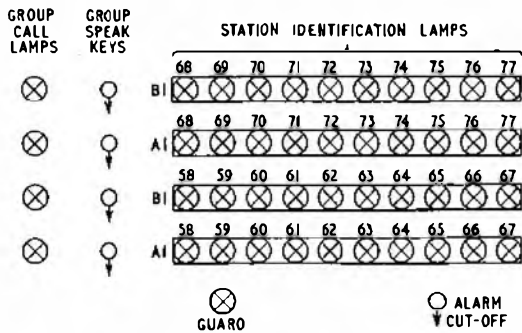

- Notes: 1. AI identifies the north-bound carriageway of route M1; BI identifies the south-bound carriageway of route M1.
2. The numbers that identify the stations indicate the distances, in miles, from London.

FIG. 2—TYPICAL LAYOUT OF THE CONTROL PANEL AT A POLICE STATION

CONTROL PANEL AND CIRCUIT DESCRIPTION

A typical layout of the control panel at a police station is indicated in Fig. 2, and Fig. 3 gives the full circuit.

When a handset is raised relay A operates in series with the line loop and rectifier MRA in the telephone. Relay A causes the uniselector to interact with relay G to drive to contact 2, where relay B operates to reverse the polarity to line and set in operation the testing circuit already described. Relay X operates to stop the uniselector when the appropriate contact is reached. Contact X1 also operates relay CD, which lights the "Group Call" lamp and sounds the buzzer. Arc U2 lights the appropriate identification lamp. Relay CD also releases relay B, which switches out the testing circuit and restores normal polarity to the line. When the police officer operates the appropriate "Group Speak" key relay CD releases, the buzzer stops and transmission conditions are set up.

At the end of the call the handset is replaced, the Group Speak key is restored and the uniselector homes. If the Group Speak key were not restored, a subsequent call would fail, and hence the circuit is arranged to light a "Guard" lamp and sound a buzzer if the Group Speak key is not restored when the caller replaces the telephone handset.

The drive circuit of the uniselector is not direct but is slowed down deliberately by relay G. This is necessary because at each step of the uniselector line capacitance introduces a delay before the potential at point P (Fig. 1) stabilizes at its new value. Without this provision line capacitance of $1 \mu\text{F}$ would be sufficient to cause the uniselector to overstep by one contact. The time taken to hunt to the tenth line is approximately $1\frac{1}{2}$ seconds.

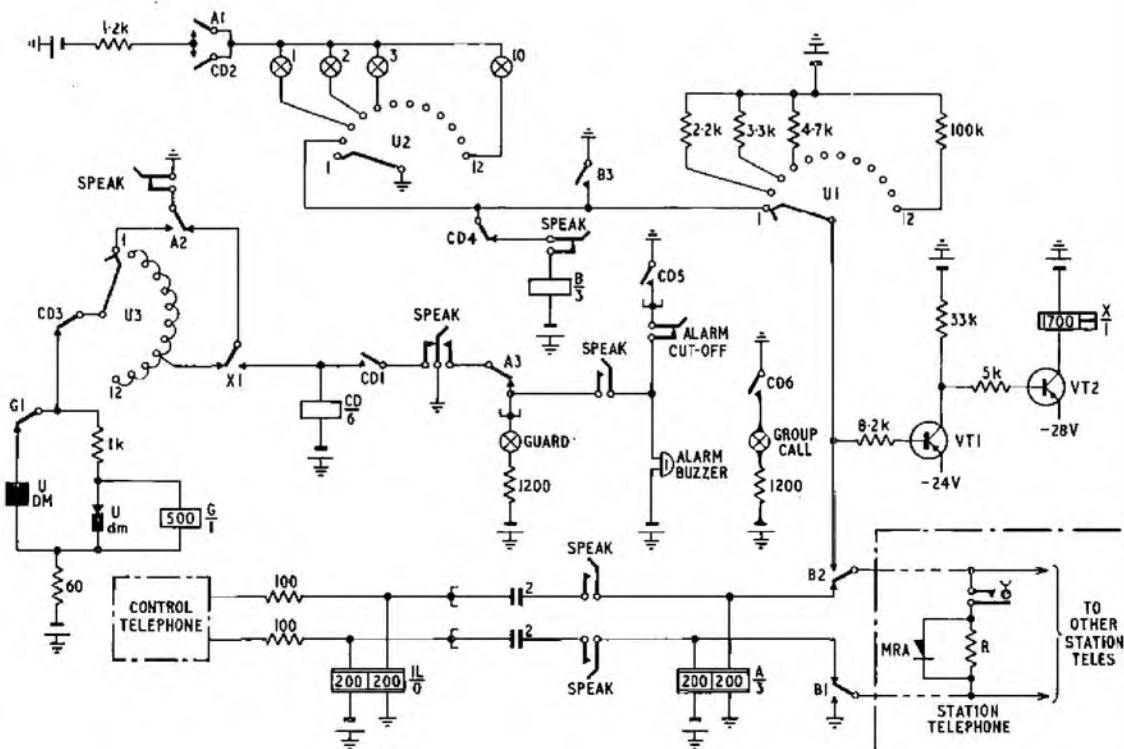

FIG. 3—SCHEMATIC DIAGRAM OF THE CONTROL CIRCUIT



FIG. 4—GENERAL VIEW OF ROADSIDE TELEPHONE

The new miniature uniselector Type 4* proved to be eminently suitable for this circuit and has enabled all the equipment components, apart from the lamps and keys in the control panel, to be strip-mounted on standard relay-mounting plates.

The power supply for the circuit is obtained from a 50-volt, 2 ampere-hour secondary battery trickle-charged from a.c. mains. The -24 -volt and -28 -volt potentials required for the transistors are obtained by direct taps from the battery.

PILLAR

The pillar used was designed by the Ministry of Transport and a general view of it is shown in Fig. 4. A 300-type telephone with dummy dial is used but a waterproof handset cord is fitted. The padding resistor and its shunting rectifier are accommodated within the telephone. To cater for conditions at night when the motorway is liable to be extremely dark the sign on the pillar is luminous and the opening of the door automatically switches on a small lamp which in the absence of other sources of power has to be operated from a primary battery.

CONCLUSION

The system so far is experimental. In the light of experience gained the Ministry of Transport will decide whether the facilities now provided cater sufficiently for the needs of high-speed motorways for them to become the standard for all new roads of this type.

* MANNING, D. J. *The Post Office Type 4 Uniselector*. P.O.E.E.J., Vol. 52, p. 215, Oct. 1959.

Book Review

"Transistor Circuits." K. W. Cattermole, B.Sc. Heywood & Co., Ltd. xi + 442 pp. 305 ill. 70s.

The history of the development of transistor circuits is one of continuous expansion, both of variety of circuit and of fields of use. The realization by circuit designers that junction transistors could be mass-produced to some engineering limits—admittedly not always immediately acceptable—with good prospects of reliability, acted as a powerful stimulus to circuit design and analysis. Many valve circuits, e.g. of Class B push-pull amplifiers, the Eccles-Jordan circuit and phase-shift oscillators, have been adapted to use transistors without major changes of configuration of the other components vital to the a.c. performance of the circuit; but the circuit analysis is often very different, because the electrical properties of the transistor differ markedly from those of valves, and the performance of the circuit may be significantly different. Other circuits have sprung from attempts to utilize the novel properties of the transistor, e.g. the low dissipation and collector-emitter impedance at saturation and the excellent linearity of the common-base current gain.

Several text-books have already tried to present both a description of the more important circuits currently in use and a basis for future designs. No unified approach has evolved and one is not likely in the near future, but, equally, no major divergences have developed. The book under review fits the broad pattern of predecessors in having much that is inevitably conventional, though with change of

emphasis in some places and occasional novelty in others. Some readers may be dissatisfied with the brevity of the chapter on the electrical properties of transistors—augmented here and there in other chapters—unless they have, to hand, a book on that subject or are sufficiently familiar with it in detail. Other readers may be left wondering how well the later designs of transistors fit the framework depicted. But these criticisms apart, the book can be welcomed and recommended to everyone engaged in the subject; it is clear that the author has given much thought to his writing, and has made a good choice of circuits for those described and analysed.

Amplification, waveform generation and counting, timing and binary circuits rightly take up two-thirds of the book, with shorter chapters on less extensive subjects such as bias stabilization, modulation, detection, frequency-changing and the measurement of transistor parameters. A few errors need attention. Thus, Fig. 2.6 is said to illustrate the doubling of the reverse current in a germanium transistor that accompanies every rise of temperature of 8°C ; it would be expected, therefore, that for a rise of 35°C (the difference between 55°C and 20°C , the two temperatures for which data are given), there would be an increase of current of about 20 times. The figure shows an increase of only six times. The statement that "a junction transistor never has a negative input impedance" is perhaps too emphatic despite its broad context. But, again, these are minor points amongst a wealth of information.

The book is well produced and has a good bibliography, emphasizing perhaps the older, classical, papers.

J. R. T.

An Analogue Computer for Investigating the Directivity Characteristics of Complex Arrays of Unit Aerials

G. MITCHELL, B.Sc.(Eng.), A.M.I.E.E.†

U.D.C. 681.142:621.3.012:621.396.677.3

The computation of the directivity characteristics of complex arrays of aerials operating in the high-frequency band is very tedious and time consuming even using a desk calculating machine. The analogue computer described in this article has been designed to perform automatically the necessary computations for any array with from 50 to 200 unit aerials, in which the aerials are arranged along from one to sixteen diametral rows intersecting at a common point, and with a maximum of 14 aerials in any one diametral row. The computer can also be used on a semi-automatic basis for dealing with larger or more complex arrays.

INTRODUCTION

IT has recently been found necessary to investigate the directivity characteristics of complex arrays of unit aerials operating in the high-frequency band. The computation of such characteristics is very tedious, even when the number of unit aerials in the array is small: when the number of such aerials is in the range 50 to 200, as in the arrays under consideration here, the amount of arithmetical work becomes prohibitive. An analogue computer has, therefore, been built to perform the necessary computations.

The computer deals with arrays which basically comprise a number of diametral rows of unit aerials intersecting at a common point. A generalized array of this type is shown in Fig. 1. It is probable that practical arrays would utilize cone aerials and the unit aerials depicted in Fig. 1 are of this form. The number of diametral rows may be from one to sixteen, and the number

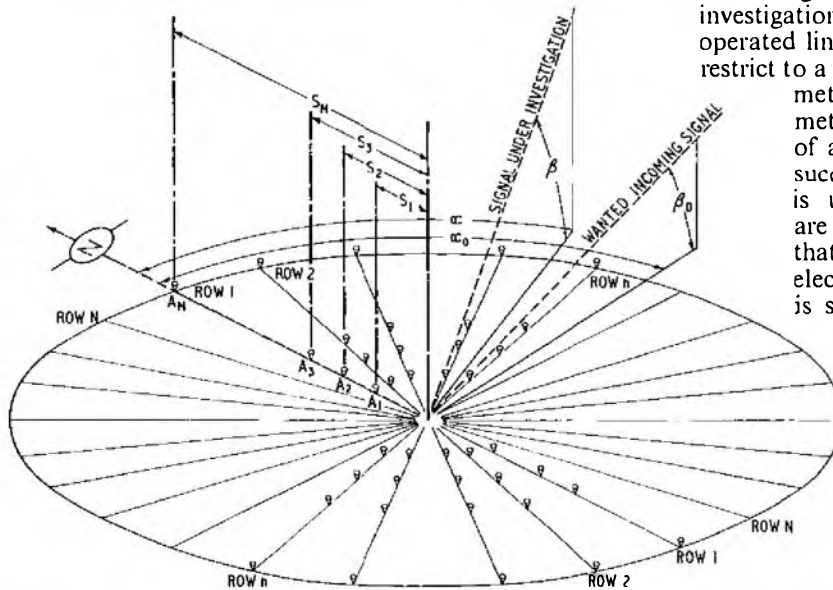

FIG. 1—GENERAL FORM OF ARRAY DEALT WITH BY THE COMPUTER

of unit aerials per diametral row (which may have a length not exceeding 36 wavelengths) must not exceed fourteen; the contributions of these aerials may have any arbitrary values, but all rows must be symmetrical about

† Senior Executive Engineer, Post Office Research Station.

the centre. Arrays of this type from which certain unit aerials have been omitted may be dealt with, subject, again, to the resultant array having symmetry about the centre. Arrays catered for can have either uniform or non-uniform row-to-row separations.

Directivity characteristics are, in general, computed for arrays in which the outputs of the unit aerials are assumed to have been so phased as to steer the array such that it will have a maximum response in some direction specified in azimuth and elevation.

The facilities provided include that of automatically computing a number of responses as the azimuthal arrival angle is varied by incremental steps; a series of such sets of results, corresponding to a number of signal frequencies, may also be produced in sequence, automatically. It is also possible to deal with arrays of unit aerials which themselves have directional properties, subject to certain conditions, and to investigate the effects of errors in the phasing of the outputs inherent in the steering process. Larger or more complex arrays than those referred to above may be dealt with on a semi-automatic basis by carrying out certain adjustments to the computer as the evaluation of responses proceeds, or by performing certain stages of the computation by hand.

The computer is of the electromechanical type. It functions by evaluating the trigonometrical expression describing the directional properties of the array under investigation, using motor-driven and magnetically-operated linear and cosine potentiometers. In order to restrict to a reasonable number the quantity of potentiometers and other items required, the trigonometrical expression, which may comprise upwards of a hundred terms, is evaluated sequentially as successive groups of terms; the same equipment is used repeatedly, and intermediate answers are stored. The speed of operation is less than that of either a digital computer or a purely electronic analogue computer. Nevertheless, it is some 200 to 2,000 times faster—depending upon the size of the array—than that likely to be attained using a desk calculating machine. Although a digital machine would have superior speed and accuracy it was rejected as being too complex, whilst purely electronic analogue machines were rejected as having insufficient accuracy.

ANALYTICAL BASIS OF DESIGN

It can be shown that the directional properties of an array of the type shown in Fig. 1 are expressed by the relationship

$$R_{\alpha_0, \beta_0} = \sum_{n=1}^{n=N} \left\{ \sum_{m=1}^{m=M} A_m \cos \{ 2\pi S_m [\cos(\alpha - \phi_n) \cos \beta - \cos(\alpha_0 - \phi_n) \cos \beta_0] \} \right\}, \dots \dots (1)$$

- where R_{α_n, β_n} = response of array phased to have maximum response in the direction (α_n, β_n)
- M = total number of annular rows
- N = total number of diametral rows
- S_m = radius of m th annular row (in wavelengths)
- A_m = relative amplitude of the contribution of each unit aerial located in the m th annular row
- Φ_n = angle of n th diametral row relative to north-south line
- α, β = azimuthal and elevational bearings of arbitrary incoming signal
- α_0, β_0 = azimuthal and elevational bearings of wanted signal (i.e. direction of steer).

If unit aeriels having directional properties are used, equation (1) requires modification. It is necessary to assume that all unit aeriels within a diametral row are similarly orientated with respect to that row, and that all diametral rows are identical in this respect. It will also be assumed that the response of each aerial is the same for two arrival directions differing by 180° . Under these conditions the response of row n will be modified by a factor K_n . K_n may be written

$$K_n = f(\alpha - \Phi_n, \beta), \dots \dots \dots (2)$$

i.e. K_n is a function of the azimuthal arrival angle of the signal relative to row n , and is also a function of the elevational arrival angle.

It follows that, when unit aeriels with directional characteristics are used, the response of the array to any signal having arbitrary bearings (α, β) when the system is phased so as to steer to the direction (α_0, β_0) is given by

$$R_{\alpha_0, \beta_0} = \sum_{n=1}^{n=N} \left\{ K_n \sum_{m=1}^{m=M} A_m \cos \{ 2\pi S_m [\cos(\alpha - \Phi_n) \cos \beta - \cos(\alpha_0 - \Phi_n) \cos \beta_0] \} \right\} \dots \dots \dots (3)$$

Equation (3) forms the basis of the design of the computer.

PRACTICAL REALIZATION OF DESIGN

The general term of equation (3) is of the form

$$R_{\alpha_0, \beta_0} = K_n A_m \cos \{ 2\pi S_m [\cos(\alpha - \Phi_n) \cos \beta - \cos(\alpha_0 - \Phi_n) \cos \beta_0] \} \dots \dots \dots (4)$$

$$= K_n A_m \cos (S_m B_n) \dots \dots \dots (4A)$$

where $B_n = 2\pi [\cos(\alpha - \Phi_n) \cos \beta - \cos(\alpha_0 - \Phi_n) \cos \beta_0]$ and is a function of the diametral-row number n but not of the annular-row number m . It is clear that the evaluation of R_{α_0, β_0} involves the summation of MN terms each having the general form of the right-hand side of equation (4); each such term represents the output of one aerial pair (m, n) .

As mentioned previously, in view of the large number of terms involved certain groups of terms are evaluated successively, using the same equipment on each occasion; these group totals can be stored and the required result obtained by an integration process. It was decided, therefore, to make the computer function on the following principles. Firstly, the quantity B_n is evaluated for the first diametral row ($n = 1$). This quantity is multiplied to give simultaneously $S_1 B_1, S_2 B_1 \dots S_m B_1 \dots S_M B_1$. The cosines of these products are obtained and multiplied by $A_1, A_2 \dots A_m \dots A_M$, respectively. The first stage of the evaluation is completed by adding these results and multi-

plying the sum by K_1 to give $R_{1\alpha_0, \beta_0}$, which is the output due to the first diametral row; this result is stored. The process is then repeated for $n = 2, n = 3 \dots n = N$. Finally, the stored outputs due to the successive diametral rows are added with due regard being paid to sign, and the resultant is recorded on the slowly-moving chart of a recording meter as well as being displayed visually on a meter for a few seconds. The value of α is now increased by from one to five degrees at a time, and the computation process just described is repeated on each occasion.

The overall accuracy of the computer depends critically upon the accuracy with which $S_m B_n$ is computed. Reference to equations (4) and (4A) shows that B_n can have a maximum value of $2\pi \times 2$. The computer has been designed to produce directivity characteristics for arrays having a maximum radius of 18 wavelengths, i.e. $S_M(\max) = 18$. Thus, the maximum value that $S_m B_n$ can attain is 72π radians, or $12,960^\circ$. An error, therefore, of one part in a thousand in the determination of $S_m B_n$ effectively results, in the worst case, in an angular error of nearly 13° in the argument of the vector representing the output of the aerial in question.

In practice it has been found convenient to assess the inaccuracies of each potentiometer, valve stage, or other unit as so many thousandths of the maximum signal level at the unit in question. Now the evaluation of $S_m B_n$ involves errors due to several such causes, and if these errors all had the same sign the required tolerances would probably be too severe for a practical design. However, the errors are, statistically speaking, unlikely to be additive (i.e. they are likely to have differing signs) and, thus, the imposition of such tolerances is avoided. Nevertheless, it has been necessary to seek the greatest accuracy reasonably attainable in all stages of the computer. This involves, firstly, the use of high-accuracy potentiometers, secondly, the application of a large amount of negative feedback to all valve amplifiers and, thirdly, the provision wherever possible of such adjustment facilities as are necessary to compensate for errors, together with facilities for checking the accuracy of such adjustments.

OUTLINE DESCRIPTION OF COMPUTER

General Facilities

A general view of the computer is shown in Fig. 2. Information regarding the spacing (S_1 - S_7) of the respective unit aeriels from the array centre, the relative amplitude of the contribution of these aeriels (A_1 - A_7) and the vertical arrival angles (β and β_0) is supplied by the adjustment of potentiometers fitted with large scales. Similar information in respect of the azimuthal arrival angles (α and α_0) is supplied by setting cosine potentiometers. This adjustment is carried out in one-degree steps and continuous-stepping facilities are provided so as to facilitate large angular movements. The required information in respect of the number of rows and the resolution is supplied by the operation of multi-position switches. When it is desired to omit certain aeriels from an array, straps are inserted as necessary on an aerial-selection panel.

Facilities are available for either single calculations or automatic operation; under the latter condition a series of calculations, corresponding to successive values of the azimuthal arrival angle, is carried out until 180° (or 360°) of azimuth have been covered. At this point the computer stops or, alternatively, the simulated operational

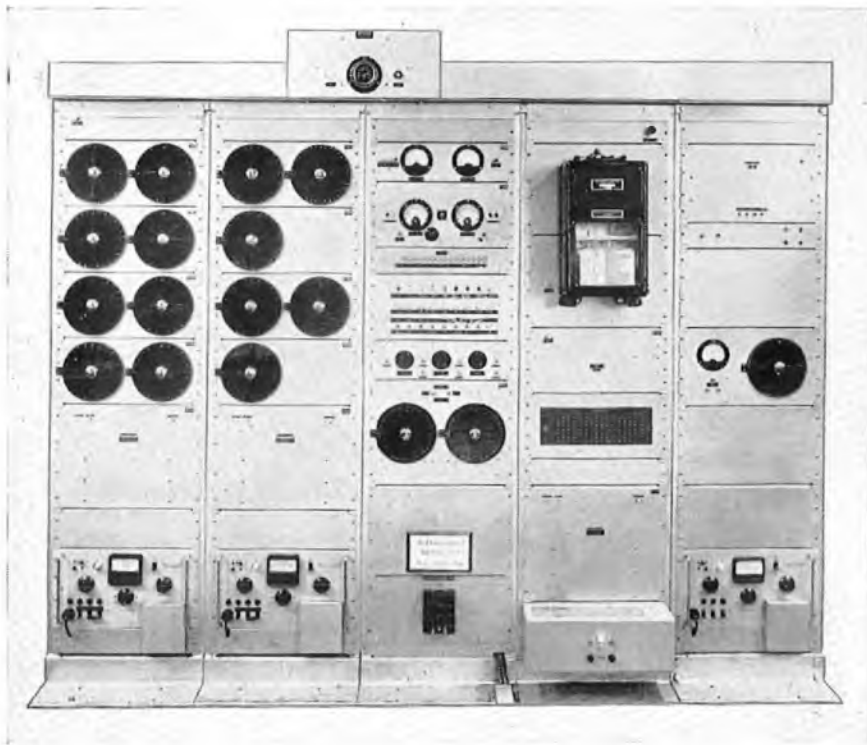

FIG. 2—GENERAL VIEW OF COMPUTER

frequency is changed and the series of calculations repeated. This cycle of operations can be repeated for a pre-determined series of frequencies, normally 30, 25, 20, 15, 10, 5 and 2.5 Mc/s. If the calculations involve arrays comprising unit aerials whose response depends upon the azimuthal bearing of the signal, information regarding the law relating response to bearing is provided in the unit-aerial directivity-characteristic unit by means of

a cam having the appropriate profile.

Facilities have been provided enabling the calculation to be temporarily interrupted after the computation of the output of each aerial row so that, if desired, these intermediate results may be noted. Thus, the computer can be used to calculate the directivity characteristics of single-row arrays.

When carrying out a series of computations automatically, the machine stops operating and causes an alarm lamp to glow under certain fault conditions which would result in errors.

The required responses are recorded on the chart of a recording meter, on either a linear-law or logarithmic-law basis. A second trace on this chart indicates the sign of each output, i.e. its phase relationship to the output of a hypothetical aerial at the phase centre of the array, by means of a short mark to the right hand or left hand of the base line; this trace also indicates every tenth degree of azimuth by a long mark. Each result produced by the computer is also displayed on a meter, the sign of the output being shown by a pair of indicating lamps. A second meter and pair of lamps provide similar information in respect of the outputs due to the individual rows.

Operation

The simplified block-schematic diagram of the computer is shown in Fig. 3. The transmission of the "signal", derived from the stabilized 200 c/s oscillator, will now be traced through the computer, and the level of the signal at the various points in the chain will be

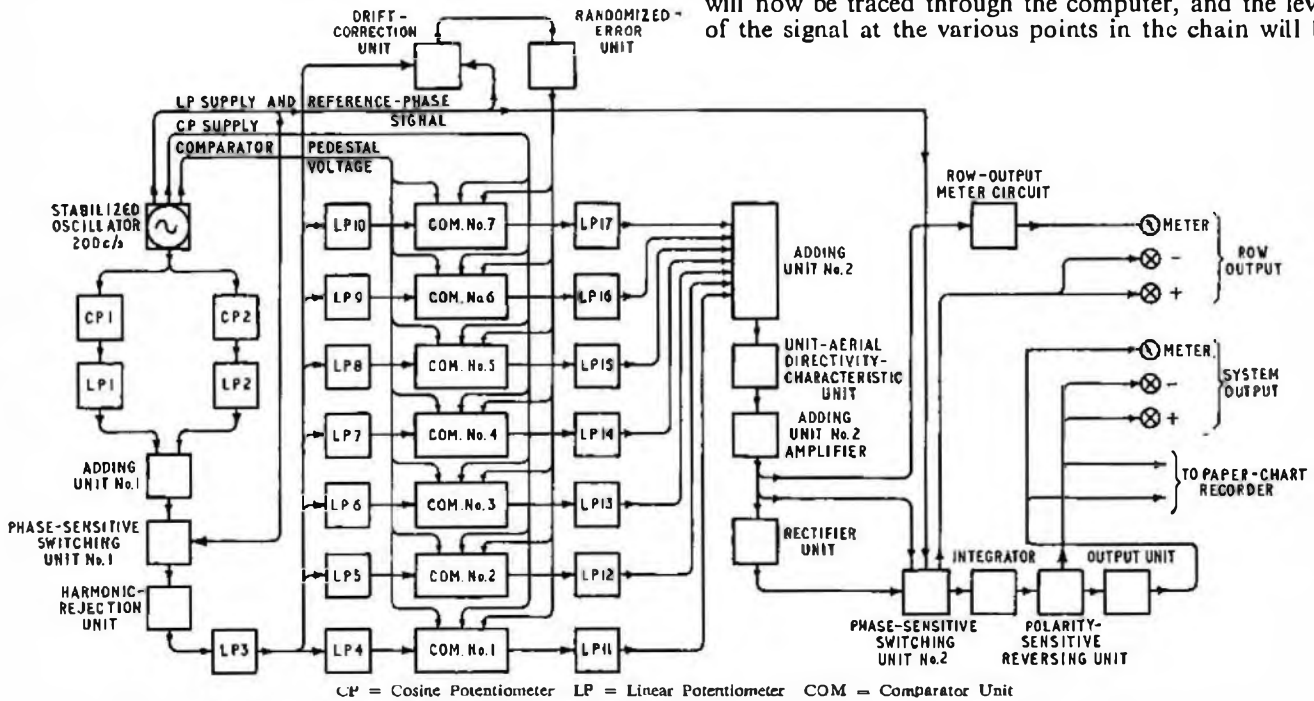

FIG. 3—SIMPLIFIED BLOCK SCHEMATIC DIAGRAM OF COMPUTER

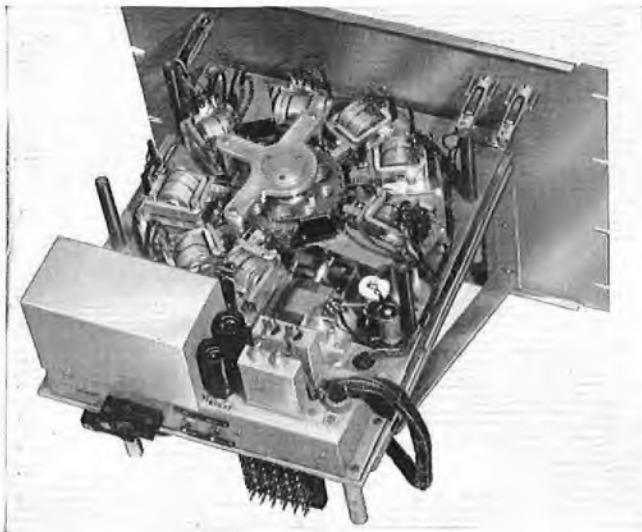

FIG. 4—A COSINE-POTENTIOMETER UNIT

related to the various stages encountered during the evaluation of $R_{\alpha, \beta}$, by means of equation (3).

The principal output of the oscillator is applied first to two cosine potentiometers in parallel, CP1 and CP2, one of which is shown in Fig. 4. Consider the potentiometer CP1, which supplies an output $\cos(\alpha - \Phi_n)$. This quantity is a function of α and Φ_n , both of which are, therefore, applied as mechanical inputs to the potentiometer. The α input is applied to the body of the potentiometer, i.e. the track, and the Φ_n input is applied to the shaft, i.e. the wiper. The output of CP1 is connected to the linear potentiometer LP1, which simulates the factor $\cos \beta$, so that the output of LP1 is proportional to $\cos(\alpha - \Phi_n) \cos \beta$. Potentiometers CP2 and LP2 perform exactly similar operations for α_0 and β_0 : the input to CP2 is, however, reversed in phase as compared with that to CP1, and the output of LP2 is, thus, $-\cos(\alpha_0 - \Phi_n) \cos \beta_0$.

The outputs of LP1 and LP2 are now added together in adding unit No. 1, thus giving

$$\cos(\alpha - \Phi_n) \cos \beta - \cos(\alpha_0 - \Phi_n) \cos \beta_0.$$

This represents, to a different voltage scale,

$$B_n = 2\pi [\cos(\alpha - \Phi_n) \cos \beta - \cos(\alpha_0 - \Phi_n) \cos \beta_0].$$

This signal represents not only the magnitude of B_n but also its sign, since the latter is implicit in the phase of the signal to a reference-phase signal derived from the oscillator. However, the quantity of interest is $\cos(S_m B_n)$ and, since $\cos(S_m B_n) = \cos(-S_m B_n)$, the sign of B_n is of no mathematical significance. On the other hand, the units which give an output $\cos(S_m B_n)$ when supplied with an input $S_m B_n$ (i.e. the comparators, described briefly below) require, in addition to the signal voltage $S_m B_n$ a "pedestal" voltage of fixed amplitude, and it is necessary for this pedestal voltage to be out of phase with the signal voltage. The phase of the signal from adding unit No. 1 is, therefore, compared with that of a reference-phase signal from the oscillator: if these two voltages are in phase, the phase of the signal is reversed, but if the two are out of phase, the phase of the signal is not changed. This conditional phase-reversing function is performed by the phase-sensitive switching unit No. 1. It is followed by a harmonic-rejection unit which attenuates harmonics of the 200 c/s signal produced in the preceding units.

It is now necessary to multiply B_n by S_1, S_2, \dots, S_M simultaneously, where M is any integer up to seven. This is accomplished by passing signal B_n through the manually-controlled potentiometers LP4 to LP10, respectively, in parallel. If the frequency-factor unit is to be used, the signal B_n is passed through potentiometer LP3 before it is passed through LP4 to LP10, and a change in the setting of LP3 multiplies S_1 to S_7 by a common factor. Thus, the signal fed by LP4 into comparator No. 1 is

$$S_1 B_n, \text{ i.e. } 2\pi S_1 [\cos(\alpha - \Phi_n) \cos \beta - \cos(\alpha_0 - \Phi_n) \cos \beta_0],$$

that fed by LP5 into comparator No. 2 is $S_2 B_n$, and so on.

At this stage it is necessary to consider briefly the action of a comparator, shown in Fig. 5. Basically, the requirement is that a cosine potentiometer should be rotated through an angle proportional to the incoming voltage $S_m B_n$. If due regard is paid to the voltage scale, the output of the cosine potentiometer will be equal to $\cos(S_m B_n)$. Each comparator comprises, essentially, a circuit which compares two voltages for equality and which controls the direction of rotation of a small motor. If the two voltages are unequal the motor rotates, the direction of rotation depending upon which voltage predominates; the motor remains stationary when the voltages are equal. The motor drives two potentiometers, each supplied from the 200 c/s source, one of which has a cosine law and the other a linear law. One of the two voltages that are compared for equality is the incoming signal voltage, whilst the other is derived from the 200 c/s source via the linear potentiometer. Thus, when a signal voltage is applied to the comparator the balance is disturbed and the motor runs, driving the linear potentiometer until balance is restored. The linear potentiometer, and hence the cosine potentiometer, is thereby rotated through an angle proportional to the level of the incoming signal.

The output of comparator No. 1, viz. $\cos(S_1 B_n)$, is multiplied by A_1 by means of potentiometer LP11 and is then fed to adding unit No. 2. This adding unit is supplied simultaneously with inputs of $\cos(S_2 B_n)$, $\cos(S_3 B_n)$, etc., from comparators Nos. 2, 3, etc., and their respective A-factor potentiometers. Thus, the output of adding unit No. 2 is

$$\sum_{m=1}^{m=M} A_m \cos(S_m B_n),$$

i.e. $\sum_{m=1}^{m=M} A_m \cos\{2\pi S_m [\cos(\alpha - \Phi_n) \cos \beta - \cos(\alpha_0 - \Phi_n) \cos \beta_0]\}.$

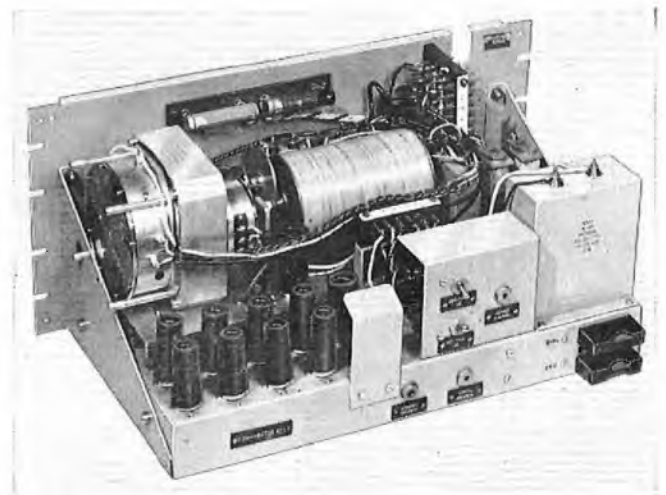

FIG. 5—A COMPARATOR UNIT

This sum when multiplied by K_n in the unit-aerial directivity-characteristic unit represents $R_{n\alpha\beta_0}$, the output of the n th diametral row. $R_{n\alpha\beta_0}$ is represented in both magnitude and phase, the latter being implicit in the phase relationship which exists between the signal and a reference-phase signal. This signal, representing $R_{1\alpha\beta_0}$, is now rectified and stored as a charge on a capacitor in the integrator whilst the outputs due to the other rows are evaluated. However, to avoid losing the sign of the quantity $R_{n\alpha\beta_0}$, upon rectification, phase-sensitive switching unit No. 2 is used. In this unit the phase of the output of adding unit No. 2 is compared with that of a reference-phase signal from the oscillator. The polarity of the rectified output from the adding unit is then reversed, or not, depending upon whether the signal is, or is not, in phase with the reference-phase signal.

The summation of the N terms, where N is any integer up to 16, is carried out in the integrator. Each term is of the form

$$K_n \sum_{m=1}^{m=M} A_m \cos(S_m B_n),$$

and the summation therefore gives the computation of

$$R_{\alpha\beta_0} = \sum_{n=1}^{n=N} \left\{ K_n \sum_{m=1}^{m=M} A_m \cos(S_m B_n) \right\}.$$

The integrator consists, essentially, of 16 capacitors, the first of which is charged to a potential whose magnitude and sign represent the output of the first diametral row ($n = 1$), the second to a potential representing the output of the second diametral row ($n = 2$), and so on. After the appropriate number of capacitors have been charged they are connected in parallel. The number of capacitors charged and paralleled depends, of course, on the number of diametral rows in the array under investigation. The resultant potential represents the required summation term, viz. $R_{\alpha\beta_0}$, in both magnitude and sign.

The output unit contains a linear/logarithmic-law conversion-network of the diode/resistance-network type, and thus requires a unidirectional input potential for correct operation. The output of the integrator, which may be of either positive or negative potential, is, there-

fore, converted into a unipotential signal by means of a polarity-sensitive reversing unit and associated reversing switch. The use of the linear/logarithmic-law conversion-network is optional; whether or not this conversion is used, the output unit supplies an output current to the recording milliammeter and the direct-reading meter referred to above. The "sign" information displayed in each case is supplied by the polarity-sensitive reversing unit.

The drift-correction unit ensures that the relative levels of the two inputs into the comparators are not significantly affected by changes in ambient temperature or supply voltages, or by component-aging. This unit must restrict unwanted changes in the ratio of the two inputs into the comparators to a very few parts in ten thousand. The unit performs this function by controlling the amplitude of the linear-potentiometer supply to the comparators over a range of ± 1 per cent under the control of a sensitive amplitude-comparing circuit.

The purpose of the randomized-error unit is to simulate the phasing errors which must inevitably occur in any practical steerable-aerial system, and to enable the effects of such errors on the directivity-characteristics of the system to be determined. It comprises, essentially, a means for introducing substantially-random variations into the amplitude of the linear-potentiometer feeds to the comparators, thereby producing a correspondingly random variation in the phasing of the vectors representing the outputs of the various unit aerials. This is done by switching successively, once per row-computation, a range of resistances into the linear-potentiometer supply-leads, using a system of uniselectors with resistors wired directly to their banks. The resistors are chosen so as to give the required phasing-error law. For example, they may be chosen to give a Gaussian distribution having a known standard deviation.

ACKNOWLEDGEMENTS

The author gratefully acknowledges the help given by several colleagues during the development of the computer. The contributions of Messrs. R. J. Westcott and C. F. Standage are worthy of special mention.

Book Review

"Solution of Problems in Electrical Technology." H. Cotton, M.B.E., D.Sc., M.I.E.E., and J. V. Parry, M.Sc.(Eng.), A.M.I.E.E. Sir Isaac Pitman & Sons, Ltd. 315 pp. 116 ill. 20s.

This is a well printed and illustrated book containing 225 worked examples and 124 additional problems requiring solution. As the title indicates, the major part of the book is devoted to the solution of problems and in this very important respect it differs from the other well-known books of examples covering somewhat similar ground.

The questions cover a wide range in electrical technology and are classified in 18 chapters under much the same headings as the chapters in a text-book on the subject. Each chapter commences with a summary of the relevant theory and formulae and where necessary appropriate notes are included in the solutions. M.K.S. units are employed throughout and these are introduced in the first chapter by a collection of questions in engineering science. There are chapters on electromagnetics and electrostatics

and a number dealing with the various forms of a.c. and d.c. machinery and transformers. Problems are also given on circuits and networks, a.c. theory, and batteries, and there are sections devoted to power-factor improvement, electronics, measurements and illumination.

The book was written for the benefit of 1st and 2nd year degree students and as an aid to those studying for the O.N.C. and H.N.C. in Electrical Engineering. It is well written and the solutions given are clear and concise. Most students would be wise to seek their lecturers' guidance before investing in any book, but this one can be recommended to the student who wishes to develop his skill in the solution of problems. For the individual studying privately at home it should prove a valuable substitute for class tutorial work and should be of use to the candidate taking Advanced Electrotechnology in the Limited Competition for Executive Engineers. This book can also be recommended to those people who have finished their formal studies and to whom this book may appeal as a form of revision.

L. W. O.

The Work of the Joint Post Office and Ministry of Works Research and Development Group

W. K. MACKENZIE†

U.D.C. 725.16.001

The increasing need to reduce both the first cost and the recurrent charges of Post Office buildings led, in 1956, to the setting-up of the Joint Post Office and Ministry of Works Research and Development Group. The Group has already planned and designed new telephone-exchange and postal buildings which show large savings in estimated cost compared with other similar buildings.

NO informed student of industry can ignore the growing part which, under the spur of competition, costing plays in planning and design. Indeed, both are increasingly influenced by considerations of first cost and of recurrent maintenance charges. However much the planner or designer may deprecate it, cost analysis and cost planning are now essential tools of his trade.

It is hardly surprising, therefore, that both the first and recurrent costs of Post Office buildings have been examined very critically in recent years. The Post Office is only one of a number of claimants for a share of the capital available for investment in the publicly-owned industries; successive cuts and restrictions have put a premium on getting the most for the money available. No less important is the need to keep annual charges as low as possible so that the telephone service may compete effectively with the other claims on the purses of people with modest incomes, with whom most of its future growth must lie.

The cost of its buildings has always been a matter of moment to the Post Office; nevertheless, these costs gave little cause for serious concern until the buildings planned in the late 1940's took form under changed conditions of cost and availability of funds. That some of these buildings were expensive for their purpose few would now deny. Overmuch consideration for prestige and a too-generous estimate of initial requirements—both an almost inevitable outcome of the desperate shortage of accommodation during the war and a desire worthily to repair its ravages—produced a number of fine buildings well worthy of their place in contemporary town and city planning. However desirable this may have been on broad æsthetic grounds, the Post Office had to remind itself that it is essentially a communication service which must stand or fall by its annual balance sheet—the Commercial Account. Some reduction in the cost of Post Office buildings was clearly essential.

In 1955 the Ministry of Works (the agent for the provision of Post Office buildings) set up a Research and Development Group to consider ways and means of reducing the cost of telephone-exchange buildings. Being responsible only to the Minister of Works and having no formal Post Office representative, its report (the Creamer Report) inevitably tended towards a one-sided commentary on the problem—indeed, it tended to emphasize the gap imposed by the separation of client and agent in independent Departments. Such separation was hardly conducive to the free and unfettered discussion which is essential if a building is to be integrated with the equipment and operational requirements that

are the sole reason for its existence. The report listed a number of ways in which Post Office buildings might be cheapened, mainly by adjustment of Post Office administrative and technical policies. These changes were under examination—or re-examination, since most of them had already been canvassed within the Post Office—when, late in 1955, the Postmaster General proposed the setting-up of a Joint Working Party of the two departments to consider what positive measures could be taken within the framework of the existing division of responsibility between the Post Office and the Ministry of Works to speed-up and cheapen the provision of Post Office buildings.

The Working Party comprised, on the Post Office side, a Staff Engineer and a Deputy Regional Director and, on the Ministry of Works side, an Under Secretary and the Deputy Director General of Works. It was chaired by the Post Office Director of Mechanization and Buildings. In February 1956 it recommended, among other things, that a new Research and Development Group representing both departments be set up to meet the need for joint action to secure economy in building. The Working Party's report also referred to the growing need for joint action because of the effect of developments in mechanization and electronics on building requirements, and for joint study of the use of various forms of construction and finish as well as the design of individual parts of buildings.

The Group started work late in 1956 and is chaired by a Superintending Architect. It comprises, on the Ministry of Works side, architects, surveyors and accommodation-services engineers. The Post Office element is lead by a Deputy Regional Director supported by an Assistant Staff Engineer, an Assistant Postal Controller, and a Senior Executive Officer from the Accountant General's Department. Its activities are directed by a small high-level committee chaired by the Post Office Director of Mechanization and Buildings. The Group, housed and working together as a team, is thus able to bring to bear an integrated range of authoritative opinion on practically any problem connected with Post Office buildings. The inclusion of a quantity surveyor ensures that the Group is kept constantly aware of the effect on building costs of its trends of thought. The Group is virtually self-contained on the Ministry of Works side: the vastly greater range of operational and technical interests on the Post Office side necessarily involves frequent reference to expert knowledge within the Post Office. Even when this is not essential, the Post Office element invariably consults interested colleagues in order to avoid any suggestion that it is working in isolation.

As its first task the Group planned and designed buildings for a 10,000-line automatic telephone exchange at Altrincham and a head post office for Hitchin; it is now completing the planning of a telephone engineering centre for Plymouth. The estimated cost of the exchange and post-office buildings is 50 per cent and 60 per cent, respectively, of that of comparable buildings erected in

† Deputy Regional Director, Joint Post Office and Ministry of Works Research and Development Group.

recent years. Much of the saving stemmed directly from reduced requirements for space. The new type of main distribution frame with 400 connexions per vertical, the substitution of mains rectifiers for motor generators and the elimination of a separate meter room made significant contributions to the saving of space in the telephone exchange. An above-ground cable lead-in with a jointing trench in place of the usual cable chamber, and a combined oil-fired air-heating, ventilation and filtration unit also helped; both have been developed in the Group for field trial in Altrincham exchange. The planning efficiency* of the building (98.9 per cent) is a high figure, even for a single-storey building, and is indicative of the extent to which circulation space has been reduced by careful planning.

This work demonstrated clearly that size is the controlling factor in the cost of Post Office buildings, the influence of design, construction, finish and fittings being considerably less important. It therefore follows that a material saving in cost involves a reduction in size. Such a reduction can be achieved only by the closest attention to actual needs for both working and circulation purposes. This in turn calls for a re-appraisal of need in terms of cost as well as of productivity, convenience or prestige. What may be intolerable if repeated every few minutes may be no more than an acceptable inconvenience which involves no real loss of productivity if it occurs only once a week. Corridors and entrance halls are often provided for traditional or prestige reasons, and the use made of them is quite insufficient to warrant the reservation of space solely for such purposes. A staircase carefully planned in the centre of a building is often quite as convenient as one at each end and is a lot cheaper—if a second is required solely as a fire escape, an enclosed and heated staircase is usually quite unnecessary.

Requirements include provision for growth. The past practice of including everything which might be required during the planned life of the building inevitably led to large areas lying idle for much of that life. In the meantime, this space has to be heated, lighted, cleaned and decorated. Much of it is provided on a forecast which, however skilfully prepared, is partly guesswork. The Group has therefore come to the view that a fresh approach to planning is essential if a significant reduction in the cost of new buildings is to be secured. In its view, the aim should be, whenever possible, to restrict initial construction to reliably foreseeable needs in a building so planned and constructed that the uncertainties in forecasting can be met by simple rearrangement and extension if and when required. When space must be provided initially for a much later need, e.g. the space provided for the post-20-year extension of the main distribution frame, such space can often be partitioned off and used for many years for other purposes.

The foregoing is only one facet of planning. Although essentially an envelope for the apparatus, the building has an entity of its own. Its perimeter is often determined by site conditions; its facade by town-planning considerations; the ratio of external walls to floor area must be as low as possible to ensure the economical enclosure

* Planning efficiency is the ratio of net to gross area. Net area is the gross area less circulation space in lobbies, corridors, stairs and lifts.

of space; spans and floor loadings must be such that an economical structure may be secured.

It may be that in time the Group will be able to issue general guidance in planning to ensure the most economical marriage of Post Office needs and architectural provisions. But as planning will probably always resemble a series of equations with one too many variables, it is unlikely that any amount of formal guidance will ever take the place of the skill developed on the job by the planning engineer (or postal expert) and the architect in an association in which both have enough freedom of movement to ensure an economical overall solution to the problem.

In addition to this work on planning generally, the Group has many research problems to deal with. The following are but a few on the engineering side:

- Multi-storey and single-storey construction
- Layout of apparatus rooms (width and bay sizes)
- Modular co-ordination of building grids and apparatus-rack layout
- Cable lead-in arrangements
- The design of jibs
- Floor finishes
- Lighting, heating, ventilation and acoustics
- Design of standard buildings.

One of the Group's main preoccupations has been the determination of cost yardsticks for telephone-exchange buildings. Ideally, the cost yardstick should be related to the revenue from the subscribers connected to the exchange, but this is impracticable since the size of the building varies with the switching pattern and with other factors which have no relation to revenue. A sample of recent and current buildings confirmed that there is, in fact, no constant relationship between their cost and the number of connexions, nor indeed with the number of racks, which was also thought to offer a basis for costing. This may not always be so; the sample covered a period of wide technical change and thus included considerable variations in the size of the ancillary accommodation, e.g. power, battery and meter rooms. If current developments in these fields reduce this accommodation to small proportions, the number of racks may still emerge as a yardstick for fixing building costs.

At this point in its researches, the Group felt unable to do more than recommend a limit of cost, based on floor area, which should apply to the broad range of buildings. This is 65s. per square foot gross of the main building, detached ancillary buildings such as motor-transport workshops and garages being covered by a lower limit of 40s. External works, which are largely dependent on site conditions, do not lend themselves to control by means of a cost limit; these works must be assessed separately. It is expected that main buildings will have a planning efficiency of at least 95 per cent if single storey and 90 per cent if multi-storey.

A cost limit based on area provided clearly suffers from the disadvantage that it imposes no control over the amount of accommodation asked for: neither is it a complete control within itself since a building of lower overall cost may well produce a higher unit cost than a more expensive building. This illustrates the intricacy of marrying requirements and provision, and the need for joint research into the many problems involved.

The South Lancashire Radiophone Service

L. T. ARMAN and V. C. MELLER†

U.D.C. 621.396.65:621.396.931

The South Lancashire Radiophone Service provides telecommunication between mobile radio stations and subscribers on the public telephone network. The scheme is a pilot one intended to test the public demand for such a service; if the demand is sufficient the service will be extended to other areas of the United Kingdom.

INTRODUCTION

THE South Lancashire Radiophone Service is a v.h.f. mobile-radio service providing communication between mobile stations and subscribers on the public telephone network. It was opened by the Postmaster-General, The Rt. Hon. Reginald Bevins, M.P., on 28 October 1959. It is of interest to note that private v.h.f. mobile-radio land services operating in the 80 Mc/s and 160 Mc/s frequency bands have been in use in the United Kingdom for a number of years but they do not provide direct connexion with the public telephone network.

The Post Office decided recently to set up a pilot system to test the demand for a public mobile radiotelephone service, and the Lancashire area was chosen as being representative for the purpose. Tests to determine the coverage obtainable were carried out late in 1958 from a number of possible sites; the most favourable one appeared to be on Winter Hill, near Horwich, about 15 miles north-west of Manchester. As this site was found to give coverage as far as the outskirts of Liverpool it was decided to extend the service to include Liverpool and Wallasey; an additional base station at Telephone House, Liverpool, was accordingly selected. The Winter Hill base station does not provide entirely satisfactory coverage in the centre of Manchester and further tests showed that a useful improvement could be obtained by the use of auxiliary radio receivers and aerials on Telephone House, Manchester. As a result of these tests it was decided to proceed with the South Lancashire Radiophone Service, with a view to providing service by the autumn of 1959.

It is to be noted that, while the Post Office has provided and operates the base stations, it is for the mobile-service user to obtain equipment from commercial sources. This equipment must meet a performance specification laid down by the Post Office and, in addition, the mobile-service user must obtain a licence from the Postmaster-General.

ARRANGEMENT OF RADIO CHANNELS

It was decided to use voice calling for the pilot scheme, the radio channel provided for this purpose making use of the same frequencies at the Horwich (Winter Hill) and Liverpool base stations. Two traffic channels on different frequencies at each of these base stations have been provided. Additional channels for engineering development purposes have been included.

All channels are two-frequency, the actual frequencies being shown in Table 1.

It will be seen that the channel frequencies are in two blocks separated by 4.5 Mc/s. This separation has been

† The authors are, respectively, Senior Executive Engineer and Executive Engineer, Inland Radio Planning and Provision Branch, E.-in-C.'s Office.

TABLE 1
Radio Channels

Station	Channel Number	Function	Transmitting Frequencies (Mc/s)	
			Base Station	Mobile Station
Horwich	1	Calling	164.05	159.55
	1	First traffic channel	164.1	159.6
	2	Second traffic channel	164.25	159.75
	3	Engineering development	164.35	159.85
Liverpool	1	Calling	164.05	159.55
	1	First traffic channel	164.15	159.65
	4	Second traffic channel	164.2	159.7
	5	Engineering development	164.3	159.8

chosen to fit in with the pattern of frequency allocation for other services in the adjacent parts of the frequency spectrum; furthermore, it is large enough to permit duplex working without entailing large physical separations of the transmitting and receiving aerials at base stations. The frequencies chosen for the channels ensure that third-order intermodulation products from the traffic channels do not fall in the frequency band of the calling channel; since the mobile channel must keep watch on the calling channel it is essential to avoid interference from the traffic channels. This form of interference could be generated in and radiated from the transmitting stations, or generated in the mobile radio receiver. The range from the base station over which such interference is received can be minimized by careful engineering, but would probably be significant in Liverpool where the base station is in the urban area and mobile stations are likely to operate in the vicinity. Intermodulation products falling in the traffic channel are relatively unimportant, since under these conditions the mobile receiver picks up a comparatively strong wanted signal which "captures" the receiver and suppresses the interference. The use, at a later stage, of selective signalling on the calling channel will be of value in mitigating such interference.

Frequency modulation is used with pre-emphasis at the transmitter and de-emphasis at the receiver of 6 db per octave in the pass band 300-3,000 c/s, and a maximum frequency deviation of ± 15 kc/s is permitted. These characteristics are similar to those agreed internationally for the v.h.f. public maritime services; indeed, the choice of 50 kc/s spacings between the carrier frequencies was made because of the satisfactory experience obtained in the public maritime service and because suitable equipment was available. However, the possible use of smaller spacings between the carrier frequencies is being studied with a view to greater economy in the use of the spectrum.

The effective radiated power of each base-station transmitter is about 35 watts; the power of the mobile-station transmitters is limited to 25 watts by licence, but it is expected that most will have a maximum power of 15 watts.

The base stations are operated on a duplex basis but

for mobile stations there is a choice of duplex or simplex operation. The relative merits of duplex and simplex operation are discussed later.

RADIO STATIONS

The base station at Horwich (Winter Hill) is about 1,500 ft above sea level and comprises a brick building 20 ft x 12 ft and a stayed lattice mast 186 ft high supporting the aerial system.

The other base station is at Lancaster House, Liverpool. The aerial mast has a height of 86 ft; it is mounted on the roof of the building, which itself has a height of about 120 ft above sea level. The radio equipment is installed in a repeater room on the ground floor.

The auxiliary receiving station at Manchester is in Telephone House; it comprises five radio receivers and five aerials, the latter being mounted on masts already provided for microwave radio-relay systems.

AERIAL SYSTEMS

The aerial systems at the Horwich and Liverpool base stations are identical and it will suffice to describe the former; it can be seen in detail in Fig. 1. Separate aerials are provided for each radio receiver and each transmitter; the aerials are half-wave folded dipoles mounted vertically on booms from the mast and are connected to

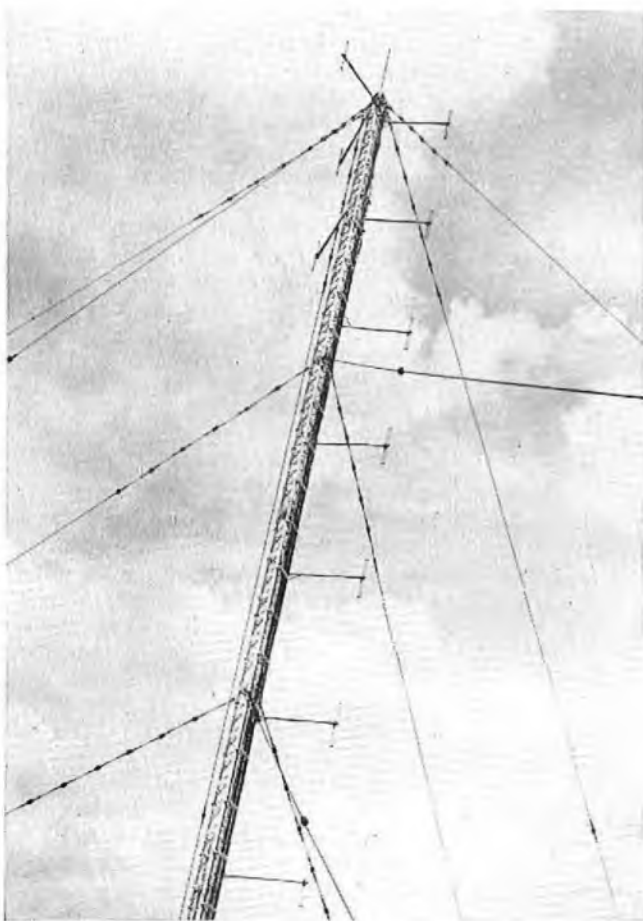

FIG. 1—AERIAL SYSTEM AT THE HORWICH BASE STATION

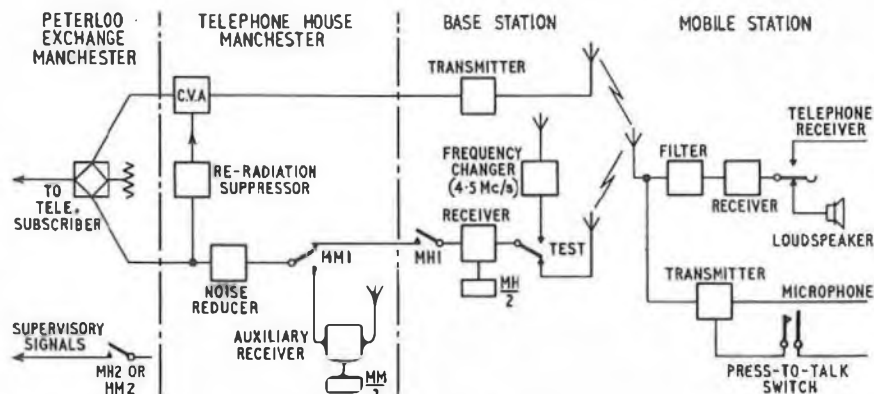

FIG. 2—BLOCK SCHEMATIC DIAGRAM OF SYSTEM

the radio equipment by means of coaxial feeders. These are helical-membrane cables with a characteristic impedance of 75 ohms and an attenuation of 1 db per 150 ft.

There are 11 aerials in all, 10 to serve the calling and traffic channels and one for test purposes, as discussed later. The receiving aerials are at the top of the mast, three at the highest level and two about 12 ft below. Spaced below them at 12 ft intervals are the five transmitting aerials, the lowest of these being about 114 ft above the ground; the test aerial is mounted some distance below the other aerials. The spacing of 12 ft between the transmitting aerials provides sufficient attenuation to ensure that any radiated intermodulation products are at an adequately low transmission level. The mast at the Liverpool station is similarly arranged.

At Manchester a half-wave dipole is provided for each receiver.

CIRCUIT ARRANGEMENT

The overall circuit from the telephone subscriber to the mobile-radio user is shown schematically in Fig. 2. For connexion to the radio equipment the 2-wire telephone circuit must be transformed into a 4-wire circuit with separate transmitting and receiving paths. A wide range of speech volumes can be expected from the 2-wire line, and in the interests of a satisfactory signal/noise ratio at the mobile stations it is essential that the base-station transmitter be fully modulated. This is accomplished by a voice-operated constant-volume amplifier (C.V.A.), the gain of which is set automatically in inverse proportion to the input signals over a prescribed range of levels. Furthermore, it is necessary to avoid the re-radiation of signals from the receiving path which appear in the transmitting path due to unbalance in the hybrid transformer at the junction of the 2-wire and 4-wire circuits. These unwanted signals could be accentuated by the gain of the C.V.A. and could appear as excessive side-tone at the mobile station. In order to avoid this difficulty a re-radiation suppressor is connected to the receiving path which, when operated by signals from the base-station receiver, partially blocks the transmission path through the C.V.A.

The signals passed to line from the receiver should have a minimum signal/noise ratio of 25 db. To this end the radio receiver is disconnected from the line by a muting circuit in the receiver until signals are received which would produce signal/noise ratios not less than 25 db; under these conditions relay MH operates, but releases if the signal/noise ratio drops to 15 db. In the

case of the auxiliary radio receivers located in Manchester it will be seen from Fig. 2 that if muting relay MM is operated the signals received from the Manchester receivers are transmitted to line instead of those from the receivers at the Horwich base station; it is arranged that relay MM operates for signals with a signal/noise ratio exceeding 35 db.

Relays MM and MH also give supervisory signals at Peterloo Exchange. The Horwich station is in a storm danger area and high-voltage transformers had to be used on the land lines; d.c. signalling was thus precluded. Use was made therefore of six channels of a G.E.C. Multiplex Indicating Equipment between Horwich and Manchester for the supervisory and control signalling circuits. This is essentially a v.f. signalling system for on-off signals at low speeds.

In gaps between speech, relays MH or MM may remain operated and, in the absence of suitable precautions, noise would then be re-radiated at a level dependent upon the unbalance of the hybrid circuit and the gain of the C.V.A., the re-radiation suppressor not being operated. To avoid this undesired effect, a noise reducer is connected in the receiving line; this device operates in such a manner that low-level inputs, i.e. noise in this case, are attenuated significantly whilst signals of normal level are unaffected.

The mobile station is shown as semi-duplex in Fig. 2, i.e. the receiving path is always open, but the radio transmitter is energized at will by means of the "Press-to-Talk" switch; however, simplex or full-duplex operation is also permissible, as discussed later.

The test frequency-changer shown in Fig. 2 is used for routine testing and in effect connects the base-station transmitter to the receiver. The transmitted signals are picked up on the test aerial, converted to the relevant receiving frequency, i.e. 4.5 Mc/s lower, and connected to the input to the radio receiver. Mobile station equipment has also been provided at two permanent locations and arranged to simulate mobile stations at the fringe of the service areas. These are under the control of the operating staff and enable the operators to talk through the base stations and thus make subjective tests of the overall performance of the system.

DESCRIPTION OF EQUIPMENT

Radio Transmitter

A block schematic diagram of a base-station transmitter is shown in Fig. 3. The audio-frequency input to the transmitter is amplified and passed through a limiter which introduces full-wave clipping at a prescribed level to restrict the amplitude of the signals so that the deviation of the carrier frequency cannot exceed ± 15 kc/s if the signal level becomes abnormally high. A low-pass filter follows the limiter to eliminate harmonics above 3 kc/s, which would otherwise result in distortion and/or excessive unwanted sidebands in other channels. The audio signal is then applied to the phase modulator of a

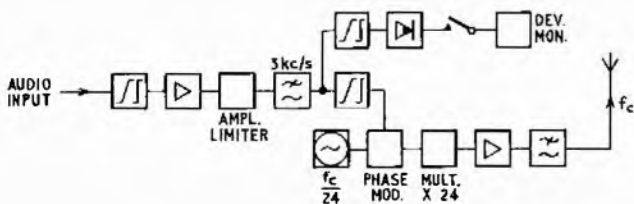

FIG. 3—RADIO TRANSMITTER

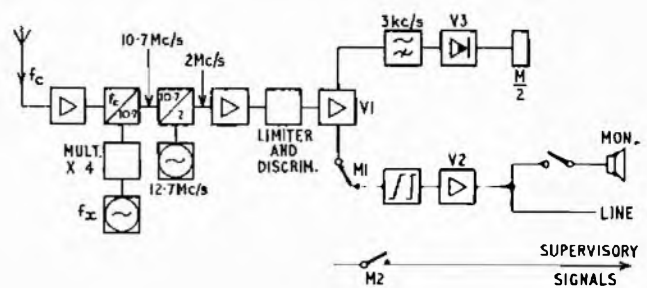

FIG. 4—RADIO RECEIVER

crystal oscillator having a frequency of about 6.8 Mc/s; this modulator is followed by four frequency-multiplying drive stages giving a final product frequency 24 times the crystal frequency. Each of these stages has a limiting action designed to remove unwanted amplitude-modulation products produced by the modulating stage.

Finally, the phase-modulated v.h.f. signal is amplified to nearly 50 watts in a power amplifier, which is coupled to the aerial feeders, and a filter is incorporated in this stage to restrict unwanted sidebands. The transmitter output, therefore, is equivalent to that of a frequency-modulated transmitter but with a modulation-frequency/deviation characteristic between 300 c/s and 3,000 c/s that rises by 6 db per octave relative to 1,000 c/s; thus, for a modulating signal of constant amplitude, the carrier deviation will increase proportionately with an increase in the frequency of the modulating signal. The arrangement of the limiter, however, is such that a frequency deviation approaching ± 15 kc/s can be obtained at all frequencies between 300 c/s and 3,000 c/s providing that the required level of modulating signal is applied to the transmitter. The deviation-monitor circuit measures the amplitude of the audio-frequency signal and gives an indication of the corresponding frequency deviation of the carrier.

Radio Receiver

The receiver is shown in block schematic form in Fig. 4. It has two stages of frequency changing preceded by v.h.f. amplification; in the first stage the v.h.f. input signal, f_c , is modulated with another frequency, obtained from the first crystal oscillator after multiplication by four, so that the carrier frequency of the output signal is 10.7 Mc/s. The actual oscillator frequency f_x therefore is

$$f_x = \frac{f_c - 10.7}{4} \text{ Mc/s.}$$

The first i.f. signal is applied to the second frequency changer and is there modulated with a frequency of 12.7 Mc/s and the lower sideband selected so that the output which is applied to the second, intermediate-frequency, amplifier has a carrier frequency of 2.0 Mc/s. This stage is followed by a limiter and discriminator and audio amplifying stages V1 and V2. The former supplies two outputs, one to the muting circuit and the other to V2, which is connected at its output to the line and a monitoring loudspeaker, as required.

The muting circuit comprises a high-pass filter and amplifier-detector, V3, which controls relay M. In the absence of a signal from the aerial the receiver noise is rectified in the amplifier-detector V3 and relay M is operated to disconnect the audio input to V2 at M1. Signals better than a prescribed level at the input to the receiver reduce the set noise so that relay M releases,

the high-pass filter producing sufficient discrimination between noise and signals. The signal levels at which the muting condition is removed and re-applied when the signal falls can be adjusted by independent controls. As stated earlier the muting circuit is disabled by a signal which produces a signal/noise ratio of 25 db at the output of the receiver but is restored when that ratio falls to 15 db (except at Manchester).

It should be noted that exceptionally the second oscillator has a frequency of 8.7 Mc/s, the change from 12.7 Mc/s having been made on account of interference from the transmitters.

Radio Terminal Equipment

The general purpose of the radio terminal equipment has been stated in the foregoing but, on account of its considerable interest, a more detailed description is merited. It will be seen from Fig. 5 that the whole equipment comprises a constant-volume amplifier (C.V.A.), re-radiation suppressor, noise reducer and hybrid terminating set.

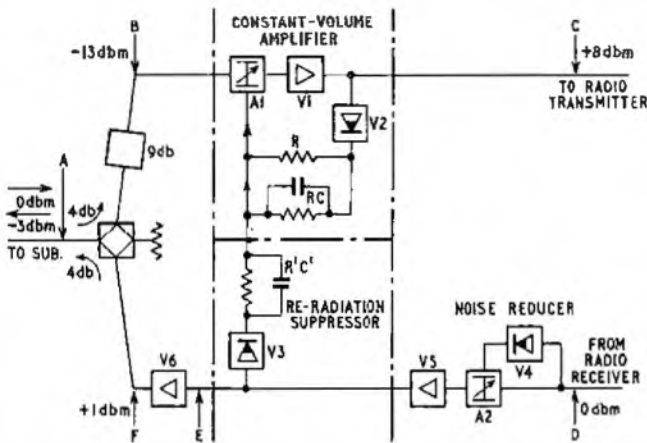

FIG. 5—RADIO TERMINAL EQUIPMENT

The C.V.A. consists of an amplifier V1 preceded by an automatically-controlled attenuator A1 and d.c. control circuits. Attenuator A1 is a conventional transformer-rectifier network by which the loss to a.c. signals in the transmitting path is made inversely proportional to the amount of direct current flowing through the rectifiers. Control is affected by applying the signal voltage at the output of V1 to an amplifier-detector, V2; the resultant direct current is applied through two paths to the attenuator A1, one through R which introduces very little time delay, and the other through the delay network RC. The former provides for insertion of attenuation as required in A1 almost immediately signals are received, but if left to itself would permit the attenuation to follow the modulation signal level. This is prevented by the voltage across RC, which is representative of the syllabic average amplitude and therefore is delayed in application to A1; a hangover time of about 4 seconds ensures that in general during breaks in the conversation the gain of the C.V.A. remains as set by the speech of the telephone subscriber.

Curve A in Fig. 6 is a graphical representation of the operation of the C.V.A. It will be seen that the output is constant at +8 dbm* over the input range of -13 dbm to -38 dbm. The actual input/output characteristic corresponds closely to this curve.

The re-radiation suppressor is an amplifier-detector, V3, which produces direct current through R'C' from the signals in the receiving path; the voltage so derived is applied to the attenuator A1 to reduce the net gain of the C.V.A. to zero. The network R'C' provides for the necessary hangover time, about 0.5 seconds, between words; this voltage is cumulative with any that may be across R or RC at the time.

The noise reducer (expander) comprises an amplifier-detector, V4, controlling a variable attenuator, A2, in a similar manner to the control of A1 in the C.V.A.; A2 is followed by an amplifier, V5, in the signal path. The operating characteristic of this device is shown graphically by curve B in Fig. 6; for input levels of from 0 to -15 dbm it is a linear amplifier with zero gain, but for levels lower than -15 dbm the device has an expansion ratio of 2 to 1, i.e. for every 1 db decrease in the input, the output is decreased by 2 db.

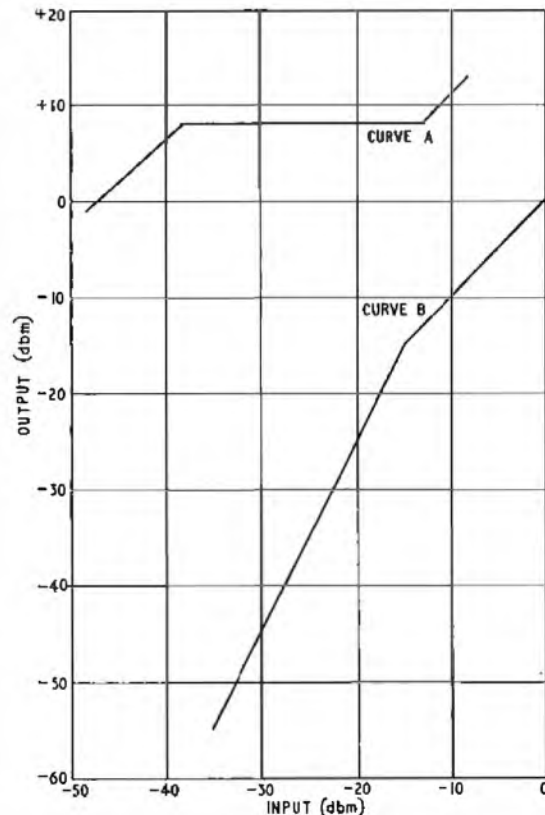

Curve A—Constant-Volume-Amplifier Characteristic
Curve B—Noise-Reducer Characteristic
FIG. 6—OPERATING CHARACTERISTICS OF THE CONSTANT-VOLUME AMPLIFIER AND NOISE REDUCER

OPERATION OF THE EQUIPMENT

It will already have been appreciated that the talker volume from the 2-wire line varies considerably, and that in order to meet the requirement of full modulation of the radio transmitter, the C.V.A. is inserted in circuit to compensate for low signal levels, but what has not so far been examined fully here is the penalty this involves. There are two main effects to be considered:

(a) Noise from the radio receiver, which does not normally operate the re-radiation suppressor, leaking across the hybrid and resulting in degradation of the

* dbm—decibels relative to 1 mW.

signal/noise ratio of speech in the transmitting path.

(b) The re-radiation by the transmitter of received speech, which could appear as excessive side-tone at the mobile station.

The problem will be best understood from an analysis of the limiting conditions in comparison with an average set of circumstances. The worst conditions that are assumed in practice are a 25 db signal/noise ratio at the output of the radio receiver, which is not operative for lower ratios, a hybrid loss of 10 db (from the receive line to the transmit line) and a signal level of -25 dbm from the 2-wire line; the signal arrives at the C.V.A. at -38 dbm, which is the lower limit of control. The normal line-up conditions are shown in Fig. 5; it will be seen that a signal at point A at a level of 0 dbm is sent to the transmitter from point C at a level of +8 dbm, and 0 dbm at D is sent to line at A at -3 dbm. If the level from A is -25 dbm it still appears at A as +8 dbm, but the gain of the C.V.A. would be 46 db instead of 21 db as for the 0 dbm case. The effect of noise levels of -30 dbm, -25 dbm and -15 dbm at point D on the signal/noise ratio of signals from A at C, assuming a hybrid loss of only 10 db, is shown in Table 2.

ratio of the outgoing signals at C by noise from D depends upon whether the mobile station is operating on a simplex or duplex basis; in the former case the degradation would only occur during the hangover time of the receiver muting circuit, which might be nullified by the necessity for the line subscriber to pause before speaking to allow the mobile subscriber to switch to receive; whilst in the latter condition the degradation could be continuous. Similarly re-radiation of the received speech is of little importance at simplex mobile stations.

MOBILE-STATION EQUIPMENT

The present policy with regard to the supply of mobile-station equipments is that subscribers to the system must obtain them from commercial sources. A limited number of mobile sets have been obtained by the Post Office and are used for official purposes, tests and demonstrations. It is essential that all mobile-station sets should conform to Post Office requirements to ensure that they are complementary to the base-station equipment and meet the minimum standards of performance required.

TABLE 2
Effect of Received Noise on Signal/Noise Ratio of Transmitted Speech

No.	Condition		Noise Levels at Circuit Points (dbm)				Signal/Noise Ratio at Point C (db)
	Level of Signal from Line at Point A (dbm)	Level of Noise from Receiver at Point D (dbm)	E	F		C	
1	0	-25	-35	-34	-53	-32	40
2	0	-15	-15	-14	-33	-12	20
3	-25	-25	-35	-34	-53	-7	15
4	-25	-15	-15	-14	-33	+13	-5
5	-25	-30	-45	-44	-63	-17	25

Note: Points A-F are shown in Fig. 5.

It should be remembered from the foregoing that the radio receiver is inoperative for signals which would produce a signal/noise ratio at D of less than 25 db, but once the receiver is operative this ratio can drop to 15 db before the receiver is disabled by the muting circuit. In the absence of signals from the receiver this noise would affect signals from A at C, as shown in Items 3 and 4 in Table 2. The signal/noise ratios in the last column for Item 3 would probably be tolerable to the mobile subscriber but that for item 4 would not, and the call would have been disconnected; of course, an increase in the signal level from A, as exemplified in Items 1 and 2, would result in the considerable improvements shown in the last column.

Referring to the re-radiation of signals from the radio receiver at D, these would arrive at C, assuming a 10 db hybrid loss, at -18 dbm (the C.V.A. having zero gain by virtue of the operation of the re-radiation suppressor), i.e. they would be re-radiated at 26 db below normal signals, which would be tolerable; hybrid losses better than 10 db would reduce this level.

The significance of the degradation of the signal/noise

The transmitters and receivers of the sets used by the Post Office are similar to those used at the base stations, the main points of difference being in the lower power of the transmitter of the mobile-station set (15 watts) and the provision for switching to any one of six channels at will, to provide for channel selection. The transmitter/receiver unit is contained in the boot of the car, and a control panel is provided on the dashboard. These can be seen in Fig. 7 and 8.

The Post Office sets are arranged to operate on a duplex basis, as shown schematically in Fig. 9(a). The receiver is brought into use by means of the "Receiver On" switch, and the transmitter is put into the standby condition by means of a switch which connects the power supply to the valve heaters; the h.t. supply is connected to the transmitter when the telephone handset is removed from its cradle. The control panel also houses a loudspeaker, which is connected to the radio receiver output in the idle condition but is disconnected when the "Press-to-Talk" switch is operated; the switch leaves the telephone receiver in circuit and connects the microphone to the transmitter. The "Press-to-Talk" switch prevents



FIG. 7—MOBILE-STATION EQUIPMENT

possible false operation of the re-radiation suppressor in the radio terminal equipment (see Fig. 2) by background noise, when the vehicle is in noisy surroundings, and also permits the use of a loudspeaker for reception, which is also advantageous under such conditions. The simultaneous use of the microphone and loudspeaker would probably lead to acoustic-feedback difficulties.

In addition to the controls mentioned above, one control for volume and one for the receiver-muting sensitivity, for use against weak interference signals, are provided. The band-pass filters shown in Fig. 9(a) prevent the radio receiver being desensitized by noise from the radio transmitter. The 4.5 Mc/s separation between the frequencies is not sufficient in itself, particularly when using a common aerial.

The arrangement for a typical simplex mobile station is shown in Fig. 9(b). In this case the receiver is connected direct to a loudspeaker and is put in the operating condition by means of the "Receiver On" switch. The "Press-to-Talk" switch operates relay HT1, which switches the h.t. supply from the receiver to the transmitter, and thereby causes relay A to operate to switch the aerial from receiving to transmitting; the transmitter l.t. supply switch will also have been operated.

It has been stated earlier that the mobile-station subscriber has a choice of the system of operation as far as his own equipment is concerned, and it will be appropriate here to point out the relative merits of simplex and duplex operation. True duplex operation is not practicable in this system on account of the re-radiation suppressor (see Fig. 2), which can make it difficult for the fixed-station sub-

scriber to break in on the mobile-station subscriber. Simplex operation has this disadvantage to a much greater degree as it is impossible for the fixed-station subscriber to break in, and there are inevitably delays between speech in the two directions, depending upon the skill of the two talkers.

From the operational aspect duplex operation is preferred because during a call the telephone exchange continuously receives supervisory signals from the mobile station. For the mobile-station equipment there is an overwhelming advantage in favour of simplex operation. The equipment is somewhat cheaper and the power drain on the batteries is significantly lower for the same power rating of the transmitter. There is also an improvement in performance since, unless comparatively costly filters (see Fig. 9(a)) are used, their insertion could reduce receiver sensitivity and transmitted power. In consequence mobile-station subscribers may, in general, prefer

simplex operation. The Post Office have arranged the operating procedure at Peterloo exchange to accept either simplex or duplex operation.

SERVICE AREA

Radio surveys made from the Horwich and Liverpool base stations, using a mobile transmitter power of 15 watts, indicate that the service area should be substantially that shown in Fig. 10. The service area is determined mainly by transmission in the mobile-base station direction. In the reverse direction the range may be somewhat greater for two reasons; firstly, the base station radiates a higher power and, secondly, there is



FIG. 8—CONTROL POSITION IN VEHICLE

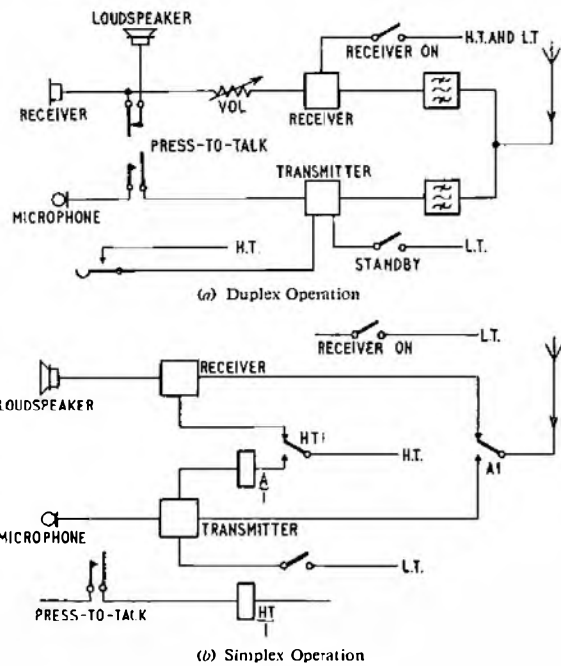

FIG. 9—BLOCK SCHEMATIC DIAGRAMS OF TYPICAL MOBILE-STATION EQUIPMENTS

not the need to reject signals at the mobile station with less than a 25 db signal/noise ratio. In the primary service area in Fig. 10 there should generally be good service, but there will be a few bad spots due to the local screening or the local topography. In the secondary service area, service may be good on high ground or be satisfactory if the vehicle is stopped at a suitable spot, thus avoiding "flutter" from variations of signal strength due to screening and/or reflections. Experience of the system has shown that service is also obtainable on some high ground well outside the secondary area.

FUTURE DEVELOPMENTS

The question of future development depends upon public response to the pilot scheme, but if this is satisfactory there would be two aspects to be considered, one, engineering development of the system, and the other, extension of the system to other areas, possibly eventually providing nation-wide coverage.

The main line of engineering development would be a selective-calling system which could also provide a measure of privacy by locking out all mobile-station sets until their selective-calling units operated. The success of a selective-calling system depends very much on the development of a satisfactory low-cost unit; at present the cost is too high for general use.

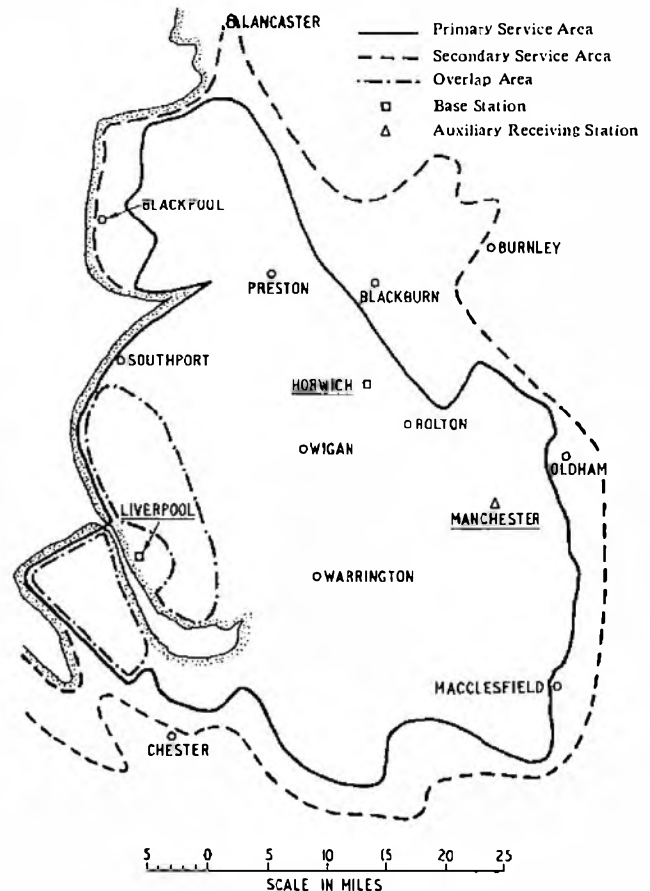

FIG. 10—AREA OF THE SOUTH LANCASHIRE RADIOPHONE SERVICE

Extension of the system to other areas would in general involve a national frequency plan with allowance for through traffic and possibly the use of smaller carrier spacings than 50 kc/s in order to obtain sufficient channels. Tests with such smaller carrier spacings are already in hand.

Experience with the South Lancashire scheme will also provide valuable data on the number of mobile units that can be satisfactorily accommodated on each radio channel.

ACKNOWLEDGEMENTS

The authors' thanks are due to colleagues in the Engineer-in-Chief's office, and in particular to the staff of the North Western Region and the staff of Pye Telecommunications, Ltd., who participated in the South Lancashire system. The photographs for Fig. 1, 7 and 8 were supplied by Pye Telecommunications, Ltd., to whom acknowledgement is made.

Book Received

"Wireless World Diary, 1960." T. J. & J. Smith, Ltd., in conjunction with *Wireless World*. Eighty pages of reference material plus diary pages of one week to an opening. Size 4½ in. × 3½ in. Leather, 6s. 3d.; Rexine, 4s. 6d.; postage, 4d.

The comprehensive reference section includes general

information, such as abbreviations, screw sizes and weights and measures, and information on radio topics such as addresses of radio organizations, licence regulations, frequency allocations and v.h.f. sound and television broadcasting stations; over half the reference section is occupied by miscellaneous circuits, formulae and general circuit-design data.

Model Electronic Exchange in Dollis Hill Laboratories

U.D.C. 621.395.345:621.395.722

SINCE 1956 the Post Office and the five principal manufacturers* of exchange switching equipment in this country have been co-operating on the problem of electronic exchanges. Prior to that time the Post Office and each of the manufacturers had independently investigated the potentialities of electronics in telephone exchanges and had become convinced that at some time in the future at least some of the electromechanical apparatus at present used would be replaced by electronic apparatus. Semi-electronic systems in which electro-mechanical switches for interconnecting the speech circuits are controlled electronically were known to show some advantages over conventional fully electro-mechanical systems. However, it was urgently necessary to know if, and by how much, fully electronic systems might be better than semi-electronic systems in respect of cost, space, reliability and so forth. To use electronic speech-circuit switching as well as electronic control is a major step involving a considerable amount of research and development effort in design, construction and laboratory testing and the magnitude of this task was a major factor in the decision by the Post Office and the manufacturers to pool their resources in one comprehensive organization.

It is a well-known and readily appreciated fact that to produce high-quality industrial products requires not only the right technology but also lengthy experience of operation of the products under actual field conditions.

It was soon decided to obtain electronic-exchange field experience without delay by jointly producing first a model exchange, and then an exchange in public service; the model exchange would be erected in a laboratory to ensure, so far as that is possible, that it would perform reliably and provide adequate service. The first part of this program is now complete. The model exchange (Fig. 1) has been designed, manufactured and tested jointly by the Post Office and the manufacturers, and has been working at Dollis Hill for some time. It is being used to evaluate speech transmission through the exchange, costs and reliability.

Based on this experience it is planned to construct an exchange for public service and to install it alongside the new Highgate Wood exchange in North London, now being built under the normal exchange provision plan. When satisfied that the electronic exchange is capable of satisfactory public service the Highgate Wood lines and junctions will be transferred to it from the regular exchange, which will be maintained for some time as a standby for the electronic exchange. In this way the public service will be protected to the maximum extent against difficulties which are always likely to occur unexpectedly until new techniques become firmly established.

* Automatic Telephone & Electric Co., Ltd.; Ericsson Telephones, Ltd.; General Electric Co., Ltd.; Siemens Edison Swan, Ltd.; Standard Telephone & Cables, Ltd.

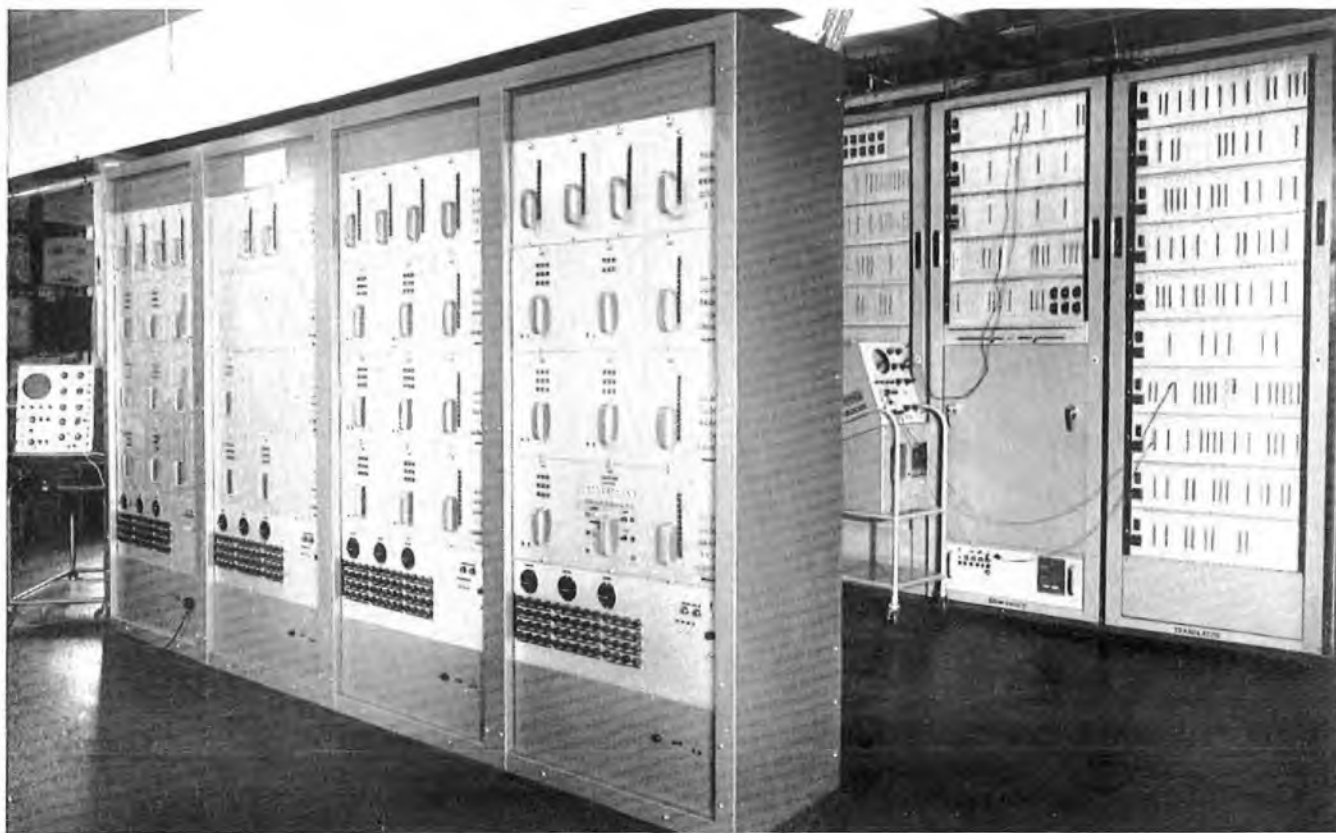

FIG. 1—THE MODEL ELECTRONIC EXCHANGE

The model exchange uses 100-channel time-division-multiplex switching of the type previously described in the Journal¹ but modified and extended by highway switching² so that exchanges up to the largest sizes can be constructed. Fig. 2 illustrates the principles involved.

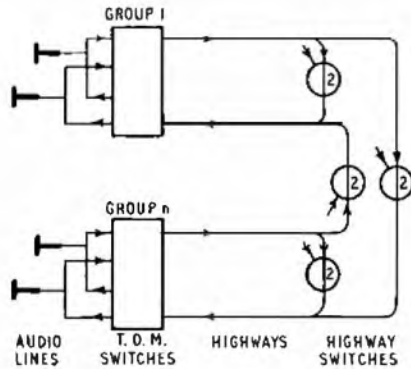

FIG. 2—PRINCIPLE OF HIGHWAY SWITCHING

Subscribers' and junction lines and, in fact, all kinds of lines terminated on the exchange are spread evenly over

a number of multiplex groups, as shown. Each group is a 100-channel time-division-multiplex switch providing 4-wire speech and signal transmission between the audio circuits and the time-division-multiplex channels or highways; a 2-4 wire termination is provided for each audio circuit. Any audio circuit in a group may be connected by the exchange control system to any of the 100 multiplex circuits within the group. The group highways are fully interconnected by so-called highway switches so that a channel in the transmit multiplex highway of any group can be connected to the corresponding channel in the receive highway of any group including its own. A speech path between two lines on the exchange is established by allocating the same multiplex channel throughout the connexion from the transmit multiplex of one line through the appropriate highway switch to the receive multiplex of the other line, which may be in the same or a different group.

¹ SCOWEN, F. A Small Experimental Electronic Automatic Telephone Exchange. *P.O.E.E.J.*, Vol. 47, pp. 1, 102 and 138, Apr., July and Oct. 1954.

² HARRIS, L. R. F. Time Sharing as a Basis for Electronic Telephone Switching. *Proceedings I.E.E.*, Paper No. 1993R, Mar. 1956 (Vol. 103, Part B, p. 722).

Book Review

"Modern Electronic Components." G. W. A. Dummer, M.B.E., M.I.E.E., Sen. Mem. I.R.E. Sir Isaac Pitman & Sons, Ltd. viii + 472 pp. 232 ill. 55s.

Which modern electronic components are dealt with in this book are revealed by the headings of Chapters 5-17. They are: "Fixed Resistors," "Variable Resistors," "Fixed Capacitors," "Variable Capacitors," "Wires," "Covered Wires and Sleeveings," "Radio-frequency Cables," "Plugs and Sockets," "Relays," "Switches," "Inductors and Magnetic Materials," "Transformers, Transducers and Pulsactors," "Batteries and Accumulators," and "Miscellaneous Components." The last are terminal boards, stand-off insulators, and seals. The list is completed by printed wiring boards, which are dealt with in Chapter 24. Valves, semi-conductors, quartz crystals and waveguides are not included and are not dealt with in any detail in the book.

The book opens with a brief historical outline of component development in Great Britain. The next three chapters are given up to lists of current national and international component specifications, colour codes, and a list, extracted from B.S. 530, of conventional symbols. All the preferred resistor values from 10 ohms to 10 megohms are set out in tabular form and against each one the colour code is shown. Separate lists are provided for 5 per cent, 10 per cent and 20 per cent tolerance resistors which is making rather heavy weather of it as the 10 per cent list is derived from the 5 per cent list by omitting every other value, and the 20 per cent list is similarly derived from the 10 per cent list. Incidentally, there is an obvious typographical error in the 10 per cent list where 210,000 is shown in error for 120,000.

The chapter on fixed resistors starts with a general classification of resistors—high-stability and general purpose—followed by a list of the characteristics which need to be known if informed choice is to be made. Each characteristic is then discussed in some detail. A description of the physical construction and methods of manufacture of the

various types of resistors follows with adequate sketches, and at the same time a considerable amount of information regarding tolerance, stability, range, power-handling capacity, voltage limits, maximum working temperature and temperature coefficients is given. When discussing some of the less well-known resistors specific applications are mentioned to illustrate their use. An interesting one is the use of high-value resistors (10^7 - 10^{13} ohms) in measuring equipment for atomic-energy work where measurement of currents as low as 10^{-13} amp is required. These resistors are of the carbon-film type sealed in an evacuated glass bulb, and if the current is passed through them the resultant voltage drop may be measured by means of a valve or other suitable device. The chapter ends with a selected bibliography. This is the general plan adopted for all chapters on components.

The chapters on resistors and capacitors, which average about 50 pages each, are the most complete and also the most satisfying. The rest average 13 pages each, but, as the plan adopted is to cover the whole field, they are, at times, somewhat sketchy.

The book continues with a chapter on the trend of development and then goes on to discuss reliability and fault liability, the effects of climatic and temperature extremes, casting resins and nuclear radiation, vibration and shock. There is a chapter on transistor circuit components, and another on components for printed wiring and automatic assembly systems. The general methods used for testing components are outlined. The last chapter tackles packaging, preservation and identification of components. Finally, there is a good index.

The book itself is handsome, the diagrams and illustrations beautifully done, the type clear and, most important, easy to read.

The author has succeeded in producing a very readable book, full of interest and packed with information albeit rather uneven perhaps because, as stated in the preface, it is the first comprehensive book of its kind to be published in the world.

W. S. A

Working Aloft

J. J. MOFFATT, A.M.I.Mech.E., A.M.I.E.E., and E. W. CHARLTON, A.M.I.Mech.E.†

U.D.C. 621.315.17

The various means used to facilitate the efficient performance of external work above ground level are surveyed, and two recently introduced appliances are described in some detail.

INTRODUCTION

TO perform work on overhead telephone lines with efficiency it is essential to provide adequate means of reaching the job, and the more involved the job the better should be the means of access. Similarly, if staff are to work aloft for long periods the facilities provided should be such as to avoid conditions that are liable to cause fatigue and the risk of accidents.

For many years ladders were adequate for overhead work, but the increase in aerial cabling and the need to speed-up tree-trimming work led to a demand for a mobile unit. A lorry-mounted ladder-derrick was then designed, using standard ladders with a range of attachments. This served a useful purpose for some years although it had limited reach and had to be frequently dismantled to pass bridges and other overhead obstructions.

The need to joint and repair large aerial cables led to the production of a working platform capable of accommodating a joiner's tent and of being mounted on poles or secured to suspension wires. The time taken for the erection of this device is, however, considerable. Fig. 1 shows two aerial-cable jointing platforms erected on a pole to provide the required access and facilities for splicing-in a short length of aerial cable.

The introduction of vehicles with rigid bodies, as distinct from "tilts," into the Post Office fleet led to the

production of a variety of experimental vehicle-mounted gantries, but their limited reach reduced their value. Their use also entailed certain elements of risk. Legislation relating to safe working conditions for men working at heights of over 6½ ft above ground level was passed and this rendered the ladder derrick and the bulk of the vehicle-top gantries illegal.

In considering the essential requirements for such a device it was appreciated that tree-trimming work was seasonal in character and also that aerial cabling formed only part of the load of a maintenance party; hence, a design was required which would not interfere with the normal use of a maintenance party's vehicle and yet be of sufficiently low cost to warrant its production and supply. These considerations led to the production of a turntable-mounted ladder-assembly secured to the roof of a box-bodied vehicle, as described below. This design incorporates a number of features entailing hand operation to keep the costs to a reasonable limit, and consequently its operation is somewhat slower than if it were power-operated.

The increasing use by the Post Office of self-mobile hydraulically-operated cranes led to the logical development of a working platform that could be attached to the jibs of such cranes and provide safe working conditions for three or four men per platform. This appliance served a useful purpose but, because the parent cranes were not capable of being slewed, an undue amount of manoeuvring time was necessary to move the working platform into the desired position.

In a number of Telephone Areas the amount of overhead work, including work on the outside of tall buildings, was found to be so large that the full-time use for a more-rapid power-operated appliance was considered to be justified. A commercial device, developed to meet the safety regulations and the general requirements of various utility undertakings, has been adopted by the Post Office for this purpose. This elevating platform is also described below.

TURNTABLE-MOUNTED LADDER VEHICLE

The turntable-mounted ladder vehicle (Fig. 2) is a dual-purpose vehicle catering for general overhead-maintenance and stores-carrying duties. Hence, one of the basic design features was that the inside of the vehicle body should be free of all obstructions when the ladder assembly was not in use. To meet this requirement the turntable ladder is mounted on top of a reinforced box-type body and access is gained through a sliding portion of the roof by means of a short access ladder. The access ladder is part of the ladder assembly and can be drawn downwards through the sliding-roof opening and located by means of a pivoting peg in a hole in the vehicle floor. The access ladder is thus able to rotate with the main assembly and always be in line with it for direct access.

The main ladder consists of a two-section aluminium-alloy extension ladder providing an extended length of 20 ft, and is fitted with a working cage or platform at the upper end. The ladder is a commercial item and

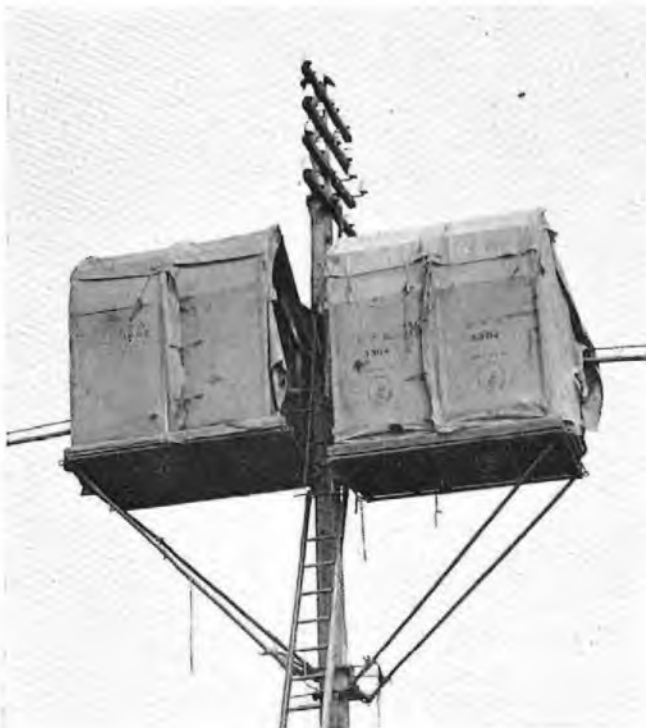

FIG. 1—AERIAL-CABLE JOINTING PLATFORMS

† External Plant and Protection Branch, E.-in-C.'s Office.



FIG. 2—TURNTABLE-MOUNTED LADDER VEHICLE

its use as a cantilever necessitates additional bracing to increase the stiffness. These additional bracings provide convenient hand grips for staff using the ladder. Extension of the main ladder with the working platform is accomplished by means of a rope passing around the barrel of a hand windlass. The customary locking-latch and latch-release rope are also provided.

The main ladder assembly is elevated by means of a hand-operated hydraulic pump serving a pair of hydraulic rams mounted on the turntable ring. The rams permit the ladder to be elevated to a maximum angle of 64°. A pressure-release valve is fitted to the side of the hand pump for lowering the ladder. The lowering speed is controlled by preset restrictor valves, one of which is incorporated in the head of each ram unit.

The working platform, shown in Fig. 3, is pivoted at the free end of the main ladder assembly and, by means of a pair of quadrant arms, may be adjusted so that the floor is horizontal irrespective of the angle of the ladder. This adjustment is also used to keep the overall height of the vehicle and ladder to a minimum for road travel (Fig. 2). Guard rails, a tool tray, and a means of attaching a safety belt are also incorporated in the working platform.

The turntable unit consists of a 5 ft 4 in. diameter steel-channel ring secured to the vehicle body, which contains a rotating assembly running on four trunnions in the flanges of the ring. The pivoting bearings for the main ladder and the elevating mechanism are all mounted on the rotatable assembly, which permits the unit to be rotated through a full circle. The unit is rotated manually by means of a rope attached to an upper rung of the main ladder unit (see Fig. 3). When the ladder has been rotated into the required position it is secured by a friction brake which operates against the turntable ring. The complete assembly provides a hemisphere of possible working positions 44 ft in diameter above the level of the top of the vehicle body, which is 11 ft high.

The vehicle has a stores-carrying box-type body and is reinforced between the inner and outer panels to withstand the stresses caused by the turntable ladder assembly. Trapdoors in the front of the body above the driving cab (Fig. 2) enable long items of stores to be carried. Interior lighting, hat and coat hooks and a series of lashing rings for securing stores have also been included. Interior shelving units have been omitted as they tend to restrict the pay load (which is 25 cwt) and the general usefulness of the vehicle for carrying stores. The vehicle cab is of the type now used on gang vehicles in which is provided seating for five men, a writing table, accommodation for papers, and a first-aid kit. A towing coupling for heavy or light trailers and a trailer vacuum-brake coupling are also provided.

HYDRAULIC ELEVATING PLATFORM

This appliance is the latest item in the range of equipment intended to improve access to overhead external work. It is a commercially produced item that meets the requirements in Telephone Areas where the volume of overhead work is sufficient to warrant the full-time employment of a comparatively expensive power-



FIG. 3—LADDER ROTATED, ELEVATED AND EXTENDED

operated unit. The makers are Messrs. Simons Engineering (Midlands), Ltd.

From Fig. 4, which shows the unit in the travelling position, it will be seen that it consists of an upper and lower boom hinged together and mounted on a turntable which in turn is secured to a 5-ton long-wheelbase lorry chassis. The turntable is capable of rotating through a full 360° and has mounted on it a petrol-engine-driven hydraulic-pump supplying power to hydraulic rams which raise and lower the main booms. The same engine supplies power to rotate the platform. An interesting feature is that the operating controls are in duplicate; one set is accessible from the turntable platform while the second, which consists of foot pedals and a rudder bar, is located in the operator's working cage and enables the operator to position himself in exactly the required position. The floor of the operating cage is maintained horizontal, irrespective of the angle or position of the main booms, by means of linkage rods (see Fig. 5). Incorporated in the operator's working cage are guard rails which fold to minimize the overall travelling height and which can also be used conveniently as a short ladder to gain initial access to the working platform.

The maximum unbalanced load imparted to the lorry chassis is much greater with this appliance than with the



FIG. 4—HYDRAULIC ELEVATING PLATFORM

turntable-ladder vehicle, and although a large counter-balance weight is provided below the petrol engine, it is necessary to employ stabilizing feet at each side and at the rear of the lorry chassis. The stabilizing feet on each side of the vehicle are mounted on extendible booms to give the required spread. When not in use the stabilizing feet are raised and stowed within the outline of the vehicle. In order to further steady the unit when in use a hydraulic ram is used to mechanically bridge the lorry chassis springs and lock the superstructure to the rear axle.

The use of hydraulic power has the advantage that it can be readily applied, by means of piping, to any points where power is required and permits effective safety features to be provided by means of simple pressure cut-off valves. Thus, the hydraulic power is automatically cut off when either, or both, of the main booms reaches its maximum or minimum position or if the working platform is accidentally lowered on to an obstruction. Similarly, power is cut off should the unit meet an obstruction during rotation. Facilities are also included for the extension of electrical or pneumatic power and a telephone connexion from ground level to the working platform should they be required.

When work that will occupy a considerable time is to be carried out the petrol engine may be switched off from either the working or the turntable platform. The working platform may then be lowered at the completion of the work or when it is required to restart the engine. The engine cannot however be restarted from the working platform.

There are three sizes of this appliance in general production, offering maximum working heights of 30, 40 or 54 ft. The 40 ft model is most generally suited to Post Office requirements. The maximum platform load, when the vehicle is standing on hard level ground and the stabilizing feet are in use, is 750 lb. Without the stabilizers in use the load must not exceed 275 lb. One of the 54 ft models has also been obtained for use on high buildings in the London area. The stabilizing feet must always be used on this model and the maximum safe working load is 300 lb. The 40 ft and 54 ft models permit work to be carried out within diameters of 53 ft and 60 ft, respectively.



FIG. 5—HYDRAULIC ELEVATING PLATFORM IN USE

A New Power Plant for U.A.X.s No. 12 and 13— Power Plant No. 214

D. H. SANDER†

U.D.C. 621.311.6:621.395.722

A new power plant, designated Power Plant No. 214, has been introduced to supersede the single-battery automatic power plants previously used in U.A.X.s No. 12 and 13. The plant is fully automatic in operation.

INTRODUCTION

THE problem of designing a power plant suited to the needs of a telephone exchange is to a large extent that of providing a reliable d.c. supply at the lowest overall cost per kilowatt-hour.

The prime use for the plant to be described in this article is at small unattended telephone exchanges, where automatic operation is essential to minimize the number of visits to the exchange. The need to keep the initial cost per exchange line to a minimum and the small number of lines for which the plant will provide a supply impose a limitation on the first cost and make it imperative to simplify the design as much as possible.

Experience gained with the previous type of automatically controlled plant used in U.A.X.s for more than 20 years has shown that improved performance would result from the elimination of certain features of its design. Whilst the use of a single battery with automatic control of battery charging has been retained, the use of ampere-hour meters, counter-e.m.f. cells and mercury switches has been avoided in the new design.

CONSIDERATIONS INFLUENCING THE DESIGN OF THE PLANT

Before describing the design of the new power plant it is worth while to summarize some of the difficulties experienced with the earlier type of plant. This can perhaps best be done by considering the shortcomings of the components used.

Ampere-Hour Meters

Experience has shown that the accuracy of these instruments at light loads is inadequate to ensure satisfactory operation with small currents. This results in a progressive discharge of the battery.

Contact Voltmeters

These instruments usually consist of a standard voltmeter movement with a suppressed lower portion of the scale and having a contact assembly added. The relatively low torque obtainable is inadequate to ensure reliable operation. The presence of a voltage scale offers no advantage and can in fact lead to confusion due to discrepancies between instruments caused by manufacturing tolerances. These difficulties have been overcome in the design of the moving-coil relay which is described later.

Relays with Mercury Contacts

In the new design, heavy-current switching functions are performed by small contactors, which are more reliable than mercury-contact relays. The new contactors are described later.

Counter-E.M.F. Cells

Planté-type cells (P.O. Cells, Secondary, Enclosed, No. . . .) have been used for voltage-regulating purposes at U.A.X.s for many years. Voltage-control failures have occasionally been caused by excessive counter-e.m.f. battery voltages. Sulphation of the lightly-used group of cells is the principal cause of this trouble. Furthermore the principle of voltage regulation by means of counter-e.m.f. cells in the discharge circuit has the disadvantage that the voltage of the counter-e.m.f. battery is dependent on the exchange load current. Consequently, when the load is small the counter-e.m.f. is low although it is in fact required to be high to compensate for the rise in the voltage of the main battery due to the application of the charging current. This feature necessitates the use of a charging rectifier with a tapering output-current/voltage characteristic to prevent the voltage of the main battery exceeding the value for which the counter-e.m.f. battery can apply compensation under adverse conditions.

PRINCIPLES OF OPERATION

Three ways of determining the state of charge of a secondary-cell battery were considered:

(a) By the summation of the quantity of electricity flowing into or out of the battery over a period. This requires an ampere-hour meter.

(b) By measurement of the specific gravity.

(c) By measurement of the terminal voltage while the battery is on charge or discharge. With this method the rate at which the battery is being charged or discharged is of importance.

The first method was not favoured for the new plant because of the difficulties already described. The second method was not considered to be practicable, and a method of controlling the charge by measurement of the battery terminal voltage has been adopted. This has enabled the voltage-monitoring circuit needed for the regulation of the exchange supply voltage to be used for the control of the charging rectifier.

The exchange-supply voltage is regulated by tapping the exchange-supply negative connexion down the battery, the tapping point depending on the actual voltage of the supply to the exchange. The voltage-detection circuit, which determines when these switching sequences should occur, also determines when the charge rectifier should be switched on or off.

Basic Operation

The basic circuit is shown by the heavy lines on Fig. 1, which shows the output of the charging rectifier disconnected and 24 cells connected to the exchange. When, due to the load current, the terminal voltage of the battery has fallen to a predetermined value, the voltage monitor will respond and cause contact CE1 to apply charging conditions. The capacity of the rectifier exceeds the exchange load so that part of the rectifier output is available for charging the battery; the value

† Assistant Engineer, Power Branch, E.-in-C.'s Office.

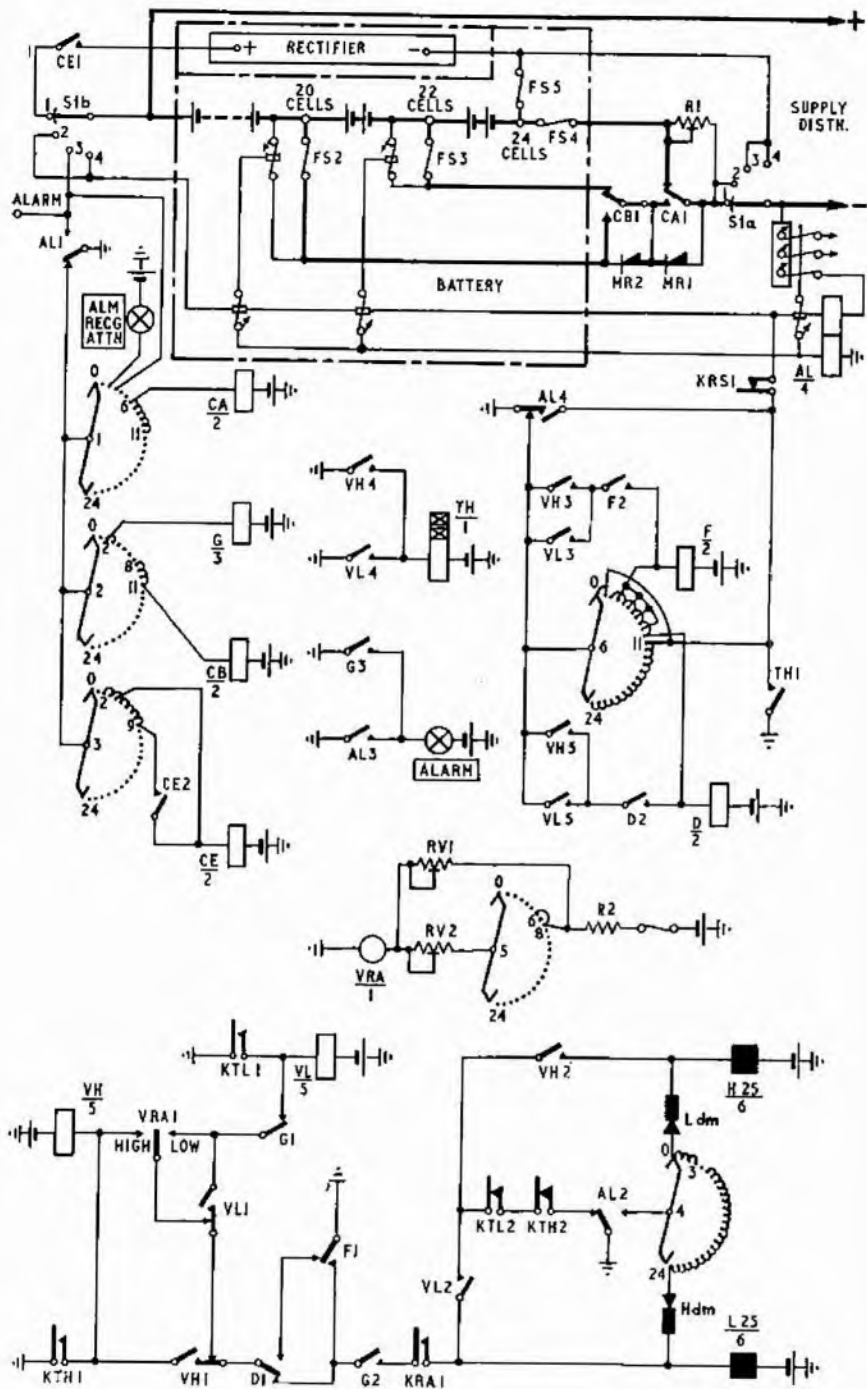

FIG. 1—CONTROL CIRCUIT

of the charging current being the difference between the rectifier current output and that taken by the exchange. The voltage across the 24 cells will eventually rise to 52 volts, and the voltage monitor will then cause contact CA1 to transfer the exchange load connexion to the "22 cells" terminal. Rectifier MR1 is connected so as to maintain the supply to the exchange during the contact change-over period and obviates the need for a make-before-break contact sequence which would give rise to a momentary low-resistance circuit across the two end-cells. When the voltage of the supply to the exchange, i.e. the voltage across 22 cells, rises to 52 volts,

contact CBI will be operated to transfer the exchange connexion to the "20 cells" terminal. Rectifier MR2 performs a similar function to MR1. The exchange voltage will continue to rise until the voltage of the 20 cells reaches 52 volts, when the voltage monitor will cause the charge to be disconnected at contact CE1. The battery voltage will then fall and the exchange will be connected first to the "22 cells" and later to the "24 cells" terminals by the restoration of CBI and CA1 respectively.

During the charging cycle the charge rectifier is connected across the whole of the 24-cell battery until the voltage across 20 cells has reached 52 volts, i.e. a terminal voltage of 2.6 volts per cell.

Charge Rate

The manner in which the terminal voltage of the battery will vary with the state and rate of charge under the conditions applicable to this plant is shown in Fig. 2. After the initial rise in voltage due to the connexion of the charge, the battery voltage rises slowly until gassing commences; the voltage then rises more rapidly due to the polarizing potential of the gas. The dotted lines B and C indicate the approximate values of battery voltage at which the regulating equipment operates to control the voltage of the supply to the U.A.X. Values A and D show the points on the battery-voltage curve at which the charge current is applied and disconnected.

The minimum value of charge current needed to raise the voltage of 20 cells to a total of 52 volts is approximately 2 per cent of the nominal capacity of the battery. When the rectifier is on, only a portion of its output is available for charging purposes. For this reason the rectifier has an output characteristic as shown in Fig. 3 and, at 62.4 volts, applies a current approximately equal to 5 per cent of the nominal capacity of the battery. This prevents overcharging which would arise if the charging rate were insufficient to raise the battery voltage to the value at which the charge is disconnected.

Voltage Monitoring

The voltage-monitor circuit comprises a moving-coil relay and series network. This arrangement provides a more robust device than can be obtained with the conventional contact voltmeter.

The positions of the high-value and low-value contacts of the relay are adjusted initially with the aid of a "precision grade" voltmeter. These positions are related to the need to maintain the voltage of the supply to the exchange equipment within the range 46–52 volts. The value of 52 volts is satisfactory for indicating that the

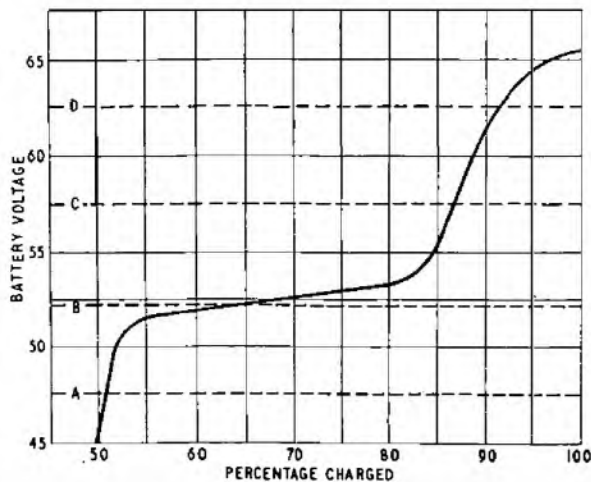

FIG. 2.—BATTERY VOLTAGE FOR VARIOUS STATES OF CHARGE WHEN RECEIVING CURRENT AT APPROXIMATELY 5 PER CENT OF THE NOMINAL CAPACITY

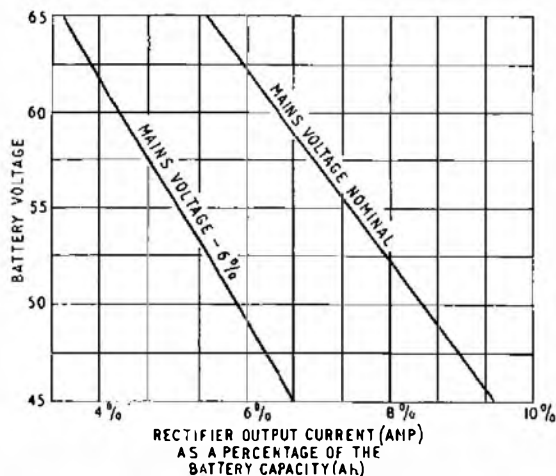

FIG. 3.—RELATIONSHIP BETWEEN BATTERY VOLTAGE AND OUTPUT CURRENT OF CHARGE RECTIFIER

20-cell portion, and consequently the whole of the battery, is fully charged.

To ensure an adequate battery reserve at all times the charging current should be applied before the battery has discharged more than 50 per cent of its capacity. The low rates of discharge often experienced at U.A.X.s can result in this figure being exceeded with but little reduction in terminal voltage. It is therefore necessary to connect the charge before the voltage across the 24-cell battery has fallen to 46 volts. Consequently the lower limit for the exchange supply cannot be used as the voltage value at which the charging current is applied. For this reason it is connected when the voltage of the 24-cell battery falls to 47.5 volts. This, however, results in a difference of only 4.5 volts between the upper and lower contact values, which is less than the change in voltage which can arise from the operation of the end-cell switching contactors. For this reason the

values of 46 volts and 52 volts are used for voltage-regulating purposes, and a voltage-biasing arrangement is used to cause the lower-value contact to close at 47.5 volts when the rectifier is disconnected and the load is connected across the whole battery.

Charge By-pass Resistor

Reference to Fig. 1 will show that towards the end of the charge, i.e. when CA1 and CB1 are operated, but for resistor R1 the end-cells would receive the whole of the rectifier output, while the 20-cell section would only receive the difference between the rectifier output and the exchange load. By-pass resistor R1 is therefore connected by CA1 and CB1 to prevent overcharging of the four end-cells when the charge is nearing completion.

OUTLINE OF CONTROL-CIRCUIT OPERATION

The main components in the control circuit (Fig. 1) and their functions are as follows:

- (a) A moving-coil relay (VRA) which acts as a voltage-monitoring device.
- (b) A bothway uniselector which acts as a discriminator to ensure that all the functions of the control circuit are carried out in the correct sequence, and acts to control the biasing of the moving-coil relay. The wipers of this bothway uniselector (described later) step in the direction 0 to 24 or 24 to 0 on the operation of the H or L drive magnets respectively.
- (c) End-cell switching and charge contactors operated from the banks of the uniselector.
- (d) Relays VH and VL, which are slave relays on the moving-coil relay.
- (e) Relays F and D, which interact with each other to disconnect relays VH and VL following a high or low voltage, and to restore the circuit to normal after switching has taken place.

Sequence of Operations

In a complete cycle of charge and partial discharge of the battery the control circuit will carry out a minimum of 10 operations which are all basically similar except for the functions of the end-cell switching and charge contactors CA, CB and CE. The combination of these is controlled by the position of the wipers on the arcs of the uniselector. It is therefore proposed to describe only the basic control-circuit operation and to show the operation and release of contactors CA, CB and CE by means of Table 1.

TABLE 1
Sequence of Operations

Stage	Charge	Voltage	VRA range (volts)	No. of cells connected to exchange	Uniselector position or contact	Contactors and relays operated
1	Off	Low	47.5-52	24	5	F
2	On	High	47.5-52	24	4	CE, D
3	On	High	46-50.5	22	6	CA, CE, D
4	On	High	47.5-52	22	7	CA, CE, F
5	On	High	46-50.5	20	8	CA, CB, CE, D
6	On	High	47.5-52	20	9	CA, CB, CE, F
7	Off	Low	47.5-52	20	10	CA, CB, D
8	Off	Low	46-50.5	20	8	CA, CB, D
9	Off	Low	47.5-52	22	7	CA, F
10	Off	Low	46-50.5	22	6	CA, D

Basic Circuit Operation

The control-circuit operation following a high-voltage or low-voltage condition is as follows.

High Voltage with the Uniselector Standing on an Even-numbered Contact 2-10. Relay D will be operated and, when the moving-coil-relay contact VRA1 makes on its high side, relay VH operates via VL1 and locks via VH1 and F1 normal, VH1 and D1 operated; VH2 operates the uniselector H magnet, which causes the wipers to step to the next contact in a clockwise direction. The operation of the uniselector will cause the moving-coil-relay contact VRA1 to break by changing the bias on VRA or correcting the exchange voltage, or by a combination of both, depending on the stage reached before the high-voltage condition occurred. The moving-coil-relay contact VRA1 will then assume an intermediate position. A change in bias is controlled at arc 5 and an exchange-voltage correction is caused by the operation of an end-cell switching contactor or the disconnection of the charge. Relay F operates via arc 6; F1 releases relay VH; VH5 releases relay D, and D1 restores the voltage-testing circuit to normal to await the next high-voltage or low-voltage condition.

Low Voltage with the Uniselector Standing on an Even-numbered Contact 2-10. Relay D will be operated and, when the moving-coil-relay contact VRA1 makes on its low side, relay VL operates via VL1 normal to lock via VH1 and F1 normal, VL1 and D1 operated; VL2 operates the uniselector L magnet, which causes the wipers to step to the next contact in an anticlockwise direction. The operation of the uniselector will cause the moving-coil-relay contact VRA1 to break by changing the bias on VRA or correcting the exchange voltage, or by a combination of both, depending on the stage reached before the low-voltage condition occurred. The moving-coil-relay contact VRA1 will then assume an intermediate position. A change in bias is controlled at arc 5 and an exchange-voltage correction is caused by the release of an end-cell switching contactor or the connexion of the charge. Relay F operates via arc 6; F1 releases relay VL; VL5 releases relay D and D1 restores the testing circuit to normal to await the next high-voltage or low-voltage condition.

High or Low Voltage with the Uniselector Standing on an Odd-numbered Contact 3-9. Relay F will be operated and the circuit functions following a high-voltage or low-voltage condition are as described above with certain exceptions. The duties of relays F and D are transposed and the correction of the exchange voltage is accomplished by the functioning of the end-cell switching and charge contactors in a reverse sense.

ALARM, MAINTENANCE AND ROUTINE-TEST FACILITIES

Alarm Facilities

The alarm circuits perform two functions:

(i) To extend an alarm should a low-voltage condition occur due to a failure of the charge or the public mains supply.

(ii) To extend an alarm, prevent further switching operations and to connect all 24 cells of the battery across the exchange load until the alarm receives attention following a circuit or fuse failure.

The switching to 24 cells (Stage 2, Table 1) and the extension of an alarm is accomplished by relay AL, which disconnects the holding earths of any contactors that may be operated, "homes" the uniselector to

contact 4 and extends an alarm. Relay AL is also operated by the failure of any fuse, or an uncorrected high-voltage or low-voltage condition. To ensure that the plant is not shut down when a persistent low-voltage condition occurs due to a public-supply failure, relay G is provided to discriminate between the two types of low-voltage alarm.

An immediate alarm is given following the operation of an alarm-type fuse, but an uncorrected high-voltage or low-voltage condition is monitored for approximately 30 seconds before an alarm is given. The delay period is provided by a thermal relay, TH.

A "Receiving Attention" key (KRA) is provided for use under public-supply-failure conditions only, to prevent the masking of exchange equipment alarms.

Maintenance Facilities

To facilitate maintenance of the control circuit the end-cell switching contactors may be by-passed by switch S1. They may then be isolated if necessary by removing fuses FS2, FS3 and FS4 (Fig. 1).

To permit the bothway uniselector to be removed for maintenance all wiring to it is taken through a plug and socket.

Routine-Test Facilities

The "Test High" and "Test Low" keys (KTH and KTL) simulate the operation of the moving-coil relay, thus providing facilities for checking all normal and alarm switching sequences. By carrying out these routines with the charge off and the contactor by-pass switch S1 in the "contactor short-circuit" position, the moving-coil relay will remain in an unoperated position throughout the test because the voltage of the exchange is unaffected.

POWER SWITCHBOARD NO. 4 AND ASSOCIATED ITEMS

The power switchboard comprises all the apparatus for controlling the output voltage and the connexion of the charge rectifier. The requisite items are mounted on one panel of insulating material which is small enough to fit within the framework of a unit at a U.A.X. No. 13, as shown in Fig. 4. Alternatively, the panel may be mounted on an iron framework, which can also accommodate the charge rectifier.

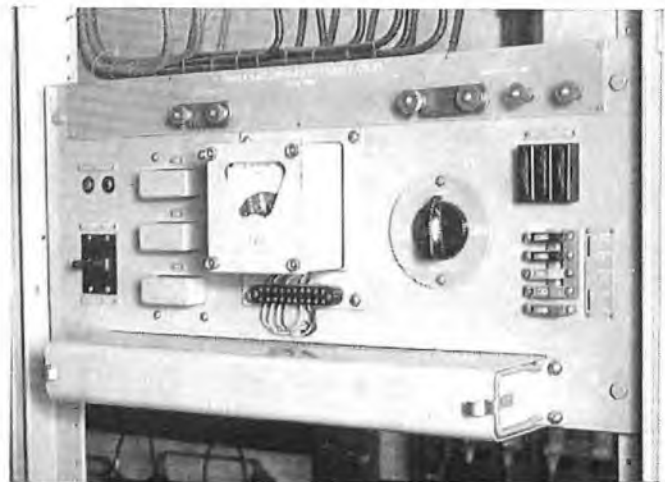

FIG. 4—POWER SWITCHBOARD NO. 4

The following components of the switchboard are worthy of note.

Moving-Coil Relay

The relay has a movement similar to that of a moving-coil voltmeter but has approximately five times greater torque.

End-Cell-Switching Contactors

The contactors, of a type used extensively by the Ministry of Supply, can carry 25 amp continuously. For this application, the voltage drop across the contacts is important because they are in series with the load, and at the maximum load likely with this plant (15 amp) the voltage drop does not exceed 50 mV per contact.

Bothway Uniselector

The bothway uniselector has a 25-outlet bank with 6 arcs. Its bridging-type wipers can be stepped in either

direction, two independent drive magnets and mechanisms being used—one at each end of the bank. Direct drive as distinct from the more usual reverse drive is used.

CONCLUSION

The new power plant has been introduced to meet the need for an automatically controlled 50-volt power plant of low first cost in which the undesirable features of earlier designs would be absent.

The placing of the power switchboard in the B1 unit at U.A.X.s No. 13 has released space which enables a larger-capacity power plant to be provided without recourse to building alterations.

Experience with installations over the past three years indicates that battery reserve capacity is well maintained and that the need for battery replacements should be less frequent than with plants of the superseded type.

Book Reviews

"Basic Electricity." Parts I-V. The Technical Press, Ltd., London. 12s. 6d. per part or 55s. per set.

This really is something new in text-books. It is a course in technical electricity which is based on pictures, vividly presented and vigorously drawn. The publication is of American origin, having been produced for the U.S. Navy by a New York firm of management consultants specializing in pictorial methods of tuition. They claim that it has halved the time taken to train electrical technicians. The material has now been released to the general public in the United States, and has also been adapted to British use by Training Headquarters of the Royal Electrical and Mechanical Engineers at Arborfield.

The manuals are intended for the training of technicians and students who start without any knowledge of electricity and with only a very limited mathematical background. Their general educational standard is assumed to be such that they have not been disciplined to logical and analytical thinking. In style, the manuals are written in the second person singular, tending to an informed, friendly presentation; facts are given singly and clearly, all non-essential material having been excluded. Very occasionally the purist might object to some assertion ("the electron in electricity"), but it has to be admitted that short, direct statements of this kind are very likely to be remembered by students of a type that would be unlikely to memorize more formalized explanations.

The principal feature of the publication is, however, the liberal use of pictorial methods of presenting facts. Approximately one-third of the available space is occupied by simple pictorial sketches and diagrams which are invariably lucid and accurate. Each sketch or diagram has large and clear explanatory captions—a wide variety of lettering methods being used—and is made strikingly distinctive by such devices as the use of hatched or shaded background patterns. Such tricks undoubtedly assist the visual memory by giving each diagram an individualistic overall shape which implants it in the memory of the reader in the correct context.

These manuals can be recommended to organizations concerned with the training of electrical apprentices and technicians. Moreover, the methods employed are very powerful and should be investigated by anyone concerned with the training of large numbers of elementary students.

C. F. F.

"Mathematics for Higher National Certificate," Volume II (Electrical). S. W. Bell, B.Sc., and H. Matley, B.Sc. Cambridge University Press. 486 pp. 114 ill. 35s.

This book is primarily intended to cover the work done in the final year of the Higher National Certificate in Electrical Engineering, and to form a basis of an A3 Mathematics course for electrical engineers.

The various topics included in this volume are intentionally treated in a very practical manner, emphasis being given to practical applications of the mathematics rather than to formal proofs. The restriction of this volume to electrical engineering has enabled the authors to cover a much wider variety of applications of mathematics to electrical problems than are given in most books of the same standard.

The first four chapters cover the theorems of Taylor and Leibnitz, harder integration and partial differentiation. These are followed by a chapter on complex variables. The next six chapters, which should be particularly useful to students of telecommunications engineering, deal with ordinary and partial differential equations considering familiar electrical circuits and transmission lines. These should be more acceptable than the less familiar examples which one may encounter in a less specialized work.

Chapter 12 further develops the treatment of Fourier's series given in Volume I. This is followed by a chapter on determinants, which is quite adequate, but may not arrive in time to help a student who encounters them for the first time in Chapter 8, where they are used for the Harwitz-Routh conditions for stability of oscillatory circuits.

After a brief introduction to double integrals in Chapter 14 there are two chapters on matrix algebra which are a useful introduction to network analysis for those students wishing to progress further in this field. The volume concludes with an appendix on inversion and current loci.

There are sufficient worked examples included in the text to make it easy to follow and also a generous supply of exercises complete with answers and, where appropriate, hints on the method of solution. The examples and exercises include problems in both the C.G.S. and M.K.S. units, but some of the older questions and examples in C.G.S. units still retain their original terminology. These would have been improved by using the current terminology and so making them consistent with the remainder of the text.

I.P.O.E.E. Library No. 2520.

A. E. S.

The London-Oxford-Birmingham 12 Mc/s Coaxial Line System

U.D.C. 621.395.91:621.395.44:621.315.212

INTRODUCTION

IN November 1954 the Post Office Engineering Department prepared an outline specification for a "2-broadband" coaxial line system; this was considered to be the next step in development following the successful exploitation of the 0.375 in. coaxial cable, first for 600 telephone circuits (e.g. Coaxial-Equipment, Line (C.E.L.), No. 2A) and later for 960 circuits (e.g. Coaxial-Equipment, Line, No. 6A*). After extensive discussions with a contractor (Standard Telephones & Cables, Ltd.), a contract was placed for the installation of a 12 Mc/s band-width line link, with 3-mile spaced repeaters, on the London-Birmingham No. 5 cable.

The first phase of the installation of the London-Birmingham link is now nearing completion and this is an appropriate time to introduce the new system, which is to be known as C.E.L. No. 8A. There are 49 intermediate dependent repeater stations on the route, "back-to-back" line terminals being fitted at Oxford to give full flexibility of interconnexion.

FREQUENCY ALLOCATION

It was specified initially that the link should carry at least 1,860 telephone circuits or, alternatively, 900 telephone circuits plus a television channel in each direction. Subsequently, international agreement was reached and the C.C.I.T.T.† has made recommendations on the characteristics necessary for interconnexion with other transmission systems.

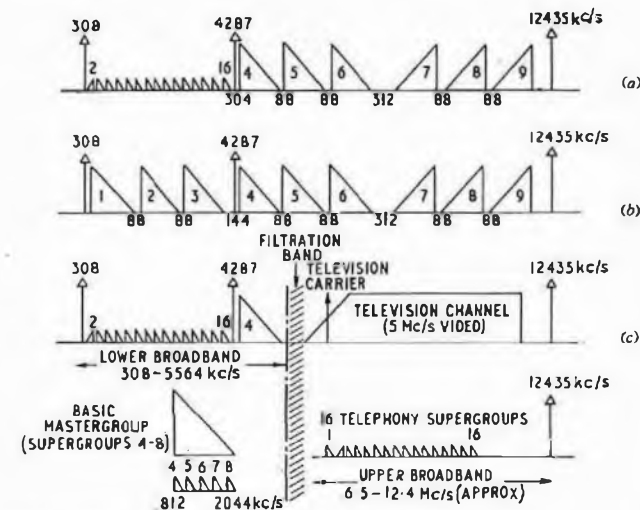

(a) C.C.I.T.T. Allocation "A" (15 Supergroups plus 6 Mastergroups)
 (b) C.C.I.T.T. Allocation "B" (9 Mastergroups)
 (c) Interim Post Office Allocation with Upper Broadband available for Television or Telephony

FIG. 1.—FREQUENCY ALLOCATION FOR 12 MC/S BAND-WIDTH COAXIAL LINE SYSTEM

Fig. 1 shows the internationally agreed frequency allocations for the line frequency band, 300–12,435 kc/s, with a main (cable-temperature) regulating pilot at

* COLLIER, M. E., and SIMPSON, W. G. A New 4 Mc/s Coaxial Line Equipment—C.E.L. No. 6A. *P.O.E.E.J.*, Vol. 50, p. 24, Apr. 1957.

† C.C.I.T.T.—International Telegraph and Telephone Consultative Committee.

4,287 kc/s and two auxiliary pilots (ambient-temperature and valve-ageing control) at 308 kc/s and 12,435 kc/s. This allocation allows for 2,700 telephone circuits or, alternatively, 1,200 telephone circuits plus a 5 Mc/s video band-width television channel in each direction.

It will be seen that for telephony a new flexibility unit, the mastergroup, has been introduced; the basic mastergroup being formed from supergroups No. 4 to No. 8 (five supergroups each of 60 circuits) in the frequency band 812–2,044 kc/s. Mastergroup working is not likely to be introduced into the Post Office network in the near future, the initial use of the new London-Birmingham link being for 15 supergroups in the lower-frequency part of the band. At a later stage, filter equipment for separating the lower-frequency and upper-frequency parts of the band will be installed at the line terminals and an independent upper-frequency broadband channel will become available. This will be suitable for television or 16 supergroups (960 circuits) of telephony.

DEPENDENT-STATION EQUIPMENT

Fig. 2 shows the layout of C.E.L. No. 8A at a typical dependent station. The new equipment is similar in construction and appearance to C.E.L. No. 6A but, due to the greater bulk of amplifiers and power equipment,

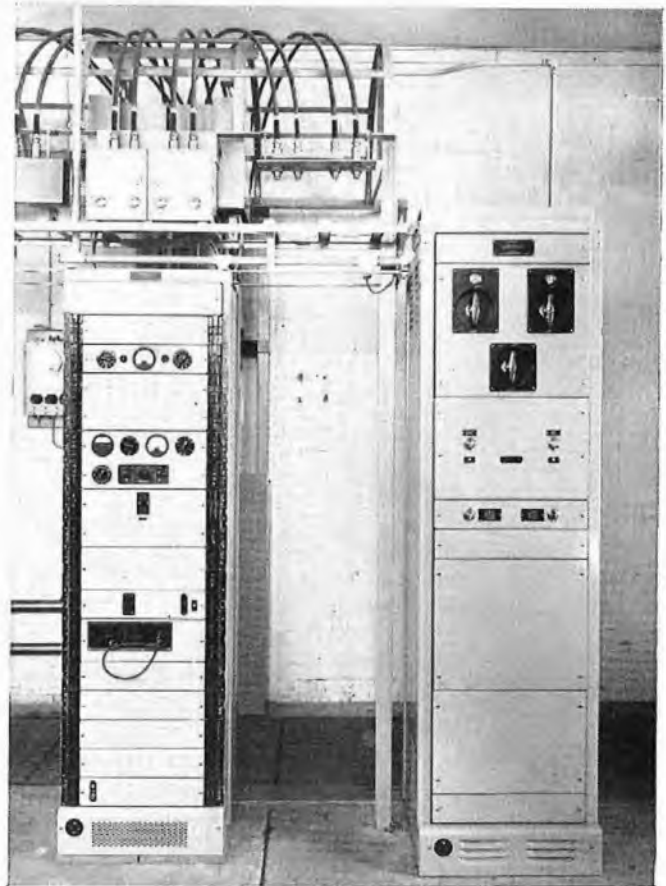

Left, transmission equipment rack and, right, power cubicle
 FIG. 2.—DEPENDENT-STATION EQUIPMENT

all the high-voltage equipment has been removed from the two transmission-equipment rack-sides. The power-separating filters are mounted behind the cable-terminating box, and the cable-power equipment (high-voltage transformer, switchgear and regulator) is mounted in one half of the separate power cubicle.

The line amplifier, which is designed to compensate for the transmission loss of 3.125 miles of 375E-type coaxial cable (6.5 db at 300 kc/s and 41.5 db at 12,435 kc/s), uses specially-developed repeater valves.† A departure from current Post Office practice for wide-band transmission equipment is that plug-in valves are used but, due to the use of gold plating on both valve pins and valveholder contact springs, it is considered that reliability equal to that of wired-in valves will be achieved in practice.

TERMINAL-STATION EQUIPMENT

The final design of line-terminal equipment, incorporating pilot generating and regulating equipment for the three pilots, as well as delay equalization, will not be completed initially. The line link will be brought into use with temporary terminal racks providing a single pilot only. Each terminal station will ultimately have six rack-sides, as follows:

- (a) Cable-terminating.
- (b) Supervisory.
- (c) Transmit.
- (d) Receive (three rack-sides).

POWER SUPPLY

The dependent repeater stations are fed from an a.c. power supply over the coaxial pairs at 1,000-0-1,000 volts r.m.s., up to a maximum of 13 stations on each side of a power-feeding station. Security of service has been ensured by providing two special facilities:

(a) Each dependent station will revert automatically to operation from a local power supply on failure of cable power.

(b) Reverse power-feeding from an end dependent station (High Wycombe and Ettington) can be brought into operation by remote control from any dependent station. Fig. 3 shows the reverse-power-feeding cubicle.

† CV 3998 (beam tetrode) and CV 5112 (triode).



FIG. 3—REVERSE-POWER-FEEDING CUBICLE

Closely-regulated power supplies have been provided for this first installation. Each dependent station has an automatic power regulator while the terminal power-feeding stations (London/Museum, Oxford and Birmingham) are provided with a.c. mains supplies that are voltage regulated to within 0.1 per cent. This degree of regulation may not be needed on subsequent installations but is desirable on a prototype scheme to enable the stability of the transmission path to be closely watched.

M. B. W.

Book Review

"The Principles of Alternating Currents." W. Sluckin, Ph.D., B.Sc.(Eng.), and J. R. Greener, M.B.E., B.Sc.(Dun.), A.Inst.P. Cleaver-Hume Press, Ltd. 338 pp. 173 ill. 15s.

This is the second edition of the book, which is one of the Cleaver-Hume series of electrical books. It is an introduction to alternating currents and is suitable for studies leading to the National or City and Guilds Technicians' Certificates. A.C. machines are not dealt with as these are covered in a separate book of the series. The M.K.S. system of units is used, and only an elementary knowledge of electricity and mathematics is necessary to study the book.

The early chapters deal with simple a.c. theory and circuits, resonance and polyphase currents, whilst other chapters deal adequately with transformers, power trans-

mission and distribution, power-factor improvement and a.c. measurements. The chapter on electronics is very useful; it describes electron emission and the different types of valves, rectifiers of the valve, copper-oxide, selenium and the new semi-conducting junction types, and also valve oscillators and amplifiers. In the last chapter some of the well-known applications of alternating currents are described and these include heating, electrotherapy and fluorescent lighting. An excellent feature of the book that will appeal to students is that each chapter contains a few worked-out examples and, in addition, at the end of the book there is a set of test questions on each chapter with the answers given for the numerical questions.

The book is clearly and simply written, the line illustrations are particularly good and well chosen, and it can be recommended to students requiring knowledge of elementary alternating current principles.

R. S. P.

Development of Postal Self-Service Machines

S. THOMPSON, A.M.I.E.E.†

U.D.C. 681.13

The Post Office has had postal self-service machines in operation since 1906. Modern developments, which are reviewed in this article, consist of extending the range and improving the reliability of stamp-selling machines, and meeting the public demand for more facilities in the form of stamp-booklet, letter-card, stamped-envelope and change-giving machines.

INTRODUCTION

THE term "postal self-service machine" relates to machines for selling stamps, stamp booklets, letter cards, stamped envelopes or postal orders, and giving change. All these machines are in operational use, but further development is aimed at the improvement of existing machines and the introduction of new types.

STAMP-SELLING MACHINES

The early types of stamp-selling machines (s.s.m.) were described by H. J. Loney in 1921.¹ The study was continued by R. H. Combridge in 1937 in an article² in which the 6d. and 2s. booklet machines were briefly described. At that date, booklet machines were not popular and were withdrawn from all but the busiest offices.

The British Post Office was a pioneer in the use of automatic selling machines. The first stamp-selling machine, submitted to the Post Office in 1906, was a coin-freed mechanism; that is, the insertion of a coin only freed the mechanism, stamp delivery being completed by the user raising a sliding knob. However, during the initial development, the coin-freed mechanism was changed to a mechanism driven by a falling weight. The weight is raised by the user inserting a coin. After the coin has been tested and deposited in the till the weight is released to do its work of delivering the stamp. Any future changes in postal rates may make necessary the use of coins of small dimensions. Raising a heavy weight by inserting a small coin can be difficult, and unless further devices are introduced to assist the user of the coin-operated machines, design may be influenced in the direction of coin-freed mechanisms.

Since 1937 the basic principles of the automatic stamp-selling machines used by the Post Office have not altered significantly and the coin-operated machine is still standard. Development has been mainly confined to removing operational weaknesses, simplifying maintenance, and designing a new machine to accept a 3d. piece for one 3d. stamp to meet the postal-rate changes of 1958. As mechanization proceeds maintenance costs become of increasing importance. There are approximately 20,000 machines in use today compared with 12,000 in 1937; further, more use is made of the individual machines today.

Much work has also gone into the problem of treatment of stamps to mitigate the effects of dampness, and into the problem of easier and more simple loading of stamp-selling machines. Slow loading allows the entry of damp into outdoor machines, and this led to the devel-

opment and field trial of the B5 machine, which was magazine loaded, and had the merit of fast and simple loading. However, the machine proved disappointing on trial, as it encountered unforeseen operational difficulties.

The Type B4 Machine (Issues one ½d., 1d. or 3d. stamp for the appropriate coin)

The B4 machine issues one stamp for one coin, either for ½d., 1d. or 3d. according to the size of the coin slot, coin tester and escapement weight fitted. It is designed for fixing into a mounting plate or cast-iron case, and is suitable for either indoor or outdoor use. Fig. 1

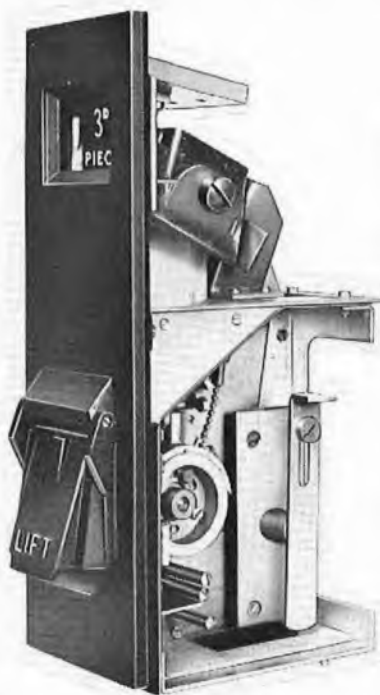

FIG. 1.—3d. STAMP-SELLING MACHINE, TYPE B4

gives a view of a 3d. machine. The energy required for operating the machine is derived from a driving weight which is raised by the pressure of a coin being inserted. The coin-testing arrangements are stable and trouble-free and will pass at the first attempt coins which would be accepted in commerce, but will reject coins of incorrect value and disks. The simple tests cover over-diameter and over-thickness, under-diameter, under-weight and repeated operation. The gear ratio of the escapement pinion to the gear wheel is 1 : 6, and, thus, the stamp-feed wheel makes one-sixth of a revolution, and one stamp is issued, for each coin tested and deposited in the till. Arrangements are also made to reject foreign matter inserted in the coin slot when the machine is at rest. The machine incorporates various precautions against dampness, and against the entry of rain. It also exhibits a visual signal when the stamp roll breaks or is approaching exhaustion.

† Executive Engineer, Power Branch, E.-in-C.'s Office.

¹ LONEY, H. J. Automatic Stamp-Vending Machines. *P.O.E.E.J.*, Vol. 14, p. 122, July 1921.

² COMBRIDGE, R. H. Development of Stamp-Selling Machines in the British Post Office. *P.O.E.E.J.*, Vol. 30, p. 18, Apr. 1937.

The Type C4 Machine (Issues two ½d. stamps for 1d.)

The C4 machine operates on the same general principles as the B4 type, except that the gear ratio of the escapement pinion to the gear wheel is 1 : 3; thus, the feed wheel travels twice as far for an operation as in the B4 machine, and two stamps are issued instead of one.

The Type D6 Machine (Issues one 2d. stamp for two pennies)

The D6 machine has similar coin-testing arrangements to the B4 type, but differs from it in two ways:

(a) The escapement pinion arm provides a two-stage escapement action which prevents the issue of a stamp until the second coin has been inserted and tested.

(b) An auxiliary retaining arm is fitted to the driving weight so that when the stamp roll approaches exhaustion the "empty" plate is prevented from falling after a user has inserted only one coin.

The Type B5 Machine (Issues ½d. or 1d. stamp for the appropriate coin)

In this machine the stamp roll, peeler, tearer, feed-wheel and its cover are fitted into a light-alloy magazine (Stamp-Loader No. 1) which has a transparent spring-fit cover. The coupling between the magazine and the other parts of the machine is simple as the magazine is correctly located by fixed parts of the machine body, and it is an easy matter to "jack-out" an old magazine and "jack-in" and lock the new magazine (loaded previously under cover) without danger of dampness in the stamp roll or machine.

In 1947, 100 of these machines were purchased, but they encountered such operational difficulties that they were replaced in 1953. Even the improved design, however, has encountered difficulties and some work remains to be done before the B5 type approaches the performance of the B4 type, which is the result of 30 years of evolution.

Multi-Coin Stamp-Selling Machines

Traditionally, the Post Office has designed its stamp-selling machines to be fully automatic, i.e. the insertion of a coin prepares the mechanism to deliver the stamp, without further assistance of the user, once the coin or coins have been tested and deposited in the cash till. As postage rates change, a number of coins of different sizes and value may be required to purchase a single stamp from a machine. Also, considerable effort is required on the part of the user to insert small-size coins into a coin-operated machine. Thus, there is a demand for a machine which will accept a multiplicity of coins, no matter how small, for the sale of a single stamp, especially if the coins could be used to free the mechanism only, with the delivery of the stamp effected by the user operating a pull-bar or other device.

STAMP-BOOKLET MACHINES

In 1937, 6d. stamp-booklet machines were installed in a number of offices, but they did not prove popular and all were recovered. After the war the public became more machine minded, and previous suspicions of machines which required shillings, florins or half-crowns before producing the stamps were less acute. By 1950, a 1s. machine with a greatly improved coin tester was developed and installed. As the demand for such machines continued to rise the number of 1s. booklet machines in use was increased, and development of machines to sell 2s. 6d. booklets began. The 1s. machine was also modified to accept a 2s. piece.

1s. Booklet Machine (Type F1)

Between 1950 and 1956, 200 of these machines were purchased; they are compact, and can be mounted in a standard s.s.m. mounting. They are coin-free machines, delivery being effected by operating a pull-bar. Stacking of the booklets is straight, as against the "Maltese Cross" stacking of the 2s. 6d. machine, and the bottom booklet is pushed forward from the stack and between the feed rollers by means of a blade attached to the pull-bar. The machines are reasonably easy to maintain, but further machines have not been purchased because the shilling coin is generally in short supply, due to its increasing use in domestic meters, and possible rises in postage rate make a 1s. book of stamps too small a stock for a booklet user.

2s. 6d. Booklet Machine

This machine had a coin-free mechanism with a pull-bar delivery. The first machines, four in number, were constructed and placed in operational use in 1956. They were simple in construction and to maintain. The loading of the booklets followed a "Maltese Cross" pattern similar to that now used on letter-card and stamped-envelope machines. These machines were very satisfactory in service, but they were physically large, and could not be accommodated in a standard s.s.m. mounting. For this reason, and because of the development of the 2s. booklet machine, which could be mounted in a standard s.s.m. mounting, the 2s. 6d. booklet machines have been recovered, and no further purchases have been made.

2s. Booklet Machine (Type F1)

In 1957 a prototype 2s. machine was produced by modifying a 1s. machine so that the delivery mechanism would take a thicker booklet and the coin tester would accept a florin. A field trial of 35 machines in selected offices commenced in May 1959 and further machines have been ordered for operational use. The machine is shown in Fig. 2.

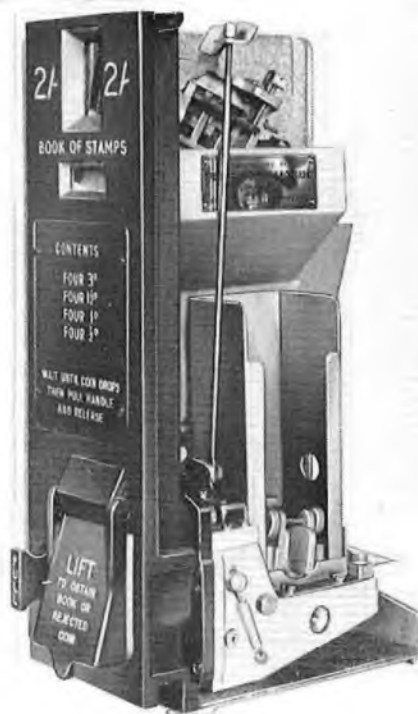

FIG. 2—2s. STAMP-BOOKLET MACHINE, TYPE F1

LETTER-CARD AND STAMPED-ENVELOPE SELLING MACHINES

Letter-Card Selling Machine No. 1

In recent years a demand has arisen for letter-card machines, especially in busy railway stations. The original machine was constructed in 1950, and two more were constructed later. In 1957, 10 more machines were constructed and converted in October 1957 to 4d. working; the original three machines were recovered as they could not be converted. Two more machines were purchased in 1959 for inclusion in "self-service suites" at selected offices. It is intended to include these machines in future self-service suites where the sales justify it. A machine to accept a 6d. piece and to give 2d. change with the letter card has been considered but is not being developed. A type to accept a 3d. piece plus a penny, with facilities to cater for subsequent changes in postal rates, is expected to be available shortly.

The loading of the letter-card machine follows a "Maltese Cross" pattern, which is simple and free from mis-delivery. The machine displays a visual signal, and prevents insertion of further coins, when the load is approaching exhaustion.

Stamped-Envelope Machine

The stamped-envelope machine is similar to the letter-card machine, the only physical differences being in the dimensions of the loading hopper. Two machines have been made and installed for trial purposes in self-service suites at the South-East District Office and the Remnant Street Branch Office in London.

Combined Letter-Card and Stamped-Envelope Machine

As space is of great importance in most Post Offices, the concept of a combined letter-card and stamped-envelope machine is, at first sight, attractive. The machine would occupy less space than two single machines, and would be slightly cheaper, as only one coin selector would be required. The machine would allow the user to choose either type of stationery by the operation of a selecting device. Three types of machine were envisaged as operating with (a) four pennies, (b) a 3d. piece plus one penny, and (c) with a 6d. piece and twopence change. There are, however, several factors to be considered; for example, all offices do not sell large quantities of both types of stationery, but may only sell appreciable quantities of one or the other. With separate machines flexibility is assured and the machines can be deployed to the best advantage, whereas with a combined machine the non-paying part is a fixed loss. Development of the combined machine is at present in abeyance, pending assessment of economic and other factors.

POSTAL-ORDER SELLING MACHINE

Millions of postal orders are sold over the counters of post offices, the most popular values being 2s., 2s. 6d. and 5s. There is therefore a good field for a machine which will offer date-stamped postal orders in exchange for the above money plus 3d. poundage in each case, especially in offices which carry heavy football-pools traffic. In 1958, a suite of postal-order selling machines was developed and installed for public use in Remnant Street Branch Office in April 1959 (see Fig. 3).

The machines incorporate the "Maltese Cross" system of loading into hoppers, which means that, as postal orders are manufactured today, each order has to be



FIG. 3.—SUITES OF POSTAL-ORDER SELLING AND OTHER MACHINES AT REMNANT STREET BRANCH OFFICE

manually date-stamped and loaded singly into the loading hopper in a criss-cross pattern. This type of paper feed is very reliable, but if the loading is carefully performed it is a lengthy process.

To obtain a postal order, the user inserts a florin or one or two half-crowns in the appropriate slot, together with a 3d. piece in an adjacent slot. After the coins have been tested and deposited in the cash till, the mechanism is released, and the postal order is delivered when the user operates a pull-bar. An "empty" device is fitted to each machine, which operates to give a visual signal and bars further coin entry when the machine approaches exhaustion. Coins failing the test are returned to the user. To reduce, as far as possible, the time spent in the loading and manual date-stamping of the orders, development of a second machine is in hand, which will use blocks of postal orders as supplied from the Stationery Office and date-stamp each order automatically before delivery.

EXPERIMENTAL CHANGE-GIVING MACHINE

Recent rises in inland-letter rates have tended to make the 3d. stamp the most frequently purchased and, as the 6d. piece is a coin always in good supply, it was considered that a machine which offered two 3d. pieces in exchange for one 6d. piece might prove attractive to Post Office customers, especially if the change-giver was mounted near to the 3d. stamp machine.

It was decided to develop such a machine on very simple lines, as an experiment to ascertain public and staff reactions. Two machines, similar in external appearance to a stamp-booklet machine (Fig. 2), were constructed for fitting in selected offices. The change is stacked in the machine in two vertical columns, each column holding about eighty 3d. pieces. When a sixpence is inserted and the pull-bar operated, a 3d. piece is slid off the bottom of each column and



FIG. 4—SELF-SERVICE SUITE AT SOUTH-EAST DISTRICT OFFICE

delivered into an external recess of the machine. A visual signal is given, and entry of further coins barred, when the machine needs re-charging. The machine occupies a standard stamp-selling-machine mounting, and is thus suitable for mounting in a self-service machine suite.

SELF-SERVICE SUITES

The general expansion of postal self-service machines from 1906 up to date is reflected in the siting of machines in and around any busy Post Office. The machines are fitted in walls, wooden cabinets, cast-iron cases and metal mounting plates. Sometimes the public must search for the machine which sells the value of stamp they require. Mounting the new types of machines in offices is a serious problem, and sometimes would not be possible unless a means could be found of assembling all self-service machines together, and in full view of the public. In 1957 the concept of a self-contained battery of postal self-service machines, to be known as a self-service suite, was the natural outcome of the continuing expansion of mechanization. Drawings were produced offering choices of cabinet design, and in January 1958 a suite was built carrying six machines in standard stamp-selling-machine mountings, a letter-card machine, and a stamped-envelope machine. The suite was brought into operational use in April 1958 at the South-East District Office and contains $\frac{1}{2}$ d., 1d., 2d., and 3d. stamp-selling machines, two 1s. booklet machines, a letter-card machine and a stamped-envelope machine (see Fig. 4). The cabinet is provided with two built-in recesses, to act as bag shelves for the convenience of the public.

A second suite, of different design, containing $\frac{1}{2}$ d., 1d., 2d., and 3d. stamp-selling machines, a letter-card machine, a stamped-envelope machine and a file of forms in general use by the public was installed for public use in Remnant Street Branch Office in March 1959 (see Fig. 5). This suite is more austere, and is not provided with bag shelves.

Also installed at this office is a small matching suite containing a change-giving machine (two 3d. pieces for a 6d. piece) and a 1s. booklet machine (see Fig. 3).

Future Developments of Self-Service Suites

In future the untidy siting of self-service machines is to be prevented as far as possible by development of self-service suites on a unit basis. Development of such units is in hand and designs of a "centre-section," "build-out sections" and "end-sections" are being considered. The end-sections will be removable to permit build-out sections to be added or removed as required.

CONCLUSIONS

The use of a postal self-service machine is governed by whether the machine will offer a service useful to the customer and be of value to the Post Office.

Machines which offer change with the article sold require careful consideration. These machines function best when loaded with all coins in good condition. This could prove to be a difficult administrative proposition for any organization.

The present requirement that all postal self-service machines should be manually-operated either by insertion of a coin, or the insertion of a coin plus the operation of a pull-bar or other device, may also call for revision with modern developments. Some of these developments call for a drive of constant speed and power for their efficient operation; others which utilize sequences of rollers, cams and date-stamps demand an operational energy approaching the limits which can be reasonably expected to be exerted, manually, by all users. Electric drive, set in motion automatically by storage of the correct coins, or manually by operation of a light-weight starting device after correct storage, is the answer to both these problems. Thus, although at the moment there is a preference for self-service machines to be manually operated, the use of electric-power drives may become necessary in future design if the self-service principle is to be fully exploited.



FIG. 5—SELF-SERVICE SUITE AT REMNANT STREET BRANCH OFFICE

Laboratory Test Equipment for Synchronous Regenerative Radio-Telegraph Systems

R. P. FROOM, B.Sc.(Eng.), A.M.I.E.E., F. J. LEE, B.Sc.(Eng.), A.M.I.E.E., C. G. HILTON and P. MACKRILL†

U.D.C. 621.317.74:621.018.78:621.394.3:621.371

Traditional methods of measuring distortion in radio-telegraph equipment give results that are difficult to interpret operationally. With synchronous regenerated signals the occurrence of errors in the printed copy is closely related to the element-error liability, and this has led to the development of error-counting test equipment in which signals passed through a system under test are compared with perfect signals direct from the signal source. The equipment covers a wide range of telegraph speeds, is easy to use, and is silent in operation. It has proved to be a powerful tool in investigations of system behaviour and in development work. This article is based on material previously published by H. B. Law and others, who were responsible for the original conception and development of the equipment and testing technique.

INTRODUCTION

THE development of a communication system and the specification of the individual units comprising it depend greatly on effective methods of measuring their performance. A good method will be easy to use, suitably accurate, and reasonable in its test-apparatus requirements. The performance of the system as measured in the laboratory should bear a close relationship to its actual behaviour under normal operating conditions. The performance of telegraph systems is usually described in terms of telegraph distortion, which is the ratio of displacements of transitions from their correct instants in time to the duration of a telegraph element. Telegraph distortion is easily measured, and its use as a basis for specification facilitates the sub-division of tolerances among a number of links operating in tandem; this is very convenient in line-telegraph practice. In long-distance radio telegraphy, however, the question of subdividing tolerances hardly arises, for radio links are not normally operated in tandem without regeneration, and the distortion arising in any line tails associated with the radio link should be small. Thus the advantage of easy subdivision is of little significance. Experience has shown that on radio-telegraph systems "splits" and "extras" in the received signal form the major sources of error. These phenomena, which are shown in Fig. 1, are the result of additional spurious

transitions. They are caused by radio noise, fading and interference, and cannot be described in terms of telegraph distortion.

Most of the important point-to-point radio-telegraph services operated by the Post Office are of the direct-printing synchronous kind in which the received telegraph signals are regenerated by sampling at the centre of each telegraph element. The operational criterion of performance is the proportion of errors in the printed copy, and this is determined by the proportion of telegraph elements that are of the wrong kind at the instants of sampling. This error liability cannot readily be deduced from telegraph-distortion measurements. In laboratory tests, the element-error rate can be measured directly by comparing, element by element, the received signals after regeneration with the signals as transmitted, and counting the errors and the total number of elements in a test period. Apparatus operating in this way has been in use since March 1955, and the results have shown the error-counting technique to be a powerful one. It has helped towards a better understanding of the noisy-signal performance of radio-telegraph receivers,¹ and has demonstrated that designs based on distortion considerations may not give optimum performance in regenerative systems.

PRELIMINARY CONSIDERATIONS

When measuring the performance of equipment in the laboratory it is desirable that the conditions of the test correspond closely to those encountered in normal use. Thus, test equipment for synchronous radio-telegraph systems should cater for operation in the telegraph speed range used in normal service, say 40-200 bauds; it should also allow tests to be made at much higher speeds, to cover possible developments and to permit investigation of limiting conditions of operation. Likewise, it should cater for a wide variety of test signals, including simulated traffic for normal assessments and repetitive signals of variable mark/space ratio for detailed studies of circuit behaviour. Since radio-telegraph systems usually carry two-condition, or binary, signals it is appropriate to design test equipment on a binary-signal basis; two-channel four-condition systems,² which are not uncommon, can be tested in terms of the individual binary channels after they have been separated.

The special problems of fading, noise, and multi-path propagation that arise in long-distance radio links have led to the development of a fading machine³ to simulate these effects in the laboratory. It is an essential part of the radio-telegraph test equipment but its design depends more on considerations of ionospheric propagation than on telegraphy requirements. The improved version in current use has been described elsewhere.⁴

Element-error counting was adopted instead of the

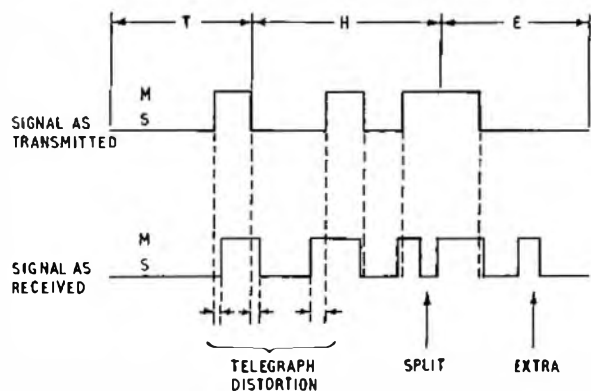

The example shows typical disturbances of a 5-unit-code telegraph signal before regeneration
FIG. 1--TYPICAL DISTURBANCE OF RECEIVED RADIO-TELEGRAPH SIGNAL

† Mr. Froom was formerly a Senior Executive Engineer, Post Office Research Station. Mr. Lee is an Executive Engineer, and Messrs. Hilton and Mackrill are Assistant Engineers, Post Office Research Station.

obvious method of counting the character errors in printed copy for several reasons. In the first place the element-error method is, from the equipment point of view, simpler and it lends itself to automatic counting and to automatic discrimination between mark and space errors. Also it gives more readily the desired flexibility in speed of working. Again, unlike tape readers and machine printers, it can be completely silent in operation. Element-error counting does not, of itself, cater for the observation of characteristic errors in mixed signals, or for recording the distribution of errors in time; thus, it is desirable that error-counting facilities be supplemented by recording arrangements so that, when necessary, failures can be analysed in detail.

DESCRIPTION OF APPARATUS

The arrangement of the test apparatus is shown in Fig. 2. Signals from a telegraph signal generator control

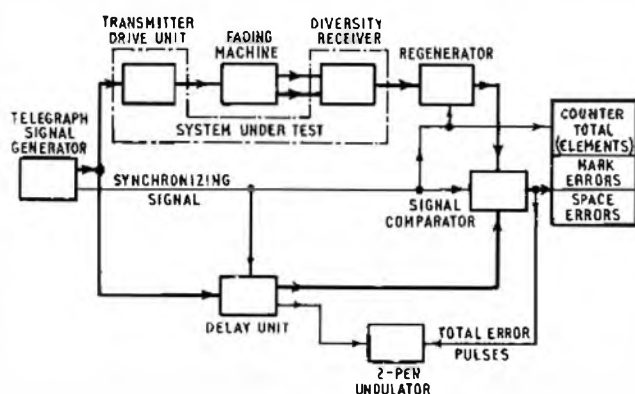

FIG. 2—RADIO-TELEGRAPH SYSTEM TESTING EQUIPMENT

a "transmitter," the output of which is passed through the fading machine, to simulate propagation, to a receiver. The transmitter and receiver constitute the system under test, and the receiver may well be the complete unit, as used at radio stations. Fortunately, the high-power stages of radio transmitters usually pass telegraph signals without significant distortion, so that there is no problem of reproducing transmitter distortion in the test equipment; a rudimentary "transmitter," usually consisting of a low-power transmitter drive unit, suffices. The received signals are regenerated by inspection at the centre of each element and are then compared with perfect signals from the telegraph signal generator. The signals are delayed in passing through the system under test since the effective band-width of telegraph receivers is small, and it is necessary to delay the perfect signals by the same amount before feeding them to the signal comparator. Whenever an error occurs the signal comparator produces an error pulse. Separate counters are provided for mark errors, i.e. marks received as spaces, and for space errors, and a third counter records the total number of elements in a test period. A 2-pen undulator may be used to record the total error pulses, i.e. mark and space errors together, simultaneously with the perfect signal from the delay unit.

Telegraph Signal Generators

For developing and testing individual sections of radio-telegraph receivers, and for tests on complete systems, sources of reliable signal waveforms, free from telegraph distortion and of constant amplitude over a wide range

of signalling speeds, are required. For preliminary tests a 1 : 1 square wave is often sufficient but for the majority of tests a more realistic signal which simulates an actual transmission is required. For specific tests a repetitive signal with a given mark/space ratio is sometimes useful. To meet these requirements two signal generators have been developed.

The principle of operation of both the signal generators is essentially the same. The telegraph speed is controlled by a Wien-bridge-type oscillator whose sinusoidal output is squared and differentiated to provide a train of timing pulses. The manner in which these pulses are used depends on the output waveform desired, and it is in this part of the circuit arrangements that the various signal generators differ. The direct-current output stages are similar; a low-impedance double-current output is derived from a cathode-follower stage and signal shaping, when provided, is achieved by means of simple resistance-capacitance integrating networks and diode clamps. The sinusoidal output from the Wien-bridge oscillator is available for synchronizing external equipment.

As an alternative to control by their internal oscillators the signal generators may be driven from an external source. This is useful when a very stable speed control is required or when two signal generators have to be run synchronously.

When repetitive 1 : 1 signals are required the pulse train is made to operate a bi-stable trigger. The 1 : 1 mark/space ratio is ensured by utilizing only pulses of the same polarity. Repetitive signals having other mark/space ratios based on multiples of the basic-element duration are generated by feeding the pulse train via a ring-counter circuit to the bi-stable trigger. Two pulse outputs are taken from the counter, one to switch the trigger to mark and the other to switch it to space. If one output is taken from the first stage of the counter then the subsequent stage of the ring from which the other output is taken determines the mark/space ratio. The number of stages in the ring determines the character length.

The principle used for generating a random train of signals to simulate traffic conditions is to sample the output of a noise source at intervals corresponding to the desired signalling speed. The pulse train determines the sampling rate, and if the noise voltage is positive at the instant of sampling, then the sampling circuit or regenerator delivers a pulse which switches a bi-stable trigger to, say, mark; if the noise voltage is negative at the instant of inspection the trigger is set to space. A binary stage is provided between the noise source and the sampling circuit to ensure that the number of mark and space elements generated, in a signal train of the order of 1,000 elements or more, is approximately equal.

The band-width of the noise source and the manner in which it is used determine the mark/space distribution of the output signal. A random telegraph signal may be defined as one in which at each instant of sampling the occurrence of mark or space is equally likely, i.e. a probability of 0.5. The probability distribution of mark elements may be determined as follows. An isolated mark element must be preceded and followed by at least one space element, i.e. SMS, and since there are only seven other possible combinations of three elements taken together (SSS, SSM, SMM, MSS, MSM, MMS and MMM) the probability of SMS occurring is $\frac{1}{7}$. By similar reasoning the probability that n mark elements

will occur together, i.e. $SM_1 \dots M_n S$, will be found to be $2^{-(n+2)}$. If one considers a long train of elements following each other in random order, the proportion of the total number of elements in the train occurring in groups of n mark elements together is given by $[n \times 2^{-(n+2)}]$. This gives rise to the series representing a random train:

$$S_\infty = \frac{1}{8} + \frac{2}{16} + \dots + \frac{n}{2^{n+2}} + \dots = \frac{1}{2}$$

Since mark and space are equally likely to occur this series also represents the distribution of space elements.

In both types of signal generator the output is obtained from a cathode-follower stage which delivers ± 6 volts e.m.f. The source impedance is padded up to 600 ohms.

Fading Machine

The transmission over long distances of signals in the 3–30 Mc/s band is made possible by reflection from an ionized layer known as the F1 layer. Due to irregularities of the reflecting medium the received signal, being the vector sum of a large number of components of differing amplitudes and random phases, suffers from fading, i.e. the signal voltage appearing at the aerial terminals of the receiver varies in amplitude and phase in a random manner. When transmission takes place via one path only all modulating frequencies fade in unison, but if transmission takes place by two or more paths of different lengths selective fading occurs. When a frequency-shift telegraph signal is subjected to selective fading the mark and space frequencies fade independently of one another.

The fading machine simulates both these conditions as well as subjecting the signal to interference from white noise. Referring to Fig. 3, it will be seen that the input,

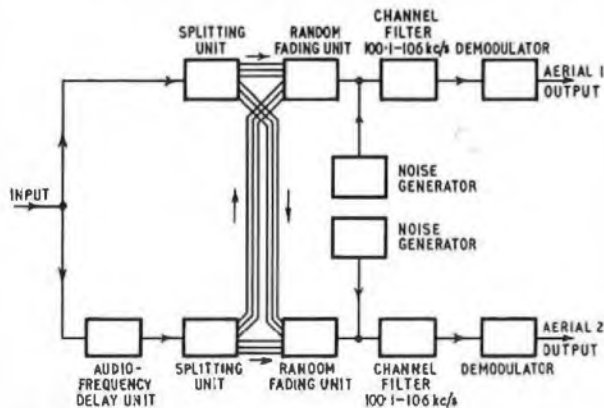

FIG. 3—SIMULATION OF FADING SIGNALS UNDER TWO-PATH PROPAGATION CONDITIONS

which accepts frequencies in the 0–6 kc/s band, is split to provide two “aerial” outputs for simulating space-diversity working. Apart from an audio-frequency delay unit shown in the lower path, the arrangement is symmetrical. In each path the signal is split again to provide six outputs. Each random fading unit consists of six balanced modulators with associated crystal oscillators providing the carrier frequencies, which are modulated by outputs from the splitting units. The carrier frequencies are nominally 100 kc/s but are spaced about 0.1 c/s apart. The outputs from the balanced modulators are added in resistive networks and the upper sideband selected. The short-term stability of the crystal oscillators is such that the six equal-amplitude

signals can be considered to have random phase relationships. In fact, the fading pattern is repeated about every 10 seconds, but each is a blurred image of the preceding pattern. It was shown theoretically, and confirmed experimentally, that six equal amplitude vectors added in random phase simulate natural fading very closely. The quasi-fading period, usually in the range 1–15 seconds, is determined by the frequency spacing of the 100 kc/s oscillators. Selective fading is obtained by means of the delay unit. From the diagram it will be seen that when delay is introduced the cross-connection from the splitting units provides three vectors without delay and three with delay to each of the random fading units; this arrangement simulates two-path propagation. Delays of up to 2 ms can be introduced, and from measurements made on pictures transmitted by radio over a number of years it has been found that the path-time-delay spread on typical working circuits rarely exceeds this figure.

Error-Counting Equipment

The error-counting equipment (see Fig. 4) consists basically of a delay unit, regenerator, comparator and counter. In order to allow for the time taken for the test signal to pass over the transmission path and through the receiver, delay is introduced in the reference-signal path before comparison (see Fig. 2). This is achieved by applying the signal to a chain of binary stages along which the signal is progressed by pulses at element intervals, which are derived from the synchronizing-signal output of the telegraph-signal generator. A short “memory” is provided in the coupling between the binary stages, so that on the arrival of the progressing pulse each stage acts in accordance with the information stored in the preceding stage.

The signal output of the receiver is fed to the regenerator. A double triode is used as a balanced pulse

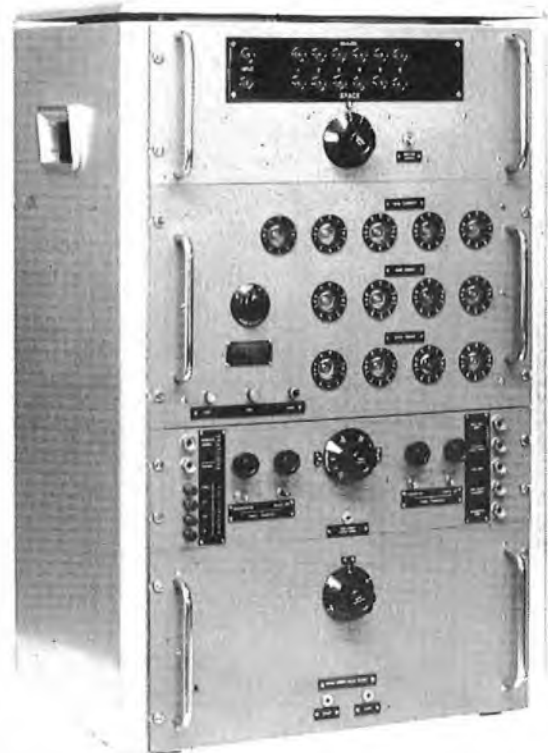

FIG. 4—RADIO-TELEGRAPH ERROR-COUNTING EQUIPMENT

amplifier, fed with pulses derived from the synchronizing signal, and the two outputs are applied to the grids of a bi-stable trigger. Application of the signal results in a differential change in the pulse outputs which determine the condition of the trigger. Precautions are taken to inhibit the "memory" of the trigger, and reliable operation of the regenerator is obtained with an input voltage of ± 1 volt. The regenerator inspection pulses are adjusted to fall in the centres of the telegraph signal elements (see Fig. 5).

The comparator, to which the regenerated signal and the delayed reference signal are applied, consists of a pair of coincidence gates. Anti-phase signals from the two sources, and inspection pulses from the synchronizing source, are applied to the mark-error gate, so that a mark-error results in a pulse being passed to the mark-error counter. Signals of opposite sense are fed to the other gate, so that this passes a pulse to a separate space-error counter when a space error occurs.

The delay in the reference path is set by selecting the appropriate number of delay stages so that signals from the two sources overlap by at least half an element at the gate inputs, and the comparator inspection pulse is set within the overlap area by an adjustable phase shifter in the feed from the synchronizing source (Fig. 5).

Three cold-cathode decade counters are provided, recording, respectively, the total number of telegraph elements transmitted and the number of mark and space elements in error. The mark-error and space-error counters are driven as described by outputs from the comparator gates, and the total-elements counter is operated by pulses derived from the synchronizing signal. The counters are of conventional design, and incorporate a selector switch by which the count may be

stopped after samples of 100, 1,000, 10,000 or 100,000 elements, or allowed to continue until stopped by the manual control. Resetting of the counters, and the start of the count, are controlled by press-button switches.

A monitor switch selects appropriate waveform displays for an oscilloscope, to allow correct setting of the three phase shifters, and for observation of the received signal.

CONCLUSION

The equipment described has been used in investigations of several systems, and it has helped towards an improved understanding of the noisy-signal performance of radio-telegraph receivers. Tests carried out with steady signals plus noise have shown that in general the error liabilities of frequency-shift telegraph receivers are simple exponential functions of the signal/noise ratio. Fading-signal tests give results which are in good agreement with figures calculated from the steady-signal test results. Thus, the performance of a receiver at the particular telegraph speed used in the tests can be estimated simply, and expressed as a single quantity extracted from the curve of error rate against signal/noise ratio. The error-counting technique has led to a simple way of describing receiver performance, so that comparisons between receivers can easily be made or comparisons can be made with theoretical results obtained for an ideal receiver⁵ of similar type. This measure of imperfection of practical receivers can be generalized to take account of diversity and selective fading.

It can be claimed that error-counting test equipment is easy to use and is a powerful aid to the system designer. Since the accuracy of the printed copy, by which systems are judged in practical operation, is simply related to the element-error liability, it is logical to specify the performance of synchronous regenerative radio-telegraph systems in terms of this error liability rather than telegraph distortion. The two main advantages of measuring performance in this manner are, firstly, the assessment of equipment performance immediately becomes simpler and more realistic, and secondly, it should lead in the long run to improved equipment, for design methods based on distortion considerations do not generally lead to optimum performance in respect of error liability.

ACKNOWLEDGEMENT

Acknowledgement is due to Mr. H. B. Law who was primarily responsible for the conception of the equipment described in this article and who permitted the authors to make use of material previously published by him.

References

- ¹ LAW, H. B. The Signal/Noise Performance Rating of Receivers for Long-Distance Synchronous Radio-Telegraph Systems using Frequency Modulation. *Proceedings I.E.E.*, Paper No. 2103R, July 1956 (Vol. 104, Part B, p. 124).
- ² COLE, A. W. H.F. Communication Systems. *Electronic Engineering*, Vol. 26, p. 232, June 1954.
- ³ BRAY, W. J., JILLICRAP, H. G., and OWEN, F. C. The Fading Machine and its use for the Investigation of the Effects of Frequency-Selective Fading. *Journal I.E.E.*, Vol. 94, Part IIIA, p. 283, 1947.
- ⁴ LAW, H. B., and others. An Improved Fading Machine. *Proceedings I.E.E.*, Paper No. 2150R, Aug. 1956 (Vol. 104, Part B, p. 117).
- ⁵ LAW, H. B. The Detectability of Fading Radio-Telegraph Signals in Noise. *Proceedings I.E.E.*, Paper 2104R, July 1956 (Vol. 104, Part B, p. 130).

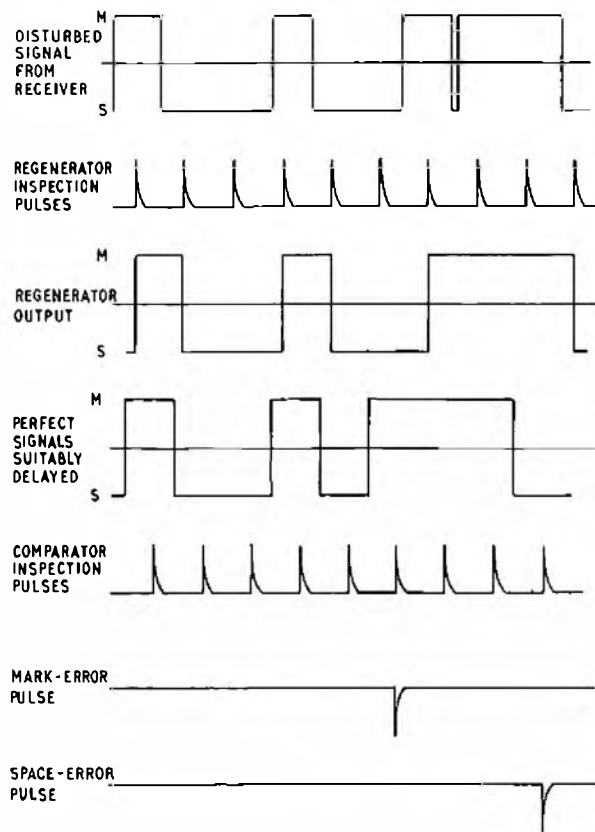

FIG. 5—MONITOR WAVEFORM DISPLAY

A Self-Tuning Insertion-Loss Measuring Equipment (10 kc/s–1.5 Mc/s)

G. J. CRANK, B.Sc.(Eng.), A.M.I.E.E., and H. A. HATHAWAY†

U.D.C. 621.317.741:621.315.28

Insertion-loss measuring equipment covering the range 10 kc/s–1.5 Mc/s is described. The equipment, which was developed primarily for use at cable factories in connexion with submarine cable submerged repeater systems, has a measuring sensitivity of ± 0.001 db when measuring attenuations of less than 80 db; attenuations of up to 140 db may be measured with reduced accuracy.

INTRODUCTION

THE development of modern submarine cable systems using transmission band-widths of hundreds of kilocycles per second and having submerged repeaters at relatively close intervals has created a demand for insertion-loss measuring equipment of very high accuracy and stability. On such cable systems, particularly those having a large number of repeater sections, it is essential that the gain/frequency characteristic of a repeater should be precisely matched by the attenuation/frequency characteristic of the associated cable section, otherwise the cumulative effects of even small errors would seriously affect the overall transmission performance of the system.

The equipment to be described in this article has been designed primarily for use at submarine-cable factories during acceptance testing and in the determination of repeater-section cutting lengths. The determination of cutting lengths necessitates a high standard of absolute accuracy of measurement but, in addition, stringent demands on the differential accuracy are made by the need for:

- quality control of the cable during manufacture,
- determination of changes in cable parameters during the various stages of manufacture, and on loading into the ship,
- assessment of attenuation changes as the cable ages,
- determination of temperature coefficients, and
- the estimation of repeater-section attenuation from measurements on short lengths of cable.

A great deal more information is required during the manufacture of a submarine cable system and to be of

real use an absolute accuracy of measurement of the order of 0.01 db is necessary and, for the detection of changes in cable attenuation, a somewhat higher differential accuracy is desirable. For reasons that are given later, a narrow-band selective measuring equipment is necessary to achieve this. Also, as acceptance testing requires large numbers of attenuation/frequency response measurements, a self-tuning equipment is desirable in the interests of speed and ease of measurement.

GENERAL DESCRIPTION

A block schematic diagram of the equipment is shown in Fig. 1 and a photograph is given in Fig. 2. As can be seen, the equipment comprises:

- an oscillator unit,
- a detector unit,
- an insertion-loss unit, and
- a frequency-check unit.

A comparison-type method of measurement is employed in which the cable attenuation is compared with that of a chain of high-grade attenuators which are adjusted to give equality of loss.

Unfortunately, test conditions in a cable factory do not always permit the cable ends to be brought close to the test equipment and it is often necessary to make measurements over long test leads. Insertion-loss measurements are then made on the cable plus test leads and on the test leads only and the difference is taken as being the insertion loss of the cable. Strictly speaking, this is not a true insertion-loss measurement of the cable but by ensuring that the test leads accurately match the cable under test (the same type of cable normally being employed as test leads) the errors involved become extremely small.

† The authors are, respectively, Executive Engineer and Assistant Engineer, Cable Test Section, Test and Inspection Branch, E.-in-C.'s Office.

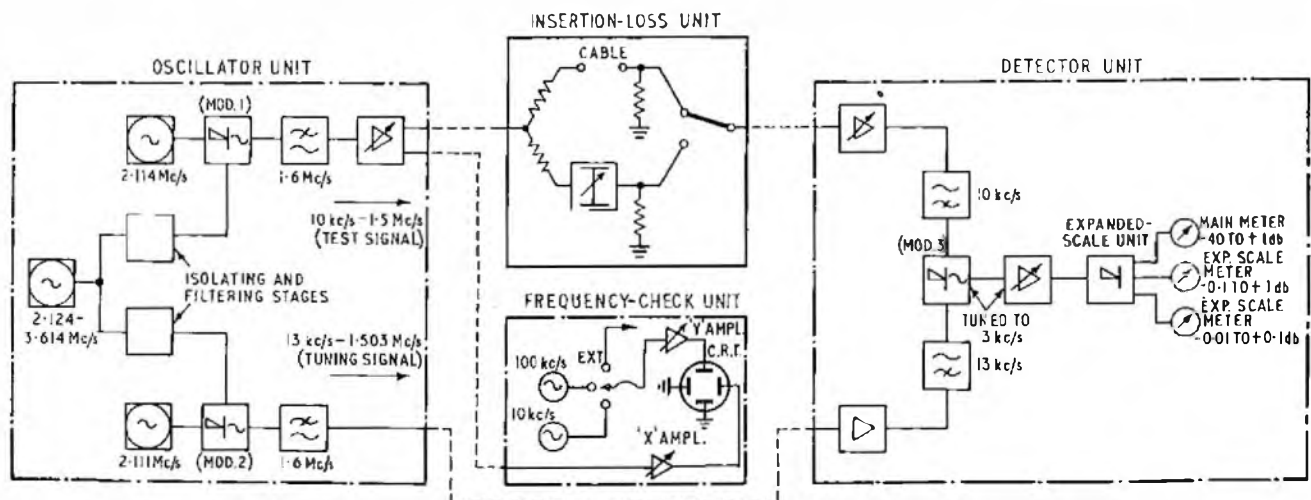

FIG. 1.—BLOCK SCHEMATIC DIAGRAM OF THE MEASURING EQUIPMENT

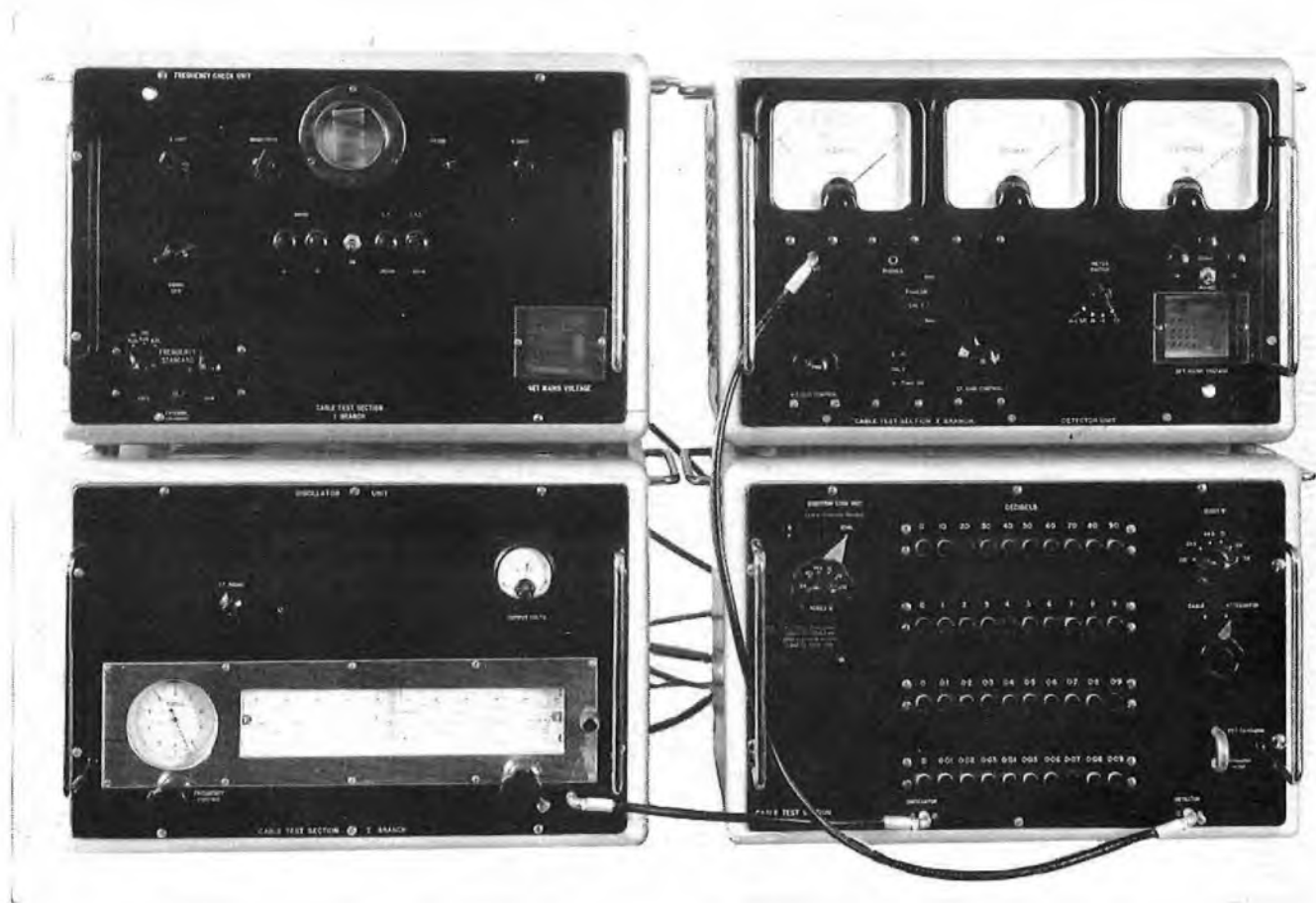

FIG. 2--SELF-TUNING INSERTION-LOSS MEASURING EQUIPMENT

Principles of Operation

Two variable-frequency signals having a constant difference of 3 kc/s are produced in the oscillator unit. One of these, the "tuning" signal, is fed directly to the detector unit as the carrier supply to a modulator whose output is tuned at 3 kc/s. The second signal, known as the "test" signal, in the frequency range 10 kc/s–1.5 Mc/s but having a frequency 3 kc/s lower than the tuning signal, is applied to the insertion-loss unit and thence to the detector unit via either the cable under test or a calibrated attenuator network. After amplification, the low-level test signal modulates the tuning signal and the 3 kc/s difference component is selected, filtered and amplified in circuits that provide the necessary discrimination against noise and other unwanted components. The 3 kc/s component, at a level proportional to that of the test signal at the input to the detector unit, is then rectified and used to operate calibrated decibel-meters.

Circuit Arrangements

Referring to the block schematic diagram (Fig. 1), it will be seen that the variable section of the oscillator covers a frequency range of less than one octave, i.e. 2.124–3.614 Mc/s, so that harmonics can be simply removed by a succeeding low-pass filter stage. Two variable-frequency signals are obtained from two identical band-pass tuned-anode stages, which combine the function of harmonic rejection with the more important one of isolating the two signals. These two

signals then pass to separate double-balanced modulators where they are each combined with a different fixed-frequency signal; the latter are provided by separate crystal oscillators operating at 2.114 and 2.111 Mc/s. Subsequent selection of the lower side-frequencies is effected by low-pass filters, having infinite-attenuation points at the crystal-oscillator frequencies. The side-frequency in the range 10 kc/s–1.5 Mc/s is termed the test signal and is amplified to a level sufficient for high-attenuation measurements; the level may be varied up to a maximum of 5 volts across 100 ohms, which is the approximate input impedance of the insertion-loss unit. The side-frequency in the range 13 kc/s–1.503 Mc/s is termed the tuning signal.

The insertion-loss unit, to which the cable under test is connected, contains the necessary splitting pads, attenuators, terminations and switch for making comparison-type measurements, and will be described more fully later in the article.

After passing through the insertion-loss unit the test signal is amplified by a variable-gain wideband amplifier and applied to a 10 kc/s high-pass filter, for the removal of unwanted noise and power-frequency components; it is then combined with the tuning signal in the third modulator to produce the required 3 kc/s component.

The tuning signal forms the high-level input to the third modulator and therefore requires amplification after the low-pass filter stage. The fixed-gain amplifier for this purpose, which is fitted in the detector unit, is followed by a 13 kc/s high-pass filter which performs a

function similar to that of the high-pass filter in the test-signal path.

The third modulator and following amplifier are tuned to a frequency of 3 kc/s and pass a band-width of 25 c/s (3 db points). The 3 kc/s signal is rectified and the resulting voltage, which is proportional to the test signal input-level to the detector, is applied to a d.c. meter system.

A crystal-controlled frequency-check unit is employed for precise frequency setting and this unit also houses the stabilized power supply for the oscillator unit. The detector unit is run from its own self-contained stabilized power supply, housed in the same cabinet.

DESIGN CONSIDERATIONS

A general discussion of some of the basic problems and features of the design is given below.

Possible Causes of Measuring Error

The need for a narrow-band equipment has been mentioned and the method of achieving it has been described in earlier sections, but the necessity for using frequency-selective equipment has not been explained. This is best done by considering the errors that would be introduced if the detector were unable to reject the various unwanted components that are generated by the equipment or that are picked up from the cable under test.

If the detector responds to oscillator harmonics, two obvious sources of measuring error arise.

(a) Error due to the fact that a cable, whose attenuation increases approximately in proportion to the square root of the frequency, is being compared with an attenuator whose attenuation is virtually independent of frequency.

(b) More serious errors due to phase change in the cable. This results in the relative phasing of the fundamental and harmonics continuously altering over the frequency range so that at some frequencies the harmonics add to the resultant rectified signal while at others they subtract from it.

The error referred to in (b) above is usually most serious when short cable lengths are being measured because the extra attenuation of the harmonics by the cable is then negligible. It results in a ripple being obtained on the insertion-loss/frequency curve whose frequency interval is dependent upon the length of cable under test. It may be difficult to distinguish ripples due to this cause from ripples due to mismatch at the ends of the cable, which are also most pronounced on short cable lengths.

A further measuring error may occur due to the response of the detector to mains-frequency components (hum) which may be present in the oscillator output or be picked up from the cable. This is readily illustrated by considering the case of high-frequency attenuation measurements on long cable lengths.

Consider a signal/hum ratio of 40 db at the oscillator output socket. Then, for a cable attenuation of, say, 90 db at some frequency over a megacycle per second, the corresponding attenuation to the hum components will be negligible. When the detector is switched to the attenuator branch of the insertion loss equipment, the signal/hum ratio remains at 40 db since all frequencies are then attenuated equally. On switching to the cable side, the ratio is degraded by nearly 90 db so that the hum level is now some 50 db higher than the signal. It is obvious that the detector must have negligible

response to hum components otherwise excessive hum level, which is obtained on the cable side only, might result in the overload of one of the later detector stages; hum modulation of the test frequencies could also lead to measuring errors.

This consideration is even more important when an attenuation much greater than 100 db is being measured and to cater for this the wideband amplifiers are made to cut off very steeply outside their required pass-bands by the use of suitable resistance-capacitance coupling and high-pass filters.

Further needs for a selective measuring set arise from the great deal of unwanted interference of all types that may be picked up on a long length of cable. Such interference components are not, of course, present when the detector is switched to the reference path and a measuring error can therefore be introduced, or at least excessive noise experienced, when the detector is switched to the cable path. The main types of interference generally encountered are due to radio transmissions, and to electrical equipment of various types which generate high-frequency components as a result of switching, commutation, discharges, etc., or give rise to heavy mains surges on starting, as for example, armouring, stranding and taping machines and arc welding apparatus.

Apart from the desirability of rejecting the unwanted components so far discussed, the noise and stability of the measuring equipment are obviously improved by the use of a narrow band-width and the range of attenuation measurement is correspondingly increased. Improved stability also results in greater ease and speed of measurement as well as increased reading accuracy.

Choice of Frequencies

It has been arranged that the test and tuning signal frequencies are relatively closely spaced so that the difference frequency lies well away from the fundamental frequencies and the upper side-frequency. This simplifies the filtering problems in the detector and ensures that troublesome low-order intermodulation products can be adequately rejected. Furthermore, the low fixed-difference frequency makes a narrow band-width an easy matter to achieve in the detector, as simple inductance-capacitance tuned circuits then give adequate selectivity.

The choice of difference frequency is largely determined by the lowest test-signal frequency required. The test-signal frequency must not be allowed to approach too close to the difference frequency if trouble due to unwanted low-order intermodulation products is to be avoided. For the same reason, the tuning-signal frequency has been made higher than the test-signal frequency, rather than lower, so that its minimum frequency is 13 kc/s instead of 7 kc/s. On the other hand, the difference frequency must not be too low or mains components may prove troublesome when the detector is working at very low signal-levels. A figure of about 3 kc/s was finally chosen as being the best compromise and even then mains components of about the 60th order proved troublesome, in the earlier development stages, when attenuations in excess of 100 db were being measured. This was due to the wanted 3 kc/s component beating with the nearest mains harmonic, thereby causing a rhythmic swing on the expanded-scale meters; particular attention had to be given to hum reduction in the detector design before the effect was removed.

The minimum frequency (2.1 Mc/s) of the variable oscillator has been kept as low as possible, consistent

with a range of less than one octave, in order to achieve a good frequency stability. As the oscillator is of the beat-frequency type, a very high order of variable-oscillator stability is required to attain even a moderate degree of frequency stability at the lowest test frequency of 10 kc/s, e.g. to obtain an overall short-term stability of 1 part in 10^4 at 10 kc/s, a variable-oscillator stability of 5 parts in 10^7 is necessary, since the variable-oscillator frequency is then about 2 Mc/s.

It is important to use a frequency range of less than one octave for the variable oscillator because a wider frequency range than this would prevent the rejection of harmonics before the first two modulator stages and of low-order intermodulation products after them. The net result would be that products of the type $2f - k_1$ and $2f - k_2$ (k_1 and k_2 being the respective crystal oscillator frequencies) would fall in the pass-band of the low-pass filters. These two unwanted signals would combine in the third modulator to produce the difference frequency ($k_1 - k_2$). Thus, a variable-oscillator range of more than one octave results in response of the detector to oscillator harmonics as in this case the harmonic produces its own self-tuning frequency. On the other hand, if a range of less than one octave is used, harmonics of the variable oscillator are outside the working band and can be suppressed in a succeeding filter stage. More important still, if they are produced in the first and second modulators they do not produce a low-order component that falls in the range of the succeeding low-pass filter, i.e. products like $2f - k_1$ and $2f - k_2$ are always higher than the cut-off frequency of the filter.

Variable Oscillator

The variable oscillator circuit due to Mr. F. G. Clifford (of Research Branch) was chosen as it offered considerable advantages over the more widely used types of oscillator. The particular merits of this design are:

- (a) very good frequency stability,
- (b) extremely low harmonic content,
- (c) low output impedance,
- (d) relatively high output voltage, and
- (e) flat overall response.

The short-term frequency stability obtained in practice proved to be at least as good as required and the good harmonic performance obviated the necessity for complicated low-pass filtering prior to the first and second modulator stages.

Isolating Stages

The main function of the isolating stages is to prevent feedback from one channel to the other through the common variable-oscillator impedance. It will readily be seen that any path existing between either crystal oscillator and the modulator not directly associated with it would produce the difference frequency of 3 kc/s, together with other spurious components. Measuring errors, at low levels, could therefore be introduced by direct transmission of the 3 kc/s signal through either branch, or by generation of an unwanted 3 kc/s component due to intermodulation effects in the remainder of the equipment. This unwanted feedback path is effectively removed by interposing a valve in each channel, which, as previously mentioned, acts as a combined filtering and isolating stage. To reduce further the possibility of unwanted feedback of this sort the crystal-oscillator signal to each modulator is at a low level and the

variable-oscillator signal is the high-level "switching" signal, an arrangement which also leads to a flatter overall response.

Crystal Oscillators

The two crystal oscillators are of identical design and construction and use a similar type of crystal. As both tend to drift together with temperature variations a very constant difference frequency can be obtained without the need for temperature control of the crystals.

Variable-Gain Wideband Amplifier

The wideband amplifier preceding the third modulator, in the test-signal path, is at the most critical point of the circuit as the signal level is here at its lowest. Special precautions have, therefore, been taken to minimize the noise output so that for any particular operating condition the signal/noise ratio is as high as possible.

For cable attenuations up to about 90 db the gain of this amplifier is adjusted to give 30 millivolts output level, which is the required level into the third modulator. The minimum gain of the 3 kc/s tuned amplifier has been adjusted so that this level at the modulator just brings the expanded-scale meters into operation. For cable attenuations higher than 90 db there is insufficient gain in the wideband amplifier to give the required 30 millivolts output level, and so the gain control in the tuned amplifier is brought into operation.

It is not advisable in this case to use a fixed-gain amplifier with a variable input potentiometer for level adjustment as the amplifier gain is always a maximum and consequently the signal/noise ratio of the amplifier is always a minimum. Some improvement may be obtained by the use of a variable output-potentiometer but this increases the risk of amplifier overload (due to incorrect level and gain settings) with consequent loss of operating flexibility. The amplifier in this equipment has staggered inter-stage control of gain which is progressively reduced from the later to the early stages as the input level is increased. In this way the early stages always work at the maximum signal levels for any particular set of circumstances. The use of a gain control of this type has led to increased difficulty in the amplifier design as it is not possible to use overall negative-feedback to obtain the required standard of performance, as gain variation is not normally possible within the feedback loop. However, the reduction in noise obtained during low-attenuation measurements, coupled with simplicity of operation (overload troubles being removed), has fully justified the extra amplifier complexity.

The design of the insertion-loss unit ensures that the maximum output level can never exceed -26 db (relative to 5 volts) no matter what the test conditions. For this reason it is unnecessary to provide any gain control at the grid of the first amplifier valve so that the source impedance of its input circuit is always the very low impedance of the terminated cable or attenuator in the insertion-loss unit. Ideal conditions for the first valve are thus ensured, as it always works at low grid-impedance and noisy moving contacts or wipers are not associated with it. This point is quite important as a high detector-input impedance is required and gain variation at the first grid would have necessitated the use of a high-impedance input potentiometer. Only at full gain would the grid then see the low output-impedance of the insertion-loss unit; at lower gain settings a much higher

effective grid impedance would result, with consequent unnecessary degradation of signal/noise ratio on lower attenuation measurements.

Tuned Modulator-Amplifier

This modulator is of the double-balanced type, having a bridge ring of germanium diodes and an output circuit tuned to 3 kc/s. The following tuned amplifier employs two sharply-tuned triode circuits and supplies the expanded-scale circuit, which employs a tuned pentode for each expanded-scale meter.

When low-attenuation measurements are being made, the wideband amplifier stages are working at a relatively high level and the resultant overall noise performance is dependent upon the level at which the third modulator is operated. A figure of 30 millivolts for the low-level input signal has been chosen as this ensures that the modulator is working under linear conditions, and also this level is sufficiently high to achieve a signal/noise ratio adequate for a measuring accuracy of 0.001 db.

The overall signal/noise ratio when low attenuations are being measured is, of course, determined by the first tuned stage; the wideband amplifier is then operating at relatively high signal levels. When high attenuations are being measured the limiting noise is that existing at the first stage of the wideband amplifier.

The gain of the tuned amplifier is variable but minimum gain is employed until the full oscillator-output voltage and maximum wideband-amplifier gain are already being used; optimum input level to the third modulator is thereby maintained.

The Expanded-Scale Meters

Three meters are mounted in the detector. Meter M1 is always in operation and is calibrated from -40 to +1 db. When this meter reaches a reading of 0 db meter M2 begins to indicate and gives full-scale deflexion for a further increase of 1 db; M3 gives full-scale deflexion for 0.1 db and commences to indicate at about two-thirds the full-scale deflection of meter M2. Meters M2 and M3 are calibrated in 0.01 and 0.001 db divisions, respectively. An audio output signal at 3 kc/s, for aural bridge work, is also available from this unit.

The operation of the expanded-scale unit (Fig. 3) is as follows.

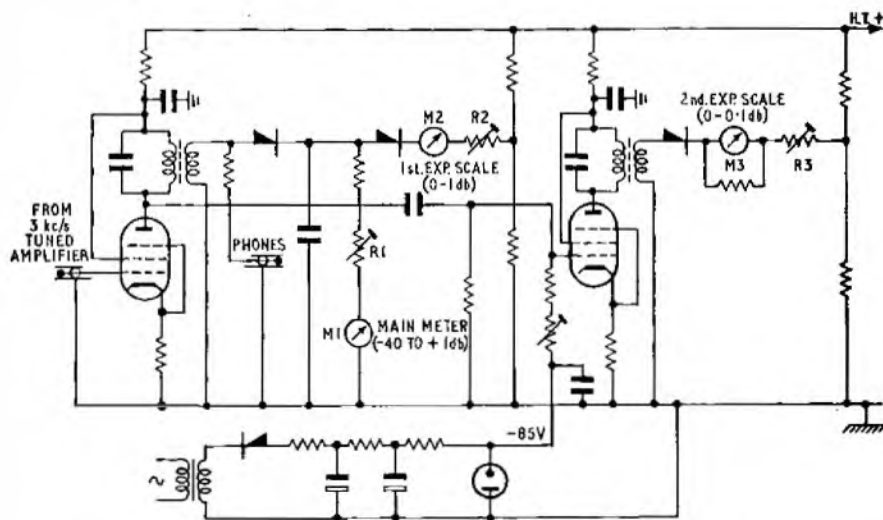

FIG. 3—EXPANDED-SCALE UNIT

The output signal from the driver stage is rectified, operates the meter M1, and drives also a second diode, which is biased-back from a tapping on the stabilized h.t. supply. The first expanded-scale meter, M2, is connected in series with this second diode, and therefore does not commence to conduct until the peak voltage applied exceeds the bias voltage. At this point, M1 is approaching full-scale deflexion and the series resistor, R1, is used to adjust its deflexion to 0 db at the point where M2 commences to read.

A second series resistor, R2, adjusts the sensitivity of the meter, M2, to give full-scale deflexion for a further increase of 1 db in the level of the input signal. The second expanded-scale meter, M3, is operated in a somewhat similar fashion but a further stage of amplification is employed. The grid of this amplifying stage, under no-drive conditions, is biased far beyond cut-off (-85 volts) by a negative supply. It is arranged that this valve only commences to conduct when the other two meters are approaching full scale deflexion. The meter, M3, is connected via a diode to a tapping across the h.t. supply; the meter does not then conduct before the driver valve is working on the linear part of its characteristic. The gain of this stage results in full-scale deflexion being obtained for a 0.1 db increase in input signal level.

A series diode in each of the expanded-scale meter circuits ensures that reverse deflexion does not occur when the peak drive-voltage is less than the meter "backing off" voltage. As the working level of these diodes is high they do not introduce any significant non-linearity in the scale shape.

Overload protection of the meters is obtained by ensuring that at full-scale deflexion the driving valves are themselves approaching their overload points so that excess drive, due to misoperation of the equipment, cannot result in damage to the meters.

The Insertion-Loss Unit

The insertion-loss unit (Fig. 4) comprises the attenuators, splitting pads, terminations, and switch required for making comparison-type measurements.

The input signal is taken via a coaxial choke to a change-over switch (S1) having two positions labelled 0 db and +20 db.

In the 0 db position of the switch, an accurate 1,350-ohm resistor is connected in the common path before the splitting point and therefore does not affect the measurement, but merely reduces the signal level at the splitting point. In the +20 db position the 1,350-ohm resistor is connected in series with the attenuator path only and may be treated as an additional step on the attenuators in that path; the full oscillator output signal is then applied to the "unknown," or cable path.

The purpose of this 1,350-ohm resistor is fourfold.

(a) It ensures that the maximum level from the insertion-loss unit is, under all conditions, never sufficient to overload the first stage of the wideband amplifier.

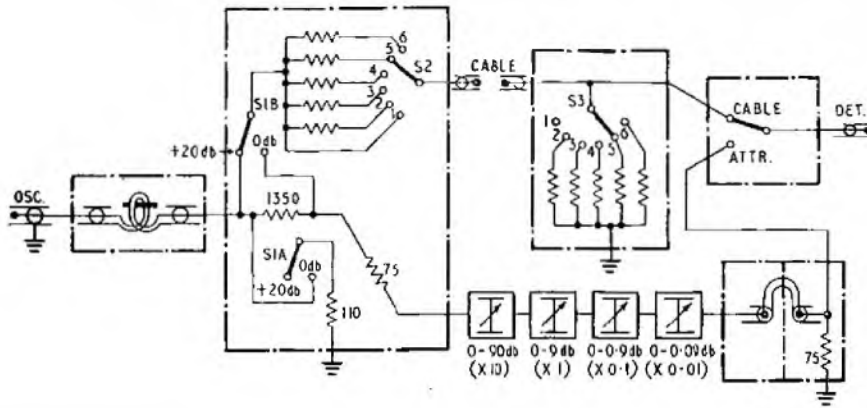

FIG. 4—INSERTION-LOSS UNIT

(b) As the 1,350-ohm resistor is always interposed between the oscillator and the attenuator chain it ensures that the input to the attenuators is always of very low level (0.25 volts maximum) irrespective of the oscillator output voltage.

(c) The effective load on the power amplifier is considerably reduced, the output power required being almost halved; this is an important consideration for portable equipment.

(d) It increases the range of the attenuators by 20 db.

To ensure that the load on the power amplifier in the oscillator unit remains substantially constant, a second pair of switch contacts connect a 110-ohm resistor across the input when the switch is in the 0 db position, i.e. when the 1,350-ohm resistor is connected in the common path. This prevents a change in oscillator output voltage when the switch is operated.

In use, the 0 db position is selected for measurements up to about 30 or 40 db. For higher attenuations the +20 db position is used, thus allowing the full signal voltage to be applied to the cable path.

A range of series resistors and shunt terminations, between which the cable is measured, can be selected by means of switches. A change-over switch is included to permit the detector to be connected either to the cable path or the comparison path.

Attenuators

Four decades of push-button attenuators are employed, i.e. 0-90, 0-9, 0-0.9 and 0-0.09 db respectively. Their elements are high-stability cracked-carbon resistors (except for the 0-0.9 and 0-0.09 db attenuators, which have wire-wound series arms) and, for the greatest accuracy, the 0-90 and 0-9 db attenuators have to be used in conjunction with a calibration chart.

Exact attenuator and cable terminations are built into the insertion-loss unit and the input impedance of the detector unit is made sufficiently high to ensure that no significant shunting effect is introduced. This simplifies the problem of comparing the voltage across a 75-ohm attenuator with that across a variety of different cable impedances.

The Frequency-Check Unit

The Lissajous-figure method of frequency setting is used, whereby the test frequency is compared with an accurate crystal-controlled frequency-standard on a cathode ray tube (c.r.t.). As this unit is intended for use during insertion-loss/frequency measurements cover-

ing the range 10 kc/s-1.5 Mc/s it was considered that two frequency standards only were required. These are 10 kc/s and 100 kc/s and a separate crystal oscillator is used for each frequency.

Separate "X" and "Y" amplifiers are provided for the c.r.t. display. The frequency standard is connected via the variable gain "Y" amplifier to the "Y" plates and sufficient e.h.t. and amplification are provided to permit the selection of 5 kc/s points up to 1.5 Mc/s.

The test frequency is taken to the "X" plates via a separate two-stage variable-gain amplifier having a maximum gain of 54 db and a flat gain/frequency response from 2 kc/s-2 Mc/s.

Mechanical Construction

The complete equipment is housed in four similar cabinets (see Fig. 2).

In view of the high maximum attenuations that have to be measured, it was decided to mount the individual oscillators, amplifiers, modulators and filters in separate screening cans, rather than to employ a more normal open-chassis technique. In this way, crosstalk is kept to a minimum and fault finding is probably simplified.

To improve reliability and to decrease noise and microphony soldered-in valves have been used entirely in the oscillator and detector units (excluding power supplies). To simplify maintenance one valve type only (CV 2000) has been used throughout the equipment.

Performance

The measuring stability obtained is sufficient to enable measurements to be made at low attenuations with an accuracy of better than 0.001 db. For higher attenuations the measuring sensitivity is as follows:

80 db	— ±0.001 db
100 db	— ±0.01 db
120 db	— ±0.1 db
140 db	— ±1 db

The absolute limit of measurement under normal conditions is about 155 db. However, in crosstalk measurements this can be extended down to about 170 db by preceding the wideband amplifier with a manually-tuned amplifier specially developed for this purpose. All the figures quoted are with the oscillator maximum output level of 5 volts. By use of an external power amplifier it is possible to increase the sending level by 20 db thus allowing the absolute limit of measurement to be extended to about 190 db at which level there is still no indication of spurious coupling between receive and send units.

CONCLUSION

The equipment described has been used extensively in the field and the performance has been satisfactory, despite the considerable amount of travelling the equipment has undergone. Much saving in time has resulted together with a marked increase in precision. There has been complete freedom from interference under all test conditions so far encountered, and the stability has been unaffected by operation from noisy mains supplies.

Mechanization of the Initial Stages of Processing Mail

Part 1—Segregation of the Various Classes of Mail

G. P. COPPING, B.Sc.(Eng.), A.M.I.E.E., and T. R. MYERS†

U.D.C. 681.178

Machinery at present undergoing field trial at Southampton and described in Part 1 of this article automatically separates mixed mail into groups of packets, large envelopes, medium-sized envelopes and small envelopes. It arranges the last class of envelopes into stacks for further processing. The machine which performs this further processing will be described in Part 2.

INTRODUCTION

A SURPRISINGLY wide variety of postal items are collected from pillar-boxes and other sources. Every item has, of course, to be date-stamped and the postage stamps cancelled before any routing or sorting can commence; this entails segregating the various classes of mail. Until recently, the only method by which this pre-sorting processing could be effected was by hand. The established method is to provide tables on to which the contents of the collection bags are emptied for manual examination. Each table has a shelf and two conveyor bands, arranged one above the other, running down the centre of the length of the table. According to the flow of traffic, 12 or more men may gather along each side of such a table when a collection is brought into an office and busy themselves with picking the items up separately and treating them according to their nature.

All very large flat items, i.e. those larger than 10 in. by 6 in., are placed on the shelf ready for removal by other staff; packets and bulky items are placed on the upper conveyor which carries them to another table to be stamped by hand. The remaining matter, consisting of long and short envelopes, is picked up keeping long and short items and first-class and second-class mail* separate. As each letter is picked up with one hand, it is rotated to bring the stamp into a common position and simultaneously collected into a small pack by the other hand. Before the pack builds up to an unmanageable size it is deposited carefully on the lower conveyor, which carries it to an operator who manually feeds the packs to an automatic stamp-cancelling machine.

The above processing is termed facing; it is tedious, labour consuming, forms a considerable proportion of the total work of the sorting-office and yet, until the mail has passed this stage, the basic function of a sorting office cannot commence. There is, therefore, much scope for mechanizing the process, and equipment installed at Southampton for field trial has been designed to separate box-collection mail into the following categories: packets, large, medium-sized, and small envelopes. A unit, to be described in Part 2 of this article, automatically faces small letters and cancels the stamps they carry.

AUTOMATIC SEGREGATING EQUIPMENT

Fig. 1 shows the feed hopper of the segregating equipment into which the collection bags of mixed mail are emptied and from which a fairly evenly spread stream of

† The authors are, respectively, Assistant Staff Engineer and Assistant Engineer, Post Office Research Station.

* First-class mail consists of sealed letters, postcards and packets for which postage has been paid at the full rate; second-class mail consists of printed papers and secondary matter for which postage has been paid at a reduced rate.

items is carried at 20 ft/min (adjustable) by a rough-surfaced inclined conveyor into a large rotating drum. Besides carrying the mail from the hopper to the drum, the conveyor performs the vital function of smoothing the feed into the drum. An even flow of mail is essential for the efficient operation of the equipment and, as the material requiring processing appears in large batches, every precaution has to be taken to prevent momentary choking of any of the component units of the equipment.

The drum into which the mail first flows has been evolved to perform two functions. The primary purpose is to separate all thin flat items from those more cubic in form; the secondary function is to effect a further smoothing of the mail flow. The drum is open-ended to allow for continuous operation; it is inclined at approximately 6° to the horizontal and rotates at 8 r.p.m. on two lines of supporting rollers through which it is frictionally driven by a 2 h.p. motor. The walls are formed of eight overlapping longitudinal slats which are freely pivoted but which are arranged to settle, in all but the top-dead-centre position, with a gap of approximately $\frac{3}{8}$ in. at each overlapping point. Fig. 2 illustrates the unit.

Segregation of Thin Flat Items

As the drum rotates, the mail contained within it is continually presented to the gaps with the result that thin items slip out between the overlapping slats whilst items too thick to escape in this manner follow a helical path down the drum, due to the slope and rotation, to fall out on to a table at the lower end to be stamped by hand.

The pivoting of the slats is all important. By means of rolling counter-weights the normal $\frac{3}{8}$ in. gap between slats is automatically increased at top dead centre to an inch or more; this enlargement effectively permits any items which have attempted to slip out, failed and become lodged, to drop back to rejoin the material still under process. Without this feature the drum becomes choked within a few revolutions.

The maximum handling rate of the drum is not less than 60,000 items/hour. This is considerably higher than the handling rates of the units which follow and, for this reason, the stream of escaping thin items, which are collected on a conveyor beneath the drum, is divided into two and directed to two identical sets of further-processing equipment.

The experimental drum is 5 ft in diameter and 20 ft long; it is now realized that a considerably smaller unit could be constructed without causing a reduction in the handling rate. A very much smaller unit could be fabricated to suit small offices and more closely match the performance of following equipment.

Segregation of Large Envelopes

Each half of the divided stream of thin items from the drum is carried along a short 2 ft wide path; each route initially runs horizontally but finally curves upwards through 90° to eject the carried mail vertically, like water from a fountain, into the operative section of a large-letter

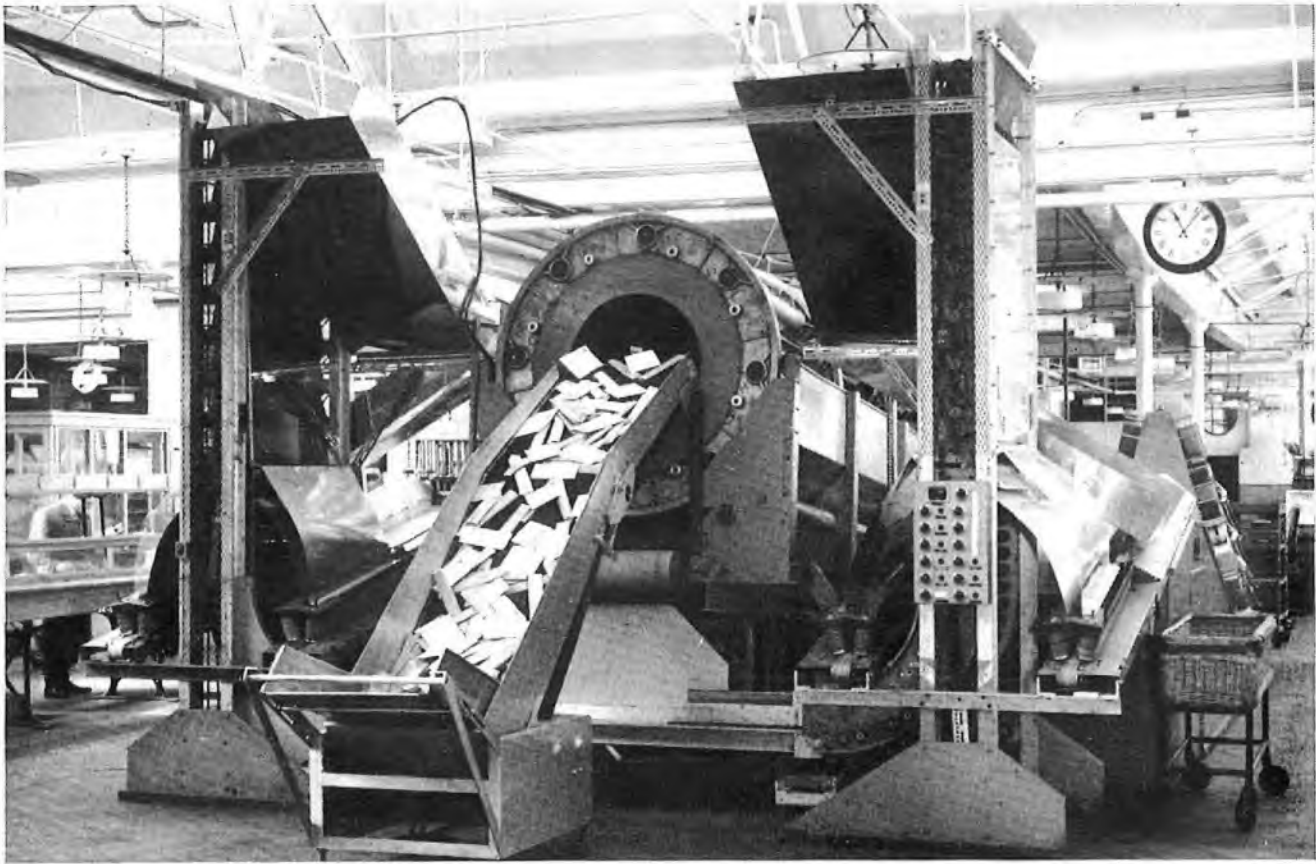

FIG. 1—FEED HOPPER

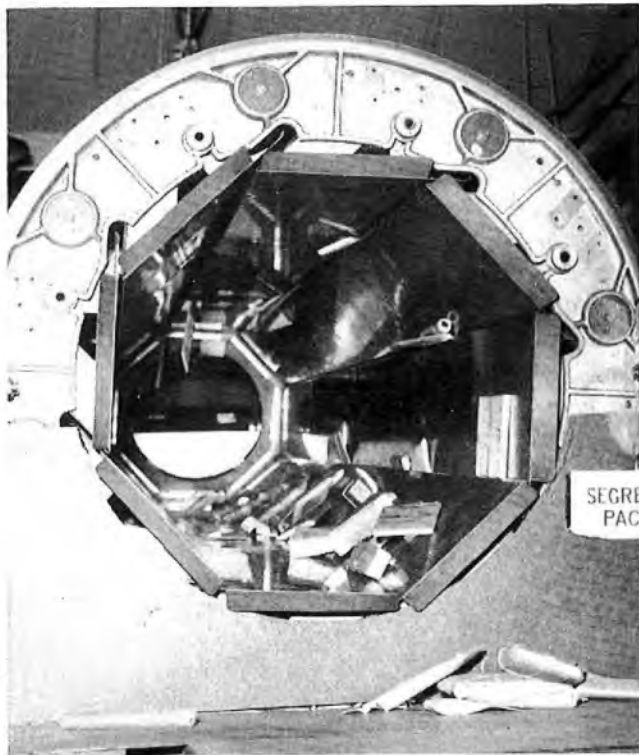

FIG. 2—DRUM UNIT

segregating unit. The paths comprise a length of belting, a short run of rods, fitted with tires which are staggered relative to the tires on adjacent rods, and finally a curved section of wide driven rollers against which the passing items are held in contact by further rollers which are, in this instance, free running and sprung.

The rollers with tires are provided to separate unwanted material such as string and rubber bands which appear in considerable quantity due to items being posted in bundles and falling loose in the collection bags or in the drum. Hotel keys are another example of postal matter which must be trapped before it passes further into the equipment. The staggering of the tires on the rod section of the path effectively prevents the further travel of all except items with definite area. Other items fall between the tires and collect in a tray beneath.

The curved sections of the letter paths described above can be discerned at the foot of each of the tower-like structures in Fig. 1. They appear in duplicate due to the division of the letter stream from the drum. The upper section of each structure functions as an extractor of the very large flat items and as a further spreading agent for the breaking-up of any bunches of smaller items. As already described, the mail enters the operative section of the unit vertically; at this point it passes into a series of horizontal parallel pairs of rollers arranged like rungs in a ladder. The lower pairs of rollers are equally spaced at a nominal 8 in. with the result that single envelopes shorter than this fail to bridge the gap and fall away downwards under gravity from both sides of the ladder

of rollers as they issue vertically from between the bottom pair. Short envelopes which are travelling bunched together may carry across several gaps between rollers due to being interlocked, but items usually fall away steadily from the outsides of such bunches at each passage of a gap until the bunch has disappeared.

Any envelope whose length, measured in the direction of travel, is greater than 8 in. is passed along the rollers until it reaches the top gap, which measures approximately 12 in. At this point it either drops back to rejoin the smaller letters or moves across the 12 in. gap, if capable of bridging it, to be ejected into a chute. This chute routes the letter to the appropriate collecting basket. In production machines, however, such large letters will be conveyed automatically to the packet-stamping table at the lower end of the drum.

It will be appreciated that the height of the unit arises from the need to cater for letters which are travelling bunched together. If the stream were spread perfectly evenly, a single pair of rollers 12 in. apart would suffice to effect the desired separation.

Segregation of Long, Short and Medium-Sized Envelopes

Escaping letters collect in sloping V-shaped conveyors on either side of the ladder, according to the side from which they effect their escape. These conveyors carry them away resting on edge in a vertical plane. It will be appreciated that the original flow of letters from the drum has at this stage in the processing been split into four streams. The second division is introduced partly due to the nature of the large-letter separator and partly to ease the load on following equipment, which is multiplied suitably. A description of one V-shaped conveyor and

the associated equipment will suffice to describe all four.

Items travelling in a V-shaped conveyor are arranged in a random fashion. Some are the right way up, some upside down, whilst some move resting on their side edges. The stream at this point is, however, composed entirely of long, short and medium-sized envelopes; all packets and large envelopes have by now been diverted elsewhere. These three remaining classes must now be separated and as a first step towards this they are processed to bring all to rest on a long edge; it is for this reason that the conveyor is inclined. For the same purpose steps are introduced in the floor belt, by suitably routing the belt over rollers, so that besides carrying the items in a somewhat unstable position, they are also simultaneously joggled at each step to cause them to settle in the most stable condition—namely, resting on one or other of their longer edges. Square letters are only handled correctly by chance but their numbers are very small. The settling treatment is very effective if the stream is not too tightly bunched, hence the need for spreading action in the preceding units.

Segregation of Medium-Sized Envelopes. The rising section of each V-shaped conveyor, seen on the left in Fig. 3, extends some 8 ft to a point at which it turns down to bring the mail to a more convenient level. At the peak point, a series of pairs of rollers are installed which overhang the conveyor. These rollers are carried on spindles which are suspended from their bearings in an overhead framework. As all items in the conveyor have been settled on to one or other of their two long edges by the time they reach the top of the slope, an accurate separation of all items with a vertical measurement in excess of some set figure can be effected by the suspended

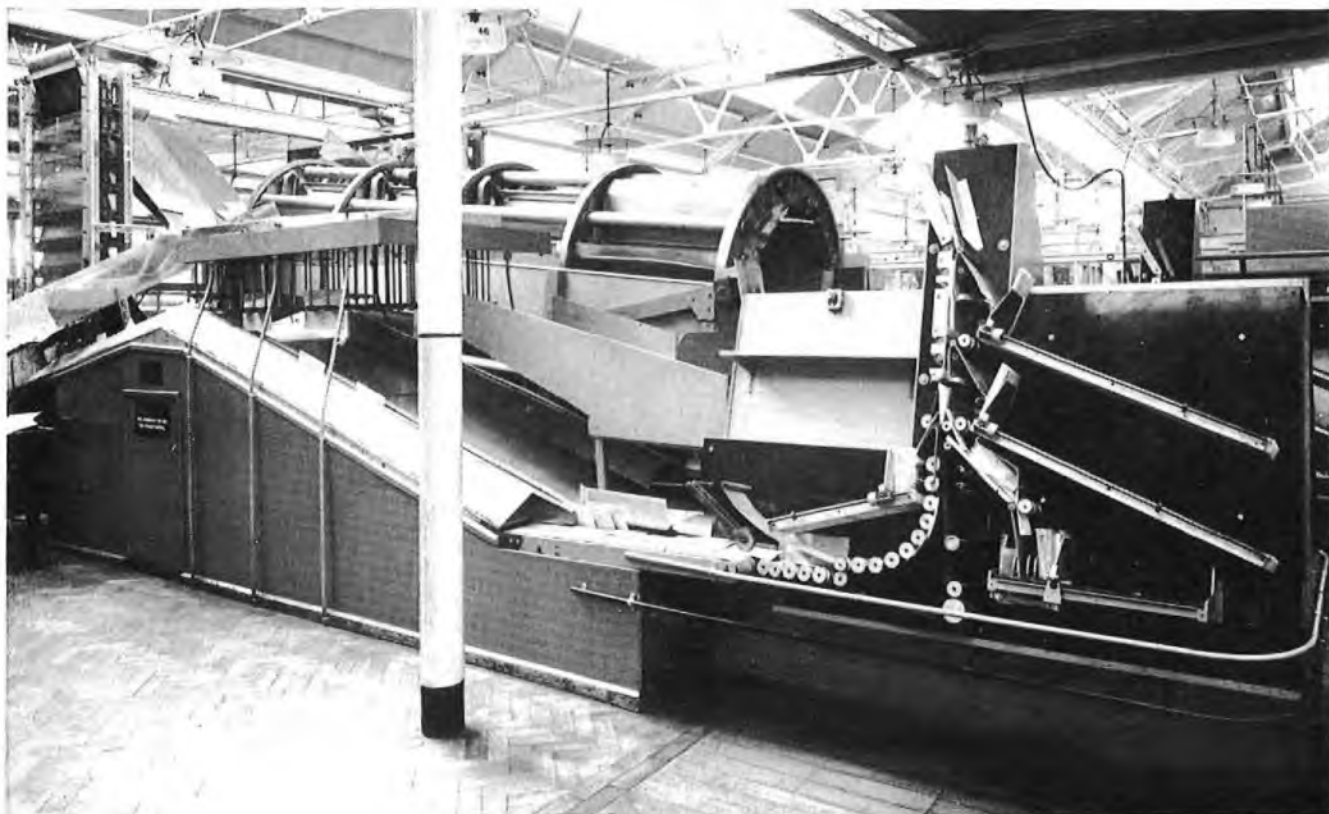

FIG. 3—V-SHAPED CONVEYORS AND SIZING SECTION OF FINAL UNIT

rollers by locating the first few pairs at a critical height above the conveyor. Fig. 3 illustrates the action and shows medium-sized letters travelling away from the "Vee" stream for separate collection.

Once past this separating point only long and short envelopes remain in the stream; these must also be separated and, in addition, must be tidily stacked ready for passage through the facing unit.

At the lower end of the downward sloping section of the V-shaped conveyor the stream of items is deflected by a blade to lie flat on a wide horizontal conveyor (Fig. 3 foreground). It will be appreciated that those long edges on which the items had been resting will be in fairly good alignment. Unfortunately, the laying-over action introduces some disarrangement, and realignment of all the long edges of the items is necessary. This is effected by feeding the stream across a line of polished helically-scrolled rollers whose peripheral speed is considerably higher than that of the stream. The items are therefore skidding on the rollers as they pass across and the helical scrolls tend to screw the items sideways until they edge against an aligning plate as they move on into the final processing unit of the equipment.

Separation of Long and Short Envelopes. The sizing section of this final unit is illustrated on the right and in the foreground of Fig. 3. It is a miniature version of the large-letter extractor. Unlike the latter, however, it is fed with a carefully aligned stream of letters, all moving in a direction parallel to their long edges. This permits short rollers to be used for the "rung" pairs and the accuracy of separation is not impaired by items which are moving in line with their diagonals as happens in the case of the large-letter extractor.

Three sets of "rung" rollers are incorporated in the unit. The bottom gap measures 8 in., whilst the upper measures 9 in. Envelopes shorter than 8 in. in length therefore escape after passing the first "rung," those between 8 in. and 9 in. escape after the second, whilst envelopes more than 9 in. in length only escape after reaching the top of the unit. The shortest envelopes are permitted to escape from either side of the stream in order to prevent congestion; medium-length and long envelopes escape only to one side as the numbers at these points have been greatly reduced.

Stacking

A moving stream of overlapping letters can readily be telescoped to form a stack if the overlap is always in the same direction—as with tiles on a roof. If any cases of overlapping in the opposite direction occur in the stream, such odd items attempt to force their way into the side of the stack as they reach it, instead of entering at the head, and this invariably necessitates a shut-down. In the grading unit which separates the long and short envelopes, the pairs of rollers, in addition to measuring the lengths of the envelopes, perform the vital task of settling escaping letters so that, if overlapping, they form a "tile" with its overlap in the right direction. The escaping streams are therefore ready for telescoping into

stacks when directed downwards against horizontal stacking plates on and along which the stacks form. Fig. 3 illustrates the action. The serrated rollers or "star-wheels" which are mounted at the entry point of each stack provide both agitation for complete settlement and pressure to move the stack sideways as it builds up. The far end of the stack is maintained upright by means of a sprung sliding plate.

Attention is drawn to the fact that various designs of stacking mechanisms are under test; in Fig. 3 the lower right-hand unit, for example, incorporates a rotating open helix to provide the necessary lateral drive on the stack instead of a "star-wheel." In this mechanism, items enter the turns of the helix and so are fed sideways into the stack. The effect is to build a more tidy stack. The slope of the face of the separator-stacker also deserves comment; this feature is vital to the stability of the stacks and contributes to their general neatness.

Speed of Letter Streams

The velocity of movement of the various letter streams in the equipment, except in the case of the drum feed-conveyor, is a nominal 120 ft/min. The velocity of the rising section of the V-shaped conveyors is slightly higher (approximately 150 ft/min) in order to assist the settling of the items on to a long edge when they fall into the conveyor. For the same purpose, at the end of the rising section a forward toppling action results at the transfer point from the higher-speed rising section to the lower-speed falling section of the conveyor.

CONTROL EQUIPMENT

A warning system has been installed throughout the equipment to guard against jams. This precaution is essential because, although they are infrequent, jams inevitably occur due to misshapen items, etc.; they are, however, of little consequence if observed immediately. Conversely, if undetected for a few minutes, clearance may be a lengthy operation. The guard system adopted comprises a number of photocell-light-beam units, which direct beams across the various letter paths. The units are coupled to electronic switching circuits which react if any beam remains broken for more than a certain brief period. This period must not be so short that a heavy traffic flow can cause false operation, but it must be sufficiently brief to avoid a serious build-up of material in the event of a definite jam.

A further feature of the equipment is the starting control. Starting offers no problem when the equipment is empty, but if an emergency stop is made it is necessary to restart the various units in sequence, commencing with those at the far end of the process and finishing with the feed conveyor. This ensures that no temporary overloading occurs due to the chance swamping of a unit by an earlier unit before the swamped unit can get into its stride. The desired effect is provided by a system of interlocking relays.

(To be continued)

Repeater Station Testing Methods and Equipment

C. E. E. CLINCH, B.Sc.(Eng.), A.M.I.E.E., F.S.S.†

U.D.C. 621.317.74:621.395.724

Although articles describing individual items of testing equipment have appeared in this Journal from time to time, there has been no recent comprehensive survey of the transmission testing equipment used in repeater stations. This article traces the development of a wide range of transmission testing equipment for audio, carrier and coaxial systems and provides a complete picture of the testing facilities available in repeater stations.

INTRODUCTION

IT is the aim of this article to cover briefly the whole field of telephone transmission testing equipment used in repeater stations, leaving other authors to depict, in greater detail, particular items of test equipment or particular testing methods. There have been few published articles that have surveyed repeater station testing equipment and techniques, although the first commercial repeater station in this country was opened in 1916 in Birmingham. An important early paper¹, read before the Institution of Electrical Engineers in 1924, described American testing methods and introduced a new unit "the decibel," and in 1926 audio comparison methods² were still an important part of repeater station testing technique. In the following 30 years telephone transmission equipment has grown in quantity and complexity. It is convenient, therefore, to consider repeater station testing methods in terms of the type of transmission equipment with which it is used (audio, carrier and coaxial) and in relation to the type of fault that it is designed to detect and locate, i.e. continued transmission-level change, intermittent transmission-level variations, noise and intermodulation faults.

AUDIO FREQUENCY MEASUREMENTS

Measurement of Transmission Level

Initially, gain and loss were approximately measured by an audible comparison method, as shown in Fig. 1.

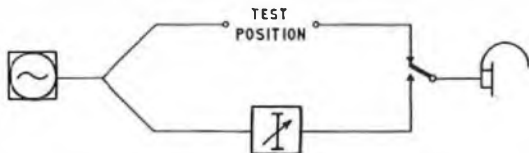

FIG. 1—AUDIO COMPARISON-TEST CIRCUIT

The measurement of power levels at audio frequencies was one of the earliest problems that had to be solved. At first circuits were set up using thermo-couple voltmeters; the Peel-Connor Telephone Co. produced a measuring set using a mirror-galvanometer and the Western Electric Co. soon followed, in about 1927, with what was to become commonly known as the 6G Test Set. The latter made a comparison-type measurement where the power to be measured was compared, via a potentiometer, with a stabilized reference signal at -30 db relative to 1 mW and the difference-voltage measured on a thermo-couple meter, built-in calibration being provided. This proved an accurate

† Senior Executive Engineer, Main Lines Development and Maintenance Branch, E.-in-C.'s Office.

but relatively slow operating instrument, its slowness in operation being largely due to the complication of setting up the oscillator frequency and the d.c. calibration of the thermo-couple. Had ratio-meter circuits been developed, all measurements may still have been made using comparison methods but about this time rapid direct-reading instruments were produced. In an article³ published in 1939 the following opinions were expressed:

"The advent of these direct-reading sets was brought about by the following developments in technique:

(a) Improved coils, enabling amplifiers with a very flat gain/frequency characteristic to be developed. The modern feedback amplifier has made possible further improvements in this direction.

(b) Production of "shaped-pole" meters in which the current/deflexion law is such that an approximately evenly-divided decibel or neper scale can be achieved.

(c) Application of the metal-rectifier meter, a useful instrument for measuring alternating currents. Though not so accurate . . . it was found possible to substitute it for the thermo-couple junction in voice-frequency measurements."

Another important development in the audio-frequency measuring field was the precision heterodyne Ryall-Sullivan oscillator and attenuation-measuring sets, "Testers RP 125 and 631."⁴ This continuously-variable oscillator and direct-reading measuring set was a standard provision in repeater stations for a very long time. From the Tester RP 125 the present standard measuring instrument, Tester RP 790, was developed. Fig. 2 shows

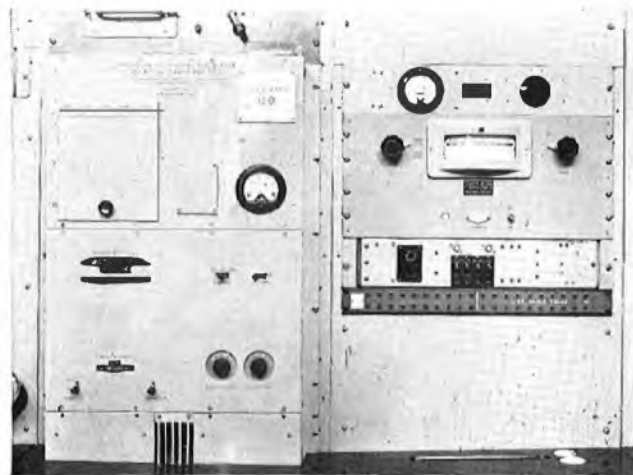

FIG. 2—RYALL-SULLIVAN OSCILLATOR AND TESTER RP 790

a Ryall-Sullivan oscillator with a Tester RP 790 measuring set.

A portable decibelmeter, a simple rectifier instrument, was introduced for making measurements at relatively high power levels. These portable instruments were rather inaccurate and had a high fault rate partly due to their design limitations, and partly due to the ease with which they could be damaged. Single-frequency oscillators, Oscillators No. 13,⁵ were introduced in 1932 to provide a stable and ready reference tone for the

majority of fault tracing, leaving the variable oscillators for lining-up and special fault investigation. Subsequently, the Ryall-Sullivan oscillator was replaced by a cheaper multi-frequency oscillator (Oscillator No. 22).

The introduction of audio amplifiers in small numbers at scattered installations brought a requirement for portable test equipment. In about 1931 the Tester No. 109 was developed. This consisted of a variable-frequency oscillator and amplifier-detector for measuring transmission level and insertion loss. It is interesting to note that it provided for the first time the facility of being able to take measurements over a complete circuit including switching equipment, a "holding loop" condition being maintained throughout the tests. This tester, which consisted of two units, one a transmission measuring set (t.m.s.) and the other a battery box, was replaced by two mains-driven units, i.e. oscillator and measuring set, and this is now itself to be superseded by a transistor version of the Tester No. 109. The new unit is a t.m.s. with its batteries in one case. The Tester No. 109 weighed 39 lb plus 36 lb of batteries and the new unit will have a total weight of only 13 lb., including batteries.

The automatic recording of the gain/frequency responses of audio channels was introduced for international circuits relatively early in the development of testing equipment, and the equipment used has been described in detail in this Journal.⁶ The use of this equipment was not extensive because of the high cost relative to the amount of use that could be made of the instrument. Electronically controlled sweep-oscillator equipment is, however, now being developed, and its use may become widespread.

From this brief history of audio level-measuring equipment the following pattern emerges:

(a) The simple valve-voltmeter, not entirely suitable for the low transmission levels to be measured, which was followed by,

(b) the relatively complex sets for measuring these low transmission levels, then,

(c) the development of the amplifier-rectifier instrument and multi-frequency oscillator, which cover the range required with simple operation.

The future development in this field may be the return to continuously variable oscillators but with the simplicity of operation and low cost of the existing multi-frequency types. Multi-frequency oscillators will not be completely superseded for a long time, especially for routine measurements. For portable use there will be a reduction in size and weight. It will be this pattern of striving towards an ideal in steps dictated by technical ability and economics of design that appears throughout the history of repeater station testing equipment.

Locating Intermittent Faults

The tracing of the intermittent fault has been a problem since the beginning of telecommunications. Early attempts were based on the idea of detecting and counting the occurrences of interruptions. The Tester RP 1620 still exists in many repeater stations as evidence of this. This tester is capable of indicating interruptions but its behaviour is erratic on signals which vary in level or which have interruptions that are not clean breaks. This is not a failure of this design but is common to all instruments of this type—they only count accurately clearly defined interruptions, a phenomena rarely found in communication circuits. From about 1945 onwards

a change of technique was evolved. The location of faults was to be determined by continuously recording the transmission level of a test signal at different points on the circuit and the fault was finally traced within a panel by vibration testing. This is a technique where a carrier signal, applied to the panel under test, is modulated by impedance changes that occur when the panel is mechanically tapped, and the resultant modulation is detected and applied to a high-gain amplifier and loudspeaker. By this method it is possible to detect changes of the order of 0.01 db under favourable conditions and 0.1 db with ease.

The development of this method has been described in detail elsewhere,⁷ and the subsequent work on improving the recording instrument and its associated pen and ink has been reported in recent issues of the Journal^{8,9}. This technique and the work of the field staff in applying it enthusiastically has resulted in considerable improvement in the performance of the trunk network. It cannot be too strongly emphasized that vibration testing is not expected to, and cannot, find all faults, but it has proved an invaluable aid to visual inspection and intermittent-fault locating. It is hoped that it will be used as a normal maintenance technique for dealing with all intermittent-interruption and transmission-level-variation faults.

Noise and Crosstalk Fault Tracing

As far as crosstalk is concerned repeater stations have always used their standard measuring equipment and made tests on a single-frequency basis. The measurement of noise is made using a special measuring set, termed a psophometer, comprising a high-gain, low-noise amplifier, a meter having closely controlled time constants and a specially designed network (known as the weighting network). This network ensures that the measurement is related to the interference that would be experienced by a listener using a standard telephone set. The psophometer characteristics are specified in C.C.I.T.T. documents and the instrument has been described elsewhere.^{10,11} It has had a common form for many years except that the weighting network has been changed to conform with the improvements in subscribers' telephone sets. The major change was made in 1951 when both the reference frequency and the shape of the weighting network were changed.

CARRIER EQUIPMENT

Transmission Level Measurements

Twelve-circuit carrier equipment was first installed in this country in 1936 and its maintenance was based on the use of test equipment primarily designed for the installation and acceptance testing of the equipment. Each manufacturer provided a selection of test equipment assembled on a trolley for use at the terminal stations and a portable unit at the intermediate stations.¹²

The development of maintenance techniques ceased during the war and although the trunk network expanded rapidly no major changes were made to the test equipment until about 1947, by which time 24-circuit carrier working had been introduced. It was decided that, if possible, all routine measurements and fault locating, where all circuits were not faulty, should be made without taking channels out of service. Temporary expedients were designed to approach this aim in advance of the development of the necessary testing equipment. One of

the most successful expedients was the introduction of high-level testing on 12-channel carrier lines. A 60 kc/s signal from the carrier generating equipment was applied via a high-impedance tee to the carrier line to be tested so as to send at a level of 7 db above channel test level. It was possible to measure this signal with reasonable accuracy using the the existing wideband measuring sets. This technique was applicable only to 12-circuit working on symmetrical-pair cable and not to carrier groups routed over coaxial line links. Hence, it was followed by the development of a measuring set based on the "synchrodyne"¹³ principle, using a 33 c/s modulation of a carrier at a channel-carrier frequency. This development was rapidly superseded when the problem of selecting a test signal that was close to a channel-carrier leak was solved by improved filter design resulting in a simpler design of test set. At the same time the problem was discussed internationally and the following comprehensive testing pattern emerged.

(a) Maintenance of the line links was to be based on one or two line pilot signals (one at 60 kc/s for 12-circuit and 24-circuit line links). The pilot was to be stabilized in level at the transmitting end of each line link and measured with a selective measuring set at the receiving end.

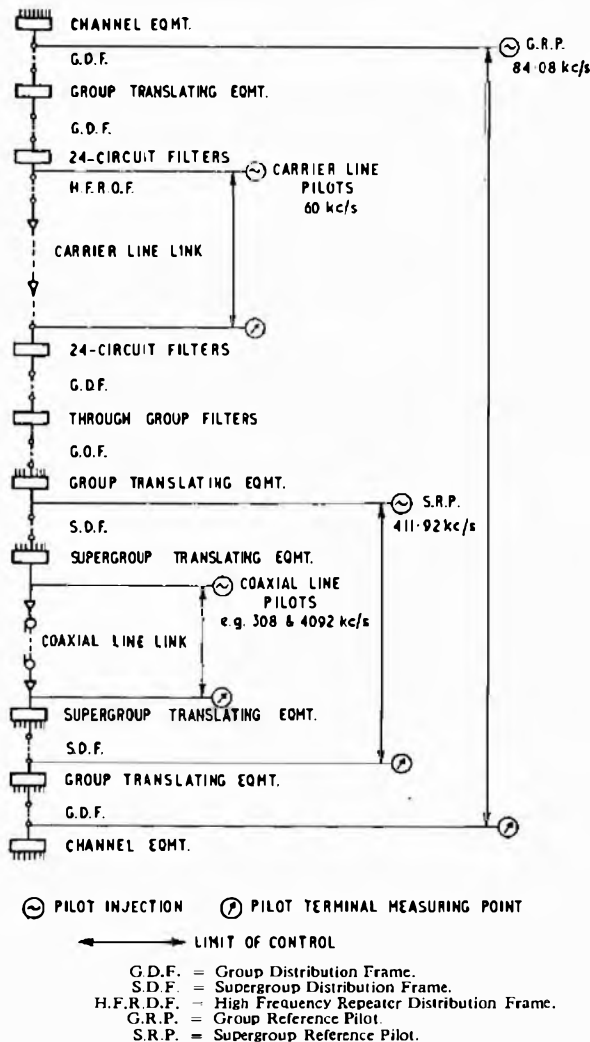

FIG. 3—SCHEMATIC DIAGRAM OF REFERENCE PILOTS

(b) Each carrier group was to have its own group-reference pilot at 84.08 kc/s in the basic group range, i.e. 80 c/s away from the virtual channel-carrier at 84 kc/s. The pilot was to be stabilized in level and permanently applied at the transmitting terminal of all groups at a level of -20 db relative to channel test level and measured on a selective measuring set at the receive terminals. Fig. 3 shows schematically the reference pilots. For routine maintenance, measurements were to be made at each group distribution frame. It would thus be possible to check the group level at any time without co-operation having to be obtained from any other station. This was to be followed by the provision of an alarm which operated when the level of the pilot fell significantly, and thus the need for routine measurements would disappear. The most economic alarm arrangement might possibly be on the automatic-routiner principle. Automatic gain control operated by the group-reference pilot might also be provided on long carrier groups.

The introduction of such a comprehensive scheme has not been without its technical problems in the design of selecting filters, pilot injection and "pick off" arrangements. For example, it was found that the impedances at the measuring points were not sufficiently constant to be ignored and "skew" hybrid circuits were produced to overcome the effect of these impedance changes. A "skew" hybrid is a network designed to have three connexions made to it such that the attenuation between two connexions is small (usually 0.75 db) while the attenuation from these two connexions to the third connexion is relatively large (usually 25 db).

Whilst the provision of the pilots and measuring equipment so far described is adequate for the measurement of gain over a carrier-group section, the tracing of faults within the equipment while it is in service is not yet possible. Ideally, to locate a fault to a particular panel a selective measuring set is required capable of measuring the pilot at all the levels and frequencies where it occurs. Until such a set can be produced economically there are two methods to be used:

(i) Temporarily to abandon the ideal of doing all faulting without affecting service and to take a channel for test and find the fault using simple selective equipment to measure a test signal applied to the channel, or

(ii) to raise the level of the group reference pilot to channel test level and use a lower-selectivity measuring set similar to that required in (i). This, however, has difficulties where alarm or automatic-gain-control equipment is operated by the group reference pilots.

It will be appreciated that the limit set here is an economic one. It is not the technical problem of producing a given performance but of achieving it at a low enough cost to make it worthwhile not to accept some deterioration in service.

Intermittent Faults

The history of the problem of intermittent faults in carrier equipment follows closely on that of its audio counterpart. The faults are now traced using recording decibel meters which operate from specially applied test signals. When group reference pilots are provided it becomes easier to localize intermittent level changes into group sections. The locating of faults to a station will also be achieved by using the line pilots and the pilot-measuring equipment with built-in recording facilities that are being provided on all links. Once a fault has

been located to a station the vibration testing technique is used.

Intermodulation-Noise Tests

When carrier systems were introduced, test equipment was necessary for checking the harmonic production in the early design of line amplifiers. It was, however, necessary to disconnect the carrier group to make the test and the effects of the interruptions caused by "patching out" the line amplifiers were minimized by setting a date and time when all such tests should be performed. As designs improved it was found unnecessary to continue these tests; sufficient control of intermodulation could be achieved by regularly checking the anode currents of the line-amplifier valves, particularly the output valve. Tests have been made of the intermodulation performance of a group by measurements at the terminal stations but the locating of faults between the terminal stations is difficult and has not been continued.

Noise faults, other than intermodulation, are located from the channel ends on an audio basis.

COAXIAL LINE LINKS

Measurement of Transmission Level

Initially coaxial line links were installed and maintained using the Moullin valve-voltmeter as a portable line measuring instrument and using a rack-mounted oscillator, operating on the dynatron principle, as the sending source. Test signals were sent at high level and wideband measurements were made. This equipment

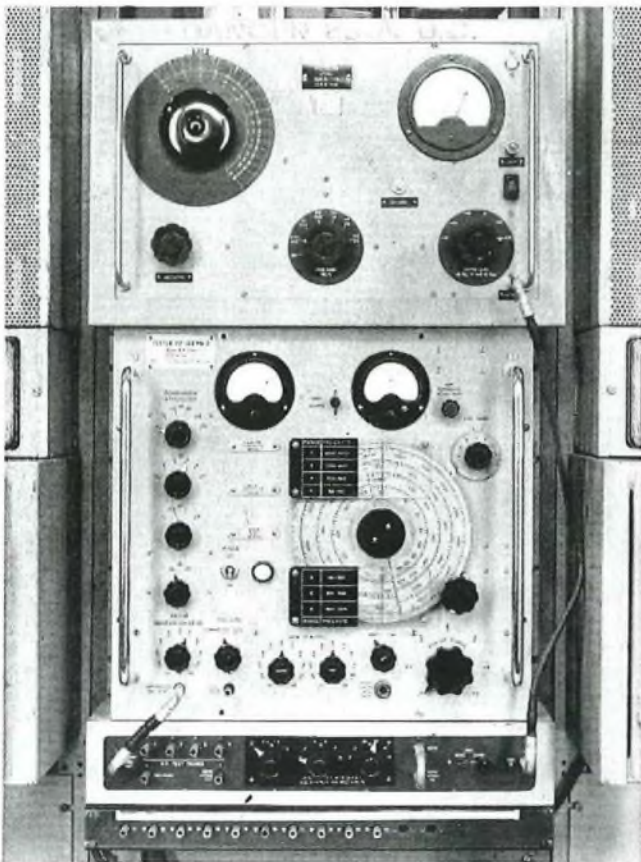

FIG. 4—TESTER RP3110 AND OSCILLATOR NO. 28A

was later superseded by the Tester WL 56265, some of which are still in use to-day. This provided means of selectively measuring two pilot frequencies as well as carrying out wideband insertion-loss measurements. The Tester WL 56265 was itself superseded by a Tester W6, but this did not differ from its predecessor in principle.

With the increase in the number of coaxial line links and the introduction of "in service" testing, the development was started of a selective measuring set capable of measuring a signal at test level on any channel with the remaining channels in service. The frequency and level ranges of a war-time test set developed for the armed services were adapted to produce the Tester RP 3110, shown in Fig. 4, together with an Oscillator No. 28A. This selective measuring set was initially developed for terminal-equipment maintenance, but with the aid of a special calibration of the Oscillator No. 28A to give inter-supergroup frequencies, it was used for the maintenance of coaxial line links.

Test equipment specially developed for measuring on line links with the system carrying traffic is now becoming available. This equipment will measure selectively pilot signals at 20 db below test level at the line pilot and inter-supergroup test frequencies.

The provision of these selective sets was hastened by the introduction of line links that needed the line pilots for control purposes, and consequently the pilots could not readily be removed to enable wideband measurements to be made. The use of the inter-supergroup measuring technique may be extended to wideband (12 Mc/s) line links or may be superseded by equipment that displays the gain/frequency response on a cathode-ray tube. Whether the latter equipment is developed for "in service" testing will depend upon the field trials of equipments that are to be made in the next few years.

The terminal equipment associated with coaxial links was initially maintained using the Oscillator No. 28A and various voltmeters. Later, the Halsey-Sullivan oscillator (a development from the Ryall-Sullivan oscillator for the higher frequency range) was introduced together with thermo-couple transmission-level measuring sets.

With the introduction of "in service" testing, a temporary scheme was commenced which involved sending into any carrier group, when required, a 72 kc/s test signal at 3 db above channel test level and using the selective measuring set (RP 3110), but it became obvious that this would be superseded by the use of group reference pilots and ultimately by supergroup reference pilots. Hence the introduction of 72 kc/s testing did not extend to more than four or five coaxial line systems. As with carrier line equipment, it is necessary, for the present, to take channels from service for fault-tracing purposes.

In addition to the above, a number of general purpose items of test equipment have been produced. The Oscillator WX4 (now renamed Oscillator No. 28A) and the 3-unit STC 74602 insertion-loss measuring equipment shown in Fig. 5 served for a long time. It will be appreciated that the introduction of selective measuring equipment reduced considerably the use of non-selective measuring equipment for maintenance work on the line link. However, with modern systems, once a fault has been traced to a panel, it is possible to change the panel and make satisfactory wideband measurements on the faulty unit, now out of service. For a long time much of this fault tracing was carried out at special repair centres.



Left—Level measuring set. Centre—Oscillator. Right—Power unit
 FIG. 5—WIDEBAND TRANSMISSION MEASURING SET STC 74602

For newer systems, and eventually for the existing systems, this work is being devolved to repair centres being set up in the field. These field repair centres are being equipped with insertion-loss measuring equipment for this work. One such repair centre is shown in Fig. 6. Facilities are given on the test racks for:

- (a) controlling the power supplies and the equipment under test,
- (b) measuring insertion loss by comparison methods, and
- (c) checking the performance of gain regulators.

Intermittent Faults

The provision of recording facilities with all transmission-level-measuring equipment used on coaxial line links gives a satisfactory means of locating intermittent faults to a station. Many temporary expedients have been used on coaxial line links. On the 3 Mc/s band-width line links designed by the Post Office the use of a recording decibelmeter operated by the cathode current of the valve in the pilot selector at any intermediate station proved relatively successful with low cost. The use of a specially provided selective amplifier with a large amount of feedback to stabilize its performance was more costly

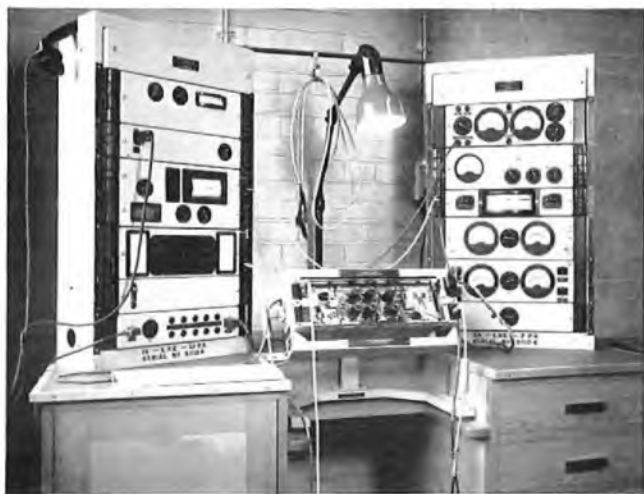

FIG. 6—REPAIR CENTRE AT STOCKPORT REPEATER STATION

but gave a better performance. Production is now under way of a 300 kc/s pilot monitor for the Post Office type of line links that is less temperature-sensitive and varies less with supply-voltage changes than the temporary equipment. The more recent regulated line links are being provided from the outset with pilot monitoring and recording equipment. The principle that is being established is that in addition to any pilots used for automatically regulating the line link a pilot should be provided for monitoring and locating intermittent faults. The pilot should ideally be at a frequency at which the greatest change in line characteristic will occur.

Once a fault has been proved to be within a repeater station, vibration testing techniques are used to assist in tracing the fault. On coaxial line links, because of the large number of circuits that can be affected by the fault, arrangements are being made to enable transportable equipment to be installed at any intermediate station to enable the working equipment to be fully investigated. The terminal equipment is treated in the same way as other carrier system equipments.

Intermodulation-Noise Tests

It was the practice to change all valves in the line amplifiers on coaxial line links at yearly intervals. This no doubt reduced the number of intermodulation faults and those that remained were traced by changing amplifiers. Annual changing of valves is, however, unnecessarily costly. Early Post Office designs of coaxial line links used high-level pilots and it was found possible by measuring selectively the level of the signal resulting from the intermodulation of the two line pilots to determine the overall intermodulation level for these line links. Although any test made at one frequency only cannot give complete information about the performance of a wideband line link it has been proved sufficiently accurate to enable the regular changing of valves to be discontinued. Post Office-type coaxial line links are now routine tested end-to-end for intermodulation by the above method and when the result is outside specified limits the amplifiers are changed in sequence to trace the fault. On the newer, continuously regulated, systems the line pilots are at a low level and it is not possible to measure directly the intermodulation product that results from interaction of the line pilots. Valve anode (or cathode) currents are, however, continuously monitored and previous investigations have shown that nearly every fault of high intermodulation on a line link was due to a valve with low anode (or cathode) current. Hence, it has not been found necessary to institute special testing methods on these systems. New wideband (12 Mc/s) line links having no continuous valve monitor and reduced feedback at the higher frequencies may bring their own problems.

Return-Loss Measurements

The setting up of some modern coaxial line amplifiers and associated equipment requires the measurement of impedances. This has been achieved by using a wideband hybrid transformer and measuring the impedance as a balance return loss against a standard resistance.

MISCELLANEOUS EQUIPMENT

In addition to the main equipment already mentioned, there are a number of special items provided in repeater stations such as valve testers and power-supply meters.

Little need be said about these items as their requirement is self-evident. Valve testers and testing methods are a major problem in repeater station maintenance. Most valves are rejected on the evidence of a "panel" test, e.g. the gain of an amplifier is checked and found to be unsatisfactory until one or more valves are changed, and hence valves are often rejected without being tested. Most equipment is provided with valve-anode-current or equivalent measuring facilities and since there is satisfactory correlation between the anode current and the mutual conductance of a valve this is often a satisfactory test on which to change valves. This method cannot be completely successful but has the merit of being a test that can be made without affecting the service given by the panel. There are few valve testers that enable the specification tests to be applied to a valve and at present there is nothing that could be called a repeater station standard valve tester.

CONCLUSIONS

Not all items of test equipment have been discussed for this would take too much space but the general pattern of development has been explained. The study of repeater station test equipment has shown continuous progress towards the ideals of low cost, high accuracy, minimum interference to working circuits, and minimum operating effort. Also, although they conflict in some ways with these ideals, the requirements of simplicity and minimum maintenance of the testing equipment itself have been met.

ACKNOWLEDGEMENTS

The author wishes to acknowledge the help given by his many colleagues in the Post Office and industry in preparing this article.

References

- ¹ERIKSON, P. E., and MACK, P. A. Transmission Maintenance of Telephone Systems. *Journal I.E.E.*, Vol. 62, p. 653, 1924.
- ²RITTER, E. S., and MILTON, G. P. Testing of Telephone Circuits and Apparatus with A.C. *I.P.O.E.E. Printed Paper No. 110*, 1926.
- ³HERRICK, R. E., and MELLING, H. Transmission Testing Apparatus for 30-10,000 c/s Communication Systems. *Electrical Communications*, Vol. 17, p. 239, Jan. 1939.
- ⁴RYALL, L. E. A Few Recent Developments in Telephone Transmission Apparatus. *I.P.O.E.E. Printed Paper No. 155*, 1934.
- ⁵RYALL, L. E., and BURGESS, A. G. A Simple Transmission Measuring Equipment. *P.O.E.E.J.*, Vol. 30, p. 52, April 1937.
- ⁶WILLIAMS, H. The Automatic Level Recorder. *P.O.E.E.J.*, Vol. 36, p. 103, Jan. 1944.
- ⁷MYERS, H. G. Fault Location in Transmission Equipment by Vibration Testing and Continuous Monitoring. *P.O.E.E.J.*, Vol. 42, p. 189, Jan. 1950.
- ⁸PARSONS, A. P., and DIBCOCK, F. E. Recording Decibel-meters. *P.O.E.E.J.*, Vol. 51, p. 145, July 1958.
- ⁹NICOLLS, A. C., and HARRISON, J. C. Recent Improvements in the Inking Systems of a Recording Decibelmeter. *P.O.E.E.J.*, Vol. 52, p. 26, April 1959.
- ¹⁰HARBOTTLE, H. R. The Circuit Noise-Meter (Psophometer) and its Applications. *Journal I.E.E.*, Vol. 83, p. 261, 1938.
- ¹¹GOLDSMITH, F. H., and WIDDICKS, J. A. A Mains-Operated Psophometer. *P.O.E.E.J.*, Vol. 46, p. 112, Oct. 1953.
- ¹²MORRELL, F. O. Maintenance of Multi-Channel Carrier Telephone Systems. *I.P.O.E.E. Printed Paper No. 194*, 1948.
- ¹³TUCKER, D. G. The Synchrodyne. *Electronic Engineering*, Vol. 19, No. 229, p. 75, Mar. 1947.

The Inspection and Subsequent Treatment of Recovered Stores

U.D.C. 654.1.004.8

LARGE quantities of engineering stores of all types are returned each year to the various Post Office Supplies Department Depots. The condition of these stores varies from new and unused on the one hand to worn out and fit only for scrapping on the other, and careful examination and sorting is essential if the maximum economy is to be achieved.

The bulk of recovered and surplus engineering stores is returned to the Supplies Department Depots in London, Birmingham and Edinburgh. Some items of scrap metal such as pole fittings can be more economically disposed of locally by the Telephone Areas. Certain telephone instruments and bell-sets which are repaired by the Factories Department in South Wales using modern "flow-line" methods are returned direct to the Supplies Department Depot at Hereford. Apparatus which is considered by the sender to be fit for re-issue with little or no attention is, however, returned to the normal main depot, the delivery note being suitably annotated.

After check against the delivery notes, a preliminary sorting is carried out by the Supplies Department. Items which have only scrap value, such as recovered line wire or worn cordage, and items which are obsolete, and are therefore scrapped on recovery regardless of condition, are segregated. All other items are then laid out on large

tables in readiness for examination by a joint team of Engineering Department and Factories Department staff. This examination is known as "grading" and the staff involved are termed "Joint Examiners." It is their responsibility firstly to put aside for scrapping any items which are beyond economic repair. Secondly, they are required to segregate for detailed Engineering Department inspection and functional test any equipment which appears to be suitable for return to stock with little or no attention other than superficial cleaning or minor adjustments. Thirdly, they classify into "Minor" or "Major" repair categories the items which have not already been dealt with as "scrap" or "fit for re-use." The difference between the two repair categories lies, broadly, in the amount of repair work which is necessary either by the Factories Department, or, for proprietary equipments, by the original manufacturer, to restore the item to a condition in which a further period of reliable service can be ensured.

This process of grading may take place at any one, or all, of the three main Supplies Department Depots, and it is necessary for standardized and detailed information on which to base decisions to be readily available at all these depots. This information normally consists of repair specifications and grading instructions, which are

issued by the Engineering Department to all interested parties after full consultation with and agreement by the Factories Department. The information provided consists of details of the repair work which is proper to the Major and Minor repair categories and of references to the appropriate specifications, diagrams and drawings. In some instances, information may also be supplied regarding the treatment to be given to a particular "mark number" of an item which has been changed or modified over the years.

The grade into which the item is finally placed by the examining team is indicated to the Supplies Department staff by the application of a water-paint mark, a distinctive colour being used for each category. It is then the responsibility of the Supplies Department to arrange for the scrapping of items which are not to be repaired, to submit items in good condition for examination by the Engineering Department and to store items awaiting repair until required. It should be noted that the scrapping of an item does not necessarily mean its destruction. Wherever possible dismantling is carried out, any component parts which are required for normal Supplies Department stocks being submitted to the Engineering Department for inspection. Considerable quantities of old equipment are sent to H.M. Prisons for breakdown into component parts.

When exchanges and repeater stations are being dismantled or modernized, quantities of non-standard rack-mounted equipment and non-standard power plant are frequently returned to Supplies Department Depots. It is the responsibility of the Joint Examiners to report on the condition and construction of such apparatus to assist the appropriate Branch of the Engineering Department to reach a decision regarding its disposal. It frequently happens, of course, that the only source of supply of some of this old equipment for extensions and maintenance purposes is from the careful repair or breakdown of recovered apparatus. The Joint Examiners are also responsible for the examination and assessment of damaged apparatus for which a repair charge is to be made against the renter in whose premises the damage occurred.

Apparatus is repaired by the Factories Department under either the "Scheduled Output" procedure whereby a specified quantity of items per month is repaired, or under the "Non-Scheduled Output" procedure, which will normally apply to a request for the repair of a certain quantity of equipment spread over a specified period of, perhaps, six months. In each case the rate of repair can be varied from time to time, depending on the new stock position, deliveries of new items, if any, from contractors, and the quantity of the item held in "Old Stock" awaiting repair. It will be appreciated that a given monthly output requires to be supported by an adequate supply of old stock upon which to draw, if smooth operation of the repair organization is to be ensured. The "Non-scheduled Output" procedure normally applies to equipment which either has a slow recovery rate or which for some reason is temporarily in

short supply. The repair specification and associated information, to which reference has already been made, form the basis on which the repair work is executed, the main object being the production of a repaired item which will give a sufficient period of reliable life to justify the expense incurred. An identification code marking similar to that used on new equipment is added to indicate that the item has been repaired in a Post Office Factory. This marking takes the form of, for example, "FBR/59," the "FR" indicating "Factory Repair," the middle letter the location of the repairing Factory, and the figures after the stroke the year. "B" indicates Birmingham, "H" London, "N" Edinburgh and "W" the South Wales Factory at Cwmcarn, near Newport. This marking is most useful when information is subsequently required regarding the location and date of the repair.

Apart from certain piece parts, all items are subjected after repair to visual inspection and, where appropriate, a comprehensive functional test by the Engineering Department before being approved for stock. Some items, notably dials and most telephone instruments, are already repaired on a flow-line basis, and the Factories Department intend to extend the scope of this method in future. The Engineering Department inspection then consists of the detailed examination and performance test of a regular sample of the repaired product.

It is clearly impracticable, from both a technical and economic viewpoint, to obtain a standard of finish and performance equal to new for equipment which may already have seen many years' service since its original purchase. Nevertheless, such relaxations of standards which may be permitted from time to time are closely controlled by the Engineering Department and are modified in the light of experience gained in the use of the repaired equipment.

It will readily be appreciated from the foregoing survey that the manner in which equipment is treated following its recovery or during its return to Supplies Department as surplus can have a very considerable effect on the subsequent repair costs. It is essential that apparatus of all types should be recovered carefully, even though it may appear to be already in poor condition, and it should be packed with equal care for return to the Supplies Department Depot. Surplus equipment will normally be in new condition and therefore care in packing and shipment is even more important if subsequent expensive repair owing to damage in transit is to be avoided. The appropriate special packs should invariably be used as serious damage does frequently occur in transit as a result of inadequate packing.

Continuous efforts are being made by the Supplies, Factories and Engineering Departments to make the best and most economical use of recovered and surplus stores. Engineers in the field can assist very considerably by bearing in mind that recovered and surplus equipment may well be repaired for a further period of useful service.

R. S. I. O.

Book Reviews

"Mathematics for Telecommunication Engineers." S. J. Cotton. Chapman & Hall, Ltd. x + 245 pp. 89 ill. 37s. 6d.

According to the author the purpose of this book is to bridge "...the gap between the level of mathematics reached on many courses, such as the Higher National Certificate Course, and that required to read intelligently many of the articles in professional journals or to tackle the many problems facing engineers . . .", an objective which seems perhaps a little optimistic when read in conjunction with a subsequent statement that the contents cover the syllabus of the fourth and fifth years of the City and Guilds of London Institute course in telecommunications.

Chapter 1, entitled "Revision and the Differential of x " for any Index" makes an unhappy start, which rather tends to shake one's confidence, firstly by using the words differential and derivative as if they were equivalents and then by giving a proof of the formula for the derivative of x^n which involves an argument in a circle; such mistakes might be overlooked in a book on engineering but are surely inexcusable in any book on mathematics. Determinants are introduced in Chapter 2 by the unusual, and possibly rather confusing, method of expressing the condition for the consistency of n linear equations in $(n-1)$ unknowns as the vanishing of an n th order determinant; a little later in this chapter the author solves a network problem by equating to zero a determinant with more columns than rows!

The next six chapters deal with the elements of the calculus and include 24 pages devoted to functions of a complex variable, whilst the remaining four chapters are concerned with more advanced topics such as Fourier series and integrals, vector methods, special functions and probability theory. The mathematical standard set by the first two chapters prevails throughout the remainder of the book and it provides excellent material for the student of mathematical howlers. Particularly noteworthy is the calculation on page 49 that gives the current in a pure square-law device ($i = nv^2$) as $aV^2 \cos 2\omega t$, when $v = V \cos \omega t$.

Some of the sections are marked with an asterisk to indicate either that they are of interest only to students or else not likely to interest practising engineers; the latter will be relieved to learn that although they may have to obtain areas with the calculus, volumes are considered too academic, and infinite series only diverge in examinations.

In addition to setting a low standard of mathematics the book makes no serious attempt to explain to the student the principles underlying the various mathematical processes so that he will later be able to use them as an effective tool. Instead, the subject is presented as a dull and haphazard collection of facts which must be memorized for the purpose of passing examinations: teaching of this kind can be guaranteed to make almost any engineer dislike mathematics. *I.P.O.E.E. Library No. 2561.*

H. J. O.

"Automatic Process Control." Donald P. Eckman. John Wiley & Sons, N.Y. Chapman & Hall, Ltd. vi + 368 pp. 216 ill. 72s.

This book, of American origin, is written for the undergraduate and deals with the automatic control of processes which are perhaps more difficult to analyse than electric circuits. Processes such as the flow of a liquid or gas, mechanical systems and liquid heating systems cannot be described with great precision and the author draws the electric analogy. The comparison is first made statically, and later the dynamic response is considered but is restricted in the early chapters to linear systems which can be represented by differential equations of the second order with constant coefficients.

Automatic controls are basically feedback systems but

many different types of feedback are considered. The treatment of simple "proportional" feedback is followed by a study of the effect of integral and differential and mixed feedback. The possibility of "two-position" systems is discussed.

The book contains many diagrams some of which depict valves, pistons, diaphragms, etc., which may well be of interest to the practical man. The mechanism of the controlling path need not resemble that of the process to be controlled and the merits of hydraulic, pneumatic, electric and electronic systems are discussed.

The last two chapters and the appendix are more mathematical in nature but the methods used are introduced by easy stages and should not prove difficult to those with a knowledge of electric-circuit analysis. Analysis of the system by the study of its response to sinusoidal inputs is dealt with by the classical, complex-frequency and operational methods. Examples of graphical plots of the amplitude and phase-frequency characteristics are given. The well-known works of Nyquist and Bode are employed in the last chapter, which discusses the stability of the system. This chapter also uses Laplace transforms and the appendix enlarges on this subject.

The book contains many examples with answers which adds to its usefulness for training purposes. It provides an excellent guide to the student of electrical circuitry who wishes to apply his knowledge to other fields.

W. T. D.

"Practical Television." T. J. Morgan, A.M.I.E.E. Ward Lock & Company, Ltd. 256 pp. 200 ill. 25s.

Although not so indicated, this is really the second edition of a book that was reviewed in the *P.O.E.E. Journal* in January 1953. The sub-title of the earlier edition, "How it Works," has been dropped, yet this is exactly what the book attempts to show. It is an ambitious work, starting from the first principles of magnetism, electricity and wave motion, and building up a picture of sound and vision transmission by radio. It finishes with a short chapter on colour television.

The first edition contained inaccuracies and typographical errors, some of which have now been corrected. Thus, whereas a schoolboy-howler type of reference to a cathode-ray-tube "iron trap" has now been corrected to "ion trap," "change" is incorrectly printed as "charge" twice in quick succession on p. 170, an error that also appeared in the first edition. More careful proof-reading would have eliminated errors of this type.

There is still a good deal of material open to criticism. For example, the "jumping-dog toy" is cited on p. 14 as an illustration of persistence of vision, yet it is stated that the dog appears to jump in and out of the kennel—the very opposite of persistence. Surely the point of this toy (and similar "bird-in-cage" varieties) is that the kennel (or cage) is printed on one side of the card and the dog (or bird) on the other. When the card is rotated rapidly enough, the dog appears to be quite stationary inside the kennel (or the bird in the cage)—a true persistence-of-vision effect.

The contents of the book follow the same general pattern as before and, indeed, most of the material is unchanged. However, some sections have been brought up to date. For example, transistors, almost unknown in 1953, are now described, somewhat briefly, in the chapter on valves. The photographs have been completely replaced by a new set including a representative selection from the independent television service, which did not exist when the earlier book was prepared.

The book makes interesting reading and can be recommended for the layman, or for those not too intimately connected with the field of television engineering. *I.P.O.E.E. Library No. 2044.*

T. K.

Notes and Comments

Retirement of Mr. E. H. Jolley, O.B.E., M.I.E.E.

On 4 January 1960 Mr. E. H. Jolley, Staff Engineer, Telegraph Branch, retired after 45½ years in the Post Office, most of which was spent in the Engineering Department.

Mr. Jolley entered the Post Office as a youth in July 1914 at Douglas, Isle of Man. After the First World War, in 1923, he came to Dollis Hill as an acting Inspector on cable testing and while in this group he advanced to Assistant Engineer (old style) in 1925, and gave a paper to the I.P.O.E.E. for which he received the



Silver Medal. In 1931 Mr. Jolley was transferred to the Telegraph Group, Research Branch, remaining there until 1933, when he transferred to Nottingham. He was not left there long, however, because after five months he was brought back to Research Branch as an Executive Engineer (old style) in charge of the Telegraph Group. In 1937 Mr. Jolley was promoted to Telegraph Branch as Assistant Staff Engineer, and in 1947 returned to Research Branch as Staff Engineer to build up a new division. On the retirement of Mr. F. E. Nancarrow, in 1952, he transferred to the City office to take charge of the Telegraph Branch.

At Staff Engineer level all the anxieties of the administration and major technical matters of the Branch come together with the pressures of urgent projects. Mr. Jolley was able to take these in his stride and carry them through efficiently and always with an eye to the well-being of his staff.

Telegraphy is a branch of telecommunications in which equipments of great variety both in age and type exist, often side by side. Mr. Jolley's great strength was his ability to bring his store of knowledge of these equipments to bear on the development of systems incorporating new techniques, for which he was always on the look-out. One of the major developments in telegraphy in recent years has been the growth of switching systems, both national and international public and private networks. The Telegraph Branch had to be reorganized to deal with this situation and Mr. Jolley contributed to the full. In the international field he became chairman

of the C.C.I.T. Study Group which dealt with telegraph switching, in addition to being chairman of the Photo-telegraphy Study Group. When the C.C.I.T. was incorporated in the C.C.I.T.T. in 1956 he retained the chairmanship of Study Group X dealing with telegraph switching. He was leader of the United Kingdom delegation to the final Plenary Assembly of the C.C.I.T. and attended the special meetings leading up to the amalgamation.

Mr. Jolley has written articles and papers on telegraphy and a book on Telegraph Transmission; and he was, in fact, one of the greatest authorities on telegraphy. He was outspoken and refused to yield in argument when he was justified, but he was always cheerful and helpful and a loyal and popular colleague. We are very sorry he has left and sincerely hope he will have a long and happy retirement after such a strenuous official life.

H. W.

J. Rhodes, M.B.E., B.Sc.(Eng.), A.M.I.E.E.

Mr. Rhodes, who has been appointed Staff Engineer of Telegraph Branch following the retirement of Mr. Jolley, graduated at London University in 1930. He spent three years with Metropolitan Vickers working on heavy electrical machinery and then joined the Post Office as a Probationary Assistant Engineer (old style). After training he was posted to Equipment Branch on automatic telephone exchange work.



In 1940 Mr. Rhodes was promoted to Executive Engineer (old style) in the Lines Branch and was in charge of submarine telephone cable systems and transmission equipment development. On promotion in 1949 to Assistant Staff Engineer in the Transmission and Main Lines Branch he became responsible for cable and transmission equipment maintenance but retained his submarine cable system duties.

He was concerned with the planning and provision of the cross-channel cables for the Normandy invasion and for this work was appointed M.B.E.

After the war Mr. Rhodes had the task of re-building the line network to the continent, and the equipment on

every submarine cable system now working on these routes was provided under his direction. This marked the beginning of a long period during which he acquired what must be an unequalled experience in the international telecommunications field. He was closely associated with the Western Defence Union and N.A.T.O. and, when chairman of a working party of experts on the Infrastructure program, visited most of the N.A.T.O. countries, including Turkey. Since the end of the war he has taken an active part in the work of the C.C.I.T.T., and has recently been elected chairman of the Working Party on Data Transmission, an appointment for which he is very well equipped now that he is head of the Telegraph Branch as well as being a telephone transmission expert.

His many friends at home and abroad will wish him every success in his new appointment.

R. H. F.

Board of Editors

Mr. R. F. Waldegrave has been co-opted as a member of the Board of Editors.

Mr. D. M. Gambier has resigned from the post of Assistant Editor and Mr. R. A. Sudell has been appointed to take his place. The Board of Editors takes this opportunity of thanking Mr. Gambier for his services.

Mr. B. Cross has been appointed Advertisement Manager.

Journal Price Change

In recent years the Journal has been much enlarged to enable readers to be kept informed about the ever-widening field of Post Office engineering activities; in 1951-1952 the total number of pages of text (excluding advertisements) and supplement was 252, while in 1958-1959 it was 475 pages (or about 420 pages if the extra pages of the special S.T.D. issue are excluded). During the same period the cost of printing and block-making rose appreciably. As a result of these and other changes the cost of producing the Journal has greatly increased, and in spite of recent economies an increase in price is now necessary.

The Board of Editors has therefore regretfully decided to increase the price of the Journal to Post Office readers from 2s. to 2s. 6d. per copy, commencing with the April 1960 issue. The price to readers who are not Post Office employees will remain at 2s. 6d. but to cover the

increased cost of postage and packing the post-paid price will be increased from 3s. 3d. to 3s. 6d. per copy (14 shillings or 2 dollars 25 cents per year, post paid).

Subscriptions

Some subscriptions for the Journal have in the past been dealt with by Messrs. Birch & Whittington (Prop. Dorling & Co. (Epsom), Ltd.), but in future all correspondence about subscriptions, including renewals, should be sent to the following address:

The Post Office Electrical Engineers' Journal,
G.P.O.,
2-12 Gresham Street,
London, E.C.2.

Supplement and Model Answer Books

Students studying for City and Guilds of London Institute examinations in telecommunications are reminded that the Supplement to the Journal now includes model answers to examination questions set in all the subjects of the new Telecommunication Technicians' Course. Back numbers of the Journal are available in limited quantities only and students are urged to place a regular order for the Journal to ensure that they keep informed of current developments in telecommunications and receive all copies of the Supplement.

Books of model answers are available for some telecommunications subjects and details of these and new books being prepared are given at the end of each Supplement.

Notes for Authors

Some notes have been written to help authors prepare the manuscripts of their Journal articles in a way that will assist in securing uniformity of presentation, simplify the work of the Journal's printer and draughtsmen and help ensure that authors' wishes are easily interpreted. Any author preparing an article for the Journal who is not already in possession of the notes is asked to write to the Managing Editor to obtain a copy.

Journal Binding

This issue completes Vol. 52 and readers wishing to have the volume bound should refer to page 313 for details of the facilities available.

Institution of Post Office Electrical Engineers

Annual Awards for Associate Section Papers— Session 1958-59

The Judging Committee having adjudicated on the papers submitted by the Local Centre Committees, prizes and Institution Certificates have been awarded to the following in respect of the papers named:

First Prize of £7 7s.

H. Williams, Technical Officer, Bangor Centre—"The Development of Carrier Telephony."

Prizes of £4 4s. each

J. W. Milne, Technical Officer, Aberdeen Centre—"Telex."

J. L. Garland, Technical Officer, London Centre—"The Transatlantic Telephone Semi-Automatic Switching Equipment."

D. G. Greenaway, Technical Officer, London Centre—"Mobile Artificial Traffic Equipment."

C. D. Wickenden, Technician I, Tunbridge Wells Centre—"Gas Pressurization of Cables."

In addition, the following papers, which were considered worthy of submission to the Judging Committee for the main awards, have been awarded a prize of one guinea each:

W. A. Kane, Technical Officer, Belfast Centre—"500 kc/s to 500 Mc/s—A Review of Receiving Techniques from Early Crystal Detectors to Modern V.H.F. Equipment."

W. Bradley, Technical Officer-in-Training, Scarborough Centre—"Fluorescent Lighting."

J. S. R. Lawson, Technical Officer, Dundee Centre—"Aeromodelling."

The Council of the Institution is indebted to Messrs. C. E. Moffatt, R. E. Burt and R. M. Angerson for kindly undertaking the adjudication of the papers submitted for consideration.

S. WELCH
General Secretary.

Regional Notes

Midland Region

THE MIDLAND REGION'S LAST MAGNETO EXCHANGE

Oadby, the last magneto exchange in the Midland Region, was transferred to automatic working on 8 July 1959. The old exchange, which had been housed in the same building since the original 40-line switchboard was provided in 1900, consisted of three suites of four positions each, situated in three different rooms in an ordinary house. To provide for the rapid growth in the area a relief U.A.X. No. 13 (South Oadby) had been provided in 1955, and subscribers on this exchange were transferred to the new automatic exchange simultaneously with the conversion of the magneto exchange. Subscribers on South Oadby were given numbers on the new exchange which consisted of their previous numbers prefixed by 5, and the old junctions from Leicester to South Oadby have been connected to the level 5 second selectors in Oadby automatic exchange until the issue of the next directory.

The opening ceremony was performed in the Council Chamber of the local Urban District Council by the Chairman of the Council, who gave the signal for the opening of the new exchange and originated the first call. During pre-transfer testing of the subscribers' lines, to avoid the necessity for engineering attendance at the old exchanges, arrangements were made for the operators at the magneto exchange to disconnect the old equipment by the insertion of a peg in the multiple, and at the U.A.X. spare 1st selectors, with their negative and positive wipers disconnected, were connected to telephones in the new exchange. By dialling on these telephones the last two digits of any subscriber's number on the respective final selectors the subscriber's calling equipment was busied, and the subscriber's line could then be connected to the new automatic equipment. If the subscriber's line was engaged, busy tone was returned from the final selector and further tests could be made at a later time.

This method proved so efficient and labour-saving that it is being adopted as standard for all suitable transfers in the Leicester area.

W. L. S.

London Postal Region

POST OFFICE RAILWAY—CHANGE TO MERCURY-ARC RECTIFIERS

For the past 30 years or so the Post Office Railway has been served with direct current from rotary convertors; the railway operates on a line voltage of 440 volts in the tunnel and 150 volts in the stations. Recent costly repairs led to an examination of the machines and to the conclusion that they have now reached the end of their economic life. A decision was taken, therefore, to replace them by mercury-arc rectifiers.

The original installation consisted of six rotary convertors in three pairs, at Liverpool Street (British Railways station), Mount Pleasant, and Western District Parcels Office. Each station has been supplied by duplicate power feeders of 6.6 kV from the bulk electricity supply intake at King Edward Building, but in planning the change to mercury-arc rectifiers the opportunity was taken to provide new equipment suitable for 11 kV working.

Each rotary convertor was of 400 kW output, only one convertor at each station running at any time. The load only approached the rated output at peak periods of traffic, the convertor working at about half rated output for most of the day. This condition would be very inefficient for rectifier working and it was decided to provide 250 kW rectifiers throughout, one rectifier on load at each station during periods of light traffic, and two at peak-load times.

The rectifiers have been designed as special compact units to fit into the restricted space under the railway-station

platforms. The chokes, anode fuses and fan-starting equipment have been removed from the bulb cabinets and built into a special cabinet under the d.c. circuit-breaker panel. Each rectifier has two bulbs. The photograph shows one bulb cabinet with the doors open; the cradle which carries the bulb has wheels to enable it to be easily withdrawn.

The delivery of the rectifiers will be spread over three years, the final pair being provided at the new Western District Office (W.D.O.) which is under construction at Rathbone Place, W.1. The station at this office will replace the sub-station at the Western District Parcels Office (W.P.O.).



RECTIFIER-BULB CABINET

The distant end of the railway line at Paddington station received its d.c. supply from W.P.O. via three 0.5 in² paper-insulated lead-covered armoured cables, each 2,050 yd long. The movement of the electricity sub-station from W.P.O. to the new W.D.O. at Rathbone Place would have added 1,400 yd to the length of these cables, and would have aggravated the difficulties that have occurred in the past due to the voltage drop over the original cables causing trains to stall at Paddington. Consideration was given to increasing the cross-sectional area of copper to provide for a supply from the rectifiers at the new W.D.O. at Rathbone Place. The cost of the necessary cable would have amounted to £7,000 and it was, therefore, decided that a more satisfactory supply could be obtained by having the London Electricity Board (L.E.B.) provide a high-voltage supply at Paddington and the Post Office install a rectifier at that station. This course was adopted at less cost than that of additional cable.

At Liverpool Street Station and Rathbone Place both

6.6 kV from the bulk-supply network and 11 kV from the L.E.B. street network will be available, but only 6.6 kV is available at Mount Pleasant and Paddington Station. In order that the apparatus shall be fully interchangeable, the transformers have been manufactured for a primary voltage of 11 kV star with tapplings for 6.6 kV, tap changing being by an off-load switch.

Each transformer is also provided with a 70 kVA 415/240-volt star-connected tertiary winding which eventually will be used to provide for 30 kW 150-volt output rectifiers to replace the present motor-generator sets, which are used for train movement in the station areas. Two such rectifiers have already been ordered for Rathbone Place. The additional spare capacity will be used for emergency lighting or other local services. The transformers have been constructed to have a low reactance in order to give close voltage control between 5 per cent full load and full load on the rectifiers. The no-load d.c. voltage is 528 volts, and at 5 per cent full load 448 volts, the full-load voltage being 424 volts. The 30 kW motor-generator sets will be connected to the rectifiers and will, therefore, ensure that they do not work below 5 per cent full load.

In order to provide against the shut-down of the railway in the event of long-term failure of the 11 kV supply, the 6.6 kV feeder from the bulk-supply station at King Edward Building will be retained as a standby at Rathbone Place and Liverpool Street. To provide for short-term failure, link feeders interconnecting the stations are available and enable 440 volt d.c. to be fed to any station which may lose the high-voltage supply, thus maintaining a restricted service of trains.

The completion of the work, which includes changes to the switchgear and off-load isolators, will provide the railway with a flexible power system, safeguarded against failure by the provision of a number of feeding points from different power networks of the L.E.B. The new equipment should ensure more satisfactory voltage conditions at the conductor rail and give many years of trouble-free service.

L. W. K.

London Telecommunications Region

EXTENSION OF THE INTERNATIONAL TELEX SWITCHBOARD, C.T.O.

In view of the decision taken some time ago to cease production of Switchboards, Teleprinter, No. 19, it was inevitable that the problem of handling the increasing international telex traffic would become acute in the Central Telegraph Office (C.T.O.). Switchboards made available as a result of the provision of automatic exchanges at Leeds and Sheffield had already been installed and put into service. Meanwhile, traffic was still increasing and, it was estimated, would continue to do so, thereby posing the immediate problem of handling traffic during the period which must necessarily elapse before switchboards could be obtained from Liverpool and Manchester when these exchanges are converted to automatic working.

Of the various schemes and improvisations which were explored the most suitable seemed to be the modification of the Switchboard, Teleprinter, No. 9. This DTN-type switchboard, used successfully by the services during the war, had the advantages of the built-in teleprinter and identical physical dimensions with the Switchboard, Teleprinter, No. 19. The main disadvantages were, however, unsuitable circuitry and the fact that the switchboard machine was a Teleprinter No. 7.

It was decided to recover the switchboard keyshelf completely and fit a new one which would accommodate the minimum number of keys and timing clocks consistent with the efficient handling of incoming calls from United Kingdom subscribers for routing to overseas telex subscribers. It was decided that four cord circuits per position were sufficient, and a new switchboard wiring form was made up accordingly. A teleprinter jack suitable for a Teleprinter

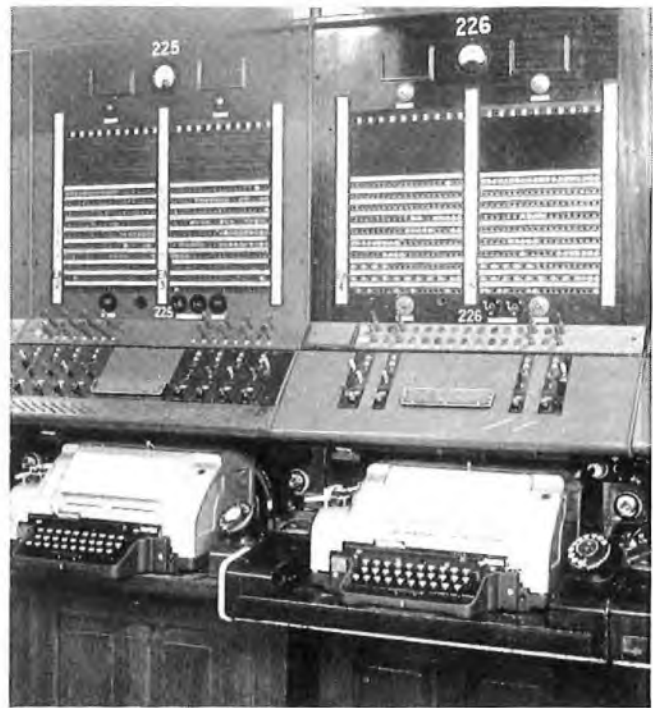

SWITCHBOARD, TELEPRINTER, NO. 19 AND MODIFIED SWITCHBOARD, TELEPRINTER, NO. 9

No. 11 was provided, and longer stile bars and casings were fitted to gain increased height for jack space to accommodate a 360-incoming-line multiple and a 560-outgoing-junction multiple.

Minor additions to the face of the switchboard were "pilot," "engaged," and "out-of-order" lamps, and also milliammeters. At the rear, mild-steel supports were provided for tag blocks, relay mountings, miscellaneous position equipment, and also to support the conventional chains and pins for carrying the cables within the switchboard. Some modifications were necessary to the pulleys and associated items to make the cord travel and length of run similar to that of the adjacent switchboards. The photograph shows Position 226, the first of 11 modified switchboards, lined up with Position 225, the end position of an existing suite of 25 Switchboards, Teleprinter, No. 19.

Modifications to the woodwork and ironwork were carried out by the L.T.R. Power Section, and the installation and testing by the L.T.R., City Area, C.T.O. construction staff.

E. J. C. O.

THE GENERAL ELECTION TELEVISION BROADCASTS

Television broadcasting for the General Election commenced at 9.0 p.m. on 8 October 1959, and continued throughout the night and much of the next day with a short break between 4.0 a.m. and 5.55 a.m. on 9 October. Post Office specialist staff were on duty continuously at all outside-broadcast sites, at intermediate television-amplifier points (sited where possible in telephone-exchange buildings), at the Associated Rediffusion television building, Television House, Kingsway, and at the London television-network switching centre (N.S.C.) in Museum exchange building.

At this last point—the "Museum" N.S.C.—an Assistant Engineer was in charge and eight other staff were involved, including one outstationed at Television House. The television-network switching console which has been installed at Museum for the rapid switching of both vision and sound channels on the Independent Television network

is always staffed until the conclusion of program transmission (usually about 11.30 p.m.) and special arrangements were necessary on this occasion to meet the prolonged broadcasting period. The normal maintenance teams in attendance on the test console and line and radio equipments were also supplemented. The overall duration of special attendance was 36 hours.

The B.B.C. set up a network control point at Lime Grove to handle the contributions from their provincial studios and from 25 outside-broadcast sites. The I.T.A. program contractors joined together to contribute to a common program produced by I.T.N. (Independent Television News), and their main control point at Television House was fed with contributions from the studios of all the program contractors and from 22 outside-broadcast sites. The Museum N.S.C. thus became a focal point for two large incoming contribution networks and two extensive distribution networks feeding the vision and sound signals to 23 B.B.C. transmitters and eight I.T.A. transmitters. At the B.B.C. premises in Lime Grove the Post Office installed a 20-line and a 30-line keyboard for control purposes, and in the Associated Rediffusion television premises in Television House two 10-line keyboards were installed for a talk-back and production-control network.

Of the 15 television outside-broadcast points around London, five used radio links provided by the B.B.C. or the I.T.A. contractor for vision and Post Office line circuits for sound and control, one used an injection into a main television radio link for vision, and the others used Post Office line plant for vision, sound, and control. For the transmission of video signals by line plant coaxial tube, balanced-pair cable and telephone cable were all brought into use and video amplifiers were provided as necessary.

The Post Office, therefore, had the task of: (i) maintaining the permanent vision, sound, and control networks of the B.B.C., I.T.A., and program contractors free from any form of interruption for the whole period; (ii) providing and maintaining, widely scattered throughout the country, numerous temporary vision, sound, and control circuits together with two injections at intermediate points on the permanent vision network; (iii) staffing continuously the network-switching centres, the program switching centre in Television House, outside-broadcast sites and sites where intermediate line amplifiers were used.

To ensure that all the necessary arrangements were made, as and when required, comprehensive schedules were produced showing details of all the circuits provided for the B.B.C., and by and for the program companies. Pictorial representation was also used, and the mass of information comprising six large diagrams and six schedules was assembled in book-form. Four such "books" were placed at strategic points throughout the switching centre so that they were accessible to any member of the staff; all staff were then briefed so as to be familiar with the contents of these books. As a result of all this preparation there were no failures and few incidents, and the staff took the affair well within its stride. Thanks and congratulations were received from our "customers" for service rendered.

E. B. M. B.

WASPS' NEST IN FOOTWAY BOX

The underground-jointing staff are often called upon to clear unusual faults; one such fault occurred recently in the Buckhurst telephone exchange area. A report was received from a member of the public that wasps were emerging from a Post Office footway box in Theydon Grove, and were causing considerable annoyance to the local inhabitants.

Upon investigation it was found that a complete wasps' nest had been constructed on the underside of a footway joint-box cover, as shown in the photograph. Expert advice was then sought as to how to get rid of the wasps with the least inconvenience to all concerned. Pure D.D.T. powder was puffed into all entrances and exits of the nest and on its surroundings, and the cover was replaced and left for two

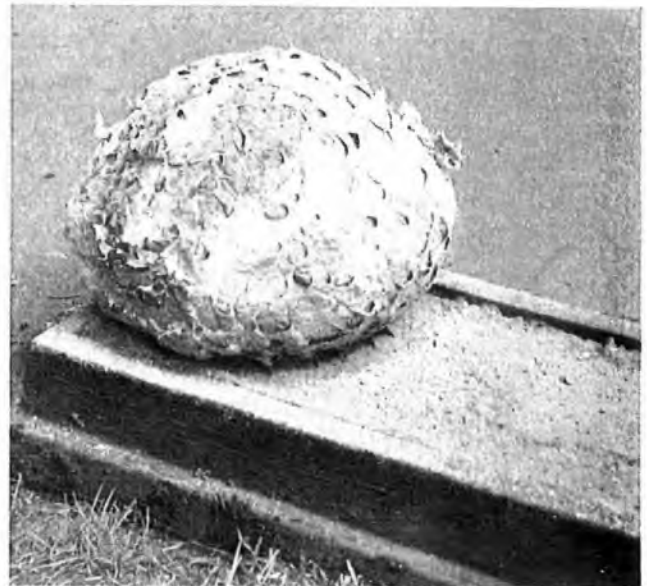

WASPS' NEST ATTACHED TO FOOTWAY JOINT-BOX COVER

days to allow the D.D.T. to take effect. After this lapse of time the joint-box was reopened and the nest removed from the underside of the cover, inspected and finally burnt, much to the satisfaction of the nearby inhabitants.

R. A.

CRESCENT CABLE CHAMBER

Crescent, a new 10,000-line multiple director exchange opened on 3 December 1959, was designed to relieve the existing exchanges at Valentine and Wanstead, and serve the Barkingside and Clayhall portions of the borough of Ilford. There is nothing particularly remarkable about the exchange

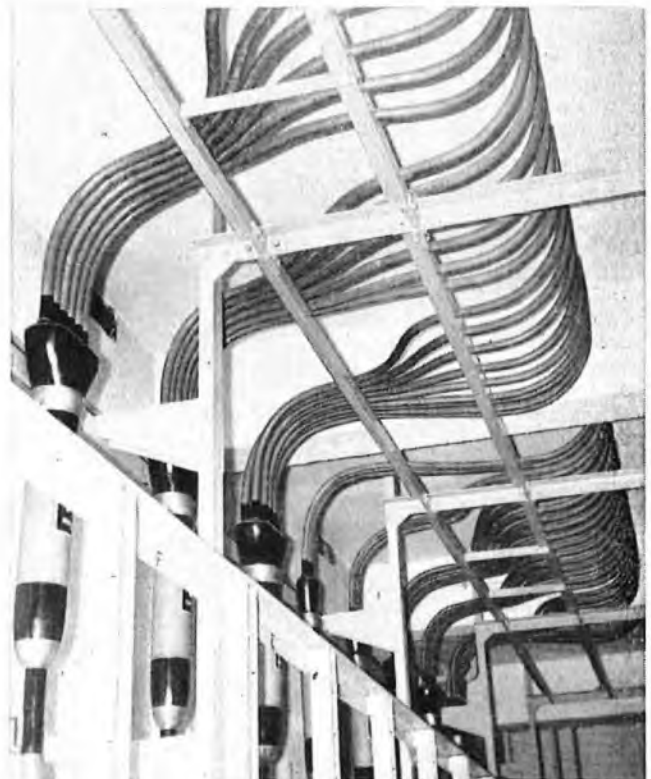

CRESCENT EXCHANGE CABLE CHAMBER

in itself, but in the cable chamber the external staff have carried out a job of work thought to be worthy of wider notice.

Requirements for access to the cable chamber necessitated the running of cables, from the lead-in, along the outside wall of the exchange remote from the pipes rising to the M.D.F. on the ground floor. To retain freedom of movement in the cable chamber it was, therefore, necessary to cross the cable chamber at a high level. For ease of jointing, the tail cable joints were made vertically, the tails being taken across the chamber and up the riser pipes. This resulted in a large number of silk and cotton tail cables crossing the cable chamber at different angles, each with two right-angle turns and a horizontal section of varying length and shape. In the circumstances it would have been all too easy to produce a job that, while adequate, would have fallen far short of the standards of workmanship normally seen in cable chambers.

However, by careful planning, attention to detail and first-class workmanship the final result, illustrated in the photograph, is a most impressive example of the plumber-jointer's art. It reflects great credit on all the staff concerned in the work.

R. H. A.

North Eastern Region THE MIDDLESBROUGH NEW TELEPHONE EXCHANGE

In 1885 the Northern District Telephone Company provided a magneto telephone switchboard in Middlesbrough so that a dozen or so subscribers with premises nearby could talk to each other. In May 1959, 74 years later, the Post Office brought into service a telephone exchange which enables the 4,000 subscribers in the town to talk not only to each other but to almost anyone else anywhere in the world where telephones are used. Two other exchanges have served the town in between these times; one, with a magneto multiple switchboard, was replaced in 1929 by a non-director automatic exchange with three satellites.

The need to expand the telephone services at Middlesbrough to satisfy post-war industrial growth on Tees-side was officially recognized in 1946. Many difficulties were met while a site for a new building was being sought. Eventually a builder's yard, with a beck across it and $\frac{3}{4}$ mile away from the old exchange, was acquired. In January 1953 the beck was diverted into a specially built culvert before the foundations and basement could be built. Most of the cables leading into the exchange had to cross the beck near to the building and a 40-way nest of octagonal ducts was laid under the beck.

The Area electric-light and power staff worked in close co-operation with the architects and builders, installing conduits and trunking, from the time the overground building work began. By January 1957 the building work, although not by any means completed, was advanced far enough, and the ground floor had been dried out by the new central-heating plant served by automatic thermostat-controlled oil-fired boilers, to enable the equipment contractor to install the local M.D.F. From then onward, the installation work accelerated, so that the call-through test was completed in March 1959, and the transfer from the old exchange was made at 1.0 p.m. on Saturday, 23 May 1959. The exchange was ceremoniously opened by the Lord Lieutenant of the North Riding, Sir William Worsley, Bt., on 30 June 1959.

The new exchange has two Strowger switching units. One switching unit, for local subscribers, has a 6,000-line multiple and 5,700 calling equipments, of which 4,000 were in use at the opening. The other is a trunk and junction tandem switching unit for subscriber-to-subscriber dialling between exchanges in the local and adjacent charging groups, and for operator-to-subscriber dialling in those groups and over longer trunk routes.

The manual switchboard is of the cordless pattern, similar to that used at Thanet exchange since March 1955. There are 43 controlling and incoming positions, and 17 other positions for directory inquiries, monitor duties, etc. All calls to the manual board are connected by call-queueing equipment.

At the transfer 2,164 trunks and junctions were in use; among these are 4-wire audio circuits and a 24-channel carrier system to Newcastle. The methods used for signalling over the trunks and junctions are A.C.1, A.C.3, D.C.2, C.B., and loop dialling, but the operators use the same procedure on all circuits. Every call extended by an operator is set up by the use of a key sender and not a dial.

Power for the telecommunications plant is supplied by the mains via two separate divided-battery motor-generator float sets to the switching units and manual board, and via a continuously run no-break set to the transmission equipment. Additional protection against a prolonged mains failure is provided by three diesel-engine a.c. generator sets, one of which is designed to start automatically immediately the mains supply fails, and to supply all the needs of the telecommunications plant and essential lighting services within 15 seconds of the mains supply being interrupted.

A ventilating and air-conditioning plant has been installed to keep the atmosphere in the basement appropriate to the needs of personnel and equipment. Air in the ground-floor apparatus room is freshened by a centrifugal fan drawing air through Vokes dry filters, and thence through ducting to punkah louvres.

The local underground-cable system was enlarged, extended and modernized, and the work was completed early enough to allow the pre-transfer testing to be carried out before the new exchange was opened. Among the additions are 16 miles of new duct line, 40 miles of new cable, 20 cabinets, 37 pillars, and 500 new distribution points. The three largest cables have 1,800 pairs of 4 lb/mile conductor.

F. W. A.

RECOVERY OF A REPEATER STATION AT MIDDLESBROUGH

After the opening of the new Middlesbrough automatic telephone exchange and repeater station, the question of the dismantling of the old equipment had to be considered. No difficulty was seen with regard to the equipment on the ground floor. The repeater station equipment, however, was upstairs and the only way down consisted of a twisty staircase having closed sides.

Part of the heavier equipment, such as the 10 ft 6 in. ringer bays, had been partly dismantled when they had originally been brought into position. The actual lowering to the floor of these racks is also something of a hazard on a polished floor and in a confined space. However, the problem was solved in the following manner. The Ministry of Works provided sufficient scaffold tubes and fixings to make a staging of sufficient height and strength to lower each rack to the floor by means of a block and tackle. The staging was provided with wheels for manoeuvrability. A similar staging in the form of a slide was erected, by the Ministry of Works, from a window into a back yard, and this was covered with wooden planks. A wooden sledge, to carry a repeater rack, could be pulled up or lowered down this slide.

Altogether some 51 racks had to be dealt with. The racks were handled easily by means of this equipment, and the method showed a saving in manpower, time, and energy. There was also a considerable reduction in the accident risk attendant upon an undertaking of this type. It is estimated that without these aids the work would have needed 50 per cent more men and taken some 150 per cent more time. It was found possible to lower a rack from its upright position on the apparatus-room floor to the street outside in less than half an hour.

E. A. C.

Associate Section Notes

Edinburgh Centre

The officers who have been elected for the 1959-60 session are as follows: *Chairman*: Mr. T. J. Potter; *Secretary/Treasurer*: Mr. D. M. Plenderleith; *Librarian*: Mr. A. M. Kirkcaldy; *Committee*: Messrs. W. Hay, R. P. Donaldson, D. Stewart, P. J. Peebles and T. C. Watters.

The first meeting of the Centre was held on 15 September 1959, when a talk on "The Traffic Division" was given by Mr. S. M. Young, Senior Traffic Superintendent in the Edinburgh Telephone Area. The talk was most interesting, as proved by the many questions raised.

On 20 October a party of 15 members visited the M.A.T.S. (Mechanized Accounting, Telephone Service) Room and were given an insight into the accounting system used in Edinburgh. The various punched-card and tabulating machines were demonstrated, as well as the "Autoskop," the projector used in connexion with meter photography.

On 24 November 1959, Messrs. Hubbard and Mack, Telephone Exchange Standards and Maintenance Branch, Engineering Department, gave a talk on "Optical Aids to Development and Maintenance."

Future lectures include:

17 January 1960: "Identification and Testing of Precious Stones," by Mr. H. J. Whitehead.

16 February 1960: "Printed Circuits," by Mr. W. Morrison.

15 March 1960: "Radio Interference," by Messrs. W. Johnstone and C. Forbes.

D. M. P.

Aberdeen Centre

Twenty-eight of our members and guests travelled by luxury coach to our neighbouring Area, to meet our Dundee colleagues and see their new telephone exchange. The most striking features in the new exchange building are: the cream-coloured racks and relay-set covers of the telex section; the new space-saving carrier equipment; the greatly reduced height of the new-style telephone switchboard; the S.T.D. equipment, which was in the process of being installed; and the large well-ventilated power rooms. May we, through the medium of the Journal, thank the officers and members of the Dundee Centre for their friendliness and efficiency.

An evening visit to a local paper mill was made by 36 of our members and guests. The mill covers an area of 40 acres, employs 1,350 personnel and has its own research section.

On 14 October 1959, Mr. J. J. Loughlin, of the P.O. Headquarters, Scotland, gave your Centre an outline of the principles of S.T.D. His talk on this vast subject was delivered in an easy-to-understand step-by-step manner. The talk was relayed to out-stations at Peterhead, Inverness, Wick, Gairloch, Stornoway and Kirkwall, with a total of 70 members attending. The talk was well illustrated by slides at Aberdeen, and Mr. Loughlin made repeated references to diagrams in the *P.O.E.E. Journal*, Vol. 51, Part 4, Jan. 1959, for the benefit of the out-stations.

J. G. P.

Ayr Centre

The annual general meeting was held on Friday, 5 June 1959. The following officers were elected: *President*: Mr. H. M. Pringle; *Chairman*: Mr. A. Edgar; *Secretary*: Mr. J. Halliday; *Treasurer*: Mr. R. S. Campbell. *Committee*: Messrs. Ireland, McDonald, Parry, McIntyre, Johnstone, and Claymore. A program, which we hope will be interesting and enjoyable, was arranged.

The first meeting, on Tuesday, 20 September 1959, was a visit to Hunterston nuclear generating station, an outing enjoyed by 27 members. The second meeting, on Tuesday, 21 October 1959, was a quiz between a Kilmarnock team

(Messrs. Ireland, Copeland, Mason and Haswell) and an Ayr team (Messrs. Bagnall, Caughtrie, Graham and Ferguson). Under the chairmanship of Mr. J. A. McIntyre this proved a most enjoyable meeting.

Details of other meetings have been published and the committee hope that members will make an effort to attend, for the Centre needs your support.

J. H.

Newport (Monmouthshire) Centre

This new Centre opened with its first meeting on Monday, 23 March 1959, and the following officers were elected: *Chairman*: Mr. B. Wakeham; *Vice Chairman*: Mr. D. Payne; *Secretary/Treasurer*: Mr. D. A. Evans; *Committee*: Messrs. C. Thomas, C. N. Grear and A. D. Phillips. Following the meeting a film show entitled "Travels in West Africa" was given by Mr. Tom Skuse of the Government Survey Branch, Sierra Leone. This was fully appreciated by the 40 members present.

On 9 May 1959 our summer program commenced with a visit to the new power station, Rogerstone. On Monday, 8 June 1959, the chairman conducted a party of members on a tour of the Newport automatic exchange. The closing of our summer session came with a visit to the tube-making firm of Stewarts & Lloyds on 16 July 1959; many thanks to the training staff for a very successful evening.

Our winter program commenced on Monday, 14 September 1959, with films kindly loaned by Shell & B.P. Ltd., I.C.I., Ltd., and Phillips Electrical, Ltd. During the evening our chairman was presented with a certificate of registration by Mr. P. L. Barker, the Chief Regional Engineer. We were also pleased to have with us Mr. Perris, the Telephone Manager, and Mr. Gandon, the liaison officer.

Our next meeting, on Saturday, 17 October 1959, was a visit to Bristol central S.T.D. and trunk exchange.

D. A. E.

Hereford Centre

A new Centre was formed at Hereford on 3 June 1959, and from those present at the meeting the following officers were elected: *Chairman*: Mr. E. Wellington; *Treasurer*: Mr. H. D. Goodman; *Secretary*: Mr. E. A. Tallboys; *Committee*: Messrs. I. J. Cound and F. E. R. Page.

On 18 June 1959 members attended a film show presented by Mullard, Ltd., when the films shown were "Modern Magnetic Materials" and "The Manufacture of Junction Transistors." These films stimulated questions which were very ably dealt with by the lecturer.

The visit on 25 July 1959 to Edison Cable Works, Lydbrook, was well attended, and many thanks were expressed to the management of this factory for organizing such a detailed and informative tour.

A further visit on 1 September 1959 to Rank Precision Industries, Cine and Photographic Division, Mitcheldean, proved well worth while, and many interesting matters concerning photographic equipment were well explained.

Items for the future program will include a paper on "Subscriber Trunk Dialling." Information about the program will be placed on notice boards.

The committee would welcome applications to join the Centre from any members of the staff in the Hereford Area, and the necessary forms can be obtained from any member of the committee.

E. A. T.

Shrewsbury Centre

This Centre, which has been dormant for several years, has been re-formed. It got off to a good start by a visit to Goodyear Tyre Co., Ltd., Wolverhampton, on 1 July 1959. A special meeting was held on 10 July 1959 to discuss a

winter program, and this was followed by a demonstration of recording by Mr. H. Christmas.

At the annual general meeting on 30 July 1959 the following officers were elected for the 1959-60 session: *Chairman*: Mr. F. I. Roberts; *Treasurer*: Mr. G. W. Poulson; *Secretary*: Mr. H. Christmas; *Committee*: Messrs. K. Nicholson, E. Dodd, R. A. Jervis, C. R. Ridgeway, A. Fielden and J. Flemming.

The first meeting of the session was held on 18 September 1959 when Mr. Price gave a paper on S.T.D. There was a very good attendance of the members, who helped towards a most successful "opening night" by a lively discussion. The next meeting was in October 1959 when a visit was made to Shrewsbury to see the new automatic exchange and repeater station. Then followed a film show in November 1959, and a demonstration of stereophonic sound in December 1959.

The remainder of the program is as follows:

January 1960: Lecture and film on metals.

February 1960: Member night.

March 1960: Lecture on cable fault location.

For these three meetings the actual dates will be advised on the notice boards.

The membership has now exceeded 120, but the secretary would like to remind anyone who is not already a member that he has a liberal supply of enrolment forms and would be only too pleased to forward one on request.

H. C.

Pontypridd Centre

At the second meeting of this winter's session, on Wednesday, 21 October 1959, the members of the Centre were presented with a paper and demonstration on "Photography" by three of the members. It is felt that the occasion must not pass without due thanks to our members, who spoke with considerable knowledge and enthusiasm on a subject outside their normal daily tasks.

Mr. H. B. Cheeseman, who started the lecture, explained the various materials and elements used in photography, including the construction of the film and camera, the use of developer and jar, the importance of time, temperature and quantity of developer, fixing fluid, and the use of correct printing paper.

The second speaker was Mr. F. G. Knight and his subject was the "Enlarger." He spoke about, and demonstrated with his own equipment, the process of enlarging a print from negative films between 35 mm and 2½ in. sizes. The parts of the enlarger were shown and explained, each performing a function in focusing the image of a negative on to the printing paper. He stressed the importance of time in this process, which brings out the various tones ranging from black to white.

The final speaker was Mr. C. J. Hurley. He spoke on colour photography, giving a brief explanation of colour images produced on transparent film by the use of three primary colours in various densities, thus producing the variety of shades. Mention was made of two methods of colour photography which are in the forefront to-day—the additive process, as used in colour television, and the subtractive process, which gives transparent stills or slides of the subject photographed. He completed his paper by projecting a great number of stills which he had taken in colour.

Judging by the number of questions asked at the end of the demonstration, the subject for the evening was enjoyed by everyone, and it was with great reluctance that the chairman, Mr. D. Thomas, had to close the meeting with a vote of thanks for a very enjoyable and instructive evening.

R. E. J.

London Centre

The 1959-60 session of the London Centre started in September with an inaugural lecture on "Exploring Space,"

given by Dr. Tom Margerison, scientific editor of the magazine *New Scientist* and well known for his appearances on B.B.C. television science programs. Topicality was given to the talk, which dealt with the results obtained by satellites and rockets in the exploration of inner and outer space, by the moon-hit of the Russian space-rocket, Lunik II, only two days previously; so much so that the lecturer had to change his script considerably at the last moment. Dr. Margerison also dealt with the discovery of the Van Allen radiation belt by an American rocket, and its link with developments in the production of controlled thermonuclear energy in such machines as Zeta. At the end of the talk a film of the preparation and launching of the first unsuccessful American moon rocket, Pioneer I, was shown. Continuing the practice of recent years, the lecture was open to members and their wives and friends, and with an attendance of over 300 in the Royal Commonwealth Hall it would seem that the open inaugural lecture is here to stay.

The October lecture, "The Automatic Telex Service," was given by Messrs. E. E. Daniels and W. A. Ellis, and showed how the new national telex network will connect with the international network via the new switching centre at Fleet Building. Two of the latest types of subscribers' stations had been installed in the lecture room and calls between them were set up through the model exchange in the Telegraph Branch, Engineering Department, laboratory. The lecture concluded with the setting up of calls to Berlin, Munich, Paris, Marseilles and other European cities, an impressive tribute to the reliability of modern international telegraph working.

After the experiences of the past session, when overcrowding and its resulting inconvenience had occurred at some meetings held in the conference room at Waterloo Bridge House, the Centre committee decided that Centre meetings in future would be held in the refreshment club in the same building. In addition to a larger seating capacity the club is being wired for an amplifying system so that larger audiences on future occasions should present no problems.

The first lecture of the New Year will be entitled "Analysis Synthesis Telephony" and will be given by Messrs. J. N. Holmes and J. N. Shearme of the Joint Speech Research Unit at Ruislip. They will survey the developments taking place at the present time in the field of synthetic speech and will deal, amongst other fascinating lines of development, with the compression of many more speech channels for passing over cables of the future, using this technique.

The next lecture, in February, on "Subscriber Trunk Dialling" is by Mr. H. E. Francis, who was the Assistant Staff Engineer (now Staff Engineer, Exchange Equipment and Accommodation Branch, Engineering Department) in control of the group in the Engineering Department responsible for the circuit designs used in the S.T.D. equipment. The lecture in March, "The Pay-on-Answer Coin-Box System", to be given by Messrs. J. D. Collingwood and E. Newell, will explain this new development in the evolution of the telephone system.

A new contest for the inter-Area technical quiz trophy will shortly be starting. Seven Areas are entering teams and it is hoped that the eliminating round will have been played by Christmas. The general purposes committee have been busy compiling questions during the summer recess, and the participating teams look forward to support from their Areas, in the form of audiences, at these entertaining battles of wits, to be held at a convenient exchange or over land lines if the distances between the Areas is great.

Production of the Centre's quarterly journal continues and recent issues have contained articles on "Atomic Energy as applied to Telecommunications" and the London Electronic Agency for Pay and Statistics (LEAPS) computer. The next issue will contain a questionnaire which it is hoped will elicit from our members pointers for future policy. Two Areas have launched out independently in this field,

North Area producing their own quarterly journal and West Area a news sheet.

In the visits sector of our activities the Centre has followed up the lecture on plastics given by two members of the staff of Ericsson Telephones, Ltd., last session, by a visit during October 1959 to the company's factory at Beeston.

D. W. W.

Tunbridge Wells Centre

The 1959-60 program opened with a visit to the cableship *Ariel* at Dover on 22 September 1959. This was followed by a talk entitled "Telephones, Past, Present and Future," given by Mr. Scantlebury, Chief Telecommunications Superintendent. The session continued with the following lectures and visit:

- 21 October 1959: "Development of British Railways Southern Region." A talk by Mr. J. K. Blue, of British Railways.
 - 4 November 1959: "Tunbridge Wells Exchange Conversion," by Messrs. Pope and Jury, of the External Planning Group.
 - 18 November 1959: Visit to Lancashire Dynamo Nevelin, Ltd., at Hurst Green, Surrey.
 - 3 December 1959: "The A.N. Minor Works Party," by Mr. Cheal.
 - 13 January 1960: "Metals," by Mr. Cockett.
- The remainder of our program is as follows:
- 28 January 1960: "Television Switching Centre." A talk by Mr. Newman.
 - 11 February 1960: "The Romance of Oak," by Mr. Barrett, Area Engineer.
 - 9 March 1960: "Improved Stores Procedure," by Mr. Young.
 - 24 March 1960: Visit to L.P.S. Cable Works, Hastings.
 - 7 April 1960: Annual social event.
 - 28 April 1960: Annual general meeting.

R. A. D.

Ipswich Centre

Since our last report we have held our annual general meeting, which was well attended. The highlight of the evening was the presentation of the "Achievement Cup," which has been generously given by our chairman, Mr. P. E. Buck, to be presented annually for outstanding achievement by any member of the Centre. The presentation for the 1958-1959 session was made by Mr. Buck to our secretary, Alan Green.

The rest of the program took the form of a "Hobbies" night in which four members gave talks on their hobbies, including home foundry and making musical instruments.

The summer program proved to be as excellent as the weather, starting with a visit to Fords of Dagenham, where members saw assembly-line processes from raw material to the finished article.

A local visit in June to Cowells printing works proved most interesting to all concerned and made one realize the complexity of this industry.

Thanks to the efforts of our vice-chairman an extra visit was arranged to R.A.T.C.C., Wattisham, in June, where, by the kindness of the U.S.A.A.F., members saw air traffic control at work. Every effort was made to answer members' questions with demonstrations of working equipment. It was apparent that the need for such control is growing daily.

A visit to Strammit Boards, Ltd., in July gave members a chance to see the wide uses of this new material for building projects.

August brought a visit to Fisons, Fertilizer Division, at Levington, where research into, and development of, soil improvement methods were demonstrated. Members were greatly impressed by the wide variety of problems investigated by this vast organization.

Our local gas works was visited in September, and here

again members were able to see a variety of processes which provide many products in addition to our gas supply.

Fords of Dagenham proved such a popular visit in May that a further visit was arranged in October, to allow members who were unlucky previously to have the chance to see these works. This visit was as successful as the one in May.

Our membership now stands at 222 out of a total staff at Ipswich of approximately 290, and is most encouraging for a section only two years old.

E. W. C.

Isle of Wight Centre

Following the successful annual dinner last April, attended by Mr. A. H. C. Knox, President of the Associate Section, Mr. H. W. Harrison, Regional Liaison Officer, Mr. R. Goford, Area Engineer, and Mr. R. S. Francis, Area Engineer, the committee decided to embark on a program more ambitious than those of previous years.

We have already had a visit to the Pressed Steel Company's works at Cowley, and a quiz with the Portsmouth Centre. Both events were well supported. Our next two meetings were:

- 11 November 1959: Talk by Mr. W. Rowbotham (Borough Surveyor, Ryde).
 - 9 December 1959: Talk by Mr. E. P. Metcalfe, Engineer-in-Charge, Rowridge television station.
- The program for the rest of the session includes:
- 11 February 1960: Film show.
 - 10 March 1960: Visit to the Isle of Wight Museum, Carisbrooke Castle, and a talk by the Curator, Mr. J. D. Jones.
 - 6 April 1960: Visit to Esso Refinery, Fawley.
 - 13 April 1960: Annual general meeting.

The committee sincerely hope that the support shown so far this session will continue.

A. J. E.

Southend-on-Sea Centre

The long absence of notes from this Centre does not indicate any apathy—far from it, and it is pleasing to report that the Centre is flourishing, with a steadily increasing membership.

The election of officers at the annual general meeting was as follows: *President*: Mr. J. L. Howard (Telephone Manager); *Vice-President*: Mr. C. J. Vann (Area Engineer); *Chairman*: Mr. S. I. Restorick; *Vice-Chairman*: Mr. A. J. Humby; *Secretary*: Mr. D. W. Everitt; *Treasurer*: Mr. J. Gollin; *Committee*: Messrs. G. Austin, L. Grant, R. Playle, A. N. Topsfield and F. Wright.

Included among our summer visits were trips to S. T. & C. Woolwich, Crompton Parkinsons, and the nuclear power station at Bradwell.

Following a successful program for 1958-59, which included talks on the magnetic drum, transistors and stereophonic sound, we have had two interesting talks:

- 18 October 1959: Optical aids to development and maintenance.
 - 3 December 1959: The new telephone sets.
- Our program then continues as follows:
- 25 February 1960: Telecommunications in the U.S.A.
 - 17 March 1960: Ipswich-Southend quiz.
 - 21 April 1960: Annual general meeting and film show.

Sincere thanks from the committee for your support and hopes that the present enthusiasm will be maintained.

D. W. E.

North Eastern Region

Mr. A. C. Holmes, well known to all our Centres as Regional Liaison Officer and editor of their "Journal," has been promoted to Executive Engineer in the Engineering Department, Training Branch. In recognition of his service to the Associate Section for the past nine years, and as a

token of goodwill from all his colleagues, he was presented with a handsome wristlet watch on his departure for London, on 4 September 1959.

J. A. H.

Huddersfield Centre

The 1959-60 session began on 24 September 1959 with a talk given by Mr. A. C. Holmes of the Training Branch, Engineering Department. His subject, "Fundamentals of Telephone Cable Design," was illustrated by slides and a film showing the manufacture and installation of the Alexandra Palace-Sutton Coldfield television cable. The meeting concluded with questions from the members.

On Thursday, 1 October 1959, an afternoon visit was made to the Manchester Ship Canal Company's docks at Salford. The visit consisted of a tour by "waterbus" around docks No. 7, 8 and 9, after which we were able to observe the loading and unloading of cargoes from ships of many different countries. The canal, which is 35 miles long and takes ships of up to 12,000 tons, provided a most interesting and enjoyable afternoon for the 32 members of the party.

The program continued with the following talks and visit:

28 October 1959: "Everyday Gardening." A talk by Mr. G. Howarth.

24 November 1959: Evening visit to West Riding Police, C.I.D. Block, Wakefield.

December 1959: "Outline of Amateur Radio." A demonstration and talk by Mr. G. Mallinson.

The remainder of the program for the 1959-60 session is as follows:

26 January 1960: Afternoon visit to H. J. Heinz, Ltd., Wigan.

15 February 1960: "Sales and Service." A talk by Mr. G. F. Stansfield.

2 March 1960: Day visit to Automatic Telephone & Electric Co., Ltd., Liverpool.

6 April 1960: Afternoon visit to Slazengers, Ltd., Horbury, Wakefield.

May 1960: Annual general meeting.

D. B.

Leeds Centre

The 1959-60 session of the Leeds Centre commenced on Thursday, 10 September 1959, at the Griffin Hotel, Leeds, with an illustrated talk on "Coaxial Line Equipment Development," presented by Mr. W. G. Simpson of the Post Office Research Station, Dollis Hill. Mr. Simpson described in detail the various systems in use in the British Post Office, with references to the many improvements in the circuit design. It was interesting to see the amount of floor space the early equipment required in comparison with that for our present systems. The development in circuit design has given sound economy from the installation and maintenance aspect. The talk was very well illustrated by slides, and to conclude, a number of questions were answered by the lecturer. It was generally agreed to be a very interesting and informative talk, and the chairman thanked Mr. Simpson for the presentation.

On Monday, 12 October 1959, Mr. Nicholson of Mullards, Ltd., London, presented an illustrated talk on "The Principle and Manufacture of Junction Transistors." This meeting, being on a subject of topical interest, was very well attended, and included a strong delegation of our Sheffield members. It was encouraging to see such a good attendance. The meeting started with a film entitled "The Conquest of the Atom" and, although it had no direct connection with transistors, it proved to be an excellent introduction. Mr. Nicholson, aided by two films, spoke on both the principle and manufacture of transistors. The talk was concluded by a very interesting question period, and it was agreed to be an excellent paper. Thanks were paid to Mr. Nicholson and the Mullard organization.

Arrangements are being made for an inter-Centre quiz between the Leeds and Sheffield Centres within the near future, details of which will be reported later.

C. B.

Sheffield Centre

On 19 August 1959 a pleasant evening coach run into Derbyshire was taken, and a visit was made to the Sheffield Corporation waterworks installation at Ladybower Dam.

Our lecturer on 30 September 1959 was Mr. C. A. May, of the Telephone Exchange Systems Development Branch, Engineering Department. Speaking about "Two-State Electronic Circuit Devices," he pointed out that any device which would remain stable when set in one of two or more conditions could be regarded as a memory. After explaining the binary notation of counting, he showed that a numerical memory or store could be built up using bi-stable devices. Mr. May used an ingenious digram-model to illustrate the principle of the ferrite core; in this device the stored information is destroyed by the reading-off process. Conversely, on a magnetic drum, the memory is permanent until deliberately erased, and can be read off as many times as required. To give an example, these two devices might be used to meter calls: a ferrite core connected to the subscriber's meter wire would be "inspected" at half-second intervals; if a pulse had been recorded it would be read off, cancelled from the core, and transferred to the totalling register on a magnetic drum. A display of bi-stable devices evoked great interest, and the speaker was surrounded by questioners well after the lecture itself was over.

The lecture was preceded by the presentation to Mr. J. Williams of a certificate of merit awarded to him in the I.P.O.E.E. essay competition for his essay on "Basic Routines by Comparison." The presentation was made by our Telephone Manager, Mr. E. S. Loosmore.

On 12 October 1959 a coach-load of our own members and Senior Section members attended the meeting of the Leeds Centre. The lecture and film show on the principles and manufacture of junction transistors proved most entertaining and informative, and we thank our hosts for their kind invitation.

J. E. S.

Sunderland Centre

At Sunderland we have a small membership, 70 in all, but despite the fact that half of the members live some distance away from the Centre headquarters, our average attendance at meetings and on visits is 20 per cent; on some visits this is increased to 45 per cent. Our keenest member, the present chairman, lives the farthest distance away but never fails to turn up.

Outside the Region it may not be realized that the Newcastle Telephone Area, of which Sunderland is a part, covers the greatest area in England. Some of our members are at present on detached-duty working within the Area, but 60 miles away. Nevertheless, we commenced the 1959-60 session with a visit to Pyrotex Cables, Ltd., Hebburn-on-Tyne, in July 1959; 28 members attended and were transported in a chartered bus. A splendid visit, was the general opinion, even without counting the generous refreshment.

On 5 September 1959, 18 of us tramped out along the North Pier at Sunderland to see the lighthouse at the river mouth. A glorious day set the tempo for an extremely interesting examination of one of the most powerful lights on the British coast line. The apparatus for rotating the lamp, the fog horn, and compressor, were well worthy of the long walk. We went down into the subway, which connects the shore with the light and which is used in bad weather only, but preferred the sunshine and fresh air for the return trip. Our guide, the chief lightkeeper, a young 68, told us stirring tales of seas breaking through into the subway, and how he had to walk a mile in a diver's suit in total blackness.

(Continued on page 310)

Staff Changes

Promotions

Name	Region, etc.	Date	Name	Region, etc.	Date
<i>Assistant Staff Engineer to Staff Engineer</i>			<i>Inspector to Assistant Engineer—continued</i>		
Rhodes, J.	E-in-C.O.	5.1.60	Pither, C. E.	S.W. Reg.	24.8.59
<i>Area Engineer to Regional Engineer</i>			McHarg, J. T.	Scot.	19.10.59
Triffitt, L. A.	N.W. Reg.	26.7.59	<i>Technical Officer to Assistant Engineer</i>		
<i>Executive Engineer to Area Engineer</i>			Lowes, A. T.	H.C. Reg.	28.8.59
Hayman, H. W. S.	W.B.C. to S.W. Reg.	31.8.59	Manning, D. J.	H.C. Reg.	28.8.59
McDonald, T. H.	S.W. Reg.	9.9.59	Warboys, R. C. T.	H.C. Reg.	7.9.59
Apperley, H. L.	S.W. Reg.	9.9.59	Donald, G. H.	H.C. Reg.	1.9.59
Bingham, J.	N.E. Reg.	15.7.59	Harvey, G. W.	H.C. Reg.	1.9.59
Spratley, E. W. F.	H.C. Reg.	28.9.59	Martin, H. W.	E.T.E.	21.8.59
Hart, J. A.	W.B.C. to Mid. Reg.	5.10.59	Fox, A. J. A.	L.T. Reg.	3.10.59
Buckley, G.	W.B.C. to N.W. Reg.	5.10.59	Eager, J. H.	L.T. Reg.	3.9.59
Simpson, E.	Scot. to N.W. Reg.	26.10.59	Hyland, B. J.	L.T. Reg.	3.9.59
Williams, J. B. F.	N.W. Reg.	19.10.59	Batt, C. A.	L.T. Reg.	3.9.59
<i>Executive Engineer to Senior Executive Engineer</i>			Grover, R. E.	L.T. Reg.	3.9.59
Anderson, F.	E-in-C.O.	9.9.59	Watson, A. C.	L.T. Reg.	3.9.59
Stevens, A. J.	N.W. Reg.	5.10.59	Solaini, D. A.	L.T. Reg.	3.9.59
Howard, R. F.	E-in-C.O.	28.10.59	Duchesne, D. G.	L.T. Reg.	16.9.59
<i>Assistant Engineer to Executive Engineer</i>			Clubley, G. N.	Scot.	15.6.59
Foster, F. W.	E-in-C.O.	7.9.59	Whyte, H.	Scot.	17.6.59
Copley, F. A.	N.E. Reg.	26.8.59	Whitehead, M. G.	N.W. Reg. to E-in-C.O.	6.8.59
Sanders, F. V.	S.W. Reg. to E-in-C.O.	31.8.59	Wilson, W. T.	L.T. Reg. to E-in-C.O.	6.8.59
Turner, P. A.	E-in-C.O.	24.8.59	Wicken, C. S.	E-in-C.O.	6.8.59
Stollard, A. C.	N.W. Reg.	9.9.59	Lovering, R. T.	E-in-C.O.	6.8.59
Gent, P. E.	N.E. Reg.	4.9.59	Tuerena, V. H.	L.T. Reg. to E.T.E.	15.7.59
Vigar, C. D.	E-in-C.O.	4.9.59	Williams, R. J.	S.W. Reg.	5.8.59
Gates, J. F.	L.T. Reg. to E-in-C.O.	3.9.59	<i>(In absentia)</i>		
Price, A. H.	L.T. Reg. to E-in-C.O.	14.9.59	Whiting, G.	S.W. Reg.	5.8.59
Mather, A. L.	Scot. to E-in-C.O.	14.9.59	Pitt, W. H.	S.W. Reg.	5.8.59
Taverner, A. L.	L.T. Reg.	4.9.59	Minter, R.	S.W. Reg.	5.8.59
Gates, N. P.	H.C. Reg.	29.7.59	Lobb, S. H.	S.W. Reg.	5.8.59
Hall, R. R.	E-in-C.O.	4.8.59	Sanderson, H. A.	N.E. Reg.	24.8.59
Mann, L. A.	E.T.E.	25.7.59	McDonald, J.	Scot.	24.8.59
Astle, E.	Mid. Reg.	21.7.59	Morris, H. G.	W.B.C.	17.9.59
Holmes, A. C.	N.E. Reg. to E-in-C.O.	7.9.59	Bewick, T. R.	L.T. Reg. to E-in-C.O.	1.10.59
Chesterman, D. A.	L.T. Reg. to E-in-C.O.	7.8.59	Williams, W. R.	E-in-C.O.	1.10.59
Moxon, R. L.	E-in-C.O.	7.8.59	Cartwright, F. A.	E-in-C.O.	1.10.59
Ashwell, J. L. K.	E-in-C.O.	7.8.59	Hooper, K. L.	L.T. Reg. to E-in-C.O.	1.10.59
Stone, R. A.	Mid. Reg. to N.W. Reg.	5.8.59	Bennett, W. L. G.	Scot. to E-in-C.O.	1.10.59
Makemson, A. A.	E-in-C.O.	17.8.59	Clay, D. F.	L.T. Reg. to E-in-C.O.	28.10.59
Anderson, G. P.	E-in-C.O.	17.8.59	Witts, A. S.	E.T.E. to E-in-C.O.	28.10.59
Searls, A. W.	E-in-C.O.	5.10.59	Felgate, R. W.	L.T. Reg. to E-in-C.O.	28.10.59
Crosby, E.	H.C. Reg. to E-in-C.O.	1.10.59	Earnshaw, G. E.	N.E. Reg.	29.10.59
Ridcut, J. D.	S.W. Reg.	28.9.59	<i>Technical Officer to Inspector</i>		
Reid, D. F.	Scot. to E-in-C.O.	5.10.59	Thacker, L. B.	Mid. Reg.	14.9.59
Norton, F. A.	H.C. Reg. to N.E. Reg.	5.10.59	Amos, E. G.	L.T. Reg.	16.9.59
Board, A. D.	S.W. Reg.	21.9.59	Riddick, S.	Scot.	13.7.59
Snell, H.	E-in-C.O. to E.T.E.	5.10.59	Simpson, R.	Scot.	24.8.59
Sumner, G. C.	N.W. Reg.	23.10.59	Phillips, E. H.	Mid. Reg.	18.8.59
<i>Assistant Engineer (Open Competition)</i>			Foulkes-Jones, G. B.	Mid. Reg.	18.8.59
Tarbet, R.	E-in-C.O.	10.8.59	Anderson, D. H.	Mid. Reg.	18.8.59
Morse, M. J.	E-in-C.O.	10.8.59	Burrell, E. A.	Mid. Reg.	18.8.59
Culver, R. C. L.	E-in-C.O.	10.8.59	Medland, J. R. B.	Mid. Reg.	18.8.59
Whittaker, D.	E-in-C.O.	10.8.59	Haynes, F. E.	Mid. Reg.	18.8.59
Knappett, T. J.	E-in-C.O.	10.8.59	Procter, F. D.	Mid. Reg.	12.10.59
Thomas, P. J.	E-in-C.O.	10.8.59	Edwards, W. M. T.	Mid. Reg.	5.10.59
Jackson, M. J.	E-in-C.O.	31.8.59	<i>Technician I to Inspector</i>		
Greenhill, J.	N.E. Reg.	31.8.59	Mack, G. J.	H.C. Reg.	1.9.59
Hurcom, J. G.	E-in-C.O.	28.9.59	Curtis, N. R. A.	H.C. Reg.	28.8.59
Mapes, R. J.	E-in-C.O.	28.9.59	Blackman, C. T.	H.C. Reg.	28.8.59
Loveday, R. C. H.	E-in-C.O.	26.10.59	Lawson, J.	Scot.	26.6.59
<i>Inspector to Assistant Engineer</i>			Hatton, C.	Scot.	19.6.59
Rhodes, R. E.	H.C. Reg.	1.9.59	Tombs, F. A.	Mid. Reg.	4.8.59
Bruce, J.	N.E. Reg.	24.8.59	Cameron, L. R.	Scot.	31.8.59
Richardson, W.	N.E. Reg.	1.9.59	Davidson, J. B.	Scot.	6.8.59
Lucas, W. D.	N.E. Reg.	24.8.59	Thorley, T. M.	Mid. Reg.	24.8.59
Evered, L. W.	L.T. Reg.	3.9.59	Brown, J. H.	Mid. Reg.	18.8.59
Westwood, T.	Scot.	1.7.59	McClelland, J. H.	S.W. Reg.	10.8.59
Waite, J. R.	S.W. Reg.	5.8.59	Grant, A.	Scot.	7.9.59
Kendall, O. W.	S.W. Reg.	5.8.59	Bruce, J. R.	Scot.	13.9.59
			Jones, W. G.	W.B.C.	1.9.59
			Rushton, J.	Mid. Reg.	6.10.59
			Papani, S.	L.T. Reg.	7.10.59
			Linsey, T. J.	S.W. Reg.	20.10.59

Promotions—continued

Name	Region, etc.	Date	Name	Region, etc.	Date
<i>Senior Scientific Officer (Open Competition)</i>			<i>Technical Assistant I to Motor Transport Officer III</i>		
Baker, D.	E-in-C.O.	8.9.59	Barrett-Jolley, S. R. ..	E-in-C.O.	23.10.59
Holloway, H.	E-in-C.O.	8.10.59	North, H. E.	E-in-C.O.	23.10.59
Merlo, D.	E-in-C.O.	28.9.59	James, H. S.	E-in-C.O.	23.10.59
<i>Experimental Officer (Open Competition)</i>			<i>Workshop Supervisor II to Technical Assistant II</i>		
Waldie, F. A.	E-in-C.O.	24.8.59	Hare, L. V.	H.C. Reg.	17.8.59
<i>Assistant Experimental Officer (Open Competition)</i>			<i>Leading Draughtsman to Senior Draughtsman</i>		
Fairbrother, L. R. ..	E-in-C.O.	8.9.59	Robson, G. W.	L.T. Reg.	27.8.59
Whitehouse, D. L. ..	E-in-C.O.	27.7.59			
Levett, A. L.	E-in-C.O.	19.10.59			

Retirements and Resignations

Name	Region, etc.	Date	Name	Region, etc.	Date
<i>Staff Engineer</i>			<i>Assistant Engineer—continued</i>		
Jolley, E. H.	E-in-C.O.	4.1.60	Wilton, J. J.	N.E. Reg.	30.8.59
<i>Area Engineer</i>			Fox, H. W.	Mid. Reg.	31.8.59
Arnold, C. W.	L.T. Reg.	30.9.59	Etridge, S. J.	E.T.E.	30.9.59
Lewis, C. H.	S.W. Reg.	14.7.59	Collett, W. H.	S.W. Reg.	1.10.59
Brown, R. C. C.	S.W. Reg.	6.8.59	Hill, W. J.	L.T. Reg.	2.10.59
<i>Senior Executive Engineer</i>			Mitchell, S. C.	S.W. Reg.	7.10.59
Evans, H. E.	E.T.E.	31.12.58	Godfrey, J.	Scot.	31.10.59
<i>Executive Engineer</i>			Coe, W. D.	H.C. Reg.	1.11.59
Mockridge, W. C. ..	S.W. Reg.	31.8.59	<i>Inspector</i>		
Treglow, P. G.	S.W. Reg.	20.9.59	Harper, J.	Scot.	12.9.59
Williams, W.	N.W. Reg.	8.9.59	Henzell, C. G.	L.T. Reg.	15.9.59
Gregory, A. R.	E-in-C.O.	10.8.59	Chaney, W. J. E.	H.C. Reg.	20.9.59
(Resigned)			Knight, T.	S.W. Reg.	25.9.59
Powning, S. H.* ..	W.B.C.	31.7.59	Stronach, J. A.	Scot.	1.7.59
Hartshorn, H.	Mid. Reg.	30.6.59	Kennedy, J.	Scot.	25.7.59
Sharpe, J.	L.T. Reg.	31.7.59	Sheppard, P.	W.B.C.	20.9.59
Gallacher, J. (Resigned)	E-in-C.O.	20.10.59	Kidd, J. H.	L.T. Reg.	20.10.59
<i>Assistant Engineer</i>			Johnson, L.	L.T. Reg.	28.10.59
Talbot, W. R. D. ..	E.T.E.	20.8.59	Mallett, J.	H.C. Reg.	31.10.59
Harvie, A.	Scot.	1.9.59	<i>Senior Assistant (Scientific)</i>		
Wrench, W. R. L. ..	L.T. Reg.	1.9.59	Hook, S. S. (Resigned)	E-in-C.O.	30.10.59
Bremner, R. C.	Scot.	1.9.59	<i>Assistant Experimental Officer</i>		
Winter, J. L.	N.I.	6.9.59	Richardson, D. (Miss)	E-in-C.O.	16.10.59
James, J. K.	N.E. Reg.	29.9.59	(Resigned)		
Wilson, F. E.	H.C. Reg.	30.9.59	<i>Technical Assistant I</i>		
Stanbrook, J. A. ..	H.C. Reg.	8.8.59	Copeman, S. W.	H.C. Reg.	20.2.59
(Resigned)			Jackson, A. A. S. ..	E-in-C.O.	2.9.59
Davie, J. C.	Scot.	21.7.59	<i>Higher Executive Officer</i>		
Jackson, A. A.	N.W. Reg.	31.7.59	Hutchinson, A. J. ..	E-in-C.O.	1.9.59
Jackson, I.	N.W. Reg.	11.8.59	<i>Executive Officer</i>		
Brock, S.	S.W. Reg.	15.8.59	Flint, W. D.	E-in-C.O.	14.10.59
Taylor, H. C.	L.T. Reg.	22.8.59			
Mickler, L.	N.E. Reg.	30.8.59			

* Mr. S. H. Powning is continuing as a disestablished officer with W.B.C.

Transfers

Name	Region, etc.	Date	Name	Region, etc.	Date
<i>Senior Executive Engineer</i>			<i>Assistant Engineer—continued</i>		
Griffiths, R. J. ..	E-in-C.O. to L.T. Reg. ..	1.10.59	Muir, B. R.	Pakistan to E-in-C.O. ..	11.9.59
Aucott, A. T.	Mid. Reg. to War Office ..	21.9.59	Ray, M. A.	L.T. Reg. to E-in-C.O. ..	1.9.59
<i>Executive Engineer</i>			Russell, C. H.	E-in-C.O. to Mid. Reg. ..	2.11.59
Saunders, J. C.	Approved Employment to Mid. Reg.	21.9.59	<i>Assistant (Scientific)</i>		
Widdicks, J. A. ..	Approved Employment to E-in-C.O.	21.9.59	Waller, W. J.	E-in-C.O. to D.S.I.R. ..	5.10.59
<i>Assistant Engineer</i>			<i>Executive Officer</i>		
Foster, G. J.	Foreign Office to E-in-C.O. ..	7.9.59	Perry, J.	A.G.D. to E-in-C.O. ..	1.10.59
Muir, W. W.	E-in-C.O. to Scot.	31.8.59	Carruth, G.	E-in-C.O. to A.G.D. ..	1.10.59

Deaths

Name	Region, etc.	Date	Name	Region, etc.	Date
<i>Regional Engineer</i>			<i>Assistant Engineer—continued</i>		
Stretch, W.	N.W. Reg.	27.5.59	Phillips, C. I. L.	W.B.C.	16.2.59
<i>Senior Executive Engineer</i>			Day, L. C.	L.T. Reg.	7.10.59
Thompson, C. D.	E.-in-C.O.	22.7.59	<i>Inspector</i>		
<i>Executive Engineer</i>			Stopford, J.	L.T. Reg.	6.9.59
Blease, R. C.	N.W. Reg.	4.8.59	Boyle, G. P.	N.W. Reg.	12.9.59
<i>Assistant Engineer</i>			Purvey, A. W. J.	L.T. Reg.	8.10.59
Carder, S. G. S.	S.W. Reg.	17.6.59	Lloyd, I. G.	S.W. Reg.	21.10.59
Conway, J. W. H.	N.W. Reg.	28.6.59	<i>Motor Transport Officer III</i>		
McFwan, J. H.	Scot.	2.7.59	Pounder, L.	E.-in-C.O.	12.9.59
Moore, E.	Scot.	9.7.59	<i>Technical Assistant II</i>		
Kelly, F.C.F.	L.T. Reg.	13.7.59	Twycross, W. J.	W.B.C.	23.5.59
Britton, A. W.	L.T. Reg.	19.7.59	<i>Senior Executive Officer</i>		
Trapnell, F. S.	S.W. Reg.	11.9.59	Ridland, L.	E.-in-C.O.	2.6.59

ASSOCIATE SECTION NOTES (continued from p. 307)

Our first film show of the session was on 22 September 1959 when two films each from Mullard, Ltd., and Phillips, Ltd., were shown. The subjects were transistors and cathode-ray tubes.

On 20 October 1959 Mr. C. J. R. Hall, of the Newcastle Planning Group, gave us a talk on "External Planning."

A visit to Gateshead Technical College was made on Saturday, 31 October 1959, to see some of the latest electrical testing equipment for motor vehicles in the country.

On 18 November 1959 Mr. Hewitt, of Pyrotenax, Ltd., paid us a visit to demonstrate and tell us more about their copper-covered cables.

On 10 December 1959 Mr. J. M. Trotter of the Gateshead Technical College came to Sunderland to talk about the lighting and charging systems of vehicles.

January 1960 brings us the second film show of the session, while on 16 February 1960 the chief fire officer is sending one of his staff to explain the work of the fire service.

In March 1960 we are hoping to visit a colliery about five miles away. This will be a daylight visit and should prove interesting as the colliery surface-gear has just recently been rebuilt.

April brings the annual general meeting, supplemented by a film show.

We are looking forward to a visit to the Tyne-Tees television studios at Newcastle (date to be announced) where we have been promised a tour of the technical equipment. This visit has been held over for some time now, due to the long waiting list.

W. C.

Model Answer Books

CITY AND GUILDS OF LONDON INSTITUTE EXAMINATIONS
FOR THE TELECOMMUNICATION TECHNICIANS' COURSE

Books of questions and model answers for the following subjects of the Telecommunication Technicians' Course are being prepared and will be available shortly. Books ordered now will be supplied as soon as copies are received from the printer.

TELECOMMUNICATION PRINCIPLES A

Available in January or early February 1960

TELECOMMUNICATION PRINCIPLES B

Available in February or early March 1960

Price 7s 6d each · Post Paid 8s

Orders may be sent to the *Journal* Local Agents or to

The Post Office Electrical Engineers' Journal, G.P.O., 2-12 Gresham Street, London, E.C.2.

The Post Office Electrical Engineers' Journal

Volume 52, April 1959—January 1960

INDEX

	PAGE NO.		PAGE NO.
A		D (continued)	
Aerial-Cable Construction, Experiments in	47	Decibelmeter, Recent Improvements in the Inking System of a Recording	26
Aerials, An Analogue Computer for Investigating the Directivity Characteristics of Complex Arrays of Unit Aloft, Working	246	Development of Postal Self-Service Machines	272
Amplifiers of Low Intrinsic Noise, The Principles and Possible Application of Some	212	Directivity Characteristics of Complex Arrays of Unit Aerials, An Analogue Computer for Investigating the	246
Analogue Computer for Investigating the Directivity Characteristics of Complex Arrays of Unit Aerials, An Analyser—a Survey of its Use and Limitations, The Electronic Traffic	246	Distortion in Television Links, Waveform (Parts 1 and 2) 108, 188	108, 188
ANDREWS, J. D. A Code Translator for Letter-Sorting Machines	19	Distortion on Physical (D.C.) Lines and Telegraph Machines, Telegraph	61
ARMAN, L. T., and MELLER, V. C. The South Lancashire Radiophone Service	199	DRIVER, E., and BARKER, A. J. Subscribers' Line Con- nectors	237
Arrays of Unit Aerials, An Analogue Computer for In- vestigating the Directivity Characteristics of Complex ASPINALL, E., and THWAITE, H. A Transistor Hearing Aid	253	E	
Associate Section Notes	79, 155, 231, 304	Efficient Electronic Switch—the Bothway Gate, An	37
Automatic Telex Service, Generation of Meter Pulses for the	196	Electronic Computer Systems for Office Use, An Intro- duction to	13
B		Electronic Exchange in Dollis Hill Laboratories, Model	260
BARKER, A. J., and DRIVER, E. Subscribers' Line Connectors	237	Electronic Switch—the Bothway Gate, An Efficient	37
Birmingham 12 Mc/s Coaxial Line System, The London- Oxford	270	Electronic Traffic Analyser—a Survey of its Use and Limitations, The	19
BLURING, J., and SNOW, H. F. Experiments in Aerial- Cable Construction	47	Emergency Telephones for the London-Yorkshire Motorway	243
BYRNE, S. H. L., and STOTESBURY, K. E. The London International Maintenance Centre	96	Equipment for Training Letter-Sorting-Machine Operators Experimental Equipment for Measuring Group Delay in the Frequency Band 3.8-4.2 Gc/s	55 207
C		Experiments in Aerial-Cable Construction	47
C.C.I.R., Los Angeles, April 1959, The IXth Plenary Assembly of the	101	F	
C.M.I. Validation at Freiburg, West Germany, June 1959	198	FERGUSON, K. H., SCARBROUGH, R. J. D., and SEARLS, A. W. The Generation of Stable Carrier Frequencies in the Range 3,800-4,200 Mc/s	125
Cable Creepage	115	First International Conference on Information Processing at Paris, June 1959	206
Carrier Frequencies in the Range 3,800-4,200 Mc/s, The Generation of Stable	125	First Months of Subscriber Trunk Dialling, The	144
Carrier Terminal Equipment, A Medium-Distance, Built-in Out-Band Signalling (Parts 1 and 2)	122, 179	FRENCH, J. A. T., and HARDING, D. J. An Efficient Electronic Switch—the Bothway Gate	37
CARTWRIGHT, A. D., and DAVIDSON, C. F. A Resonance Isolator for Use at 4,000 Mc/s	69	Frequency-Meter Operating in the H ₀₁₁ Mode in the Range 3,975-4,275 Mc/s	129
CHARLTON, E. W., and MOFFATT, J. J. Working Aloft	262	FROOM, R. P., LEE, F. J., HILTON, C. G., and MACKRILL, P. Laboratory Test Equipment for Synchronous Regenerative Radio-Telegraph Systems	276
CLINCH, C. E. E. Repeater Station Testing Methods and Equipment	290	FROST, A. C., and WHEELER, L. K. Telegraph Distortion in the Trunk Network of the Telegraph Automatic Switching System	103
Coaxial Line System, The London-Oxford-Birmingham 12 Mc/s	270	G	
Code Translator for Letter-Sorting Machines, A	199	Generation of Meter Pulses for the Automatic Telex Service	196
COLLIER, E. G., and WHEELER, D. W. E. Telegraph Dis- tortion on Physical (D.C.) Lines and Telegraph Machines	61	Generation of Stable Carrier Frequencies in the Range 3,800-4,200 Mc/s, The	125
COLLINS, J. H. Generation of Meter Pulses for the Automatic Telex Service	196	GIBSON, R. D., and WHITTON, H. E. Parcel-Label Printing and Issuing Machines	218
Computer Systems for Office Use, An Introduction to Electronic	13	Group Delay in the Frequency Band 3.8-4.2 Gc/s, Experimental Equipment for Measuring	207
Concrete	29	H	
Continental Telephone Services, Introduction of Semi- Automatic Operation of	89	HALSEY, R. J., and RENDALL, A. R. A. Prospects for Transatlantic Television by Cable	136
COPPING, G. P., and MYERS, T. R. Mechanization of the Initial Stages of Processing Mail (Part I)	286	HARDING, D. J., and FRENCH, J. A. T. An Efficient Electronic Switch—the Bothway Gate	37
CRANK, G. J., and HATHAWAY, H. A. A Self-Tuning Insertion-Loss Measuring Equipment (10 kc/s- 1.5 Mc/s)	280	HARDING, J. P. Concrete	29
Creepage, Cable	115	HARRIS, E. T. C., and KING, K. C. A. A Medium-Distance, Built-in Out-Band Signalling, Carrier Terminal Equipment (Parts 1 and 2)	122, 179
D		HARRIS, R. H. Cable Creepage	115
DAVIDSON, C. F., and CARTWRIGHT, A. D. A Resonance Isolator for Use at 4,000 Mc/s	69	HARRISON, J. C., and NICOLLS, A. C. Recent Improve- ments in the Inking System of a Recording Decibelmeter	26
		HATHAWAY, H. A., and CRANK, G. J. A Self-Tuning Insertion-Loss Measuring Equipment (10 kc/s-1.5 Mc/s)	280

	PAGE NO.
H (continued)	
Hearing Aid, A Transistor	163
Her Majesty the Queen's Visit to Canada	140
HILTON, C. G., FROOM, R. P., LEE, F. J., and MACKRILL, P. Laboratory Test Equipment for Synchronous Regenerative Radio-Telegraph Systems	276
I	
Increasing the Traffic Capacity of Transatlantic and Other Submarine Telephone Cables	140
Information Processing at Paris, June 1959, First International Conference on	206
Inking System of a Recording Decibelmeter, Recent Improvements in the	26
Insertion-Loss Measuring Equipment (10 kc/s-1.5 Mc/s), A Self-Tuning	280
Inspection and Subsequent Treatment of Recovered Stores, The	295
Institution of Post Office Electrical Engineers 75, 146, 226, 299	96
International Maintenance Centre, The London	89
Introduction of Semi-Automatic Operation of Continental Telephone Services	13
Introduction to Electronic Computer Systems for Office Use, An	170
Introduction to Printed Circuits and their Application to Telecommunications, An	170
K	
KING, K. C. A., and HARRIS, E. T. C. A Medium-Distance, Built-in Out-Band Signalling, Carrier Terminal Equipment (Parts 1 and 2)	179
L	
Laboratory Test Equipment for Synchronous Regenerative Radio-Telegraph Systems	276
LAVER, F. J. M. An Introduction to Electronic Computer Systems for Office Use	13
LEE, F. J., FROOM, R. P., HILTON, C. G., and MACKRILL, P. Laboratory Test Equipment for Synchronous Regenerative Radio-Telegraph Systems	276
Letter-Sorting-Machine Operators, Equipment for Training	55
Letter-Sorting Machines, A Code Translator for	199
Line Connectors, Subscribers'	237
LITTLE, S. J. The Post Office and the Supply of Electrical Energy by Statutory and Non-Statutory Undertakings in the United Kingdom	184
London International Maintenance Centre, The	96
London-Oxford-Birmingham 12 Mc/s Coaxial Line System, The	270
London Payroll Computers, The	142
London-Yorkshire Motorway, Emergency Telephones for the	243
Long-Distance Transmission by Waveguide	213
M	
MACDIARMID, I. F. Waveform Distortion in Television Links (Parts 1 and 2)	108, 188
MCGRATH, H. T. The Electronic Traffic Analyser—a Survey of its Use and Limitations	19
MCGRATH, H. T. The London Payroll Computers	142
MACKENZIE, W. K. The Work of the Joint Post Office and Ministry of Works Research and Development Group	251
MACKRILL, P., FROOM, R. P., LEE, F. J., and HILTON, C. G. Laboratory Test Equipment for Synchronous Regenerative Radio-Telegraph Systems	276
MANNING, D. J. The Post Office Type 4 Uniselector	215
Measuring Equipment (10 kc/s-1.5 Mc/s), A Self-Tuning Insertion-Loss	280
Mechanization of the Initial Stages of Processing Mail Part 1—Segregation of the Various Classes of Mail	286
Medium-Distance, Built-in Out-Band Signalling, Carrier Terminal Equipment, A	122
Part 1—General Performance Requirements	179
Part 2—Description of Equipment	179
MELLER, V. C., and ARMAN, L. T. The South Lancashire Radiophone Service	253
Ministry of Works Research and Development Group, The Work of the Post Office and	251
MITCHELL, G. An Analogue Computer for Investigating the Directivity Characteristics of Complex Arrays of Unit Aerials	246

	PAGE NO.
M (continued)	
Model Electronic Exchange in Dollis Hill Laboratories	260
MOFFATT, J. J., and CHARLTON, E. W. Working Aloft	262
Motorway, Emergency Telephones for the London-Yorkshire	243
MYERS, K., and SKINNER, P. H. A Portable Equipment for Analysing Traffic at Non-Director Automatic Telephone Exchanges	176
MYERS, T. R., and COPPING, G. P. Mechanization of the Initial Stages of Processing Mail (Part 1)	286
N	
New Power Plant for U.A.X.s No. 12 and 13—Power Plant No. 214, A	265
New 700-Type Table Telephone—Telephone No. 706, The	1
NICOLLS, A. C., and HARRISON, J. C. Recent Improvements in the Inking System of a Recording Decibelmeter	26
Notes and Comments	74, 146, 221, 298
O	
Out-Band Signalling, Carrier Terminal Equipment, A Medium-Distance, Built-in (Parts 1 and 2)	122, 179
P	
Parcel-Label Printing and Issuing Machines	218
Payroll Computers, The London	142
Plenary Assembly of the C.C.I.R., Los Angeles, April 1959, The IXth	101
Portable Equipment for Analysing Traffic at Non-Director Automatic Telephone Exchanges, A	176
Post Office and Ministry of Works Research and Development Group, The Work of the Joint	251
Post Office and the Supply of Electrical Energy by Statutory and Non-Statutory Undertakings in the United Kingdom, The	184
Post Office Type 4 Uniselector, The	215
Postal Self-Service Machines, Development of	272
Power Plant No. 214, A New Power Plant for U.A.X.s No. 12 and 13—	265
Principles and Possible Application of some Amplifiers of Low Intrinsic Noise, The	212
Printed Circuits and Their Application to Telecommunications, An Introduction to	170
Processing Mail, Mechanization of the Initial Stages of (Part 1)	286
Prospects for Transatlantic Television by Cable	136
R	
Radio Interference	43
Part 6—The Control of Radio Interference	43
Radio-Telegraph Systems, Laboratory Test Equipment for Synchronous Regenerative	276
Radiophone Service, The South Lancashire	253
Recent Improvements in the Inking System of a Recording Decibelmeter	26
Recording Decibelmeter, Recent Improvements in the Inking System of a	26
Recovered Stores, The Inspection and Subsequent Treatment of	295
Regional Notes	76, 148, 227, 300
RENDALL, A. R. A., and HALSEY, R. J. Prospects for Transatlantic Television by Cable	136
Renewal of Relay-Spring Contacts	211
Repeater Station Testing Methods and Equipment	290
Resonance Isolator for Use at 4,000 Mc/s, A	69
S	
SANDER, D. H. A New Power Plant for U.A.X.s No. 12 and 13—Power Plant No. 214	265
SCARBROUGH, R. J. D., FERGUSON, K. H., and SEARLS, A. W. The Generation of Stable Carrier Frequencies in the Range 3,800-4,200 Mc/s	125
SEARLS, A. W., SCARBROUGH, R. J. D., and FERGUSON, K. H. The Generation of Stable Carrier Frequencies in the Range 3,800-4,200 Mc/s	125
Self-Tuning Insertion-Loss Measuring Equipment (10 kc/s-1.5 Mc/s), A	280
700-Type Table Telephone—Telephone No. 706, The New Signalling, Carrier Terminal Equipment, A Medium-Distance, Built-in Out-Band (Parts 1 and 2)	122, 179

S (continued)	PAGE NO.
SKINNER, P. H., and MYERS, K. A Portable Equipment for Analysing Traffic at Non-Director Automatic Telephone Exchanges	176
SNOW, H. F., and BLURING, J. Experiments in Aerial-Cable Construction	47
Sorting Machines, A Code Translator for Letter-South Lancashire Radiophone Service, The	199
SOWTON, C. W. Radio Interference (Part 6)	253
SPENCER, H. J. C., and WILSON, F. A. The New 700-Type Table Telephone—Telephone No. 706	43
Staff Changes	1
Statutory and Non-Statutory Undertakings in the United Kingdom, The Post Office and the Supply of Electrical Energy by	84, 159, 234, 308
STOTESBURY, K. E., and BYRNE, S. H. L. The London International Maintenance Centre	184
Subscriber Trunk Dialling, The First Months of	96
Subscribers' Line Connectors	144
T	
TATTERSALL, R. L. O. Frequency-Meter Operating in the <i>Hot</i> Mode in the Range 3,975-4,275 Mc/s	237
Telegraph Automatic Switching System, Telegraph Distortion in the Trunk Network of the	103
Telegraph Distortion in the Trunk Network of the Telegraph Automatic Switching System	103
Telegraph Distortion on Physical (D.C.) Lines and Telegraph Machines	61
Telegraph Machines, Telegraph Distortion on Physical (D.C.) Lines and	61
Telephone No. 706, The New 700-Type Table Telephone—Television by Cable, Prospects for Transatlantic	1
Television Links, Waveform Distortion in (Parts 1 and 2)	136
Testing Methods and Equipment, Repeater Station	108, 188
THOMPSON, S. Development of Postal Self-Service Machines	290
THWAITE, H., and ASPINALL, E. A Transistor Hearing Aid Traffic Analyser—A Survey of its Use and Limitations, The Electronic	272
Traffic at Non-Director Automatic Telephone Exchanges, A Portable Equipment for Analysing	163
Traffic Capacity of Transatlantic and Other Submarine Telephone Cables, Increasing the	19
	176
	140

T (continued)	PAGE NO.
Training Letter-Sorting-Machine Operators, Equipment for	55
Transatlantic and Other Submarine Telephone Cables, Increasing the Traffic Capacity of	140
Transatlantic Television by Cable, Prospects for	136
Transistor Hearing Aid, A	163
Transmission by Waveguide, Long-Distance	213
TURNBULL, M. G. Introduction of Semi-Automatic Operation of Continental Telephone Services	89
TURNER, G. Emergency Telephones for the London-Yorkshire Motorway	243
TURNER, R. J. Experimental Equipment for Measuring Group Delay in the Frequency Band 3.8-4.2 Gc/s	207
Type 4 Uniselector, The Post Office	215

U

U.A.X.s No. 12 and 13—Power Plant No. 214, A New Power Plant for	265
--	-----

W

Waveform Distortion in Television Links	
Part 1—Introduction to Waveform Distortion	108
Part 2—The Measurement and Correction of Waveform Distortion	188
Waveguide, Long-Distance Transmission by	213
WHEELER, D. W. E., and COLLIER, E. G. Telegraph Distortion on Physical (D.C.) Lines and Telegraph Machines	61
WHEELER, L. K., and FROST, A. C. Telegraph Distortion in the Trunk Network of the Telegraph Automatic Switching System	103
WHITTON, H. E., and GIBBON, R. D. Parcel-Label Printing and Issuing Machines	218
WILLMOT, J. W. An Introduction to Printed Circuits and their Application to Telecommunications	170
WILSON, F. A., and SPENCER, H. J. C. The New 700-Type Table Telephone—Telephone No. 706	1
Work of the Joint Post Office and Ministry of Works Research and Development Group, The	251
Working Aloft	262
WYLIE, G. A. Equipment for Training Letter-Sorting-Machine Operators	55

BOARD OF EDITORS

D. A. BARRON, M.Sc., M.I.E.E., Chairman.
 L. F. SCANTLEBURY, Whit.Sch., A.C.G.I., D.I.C., M.I.E.E.
 T. H. FLOWERS, M.B.E., B.Sc.(Eng.), M.I.E.E.
 W. J. E. TOBIN, B.Sc.(Eng.), A.C.G.I., D.I.C., M.I.E.E.
 A. J. LECKENBY, M.B.E.
 G. J. MILLEN, A.M.I.E.E.
 R. F. WALDEGRAVE.
 E. DAVIS, A.M.I.E.E., Managing Editor.
 A. G. LEIGHTON, B.Sc.(Eng.), A.M.I.E.E., Deputy Managing Editor.
 J. MARTIN, B.Sc.(Eng.), A.M.I.E.E. } Assistant Editors.
 R. A. SUDELL }
 B. FARR, Secretary-Treasurer.
 B. CROSS, Advertisement Manager.

Copyright

The entire contents of this Journal are covered by general copyright, and special permission is necessary for reprinting long extracts, but editors are welcome to use not more than one-third of any article, provided credit is given at the beginning or end thus: "From *The Post Office Electrical Engineers' Journal*."

The Board of Editors is not responsible for the statements made or the opinions expressed in any of the articles in this Journal, unless such statement is made specifically by the Board.

Subscriptions and Back Numbers

The Journal is published quarterly, in April, July, October and January, price 2s. 6d. (3s. 3d. post paid) per copy or 13s. per year post paid. Back numbers will be supplied, if available, price 2s. 6d. (3s. 3d. post paid) per copy. All orders should be sent to *The Post Office Electrical Engineers' Journal*, G.P.O., 2-12 Gresham Street, London, E.C.2.

Employees of the British Post Office can obtain the Journal through local agents at the reduced price of 2s. per copy.

Binding Cases

Readers can have their copies of volumes bound at a cost of 10s. 6d. by sending the complete set of parts to the local Post Office distribution agent or to *The Post Office Electrical Engineers' Journal*, G.P.O., 2-12 Gresham Street, London, E.C.2. Alternatively, binding cases are available, price 3s.

Remittances

Remittances should be made payable to "*The P.O.E.E. Journal*" and should be crossed "& Co."

Advertisements

All correspondence relating to advertisement space reservations, copy, proofs, etc., should be addressed to the Advertisement Manager, *The Post Office Electrical Engineers' Journal*, G.P.O., 2-12 Gresham Street, London, E.C.2.

Communications

With the exceptions indicated above, all communications should be addressed to the Managing Editor, *The Post Office Electrical Engineers' Journal*, G.P.O., 2-12 Gresham Street, London, E.C.2. Telephone: HEADquarters 1234.

Model Answer Books

Books of model answers to certain of the City and Guilds of London Institute examinations in telecommunications are published by the Board of Editors. Details of the books available are given at the end of the Supplement to the Journal.

ADCOLA

REGISTERED TRADE MARK
(Regd. Trade Mark)

FOR
**SOLDERING INSTRUMENTS
and EQUIPMENT**
SUPPLIED FOR ALL VOLTAGES



illustrated

**DETACHABLE
BIT**
MODEL $\frac{3}{16}$ "
List 64

**PROTECTIVE
SHIELD**
List 68

..... Write for Catalogues
HEAD OFFICE, SERVICE AND SALES
ADCOLA PRODUCTS LTD.
GAUDEN ROAD, CLAPHAM HIGH STREET, LONDON, S.W.4
Phone: MACaulay 3101, 4272

CATHODEON

**BAND-PASS
CRYSTAL FILTERS**
NOW 90 dBs

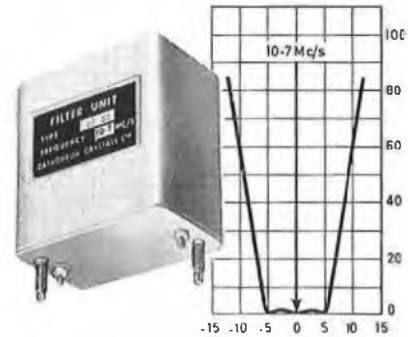

Types BP 50 and BP 25
for 50 Kc/s and 25 Kc/s
Channel Spacing

CATHODEON CRYSTALS LIMITED

LINTON CAMBRIDGE

ENGLAND

TEL: LINTON 501

VALUABLE FREE BOOK



**Tells You How to Pass Your C. & G. or
Promotion Exam. at First Attempt!**

All Post Office Engineering personnel who are anxious to obtain early promotion should at once send for a copy of our handbook "ENGINEERING OPPORTUNITIES," which among other intensely interesting matter describes our unique methods of preparation for **TECHNICAL APPOINTMENTS IN THE POST OFFICE** (Assistant Engineer—New Style and Assistant Traffic Superintendent), **CITY AND GUILDS EXAMINATIONS** in Principles of Telecommunications (1-5), Radio (1-4), Telephone Exchange Systems (1-3), Telegraphy (1), Line Transmission (1 and 2), Lines Plant Practice (1 and 2), Mathematics for Telecommunications (1-5), Electrical Engineering Practice (Prelim. Inter. and Final), and outlines a wide range of non-examination courses in all branches of Electrical, Mechanical, Civil, Automobile, Aeronautical and Radio Engineering.

Assistant Engineer and Assistant Traffic Superintendent Open competitions now resumed. Age extensions for established Civil Servants. Ask us for full details.

**We definitely guarantee
"NO PASS—NO FEE"**

If you intend to make the most of today's opportunities, you cannot afford to miss reading "ENGINEERING OPPORTUNITIES." It tells you everything you want to know to secure advancement, and describes many opportunities you may now be missing through lack of information. Send for your copy to-day—FREE and without obligation.

**BRITISH INSTITUTE
OF ENGINEERING TECHNOLOGY**
369 COLLEGE HOUSE,
29-31 WRIGHT'S LANE, LONDON, W.8

BIET

on top of

EVERY job

Installation and maintenance of overhead telephone lines is a job for the Simon Hydraulic Platform—it has a head for heights. At the touch of a control it moves men, tools and equipment up, down, across or around, reaching the precise working spot in seconds. A fleet of these machines has been bought by the Post Office Engineering Department for use in all Post Office regions in Great Britain and Northern Ireland. They are saving time and money on wiring, tree-trimming, pole-felling, cork fitting, etc.

Truck, trailer and lorry-mounted models are available with maximum working heights from 25 ft. to 54 ft.

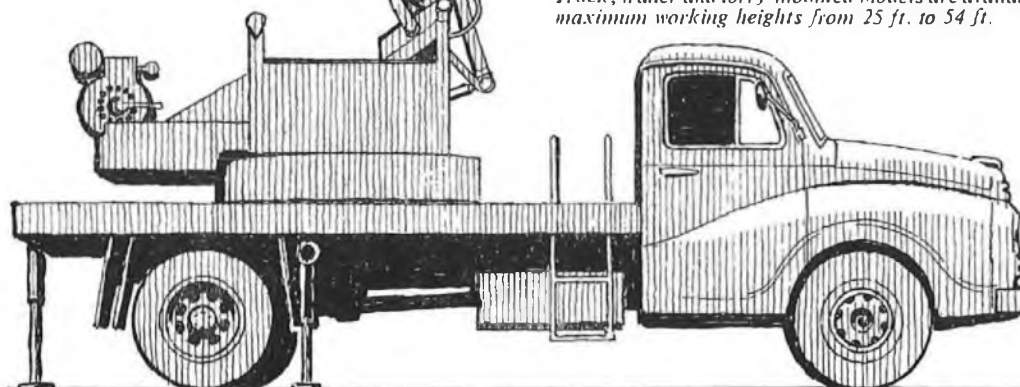

Part of the large P.O.E.D. fleet ready to move off.

SIMON
HYDRAULIC PLATFORM

For details or demonstrations write or phone:

SIMON ENGINEERING (Midlands) LTD



QUEEN'S CROSS · DUDLEY · WORCS · ENGLAND · Telephone: Dudley 54661

HIGH SPEED AUTOMATIC MORSE EQUIPMENT



**Keyboard Perforator
Model 50**

Provided with locking device which prevents the simultaneous depression of two keys. Max. operating speed 750 characters per minute.

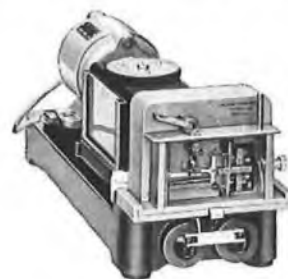

Transmitter Model 112

Speed range 13-250 words per minute. For training schools model 113 having a speed range of 5-35 words per minute is recommended.



Undulator Model 309

Max. operating speed 300 words per minute. Other models available with double recording part and with amplifier/rectifier for tone frequency signals.

G.N.T.

Reperforator Model 451

A truly synchronous receiver which produces a perforated tape similar to the one used for transmission. Normal speed range 40-200 words per minute.

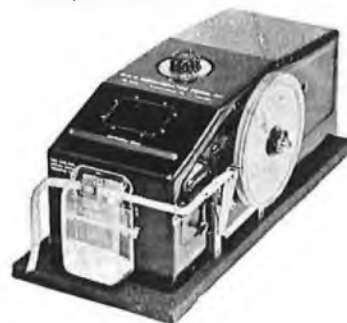

Morseinker Model 1515

Used for training purposes. Motor-driven. Also available with built-in amplifier/rectifier for tone frequency signals. Spring-driven models also available.



Converter Model 2201

For the conversion of a perforated Morse Code, or Cable Code, tape into a perforated 5-unit Code tape or into 5-unit signals at standard teleprinter speed.

Converter Model 2206

For the conversion of a perforated 5-unit Code tape into a perforated Morse Code, or Cable Code, tape.



GREAT NORTHERN TELEGRAPH WORKS

DIVISION OF THE GREAT NORTHERN TELEGRAPH CO. LTD.

4, SYDHAVNS PLADS
COPENHAGEN SV, DENMARK

LONDON OFFICE: 5, ST. HELEN'S PLACE
LONDON E. C. 3.

ferrites and laminates

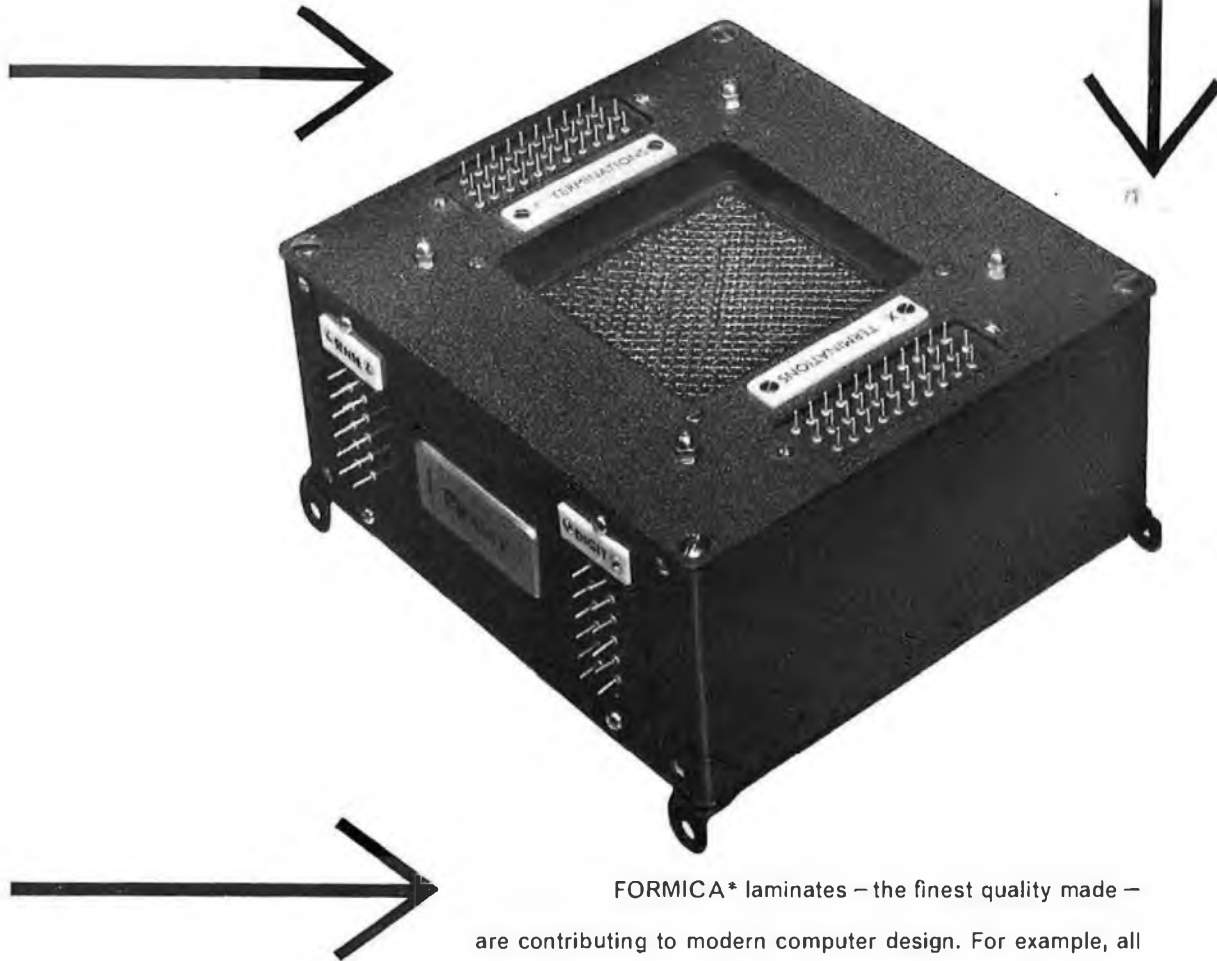

FORMICA* laminates – the finest quality made – are contributing to modern computer design. For example, all terminal panels and matrixes of this 1024 word ferrite core store by *The Plessey Company Limited* are produced from FORMICA GE.10 Epoxy Glass fibre laminate—a grade of exceptional mechanical and electrical properties with remarkable resistance to heat, moisture and chemicals. Another illustration of FORMICA's part in the electrical development of today. All FORMICA laminates are tested for quality, performance and reliability.

FORMICA LTD
for electrical insulation



Paper, fabric, glass and copper clad laminates. Engraving and printed material

A SUBSIDIARY COMPANY OF THE DE LA RUE COMPANY LTD.
P.O.E.F.J. DE LA RUE HOUSE, 84/86 REGENT STREET, LONDON W.1

*FORMICA is a registered trademark



MARCONI

Telecommunications

The post and telegraph authorities of more than 80 countries use Marconi equipment

Electronics for Aviation

More than 50 Civil Airlines and 30 Air Forces use Marconi radio, radar and navigational aids

Television

18 countries rely on Marconi Television Transmitting or Studio Equipment

Broadcasting

80 countries rely on Marconi broadcasting equipment

Radar

29 countries use Marconi Radar

MARCONI

COMPLETE SYSTEM PLANNERS



NEW

HIGH TEMPERATURE CAPACITORS

efficient at **250°C**

Type H precision silvered mica capacitors—the latest addition to the JMC range—are suitable for use from -70°C to $+250^{\circ}\text{C}$. Silicone rubber protection safeguards their outstanding performance at very high operating temperatures.

- ★ Fired construction
- ★ Two standard sizes covering all values from $5\mu\text{F}$ to $50,000\mu\text{F}$
- ★ Minimum tolerance $\pm\frac{1}{2}\%$ or $\pm 1\mu\text{F}$ (whichever is greater)
- ★ Small physical size
- ★ Silver or silver-clad connecting leads

Catalogue sheets describing the complete range of JMC precision capacitors are available on request

Johnson  **Matthey**

JOHNSON, MATTHEY & CO., LIMITED
73-83 HATTON GARDEN, LONDON, E.C.1 Telephone: Holborn 6989
Vittorio Street, Birmingham, 1. Telephone: Central 8004
75-79 Eyre Street, Sheffield, 1. Telephone: 29212

Your car is on the phone!

The British Post Office recently opened in South Lancashire the first public radiotelephone system for motorists. The new service enables motorists to make and receive calls from their cars to telephone subscribers throughout the whole of Britain; with it your car is on the 'phone.

The equipment is manufactured and designed throughout by Pye — the world's largest exporters of mobile radiotelephones. Pye have supplied over 80% of the mobile radiotelephone installations in Britain.

For Post Office approved radiotelephones for cars and vans, write or 'phone to:—

MANCHESTER Pye Telecommunications Limited,
140 Kingsway, Manchester 19.
Tel: Rusholme 1558

or

CAMBRIDGE Pye Telecommunications Limited,
(Head Office) Cambridge.
Tel: Teversham 3131



BY APPOINTMENT
TO HER MAJESTY THE QUEEN
SUPPLIERS OF
RADIO TELEPHONE EQUIPMENT
PYE TELECOMMUNICATIONS LTD



The first Post Office Public Mobile Radiotelephone Service

PYE TELECOMMUNICATIONS LIMITED • CAMBRIDGE

A.T.E. 12-CHANNEL 2-WIRE CABLE SYSTEM TYPE C12G

- *12 telephone circuits over a single cable pair.*
- *Fully transistorised.*
- *Power-fed and Frogging Repeaters.*
- *C.C.I.T.T. performance.*
- *Inbuilt signalling*

An item in the comprehensive range of A.T.E.
Type CM transmission equipment.
For further details write for Leaflet TEL 3201.



TRANSMISSION EQUIPMENT TYPE CM.

AUTOMATIC TELEPHONE & ELECTRIC CO. LTD

STROWGER HOUSE, ARUNDEL STREET, LONDON, W.C.2.

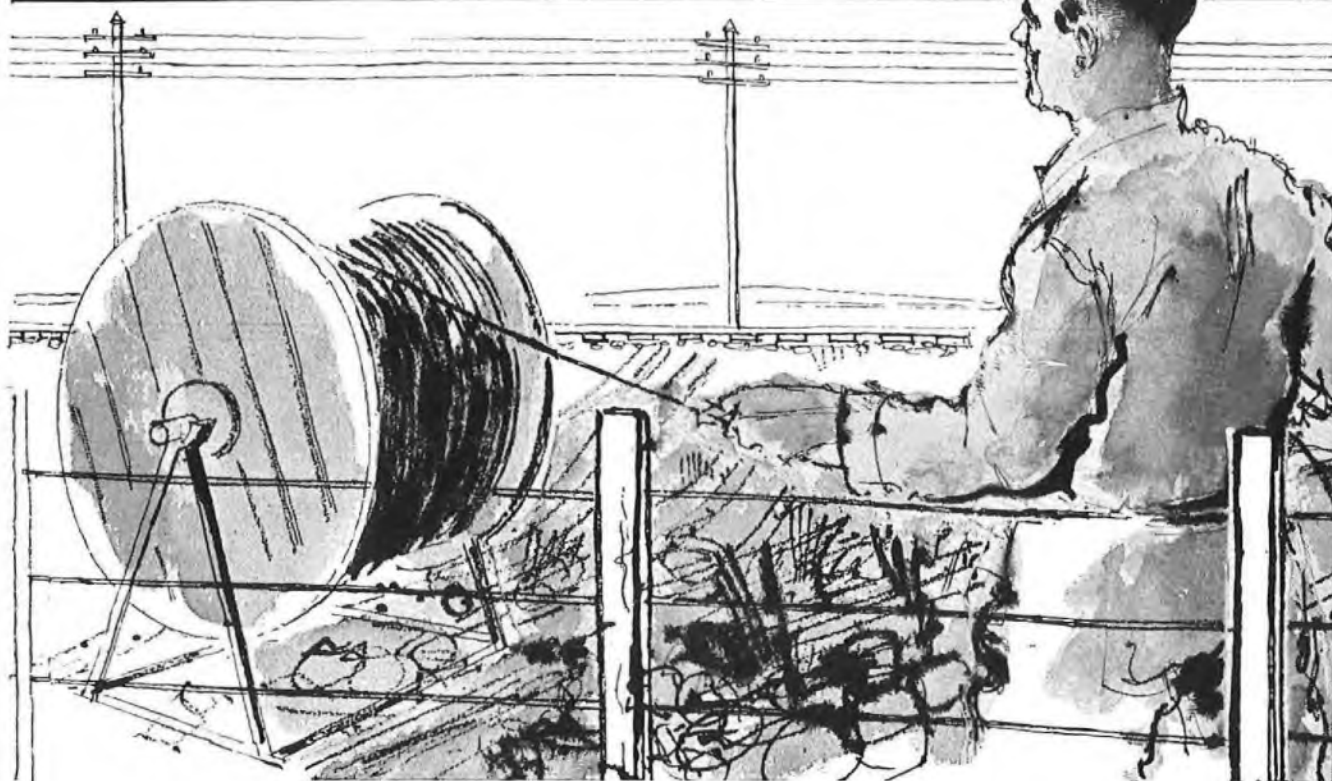

TMC

Telephone and Telegraph **RADIO**

CARRIER TELEPHONE SYSTEM

R40C

- * 6 kc/s channel spacing
- * channel bandwidth 300-3400 c/s
- * out-band dialling (E & M) or ringdown facilities
- * low-level signalling (-20dbm0) tone-on or tone-off idle
- * 40 circuits on one double-sided 9 foot rack including carrier, signalling and power supplies
- * alternative arrangements for small systems (up to 16 channels) or for large systems
- * conforms with latest CCITT recommendations on levels and impedance for radio equipment

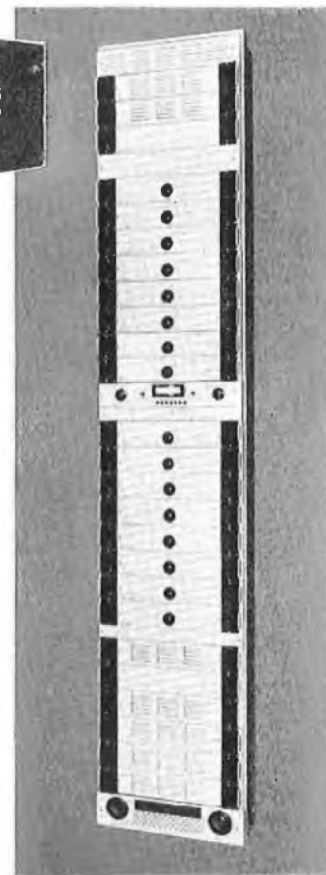

THESE TWO SYSTEMS
ARE PART OF THE **T.M.C.**
RANGE OF TRANSMISSION
EQUIPMENT WHICH INCLUDES:

2, 3, 4 and 6 kc/s spaced carrier
telephone equipment for cable, radio and open
wire systems. Transistorized 120 c/s and
170 c/s FM Telegraph Equipment. Transistorized
VF Repeater Equipment.
Transistorized privacy equipment.

TELEPHONE MANUFACTURING

TRANSMISSION DIVISION · CRAY WORKS

channelling equipment for . . .

LINKS

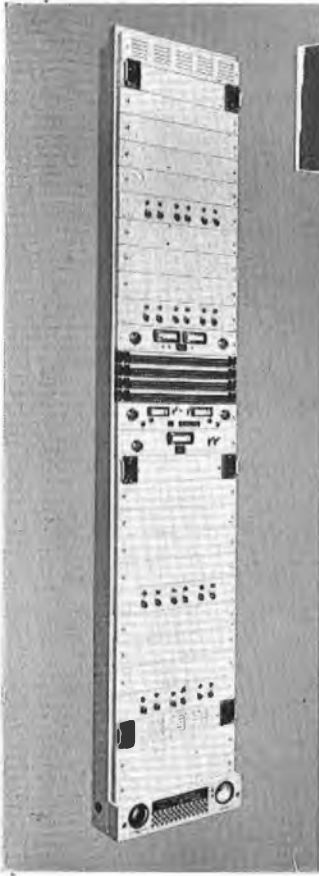

T24D

VF TELEGRAPH SYSTEM

- * Fully transistorized
- * Frequency modulated (± 30 c/s)
- * 120 c/s spaced channels
- * 24 bothway channels on one speech circuit (300-3,400 c/s)
- * Pilot frequency control, if required
- * Plug-in channel units simplify maintenance and extensions
- * Robust circuits using only 7 transistors per channel
- * Mains or battery operation
- * 24 channels with pilot equipment, test panel and double current telegraph supplies on 9' rack-side

SELLING AGENTS

AUSTRALIA AND NEW ZEALAND

CANADA AND U.S.A.

ALL OTHER COUNTRIES

(For Transmission Equipment Only)

Telephone Manufacturing Co. (A'sia) Pty. Ltd.
Sydney, N.S.W.

Telephone Manufacturing Co. Ltd., Toronto, Ont.

Automatic Telephone & Electric Co. Ltd., London.

COMPANY LIMITED

SEVENOAKS WAY · ORPINGTON · KENT

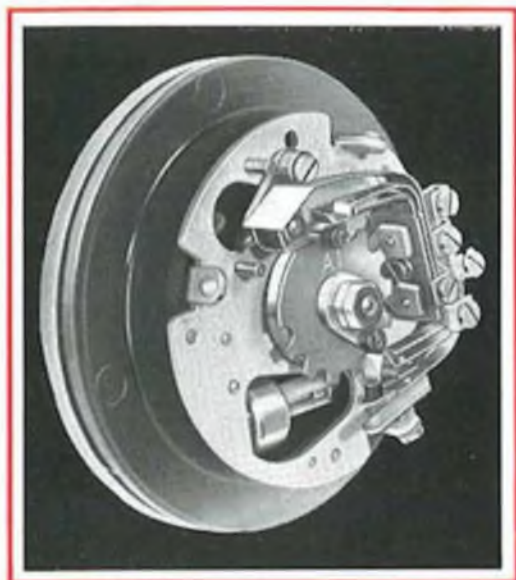

The NEW **S.E.C.** Trigger

STANDARDISED BY THE BRITISH POST OFFICE
APPROVED BY THE COUNCIL OF INDUSTRIAL DESIGN

This revised and improved dial retains the familiar and well-known trigger action that has given reliable service in G.E.C. dials for many years. The main new features of the dial include:

A moulded, hard-plastic case replacing the former metal case

A plastic finger plate available in seven attractive colours to match the cases of the New Gecophone and the B.P.O. Telephone No. 706

The instruction card cover fits flush with the finger plate so giving a pleasing appearance

Palladium contacts are fitted to the impulsing springs

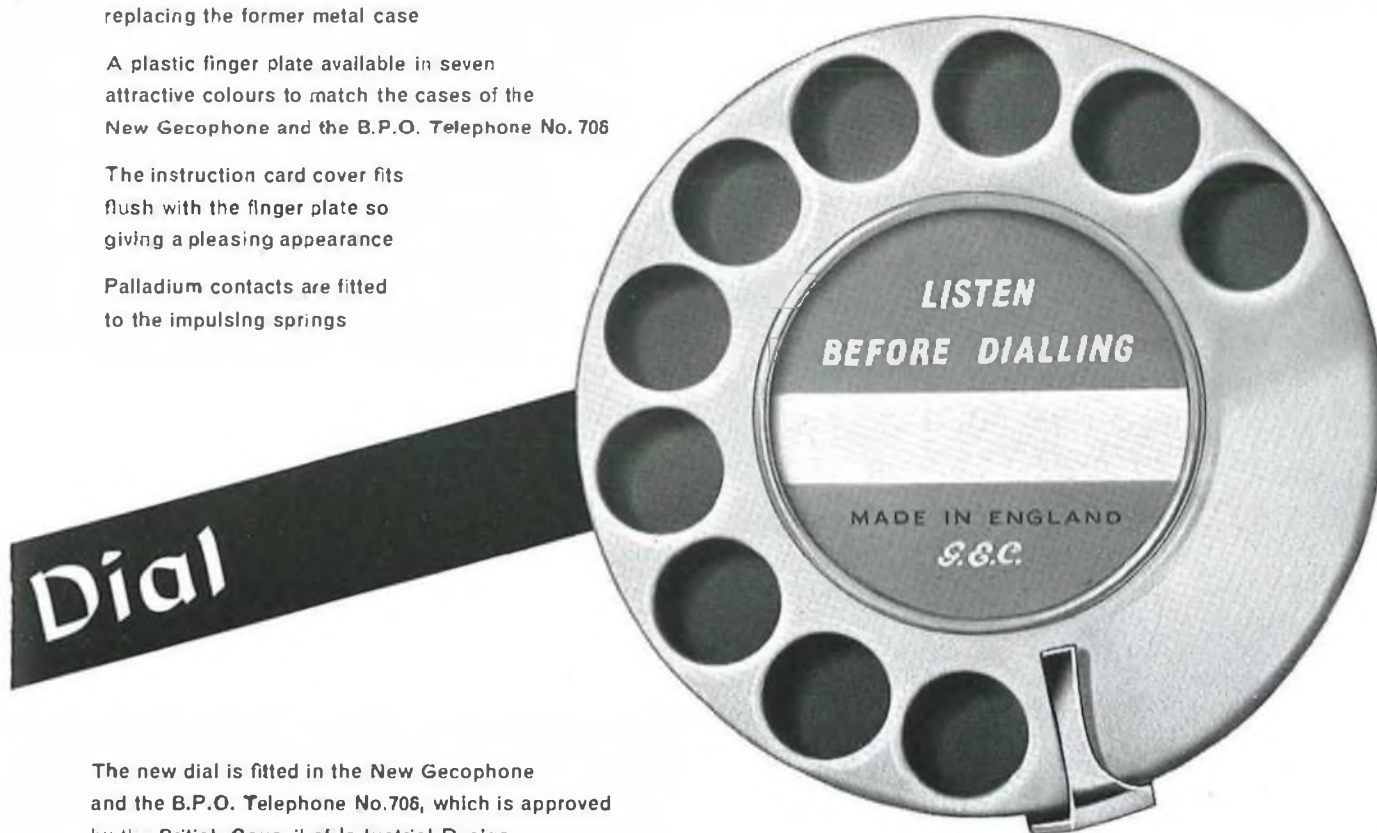

The new dial is fitted in the New Gecophone and the B.P.O. Telephone No.706, which is approved by the British Council of Industrial Design. In these applications the dial number ring, which is coloured to match the telephone handset, is left blank as a number ring is fitted to the case of the telephone. However, the dial can also be fitted to any telephone that uses the previous G.E.C. trigger dial. For these uses the numbers are featured on the dial number ring in the conventional manner. When required, plastic covers are supplied to protect the mechanism from dust and damage.

The dial has been accepted as standard by the British Post Office and has been designated the P.O. Dial No. 21



THE GENERAL ELECTRIC COMPANY LIMITED OF ENGLAND
 Telephone, Radio and Television Works, Coventry, England.



TUNGSTONE BATTERIES have been designed to meet Post Office, British Standards and other national Post and Telegraph Specifications. They are being used in Power Stations, Telephone Exchanges, etc., all over the United Kingdom, Australia, India, South Africa, West Africa, West Indies, Portugal, Venezuela, etc.

This illustration shows . . . the installation of a 126 cell TUNGSTONE Battery, Type BSSFW9 giving capacity of 800 a.h. at the 9 hr rate.

TUNGSTONE PRODUCTS LTD

Salisbury Square, London, E.C.4. Telephone: LUDgate Circus 0432

WORKS: Market Harborough, Leics.

EARTH LOOP TESTING

What are YOU
doing about I.E.E.
regulations
406 & 507?



With the New MEGGER Line-Earth Loop Tester you can comply fully. A robust instrument which, in the Evershed tradition, combines simplicity of operation with accurate measurement.

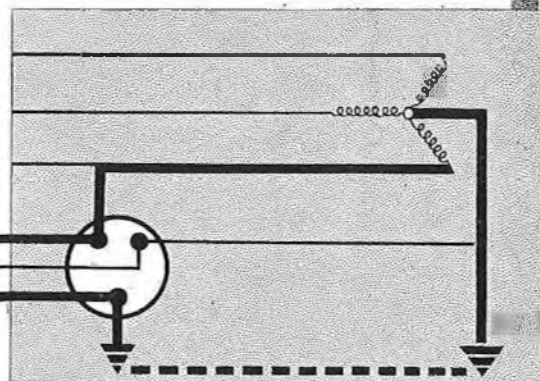

- 1 Direct reading of the earth loop in Ω ms.
- 2 Suitable for earth loop measurement in single phase or 3-phase installations.
- 3 Permits readings to be related directly to fuse ratings and circuit breaker settings.
- 4 Warning lamp to ascertain correct polarity of sockets.
- 5 Permits tests of the earthing efficiency of electrical appliances.
- 6 Completely safe in operation.
- 7 Can be supplied with built-in voltmeter for tests where mains voltage is unknown or subject to change.

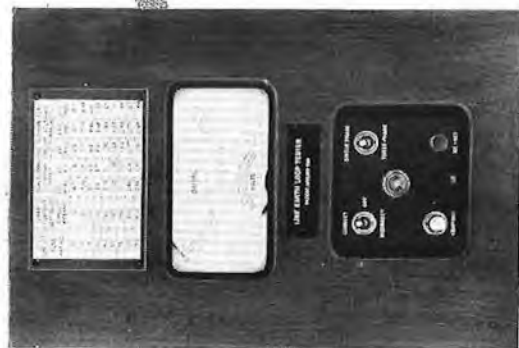

MEGGER

LINE-EARTH LOOP TESTER

AN
EVERSHED
PRODUCT

EVERSHED & VIGNOLES LTD.

Acton Lane Works, Chiswick, London. W.4.

Telephone: Chiswick 3670. Telegrams & Cables: Megger London Telex No. 22583

7/121

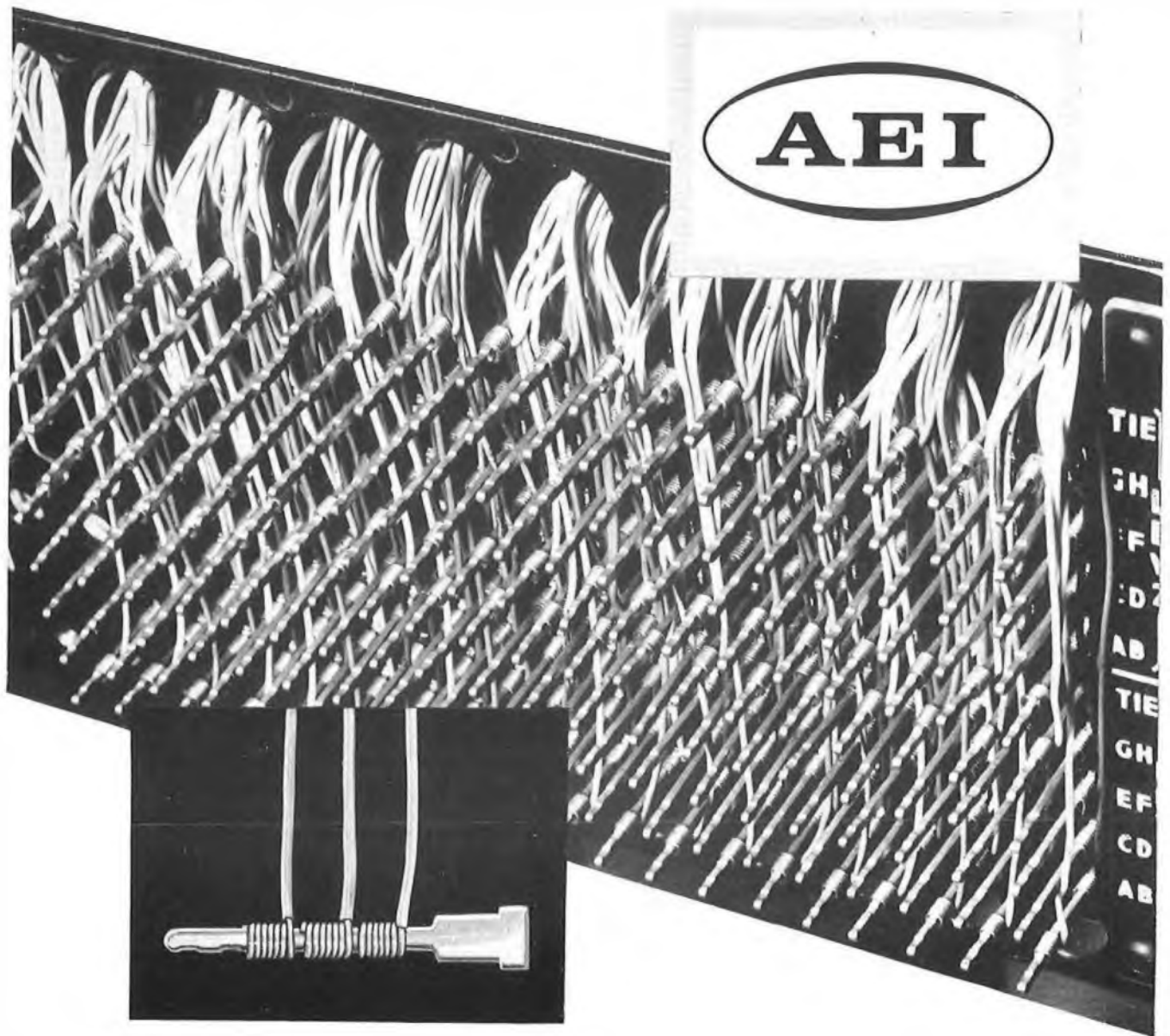

a million solderless joints

For the Springpark Exchange (London Toll Area) recently installed by Siemens Edison Swan, approximately one million connections were made using tools designed for a solderless wrapping technique in place of conventional soldering methods.

The new wrapping technique not only speeds completion of the vast number of joints involved in automatic telephone exchanges, avoids faults caused by stray particles of solder and heat

damage to plastic insulation, but—even more important in the long view—produces more uniform, stable and reliable joints.

The A.E.I. Telecommunications Division is therefore in the forefront of yet another interesting development in the science of telecommunications, and by reason of work in this and many other fields are able to offer equipment incorporating every worthwhile technical advance.



Associated Electrical Industries Limited

Telecommunications Division P.D.5

Woolwich, London, S.E.18. Telephone: Woolwich 2020

formerly **Siemens Edison Swan Ltd, Telecommunications Division**

A NEW CONCEPT



IN POT CORE DESIGN

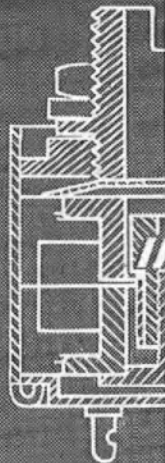

VINKOR

Mullard

range of

adjustable pot cores gives you

outstanding

advantages

- Wide range of sizes
- Easily assembled
- Close tolerance permeability
- Precise and easy inductance adjustment
- Stability
- Single hole chassis mounting

Mullard Vinkors are the most efficient adjustable pot core assemblies commercially available. In addition to high performance, they have the distinct advantage of close tolerance permeability, thus enabling designers to precalculate to within $\pm 3\%$ the inductance of the core when wound. Final adjustment, taking into account normal capacitor tolerance, can be easily effected to an accuracy of better than 0.02%, by means of a simple self-locking device built into the core.

Write today for full details of the wide range of Vinkors currently available.

Mullard

VINKOR POT CORES



MULLARD LIMITED · COMPONENT DIVISION · MULLARD HOUSE · TORRINGTON PLACE · LONDON W.C.1

MC260

ET4

ERICSSON



EXTENSIBLE CORDLESS P.A.B.X.

The E. T. 4 Extensible Cordless P.A.B.X., fully approved by the British Post Office, is specially designed for use in the larger offices, factories, etc., where over fifty extensions are needed initially. The design permits its capacity to be increased in respect of extension lines, exchange lines or manual positions as occasion demands.

This system is equally suitable for use as a single self-contained exchange or as a network of exchanges having one central group of manual positions and a common numbering scheme. Since there is no difference in operating procedure, the full facilities are available for all extensions.

The console style switchboards have been designed to cut operating time to a minimum thus often reducing the number of positions required. Control is affected entirely by push-buttons conveniently placed to be handled with a minimum of effort and key sending is employed for setting up internal and exchange calls.

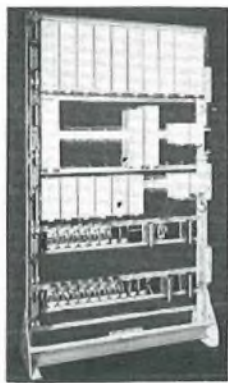
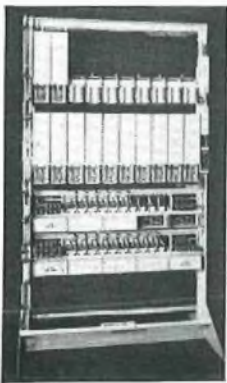

- PUSH-BUTTON CONTROL OF MANUAL POSITIONS
- LAMP AND TONE SUPERVISION ON ALL SWITCHBOARD CALLS
- DISCRIMINATING BUSY-TONE FOR LOCAL AND EXCHANGE CALLS
- OPERATORS "WAITING CALLS" INDICATOR
- PREFERENCE FACILITIES ALLOW INTRUSION BY SELECTED EXTENSIONS INTO EXISTING LOCAL CALLS
- ANY EXTENSION CAN BE COMPLETELY BARRED FROM THE PUBLIC EXCHANGE
- MULTI-EXCHANGE OR SATELLITE NETWORKS CAN BE PROVIDED
- COVERS ALL REQUIREMENTS OF S.T.D.

ERICSSON TELEPHONES LIMITED — ETELCO LIMITED



HEAD OFFICE—22 LINCOLN'S INN FIELDS, LONDON, W.C.2. TEL: HOL. 6936

WORKS—BEESTON, NOTTINGHAM AND SUNDERLAND

The MULTIMINOR

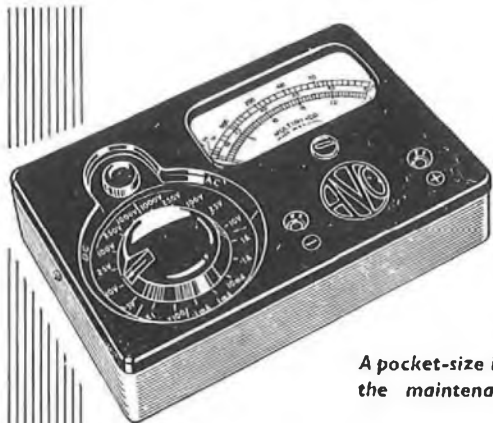

A pocket-size instrument for the maintenance engineer

19 RANGES

D.C. Voltage	A.C. Voltage
0—100 mV.	0—10 V.
0—2.5V.	0—25 V.
0—10 V.	0—100 V.
0—25 V.	0—250 V.
0—100 V.	0—1000 V.
0—250 V.	
0—1000 V.	

Resistance
0—20,000Ω
0—2 MΩ

D.C. Current
0—100μA
0—1mA
0—10mA
0—100mA
0—1 A

Sensitivity:
10,000 ohms per volt on D.C. voltage ranges.
1,000 ohms per volt on A.C. voltage ranges.

Accuracy:
On D.C. 3% of full scale value.
On A.C. 4% of full scale value.

Pocket Size: 5½ × 3½ × 1½ inches.
Weight: 1 lb. approx.

List Price:

£9:10s.

complete with Test Leads and Clips

Leather Case if required 39/-

Write for illustrated leaflet.

Designed and Manufactured by

AVO Ltd.

AVOCET HOUSE · 92-96 VAUXHALL BRIDGE ROAD · LONDON · S.W.1

Telephone: VICTORIA 3404 (12 lines)

A MEMBER OF THE METAL INDUSTRIES GROUP OF COMPANIES

MM2

PRINCIPLES OF ELECTRONIC INSTRUMENTS AND INSTRUMENTATION

By Gordon R. Partridge, Ph.D. This new book is an essential aid to the many technologists and research workers who are nowadays faced with instrumentation problems. Based on a series of American postgraduate lectures, it covers the fundamental Principles and technique in an outstandingly clear and easy-to-read manner. 40/- net.

FUNCTIONS OF THE COMPLEX VARIABLES

By Philip Franklin. This book is outstanding for its clear and precise explanation of a branch of mathematics which has often been obscured in a haze of highly abstract concepts. Logical and essentially complete, its purpose is to introduce the reader to the general properties of an analytical function of a single complex variable. 25/- net.

TELEGRAPHY

By J. W. Frcebody, Whit. Schol., etc. A new textbook covering all aspects of Telegraphy, including Codes, Instruments, Circuits and Switchboards. For students taking the appropriate City and Guilds examinations and also for those taking the G.P.O. exams. 80/- net.

FROM ALL BOOKSELLERS

PITMAN TECHNICAL BOOKS

Parker St., Kingsway, London, W.C.2

for the right connection



FREDERICK SMITH AND COMPANY
ANACONDA WORKS · SALFORD 3 · LANCs



CONSTANT POTENTIAL RECTIFIERS

are associated with the d.c. power supplies to
THE SUBSCRIBER TRUNK DIALLING SYSTEM



A Westinghouse transductor controlled rectifier set forms the basis of the power supply to the register translator in the new subscriber trunk dialling system. Equipments of this type are designed to stabilise the d.c. output voltage to less than $\pm 1\%$ over a load range of 10% full load to full load despite simultaneous mains input voltage variations of $\pm 6\%$ and frequency changes of $+1\%$ to -2% .

WESTINGHOUSE BRAKE AND SIGNAL CO. LTD., 82 York Way, King's Cross, London, N.1
Tel.: TERminus 6432

The man
 who's using
AUSTINLITE
 without
 knowing it

Any man in the know rings up Austinlite when he wants something slightly — or considerably — out of the ordinary in electrical control gear. In doing so it is almost a certainty that he is depending on Austinlite for his connection: the G.P.O. uses hundreds of Austinlite standby sets and control cubicles.

So do other public services. In fact wherever control gear must be more than usually reliable you tend to find it is made by Austinlite. Not surprising really. Austinlite gear was in its early days developed for use in lighthouses. Millions of tons of shipping depend on ...

Austinlite
ELECTRICAL EQUIPMENT
Custom-built by
STONE-CHANCE LTD.

(Makers of Sumo Pumps and Stone-Chance Lighthouses)

CRAWLEY, SUSSEX, ENGLAND

London Office: 28 St. James's Square, S.W.1.

Telephone: TRAfalgar 1954.

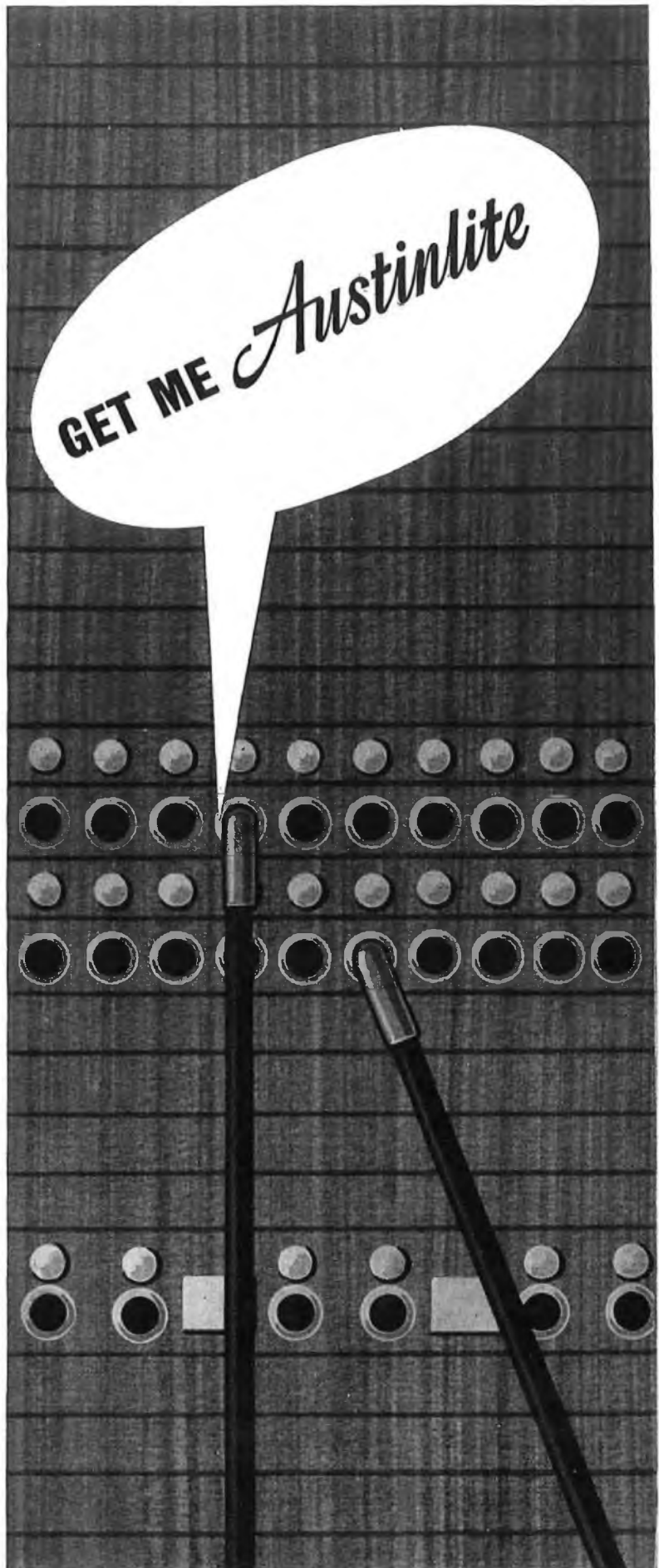

ATOMIC PLANT OR LINE TAP

corrosion prevention by the correct

DENSO

method is complete and enduring

Electrical Engineers the world over use Denso Tapes, Cords and Mastics for: protection of machined surfaces in store or transit; temporary cable repairs; anti-galvanic insertion; anti-fusion lubrication; waterproofing, sealing, plugging, etc., etc.

Copper-aluminium line tap coated with Denso Paste, wrapped in Denso Tape.

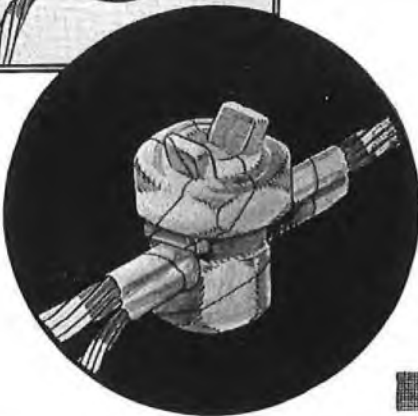
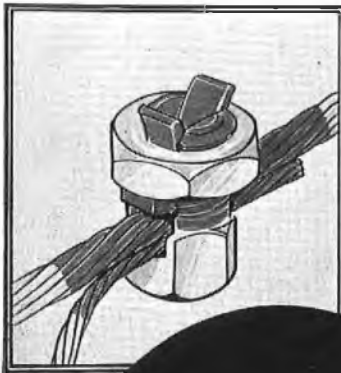

By courtesy of Geartight Unions Limited, manufacturers of the control rod standpipe closure assemblies for the Hunterston Generating Station being constructed by The General Electric Company Ltd. for the South of Scotland Electricity Board.



WINN & COALES LTD.

DENSO HOUSE, CHAPEL ROAD, LONDON, S.E.27

Telephone: GIPsy Hill 4247

Telegrams: Denselte, Westnor, London

Northern Area Headquarters: Denso House, Glebelands Road, Sale, Cheshire

Telephone: Sale 8271

Telegrams: Denselte, Sale, Cheshire

Over 5,000,000  Permanent Magnets are manufactured each year in this Modern & Efficient Factory



LOUD SPEAKER MAGNETS

in Alcomax

& Semi-Columnar Alcomax

* Write for literature

PM 108/56—Loud Speaker Magnets.

PM 169/57—Semi-Columnar Alcomax Magnets.

Bulletin M 10/57—Eclipse Shell-Moulded Permanent Magnets.



Made by the designers & manufacturers of Eclipse permanent magnets & chucks
JAMES NEILL & CO. (SHEFFIELD) LTD · SHEFFIELD · ENGLAND

G.E.C.

nine-circuit VHF Junction Radio Equipment

System SPO 5060

This new junction radio equipment provides up to nine speech circuits over a frequency modulated radio link. Each speech circuit has a bandwidth of 300 c/s - 3400 c/s, with out-of-band signalling at 3825 c/s.

The equipment is complementary to the well-known GEC 5-circuit junction radio equipment, in service in many parts of the world.

The layout provides for the transmitter and receiver to be housed on one standard 6 ft. (1.83 metres) rack. The multiplexing equipment is mounted on a second 6 ft. rack which allows it to be located in an exchange, whilst the radio equipment is sited in the most advantageous location for propagation

Please write for further information

Everything for TELECOMMUNICATIONS

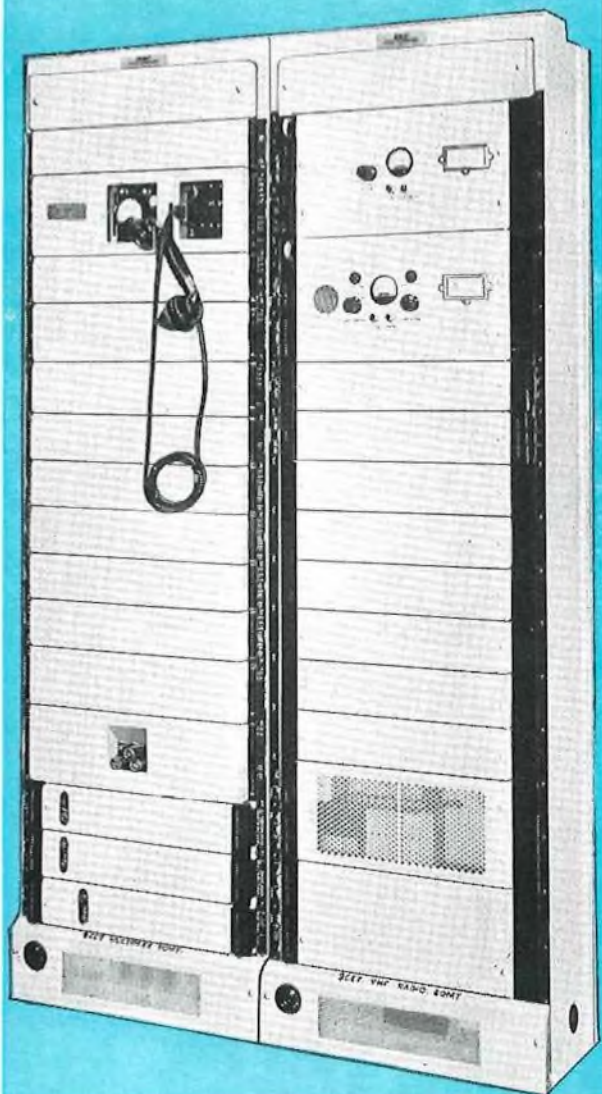

PLAN
FOR
THAT
EXTRA
LOAD
NOW!

**60 AMP
TODAY...**

**100 AMP
TOMORROW**

Henley Series 3 Service Fuses are the ideal solution to the present day problem of ever-increasing loads. 60 amp service fuses installed today can be easily converted to 100 amp when the load demands by the use of a Series 3-100 conversion set (comprising 100 amp carrier, turret etc.) together with a suitable fuse-link.

Full details are given in our Catalogue 43—may we send you a copy?

All enquiries to:

Associated Electrical Industries Limited
CABLE DIVISION

51-53 Hatton Garden • London E.C.1 • Phone: CHAncery 6822

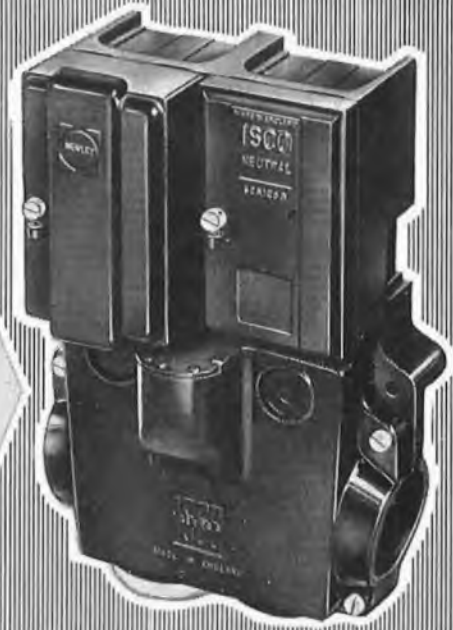

**BY MEANS OF THE
HENLEY SERIES 3-100
CONVERSION SET**

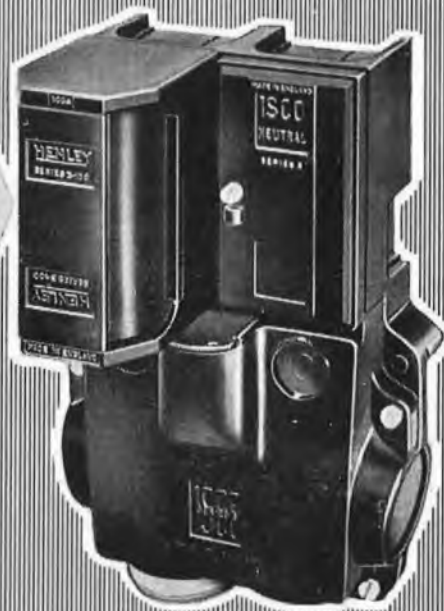

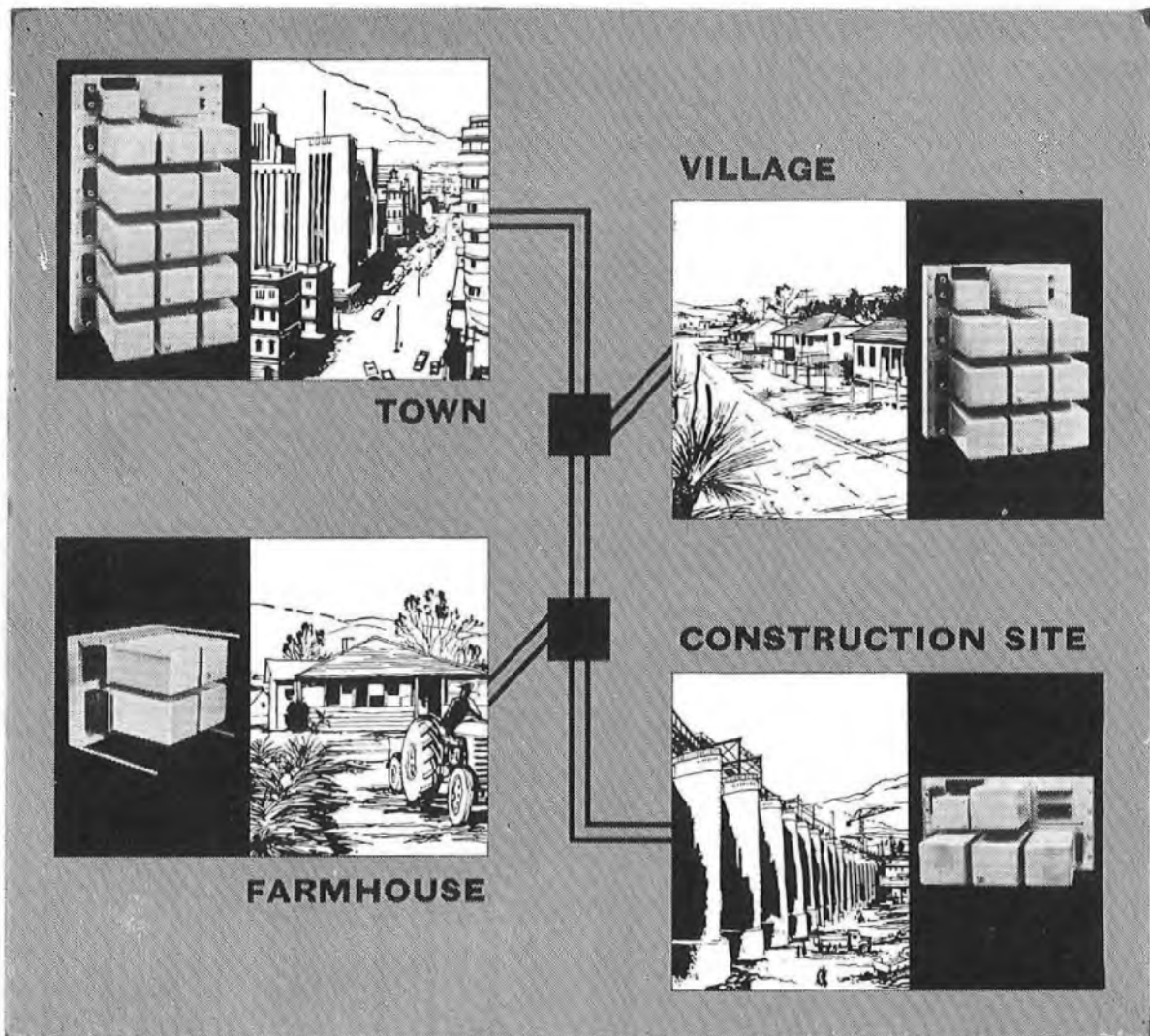

Transistorised rural carrier telephone system-TRC7

in service in many parts of the world

A PRODUCT OF
MULLARD EQUIPMENT LIMITED
A COMPANY OF THE MULLARD GROUP

- Fully transistorised
- Simple installation
- Low power consumption
- Up to seven extra speech channels
- Ideal for temporary extra lines
- Fully tropicalised
- Pole mounted drop-off filters for greater flexibility

Write for descriptive literature

Mullard House · Torrington Place
London · W.C.1 · Tel: LANgham 6633

ME626C



Cordless Switchboards

Typical of the latest type of 'cordless' telephone switchboards are these operating positions installed by Siemens Edison Swan in one of the British Post Office Trunk Exchanges where operator controlled long distance calls are handled. These switchboards are noteworthy for their use of remote-controlled automatic selectors in place of outmoded cords and plugs, and for such other advances as automatic call queueing and digit key sending. Calls can be established quickly and without effort, and for the subscriber this means an end to irritating delays.

Leading telephone operating administrations have co-operated in the physical design of the board to ensure the provision of more comfortable and congenial working conditions for the operator, and to eliminate the fatigue associated with conventional type boards.

In every important aspect of design, construction and function the Siemens Ediswan cordless switchboard is a further example of our technical leadership in the science of telecommunications gained over many years.

vast experience



in the science of telecommunications



Associated Electrical Industries Limited

Telecommunications Division P.D.5,
Woolwich, London, S.E.18. Telephone: Woolwich 2020

formerly Siemens Edison Swan Ltd, Telecommunications Division

British progress in

electr

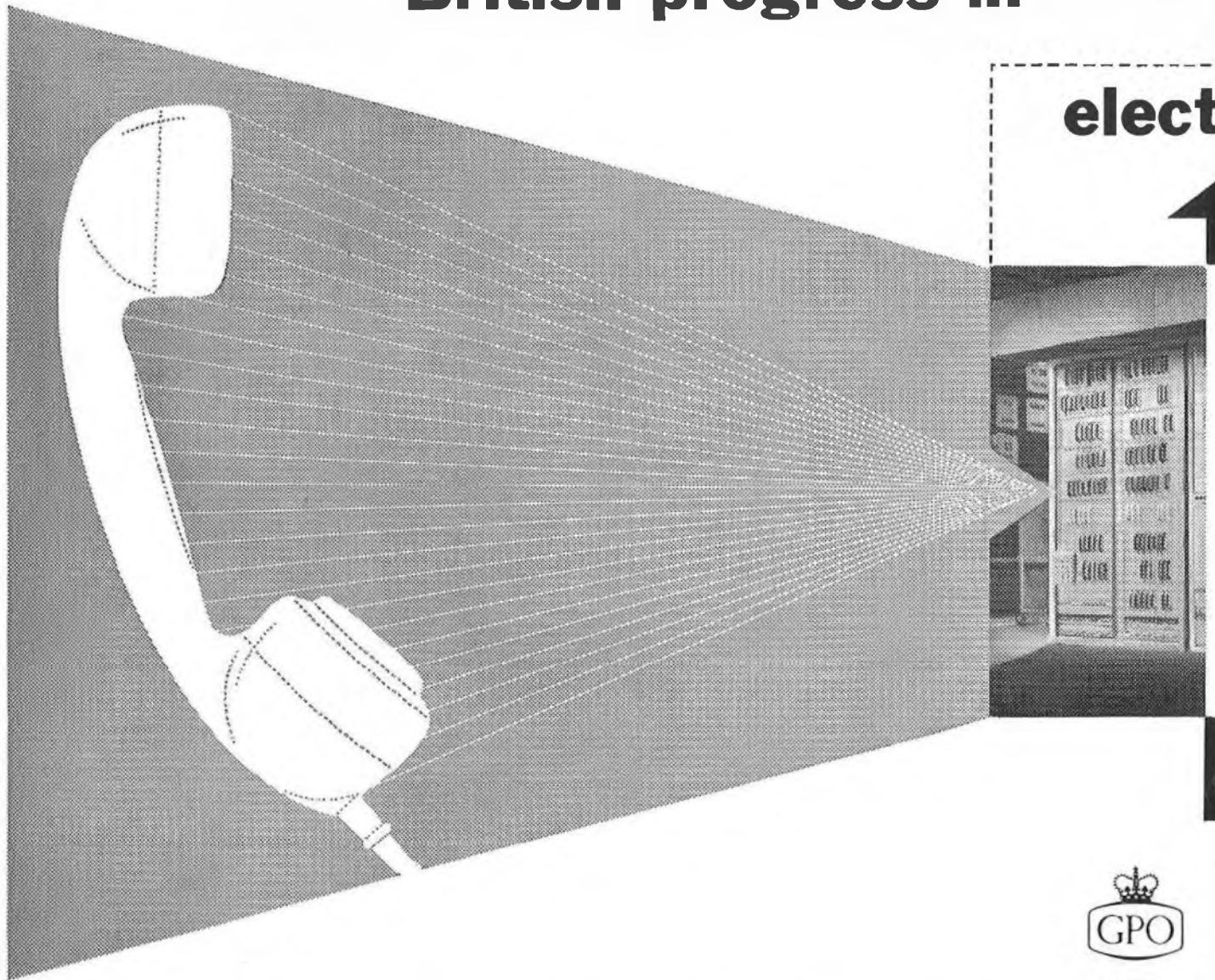

G.P.O. TEAMS UP WITH INDUSTRY

Last November saw the inauguration of a British experimental electronic telephone exchange at the G.P.O. Research Station, Dollis Hill. The exchange has been developed by the Joint Electronic Research Committee—comprising engineers from the G.P.O. and the five leading British manufacturers of telephone equipment.

Although this does not mean an overnight transformation of present telephone systems, the Committee's confidence is such that plans have gone ahead for a trial exchange to be built and installed at Highgate Wood, London. This will be ready in about two years' time, and will be used for public traffic.

Progress to date supports the belief that electronic switching will eventually bring about, not only substantial economies in equipment and maintenance, but also a greater efficiency in service.



telephone exchanges

onic

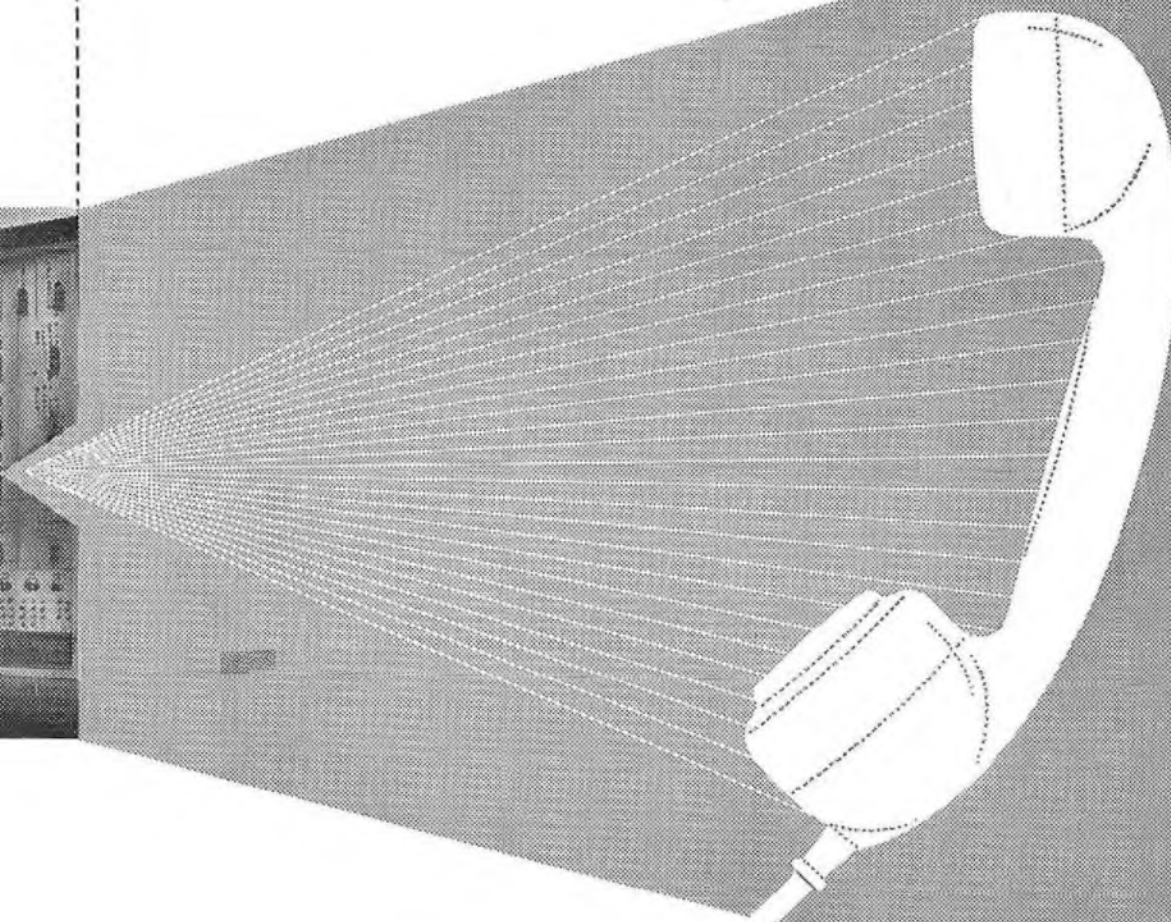
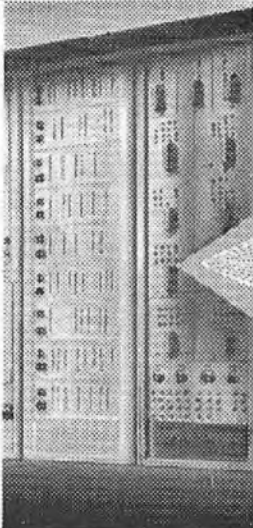

THE GENERAL POST OFFICE

AUTOMATIC TELEPHONE AND ELECTRIC COMPANY LIMITED

ERICSSON TELEPHONES LIMITED

THE GENERAL ELECTRIC COMPANY LIMITED

SIEMENS EDISON SWAN LIMITED

STANDARD TELEPHONES AND CABLES LIMITED

NORWAY

STC S.T.C. WORLD



SWEDEN



Terminal	Repeater	
		960-Circuit Capacity 2-Way Telephone Channel, Standby Channel and Baseband Switching.
		2-Way Channel for Television and Sound
		1-Way Channel for Television and Sound
		Television and FM Sound Programme Broadcast Transmitter

-WIDE EXPERIENCE

S.T.C. are supplying main line microwave telephone systems to 18 countries and have already supplied systems with a capacity of over 4½ million telephone circuit miles, 5,000 television channel miles and an equal capacity of standby equipment.

S.T.C. have a contract to supply and install a 4,000 Mc/s multi-channel telephone and television network for the Royal Board of Swedish Telecommunications. Including spur routes it covers an approximate total of 670 miles (1,100 km). The network will join the large communications network of the south of Sweden to that of the north by connecting the Stockholm-Sundsvall coaxial system with Boden where a coaxial system extends to Kiruna. Thus, S.T.C. coaxial and microwave equipment will be in service over nearly the whole route from Malmö in the south to Kiruna within the Arctic Circle; a distance of over 1,600 km (1,000 miles).

Working and standby radio channels will be equipped with automatic baseband switching equipment to ensure interruption-free service.

Each radio channel will have a traffic capacity of 960 telephone circuits, or one television circuit carrying both picture and sound transmissions.

Standard Telecommunications Laboratories are responsible for the propagation tests on the route.

One of 18 countries having S.T.C. MICROWAVE SYSTEMS

S.T.C. ARE ALSO
SUPPLYING ON
THIS CONTRACT

An independent 4,000 Mc/s system using the same radio antenna system and carrying: Supervisory and service channels, three broadcast programme channels.

Remote Control equipment, Parabolic aerials,
Test Equipment, Entrance Cables



601C

Standard Telephones and Cables Limited

Registered Office: Connaught House, Aldwych, London, W.C.2

TRANSMISSION DIVISION: NORTH WOOLWICH · LONDON · E.16

PAINTON Miniature Vitreous Wirewound Resistors

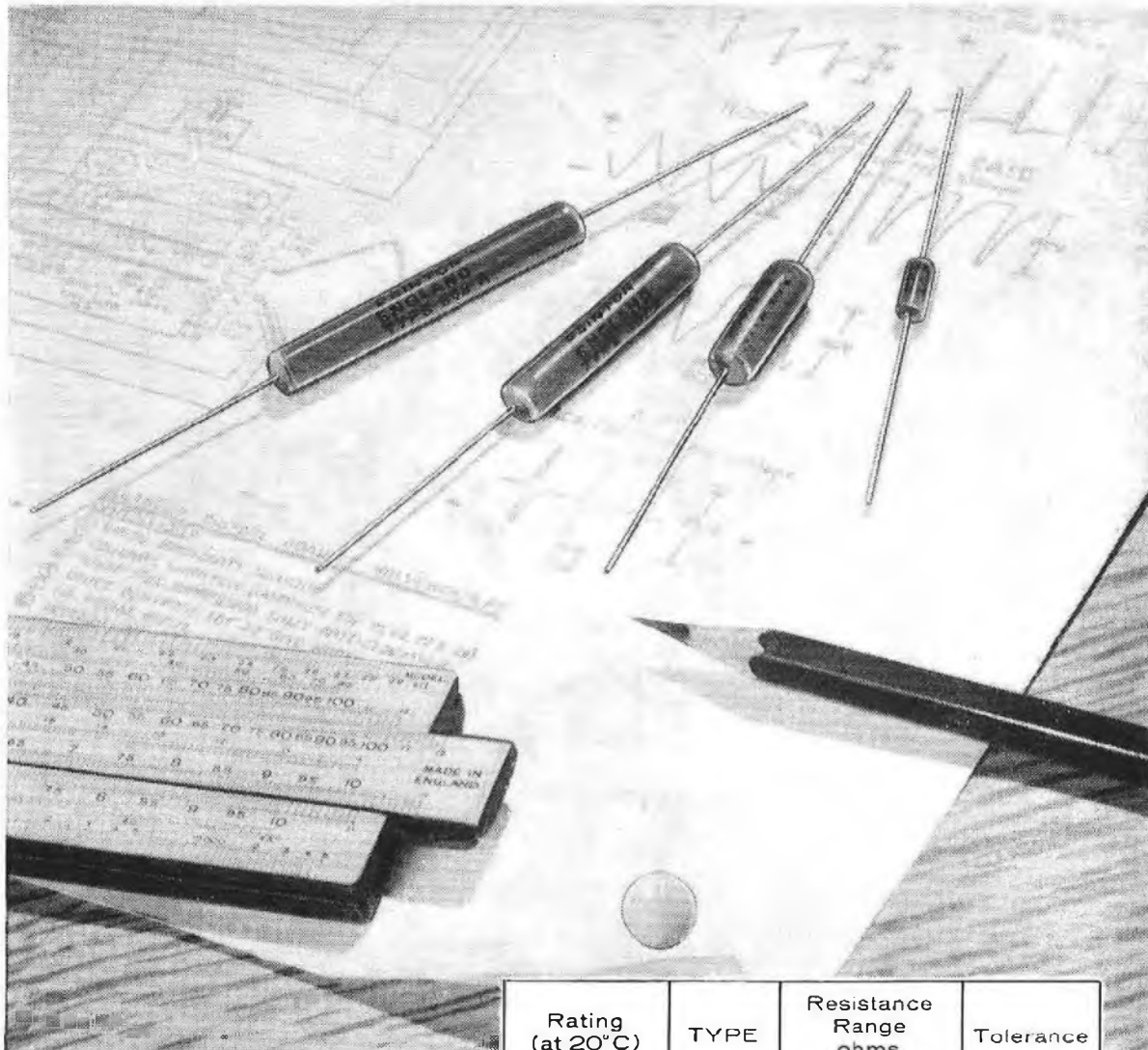

Rating (at 20°C) Watts	TYPE	Resistance Range ohms		Tolerance
		Min	Max	
4	MV1A	1	9.9	10%
		10	6,800	
7	301A	2	68,000	5%
10	302A	4	140,000	5%
5	306A	1	33,000	5%

Protected by Patent Nos. 626128 & 675279



Painton & Co. Ltd.

KINGSTHORPE NORTHAMPTON
Tel: 32354-7 Telegrams: 'Ceil Northampton'

★ Fully Type Approved to RCS 111

★ Top Quality ★ Quick Delivery

★ Competitive Prices

Always specify Painton Wirewounds



**TRANSISTORISED
THREE-CIRCUIT CARRIER
TELEPHONE EQUIPMENT FOR
OPEN-WIRE LINES**

System SPO. 1012

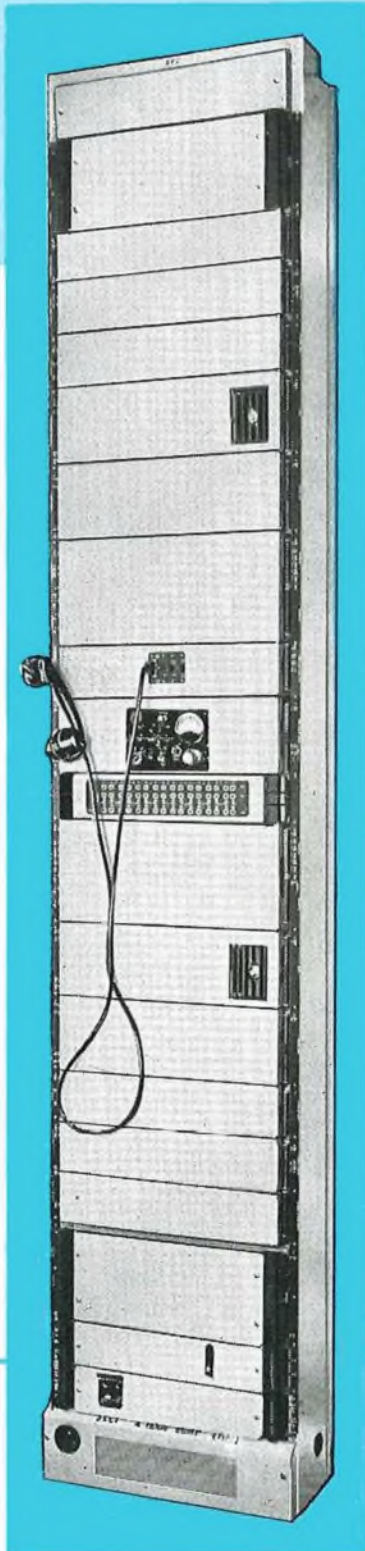

- * Three speech circuits each 300—3,400 c/s
- * Out-of-band signalling
- * Four duplex voice-frequency telegraph channels
- * Physical circuit up to 2,700 c/s

All these facilities are provided by this new G.E.C. transistorised equipment, which operates in the frequency band 3.16 kc/s to 31.11 kc/s over two-wire lines. Four separate systems are available, differing only in their use of erect or inverted sidebands, and staggered frequency bands, to reduce crosstalk when several systems use the same pole route.

Alternatively, 24 voice-frequency telegraph circuits can be provided over any of the carrier telephone circuits, or a programme channel of approximately 10 kc/s bandwidth can replace three speech channels.

The complete terminal equipment for two systems can be mounted on one rack 9 ft. high, or for one system on a 6 ft. rack.

Using suitably spaced repeaters, the system will operate over distances of up to 2,000 miles, depending on line conditions.

A 12-circuit carrier telephone system in the frequency band above 36 kc/s can operate over the same open-wire pair.

Please write for further information

Everything for Telecommunications

THE GENERAL ELECTRIC COMPANY LIMITED OF ENGLAND
Telephone, Radio & Television Works, Coventry, England

A.T.E

constructs

for

Canada



The A.T.E. Group recently completed their part of an important telecommunication project in Newfoundland and Nova Scotia. The contract was placed by the Canadian National Telegraphs and included ATE high grade channelling equipment for use over microwave radio relay links supplied by Standard Telephones & Cables Ltd.

The newly completed communications route stretches from St. Johns, Newfoundland, to Sydney, Nova Scotia, and the ATE equipment comprises units for an initial 2 supergroups, one of which is fully equipped for 60 circuits. Equipment for one bothway and one unidirectional 10 kc/s broadcast channel has also been supplied.

A.T.E. have also been commissioned to provide equipment for an additional link between Cornerbrook and Deer Lake. This spur will cater for three 12-channel groups working into American 'L' type carrier equipment at Deer Lake.

Canada is one of 20 countries in which the ATE Group has recently completed large telecommunication projects.

AUTOMATIC TELEPHONE & ELECTRIC CO. LTD.

STROWGER HOUSE, ARUNDEL STREET, LONDON. W.C.2. TEL: TEMPLE BAR 9262. TELEGRAMS: STROWGER, ESTRAND, LONDON



AT8901

*Newfoundland
linked with
Nova Scotia*



INDEX TO ADVERTISERS

	PAGE		PAGE
Adcola Products, Ltd.	2	Neill, James, & Co. (Sheffield), Ltd.	23
Automatic Telephone & Electric Co., Ltd.	9, 28-29, 34-35	Painton & Co., Ltd.	32
Associated Electrical Industries, Ltd.	16, 25, 27, 28-29	Pirelli-General Cable Works, Ltd.	37
Avo, Ltd.	20	Pitman, Sir Isaac, & Sons, Ltd.	20
British Institute of Engineering Technology	2	Pye Telecommunications, Ltd.	8
Cathodeon Crystals, Ltd.	2	Siemens Edison Swan, Ltd.	16, 27, 28-29
Ericsson Telephones, Ltd.	18-19, 28-29	Simon Engineering (Midlands), Ltd.	3
Evershed & Vignoles, Ltd.	15	Smith, Frederick, & Co.	20
Formica, Ltd.	5	Standard Telephones & Cables, Ltd.	28-29, 30-31, 38
General Electric Co., Ltd., The	12-13, 24, 28-29, 33	Stone-Chance, Ltd. (Austinlite)	22
Great Northern Telegraph Co., Ltd.	4	Telephone Manufacturing Co., Ltd.	10-11
Henleys, W. T., Telegraph Works Co., Ltd.	25	Tungstone Products, Ltd.	14
Hivac, Ltd.	36	Turner, Ernest, Electrical Instruments, Ltd.	37
Johnson, Matthey & Co., Ltd.	7	Westinghouse Brake & Signal Co., Ltd.	21
Marconi's Wireless Telegraph Co., Ltd.	6	Winn & Coales, Ltd.	23
Mullard, Ltd.	17, 26		

XS2

Dry Reed Relay Insert

A gold-plated relay contact hermetically sealed
in inert gas for absolute reliability, high speed
and low contact bounce.

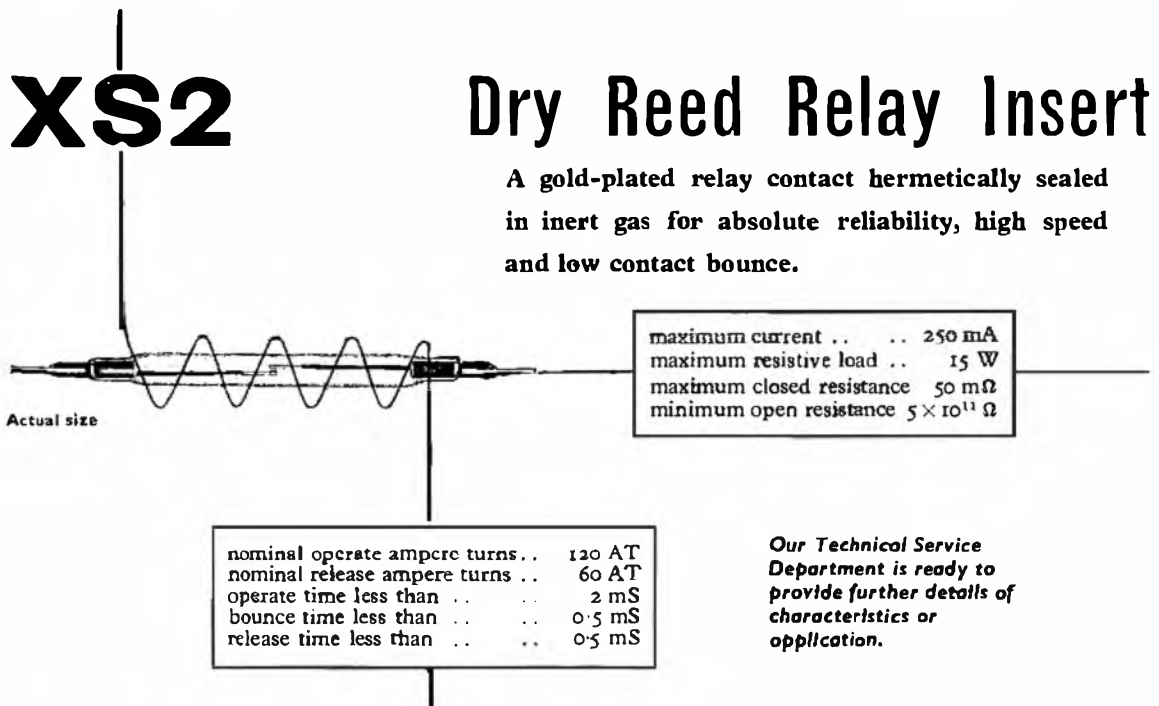

maximum current	250 mA
maximum resistive load	15 W
maximum closed resistance	50 mΩ
minimum open resistance	$5 \times 10^{11} \Omega$

nominal operate ampere turns	120 AT
nominal release ampere turns	60 AT
operate time less than	2 mS
bounce time less than	0.5 mS
release time less than	0.5 mS

Our Technical Service Department is ready to provide further details of characteristics or application.

Hivac Limited

A member of the Automatic Telephone & Electric Group

Stonefield Way · South Ruislip · Middlesex

Telephone: Ruislip 3366

Ernest Turner

Electrical Measuring Instruments

Ideally matching contemporary panel design, the Ernest Turner Model 703, illustrated here, is enhanced by the flush-fitting surround. A high degree of accuracy is adequately supported by the easy-to-read scale and clean dial layout. Full details of the range of rectangular electrical measuring instruments and flush mountings are contained in Leaflets 85/G and 85/AF, available on request.

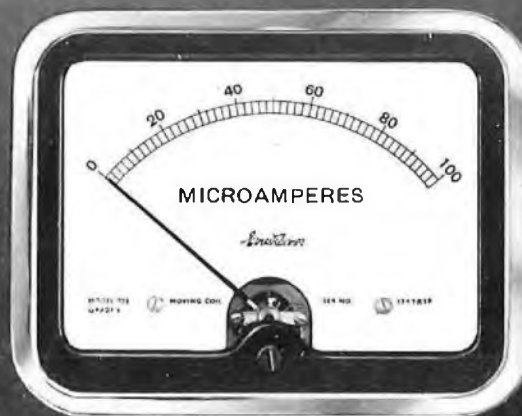

Ernest Turner Electrical Instruments Ltd

HIGH WYCOMBE · BUCKINGHAMSHIRE · ENGLAND



PIRELLI GENERAL
CABLE WORKS LTD.

PAPER INSULATED TRUNK CABLES
TELEVISION CABLES
RADIO FREQUENCY CABLES
COAXIAL CABLES

PIRELLI-GENERAL CABLE WORKS LIMITED, SOUTHAMPTON

Over 2,000 conversations on one cable

59. Development of the coaxial cable made a large reduction in the cost of long distance telephone conversations. In modern coaxial cables up to 960 simultaneous conversations can be transmitted over a pair of coaxial tubes, of which there may be several in each cable. But engineering development is now being pushed a stage further. By reducing the spacing between repeater stations from 6 to 3 miles the capacity of existing cables will cater for about 2,400 simultaneous conversations or 1,000 conversations plus a two-way television channel. 60. Microwave radio systems providing simultaneously for telephony and television have been developed and brought into service.

*extract from the Post Office Report
and Commercial Accounts 1957-58.*



S.T.C.

were the first in Europe to
manufacture Coaxial

Cables in 1935 and have pioneered
all subsequent developments.

S.T.C. have installed or have on order
over 10,000 route miles of Coaxial Cable
incorporating 36,000 miles of Coaxial tube.



CABLE
AND WIRE
GROUP

Standard Telephones and Cables Limited

Registered Office: Connaught House, Aldwych, London, W.C.2

TELEPHONE CABLE DIVISION: NORTH WOOLWICH . LONDON E.16