

THE POST OFFICE ELECTRICAL ENGINEERS' JOURNAL

Vol. 44

APRIL 1951

Part 1

CONTENTS

	PAGE
ACCEPTANCE TESTING OF COAXIAL PAIRS FOR THE INLAND TRUNK NETWORK —R. E. Taylor, A.M.I.E.E., and R. J. Turner, B.Sc.(Eng.), A.M.I.E.E.	1
A NEW PORTABLE GENERATING SET FOR MANHOLE LIGHTING—B. C. Hill, B.Sc.(Eng.), A.M.I.E.E., and E. E. M. Smith, A.M.I.E.E.	7
INTRODUCTION TO ELECTRONIC EXCHANGES—TRUNKING AND SELECTION SYSTEMS—T. H. Flowers, M.B.E., B.Sc.(Eng.), M.I.E.E.	10
WHITEHALL GARDENS P.A.B.X.—F. T. Perkins	15
ALTERATIONS TO H.M.T.S. ARIEL'S CABLE PAYING-OUT GEAR	17
THE SINGLE-COMMUTATION DIRECT CURRENT SIGNALLING AND IMPULSING SYSTEM—S. Welch, M.Eng., A.M.I.E.E., and B. N. Horsfield, A.M.I.E.E.	18
THE NEW LONDON RADIO-TELEPHONY TERMINAL—C. W. Sowton, B.Sc.(Eng.), A.C.G.I., A.M.I.E.E., and D. B. Balchin, B.Sc.(Eng.), A.M.I.E.E.	25
AN APPLICATION OF EQUALISER CURVES TO THE DESIGN OF TWO-TERMINAL NETWORKS—P. W. Seymour, A.M.I.E.E.	31
THE MANCHESTER-EDINBURGH TELEVISION RADIO RELAY SYSTEM	33
COMMONWEALTH TELECOMMUNICATIONS	35
NOTES AND COMMENTS	36
INSTITUTION OF POST OFFICE ELECTRICAL ENGINEERS	38
REGIONAL NOTES	39
JUNIOR SECTION NOTES	43
STAFF CHANGES	46
BOOK REVIEWS	24, 30, 32, 34, 45, 48

Price 1/6 net

THE INSTITUTION OF POST OFFICE ELECTRICAL ENGINEERS

STUDY
AT
HOME

You Can Have a College Training
For a Few Shillings Monthly

IN YOUR
SPARE
TIME

CITY and GUILDS (Telecommunication) EXAMINATIONS

To every student we send
a written Guarantee of
Tuition until the
examination is
actually
passed

Our
tuition
is so graded
that each stage
is reached without
difficulty.

Personal attention is given
to every student.

FULL PARTICULARS AND
ADVICE SUPPLIED FREE.

WE TEACH BY POST IN ALL
PARTS OF THE WORLD.

*The most progressive and most successful
Correspondence College in the world*



Dept. 24, THE BENNETT COLLEGE, SHEFFIELD



A.C. Polyphase Wound
Rotor - Rotor Rheostat.

FOR EVERY PHASE OF ELECTRICAL WORK

The British Electric Resistance Co. Ltd. can answer the multitude of resistance problems that beset the electrical circuit designer. For twenty years Berco resistances have been giving reliable and steadfast service, and the Berco range is designed to meet every requirement.

Berco engineers are specialists in resistance design and their knowledge is at your disposal.



RESISTANCES

THE BRITISH ELECTRIC RESISTANCE CO. LTD.
Queensway, Ponders End, Middlesex

Telephone: Howard 1492

Telegrams: Vitrohm, Enfield

BR2033-AQ

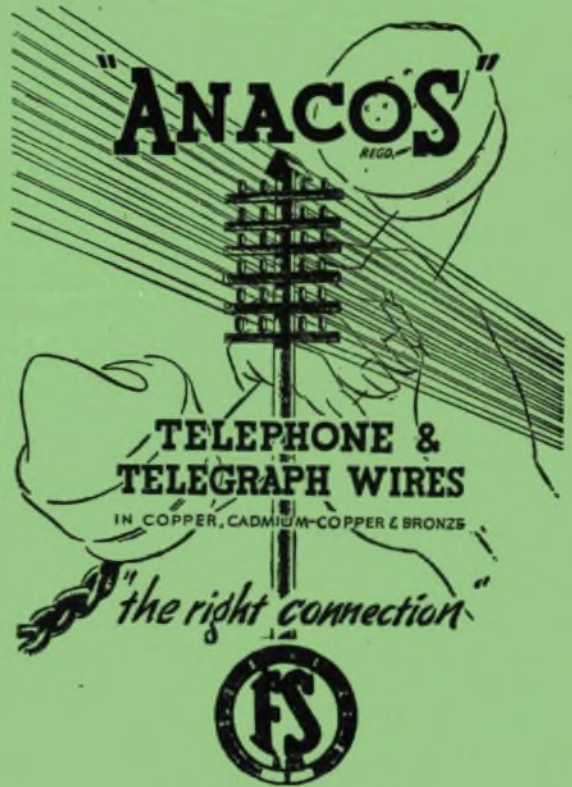

FREDERICK SMITH & COMPANY
(Incorporated in The London Electric Wire Company and Smiths, Limited)
ANACONDA WORKS, SALFORD 3, LANC.
Phone: Blackfriars 6701 (7 lines) • Grams: "Anacanda," Manchester



QUANTITY but not MASS production

Each transformer we design is produced with the infinite care and accuracy of a well-tailored garment.

The results regularly achieved bring us many letters of appreciation and congratulation from Home and Overseas.



SAVAGE TRANSFORMERS LTD. • NURSTEED ROAD, DEVIZES, WILTS.

THE POST OFFICE

ELECTRICAL ENGINEERS' JOURNAL

Vol. 44

April 1951

Part 1

Acceptance Testing of Coaxial Pairs for the Inland Trunk Network

R. E. TAYLOR, A.M.I.E.E., and
R. J. TURNER, B.Sc.(Eng.), A.M.I.E.E. †

U.D.C. 621.315.212 : 621.397.5 : 621.395.741

To ensure that coaxial pairs meet specified requirements, acceptance tests are required as outlined in this article. The equipment and methods described were employed on the London-Birmingham television cable for measurements at frequencies up to 26 Mc/s.

Introduction.

IN general, trunk cables containing coaxial pairs are ordered by the Post Office on a basis which provides for the laying of the cable by the manufacturer. The cable is then accepted or rejected in so far as the coaxial pairs are concerned on the results of measurements made on repeater sections of cable, which are generally from 3 to 6 miles long. Cables are manufactured in lengths of about one-tenth of a mile to a factory length specification; the cable is then laid and terminated, and complete overall tests are made on each repeater section of cable. The most important side of Post Office measurement work in connection with the initial testing of coaxial cables is thus concerned with repeater section lengths of cable. When new types of cable are being introduced, however, measurements are required on factory lengths of cable and for such measurements a different technique is required.

The frequency range over which the measurements are to be made depends largely on the diameter of the coaxial pair under consideration. Thus, for the 0.375-in. diameter coaxial pairs, which form a large part of the trunk network, acceptance tests up to 3 Mc/s are required. The introduction of 0.975-in. diameter coaxial pairs¹ has necessitated an extension of the testing range up to 26 Mc/s.

TEST SPECIFICATIONS FOR COAXIAL PAIRS

As measurements for acceptance tests are bound up with the requirements of test specifications, some consideration will first be given to methods of specifying the requirements for coaxial pairs in cables for Post Office use. The cable whose performance is to be specified consists, in general, of a number of coaxial pairs, sometimes of differing sizes, with their outer conductors insulated from one another, together with ordinary pairs, all enclosed in a lead sheath. The specification and testing of ordinary pairs follows well-established practice and no further details will be given in this article. It may be noted, however, that it is usual to provide power for some repeater stations by feeding 50 c/s alternating current supplies over the coaxial pairs. It is thus necessary to make measurements to ensure that the noise level on the ordinary pairs is not excessive.

The performance of a uniform coaxial pair is completely specified by the resistance, inductance, conductance and capacitance per unit length. It can also be completely

specified by the dimensions of the conductors and the conductivity, permeability and permittivity of the conductors and the dielectric. It is more practical, however, to specify the resistive and reactive component of the characteristic impedance, the attenuation coefficient and the phase-change coefficient; for some purposes it is more convenient to deal in terms of relative velocity rather than the phase-change coefficient. All these parameters are functions of frequency, and, provided the frequency is not too low, are given by the following relations:—

$$\alpha = A \sqrt{f} + Ef \dots\dots\dots(1)$$

$$\rho = \rho_1 - D/\sqrt{f} \dots\dots\dots(2)$$

$$Z_0 = R_1 + (1 - j) H/\sqrt{f} \dots\dots\dots(3)$$

where α is the attenuation coefficient,

ρ is the relative velocity,

Z_0 is the characteristic impedance,

f is the frequency in Mc/s,

and A, B, ρ_1, D, R_1 and H are constants for a particular coaxial pair.

Owing to inevitable variations in the dimensions of the coaxial pair and to irregularities in the properties of the conductors and the dielectric, the characteristic impedance and propagation coefficient vary along the length of a coaxial pair. It is thus necessary, particularly for pairs to be used for television purposes, to apply limits to these irregularities or to their effects. Ideally the smooth curve to be expected from the variation of the input impedance with frequency of a long terminated line should follow equation (3); due to the irregularities in the cable, however, this curve has superimposed on it variations in both the resistive and reactive components. In Post Office practice the resistive component of the input impedance is measured; limits are then placed on the permissible amount of deviation of the irregular curve that results, from a mean curve drawn through it. Limits are also applied to the value of the smooth mean curve at a particular frequency.

In Post Office specifications the attenuation of a repeater section at acceptance is required to be within certain limits of the attenuation given by a relation similar to equation (1). The attenuation of a cable changes with temperature and the measured attenuation of the cable must be corrected to allow for this.

Where there is more than one coaxial pair in a cable, the question of cross-talk between them arises. In Post Office specifications, the minimum permissible cross-talk attenuation is quoted by laws similar to the following:—

$$\alpha_n = J + K \sqrt{f} \dots\dots\dots(4)$$

$$\alpha_j = M + N \sqrt{f} \dots\dots\dots(5)$$

†The authors are respectively Factories Executive Engineer, Factories Dept. (formerly with Test and Inspection Branch, E.-in-C.'s Office), and Executive Engineer, Radio Experimental and Development Branch, E.-in-C.'s Office.

¹Stanesby, H., and Weston, W. K. "The London-Birmingham Television Cable." *P.O.E.E.J.*, Vol. 41, p. 183; Vol. 42, p. 33.

where α_n and α_f are the near-end and far-end cross-talk, respectively, and J , K , M and N are constants for the two coaxial pairs concerned.

ACCEPTANCE TESTS ON REPEATER SECTION LENGTHS

General.

In testing a repeater section length of a cable containing both coaxial pairs and ordinary pairs, the order of carrying out the tests is of importance since it would be a waste of time to carry out high-frequency tests on the coaxial pairs when there may be a contact fault or low insulation resistance on the ordinary pairs which would necessitate rejection of the section, with perhaps the need to replace a drum length of cable. When a length has to be replaced after acceptance tests have commenced, it is, of course, necessary to repeat all the tests so far made. The order of testing shown below has been found to be sound practice to ensure that simple but important faults are found early on by means of D.C. tests which do not take long to carry out.

- (1) Resistance of all conductors
- (2) Insulation breakdown on coaxial pairs
- (3) Insulation resistance of all conductors
- (4) Attenuation of the coaxial pairs
- (5) Impedance and/or reflection coefficient of the coaxial pairs from both ends of the section
- (6) Cross-talk between coaxial pairs
- (7) Attenuation of ordinary pairs
- (8) Cross-talk between ordinary pairs.

The tests concerned with the coaxial pairs will be described in turn.

Conductor Resistance.

There are two reasons for making accurate measurements of conductor resistance. The first is to check that no high resistance joints have been made during installation; the difference between the resistances of any two inner conductors is specified not to exceed 0.2 ohm for a repeater section of 0.375-in. coaxial pair, and any value higher than this is specially investigated by comparison with the values obtained on drum lengths at works. The second reason is that, since the resistance of the inner conductor varies with temperature and is stable with time, it can be used to assess the mean temperature of a cable; the measured resistance of the inner conductor is compared with that calculated from measurements made on factory lengths of cable at a known temperature by making use of the known value of the coefficient of variation of resistance of copper with temperature. The length of the cable when jointed is less than that at the contractor's works and allowance must be made for this.

The resistances to be measured are small in magnitude, being 5.0 and 3.5 ohms per mile at 10°C for the inner and outer conductors, respectively, of the 0.375-in. diameter coaxial pair. It is thus important to allow for the resistance of the test leads and to ensure that there are no troubles due to contact resistance at the points of connection of the test leads. To this end, special connectors which can be tightly clamped to the cable termination are employed. To obtain consistent results and to check that there are no high resistance difficulties, it is customary to deal with two coaxial pairs at a time and take all six combinations of the four conductors looped two at a time at the far end with a connection of known resistance; from these results the sum of the resistances of all four conductors can be obtained in three different ways and any discrepancy shows up connection troubles.

Insulation Breakdown.

The insulation breakdown test is used to detect incipient contacts between the inner and outer conductors of the coaxial pair due to slivers of copper, metallic dust or faulty joints. An A.C. supply at 2,000V, 50 c/s is applied between the inner and the earthed outer conductor for a period of two minutes. The test is used extensively by the contractor during installation and is made jointly by the Post Office and the contractor for the acceptance test.

One form of the apparatus for this test consists of a battery-driven motor alternator feeding a 50 c/s voltage to a step-up transformer. The output voltage and current are indicated by a 3-kV electrostatic voltmeter and by a milliammeter, and the voltage is controlled by a rheostat in the field circuit of the alternator. The voltage applied to the cable is increased from zero to 2 kV and then maintained at this value for two minutes. The whole of the equipment is mounted in a joiner's truck and long leads are used to connect to the cable end.

A disadvantage in using an alternating voltage supply is that a fairly high current is normally taken by the pair under test and fault currents may pass unnoticed. In the future it is proposed to use 3 kV direct voltage for the test.

The elaborate safety precautions employed on complete coaxial systems to prevent access to the cable pair while it is carrying current are not available when these breakdown tests are made, and it is, therefore, the practice to arrange for a responsible person to be at the remote end of the repeater section under test and in telephonic communication with the tester to ensure that the cable end is not touched while under test.

Insulation Resistance.

Measurements are made of the insulation resistance of the coaxial pair to check that the insulation has not been affected by moisture.

A 500-V motor-driven ohmmeter is used and the insulation resistance of each conductor in the cable is measured between that conductor and all other conductors and the cable sheath which are connected together and to earth. When testing on short sections, this test is sometimes not sensitive enough, and in such cases the high direct voltage required is obtained from batteries and applied to the cable through a sensitive galvanometer.

Attenuation.

It is the practice to make attenuation measurements on all coaxial pairs over their working frequency range on every repeater section length; two coaxial pairs are dealt with at a time, the far ends being looped together with a short length of flexible coaxial pair. It is required to deduce the attenuation per mile corrected to a specified temperature, and the accuracy of the result depends not only on the accuracy of the measurement of the attenuation but also on the accuracy with which the length and the temperature at the time of test can be assessed.

As already described, the temperature of the cable is calculated from the resistance of the inner conductor. The attenuation of a coaxial pair is proportional to its high-frequency resistance which, at the frequencies concerned here, is proportional to the square root of the resistivity; it follows that the coefficient of change of attenuation with temperature is one-half that of the temperature coefficient of resistance of the conductors.

The distance between the centres of manholes is measured to the nearest foot, i.e. ± 6 in., and this, together with a knowledge of the additional length of cable used in following the contour of the walls of the manholes, gives the length of a repeater section to about ± 0.1 per cent. This measurement is not necessarily the true length of the cable, however

because, apart from inaccuracies in the many separate measurements involved, no allowance is made for the increase in length due to the varying depths at which the cable is laid. The importance of this factor varies and is greatest in built-up areas where the changes in depth are likely to be more severe. It may be remarked here that the practice of including a length-tape in a cable has advantages; the length of the individual lengths can then be assessed at the time of jointing, the only uncertainty being the amount the cable has stretched during pulling in—a factor that normally should be negligible.

The attenuation of the coaxial pair (i.e. the attenuation coefficient \times the length) is measured on an insertion loss basis. The attenuation is equal to the insertion loss only when the latter is measured between impedances equal to the characteristic impedance of the cable. The error is negligible, however, if the terminating resistors are within a few per cent. of the characteristic impedance, as is likely in these tests, but if one termination is in error by 5 per cent. and the other by 50 per cent. then the error can be as much as 0.14 db.

The maximum value of attenuation to be measured is, of course, that of the longest length at the highest frequency at which measurements are required. For 0.375-in. diameter coaxial pairs the attenuation of a looped 6-mile repeater section is about 80 db. at 3 Mc/s. For a looped 3-mile repeater section of 0.975-in. pair the attenuation is 50 db. at 26 Mc/s. In some circumstances, repeater sections as short as a mile are encountered and hence the minimum attenuation to be measured is the attenuation of this length of 0.975 in. pair at the lowest frequency at which measurements are required; this frequency is 1 Mc/s and the attenuation of the looped section is only 3 db.

For the 0.375-in. coaxial pairs, attenuation measurements are made over the frequency range 60 kc/s–3 Mc/s at intervals of 20 kc/s at the lower frequencies and at wider frequency intervals at higher frequencies.

The apparatus used consists of an oscillator feeding into two 0.61.5db. attenuators, A and B, in parallel (see Fig. 1). The coaxial pairs under test are connected in series with

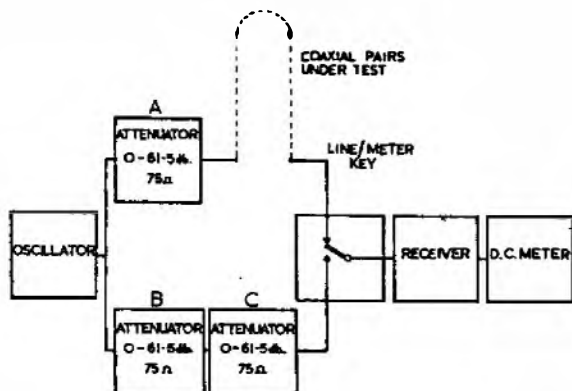

FIG. 1.—BLOCK SCHEMATIC DIAGRAM OF EQUIPMENT FOR ATTENUATION TEST UP TO 3 MC/S.

attenuator A and a further attenuator, C, is connected in series with attenuator B. The voltage at the output of the return coaxial pair is compared with that at the output of attenuators B and C by means of a super-heterodyne receiver of the communications type having an input impedance of 75 ohms; the intermediate frequency heterodyne oscillator is used to produce an audible beat note which is rectified at the output of the receiver and indicated by a sensitive D.C. meter. The comparison of the two voltages is facilitated by a changeover key which copies mechanically the action of plugging the receiver lead into the coaxial pair or the attenuators.

Attenuator A is kept at as high a value as possible in order to present a 75-ohm source impedance to the coaxial pair under test. To make a measurement, attenuators B and C are adjusted so that the same meter reading is obtained in both positions of the Line/Meter key. These attenuators are variable in steps of 0.5 db. and the attenuation of the coaxial pair is obtained to the nearest tenth of a decibel by interpolation with reference to the meter. It will be seen that in this method the output not connected to the receiver is open-circuited. The effect of this on the oscillator output voltage is small, however, since the attenuation in both the cable side and in the measuring side is always kept as high as possible.

On the 0.975-in. coaxial pair measurements of attenuation are taken over the range 1–30 Mc/s at frequency intervals of 1 Mc/s up to 5 Mc/s, and thereafter at intervals of 5 Mc/s. The method of measurement is in principle the same as that used at lower frequencies, but the oscillator and reference attenuators are replaced by a signal generator that has been developed for the purpose. The instrument gives two outputs from a crystal oscillator incorporated in it, and one of these outputs can be varied by means of an accurate piston attenuator.²

Characteristic Impedance.

For repeater section lengths of coaxial pair, the input impedance when the far end is terminated in the approximate value of the characteristic impedance is taken as the value of the characteristic impedance. The error in taking the input impedance to be the characteristic impedance depends upon the attenuation of the line and the closeness of the terminating resistance to the characteristic impedance. Thus, if the terminating resistance is within one per cent., the error in taking the input impedance of a line of attenuation 20 db. to be the characteristic impedance will be 0.01 per cent. and will be negligible compared to the measurement error.

The value of the input impedance varies with frequency in two ways; the impedance decreases as the frequency increases owing to full establishment of skin effect; superimposed on this smooth decrease are irregular variations due to the non-uniformity of the coaxial pair. To determine as far as possible the maximum impedance excursion of these irregularities, it is necessary to take readings at small frequency intervals. Thus, for the 0.375-in. coaxial pair, readings are taken over the frequency range 60 kc/s–3 Mc/s at 20 kc/s intervals; for the 0.975-in. pair, readings are taken at 20 kc/s intervals over the range 3–10 Mc/s and at 40 kc/s intervals from 10–26 Mc/s, a total of 750 measurements. To make such large numbers of measurements, a direct-reading bridge which is accurate, quick to operate and independent of frequency is necessary. It need have only a limited range above and below 75 ohms.

A bridge developed for this work³ employs capacitive ratio arms C_3 , C_4 (see Fig. 2); the unknown impedance

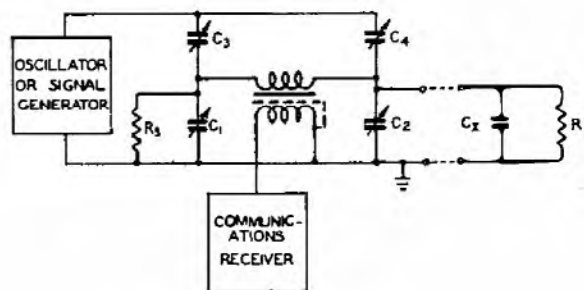

FIG. 2.—SIMPLIFIED CIRCUIT OF IMPEDANCE BRIDGE.

² P.O.E.E.J., Vol. 43, p. 192.

³ British Patent Application No. 10375, 1948.

represented by the shunt combination of R_x and C_x is connected in parallel with a variable capacitor C_2 and the fourth arm of the bridge consists of a standard resistor, R_s , in parallel with a variable capacitor, C_1 .

When the bridge is balanced it can be shown that

$$R_x = (C_3/C_4) R_s \dots\dots\dots(6)$$

$$\text{and } C_x = C_1 (C_4/C_3) - C_2 \dots\dots\dots(7)$$

The resistor R_s is of a plug-in type arranged in a coaxial mounting and consists of a high stability carbon resistor of resistance corresponding to the mean of the range to be measured. The capacitances C_1 and C_2 are formed by the two halves of a differential capacitor. A second differential capacitor C_3, C_4 provides the resistance balance and the dial is directly calibrated in terms of resistance. To check the calibration before using the bridge, a high stability carbon resistor, of which the D.C. resistance is known, is connected to the unknown terminals of the bridge and a balance made at a convenient low frequency. Allowance can then be made for any change in the value of the standard resistor with temperature and/or time by bodily rotating the resistance scale after loosening the clamping screws. Two types of the bridge have been developed, one for the range 60 kc/s–5 Mc/s and the other for the range 2–40 Mc/s.

An early model of the bridge for the range 60 kc/s–5 Mc/s covers two resistance ranges. The lower scale on the dial, which is concerned with the work described here, covers the range 66–83 ohms, with a standard resistor of 75 ohms, for a capacitor rotation of 180 deg. By using a standard resistor of 60 ohms, the upper scale may be used to cover the range 53–67 ohms, for work on submarine coaxial cables of nominal impedance 60 ohms. The capacitor C_3, C_4 , which provides only a small variation of capacitance above a large fixed value, has only a few semi-circular plates, the remaining plates being full circles. The transformer from the bridge to the detector is balanced and screened; it has two screens, one of which is earthed. The pair under test is connected to the bridge by a flexible cable not longer than 5 ft., and provided the characteristic resistance of the flexible cable is within ± 4 per cent. of the resistance being measured, the error at 3 Mc/s caused by the connecting lead will not exceed ± 0.2 per cent. When a frequency run is being made, the presence of the lead shifts the frequencies at which maxima and minima occur, but affects their magnitudes to only a slight extent; hence the actual error due to the lead in measuring impedance excursions is less than indicated above and is not of practical importance.

The bridge for the frequency range 2–40 Mc/s is shown in Fig. 3. To obtain the small change of capacitance on a fairly large fixed value for C_3, C_4 , a cam and lever mechanism is employed. One advantage of this is that by suitably shaping the cam, a linear scale can be obtained; also, the capacitors can be mounted close together with the control knobs spaced apart, and in addition, about 350° rotation of the control knob can be obtained with consequent lengthening of the scale. When measuring at high frequencies, it is essential to connect the bridge to the coaxial pair under test by the shortest possible lead. In practice, a flexible lead only 6 in. long is used, and as before, provided the characteristic resistance of the flexible cable is within ± 4 per cent. of the resistance being measured, the error at 26 Mc/s caused by the connecting lead will not exceed ± 0.2 per cent. As the cable end is normally 6 ft. 6 in. from the ground, the tester has to operate the bridge from a high chair with a suitable support for the bridge. Even so, this form of bridge, together with the one for lower frequencies, is so easy to operate that an experienced tester can make more than 300 measurements in an hour without undue fatigue.

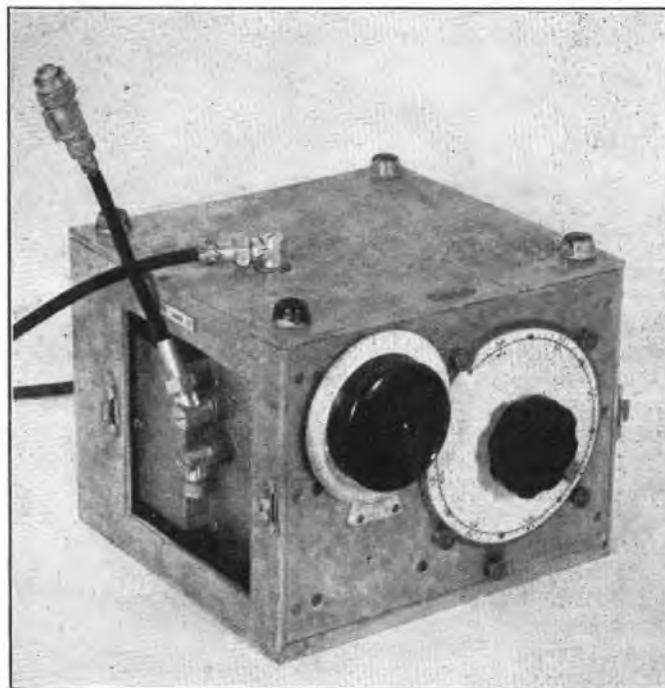

FIG. 3.—PROTOTYPE IMPEDANCE BRIDGE FOR USE IN FREQUENCY RANGE 2–40 Mc/s.

Reflection Coefficient.

Although the bridges described above are quickly and easily operated, a method involving a continuous frequency sweep would much reduce the testing time. This implies that the quantity to be measured and the method of measurement must be such that the result can be exhibited continuously by the deflection of a meter. A quantity that lends itself to measurement in this way is the modulus of the reflection coefficient of an unknown impedance Z with respect to some specified reference resistance R .* This quantity forms a convenient measure of the amount by which Z differs from R ; it is approximately proportional to the impedance deviation $|Z - R|$ when the latter is small.

The reflection coefficient can be measured by means of a bridge network that satisfies two simple conditions: the bridge must be balanced when the reference resistance R is connected to the “unknown” terminals, and the impedance looking into the unknown terminals must be equal to R . The second of these conditions need only be approximately met if the values of reflection coefficient to be measured are small. Then, if an impedance Z is connected to the terminals in place of R , the out-of-balance voltage from the bridge is proportional to the reflection coefficient of Z with respect to R . This principle is used in apparatus designed to measure the modulus of the reflection coefficient of the input impedance, Z , of a terminated coaxial pair with respect to a resistance, R , which is chosen to have the expected mean value of the characteristic impedance.

In addition to the bridge it is necessary to have a source of power and means of amplifying the out-of-balance voltage and indicating its magnitude. A block schematic diagram of the complete arrangement is shown in Fig. 4; most of

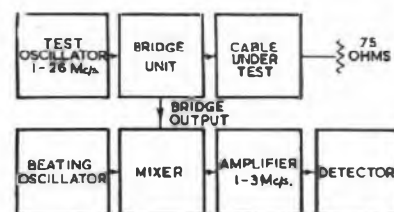

FIG. 4.—BLOCK SCHEMATIC DIAGRAM OF EQUIPMENT FOR REFLECTION CO-EFFICIENT TEST.

*The reflection coefficient is regarded as a property of the impedance Z with respect to the reference resistance R and does not imply the existence of echo signals such as are observed in pulse testing.

the units are conventional, but the following details of the bridge may be of interest. It is made up in a small unit (Fig. 5) which is connected to the rest of the equipment

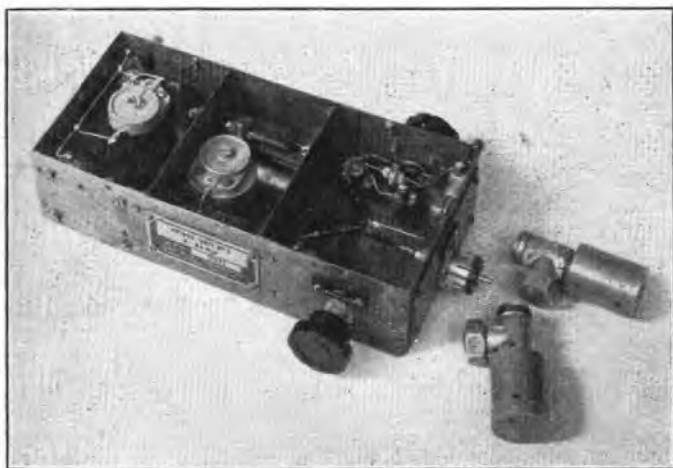

FIG. 5.—BRIDGE UNIT FOR REFLECTION COEFFICIENT TEST.

with flexible cables; thus, it can be plugged directly into the cable under test. This feature is an asset when cable terminations are situated some distance from the ground. A screened and balanced input transformer T_1 (Fig. 6)

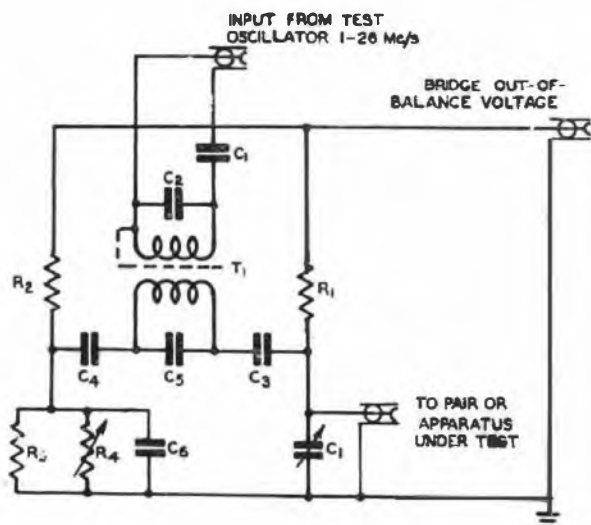

FIG. 6.—CIRCUIT OF BRIDGE UNIT FOR REFLECTION COEFFICIENT TEST.

provides a balanced supply to the bridge; two types of transformer are used—one covering the range 1–7 Mc/s, and the other the range 4–26 Mc/s. The bridge arms consist of two high stability carbon resistors R_1 and R_2 ; the impedance under test is connected across a variable capacitor C_1 , and the fourth arm consists of a fixed resistor R_3 , a variable resistor R_4 , and a fixed capacitor C_6 in parallel.

The remainder of the apparatus is largely standard equipment. A test oscillator covering the range 1–26 Mc/s feeds into the bridge unit. The output from the bridge is taken to a linear frequency changer where it is mixed with a supply from a beating oscillator to give a signal which is in the range 1–3 Mc/s.* This signal is fed to an

amplifier which has a response flat to ± 0.1 db. over the frequency range 1–3 Mc/s; the output is rectified and measured on a microammeter.

Tests are made over frequency bands 2 Mc/s wide; thus, to measure the reflection coefficient over the range $f \pm 1$ Mc/s the test oscillator is set to f Mc/s and the beating oscillator to $f + 2$ Mc/s. A difference frequency of 2 Mc/s then passes to the amplifier. A resistance of the value of the expected mean impedance of the cable under test (the reference resistance R_0) is connected to the “unknown” plug of the bridge and the bridge balanced by means of the controls, R_4 and C_1 . The equipment is calibrated by connecting in place of R_0 a resistance giving a known reflection coefficient with reference to R_0 , and varying the gain of the apparatus to obtain the correct reading. The apparatus is then ready for use; the coaxial pair under test is connected to the unknown terminals and the test oscillator swept through the frequency range $f \pm 1$ Mc/s.

The meter reading gives the reflection coefficient directly to an accuracy of ± 10 per cent. provided the test oscillator output remains constant throughout the sweep. Thus, when the impedance deviation is 1.5 ohms, the accuracy of measurement is ± 0.15 ohm. For a measurement at the frequency at which the bridge is balanced, the accuracy is greater.

As mentioned previously, the type of specification at present used limits only the variation of the resistive component of the input impedance. Thus, since the reflection coefficient apparatus also takes account of the reactive component of the input impedance, results obtained with it cannot be interpreted directly in terms of the specification. Thus, suppose that for a particular coaxial pair it is specified that the resistive component of the input impedance at any frequency in the band tested shall not differ by more than ± 3 per cent. from the value, at that frequency, of the smooth mean curve drawn through the plot of the resistive component of the input impedance. Ignoring the smooth variation of impedance with frequency the above tolerance indicates that if the reflection coefficient does not exceed 0.015 then the specification is met. However, the reflection coefficient might considerably exceed 0.015 due to the reactive component of the input impedance without the resistive component exceeding the specified tolerance; such a case would meet the present specification requirements.

It has been the practice to employ the reflection coefficient apparatus as a quick means of testing each end of each 0.975-in. coaxial pair in the frequency range 3–26 Mc/s. From the results so obtained on a given repeater section it has been possible to select the pair which was likely to give the worst results for impedance, and full impedance frequency tests have been made from one end on this pair only, unless it was thought from experience that other pairs also warranted impedance tests.

Crosstalk Attenuation.

The measurement of crosstalk attenuation is a special case of the measurement of insertion loss in which losses of up to 165 db. are to be measured. The attenuation to be measured increases with frequency. Measurements are made from 60 kc/s to a frequency where the attenuation is outside the limit of measurement; this frequency is seldom higher than 1.5 Mc/s. A method similar to that described for attenuation measurement is used, the arrangement being as shown in Fig. 7. To increase the maximum attenuation measurable an oscillator with a power output of about 5 watts is used and the range of the attenuators increased. To prevent damage to the attenuators by the high power used, they are preceded by a 7,425-ohm series resistor, which, with the 75-ohm input impedance of the attenuator gives 40db. attenuation; this arrangement is admissible

*The arrangements described apply strictly to tests over the frequency range 5–26 Mc/s; for the range 1–5 Mc/s certain modifications are made.

at the low frequencies at which measurements are required, but would become inaccurate at high frequencies owing to stray capacitances. Sometimes, to economise in the use of attenuators, an 80db. pad is used, made on the same principle, but employing two stages. For near-end crosstalk the attenuation is measured between the adjacent ends of two coaxial pairs with the far ends terminated in 75-ohm screened resistors of an adequate power rating. For far-end crosstalk measurements the oscillator feeds into the near end of the disturbing pair and the near end of the disturbed pair of the cable is terminated in a 75-ohm resistor. The attenuation is measured between the

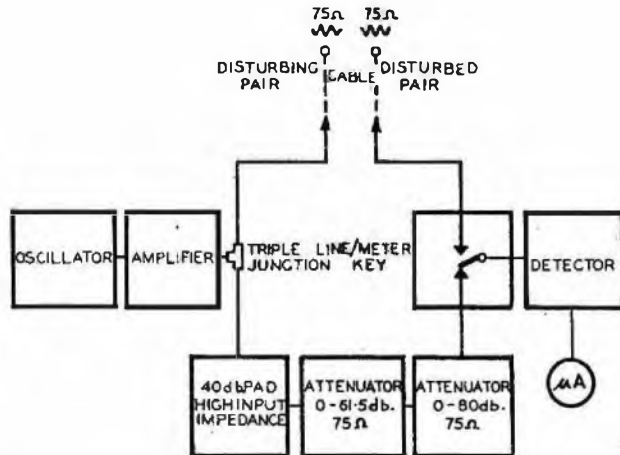

FIG. 7.—BLOCK SCHEMATIC DIAGRAM OF EQUIPMENT FOR CROSSTALK TEST.

Connections shown for near-end tests. For far-end crosstalk measurements the oscillator and amplifier are moved from the position shown and connected in place of the resistor terminating the disturbing pair.

terminated far end of the disturbing pair and the far end of the disturbed pair; the attenuation of the section of coaxial pair is added to the measured value of attenuation to obtain the value of the far-end crosstalk attenuation.

For check measurements covering the frequency range up to 26 Mc/s a piston attenuator is used as the reference attenuator; the outer conductor of the coaxial connecting leads for the equipment are made from annealed copper pipe to ensure that no leakage occurs from this source.

DESIGN OF EQUIPMENT FOR ROUTINE ACCEPTANCE TESTING

In the design of equipment for the routine acceptance testing of coaxial pairs, due consideration must be given to the conditions under which the equipment is used. These are often far from ideal and the simpler the operation of the equipment the easier it is to obtain the required accuracy of measurement. The apparatus has to be loaded and unloaded to and from test vans frequently and has to travel with little or no packing. Hence the equipment should be in units which can be handled easily, which are light and compact but which are robust. Since mains supplies are often not available, the power consumption of the equipment should be kept to a minimum and suitable portable power supplies should be included in the equipment of a testing group.

With regard to the future development of equipment, it may be possible to reduce the number of units of equipment required and simplify operation by the development of a

combined oscillator and detector unit. The type of unit envisaged would have a single control to alter the oscillator frequency and to tune the detector at the same time; such a unit would save time in the measurements of impedance and insertion loss.

The same basic type of unit is applicable to the reflection coefficient measuring apparatus, but in this case the output level of the oscillator must be maintained constant. With reflection coefficient equipment an ideal arrangement would be to have an automatic recording of reflection coefficient against frequency.

The reflection coefficient apparatus has hitherto been used mainly at frequencies above 3 Mc/s and the reflection coefficient has been measured with respect to a fixed resistor having a value equal to the expected mean resistance of the pair. If the use of the equipment is to be extended to lower frequencies the reflection coefficient should be related to the true characteristic impedance of a uniform coaxial pair which changes appreciably at the lower frequencies. A network can be designed to simulate closely this impedance and the bridge can be arranged to measure the reflection coefficient relative to this impedance by replacing R_1 (see Fig. 6) by this simulating network; the impedance against which the bridge is initially balanced should also be a simulating impedance.

ORGANISATION OF ACCEPTANCE TESTING

The amount of coaxial acceptance testing varies greatly from time to time. To economise in the provision of testing equipment it has been found that a good way of organising the work of acceptance testing a long cable is to divide the work into portions. Thus, for the London-Birmingham television cable¹ the work was divided and carried out by four testing groups. The first group working in advance of the others carried out conductor and insulation resistance tests on all conductors, insulation breakdown tests on all coaxial pairs and attenuation and reflection coefficient tests on the 0.975-in. pairs in the frequency range 3-26 Mc/s. The second group made such impedance tests as were necessary on the 0.975-in. pairs over the frequency range 3-26 Mc/s; at least one impedance/frequency run was made on each 3-mile repeater section. The third group carried out all the remaining tests on the coaxial pairs, namely, the impedance and attenuation on the 0.375-in. pairs, and crosstalk on all combinations of the coaxial pairs. The fourth group dealt with the tests on the ordinary pairs.

At the time of acceptance tests, there was often no main electricity supply available at the repeater stations. Hence each testing group had a 1-kW petrol generator supplying 230V A.C. To make each group self-sufficient and mobile such items as tables, chairs, lights and heating stoves were included in their equipment. To facilitate connection of equipment comprehensive sets of test leads were carried together with all the connectors, adaptors, terminations, leads and spanners necessary.

ACKNOWLEDGMENTS

Most of the apparatus described has been developed in the Radio Experimental and Development Branch and in the Test and Inspection Branch. The authors wish to express their thanks to their colleagues for their help in the preparation of the paper and to Standard Telephones & Cables, Ltd., for permission to publish information on their high voltage breakdown test.

A New Portable Generating Set for Manhole Lighting

B. C. HILL, B.Sc.(Eng.), A.M.I.E.E., and
E. E. M. SMITH, A.M.I.E.E.†

U.D.C. 621.311.28 : 628.9 : 621.315.233

The new "Generator, P.E.D., Portable," described in this article, is for use in conjunction with a 24-V battery to give improved lighting of manholes. The automatic voltage regulation is such that a compensated output voltage characteristic is obtained, making the plant suitable both for battery charging, and for possible use in operating equipment such as cable driers and soldering irons.

Introduction.

FOR many years the acetylene lamp has been the standard means of lighting Post Office underground plant. It has long been realised, however, that this method of illumination, although providing adequate light, has a number of disadvantages, e.g. the risk of ignition of combustible gases, the emission of fumes and heat which may be distressing to operators when the lamp is used in a confined space and the difficulty in disposing of spent carbide.

Prior to 1939, efforts were made to develop a suitable portable electric lamp, and field trials were conducted with the "Handlamp, Electric, No. 3A," but it was found that the illumination provided was insufficient and difficulty was experienced in providing charging facilities.

At the outbreak of war further development work was abandoned, and it was not until 1945 that the matter again came under active consideration. It then appeared that the only satisfactory method of obtaining an adequate light in manholes for prolonged periods was by a portable generating set, and experiments were carried out under practical conditions with a petrol-engine-driven set lent by a manufacturer; promising results were obtained.

In 1946, however, supplies of war-surplus petrol-engine-driven battery charging sets became available, and after examining a number of types, it was decided that a 24V, 300W set of U.S.A. manufacture was the most suitable for the Department's purpose. The set consists essentially of a 68 c.c. four-stroke petrol engine with an extended crankshaft which carries the generator armature. As the engine is fitted with coil ignition, a secondary battery is necessary and 12V, 22 Ah lead-acid batteries were therefore obtained from the same source as the generating sets. This type of battery is contained in a wooden case with a hinged lid and carrying strap, the output being terminated on a two-pin, non-reversible, weatherproof socket.

A combined clip and stand lamp was developed for general use in underground plant, and 40W traction type lamps used because of their more robust construction.

The complete equipment is illustrated in Fig. 1.

Experience with Generating Sets in Service.

Distribution of the war-surplus equipment commenced in 1947 and it has proved extremely popular with external staff as a result of the great improvement experienced in working conditions in manholes.

However, with the introduction of these sets, maintenance difficulties also began to arise as many sets were found to be damaged or incomplete on receipt, and the small stock of spares, which could not be replaced, was quickly dissipated in making them serviceable. Many of the batteries were also found to be unserviceable from the effects of prolonged storage or damage sustained in transit.

Day-to-day maintenance of generating sets and batteries is carried out by the external staff using the equipment, but larger overhauls and repairs are handled by Motor Transport staff who have been obliged to exercise much ingenuity in order to overcome the shortage of spares.

Design of Replacement Generating Sets.

In 1948, the design of a generating set to supplement and ultimately replace the war-surplus equipment came under consideration.

The following features appeared to be desirable:—

- (a) The voltage should be retained at 24V to facilitate interchangeability with the existing equipment but the output should be increased to 500W to allow for

† The authors are, respectively, Executive Engineer and Assistant Engineer, External Plant and Protection Branch, Engineer-in-Chief's Office.

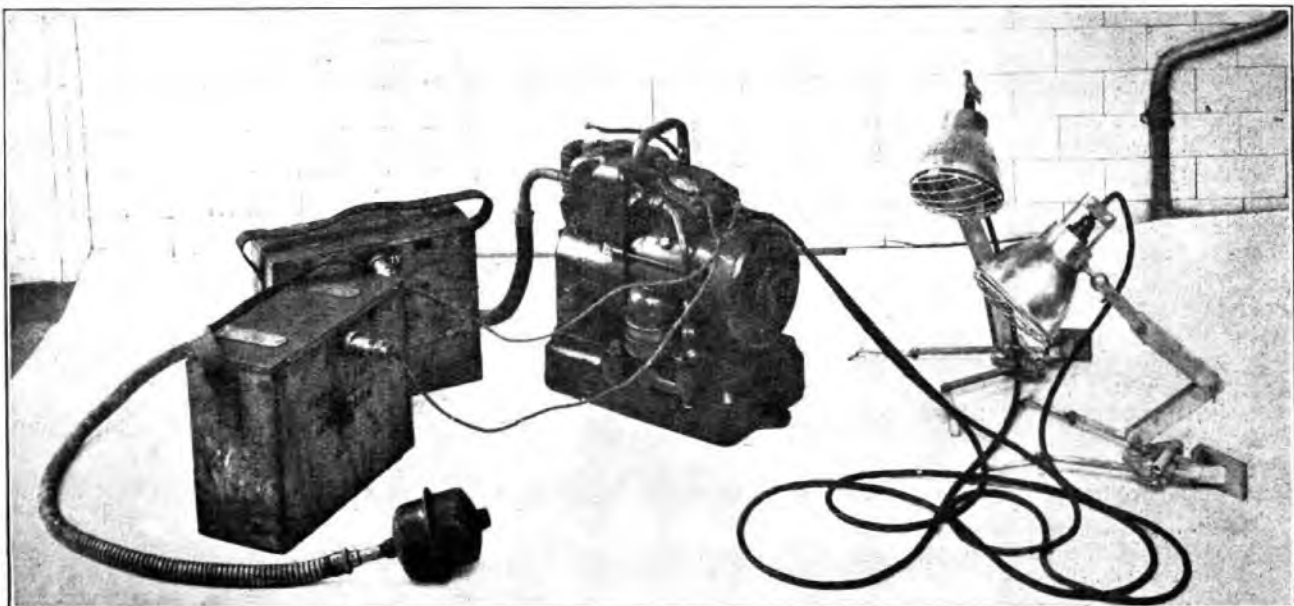

FIG. 1.—COMPLETE EQUIPMENT USING WAR SURPLUS CHARGING SET AND BATTERIES.

operation of various other items of equipment at present under consideration.

- (b) The weight should not greatly exceed that of the war-surplus set (93 lb.).
- (c) The set should be of unit construction for lightness and compactness.
- (d) The set should be simple to operate and voltage regulation should be automatic.
- (e) The set should be operated in conjunction with a 24V battery. This is necessary because it is undesirable from the noise aspect to run the engine at night when shift work is being carried out in a residential area; also, the provision of a battery saves unnecessary wear and tear on the engine since the set may be shut down when light loads are connected and started up only when it is necessary to recharge the battery.
- (f) A four-stroke engine should be employed. Two-stroke engines are not favoured because of (i) noise and (ii) the lubrication system relies on mixing oil with the petrol, a requirement which is apt to be overlooked by the operator, with consequent damage to the engine and increased major maintenance.
- (g) It should be possible to supply a load from the generator whilst battery charging is in progress.
- (h) The ignition should be switched off automatically when the battery voltage reaches a predetermined figure in order to avoid unnecessary engine wear.

In the production form of the generator set, known in the Post Office as "Generator, P.E.D., Portable," unit construction was found to be too expensive, and standard commercial engine and generator units had to be employed with inevitable increase in weight.

Description of Generator, P.E.D., Portable.

Illustrations of the new generator set appear in Fig. 2. The engine drives the generator through a flexible coupling and both units are mounted on a bed-plate fabricated from sheet steel.

A control panel is mounted on the guard frame over the generator with the output of the generator terminated on five 2-pin non-reversible weatherproof sockets connected in parallel and mounted on the front of the control panel. At the back of the panel are housed the combined voltage regulator and cut-out unit and the voltage sensitive relay, a lid protecting these units from dirt and water.

Also mounted on the control panel are a moving coil ammeter reading 0 to 30 amps., and a 25 amps. slydlock fuse, both of which are connected in the generator circuit. The starter and voltage sensitive relay reset buttons are mounted on top of the control box for convenience in operation.

A petrol tank, having a capacity of one gallon (sufficient for 5 to 6 hours' running on full load) is mounted on the guard frame as shown in the illustrations.

Engine. The engine, a single-cylinder four-stroke air-cooled unit, develops 1.3 b.h.p. at 3,000 r.p.m., and is maintained at this speed by a centrifugal governor enclosed in the crankcase. The governor operates the throttle butterfly valve by means of an external linkage and provision is made for the speed of the engine to be varied within small limits by adjustment of a tension spring attached to the linkage.

A fan is attached to the flywheel, air being directed over the cylinder by a cowling to cool the engine. Flywheel-magneto ignition is employed, which makes it possible for the set to be operated without batteries if necessary, and the ignition system is fully screened to avoid interference with radio reception. A pulley fitted on the end of the crankshaft remote from the generator enables hand starting to be effected by a rope in the event of the battery charge being so low that it will not motor the generator. The engine is fitted with two controls only—the choke, which consists of a shutter on the air intake filter, and the magneto cut-out button.

Generator. The generator is a two-pole shunt wound machine, fan-cooled and of drip-proof type with grease-packed ball bearings. The armature conductors are wound in semi-enclosed slots, the slot insulation being glass fibre, and an auxiliary field winding is provided to enable the machine to be motored from the battery when starting.

Automatic Voltage Regulator. A combined cut-out and voltage regulator unit is fitted. The cut-out is provided with shunt and series windings and is adjusted so that the points close when the generator voltage reaches 24.5V, thus completing the circuit between generator and load. The series coil is connected to assist the shunt winding under these conditions. If a battery is connected, however, and the generator voltage falls below the battery voltage, a reverse current will flow. The magnetic field of the series winding then opposes that due to the shunt winding, causes the armature to release, opens the cut-out points and thereby prevents the battery from discharging through the

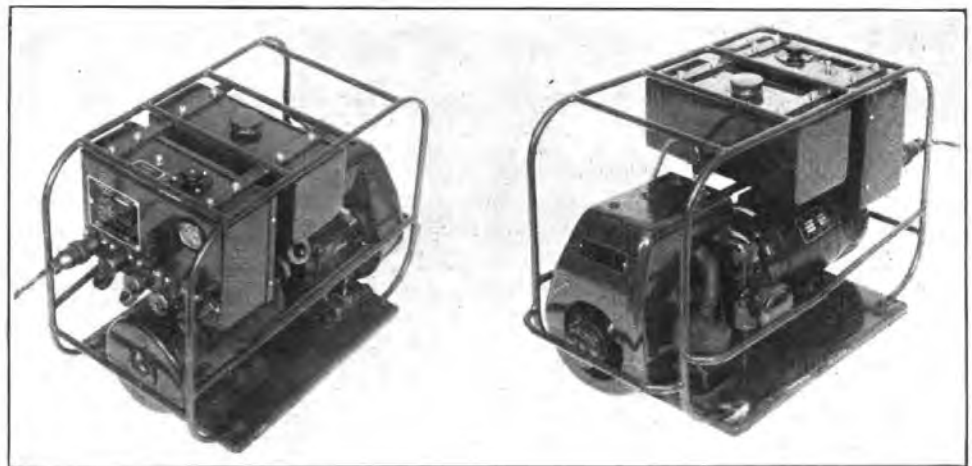

FIG. 2.—TWO VIEWS OF A GENERATOR, P.E.D., PORTABLE.

generator. Release occurs when the reverse current is between 3 and 4 amps.

The voltage regulator electro-magnet also carries shunt and series windings. As the generator voltage rises, the magnetic effect of the shunt winding increases until the armature operates and the moving contact C1 (see Fig. 3), which is normally held against the fixed contact A, moves

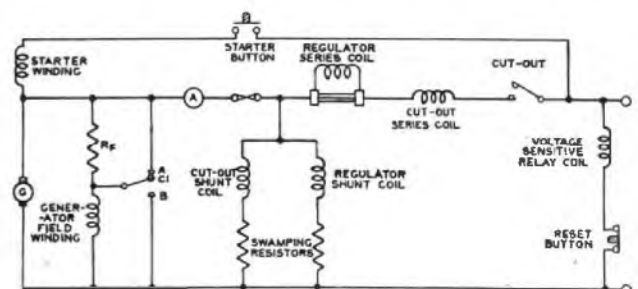

FIG. 3.—CIRCUIT DIAGRAM OF GENERATOR, P.E.D., PORTABLE.

to its mid-position thus removing the short-circuit on the series field resistor, R_s . The generator field is weakened therefore and the generated voltage reduced. Under this condition the pull of the shunt coil also diminishes and the armature of the voltage regulator therefore restores to normal. Contact C1 then makes again with the fixed contact A, thus short-circuiting the field resistor, R_F , and strengthening the generator field, and the generator output voltage is thus held substantially constant as the generator speed increases. Ultimately a speed is reached at which the required output voltage is generated with the resistor R_s permanently in circuit. Above this speed the contact C1 makes with the fixed contact B, short-circuits the generator field windings and connects the resistor R_s across the generator armature thus almost completely destroying the excitation. The moving contact continues to alternate between its mid-position and the fixed contact B until, if the speed were increased to a value above the normal operating range, a point would be reached at which the required voltage would be generated solely due to the residual magnetism of the machine. The series turns aid those of the shunt winding and by arranging for the former to carry a proportion of the load current, a compensated voltage characteristic is obtained. The heavier the load current, the lower is the voltage at which regulation occurs, thereby ensuring that the generator is not overloaded, and limiting the initial current when a completely discharged battery is connected in circuit.

Output Characteristics.

The compensated voltage characteristic is illustrated by the curves in Fig. 4, which were plotted from the results of

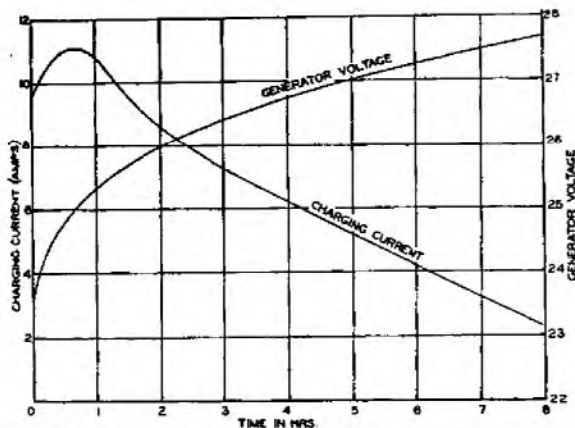

FIG. 4.—VARIATION OF GENERATOR OUTPUT DURING BATTERY CHARGING.

tests on the prototype generating set. The generator was connected to a 54Ah 24V battery which had been discharged to 1V per cell. In spite of the discharged state of the battery the initial charging current did not exceed 11 amps., the generator voltage being regulated to approximately 23V. As the battery terminal voltage rose on charge, the regulator allowed the generator voltage to increase at a somewhat slower rate, giving a battery charging current which gradually tailed off as shown.

At hourly intervals a resistive load was switched in circuit and the division of generator current between load and battery measured. These results are plotted in Fig. 5. The battery charge continued until the point was reached where the battery voltage equalled the generator voltage when a load was being taken from the set. From that point onwards, the battery commenced to take an increasing share of the load. The heavier the resistive load, the lower was

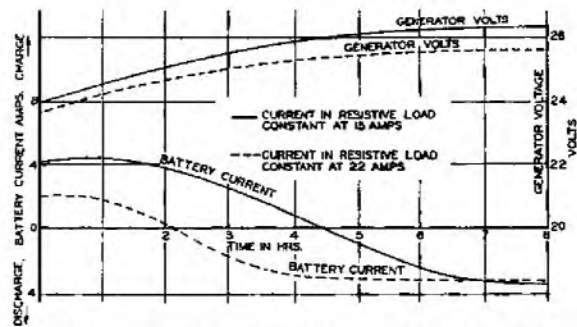

FIG. 5.—EFFECT OF RESISTIVE LOADS ON GENERATOR VOLTAGE AND BATTERY CHARGE AND DISCHARGE CURRENTS.

the generator voltage and the lower the voltage at which the battery commenced to discharge.

The dual requirements of battery charging and operation of other equipment are conflicting since the former demands varying voltage characteristic whilst the latter requires that the voltage should remain as steady as possible. The compensated voltage control provides a compromise. Excessive charging currents are avoided and the output voltage variations are restricted to a reasonable amount, at the expense of a certain proportion of the battery capacity since the charge is stopped before gassing commences.

Electrical Circuit.

A voltage-sensitive relay, which may be adjusted to operate within the range 28-31V, is connected across the circuit on the battery side of the cut-out. The contacts are normally open, but when the battery voltage reaches the relay setting the relay operates and its contacts short-circuit the magneto contact-breaker points, thus stopping the engine. The relay will not restore to normal until the voltage applied to the coil falls to a low value. It is desirable, however, to be able to restart the set at any battery voltage, and a reset button is provided, therefore, to trip the relay by breaking the coil circuit.

Batteries.

A 24V 40Ah battery, with the Post Office title of "Battery, Secondary, Portable, No. 14," which is suitable for use with both Generators, P.E.D., Portable and the original generating sets has been produced in conjunction with the Telephone Development and Maintenance Branch of the Engineer-in-Chief's Office. The battery is contained in a reinforced hardwood case with a hinged lid, and the output is terminated on a 5 amp., non-reversible 2-pin weatherproof socket accessible from the outside of the box.

Future Developments.

250 Generators, P.E.D., Portable are now in course of delivery, but as there was insufficient time to carry out extensive field trials before a large number of the original sets required replacement, further modifications may be made to the specification as the result of experience gained with the new sets.

Consideration is also being given to the design of accessories for use with the generating sets, including a 500W portable cable drier, and an electric soldering iron.

Acknowledgments.

Acknowledgments are due to officers of the Power, Motor Transport and Test and Inspection Branches of the Engineering Department for their constructive criticism and advice which proved most helpful during the development of the set, and to the L.T.R. Engineering Branch and City Area for co-operation in arranging trials.

Introduction to Electronic Exchanges— Trunking and Selection Systems

T. H. FLOWERS, M.B.E., B.Sc.(Eng.), M.I.E.E.†

U.D.C. 621.395.34

In a general analysis covering all forms of trunking and selection the author re-evaluates the basic principles of automatic telephony and then shows how these principles can be applied to electronic exchanges.

General.

WHEN the study of the possibilities of applying electronic switching techniques to automatic exchanges was first commenced, the question which naturally arose was whether the basic principles of known exchanges would necessarily apply to electronic exchanges. It seemed very likely that this would be the case. Certainly an electronic analogue of every electro-mechanical switching device can be produced, so that partially or fully electronic exchanges which are analogues of the existing exchanges in their various forms are possible. The analogues are not, however, exactly equivalent, notably in cost, reliability and speed of operation; existing exchange systems are solutions to a highly complex problem, and the solutions no longer apply when the characteristics of the apparatus on which they are based is changed. Moreover, to have proceeded by way of analogues would have neglected the possibility, which is shown in this article to exist, of an electronic exchange for which there is no electro-mechanical analogue. Hence, there was a need for a re-examination of the basic principles of automatic telephony. An outline of this process is one of the objects of these articles. In the first article¹ it was shown that a speech path switch of any size can be built up from element switches which, in turn, may be constructed from any means of making and breaking a speech channel. In automatic exchanges, except those of the smallest size, it is uneconomic for element switches to be built up into one switch large enough for the whole exchange. The use of a number of smaller switches to achieve the result of one large switch is the main subject of this article.

Problems and Definitions.

The general problem of a telephone network of any size can be reduced to that of the single exchange which is connected by junction circuits to at least one other exchange and connected by what will be termed terminal circuits to subscribers' stations, manual board jacks and a variety of other services. A terminal circuit which starts a call is said to call, or be a calling circuit; a calling terminal circuit indicates by dialling or other signals, which are termed called number signals, that connection is required to another terminal circuit which is then termed a called circuit. If the called circuit is on the same exchange as the calling circuit, the connection can be completed in that exchange. If the called circuit is not on the same exchange as the calling circuit, the calling circuit is connected to a junction circuit in the line of advance of the call, the junction circuit being a called circuit at the first exchange and a calling circuit at the next exchange. A calling junction circuit indicates, again by called number signals, that connection is required to a terminal circuit, and the whole process is repeated (that is, connection of a calling circuit to a called terminal or called junction circuit) until the required connection is completed.

From the description so far given there does not appear to be much difference, from an exchange switching point of view, between a junction and a terminal circuit and many

of the distinctions commonly drawn are arbitrary. Subscribers' circuits generally, but not invariably, have to be operated bothway, that is, as both calling and called circuits; junction circuits, generally, but not invariably, are worked unidirectionally. Analytically, there is every reason to regard bothway working as the general case for all circuits and unidirectional working as the special case. Again, junctions are generally heavily-loaded circuits provided in groups of more than one line, and subscribers' circuits relatively lightly-loaded single circuits or P.B.X. groups; but the switching system must be capable of accommodating junction circuit groups down to one circuit and subscribers' circuit groups of any number of circuits from one upwards, and the most heavily loaded P.B.X. circuits carry more traffic than the least heavily loaded junction circuits. In this article, the possibility of any essential difference between the various groups of circuits connected to an exchange will be neglected. An exchange is regarded as a switch to which groups of circuits are connected, the groups varying in size from one circuit upwards, the switch providing the possibility of bothway working for each circuit and having the function that, in response to called number signals from a calling circuit, it makes or attempts to make a connection between the calling circuit and a free circuit in a called group of circuits designated by the called number signals.

The traffic which an exchange is required to handle is never known with precision in all its aspects. For example, the calling traffic originated by individual groups of subscribers' circuits is in general known only very roughly from the meter readings and ticket records on which the charges are based, and the traffic received by individual groups of subscribers' circuits is in general known even more approximately from the assumption that it is equal to the calling traffic. The effects of defective knowledge of the traffic and unexpected variations in the traffic can be minimised, as is well known, by utilising simple principles based on probability theory. Briefly, this means keeping the traffic in the largest blocks possible, the traffic in each block being derived from as many independent sources as possible. The economy of, and service given by, an exchange are largely dependent on the extent to which these principles can be carried out.

The trunking problem arises because, for practical and economical reasons, it is necessary to build exchange switches up from smaller switches assembled in ranks and connected in series by trunks between the ranks. Circuits between ranks of switches will be referred to as trunks, the term "circuit" being reserved for terminal and junction circuits. Trunking is concerned with the number and arrangement of the circuits, switches and trunks to form an exchange which will carry the traffic offered at the least cost and with the best service to the users. The selecting system is concerned with individual connections as demanded by calling circuits. The trunking and selecting systems are not, however, independent of one another. The selection system usually depends on a particular system of trunking which may reflect on the amount of plant needed; the selection system may also not be capable of utilising to its maximum capacity, the plant provided, a fact which again reflects on the amount of plant needed.

† Staff Engineer, Research Station.
¹P.O.E.E.J., Vol. 43, p. 61.

TRUNKING SYSTEMS

For manufacturing reasons, groups of element switches are made up into unit switches in the factory. In Strowger systems the unit switch is usually ten 2-motion switches made up into a shelf, and in the Bell cross-bar system the cross-bar switch is a unit of either 10×10 or 10×20 contact assemblies, a number of which are made up into a still larger unit called a frame. For each exchange a number of unit switches are installed, connected together, and interconnected by trunks to form a switch of the requisite size. The processes involved will be generalised with the aid of the following symbols.

Symbols.

Trunking diagrams are usually drawn in symbols which are related to particular kinds of switches. To appreciate the basic principles, a set of symbols is required to generalise all types of switches. In this article the symbols in Fig. 1 will be used. The plain rectangle of Fig. 1 (a) is the general symbol for a switch of any kind. It is understood that there are circuits connected to the left-hand side, and other circuits connected to the right-hand side, and the switch can connect each circuit on one side to at least some of the circuits on the other side. The symbol itself conveys no idea of the size of the switch; for example, the effect of multiplying or otherwise associating two switches together is to produce a larger switch. The two switches may each be represented by a rectangle or a single rectangle may represent both switches, depending on whether it is desired to treat them as two separate switches or one larger switch. Hence the rectangle symbol may represent any size of switch from an element-switch to a complete exchange. Fig. 1 (b), (c) and (d) represent switches having some specified characteristic, but again not conveying the size of the switch. Thus, (b) represents a full-availability switch of any sort in which any one of N circuits connected on one side of the switch may be connected to any one of M circuits on the other side, the number of simultaneous connections being limited only by N or M , whichever is the less. The symbol may thus represent, among others, a single Strowger switch, or a shelf of multiplied Strowger switches, or a cross-bar switch. If, due to the characteristics of a switch, a circuit on one side of it cannot be connected to a circuit on the other side, even though the circuit on the other side is free, the switch is said to be a limited availability switch. Limited availability takes two forms. In one form, the switch is not able under any circumstances to connect some of the circuits connected on one side of it to some of the circuits connected on the other side. For example, in a Strowger exchange, a number of 2-motion switches are usually formed into a rank with their bank contacts connected in graded multiples, and each circuit connected to a set of wipers can be connected by the wipers to only a limited number of circuits in each grading. This form of limited availability switch is indicated, as in (c), by a dot placed inside the rectangle which represents the switch.

The second form of limited availability is inherent in any useful arrangement of switches connected in ranks in series. It is illustrated in a very simple form in Fig. 2. Three unit switches on the left each have one trunk connecting them to each of the three unit switches on the right. Each switch on the left has circuits connected on its left side and each switch on the right circuits connected on its right side. Treating the whole assembly as a single switch, it can be seen that any circuit on the outside left may be connected to any circuit on the outside right, but only if the trunk between the switches concerned is not already engaged on another connection. If the whole assembly of Fig. 2 is treated as a trunking unit, it is represented by the symbol of Fig. 1 (d). This method of forming self-contained units from smaller switches is common in systems which employ small capacity switches, cross-bar switches or 10-point uniselectors for example. A unit is usually made up of two ranks of the small switches, with a uniform cross-net of trunks between the ranks and one hundred or more circuits connected on each of the two sides of a unit. The size of the switch thus produced is more convenient as a trunking unit than the smaller switches from which it is formed.

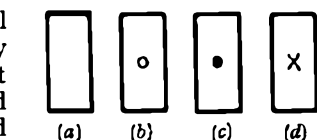

FIG. 1.—SWITCH SYMBOLS.

In addition to the symbols for switches, it is useful to have symbols for the connection of groups of circuits to the switches and for the trunking between switches. In Fig. 3 (a)

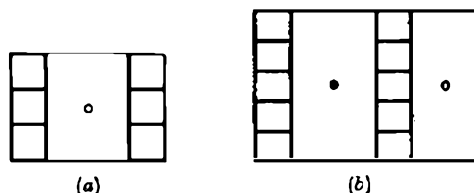

FIG. 3.—TRUNKING SYMBOLS.

two ranks, each of three switches, are connected by a network of trunks represented by the straight lines connecting the extremities of the two ranks, the network having the characteristic, denoted by the circle placed between the two straight lines, that there is at least one trunk from each switch in one rank to each switch in the other rank. This form of network is said to be a full network. A full network between the ranks may not, however, be desirable; if the number of switches in one rank exceeds the number of trunks connected to each switch in the other rank, a full network is not possible. A network of trunks which does not provide a trunk between each switch in one rank and every switch in the next rank is a limited network and denoted by a dot as shown in Fig. 3 (b). To the right is also shown another symbol, a dashed line, which represents a block of groups of circuits connected to a rank of switches. The circle conveys that every switch in the rank has connected to it at least one circuit in each group of circuits; a dot instead of the circle would mean that not every switch had connected to it at least one circuit in each group of circuits.

General Solution.

Fig. 4 represents in the symbols just described the general solution to the problem of an exchange which will interconnect, by means of ranks of switches in series, the circuits connected to it. Bothway circuits are connected to two points on the exchange. A calling circuit calls on the left connection and communicates called number signals to the exchange, which then finds a path from left to right through the exchange to a free circuit in the designated group of circuits. If no such path exists other action is taken but is here neglected. The transmission and reception of signals and the finding of free paths will also be neglected for the time being, and attention concentrated on the provision and arrangement of switches

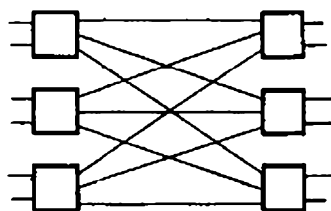

FIG. 2.—TWO RANKS OF SWITCHES IN SERIES.

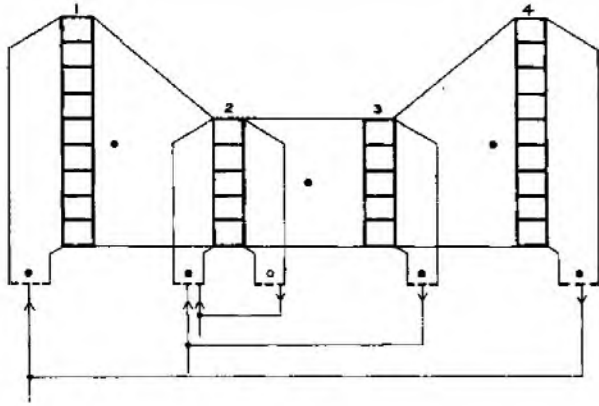

FIG. 4.—GENERAL FORM OF EXCHANGE TRUNKING.

and trunks between them so that free paths can exist often enough to satisfy the grade of service demanded.

The number of ranks of switches will vary according to a number of factors. Four ranks of switches are shown in Fig. 4 and numbered 1 to 4. Selection starts from rank 2 to which large groups of circuits are directly connected for their calling traffic. Small groups of circuits are connected to rank 1 which concentrates the calling traffic from these circuits to a smaller number of trunks connected to rank 2. Between ranks 1 and 2 is a limited network which provides trunks between ranks 1 and 2 sufficient to satisfy the appropriate grade of service. Calls start their selection operations from the circuits and trunks connected to the left of rank 2. Rank 2 is connected to rank 3, and rank 3 to rank 4, each by a limited network adequate to the traffic.

Selection starts at some time or other from every circuit and trunk connected to the left side of rank 2. A circuit or trunk has access only to the trunks on the right hand side of the switch to which it is connected, and this switch has access to only a limited number of switches in rank 3 and so on. However, it will be clear that, provided each switch in one rank has access to at least two switches in the next rank, and there are enough ranks of switches, a number of paths will exist from every circuit and trunk on the left of rank 2 to even a single circuit on a later rank, and that the availability of a group of circuits to a calling circuit is dependent *inter alia* on the size of the group, the rank of switches to which it is connected and the distribution of the circuits over the switches of that rank. Groups of circuits are thus connected for their called traffic to the earliest rank which gives them enough availability from the calling side of rank 2 to satisfy the grade of service. Of a group of circuits connected to the called side of the first rank of selectors (rank 2 in Fig. 4) some must be available to all the switches in that rank, but this is not necessary in later ranks or possible for small groups.

Particular Solutions.

A number of particular cases of the general solution which has just been described will now be discussed. The most important of these is the one which has (a) the trunks between ranks arranged in networks which follow as regular a pattern as is possible with the trunks from one switch spread over as many switches in the next rank as possible; (b) the circuits of each group distributed on both the calling and called sides as evenly as possible over as many switches as possible of the rank to which they are connected; (c) circuits connected on the calling and the called sides of the switches in the ranks so that the traffic is evenly distributed over the switches according to the best available data on calling and called traffic. This solution

results in the minimum of switches of a given size and the minimum number of trunks between switches and, by minimising the effects of deficient traffic data and unexpected overloads, gives the best service to the subscribers. Other factors affect the total cost and practicability of this particular solution; although very nearly all existing telephone switching systems use this solution on the calling side, none does so fully on the called side.

The trunking system usually adopted in practice differs from that just described in two respects. First, on the called sides of the switches the circuits are connected as groups each to one switch and not distributed over the switches in the rank to which they are connected. The traffic per switch is still distributed according to the best available traffic data so that each switch in a rank is as equally loaded as possible, but the distribution cannot be so uniform or the overload on a group spread so much as in the first particular solution described. Secondly, the networks of trunks between the ranks of switches are divided into groups each sufficient to carry the expected traffic to a discrete section of the switches in the higher rank of switches. The system is illustrated in Fig. 5 for systems

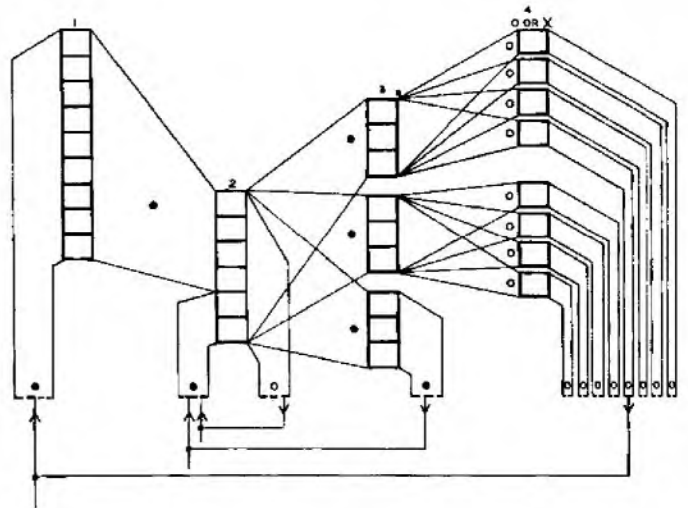

FIG. 5.—EXCHANGE WITH GROUP TRUNKING.

which use full availability switches to Fig. 1 (b) or limited availability switches to Fig. 1 (d), and in Fig. 6 for systems

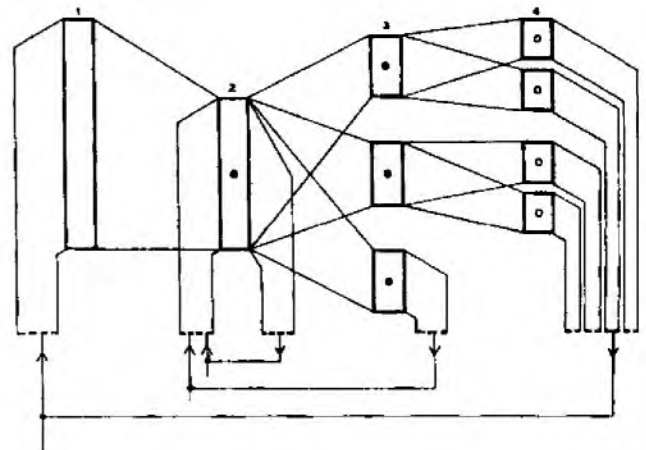

FIG. 6.—EXCHANGE WITH GROUP TRUNKING AND GRADED MULTIPLE.

which use graded multiple types of limited availability switches for all ranks of selectors except the last, which must be composed of full availability switches (or switches to Fig. 1 (d)).

In addition to its better traffic distribution, the first-described particular solution has a further considerable advantage over those of Figs. 5 and 6 in the allowance which has to be made for growth of the groups of circuits. Since, in the last two cases, the circuits are connected as groups, space has to be allowed at each switch for the growth of each group which is likely to increase in size, notably P.B.X. groups. The total space which is thus provided is inevitably greater than that which will eventually be taken up. With the first arrangement on the other hand, since any circuit can be connected anywhere in its appropriate rank, the space left for growth can be much more nearly equal to the eventual requirements.

A development of Fig. 4 which can, and usually does, result in still further economy in switches is shown symbolically in Fig. 7. Circuits there have only one point of

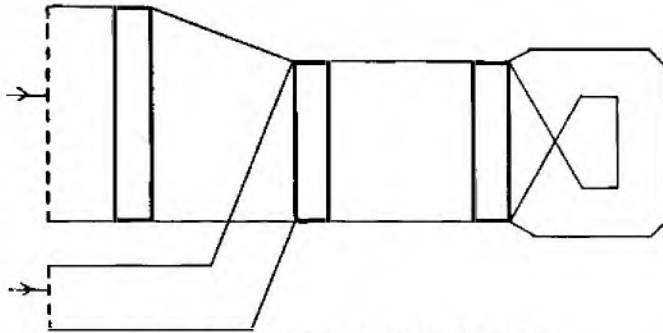

FIG. 7.—EXCHANGE WITH LOOPED TRUNKING.

connection to the exchange switches. The bothway feature is provided by a loop path within the exchange. With this arrangement most, if not all, the ranks of switches and networks of trunks between the switches have to carry bothway traffic. The economy of the arrangement arises from the assembly of the traffic into blocks made up of both calling and called traffic.

SELECTION SYSTEMS

Selection can be reduced to sequences of the following basic operations :

- (a) A signal, called a mark, which defines the circuit or trunk from which selection starts.
- (b) A signal (or signals) which defines the connection to be made.
- (c) The marking of a free trunk or circuit in a group of trunks or circuits, any one of which when connected to the trunk or circuit defined in (a) will satisfy the condition (b).
- (d) The control of a switch to make the connection between the circuit or trunk defined in (a) to the trunk or circuit defined in (c).

These operations can perhaps be best explained by reference first to the familiar Strowger system of selection, and to Fig. 6. Calls from circuits connected to rank 1 will be neglected for the time being, and selection considered to start from rank 2. A calling circuit connected to a selector in rank 2 defines itself as the circuit from which selection is to start by looping the line to give a calling signal. Called number signals which define the connection to be made are then received in the form of trains of dialling impulses. All the trains taken together define a circuit in a group of circuits connected, say, to rank 4, a free circuit of which is to be connected to the calling circuit. In the Strowger system, this is accomplished not directly, but in stages. The group trunking and the connection of groups of circuits as groups each to one switch is chosen so that each stage is defined by one train of impulses. The trunks connected to the called side of rank 2 are

divided into a maximum of ten groups. Each first selector has access to a maximum of, say, ten trunks in each group. Each selector has ten levels, each of ten contacts in a marking, i.e., P bank, one contact for each of the circuits, and one level for each of the groups of circuits to which the selector has access. For each impulse of the first digit the wipers of the first selector are raised one level. At the end of the train the P-wipers are standing at the entrance to a level of marking contacts associated with ten trunks, any one of which is suitable for connection to the calling trunk. The free circuits are marked on their marking contacts. The wipers are rotated, the P-wiper testing the marking contacts, until a contact which is marked free is reached, when the wiper rotation is stopped. The position of the wipers marks a trunk according to basic operation (c). Basic operation (d), viz., the control of a switch to make the connection, has in fact been partly completed during operation (c). The line wipers, which are disconnected at this stage from the calling trunk, are already in contact with the marked trunk, which is connected to the line bank contacts. Completion of operation (d) merely requires the line wipers to be connected to the calling trunk (H relay operation). The connection thus made through rank 2 is extended to rank 3 to define the trunk from which the next selection is to start, the next train of impulses is received and so on as just described.

A circuit terminated on rank 1 is connected, on the initiation of a calling signal, through that rank to a trunk terminated on rank 2 by a series of operations which are basically the same as those described for selection through the other ranks. If rank 1 consists of uniselector line switches, one for each circuit connected to the rank, then the calling signal on any circuit defines both the circuit from which selection is to start and the connection to be made, and the uniselector acts as a one-level selector. If rank 1 consists of groups of 2-motion switch line-finders, a calling signal takes part in two sequences of basic operations, one through the common start lead to activate an allotter which selects a free line-finder, from which in the second sequence selection starts; in the second sequence, the calling signal, by marking the line-finder bank, defines the connection which the selected line-finder is to make.

The system of selection just described has a number of advantages, which include that it is easy to follow both in principle and in maintenance operations, that each selection is independent of every other so that as many calls can proceed simultaneously as is desired, and one faulty switch has a relatively minor effect on service. It has disadvantages which include that it requires a trunking system which is not as efficient or flexible as possible, and each element switch has to be equipped with an expensive controlling element which is idle for 99 per cent. or more of its time. This last feature has prompted systems in which the element or unit switches are made as simple as possible and the bulk of the control equipment is located in common control or marker apparatus, which serves a group of switches. The additional problem in this type of system is that when the common equipment is serving one switch in the group, none of the other switches can set up calls; the effect of faulty common equipment can, obviously, be very serious. Nevertheless, the principle has been extended to common markers which set up connections through more than one switching stage at a time, for example, through four ranks of cross-bar switches. An even greater part of the exchange is then limited to one call being set up at a time, and speed of setting-up becomes all important. In the limit, if one marker sets up all the connections through all the ranks then only one connection at a time can be in the process of setting up. In large exchanges this means less than 100 millisecs. per connection, which

is beyond the powers of economically constructed electro-mechanical equipment. Hence group trunking has been retained in order to permit the simultaneous operation of a number of markers. A fully electronic system can be made to work much faster than the existing systems and introduces the possibility, therefore, of single marker exchanges using the highly desirable trunking arrangements described as the first particular case of Fig. 4. Marker operation requires register-senders or register-translators to receive the called number digits at a relatively slow rate and then to pass the necessary information to a marker as quickly as possible. Electronic register-translators have been described in a previous article.² A single marker exchange would be very dependent on the reliability of the marker and this and many other factors which are outside the scope of this article have to be considered before it can be said that single-marker exchanges are practicable and economic. The important point at this stage is that, with electronic switching selection, trunking systems hitherto impracticable can now be considered.

APPLICATION OF GENERAL PRINCIPLES TO ELECTRONIC EXCHANGES

So far as the application of the general principles of trunking and selecting systems is concerned, space in this article permits only brief mention of two ways of selecting and marking one free trunk out of a number of free trunks in a group of trunks. This problem is selected for illustration as it is the only one of the four basic selection operations which presents any difficulty. The first solution is shown schematically in Fig. 8 and is based on the well-

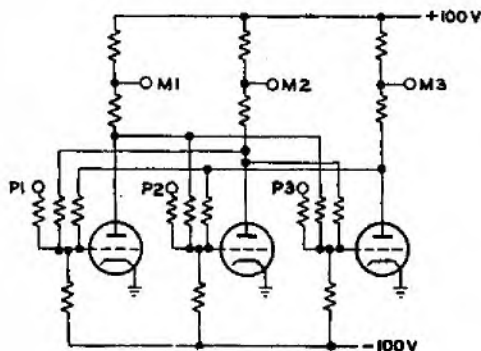

FIG. 8. TRIGGER CIRCUIT SELECTOR.

known multi-position trigger circuit. Three valves are shown with their anodes inter-connected with their grids by resistor networks. In addition, each grid circuit has connected to it, through a resistor, a terminal P. Assume first of all that all the P-terminals are at earth potential. Then it can be designed that the whole circuit will take up one of three stable positions, each corresponding to one valve being conducting on its anode circuit and the other two non-conducting. The position at any given time may be dependent mostly on chance. Each valve anode is connected to a terminal M to which is connected the marking lead of a trunk in the group to be controlled. The trunk is unmarked when its M-terminal is near the anode supply potential, and becomes marked when the associated valve conducts; the P-terminal of the same valve is connected to the trunk which, when it is free, holds the terminal at earth potential and, when it is engaged, at a negative potential. The negative potential on a P-terminal is sufficient to prevent its valve from conducting, whatever the control from the other valves. Hence the trigger can

never set itself to mark an engaged trunk and, as it can mark only one trunk at a time, will always set itself to mark a free trunk, or no trunk if there is none free. When it marks a trunk which later becomes engaged, the trigger will change without any further control to mark another free circuit. The three-valve trigger shown can be extended by various means to any number, but hot-cathode valves are, of course, expensive, and the method may eventually have only academic interest.

Fig. 9 also shows a similar arrangement of three valves,

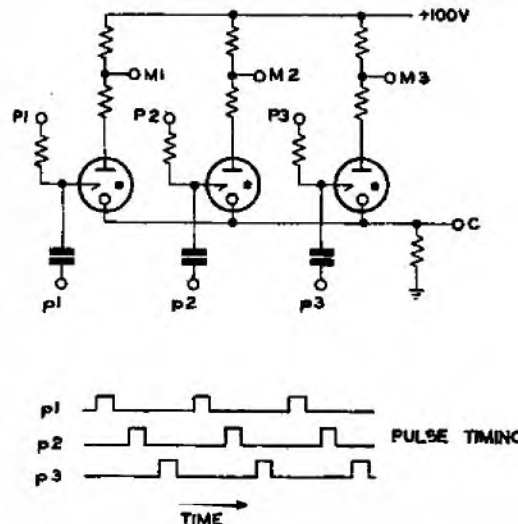

FIG. 9.—COLD-CATHODE GAS-DISCHARGE-TUBE SELECTOR.

but the number of valves may easily be extended almost indefinitely. The valves are cold-cathode gas-discharge tubes which once fired will hold in that condition until the anode current is interrupted, or the anode-to-cathode voltage reduced below the voltage which will sustain the discharge. The common cathode resistor prevents a second tube from firing if one is already conducting. The P- and M-terminals have the same functions and operate with the same potentials as in Fig. 8, but there is an additional control on the primers in the form of the time-spaced pulses. A tube will fire only if (a) there is no other tube fired, (b) its P-terminal is at earth potential, and (c) it receives a pulse from its pulse source. One form of spacing of the pulses is shown in the diagram, the pulsing in this case being continuous. Suppose that, normally, a control voltage is applied to the point C, by apparatus not shown in the diagram, to raise the cathode potentials of the tubes so that none will be conducting. If, now, the control voltage to the tubes is switched off, one tube corresponding to a free circuit will fire, the actual tube depending on the phase of the pulses at the instant of switching off the control voltage. This form of selection is analogous to selection by a non-homing uniselector. If, however, the pulses are normally absent and, after switching off the control voltage, pulses are applied to the tubes in order starting, say, from the left, the selection becomes analogous to the fixed-order testing provided by a homing uniselector.

Conclusion.

This article completes the series on the introduction to electronic exchanges. It is hoped that some of the possibilities have been made clear. There is no doubt that electronic exchanges will be produced, but how well and how soon their particular merits will enable them to compete with electro-mechanical equipment in the expanding art of switching, only the future can decide.

* P.O.E.E.J., Vol. 43, p. 177.

Whitehall Gardens P.A.B.X.

F. T. PERKINS†

U.D.C. 621.395.251

This article describes a recent Private Automatic Branch Exchange installation with ultimate capacity for 3,000 lines. Certain non-standard facilities have been provided to meet the requirements of the various Government Departments served by the exchange, and enquiry positions of novel design are fitted to suit the local conditions.

Introduction.

IN October 1950, the largest P.A.B.X. in the country was opened to serve various Ministries accommodated in the new block of Government offices in Whitehall Gardens, London, the exchange being situated on the ground floor of the building at its north-east end and on the Thames Embankment side. Apart from the special features of the equipment and its installation which are referred to later, interest arises from the historical associations of the site since, in Tudor times, it was occupied by the Palace of Whitehall.

During the excavations for the new building, several parts of the old Palace wall were uncovered, and it is known that the steps which originally led from the Palace to the river, together with an old riverside terrace, still lie below ground level; these will be uncovered and reconstructed in sunken gardens to be built facing the Embankment.

An interesting feature of the construction work was the moving of the Tudor wine cellar or crypt (built in Cardinal Wolsey's time), Parliament having decided that this, one of the few portions of the Palace still remaining, should be preserved as an ancient monument. The Crypt protruded over the building line on the Horse Guards Avenue side, and it was decided that it should be moved intact to a new location some 10 ft. to the west and lowered 18 ft. This could not be carried out as a direct move without an extremely complex operation. The operation was arranged, therefore, by mounting the crypt on rollers, moving it bodily on to a steel gantry, jacking down on this gantry, and then moving it back horizontally some 33 ft. to its final position.¹

General.

Proposals for the building of the new block of Government offices were first put forward in 1912, and the whole scheme was designed by Vincent Harris, O.B.E., R.A., F.R.I.B.A., but the first World War delayed the start of construction until 1936, while the second World War caused work to be suspended in 1940. When it was decided, in 1946, once more to proceed with the scheme, provision of a suitable P.A.B.X. to serve a number of Ministries had to be considered.

As the Post Office standard P.A.B.X. has been designed to cater for a total of 1,200 extensions only, the use of this type of equipment would have involved design work to extend the ultimate capacity to the 3,000 lines required. Additionally, the standard P.A.B.X. facilities do not include the control and timing of trunk and toll calls. It was decided, therefore, that in view of the time factor, the automatic equipment should be of the standard 2,000-type, non-director, with a sleeve control auto-manual switchboard equipped similarly to a group trunk exchange. This equipment does not, however, provide many of the facilities that are standard on modern P.A.B.X.s.

The initial equipment comprises 2,200 auto. and 100 manual calling equipments, 3,000 multiple, 15 "A" positions, 14 "B" positions, 4 dummy and unequipped

positions, 400 dialling, 20 auto. and 70 generator signalling tie lines and an 8-position enquiry table.

The building is designed throughout for offices and physical difficulties, due to low ceiling heights, were encountered therefore in accommodating the automatic equipment. The general heating arrangements for the building comprise a network of copper tubes concealed in the ceilings, and as this was considered to be unsuitable for apparatus rooms, floor radiators were specially installed.

The clear height under beams varies from 10 ft. 7 in. to 10 ft. 8 in., and as 10 ft. 6½ in. racks were necessary to provide the required capacity within the accommodation allocated, the overhead 1-in. twin bars securing the racks had to be sunk into the plaster in several places; moreover, normal practice of cabling over the top of the racks could not be followed and large runways had to be installed at 9 ft. 1½ in. from the floor, suspended by subsidiary girders along the gangways. The presence of these runways precluded the use of standard main battery bus-bars located in the gangways above the racks and to overcome this difficulty it was decided to use the feeder fuse board method of distribution.

The auto-manual switchboard (Fig. 1) is of a modern

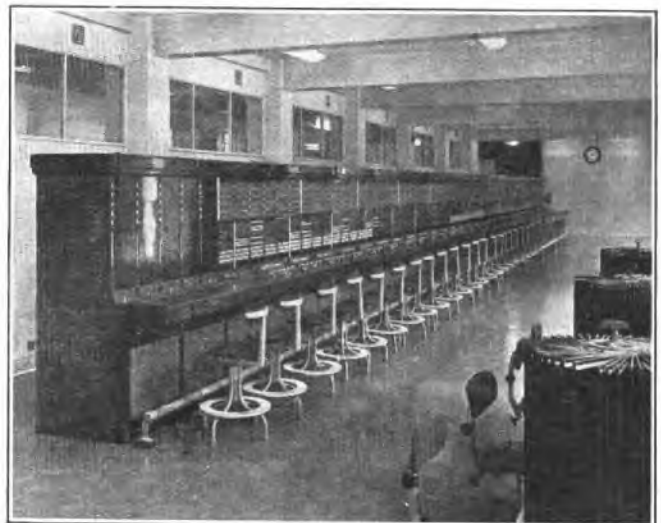

FIG. 1.—THE AUTO-MANUAL SWITCHBOARD.

design of the sleeve control type incorporating improvements such as cord fastener units, and with battery jacks located above the kicking panels and rear equipment layouts. A rear cable-shelf specially designed for the extension multiple is also included.

The "A" positions are each equipped with 14 cord circuits, 4 of which include chargeable-time clocks and handle all originating traffic on a "single-channel" basis, i.e. "0" is dialled for Assistance, Trunk or Toll calls. The "B" positions are equipped with 15 cord circuits and handle all incoming traffic including tie line "0" level circuits.

In other respects the exchange is generally similar in construction to a non-director exchange and includes separate subscribers' and equipment I.D.F.s and graded group selector racks.

† Executive Engineer, London Telecommunications Region.

¹ "Government Offices, Whitehall Gardens. The Special problem of the re-siting of an Historic Building." *Institution of Civil Engineers*, Paper No. 5765.

Facilities.

Standard circuits are used as far as possible, but departures were necessary to a degree, and it is therefore proposed to explain the facilities which are special to this exchange.

It was not considered desirable to give the exchange a name and code to allow dialling direct to extension on incoming traffic from the public network; therefore, a group of incoming exchange lines from an 11-and-over final selector unit at an adjacent public exchange was provided for each Ministry, as for any other P.B.X. These lines appear in the answering multiple of the auto-manual board at Whitehall Gardens P.A.B.X., and are lamped over the "B" positions.

A multiple of all the extensions is provided on this switchboard, with stile bar numbering similar to C.B. exchange practice, to give direct access by the operators for incoming traffic, thus avoiding dialling through the manual board selectors for each call and saving time and provision of positions. This multiple involved a relay set for each extension line and as the calling equipments are 700 less than the multiple, the relay set provision is based on the calling equipments in the interest of economy and to avoid extravagant cabling and jumpering. The multiple-access relay sets are terminated on the same connection strips as the subscribers' unselector circuits, using 6 x 20 strips with the tags arranged for open wire straps for fault localising. This was made possible by dispensing with the usual M and M1 terminations as subscribers' meters are not fitted.

The dialling tie lines between this and other P.A.B.X.s and P.M.B.X.s could not be arranged with dialling codes from selector levels owing to the large number of groups, and it was decided, therefore, to use 2-10 and 11-and-over final selectors, according to the size of the groups, with 3-digit dialling codes. The majority of the lines are equipped for both-way working, using subscribers' uniselectors, but where line resistances are in excess of the standard for unselector working, they are arranged on a unidirectional basis with the incoming lines connected to 1st selectors. Equipment is also provided for tie lines with resistances outside dialling limits to be worked manually using auto. or generator signalling. Facilities are available on the manual board for operators to obtain direct access in the outgoing junction multiple on most of the tie lines. Local extensions have access to all the dialling tie lines.

A group of 100 manual extensions is also provided, with facilities for manual working to and from the switchboard and connection to final selectors if automatic working is required for incoming traffic. Where automatic working is not required, N.U. tone is connected to the final selector number.

Originating calls from extensions to the London area are obtained by dialling "9" which routes the caller from the 1st selector level, via an auto-auto relay set, to a barred-trunk unselector at the public exchange. Excess fee calls are obtained by dialling "0" and the P.A.B.X. operator extends the callers to the public exchange by full facility exchange lines which appear in the outgoing junction multiple.

Trunk and toll calls are obtained by dialling "0" and the Whitehall Gardens operators have complete control of timing as in a trunk exchange, with direct channels to London Trunk and Toll exchanges.

The numbering scheme is, 2000-2999; 6000-7999, the trunking diagram being given in Fig. 2.

Enquiry Tables.

The requirements for enquiry traffic are such that a monitor's desk as used in non-director exchanges is inadequate, drum files being necessary to contain the very

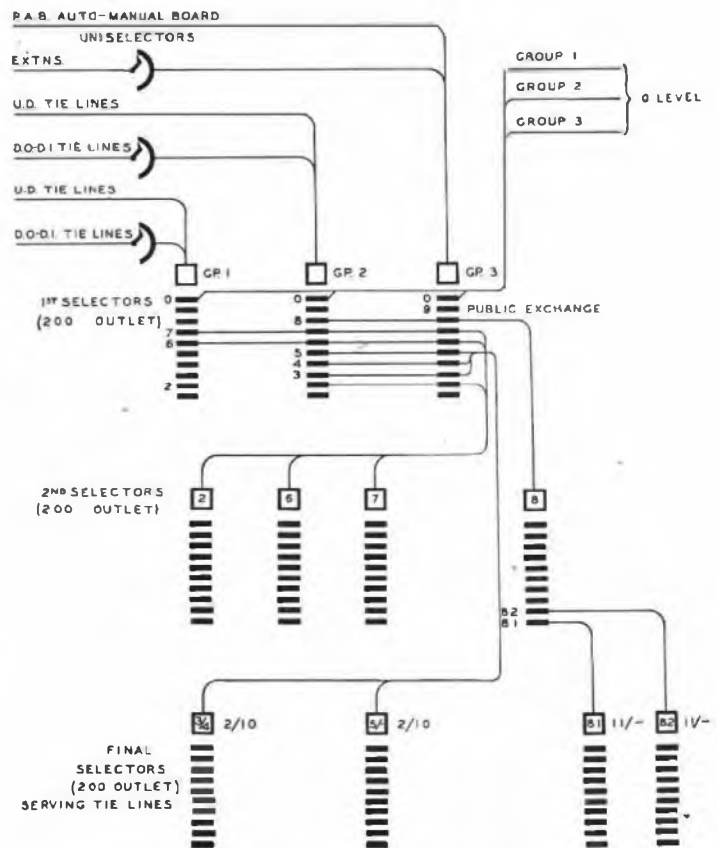

FIG. 2.—TRUNKING DIAGRAM OF WHITEHALL GARDENS P.A.B.X.

large number of entries for each of the Ministries. In the absence of a suitable standard, the Engineering Department agreed to the tables being designed to suit the local conditions and two 4-position, double-sided, cordless tables are provided to accommodate up to six drum files and directory and card compartments. (See Fig. 3.)



FIG. 3.—ENQUIRY TABLES WITH DRUM FILES.

Double-sided sloping panels are fitted in the centre of each table with capacity for 11 keys on each side. The circuits to and from the manual board are arranged for enquiries for each Ministry to be dealt with by separate operators and this is achieved by terminating two groups of circuits incoming from the manual board multiplied on positions 1, 4, 6 and 7 and 2, 3, 5 and 8; the drum files

for each Ministry are located in a manner to suit the circuits. The arrangement also allows for concentration on position No. 1 with coupling between positions Nos. 1 and 2.

Power Plant and Distribution.

Power is supplied by two batteries of open-type lead-acid cells, each of 1,100 ampere-hour capacity, and two mercury arc rectifiers, each with an output of 50 amps. at 50 V, operating as a parallel battery automatic power plant. Space is available for the provision of a third rectifier to meet ultimate load requirements. Standard ringing and tone supplies are obtained from 75-watt inductor tone generators.

The power distribution is by twin bus-bars from the power board to the first feeder fuse board, from which the main negative feed is continued to the second feeder fuse board by two 61/-103 V.I.R. cables in parallel. The groups of racks are served by smaller V.I.R. cables from group fuses mounted on the D.F.B.s.

The feeder fuse boards (Fig. 4) are each designed to accommodate 7 group fuses and, to preserve standard arrangements as far as possible, each group is equipped with a 125 amp. regular and stand-by fuse with separate alarm lamps for each group, identical to 2000-type group fuse panels, but in this case, centralised on feeder fuse boards.

The battery positive connection is continued over all the racks by 2 in. \times $\frac{1}{2}$ in. copper bar laid flat and bolted to the tops of the racks thereby also serving as the earth connection for each suite of racks.

Conclusion.

The contract for the manufacture and installation of the exchange was placed in June 1948, with Standard Telephones & Cables, Ltd., the work being completed in September 1950, and the exchange brought into service on the 16th October 1950.

In conclusion, the author desires to express his thanks

to Standard Telephones & Cables, Ltd., for supplying photographs of the installation.

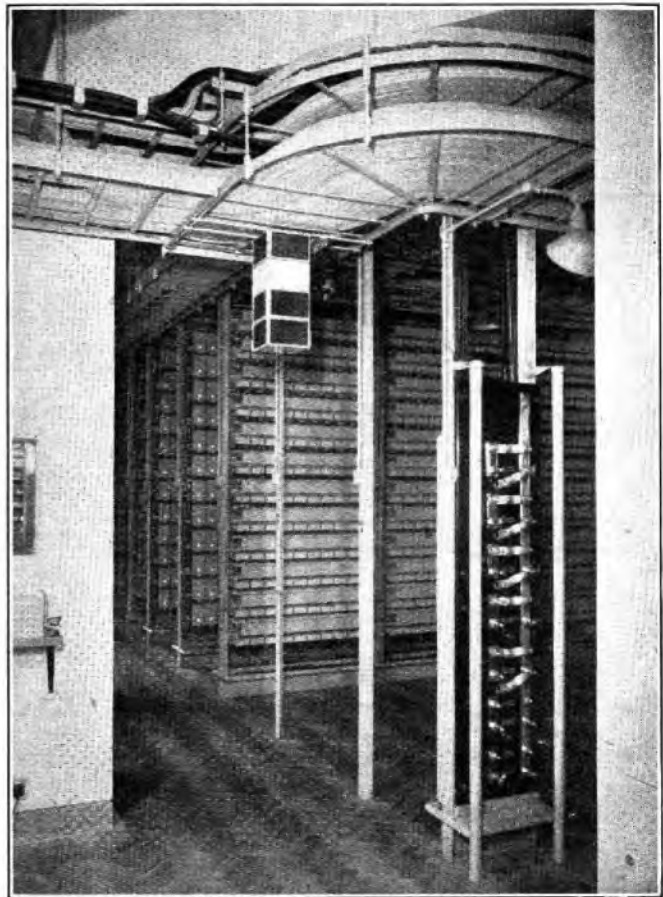

FIG. 4.—VIEW OF APPARATUS ROOM SHOWING FEEDER FUSE BOARD, CABLE RUNWAY AND RELAY SET RACKS.

Alterations to H.M.T.S. Ariel's Cable Paying-Out Gear

It has been necessary in recent years for H.M.T.S. *Ariel* to be employed in laying cables in water of depths exceeding 1,000 fathoms, and for this purpose the existing brake gear was inadequate. This gear consists of a winding drum driven from a steam engine through spur gearing. The tension on a cable during paying out operations is controlled by a brake associated with the drum, the brake consisting of an adjustable steel band which is wood-lined and water-cooled. This equipment operates satisfactorily on the type of work for which it was intended, i.e. maintenance of P.O. cables in shallow coastal waters. At the request of Submarine Branch, consideration was given to improving the design or strengthening the brake, but this was not practicable, and some form of auxiliary brake seemed the best solution to the problem.

It was ultimately decided to provide a Heenan & Froude hydraulic brake which was fitted adjacent to the winding drum and coupled to its shaft by a Morse Duplex roller chain drive immersed in oil. The basis of design was that the brake should hold a cable tension of 20 cwt. when the ship was steaming at 5 knots, under which conditions the

drum shaft would be revolving at 124 r.p.m. The chain drive from this shaft to the hydraulic brake provided a speed increase of 6 to 1, i.e. 744 r.p.m., which enabled the use of a hydraulic brake of reasonable size. The size chosen was such that it is capable of holding all cable tensions likely to be experienced at all speeds above $1\frac{1}{2}$ knots. Below this speed, the mechanical band brake will be used to assist the hydraulic brake and to hold the cable when the ship is stationary. It was confirmed by the manufacturers that the use of sea water from which all solid matter had been strained would be satisfactory as the brake elements are aluminium bronze and the duties light and intermittent. The space available on the ship was limited and this largely determined the type and size of equipment that could be accommodated. The brake control is extended by shafting and bevel gears to the main deck.

This new equipment has been used on cable laying operations and has proved so satisfactory that work is now in hand for providing similar auxiliary brake gear on H.M.T.S. *Iris*.

R. S. P.

The Single-Commutation Direct Current Signalling and Impulsing System

S. WELCH, M.Eng., A.M.I.E.E., and
B. R. HORSFIELD, A.M.I.E.E.†

U.D.C. 621.395.34

A new D.C. signalling and dialling system is described which is suitable for use on long audio circuits. The system employs double-current signals for impulsing, incorporates features to minimise impulse distortion, and provides duplex signalling by simple means. The article covers both the general principles of the new system and its practical application to trunk working.

Introduction.

THE increasing automatism of telephone networks is giving rise to a growing demand for dialling facilities over trunk and junction circuits, to permit the maximum economy in operating staff, and to provide a fast and efficient service for the subscriber.

On short-distance audio circuits, loop-disconnect direct current impulsing (loop dialling) may be employed. On circuits routed in multi-channel systems, the use of voice frequency A.C. signalling systems is essential. There are, however, many long audio circuits capable of carrying direct current signals, over which loop-disconnect impulsing is unsatisfactory, or impossible. It is primarily for this type of circuit that the Single-Commutation Direct Current system has been developed.

The new system gives the usual signalling and dialling facilities (including busy flash, when required), both unidirectional and bothway, on 2-wire or 4-wire audio circuits, and the duplex signalling feature of the system allows these facilities to be obtained by simple arrangements. The double current impulsing and the signal waveform improvement features of the system allow dialling with very small impulse distortion on audio circuits of length up to 100 miles of 4-wire 20 lb., or the equivalent of other types of audio circuit. The system utilises the phantom of 4-wire circuits for signalling purposes, but does not require the phantom to be extended separately to the signalling equipment.

The single-commutation system will supersede the L.D.D.C. (differentiated current) system described elsewhere¹, as it permits much simpler relay set circuit arrangements, is not so prone to false operation due to interference and no complications arise when the phantom of 4-wire circuits cannot be extended separately to the signalling equipment.

PRINCIPLES OF SYSTEM

Duplex Signalling.

The single-commutation system is based on the balanced bridge principle as shown in Fig. 1. R represents the line and r_1, r_2, r_3 and r_4 the windings of signalling relays. Series sources of signal current e_1 and e_2 complete the line loop circuit and sources e_3 (or e_4) have earth returns. The arrangement is balanced with respect to earth and resembles a Wheatstone bridge. Any circuit change across equal potential points such as A and B (or C and D), or a reversal of polarity of both e_1 and e_2 cannot affect the potential between points X and Y and hence cannot affect the earth current flowing between X and Y, although the distribution of the current between the line wires may be modified. Hence the conditions

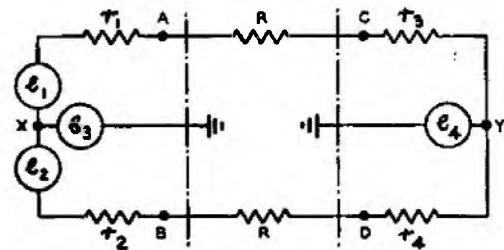

FIG. 1.—DUPLEX SIGNALLING PRINCIPLE.

for pure loop signalling (i.e. no change in earth current) are established.

Potential e_3 (or e_4) will produce line current of equal magnitude in each wire, flowing in the same direction. Any change in e_3 (or e_4), or a disconnection between X and Y will produce similar effect in each wire. Hence, conditions for pure earth signalling are established. Thus, loop signalling currents and earth signalling currents flow simultaneously and duplex signalling is established when these currents are detected independently.

The potential across CD, which is the algebraic sum of the voltages across the balanced series resistances r_3 and r_4 , is zero for earth currents and finite for loop currents, while the algebraic differences are respectively finite and zero. The same is true of points AB and resistances r_1 and r_2 . Now r_1 and r_2 are balanced windings of a line relay and r_3 and r_4 the windings of another. If the windings be connected series-aiding in a loop sense, the relay will respond only to loop currents (sum of voltages finite) and not to earth currents (sum of voltages zero). If the windings be connected in series-opposition in a loop sense, the relay will respond to earth currents (difference of voltages finite) and not to loop currents (sum of voltages zero). In this manner loop and earth current signals may be detected independently.

Fig. 2 shows the practical arrangement of the signalling and impulsing element, based on the theoretical element of Fig. 1. The adopted arrangement uses double-current loop forward signals from the outgoing end and earth-current

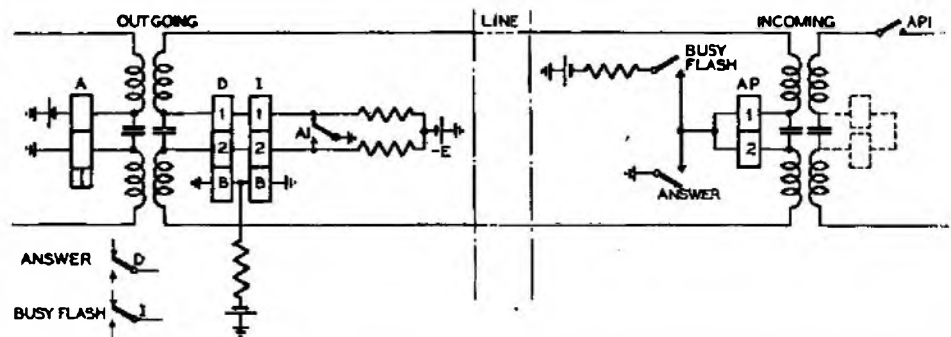

FIG. 2.—SIGNALLING AND IMPULSING ELEMENTS.

backward signals from the incoming end. The double-current loop signals are obtained by the single changeover contact A1 commutating the single battery—E; hence the name of the system. The polarised relay AP, with balanced

† The authors are, respectively, Senior Executive Engineer, Research Station, and Executive Engineer, Telephone Development and Maintenance Branch, Engineer-in-Chief's office.

¹ I.P.O.E.E., Printed Papers No. 178 and No. 184.

windings 1 and 2 connected series-aiding, operates in double-current manner to the forward loop current reversal signals transmitted by A1, but does not respond to the earth current signals transmitted back.

Relays D and I, with line windings 1 and 2 connected in series-opposition, are non-inductive and thus non-responsive to the loop currents, including impulsing, from the outgoing end, but are responsive to earth current signals from the incoming end.

An earth at the centre point of relay AP gives an earth current in one direction, to give one backward signal (say answer) and an earthed battery would give an earth current in the reverse direction to give a second backward signal (which could be busy flash if required). The D and I relays are of polarised type to (a) obtain adequate signalling sensitivity, and (b) discriminate between earth currents in opposite directions should the two backward signals be required. To detect the absence of earth current (e.g. backward clear) in addition to the presence and reversal of earth current, it is necessary to add locally-energised bias windings to the D and I relays. Earth current in one direction reinforces the bias on relay I, which does not "operate," and opposes the bias on relay D, which "operates" against its bias to give, say, the answering condition. Earth current in the reverse direction reinforces the bias on relay D, which does not operate, and opposes the bias on relay I which operates against its bias to give, say, busy flash. Relay AP is not affected by the application or cessation of earth current signals, the current being merely re-distributed between the line wires.

Normal automatic exchange switching equipment works single-current and the line impulsing system, worked double-current, must work single-current at its two ends by conversions. At the outgoing end, relay A (Fig. 2) operates in single-current manner to the received single-current signals and at contact A1 transmits double-current signals to the system. At the incoming end, relay AP operates in double-current manner and the signals are converted to single-current by working on the make side only of contact API to transmit the signals forward.

Extraneous Earth Currents.

Unwanted earth currents are a feature of earth signalling systems. These currents, which influence the operation of the D and I relays, but not AP, may arise from differences in earth potential (e.p.d.) and by potentials induced longitudinally into the line wires from 50 c/s power lines. Both these causes will be referred to as e.p.d. for the purpose of discussion; e.p.d. can have effect only when the centre point of relay AP is earthy and this applies during backward signalling.

Assuming the loop signalling current due to potential $-E$ at the outgoing end to be flowing, and the centre point of relay AP not earthy, this point (Y, Fig. 3) will be at

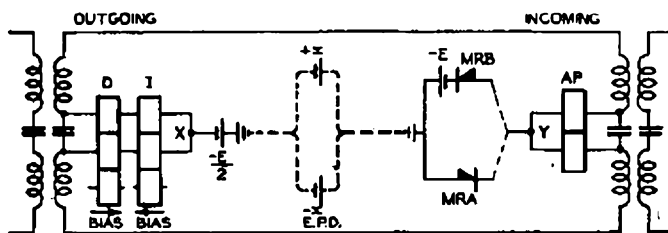

FIG. 3.—THE EFFECTS OF EARTH POTENTIAL DIFFERENCE.

potential $-E/2$ reference earth zero. If now point Y be joined via the earth to the earth (zero potential) point at the outgoing end, as would occur during backward signalling, the current in the earth path will flow from the

high potential point (zero) at the outgoing end, to the low potential point Y ($-E/2$) at the incoming end. This current in the earth path may be considered as due to an assumed source of potential $-E/2$ located in the earth path, and, as far as the flow of earth current in the line (as distinct from the earth path) is concerned, point Y is at zero potential and the earth point X (Fig. 3) at the outgoing end is at potential $-E/2$. Thus, considering the earth, but not the loop, current aspect, with point Y at zero, i.e. full earth applied, a potential of $-E/2$ can be assigned to point X. This assumption simplifies the consideration of e.p.d. effects and Fig. 3 shows the derived circuit for the earth current aspect. The resultant effect on the system of both the loop and earth currents acting simultaneously can be determined by application of the principle of superposition assuming the loop and earth currents to flow independently and using the above treatment for the earth currents.

Consider first the e.p.d. in the presence of earth applied at Y. If X is regarded as fixed and the e.p.d. as affecting Y, an e.p.d. of $-x$ volts will lower the potential of Y and reduce the potential difference between X and Y to reduce the earth current. An e.p.d. of $+x$ will raise the potential of Y and so tend to increase the potential difference between X and Y to increase the earth current. If x equals $-E/2$ (25V in a 50V system) the potential between X and Y will be zero and the earth current (and the signal) will cease. If x is greater than $-E/2$ in a negative sense, the potential of Y will be lower than that of X and the earth current will reverse in direction. This would normally give a false signal, as relay I would operate instead of D, but may be prevented by rectifier MRA connected as shown.

Similarly, in the presence of an earthed battery at Y, an e.p.d. of $-x$ will increase the potential difference between X and Y to increase the earth current, but an e.p.d. of $+x$ will reduce the potential difference between X and Y to lower the earth current. If x equals $+E/2$ (25V in a 50V system) the potential between X and Y will be zero and the earth current will cease. Again a false signal, relay D operating instead of I, due to the reversal of earth current should $+x$ exceed $E/2$, may be prevented by rectifier MRB as shown.

Induction from power lines may also cause unwanted earth currents to circulate via the wire-to-earth capacitances even when point Y is not earthy.

E.p.d.s and induced voltages, in reducing the magnitude of the earth signalling currents, reduce the signalling limit of the system.

Improvement in Received Signal Waveform.

A square wave signal may be assumed to consist of a number of sine waves of different frequencies, i.e. a fundamental and a number of harmonics. If the transmission medium, including the reception apparatus, introduces amplitude and/or phase distortion, some frequencies are distorted relative to others and the received signal is not the same shape as that transmitted.

On most types of line to which the signalling system will be applied phase distortion produces the greater effect since it delays the attainment of the steady state value to a greater degree than amplitude distortion. With phase distortion, the delay in the reception of the higher frequency components is not so great as for the lower frequency components, with the result that the attainment of steady state is spread over a longer period of time.

It was desired that, with a minimum signal of 20 milliseconds duration, the impulse distortion should be as small as possible on lines of microfarad-ohm value (CR^2) of up to 75,000 (more conveniently expressed as line time-

constant $T = 75$ milliseconds) which represents 100 miles of 20 lb. 4-wire P.C.Q.T. Waveform A in Fig. 4 shows the

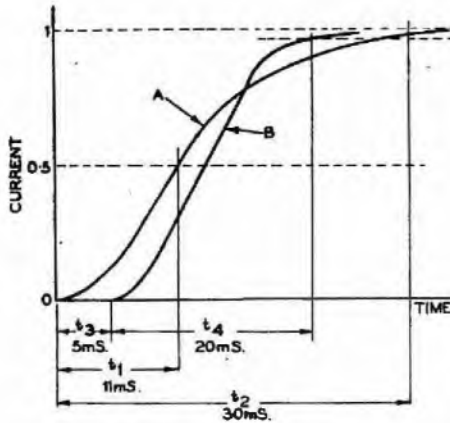

FIG. 4.—RECEIVED SIGNAL WAVEFORMS ON 75MS. TIME-CONSTANT LINE.

received signal build-up on a line of $T=75$ milliseconds. The current reaches substantially steady state in some 30 milliseconds (t_2) and it is clear that mutual interference between the build-up and decay waveforms will arise with a 20 millisecond signal and impulse distortion will result. It is necessary, therefore, to improve the received waveform by reducing the build-up time and a phase correcting feature has been incorporated.

On the types of line to which the system will be applied the phase-angle/frequency characteristic is not linear, and the line phase angle of the received current lags on the sent volts. For the system to be free from phase distortion, it is required that the phase-angle/frequency characteristic should be linear.

If the line be terminated with a suitably designed LC shunt resonant circuit introducing a further lagging phase angle which increases with frequency, the phase-angle/frequency characteristic of the combined arrangement is made linear over a limited, but significant, frequency range on a line of specific time-constant, and the phase distortion is reduced.

The frequencies of importance to impulsing may be assumed to be the range 10 to 200 c/s and, while the single resonant circuit termination, as designed, gives a linear phase angle characteristic over the useful frequency range 0 to 75 c/s, this range is limited and a wider range would give further improvement. This can be obtained by the addition of a similar resonant circuit which results in a linear phase angle characteristic over the wider range 0 to 85 c/s and it was considered that phase correction over this frequency range was adequate. For convenience, a shunt resonant circuit is located at each end of the line as shown in Fig. 5, where, as it will be seen later, L and r

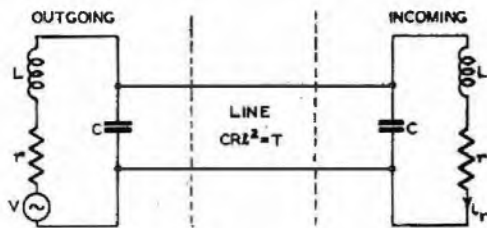

FIG. 5.—LINE TERMINATED WITH PHASE CORRECTING SHUNT RESONANT CIRCUITS.

represent the impulse receiving relay and i , the received relay current; V being the sent volts.

The resonant circuits are resonant at one frequency only and thus, for a fixed design, the phase correcting feature gives optimum performance at one line time-constant

only. This line has been adopted as $T = 75$ milliseconds, this being the highest line time-constant over which impulse distortion is required to be a minimum and thus where correction is most required. A substantial improvement, however, is realised on lines of lesser time-constant, the improvement decreasing with T .

In the practical design the capacitance of the shunt resonant circuit is conveniently given by the $2 \mu\text{F}$ capacitors already present in the transformer type transmission bridges in the outgoing and incoming relay sets. At the incoming end the inductance of the impulse receiving relay AP completes the incoming end resonant circuit and at the outgoing end an inductor is added to give the required inductance. With C fixed at $2 \mu\text{F}$, the inductor of the resonant circuit may be defined as 5.3 henrys with time-constant 4 milliseconds.

In addition to phase correction, the resonant circuits give an improved amplitude/frequency response over the useful frequency range compared with that of the line without terminations. For best performance the send and receive end resistances should be as small as possible during impulsing.

Waveform B in Fig. 4 shows the build-up of the received signal current in the relay AP on a line $T = 75$ milliseconds and the system incorporating the phase correcting feature. This waveform is a careful reproduction of the experimental waveform except that, for clearness of comparison, the kinks in the actual waveform produced by the E.M.F. generated by the relay when its armature moves, have been omitted. Waveform A shows the build-up of the current on the same line without the shunt resonant circuits and the considerable improvement of B compared with A will be noted. Waveform B attains substantially steady state in 20 milliseconds (t_4) compared with the 30 milliseconds (t_2) of A, the waveform is more symmetrical about the half amplitude current value and its slope is greater. All these factors contribute to reduced impulse distortion. There is a 5-millisecond delay time (t_3) before the received current waveform B begins to build up, but as this delay occurs on all signals, which may be successive impulses, it is of no consequence.

Impulsing Relay Transit Time Compensation.

The AP polarised relay transit time results in negative impulse distortion (loss of make) due to the conversion from double to single current working, and it was desired to compensate for this. The transit time of the Relay, Polarised No. 2B/106, used in the system varies with slope of signal and thus with line time-constant as shown in Fig. 6. The characteristic is not linear, but little error is

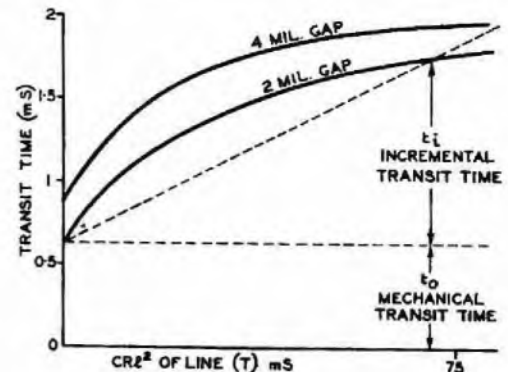

FIG. 6.—TRANSIT TIME OF RELAY, POLARISED, NO. 2B/106.

introduced if it is assumed to be so and with this assumption it can be stated that :—

$$t = t_0 + t_i \\ = t_0 + K/S$$

where t = total transit time
 t_0 = constant mechanical transit time
 k = incremental transit time
 S = signal wavefront slope
 K = a constant.

The mechanical transit time depends upon the mechanical construction of the relay and the contact gap and cannot be reduced regardless of current amplitude and steepness of signal slope. Signals of more gradual slope will cause the transit time to increase by the incremental transit time. This increase is not linear with signal slope due to the magnetic toggle with which the relay operates.

It can be shown that a constant dis-symmetry in the operate and release current values of the relay is capable of compensating for the incremental transit time. The necessary dis-symmetry is obtained with an electrical bias by using a third winding on the AP relay, the arrangement being of bridge form. The bias affects the value of K in the transit time equation above, and for any given relay there is a value of bias which makes K zero. With this bias the repetition distortion on the relay make contact is equal to the mechanical transit time t_0 ; the distortion appears as shortening of the make periods of the impulses. This is true for any wavefront slope and therefore for any line. The bias adjustment is carried out as follows:—

- (a) with no bias and no line the relay is pulsed with square wave pulses, the distortion is measured and will be equal to the mechanical transit time,
- (b) the relay is pulsed via a network simulating a line of $T = 75$ milliseconds, and the bias adjusted to obtain the same distortion as in (a).

The bias adjustment is carried out on initial set-up of the incoming relay set and not on a per line basis. It is pre-set for the longest line but as the compensation given by the pre-set adjustment will vary with the signal slope, and thus linelength, the output of the relay is substantially constant, and distorted by the mechanical transit time, on lines of lesser T value.

Compensation for the mechanical transit time by means of the AP relay bias would give correct compensation at one line length only. The compensation would vary with signal slope, and thus line length, and while this is a correct condition for incremental transit time compensation, it would not be correct for the mechanical transit time as this has a constant value independent of signal slope. For this reason the mechanical transit time is compensated for by the adjustment on the high speed relief relay AA in the incoming relay set, the make contact of which gives the final output from the system.

APPLICATION TO A PRACTICAL SIGNALLING SYSTEM

General.

The foregoing principles have been embodied in a new D.C. dialling system for use on circuits carrying trunk traffic (Signalling System D.C. No. 2). A trunk signalling system is not required to repeat the busy flash signal and the system does not provide this facility. The new method of signalling would, however, be capable of providing this facility in a system designed for use on non-trunk circuits. Since it is not required to transmit the busy flash signal, only one earth-responsive relay is needed in the outgoing relay set and relay I (Fig. 2) has been omitted; the battery connection to the mid-point of relay AP in the incoming relay set has also been omitted for the same reason.

The circuits are so designed that when a trunk is not in use, earth current normally flows through the line and holds the line relay (relay D) in the outgoing relay set in the position required to maintain a free condition for a testing selector or operator. This current also ensures that the line relay (relay AP) in the incoming relay set is held in its

normal position. If the continuity of the line circuit is broken, the line relay in the outgoing relay set responds to the cessation of earth current and engages the circuit.

The continuity of the earth return path is broken if,

(1) the incoming relay set, or selector, is removed from the shelf jack;

(2) the incoming relay set, or selector, is undergoing a routine test;

(3) the line circuit is disconnected, as, for example, during line fault conditions,

and the outgoing relay set is caused to test engaged during the existence of any of these conditions. The continuity of the earth return circuit is also broken until the release of the incoming equipment at the end of a call is complete, and the engaged test is therefore maintained at the outgoing end until a signal (the reconnection of earth current) is received to indicate that the incoming equipment is ready for the next call; this feature is referred to as the "sequenced release" facility.

During the progress of a call over a unidirectional circuit the following signals are used:

From the Outgoing End.

Seizure and holding	Transmission of loop current in such a direction as to switch the line relay in the incoming equipment from its normal position.
Dialled Impulses	Reversals of the direction of the loop current.
Forward Release	Transmission of loop current in the opposite direction to the holding current.

When a signal is received to indicate that the incoming equipment has released, the circuit is made available for the next call.

From the Incoming End.

When the seizure signal is received, the earth current is disconnected in the incoming relay set.

Called Party Answers	The earth current is re-connected.
Called Party Clears	The earth current is disconnected.
Backward Release	When the incoming equipment has restored to normal, the earth current is re-connected.

If a battery-connected earth signal were used to indicate the answered condition, the connection of earth to one of the line conductors would switch the line relay in the incoming relay set and release the connection. When an earth-connected signal is used, the connection of a battery potential to one of the line conductors produces the same result, but since irregular earth contacts (due to working parties, etc.) are more probable than irregular contacts with the exchange battery, a greater immunity from "cut off" faults should result from the use of an earth-connected signal. As use is made of only one type of earth signal, the need to guard against false signals due to e.p.d. effects by means of rectifiers does not arise.

Impulse Correction at Tandem Switching Points.

The impulsing performance of the system offers a means of dialling over a number of links in tandem without the need for impulse correction or regeneration. To enable full advantage to be taken of this feature it is essential to minimise the impulse distortion which occurs at tandem switching points where the impulses are converted from double current signals to loop-disconnect signals and back to double current signals; this conversion, which takes place in the incoming and outgoing junction relay sets, is necessary to meet the requirements of the selectors at tandem switching points. Adjustable impulse correcting

elements have therefore been built into the relay sets. The element in the incoming relay set corrects for shortening of the "make" periods of the impulses due to the mechanical transit time of the line relay, and the element in the outgoing relay set corrects for lengthening of the "make" periods of the impulses due to the performance characteristics of the impulse repeating relay.

The greater the amount of impulse correction which it is necessary to introduce, the more sensitive the performance of the correcting elements becomes to variations in exchange battery voltage, and for this reason it is desirable to keep the amount of impulse correction to a minimum.

When a connection has been set up through a tandem switching point, the impulse repeating relay in the auto-auto relay set is controlled by the impulsing contact in the incoming relay set preceding it. Since the impulsing contact in the incoming relay set is also required to step selectors in the same exchange, it is desirable to protect this contact by providing a spark quench circuit, but, since the introduction of capacitance at this point increases the amount of correction required in the outgoing relay set, a capacitance of $0.5 \mu\text{F}$ has been used in place of the more usual value of $2 \mu\text{F}$.

The last incoming relay set in a tandem connection repeats the impulses into the local switching equipment. The use of a $0.5 \mu\text{F}$ spark quench capacitor in the incoming relay set, instead of the $2 \mu\text{F}$ capacitor normally connected across impulsing sources, results in a slight decrease in the effective "make" periods of the impulses controlling the local selectors, which is partly compensated for by the effect of the $2 \mu\text{F}$ capacitor in the operator's position circuit on the impulse repeating relay in the outgoing relay set at the originating exchange. The compensation is not complete, however, and in any given set of local conditions the effective "make" periods of the impulses tend to be shorter than in the same set of conditions when the local equipment is controlled directly from an impulsing source provided with a $2 \mu\text{F}$ spark quench capacitor. The reduction in effective "make" period is of the order of 1 millisecond and is a characteristic feature of the present design of the system.

The outgoing auto-auto and incoming relay set circuits have been designed, as described above, to meet the impulsing requirements at tandem switching points. The impulsing performance of the outgoing sleeve control manual board relay set has been arranged to simulate that of the auto-auto relay set when seized via selector levels from a sleeve control manual board in the same building. The overall impulsing performance of the system has thus been made independent of the type of access provided at the controlling exchanges.

Outgoing Relay Set.

The practical circuit of the auto-auto relay set is shown in Fig. 7. Relay AA and the associated components comprise the impulse correcting element which is required to reduce the duration of the "make" periods of the impulses. When contact A1 closes, an operating current flows through the operating coil of relay AA and at the same time an opposing current flows through the other coil to charge capacitor QD. The effect of the current charging capacitor QD is to delay the operation of

the relay. The rectifier reduces the discharge current from the capacitor to a value which has no appreciable effect on the release timing of the relay, and the overall effect is to decrease the period for which relay AA is operated. Resistor YH provides a means of adjusting the amount of correction introduced.

The arrangement of resistors YC and YD and rectifiers MRD and MRE, in conjunction with the sending element resistors YA and YB, ensures that the values of the impedances to earth connected to the two line wires via relay D, inductor LA and the line transformer, are approximately equal irrespective of the position occupied by contact AA1. Since the windings of relay D, which is an earth-responsive relay, are astatic to loop currents, a separate inductance, LA, has been provided to assist in improving the waveform of the received signals during impulsing.

The contact of relay D is shown in the position which it normally occupies when the circuit is not in use, i.e. when an earth return current is flowing. If this current is disconnected, the contact of relay D switches to the other position and operates relay DB. If the circuit is not in use, relay DB connects an engaging condition to the P-wire, thus giving the automatic busying facility to guard against seizure during fault conditions or during testing operations. Relay DB also maintains an engaged condition during the release of the incoming equipment at the end of a call.

A similar selector level circuit incorporating battery testing elements has been produced for use in mechanised trunk exchanges.

An outgoing manual board circuit embodying the same principles has been developed for use in sleeve control exchanges. This relay set follows conventional sleeve control design principles. Seizure of the distant incoming equipment is delayed until the dial key is thrown, thus enabling a bothway circuit to be used for calls incoming to an exchange while a plug is inserted in the manual board multiple jack at that exchange. The development of an outgoing circuit for use at C.B. exchanges is at present under consideration.

Incoming Relay Set.

The practical circuit of the incoming relay set is shown in Fig. 8. Relay AA and the associated components constitute the impulse correcting element. When the circuit is seized, relay AA is normally held operated by

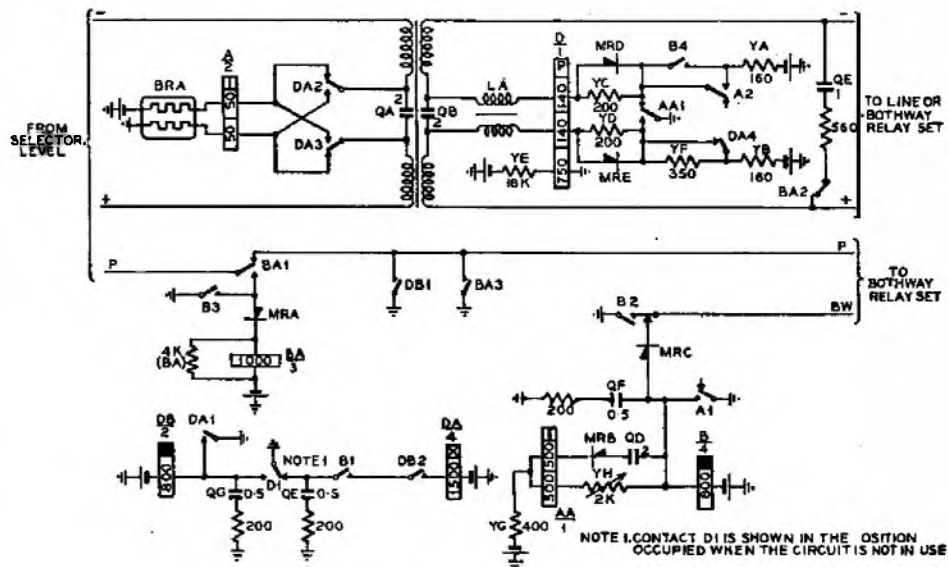

FIG. 7.—SIMPLIFIED CIRCUIT DIAGRAM OF AUTO-AUTO RELAY SET.

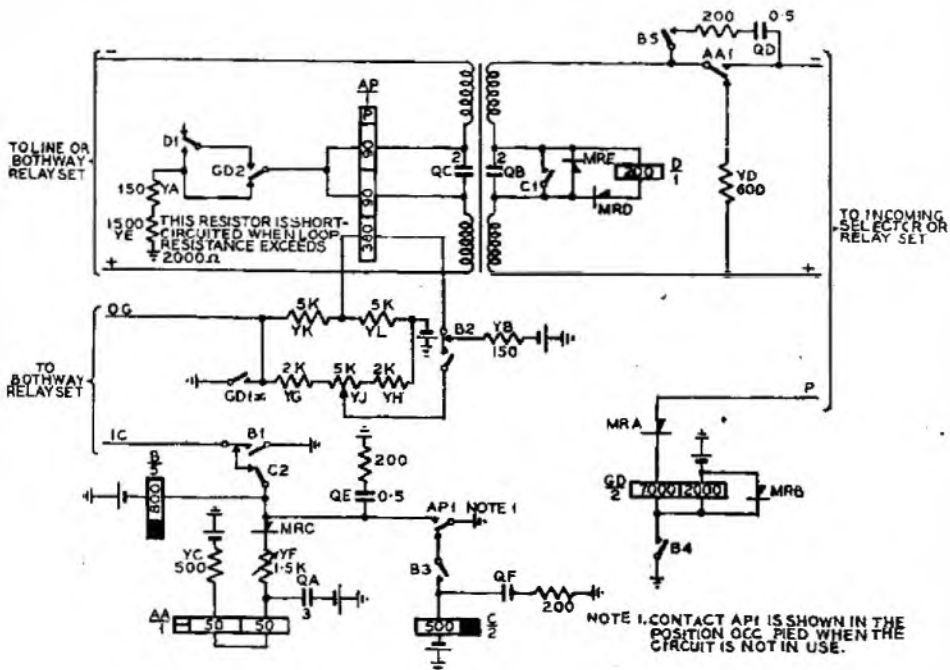

FIG. 8.—SIMPLIFIED CIRCUIT DIAGRAM OF INCOMING RELAY SET.

contact AP1. During the "break" periods of the impulses, when contact AP1 restores to its normal position, the current through the coils of relay AA is prolonged while capacitor QA discharges, and the release of the relay is delayed. The effect is to prolong the operated period of the relay and hence to increase the duration of the "make" periods of the impulses. Resistor YF provides a means of adjusting the amount of correction introduced.

The 380 ohms winding of relay AP constitutes the bias coil. While a call is in progress, the current through the coil is derived from the network of resistors YG, YH, YJ, YK and YL, resistor YJ being adjustable to provide the necessary compensation for incremental transit time. At the conclusion of a call, during the release lag of relay GD, a larger current is passed through the bias winding of the relay to hold it in the idle position. This is required to prevent irregular operation of the relay resulting from an oscillatory discharge from capacitor QC at the conclusion of an incoming call on a bothway circuit.

Bothway Switching Circuit.

To hold the line relays in the two incoming relay sets in a bothway circuit, and to provide the sequenced release and automatic busying features, it is necessary to maintain earth currents in both directions over the line circuit. This requirement necessitates a departure from the normal practice on bothway circuits and the bothway switching equipment is so designed that each line conductor terminates in an incoming relay set at one end of the circuit and in an outgoing relay set at the other end. The method of connecting a bothway circuit is shown in Fig. 9. Since only one line conductor is connected between each outgoing relay set and the distant incoming relay set when the circuit is not in use, it is not possible to transmit a loop signal to seize the incoming equipment. This difficulty has been

overcome by arranging for a pulse of current from a positive battery at the outgoing end to be transmitted as a seizure signal. This pulse of current simulates the effect of a loop current on the line relay in the incoming relay set and seizes the incoming equipment. As soon as the incoming equipment is seized both line conductors are extended to the incoming relay set and the call proceeds in the same way as on a unidirectional circuit.

The principle of the bothway switching circuit is shown in Fig. 10. When the outgoing relay set is taken into use an earth is connected to the BW lead and relay PB operates for a period equal to the operate lag of relay OG. The contact of relay PB transmits a pulse of positive battery current to seize the distant incoming equipment.

When an incoming call is originated, a pulse of positive battery current is received by the incoming relay set over the + wire, causing the operation of relay AP in that

relay set and the immediate connection of earth over the IC lead to operate relays IC and ID. A contact of relay IC engages the outgoing circuit. All the relays involved in the seizing function are of the high speed type and the unguard period between seizure at the distant end and the engaging of the outgoing equipment at the incoming end, is reduced to a minimum. In the case of a bothway circuit terminating on a sleeve control manual board an appreciable delay may occur between the insertion of the plug in the switchboard jack and the operation of the dial key, and during this period the circuit tests free at the distant end. If the circuit is seized at the distant end during this period, the operator receives N.U. tone and is thus informed that the opportunity of using the circuit has passed.

The impedance coil, IA, reduces the amplitude of the longitudinal surge resulting from the connection of positive battery to the line conductor in place of the negative battery, during transmission of the seizing pulse, and thus minimises interference with other circuits in the same cable.

Signalling and Impulsing Performance.

The signalling limit of the system is 6,200 ohms loop line resistance representing 140 miles of 20 lb. P.C.Q.T. 4-wire (phantom). This limit is set by the earth current signalling

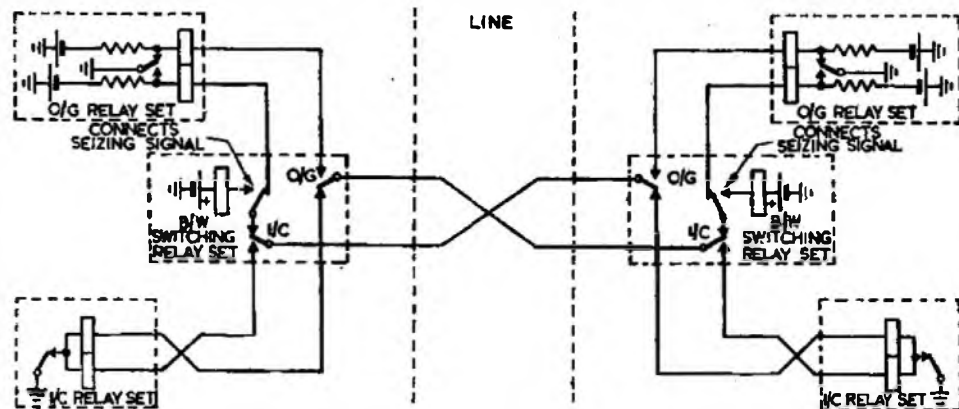

FIG. 9.—METHOD OF CONNECTING BOTHWAY CIRCUITS.

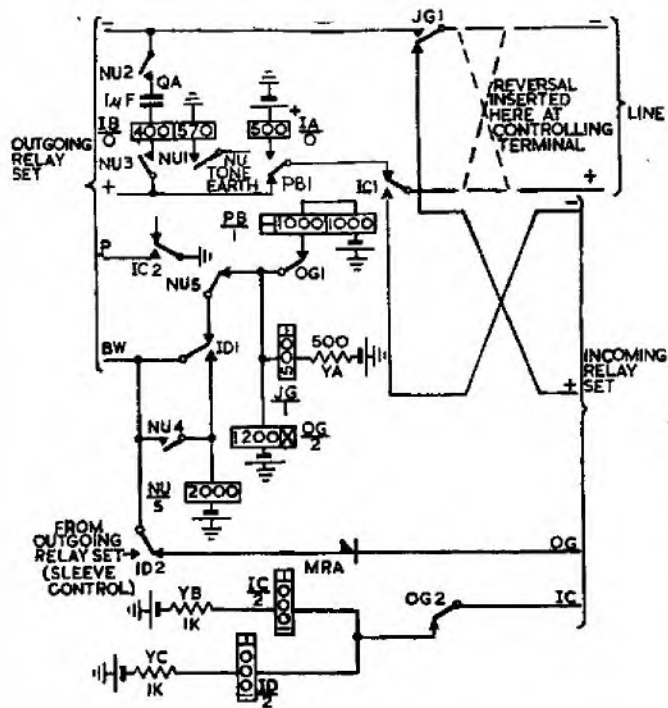

FIG. 10.—SIMPLIFIED CIRCUIT DIAGRAM OF BOTHWAY SWITCHING CIRCUIT.

and assumes 4V e.p.d. and induction from power lines assumed to be the equivalent of a further 4V e.p.d. Increase in e.p.d. above this value, which is liable to occur particularly during magnetic storm periods, will reduce the signalling limit.

Fig. 11 shows the overall impulsing performance with 50V working and a 20 millisecond signal. The distortion does not exceed 1 millisecond on lines of microfarad-ohm values (CR^2) up to 75,000 (100 miles of 20 lb. 4-wire P.C.Q.T.). This line is less than the signalling limit of the system, but the high signalling limit permits the application of the system to the isolated cases of very long lines where the increased impulse distortion above 1 millisecond may

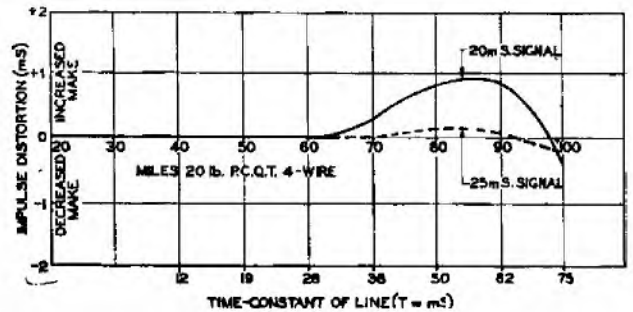

FIG. 11.—OVERALL IMPULSING PERFORMANCE (50-VOLT SYSTEM)

be tolerated. The distortion is less than that shown when the signal length is increased above 20 milliseconds.

The shunt resonant terminations are designed for correct condition on lines of microfarad-ohm value of 75,000. The increase in distortion on lines of lesser microfarad-ohm values with short signals is due to the oscillatory properties of the terminations, which, while highly damped, have not died out sufficiently to avoid mutual interference between wavefronts.

Field tests of the impulsing performance of the system on multi-link connections have confirmed the laboratory results.

Conclusion.

The Single Commutation Direct Current system is based on simple principles and provides a means of dialling with small impulse distortion over long-amplified and unamplified physical circuits. It also provides a means of dialling without regeneration over several circuits in tandem where this facility is required.

The desirability of adhering to simple arrangements has been kept in the forefront throughout the development and the application of the system should not give rise to special maintenance requirements.

Acknowledgments.

The authors wish to acknowledge the work done by past and present colleagues in the Research and Telephone Branches, who were associated with this development.

Book Review

"Telephony." Vol. 2 (Automatic Exchange Systems). J. Atkinson, A.M.I.E.E. Sir Isaac Pitman & Sons. 872 pp. 808 ill. 50s.

The very considerable task undertaken by Mr. Atkinson in preparing a completely new edition of Herbert & Procter's "Telephony" has now been successfully concluded by the publication of Volume 2, covering Automatic Exchange Systems, and this book, together with Volume 1 (General Principles and Manual Exchange Systems), makes available an up-to-date tabulated exposition of the Telephone Exchange Systems of the British Post Office, and gives an outline of switching systems used by other telephone administrations, i.e., step-by-step systems other than the B.P.O. standard, those employing marker control Uniselectors, Power Drive Systems, the Relay System, and Crossbar Switching.

The method of exposition adopted in Volume 2 is to devote the opening chapters to a broad picture of Automatic Exchange design, including the general principles of switching, traffic and trunking, switching mechanisms and apparatus racks and cabling. Six chapters then follow describing in detail the wide range of basic circuit elements used in building-up complete circuits. Those already in possession of Volume 1, in which a similar method was followed, will at once appreciate the

comparative ease with which it is then possible to tackle the complex circuit arrangements found in complete switching systems.

Having thus prepared the reader, the author then covers in considerable detail the Non-Director and Director systems, Unit Automatic Exchanges, and the means of communication between Manual and Automatic Exchanges.

The concluding chapters deal with the important subject of long-distance dialling, mechanisation of Trunk and Toll services, Private Branch Exchanges, and include an informative survey of the problems arising in the conversion of exchanges from manual to automatic working.

There can be no doubt that this authoritative volume will be regarded as the standard work on Automatic Exchange systems for many years to come, and the author is to be congratulated on the results of his labours. A striking feature of the book is the wealth of illustrations and their exceptional quality; furthermore, the page size (10 in. x 7 in.) allows close association of illustrations and relevant text, thus greatly simplifying reading and study.

The price of the book—and it is quite low compared with others of similar size and production standard—should not deter those interested in this subject from acquiring a copy of the volume, which is quite indispensable both to student and to practising telephone engineers.

J. R.

The New London Radio-Telephony Terminal

U.D.C. 621.396.5

C. W. SOWTON, B.Sc.(Eng.), A.C.G.I., A.M.I.E.E., and
D. B. BALCHIN, B.Sc.(Eng.), A.M.I.E.E. †

To cater for expansion in traffic, a new radio-telephony terminal has recently been opened with initial provision for the simultaneous control of 48 circuits. This article describes the special equipment needed for technical control and supervision of radio-telephone circuits and details that which has been provided. A broad outline of circuit operation is also included.

Introduction.

THE long-distance radio telephone service between the United Kingdom and other countries was inaugurated in 1927, with the establishment of one circuit between London and New York, since when the service has grown until, by January 1951, 41 circuits to various parts of the world were in operation. These circuits are shown in the azimuthal graticule of the world (Fig. 1) which gives the true bearing and distance of all

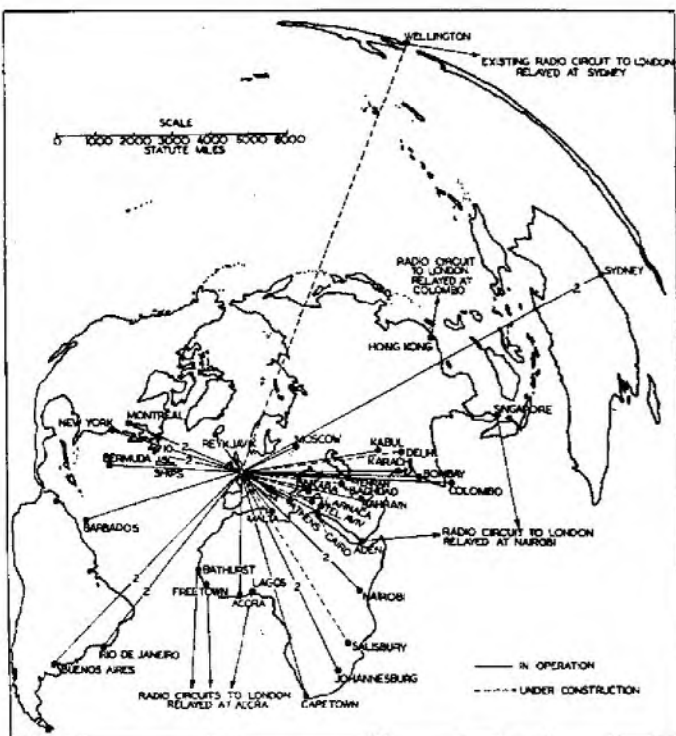
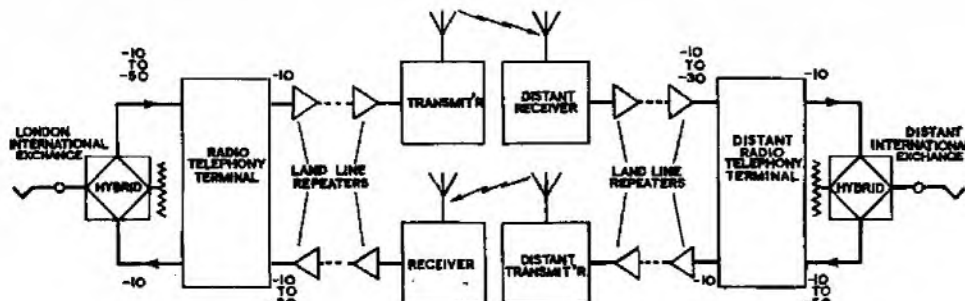

FIG. 1.—RADIO TELEPHONE CIRCUITS, JANUARY, 1951.
(ZENITHAL EQUIDISTANT PROJECTION GIVING TRUE BEARING AND DISTANCE FROM LONDON).

points from London. Technical control and supervision of these circuits is provided with the aid of special apparatus



NOTE:—LEVELS ARE IN dB RELATIVE TO REFERENCE TELEPHONE POWER.
FIG. 2.—BLOCK SCHEMATIC DIAGRAM OF LONG-DISTANCE RADIO TELEPHONE CIRCUIT.

† Mr. Sowton is Senior Executive Engineer and Mr. Balchin Executive Engineer, Radio Planning and Provision Branch, Engineer-in-Chief's Office.

at a station known as the Radio Telephony Terminal (R.T.T.) where connection is made between the radio and inland circuits. The first R.T.T., which was located at Faraday Building, London, was in service from 1929 to 1949 and, at the end of that period, provided for the simultaneous control of 13 circuits. It has now been superseded by a new R.T.T. at Brent Building, London, N.W.2, which is equipped for the simultaneous control of 48 circuits at present and has an ultimate capacity for 80 working circuits and an appropriate amount of spare equipment.

RADIO-TELEPHONE CIRCUITS

Before describing the Brent R.T.T. the nature of a long-distance radio telephone circuit will be considered and the necessity for the various types of apparatus required at the R.T.T. for the control of the radio circuit and for its connection to the telephone network will be examined. The radio transmitting and receiving stations in each country are well separated to prevent the signals radiated from the transmitters affecting the receivers, and both stations may be remote from the R.T.T. and the international exchange, the latter being usually situated in the metropolis. The radio stations are therefore connected by repeatered landlines to the R.T.T. and the exchange.

Fig. 2 illustrates a typical circuit between the international exchange in London and a similar exchange in a distant country. Signals over the inland telephone network arriving at the London International exchange switchboard, pass via the hybrid transformer to the transmit path of the radio terminal apparatus and continue by repeatered land line to the radio transmitting station where the audio frequency signals are translated to radio frequency and "beamed" to the distant receiving station. There they are translated back to audio frequency and pass over landlines to the distant R.T.T. and exchange. Signals from the distant exchange follow a similar but separate path between the hybrid transformers at the distant and near ends of the circuit. Different radio frequencies are used for the two directions of transmission and the "go" and "return" channels of the radio circuit constitute a "four-wire" circuit.

Speech signals from subscribers arrive at the radio terminal at widely different average levels, owing to the differences in subscribers' average talking volumes and in the transmission losses of inland connections, and superimposed upon these differences are the normal modulations of a subscriber's talking volume. A radio telephone transmitter which could provide, over a long-distance circuit, an acceptable signal-to-noise ratio with the lowest speech levels yet not be overloaded by the highest speech levels would be of exorbitant cost and size and for most of

the time would be operating inefficiently. If, however, the average modulation of the transmitter is maintained at a high and substantially constant level a major economy in

transmitter size and power can be obtained. This condition is achieved by inserting, in the transmit path at the R.T.T., an automatic variable gain amplifier which maintains a constant output speech volume over a wide range of input volumes. This unit is known as a "transmit constant volume amplifier."

Radio signals transmitted via the ionosphere are subject to both general and selective fading—with selective fading the different frequency components of the signal fade in and out independently of one another. In double-sideband radio telephone systems, the average level of the emitted radio signal, i.e. of the carrier plus sidebands, is constant and, but for fading, the average level of the received signal would also be constant. Fading can, therefore, be adequately compensated in the receiver by short time-constant automatic gain-control circuits responsive to the average level of the received signal. In single-sideband radio-telephone systems, however, no such constancy of signal level exists since the level of the emitted radio signal varies with the modulation depth, so a pilot carrier is also emitted at a constant low level for automatic gain control at the receiver. The time-constant of the A.G.C. circuit used in this case must be relatively long (of the order of ten seconds), so that while it responds to general fading, which usually occurs at a relatively slow rate, it ignores the rapid variations in level to which the carrier may be subject due to selective fading. Although by this means the output of the receiver is maintained at a substantially

sometimes even lower, and thus in the loop circuit formed by the go and return channels, there may be a net gain of more than 40 db. Singing, which would otherwise inevitably occur, has to be prevented by the use at the radio terminals of voice-operated singing suppressors, which block the transmit path while the receive path is open for the passage of speech signals and vice-versa.

The primary requirements so far outlined are met for each radio-telephone circuit by the provision at the R.T.T. of a unit of apparatus known as a "terminal bay." Most circuits, however, require additional apparatus such as privacy equipment and channelling equipment (for multi-channel systems) and this is also installed at the radio terminal to facilitate the engineering operation and supervision of the complete radio-telephone circuit. Finally, monitoring and testing equipment and an extensive network of telephone "speaker" circuits to the radio transmitting and receiving stations and to the International exchange are also required.

CIRCUIT ARRANGEMENTS

Basic Circuit.

With the general nature of a long-distance radio telephone circuit and the necessity for the various types of apparatus in mind, the basic circuit arrangements of the radio terminal equipment will be considered in more detail. Referring to Fig. 3, speech incoming to the London International

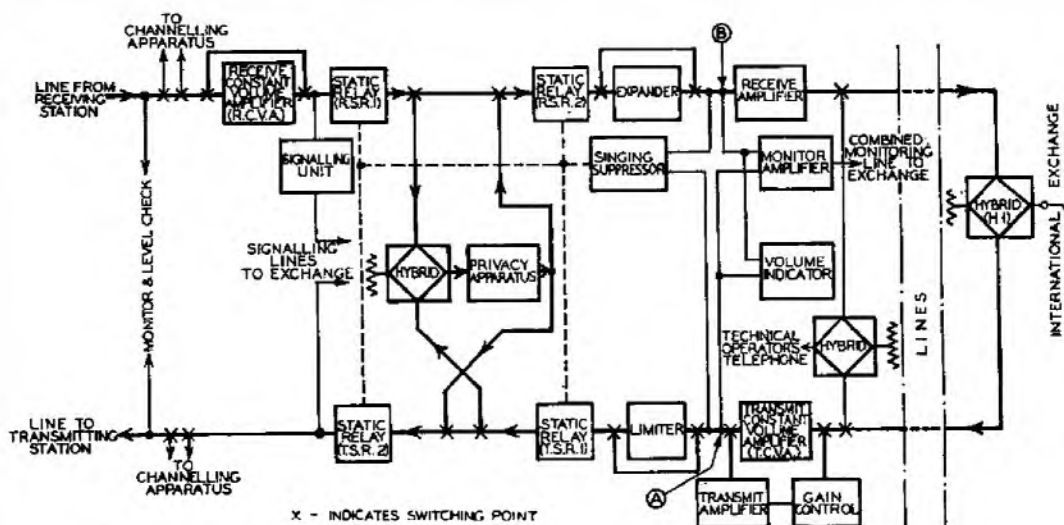

FIG. 3.—BLOCK SCHEMATIC DIAGRAM OF RADIO TELEPHONE TERMINAL EQUIPMENT.

constant average level, it may still be subject to short-term variations of up to 20 db. These variations have to be corrected by means of a device known as a "receive constant volume amplifier" which is generally located at the R.T.T.

Radio frequency noise of continuously varying level may be associated with the received signal, and in multichannel radio telephone systems interchannel crosstalk may also be present. The effect of noise and crosstalk on the intelligibility of speech may be reduced by limited range volume expansion in the receive path, so suitable expanders are included in radio terminal equipment.

At the radio terminals at each end of the circuit, gain may have to be inserted in the transmit and receive paths as the levels shown in Fig. 2 indicate. The net gain in a go or return channel between the hybrid transformers is dependent on the subscribers' speech level and may approach 40 db. in the extreme case. The loss across each hybrid transformer, however, (which is mainly dependent on the two-wire balance) is often as low as 20 db.,

exchange from the inland network passes through the hybrid transformer H1 and over a landline to the Brent R.T.T. where it is amplified by the transmit constant volume amplifier (T.C.V.A.) to a constant average level at the point "A." (A manually-operated gain control and transmit amplifier are also provided, for use in place of the T.C.V.A. for lining-up the radio circuit on tone and for other purposes.) The speech then passes via static relays to the radio transmitting station. In the receive path a receive constant volume amplifier (R.C.V.A.) removes the residual rapid fluctuations in speech level due to selective fading and provides a constant speech volume at its output. The speech signals continue via the static relays to a limited range volume expander, which is used to improve intelligibility by reducing the effective noise level, and arrive at a predetermined constant level at the point "B." A receive amplifier with preset gain adjustment permits final control of speech level to the exchange but its more important function is to prevent speech signals from the exchange reaching the point "B."

The static relays TSRI and 2 and RSRI and 2 which form part of the singing suppressor are metal rectifier networks which can be made to have either low or extremely high insertion losses by changing the direction of a D.C. control current flowing through them. The control current is generated in the singing suppressor and its direction, which determines whether the transmit path is open and the receive path blocked or vice-versa, is dependent on the relative signal levels at the points "A" and "B". The need for two static relays in each path is due to the use of privacy equipment on a "two-wire" basis. Privacy equipment is expensive and considerable economy can be effected by using the same apparatus for both directions of transmission, as indicated in Fig. 3, but this introduces a second potential singing path and requires the provision of additional static relays.

Transmit Path.

Radio telephone transmitters are adjusted to give a standard modulation depth when 1 mW of tone is applied at the measuring point "A" (Fig. 3). The working modulation depth for speech signals is then dependent on the speech volume, which is maintained at a substantially constant pre-determined level at the point "A" by the transmit constant volume amplifier, which for a range of input levels from -50 db. to -10 db., R.T.P.* delivers a constant output volume of -10 db. \pm 3 db., R.T.P. Fig. 4,

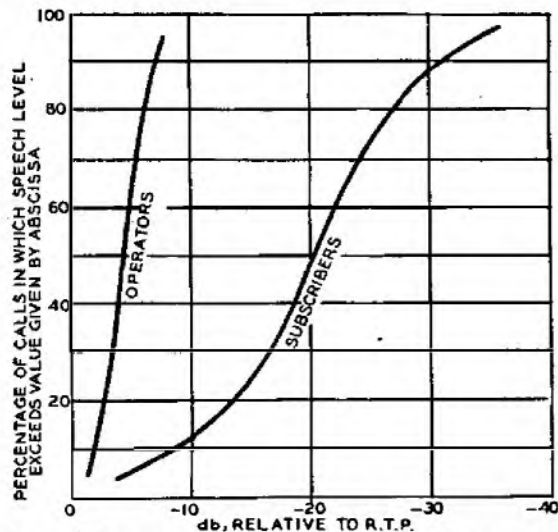

FIG. 4.—SPEECH LEVELS AT INTERNATIONAL EXCHANGE.

which has been drawn from measurements of speech volumes in about 800 telephone calls during two weeks in 1949, is illustrative of the range of speech volume from subscribers and from operators at the International exchange, and it will be seen that the T.C.V.A. adequately caters for all volumes likely to be received from subscribers. The automatic operation of the T.C.V.A. is fully effective only while a D.C. signal is received from the International exchange, which is the condition while a subscriber is actually connected; the absence of this signal sets the gain of the T.C.V.A. to a low value suitable for the high speech levels from both technical and traffic operators. When the speech input level increases, the gain of the T.C.V.A. begins to decrease within about two milliseconds and the correct output level is attained in some 20 milliseconds. When the speech level decreases, the gain remains almost unchanged for about one second and then rises at a rate such that the correct output level is attained in about five seconds.

* The abbreviation "db., R.T.P." is used throughout to indicate speech volume in decibels relative to Reference Telephonic Power.

These characteristics maintain substantially constant speech volume during passages of speech, reduce overloading of subsequent apparatus, yet preserve most of the natural modulations of speech occurring at syllabic frequency. In the absence of a speech signal input, the T.C.V.A. gain remains at the setting determined by the last passage of transmitted speech, to allow for the natural pauses in conversation. A circuit is incorporated for discrimination against operation by line noise, which is usually of a steady character as distinct from the syllabic nature of speech. A connection (not shown in Fig. 3) from the singing suppressor is provided to prevent the gain of the T.C.V.A. from being affected by speech signals from the receive path traversing the hybrid transformer H1.

To ensure the highest working efficiency for Post Office radio telephone transmitters the modulation depth used at present is such that slight overloading occurs at the peaks of most syllables. To minimise interchannel crosstalk in multichannel systems, however, it is desirable that overloading should not occur at or after the point at which channels are combined, and it is proposed to insert peak limiters in all terminal equipment, as indicated in Fig. 3. Field trials of these limiters, now proceeding, indicate that their use will permit an increase in average modulation depth at the expense of speech quality, but, nevertheless with a resultant improvement in intelligibility of received signal when the signal-to-noise ratio is poor.

Receive Path.

The R.C.V.A.s used at Brent R.T.T. provide a constant speech volume of -10 db. \pm 2 db., R.T.P. for a range of input volumes of -10 to -30 db., R.T.P. An auxiliary control circuit causes the gain of the R.C.V.A. to be set to 0 db. for input volumes below -32 db., R.T.P., so that relatively low-level noise or crosstalk is not amplified in the absence of a speech signal and thus in the intervals between passages of speech the noise level is normally reduced. This threshold level of -32 db. may be increased to -24 db., R.T.P. to cater for conditions of high noise level. The response of this device, although fast enough to correct the speech volume variation due to selective fading is not sufficiently fast to follow syllabic variations. Although the most probable value of signal-to-noise ratio is between 32 and 40 db., it falls below the minimum allowable value of between 20 and 25 db. for 2 per cent. to 10 per cent. of the scheduled times of the services. The percentage of time "lost" on this account may be reduced by the use of limited range expanders which are provided in each terminal equipment. For signal input levels down to a preset datum level, the output level of the expander is the same as the input level, but as the input level drops n db. below this datum level the output level falls $2n$ db. The expander is said to have a 2:1 expansion characteristic in terms of levels measured in db. below the datum level; for example, if the datum level is -15 db., then for an input level of -25 db. the output level would be -35 db. The time required for the appropriate output level to be established after the input level changes is about 20 mS, which is sufficiently short for the expander to be able to follow changes occurring at syllabic rate. The speech signal amplitudes are generally above the datum level and the speech wave form is reproduced faithfully except for slight distortion at the beginnings and ends of syllables. In the intervals between syllables or words the expander output falls to that appropriate for the level of noise or crosstalk and (assuming that this level is below the datum level) the expander causes the noise or crosstalk to be reduced in level relative to the signal. The reduction in the disturbing effect of noise or crosstalk improves the intelligibility of the speech despite the slight distortion of the

speech signals. The distortion could be virtually eliminated by the use of compressors in the outgoing channels at radio terminals, but the distortion is so small when expansion is applied to the lower speech amplitudes only that the provision of compressors is not considered to be worth while.

Suppression of Singing.

The net gain which may exist around the four-wire loop formed by the outgoing and incoming channels and the two terminal equipments is unlikely to exceed 48 db., even with quite low loss across the hybrid transformers, and as the static relays of the singing suppressor have insertion losses which change from 2 db. to 110 db. according to the direction of speech transmission, effective control of the direction of transmission is attained. In the absence of speech signals the static relays in the receive path are in the condition of low loss and those in the transmit path are of high loss. When a speech signal from the near-end subscriber reaches the point "A" (Fig. 3) in the transmit path, a portion of it is amplified in the control amplifier in the singing suppressor, and then rectified to operate a "trigger" type of thermionic relay. The operation of the thermionic relay reverses the direction of the D.C. control current through the static relays, thus reducing the attenuation in the transmit path to a low value and inserting a high attenuation in the receive path. This operation is completed within some two milliseconds and results in slight but generally imperceptible "clipping" of the initial sounds of a passage of speech. On the cessation of the speech signal the original "no signal" condition of the singing suppressor is not restored until some 180 mS. have elapsed; this "hangover" time is sufficiently long to cover the normal intervals between words and avoids clipping at the beginning of each word or syllable. When speech is passing in the receive direction, a signal is taken from the constant level point "B" (Fig. 3) in the receive path, and is amplified and rectified to provide a D.C. control signal, which reduces the gain of the control amplifier of the singing suppressor. This, and the stabilisation of the T.C.V.A. gain during receive speech, prevent unwanted operation of the thermionic relay by speech from the receive path traversing the hybrid transformer H1 and reaching the point "A," and also prevents the near-end subscriber "breaking in." This control from the receive path has a "hangover" time of some 60 mS. to prevent

false operation by echo signals from the two-wire line. Radio noise of high level in the receive path will also reduce the gain of the control amplifier in the singing suppressor in the same way as do speech signals (since for a speech volume of -10 db., R.T.P. the power averaged over a short interval may be only of the same order as that of the noise) and the gain may be so reduced that speech signals of normal level in the transmit path are unable to operate the thermionic relay. To overcome this a manual adjustment is provided to enable the sensitivity of the control from the receive path ("receive sensitivity") to be reduced at times when the radio noise level is high.

The adjustments which are provided enable the singing suppressor to handle nearly all the possible adverse combinations of inland transmission loss, poor return loss and high radio noise, but in a small number of cases (less than 2 per cent. in a sample count) a call has to await less unfavourable conditions.

Signalling and Control.

Non-automatic signalling between the international exchanges at the ends of long-distance radio telephone circuits is provided by means of 500/20 c/s or 1,000/20 c/s signals (according to the arrangements at the distant terminals) transmitted over the radio channels. The radio terminal bays at Brent incorporate apparatus for converting D.C. signals from the exchange to 500/20 or 1,000/20 c/s signals, and for receiving 500/20 c/s signals. P.O. Units, Signalling, No. 9 are used for the incoming signals. The signal conversion takes place at the transmit path output and the receive path input of the radio terminal bay, the singing suppressor and privacy equipment being by-passed by the D.C. signals.

Four pairs of lines are provided between the R.T.T. and the International exchange, for each radio circuit. Two pairs are used for the radio channels, one pair for a monitoring signal fed from the R.T.T. to the exchange, and one pair for an order wire between the technical operator and the traffic operator. The various D.C. signals and associated circuits have been described in an article¹ on the International exchange (formerly known as the Overseas exchange).

Details of the various telephone and control facilities

¹ P.O.E.E.J., Vol. 41, p. 76.

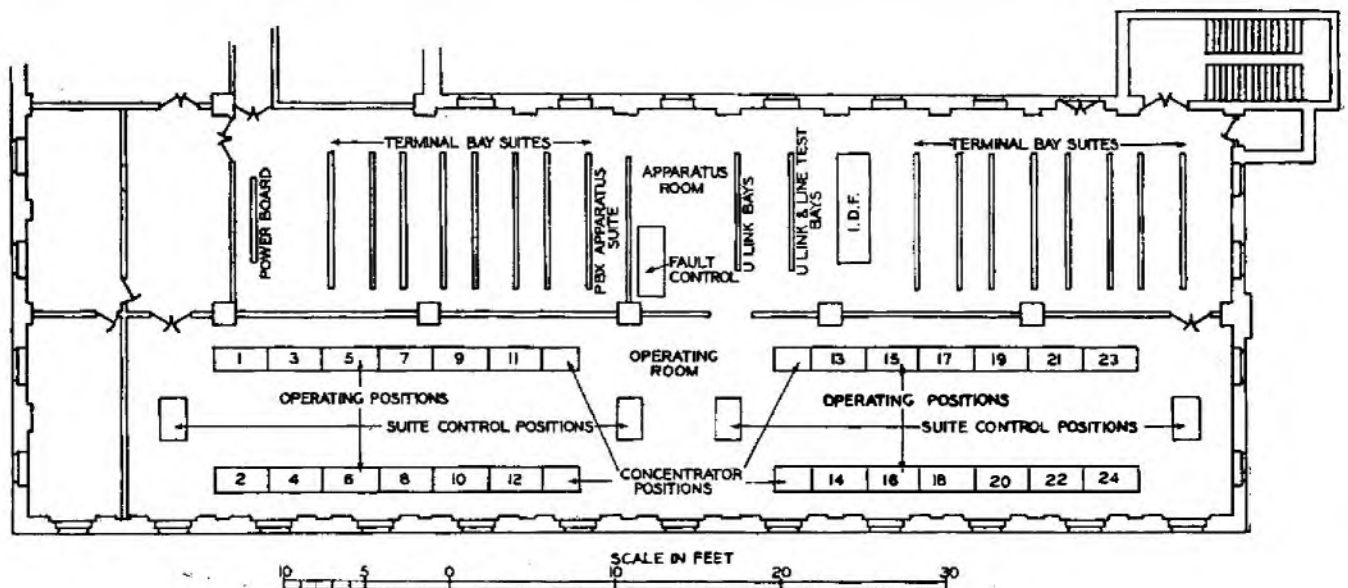

FIG. 5.—LAYOUT OF EQUIPMENT ON 1ST FLOOR AT BRENT R.T.T.

available to the technical operators are given in the next section.

LAYOUT AND EQUIPMENT

To facilitate the supervision of the radio circuits by a relatively small staff, the controls necessary for the operation of a number of circuits should be grouped in close physical proximity. At the Brent R.T.T. this has been achieved by segregating the control and supervisory equipment from the rest of the terminal apparatus. The privacy and channelling equipments have also been segregated from the main terminal apparatus, to permit full flexibility in the interconnection of these equipments, and to facilitate the specialised maintenance required for the privacy equipment.

The R.T.T. equipment has been installed on the first and ground floors of the building and on the first floor there are (a) an apparatus room containing the terminal bays and miscellaneous equipment; (b) an operating room containing the positions from which remote control of the terminal bays is effected and where the other control and supervisory facilities required by the technical operators are provided. The layout of this equipment is illustrated in Fig. 5.

The ground floor accommodates (a) an apparatus room containing privacy equipment and channelling equipment (the initial installation of channelling equipment provides for one 4-channel system, three 3-channel systems and 14 2-channel systems); (b) operating positions and apparatus for dealing with the transmission of broadcast programmes; and (c) a small studio provided for special purposes.



FIG. 6.—A TERMINAL BAY.

Terminal Bays and Associated Apparatus.

The terminal bays, as illustrated in Fig. 6, are assembled in suites, and associated with each pair of suites are test and miscellaneous apparatus bays which provide comprehensive facilities for transmission testing and routine performance checking, power switching and distribution, tone and pulse distribution and interconnection of terminal bays and operating positions. Included in the performance checking apparatus is a $\frac{1}{2}$ -millisecond chronometer of the electronic pulse-counting type (recently developed by the Post Office) for timing the operate and release periods of the voice-operated devices in the terminal equipment.

The initial installation is 48 terminal bays but the apparatus room will accommodate approximately 100 bays and associated equipment. Extensive patching facilities are provided for testing purposes and to enable faulty equipment to be replaced by spares. A special injection-cum-extraction ventilating system has been installed to ensure adequate cooling of the apparatus and the room in general.

Channelling and privacy equipment is connected into the circuits of the terminal apparatus through

U-link fields and a distribution frame to facilitate short-term or long-term reallocations of the types of channelling or privacy apparatus.

Operating Positions.

Four suites of six operating positions are installed, and Fig. 7 shows two of the suites (with concentrator positions



FIG. 7.—VIEW OF TWO SUITES OF OPERATING POSITIONS AND ASSOCIATED CONTROL POSITIONS.

at the near ends) and associated suite control positions. Fig. 8 is a close-up of an individual operating position. In



FIG. 8.—AN OPERATING POSITION.

the centre of each position is a "Position Control Panel" on which general telephone and monitoring facilities are available and flanking this are four "Circuit Control Panels" from each of which control of one radio circuit via a terminal bay can be effected. Thus, by keys and rotary switches on the circuit control panels adjustments can be made to the transmit and receive sensitivities and receive hangover time of the singing suppressor, the threshold level of operation of the R.C.V.A. and the gain of the transmit amplifier. Test speech from a continuously replayed tape recording, or test tone at standard level (either continuous or pulsed) can be applied to the transmit path of the terminal equipment or directly to line, and a morse key provides for keyed tone transmissions. The technical operator can ring over the radio circuit and

extend the ringing facility to the traffic operator at the International exchange.

The position control panel provides monitoring and speaking facilities for the four radio circuits connected to the position. Volume indicators are provided for the measurement of speech volumes and tone and noise levels on any of the circuits. The monitoring, volume indicator, and speaking facilities are indicated in Fig. 3. Each position has two extensions from the Brent P.B.X., and private wire speaker circuits to the radio transmitting and receiving stations are multiplexed over all operating, programme control and concentrator positions. Other direct telephone circuits connect with the International exchange, the Brent apparatus rooms, and the operating room Supervisors.

The facilities which can be extended to the concentrator position at the end of each suite are monitoring, International exchange speaker circuit and P.B.X. extensions. A lamp display shows the circuits which have been transferred to the concentrator position, at which the operator is able to check occasionally the condition of any radio circuit controlled by him, and to communicate with the exchange and the radio stations. Overall supervision is exercised by engineering officers at the suite control positions.

Programme Control Positions.

For broadcast work three programme control rooms and a studio are provided. Programme material is carried over point-to-point radio telephone circuits for retransmission by broadcasting organisations or for the use of private concerns. This type of traffic, which demands the highest quality transmission, is handled in four-wire circuits without hybrid transformers, singing suppressors, privacy or any of the special equipment used for telephone traffic. The frequency bandwidth is generally at least 5.5 kc/s, and high-quality microphones are used. Duplicate channels may be provided as reserves, and sometimes it is necessary to switch and interconnect a number of radio channels and landline channels converging on the Brent R.T.T.

One of the programme control positions for controlling and switching networks of landlines and radio circuits used in international relays of broadcast programmes and public addresses is shown in Fig. 9. The two centre panels contain a clock, volume indicators, monitoring loudspeaker, switches for inter-connecting channels, and manual gain

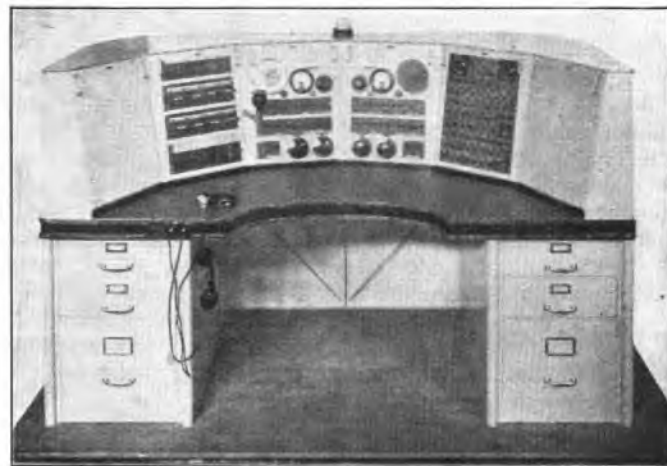

FIG. 9.—A PROGRAMME CONTROL POSITION.

controls. Automatic gain controls of the T.C.V.A. type, expanders, amplifiers, and associated apparatus are mounted on separate equipment bays. The two outer panels in the programme position contain telephone keys giving access to the landline network, and a U-link field for testing and interconnection purposes.

Conclusion.

The improvement in the signal-to-noise ratio of long distance radio-telephone circuits which has been made by the introduction of single-sideband systems and otherwise, has facilitated the automatic control of the circuits at the R.T.T. thus avoiding the need for continuous monitoring and frequent manual adjustment of individual circuits. The introduction of multi-channel working has resulted in a further reduction in the technical supervision necessary for each circuit, since many of the control operations (e.g. arranging for changes of radio carrier frequency to suit varying propagation conditions) are now common to several circuits. These factors have had a major influence on the design of the new R.T.T. at Brent, and whereas at the Faraday R.T.T. one technical operator was required for each circuit, at Brent R.T.T. an operator normally controls up to four circuits.

Future development may tend towards the remote control from the R.T.T. of transmitters and receivers for long distance point-to-point radio-telephone systems.

Book Review

"Microwave Measurements." H. M. Barlow, B.Sc.(Eng.), Ph.D., M.I.E.E., and A. L. Cullen, B.Sc.(Eng.), A.C.G.I., A.M.I.E.E. Constable & Co., Ltd. 399 pp. 214 ill. 30s.

Recent years have seen many applications of microwaves to communications and it is likely that the future will see an increased use of such waves for the radio relaying of television and telephony. Progress in this field, as in many others, depends on the ability to make measurements accurately and readily. This book is welcomed for the very real contribution it makes to the theory and practice of microwave measurements.

The first three chapters are introductory and contain a well-written and clear statement of the fundamental characteristics of guided waves and the transformation of wave impedance using the circle diagram, followed by a description of the characteristics of cavity resonators. The next six chapters are concerned with the measurement of fundamental quantities such as wavelength and frequency, power, attenua-

tion, the properties of materials, including permittivity and loss factor, impedance and standing-wave ratio. This section of the book is especially useful and is of wide application, since the emphasis is primarily on the fundamental theory and principles rather than on the details of the equipment.

Two chapters are given on the measurements of the characteristics of transmitters and receivers; these are written mainly from the radar standpoint and are of less value to the communications engineer. The final chapter discusses briefly the measurement of the gain and radiation pattern of aerials. The book includes a number of theoretical appendices, including an excellent treatment of the theory of wave impedance transformation.

This book is confidently recommended to all engineers concerned with the design, operation and maintenance of radio equipment operating in the centimetric waveband.

W. J. B.

An Application of Equaliser Curves to the Design of Two-Terminal Networks

P. W. SEYMOUR, A.M.I.E.E.†

U.D.C. 621.392.4

A method is described which permits a two-terminal network, possessing a desired impedance (modulus)/frequency characteristic, to be derived from design data readily available for a four-terminal constant impedance equaliser, having an insertion-loss/frequency characteristic similar in shape to the required impedance (modulus)/frequency characteristic.

Introduction.

IN the design of line communication amplifiers, it is often convenient to carry out part or total line equalisation by means of a suitable electrical network in the amplifier feedback circuit. Under certain conditions which are related to the principles of negative feedback amplifier design, this electrical network may assume the form of a two-terminal network.

The determination of a sufficiently accurate impedance (modulus)/frequency characteristic for this two-terminal network, either empirically or by calculation can involve considerable labour.

It was found, however, as described below, that if an insertion-loss/frequency characteristic of a particular form of four-terminal constant impedance equaliser could be selected which suitably fitted the shape of the required impedance (modulus)/frequency characteristic, then the element values of the two-terminal network could be rapidly calculated from data which are available for the four-terminal network.

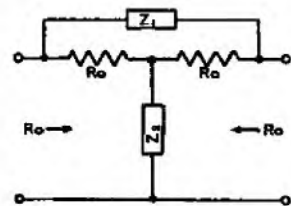

FIG. 1.—GENERAL FORM OF CONSTANT IMPEDANCE EQUALISER (R_0 BEING THE EQUALISER RESISTANCE).

The convenience of the method is due to the fact that families of curves representing the insertion-loss/frequency response of four-terminal constant impedance equalisers are readily available.¹

Insertion-Loss/Frequency Characteristic of a Four-Terminal Equaliser.

The general form of a four-terminal constant impedance equaliser is shown in Fig. 1, in which the impedance arms Z_1 and Z_2 are inverse networks. Fig. 2 shows a particular form of Fig. 1, which

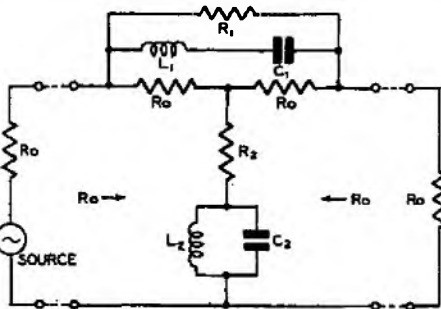

FIG. 2.—PARTICULAR FORM OF CONSTANT IMPEDANCE EQUALISER OPERATING BETWEEN SOURCE AND LOAD EACH OF RESISTANCE R_0 .

is widely used for equalisation purposes and gives an insertion-loss/frequency characteristic of the form shown in Fig. 3.

Considering Fig. 2 and evaluating the mesh equations, it can be shown that the modulus of the ratio obtained by dividing the current I_1 (which flows in the load resistor R_0 , when the source is connected to it directly) by the current I_0 (which flows in the same load resistor R_0 , when the network is inserted between the source and this load) is given by:—

$$\left| \frac{I_1}{I_0} \right|^2 = 1 + \frac{K^2 - 1}{1 + K \left\{ \frac{m}{x - 1/x} \right\}^2} \dots \dots \dots (1)$$

and the insertion loss, A , in decibels, of the network is:—

$$A = 20 \log_{10} \left| \frac{I_1}{I_0} \right| = 10 \log_{10} \left\{ 1 + \frac{K^2 - 1}{1 + K \left\{ \frac{m}{x - 1/x} \right\}^2} \right\} \dots \dots (2)$$

where, $m = b - \frac{1}{b}$

$b = \omega_0 / \omega_r$, where $b > 1$

$x = \omega / \omega_r$

$\omega_r = 2\pi f_r$ = resonant angular frequency of the impedance arms Z_1 and Z_2

$\omega_0 = 2\pi f_0$ = angular frequency of one half pad loss

$\omega = 2\pi f$ = any angular frequency

and K is defined by the equation, Pad Loss (maximum loss in db.) = $20 \log_{10} K$

A re-arrangement of expression (2) gives:—

$$A = 10 \log_{10} \left\{ \frac{K^2(x^2 - 1)^2 + Km^2x^2}{(x^2 - 1)^2 + Km^2x^2} \right\} \dots \dots \dots (3)$$

Impedance Characteristic of a Two-Terminal Network.

Consider the network shown in Fig. 4. The impedance of this network at any angular frequency ω can be shown to be:—

$$Z = \frac{R \left(r + j\omega L + \frac{1}{j\omega C} \right)}{\left(R + r + j\omega L + \frac{1}{j\omega C} \right)} \dots \dots (4)$$

If now the constants P and Q are introduced, then, defining them as $P = R/r$, and $Q = \omega_r L/r = 1/\omega_r C r$, expression (4) may be written:—

$$Z = R \left\{ \frac{Q(1 - x^2) + jx}{Q(1 - x^2) + jx(1 + P)} \right\} \dots \dots \dots (5)$$

or

$$\left(\frac{|Z|}{R} \right)^2 = \frac{Q^2(1 - x^2)^2 + x^2}{Q^2(1 - x^2)^2 + x^2(1 + P)^2} \dots \dots \dots (6)$$

where ω_r and x have their previous meanings.

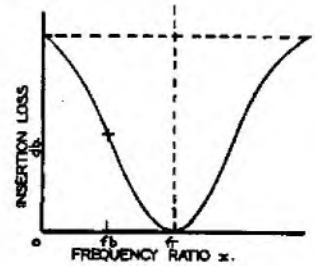

FIG. 3.—INSERTION-LOSS/FREQUENCY CHARACTERISTIC FOR EQUALISER SHOWN IN FIG. 2.

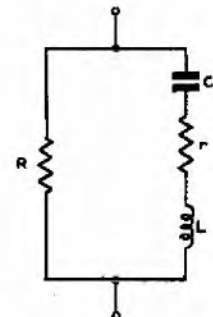

FIG. 4.—FORM OF TWO-TERMINAL NETWORK.

† P.M.C.'s Department, Australia (formerly Executive Engineer, P.O. Research Station).

¹ P.O. Research Report No. 11867.

The impedance (modulus)/frequency characteristic of the two-terminal network may now be represented for this purpose by the expression :—

$$N = 20 \log_{10} \frac{|Z|}{R} \dots \dots \dots (7)$$

which is in the form of expression (2) and conveniently permits N to be plotted on the same scale as A , the insertion loss of the four-terminal network; it being noted that the above expression and that for the insertion loss are functions of a common independent variable, x .

At the resonant angular frequency, ω_r , the above expression (7) will thus assume a minimum value of :—

$$20 \log_{10} \frac{1}{1 + P}$$

Comparison of the Four-Terminal and Two-Terminal Results.

The insertion-loss/frequency characteristic of the four-terminal network given by expression (3) could now be compared with the characteristic obtained by plotting $20 \log_{10} |Z|/R$ against frequency. However, inspection of expression (3) shows that at the resonant angular frequency ω_r , the insertion loss becomes zero; so, to allow the four-terminal and two-terminal network characteristics to have the same minimum value at this resonant angular frequency the expression for $|Z|/R$ can be multiplied by a factor $(1 + P)$, and expression (3) then compared with the characteristic obtained by plotting $20 \log_{10} (1 + P) |Z|/R$ against frequency.

If now some simple relations are imposed between the basic parameters of the networks, it is possible to make the characteristic obtained by plotting $20 \log_{10} (1 + P) |Z|/R$ against frequency have exactly the same shape as the characteristic obtained by plotting expression (3) against the same frequency axis.

The necessary relations are :—

$$K^2 = (1 + P)^2 \text{ and } Km^2 = \frac{(1 + P)^2}{Q^2}$$

Since there are an infinite number of two-terminal networks which will give the required characteristic, it is desirable to evaluate the element values in terms of R , the highest value of impedance which the two-terminal network assumes.

Hence, in the case of a given two-terminal network design, R and ω_r are determined by the nature of the particular problem for which the network is intended. For example, in the case of an amplifier design, as mentioned in the introduction, R may bear a simple relation to the gain of the amplifier at the theoretical limits of zero and infinite frequency; and where the maximum gain occurs at ω_r . Hence R and ω_r may be determined for this problem.

Assuming that the two-terminal network will be operating in a constant-current feedback circuit, it then remains for a suitable equaliser characteristic to be chosen by trial to match the particular characteristic required for the feedback circuit. Element values can then be calculated for the two-terminal network using the following relations which involve the values of b and K :—

$$L = \frac{R}{\omega_r} \cdot \frac{\sqrt{K}}{K-1} \cdot \frac{b}{b^2-1} \dots \dots \dots (8)$$

$$C = \frac{1}{\omega_r R} \cdot \frac{K-1}{\sqrt{K}} \cdot \frac{b^2-1}{b} \dots \dots \dots (9)$$

$$r = \frac{R}{K-1} \dots \dots \dots (10)$$

Conclusion.

The treatment has been confined to the well-known section in Fig. 2, and the success of the method is due to the availability of prepared families of insertion-loss/frequency characteristics for this section.

It is probable that the method could be extended to certain more complicated equaliser sections and their transfer into more complicated two-terminal networks. The success of the method would, however, again depend upon the availability of prepared families of insertion-loss/frequency characteristics relating to the chosen sections.

For those interested in this subject much useful information is contained in "Motion Picture Sound Engineering" (Chapters XVI and XVII, by Harry Kimball), published by D. Van Nostrand Company Inc., New York.

Acknowledgment.

The author is indebted to Mr. W. T. Duerdoth, who indicated that some simple relations of the form obtained should exist, and gave guidance in this work.

Book Review

"Technical Instruction for Marine Radio Officers." H. M. Dowsett, M.I.E.E., F.Inst.P., and L. E. Q. Walker, A.R.C.S. Iliffe & Sons, Ltd., London. 899 pp. 700 ill. 60s.

This volume is the ninth edition of a handbook of technical instruction for wireless telegraphists originally published in 1913, this latest edition appearing under a slightly different title from the earlier editions. The fact that it has, since its first appearance, passed through so many editions is a clear indication of the popularity and usefulness of the book and that the authors are fully alive to the need for keeping pace with the development of radio technique and practices.

As the title implies, the book is written primarily for the marine radio officer with the object of providing him with simple instruction in the principles and practice of radio equipment associated with the maritime radio service. To-day, a radio officer is likely to be in control of and operate equipment employing radio frequencies lying in the range between 16 kc/s and 9,000 Mc/s, and to gather together in a single volume the more important features of such equipment is no mean task and one which the authors have accomplished with some success. A balance has been struck between the theoretical and practical aspects of the subject with the emphasis, quite

properly, placed on the practical side whilst, at the same time, giving the reader sufficient theoretical background to understand the principles underlying the practical applications.

With such a wide field, it must have been difficult to decide what material to omit and what to include, and, in this respect, the authors' choice can be criticised on some points. They might well have excluded such items as the quadrant electrometer, the wave aerial, and short-wave arrays, which can only be of academic interest to the average marine radio officer, and given the space to more detailed discussion of the practical difficulties of radio communication. Many ships are now fitted with equipment working in the frequency range 4-25 Mc/s for long-range communication and, to obtain the advantage of such equipment, it is most important that the propagational properties of these high frequencies should be well understood. The authors have not given this aspect the attention it deserves and, even in the propagation curves that are included for the guidance of radio officers, a figure of 10 kW of radiated power is used in their derivation which is very much higher than likely to be met with on the average ship. Another important criticism is the continued use of wavelen. this w frequency would be a more appropriate term.

Apart from these minor criticisms, the book, which contains such a large amount of practical information on such a complex subject, can be confidently recommended to radio officers as an invaluable source of information and guidance. E. P.

The Manchester-Edinburgh Television Radio Relay System

U.D.C. 621.397.743

THE main Scottish television broadcast transmitting station now under construction at Kirk O'Shotts, a point about midway between Edinburgh and Glasgow, is being connected to the television relay network by means of a radio system linking Kirk O'Shotts and Manchester. Invitations to tender for this radio system were issued by the Post Office early in January last year, the contract being placed with Standard Telephones & Cables in June, 1950.

The route, shown in Fig. 1, was influenced to some extent

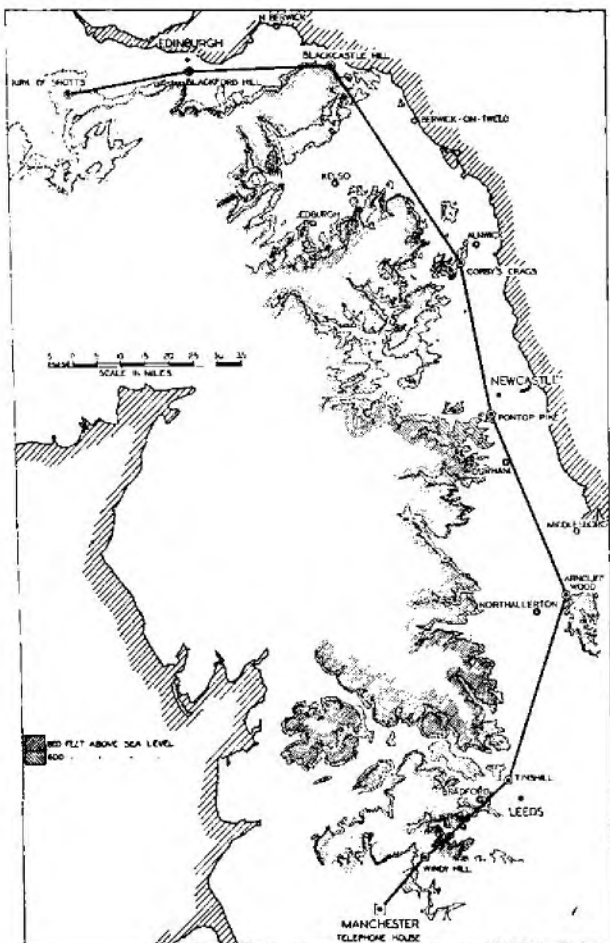

FIG. 1.—ROUTE OF MANCHESTER-EDINBURGH BROAD BAND RADIO RELAY LINK.

by the requirement that it should pass reasonably close to Newcastle to enable a short spur to be provided at some future date for the proposed B.B.C. television station for that area, and also by the desirability of passing near Leeds and Edinburgh so that programmes could be injected at the intermediate relay stations near these towns—a new requirement for television relay systems. In fact, this facility will be provided at all relay stations. The longest link will be some 46 miles, and the total mileage nearly 250.

Before detailing the radio equipment, it may be of interest to indicate the main respects in which it will differ from the London-Birmingham radio system which has already been described:—

- (i) It will operate at the much higher frequency of 4,000 Mc/s.

- (ii) Although it will provide for two-way simultaneous operation, only two carrier frequencies will be used throughout the system compared with the four required for the full two-way installation between London and Birmingham. Both frequencies will be used alternately throughout each channel, but any one link in the chain will use different frequencies in the two directions.
- (iii) The equipment will all be housed in a single building at each station, and only the aerial system will be located at the top of the masts.
- (iv) A travelling wave amplifier is used as the output stage of each repeater and terminal transmitter, this being the first commercial application of this technique.
- (v) The receivers and transmitters will be connected to their respective aerial systems by means of waveguides, the first commercial use of these by the Post Office.

Since it is too early to give more than a brief description of the equipment, the main points of difference will be emphasised and details having a resemblance to the existing radio system omitted.

A typical mast may be 50 ft. or so in height and carry four paraboloid aerials, each some 10 ft. in diameter, and connected to the radio equipment at the base of the mast by waveguide transmission lines, the lines being filled with dry nitrogen under a pressure of about $\frac{1}{2}$ lb. per sq. in., to prevent internal corrosion. The paraboloids will have a gain of about 40 db. relative to a half-wave dipole, and an angular beam width of about $2\frac{1}{2}^\circ$. At Blackcastle Hill, a 220-ft. mast is required to provide the necessary clearance over the difficult terrain on the two links radiating from it.

A schematic of a typical transmitter for use at a terminal station is shown in Fig. 2. The incoming video signals

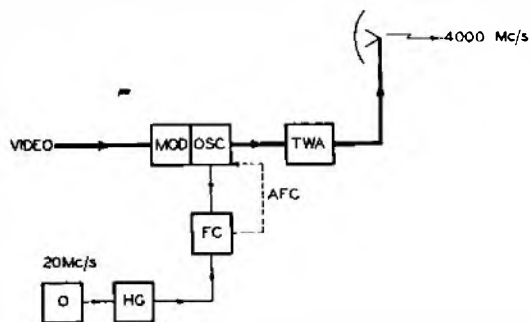

FIG. 2.—BLOCK SCHEMATIC DIAGRAM OF TERMINAL TRANSMITTER.

from the B.B.C. switching centre are applied to the reflector electrode of a klystron (MOD/OSC) oscillating at the radiated frequency. This produces a frequency modulated signal, the mean frequency of which is stabilised by an automatic frequency control loop (AFC). This loop derives its controlling action from a frequency comparison (FC) of the radio frequency oscillator (OSC) with that of a stable reference signal derived from a harmonic generator (HG) which is driven by a 20 Mc/s crystal-controlled oscillator (O). The output of the klystron oscillator is amplified by the travelling wave amplifier (TWA). The novel features of this valve are its aperiodicity, that is, its ability to amplify signals over a very wide range of frequencies, its relatively high gain, and its relative simplicity. The gain of the wave amplifier is some 17 db., and its output power 1 W.

¹ P.O.E.E.J., Vol. 43, p. 23.

The output of the amplifier is connected by a waveguide to the focus of the paraboloid reflector.

The probable arrangement of equipment at a relay station is shown in Fig. 3. It will be seen that the incoming

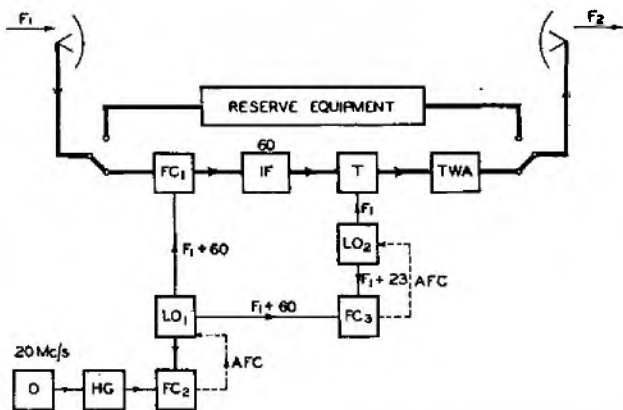

FIG. 3.—BLOCK SCHEMATIC DIAGRAM OF TYPICAL REPEATER.

signals are applied to a crystal frequency changer (FC_1), converted to an intermediate frequency of 60 Mc/s, and amplified. The frequency of the coaxial line oscillator (LO_1) is stabilised by an automatic frequency control loop

(AFC) using a reference frequency derived from a harmonic generator (HG), driven from a crystal oscillator (O) having a frequency of 20 Mc/s. The frequency of the outgoing signals has to differ by some 37 Mc/s from that of the incoming signals. This is achieved by applying the I.F. signals to a hybrid mixer unit (T), which includes a balance crystal frequency changer, and mixing them with the output of a local oscillator (LO_2) whose frequency has been stabilised to the appropriate value by the second A.F.C. loop. This second A.F.C. loop is controlled by comparing the frequency output of the oscillator (LO_2) with that of the oscillator (LO_1) which, as already mentioned, is continuously stabilised by comparison with the 20-Mc/s crystal oscillator. By this means frequency stability throughout the system is assured. Finally, the output of the crystal mixer (T) goes via a waveguide filter which selects the wanted sideband and passes it to a travelling wave amplifier and thence to the outgoing aerial waveguide.

As in the case of the London-Birmingham link, standby equipment is being provided, together with comprehensive remote control and supervisory facilities, which uses 4-wire line interconnecting all stations. Additional accommodation is being provided at Newcastle to cater for the future spur extension and at Kirk O'Shotts for a future extension to Aberdeen.

A. H. M-

Book Reviews

PHILIPS TECHNICAL LIBRARY (*Series on Electronic Valves*). N. V. Philips' Gloeilampenfabrieken, Eindhoven. Distributed in the U.K. by Cleaver-Hume Press, Ltd. Book I: "Fundamentals of Radio-Valve Technique." 535 pp. 384 ill. 35s.

This is the first of a series of seven books on electronic valves now being published by the well-known Dutch firm of N. V. Philips. Since it appears that the volume under review has already been published in Dutch, English, French, German and Swedish, while Italian, Spanish, and Finnish editions are in preparation, one is led to expect a series of more than ordinary merit. If the standard of this first volume is maintained few will be disappointed.

The fundamental physical principles underlying the operation of electronic devices are explained in a clear and comprehensive manner, and the book can be recommended to anyone wishing to obtain a good knowledge of the basic theory of radio valves. Manufacturing processes are described in some detail, and operational difficulties such as hum, microphony, negative grid current, and insulator charging effects are discussed more fully than is usual in books on valves. Mathematical analysis has been used where it is essential, but is of an elementary character, and the unnecessary use of advanced or elaborate mathematics has been wisely avoided. A commendable feature is the use of the rationalised m.k.s. system of units, and the inclusion in an appendix of a clear account of Giorgi's system for readers not already familiar with it. The appendix also contains a useful collection of summarised data in the form of definitions, formulae, tables and graphs. R. W. W.

I.P.O.E.E. Library No. 1962.

Books II and III: "Data and Circuits of Receiver and Amplifier Valves." Book II: 405 pp. 532 ill. 21s.; Book III: 220 pp. 267 ill. 12s. 6d.

These books are in effect a detailed catalogue of the valves developed in the Philips Research Laboratories at Eindhoven, Holland, during the years 1933-1940 (Book II) and 1940-1941 (Book III); additional books are promised to cover valves developed in subsequent years. The valves surveyed comprise receiving, amplifying and rectifying valves, current regulators

and stabilisers; also other electronic devices such as cathode ray tubes, photo-electric cells, electronic indicators and various secondary emission devices. The technical data included are exceptionally complete; for example, curves are given showing the cross-modulation and hum-modulation characteristics of R.F. amplifiers and the distortion characteristics of A.F. amplifiers, as well as the more usual characteristics relating to electrode voltages and currents. Circuit diagrams for a range of radio receivers, including A.C./A.C./D.C. and battery types, and gramophone amplifiers are given to illustrate typical applications of the various types of valve. A range of test equipments comprising A.F. and R.F. oscillators, oscilloscopes, measuring bridges and other items developed in the Philips Research Laboratories are also described.

It is perhaps a matter for regret that only Philips valves are described in these volumes; a similarly comprehensive and detailed survey of other makers' valves would have been of great value to the equipment designer.

Book IV: "Application of the Electronic Valve in Radio Receivers and Amplifiers." 467 pp. 256 ill.

This book is the first of three volumes on the application of valves in radio receivers and amplifiers. This volume deals with the following aspects of receiver and amplifier design: R.F. and I.F. amplification; frequency changing; oscillator tracking problems in super-heterodyne receivers; distortion due to causes such as non-linearity of valve characteristic modulation-hum, cross-modulation, production of whistle and finally the various methods of detection. Other matters such as A.F. power amplifiers, H.T. and L.T. supplies are to be treated in later volumes.

The subject is discussed both descriptively and analytically, the treatment being exceptionally thorough. A feature which is especially commended is the large amount of measured data derived mainly from tests made in the Philips Research Laboratories, which has been included and which will be of considerable assistance to radio receiver designers. Each chapter concludes with a survey of the literature on the subject matter of that chapter; these surveys include many references to work in Dutch, French and German technical periodicals and serve perhaps as a reminder that the countries have made notable contributions in this field.

W. J. B.

Commonwealth Telecommunications

Under the auspices of the Commonwealth Telecommunications Board, a meeting of telecommunications engineers and traffic experts of Commonwealth countries, presided over by Sir Stanley Angwin, was held in London between 16th October and 3rd November 1950. The objects of the meeting were to provide a general review of recent technical developments in radio and cables, including the research work in telecommunications, in hand, or projected, in each country, and the application of these developments to the Commonwealth system.

Representatives attended from the United Kingdom, Canada, Australia, New Zealand, South Africa, India,

Pakistan, Ceylon, Southern Rhodesia, the Gold Coast, Nigeria, Trinidad, British Guiana, Singapore and Malaya. Officers from the Engineering Department and the Overseas Telecommunications Department took part in all the discussions and visits, and provided many of the papers.

A wide measure of agreement was reached on a number of scientific, engineering and traffic matters in regard to the Commonwealth network of wireless and cable communications. Recommendations have been submitted in a confidential report to the Commonwealth Telecommunications Board, which will in due course submit its findings to the respective Governments.

A. H. M.



Back row, left-right: H. Everett (Assistant Secretary, Commonwealth Telecommunications Board (C.T.B.), Secretary of the Meeting); E. G. L. Howitt (Assistant Traffic Manager, Cable & Wireless, Ltd.); G. H. Webster, C.M.G., O.B.E. (Colonies Member, C.T.B.); D. C. Balaam (Overseas Telecommunications Department, G.P.O.); J. H. Tudhope (Canadian Member, C.T.B.); Lieut.-Colonel H. Myers, O.B.E. (South African Member, C.T.B.); D. F. Bowie (Canadian Overseas Telecommunications Corporation); D. G. Peck (Assistant Controller of Telecommunications, Singapore and Malaya); J. C. Dallow (Controller of Telecommunications, Singapore and Malaya); J. Briggs (Acting Assistant Engineer-in-Chief (Wireless), Nigeria); A. H. Mumford, O.B.E. (Staff Engineer, G.P.O.); A. M. Humby (Royal Naval Scientific Service and British Joint Communications Board).

Middle row, left-right: P. A. Courtney (Director of Posts and Telegraphs, Nigeria); N. S. Wickremasinghe (Superintending Telecommunications Engineer, Ceylon); Colonel A. H. Read, O.B.E., T.D., D.L. (United Kingdom Member, C.T.B.); N. C. Chapling (Traffic Manager, Cable and Wireless Ltd.); J. G. Young, C.B.E. (New Zealand Member and Vice-Chairman, C.T.B.); F. A. Binden (Cable and Wireless Ltd.); Dr. R. L. Smith-Rose (Director of Radio Research, Department of Scientific and Industrial Research); H. J. Hutchinson (General Traffic Supervisor, Overseas Telecommunications Commission (Australia)); S. R. Kantebet (General Manager, Overseas Communications Service, India); C. F. Brimblecombe (Southern Rhodesian Member, C.T.B.); J. L. Creighton (Telecommunications Liaison Officer, Colonial Office); V. H. Winson (Consulting Engineer, Crown Agents for the Colonies); H. Faulkner, C.M.G. (Deputy Engineer-in-Chief, G.P.O.); J. A. Smale (Engineer-in-Chief, Cable & Wireless Ltd.); K. W. Hargrove (Office-in-Charge, Government Wireless Service, Trinidad); A. F. E. Evans, O.B.E. (Engineer Officer, C.T.B.); D. J. Robinson (Senior Wireless Engineer, Posts and Telegraphs Department, Gold Coast).

Front row, left-right: A. E. Gagan (Acting Engineer-in-Chief, Posts and Telegraphs Department, British Guiana); G. Apperley (Australian alternate Member, C.T.B.); L. S. Payne (Canadian Overseas Telecommunications Corporation); E. H. R. Green (Chief Engineer, New Zealand Post Office); Rt. Hon. Lord Reith, G.C.V.O., G.B.E., C.B., T.D. (Chairman of C.T.B.); Colonel Sir A. Stanley Angwin, K.B.E., D.S.O., M.C., T.D. (Chairman of the Meeting and Chairman of Cable & Wireless Ltd.); R. V. McKay (Australian Member, C.T.B.); M. N. Mirza (Chief Engineer, Posts and Telegraphs Department, Pakistan); A. S. McDonald (Chief Engineer, Overseas Telecommunications Commission (Australia)); Colonel W. W. Shaw-Zambra, C.B.E., T.D. (Secretary-General, C.T.B.).

Notes and Comments

New Year Honours

The Board of Editors offers congratulations to the following members of the Engineering Department honoured by H.M. the King, in the New Year Honours List :—

Engineering Department	.. Turner, A.	.. Technician, Class I British Empire Medal
Guildford Telephone Area	.. Pendry, S. D.	.. Executive Engineer Member of the Order of the British Empire
H.M.T.S. " Monarch "	.. Tilly, T.	.. Radio Operator British Empire Medal
Leicester Telephone Area	.. Healey, S.	.. Lately Technician, Class I British Empire Medal
London Telecomms. Region	.. Gregory, E. G. S.	.. Assistant Engineer Member of the Order of the British Empire

Obituary—Mr. J. Morgan, O.B.E., A.R.C.Sc., M.I.E.E.

John Morgan, O.B.E., A.R.C.Sc., M.I.E.E., Chief Regional Engineer, Welsh and Border Counties Region, died on 12th January, 1951, following an operation on the previous day.

Born at Sheerness on 22nd December, 1890, he entered the Dockyard as an engine-fitter apprentice in 1905, taking first place in the examination ; he attended the Dockyard school for four years and, in 1909, won a Whitworth Exhibition and a Royal Scholarship, which enabled him to further his technical education at the Royal College of Science, South Kensington. He was awarded a 1st Class Diploma of the College in mathematics and mechanics in 1912, and continued as a post-graduate student at the City and Guilds Institute until his entry to the Engineering Department as Assistant Engineer in 1913, taking second place in the open competitive examination.

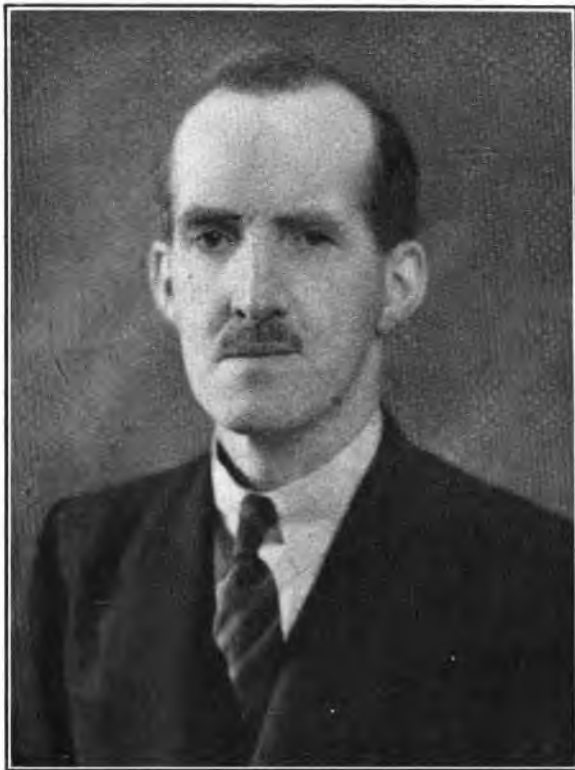

He was first appointed to the Local Lines Section of the Engineer-in-Chief's Office, and was transferred in 1914 to the Exeter Section. He served with commissioned rank in the R.E. Signals in France, and on demobilisation returned to Exeter, where he remained until 1924. After a further period of five years in the, Local Lines Section

he was promoted Sectional Engineer at Exeter, and in 1934 to Assistant Superintending Engineer, Scotland West. He came south again to Bristol in 1936 and succeeded Mr. P. T. Wood as Superintending Engineer in 1938. As Chief Regional Engineer, he was transferred to Cardiff in 1944, where he carried out the dual duties of C.R.E. and D.R.D. His services to the Post Office were recognised by his inclusion in the New Year Honours List, 1949.

By his sound judgment, fairness and humanity he earned the esteem and respect of all grades : of a quiet and retiring disposition, he shunned the limelight, but was firm and convincing in the presentation of his views. From his youth he had always taken a keen and active interest in a number of indoor and outdoor sports and, indeed, excelled in some. He was a member of the Penarth Golf Club, and looked forward to his Saturday afternoons on the course with some of his friends and colleagues in the Region.

He was a gentle and affectionate husband and father—he leaves a widow and one daughter—and found much happiness and contentment in family life. A staunch nonconformist, he was at the time of his death a Deacon of Christchurch, Penarth, a fitting tribute to his Christian way of life. He was sympathetic and kind to those in adversity and his generosity in any case of need which came to his notice was a secret he withheld even from his most intimate friends.

As a good companion and a loyal friend John Morgan will be sadly missed.

W. F. B.

Journal Changes

Since 1934, there have been very few changes in the appearance of the Journal and such as have been introduced were of a minor character. With the current issue, however, readers will notice, possibly with some regret, that the generous page margins to which they are accustomed, have now been considerably reduced due to the adoption of a revised format.

This change, designed to economise in paper without reducing the contents of the Journal, will assist materially in offsetting rising production costs and will, it is hoped, avoid the necessity for increasing the price of the Journal.

At the same time, opportunity has been taken to introduce a new Journal cover styled on more modern lines, but retaining the clarity of layout which has proved popular in the past.

Corrections

In the article on National Trunk Dialling, published in the previous issue of the Journal, there is a typographical error on page 171. The demand traffic completed over two trunk links is 93 per cent., and not 3 per cent., as stated.

In Fig. 1 (b) on the same page, the wrong symbol is shown for the C relay, which is a 2-winding relay, but without slug.

**Retirement of Capt. J. Legg,
I.S.O., B.Sc.(Eng.), A.M.Inst.C.E., A.M.I.E.E.**

Capt. J. Legg, Assistant Engineer-in-Chief, retiring on 31st March after 39½ years' service in the Post Office, entered the Engineering Department by examination as an Assistant Engineer (as the title then was) in 1911. He had been a student at King's College, London, where he obtained his Engineering Degree and later served for two years as a Pupil Apprentice at the Royal Ordnance Factory, Woolwich. His early experience in the Post Office was in



the Test and Inspection Branch where his service was broken by the first World War in which he served from 1914-1919, reaching the rank of Captain.

Later he was Assistant Staff Engineer and then Staff Engineer in charge of the Telephone Development and Maintenance Branch during a period which saw spectacular development in the local telephone service and the change-over to "on demand" working on the trunk service throughout the country. This improvement in the service given by trunks, together with the 1s. night calls which were introduced during this period, were the means of causing extremely rapid growth which the Department found some difficulty in meeting. He was promoted Assistant Engineer-in-Chief in 1941, and until 1944 was in charge of the Engineering Department's activities out-stationed at Harrogate.

He has been closely concerned with training and welfare and was largely concerned with the setting up of the Engineering Department Residential School at Stone which has proved of such great value.

He acted as Chairman of the British Telephone Technical Development Committee for about 10 years during which period many important developments in the standardisation of switching plant took place. For some years he has been Chairman of the Sub-Committee of the 8th Study Group of the International Telephone Advisory Committee, charged with the development and trial of the methods of signalling and dialling on international circuits, which will

no doubt prove invaluable to our future international communications.

He was responsible for the recent reorganisation of the Draughtsmen grades and has been Chairman of the Assistant Engineers' and Draughtsmen's Promotion Boards.

He was a very keen tennis player and twice played in the singles championships, and with his brother in the doubles at Wimbledon. A few years ago he took up golf, where his capacity for going "straight down the middle" served him in good stead; he was a very popular captain of the Engineering Department Golf Society in 1949.

His sound judgment on telephone matters and his pleasant personality will be sorely missed by his colleagues. We wish him every happiness in his retirement and a favourable "rub of the green" in his future activities.

H. F.

Mr. A. H. Mumford, O.B.E., B.Sc.(Eng.), M.I.E.E.

Mr. A. H. Mumford, who has been appointed Assistant Engineer-in-Chief on the retirement of Capt. J. Legg, entered the Department as a Probationary Assistant Engineer in 1924, after completing his studies at East London College, and ever since has been concerned primarily with radio. After a short period in the City, he joined the band of enthusiasts at the Dollis Hill Laboratory, was promoted to Executive Engineer in 1933, to Assistant Staff Engineer in 1935, and three years later returned to the City as Staff Engineer of the Radio Branch.

At Dollis Hill Mr. Mumford was particularly concerned with short and ultra-short wave radio systems and with



multi-channel telephony and television transmission over coaxial cables. He had a considerable bent for experimental work and, as his responsibilities increased, showed the attributes needed to build up, and to lead, a large team. He took charge of the Radio Branch at a time when radio was playing an increasingly important role in both civil and military communications and between 1939 and 1945 he carried heavy responsibilities. His efforts during this

period were recognised by the well-merited award of the O.B.E. in 1945. During his period as Staff Engineer the Radio Branch was split into three separate Branches dealing respectively with Planning and Provision (WP), Development and Experiment (WE) and with Station Operation and Maintenance (WM), and he took over WP Branch. His one break with the work of the Radio Branches was during 1948, when he attended the Imperial Defence College.

In the last five years Mr. Mumford has been particularly occupied with the international aspects of radio and has attended many international conferences. Those who have been concerned with post-war radio conferences will realise the burden that this work must have entailed.

Following the pattern set by his predecessors, Mr. Mumford has been active in the work of the Radio Section of the I.E.E. He has been a member of the Section Committee for some 15 years and was Chairman of the Section in the 1945-1946 Session. He made the Students' Lecture Tour

in 1947-1949 and gave the L.C.C. Children's Lecture in 1951. He has contributed several papers to the I.P.O.E.E., was Chairman of the London Centre, 1947-1948, and has been a frequent contributor to this Journal, of which he has been a member of the Board of Editors for many years.

It is characteristic of Mr. Mumford that he has found time to lead his team as a Staff Engineer, to make major contributions to post-war radio conference work and to the Radio Section of the I.E.E. He has unbounded energy, an analytical mind (which he can readily focus on diverse problems, sometimes with devastating effect) and the quality of leadership, all of which are cemented with a ready wit. These qualities will serve him well in whichever sphere he is directed and will enable him to grapple with the problems awaiting him in his new post. All his immediate colleagues, in fact, all who have been privileged to come into contact with him, will say "well done, and good luck for the future."
C. F. B.

Institution of Post Office Electrical Engineers

Festival of Britain, 1951

A number of subscribers to the Journal who live abroad and Corresponding Members of the Institution may be visiting England for the Festival of Britain, 1951. On behalf of the Institution, we should like to extend them a cordial welcome and hope that they will get in touch with the Secretary, Col. J. Reading, Equipment Branch, Engineer-in-Chief's Office.

While in Great Britain, they may wish to visit various Post Office installations, such as exchanges and repeater stations, etc., and we should be very pleased to make any necessary arrangements.

Recent Additions to the Library

1957 *Electric Cables*. F. W. Main (Brit. 1949.)

Deals with the construction, technical characteristics and manufacture of electric cables for lighting, power, telegraphy and telephony.

1958 *Large-Scale Organisation*. (Ed.) G. E. Milward (Brit. 1950).

An authoritative account of how eleven great industries and services are organised.

1959 *Wood Adhesives*. E. H. Pinto (Brit. 1948).

Covers the use of a large range of adhesives from the technical, commercial and economic points of view.

1960 *Micro-Wave Measurements*. H. M. Barlow and A. L. Cullen (Brit. 1950).

Presents, primarily, those techniques of wide application, particular attention being given to principles of operation rather than details of apparatus.

1961 *Radio Aerials*. E. B. Moullin (Brit. 1949).

Intended mainly for those concerned with the electromagnetic aspects of the design of short-wave aerials.

1962 *Fundamentals of Radio—Valve Techniques*. J. Deketh (Dutch 1949).

Aims at giving technicians and research workers a lucid account of the properties, functions, assembly and applications of radio valves.

1963 *Short Wave Radio and the Ionosphere*. T. W. Bennington (Brit. 1950).

Presents in simple form, avoiding the use of mathematics, all the available information on the role of the ionosphere in long-distance short-wave communication.

1964 *Protective Coatings for Metals*. J. W. Gailer and E. J. Vaughan (Brit. 1950).

Describes the most important of the various films or coatings applied for the protection of the more commonly used metals; the theory of their action; the methods of application; and the scientific choice of coatings for particular environments.

1965 *University Text-book of Physics*. Vol. II. (Sound) Poynting and Thomson (Brit. 1949).

Designed to serve those taking Honours Courses in branches of Science other than Physics, who have chosen Physics as a subsidiary subject for their degree.

1966 *Concrete Construction*. C. E. Reynolds (Brit. 1950).

Describes the temporary and permanent work in the construction of most plain and reinforced concrete structures.

1967 *Electronics*. P. Parker (Brit. 1950).

Written from the point of view of a physicist interested in the applications of a branch of his subject, it is intended to provide a background for the circuit specialist, and a starting point for the tube specialist. Roughly of the standard expected in the electronics Paper for the London first degree in engineering.

1968 *Advanced Mathematics for Technical Students*. Pt. II. Lowry & Hayden (Brit. 1950).

Covers the work normally done by students taking mathematics as a subject in Part II of an engineering degree.

1969 *Semi-Conductors*. D. A. Wright (Brit. 1950).

Gives an elementary account of their properties, being especially concerned with the theory of electron flow in them, and across the boundary between them and either a metal or a vacuum.

1970 *Engineering Science*. Vol. III. H. B. Brown and A. J. Bryant (Brit. 1950).

Mainly concerned with experimental work, testing and full-scale trials of prime movers, to the standard required for the Ordinary National Certificate Course in Mechanical Engineering and the Engineering Science of the Ordinary National Certificate in Electrical Engineering.

1971 *A.C. Motor Windings*. H. Hopwood (Brit. 1950).

Written with the intention of explaining some of the rules peculiar to A.C. armature windings.

Regional Notes

Northern Ireland Region

STORM DAMAGE

The arrival of the New Year was heralded by a short but severe freak snow storm in the Belfast Telephone Area. During the early hours of 1st January, a heavy fall of snow caused extensive damage over an area of some 2,000 square miles. All overhead plant east of a line from Limavady in the north, to Newcastle, Co. Down, in the south, was affected. The weather conditions favoured the "build up" of snow on the line wires, and as a result, approximately 160,000 wires were broken and the remainder were stretched beyond tolerance limits. Practically every wire in the affected area will have to be renewed. In addition, some 40 poles were broken and several hundreds deflected, whilst many stays were pulled or broken. In all, about 11,000 subscribers' lines (including 320 emergency lines) and 300 trunk and junction circuits were put out of service. Belfast Central and its satellite exchanges had 6,400 lines faulty out of a total of 29,269 working lines, while in some of the U.A.X. areas every subscriber's line was out of order. A total of 40 exchanges were isolated.

At the end of the first day it was apparent that the normal staff in the Area would be unable to cope with the repair work, and other Regions were asked for assistance. Response was excellent, and altogether 14 gangs were kindly lent, complete with lorries and tools, from the Liverpool, Birmingham, Leicester, Newcastle-on-Tyne, Bristol, Exeter, Gloucester, Taunton and Brighton Areas. This assistance was much appreciated and greatly helped in the preliminary restoration of service.

To effect speedy restoration of service on a temporary basis, use was made of covered wire, Army D8 cable, interruption cable and recovered wire. A special Central Storm Repair Control was set up to deal with the temporary repairs. The main function of this Control was the deployment of gangs to meet the constantly changing requirements of the situation. In addition to the main Control, seven detached Control Centres were introduced, each being under the direction of an Assistant Engineer who implemented the instructions given by the Central Control. This proved to be a most satisfactory arrangement. The Control Officers from the detached Centres supplied information daily to the Central Control. First priority was given to the restoration of the more urgent emergency lines (hospitals, fire stations, etc.), 50 per cent. of the trunk and junction circuits, the clearance of road obstacles, and broken poles dangerous to property.

With the exception of rural kiosks all faults on emergency circuits, and 50 per cent. of the junction circuits, had been cleared at the end of the first week. The methodical restoration of other services in each exchange area was then carried out in geographical D.P. order.

Although one in seven of the staff was sick due to the severe influenza epidemic prevalent at the time, the unstinted efforts of the combined staffs enabled the temporary restoration of all damage to be completed by 31st January. From surveys made of typical exchange areas by the Area Development Group, it was estimated that 66 gangs will be required to complete the repair work before the arrival of next winter.

A novel feature of the damage caused by the storm was the displacement of a section of a steel pole, the top section of the pole turning out of alignment at the first joint due to uneven breaking of the wires.

E. H. W.
T. S. W.

North Eastern Region

CABLE DAMAGE BY SQUIRREL

While locating a cable breakdown in a 15-pair cable, it was observed that the U.G. cable from the terminal block on a D.P. which was served by aerial cable, had been badly gnawed for a distance of 6 ft. from the terminal block; in one place the conductors were exposed. In addition, the aerial cable had also been damaged in the same way from the point of exit from the terminal block, to approximately 4 ft. from the pole.

The route concerned is adjacent to a densely wooded area

in which grey squirrels abound, and they have often been seen climbing the poles and running along the aerial cable. Although the "culprit" was not caught "at work," it can



DAMAGE CAUSED BY SQUIRREL TO 15-PAIR L.C. CABLE.

clearly be seen from the accompanying photograph that the cable had been damaged by sharp teeth, and there appears to be little doubt as to how the damage was caused.

A. J. C. H.

Home Counties Region

BARMING A.T.E. FIRE

On the 18th December, 1950, at 2.0 a.m., an emergency lineman was called out to attend to a prompt alarm at Barming A.T.E., a satellite exchange in the Maidstone multi-office area. On arrival, he found the building full of smoke and the exchange lighting out of order. Entering the building, he crawled through the smoke and removed the fuses from the main battery and cut off the electricity and gas supplies. The smoke was so dense that he could not locate the source, and so he then summoned assistance from the nearest telephone connected to another exchange. The fire was then located and extinguished with teletetra extinguishers.

The outbreak occurred on a 100-line, line switch and final unit (one of four) and the upper half was completely burnt out, including jumpers, cabling, and connection strips. Cabling to the next unit was also destroyed together with the ceiling immediately over the unit and the lead-covered electric light cabling.

The damaged equipment was disconnected and the remaining two units put back into service by 5.0 a.m. Arrangements were then made for all incoming calls to the affected units to be routed to the manual board at Maidstone, and full service was given to five kiosks and 22 emergency subscribers by shifting them to the unaffected equipment and allocating temporary numbers.

Information was received that a unit could be obtained from Headington exchange in the Oxford Area, and whilst this was being collected the damaged unit was recovered and the ceiling repaired by the Ministry of Works' contractor. Cabling was also renewed to the fourth unit. At 3.0 p.m. on 19th December, the unit arrived from Headington and all subscribers were restored to service by 10.0 p.m. on 21st December. Considerable trouble was caused by deposits of soot and beads of lead which had splashed over the equipment in a molten state. This necessitated cleaning all banks, wipers, and electrical contacts on the switches, and somewhat delayed the restoration of full service.

It is considered that the initial handling of the situation by the emergency lineman and the subsequent efforts of all staff reflects great credit on all concerned.

C. W. C.

RECONSTRUCTION OF HONEYWOOD BRIDGE

Honeywood Bridge, near Folkestone, is part of the A.20 trunk road where it crosses the railway between Sandling Junction and Westenhanger station. For many years it has remained a bottleneck to the traffic along this road and recently the Ministry of Transport planned to widen it, to provide two lanes for vehicles and a footway.

The design for the reconstruction of the bridge comprised the building of precast, reinforced concrete cantilever beams on to the existing brick arches to support a reinforced concrete road. It will be seen from the illustration that the cantilever beams are incorporated in the concrete road, and that the footway extends beyond the brick arch.

As the Post Office was considering an underground main cable route between Ashford and Folkestone, the Ministry of Transport was asked if provision could be made for two 4-in. steel pipes to be laid across the bridge, but it became clear from discussion that, owing to the novel design, normal methods were impracticable.

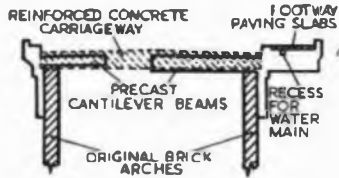

SECTION OF RECONSTRUCTED BRIDGE.

Provision had already been made in the design, for a 4-in. water main to be laid in a 6-in. square recess in each of the cantilever beams under the footway paving slabs. As any enlargement of these slots would have seriously weakened the cantilever, the same method could not be adopted for the P.O. pipes. It was decided, however, that subject to a maximum loading of 32 lb. per ft. run for pipes and cables, two 4-in. steel pipes could be slung underneath the beams, directly under the water main, and secured by stirrups hung from the slots.

This work has now been carried out and the two 4-in. steel pipes are securely fixed below the overhanging footway. The stirrups (shaped like an inverted letter U), two to each beam, were made locally from $\frac{3}{4}$ -in. round mild steel, heavily galvanised, and were positioned prior to the laying of the water main. The pipes were then hoisted into position and clamped against the underside of the beams by plates of 15 in. x 2 $\frac{1}{2}$ in. x $\frac{3}{4}$ in. galvanised mild steel. As a precaution against vibration, lock nuts were fitted, and to protect against corrosion all the threads were liberally coated with tallow tar and pitch composition.

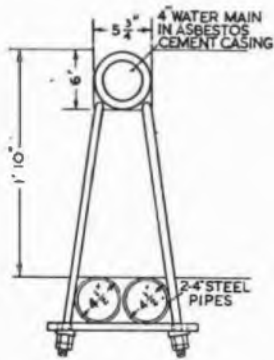

METHOD OF SUSPENDING CABLE PIPES.

As a matter of interest, before the reconstruction work commenced, a Bailey bridge was slung across the railway cutting, alongside the old bridge, by the 61st Engineering Squadron of the 36th Army Engineering Regiment, to provide for the light road traffic, vehicles of 20 tons and over being diverted along the Hythe Road.

H. J. P.

STORM DAMAGE.—GUILDFORD AREA

The severe snow storm on the 2nd January caused widespread damage over most of the Guildford area to the extent of 8,120 subscribers' lines becoming out of order. This followed the snow storm of only eight months previously when 14,200 lines were affected, as reported in the July 1950 issue of the Journal. Again the Guildford area was by far the most severely hit in the Home Counties Region.

The recent damage was appreciably extended on two occasions some days later by gales which increased the number of lines affected to over 10,000. The main damage was caused by the weight of snow on the wires, without accompanying wind, and resulted in a mass of odd-wire breakages both in subscribers' drops and also along routes, this time without pole breakages whereas in the previous storm the greater build-up of snow caused consequent pole breakages to an overall total of some 410.

On the earlier occasion the heaviest routes, irrespective of size of conductor, were the most damaged. In the January storm, however, there was no damage to conductors above 40 lb. Where most of the wires along rural routes were down, about 10 miles of interruption cable has been used.

The centralised control system to deal with priorities, stores, etc., for the restoration of the heavier routes, as mentioned in the previous note, was not found of much value on this occasion. Instead, decentralisation to the maximum extent was employed, resulting in individual field Inspectors having wide powers over the gangs under their immediate control. Each Inspector was responsible for gangs working in a well-defined territory, the control being used more as a message

centre and to receive information, e.g. on the movement of gangs from one exchange area to another.

Permanent repairs were effected initially in the great majority of cases, the exceptions being where interruption cable was used. The exchange areas affected were completely surveyed by the planning staff, but investigations are now proceeding to determine whether, in fact, this work was necessary or profitable, at least for the general type of damage caused by this storm.

Thanks to the sustained efforts of some 65 gangs and 2-man parties (including 18 borrowed from surrounding Areas), together with the maintenance and auxiliary staffs and supervising officers, service was restored to all subscribers by the evening of the 22nd January.

H. M. W.

COM—"BAT WILLOW"

Considerable difficulty has been experienced on major works by the mass root formation of the Bat Willow tree (*Salix caerulea*). This tree is found in large numbers in Essex and is usually planted to support and retain river banks. Its wood is used for the manufacture of cricket bats.

The illustration shows fibrous roots, which have entered a



BAT WILLOW ROOTS FILLING DUCT.

duct line at a coupling point, completely filling the adjoining ducts and split coupling and forcing the cable to the top of the duct.

L. G. H.

North Western Region

TECHNICAL EDUCATION

The Lancaster Telephone Area is now completing the fourth year of a systematic and sustained drive in the technical education of its staff. In the three completed years, engineering personnel have gained 352 City and Guild Certificates, the average area-staff-strength over the last three years being well under 500 men. The Area is large (over 3,000 square miles) and there are six main centres of staff concentration. These several groupings of staff in small units, with their differing employment and technical standards, have presented obstacles to the organisation of classes and the willing support of the staff has been the main contributory factor in overcoming the difficulties encountered.

In the winter of 1946-47 there existed in the area one class only; this was in the subject Elementary Telecommunications Practice. The general technical knowledge of the Area staff was then regarded as capable of improvement, and a decision was made to initiate a recruitment drive for technical classes. It was appreciated that the projected scheme could only succeed with the large-scale co-operation of the staff, and that considerable and prolonged publicity would be necessary to obtain this co-operation.

Following a period of intensive publicity and within about four weeks of the opening of the 1947-48 session, meetings were held at all centres, and the staff was addressed, advised and recruited with the result that the session opened with 12 classes. During subsequent sessions, and between sessions, no opportunity was lost to emphasise that technical classes had come to stay.

The continued success of the recruiting methods is indicated by the fact that 18 classes are running in the current session, divided thus: Lancaster 5, Carlisle 4, Kendal 3, Barrow 2, Whitehaven 2 and Penrith 2.

In each year the ratio of 1st Class to 2nd Class certificates has been higher than the national average, and a very pleasing feature of the 1950 examination successes is that the 2nd, 3rd and 4th year subject certificates taken together exceed the number of 1st year certificates.

The classes were taken (with very few exceptions) by Executive Engineers, Assistant Engineers and Technical Officers, and the scheme owes a large part of its success to these tutors' efforts. An average of 117 City and Guild Certificates each year over a period of three years from a staff of less than 500 (including external staff) is considered an achievement.

J. D.

ASHTON-IN-MAKERFIELD EXTENSION NO. 2

This exchange—described in a previous article*—was a non-standard satellite exchange parented on Wigan. When an extension became necessary, it was agreed by Headquarters in 1947 that a "turn round" to a 2,000-type satellite exchange was desirable to avoid the manufacture of non-standard equipment. Owing to the limited rack space available and the height of the racks (8 ft. 6 in.), it was not possible to introduce uni-selector, and linefinder working was therefore continued. The "turn-round" in situ was effected by reducing gangway clearances and allowing for two stages of installation, accomplished as follows.

The existing traffic recorder rack was recovered and the old line and cut-off relay rack was shifted out of line. This allowed for the erection of the new line and cut-off relay, primary finder, satellite 1st selector, discriminator and final selector racks to cover the transfer of the existing 400 subscribers' multiple. Fortunately, sufficient space existed for the extension of the main distribution frame, and additional verticals were provided to cable the new exchange as a separate entity, thus providing a simple method of changing over to the new equipment. Owing to the restricted accommodation, it was not possible to replace all the existing apparatus, and therefore the old relay set, alarm equipment, meter and group selector racks were retained for further use and by various rearrangements the new equipment was installed on these racks. Sufficient space existed on the old meter rack for 400 new meters and these were installed and, after the initial cut-over, the old meters were recovered and the final 200 meters were fitted in their place.

The retention of rack 7A presented an interesting problem, the final scheme requiring the replacement of the existing 100-outlet group selectors by 200-outlet group selectors, so that these outlets could be associated with the 200-outlet satellite 1st selectors. It was found that by re-distributing the outlets on shelf A over the remaining shelves B, C and D, it would be possible to recover the shelf of 100-outlet banks and install in its place a shelf of 200-outlet banks. By reducing the number of incoming manual board circuits, it was also possible to reduce the total incoming circuits to 10.

After extensive testing, the new portion of the exchange was satisfactorily cut into service on 6th September, 1950. Within a week of this, the contractor had recovered the remaining shelves B, C and D of the 100-outlet selectors and fitted the two shelves of 200-outlet selectors, thus restoring the availability of the incoming routes to normal proportions. The old line and cut-off, group finder and final selector racks were then recovered and the remaining new primary finder, satellite 1st selector and final selector racks were installed in their place, thus completing the "turn-round." In addition to this, new miscellaneous equipment such as meter routine test, service interception, trunk offering and traffic recorder, was also installed. Last, but not least, a new power plant, batteries and ringing machines were provided.

The exchange premises consist of two buildings with approximately 30 ft. by 14 ft. and 17 ft. by 14 ft. floor space available for apparatus and power plant, respectively. The buildings are connected by a covered passage way and the cables connecting the equipment have been arranged with

"bights" to avoid disconnections by possible subsidence of the site due to coalmining. From the foregoing it will be appreciated that there was extreme congestion of space during most of the installation period, and much credit is due to the staff of the Automatic Telephone & Electric Co. for their installation work and to the Department's maintenance staff who had to keep the old exchange working under very trying circumstances. The final stage of the work was satisfactorily completed on 30th November, 1950.

G. J. S.

Welsh and Border Counties Region

BUILDING MANHOLES IN RUNNING SAND

The Chester Area was recently concerned with a contract for the construction of 51 manholes of the R1A and R2D concrete types, and at first no great difficulties were anticipated in the work. Commencing at the Chester end, the first three manholes were built in normal ground, but further excavations indicated that serious trouble was likely to arise from the type of subsoil encountered.

It was found that the route passed directly over what appeared to have been an old river bed and the manholes would, therefore, be in running sand with a water level about 3 ft. below the surface. De-watering was considered to be the best solution and as, during the war years, a Lee Howl pump had been modified for this work it was decided, for economic reasons, that the Post Office would accept responsibility for operating this plant in making the excavations.

At the commencement of de-watering operations, four well points were sufficient and the Lee Howl equipment was found to be very satisfactory. It became evident later, however, that a second pump would be necessary and one was therefore hired. The continuous use to which the two pumps were subjected caused many small and recurrent mechanical difficulties, but reasonable progress was maintained with this simple equipment.

Early in September, 1950, an effort was made to construct an R2D manhole, but after three days pumping it was realised that the two pumps were inadequate. As an alternative to the expense of hiring a single pump of adequate capacity, it was decided to hire a third small pump and adapt it for use with a set of well points lent by the Regional Training School. By means of the three small-capacity pumps, the contract was completed and it is estimated that the improvised methods resulted in a saving of about £2,074 in hiring charges. Rapid-hardening cement was used as far as possible, but, as supplies of this cement were difficult to obtain, much ordinary cement had to be used and the pumps run for longer periods in consequence.

Each manhole has since been carefully inspected and apart from minor leaks in two manholes all others are satisfactory.

The experience obtained in carrying out this contract shows that by the use of de-watering plant satisfactory building of manholes in running sand is possible and it may be well worth while having equipment of this type available in a central pool of mechanical aids.

G. B.

South Western Region

INTRODUCTION OF MULTI-METERING AT TAUNTON

The first major change-over of an existing exchange in the South Western Region to multi-metering was successfully completed in November, 1950, and details may be of interest.

The existing through-dialling scheme had not been designed for multi-metering and it was necessary to rearrange completely the existing dialling codes in use for single-fee and through dialling. Some 36 routes from selector levels, with a total of over 250 outgoing junctions, mostly to U.A.X.s, were involved. Second selector levels on 7 and 8, and third selector levels on 80 and 89 were in use on the existing scheme, and level 6 was, therefore, selected for multi-metering, with junctions routed from levels on second and third selectors. The method of change-over adopted was as follows:—

- (1) Modify U.A.X. route-discriminating equipment to enable calls to be routed on either the old or new code during the transition stage. Modify cord circuits at manual exchanges and provide additional junctions for guarded metering routes.

* P.O.E.E.J., Vol. 27, p. 290.

- (2) Complete new trunking and tee old and new levels together at Taunton.
- (3) Advise all subscribers concerned of the new codes and transfer date.
- (4) After change-over, modify U.A.X. route-discriminating equipment to cater for new codes only and connect N.U. tone to the old levels at Taunton.

To accommodate the additional codes (amounting to some 50 at each exchange) during the transition stage, common route-discriminating equipment was used at all U.A.X.s with direct routes to Taunton; discrimination was restricted to the last junction routing digit. Final modification after change-over permitted discrimination on the first subscriber's digit for nearly all codes.

The teeing was arranged simply on the I.D.F. by the provision of new permanent jumpers and twisting the old jumpers on the end of the new to facilitate recovery.

V. E. B.

London Telecommunications Region

CONVERSION OF COBHAM (KENT) C.B.S.2. EXCHANGE TO AUTOMATIC WORKING USING A MOBILE AUTOMATIC EXCHANGE

Early in December, 1950, the first mobile automatic exchange (M.A.X.) in the London Region was brought into service when the subscribers—138 in all—were transferred from the C.B.S.2 manual exchange in the local Post Office at Cobham (Kent) to a mobile automatic exchange (equivalent to a U.A.X. No. 13). The M.A.X. was used because of the need for quick conversion following notice given by the Sub-Postmaster to cease the manual exchange.

At Cobham the two vehicles containing the automatic equipment are located side by side towards the rear of the site for the permanent U.A.X. and clear of the proposed building

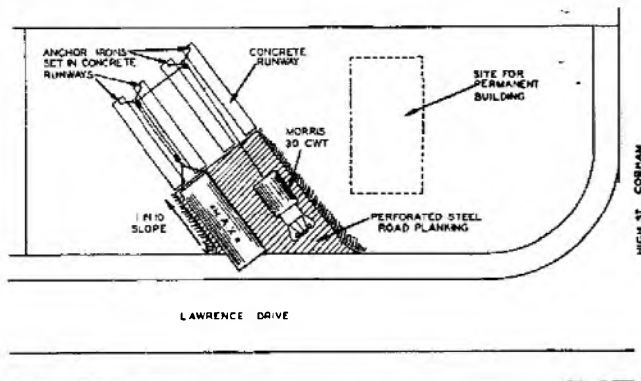

SITE PLAN SHOWING METHOD OF DRAWING-IN M.A.X.

position. Two sets of concrete runways 3 ft. wide by 24 ft. long were constructed to provide a good footing for the vehicles which may have to remain for some months. The ground level of the site was considerably higher than the adjoining roadway, and the trailers containing the M.A.X. equipment were pulled into position by means of pulley blocks and tackle. A normal 30-cwt. Morris vehicle provided the motive power. Ring bolts had been set at the end of the concrete runways to give a good fixing for the tackle. The weight of each equipped vehicle is about 8 tons.

It is interesting to note that the village of Cobham is renowned for its association with Charles Dickens, and it is

reported that the Pickwick Papers were written in the local hostelry. The local inhabitants are very proud of their association with the past, and are keen to preserve the character of the village. The two M.A.X. vehicles are, however, quite inconspicuous in their dark green paint, being set well back from the main street. A few hours after the opening a heavy snow storm laid a covering of white over everything and the Dickensian appearance of the village was complete.

S. M. E. R.

Scotland

RECOVERY OF NORTHERN UNDERGROUND CABLE

Recovery of the Northern underground cable is nearing completion in Scotland. When the contractor reaches Glasgow, he will have recovered 88.7 miles of cable in Scotland of a total weight of 1,730 tons. All this cable was transported to Reading by the Department's long-distance haulage fleet in well-planned operations. The Regional staff was responsible for removing the cable from the roadside and for temporary storage.

The cable was provided in 1905, and labels bearing the names of the workmen were found in many of the joints, including those on either side of the England-Scotland boundary. On the English side the label read as follows:—

"For Auld Lang Syne—the first and last joint in England.

"This joint was made by Fred Lofthouse, of Lancaster, assisted by John Latton, of Shap Beck, near Penrith, and was wiped and brazed by Joseph Hodpon, of Penrith, and was superintended by Robert Sharples, of Preston, on Wednesday, 13th day of September, 1905.

"In God we trust. God Save the King."

and on the Scottish side:—

"Should auld acquaintance be forgot and never brought to mind,

"Should auld acquaintance be forgot in the days of Auld Lang Syne.

"After a successful journey of 65 miles, done by R. Sharples' gang in less than 12 months, Jinter Clayton, of Birmingham, made the first joint on the Scotch side on Wednesday, 13th September, 1905.

"Plumber—J. Hodpon. Foreman—R. Sharples.

"God Save the King."

This work was done before cable jointers were stationed in Scotland and the men came from England. The brother of one is still with the Post Office in Scotland, and older members of the staff remember Foreman Sharples, but trace of the other men named has been lost.

The cable was in excellent condition after 45 years and was withdrawn without trouble, only a few short lengths having, so far, refused to move, due, it is thought, to unrecorded joints. The cast iron pipe is also in excellent condition, many sections showing no sign whatever of rust. An interesting feature is that, in spite of the extensive road widening which must have taken place in this main road, the pipe is still, mainly, in the grass verge.

The whole cable was an excellent job which did great credit to the Engineers who designed and constructed it. Only the change in transmission technique, rendering the make-up of the cable obsolete, prevented it giving many years of useful service.

Headquarters are now considering re-use of the pipe for a modern coaxial cable. In view of the extensive reconstruction planned for this road, it can hardly be expected that the pipe will remain as undisturbed as in the past 45 years.

G. J. F.

Junior Section Notes

Bishop's Stortford Centre

On the 15th November, 1950, practically our full membership attended a lecture on "Faraday Building," given by Mr. A. E. W. Lee, of Museum exchange. An excellent description of the layout of the building and the equipment therein was given, together with some astounding facts and figures. On the 22nd November, 1950, almost our full complement paid a visit to Faraday Building and saw all that our previous speaker had described—and more! We would like to express our sincere thanks to Mr. Knox, Liaison Officer, Home Counties Region, and the Cambridge Area Liaison Officer, Col. T. C. Loveday, who made the arrangements for this very interesting visit.

On 4th January, 1951, Mr. R. A. Collins gave a most instructive lecture on "Internal Combustion Engines," dealing mainly with the 2- and 4-stroke cycles, carburation and positioning of cylinders for engine balance; questions were answered both during and after his talk. Unfortunately, bad weather adversely affected the attendance at this meeting.

At the time of writing these notes the Centre was looking forward to the following programme:—

19th January, 1951.—A Film Show by the Central Office of Information.

22nd February, 1951.—Invitation from the Cambridge Centre to attend a lecture at Cambridge, given by Dr. Searle, late Professor of Physics at Cambridge University, on his personal contacts with the late Oliver Heaviside.

February, 1951.—Talk on Generation of Domestic and Industrial Power by an Engineer of the Eastern Electricity Board, followed at a later date in the same month by a visit to Brimsdown Power Station.

A creditable response is being made by our members to the Centre's activities, but more members, particularly external personnel, would be very welcome. G. E. D.

Chiltern Centre

The Annual General Meeting of the Chiltern Centre was held on Wednesday, 29th November, 1950, and officers for the coming year were elected as follows:—*Chairman*, Mr. F. J. Fagan; *Vice-Chairman*, Mr. F. Sherriff; *Secretary*, Mr. H. J. Trotman. Committee re-elected en bloc.

It is hoped to arrange a full programme for 1951, including film shows, a lecture by Mr. K. E. Felton (member), visits to local works and other activities. H. J. T.

Darlington Centre

On 21st November, 1950, a talk, "Domestic Radio" was given by one of our members, Mr. E. O. M. Grimshaw (of *Electronic Organ fame*) in his usual breezy style. A very lively discussion which followed, with the Telephone Manager (Colonel Sutcliffe) a participant, was thoroughly enjoyed. On reflection, this meeting could be voted as ideal both from the speaker's and his listeners' points of view.

Owing to the illness of Dr. Fothergill, in December, his talk on "Coloured Photography" could not be given and an interchange of programme arrangements was necessary. The talk was replaced by one on "Radar Up To Date," by Mr. R. R. Johnson, a contribution which was well received by his audience. Dr. Fothergill's talk will be given on 10th April, 1951.

"Where the Money Goes," was the title of a talk by Mr. K. Millard, given in January. This subject was certainly most enlightening—the disposal of the Budget Allocation of money to be expended in the Area by the Engineering Department gave the listeners the impression that the problem really must give a headache to those officers responsible. Mr. K. Millard proved to be a very able speaker.

Our meetings to date have been very well attended in spite of the incidence of flu., which accounted for the absence of some of our regulars.

On 25th January, several of the Centre members journeyed to Middlesbrough for the talk by a Darlington Centre member—Mr. B. V. Northall, on "Television." This was preceded

by a very pleasing ceremony—the presentation by the C.R.E. (Mr. W. F. Smith) of his prize to Mr. R. V. Heppinstall for the best paper by a Centre member in the North Eastern Region and of the Shield to the Middlesbrough Centre to mark the success of one of its members. May the Darlington Centre record their sincere congratulations in these notes.

Needless to say, the Darlington Centre has now designs on that Shield! Hitherto, our Centre has refrained from entering the Competition due to written papers of talks by our members not being available. C. N. H.

Doncaster Centre

On Wednesday, 20th December, 1950, a most interesting paper was given to the above centre by Mr. E. C. Elstree-Wilson of York. The subject, "Wood Turning," was a rather unusual one, and Mr. Elstree-Wilson, who brought along his own lathe, soon captured his audience by inviting them individually to have a try during the course of his demonstration. At the conclusion the local secretary thanked Mr. Elstree-Wilson for the most interesting paper and demonstration we have yet received. J. I. L.

Guildford Centre

The Guildford Centre continues to grow in strength and now numbers 100. Great interest is being shown by the members in all activities, factory visits being particularly appreciated.

The Secretary, Mr. F. Kelsey, tendered his resignation and at a General Meeting on 3rd November, Mr. L. G. Wallis was elected Secretary and Mr. R. J. Nicholls Assistant Secretary.

The Winter Session was opened by Mr. H. Wells, Area Engineer, who gave a most interesting talk on "Sound Recording."

A party of 33 visited the factory of Pirelli General, Ltd., at Eastleigh, on 22nd November, and were shown the complete process of telephone cable manufacture from the copper ingot to the finished cable. On 14th December, Mr. W. Hancock of British Railways, gave a talk on "Railway Signalling."

The programme for 1951 was arranged as follows:—

17th January.—The Osram Lamp Works, Wembley. (Visit). February.—Annual General Meeting.

28th February.—"Photography in the Post Office," by Mr. W. A. Paul. (Lecture).

6th March.—Harris Lebus, Ltd., Mass Production Furniture Factory. (Visit).

April.—Pirelli General Cable Works, Southampton. (Visit).

May.—Visit to a Coal Mine, Canterbury.

Other visits and lectures are in process of organisation and will be announced later. L. G. W.

London Centre

The London Centre has been very active recently. On the 14th December, 1950, over 60 members attended a most interesting lecture on "Electronic Switching" by Mr. T. Flowers, and this was followed, on 16th January, 1951, by "Some Aspects of Television" by Mr. T. Kilvington, the attendance of over 100 members being a great encouragement to the Centre Committee. An excellent tea was provided on both occasions. A pleasant ceremony was performed before Mr. Kilvington delivered his lecture, Mr. A. E. Penny, our Liaison Officer presenting a certificate and cheque for £3 3s. to Mr. Cochrane for his essay on "Precision Testing." Congratulations, Mr. Cochrane!

Are all members aware that Papers read at Junior Section Meetings are considered for the award of Institution prizes? The Judging Committee on Papers believe that if this is widely known more Papers will be forthcoming. Now then, authors, produce those Papers and keep the Judging Committee busy.

Papers are not far removed from periodicals. It may surprise members to learn that at the time of writing no less than 1,611 periodicals are circulating within the London Centre. This figure does not include local purchases by Areas. If members wish to see more of these periodicals, increased speed in circulation is required please.

East Area have recently held an inter-exchange quiz between Ilford and Seven Kings groups. After 25 difficult questions per team, Ilford were declared victors, with 69 points against Seven Kings 45.

Many visits to places of interest in and around the capital have taken place. The following is an excerpt from a typical monthly report submitted to the Centre Committee:— Premises visited, Messrs. Tate & Lyle, Standard Telephones & Cables, B.B.C. Broadcasting House, Electrical and Musical Industries, South-East Gas Works, Belling Lee Electrical Products, Kodaks, British Oxygen, Merton Board Mills, and Vickers Armstrong.

Much is being done in the London Centre, and it is the intention of the Centre Committee to maintain the interest of all staff in the Junior Section. Come on London, keep your Area Committee on their toes!
M. J. G.

Leeds Centre

A belated start to the present Session was made with a visit to Kirkstall Power Station by kind permission of the B.E.A. The attendance of 26 was very gratifying considering that the centre has been dormant for three years. An inter-centre quiz with Bradford was arranged for February with further papers for March and April, and it is hoped that interest will be maintained to give a good send off to the new Session in September.
E. G. S.

Middlesbrough Centre

On 16th November, 1950, a written paper was given by Mr. R. R. Johnson, Vice-Secretary, entitled "Radar." A short film on the subject preceded this paper.

Mr. C. Allison gave his talk on "Electricity in the Home and Workshop," in December, and has since left Middlesbrough Area to take up duties at Leeds. Mr. D. Paterson, our Chairman, thanked Mr. Allison for all his good work during his term of office as Vice-Chairman, and expressed good wishes on behalf of the Middlesbrough Centre for success in his new position.

25th January, 1951, marked a special occasion, when we were honoured by the visit of Mr. W. F. Smith, Chief Regional Engineer, and Mr. A. C. Holmes, Regional Liaison Officer, for the presentation of the Chief Regional Engineer's Book Prize for the best Paper submitted in the Regional Contest, to Mr. R. V. Heppinstall, for his paper entitled "Local Line Planning." The Chief Regional Engineer's Presentation Shield, which accompanied the Book Prize, was received by the Chairman on behalf of the Middlesbrough Centre.



Courtesy of North Eastern Evening Gazette Ltd.

PRESENTATION OF THE C.R.E.'S SHIELD TO MIDDLESBROUGH CENTRE. Reading from left to right are Mr. A. C. Pitcairn (Area Engineer), Mr. D. Paterson (Chairman), Mr. R. V. Heppinstall, Mr. J. S. Gill (Area Liaison Officer), Mr. B. V. Northall, Mr. W. F. Smith (C.R.E.), Mr. J. Brown (Secretary).

The presentation was followed by a talk on "Television," by Mr. B. V. Northall, one of our Darlington colleagues, the talk being illustrated with the aid of a film strip. We were pleased to welcome eight Darlington members, the Telephone Manager and the Area Engineer, with several other Senior Members and ten members of the Tees-Side and District Amateur Radio Club. In addition, 40 of our own members attended.

At the time of writing, our next meeting was to take place on 22nd February, 1951, with Mr. R. Dingwall, M.I.E.E., of Messrs. Dorman, Long & Co., Ltd., lecturing on "Electrical Engineering in Iron and Steel Works." This was to be followed on 13th March, 1951, by a "Two-Way Quiz," between Darlington and Middlesbrough Centres.

Sheffield Centre

The 1950/51 Session found our membership strength well over the 80 mark, and the first visit, which was to the Sheffield Transport Repair Depot, was very well attended. Since then, however, members have not attended the meetings so well as was expected. Amongst the features of the programme have been:—

August.—Visit to Sheffield Fire Station.

September.—Visit to United Steels, Ltd., Stocksbridge.

October.—Lecture—"Precision Testing of Underground Cables," by Mr. G. Wilshaw.

November.—Visit to Firth Brown's Melting Shops.

December.—"Post-War Motor Racing," by Mr. T. C. Harrison.

At the time of writing, we are again joining with the local Student Section of the I.E.E. to hold a Dance towards the end of March and hope that it will meet with the same success as last year's event.

There is still a complete absence of Youths-in-Training from the attendance at meetings. We can offer no explanation but we do hope that eventually a little enthusiasm will be shown by that section of the staff. The External members, it is pleasing to record, are very keen.

To round off the year's activities other features before the A.G.M. arranged for April were to be a lecture on "Television" and a visit to the local newspaper offices.

A letter has been drawn up by our Chairman and, with the Committee's approval, will be sent to all members in an effort to provide a future programme in the coming 1951/52 Session to suit all tastes.
G. F.

York Centre

The 1950/51 Session opened on 12th October, 1950, with a paper by Mr. G. Dale of Darlington, entitled "U.A.X. Simplified." Since then, we have had the following papers:—

"Organisation and Function of the Telephone Manager's Office," by Mr. H. A. Clibbon, A.M.I.E.E.

"Television," by Mr. C. Buckle.

"Have you Seen These?" by Mr. J. P. Allen, of Regional Training School, Harrogate.

February.—"200-line P.A.B.X.," by Mr. C. S. Mills.

March.—"Rectifiers and their uses," by Mr. B. B. Watt.

On the 16th November, 1950, a party visited the British Railway Signal Section and were conducted on a most interesting tour of the new Colour Light Signal Equipment by Mr. G. G. Halliwell.

On the 1st December, 1950, a dinner/smoker was held at the Davy Hall Restaurant. A most enjoyable evening was spent by both members and guests.

In conclusion, we take great pride in announcing Mr. W. N. Pallier's success in the National Competition for the best Junior Section Paper. On 2nd January, he was presented with a cheque and certificate at a Senior Section Meeting at Leeds, for his Paper, "Telegraph Automatic Switching System."
J. P.

Book Reviews

"Quartz Vibrators." P. Vigoureux, D.Sc., and C. F. Booth, O.B.E., M.I.E.E. H.M. Stationery Office. 371 pp. 30s.

There are many minor and often curious phenomena associated with electricity and magnetism which have been known for a considerable time but which have found little or no practical application. Among these are the Kerr, Peltier, Kundt and Zeeman effects, the electro-capillary phenomena, pyro-electricity and many others.

Up to about 30 years ago, these would have included the piezo-electric effect whereby certain dielectrics of crystalline nature exhibit signs of electrification when mechanically deformed and conversely are deformed mechanically when subjected to electric stress. The effect is present in varying degrees in many kinds of crystal both inorganic and organic, but the most important is quartz or natural rock crystal which is a form of silicon oxide. Although the piezo-electric effect in quartz is weak compared with some other substances quartz itself is highly elastic and when a piece of quartz rod or plate is set into mechanical vibration the vibration persists for an appreciable time because of the small internal loss. Quartz is thus an ideal material for a mechanical resonator and the piezo-electric effect provides a means of coupling such a vibrator to an electric circuit where it behaves as an electrically resonant circuit of extremely low loss.

The piezo-electric qualities in quartz only became important when the thermionic valve was invented and its first important application was in connection with submarine echo sounding, where it was used to impart mechanical energy to the water and also to convert the weak returning echo into an electrical signal.

In recent years a most important development has been the use of quartz resonators to control the frequency of valve oscillators and at a later date as components in electric filters. Workers in many countries have made important contributions to knowledge both in the preparation of the crystals and in their application, and it is gratifying to know that this country has been well to the fore in this respect.

Much of the early work in this country on the properties of piezo-electric quartz resonators was carried out by the late Dr. D. W. Dye of the National Physical Laboratory, and after his death this work, which was of outstanding and fundamental character, was continued by his colleagues among whom was Dr. Vigoureux, one of the authors of the present work. Dr. Vigoureux subsequently was commissioned by the Radio Research Board of the Department of Scientific and Industrial Research to produce a survey of current knowledge on "Quartz Oscillators and Resonators." and a second edition was published in 1939. The advances which have been made since then in the manufacture and in the use of quartz resonators, and the increasing importance of the place they occupy in telecommunications made a revision of this earlier edition necessary, and it was decided by the Board that the revision should include in addition to the theoretical treatment more detailed information on the manufacture, application and performance of quartz vibrators. In this revision, therefore, Capt. C. F. Booth, O.B.E., Staff Engineer of the Radio Experimental Branch of the Post Office Engineering Department, was invited to collaborate with Dr. Vigoureux.

Capt. Booth's experience and knowledge of the production of quartz resonators has made him admirably fitted to assist in this revision. About 25 years ago, the Post Office radio engineers were building short-wave radio telephone senders and encountered considerable trouble in holding the frequency of the sender steady during modulation. As a result, it was found necessary to generate the carrier frequency by amplifying harmonics of a quartz-controlled oscillator. At that time there was no very satisfactory source of prepared crystals in the country, and it was necessary to import them. This was unsatisfactory, as crystals had often to be adjusted to suit the oscillator circuits and in the end it became necessary to acquire the technique of cutting and lapping crystals in the radio laboratories. This work was started by a small team under Capt. Booth, and it has continued under his control until to-day. Capt. Booth's work has led to the production of quartz crystals of the highest precision and stability which have been used, not only for purposes of telecommunications, but also for the provision of standards of frequency and for the

measurement of time. The work of Capt. Booth and his colleagues has been valuable, not only to the Post Office but also to the Fighting Services and the B.B.C. Furthermore, the time-keeping qualities of electric clocks driven by quartz-controlled oscillators is so much better than the best mechanical clocks that a few years ago the Astronomer Royal installed in the Royal Observatory a number of quartz-controlled clocks for determining standard time.

The earlier chapters of the book deal with the properties of quartz, the occurrence and examination of quartz crystals, the piezo-electric phenomenon in quartz, the theory of the quartz resonator, the valve-maintained quartz oscillator and the various types of quartz vibrator. Then follow chapters dealing with the practical use and practical applications of quartz resonators, starting with the mounting of vibrators—the specification and testing of elements, the ageing phenomena of quartz elements, temperature control and frequency standardisation, frequency control of radio transmitters, carrier generation for multi-channel carrier systems, luminous resonators, frequency selection, ultrasonics and miscellaneous applications.

The next three chapters are devoted to descriptions of the various manufacturing processes, starting with the selection of the natural crystal, cutting, lapping and etching, plating, mounting, adjusting and testing. The design of plant for the production of resonators is next considered and the description of a typical layout of a factory for this purpose is given.

A final chapter deals with the future developments and here the authors deal with alternatives to quartz and the possibilities of growing suitable quartz crystals artificially. Other matters dealt with are artificially produced alternatives to quartz for certain classes of resonators and future possible developments in frequency standards.

Apart from the section on production, much of the information has previously appeared in articles and papers presented by the authors and others before learned societies, but the fact that both authors are thoroughly versed in the subject has enabled them to make a wise and appropriate selection of subject matter and, in consequence, this book can be regarded as probably the most up-to-date and authoritative work on the subject. It is well illustrated by drawings, diagrams and an excellent series of plates and is completed by a comprehensive bibliography of British and foreign literature on the subject and a useful index.

For a Government publication the price is rather high, but by present-day standards it is excellent value for money.

A. J. G.

"Signal Venture." Brig. L. H. Harris, C.B.E., T.D., M.Sc., M.I.E.E. Gale & Polden Ltd. 267 pp. 22 ill. 18s.

This is an autobiography with a Signals theme. The author went to Australia in 1914, at the age of 17, to learn farming and served during the 1914-18 War with the Australian Signals in the Middle East and France. Between the wars, as an engineer of the Post Office, he kept in touch with Signals as a Territorial Army Officer with the 44th Divisional Signals. During the 1939-45 War he served with the B.E.F., leaving France via Dunkirk, planned the communications for the landing in 1944 and went through the campaign as Chief, Telecommunications Section, SHAEF.

As a corporal with the Australian forces he laid D8 with the six-horse-drawn cable wagon and as a Brigadier planned the communications using the latest technique of carrier telephony on coaxial cables. The result is a most instructive book for all telecommunication engineers, be they civilians or regular or territorial officers. But the book has a wider appeal. The author has a seeing eye, has mixed with all types and can bring to vivid life both scenes and persons. He has also a nice discrimination in leaving unsaid those things which, after all, are best forgotten. There is no petty criticism, no backstairs "secrets."

The fresh air of the Australian farm and the pioneering spirit which took the author there are in evidence up to the last chapter. The only criticism I have is that the result does not make a good bedside book. I lost sleep over it—and enjoyed every page.

As a postscript may I add that my wife is doing likewise.

J. R.

Staff Changes

Promotions

Name	Region	Date	Name	Region	Date
<i>Sen. Exec. Engr. to Asst. St. Engr.</i>			<i>Tech. Offr. to Asst. Engr.—continued.</i>		
Taylor, F. J. D.	E.-in-C.O.	5.12.50	Campbell, A. I.	Scot. to E.-in-C.O.	20.1.5
Seaman, E. C. H.	E.-in-C.O.	18.2.51	Gee, J. A.	N.W. Reg. to E.-in-C.O.	13.1.5
<i>Sen. Exec. Engr. to P. Sc. Offr.</i>			Fernie, G. B.	Scot. to E.-in-C.O.	20.1.5
Scowen, J.	E.-in-C.O.	28.12.50	King, F. A.	E.-in-C.O.	13.1.5
<i>Area Engr. to Dep. T.M.</i>			Wilsdon, H. F.	Scot. to E.-in-C.O.	13.1.5
Markby, E. J.	L.T. Reg.	16.12.50	Sixsmith, J.	E.-in-C.O.	13.1.5
<i>Exec. Engr. to Sen. Exec. Engr.</i>			Hall, R.	N.W. Reg. to E.-in-C.O.	13.1.5
Green, R. G.	N.W. Reg.	1.1.51	Cruikshanks, H. K.	Scot. to E.-in-C.O.	13.1.5
Wilkinson, E. H.	N.E. Reg. to N.Ire. Reg.	1.1.51	Hilton, C. G.	N.W. Reg. to E.-in-C.O.	13.1.5
Arnold, C. W.	E.-in-C.O.	1.1.51	Pullen, A. E.	E.-in-C.O.	13.1.5
Goldsmith, F. H.	Scot. to E.-in-C.O.	6.12.50	Davis, Eduard	E.-in-C.O.	13.1.5
Holliday, R. F.	L.T. Reg.	8.1.51	Kershaw, R. J.	N.W. Reg. to E.-in-C.O.	13.1.5
Woodhead, H. C.	E.-in-C.O.	1.1.51	O'dell, S. H. G.	H.C. Reg. to E.-in-C.O.	13.1.5
<i>Asst. Engr. to Exec. Engr.</i>			Cumming, W. S.	Scot. to E.-in-C.O.	20.1.5
Giles, F. R.	E.-in-C.O.	12.12.50	Roberts, S.	N.W. Reg. to E.-in-C.O.	27.1.5
Campbell, K. W.	E.-in-C.O.	12.12.50	Richardson, G. E.	N.E. Reg. to E.-in-C.O.	13.1.5
Streeter, A. R.	E.-in-C.O.	1.1.51	Francois, R. A.	L.T. Reg. to E.-in-C.O.	13.1.5
Hall, G. W.	S.W. Reg.	1.1.51	Crawford, A.	Scot. to E.-in-C.O.	13.1.5
Robinson, R. T.	L.P. Reg.	8.1.51	Kelson, D.	Mid. Reg. to E.-in-C.O.	13.1.5
Clark, E. A.	N.E. Reg.	31.12.50	England, H. S.	E.-in-C.O.	13.1.5
Yates, G. A.	Mid. Reg.	27.1.51	Hearn, A. H.	F.-in-C.O.	13.1.5
Wallace, K. C.	N.W. Reg.	27.1.51	Tomlin, V.	H.C. Reg. to E.-in-C.O.	13.1.5
Barron, H.	N.W. Reg.	4.2.51	Shannon, W. N.	Scot. to E.-in-C.O.	13.1.5
<i>Tech. Offr. to Asst. Engr.</i>			Grandison, D. O.	S.W. Reg. to E.-in-C.O.	13.1.5
Davies, A. P.	E.-in-C.O.	13.1.51	Russell, P. S.	Scot. to E.-in-C.O.	13.1.5
Harrison, C. C.	E.-in-C.O.	13.1.51	Harrison, C. J.	Mid. Reg. to E.-in-C.O.	13.1.5
Roberts, E.	W.B.C. Reg. to E.-in-C.O.	13.1.51	Godliman, D. C.	E.-in-C.O.	13.1.5
			Moody, J. W.	L.T. Reg. to E.-in-C.O.	13.1.5
			Weller, W. F. E.	L.T. Reg. to E.-in-C.O.	13.1.5
			Hayton, F.	N.W. Reg. to E.-in-C.O.	13.1.5
			Adams, G. W.	L.T. Reg. to E.-in-C.O.	13.1.5
			Fowkes, G. E.	N.E. Reg. to E.-in-C.O.	13.1.5
			Vogan, D. H.	L.T. Reg. to E.-in-C.O.	13.1.5
			Harvey, F. J.	L.T. Reg. to E.-in-C.O.	20.1.5

Transfers

Name	Region	Date	Name	Region	Date
<i>Sen. Exec. Engr.</i>			<i>Asst. Engr.—continued.</i>		
Jeynes, E. H.	L.T. Reg. to S.W. Reg.	8.1.51	Leask, D. R.	E.-in-C.O. to Scot.	22.1.5
Harper, S. D.	E.-in-C.O. to Admiralty	8.1.51	Shaw, S.	W.B.C. Reg. to E.-in-C.O.	7.1.5
<i>Exec. Engr.</i>			Heesom, S. D.	E.-in-C.O. to Min. of Civil Aviation	15.1.5
Murray, J. B.	E.-in-C.O. to Air Ministry	1.12.50	Howcroft, F. W.	E.-in-C.O. to Admiralty	1.2.5
Hayes, C. R.	L.P. Reg. to Air Ministry	1.12.50	Hales, J. T.	E.-in-C.O. to Admiralty	1.2.5
Barnsdall, S. G. W.	E.-in-C.O. to S.W. Reg.	4.12.50	Balls, R. W.	E.-in-C.O. to H.C.R. (reverted to Tech. IIA)	5.2.5
Roberts, W. J.	E.-in-C.O. to W.B.C. Reg.	28.12.50	Carter, P. E.	E.-in-C.O. to L.T. Reg.	12.2.5
Perkins, J. J.	E.-in-C.O. to N.E. Reg.	18.12.50	Cook, R. B.	L.T. Reg. to E.-in-C.O.	12.2.5
Brown, W. D.	L.T. Reg. to E.-in-C.O.	1.1.51	Tribe, D.	E.-in-C.O. to L.T. Reg.	19.2.5
<i>Asst. Engr.</i>			Cullis, A. D. S.	L.T. Reg. to E.-in-C.O.	19.2.5
Harris, F. L.	E.-in-C.O. to I.T.D.	11.12.50	Tungate, R. G.	E.-in-C.O. to Mid. Reg.	25.2.5
Stretton, J. A.	E.-in-C.O. to P. & T. Dept., Eritrea	16.12.50	<i>Expv. Offr.</i>		
Fairhurst, H. J.	E.-in-C.O. to N.W. Reg. (reverted to T.O.)	27.12.50	Hayward, G. O.	E.-in-C.O. to P. & T. Dept., Gold Coast	15.2.5
Masdin, R. M.	E.-in-C.O. to H.C. Reg.	15.1.51	<i>Asst. Exp. Offr.</i>		
Harris, T.	L.T. Reg. to E.-in-C.O.	1.1.51	Orchin, D. I. W.	E.-in-C.O. to Admiralty	22.1.5
James, R. H.	E.-in-C.O. to Min. of Civil Aviation	8.1.51			

Deaths

Name	Region	Date	Name	Region	Date
<i>Chief Reg. Engineer</i>			<i>Inspector</i>		
Morgan, J.	W. & B.C. Reg.	12.1.51	Cox, R. D.	N.W. Reg.	2.12.5
<i>Exec. Engr.</i>			Brown, S. C. G.	L.T. Reg.	20.1.5
Marchant, H. J.	E.-in-C.O.	27.12.50	Headen, S. A.	L.T. Reg.	28.2.5
<i>Asst. Engr.</i>			<i>Tech. Asst.</i>		
Pinfield, E.	Mid. Reg.	26.11.50	Clephane, H.	E.-in-C.O.	11.12.5
Reeve, C. W.	E.-in-C.O.	16.12.50			
Ruck, A. A.	L.T. Reg.	2.2.51			

Retirements

Name	Region	Date	Name	Region	Date
<i>Sen. Exec. Engr.</i>			<i>Asst. Engr.</i>		
Worthington, C. E. ..	N.Ire. Reg.	31.12.50	Parkinson, R. N. ..	L. T. Reg. (Resigned) ..	3.10.50
Mayman, A. C.	E.-in-C.O.	31.12.50	Whitehead, D. J. ..	E.-in-C.O. (Resigned) ..	30.12.50
Barrington, R. N. ..	E.-in-C.O.	31.12.50	Cox, C. R.	N.W. Reg.	31.12.50
<i>Area Engr.</i>			McKinnon, N.	Scot.	31.12.50
Pearson, S. G.	N.W. Reg.	31.12.50	Foy, E. P.	Scot.	31.12.50
Tamplin, G. R.	S.W. Reg. (voluntary retirement)	7.1.51	Whitaker, P.	Mid Reg. (Resigned) ..	21.12.50
<i>Exec. Engr.</i>			Channon, C. G.	E.-in-C.O.	15.1.51
Tough, J. D.* ..	S.W. Reg.	23.10.50	<i>Inspector</i>		
Cawthra, W. A. ..	E.-in-C.O. (Resigned) ..	11.12.50	Scott, J. S.	Scot.	31.12.50
Talbot, H. J.	L.T. Reg.	31.12.50	Marshall, E. H. ..	Mid. Reg.	9.5.51
Strong, H. A.	Mid. Reg.	31.12.50	Headen, S. A.	L. T. Reg.	28.2.51
Ashton, H.	N.W. Reg.	31.12.50	Banks, T. B.	Scot.	28.1.51
Harris, S. R.	S.W. Reg.	31.12.50	<i>Tech. Assistant</i>		
Foulgar, E.	W.B.C. Reg.	31.12.50	Doe, F. J.	E.-in-C.O.	14.2.51
Evans, C. E.	W.B.C. Reg.	25.1.51	Williams, A. J. F. ..	L.T. Reg.	23.2.51
Matthews, W.	L.T. Reg.	28.2.51			
McDougall, R.	Scot.	28.2.51			

*Incorrectly shown under Resignations in January 1951 issue.

CLERICAL GRADES

Promotions

Name	Region	Date	Name	Region	Date
<i>H.E.O. to S.E.O.</i>			<i>C.O. to E.O.</i>		
Nelson, W. J.	E.-in-C.O.	2.12.50	Fisher, M. E. (Mrs.) ..	E.-in-C.O.	15.10.50
			Thomson, C.	E.-in-C.O.	11.12.50

Retirements

Name	Region	Date	Name	Region	Date
<i>E.O.</i>			<i>E.O.—continued.</i>		
Taylor, W. G.	E.-in-C.O.	31.12.50	Brewer, T. D.	E.-in-C.O.	31.12.51

DRAUGHTSMEN

Retirements

Name	Region	Date	Name	Region	Date
<i>L/Draughtsman</i>			<i>L/Draughtsman—continued.</i>		
Parsons, C. W.	H.C. Reg.	31.1.51	Hale, F.	N.W. Reg.	28.1.51

Book Reviews

"Ordinary Non-Linear Differential Equations in Engineering and Physical Sciences." N. W. McLachlan, D.Sc.(Eng.). Oxford University Press. 201 pp. 89 ill. 21s.

Practically all the classical mathematical physics has evolved from the hypothesis of linearity which embodies the principle of superposition. When this principle is valid for a physical problem, the descriptive differential equations are linear, and an engineer can obtain solutions by well-known methods based upon the hypothesis of linearity. But the principle often fails to accord with the requirements of modern problems; consequently, descriptive equations are often non-linear and the ingenious solutions which have grown from the hypothesis of linearity are practically valueless, or, at the best, only poor and inadequate approximations. In this book, Dr. McLachlan sets out to provide engineers with a practical introduction to methods of solving ordinary non-linear differential equations.

Owing to the absence of a general mathematical theory of non-linear equations, Dr. McLachlan has concentrated on the presentation of particular analytical methods used in the solution of important technical problems. Some of the topics treated are: oscillations in electric circuits with non-linear elements; transient surges in hydro-electric installations; mechanical systems having non-linear control and non-linear damping; stability of synchronous electrical motors; relaxation oscillations and thermionic valve oscillators; frequency modulation in sound reproduction systems and the stability of ships. Thus, the book is not an analytical treatise with technical applications, but shows how certain types of non-linear problem may be solved, and how experimental results may be interpreted by non-linear analysis. A certain amount of new material is included to fill gaps in previous knowledge: there is a discussion of graphical and numerical methods of solution applied to non-linear equations with periodic coefficients.

Dr. McLachlan is to be congratulated on producing such an excellent work: this useful and long-needed volume can be warmly recommended to any engineering research worker or advanced student.
H. J. J.

"Electronic Engineering Master Index, 1947-1948." 339 pp. 139s. 6d., and "Electronic Engineering Master Index, 1949." 296 pp. 125s. Electronics Research Publishing Co., Inc., New York.

These editions are the third and fourth volumes in the series. The 1947-48 edition contains more than 18,000 references to electronic and allied engineering literature printed throughout the world during 1947 and 1948, including 5,500 electronic and allied patents issued by the U.S. Patent Office during these two years. The 1949 edition likewise contains more than 12,000 references to literature (including 4,000 U.S. patents) printed during 1949. The references have been taken from the major international scientific magazines, journals and proceedings, from electronic and allied patents issued by the U.S. Patent Office, and from declassified documents published by the U.S., British and Canadian Governments. The 1949 edition also contains references to British and American reports on German and Japanese research developments, as well as many theses on electronic subjects submitted at major American universities.

The references are classified under subject headings, and the patents are listed separately in numerical sequence under each heading. A cumulative cross-index at the end of each book serves as a useful guide to that book and also to the previous editions. Five or six pages in each book are devoted to a Bibliography of Engineering Books in which are listed the books published in the U.S. during the periods covered, as well as a few published in other countries.

The books should find a place in the reference library of every electronic engineer, and should prove invaluable to anyone who has occasion to search for electronic literature.
D. C. G.

BOARD OF EDITORS

H. FAULKNER, C.M.G., B.Sc., M.I.E.E., Chairman.
F. E. NANCARROW, O.B.E., A.R.C.Sc., M.I.E.E.
A. H. MUMFORD, O.B.E., B.Sc.(ENG.), M.I.E.E.
W. T. GEMMELL, A.C.G.I., B.Sc., M.I.MECH.E., A.M.I.E.E.
W. WEST, B.A., M.I.E.E.
D. A. BARRON, M.Sc., A.M.I.E.E.
L. CHANT.
C. E. MOFFATT, A.C.G.I., Wh. Ex., A.M.I.E.E.
G. E. STYLES, A.M.I.E.E., Managing Editor.
W. A. HUMPHRIES, A.M.I.E.E. }
J. P. HARDING, B.Sc.(ENG.) } Assistant Editors.
A.M.INST.C.E., A.M.I.E.E. }
A. J. HUTCHISON, Secretary-Treasurer.

Copyright

The entire contents of this JOURNAL are covered by general copyright, and special permission is necessary for reprinting long extracts, but Editors are welcome to use not more than one-third of any article, provided credit is given at the beginning or end thus: "From the *Post Office Electrical Engineers' Journal*."

The Board of Editors is not responsible for the statements made or the opinions expressed in any of the articles in this JOURNAL, unless such statement is made specifically by the Board.

Communications

All communications should be addressed to the Managing Editor, *P.O.E.E. Journal*, Engineer-in-Chief's Office, Alder House, Aldersgate Street, London, E.C.1. Telephone: HEAdquarters 1234.

Remittances should be made payable to "*The P.O.E.E. Journal*" and should be crossed "& Co."

Binding Cases

Cases for binding are available, and may be obtained from the Local Agents for 2s. Subscribers can have their copies of volumes bound, at a cost of 7s. 6d., by sending the complete set of parts to the Local Agents or to the *P.O.E.E. Journal*, Engineer-in-Chief's Office, Alder House, Aldersgate Street, London, E.C.1. Orders for binding for Vols. 1-19 should indicate whether the original binding case with black lettering, or the later pattern with gold, is required. Cases with gold lettering are the only type stocked from Vol. 20 onwards.

Back Numbers

The price of the JOURNAL, which is published quarterly, is 1s. 6d. (1s. 9d. post free) per copy, or 7s. per annum post free. Back numbers can be supplied, subject to availability of stocks, at 1s. 6d. each (1s. 9d. post free). Orders for back numbers may be sent to the Local Agents or to the Publishers.

Advertisements

All communications relating to space reservations should be addressed to the Advertisement Editor, *P.O.E.E. Journal*, Alder House, Aldersgate Street, London, E.C.1. Communications regarding advertisement copy, proofs, etc., should be addressed to the Publishers, Messrs. Birch & Whittington (Prop. Doring & Co. [Epsom], Ltd.), 49 Upper High Street, Epsom, Surrey.

AUTOMATIC VOLTAGE REGULATORS by B.P.T

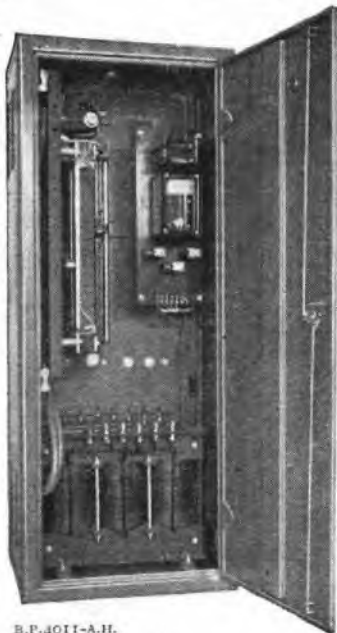

B.P.4011-A.H.

Maintaining a constant voltage unaffected by variation in the supply voltage, frequency, load and load power factor is a problem which can be solved by the aid of our standard range of Automatic Voltage Regulators. For single phase operation there are 11 models from 12½ to 240 amps, for three-phase there are 13 models from 7½ to 150 amps.

Three typical models are illustrated from our standard range of wall or floor mounting types.

- TOP* 3-phase, air cooled, wall mounting model. Input 440V ± 10%, output 440V ± 1%. 7½ amps.
- LEFT* 3-phase, air cooled, floor mounting (cubicle) model. Input 440V ± 10%, output 440V ± 1%. 40 amps.
- RIGHT* Single-phase, air cooled, wall mounting model. Input 250V ± 15%, output 250V ± 1%. 25 amps.

Please write for further information and literature. BP401:9

BRITISH POWER TRANSFORMER CO. LTD.

Phone: HOWard 1492 QUEENSWAY, PONDERS END, MIDDLESEX * Grams: "Vitrohm Enfield"

EDISWAN

Telephone Line Protectors

FOR THE PROTECTION OF LINES OF COMMUNICATION FROM SURGES INDUCED BY LIGHTNING OR FAULTS ON NEIGHBOURING POWER LINES

Ediswan Telephone Line Protectors have now been in commission for nearly twenty years. They have proved their worth in all parts of the world and are being called for and installed in ever increasing numbers.

Many thousands were employed during the war years for the protection of vital lines of communication and were eminently successful. Reports of their outstanding merit and successful operation continue to reach us and in recent years they have proved of particular interest for protection against surges caused by lightning discharges.

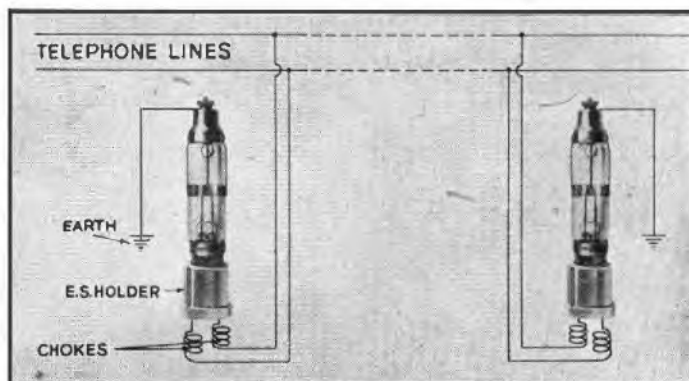

Continued research has enabled us to patent a further improvement which removes any suggestion of delay in operation.

Further information and prices on application.

THE EDISON SWAN ELECTRIC CO. LTD., 155 CHARING CROSS ROAD, LONDON, W.C.2

Member of the A.E.I. Group of Companies

T.E.3

A New

Type L

**CLIP-ON
AMMETER**

Specially designed for use with porcelain clad fuses and heavy duty conductors up to 4" diameter.

Fully insulated core



7 RANGES

- 0 — 10
- 0 — 25
- 0 — 50
- 0 — 100
- 0 — 250
- 0 — 500
- 0 — 1000

Amperes A.C.



FERRANTI
 FERRANTI LTD. HOLLINWOOD LANCS.
 LONDON OFFICE KERN HOUSE KINGSWAY, W. C. 2.

F1 80b

**ELECTRICAL MEASURING
INSTRUMENTS
OF THE HIGHER GRADES**

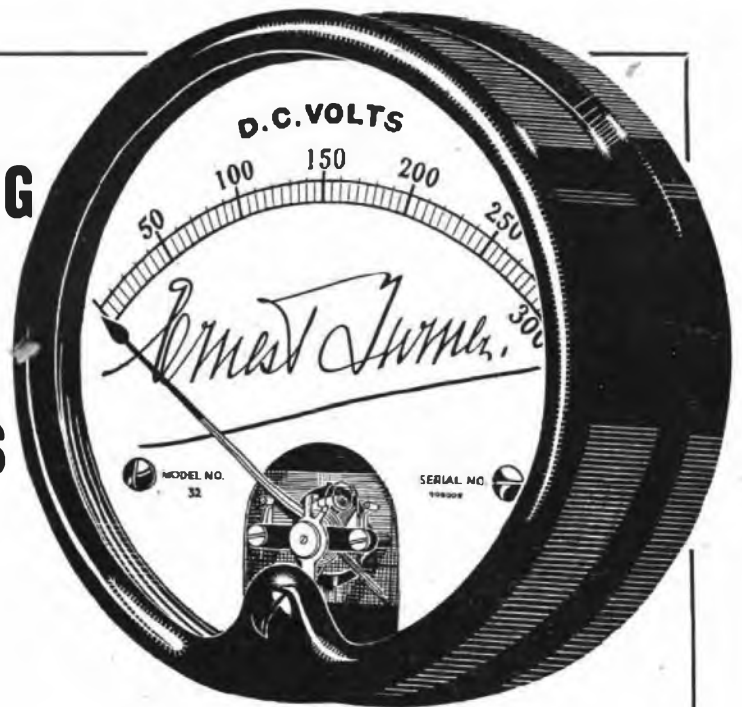

ERNEST TURNER ELECTRICAL INSTRUMENTS LTD.
 CHILTERN WORKS, TOTTERIDGE AVENUE, HIGH WYCOMBE, BUCKS.

Telephone : High Wycombe 1301/2

Telegrams : Gorgeous, High Wycombe

HR 91 RECEIVER

A pre-tuned or continuously variable double super-heterodyne International Class Telegraph Receiver, range 3-27.5 Mc/s.

- Immediate selection of one of three channels.
- Double Diversity reception with electronic path selection.
- Provision for High Speed C.W. On/Off or F.S.K. reception.
- Self-contained for 200-250V. 50-60 c/s A.C. Supply.
- Automatic frequency control.

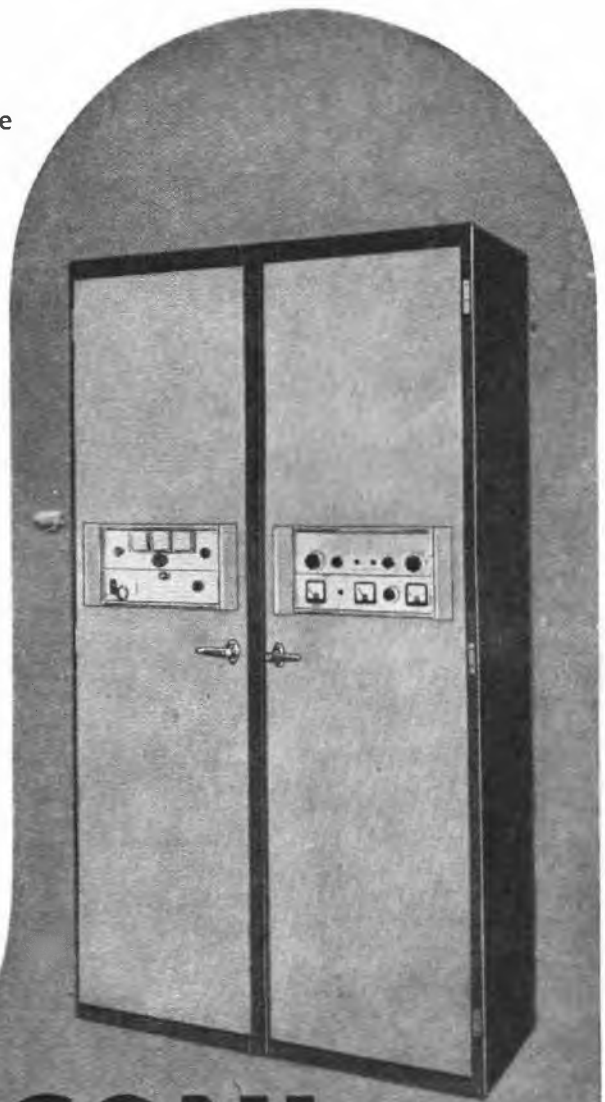

MARCONI
COMMUNICATION SYSTEMS

SURVEYED · PLANNED
INSTALLED · MAINTAINED

MARCONI'S WIRELESS TELEGRAPH CO. LTD., MARCONI HOUSE, CHELMSFORD, ESSEX

MIGHTY midget . . .

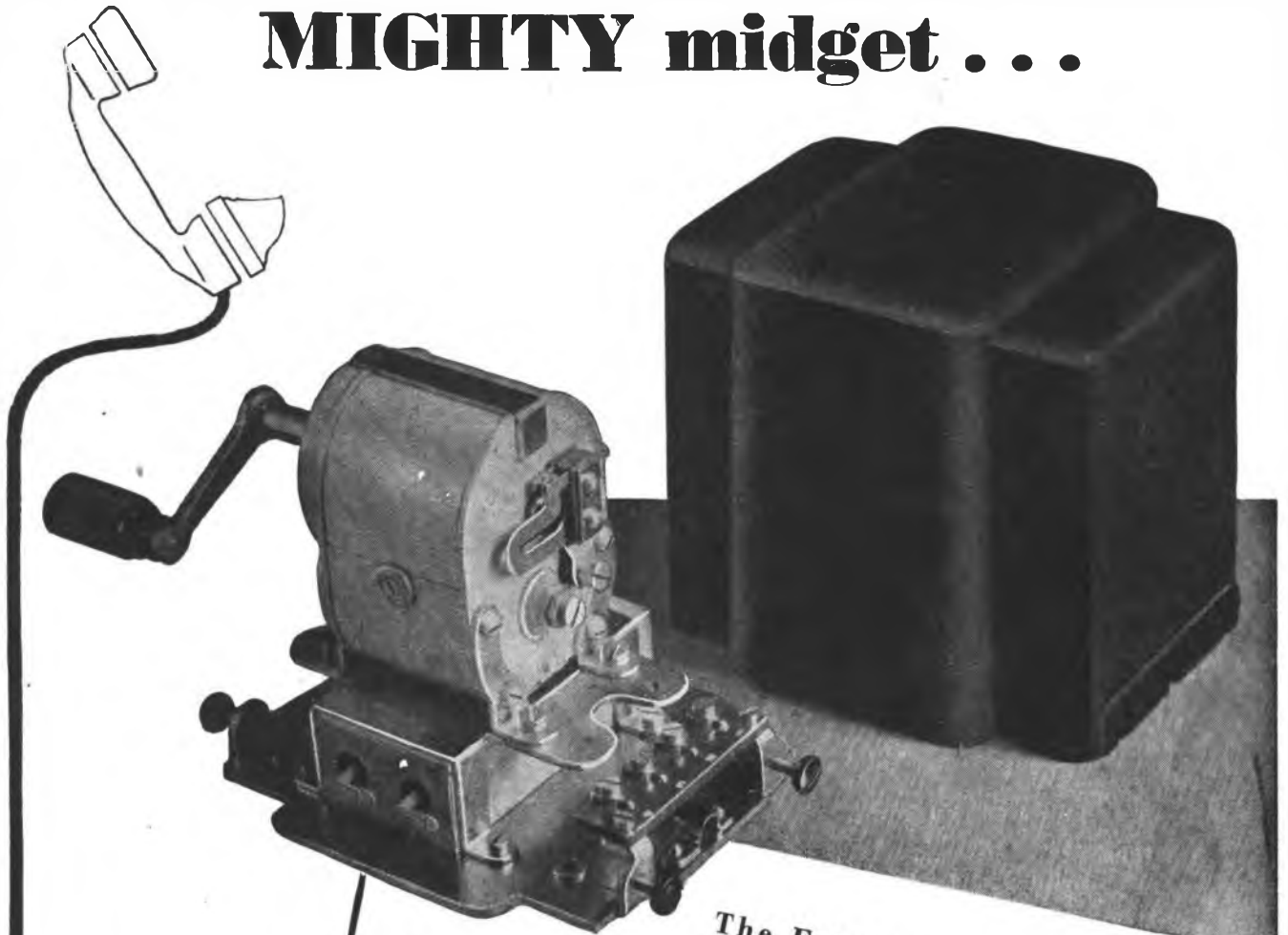

The Ericsson **ALNICO GENERATOR** illustrated is a robust yet elegant example of Ericsson practice. Has an output equivalent to the old 4-Bar unit but is less than half its size and weight. Certified safe for use in mines, and can be supplied unmounted or without the moulded bakelite case. Our heavy duty **ALNICO** generator is slightly larger but uses the same case.

THE

Ericsson

ALNICO GENERATOR

ERICSSON TELEPHONES LTD. • Head Office: 22 LINCOLN'S INN FIELDS, LONDON, W.C.2. • Tel: HOL. 6936
Works: BEESTON, NOTTS.



A STANDARD SIGNAL SOURCE

for

THE AUDIO FREQUENCY BAND

THE R.C. Oscillator Type D-330 gives a wide range of known levels into a 600-ohm load at any frequency from 20 c/s. to 20 kc/s.

BRIEF SPECIFICATION

FREQUENCY: 20 c/s—20 kc/s.

ACCURACY: $\pm 1\%$ or better.

OUTPUT LEVEL: 1W or 10mW into 600 ohms, selected by means of a switch.

ATTENUATORS: 7 steps of 10 db plus 12 db continuously variable.

HARMONICS: 1.75% total at 1W above 40 c/s. 1.0% total at 10 mW above 40 c/s.

HUM LEVEL: 50 db below output level.

DIMENSIONS: 20½-in x 12½-in x 11-in bench mounting — can be supplied for 19-in rack mounting if required.

Post this coupon

BY PASTING ON A POSTCARD

MUIRHEAD & CO. LTD · BECKENHAM · KENT · ENGLAND

Please send me Bulletin B-614 fully describing the R.C. Oscillator advertised in "The Post Office Electrical Engineers' Journal".

NAME

ADDRESS

MUIRHEAD & Co., LTD.
PRECISION ELECTRICAL INSTRUMENT MAKERS
BECKENHAM · KENT · ENGLAND

Phone: BECKENHAM 0041

Telegrams & Cables: MUIRHEADS ELMERS-END

PRECISION

MUIRHEAD

ELECTRICAL INSTRUMENTS

MU. 24.

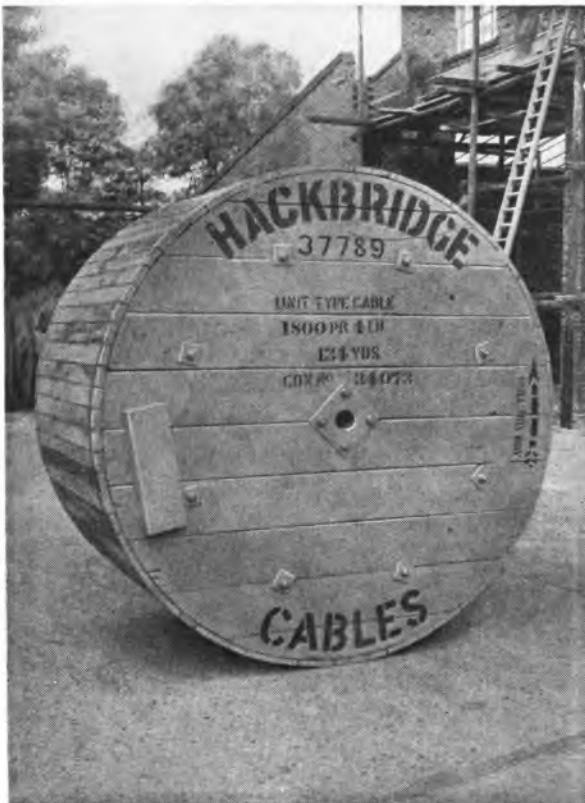

BEYOND THE BUTTON....



.... Hackbridge underground dry-core air-space lead covered and armoured cable.
Contractors to G.P.O., British Railways, British and Colonial Government Departments.



HACKBRIDGE

Cable Company Limited

KELVIN WORKS, HACKBRIDGE, SURREY

In Association with Bryce Electric Construction Company Ltd.

Branches at:

Birmingham, Bristol, Cardiff, Manchester, Newcastle, Sheffield



The Manitoba Telephone

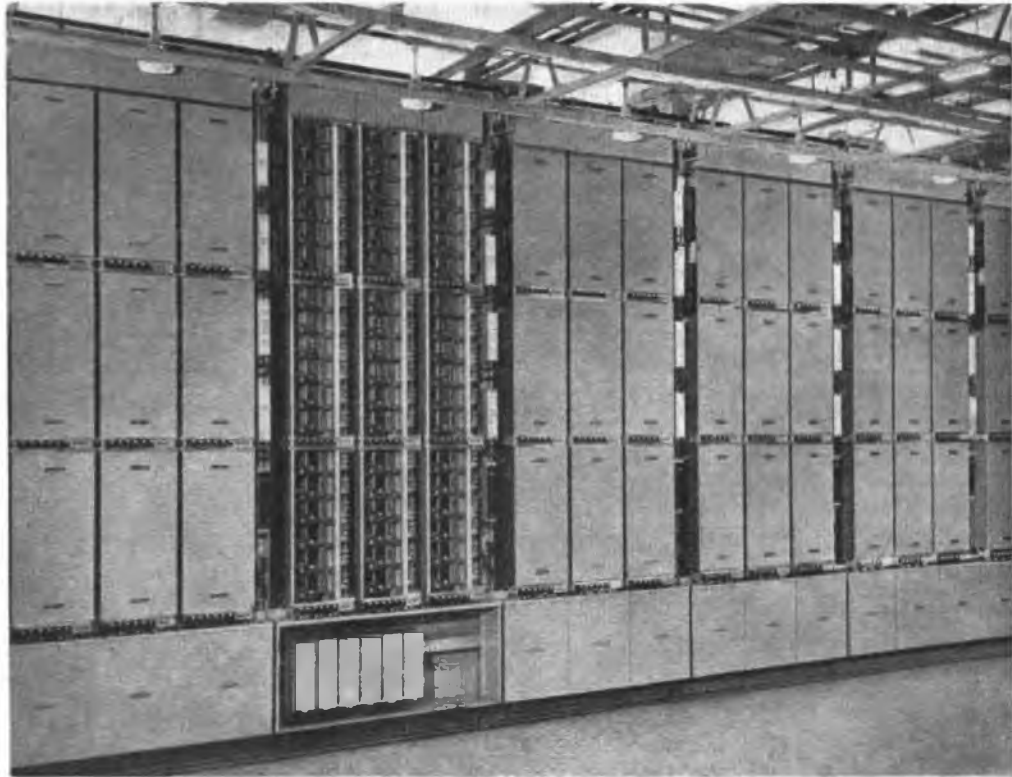

Suite of Final Selector Racks with covers removed on one rack.



The High-Speed Motor Uniselector which operates at 200 outlets per second.



The Digit Switch developed specially for this system.

Administration LEADS THE WAY

at FORT ROUGE Winnipeg

The Siemens logo, featuring the word "SIEMENS" in a bold, sans-serif font, with a curved line above it.

Nº 17 M·A·X SWITCHING EQUIPMENT

This System has Selectors controlled directly from the Dial, with covered racks and apparatus of outstanding simplicity and reliability.

Special features of the system include:

- A switch fault liability barely exceeding that of a relay, achieved largely by eliminating mechanically-operated springsets.
- Complete elimination of all wiper cordage.
- Twin contacts on wipers and banks as well as on relays,
- Easy access to all wiring points including the multiple.
- Ability to match outlet availability to traffic loading.

These features, coupled with simple circuit and trunking arrangements, set a new standard in low maintenance costs.

Exchanges are also in hand for British Columbia, Australia, Southern Rhodesia and elsewhere.

SIEMENS BROTHERS & CO., LIMITED
WOOLWICH • LONDON • S. E. 18.

MODERN CAPACITOR ENGINEERING

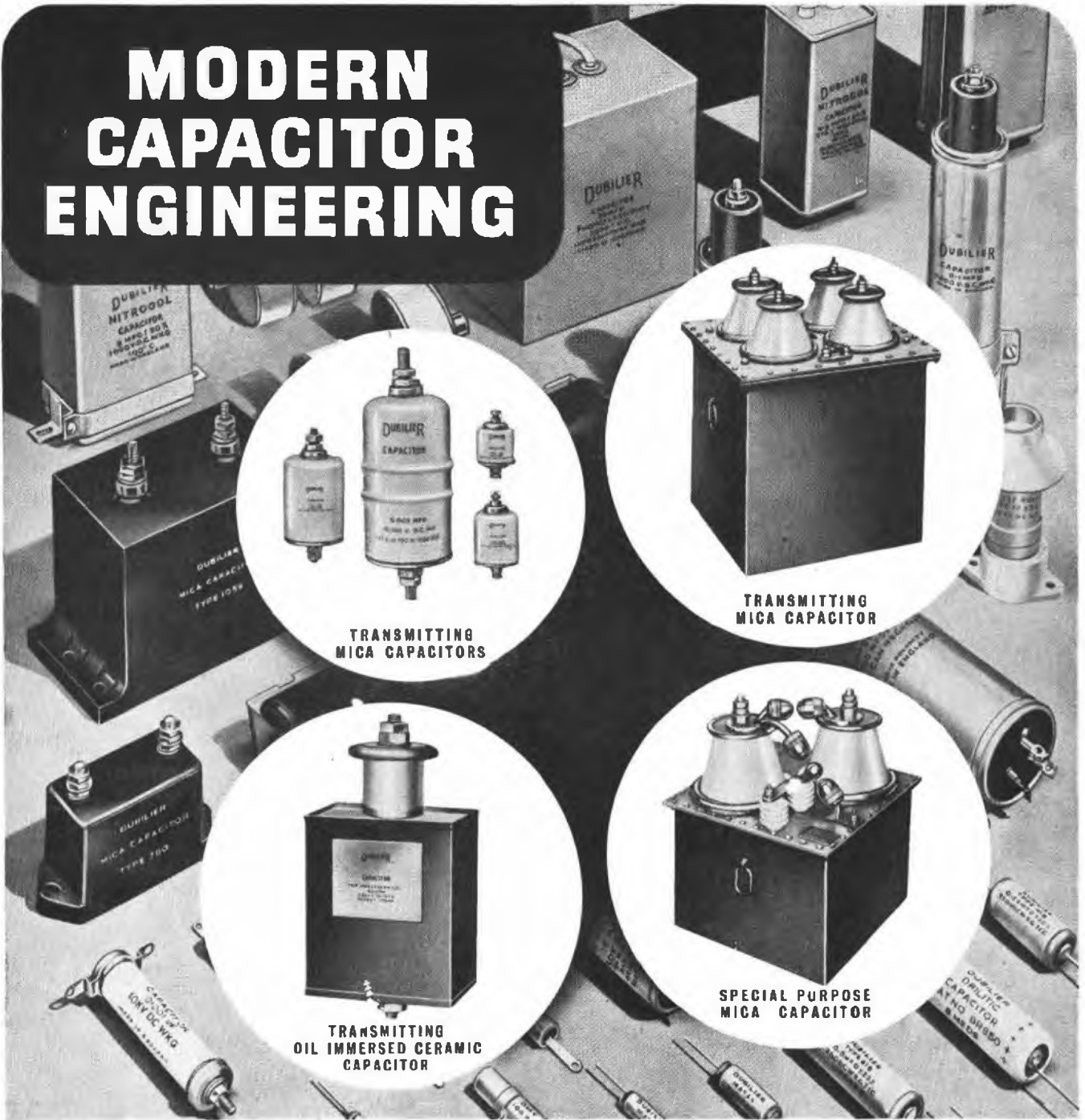

TRANSMITTING
MICA CAPACITORS

TRANSMITTING
MICA CAPACITOR

TRANSMITTING
OIL IMMERSSED CERAMIC
CAPACITOR

SPECIAL PURPOSE
MICA CAPACITOR

DUBILIER CAPACITORS

Dubilier provide the most comprehensive range of Capacitors available today for Radio Transmitting and Receiving, in addition to Capacitors for Electronic and Industrial engineering.

Dubilier Capacitors are designed and manufactured to

a high standard of specification, suitability of purpose and meticulous capacitor engineering, and they satisfy the exacting demands of the British Postal Authorities whom we are proud to number amongst our customers.

Full details and technical service upon request.

DUBILIER CONDENSER CO. (1925) LTD., DUCON WORKS, VICTORIA ROAD, N. ACTON, LONDON, W.3.

'Phone: Acorn 2241 (5 lines).

Cables: Nivoltcon, London. Marconi International Code.

'Grams: Nivoltcon, Wesphone, London.

VALUABLE FREE BOOK

Tells You How to Pass Your C. & G. or Promotion Exam. at First Attempt!

All Post Office Engineering personnel who are anxious to obtain early promotion should at once send for a copy of our handbook "ENGINEERING OPPORTUNITIES," which, among other intensely interesting matter, describes our unique methods of preparation for **TECHNICAL APPOINTMENTS IN THE POST OFFICE** (Assistant Engineer--New Style and Assistant Traffic Superintendent), **CITY AND GUILDS EXAMINATIONS** in Principles of Telecommunications (1-5), Radio (1-4), Telephone Exchange Systems (1-3), Telegraphy (1 and 2), Line Transmission (1 and 2), Lines Plant Practice (1 and 2), Mathematics for Telecommunications (1-5), Electrical Engineering Practice (Prelim. Inter. and Final), and outlines a wide range of non-examination courses in all branches of Electrical, Mechanical, Civil, Automobile, Aeronautical and Radio Engineering.

Assistant Engineer and Assistant Traffic Superintendent. Open competitions now resumed. Age extensions for established Civil Servants. Ask us for full details

We definitely guarantee
"NO PASS—NO FEE"

If you intend to make the most of to-day's opportunities, you cannot afford to miss reading "ENGINEERING OPPORTUNITIES." It tells you everything you want to know to secure advancement, and describes many opportunities you may now be missing through lack of information. Send for your copy to-day—FREE and without obligation.

BRITISH INSTITUTE
OF ENGINEERING TECHNOLOGY
369 SHAKESPEARE HOUSE,
17-19 STRATFORD PLACE, LONDON, W.1

BIET

PITMAN'S for Technical Books



Industrial Electrical Plant Maintenance

By E. G. Anness, M.I.E.E., Chartered Electrical Engineer. Deals fully with D.C. and A.C. motors and their associated control and protective gear, and with transformers and capacitors as far as they affect the works engineer. 88 illustrations. 27/6 net.

Telephony (2 vols.)

By J. Atkinson, A.M.I.E.E., Area Engineer, Post Office Engineering Dept. The standard textbook for post office engineers and students. Over 1,500 illustrations. Vol. I (General Principles and Manual Exchange Systems), 35/- net. Vol. II (Automatic Exchange Systems), 50/- net.

Telecommunications Principles

By R. N. Renton, A.M.I.E.E. A new work covering the syllabus for the City and Guilds examinations in Telecommunications Principles, Grades I, II and III. Illustrated. 37/6 net.

PITMAN. Parker Street, Kingsway, London, W.C.2

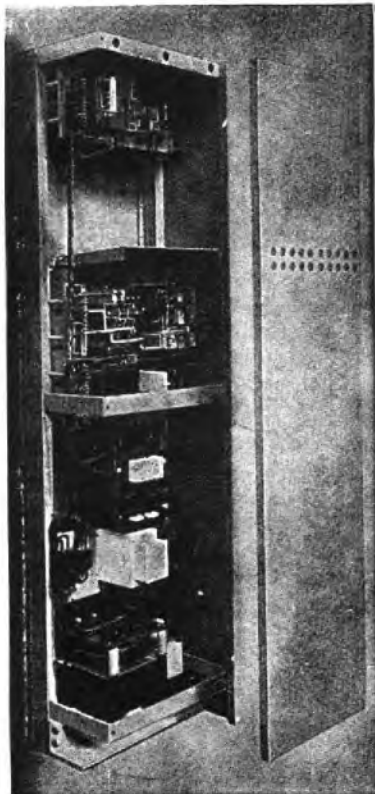

The Mark II series of

SAVAGE AMPLIFIERS

for Broadcast Relay

● These Amplifiers are examples of what careful design can achieve. A lift-off back panel affords immediate access for maintenance purposes and the removal of six screws releases the side covers of the rack and exposes all the interpanel wiring. Even when the rack is sandwiched between others the side covers can be removed just as easily.

All valves are accessible from the front of the rack, and are protected by quick release grilles. The rack is completely flat fronted. The general appearance is further enhanced by the absence of a projecting front foot, and the masking of all panel fixing bolts. Similar racks carrying auxiliary apparatus can be placed side by side with amplifiers so that the whole installation is uniform in appearance.

Complete specifications
available on request.

WESTMORELAND ROAD
LONDON N.W.9
TELEPHONE: COLINDALE 7131

**W. BRYAN SAVAGE
LIMITED**

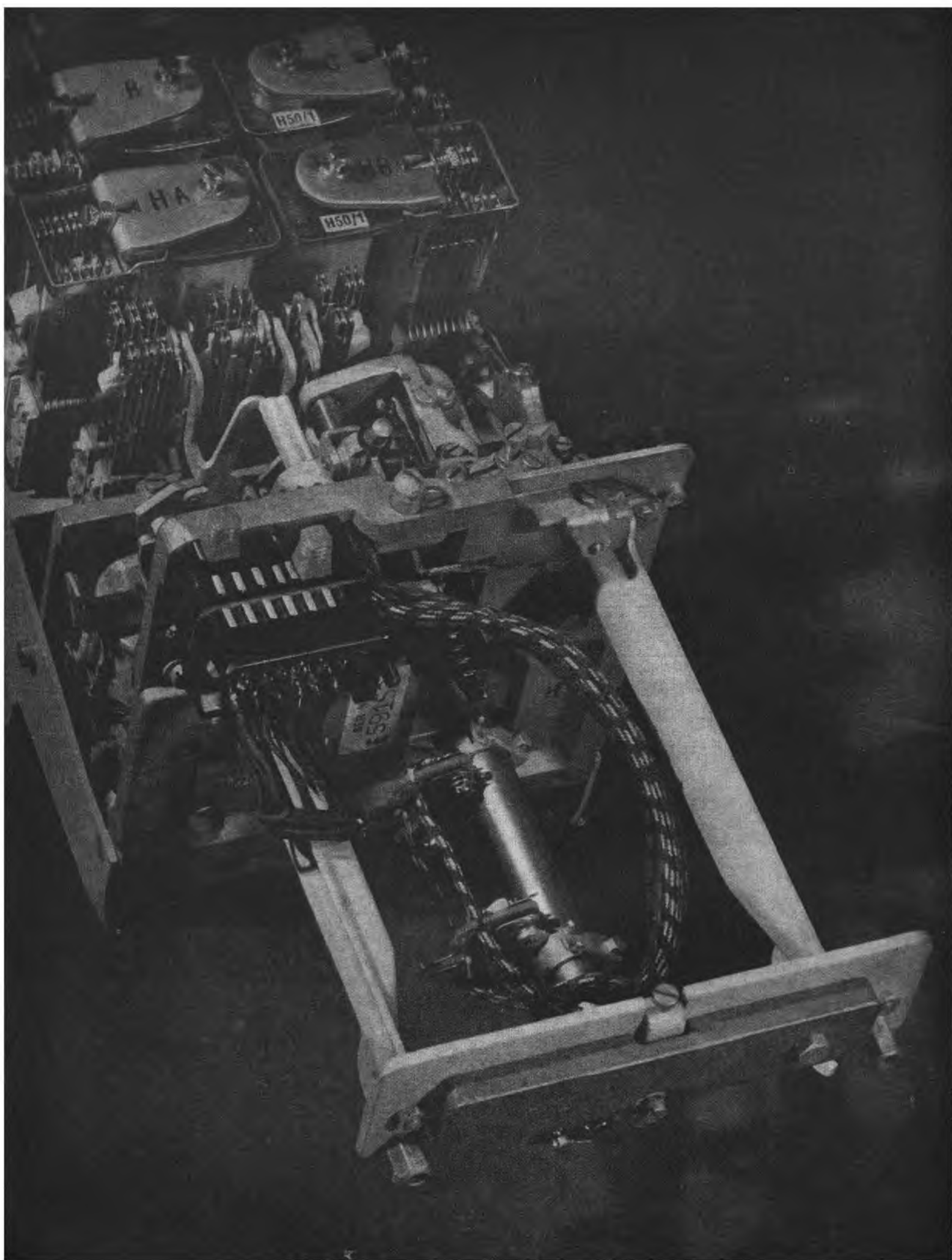

A TELEPHONE SWITCHING SYSTEM AND MECHANISM THAT HAVE FOR FIFTY YEARS DEFIED COMPETITION



Half a century has elapsed since the selecting mechanism embodying Strowger's principle of step-by-step decimal selection proved practical in service. Throughout this period there has been intense technical development on systems competitive with the Strowger System, but the Strowger System has always remained pre-eminent. It is to-day the most widely used in the world, standardized by the British Post Office, which has recently reaffirmed its confidence in the Strowger System, and adopted by the operating administrations of more than 70 countries.

The increasing demand for automatic telephone service created a need for more and more equipment facilities, particularly in respect of operating speed and bank capacity. About 1930, therefore, Automatic Telephone & Electric Co. Ltd. investigated the possibilities of alternative systems and mechanisms with a view to meeting this demand. After prolonged and intensive research the company decided, and in the light of modern requirements still maintains, that a two motion mechanism embodying vertical and rotary motion and operated on a step-by-step decimal basis represents the best method of fulfilling the complex and varied requirements of automatic switching. The type 32A Selector, introduced in 1935, retained the operating principle characteristic of previous Strowger Selectors, but possessed marked advantages in speed, capacity, size, weight and adaptability. It was standardized by the British Post Office in that year as the type 2000.

During the past fifteen years every functional improvement which has been suggested during fifty years' operating experience with the Strowger System in all parts of the world has been incorporated in the Selector, which in future will be known as Type 32A Mark II.



Automatic Telephone & Electric Co. Ltd.

EXPORT DEPARTMENT : STROWGER HOUSE, ARUNDEL STREET, LONDON, W.C.2.

TELEPHONE : TEMple Bar 9262.

CABLEGRAMS : STROWGEREX, LONDON.

STROWGER WORKS, LIVERPOOL, ENGLAND.

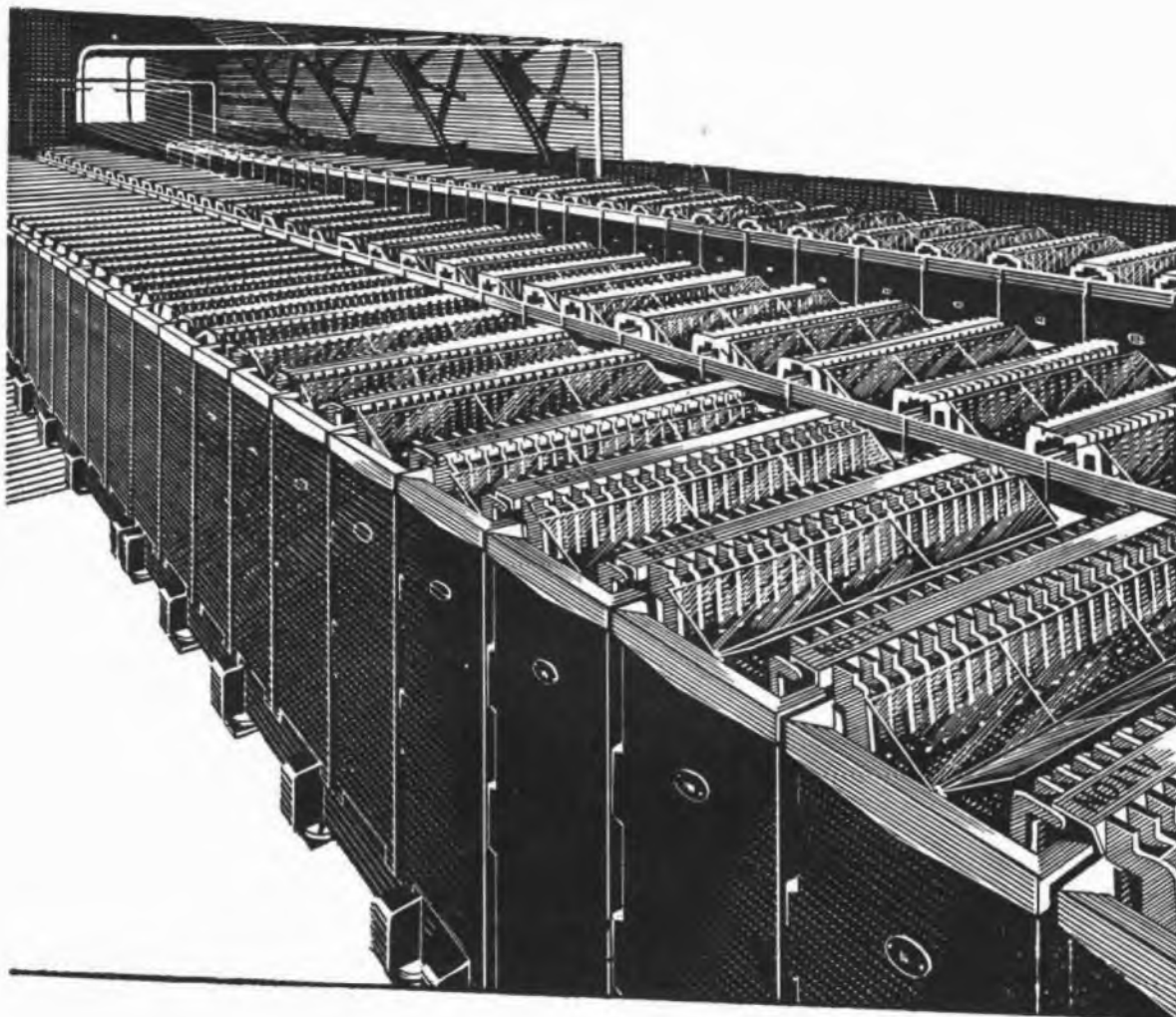

Alton Batteries of 10 to 15,000 ampere-hours are in service in sixty-five countries. The batteries now being shipped out all over the world will carry the name of Alton still further afield—Alton, shortest word in any language for good batteries and firm delivery dates.

*

Alton can also supply renewal plates for all makes of battery, British and Continental.

ALTON

BATTERIES OF MERIT

THE ALTON BATTERY COMPANY LIMITED, Alton, Hampshire · Telephone: Alton 2267 and 2268 · Telegrams: Battery, Alton



Undoubtedly the most dependable source of D.C. power supply, Westinghouse metal rectifiers are applied extensively in communication engineering, where absolute efficiency and reliability is essential. Employed in telephone and telegraph circuits, they are used either for charging the batteries of the apparatus or operating it direct from A.C. mains. They are installed in transmitting and receiving stations, and numerous other applications include spark quenching, rectifying voice and radio frequency currents and for polarising and slugging standard relays in telephone and telegraph circuits.



METAL RECTIFIERS

Write for Publication M.R.9 to Dept. P.O.E.E.J. 4.

WESTINGHOUSE BRAKE & SIGNAL CO. LTD. 82, York Way, King's Cross, London, N.1

DECADE RESISTANCES

in 3 Grades guaranteed

0.01% 0.03% 0.1%

SUPPLIED BOXED OR FOR
CLIENT'S OWN PANEL

HIGHLY LAMINATED BRUSHES

LOWER DECADES OF ABSOLUTELY
CONSTANT INDUCTANCE

EQUALLY SUITABLE FOR HIGH FREQUENCY
LOW FREQUENCY OR DIRECT CURRENT

Electrical Standards for Research and Industry

Testing and Measuring Apparatus
for Communication Engineering



A NOVEL FEATURE.—Minimising the Residual Inductance and High Frequency Resistance Error.

A patented method of reactance compensation is employed on the higher decades which compensates automatically for the screen capacitance and so renders the effective residual inductance sensibly independent of the method of screen connection. In addition, the user may, at will by the simple operation of a switch, adjust the reactance or resistance error sensibly to zero at the higher frequencies.

H. W. SULLIVAN
— LIMITED —

LONDON, S.E.15

Telephone : New Cross 3255 (P.B.X.)

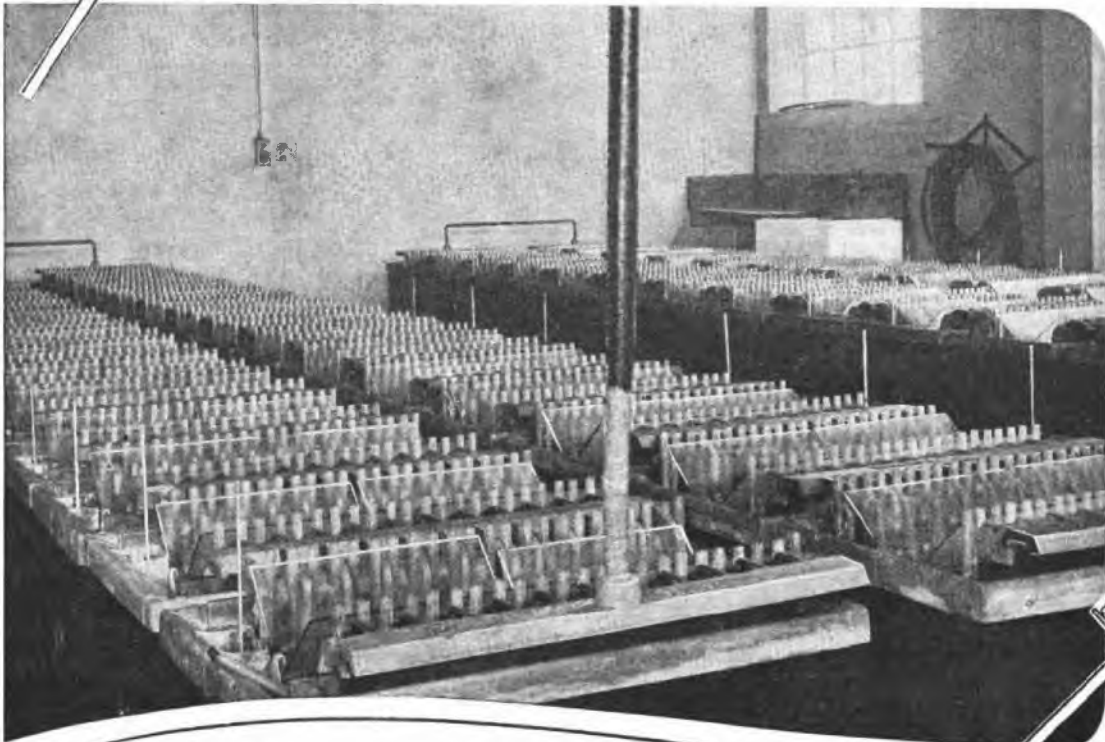

POWER BEHIND THE LINES

TUNGSTONE PLANTÉ CELLS are being supplied to the British Post Office and Post and Telegraph Departments in many countries overseas. They conform fully to G.P.O. and British Standard specifications.

OPEN TYPE CELLS

Similar to the illustration above, these are available in glass and/or lead lined wooden boxes in capacities from 100 a.h. to 500 a.h.

REPLATALS

We are in a position to supply plates for the replating of any existing Planté Battery.

ENCLOSED TYPE CELLS

As illustrated on the right, these are in moulded glass boxes with sealed-in lids. Capacity range from 10 a.h. to 200 a.h.

HIGH VOLTAGE TELEPHONE BATTERIES

Portable Type. Standard layout for 50 volts, in waxed hard wood crates, exactly to the requirements of the G.P.O.

Overseas customers are invited to cable or write their enquiries for batteries or parts. Visitors to London are welcome at our offices.

TUNGSTONE Batteries

For further particulars write : **TUNGSTONE PRODUCTS LIMITED**
10 SALISBURY SQUARE · LONDON · E.C.4 · ENGLAND. Cables: "Dilutum" London.



T.B.12



SPECIAL DUTY F.H.P. MOTORS

TYPICAL D.C. MOTORS AND GENERATORS

MOTORS

FRAME SIZE	DETAILS
FP	1/100 H.P. D.C. motor. Series or shunt or constant speed (2,000 r.p.m.). Wound for voltages 20, 110 or 220 volts with limiting resistor.
FQ	As FP, but with approx. 50% increased output.
FM	1/20 H.P. D.C. motor. Series or shunt wound. Voltages 20-220 volts. Speeds 2,000-4,000 r.p.m.
FF2	1/100 H.P. Permanent magnet D.C. motor. Wound for voltages 20-110 volts.

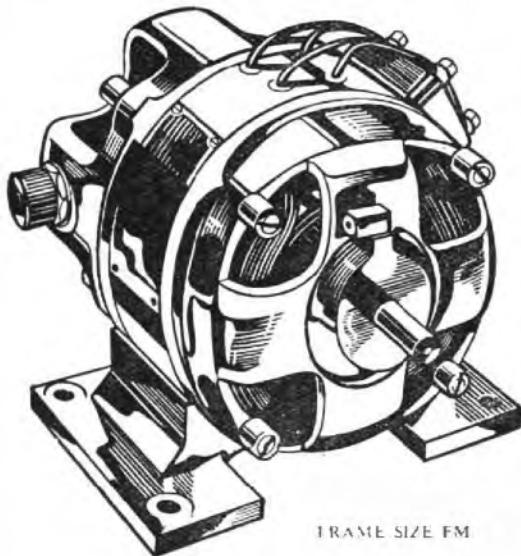
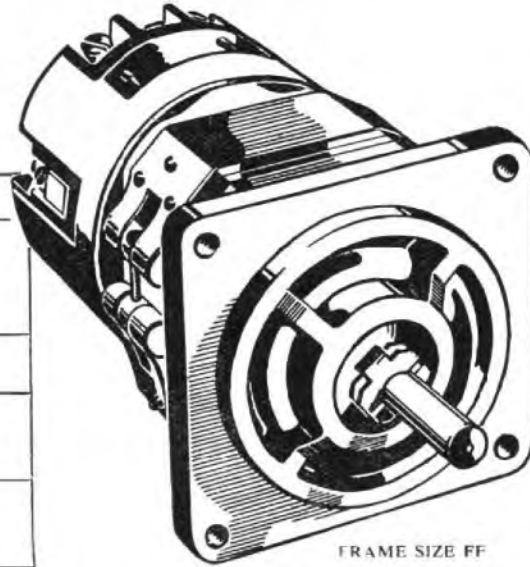

GENERATOR

FRAME SIZE	DETAILS
FF1	Permanent magnet D.C. generator for speed measurement and electronic control. Output 25V. per 1,000 r.p.m. Moment of inertia 0.5 oz. ins ² . Ripple 1 1/2% R.M.S. of generated voltage. Driving torques: 0 r.p.m. 0.75 oz. ins. 6,000 r.p.m. 2.5 oz. ins.

Send for the Evershed Small Motors' Data Book, X22

EVERSHED AND VIGNOLES LIMITED

ACTON LANE WORKS • CHISWICK • LONDON • W4

Telephone: Chiswick 3670

Telegrams: Megger, Chisk, London

Cables: Megger, London

WIDE-BAND EQUIPMENT

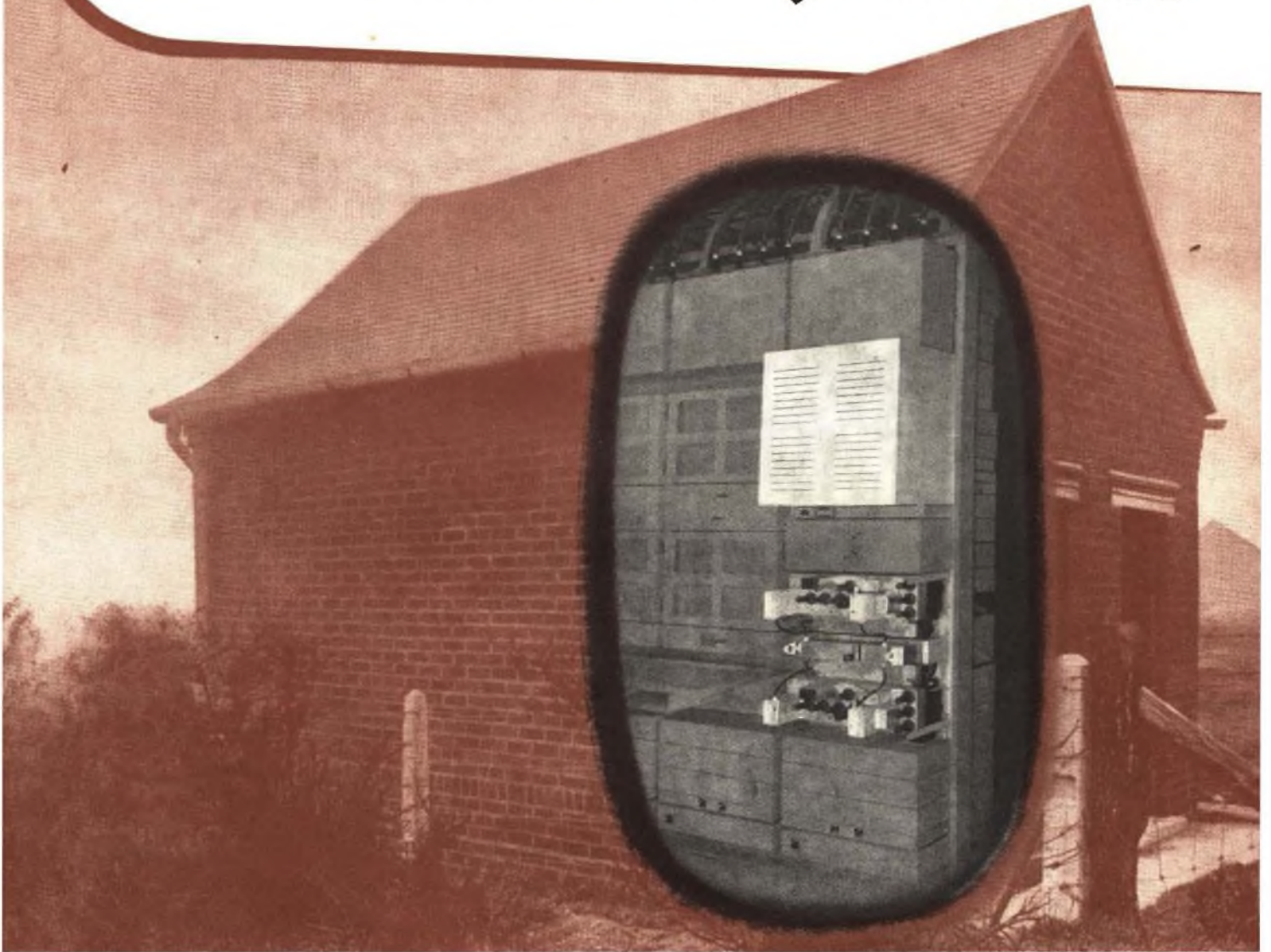

H.F. panels at Huntington Repeater Station, near Cannock, on the Birmingham-Manchester television link.

The H.F. panels, one for each direction of transmission, both mount two amplifier units, one in service and one as a standby. The amplifier units equalise each repeater section to within ± 0.1 db between 60kc/s and 4.34 Mc/s, and have a gain of 52 db at 4.4 Mc/s.

□ □ □ *The largest British electrica*

for radio and coaxial links

London - Birmingham Birmingham - Manchester and now London - Cardiff



The first television service in the provinces of the U.K. was relayed to the Sutton Coldfield transmitter by the London-Birmingham wide-band U.H.F. radio link, which was designed, manufactured and installed by the G.E.C. The next transmitter to come into service (at Holme Moss, near Manchester) will receive vision signals from Birmingham over coaxial tubes for which the G.E.C. is supplying wide-band amplifiers to a design by the British Post Office. Soon a third link, between London and Cardiff, will include similar amplifiers now in production at the G.E.C. Telephone, Radio and Television Works, Coventry.

G.E.C.

The General Electric Company Ltd. of England. Telephone, Radio and Television Works, Coventry, England. Telephone Coventry 4111 (10 lines) Telegrams and Cables "Springjack, Coventry." Head Office, Magnet House, Kingsway, London, W.C.2. Temple Bar 8000 (90 lines) "Electricity, Westcent, London." Cables, "Polyphase London."

manufacturing organisation in the world

Creed

TELEPRINTERS

*Built by specialists
in machine telegraphy~*



N° 47 TAPE MODEL

*Write for
Bulletin N° 21*

Creed & Company Limited

TELEGRAPH HOUSE
CROYDON, ENGLAND

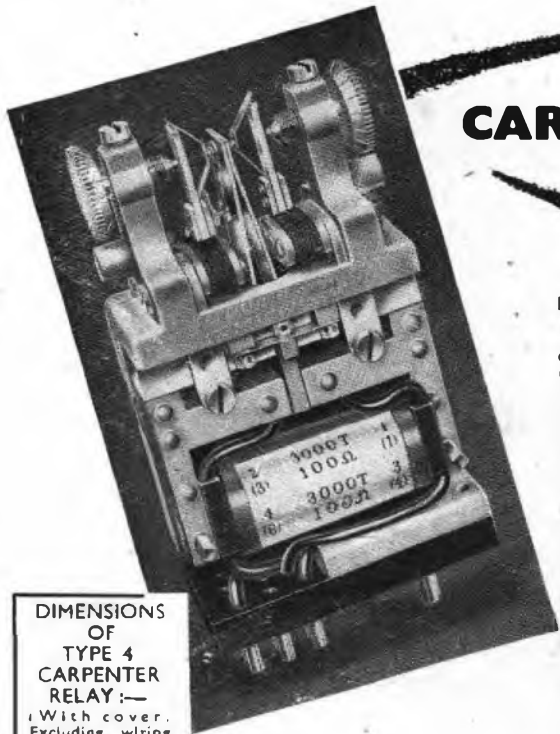

DIMENSIONS OF TYPE 4 CARPENTER RELAY:—
 (With cover. Excluding wiring tags) 3.5 ins. high x 2.2 ins. wide x 1 in. deep. Weight 13 ozs.

CARPENTER POLARIZED RELAY TYPE 4

THIS is a medium speed, sensitive polarized relay designed primarily as a telephone impulsing relay (D.C. dialling up to 100 miles and V.F. dialling on trunk circuits). It has also been successfully adopted for use in Telex systems, but can be used satisfactorily up to speeds of 100 c/s without contact chatter or serious bias disturbances.

Its sensitivity is such that when the gap is adjusted to .004 in. nominal, the relay will just operate at 50 cycles with 3.5 ampere-turns R.M.S. (corresponding to approximately 2 mVA) or on 4.5 D.C. ampere-turns at low speeds. In service, however, the relay is normally operated at currents substantially larger than the minimum operating current quoted.

Contact chatter is absent if the contact gap does not exceed .005 in. The contact gap is adjustable by means of fine pitch screws with knurled heads marked with .001 in. divisions. Contacts on the armature tongue are insulated from it and thereby from the frame.

The relay has a magnetic screening cover with transparent removable top to facilitate contact adjustment.

Dimensionally the relay is interchangeable with the type "3000" relay and can be supplied to fit directly to the drilling normally provided for the "3000" relay.

Termination can either be made by means of a 12 in. plug base as illustrated, or with soldering tags in place of the pins.

Developed & Manufactured by the Sole Licensees:— Complete details available on request.

TELEPHONE MANUFACTURING COMPANY LTD.

Contractors to the British Commonwealth and foreign Governments

HOLLINGSWORTH WORKS • DULWICH • LONDON, S.E.21 GIPsy Hill 2211 (10 lines)



DOUGLAS AND MACADIE

Automatic COIL WINDERS

The large illustration depicts the improved "Douglas" Fully Automatic Multi-Winder, specially developed for the high-speed production of large quantities of coils with or without paper interleaving. It will produce round, square

or rectangular coils up to 6 in. each in length and up to 4½ in. diameter. As many as 12 smaller coils can be wound simultaneously within the total available winding length of 12 in. at headstock speeds of between 600 and 2,000 r.p.m.

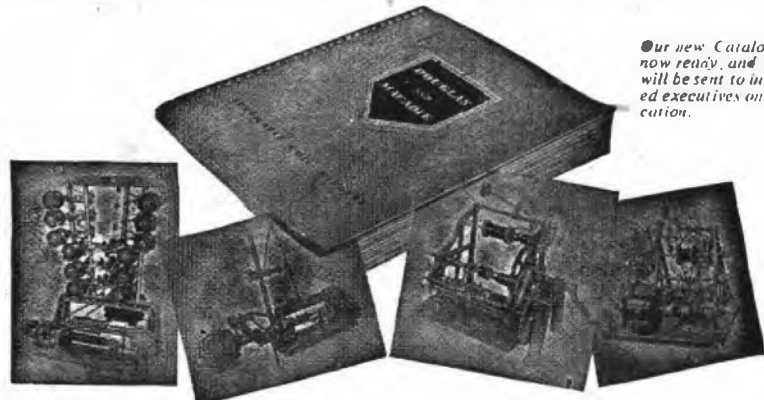

Our new Catalogue is now ready, and a copy will be sent to interested executives on application.

Sole Proprietors and Manufacturers:

The AUTOMATIC COIL WINDER & ELECTRICAL EQUIPMENT CO. LTD.
 WINDER HOUSE • DOUGLAS STREET • LONDON • S.W.1 Telephone: VICTORIA 3404/9

INDEX TO ADVERTISERS

	PAGE
Airmec Laboratories, Ltd.	xxiii
Alton Battery Co., Ltd., The	xiv
Automatic Coil Winder & Electrical Equipment Co., Ltd.	xxi
Automatic Telephone & Electric Co., Ltd.	xii-xiii
Bennett College, The	ii
Berco	ii
British Institute of Engineering Technology	xi
British Power Transformer Co., Ltd.	iii
Creed & Co., Ltd.	xx
Dubilier Condenser Co. [1925], Ltd.	x
Edison Swan Electric Co., Ltd., The	iii
Ericsson Telephones, Ltd.	vi
Evershed & Vignoles, Ltd.	xvii
Ferranti, Ltd.	iv
General Electric Co., Ltd., The	xviii-xix
Great Northern Telegraph Co., Ltd.	xxii
Hackbridge Cable Co., Ltd.	vii
International Correspondence Schools, Ltd.	xxiii
Marconi's Wireless Telegraph Co., Ltd.	v
Muirhead & Co., Ltd.	vii
Neill, James, & Co., Ltd.	xxii
Panton of Northampton	xxiv
Pirelli-General Cable Works, Ltd.	xxiv
Pitman, Sir Isaac, & Sons, Ltd.	xi
Savage Transformers	ii
Savage, W. Bryan, Ltd.	xi
Siemens Brothers & Co., Ltd.	viii-ix
Smith, Frederick, & Co.	ii
Sullivan, H. W., Ltd.	xv
Telephone Manufacturing Co., Ltd.	xxi
Tungstone Products, Ltd.	xvi
Turner Electrical Instruments, Ltd.	iv
Westinghouse Brake & Signal Co., Ltd.	xv
Winn & Coales, Ltd.	xxiii

for the best-focus on
ECLIPSE

for
PERMANENT MAGNETS
for television
radio and
telecommunications
specify **Eclipse**

EM16
JAMES NEILL & CO. (Sheffield) Ltd., SHEFFIELD

G.N.T.

REPERFORATOR MODEL 457

A truly synchronous reperforator for morse code.

Speed range:
40-200 words per minute without gear changes.

Supplied with A. C. or D. C. motor as required.

✱ Write for comprehensive catalogue.

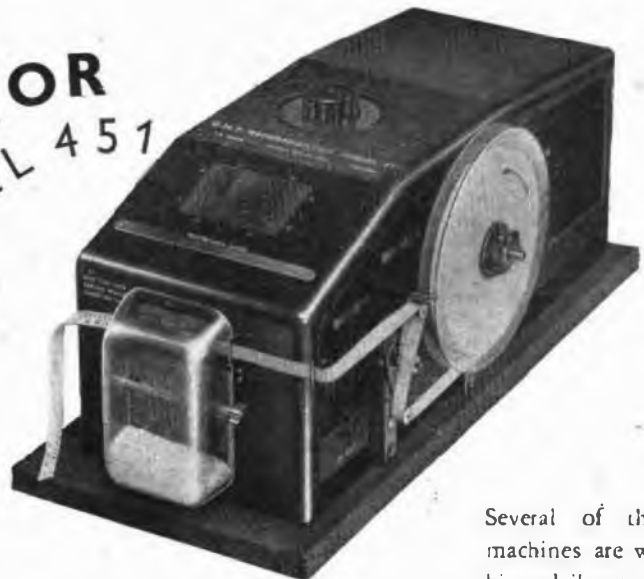

Several of these machines are working daily at 180 words per minute.

THE GREAT NORTHERN TELEGRAPH COMPANY'S FACTORY

4, SYDHAVNS PLADS
COPENHAGEN SV, DENMARK

LONDON OFFICE: 5, ST. HELENS PLACE
LONDON E.C.3.

Denso

PERMANENTLY PLASTIC PROTECTION



gives **3-FOLD** Protection for all Metalwork above or below ground.

Denso Permanently Plastic Tape seals pipes, mains, cables and all metal structures—exposed or buried—from the menace of chemical and electrolytical corrosion.

Indispensable for sealing cable ends—the temporary repair of fractured gas-mains—and a real aid to frostproofing.

Full technical details of Denso Anti-corrosive and Sealing Products gladly supplied.



WINN & COALES LTD.

DENSO WORKS, CHAPEL ROAD, LONDON, S.E.27.

Telephone : GIPay Hill 4247/8.

Telegrams : Denselte, Westnor, London.

SOUND INSTRUCTION by Postal Method

The I.C.S., largest school in the world devoted to spare-time training by the postal method, offers you highly specialised Courses for the following examinations:

- P.M.G. Certificates for Wireless Operators.
- C. & G. Illumination Engineering (Inter.)
- C. & G. Electrical Engineering Practice, Installation and Telecommunications.
- Graduateship of the B.I.R.E.

I.C.S. Examination students are coached till successful.

Other Courses meet the requirements of all who desire to qualify for responsible positions in Electric Power, Illumination, Heating and Traction Systems. Equally successful is our instruction for Telegraph and Radio Engineers, Radio Servicemen, and in Elementary Radar and Electronics, Advanced Short-Wave Radio and Television Technology.

Instruction is by correspondence from textbooks specially prepared by many experts.

WRITE FOR OUR SPECIAL BOOKLET and state the particular subject or Examination in which you are interested.

YOU MAY USE THIS COUPON

International Correspondence Schools Ltd.

Dept. 108, International Buildings, Kingsway, London, W.C.2

Please send me, free of charge, your special booklet on.....

Name..... Age.....

(BLOCK LETTERS, PLEASE)

Address.....



H.F. SIGNAL GENERATOR TYPE 701

30 kc/s — 30 Mc/s



THE use of a two-valve tuned buffer stage which operates on all ranges of this Signal Generator, enables an excellent output waveform to be obtained from 30 kc/s-30 Mc/s. This arrangement also reduces spurious frequency modulation occurring with amplitude modulation to a very low level, and ensures that the oscillator frequency remains independent of the setting of the output and attenuator controls.

An automatic gain control circuit maintains the output voltage level constant within ± 1 db over the whole frequency range, and a negative-feedback modulation circuit ensures a constant modulation depth and pure modulation envelope waveform under all circumstances.

Illustrated descriptive leaflets of this or any other Airmec instrument will be gladly forwarded upon request.



AIRMEC LABORATORIES LTD

HIGH WYCOMBE · BUCKINGHAMSHIRE · ENGLAND

TEL: HIGH WYCOMBE 3000

CABLES: AIRMEC HIGH WYCOMBE

TELEPHONE CABLES

OUR TELECOMMUNICATION CABLES CATALOGUE, GIVING INFORMATION AND SPECIFICATIONS FOR A WIDE RANGE OF TELECOMMUNICATION CABLES MANUFACTURED BY US, IS AVAILABLE UPON REQUEST.

TELEPHONE
SOUTHAMPTON
2141 (5 lines)

IRELLI-GENERAL
CABLE WORKS, Ltd., SOUTHAMPTON.

TELEGRAMS
"PICEKAYREL"
SOUTHAMPTON

ACTUAL SIZE



TECHNICAL DATA

CAT. N^o 200150

Inductance	17.3 microhenries
Resistance (d.c.)	7.4 ohms.
Self Capacity	11.3 pF
Q at self resonant frequency	64
Self resonant frequency	36 Mc/s
Dynamic Resistance at 36 Mc/s	250 K ohms.

CAT. N^o 200151

Inductance	2.3 microhenries
Resistance (d.c.)	0.4 ohms.
Self Capacity	6.5 pF
Q at resonant frequency	290
Self resonant frequency	63 Mc/s
Dynamic resistance at 63 Mc/s	264 K ohms.

THE NEW HIGH 'Q' MINIATURE
H.F. CHOKER
ANOTHER FINE EXAMPLE
OF

Control by

PAINTON

PAINTON & CO., LTD.,
PHONE: NORTHAMPTON 2820

KINGSTHORPE NORTHAMPTON
GRAMS: CEIL NORTHAMPTON