

THE POST OFFICE ELECTRICAL ENGINEERS' JOURNAL

VOL. 41

JULY, 1948

PART 2

CONTENTS

	PAGE
A SWITCHBOARD FOR A BLIND AND HANDLESS OPERATOR— J. H. Combridge, A.M.I.E.E.	63
THE EFFICIENCY OF GRADINGS—Part 2—Grades of Service for Straight Gradings : Comparative Efficiencies of Various Arrangements —H. A. Longley	67
A TRENCH-CUTTING MACHINE—J. W. Spooner, A.M.I.E.E., and W. J. R. Thomson	73
OVERSEAS EXCHANGE (RADIO SERVICES)—R. C. Devereux	76
A TESTER FOR MEASURING THE SPEED AND RATIO OF LOOP IMPULSES—R. C. Kyme, Grad.I.E.E., and C. W. Grasby	83
THE CONSTRUCTION OF ZENITHAL-EQUIDISTANT MAPS— H. T. Mitchell, M.I.E.E., T. Kilvington, B.Sc.(Eng.), A.M.I.E.E., W. E. Thomson, M.A.	85
" DEAD " ROOM FOR ACOUSTIC TESTING.. . . .	91
CALLING LINE IDENTIFICATION—N. H. Robinson	92
INTERNATIONAL TELEX—Part 2—The Switchboard Equipment— H. E. Wilcockson, A.M.I.E.E., and A. H. T. Waldram, B.Sc.(Eng.), A.C.G.I., D.I.C., A.M.I.E.E.	98
A NOTE ON AN EXPERIMENTAL PACKET-COUNTING DEVICE	103
BRITISH STANDARD CODES OF PRACTICE.. . . .	105
SIXTH PLENARY MEETING OF THE C.C.I.T., BRUSSELS, MAY 1948	108
INSTITUTION OF POST OFFICE ELECTRICAL ENGINEERS	109
NOTES AND COMMENTS	110
HEADQUARTERS NOTES	111
REGIONAL NOTES	115
JUNIOR SECTION NOTES	120
STAFF CHANGES	121
BOOK REVIEWS	72, 75, 82, 84, 110

Price 1/6 net

THE INSTITUTION OF POST OFFICE ELECTRICAL ENGINEERS

DECADE SWITCH

*A Precision Component Embodying
All The Best Design Features*

Very low contact resistance. Sturdy action.
Positive location. Twelve positions—providing two extra contacts
—30° angular spacing simplifies dial calibration.
Two types available—416A (Shorting) and 416B
(Non-Shorting).

PRICES ON APPLICATION

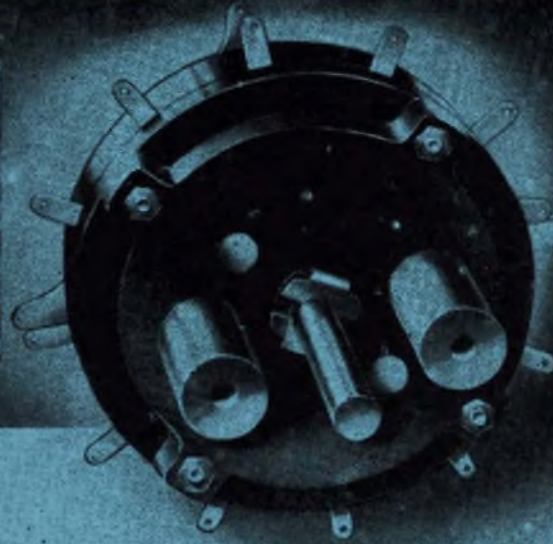

G.E.C.

PRECISION CONTROLS FOR COMMUNICATIONS & MEASURING EQUIPMENT

SALFORD ELECTRICAL INSTRUMENTS LTD.
PEEL WORKS SALFORD 3
Phone: BLA 6688 (6 lines) Grams & Cables "Sparkless, Manchester"
Proprietors: **THE GENERAL ELECTRIC CO. LTD.** England

EDISWAN

TELEPHONE LINE PROTECTORS.

FOR THE PROTECTION OF LINES OF COMMUNICATION
FROM SURGES INDUCED BY LIGHTNING OR FAULTS
ON NEIGHBOURING POWER LINES.

Ediswan Telephone Line Protectors have now been in commission
for nearly twenty years. They have proved their worth in all parts
of the world and are being called for and installed in ever
increasing numbers.

Many thousands were employed during the war years for the protec-
tion of vital lines of communication and were eminently successful.
Reports of their outstanding merit and successful operation
continue to reach us and in recent years they have proved of
particular interest for protection against surges caused by
lightning discharges.

Continued research has enabled us to patent a further improve-
ment which removes any suggestion of delay in operation.

Further information and prices on application.

THE EDISON SWAN ELECTRIC CO., LTD.
155 CHARING CROSS ROAD, LONDON, W.C.2

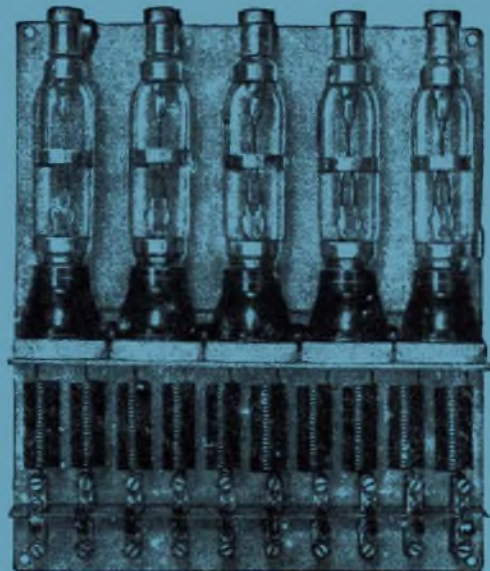

Prov. Patent
25850/45.

5-circuit
panel for
overhead
lines incor-
porating
choke
coils, spark
gaps, etc.

T.E.2

THE POST OFFICE ELECTRICAL ENGINEERS' JOURNAL

Vol. XLI

July, 1948

Part II

A Switchboard for a Blind and Handless Operator

J. H. COMBRIDGE, A.M.I.E.E.

U.D.C. 621.395.655.1

A description of a special keyboard and translating equipment connected to a cordless P.A.B.X., which makes possible the employment of a blind and handless man as a P.A.B.X. attendant.

Introduction.

IN 1943, Sir Ian Fraser, C.B.E., M.P., the Chairman of St. Dunstan's (for men and women blinded on war service), sought the aid of the Post Office in solving the intractable problem of finding a useful occupation for a man who had lost his sight and hands during Army service. There was at that date only one man so handicapped in the care of St. Dunstan's, but the total rose by the end of the war to nearly a score. Sir Ian suggested that it might be possible to find means whereby, with the help of automatic switching equipment, a man so severely handicapped would nevertheless be able to serve usefully as the operator of a Private Branch Exchange switchboard. In such employment he would be able to make use of his unimpaired faculties of voice, hearing, intelligence, and memory, while being relieved as far as possible of the need for doing physical work.

Critical analysis of the work performed by an operator reveals a need for the exercise, to a marked degree, of the power of discriminating (a) between individual members of a large assembly of "signals", to obtain information on which to base a judgment as to the action next to be taken, and (b) between individual members of a very large assembly of possible "actions".

The required power of discrimination is secured, in an operator with normal faculties, almost entirely by the use of the sense of sight, aided of course, by the sense of hearing. A person deprived of sight, only, can in favourable cases compensate for the loss by making increased use of the senses of hearing, touch, and "muscle-sense" (by which one judges forces, and the positions of one's limbs).

A blind person with hands amputated between the wrist and elbow is, however, for practical purposes, almost entirely deprived of the sense of touch. He has lost the possibility of using muscle-sense in the sensitive and important regions of the fingers, hands, and wrists, and is left only with the insensitive and crude muscle-sense of the elbows and shoulders. Further, his movements are confined to those which can be controlled by the muscles of these joints, and are necessarily somewhat clumsy.

Most of the selections made by an operator are of one "article" out of a set of ten, for example, to

select the correct finger-hole out of ten on a dial. Some of the selections are, however, of one "article" out of two, for example, to discriminate between the "ringing" or "speaking" operations of a key. From the point of view of minimising the effort required, it would appear that it would have been advantageous to have restricted the selections to be made by the disabled operator to those of the latter type. A preliminary study showed, however, that the number of consecutive selections it would then be necessary to make in performing any desired series of operations would be such that the speed of operating would be impossibly low, and that a compromise should therefore be made.

A visit was paid to St. Dunstan's, where it was found that the blind and handless man had successfully been taught the use of an ordinary typewriter. This had been achieved by fitting above the typewriter keyboard a "flight of steps" fabricated from sheet brass, with one "step" above each row of keys on the keyboard. The steps were provided with a shallow slot above each of the corresponding keys, and in the middle of each slot was a hole vertically over the centre of the key. For typewriting, the disabled man wore an L-shaped rod at his right "wrist". He located the required row by "stepping" up or down the steps with this--or later by mere judgment of their position--then counted a required number of slots to the right or left from either end while sliding the rod along the step, and finally depressed the key by lowering the vertical end of the rod through the hole. A speed of one letter in three seconds or so was attained at an early stage of training. It was decided to use the design of this device, which had been originated by Mr. P. B. Nye, Research Engineer of St. Dunstan's, as the basis for the design of a cordless telephone switchboard.

Choice of Switching Equipment.

To provide the disabled man with a useful operating load, it was evidently desirable that he should handle the traffic from an installation larger than could be accommodated on a conventional cordless P.M.B.X. switchboard. However, to extend the switching principles of such switchboards to larger capacities would have produced undesirable complications of

equipment and operating. A fortunate solution was found in the utilisation of a novel design of P.A.B.X. equipment, under development at the time, in which the normal cord-type manual board is replaced by a cordless attendant's cabinet.

As the P.A.B.X. equipment will no doubt be described in a later issue of this Journal, reference to it here will be confined to those features essential to an understanding of the functioning of the blind and handless operator's equipment. For this purpose, it suffices to say that the equipment of the attendant's cabinet normally comprises two horizontal rows of up to ten switchboard lamps, the upper row serving as calling signals for miscellaneous circuits, and the lower as calling and supervisory signals for exchange lines. Between the rows of lamps is a row of double-throw lever keys, one of which is operated towards either of the associated lamps for the purpose of speaking on any desired circuit. The remaining items comprise a dial for outgoing exchange calls, strip of digit-keys for selecting a desired extension for incoming exchange calls, receiver-rest, alarm lamps, and miscellaneous keys for such purposes as alarm cut-off, trunk offering, and testing for a free line.

Design of First Model.

The first model keyboard designed for use, in conjunction with the P.A.B.X. equipment, by the blind and handless operator, was "stepped" like the typewriter keyboard, except that to permit the use of a straight operating rod the digit keys which replaced the typewriter keys were arranged to move horizontally instead of vertically.

To allow audible signals to be used in place of lamps, the vertical faces of the "steps" in front of the keys were divided by insulating gaps into sections each containing the guide slot and hole of one key. These sections are subsequently referred to as "key-plates". To avoid the need for a flexible connection to the operator's rod, the circuit from the key-plates to the audible alarm was arranged to be completed through a horizontal metal bar along which the operator slid his rod when searching the key-plates to identify a calling line. This bar was formed by the raised front edge of the next "step" below the one in use.

The equipment behind the key-plates consisted of four rows of ten digit-keys, to serve as follows:—

- Top row.* Speak keys for miscellaneous circuits.
- Second row.* Digit keys connected to an electrical keysender replacing the normal dial.
- Third row.* Speak keys for exchange lines.
- Bottom row.* Digit keys for selecting extensions.

The design included ten pedals, arranged in a "console" below the keyboard, for performing various "common" functions. Eight of these pedals were of non-locking

type, and two of locking type operating in "see-saw" fashion.

For convenience, the external connections were made via P.O.-type connection strips and six 24-way cords with plugs and jacks, there being one cord for each strip of digit keys, one for the pedal console and one for the key-plates and tone bars.

As it was desired to confirm the practicability of the proposals before proceeding with the design of the equipment for coupling the special keyboard to the P.A.B.X. equipment, the first model was associated with a recovered house-telephone switchboard, referred to as the "teacher's switchboard", so that operation of a key on the teacher's switchboard put a signal on to any desired key-plate on the handless man's keyboard, and the depression of any key on the latter operated an associated indicator on the teacher's switchboard. By the use of this equipment, the blind and handless man was taught the operating procedure which had been worked out for the P.A.B.X., and his ability to handle a reasonable amount of traffic was confirmed.

Construction of Final Model.

Experience with the first model keyboard during the training period showed certain mechanical weaknesses, due principally to the stepped arrangement of the keys. There was also some difficulty in obtaining access to the components for maintenance. The stepped arrangement was therefore abandoned in favour of a vertical face layout for the final model, with free-standing horizontal tone bars in place of the raised edges of the steps previously used for this purpose, so that there would be no place for dust to lodge upon. The arrangement adopted is shown diagrammatically in Fig. 1.

The method of construction followed for the key-plates may be of interest. Each row of plates was made from a continuous strip of brass sheet, indented as

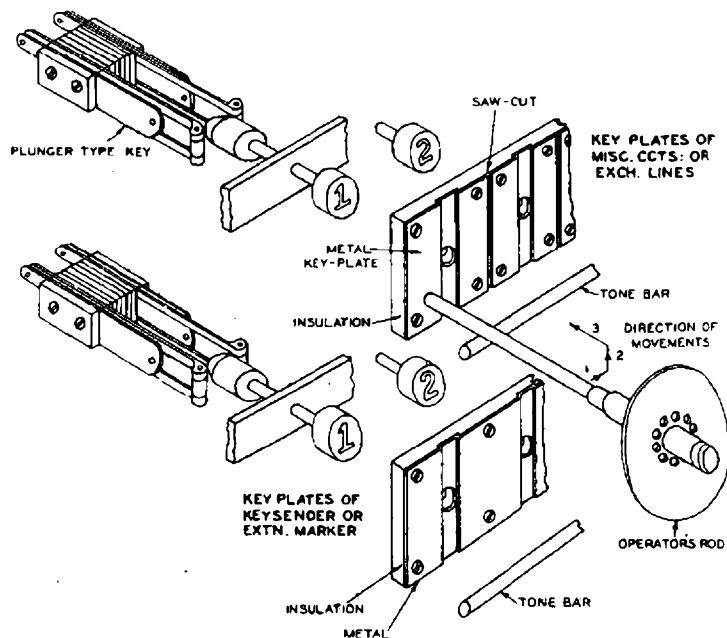

FIG. 1.—MECHANICAL ARRANGEMENT OF KEYBOARD.

banking chains both rotate as soon as the engine is started up.

The machine is of the self-hauling type and employs a ground anchor (Fig. 3) with 300 ft. of steel wire

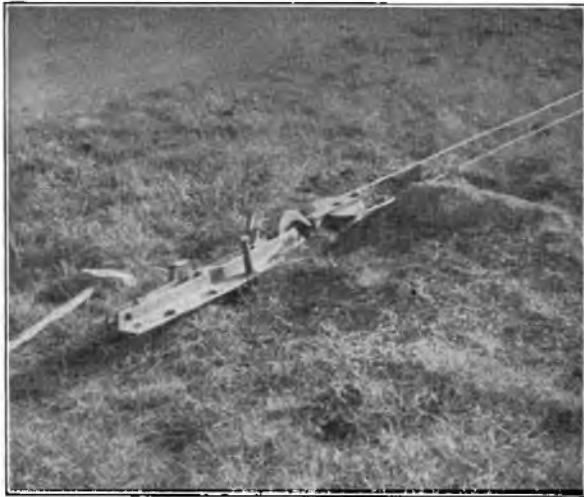

FIG. 3.—GROUND ANCHOR.

rope giving an effective length of 140 ft. maximum for one setting of the anchor. The steel wire rope passes from the winding drum through a pulley block at the anchor and back to the draw-bar of the machine. The forward movement is accomplished by winding in the steel wire rope around the drum which is rotated by a crank-operated variable-stroke ratchet drive. The stroke of the ratchet gear can be varied to take up from one-half tooth to four full teeth of the wheel at each revolution of the main shaft. The adjustment is by a hand-screw and fly nut in stages of one-half tooth. This half-tooth adjustment is made possible by using two pawls spaced one half-tooth apart.

To enable the operator to keep the machine to a line it is fitted with a steering wheel on the clear side, operating through a worm and worm-wheel. A local modification has been added in the form of a 4-ft. "sighting rod" fixed horizontally and parallel to the centre line of the machine. This, together with three marking pins placed along the proposed track enables the operator to maintain an accurate line, but without this device it is found most difficult to keep the machine straight. To obtain a good trench round curves and corners, a row of small pegs spaced equally and at short distances apart is found useful; metal meat skewers are ideal for the purpose. Owing to the worm and worm-wheel design, the steering is irreversible and must be disengaged whenever the machine is put on tow. To enable the machine to be used on sloping ground, both rear wheels are adjustable vertically through a height of 6 in., that is either 3 in. above or below the normal position. By this adjustment it is possible to

excavate a vertical trench in most grass margins. This is an advantage over certain other types of trench-cutting machines where it is necessary to use wooden sleepers as packing to maintain the machine on an even keel. The machine must be kept level otherwise trouble is experienced with the boom and excessive wear occurs in the bushes and pins. Circular guide plates are supplied with the machine to prevent side-slipping when used on steeply sloping ground, and these are attached to the rims of the front and rear wheels on the clear side. Lugs are spaced round the wheel rims for this purpose.

The spoil conveyor (Fig. 4) carries low-carbon steel scraper plates fitted to a malleable iron chain running on chilled iron sprockets. The chain is adjustable by means of a set-screw and lock nut, and it can be disposed to either side of the machine. The Post Office has had a modification made to the main horizontal beam supporting this chain, whereby the side-overhang can be reduced to enable the machine to be accommodated in a 4-ton lorry. In adjusting the chain, it is necessary to ensure that the scraper plates are as near to the ground as possible, otherwise the spoil heaps up in front of the boom. The alteration of the spoil conveyor from one side to the other is a rather laborious proceeding involving dismantling and subsequent re-fitting on the opposite side. The parts that have to be dismantled are the conveyor chain and supporting frame, the steering unit, portion of the ratchet gear connected with the forward movement and the digging-boom capstan wheel. The whole operation takes about a day to complete. When moving the machine from one site to another, the set-screw above the front wheels must be screwed down as far as possible to give the maximum ground clearance to the spoil conveyor.

Operation of the Machine.

Having sited the machine at the starting point the wire rope is payed out. As previously stated, the effective length is 140 ft. so that if the first section to be trenched is more than that, the full length can be used. The free end is passed round a pulley and secured



FIG. 4.—SPOIL CONVEYOR.

(not shown in Fig. 3) to silence the buzzer, places his rod on the tone bar of the third row, as shown in Fig. 1, and slides it along the keyplates until he comes to the one where the high-toned buzzer sounds at "flashing" periodicity, under the control of the L relay of the calling line. When he presses the "Speak" key behind this keyplate with the tip of his rod, the associated relay S operates, and locks via S1, R1, and H2. S2 sends a signal to the P.A.B.X. auto. equipment which causes it to connect the operator's instrument to the calling line. After ascertaining the extension wanted, the operator keys the required two digits on the bottom row, counting "slots" from the left for digits 1-5, and in reverse from the right for digits 0-6, and the P.A.B.X. equipment completes the connection. Supervisory indications which give continuous high-toned buzzer during ringing, interrupted for "busy," and silence for "call answered," are given on the digit keyplates from the P.A.B.X. via contacts L1 and S3, so long as relay S remains locked. When the call has been dealt with, relay S is released at R1 by pressing the "Release" pedal momentarily. Subsequently, the audible supervisory indications are still available on the exchange-line key-plate concerned, via L1 contact, and the call can be re-entered at any time by re-operating the "Speak" key. Clearing is effected automatically by the P.A.B.X. equipment when the extension receiver is replaced.

Outgoing exchange calls are normally dialled directly by the extensions, but if the assistance of the operator is required dialling of an appropriate code causes the low-toned buzzer to sound interruptedly via P1 contact. The operator in this case searches along the top row of key-plates, and answers as before. On learning that an exchange call is required, he presses the "Test" pedal (not shown in Fig. 3) temporarily. This sends a signal to the P.A.B.X. which operates the L relays of all engaged exchange lines, and hence causes the high-toned buzzer to sound when the key-plate of any engaged line is connected to the tone bar by the operator's rod,

so that a free exchange line may be selected and the "Speak" key pressed. After dialling tone has been received the "Keysender" pedal is tilted to the "On" position and the required digits are keyed on the digit keys in the second row. Incorrect keying may be cancelled by depressing a "Cancel" pedal. After keying has been completed the "Keysender" pedal is tilted "Off" and the connection supervisory telephonically. If progressing satisfactorily, the connection is left by depressing the "Release" pedal, clearing being effected automatically as before.

Practical Experience.

A P.A.B.X. installation equipped with six exchange lines and 48 extensions was installed at the head office of St. Dunstan's during 1945, and was successfully operated by the blind and handless man. This installation is, however, a busy one for its size, so far as exchange traffic is concerned, and proved in practice to be somewhat beyond his capabilities for any prolonged period. The experiment nevertheless fully confirmed the practicability of switchboard operating by a blind and handless person. It is being continued with a different operator under more favourable conditions, at a smaller installation in one of St. Dunstan's branch establishments. For this purpose, the keyboard and auxiliary equipment has been associated with a smaller size of P.A.B.X. equipment, with capacity for five exchange lines and 24 extensions.

Conclusion.

The success of the experimental installation demonstrates once more the flexibility of telephone type apparatus for meeting unusual requirements.

The author's thanks for ready co-operation throughout the work are due to his colleagues in the P.E. Engineering and Factories Departments, and to Mr. P. B. Nye, of St. Dunstan's, who constructed two models of the keyboard and pedal console, and kindly supplied the photograph reproduced in Fig. 2.

TELEGRAPH AND TELEPHONE STATISTICS—SINGLE WIRE MILEAGES AS AT MARCH, 1948.
POST OFFICE MAINTENANCE—EXCLUDING SUBMARINE CABLE

REGION	OVERHEAD			UNDERGROUND		
	Trunks and Telegraphs	Junctions	Subscribers*	Trunks and Telegraphs†	Junctions‡	Subscribers¶
Northern Ireland	10,188	12,439	36,174	108,222	43,704	147,642
Scotland	19,291	34,355	203,795	804,306	276,284	887,488
Home Counties	9,844	33,161	375,088	1,918,152	513,736	1,502,294
Midland	4,388	26,256	227,559	1,089,388	332,522	1,083,111
North Eastern	7,728	15,507	192,788	882,374	274,371	1,038,665
North Western	1,608	8,498	118,638	668,962	396,248	1,291,913
South Western	3,594	34,844	279,380	1,030,974	199,695	824,083
Welsh and Border Counties ..	6,361	31,172	156,241	536,294	92,312	343,334
Provinces	63,002	196,232	1,589,663	7,038,672	2,128,872	7,118,520
London	325	1,009	82,449	967,362	1,835,087	3,902,616
United Kingdom	63,327	197,241	1,672,112	8,006,034	3,963,959	11,021,136

* Includes all spare wires.

† All wires (including spares) in M.U. Cables.

‡ All wires (including spares) in wholly Junction Cables.

¶ All wires (including spares) in Subscribers' and mixed Junction and Subscribers' Cables.

The Efficiency of Gradings

H. A. LONGLEY
(Telecommunications Department)

Part 2.—Grades of Service for Straight Gradings

Comparative Efficiencies of Various Arrangements

U.D.C. 621.395.341.8

Methods of calculating the maximum and minimum values of the characteristic grading factors are described, and these values are used to estimate the grades of service given by individual gradings and to compare the efficiencies of certain families of gradings.

Maximum and Minimum Values of Characteristic Factors.

If it were practicable to determine the appropriate formulæ for the K factors of particular grading arrangements, the grades of service could be determined and the efficiencies compared for various levels of traffic offered, to ascertain the most efficient arrangement. The K factors for any particular arrangement form an algebraic series of a very special kind, and the complexity and variability in type of the formulæ would appear to put their determination out of the question even for one grading of the size used in practice. There are, however, some short cuts available from which interesting conclusions may be drawn.

The general character of a K factor series can be observed from consideration of the series obtained for formations, such as that of Fig. 10, element (f), consisting of parallel ungraded groups. The K factors for such formations are constant, as they do not vary with the traffic offered. They can be determined from the appropriate Erlang loss formula for one of the component groups, the traffic offered to each component group being A/d where d is the number of component groups. For example, in the four-channel arrangement of Fig. 10 (f) the probability of all four channels being simultaneously engaged is given by

$$P_4 = \frac{\left(\frac{\left(\frac{A}{2}\right)^2}{2!}\right)^2}{1 + \frac{A}{2} + \frac{\left(\frac{A}{2}\right)^2}{2!}}$$

$$= \frac{\frac{3}{4} \cdot \frac{1}{2} \cdot \frac{A^4}{4!}}{1 + A + \frac{A^2}{2!} + \frac{3}{4} \cdot \frac{A^3}{3!} + \frac{3}{4} \cdot \frac{1}{2} \cdot \frac{A^4}{4!}}$$

Hence $K_2 = \frac{3}{4}$ and $K_3 = \frac{1}{2}$

In more general terms, if p_r represents the probability of r channels being engaged simultaneously out of the total of four channels, and if p_r represents the probability of r being engaged in each component group, then

$$p_0 = p_0^2 \quad p_1 = 2 p_0 p_1 \quad p_2 = 2 p_0 p_2 + p_1^2$$

$$p_3 = 2 p_1 p_2 \quad p_4 = p_2^2$$

$$\therefore K_2 = 2 \cdot \frac{A}{2} \cdot \frac{\left(\frac{A}{2}\right)^2}{2!} \cdot \frac{3!}{A^3} = \frac{3}{4}$$

$$\text{and } K_2 K_3 = \left(\frac{\left(\frac{A}{2}\right)^2}{2!}\right)^2 \frac{4!}{A^4} = \frac{3}{8}$$

whence $K_3 = 1/2$

For a group of 20 channels comprising two ungraded groups of 10 channels each, the K factor series, derived as described above, is shown below in both fractional and decimal form :

K_{10}	K_{11}	K_{12}	K_{13}	K_{14}	K_{15}	K_{16}	K_{17}	K_{18}	K_{19}
$\frac{1023}{1024}$	$\frac{185}{186}$	$\frac{182}{185}$	$\frac{351}{364}$	$\frac{101}{108}$	$\frac{181}{202}$	$\frac{153}{181}$	$\frac{7}{9}$	$\frac{19}{28}$	$\frac{1}{2}$
.999	.995	.984	.964	.935	.896	.845	.777	.679	.500

If $K_{a,r}$ be used to represent the product of K factors from K_a to K_r inclusive, the successive products as used in the grade of service formula are as follows :—

K_{10}	$K_{10/11}$	$K_{10/12}$	$K_{10/13}$	$K_{10/14}$
.999	.994	.978	.943	.882
$K_{10/15}$	$K_{10/16}$	$K_{10/17}$	$K_{10/18}$	$K_{10/19}$
.790	.668	.519	.352	.176

While typical of any K factor series in numerical form, that is, for a particular value of A, the above are, of course, of only theoretical interest, as for this particular type of formation the grade of service is readily available from Erlang's loss formula applied to one of the parallel groups.

In Fig. 8 were given the maximum and minimum values of the K factors of grading elements, obtained by assuming $A \rightarrow 0$ and $A \rightarrow \infty$ in the appropriate formulæ. It is much easier to determine the maximum and minimum values of the K factors directly than to calculate the full formulæ, and the relative efficiencies of two arrangements can often be determined from consideration of these values. It is particularly easy to determine the maximum value of the highest K factor (K_n) and the minimum value of the lowest K factor (K_{n-1}), and since these values represent the limits within which all possible values must lie for any particular grading arrangement, they provide a ready means of comparing grading efficiencies in certain circumstances. It happens that the upper and lower limits of the K factor for the simple grading arrangement of Fig. 7 (three channels, availability two) are also the values of K_n ($A \rightarrow 0$) and K_{n-1} ($A \rightarrow \infty$) respectively. It will be convenient to demonstrate the calculation of the two limits in this simple example, first by methods that give general formulæ for K_n ($A \rightarrow 0$) and K_{n-1} ($A \rightarrow \infty$) appropriate to all straight gradings, and secondly by

methods which enable the maximum and minimum of all the K factors of any straight grading to be calculated.

In Part I it was shown that the probability that a group is in a given condition is determined by four causes: namely, the arrival of traffic during the preceding condition, the arrival and cessation of traffic during the condition itself, and cessation of traffic during the subsequent condition. When the traffic offered is indefinitely small, however, the probability of any given condition is determined only by the arrival of traffic during the preceding condition and by the cessation of traffic during the condition itself; in other words, as A approaches zero the magnitude of p_{r+1} to p_r becomes negligibly small relative to that of p_r . Under this assumption the probability of there being a disengaged channel between any engaged channel and the first channel in the division of the grading is negligible. Applying this idea to the equations given in Fig. 7, as $A \rightarrow 0$, then $p_{1c} \rightarrow 0$, and from equations (6) and (7)

$$\frac{A}{2} p_1 = 2p_{2bc} \text{ or } p_2 = 2 p_{2bc}$$

$$\text{But } K_2 = 1 - \frac{\frac{1}{2} p_{2bc}}{p_2} = 1 - \frac{1}{4} = \frac{3}{4}$$

If d is used for the number of divisions and a for the availability, and if other examples of gradings are considered, it is found that, for straight gradings

$$K_a \rightarrow \left(1 - \frac{1}{d^a}\right) \text{ when } A \rightarrow 0$$

Thus the maximum value of the highest K factor of a straight grading is found to be dependent only on the number of divisions of the grading and the availability; it is independent of the number of channels and their arrangement. The result can also be obtained by calculating the full formulæ in terms of d, a and x.

Under the assumption that the traffic offered is indefinitely small, the K factors may be calculated by a method similar to that given above for parallel ungraded groups. Thus, for the simple three-channel example under consideration,

$$p_0 = p_0^3 \quad p_1 = 2p_0p_1 \quad p_2 = 2p_0p_2 + p_1^2$$

$$p_3 = 2p_1p_2$$

Substituting for p_1 and p_2 the appropriate expressions from Erlang's loss formula for a group of two channels offered $A/2$ traffic units (but omitting the denominator for convenience):—

$$p_3 = 2 \cdot \frac{A}{2} \cdot \frac{\left(\frac{A}{2}\right)^2}{2!} = \frac{3}{4} \cdot \frac{A^3}{3!} \text{ and } K_2 = \frac{3}{4}$$

This method can be adopted to obtain the maximum values of the K factors for any straight grading. Furthermore, where there is more than one K factor the calculation gives the products of the factors as used in the grade of service formula. Where the number of divisions is more than three it is convenient to perform the calculation in successive stages. Thus, for a four-division grading, two adjacent divisions are first considered and then the two sets of two divisions each.

When the traffic offered is infinitely great, the probability of any given condition is determined only by the arrival of traffic during the condition itself and by the cessation of traffic during the subsequent condition; in other words, as A approaches infinity the magnitude of conditions p_0 to p_{r-1} becomes negligibly small relative to that of p_r . Applying this idea to the equations of Fig. 7, when $A \rightarrow \infty$

$$\text{equation (5) becomes } p_3 = Ap_2a$$

$$\text{" (6) " } p_3 = \frac{A}{2} p_{2b} \text{ or } 2p_3 = Ap_{2b}$$

$$\text{" (7) " } p_3 = p_{2c} \text{ or } 2p_3 = Ap_{2c}$$

$$\therefore 5p_3 = Ap_2$$

$$\text{But } AK_2p_2 = 3p_3$$

$$\therefore K_2 = \frac{3}{5}$$

If d is used for the number of divisions and x for the number of channels

$$K_{x-1} \rightarrow \frac{x}{d^2 + 1} \text{ when } A \rightarrow \infty$$

From consideration of the equations governing p_{x-1} for any straight grading it can be deduced that the minimum value of K_{x-1} can be determined by taking

number of vertical rows of individuals	$\times d^2$
" " " " " pairs	$\times (d/2)^2$
" " " " " threes	$\times (d/3)^2$
and so on to	
number of commons	$\times 1$

and dividing the sum of these products into the numbers of channels.

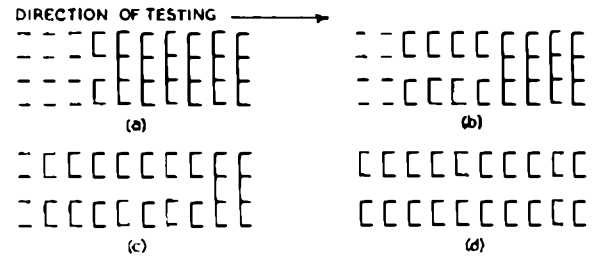

FIG. 11.—STRAIGHT GRADINGS OF 20 CHANNELS AVAILABILITY 10.

This calculation applied to the grading of Fig. 11 (a), for example, gives

$$\begin{array}{r} 3 \times 16 = 48 \\ 1 \times 4 = 4 \\ 6 \times 1 = 6 \\ \hline 58 \end{array}$$

Hence the minimum value of $K_a = \frac{20}{58} = .345$

It may here be mentioned that, as gradings are conventionally identified by denoting the number of vertical rows of individuals, pairs, threes, etc., and commons, the above calculations can be performed with only the grading symbols as data.

The general method of calculating the minimum

values of the K factors of a straight grading depends on the following :—

$$K_r = \frac{A K_r p_r}{A p_r} = \frac{A K_r p_r}{A K_r p_r + A(1-K_r)p_r} \\ = \frac{(r+1)p_{r+1}}{(r+1)p_{r+1} + A(1-K_r)p_r} \\ = \frac{r+1}{r+1 + \frac{A(1-K_r)p_r}{p_{r+1}}}$$

Now it can be demonstrated fairly readily from component diagrams and their equations that under the assumption that $A \rightarrow \infty$ the value of the expression

$$\frac{A(1-K_{r-c})p_{r-c}}{p_{r-c+1}}$$

(where c is the number of commons in the grading) is independent of the number of commons. This result derives from the fact that under the assumed conditions there is a fixed relation between the traffic lost during p_r and during p_r which is not affected by the number of commons. Hence, if \bar{K}_{r-c} and \bar{p}_{r-c} relate to a grading arrangement without commons, and correspond to K_r and p_r for the same grading with c commons added, then

$$\frac{A(1-K_r)p_r}{p_{r+1}} = \frac{A(1-\bar{K}_{r-c})\bar{p}_{r-c}}{\bar{p}_{r-c+1}} = \frac{1-\bar{K}_{r-c}}{\bar{K}_{r-c}}(r-c+1)$$

$$\text{Hence } K_r = \frac{r+1}{r+1 + \frac{1-\bar{K}_{r-c}}{\bar{K}_{r-c}}(r-c+1)} \\ = \frac{\bar{K}_{r-c}}{\bar{K}_{r-c} + (1-\bar{K}_{r-c})\frac{r-c+1}{r+1}}$$

The minimum values of the factors for a grading can therefore be determined if the values for the grading arrangement without commons are known. For example, in the simple arrangement of Fig. 7, the value of \bar{K}_1 for the first two channels is 1/2; hence, substituting this for \bar{K}_{r-c} and $c = 1$, in the above formula, K_2 for the whole grading = 3/5. This procedure may be applied to any size of straight grading; for convenience, formulæ giving the products of the factors may be used in place of the above, but these require more space for their expression than can be afforded here. For the grading of Fig. 11 (b), for example, the calculation would be performed in four stages: (1) the values of K_2 and $K_{2,3}$ for the four individuals at the beginning of the top two divisions are calculated as described earlier; (2) these values are modified, as described above, to include the four partial commons, the resultant factors being K_6 and $K_{6,7}$; (3) the two sets of eight channels are then considered together, to obtain—by a method similar to that referred to in (1)— K_8 to $K_{8,15}$ for the first 16 channels; (4) these values are modified to include the four full commons to obtain K_{10} to $K_{10,19}$ for the complete grading.

Estimate of Grade of Service given by Gradings.

If the maximum and minimum values of the K factors of a grading are known, and these values are

substituted in the grade of service formulæ, then for any given value of traffic offered, two answers for the grade of service given by the grading will be obtained, neither of which will be correct, but between which the true grade of service will lie. Thus, if the grade of service given by the simple example of Fig. 7 is calculated first with $K_2 = 3/4$ and then, with $K_2 = 3/5$, for $A = 2$ the two limits for grade of service obtained are .275 and .250, the correct value (calculated by the exact method) being .267. These upper and lower limits are themselves of value in enabling the relative efficiencies of various arrangements to be compared, but a close estimate of the grade of service may be obtained by using the approximate formula

$$K_r = \frac{K_r A + {}_0K_r}{A + 1}$$

to obtain an estimate of the value of each factor for given values of A. This approximate formula when applied to the grading elements considered in Part 1, gives results which differ to a negligible degree from the exact values. It would appear that there is no loss, and much convenience, in applying the same idea to the products of the factors, in which case an estimate of the grade of service can be obtained from

$$\beta = 1 - \frac{1 + A + \dots + \frac{A^{x-1}}{(x-1)!} + \left(A \sum_{r=a}^{x-1} {}_\infty K_{a/r} \frac{A}{r!} \right)}{1 + A + \dots + \frac{A^a}{a!} + \left(A \sum_{r=a+1}^x {}_\infty K_{a/r} \frac{A^r}{r!} \right) \frac{1}{A+1} + \sum_{r=a}^{x-1} {}_0K_{a/r} \frac{A^r}{r!} \frac{1}{A+1} + \sum_{r=a+1}^x {}_0K_{a/r} \frac{A^r}{r!} \frac{1}{A+1}}$$

The limits of grades of service and the estimate made as described above, of the grade of service, given by the gradings of Fig. 11 (d), for three values of traffic offered, have been calculated.

As an example, the calculated results obtained for 6.86 T.U. offered—at which density the ungraded arrangement gives a grade of service of .002—are given below :—

Grading	Lower limit cf g.s.	Upper limit cf g.s.	Estimate cf g.s.
(a) 3 1 6	.00009	.00111	.00098
(b) 2 4 4	.00017	.00100	.00089
(c) 1 7 2	.00063	.00127	.00118

Relative Efficiencies of Straight Gradings.

In Fig. 12 the efficiencies of the four arrangements of Fig. 11 are compared on the same basis as that used to compare those of grading elements in Figs. 9 and 10, the curves being based on the estimates of grades of service calculated as described. It will be seen that grading 2 4 4 is shown to be more efficient than the others over most of the range covered. At an average loading of more than about 0.75 T.U. per channel, grading 1 7 2 is the most efficient arrangement; consideration of the factors suggests that at a very high

loading, well beyond the range of practice, however, the ungraded arrangement might be found the most efficient. There is no doubt that, with very light traffic, grading 3 1 6 would be the most efficient. It is

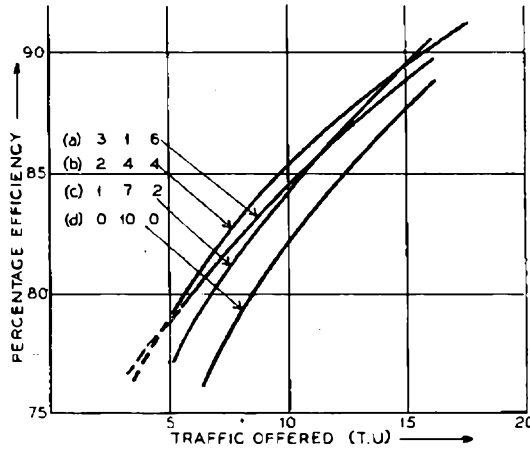

FIG. 12.—RELATIVE EFFICIENCIES OF STRAIGHT GRADINGS.

interesting to note that grading 2 4 4 is the one that would be selected as the best by applying the "smooth progression" theory, as the number of sets of individuals, partial commons and commons are most nearly equal in this arrangement.

The foregoing conclusions could have been inferred in part by consideration of the values of K_n ($A \rightarrow \infty$) and K_{n-1} ($A \rightarrow 0$), the general formulæ for which were given above. From the essential nature of the K factor as the proportion of traffic effective during a given condition, it follows that the more efficient the grading the higher its factors.

In a family of gradings for which the maximum value of K_n is the same for all the arrangements (that is, a family having a similar number of channels, divisions and availability) the relative efficiencies will be reflected in a comparison of the minimum values of K_{n-1} . As has been shown, however, the relative efficiencies of gradings may vary with the density of traffic offered, and when comparing grading efficiencies it is necessary to specify the loading levels at which the comparison is made. Since factors K_{n-1} are, for straight gradings, at a minimum when the traffic density is infinite, the relative efficiency given by comparison of the K_{n-1} values is that which applies when the groups are fully loaded, though it may also be an index of the relative efficiencies at lighter loading levels.

The maximum values of the highest K factors (K_n) are equal for the gradings in Fig. 11, being $1 - (\frac{1}{2})^{10}$. The efficiencies of the gradings at full loading may therefore be compared by consideration of the minimum values of the lowest K factors (K_{n-1}) which are as follows:

- (a) Grading 3 1 6 = .345
- (b) " 2 4 4 = .385
- (c) " 1 7 2 = .435

Thus this calculation shows that grading 1 7 2 is the most efficient of the three when the traffic is heavy. From consideration on the same basis of other combinations of channels, availability and number of divisions, it is found that the most efficient straight grading when fully loaded is that which most nearly approaches the nearest equivalent arrangement of parallel ungraded groups.

To compare the relative efficiencies of these gradings when the traffic density is low, consider first the gradings of Fig. 11 (a) and (b) with the first two sets of individuals removed: the relative efficiencies of the remainders will not be affected by this removal, and the maxima of K_n for the remainders are $1 - (\frac{1}{2})^{10}$ and $1 - (\frac{1}{2})^{10}$ respectively. Therefore, 3 1 6 is more efficient than 2 4 4 when the traffic is very light, and similarly it is seen that 2 4 4 is more efficient than 1 7 2 under the specified conditions. From consideration of other combinations it is apparent that the most efficient arrangement when traffic is very light is that with the largest number of individuals and consequently of full commons. Hence the relative efficiencies of the three arrangements are (a) to (c) when traffic is light and (c) to (a) when it is heavy and it will be noted that this result is consistent with that already obtained by consideration of the grades of service.

If any family of gradings appropriate to a given number of channels is arranged in order on the foregoing basis it will be found that the order of efficiency under heavy loading is exactly the reverse of the order of efficiency under light loading. This statement may be amplified by saying that when the traffic offered is less than a certain value one of the gradings (the first in order) is the most efficient arrangement, and when the traffic offered is greater than some other value, one other grading (the last in order) is the most efficient; and when the traffic offered is intermediate between these two values one or another of the gradings intermediate on the list is the most efficient. It is a reasonable inference that over the full range of grades of service the possible gradings take turns in being the most efficient.

Effect of Introducing "Slipped" and "Cyclic" Connections.

Whereas it appears to have been considered hitherto that the main merit of slipped and cyclic connections was their ability to cater for overloads that may occur in practice on particular divisions of gradings, it has been shown in Part I that these arrangements are intrinsically more efficient than the straight arrangement of partial commons, with pure chance traffic of constant underlying density. It seems certain that slipped and cyclic connections can, in fact, have a greater influence on efficiency than that due to minor differences between straight gradings of the same family. When slipped or cyclic arrangements are introduced, therefore, the balance may be heavily weighted in favour of those gradings in respect of which the introduction of these types of arrangement happens to be practicable. In general the introduction of slipped and cyclic arrangements favours those gradings with the largest proportion of partial commons, and it happens that these are also, in their

straight form, the most efficient gradings when the traffic offered is fairly high. Fig. 13 (a), (b) and (c)

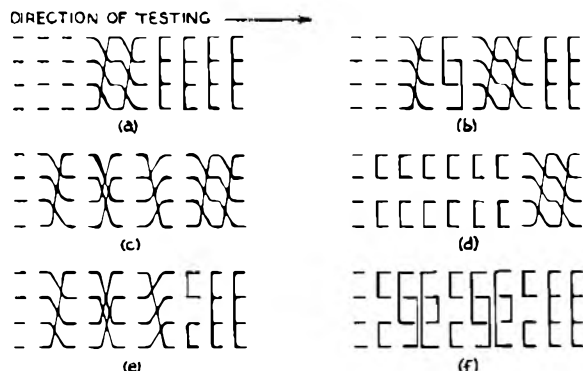

FIG. 13.—GRADINGS OF 20 CHANNELS WITH SLIPPED AND CYCLIC CONNECTIONS.

shows the gradings of Fig. 11, with the maximum amount of slipping introduced. The type of slipping applied to the first three partial commons of (b) and to the first six partial commons of (c) may be expected to increase the efficiency of the group, on the basis of the efficiency curves in Fig. 10; the available evidence supports the views that the relative efficiency of grading elements is not upset by their being placed on later contacts. The type of slipping applied in (a), and also immediately before the commons in (b) and (c), does not, however, necessarily increase the efficiency of the group. The particular arrangement illustrated is effected by combining the last two partial commons and the first two full commons (see elements (d) and (e) of Fig. 8) and it has been shown that with this type of element the slipped arrangement is the less efficient except when the traffic offered to it is above a certain value; (the critical value occurs when the K factors of the two elements are equal, which is approximately when $A = 2.25T.U.$ pure chance traffic in this particular case). Whether or not the efficiency of a grading is increased by this type of slipping arrangement will depend, therefore, on the traffic density and the position of the element in the grading. At the same time the extent that the introduction of a particular element would affect the efficiency of a grading will depend on what proportion of the total traffic is offered to the element. There is little doubt that, at ordinary grades of service, the grading of Fig. 13 (d), for example, would be slightly less efficient than that of Fig. 11 (c), while the grading of Fig. 13 (a) may be expected to be more efficient than that of Fig. 11 (a); the effect on the efficiency of the grading of Fig. 13 (b) if the final slipped combination were replaced by the equivalent straight formation would, however, be more critically related to traffic density. Fig. 13 (e) and (f) shows grading (c) of Fig. 11 in what are apparently the most efficient slipped and cyclic arrangements, the latter being, on the basis of earlier discussion, the more efficient arrangement of the two.

Fig. 14 (a) and (b), shows cyclic connections applied to the ungraded arrangement of Fig. 11 (d), over four

and six divisions, respectively. In Fig. 14 (a) there are only three possible permutations and they are necessarily repeated $3\frac{1}{2}$ times to cover the ten sets of

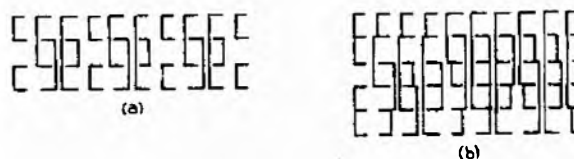

FIG. 14.—CYCLIC ARRANGEMENT OF 20 CHANNELS UNGRADED.

contacts; in Fig. 14 (b) there are ten possible permutations and therefore no repetition is necessary. Although the maximum value of K_2 is slightly less for (b) than for (a) in respect of the first four channels (.861 against .875) the later channels of (b) may be expected to be relatively more efficient than those of (a) owing to the absence of repetition.

Results Obtained with Rotary Traffic Machine.

The investigation of gradings made with the rotary artificial traffic machine (mentioned in Part 1) was mainly directed to determine the relative efficiencies of a group of 27 channels, with six divisions and availability 10. Of the 28 arrangements tested, all except two included slipped arrangements of the type shown in Fig. 13 (a) to (e); 12 of the 28 arrangements have equivalent straight arrangements, and these are listed below in the order of efficiency given by the calculations described above.

Individuals	Grading symbol			$K_{x-1}(A \rightarrow \infty)$
	Partial commons		Full Commons	
	Pairs	Threes		
3	1	0	6	.220
3	0	2	5	.223
2	3	1	4	.252
2	2	3	3	.257
2	1	5	2	.262
2	0	7	1	.267
1	6	0	3	.290
1	5	2	2	.297
1	4	4	1	.303
1	3	6	0	.310
0	8	1	1	.351
0	7	3	0	.360

As described earlier, the above list gives the order of efficiency for light loading when reading downwards and for heavy loading when reading upwards.

It is interesting to note that the most efficient of these gradings was found, by the artificial traffic tests made with the machine, to be grading 0 7 3 0, and that, as far as can be judged, the order of efficiency

in which the gradings were placed by the machine agreed broadly with the order shown above for heavy loading. More significantly, however, this is also the order according to the proportion of partial commons, and, therefore, of slipped connections. The grading with symbol 2 2 3 3 would be considered the best on the basis of the smooth progression theory, and the investigators concluded that this theory had been shown, by the tests made with the machine, to be incorrect. It should be said, however, that, in the light of the foregoing discussion, this conclusion does not necessarily follow. Firstly, the smooth progression theory was intended originally to apply at the standard British Post Office grade of service of 1 in 500, whereas the tests with the machine were made at grades of service between 1 in 40 and 1 in 80; as has been shown, the most efficient arrangement at a grade of service of 1 in 80 is not necessarily the most efficient at 1 in 500. Secondly, the smooth progression theory was devised for use with straight gradings, whereas, in the gradings tested with the machine, slipped (and in a few cases cyclic) connections were introduced wherever possible; it has been demonstrated above that the introduction of such connections most favours the grading with the largest numbers of partial commons, which is, in this particular case, grading 0 7 3 0. The smooth progression theory cannot, therefore, be regarded as disproved by the published results of tests made with the artificial traffic machine; it is rather that the theory is not so general as has been supposed, and does not apply at all grades of service or when slipped and cyclic connections are introduced.

Conclusions.

It has been shown that the relative efficiencies of gradings vary with the density of traffic offered; that cyclic, and, to a lesser extent, slipped connections increase the efficiency of gradings appreciably; that these types of connections can be introduced most freely into gradings which, in their straight form, have the most partial commons; and that these are also the most efficient grading arrangements under conditions of heavy loading. The question arises, in view of the above, whether gradings should be arranged with regard more to conditions of full loading than to conditions when the standard grade of service is given; and, in general, if cyclic connections are employed, whether the function of grading, in the conventional sense, is merely to enable groups with a number of channels which is not an exact multiple of the availability to be accommodated in a convenient manner. When the number of channels is an exact multiple of the availability, parallel groups, ungraded in the conventional sense, but with cyclic connections introduced, may well be the most satisfactory arrangement, when all considerations are taken into account.

Finally, it should be mentioned that although some of the examples quoted in the above discussion are comparatively simple in order to keep the article within a reasonable compass, the results have been tested and confirmed in an appreciable number of more complicated examples. The study is clearly at an early stage and several lines for further investigation suggest themselves.

Book Review

"The Technique of Microwave Measurements." Edited by Carol G. Montgomery. Vol. 11 of the Radiation Laboratory Series. (Massachusetts Institute of Technology, U.S.A.). 939 pp. 627 ill. McGraw-Hill Publishing Co., Ltd. 60s.

It is axiomatic that progress in a new field of science or engineering depends to a large extent on the success attained in the development of precise measuring techniques. The wartime development of radar showed that this axiom was as true in the new field as in other fields of science and engineering in the past. As a result a very considerable effort was applied during the war years to the development of precise and convenient measuring techniques for use in the microwave range (1,000-30,000 Mc/s) by workers in Services, University, Industrial and Government Laboratories in America, Great Britain and the Dominions.

The "Technique of Microwave Measurements" is a survey of the most accurate and useful methods of measurement which have so far been developed, emphasis being placed primarily on laboratory equipment and methods likely to be of value to future workers in the microwave field.

The techniques described fall under four main headings:—

- I. Power Generation and Measurement.
- II. Wavelength and Frequency Measurement.
- III. The Measurement of Impedance and Standing Waves.
- IV. Attenuation and Radiation Measurements.

Each section has been prepared by experts in the particular phase of measuring technique under discussion, reference being made to many wartime laboratory reports hitherto unpublished.

Section I describes microwave power sources such as the reflex klystron oscillator, methods of frequency stabilisation of the power source and methods of power measurement using bolometers, thermistors and water-load wattmeters. Signal generators and noise sources for use in testing receivers are discussed.

Section II deals with the measurement of wavelength by means of resonant cavities, and frequency by frequency-multiplier techniques.

Section III is devoted to the principles of impedance measurement by the standing-wave ratio method and by impedance bridges using waveguides. The measurement of dielectric constant is discussed in detail.

Section IV deals with the design of waveguide and coaxial attenuators using modes below the nominal cut-off frequency, and resistive attenuators. The application of directional couplers to the measurement of forward and reverse power is explained. The final chapter is concerned with measurements of aerial gain directivity and phase-front patterns.

This volume of some 925 pages contains a wealth of information of a practical as well as a theoretical kind and is likely to be a classic reference book for all concerned in the microwave art, for many years to come.

W. J. B.

A Trench-cutting Machine

U.D.C. 621.315.233

J. W. SPOONER, A.M.I.E.E.,
and W. J. R. THOMSON

This article gives details of an improved trench-cutting machine now being used by the Post Office and outlines the operating experience gained in the field.

Introduction.

As a result of experience gained through observing trench-cutting machines employed by Post Office contractors, the Post Office has recently placed an order for a number of Type "BA3" Aveling-Barford machines, which incorporate several modifications made to suit Post Office conditions. Although other trenching machines have points in their favour it is considered that this type of machine has certain advantages, namely, the capital cost is low, it is light, and can be transported in a standard Departmental 4-ton lorry, and a safety feature helps to protect the machine when the cut is too heavy for the type of soil encountered. The machine is designed to cut a trench either 11 or 18 in. wide to a depth of 3 ft. 6 in. and will, it is claimed, attain a maximum speed of 175 ft. per hour in favourable soil conditions. A speed of 200 yards per day seems to be a reasonable average in most soils except the very hard, and this assumes the machine is operating continuously for eight hours and digging an 11-in. trench of 24 in. depth.

By reason of the compact design and small side-overhang the machine can be operated within 2 ft. of the boundary line, whilst it is so designed that the soil can be deposited to either side of the trench. Usually, however, it is quicker to turn the machine round and work in the opposite direction rather than change over the spoil conveyor from one side to the other.

Mechanical Details.

General views of the machine are shown in Figs. 1



FIG. 2.—CUTTING A TRENCH.



FIG. 1.—AVELING-BARFORD TRENCH-CUTTING MACHINE.

and 2. A trench is excavated by means of a digging boom carrying an endless chain on which are mounted stellite-tipped carbon-steel tines and transverse spade plates which loosen and push the spoil forward and upwards where it is scraped sideways by means of a spoil conveyor to form a continuous bank at one side. If the digging boom meets subsoils which are too difficult for it, it tends to rise and so prevent damage to the tines and plates, but if a large stone does jam the chain it can be released by operating a toggle joint provided for the purpose.

The machine is powered by an 8-h.p. industrial type petrol engine complete with automatic coupling clutch. The engine is directly coupled to a worm reduction gear and thence by adjustable bush roller-chains to the digging gear and by mitre gears to the spoil conveyor. This means that the digging and

banking chains both rotate as soon as the engine is started up.

The machine is of the self-hauling type and employs a ground anchor (Fig. 3) with 300 ft. of steel wire

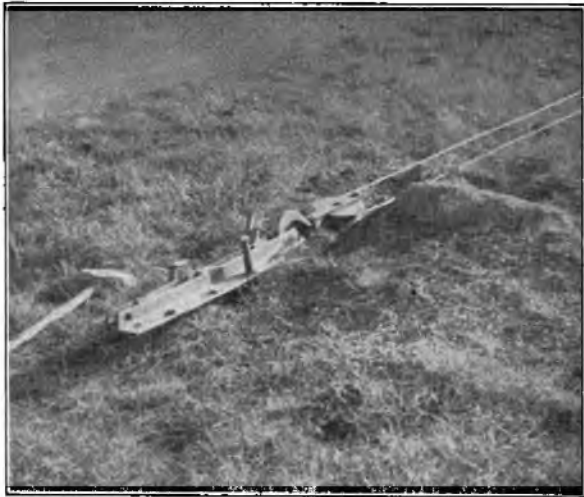

FIG. 3.—GROUND ANCHOR.

rope giving an effective length of 140 ft. maximum for one setting of the anchor. The steel wire rope passes from the winding drum through a pulley block at the anchor and back to the draw-bar of the machine. The forward movement is accomplished by winding in the steel wire rope around the drum which is rotated by a crank-operated variable-stroke ratchet drive. The stroke of the ratchet gear can be varied to take up from one-half tooth to four full teeth of the wheel at each revolution of the main shaft. The adjustment is by a hand-screw and fly nut in stages of one-half tooth. This half-tooth adjustment is made possible by using two pawls spaced one half-tooth apart.

To enable the operator to keep the machine to a line it is fitted with a steering wheel on the clear side, operating through a worm and worm-wheel. A local modification has been added in the form of a 4-ft. "sighting rod" fixed horizontally and parallel to the centre line of the machine. This, together with three marking pins placed along the proposed track enables the operator to maintain an accurate line, but without this device it is found most difficult to keep the machine straight. To obtain a good trench round curves and corners, a row of small pegs spaced equally and at short distances apart is found useful; metal meat skewers are ideal for the purpose. Owing to the worm and worm-wheel design, the steering is irreversible and must be disengaged whenever the machine is put on tow. To enable the machine to be used on sloping ground, both rear wheels are adjustable vertically through a height of 6 in., that is either 3 in. above or below the normal position. By this adjustment it is possible to

excavate a vertical trench in most grass margins. This is an advantage over certain other types of trench-cutting machines where it is necessary to use wooden sleepers as packing to maintain the machine on an even keel. The machine must be kept level otherwise trouble is experienced with the boom and excessive wear occurs in the bushes and pins. Circular guide plates are supplied with the machine to prevent side-slipping when used on steeply sloping ground, and these are attached to the rims of the front and rear wheels on the clear side. Lugs are spaced round the wheel rims for this purpose.

The spoil conveyor (Fig. 4) carries low-carbon steel scraper plates fitted to a malleable iron chain running on chilled iron sprockets. The chain is adjustable by means of a set-screw and lock nut, and it can be disposed to either side of the machine. The Post Office has had a modification made to the main horizontal beam supporting this chain, whereby the side-overhang can be reduced to enable the machine to be accommodated in a 4-ton lorry. In adjusting the chain, it is necessary to ensure that the scraper plates are as near to the ground as possible, otherwise the spoil heaps up in front of the boom. The alteration of the spoil conveyor from one side to the other is a rather laborious proceeding involving dismantling and subsequent re-fitting on the opposite side. The parts that have to be dismantled are the conveyor chain and supporting frame, the steering unit, portion of the ratchet gear connected with the forward movement and the digging-boom capstan wheel. The whole operation takes about a day to complete. When moving the machine from one site to another, the set-screw above the front wheels must be screwed down as far as possible to give the maximum ground clearance to the spoil conveyor.

Operation of the Machine.

Having sited the machine at the starting point the wire rope is payed out. As previously stated, the effective length is 140 ft. so that if the first section to be trenched is more than that, the full length can be used. The free end is passed round a pulley and secured



FIG. 4.—SPOIL CONVEYOR.

to the draw-bar of the machine. If there is any slack in the wire this is wound up by lifting the pawls and using the drum handle provided. The pulley is secured to the anchor and the latter held in position by steel pins fitted with webs to facilitate removal. (In Fig. 3 the pins are without webs.)

If the line of the track slopes transversely, the next operation is to adjust the two main wheels so that the machine remains vertical. The spoil conveyor is then adjusted so that the scraper plates just touch the ground. This is done by raising or lowering the two front steering wheels, which are mounted on a steel king post with vertical adjustment so that, as they are adjusted, the front of the machine, including the spoil conveyor, is raised or lowered accordingly. The spoil conveyor, having been disposed to its correct side, a check is then made to ensure that the digger chain is not fouling the frame or frame parts. If it is, the boom must be lowered by means of the capstan wheel until clear.

The rear wheel scrapers are adjusted so that they bear lightly on the wheels but sufficiently heavily to prevent soil building up on the rims and thereby affecting the depth of the trench.

After a final check that the machine is correctly serviced, it is ready for use, but before starting it is necessary to make sure that no one is near the digging and banking chains, for, as already stated, these commence to rotate when the engine starts.

To commence excavation the boom is lowered by means of the capstan wheel (Fig. 1) and the forward speed set to one half-tooth setting on the ratchet, i.e. the slowest speed. If soil conditions permit this can be increased in half-tooth stages. From experience gained so far, it is seldom possible to exceed a speed of three full teeth although facilities are provided to give four full teeth adjustment.

If stones larger than 6 in. are encountered the boom will shake excessively and tend to rise; it must then be raised clear until the obstruction is passed, and the trench cleared later by hand. It has been found in hard compact subsoils that the positioning of the digging tines is such that as they follow closely behind each other they tend to create a smooth surface rather than cut into it. This can be obviated to some degree by removing three or four tines, and thus allowing the remaining ones to break up the surface better. This action is not recommended for general application but only when the soil is hard and compact. The single (11 in.-wide) digging chain does not

seem as capable as the double chain (18 in. wide) of dealing with difficult subsoils—probably due to the overhang of its outer digging tines. There may be cases, therefore, where the double chain would give a greater rate of progress than the single chain. Whichever type is used, the operator should be ready to switch off the engine should any large obstruction foul the banking chain.

In common with most other types of trenching machine, difficulty is experienced in coping with wet clay. Self-cleaning spade plates are fitted but although they are partially successful they do not appear to be entirely satisfactory and clay is carried back to the trench.

To move the machine from site to site the spoil conveyor is adjusted as previously mentioned and the machine can then be accommodated in a 4-ton lorry. To effect the removal it is necessary to use a ramp under each wheel, having first adjusted the main wheels to give maximum ground clearance. The lorry winch is used to pull up the machine, the draw-wire being attached to the draw-bar of the machine. When the distance involved in a removal is less than about $\frac{1}{2}$ mile, it is usually more economical to tow the machine and in this event a safe maximum speed of 4 m.p.h. may be achieved.

Organisation of Work.

The best organisation seems to be to use a six-man gang where the foreman is in sole charge, the machine operator is a man with experience of mechanical aids, the ductlayer is usually the leading hand, one man operates the trench-filling machine, one a mechanical rammer and the sixth is on labouring duties, mostly assisting the ductlayer.

Conclusion.

The first of the machines to be supplied to the Post Office has been in use for a few months in the Lincoln Telephone Area. Although comprehensive comparative costs are not yet available, it is already clear that the saving, as compared with contract rates, is considerable. As an example may be quoted the trenching costs for approximately three miles of single-way duct (laid in subsoils varying from wet clay to hard limestone), the costs in this instance being less than one-half of the estimated contract price. Given good maintenance, the machine should prove a valuable acquisition especially now that contract labour available to the Post Office has been greatly reduced.

Book Review.

"Industrial Electric Motors," 104 pp. 35 ill. Higgs Motors Ltd. 1s.

This is the second edition of a useful little book (4 $\frac{1}{2}$ in. \times 3 $\frac{1}{2}$ in.) giving hints on the installation and maintenance of electric motors and generators. The notes are based on the firm's experience in the manufacture and supply of motors for various purposes and deal with ordinary industrial applications. Sections are devoted to short descriptions of motors, generators and starters and extracts from B.S.S. 168—1936 and I.E.E.

Regulations for the Electrical Equipment of Buildings. The remainder of the book deals with the installation and maintenance of motors with particular reference to the firm's own products. Included in the installation details are such operations as handling, fixing in unusual positions, fitting pulley and belt drives and location of faults on installation. The book is illustrated by many wiring diagrams and tables giving necessary information on horse power, current consumption, fusing requirements, etc. A useful book for the practical man.

W. T. G.

Overseas Exchange (Radio Services)

R. C. DEVEREUX

U.D.C. 621.396.65 : 621.396.7

To handle exclusively the large volume of traffic now routed over radio channels, Overseas exchange was opened in November, 1947. This article describes the main features of the installation and its interconnection with the two Radio Telephony Terminals now in operation.

Introduction.

THE 7th January, 1927, marked an historical event in the sphere of telecommunications, as on that day the peoples of two great cities were brought within speaking distance by the opening of the first transatlantic radio telephony circuit between London and New York.¹

On the 24th November, 1947, almost 21 years after the inauguration of the service, a new Overseas exchange was opened in the Monarch telephone exchange building in London to handle exclusively the large volume of traffic from England and the Continent to all parts of the world now routed daily over radio circuits. Prior to the opening of this new exchange the radio traffic was handled at the International exchange in Faraday Building.²

The radio network as at March, 1948, is shown in Fig. 1.

Services to Madrid, Lisbon, Athens and Moscow, although proper to the Continental exchange, are temporarily maintained by radio circuits owing to present difficulties in providing satisfactory land-line connections.

Direct radio-to-radio through connections can be obtained via London over all circuits. Indirect radio services are available via the Belgian and Dutch radio stations to Leopoldville in the Belgian Congo and Curacao in the Dutch West Indies. Connections are obtained by the Overseas operator via the Continental switchboard to Brussels or Amsterdam exchanges respectively.

Before proceeding to a description of the new exchange a brief reference will be made to the Radio Telephony Terminal,³ a vital link in the radio telephone service. The Overseas operating positions work in conjunction with the R.T.T., i.e. the engineering control equipment and Technical Operators' positions, at which the land lines to and from the transmitting and receiving radio stations are brought together before being extended to the switchboard. The R.T.T. equipment is at present divided between two terminals, one being just under three-quarters of a mile away in Faraday Building and the other about 8½ miles away in Brent Building at Hendon.

The Exchange Equipment.

The exchange was installed by the Automatic Telephone and Electric Co., Ltd., and has an initial equipment comprising 84 positions in the main operating suite, 21 record, enquiry and observation positions, a main ticket control position, minor ticket control tables, directory racks, supervising officers' desks and tables, together with the associated apparatus and test racks. The layout of the switch-room and apparatus rooms is shown in Fig. 2.

An M.D.F. has not been provided. Main cables

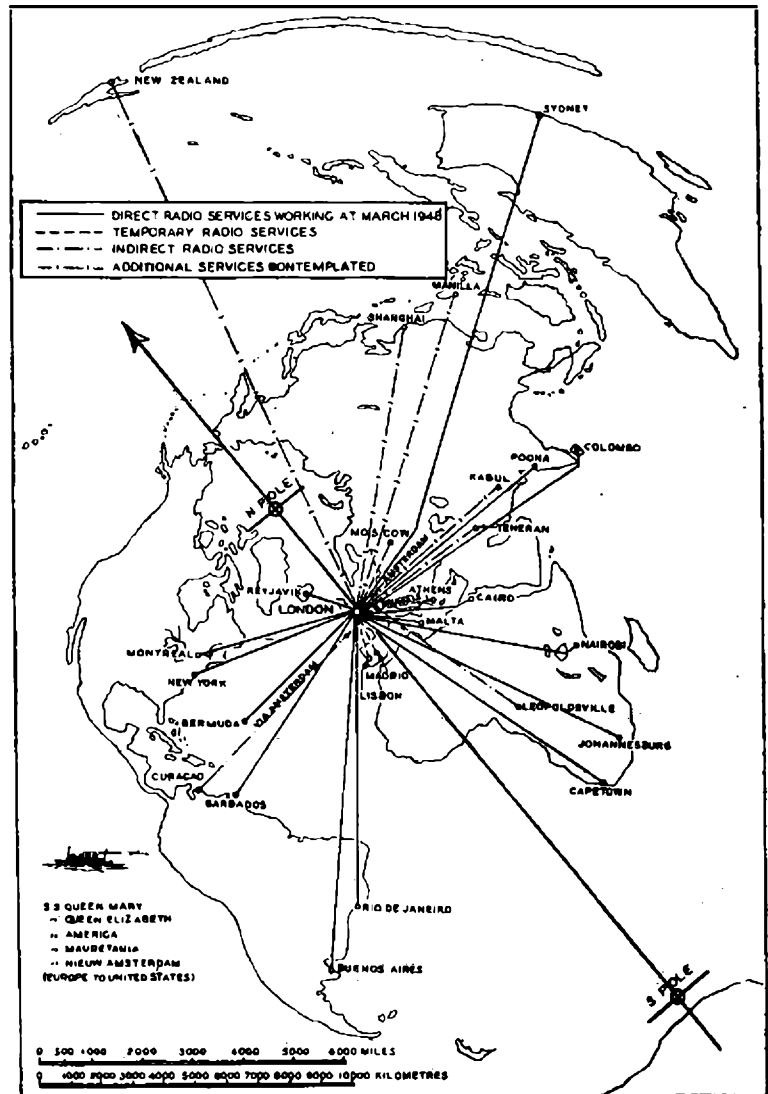

FIG. 1.—RADIO TELEPHONY NETWORK.

¹P.O.E.E.J., Vol. 20, p. 52.

²P.O.E.E.J., Vol. 21, p. 100.

³P.O.E.E.J., Vol. 24, p. 53.

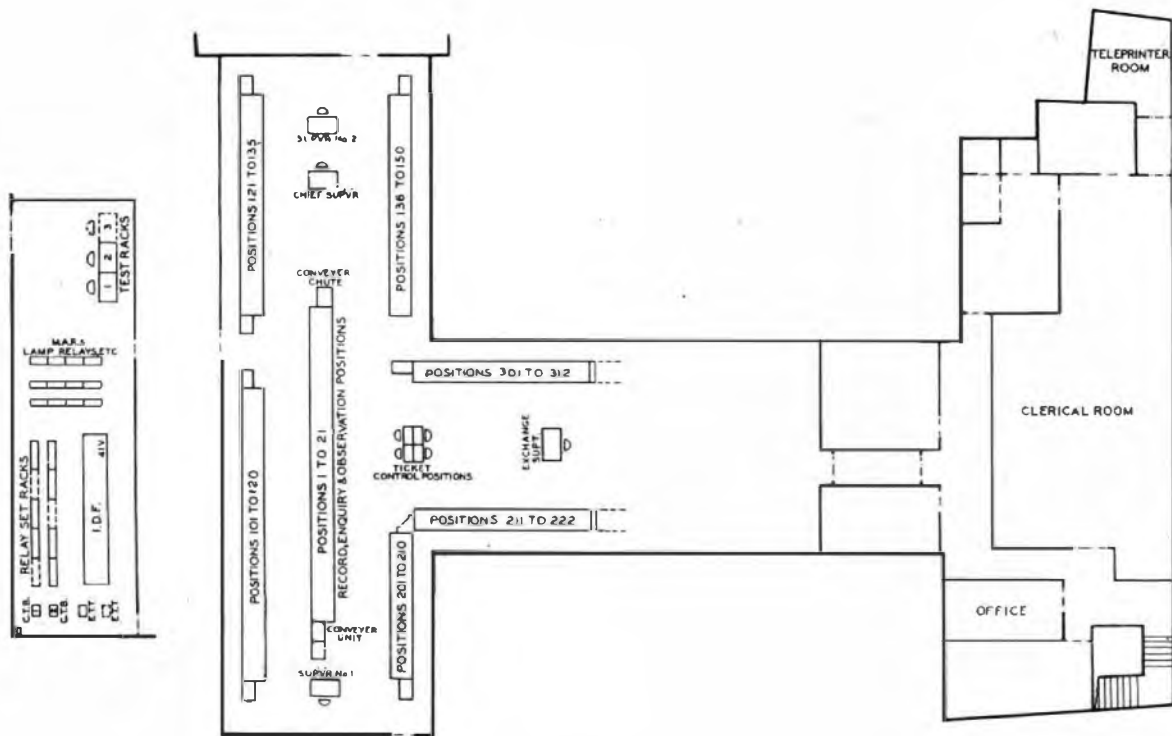

FIG. 2.—LAYOUT OF SWITCHROOM AND APPARATUS ROOM.

direct to Brent and Faraday Buildings, and a cable to the Monarch exchange M.D.F. for alternative routing via other main cables, terminate on cable test bays and are used for routing the radio channels to the R.T.T.s. All channels which are not routed on the direct cables are cabled, instead of jumpered, on any intermediate frames through which they pass. A tie cable from the I.D.F. to Monarch M.D.F. is provided for access to local junction cables. Termina-

ting and transformer equipments, cabled across the I.D.F., provide terminations for the 4-wire extensions of the radio circuits. Testing facilities are provided by two trunk type test racks. All relay sets except those for the radio circuits are of standard sleeve control type and need no special mention. The "state of channel" lamp rack is unusual and will be mentioned later, but the other lamp racks are of standard design. Battery power supply is taken from the Monarch exchange plant.

All positions are of the standard 4 ft. 8½ in. high sleeve control construction, use of these low type positions having been made possible by the absence of the large trunk multiple which was available at the old exchange. A general view of the switchroom is shown in Fig. 3 and a close-up view of the keyshelf and face equipment of one of the positions is shown in Fig. 4. It will be seen that little keyshelf equipment is fitted. Apart from the standard position keys only four pairs of cords with combined speak and monitoring keys and one single-ended cord without keys are provided. The visible index file, rhodoïd panel for bulletins, instruction circuit press-button key and lamp, stop-watches and dial complete the equipment. The three lamps on top of the position are "state of channel" lamps.

The record and enquiry positions are equipped primarily with three pairs of cords, but the first nine positions are



FIG. 3.—GENERAL VIEW OF THE SWITCHROOM.



FIG. 4.—OPERATOR'S POSITION.

arranged for observations on the radio circuits and are provided with a fourth pair of cords and a single cord. A band conveyor is mounted on the top of these miscellaneous positions for the purpose of conveying tickets to the end of the suite for collection and distribution. The conveyor is totally enclosed in a polished wood casing with apertures over each position for posting of tickets.

Double-faced clocks with 24-hour dials are mounted on pillars on top of the positions at approximately 16-ft. intervals. Alternate clocks have black or white dials and all normally show G.M.T. When, however, daylight saving is in force the clocks with white dials are advanced to indicate B.S.T.

The main ticket control position shown in Fig. 5 is used only on the New York route and was provided to accommodate the large number of tickets involved on this route. It is a 4-position table fitted with inset ticket trays containing 48 compartments. Half are used for tickets relating to outgoing calls and the other half for those relating to incoming calls. The tickets are placed in various compartments which are labelled to indicate particular stages of the calls. A plate glass panel on which tickets can be sorted fits into the raised frame over the centre of the table. Four keys, common to all positions, give outgoing access to two lines on Monarch exchange and two lines to the Overseas switchboard for the passing of calls via the trunk or toll exchanges, whilst four other keys, with associated calling lamps, terminate the circuits incoming to the ticket control from the switchboards.

Before proceeding further it will perhaps be informative, and lead to a better appreciation of the facilities provided, if the operation of the service is outlined.

• *Operation of the Service.*

A subscriber desiring to make an Over-

seas call obtains connection in the normal way to the exchange at which his trunk calls are controlled and, on quoting town and country required, he is extended to the Overseas exchange record positions, where full details are taken and entered on a special radio call ticket. The record operator passes details of the required call over an O/G multi-line circuit to a time assignment clerk (T.A.C.), who holds schedules showing the bookings on all routes, and a ticket is appointed for completion of the call. The subscriber is advised accordingly and, if the time is satisfactory, a serial number is allotted by a serialising clerk working with the T.A.C., entered on the time assignment schedule and the radio ticket, and quoted to the subscriber. The call is thereafter known by this number. After certain checks of the details have been made the ticket is passed to the channel operator controlling the required route and details

transmitted to the distant terminal at the earliest possible opportunity in order that the required subscriber may be contacted and his agreement obtained to acceptance of the call at the appointed time. (The New York route bookings are very heavy in both directions and are generally passed by teleprinter on a radio circuit which is used solely for this purpose. The teleprinter is, however, not brought into service until about 1.30 p.m. (London time) daily and urgent calls are passed verbally if necessary.) The distant operator then reports to London on the position. The calling subscriber is advised accordingly and, if the time is unsuitable to the called party, a new time is arranged. Shortly before the appointed time the channel operator advises the distant terminal that the serial number . . . will be the next call. An operator at the distant end proceeds to contact the required subscriber and at the London end an "advancing" operator working on a position adjacent to the channel operator contacts the calling subscriber and advises him that his radio call is being put through. He explains the procedure if the caller is unfamiliar with the service, and holds him on the line. When the distant terminal advises that the called subscriber

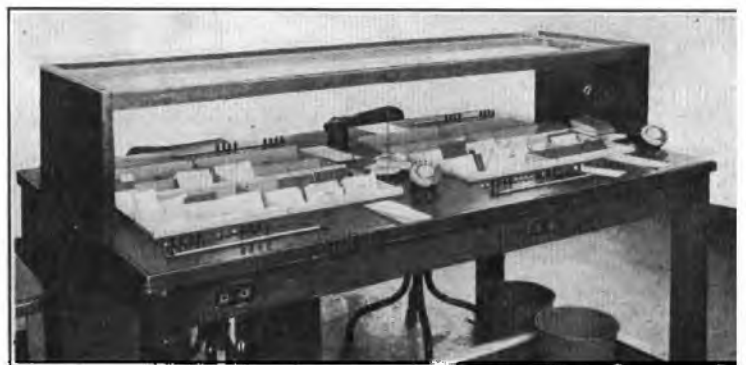

FIG. 5.—MAIN TICKET CONTROL POSITION.

aiting, the channel operator takes over the calling subscriber by overplugging with a cord on her own position the next multiple appearance of the circuit in which the subscriber was called by the advance calling operator, inserts the other plug of the cord into the channel jack and, after verifying that both subscribers are in circuit, advises them to go ahead.

Coupled stop watches, one of which is used to record total duration of the call and the other chargeable time, are then started. The operator proceeds to monitor the call in order that she may observe the quality of the transmission and stop the chargeable time whenever necessary. A running summary of all difficulties which arise is made on the ticket, and details of the total duration and chargeable time are entered on completion of the call.

At either end of a radio circuit there may be many miles of land line or, as in a few cases such as Sydney, Australia, to Wellington, New Zealand, or New York to Alaska, another radio link, to the calling and called subscribers. It will be appreciated that, depending on the prevailing atmospheric conditions, the radio circuits may under favourable circumstances be suitable for all calls, whatever their place of origin and their destination, whilst at other times routing restrictions may have to be applied and extension of calls beyond the terminal limited. A circuit may perhaps be suitable only as an "order wire" between the terminal operators or even completely unusable. The suitability of the channels for traffic is determined by the technical operator and signalled to the traffic operator by means of the state-of-channel lamps.

Arrangement of Switchboard Multiple.

The interposition, outgoing, radio channel and answering multiples are arranged in four groups as below, and are cabled separately to the I.D.F., where similar multiples terminate on adjacent rows of tags in the connection strips and are commoned with bare wire.

- 1st Group. R. & E.Q. suite. Positions 1-21
- 2nd Group. Main suite. Positions 101-150
- 3rd Group. Main suite. Positions 201-222
- 4th Group. Main suite. Positions 301-312

This arrangement permits easy splitting of the multiples if required at some later date.

Circuit Provision.

The following groups of circuits are provided in the outgoing multiple (with F.L.S.) for the purpose of recalling originating subscribers, setting up incoming calls received over the radio circuits, enquiries, etc.

- 14 to Trunk exchange Inland positions.
- 5 to Trunk exchange Continental positions.
- 2 to Trunk exchange Channel Is. positions.
- 2 to Trunk exchange Eire positions.
- 10 to Toll A automatic exchange.
- 50 to Toll B automatic exchange.

The non-F.L.S. multiple gives access to miscellaneous circuits such as lines to the Time Assignment Clerk, Ticket Control, R.T.T., Test Desk, Divisional and Section Supervisors. All positions in the main suite are connected by an interposition multiple.

The main groups of circuits appearing in the answering multiple are :—

- 10 from Trunk exchange Inland positions.
- 7 from Trunk exchange Continental positions.
- 5 from a Central exchange F.S. number.
- 10 from a City exchange F.S. number.

The final selector numbers are used by certain controlling operators who can reach them by dialling. Routing via the Trunk exchange manual positions is thus avoided.

As these circuits are for booking purposes the primary appearances are on the record suite, but to avoid unnecessary staffing of this suite, calls are answered on the main suite during slack booking periods.

Miscellaneous circuits from the Exchange Superintendent, Divisional Supervisor, Ticket Control, Enquiry positions, R.T.T.s, etc., also terminate in the answering multiple.

In the radio channel multiple provision has been made for 60 link circuits to the R.T.T.s. These circuits, which are known as Radio Channels, are each equipped with five jacks and three lamps, and are connected to the R.T.T. via radio channel relay sets, the circuit of which is shown in Fig. 6. The jacks and lamps for each channel are mounted vertically above one another in the order in which they appear in the diagram. Twenty radio channels appear in each alternate panel, thus giving a 6-panel repetition of the 60 circuits. They are also multiplied along the first nine positions of the record suite for observation purposes, but the monitor "A" jack and control circuit jack and lamp are omitted on this suite.

For channels to Brent, 8-wire junctions, which provide 4-wire transmission paths (amplified at Brent), monitoring and control pairs, connect each working relay set to the R.T.T. equipment, and superposed on these wires are the various signals which are required on circuits of this special character.

As the distance to Faraday Building is comparatively short, the arrangement is slightly different, the 4-wire circuit being unamplified and physical pairs used instead of the phantom of the 4-wire for the "red" and "green" state-of-channel signals. Ten wires are therefore required. The 4-wire circuit terminates direct on the terminating unit, the line transformer being by-passed.

The new exchange opened with 13 links to Faraday R.T.T., at which there were 12 working terminal positions, thus providing one spare link, and with 12 links to Brent at which there were six working terminal positions with six more in course of installation.

SIGNALS OVER THE LINK CIRCUITS

The following signals are transmitted over the different wires.

<i>Wire.</i>	<i>Signal.</i>
AM	Gain switching.
BM	B/W calling for Radio Channel.
AC	S.O.C. "Yellow."
BC	B/W calling for Control Circuit.
REC (Ph.) ..	S.O.C. "Red."
TRANS (Ph.)	S.O.C. "Green."

The signals will now be discussed in more detail.

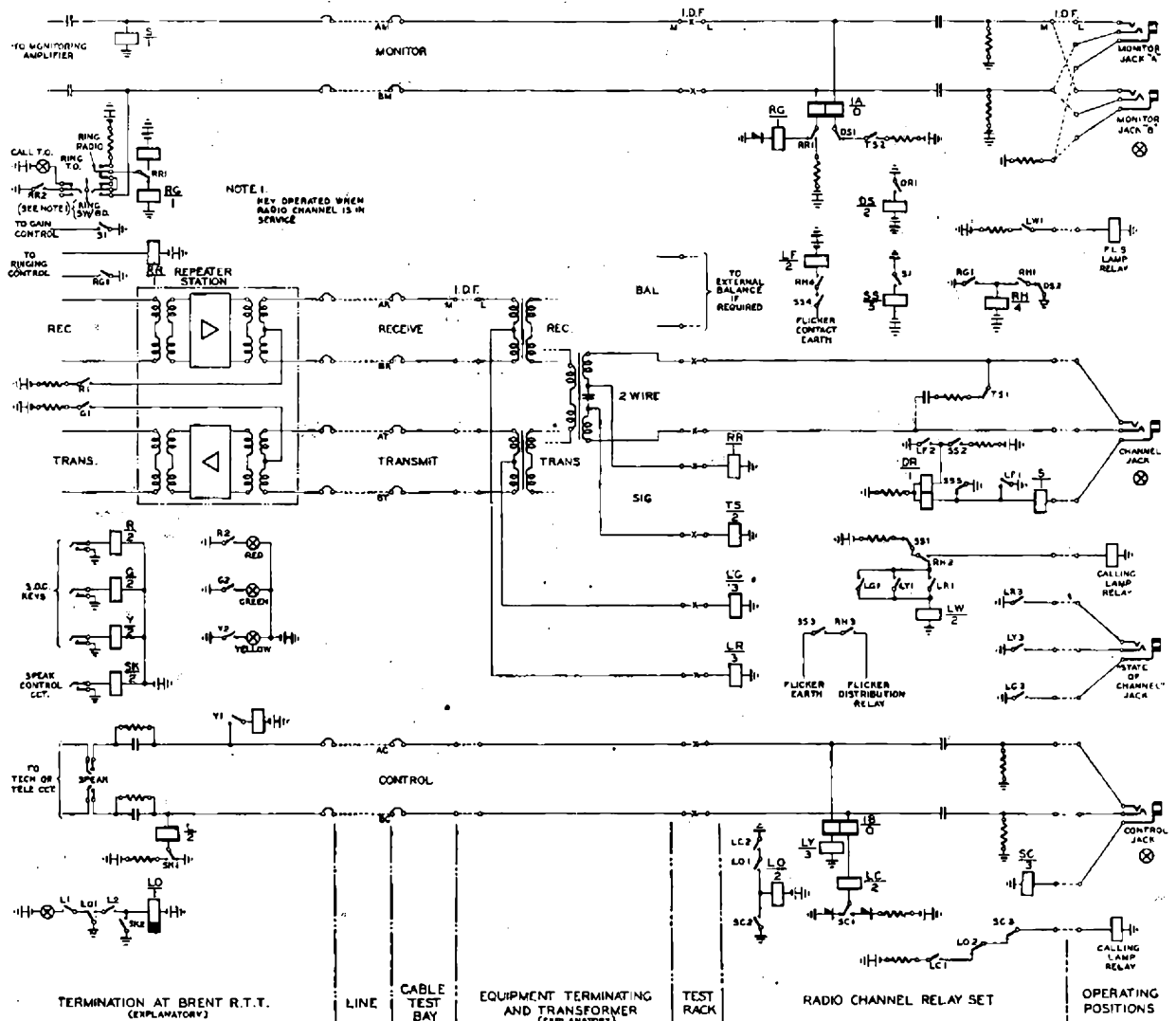

FIG. 6.—SCHEMATIC DIAGRAM OF CIRCUIT FROM OPERATING POSITIONS TO RADIO TELEPHONY TERMINAL.

Calling Over the Radio Channels.

On most routes calling is by verbal announcement, and continuous monitoring by the operator, while a channel is in service, is necessary in order that she may know when the distant operator desires to pass an incoming call. On routes which are suitably equipped, however, the exchange equipment provides for calling signals in both directions, thus obviating the need for continuous monitoring. This facility is at present provided on the New York route only, but will be extended to other routes as opportunity arises. Calling in the outward direction is effected by inserting a plug into the channel jack and operating the speak and ringing keys. Relay RR operates and at RR1 connects a battery to the BM wire to operate relay RG at the RTT, thus causing the channel ringing equipment to be operated at RG1. In the reverse direction, ringing over the radio channel causes RR relay at the terminal to operate and connect battery to the BM wire at RR1. This operates RG in the relay set at Overseas exchange.

RG1 operates relay RH which disconnects LW relay at RH2, to release the F.L.S. lamp relay, and operates the calling lamp relay. If another call is received whilst the plug is still in the channel jack, recall facilities are provided by operation of relays RG and RH. A flicker earth is connected by RH4 from SS4 (which is operated with the plug in the jack) to relay LF which, at LF1, causes the cord circuit supervisory relay to flash.

Signalling over the Control Circuit.

This circuit provides direct connection between the traffic and technical operators. Automatic signalling in both directions is effected over the BC wire. The circuit operation is self-explanatory. A plug and jack arrangement is used at the Faraday R.T.T. instead of a key as shown.

Gain Switching Signal.

The radio transmitter must, for most efficient working, be kept fully loaded and the volume o

speech received from subscribers has to be brought within prescribed limits by the gain control at the R.T.T. Should the Overseas exchange operator enter circuit and speak, however, overloading may occur owing to the higher level of the received speech. Arrangements are therefore made to reduce the gain immediately the cord circuit speak key is thrown, to a level suitable for average speech levels from the traffic operators. This is effected in the following way.

When only the subscriber is in circuit the through signalling relay TS connects battery at TS2 via DS1 to the AM wire to operate relay S at the R.T.T. With S1 operated the gain is set at the higher level suitable for the particular subscriber's speech. When the cord circuit speak key is thrown, DR and DS relays operate and the battery on the AM wire is disconnected at DS1. S relay at the R.T.T. releases and causes the gain to be switched to the level suitable for speech from the operators.

In the case of radio-to-radio through connections the switching relay at the R.T.T. must be operated, but this cannot be effected with radio channel relay sets on both ends of the same cord. Two cords are used, therefore, and one circuit is connected to another via two special jacks which are wired back-to-back with a battery and earth feed via impedance coils bridged across the tip and ring. This battery provides the switching condition over both channels. Six pairs of jacks are provided in the O/G multiple for such through connections.

The Monitoring Circuit.

To monitor a call the operator uses a separate cord in the monitoring jack which gives access, over the monitoring pair, to a high impedance amplifier at the R.T.T. This amplifier is connected on the input side of the receive channel amplifier and the output of the transmit amplifier and is arranged to transmit to the operator the same volume of speech from either side of the channel.

The second monitoring jack is provided to enable the "advance calling" operator to listen on the same circuit and anticipate the correct moment at which to commence the advance calling of the next subscriber, and thus avoid keeping him waiting on the line for an undue period before the radio circuit becomes free.

Radio Channel Free Line Signals.

The free line signalling arrangements are unusual in that the lamp for a particular radio channel lights when the F.L.S. relay for that channel operates, instead of being extinguished, and also, switching to the next free trunk is not provided. The lamps are therefore purely visual idle indicators for individual channels. As will be seen from Fig. 6, the F.L.S. relay LW cannot operate unless one or more of the S.O.C. relays is operated, i.e. until the technical operator has indicated that the radio circuit is ready for service.

State-of-Channel Signals.

Visual indications regarding the suitability of the

radio circuit for traffic and the restrictions, if any, which must be applied are conveyed to the Overseas operator by the three lamps mounted on the top of each position. These lamps are coloured red, yellow and green and are connected in that order to the tip ring and sleeve of the single cord. Insertion of the plug into the S.O.C. jack causes the lamps to glow either singly or in combination, depending upon the condition which the technical operator has set up by means of the keys shown in Fig. 6 in accordance with the prearranged colour code given below.

<i>Lamps Glowing.</i>	<i>Meaning of Signal.</i>
Yellow	Channel suitable for all calls.
Red-Yellow	Calls restricted at the London terminal.
Green-Yellow	Calls restricted at distant terminal.
Red-Green-Yellow	Calls restricted at both terminals.
Red-Green	Channel suitable for "order wire" only.
Red	Channel standing by (transmitter shut down).

At the old exchange the S.O.C. lamps were provided on a per channel basis and were mounted in the jack field with multiplied appearances. When considering the design of a new exchange with an ultimate of perhaps 150 positions and 100 radio channels having a 6-panel repetition, it became evident that there would be a very considerable drain on the A.C. supply, as even if only one lamp per channel was glowing simultaneously, almost 6,000 lamps would be alight. The cord and jack arrangement was therefore adopted as it will result in considerable saving of power and also in lamp maintenance.

Display Panels.—The plug and cord arrangement had the attendant disadvantage that the controlling officers could not see the state of all channels at a glance and thus ascertain the overall position. Display panels as shown in Fig. 7 are therefore fitted on

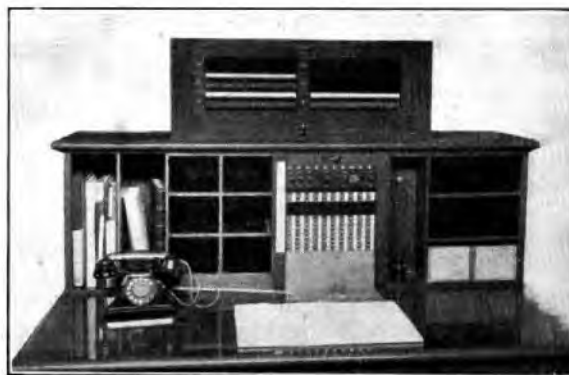

FIG. 7.—SUPERVISOR'S DESK, SHOWING THE DISPLAY PANEL.

the Traffic Superintendent's table and on each of the two Divisional Supervisors' desks. Each panel caters for duplicate indications of the F.L.S. and the three

S.O.C. lamps on a maximum of 120 radio channels, and all panels are fed from an A.C. lamp rack which

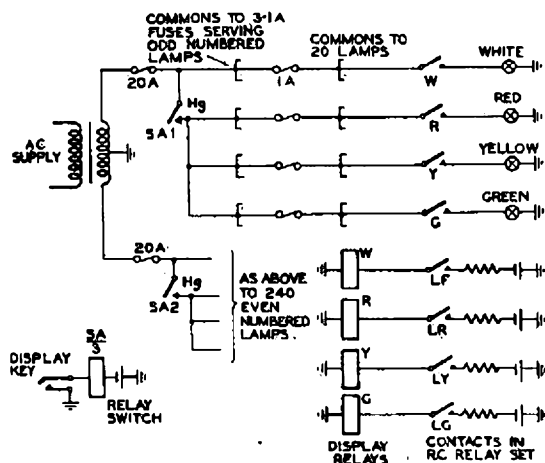

FIG. 8.—POWER DISTRIBUTION TO DISPLAY PANELS.

serves a maximum of four complete displays, i.e. the rack will feed 1,920 lamps. The F.L.S. lamps glow

continuously on all circuits which are available for traffic but not actually in use, but the S.O.C. lamps can be switched on and off by a key on each display panel. As the ultimate load with 360 lamps glowing would be approximately 14.4 ampères, the key is arranged to control a relay switch with two mercury tubes, one of which controls the "odd" lamps and the other the "even" lamps. The power distribution and fusing arrangements for these display panels are shown in Fig. 8.

These complete displays are quite independent of the single-ended cords on the positions and will function, when the display keys are thrown, whether these cords are in the S.O.C. jacks or not.

Acknowledgments.

The author wishes to thank various members of the L.T.R. Headquarters staff, the Supervising staff of the Overseas exchange and staff of the E.-in-C.O. Radio Branch for assistance they have given him on points of detail in connection with the radio telephone service. Thanks are also due to colleagues who were good enough to read the draft and offer helpful comments and suggestions.

Book Reviews

"Introduction to Electrical Engineering." G. V. Mueller. 591 pp., 481 ill. McGraw Hill Publishing Co., Ltd. 30s.

This second edition has been so extensively rewritten, and so considerably enlarged, that it may almost be considered to be a new book.

Although it is, as stated in the title, an introduction to electrical engineering, it is not a book for elementary students. The ground covered is limited, but is dealt with thoroughly, e.g. 171 pages are devoted to Ohm's and Kirchoff's laws, and a knowledge of higher mathematics is essential. Other chapters deal with conductors, insulators, non-linear resistors, electro-chemistry, magnetic circuits, induced and generated E.M.F.s, and dielectrics.

The book is almost wholly theoretical and practical examples are not extensively quoted; such as are included are sometimes poor, e.g. the descriptions of measuring instruments and secondary cells. Extensive lists of questions for the student to work out are included but answers are not given for him to check his results. American terms and spelling do not often cause confusion, but these, together with the use of M.K.S. units, produce "ohm-meter" as the unit of resistivity and such unfamiliar terms as "webers per square meter" and "mega-darafs".

A very useful book for the university undergraduate.
H. L.

"Radar Beacons." (Volume 3 of the Radiation Laboratory Series); edited by A. Roberts. 489 pp., 246 ill. McGraw-Hill Publishing Co., Ltd. 36s.

Because radar was developed for warlike purposes one of its earliest problems was that of distinguishing friendly targets from hostile targets. This was solved by installing in friendly targets, i.e. friendly aircraft, etc., small transmitters which emitted characteristic trains of pulses in a particular frequency band when radar pulses were received in certain other bands. These

characteristic trains were used, in effect, as passwords in response to the radar challenge. This technique was soon extended to fixed targets in order that they might be identified with certainty and used for navigation in somewhat the same way as lights are used by the mariner. But these radar beacons can be much more useful than lights, because the responses from a single beacon can be used to determine range as well as bearing, and a fix can be obtained on a single beacon. The measurement of range can be made with such precision that developments of the beacon principle which depend entirely on range measurement resulted in some of the most successful and precise position-finding systems evolved during the war.

"Radar Beacons," the third of 28 volumes devoted to various aspects of radar and allied subjects, describes various types of beacon and aspects of beacon design and considers the different position-finding systems that have been based on the beacon technique. The degrees of detail with which various parts of the subject are treated vary markedly. Indeed, I.F.F. is introduced only to dismiss it because details may not yet be released.

The first 120 pages are devoted to "Basic Considerations", and form the part most likely to be of general interest. They include outline descriptions of the various applications of beacons and discuss the factors governing their performance. The remainder of the volume is concerned with detailed treatments of various aspects of beacons and beacon system design, much of which has not, as far as is known, been published elsewhere. It is disappointing that no mention is made of C.W. beacons for use in association with radar, for such beacons, although they yield information on bearing only, have the advantage of great simplicity.

The book will be extremely useful to anyone concerned with beacons and allied subjects, but it is not the type of book that one would add to one's library more or less as a matter of course.
H. S.

A Tester for Measuring the Speed and Ratio of Loop Impulses

R. C. KYME, Grad.I.E.E.,
and C. W. GRASBY

U.D.C. 621.395.341.3

A brief account is given of an impulse speed and ratio tester designed for use in acceptance testing of automatic exchange equipment. To ensure simplicity in operation controls have been kept to a minimum consistent with an adequate order of accuracy in measurement.

Introduction.

DURING acceptance testing of automatic exchange equipment, a need arises for an instrument to measure the speed and ratio of impulses generated by machines and impulse regenerators. It is essential that any such tester should be compact and robust since it is frequently required to be transported by road and rail. At the same time the number of controls should be a minimum to ensure accuracy and quickness when setting up the tester on site. Existing circuits for measuring speed and ratio were examined but proved to be unsuitable for the required purpose.

The circuit of the tester developed to meet this need is based on well-known principles, but the design is thought to be sufficiently novel to be of interest. The tester was constructed with components from stock and it is realised that these may not in all cases represent the optimum values for the circuit. In practice, however, the results have proved very satisfactory.

CIRCUIT PRINCIPLES

The elements of the circuit are best explained separately, although in the practical case they are inter-related.

Speed Element.

The principles of the speed measuring element are shown in Fig. 1. When the impulsing contacts make,

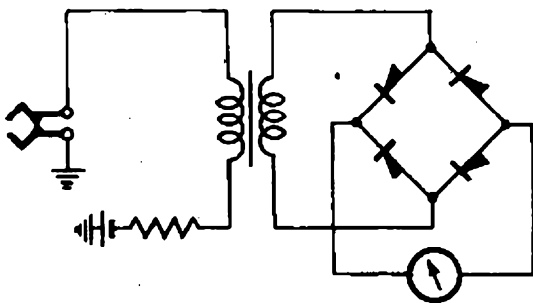

FIG. 1.—SPEED MEASURING ELEMENT.

the current builds up quickly in the primary of the transformer and remains at a steady value during the make period of the impulse. The build-up of current in the primary gives rise to a pulse of current in the secondary of the transformer which dies away when the steady state primary current is reached. At the end of the make period the impulsing contacts break and the primary current falls to zero, giving rise to another pulse in the secondary but in the opposite direction. The bridge circuit is used to rectify the

pulses, and the mean current which they represent is measured by the milliammeter. Provided the pulses do not overlap, the mean current is proportional to the rate at which the impulses are generated, i.e. to the impulse speed, and the speed so measured is independent of the impulse ratio. A suitable current meter with a linear scale may thus be calibrated to read speed direct.

Ratio Element.

The ratio measuring element is based on the well-known principle that a milliammeter with a suitable movement, connected in series with the impulsing contacts, will give a reading directly proportional to the make period of the impulses. It is thus possible to calibrate the meter with a linear scale to read "% make."

THE COMPLETE IMPULSE TESTER

The circuit finally developed is shown in Fig. 2. Use is made of a milliammeter M, already introduced

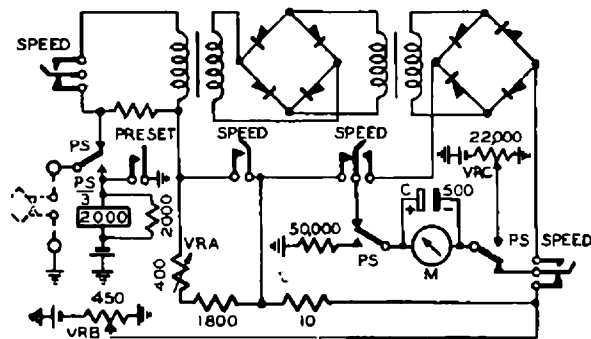

FIG. 2.—CIRCUIT ARRANGEMENT OF TESTER.

as "Impulse Meter No. 1", which has a full-scale deflection of 1 mA and has two scales, "0-100% make" and "0-15 impulses per second." The meter is connected into the ratio circuit with the speed key normal and is switched into the speed circuit when the key is operated. By using a suitable shunt the instrument is calibrated for both speed and ratio by adjusting VRA to give full-scale deflection of the meter with the impulsing contacts closed and all keys normal. This adjustment, which compensates for variations in battery voltage, is the only calibration necessary on site.

An additional adjustment provided by VRA is used when setting up the tester initially, but the rheostat is mounted below the panel, and once set is sealed. VRA is necessary to compensate for differences in the characteristics of individual components.

Since the tester is required to measure the speed and

ratio of dials and regenerators which give a maximum train of only 10 impulses at a time, a preset control has been included by means of which the needle may be positioned to the approximate reading before the train is sent into the tester. Operation of the "preset" key causes relay PS to operate and lock over its own contact to the impulsing loop. PS contacts apply a P.D. to the meter which may be adjusted by VRC. The pre-setting P.D. is removed upon the release of PS during the first break pulse. An electrolytic condenser C is connected across the meter to obtain a steadier reading. This necessitates a slow-release PS relay to obviate the flick of the needle which results if a fast relay is used, due to the condenser discharging through the meter before the first make pulse arrives.

Two stages of differentiation and subsequent rectification are introduced into the final circuit as it is found that by this means increased accuracy results

when measuring speeds with widely differing ratios. Transformers No. 48A, together with Rectifiers No. 1/6G, are used, the latter being found to be the most suitable rectifier for the purpose, provided that the elements forming each bridge are carefully matched.

Limits of Accuracy.

When compared with the laboratory standard, no measurable error occurs between the following limits :—

7% to 87% break ratio at 8 i.p.s.

10% to 87% break ratio at 10 i.p.s.

12% to 88% break ratio at 12 i.p.s.

4 i.p.s. to 15 i.p.s. at 50% break ratio.

The limits are well in excess of any values of speed or ratio which it will be necessary to measure in practice.

Book Review

"Electric Contacts." Ragnar Holm, Ph.D. Almquist & Wiksells, Stockholm. 398 pp.

The selection of material to be included in a book on contact phenomena presents the intending author with a more than usually difficult problem. The difficulty arises from the extent of the field which can be covered. There are two portions of this field which are of particular interest to the electrical engineer; the first includes the properties and use of contacts for the switching of electric circuits; the second, the behaviour and application of metal rectifiers and crystal detectors.

Switching contacts may be continuously sliding (as in the brush-slipping contact in a rotating machine); intermittently sliding (as in uniselectors and two-motion switches); normally closing and separating (as in relays); or, finally, they may be static, in circumstances such that sliding has taken place once (as in a plug and socket), or where normal closing and opening has taken place once (as in a relay left with its contacts closed for a long time). A study of these systems leads immediately, in the "light current" field, to considerations of the behaviour of tarnish films and adsorbed surface layers; and in the "heavy current" field, to investigations of the processes involved in a variety of gaseous discharge phenomena, and the properties of metals at temperatures in the vicinity of their melting and boiling points.

In the metal rectifier and crystal detector, the contact is between a metal and a semiconductor. The study of such a structure opens up a host of problems, in addition to the obvious ones of the mechanisms of rectification and of photoelectric effects.

The scope of the contact field is not, however, limited by the interests of the electrical engineer. The mechanical engineer would include most of the effects encountered in the bearing, together with extensive excursions into the properties and behaviour of lubricants. The chemist would, no doubt, wish to include certain aspects of the corrosion problem. Others with, perhaps, less practical aims, would wish to incorporate discussions of certain thermoelectric phenomena and of frictional electricity. The wide range of the subject also makes it difficult for the prospective investigator to orient himself appropriately and to decide at what point the most useful contribution can be made. Because of this, the appearance of a book giving an account of many of the significant phenomena is of importance.

To those interested in contact research, the work of Ragnar Holm and his associates in the Siemens-Schuckert laboratories has long been familiar, and it is with pleasure that we welcome an English translation of a revised edition of his "Die technische Physik der Elektrischen Kontakte" first published in Germany in 1941. It is safe to say that the English version, like its German predecessor, is likely to become, and to remain for some years, the standard work on the subject. This does not mean that the book is free from faults, or that revision is not, or is not likely to be, desirable. The book does, however, give a good survey of much of that part of the contact field which may now fairly be regarded as "classical," and shows, mainly, perhaps, by implication, which portions of the field have received, perhaps, too much attention and which have received far too little. Workers in this field, like those in other subjects on the hazy borderline between "pure" physics and engineering, have come to realise that significant improvements are likely to result only from major advances in our knowledge of the physics of the solid state. It is, perhaps, well to emphasise this, as the wealth of calculation contained in the book might suggest to the unwary that most of the important contact problems have been solved, an impression which is, of course, very far from the truth.

Opportunities to digress a little from the main theme, in order to draw attention to related items, of interest for their own sake, are not neglected and add to the interest of the book. For instance, the note on Koppelman's "Contact Converter" may help to stimulate interest in a device which is not so well-known as it deserves to be. But, in other places, the author gives the impression of being somewhat unduly preoccupied with the results of his own work and with endeavouring to establish claims to priority. Partly as a consequence of this, some of the material included in the book is of a rather controversial character. Not everyone, for instance, would find the treatment of bridge erosion acceptable. The translation has been prepared and produced in Sweden: this probably accounts for certain misprints and peculiarities of expression. These are not, however, sufficiently significant either to mislead the reader, or to make the text difficult to read. The book can be read with profit and pleasure: it is attractively produced with a pleasant absence of "austerity" methods.

A. F.

The Construction of Zenithal-Equidistant Maps

H. T. MITCHELL, M.I.E.E.
T. KILVINGTON, B.Sc.(Eng.), A.M.I.E.E.
W. E. THOMSON, M.A.

U.D.C. 526.841

The Post Office has, during the last few years, constructed a large number of zenithal-equidistant maps each giving great circle bearing, distance and path, from its centre to any other point on the earth. The data for these maps have been obtained, in the earlier cases, from an oblique stereographic graticule for the centre in question; later, bearing and distance have been obtained by means of the Navicard, a graphic-mechanical device.

Introduction.

FROM time to time radio engineers have to solve great circle problems. Very often one particular point is of interest, and what is needed is the great circle path, distance and bearing from this centre of a large number of other points in various parts of the world. In such cases it may be worth while to make a special world map which will give the required information directly.

Two such maps are shown in Figs. 1 and 2. For Fig. 1 the centre of the map is at Cairo, and the map will give the great circle path, distance and bearing from Cairo of any other point on the surface of the Earth. Once any given point is located on the map the straight line joining it to Cairo is the great circle path to Cairo and its length, as measured on the scale, gives the distance; if the straight line is produced from Cairo, through the given point, to cut the circular scale, the value indicated is the great circle bearing from Cairo, measured in degrees East of North. The special properties of such a map hold good only for great circle paths through its centre.

The projection used for this map is known to cartographers as the zenithal-equidistant. Many radio engineers will probably know it as zenithal-azimuthal, since this title is used for a well-known map with London as centre.¹ This in turn derives its title from an important article on the subject of this and similar types of map,² which uses this name.* The properties of this projection, outlined in the previous paragraph, may be specified by saying that bearing and distance from the chosen centre, distance being multiplied by a suitable scale factor, are used as polar co-ordinates to locate any point on the Earth's surface with respect to the centre; for measurement of angle the cartographical rather than the mathematical convention is, of course, used, i.e. bearings are measured clockwise from North. Although radial distances are correct, the scale in other directions varies; the circumference of the map represents a single point, the antipodes of the centre, and near the circumference distortion is severe.

One of the maps reproduced here (Fig. 2) shows bad distortion; the antipodes of Tokio lying near South America, the latter continent lies close to the border of the map and is very much distorted. On the other hand, in the case of Fig. 1, the map centred on Cairo, the distortion is not so troublesome since no important land masses lie near the antipodes of Cairo.

Several such maps for various centres have been published.¹⁻⁶ During recent years the Radio Branch of the Engineer-in-Chief's Office has had to prepare a number of such maps for centres in different parts of the world. The authors had the task of finding the best way to prepare these. Since the projection is not geometrical and cannot be constructed directly, it is a question of finding, by some means or other, the bearings and distances of a sufficiently large number of points to be able to draw in meridians and parallels, coastlines and so on.

The maps prepared by the Post Office have, as their framework, meridians and parallels for every ten degrees; the intersections of these give 614 points, for each of which bearing and distance have to be obtained, although there exists a simple relation which enables the data for half of these points to be obtained from the results for the other half. Near the circumference of the map a great many more points are required to enable meridians and parallels to be drawn with sufficient accuracy, and it may also be desirable to have the bearing and distance for towns and points on coastlines. The number of points required certainly runs into several hundreds and may approach a thousand.

Radio text-books which deal with such maps usually quote formulæ which may be used to calculate the required bearings and distances.⁷ The formulæ are not simple, and the labour involved in calculation would be considerable. The authors felt that some simpler method, of a graphical nature, would probably suffice. The accuracy required from these maps is relatively small, say to the nearest degree both for bearing and distance in degrees of arc; for distance in miles this is to the nearest 70 statute miles.

The investigation of this problem, and also of the problem of obtaining bearings alone, has led to the discovery of a number of useful methods, which are probably not known to radio engineers in general. The information lies scattered about in various works and articles, mostly on cartography, surveying, and navigation. This article includes a bibliography which gives a useful selection of papers, books, diagrams, etc., dealing with great circle problems. Some of these have been found by deliberate search; others have been come across almost by accident. Apart from calculation, the methods may be grouped under three headings:

- (1) Nomograms.
- (2) Special projections.
- (3) Mechanical and graphical methods.

Nomograms have not been found suitable for the particular problem of finding both bearing and distance of one point from another, but it may be

¹ For references see Bibliography at end of article.

* A recent Admiralty Chart³ has added a third variation—"azimuthal-equidistant."

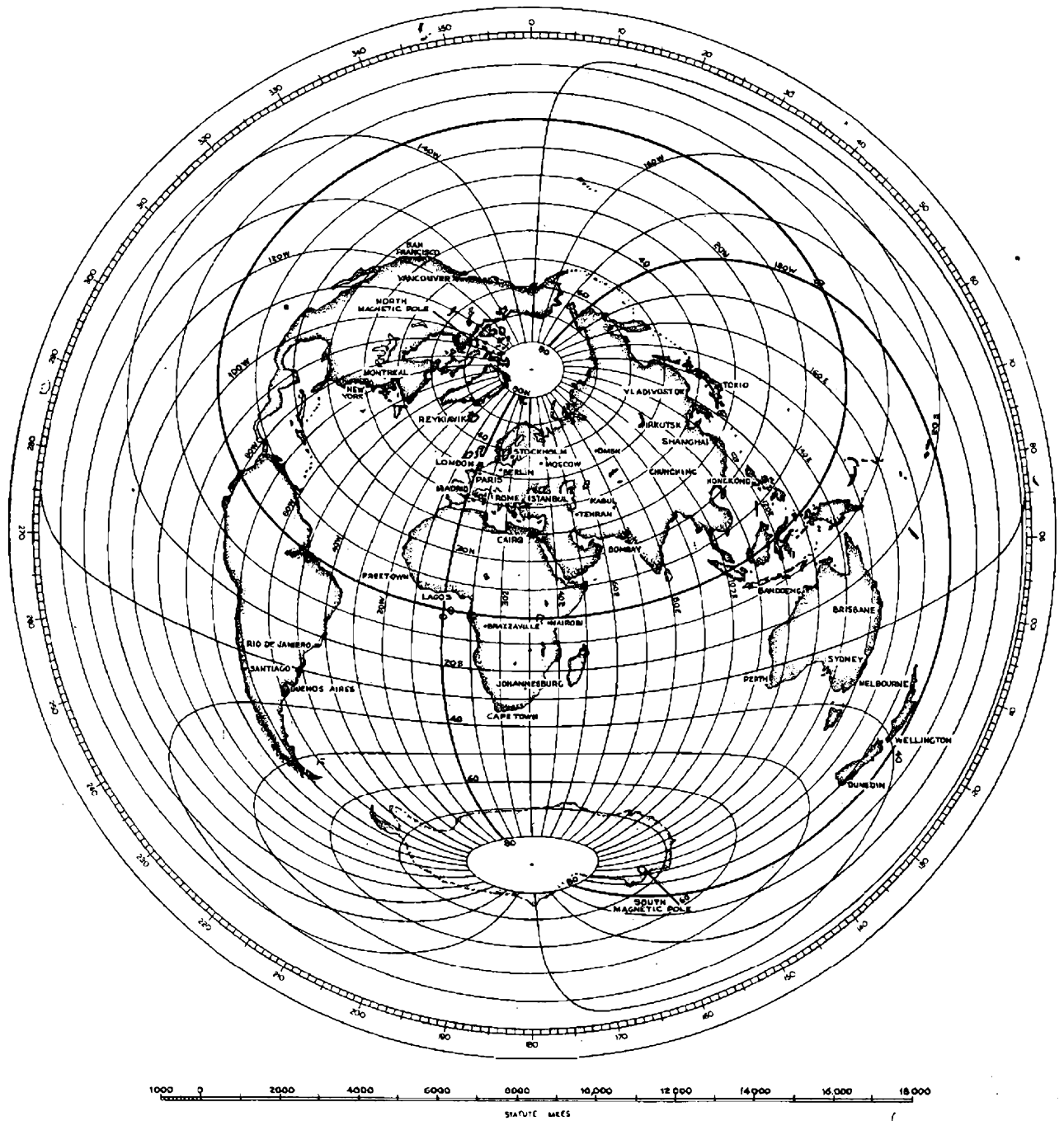

FIG. 1.—ZENITHAL-EQUIDISTANT MAP WITH CENTRE AT CAIRO.

useful to refer to a general article,⁸ and to the Weir Nomogram,⁹⁻¹² although the latter is really a special projection.

Two methods have actually been used for obtaining the data for drawing the zenithal-equidistant maps prepared in the Post Office. The first method uses the stereographic projection, only a brief account of which will be given, as it has been superseded by the second, a graphico-mechanical method.

The Stereographic Projection.

The stereographic projection^{9, 10, 13, 14, 15} has long

been used for the solution of great circle problems. It was devised by Hipparchus, a Greek astronomer, in 160 B.C. and was used for the mediæval navigational instrument, the astrolabe.¹⁵ The projection may be defined as the geometrical projection of the Earth (assumed to be a sphere), from the antipodes of a given point on a plane perpendicular to the diameter of the Earth which passes through the given point. This given point is the centre of the resultant map and it may be shown that any other point on the map is located in such a way that the angle subtended at the centre by the North Pole and this point is equal

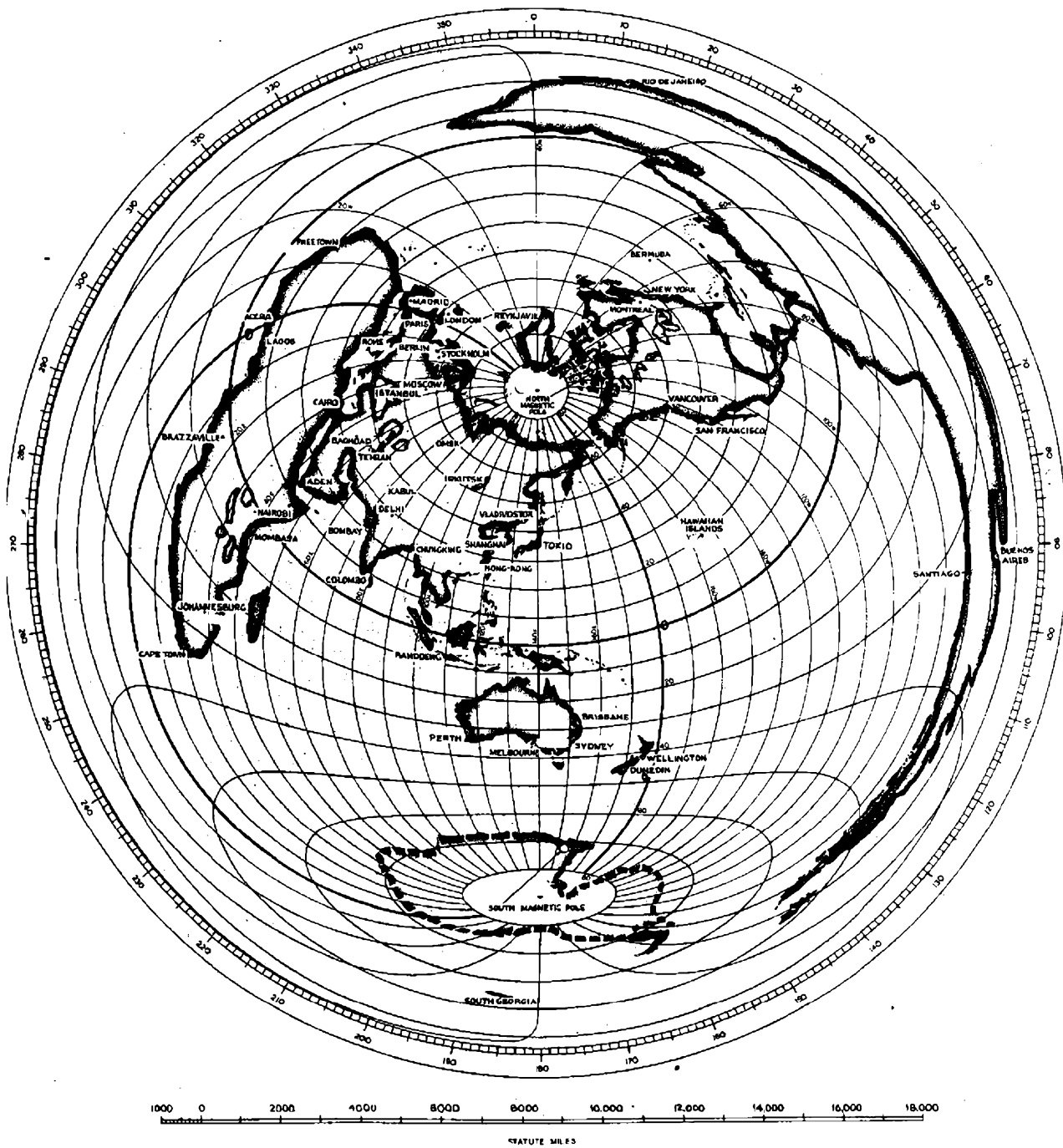

FIG. 2.—ZENITHAL-EQUIDISTANT MAP WITH CENTRE AT TOKIO.

to the great circle bearing of the point from the centre, and its distance from the centre is proportional to $\tan \frac{1}{2}d$, where d is the great circle distance in degrees of arc.

Once a stereographic projection has been drawn for a given centre, bearings and distances from the centre may be read off with the aid of a protractor and a scale graduated in terms of $\tan \frac{1}{2}d$. The big advantage of the stereographic projection is that it may be drawn comparatively quickly and easily, since all meridians and parallels are circles.

*The Principle of Rotation.*¹⁶

If on a globe, assumed to be spherical, are drawn two families of curves, one representing lines of constant bearing from a given centre, and the other lines of constant distance, in degrees of arc, from this centre, the network so produced will be exactly the same as the network of meridians and parallels. This fact may be made use of in the following way. Suppose the meridians and parallels for a globe are drawn on a transparent shell; if the latitude and longitude of two points A and B are known they may

be located on the globe. If the bearing and distance of B from A are required, the shell is rotated so that

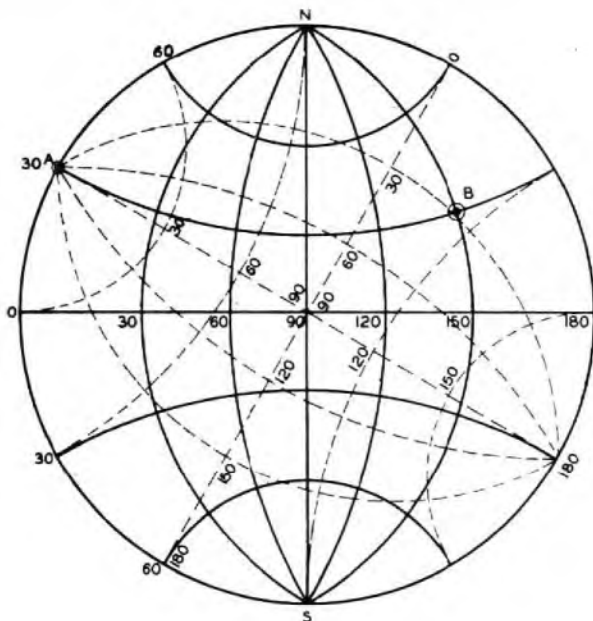

FULL LINES:- LATITUDE AND LONGITUDE DIFFERENCE
 BROKEN LINES:- BEARING AND DISTANCE
 BEARING OF B FROM A : 30° (APPROX)
 DISTANCE OF B FROM A : 110° (APPROX)

FIG. 3.—PRINCIPLE OF ROTATION.

the North Pole slides down A's meridian until it coincides with A; this rotation will be about a diameter of the globe passing through the two points on the equator 90°E. and 90°W. of A. The network can now represent lines of bearing and distance from A, and, in particular, the bearing and distance of B can be read off; the bearing line through B will also represent the great circle path from A to B. This process is illustrated in Fig. 3 which shows a hemisphere bounded by the complete meridian through A. The solid lines give the network of meridians and parallels and the broken lines show the same network after rotation. Different scales have to be assigned to the various curves for their two functions.

This principle, which allows one network to measure firstly latitude and longitude, and secondly, bearing and distance, may be applied in various ways to map projections; for zenithal projections, as in Fig. 3, the rotation on the globe becomes a rotation of the projection about its centre, and for cylindrical projections it becomes a translation of the projection.* For dealing with the world as a whole the zenithal projections are most

convenient. Two devices at least are available both of which use the stereographic projection: they are the Reeves Diagram¹⁸ and the Navicard.¹⁹ The essential part of each is an equatorial stereographic graticule. For the Navicard, it is 40 cm. in diameter and graduated, for the most part, in half degrees, and for the Reeves Diagram 18 in. in diameter, graduated every degree. The Navicard is more convenient to use as the mechanical arrangements for dealing with the rotation are superior.

The Navicard.

Fig. 4 shows the Navicard, which is printed on thick cardboard. In the centre is fixed a small pin, on which rotates the pair of arms shown in the photograph. Several circular sheets of tracing paper are also supplied, reinforced at the middle by a small metal bush which fits on the pin so that the paper can rotate about the centre. As was mentioned above, the graticule itself is 40 cm. in diameter.

The notes on the front of the card, which refer to hour angle, altitude and azimuth are associated with the astronomical triangle. On the back of the card there are instructions for finding bearing and distance. When the Navicard is used primarily

* Radio engineers may be familiar with a method¹⁷ for finding the great circle path between two points on a Mercator projection, by sliding along the equator a family of curves, somewhat like sine-waves in shape, until one of the curves passes through the two points. This curve gives the great circle path, and distance may also be obtained. This is an application of a closely related principle.

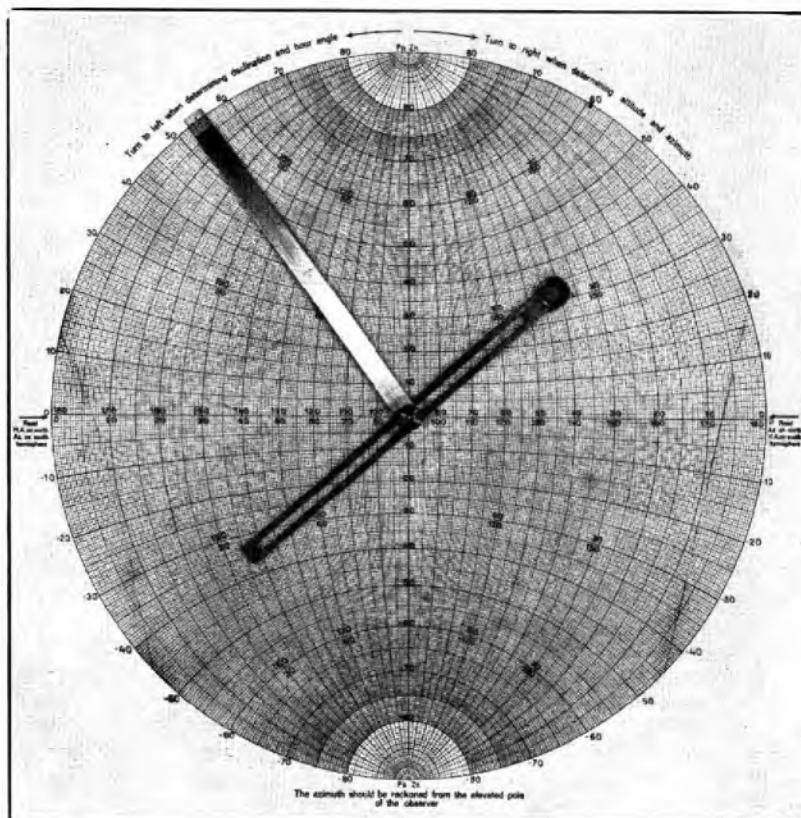

FIG. 4.—THE "NAVICARD".

to find bearings or distance on the Earth, much mental effort is saved by having additional scales and re-labelling existing scales.

To find the bearing and distance of one point from another, it is most convenient to use the arms. We shall call the two arms a and b ; a can rotate about the centre and has a mark at the end which is read against the peripheral scale; b , as well as rotating, can also slide radially through the centre so that the small dot in the centre of the circle at its end can be placed anywhere in the body of the graticule except at and near the centre. If the bearing and distance of a point B from a point A is required, we must know the latitude of A, the latitude of B, the longitude difference between them, and also whether B is east or west of A.

The graticule is first considered to represent a hemisphere; the hemisphere east of A, if B is east of A; or the hemisphere west of A, if B is west of A. The North Pole is at the top, Equator across the middle and South Pole at the bottom in the usual way. The meridians represent longitude with reference, not to Greenwich, but to A. Arm a is set so that the mark on it corresponds to the position of A, which lies on the extreme left-hand, or the extreme right-hand meridian according as B is east or west respectively of A. The dot in the centre of the ring at the end of b is now placed to correspond to the position of B, according to its latitude and longitude difference. In Fig. 4, the position of the arms corresponds to: A, latitude $53^{\circ}8'N.$; B, latitude $32^{\circ}5'N.$, longitude $138^{\circ}4'E.$ of A. This is also illustrated in Fig. 5 (a). Once the arms have been correctly positioned, they are locked together by a knurled nut at the centre. They can still rotate as one and they are rotated to bring a to the North Pole, as in Fig. 5 (b). The new position of b gives the

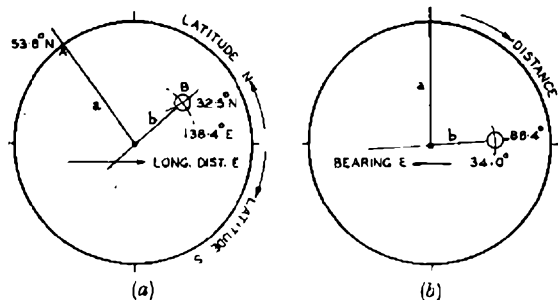

FIG. 5.—FINDING BEARING AND DISTANCE BY MEANS OF THE NAVICARD.

bearing and distance of B from A; they are read off the appropriate scales. In the case illustrated in Fig. 5, the bearing is $34^{\circ}0'$, and distance $86^{\circ}4'$.*

The tracing paper can be used instead of the arms. Two points are marked on the paper, corresponding to A and B according to the same rules as above. The tracing paper is then rotated to bring A's mark to the North Pole, and the bearing and distance read

* The solution of a spherical triangle by this means is closely related to the Agaton method^{19, 20}, which may be regarded as the analytic counterpart. The two auxiliary functions p and $K-l$ of this method are equal, respectively, to the distance of the B point from the circumference of the Navicard, and to the angle between the arms.

off as before. If the bearing and distance of one point from one other point is all that is required, the tracing paper is not so convenient as the arms. The tracing paper has two additional facilities however, which make it preferable in certain cases; these are:

- (1) In the second position, the meridian joining the points marked on the paper may be sketched in; if the paper is returned to its original position this line represents the great circle path between A and B.
- (2) In the first position, any number of B's may be marked and after rotation the bearings and distances of all these points from A may be read off.

Construction of a Zenithal-Equidistant Map.

The main framework of the map consists of meridians and parallels for every 10° , and to draw these their intersections are first plotted. The necessary bearings and distances are obtained from the Navicard, using the tracing paper. There is one simplification which will best be made clear by an illustration. Taking the same centre as is used in Fig. 1, latitude $30^{\circ}N.$, longitude $31^{\circ}E.$ approximately, and a 30° instead of a 10° interval, the longitude differences concerned are shown in Table I:

TABLE I

Meridian	60E.	90E.	120E.	150E.	180	150W.
Long.Diff.	29E.	59E.	89E.	119E.	149E.	179E.
Meridian	120W.	90W.	60W.	30W.	0	30E.
Long.Diff.	151W.	121W.	91W.	61W.	31W.	1W.

The points of intersection for the eastern hemisphere are now marked on the tracing paper of the Navicard, each with its appropriate latitude and one of the eastern longitude differences of the table above; the point for the centre, $30^{\circ}N.$, is also marked on the left as in Fig. 6 (a). If these points are now read off against the "Long. Diff. W." scale it will be seen that the values are those for the western longitude differences of the table; $29^{\circ}E.$ corresponds to $151^{\circ}W.$ and so on. Thus one set of points will do for both hemispheres, if for the western hemisphere a point at $30^{\circ}N.$ on the right is added. For the eastern hemisphere bearings and distances can be read off if the tracing paper is turned to the right; for the western hemisphere the paper must be turned to the left, as is shown in Fig. 6 (b) and (c).

It has been found most convenient to have two people at this stage. One manipulates the Navicard and reads off bearing and distance, in that order, for each point, while the other plots the points on the zenithal-equidistant map as the data are given. When all the points have been plotted, those meridians and parallels which are sufficiently well defined by 10° intersections can be sketched in. The curves towards the perimeter of the chart will inevitably need more points located before they can be drawn in. For this purpose the required meridians and parallels, or

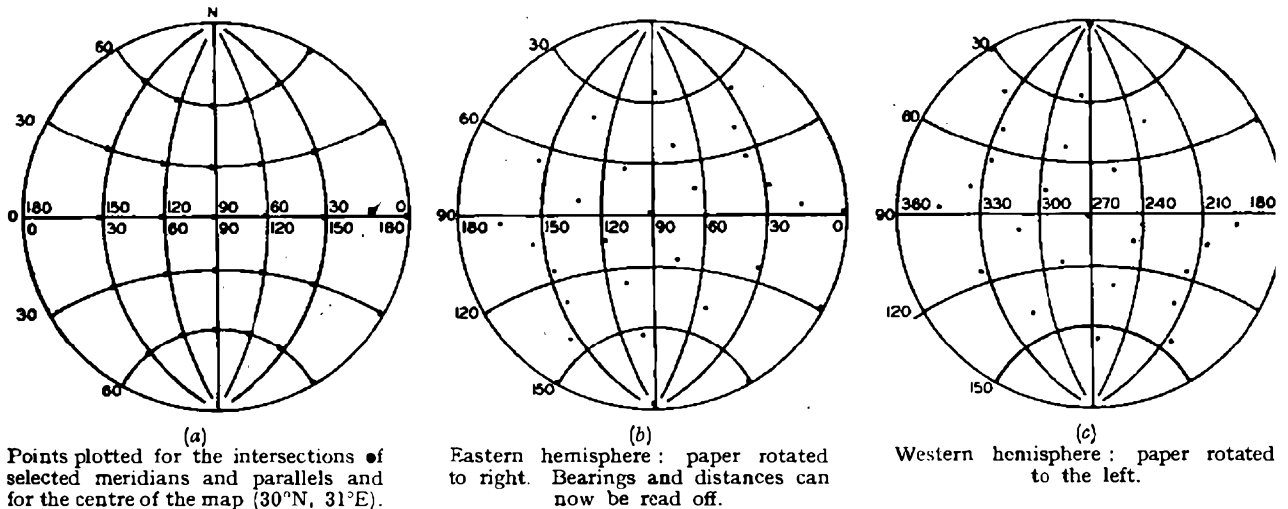

FIG. 6.—USE OF NAVICARD IN CONSTRUCTION OF ZENITHAL-EQUIDISTANT MAP.

such parts as may be needed, are drawn in full on the tracing paper, and after rotation the bearing and distance of as many points as are necessary can be read off the Navicard and the points plotted on the map.

The coastlines now require to be drawn in and selected towns located. Near the centre, where the distortion is small, the graticule just drawn can be used, as the map will have much the same appearance as the map from which it is copied. Towards the perimeter of the map, more trouble must be taken. The necessary coastlines and towns are drawn against the meridians and parallels which have already been put on the tracing paper for this area. In fact, a map is drawn on the stereographic projection. The distortion is never great, so that this can be done fairly easily. After rotation, as many bearings and distances as are necessary are read off so that the zenithal-equidistant map can be completed.

Accuracy of Zenithal-Equidistant Maps.

A detailed study of the sources and magnitudes of possible errors in these maps would be long and difficult. This section merely touches on the principles with a view to giving users of zenithal-equidistant maps a few warnings.

In the first place, there are possible errors in bearing and distance which are due to uncertainties of the positions of specified points. Points on the Earth are usually specified in terms of latitude and longitude to a certain degree of accuracy. The resulting tolerance in latitude and longitude locates the point within a certain area. Owing to the spherical nature of the Earth the effect of this on bearing and distance depends on the absolute and relative positions of the two points in question. Its effect on distance is never serious: the error is always less than the sum of the four tolerances, two for latitude, two for longitude. For bearing the error depends, among other things, on the distance between the points, and, as should be fairly obvious, becomes worse as the two points become closer together. It is also true, though not

perhaps quite so obvious, that the error increases as the two points become nearly antipodal.

These difficulties will arise in obtaining bearings and distances by any method. In the case of the Navicard, points close together or nearly antipodal involve reading off bearings from the portions of the network near the Poles, where the meridians (which are also the bearing scale) crowd close together and the discrimination is obviously poor. On a zenithal-equidistant map, for points close together, it will be clear that discrimination in bearing is poor; but near the circumference of the map the bearing discrimination, although good, is not accompanied by a corresponding accuracy. Another reason for being careful with points near the edge of the map is that the assumption of a spherical earth made in the maps described here and, as far as the authors are aware, in other similar maps, is not accurate, and, generally speaking, the errors due to this cause increase as the points become nearly antipodal.^{21, 22}

Bearings and distances obtained from the Navicard will be subject to error from three further causes:

- (1) Errors inherent in the Navicard method.
- (2) Errors in the construction of the Navicard.
- (3) Lack of care and skill on the part of the user.

A large number of checks against calculated values shows that, apart from errors due to points being near, or nearly antipodal, readings from the Navicard are generally correct to the nearest $\frac{1}{4}^\circ$.

The construction and reproduction of the zenithal-equidistant maps described here will lead to further errors, but, generally speaking, these maps should be correct to the nearest degree in bearing and distance.

Acknowledgments.

The maps referred to have been drawn by various members of the drawing offices of the Radio Development Branch of the Engineer-in-Chief's Office of the Post Office, to whom acknowledgment is made for their excellent work.

Bibliography.

1. Pletts zenithal-azimuthal graticule. *Year Book of Wireless Telegraphy and Telephony* (1922).
2. Pletts, J. St. Vincent. "Wireless maps." *Wireless World* (May, 1919).
3. The world on the azimuthal-equidistant projection, showing the true bearing and distance from London. Admiralty Chart No. 5085.
4. Gronberg, W. "World map for orientation of direction aerials, especially for short-wave communication." *Tekniska Meddelanden* 3 (1945) (contains map, centre Karlsborg).
5. British Overseas Airways Corporation. An air age map of the world. Standford. (Centre, London).
6. The following articles contain maps for the centres listed:
New York: Budenbom, H. T. "Short Wave Programmes for Waldorf Guests." *Bell Lab. Rec.* 13 (July, 1935).
London, Moscow: Kenrick, G. W., Braaten, A. M., General, J. "The relation between radio-transmission paths and magnetic-storm effects." *Proc. Inst. Radio Engrs.*, 26 (July, 1938).
New York, San Francisco, Berlin: Hallborg, H. E. "Terrestrial magnetism and its relation to world-wide short-wave communications." *Proc. Inst. Radio Engrs.*, 24 (March, 1936).
New York: Morris, R. M., Brown, W. A. R. "Transoceanic reception of high-frequency telephone signals." *Proc. Inst. Radio Engrs.*, 21 (January, 1933).
New York: Chamberlain, A. "C.B.S. international broadcast facilities." *Proc. Inst. Radio Engrs.*, 30 (March, 1942).
Washington, San Francisco: Wells, H. W. "Effects of solar activity on the ionosphere and radio communications." *Proc. Inst. Radio Engrs.*, 31 (April, 1943).
7. Keen, R. "Wireless direction finding." Iliffe (London, 1938).
8. Friauf, J. B. "Nomograms for the solution of spherical triangles." *Journal of the Franklin Institute* (August, 1941).
9. "Admiralty Navigation Manual, 1938, Vol. II." H.M.S.O. (London, 1939).
10. "Admiralty Navigation Manual, 1938, Vol. III." H.M.S.O. (London, 1939).
11. The Weir azimuth diagram. Admiralty Chart No. 5000.
12. Thomas, T. S. E. "In what direction?" *Wireless World* (January, 1941) (correction, February, 1941).
13. Potter, A. J. "The stereographic solution of the spherical triangle." *Empire Survey Review*, 2 (1933).
14. Potter, A. J. "What was that star?" *Empire Survey Review*, 3 (1935).
15. Debenham, F. "Astrographics." Heffer (Cambridge, 1942).
16. Dilloway, A. J. "The cartographic solution of great circle problems." *Journal of the Royal Aeronautical Society* (January, 1942).
17. Favé, L. Determination of great circle paths Graphique No. 1, Service Hydrographique de la Marine.
18. Reeves, E. A. A true bearing and distance diagram for setting a frame aerial on a distant station. Royal Geographical Society (London, 1929).
19. de Krausz, G. E. "Navicard" measuring chart for use in sea and aerial navigation, astronomy, scientific travel and cartography. Royal Hungarian Cartographical Institute.
20. Comrie, L. J. Hughes' tables for sea and air navigation. Henry Hughes (London, 1938).
21. Clarke, A. R. "Geodesy." Clarendon Press (Oxford, 1880).
22. Lambert, W. D. "Distance between two widely separated points on the surface of the Earth." *Journal of the Washington Academy of Sciences* (May, 1942).

"Dead" Room for Acoustic Testing

For electro-acoustic measurements a "dead" room, meaning a room in which no surfaces reflect sound, is an important part of the testing equipment. Demands for the use of the existing dead room at the laboratories of the Research Branch are such that a second one is now required, the construction of which is illustrated in the photograph. The dimensions of the

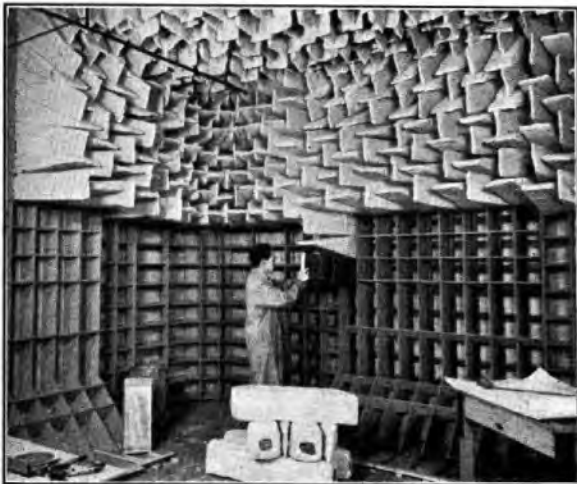

room (which was the largest existing one available for the purpose) were 19 ft. by 20 ft. by 13½ ft. high before the acoustic treatment was added. To make the room as nearly dead as is practicable (at all frequencies from about 85 c/s upwards) the treatment must be capable of absorbing practically the whole of the sound energy incident on it. The modern form of treatment, as illustrated, is an assembly of wedge-shaped pieces of suitably porous material (in this case glass wool, covered with muslin) which provide the quantity and depth needed for absorbing at low frequencies while presenting no regular surface for reflecting higher frequencies back into the room.

The honeycomb structure is made of building board to hold the wedges, which are inserted with the aid of a sheet metal tool having two parts, one (holding the wedge) sliding within the other (which acts as a guide). Where necessary, adhesive is applied to hold the wedges in position. An air space of about 4 in. is left behind the wedges, as tests have indicated that appreciable improvement in absorption at very low frequencies is gained thereby. The same treatment is also applied on the floor, and a raised platform of wide-mesh expanded metal is erected to permit walking in the room over the floor wedges. Each wedge is about 3 ft. long and 8 in. square at the base and some 3,000 of them are needed for this room.

Calling Line Identification

N. H. ROBINSON
(Automatic Telephone & Electric Co. Ltd.)

U.D.C. 621.395.364

The author describes a system, developed by the Automatic Telephone & Electric Co. Ltd., which enables the calling line to be identified when a subscriber on an automatic exchange originates a trunk call. In this system the calling subscriber's line is marked, via non-linear resistors, by a sequence of V.F. signals which are passed forward to the trunk exchange, decoded and then displayed on a cathode-ray tube. Reference is made to a trial installation worked on an 800-line P.A.X. and to the application of the system to automatic toll ticketing.

Introduction.

WHEN a subscriber on an automatic exchange wishes to originate a trunk or long-distance call, access to the manual board is obtained by dialling the appropriate digits or code. As the selectors and answering equipment are accessible to perhaps several thousand subscribers on the same or other exchanges, the operator receives no indication of the identity of the calling subscriber. In consequence it is necessary for the subscriber to announce his own identity, as well as that of the required party, so that the call may be recorded and charged to the calling subscriber.

Few subscribers have a perfect telephone voice and a small number of subscribers inadvertently, or for other reasons, announce their identity incorrectly. There is therefore always a risk that some calls may be incorrectly recorded. If traffic is being handled on a delay basis the error is, of course, apparent when an attempt is made to complete the call, but if traffic is being dealt with on a demand basis the call may be charged to the wrong subscriber. For this reason most administrations verify the identity of calling subscribers on all or a proportion of the calls that are dealt with on a demand basis. The extra operations which verification involves off-set, to a certain extent, the advantages of demand working.

In automatic working the general tendency is to extend the subscribers' dialling range to such an extent that the ordinary subscriber's meter no longer provides a wholly satisfactory means of registering all the calls dialled by subscribers.

To overcome these difficulties it is necessary to provide a method of signalling the identity of the calling subscriber's line either to the operator, when the call is being dealt with on the manual basis, or to suitable recording equipment when the call is subscriber-dialled and is not to be recorded on the subscriber's meter.

Several methods of signalling the subscriber's number have been developed or suggested,¹ but as none of them is ideal, efforts were made to devise a scheme that would meet the following requirements:—

- (a) low fault liability,
- (b) no increase in time to set up calls,
- (c) suitable for use in existing automatic and trunk exchanges with a minimum of modifications and additional equipment.

¹ British patents 189823 and 516348. *A.I.E.E. Electrical Engineering*, Vol. 63, p. 83.

PRINCIPLES OF THE SYSTEM

The elements of the scheme as applied to an auto-manual call are shown in Fig. 1. The marking equipment, upon receipt of a signal from the selector level relay set, applies a sequence of V.F. signals to the calling subscriber's line circuit. From that point

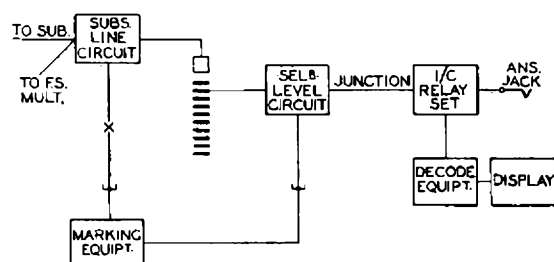

FIG. 1.—SCHEMATIC ARRANGEMENT OF C.L.I. EQUIPMENT.

the signals are passed forward, over the speech circuit, to the incoming relay set and thence to the decoding and display equipment. When a complete sequence of signals has been sent, the line circuit is disconnected from the marking equipment and the normal speech circuit is restored.² Rather less than one second is required for each identification, which can be repeated as often as may be desired. This article will not attempt to give detailed circuits, but rather to describe the general principles of the system and to show how many of the interdependent problems have been solved.

Signalling Code.

A signalling code consisting of pulses of 750 c/s, alternating with pulses of 600 c/s for synchronising purposes, was adopted in preference to a code comprising a combination of various frequencies, as the former reduces the number of V.F. generators that are required and avoids the use of complex or numerous receivers. It also permits advantage to be taken of the experience gained with the 2 V.F. system of trunk signalling.

Each signal cycle consists of a "prepare receive" signal followed by four equal intervals allocated to the thousands, hundreds, tens and units digits respectively. Each of these four intervals is sub-divided into four equal parts, which may, for convenience, be designated the W, X, Y and Z periods.

² *I.E.E. Journal*, Vol. 94, Part 3, No. 28.

The integers 1 to 0 are signalled by one or two pulses of 750 c/s applied as indicated below :—

Integers	Pulses during period
1	W
2	X
3	Y
4	Z
5	W and X
6	W and Y
7	W and Z
8	X and Y
9	Y and Z
0	X and Z

Pulses of 600 c/s are transmitted as a prepare signal and to synchronise the receiving equipment with the sending equipment.

Line Marking.

It is essential that the medium used for switching the markings to the line circuit should give the following facilities :—

- high signalling speed,
- permit signals from a common marking equipment to be applied to as many lines as may require them simultaneously, without providing any other linkage between the lines,
- allow markings to pass only upon receipt of the appropriate signal.

Previous experience indicated and investigations confirmed that non-linear resistors of the carborundum ceramic type would provide a solution to the problem. As the electrical characteristics of these non-linear resistors have been dealt with in detail elsewhere³, it will suffice to mention that they are suitable for this particular application because when subject to a small P.D. they offer a resistance of the order of megohms to both direct and alternating currents, but when subject to an increased P.D. they offer a lower resistance to D.C. and a still lower resistance to V.F. currents. These non-linear resistors can therefore be used as contact units which open and close when the appropriate P.D. conditions are applied to them.

The circuit arrangement adopted is shown in the upper half of Fig. 2. Two non-linear marking resistors, XM and XD, are associated with each subscriber's line. This arrangement takes advantage of the fact that in the range of numbers between 0000 and 9999, each combination of any pair of digits occurs in a hundred numbers. That is to say, the combinations 1 x 3 x, 1 x 4 x, etc., or x 1 x 3, x 1 x 4, etc., are each common to one hundred subscribers' numbers.

An MA relay change-over contact unit is provided for each combination of thousands/tens digits and a similar CA relay contact unit for each combination of hundreds/units digits. Each of the non-linear resistors is commoned to 99 others.

The MA and CA relays enable one resistor to connect the thousands and tens markings and the second resistor to carry the hundreds and units markings. Relay MA is operated as soon as the thousand marking has been transmitted, and relay

CA is operated as soon as the hundred marking has been transmitted, to prepare the circuits for the tens and units marking signals respectively. It will be seen that one set of marking terminals serves the thousands and tens, and a second set of terminals serves the hundreds and units.

With this arrangement the time intervals allocated to the sending of signals representing the hundreds

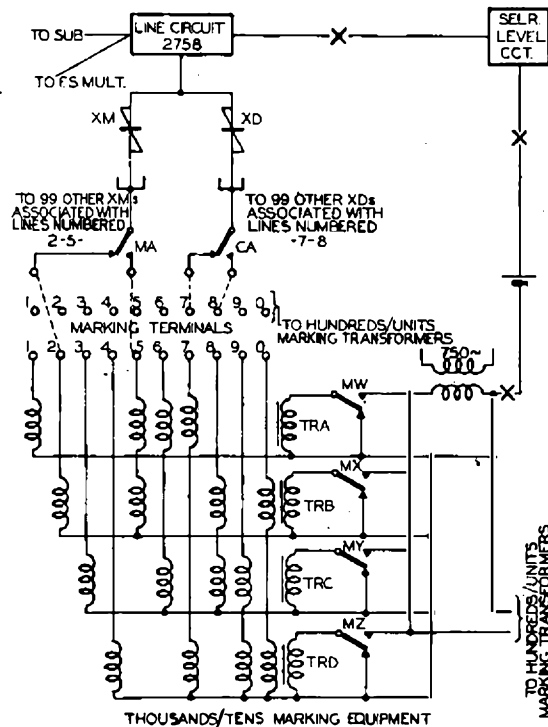

FIG. 2.—LINE MARKING EQUIPMENT.

and tens digits are available for operating relay MA and CA respectively, which may therefore be of standard 3000-type instead of the high-speed type. As a 10,000-line exchange requires 100 MA and 100 CA contact units, this is a matter of considerable importance.

Marking Transformers.

The 750 c/s marking pulses are distributed via two sets of transformers, one set for the thousands/tens signals and the other for the hundreds/units signals.

The circuit arrangement is shown in the lower half of Fig. 2. Relays MW, MX and MY and MZ are operated in the periods allocated to the W, X, Y and Z pulses respectively of the thousands and tens digits to distribute the associated signal pulses. Relays CW, CX, CY and CZ (in the hundred/units marking equipment) are operated during the appropriate periods to distribute the signal pulses for the hundreds and units digits. The transformers are each provided with a primary and four secondary windings. They are effective only during those periods in which the short circuit is removed from the primary winding. The design is such that there is a minimum of coupling impedance between the four secondary windings under

³ G.E.C. Review, Vol. 37, pp. 175 and 218, and Strowger Journal, Vol. 5, p. 17.

short-circuit conditions; this permits signals applied to a particular marking lead to pass through the secondaries of any short-circuited transformer which may be connected to the same marking lead, without inducing signals in the other secondary windings of the short-circuited transformers. Any danger of the transformers becoming saturated by direct current is overcome by connecting the secondary windings in opposite directions.

Speed of Signalling.

As the identification signals are transmitted over the speech circuit it is essential that they should occupy the circuit for a minimum time so that any appreciable delay in the setting up of the call will be avoided. A signalling speed of 30 i.p.s., which allows a four-digit number to be transmitted in approximately one second, has been adopted as most suitable for general requirements. On a trial installation, however, it has been found that the equipment will function satisfactorily, but with a reduced margin of safety, when the signalling speed is increased to 50 i.p.s.

Generation of Pulses and Signals.

The generation of the 750 c/s and the 600 c/s currents presents no difficulty. The energy required for each identification signal to be transmitted is of the order of 4 to 5 milliwatts, and the demand on the oscillator, even on a 10,000-line exchange, when signals are not being transmitted is so small that it can be ignored. Oscillators with an output of 250 milliwatts are therefore suitable sources of supply for these currents unless an exceptional number of identity signals are to be transmitted simultaneously.

A number of difficulties were encountered in the development of the equipment that is required to control the high-speed impulse signals. Various types of impulse machines were found to be unsatisfactory because of contact bounce, and these were abandoned and replaced by an all-relay pulse generation circuit which gives very reliable service. This consists of a 15 i.p.s. vibrator relay which operates at both its back and front contacts an impulse doubler relay of the polarised telegraph type, and therefore provides 30 i.p.s. This doubler relay is the only item that is required to impulse at 30 i.p.s., and special provision is made so that it can be adjusted to give equal "on" and "off" pulses. This relay is provided with a single change-over contact unit which is used to connect the signalling equipments to the 750 c/s and 600 c/s supplies in the make and break periods respectively.

Another contact unit on the vibrator relay is used to drive a series of pulse-halving circuits which provide the various pulses required for marking and control purposes.

Switching of Marking Signals to Line Circuits.

The manner in which the marking signals are switched to the subscribers' lines is shown in Fig. 3.

One half of the line circuits have their non-linear marking resistors connected to the negative line and the remainder have their resistors connected to the positive line. Point A is therefore at approximately

25 volts negative potential and the non-linear resistors XA, XB, XC and XD are, under the normal conditions when the subscriber is not on the line, each subjected to a P.D. of the order of 25 volts; at this P.D. the resistors are approximately 1 megohm.

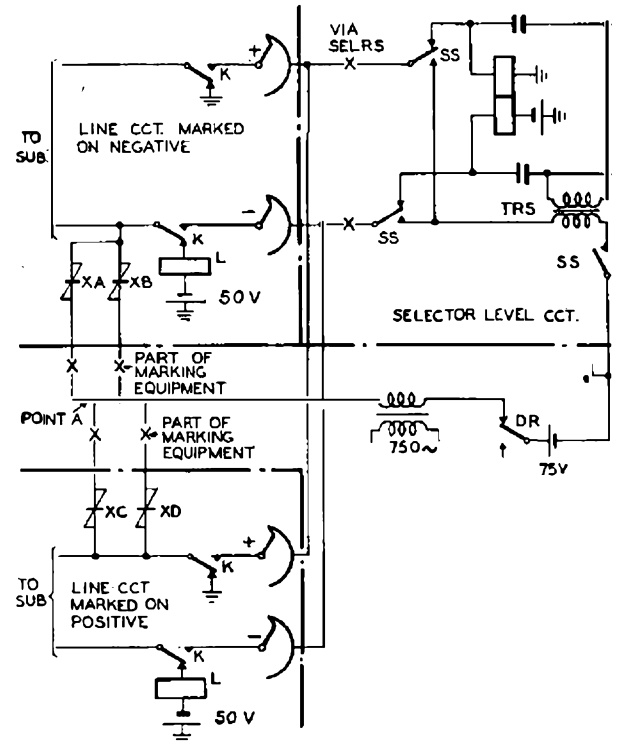

FIG. 3.—SWITCHING OF MARKING SIGNALS TO LINE CIRCUIT:

Under speaking conditions the voltage across the resistors is reduced and their resistance increases to several megohms.

When an identification signal is required the selector level circuit units in the selector level circuit are closed. This adds a biasing battery of 75 volts to the circuit of the resistors which are to pass the identification signals. Under this condition the resistors offer approximately 15,000 ohms to the passage of D.C. and a much lower resistance, approximately 3,500 ohms, to the V.F. signals. The signals are therefore switched to the line circuit and from there they travel over the speech circuit to the selector level circuit where they are accepted by the transformer TRS and sent forward to the receiving equipment.

Transmission of a Typical Identification Signal.

Assume that an operator answers a call on demand circuit. By the momentary operation of an identification key fitted on the position, common receiving equipment is connected to the position and reversed battery conditions returned from the I/relay set operate relay D in the selector level circuit (Fig. 4).

Contacts of D then prepare a circuit so that SS operates on the next ST pulse that is received. When SS operates it prepares a circuit so that the subsequent operation of SZ will cause SS to be held for the

duration of the signal cycle. The operation of SZ also causes ZA to be operated and held for the duration of the signal cycle and afterwards under the control of contacts of relay D. ZA opens the operating circuit of SS which therefore restores at the end of the signal

biasing battery, in series with the secondary winding of the 600 c/s transformer and the primary of TRS, will be connected across the non-linear resistor XS. The P.D. from the biasing battery causes XS to become a conductor to the 600 c/s current and a

600 c/s signal is sent forward, over the speech circuit, as a prepare signal to the V.F. receiver and common equipment. It will be seen that DR is normal in the first half and operated in the second half of each W, X, Y and Z period. A 600 c/s pulse, for control purposes, is therefore transmitted in the first half of each W, X, Y and Z period. When the DR contacts are in the operated position a potential is applied to XM and XD which therefore allow the marking signals, corresponding to the calling subscriber's number, to pass to the line circuit and thence, via TRS and the normal speech circuit, to the receiving equipment.

When signals to represent all four digits have been transmitted, the SZ pulse ceases and so causes relay SZ to restore. SZ releases SS which disconnects the identification signals and restores the normal speech circuit. ZA remains operated under the control of contacts of relay D.

The circuit arrangement is such that the identification signals may be repeated at any stage of the call.

Reception of Identification Signals.

The 2 V.F. receiver accepts both 600 c/s and 750 c/s signals and converts them into D.C. signals at CS and MS contacts respectively—see Fig. 5.

The prepare signal, together with the 600 c/s signal in the first half of the thousands W period which is continuous with it, causes CS to make a circuit to operate B and BA. At this stage MS operates completing a circuit via the W, X, Y and Z distributor and the digit distributor, to the thousands W storage relay. In the event of a 750 c/s marking signal being received in the second half of the W period it will operate the storage relay which will remain locked to store the signal.

The 600 c/s signal now becomes a series of impulses to which CS responds. Relay B, which is slow to release, and BA remain operated for the duration of the signal cycle. When CS restores, in the second half of the thousands W period, an earth is extended to the W, X, Y and Z distributor control where it prepares a circuit for switching the contact of MS from the W to the X lead when the CS contacts are re-operated by the next 600 c/s impulse which indicates the commencement of the thousands X period. Any marking signal received in the X period will therefore be relayed by the MS contact, over the X lead through the digit distributor, to the appropriate

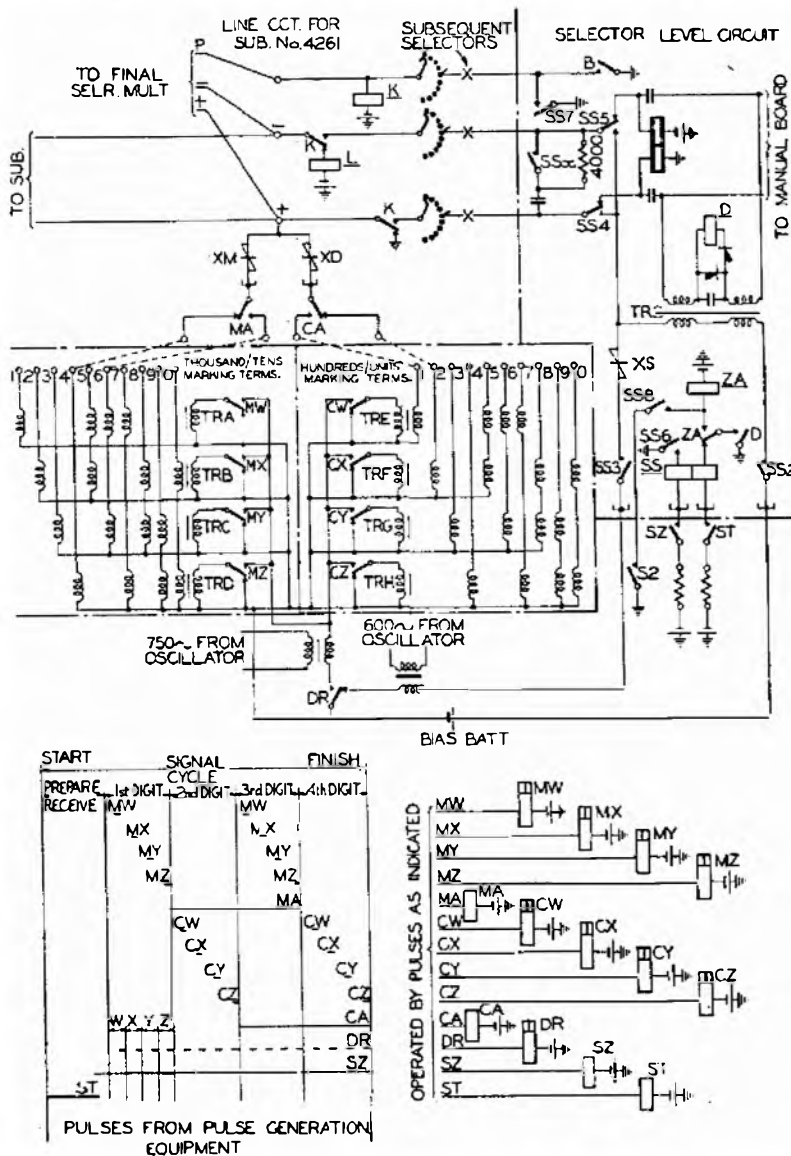

FIG. 4.—TRANSMISSION OF IDENTIFICATION SIGNAL.

cycle when the contacts of SZ open. The SS "x" contact unit is provided to eliminate the excessive click which would otherwise occur when contact units SS4 and SS5 close to short-circuit the incoming lines. It is necessary to short-circuit the incoming lines as the signals may be received on either the negative or positive line, according to how the resistors are connected on the particular line circuit from which the signal is to be received.

As relay SS can be brought to the operated position only during the ST pulse, it follows that the DR contact units will remain normal for an appreciable time after the SS contact units close and that the

storage relay. Similar switching operations take place at the end of the X and Y periods, the MS contact being connected to the Y and Z leads in turn. At the end of the Z period the MS contact is reconnected to the W lead, and a condition is extended to the digit distributor to cause it to switch the W,

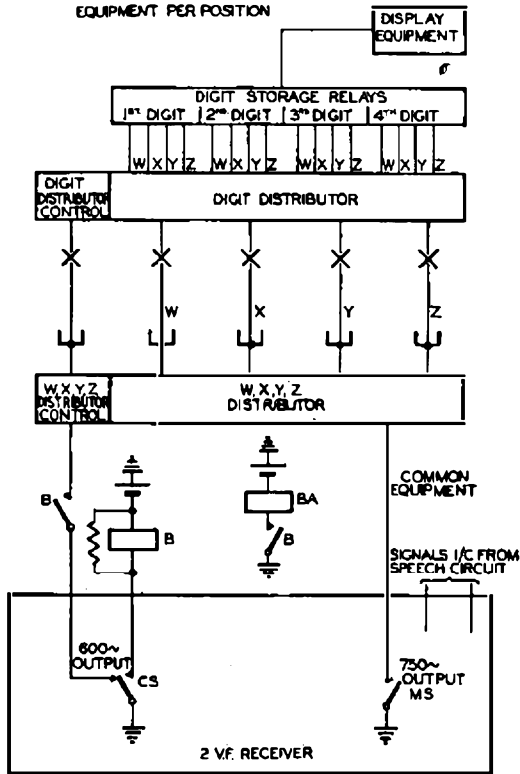

FIG. 5.—RECEPTION OF IDENTIFICATION SIGNAL.

X, Y and Z leads to the hundreds group of storage relays. Similar switching operations occur in the remainder of the signal cycle so that subsequent marking signals are extended to the appropriate storage relays. At the end of the signal cycle the 600 c/s impulses cease and the position is disconnected from the common equipment. The appropriate storage relays are now in the operated condition to cause a display to be given. The duration of the display may be under the control of the operator or it may be maintained for a predetermined period.

The W, X, Y and Z distributor and the digit distributor consist, like the pulse generation equipment, of combinations of pulse-halving circuits.

Display Equipment.

The display is given on a cathode-ray tube and is obtained by applying suitable potential variations to the X and Y deflector plates.⁴ A multi-plate motor-driven variable capacitor in conjunction with a 500 kc/s oscillator and rectifiers, provides the various X and Y potentials that are required to cause the "spot" to trace any of the numerals 1 to 0. An X and a Y capacitor, each with specially shaped vanes are provided for each of the numerals 2 to 9, a further capacitor providing both the X and Y potentials for

⁴ *I.E.E. Journal*, Vol. 94, Part 3, No. 32.

0 and the Y potential that controls 1. A further potential applied to a second X plate directs the thousands, hundreds, tens and units digits to their proper position on the screen of the tube. Fig. 4 illustrates the general principles. When a display is required, a start condition is applied to the uniselector. Wipers DD 2 and 3 therefore pick up, in turn, the marking for the thousands, hundreds, tens and units digits that are to be displayed; the potentials obtained by wiper 1 positions the various digits. A steady display is obtained by using the natural "after glow" of the tube and making the stepping speed of the uniselector such that the "trace" will be repeated before there is any appreciable fading of the display. The spot is suppressed as it moves from digit to digit

TRIAL INSTALLATION

During the course of its development the system was the subject of a number of circuit laboratory tests but it was appreciated that a trial under actual working conditions might reveal difficulties that were not apparent under laboratory conditions.

Marking equipment was therefore added to the 800-line P.A.X. serving the Strowger Works of the

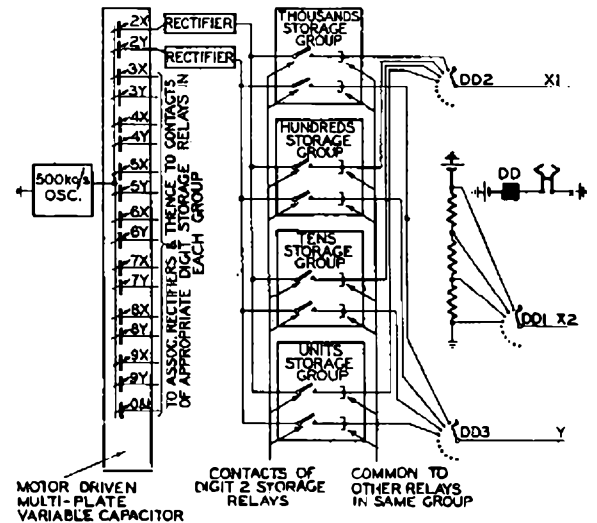

FIG. 6.—TRANSLATION AND DISTRIBUTION OF IDENTIFICATION SIGNALS TO THE CATHODE-RAY DISPLAY.

Automatic Telephone and Electric Co. Ltd. This P.A.X. was also provided with access to a standard sleeve control position via selector level circuits. Standard Post Office line finder circuits are used on this P.A.X. The equipment has now been in service for several months and during that time it has given very reliable service.

Fig. 7 shows the equipment installed to apply the appropriate markings to the 800 lines. Each connection strip at the top of the figure accommodates the marking connections for 200 lines. Immediately below these connection strips are 1,600 non-linear resistors, each mounting accommodating 200 resistors—40 on each of the five spindles. The plate below the resistors carries the MA and CA relays. The other items which are shown include marking transformers, pulse generator and control equipment which provide

for 4-digit signals and are capable of serving a 10,000-line exchange.

A number display on the trial equipment is shown in Fig. 8. The main advantages of this novel form

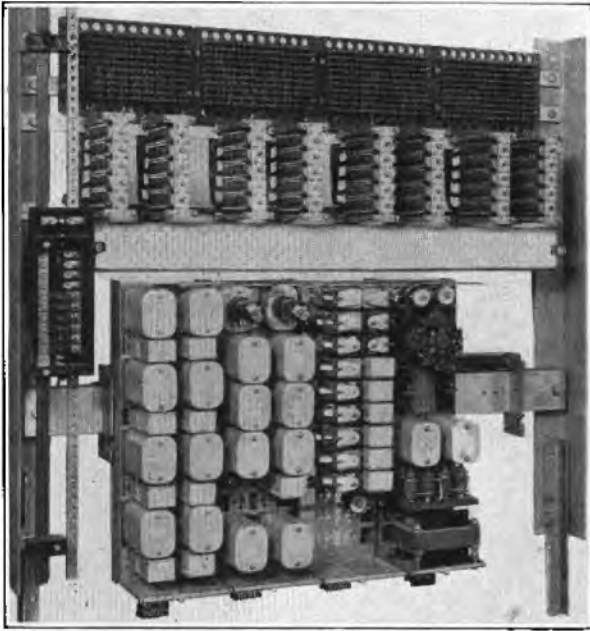

FIG. 7.—TYPICAL SET OF MARKING EQUIPMENT.

of display are that it occupies a minimum of panel space and that it provides a display which is very easy to read. The digits are well defined and can be read without difficulty in bright sunlight.

APPLICATION TO NEW AND EXISTING TELEPHONE NETWORKS

The only traffic-carrying circuits affected by the introduction of C.L.I. are the relay sets that provide access to the operator. This makes the system suitable for use at existing as well as at new exchanges.

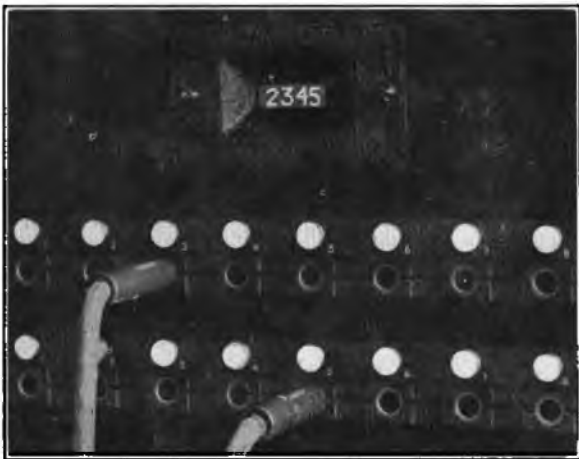

FIG. 8.—THE NUMBER DISPLAY.

For new exchanges the necessary facilities would be incorporated in the initial design of these relay sets but at existing exchanges the extra facilities can be

provided by making the following modifications:—

- (a) Selector level circuits (automatic exchanges). Add line transformer, non-linear resistor, two capacitors and two relays per circuit.
- (b) Incoming relay sets (manual board). Add one, or at the most, two relays.

The requirements, in respect of the actual C.L.I. equipment, are the same for both new and existing exchanges. At automatic exchanges two non-linear resistors per subscriber's line and a set of common equipment, are required. By mounting the connection strips at the rear instead of at the front as shown in Fig. 7, the whole of the equipment that is required for a 10,000 line exchange could be accommodated on a single apparatus rack.

At the manual board end the C.L.I. equipment consists of V.F. receivers and decoding equipment at the rate of provision of 1 per 15 to 20 manual positions. Digit display storage relays are also required at the rate of one set per position. For all but the largest of exchanges one or two apparatus racks would be sufficient to mount this equipment. On each of the manual positions a digit display panel and identification key complete the equipment.

Application of Scheme to Multi-Office Areas.

Although this description has dealt only with the transmission and reception of signals to represent a 4-digit number it will be appreciated that the arrangements can be adapted to transmit any number of digits. In non-director multi-office areas it would probably be convenient to inject extra markings, corresponding to the exchange code, at the selector level circuit.

AUTOMATIC TOLL TICKETING

This system of calling line identification signals can also be applied to automatic toll ticketing. For this purpose the arrangements at minor exchanges are as indicated in Fig. 4, except that the selector level circuit becomes an auto repeater giving access to multi-fee junctions. At main exchanges 2 V.F. receivers and common equipment, similar to that indicated in Fig. 5 but controlling recording equipment instead of display equipment, are associated with the auto-to-auto relay sets that give access to the multi-fee junctions. This concentration of the recording equipment at the main exchanges is desirable on many grounds, e.g. economics, maintenance and centralised records. The machines may be arranged to record any or all of the following particulars:—

- (a) calling subscriber's number and exchange,
- (b) called subscriber's number and exchange,
- (c) date, time and duration of call,
- (d) fee payable,
- (e) circuits used.

Conclusion.

The author wishes to thank his colleagues of Automatic Telephone & Electric Company Limited for assistance; in particular Mr. G. T. Baker, who designed and developed the system, for advice and information used in the preparation of this article.

International Telex

U.D.C. 621.394.34

H. E. WILCOCKSON, A.M.I.E.E. and
A. H. T. WALDRAM, B.Sc. (Eng.), A.C.G.I., D.I.C., A.M.I.E

Part 2.—The Switchboard Equipment

The previous part of this article described the signalling system employed for the reopening of the International Telex service, and the reasons for its adoption. The subscriber's station, and line terminating equipments, were also described. This part deals with the switchboards and associated rack-mounted equipment.

Switchboard Positions.

It will be seen from Fig. 6 that unit type floor pattern switchboards have been provided as the initial installation in the C.T.O., London. The answering and calling jacks are wired in multiple,

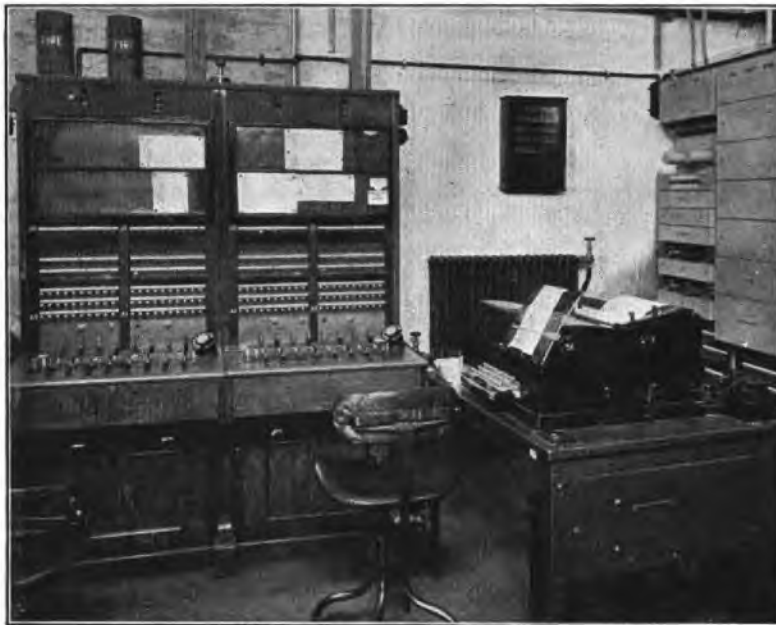

FIG. 6.—INTERNATIONAL TELEX SWITCHBOARD. C.T.O. LONDON.

and the operators' teleprinters are mounted on separate tables at the side of each switchboard, being arranged normally at an angle to it for operating convenience. For small installations requiring not more than six positions, this type of switchboard has advantages over the more elaborate pattern having a shelf-mounted operator's teleprinter below a sloping key-shelf.

The majority of the cord and position circuit relays and associated components are mounted in the rear of the switchboard, the exceptions being the relays controlling the chargeable time meters (Clocks No. 44), and the position control relays (CR), which are mounted on the common equipment rack.

Multiple and Face Equipment.—Fig. 7 shows clearly the separate answering and outgoing multiples which are provided, the former having a capacity of 120 lines with a 4-panel repetition, using strips of 10-line jacks; the latter of 120 lines with a 2-panel repetition, using strips of 20-line jacks. The lamps and designation strips are arranged above the jack strips in each case. The jack strips at the top of each panel are provided for routine test and miscellaneous

purposes as described later. The two red opal lam mounted centrally beneath each jack panel provide a visual alarm should the operator overplug an engaged line. The remaining opal under the left-hand panel glows when the "position routine test" key provided above the bulletin board (Fig. 6), is operated to enable routine testing of the Clocks No. 44 to be effected.

The second key (with associated opal), mounted above the bulletin board, is the "Night Alarm" key which the night alarm bell is brought into operation. The opal is provided to give a position visual alarm, while the central alarm lamp mounted above the positions serves as a suite visual alarm, thus ensuring prompt attention to calling or supervisory signals at times.

Keysheif.—The keysheif (Fig. 6) accommodates eight cord circuits each with double-ended cords, associated supervisory lamps and cord circuit keys and a Clock No. 44 for timing purposes with associated "time check" lamp which glows when nine minutes' elapsed time has been registered. The position keys Ans/Call/Bothway-Monitor, a Dial/Answer-Back are mounted on the left-hand side of the keysheif, and



FIG. 7.—FACE EQUIPMENT AND KEYSHEIF.

position Clear key at the right-hand side. The dial, having a special 1-5/1 break-make ratio to conform to the requirements of the Siemens and Halske automatic equipment in operation on the Continent, is also mounted at the right-hand side.

Position Teleprinter.—This is a standard B.P.O. Teleprinter No. 7B with page printing. The separate table incorporates only an instrument jack (into which the teleprinter is plugged to give connection to the position circuit) and a power socket and switch for the 160V battery supply to the teleprinter motor. One such teleprinter position is shown in the foreground of Fig. 6.

Common Equipment Rack.—This rack, which has standard dimensions of 6 ft. 6 in. × 1 ft. 8½ in., and is equipped to serve two switchboard positions, is illustrated at the left of Fig. 8. It accommodates the main

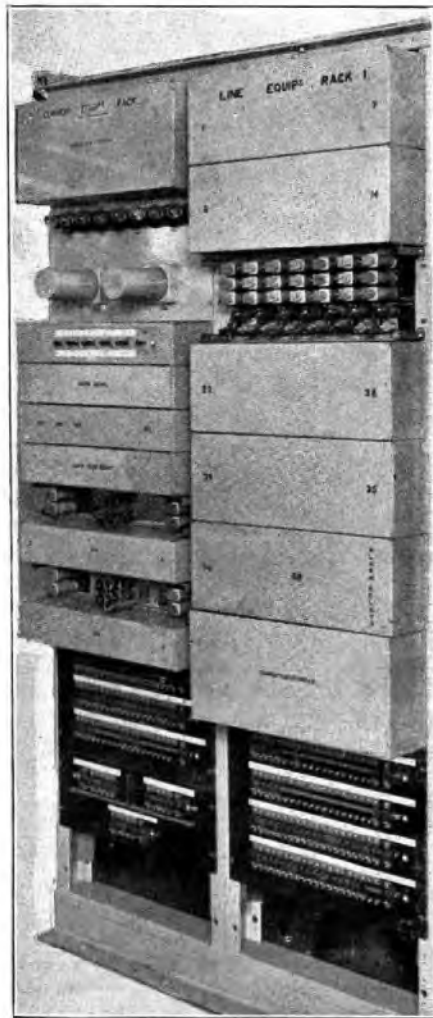

FIG. 8.—RACK MOUNTED EQUIPMENT.

and rack power distribution fuse panels, with appropriate alarms, protective bulb resistors and the relay equipment previously detailed.

Line Equipment Rack.—Fig. 8 also shows the type of rack construction employed for the manual and auto-manual line equipments described in Part I of

this article. The rack at the right of the illustration is fully equipped for serving 40 subscribers' stations, or both-way manual inter-switchboard lines. A rack of similar dimensions and construction will accommodate 12 auto-manual line equipments of the type employed to give connection with the Swiss automatic network.

Cord and Position Circuits.—These circuits are shown in Fig. 9, and it will be noted that certain features are similar to the corresponding circuits of the Switchboard, Teleprinter No. 17A.¹ Thus relay SK ensures that only one cord circuit key is effective at any one time, and relays SA, SC, P, PR and PZ serve to prevent interference with established connections due to overplugging or duplicate answering on multiple switchboards, and at the same time indicate to the operator concerned that the plug should be withdrawn, by lighting the "engaged" alarm lamps and causing the teleprinter to "race". The rectifier shunts across the low resistance windings of SA and SC have been provided to suppress inductive effects at the sleeves of the plugs when being withdrawn from the multiple, thus preventing the possibility of shock to the operator.

The clearing supervisory circuits, comprising relays CA and CB for the answering cord, and relays CC and CD for the calling cord, have similar characteristics, and function to the same limits, for the period of an established call, as the clearing relays R and A of the subscribers' station equipment already described. It will, however, be noted that when a cord circuit is not in use, relays CA and CC have marking battery connected to them via contacts SA3 and SC3, respectively, thus holding relays CB and CD normally operated. The supervisory lamps are, therefore, controlled by break contacts CBI and CDI, respectively, and are caused to glow only when a spacing supervisory relays, CA and CC, for more than 300 mS.

The functions of the remaining relays in the position circuit can, it is thought, be best covered by describing their operation in relation to the setting up of typical calls. The operating procedure outlined in this description is that at present employed at the London telex positions, and conforms to the draft operating procedure agreed by the Telex Commission of the C.C.I.T. For clarity in the description concerning calls set up via distant manual switchboards, it will be assumed that these latter are identical to the London switchboards, whereas, in fact, they are not, but nevertheless provide similar line signalling conditions.

Establishment of Calls over Inter-Switchboard Telex Circuits.

The cord circuit key is operated to "print" (KP) and the first position key to "answer" (KA) before the answer plug is inserted in the jack of the calling line. Relay SK diverts the connection to the position circuit and the earth from SK2 operates relays PA and PB so that the S wire of the calling line is connected to the tongue of the operator's teleprinter and the R wire is terminated on the position control relay CR. A second winding of this relay receives a leak

¹ P.O.E.E. J., Vol. 40, p. 102.

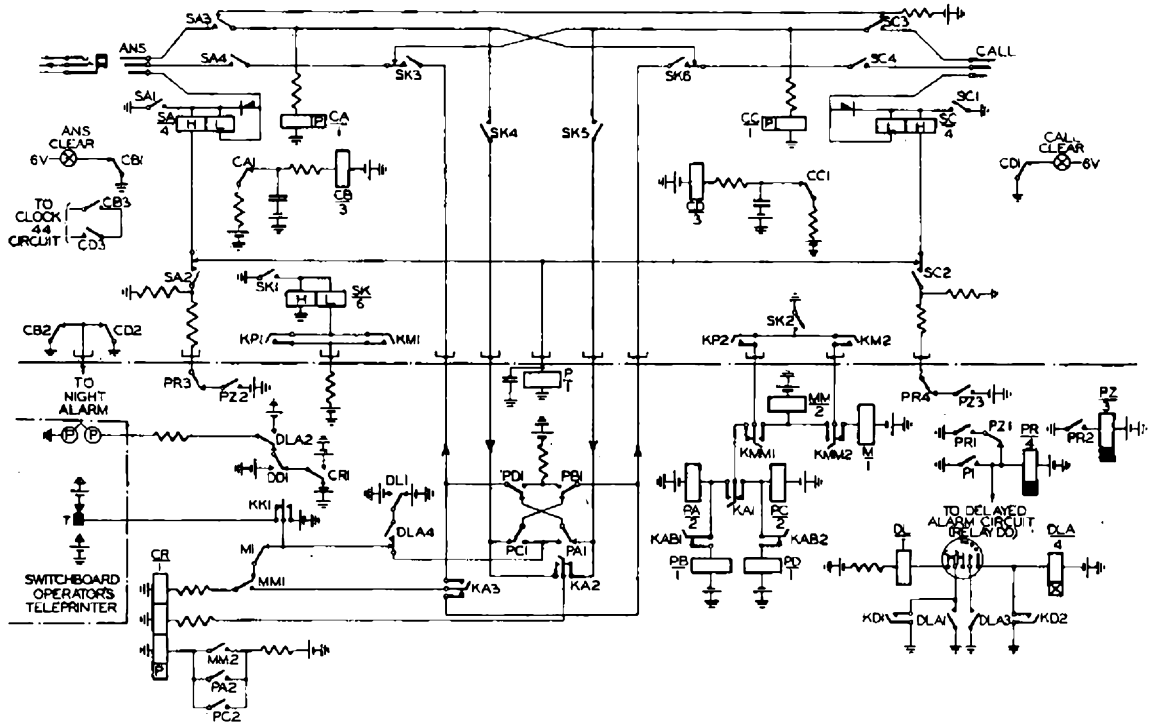

FIG. 9.—CIRCUIT SCHEMATIC OF CORD AND POSITION CIRCUITS.

from the teleprinter tongue and a third a biasing current. The three currents are so adjusted that the relay tongue is able to repeat signals received from the operator's or the calling teleprinter. The repeated signals control the operator's teleprinter electro-magnet at contact CR1. The operator announces the name of the switchboard and receives the telex number of the required subscriber. The calling subscriber is requested to wait whilst the connection is set up.

Leaving the keys as before, the operator inserts the call plug into the outgoing multiple jack of the inter-switchboard line concerned. The spacing condition on the R wire causes relay CD to release after 300 mS, so lighting the call supervisory lamp. When the distant switchboard answers, relay CD re-operates and extinguishes the lamp. The first position key is now restored to normal, i.e. to the "call" position, so as to connect together the two operators' teleprinters. The calling subscriber, meanwhile, is isolated and held on a marking battery as relays PC and PD operate and PA and PB release.

The particulars of the call are now transmitted to the distant switchboard, where the operator, after plugging into the required subscriber's line, with keys KP and KA operated, signals back "DF," and then changes over the cord circuit key to "Monitor" (KM) and the first position key to "Both-way Monitor" (KMM). Relays PA and PB release whilst relay MM operates, thus completing the cord circuit but providing the control relay (CR) with leak currents from either transmission path and also a biasing current. In this condition the distant switchboard operator receives a record of signals passing in either direction.

The code "DF" is received only by the operator of the originating switchboard and indicates that the answer-back signals may now be taken from the telex stations. The second position key (KAB) moved to the "answer-back" position, which causes relay PD to release. This has the effect of connecting the operator's transmitter to the called station, the transmitter of which is connected to the calling station. In addition, the position control relay connected in leak so that when the switchboard operator transmits the "WRU" signal the answer-back signal of the called station is printed at the calling station, at both switchboards and, via the local record circuit, at the called station.

The first position key (KA) is now moved "answer", releasing relay PC and operating relay P. This reverses the connections so that by transmitting the "WRU" signal again the answer-back signal of the calling station is printed at the called station at both switchboards, and, via the local record circuit, at the calling station. All parties now have a print record of the two subscribers concerned in the call. The second position key (KAB) is now restored to normal, the code "G" is signalled to the calling station as an indication that teleprinting may commence, and the cord circuit key restored to complete the connection by releasing SK. It is desirable that the circuit be monitored for a short period to confirm that transmission is satisfactory, after which the Clock No. 44 is started in order to record the chargeable time.

At the termination of the call a clear is originated by one or both subscribers, with the result that the wires of the circuit take up spacing polarity. The tongues of relays CA and CC move to spacing, the

disconnecting relays CB and CD which release after 300 mS. The supervisory lamps light, the audible alarm functions and the operator withdraws the plugs from the multiples.

It will be noted that the call is controlled throughout by the originating switchboard, where a docket is prepared for each call. Timing is effected only at this position and entered on the docket before the clock is reset.

Calls Dialed Direct.—For a call to a subscriber connected to an automatic switching network, and where the calls are directly dialled by the London operator, the calling plug of a cord circuit is inserted in the outgoing multiple, with the cord circuit key KP and position key KA still operated (the calling subscriber will be "held" to the answering plug, as previously described). The calling cord supervisory lamp will remain darkened until the "proceed-to-dial" signal is returned, when the spacing battery returned from the line equipment over the tip of the jack causes relay CC to "space" and relay CD to release, thus lighting the supervisory lamp at contact CDI normal.

The first position key is now returned to "call" (restoring key contacts KA to normal) and the second key to "dial" (KD), thus operating relays DL and DLA, the latter being slow to operate so as to maintain the marking polarity on the S wire. DLA2 provides a holding battery for the operator's teleprinter while dialling is in progress. The dial impulses are repeated to line by relay DL at contact DL1 in the form of marking and spacing reversals, a "break" being translated into a space and a "make" into a mark. The usual guard feature is provided to prevent premature restoration of the dial key from clipping the impulse train. When the call is switched, at the distant automatic equipment to the required subscriber's line, marking battery is returned, thus darkening the calling supervisory lamp as an indication that the answer-back signals may be taken. The ensuing operations, including clearing, are as previously described for calls over inter-switchboard lines.

When, exceptionally, incoming calls are received direct from an automatic network, e.g. from Switzerland, a calling lamp lights in the normal answering multiple but the appearances concerned are distinctively labelled, as such calls have to be controlled, timed and docketed, as for outgoing calls.

Cord Circuit Timing Facilities.—For the purpose of recording the elapsed time on telex calls, the Clock No. 44,² which is used for similar purposes on telephone switchboards, has been adopted, and is provided on the basis of one per cord circuit. The equipment employed for the control of these items is shown simplified in Fig. 10, from which it will be noted that the common equipment is provided in duplicate, for use as a reserve against breakdown, and to enable maintenance attention to be given to either equipment

without the possibility of interference with the working equipment. The importance of maintaining reliable and accurate timing facilities on international calls cannot be too strongly stressed.

After a connection has been established, and the answer-back signals verified, the controlling operator commences the timing of the call by operating the clock start key (KST) of the cord circuit concerned. This extends an earth to the common start relay ST, which at ST1 causes relay PA to pulse-operate to the 6-second pulse supply, and the clock mechanism to count in synchronism via the associated PA contact, and contacts CB3 and CD3 of the relative cord circuit supervisory relays. (The reserve common equipment is brought into service by key KR and relays RA and RC, which connect relays STR and PAR to function in place of relays ST and PA.)

The elapsed time of the call is thus recorded on the clock veeeder mechanism in steps of 1/10th minute until nine minutes is registered, at which stage the clock cams extend an earth to operate relay SPA, which disconnects the 6-second pulse from the clock and causes the "time check" alarm lamp to glow until the operator resets the clock, when relay SPA releases and the timing of the call recommences.

When a clearing condition is detected by either cord circuit supervisory relay at the end of a call, the timing pulse is immediately disconnected from the clock at contact CB3 or CD3. Key KST is then restored to normal by the operator before breaking down the connection, the recorded time is docketed, and the veeeder mechanism reset in readiness for the next call.

Miscellaneous Testing Facilities.—The importance of maintaining a high performance standard from the switchboard equipment, by reason of the type of traffic handled, has not been overlooked, and a number of novel features have been provided to enable performance checks to be carried out expeditiously, as follows:—

- (a) **Functional Test of Supervisory Circuits.** A test jack is provided in the miscellaneous jack strip into which the operator may insert a plug to check the performance of a suspect supervisory circuit. A spacing battery, connected to the tip

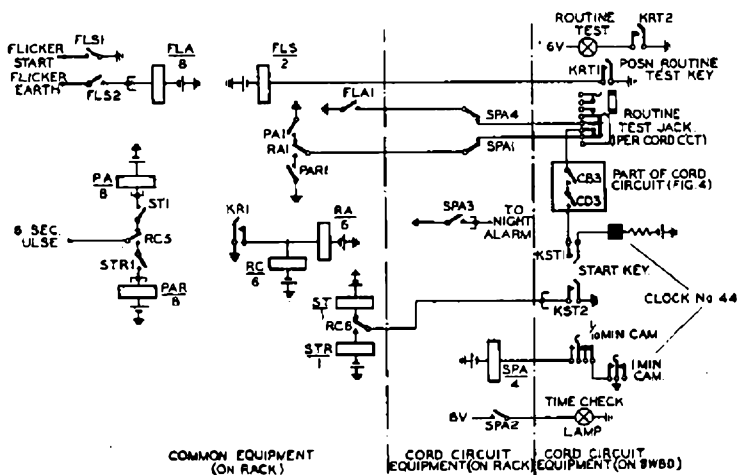

FIG. 10.—SIMPLIFIED SCHEMATIC DIAGRAM OF TIMING EQUIPMENT.

² P.O.E.E.J., Vol. 27, p. 273.

of the jack, simulates a clearing signal and should light the associated supervisory lamp.

- (b) *Functional Test of "Engaged Test" Facility.* A second test jack is also provided, which in conjunction with the supervisory test jack enables the performance of the SA or SC relays of a cord circuit, and the position relays P, PR and PZ, to be checked. The plug of a cord circuit under test is inserted in the second jack, whilst the plug of any other cord circuit is in the supervisory test jack. The sleeves of these two jacks are strapped together, so that the effect of overplugging is simulated, and the appropriate alarm conditions should ensue, i.e. the teleprinter should "race", and the engaged lamps light.
- (c) *Routine Test of Clocks No. 44.* If the start key of an idle cord circuit be rotated the clock will step at 6-second intervals and so its performance may be checked. To speed up the process, however, either plug may be inserted in the routine test jack (Fig. 10) and the "position routine test" key (KRT) operated. Relay FLA commences to pulse at flicker earth frequency and its contacts repeat the pulses to the clock so that the indication of nine minutes is reached in under 37 seconds. Any number of clocks may be tested simultaneously as individual test jacks per cord circuit are provided in the miscellaneous jack strip.
- (d) *Hold Jacks.* In the event of a telex station requiring to be placed out of service for a period, e.g. to permit maintenance work to be carried out, the switchboard is called and the operator advised accordingly. The calling plug of the cord circuit on which the call was answered is then inserted into a hold jack, of which three are provided in the miscellaneous jack strip. The station is held by a marking battery, and only the answering supervisory lamp lights when the station equipment is restored to normal.

Present and Future Developments.

The subscribers' station signalling equipment was designed with the knowledge that it would require to be mounted in an existing form of table unit of far from modern style if service were to be given by an early date. The development of a modern and aesthetically pleasing form of table unit was, therefore, carried out concurrently, for production in quantity, and has now reached a forward stage. The associated signalling equipment has been rearranged to provide for push-button control of the calling and clearing signals, which simplifies the operation of setting up a call and eliminates the need for providing the "forced release" key, as the clearing button is effective on either originated or received calls.

A relatively large proportion of subscribers to the Continental telex service require the provision of automatic transmitters and/or reperforators in association with the standard teleprinter, to obtain maximum utilisation of line time. For the initial stages, adaptations of existing key switching equip-

ment have been provided, but again the concurrent development of a modernised push-button controlled equipment has reached a forward stage. The unit will give full flexibility for the reperforation of sent or received messages, automatic transmission, and for the preparation of perforated tape, and will house the signalling and power sockets feeding the automatic equipment. The equipment will be automatically restored to normal and the teleprinter connected to line when a connection is cleared, either normally or by fortuitous circumstances.

The problems arising from "follow-on" calls on through-signalling switchboards, well known in telephony, are equally, if not more, serious in the telegraph case. The arrangements on the switchboards described in this article to prevent such occurrences are regarded as adequate, but the incorporation of automatic safeguards at a later stage in the growth of the service has always been regarded as essential. A cord circuit providing complete safeguards against the extension of follow-on calls to a distant network, and also providing for the call to appear at its normal appearance in the calling multiple, has been designed, and will shortly be available for laboratory tests.

It is interesting to note that, irrespective of the introduction of C.C.I.T. signalling circuits in this country, the problem of interworking between such circuits and those employing D.T.N. signalling has already been encountered, viz. a private wire terminated on the Continent requiring access to a self-contained private manual network in this country. The design of a signal conversion unit, associated with the circuit termination at the D.T.N. switchboard has been developed and tested, and should shortly be in service on a field trial basis.

The demand for the Continental telex service has so far been almost exclusively confined to London and its environs, but the possibility of extending the service outside the London area is under active consideration, as also is the utilisation of an exclusively telegraph network for the national telex service.

Conclusion.

The reintroduction of telex service to the Continent on a basis conforming to the recommendations of the C.C.I.T. has proved eminently successful, and leads to the conclusion that both the growth and the usefulness of the service will increase steadily. In this connection it should be recorded that in addition to the opening of the service to Holland, France, Belgium and Switzerland as described in Part 1, its extension to the Czecho-Slovakian telex network on a direct dialling basis was effected on 8th March, 1948, via two circuits to Prague. The further extension of the service to Denmark—and via the Copenhagen telex switchboard, to Norway and Sweden—should also have taken place before this article appears in print.

Acknowledgments.

The authors wish to acknowledge the help of their colleagues in the Telegraph Branch during the development period, and of the staff of the London Telecommunication Region during the construction and installation stages.

A Note on an Experimental Packet-Counting Device

U.D.C. 656.8

This note gives a brief account of an experimental device for automatically counting postal packets of a type unsuitable for machine cancellation.

Introduction.

AN accurate picture of the amount of traffic flowing through Postal Sorting Offices is very desirable from both the administrative and engineering points of view. Such information is relatively scarce because it is difficult to obtain in an economical and accurate manner without delay to mail. Ordinary letters are counted automatically when the stamps are cancelled by machine, but the odd-shaped packets, unsuitable for machine stamping and which form about 15 to 20 per cent. of the total mail, are not at present counted, except by hand at special "counts" taken usually at yearly intervals. Attempts to count such packets automatically, when they are handled individually at the hand-stamping tables, were started before 1939, but, as the work had to be abandoned until recently, the first complete experimental installation has only just been completed.

This installation at the Newcastle Station Sorting Office was designed and assembled by the E-in-C's Power and Research Branches, the mechanical parts being made in the Newcastle Workshop. The experiment is mentioned on account of the interesting circuit arrangements involved, which may find application elsewhere. Fig. 1 shows the general view of the work in progress and the type of packet being handled. The packets are segregated from the mail by hand and are placed on a conveyor which discharges on to the hand-stamping table, as shown in Fig. 1, where they move along the bed of the table on a slowly-moving band. The men take each item and, having located and cancelled the stamp, dispose of it on to a collecting conveyor running under the table. The items fall on to the conveyor after sliding down

an inclined chute at each stamper's position; Fig. 2 shows the chute (table top removed). In the base of

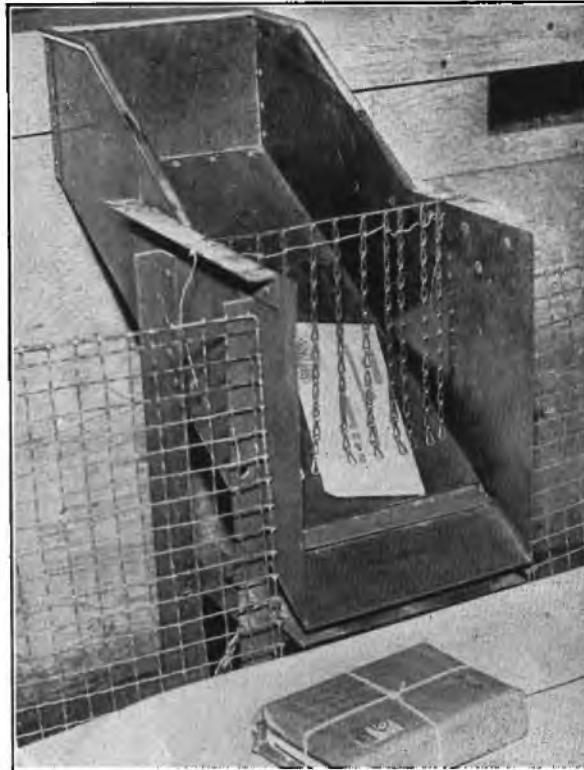

FIG. 2.—CHUTE WITH BALANCED FLAP AT LOWER END.

the chute is a balanced flap which is moved by the item as it passes. Chains are hung in the chute to eliminate the risk of an item bouncing over the flap. Thin letters containing some hard object slide down under the chains which, when mounted under the table, clear the chute by $\frac{1}{4}$ in. The packets vary in weight from approximately $\frac{1}{4}$ oz. to 4 lb., although heavier items are handled occasionally. An electrical impulse is sent by the operation of the flap to a remote relay-operated counter associated with the individual chute. This counter is a subscriber's meter (101A) which shows four figures. The circuit for the individual station is shown in Fig. 3. There are seven such stations in the experimental installation, with space for further expansion.

Counting Circuit.

The flap is mechanically interlocked with relay A (see Fig. 3) in a manner such that it cannot be returned to normal (by balance weight) until this relay has



FIG. 1.—HAND-STAMPING TABLE WITH CHUTES.

been electrically operated, and, once returned, the flap mechanically holds relay A in its operated position even after the coil is de-energised.

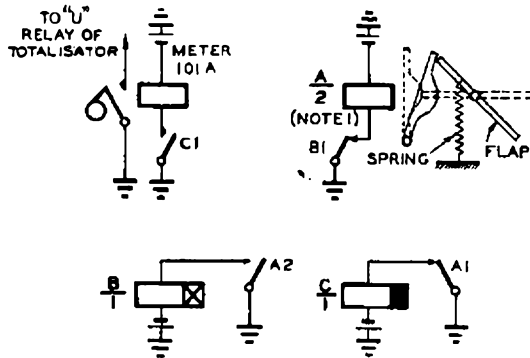

Note 1. Circuit shown Unenergised with Flap depressed.
FIG. 3.—COUNTING CIRCUIT.

When the flap is depressed by a packet the armature of relay A is released. The closing of contact A1 energises relay C which in turn energises the meter. The control relay B, although designated "slow-to-operate" is also "slow-to-release," and it is this release lag which controls the interval between the operation of the flap and the resetting of the interlock by energisation of the A relay. If the flap is held down for a prolonged period the A and B relays hunt. To prevent this from operating the counter, relay C has a large release lag and remains operated during any hunting. The counter, which records only when its coil is de-energised, thus indicates the passage of a single packet whatever the time period is for which the flap is depressed. This time is, of course, dependent upon the size of the packet and the rate at which it is travelling.

Totalisator Circuit.

In addition to the individual counting devices a totalisator circuit has been provided. This gives indication of the amount of traffic passing through all the stations (up to 50 stations can be accommodated in a full-scale installation). Signals are received at random from the individual stations according to the chance instant of packet disposal. The grand total is shown on a four-figure meter, but the last figure represents ten packets. Thus a total capacity of nearly 100,000 packets is provided. This is about a week's packet traffic at a large provincial sorting office. Seven-figure counters would be provided in a permanent installation. Various schemes for providing this total were considered but as it is desired to obtain full data on the performance of rotary switches when located in sorting offices (although mounted in normal dust-proof cabinets), it has been decided that the totalising is to be carried out as follows. (Fig. 4 gives the circuit.)

When any meter on an individual station operates, an earth is extended into the totalisator via the meter auxiliary contact, relay UA operates quickly and relay U operates slowly. Thus contact UA1 makes before U2 breaks, and this ensures that the stepping magnets on the rotary switch are operated only for a short interval (40 mS). This repeats until nine steps have been taken (nine packets dealt with) and the SA1/2 wiper is

on the ninth outlet. The tenth packet registers on the meter and the main totalising meter must now be stepped one unit. The stepping mechanism of the station uniselector SA1/2 is operated, but the switch does not move until the magnet is released. At the same time an earth from the individual station is extended through U1, the ninth outlet and R1, and relay T is energised. T locks over its own contact T1. T starts the rotary switch C50, in the totalisator control circuit, hunting whilst T2 puts an earth on a particular contact (or series of commoned contacts) on the C1/2 bank. This is, in effect, the station "calling" the totalisator and several or indeed all the stations can call simultaneously. The stations are dealt with in rotation, well within the time for any one of them to have recorded a further ten packets. No calls can therefore be lost. As soon as the C1/2 wipers of the totalisator control uniselector (C) have stepped on to the marked (T2 earth) contact, relay H operates. This cuts the C uniselector drive circuit and operates the "grand total" meter which registers one unit (indicating ten packets). The meter contact energises relays COA and COB. Contact COA1 makes, an

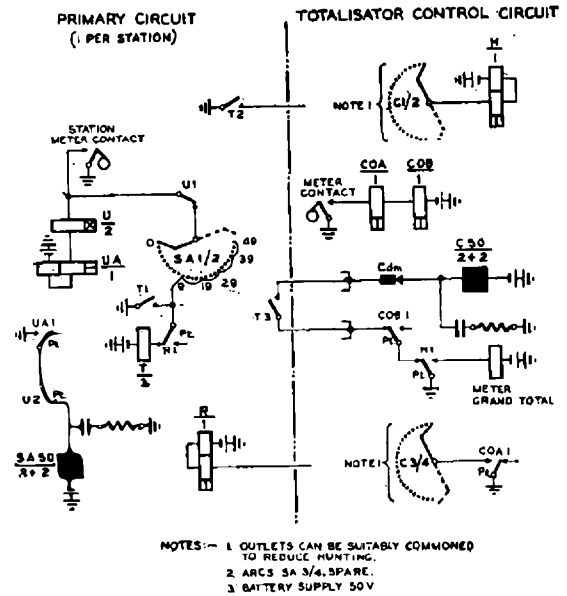

FIG. 4.—SCHEMATIC DIAGRAM OF TOTALISATOR CIRCUIT.

extends earth via C3/4 to operate relay R (calling station circuit) and so releases the T relay. The release of T2 releases relay H; contact COB1 prevents the restoration of the H1 earth to the common hunting circuit of the C uniselector until the rest of the totalisator control circuit is at normal. The release of relay COA releases the R relay of the station circuit. When relay COB is released the totalisator control circuit is free to move off to record a call from another station. Should other calls be waiting, the respective T3 contacts will have prepared the drive circuit and the C uniselector will hunt for and seize the first calling station it reaches and the cycle of recording another ten packets will proceed as before.

S. T. W.
J. P.

British Standard Codes of Practice

U.D.C. 621 (093.74)

Readers of this Journal will have noticed that many British Standard Codes of Practice bear an imprint to the effect that they are issued by the British Standards Institution on behalf of "The Codes of Practice Committee for Civil Engineering, Public Works and Building formed under the ægis of the Ministry of Works," and these notes are written to tell something of the story relating to the formation and objects of that Committee and of the character and production of the codes.

Introduction.

THE study of post-war building problems has its origin in a desire expressed by professional and other institutions connected with the building and civil engineering industries to assist and support the Ministry of Works in regard to post-war plans, and during the latter part of 1941 Lord Reith, then Minister of Works, taking advantage of these offers of assistance, encouraged the establishment of a series of committees to investigate and report on the major problems which were likely to affect post-war building. These committees were appointed by a Government Department or convened by a professional institution, a research association, or a trade federation, as seemed most appropriate in each case, and were so constituted as to ensure that their reports, known as Post-War Building Studies, contained the considered views of experts and others closely connected with the subject.

Twenty-two "Post-War Building Studies" were published by the Stationery Office and those of greatest interest to P.O. engineers are:—

No. 9—Mechanical Installations.

No. 11—Electrical Installations.

No. 12—The Lighting of Buildings.

No. 19—Heating and Ventilation.

Post-War Building Studies No. 11 was compiled by a Committee convened in 1941 by the Council of the Institution of Electrical Engineers, and its chapters deal with electrical installations in houses and flats, multi-occupier and similar buildings, schools, hospitals and farm buildings. Telecommunications are treated separately for each type of building and the publication was reviewed in an earlier issue¹.

The reports are not official publications in the sense that the Government is responsible for or necessarily accepts the views expressed, but their contents are authoritative and must have been of great value to those concerned with building since the war. The suggestions and recommendations contained have been developed in reports and manuals and have inspired various authors in the compilation of Codes of Practice.

Codes of Practice Committee.

The idea of Codes of Practice is not new or revolutionary; such codes describe the methods by which materials can be used to the best advantage to perform certain required functions, and such codes under other titles have been in use in industry for many years, both in this country and overseas. In Great Britain there have long been such guides as the "Minimum Specifications of the Institution of Plumbers," the "Institution of Heating and Ventilating Engineers' Guide to Current Practice," the

"Wiring Rules of the Institution of Electrical Engineers," and the "Code of Practice for Roof Tiling," but there was no co-ordination of the various codes.

There was evident, even before the war, a growing interest among the institutions concerned in the production of codes, and it was realised that if the quality of the work on or in a building was to be raised to a high level and maintained there, and not to be governed by commercial standards having low first costs as their principal consideration, then something in the nature of a series of authoritative codes of good practice would be needed. The British Standards Institution made efforts to secure co-operative action by the various institutions interested and at least one Code (No. B.S. 1043, "The Provision of Engineering and Utility Services in Buildings") was published; it bears the names of 75 organisations co-operating in its production. But these efforts were brought to an end by the outbreak of the war.

There the matter rested until 1942 when the Codes of Practice Committee was created by the Minister of Works and Planning to link together the work of the various institutions which had in the past contributed to the making of codes. All these agreed to pool their activities and to pursue them under the control of a single policy to be agreed between them. The British Standards Institution, The Building Industries National Council, the Building Research Station and the Ministry of Health and other Government Departments are represented on the Committee as well as the principal technical institutions; it is thus in effect a main committee of independent interests set up to decide policy, and its responsibility is to direct the preparation of Codes of Practice for building and constructional work, civil engineering and public works.

Code Framework.

In considering the formulation of a comprehensive scheme of Codes of Practice for building and civil engineering, it soon became evident that civil engineering and public works guides would require to be treated differently from the building codes.

In building practice large numbers of buildings are involved which, although varying in size and type, all require the execution of many operations that are similar and for which there is scope for uniformity of advice as to good practice; but in civil engineering the works tend to be fewer and larger, and owing to the greater diversity of function and to variations imposed by local conditions there are fewer operations of common application for a given volume of work or expenditure. Also, on examination of Codes of Practice for Building, it was evident that there are certain overriding requirements, common to all buildings, which

¹P.O.E.E.J., Vol. 37, p. 123.

are independent of the method of construction or the type of equipment installed.

It was, therefore, considered desirable to split the code framework into two main sections (1) The Civil Engineering and Public Works Codes, and (2) The Building and Construction Codes, with a further subdivision of the latter into two groups, one entitled "Code of Functional Requirements of Buildings" to cover the standard of performance required of the building as determined by its situation and the use to which it is to be put, and the other the "General Series Codes", comprising the codes for elements of the structure and the installation of equipment.

The Functional Code deals with the over-riding functional requirements of a building which are independent of the method of construction, the materials used or the type of equipment installed, and is divided into 11 chapters dealing respectively with (I) Lighting & Ventilation, (II) Space & Circulation, (III) Sound Insulation, (IV) Precautions against Fire, (V) Loading, (VI) Weather Protection, (VII) Services, including water supply, cooking, refrigeration, laundry, telecommunications and sanitation, (VIII) Heating & Heat Insulation, (IX) Durability, (X) Dirt & Vermin, (XI) Acoustics.

The General Series Codes deal with individual methods of construction, the use of specific materials and the installation of particular equipment, and are divided into four series:—The Carcase series, ranging from No. 100 to 199; the Building Finishes series, 200 to 299; the Installation of Services series, 300 to 399; the Miscellaneous Independent Installations and Equipment series, 400 to 499.

Any code may comprise a number of sub-codes and these are numbered in a three-figure decimal system. All the Codes of Practice are drafted to conform as far as practicable with a standard pattern and, for ease of reference and generally to ensure that all aspects of each subject are covered, each code or sub-code is divided into eight sections, namely (1) General, (2) Materials, appliances and components, (3) Design considerations, (4) Work off site, (5) Work on site, (6) Inspection and testing, (7) Maintenance and (8) Appendices.

The Installation of Services series is subdivided between:—Building drainage, sanitary services and refuse disposal (300-309), Cold water supply (310-319), Electricity (320-329), Gas (330-339), Central heating and hot water (340-349), and Ventilation, air heating and air conditioning (350-359).

The Electricity group of codes includes Electrical installation (321), Supply arrangements (public supply) (322), Private electric generating plant (323), Installation of domestic electrical equipment and apparatus (324), Farm and horticultural installations (325), Electrical installations to meet special conditions (326) and Telecommunications (327).

The Telecommunications Code comprises the following sub-codes:—

- 327·101 Telephones and Telegraphs—Public services.
- 327·102 Telephones and Telegraphs—Private services.
- 327·201 Broadcast reception—Sound and vision by radio.

327·300 Sound distribution systems for large buildings.

327·401 Bell and call systems.

327·402 Staff location systems.

327·403 Impulse clock and timing systems.

327·404 The installation of electrical fire alarms

The present position in regard to these Telecommunications Codes is that 327·401, "Bell and Call Systems," has been issued for comment and that the remainder (with the exception of 327·102 which is still being drafted) will all shortly be on sale to the public as drafts for comment, whilst the preparation of a sub-code on the "Broadcast Reception of Sound and Vision by Wire" has been indefinitely postponed.

Preparation of Codes.

With the exception of the Code of Functional Requirements which was drafted under the direction of the Codes of Practice Committee itself, the duty of preparing codes was placed in the hands of the professional institutions, who have appointed some 80 or so committees, sub-committees or drafting panels comprising over 400 experts, and these have given freely of their time and knowledge.

The general procedure followed in the preparation and issue of a code is for the drafting to be done by a sub-committee or drafting panel, and for its final draft to be considered and approved by the Code Committee of the relative professional institution. It is then forwarded to the independent Codes of Practice Committee and again reviewed by one of its sub-committees—for Electrical Installation Codes this is the Engineering Services Committee—before being published by the B.S.I. for comment. Throughout this process there may be discussions with technical officers of the central organisation and with its editorial group who are concerned with the clarity and uniformity of presentation.

The comment stage is a most important step in the production of a code. Some 3,000 copies are printed and well over 1,000 are distributed to interested associations and individuals at home and overseas. Copies are placed on sale for the general public and can be purchased by anyone interested who may forward his comments within the stated period and they will be considered. This general publication and acceptance of comment is an interesting and unusual procedure; by no other means could the Committee be fully assured that the subject matter of a code is regarded as acceptable by all who will be affected by it in one way or another. When the Committee is satisfied that the comments have been fully considered and dealt with, the code as amended is reproduced and published by the B.S.I. after approval by the main Codes of Practice Committee.

Arrangements have been made for the preparation of Engineering Codes outside the scope of the independent Codes of Practice Committee through the collaboration of the major engineering institutions most closely concerned in the particular subject with the British Standards Institution, under the terms of an agreement arrived at between the Councils of The Institution of Civil Engineers, The Institution of Mechanical Engineers, The Institution of Electrical Engineers and the British Standards Institution.

Such codes are allocated numbers in the series commencing 1001, according to their date of issue, and the following have already been issued :—

- 1001 Abatement of Radio Interference caused by Motor Vehicles and Internal Combustion Engines.
- 1002 Abatement of Radio Interference from Electromedical and Industrial Radio-Frequency Equipment.

A further Code, entitled "Installation and Maintenance of Flameproof and Intrinsically Safe Electrical Equipment for Industries other than Coal Mining," will be published shortly and others, dealing with Overhead Electric Transmission Lines, Earthing, Street Lighting and the Abatement of Radio Interference from Electric Discharge Lamps, are in the course of preparation.

Status of Codes.

The status of a code is a matter of considerable interest ; a code may be mandatory, that is it may be drafted initially as a legal requirement such as the London County Council by-laws or it may become mandatory by adoption either wholly or in part, or it may be adopted by consent as a permissible way of carrying out a building regulation or be cited in a contract or specification ; lastly it may be adopted by consent as a desirable method of carrying out an operation. The codes prepared and issued by the Codes of Practice Committee all emerge at this last level but they are capable of graduating with possible modifications to any of the other classes, but when issued by the Committee they are purely recommendatory in nature and each code includes the following clause :

" This Code of Practice represents a standard of good practice and therefore takes the form of recommendations. Compliance with it does not confer immunity from relevant legal requirements including by-laws."

The relation between the Codes of Practice and the Wiring Regulations of the Institution of Electrical Engineers is important. The Wiring Regulations set out the fundamental requirements to be observed for safety whilst the Codes of Practice in their encouragement of good practice may recommend the adoption of methods which go beyond the minimum requirements of the regulations. It is important to realise that the opposite situation cannot arise and that codes will never recommend a practice inadmissible under the regulations.

In regard to British Standard Specifications, the arrangement is that those shall deal with the standardisation of materials, appliances and components whilst the Codes of Practice are concerned with methods of using them. Whenever practicable the technical requirements of materials, appliances and components mentioned in the codes are based on British Standard Specifications, when these are available.

Conclusions.

The motive forces behind the preparation of the codes existing before the establishment of the Committee were varied and diverse. There were codes

that aimed principally at public safety, codes prepared by trade interests so that a high standard of performance would be obtained, and others which had a commercial implication outside the constructional industries. These codes were not directed in the first place to the benefit of the occupier or user of the building but rather to that of the owner and of those engaged in the building industry, whereas the codes now being issued are prepared with the interests in mind, as far as possible, of everyone associated with the building, from the manufacturer of an elementary component to the ultimate occupier. They are intended to be descriptive of good practice and not statements of permissible minima, and should bring together the results of practical experience and scientific knowledge with the object of obtaining increased efficiency in constructional and ancillary works and economy in labour and materials ; they should become the vehicle by which the designer can convey to those engaged in the actual construction his own intentions in clear and explicit form. Present-day conditions, including the shortage of material and components, may prevent the recommendations being followed explicitly, but the code still remains descriptive of a desirable method of construction or performance.

It would be unreasonable to delay the drafting of a code until complete and final knowledge were available on the subject covered, because such a state can never be reached, consequently it must never be assumed that a code represents anything more advanced than the state of the art at the time it was drafted. This is an essential reservation as the practical value of a code depends upon the possibility of its being followed. The inclusion of factors which were in advance of the materials and methods actually available would vitiate the code, hence all codes are subject to revision as the state of the art advances and the test of time and experience warrants.

A comprehensive series of codes covering such a wide field will provide a background against which research and development can be carried out. The use of the codes in the field will provide a test as to the direction in which research and development should proceed to be of maximum value to industry, and conversely the results of research and development can, through the medium of the codes and their associated standard specifications, be publicised and carried effectively into practice when otherwise they might lie dormant until by some accident brought to light.

The preparation of the codes has provided for the first time a forum wherein the professional men of all branches of building and allied industries meet together and pool their technical experience for the benefit of the public and industry.

Acknowledgment.

In the preparation of these notes the author is greatly indebted to Dr. C. Roland Woods, Director, Codes of Practice Committee, whose information and writings have been freely drawn upon.

H. G. S. P.

Sixth Plenary Meeting of the C.C.I.T., Brussels, May 1948

U.D.C. 654.1

THE fifth plenary meeting of the C.C.I.T.¹ was held at Warsaw in October, 1936, and at the close of that meeting it was agreed that the next plenary assembly would be held concurrently with a plenary assembly of the C.C.I.F. at Lisbon in 1940. However, events arranged otherwise, and although advantage was taken of a C.C.I.F. meeting at Paris, in 1946, to hold a short special meeting of the C.C.I.T. to elect principal reporters for the committees which were previously directed by the German administration, and although preparations were then in hand for the next plenary meeting to be held in 1947, various matters arose which required further postponement of the plenary meeting until 1948.

Although the plenary meeting was postponed much work had been done in the meantime to ensure collaboration between the various administrations, particularly with the drafting of regulations which would apply to the working of the International Telex system, a system still in its infancy but already of such stature that it allows of a private subscriber in London, for instance, communicating by means of his teleprinter to other similarly equipped subscribers in France, Holland, Belgium, Switzerland and Czecho-Slovakia.² A meeting of the committee charged with this task was held at The Hague in 1946, and a meeting of a committee charged with the task of remodelling the committees to suit the questions facing the C.C.I.T. was held in 1946 at Paris.

The plenary meeting at Brussels had to deal with all the questions left over for study by the meeting at Warsaw and with all new questions which had arisen in the period following that meeting and with the telex regulations. The new questions included, amongst others, the American proposal for the general recognition of the International Alphabet No. 2, with certain suggested minor modifications to that Alphabet, and the British proposal for the utilisation of signal No. 32 of the No. 2 Alphabet, a signal which at present is barred for international use.

The actual meetings were held at the Egmont Palace, a large mansion in its own grounds, which at one time was a private residence, but is now the property of the town of Brussels. The arrangements made for the meetings were most convenient, all the rooms being situated on the first floor of the building. Two of the largest rooms were equipped for simultaneous translation, and served for the main meetings of the various committees; the smaller rooms were used for the meetings of the sub-committees and here the successive method of translation was used.

The work of the plenary meeting was divided into six committees: Technical, Operations, Organisation, Subscribers Service (Telex), European Network and Drafting. Because of the number of committees the meetings were arranged so that there was a minimum of overlapping. The arrangement was perhaps too

rigid in its conception and led in the final stages of the meeting to very late and prolonged meetings of some of the committees and in particular, the Technical Committee. There will not be, however, another assembly of the C.C.I.T. organised in this manner since the arrangements provided for under the Atlantic City Convention require that the separate committees reach their conclusions in advance of any plenary assembly and any lesson to be learnt from the experience at Brussels cannot be applied to future meetings of the C.C.I.T.

The Technical Committee had to deal with questions arising out of six of the committees of the C.C.I.T., these dealing with (1) quality of telegraph transmission, (2) standardisation of telegraph apparatus, (3) relays, (4) co-existence in cables of telegraph and telephone circuits, (5) phototelegraphy, (6) protection, and all matters which could not be treated in the main committee were dealt with by sub-committees under the chairmanship of the principal reporters of these C.C.I.T. committees.

It can be stated that the Technical Committee worked most harmoniously and the British delegation has the satisfaction of knowing that in the main the resulting opinions and new questions were in direct line with their experience and opinions expressed in the preliminary documents. Agreement was reached on definitions of telegraph distortion and margin which will replace the definitions in the present opinions of the C.C.I.T. Agreement was reached on the detail of circuit advice to be exchanged between Administrations whenever new international telegraph circuits were set up and on the precise functions of certain testing offices on the route of such circuits this being based mainly on the practice which has been evolved in this country. Agreement was reached also on the method to be adopted for bringing into operation a reserve circuit when, for any cause, an international telegraph circuit is found to be unworkable again the procedure adopted was based on the experience gained and practice adopted in this country.

Much discussion centred in the proposition of the United States that the Telegraph Regulations should contain a paragraph advocating the adoption, with reservations, of the 5-unit code Alphabet No. 2, a code for general use in international telegraphy and after some modifications to the wording of the U.S. proposal, which were accepted by the U.S. representative, the proposal was accepted. This proposal had its origin in the deliberations of the Bermuda Conference.

Another question which gave rise to much discussion was the British proposal that the 32nd signal of the Alphabet No. 2, the all space signal, which is at present not used internationally, should be reserved for the possible use of a third case shift on teleprinter and thus make available another series of signals which would possibly be required in the future when teleprinter working is much more developed by commercial users. This question was originally raised by

¹ P.O.E.E.J., Vol. 29, p. 293.

² P.O.E.E.J., Vol. 41, p. 39.

the Creed Co. and supported by the British administration who raised the matter in the form of a new question to the C.C.I.T.

The question received general support and agreement was reached that the original question should be studied as a new question in a new general form with the British proposition as a particular case.

The main purpose of the question was to bring to the attention of Administrations the idea that there were real possibilities in the usage of this signal for the purpose of a third case, and that it would not be wise to use this signal for special national purposes which might stultify its wider use in the future.

Numerous other questions were dealt with, some matters of detail, some of much wider significance, but all were resolved or remitted for further study. Such questions included the design and utilisation of regenerative repeaters, involving the desirability or otherwise of a stop signal longer than 1 unit, e.g. 1.5 units; the blocking of the keyboard of a teleprinter after the number of letters allocated to a line has been operated; the utilisation of the full band available on coaxial cable telephone circuits for phototelegraphy and the repercussion on the design of the phototelegraphy apparatus; the use of sub-carrier frequency modulation as the transmission

method for phototelegraphy over lines; standardisation of paper sizes and line spacing on page teleprinters. In all some forty new technical questions were passed for future study by the C.C.I.T., in many cases in combination with C.C.I.R. or C.C.I.F., and a recommendation made that a permanent sub-committee should be set up to deal with all questions of maintenance on the lines of a similar committee in the C.C.I.F.

The draft regulations for the operation of the International Telex service were discussed in detail and were finally agreed.

The matter of a European switched network for the more expeditious handling of public telegrams which could not be dealt with by direct circuits, which originally had been raised by the Czechoslovak Administration, was discussed, and it was agreed that there was need for such a network and that further study should be made of the problem on the basis of an agreed memorandum which will be incorporated in the recommendations of the Conference.

At the Plenary Conference Great Britain was charged with the chairmanship of two technical committees, one dealing with phototelegraphy and the other with the technical questions of automatic switching.

F. E. N.

Institution of Post Office Electrical Engineers

Result of Ballot on the Proposed Alterations to Rules.

The Scrutineers have reported to Council the result of the ballot, on the proposals put to the membership in April last.

It is as follows:—

	<i>For the Amendment</i>	<i>Against the Amendment</i>
(1) Membership; Rule 6. Associates	767	1,171
(2) Subscription: Rule 13	1,216	718
(Total membership eligible to vote was 5,017.)		

In accordance with the provision of Rule 31, the proposal under (1) will not be brought into effect.

The proposed rates of subscription will be operative this session, and members will have seen the notices which appeared in the Post Office Circulars of the 28th April and 2nd June, 1948, in regard thereto.

ESSAY COMPETITION, 1948-9

The Council offers Five Prizes of Three Guineas each for the five most meritorious Essays submitted by members of the Engineering Department of the Post Office below the ranks of Inspector and Draughtsmen Class II, and, in addition, to award a limited number of Certificates of Merit.

A prize-winner in any previous competition is not eligible to enter, but this restriction does not apply to a competitor who has been awarded a certificate only. An essay submitted for consideration of an award in the Essay Competition and also submitted in connection with the Junior Section I.P.O.E.E.

prizes, will not be eligible to receive both awards.

In judging the merits of an essay, consideration will be given to clearness of expression, correct use of words, neatness and arrangement, and although technical accuracy is essential, a high technical standard is not absolutely necessary to qualify for an award. The Council hopes this assurance will encourage a larger number to enter. Marks will be awarded for originality of essays submitted. Competitors may choose any subject relevant to current telegraph or telephone practice.

The Essay must be written on foolscap or quarto paper, and must not exceed 5,000 words. A $\frac{1}{4}$ -in. margin to be left on each page. A certificate is required to be furnished by each competitor, at the end of the essay, in the following terms:

"In forwarding the foregoing essay ofwords, I certify that the work is my own unaided effort both as regards composition and drawing."

Signature

Address

Date

Rank

The Essays must reach The Secretary, The Institution of Post Office Electrical Engineers, G.P.O. (Alder House), London, E.C.1, by the 31st December, 1948.

J. READING, *Secretary.*

Notes and Comments

Roll of Honour

The Board of Editors deeply regrets to have to record the deaths of the following members of the Engineering Department :—

London Telecomms. Region . .	Purves, T.	..	Labourer	Sergeant, Argyle and Sutherland Highlands
Norwich Telephone Area . .	Wagg, F. Q.	..	Skilled Workman, Class II	..	Signalman, Royal Sign.

Recent Awards

The Board of Editors has learnt with great pleasure of the honours recently conferred upon the following members of the Engineering Department :—

Birmingham Telephone Area	Wood, D. F.	..	Technician	C.Q.M.S., Royal Signals	British Emp. Medal
Bournemouth Telephone Area	Hardy, A. A.	..	Technician	Sergeant, Royal Signals	British Emp. Medal
Cardiff Telephone Area . .	Batchelor, J. H.	..	Skilled Workman, Class II	Lance Corporal, Royal Signals	Belgian Croix Guerre, 1940 with Palm
Engineering Department . .	Long, F. S.	..	Assistant Engineer	Flying Officer, R.A.F.V.R.	Mentioned in Despatch

D. G. Tucker, D.Sc.(Eng.), Ph.D., A.M.I.E.E.

We would all wish to congratulate Dr. D. G. Tucker, Executive Engineer, Research Branch, on his award of the degree of Doctor of Science (Engineering) by London University. This notable academic success has been achieved by only one other member of the Engineering Department—the late Dr. R. V. Hansford, one time Assistant Staff Engineer, Radio Branch.

Dr. Tucker entered the Post Office in 1932 as a Probationary Inspector and after a short period in the N.E. District was appointed to the Research Branch in 1933. He was engaged on the development of carrier telephone equipment and, after passing the Limited Competition for Assistant Engineer in 1938, he worked on problems connected with the synchronisation of carrier systems. In 1943 he submitted to the University a thesis on closely-related work and was awarded a Ph.D. His subsequent work was connected with various aspects of frequency selection and he published a number of valuable

articles in this field; this published work was submitted to the University and has resulted in Dr. Tucker's latest academic award. R. J. H.

Supplement to the Journal

In the City and Guilds of London Institute Examinations in Telecommunication Engineering : 1948, additional papers were set in Telecommunications (Principles) IV and V, Radio IV, and Line Transmission I and II. Allowing for certain omissions and changes in the examinations, this makes a total of 15 papers to which it is proposed to publish model answers in the Supplement, commencing with the current issue.

To allow of publication of answers to four additional papers within the present paper ration, it has been necessary to modify the Supplement format—a reduction in margins; it is hoped that the advantage of obtaining a comprehensive Supplement will compensate students should they find reading slightly less easy with the revised layout.

Book Review

"Wiring a Continent." The History of the Telegraph Industry in the United States, 1832-1866. Robert Luther Thompson. Princeton University Press. (London, Geoffrey Cumberledge, Oxford University Press). 544 pp. 63 ill. 42s.

This book, fully documented and well illustrated with topical plates, is a record of the development of telegraphy in the United States from the time of the early work of Morse up to 1866, which date marks the emergence of the Western Union Telegraphy Company as the amalgam of the early pioneering companies destined to carry the torch of development into the years which followed.

The record is divided into four books of which the first is of more direct appeal to the engineer since it deals with the life and pioneer telegraph work of Morse and his efforts first to get an appropriation from Congress for the historic Baltimore-Washington telegraph line and then his failure, or rather the failure of the then

Postmaster-General, to secure governmental control of the new power then being made available.

The other three books deal in detail with the efforts of the companies which sprung up in various areas of the United States to make this new power of telegraphy available; of their difficulties and rivalries and of their eventual amalgamations into more coherent units, a process which was completed after the Civil War, the final amalgamation being the Western Union. Two other systems, those of Bell and House, were involved with that of Morse in the pioneer efforts and their application is put into proper perspective.

The range of the story is vast, but the factual record has been presented in such a masterly way as to give an air of sustained romance to the pages, and the book should prove of absorbing interest not only to those who have any attachment to telecommunications but to all readers who love a good story well told for itself.

F. E. N

Headquarters Notes

Radio Development

LONDON-BIRMINGHAM TELEVISION RADIO-RELAY SYSTEM.

The successful expansion of the television service in this country is dependent on the exchange of programme material between London and the provincial centres, as in the case of sound broadcasting. Unfortunately the provision of the communication network suitable for relaying television signals is a much more difficult problem than is the case for sound, calling as it does for the transmission of a relatively wide frequency band with good transmission characteristics. The attenuation/frequency characteristic must be flat within close limits, the phase/frequency characteristic must be linear and the performance in terms of build-up time, overshoot and decay of response to a suddenly applied signal, gain stability, signal-to-noise ratio, non-linearity and echo signals, must meet close specifications. The bandwidth required for the effective transmission of the present standard 405-line signals is some 3,000 kc/s and to achieve the transmission characteristic required, the fall in response above this frequency must be gradual.

There are two possible methods of relaying such signals, the one using the coaxial cable system and the other by radio link operating at very high frequencies. Each has its particular merits and the most effective will be found from the results of field trials on fully operating systems. It may be eventually that the trunk network will comprise an integration of both cable and radio links capable of carrying both television and multi-channel telephony signals.

When completed, the radio link will provide for the simultaneous transmission in both directions of 405-line signals from a radio terminal on the roof of the Museum telephone exchange, London, to the other terminal on the roof of Telephone House, Birmingham. The connections between Telephone House (Birmingham) and the B.B.C. local transmitter and between the B.B.C. London Studio, Broadcasting House, and Museum exchange will be by coaxial tubes. The radio link will comprise five sections with two terminal and four relaying stations (see Fig. 1.) The overall link length is some 115 miles, and the shortest and longest sections are some 6 and 39 miles, respectively. The actual sites are, of course, determined by the need to provide optical paths between corresponding transmitting and receiving aerials at the frequencies employed—some 900 Mc/s. Four different transmitter frequencies will be employed, and one of the several possible allocations of these frequencies between the several stations is shown in Fig. 1. The relatively high frequency of 900 Mc/s enables an aerial of high directivity to be employed, that is, one in which the power in the radiator elements in the case of the transmitter is concentrated in a very narrow beam which is directed towards a similar aerial at the corresponding receiver. This high directivity has two important advantages; it provides the required field strength at the receiving aerial with a minimum of radiated power, and it minimises the effect of interfering signals and of reflections or echoes from aircraft and buildings unless they arrive within the relatively narrow angle at which the aerial has a maximum response. To assist in achieving the required optical line-of-sight between corresponding aerials, these aerials will be mounted on steel towers some 100 ft. high. The four

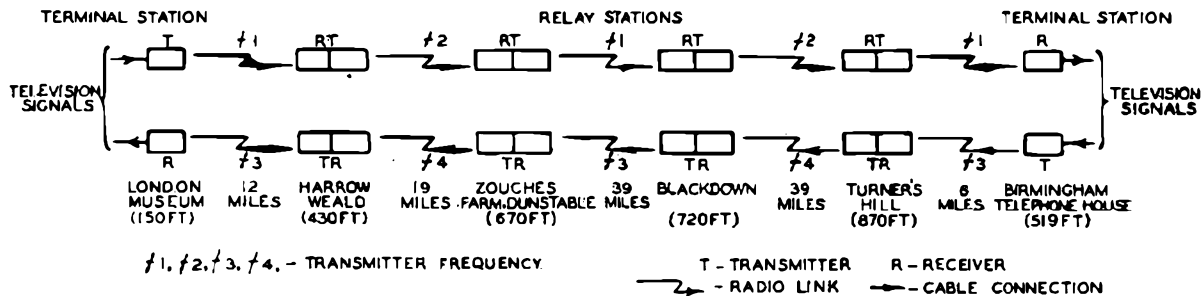

FIG. 1.

As part of the programme to provide facilities for relaying television signals between main centres of population, and at the same time to give information on the performance of both cable and radio system, work is now in hand on the provision of a new six-tube cable between London and Birmingham. The radio system which is planned to cater for the transmission in both directions of 405-line signals to and from London is being developed and provided by the General Electric Company Ltd., to the Department's performance specification. The contract for the system was placed about mid-1947 and, since it is too early to describe the link, the purpose of this note is merely to indicate the general form the link will take.

aerials at a relaying station, each some 12 ft. in diameter, will be mounted on the top of the tower and the associated radio equipment will be housed in a small cabin erected at the top of the tower. A small building near the tower base will house the power supply equipment, standby power equipment and all equipment which can with advantage be remote from the aerials. The photograph of Fig. 2 was taken during field trials at Zouches Farm.

Reserve radio equipment will be switched into service automatically in the event of a fault on the working equipment and a supervisory system will provide an indication of the fault at the control terminal. All stations with the exception of the con-

trol terminals will be unmanned, and, except for a fault condition, will be visited only for routine inspection.

As already indicated, the system is planned finally to provide for the simultaneous transmission, to and from London, of 405-line signals. Initially, however, only a single channel, together with its reserve equip-



FIG. 2.

ment, will be installed, the channel being reversible.

Regarding the progress already achieved on the link, the comprehensive field trials which must be carried out before the link can be even planned have been completed, the sites have been selected and access obtained, the installation of temporary masts for the initial phase of the work is completed at most of the intermediate sites and the design and provision by the contractor of the radio equipment is understood to be proceeding satisfactorily.

Main Lines

PROVISION OF LONG-DISTANCE PUBLIC TRUNK CIRCUITS.

During the year April 1947 to March 1948 the number of long-distance public trunk circuits (i.e. circuits over 25 miles in length) was increased by 1,195 from 13,333 to 14,528. The total authorised requirement for circuits was increased by 1,914 from 14,880 to 16,794 so that the deficit increased by 719 circuits. Present trends, however—allowing for fuel crises in 1947—indicate that the trunk traffic has only increased 3.5 per cent. so that the rate of provision of circuits is exceeding the rate of increase of traffic.

In the provision of these circuits the number of 12-circuit carrier groups in use was increased by 33, of which 24 were routed on new coaxial supergroups. Seven new coaxial supergroups were introduced on the London-Birmingham-Manchester coaxial cable, five of these working between London and Manchester and two between Birmingham and Manchester.

During the year the number of long-distance private circuits in use by the Fighting Services has been reduced by 482 from 2,313 to 1,831.

Telegraphs

TELEPRINTER NETWORK FOR METROPOLITAN POLICE

As a result of discussions with representatives of the Metropolitan Police, a teleprinter network was planned to provide intercommunication and broadcast facilities to an ultimate of 120 stations connected to teleprinter switchboard suite at a central headquarters. Initially some 97 stations will be connected.

Four separate broadcasts (A, B, C and D), each any selection of lines, may be set up simultaneously. Operation of any broadcast key cuts the associated line away from the intercommunication switchboard. The A and B broadcast groups take precedence over the C and D groups, from which lines are cut away when A and B broadcast keys are operated. Flashing signals indicate seizure of an engaged line.

Installation work is nearing completion, and when service is eventually opened the existing 30-line teleprinter broadcast system, which was installed in 1935 will be superseded.

INTERNATIONAL METEOROLOGICAL CONFERENCE, BRUSSELS, MARCH 1948.

A meeting of the International Meteorological Organisation was held at Brussels in March of this year, one of the main items on the agenda being consideration of the provision of a teleprinter network for the collection and dissemination of meteorological information in Western Europe. Representatives from the several interested P.T.T. Administrations including one from the Telegraph Branch of the Engineer-in-Chief's Office, attended. A teleprinter broadcast network was finally agreed, and work on connection with its provision has already been started.

Telephones

FUTURE DEVELOPMENT OF THE B.P.O. TELEPHONE SYSTEM.

Early in 1947 a Working Party of Headquarters engineering officers was set up with the following terms of reference :—

1. To study and report on the extent to which the existing P.O. automatic telephone switching equipment is capable of catering for the extension of subscriber-dialling beyond the present limit of four-unit fees.
2. To report on the extent to which existing plants would have to be modified or replaced in order to provide for a future programme of mechanisation comprehending very extensive subscriber-dialling with national numbering and time-zoned metering.
3. To study in a general way recent developments abroad, such as the cross-bar system, which have been directed towards better contacting, simplicity and more reliable switching and greater flexibility in the facilities offered, and to make recommendations which may seem desirable regarding the equipment to be installed by the Post Office to meet immediate and long-term requirements.

In furtherance of their studies certain of these officers have paid visits during the past year to Sweden and America to investigate developments in automatic switching practice, and comprehensive technical reports have since been prepared in respect of each visit. In both countries the parties were given the fullest facilities to make technical investigations and to inspect exchanges in operation. Following is a brief description of the principal features of the systems in use.

In Sweden, where the telephone system is State controlled, there have been extensive developments in cross-bar switching systems, especially for small unattended exchanges. These exchanges make use of the cross-bar switch in the manner of a step-by-step selector, the switches being directly controlled by impulses from the subscriber's dial. The maintenance records indicate that the cross-bar switch used in this manner is very reliable.

The visit to the United States was made primarily to study the telephone system controlled by the American Telephone and Telegraph Company (Bell System) but visits were also made to exchanges controlled by independent companies.

In the large metropolitan areas of the United States, such as New York, the switching system is a mixture of the panel system and the No. 1 cross-bar system. All new exchanges will, however, be cross-bar. Unlike the Swedish cross-bar developments the Bell System cross-bar exchanges operate on a common control basis, using large markers to set up the switching paths. The size of the markers is such that with the very high speed of switching which can be achieved, only ten markers are required to control a 20,000-line exchange, and an individual marker may carry a load of several million calls a year. The facilities afforded by this system are similar to those provided by the British director system.

Outside the metropolitan areas the standard method of switching is non-director step-by-step using a switch which resembles closely the British pre-2000 type selector. A certain amount of automatic ticketing of subscriber-dialled calls has been introduced in a large non-director network in southern California. This development is of interest since the decision to adopt automatic ticketing was made only after it had been found to be cheaper than multi-metering on subscribers' meters. The fees concerned are from one to five units and although tickets are available the accounts to the subscribers are bulked.

National numbering schemes have been adopted in both countries. In Sweden the numbering scheme is designed for subscriber-to-subscriber dialling over any distance and some progress has already been made in this direction. Charges are determined by multi-metering.

In the United States the numbering scheme is not intended for extended subscriber-dialling but merely as an aid to the introduction of a rapid trunk operating service. The subscribers are not in fact aware of the existence of a national number.

The Swedish national number consists of a prefix and eight figures whilst the American national number consists of ten digits, some of which may be letters.

INTERNATIONAL LONG-DISTANCE DIALLING.

COMITÉ CONSULTATIF INTERNATIONAL TÉLÉPHONIQUE.

Considerable progress has been made by the 8th C.R. towards the formulation of the requirements of the signalling and switching system for semi-automatic operation of international circuits.

It has not been found possible to make definite recommendations regarding the signal code to be used in the signalling system without more detailed information. To obtain the required information it has been decided to design and construct equipment based on (a) a code using two signalling frequencies and (b) a code using one signalling frequency only. The equipment will be subjected to practical trials on a few circuits between London, Paris, Zurich, Amsterdam and Brussels.

Further consideration has also been given to the performance requirements of a suitable voice-frequency receiver and a specification which covers all essential requirements has been drafted.

HIGH-SPEED FILMS.

Information of considerable value to both the Department and contractors has resulted from a further series of high-speed films produced by the E-in-C. Circuit Laboratory in collaboration with the Research Branch. These films show the performance characteristics of the proposed new standard uniselectors, the Siemens high-speed motor-driven uniselector, the Carpenter polarised relay, Siemens twin contact high-speed relay, and Dials, Auto., Nos. 12 and 13.

ARTIFICIAL TRAFFIC MACHINE.

To assist in the study of gradings with slipped common choices and of the smoothing of traffic with various gradings, the development of an artificial traffic machine has been commenced. The machine is being constructed on electronic principles and will be capable of testing gradings having availabilities of 10, 20 or 40. From the facilities thus afforded for simulating various conditions it is hoped to show that economies in plant can be effected without degradation of service.

Construction

INDUCED VOLTAGES IN POST OFFICE CIRCUITS.

On 28th March, 1948, tests were carried out to measure the voltage induced in overhead telephone circuits due to earth fault currents in power lines between Tummel Bridge power station and Clunie (near Pitlochry) and between Rannoch and Abernethy power station. The North of Scotland Hydro-Electric Board are developing the hydro-electric resources of the North of Scotland and plan to provide in that area a 132-kV grid which will be connected directly to, and will be similar to, the grid provided in England and Southern Scotland from 1928 onwards by the Central Electricity Board. Because of the mountainous nature of Northern Scotland some of the power lines proposed will necessarily follow a route near to existing telephone routes for considerable distances. In such cases the voltages induced in Post

Office lines under earth fault conditions of the power line may be considerable. On the basis of a given earth fault current, and assuming a uniform earth resistivity of value appropriate to the geological condition of the territory, it is possible to calculate precisely the induced voltage in a line paralleling the power line. The complex nature of the surface layers of the earth, and the presence of lochs which in some cases lie between the power line and the telephone line, complicate matters however, so that before money is spent on special measures for the protection of the telephone lines it is desirable that tests should be made to measure the voltages actually induced in each case.

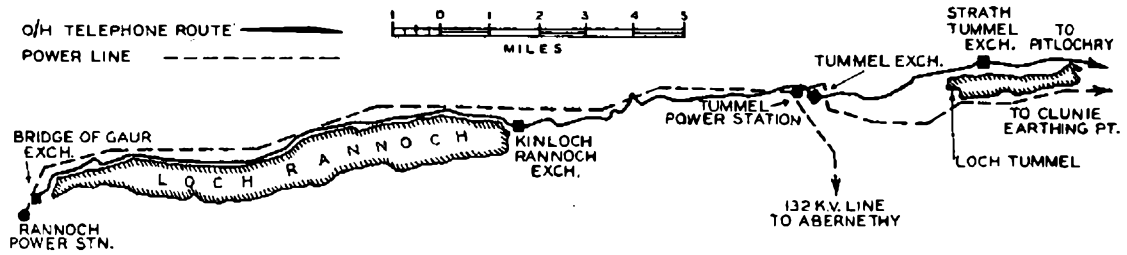

FIG. 1.

The most interesting tests carried out in March were on the sections of route shown in Fig. 1. An existing 132-kV power line erected by the Grampian Electricity Supply Co. exists from Rannoch to Tummel and then continues in a southerly direction to Abernethy. Up to the present, neutral earthing resistors at Rannoch and Abernethy have limited the earth fault current to 260 amp., which was the value specified by the Post Office when the line was erected in 1930. The Board propose to connect this line to the new lines proposed, and to connect the neutral points direct to earth, so that the earth fault current will be considerably increased. A new 132-kV line is proposed from Errochty (very near Tummel Bridge) to Clunie; fortunately a 33-kV wood pole line exists over substantially the same route as the proposed 132-kV line and was used for the tests.

Current was supplied by an 11-kV generator at Rannoch using the three-phase wires of the power line in parallel between Rannoch and Tummel. At Tummel the circuit was specially connected to the 33-kV route to Clunie where it was earthed. Earth return currents of various values from 44 amp. to 178.8 amp. were employed in the tests. On the telephone route high impedance voltmeters were used at Tummel exchange to measure the voltage to earth of four wires earthed at Bridge of Gaur (U.A.X.12), Kinloch Rannoch (U.A.X.13), Strath Tummel (Magneto) and Pitlochry (C.B.S.2). Thus the voltage induced in each section of the route was determined. Between Bridge of Gaur and Tummel the measured mutual impedance was 3.47 ohms (viz. volts induced per 1 amp. earth fault current). This compared with a figure of 2.06 ohms obtained in 1935; the difference may be due to a change in condition of the earth wire and this is being investigated. Between Tummel and Pitlochry the measured mutual impedance was 1.32 ohms as compared with 1.48 ohms predicted on the basis of measurements of earth resistivity at seven points along the route. Since these measured values of earth resistivity varied from 20,000

ohm-cms to 194,000 ohm-cms, and since the measured impedance corresponds to a uniform earth resistivity of between 30,000 and 100,000 ohm-cms, the agreement is regarded as satisfactory. The effect of the loch between the two lines thus appears to be small.

During the period of application to the power line of the maximum test current (value 178 amp.) fuses and heat coils on the junction circuits operated. At Tummel Bridge U.A.X.12 the exchange units seemed to be animated, to the considerable embarrassment of the local lineman responsible for their maintenance. At Bridge of Gaur a barretter on the exchange side of the junction relay set fused—the current passed

presumably via the 2 μ F condenser in the transmission bridge.

Further tests are proposed on telephone lines paralleling proposed 132-kV lines between Aberdeen and Keith, Glasgow and Inveruglas (near Ardlui), and Beaully and Fannich.

Training

TRAINING IN ORGANISATION AND SUPERVISION FOR ENGINEERS.

The first of the three-week courses in Organisation and Supervision for Assistant Engineers commenced at the Central Training School, Stone, on Monday, 18th May, 1948. These courses are a completely new departure for the Engineering Department and have resulted from the recognition of the need not only for training in the technical side of an engineer's work but for objective training in the human side of his work also. The courses are to some extent an experiment, but sufficient experience of this type of course in industry and business as a whole has already been obtained to indicate that this type of training is extremely valuable and yields definite results in terms of markedly improved efficiency and smoothness of staff relationships.

The courses will include some lectures on the general principles of supervision which are beginning to emerge from a scientific study of the subject. The course is, however, centred round case work taken directly from actual problems which have arisen in the practical experience of P.O. engineers. This ensures that the material presented in the course is "real," and of direct practical application to P.O. engineering work in the field. These courses only mark the beginning of courses in training for supervision which it is hoped to extend as soon as possible to engineers of all grades.

For the 12 months commencing 1st April, 1948, there will be ten courses, each of three weeks' duration, for Assistant Engineers.

Regional Notes

Home Counties Region

LONDON-DERBY CARRIER ROUTE

The London-Derby carrier cable route is being converted from 12-channel working to 24-channel working and this has involved building new repeater stations to halve the old repeater spacing.

One such new repeater station site was selected at Hockliffe on the Watling Street in the Bedford Area, but owing to various difficulties it was not possible for the Ministry of Works to provide the permanent building in time for the cable programme. It was therefore decided to build temporary accommodation at the rear of the site, leaving space clear for the erection of the permanent building later. The temporary accommodation consists of five wooden buildings, 20 ft. long by 12 ft. wide, giving sufficient head room for 10 ft. 6 in. racks together with one standard battery hut which will be used for fuel storage. Of the five buildings, two are to house carrier equipment, one is for batteries, one for rectifiers, etc., and one for the stand-by generator set.



FIG. 1.

The original proposal was for the Ministry of Works to erect the buildings under normal building contract, but, due to the time factor, it was necessary to provide the buildings quickly and the erection was carried out by the Area staff. Two buildings which were available at another point in the Area were dismantled and transported to the site, and the other three buildings were brought from a location in the L.T.R. All were over ten years old and were consequently in need of some repairs, which were carried out on site by Departmental labour. Items such as re-roofing with roofing-felt, glazing, new window frames, part of a new end section and new barge boards were dealt with by the staff. A concrete engine-bed and two concrete platforms for batteries were provided. Each building was erected on a concrete raft as a safeguard against surface water, a temporary hard-core road was built and a concrete path connecting all the buildings was provided. Among other items some 40 tons of hard-core, 8 tons of cement, 25 tons of sand and 56 tons of ballast were used and the total manhours spent were approximately 3,300.

The buildings, which are shown in Fig. 1, were provided in time for the various contractors to commence installation of equipment and the whole job provided a very interesting change from normal construction work for the staff.

E. H. P.

BUILDING WORK BY DIRECT LABOUR

A departure from the normal class of work usually undertaken by the Engineering Department arose

recently in the Canterbury Area when, due to a firm of building contractors going into liquidation, the Area staff were asked if they could complete three buildings required in connection with the London-St. Margaret's Bay co-axial cable. One of the buildings was completed up to window-sill level; one at six courses above damp-course and the third at damp-course level only. Before work could proceed there was the question of materials and the requisite permits for the supply of "Priority" materials. Certain materials, already obtained by the contractor against permits were lying on the various sites, and as regards the remainder of those required, arrangements were made through the good offices of the Ministry of Works for the original priority symbols to be transferred to the Telephone Manager.

Then arose the question of staff and tools. The former presented little difficulty; four skilled bricklayers and four experienced bricklayers' labourers were readily forthcoming from among the staff of the External Works Group (and double that number could easily have been secured). These men were placed under the control of the original Clerk of Works—who previous to employment in the Post Office was a general foreman in the building trade with considerable experience and ability—as general foreman. Tools not normally used such as barrows, buckets, trowels, levels, lumphammers, etc., being in very short supply presented a little difficulty, but by sending a man scouting around the larger towns in the Area, they were quickly obtained under local purchase. The problem of scaffolding was solved by the use of tubular steel and fittings—previously used by the military as tank obstacles—and that of scaffold boards by having some otherwise scrap stout poles sawn into 1½-in. planking at a local sawmill.

As regards the actual building work, apart from having to contend with frost and much rain, little difficulty arose when once certain defects had been corrected. Due to the skill and good will of the staff



FIG. 1.

employed, the work proceeded smoothly and efficiently in every aspect. Bricklaying, concreting, laying of drains, laying of paths, carpentering, glazing, painting and the erection of fences all proceeded by direct labour to a satisfactory finish. A completed building is shown in Fig. 1.

One variation of the specification was found necessary and that was in connection with the oak curb to the cable trench. The oak supplied, being home-grown and green, developed a really remarkable will of its own—it decided in the matter of a week or so that it really wasn't cut out for a curb and developed a most weird and grotesque shape. The idea of using recovered oak arms for the purpose was explored, but eventually the job was satisfactorily carried out in 1½-in. angle iron.

The staff was drawn from all grades from technician to labourer, purely and simply on their skill and ability for the respective building tasks. Several members of the crew expressed a keen desire to remain working together if this was at all possible and their wishes have been met to our mutual advantage by setting up a small unit complete with the necessary transport and aids as a specialist manhole and box building gang. W. A. C.

London Telecommunications Region

BETCHWORTH U.A.X. 14

The conversion of Betchworth (Surrey) exchange area to automatic working was completed at 1.30 p.m. on Wednesday, 5th May, 1948, when a new U.A.X.14 was opened to replace the C.B.S.2 manual exchange. An initial multiple capacity for 600 subscribers was provided and the exchange opened with 458 subscribers' lines and 70 junctions. Standard parallel battery automatic type charging plant was installed with two 120-Ah batteries charged by three 5-amp. rectifiers. The parent traffic is routed to Redhill C.B.I. exchange, where it was necessary for the Department to install three additional positions.

This is the first U.A.X. to be provided with a direct route from Toll 'A' Auto, and consequent upon the introduction of 4th-fee metering, many subscribers in the director area will before long be able to dial this exchange without the assistance of an operator. The equipment contractors for the U.A.X. were Ericssons, Ltd. J. H. E.

North-Western Region

BLACKPOOL CENTRAL EXCHANGE

The Blackpool Central non-director exchange was brought into service at 1.0 p.m. on Wednesday, 28th January, 1948, in the presence of the Mayor of Blackpool and members of the Town Council. The Regional Director and the Chief Regional Engineer were also present, along with the Telephone Manager of the Preston Area and the Head Postmaster of Blackpool.

The new equipment replaced the C.B. No. 10 exchange which had been in service since 1912. A peculiar feature about the transfer was that the auto-manual board had been working for some considerable time serving the satellite exchanges at North and South Shore, as well as Fleetwood, which is the only public exchange in this country working on the relay system. A number of unit automatic exchanges are also parented on Blackpool.

An extension of the manual board to the extent of 37 positions was carried out in two stages by Siemens Bros. in preparation for the transfer. The first stage of 18 positions was installed for the summer season of 1942, the remaining 19 positions being stored on site. Prior to the transfer the latter were completed and brought into service. The main and intermediate distribution frames were installed at the same time as the initial positions of the manual board. The automatic equipment for 6,100

multiple was provided and installed by the G.E.C. and is of the 2,000 type. A suite of seven test desks exists in an enclosed wing at one end of the apparatus room, which is on the floor below the manual switch room. The power plant comprises two 1,600-Ah batteries worked on the divided battery float system. An idea of the size of the exchange will be obtained from the following details of equipment installed :—

Uniselectors	..	5,600
Group Selectors	..	1,540
Final Selectors	..	540
Relay Sets	..	1,664

The Department's work in preparation for the transfer involved the usual changes to subscribers' apparatus, and the provision of an external development scheme with consequent overhead rearrangements. The development scheme was divided into three sections known locally as Schemes A, B and C. Scheme A followed the tapering cable arrangement of pre-cabinet and pillar days. Schemes B and C were designed to use cabinets and pillars, but Scheme B proceeded to completion before the items were available. As a result mechanical joints have been provided in lieu so that the cabinets and pillars can be inserted at a later date. On Scheme C cabinets and pillars were installed, this being the first large area in the Region to utilise the new items.

The following figures give some indication of the extent of the Department's work which was efficiently carried out and resulted in a smooth transfer :—

Exchange Lines	4,184
Stations	7,798
Call Offices	268
Cabinets	22
Pillars	116
Underground Cable (miles)	35
Underground Wires jointed	77,500
Poles recovered	60
Break jacks for transfer	5,000

All the circuits concerned in the transfer were routed via the new main frame and thence via break jacks and tie cables to the old exchange which was within the same curtilage as the new exchange. At the time of transfer wedges were inserted into the break jacks to cut out the old equipment and the wedges were withdrawn from the protectors to cut in the automatic equipment. A two-way bell signalling system was used between the control switchboard, situated in the test room, and the main frame. One ring was used to indicate "cut out" and two rings for "cut in."

The officers scheduled for the transfer were assembled for a rehearsal on the day before so that all concerned would know their stations and duties. Some minor potential errors were corrected at the practice with beneficial results at the time of the actual event. The equipment has now been in service three months and is giving every satisfaction. W. O.

South-Western Region

LAYING THREE CABLES SIMULTANEOUSLY BY MOLEDRAINER

A demand for additional circuits made it necessary to replace, by 921 yd. of cable, an overhead route which ran over open moorland and the fairway of a golf course—an unappreciated hazard. 40 pairs of 40-lb. conductor were required and it was decided to lay three 14/40 protected ex-army cables which were available. Pilot holes indicated 16 to 18 in. of soil and it was decided to try to moledrain the three cables at the same time.

The moledrainer was modified by fixing three tubes vertically one behind the other between extended side



FIG. 1.

plates, welded on to preserve smoothness (Fig. 1). Each tube was shaped at the bottom and fixed relative one to the other, so that the cables would come out one above the other without much space between them. Previous modifications to the standard moledrainer were (a) an extension of approximately 5 ft. to the carriage and (b) an additional, slightly hook-shaped, coulter. The moledrainer was towed by a tractor (International Harvester TD9) using a stay-wire link approximately 12 ft. long.

The three cables were laid out, two on one side and one on the other side of the line to be taken by the machines (Fig. 2). Six men fed the cables into the machine which



FIG. 2.

was pulled along at approximately 3-4 m.p.h. which, whilst being a good pace, was well within the capabilities of the men.

Lubrication of the cables, both by grease and white-wash, using a biscuit tin fastened round the pipes, was

tried but proved difficult to carry out effectively. Lubrication was then omitted over a short distance and the cables exposed and examined. As there was no sign of friction, lubrication was considered unnecessary and dispensed with entirely.

It is possible, however, that in hot weather tackiness of the protective covering could be prevented by liberal application of whitewash prior to laying.

The experiment proved that moledraining of more than one cable was no more difficult than with one and that direct pulling by a tractor, as distinct from a pull by an anchored winch, was practicable and more speedy where the ground was not too wet. A winch on the tractor would however be an asset when unsuitable conditions are encountered.

Reinstatement over the moorland section was carried out by running one "caterpillar" of the tractor over the ground. The golf course fairway required more careful treatment. The earth was in the shape of an inverted V approximately 1 ft. high. Each side was pressed down as far as possible by foot pressure and subsequently consolidated by running over by lorry wheels. The final appearance was very creditable and unlikely to give rise to complaint.

Two gangs were employed and the whole work over the length of 921 yd., involving 2,763 yd. of cable, was covered in three sections and completed well inside two days.

W. J. P.

REGIONAL ENGINEERING TRAINING SCHOOL

During 1944 a detailed survey was made of the anticipated training requirements of the engineering staff of the South-Western Region for the first two post-war years to meet the needs of the development of the service and the rehabilitation of staff returning from the Forces. The survey revealed that the school would be called upon to cater for over 7,000 student-weeks annually and as the existing buildings would provide for only 4,500 student-weeks each year it was essential to provide additional accommodation.

The school premises¹, were purchased in 1942 together with 2½ acres of adjoining pasture land. Fortunately, the question of a new location did not arise as additional buildings could be erected on the site. An informal discussion was held with the local Ministry of Works representatives who suggested that our requirements should be based on "standard hutting" 24 ft. or 18 ft. 6 in. wide. The existing building accommodation was reallocated and provided, in addition to the wooden huts which were adequate for the Youth A and B course requirements, only sufficient for Welfare, Stores, Office, and a small part of lecture room requirements.

The school staff presented many suggestions for incorporation into the new building scheme and, with the broad training requirements known, the first detailed layout was made in January 1945. After various modifications work commenced on the new buildings in April 1946.

The new layout provided for the construction of a concrete road, behind the existing premises, to serve ten new buildings located on either side (Fig. 1). Eight of these buildings were of standard Ministry of Works hutting and were allocated for a canteen, three lecture rooms and four practical huts. Of the other two, one of brick construction caters for boiler house and lavatory requirements and the other, of Nissen hut design, provides facilities for overhead instruction in inclement weather.

The lecture rooms are 30 ft. long by 24 ft. wide, fully glazed along the two 30-ft. sides, and facilities are

¹P.O.E.E.J., Vol. 29, p. 101.



FIG. 1.

provided to darken the rooms for film projection requirements. Huts for practical work are 72 ft. long by 18½ ft. wide and except for one panel are fully glazed along the length, giving maximum natural lighting. Two of these huts have been allocated for underground courses and two for internal.

In each of the "Underground" huts (Fig. 2) brick



FIG. 2.

stalls 5 ft. square by 3 ft. high have been installed on the suggestion of the school staff. The stalls have been arranged in two ranks of ten and represent to the students a series of manholes in which they will co-operate with other students to install a cable scheme. The scheme has the advantage that each student works individually in a space resembling that of a joint box and in a position



FIG. 3.

where his work can be easily followed and inspected by the instructors.

A separate room with combined distribution frame and standard U.A.X.14 cable trench is provided to which the work of all students is connected. The provision of equipment to simulate subscribers' and exchange circuits give the students field conditions under final tests. For the advanced courses the installation of cabinets and pillars has been arranged.

In the "Internal" huts, suitably boarded 9-in. brick walls, 6 ft. high and 5 ft. wide, have been erected at right angles to the length of the building to provide facilities for students to work individually (Fig. 3).

Sixteen of these walls have been erected in one hut which is regularly used for the normal subscribers' installation courses. A P.B.X. has been installed for demonstration and testing. The second internal hut which is being used for courses of Exchange Construction, Subscribers' and Line Maintenance, etc., has been provided with eight of the walls, the remainder of the accommodation being laid out to meet the special requirements of the courses covered. e.g. special frameworks have been provided so that each student on an Exchange Construction course has an operator's circuit, one cord circuit, one answer jack, one outgoing multiple jack and one frame vertical on which he can work to give the working conditions of a full exchange. For the Subscriber and Line Maintenance course arrangements have been made for the subscriber and exchange equipment to be linked through the underground and overhead network around the school grounds for testing purposes.

The Nissen hut is 170 ft. long and 20 ft. wide and was provided to allow training on overhead construction work to continue even in the worst weather conditions. It has been found possible to erect two rows of 16-ft. poles sufficient to meet the needs of a full overhead course.

Occupation of the new accommodation began during the late summer of 1947 and it is gratifying to the school staff to see so many of their ideas for improved training incorporated into the new buildings. Experience in the new surroundings and with the improved methods already showing better results and it is confidently anticipated that the standard of training will be substantially above that previously achieved. H. L. A.

Midland Region

MODIFICATION OF MORRIS MINOR VAN

In a fairly extensive Area such as Nottingham, external planning officers are often called upon to make detailed surveys of plant at considerable distances from Headquarters. When the survey is recorded in the form of rough notes which are written up on return to Headquarters, there is a danger that some of the notes may not be clear, or that some small but essential item of the survey has been overlooked.

With this in mind, the writer proposed at a recent Joint Production Committee meeting that Morris Minor van used by the Local Line Planning Group should be modified by the addition of a folding table and seat to the rear portion of the vehicle.

The Motor Transport staff have modified a van experimentally and it is now undergoing field trials. A table has been fitted on the off side of the body and a seat attached to the partition dividing the rear portion of the van from the driving cab. Both fold flat when not in use and occupy a negligible amount of space. A lamp, operated from the car battery, illuminates the table when required.

It is now possible to use the van as a "travelling office." Plans, maps, diagrams, etc., which previously were carried folded, and opened out in the confined space of the driving cab—often becoming torn in the process—

now be opened flat, out of the wind, and in comparative comfort. (Too much comfort was not aimed at, as it may defeat the object of the suggestion!) Summaries, survey forms, diagrams, etc., may be prepared on site. Although the modification has only recently been completed, its benefit has already become apparent, and apart from the



FIG. 1.

better working conditions provided, it is anticipated that the number of journeys necessary for surveys on local line planning schemes will actually be reduced. It may be found in the light of experience that vans modified on these lines will prove useful in other directions, e.g. for Advice Note survey officers, etc.

Fig. 1 shows the modified van in use.

A. D. H.

BRIDGE DIVERSION

The L.M. & S. Railway Company's bridge in Hill Street, Birmingham, is to be demolished, and will be replaced by a more modern structure, designed to withstand the exceptional loads imposed by the road traffic

and Post Office cables (eight trunk and nine junction type) which have been diverted from the old bridge.

To effect the diversion, four intercepting chambers, two on the west footpath and two on the east footpath, were built near the ends of the bridge. The majority of the cables were picked up on the side of Hill Street remote from the temporary bridge, and to accommodate the diversion cables four 6-in. Stanton pipes were laid across the road near each end of the original bridge.

Access to the temporary bridge, from a surface box in the footway at the south end, was gained by constructing a channel from the box to the far side of the parapet, a granite block forming part of the stringer course being removed for this purpose, and by erecting a steel lattice framework over the railway lines to the main longitudinal H girder, which constituted the parapet of the temporary bridge. The arrangement is illustrated in Fig. 1. The main H girder, placed with flanges horizontal, was used to carry the diversion cables, a measure of protection for the cables during work on the new bridge being afforded by planks which rest on the upper tie bolts; a level bearing surface for the cables is given by a lower set of planks. All the timber has been treated with fire-resisting paint as a precaution against ignition by sparks thrown up from engines passing below.

At the north end, a steel lattice ramp was constructed to carry the cables from the top flange of the girder to the underside of the bridge. Special cable bearers were suspended from the R.S. transverse joists under the bridge, and the cables were led through the old parapet and a concrete channel to a footway joint box.

The cable interceptions were distributed between nine different jointing chambers and in addition to the construction work mentioned above, it was necessary to enlarge two existing manholes, to lay 15 yards of two 6-way ducts and a section of six 3½-in. steel pipes.

It is estimated that 18 months will be required for the bridge demolition and reconstruction. During the final stages three 3½-in. steel pipes will be laid in the west footpath and twenty four 3½-in. steel pipes in the east footpath for the restoration of the Post Office cables and for future development.

Several of the main cable lengths which have been

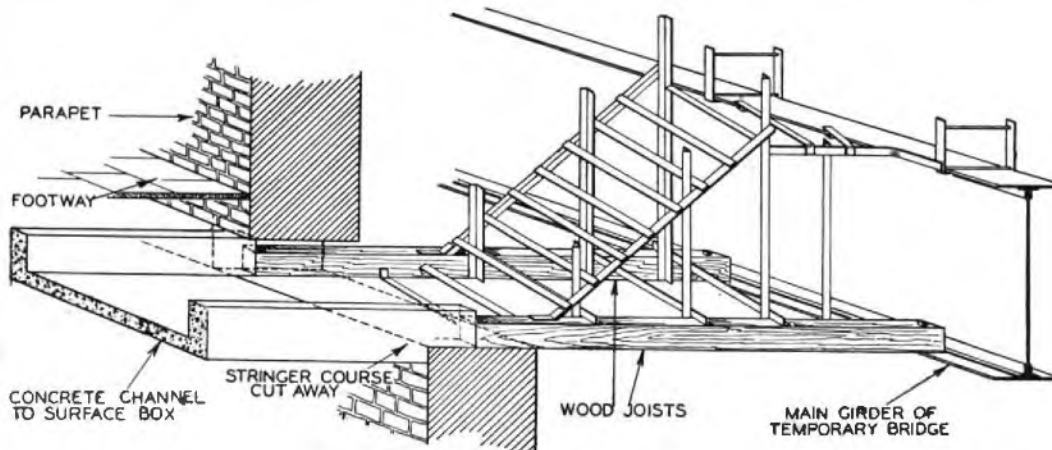

FIG. 1.

in this part of the city. A temporary bridge has been erected adjacent to the existing bridge, which will carry the vehicular and pedestrian traffic during the reconstruction period, and will also serve to support the electric

recovered are being retained and will be re-inserted at the final stage, so that the ultimate cable balances should closely approximate the conditions obtaining prior to the diversion.

E. B. T.

Junior Section Notes

Stoke-on-Trent Centre

For the Session 1947-48 a full programme of lectures and visits was arranged. The programme of lectures was carried out in full, but due to the incidence of the five-day week it was not possible to make any visits as the various industrial firms were unable to accommodate us on Saturdays, the only days available to the Centre for visits. However, opportunity was taken for a party to visit the Atom Train and an associated film. Various members have also attended, as guests, lectures given locally by the Institution of Electrical Engineers and the Power Engineers' Association. These invitations have been much appreciated.

Notice board publicity has been particularly well executed and an energetic committee has done excellent work in this, the first full session since the Centre was restarted.

Chiltern Centre

The 1947-48 session was started on 17th September, 1947, with a visit to Creeds' works at Croydon, which proved to be most interesting; Creeds' staff are to be congratulated on the way our visit was conducted.

The second meeting was held at Aylesbury on 14th January, 1948, and a paper on "Multi-Channel V.F." was read by Mr. Mayo, Area Engineer.

Our third meeting took the form of a Telephone Quiz which took place on 25th February between members at Aylesbury and High Wycombe and Chesham. This meeting was a great success and another Quiz is being arranged in the near future. L. B. S.

London Centre

Since our last notes, we have finished the second half of our 1947/48 session and are busily arranging the programme for 1948/49. We commenced the session of 1948 with a lecture on "Short Distance Line Television Transmission," given by T. Kilvington, B.Sc. (Eng.) of Dollis Hill Research Branch. His lecture was of immense interest, being illustrated by practical demonstrations of a new scheme of equalising cable pairs by means of pulse transmission and a cathode ray oscilloscope.

The following month of February brought a joint lecture by G. H. Rouse and M. B. Moore, on "The New Standard Uniselector and the 2,000 Type Selector—Some Mechanical Developments." This lecture set a new high standard for talks by Junior Section members, being most popular, interesting and extremely well illustrated by slides and slow-motion films.

"Impulsing," by R. F. Howard, another Junior Section member at that time, was complementary in many ways to the previous months' lecture. Problems connected with impulsing and solutions for difficulties experienced, were ably conveyed and once again well illustrated by slides, working models and the large demonstration C.R.O.

In April, we had a lecture entitled "Frequency Modulation," by D. O'R. Macnamara, a Junior Section member. This lecture, in common with the others, was well attended, well illustrated and a high level of discussion followed.

The lectures given by Junior Section members have been forwarded to the Senior Section for consideration for the annual award of prizes and certificates.

The annual general meeting in May brought to a close one of the longest sessions in our Centre's history, and as our published report shows, it has been a very full

session. Some 19 lectures and talks were held on a local Area basis and more than 63 visits were paid by 859 members to industrial establishments, public works, the B.B.C. and many others to whom we are indebted.

It is hoped that with the introduction of subscriptions from pay on a weekly basis of 1d. membership will show a further increase beyond our present figure of 1,150. We note, with thanks, that the contribution by the Department towards the cost of fares of members attending meetings has been increased to two shillings per meeting.

We would mention that Diaries for 1949 will be on sale later in the year.

A report on A.G.M., Election of Officers and Programme for 1948/49 session will be given later. J. G.

Brighton Centre

The annual general meeting of the above centre was held on Wednesday, April 21st, at the conclusion of a very successful session.

The following officers and committee were elected:—

Chairman: K. W. Chandler; *Vice-Chairman:* F. G. Anderson; *Secretary:* R. F. J. Beddis; *Treasurer:* G. J. Pearce; *Committee:* H. Baragwanath, A. G. Beckett, J. P. Bradley, W. R. Excell, F. Hulse, W. A. T. Moore, C. B. Pitt, A. A. Pope, J. G. Rochell, R. Trist.

We hope that the success of the past session will lead to even greater support for this Centre in the forthcoming session. R. F. J. B.

Carlisle Centre

The annual general meeting of the Carlisle Centre took place in the Kings Head Hotel, on Tuesday, April 13th, when Mr. W. D. Tweddle presided in the unavoidable absence of the President, Mr. A. S. Carr.

The Secretary, in his annual report, gave a review of the achievements of the centre during the previous twelve months, and paid tribute to the high standard of papers which had been presented. The programme for the next session was a comprehensive one and its success was dependent largely on the interest and enthusiasm of the members. The financial statement showed a credit balance which was satisfactory. Several visits to places of interest are to be arranged and it is hoped that the enthusiasm of the members will make their success a foregone conclusion.

The new committee is as follows:—

Chairman: Mr. W. D. Tweddle; *Vice-Chairman:* Mr. G. H. Wood; *Secretary and Treasurer:* Mr. J. Molloy; *Deputy Secretary:* Mr. J. M. Gibson; *Librarian:* Mr. H. Whiteside.

Committee: Messrs. E. Ashley, W. Barker, E. Irving, J. J. McGuffie and J. Robinson.

Hon. Auditors: Messrs. F. J. Griffiths and W. S. Smith.

The proposed programme for Session 1948-49 is as follows:—

Sept.—"Maintenance of a Non-Director Exchange." E. Ashley.

Oct.—"Motor Transport Maintenance." W. Gardner and E. Watson.

Nov.—"Some Thoughts on the Atom." C. S. Jex.

Dec.—Film Show.

Jan.—"Cable Maintenance." J. Molloy and J. McGuffie.

Feb.—"Carrier Telephony." J. M. Gibson.

March.—Overhead Construction (to be arranged). J. M.

Staff Changes

Promotions

Name	Region	Date	Name	Region	Date
<i>Exec. Engr. to Tel. Man.</i>			<i>Tech. Asst. to A.R.M.T.O.</i>		
Howard, J. L.	Scot. to H. C. Reg.	1.3.48	Wiles, E. J.	W. & B. C. Reg. to N. W. Reg.	18.4.48
<i>Engineer to Exec. Engr.</i>			<i>Tech. Asst. to M.T.O.III</i>		
Dolan, W. H.	E.-in-C.O.	3.3.48	Jenkinson, W.	Mid. Reg. to E.-in-C.O.	1.4.48
Cooper, A. B.	L. T. Reg.	3.3.48	Bailey, C. S.	E.-in-C.O.	19.3.48
Walton, W. R.	L. T. Reg.	3.3.48	<i>Mech. IIC. to Tech. Asst.</i>		
Ellen, L. W.	E.-in-C.O.	3.3.48	Clephane, H.	Scot. to London	1.4.48
Hayward, R. K.	E.-in-C.O.	3.3.48	Copeman, S. W.	H. C. Reg.	11.2.48
Morris, D. W.	E.-in-C.O.	3.3.48	Trimmer, G. J. P.	N. E. Reg. to London	11.4.48
Copping, G. P.	E.-in-C.O.	3.3.48	Smith, W.	Mid. Reg. to E.-in-C.O.	6.4.48
Laver, F. J. M.	E.-in-C.O.	3.3.48	<i>D'man. Cl. I to Sen. D'man.</i>		
Hickox, W. F.	L. T. Reg.	23.4.48	Thorpe, W. R.	L. T. Reg.	1.4.48
Lunn, G. R.	W. & B. C. Reg. to Scot.	11.4.48	<i>D'man. Cl. II to D'man Cl. I</i>		
<i>Engineer to S.Sc.O.</i>			Davenport, A. R.	Mid. Reg.	29.2.48
Lynch, A. C.	E.-in-C.O.	13.4.48	Gibbins, F. J.	H. C. Reg.	9.11.47
Roberts, F. F.	E.-in-C.O.	13.4.48	Taylor, L.	Scot.	23.11.47
Holmes, M. F.	E.-in-C.O.	13.4.48	Deeks, E. P.	H. C. Reg.	29.2.48
Thomson, W. E.	E.-in-C.O.	13.4.48	Holding, H. J.	H. C. Reg.	To be fixed later
<i>Prob. Engr. to Sc.O.</i>			Simpson, G. E.	N. E. Reg.	1.4.48
Reynolds, F. H.	E.-in-C.O.	13.4.48	Challis, A. L.	H. C. Reg.	29.2.48
<i>Asst. Engr. to Engr.</i>			Hodges, R. R.	S. W. Reg.	20.2.48
Gray, W.	E.-in-C.O.	19.4.48	Johnson, C. W.	H. C. Reg.	5.3.48
Pooley, A. B.	E.-in-C.O.	19.4.48	Carberry, T.	N. I. Reg.	7.3.48
Dean, G. A.	W. & B. C. Reg.	19.4.48	Ross, J. G.	Scot.	29.2.48
<i>Technician to Asst. Engr.</i>			Ebbage, J. G.	N. I. Reg.	To be fixed later
Ball, H.	E.-in-C.O.	5.8.47	Nisbett, R.	Scot.	26.2.48
Anderson, G. J.	E.-in-C.O.	1.3.47	Chalmers, H. C. D.	Scot.	4.1.48
			Laws, H. G.	Scot.	26.2.48
			Rawlings, L. J. J.	S. W. Reg.	20.2.48

Transfers

Name	Region	Date	Name	Region	Date
<i>Exec. Engr.</i>			<i>Inspector</i>		
Lyddall, A. G.	N. E. Reg. to L. T. Reg.	15.3.48	Stears, A. D. S.	Scot. to E.-in-C.O.	11.4.48
Thomas, G. E. T.	L. T. Reg. to N. E. Reg.	15.3.48	<i>A.R.M.T.O.</i>		
Markby, E. J.	Scot. to L. T. Reg.	11.4.48	Green, G. A.	N. W. Reg. to London	25.4.48
Haliburton, F. C.	E.-in-C.O. to H. C. Reg.	18.5.48	Border, W. A.	Mid. Reg. to E.-in-C.O.	18.5.48
<i>Engineer</i>			<i>Tech. Asst.</i>		
Atkinson, J.	L. T. Reg. to H. C. Reg.	14.3.48	Brown, G.	London to Mid. Red.	1.4.48
Crowther, R. A.	E.-in-C.O. to Mid. Reg.	1.4.48	Coppin, W. L.	London to E.-in-C.O.	6.4.48
Charles, E. E.	E.-in-C.O. to L. P. Reg.	2.5.48	Heath, J. C.	E.-in-C.O. to W. & B. C. Reg.	13.4.48
<i>Asst. Engr.</i>			<i>D'man. Class I</i>		
Tarry, K. W. D.	E.-in-C.O. to Ministry of Supply	1.4.48	Hall, G. H.	H. C. Reg. to Mid. Reg.	5.3.48
Perkins, D. G.	L. P. Reg. to L. T. Reg.	5.4.48	Holt, J. V. O.	Scot. to N. E. Reg.	29.2.48
Green, J.	E.-in-C.O. to N.I. Reg.	10.4.48	Challenger, D.	N. I. Reg. to W. & B. C. Reg.	7.3.48
Wood, J. G.	N.W. Reg. to E.-in-C.O.	25.4.48	Clement, N. C.	S. W. Reg. to W. & B. C. Reg.	1.10.47
Sale, K. W.	E.-in-C.O. to NW. Reg.	16.5.48	Smedley, J. L.	N. E. Reg. to S. W. Reg.	1.4.48

Retirements

Name	Region	Date	Name	Region	Date
<i>Asst. Staff Engr.</i>			<i>Asst. Engr. - continued</i>		
Doust, J. F.	E.-in-C.O. (Resigned)	29.2.48	Walters, T. L.	E.-in-C.O. (Resigned)	25.4.48
<i>Reg. Engr.</i>			Hilliar, T. E.	L. T. Reg.	31.5.48
Morice, A. B.	H. C. Reg.	31.3.48	Lane, V. E.	Mid. Reg.	31.5.48
<i>Engineer</i>			Merrifield, F.	E.-in-C.O.	31.5.48
Burrells, W.	L. T. Reg.	31.3.48	<i>Inspector</i>		
Wall, A. A.	L. T. Reg.	31.3.48	Lumber, A. J.	L. T. Reg.	1.3.48
McIntosh, H. B.	Scot.	31.3.48	Squire, F. H.	L. T. Reg.	25.3.48
Dunk, W. G.	E.-in-C.O.	12.5.48	Richards, S. A.	L. T. Reg.	31.3.48
<i>Asst. Engr.</i>			Minsball, G. W.	N. W. Reg.	31.3.48
Blackman, R. W.	E.-in-C.O.	20.3.48	Anderson, W. J.	E.-in-C.O.	31.3.48
Quickenden, W. L.	L. T. Reg.	31.3.48	Rich, W.	L. T. Reg.	31.3.48
Brede, H. F.	E.-in-C.O.	10.4.48	Thatcher, E. J.	W. & B. C. Reg.	1.4.48
			Fry, G. F.	L. T. Reg.	18.5.48

Deaths

Name	Region	Date	Name	Region	Date
<i>Asst. Engr.</i>			<i>Inspector</i>		
Smith, J. R.	E.-in-C.O.	18.4.48	Jenkins, J. D.	N. I. Reg.	2.3.4
Wootten, J. C.	N. W. Reg.	20.4.48	Frankland, W.	N. W. Reg.	8.3.4
			Lambert, J. G.	Scot.	15.3.4

CLERICAL GRADES

Promotions

Name	Region	Date	Name	Region	Date
<i>C.O. to A.P.C.II.</i>			<i>C.O. to E.O.—continued</i>		
Glover, A. E.	H. C. Reg.	6.1.48	Streeter, C. D.	E.-in-C.O.	1.4.4
			Cowan, P. R.	E.-in-C.O.	22.4.4
			Just, W.	E.-in-C.O.	22.4.4
<i>C.O. to E.O.</i>					
Thurogood, Miss G. J.	E.-in-C.O.	22.3.48	Brunwin, A. E. J.	E.-in-C.O.	22.4.4
Anderson, C.	E.-in-C.O.	1.4.48	Buckmaster, V. R.	E.-in-C.O.	6.5.4
Florence, W. D.	E.-in-C.O.	1.4.48	Hart, J. A.	E.-in-C.O.	6.5.4
Pinkney, L. W.	E.-in-C.O.	1.4.48	Duifon, Miss A. M.	E.-in-C.O.	18.5.4
Watkins, E. W. H.	E.-in-C.O.	1.4.48	Wright, Miss A. E.	E.-in-C.O.	9.4.4
			Pearson, E. J.	E.-in-C.O.	1.5.4

Transfers

Name	Region	Date	Name	Region	Date
<i>H.E.O.</i>			<i>E.O.—continued</i>		
Inskip, C. R.	To Min. of Ag. & Fish.	15.3.48	Farrell, W.	To Min. of Nat. Ins.	5.4.4
<i>E.O.</i>					
Stark, A. B.	To Dept. of Health for Scotland	15.3.48	Carter, L. A.	E.-in-C.O. to Board of Trade	1.5.4
Penycate, J. A. E.	E.-in-C.O. to Min. of Nat. Ins.	15.3.48	Hurdle, D. F.	E.-in-C.O. to Min. of Nat. Ins.	18.5.4
			Brunwin, A. E. J.	E.-in-C.O. to War Damage Comm.	31.5.4

BOARD OF EDITORS

H. FAULKNER, B.Sc., M.I.E.E., Chairman.
 F. E. NANCARROW, O.B.E., A.R.C.Sc., M.I.E.E.
 P. B. FROST, B.Sc., M.I.E.E.
 A. H. MUMFORD, O.B.E., B.Sc.(ENG.), M.I.E.E.
 C. W. BROWN, A.M.I.E.E.
 C. E. C. SKUSE.
 G. E. STYLES, A.M.I.E.E., Managing Editor.
 J. P. HARDING, B.Sc.(ENG.),
 A.M.INST.C.E., A.M.I.E.E. } Assistant Editors.
 F. WARREN, A.M.I.E.E.
 A. J. BAKER, Secretary-Treasurer.

Copyright

The entire contents of this JOURNAL are covered by general copyright, and special permission is necessary for reprinting long extracts, but Editors are welcome to use not more than one-third of any article, provided credit is given at the beginning or end thus: "From the *Post Office Electrical Engineers' Journal*."

The Board of Editors is not responsible for the statements made or the opinions expressed in any of the articles in this JOURNAL, unless such statement is made specifically by the Board.

Communications

All communications should be addressed to the Managing Editor, *P.O.E.E. Journal*, Engineer-in-Chief's Office, Alder House, Aldersgate Street, London, E.C.1. Telephone: HEADquarters 1234. Remittances should be made payable to "*The P.O.E.E. Journal*" and should be crossed "& Co."

Binding Cases

Cases for binding are available, and may be obtained from the Local Agents for 2s. Subscribers can have the copies of Volumes bound, at a cost of 7s. 6d., sending the complete set of parts to the Local Agent or to the *P.O.E.E. Journal*, Engineer-in-Chief's Office Alder House, Aldersgate Street, London, E.C.1. Order for binding for Vols. 1-19 should indicate whether the original binding case with black lettering, or the lat pattern with gold, is required. Cases with gold lettering are the only type stocked from Vol. 20 onwards.

Back Numbers

The price of the JOURNAL, which is published quarterly is 1s. 6d. (1s. 9d. post free) per copy, or 7s. per annum post free. Back numbers can be supplied, subject to availability of stocks, at 1s. 6d. each (1s. 9d. post free). Order for back numbers may be sent to the Local Agents to the Publishers.

Advertisements

All communications relating to space reservations should be addressed to the Advertisement Editor *P.O.E.E. Journal*, Alder House, Aldersgate Street, London, E.C.1. Communications regarding advertisement copy, proofs, etc., should be addressed to the Publishers, Messrs. Birch & Whittington (Prop. Dorli & Co. [Epsom], Ltd.), 49 Upper High Street, Epsom, Surrey.

MODEL ANSWERS

TO

CITY AND GUILDS OF LONDON INSTITUTE EXAMINATIONS

TELECOMMUNICATIONS (PRINCIPLES) I and TELEPHONE EXCHANGE SYSTEMS I

A limited number of these books is still available and orders should be placed at an early date to avoid disappointment.

TELEGRAPHY I and RADIO I

Printing difficulties have delayed production of these two new books but publication is now imminent, and orders will receive prompt attention.

TELECOMMUNICATIONS (PRINCIPLES) II and TELEPHONE EXCHANGE SYSTEMS II

All preparatory work has been completed and books covering these subjects will be available in time to assist students preparing for the 1949 examinations. Watch for further announcements and meanwhile place an order to ensure delivery as early as possible.

Orders may be placed with the JOURNAL LOCAL AGENTS or with THE MANAGING EDITOR, POST OFFICE ELECTRICAL ENGINEERS' JOURNAL, ALDER HOUSE, ALDERSGATE STREET, LONDON, E.C.1. Books are price 2/6 each (2/9 post free).

THE INSTITUTION OF POST OFFICE ELECTRICAL ENGINEERS

PRINTED PAPERS

The following papers contributed to the proceedings of the Institution have been printed by the authority of the Council and may be obtained, if still in print, from

"THE LIBRARIAN, THE INSTITUTION OF POST OFFICE ELECTRICAL ENGINEERS, G.P.O. (ALDER HOUSE), LONDON, E.C.1."

The prices do *not* include postage. Members, Associate Members, and Associates have the privilege of purchasing copies at two-thirds the stated price.

†No. 167.	"TWELVE-CIRCUIT CARRIER TELEPHONE SYSTEMS."—G. J. S. LITTLE, B.Sc., A.M.I.E.E. 1938	6d.
†No. 168.	"THE DEVELOPMENT OF MAGNETIC MATERIALS."—C. E. MORGAN, A.M.I.E.E. 1938	6d.
†No. 169.	"CROSSTALK"—H. C. S. HAYES, A.M.I.E.E., R. A. SEYMOUR and P. R. BRAY, M.Sc.(Eng.), Grad.I.E.E. 1938	1s. 3d.
No. 172.	"CORROSION AND COMMUNICATIONS."—C. E. RICHARDS, F.I.C. 1939	6d.
No. 173.	"AUDIO-FREQUENCY RIPPLE FROM D.C. POWER SUPPLIES IN COMMUNICATION ENGINEERING."—H. R. HARBOTTLE, B.Sc., D.F.H., M.I.E.E., J. A. SHEPPARD, B.Sc., A.M.I.E.E., and D. L. RICHARDS, B.Sc. 1939	1s.
No. 174.	"METALLURGY AND COMMUNICATIONS."—E. V. WALKER, B.Sc., A.R.S.M. 1940	6d.
No. 180.	"SUBSCRIBERS' CABLE DISTRIBUTION—SOME FURTHER CONSIDERATIONS."—F. SUMMERS, A.M.I.E.E. 1944	1s.
†No. 181.	"POST-WAR EXCHANGE DESIGN."—H. E. FRANCIS, A.M.I.E.E. 1943	1s.
†No. 182.	"LONDON INLAND TRUNK SERVICES."—W. H. SCARBOROUGH, A.M.I.E.E. 1943	1s. 6d.
†No. 183.	"FREQUENCY MODULATION."—J. H. H. MERRIMAN, M.Sc., A.Inst.P., A.M.I.E.E., and R. W. WHITE, B.Sc., F.Inst.P., A.M.I.E.E. 1945	1s. 6d.
†No. 184.	"THE FUNDAMENTALS OF DIRECT CURRENT IMPULSING IN MULTI-EXCHANGE AREAS."—S. WELCH, M.Sc.(Eng.), A.M.I.E.E. 1944	1s. 6d.
†No. 186.	"TELEPHONE SERVICE OBSERVATIONS."—J. J. PERKINS, A.M.I.E.E. 1945	1s.
†No. 187.	"CABLING PROBLEMS IN SUBWAYS AND TUNNELS."—T. G. TURLEY, A.M.I.E.E. 1945	1s.
No. 188.	"POWER SUPPLIES FOR TELEGRAPHS."—G. N. DAVISON, B.Sc.(Eng.), D.I.C., A.M.I.E.E. 1945	1s. 6d.
†No. 189.	"DEVELOPMENT OF TELEGRAPH SWITCHING IN GREAT BRITAIN."—J. A. S. MARTIN, A.M.I.E.E., and J. W. FREEBODY, Whit. Schol., B.Sc.(Eng.), D.I.C., A.M.I.E.E. 1944	1s. 6d.
†No. 190.	"WIDEBAND TRANSMISSION OVER COAXIAL CABLES."—R. A. BROCKBANK, Ph.D., B.Sc., A.M.I.E.E., and C. F. FLOYD, M.A., A.M.I.E.E. 1946	1s. 6d.

† The Council have awarded Institution Medals for these papers.

INDEX TO ADVERTISERS

	<i>Page</i>		
Alton Battery Co., Ltd., The	vii	Painton & Co., Ltd.	
Automatic Coil Winder & Electrical Equipment Co., Ltd.	xviii	Parmeko, Ltd.	
Automatic Telephone & Electric Co., Ltd.	xiv, xv	Pirelli-General Cable Works, Ltd.	
Bennett College, The	v	Pitman, Sir Isaac, & Sons, Ltd.	
British Institute of Engineering Technology	x	Salford Electrical Instruments, Ltd.	
Creed & Co., Ltd.	ix	Savage, W. Bryan, Ltd.	
Edison Swan Electric Co., Ltd., The	ii	Siemens, Brothers & Co., Ltd.	xvi,
Ericsson Telephones, Ltd.	xxii	Smith, Frederick, & Co.	
Evershed & Vignoles, Ltd.	xii	Standard Telephones and Cables, Ltd.	v
General Electric Co. Ltd., The	xix	Sullivan, W. H., Ltd.	
Great Northern Telegraph Co., Ltd., The	xvi	Telephone Manufacturing Company, Ltd. . . .	
H. T. A., Ltd.	viii	Tudor Accumulator Co., Ltd.	
International Correspondence Schools	v	Tungstone Products Ltd.	
Muirhead	xviii	United Insulator Co., Ltd.	
Neill, James, & Co., Ltd.	x	Westinghouse Brake & Signal Co., Ltd.	
Neosid, Ltd.	xx	Winn & Coales, Ltd.	

THE *Quality* PRODUCTS OF

PAINTON



VITREOUS RESISTORS FOR EVERY PURPOSE BY
PAINTON & CO LTD KINGSTHORPE NORTHAMPTON

SOUND INSTRUCTION by Postal Method

The I.C.S., largest school in the world devoted to spare-time training by the postal method, offers you highly specialised Courses of Instruction for the following Examinations:

**P.M.G. Certificates in Wireless Telegraphy
Associate Membership of I.E.E.**

C. & G. Electrical Engineering Practice, Installation and Telecommunications.

Graduateship of the B.I.R.E.

Other Courses meet the requirements of all who desire to qualify for responsible positions in Electric Power, Illumination, Heating and Traction Systems. Equally successful is our instruction for Telegraph Engineers, Radio Engineers and Radio Servicemen.

Instruction is by correspondence from textbooks specially prepared by many experts.

WRITE FOR OUR SPECIAL BOOKLET and state the particular subject or Examination in which you are interested. *I.C.S. Examination students are coached till successful.*

..... **YOU MAY USE THIS COUPON**

International Correspondence Schools Ltd.

Dept. 108, International Buildings, King'sway, London, W.C.2

Please send me, free of charge, your special

booklet on.....

Name..... Age.....

Address.....



STUDY
AT
HOME

You Can Have a College Training
For a Few Shillings Monthly

IN YOUR
SPARE
TIME

FOUNDED 1900

40 YEARS OF SUCCESS

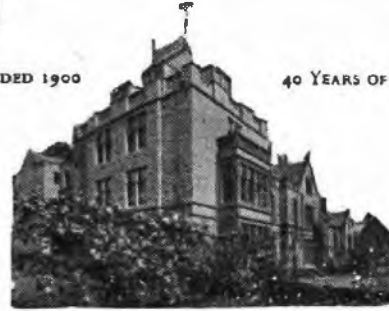

CITY and GUILDS (Telecommunication) EXAMINATIONS

To every student we send a written Guarantee of Tuition until the examination is actually passed

Our tuition is so graded that each stage is reached without difficulty.

Personal attention is given to every student.

FULL PARTICULARS AND ADVICE SUPPLIED FREE. WE TEACH BY POST IN ALL PARTS OF THE WORLD.

*The most progressive and most successful
Correspondence College in the world*



*For large scale
Electrical
Purposes*

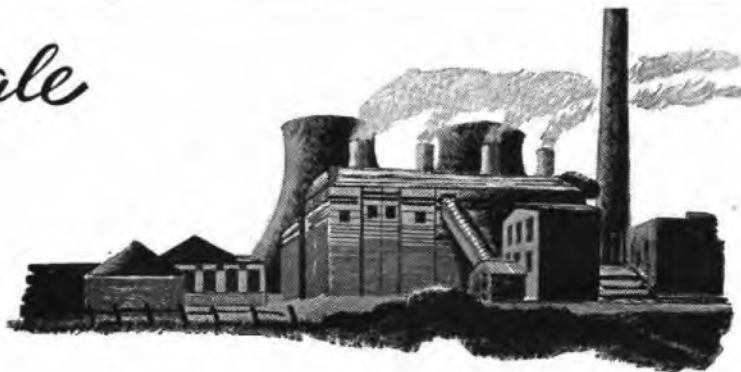

It is noteworthy where Tudor accumulators are to be found fulfilling the most important duties: over 500 British Power Stations installed Tudor. Many Tudor installations rank among the largest in the land and have an enviable reputation for long-lived reliability. No matter whether they were installed only yesterday, or over thirty

years ago—as many of them were—they are to-day functioning with consistent efficiency.

SAFETYLYTE is the Tudor Emergency Lighting System, which is automatic and instantaneous in operation. It is installed in thousands of schools, hospitals, factories and other large buildings.



TUDOR ACCUMULATORS

THE TUDOR ACCUMULATOR CO. LTD
50 GROSVENOR GARDENS, LONDON, S.W.1

permal perme

STANDARD MAGNETIC MATERIALS have the unique advantage which itself is a large scale user of these materials, as a result of their long experience in the use of magnetic alloys has become available. They are particularly suitable in cases which demand high permeability and low hysteresis loss; they should, however, be selected according to individual requirements. The Cobalt/Iron alloys, should be employed where high permeability and high flux densities is called for, and it finds special application in diapir receivers.

PERMALLOY C. Gives the highest initial permeability of any magnetic material yet known. *Applications:* wide frequency-band transformers; accurate current transformers, chokes, sensitive relays and magnetic shielding.

PERMALLOY B. Lower initial permeability than "C," but higher flux densities possible.

PERMALLOY D. High resistivity without undue lowering of flux density or of the Curie Point. Very suitable for certain high frequency applications since frequency/permeability variation is small.

PERMENDUR. A Cobalt/Iron alloy with high flux density. It can

	Perma " B
Specific gravity ...	8
Electrical resistivity, microhms per cm. cube ...	5
Temperature for heat treatment °C...	90
Initial permeability μ_0	1,8 2,4
Maximum permeability μ_{max}	10,0 20,0
Magnetising force for μ_{max} oersteds ...	

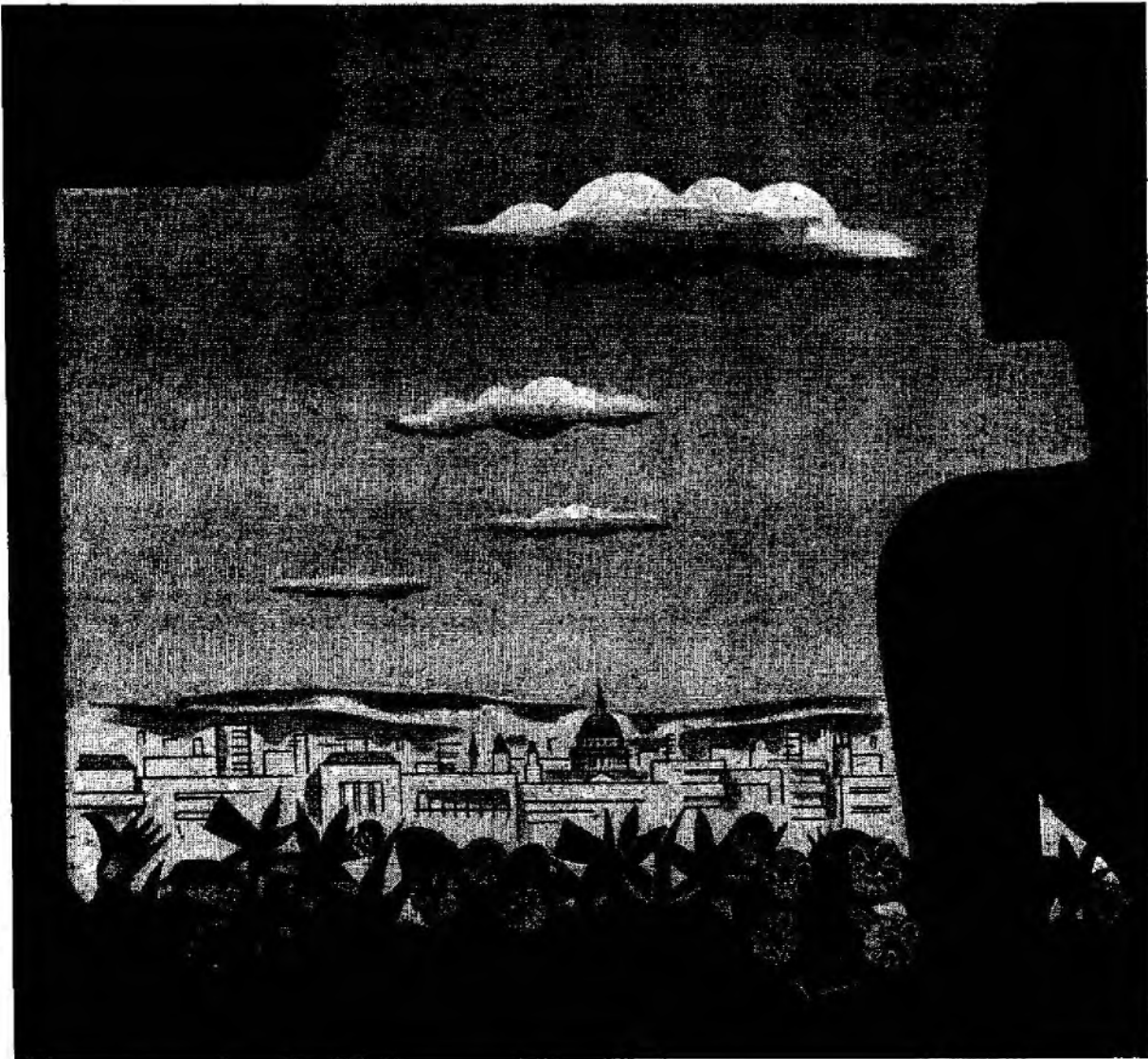

15

CITY OF SOOT REBORN

'Come to the window and enjoy the view. How close the hills look — there behind St. Paul's. Queer to think that, in living memory, this was a desolate vista of soot and bricks . . .'

Not very far ahead of us now, lies the Electric Age. The era of universal, unlimited supplies of electricity. When plans of today mature, when a chain of great generating stations is feeding heat and light and power to the four corners of Britain — no city will any longer find an excuse to foul its own air with smoke and soot. Better days for all of us, then. And here in Alton, where we make the batteries for power stations all over the world, busier days than ever. Hydro-electric, Atomic, or what you will, the new power stations will all need batteries. Good batteries. The kind we have always made at Alton.

ALTON

BATTERIES OF MERIT

THE ALTON BATTERY COMPANY LTD • ALTON • HANTS
Sole Suppliers of Fuller Stationary Batteries
 Telephone: ALTON 2267 & 2268 • Telegrams: 'BATTERY, ALTON'

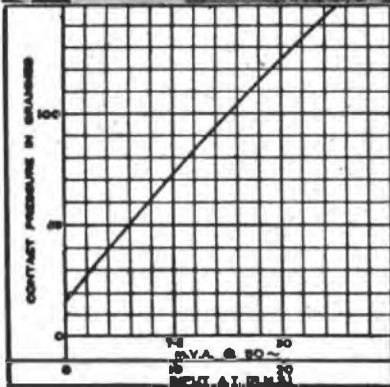
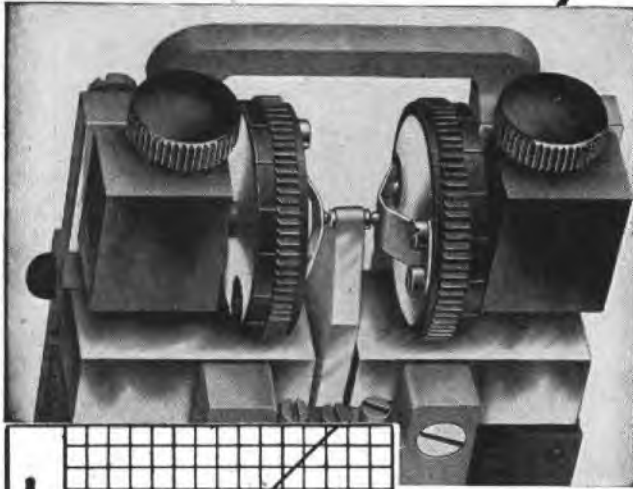
CARPENTER*High Speed Polarised***RELAY**

● Contact mechanism of Relay showing damped compliant mountings of side contacts.

● Graph showing contact pressures developed as 50 c/s against mVA and ampere turns input for type 3E Carpenter Relay.

The Carpenter Relay in its standard adjustment reproduce with a 5 AT input, square pulses from less than 2 mill seconds upwards with a distortion of 0.1mS, i.e., 5% for 2m pulses or 1% at 10mS.

This unequalled performance is due to inherent features of the design of the relay, ensuring short transit time, high sensitivity and low hysteresis. There is complete absence of contact rebound at any input power and contact pressures are exceptionally high (see graph). Adjustment can be made with great ease. Moreover, since the armature is suspended at its centre of gravity, the relay has high immunity from effects of mechanical vibration and there is no positional error. Effective screening is provided against external fields. Because of these characteristics, the Carpenter Relay has many applications in the fields of measurement, speed regulation, telecontrol and the like, in addition to the obvious use in telegraph circuit details of models suitable for such purposes will be supplied willingly on request.

DIMENSIONS IN COVER: 2½ x 1½ x 4½
WEIGHT with standard socket: 22 ozs.

Ask for booklet 1017 P.O.

TELEPHONE MANUFACTURING CO. LTD

HOLLINGSWORTH WORKS • DULWICH • LONDON • S.E.2

Telephones: GIPsy Hill 2211 (10 lines)

A Typical Example of **H.T.A. DESIGN**

Included in the range of H.T.A. Products are Telephone Coin Collectors, Stamp Selling Machines, Autodials, Commodity Vending Machines, Coin Operated Mechanisms, Kitchen Control Units, Gas Leak Indicators and Ticket Printing and Issuing Machines of which the model illustrated is a typical example.

★ *This H.T.A. all-electric Ticket Issuing Machine prints and dates each ticket when coin is inserted*

Designed for selling of railway travel and platform tickets this model can be adapted for a variety of other purposes. Tickets are printed and dated on the insertion of the appropriate coin or coins from a roll of blank paper, the size of the ticket issued being approximately 3" x 1½" x .015" thick. The machine is electrically operated and full details and specification will be supplied on request.

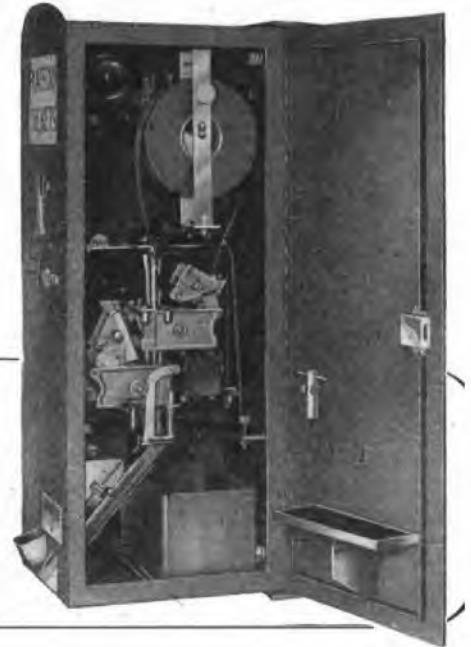
**H.T.A. LIMITED**

FORMERLY HALL TELEPHONE ACCESSORIES (1928) LTD

Precision Engineers & Instrument Makers

DUDDEN HILL LANE • WILLES DEN • LONDON • N. W. 10

PHONE: WILLES DEN 5141

No. 47 TAPE MODEL TELEPRINTER

FOR —

MODERN TELEGRAPHY—

A NEW PRODUCT



Creed



- Printing point is in ideal position on left side.
- Receiving cam orientation device facilitates optimum adjustment.
- Conforms to C.C.I.T. recommendations.
- Tape and ink ribbon are replenished without removing cover.
- Accessible printing unit using typewriter ink ribbon.
- Answer-back unit (20 characters).
- A cover attachment for accommodating message forms, etc., can be provided for handling heavy traffic.
- Simplified maintenance with unit construction.
- Quiet in operation.

Creed and Company Limited

TELEGRAPH HOUSE · CROYDON · ENGLAND

TELEGRAMS : "CREDO, TELEX, CROYDON."
TELEPHONE : CROYDON 2121 (7 lines).

● CABLES : "CREDO, CROYDON."
● TELEX : CROYDON, TELEX 1082

Eclipse PERMANENT MAGNETS

1948
MACHINE TOOL
READ ENGINEERING
COURTNEY LONDON
ENGLAND

IN
**TUNGSTEN · CHROME
COBALT · ALNI · ALNICO
& ALCOMAX**

Our Technical Development Section will be pleased to advise on any problem connected with applied magnetism

Made by the manufacturers of
"ECLIPSE"
PERMANENT MAGNET CHUCKS

EM 7
JAMES NEILL & CO. (Sheffield) LTD., SHEFFIELD, ENGLAND

A PRACTICAL PLAN for EARLY PROMOTION

Valuable Free Handbook Tells You
How to Pass Your C. & G.
or Promotion Exam. at First Attempt!



All Post Office Engineering personnel who are anxious to obtain early promotion should at once send for a copy of our handbook "ENGINEERING OPPORTUNITIES," which, among other extremely interesting matter, describes our unique methods of preparation for **TECHNICAL APPOINTMENTS IN THE POST OFFICE** (Assistant Engineer New Style and Assistant Traffic Superintendent), **A.M.I.E.E., CITY AND GUILDS EXAMINATIONS** in Principles of Telecommunications (1-5), Radio (1-4), Telephone Exchange Systems (1-3), Telegraphy (1 and 2), Line Transmission (1 and 2), Lines Plant Practice (1 and 2), Mathematics for Telecommunications (1-5), Electrical Engineering Practice (Prelim. Inter and Final), and outlines a wide range of non-examination courses in all branches of **Electrical, Mechanical, Civil, Automobile, Aeronautical and Radio Engineering.**

**We definitely guarantee
"NO PASS—NO FEE"**

If you intend to make the most of your opportunities, you cannot afford to miss reading "ENGINEERING OPPORTUNITIES." It tells you everything you want to know to secure advancement, and describes many opportunities you are now missing through lack of information. Send for your copy today — **FREE** and without obligation.

BRITISH INSTITUTE OF ENGINEERING TECHNOLOGY
369 SHAKESPEARE HOUSE, 17-19 STRATFORD PLACE, LONDON, W.1

NEW DESIGNS
In the range of
U.I.C.
High Stability
CAPACITORS

1 LEAD-THROUGH "HI-LOAD" CAPACITOR

90 MM
45 MM
72 MM
115.4 MM
4 BA. CLEAR

Further technical details furnished on request

This new Ceramic "Hi-Load" Capacitor has been specially designed as H.T. or Heater By-Pass and Lead-Through Capacitor. Although very small in dimensions the capacitor has a capacitance of 1,000 pF and it is rated at 40 KVA R.F. with a maximum R.F. current of 20 amps. The sturdy rod forming the lead-through connection is capable of handling all normal currents. The high rating also makes the capacitor suitable as a tank capacitor.

UNITED INSULATOR CO. LTD. OAKCROFT RD. TOLWORTH SURBITON SURREY
Telephone: Elmbridge 5241 (4 lines) Telegrams: Calanel, Surbiton

SenTerCel SELENIUM RECTIFIERS

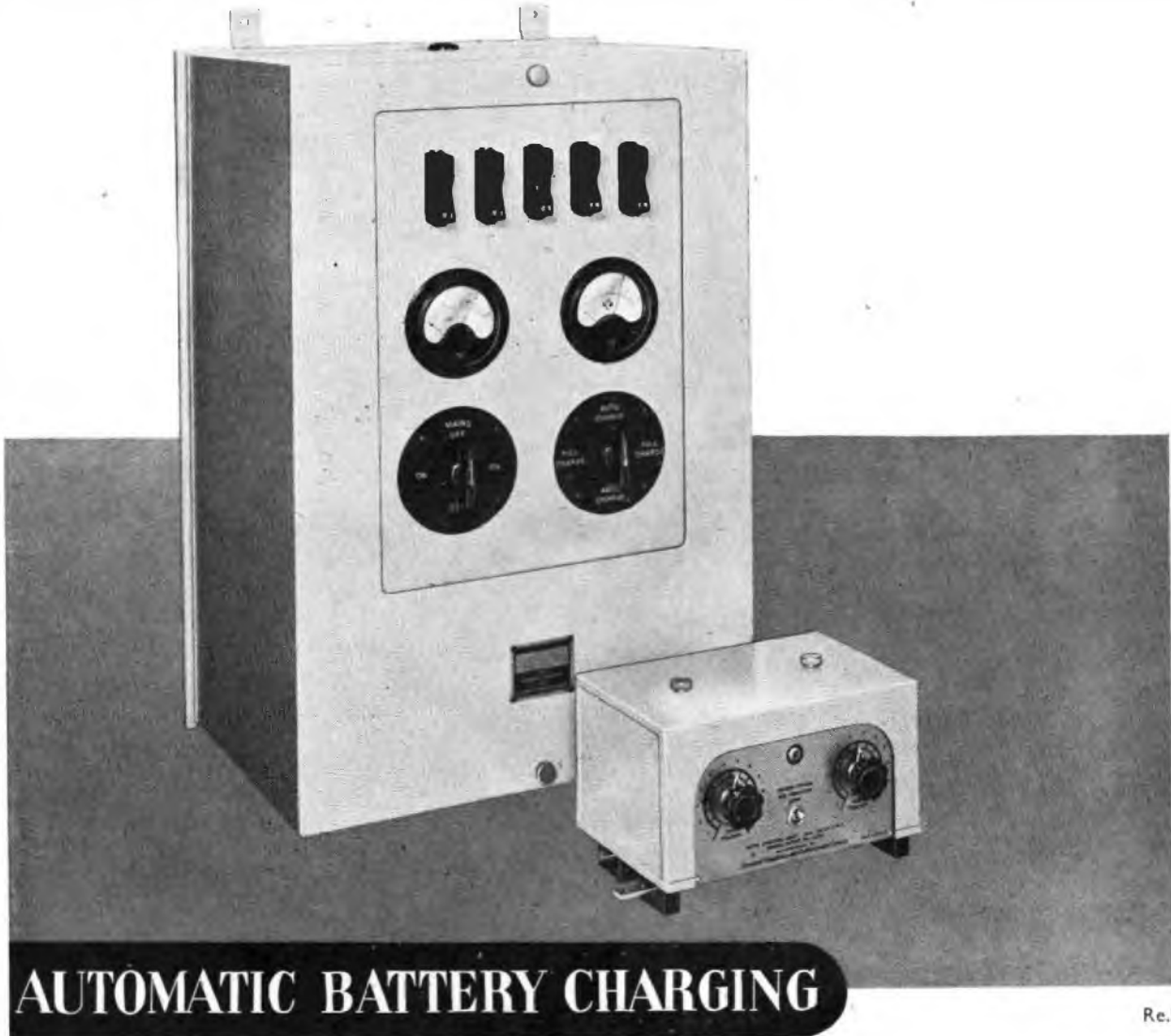

Re.5

AUTOMATIC BATTERY CHARGING

POWER supplies for telephone supervisory and signalling systems are usually provided by batteries, the voltage of which must be kept within closely controlled limits if the equipment is to operate satisfactorily. Battery maintenance, therefore, is of the greatest importance.

The SenTerCel Automatic Charger maintains battery voltages within $\pm 2\frac{1}{2}\%$ of their nominal value and needs no maintenance whatever, control being obtained from the battery voltage itself by means of vacuum tube thermal relays.

Bulletin SRT.37 gives details of the standard range and special designs can be produced to individual requirements.

Standard Telephones and Cables Limited

Selenium rectifiers of all types including Uniplate, tubular and spindle mounted stacks. Equipments for stationary or vehicle battery charging, electrostatic precipitation, aircraft and vehicle engine starting, electro-plating and similar electrolytic processes. Power supplies for circuit breaking and other operations.



RECTIFIER DIVISION • OAKLEIGH ROAD • NEW SOUTHGATE • LONDON • N.11

DON'T TRY ANY TRICKS
WITH A PUFF ADDER . . .

and if you don't believe us
just ask any Indian fakir
you see walking down the
street and he'll
tell you.

In a similar
vein of thought
don't try any
tricks with
Transformers
under
abnormal conditions,
just make a firm re-
solve to think of
the Parmeko Mercury
series (hermetically
sealed) when you
desperately want
-40c or +100c
or when you're
crazed for 50,000
ft. up or down to
you know where.

Under such con-
ditions just you
try using Trans-
formers which
are not quite
reliable and
you'll start a
chain reaction
or get yourself
puff addered -
get what
we mean ?

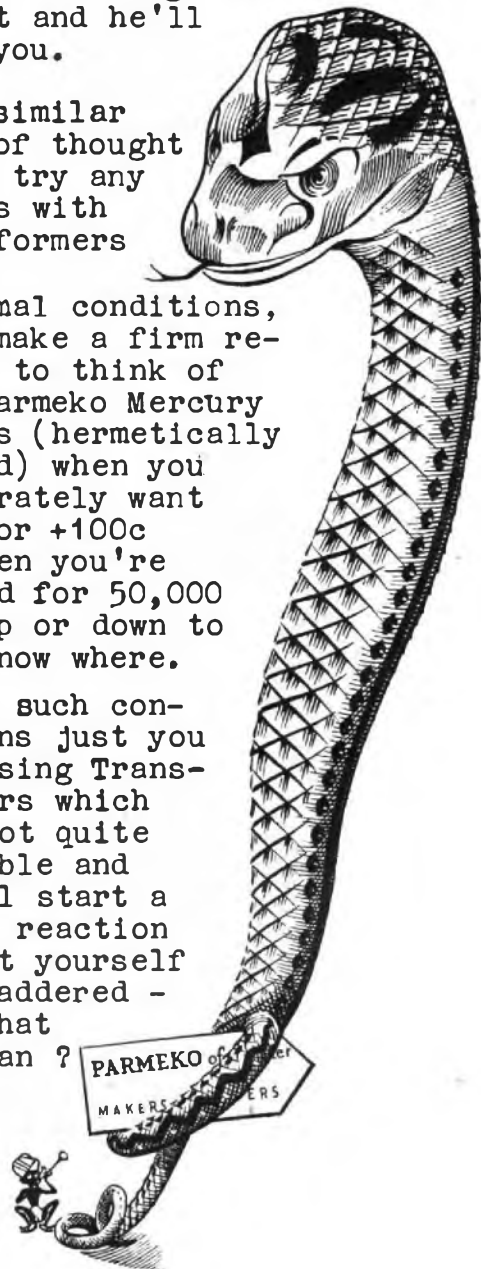

PARMEKO OF LEICESTER,

Makers of Transformers for
the Electronic, Signal,
Luminous Tube, Oil Ignition
Industries, etc. 

THE PROBLEM OF THE TELEPHONE BATTERY

*solve it simply and
easily by installing a*

◀ WESTAT ▶

FULLY AUTOMATIC RECTIFIER EQUIPMENT

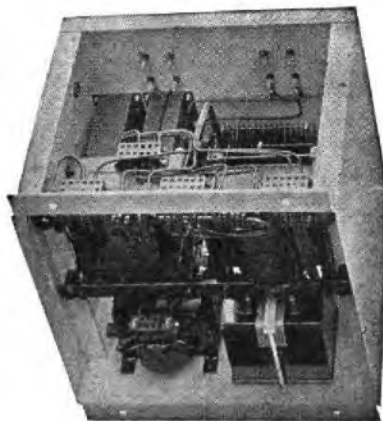

250-watt* equip-
ment with cover
removed to show
internal con-
struction. No gas
discharge tubes,
barreters, D.C.
saturated chokes
or relays.

- Battery automatically maintained in a charged and healthy condition despite erratic loads.
- Battery cannot be overcharged even if left unattended for very long periods. Maximum cell voltage is accurately controlled.
- Battery cannot gas and, therefore, will not give off corrosive spray. "Topping-up" is seldom required.
- Battery cannot be overdischarged — the "Westat" automatically provides a heavy charge when battery voltage is low.
- Battery life prolonged without any added attention.
- Fully compensated for mains voltage variation.

* Made in a range of sizes with outputs from 40 to 1800 watts

Write for descriptive pamphlet No. M.R.12 to Dept. P.O.E.2.

WESTINGHOUSE BRAKE & SIGNAL CO. LTD.
82, YORK WAY, KING'S CROSS, LONDON, N.1

Great cities of the world rely on

DURBAN

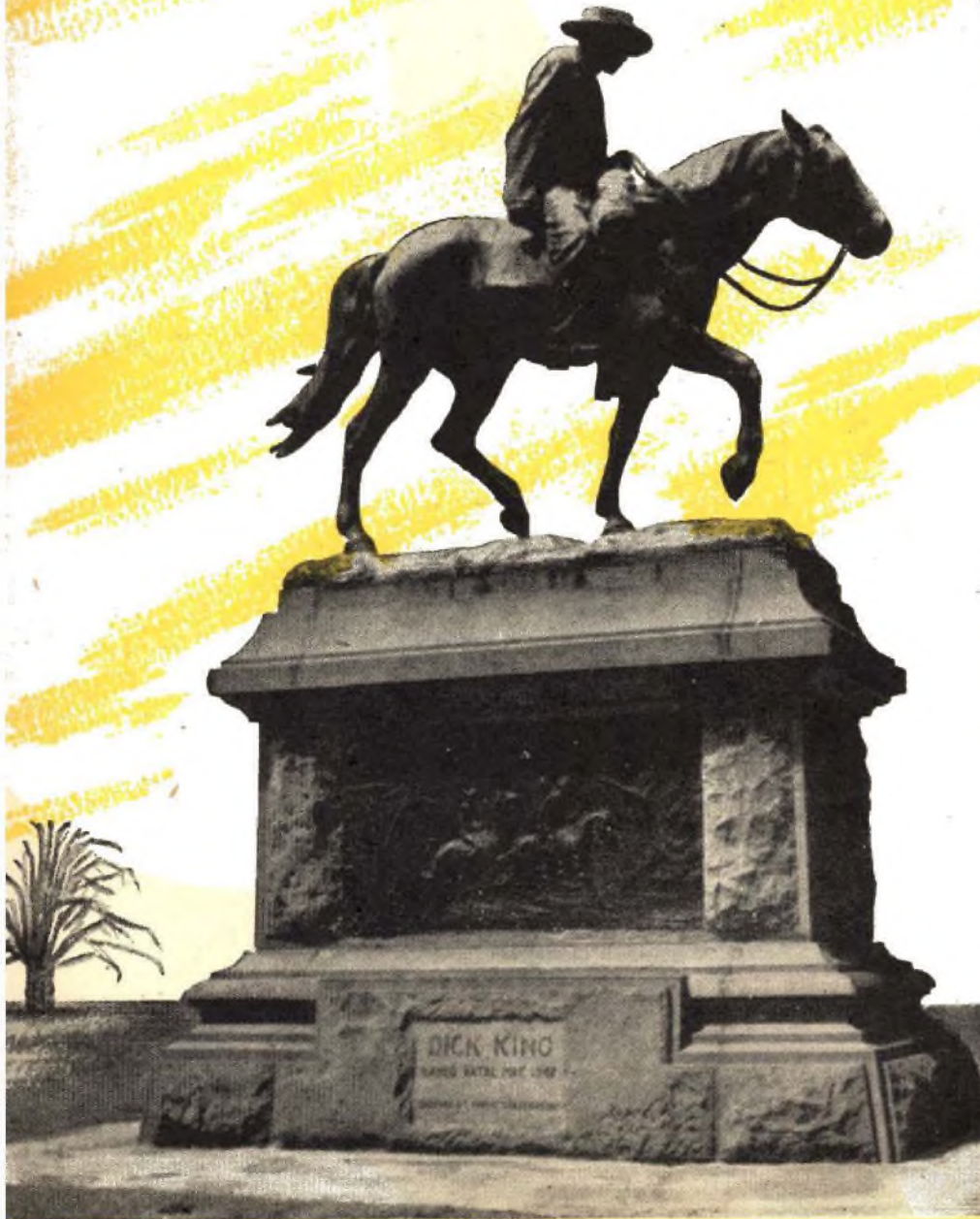

Splendidly situated on the Natal coast, both a busy seaport and a popular holiday resort, Durban is a beautiful city. The lagoon harbour is screened from the sea by the two-hundred-foot-high Bluff, and by the sea wall. Its importance was greatly increased when diamonds were found in the rich interior, whilst among the seafaring activities local is that of whaling. Along the ocean front is a beautifully laid-out Embankment; the miles of bathing beaches and a fine residential district, whilst Berea is a pleasant residential suburb. During the three centuries which have passed, Durban has become one of the greatest and most attractive cities in the world.

The Dick King Statue, Durban
(Photo: Courtesy South African Railways)



STROWGER AUTOMATIC ROUTINER

- ★ They carry out automatic whole of the routine tests using the automatic equipments.
- ★ They subject each selector series of thorough functional series of thorough functional
- ★ They function with extreme accuracy each selector in turn. They give defective selector is encountered indications of both the selector nature of the defect.
- ★ They function within fine



N

Strowger telecommunications

The Durban automatic telephone network provides service for subscribers throughout a wide area which extends some distance beyond the boundaries of Durban itself. The Durban Corporation is responsible for exchange within the city limits, whilst the Government of South Africa operates those outside the town boundaries. In consequence, Strowger engineers were faced with a number of unusual operating and trunking problems. For example, in the Corporation area many call office lines with a high calling rate are required, but in the Government area the number of such lines is comparatively small. Again, certain special services such as local enquiry, test clerk, and complaints, need to be duplicated so that one appropriate set is available to subscribers in each area. The latest development in the area is the provision of an automatic trunk exchange which is in process of design and manufacture and whose function is to link the Durban automatic area with the remainder of the Union.

Central Main Exchange, Durban

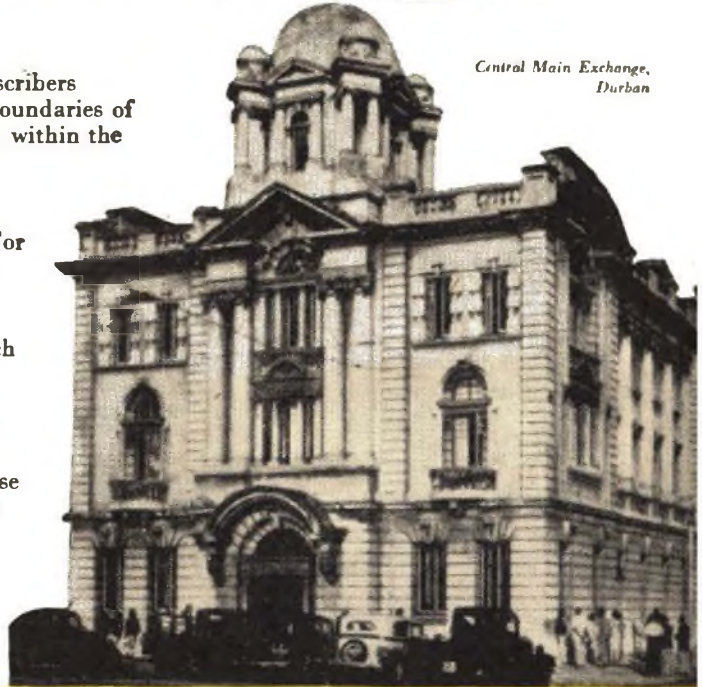

AUTOMATIC TELEPHONE & ELECTRIC CO. LTD.
 Norfolk House, Norfolk Street, London, W.C.2
 Temple Bar 9262. Cables: Autelco, London.
 STROWGER WORKS, LIVERPOOL, 7, ENGLAND



THE DURBAN NETWORK

1. Durban North
2. Stamford Hill
3. Overport
4. Central
5. Tollgate
6. Congella
7. Rossburgh
8. Fynnlands
9. Malvern



11. Kloof
12. Hillcrest
13. Westville

SIEMENS

TECHNICAL

DEVELOPMENTS

FOR LARGE AUTOMATIC EXCHANGE NETWORKS

THIS is a rack of twenty 7-digit Directors. The "BC" switch in each Director is a high-speed motor uniselector. The remaining apparatus including that for impulse generation consists entirely of relays. The translation field is at the rear of the "BC" switch unit. This design has been based on the Sender employed in the Company's automatic trunk system already working in the state of Victoria, Australia, and which is being provided for the Union of South Africa as well as for Canadian Administrations.

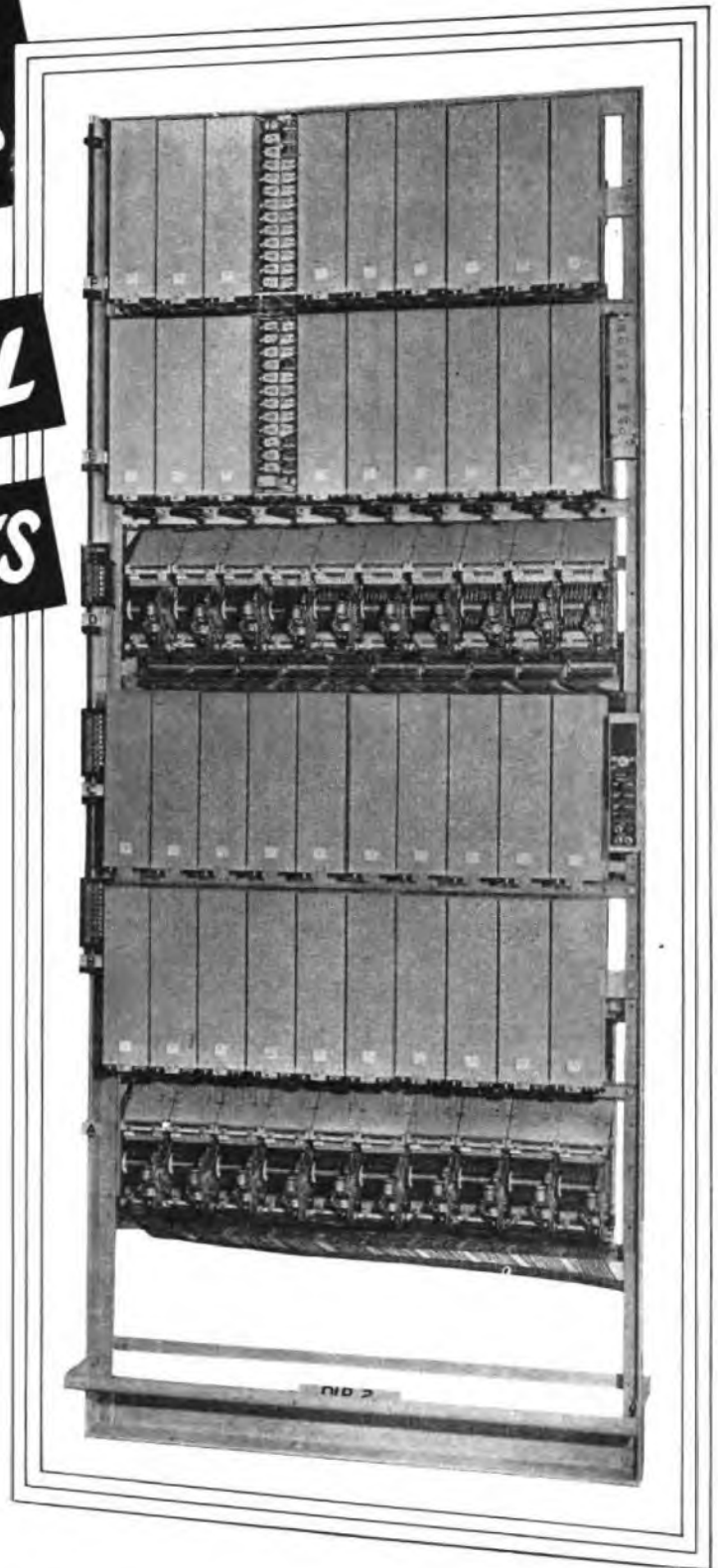

SIEMENS BROTHERS & CO., LIMITED
WOOLWICH • LONDON • S. E. 18.

Automatic Trunk Switching Developments in the Union of South Africa

In 1933 the South African Post Office acquired from our Company an Automatic Trunk Exchange for installation at Cape Town. It was the first in the world to afford comprehensive facilities for handling trunk traffic. It employed switches of the bimotional type.

As part of its post-war plans, the South African Post Office is now introducing automatic trunk switching on an extensive scale, commencing with installations at—

Bloemfontein
Pietermaritzburg
Port Elizabeth
and Durban

The system chosen for all these exchanges is to our Company's design, retaining the original facilities provided at Cape Town, but now employing our design of high-speed motor uniselector throughout. The associated voice-frequency signalling and transmission control equipment is also of our design.

There's more in resistance work than meets the eye!

Many have remarked on the fine appearance of Muirhead Decade Resistance Boxes — but we are even more concerned with what we put inside them. Take, for instance, the A-25 series; all resistors are wound on cards by methods that ensure very low time — constants. The internally mounted switches are protected from contamination and have low and constant contact resistance.

Write for Publication C-102-A which gives full details and specification.

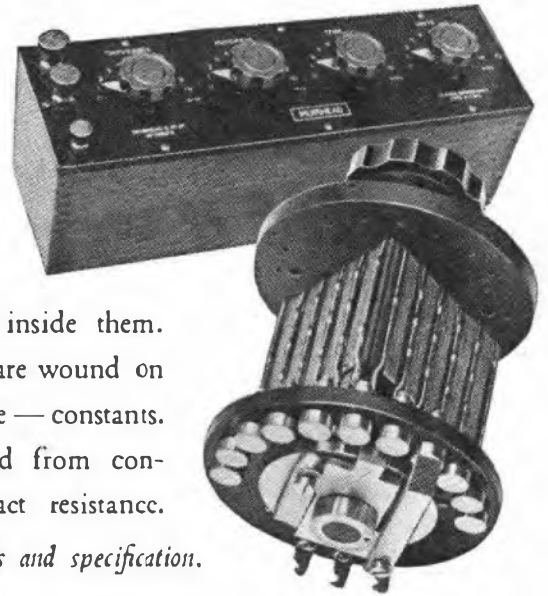

MUIRHEAD

Muirhead & Co. Limited, Elmers End, Beckenham, Kent. Tel. Beckenham 0041-2

FOR OVER 60 YEARS DESIGNERS & MAKERS OF PRECISION INSTRUMENTS

CRC 67b



The AvoMeter is one of a useful range of "Avo" electrical testing instruments which are maintaining the "Avo" reputation for an unexcelled standard of accuracy and dependability—in fact, a standard by which other instruments are judged.

ONE INSTRUMENT measures:—

Current, A.C. and D.C. (0 to 10 amps.)
Voltage, A.C. and D.C. (0 to 1,000 v.)
Resistance (up to 40 megohms)
Capacity (0 to 20) mfd.s.)
Audio-frequency Power Output (0 to 2 watts)
Decibels (—25 Db. to + 16 Db.)

Write for fully descriptive pamphlet.

AVO

Meters that Matter

THE Model 7 Universal AvoMeter is the world's most widely used combination electrical measuring instrument. It provides 50 ranges of readings on a 5-inch hand-calibrated scale, and is guaranteed accurate to B.S. first grade limits on D.C. and A.C. from 25 c/s to 2 kc/s. It is self-contained, compact and portable, simple to operate and almost impossible to damage electrically. It is protected by an automatic cut-out against damage through severe overload.

Sole Proprietors and Manufacturers:—

THE AUTOMATIC COIL WINDER & ELECTRICAL EQUIPMENT Co.
Winder House, Douglas Street, London, S.W.1. Phone: VICTORIA 34

TELEPHONE TRANSMISSION EQUIPMENT
SUBSCRIBERS' TELEPHONES • LOADING COILS
AUTOMATIC AND MANUAL EXCHANGES
TRUNK AND LOCAL CABLES • OVERHEAD LINES
TEST EQUIPMENT OF ALL KINDS

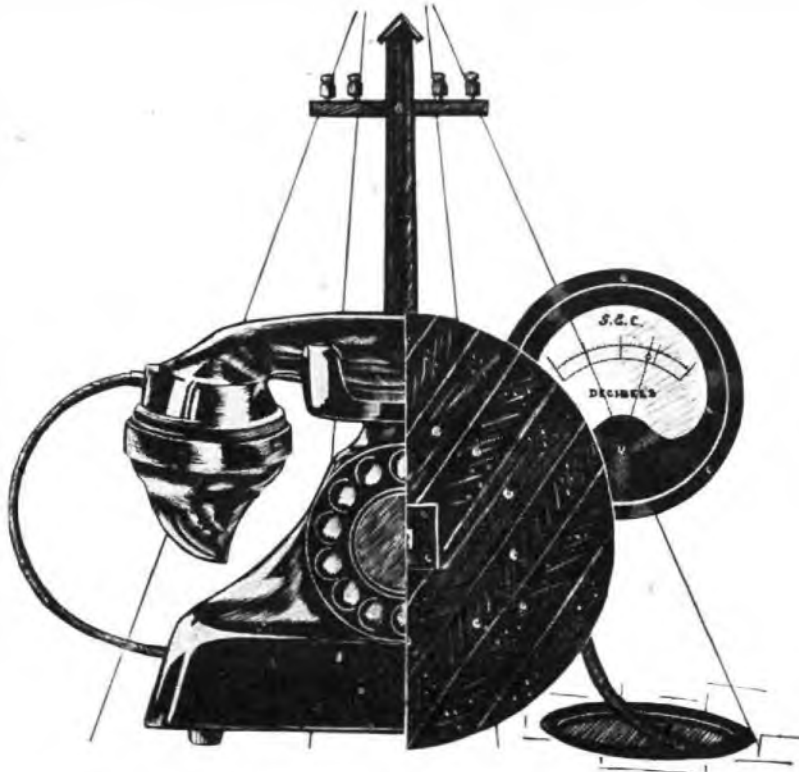

*Telecommunication
Equipment
by G.E.C.*

THE GENERAL ELECTRIC CO. LTD. OF ENGLAND
HEAD OFFICE: MAGNET HOUSE, KINGSWAY, LONDON

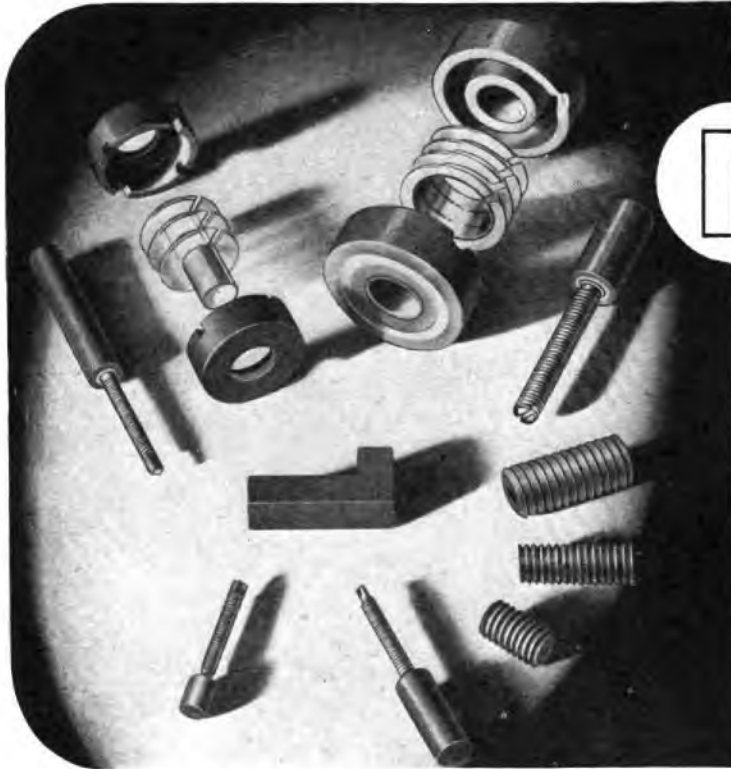

neosid

IRON DUST CORES

High performance : Strength : Stability
Close electrical and mechanical tolerances
Grades to suit various applications

neosid *limited*

23 and 25 Hyde Way, Welwyn
Garden City, Herts.

Tel : Welwyn Garden 925

P.O.

DENSO *at the service of the*
ELECTRICAL ENGINEER

"I honestly find that Denso is the greatest boon and blessing to Mainsmen ever invented

. . . As a matter of National importance all Mains Engineers should be informed of the usefulness of Denso, particularly for waterproofing temporary openings during fault location, even on 11,000 volt cables."

These are two extracts taken from a letter sent to us by a District Mains Engineer. They are spontaneous and represent the opinion of a man who knows the materials to meet the job.

"DENSO,"
Regd.



PRODUCTS

IMITATED BUT NOT EQUALLED

Write for Specification and price list
WINN & COALES LTD

TERMINAL HOUSE, GROSVENOR GARDENS, LONDON, S.W.1
Telephone: Sloane 6264 Telegrams: Denselte. Sowest. London

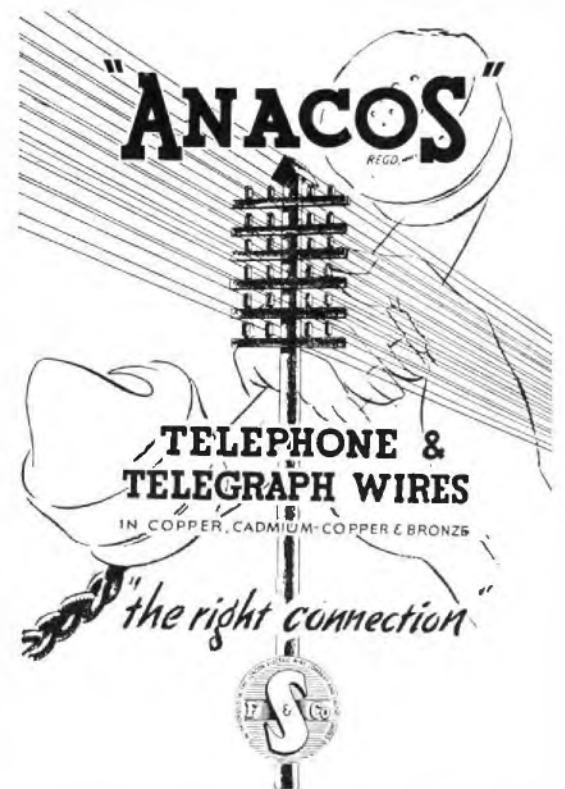

FREDERICK SMITH & COMPANY

(Incorporated in The London Electric Wire Company and Smiths, Limited

ANACONDA WORKS, SALFORD 3, LANCs.

Phone : Blackfriars 8701 (9 lines) • Grams : "Anaconda," Mancheste

POWER BEHIND THE LINES

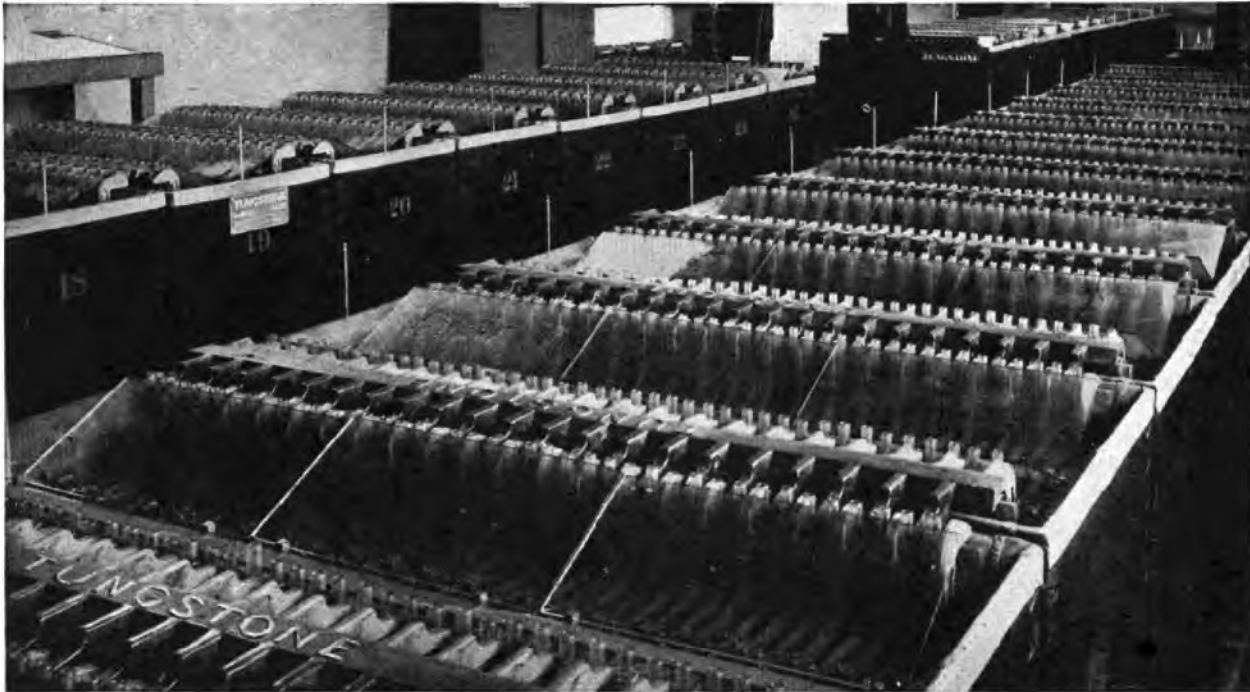

Tungstone Planté cells are being supplied to the British Post Office and to Posts and Telegraph departments abroad and conform fully to *G.P.O.* and *British Standard* specifications. Delivery is reasonable on all types and sizes.

Open type cells

Similar to the illustration above, these are available in glass and/or lead-lined wooden boxes, in capacities from 100 a.h. to 5000 a.h.

Replating

We are in a position to supply plates for the replating of any size of existing Planté batteries.

Overseas Enquiries

Export customers are invited to cable or write their enquiries for batteries or parts. Visitors to London are welcome at our offices.

Enclosed cells

Illustrated on the right, these are in sealed glass boxes, in capacities from 10 a.h. to 200 a.h., delivered in the U.K. filled and charged.

Technical Service

We are glad to advise on most suitable types and layouts for any installation and for any purpose.



ENCLOSED TYPE CELL

TUNGSTONE *Batteries*

For further particulars write: **TUNGSTONE PRODUCTS LIMITED,**

St. Bride's House, Salisbury Square, London, E.C.4. Telephone: CENTral 8156 (4 lines.)

Cables: DILUTUM, London Works: Market Harborough, Leicestershire.

VITAL LINKS

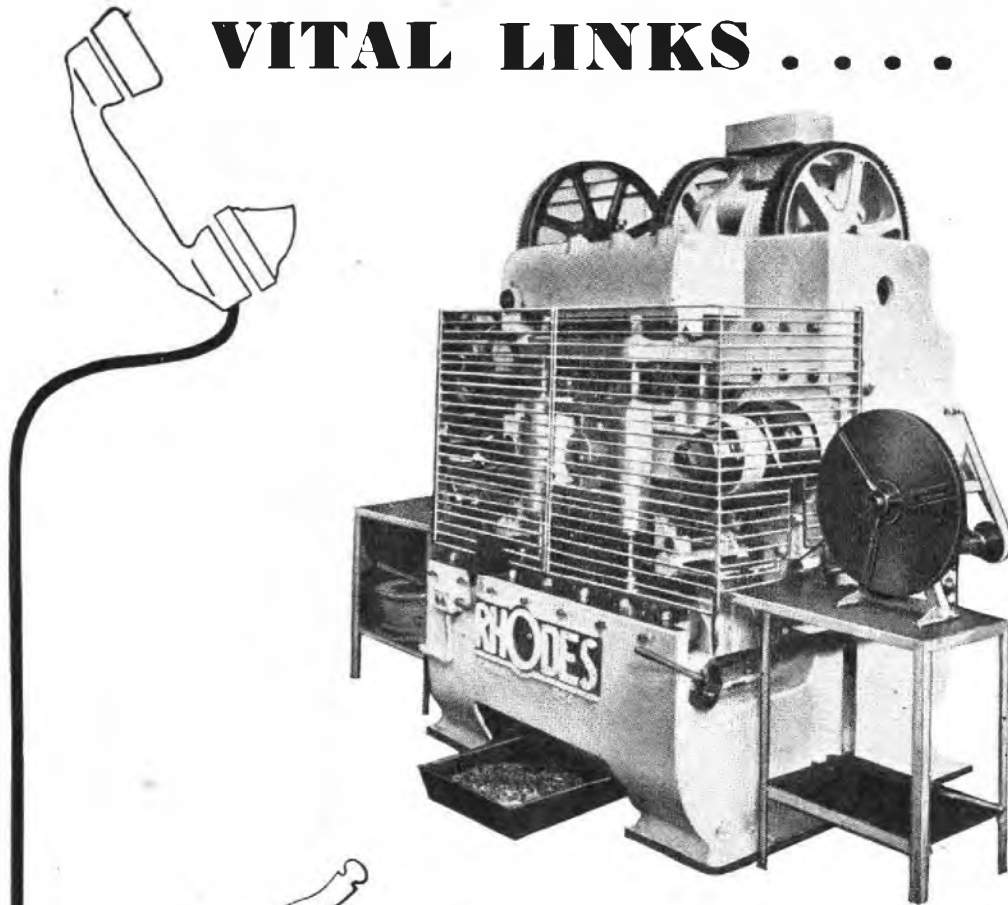

More than one million such contacts, i.e. sufficient for a 1000 line exchange, can be stamped out in 8 hours by this automatic press at our Beeston Factory.

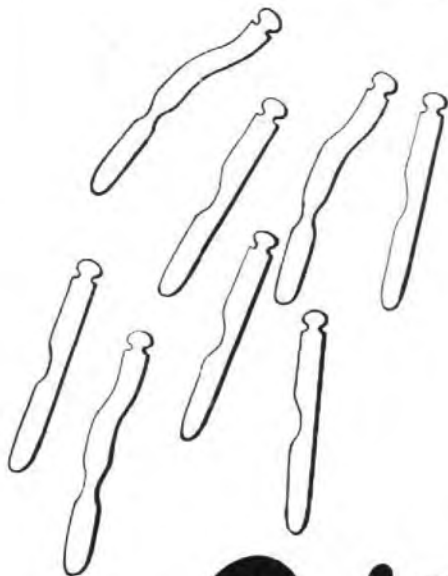

In the chain of connections between subscribers on an automatic telephone exchange are the brass or nickel-silver contacts over which the automatically operated switches are stepped.

Ericsson

TELEPHONE EQUIPMENT

ERICSSON TELEPHONES LTD. · Head Office: 22 LINCOLN'S INN FIELDS, LONDON, W.C.2. · Tel: HOL 6936
Works: BEESTON, NOTTS.

A new series of **SAVAGE AMPLIFIERS**

FOR BROADCAST RELAY

With output of 250, 500 & 1,000 watts, these amplifiers incorporate the latest technique in electrical and mechanical design.

Specification of the Savage Mark II Kilowatt Amplifier

Output	1,000 watts	Gain	84 dB
Output regulation	9% (0.8dB)	Noise level	-72 dB
Total Distortion @ 1,000~	<0.75%	Frequency response 50-10,000~	±1 dB

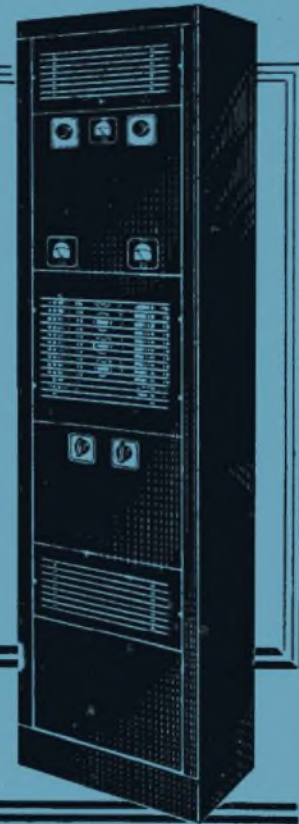

W. BRYAN SAVAGE LIMITED

WESTMORELAND ROAD • LONDON, N.W.9 • Phone: Colindale 7131

A Handbook of Telecommunication

By Bertram S. Cohen, O.B.E., M.I.E.E., F.Inst.P.; edited by F. G. C. Baldwin, O.B.E., M.I.E.E. An important book describing in full technical detail and with numerous illustrations the present practice and latest developments in telegraphy and telephony. The information given not only concerns British practice, but includes accounts of techniques in use in other European countries and in the U.S.A. 30/- net.

Whittaker's Electrical Engineer's Pocket Book

Edited by R. E. Neale, B.Sc.(Hons.), A.C.G.I., A.M.I.E.E. A comprehensive collection of practical and up-to-date information including diagrams, tables and data relating to every kind of electrical work. Revised, completely up-to-date Seventh Edition. 938 pages. 30/- net.

Fault Localizing and Testing of Electric Mains

By F. Charles Raphael, M.I.E.E., F.I.E.S., M.Cons.E., and Charles A. Grover, M.I.E.E. 143 illustrations. 20/- net.

Electric Wiring Tables

By W. Perren Maycock, M.I.E.E., and F. Charles Raphael, M.I.E.E., F.I.E.S., M.Cons.E. Waistcoat pocket size, 5/- net.

Electric Wiring Diagrams

By W. Perren Maycock, M.I.E.E. Revised by H. C. Fabian. Third Edition. 6/- net.

PITMAN, Parker Street, Kingsway, London, W.C.2

TELEPHONE CABLES

OUR LATEST BROCHURE No. 9E (1947)
IS NOW AVAILABLE, GIVING INFOR-
MATION AND SPECIFICATIONS FOR A
WIDE RANGE OF TELECOMMUNICA-
TION CABLES MANUFACTURED BY US.
COPIES WILL BE SENT ON REQUEST.

TELEPHONE
SOUTHAMPTON
2141 (5 lines)

PIRELLI-GENERAL
CABLE WORKS, Ltd., SOUTHAMPTON.

TELEGRAMS
"PIREKAYBEL"
SOUTHAMPTON

MAY WE SUGGEST THAT NOW IS THE
OPPORTUNE TIME FOR RE-EQUIPPING
YOUR LABORATORIES WITH
STANDARDS.

ADJUSTED AND CALIBRATED IN

THE NEW ABSOLUTE UNITS

WHICH ARE NOW ADOPTED INTERNATIONALLY.

(Adopted on 1st January of this year.)

MAY WE ALSO SUGGEST THAT ALL THE EXISTING STANDARDS
IN YOUR LABORATORY SHOULD BE MARKED "INTERNATIONAL"
IN ORDER TO AVOID CONFUSION OF UNITS IN TIME TO COME.

H. W. SULLIVAN
— LIMITED —

LONDON, S.E.15

Telephone: New Cross 3225 (P.B.X.)

Electrical Standards for Research and Industry

Testing and Measuring Apparatus
for Communication Engineering

A PRICE SCHEDULE FOR THE CONVERSION
OF STANDARDS TO THE NEW UNITS
WILL BE SENT UPON APPLICATION