

# THE POST OFFICE ELECTRICAL ENGINEERS' JOURNAL

**VOL. 40**

**JANUARY 1948**

**PART 4**

## CONTENTS

	PAGE
POST-WAR TELEPHONE DEVELOPMENTS—B. L. Barnett, C.B., M.C. . . . .	145
THE EFFECT OF DOPPLER'S PRINCIPLE ON THE COMPARISON OF STANDARD FREQUENCIES OVER A TRANSATLANTIC RADIO PATH—C. F. Booth, O.B.E., M.I.E.E., and G. Gregory . .	153
THE ARTIFICIAL TRAFFIC EQUIPMENT—E. C. Elstree-Wilson and C. Lawrence . . . . .	159
THE REINSTATEMENT OF THE CENTRAL TELEGRAPH OFFICE PNEUMATIC TUBE SYSTEM—J. B. Murray, B.Sc.(Eng.), A.M.I.E.E. . . . .	164
THE MANUFACTURE OF STAR QUAD TELEPHONE CABLE—Part 2—The Process of Sheathing—J. E. Deering . . . . .	170
INTERNATIONAL TELECOMMUNICATIONS CONFERENCES, ATLANTIC CITY, 1947 . . . . .	175
EARLY CORRESPONDENCE BETWEEN SIR WILLIAM PREECE AND THE MARCHESE MARCONI . . . . .	179
INSTITUTION'S LIBRARY . . . . .	180
NOTES AND COMMENTS . . . . .	181
JUNIOR SECTION NOTES . . . . .	183
REGIONAL NOTES . . . . .	184
STAFF CHANGES . . . . .	189
INDEX, TO VOL. 40 . . . . .	191
BOOK REVIEWS . . . . .	169, 178

Price 1/- net

**THE INSTITUTION OF POST OFFICE ELECTRICAL ENGINEERS**

## DECADE SWITCH

A Precision Component Embodying  
All The Best Design Features

Very low contact resistance.      Sturdy action.  
Positive location.      Twelve positions—providing two extra contacts  
—30° angular spacing simplifies dial calibration.  
Two types available—416A (Shorting) and 416B  
(Non-Shorting).

PRICES ON APPLICATION

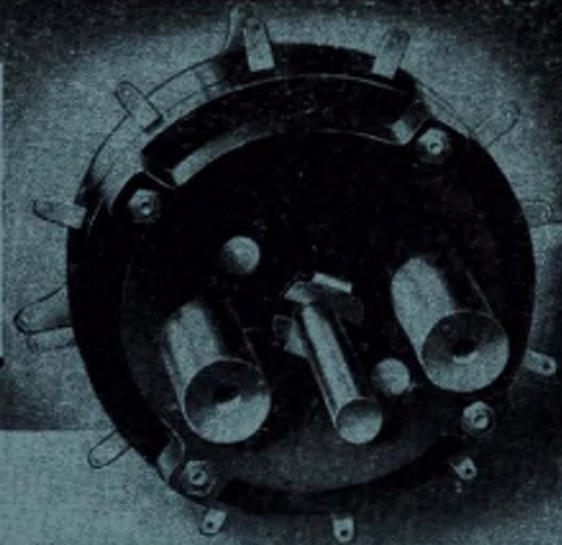

# G.E.C.

**PRECISION CONTROLS** FOR COMMUNICATIONS & MEASURING EQUIPMENT

**SALFORD ELECTRICAL INSTRUMENTS LTD.**

PEEL WORKS SALFORD 3

Phone: BLA. 6688 (4 lines) Grams & Cables "Sparkless, Manchester

Proprietors: **THE GENERAL ELECTRIC CO. LTD.** England

# EDISWAN

## TELEPHONE LINE PROTECTORS.

FOR THE PROTECTION OF LINES OF COMMUNICATION  
FROM SURGES INDUCED BY LIGHTNING OR FAULTS  
ON NEIGHBOURING POWER LINES.

Ediswan Telephone Line Protectors have now been in commission  
for nearly twenty years. They have proved their worth in all parts  
of the world and are being called for and installed in ever  
increasing numbers.

Many thousands were employed during the war years for the protec-  
tion of vital lines of communication and were eminently successful.  
Reports of their outstanding merit and successful operation  
continue to reach us and in recent years they have proved of  
particular interest for protection against surges caused by  
lightning discharges.

Continued research has enabled us to patent a further improve-  
ment which removes any suggestion of delay in operation.

Further information and prices on application.

**THE EDISON SWAN ELECTRIC CO., LTD.**   
155 CHARING CROSS ROAD, LONDON, W.C.2

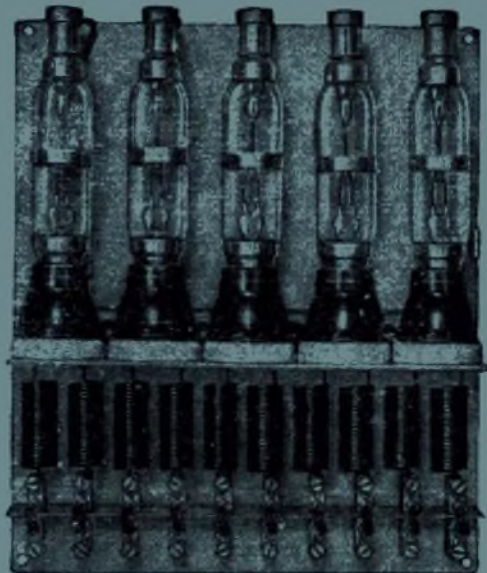

Prov. Patent  
25850/5.

5-circuit  
panel for  
overhead  
lines incor-  
porating  
choke  
coils, spark  
gaps, etc.

T.H.2

# THE POST OFFICE ELECTRICAL ENGINEERS' JOURNAL

Vol. XL

January, 1948

Part IV

## Post-War Telephone Developments

B. L. BARNETT, C.B., M.C.  
(Telecommunications Department)

U.D.C. 654.15

Since the war the number of telephones connected to the Post Office system has increased by 35 per cent. over the corresponding pre-war figure, double the number of trunk calls are now handled and 10 per cent. more local calls. In spite of this active development some 400,000 applications for telephone service are outstanding. This article (prepared in October, 1947) describes the many war-time and post-war difficulties which have caused these conditions and indicates the lines on which future development will proceed.

### Introduction.

IN order to study the development of the telephone service since the war, it seems best to look at what the Post Office had in hand at the end of the war; what its expectations were, at that time, of future demand; what it did to meet that expected demand; what the actual demand turned out to be; what conditions, difficulties and frustrations stood in the way of keeping abreast of the actual demand; and, finally, where it stands at present. This article reviews, from these different angles, each of the many different aspects of the complex organisation of the telephone service.

### EQUIPMENT, LINE PLANT AND STORES

#### Exchange Equipment.

Taking telephone exchange equipment first, it will be seen from the heavy line on the graph (Fig. 1) that

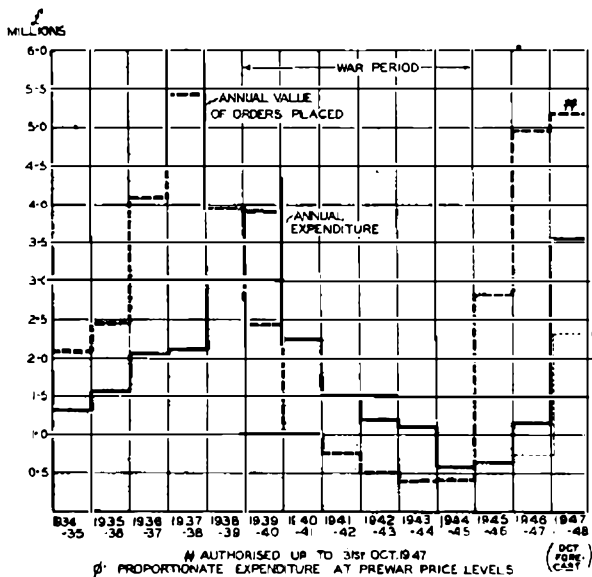

FIG. 1.—TELEPHONE EXCHANGE EQUIPMENT.

the annual expenditure on exchange equipment dropped from nearly £4 millions in 1939-40 to £2.28 millions in 1940-41, and then very rapidly down to

£.65 million in 1944-46. The dotted line shows the amount of orders placed for equipment, and here also it will be seen that the level fell away to a negligible quantity during the war. Many of the orders placed before the war were suspended and the Post Office is now taking delivery of these and of the small war-time orders. But, as will be seen, orders for future delivery have been swiftly stepped up to about the pre-war peak. The position is, therefore, that at the end of the war, there was a trickle of new equipment coming in, but heavy orders were placed to meet future growth. Unfortunately, placing the orders is only the first stage. The equipment manufacturers had to convert their factories from war-to peace-time production, they had to recruit and train new operatives to meet the heavy wastage which followed on demobilisation of the armed forces (this was mainly owing to married women leaving at that time) and they still have a rapid turn-over of staff. Apart from these troubles, they were seriously hampered by the fuel crisis at the beginning of 1947, and by continued shortage of raw and semi-processed materials. Now that they are beginning to get their affairs in reasonable order after all these troubles, they have to devote their main energy to export orders and the Post Office will have to be content with taking only about £5 millions' worth of exchange equipment for the next few years. This means about £2.8 millions' worth at pre-war prices. At best, therefore, the Post Office will get new exchange equipment for the next few years at about the level reached in 1938-39.

#### Effect of Equipment Shortage on Spare Exchange Capacity.

The effect of the equipment position in terms of spare lines is illustrated by Fig. 2, which shows that during the war period the percentage of spare to total capacity rose to nearly 25 per cent. and fell gradually to 18 per cent. This relatively high percentage of spare equipment was largely due to the virtual refusal to connect subscribers not directly concerned with the war effort, thus putting off six years' normal growth of residential and minor business subscribers. It will be seen that when the Post Office drive for new subscribers got into its stride in 1946, with only a meagre amount of equipment being added, the percentage of spare equipment was reduced from 18 per

cent. to 12½ per cent. in one year. At the end of 1946 then, the spare capacity was practically back to the 1939 level.

*Growth in Lines and in Waiting List.*

The reason for this rapid eating into the spare capacity was the tremendous demand for service pent up during the war, which fell like an avalanche in March, 1946, and has persisted, though with a steady

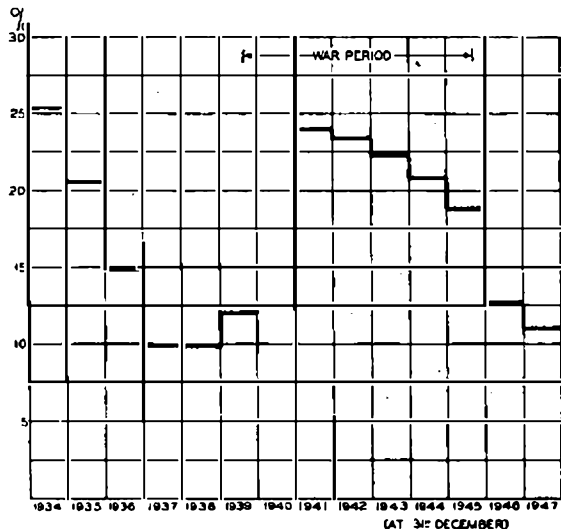

FIG. 2.—SPARE CAPACITY IN EXCHANGE LINES (AS PERCENTAGE OF TOTAL EXCHANGE CAPACITY). (AT 31st DECEMBER)

decline, ever since. Whereas towards the end of the war it was thought that post-war demand would be about 50 per cent. above the pre-war level and would gradually build up, it started off at more than twice the pre-war volume; and it is mainly the difficulty of meeting this demand, with the consequent waiting list, that has checked the flow of applications.

Fig. 3 shows the number of lines connected. During

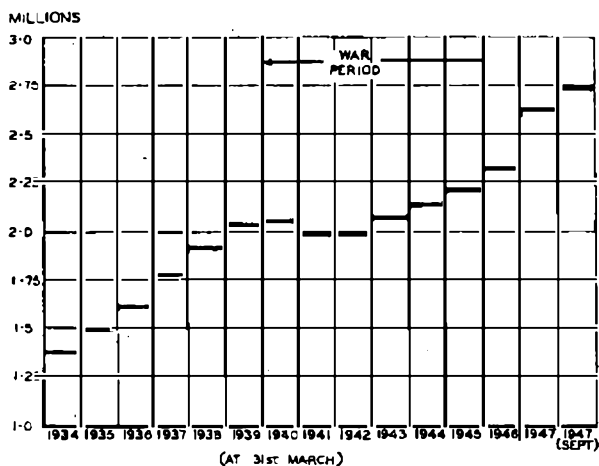

FIG. 3.—YEARLY GROWTH IN SUBSCRIBERS' LINES. (AT 31st MARCH)

the war, and up to March, 1946, growth was relatively steady, but as soon as the war was really over, it began to shoot up and, as already mentioned, the growth in 1946-47 ate deeply into the spare plant.

With the restricted amount of equipment which can be installed during the next few years, it is clear that the waiting list will increase even more rapidly than before and that the ordinary residential applicant will find it increasingly difficult to obtain service.

The waiting list is shown in Fig. 4, which demon-

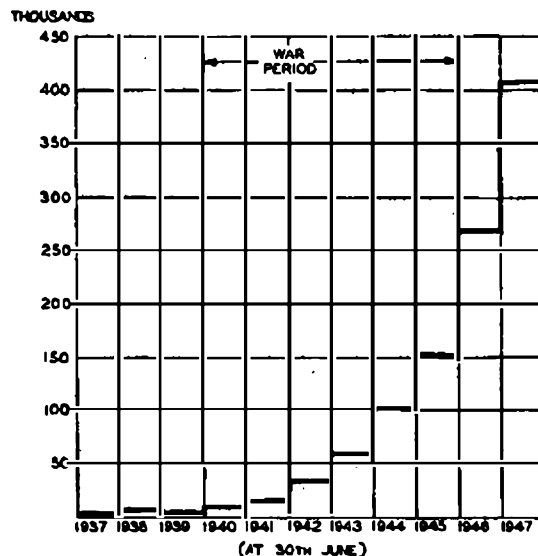

FIG. 4.—OUTSTANDING APPLICATIONS FOR TELEPHONE SERVICE. (AT 30th JUNE)

strates how rapidly it has grown during the last two years.

*Buildings.*

Fig. 5 shows that in 1938-39 and 1939-40 the Post

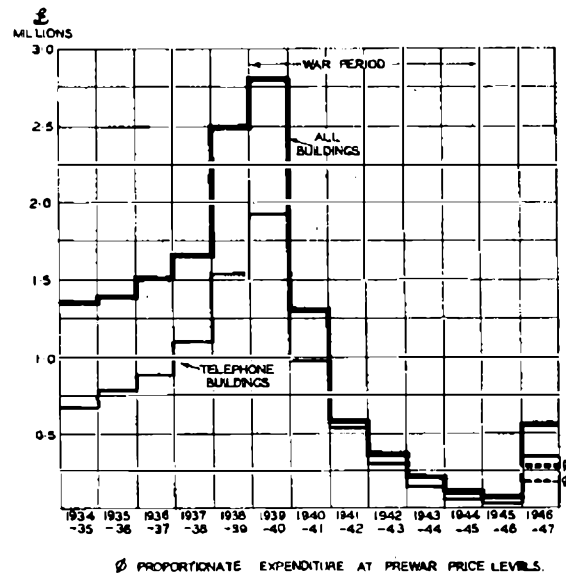

FIG. 5.—POST OFFICE ANNUAL EXPENDITURE ON BUILDINGS

Office was spending between £2.5 and £3 millions ; year on buildings, but during the war this dropped to an average annual figure of about £.25 million. Under the new restrictions on building work, there will be a maximum expenditure of about £1.2 million.

a year for the next few years for all Post Office buildings, and this figure is equivalent to £6 million at pre-war prices. If the whole of this sum is devoted to telephone buildings, it will only amount to 33 per cent. of the expenditure on telephone buildings in 1938-39. These figures show why the Post Office is being driven to devise "expedients" for its exchanges, and is forced to be content with small temporary buildings to provide these expedients. The basic fact is that new buildings on the scale needed to arrange for normal housing of the expanding exchange system cannot possibly be obtained and the Post Office has accordingly to "make do and mend".

**Local Lines.**

The position in regard to local line plant is shown in Fig. 6. Expenditure throughout the war was very

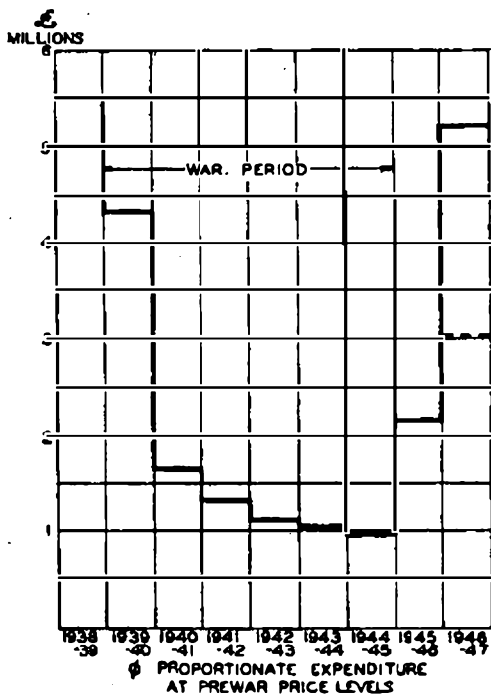

FIG. 6.—ANNUAL EXPENDITURE ON LOCAL LINES.

low—about £1½ million a year on average, compared with about £5-6 millions in the pre-war years. At the end of the war, it was realised that a rapid increase was essential in the provision of new local line plant and in 1946 this type of work was stepped up to nearly the pre-war peak on a monetary basis. In fact, the £5 millions odd spent in 1946-47 is equivalent to about £3 millions in 1938-39, and the provision in the next few years will be even less, as the restriction of building work has resulted in a reduction of labour on local duct work to about one-third of the 1946-47 level. What this will mean is vividly brought out in Fig. 7, from which it will be seen that, although the total number of distribution points has risen steadily until it now stands at about 400,000, the percentage of closed distribution points has already risen from about 17 per cent. pre-war to 33 per cent. now, while those with less than 25 per cent. spare pairs have also

increased similarly. This position may be eased as flexibility points (cabinets and pillars) are gradually

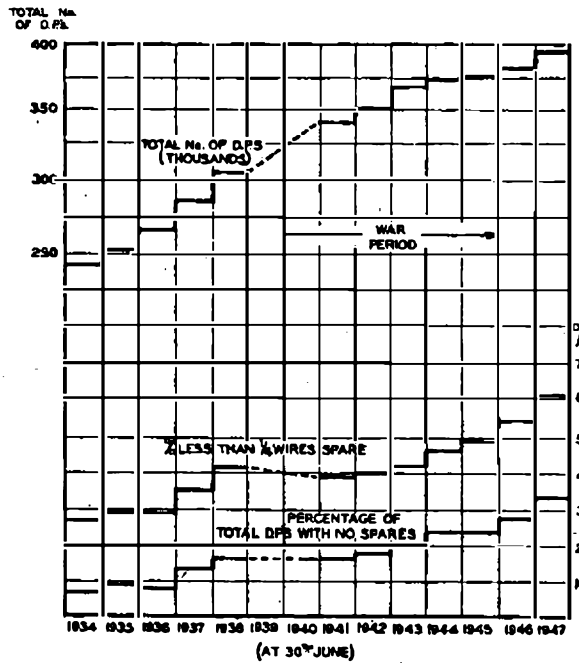

FIG. 7.—TOTAL DISTRIBUTION POINTS AND PERCENTAGE WITH ¼ SPARE AND NO SPARES (U.K.).

installed, as these will facilitate the diversion of unused spares to points where they are needed.

**Trunk Service.**

So far, only the local service has been considered. As regards the trunk service, the first step is to examine the growth of traffic. As shown in Fig. 8, there

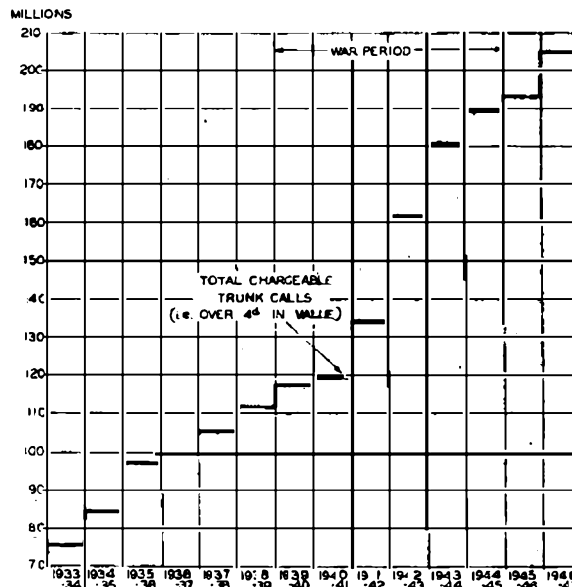

FIG. 8.—YEARLY GROWTH IN TOTAL TRUNK TRAFFIC.

has been a huge growth in traffic both during and since the war—in fact, the volume now is practically double

that of 1938-39 and is still rising. To meet this rapid and continuous growth, considerable sums of money have been spent on main underground cables and repeater and transmission equipment. These are mentioned together because, since the beginning of the war, there has been a very marked development in carrier and coaxial cables; and this type of long-distance plant involves relatively smaller costs on the cables themselves, and larger costs on repeater and transmission equipment, than for audio long-distance cables providing the corresponding capacity.

The main underground cable and duct expenditure year by year is shown in Fig. 9 and it will be seen

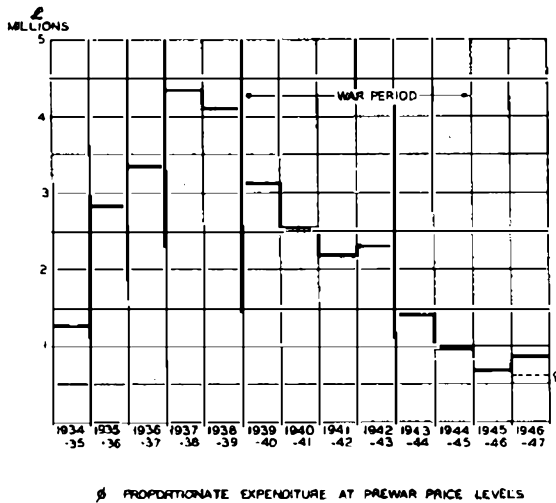

FIG. 9.—ANNUAL EXPENDITURE ON MAIN UNDERGROUND

that the amount has steadily fallen, whereas from Fig. 10 it will be seen that from 1937-38 onwards,

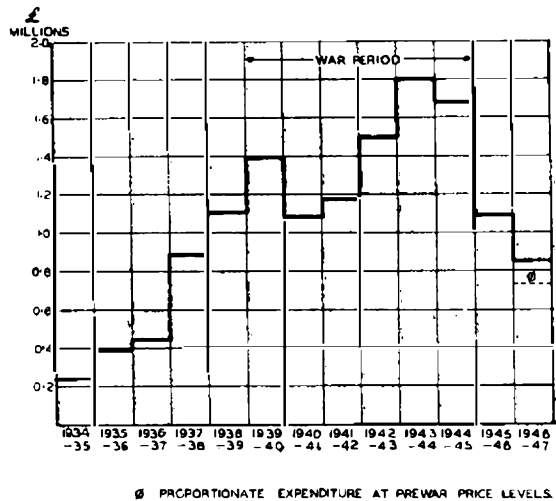

FIG. 10.—ANNUAL EXPENDITURE ON REPEATER STATIONS

expenditure on repeater and transmission equipment was being stepped up practically until the end of the war. Expenditure during the war was mainly directed to providing operational circuits for the Defence Services, which at one period practically equalled in number those in the public trunk service, although the

latter had to carry all the important business calls required for the rapid development of war production and for other non-operational war needs. At the end of the war, there was a fund of private-wire circuits available from the Defence Services which were converted for use in the public service, and there was also a certain amount of spare repeater and transmission equipment. It is the transfer of this capacity to the public service that has enabled it to cope with the ever increasing demand for trunk calls without any serious disturbance. The change-over of circuits is shown clearly in Fig. 11.

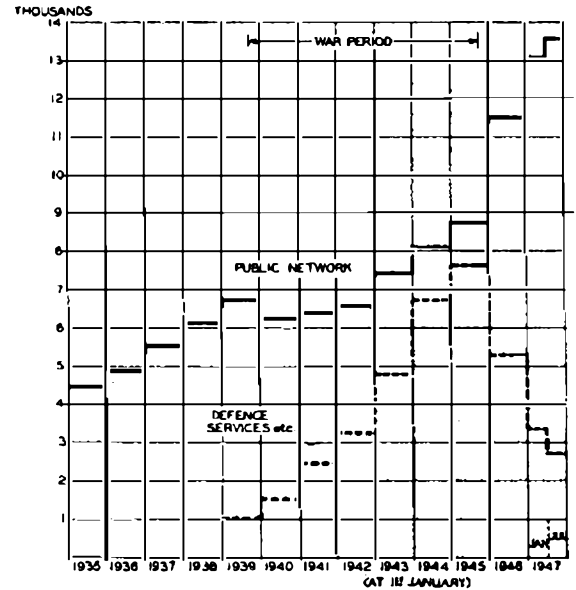

FIG. 11.—NUMBER OF TRUNK CIRCUITS (OVER 25 MILES).

The increase in trunk traffic shows no sign of falling off and the long-distance network is being steadily built up to meet future needs, although even here the contractors are being hampered by difficulties of labour and materials. The Post Office, for its part, is having its own troubles in regard to purchase of sites for repeater stations, and labour difficulties in the building of the repeater stations, and in providing the necessary ducts and manholes.

#### Stores.

The provision of service, whether in the way of exchange equipment, local line work, or actual connecting up of subscribers, and the development of the trunk and junction services, all call for a vast amount of engineering stores running into something like 29,000 different items. These stores have to be estimated as to quantities, ordered, manufactured, tested and distributed. This colossal job—and it is a colossal job—is undertaken jointly by the Engineering Department, the Stores Department, and the Contracts Department. When it is considered that the orders now have to be placed about 12 months in advance of expected delivery, and that all sorts of troubles have to be met, such as shortage of labour and materials, or strikes, not to mention the mere sending out and receiving of tenders for the enormous

ange of items affected, it is possible to gauge the magnitude of the task and of the results of any underestimating of requirements or unbalance of deliveries. Underestimating comes to light more than a year after the deed, and there is little that can be done to rectify matters quickly. As mentioned earlier, it was assumed at the end of the war that demand would be at about 50 per cent. above the pre-war rate and orders for stores were based on this assumption. By about May 1946, demand was actually more than 100 per cent. above the pre-war rate, and immediate steps had to be taken to place supplementary orders to make up the deficiency. Unfortunately, these new orders could not be expected to produce results until about the spring of 1947 and the whole situation was thrown into confusion by the unprecedented storms in the first quarter of that year, followed by the fuel crisis. The storms made great inroads into the stores which it was hoped to accumulate, while the fuel crisis stopped production and put back deliveries by at least six months. Although this trouble is now over, there are still difficulties of shortage of materials and in view of the drive for export now being pressed forward, the prospects of stepping up production of engineering stores for home use do not look very rosy. Two very important items of stores, from the point of view of development of local line plant, are cabinets and pillars. First there was a lag in production of the outer casings, then there was a hitch in production of the internal components, which involve the use of many items, including plastics, which are in short supply. However, the position is steadily improving and it is the intention to keep it so, as even if there is a shortage of local cable, the provision of cabinets and pillars must be pressed on as rapidly as possible. These flexibility points will not only enable more effective use to be made of existing local cables, but should also facilitate the expansion of the local line networks when supplies of cable in due course become easier.

The foregoing review covers the plant and equipment side of the service. These things, however, do not work by themselves—even the so-called *automatic* exchange needs expert engineers to maintain it—and it is necessary now to consider the human aspect of the system.

## STAFF

### *Engineering Staff.*

As the war drew to its close, it was clear that there was a mass of new work to be undertaken in the physical expansion of the telephone service; and as soon as demobilisation began, steps were taken to increase the engineering force, not only by absorbing returning staff, but also by recruiting skilled, or potentially skilled, men from Signals, R.E.M.E., and other similar technical branches of the Services. The speed with which this expansion was effected is illustrated in Fig. 12. It will be seen that from 1945 to 1947 the total number has grown from about 35,000 to 53,000. What this has meant in staff work (i.e. selection, recruitment, etc.), refresher training for returning P.O. staff, primary training for new staff, provision of the necessary additional mechanical

transport, and of the appropriate supervising staff, can well be imagined. Area schools, Regional schools, National schools, all had to be expanded and worked at full pressure, and even then much of the training

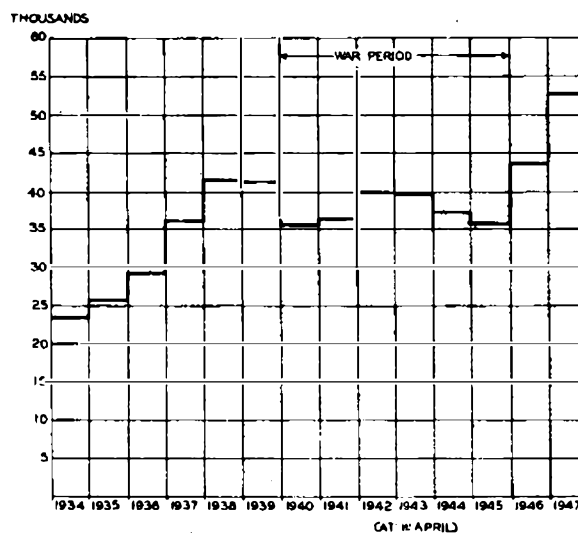

FIG. 12.—NUMBER OF ENGINEERING WORKMEN (U.K.).

had to be carried out "on the job," by grouping the new men in gangs with more experienced men. Some of this grouping was unavoidable owing to shortage of mechanical transport and lack of tools, so that for some time it has not been possible to get as much output from the staff as they were capable of. Just before the summer of 1947, the total engineering staff was "pegged," and this should help in stabilising the position and so reducing the volume of training. The engineering staff problems are by no means solved, however, as the need for more skilled men to maintain automatic exchanges and repeater stations calls for selection, training and gradual absorption of suitable men on to the new duties. The smooth transition to post-war needs has been complicated by the recent complete reorganisation of the engineering staff<sup>1</sup> and by the introduction of the 5-day 44-hour (net) week.

A further step in the endeavour to improve output and efficiency is the recent formation of Joint Production Committees in every Area. It is too early to judge how these will work, but it is hoped that they will be productive of increasingly worthwhile results.

### *Operating Staff.*

The next point that calls for comment is the operating side of the service. There are still numerous manual local exchanges (about 2,050 out of a total of 5,800), as well as the toll and trunk service, which require the services of operating staff. Fig. 13 shows the growth of the operating staff, which has now reached a figure of about 40,000, compared with 28,000 in 1938. Of the 40,000, as many as 25,000 are temporary staff, quite a high proportion of whom are not willing to accept establishment and presumably have no permanent attachment to the service. In London, which in lines, stations, or any other criterion

<sup>1</sup>P.O.E.E.J., Vol. 40, p. 28.

of comparison, represents about one-third of the whole national telephone system, the position has been, and still is, extremely difficult. In the twelve months ended May 1947, of a total female telephonist

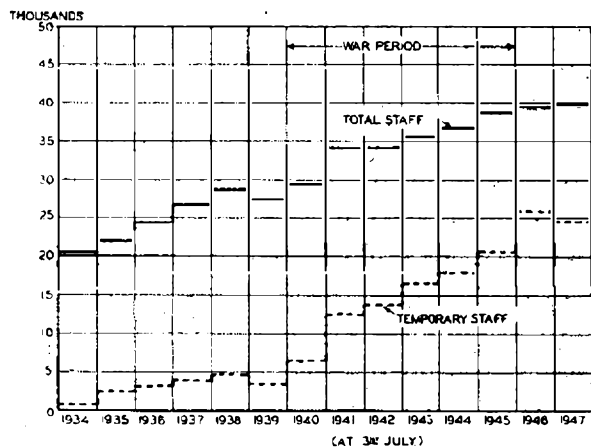

FIG. 13.—TELEPHONIST STAFF.

force of 9,000 in London, over 4,000 left the service. Wastage has continued to be at a high level but there now are reasons for believing that it will be less in future. The results of this wastage on the amount of staff work, etc., do not need to be stressed. In particular, this rapid turn-over of staff has necessitated an enormous expansion of training arrangements, both for the rank and file and for supervisors.

The effect of this continuous, rapid, and heavy change of staff is, of course, reflected in the quality of the service. Fig. 14 shows the percentage of calls

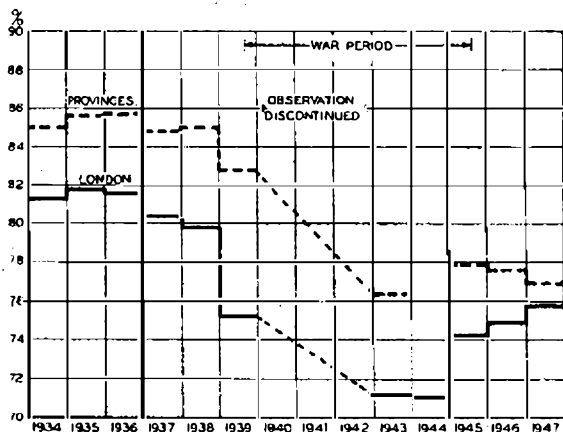

FIG. 14.—PERCENTAGE OF TIMED CALLS COMPLETED ON DEMAND.

completed on demand in London and the provinces. It will be seen that the London figure is well below the pre-war level and this is not due to line shortage, but rather to staff shortage and inexperience. Similar conditions apply in the provinces.

Fig. 15 shows the deterioration in the time to answer. The average in London has recently improved to 11.9 seconds from a figure of 15.1 seconds, and this compares with 6.4 seconds pre-war; while in the provinces it has recently deteriorated from 7.5 seconds

to 8.7 seconds as compared with 5.8 seconds pre-war. All this brings out how serious the telephone staffing

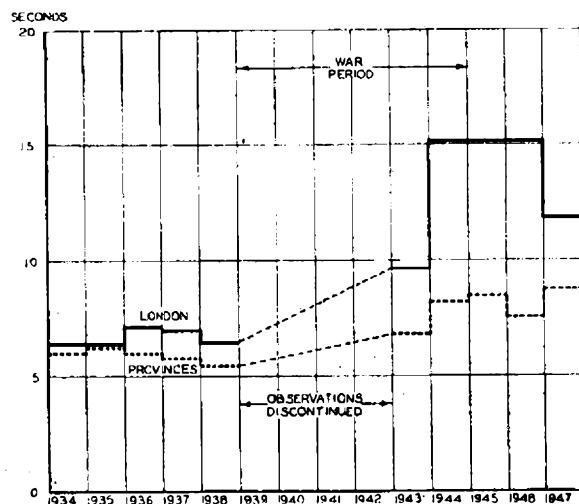

FIG. 15.—TIME TO ANSWER.

position has become—it will not improve materially until more stability can be obtained in the operating staff.

#### Traffic Staff.

The difficulties of expanding the telephone system owing to the present restricted building and equipment resources, have resulted in a large increase in the work falling on the traffic staff (as well as the engineers) in examining the possibilities of devising "expedients" and maintaining the operation of the service. Before the war, there was a total of 651 Traffic Officers throughout the country, assisted by about 300 Clerical Officers. At the present time the number is 605, with 420 Traffic Assistants, to cover work which is much greater in volume, and has to be carried out at much greater speed, than before the war. Of the 605 Traffic Officers now at work 200 served in the Forces, 125 were newly appointed during the war, and 57 have been appointed since. 264 of these officers have been given a course since the end of the war, to bring them up to date.

#### Sales Staff.

The Sales side of Telephone Managers' Offices has also presented a very difficult problem. Before the war, there was a total Sales Representative force of just under 800 men. During the war the number of men on sales duties was reduced to less than 80, and many of the Sales Officers who had not joined the Forces or been loaned to other Government Departments, were placed on clerical work. Since the war there has been a growing need for Sales Officers both to carry out development studies and to explain to potential subscribers the difficulties in providing service, and the force has been increased by return from loan and by withdrawing officers from clerical duties and restoring them to outdoor work. It has been expected that with a forward policy of telephone provision, it would be necessary to increase the Sale



force substantially, but with the limitation now placed on growth as a result of the restriction of capital expenditure, it is difficult at present to judge whether and, if so how far, it will be necessary to expand the present force. Meantime, out of a total force of 544 men, 370 have been given a refresher course on sales duties and nearly 100 on development duties, the remainder being still employed on clerical work.

#### *Clerical Staff.*

On the commercial side of the service, covering staff questions, pay arrangements, statistics, subscribers' accounts and the numerous other matters dealt with in the Chief Clerk's Division of a Telephone Manager's office, the total clerical staff in Area offices is at present 10,300, compared with 5,300 before the war. This increase is due to the fact that the number of trunk tickets to be handled has practically doubled, the number of accounts has increased by about 21 per cent. and the total staff to be paid and administered has increased by over 100 per cent. The figures themselves are not directly comparable, as the bulk of the clerical staff before the war had reached reasonable stability, whereas now at least 40 per cent. of the clerical staff is unestablished or of short experience. Here, again, there is a formidable training problem to tackle and there is much lee-way to be made up before the pre-war level of efficiency can be reached.

#### *" Profits " of the Telephone Service.*

As to the financial side of the telephone service, comments are often made about the high " profits "—for example, £14 millions in 1946-47. Local rentals were raised by 15 per cent. during the war and trunk charges by 50 per cent.; and while these increases were adopted mainly in order to check growth, the charges are now by no means high in the light of present price levels. Moreover, as already shown, little was spent on buildings, exchange equipment and local line plant during the war, and the additional amounts for depreciation and interest under these headings have consequently been correspondingly small. What is happening is that the Post Office's reserve plant is being rapidly exhausted without corresponding provision being made for further growth. If sufficient buildings, exchange equipment and line plant had been provided during the war to give the pre-war percentage of spare to working plant at the present time, the depreciation and interest on the additional expenditure involved, together with the relative maintenance costs, would have reached £5-6 millions a year by 1946-47, and the profit for that year would have been reduced to £8-9 millions. It is a great pity that it was not possible for this additional plant to be provided at the time, because owing to the continued increase of costs, the figure of £5-6 millions will be £8½-9 millions at the very least when the additional capacity is eventually provided. In fact, all plant, buildings, etc., provided from now onwards, as well as renewals of existing plant and buildings, will have to be paid for at current high prices. At present the general price level is roughly 100 per cent. above the pre-war level, while the charges to the public are 50 per cent. above pre-war rates for trunks, 25 per

cent. for private wires, and 15 per cent. for local service. It is obvious, therefore, that rising costs are rapidly eating away profits and that the profit obtained in 1946-47 is no criterion of the future financial healthiness of the service.

#### FUTURE DEVELOPMENTS

The foregoing represents a very broad review of what might be called the tactical aspect of the telephone service up to the present time.

What have been the strategic results? In the first place 1,347,400 telephones have been added to the system in the 21 months since the end of 1945—this is equivalent to 37 months' growth before the war. The total number of telephones now connected to the system is 4,495,000 compared with 3,284,000 in June, 1939, an increase of over 35 per cent. In addition, the system is carrying double the pre-war load of trunk calls and about 10 per cent. increase on pre-war local calls, while, as regards supplementary facilities, the TIM and 999 service have been extended to many places not served before the war. All this activity since the war is really a magnificent achievement, especially when considered against the difficulties on all sides with which the Post Office has had to contend.

This review covers developments up to the present time. What of the future?

It is, of course, a cardinal principle in the Post Office not to let present troubles deflect it from its responsibilities to the future and there are accordingly many technical developments which are being vigorously pursued, even though they are not likely to be immediately available. For example, the extension of operator long-distance dialling, which will materially reduce the number of operators involved in any individual call and should thus reduce the operating force required for a given load, is being examined in detail in order that it may be available as soon as the manufacturing situation permits. Another example is multi-metering, which will avoid the need for operator-handling of a large number of local calls. Here again, the introduction of the new arrangement should eventually effect a material overall reduction in the number of operators. A further example, not connected with the immediate operation of the service, is the mechanisation of trunk call accounting. Here the proposal is to abolish much of the routine clerical work at present performed in making up the trunk call account and at the same time introducing a much-felt public want, viz., an indication of the called exchange for each call. Another development which is being pursued is that of the cordless switchboard. It seems difficult to justify the use of the old cord-and-plug type of switchboard in this year of grace, 1947, and, indeed, had it not been for six years' war, it is probable that the Post Office would have been well on its way to having the cordless switchboard as a standard type of equipment. In a way, this enforced deferment of the adoption of cordless switchboards has proved an advantage, as it has enabled the Post Office to study the various stages of development in Holland, Sweden, South Africa and Australia, and so design a type of equipment based on all the good points incorporated in these other equipments and avoiding their obvious faults.

As to the immediate effects of the restriction of capital expenditure, these have already been touched upon so far as they affect the provision of plant. The effect on would-be subscribers is likely to be drastic. Severe restriction of local cable works will limit the amount of spare plant available, and service will have to be provided in order of priority—essential services, life-saving services, export business, farmers, etc., and finally non-essential subscribers, including ordinary residential subscribers. It is clear that with an existing waiting list of 400,000, this further virtual closure of service to the ordinary subscriber is likely to be extremely unpopular, and the Post Office will have to see what it can do to relieve this "famine". Shared service may be a partial answer to this question, and as it will be the only practical service available to

many residential applicants, it will probably be accepted by a large proportion of them. At present the public seems to show an instinctive dislike to this non-secret shared service, but when it has to be accepted because there is nothing better available, experience may show that it is not nearly so bad as was thought, and in due course the Post Office may well be in a position to go out boldly and sell this form of service, after making the price really attractive.

It is likely that the new situation will last for three or four years, or even more, and the Post Office will therefore have a herculean task, when the restrictions are removed, in bringing the service up to the level necessary to give prompt service to new applicants.

## International Congress on the Fiftieth Anniversary of Marconi's Discovery of Radio

An international congress convened by the Italian National Council of Research was held in Rome from September 28th to October 5th, 1947, under the presidency of Prof. Gustavo Colonnetti to celebrate the fiftieth anniversary of Marconi's discovery of Radio. About 150 delegates, scientists, industrialists and engineers attended from many different countries, including Australia, Chile, France, Great Britain, Eire, Italy, Holland, Spain, U.S.A., Sweden, Switzerland and Uruguay, and more than fifty papers were read covering the very wide field of modern Radio.

The Congress was inaugurated in the Campidoglio, surrounded by many reminders of an earlier civilisation, perhaps a fitting juxtaposition of the old and the new. The assembly was addressed in Italian by the President of the Congress and by the Hon. Umberto Merlin, Minister of Posts and Telegraphs, who traced the history of the discovery of wireless waves and the particular part played by Guglielmo Marconi therein.

The technical sessions were held in the modern National Research Laboratories, two halls being used simultaneously, the papers being divided into four sections—

- (A) Electromagnetic waves
- (B) Electrical and Acoustical oscillations
- (C) Electronics
- (D) Radio communication

Owing to the large number of papers and the short time available it was not possible to allow more than about 20 minutes each for the reading of abstracts, the majority in Italian. The papers will be published in full in a special volume, which should provide a fitting commemoration of the jubilee of Marconi's

discoveries. Papers were presented by all the representatives of Great Britain, including Dr. R. L. Smith Rose, Dr. E. C. S. McGaw and R. Naismith, S. B. Smith and K. W. Tremellen,\* and the writer of these notes, while papers by T. L. Eckersley, and J. T. Randall were read *in absentia*.

The Marchesa Marconi, the widow of the inventor, and their daughter Elettra, attended most of the functions associated with the event and much endeared themselves to the delegates by their graciousness. They were particularly interested in the late Mr. Mullis' account of the first meeting of Preece and Marconi, an extract from which recently appeared in the *Journal*<sup>1</sup>.

One of the highlights of the Congress was the reception of the delegates in audience by the Pope, who addressed the gathering at length and afterwards spoke to each delegate in his own tongue, and bestowed on all his Apostolic Blessing.

Outside the Congress the British delegates were led to feel that they must possess at least some obvious national characteristics since they had only to walk a few paces down the street to be approached with the confidential question "changa da monnaie?", or pressed to buy imported cigarettes.

For the rest we have returned with memories of blue skies and sunshine, the ancient monuments, the colours in the polished marbles of St. Peter's, the wealth of the works of Michael Angelo, the luscious fruit and wide range of the wines of the country, the Colosseum by moonlight, and—the noisy motor cars.

H. F.

<sup>1</sup>*P.O.E.E.J.*, Vol. 37, p. 29.

# The Effect of Doppler's Principle on the Comparison of Standard Frequencies over a Transatlantic Radio Path

C. F. BOOTH, O.B.E., M.I.E.E.,  
and G. GREGORY

U.D.C. 621.396.11 : 621.317.361

A description is given of the calibration, in terms of British and American time determinations, of an oscillator incorporated in the Post Office Standard of Frequency at Dollis Hill, how this oscillator was employed in frequency comparisons with the United States National Bureau of Standards' standard frequency transmissions from Washington, D.C., on 10 Mc/s and 15 Mc/s, and how apparent frequency changes of up to approximately  $\pm 25$  parts in  $10^6$ , due to the Doppler effect, were found in the received standard frequency signals. The possible importance of such frequency comparisons in ionospheric investigations is stated.

## Introduction.

IN a recent article<sup>1</sup> an outline was given of the ionosphere and its importance in long-distance radio communication. Briefly, several ionised layers appear in the upper atmosphere, including the E-layer and the F-layer at respective heights of approximately 100 kilometres and 300 kilometres above the earth, and their intensities of ionisation and virtual heights vary according to daily, yearly and to the 11-year sunspot cycles. Considering the daily cycle, during darkness, the E-layer disappears and the F-layer ionisation intensity diminishes. With the incidence of daylight the E-layer reforms and the F-layer divides into two parts, called the F1-layer and the F2-layer respectively, the latter rising some 50 to 100 kilometres above the former (see Fig. 1).

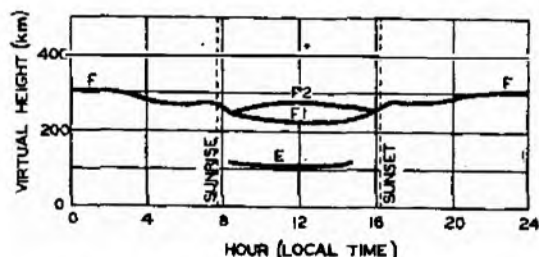

FIG. 1.—APPROXIMATE MONTHLY AVERAGE VIRTUAL HEIGHTS OF E- AND F-LAYERS (DECEMBER 1933).

The F-layers are, more or less, essential for high-frequency radio communication over long distances, the radio waves being refracted and reflected back to

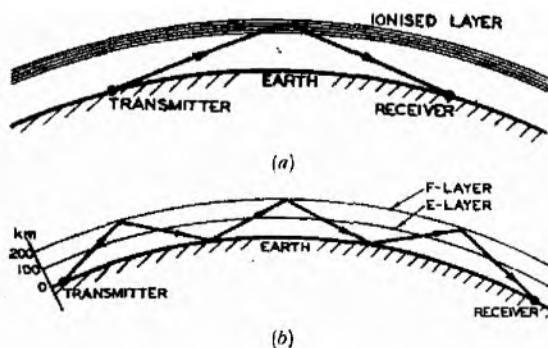

FIG. 2.—IDEALISED TRANSMISSION.

(a) ONE HOP TRANSMISSION SHOWING REFRACTION WITHIN IONISED LAYER.

(b) THREE HOP TRANSMISSION VIA THE F-LAYER.

earth as shown diagrammatically in Fig. 2 (a). In the case of the high-frequency radio circuits between Rugby and New York, the waves may be reflected between earth and the F-layer some two or three times, Fig. 2 (b). This form of propagation is appropriately known as multiple-hop propagation and the transmissions are referred to as two-hop or three-hop transmissions as the case may be. The diagrams of Fig. 2 are idealised, since, in practice, the ionisation densities and the heights of the layers, and consequently their refractive or reflective characteristics, are in a state of continuous change, particularly during the periods of sunrise and sunset. In general, the virtual heights of the layer from which high frequency transmissions are reflected increases about the time of local sunset, remains fairly constant during total darkness over the transmission path and decreases at sunrise to a more or less steady daylight value.

The combination, at the receiver, of radio waves which have arrived by various paths results in mutual interference between them and causes the well-known effect called fading. The continuous variation in the layer's virtual height, even for the one-hop condition, also gives rise to fading, but, in addition, it produces a phenomenon of special interest to those concerned with the reception and precise measurement of the highest grade standard frequency transmissions. This takes the form of apparent changes in the frequency of such transmissions due to changes in the length of the path taken by the signal, and is in accordance with Doppler's principle. The phenomenon sets a definite limit to the accuracy of a long-distance transmission of standard frequency signals, a matter of considerable moment in the international comparison of frequency standards.

It is not proposed to discuss fading in this article, but to outline the results of a series of precise measurements carried out at Dollis Hill on standard frequency transmissions from the United States of America in which the frequency changes over the transatlantic path due to the Doppler effect, were accurately determined.

## Doppler's Principle.

Doppler's principle states that for all waves the apparent frequency depends on the relative motion of the wave source and the observer and, for certain types of waves, e.g. waves in matter, may depend on the motion of the medium. If there is no relative

<sup>1</sup>P.O.E.E.J., Vol. 40, p. 76.

motion the apparent and source frequencies are the same; in all other cases the frequency is modified. In electro-magnetic waves no material medium is, of course, involved and the ratio of the observed to the source frequency, for uniform relative motion of the source towards the observer is given by:—

$$\frac{f_o}{f_s} = \sqrt{\frac{C+v}{C-v}} = \sqrt{\frac{(C+v)^2}{C^2-v^2}} \dots\dots\dots (1)$$

where  $f_o$  and  $f_s$  are the observed and source frequencies respectively,

$v$  = the relative motion in metres per second,  
 $C$  = the wave velocity ( $3 \times 10^8$  metres per second).

Since, in radio,  $C \gg v$ , equation (1) is thus

$$\frac{f_o}{f_s} \doteq \sqrt{1 + 2\frac{v}{C}}$$

$$\doteq 1 + \frac{v}{C}$$

so proportionate frequency change  $\left(\frac{f_o - f_s}{f_s}\right) = \frac{v}{C}$

or frequency change in parts in  $10^8 = \frac{v}{3} \dots\dots\dots (2)$ .

Reference to Fig. 1, which represents roughly the monthly average virtual height of the F-layer changes with time for a December day in 1933 (i.e. about 1.2 sunspot cycles prior to the December, 1946, tests to be described), shows that the layer height decreased by about 60 km. in about one hour around the time of local sunrise, corresponding to a mean rate of some -17 m. per second. Assuming a two-hop Washington-London transmission and a wave incidence angle relative to the layer of  $20^\circ$  at the final reflection point, the corresponding path reduction would amount to about 12 m. per second. Hence,  $v$ , in the formula for the relevant time and period of the original tests (December, 1946) should be of a sensibly similar order, i.e. 12 m. per second, and the frequency change to be expected should amount to some +4 parts in  $10^8$ .

*Standard Frequency Transmissions.*

The determination of a standard's absolute frequency is ordinarily in terms of time determinations made at an associated national observatory, the ultimate accuracy being dependent upon the accuracy of the observatory time determinations and upon the precision with which they can be disseminated to, and employed in, distant laboratories for calibrating the standards. Much elaborate equipment is necessary to meet present-day requirements, and the technique, particularly at the observatory, is very complex. In the United States, frequency standardisation is facilitated by a service operated by the U.S. National Bureau of Standards (N.B.S.), Washington, D.C., which broadcasts continuously, from associated nearby transmitters at Beltsville (call sign WWV),

standard frequencies and time signals on a number of channels in the high-frequency band. The frequencies and time signals, both based on the U.S. Naval Observatory time determinations, are accurate, as transmitted, to  $\pm 2$  parts in  $10^8$  and are intended for world-wide reception.

With the aid of special equipment and the special co-operation of the N.B.S., a series of very precise time and frequency comparisons has been made, during 1946 and 1947, between unit 4A, of the Dollis Hill frequency standard and 10 Mc/s and 15 Mc/s standard frequency carriers radiated by WWV. Similar, but less precise, comparisons carried out at Teddington between the National Physical Laboratory's (N.P.L.) frequency standard and the WWV 5 Mc/s standard frequency transmissions in 1934<sup>2</sup> showed differences in the values of the transmitted and received frequency of up to  $\pm 20$  parts in  $10^8$ . These differences were too great to be attributable to uncertainties in the absolute values of the respective comparison standards (at that time about  $\pm 5$  parts in  $10^8$ ) and were considered to be due to the effect of Doppler's principle. Further evidence of the Doppler effect on the received frequency of the WWV transmissions was later obtained at the N.P.L., at Dollis Hill and at the Tatsfield station of the British Broadcasting Corporation.<sup>3</sup>

Examples of apparent frequency changes in accordance with the principle are, of course, well known and early studies of the ionosphere indicated that the phenomenon would occur in radio waves under certain propagation conditions, the requirement being that of equivalent relative motion between source and observer. Such equivalence of relative motion between source and observer is produced by changes in the virtual height of the ionospheric refracting layers which cause changes in the length of the radio transmission path for all high-frequency signals dependent on sky wave propagation.

*Determination of the Frequency Change Due to the Doppler Effect.*

Although the WWV standard frequency transmissions are maintained to  $\pm 2$  parts in  $10^8$  of their nominal values, the N.B.S. kindly agreed to measure the actual deviations of the 10 Mc/s transmissions from nominal at Washington, D.C., during the periods

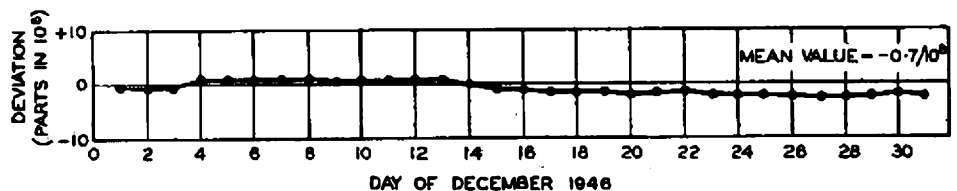

FIG. 3.—DEVIATION OF WWV FROM NOMINAL FREQUENCY DURING THE PERIODS 0900 G.M.T. TO 0915 G.M.T. (N.B.S. ABSOLUTE VALUES).

0900 G.M.T. to 0915 G.M.T. daily in December, 1946, while the transmissions were also being measured at Dollis Hill in terms of the local standard. The N.B.S.

<sup>2</sup>Proc. Roy. Soc., April, 1935, A149, p. 506.

<sup>3</sup>Wireless Engineer, Vol. XXIV, p. 162.

measurements were notified to Dollis Hill where they were used to correct the transmissions to exactly 10 Mc/s (within the accuracy limitations of the N.B.S. determinations which were  $\pm$  a few parts in  $10^9$ ) in evaluating the results obtained at Dollis Hill. The mean deviation of the 10 Mc/s transmissions from nominal, as measured by the N.B.S. at the transmitter during the periods quoted in December, 1946 (see Fig. 3), was  $-0.7$  parts in  $10^8$  and the maximum variations about the mean were  $+1.8$  and  $-1.6$  parts in  $10^9$ .

A brief description of the equipment at Dollis Hill for these comparisons and the method of measurement employed is as follows (see Fig. 4). The local comparison signal was derived from a quartz crystal oscillator, nominal frequency 100 kc/s, (incorporated in the standard) via harmonic generators from which outputs corresponding to the 100th or 150th harmonic could be selected. The frequency changers F.C. (a) and F.C. (b), in the intercepted signal and local signal sections respectively, were fed with the same beating oscillator signal of nominal frequency 10.465 Mc/s or 15.465 Mc/s (according to the WWV frequency under comparison) from a stable (crystal) oscillator and the nominal 465 kc/s intermediate frequencies resulting from the WWV carrier and the local comparison signal, in I.F. (a) and I.F. (b) respectively, were applied to a detector. The output of a second beating (crystal) oscillator, nominal frequency 464 kc/s, was also fed to the detector so that a beat tone of approximately 1 kc/s modulated at the difference frequency,  $\Delta$  c/s, between the WWV carrier and the selected

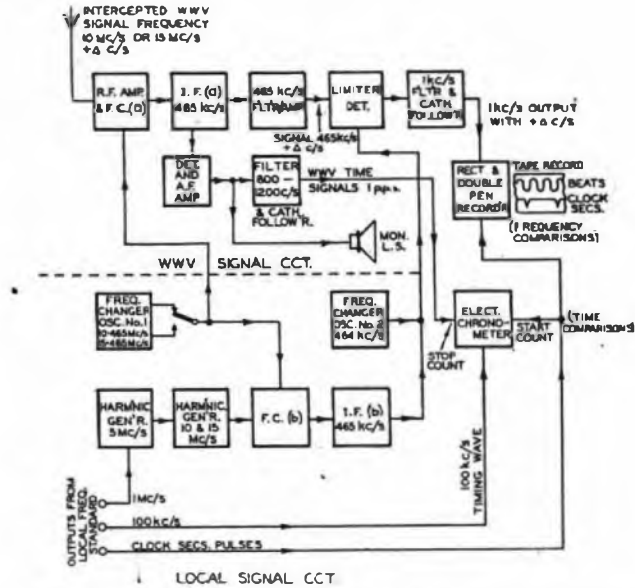

FIG. 4.—ARRANGEMENT OF EQUIPMENT FOR THE RECEPTION AND MEASUREMENT OF WWV SIGNALS.

harmonic of the local standard was obtained in the detector output. This difference frequency, of value less than 14 c/s, was then rectified and recorded against standard seconds on a double-pen tape recorder. The beat (difference) frequency sense was found and its value in cycles/second was then determined to within 1 part in  $10^9$ . Generally, three tape

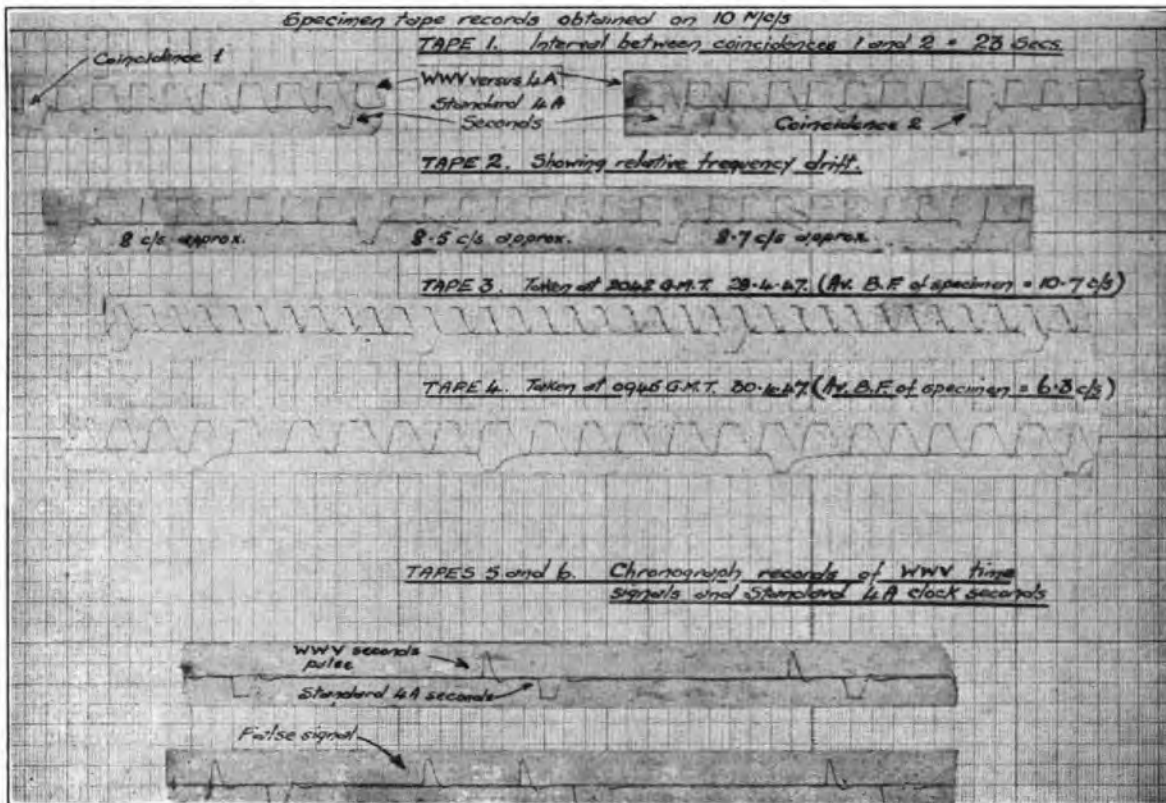

FIG. 5.—COMPARISON OF POST OFFICE AND N.B.S. (WWV) STANDARDS.

records were taken over periods of from 30 to 60 seconds at intervals of about one minute, the exact number of beats in a precise time interval being determined by the coincidence method (See Fig. 5, Tape 1).

In addition to the frequency comparisons described, the local synchronous motor clock associated with, and controlled by, the frequency standard employed in the frequency measurements, was compared with the standard time signals superposed on the WWV carrier. These time signals, consisting of one pulse per second, were fed to the "stop" circuit of an electronic chronometer and seconds pulses from the local clock were applied to the chronometer "start" circuit. Ambiguities in the chronometer readings due to false operations by static were removed by making dual but less precise comparisons on a chronograph (accuracy  $\pm 3$  mS) as shown by the specimen tapes, Tapes 5 and 6, in Fig. 5. In this way, a chronometer comparison accuracy within 0.0001 sec. was possible between the intercepted time signals and the local clock and the overall daily mean frequency determination accuracy of the local standard in terms of U.S. Naval Observatory time was to better than  $\pm 2$  parts in  $10^8$ .

The results of the calibration of the local standard in terms of the British and American time determinations during the period of the December, 1946, tests are shown in Fig. 6. The mean deviation of the standard

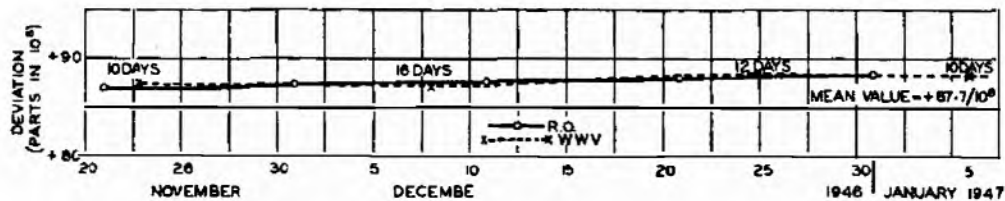

FIG. 6.—DEVIATION OF LOCAL STANDARD FROM NOMINAL FREQUENCY IN TERMS OF ROYAL OBSERVATORY TIME AND WWV TIME SIGNALS.

from its nominal value, 100 kc/s, was  $+87.7$  parts in  $10^8$  for both calibrations,<sup>4</sup> the maximum disagreement being less than 1 part in  $10^8$ .

Since it was known that the mean frequency of the WWV transmissions at the source, as measured in terms of the WWV time signals, was  $-0.7$  part in  $10^8$  from nominal, it follows from the agreement quoted above that the mean frequencies of the N.B.S. and Dollis Hill standards for December, 1946, agreed to within 1 part in  $10^8$ .

Fig. 7 shows the measured deviations at Dollis Hill

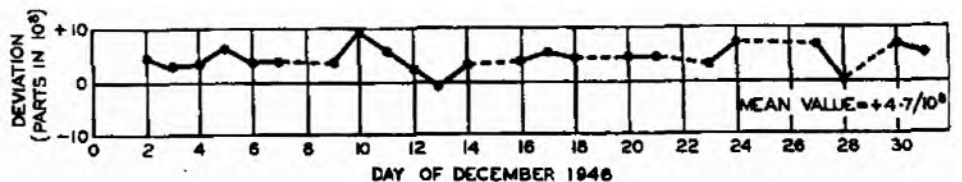

FIG. 7.—DEVIATION (FROM 10 Mc/s) OF THE RECEIVED WWV SIGNALS IN TERMS OF THE LOCAL STANDARD.

<sup>4</sup>It should be explained that the use of a standard whose frequency differed from the nominal value by some 88 parts in  $10^8$  conferred advantages in the measurement procedure in that (a) the resultant difference frequency, local standard versus the WWV carrier, was a convenient value (6 c/s to 13 c/s) for tape recording and (b) the need for proving the sense of the beats continuously was completely avoided, a course which would have been necessary for a comparison whose frequency deviation was within a few parts in  $10^8$  of nominal.

of the received WWV carrier frequency from 10 Mc/s in terms of the local standard after correction for the actual deviations as measured by the N.B.S. at the transmitter (see Fig. 3).

The mean frequency deviation for December, 1946 (at the quoted times, i.e. 0900 G.M.T. to 0915 G.M.T.), was  $+4.7$  parts in  $10^8$  from 10 Mc/s. Thus the average values of frequency for the transmitted and received WWV 10 Mc/s carrier differed by approximately  $+5$  parts in  $10^8$ . This discrepancy is considerably larger than the errors of measurement permit and can be explained in terms of a diminishing Washington-London radio path length due to ionospheric changes during the measurement periods. It is, in fact, of the same order of magnitude as that quoted in the example already given in which, for a two-hop path, it has been assumed that the virtual height of the effective layer is decreasing some 17 m. per second, which is equivalent to a path length reduction of 12 m. per second.

Since the movements of the ionospheric layer concerned are related to the earth's diurnal motion, a series of frequency comparisons made over 24-hour periods should, if the Doppler effect was responsible for the observed frequency shift, show corresponding diurnal changes in the received WWV frequency. The frequency shifts should be negative following local sunset, sensibly zero during the period of darkness over the transmission path and positive after local sunrise at the receiving point; the mean frequency shift over the 24 hours should be zero approximately. Accordingly, a dual series of comparisons was carried out in April-May, 1947, between an oscillator in the Dollis Hill standard and the WWV 10 Mc/s and

15 Mc/s transmissions. Since the frequency changes were expected to be large compared with normal inaccuracies of the WWV carrier frequencies ( $\pm 2$  parts in  $10^8$ ) the special co-operation of the N.B.S. was not

solicited for these tests. As it was not practicable to cover the whole 24 hours, the comparisons were made between 2000 G.M.T. and about 0800 G.M.T. The London sunset and sunrise times for the period of the tests were 1920 G.M.T. and 0440 G.M.T. respectively. The results of these comparisons, which extended over four successive nights, are shown in Fig. 8. The graphs in Fig. 8(b) show that for each night the frequency of WWV, as received, was low on the nominal value somewhat after the sunset time

(London), gradually rising to the nominal value (approximately) during the periods of total darkness over the whole of the propagation path and attaining appreciable positive values from nominal after sunrise in London. An example of the order of the frequency shift encountered is given by the specimen tape

*Correlation of the Results with Ionospheric Data.*

At the time concerned in the December, 1946, tests (0900 G.M.T.) 10 Mc/s signals from Washington to London were most likely to have travelled by a two-hop path via the F-layer with ionospheric reflecting points at 47°N, 60°W and 53°N, 22°W approximately.

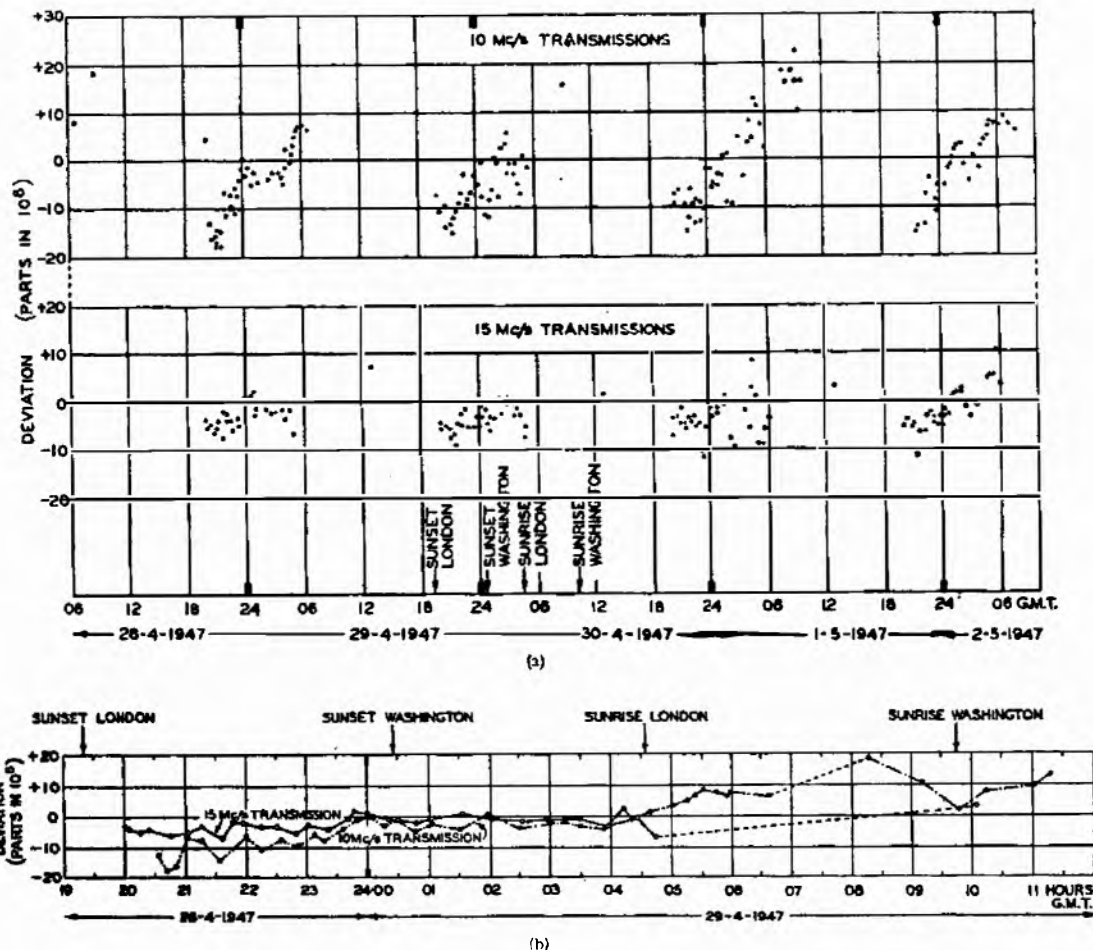

FIG. 8.—DEVIATIONS OF THE RECEIVED WWV 10 Mc/s AND 15 Mc/s TRANSMISSIONS FROM THEIR NOMINAL VALUES IN TERMS OF THE LOCAL STANDARD.

records of the difference frequency, WWV versus the local standard, on 10 Mc/s, Tapes 3 and 4, shown in Fig. 5. Tape 3, taken at 2042 G.M.T., about one hour after sunset (London), has an average beat frequency of 10.7 c/s or 107 parts in 10<sup>8</sup>, while Tape 4, taken at 0945 G.M.T., some five hours after sunrise (London), records an average of only 6.3 c/s or 63 parts in 10<sup>8</sup>, a difference of 44 parts in 10<sup>8</sup>. Tape 2 shows an apparent frequency change of some 0.7 c/s, or 7 parts in 10<sup>8</sup>, which occurred in a few seconds. Referring to Fig. 8(a), it will be noted that the frequency shifts for the 15 Mc/s transmissions were considerably less than the shifts which occurred on the 10 Mc/s transmissions. The plotted points, particularly those for the 10 Mc/s transmissions, are obviously sections of sensibly smooth diurnal cycles of magnitude up to about  $\pm 20$  parts about the mean and provide further examples of the apparent frequency changes that occur at sunset and sunrise.

While the effective height of the F-layer at the first reflecting point, being in darkness, would be comparatively stable, the effective height of the F-layer at the final or more easterly reflecting point, being subject to sunrise conditions, would be falling rapidly. The propagation path length would, in consequence, be diminishing and the received frequency of the WWV signals would thus have an apparent value higher than the true or transmitted frequency. Examination of ionospheric data from Ottawa and Slough<sup>5</sup> research stations (which lie near the Washington-London great circle) for the periods of the December, 1946, tests has enabled the approximate frequency shift of the WWV 10 Mc/s transmissions to be computed. The value derived, +3 parts in 10<sup>8</sup>, compares with the observed mean value of +4.7 parts.

<sup>5</sup> The Slough data for December, 1946, was rather meagre due to spread echoes.

The results obtained in the spring of 1947 have not yet been correlated with the ionospheric data. However, the difference in the results obtained on 10 Mc/s and 15 Mc/s are particularly interesting and show that the very simple treatment already given is not sufficient to explain all the phenomena. The discrepancy between the frequency shifts for the two transmissions may be due to the development of the E-layer beneath the F-region in the daytime. If both transmissions penetrate the E-region then, over a given section of the path, the presence of the E-region has the effect of increasing the phase velocity and so reducing the apparent path-length, and the effect will be greater for 10 Mc/s than for 15 Mc/s. On the other hand, the extent to which the respective signal paths are deviated in traversing the E-region is not yet known. A second possibility, and indeed a probability, is that both the 10 Mc/s and 15 Mc/s do not always penetrate the E-region. The complete interpretation of the results is, in fact, best left to expert workers in the ionospheric field.

#### Frequency Stability of the Local Standard.

To remove any doubt from mind that frequency variations of the local standard might have been appreciable contributory factors in the frequency comparisons, it is known from the results obtained over a period of years that the best oscillators in the Dollis Hill standard possess relative frequency stabilities of the order of  $\pm 2$  parts in  $10^{10}$  over periods of minutes,  $\pm 1$  part in  $10^9$  over periods of hours and of  $\pm$  a few parts in  $10^9$  over periods of days. For example, during the period April 28th to May 2nd, 1947, when comparisons with WWV were in progress, the maximum relative frequency variations between the Dollis Hill standard used for the comparisons and a Royal Observatory standard were less than  $\pm 2$  parts in  $10^9$  and the maximum variations of the same standard relative to another Dollis Hill standard during the

same period were within  $\pm 4$  parts in  $10^9$ . The variations in the absolute frequency of the Dollis Hill standard used in the WWV tests during the whole of 1946 were within  $\pm 5$  parts in  $10^8$ .

#### Conclusions.

A series of comparisons between a unit of the Post Office Standard of Frequency, Dollis Hill, London, and the United States National Bureau of Standards standard frequency transmissions from Beltsville Radio, WWV, on 10 Mc/s and 15 Mc/s, made with the primary object of determining the agreement between the absolute values of the two Standards have shown that the effect of ionospheric movements may cause apparent frequency changes in the received signals in accordance with Doppler's principle.

This effect, in conjunction with other phenomena which have not been fully resolved, leads to apparent frequency shifts of up to  $\pm 25$  parts in  $10^8$ , depending upon the time of day or night (in the seasonal and 11-year sunspot cycles) at which the comparisons are made and upon the frequency employed for the transmissions.

Since the degree of precision desired in international frequency comparisons is to  $\pm 1$  part in  $10^8$  the effects introduced by ionospheric changes over the transmission path (unless they can be allowed for to an equal degree of accuracy) may render such comparisons virtually abortive for the primary purpose. Conversely, it may well be possible, eventually, that the measurement of the frequency shifts in standard frequency transmissions will provide the ionospheric physicist with information on the state of the ionosphere in areas remote from a measuring site so that, in association with data obtained at existing ionospheric research stations, the Doppler effect in frequency comparisons may be countered by the application of corrections.

TELEGRAPH AND TELEPHONE STATISTICS—SINGLE WIRE MILEAGES AS AT SEPTEMBER, 1947.  
POST OFFICE MAINTENANCE—EXCLUDING SUBMARINE CABLE

REGION	OVERHEAD			UNDERGROUND		
	Trunks and Telegraphs	Junctions	Subscribers*	Trunks and Telegraphs†	Junctions‡	Subscribers§
Northern Ireland .. .. .	10,188	12,326	35,311	109,780	43,704	145,878
Scottish .. .. .	19,358	34,801	198,556	805,966	271,424	879,430
Home Counties .. .. .	10,535	39,563	362,732	1,844,121	486,074	1,472,184
Midland .. .. .	4,596	32,444	223,375	1,025,803	303,530	1,068,089
North Eastern .. .. .	8,631	20,723	186,061	873,913	257,617	1,036,983
North Western .. .. .	1,763	9,148	116,565	670,379	396,403	1,281,534
South Western .. .. .	3,917	35,584	275,023	992,098	191,860	816,843
Welsh and Border Counties	6,704	30,903	154,055	545,380	88,284	339,411
Provinces .. .. .	65,692	215,492	1,551,678	6,867,440	2,038,896	7,040,352
London .. .. .	512	1,005	80,727	914,639	1,841,752	3,843,540
United Kingdom .. .. .	66,204	216,497	1,632,405	7,782,079	3,883,648	10,883,892

\* Includes all spare wires.

† All wires (including spares) in M.U. Cables.

‡ A.I. wires (including spares) in wholly Junction Cables.

§ All wires (including spares) in Subscribers' and mixed Junction and Subscribers' Cables.



# The Artificial Traffic Equipment

E. C. ELSTREE-WILSON  
C. LAWRENCE

U.D.C. 621.395.364

Equipment has been designed to provide a ready means of checking the overall performance of automatic exchange plant. Calls are originated mechanically and passed through the complete exchange equipment, provision being made for the progress of the calls to be checked at each stage. A valuable feature of this new maintenance aid is that tests of bank wiring, T.D.F.s etc. are included in the sequence of operations.

## Introduction.

THIS equipment has been developed with two objects in view:—

(1) To determine by artificial traffic the overall performance of exchange plant.

(2) To provide a ready means of tracing "lost calls" to discover weak spots in the system.

These objects have been achieved by originating calls mechanically and passing them into the exchange equipment with normal subscribers' traffic, the correct progress of the calls being checked through all stages to maturity. It will be noted that subscribers' errors and line plant faults are eliminated so that the success of the calls is dependent wholly on the condition of the exchange equipment and wiring.

The equipment has been developed particularly for use in exchanges where the condition of the plant has deteriorated from various causes, age, wartime maintenance difficulties, etc. It differs from Service Observation equipment and routiners in that it is concerned only with the exchange plant and does not apply limiting tests.

## Outline of the Scheme.

The equipment consists essentially of two access switches, an impulsing element with its associated strapping field by which the required numbers to be impulsed are arranged, and circuit elements for checking certain conditions.

The access switches are associated with 24 spare subscribers' calling equipments and 25 spare numbers in the final selector multiple. It is arranged that each of the calling equipments in turn originates calls to the final selector numbers and upon completion the cycle is repeated. A cycle therefore consists of  $24 \times 25$  i.e. 600 separate calls. The selected spare equipments are dispersed throughout the exchange and by rearrangement from time to time the whole of the equipment can reasonably be covered.

The impulsing element and strapping field follow the familiar lines of the director circuit.

During the progress of each call, checks are made for the continuity of the outgoing loop and for complete and intermittent disconnections of the private wire. Upon reaching the required final selector number, a check is made of the receipt of two periods of interrupted ringing current, D relay reversal, subscriber's flashing and for premature and non-release conditions. Failure to receive correct conditions results in either (a) registration of the failure on a meter, or (b) cessation of the cycle for tracing the fault with forward holding applied to the P wire through the chain of selectors.

## Construction.

In the interests of economy in floor space and for

reasonable portability the equipment has been mounted on a single-sided rack, 1 ft. 9 in. wide by 6 ft. 5 in. high and wired to connection strips fitted at the top (Fig. 1). The unit is self-contained. The

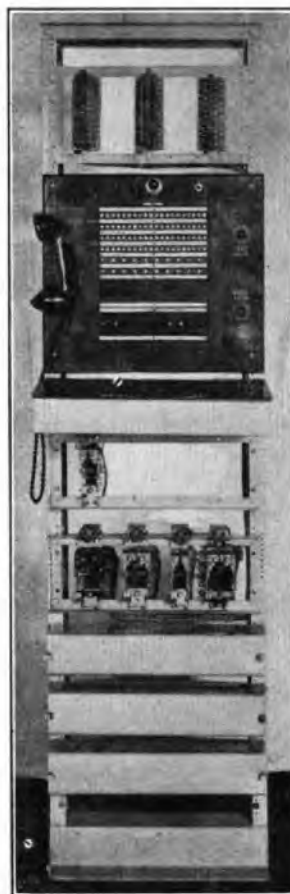

FIG. 1.—THE RACK OF EQUIPMENT.

source of impulses is a recently developed inter-acting relay circuit element which generates 10 i.p.s. at 66 per cent. break. On the earlier equipments it was necessary to utilise a set of impulsing springs on the exchange impulse machine.

Two of the connection strips mounted at the top of the rack afford easy access for cabling to the I.D.F. and thence via jumpers to the calling equipments and final selector numbers. The centre strip is also used for the digit strapping field, and the third strip for miscellaneous connections.

Below the strips is the control panel carrying the alarm lamp, meters, supervisory lamps and control keys. A telephone is provided for monitoring and

speaking. The upper jack on the right-hand side in association with a plug and cord is used for gaining direct access to equipment for special tests which will be described later. When not in use the plug and cord, together with miscellaneous test equipment, are kept in the writing desk.

Below the writing desk is a time-pulse uniselector. On the lower uniselector shelf are the access switches, the distributor switch associated with the checking elements, and a send switch for impulsing. Beneath the covers are the relays, resistors, condensers, etc.

#### Outline of Operation.

As previously stated the Artificial Traffic Equipment has two functions. When used to simulate subscribers' calls with "holding" on failures, the cycle is commenced by the operation of a start key. As the access switches are non-homing it is generally found convenient before starting to position them on outlet 1 by the access stepping keys. The digits appropriate to the relative final selector number are transmitted via a simulated 600-ohm line. A check of the continuity of the loop forward is made during each inter-train pause and a lamp indication is given of failure. As each digit is sent lamps designated "1st Dig.", "2nd Dig." etc., indicate progress. When the final selector number is reached the check is made for two cycles of ringing current, during which time a "Ring fail" lamp glows. This is followed by the closing of the loop which should trip the ringing and operate the final selector D relay. A check is made at this stage for the premature release of the final selector by the "Pre-rel." lamp indication. Subscriber's flashing conditions are simulated, followed by the opening of the calling loop, and failure to release is indicated by a "No rel." lamp.

During the whole of this time the outgoing private wire is being "observed" for intermittent and complete disconnections, lamp indications being given of failure.

The distributor switch provides for the connection of the appropriate checking elements to the exchange equipment, and its step-on impulse is controlled stage by stage by the receipt of correct conditions. Under failure conditions the distributor switch fails to step and after a time-pulse period an alarm is given.

If the call is completed successfully both access switches take one step forward and the next call is made. If the call should fail at any stage, forward holding is applied immediately to the private wire. All calls, whether successful or not, are registered on a "total calls" meter.

When the access switches have passed contact 24, the outgoing (calling side) access switch steps to contact 1, and the incoming (final selector side) access switch steps to contact 25; thus on each half-revolution of the incoming access switch the outgoing switch is out of sequence by one step. A 600-call cycle is thereby achieved.

The other function of the equipment, that of assessing the condition of the exchange equipment, is brought into use by the operation of a key designated "Observe Service." Under this condition the A.T.E. does not stop when a failure is encountered, but

records each call on the "total calls" meter and each failure on a "faulty calls" meter. Thus after a cycle of 600 calls (or any other representative sample) the percentage failures due to the plant faults can be easily calculated. Furthermore, if an initial check of the percentage of the exchange plant faults is made, and later compared with a further check, after completion of a fault locating cycle, the effectiveness of the fault clearing period can readily be assessed.

#### Other Facilities.

The equipment can be arranged to transmit 4- or 5-, or mixed 4- and 5-digit trains, the desired condition being automatically applied, and 7-digit impulsing, for use in director areas, can be provided by the operation of the appropriate key. Each impulse train can be controlled by keys, and released in sequence so that a call may be traced stage by stage and observed. A distinctive tone generated by a small buzzer, or by a special arrangement of interrupted N.U. tone, can be extended to assist in call tracing. The tone is picked up on a Tele. No. 80 at the selector or relay set test-jacks at any stage of the call. The selected final selector numbers are normally busied until immediately before seizure by the A.T.E. when they become free. They are therefore not accessible to ordinary subscribers. Both incoming and outgoing access switches can be stepped by keys manually operated, and lamps indicate the position of the wipers on the outlets. "Camp-on" keys are provided for continuous operation between one calling number and one final selector number as desired. Outlet 25 of the calling access switch is wired to a jack and by "camping-on" this outlet and connecting the jack to a selected piece of equipment, calls can be passed over a specified route. This facility has proved useful in connection with 2-V.F. equipment.

#### Cabling Arrangement.

A typical method of cabling the equipment to the spare subscribers' line and final selector circuits in a non-director exchange is shown in schematic form in Fig. 2. Two 80-wire switchboard cables are connected

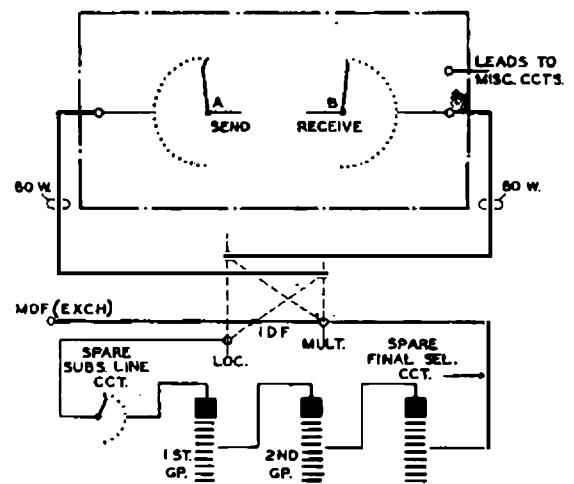

FIG. 2.—TYPICAL CABLING ARRANGEMENTS.





The trunking arrangements for this area are shown in Fig. 6, access to satellite equipment being obtained

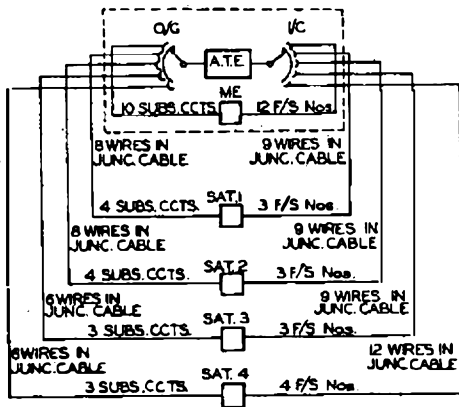

FIG. 6.—TYPICAL SCHEME IN A NON-DIRECTOR AREA.

via spare wires in the junction cables. In spite of the limitations imposed by the small number of wires available, and also the fact that forward holding could not be applied beyond the main exchange, the number of normal and incipient faults cleared was very gratifying.

In the development of the equipment, special attention has been paid to reliability of operation, it being regarded as the most important factor, and additional facilities have been sacrificed to this principle. How successful this has been can be deduced from the following:—

At exchange B, 58,056 calls were made and the only faults in the equipment were as follows:—

- (1) S unselector interruptor spring contact became detached.
- (2) S unselector wiper assembly out of alignment.
- (3) welded contacts on relay PT.

Such a high performance figure at once gains the confidence of the staff operating the equipment.

The equipment's greatest asset is that tests of the bank wiring, T.D.F. etc., are included in its sequence of operations, and there is no doubt that faults, lying undetected for considerable periods, have been brought to light. Furthermore, defects have been revealed at exchanges particularly those with apparatus of "mixed vintage" when tested in concert, although separately the items appear satisfactory. Experience has shown that the use of the equipment is most effective when the responsibility for running it is delegated to one competent and enthusiastic officer who is employed full time in investigating the faults revealed. He should not be handicapped by considerations of fault duration because many failures are caused by defects occurring at widely spaced

intervals and can be traced only by repetition and gradual elimination.

The special tests on 2-V.F. equipment already referred to have provided useful information in respect of the relationship between failures in the 2-V.F. equipment, the auto-network and on the trunk line itself, and some interesting causes of 2-V.F. call failures have been revealed.

In these tests, the test jack associated with the 25th outlet of the outgoing access switch was associated with selected O/G 2-V.F. equipments in turn. Each O/G 2-V.F. equipment was then patched at the local trunk test to an I/C 2-V.F. equipment, and calls were passed into the local auto network and detailed records of all failures taken. The same circuits were then patched at the distant trunk test and the same cycle carried out. By this means the fault incidence between 2-V.F., auto and trunk line equipment can be compared.

A modified equipment has been built for use in Siemens' 16 areas, the main features being:—

- (a) substitution of the forward loopcheck by a check of each leg forward to the first selector transmission bridge.
- (b) the provision of a check of continuity of each leg from the final selector to the first selector transmission bridge.
- (c) modification of the circuit element covering the check of the subscriber's answering signal.
- (d) forward holding over the speaking wires.

It is hoped that this type of equipment will be useful in extending the life of the older Siemens' 16 exchanges.

#### Conclusions.

Further development of improved equipments of this type is envisaged, but it is thought that considerable useful work can be done with it in its present form. The limited number of equipments held are being fully employed and are likely to continue to be because many exchanges, by war-time depreciation, are in need of an equipment to diagnose rapidly where attention is needed most. It is hoped ultimately to provide a small number in each Region for use where and when necessary.

#### Acknowledgments.

It is desired to place on record appreciation of the invaluable work done by the staff of the Circuit Laboratory in the development of this equipment, and to the Regional and Area staffs concerned in the trials for the many helpful suggestions for improvements. The authors also wish to express their thanks to Messrs. H. S. Smith and C. H. Wright for assistance in the preparation of this article.

# The Reinstatement of the Central Telegraph Office Pneumatic Tube System

J. B. MURRAY, B.Sc.(Eng.), A.M.I.E.E.

U.D.C. 621.547

This article refers to the damage done to the pneumatic tube system when the Central Telegraph Office was destroyed by fire and describes the temporary and permanent schemes for the restoration of the service.

## Introduction.

THE pneumatic tube system in London which radiates from the Central Telegraph Office is used for the conveyance of telegram forms between the C.T.O. and a number of branch offices and other local hand distribution centres, and also between the C.T.O. and the offices of a number of private firms with whom there is heavy telegram and cable traffic as, for instance, the majority of the cable companies and the larger newspapers. There are about seventy tubes in all ranging in length from approximately 300 yards for the tube to Headquarters Building to approximately 4,500 yards for the two tubes to the Western District office.

The system and the automatic carrier switchgear associated with it and installed in the C.T.O., as they existed prior to December 1940, were described in a previous article<sup>1</sup>.

## Damage in 1940.

The C.T.O. was practically destroyed by fire caused by enemy action in December 1940<sup>2</sup>, and all telegraph traffic was transferred to C.T.O. 'R' and other offices in London. All the pneumatic plant above the basement level, and the compressor plant which was installed under a light roof in one of the areas, came to grief on this occasion, but the main pneumatic switchgear and the internal street tube connections escaped serious damage. There was considerable debris on the roof of the switchroom, but it was possible to clear this away and to leave the plant in a reasonable condition during the reconstruction of the building.

## PROVISION OF TEMPORARY FACILITIES.

The loss of the pneumatic tube facilities was soon felt in the working of C.T.O. 'R', and in July 1941 it was decided to proceed at once with the reinstatement of the more important tubes. As at this time the reconstruction of the C.T.O. had not passed the demolition stage it was not possible to commence reconditioning the equipment or to erect new plant in C.T.O. basement. Arrangements were made, therefore, for manually operated terminal switchgear for six up, six down and one both-way tube to be installed in the basement of King Edward Building adjacent to

C.T.O. 'R', and for compressor plant suitable for eleven tubes to be installed in a room nearby. Two of the tubes were those that connected C.T.O. to the tube centre at the War Office, where there already existed compressing plant which could provide the air supplies for them<sup>3</sup>. The arrangement of the terminal equipment at C.T.O. 'R' is shown in Fig. 1.

The compressor plant installed in King Edward Building comprised rotary machines, one air-cooled, manufactured by Reavell & Co. Ltd., and driven by a 35-h.p. motor, which was used for the vacuum supplies, and one water-cooled, manufactured by Messrs. Hick, Hargreaves & Co. Ltd., driven by a 27½ h.p. motor, for the pressure supplies.

Tubes from out-offices west of C.T.O. passed either through, or adjacent to, King Edward Building, and these were cut at the nearest point and extended from the cut to the new terminal equipment. The dead-ends between C.T.O. and the point where the cut was made were connected by loops in C.T.O. to tubes from out-offices east of C.T.O. and similarly extended from the cut to the new terminal equipment. A number of spare tubes between C.T.O. and King Edward Building were also used in this manner. These tubes were brought into use in November 1941, and the service was maintained until the tubes were transferred back to the main C.T.O. system in 1947, in spite of the fact that there was no standby compressing plant available.

When the C.T.O. was brought back into use

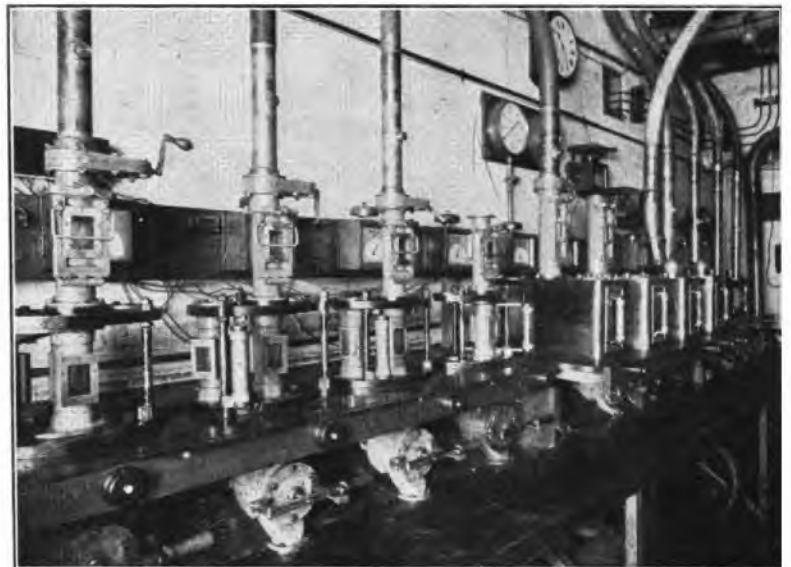

FIG. 1.—C.T.O. 'R' PNEUMATIC TUBE TERMINAL.

<sup>1</sup> P.O.E.E.J., Vol. 27, p. 173.

<sup>2</sup> P.O.E.E.J., Vol. 38, p. 11.

<sup>3</sup> P.O.E.E.J., Vol. 19, p. 3.

pneumatic tubes with separate compressors (Root's blowers) were installed between the C.T.O. 'R' tube terminal and the C.T.O. main circulation point for use until the new pneumatic equipment was available to convey traffic between these two points.

**PERMANENT REINSTATEMENT.**

In 1943 work on the reinstatement of the main tube system was commenced. This was dealt with under a number of headings.

*Street Tubes.*

The main street tube system was still in existence but had been seriously damaged as a result of air raids. The tubes had, in many cases, been flattened or otherwise distorted by heavy debris falling on the ground above, and the general earth vibrations that were experienced caused cracks in the wiped joints in the lead tubes, the majority of which were laid over fifty years ago.

The task of getting these tubes into a workable condition was difficult and prolonged for several reasons. The tubes having been out of use for three or four years, there had been no indication of the occurrence of faults during this period, and it was not until pressure was applied to a tube that its condition could be checked. In many cases there was more than one fault on a tube, and the tracing of them became rather involved. In the early stages of the testing only small capacity compressing plant was available so that it was necessary to stagger the tests on the tubes to keep the compressed air demand to a practical figure. It was not possible to maintain pressure on a tube after it had been passed as satisfactory, and in several cases a subsequent test revealed that further faults had occurred due to further air raids or the operation of other undertakings near tube runs.

*Local Tubes.*

In the pre-war arrangement at the C.T.O. the tube traffic was received and dispatched at a point on the

third floor adjacent to the main circulation positions, but when the building was reconstructed it was decided that the traffic should be handled in a room in the basement and transferred by a conveyor to the first floor where the new main circulation positions would be. The outgoing carriers are dispatched from the tube table shown in Fig. 2. This table is equipped

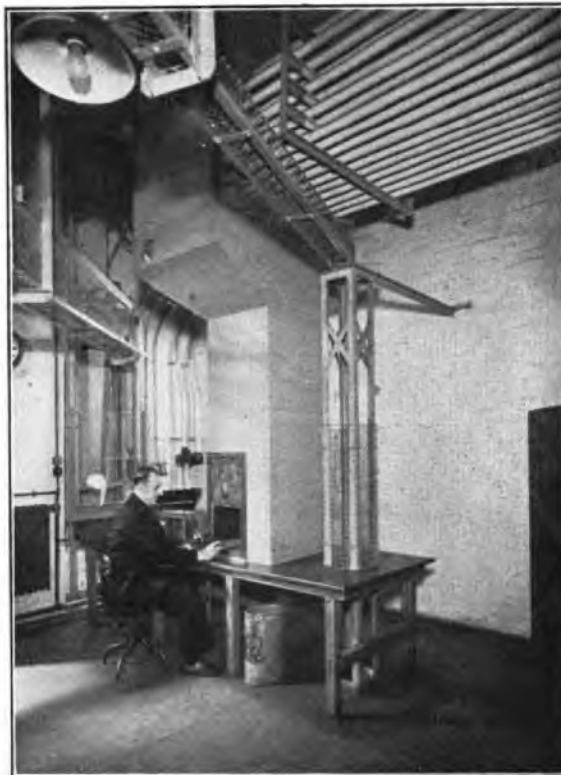

FIG. 3.—RECEIVING POINT FOR LOCAL TUBES.

with the tube dispatch terminals and their associated signalling and indicating equipment in a similar manner to the pre-war installation. There was an innovation in the method of receiving incoming carriers. All the local tubes which carry 'up' traffic to this room from the pneumatic switchgear are terminated in a nest at high level so that carriers are ejected from the open ends of the tubes into a large hopper from which they then fall down a zig-zag chute to table level. With this arrangement, which is shown in Fig. 3, it is possible to bring all the carriers to one point so that they are within reach of one operator without the use of a conveyor.

The local tubes themselves, which are used to transport the 'down' carriers between the table and the pneumatic switchgear and the 'up' carriers between the pneumatic switchgear and the receiving hopper, are supplied by centrifugal type fans. Three of these are installed; one is used for pressure-operated



FIG. 2.—DISPATCH TERMINALS.

'up' tubes, one for the vacuum-operated 'down' tube, and the third may be connected to either system. There is little difference in level along the runs of these tubes in the present scheme, so that pressures and vacua of about 8 in. water gauge are sufficient to operate them.

#### *Switchgear.*

The automatic pneumatic switchgear is used to transfer carriers from the 'up' or vacuum street tubes to the local pressure tubes and from the local vacuum tubes to the 'down' or pressure street tubes; it also controls the supply of pressure, or vacuum, to those street tubes which are worked alternatively in either 'up' and 'down' direction. This equipment remains substantially as it was but has been completely overhauled and cleaned. The electrical control and signalling equipment was entirely rewired. All the relay sets were thoroughly overhauled and apparatus renewed as necessary. The common apparatus is mounted on redesigned racks and made more flexible by the greater use of intermediate distribution frames (see Fig. 4). The relays and other apparatus used are all of the present standard Post Office telephone type. The electrical circuits remain standard, but advantage was taken of the rewiring to include some improvements. One of these is in the apparatus used for the regulation of the carrier feeding on the long 'up' tubes. Before 1940 block instruments and service regulators similar to those used on non-automatic systems had been adopted, but the control has now been modified so that the timing is done at the C.T.O. end of the tube by uniselectors stepped by time pulses and the signalling at the out-office is by dollsey indicators.

Another major modification is in the method of operation of the 'up' traffic failure alarm. This device is intended to give a warning when there has been no traffic on an 'up' tube for a given period, say half an hour or an hour. There is no supervisory signal on these tubes of the arrival of a carrier at

C.T.O., and in the event of a carrier sticking in a tube the only intimation given would be the failure of the vacuum at the out-office after a number of carriers had been fed into the tube and formed a blockage. The purpose of the alarm is to give an indication of this condition before any serious blockage exists. The alarm also operates, of course, when the traffic on a particular tube is very light, but this is not regarded as a major disadvantage. The passage of a carrier through the 'up' tube concerned resets the timing device, and on the original installation this event was signalled by the operation of a flap on the outlet of the associated local pressure tube as the carrier was ejected from it. These flaps are not fitted on the new system and the signal is now obtained by the passage of a carrier through the automatic pneumatic switch.

#### *Main Compressing Plant.*

There is a considerable modification in type and method of operation of the main compressing plant, three main points being given consideration in the preparation of the specification for this plant.

(1) When tubes of varying length are worked at a constant carrier-in-tube velocity the pressure or vacuum required to give this condition varies with the length of the tube, and when the required air is supplied from a constant pressure header, as was done in the pre-war installation, it is necessary to provide some throttling device between the header and the tube. This method is simple and easily adjusted, but is not efficient from a thermodynamical point of view. The ideal method, of course, would be to have a compressor for each individual tube and compress the air to the required value only. This was obviously impracticable, but it was found possible to group the tubes into two types, viz., "short tubes" and "long tubes", without making any major modification to the pneumatic switching plant, by a rearrangement of the street tube connections at C.T.O.

The "short tubes" are those tubes which require pressures of 0-6 lb./sq. in. above atmospheric pressure and vacua of 0-9 in. Hg below atmospheric pressure, and the "long tubes" are those which require corresponding pressures of 6-12 lb./sq. in. and vacua of 9-14 in. Hg.

It was thus necessary to provide compressing and exhausting plant to cater for a pressure header working at 12 lb./sq. in., a pressure header working at 6 lb./sq. in., a vacuum header working at 9 in. Hg and a vacuum header working at 14 in. Hg. To meet this requirement three compressors were specified, each of which was to be suitable for compressing to either header pressure, and each of which could be connected to either header. The working arrangement was to be that one compressor would be connected to each header and one would be available as spare. Three vacuum pumps were also called for to be connected and worked in a similar manner.

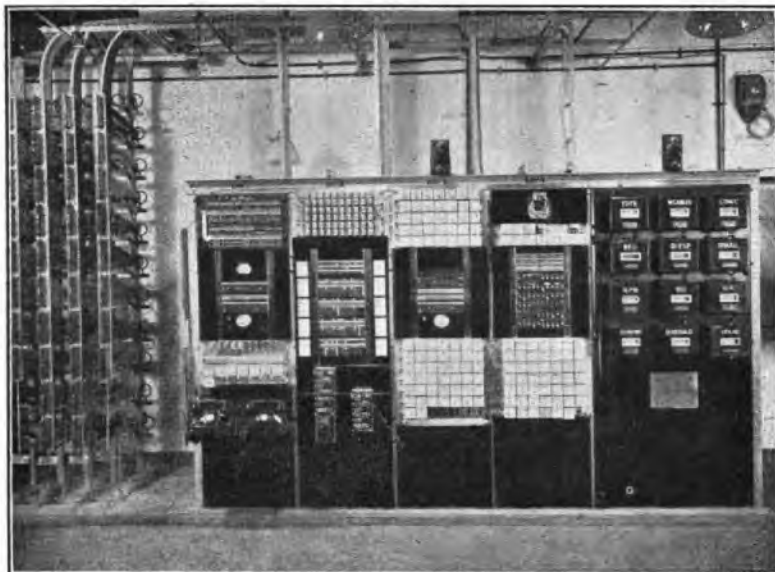

FIG. 4.—CONTROL APPARATUS.



To cater for the night traffic conditions when the number of tubes in use does not justify the running of two compressors or two vacuum pumps, it is arranged that the low-pressure and low-vacuum headers are supplied respectively from the high-pressure and high-vacuum headers. This is done in each case by a reducing valve of the "Arca" relay type, in which the main valve is operated by water from a constant head source controlled by a relay valve responding to header air pressure.

(2) While the demand for compressed air by the "down" street tubes and for rarefied air by the "up" street tubes is approximately constant, the demand made by the "both-way" tubes is a variable quantity depending upon the direction of working of each tube. A proportion of the tubes on each header are both-way so that in every case the machines are called upon to supply a continuously varying load. In theory the load on any given header could vary between the condition when all the both-way tubes are connected to the header concerned and the condition when none is connected. These conditions correspond to full and about half load. It is thus necessary for the compressors to be suitable for supplying this variable load and for them to have control gear which will adjust their outputs without permitting the header pressure to vary more than about 0.25 lb./sq. in. from nominal value.

The control of the compressor outputs in the old installation was in the form of a manually operated throttle on the compressor inlets, but it was considered that a more efficient method would be by speed control of the driving motor, and this has been adopted. As a D.C. supply is available it is possible to use simple shunt field control for this purpose.

(3) Since the original plant was installed there has been considerable development in compressors of the rotary positive displacement type and of the turbine type, and quotations for these types of machines, as alternatives to the reciprocating type, were invited in order that the efficiencies and costs could be compared. Representative isothermal efficiencies of the three types of plant are given in Table 1.

TABLE 1

	Rotary	Turbine	Reciprocating
(a)	61	64	44
(b)	70	62	52
(c)	55	65	32
(d)	64	60	40

- (a) Machines run as compressors delivering nominally 1,400 cubic feet of free air per minute at 6 lb./sq. in.  
 (b) The same machines as in (a) delivering at 12 lb./sq. in.  
 (c) Machines run as vacuum pumps aspiring nominally 1,800 cubic feet of air per minute from a vacuum of 9 in. Hg.  
 (d) The same machines as in (c) aspiring from a vacuum of 14 in. Hg.

The contract for the new plant was placed with Messrs. Hick, Hargreaves & Co. Ltd., of Bolton, and

was for six machines of their rotary positive displacement type, three for use as compressors and three as vacuum pumps. Fig. 5 shows typical axial and trans-

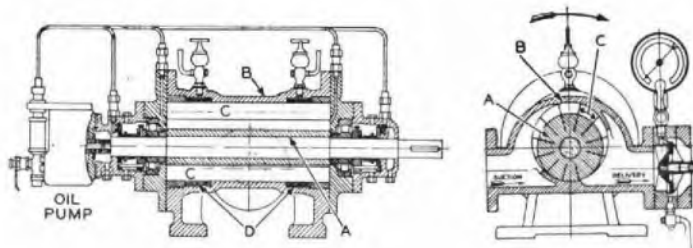

FIG. 5.—CROSS-SECTIONAL DIAGRAMS OF ROTARY COMPRESSOR.

verse sections of the compressor of this type. The solid cast-iron rotor A is mounted eccentrically in the cylinder B and rotates in the direction of the arrow, carrying with it the steel blades C which slide in milled axial slots. These blades are kept in contact with the cylinder by centrifugal force during rotation of the rotor and sweep through the crescent-shaped space between the cylinder and rotor. The portion of this space between any two adjacent blades is at a maximum at the trailing edge of the suction port and is gradually reduced as the rotor turns. The air in this space is thus compressed until the leading edge of the delivery port is reached, when it is discharged at the higher pressure. The blades are not actually in contact with the cylinder wall but are held a few thousandths of an inch away by two restraining rings D. These rings are free to rotate in slots in the cylinder wall and are carried round by the blades. The space between the edges of the blades and the cylinder wall is sealed by a film of oil, the friction between the blades and the cylinder wall being reduced appreciably by this device.

The compressors are driven by 80-h.p. Crompton Parkinson motors over a speed range of 300–600 r.p.m. and the vacuum pumps by 65-h.p. motors over the range 250–500 r.p.m. All the machines are air-cooled. Fig. 6 shows a side-view of a compressor and

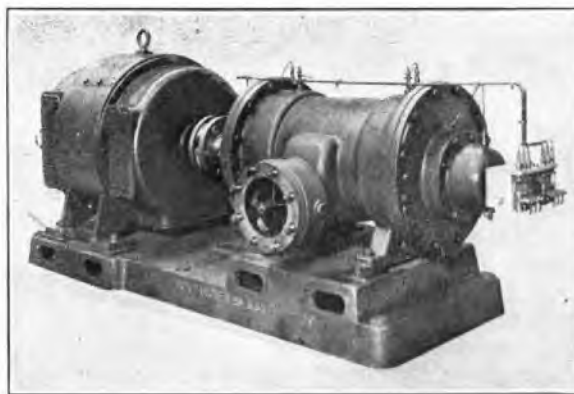

FIG. 6.—COMPRESSOR SET.

driving motor before installation. The machines are fitted with non-return valves because a reversal of air flow with this type will cause them to run as motors in the reverse direction and, since the resistance to

motion is very small, to acquire a dangerously high speed in a very short time.

Each compressor is arranged so that it can supply either the 12 lb./sq. in. or the 6 lb./sq. in. header, as has already been described. Air is drawn in from the engine room through a filter of the Visco oil type and a silencer, and the compressed air in each header is passed through a cooler before distribution to the tubes. The two coolers are of a novel type in which air is both the cooling and cooled medium. The compressed air is passed through tubes about 2 in. diameter with external gills and the cooling air is drawn from the engine room by a centrifugal fan and blown over these tubes. The fan and driving motor can be seen in the foreground of Fig. 7 with the cooler

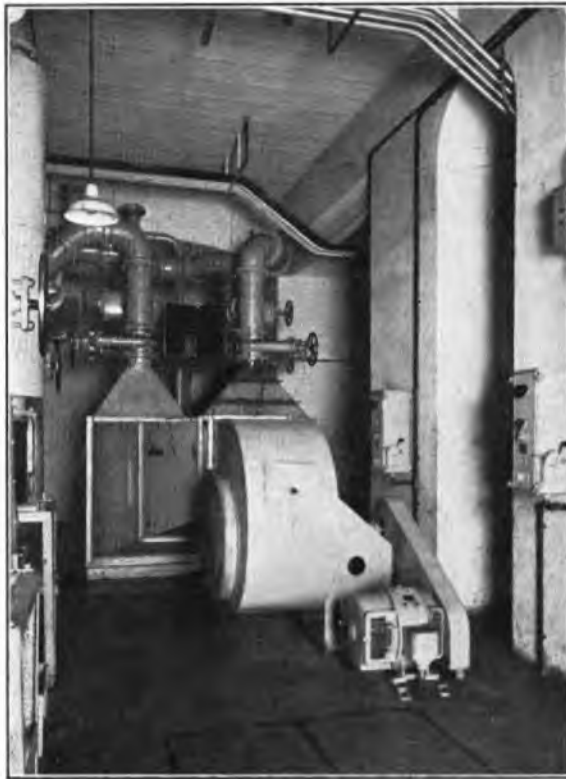

FIG. 7.—FAN AND COOLING PLANT.

housing behind. The compressed air passes four times through the cooling air stream and is cooled from about 180°F. to 100°F. for air at 12 lb./sq. in. and twice through the cooling air stream while being cooled from about 140°F. for air at 6 lb./sq. in. The air coolers were manufactured by Messrs. Hunt & Moscrop Ltd.

Each vacuum pump can be connected to draw air from either of the vacuum headers. A filter, also of the Visco oil type, is fitted in each vacuum header between the tubes and the vacuum pump, and the discharge from each pump passes into a common pipe leading to the atmosphere outside the engine room.

#### *Compressor Control Equipment.*

The control equipment for all the machines was supplied by the Watford Electrical & Manufacturing Co. Ltd. Each machine has associated with it a starter

of the straightforward automatic rheostatic type with push-button control and incorporating a motor-driven shunt field regulator. This motor moves in the forward or reverse direction to raise or lower the associated machine's speed in response to the closing of one or other of two interlocked contactors mounted in the starter.

Four controllers are provided, one for each header, and a plug and socket arrangement is included whereby either of the controllers associated with the pressure headers can be connected with any one of the three compressors, and similarly so that either of the controllers connected with the vacuum headers can be connected with any one of the three vacuum pumps. The controllers are of a novel type and were developed by the Watford Electrical & Manufacturing Co. Ltd. specially for this installation, using their Watford Pigrall system.

The pressure-sensitive device on each controller, which is visible through the lower windows in the controller housing (see Fig. 8), is a small transformer,



FIG. 8.—COMPRESSOR CONTROLLERS.

the primary of which can move relatively to the secondary. This primary winding is mechanically coupled to a bellows arrangement connected to the source of pressure and is loaded by a dead weight applied through a lever so that it stabilises at the required pressure. An increase in pressure causes the coupling between the primary and secondary winding to increase, and thus, with a constant voltage applied to the primary, the secondary voltage, over a small range, is proportional to the applied air pressure. This secondary voltage is rectified and compared with

another unidirectional voltage and the difference, if any, applied to a sensitive galvanometer. When operated the galvanometer closes one or other of its two contacts according to the direction of the difference, and, by means of various relays and the contactors in the starter already referred to, corrects the speed of the associated compressor by causing a movement of the shunt field regulator. Cam-operated contacts driven by a constant speed motor in the controller connect the galvanometer to the circuit in two states of sensitivity. If it responds in its less sensitive state the change in the speed of the associated compressor is about three times the change if it responds in the more sensitive state. The tests are made at regular intervals of time, and thus, to a certain extent, the controller takes note of the rate of change of pressure as well as the change of pressure.

The second unidirectional voltage referred to, with which the pressure-proportional voltage is compared, is derived from a potentiometer mechanically coupled to the shunt field regulator of the associated compressor, and the system is arranged so that when this regulator moves in response to the controller the voltage across the galvanometer is reduced. This device thus anticipates the change in pressure which results from the action of the controller, as far as the galvanometer is concerned. By this means the hunting which would be caused by the time-lag between controller

operation and header pressure change, due to the capacity of the air system and the inertia of the compressor, is prevented. A drooping control characteristic is introduced, however, with the controlled pressure varying from about 0.1 lb./sq. in. above the nominal value at minimum load to about 0.1 lb./sq. in. below at maximum load. Except for the initial swings which occur when a tube is opened or closed, the pressure is controlled to this value within the limits of  $\pm 0.25$  lb./sq. in. The capacities of the compressed air header systems are, of necessity, not large compared with the capacity of a street tube and it is not practical, therefore, to reduce the initial pressure deviation caused by the opening or closing of a tube to less than about 1 lb./sq. in. This is corrected in about 15 seconds by the controller without any overswing beyond the normal limits of tolerance.

#### *Acknowledgment.*

Much of the reinstatement work including the rerouting of the local tubes in the C.T.O., the design of the new tube dispatch table and of the new layout of the electrical apparatus associated with the automatic switchgear was done by staff of the London Telecommunications Region, to whom the author must acknowledge his indebtedness for information supplied.

## **Book Reviews**

"Report on Defective Colour Vision in Industry." London: The Physical Society, 1946. 52 pp. 3s. 6d.

In 1942 the Colour Group of the Physical Society appointed a committee to study the practical aspects of defective colour vision. Information was obtained from most of the leading authorities in physics, physiology, biology and medicine, as well as in those branches of industry, the arts, sciences and public services, etc., in which colour perception plays an important role.

From this information a well-balanced Report of under 50 pages of actual text has been produced. After a short but sufficient account of the nature and incidence of defective colour vision, over 50 tests for this abnormality are considered. The third and longest section of the Report discusses the social and vocational consequences of such deficiencies. The inefficiency and even danger which may result if a person with defective colour vision takes part in activities requiring normal colour vision are rightly emphasised. Logically, therefore, the committee strongly recommends that tests be made at school on all children of 13 or over and that adequate pre-vocational tests be more generally applied in appropriate cases. For the former and for many of the latter simple "Confusion Chart" tests, such as the Stilling and the Ishihara tests, are recommended. The precautions necessary to ensure reliable and fair results in such tests are indicated, but more stress might, perhaps, have been laid on the need to avoid creating a feeling of inferiority in individuals who fail in such a test.

The Report can be read with ease by both the expert and the interested, intelligent layman. It should be particularly valuable to all concerned in giving vocational guidance to young people and in the selection of staff. Forty-three references to technical literature are quoted.

E. A. S.

"Electric Installation Rules and Tables." W. S. Ibbetson, B.Sc., A.M.I.E.E., M.I.Mar.E. 192 pp. E. & F. N. Spon, Ltd. 7s. 6d.

This is the fourth edition of a book compiled particularly for those engaged in installation work, and was first published in 1921.

As may be expected, a considerable part, nearly one half in fact, is given to the I.E.E. Regulations, the substance of the more important rules being either quoted in full or summarised; the 1946 supplement is included. The tables of current rating of cables, fuses, conduit capacity, etc., are included, but in most of them reference has to be made to the I.E.E. Rules book itself for the footnotes to which the asterisks refer.

The next largest section is that on illumination data and design, in which standard room indexes, coefficients of utilisation, etc., are included and a design worked out. This section includes notes on fluorescent lighting; it may be noted that the figures quoted for lumen output and efficiency have been appreciably improved upon in the makers' latest statements.

In the schedule of possible causes of trouble with fluorescent tubes, the word "switch" is used indiscriminately for the circuit switch and for the starter; the use of "starter" or "starting switch" where that is intended would avoid any ambiguity to those not familiar with the subject.

Some of the other data included in the book are motor h.p. required for various classes of work, current taken by motors, calculation of cable sizes, power factor correction and notes on H.R.C. fuses and electric heating; wages and price tables are also included.

The information included in the little book—it is literally of pocket size, being approximately 5 in.  $\times$  3 $\frac{3}{4}$  in.  $\times$   $\frac{1}{2}$  in. thick—is that which a practical wireman or installation man needs, and it is in a form to which rapid reference can be made; it is well and clearly printed.

H. R. M.

# The Manufacture of Star-Quad Telephone Cable

J. E. DEERING

U.D.C. 677.73 : 621.315.213

## Part 2.—The Process of Sheathing

Part 1 of this article dealt with the manufacture of the standard cable core. In this part the author describes the process of lead sheathing the core and gives details of the principal types of lead press employed.

### Composition of the Sheath.

THE final process in the production of the cable core was a double lapping with paper tape. The outer of these lappings is coloured to indicate the composition of the sheath. The colours are :—

Lead	White or Neutral paper
Lead/antimony (Alloy B)	Red
Lead/tin/antimony (Alloy E)	Green
Lead/tellurium	Orange

The stranded core is thoroughly dried at a temperature not greater than 275° F. before it is sheathed, and often it is electrically tested to ensure that no faults exist; in such instances the cost of stripping off the sheath is avoided.

The lead or lead alloy used for sheathing the stranded core is extruded over the core at a temperature not greater than 600° F. The sheath must form a perfectly cylindrical tube, free from pin-holes, joints, mended places, and defects of every kind, and be able to withstand an internal air pressure of 75 lb. per square inch for three hours after equalising. The composition of the lead should comply with B.S. No. 801, from which the following is an extract :

Composition of Sheath (% by weight)

Lead	Zinc	Bismuth	Total of Impurities including Zinc and Bismuth
Min.	Max.	Max.	Max.
99.90	0.002	0.05	0.10

If the lead has a purity higher than 99.995 per cent., it is usual to add a small percentage of tin or antimony to ensure satisfactory working and service, in which case it is still classed as plain lead. For aerial, submarine, and other cables, where vibration is a factor and mechanical strength is required, a lead alloy is used. The composition of the alloys that are used is given below.

Composition of Sheath (% by weight)

Alloy	Tin		Antimony	
	Min.	Max.	Min.	Max.
B	-	-	0.8	0.9
E	0.35	0.45	0.15	0.25

The lead/tellurium alloy has a nominal percentage of 0.15 of tellurium.

The endurance limits measured by the Haigh method, expressed as the range of stress which will cause failure after 10 million reversals are :—

Lead	Endurance limit, tons/sq. in.	± 0.18
Alloy B	" " "	± 0.60
" E	" " "	± 0.41

Routine analysis either by chemical or spectrographic means is employed to satisfy that the materials comply with the specification.

### Types of Lead Press.

The sheathing is applied by a lead press, the types of which differ somewhat in principle, and are briefly described below :—

(1) *Single-ram Upright*. This is the type at present most in use. It has to be filled with molten lead, which must then be allowed to cool so that it is only just sufficiently plastic to enable it to be forced out through a die and solidify directly afterwards.

(2) *The Double-ram Horizontal Press*. This is not so common now, as it needs two lead containers and the temperature control of the lead is more critical than in the single container type. One of the difficulties encountered in sheaths extruded from this press is what is called a "cold shut," generally due to a difference in temperature between the two lead containers. The origin of defects in sheaths will be dealt with in a later part of this series.

(3) *Straight-through Press*. This was designed and introduced about 1933 to apply the lead in a direction parallel with the cable core, and it is claimed that the sheath so formed is an improvement on that formed by the two types so far mentioned. It works intermittently, with periods of charging up with fresh lead occurring between periods of extrusion of the sheath, as with the older types of press.

(4) *The Continuous Press*. This sheathes cables of any length without the need of having to stop for recharging. Broadly speaking, it works on the principle of a mincing machine, and the lead or lead alloy in a state which generally changes from molten to semi-plastic and then to plastic and almost solid, is thrust forward and through the forming die by a double-threaded screw device working in a double-rifted barrel. The supply of fresh molten lead is continuously fed into the extrusion chamber.

Further details of these presses follow.

### Single-ram Upright Type Lead Press.

A general view of a press of this type is shown in Fig. 1. It consists of a hydraulic cylinder mounted

on a foundation below floor level. Mounted on the cylinder are four stout columns which support a cross-

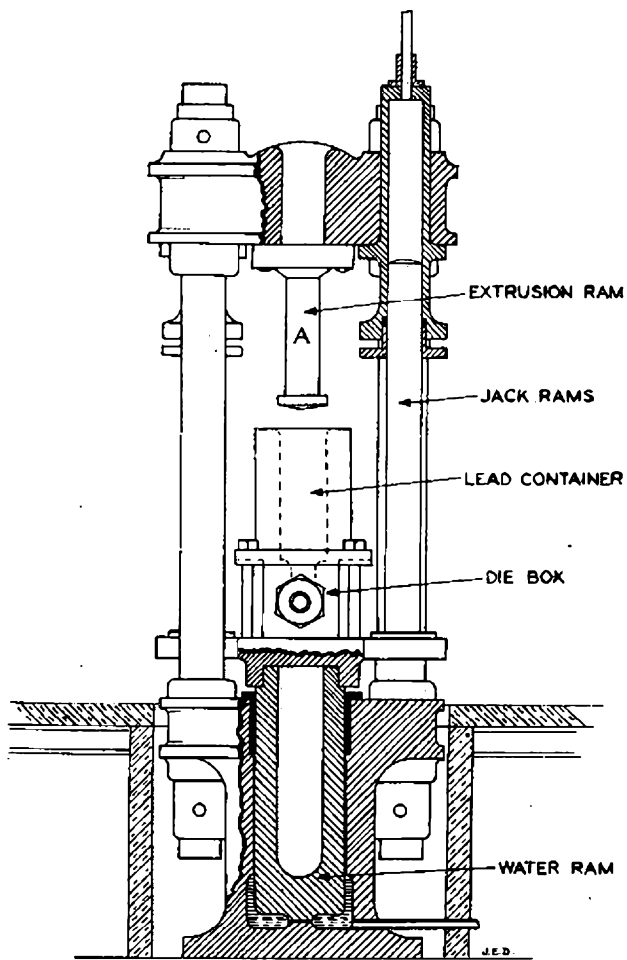

FIG. 1.—SINGLE-RAM, UPRIGHT TYPE LEAD PRESS.

head. To the cross-head is fixed a steel extrusion ram A. In the cylinder a hydraulic pressure ram is housed, the top of which is fitted to a rising table attached to slide guides which engage with columns forming jack rams. The columns also ensure alignment of the water ram with the extrusion ram. On the top of the table is mounted the core and die box, and on the top of the die box the lead container is mounted and secured to the rising table by long bolts. A lead furnace is situated near to the press from which molten lead is conveyed to the lead container of the press by a removable chute. Directly the container is full of molten lead, the top surface is skimmed to remove any dross. The water ram is then set in motion until the lead in the container contacts with the extrusion ram A. The press is left standing in this fashion for about 7 or 8 minutes

with a pressure on the lead or lead alloy of approximately 1 ton per square inch to minimise oxidation while the lead is setting to a plastic state suitable for extrusion. The press is then set in motion again and the pressure on the water rams increased to about 2½ tons per square inch, and extrusion then continues until the lead in the container is discharged to within about 2 in. of the bottom of the container. The container is then returned by the hydraulic jack rams, and the cycle of operations continued.

Fig. 2 gives a diagrammatic view of a core and die box, in which the cylindrical sheathing is formed. When the press is in operation, the pressure from the ram forces the plastic lead to flow into the upper half of the die box, and through two highly polished passages which merge into one at the point of extrusion. The two passages are separated by a cylindrical nipple through which the stranded cable core passes. The plastic lead merges around a tapered nose A fitted to the cylindrical nipple. This nose comfortably accommodates the stranded core, and controls the internal diameter of the extruded sheath. Situated around the extremity of this cone die is a ring die B, which in conjunction with the nipple governs the external diameter of the extruded sheath. The correct concentricity of the sheath is obtained by the transverse adjustment of the ring die by the taper bolts C.

The essential points in operating a lead press are to prevent extraneous substances entering the molten lead (the use of remelted or scrap lead is not encouraged for this reason), to prevent oxidation of the molten lead during the refilling process, and to produce a sheath of even thickness and correct dimensions. It is essential that the die box is kept at a uniform temperature as far as possible, usually about 330° F. Either gas jets playing on the sides of the die box, or electric heating elements clamped to the sides of the box, are used for this purpose. It is quite usual to fit thermocouples at four points in the front of the die box to provide visual temperature recordings. The pressure of extrusion is sufficient to

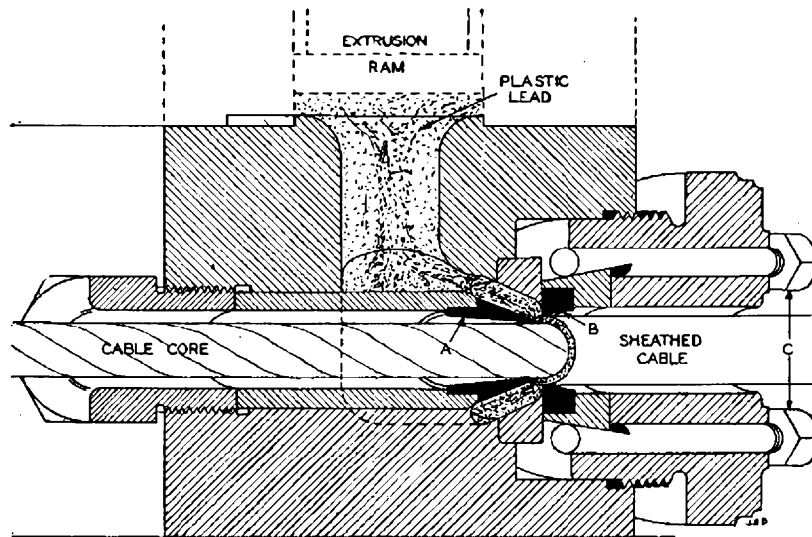

FIG. 2.—CORE AND DIE BOX.

propel the cable core through the press unaided. As it emerges it is cooled through a bath of water and probably smeared with a thin layer of tallow to prevent cohesion between the turns when wound on to a drum.

#### *The Henley Straight-through Lead Press.*

The essential feature of this press is that the pressure is applied to the lead in a direction parallel with the cable, which passes axially through the lead container, so that the lead flows first longitudinally and then radially inwards without being forced to flow in a circumferential direction round the cable. There is thus no longitudinal weld in the sheathing. The straight-through press gives a very satisfactory joint between the metal which remains in the container at the end of the stroke of the ram and that forming the new charge.

The layout of the complete equipment includes, in addition to the press, a three-throw hydraulic pump driven by a 100-h.p. motor capable of giving a pressure of 3 tons per square inch, a gas-fired lead melting pot, and a hand-operated hoist by which the lead pigs are charged into the pot. The press (Fig. 3)

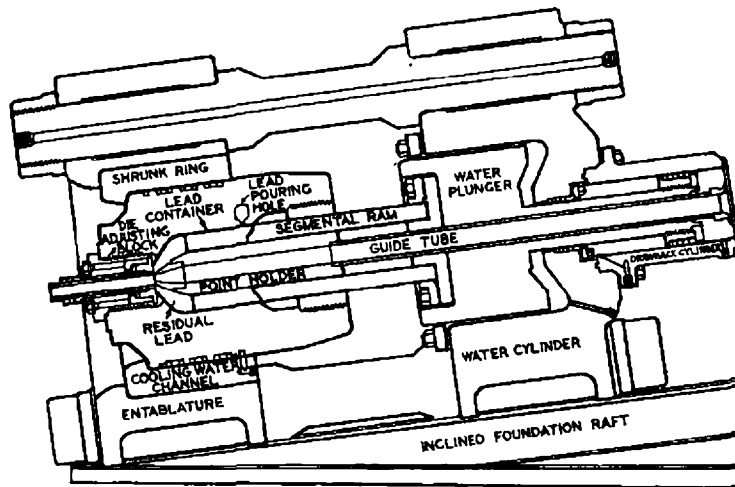

FIG. 3.—HENLEY STRAIGHT-THROUGH LEAD PRESS.

is inclined downwards towards the front end to prevent air being trapped in the lead container during the operation of charging. The lead container is 18 in. in diameter internally and is capable of holding a charge of 1,000 lb. of lead, the die and cylindrical nipple, known in this press as the point, being placed at the front end of the container. The point holder base is formed with four segment shaped openings, through which the four similarly shaped legs of the ram pass. The shape of the lead ram is shown in Fig. 3, from which it will be seen that the end in contact with the lead in the container is in the form of a ring through which the point holder passes, while the other ends of the legs are screwed into a ring attached to the hydraulic ram.

The hydraulic ram has a diameter of 3 ft. and a stroke of 19 in., its effective area being such that a force of 2,800 tons is applied to the lead ram with a

water pressure of 3 tons per square inch; this, it may be noted, gives a pressure of 15 tons per square inch on the lead in the container. The ram is provided with a tubular extension at the rear carrying an annular piston which works in a cylinder of 18-in. bore, and is used for effecting the return stroke of the main ram. A steel tube,  $4\frac{1}{2}$  in. in internal diameter, passes through a hole in the ram and is screwed into the point holder. Through this tube the cable to be sheathed is threaded; it is fed forward during the sheathing process entirely by the flow of the metal.

Lead forced out of the container to form the sheath first flows over a concave forming ring, held in position by a screw block screwed with a buttress thread. At the back of the forming ring is a wedge ring in which the die is fitted and this wedge ring is allowed a small radial movement. The wedge ring, and therefore the die, can be accurately centred with the point by eight wedge bolts. Large points are fitted direct into the point holder, but smaller points are screwed into an adaptor which fits into the point holder.

It will be appreciated that, at the end of the forward stroke, a block of solid lead will be left in the container shown in Fig. 3. This lead is melted and mixed with the new charge when the latter is run in, but if it is desired to change the die and point to sheath a cable of a different diameter, the lead must be cut through to enable the point to be withdrawn. For this purpose, a tubular cutter bar, fitted with a cylindrical cutting head is inserted in the screw block which holds the die in position and is rotated by a 5-h.p. motor through spur and worm reduction gear.

When the hole has been cut and the cutter bar removed, the point and point adaptor are forced out, by applying pressure to an ejector tube which fits into the cable-guiding tube from the rear end of the press.

An opening is provided for filling the container with lead; lead is gravity fed into the press from an adjacent melting plant by a movable loader, the flow being regulated by a sluice valve. As the lead is poured into a practically closed chamber, the exposure of metal to air is considerably less than with the

ordinary type vertical press. In addition, after the container has been filled, the ram is advanced to cover the pouring hole while the lead solidifies. The surplus lead with the oxide is consequently forced back through the pouring hole out of the container. For the charging operation as well as the normal working of the press, it is necessary to know accurately the position of the ram, and a continuous indicator is provided for the purpose. Thermocouple type pyrometers are provided to indicate continuously the temperature of the top and bottom and at each side of the lead container, the couples being inserted in holes drilled in the metal to within  $\frac{1}{2}$  in. of the lead chamber.

The working stroke occupies from  $3\frac{1}{4}$ – $4\frac{1}{2}$  minutes, depending upon the size of cable being covered, the thickness of the sheathing and the particular alloy being employed. The return stroke takes  $1\frac{1}{2}$  minutes,

and the operation of cleaning the ram and moving it into position for filling another  $1\frac{1}{2}$  minutes.

Pouring takes 1 minute, and after moving the ram forward to close the filling hole, which takes half a minute, a wait of from 3-5 minutes is necessary to allow the metal in the container to solidify. The

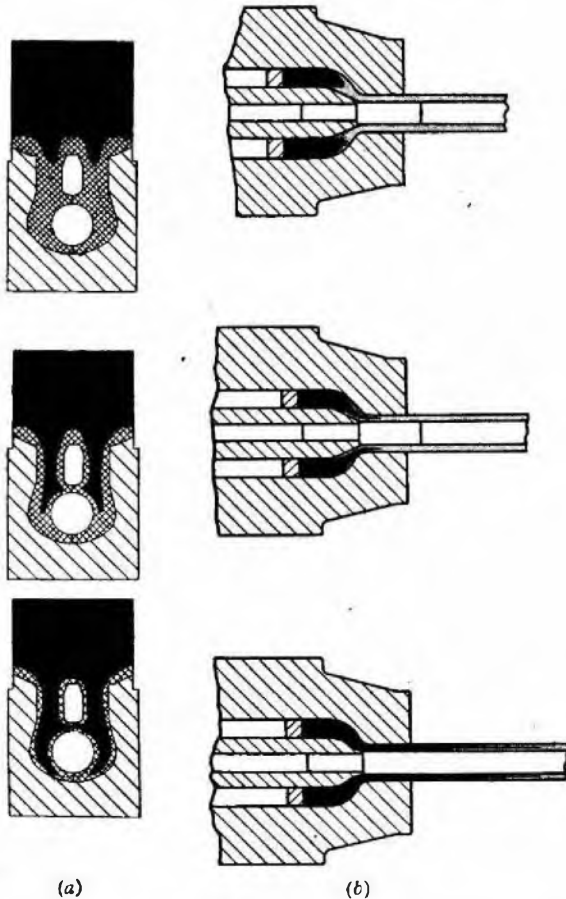

FIG. 4.—FLOW OF LEAD IN DIE BOX OF (a) VERTICAL PRESS, (b) HENLEY STRAIGHT-THROUGH PRESS. SOLID SHADING SHOWS NEW CHARGE JOINING WITH OLD.

whole cycle of operations thus takes about 13 minutes, so that 4-6 cycles can be carried out per hour, and, since the weight of sheathing applied per cycle is 1,000 lb., the hourly output amounts to 4,600 lb. The maximum size of cable that can be covered is 4 in. in diameter under the lead, and any smaller size can be dealt with. The press can be used equally well on paper- or rubber-insulated cables.

It will be seen that this type of press produces a sheath which is free from any longitudinal seam, and differs in this respect from the vertical ram type press previously described which produces one or two seams depending upon the construction

of the press. These seams are due to the fact that the lead has to flow circumferentially round the point holder, and a perfect weld at the junctions between successive charges cannot always be guaranteed, due in the main to fine oxide inclusions.

In the presses so far described, the old charge of lead cannot be completely extruded before a new charge is run in, and owing to the frictional drag or cohesion, the new lead is forced in a spear-like manner towards the centre of the residue. This is illustrated in Fig. 4 (a) for a vertical ram type press showing a new charge entering the old charge as the ram is slowly advanced. This serves to explain how the longitudinal seam originates. In comparison Fig. 4 (b) is the equivalent for the straight-through press, and shows how the long scarf joint is formed in the sheath, which may have an effective length of 15 to 20 yards depending on the cross-sectional area of the sheath.

#### The Pirelli Continuous Lead Press.

The types of press so far described are intermittent in action, that is the press has to be stopped when the lead container is emptied, the ram withdrawn, the container refilled with molten lead, and extrusion recommenced after the lead has become plastic. In the Pirelli continuous press, extrusion is maintained by continuously feeding molten lead into the press under an air seal, with the result that no air enters with the lead.

To explain the principles of operation of this type of press, a simplified explanation will first be given. In Fig. 5 a steel screw S, driven by a gear wheel G, revolves in a cylindrical barrel B. The bore of the barrel is provided with a number of channels or grooves cut longitudinally. Molten lead enters at the lead entry port, this part of the machine being maintained at a suitable temperature by heaters. The lead fills the grooves and the thread of the screw. Owing to the presence of the cooling jacket, the metal in the grooves becomes solid. As the screw rotates it tries to carry the lead lying in its thread around with it, but owing to the friction between the lead in the thread and the solid lead in the grooves, considerable resistance to rotation is set up. As the coefficient of friction between lead and steel is less than between lead and lead, the plastic lead spiral lying in the thread of the screw is forced forward through the machine into the die chamber. Here the plastic lead is compressed to a homogeneous mass

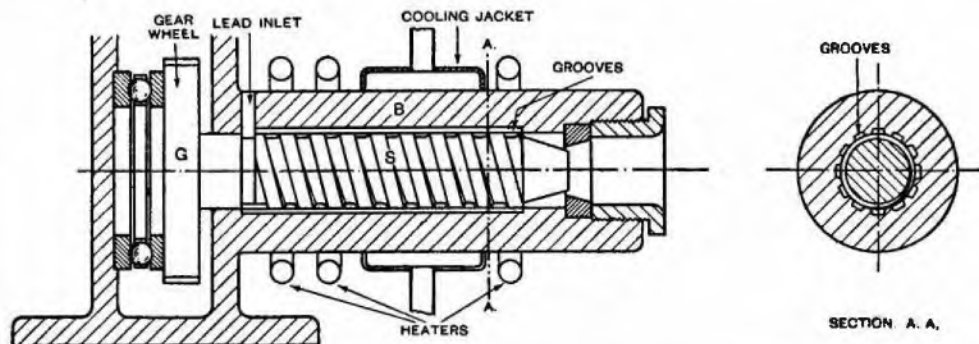

FIG. 5.—DIAGRAMMATIC ARRANGEMENT OF LEAD EXTRUDING MACHINE.

and forced through the dies and out of the machine in the form of a pipe.

The actual press (Fig. 6) consists essentially of a

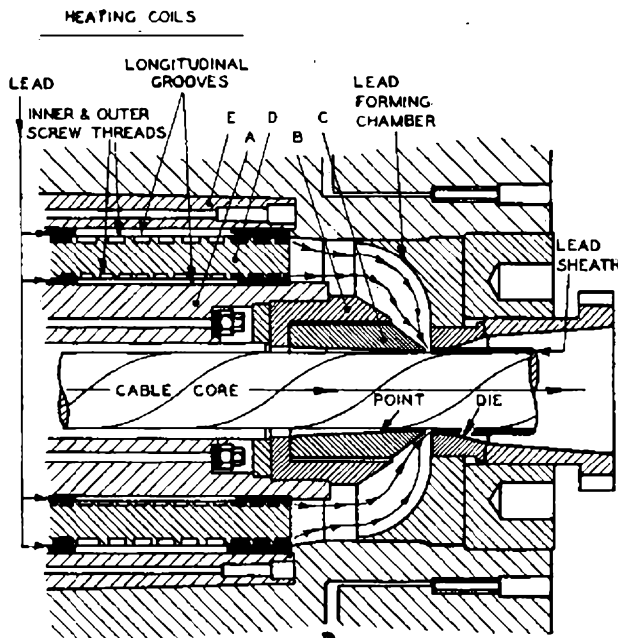

FIG. 6.—SCHEMATIC ILLUSTRATION OF THE PIRELLI CONTINUOUS LEAD PRESS.

stationary tube (A) through which the cable to be sheathed travels. The tube carries a core die (B, C) at one end, and is surrounded by a revolving hollow steel cylinder (D) which in turn is surrounded by a stationary barrel (E). This steel cylinder has screw threads on its inner and outer surfaces which co-operate in the manner previously described, with a series of longitudinal grooves forming keys in the bore of the barrel and the outer surface of the stationary tube. Molten lead is admitted to the barrel through the lead entry and passes through ports in the revolving cylinder to the underside of the tubular screw as well as the outer side, thus giving a double extrusion effect.

The operation of the machine is that the heating coils are energised to heat the barrel to about 300°C. at which point the driving motor may be started up to turn the machine over. If a lead supply valve is used it is now opened to admit lead to the machine, or if no lead valve is used, the supply is controlled by melting or solidifying the lead in the

connecting pipe between the lead pot and machine. As soon as molten lead has access to the machine, water is circulated through the cooling channels around the barrel to create the plastic condition to cause the reaction between the lead in the screw threads and that in the channels. The speed of sheathing can be controlled by changing the degree of cooling, and once this has been set to a suitable value, the machine will continue to extrude as long as molten metal is fed into it. The weight of metal extruded is constant throughout the range of a particular size of machine and does not vary with the size of sheath extruded. The output in tons per hour is claimed to be higher than that obtained from corresponding hydraulic presses. Although the actual speed of extrusion may be lower, it is continuous, whereas the hydraulic press must stop frequently for the refilling of the container and the setting of the metal. On account of the design of the machine, and the absence of air entering with the lead, it is claimed that there is an entire absence of lead press defects such as pin-holes or air blisters, red lead and weak seams.

#### Sheath Thickness.

The cable sheath must be thick enough to withstand normal handling and drawing into ducts without puncturing or fracturing. The thickness adopted is based on experience with pure lead, and is calculated from the formula,

$$t = 0.0372d + 0.05 \text{ in.},$$

where  $d$  is the calculated mean diameter of the cable core. The specified minimum thickness is 0.065 in., which is regarded as the least thickness of lead which will give satisfactory parallel jointing to large cables.<sup>1</sup> The maximum specified diameter for the completed cable is calculated from the foregoing expression, plus an allowance of 2 per cent. together with an addition of 0.025 in. This allows an increase in core space over the calculated mean value should a manufacturer require it. The maximum external diameter  $D$  of the cable is thus

$$1.02(d + 2t) + 0.025 \text{ in.}$$

A saving of lead during the war was effected by adopting a lead thickness based on

$$t = 0.029d + 0.0538 \text{ in.}$$

<sup>1</sup> Sheath thickness has now been revised in view of the acute lead shortage and is based on

$$t = 0.025d + 0.05 \text{ in.}$$

with a minimum of 0.065 in. At the time of compiling this article it is expected that the thickness will be reduced still further with perhaps a protection overall.



# International Telecommunications Conferences, Atlantic City, 1947

U.D.C. 061.4 : 654.1

## *Introduction.*

THERE were, in effect, four Conferences, as follows:—

(i) The Radio Conference, scheduled for two months from the 15th May, the object of which was to revise the Radiocommunication Regulations governing the working of radio services; this included the replanning of the frequency spectrum;

(ii) the Plenipotentiary Conference, scheduled for six weeks from 1st July, which dealt with the revision of the International Telecommunication Convention, the basic international treaty to which the Radiocommunication and other agreed regulations are annexed;

(iii) the High Frequency Broadcasting Conference, scheduled for one month from 15th August, which was intended primarily to assign specific frequencies to long-distance broadcasting stations; and,

(iv) a preliminary European Broadcasting Conference, which had not been scheduled beforehand but was decided upon during the course of the Radio Conference in view of the presence in Atlantic City of delegates of the European countries concerned.

Seventy-eight countries attended the Conferences, the sizes of the respective delegations varying from well over fifty in the case of the U.S.A., to a single representative in the cases of Burma and the Lebanon. The total number of participants, including secretarial and interpreting staffs, was about seven hundred. Throughout the Conferences, a simultaneous translation system was employed, covering the English, French, Russian and Spanish languages. The main advantage of this system lies in the great saving of time over that of consecutive translations from "floor" interpreters.

The problems in which greatest difficulty was encountered were, as expected, those involving questions of political prestige and the question of the languages to be used both in the official publications of the Union and at future Conferences.

## RADIO CONFERENCE

The difficulties in framing a new set of Radio Regulations were increased by the long interval since the previous regulations were drawn up at the Cairo Conference in 1933<sup>1</sup>, and by the very great developments in radio in recent years, not only in expansion of the older forms of service but also in the introduction of new techniques and types of service developed during the war. The Conference ended on 2nd October, having been in continuous session for 20 weeks.

## *Frequency Allocation.*

The most important and also the most pressing work confronting the Radio Conference was the drawing up of a new Frequency Allocation Table to provide for the redistribution of bands of frequencies among the various types of radio service. In particular, it was necessary to make provision for a great increase in the requirements for aeronautical communications, for numerous radio navigational systems developed during the war, and to take account of the introduction of new basic techniques and the enormous increase in the upper limit of the usable frequency spectrum that has resulted therefrom. Comparing the Atlantic City and Cairo Regulations, from the point of view of frequency allocation the changes that have been introduced fall broadly into three categories, namely:—

- (a) The formulation of service definitions to cover new types of service.
- (b) The introduction of new regional boundaries for allocation purposes.
- (c) Changes in the frequency allocation table itself.

As regards new types of service it will perhaps suffice to say that, in addition to the services to which bands were allocated under the Cairo Regulations, specific provision is now made for radio navigation systems, for radio aids to meteorology, and for the transmission of standard frequencies of high accuracy. In addition, certain limited bands have been designated for industrial, scientific, and medical equipment which results in the transmission of energy by radio capable of causing radio interference, radio services operating within these bands now having to accept any harmful interference that may be experienced from the operation of the equipment in question.

As regards new regional boundaries, it became evident at the outset that the division of the world's surface between the "European Region" and "Other Regions," as in the Cairo Regulations, was far from satisfactory and it is now divided, for allocation purposes, into three regions, Region 1 comprising Europe and Africa together with Outer Mongolia and the extra-European territory of the U.S.S.R.; Region 2 comprising the Americas; and Region 3 comprising Australasia and Asia except Outer Mongolia and the U.S.S.R.

Although the so-called "European Region" of the Cairo Regulations is no longer used for general allocation purposes, it has been retained as a basis for the control of long and medium wave European broadcasting; however, it is now termed the "European Area." In addition it was found necessary, in controlling the use of certain frequency bands for national broadcasting in tropical and quasi-tropical areas (the so-called "tropical broadcasting"), to redefine and extend a "Tropical Zone." This now completely girdles the earth between the tropics of

Cancer and Capricorn, with certain local extensions outside those limits in areas of high atmospheric noise.

Turning to the frequency allocation itself, the frequency range allocated is now 10 kc/s—10,500 Mc/s as compared with the range of 10 kc/s—200 Mc/s covered by the Cairo table. Below 4 Mc/s the changes are primarily in the nature of redistribution with increased allocations for the aeronautical and broadcasting services. The principal difficulties arose, of course, in allocating the frequencies between 4 and 25 Mc/s, this range being that essential for long-distance communication. The problem was that of redistributing the available spectrum space between existing types of service rather than catering for radically new developments; the principal changes being: (i) increased allocations for the aeronautical, amateur and broadcasting services with somewhat reduced allocations for the maritime and fixed services; (ii) the almost complete elimination of shared bands; (iii) the use of a harmonic relationship for the ship-shore sections of the maritime mobile bands.

As regards the spectrum between 25 and 10,500 Mc/s, that part between 25 and 200 Mc/s, which was already allocated to various services in the Cairo Regulations but only for the European Region, has now been re-allocated, partly to effect a redistribution of spectrum space between the established requirements and partly to make space for new developments. The spectrum above 200 Mc/s, entirely unallocated prior to the Conference, has now been allocated to cater for new developments, either existing or foreseen. The frequencies in this part of the spectrum have only a limited range of propagation so that it has been possible to make the allocations mainly on a regional basis, exceptions being made in the case of certain bands allocated, for example, to mobile or navigational services required for world-wide use.

New developments for which provision has been made are too numerous to list exhaustively but the allocations include: (i) extensive provision for radio-navigation systems, throughout this part of the spectrum; (ii) provision for television using the existing system and also for the development of higher definition or colour television; (iii) provision for new forms of broadcasting; (iv) provision for the development of wide-band point-to-point communication links and relay systems on frequencies above 1,000 Mc/s; (v) allocation of various bands suitable for experimental work in this relatively new part of the spectrum for use by amateurs.

The new allocation table was finally accepted, without any reservations, by every country attending the Conference. This is noteworthy since it is always open, at an International Conference, to reserve against a particular clause in a regulation, although subscribing as a whole and, as a general rule, controversial issues can be resolved by vote. In the field of radio frequency allocation, however, unanimous agreement is virtually essential because should a country insist, by a formal reservation, on using frequencies in derogation of the allocation table intolerable interference will almost invariably result.

#### *The International Frequency Registration Board.*

To date, countries which wished to establish a new radio channel made observations to find a "free" frequency in a band of frequencies suitable for, or allocated internationally to the class of service in question and then proceeded to take that frequency into use, notifying this to the Bureau of the I.T.U. which merely recorded the information and circulated it, in due course, to other Administrations. If interference to the service of another country resulted, the only redress lay in a request, by the country suffering the interference, to the Administration which had opened the new service, to find an alternative frequency for the new service. This system operated quite successfully in the earlier days when radio services were much less widespread but has become increasingly inadequate to deal with the large number of radio services which had been brought into use.

The Radio Conference decided, therefore, that, in future, the allocation of frequencies to individual services should come under the surveillance of a permanently constituted International Frequency Registration Board (I.F.R.B.). Administrations before taking a new frequency into use will, in future, notify this frequency to the I.F.R.B. which will examine the proposed use of this frequency from the aspect of possible interference with other services. As a result of this examination, the Board will either approve the use of the frequency, in which case it will be "registered" and taken into use and will be given protection against interference by later stations operating on the same or adjacent frequencies, or the Board, should they consider that the use of the frequency will cause interference to another station, will notify the Administrations accordingly and advise of the selection of an alternative frequency. The Board, among other auxiliary functions, will maintain a register of all radio services, arrange for the periodic publication of current lists of frequencies and other related material, watch over the operation of radio services by monitoring observations, investigate cases of alleged interference and plan, in collaboration with the C.C.I.R. the better utilisation of the radio-frequency spectrum.

Because of the important role which the I.F.R.B. will play, there was keen competition by the various member-countries of the I.T.U. for a seat on the Board. The countries elected by a secret ballot to provide the initial members were Argentina, Australia, Chile, Cuba, Czechoslovakia, France, India, South Africa, United Kingdom, U.S.A. and the U.S.S.R.

#### *The Provisional Frequency Board.*

The changes in the number of frequencies available to the various classes of radio service under the new frequency table involve substantial cuts (over 10 per cent) in the number of channels available for fixed and marine services (which formerly were the least congested) in order to provide increased allocations for broadcasting services and more particularly for aeronautical services and services of radio aids to navigation.

After a long study of the difficulties attendant on the transition from the old to the new table it was

decided that the only solution lay in a complete re-engineering of the whole spectrum by which a more efficient utilisation of frequencies could be made. It was urged that this work should be undertaken by a so-called Provisional Frequency Board (P.F.B.) consisting of the members of the I.F.R.B. together with representatives of any countries which desired to participate in the work.

The work of the P.F.B. will be of very great importance to United Kingdom interests as the future structure and scope of our radio services will largely hang on the general structure of the new frequency plan and the specific allocations which are granted to us. The work will be complicated as regards long-distance services, by the changes in the ionospheric cycle which involve changes of operating frequencies from time to time in order to maintain service. This point will have to be watched very closely in regard to the many long-distance services operated by the United Kingdom.

#### *C.C.I.R.*

Unlike the international consultative committee on telephony (C.C.I.F.) which has been very active since its inception, the corresponding committee for radio (C.C.I.R.) has been comparatively lethargic and has not met for several years. The conference decided that a live C.C.I.R. could undertake extremely valuable work in the international radio field and decided that this Committee should be remodelled on the lines of the C.C.I.F. in having a permanent full-time Director and a small specialised Secretariat.

It was agreed that a Plenary Assembly of the C.C.I.R. should be held in Stockholm in 1948.

#### *Operating Regulations.*

The Conference made a very large number of changes to the regulations governing the operation of, and accounting for, radio services, mainly in the nature of simplification and bringing them up to date.

The Conference also drew up new tables for frequency stability of radio transmitters, for permissible harmonic distortion and for band-widths of emission for various types of radio service.

#### THE PLENIPOTENTIARY CONFERENCE

This conference, opening on 1st July and signing the new Convention on 2nd October, set up an Administrative Council, composed of nominees of 18 member countries, to be the governing body of the Union in between the Plenipotentiary Conferences which elect the countries forming the Council. Its members will not be permanent officials of the Union but unpaid nominees of the elected Administrations, normally meeting only about once a year. In future, Plenipotentiary and Administrative Conferences will be held together at five-yearly intervals; the next are to be held at Buenos Aires in 1952.

The Conference also approved the creation of the International Frequency Registration Board on the recommendation of the Radio Conference, and provided for the strengthening of the Consultative Committees. Under the new Convention both the Radio Committee and the Telegraph Committee will have permanent Directors and the former will also

have a Deputy Director specialising in the technical problems of broadcasting; and all the Committees will have small specialised Secretariats. Apart from the members of the I.F.R.B. and the Directors of the Consultative Committees, the permanent staff of the Union is to be headed by a Secretary-General and two Assistant Secretaries-General.

A relationship agreement was initiated without much difficulty between the United Nations and the International Telecommunication Union, providing for the latter to become a "specialised agency" of the United Nations in accordance with the Charter. The agreement has been approved by the General Assembly of the United Nations.

The Conference agreed that the permanent seat of the Union should be moved from Berne to Geneva. It accepted in principle the view that, in future, voting membership should be confined to sovereign independent states and that non-sovereign territories (e.g. Colonies and groups of Colonies) should be eligible for separate representation without a vote; very substantial exceptions were, however, made to the principle of sovereignty to satisfy the European Colonial powers. Proposals to admit new members now require a two-thirds vote.

There was a strong feeling that all countries who subscribe to the Convention should also undertake to observe regulations applicable to each type of service and provision to this effect is incorporated in the new Convention; some countries, including the U.S.A. and Canada made formal reservations contracting out of this.

#### HIGH-FREQUENCY BROADCASTING CONFERENCE

As the Radio and Plenipotentiary Conference deliberations were far more protracted than anticipated it was agreed to restrict the agenda and concentrate on preparing the way for a full discussion to be held in Mexico City on 22nd October, 1948, by an Administrative Conference under the I.T.U. Convention.

The preparatory work at Atlantic City, which was spread over a period of some six months, was organised through three main committees. The first dealt with the technical principles underlying the preparation of an international frequency assignment plan for high-frequency broadcasting stations. This technical committee prepared guides on wave propagation and laid down conditions for the use of frequencies to cover typical zones; specified target figures for the frequency separation between assigned channels, signal-to-noise ratios, normal power limits, frequency tolerances for simultaneously shared and non-simultaneously shared frequencies, band-widths of emissions, permissible limits of transmitter distortion, and the required ratios of wanted to unwanted signals on shared adjacent and quasi-adjacent channels having regard to average receiver characteristics.

The second committee failed in its task of analysing the total requirements for high-frequency broadcasting services because a number of countries did not submit their high-frequency broadcasting requirements at all and some others submitted them too late or with insufficient data to enable any useful analysis to be made. The Committee did, however, make a number of useful recommendations in regard to economising

in high-frequency channels by such methods as the simultaneous use of the same frequency, use of relay stations and telephone networks, and recordings.

The third committee dealt with the preparations for the full high-frequency broadcasting conference, and agreed to the preparation of a draft assignment plan in consultation with the I.F.R.B. by a Committee of five countries—India, Mexico, United Kingdom, United States and the U.S.S.R.—meeting in Geneva during March to May, 1948.

#### PRELIMINARY EUROPEAN BROADCASTING CONFERENCE.

Advantage was taken of the presence of representatives of the European countries at Atlantic City to prepare the way for a European Broadcasting Conference in 1948, the main task of which will be to establish a new wavelength plan for European broadcasting stations. It was clearly recognised that such a new plan was long overdue, as, due to the War, a plan which was prepared at the Montreux Conference in 1939 was never implemented, and the operation of the European broadcasting stations is still based on the Lucerne wavelength plan of 1933. In order not to delay the work of the other International Conferences, a series of meetings was held in the evenings during the late stages of the Atlantic City proceedings.

Little difficulty was experienced in reaching general agreement on the technical principles on which a new frequency assignment plan should be based and the four main issues, which proved highly controversial, were as follows.

#### (i) *Preparation of a preliminary plan.*

The preliminary plan will be prepared in Brussels during the early months of 1948 by a Committee of representatives of eight countries:—Belgium, France, Holland, Sweden, Switzerland, United Kingdom, U.S.S.R., and Yugoslavia. This plan will be circulated to all countries in the European Area for their observations prior to the opening of the European Broadcasting Conference.

#### (ii) *Time and place of the Conference.*

Consideration had to be given to avoiding a clash with the projected International Conference on high-frequency broadcasting and it was finally agreed that the European Conference should be held in Copenhagen in July, 1948.

#### (iii) *Status of the Conference.*

After considerable discussion, it was finally agreed that the Conference should be a Regional Conference of the I.T.U. which would draw up a European "Agreement" and not a Plenipotentiary Conference which would draw up a "Convention"; thus the Conference will be bound by I.T.U. regulations, membership and rules of procedure.

#### (iv) *Membership.*

After a long period of complete deadlock on this issue, a compromise was adopted under which the Conference will be composed of member-countries of the I.T.U. but will have the power to invite additional countries from among the European nations which are not full members of the I.T.U.

A. H. M

## Book Review

"Television Explained." W. E. Miller, M.A.(Cantab), M.Brit.I.R.E. 52 pp., 56 ill. The Trader Publishing Co. Ltd. 3s. 6d.

This book is based on a series of articles which appeared in *The Wireless and Electrical Trader* and which were published with a view to helping dealers and service engineers to pick up the threads of television technique again after the seven years' interval in television transmission caused by the war. Written in simple language it will prove very valuable to the amateur with a good grounding in radio technique who wishes to understand the television receiver or to build his own set.

After dealing briefly with the types of receiving aerial which may be used, a chapter is devoted to a description of the standard television waveform and to a discussion of the bandwidth necessary for its satisfactory transmission—matters on which a good knowledge is essential if the functioning of the receiver as a whole is to be fully understood. The main part of the book is devoted to a description of typical circuits used in television receivers. No attempt is made to give the complete circuit diagram

of a receiver but the various parts are split up on a functional basis and the manner in which each performs its allotted task is clearly explained. The majority of the space devoted to the receiver proper deals with superheterodyne types. From this it should not be assumed that this type is necessarily better than the straight receiver; it is merely that a description of the former type also covers the latter since the make-up of the straight receiver is very similar to that of the I.F. portion of the superheterodyne except that the frequency is considerably higher.

The auxiliary circuits—synchronising separator, time bases, power supplies, etc., are all dealt with, and a chapter is devoted to the description and principles of operation of cathode-ray tubes. The book concludes with a chapter on the installation and operation of television receivers which gives some useful hints on the setting of the various controls, together with a series of photographs showing the appearance of the picture with incorrect settings. Unfortunately the poor quality of reproduction of the latter, due no doubt to present-day printing difficulties, detracts somewhat from their value

T. K.

## Early Correspondence between Sir William Preece and the Marchese Marconi

Through the generosity of Sir Arthur Preece, son of Sir William (Engineer-in-Chief to Post Office, 1892-1899), the Post Office has been presented with a number of letters and papers of great historical interest dealing with early aspects of telecommunications. These documents, now housed in the Post Office Muniments Room, Headquarters Building, were found amongst the records of Messrs Preece, Cardew and Rider, the firm of consulting engineers founded by Sir William on leaving the Post Office.

One of the most interesting items is a letter from Marconi to the then Mr. Preece outlining proposed experiments on "signalling without wires." The accompanying illustration shows the first

page of this letter, the full text of which follows.

"Dear Mr. Preece,

I have been thinking this some time of writing to you in reference of the proposed experiments on telegraphy without wires which are going to be carried out near Cardiff.

The experiment which I and Mr. Kempe purposed to carry out was according to the following principle.

A conductor or capacity (such as a cube cylinder or sphere) is fixed at the top of a pole (which might be the mast of a ship).

The capacity is electrically charged and discharged by means of a conductor communicating with an induction coil at the rate of several millions of charges and discharges per second.

This is obtained by obliging the spark of the coil to take place in an insulating liquid such as oil.

This very rapid charging and discharging of the capacity throws the ether all round into vibrations which affect the conductor at the receiver (which ought to be electrically tuned with the transmitter) and actuate my relay.

If the transmitter is connected to earth a great part of the vibrations pass to earth, and are transmitted along the surface all around to a considerable distance.

The experiments on this system which I carried out at my home in Italy gave me the following results, which I take from my notes.

A coil giving a three inch spark was used.

With cubes of tin  $30 \times 30 \times 30$  centimetres, at the transmitter and receiver, on poles 2 metres high, signals were obtained at 30 metres from the transmitter; with the same cubes on poles 3 metres high signals were obtained at 100 metres, and with the same cubes at a height of 8 metres (other conditions being equal) morse signals were easily obtained at 400 metres from the transmitter.

With larger cubes  $100 \times 100 \times 100$  centimetres, having a surface of 6 square metres, fixed at a height of 8 metres, reliable signals were obtained at 2,400 metres all round, equal to 1 mile and  $\frac{1}{2}$ .

The cylinders which we purpose to use down at Cardiff will have a surface of about 60 square feet, and are to be fixed, and insulated at the top of poles 14 metres high.

If my calculations (based on the figures obtained in other experiments) are correct, signals should be obtained in this case at nearly 3 miles from the transmitter.

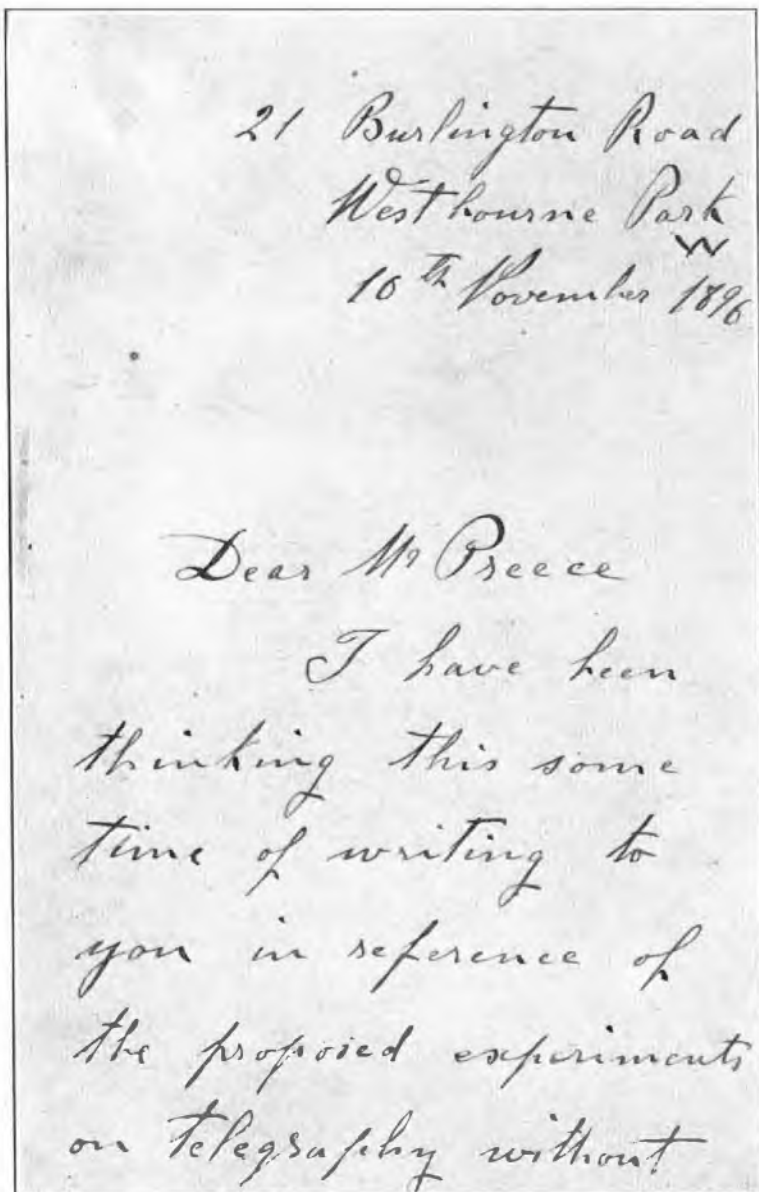

As the distance at which signalling is possible seems to increase very rapidly by increasing the height of the capacities (as the figures I have found tend to show) I think it would be very interesting from a theoretical and practical point of view to test this point by still more increasing the height of the capacities, and observing if the effects go on increasing in the same proportion as has been found for small heights.

In order to prove this I would propose with your consent to experiment during the trials at Cardiff with two small captive balloons covered with tin foil, and communicating with the apparatus by means of a wire.

These balloons would be used in place of the metallic cubes or capacities, and if the weather permits they would be allowed to ascend to a height of about 100 yards.

By this means one would be enabled to observe the effects obtainable by increasing or diminishing their height so as to obtain reliable figures on which to base the calculations for this system.

In the event of these experiments being tried I am willing to supply the captive balloons, together with a few cylinders of hydrogen for inflating them.

Hoping that you will kindly let me know your opinion on this subject.

Believe me, dear Sir,  
Yours very truly,  
Guglielmo Marconi.

W. H. Preece, Esq., C.B., F.R.S.  
General Post Office.

P.S. As I am preparing a detailed description of my studies and experiments on signalling without wires, which I carried out in Italy and in this country, I should be very glad to forward you a copy of the same when I have got it ready (in the event of it being of interest to you) prior to any publication taking place."

G. M.

It is evident that the encouragement and assistance given by Sir William was not forgotten, for Marconi sent the following telegram to "The Times" on the day of Sir William's death (7th Nov., 1913).

"Deeply regret death of Sir William Preece who was first person in England to take interest in my early experiments and to lecture upon them. It was due to his influence that I received considerable encouragement from the British Post Office. Guglielmo Marconi."  
E. C. B.

## Institution's Library

Recent additions to the Library include the following :

1757 *Electric Filters*. T. H. Turney (British 1946).

A simplified treatment of the four-terminal networks commonly used in telephone work, covering filters, attenuators, phase shifting networks, and attenuation equalisers.

1758 *The Reader over your Shoulder*. Graves and Hodge (British 1947).

This book has been compiled to serve a twofold purpose: it is a guide for the potential as well as the actual writer, and an invaluable assistant for the teacher of English. It deals with the peculiar qualities of English, the present confusion of English prose, use and abuse of official English, principles of clear statement, graces of prose, and poses the question "Where is good English to be found?"

1759 *Atomic Physics*. Max Born (British 1946).

This book contains a lucid and up-to-date account of the physics of the atom and of the various forms of the quantum theory. It is chiefly, but not solely intended, for honours students. More advanced mathematical developments are separated from the main text which, complete in itself, deals with the kinetic theory of gases, elementary particles, nuclear atom, wave-corpuscles, atomic structure and spectral lines, spin of the electron and Pauli's principle, quantum statistics and molecular structure.

1760 *Central Film Library Catalogue*.

Besides detailing the films available in the Central Film Library (distributors of M.O.I. films), this booklet gives information on running time and sizes (most films are 16 mm. or 35 mm.), method of booking and borrowers' responsibilities.

1761 *Servomechanisms*. MacColl (American 1945).

A comprehensive introduction to the fundamental theory of automatic control, concerned

mostly with the general theory which is applicable to all linear continuously operating servomechanisms, with the emphasis placed on the essential identity of that theory with the highly developed theory of feedback amplifiers.

1762 *High Frequency Transmission Lines*. Jackson (British 1947).

Brings out the restrictions associated with the application of electromagnetic theory to high frequency line systems, and considers the characteristic properties of lines and their applications in high frequency technique.

1771 *The Physics of Music*. A. Wood (British 1947).

This book is an attempt to present to those who are interested in music the knowledge which we have to-day of that interesting borderline territory which lies between physics and music. Presentation is designed primarily for those whose main interest is on the musical side. The book contains a fairly full account of recent work on the analysis of musical tone, a discussion of the production of tone by typical musical instruments, as well as a descriptive treatment of the design of rooms and halls for good musical tone and the various methods of recording and reproducing sound. An appendix includes some of the more mathematical material, and references will enable those whose interest is physical to pursue their studies further.

1775 *Telephone Manufacturers of India Ltd. Report on the proposed conversion of the Calcutta Telephone Network to Automatic Working*.

Vol. I. Consultants' Recommendations.

1776 *Telephone Manufacturers of India Ltd. Report on the proposed conversion of the Calcutta Telephone Network to Automatic Working*.

Vol. II. Appendices.

L. A. CARTER,  
Librarian.

# Notes and Comments

## Roll of Honour

The Board of Editors deeply regrets to have to record the deaths of the following members of the Engineering Department :—

Brighton Telephone Area	..	Newton, T. H. H.	Labourer	..	..	..	..	Corporal, The Buffs
Bristol Telephone Area	..	Leary, K. S. P.	Skilled Workman, Class II	..	..	..	..	Stoker Mechanic, R.N.
London Telecomms. Region	..	King, L. A. L.	Skilled Workman, Class II	..	..	..	..	Signalman, Royal Signals
Southampton Telephone Area	..	Edwards, A. C.	Skilled Workman, Class II	..	..	..	..	Flight Lieutenant, R.A.F.

## Recent Awards

The Board of Editors has learnt with great pleasure of the honours recently conferred upon the following members of the Engineering Department :—

Brighton Telephone Area	..	Borrer, R. W.	..	Skilled Workman, Class II	..	Corporal, Royal Signals	..	Mentioned in Despatches*
Cambridge Telephone Area	..	Cater, J.	..	Technician	..	Squadron Leader, R.A.F.	..	Air Force Cross & twice Mentioned in Despatches
Gloucester Telephone Area	..	Wicks, C. L.	..	Skilled Workman, Class I	..	Lieut.-Colonel, Royal Signals	..	Officer of the British Empire and American Bronze Star
Leicester Telephone Area	..	Brown, C. E.	..	Technician	..	Corporal, Royal Signals	..	Bronze Medal of the Order of Orange Nassau with Swords
London Telecomms. Region	..	Burgess, D. W. H.	..	Skilled Workman, Class II	..	Signalman, Royal Signals	..	Mentioned in Despatches
Manchester Telephone Area	..	Moon, D. R.	..	Skilled Workman, Class II	..	Corporal, Royal Signals	..	British Empire Medal
Manchester Telephone Area	..	Thompson, W.	..	Technician	..	L/Cpl., Royal Signals	..	Mentioned in Despatches
Oxford Telephone Area	..	Felton, K. E.	..	Skilled Workman, Class II	..	Sergeant, Royal Signals	..	British Empire Medal
Scotland West Telephone Area	..	Cravens, W. J.	..	Skilled Workman, Class II	..	Wt. Offr., Class II, Royal Signals	..	Mentioned in Despatches

\* Incorrectly shown as Medaille de la Reconnaissance Française in October 1947 issue.

## E. H. Jolley, M.I.E.E.

A career devoted to the advancement of telegraphy has been diverted, but it is hoped not permanently, by the promotion of Mr. E. H. Jolley to take up a post in the Research Branch as Staff Engineer.

Mr. Jolley, a Manxman, was one of those of bright promise whose early ambitions were frustrated by the first world war and we first meet him as acting Inspector in the Research Branch in 1923, where his advance to Probationary Inspector in 1924 and Probationary Assistant Engineer in 1925 gave indication of his future promise.



His early work was in connection with balancing and testing underground and submarine cables during a period of great expansion and here his keen interest in all matters fundamental was reflected in a paper to the I.P.O.E.E. which gained him a Silver Medal of the Institution.

Transferred to the Telegraph side of the Research

Branch in 1931 he has since, with the exception of a period in 1933 when he served as an Assistant Engineer at Nottingham, devoted his talents to telegraph matters. In 1933 he was promoted Executive Engineer in charge of the Telegraph Section at Dollis Hill and in 1937 Assistant Staff Engineer in the Telegraph Branch at Headquarters.

To say that Mr. Jolley has left his mark on the development of telegraphy is an understatement. Quite early his enquiring mind and grasp of fundamentals led to the development of the Teleprinter Margin Tester, an instrument which is a landmark in the advance of telegraphy and the principles of which have been widely adopted. He has written various articles and papers on telegraphy including a recently published book on Telegraph Transmission; served on various Departmental and Inter-Service Committees and has taken an active part in the activities of the C.C.I.T.

His lively personality, his regard for essentials, his nature, essentially loyal and co-operative, endeared him to all who had occasion to work in close contact with him and all his friends and colleagues will wish him success in his new field of endeavour.

F. E. N.

### **R. F. J. Jarvis, Ph.D., A.M.I.E.E.**

Dr. R. F. J. Jarvis, receiving his engineering training at the City and Guilds Engineering College where he also carried out 18 months' post-graduate research work, entered the Engineering Department in December, 1928.

After a spell of training in the London Engineering District, he found his niche in the radio laboratories of the Radio Branch, to which he was posted in September, 1929, receiving promotion there to Executive Engineer in September, 1936 and Assistant Staff Engineer in June, 1942. He has been associated with many phases of radio and television development and is well known for the activity he has displayed in the development of the coaxial cable carrier system. It is not surprising, therefore, that he has been a member of the British Delegation to the C.C.I.F. 3rd CR dealing with telephone and television line transmission,



attending the Paris and Montreux Conferences, 1946, and Paris, 1947. For many years he has been a member of the Inter-Services Radio Measurements Committee—he has a weakness for measurements—and the Inter-Services Technical Valve Committee with its various sub-committees. He was elected a member of the Radio Section Committee of the I.E.E. in 1946, for a period of three years.

The Radio Branch and his many friends in the branch will miss this man, quiet, unassuming and good humoured and will follow with interest the further development of his career in his new home, the Research Branch, where he takes up a post as Senior Principal Scientific Officer.

A. H. M.

### **C. E. Richards, F.R.I.C.**

Mr. C. E. Richards, who has recently been appointed as a Senior Principal Scientific Officer in charge of that side of the work of the Research Branch concerned with Chemical, Metallurgical and Physical investigations, started his career in the Post Office at Liverpool in 1922. He had previously served an apprenticeship in chemistry in the Research Department of Lever Brothers, at Port Sunlight, followed by two years as works and development chemist to a chemical manufacturing firm in Manchester. On joining the Engineering Department, Mr. Richards, for the time, broke his connection with chemistry, but on coming to Dollis Hill as a trainee cable tester, in 1923, his chemical training and experience became known and he was transferred to the Materials and Measurements Group of the Research Branch. Mr. Richards became an Associate of the Institute of Chemistry in 1925; he later passed the examination for Probationary Assistant Engineers, and was graded as an Assistant Engineer in 1930. In 1936 he obtained a Fellowship of the Institute of Chemistry and on the creation of separate grades for chemists in the Engineer-

ing Department he was appointed as a senior chemist in 1937. In 1944 he rejoined the ranks of the engineers as an Assistant Staff Engineer.

During his career in the Research Branch, Mr. Richards has been engaged on a wide range of researches and investigations on such subjects as the corrosion of metals, the physical and chemical properties of lead and lead alloys, the development of spectrographic methods of analysis, the production of carbon granules, and detection of inflammable or poisonous gases in man-holes.

During the war some of his work was of a highly confidential nature. Amongst his wartime activities may be mentioned his work as a member of the Ministry of Supply Iron-dust Committee.

Mr. Richards has contributed papers to the I.P.O.E.E., I.E.E., and the Iron and Steel Institute, and several articles in this Journal have described interesting aspects of his work. His many friends and particularly his old colleagues of the Materials and Measurements Group will wish Mr. Richards (Dick) every success in his new appointment.

F. O. B.



### **L. E. Ryall, Ph.D.(Eng.), A.M.I.E.E.**

Dr. Ryall, who needs no introduction to readers of this Journal, has had a career which fits him well for his latest appointment as Senior Principal Scientific Officer in the Research Branch.

Having completed his studies at East London College, he joined the G.E.C., Osram Lamp Works, in 1922 and three years later entered the Post Office Engineering Department. For the next fourteen years he was employed in the Research Section of the Engineer-in-Chief's Office, first at Marshalsea Road and later at Dollis Hill. His wholly remarkable enthusiasm and energy were at once apparent, for in 1928 he gained his Ph.D. degree with a thesis based on an investigation of the characteristics of neon lamps, a subject which did in fact foreshadow much of his subsequent work. His interest in non-linear elements has never abated, but his intuitive mind could see far beyond the plain statement of a scientific fact, and innumerable applications of these devices to telephone transmission equipment—echo suppressors, oscillators, loudspeaking telephones—bear eloquent, sometimes outspoken, witness to his inventiveness in this field. Many of these he has described in the pages of this Journal and in printed





papers of the I.P.O.E.E. He received the Silver Medal of the Institution in 1934.

He was promoted Executive Engineer in April 1934 and in November 1939 Regional Engineer in Scotland. There, he was vitally concerned with the unprecedented growth of long-distance communications during the war, when again his enthusiasm and essentially practical outlook cleared away many of the difficulties inevitable in such circumstances. But his absence from research was only temporary, and probably not complete at that. His return to Dollis Hill brings no surprise to his colleagues, who, whilst offering him their best wishes, are confident that under his inspiring and sincere guidance the development of this new extension of Research Branch activities is assured.

F. O. M.

### Post-War Telephone Developments

We have pleasure in publishing in this issue an important article by Mr. B. L. Barnett, C.B., M.C.

(Director of Inland Telecommunications), explaining the many difficulties attending telephone development in the post-war period and indicating the lines on which future development will proceed.

The subject matter was covered in a paper read by Mr. Barnett before the Post Office Telephone and Telegraph Society of London on October 29th, 1947, and in view of its great general interest the Board of Editors welcomes the opportunity of according it a wider circulation.

### Increase in Journal Price

Journal production costs have risen steeply during the past few years and the Board of Editors has decided that an increase in price must take effect at an early date to ensure continued publication on a self-supporting basis.

We have to announce, therefore, that commencing with the April 1948 issue the price of the Journal will be 1s. 6d. (1s. 9d. post free) per copy and the subscription rate 7s. per annum, post free.

---

## Institution of Post Office Electrical Engineers

### Election of Council for Year 1947-48

#### REPRESENTATION OF CHIEF INSPECTORS, etc. (PROVINCES)

The result of the recent election to the vacancy in respect of the representation of the above group on the Council is given below. The successful Candidate is indicated by an asterisk, and the names are arranged in the order of votes polled.

J. READING,  
*Secretary.*

\*HARGRAVE, L. R.  
Shipley, F. H.  
Brown, W. D.  
Cooke, E. M.  
Jordan, T.

### Junior Section

#### Bradford Centre

The above centre recommenced activities on 20th March, 1947, when a General Meeting elected the Officers and Committee for the 1947/1948 session.

During the early summer a visit was made to the Bradford Corporation electricity works. Keen interest was displayed in the control room, where the application of the Central Electricity Board electricity cuts was explained.

The winter session commenced in October with a visit to the works of the British Insulated Callender's Cable Co. at Prescott, to whom we extend our thanks for a most instructive tour of the works and an excellent tea. A full programme has been arranged for this session including visits to an electrical engineering works and a coal mine.

The membership is now 60, but it is hoped to increase this figure considerably during the current session.

#### London Centre

We shall have commenced the second half of our winter programme by the time of publication of these notes and the first lecture will be once again on television, but on a specialised branch of the technique known as "Short-Distance Line Television Transmission." The lecturer will be T. Kilvington, B.Sc.(Eng.). Following in February and March are two lectures both given by Junior Section members on different aspects of automatic telephony, "The 2,000 Type Selector and the New Standard Uniselector—Some Mechanical Developments," by G. H. Rouse and M. B. Moore, in February, followed in March by R. F. Howard on "Impulsing." Both these lectures will be supported by slides and working models. We complete the programme in April with a lecture on "Frequency Modulation" by D. O'R. Macnamara.

Through the good offices of a previous lecturer we have been able to organise visits to the B.B.C. Broadcasting House but although we have secured some ten visits the number of places available is only ten per visit and these have been allocated on an Area membership basis.

The annual Junior Section award of prizes for Session 1946/47 for the best papers read before Centre meetings was headed by J. Gregory of L.D. Area for his paper entitled "12 Channel Carrier System No. 7." The award of £3 3s. 0d. and Institution Certificate was made by the Chief Regional Engineer, Mr. A. Morris, M.I.E.E., at Faraday Building in October last.

The membership to date is in excess of 1,100 and we hope to reach an even higher figure before the session is over. Any member or prospective member who hasn't a representative within his building is urged to communicate with the Secretary whenever advice or information is desired, especially if willing to act as local representative.

J. G.

# Regional Notes

## London Postal Region

### LETTER-DRYING MACHINE

From time to time bags of mail which have been salvaged after immersion in sea water arrive at the Returned Letter Section. It is most desirable that this mail be handled expeditiously, but before normal circulation can be followed each item must be dried, repaired, and examined. Delay in the past has arisen due to the primitive methods available for the drying of the letters. Improvisations such as spreading the letters on tables and radiators have been adopted. These methods were not only slow, but were objectionable from the point of view of health.

Many experiments were carried out prior to the war to ascertain the most efficient and quickest method of drying the letters, which are usually in such a condition that very careful handling is necessary. From these experiments it was found that hot air, blown across the letters at high velocity, gives the best results. The surface moisture is removed by the air movement and the heat drives the moisture to the outside surface. A further requirement was for the drying out to be a continuous process.

Enquiries made of a number of manufacturers indicated that a machine based on these principles was already in use in some laundries for drying garments. With the co-operation of Messrs. Lister Bros., of Woolwich, further experiments were made on one of these machines and it was found that, with slight modifications, a standard machine would adequately meet the requirements.

The machine consists of a continuous chain conveyor passing through a duct which is divided into four

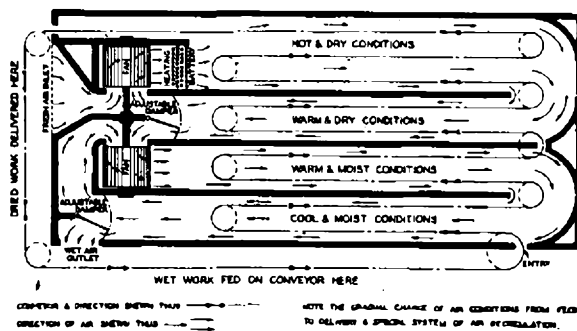

FIG. 1.

compartments, as shown in Fig. 1. The wet articles are attached to the conveyor. Air heated by a heater battery supplied with steam at 80 lbs. per square inch pressure is blown along the ducts at high velocity. Wet letters which enter the machine at one end are dry by the time they pass out of the machine at the other end. Experiments showed that the thicker letters require some 30 minutes to dry and the machine had to be equipped with a special variable speed gear which enables the chain conveyor to run at a speed variable between one and three feet per minute in order that the drying time may be varied from 10-30 minutes.

The standard machine has patent clips attached to the chain for carrying blankets, etc. In the Post Office machine these clips have been retained to enable the machine to be used for drying uniforms. For letters, special wire mesh racks have been designed. Each rack is fitted with seven compartments, six of which con-

tain a centre partition for holding short letters, the seventh being for use with long letters. Not more than three letters per compartment gives effective drying, so that each rack holds up to 40 letters. One hundred racks can be accommodated in the machine at one time, so that the machine has a drying capacity of some 8,000 letters per hour.

The machine is arranged so that the drying is a continuous process, racks being loaded with saturated mail at one end whilst racks containing the dried letters are taken from the conveyor as it passes out of the machine.

D. G. P.

## London Telecommunications Region

### MONARCH AUTOMATIC EXCHANGE

Monarch automatic telephone exchange was brought into service on the 13th September, 1947, when 4,353 subscribers were transferred from City automatic exchange to which they had been connected since the destruction by enemy action of the exchanges in the Wood Street building. It will be recalled that National, Metropolitan and London Wall exchanges, housed in this building, were destroyed in the fire raid on London in December, 1940. A full description of the event and the measures taken in the emergency were dealt with in an article previously published in the Journal<sup>1</sup>.

Monarch exchange is the first unit to be replaced and the reinstatement work was decided upon in 1941, when a contract was placed for the equipment to be manufactured and delivered to site; apart from the auto-manual boards and frames, however, the installation of the automatic equipment was not proceeded with until the cessation of hostilities. The equipment, comprising a complete 10,000 line unit with 85 manual board positions, is of the "2000" type and was installed by the Automatic Telephone and Electric Company Ltd. The installation work was carried out in three stages as follows:—

#### Stage 1.

55 auto-manual positions and associated equipment. A junction M.D.F. of 154 verticals on the 2nd Floor and 2 test desk positions. This was commenced in September 1943 and brought into service in April 1945 for the purpose of giving relief to Faraday Building by transferring the City/Central auto-manual traffic to the Wood Street building.

#### Stage 2.

The subscribers' M.D.F. of 178 verticals on the 3rd Floor, which is situated immediately above the junction M.D.F. on the 2nd Floor with pipes to facilitate inter-frame jumpering, was started in August 1945 and completed in December 1945, thus making it possible for the external terminations to be commenced in advance of the main equipment being installed. This included the diversion of all existing junction and subscribers' circuits from the temporary M.D.F. on the 1st Floor to their permanent positions on the 2nd and 3rd Floor M.D.F.s respectively. The temporary frame was installed as a part of the emergency measures immediately after the destruction of the original exchanges.

#### Stage 3.

Installation of the 10,000 line automatic unit, the remaining 30 auto-manual and 7 test desk positions was carried on concurrently with Stage 2, and completed in September 1947.

The power plant is designed to meet the ultimate

<sup>1</sup>P.O.E.E.J. Vol. 36, p. 20.

requirements of the building for Monarch, Metropolitan and Headquarters exchanges, also the new Overseas exchange. It is operated on the divided battery float scheme and comprises :—

(a) Two of the original 1,600A output motor generator sets (overhauled by the E.C.C.).

(b) A new 600A output motor generator manufactured by the E.C.C. for light load conditions.

(c) Two of the original sets of 10,000Ah. battery boxes, reconditioned and plated to a capacity of 5,160Ah. by the Alton Battery Company.

(d) Ringing and tone distribution supplied from power and stand-by battery machines with 4A output.

It should be mentioned that much of the salvaged equipment from the original Wood Street power plant was re-used.

The change-over was complicated by the fact that the lines to be transferred from the City unit at Faraday Building to the Monarch unit at Wood Street, were spread over the whole range of the City multiple, and also that the standard method for an auto transfer at the losing exchange could be employed for only 1,600 of the lines owing to an acute shortage of the necessary change-over equipment.

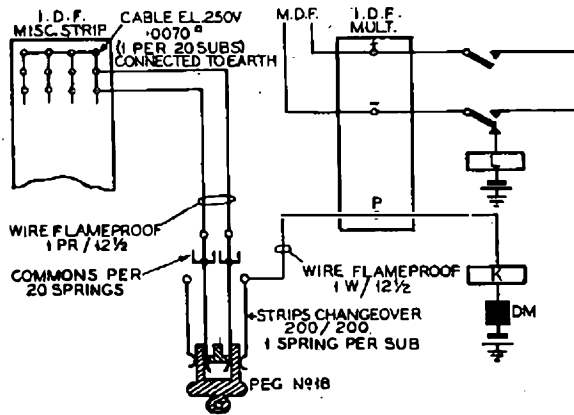

As an expedient the following scheme (see diagram) was adopted for the remaining 2,753 lines. Each subscriber's K relay was connected via its "P" wire terminal to a change-over strip fitted with an insulating peg to earth, and at the time of the transfer all the insulating pegs were withdrawn and the K relays operated, thus simulating a "busy" condition at City exchange.

Immediately the cut-over had been effected the transferred lines were isolated on the City M.D.F. by inserting insulating pegs in the test springs of the associated exchange protectors. The insulating pegs were then replaced in the change-over strips, thus releasing the K relays and avoiding a prolonged drain of 100A from the exchange battery.

A. F. D.  
E. L.

### A NEW OVERSEAS EXCHANGE

Towards the end of 1944 when consideration was given to the post-war development of Continental and Overseas (Radio) services, Headquarters forecast exceptional growth of both types of traffic, and it became evident that if the expected growth materialised the International exchange in Faraday Building would require considerable extension. As no accommodation was available in Faraday Building it was decided that the Overseas service must be handled elsewhere and the positions thrown spare used to extend the Continental suite. Plans were therefore

made for provision of a new Overseas exchange and suitable accommodation was found in the Wood Street Building which, with a capacity for 150 positions, will meet the requirements until about 1960.

A contract for an initial installation of 84 operating positions (50 to be provided as an advance stage) and 21 miscellaneous positions, together with the associated apparatus, was placed in March 1946 with the A. T. & E. Company. The first stage was ready for service by mid-October, 1947. After undergoing the customary engineering tests and traffic trials the new exchange was brought into service on the 24th November. Installation of the further 34 positions has now been completed.

It is hoped that an article on this new exchange will appear in a later issue of the Journal. R. C. D.

### North-Eastern Region

#### BRADFORD—CONVERSION TO AUTOMATIC

The non-director system was introduced to the Bradford exchange area on 26th July 1947, and coincided with Bradford's centenary celebration of incorporation. The official opening was attended by the civic dignitaries of the Local Authorities for Bradford, Shipley and Baildon, and it was a great moment when the Lord Mayor of Bradford made the first call to the Postmaster-General. All present could hear the progress of the call, which was radiated by loudspeakers, and it is noteworthy that line and plant gave a very fine reproduction of distortionless speech.

The old manual exchange catered for 12,000 lines. It comprised a C.B. No. 1, 22-volt board with a normal capacity of 10,000 lines, the additional multiple capacity being obtained via a relief board equipped with a 2,000-line multiple. Access to the latter was on an order-wire basis. The subscribers' calling equipment required for this extension was connected to another relief board which had full O.G. junction facilities, but no subscribers' multiple. In effect, the subscribers' service was unidirectional both in theory and in practice.

As the transfer had been deferred owing to the war, some concern was felt about the condition of the new apparatus which had been stored during hostilities. There proved, however, to be no cause for alarm—cleaning and lubrication brought the plant up to standard.

The main exchange, installed by the A.T.E. Co., is situated in the centre of Bradford. The building has very modern lines and reflects credit on the architect. In the basement is the cable chamber, and on the ground floor are the M.D.F., test desk, power plant and amplifying equipment. The automatic plant is on the first floor, while the automanual board, together with relay set racks, are on the floor above. Staff and canteen accommodation are provided on the top floor.

The central auto exchange has a multiple capacity of 9,600 lines, and the manual board comprises 96 positions. There are five satellite exchanges, viz :—

Shipley (G.E.C.)	4,900 lines.
Manningham (G.E.C.)	4,500 lines.
Horton Bank (Ericssons)	1,600 lines.
Laisterdyke (G.E.C.)	1,200 lines.
Undercliffe (G.E.C.)	1,400 lines.

Concurrently with the transfer, external development schemes were carried out for the satellite exchanges. These schemes were based on post-war planning methods, the cables being formed into cabinet and pillar areas. The plant required for the schemes involved 74 miles of cable, 16 miles of duct and 490 poles. A development scheme for the main exchange was planned in 1938, and was carried to completion by 1946. This scheme was

based on pre-war methods of planning and, sad to relate, already requires augmentation.

As in most Areas, the telephone development increased considerably in the last few years, and prior to the transfer, it had been necessary to open relief manual exchanges in the satellite buildings to cater for outstanding applications. These relief exchanges are no longer in use, but it is possible that they may be reopened to meet the continual demand for service in advance of extensions to the automatic equipment.

The progress of the external work connected with the transfer was seriously hampered and delayed by the severe winter conditions followed by gales and floods in the spring and early summer. It did seem at one time that the "odds" were too great and that the target date for the transfer would not be met. The fact that it was met despite these handicaps is something of an achievement.

To provide for development at the main exchange, a 1,400-line multiple extension is now under design, and the opportunity will be taken to introduce multi-metering so as to give relief to the automanual board by allowing subscribers to dial up to four unit calls. As for the external plant, the next relief for the main exchange should see the fitting of cabinets and pillars, providing full flexibility as well as cross-connection points for external extensions.

It should not be supposed that the line plant and apparatus thrown spare by the conversion has reached the end of its life. The boards, apparatus and cable are being packed and despatched to exchanges waiting for extensions, and the underground cables are being reconditioned for further development schemes.

J. H.  
F. L. S.

### Northern Ireland Region

#### UNORTHODOX EXTENSIONS TO AUTOMATIC EXCHANGES

Early in 1945 it became apparent that the exchange extension programme would not be implemented in time to cater for the ever increasing list of applicants for telephone service. Some interim measure of relief was decided upon and two schemes were devised, one for Belfast Central exchange and one for the satellites. For the Belfast Central scheme, semi-auto equipment was used and the relief equipment grafted into the main exchange in such a manner as would not obstruct the provision of the exchange extension proper (see Fig. 1).

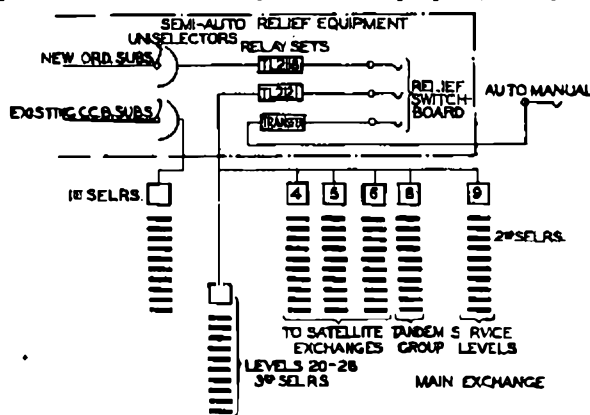

FIG. 1.

In Central exchange the existing final selector multiple exceeded the primary finder multiple by approximately 800 available lines and these numbers were allocated to the subscribers to be served by the relief equipment.

Initially 9 sleeve control positions, six of which were obtained from the Belfast manual emergency scheme, were provided to deal with the originating traffic, and transfer circuits to the main auto-manual switchboard provide access to trunks and junctions not contained in the auto-tandem group. Access to the tandem group and satellite exchanges is obtained via directly-connected 2nd selectors and to local subscribers via directly-connected 3rd selectors. Incoming calls to the new subscribers from local subs., satellite and D/I exchanges are completed automatically and do not require the assistance of the relief exchange operator.

It will be seen from Fig. 1 that the existing C.C.B.s have been connected to the new semi-auto uniselectors; this arrangement was designed to remove the extremely heavy traffic from the existing C.C.B. primary finder groups. The two P/F groups concerned are of the "25 and under" type so that a maximum of only 50 first selectors could be connected. Under the new arrangement the first selectors were increased to 60 and graded to the uniselector groups accordingly.

In no instance was the existing exchange grading modified; this was important because the new contract extension, which includes the provision of the new 2,000-type graded rack, will require a clear field for the provision of the grading arrangements.

#### Satellite Scheme.

Switchboards AT 3796 were used in this scheme and installed in the satellite exchanges concerned. The relief switchboards were connected to the satellite exchange equipment as shown in Fig. 2.

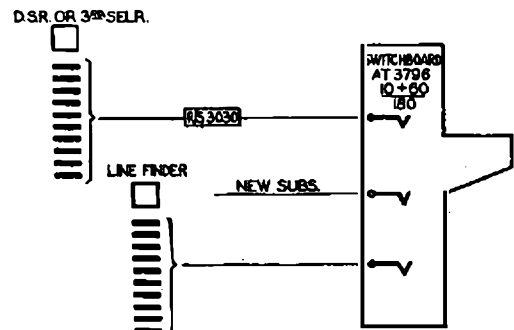

FIG. 2.

Subscribers' lines were allocated numbers in the numbering range of the satellite exchange and connected to the extension jacks of the relief switchboard. Outgoing circuits to the linefinders are terminated on a strip of specially fitted O/G jacks and distributed over the various linefinder groups. Incoming circuits from the selector levels are terminated on the normal exchange line jacks and the indicators modified for C.B. signalling conditions and to give back ringing tone.

The battery feed retardation coils are disconnected from the cord circuits and only the supervisory relays are left in circuit. The answering cords of specially selected pairs are permanently plugged into the O/G jacks associated with the linefinder equipment, so that only one operation, i.e. plugging the associated calling cord into the calling line, is required to connect the subscriber to a linefinder group. The scheme is, in effect, a device to increase the capacity of a linefinder group to something over 200. Incoming calls are metered automatically and credit dockets issued for calls which are not completed. All outgoing calls are docketed by the relief switchboard operator after the connection has been monitored to verify that the call has been successfully set up.

J. C.

## North-Western Region

### P.C.Q.L. CABLE USED IN LIEU OF SWITCHBOARD CABLE, ANFIELD EXCHANGE, LIVERPOOL

In the Liverpool Telephone Area there are several major manual public exchange extensions in hand, and the following experiment in the substitution of switchboard cable by P.C.Q.L. cable has proved to be so successful that it is being adopted where possible in other exchanges, in an endeavour to overcome the present shortage of switchboard cable.

At Anfield exchange, Liverpool, a manual exchange of the C.B. 10 type comprising 24 positions (14A, 2J.E.B., 2 P.E.B., 5 D/O, 1 T. & P.U.) with a 4-panel multiple of 2,800, it was not possible to extend the multiple and, to meet development, arrangements were made to install a suite of 9 C.B.1 positions with 6-panel multiple. To avoid transfer-working on incoming calls all incoming circuits were to be terminated on the new suite. "A" operators obtain access to numbers outside the 2,800 range via order-wire circuits to the "B" positions. The multiple over the existing suite had therefore to be extended to the new suite and the additional multiple had to be run to the new suite only.

The 140 multiple tie cables required between the suites were each 17 yds. in length. Some 60-wire flat cable was held locally, enough to make the multiple for the new suite and for 45 tie cables. Supplies of cable from Depot being uncertain, it was decided to extend the whole of the existing multiple to the new



suite by means of P.C.Q.L. cable. The racking erected for the 60-wire flat switchboard tie cables was strengthened, and seven 600/10 P.C.Q.L. cables each 17 yds. in length were run between the two suites. Short pieces of switchboard cable were spliced to the multiple on the two suites leaving tails of 4-5 feet for jointing to the lead-covered cables. 60-wire oval switchboard cable was used for the C.B. 10 suite tails and 60-wire flat switchboard cable for the C.B.1 suite tails. The spliced tails

were made into seven groups each of 20 cables, stripped, waxed and bound into round forms. Included in each form was a 12-wire switchboard cable to take the three extra quads in each of the 600/10 cables and these 12-wire cables were terminated on connection strips mounted in the cable turning sections. Lead collars 4 ins. in diameter and 6 ins. in length were threaded over the cable forms, and lead sleeves 4 ins. in diameter and 24 ins. in length were slipped over the lead cable ends. The illustration shows the completed joints for the new C.B.1 suite.

The conductors in each 600/10 P.C.Q.L. cable were divided into 20 groups each of 15 quads, each group to take one 60-wire switchboard cable. In jointing, each group of 60 wires was treated as a unit, sleeve conductors being grouped together in quads in the P.C.Q.L. cable.

The joint at either end of a 600/10 cable was made simultaneously, and as each 60-wire cable was extended to the new multiple via the P.C.Q.L. cable, simple tests were made from the new multiple jacks to prove the accuracy of the jointing. Standard paper-core-jointing methods were employed and all joints were soldered. The joints were made by exchange construction staff who were formerly employed on underground cable jointing duties and were familiar with the colour codes for both types of cable.

On completion of a 600-pair joint, the joint was wrapped with linen tape and the lead collar was brought down into position. The bottom of the collar was tightly packed with cotton wool. The lead sleeve was drawn over the joint and plumbed to the cable and to the lead collar. Hot beeswax was then poured into the collar to a depth of approximately 3 in. and when cool the collar was filled to the brim with paraffin wax. It was felt that the wax should be prevented from entering the lead sleeve as a waxed joint might prove troublesome if it were found necessary to open a joint at some later date for maintenance purposes, and the cotton wool seal used proved to be very effective.

After the lead sleeve was drawn over the joint, and prior to plumbing, a multiple test was made. All working circuits extended via the 600/10 cable and all spare circuits were tested to prove them free from fault. On completion of the test the joint was plumbed and sealed.

By using P.C.Q.L. cable, the remainder of the 60-wire, flat, switchboard cable in hand has been made available to provide additional multiple capacity on the new suite. This provision was not made in lead-covered cable because the run to the new I.D.F. is very short—approximately 7 yards.

The new suite is in service, the exchange has now come off the "closed" list, and the slogan is "Business as usual" to the 600 odd applicants who have been patiently waiting 12 months for service.

A. C. B.

## Scottish Region

### STORES DELIVERY PROBLEMS IN THE WESTERN ISLES

To our colleagues in telephone areas further south, where the territory covered, due to the high telephone density, is relatively small, mention of some of the difficulties met with in one of the more sparsely populated sections of Great Britain may be of interest. The Scotland West Area covers thousands of square miles, and stretches some 250 miles from the Scottish border to the Hebrides. It takes in a large section of the Highlands of Scotland and most of the islands which fringe the western coast. Large-scale development of these islands from a telephone aspect is taking place and it is with stores

delivery problems associated with this development that these notes will deal. Transport arrangements to the islands are poor and in some cases almost non-existent. In the lucky cases, small steamers, carrying both passengers and cargo, operate on a scheduled service, but many of the calls at ports are between midnight and sunrise. In some cases the steamer can come alongside a pier, but in many instances the ship anchors offshore and passengers, mail and light cargo are transferred to the shore by means of ferry boats.

It will be appreciated that when large consignments of telephone stores are required the ordinary transport facilities cannot cope with delivery and special arrangements have to be made for shipment. Recently two consignments of poles and other items were received from the Controller of Stores. The steamship company just could not handle them and ships were chartered to make the delivery. In one case some 600 poles were to be delivered to the Island of Colonsay. A pier was available and the special ship got alongside at high tide, the only time when there was sufficient depth of water, and unloading proceeded during ebb tide with the ship sitting on the bottom. There were, of course, no dockers to assist with unloading, neither were any gangs available, and the discharge of the cargo was carried out by local estate workers and fishermen under the supervision of one P.O. representative. The men, although unacquainted with such work, discharged the cargo in the stipulated time for unloading. It may be of interest to mention that demurrage on the chartered ship of 120 tons was £11 per day.

In the second case approximately 400 poles were to be delivered to three different islands, and the chartered ship made a three-port call. On the first two islands, piers existed, and gangs working locally were able to unload without any great difficulty. On the third island (Berneray) there was no port, and ships never called on any regular schedule. The poles were therefore thrown overboard, rafted and towed ashore by small motor boats. Fortunately the weather was good or this could not have been attempted.

These two examples are typical of the difficulties the Department is up against in bringing the telephone to the Western Islands of Scotland. Even smaller consignments of stores, if the shipping company will accept them, are often delayed by weather conditions preventing unloading.

As a rule there is little difficulty in arranging for the transport of men to the islands, weather permitting, but tools and vehicles are a different matter. Unless the ship can get alongside a pier it is not practicable to get a vehicle ashore and in these cases the handling of stores on land raises other problems. Even if a pier is available, only stores-carrying type vehicles are light enough to be conveyed. Even with these, all tools, lockers and everything detachable must be removed and consigned separately to reduce weight. Utility vehicles are taboo.

"The Road to the Isles" is strewn with many headaches for the engineering staff and it is only by dealing with some of them that one truly realises the blessing of the good roads and railway service available on the mainland.

M. McL.

## EDINBURGH MANUAL RELIEF EXCHANGES

In common with many other automatic exchange areas, two manual exchanges were opened for relief purposes during the past summer. The Edinburgh automatic system was installed in 1926 and its rate of growth has always made it difficult to install exchange extensions fast enough. The difficulties consequent upon the length of the post-war list of unsatisfied applicants for telephone service, the number of exchange buildings that need extension and the delay in building work, the approaching saturation of the 5-digit numbering scheme and the delay in progress with the conversion of the system to director working have made relief by normal extensions to the automatic exchanges either too slow or impossible.

One director exchange has been installed and small extensions of the existing Siemens No. 18 exchanges are being provided where possible to ease the situation until the remainder of the director system is available, but these measures will be inadequate. It was therefore decided to undertake the installation of manual relief exchanges centred on the blocked automatic exchanges and given separate names and numbering suitable to the ultimate director scheme, as this provided a quick stop-gap solution.

The first of these, Peggy's Mill, centred on Davidson's Mains auto., was installed by the Telephone Manager's staff and was opened on the 26th May, 1947. It consists of 4 new C.B.10 positions with 400-line multiple.

The second, called Bypass, was centred on Edinburgh Central auto. and opened on 7th July, 1947. It consists of 27 C.B.1 positions with 2000-line multiple recovered from Kingston (Surrey), and renovated and installed by the Factories Department under the supervision of the Telephone Manager's Clerk of Works. This equipment when recovered was very old and worn, but so well have the Factories Department carried out their work that it is now quite difficult to distinguish the equipment from new in appearance and performance.

A third exchange, Jubilee, centred on Morningside auto. and consisting of 24 C.B.1 positions and 3,400-line multiple has been recovered from Wimbledon, London, and is in course of renovation and installation by the Telephone Manager's staff. Other C.B. exchanges are in the planning stages.

Apart from the fact that auto. and manual subscribers are mixed up in the same district, the new exchanges operate as standard manuals and calls are completed over "dialling in" and "dialling out" junctions to the normal auto. network, though difficulty is being encountered in providing the necessary "dialling out" code levels in view of the restricted numbering available.

It is also planned to use these manual exchanges as reliefs to the Edinburgh joint trunk switchboard by diversion of part of the "0" line traffic to them.

The Edinburgh multi-exchange area is now probably in the unique position of having director, non-director, C.B.1 and C.B.10 exchanges all in the unit-fee area.

J. J. L.

# Staff Changes

## Promotions

Name	Region	Date	Name	Region	Date
<i>A.S.E. to Staff Engr.</i>			<i>Engr. to Exec. Engr.—continued.</i>		
Jolley, E. H.	E.-in-C.O.	27.10.47	Scowen, F.	E.-in-C.O.	19.8.47
<i>A.S.E. to S.P.S.O.</i>			Watt-Carter, D. E.	E.-in-C.O.	1.9.47
Ryall, L. E.	Scot.Reg.toE.-in-C.O.	21.9.47	Bickley, H. D.	E.-in-C.O.	19.8.47
Jarvis, R. F. J.	E.-in-C.O.	1.9.47	Smith, R. C.	S.W. Reg. to W. & B.C. Reg.	1.10.47
Richards, C. E.	E.-in-C.O.	1.8.47	Rule, F. T.	E.-in-C.O.	17.9.47
<i>Exec. Engr. to Asst. Staff Engr.</i>			Duerdoth, W. T.	E.-in-C.O.	23.10.47
Baker, T. W.	E.-in-C.O.	1.9.47	Swaffield, J.	E.-in-C.O.	23.10.47
Thorn, D. A.	E.-in-C.O.	1.9.47	Pugh, S. E.	L.P.R.	31.10.47
Hall, L. L.	E.-in-C.O.	1.9.47	<i>Asst. Engr. to Engr.</i>		
Lucas, F. N.	N.E.Reg.to Scot.Reg.	21.9.47	Steedman, C. A.	S.W.Reg.	13.10.47
Mead, F. C.	E.-in-C.O.	5.11.47	<i>Tech. Asst. to A.R.M.T.O.</i>		
Freebody, J. W. H.	E.-in-C.O.	27.10.47	Smith, W.	S.W.Reg.	6.8.47
<i>Exec. Engr. to P.S.O.</i>			Waterfield, A. J. B.	London	22.8.47
Speight, E. A.	E.-in-C.O.	1.1.46	Dornon, A. E.	H.C.Reg.to N.I.Reg.	30.8.47
Metson, G. H.	E.-in-C.O.	1.1.46	<i>Tech. Asst. to M.T.O. III</i>		
Fairweather, A.	E.-in-C.O.	1.1.46	Pounder, L.	N.E.Reg.toE.-in-C.O.	21.9.47
Tillman, J. R.	E.-in-C.O.	14.5.46	Worthington, J. S.	N.E.Reg.toE.-in-C.O.	21.9.47
<i>Sen. Phys. or Sen. Chem. to P.S.O.</i>			<i>Mech. i/c to Tech. Asst.</i>		
Glover, D. W.	E.-in-C.O.	1.1.46	Edwards, W. H.	N.E.Reg.toE.-in-C.O.	7.9.47
Josephs, H. J.	E.-in-C.O.	1.1.46	Ninnim, S. W.	N.E. Reg.	21.9.47
Taylor, R.	E.-in-C.O.	1.1.46	Langridge, E. J. J.	London to H.C.R.	6.10.46
<i>Exec. Engr. to Principal</i>			Payne, F.	N.E. Reg.	21.9.47
Beastall, J. G.	L.P.R. to War Damage Commission	27.10.47	Dalziel, W.	Scot.Reg.to S.W.Reg.	12.10.47
Hibbs, N. L.	L.T.R. to War Damage Commission	27.10.47	Brown, J.	H.C.Reg.to E.-in-C.O.	7.9.47
<i>Engr. to Exec. Engr.</i>			Kimberley, R. G.	London to E.-in-C.O.	21.9.47
Glover, R. P.	S.W.Reg.	1.9.47	Heath, J. C.	W. & B.C. Reg. to E.-in-C.O.	14.9.47
Joyce, R. M.	E.-in-C.O.	19.8.47	Leggett, F. W. A.	London to E.-in-C.O.	14.9.47
Hopwood, R. W.	L.T.R.	19.8.47	Fisher, P. E.	H.C.Reg.toE.-in-C.O.	7.9.47
Harper, S. D.	E.-in-C.O.	19.8.47	Lyndoe, H. L.	London to E.-in-C.O.	7.9.47
James, M. H.	L.P.R. to E.-in-C.O.	5.10.47	Beeton, F. E.	London to E.-in-C.O.	1.10.47
Tucker, D. G.	E.-in-C.O.	19.8.47	<i>Exec. Engr. to Engr.</i>		
Revell, H. J.	Scot.Reg.	14.9.47	Loosemore, E. S.*	S.W. Reg.	1.7.47

\* Reverts to substantive rank on return from Admiralty.

## Transfers

Name	Region	Date	Name	Region	Date
<i>Reg. Engr.</i>			<i>Asst. Engr.—continued.</i>		
Lewis, N. W. J.	S.W.Reg.toE.-in-C.O.	2.11.47	Brown, E. M.	E.-in-C.O. to W. & B.C. Reg.	20.9.47
Blake, D. E.	H.C.Reg.to S.W.Reg.	2.11.47	Warnock, W. T.	E.-in-C.O.toScot.Reg.	1.10.47
<i>Exec. Engr.</i>			Roberts, C. A.	E.-in-C.O.toScot.Reg.	19.10.47
Balcombe, J.	E.-in-C.O.toH.C.Reg.	1.11.47	Littler, C.	E.-in-C.O. to Patent Office	1.11.47
Prickett, W.	S.W.Reg.toE.-in-C.O.	10.11.47	Radley, M.	E.-in-C.O.toN.E.Reg.	1.11.47
<i>Area Engr.</i>			Sandeman, W. P.	E.-in-C.O. to S. Africa	6.11.47
Mayo, S. J.	W. & B.C. Reg. to H.C. Reg.	10.9.47	Humber, A. J.	E.-in-C.O. to Min. of Supply	10.11.47
Crook, H. G.*	Scot.Reg.toN.W.Reg.	1.10.47	Campbell, G. R.	E.-in-C.O.toScot.Reg.	16.11.47
<i>Engr.</i>			King, E. S. F.	E.-in-C.O. to Min. of Tpt.	17.11.47
Read, R. A.	N.E. Reg. to Malayan Postal Service	21.7.40	Taylor, M. R.	E.-in-C.O. to Malaya (Seconded)	27.11.47
Dunkley, L. W.	N.E.Reg.to Mid. Reg.	30.9.47	Jenkinson, H. C.	E.-in-C.O.to N.E.Reg.	7.9.47
Wilcher, F. B.	E.-in-C.O.toS.W.Reg.	1.10.47	Walesby, H. N.	E.-in-C.O.to Patent Office	14.9.47
Queen, J.	E.-in-C.O.toN.E.Reg.	1.10.47	<i>Inspr.</i>		
Wilkinson, E. H.	E.-in-C.O.to N.E.Reg.	6.10.47	Stewart, D. H.	N.E.Reg.toScot.Reg.	14.4.47
Dennison, R. T. A.	N.E.Reg.to E.-inC.O.	6.10.47	<i>A.R.M.T.O.</i>		
Palk, E.	E.-in-C.O. to L.T.R.	19.10.47	Mathewson, F. J.	N.I.Reg.toN.E.Reg.	30.8.47
<i>Asst. Engr.</i>					
Hinks, W. L. W.	E.-in-C.O. to Colonial Service, Malaya	12.11.40			
Cobbe, B. M.	E.-in-C.O. to Min. of Tpt.	20.9.47			

\* In absentia

**Transfers (continued)**

Name	Region	Date	Name	Region	Date
<i>M.T.O. III</i>			<i>Tech. Asst.</i>		
Lakey, J.	E.-in-C.O. to H.C. Reg.	29.8.47	Dalziel, W.	S.W. Reg. to Scot. Reg.	21.11.47

**Retirements**

Name	Region	Date	Name	Region	Date
<i>Area Engr.</i>			<i>Inspr.—continued.</i>		
Mortimer, H.	H.C. Reg.	31.10.47	Proudlove, R.	H.C. Reg.	31.3.47
<i>Engr.</i>			Bailey, E. E.	L.T.R. (Res.)	11.4.47
Greenbury, L. J.	Scot. Reg. (Health)	11.9.47	Lane, W. J.	N.E. Reg.	18.4.47
Whitehead, W. C.	Mid. Reg.	29.9.47	Shipway, A. M.	L.T.R.	31.5.47
Short, P.	S.W. Reg. (Res.)	30.9.47	Chapman, T.	N.E. Reg.	3.6.47
Yeatman, H. G.	S.W. Reg.	6.10.47	Peck, H. J.	H.C. Reg.	30.6.47
<i>Asst. Engr.</i>			Millett, J. A.	S.W. Reg.	31.7.47
Dickson, J. S.	E.-in-C.O. (Res.)	11.8.47	Rabbitts, A. E.	L.T.R.	19.9.47
Wade, W.	Mid. Reg.	31.8.47	Jarvis, R.	Mid. Reg.	19.9.47
Gray, G.	E.-in-C.O. (Res.)	26.9.47	Essam, T. H.	L.T.R.	24.9.47
MacQueen, J. J.	E.-in-C.O.	1.10.47	Smith, A.	E.-in-C.O.	30.9.47
Oultram, J. H.	Mid. Reg. (Res.)	31.10.47	Prujean, J. E.	W. & B.C. Reg.	1.10.47
Chance, A. H.	E.-in-C.O.	15.11.47	Dring, J. W.	Mid. Reg. (Res.)	27.10.47
<i>Inspr.</i>			Osborn, J. G.	L.T.R.	5.11.47
Bartlett, F. W. G.	S.W. Reg. (Res.)	31.12.45	Bull, T. G.	L.T.R.	14.11.47
Harris, W. C.	S.W. Reg.	13.1.47	Pattington, J. L.	L.T.R.	28.11.47
Burton, A.	N.E. Reg.	18.1.47	<i>R.M.T.O.</i>		
Bew, G.	N.E. Reg.	2.2.47	Malcolm, A. I.	W. & B.C. Reg.	5.8.47
Stroulger, A. J.	H.C. Reg.	8.3.47	<i>Tech. Asst.</i>		
Chambers, A. W.	L.T.R.	9.3.47	Webster, H. R. F.	Scot. Reg.	20.11.47
Rhodes, E.R.	L.T.R.	31.3.47			

**Deaths**

Name	Region	Date	Name	Region	Date
<i>Engr.</i>			<i>Inspr.</i>		
Sinstead, H. A.	L.T.R.	27.8.47	Mason, C. A.	L.T.R.	12.11.47
Bailey, W. H.	L.T.R.	6.10.47			

**CLERICAL & DRAUGHTSMEN**

**Promotions**

Name	Region	Date	Name	Region	Date
<i>E.O. to S.O.</i>			<i>D'man. II to D'man. I</i>		
Kirby, H. K.	E.-in-C.O.	13.6.47	Smith, J. L.	E.-in-C.O.	7.8.47
<i>D'man. I to Sen. D'man.</i>			Edwards, P. W.	E.-in-C.O.	7.8.47
Jury, R. J.	E.-in-C.O.	28.11.47			

**Retirement**

Name	Region	Date
<i>D'man. I</i>		
Sabine, D. C. W.	S.W. Reg. (Health)	9.11.47



# Post Office Electrical Engineers' Journal

Volume XL, April 1947—January 1948

## INDEX

A	PAGE NO.	G	PAGE NO.
Anglo-German Submarine Cable Scheme, The .. .	49	Gerry, P. R. Decay in Poles .. .	116
Atlantic City, 1947, International Telecommunications Conferences .. .	175	Gleadle, G. H. M., and H. Stanesby. The Prediction of Optimum Working Frequencies for Short-Wave Radio Circuits .. .	76
Artificial Traffic Equipment. The .. .	159	Glover, D. W., and R. L. Bull. The Production and Properties of Silicones .. .	130
<b>B</b>		Gregory, G., and C. F. Booth. The Effect of Doppler's Principle on the Comparison of Standard Fre- quencies over a Transatlantic Radio Path .. .	153
Barnes, E. J., A. E. Wood and D. L. Richards. Standards of Transmission and Local Line Limits .. .	8	<b>H</b>	
Barnett, B. L. Post-War Telephone Developments .. .	145	Hall, L. L. A 625 kVA Emergency Generating Plant at Leafield Radio Station .. .	124
Book Reviews .. .		Hall, I. L., and D. E. Watt-Carter. Tension Limiting Gear for a Power-Driven Winch .. .	80
24, 32, 48, 56, 68, 75, 83, 101, 119, 144, 169, .. .	178	Halsey, R. J., and H. Williams. The Anglo-German Submarine Cable Scheme .. .	49
Booth, C. F., and G. Gregory. The Effect of Doppler's Principle on the Comparison of Standard Fre- quencies over a Transatlantic Radio Path .. .	153	Harding, J. P., and J. F. Harmon. The Reconstruction of Leafield Long Wave Radio Masts .. .	1
Boryer, W. F. Some Features of Deep Level Tunnelling in London .. .	14	Harnon, J. F., and J. P. Harding. The Reconstruction of Leafield Long Wave Radio Masts .. .	1
Bull, R. L., and D. W. Glover. The Production and Properties of Silicones .. .	120	<b>I</b>	
<b>C</b>		International Congress on the Fiftieth Anniversary of Marconi's Discovery of Radio .. .	152
Cable, Star-quad Telephone, The Manufacture of .. .	97, 170	International Telecommunications Conferences, Atlantic City, 1947 .. .	175
Cabling Operations—A Note from Germany .. .	129	Introduction of Manual Switching of Teleprinter Circuits in the Public Telegraph Service, The Part 1.—The Teleprinter Switching Network .. .	69
Calvcley, C. E. The Central Training School, Stone .. .	19	Part 2.—The Switching Equipment .. .	102
Central Telegraph Office Pneumatic Tube System, The Reinstatement of the .. .	164	Institution's Library .. .	85, 139, 180
Central Training School, Stone, The .. .	19	Institution of Post Office Electrical Engineers .. .	183
Clarke, E. F. S., and T. F. Reed. Through-Group Working in the Coaxial Cable Network, Part 2 .. .	109	<b>J</b>	
Coaxial Cable Network, Through-Group Working in the .. .	57, 109	Junior Section Notes .. .	45, 93, 141, 183
Criggion Radio Station, Floods at .. .	37	<b>L</b>	
<b>D</b>		Lawrence, C., and E. C. Elstree-Wilson. The Artificial Traffic Equipment .. .	159
Decay in Poles .. .	116	Leafield Long Wave Radio Masts, The Reconstruction of .. .	1, 63
Deering, J. E. The Manufacture of Star-Quad Tele- phone Cable .. .	97, 170	Leafield Radio Station, A 625 kVA Emergency Generating Plant at .. .	124
Doppler's Principle, The Effect of, on the Comparison of Standard Frequencies over a Transatlantic Radio Path .. .	153	Legg, Capt. J. Some Notes on Telephone Switching Development in Sweden .. .	25
Driving Steel Tubes into the Ground, A New Tool for .. .	115	<b>M</b>	
<b>E</b>		Manufacture of Star-Quad Telephone Cable, The Part 1.—Quadding and Stranding .. .	97
Early Correspondence between Sir William Preece and the Marchese Marconi .. .	179	Part 2.—The Process of Sheathing .. .	170
Earthing, Some Aspects of .. .	130	Marconi, The Marchese, and Sir William Preece, Early Correspondence between .. .	179
Effect of Doppler's Principle on the Comparison of Standard Frequencies over a Transatlantic Radio Path, The .. .	153	Marconi's Discovery of Radio, International Congress on the Fiftieth Anniversary of .. .	152
Elstree-Wilson, E. C., and C. Lawrence. The Artificial Traffic Equipment .. .	159	Mitchell, C. W. A., and H. E. Wilcockson. The Intro- duction of Manual Switching of Teleprinter Circuits in the Public Telegraph Service .. .	69, 102
Emergency Generating Plant, A 625 kVA, at Leafield Radio Station .. .	124	Mitchell, H. T. The Provision in London of Television Channels for the B.B.C. .. .	33
Engineering Stores, Road Haulage Service for .. .	135	Murray, J. B. The Reinstatement of the Central Telegraph Office Pneumatic Tube System .. .	164
<b>F</b>		<b>N</b>	
Floods at Criggion Radio Station .. .	37	New Tool for Driving Steel Tubes into the Ground, A .. .	115
Floyd C. F. Through-Group Working in the Coaxial Cable Network. Part 1. .. .	57	Notes and Comments .. .	38, 84, 136, 181
		Notes, Junior Section .. .	45, 93, 141, 183
		Notes, Regional .. .	41, 87, 140, 184

P	PAGE NO.
Poles, Decay in .. .. .	116
Post-War Telephone Developments .. .. .	145
Prediction of Optimum Working Frequencies for Short Wave Radio Circuits, The .. .. .	76
Preece, Sir William, and the Marchese Marconi, Early Correspondence between .. .. .	179
Production and Properties of Silicones, The .. .. .	120
Provision in London of Television Channels for the B.B.C., The .. .. .	33

R	
Reconstruction of Lcafield Long Wave Radio Masts, The .. .. .	
Part 1.—Design Problems .. .. .	1
Part 2.—Constructional Methods .. .. .	63
Reed, T. F., and E. F. S. Clarke. Through-Group Working in the Coaxial Cable Network, Part 2 .. .. .	109
Regional Notes .. .. .	41, 87, 140, 184
Reinstatement of the Central Telegraph Office Pneumatic Tube System, The .. .. .	164
Reorganisation of the Skilled Workman and Inspec- torate Classes .. .. .	28
Richards, D. L., E. J. Barnes and A. E. Wood. Standards of Transmission and Local Line Limits .. .. .	8
Rimes, R. E. Some Aspects of Earthing .. .. .	130
Road Haulage Service for Engineering Stores .. .. .	135

S	
Scantlebury, L. F. Reorganisation of the Skilled Workman and Inspectorate Classes .. .. .	28
Short Wave Radio Circuits, The Prediction of Optimum Working Frequencies for .. .. .	76
Silicones, The Production and Properties of .. .. .	120
Some Aspects of Earthing .. .. .	130
Some Features of Deep Level Tunnelling in London, Part 2.—Engineering Services .. .. .	14
Some Notes on Telephone Switching Development in Sweden .. .. .	25

S (cont.)	PAGE NO.
Staff Changes .. .. .	46, 95, 142, 189
Standards of Transmission and Local Line Limits Part 2.—The Effective Transmission Technique .. .. .	8
Stanesby, H., and G. H. M. Gleadle. The Prediction of Optimum Working Frequencies for Short Wave Radio Circuits .. .. .	76
Star-Quad Telephone Cable, The Manufacture of .. .. .	97, 170
Submarine Cable Scheme, The Anglo-German .. .. .	49
Sweden, Some Notes on Telephone Switching Develop- ment in .. .. .	25

T	
Teleprinter Circuits in the Public Telegraph Service, The Introduction of Manual Switching of .. .. .	69, 102
Television Channels for the B.B.C., The Provision in London of .. .. .	33
Tension Limiting Gear for a Power-Driven Winch .. .. .	80
Through-Group Working in the Coaxial Cable Network Part 1.—Performance Requirements .. .. .	57
Part 2.—The Complete Installation: Performance Characteristics, Installation Details .. .. .	109
Tool, for Driving Steel Tubes into the Ground, A New .. .. .	115
Training School, Stone, The Central .. .. .	19
Transmission and Local Line Limits, Standards of .. .. .	8
Tunnelling in London, Some Features of Deep Level .. .. .	14

W	
Watt-Carter, D. E., and L. L. Hall. Tension Limiting Gear for a Power-Driven Winch .. .. .	80
Wilcockson, H. E., and C. W. A. Mitchell. The Intro- duction of Manual Switching of Teleprinter Circuits in the Public Telegraph Service .. .. .	69, 102
Williams, H., and R. J. Halsey. The Anglo-German Submarine Cable Scheme .. .. .	49
Winch, Tension Limiting Gear for a Power-Driven .. .. .	80
Wood, A. E., D. L. Richards and E. J. Barnes. Standards of Transmission and Local Line Limits .. .. .	8

#### BOARD OF EDITORS

H. FAULKNER, B.Sc., M.I.E.E., Chairman.  
 F. E. NANCARROW, O.B.E., A.R.C.Sc., M.I.E.E.  
 P. B. FROST, B.Sc., M.I.E.E.  
 A. H. MUMFORD, O.B.E., B.Sc.(ENG.), M.I.E.E.  
 C. W. BROWN, A.M.I.E.E.  
 C. E. C. SKUSE.  
 G. E. STYLES, A.M.I.E.E., Managing Editor.  
 J. P. HARDING, B.Sc.(ENG.),  
 A.M.INST.C.E., A.M.I.E.E. } Assistant  
 F. WARREN, A.M.I.E.E. } Editors.  
 A. J. BAKER, Secretary-Treasurer.

#### Copyright

The entire contents of this JOURNAL are covered by general copyright, and special permission is necessary for reprinting long extracts, but Editors are welcome to use not more than one-third of any article, provided credit is given at the beginning or end thus: "From the *Post Office Electrical Engineers' Journal*."

The Board of Editors is not responsible for the statements made or the opinions expressed in any of the articles in this JOURNAL, unless such statement is made specifically by the Board.

#### Communications

All Communications should be addressed to the Managing Editor, *P.O.E.E. Journal*, Engineer-in-Chief's Office, Alder House, Aldersgate Street, London, E.C.1. Telephone: HEADquarters 1234. Remittances should be made payable to "The *P.O.E.E. Journal*" and should be crossed "& Co."

#### Binding Cases

Cases for binding are available, and may be obtained from the Local Agents for 2s. Subscribers can have their copies of Volumes bound, at a cost of 7s. 6d., by sending the complete set of parts to the Local Agents or to the *P.O.E.E. Journal*, Engineer-in-Chief's Office, Alder House, Aldersgate Street, London, E.C.1. Orders for binding for Vols. 1-19 should indicate whether the original binding case with black lettering, or the later pattern with gold, is required. Cases with gold lettering are the only type stocked from Vol. 20 onwards.

#### Back Numbers

The price of the JOURNAL, which is published quarterly, is 1s. (1s. 3d. post free) per copy, or 5s. per annum post free. Back numbers can be supplied, subject to availability of stocks, at 1s. each (1s. 3d. post free). Orders for back numbers may be sent to the Local Agents or to the Publishers.

#### Advertisements

All communications relating to space reservations should be addressed to the Advertisement Editor, *P.O.E.E. Journal*, Alder House, Aldersgate Street, London, E.C.1. Communications regarding advertisement copy, proofs, etc., should be addressed to the Publishers, Messrs. Birch & Whittington (Prop. Dorling & Co. [Epsom], Ltd.), 49 Upper High Street, Epsom, Surrey.

# A PRACTICAL PLAN for EARLY PROMOTION



**Valuable Free Handbook Tells You  
How to Pass Your C. & G.  
or Promotion Exam. at First Attempt!**

All Post Office Engineering personnel who are anxious to obtain early promotion should at once send for a copy of our handbook "**ENGINEERING OPPORTUNITIES**," which, among other intensely interesting matter, describes our unique methods of preparation for **TECHNICAL APPOINTMENTS IN THE POST OFFICE** (Assistant Engineer—New Style and Assistant Traffic Superintendent), **A.M.I.E.E., CITY AND GUILDS EXAMINATIONS** in Principles of Telecommunications (1-5), Radio (1-4), Telephone Exchange Systems (1-3), Telegraphy (1 and 2), Lines Transmission (1 and 2), Lines Plant Practice (1 and 2), Mathematics for Telecommunications (1-5), **Electrical Engineering Practice** (Prelim. Inter. and Final), and outlines a wide range of non-examination courses in all branches of **Electrical, Mechanical, Civil, Automobile, Aeronautical and Radio Engineering.**

**We definitely guarantee  
"NO PASS—NO FEE"**

If you intend to make the most of to-day's opportunities, you cannot afford to miss reading "**ENGINEERING OPPORTUNITIES**." It tells you everything you want to know to secure advancement, and describe many opportunities you may now be missing through lack of information. Send for your copy to-day — **FREE** and without obligation.

**BRITISH INSTITUTE OF ENGINEERING TECHNOLOGY**  
69 SHAKESPEARE HOUSE, 17-19 STRATFORD PLACE, LONDON, W.1

## INDEX TO ADVERTISERS

Alton Battery Co., Ltd., The .. .. .	v
Automatic Coil Winder & Electrical Equipment Co., Ltd.	iii
Automatic Telephone & Electric Co., Ltd. .. .. .	x, xi
Bennett College, The .. .. .	viii
British Institute of Engineering Technology .. .. .	iii
Caplin Engineering Co., Ltd. .. .. .	xii
Creed & Co., Ltd. .. .. .	xix
Edison Swan Electric Co., Ltd., The .. .. .	ii
Ericsson Telephones, Ltd. .. .. .	ix
Evershed & Vignoles Ltd. .. .. .	xiii
General Electric Co., Ltd., The .. .. .	xv
H. T. A., Ltd. .. .. .	vii
International Correspondence Schools .. .. .	xvi
Muirhead .. .. .	xiv
Parmeko, Ltd. .. .. .	xvi
Pirelli-General Cable Works, Ltd. .. .. .	xx
Pitman, Sir Isaac, and Sons, Ltd. .. .. .	viii
Salford Electrical Instruments Ltd. .. .. .	ii
Savage, W. Bryan, Ltd. .. .. .	xiv
Siemens Brothers & Co., Ltd. .. .. .	vi
Smith, Frederick, & Co. .. .. .	xvi
Standard Telephones and Cables, Ltd. .. .. .	xvii
Sullivan, H. W., Ltd. .. .. .	xx
Telephone Manufacturing Company, Ltd. .. .. .	vii
Tudor Accumulator Co., Ltd., The .. .. .	xii
Turners Asbestos Cement .. .. .	xviii
United Insulator Co., Ltd. .. .. .	iv
Westinghouse Brake & Signal Co., Ltd. .. .. .	iv
Winn & Coales, Ltd. .. .. .	viii

*Time Limits*  
**OF ACCURACY**

The 50-range Model 7 Universal AvoMeter, the pioneer of the comprehensive range of "Avo" Precision Instruments, is the world's most widely used combination Electrical Measuring Instrument. Fully descriptive pamphlet available on application to the Sole Proprietors and Manufacturers:

**AVO** Electrical Measuring Instruments

**THE AUTOMATIC COIL WINDER & ELECTRICAL EQUIPMENT CO. LTD.**  
Vinder House, Douglas Street, London, S.W.1 Phone: VICTORIA 3404.9

★ **Unsurpassed for use  
in Transmitter and  
other high voltage  
electronic equipment**



# U.I.C.

## CERAMIC POT CAPACITORS

Owing to high R.F. rating and small dimensions, U.I.C. Ceramic Pot Capacitors are eminently suitable for working at high loads and high voltages.

Full technical data furnished on request.

**UNITED INSULATOR CO. LTD.,**

OAKCROFT ROAD, TOLWORTH,  
SURBITON, SURREY.

Telephone: Elmbridge 5241 (6 lines)

Telegrams: Colanel, Surbiton.

**U**nsurpassed  
**I**n  
**C**eramics

## The **STABILISTOR** FOR STABILISING A.C. SUPPLY



Type "A"  
Stabilistor  
with cover  
removed.

Type "A" provides an A.C. voltage of good waveform substantially independent of load current and/or variations in the A.C. supply voltage. The output voltage is 230 volts single-phase.



Type "B" Stabilistor with cover removed.

Type "B" (dual purpose) has two outputs, which are available alternatively but not simultaneously. No. 1s frequency and voltage compensated at a fixed load while No. 2 gives the standard type "A" output. Output No. 1 may be any desired voltage at the stated rating.

**A**

**WESTINGHOUSE**

**PRODUCTION**

Write for publication  
E.E.2 to Dept. P.O.E.J.

**WESTINGHOUSE BRAKE & SIGNAL CO. LTD**  
82 York Way, King's Cross, London, N



A17

## TERMINUS CIRCA 1997

*Tomorrow's youngsters, luckier than they know, will take it all for granted. This, to them, will be a railway terminus and much like any other. Only the old will see it against a different background. For only they will have lived in the days when steam-driven trains were still let into London.*

Almost within our grasp, today, is a source of unlimited power. When science has tamed the force of the atom, broken it to industrial harness, whittled down its cost, the electrification of Britain will start in earnest. Those will be busy days for us here in Alton, where we make the batteries for generating stations all over the world. Whatever their source of power, the new generating stations will still need batteries. Good batteries. The kind we have always made at Alton

# ALTON

## BATTERIES OF MERIT

THE ALTON BATTERY COMPANY LTD · ALTON · HANTS

*Sole Suppliers of Fuller Stationary Batteries*

Telephone: ALTON 2267 & 2268 · Telegrams: 'BATTERY, ALTON'

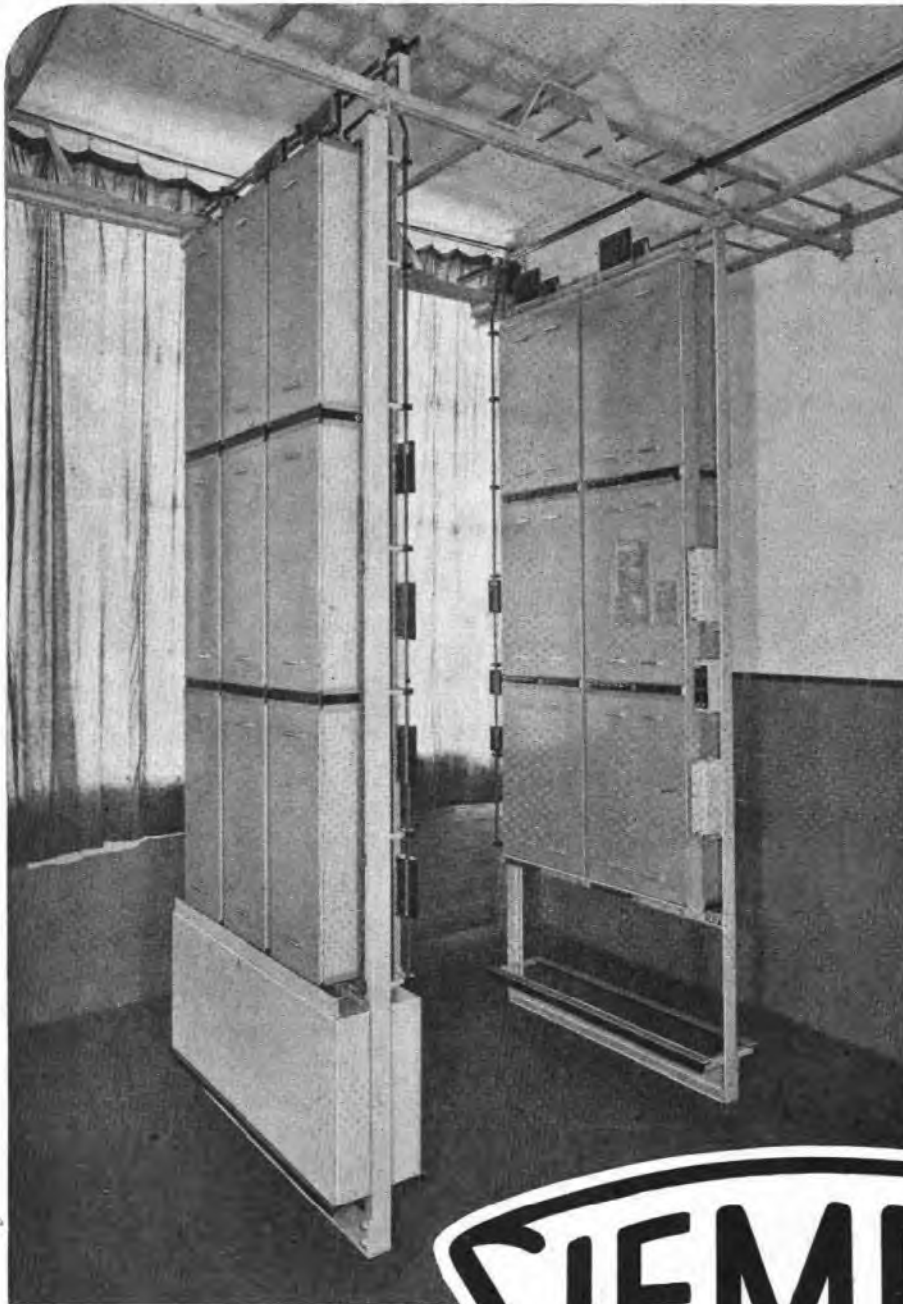

# SIEMENS

## No. 17 SYSTEM

The rack in the foreground is typical of all linefinders and local selectors throughout this new automatic telephone exchange system.

**SIEMENS BROTHERS & CO., LIMITED**  
WOOLWICH • LONDON • S. E. 18.

# A Typical Example of H.T.A. DESIGN

Included in the range of H.T.A. Products are Telephone Coin Collectors, Stamp Selling Machines, Autodials, Commodity Vending Machines, Coin Operated Mechanisms, Kitchen Control Units, Gas Leak Indicators and Ticket Printing and Issuing Machines of which the model illustrated is a typical example.

★ *This H.T.A. all-electric Ticket Issuing Machine prints and dates each ticket when coin is inserted*

Designed for selling of railway travel and platform tickets this model can be adapted for a variety of other purposes.

Tickets are printed and dated on the insertion of the appropriate coin or coins from a roll of blank paper, the size of the ticket issued being approximately 3" x 1½" x .015" thick. The machine is electrically operated and full details and specification will be supplied on request.

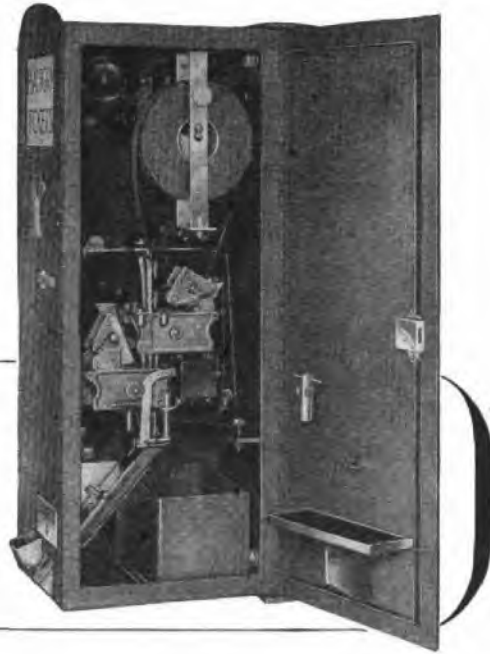

**H.T.A. LIMITED** FORMERLY HALL TELEPHONE ACCESSORIES (1928) LTD  
*Precision Engineers & Instrument Makers*  
DUDDEN HILL LANE • WILLESDEN • LONDON • N. W. 10  
PHONE: WILLESDEN 5141

## CARPENTER

# High Speed Polarised

## RELAY

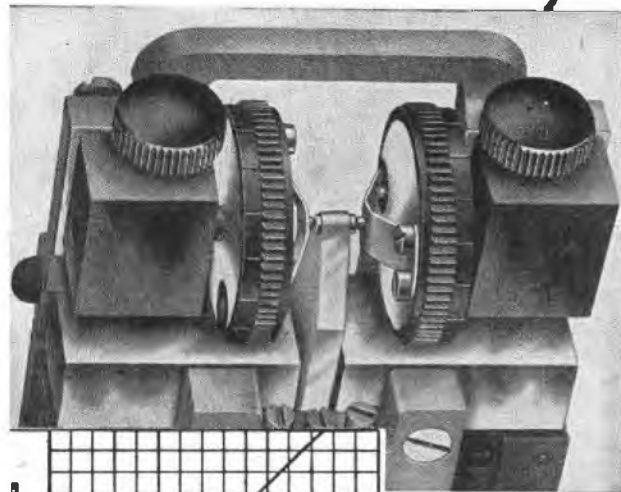

● Contact mechanism of Relay showing damped compliant mountings of side contacts.

● Graph showing contact pressures developed at 50 c/s against mA and amperes input for type 3E Carpenter Relay.

The Carpenter Relay in its standard adjustment reproduces, with a 5 AT input, square pulses from less than 2 milliseconds upwards with a distortion of 0.1mS, i.e., 5% for 2mS pulses or 1% at 10mS.

This unequalled performance is due to inherent features of the design of the relay, ensuring short transit time, high sensitivity and low hysteresis. There is complete absence of contact rebound at any input power and contact pressures are exceptionally high (*see graph*). Adjustment can be made with great ease. Moreover, since the armature is suspended at its centre of gravity, the relay has high immunity from effects of mechanical vibration and there is no positional error. Effective screening is provided against external fields. Because of these characteristics, the Carpenter Relay has many applications in the fields of measurement, speed regulation, telecontrol and the like, in addition to the obvious use in telegraph circuits; details of models suitable for such purposes will be supplied willingly on request.

**DIMENSIONS IN COVER: 2½ x 1½ x 4½**  
**WEIGHT with standard socket: 22 ozs.**

Ask for booklet 1017 P.O.

**TELEPHONE MANUFACTURING CO. LTD.**

HOLLINGSWORTH WORKS • DULWICH • LONDON • S.E.21

Telephone: GIPsy Hill 2211 (10 lines)

**STUDY AT HOME**      **You Can Have a College Training For a Few Shillings Monthly**      **IN YOUR SPARE TIME**

FOUNDED 1900      40 YEARS OF SUCCESS



**CITY and GUILDS (Telecommunication) EXAMINATIONS**

To every student we send a written Guarantee of Tuition until the examination is actually passed

*The most progressive and most successful Correspondence College in the world*

Our tuition is so graded that each stage is reached without difficulty. Personal attention is given to every student.

FULL PARTICULARS AND ADVICE SUPPLIED FREE.

WE TEACH BY POST IN ALL PARTS OF THE WORLD.



Dept. 24, THE BENNETT COLLEGE, SHEFFIELD

# DENSO TAPE

## for Protection against Corrosion

Denso Tape—for emergency sealing of cable ends . . . for protection during jointing process . . . a permanent safeguard against chemical and electrolytical corrosion on cables, conduits, etc. . . . ready for instant use without heating. Denso Tape is just one of a wide range of Denso anti-corrosive products.



Write for Specification and price list

**WINN & COLES LTD**

TERMINAL HOUSE, GROSVENOR GARDENS, LONDON, S.W.1

Telephone: Sloane 6264      Telegrams, Denselte, Sowest, Londo

# Telephony

By [T. E. HERBERT, M.I.E.E., and W. S. PROCTER, A.M.I.E.E.]

## Vol. I. *Manual Switching Systems and Line Plant*

For many years this book has been recognized as the standard authority on manual telephony. It covers the syllabus of the City and Guilds of London Institute examinations, and deals helpfully with many problems which occur in the servicing and maintenance of line plant. 30/- net.

## Vol. II. *Automatic Telephony*

A detailed exposition of the automatic system which is employed in Great Britain, providing a valuable work of reference for all concerned with telephony. Candidates for the Post Office Engineering Department will find this volume particularly useful. With 440 illustrations. 23/- net.

# PITMAN BOOKS

Pitman House, Parker Street, Kingsway, London, W.C.2

## Whittaker's ELECTRICAL ENGINEERS' POCKET BOOK

Edited by

R. E. NEALE, B.Sc. (Hons.),  
A.C.G.I., A.M.I.E.E.

A comprehensive collection of practical information, diagrams, tables and data relating to every kind of electrical work. Revised, completely up-to-date Seventh Edition. 938 pages. 30/- net.



*Achievement...*  
*by*  
**Ericsson**



**ERICSSON TELEPHONES LTD., Head Office: 22 Lincoln's Inn Fields, London, W.C.2**

Phone: HOLborn 6936

# Great Cities of



Greater London is the largest city in the world and within its limits can be seen every aspect of British national life. In the West End are fashionable shops and theatres. The East End includes dockland whilst "the City" is the centre of the nation's business life. In London is the home of the Royal Family, Buckingham Palace and the seat of democratic government, the Houses of Parliament. Green amidst the grey brickwork are leafy parks, Hyde Park, St. James's Park where Henry VIII played tennis and Hampstead Heath where the Cockneys throng the fairgrounds on Bank Holidays. Reverent peace lingers beneath the old towers of Westminster Abbey and the great dome and golden cross of St. Paul's whilst the applause of the sporting crowds resounds in the football arenas of Wembley and Twickenham and the cricket-grounds of Lord's and the Oval. So vast that it is a city and a county in one, London is the throbbing heart of a mighty Empire.



# of the World rely on-

## STROWGER TELECOMMUNICATIONS

The conversion of the telephone system of London from manual to automatic working was an undertaking of the utmost magnitude. Several factors contributed to this. Firstly, the complete change-over could not be effected at one time but had to be made over a long period, throughout which time there could be no disruption of the service as a whole. Secondly, manual and automatic systems had to work smoothly and efficiently in conjunction with each other during the gradual process of change-over. Thirdly, the total number of subscribers to be provided with automatic service was an enormous one. After thoroughly investigating the merits of the various systems of automatic telephony available the British Post Office selected Strowger as the most advantageous. In their decision they were influenced by the simplicity of the step-by-step principle; its comparatively low initial capital outlay and its adaptability to both large and small areas and to both main and satellite exchanges. To meet the special problems of effecting mechanical switching throughout very large areas Strowger engineers evolved the "Director" as an adjunct to equipment already existing. To-day there are some one hundred and twenty Strowger "Director" Exchanges in London with nearly half-a-million direct lines serving a total of more than three-quarters-of-a-million telephones.



**AUTOMATIC TELEPHONE & ELECTRIC CO. LTD.**

*Export Department*

NORFOLK HOUSE, NORFOLK STREET, LONDON, W.C.2

TEmple Bar 9262

STROWGER WORKS, LIVERPOOL, 7, ENGLAND

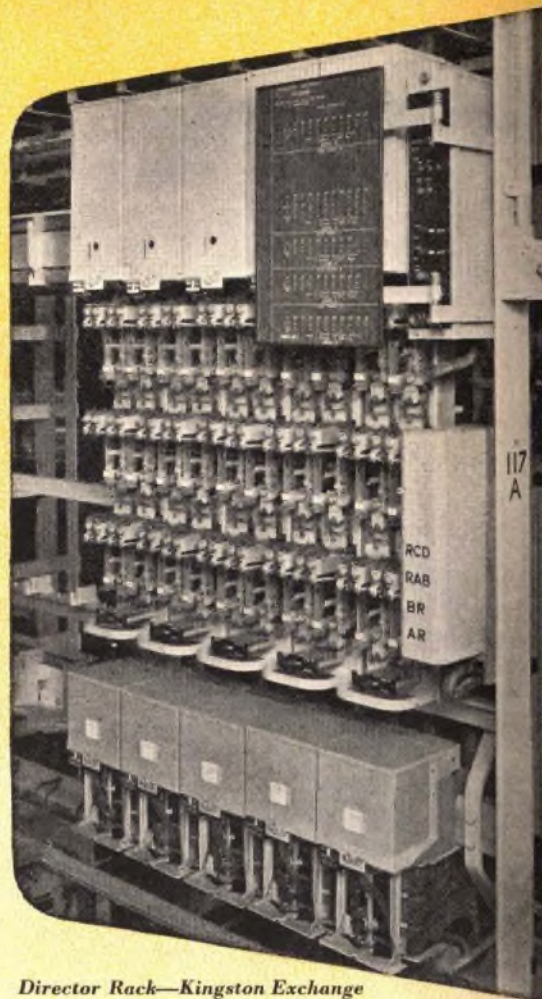

*Director Rack—Kingston Exchange*

A7293-A22



# CAPCO

REGD. TRADE MARK

## MACHINES FOR

- QUARTZ AND GLASS CUTTING
- WIRE CLEANING
- SURFACE GRINDING

EXPORT ENQUIRIES SPECIALLY WELCOMED.

WRITE FOR FULL PARTICULARS TO

## CAPCO (SALES) LTD.

SOLE AGENTS FOR

### CAPLIN ENGINEERING CO. LTD.

BEACONSFIELD ROAD, WILLESDEN, LONDON, N.W.10

Telephone : WILLESDEN 0067-8

EST. 1918

Cables : CAPLINKO, LONDON

*For large scale  
Electrical  
Purposes*

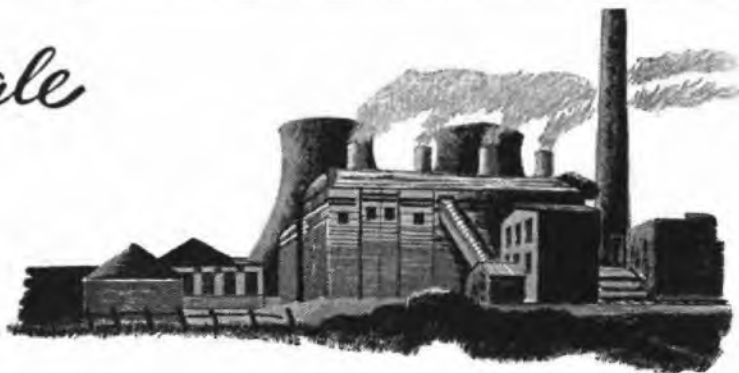

It is noteworthy where Tudor accumulators are to be found fulfilling the most important duties: over 500 British Power Stations installed Tudor. Many Tudor installations rank among the largest in the land and have an enviable reputation for long-lived reliability. No matter whether they were installed only yesterday, or over thirty

years ago—as many of them were—they are to-day functioning with consistent efficiency.

*SAFETYLYTE is the Tudor Emergency Lighting System, which is automatic and instantaneous in operation. It is installed in thousands of schools, hospitals, factories and other large buildings.*



# TUDOR ACCUMULATORS

THE TUDOR ACCUMULATOR CO. LTD  
50 GROSVENOR GARDENS, LONDON, S.W.1

# STANDARD WITH THE BRITISH POST OFFICE

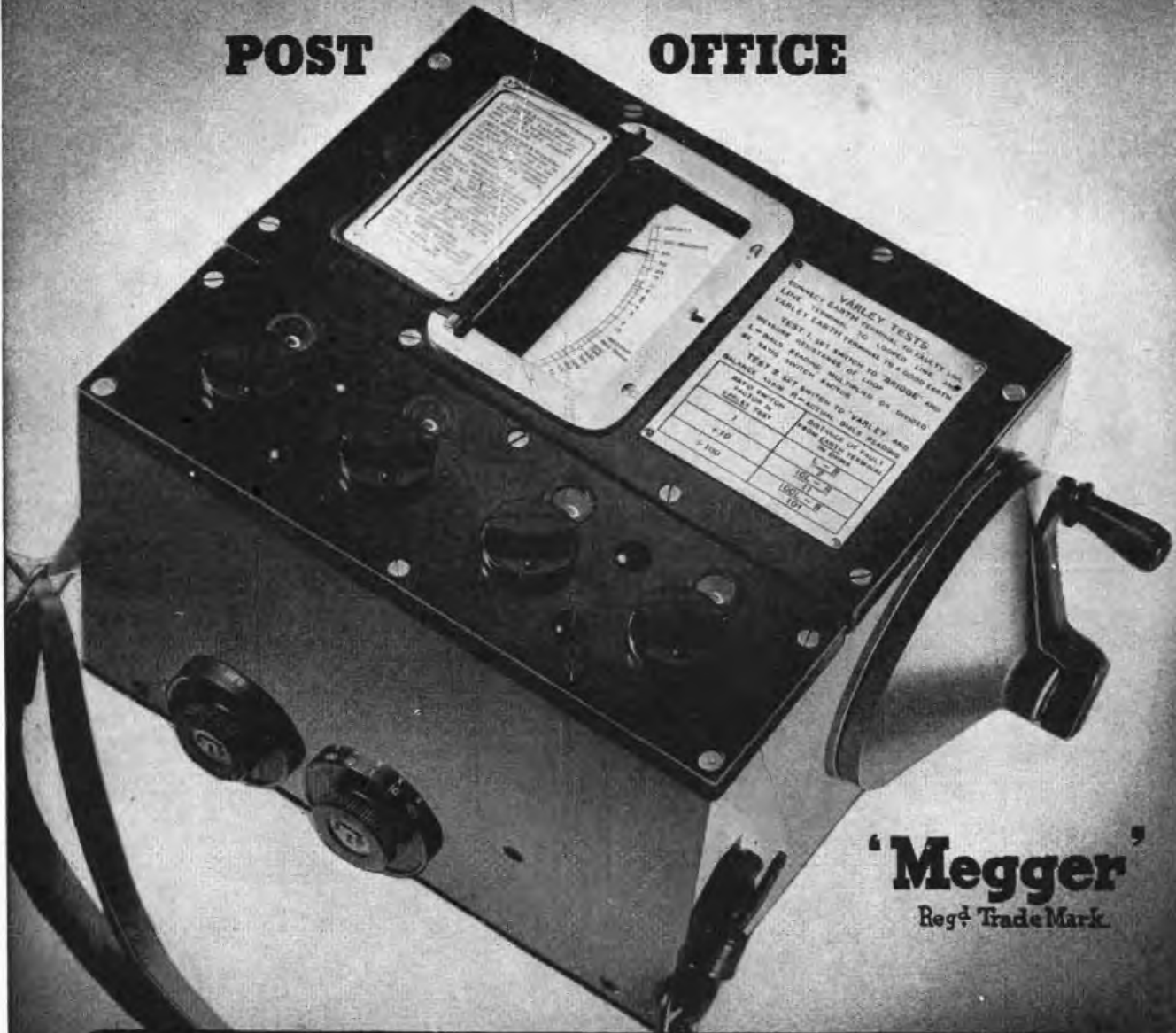

**THE BRIDGE-MEG TESTING SET** used by the British Post Office is a portable, self-contained instrument combining the functions of an Insulation Tester and a Wheatstone Bridge; it can be used for fault location by the Varley Loop method. Facilities can also be provided whereby, with the use of an external galvanometer and resistance box, the instrument may be used for making Murray Loop tests. Insulation range 100 megohms at 500 volts. Bridge range 0.01 to 999,900 ohms. Size  $7 \times 8\frac{3}{4} \times 12$  ins. Weight  $12\frac{3}{4}$  lbs. Mains operated instruments are also supplied to the British Post Office. Ask for list X 212.

**EVERSHED & VIGNOLES LTD., CHISWICK, LONDON, W.4**  
TELEPHONE: CHISWICK 1370 \* TELEGRAMS: "MEGGER" CHISK, LONDON

# WIDE-RANGE TRANSFORMERS

## TYPES D-106 & D-139

*For Modern Communications  
Equipment*

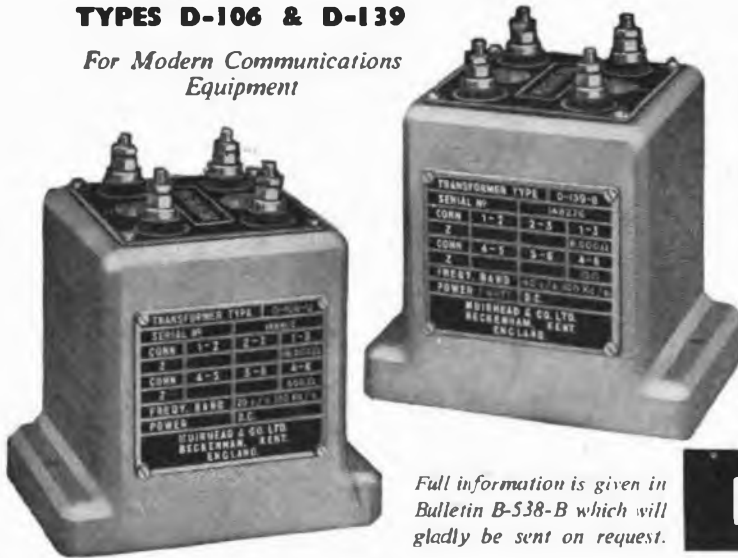

*Full information is given in  
Bulletin B-538-B which will  
gladly be sent on request.*

### FREQUENCY CHARACTERISTICS.

Practically linear from the lower audio frequencies to over 100 kc/s.

**IMPEDANCE RATIOS:** Many impedance ratios are available, from 1 : 1 to 500 : 1.

**POWER:** Types D-139 will handle up to one watt AC power above 40 c/s. Types D-106 are designed as input and interstage transformers where the power is negligible.

**SCREENING:** Inner case — nickel-iron. Outer case — cast aluminium.

**DIMENSIONS:** 2½" × 3½" × 3" high overall.

**WEIGHT:** 2½ lb.

# MUIRHEAD

*Muirhead & Co. Limited, Elmers End, Beckenham, Kent. Tel. Beckenham 0041-2*

**FOR OVER 60 YEARS DESIGNERS & MAKERS OF PRECISION INSTRUMENTS**

C.R.C. 39F

# SAVAGE

## Broadcast Relay Equipment OF PROVED RELIABILITY

W. BRYAN SAVAGE LIMITED

WESTMORELAND ROAD · LONDON, N.W.9 · CABLES : DECIBEL · LONDON



**RECOGNISED  
ACROSS THE  
WORLD AS  
DESIGNERS  
PRODUCERS  
and  
INSTALLERS  
of**

**A  
Complete  
Range of  
Telecommunication  
Equipment**

Subscribers' Telephones  
Automatic and Manual Exchanges  
Telephone Transmission Equipment  
Trunk and Local Cables  
Overhead Lines — Loading Coils  
Test Equipment of all kinds

**THE GENERAL ELECTRIC CO. LTD. OF ENGLAND  
HEAD OFFICE: MAGNET HOUSE, KINGSWAY, LONDON**

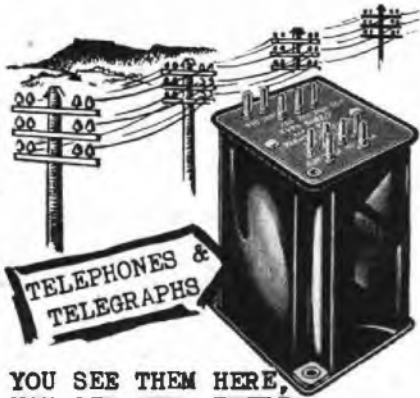

YOU SEE THEM HERE,  
YOU SEE THEM THERE,  
YOU SEE THEM EVERYWHERE,  
THOSE DAMNED ELUSIVE PARMEKOS.

We make no excuse for the fact that some Parmeko Transformers are available only on long delivery dates . . . in fact we are rather proud that everyone who uses Transformers seem to come to us these days and are prepared to wait some time.

Consider well and we know you will be writing to us . . . we're looking forward to it . . . time we knew you anyway !

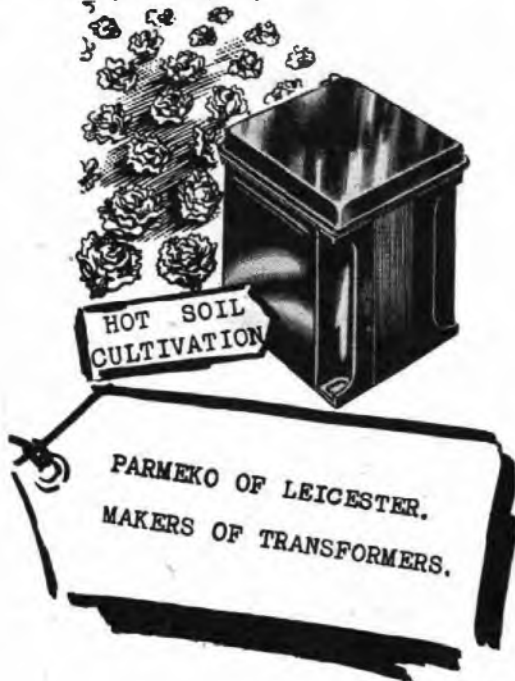

## SOUND INSTRUCTION by Postal Method

The I.C.S., largest school in the world devoted to spare-time training by the postal method, offers you highly specialised Courses of Instruction for the following Examinations:

- P.M.G. Certificates in Wireless Telegraphy .
- Associate Membership of I.E.E.
- C. & G. Electrical Engineering Practice, Installation and Telecommunications.
- Graduateship of the B.I.R.E.

Other Courses meet the requirements of all who desire to qualify for responsible positions in Electric Power, Illumination, Heating and Traction Systems. Equally successful is our instruction for Telegraph Engineers, Radio Engineers and Radio Servicemen.

Instruction is by correspondence from textbooks specially prepared by many experts.

WRITE FOR OUR SPECIAL BOOKLET and state the particular subject or Examination in which you are interested. I.C.S. Examination students are coached till successful. . . . . YOU MAY USE THIS COUPON . . . . .

### International Correspondence Schools Ltd.

Dept. 108, International Buildings, Kingsway, London, W.C.2

Please send me, free of charge, your special

booklet on \_\_\_\_\_

Name \_\_\_\_\_ Age \_\_\_\_\_

Address \_\_\_\_\_

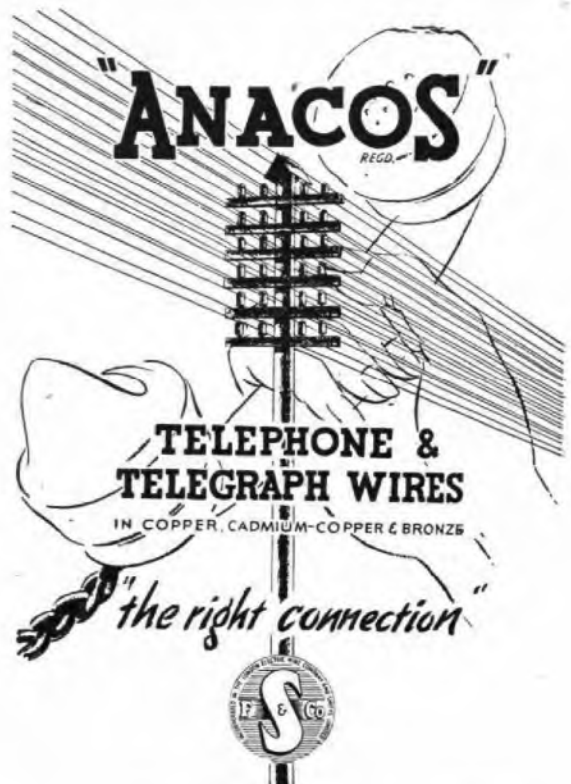

**FREDERICK SMITH & COMPANY**  
(Incorporated in The London Electric Wire Company and Smiths, Limited)  
**ANACONDA WORKS, SALFORD 3, LANCS.**  
Phone: Blackfriars 8701 (9 lines) • Grams: "Anaconda," Manchester



# Sir LOWRY PASS

Cape Province  
South Africa

typical of the difficult  
country through which  
additional telephone cir-  
cuits at low cost have  
long been needed, a re-  
quirement which has been  
met by



## *Standard 12-Channel Carrier Systems*

the modern means of linking widely separated centres by open wire lines

## *Standard Telephones and Cables Limited*

(TRANSMISSION DIVISION)

NORTH WOOLWICH • LONDON • E. 16



THESE "EVERITE" ASBESTOS-CEMENT DISTRIBUTION PILLARS ARE USED BY THE GENERAL POST OFFICE IN CONJUNCTION WITH "EVERITE" ASBESTOS-CEMENT CABLE CONDUITS AND BENDS — THE OBJECT BEING THE USE OF SPARE WIRES IN CABLES WITHOUT THE NECESSITY FOR LARGE SCALE AND EXPENSIVE RE-ARRANGEMENT OF PLANT. THE "EVERITE" ASBESTOS-CEMENT DISTRIBUTION PILLARS ARE MADE IN THREE SECTIONS — THE COVER, BASE AND SLEEVE.

**TURNERS ASBESTOS CEMENT CO LTD**

TURNER & NEWALL LTD

TRAFFORD PARK • MANCHESTER • 17

No. **47** TAPE MODEL  
**TELEPRINTER**  
FOR —

**MODERN TELEGRAPHY**

A NEW  PRODUCT  
*Creed*



- Printing point is in ideal position on left side.
- Accessible printing unit using typewriter ink ribbon.
- Receiving cam orientation device facilitates optimum adjustment.
- Answer-back unit (20 characters).
- Conforms to C.C.I.T. recommendations.
- A cover attachment for accommodating message forms, etc., can be provided for handling heavy traffic.
- Tape and ink ribbon are replenished without removing cover.
- Simplified maintenance with unit construction.
- Quiet in operation.

*Creed and Company Limited*

TELEGRAPH HOUSE · CROYDON · ENGLAND

TELEGRAMS : "CREDO, TELEX, CROYDON."      ● CABLES : "CREDO, CROYDON."  
TELEPHONE : CROYDON 2121 (7 lines).      ● TELEX : CROYDON, TELEX 1082

# TELEPHONE CABLES

OUR LATEST BROCHURE No. 9E (1947)  
IS NOW AVAILABLE, GIVING INFOR-  
MATION AND SPECIFICATIONS FOR A  
WIDE RANGE OF TELECOMMUNICA-  
TION CABLES MANUFACTURED BY US.  
COPIES WILL BE SENT ON REQUEST.

TELEPHONE:  
SOUTHAMPTON  
2141 (5 lines).

**PIRELLI-GENERAL**  
CABLE WORKS, Ltd., SOUTHAMPTON.

TELEGRAMS  
"PIRELLI-KAYBEL"  
SOUTHAMPTON."

HIGH GRADE  
DECADE ATTENUATORS

0.1% GRADE  
T or H NETWORKS

RANGE 0.1 to 110 db.  
0.01 to 10 nepers

ASSEMBLED INTO A DECADE SERIES  
OR AS  
PANEL MOUNTED UNITS

**H. W. SULLIVAN**  
— LIMITED —  
LONDON, S.E. 15

Telephone: New Cross 3255 (P.B.X.)

TEMP.  
COEFF.  
0.0025% C

**Electrical Standards for  
Research and Industry**  
Testing and Measuring Apparatus  
for Communication Engineering

NO ERRORS UP TO FREQUENCIES  
OF 100 Kc/s AND EXTREMELY USE-  
FUL FOR FREQUENCIES UP TO 0.5  
OR 1 Mc/s

A SERIES OF METAL CASED HIGH FREQUENCY  
UNITS ARRANGED IN DEGREES OF ATTENUATION  
IN ASSOCIATION WITH SPECIALLY DESIGNED  
SWITCHES HAVING FINELY LAMINATED BRUSHES