

# THE POST OFFICE ELECTRICAL ENGINEERS' JOURNAL

**VOL. 34**

**JULY, 1941**

**PART 2**

## CONTENTS

	PAGE
GLASGOW DIRECTOR SYSTEM—F. Coote .. . . .	51
THE NEW AMPLIFIER No. 32 AND ASSOCIATED EQUIPMENT— H. Williams, A.C.G.I., A.M.I.E.E. .. . . .	60
THE ATTENUATION AND IMPEDANCE OF SINGLE COAXIAL CABLES—R. A. Brockbank, Ph.D., B.Sc., A.M.I.E.E. .. . . .	66
MODERN MATERIALS IN TELECOMMUNICATIONS—W. G. Radley, Ph.D., M.I.E.E., E. A. Speight, Ph.D., D.I.C., A.R.C.S., C. E. Richards, F.I.C., E. V. Walker, B.Sc., A.R.S.M. Part V—Metallic Conductors	72
A SIMPLE INTRODUCTION TO THE USE OF STATISTICS IN TELECOMMUNICATIONS ENGINEERING—J. F. Doust and H. J. Josephs, F.S.S., A.M.I.E.E. Part II—Analysis of Small Samples	79
THE ECONOMIC DESIGN OF MANHOLES—J. P. Harding, B.Sc.(Eng.) Part II—Reinforced Concrete Theory .. . . .	85
LONG DISTANCE POSITION FINDING BY D.F.—F. Addey, B.Sc., F.R.A.S., M.I.E.E. .. . . .	94
NOTES AND COMMENTS .. . . .	96
REGIONAL AND LOCAL CENTRE NOTES .. . . .	98
STAFF CHANGES .. . . .	99

Price 1/- net

**THE INSTITUTION OF POST OFFICE ELECTRICAL ENGINEERS**

# G.E.C.

## CRYSTAL CALIBRATOR

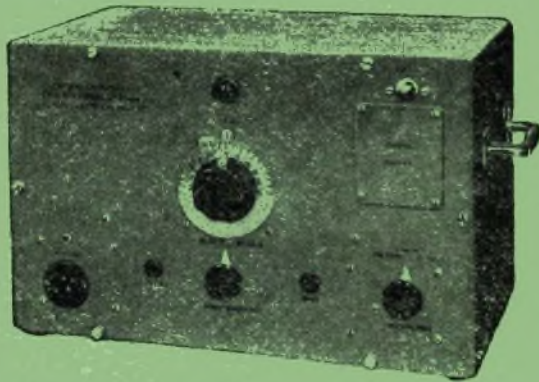

A new precision instrument for the rapid and accurate checking and adjustment of radio frequency oscillators, receivers, transmitters and similar apparatus.

It is crystal controlled and A.C. mains operated.

*Ask for full information from :*

**SALFORD ELECTRICAL INSTRUMENTS LTD.**

SALFORD. Telephone : Blackfriars 6688 (6 lines). Telegrams and Cables : "SPARKLESS, MANCHESTER"

PROPRIETORS: THE GENERAL ELECTRIC CO., LTD.

# EDISWAN

## TELEPHONE LINE PROTECTOR PANELS

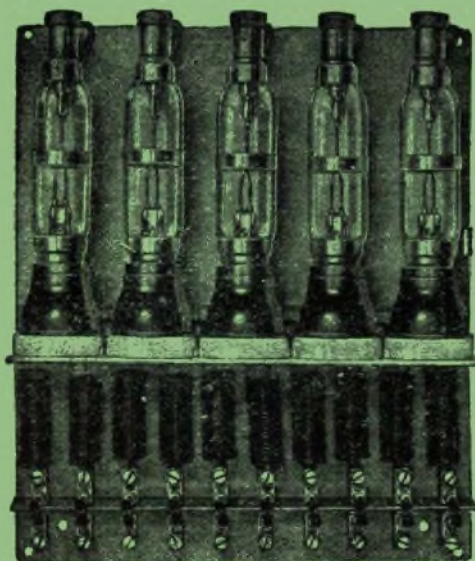

5-circuit panel for overhead lines incorporating choke coils, spark gaps, etc.

EDISWAN-SHOTTER-GREETHAM PATENT

(British Patent No. 353924)

for the protection of telephone systems against surges induced by faults on neighbouring power lines

Of the difficulties attendant upon the employment of overhead systems one of the most serious is to ensure uninterrupted working of the telephone system, by providing adequate protection against induced surges caused by switching or line faults in adjacent power lines or by lightning.

The Ediswan Patent Protectors provide the solution. They are inert at the normal working pressure of the telephone line, they keep the voltage on the line down to a pre-determined figure by providing a path of low resistance to earth whereby the surge is cleared and they again become inert immediately the surge is cleared.

They ensure simultaneous discharge of both lines and are capable of clearing heavy discharges without detriment to the system or the protector.

Ediswan Telephone Line Protectors have now been in use by Supply Companies for many years.

THE EDISON SWAN ELECTRIC CO. LTD.,  155 CHARING CROSS ROAD, LONDON, W.C.2

# SIMPLIFIED SERVICING MAINTENANCE & FAULT FINDING



BRITISH MADE

**46 Ranges**  
of  
Direct  
Readings

**DESIGNED** by technicians who have made a special study of the service and maintenance engineers' problems, the Model 7 Universal AvoMeter is acknowledged throughout the world as the one indispensable combination testing instrument. A single meter, yet at the touch of two simple switches it provides for any one of the 46 ranges of measurements for testing and tracing all electrical faults.

Entirely self-contained, the Model 7 Universal AvoMeter is essentially portable and, above all, simple to use. It is dead-beat in action, has a 5-inch hand-calibrated scale with anti-parallax mirror, and conforms to B.S. 1st Grade accuracy requirements. It is fully protected by an automatic cut-out against damage through overload.

#### Also available

Model 7 Resistance range Extension Unit (for measurements down to 1/100th. ohm)

40-range Universal AvoMeter

In spite of greatly increased production, most of our output of "AVO" Instruments is being taken by the Services. Delay in delivery of Trade orders is consequently inevitable, but we shall continue to do our best to fulfill your requirements as promptly as possible.

● Write for fully descriptive literature and current prices.

Sole Proprietors and Manufacturers :—

**The Automatic Coil Winder & Electrical Equipment Co., Ltd.,**  
Winder House, Douglas Street, London, S.W.1. Telephone : Victoria 3404/7

A.C.		D.C.	
Range.	Value per division	Range.	Value per division
0- 5 Volts	50 mV.	0- 50 mV (1 mA range)	0.5 mV.
0- 10 "	100 "	0- 100 mV (2 mA range)	1 "
0- 50 "	500 "	0- 500 mV	5 "
0- 100 "	1 Volt	0- 1 Volt	10 "
0- 200 "	2 "	0- 5 "	50 "
0- 400 "	4 "	0- 10 "	100 "
0- 500 "	5 "	0- 50 "	500 "
0-1,000 "	10 "	0- 100 "	1 Volt
		0- 200 "	2 "
		0- 400 "	4 "
		0- 500 "	5 "
		0-1,000 "	10 "

A.C.		D.C.	
Range.	Value per division	Range.	Value per division
0- 5 mA	50 $\mu$ A	0- 1 mA	10 $\mu$ A
0- 10 "	100 "	0- 2 "	20 "
0- 50 "	500 "	0- 5 "	50 "
0-100 "	1 mA	0- 10 "	100 "
0-500 "	5 "	0- 50 "	500 "
0- 1 Amp.	10 "	0-100 "	1 mA
0- 5 "	50 "	0-500 "	5 "
0- 10 "	100 "	0- 1 Amp.	10 "
		0- 5 "	50 "
		0- 10 "	100 "

RESISTANCE	
Range.	First indication.
0-10,000 ohms	0.5 ohms
0-100,000 "	5 "
0- 1 megohm	50 "
0-10 "	500 "
0-40 "	2,000 "

using internal 1½-volt cell.  
using internal 9-volt battery.  
using external source of A.C. or D.C. voltage.

CAPACITY	POWER	DECIBELS
0 to 20 mFd.	in 4,000 $\Omega$ internal resistance	reference level 50 mW
First indication 0.01 mFd.	0 to 4 watts First indication 1 mW	-10 Db. to +15 Db.

The 46-RANGE UNIVERSAL

# AVOMETER

Regd Trade Mark

Electrical Measuring Instrument

Model 7

# ALTON

## *Batteries of Merit...*

The list of installations of ALTON Batteries of Merit becomes even more imposing. Proof is being piled upon proof—if such be needed—that these Batteries respond whole-heartedly to the confidence placed in them by discerning Supply Authorities and Engineers throughout the world. The most important trust may be reposed in ALTON Batteries of Merit with complete confidence.

### ALTON BATTERIES

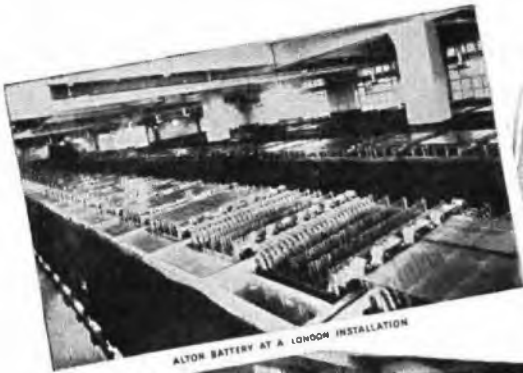

ALTON BATTERY AT A LONDON INSTALLATION



PART OF THE ALTON BATTERY EQUIPMENT INSTALLED AT A B.B.C. TRANSMITTING STATION



BATTERY OF 50 HENRY TYPE ALTON CELLS INSTALLED IN AN IMPORTANT LONDON ESTABLISHMENT



TWO ALTON BATTERIES OF JUV27/31 TYPE CELLS AT A YORKSHIRE ESTABLISHMENT



ALTON BATTERY OF 254 SWH TYPE CELLS AT A CORPORATION ELECTRICITY WORKS



TWO ALTON BATTERIES OF CHW3/15 TYPE CELLS AT A NORTHERN TELEPHONE EXCHANGE

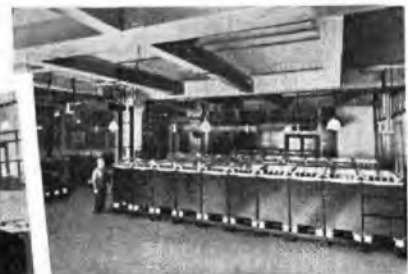

TWO BATTERIES OF SWH TYPE ALTON CELLS AT A LARGE CITY TELEPHONE EXCHANGE

THE ALTON BATTERY COMPANY LTD.  
ALTON, HANTS

Telephones: Alton, 2267/2268.  
Telegram: "Battery, Alton."





# CONDENSERS

*for Service & the Services*

- 1 CERAMIC PEARL TYPE CONDENSERS
- 2 CERAMIC COIL FORMERS
- 3 SILVERED MICA CONDENSERS
- 4 POT CONDENSERS
- 5 FIXED CERAMIC CONDENSERS
- 6 CERAMIC TRIMMER CONDENSERS

SEND FOR DETAILS.

CONTRACTORS TO ALL SERVICE DEPARTMENTS.  
ON A.I.D. APPROVED LIST.

1

2

3

4

5

6

# UNITED INSULATOR CO LTD

*The Pioneers of Low Loss Ceramics*

12-16 LAYSTALL STREET

LONDON. E.C.1

Tel: TERMINUS 4118-9

Grams: CALANEL, SMITH, LONDON





# ELECTRICAL

*Manufacture*

## TELEPHONE CABLES

Aerial, Underground, Submarine

## LOADING COILS

## ELECTRIC WIRES & CABLES

of all types

## CABLE JOINT BOXES

## OVERHEAD LINE MATERIAL

## MARINE APPARATUS

## WIRELESS EQUIPMENT FOR SHIPS

Contractors for the  
laying and  
maintenance of  
Submarine  
and  
Land Cables  
for  
Telegraphy,  
Telephony  
and  
Power Transmission.



**SIEMENS BROTHERS**

WOOLWICH, LONDON

Telephone : WOO



# PRODUCTS

*urers of*

PUBLIC TELEPHONE EXCHANGES

PRIVATE TELEPHONE SYSTEMS

ELECTRIC TOTALISATORS

CELLS & BATTERIES

Dry, Fluid and Inert

MEASURING & RECORDING  
INSTRUMENTS

ELECTRICITY METERS

ELECTRIC LAMPS

Contractors for the  
erection and  
maintenance of  
Marine Wireless  
Installations,  
Public and  
Private Telephone  
Exchanges,  
and  
Carrier Equipment  
for  
Telephone Lines.



**IS & CO. LIMITED**

ONDON, S.E.18

OLWICH 2020.

---



---

**CAPCO**

---



---

REGISTERED TRADE MARK

# Quartz Cutting Machine

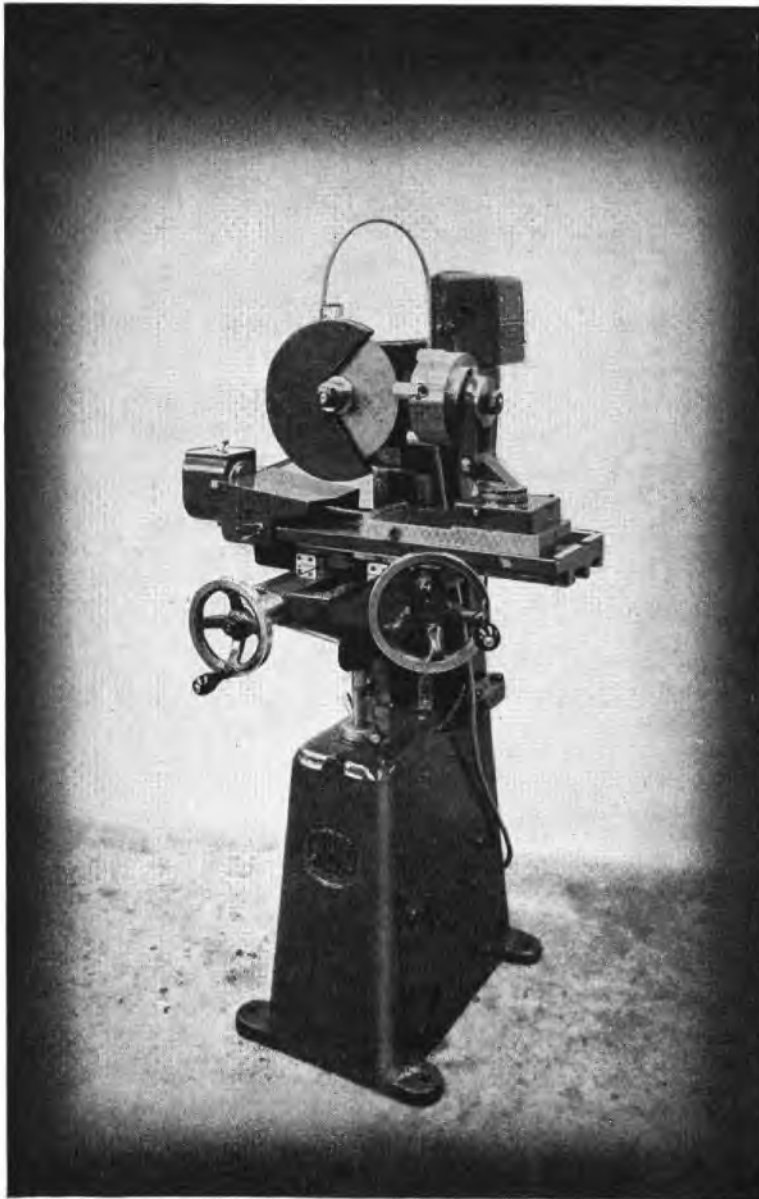

*Designers and Manufacturers of Capco Sound-on-Film recorders and equipment. Capco built recorders are in use at Elstree, Pathe News and British Talking Pictures, etc. Patentees and Manufacturers of Capco Enamelled Wire cleaning machines.*

Illustration shows latest Model of the Quartz Cutting Machine developed and designed in collaboration with engineers of the Radio Branch of the Post Office.

Similar machines have been supplied to the Post Office and to the leading Telephone and Radio Manufacturers.

Standard and heavy duty cutting machines with high rates of cutting to accuracies of .001 in.

Fixtures to hold any shape of crystal can be supplied.

Heavy Duty Machine can now be supplied with nine rates automatic feed through specially designed gear box, sensitive instantaneous stop through specially designed clutch.

Acknowledged to be the finest machines of their kind for this class of work.

*Manufacturers :*

**CAPLIN**  
**ENGINEERING CO. LTD.**

Precision Engineers

BEACONSFIELD RD., WILLESDEN  
LONDON, N.W.10

Telephone :  
WILlesden 0692.

Cables :  
Caplinko, London.

ESTABLISHED 1918

Sole Agents : CAPCO (SALES) LTD.

---



---



# THIS YEAR—WE CLIMB TO VICTORY

YOU CAN HELP YOUR COUNTRY and yourself at the same time if you do your best, but you are not doing your best if you waste time.

By becoming efficient in your vocation you can give the best service to your country and to yourself. The more you increase your earning power the better it is for the country and for yourself personally.

War or no war, earning power always brings its possessor to the front. It is no use waiting for better times. The ideal opportunity never arrives. We have to make the best of existing conditions. Therefore, delay is useless; it is worse, it is harmful.



TO ACHIEVE VICTORY, we must be efficient—to be efficient we must be trained.

If it is your desire to make progress and establish yourself in a good career, write to us for free particulars on any subject which interests you, or if your career is undecided, write and tell us of your likes and dislikes, and we will give you practical advice as to the possibilities of a vocation and how to succeed in it. You will be under no obligation whatever. It is our pleasure to help. We never take students for courses unless we feel satisfied they are suitable. Do not forget that success is not the prerogative of the brilliant. Our experience of over thirty years proves that the will to succeed achieves more than outstanding brilliancy.

## EARNING POWER IS A SOUND INVESTMENT

DO ANY OF THESE SUBJECTS INTEREST YOU ?



Accountancy Examinations  
Advertising and Sales Management  
Agriculture  
A.M.I. Fire E. Examinations  
Applied Mechanics  
Army Certificates  
Auctioneers and Estate Agents  
Aviation Engineering  
Aviation Wireless  
Banking  
Blue Prints  
Boilers  
Book-keeping, Accountancy and Modern Business Methods  
B.Sc. (Eng.)  
Building, Architecture and Clerk of Works  
Builders' Quantities  
Cambridge Senior School Certificate  
Civil Engineering  
Civil Service  
All Commercial Subjects  
Commercial Art  
Common Prelim. E.J.E.B.  
Concrete and Structural Engineering

Draughtsmanship. All branches  
Engineering. All branches, subjects and Examinations  
General Education  
G.P.O. Engineering Dept.  
Heating and Ventilating  
Industrial Chemistry  
Institute of Housing Insurance  
Journalism  
Languages  
Mathematics  
Matriculation  
Metallurgy  
Mining. All subjects  
Mining. Electrical Engineering  
Motor Engineering  
Motor Trade  
Municipal and County Engineers  
Naval Architecture  
Novel Writing  
Pattern Making  
Play Writing  
Police, Special Course  
Preceptors, College of

Press Tool Work  
Pumps and Pumping Machinery  
Radio Communication  
Radio Service Engineering  
R.A.F. Special Courses  
Road Making and Maintenance  
Salesmanship, I.S.M.A.  
Sanitation  
School Attendance Officer  
Secretarial Exams.  
Sheet Metal Work  
Shipbuilding  
Shorthand (Pitman's)  
Short Story Writing  
Speaking in Public  
Structural Engineering  
Surveying  
Teachers of Handicrafts  
Telephony and Telegraphy  
Television  
Transport Inst. Exams.  
Weights and Measures Inspector  
Welding  
Wireless Telegraphy and Telegraphy  
Works Managers



If you do not see your own requirements above, write to us on any subject. Full particulars free.



CAN YOU CHANGE MY EXPRESSION ?

IF SO, YOU MAY BE THE ARTIST THAT COMMERCE IS WAITING FOR.

Just try it for yourself. Trace or draw the outline and then put in the features.

There are hundreds of openings in connection with Numerous Papers, Advertisement Drawing, Posters, Calendars, Catalogues, Textile Designs, Book Illustrations, etc.

60 per cent. of Commercial Art Work is done by "Free Lance Artists" who do their work at home and sell it to the highest bidder. Many Commercial Artists draw "retaining fees" from various sources, others prefer to work full-time employment or partnership arrangement. We teach you not only how to draw what is wanted, but how to make buyers want what you draw. Many of our students who originally took up Commercial Art as a hobby have since turned it into a full-time paying profession with studio and staff of assistant artists; there is no limit to the possibilities. Let us send full particulars for a FREE TRIAL and details of our courses for your inspection. You will be under no obligation whatever.

*John Duck* ART DEPT. 24

Every Department is a Complete College :  
Every Student is a Class to Himself



THE MOST SUCCESSFUL AND MOST PROGRESSIVE COLLEGE IN THE WORLD.

STUDY AT HOME IN YOUR SPARE TIME

### JOURNALISM

Short Story, Novel and Play Writing

There is money and pleasure in Journalism and in Story Writing. No apprenticeship, no pupilage, no examinations, no outfit necessary. Writing for newspapers, novels or pictures is not a gift; it is a science that can be acquired by diligent application and proper guidance. It is the most remunerating way of making part-time profitable. Trained ability only is required, we do the training by post. Let us tell you about it.

DEPARTMENT OF LITERATURE 24

If you attend to this now, it may make a wonderful difference to your future

### COUPON—CUT THIS OUT

To Dept. 24, THE BENNETT COLLEGE LTD., SHEFFIELD

Please send me (free of charge) Particulars of.....

Your private advice about.....

(Cross out line which does not apply)

PLEASE WRITE IN BLOCK LETTERS

Name.....  
Address.....



# PRECISION

Notwithstanding the difficulties met with under present conditions, the Telephone Manufacturing Company, Ltd., is maintaining the well-known reliability of its condensers. These are manufactured in a modern condenser plant, and are notable for the following features :—

Rigid construction.	Maintenance of initial capacitance values.
Small size and weight.	Low power factor.
Extreme stability.	Adequate safety factor. and
Low temperature co-efficient of capacity.	Long life.
High insulation resistance.	

Only high grade materials are used, which have been proved to be suitable by chemical, physical and electrical tests, and careful supervision is given at all stages of manufacture.

Enquiries are solicited in respect of the following types :—

**(a) Mica Condensers.**

These are manufactured in copper or other metal cans, as required, which are marked with the actual and nominal capacities. They may be supplied and adjusted to within  $\frac{1}{2}$  per cent. from the nominal capacity. The temperature co-efficient is not greater than '0045 per cent. and the power factor at 1,000 cycles/second is not greater than '001.

**(b) Precision Paper Condensers.**

These are of the oil impregnated, oil filled, clamped paper dielectric type. The capacity is adjusted to within 2 per cent. of the nominal capacity and departures from the actual capacity due to temperature variations from 0 deg. C. to 50 deg. C. are not greater than 2 per cent. These condensers are fitted with terminals constructed from Mica-filled bakelite and having an insulation of not less than 10,000 Megohms at normal temperature and humidity.

*Prompt attention given to enquiries and deliveries expedited.*

**TELEPHONE MANUFACTURING COMPANY LTD.**  
**WEST DULWICH, S.E.21**

*View of a corner of the Condenser Test Department (gauging thickness of mica).*



# THE POST OFFICE ELECTRICAL ENGINEERS' JOURNAL

Vol. XXXIV

July, 1941

Part II

## Glasgow Director System

F. COOTE

U.D.C. 621.395.34

The progress of the conversion of Glasgow telephone system to director working is described and details are given of the plant installed at Telephone House, Glasgow.

### *Conversion Programme.*

THE Glasgow director system serves an area 14 miles in diameter and comprises 36 local exchanges, together with trunk and tandem exchanges. The conversion of this area to automatic working, which is now well advanced, will result in only one change in exchange name, that of Queens Park which, owing to the absence of the letter Q on the director dial, will be known, on conversion, as Pollok.

The first stage in the original scheme of conversion entailed the opening of the new Trunk, Tandem and Central exchanges, all to be housed in the building to be known as Telephone House and, to simplify junction routings, a number of the larger exchanges in the central area. It was planned to transfer the remaining manual exchanges in small groups coincident with directory issues and to complete the scheme by the end of 1942.

When the Office of Works commenced work on the Telephone House site in 1936 it was found that it would be necessary to pile the site and that a delay of 12 months in the completion of the building would ensue, with consequent delay to the opening date for the main group of exchanges. The replacement of several small manual exchanges due to inability to extend the equipment on the existing site and the necessity for providing relief in a few other areas to avoid wasteful underground cabling schemes, had meanwhile become an urgent matter. A scheme for relieving Ibrox and Paisley exchanges by providing, in advance of the main scheme, a relief exchange to be known as Halfway with a small suite of sleeve control positions at Central manual exchange for assistance traffic, was already in progress. A revised programme catering for the conversion of the area in three stages was therefore arranged.

### *Stage 1.*

Orders were placed with the Automatic Telephone & Electric Co. Ltd., who were installing the Halfway equipment, for nine additional small exchanges as an advance portion of the conversion scheme. The nine exchanges were Milngavie, Shettleston, Newton Mearns, Barrhead, Thornly Park, Provanmill, Busby, Possil and Springburn. The General Electric Company were asked to extend the Halfway auto-manual suite to 30 positions for "0" line and assistance traffic.

As it was not possible to provide a tandem exchange in advance of the opening of the initial ten director exchanges, direct routes were provided from each exchange to the other nine exchanges and to adjacent manual exchanges. A small tandem equipment consisting of 40 group selectors and relay sets was, however, installed at Central manual exchange to afford economy in equipment and lines in respect of miscellaneous services, i.e., INF, TIM, TEL, etc.

### *Stage 2.*

It was decided that the second and main portion of the scheme should consist of the following items:—

(a) The transfer of the demand trunk service from the old trunk exchange at Glasgow to the new exchange and the bringing into use of the mechanical trunk exchange.

(b) The transfer, after a brief interval, of lending traffic and U.A.X. traffic from Central manual exchange to the new exchange; the transfer of "●" line and assistance traffic from the advance group of exchanges to the new exchange, and the opening up of Toll Tandem.

(c) The opening of Director Area Tandem.

(d) The simultaneous opening of the new Central, Bell, Douglas, Paisley and South exchanges three months after the completion of item (a).

At a later stage it became apparent that Central exchange as a full unit would not long suffice for the needs of the Central area and, to avoid changes later, it was decided to install the new City exchange in Telephone House with an initial multiple of 2100 to open concurrently with the five exchanges named above. Further, it was decided to install a P.A.B.X. in Telephone House to serve the offices of the Postmaster-Surveyor, Glasgow, and of the Telephone Manager, and to bring the equipment into use prior to the opening of Central exchange.

### *Stage 3.*

This comprised the conversion of the remaining manual exchanges in small groups as indicated earlier.

### METHODS OF WORKING.

Early consideration was given to possible methods of handling, during the period of conversion, toll and trunk traffic and junction traffic between automatic and manual exchanges.



FIG. 1.—JOINT TRUNK SUITES, NOS. 1, 2 AND 4.  
INFORMATION SUITE IN CENTRE.

*Auto to Manual Traffic in the Director Area.*

In consideration of the relatively short period of conversion and of the maintenance problems involved, it was deemed inadvisable to install C.C.I. equipment for dealing with automatic to manual calls. Such calls are routed either direct or via Area Tandem exchange. The codes to be dialled for calls to manual exchanges are shown in the telephone directory in thin type capitals to enable the subscriber on an automatic exchange to distinguish between calls for which code only is dialled and calls for which it is necessary to dial seven digits.

At Bridgeton, Pollok, Giffnock, Govan and Maryhill exchanges it was impracticable to provide jack-ended junction positions to cope with this class of traffic. To maintain uniformity of procedure from the subscribers' point of view it is arranged that such calls are routed to the joint trunk switchboard, the operator answering in the name of the objective exchange and completing the call over an order-wire group of junctions. The call is metered when the called subscriber answers.

*Manual to Auto Calls.*

Calls from manual exchanges to subscribers on automatic exchanges are either dialled direct to the 1st numerical switches at the objective exchange or via 4-digit or 7-digit

keysender equipment\* at Telephone House.

*Trunk Circuits.*

It was decided to provide equipment for 2 V.F. dialling over the circuits to distant zone centres similarly equipped, but to retain generator or C.B. signalling to other zone and group centres.

*Toll Circuits.*

It has been past practice in provincial director areas to employ S.F.J. working for calls from toll exchanges to subscribers in the director area. As it was known that Headquarters had in hand the design of a first code selector to permit toll exchanges to dial in to the director network, it was considered undesirable to install S.F.J. equipment.

The temporary scheme adopted therefore employs a group selector as a first toll tandem switch and telephonists at toll exchanges dial the director translation of the code of the objective exchange pending provision of the new first code selectors

and the association of "A" digit selectors and directors with the toll tandem plant. Under present conditions the temporary scheme must remain in use indefinitely.

U.A.X.'s parented on Glasgow have no access to the director network and dial "0" for calls to Glasgow subscribers.

Dialling by toll exchanges is confined initially to

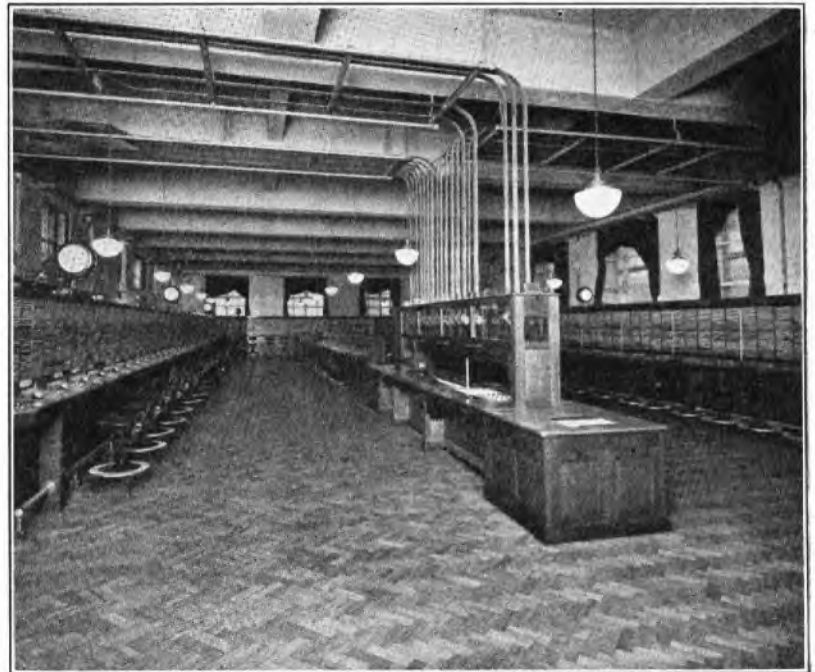

FIG. 2.—JOINT TRUNK SUITE NO. 3. PNEUMATIC DISTRIBUTION POSITION AND KEYSENDER SUITE IN CENTRE.

calls to the director area, "0" being dialled for through calls. Dialling from one toll exchange to another through Toll Tandem, involving second, third and fourth fee metering is to be introduced at a later date. Dialling codes have already been earmarked for 25 such routes.

#### EQUIPMENT AT TELEPHONE HOUSE.

The centre of the system is Telephone House, which houses the Central and City local exchanges, the whole of the manual services for the area including the trunk board, and the mechanical tandem equipment for both the inter-area traffic and the toll traffic to the area.

#### The Joint Trunk Board.

The manual board serving the whole area is worked on the joint trunk principle and subscribers dial "0" for both trunk and toll calls. A total of 253 joint trunk positions made up of three-position sections 6 ft. 4½ in. high and divided into four suites is installed. Fig. 1 shows suites Nos. 1 and 2 in a continuous line of 115 positions to the left of the picture, an information suite of 55 positions in the centre of the floor and suite No. 4 with 64 positions on the right of the picture. Fig. 2 indicates suite No. 3 of 74 positions, including 30 delay positions, in the north-east wing of the switchroom, the pneumatic distribution position, and, in line with the P.D.P., a suite of 17 keysender positions—four seven-digit, 13 four-digit.

The multiple and cord circuit equipment is as follows :—

Item	Suite 1	Suite 2	Suite 3	Suite 4	Information Suite
Outgoing Junction Service Multiple without Free Line Signals .. .. .	100	100	100	100	—
Outgoing Junction Multiple wired for F.L.S., but minus F.L.S. relays initially ..	500	500	500	500	100
Outgoing Junction Multiple with Free Line Signals .. .. .	1,800	1,900	1,300	1,300	360
Trunk Multiple with Free Line Signals .. .. .	600	600	600	600	—
Answering Multiple—12 panel repetition .. .. .	720	720	720	600	420
Cord Circuits per position ..	13	13	13	15	7
18 min. Chargeable Time Indicators, per position .. .. .	6	6	6	6	—

The large number of circuits to be accommodated in the outgoing multiples made it necessary to dispense with the lower cornice and to adopt a five-panel instead of the standard four-panel repetition. Even this did not provide sufficient jacks to enable every circuit to have an appearance on each suite and it was decided to spread large groups of circuits over the four suites. It was necessary on this account to

cable the multiples from each suite separately to the I.D.F. This had the result of extending the manual and tandem I.D.F. to 200 verticals and produced the problem of finding the best method to jumper jacks on four and sometimes five suites to one relay set.

The scheme adopted is shown in Fig. 3. Eight-way connection strips are used in place of the standard four-way type. Supposing the circuit on the connection strip to be Jack No. 0 on Panel 2 of each suite, the insertion of bare wire straps on each connection strip ties together the four multiples and one jumper wire to the relay set suffices. The omission of the strap on connection strip No. 3 permits Jack No. 0 on Panel 2 of suites 1 and 3 to be

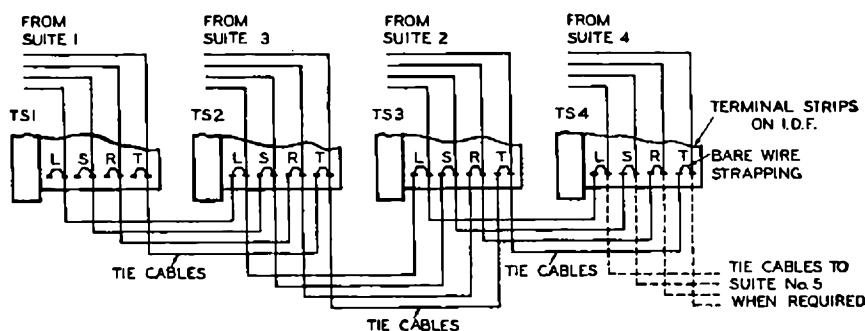

FIG. 3.—TYING OF MULTIPLE CABLES ON I.D.F.

used for one circuit and the corresponding jack on suites 2 and 4 for a separate circuit. The omission of all the straps dissociates the multiples and allows the connection of a separate circuit on each of the four jacks. The tie cables are run from each connection strip horizontally to the corresponding strips further along the I.D.F. and are laced to the horizontal members of the frame.

Each of the four multiples has its own complement of lamp relays. There are five racks for multiple answering relays and 30 for free line signals. A total of 11,400 relays is mounted on these racks. The number of 6-volt lamps used on the manual board is approximately 285,000.

#### Directory Enquiry Bureau.

The equipment is of the standard design for provincial directory enquiry bureaux and consists of 16 enquiry positions at which local, toll and trunk directory enquiry traffic is handled, and a suite of 6 monitors' positions. Subscribers at automatic exchanges in the director area dial DIR to obtain connection to the suite. Lines to the suite are also available to manual exchanges in the director area via 7-digit tandem and to exchanges in the toll area via toll tandem.

Each directory enquiry operator has access to the complete directory record which is contained on three Linedex double-tier drums, the local record being accommodated on two drums and the upper tier of the third drum. The toll and trunk directories are held in a revolving bookcase forming the lower tier of the third drum. The ultimate capacity of the drums for local records is 151,200 entries.

Fig. 4 shows the layout of the suite. Drum C1 is the combined local record and trunk directory Linedex drum and is available to operators 1, 2 and 3. The speaking circuit equipment is mounted beneath the table. The key-ended circuits and lamps are mounted between drums A1 and B1, C1 and A2, etc.

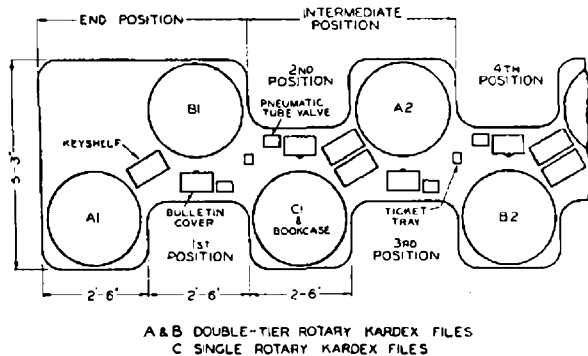

FIG. 4.—LAYOUT OF DIRECTORY ENQUIRY BUREAU.

Circuits incoming to the bureau being key-ended, instead of jack-ended and panel mounted, permit quiet operating and render available a maximum space for filing equipment. Fig. 5 shows the scheme in straight-line form. Each enquiry position at Glasgow has three connecting circuits, but two per position is the later standard. The connecting circuits from all

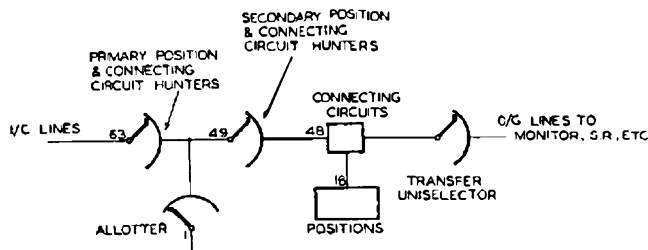

FIG. 5.—SCHEMATIC OF DIRECTORY ENQUIRY BUREAU.

positions are wired to the banks of secondary position and connecting circuit hunters. Incoming circuits terminate on primary position and connecting circuit hunters, the banks of which are wired to the secondary hunters. The destination of each call is governed by an allotter.

The following special facilities are covered in the design :—

1. Automatic hunting for an outlet to a disengaged operator.
2. Queuing of waiting calls if a free position is not available.
3. The connection of these calls to disengaged positions in the order of their origination.
4. Automatic transfer of a call to the monitor, section supervisor or to the manual board.

**Circuit Details.** The circuits employed follow, in general, well-known principles, but one feature of note is the simple method employed to permit queuing and enable calls to be connected to an operator in the order of their origination. Fig. 6 shows the basic principle of the secondary hunter and of the allotter.

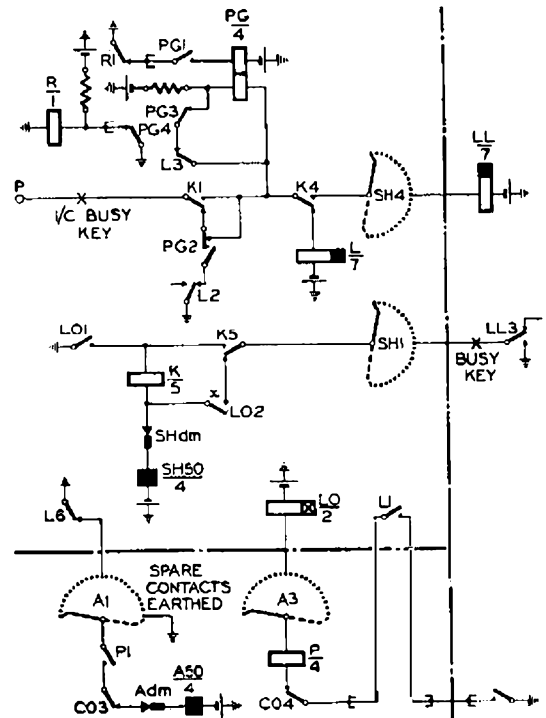

FIG. 6.—PART OF SECONDARY HUNTER AND ALLOTTER CIRCUIT.

Incoming calls from the primary hunter select the first free secondary hunter, operating relay L over the P wire. If there is a free position, the earth on the common lead to the allotter allows relay P to operate in series with relay LO which is slow to operate. P causes the allotter to step to the secondary hunter, marked by absence of earth on the A1 bank. When the allotter has found the secondary hunter in which the call is waiting the LO relay operates and causes the secondary hunter to search for the idle connecting circuit. When this is found the K relay operates and switches all lines through to the connecting circuit, thus operating relay LL which lights the calling lamp. The operator answers by throwing a key, after which the lamp functions as an answering supervisory.

Should all positions be engaged the queuing facility is arranged as follows :—

The primary hunters are homing switches and offer calls to the secondaries always in the same sequence. Any secondary hunters becoming free before calls have been offered to the last secondary hunters in the sequence are artificially busied. Calls are thus distributed to the secondary hunters in cyclic order. When at any stage there is no free position, incoming calls queue by marking the succeeding contacts of allotter bank A1 in chronological order, and the allotter which is meanwhile standing on the contacts of the last secondary hunter allotted a position, allots positions to the secondary hunters in rotation as they become free.

The artificial busying of circuits is achieved by relay PG in parallel with relay L on the incoming P wire. PG operates on an incoming call and locks to a common earth. When relay L releases at the end of a call a contact of PG artificially busies the circuit.

The earthed PG contacts of disengaged secondary hunters shunt relay R, and when a call is taken by the last choice the shunt is removed and R operates and removes the common earth holding the PG relays which release and the cycle repeats.

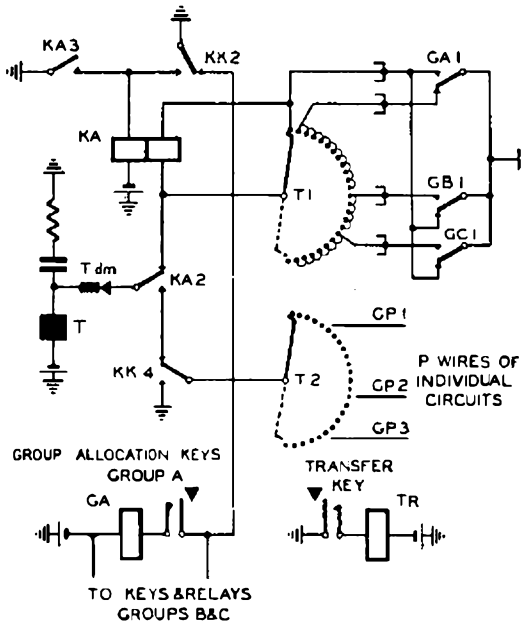

FIG. 7.—PART OF CONNECTING CIRCUIT, DIRECTORY ENQUIRY BUREAU.

Outgoing lines are terminated on the banks of a transfer uniselector. If the operator desires to refer a query to the monitor, supervisor or distant exchange the speak call key is thrown and the relative group allocation key (Fig. 7) pressed. This marks the group concerned on arc T1 of the transfer uniselector which steps until the group is reached. Relay KA operates and switches the driving magnet over to arc T2 on which the P wires of outgoing circuits terminate. The uniselector then hunts for the first free circuit in the group. Should all circuits be engaged, the uniselector switches to the spare contact following the group. This contact is connected to positive battery on the T3 arc. Busy tone and flash are returned to the operator.

Having obtained a free outlet, the operator can, if

desired, connect the caller to the outgoing line by operation of the transfer key which extends the incoming to the outgoing lines, dissociates her headset from the circuit and renders the second connecting circuit of the position available for a further call.

#### Pneumatic Distribution Positions (P.D.P.).

The adoption of joint trunk working entailed the provision of ticket tubes from all the operators' positions instead of restricting their use to a limited number of positions dealing exclusively with trunk traffic. The provision of access to ticket tubes from all positions made practicable the collection of toll tickets by this method.

This increase in the number of tubes and in ticket traffic rendered the standard four-position double-sided P.D.P. inadequate for the purpose. It was estimated that Glasgow would need a P.D.P. of 10 positions initially and of 16 positions ultimately.

In 1938, a committee considered the general question of the use of ticket tubes in joint trunk exchanges and new methods of ticket sorting, and a new combined Pneumatic Distribution Position and Ticket Filing Position (P.D.P. and T.F.P.) was designed. The principles of the new design are illustrated in Fig. 8. See also Fig. 2. Tickets are delivered from the vacuum header valves to an upper conveyor band A moving at a rate of 200 ft. per minute, which conveys the tickets to a trough G. Two operators, at positions F1 and F2, have access to the trough and it is their sole duty to face up tickets with "sails" in one direction, arrange them in small bundles and place them on a slow-moving (80 ft. per minute) lower band B to primary sorting operators—PS.1-4.

This team of operators sorts the tickets into five categories:—

1. Completed trunk tickets.
2. Cancelled trunk tickets.
3. Tickets for delay calls.
4. Completed toll tickets.
5. Cancelled toll tickets.

Tickets in classes 2, 4 and 5 are sorted into ticket trays in front of the operator.

Immediately in front of the operators on both sides of the table are two one-inch V conveyor bands

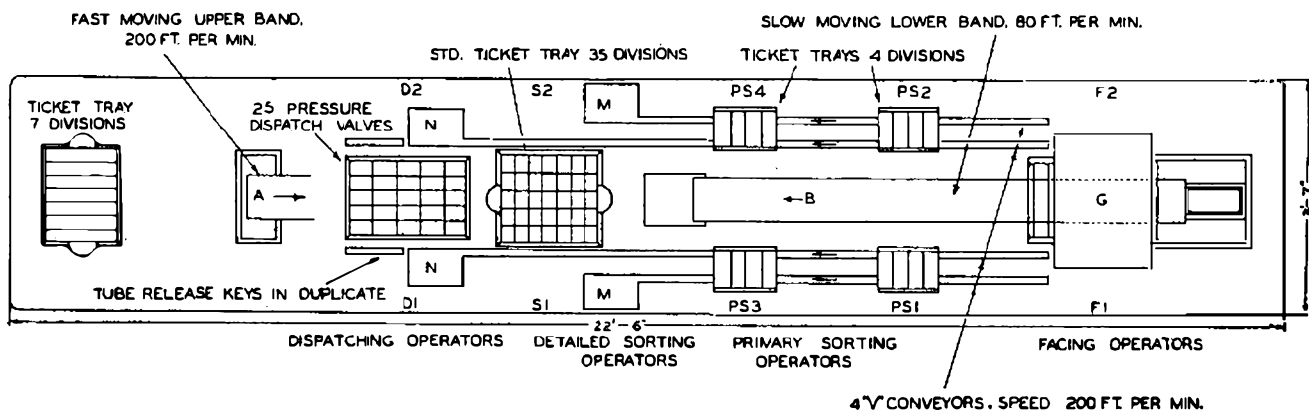

FIG. 8.—LAYOUT OF COMBINED PNEUMATIC DISTRIBUTION POSITION AND TICKET FILING POSITION.

moving at a rate of 200 ft. per minute. Delay tickets are placed on one of these conveyor bands which transmits them to troughs N on two positions where access is available to the pressure despatch valves by which they are forwarded by despatching operators D1 and D2 to the delay positions.

Tickets in category 1 are placed individually on the other conveyor band which transfers them to troughs M for detailed sorting by two operators S into a standard ticket tray of 35 divisions. General practice is to sort them in alphabetical order of the name of the objective exchange, but in Scotland, for geographical reasons, it is found to be preferable to sort them into alphabetical order of the originating exchange name.

Tickets in respect of toll calls are not given detailed sorting at the P.D.P. Demand trunk tickets receive detailed sorting at the P.D.P., so that enquiries by subscribers as to the duration and cost of demand trunk calls can be answered readily.

Details of the ticket tubes provided are :—

From		Vacuum or Pressure	No. of Tubes	Average Length feet	Despatch Valves	Receiving Terminals
From	To					
Joint Trunk Positions, Information Suite.	P.D.P.	V.	28	170	245	29
	"	V.	1			
P.D.P.	Joint Trunk Positions Information Suite.	P.	15	110	18	18
"	Directory Enquiry Bureau.	P.	1	95		1
Directory Enquiry Position.	Directory Enquiry Monitor.	V.	2	85	18	2

#### City and Central Exchanges.

The manufacturing period for Stage 2 exchanges coincided with the changeover of policy from line-finder to uniselector working for exchanges with an average busy-hour calling rate per subscriber of .6 or over. The General Electric Company were able to make the changeover from line-finder to uniselector working at Central and City exchanges and also at Bell exchange.

The exchanges opened concurrently, the contractor concerned and the number of subscribers' lines involved in the transfer were :—

Exchange	Type of Exchange		Number of lines transferred	New Exchange installed by
	Old	New		
Central	C.B.1	Uniselector	7,092	G.E.C. G.E.C.
City	C.B.1 (Hypothetical on Central)	"	304	
Bell	C.B.1	Line Finder	2,530	G.E.C. A.T.E. Co. Ericsson's Ericsson's
South	C.B.1	"	2,136	
Douglas	C.B.1	"	5,376	
Paisley	N.D. Keith Line Switch	"	2,201	
Total			19,728	

The trunking of Central and City exchanges follows standard practice. Central is a full unit and City is planned for a multiple capacity of 7,000 lines at the

ultimate date. The exchanges have common directors, "A" digit selectors and outgoing junctions. Owing to the high percentage of private branch exchanges, final selectors are all of the P.B.X.2-10 or 11 and over types.

#### Service P.A.B.X.

A Service P.A.B.X. of 600 lines multiple is provided for the Postmaster-Surveyor, Glasgow, and Telephone Manager, Glasgow Area. The numbering range is 2,200-2,799, but the initial digit is not dialled on inter-extension calls. Access to the director area is obtained by dialling "9" plus the code and number of the objective subscriber. For trunk and toll calls, the attention of the joint trunk exchange operator is gained by dialling the digit "8." By dialling "0" extension users are routed to the P.A.B.X. assistance positions which are the first three positions on the information suite.

Subscribers desiring an official call to an extension, the number of which is not known, dial GPO 1234 and the initial numerical digit routes the call to the assistance position. Trunk zone centres employing 2 V.F. dialling, toll exchanges and subscribers in the director area can obtain extensions direct by dialling the code GPO and the extension number. The first numerical digit routes the call from tandem to second selectors in the P.A.B.X. plant.

#### Tandem Equipment.

The unusual routings employed have been explained earlier. A simplified trunking diagram showing the tandem routings is given in Fig. 9.

A total of 600 auto-to-auto relay sets with impulse regenerators are installed. They are used on junctions outgoing from director area tandem where they are connected between first and second tandem selectors and on junctions outgoing from toll tandem where they are placed between first and second code selectors.

It will be recollected that the use of mechanical impulse regenerators permits tandem junction working over networks of any complexity, providing that no junction exceeds 1,500 ohms resistance, but present practice limits their use to a maximum of three links. In the Glasgow director area there were few routes where the use of mechanical impulse regenerators was justified on account of the resistance of the outgoing junctions. It will be appreciated, however, that the number of relay sets required by the policy adopted is equal to the number of trunks between first and second tandem selectors, which is far less than would have been necessary had they been connected, as in past practice, to the outgoing level junctions. Although the auto-to-auto relay set with mechanical impulse regenerator is more costly than the normal auto-to-auto relay set, the overall balance is in favour of the use of the former item. Dialling out to 25 toll exchanges within the 15-mile circle is visualised, which also justifies the provision of mechanical impulse regenerators initially.

These remarks refer also to the use of mechanical impulse regenerators in relation to the toll tandem



equipment. Their inclusion in the trunking scheme is dictated by reasons of economy, dialling in to the automatic network being achieved in some instances where it would otherwise have been impossible and through dialling to other toll exchanges in the 15-mile circle in the future will be facilitated.

**2,000 Type Equipment.**

The automatic equipment throughout the area is of the 2,000 type and presents a neat and orderly appearance, two typical views being given in Figs. 10 and 11. The keysender equipment with the keysender junction and outlet relay sets is of the pre-2,000 type and presents a striking contrast to the remainder of the plant.

at Birmingham<sup>1</sup> as against a measure of decentralisation as applied in the Manchester Area<sup>2</sup>. It was decided that the latter scheme would best meet the needs of the Glasgow Director Area. Consequently, it was arranged that five ENG centres and maintenance controls would be set up at Central, Paisley, Bridgeton, Langside and Western, and that any exchange converted in advance of its respective fault centre would be controlled at Central temporarily.

Central, City and Douglas exchanges are provided with direct ENG circuits to the Central test desk during normal hours. ENG traffic from all other exchanges controlled from Central circulates via Area Tandem.

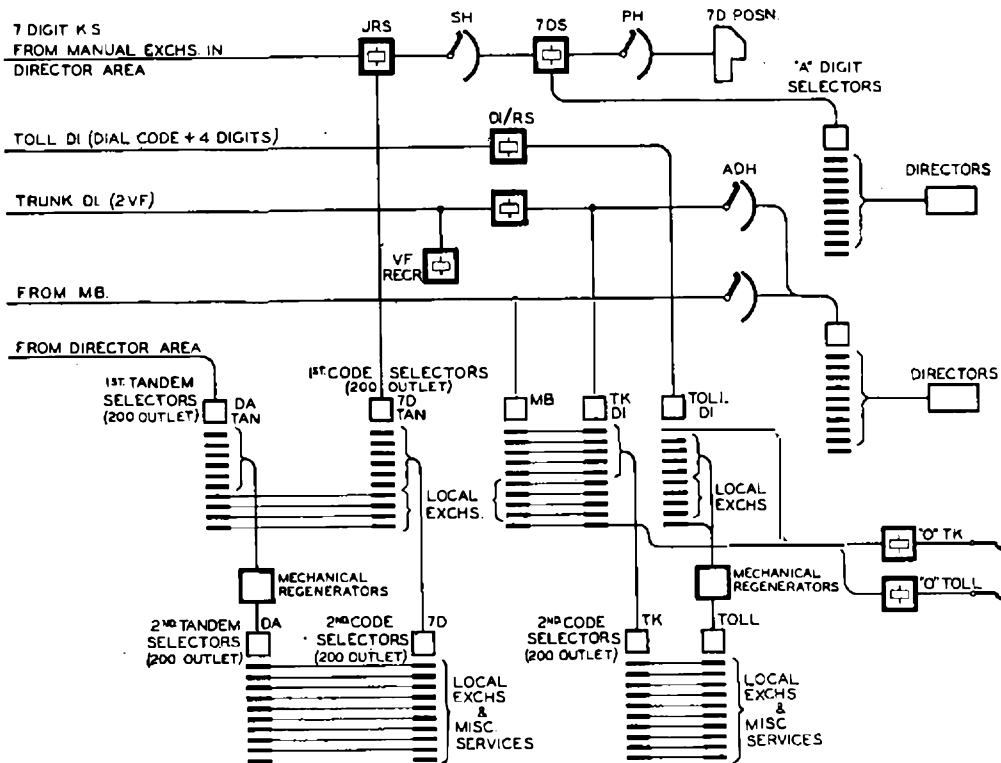

FIG. 9.—SIMPLIFIED TRUNKING DIAGRAM OF TANDEM ROUTINGS.

**Maintenance Testing Facilities.**

**Trunk Test Racks.**—The maintenance of demand and toll trunks and the busying of faulty circuits on the manual board outgoing junction multiples are controlled on a suite of nine trunk test racks, the equipment on which is summarised below.

Type of Position	No. of positions	No. of equipments			
		Without busy keys	With busy keys	Special Arrangements	Duplicate busy keys
Demand Trunk Test	4	320	880	80	—
Toll Trunk Test ..	2	630	800	—	—
Junction Test ..	2	800	1,200	—	—
Records ..	1	—	—	—	2,88

**Engineering Fault Complaint and Repair Service (ENG Service).**—The ENG service has been introduced at each exchange coincident with conversion to automatic working. Early consideration was given to the relative merits of a centralised scheme as in use

During periods of light traffic, ENG traffic from Central, City and Douglas, together with that from other ENG centres, is switched into the Tandem route, and the final two digits in the director translation, inoperative under day conditions, perform the desired trunking diversion. This facilitates the concentration of night ENG traffic to two telephones in the automatic switchroom if desired and the busying of the remaining choices in the tandem grading.

**Central Exchange Test Desks.**—Two suites, each of nine positions, are provided with functions as follows:—

- Suite No. 1.
  - 2 Junction Test Sections.
  - 2 Advice Note Sections.
  - 5 Fault Control Sections.
- Suite No. 2.
  - 9 ENG Test Sections.

<sup>1</sup>P.O.E.E.J., Vol. 30, p. 304.  
<sup>2</sup>P.O.E.E.J., Vol. 27, p. 116.

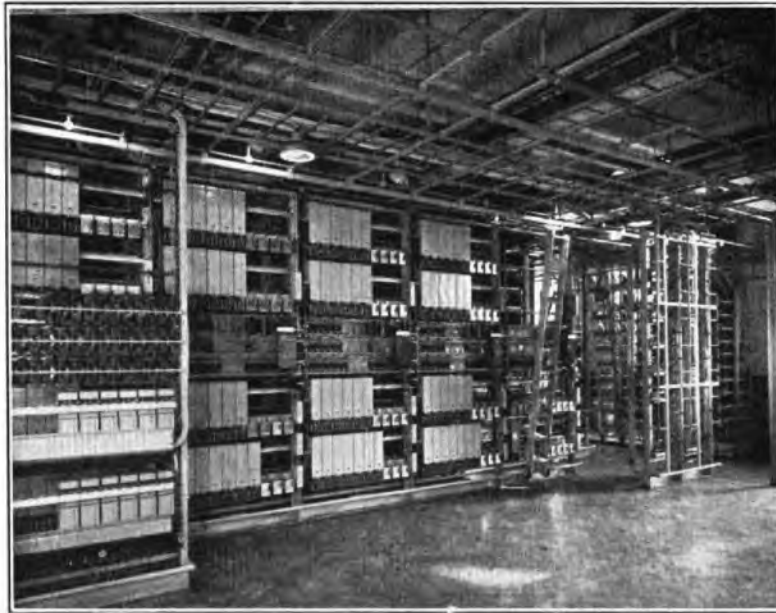

FIG. 10.—1ST CODE RACKS AND I.D.F.—CITY EXCHANGE.

Equipment for 60 ENG lines and 60 lines to test selectors is provided. The Central test desk is given access to all the test selectors at the exchanges controlled from it, and also, for night service when other centres are closed, to one test selector at each other automatic exchange in the director area. The test selector junctions, except internal junctions, are five wire circuits, arranged to switch in the transmission bridge at the distant exchange over the fifth wire for transmission tests.

#### *Power Plant.*

The building is supplied by two duplicate services. As a safety precaution one is led into a transformer chamber from the street in front of the building and the other from the street at the rear. One is a 6.6 kV ring main fed from a local generating station and the other a 6.6 kV ring main fed from the grid. Each duplicate supply serves a 800 kVA, 6,600/440 volt, 3-phase transformer, and each transformer serves half the load of the building. In the event of a failure of one of the transformers or duplicate supplies the other transformer can be readily switched to take the whole load of the building. The daily current consumption of the equipment at the conclusion of the conversion scheme was calculated to reach 25,000 ampere hours with a busy-hour load of 3,700 ampere hours. It was also estimated that these figures would ultimately be doubled.

The ideal situation for the power plant is naturally the centre of the building, but installation of the plant in this position would have divided the automatic switches on the sub-ground floor into two sections. The positioning of the power plant in the

north east wing of the building has necessitated heavy battery bus-bars and distribution bus-bars to keep within the limit of one volt drop from the battery terminals to the distribution fuses on the rack panels.

A divided battery float scheme<sup>3</sup> is provided and consists of:—

Two batteries each of 10,200 ampere hours capacity supplied by the D.P. Battery Co.

Two battery circuit breakers rated at 8,000 amps.

Three motor-generator sets manufactured by the Electric Construction Company, Wolverhampton.

Input 440 volt, 3-phase, 50 c/s.

Output 3,000 amps at 51 volts.

#### *Underground Cable Construction.*

In view of the large number of cables to be accommodated initially and ultimately, considerable underground plant had to be provided, including a tunnel 200 yds. long and 8 ft. internal diameter, and four main new duct routes varying from 40- to 96-way. Earthenware non-self-aligning ducts of octagonal exterior and circular interior were used and were laid in concrete. Sixty-three large new man-holes have been constructed. The new duct work comprising 100 miles or more of single duct was commenced in February, 1938, and, as the Glasgow Empire Exhibition was due to open in May, 1938, it was necessary to complete all excavation work by that date. That this engineering feat was successfully accomplished was a tribute to the Telephone Manager's organisation and to the willing co-operation of the Contractors employed.

<sup>3</sup>P.O.E.E.J., Vol. 33, p. 12.

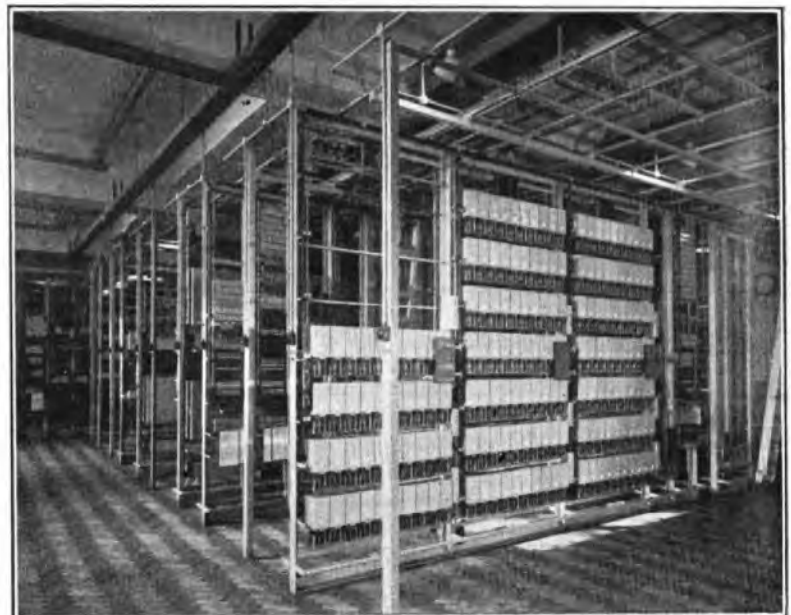

FIG. 11.—"A" DIGIT SWITCHES AND 1ST CODE ROUTINER, ETC.

### *Transfer Operations.*

The group of 10 small exchanges, comprising Stage 1, were cut into service between September, 1937, and September, 1939. The next major step in the programme was the transfer on 17th November, 1940, of the Trunk Exchange in Glasgow Head Post Office to Telephone House. The transfer was accomplished in two stages, half the circuits being cut over at 9.15 a.m. and the remainder at 12.30 p.m. The circuits concerned totalled 786. The trunk tandem equipment was brought into use and two-voice frequency dialling was introduced on the demand trunk routes to London, Birmingham, Manchester, Bristol, Newcastle and Leeds. Circuits on other demand routes continue to be worked by the generator signalling method.

On the 1st December, 1940, toll area traffic and assistance traffic from the early group of exchanges were transferred from Central manual exchange to Telephone House in one operation. Toll area tandem and the 7-digit keysender equipment were brought into use. The number of junctions and toll trunks involved was 1,802.

Under the heading "Methods of Working" earlier in the article, reference was made to the fact that auto-to-auto traffic between exchanges in the "early" group was routed over direct circuits and miscellaneous services were carried by a temporary tandem equipment at Central manual exchange. The next step in the conversion scheme, therefore, was the diversion of this traffic to its permanent routing through director area tandem. This was achieved at each exchange in turn and was completed by the 19th January, 1941. On this date the ENG service, which had been operated from a small suite of positions at Central manual exchange was transferred to the new test desks at Telephone House.

The next operation was the closing down on the 1st February, 1941, of three service P.M.B. exchanges and the opening of the service P.A.B.X. referred to earlier.

The conversion of 381 call office and 573 subscribers' coin box lines on Central, City, Bell, Douglas, Paisley and South exchanges needed special attention. The new assemblies were wired in a central workshop. Six weeks before the main transfer, the work of replacing the existing equipment was commenced. As each station was proved to function correctly, the circuit was transferred to the automatic exchange, where the director and "A" digit selectors, together with the coin box group of uniselectors (or linefinders) and first code selectors were brought into use in advance of the main equipment.

It was necessary for transferred call offices and coin box subscribers to dial "0" for all calls until the main transfer. To enable the joint trunk operator

to connect any transferred station to a number on one of the manual exchanges, special groups of circuits from the outgoing junction multiple at the new exchange to the old exchange were provided. The coin box "0" line groups were temporarily augmented.

The next operation was the transfer at 1.30 p.m. on the 1st March, 1941, from manual to automatic working of 19,728 subscribers' lines at the six local exchanges included in Stage 2. This is thought to be the greatest number of lines yet transferred at one operation by the British Post Office. Forty-three per cent. of subscribers in the director area are now connected to automatic exchanges.

The transfer of the Glasgow Directory Enquiry Bureau, formerly accommodated at Bell exchange, was accomplished in two stages. Half the number of available index drums was transferred over night from the old exchange to Telephone House. The new bureau opened at 8.30 a.m. on the 1st March, 1941, with traffic from the joint trunk manual board, from the 7-digit keysender positions and from the ten exchanges already converted to automatic working. The balance of the traffic was taken over by the new bureau coincident with the main transfer and the remaining index drums were then taken to Telephone House.

### *Conclusion.*

The devolution from Headquarters of automatic exchange design work and the preparation of specifications for new exchanges supplied under contract took place as far as work in the Scottish Region is concerned in August, 1936. The engineering of the Glasgow Director Scheme was the most pressing problem at the time of devolution and the successful completion of the first major work engineered under Regional organisation is therefore a matter of gratification to the staffs concerned.

Reference should certainly be made to the conditions under which the staff of the Glasgow Area have carried the work to its final conclusion. To have completed a work of this magnitude, involving, as it did, intricate jointing operations, modifications to subscribers' installations and to equipment at outlying exchanges, the supervision of the installation by contract of six automatic exchanges, the provision and training of large staffs for construction and maintenance work, all under the conditions existing since September, 1939, is an engineering triumph which should live long in the memory of telephone engineers.

In conclusion the writer desires to express his thanks to the General Electric Company for the photographs illustrating this article which were kindly supplied by them.

# The New Amplifier No. 32 and Associated Equipment

U.D.C. 621.395.645.34

H. WILLIAMS, A.C.G.I., A.M.I.E.E.

Outstanding points in the design of the new amplifier (No. 32) and its associated line and corrector equipment are described. The amplifier is designed to replace all existing types of audio frequency repeaters and amplifiers for new work.

## Reasons for the Introduction of a New Amplifier.

ALTHOUGH the most modern of the audio frequency repeaters and amplifiers in use in the Post Office were introduced in 1932 and 1933 respectively, it was thought that the time was ripe to standardise an amplifier which would cover the functions of all the existing types (excluding music amplifiers), and by incorporating a feed back circuit, give an improved performance, at a low cost.

Most of the present repeaters incorporate attenuation-frequency equalisers, and both repeaters and amplifiers have a range of gain adjustment. In the new amplifier the gain adjustment is strictly limited and attenuation-frequency equalisers are not provided. The correct output level of the amplifier is obtained by an attenuating pad and, where necessary, an equaliser added to the receiving cable pair so that the attenuation of each pair between repeaters is built out to 27 db. By this means circuits may be set up and switched by merely running jumpers. Although it is realised that the relative merits of this and other methods are controversial, it is felt that great benefit will result in maintenance and setting up circuits by reason of the fact that there will be no necessity to interfere with the amplifier. In this connection it should perhaps be mentioned that this method was conceived for a toll network in which unloaded cables were to be used. This would, of course, necessitate short distances between repeater stations and an equaliser on each section. When the scheme is applied to loaded cable, equalisers will, of course, not be necessary on each section.

## GENERAL CONDITIONS TO BE MET AND FACILITIES PROVIDED.

### The Amplifier.

The gain adjustment to be provided in an amplifier depends on the:—

- Output required to cater for a long local end.
- Variation of gain due to valve changes.
- Variation of attenuation of the line due to temperature changes.

As regards (a), in the past a  $\pm 13$  db. output level has been assumed the maximum that can be tolerated.

The limits of mutual conductance of the valve fixed tentatively are 1.65 to 2.75 mA per volt. This should result in a total change in gain of about 1.0 db.

The worst condition for variation of cable attenuation would be that experienced by an unloaded cable in which the attenuation may be assumed proportional to  $\sqrt{R}$ . At audio frequencies the change in R can be considered to be the D.C. change, and assuming a summer to winter variation of 14°C this would result in a change of 0.7 db. on a 26 db. section of cable.

It has therefore been considered necessary to

provide, until more data are available, six 1 db. taps, the normal gain of the amplifier being 27 db.

The existing repeater power supplies consist of 130 volts for the H.T. and 24 volts for the L.T. In addition to this, however, a number of amplifier stations operate from a 6-volt filament supply and, as a number of power plants of this type exist or are on order, it has been necessary to cater for alternative 24 or 6 volt working. This is accomplished by strapping on the amplifier panel.

### Associated Equipment.

The general conditions to be met by an amplifier, assuming a zero circuit is obtained, are shown in Fig. 1.

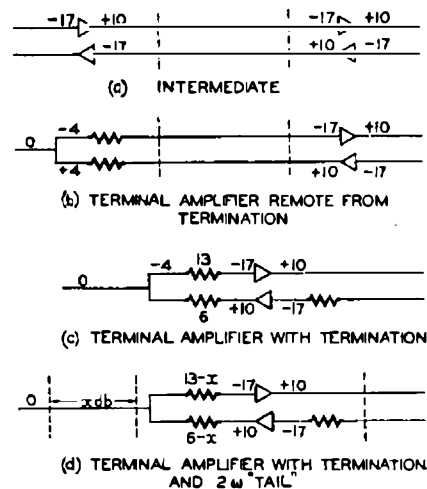

FIG. 1.—GENERAL CONDITIONS TO BE MET.

In addition to the amplifier bays, two bays of associated equipment have been designed to meet these conditions, the first containing terminations, and the second, line transformers, attenuators and correctors. Since provision has not hitherto been made for fitting attenuators on line transformer bays, a special bay of attenuators is being provided for association with existing line transformers.

The particular conditions which may have to be met in part or in whole at a repeater station are therefore as shown in Fig. 2. From this it will be seen that when Units Amplifying No. 32 are installed in a station where cables exist already terminated on old type transformer bays, it is necessary to make provision for the jumpering of attenuators if it is not desired to fit the new transformer racks.

Pads must be provided therefore:—

- In association with line transformers and equalisers for new cables or re-terminated old

cables. (The rack of units is known as a "Transformer and Line Corrector Equipment Bay.")

(2) On special bays for association with old cables.

(3) For use with terminations. This will be done by a fixed value pad, room for which will be found on the terminating units (Nos. 5A and 6A).

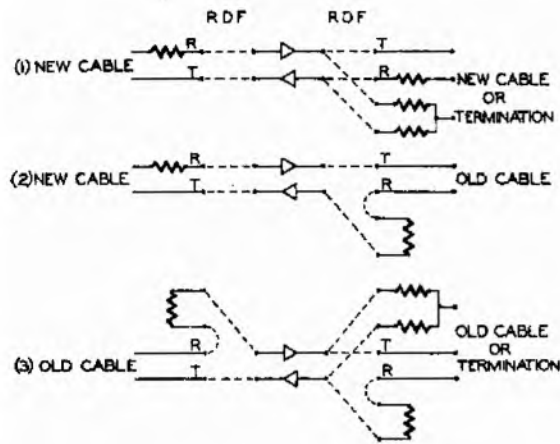

FIG. 2.—PARTICULAR CONDITIONS AT A REPEATER STATION.

It has been considered that the number of unloaded cables in the country will increase materially due to the difficulties and undesirable features in respect to obtaining accurate loading manhole sites, cost of loading, and especially with a view to the possible utilisation of the cables later for carrier work. It has been necessary, therefore, to allocate space for an equaliser for each receiving pair entering a station.

"Group" and "Quad" Working.—Most cables are, of course, balanced in groups for 4-wire working, and the 2-wire circuits are sandwiched between them to form a screen. Of the 4-wire circuits a number are operated by the use of voice frequency signalling of one sort or another. A proportion, however, utilise direct current signalling or dialling, or 17 c/s ringing, for which the phantom is brought out from the line transformers. The method of working is evident from Fig. 3.

Considering the conditions on two quads, however, it will be seen that various difficulties would arise if an attempt were made to signal over the loop formed by the phantoms on pairs in the two directions of transmission where group working is employed. With reference to Fig. 3 (a):—

(1) It is evident that since pair 1 is coupled by a large capacitance to pair 2, and the current is equivalent to single wire transmission, the return circuit for the signalling current being in a remote part of the cable, interaction will not only take place between the signalling circuits but considerable noise will result.

(2) The method of curing this is to "signal within quad" (Fig. 3 (b)), i.e. the go and return signalling circuits are arranged to be on the phantoms of a true quad. Even so, crosstalk may occur in the following manner: speech from circuit 2 will be injected, due to the potential across the  $1\mu\text{F}$  con-

denser, on to the phantom of quad No. 2. Crosstalk to the side circuit of quad 2 takes place and the speech is then heard in circuit 1 due to the amplification given by the receiving amplifier in circuit 1. The effect of this is usually a crosstalk of about 60 db. between zero circuits assuming a phantom-to-side crosstalk of 65 db. and a receiving gain of 20 db. It is feared that some older cables will not be good enough for this method of working, and as it is desired to obtain the benefits of group working it has been necessary to make tentative provision for a low-pass filter which will be inserted as shown and which will prevent speech from traversing the phantom. Surges caused by signalling will, in a future termination, be prevented from reaching the grid of the transmitting valve by making the loss of the termination very high at frequencies below, say 100 c/s.

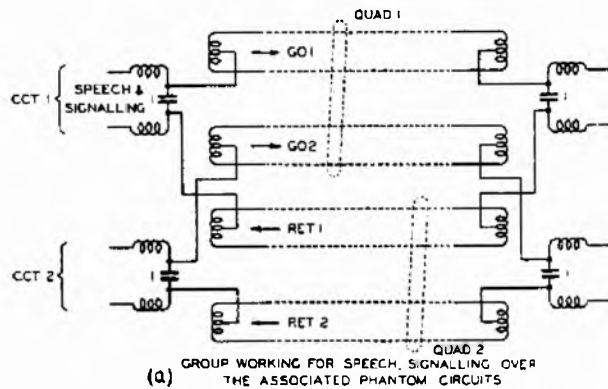

(a) GROUP WORKING FOR SPEECH, SIGNALLING OVER THE ASSOCIATED PHANTOM CIRCUITS

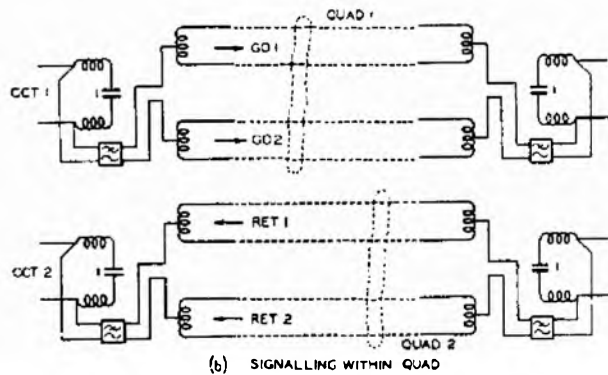

(b) SIGNALLING WITHIN QUAD

FIG. 3.—GROUP AND QUAD WORKING.

The facilities required on the transformer and line corrector equipment are, therefore:—

(1) Provision for attenuator and equaliser associated with each receiving line transformer.

(2) Phantoms led out for signalling.

(3) Facilities for conversion from "group" to "within quad" working.

(4) Under group working conditions receiving line equipment to be kept separate from transmitting line equipment to minimise risk of crosstalk between points of high level difference.

(5) Space for mounting low-pass filters for signalling circuit.

## AMPLIFIER.

The amplifier, which has 30 db. maximum gain, was developed in its basic form by the Post Office Research Branch. Owing to differences in manufacturing technique, the two firms manufacturing the amplifier have produced differing circuit diagrams, although, since the individual components are in "pots", the resulting articles as seen externally are almost identical. The basic specification to which the amplifier is built is as follows:—

Valve—V.T. No. 149. An indirectly heated pentode valve having a metallised envelope and an octal base.

filament current .. 0.25 amps.  
filament voltage .. 4.0 volts.

In an attempt to get over disconnections in grid circuits suspected to be due to "dry" contacts, the grid of this valve has been brought out to a top connection. If necessary, a special cup can be designed for this connection or it may even be soldered.

Input and output impedance of each amplifier expressed as a singing point against 600 ohms shall be greater than 20 db. at 800 c/s, and greater than 15db. at all frequencies within the range 300—3,000 c/s.

The maximum gain shall be  $30 \pm 0.5$  db. at 800 c/s, the output power being adjusted to + 10 db. above 1 mW. The gain at 200 c/s shall not be more than 1.5 db. lower than the gain at 800 c/s. In the frequency range 300—3,400 c/s the gain shall not differ from that at 800 c/s by more than 0.5 db. and in the range 3,400—6,000 c/s by more than 1.0 db. The gain shall be adjustable in 6 steps of 1.0 db.  $\pm 0.1$  from the maximum setting by taps on the secondary of the input transformer.

The harmonic distortion with an output of + 17 db. at 800 c/s shall not exceed 5 per cent. of the fundamental. In addition, the following crosstalk requirement has been set. With both disturbing and disturbed amplifiers set at maximum gain and with an output power from the disturbing amplifier of 10mW at 800 c/s, and the output circuit of the disturbing amplifier and the input circuit of the disturbed amplifier closed with 600 ohms, the crosstalk measured between the input of any one amplifier and the output of any other on the same panel shall not be worse than 53 db. This requirement has been estimated on the assumption that crosstalk introduced in amplifier stations should not exceed that introduced in the cables. For circuits worked in groups, the far-end crosstalk will predominate, the crosstalk in amplifier stations and cables accumulating in neighbouring circuits on a power basis, and a value of 80 db. far-end (signal/noise ratio) crosstalk for modern cables has been assumed. The value of 53 db. allowed for amplifiers corresponds to a value of 83 db. output to output and this value allows 83 db. for station wiring, line transformers, etc. Thus the accumulation of crosstalk in four repeater sections would amount to 71 db. and in eight sections to 68db. It is thought that eight sections will be the maximum number likely to occur, even allowing for sections consisting of 15 miles of unloaded cable. The crosstalk

value of 53 db. specified thus meets the 65 db. allowance for crosstalk between circuits recommended by the C.C.I.F., allowing a small margin for crosstalk in terminal equipment.

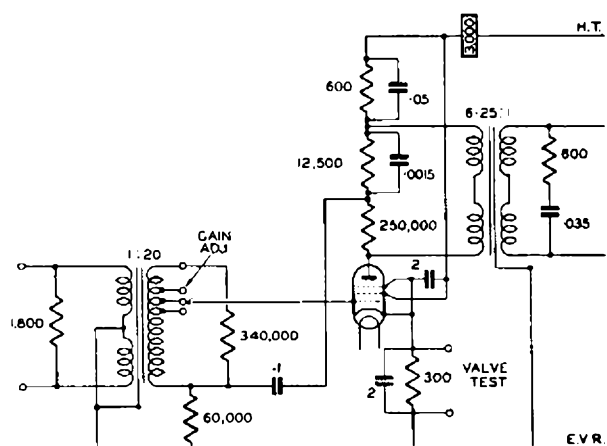

(a) S.T.C. CIRCUIT.

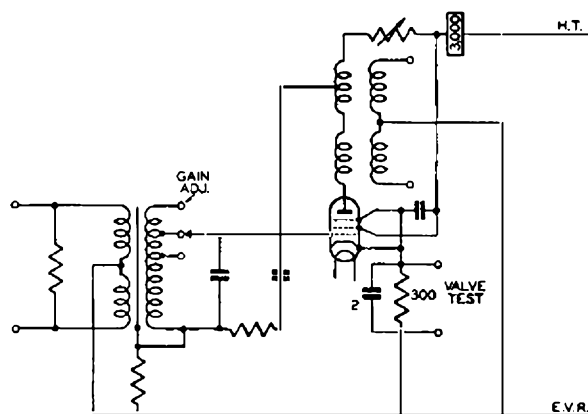

(b) G.E.Co. CIRCUIT.

FIG. 4.—SIMPLIFIED CIRCUIT DIAGRAMS.

It will perhaps be of interest to examine the simplified circuit diagrams (Fig. 4). The salient points of the S.T.C. amplifier are:—

(1) Input impedance obtained partly by the 1,800 ohm resistance on the primary and partly by the resistance across the secondary of the input transformer.

(2) The "feedback" is obtained by both series and parallel arrangements, the series portion being from the 600 ohms resistance in parallel with the  $0.05 \mu\text{F}$  condenser and the parallel portion across the 12,500 ohm resistor. Thus, roughly 0.1 of the output voltage is fed back to the input giving a reduction of gain of the amplifier of approximately 12 db.

In the G.E.Co. amplifier it will be noted that the details differ from those of the S.T.C. and that, in particular, the "voltage" feedback is obtained by a tapping on the output transformer. Fig. 5 will also be

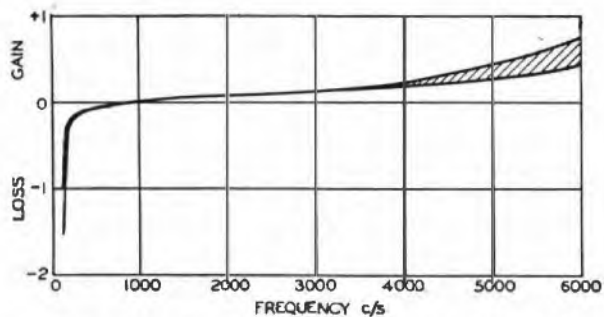

(a) GAIN ON TAP 6 RELATIVE TO THAT AT 800 c/s.

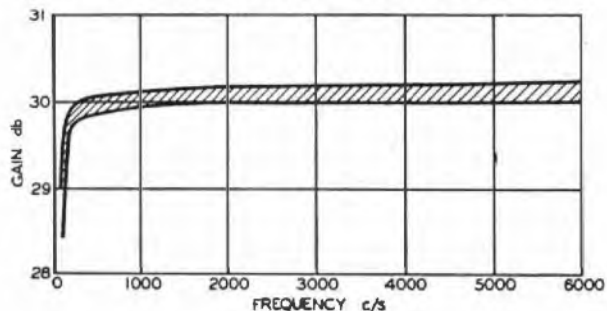

(b) ACTUAL GAIN ON TAP 12.

FIG. 5.—ENVELOPES OF GAIN.

of interest showing (a) envelopes of the gain relative to 800 c/s of the four amplifiers on a panel, and (b) the actual gain of the amplifiers on tap 12. It will be

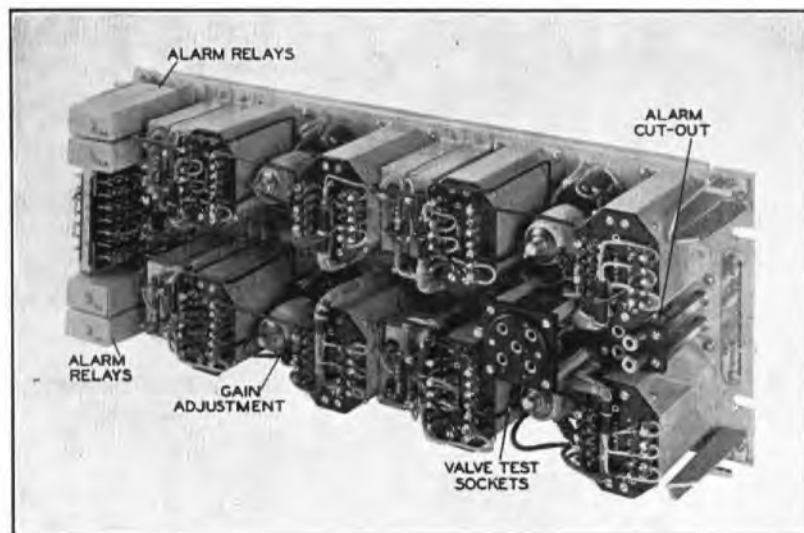

FIG. 6.—PANEL MOUNTING FOUR AMPLIFIERS.

apparent from this that very little difference between panels is to be expected in practice.

A photograph of the amplifier is given in Fig. 6.

#### Testing Points.

The testing points associated with the amplifiers consist of level jacks at the input and output. These are 600 ohms points, and a true level may be taken, since the singing points of both input and output are

specified so that sufficient accuracy is ensured. The method of valve test, which is novel as regards Post Office amplifiers, and which, it is felt, will give a better picture of the condition of the valve, without removing it from the amplifier, consists of a measurement of the mutual conductance.

This is done by measuring the anode current change for a given change in grid bias, and may even be done while the amplifier is in use. The principle of the test will be understood by reference to Fig. 7, which represents a valve, the grid of which is biased by resistor R. This bias is changed by short-circuiting a portion of this resistor. Assuming r is small compared to R, an approximate analysis follows:—

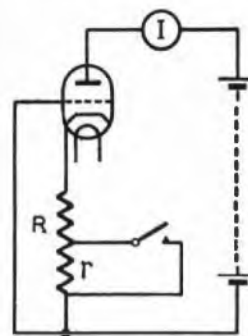

FIG. 7.—PRINCIPLE OF VALVE TEST.

Anode current for resistance R = I

Anode current for resistance R—r = I + ΔI

Change in current = ΔI = m (Ir)

Where m = mutual cond.

$$\text{i.e. } m = \frac{\Delta I}{I} \times \frac{1}{r}$$

i.e., the value m is proportional to the percentage change in anode current. The actual circuit and method of making use of this fact in the tester is as follows (see Fig. 8).

Instead of short-circuiting the portion of the grid bias resistor, a resistor R<sub>1</sub> is placed across it. To use the tester the plug P is inserted in the valve test socket on the amplifier panel, and this enables the anode current to be read directly on μA. KB is then pressed and the needle backed off to zero by manipulation of the resistance Q. KA is then pressed as well as KB, which causes the needle to register a new current. Bringing the needle back to zero by turning switch S, the mutual conductance of the valve is read directly from the switch. The grid bias resistor is the 300 ohm resistor indicated in Fig. 4.

The amount of gain given by the amplifier station may in certain circumstances be measured in the orthodox manner by connecting the gain set to the test tablet (office side)

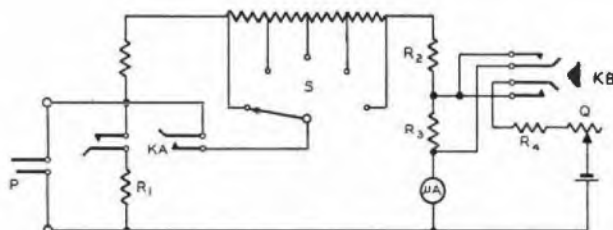

FIG. 8.—VALVE TEST CIRCUIT.

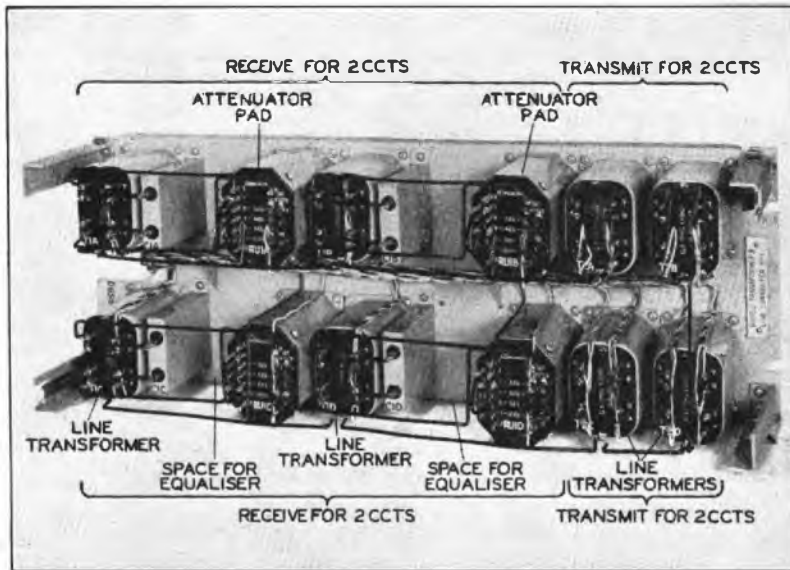

FIG. 9.—TRANSFORMER AND LINE CORRECTOR UNIT.

in place of the cable pairs, the latter being plugged through to avoid interruption of signalling circuits, if necessary.

*Emission Failure Alarm.*

Relays in the anode circuits of the four valves are located on the amplifier panel. These relays are normally held operated by the anode current. If the

anode current fails in any valve the relay releases and breaks a circuit through a pilot relay located at the top of the amplifier bay. The pilot relay controls the panel alarm lamp and station alarm bell. On each panel an alarm cut-out U link is provided. When it is desired to hold the pilot relay operated while making adjustments, which might otherwise cause the alarm circuit to operate, the alarm cut-out U link is inserted in sockets across the anode relay contacts. The cover cannot be replaced on an amplifier panel while the alarm cut-out U link is in circuit.

TRANSFORMER AND LINE CORRECTOR EQUIPMENT.

The line equipment for a quad consists of go and return line transformers, pad, space for equaliser and condensers for low frequency correction. Equipment for four 4-wire circuits is mounted on two 7 in. panels. As each pad is in effect

building out a cable pair to a definite attenuation, this equipment is associated directly with the line, and the R.D.F. jumper field follows and is used to insert the amplifiers. In the interim period pending complete operation of the scheme it has been necessary to provide an adjustable attenuator. This will ultimately be replaced by a combined attenuator and equaliser when the required

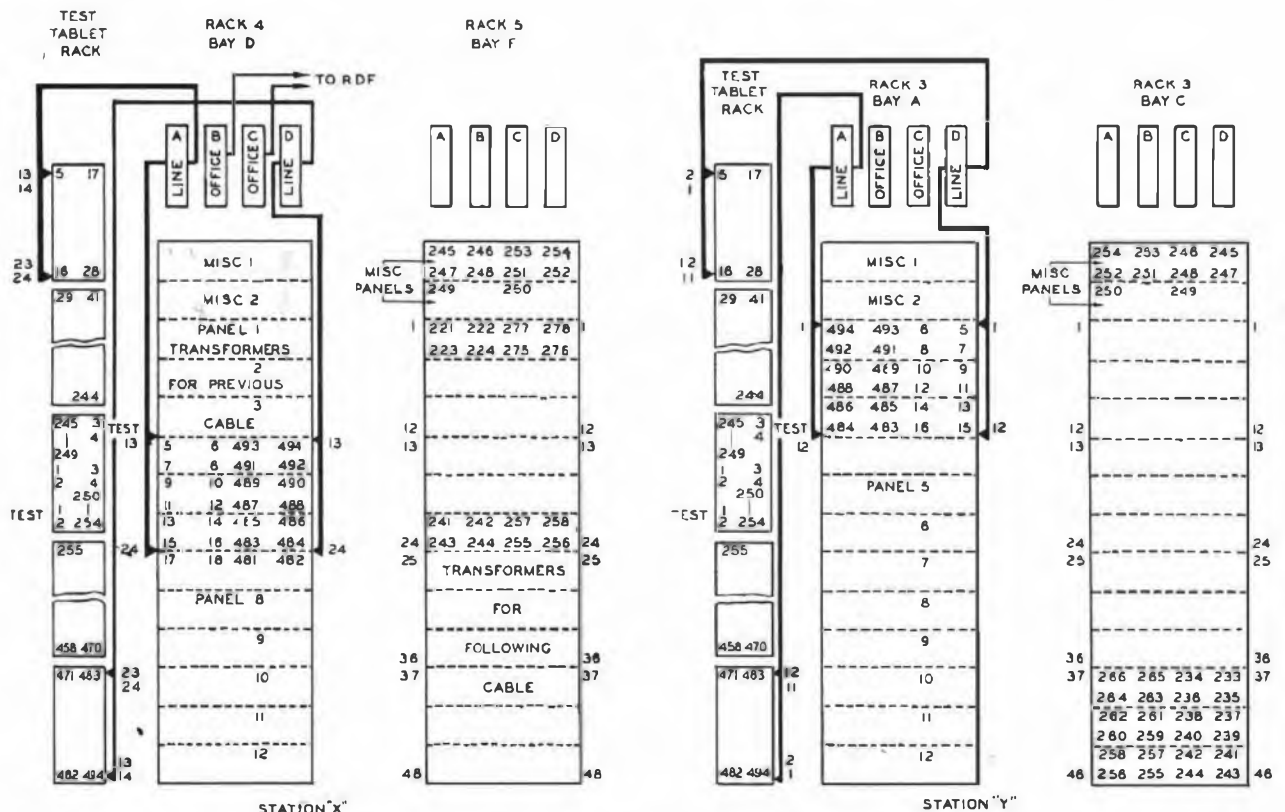

FIG. 10.—CABLING BETWEEN TEST TABLETS AND TRANSFORMER BAYS SHOWING TYPICAL LAYOUT FOR 490 ÷ 4 SCREEN PAIR CABLE.



disposition of amplifiers has been achieved. Where amplifiers or terminations are fitted in exchanges usually only a small percentage of the cable pairs are amplified and it would be wasteful to adopt this principle. The line and corrector panels therefore follow the main frame jumpers, i.e., only sufficient equipment is fitted to deal with pairs joined to amplifiers or terminations. Protection of the jumper field in repeater stations is obtained by the line transformers and in exchanges by the fuses on the main frame. Change from group to quad working is obtained by a simple wiring modification on the panel. A unit is shown in Fig. 9.

For 2-wire working it is proposed to use the same amplifiers, by using in association with them a 7 in. panel comprising differential and balance transformers, filter, balance, etc., for each pair of uni-directional amplifiers.

To make a simple change for within quad to group working it is necessary that the quads from the cable be extended as quads to the tag block at the top of the transformer and line corrector bay. On these blocks are tags for 48 "go" pairs in and out and 48 "return" pairs in and out. A test tablet deals with 24 pairs, and in order that cabling may be carried out in a standard manner using 6 quad cable, it has been decided that when choosing go and return pairs for group working in main cables the pairs shall be appropriated from opposite ends of the cable numbering sequence. Typical examples of the cabling between test tablets and transformer bays are shown in Fig. 10 for both ends of a 490 + 4 screen pair cable.

On a transformer and line corrector panel the utilisation of the components would be as shown in Fig. 11, the essential points being (a) transformers carrying different circuits at different levels should be kept a distance apart, (b) the wiring change from group to quad working should be as simple as possible.

These arrangements are economical since if the selection of go and return pairs were made in the orthodox way it would be necessary either to commence each balancing group on a fresh test tablet or to employ a more costly and complicated cabling scheme

between the test tablets and transformers. The arrangement will also result in a somewhat better crosstalk by utilising the extreme outer and inner layers for high-class circuits.

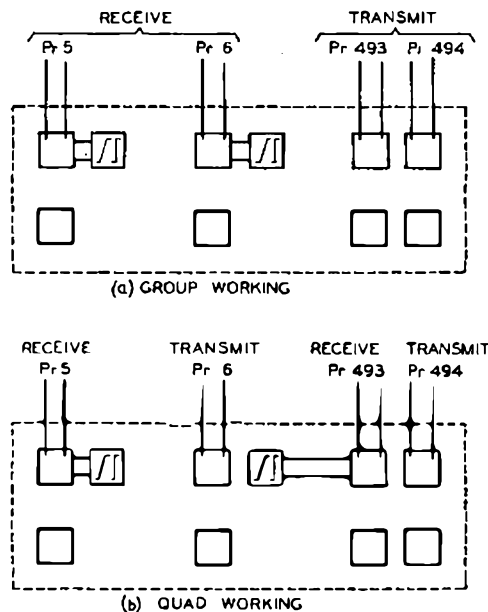

FIG. 11.—UTILISATION OF PANEL COMPONENTS.

#### Conclusion.

These amplifiers and new type line equipment are being fitted at a number of stations in the country, and where modern cables are being utilised it is hoped to obtain the advantages of group working even though signalling over the phantoms is used, without the use of signalling filters.

The author desires to thank his colleagues in the Research, Lines and Equipment Branches for their efforts in the standardisation of this product and also Messrs. General Electric Co. and Standard Telephones Co. for their suggestions and photographs.

### TELEPHONE AND TELEGRAPH STATISTICS SINGLE WIRE MILEAGE AS AT 31st DECEMBER, 1940 THE PROPERTY OF, AND MAINTAINED BY THE POST OFFICE

REGION	OVERHEAD			UNDERGROUND		
	Trunks and Telegraphs	Junctions	Subscribers *	Trunks and Telegraphs †	Junctions ‡	Subscribers §
Home Counties .. .. .	14,427	39,081	286,178	890,299	206,240	1,109,359
South Western .. .. .	9,609	33,040	211,357	439,927	89,001	585,580
Midland .. .. .	11,036	25,688	179,317	625,532	241,863	771,736
Welsh & Border Counties ..	9,554	23,429	118,837	337,280	57,143	236,271
North Eastern .. .. .	13,670	22,114	147,020	537,589	181,622	832,871
North Western .. .. .	2,268	8,025	104,294	483,945	281,188	1,057,999
Northern Ireland .. .. .	8,928	7,456	25,607	41,936	14,190	101,414
Scottish .. .. .	24,345	32,318	158,804	467,829	155,754	622,173
Provinces .. .. .	93,837	191,151	1,231,414	3,824,337	1,227,001	5,317,403
London .. .. .	826	1,465	66,089	542,244	1,384,642	3,476,105
United Kingdom .. .. .	94,663	192,616	1,297,503	4,366,581	2,611,643	8,793,508

\* Includes all spare wires.

† All wires (including spares) in M.U. Cables.

‡ All wires (including spares) in wholly Junction Cables.

§ All wires (including spares) in Sub's. and mixed Junction and Sub's. Cables.

# The Attenuation and Impedance of Single Coaxial Cables

R. A. BROCKBANK, Ph.D., B.Sc., A.M.I.E.E.

U.D.C. 621.315.212

The relationships existing between the attenuation and characteristic impedance of single coaxial cables are examined with a view to obtaining uniformity in the design and construction of coaxial cable systems. The benefits to be obtained from a standardisation of the characteristic impedance are reviewed. Results indicate that all single coaxial cables could be designed economically to a characteristic impedance of 75 ohms.

## Introduction.

THE greatly increased use of radio frequencies for line transmission purposes has been made more readily possible by the unique properties possessed by shielded types of cables. Shielded cables can be constructed with various dispositions of inner and outer conductors, but by far the most general form is a single coaxial cable (Fig. 1) consisting of an inner

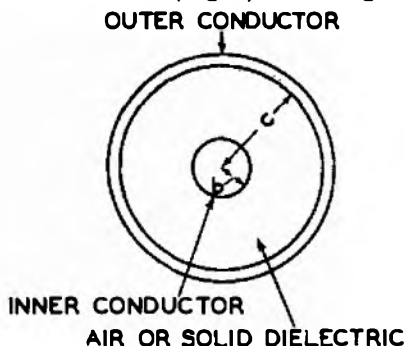

FIG. 1.—SINGLE COAXIAL CABLE.

conductor of circular cross-section surrounded by an outer concentric annular conductor and it is the characteristics of this type of cable which will be discussed in this article.

In practice the inner conductor consists invariably of a copper wire or strand, but the outer conductor may be composed of copper tapes, foil or braid with or without an outer protecting sheath of lead, or alternatively the lead tube alone may form the outer conductor. It is important to appreciate that at radio frequencies the high frequency currents are confined almost entirely to the outer surface of the inner conductor and the inner surface of the outer conductor, and it is the conductivity of these surface layers, possibly only a few mils thick, that determines the attenuation of the cable.

The ideal dielectric medium is air, but since some solid material must necessarily be introduced to retain the inner conductor in a central position this condition cannot be wholly obtained. The insulating material may take the form of spacers, helical string or paper tube, the aim being to produce a cable of the "air space" type. An alternative construction is obtained in the "solid" type of cable, the space between the conductors being completely filled with a solid dielectric, e.g. polystyrene or polyethylene base. The solid type of cable has excellent mechanical properties, as it will not collapse with external pressure and its electrical reliability is high since water cannot penetrate along the tube when punctured.

The properties which make single coaxial cables so valuable for transmission at radio frequencies are simple construction, small bulk, underground installa-

tion, accurately calculated performance and immunity from external interference. Single coaxial cables are now used for h.f. wiring, long distance multi-circuit telephony and television, radio transmitter and receiver links between aerials and equipment, etc. Probably the most important single application by the British Post Office is to long distance multi-circuit telephony. The London to Birmingham coaxial cable system<sup>1</sup> has been in commercial operation since early 1938 and carries 120 circuits. Other systems have been completed since or are under construction and the present standard system is capable of carrying 600 circuits in the range 312-2788 kc/s over coaxial tubes having an internal diameter of the outer conductor of only 0.375 in.

All systems so far designed by the Post Office for land routes operate over air space cables with copper conductors, but in view of recent advances in dielectrics suitable for solid cables it becomes desirable to review the position in regard to future development. The following analysis was therefore carried out to determine to what extent uniformity in the design of different types of single coaxial cables could be obtained efficiently.

## The Attenuation Constant.

It is well known that the performance of any symmetrical network is completely specified by the propagation constant and characteristic impedance of the network. In general, both these parameters are complex and they can be evaluated from a knowledge of the four primary constants defined below.

The c.g.s. electromagnetic system of units is used.

Let  $R_1$  = Effective Resistance of the inner conductor in abohms per cm.

$R_0$  = Effective Resistance of the outer conductor in abohms per cm.

$R = R_1 + R_0$  in abohms per cm.

$L$  = Inductance in abhenries per cm.

$C$  = Capacitance in abfarads per cm.

$G$  = Leakance in abohms<sup>-1</sup> per cm.

1 abohm =  $10^{-9}$  ohms

1 abhenry =  $10^{-9}$  henries

1 abfarad =  $10^{-9}$  farads

all at a frequency  $f$  cycles per second. Then it can be shown<sup>2,3</sup> that the attenuation constant, the real part of the propagation constant, of a transmission line with uniformly distributed constants and assuming that  $(2\pi f)^2 L^2$  is large compared with  $R^2$  and  $(2\pi f)^2 C^2$  is large compared with  $G^2$ , reduces to

$$A = \frac{R}{2} \sqrt{\frac{C}{L}} + \frac{G}{2} \sqrt{\frac{L}{C}} \text{ nepers per cm.} \dots \dots (1)$$

<sup>1</sup> P.O.E.E.J. Vol. 30, pp. 206.

<sup>2</sup> K. S. Johnson, "Transmission Circuits for Telephonic Communication," New York, 1925.

<sup>3</sup> B.S.T.J., April, 1936.

These assumptions are nearly always justified at radio frequencies.

The second term is the contribution to the attenuation due to the dielectric loss.

Now let  $b$  = outer radius of inner conductor in cms.

$c$  = inner radius of outer conductor in cms.

$\lambda_1$  and  $\lambda_2$  = conductivities of the materials of the inner and outer conductors respectively.

$\epsilon$  = permittivity of the dielectric.  
=  $1/9 \times 10^{-20}$  for air.

$\cos \phi$  = power factor of the dielectric.

Then for practical cable dimensions and at frequencies above about 100 kc/s the following formulæ can be shown to hold very closely :—

$$R_1 = \frac{1}{b} \sqrt{\frac{f}{\lambda_1}} \text{ abohms per cm.}$$

$$R_2 = \frac{1}{c} \sqrt{\frac{f}{\lambda_2}} \text{ abohms per cm.}$$

(these values assume unit permeability for the conductors)

$$L = 2 \log_e c/b \text{ abhenries per cm.}$$

$$C = \frac{\epsilon}{2 \log_e c/b} \text{ abfarads per cm.}$$

$$G = 2\pi f C \cos \phi$$

$$= \frac{\pi f \epsilon \cos \phi}{\log_e c/b}$$

Substituting these values in (1) we obtain

$$A = \frac{1}{4c \log_e \frac{c}{b}} \left( \frac{c}{b} + \sqrt{\frac{\lambda_1}{\lambda_2}} \right) \sqrt{\frac{f \epsilon}{\lambda_1}} + \frac{2\pi f \sqrt{\epsilon} \cos \phi}{2}$$

nepers per cm ..... (2)

Considering first the second term of this equation it is seen that the attenuation due to dielectric loss is independent of the physical dimensions of the cable. This is a very interesting result which, to the author's knowledge, does not appear to have been pointed out in previous literature. It follows that once the dielectric medium has been fixed the attenuation due to dielectric loss is independent of the overall size and relative proportions of the cable.

The attenuation due to dielectric loss will not in general become appreciable except at very high radio frequencies, e.g. 100 Mc/s, and for the moment it will be assumed that the frequency is sufficiently low to neglect the effect of this term.

The first term represents the attenuation due to the copper loss, and on examination it is found that for any

given value of  $\sqrt{\frac{\lambda_1}{\lambda_2}}$  there is an optimum value of the ratio  $c/b$  which gives the minimum loss for any given value of the outside radius  $c$ . This optimum ratio  $c/b$  has been evaluated and is shown plotted in the middle curve of Fig. 2. The two conditions of most general practical interest are for copper inner and outer

conductors ( $\frac{\lambda_1}{\lambda_2} = 1$ ), and for copper inner conductor

and lead outer conductor ( $\frac{\lambda_1}{\lambda_2} = 12.5$ ), and the

optimum ratios for these conditions are shown to be 3.6 and 5.3 respectively. It is of interest to note that these optima obtain at values of  $c/b$  particularly suited to mechanical construction and low electric stress. Minimum electric stress at the surface of the inner conductor occurs at a ratio  $c/b = e = 2.718$ . The electric stress is increased by 3% and 17% for ratios of  $c/b$  of 3.6 and 5.3 respectively.

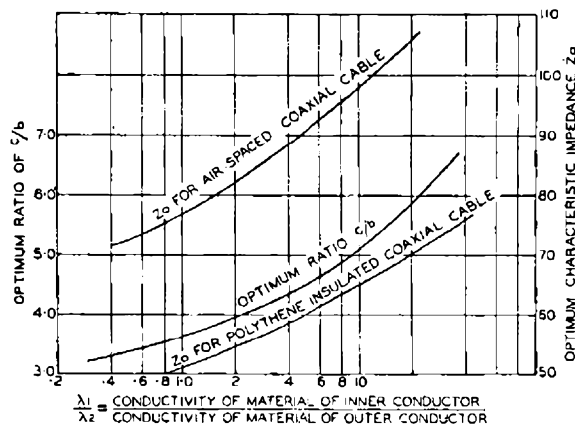

FIG. 2.—VARIATION OF OPTIMUM RATIO  $c/b$  AND CORRESPONDING OPTIMUM  $Z_0$  WITH VARIOUS CONDUCTIVITY RATIOS.

The next important step is to determine to what extent the attenuation increases due to departures from these optimum ratios. These results can be calculated from (2) and the percentage increases in attenuation above the minima obtainable are shown in Fig. 3 for copper-copper conductors and in Fig. 4 for

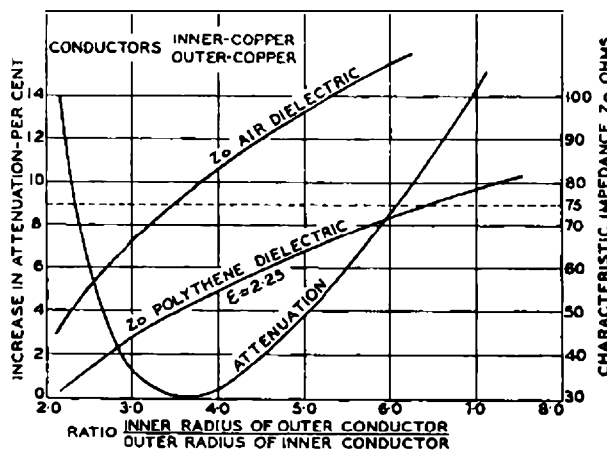

FIG. 3.—CHARACTERISTICS OF COAXIAL CABLES WITH COPPER CONDUCTORS.

copper-lead conductors for a wide range of values of  $c/b$ . These curves show that the increase is relatively small, even for quite a large departure from the optimum, and that in the actual region of the optimum the increase is negligible. These two curves can be

related as regards basic attenuation by Fig. 5 which indicates in graphical form the relatively large losses which are incurred by the substitution of a lead sheath in place of a copper sheath. Fig. 5 is correct for insulation of any permittivity provided this remains unchanged. Additional information can also be obtained from Fig. 5 since it is seen from equation (2)

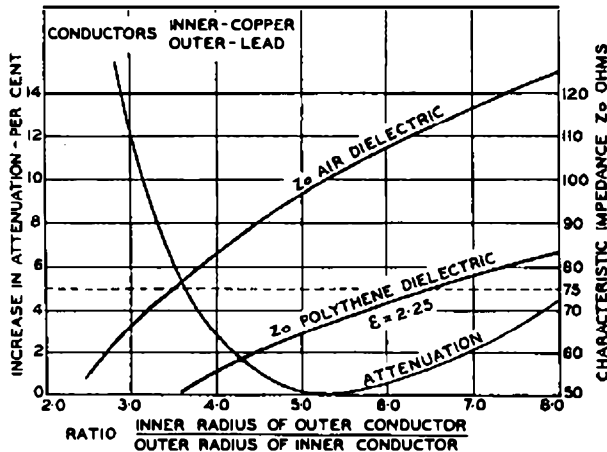

FIG. 4.—CHARACTERISTICS OF COAXIAL CABLES WITH COPPER-LEAD CONDUCTORS

that with  $c/b$  constant the attenuation is inversely proportional to the overall diameter ( $2c$ ) of the cable. This curve therefore indicates the percentage increase in diameter of a copper-lead cable required to produce the same attenuation as a copper-copper cable with the same value of  $c/b$ .

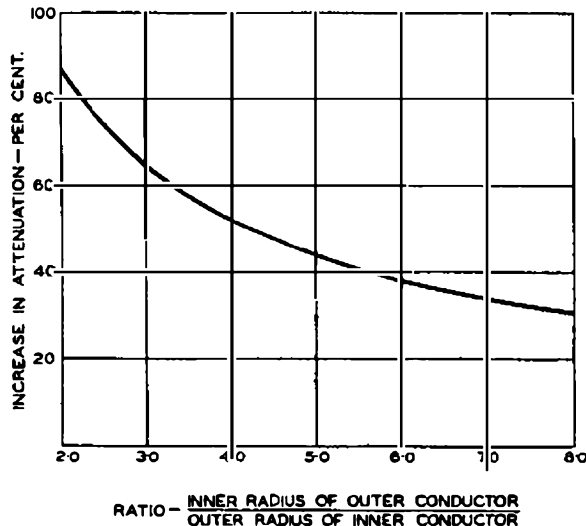

FIG. 5.—INCREASE IN ATTENUATION DUE TO REPLACING OUTER COPPER CONDUCTOR BY LEAD CONDUCTOR.

#### Characteristic Impedance.

The formula for the characteristic impedance of a single concentric cable reduces to a very simple form if the same assumptions are made as for the attenuation constant, i.e.,  $R^2$  and  $G^2$  small compared with  $(2\pi fL)^2$  and  $(2\pi fC)^2$  respectively. This is, in general, justified at frequencies above 100 kc/s.

The characteristic impedance is then given by <sup>2, 3</sup>

$$Z_0 = \sqrt{\frac{L}{C}} \text{ abohms} \dots \dots \dots (3)$$

which is a real quantity independent of frequency.

Substituting the values of  $L$  and  $C$  given above

$$Z_0 = \frac{2 \log_e c/b}{\sqrt{\epsilon}} \text{ abohms} \dots \dots \dots (4)$$

$Z_0$  is therefore only a function of the ratio  $c/b$  and the permittivity of the insulation.

It is of interest now to evaluate  $Z_0$  for certain practical conditions. Consider therefore four typical types of construction employed for single coaxial cables. These types A, B, C and D shown in Table I probably cover more than 95% of the single coaxial cables in service or envisaged for future operation.

TABLE I  
TYPES OF SINGLE CONCENTRIC CABLES

Type	Conductor Materials		Dielectric Medium	Permittivity*
	Inner	Outer		
A	Copper	Copper	Air	1.00
B	Copper	Copper	Polythene	2.25
C	Copper	Lead	Air	1.00
D	Copper	Lead	Polythene	2.25

\* in practical units.

$Z_0$  can now be evaluated with respect to the ratio  $c/b$  for these four cable types, and the results are shown plotted in practical units in Figs. 3 and 4. These figures show that the characteristic impedance varies considerably for only relatively small changes in the attenuation.

#### Economic Design of Coaxial Cable Systems.

There is no obvious reason why the general design of coaxial cable systems should not proceed on the same lines as the design of audio frequency transmission systems since the same parameters are involved and there is no fundamental difference in their application. The modern economic design of audio frequency systems is the result of years of experience and is based on a standardised value of characteristic impedance for all networks, i.e., 600 ohms. This figure of 600 ohms was approximately the characteristic impedance of heavy gauge copper aerial conductors then in use, and it has since proved to be a very satisfactory value to standardise.

Coaxial transmission has developed rapidly and so far there has been little attempt to determine if a suitable value of impedance could be standardised for all coaxial cable equipment. The present position is probably due to three causes:—

(a) Lack of precise knowledge on the interdependence of attenuation and characteristic impedance from the economic, electrical and mechanical aspects.

(b) Lack of appreciation of the benefits conferred by a universally adopted value of characteristic impedance.

<sup>2</sup> Loc. cit.

<sup>3</sup> Loc. cit.

(c) The quasi-standardisation by cable makers of a large range of cables of various characteristic impedances. These cables usually originated from customers' enquiries modified by the necessity of using the nearest available size of wire, die or polisher. The standardisation of a single value of characteristic impedance would considerably reduce the range of sizes which the cable maker is at present called upon to manufacture and would enable design and construction to be placed on a more economic basis.

Regarding (b), all benefits realised in audio frequency operation obtain, but many become of increasing importance at high frequencies, e.g.:

(1) Coaxial systems often operate with very wide frequency bands, e.g., multi-circuit telephony or television. The design and construction of satisfactory wide-band transformers for matching networks of different impedances is particularly difficult at high frequencies, and the frequency band over which such transformers are satisfactory is restricted.

(2) The calculations and designs involved in equipment for coaxial systems are often very complex, e.g., filters, repeaters and test gear. The work involved in redesigning such equipment to operate with different values of characteristic impedance would be very laborious.

(3) Coaxial systems like audio systems usually involve the repetition of a large number of essentially similar units. It is highly desirable that such units be interchangeable within and between systems.

(4) Gains and losses due to departures from ideal matching between networks may be very serious at radio frequencies and such irregularities are often not amenable to calculation.

These arguments indicate that every effort should be made to standardise a value of characteristic impedance to be used in the design of all single coaxial cable networks. An examination of the characteristics of single coaxial cables will now be made to determine if a single value of impedance can be specified without serious loss in efficiency.

#### *Interdependence of Attenuation and Impedance Characteristics.*

Consider the four cable types A, B, C and D and their performance characteristics shown in Figs. 3, 4 and 5.

Equation (2) shows that the attenuation of a single coaxial cable is proportional to  $\sqrt{\epsilon}$  which with a dielectric of polythene results in an increase in attenuation of 50% over the ideal air space cable. It is evident, therefore, that type A is the most efficient cable, and since it possesses no inherent disadvantages it appears reasonable as a first step to see if the

optimum value of the characteristic impedance of this cable is suitable for adoption as a general standard. It is excellent policy to standardise the most efficient design if this can be conveniently arranged.

The theoretical characteristic impedance for this cable is 77 ohms (see Fig. 3) but in practice the small amount of solid dielectric necessarily present reduces this value to about 75 ohms and it is this figure which is tentatively suggested as a standard.

From Figs. 3, 4 and 5 a comparison can be effected between the different types of cables for two conditions.

(a) Each cable operates at its optimum characteristic impedance (i.e., optimum ratio  $c/b$ ).

(b) The characteristic impedance of each cable is adjusted to 75 ohms by varying the ratio  $c/b$ .

The attenuation of cable type A is taken as 100 and the overall dimension  $c$  is constant for all cables. The attenuation due to the dielectric losses has been neglected. This is quite justified at the lower radio frequencies, and at higher frequencies of several hundreds of megacycles per second the comparison is still maintained since the air space cable and the polythene insulated cable possess almost identical power factors (about 0.0008).

This comparison is shown in Table II

TABLE II

Cable Type	Cable Construction	Optimum $Z_0$			$Z_0 = 75$ ohms	
		Relative Attenuation	$Z_0$	$c/b$	Relative Attenuation	$c/b$
A	Copper-Copper Air space	100	77	3.6	100	3.6
B	Copper-Copper Polythene	150	51	3.6	167	6.5
C	Copper-Lead Air space	147	100	5.3	155	3.6
D	Copper-Lead Polythene	221	66	5.3	224	6.5

It will be seen that the most serious increase in attenuation due to adopting a value of characteristic impedance of 75 ohms occurs using copper-copper conductors with a polythene dielectric. Polythene is at present the most satisfactory material for solid type low loss cables, but in the future an improved material with a still lower permittivity may become available, in which event this increase will be reduced and finally disappear as the optimum conditions for an air spaced cable are approached. The adoption of a 75 ohm impedance makes provision for future improvements in dielectric characteristics (particularly the permittivity). The ratio of 6.5 is satisfactory mechanically and would probably tend to reduce the cost of the cable.

These results suggest that a characteristic impedance of 75 ohms could be standardised for all the usual types of single coaxial cables with a loss in efficiency which could probably be tolerated.

An interesting result is obtained in the design of single coaxial cables for ultra high frequency

operation (i.e., above about 500 Mc/s). Equation (2) shows that the copper loss varies as the square root of the frequency whereas the dielectric loss increases linearly with frequency, assuming  $\cos \phi$  is constant. Copper and dielectric loss curves are shown in Fig. 6 for a typical air space coaxial cable of  $\frac{3}{8}$  in. external

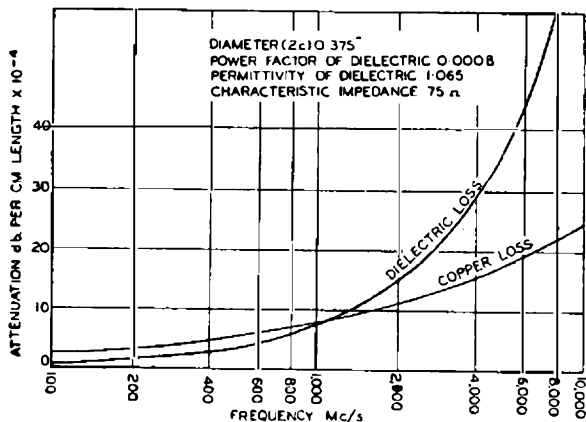

FIG. 6.—THEORETICAL ATTENUATION OF AIR SPACE SINGLE COAXIAL CABLE.

diameter. Above 1,000 Mc/s the dielectric loss exceeds the copper loss, and since it has been shown that the dielectric loss is independent of all cable dimensions it is possible to proportion the cable to give any desired characteristic impedance, e.g., 75 ohms, without seriously affecting the total cable loss at these frequencies. It is also to be noted that for very high frequencies the diameter of the cable can be considerably reduced without appreciably increasing the overall loss. The dielectric loss curve in Fig. 6 was calculated on the assumption of a power factor of 0.0008, but with an inferior dielectric or with a larger diameter cable the point of intersection will occur at a lower frequency. It also follows as a corollary that at low radio frequencies or with very small diameter cables the total loss is substantially independent of the power factor of the medium. Since in the total attenuation formula (2) the factor  $\sqrt{\epsilon}$  occurs in the terms for the copper loss and the dielectric loss, it is always of importance to secure the minimum value of the permittivity.

#### Manufacturing Tolerances and Operating Variations.

In designing a cable system it is of importance to assess the magnitudes of the variations of attenuation and characteristic impedance which can occur due to (a) manufacturing tolerances and (b) operating conditions. It is not proposed to suggest actual manufacturing tolerances as the author is not aware of the degree of uniformity which can reasonably be expected during the manufacturing design and construction.

In accordance with this discussion it is assumed that the characteristic impedance of a cable will be specified within predetermined limits and a suitable size of cable will then be chosen to yield the required attenuation. As a basis for comparison it will be assumed that the characteristic impedance of air space cables will be specified to limits of  $\pm 2$  per cent. and of solid type cables to  $\pm 5$  per cent.; the higher

tolerance for solid cables is assumed to be necessitated by variations in the characteristics of the dielectric.

The chief manufacturing tolerances will occur due to

- (a) variation of ratio  $c/b$ ,
  - (b) eccentricity of centre conductor,
  - (c) variation of permittivity of dielectric,
- and the chief operating variations will be due to
- (d) temperature coefficient of permittivity of the dielectric,
  - (e) temperature coefficient of resistivity of the conductors.

The effect of these variations on the attenuation of the cable will be tabulated, assuming the tolerances of characteristic impedance stated above. Cables A, B, C and D will be examined for two conditions, i.e., optimum  $Z_0$ , and  $Z_0$  equal to 75 ohms.

Examining these effects in more detail:—

(a) The permissible range of  $c/b$  for a given tolerance on  $Z_0$  can be obtained directly from Figs. 3 and 4.

(b) Eccentricity of the conductor affects both the characteristic impedance and the attenuation. For small values of eccentricity it can be shown that the following changes occur.<sup>4</sup>

The characteristic impedance decreases by

$$\frac{100 e^2 k^2}{(k^2 - 1) \log_e k} \text{ per cent.}$$

and the attenuation increases by

$$100 \left[ \frac{2e^2}{k} + \frac{e^2 k^2}{(k^2 - 1) \log_e k} \right] \text{ per cent.}$$

where  $e = \frac{\text{distance between axes of conductors}}{\text{inner radius of outer sheath } (c)}$

and  $k = c/b$

Fig. 7 shows the percentage decreases in characteristic impedance for the three values of  $c/b$  in Table II plotted against eccentricity.

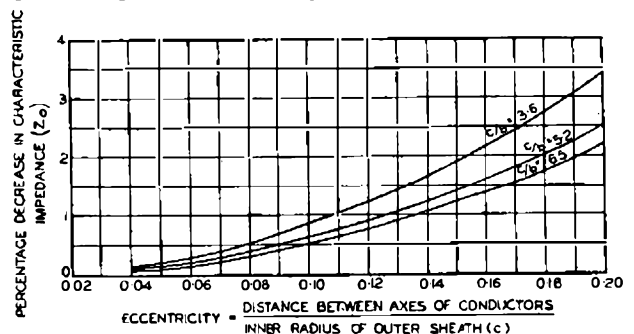

FIG. 7.—REDUCTION IN CHARACTERISTIC IMPEDANCE WITH ECCENTRICITY OF CONDUCTORS FOR VALUES OF  $c/b$ .

Fig. 8 shows the percentage increase in attenuation under similar conditions.

For the purpose of the comparison effected in Table III an eccentricity of 10 per cent. has been assumed.

(c) The accuracy with which the final permittivity of a solid dielectric cable can be specified is unknown, but it is tentatively assumed that the cable manufacturer would not be prepared to guarantee a closer tolerance than 2 per cent. for the finished cable. This tolerance would produce a

<sup>4</sup> B.S.T.J., October, 1934.

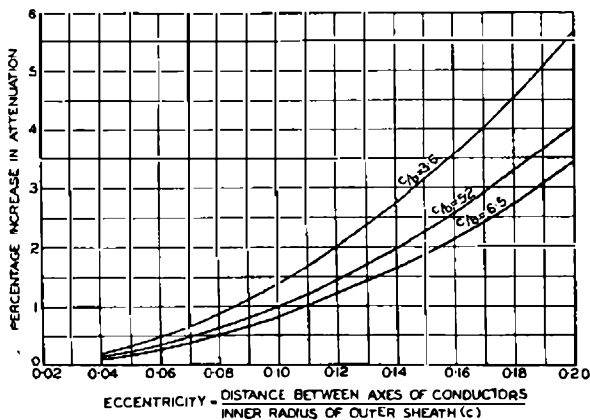

FIG. 8.—INCREASE IN ATTENUATION WITH ECCENTRICITY OF CONDUCTORS FOR VALUES OF  $c/B$ .

change of  $\pm 1$  per cent. in the attenuation and characteristic impedance.

(d) The temperature coefficient of the permittivity of polythene has been reliably quoted as  $-0.1$  per cent. per  $^{\circ}\text{C}$ , and this will result in a change of attenuation of  $-0.05$  per cent. per  $^{\circ}\text{C}$ . The British Post Office has found that for coaxial cables laid underground in England provision must be made for equalising for yearly changes in temperature of  $\pm 15^{\circ}\text{C}$  from the mean value. This figure is therefore assumed in Table III.

(e) An effective temperature coefficient of  $+0.25$  per cent. per  $^{\circ}\text{C}$  is assumed for all cables. The same temperature variation applies as for (a).

An examination of Table III is interesting, e.g. :

(1) The last two columns indicate that the two main causes of operating variations with polythene cables tend to neutralise each other. The resulting variation for the temperature limits assumed is  $+6.0$  per cent. If the negative temperature coefficient of permittivity of the dielectric could be increased to  $0.5$  per cent., all first order temperature variations would disappear. This would be a very valuable result if it could be obtained.

TABLE III  
COMPARISON OF MANUFACTURING AND OPERATING VARIATIONS

Cable	$Z_0$	Range of $c/b$ for $Z_0 \pm 2\%$ (Air Space) $Z_0 \pm 5\%$ (Polythene)	Percentage Total Variation of Attenuation Due to				
			Limits of range of $c/b$	10% Eccentricity	2 per cent. Variation of Permittivity of Polythene	Temp. Coeff. of Permittivity $30^{\circ}\text{C}$ Change	Temp. Coeff. of Resistivity $30^{\circ}\text{C}$ Change
A	Optimum and $75 \Omega$	3.5—3.7	0.1	1.4	—	—	+ 7.5
B	Optimum $75 \Omega$	3.35—3.85	0.2	1.4	1.0	- 1.5	+ 7.5
C	Optimum $75 \Omega$	6.0—7.0	5.7	0.9	1.0	- 1.5	+ 7.5
D	Optimum $75 \Omega$	5.07—5.43	0.1	1.0	—	—	+ 7.5
	Optimum $75 \Omega$	3.5—3.7	1.4	1.4	—	—	+ 7.5
	Optimum $75 \Omega$	4.7—5.7	0.5	1.0	1.0	- 1.5	+ 7.5
	Optimum $75 \Omega$	6.0—7.0	1.6	0.9	1.0	- 1.5	+ 7.5

(2) The percentage changes in attenuation due to various manufacturing tolerances are very small and in only one condition does the attenuation change more than  $0.8$  per cent., i.e., the effect of not operating at the optimum ratio is almost negligible.

(3) The one exception is for a polythene cable with copper conductors where a change of  $5.7$  per cent. from the nominal value occurs. This is based on a  $5$  per cent. change in characteristic impedance. If the manufacturer can maintain the permittivity of the dielectric to  $\pm 2$  per cent., then a tolerance of  $3$  per cent. on  $Z_0$  appears more reasonable. The maximum change in attenuation is then reduced to  $\pm 1.6$  per cent., which is not serious.

It should be noted that for the uses of this type of cable where no temperature compensation is incorporated the specification of the cable attenuation to closer limits than, say,  $\pm 2$  per cent. is not justified, and for circuits which are temperature equalised to maintain a constant overall frequency response a variation of  $\pm 2$  per cent. only means a change in the initial theoretical setting of the temperature equaliser.

It is concluded that the manufacturing tolerances on cables designed for a characteristic impedance of  $75$  ohms do not produce variations in the attenuation characteristics which would prove to be serious in practice.

#### Characteristic Impedance of Transmission Equipment.

The discussion and suggestions outlined above are based solely on an analysis of the performance of single coaxial cables. Coaxial cables, however, are not the only components of a coaxial system and it might be found that  $75$  ohms was not a suitable impedance for the design of the associated transmission equipment. The British Post Office during the last few years has designed and constructed a considerable number of coaxial systems on a  $75$  ohm impedance basis, and it has been found that at least over the range  $60$ — $5,000$  kc/s this value is admirably suited to the economic design of all associated equipment.

#### Conclusion.

It is naturally appreciated that any proposal regarding the universal standardisation of a characteristic impedance of  $75$  ohms must be critically examined and approved by all concerned in the design of coaxial cable systems with a special view to future developments. It is hoped however that this contribution to the subject may be of value in discussion and may expedite a decision towards uniformity which it is very desirable to effect at the present stage of development.

# Modern Materials in Telecommunications

U.D.C. 537.3

W. G. RADLEY, Ph.D., M.I.E.E.

C. E. RICHARDS, F.I.C.

E. A. SPEIGHT, Ph.D., D.I.C., A.R.C.S.

E. V. WALKER, B.Sc., A.R.S.M.

## Part V—Metallic Conductors

This article describes how, in a solid body, an electric current is carried by "free" electrons which have become detached from their parent atoms and move about within the body. By treating the motion of these electrons according to the principles of the quantum theory and wave mechanics a satisfactory explanation is obtained of most of the important phenomena of metallic conduction. The article concludes with a short description of some of the fascinating, but still unexplained phenomena of superconductivity.

### *Introduction.*

IN its telecommunications network, the Post Office uses an enormous mileage of wire conductors. Add to this the vast quantities of wire used in winding the coils of millions of relays, transformers and telephone receivers—to choose but a few examples—and in all the other branches of the electrical industry, and the total length reaches truly astronomical figures. Perhaps the most striking feature of this vast array of electrical conductors is that by far the greatest proportion of these conductors consists of the metal copper—the same metal which Faraday used in his pioneer experiments over one hundred years ago. Why has a century of research failed to reveal any other material except, for certain specialised applications, aluminium and silver, which can challenge the supremacy of copper in this field of use? Although there are still several points for which there is no complete explanation, the electron theory and quantum mechanics have gone far towards elucidating the mechanism whereby an electric current is carried through a conductor and the structural features which distinguish good and bad conductors.

### THEORIES OF METALLIC CONDUCTION

Before discussing the theory of metallic conduction it may be helpful to state the more important of the phenomena which it should explain. First, there is the enormous difference between the orders of magnitude of the conductivities of the common metals and of the insulators, the actual ratio between the two types being about  $10^{17}$ . Secondly, there is the fact that the ratio of the thermal conductivity to the electrical conductivity at any given temperature is nearly the same for most metals. This is known as the Wiedemann-Franz law. As shown by Lorenz, the ratio is proportional to the absolute temperature. A further distinction between metals and insulators is that increase of temperature reduces the conductivity of metals but increases that of nearly all insulators.

The results of alloying are rather complex and will be considered in more detail later. Here it is necessary to state only that, although there are exceptions to this rule, the effect of impurities or of deliberately added constituents is generally to increase the resistivity of the material.

### *Theory of Drude and Lorentz.*

Modern ideas of metallic conduction have grown from the theory propounded by Drude during the years 1900-1904 and amplified later by Lorentz.

The fundamental assumption is that in a solid metal certain of the electrons—those outer electrons now termed the valency electrons (see Part IV)—are not bound to their parent atoms but are free to move about within the space lattice. If an electric field is applied there will be a drift of electrons from the point of lower (negative) potential to the point of higher (positive) potential. This electron drift constitutes the current flow.

Coming so soon after the discovery of the electron this theory attracted considerable attention but several years elapsed before any experimental evidence was obtained in support of its fundamental assumption. Such evidence was first obtained by Tolman and Stewart in 1916. A coil of wire rotating at high speed about its axis was connected to a ballistic galvanometer. If the coil was suddenly brought to rest a momentary deflection was observed indicating the passage of a current impulse. This current impulse was presumably due to current-carrying particles "overshooting the mark," when the coil was stopped, as a result of the kinetic energy acquired during the previous rotation of the coil. That these particles were electrons was shown by calculations of the ratio of their charge to their mass which gave a result very close to the accepted figure for the electron, viz.  $1.77 \times 10^7$  e.m.u. per gram.

Making certain assumptions as to the mode of motion of the so-called "free" electrons in a solid, Drude and Lorentz deduced expressions for the electrical conductivity of metals in terms of known physical constants. These expressions yielded figures of the right order of magnitude, but the theory could not predict the actual values for individual metals. More important, however, was the fact that the theory could explain the Wiedemann-Franz law.

Despite these successes, the Drude-Lorentz theory failed in several important particulars. To a large extent these weaknesses have been overcome by the Sommerfeld-Bloch theory which will be considered later in this article. First, however, it will be necessary to refer briefly to some aspects of modern physical theory on which the later theory depends.

### *Some Consequences of the Quantum Theory.*

In previous articles in this series reference has been made to Planck's quantum theory. This has been responsible, in very large measure, for many of the recent advances in physical knowledge, not the least of which is its contribution to the present-day theory of electrical conductivity. Although the quantum theory abounds in complex mathematical



arguments, its basic concepts are comparatively simple and a brief summary of some of these may lead to a better understanding of the discussions which follow.

Planck's postulate concerned the interaction of matter and radiation and stated that emission or absorption of radiant energy, at any given frequency, does not take place continuously but only in fixed, finite amounts or "quanta of energy." The value ( $E$ ) of a quantum of energy is not, however, a constant but varies with the frequency ( $f$ ) of the radiation according to the equation  $E=hf$ . It is possible to estimate the value of  $E$  by various experimental methods and  $f$  can be measured directly. In this and other ways  $h$  can be calculated and turns out to be a universal constant ( $6.55 \times 10^{-27}$  erg. sec.). It is known as Planck's constant.

Bohr's application of these principles to the nuclear theory of the atom has yielded results of the greatest importance in many branches of physics. When first put forward his views were thought very revolutionary. Their subsequent general acceptance was due not to direct proof of their correctness, but to the fact that, by their aid, it was possible to give convincing explanations of a wide range of previously inexplicable phenomena. Bohr's fundamental assumption is that, contrary to classical electromagnetic theory, an electron can remain indefinitely in one or other of certain permitted orbits without gain or loss of energy, and in these only, and that the size of these orbits was fixed by the total amount of energy possessed by the electron. If the electron moves from one such orbit to another energy must be emitted or absorbed.

Applying the first postulate of the quantum theory to changes of electronic energy, it follows that the electron must jump, and not move gradually, in passing from one permitted orbit to another. Further, adjacent orbits must differ in size by finite amounts in order that the corresponding energy values may differ by one quantum. The permitted orbits in which

an electron can remain in equilibrium are described as discrete, stationary states. Since this term might be interpreted as implying cessation of motion, it is better used to denote the corresponding energy values or energy levels. These conceptions are very conveniently illustrated by the example of the hydrogen atom for which the detailed predictions of theory are comparatively easily derived and agree extremely well with the results of experiment. Fig. 1 (a) is a pictorial representation of a hydrogen atom showing the positive nucleus and five of the possible orbits for the one electron. The orbit (1) is that in which the potential energy is a minimum, and is known as the ground state. The larger orbits are those of higher energy.<sup>1</sup> The corresponding energy levels are represented in Fig. 1 (b).

#### *The Exclusion Principle and the Wave Properties of Electrons.*

As will be seen later the electrical properties of a substance are largely governed by the distribution of its electrons among the permitted energy levels. In a single atom, at least, there is very strong evidence that this distribution must obey Pauli's exclusion principle, by which not more than two electrons may simultaneously be in the same state (see next paragraph). There is reason to believe that this principle applies not only to single atoms but also to molecules and, in solids, to clusters of molecules. When considering the behaviour of tangible masses of a solid it is convenient to assume that this principle applies also to the whole of each single crystal. Although this has not been experimentally demonstrated there is, at least, no contradictory evidence, and the use of the assumption has given rise to reasonable explanations of several well established facts.

The expression "in the same state" is perhaps most easily understood in terms of a property of the electron first suggested by de Broglie. This is the wave property of the electron and can be described as follows:—Associated with every moving electron is a short train of waves or "wave-packet," which is propagated in the direction of motion of the electron. In the simplest condition the wavelength is given by the expression  $\lambda = h/mv$  where  $v$  is the velocity of the electron and  $m$  the mass it has when moving at that velocity. The experimental proof of this fact by Davisson and Germer and some of the practical uses to which it has been put were referred to in Part I of this series. In terms of the wave concept the exclusion principle states that not more than two electrons can simultaneously have the same de Broglie wavelength. The figure two arises from the two opposite directions of electron spin referred to in Part IV of this series.

The application of these principles to the theory of electrical conductivity will now be briefly considered.

<sup>1</sup> Progressing outwards from the ground state the kinetic energy of the electron decreases. The potential energy, however, increases at a greater rate, hence the net result is an increase.

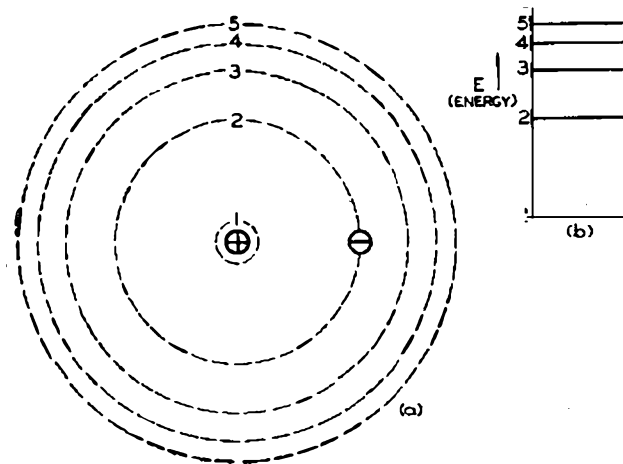

If the frequency emitted during transition from a level "m" to a level "n" is  $f_{mn}$ ,  $E_m - E_n = hf_{mn} = 1$  quantum of frequency  $f_{mn}$ .

FIG. 1.—PERMITTED ORBITS AND ENERGY LEVELS OF A HYDROGEN ATOM (BOHR'S THEORY).

### *The Sommerfeld-Bloch Theory of Conduction.*

The basic assumptions of the present day theory of conductivity, which was advanced largely by Sommerfeld and Bloch (1928), are the same as those made by Drude and Lorentz, namely, that the current is carried by the free electrons in a conductor. The chief differences are that account is taken of the wave properties of electrons and the motion of the electrons is treated by the methods of quantum mechanics instead of by those of classical mechanics.

The first result of Sommerfeld's application of the wave principle is that the mean velocity of the conductivity electrons, under given conditions, is much greater than was calculated by the earlier theory. Secondly, the mean free path of the electrons (i.e., the mean distance between successive collisions with atoms or other electrons) is, at room temperature, about one hundred times the distance between adjacent atoms instead of about equal to this distance as was thought earlier. As the temperature is lowered the mean free path increases steadily. This provides an explanation of the very long paths which the Drude-Lorentz theory required, but could not explain, to account for the vanishing of resistance at or near absolute zero.

The most important of Bloch's contributions to the modern theory is his treatment of the effect of the atoms in the crystal lattice. It was, of course, recognised by Drude and Lorentz that an atom which gives up an electron becomes thereby a positively charged ion whose field will affect any nearby moving electron. For want of an adequate mathematical treatment of such conditions Drude and Lorentz were, however, forced to assume that, between successive collisions, the electrons were subject to no forces other than those due to the applied field. Bloch's success lay in treating the motion of the electrons as occurring in a potential field which varied in a periodic manner corresponding to the spacing of the atoms in the crystal lattice.

Perhaps the most striking result of this treatment was the deduction that a metal whose lattice was perfectly periodic would have no resistivity and that resistance would arise from irregularities in the lattice. As will be seen later, this leads to a satisfying explanation of the effects of alloying and of temperature on resistance and, to some extent, of the magnitudes of the resistivities of actual metals. Before these points are discussed, however, it will be of interest to consider the way in which the distribution of electron energy levels in a crystal determines whether the crystal will be a conductor or an insulator.

#### *Energy Levels of the Electrons in a Crystal.*

In a single free atom the electrons will occupy one or more of the discrete energy levels allowed by the quantum theory. If the atom is unexcited, i.e., in its condition of lowest total energy, every electron will be in the nearest possible level to the ground state. The lowest energy levels will be occupied by pairs of electrons (cf. the exclusion principle) but the next higher energy levels, depending on the kind of atom, will be empty or, at most, partially filled.

When two or more atoms combine to form a molecule a new energy distribution comes into being as a result of interaction between the atoms. The lower energy levels suffer little change whereas the energy levels of the outermost or valency electrons, which have the highest energies, are considerably altered. If the molecule consists of two atoms, each of the original levels sub-divides into two of nearly equal energy value; if the molecule is triatomic the sub-division is into three and so on. This is illustrated in the first three diagrams of Fig. 2.

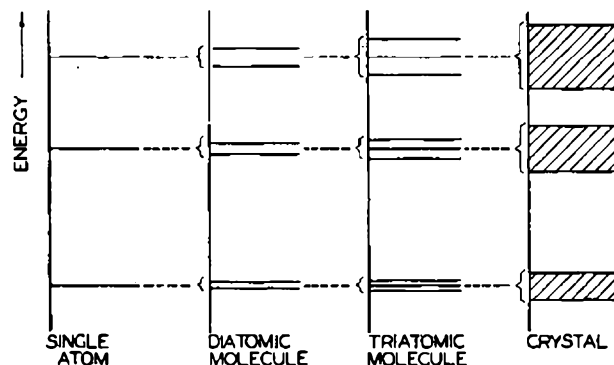

FIG. 2.—ENERGY LEVELS IN ATOMS, MOLECULES AND CRYSTALS.

There is evidence from the science of spectroscopy that this splitting of the levels does occur and, further, that the arguments of the previous paragraph apply when several molecules combine to form a crystal. Now, quite a small crystal may contain  $10^{20}$  atoms and, therefore, at least the same number of valency electrons. Thus, in such a crystal, each single energy level in the atom becomes a group of  $10^{20}$  levels in the crystal. (If, as seems to be true, the exclusion principle applies to the whole crystal, at least  $0.5 \times 10^{20}$  levels would be necessary to accommodate the valency electrons alone.) In short, the single discrete levels in the atom, broaden out into bands or zones of closely grouped energy levels with a corresponding reduction in the size of the gaps of forbidden energies. This is illustrated in the fourth diagram of Fig. 2 and the effect on the electrical properties of the crystal will now be considered.

#### *Conductors and Insulators.*

When a potential difference is applied to a solid the electric field tends to accelerate the electrons, i.e., to increase the total of their energies. This increase cannot actually occur, however, unless there are vacant, in the crystal, adjacent higher energy levels which individual electrons can attain. This is likely to be possible only for electrons in the uppermost occupied bands, i.e., for the valency electrons. If vacancies exist a net movement of charge can occur and a current will flow.

In crystals composed of monovalent atoms (one valency electron per atom) there will be as many levels per band as there are valency electrons, whereas the exclusion principle would allow twice as many electrons. The upper occupied energy band will be,

therefore, only half full; very small electric forces will be able to raise the electrons to higher levels in the band and the substance should be a good conductor. This is the case; crystals of this type are those of the alkali metals and the metals copper, silver and gold. The energy situation is shown in Fig. 3(a).

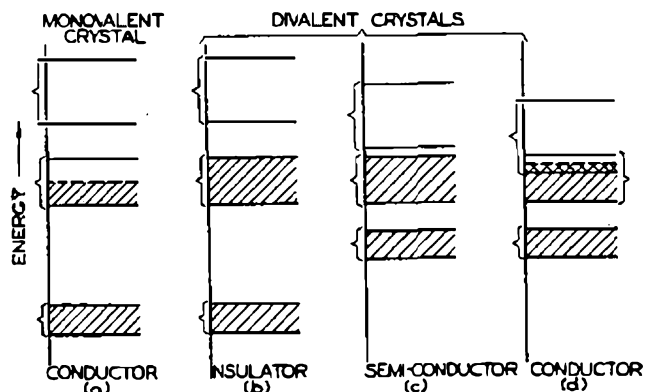

FIG. 3.—ENERGY LEVELS IN CONDUCTORS AND INSULATORS.

Crystals composed of atoms of even valency will have two electrons in each occupied level. Any energy band that contains any electrons at all will, in general, be completely filled. In consequence, the only possible transition by which an electron can gain energy is a jump to an entirely new band. If, as shown in Fig. 3(b), wide gaps of forbidden energies exist between consecutive bands, very large electric fields would be required to cause such jumps and small fields will have no effect. Crystals which appear to be of this type are those, for example, of sulphur, diamond and silica which are good insulators.

In some even valency crystals, such as those of silicon, carborundum, and the oxides and sulphides of many metals, the gap between adjacent energy bands is small (Fig. 3(c)). At low temperatures these behave as insulators. At higher temperatures the electrons can move to the higher, previously empty, band by absorbing thermal energy. Such electrons can then be accelerated by an electric field and the crystal therefore becomes a semi-conductor when heated. A somewhat similar situation arises if a crystal which, if pure, would be an insulator, has impurities in it. The energy bands of the impurity atoms may coincide with and be wide enough to bridge the energy gaps of the pure crystal and conduction can occur.

A further possibility arises when two energy bands are wide enough partially to overlap as in Fig. 3(d). Some of the electrons which, otherwise, would complete the filling of the lower of these two bands will actually be found in the higher band as this leads to a smaller total energy in the normal state. There will thus be, in the upper band, a number of vacant levels adjacent to those of these particular electrons and the substance will be a conductor. The conductivity of the divalent metals such as zinc, cadmium, mercury and the alkaline earth metals appears to arise in this way.

### The Resistance of Pure Metals.

Bloch's conclusion that a perfectly periodic lattice would have no resistance has already been mentioned. Such perfection is never attained in practice. At all temperatures above absolute zero the atoms are in a state of continual vibration. This thermal motion detracts from the regularity of the lattice, resistance is therefore present and the magnitude of the resistance will depend on the amplitude of the atomic vibrations.

If an attempt is made to express this fact in a quantitative manner, difficulty is experienced due to the fact that, as the quantum theory shows, collisions between the electrons and the crystal lattice are not truly elastic. However, by making certain assumptions and approximations which appear to be justified by the results obtained, it can be shown that, near absolute zero, the resistance of a pure metal should be proportional to the fifth power of the absolute temperature. This is the actual behaviour of most metals and at least a partial explanation can be given of those transition metals (e.g. iron, cobalt and nickel) which do not follow this law.

At progressively higher temperatures the inelasticity of the collisions becomes of relatively less and less importance and the quantum mechanical treatment of the collisions approximates more and more closely to the treatment by classical methods. In the temperature range over which this is true, it can be shown that the probability of a collision between an electron and a lattice atom is proportional to the mean square amplitude of motion of the atoms which is proportional to the absolute temperature. The resistance of a metal should therefore vary in the same way. This, also, is in agreement with experiment.

Up to this point the deductions from theory are in very good agreement with experimental fact. When it comes to the important question of predicting the absolute magnitudes of the conductivities of different metals it must be admitted that only partial success has, so far, been obtained. The obstacles still outstanding are partly practical and partly theoretical. The calculations involved are extremely complicated and, except as regards the simplest metals, it is necessary to make certain rather arbitrary assumptions regarding the nature of the wave properties of the electrons within a solid metal and the influence of the vibrations of the atoms in the lattice. Bardeen, Peterson and Nordheim have attempted the task for the simpler metals. Their results correspond fairly well with the relative magnitudes of the experimental figures and, for sodium and potassium, quite good numerical agreement has been achieved.

### Effect of Impurities.

If the fifth power law mentioned in the previous section is assumed to hold down to absolute zero, the resistivity of metals at that temperature should be zero. The values of resistivity would thus lie on a curve such as the lower dotted curve in Fig. 4. If actual measured values are plotted, however, the trend of the curve changes below about 5° absolute

and the resistivity tends towards a small constant value, termed the residual resistivity, which appears to persist however low the temperature falls.

The resistivity of an ordinary metal thus appears to be the sum of two terms one of which, the residual

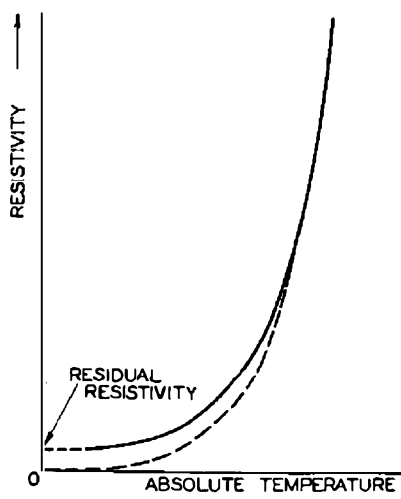

FIG. 4.—TYPICAL RESISTIVITY-TEMPERATURE CURVES FOR METALS NEAR ABSOLUTE ZERO.

resistivity, is independent of temperature and the other, the true resistivity, is a function of temperature. This is known as Matthiessen's rule. Experiment also shows that the magnitude of the residual resistivity is roughly proportional to the amount of impurity present in the metal. There is little doubt, therefore, that residual resistivity arises mainly from disturbance of the lattice periodicity due to the presence of the impurity atoms. Similarly any other lattice defect, such as porosity, produces residual resistivity even in very pure metals.

#### The Resistance of Alloys.

The connection between lattice irregularities and conductivity is well brought out by a study of the

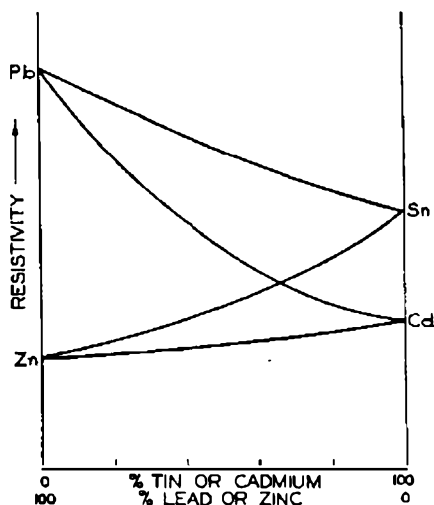

FIG. 5.—RESISTIVITY CURVES FOR ALLOYS OF HETEROGENEOUS MIXTURES.

resistivities of alloys. For simplicity only binary alloys (i.e., those containing two elements) will be considered. The simplest example is that of heterogeneous mixtures, that is, of alloys composed of mutually insoluble metals. In the solid state these consist of crystals each of which is composed of one or other of the pure constituents. The resistivities of individual crystals will be substantially unaffected by the proximity of other crystals and the overall resistivity of the alloy will therefore be roughly the weighted average of the components. This is illustrated by Fig. 5 which is based on values determined by Meissner.

When, on the other hand, the metals form one or a series of solid solutions the lattice periodicities will be profoundly disturbed. This is shown by the fact that, as a rough general rule, the resistivity of a metal, even at room temperature, is frequently doubled by the addition of as little as 1 atomic per cent. of a second metal.

Where the relative proportions of the two constituents are more or less of the same order the simplest type of alloy, from the present point of view, is that in which the constituent atoms are distributed at random over the lattice points. The lattice disturbance will then be roughly proportional to the number of atoms of the smaller constituent present. The behaviour of this type of alloy is shown

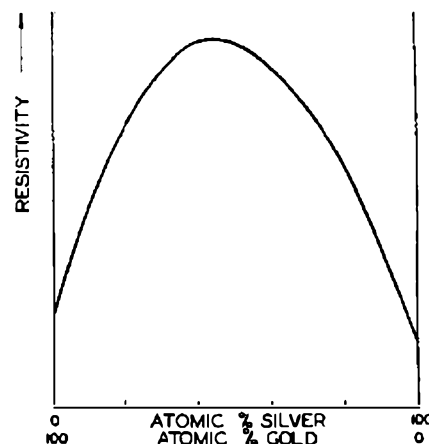

FIG. 6.—RESISTIVITY CURVES FOR GOLD-SILVER ALLOYS.

in Fig. 6 which refers to alloys of gold and silver and shows a maximum of resistivity at roughly 50 atomic per cent.

Not all alloys behave in this simple manner. Depending on the heat-treatment given, the atoms in some alloys may be distributed either at random, as in the previous example, or in an orderly manner throughout the crystal. An example which has been very thoroughly studied is the copper-gold series of alloys, the resistivities of which are plotted, in Fig. 7, from the data of Johansson and Linde.

The smooth curve (a) represents the resistivities of alloys quenched from above 650°C. These alloys are disordered and the curve is very similar to that for the gold-silver alloys. If, however, the alloys are

slowly cooled from above 650°C. the resistivity of many of them decreases considerably and curve (b) is obtained. This shows two sharp minima, at which the resistivity approaches that for a pure metal, at

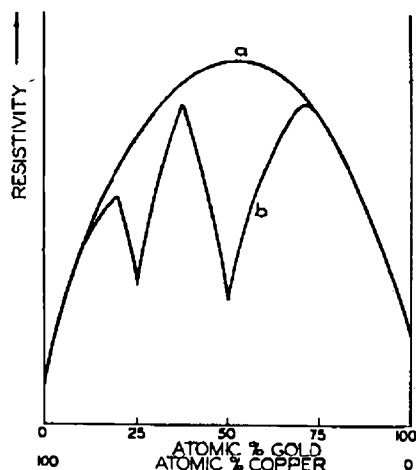

FIG. 7.—RESISTIVITY CURVES FOR COPPER-GOLD ALLOYS SUBJECTED TO HEAT-TREATMENT.

compositions which correspond to  $\text{Cu}_3\text{Au}$  and  $\text{Cu Au}$  respectively.

X-ray examination of alloys of these two compositions shows that the atoms are arranged in a regular manner forming a "superlattice" (see Part III) and, in fact, that they partake more of the nature of chemical compounds. Alloys of other compositions are not truly homogeneous but consist of a mixture of the intermetallic compound and a (disordered) solid solution. In short, slow cooling from above 650°C. leads to a disorder  $\rightarrow$  order transformation, which is complete at two points, and the consequent regularity of the lattice results in the manifestation of a greatly reduced resistivity as the theory predicts.

#### Temperature Coefficient of Resistivity of Alloys.

For an alloy of the heterogeneous mixture type the contributions of the individual pure metal crystals can be summed to compute the total resistivity. This is substantially true whatever the temperature and it therefore follows that the temperature coefficient of resistivity of such alloys is roughly the weighted average of the coefficients of the two components.

Where the alloy consists of a disordered solid solution the result is quite different. The residual resistivity will be very high and the temperature-dependent term of the total resistivity will appear to be relatively smaller. Such an alloy will generally have a lower temperature coefficient than either of its constituents.

If order  $\rightarrow$  disorder phenomena occur the result is rather more complicated though still easily understood in the light of the new theory. An interesting example is that of  $\beta$ -brass (51.25 atomic per cent. Cu, remainder Zn), resistivity-temperature curves for which, obtained from the data of Johansson and Linde, are shown in Fig. 8.

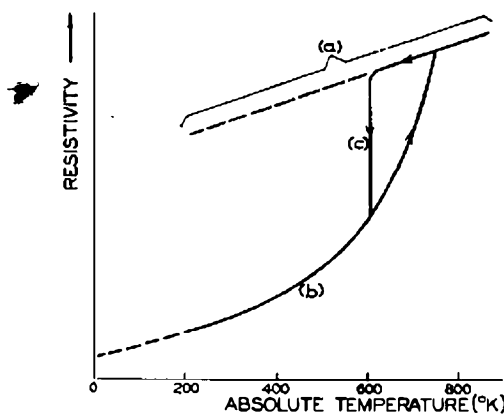

FIG. 8.—RESISTIVITY-TEMPERATURE CURVES FOR  $\beta$ -BRASS.

At temperatures above about 750°K. the alloy is disordered, its resistivity is high and its temperature coefficient of resistivity low. If the alloy is cooled rapidly from above this temperature to some lower temperature the resistivity will follow the curve (a). With very slow cooling, on the other hand, the alloy passes into the ordered state and curve (b) is followed. Both the total resistivity and the residual resistivity are much lower but the temperature coefficient is higher. With intermediate rates of cooling a kind of hysteresis effect occurs and curves such as (c) can be obtained.

## SUPERCONDUCTIVITY.

### Discovery of Superconductors.

In 1893 Dewar and Fleming made their classical experiments on the effect of low temperatures, down to that of liquid hydrogen, on the electrical conductivity of metals. Their results suggested that with progressive lowering of the temperature the conductivity would steadily increase and ultimately become infinite at the absolute zero of temperature. Even to-day, there is, for many metals, no indication of any departure from this trend except that traces of impurity give rise to residual resistivity. In all the foregoing discussions it has been assumed that this is the normal behaviour of metals and no exceptions have been considered.

It is known, however, that this is far from being the whole story of many of the common metals. This knowledge dates from 1911 when Onnes, at Leyden, discovered that when solid mercury was cooled in liquid helium it suddenly lost all resistance when a temperature of 4.2°K. was reached. Since that time many other metals have been found to behave in a similar manner. In every instance the loss of resistance is sudden and complete and occurs at a definite temperature which is characteristic of the metal.

The phenomenon is known as superconductivity and, as its onset appears to involve some fundamental change of state, the temperatures at which it occurs are termed transition temperatures. Some

superconductors and their transition temperatures are listed in the following table.

Metal	Transition Temperature (absolute °K)
Niobium .. ..	9.2
Lead .. .. .	7.2
Mercury .. ..	4.22
Tin .. .. .	3.7
Titanium .. ..	1.75
Aluminium .. .	1.14
Zinc .. .. .	0.79
Cadmium .. ..	0.6

So far no superconductor has been found to revert to the normally conducting state on further cooling. On the other hand, many of the common metals, such as copper, silver, gold, magnesium, bismuth, iron and nickel do not become superconducting at the lowest attainable temperatures—and some of these have been subjected to temperatures only  $\frac{1}{10}$  of a degree above absolute zero. Strangely enough, however, the sulphides, nitrides, carbides, borides and silicides of many of these latter metals and some alloys of two or more of them are superconductors.

#### Persistent Currents.

A current can be set up in a superconducting ring by bringing a bar magnet or an energised solenoid close to it or by cooling the ring below its transition point in the presence of a magnet, etc., and then removing the latter. The magnitudes of such currents can be deduced from the external magnetic effects they produce and are found to be very large—often reaching hundreds of amperes in quite fine wires. In fact, the current produced by a given change of flux is limited only by the self-inductance of the ring and, for rings of the same dimensions, is independent of the composition of the superconductor. There is, however, an upper limit to the current density which can be produced.

Experiments on superconductivity phenomena have been conducted over periods as long as 13 hours and in no experiment has the induced current, once established, been found to diminish with time. In short, the most careful measurements, along these and other lines, have failed to yield any evidence that the disappearance of resistance is other than strictly complete. Naturally, therefore, no heating effects are produced by the flow of current in a superconductor.

#### Magnetic Effects.

Some of the most interesting phenomena associated with superconductivity came to light when the magnetic properties of superconductors were examined. If a superconducting metal at a temperature below the transition point is subjected to a gradually increasing magnetic field, the electrical resistance suddenly reappears when a certain critical field strength is reached. Conversely, if the metal is subjected to a constant magnetic field during cooling from above its transition temperature, the change from the normally conducting state to the superconducting state occurs at a lower temperature

than in the absence of the field. A curve, such as Fig. 9, can therefore be plotted showing the relation

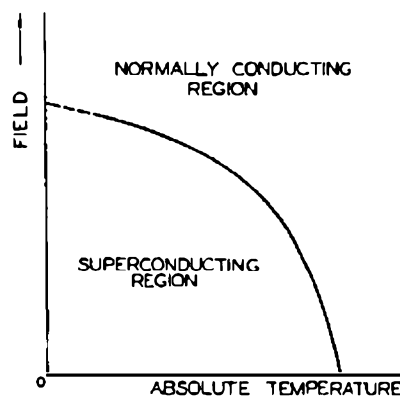

FIG. 9.—RELATION BETWEEN TRANSITION TEMPERATURE AND APPLIED FIELD.

between the transition temperature and the applied field. For all points in the area above the curve the conductivity will be normal and at all points below the curve the metal will be superconducting.

As was first demonstrated by Silsbee, this magnetic effect explains the existence of an upper limit, which varies with temperature, to the density of the persistent currents which can be set up in superconductors. These currents produce a magnetic field and, when an attempt is made to set up a current which would give rise to a magnetic field in excess of the critical field at the temperature of the experiment, the material ceases to be superconducting.

Further to this it can be shown theoretically that a necessary consequence of superconductivity is that the magnetic field within a superconductor cannot be changed by any external means and, hence, the magnetic permeability should be zero. Meissner and Ochsenfeld in 1933 succeeded in confirming this by experiment.

#### Alternating Current Phenomena in Superconductors.

Some very interesting results have been obtained in studying the alternating current properties of superconductors. Space does not permit a discussion of these results but, it can be stated, there is evidence that up to high radio frequencies ( $10^7$ – $10^8$  c/s) superconductivity is maintained. On the other hand there is some evidence that superconductivity is not exhibited at optical frequencies (say  $10^{14}$  c/s).

#### Theory of Superconductivity.

In recent years much research on superconductivity has been carried out in spite of the difficulty and expense of the experiments. Unfortunately, theoretical development has failed to keep pace with the accumulation of data and no satisfactory explanation has yet been given. It now seems likely that superconductivity is merely a symptom of more fundamental changes in the magnetic properties of the materials concerned and that a satisfactory theory will ultimately lead to a greatly increased knowledge of a wide range of natural phenomena which, at present, appear unrelated and obscure.

# A Simple Introduction to the Use of Statistics in Telecommunications Engineering

U.D.C. 519.2 : 621.39

J. F. DOUST and  
H. J. JOSEPHS, F.S.S., A.M.I.E.E.

## Part II—Analysis of Small Samples

The first article of this series dealt with analysis of samples obeying the normal probability law. The present article discusses the probability analysis of very small samples and shows how Fisher's "t" test can be applied to the solution of engineering problems without laborious calculation or integration.

### Introduction.

THE examples considered in the previous article were of a pleasing type in that if the data available appeared to be insufficient it was always possible to secure more. By this means, fairly definite conclusions as to the properties of the parent populations from which the samples were drawn could be reached. It must now be admitted that examples of this kind are not wholly representative, for it often happens that the unfortunate engineer is faced with limited data which it is not possible to augment. In these circumstances it is necessary to make sure that the maximum of information is extracted from the data that can be obtained, and means of dealing with small samples to that end are described in this article.

When samples are small it is not possible to draw exact conclusions as to the properties of the parent population from which they were drawn, but limits between which those properties must lie can be determined with any desired degree of certainty. The determination of such limits is often of great value.

As a necessary preliminary to the introduction of special methods of dealing with small samples, a brief explanation of the building up of normal probability tables is given, but it will be found that it is possible to "make it easy by leaving out all the difficult parts."

### Sheppard's Tables.

In the previous article it was shown that many variables which arise in telecommunication engineering show, in their frequency distribution, only minor deviations from the normal bell-shaped frequency curve. This curve may be defined by the equation

$$f = \frac{N}{\sigma \sqrt{2\pi}} e^{-\frac{1}{2} \left(\frac{x}{\sigma}\right)^2} \dots \dots \dots (1)$$

where  $f$  is the frequency of occurrence of the deviation,  $x$ , from the arithmetic mean,  $M$ , and  $N$  is the number of observations. In this definition,  $\sigma$  is the standard (or root-mean-square) deviation. It is a measure of the dispersion of the deviations around the mean, and is a constant for any particular curve.

Equation (1) can be considered as showing the frequency of

occurrence,  $f$ , of a deviation,  $x/\sigma$ . This method of expressing deviations in terms of the standard deviation is very convenient and will be used in the curves shown in this article.

By multiplying both sides of equation (1) by  $(\sigma/N)$  and replacing  $f(\sigma/N)$  by the symbol  $Z$ , the above equation reduces to the simple form—

$$Z = \frac{e^{-\frac{1}{2} \left(\frac{x}{\sigma}\right)^2}}{\sqrt{2\pi}} \dots \dots \dots (2)$$

which involves only the quantity  $(x/\sigma)$ . Since  $(x/\sigma)$  varies in actual practice only from 0 to 6, it can be seen that values of  $Z$  can be tabulated for all the values of  $(x/\sigma)$  likely to arise. Any given value of  $Z$  can then be transformed to  $f$  by multiplying by  $N/\sigma$ . In other words, for a given population for which  $N$  and  $\sigma$  are known, it is possible, with the aid of a table of  $Z$  values, to plot a smooth curve, which is an estimate of the form of that population.

The fraction of the population having deviations lying between any particular values of  $x/\sigma$  will be equal to the fraction of the total area under the curve which is enclosed by the ordinates erected at those particular values. As explained in the previous article, it follows that the probability of the occurrence of deviations lying between any given values of  $x/\sigma$  will also be defined by the fraction of the area enclosed between the ordinates at those values.

In Fig. 1 the area within the limits  $+x/\sigma$  and  $-x/\sigma$  is represented by  $\alpha$  for a value of  $x/\sigma$  equal to  $d$ . If, as is usual, the total area under the normal

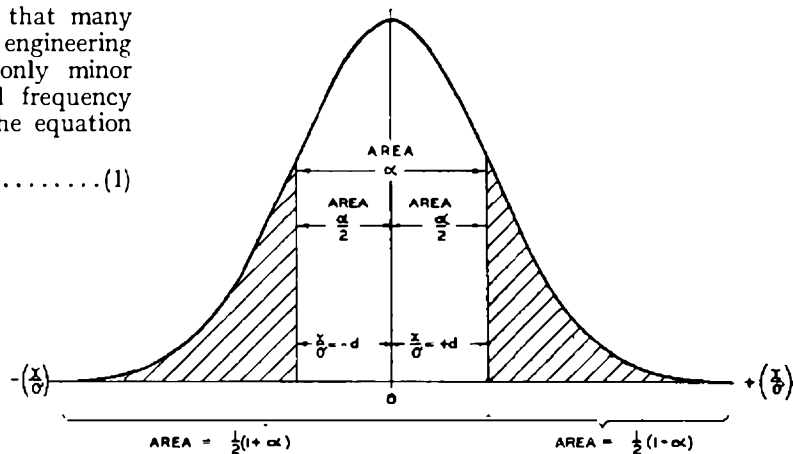

FIG. 1.—NORMAL PROBABILITY CURVE, SHOWING AREA,  $\frac{1}{2}(1 + \alpha)$ , TABULATED IN SHEPPARD'S TABLES.

curve is regarded as unity, it follows that the area from  $x/\sigma = -\infty$  to  $x/\sigma = d$  can be written as  $\frac{1}{2} + \frac{1}{2}a$  or  $\frac{1}{2}(1+a)$ . Then the probability of the occurrence of a deviation between  $-\infty$  and  $+d$  is  $\frac{1}{2}(1+a)$ , and the probability of a deviation exceeding  $+d$  is  $1 - \frac{1}{2}(1+a)$ , or  $\frac{1}{2}(1-a)$ . Since the curve is symmetrical about the mean, the probability of a deviation exceeding  $\pm d$  is  $\frac{1}{2}(1-a) \times 2$  or  $(1-a)$ .

The late Dr. W. F. Sheppard tabulated the values of  $Z$  and  $\frac{1}{2}(1+a)$  for all values of  $x/\sigma$  from 0 to 6 proceeding by intervals of 0.01. Sheppard's tables, originally published by the British Association under the title, "Tables of Area and Ordinates in terms of Abscissæ," can now be found in almost every book of mathematical tables. From Sheppard's tables (a short extract of which is given in Table 1 below), the chances that a single item chosen at random from a normal population will lie at least as far from the mean as a given number of standard deviations, can be readily computed.

TABLE 1.

$\frac{x}{\sigma}$	$Z$	$\frac{1}{2}(1+a)$
1.96	0.0584409	0.9750021
1.97	0.0573038	0.9755808
1.98	0.0561831	0.9761482
1.99	0.0550789	0.9767045
2.00	0.0539910	0.9772499
2.01	0.0529192	0.9777844
2.02	0.0518636	0.9783083
2.03	0.0508239	0.9788217
2.04	0.0498001	0.9793248

As a practical example of the use of Sheppard's tables, consider the 3,890 head measurements discussed in the previous article.

The mean  $\bar{x}$  was found to be 13.7 cms., and the standard deviation  $\sigma$  was 0.9 cm. Suppose it is required to find the probability that a single person selected at random from the population will have a head measurement of at least 15.5 cms.?

Here,  $\bar{x} = 13.7$  cms. and  $\sigma = 0.9$  cms.;

thus  $x = 15.5 - 13.7 = 1.8$ ,

$$\therefore \frac{x}{\sigma} = \frac{1.8}{0.9} = 2,$$

and from Table 1,

$$\frac{1}{2}(1+a) = 0.9772.$$

$\therefore$  the probability =  $1 - 0.9772 = 0.0228$

Thus there are approximately 23 chances per 1,000 of finding a person with a head measurement greater than 15.5 cms.

There is a slight extension of the example to which attention should be drawn. Suppose it is required to determine the probability of selecting at random a person whose measurement differs by at least  $\pm 1.8$  cm., i.e.  $\pm 2\sigma$ , from the mean of the population.

This involves the erection of two ordinates, one at  $(x/\sigma) = +2$  and one at  $(x/\sigma) = -2$  and the determination of the area in both tails of the bell-shaped curve. Obviously this will be

$$2[1 - \frac{1}{2}(1+a)] = (1-a),$$

and in the head measuring problem this becomes  $2 \times (1 - 0.9772)$  or 0.0456. Thus the probability that a single variate will deviate by an amount equal to or greater than  $\pm 2\sigma$  is 0.0456 or approximately 5 per cent., which agrees with the result obtained in the previous article.

Table 2 is a short tabulation of the chances that an item chosen at random from a normal population will differ from the mean by the stated number of standard deviations.

TABLE 2.

$x/\sigma$	Chances	$x/\sigma$	Chances
0.0	1.000	2.0	0.0456
0.2	0.841	2.2	0.0277
0.4	0.689	2.4	0.0163
0.6	0.549	2.5	0.0124
0.8	0.424	2.6	0.00932
1.0	0.317	3.0	0.00270
1.2	0.230	3.5	0.000465
1.4	0.162	4.0	0.000063
1.6	0.109	4.5	0.0000068
1.8	0.0719	5.0	0.0000057

From Table 2 it can be seen that there are 124 chances out of 10,000 that an item chosen at random from a normal population will differ from the mean by as much as 2.5 times the standard deviation. By dividing the chances in the above table by two it is possible to find the chance that an item chosen at random from a normal population will differ from the mean either in a positive direction or in a negative direction by a given number of standard deviations.

#### The Control Chart.

Suppose the mean efficiency of a sample of ten telephone transmitters taken from a large delivery is calculated from measurements of their individual efficiencies. The result is not an absolute and invariable quantity which can be reproduced by taking another sample of ten transmitters from the same delivery. Indeed, another sample would probably give a different mean. All results, however, are not equally likely. The values which are obtained for the mean are governed by probability in exactly the same way as any other quantity which is subject to accidental fluctuations. It has a certain distribution law with its own standard deviation; the same is true for any statistic<sup>1</sup> that can be calculated from the data. The question arises, therefore, as to how widely and according to what law a statistic, such as a mean or a standard deviation, may be expected to vary. These two important statistics obey laws of distribution which are very nearly normal; they are exactly normal when derived from data which

<sup>1</sup> Any quantity such as a mean, standard deviation, a median, etc., when calculated from a sample is called a *statistic*; the corresponding quantity in the population is called a *parameter*. Thus a *statistic* may be regarded as the small brother of a *parameter*.



satisfy the normal law, and approximately normal for those cases in which the data satisfy skew (or unsymmetrical) distribution laws. Since the frequency distribution of a statistic follows a normal law it is apparent that the determination of its standard deviation (or "standard error" as it is called in this case) makes it possible to form an estimate of the confidence that can be placed in the observed values of that statistic. The standard errors of the mean,  $\bar{x}$ , and of the standard deviation,  $s$ , of a normal sample are given approximately by the simple expressions  $\sigma/\sqrt{N}$  and  $\sigma/\sqrt{2N}$  respectively. In these expressions  $\sigma$  is the standard deviation of the sampled population and  $N$  is the number of items taken in the sample. Since both mean and standard deviations are normally distributed Table 2 will apply to them except that standard errors will be read for standard deviations.

As an example of the use of the standard error formulæ quoted above, suppose that samples of 100 items are taken from a normal population with an average,  $M$ , of 11.2 and a standard deviation,  $\sigma$ , of 2.6.

Then the standard error of the mean is given by—

$$\frac{\sigma}{\sqrt{N}} = \frac{2.6}{\sqrt{100}} = 0.260$$

and the standard error of the standard deviations is given by—

$$\frac{\sigma}{\sqrt{2N}} = \frac{2.6}{\sqrt{200}} = 0.184$$

From Table 2 it is seen that the chance of a deviation exceeding 2.5 times the standard error is about 1 in 80.

$$\begin{aligned} \text{Now } 2.5 \times 0.260 &= 0.65 \\ \text{and } 2.5 \times 0.184 &= 0.46 \end{aligned}$$

Thus it can be stated that the chances are 80 to 1 that the mean of the sample will lie between  $(11.2 \pm 0.65)$  and that the standard deviation of the sample will lie between  $(2.60 \pm 0.46)$  if the experimental data really comes from a normal population. Thus it can be seen that if all the samples were drawn from the same normal population (i.e., manufactured under the same essential conditions) it is improbable that the difference between means will be greater than two and a half times the standard error.

The knowledge as to the nature of the distribution law obeyed by the mean and other statistics that are commonly calculated from measured data has been used in an elegant way in the construction of "control charts,"<sup>2</sup> the purpose of which is to reveal at a glance whether or not the population from which a sample is drawn is of the normal type. Provided the value of the parameter  $\sigma$  is known the control chart can be made into a useful engineering tool. For a full discussion of the control chart technique readers are referred to an article by K. L. Parker, entitled, "Statistical Theory Applied to the Testing of Mass-Produced Articles."<sup>3</sup>

#### Outline of "Student's" Theory.

It has been stated that if samples of  $N$  items are drawn from a normal population, it will be found that the means of the samples are distributed around the mean of the population according to the normal probability law with a standard error of  $\sigma/\sqrt{N}$ , where  $\sigma$  is the standard deviation of the sampled population. To test any assumption concerning the mean of a random sample, as for example, that the mean  $\bar{x}$  of the sample deviates by more than a specified amount from the mean  $M$  of the population, it is necessary to calculate,

$$t = \frac{\bar{x} - M}{\frac{\sigma}{\sqrt{N}}} \dots\dots\dots(4)$$

which is the ratio of the deviation of the mean of the sample to the true standard error of the mean. Then the equation,

$$f = \frac{1}{\sqrt{2\pi}} e^{-t^2} \dots\dots\dots(5)$$

will define the frequency distribution of the statistic,  $t$ , if it is distributed normally. By calculating the area under this curve between  $-\infty$  and the ordinate at the value of  $t$  obtained from the sample, it would be possible to state the probability of obtaining a greater value of  $t$ , and hence a greater deviation of  $\bar{x}$  from  $M$ , if another sample were tested.

It is important to note, however, that the value of the standard deviation  $\sigma$  is usually unknown, and consequently it is necessary to estimate it from the  $N$  items in the sample. Use might be made of the standard deviation of the sample, namely,

$$s = \sqrt{\sum(x - \bar{x})^2/N}$$

where the summation extends over all the observed  $x$  values in the sample. Professor R. A. Fisher,<sup>4</sup> however, has shown by the method of maximum likelihood, that the most probable estimate of  $\sigma$  is given by,

$$s \times \sqrt{N/(N-1)}$$

Replacing  $\sigma$  by its estimated value, equation (4) becomes

$$t = \frac{\bar{x} - M}{\frac{s}{\sqrt{N-1}}} \dots\dots\dots(6)$$

where  $\frac{s}{\sqrt{N-1}}$  is the estimated standard error. It

will be observed that the quantity  $t$  is now the ratio of the deviation of the mean of a small sample to the estimated standard error of the mean. It was one of Student's great achievements to find that, for small values of  $N$ , the ratio (or statistic)  $t$  given by

<sup>4</sup> "Student" was the pen-name under which W. S. Gosset (1876-1937) wrote his statistical papers. He discovered the distribution expressed by equation (7) in 1908. *c.f. Biometrika*, Vol. VI, 1908, pp. 1-15.

<sup>5</sup> *Philosophical Transactions of the Royal Society of London*, A, ccxxii, 309-368, 1921. Also *Review of Modern Physics*, Vol. 6, 1934, pp. 119-161.

<sup>2</sup> *Bell System Technical Journal*, Vol. 6, October, 1927, pp. 722-735.

<sup>3</sup> *P.O.E.E.J.*, Vol. 31, p. 305.

equation (6), is not distributed normally like equation (4), but takes the form,

$$f = \frac{[(n-1)/2]!}{[(n-2)/2]! \sqrt{n\pi}} \left(1 - \frac{t^2}{n}\right)^{-(n+1)/2} \dots (7)$$

where  $n = (N - 1)$ .

Equation (7) is called Student's distribution, and although it is not normal the probability of obtaining a greater or less value of  $t$  than that given by a particular sample can be obtained as before by integrating the area under the curve between  $-\infty$  and the ordinate at the value of  $t$  under consideration.

As  $N$  becomes larger, Student's distribution approaches a normal distribution. For  $N > 30$  it is permissible to use the tables of the normal probability integral calculated by Sheppard from equation (5) by replacing the independent variable by  $t[(n-2)/n]^2$  and for  $N > 100$  the quantity  $t$  itself may be used as the independent variable.

#### Probability Chart.<sup>6</sup>

By integrating the frequency distribution expressed by equation (7), between the limits  $-\infty$  and  $t$ , R. A. Fisher and Student in 1925 tabulated<sup>7</sup> the probability that the ratio (6) will be less than a specified value  $t$  for various values of  $N$ . These tables, which are based upon the expansion of Student's distribution by R. A. Fisher, are bulky and are not easy to obtain. It can be shown,<sup>8</sup> however, that for engineering applications, it is possible to construct a nomograph from Fisher's solution and thereby dispense with the necessity for obtaining the original tables. This probability chart is shown in Fig. 2 and covers most of the practical values of  $t$ ,  $N$  and  $p$  likely to be met in engineering practice. As a simple example of the use of this nomograph consider a small sample of 6 observations and suppose it is found by calculation that  $t=2.2$ ; then, putting a straight edge on the chart between  $N=6$  and  $t=2.2$  the probability value of 0.96 can be read from the  $p$  scale. Thus, the probability that random samples will give values of  $t$  less than 2.2 is 0.96 approximately: the probability is therefore  $(1-0.96)$  that random samples of this size will have values of  $t$  greater than 2.2 and 2  $(1-0.96)$  that this value lies outside the range  $-2.2$  to  $+2.2$ .

As an example of the engineering application of the above theory, suppose that a machine which produces insulating washers for use in electrical apparatus is adjusted to produce washers having a mean thickness of 100 mils. To check the adjustment of the machine, samples consisting of a number of washers are taken from time to time and the mean thickness of each sample is calculated. Suppose the mean of such a sample of 10 washers to be  $\bar{x}$ . It is required to test whether  $\bar{x}$  differs significantly from 100 mils, that is, whether the difference is such as might be ascribed to chance or whether it indicates

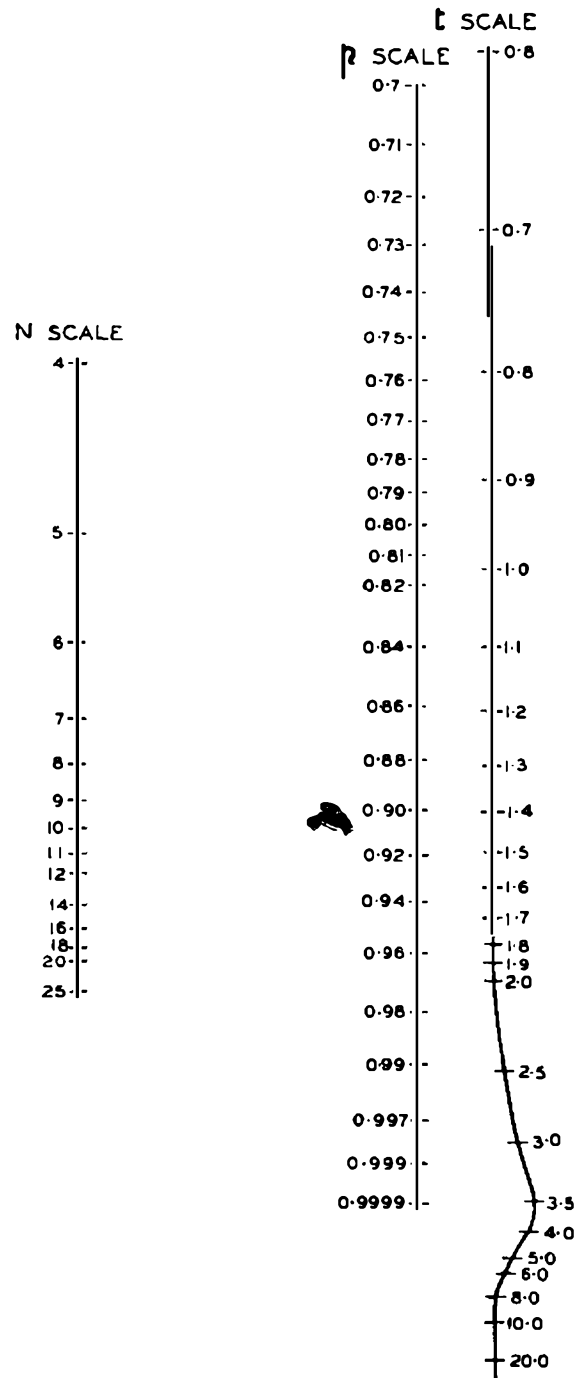

FIG. 2.—PROBABILITY CHART FOR "t" TEST.

that time would be well spent in checking the adjustment of the machine. To make the test, the standard deviation of the sample,  $s$ , must also be calculated (see Appendix to previous article).

Suppose that the  $\bar{x}$  and  $s$  values are 95.2 and 6 mils respectively, then, the next step in the test for significance is to calculate the value of  $t$ , where,

$$t = \frac{\bar{x} - M}{\frac{s}{\sqrt{N-1}}} = \frac{95.2 - 100}{\frac{6}{\sqrt{9}}} = -2.4$$

<sup>6</sup>Copies of the probability chart for applications of the "t" test, to which a table of the 5% and 1% probability limits of  $t$  has been added, can be obtained from the Research Branch of the E-in-C's office.

<sup>7</sup> *Metron.*, Vol. 2, No. 3, 1925.

<sup>8</sup> *Metron.*, Vol. 8, pp. 95-99, 1930.

Reverting to the probability nomograph of Fig. 2, and putting a straight edge between  $N=10$  and  $t=2.4$ , the probability value of 0.98 can be read off from the  $p$  scale. This is the probability that in random samples of the same size the  $t$  values will be less than 2.4. The probability that  $t$  will be greater than 2.4 is therefore  $(1-0.98)$ , or 0.02, and the probability that  $t$  lies outside the range  $\pm 2.4$  is  $2 \times 0.02$ , or 0.04. In other words the probability of picking a random sample of 10 washers with a mean and a standard deviation leading to a  $t$  value greater than 2.4 or less than  $-2.4$  is 0.04. In mathematical notation this may be written as,

$$P(|t| > 2.4) = 0.04,$$

which means that if a large number of samples of 10 were taken, it would be found that, on the average, about 4 samples per 100 had  $t$  values outside the range  $-2.4$  to  $+2.4$ . Consequently it may be inferred that the deviations observed in the sample are not altogether due to chance and that the assumption that the machine is turning out washers having a mean thickness of 100 mils may be wrong. These considerations lead to the discussion of what are to be regarded as "significant probabilities."

#### Significant Probability Table.

At this stage it will be interesting to see how  $t$  behaves in multiple sampling. As an example consider the distribution of  $t$  values obtained from 500 samples of 10 items. The frequency distribution of the  $t$  values obtained from these samples are shown by the dots in Fig. 3, and the solid curve to

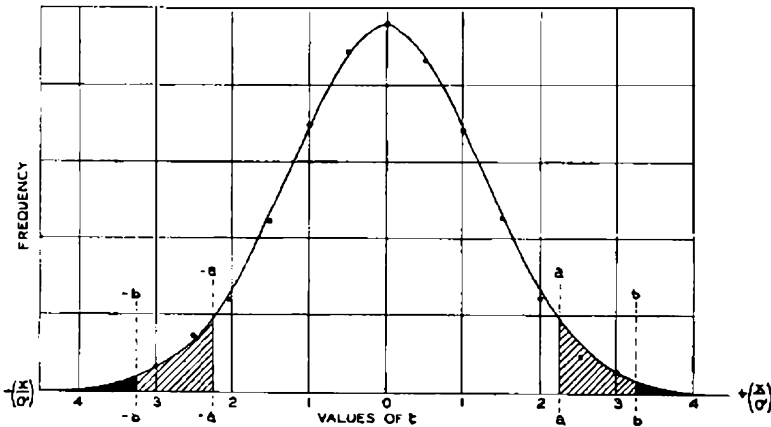

FIG. 3.—THEORETICAL FREQUENCY CURVE DRAWN TO FIT FREQUENCIES OBTAINED FROM 500 VALUES OF "t" IN SAMPLES OF 10.

fit these dots may be calculated from Student's distribution. It will be found that the departure of the  $t$  distribution from the normal distribution is much too small to be noticed. Of the area under the curve only 5 per cent. lies beyond the ordinates erected at  $a$  and  $-a$ , and only 1 per cent. lies beyond

the ordinates erected at  $b$  and  $-b$ . For samples of 10 items the  $t$  value corresponding to  $\pm a$  is  $\pm 2.26$ , the  $t$  value corresponding to  $\pm b$  being  $\pm 3.25$ . It will be seen that only a few values of  $t$  are larger than 2.26 or smaller than  $-2.26$ , and very few values indeed are found to exceed the limits of  $\pm 3.25$ . Nevertheless, these extreme values do occur at times in sampling, but the probability of their occurrence (usually written as  $P(|t| > t)$ ) is very small. Thus, the significance of the mean  $\bar{x}$ , is determined by the value of  $P(|t| > t)$ , which is the probability that, if another sample of the same size be taken, the value  $|t|$  calculated from it will exceed the value calculated from the original sample. If this probability is greater than 5 per cent., then the probability is regarded as "not significant." In other words, the deviations observed in the sample are such as may be ascribed to pure chance. If this probability lies between 1 per cent. and 5 per cent., the deviations may not be due to pure chance, and then the probability  $P(|t| > t)$  is referred to as "significant." If this probability is much less than 1 per cent. the deviations observed are almost certainly not due to chance and the probability is said to be "highly significant." Hence the actual probability limits below which samples are regarded as significant are:—

- (1) ...  $P(|t| > t) \geq 0.05$  ... Not Significant.
- (2) ...  $P(|t| > t) \geq 0.01$  and  $< 0.05$  ... Significant.
- (3) ...  $P(|t| > t) < 0.01$  ... Highly Significant.

Reverting to the sample of 10 washers, it was found that,  $P(|t| > 2.4) = 0.04$ , which is a "significant" probability. In accordance with the above definition, if a sample of 10 items yields a figure for  $t$  greater than 2.262 in absolute value (i.e.,  $|t| > 2.262$ ), the truth of the assumption concerning the value of the mean  $M$  of the sampled population is regarded as doubtful. On an average the absolute value  $|t|$  of 2.262 is exceeded only 5 times per 100 in samples drawn from a homogeneous normal population. For this reason it is referred to as the "5 per cent. level of  $t$  for samples of 10 items." In Fig. 3 only 1 per cent. of the total area under the curve lies beyond the ordinates erected at  $b$  and  $-b$  and this small area is shaded black in the figure. The  $t$  value corresponding to  $\pm b$  is 3.25 and is a value that will be exceeded, on an average, only once per 100 samples. If a sample of 10 items gave a  $t$  value greater than 3.25, the assumption about the value of the mean  $M$  would be abandoned. It will be observed that the distribution of  $t$  changes with the number  $N$  of items in the sample. To meet this difficulty the 5 per cent. and 1 per cent. probability levels of  $|t|$  have been calculated for various values of  $N$  and are given in Table 3.

TABLE 3.

N	5%	1%	N	5%	1%	N	5%	1%
2	12.708	63.657	13	2.179	3.055	24	2.069	2.807
3	4.303	9.925	14	2.160	3.012	25	2.064	2.797
4	3.182	5.841	15	2.145	2.977	30	2.045	2.766
5	2.776	4.604	16	2.131	2.947	35	2.030	2.724
6	2.571	4.032	17	2.120	2.921	40	2.021	2.704
7	2.447	3.707	18	2.110	2.898	50	2.008	2.678
8	2.365	3.499	19	2.101	2.878	60	2.000	2.660
9	2.306	3.355	20	2.093	2.861	80	1.990	2.638
10	2.262	3.250	21	2.086	2.845	100	1.984	2.626
11	2.228	3.169	22	2.080	2.831	200	1.972	2.601
12	2.201	3.106	23	2.074	2.819	1000	1.962	2.581

Confidence Limits.

In the example of the 10 mica washers it was assumed that the mean thickness  $M$  of the population was 100 mils. The  $t$  test showed that the truth of this assumption was doubtful. Instead of making guesses about the true value of  $M$  and applying the  $t$  test to each guess, it is better to determine, from equation (6), the limits of  $M$  required to satisfy given probability conditions. Suppose it is required to be 95 per cent. sure that the mean  $M$  of the population of washers will lie within certain limits. For the 10 items in the sample, the  $t$  value corresponding to a probability of  $(100-95)$  per cent. or 5 per cent. is, from Table 3, found to be 2.262. If, then,  $M$  is taken to satisfy either of the relations,

$$\frac{95.2 - M}{\frac{6}{\sqrt{9}}} = 2.262 \text{ or } \frac{M - 95.2}{\frac{6}{\sqrt{9}}} = 2.262$$

then the value of  $M$  would satisfy the 95 per cent. condition of certainty. These limiting values are 90.676 and 99.724 respectively and consequently the inequality  $90.68 \leq M \leq 99.72$  may be written. If  $M$  were taken as less than 90.68 or greater than 99.72, then  $|t|$ , found from the sample values of  $\bar{x}$  and  $s$ , would exceed 2.262, and the sample would be regarded as inconsistent at the 5 per cent. level of significance. On the other hand, if any value of  $M$  for which  $90.68 \leq M \leq 99.72$  were chosen as a hypothetical mean, then for this choice,  $|t|$  would be less than 2.262 and the sample would be regarded as consistent with such a hypothesis at the 5 per cent. level of significance. But, whatever the true value of  $M$  may be, in repeated samples, simultaneous values of  $\bar{x}$  and  $s$  would be obtained such that  $|t| \leq 2.262$  in 95 per cent. of cases. The values of 90.68 and 99.72 may be called the 95 per cent. confidence limits of  $M$  corresponding to the 10 items in the sample and it may be concluded that,

$$M = (95.2 \pm 4.5) \text{ mils with 95 per cent. confidence.}$$

It is obvious, of course, that the 1 per cent. level of  $t$  may be used to give confidence limits at that level, and it is convenient to notice that the two equations giving the confidence limits can be written in the general form,

$$\frac{\bar{x} - M}{\frac{s}{\sqrt{N-1}}} = \pm t \text{ or } M = \bar{x} \pm \frac{s}{\sqrt{N-1}} \cdot t$$

where  $s/\sqrt{N-1}$  is the estimated standard error.

The Two Mean "t" Test.

R. A. Fisher has shown<sup>9</sup> that Student's distribution can be applied to the solution of a variety of problems beyond that for which it was originally deduced. Of these problems, one that appears quite frequently is the comparison of two samples obtained from different sources. The means may be different and it is then necessary to determine the probability that the difference is due to the samples having been drawn from different populations, or the probability that the samples have been drawn from the same population and that the difference is due to chance. These probabilities may be determined as follows:—

Let  $\bar{x}_1$  and  $\bar{x}_2$  be the means of two samples of  $N_1$  and  $N_2$  items respectively and let  $s_1$  and  $s_2$  be their standard deviations. Then to test for significance, calculate,

$$t = \frac{\bar{x}_1 - \bar{x}_2}{\left( \frac{N_1 + N_2}{N_1 + N_2 - 2} \right)^{\frac{1}{2}} \left( \frac{N_1 s_1^2 + N_2 s_2^2}{N_1 N_2} \right)^{\frac{1}{2}}}$$

and  $N = N_1 + N_2 - 1$ .

By means of the chart the probability that two other similar samples would give a value of  $|t|$  exceeding that given by the samples under consideration can be determined. The significance or otherwise of this probability,  $P(|t| > t)$ , can be found from Table 3.

The following example will illustrate the method.

Samples of rubber insulating material were received from two sources and to determine the amount of mineral matter in each a number of ash content determinations were made. The results were as shown in Table 4.

TABLE 4.—PER CENT. ASH CONTENT.

No.	Source A.	Source B.
1	24.3	18.2
2	20.8	16.9
3	23.7	20.2
4	21.3	16.7
5	17.4	—
Mean	21.5	18

Applying the above test,

for Source A,  $N_1 = 5$ ,  $\bar{x}_1 = 21.5$ , and  $s_1^2 = 6.004$ ,

„ „ B,  $N_2 = 4$ ,  $\bar{x}_2 = 18$ , and  $s_2^2 = 1.945$ .

Substituting these values in the expression for  $t$ ,

$$t = \frac{21.5 - 18.0}{\sqrt{\left( \frac{9}{7} \right) \left( \frac{30.02 + 7.78}{5 \times 4} \right)}} = 2.245$$

$$\text{and } N = 5 + 4 - 1 = 8.$$

For  $t = 2.245$  and  $N = 8$  the chart of Fig. 2 gives  $p = 0.97$  and thus the probability  $P(|t| > 2.245)$  is given by  $2(1 - 0.97)$  or 0.06. Thus there are about 6 chances in 100 of observing a greater difference in percentage ash content, and at the 5 per cent. level of significance we find from Table 3 that for  $N = 8$ ,  $2.245 < 2.365$

and therefore no significant difference has been detected between the two sources on this count.

<sup>9</sup> *Metron.*, Vol. 5, Pt. 3, pp. 100-104, 1926.

# The Economic Design of Manholes

J. P. HARDING, B.Sc.(Eng.)

U.D.C. 621.315.233 : 666.97

## Part II—Reinforced Concrete Theory

This article describes briefly the theories used in the design of the beams and slabs employed in reinforced concrete manhole construction. The final article will give details of manholes constructed in accordance with these design formulae.

### *Novel Forms of Construction.*

IT is possible to devise a manhole, the walls and roof of which could be constructed in unreinforced concrete. It will be shown later that for straight slabs and beams of the same thickness, unreinforced concrete possesses only about one-tenth of the strength in bending of reinforced concrete (reinforced to the "economic" percentage). To realise a strength equal to reinforced concrete, the thickness of unreinforced concrete would require to be about  $2\frac{1}{2}$  times that of reinforced concrete. This is due to the small tensile strength of concrete, and it would be necessary, therefore, to ensure that wall tensile stresses are kept within small limits for this reason.

It can be shown that for a parabolic wall, a uniformly distributed loading will produce zero tensile stress in the wall and, although the wall loadings to which a manhole is subjected in practice are not uniform, the resulting tensile stresses in a parabolic wall would be low and capable of being withstood by the tensile strength of the concrete (unreinforced). It is seen, therefore, that although steel reinforcement could be dispensed with in the walls and floor of a manhole built in this way, a greater quantity of concrete would be required and considerably increased labour costs would be involved in building walls to this form. Moreover, due to the curvature of the walls, most of the wood shuttering would be difficult to set up and would not be recoverable.

In addition, for the same size excavation, the reduced floor space would hinder working and restrict loading coil accommodation in the manhole.

There is nothing to be gained in conserving steel reinforcement at the expense of using perhaps 50 per cent. more concrete in the manhole and, for this reason and in view of the objections to shaped walls previously mentioned, it was decided to pursue a form of reinforced concrete construction utilising vertical straight-sided walls of a strength sufficient to give a reasonable factor of safety at all points taking into account traffic, earth and anchor iron loadings.

### GENERAL THEORY OF BENDING.

It may be of interest to consider the general theory of bending before examining the theory of reinforced concrete.

When a beam of uniform material is subjected to a bending action, the fibres on the upper part of the beam will be in compression and those on the lower part in tension. By considering the forces acting in a small portion of the beam it may be shown that,

$$\frac{f}{y} = \frac{M}{I} = \frac{E}{R} \dots\dots\dots(1)$$

where  $f$  is the fibre stress at a distance  $y$  from the neutral axis.

$M$  is the bending moment.

$I$ , the moment of inertia of the section.

$E$ , the modulus of elasticity of the material of the beam.

$R$ , the radius of curvature.

### *Shear Force in a Beam.*

It is evident that a long shallow beam will, under load, fail in bending, i.e., by failure in fibre stress. A short deep beam, however, is subject to a small bending action and will fail in shear, the centre portion being sheared away from the side portion by the load. The vertical shear force at a point is the total upward force acting to one side of the point.

When a beam bends there is also a horizontal shear force induced in it which, if not resisted, would allow the beam to slide in layers as a series of planks might behave if not strapped securely. Obviously shear failure in this way would cause serious loss of strength.

The horizontal shear forces produced by bending and the vertical shear force at any point in a beam are always equal in magnitude and at right angles to each other.

### *Bending of a Beam of Unreinforced Concrete.*

For a beam of symmetrical section, bending produces equal compressive and tensile stresses on the upper and lower faces respectively. Thus, a beam of steel, which possesses equal strength in compression and tension, would fail in bending from simultaneous failure of the upper fibres in compression and the lower in tension at a stress of about 66,000 lbs./sq. in. (mild steel).

Concrete, however, unlike steel, possesses unequal compressive and tensile strengths, being approximately ten times stronger in compression than in tension. Thus, the compressive stress at failure might be 2,400 lbs./sq. in. and the tensile stress 240 lbs./sq. in. Accordingly, a beam of unreinforced concrete would, under load, fail when the tensile stress reached about 240 lbs./sq. in. If of symmetrical section, as in a rectangular beam or slab, the maximum compressive stress would also be 240 lbs./sq. in. The beam would, therefore, have failed in tension, although capable of withstanding a stress ten times as great in compression.

Clearly, if some means can be adopted by which the low tensile strength of concrete can be augmented, it would be possible to gain full advantage of its superior compressive strength. This may be achieved

by embedding bars able to resist a tensile loading in the portions of concrete in tension. The bars must be so anchored that no slipping is possible between a bar and the surrounding concrete. This may be obtained by the natural bond between the reinforcing material and the concrete or, where this is insufficient, additional anchoring may be secured by forming hooks in the ends of the reinforcing material. The bars must be of a material capable of withstanding the tensile stress imposed. Steel, either mild or high tensile, is used almost exclusively for this purpose, although glass and wood have been used latterly and in some circumstances are found satisfactory.

**THEORY OF REINFORCEMENT.**

*Tensile Reinforcement.*

The theory to be developed is that most commonly accepted and requires certain basic assumptions to be made. The effect of plastic yield in both concrete and steel is ignored. A fixed proportionality between stress and strain in both materials is assumed, which allows the use of constant values for the respective elasticities. When setting concrete shrinks very slightly. The adhesion between the concrete and steel reinforcement therefore produces a small forced contraction in the length of the steel and a similar elongation of the concrete. The extent of these movements and the values of the induced stresses can, if necessary, be calculated from the cross sectional areas of the steel and concrete, the respective elasticities, and the free shrinkage co-efficient of the concrete. The stresses are, however, found to be very small and may be safely neglected. It is fortunate that the linear expansions of steel and concrete are almost equal (steel 0.000065/°F, concrete 0.000061/°F). Relative stresses caused by temperature changes are, therefore, small and will be ignored.

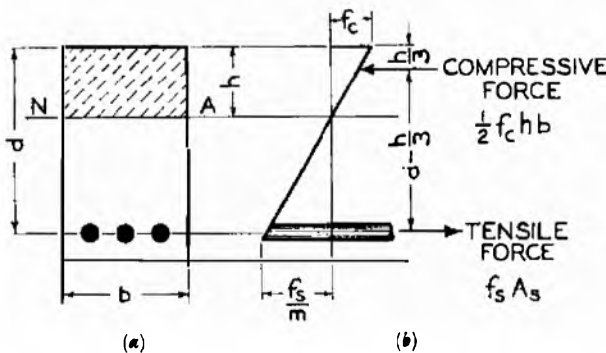

FIG. 1.—STRESS DIAGRAM.

Consider the reinforced concrete beam shown in Fig. 1(a). The effective depth of the beam ( $d$ ) is taken from the top of the beam to the centre of the reinforcement at the bottom, the concrete below this level serving only as cover for the steel reinforcement. When the beam is under load, the steel reinforcement will accept the total tensile force below the neutral axis NA, and the concrete the

total compressive force above it, the tensile strength of the concrete below the neutral axis being neglected.

- Suppose the permissible tensile stress in the steel is  $f_s$ ,
- the permissible compressive stress in the concrete is  $f_c$ ,
- the elasticity of steel is  $E_s$ ,
- the elasticity of concrete is  $E_c$ ,
- the ratio of elasticity  $\frac{E_s}{E_c} = m$ ,
- the total sectional area of steel reinforcement is  $A_s$ .

Since the compressive stress in the concrete varies uniformly from zero at the neutral axis to a maximum of  $f_c$  at the top face of the beam, the average stress will be  $\frac{1}{2}f_c$  acting at a point  $\frac{2}{3}h$  above the neutral axis.

For equilibrium, the total compressive force in the concrete above the neutral axis must equal the total tensile force in the steel below the neutral axis.

$$\therefore \frac{1}{2}f_c b h = f_s A_s \dots \dots \dots (2)$$

From similar triangles in Fig. 1(b)

$$\frac{h}{d-h} = \frac{f_c}{f_s/m}$$

Denoting  $h/d$  by  $k$ ,  $k = \frac{1}{1 + \frac{f_s}{m f_c}} \dots \dots \dots (3)$

If now  $A_s$ , the section of steel be expressed as a fraction  $p$  of the effective area of the beam  $A_s = p b d$ .

Using this relation in equation (2) and putting  $h = kd$

$$\frac{f_s}{f_c} = \frac{k}{2p}$$

Inserting in equation (3)  $k = \frac{1}{1 + \frac{k}{2pm}}$

i.e.  $k^2 + 2 pmk - 2 pm = 0$

and  $k = \sqrt{p^2 m^2 + 2pm} - pm \dots \dots \dots (4)$   
(the -ve root is inadmissible since  $k$  would then be -ve).

Also the total internal resisting moment supplied by the concrete and steel together must equal the externally applied moment  $M$ .

$$\therefore M = \frac{1}{2}f_c h b (d-h/3) = f_s A_s (d-h/3) \dots \dots \dots (5)$$

If  $Q$  be substituted for  $f_s p (d-h/3)/d$  or  $\frac{1}{2}f_c h (d-h/3)/d^2$  then  $M = Q b d^2 \dots \dots \dots (6)$

For purposes of design, the allowable working stresses in the steel and the concrete  $f_s$ ,  $f_c$  and the modular ratio ( $m$ ) will be known and  $Q$  therefore fixed.

It is instructive to examine the values assumed by  $Q$  with variations in the percentage ( $p$ ) of steel reinforcement. Fig. 2 is a plot of  $Q$  with various values of  $f_s$ ,  $f_c$  and for a fixed value of  $m=15$ . The

variation in  $k$  which governs the position of the neutral axis is also shown.

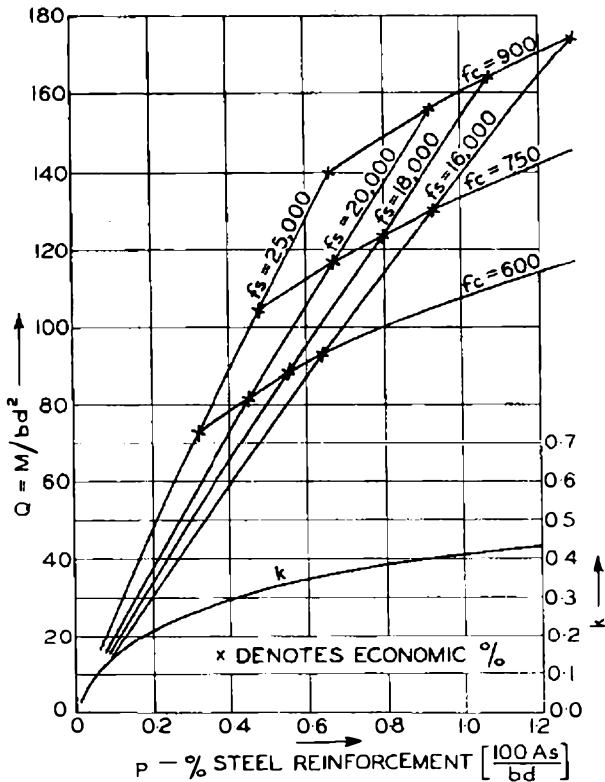

FIG. 2.—VALUES OF  $Q$  AND  $k$  WITH VARIATIONS IN  $f_s$  AND  $f_c$ ;  $m = 15$ .

$Q$  is seen to be a measure of the overall strength of the reinforced concrete for the particular values of  $f_s$ ,  $f_c$  and  $m$ . It is of interest to examine the effect of changes in the density of reinforcement on the strength of the section. Suppose, for example, that a beam or slab is to be designed for maximum permissible stresses  $f_s$  and  $f_c$  of 20,000 and 750 lbs./sq. in. respectively. It is seen that at first the strength of the section increases uniformly with increase in reinforcement, the stress in the concrete increasing also, and the stress in the steel remaining constant at 20,000 lbs./sq. in.

The initial rate of increase in strength is only maintained, however, until the stress in the concrete reaches its maximum permissible stress of 750 lbs./sq. in. At this point, for which  $p = 0.67$  per cent., the stresses in both concrete and steel have assumed their respective maximum permissible values and the particular percentage of steel at which these conditions obtain is called the "economic percentage." Further increase in the steel beyond this point still causes an increase in strength but at a much lower rate, and the stress in the steel is now decreasing, whereas the stress in the concrete is maintained at its maximum permissible value of 750 lbs./sq. in. It is seen that for any design in which maximum values of  $f_s$  and  $f_c$  are fixed there will be a certain value of  $p$  for reinforcement to the economic percentage.

#### Values of $f_s$ and $f_c$ employed.

It is not possible owing to the disconnected character of manhole construction to make detailed measurements of the strength of the materials to be used on site or to employ a resident engineer to supervise the construction. Moreover, the materials used are necessarily those available locally and cannot always be relied upon to conform to the stringent conditions which must be met to realise a high ultimate strength. It is also nearly always necessary with the 1:2:4 mix used on P.O. work to sacrifice a little strength by using more water so as to obtain a workable consistency. Finally, a further handicap is imposed by working below ground, since it is almost impossible to prevent a certain contamination of the concrete by dust and dirt. These limitations entirely preclude the use of a high working stress such as 850 or 900 lbs./sq. in., figures now commonly used on closely supervised over-ground structures. The rather low figure of 600 lbs./sq. in. has, accordingly, been decided upon as one which may reasonably be expected of concrete used on P.O. work.

The corresponding maximum working value for steel is fixed from quite different considerations. Steel can be relied upon to accept a uniform working load depending upon its quality, whether mild or high tensile. It is necessary only to find the working stress which will allow of the greatest conservation of both steel and concrete.

Referring to Fig. 2, it will be seen that for  $f_s = 18,000$  lbs./sq. in. (mild steel),  $f_c = 600$  lbs./sq. in. and for reinforcement to the economic percentage, the value of  $Q$  is 89 and  $p = 0.56$  per cent. Suppose now high tensile steel ( $f_s = 25,000$  lbs./sq. in.) be substituted in reduced section so as to give the same tensile force, the corresponding value of  $p$  will be  $\frac{18,000}{25,000} \times 0.56 = 0.40$  per cent. For this value of  $p$ ,  $Q = 78$ . The strength of the section when reinforced in this way is therefore  $78/89 = 88$  per cent. of its initial value, whereas  $18,000/25,000 = 72$  per cent. of the original quantity of steel has been used. To realise the same strength as before, i.e. a value for  $Q$  of 89, the percentage of high tensile steel would need to be 0.56 per cent. as for mild steel and no saving in steel will have been made.

It is therefore fallacious to suppose that a smaller section of high tensile steel than mild steel may be used in a structure designed for the latter while maintaining the same strength. Economy in steel can be made by the use of high tensile steel only if an additional thickness of concrete be used, and, even in this instance, the financial saving will be little or nothing from the increased cost of high tensile steel over mild steel. It has been shown that the greatest economy of steel and concrete is realised when the former is employed at its economic percentage. The economic percentage for  $f_s = 25,000$  lbs./sq. in.,  $f_c = 600$  lbs./sq. in. is 0.32 per cent. The value of  $Q$  for this percentage is 72.5. It is not possible economically to alter this value of  $Q$ , as has been explained, but the effective strength of the section may be augmented by using an increased depth of

concrete and a proportionate increase in steel. Equation (6) shows that the strength of a reinforced concrete section is proportional to the square of the depth. To increase the strength of a section in the ratio 72.5 : 89, the corresponding increase in depth

will therefore be  $\sqrt{\frac{89}{72.5}} = 11$  per cent. The amount of steel used will be  $0.32 \times \frac{11}{100} = 0.36$  per cent. This value is less than 0.56 per cent., the quantity needed for reinforcement by mild steel, and a saving of steel has therefore been made, but only at the expense of an increase in the thickness of concrete of 11 per cent.

For manhole construction, both on account of increased excavation costs and from the use of more concrete, this additional thickness in the wall or slab is uneconomic and far outweighs the slight saving of steel reinforcement.

*Part Compression Reinforcement.*

It has been shown in Fig. 2 that reinforcement beyond the economic percentage is wasteful in steel since the strength of the section is limited by the maximum permissible stress in the concrete. As an alternative to increasing the depth of a beam or slab where additional strength is required, it is possible to reinforce the concrete in compression by placing steel above the neutral axis, as in Fig. 3(a). If the concrete is still to be relied upon for compressive strength, its stress must not exceed its

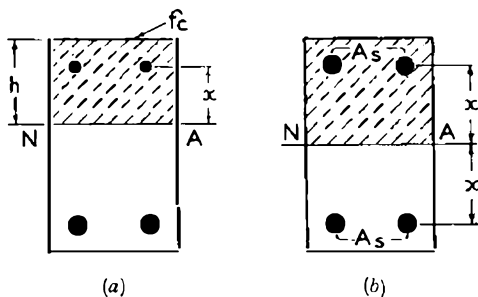

FIG. 3.—PART COMPRESSION (a) AND FULL COMPRESSION (b) REINFORCEMENT.

maximum permissible value  $f_c$ , when from Fig. 3(a) it is seen that the corresponding steel stress will be  $\frac{x}{h} f_c m$ . For a value of  $f_c$  of 600 lbs./sq. in.,  $m$  of 15, and  $x/h$  of  $\frac{2}{3}$ , the steel stress will be  $\frac{2}{3} \times 15 \times 600 = 6,750$  lbs./sq. in., which may only be about  $\frac{1}{3}$  of the normal permissible stress. The compression reinforcement is, therefore, working inefficiently and, although this method is sometimes used to gain a small increase in strength in a given concrete section, it is usually more economic in steel and concrete to reinforce in full compression.

*Full Compression Reinforcement or Double Reinforcement.*

In this method, the compressive strength of the concrete is ignored, it being assumed that the steel for compression reinforcement accepts the whole

of the compressive loading. The steel is then assumed to operate at its maximum working value of, say, 18,000 lbs./sq. in. Steel is, therefore, provided in equal section at the top and bottom of the beam as in the flanges of a steel joist. Although the concrete in beams reinforced in this way will, when the beam is under load, have failed in both compression and tension, experience has shown that doubly reinforced beams are quite satisfactory so long as the steel section in either flange does not exceed more than about 2½ per cent. of the total concrete section.

With the nomenclature of Fig. 3(b) the bending moment (M) of the beam is given by

$$M = 2f_s A_s x \dots \dots \dots (7)$$

Doubly reinforced beams are particularly suitable for supporting the frame and cover in manhole construction since, being more compact than a singly reinforced beam of equal strength, they take up less headroom. Moreover, not relying on any specific working stress in the concrete, such beams are immune from changes in their factor of safety arising from the use of inferior concrete.

*Shear Reinforcement.*

The existence of shear stress in a loaded beam has already been explained. It is necessary to examine any reinforced concrete beam to ensure that the shear stresses induced can be safely withstood.

It has been stated that the horizontal and vertical shear forces in a beam are equal. The resultant shear force will therefore be along a line inclined at 45°, as shown in Fig. 4. Unless the concrete itself is able to withstand the shear forces induced, stirrups or bent-up bars or both must be used to provide adequate reinforcement. The diagonal shear force will be  $\sqrt{2}$  times the vertical force, and if bent bars are used, the latter must, at their normal working stress, together be capable of resisting this force.

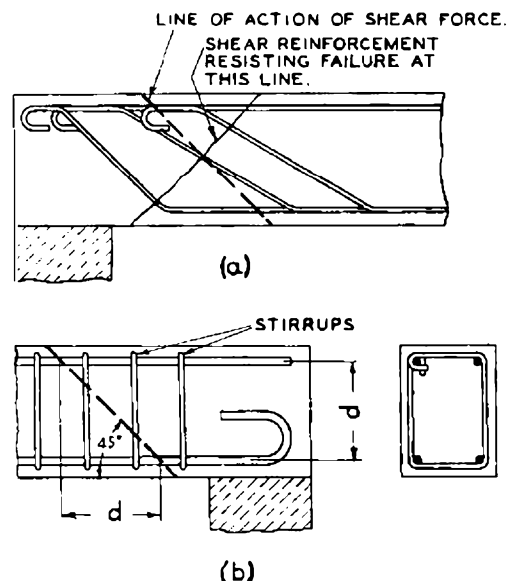

FIG. 4.—SHEAR REINFORCEMENT.



If stirrups are used, these must be of a sufficient section to accept the vertical shear force. If the section of the rod of a stirrup is  $S_s$  and its working stress  $f_s$ ,  $n$  stirrups will accept a load of  $2nf_s S_s$ . Equating this to the vertical force  $F$

$$F = 2nf_s S_s \text{ or } n = \frac{F}{2f_s S_s} \dots\dots\dots(8)$$

For a doubly reinforced beam, the spacing of the stirrups must be such that this number ( $n$ ) of stirrups occurs in the distance  $d$ , the spacing being  $d/n$ . Experience has shown that it is best to choose  $S_s$  so that the spacing of the stirrups lies between  $\frac{1}{3}d$  and  $\frac{2}{3}d$ .

**Bond Stress and Minimum Grip Length.**

When a steel bar is embedded in concrete the latter in setting shrinks and provides a certain bond stress between the steel and concrete from adhesion and friction. The steel must be free from loose rust, scale, grease or paint for the development of a satisfactory bond.

For any diameter of round steel bar, there will be a certain length which, if embedded in concrete, will just slip out before failing itself in tensile loading. This length is called the minimum grip length and will, obviously, depend upon the diameter of the bar, being small for a wire and large for a thick bar.

If "d" be the diameter and "L" the length of a bar embedded in concrete :--

The permissible tensile loading =  $f_s \cdot \pi \cdot \frac{d^2}{4}$

The permissible force permitted by the bond strength =  $S_b \cdot \pi \cdot d \cdot L$ , where  $S_b$  is the permissible bond strength in lbs./sq. in.

These forces will be equal  $\therefore \frac{f_s \pi d^2}{4} = S_b \cdot \pi \cdot d \cdot L$

and the minimum grip length  $L = \frac{f_s d}{4S_b} \dots\dots(9)$

This equation is not strictly accurate in so far as it assumes a constant value of  $S_b$  throughout the length of the bar. This is not true except for the less usual condition of a constant bending moment. The permitted bond stresses are, however, based on the use of this equation which is found satisfactory in practice.

For the particular grades of concrete and steel to be used in the ensuing designs :--

$f_s = 18,000$  lbs./sq. in. and  $S_b = 120$  lbs./sq. in.

Whence  $L = \frac{18,000d}{4 \cdot 120} = 37.5d \dots\dots(10)$

Where it is found impossible to accommodate this total length the natural bond may not provide a sufficient anchorage. In these instances additional anchorage may be provided by the use of a hook of the dimensions shown in Fig. 5. Such a hook can be reckoned to have an anchorage equivalent to a straight rod of length of  $14d$ .

The use of manipulated bars of irregular section permits a slightly increased bond strength ( $S_b$ ) to be employed; such bars are, however, almost

invariably of work-hardened steel and are operated at a higher tensile stress ( $f_s$ ) than mild steel. Equation (9) shows that the minimum grip length for a bar is proportional to  $\frac{f_s d}{S_b}$ , and in those instances where the proportionate increase in  $S_b$  is less than that in  $f_s d$ , the minimum grip length may be actually greater for a deformed bar than for a mild steel bar of equivalent tensile strength. For this reason the employment of bars of irregular section may confer little or no advantage in bond strength.

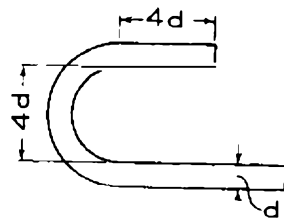

FIG. 5.—HOOK FOR ADDITIONAL ANCHORAGE.

**DESIGN OF SLABS.**

It has been shown in the previous article that the walls, floor and roof of a manhole are subject to distributed loads, and the walls also to concentrated loads from anchor iron pulls.

It is necessary, therefore, to find the bending moment produced in either direction in a slab under the action of distributed and concentrated loads in order that the thickness of concrete and the reinforcement required in each direction may be determined.

It is not possible to ascertain the bending moment in one direction on the basis that the uniform loading acts on a narrow strip in that direction since, depending on the dimensions of the slab, only a certain fraction of the load will be carried in each direction. Moreover, the action of strips in either direction is not an independent one.

**Determination of Bending Moment Due to Distributed Loads.**

A theory for determining the bending moments produced by distributed loads, taking these factors into account, has been developed by Dr. Marcus, and is briefly as follows :--

*Marcus' Theory for Slab Design.*—This method, which is widely used in this country and on the continent, consists in dividing the slab into two series of strips parallel to the sides of the slab and deducing the load carried in either direction by equating deflections of strips at mid-span.

Assume a rectangular slab of dimensions  $L_x$ ,  $L_y$  is subjected to a total loading  $\omega$  lbs./sq. in. (Fig. 6). If the slab were freely supported by the longer supports only, the bending moment would be  $\frac{\omega L_x^2}{8}$ , and if by the shorter supports only,  $\frac{\omega L_y^2}{8}$ .

Suppose now that the slab is freely supported on all four edges and the uniform load  $\omega$  be assumed to be divided in the direction  $L_x$  and  $L_y$ ,  $\omega_x$  being the proportion of load carried in the direction  $L_x$ , and  $\omega_y$  in the direction  $L_y$ , the division between  $\omega_x$

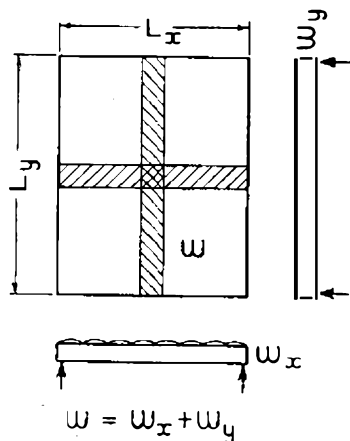

FIG. 6.—LOADED CONCRETE SLAB.

and  $\omega_y$  being such as to produce equal deflections of the two centre strips where they join.

Then  $\omega = \omega_x + \omega_y$

Equating deflections at mid-span

$$\frac{5}{384} \cdot \frac{\omega_x L_x^4}{EI_x} = \frac{5}{384} \cdot \frac{\omega_y L_y^4}{EI_y}$$

and assuming  $I_x = I_y$  (it can be shown that differences in density of reinforcement in the directions  $L_x$  and  $L_y$  do not appreciably affect this equality).

$$\therefore \omega_x = \frac{\omega L_y^4}{L_x^4 + L_y^4}$$

$$\text{and } \omega_y = \frac{\omega L_x^4}{L_x^4 + L_y^4}$$

$$\text{thence } M_x = \frac{\omega L_x^2 \cdot L_y^4}{8(L_x^4 + L_y^4)} \dots \dots \dots (11)$$

$$M_y = \frac{\omega L_y^2 L_x^4}{8(L_x^4 + L_y^4)} \dots \dots \dots (12)$$

These moments are those which would be produced in a freely supported slab at its centre. Such a slab would, however, lift at its corners from the torsional moment exerted by strips in one direction on those in the other. When the corners of a slab are prevented from lifting by corner reinforcement or other means, there is a small increase in rigidity. It can be shown that the moments  $M_x$  and  $M_y$  may be reduced by the correction factors,  $1 - \frac{5M_x}{6M'_y}$  and  $1 - \frac{5M_y}{6M'_x}$  respectively where  $M'_x$ ,  $M'_y$  are the bending moments in the directions  $L_x$ ,  $L_y$ , if the total slab load  $\omega L_x L_y$  were carried by reinforcement in one direction only.

$$\text{Thus } M'_x = \omega L_y^2 / 8$$

$$M'_y = \omega L_x^2 / 8$$

By embodying these correction factors and the terms  $\frac{L_y^4}{(L_x^4 + L_y^4)}$ ,  $\frac{L_x^4}{(L_x^4 + L_y^4)}$  from equations (11), (12) in the constants  $C_x$  and  $C_y$ , the maximum moments for a freely supported slab with corners anchored may be expressed:—

$$M_x = C_x \frac{\omega L_x^2}{8}, M_y = C_y \frac{\omega L_y^2}{8} \dots \dots (13)$$

The values of the constants  $C_x$  and  $C_y$  for a slab supported as described are given in Fig. 7.

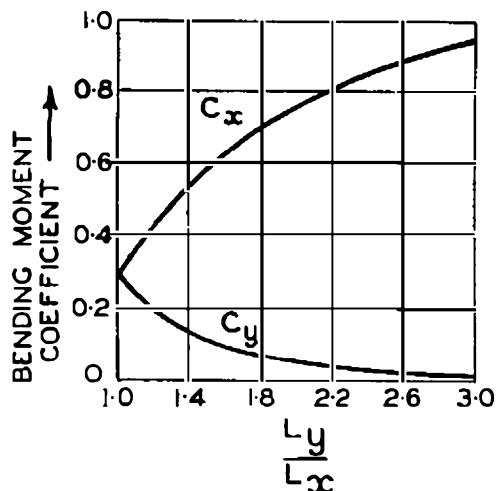

FIG. 7.—BENDING MOMENT COEFFICIENTS FOR FIXED SLABS.

*Determination of Bending Moments due to Concentrated Loads.*

The mathematical determination of the moments produced in slabs by concentrated loads is involved and laborious. Although the fundamental equations were deduced by Lagrange over two hundred years ago, it was not until 1921 that M. Pigeaud published the results of calculations by which the design of slabs for concentrated loads was presented in a form suitable for use by engineers. It may be mentioned that the design of slabs on this basis permits the use of considerably smaller sections than would be needed on the basis of the early empirical formulæ.

When a concentrated load acts upon a slab, the deflection contours or lines of equal deflection are circular in the immediate region of the load, no matter what may be the shape of the slab. The contours, in spreading to the supports, depart from their circular form and assume a shape more resembling the line of the restrained slab edges. The formation of circular contours in the immediate vicinity of the load in a rectangular panel is of considerable importance, since it means that the bending moments induced at that point in either direction may be nearly equal.

*Load Spread.*—A concentrated load acting on a slab will operate over a greater area than its area of contact, the precise "spread" depending upon the dimensions of the load and the size and thickness of the slab.

Suppose the concentrated load, Fig. 8, acts on a rectangular area of dimensions  $a$ ,  $b$ , and the thickness

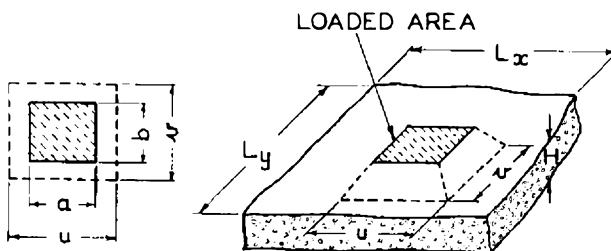

FIG. 8.—SPREAD OF A CONCENTRATED LOAD.

of the slab is  $H$ , the load is assumed to spread itself through the thickness of the slab over an area of dimensions  $u$ ,  $v$ , where—

$$u = \sqrt{c^2 + H^2}$$

$$v = \sqrt{b^2 + H^2}$$

*Determination of Bending Moments.*—It will not be necessary to include in this article the mathematical theory or detailed graphical work given by M. Pigeaud. Accordingly, a summary has been made of the relevant curves and is embodied in Fig. 9.

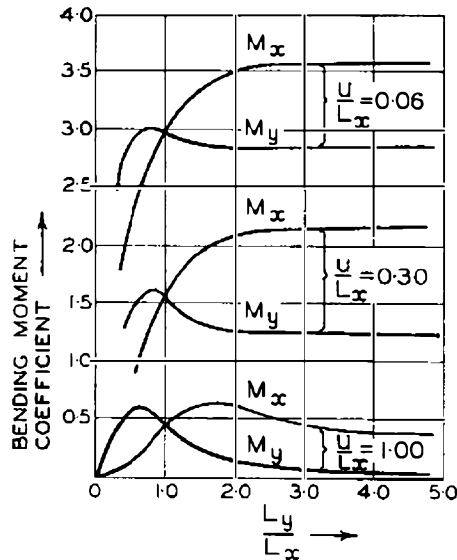

FIG. 9.—BENDING MOMENT COEFFICIENTS FOR SLABS (CONCENTRATED LOADS).

A family of curves has been drawn for various ratios of  $u/L_x$  which has, for simplicity, been assumed equal to  $v/L_y$ .

The method of use is as follows:—

From the curves of  $M_x$  and  $M_y$ , appropriate to the ratio of  $u/L_x$  and the ratio of slab sides, the values of the bending moment co-efficient may be read. The corresponding values for uniform loading, i.e. when  $uL_x/vL_y = 1$ , may also be read and the ratios of the bending moment co-efficients for the concentrated load to those for the same load if uniformly distributed, may be found.

The method of deducing the bending moments produced in either direction in a slab when subjected to a uniform loading has already been given, and it is seen therefore that the moment produced by a concentrated load may readily be assessed by multiplying the moments due to uniform loading by the ratio of bending moment co-efficient for concentrated and uniform loading derived from Fig. 9.

The method described is applicable only in those instances where the load is symmetrically disposed in relation to the edges of the slab, when the maximum moments will be produced. A certain reduction based on experience may be made when calculating the moments induced in a slab if unsymmetrically loaded.

### Estimation of Degree of Fixity of Edges of a Slab.

In determining the bending moment, account must be taken of the varying degrees of fixity which may be provided by the different edges of the slab. It can be shown, for example, that a slab if fixed at all four edges is able to bear a considerably greater load than if freely supported on four edges. In a manhole, the walls, floor and roof are neither freely supported nor wholly fixed, but are subject to a degree of fixity intermediate between these conditions. The particular degree of fixity of a slab edge depends upon the dimensions, moment of inertia and fixing of the supporting slabs. Thus the end wall of the manhole shown in Fig. 10 is almost fully fixed in a vertical plane from being supported at its upper end by a short and stiff roof slab terminating in a stout fixed beam, and at its lower end by the floor. The same end wall is, however, more nearly freely supported with regard to bending in a horizontal plane since the supporting side walls are longer than the width of the end wall and may not derive appreciable fixity from the earth at the back.

The valuation of the particular degree of fixity to which a slab is subjected and the method of employing this in the slab theory already described is given below:—

Consider the effect of a side load such as the earth or induced traffic loading on one wall of a manhole, Fig. 10. Assuming adequate corner reinforcement has been provided at the edges of adjacent slabs, and if the earth is not tightly packed against

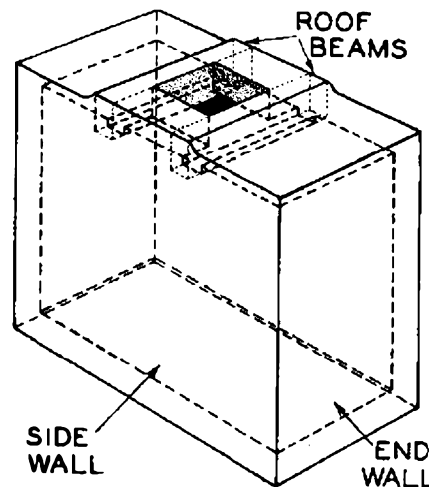

FIG. 10.—ISOMETRIC VIEW OF MANHOLE.

the manhole walls the deflection of the central strips in the loaded wall, roof (neglecting, at this stage, cover and roof beams), opposite wall and floor would approximate to those shown (exaggerated) in Fig. 11(a). The corresponding bending moment diagram is shown in Fig. 11(b). In practice, the precise curvature assumed by the slabs would naturally be limited by the degree of back pressure produced by the earth back filling. Moreover, it is unlikely that a side loading on one wall would transmit an appreciable loading to the opposite wall by virtue of thrusting it against its back filling, since this pressure would

be opposed by the tangential friction arising from the normal earth pressure on the joining walls, roof and floor. The deflections (exaggerated) and the bending moments would, in practice, approximate to those shown in Fig. 13(c) and (d). It may be pointed out at this stage that in the manholes to be described, other considerations necessitate the employment of a

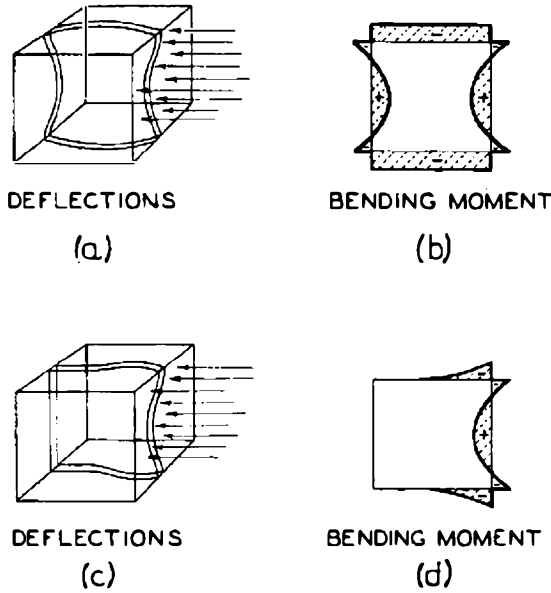

FIG. 11.—DEFLECTIONS AND BENDING MOMENTS FOR SIDE LOAD ON MANHOLE WALL.

certain amount of reinforcement in the outside of slabs which reinforces them against bending outwards and provides a safeguard in those instances where little or no support is provided by the earth back filling.

It has been previously explained that the degree of fixity of a slab depends upon its own moment of inertia and dimensions and also the dimensions, fixity and moment of inertia of the supporting slabs.

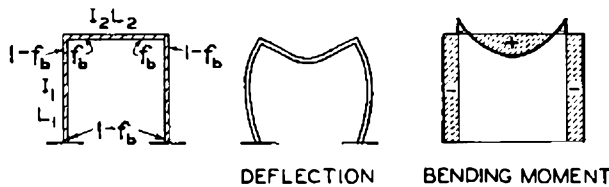

FIG. 12.—DEGREE OF FIXITY OF SLAB EDGE OR BEAM.

The degree of fixity of a slab edge or beam may be estimated in the following way:—

Fig. 12 shows a beam of length  $L_2$  and moment of inertia  $I_2$ , rigidly fixed at each end to columns of corresponding values  $L_1$  and  $I_1$ . Suppose the degree of fixity of the beam relative to the columns is  $f_b$ . The degree of fixity of the columns relative to the beam will be  $1-f_b$  (at both ends). The stiffness of a beam or column is directly proportional to its moment of inertia and inversely proportional to its length.

The degree of fixity provided by a support is directly proportional to its stiffness:—

$$\text{hence } \frac{\text{Stiffness of beam}}{\text{Fixity provided by beam}} = \frac{\text{Stiffness of column}}{\text{Fixity provided by column}}$$

$$\text{i.e. } \left( \frac{I_2}{L_2} / 1-f_b \right) = \frac{I_1}{L_1} / f_b$$

$$\text{or } f_b = \frac{1}{1 + \frac{I_2 L_1}{I_1 L_2}} \dots \dots (14)$$

Values of  $f_b$  for different values of  $I_1/I_2$  and  $L_2/L_1$  are shown graphically in Fig. 13.

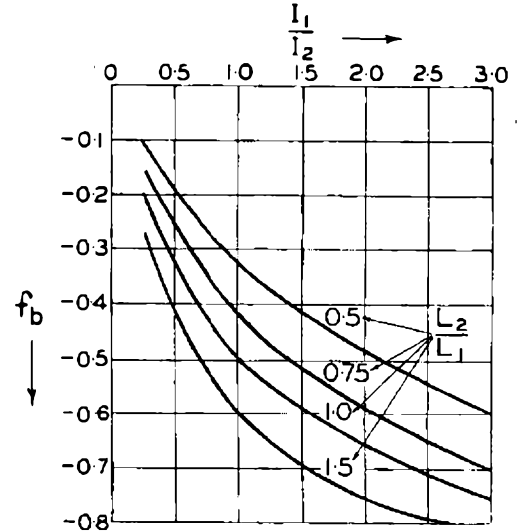

FIG. 13.—CURVES SHOWING RELATION BETWEEN  $f_b$  and  $I_1/I_2$ .

These values of  $f_b$  are those which would be realised, for example, in a rectangular culvert of indefinite length or in a manhole if the unloaded walls were removed. As an example, the value of  $f_b$  for a square culvert with walls, floor and roof of equal thickness can be seen to be  $-0.5$  by using the curve for  $L_2/L_1=1.0$  and taking the value at  $I_2/I_1=1.0$ . The normal "free" bending moment which would be produced in the wall if freely supported would be  $\frac{\omega L^2}{8}$ ; the degree of fixity of  $-0.5$  means that the negative corner moment is  $-0.5$  of its maximum value of  $\frac{\omega L^2}{12}$  i.e.  $\frac{\omega L^2}{24}$ , and the central bending moment is  $\frac{\omega L^2}{8} - \frac{\omega L^2}{24} = \frac{\omega L^2}{12}$ .

In this instance the central bending moment is seen to be 50 per cent. less than the moment in a freely supported span.

*Final Estimation of Slab Moments in either Direction.*

To estimate the central and corner moments in a manhole wall or roof slab where the slab is partly restrained on each edge, it is necessary to use the values of the degree of fixity obtained from Fig. 13 in conjunction with the "free" values of moments for slabs given from Fig. 7. The method adopted is

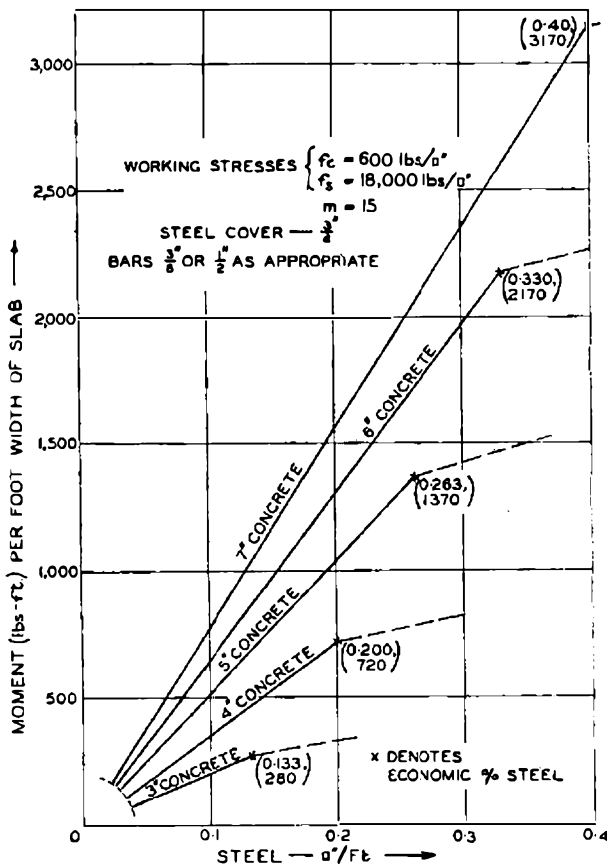

FIG. 14.—RESISTANCE MOMENTS FOR CONCRETE SLABS REINFORCED WITH STEEL.

first to find from Fig. 7 the "free" moments in either direction from a knowledge of the slab dimensions on the basis of the slab being freely supported. Secondly, the respective values of  $f_b$  may be deduced from Fig. 13 for the degree of fixity in either direction using appropriate values of  $L_1$ ,  $L_2$ ,  $I_1$  and  $I_2$ . The values of  $f_b$  may then be used to ascertain, from the "free" moments already found, the actual central and corner moments produced in either direction under the particular degree of fixity existing. The separate determination

in this way of moments in either direction is not strictly accurate, since a variation in the degree of fixity of a slab edge in one direction produces a redistribution of moments and a change in the loading on the slab in the other direction. It may be shown, however, that for the slabs of a manhole where there are not extreme differences in the degree of fixity of the different edges, the error introduced is small. It is considered that the method evolved is justified, more particularly since an exact mathematical investigation of the mechanics of slabs when restrained fully or partly along their edges has so far only been made for the more simple cases.

#### Reinforcement of Slab.

Having found the bending moments produced in a slab in either direction, it is now necessary to deduce the thickness of concrete needed and the reinforcement required in each direction. It is convenient in the design of slabs to consider the bending moment of a unit width of the slab, usually 1 ft. The value of  $M$  in lbs. ft. per foot width of slab corresponding to the density of reinforcement employed has been plotted from equation (6) for different thicknesses of concrete and is shown in Fig. 14. The thickness of concrete required will, naturally, be governed by the greater bending moment and may be obtained directly from Fig. 14. The reinforcement needed in this direction may be read at the same time. To meet the lesser bending moment, the density of reinforcement needed in the other direction may also be found from Fig. 14 using the curve appropriate to the thickness of concrete decided upon. The reinforcement against the central positive bending moment will be placed on the inside of the wall or roof and that for the negative corner moment on the outside. The latter must extend at least to the point of contraflexure, which, for a beam fully fixed at its ends, is at a distance  $0.21L$  (approximately one-fifth) from the end, where  $L$  is the length of the beam. Since in practice the slab edges are not fully fixed, the point of contraflexure will be at a less distance from the end than this depending upon the degree of fixity at the end. The length of corner reinforcement needed may, accordingly, be obtained with sufficient accuracy by interpolation from the actual degree of fixity existing.

# Long Distance Position Finding by D.F. F. ADDEY, B.Sc., F.R.A.S., M.I.E.E.

U.D.C. 621.396.663

In a recent article in this Journal a simple method of calculating the great circle bearing between two stations was described. The present article extends this method of calculation to give the latitude and longitude of the distant station.

THE ordinary method of fixing the position of a transmitting station on which bearings have been taken by two D.F. stations is by drawing on a chart the observed lines of bearing through the positions of the D.F. stations concerned. The point of intersection of these lines is the required position of the transmitting station.

It sometimes happens, however, that the distance of the transmitting station from the D.F. stations is so great that the lines of bearing do not intersect on any available chart. The position of the point of intersection must then be found by calculation.

Let P and Q, Fig. 1, be the two D.F. stations, the positions of which are known, and R the transmitting station of which the position is required. N is the north pole of the earth.

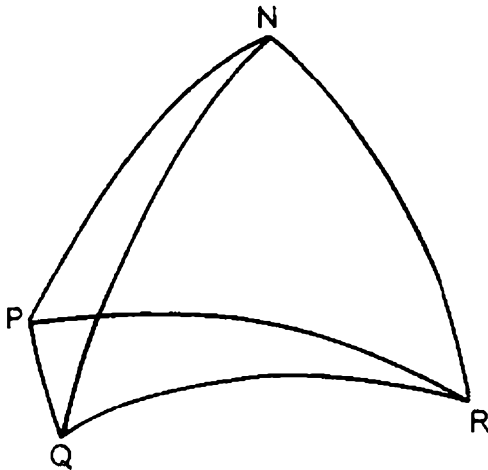

FIG. 1.

The angles NPR and NQR have been observed. It is required to find the latitude and longitude of R.

An outline of the steps in the calculation is first given, in order that the reader may more easily follow the subsequent detailed discussion.

(1) In the triangle NPQ the side PQ is calculated from the given data.

(2) In the triangle PQR, PQ has been found and the angles QPR and PQR are calculated from the given data. PR is then calculated.

(3) In the triangle NPR, from the known values of NP, PR and the angle NPR, NR is calculated. This gives the latitude of R.

(4) Then from the triangle NPR, knowing NR, PR and the angle NPR, the angle PNR is calculated. PNR is the difference in longitude between P and R. The longitude of P is known, so that the longitude of R can be found.

The formulæ used in the calculations are given below. The proofs of these formulæ can be found in any book on spherical trigonometry.

In the spherical triangle ABC, Fig. 2 :—

$$\cos a = \cos b \cdot \cos c + \sin b \cdot \sin c \cdot \cos A \quad \dots (A)$$

$$\cos c \cdot \cos A = \sin c \cdot \cot b - \sin A \cdot \cot B \quad \dots (B)$$

$$\text{and } \frac{\sin a}{\sin b} = \frac{\sin A}{\sin B} \quad \dots (C)$$

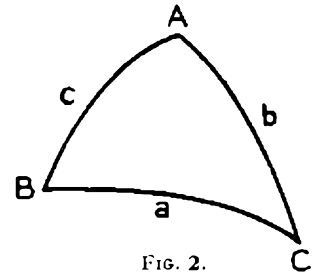

FIG. 2.

(1) PQ is found by formula (A).

$$\cos PQ = \cos PN \cdot \cos QN + \sin PN \cdot \sin QN \cdot \cos PNQ$$

$$PN = 90^\circ - \text{latitude of P,}$$

$$QN = 90^\circ - \text{latitude of Q,}$$

and PNQ is the difference in longitude between P and Q.

Therefore :—

$$\cos PQ = \sin \text{lat P} \cdot \sin \text{lat Q} + \cos \text{lat P} \cdot \cos \text{lat Q} \cdot \cos \text{d. long PQ} \quad \dots (1)$$

This gives PQ.

(2) The angles NPQ and NQP are calculated from the known positions of P and Q by the method given in the *P.O.E.E. Journal*<sup>1</sup>.

In the triangle PQR, the angle QPR, which is NPQ — the observed angle NPR, the angle PQR, which is NQP + the observed angle NQR, and the side PQ are known. The side PR is then obtained by applying formula (B) :—

$$\cos PQ \cdot \cos QPR = \sin PQ \cdot \cot PR - \sin QPR \cdot \cot PQR \quad \dots (2)$$

Thus PR is known.

(3) In the triangle NPR the sides NP and PR and the angle NPR are known. The side NR is then obtained by using formula (A) :—

$$\cos NR = \cos NP \cdot \cos PR + \sin NP \cdot \sin PR \cdot \cos NPR$$

or

$$\sin \text{lat R} = \sin \text{lat P} \cdot \cos PR + \cos \text{lat P} \cdot \sin PR \cdot \cos NPR \quad \dots (3)$$

Thus the latitude of R is found.

(4) Applying formula (C) to the triangle NPR :—

$$\frac{\sin PR}{\sin NR} = \frac{\sin NPR}{\sin NPR}$$

$$\frac{\sin PR}{\cos \text{lat R}} = \frac{\sin \text{d. long PR}}{\sin NPR}$$

or

$$\sin \text{d. long PR} = \sin PR \cdot \sec \text{lat R} \cdot \sin NPR \quad \dots (4)$$

Thus the difference in longitude between P and R is found. Since the longitude of P is known, that of R can at once be obtained.

*Example.*

The observed bearing of Rügen from Wick is  $105^\circ.5$  and from Cullercoats is  $87^\circ$ . What is the latitude and longitude of Rügen ?

The observations show that Rügen is to the east of the D.F. stations.

<sup>1</sup> *P.O.E.E.J.*, Vol. 32, p. 142.

The positions of the D.F. loops at Wick and Cullercoats are as follows:—

	Lat.	Long.
Wick :	58° 25' 41" N.	3° 06' 59" W.
Cullercoats :	55° 02' 16" N.	1° 25' 39" W.

$$\text{d. long : } \underline{\underline{1^{\circ} 41' 20''}}$$

In Fig. 1, let P be Wick, Q Cullercoats and R Rügen. The relative positions are approximately as shown.

The angle NPQ, the bearing of Cullercoats from Wick, is found by calculation to be 164° 01'. The angle NQP is found to be 14° 35'. PNQ, the difference in longitude between Wick and Cullercoats, is 1° 41'. The data and subsequent working are taken to the nearest minute.

Therefore, equation (1),

$$\cos PQ = \sin 58^{\circ} 26' \cdot \sin 55^{\circ} 02' + \cos 58^{\circ} 26' \cdot \cos 55^{\circ} 02' \cdot \cos 1^{\circ} 41'.$$

$$\log \sin 58^{\circ} 26' = 9.9304557$$

$$\log \sin 55^{\circ} 02' = 9.9135413$$

$$\text{Sum} = 9.8439970 = \log \text{ of } 0.698228$$

$$\log \cos 58^{\circ} 26' = 9.7189086$$

$$\log \cos 55^{\circ} 02' = 9.7582302$$

$$\log \cos 1^{\circ} 41' = 9.9998125$$

$$\text{Sum} = 9.4769513 = \log \text{ of } 0.299883$$

$$\text{Sum} = 0.998111$$

$$= \cos \text{ of } 3^{\circ} 31'.$$

Therefore PQ = 3° 31'.

The angle QPR = NPQ - NPR

$$= 164^{\circ} 01' - 105^{\circ} 30' = 58^{\circ} 31'.$$

The angle PQR = NQP + NQR

$$= 14^{\circ} 35' + 87^{\circ} = 101^{\circ} 35'$$

Therefore, equation (2),

$$\cos 3^{\circ} 31' \cdot \cos 58^{\circ} 31' = \sin 3^{\circ} 31' \cdot \cot PR - \sin 58^{\circ} 31' \cdot \cot 101^{\circ} 35'.$$

or

$$\cos 3^{\circ} 31' \cdot \cos 58^{\circ} 31' = \sin 3^{\circ} 31' \cdot \cot PR + \sin 58^{\circ} 31' \cdot \tan 11^{\circ} 35'.$$

Therefore:—

$$\cot PR = \frac{\cos 3^{\circ} 31' \cdot \cos 58^{\circ} 31'}{\sin 3^{\circ} 31'}$$

$$\frac{\sin 58^{\circ} 31' \cdot \tan 11^{\circ} 35'}{\sin 3^{\circ} 31'}$$

$$= \cot 3^{\circ} 31' \cdot \cos 58^{\circ} 31' - \frac{\sin 58^{\circ} 31' \cdot \tan 11^{\circ} 35'}{\sin 3^{\circ} 31'} \cdot \operatorname{cosec} 3^{\circ} 31'.$$

$$\log \cot 3^{\circ} 31' = 1.2114456$$

$$\log \cos 58^{\circ} 31' = 9.7178789$$

$$\text{Sum} = 0.9293245 = \log \text{ of } 8.498152$$

$$\log \sin 58^{\circ} 31' = 9.9308432$$

$$\log \tan 11^{\circ} 35' = 9.3116848$$

$$\log \operatorname{cosec} 3^{\circ} 31' = 1.2122641$$

$$\text{Sum} = 0.4547921 = \log \text{ of } 2.849653$$

$$\text{Difference} = \underline{\underline{5.648499}}$$

$$= \cot \text{ of } 10^{\circ} 02'$$

Therefore PR = 10° 02'.

Then, from equation (3),

$$\sin \text{ lat } R = \sin 58^{\circ} 26' \cdot \cos 10^{\circ} 02' + \cos 58^{\circ} 26' \cdot \sin 10^{\circ} 02' \cdot \cos 105^{\circ} 30',$$

or

$$\sin \text{ lat } R = \sin 58^{\circ} 26' \cdot \cos 10^{\circ} 02' - \cos 58^{\circ} 26' \cdot \sin 10^{\circ} 02' \cdot \sin 15^{\circ} 30'.$$

$$\log \sin 58^{\circ} 26' = 9.9304557$$

$$\log \cos 10^{\circ} 02' = 9.9933068$$

$$\text{Sum} = 9.9237625 = \log \text{ of } 0.8390010$$

$$\log \cos 58^{\circ} 26' = 9.7189086$$

$$\log \sin 10^{\circ} 02' = 9.2411007$$

$$\log \sin 15^{\circ} 30' = 9.4268988$$

$$\text{Sum} = 8.3869081 = \log \text{ of } 0.0243729$$

$$\text{Difference} = \underline{\underline{0.8146281}}$$

$$= \sin \text{ of } 54^{\circ} 33'$$

Therefore the latitude of Rügen is 54° 33'.

Finally, applying equation (4),

$$\sin \text{ d. long } PR = \sin 10^{\circ} 02' \cdot \sec 54^{\circ} 33' \cdot \sin 105^{\circ} 30' - \sin 10^{\circ} 02' \cdot \sec 54^{\circ} 33' \cdot \cos 15^{\circ} 30'$$

$$\log \sin 10^{\circ} 02' = 9.2411007$$

$$\log \sec 54^{\circ} 33' = 0.2365778$$

$$\log \cos 15^{\circ} 30' = 9.9839105$$

$$\text{Sum} = 9.4615890 = \log \sin \text{ of } 16^{\circ} 50'$$

That is, Rügen is 16° 50' of longitude to the east of Wick. But the longitude of Wick is 3° 07' W. Therefore the longitude of Rügen is 16° 50' - 3° 07' = 13° 43' E.

The correct values for Rügen are:—

Latitude : 54° 34' 55" N.

Longitude : 13° 37' 01" E.

It will be noticed that the values of the latitude and longitude deduced from the D.F. observations are not quite correct, the error in longitude being the greater. This is due to the original observations not being absolutely correct. In the triangle PQR, Fig. 1, formed by Wick, Cullercoats and Rügen, the side PQ is 211 nautical miles, whereas the side PR is 602 nautical miles and the length of QR is about the same as that of PR. The sides PR and QR are therefore inclined to one another at a fairly small angle, and consequently small changes in one or both of the angles P and Q cause considerable displacements of the apex R towards or away from the base PQ. The corresponding displacements of R at right angles to PR will evidently be smaller.

The magnification of the effect of errors of observation when lines of bearing cut at a small angle is, of course, well known, and occurs whether the point of intersection of the bearings is obtained graphically or by calculation.

A roughly correct diagram should always be drawn for any similar problem, which should be dealt with from first principles on the lines indicated above. The details of the calculation will vary according to the relative positions of the stations concerned.

## Notes and Comments

### Roll of Honour

The Board of Editors deeply regrets to have to record the deaths of the following members of the Engineering Department :—

*While serving with the Armed Forces, including Home Guard.*

Belfast Telephone Area	..	Robinson, T.	..	Unestablished Skilled Workman	Sergeant, Royal Air Force.
Belfast Telephone Area	..	Tozer, J. J.	..	Unestablished Skilled Workman	Pilot Officer, Royal Air Force.
Birmingham Telephone Area		Madeley, G. A.	..	Unestablished Skilled Workman	Signalman, Royal Corps of Signals.
Birmingham Telephone Area		Thacker, W.	..	Unestablished Skilled Workman	Private, Royal Warwickshire Regiment.
Birmingham Test Section	..	Hawkins, W. E.	..	Assistant Chemist	Home Guard.
Birmingham Test Section	..	Phillips, D. H.	..	Assistant Chemist	Home Guard.
Brighton Telephone Area	..	Miles, J. C.	..	Unestablished Skilled Workman	Corporal, The Buffs.
Dundee Telephone Area	..	Peter, A. T.	..	Unestablished Skilled Workman	Home Guard.
Dundee Telephone Area	..	Wanless, H. H.	..	Unestablished Skilled Workman	Home Guard.
Exeter Telephone Area	..	Chave, F. S. H.	..	Unestablished Skilled Workman	Aircraftsman, Class I, Royal Corps of Signals.
Gloucester Telephone Area		Smith, G. S.	..	Unestablished Draughtsman	Pilot Officer, Royal Air Force.
Guildford Telephone Area		Hinde, A. L.	..	Unestablished Skilled Workman	Bombardier, Royal Artillery.
Guildford Telephone Area		Nash, F.	..	Unestablished Skilled Workman	Able Seaman, Royal Navy.
London Telecommunications Region.		Mason, R. W.	..	Labourer	Signalman, Royal Corps of Signals.
Nottingham Telephone Area		Hobin, B. A.	..	Unestablished Skilled Workman	Able Seaman, Royal Navy.
Plymouth Telephone Area		Jewell, E. J.	..	Labourer	Home Guard.
Sheffield Telephone Area	..	Hockold, W.	..	Unestablished Skilled Workman	Signalman, Royal Corps of Signals.
Stoke-on-Trent Telephone Area.		Brinkworth, W. J.	..	Unestablished Skilled Workman	Stoker, 1st Class, Royal Navy.
Stoke-on-Trent Telephone Area.		Hall, J.	..	Unestablished Skilled Workman	Sergeant, Royal Engineers.
Stoke-on-Trent Telephone Area.		Price, J.	..	Unestablished Skilled Workman	Private, North Staffs Regiment.

*While serving with the Civil Defence Forces or on Post Office duty.*

Engineering Department	..	..	..	Foster, P. J.	..	..	Mechanic.
Leicester Telephone Area	..	..	..	Smith, S.	..	..	Skilled Workman, Class II.
Liverpool Telephone Area	..	..	..	Haugh, T. S.	..	..	Unestablished Skilled Workman.
London Telecommunications Region	..	..	..	Allan, C. C.	..	..	Unestablished Skilled Workman.
London Telecommunications Region	..	..	..	Gould, W. E.	..	..	Unestablished Skilled Workman.
London Telecommunications Region	..	..	..	Bedford, R. A.	..	..	Skilled Workman, Class I.
Norwich Telephone Area	..	..	..	Creasy, E. E.	..	..	Skilled Workman, Class I.

### Birthday Honours



COLONEL SIR STANLEY ANGWIN,  
D.S.O., M.C., T.D., B.Sc.

It was a matter of gratification to the whole of the engineering staff of the Post Office to see the name of the Engineer-in-Chief, Col. A. S. Angwin, included in the Birthday Honours list published last month. His valuable contributions to telecommunications, particularly in the development of the overseas radio telephone services and in outstanding work in connection with international conferences at Madrid, Lisbon, Bucharest, Cairo, Lucerne and Montreux, have earned widespread respect in telecommunications circles. The knighthood which has been bestowed on him will be a source of interest and satisfaction to friends and associates throughout the world.

Another well-known personality in the communications service of this country who received a knighthood in the same list is Mr. Frank Gill. At the time of the transfer of the National Telephone Co. to the Post Office in 1911, Sir Frank was the Chief Engineer of the Company, and he has remained a leading figure in the telecommunications industry throughout the following 30 years. Sir Frank Gill particularly interested himself in encouraging the growth of European telephony and his efforts were largely responsible for the setting up of the C.C.I.F., the international advisory committee on telephony.



Other members of the Post Office Engineering Department included in the list are Mr. F. Holmes, Chief Inspector, Bournemouth, who becomes a Member of the Order of the British Empire, and Messrs. L. L. Dutson, Skilled Workman, Class I, Portsmouth; D. Bell, Inspector L.T.R.; S. T. Willis, Inspector, E.-in-C.'s Office, and C. E. Hislop, Acting Inspector, Southampton, who receive the Medal of the Order of the British Empire.

To all these gentlemen we offer our sincere congratulations.

### Recent Honours

The Board of Editors has learnt with great pleasure of the honours recently conferred on the following members of the Engineering Department :—

#### *While serving with the Armed Forces.*

Belfast Telephone Area.	Muckle, W. A.	Skilled Workman, Class II	Signalman, R.C. of S.	Military Medal.
Engineer-in-Chief's Office	Ross, G. R.	Unestablished Skilled Workman	Pilot Officer, R.A.F.	Distinguished Flying Cross.
Liverpool Telephone Area	Ward, J. . .	Unestablished Skilled Workman	Telegraphist, R.N.V.R.	Mentioned in Despatches.

#### *While serving with the Civil Defence Forces or on Post Office Duty.*

Canterbury Telephone Area	Bax, C. . . . .	Unestablished Skilled Workman		Commended by H.M. the King.
Canterbury Telephone Area	Goodwin, W. O. L.	Inspector . . . . .		Commended by H.M. the King.
London Telecommunications Region.	Hennis, A. W. . .	Skilled Workman, Class II		British Empire Medal.
Manchester Telephone Area	Johnson, S. R. . .	Youth-in-Training . . . . .		Medal of the Order of the British Empire.
Manchester Telephone Area	Moore, F. . . . .	Skilled Workman, Class I . . . . .		Medal of the Order of the British Empire.
Portsmouth Telephone Area	Hishon, C. H. . .	Inspector . . . . .		Medal of the Order of the British Empire.
Portsmouth Telephone Area	McTrusty, H. . . .	Unestablished Skilled Workman		Commended by H.M. the King.
Sheffield Telephone Area . .	White, A. H. . . .	Chief Inspector . . . . .		Medal of the Order of the British Empire.
South Western Region . . . .	Morton, R. N. . . .	Unestablished Skilled Workman		Commended by H.M. the King.
Swansea Telephone Area . . .	Hunter, J. St. L.	Inspector . . . . .		George Medal.
Tunbridge Wells Telephone Area.	Hamley, C. I. . . .	Skilled Workman, Class II		Commended by H.M. the King.

### Appointments

We offer our congratulations to Mr. G. F. Odell, who was recently appointed Deputy Director of the new Post Office Contracts Department, and to Capt. J. Legg and Mr. C. W. Brown, who become Assistant Engineer-in-Chief and Staff Engineer, Telephone Branch, respectively, as a result of this appointment. We regret that owing to the enforced reduction in size of this Journal we are not able to publish the usual personal paragraphs, but our congratulations are none the less sincere.

### I.E.E. Awards

We are pleased to observe among the recipients of the I.E.E. awards for papers read during the session 1940/41, or accepted for publication, the following members of the Post Office Engineering Department :

- Mr. C. F. Booth, who is awarded the Institution Premium.
- Mr. A. Fairweather, who shares the Fahie Premium with Mr. J. Ingham, and
- Mr. G. H. Metson, now serving with the Army, who is awarded an extra Premium.

# Regional Notes

## North Eastern Region

### STORM DAMAGE

Severe damage was caused to overhead telephone plant in the Middlesbrough Telephone Area by a snow-storm which commenced early on February 19th. An average of 9 in. of exceptionally wet and heavy snow fell in the first few hours after dawn on February 19th accompanied by a 20 m.p.h. north-north-east wind. Sleet or snow fell all day on the 20th and until dawn on the 21st, the wind having veered to north-north-west at about the same velocity, the snow reaching a final average depth of 16 in. in the Tees Valley. On the moor and dale roads 6 ft. to 8 ft. of snow was not unusual.

Most of the damage occurred on February 19th, and all main routes or sections of main route running approximately across the direction of the wind were severely damaged. In addition, great havoc was wrought among D.P.s and service routes of local line plant. Thirty-two exchanges were isolated: 36 trunks and private wires, 156 junctions and 5,450 subscribers (out of a total of 18,141) were put out of service. The snow-storm was followed by very high winds on February 27th which caused the isolation of a further 16 exchanges.

Plant damage included 93 broken poles, 5,801 deflected poles, 313 broken arms, 1,700 broken and drawn stays and stay wires and about 1,400 pulled spikes and brackets; 2,178 miles of line wire were broken and 4,877 miles required re-regulation. Out of a total of 3,170 D.P.s, 1,583 were affected by the storm.

The storm was generally accepted as the worst in the neighbourhood for fifty years, the dislocation of communications of all kinds being severe. Blocked roads slowed up initial repairs considerably, but by February 25th all isolated exchanges were restored to service together with the majority of the 1E priority subscribers. During this period 86 of the junctions, trunks and private wires were diverted to underground routes—

work which involved in many cases breaking into main underground cables for the purpose of forming T.P.s and diverting additional pairs to M.D.F.s. Some 30 miles of interruption cable were used in effecting preliminary repairs.

The thaw, which was an extremely rapid one and occurred around February 27th, gave rise to floods, causing a number of cable faults and rendering many hundreds of deflected poles dangerous due to the softening of the ground. Restoration of service was considerably hampered by the necessity for making safe these poles and by the extreme shortage of both skilled and unskilled labour.

A second snowstorm occurred on March 25th and resulted in the isolation of three exchanges and the stoppage of service to a further 330 subscribers.

At the time of writing all subscribers' circuits and private wires have been restored to service together with the majority of the junctions and trunks. Many heavily loaded local routes and some main routes have been dispensed with and replaced by existing or new cables.

C.J.G.

## London Telecommunication Regions

### DENHAM (BUCKS) EXCHANGE TRANSFER

The new automatic exchange at Denham was brought into service at 12.30 p.m. on March 26th, 1941. 382 subscribers' lines and 108 junctions were transferred. Auto-manual facilities are provided at Uxbridge manual exchange.

The Exchange is housed in a one-storey building pleasantly situated in rural surroundings and serves an important section of the British film industry.

The equipment is of the non-director, 2,000-type with uniselectors. It has initial multiple capacity for 1,100 lines, and was installed by Messrs. Standard Telephones & Cables, Ltd.

## Local Centre Notes

### Scottish Centres

The Scottish I.P.O.E.E. prizes awarded by the Co-ordinating Committee of the Scottish Region on behalf of the members of both Scottish Centres for Workmen's Classes in Telecommunications subjects at Glasgow, Aberdeen and Edinburgh have been won by the following students:—

#### Glasgow.

Grouped Course, 1st year ..	1. R. Anderson
	2. W. Craig
	3. R. A. Forrest
Grouped Course, 2nd year ..	1. W. A. R. Dykes
	2. A. P. Maule
Grouped Course, 3rd year ..	G. S. Monaghan
Non-Grouped Classes, 1st year	G. Imlach
Non-Grouped Classes, 2nd year	A. Crawford
Non-Grouped Classes, 3rd year	N. F. McDaid
Non-Grouped Classes, 4th year	H. H. Beck

#### Aberdeen.

Grouped Course, 1st year ..	1. D. Brown
	2. T. G. Smith
Grouped Course, 2nd year ..	1. J. D. Watson
	2. { R. Jardine
	{ G. W. A. Duguid

#### Edinburgh.

Grouped Course, 1st year ..	1. J. W. I. Hendry
	2. J. D. Stewart

Grouped Course, 2nd year	R. M. More
Non-Grouped Classes, 1st year	D. M. Plenderleith
Non-Grouped Classes, 2nd year	J. E. Adams

Congratulations are offered to the successful students, and it is hoped their success will encourage further study and act as an incentive to others.

### Colchester Sub-centre

Owing to the restrictions on centre activities, and the strong desire on the part of the local members to continue the functions of the Institution in spite of the war, it was felt that a local sub-Centre could be formed within the Colchester Area. The Cambridge Committee was only too willing to authorise this proposal, with the result that the Centre was formed and a successful session ensued.

The meetings were held at Colchester and were attended by both Colchester and Ipswich members. The papers were all prepared and read by members of the above staffs, and covered the following subjects: The Cathode Ray Oscillograph, Underground Fault Localisation, V.F. Telegraphs, Power Supplies to T.E.s, Manhole Construction, and Area Organisation and Accounting.

An average attendance of 22 was obtained, including the Area Engineer who acted as chairman. The session was made all the more successful by the use of the lantern and slides kindly lent by the Cambridge Centre.

# Staff Changes

## Promotions

Name	Region	Date	Name	Region	Date
<i>From Staff Engr. to Acting Asst. Engr. in-Chief.</i>			<i>From Chief Insp. to Chief Insp. with tempy. Allce.—continued</i>		
Legg, J.	E.-in-C.O.	1.4.41	Howard, A. A.	L.T.R.	1.5.41
<i>From Deputy C.R.E. to Acting Staff Engr.</i>			Tough, J. D.	S.W. Reg.	22.5.41
Brown, C. W.	L.T.R. to E.-in-C.O.	1.4.41	<i>From Insp. to Actine Chief Insp.</i>		
<i>From Regional Engr. to Acting Deputy C.R.E.</i>			Coles, F. S.	S.W. Reg.	11.9.40
Phillips, C. H.	L.T.R.	1.4.41	Hay, J.	Test Section (Ldn.)	12.3.41
<i>From Exec. Engr. to Acting A.S.E.</i>			Casey, E. S.	L.T.R.	26.11.40
Ilalsey, R. J.	E.-in-C.O.	27.3.41	Jalland, F. R.	Test Section (B'ham)	1.1.41
Brent, W. H.	Scot. Reg. to Mid. Reg.	20.4.41	Loveland, F. T.	L.T.R.	23.9.40
Milton, G. P.	L.T.R.	25.4.41	Crooks, R. H.	L.T.R.	2.12.40
<i>From Area Engr. to Area Engr. with Allce.</i>			Eagle, R. J. A.	L.T.R.	9.12.40
Hudson, A.	H.C. Reg. to N.W. Reg.	20.4.41	Owen, F. C.	E.-in-C.O.	1.10.40
Brown, A. H.	Scot. Reg.	20.4.41	Forster, J. H.	L.T.R.	16.2.41
<i>From Asst. Engr. to Acting Exec. Engr.</i>			Jones, E. T.	L.T.R.	5.4.41
Gunston, J. A.	L.T.R.	30.4.41	Page, W. F.	Test Section (Ldn.)	19.11.40
Elliott, G.	L.T.R.	30.4.41	Lawton, J.	N.W. Reg.	6.4.41
Sowton, C. W.	E.-in-C.O.	23.5.41	Doherty, G.	E.-in-C.O. to N.E. Reg.	16.3.41
<i>From Chief Insp. to Acting Asst. Engr.</i>			Walker, H.	E.-in-C.O.	6.4.41
Challinor, W.	L.T.R.	5.3.41	Hudson, F. S.	E.-in-C.O.	1.1.41
Abbott, G. A.	L.T.R.	5.3.41	Edwards, A. G.	E.-in-C.O. to Scot. Reg.	20.4.41
Hogg, T. E.	E.-in-C.O.	5.3.41	Baldwin, A. W. T.	E.-in-C.O. to S.W. Reg.	23.3.41
Pendry, S. D.	H.C. Reg.	26.3.41	Heron, K. M.	E.-in-C.O.	23.2.41
Arnold, C. W.	Scot. Reg. to E.-in-C.O.	20.4.41	Yeatman, H. G.	H.C. Reg.	31.3.40
Hull, J. A.	Scot. Reg. to E.-in-C.O.	1.5.41	Birss, R. R.	E.-in-C.O.	7.2.41
Arnold, A. F.	Scot. Reg. to E.-in-C.O.	1.5.41	McHugh, G. P.	N.E. Reg.	23.2.41
Todkill, H.	N.W. Reg. to E.-in-C.O.	4.5.41	Evans, D. O. M.	W. & B.C. Reg. to N.E. Reg.	27.4.41
Latimer, E. D.	Test Section (Ldn.) to E.-in-C.O.	30.4.41	Inwood, F. W.	H.C. Reg.	11.8.40
Margetts, A. W.	Mid. Reg.	30.4.41	Hill, A. F.	E.-in-C.O.	1.1.41
Roberts, E.	L.T.R. to E.-in-C.O.	30.4.41	Tuck, R. F.	Mid. Reg.	26.9.40
Pride, C. A.	E.-in-C.O. to L.T.R.	30.4.41	<i>From Draughtsman Class II to Acting Draughtsman Class I.</i>		
Wootten, L. G.	L.T.R.	30.4.41	Plumb, W. A.	E.-in-C.O.	1.2.41
Owens, W. H.	L.T.R.	30.4.41	Higgins, R. H.	E.-in-C.O.	1.2.41
<i>From Chief Insp. to Chief Insp. with tempy. Allce.</i>			<i>From S.W.I. to Acting Insp.</i>		
Maynard, H. O.	L.T.R.	16.2.41	Williams, E. R.	E.-in-C.O.	1.9.39
Baily, W. H.	L.T.R.	1.5.41	Harris, F. L.	E.-in-C.O.	2.3.41
Cockshott, W. E.	L.T.R.	7.5.41	Southerton, T. H.	E.-in-C.O.	23.2.41
Prosser, P.	L.T.R.	30.3.41	Garbutt, A. W. N.	E.-in-C.O.	25.1.41
			Axford, E. R.	E.-in-C.O.	25.1.41
			Mitchell, S. F.	E.-in-C.O.	23.3.41
			Packham, E. C.	E.-in-C.O.	8.2.41
			Howell, T. W. H.	E.-in-C.O.	29.3.41
			Ward, J. H.	E.-in-C.O.	29.3.41

## Transfers

Name	Region	Date	Name	Region	Date
<i>Asst. Engineer.</i>			<i>Inspector.</i>		
De Courcy, F. J.	E.-in-C.O. to N. Ire. Reg.	8.4.41	Newton, A. W.	L.T.R. to E.-in-C.O.	10.3.41
Green, F. C.	E.-in-C.O. to L.T.R.	1.5.41	Mullard, R.	Test Section (Ldn.) to E.-in-C.O.	1.4.41
Lee, A.	Test Section (B'ham) to E.-in-C.O.	1.5.41	<i>Prob. Inspector.</i>		
			Pickard, R. J.	N.E. Reg. to E.-in-C.O.	2.3.41

## Retirements

Name	Region	Date	Name	Region	Date
<i>Area Engr. with Allce.</i>			<i>Chief Insp.</i>		
Cowburn, W.	N.W. Reg.	31.3.41	West, F. W.	N.W. Reg.	29.4.41
Green, H. W.	N.W. Reg.	31.5.41	Akister, F.	N.W. Reg.	30.4.41
<i>Chief Insp. with Allce.</i>			Tompkin, J.	Mid. Reg.	31.5.41
Burrell, G. E.	N.E. Reg.	28.3.41	<i>D'sman Cl. I.</i>		
Stow, G.	L.T.R.	29.3.41	Hardy, A. H.	L.T.R.	22.4.41
Evans, W.	L.T.R.	26.4.41			
Chilvers, W.	L.T.R.	30.4.41			
Bines, H. T.	L.T.R.	6.5.41			

**Deaths**

Name	Region	Date
<i>Chief Insp.</i>		
Bradley, H. .. ..	Mid. Reg.	14.5.41

**CLERICAL GRADES**

**Promotions**

Name	Region	Date	Name	Region	Date
<i>From E.O. to Acting S.O.</i>			<i>From C.O. to Acting E.O.—continued.</i>		
Robertson, N. ..	E.-in-C.O.	15.3.41	Brown, B. S. ..	S.W. Reg.	8.4.41
Murray, C. E. ..	E.-in-C.O.	12.5.41	Haigh, E. ..	N.W. Reg.	16.4.41
Inskip, C. R. ..	E.-in-C.O.	12.5.41	(Notionally in absentia)		
Ford, A. W. ..	E.-in-C.O.	12.5.41	Suchsland, V. F. ..	N.W. Reg.	16.4.41
<i>From C.O. to Acting E.O.</i>			<i>From C.O. to Acting H.C.O.</i>		
Reason, P. C. ..	E.-in-C.O.	11.3.41	Langton, H. ..	H.C. Reg. ..	30.3.41
Turton, A. ..	E.-in-C.O.	11.3.41	Pengelly, R. H. ..	S.W. Reg.	7.3.41
Sheppard, Miss A. M.	E.-in-C.O.	11.3.41	Wilde, S. ..	N.W. Reg.	16.3.41
Treadaway, W. J. ..	E.-in-C.O.	25.3.41	Green, W. ..	N.W. Reg.	16.3.41
Howers, Miss W. A. ..	E.-in-C.O.	25.3.41	<i>From S.O. to Senior Contract Officer.</i>		
(Notionally in absentia)			Smalley, A. T. ..	E.-in-C.O.	15.4.41

**Deaths**

Name	Region	Date
<i>H.C.O.</i>		
Balley, H. .. ..	H.C. Reg.	8.4.41

**BOARD OF EDITORS**

- A. J. GILL, B.Sc., M.I.E.E., M.I.R.E., Chairman.
- F. E. NANCARROW, A.R.C.Sc., M.I.E.E.
- P. B. FROST, B.Sc., M.I.E.E.
- A. H. MUMFORD, B.Sc.(ENG.), M.I.E.E.
- C. W. BROWN, A.M.I.E.E.
- R. E. JONES, M.Sc., A.M.I.E.E.
- H. LEIGH, B.Sc.(ENG.), A.M.I.E.E., Acting Managing Editor.
- G. E. SYLERS, A.M.I.E.E., Acting Assistant Editor.

**Copyright**

The entire contents of this JOURNAL are covered by general copyright, and special permission is necessary for reprinting long extracts, but Editors are welcome to use not more than one-third of any article, provided credit is given at the beginning or end thus: "From the *Post Office Electrical Engineers' Journal*."

The Board of Editors is not responsible for the statements made or the opinions expressed in any of the articles in this JOURNAL, unless such statement is made specifically by the Board.

**Communications**

All Communications should be addressed to the Managing Editor, *P.O.E.E. Journal*, Engineer-in-Chief's Office, Alder House, Aldersgate Street, London, E.C.1. Telephone: HEADquarters 1234. Remittances should be made payable to "*The P.O.E.E. Journal*" and should be crossed "& Co."

**Binding Cases**

Cases for binding are available, and may be obtained from the Local Agents for 1s. 9d. Subscribers can have their copies of Volumes bound, at a cost of 3s., by sending the complete set of parts to the Local Agents or to the *P.O.E.E. Journal*, Engineer-in-Chief's Office, Alder House, Aldersgate Street, London, E.C.1. Orders for binding for Vols. 1-19 should indicate whether the original binding case with black lettering, or the later pattern with gold, is required. Cases with gold lettering are the only type stocked from Vol. 20 onwards.

**Back Numbers**

The price of the JOURNAL, which is published quarterly, is 1s. (1s. 3d. post free) per copy, or 5s. per annum post free. Back numbers can be supplied, subject to availability of stocks, at 1s. each (1s. 3d. post free). Orders for back numbers may be sent to the Local Agents or to the Publishers.

**Advertisements**

All communications relating to space reservations should be addressed to the Advertisement Editor, *P.O.E.E. Journal*, Alder House, Aldersgate Street, London, E.C.1. Communications regarding advertisement copy, proofs, etc., should be addressed to the Publishers, Messrs. Birch & Whittington (Prop. Dorling & Co. [Epsom], Ltd.), 49 Upper High Street, Epsom, Surrey.

## MERCHANT VENTURERS

Across the seven seas sail the seamen of Britain—merchant venturers in truth.

On them depend our food, our arms, our very lives. By their skill in seamanship, by the goodness of their ships, by their courage they will defeat the lurking U-Boat and bring us to Victory.

We, who make many of the instruments on which they depend will see that those instruments are worthy of the brave men they serve.

MUIRHEAD & CO. LTD., ELMERS END,  
BECKENHAM, KENT.  
TELEPHONE: BECKENHAM 0041-0042

# MUIRHEAD

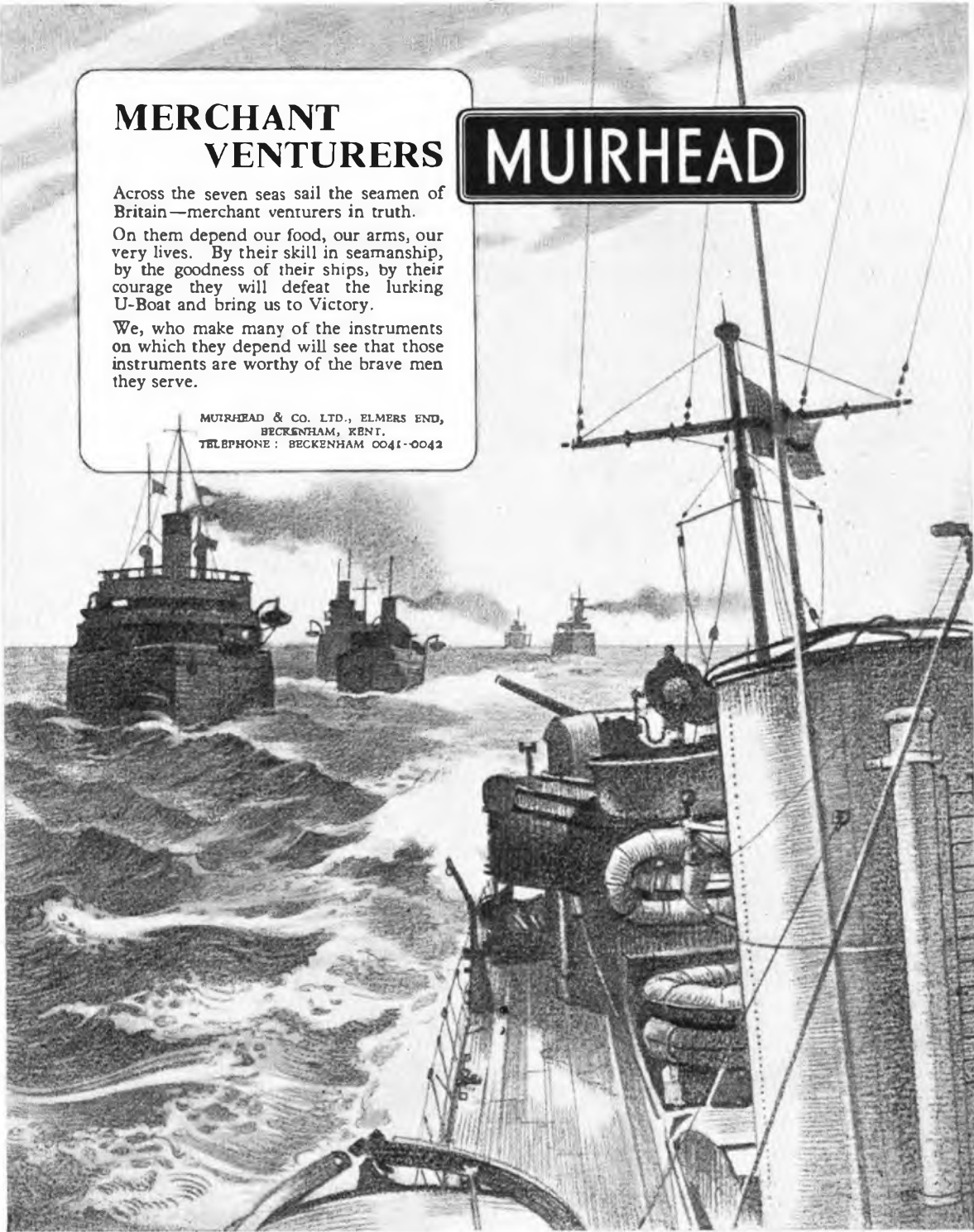

FOR OVER 60 YEARS DESIGNERS & MAKERS OF PRECISION INSTRUMENTS

C.R.C. 27

# “AUSTRALIA WILL

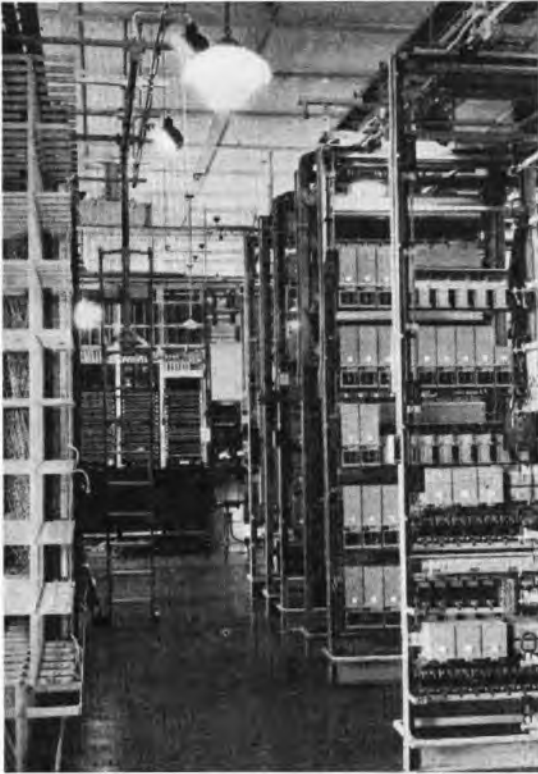

*An interior view of Rockhampton Exchange.*



*This exterior view shows the modern two-story building in which the equipment is installed.*

It is traditional that Australia is in the forefront, whether in the defence of the nation or in the application of modern developments to her national or civic needs. An example of the latter is provided by the new Rockhampton Automatic Telephone Exchange. 1,600 lines are installed initially with an associated 8 position trunk board. The exchange has an ultimate capacity of 2,900 lines. It is equipped with the 32A Selector (B.P.O. type 2,000), the last word in automatic telephone switching. In result Rockhampton subscribers have a standard of telephone service equal to that in any part of the world.

In 1889 the first telephone exchange was installed at Rockhampton and it was

in a wooden building which was really little more than a shack—a striking contrast when compared with the large and up-to-date building in which the exchange is now housed. At that time there were only 37 subscribers and even this number dwindled during the next few years. In 1900, however, the number had increased to 130, and to-day about 1,700 subscribers enjoy the advantages of Strowger Automatic Telephone Exchange. Rockhampton, Australia, provides yet further proof that the telephone dial rotates with the world.



## STROWGER AUTOMATIC TELEPHONE EQUIPMENT

# ...LL BE THERE !”

the Empire  
An example  
Exchange.  
ard and the  
ne Strowger  
itching, and  
qual to that

was housed

w contained.

this number

ver, the total

scribers enjoy

ony. Rock-

he Strowger



## AUTOMATIC TELEPHONE & ELECTRIC CO. LTD.

NORFOLK HOUSE, NORFOLK ST., STRAND, W.C.2.

Phone, Temple Bar 9262 • Grams, 'Autelco, Estrand, London'

STROWGER WORKS, LIVERPOOL, 7

Phone, Stoneycroft 4830 • Grams, 'Strowger, Liverpool'

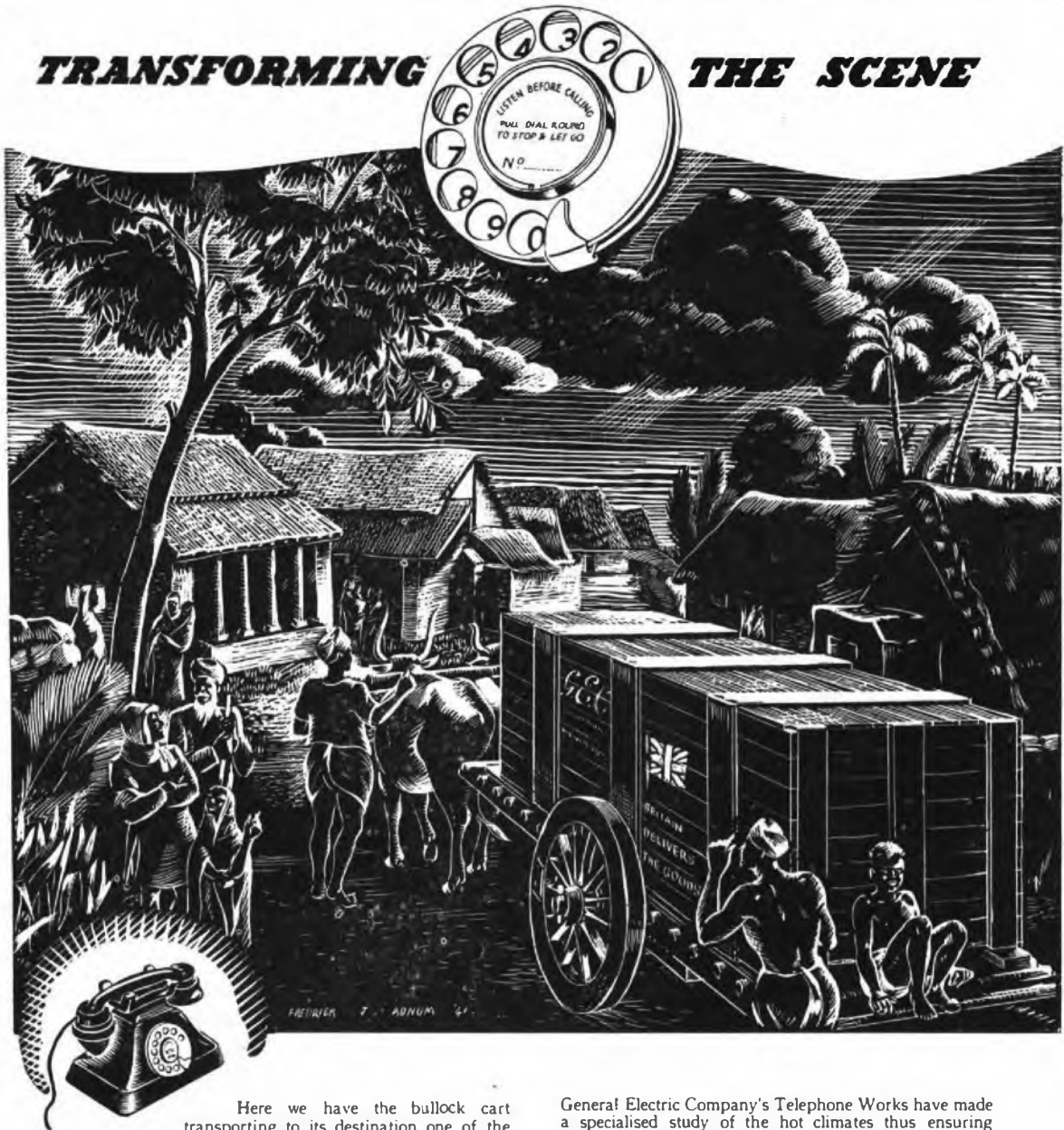

**TRANSFORMING****THE SCENE**

Here we have the bullock cart transporting to its destination one of the most essential forms of up-to-date communication. After travelling by road, rail and sea, our telephone equipment often completes the final stages of its journey by old traditional Eastern methods of transport. It is because overseas administrators have realised that modern science can, perhaps more than anything else, improve the conditions of the tropical countries, that we get such scenes as the old carrying in the new Engineers of the

General Electric Company's Telephone Works have made a specialised study of the hot climates thus ensuring production of telephone equipment which will withstand the effects of heat and humidity and the ravages of insects. At the present time, this organisation is largely occupied on National Work, but we are still manufacturing, exporting and installing improved means of communication in large cities, towns, and for small isolated communities overseas. The G.E.C. hope soon to be able to serve their customers to an even greater degree and look forward to that future, but meanwhile ask you to remember that Britain still delivers the goods!

# G.E.C.

REGD. TRADE MARK

THE GENERAL ELECTRIC COMPANY LIMITED OF ENGLAND  
HEAD OFFICE.—MAGNET HOUSE, KINGSWAY, LONDON, W.C.2



## High Quality mouldings

Ebonestos have produced many of the finest mouldings manufactured in compositions, Bakelite, Urea, Diakon, and other synthetic resins. For the past 42 years, our reputation for finish and accuracy has been second to none.

Let us know your moulding requirements, and we shall be pleased to send one of our technical experts to discuss the matter with you, or, if you prefer it, meet you at our factory.

Moulders to the General Post Office, Admiralty, Air Ministry and other Government Departments.

**EBONESTOS INDUSTRIES LIMITED**  
EXCELSIOR WORKS, ROLLINS STREET,  
LONDON, S.E.15 Telephone: New Cross 1913 (6 lines)

## NO WAITING FOR CEMENT TO DRY

if you use

**RAWLBOLTS**  
the speediest method  
of machine fixing  
yet devised

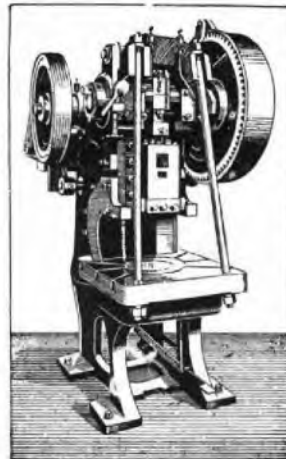

More and more firms are using Rawlbolts for really heavy fixing work. Rawlbolts require no grouting and only a small hole is needed to accommodate them. They can be fixed immediately as there is no waiting for cement to dry. Not only is the Rawlbolt speedy, and therefore very economical, but it is absolutely reliable, too. The two types of Rawlbolts solve every fixing problem with bolts, while the fact that they are available with pipe clips, round and square hooks and eye bolts still further increases their scope and utility. Rawlbolts are sold in stock sizes from  $\frac{1}{4}$ " to  $\frac{3}{4}$ " diameter.

## RAWLBOLTS

Fully illustrated descriptive literature will be supplied on request to:—  
THE RAWLPLUG CO. LTD., CROMWELL ROAD, LONDON, S.W. 7  
B255



Clip-on  
**HERE..**

Clip-on  
**THERE..**

Clip-on  
almost  
**EVERYWHERE**



The range of the instrument is changed by a half turn of the switch.

Comprehensive Ranges Available.	
0 — 10 — 50 amp.	
0 — 20 — 100 ..	
0 — 50 — 250 ..	
0 — 100 — 500 ..	
0 — 200 — 1000 ..	

Quick  
Change  
to  
New  
Range

Write for List IN.11.

FOR CHECKING CURRENT IN  
BUSBARS, FUSES & CABLES

**FERRANTI**  
DUAL RANGE  
Clip-on **AMMETER**

FERRANTI LTD., HOLLINWOOD, LANCS.  
London Office: Bush House, Aldwych, W.C.2.

# *Solder* THE MODERN AND SPEEDY WAY

## USE ERSIN MULTICORE

THE SOLDER WIRE  
WITH 3 CORES OF  
NON-CORROSIVE  
ERSIN FLUX



- Avoids Dry Joints
- Increases Electrical Efficiency of Joints
- Speedily makes Sound Joints on Dirty or Oxidised Surfaces
- Always Correct Proportions of Flux and Solder
- No Additional Flux Required
- Low Melting Point (190° C. for 60/40 alloys)
- Approved by Air Ministry & G.P.O.
- All-British and acknowledged by the Leading Manufacturers to be the finest Cored Solder in the World.

**FREE** Two informative publications on soldering have been issued by Multicore Solders Ltd. Executives are invited to send for copies and a free sample of Multicore Solder.

**MULTICORE SOLDERS LTD., BUSH HOUSE, LONDON, W.C.2**

Telephone: TEMple Bar 5583/4



A variable air condenser built by

**H. W. Sullivan Limited**

is the result of many years experience and development and can be implicitly relied upon to maintain its stability.

Whether it be single range, dual range, logarithmic, linear frequency, linear capacitance or any other law it can be supplied in any value to suit clients' special requirements.

Particulars from H. W. Sullivan Limited, London, S.E.15. Telephone : New Cross 3225 (Private Branch Exchange)

For New Telephone Developments—Technical, Plant, Commercial, Traffic, as well as late news affecting use of telephones—**READ**

## TELEPHONY!

The weekly journal of the telephone industry.

In these changing times the best investment a telephone man can make is to invest in himself. Competent men—the men who are well informed about their particular work and the business as well—are the ones who win promotion.

"TELEPHONY" covers every department of the telephone industry. It is informative, factual, inspirational; it publishes the latest developments, tells the approved telephone practices and current telephone news.

## READ TELEPHONY!

Subscription price, \$5.00 per year; 52 issues. Published since 1901.

Address: Odhams Press, Ltd., Technical Book Dept., 85 Long Acres, London, W.C.2 (Telephone: Temple Bar 2448) for a sample copy of TELEPHONY, or write direct to:

**TELEPHONY PUBLISHING CORPN.**  
698 S. Dearborn Street, Chicago, Ill., U.S.A.

## LONDEX for RELAYS

OF ALL TYPES (except telephone relays) including time lag relays, high sensitive relays, etc. for A.C. or D.C. operation. 2 V.A. coil consumption from 2-600 volts, tested to 2,000 volts, unmounted and in cast iron casing. Synchronous Process Timers and complete control plants.

Apply for leaflet SPN/PO



Midget Relay ML  
(for D.C.)

## LONDEX LTD.

Electrical Remote Control Engineers and Manufacturers  
Anerley Works, 207 Anerley Road, London, S.E.20  
Telephone: SYDENHAM 6258/6259

# STANDARD WITH THE BRITISH POST OFFICE

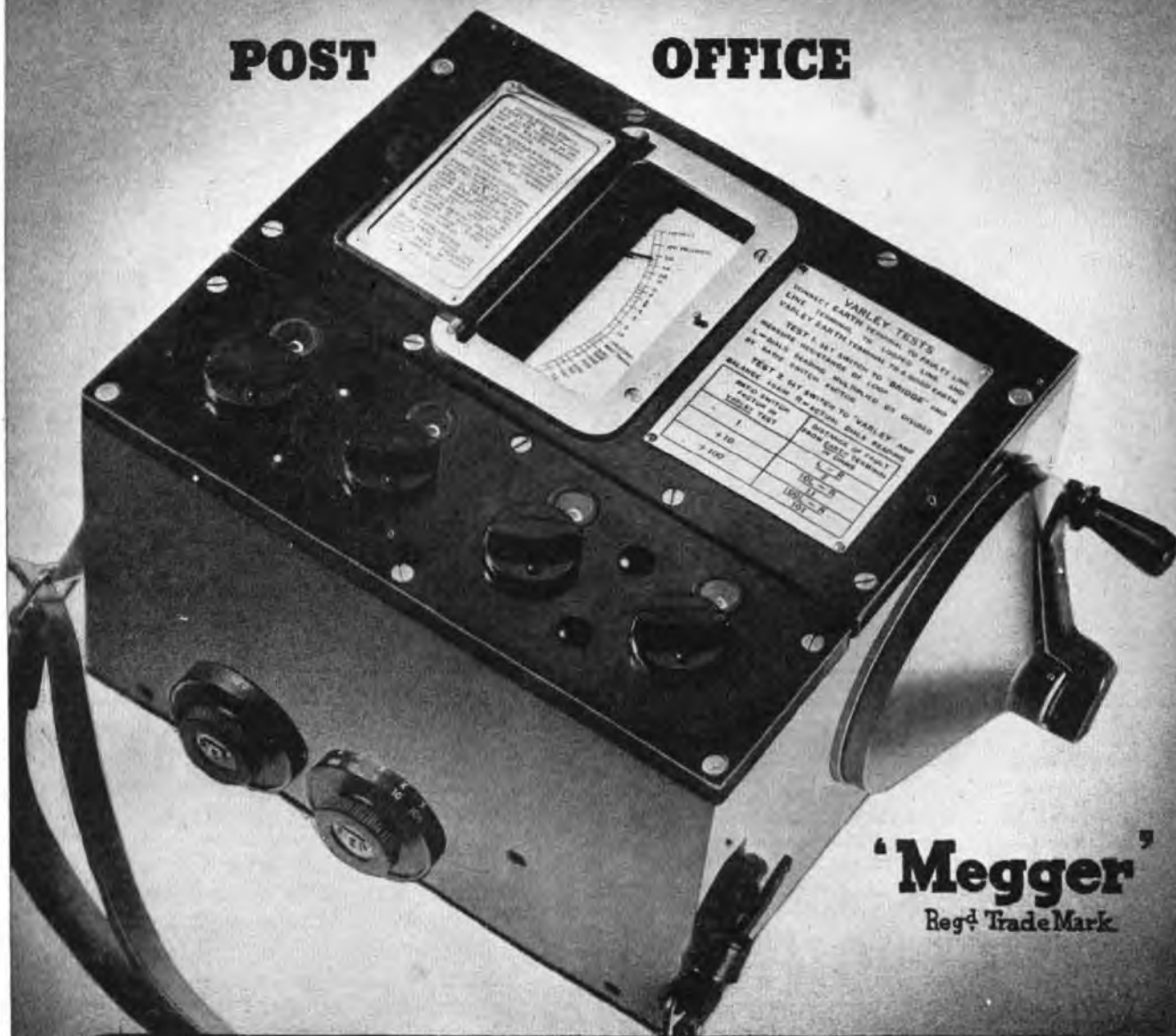

**THE BRIDGE-MEG TESTING SET** used by the British Post Office is a portable, self-contained instrument combining the functions of an Insulation Tester and a Wheatstone Bridge; it can be used for fault location by the Varley Loop method. Facilities can also be provided whereby, with the use of an external galvanometer and resistance box, the instrument may be used for making Murray Loop tests. Insulation range 100 megohms at 500 volts. Bridge range 0.01 to 999,900 ohms. Size  $7 \times 8\frac{3}{4} \times 12$  ins. Weight  $12\frac{3}{4}$  lbs. Mains operated instruments are also supplied to the British Post Office. Ask for list X 267.

**EVERSHED & VIGNOLES LTD., CHISWICK, LONDON, W.4**  
TELEPHONE: CHISWICK 1370 \* TELEGRAMS: 'MEGGER' CHISK, LONDON



# A NEW EDITION!

The new revised edition of descriptive pamphlet No. 11H is a necessity to all communication engineers. The latest developments and the principles of many circuits used in telecommunication are included, together with the design of power units for radio transmitters, carrier equipment, and telephony and telegraphy apparatus.

The book has been divided into three sections—1. Telegraphy and telephony power supply . . . direct operation . . . single battery . . . automatic single battery . . . two battery; 2. Telegraphy and telephony circuit applications . . . relays . . . attenuators . . . modulators . . . V.F.

rectifiers; and 3. Radio communication power supplies . . . transmitters . . . receivers . . . relay services . . . public address; while an Appendix gives details of standard rectifier sets for H.T., L.T., and G.B. power supply.

# WESTINGHOUSE

## rectifiers for telecommunication

Write for a copy of descriptive pamphlet No. 11H to Dept. P.O.E.J.

WESTINGHOUSE BRAKE & SIGNAL CO., LTD., Pew Hill House, Chippenham, Wilts.

# The New Star of the Telephone World

**T**HE new Ericsson Automatic Telephone No. 1002 shown here has a casework of black moulded bakelite in a modern, distinctive and pleasing design. It incorporates a form of cradle or micro-telephone rest which is not readily damaged should the instrument get violently knocked or fall to the ground.

The whole of the interior apparatus which is mounted on a frame can be removed as a unit, the base plate which incorporates a useful sliding tray fitment being first removed. Dimensions, 6 by 9½ by 8½ inches ; weight, 6 lbs.

**NOW AVAILABLE TO P.O. SUBSCRIBERS**

*Full particulars from makers :*

**ERICSSON TELEPHONES LTD.**

**HEAD OFFICE : 22 LINCOLN'S INN FIELDS, LONDON, W.C.2.**

**Works : Beeston, Notts.**

**(Telephone : HOLborn 6936)**



CREATED BY

**Ericsson**

TELEPHONES LTD.

## INDEX TO ADVERTISERS

Alton Battery Co., Ltd., The .. .. .	iv	Institution of Post Office Electrical Engineers, The ..	xxiv
Automatic Coil Winder & Electrical Equipment Co., Ltd.	iii	Londex, Ltd. . . . .	xvii
Automatic Telephone & Electric Co., Ltd. . . . .	xii & xiii	Muirhead & Co., Ltd. . . . .	xi
Bennett College .. .. .	ix	Multicore Solders, Ltd. . . . .	xvi
Caplin Engineering Co., Ltd. . . . .	viii	Pirelli-General Cable Works, Ltd. . . . .	xxvi
Creed & Co., Ltd. . . . .	xxiii	Rawplug Co., Ltd., The .. .. .	xv
Ebonestos Industries, Ltd. . . . .	xv	Siemens Brothers & Co., Ltd. . . . .	vi & vii
Edison Swan Electric Co., Ltd., The .. .. .	ii	Smith, Frederick & Co. . . . .	xxv
Elliott Bros. (London), Ltd. . . . .	xxv	Sullivan, H. W., Ltd. . . . .	xvii
Ericsson Telephones, Ltd. . . . .	xx & xxi	Telephone Manufacturing Company, Ltd. . . . .	x
Evershed & Vignoles, Ltd. . . . .	xviii	Telephony Publishing Corporation .. .. .	xvii
Ferranti, Ltd. . . . .	xv	Turner, Ernest .. .. .	xxii
General Electric Co., Ltd., The .. .. .	ii & xiv	United Insulator Co., Ltd. . . . .	v
Hall Telephone Accessories (1928), Ltd. . . . .	xxiii	Westinghouse Brake & Signal Co., Ltd. . . . .	xix

# TURNER DIFFERENTIAL MILLIAMMETERS G.P.O. No. 17 & No. 18

Meet the most  
exacting demands  
for balancing currents  
in multiplex telegraph circuits.

—A quality  
product of outstanding  
merit—

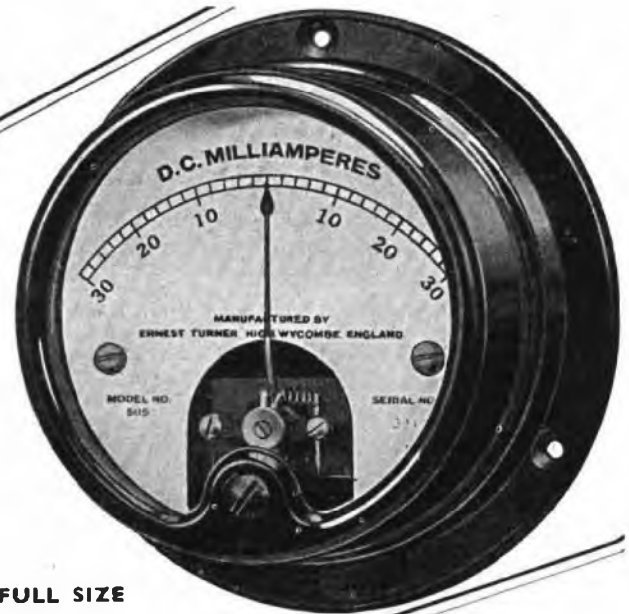

FULL SIZE

Also manufacturers of G.P.O. Detector No. 4, and a comprehensive line of instruments for precision electrical measurements.

**ERNEST TURNER ELECTRICAL INSTRUMENTS, Ltd.**

**CHILTERN WORKS,  
49-73 TOTTERIDGE AVENUE,  
HIGH WYCOMBE,  
BUCKS. ENGLAND**

Telephone : High Wycombe 1301, 1302.  
Telegrams : Gorgeous High Wycombe.



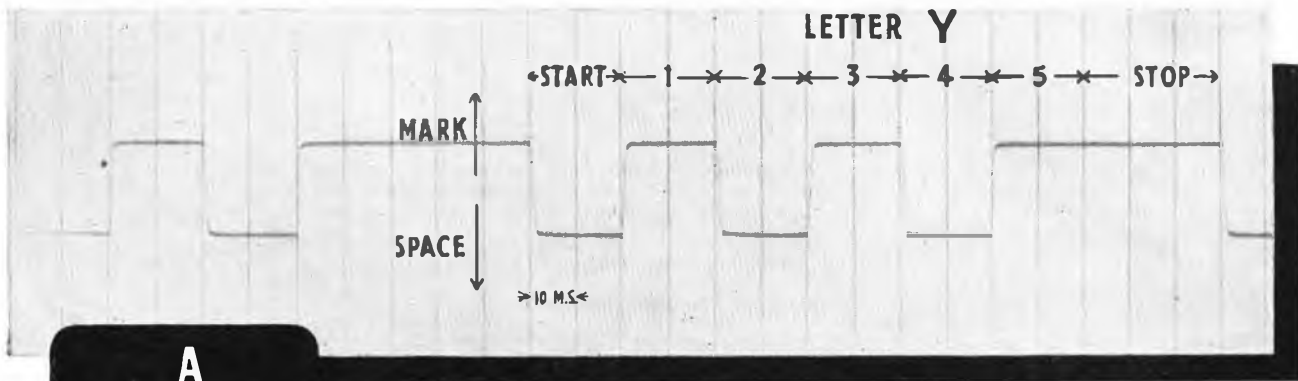

**A  
NOTEWORTHY  
ADVANCE IN**

# TELEGRAPH TRANSMISSION

In the Creed Laboratory efforts are constantly directed towards effecting further progress in Printing Telegraph Communication. A new Teleprinter Transmitter designated Transmitting Unit S.2184, is a recent Creed development of considerable importance. Some of its outstanding features are :-

The provision of high quality Transmission with greatly reduced maintenance.

The Transmission performance is attained without critical adjustment and remains constant over extended periods without readjustment.

Accurate timing, complete freedom from contact rebound and the almost imperceptible transit time will be noted from the above reproduced oscillogram of actual Transmission.

Transmitting Unit S.2184 is now standardized on all Model 7 Creed Teleprinters, and is interchangeable with the previously fitted Transmitting Unit S.1842.

**CREED & CO. LTD., TELEGRAPH HOUSE, CROYDON.** Telephone: CROYDON 2121 (6 lines)

## Hall Telephone Accessories (1928) Limited

Suppliers to the British Post Office, Air Ministry, Admiralty, War Office and Foreign Government Departments.

Manufacturers of prepayment telephone multi-coin collectors, gas leak indicators, precision instruments, automatic stamp selling and ticket selling machines, automatic slot machines and fire alarm apparatus.

*Registered Office:*

**70, DUDDEN HILL LANE, WILLESDEN,  
LONDON, N.W.10**

Tel. WILLESDEN 5141/2/3.

Also SOUTH WALES

## Order Your Next JOURNAL Now!

THE Post Office Electrical Engineers' Journal is, like all other publications, subject to paper rationing. It is therefore essential to reduce to a minimum the margin of the number of copies printed over those ordered in advance. If you have not previously given a standing order please do so now, and if you are a regular subscriber please advise your local agent or the publishers, as early as possible, of any change in your requirements. In this way you will assist in eliminating waste and also ensure that your copy of the Journal is available each quarter.

# THE INSTITUTION OF POST OFFICE ELECTRICAL ENGINEERS

## PRINTED PAPERS

The following papers contributed to the proceedings of the Institution have been printed by authority of the Council and may be obtained, if still in print, from

**"THE LIBRARIAN, The Institution of Post Office Electrical Engineers, G.P.O. (ALDER HOUSE), LONDON, E.C.1."**

The prices do *not* include postage, and in every case, Members, Associate Members and Associates have the privilege of purchasing copies at two-thirds the stated price.

No. 121	"X-RAYS, AND THE STRUCTURE OF SOME ENGINEERING MATERIALS."—W. G. RADLEY, B.Sc. 1929 .. .. .	9d.
No. 122	"THE MEASUREMENT OF RELAY TIMES."—R. W. PALMER, A.M.I.E.E. 1929.. .. .	9d.
No. 123	"MODERN ELECTRICAL ILLUMINATION."—J. J. EDWARDS, B.Sc.(Eng.), A.C.G.I., D.I.C. 1928 .. .. .	9d.
No. 124	"THE MEASUREMENT OF SOUND AND ITS APPLICATION TO TELEPHONY."—A. J. ALDRIDGE, A.C.G.I., A.M.I.E.E. 1929 .. .. .	9d.
No. 125	"THE DEVELOPMENT OF AUTOMATIC ROUTINERS IN THE BRITISH POST OFFICE."—A. SPEIGHT, A.M.I.E.E. 1929 .. .. .	9d.
No. 134	"SOUND AND HEARING."—Capt. N. F. CAVE-BROWNE-CAVE, B.Sc., A.M.I.E.E. 1930.. .. .	1s.
No. 136	"SOME DEVELOPMENTS IN TELEGRAPH TECHNIQUE AS APPLIED TO RADIO CIRCUITS."—H. FAULKNER, B.Sc., A.M.I.E.E., and G. T. EVANS. 1931. .. .. .	1s.
No. 139	"DISTRICT ACCOUNTING."—T. FEWSTER. 1931 .. .. .	9d.
No. 140	"SOME NON-METALLIC SUBSTANCES AND THEIR CHARACTERISTICS."—Capt. N. F. CAVE-BROWNE-CAVE, B.Sc., A.M.I.E.E. 1931 .. .. .	9d.
No. 142	"PRIVATE BRANCH EXCHANGE INSTALLATIONS."—R. T. A. DENNISON. 1932 .. .. .	1s. 3d.
No. 146	"LAYING ARMoured CABLE BY MEANS OF A MOLE-DRAINER."—L. G. SEMPLE, B.Sc.(Eng.), and R. O. BOCOck, B.Sc.(Eng.). 1932 .. .. .	9d.
No. 147	"DESIGN AND CONSTRUCTION OF ELECTRIC WAVE FILTERS."—R. J. HALSEY, B.Sc., etc. 1932. .. .. .	1s. 3d.
No. 148	"STORES SPECIFICATIONS AND ACCEPTANCE TESTING."—Capt. J. LBBG, B.Sc., A.M.I.E.E. 1933 .. .. .	9d.
No. 149	"RECENT DEVELOPMENTS IN UNDERGROUND CONSTRUCTION, LAYING AND LOADING ARMoured CABLES."—J. E. Z. BRYDEN, B.Sc.(Eng.), A.M.I.E.E., and T. HARGREAVIS, A.M.I.E.E. 1933 .. .. .	1s.
No. 150	"TELEPRINTERS."—E. S. RITTER, M.I.E.E. 1933 .. .. .	1s.
No. 151	"RECENT REPEATER STATION INSTALLATIONS."—Major F. E. A. MANNING, M.C., B.Sc.(Eng.), M.I.E.E., A.M.I.Mech.E. 1933 .. .. .	1s.
No. 152	"SOME NOTES ON EXCHANGE EQUIPMENT FACTORY COSTING AND THE ECONOMICS OF PRODUCTION."—S. J. HUSBAND, Assoc.I.E.E. 1933 .. .. .	1s. 3d.
No. 153	"MODERN DEVELOPMENTS IN TELEPHONE TRANSMISSION OVER LINES."—J. STRATTON, A.C.G.F.C., and W. G. LIXTON. 1933 .. .. .	1s. 3d.
No. 154	"THE TELEGRAPH POLE."—W. H. BRENT, B.Sc., A.M.I.E.E. 1933 .. .. .	1s.
No. 156	"MODERN TENDENCIES IN THE SUPPLY OF POWER TO TELEPHONE EXCHANGES."—H. C. JONES, B.Sc.(Eng.). 1935 .. .. .	9d.
No. 158	"ULTRA SHORT WAVE RADIO TELEPHONE CIRCUITS."—D. A. THORN, B.Sc.(Eng.), A.M.I.E.E., and H. T. MITCHELL, A.M.I.E.E. 1935 .. .. .	1s.
No. 159	"MODERN ELECTRIC PASSENGER LIFTS."—R. S. PHILLIPS, A.M.I.E.E. 1935 .. .. .	9d.
No. 161	"MODERN TELEPHONE REPEATER STATION POWER PLANT."—F. W. G. DYE. 1936	6d.
No. 162	"VOICE FREQUENCY SIGNALLING ON TRUNK CIRCUITS."—T. H. FLOWERS, B.Sc., A.M.I.E.E., and B. M. HADFIELD, B.Sc., A.M.I.E.E. 1937 .. .. .	1s.
No. 163	"AUTOMATIC EXCHANGE DESIGN."—H. E. FRANCIS. 1936 .. .. .	1s. 3d.
No. 164	"THE LONDON-BIRMINGHAM COAXIAL CABLE SYSTEM."—A. H. MUMFORD, B.Sc.(Eng.), A.M.I.E.E. 1937 .. .. .	1s. 3d.
No. 165	"PROPERTIES AND TESTING OF DI-ELECTRIC MATERIALS."—J. F. DOUST and W. J. SULSTON, M.Sc., A.Inst.P. 1938 .. .. .	1s.
No. 166	"CHEMISTRY AND COMMUNICATIONS."—D. W. GLOVER, M.Sc., A.I.C. 1937 .. .. .	6d.
No. 167	"TWELVE-CIRCUIT CARRIER TELEPHONE SYSTEMS."—G. J. S. LITTLE, B.Sc., A.M.I.E.E. 1938 .. .. .	6d.
No. 168	"THE DEVELOPMENT OF MAGNETIC MATERIALS."—C. E. MORGAN, A.M.I.E.E. 1938.. .. .	6d.
No. 169	"CROSSTALK."—H. C. S. HAYES, A.M.I.E.E., R. A. SEYMOUR and P. R. BRAY, M.Sc.(Eng.), Grad.I.E.E. 1938 .. .. .	1s. 3d.
No. 170	"SUBSCRIBERS' CABLE DISTRIBUTION—RECENT DEVELOPMENTS."—L. MEEK, A.M.I.E.E. 1939 .. .. .	6d.
No. 171	"MULTI-CIRCUIT CARRIER TELEPHONY."—E. M. RICHARDS, A.C.G.I., B.Sc. (Eng.), M.I.E.E., and F. J. D. TAYLOR, B.Sc. (Eng.). 1938 .. .. .	1s. 6d.

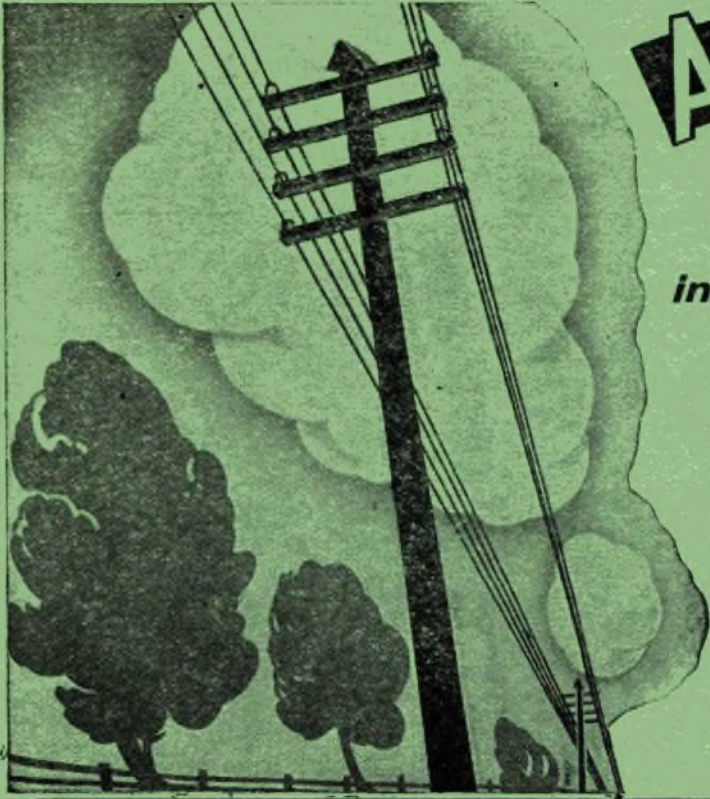

# ANACOS

REGD.

## WIRES

in

### BRONZE AND CADMIUM-COPPER

AS SUPPLIED TO H.M. POST OFFICE  
FOR TELEPHONE LINES

SEND US PARTICULARS OF YOUR JOB  
AND OUR TECHNICAL ENGINEERS WILL  
PROVIDE YOU WITH THE DATA YOU NEED

TELEPHONE  
BLACKFRIARS  
B/01 (5 lines)

**FREDERICK SMITH & COMPANY**  
(INCORPORATED IN THE LONDON ELECTRIC LIGHT COMPANY AND SMITHS LIMITED)  
ANACONDA WORKS, SALFORD, 3, LANC'S.

TELEGRAMS  
ANACONDA  
MANCHESTER

★  
**TELEGRAPH APPARATUS**  
*for*  
**MORSE SYSTEMS**

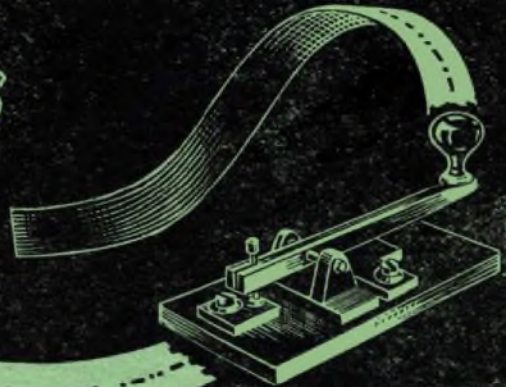

*Makers of:*

**GALVANOSCOPES · INKERS  
RESISTANCES · RELAYS  
SOUNDERS · DETECTORS  
KEYS · MILLIAMMETERS  
AUTOMATIC RECEIVERS  
& TRANSMITTERS ETC**

*Write for illustrated catalogue*

**ELLIOTT BROTHERS (LONDON) LTD.** CENTURY WORKS,  
LEWISHAM, S.E.13

# MAINTAINING EFFICIENCY



THE HIGH STANDARD OF EFFICIENCY OF  
 PIRELLI GENERAL TELEPHONE CABLES IS  
 MAINTAINED BY THE CONTINUOUS  
 RESEARCH WORK OF AN EXPERIENCED  
 TECHNICAL STAFF.

TELEPHONE  
 SOUTHAMPTON  
 2141 (5 LINES)

**PIRELLI-GENERAL**

CABLE WORKS, Ltd., SOUTHAMPTON.

TELEGRAMS:  
 "PIRELLI-KAYBEL,  
 SOUTHAMPTON."