

THE POST OFFICE ELECTRICAL ENGINEERS' JOURNAL

VOL. 34

APRIL, 1941

PART 1

CONTENTS

	PAGE
THE ECONOMIC DESIGN OF MANHOLES—J. P. Harding, B.Sc. (Eng.) Part I—Estimation of Loads	1
ALKALINE TYPE C.E.M.F. CELLS—L. H. Catt	9
THE APPLICATION OF 12-CIRCUIT CARRIER TELEPHONY TO EXISTING CABLES—A. J. Jackman, B.Sc. (Eng.), A.C.G.I., and R. A. Seymour	12
MODERN MATERIALS IN TELECOMMUNICATIONS—W. G. Radley, Ph.D., M.I.E.E., C. E. Richards, F.I.C., E. A. Speight, Ph.D., D.L.C., A.R.C.S., E. V. Walker, B.Sc., A.R.S.M. Part IV—Magnetic Materials	19
THE POST OFFICE AND PUBLIC ADDRESS—E. J. Casterton	26
AN IMPULSE GENERATOR—B. M. Hadfield, B.Sc., A.M.I.E.E., and W. W. Chandler, B.Sc.	31
A SIMPLE INTRODUCTION TO THE USE OF STATISTICS IN TELE- COMMUNICATIONS ENGINEERING—J. F. Doust and H. J. Josephs, F.S.S., A.M.I.E.E.	36
A NOTE ON AMPLITUDE, PHASE, AND FREQUENCY MODULA- TION—H. D. Bickley, B.Sc., Grad.I.E.E.	42
NOTES AND COMMENTS	46
THE INSTITUTION OF POST OFFICE ELECTRICAL ENGINEERS ..	47
REGIONAL NOTES	48
STAFF CHANGES	49

Price 1/- net

THE INSTITUTION OF POST OFFICE ELECTRICAL ENGINEERS

G.E.C.

CRYSTAL CALIBRATOR

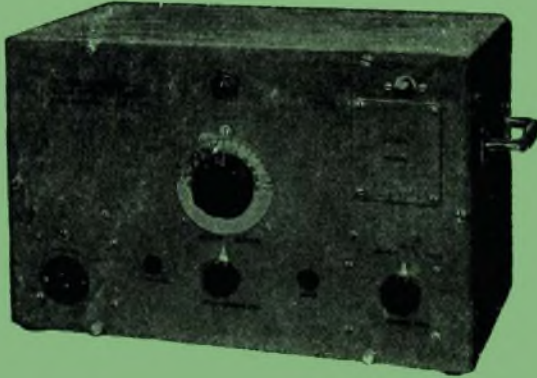

A new precision instrument for the rapid and accurate checking and adjustment of radio frequency oscillators, receivers, transmitters and similar apparatus.

It is crystal operated and A.C. mains operated.

Ask for full information from :

SALFORD ELECTRICAL INSTRUMENTS LTD.

SALFORD

PROPRIETORS: THE GENERAL ELECTRIC CO., LTD.

EDISWAN

TELEPHONE LINE PROTECTOR PANELS

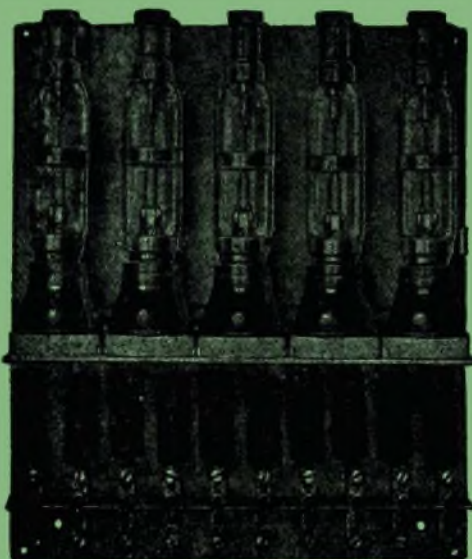

5-circuit panel for overhead lines incorporating choke coils, spark gaps, etc.

EDISWAN-SHOTTER-GREETHAM PATENT

(British Patent No. 35392-9)

for the protection of telephone systems against surges induced by faults on neighbouring power lines

Of the difficulties attendant upon the employment of overhead systems one of the most serious is to ensure uninterrupted working of the telephone system, by providing adequate protection against induced surges caused by switching or line faults in adjacent power lines or by lightning.

The Ediswan Patent Protectors provide the solution. They are inert at the normal working pressure of the telephone line, they keep the voltage on the line down to a pre-determined figure by providing a path of low resistance to earth whereby the surge is cleared and they again become inert immediately the surge is cleared.

They ensure simultaneous discharge of both lines and are capable of clearing heavy discharges without detriment to the system or the protector.

Ediswan Telephone Line Protectors have now been in use by Supply Companies for many years.

THE EDISON SWAN ELECTRIC CO. LTD.,  155 CHARING CROSS ROAD, LONDON, W.C.2

SIMPLIFIED SERVICING MAINTENANCE & FAULT FINDING



BRITISH MADE

46 Ranges
of
Direct
Readings

DESIGNED by technicians who have made a special study of the service and maintenance engineers' problems, the Model 7 Universal AvoMeter is acknowledged throughout the world as the one indispensable combination testing instrument. A single meter, yet at the touch of two simple switches it provides for any one of the 46 ranges of measurements for testing and tracing all electrical faults.

Entirely self-contained, the Model 7 Universal AvoMeter is essentially portable and, above all, simple to use. It is dead-beat in action, has a 5-inch hand-calibrated scale with anti-parallax mirror, and conforms to B.S. 1st Grade accuracy requirements. It is fully protected by an automatic cut-out against damage through overload.

Also available

Model 7 Resistance range Extension Unit (for measurements down to 1/100th. ohm)

40-range Universal AvoMeter

•Write for fully descriptive pamphlet.

Sole Proprietors and Manufacturers

The Automatic Coil Winder & Electrical Equipment Co., Ltd.,
Winder House, Douglas Street, London, S.W.1. Telephone: Victoria 3404/7

VOLTAGE			
A.C.		D.C.	
Range.	Value per division	Range.	Value per division
0- 5 Volts	50 mV.	0- 50 mV (1 mA range)	0.5 mV.
0- 10 "	100 "	0- 100 mV (2 mA range)	1 "
0- 50 "	500 "	0- 500 mV	5 "
0- 100 "	1 Volt	0- 1 Volt	10 "
0- 200 "	2 "	0- 5 "	50 "
0- 400 "	4 "	0- 10 "	100 "
0- 500 "	5 "	0- 50 "	500 "
0-1,000 "	10 "	0- 100 "	1 Volt
		0- 200 "	2 "
		0- 400 "	4 "
		0- 500 "	5 "
		0-1,000 "	10 "

CURRENT			
A.C.		D.C.	
Range.	Value per division	Range.	Value per division
0- 5 mA	50 μ A	0- 1 mA	10 μ A
0- 10 "	100 "	0- 2 "	20 "
0- 50 "	500 "	0- 5 "	50 "
0-100 "	1 mA	0- 10 "	100 "
0-5 "	5 "	0- 50 "	500 "
0- 1 Amp.	10 "	0-100 "	1 mA
0- 5 "	50 "	0-500 "	5 "
0- 10 "	100 "	0- 1 Amp.	10 "
		0- 5 "	50 "
		0- 10 "	100 "

RESISTANCE			
First Indication.			
0-10,000 ohms	0.5 ohms	} using internal 1½-volt cell.	
0-100,000 "	5 "	} using internal 9-volt battery.	
0-1 megohm	50 "	} using external source of	
0-10 "	500 "	} A.C. or D.C. voltage.	
0-40 "	2,000 "		

CAPACITY	POWER	DECIBELS
0 to 20 mFd.	In 4,000 Ω	reference level
First Indication	Internal realisance	50 mW
0.01 mFd.	0 to 4 watts	-10 Db. to
	First indication	+15 Db.
	1 mW	

The 46-RANGE UNIVERSAL

AVOMETER

Regd. Trade Mark

Electrical Measuring Instrument

Model 7



Illustration shows an installation of Alton Batteries of Merit at an important London Telephone Exchange.

ACHIEVEMENT

*And now the matchless deed's achieved
Determined, dared and done.
Christopher Smart.*

There is a common tendency to admire mere size. Talented men and promising businesses are apt to be overlooked until their merits bring the success and importance which command attention. By the test of size the Alton Company would not have attracted much notice when it started. It was small, but it had a product and a policy which could not be denied

success. It made batteries of the finest quality; carried out replating of the highest standard at the lowest rates which could show a reasonable profit; experimented with improvements and learned from experience. This policy has made the Alton Company big not only in size but in reputation, and it will continue to rely on this policy to carry it to still greater success.

ALTON BATTERIES

THE ALTON BATTERY CO. LTD. ALTON HANTS

Incorporating

FULLER Accumulator Co. (1926) Ltd.

TELEPHONE : 2267 & 2268 ALTON
TELEGRAMS : "BATTERY, ALTON"

ALTON BATTERIES OF MERIT



CERAMIC TRIMMER CONDENSERS



...GIVE MAXIMUM EFFICIENCY
FOR SHORT WAVE WORK

U.I.C. CERAMIC TRIMMER CONDENSERS successfully fulfil every requirement of modern H.F. radio and short-wave technique.

In actual practice they have established a definite superiority over Air and Compression type Trimmers. Note these obvious advantages.

- | | |
|---|--|
| 1. Simplicity of design and small size. | 4. Unaffected by temperature and humidity. |
| 2. Low Power Factor. | 5. Linear Capacity Law. |
| 3. Perfect mechanical and electrical stability. | 6. Small Stray Field |

A wide range of varieties and sizes are immediately available from stock.

Write for brochure and full details

Contractors to G.P.O. and Government Departments.
On A.I.D. Approved List

UNITED INSULATOR CO LTD

The Pioneers of Low Loss Ceramics

12-16 LAYSTALL STREET
LONDON. E.C.1

Tel: TERMINUS 4118-9

Grams: CALANEL, SMITH, LONDON

vi



SIEMENS

ELECTRICAL

Manufacturers

TELEPHONE CABLES

Aerial, Underground, Submarine

LOADING COILS

ELECTRIC WIRES & CABLES

of all types

CABLE JOINT BOXES

OVERHEAD LINE MATERIAL

MARINE APPARATUS

WIRELESS EQUIPMENT FOR SHIPS

Contractors for the
laying and
maintenance of
Submarine
and
Land Cables
for
Telegraphy,
Telephony
and
Power Transmission.



SIEMENS BROTHERS

WOOLWICH

Telephone : D.L.V.



PRODUCTS

urers of

PUBLIC TELEPHONE EXCHANGES

PRIVATE TELEPHONE SYSTEMS

ELECTRIC TOTALISATORS

CELLS & BATTERIES

Dry, Fluid and Inert

MEASURING & RECORDING
INSTRUMENTS

ELECTRICITY METERS

ELECTRIC LAMPS

Contractors for the
erection and
maintenance of
Marine Wireless
Installations,
Public and
Private Telephone
Exchanges,
and
Carrier Equipment
for
Telephone Lines.



S & CO. LIMITED

LONDON, S.E.18

DULWICH 2020.

CAPCO

REGISTERED TRADE MARK

Quartz Cutting Machine

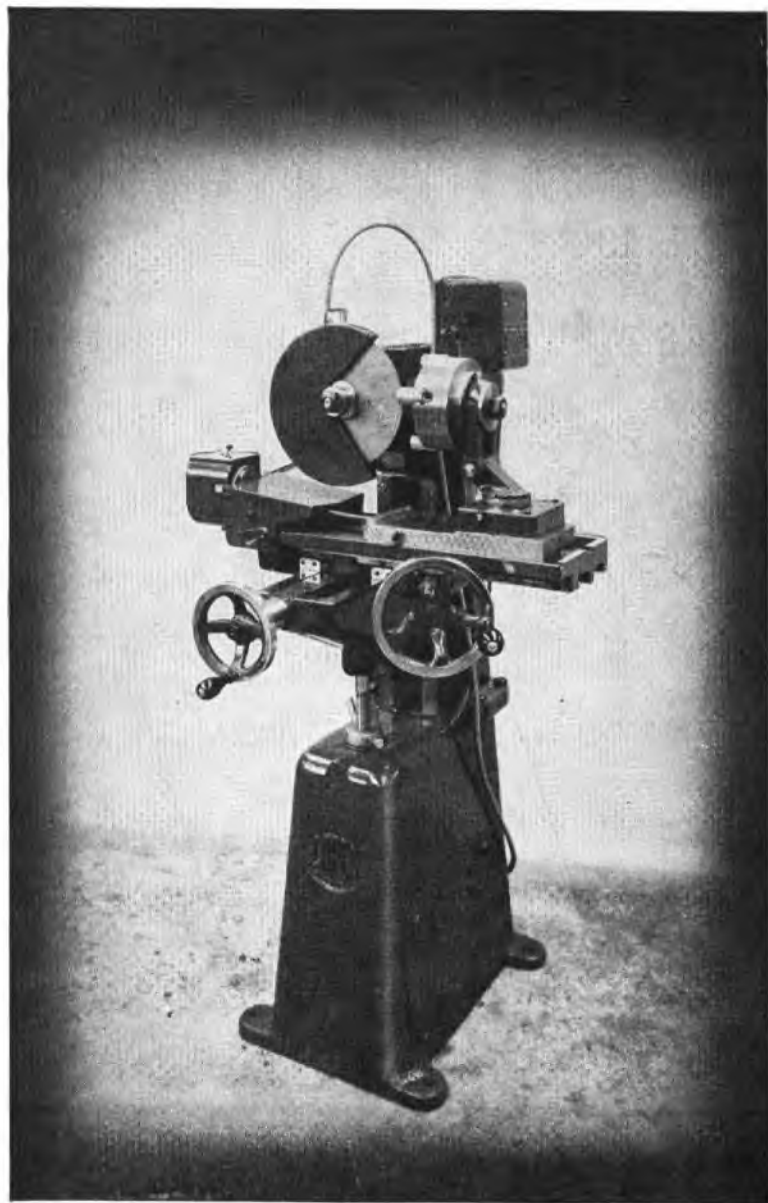

Designers and Manufacturers of Capco Sound-on-Film recorders and equipment. Capco built recorders are in use at Elstree, Pathe News and British Talking Pictures, etc. Patentees and Manufacturers of Capco Enamelled Wire cleaning machines.

Illustration shows latest Model of the Quartz Cutting Machine developed and designed in collaboration with engineers of the Radio Branch of the Post Office.

Similar machines have been supplied to the Post Office and to the leading Telephone and Radio Manufacturers.

Standard and heavy duty cutting machines with high rates of cutting to accuracies of .001 in.

Fixtures to hold any shape of crystal can be supplied.

Heavy Duty Machine can now be supplied with nine rates automatic feed through specially designed gear box, sensitive instantaneous stop through specially designed clutch.

Acknowledged to be the finest machines of their kind for this class of work.

Manufacturers :

CAPLIN

ENGINEERING CO. LTD.

Precision Engineers

BEACONSFIELD RD., WILLESDEN
LONDON, N.W.10

Telephone :
WILlesden 0692.

Cables :
Caplinko, London.

ESTABLISHED 1918

Sole Agents : CAPCO (SALES) LTD.

THIS YEAR—WE CLIMB TO VICTORY

YOU CAN HELP YOUR COUNTRY and yourself at the same time if you do your best, but you are not doing your best if you waste time.

By becoming efficient in your vocation you can give the best service to your country and to yourself. The more you increase your earning power the better it is for the country and for yourself personally.

War or no war, earning power always brings its possessor to the front. It is no use waiting for better times. The ideal opportunity never arrives. We have to make the best of existing conditions. Therefore, delay is useless; it is worse, it is harmful.



TO ACHIEVE VICTORY, we must be efficient—to be efficient we must be trained.

If it is your desire to make progress and establish yourself in a good career, write to us for free particulars on any subject which interests you, or if your career is undecided, write and tell us of your likes and dislikes, and we will give you practical advice as to the possibilities of a vocation and how to succeed in it. You will be under no obligation whatever. It is our pleasure to help. We never take students for courses unless we feel satisfied they are suitable. Do not forget that success is not the prerogative of the brilliant. Our experience of over thirty years proves that the will to succeed achieves more than outstanding brilliancy.

EARNING POWER IS A SOUND INVESTMENT

DO ANY OF THESE SUBJECTS INTEREST YOU ?



Accountancy Examinations
Advertising and Sales Management
Agriculture
A.M.I. Fire E. Examinations
Applied Mechanics
Army Certificates
Auctioneers and Estate Agents
Aviation Engineering
Aviation Wireless
Banking
Blue Prints
Boilers
Book-keeping, Accountancy and Modern Business Methods
B.Sc. (Eng.)
Building, Architecture and Clerk of Works
Builders' Quantities
Cambridge Senior School Certificate
Civil Engineering
Civil Service
All Commercial Subjects
Commercial Art
Common Prelim. E.J.E.B.

Concrete and Structural Engineering
Draughtsmanship. All branches
Engineering. All branches, subjects and Examinations
General Education
G.P.O. Engineering Dept.
Heating and Ventilating
Industrial Chemistry
Institute of Housing Insurance
Journalism, Languages
Mathematics
Matriculation
Metallurgy
Mining. All subjects
Mining. Electrical Engineering
Motor Engineering
Motor Trade
Municipal and County Engineers
Naval Architecture
Novel Writing
Pattern Making
Play Writing
Police, Special Course

Preceptors, College of Press Tool Work
Pumps and Pumping Machinery
Radio Communication
Radio Service Engineering
Road Making and Maintenance
Salesmanship, I.S.M.A.
Sanitation
School Attendance Officer
Secretarial Exams.
Sheet Metal Work
Shipbuilding
Shorthand (Pitman's)
Short Story Writing
Speaking in Public
Structural Engineering
Surveying
Teachers of Handicrafts
Telephony and Telegraphy
Television
Transport Inst. Exams.
Weights and Measures Inspector
Welding
Wireless Telegraphy and Telephony
Works Managers

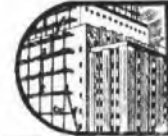

If you do not see your own requirements above, write to us on any subject. Full particulars free.



CAN YOU CHANGE MY EXPRESSION?
IF SO, YOU MAY BE THE ARTIST THAT COMMERCE IS WAITING FOR.
Just try it for yourself. Trace or draw the outline and then put in the features.

There are hundreds of openings in connection with Humorous Papers, Advertisement Drawings, Posters, Calendars, Catalogues, Tackle Designs, Book Illustrations, etc.

60 per cent. of Commercial Art Work is done by "Free Lance Artists" who do their work at home and sell it to the highest bidder. Many Commercial Artists draw "retaining fees" from various sources, others prefer to work full-time employment or partnership arrangement. We teach you not only how to draw what is wanted, but how to make buyers want what you draw. Many of our students who originally took up Commercial Art as a hobby have since turned it into a full-time paying profession with studio and staff of assistant artists; there is no limit to the possibilities. Let us send full particulars for a FREE TRIAL and details of our course for your inspection. You will be under no obligation whatever.

Jim Duval ART DEPT. 24

Every Department is a Complete College:
Every Student is a Class to Himself



If you attend to this now, it may make a wonderful difference to your future

COUPON—CUT THIS OUT

To Dept. 24, THE BENNETT COLLEGE LTD., SHEFFIELD

Please send me (free of charge) Particulars of.....

Your private advice about.....

(Cross out line which does not apply)

PLEASE WRITE IN BLOCK LETTERS

Name.....
Address.....

STUDY AT HOME IN
YOUR SPARE TIME

JOURNALISM

Short Story, Novel and Play Writing

There is money and pleasure in Journalism and in Story Writing. No apprenticeship, no pupilage, no examinations, no outfit necessary. Writing for newspapers, novels or pictures is not a gift; it is a science that can be acquired by diligent application and proper guidance. It is the most interesting way of making pastime profitable. Trained ability only is required, we do the training by post. Let us tell you about it.

DEPARTMENT OF LITERATURE 24



PRECISION

Notwithstanding the difficulties met with under present conditions, the Telephone Manufacturing Company, Ltd., is maintaining the well-known reliability of its condensers. These are manufactured in a modern condenser plant, and are notable for the following features:—

Rigid construction.	Maintenance of initial capacitance values.
Small size and weight.	Low power factor.
Extreme stability.	Adequate safety factor, and
Low temperature co-efficient of capacity.	Long life.
High insulation resistance.	

Only high grade materials are used, which have been proved to be suitable by chemical, physical and electrical tests, and careful supervision is given at all stages of manufacture.

Enquiries are solicited in respect of the following types:—

(a) Mica Condensers.

These are manufactured in copper or other metal cans, as required, which are marked with the actual and nominal capacities. They are suitable for continuous use up to a pressure of 100 volts R.M.S. and at any frequency up to 200 Kc. They may be supplied and adjusted to within $\frac{1}{2}$ per cent. from the nominal capacity. The temperature co-efficient is not greater than '0045 per cent. and the power factor at 1,000 cycles/second is not greater than '001.

(b) Precision Paper Condensers.

These are of the oil impregnated, oil filled, clamped paper dielectric type. The capacity is adjusted to within 2 per cent. of the nominal capacity and departures from the actual capacity due to temperature variations from 0 deg. C. to 50 deg. C. are not greater than 2 per cent. These condensers are fitted with terminals constructed from Mica-filled bakelite and having an insulation of not less than 10,000 Megohms at normal temperature and humidity.

Prompt attention given to enquiries and deliveries expedited.

TELEPHONE MANUFACTURING COMPANY LTD.
WEST DULWICH, S.E.21

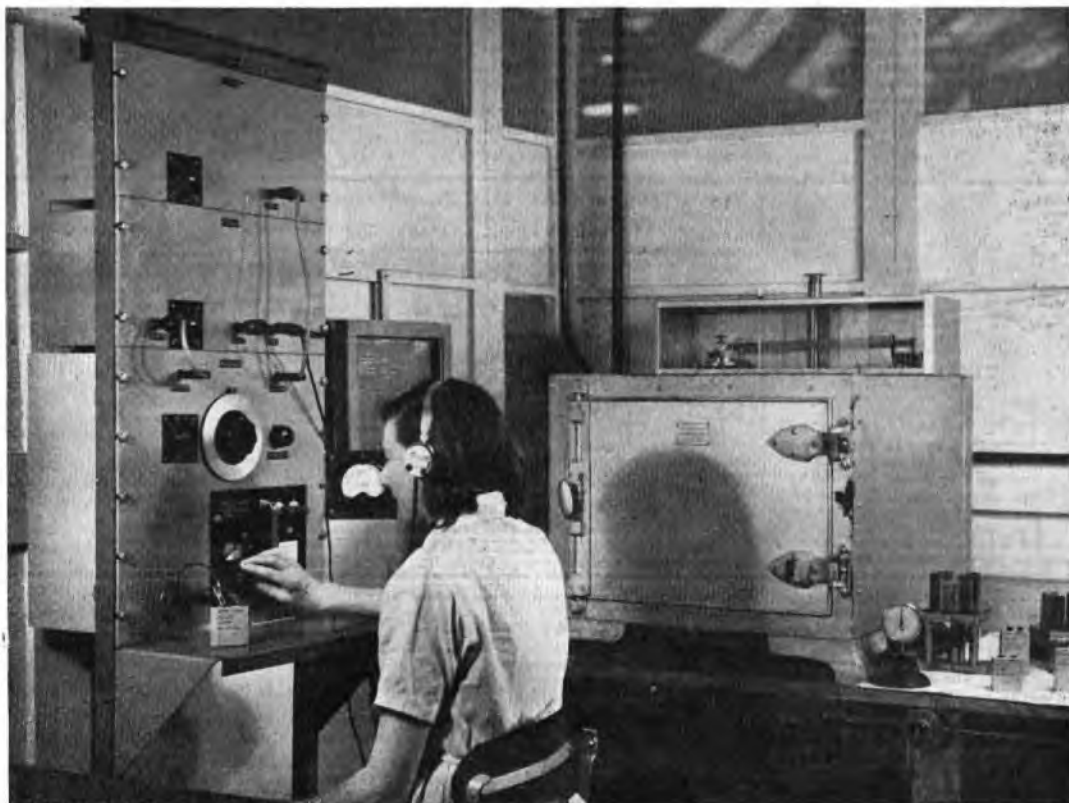

THE POST OFFICE ELECTRICAL ENGINEERS' JOURNAL

Vol. XXXIV

April, 1941

Part I

The Economic Design of Manholes

J. P. HARDING, B.Sc.(Eng.)

U.D.C. 621.315.233

Part I.—Estimation of Loads

This article deals with the estimation of the stresses to which an underground manhole may be subjected. These comprise earth pressures, traffic loadings, and miscellaneous stresses due to anchor iron loadings and loaded cable bearers. A second article will describe the design of manholes to withstand these stresses.

Introduction.

THE design of underground manholes has, in the past, been mainly influenced by considerations of total financial cost and the limitations imposed by comparatively unskilled labour. Reinforced concrete, being cheaper than brick, has been largely employed, and to secure the necessary strength with a simple arrangement of reinforcement such designs have, in parts, required a more generous use of steel and concrete than would be needed for a manhole built on more scientific principles in which the wall thicknesses and arrangement of reinforcement are designed to give the exact strength required at the various points with a reasonable factor of safety. The need for strict economy of materials, which has been accentuated by the war, has justified the work entailed in the production of a scientifically-balanced design in which all parts are proportioned to meet, with a uniform factor of safety, the stresses to which, in practice, they may be subjected.

In the following pages an attempt is made to describe the way in which these stresses may be assessed. Part II of this article will describe manholes designed to withstand these stresses.

STRESSES IN A TYPICAL MANHOLE

A manhole is required to withstand wall, floor and roof stresses, arising from direct static earth loading and traffic loading, either from traffic near to or directly over the manhole. Stresses will also be induced by loads on anchor irons during cabling operations, and there are, in addition, certain static loadings of less importance, but which, nevertheless, require to be considered, such as the induced stresses from laden cable bearers and the dead weight of loading coil pots or other apparatus which may be placed on the floor.

Static Earth Pressure on Walls.

There will be a certain horizontal loading on the side and end walls of a manhole which may be expressed in lbs./sq. ft. and estimated from the following considerations:—

Angle of Repose or Friction.—If dry loose soil is piled into a heap on horizontal ground, it will assume an approximately conical shape. The friction

between particles of earth enable it to stand at a certain angle (ϕ) to the horizontal, which will vary according to the nature of the earth. This angle is called the "angle of repose" or "angle of friction," and is given in Table 1 for various materials.

TABLE 1

Material	Angle of Repose	Weight (lbs./cu. ft.)
Water	0°	62½
Clay	15°—40°	110—120
Sand and Gravel ..	25°—45°	120
Sand	25°—35°	100—120
Gravel	45°	110
Shingle	30°—35°	115—120
Vegetable Earth ..	15°—30°	95—105

Cohesion.—There is, however, another factor which requires to be taken into account in the calculation of earth pressure, namely cohesion. Earth may possess frictional qualities manifested by a certain angle of repose as described above and show cohesive properties independently. Cohesion, as the name implies, is the property of resistance to tangential separation and, in a mass of earth, the tendency to separate under shear stress is resisted by cohesion. The force of cohesion in a given plane is equal to the areas in contact multiplied by the coefficient of cohesion. The cohesion, therefore, is dependent only on the coefficient and the areas in contact, and, unlike friction, is independent of the normal pressure between the surfaces. Approximate values of cohesion for common soils are given in Table 2.

TABLE 2

Soil	Cohesion lbs./sq. ft.
Dry Sand ..	0—50
Wet Sand ..	400
Dry Gravel ..	200—250
Wet Gravel ..	0—50
Dry Loam ..	600—700
Wet Loam ..	150—250
Clay	900
Wet Clay ..	600—700

The separate properties of friction and cohesion are well shown in a steep or overhanging cliff which may, in parts, have crumbled and fallen. The fallen earth will usually have dried out somewhat and will have assumed an inclination approximating to the angle of repose, a much smaller inclination than the unbroken parts of the cliff. The earth which has fallen is the same as that in the cliff and possesses the same angle of repose. The reason for the varying inclinations is in the difference in cohesion. The natural earth in the cliff, having a certain moisture content and, in its lower portions being subjected to the compacting action of the weight of soil above it, is able to assume a steep or even an overhanging slope, although, perhaps, in a rather unstable state. The fallen earth is subject to neither of these conditions, having crumbled from becoming dried in hot weather and being of an insufficient depth to derive appreciable cohesion by compaction. Accordingly, this earth will assume a slope nearly equal to the angle of repose which may only be about 20-30°, according to the nature of the soil.

When a trench is dug in an area where the surrounding soil has been compacted by traffic, there is frequently considerable cohesion in the soil excavated from the surface. For a certain depth there may, therefore, be no necessity to brace or shore the sides of trenches unless the close proximity of traffic produces a disturbing vibration. Weathering and relatively distant traffic will, however, eventually destroy this cohesion and, unless the trench is shored, it will fall in when the earth on its surface becomes dry. As the depth of a trench increases, the soil may be found to have a greater cohesion at the lower level from the additional weight of soil above, and it is possible on this account that the lateral earth pressure against the side support of a trench may, for a time, be actually least at the lowest depths.

For purposes of calculating earth pressures for permanent underground structures at small depths, particularly in urban areas or in roads, it would be unwise to assume that any reduction in lateral force may be allowed on account of cohesion. Although the forces of cohesion in favourable soil might permit a complete manhole to be built without recourse to shoring the sides of the excavation, it could not be assumed that there would always exist zero or small lateral loadings on the walls. At any moment, and almost certainly in the course of time, a fraction if not the whole of the calculated side loading may be imposed on the walls. This may result from the forming of cracks in the earth or by close settling of the soil to the sides of the manhole. The vibration from traffic and, down to the level of the frost line, the alternate freezing and thawing of the soil may also cause considerable disintegration and loss of cohesion.

Calculation of lateral earth pressures requires to be made, therefore, on the assumption that cohesion is zero, so that the angle of repose only is taken into consideration.

There are several theories from which lateral earth pressures at various depths may be calculated, neglecting cohesion, but the one most commonly used is that due to Professor Rankine.

Rankine's Theory of Earth Pressure.

This theory is based on the assumption that the earth is a dry granular mass of indefinite extent wholly devoid of cohesion, and possessing internal friction only as shown by the natural angle of repose.

If ϕ be the angle of repose
 w weight of earth/cu. ft.
 h the depth

then p , the active horizontal or lateral pressure at a depth h , is given by

$$p = wh \frac{1 - \sin \phi}{1 + \sin \phi} \text{ lbs./sq. ft.}$$

This is the pressure that would require to be resisted by, for example, a retaining wall or earth dam. The reaction of the earth outside the wall is the passive resistance which a mass of earth exerts against the active pressure and is of magnitude

$$wh \frac{1 + \sin \phi}{1 - \sin \phi}$$

Thus, for $\phi = 30^\circ$, the fraction $\frac{1 - \sin \phi}{1 + \sin \phi} = \frac{1}{3}$, and, therefore the passive pressure is 9 times the active pressure.

It is seen that the active earth pressure for an angle of repose of, say, 30° , which has been taken as an average value in the succeeding work, and for $w = 120$ lbs./cu. ft. may be evaluated:—

$$\text{as } p = wh \frac{1 - \sin 30^\circ}{1 + \sin 30^\circ}$$

$$\text{i.e. } p = 120 h \cdot \frac{1}{3} = 40h.$$

The corresponding expression for water pressure would be $p = wh = 62\frac{1}{2}h$ lbs./sq. ft.

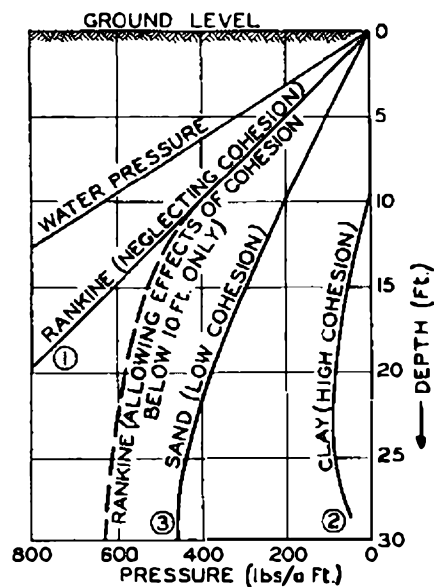

FIG. 1.—VARIATION OF LATERAL EARTH PRESSURE WITH DEPTH FOR SOILS, COMPARED WITH WATER PRESSURE.

The lateral earth pressure is, therefore, about $\frac{2}{3}$ that of water pressure at the same depth, as shown in Fig. 1, curve (1).

The effect of cohesion is to reduce the pressure to an extent depending on the nature of the soil.

For example, in clay, which possesses considerable cohesion, the pressure might be as in Fig. 1, curve (2), and for sand or gravel which possess low cohesion, as in curve (3).

Although, as has been previously stated, reliance should not be placed on the effects of cohesion at small depths, it is, nevertheless, reasonable to assume that for depths in excess of about 10 ft. which are remote from the effects of weathering and traffic vibration the force of cohesion, which increases progressively with depth due to the increasing weight of the soil above, will cause curve (1) to flatten somewhat as shown by the dotted line. Thus it is seen that the normal earth pressure increases approximately uniformly with depth up to a value of about 600-650 lbs./sq. ft. at a depth of 20-25 ft. and undergoes no appreciable increase beyond this depth. A practical illustration of this is the fact that it is common practice to use the same section of timber for shoring up the walls of a deep shaft at the bottom as at the top.

Increase in Pressure Due to Flooding.

An allowance must be made for any changes in pressure which may be produced as a result of flooding arising from a burst water main in the vicinity or from other causes. The effect of serious flooding is to destroy almost entirely the frictional properties of the soil by changing it to mud. The mixture of soil and water will, however, possess a density intermediate between that of water ($62\frac{1}{2}$ lbs./cu. ft.) and soil (say 120 lbs./cu. ft.). A reasonable estimation will be to allow for an angle of repose of zero and for a density of 90 lbs./cu. ft. when the pressure will be:—

$$p \text{ lbs./sq. ft.} = 90h \text{ (compared with the pressure of } 40h \text{ when dry).}$$

This necessitates a design to withstand an increase of 125 per cent. on the "dry" pressure value, and reference will be made to this at a later stage (second article).

TRAFFIC LOADING

The presence of traffic near or over a manhole will induce an increased loading on the side walls by

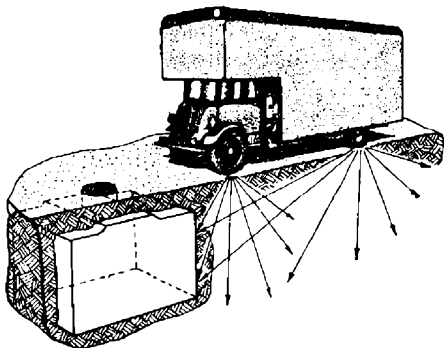

FIG. 2.—TRANSMISSION OF SIDE PRESSURE ON WALLS.

transmission of pressure in a way shown diagrammatically in Fig. 2.

The pressure may be estimated in lbs./sq. ft. in the following way:—

For approximate purposes in the design of culverts and retaining walls, it is frequently assumed that the induced lateral thrust due to road traffic may be allowed for by an addition of 200-300 lbs./sq. ft. to the static earth loading. This, however, does little more than admit the existence of a superimposed load and is not sufficiently accurate for the design of manholes at various depths since, as will be seen subsequently, calculations of the induced traffic loading show that allowances up to 1,000 lbs./sq. ft. may need to be made according to depths. The problem resolves itself into one of finding the magnitude and disposition of the pressure lines in the earth under and adjacent to a concentrated load.

A load placed on the surface of the ground produces a certain depression in the surface, and proportionate depressions and stresses are transmitted through the earth for a considerable distance below and adjacent to the loaded area. Practical measurements have shown that the pressures under loaded pillars and columns in soils of small cohesion assume an approximately parabolic distribution, the pressure being greatest at the centre and less at the edges of the footing. If a section of earth as shown in Fig. 3

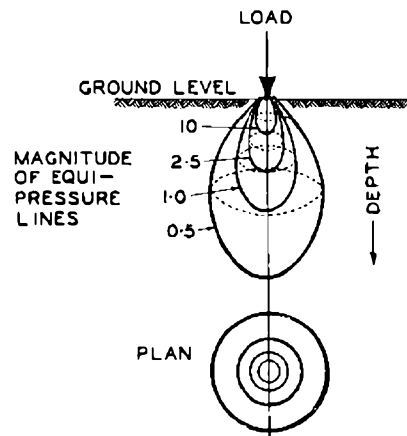

FIG. 3.—EQUIPRESSURE LINES BELOW AND ADJACENT TO A CONCENTRATED LOAD.

be considered, it is found that lines can be drawn connecting points of equal pressure (equi-pressure lines). A horizontal section of the various pressure curves would be concentric circles, and the volume of compressed soil enclosed by the equi-pressure lines, or, more correctly equi-pressure surfaces, are spoken of as bulbs of pressure. The earth within these bulbs provides the support for the load by the cohesion and internal friction of the soil.

A method of estimating the distribution of pressure resulting from an external load on the surface of an infinite homogeneous elastic body has been deduced by Boussinesq.¹ Although no soils are, in fact, perfectly elastic or homogeneous, experiment has shown that the theory developed is in close accordance with practical results and has been recommended for use by the American Society of Civil Engineers.²

¹ Application des Potentials.

² Proc. Am. Soc. C.E., Vol. 59, 1933.

Boussinesq's Method for Estimation of Earth Pressure.

Boussinesq states that a force P (Fig. 4), acting on the surface of a body induces a stress f_a at any point x at a radius r inclined at α° to the vertical,

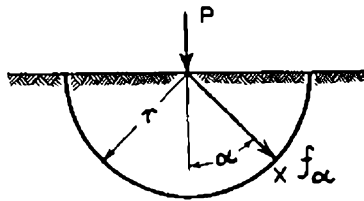

FIG. 4.

where $f_a = \frac{3P}{2\pi r^2} \cdot \cos^2 \alpha$ (1)

Resolving vertically $f_v = \frac{3P}{2\pi r^2} \cdot \cos^3 \alpha$ (2)

Resolving horizontally $f_h = \frac{3P}{2\pi r^2} \cdot \cos^2 \alpha \sin \alpha$.. (3)

These formulae may alternatively be expressed in Cartesian form :

Thus, when the point x is expressed as (x, y)

$\cos \alpha = \frac{y}{\sqrt{x^2+y^2}}$ and $\sin \alpha = \frac{x}{\sqrt{x^2+y^2}}$

i.e., $f_a = \frac{3P}{2\pi} \cdot \frac{y^2}{(x^2+y^2)^2} \cdot \frac{1}{(\frac{x^2}{y^2}+1)^2}$ (4)

$f_v = \frac{3P}{2\pi} \cdot \frac{y^3}{(x^2+y^2)^2 \cdot (\frac{x^2}{y^2}+1)^{3/2}}$
 $= \frac{3P}{2\pi y^2} \cdot \frac{1}{(\frac{x^2}{y^2}+1)^{5/2}}$ (5)

$f_h = \frac{3P}{2\pi} \cdot \frac{y^2}{(x^2+y^2)^2} \cdot \frac{x}{(x^2+y^2)^{1/2}}$
 $= \frac{3P x}{2\pi y^2} \cdot \frac{1}{(\frac{x^2}{y^2}+1)^{5/2}}$ (6)

Formulae (4), (5) and (6) have been expressed in P, y and $\frac{x}{y}$, which facilitates the insertion of values.

It may be of interest to note at this stage that, at a depth of 5 ft., which is approximately that at the centre of the wall of a surface manhole and at a horizontal distance of 4 ft., equation (6) shows that a single load of 10 tons on the surface produces a lateral side thrust on the wall of 99 lbs./sq. ft.

It is possible from equations (1), (2), (3) to evaluate the magnitude of the earth pressures caused by a train of wheels from one or more vehicles such as may occur in practice. Fig. 5 shows the values of f_a in lbs./sq. ft. at various depths and inclinations

for a 1-ton load. Similar curves for f_h and f_v are incorporated in Figs. 8 and 10. From these values, the total effects of any train of wheel loadings can be assessed.

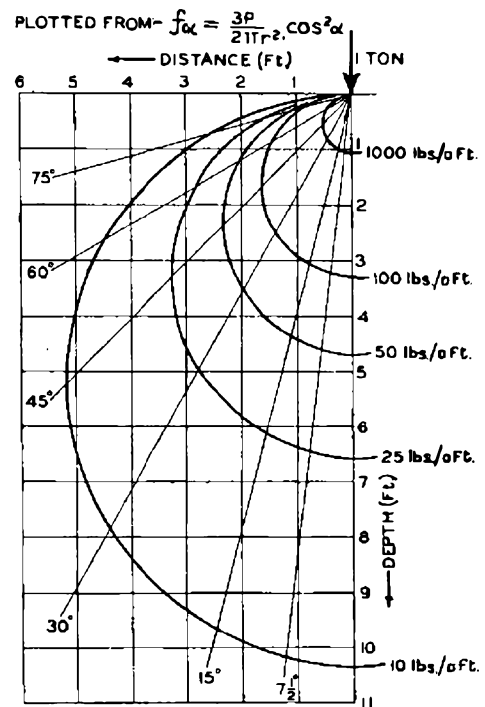

FIG. 5.—VARIATION OF RADIAL PRESSURE (f_a) BELOW AND ADJACENT TO A 1 TON LOAD.

Traffic Loadings Occurring in Practice.

A standard loading for highway bridges has been laid down by the Ministry of Transport, and, since this train will travel out over public roads to reach bridges to be tested, it is necessary to design any underground structure in the carriage-way to accept this loading. Details of the train are given in Fig. 6, which shows the dead weight of the various wheels, the figures in brackets allowing 50 per cent. increase for impact. Although it is unlikely that all wheels in the train will exert their full 50 per cent. impact load simultaneously, no reduction is allowed on this account, and for design purposes, the structure must be capable of withstanding the total live loads.

The train consists of an engine of 20 tons dead weight drawing three trailers each of 13 1/3 tons dead weight. The maximum width of the engine is 9 ft. and that of the trailers 6 ft.

It may happen, in addition, that other traffic will be passing near to the M.O.T. train. From the

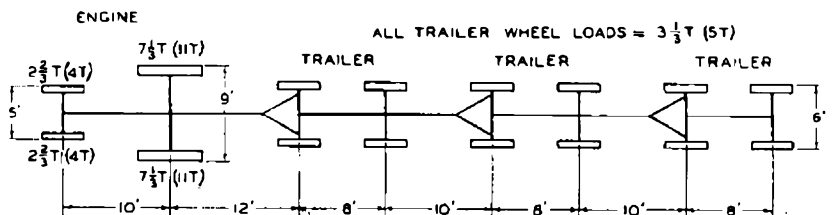

FIG. 6.—M.O.T. TRAIN.

point of view of loading of manholes, the greatest stresses will be produced when another load is close to one of the eleven-ton wheel loads of the M.O.T. train as shown in Fig. 7. The maximum wheel loading (eleven tons) of the M.O.T. train is an

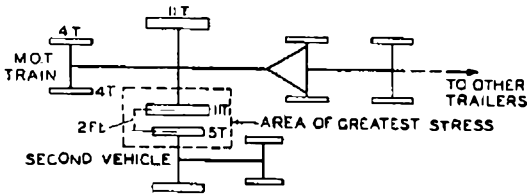

FIG. 7.—M.O.T. TRAIN WITH ADDITIONAL LOAD.

exceptionally severe one, and it is extremely unlikely that other traffic will result in a second loading of eleven tons occurring near to one of the eleven-ton loads of the M.O.T. train. The additional wheel load, for which it has been decided to allow, is one of five tons, and it has been assumed in the succeeding work that it will operate at a distance of 2 ft. from one of the eleven-ton loads of the M.O.T. train.

Estimation of Equivalent Uniform Lateral Pressure on Walls.

Fig. 8(a) shows the variation in lateral pressure

with depth and position of a single load as calculated from equation (3). These curves enable the position of the load in relation to the manhole wall, which will subject the wall to the greatest stress, to be determined. With the load as shown in Fig. 8(a), this position of the manhole wall is at AB. It can be seen from inspection that if the load were either further from or nearer to the wall, it would induce a smaller stress by subjecting the wall to smaller lateral loadings, or to slightly greater stresses operating, however, at a further distance from the mid-height of the wall where the loadings are able to produce the greatest effect. The position of maximum stress could be deduced mathematically, but it is considered sufficiently accurate for practical purposes to arrive at the position by a method of trial and error. The surface of the wall will intersect the envelopes formed by the rotation of the pear-shaped bulbs about the vertical axis of the load. These intersections will, when viewed horizontally, produce equi-pressure contours on the wall as shown in Fig. 8(b). Two sets of pressure contours have been drawn corresponding respectively to loads of 1 ton and 5/11th ton at a distance of 2 ft. apart. These particular loads have been chosen so that, by multiplying by 11, the actual pressures due to the eleven and

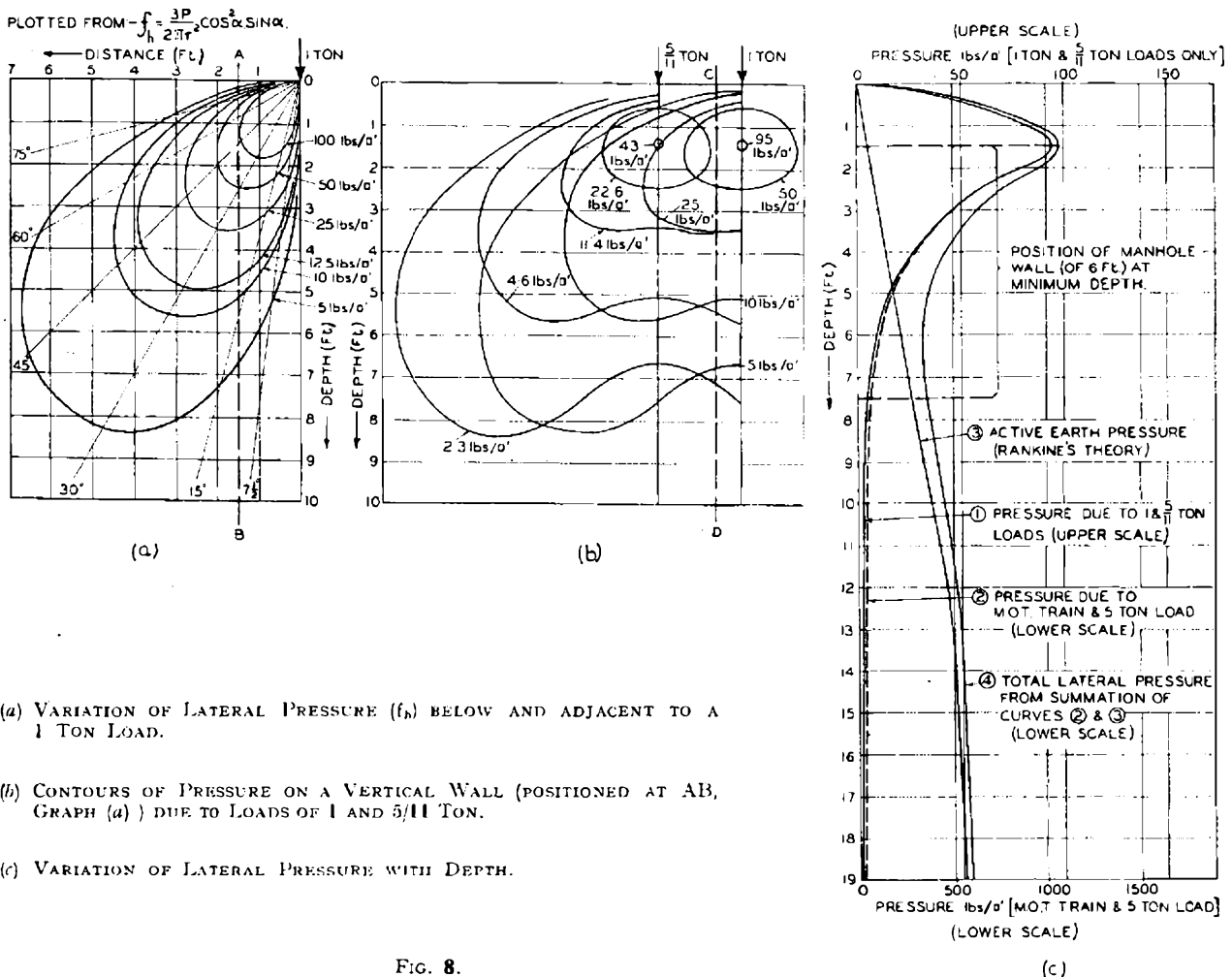

- (a) VARIATION OF LATERAL PRESSURE (f_h) BELOW AND ADJACENT TO A 1 TON LOAD.
- (b) CONTOURS OF PRESSURE ON A VERTICAL WALL (POSITIONED AT AB, GRAPH (a)) DUE TO LOADS OF 1 AND 5/11 TON.
- (c) VARIATION OF LATERAL PRESSURE WITH DEPTH.

FIG. 8.

five-ton loads as shown in Fig. 7, may be deduced. It may be of interest to note that these contours have been drawn in the usual way by plotting points of intersection of the manhole wall and the respective pressure envelopes for horizontal sections at various depths. It can be seen from the contours that, for a width equal to that of a manhole wall, the pressures are reasonably uniform over the width of the wall. The final curve of variation of pressure with depth for the line CD may now be drawn as in Fig. 8(c), curve (1). The pressures at any point have been estimated by the arithmetic addition of the respective pressure values of the contours of the 1 and 5/11ths ton loads through that point. Although the line CD has been chosen to give the greatest values of pressure, the curves of pressure variation on lines 1 ft. or 2 ft. either side of CD are approximately the same. For loads on walls, those pressures acting nearest to the centre of the wall produce the greatest effect, and a slight reduction in pressure towards the edges of the walls will cause only a very small reduction in wall stress. It is permissible, therefore, to assume that the variation in pressure for the line CD operates throughout the horizontal width of a manhole wall. For convenience, this curve has been drawn with two pressure scales; the upper scale is appropriate to the 1 and 5/11ths ton loads, and the lower scale reads pressures of eleven times these values, i.e. appropriate to the eleven- and five-ton loads occurring in practice.

In Fig. 9 the variation of lateral pressure with depth is given for some of the more remote loads of the M.O.T. train. It can be seen that at shallow

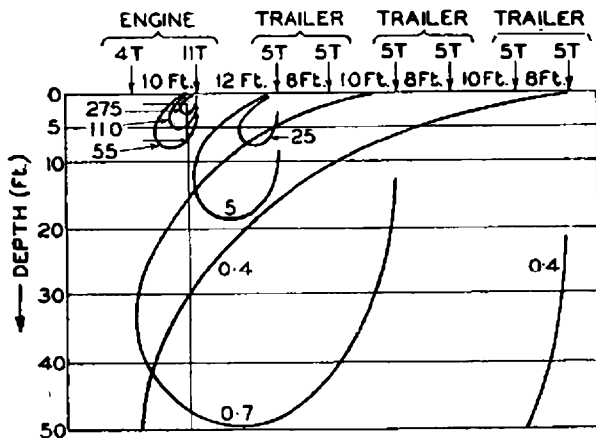

FIG. 9.—EFFECT OF M.O.T. TRAIN TRAILER LOADS IN RELATION TO LOADINGS PRODUCED NEAR OR DIRECTLY UNDER THE MAXIMUM LOAD (11 TONS).

depths the trailers loads make an extremely small contribution to the loading produced by the eleven- and five-ton loads. At greater depths (15 ft. or more) the trailer loads, although still producing small pressures, cause a greater relative increase in the total lateral pressure at these depths. An estimate has been made of these effects and is shown by a slight increase in lateral pressures at depths below 3 ft., as shown in curve (2) of Fig 8(c).

The total lateral pressure on the walls of a manhole will be due to the combination of static earth pressure

(Rankine's formula) and the pressure due to traffic loading (Boussinesq's formula). The variation of lateral earth pressure with depth (Rankine's formula, allowing for cohesion below ten feet) is drawn in curve (3). The total lateral pressure on walls at any depth is the arithmetic sum of curve (2) (traffic loading) and curve (3) (static earth pressure). This is represented in curve (4), which gives the total uniform lateral pressure at any depth for which manholes should be designed.

It is of interest to examine the variations of pressure with depth as shown by curve (4) for manholes with walls 6 ft. high and set at shallow depth. The walls may lie between depths of 1½ and 7½ ft. and the lateral pressure will vary from about 1,000 lb. per square ft. to 350 lb. per square ft. It is not practicable in the design of slabs to assume loadings other than uniform ones, and, accordingly, it is necessary to express these pressures in terms of the equivalent uniform pressure which would produce the same stress in the manhole wall. This may be done by resolving the pressure values between these depths into an equivalent uniform and triangular loading. It may then be deduced that the uniform pressure to which the actual pressures are equivalent is 620 lb. per square ft. It is further evident from curve (4) that the equivalent lateral pressure at greater depths will never exceed 620 lb. per square ft. A figure of 620 lb. per square ft. can, therefore, be safely used for the design of manholes at any depth.

Estimation of Equivalent Uniform Vertical Pressure on Rocks.

Fig. 10(a) shows in graphical form the results of evaluating equation (2) for the vertical stress. The contours of pressure which would be produced on a horizontal surface at a depth of 2 ft. by loads of 1 ton, and 5/11th ton, 2 ft. apart, have been drawn by projection from Fig. 10(a), and are shown in Fig. 10(b). These contours are concentric circles and, to estimate the uniform loading to which these contours are equivalent, the variation of pressure along two axes at right angles to each other in the horizontal plane has been plotted (Figs. 10(c) and (d)). The final equivalent uniform loading has been drawn using the method of combining triangular and uniform loadings.

The equivalent uniform pressure at various depths has been assessed in this way allowing for the effects of the other wheels of the M.O.T. train and are shown in Fig. 11. In these calculations a surface 3 ft. × 4 ft. has been assumed for purposes of finding the equivalent uniform pressure, since this approximates closely to the size of the separate roof slabs in the manholes to be designed. The uniform loading due to the weight of soil above the manhole roof has also been plotted on this graph on the assumption that the roof bears the whole of the weight of the soil above it (curve (2)). Although this is not entirely true for manhole roofs deeper than a few feet, it is unnecessary to estimate the proportion of the weight of soil actually borne at the various depths, since it is evident from curve (3), which represents the summation of curves (1) and (2), that the greatest pressure to which a very deep manhole roof may be

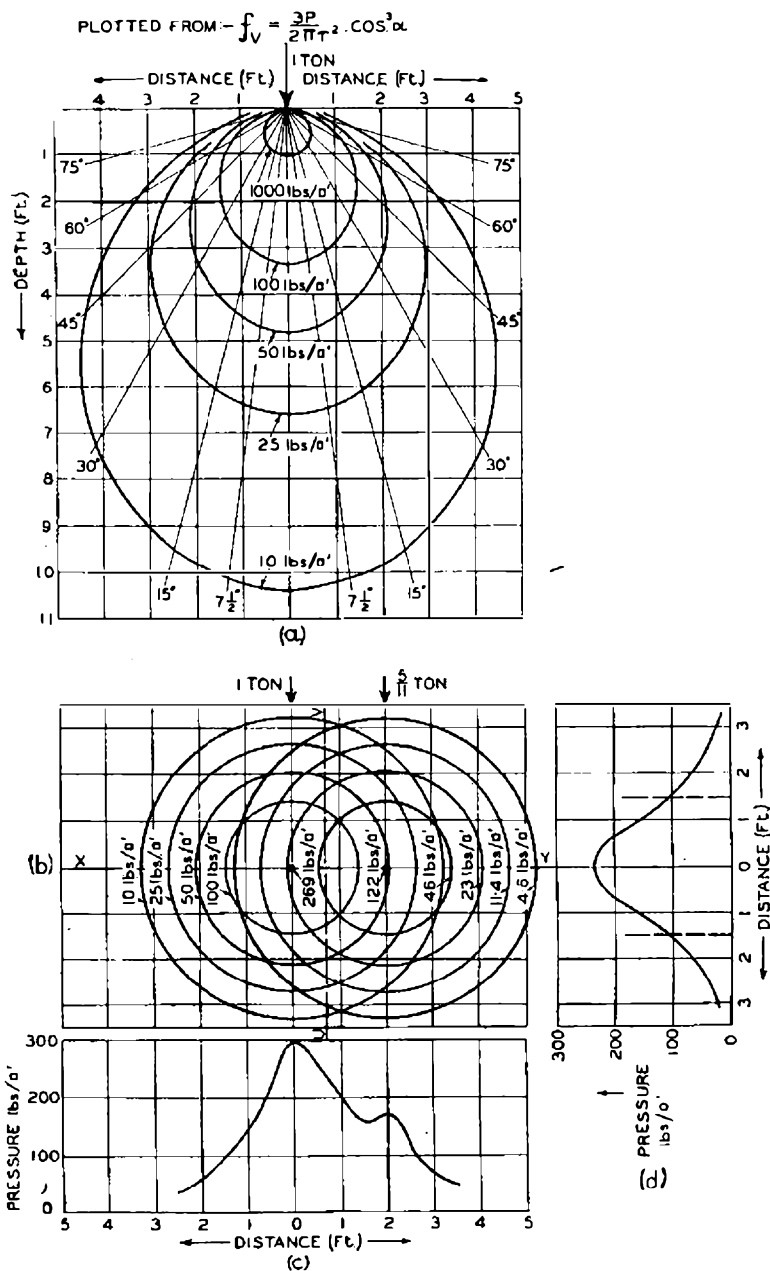

FIG. 10.

subjected is less than that for a manhole roof at the minimum depth of $10\frac{1}{2}$ in.

Anchor Iron Loadings

During cabling operations, stresses of considerable magnitude are produced in the manhole end walls.

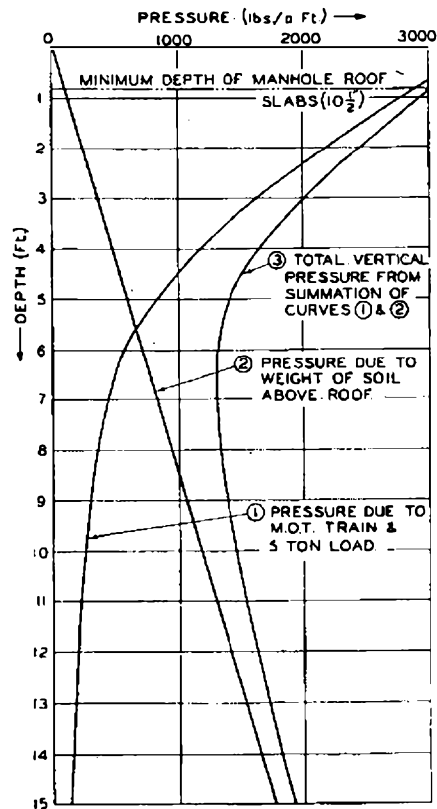

FIG. 11.—EQUIVALENT UNIFORM PRESSURE AT VARIOUS DEPTHS.

The motor winches in use by the Post Office are capable of exerting a steady pull of 2 tons and a maximum pull of approximately $2\frac{1}{2}$ tons. Although dynamometer tests have shown that, even when drawing in large cables through tortuous duct lines pulls of 1 ton or less have sufficed, there always remains the possibility that, due to an obstruction in the line, the winch may be pulled to a standstill and, if running at full speed, exert its maximum pull of $2\frac{1}{2}$ tons.

It is, therefore, necessary to design on the basis of a maximum rope pull of $2\frac{1}{2}$ tons. This will necessitate the end walls withstanding a maximum pull of 5 tons, since it may sometimes be necessary in cabling operations to return the rope back round the snatch block in a parallel direction. Further, an anchor iron may be subjected to a side in addition to a direct pull in those instances where, for example, an anchor is located in the floor of a manhole and the rope turns at right angles around the snatch block attached to it.

Stresses Due to Loaded Cable Bearers.

The weight of cables supported on the cable bearers will produce a certain stress in the manhole walls.

Thus in Fig. 12, the greatest stress on the wall will be produced when the channel of the cable bearer is accepting the full weight of itself, the bearers and the cables supported. The weight of the channel may be safely neglected in comparison

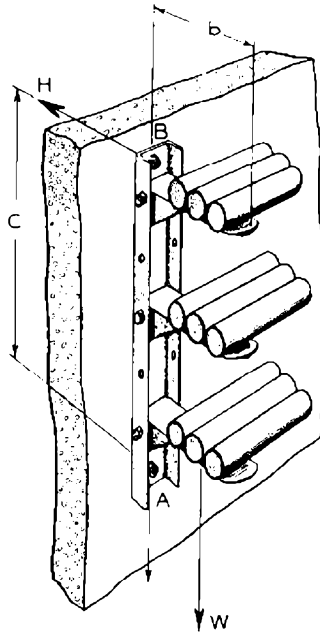

FIG. 12. EFFECT OF LADEN CABLE BEARERS ON WALL LOADINGS.

with the weight of the cables and bearers, and, since the restoring moment supplied by the wall (Hc) must equal the turning moment produced by the weight of the cables —

$$W \cdot b/2 = Hc$$

Where W = total weight of cable supported and bearers

c = distance between points of fixing of the channel.

H = the horizontal force to be supplied by the wall at B

b = the length of the cable bearers.

For a medium size of manhole, values of c , b , and W per cable bearer may be—

$$c = 36 \text{ in.}$$

$$b = 24 \text{ in.}$$

$$W = 1,200 \text{ lbs. (bearers fully loaded).}$$

$$\text{Hence } H = \frac{1200 \cdot 12}{36} = 400 \text{ lbs.}$$

The vertical force transmitted to the lower fixing point A is, of course, equal to W (1,200 lbs.), i.e. the total weight of the channel, cables and bearers, and the manhole side walls must, accordingly, be capable of accepting loadings such as these calculated on the basis of the maximum number of cables which may, at any time, require to be supported.

Summary of Loadings.

It is convenient, in conclusion of the first part of this article, to summarise the loadings which have been deduced and consider their variation with depth. It has been seen that the total equivalent lateral pressure on a manhole wall varies very little with depth, and since anchor iron loads are, of course, independent of depth, it is possible to employ the same wall loadings for manholes at all depths. Curve (3), Fig. 11, shows that the vertical loading on roof slabs varies considerably with depth, reaching a value of approximately 3,000 lbs. per square ft. at a depth of $10\frac{1}{2}$ in., the minimum depth of a manhole roof. The manholes to be described in the second part of this article incorporate reinforced concrete beams in the roof for support of the frame and cover. These beams must be designed to withstand the maximum wheel load of the M.O.T. train (eleven tons), since this load may be transmitted directly to them through the frame, cover and entrance shaft (if any) at whatever depth the manhole may be situated. For this reason it is necessary to design roof beams of the same strength at all depths, but it would be permissible to use a smaller section of concrete and reinforcement in the roof slabs at the greater depths. Such a course, although effecting a small economy in the design of manholes for greater depths, would prevent standardisation of design for manholes at all depths. The savings in those instances where manholes are built at the greater depths would not justify departure from standardisation and, accordingly, the designs of manholes which have been finally adopted are applicable for all depths.

Alkaline Type C.E.M.F. Cells

U.D.C. 621.355.8

L. H. CATT

The construction and principle of operation of the alkaline type of C.E.M.F. cell standardised by the Post Office are described.

Introduction.

MODERN developments in the design of telephone exchange power plant necessitate the use of C.E.M.F. cells in the exchange discharge lead to reduce the voltage applied to the exchange busbars while the main batteries are on charge. These cells are required to be switched into and out of circuit to reduce the voltage to a value within the limits fixed for working the equipment. The lead-acid type of C.E.M.F. cell acquires residual capacity and when it is desired to cut the C.E.M.F. cells out of the circuit the switching contacts are required to withstand momentarily almost the short-circuit current of the cells plus the normal exchange load. Under such conditions the life of the cells is fairly short. It therefore became necessary to obtain C.E.M.F. cells which can be short-circuited without detriment to the cells, and which will not act as storage cells. The outcome was the introduction by the Post Office of alkaline C.E.M.F. cells under the title "Cells, C.E.M.F." Such cells have been in service for some two or three years, and it is now possible to consider whether the anticipated advantages have been realised.

General.

When a direct current is passed through water hydrogen is liberated at the negative and oxygen at the positive electrode. If the plates are of inert material such as platinum these gases instantaneously cover them with a molecular layer and transform them into gas electrodes which generate a definite E.M.F. in opposition to that which called the gases into being. The quantity of gases thus absorbed is infinitesimal, and any further passage of electricity causes the gases to be liberated in their normal form. When this stage is reached increase in the current only causes a slight rise in the counter E.M.F. owing to ohmic resistance. Such a cell has negligible capacity.

If, however, the electrodes are not inert, cumulative chemical action between the liberated gases and the material of which the plates are made may occur

(e.g., lead peroxide is formed at the positive electrode when lead plates are used); a counter E.M.F. depending in value upon the nature of the new chemical compounds formed is generated, but in addition an appreciable electrical capacity proportional to the quantity of chemical change caused is developed. This is undesirable in a practical C.E.M.F. cell and inert electrodes are therefore required. It is also necessary to reduce the electrical resistance of the water by dissolving in it a substance which will also remain unaffected by the operating conditions.

Although choice is restricted by economic and chemical considerations a reasonably satisfactory combination of electrode material and electrolyte is found in nickel-plated iron and caustic potash solution. Caustic soda would also be suitable but its resistance is rather higher than that of caustic potash of equal concentration. These give a capacity which is just sufficient to prevent instantaneous collapse of the counter E.M.F. when the cell is switched out of circuit, but is insufficient to damage the short-circuiting contacts. The voltage rise is very smooth when current is switched on and its build-up time is of the order of one or two milliseconds for currents above about 10 per cent. of the cell rating.

In practice close spacing of the electrodes is adopted to minimise ohmic resistance, and their superficial area is determined by the maximum current to be carried.

Post Office Standard Cells.

Messrs Nife Batteries, Ltd., co-operated in the design of the cells standardised by the Post Office. The glass boxes used are from the Post Office standard range as used for secondary cells, and the main details of the cells are given in Table 1.

The plates used in the No. 1, 2 and 3 sizes measure approximately 3 in. by 5 in., and those used in the 4 and 5 sizes measure approximately 3 in. by 7½ in. The continuous rating of the cells results in a current density of approximately 0.1-0.12 amps. per square inch of plate surface.

TABLE 1

Type of Cell	Maximum continuous rating amps.	Maximum intermittent rating amps.	No. of plates	Weight complete with electrolyte lbs.	Quantity of electrolyte at normal level galls.	Estimated hours at continuous rating before topping up	Overall dimensions per cell		
							Width ins.	Length ins.	Height ins.
Cell C.E.M.F. No. 1	15	22.5	13	25	0.85	365	8 ³ / ₈	9 ¹ / ₈	14 ¹ / ₄
Cell C.E.M.F. No. 2	50	75	39	32.5	1.07	138	8 ³ / ₈	10 ² / ₈	14 ¹ / ₄
Cell C.E.M.F. No. 3	75	112.5	59	39	1.28	114	8 ³ / ₈	12 ⁵ / ₈	14 ¹ / ₄
Cell C.E.M.F. No. 4	100	150	55	61	1.85	106	10 ⁵ / ₈	11 ⁶ / ₈	20 ¹ / ₄
Cell C.E.M.F. No. 5	150	225	83	71.5	2.15	88	10 ⁵ / ₈	13 ³ / ₈	20 ³ / ₃₂

The construction of the standard cells may be seen from Fig. 1. The electrode assembly is suspended from an ebonite lid and is immersed in the electrolyte contained in the glass box. The electrode assembly comprises the plates interleaved in a manner similar to that used in ordinary secondary cells, and con-

between the box and the lid so that the gases released by the operation of the cell are forced to escape by the vent plug. The design of the vent plug was based on a type which has proved successful for enclosed type secondary cells. The principle is that the passages in the vent plug are relatively large

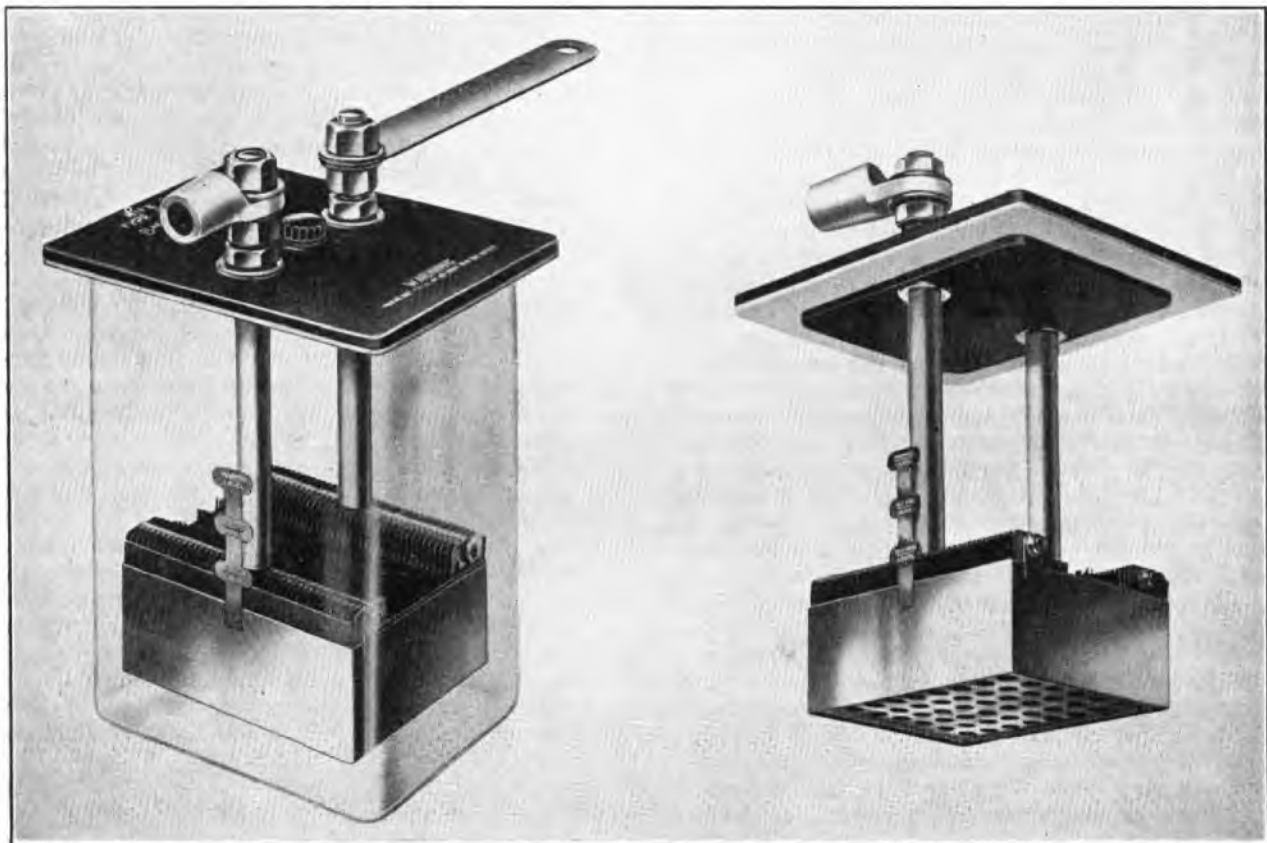

FIG. 1.—CONSTRUCTION OF CELL.

nected alternately to the two posts which form the terminals of the cells as well as supporting the assembly from the lid. Ebonite separators in the form of a narrow U are included in the assembly, and are held in position by projections formed in the plates.

The plate assembly is enclosed in a rectangular metal box open at the top. Holes are provided in the bottom to allow free circulation of the electrolyte; the positions of the holes are arranged so that the separators rest on the floor of the box. The box is supported by one pole of the plate assembly. A thin sheet of ebonite is inserted between the edges of the plates and the end walls of the box to prevent the possibility of a contact occurring between the box and the edges of the plates connected to the opposite terminal.

The lid is built up of a moulded top portion of ebonite, a rubber gasket and a lower portion of ebonite. The top portion, which carries the title of the cell and a warning notice regarding the danger of adding acid to the electrolyte, is of similar dimensions to the gasket. The lower portion is smaller and acts as a spigot to prevent accidental displacement of the lid. The gasket is intended to form a gas tight seal

so that the velocity of the gases is low and, therefore, the spray emitted from the cell is negligible.

All parts of the cell below the lid are nickel-plated, but in view of the fact that the cells are usually installed in the same room as lead-acid secondary cells, all parts above the lid are lead-plated.

Electrolyte.

The electrolyte consists of commercially pure potassium hydroxide and the specific gravity as supplied by the Stores Department is 1.190. In determining the volume of electrolyte required, consideration was given to the desirability of reducing the maintenance attention by arranging that topping-up is as infrequent as possible. The specific gravity of the electrolyte rises as the cell operates owing to the decomposition of some of the water, and it is also necessary, therefore, to arrange that the maximum variation does not cause the characteristics of the cell to vary widely. A gauge is therefore fitted to the electrode assembly, carrying 3 electrolyte level indications. The upper and lower points indicate the maximum and minimum levels respectively, and the middle point indicates the level

to which the cells should be filled with electrolyte of 1.190 specific gravity. Water should then be added to bring the electrolyte to the maximum level. The specific gravity of the electrolyte when the cell is filled as described is then approximately 1.150, and when the level of the electrolyte has fallen to the minimum level due to the consumption of water by the operation of the cell, the specific gravity is approximately 1.250. During operation considerable disturbance takes place within the cell and a suitable space is left between the maximum level of the electrolyte and lid to prevent the possibility of froth issuing from the vent plug.

Fig. 2 shows the voltage characteristics of the cell with the electrolyte level at the maximum, central and minimum positions. It will be seen that the counter voltage produced by the cells is dependent

slightly and when switched out of circuit, air is drawn in via the vent plug owing to the cooling down of the cell. The carbon dioxide (CO_2) present in the atmosphere combine with the electrolyte (KOH) and potassium carbonate (K_2CO_3) is formed, which is a poor conductor. It is proposed that the point at which the electrolyte should be changed should be determined by measuring the counter voltage produced by the cell when passing a proportion of the rated current; the provision of hydrometers for the purpose of determining the specific gravity of the electrolyte is not favoured owing to the possibility of their being used with lead-acid cells and thereby incurring a risk of introducing acid into the alkaline cells. Furthermore the specific gravity is not a good test of the amount of potassium carbonate present as the specific gravity of equivalent solutions of this substance and of caustic potash are not very different.

Investigations into the most suitable method of testing to check the condition of the electrolyte, are proceeding.

It has been observed at a number of installations that a brownish discolouration appeared on the positive electrodes after the cells had been in operation for a time. This is at present under investigation and appears to be an oxide of nickel.

No grease or oil of any sort must be allowed to come into contact with the electrode assembly or any point below the lid. If grease or oil is present in the electrolyte a soapy substance may be produced, and, due to the disturbance of the electrolyte when in circuit, soap suds are formed which, being of a more persistent character than the normal froth produced, are expelled from the vent plug. Also the ease with which the gas bubbles are released may be affected by grease or oil, and the voltage

characteristics of the cell completely altered if a large area is contaminated. The natural oil of the skin is sufficient to cause these effects and for this reason the electrodes should not be handled in any way. Messrs. Nife Batteries, Ltd., have adopted the method of wrapping the elements to limit the possibility of the elements being handled during the installation period.

Acknowledgment

In conclusion the author would like to express his thanks to Messrs. Nife Batteries, Ltd., and colleagues in the Post Office Engineering Department, in particular Mr. D. W. Glover of the Research Station, for assistance and advice given in the preparation of this article.

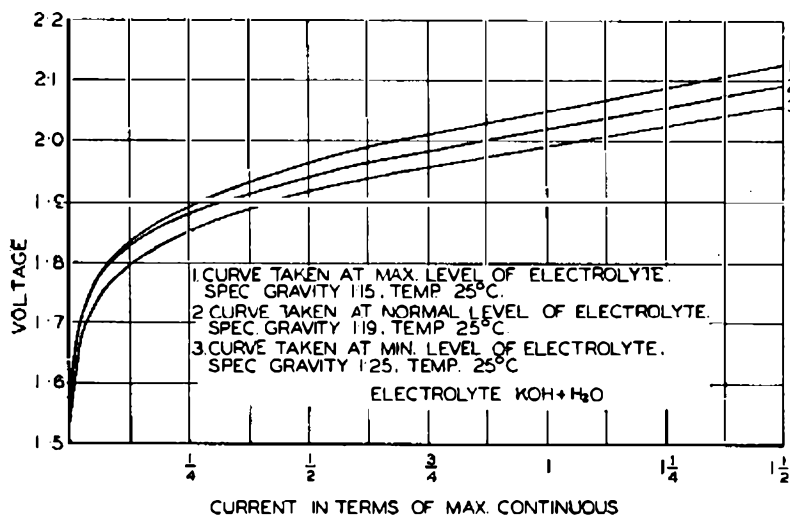

TEMPERATURE OF ELECTROLYTE ABOVE SURROUNDING AIR AFTER INDEFINITE PERIOD AT MAXIMUM CONTINUOUS LOAD, 20°C. DITTO, FOLLOWED IMMEDIATELY BY 50% OVERLOAD FOR 15 MINUTES, 22°C.

FIG. 2.—VOLTAGE CHARACTERISTICS OF CELL.

on the current passing through the cells and under "No load" conditions the cells offer little or no effective counter voltage. With loads below about 10 per cent. of the continuous rating of the cell, the counter voltage produced is erratic.

The Cells in Service

The only maintenance attention required by the cells is the topping-up of the electrolyte when necessary, the usual external cleansing and the renewal of the protective film of petroleum jelly covering the exposed metal parts. No installation has been brought to notice up to the time of writing, where it has become necessary to change the electrolyte, although it is anticipated that instances will arise. During operation the temperature of the cell rises

The Application of 12-Circuit Carrier Telephony to Existing Cables

A. J. JACKMAN, B.Sc.(Eng.), A.C.G.I., and
R. A. SEYMOUR

U.D.C. 621.315.213.1 : 621.395.443.2 621.395.8

Particulars are given of tests made on two old multiple twin cables between Leeds and Derby to determine the suitability of audio cables of this type for carrier working. Details of the remedial measures applied to improve their electrical characteristics are also included. The most troublesome feature was the indirect crosstalk which poled badly and limited the use of carrier working in one of the cables to one pair in each quad.

General Characteristics of Cables at Carrier Frequencies.

THE transmission of carrier frequencies over cables has been widely discussed in the last few years, but most of the information published in Great Britain regarding the transmission of frequencies above 16 kc/s has focused attention on the use of special types of cable. For example, for the transmission of 12-circuit carrier telephony a special twenty-four pair carrier quad cable has been introduced. This article describes certain points of interest in the utilisation of existing multiple twin trunk cables for 12-circuit carrier transmission. The data will be drawn from an experiment in the utilisation of multiple twin cables between Derby and Leeds; this experiment has been in hand for about three years.

A fairly brief reference to the most relevant principles of transmission might help to render the subsequent paragraphs clear. The most important requirements of a cable for the transmission of carrier telephone frequencies are, low attenuation, good crosstalk levels and freedom from susceptibility to noise, and uniformity of electrical characteristics throughout the length of the cable. Attenuation at frequencies above 10 kc/s is expressed by the formula

$$\text{Attenuation} = \frac{R}{2} \sqrt{\frac{C}{L}} + \frac{G}{2} \sqrt{\frac{L}{C}}$$

where R, L, G, C are the primary characteristics of the cable pair, resistance, inductance, leakage and mutual capacitance. Inductance and capacitance are functions of the geometric spacing of the wires in the cable and greater spacings will increase the inductance and reduce the capacitance. Leakage is directly proportional to capacitance if the power factor of the dielectric is constant. Effective resistance, for a given cross-section of copper, is also influenced by the spacing of the wires, and is lower at greater spacings because proximity effects due to neighbouring conductors are less. Hence attenuation is seen to be dependent on the geometric design of the cable, and, other things being equal, would be less in a more loosely packed cable core. Direct crosstalk between two cable pairs is expressed by various formulæ which are based on the mutual coupling in an elemental length of the two pairs, this coupling being an

$$\text{admittance } j\omega \left[K \pm \frac{4M}{Z_0^2} \right] \text{ where}$$

K is a mutual admittance due almost entirely to capacitance unbalance of the pairs,

M is a mutual impedance due largely to the mutual inductance of the pairs.

In an elemental length K and M are functions of the geometric spacing between the wires of the two pairs and it can be shown that the + and - signs, refer respectively to near-end and distant-end crosstalk.

Cable circuit noise, originating within the cable, is dependent on the crosstalk coupling and is also dependent on the admittance and impedance balance of the two wires to earth.

These considerations have influenced the design of a special quad type cable for carrier operation in the following manner. To obtain low attenuation the spacing of wires from one another and from the lead sheath has been made greater than corresponding dimensions in audio type quad trunk cables, the centre-to-centre spacing of a pair being of the order of 0.150 in. instead of 0.105 in. as in the standard audio type cable. The overall diameter of a carrier type quad cable of 24 pairs of 40 lb/mile wire is 1.15 in. whereas the diameter of the corresponding audio cable is 0.91 in. The effect of the different spacing on the primary characteristics R and L of the two cables is illustrated in Fig. 1 and the

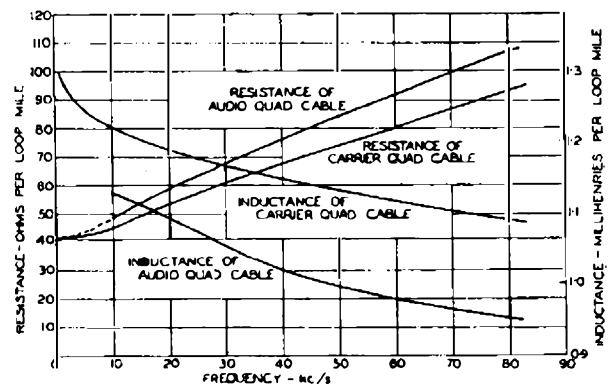

FIG. 1.—PRIMARY CHARACTERISTICS OF AUDIO TYPE AND CARRIER TYPE QUAD CABLES.

effect on attenuation in Fig. 2. The capacitance of the audio quad cable is 0.066 $\mu\text{F}/\text{mile}$ and that of the carrier quad cable is 0.057 $\mu\text{F}/\text{mile}$. To obtain minimum crosstalk within the cable, the factor K in the crosstalk coupling per elementary length of pair is controlled by careful attention during the manufacture of the cable, closer limits being worked to than with an audio cable. The factor M is also controlled during manufacture, but more particularly by ensuring that no two quads in the cable have the same length of lay. It has been found that if two quads in the same layer of the cable have the same lay they will have a very

bad magnetic coupling factor M , and if quads of the same lay are in adjacent layers which have opposite directions of stranding, they will have a bad capacitive coupling factor K . Quads of the same lay are freely used within a layer in an audio trunk cable because such cables, being loaded, have a high value of Z_0 , so that the fraction $\frac{4M}{Z_0^2}$ is relatively small compared with K , whereas carrier

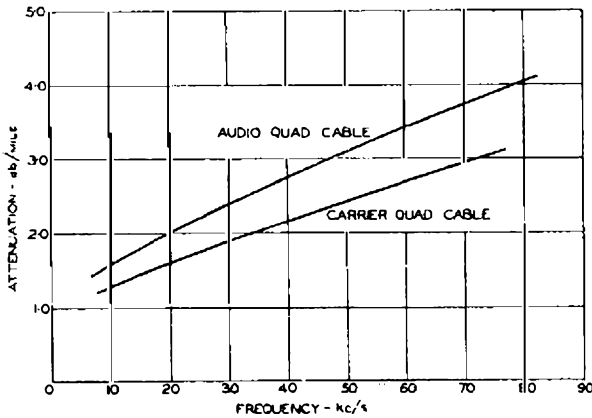

FIG. 2.—ATTENUATION OF AUDIO TYPE AND CARRIER TYPE QUAD CABLES, 40 LB. CONDUCTORS.

cables, being non-loaded, have a lower value of Z_0 , e.g. $\frac{1}{3}$ th, so that the mutual impedance factor $\frac{4M}{Z_0^2}$ becomes relatively so important that quads of the same lay are not permissible. Having, in this way, obtained a good-quality cable, further control over the resultant crosstalk in a repeater section is exercised by a cable jointing scheme based on test-selection. Briefly the test-jointing scheme secures equalisation of the primary characteristics of all pairs by selecting the order in which cable lengths are laid along the route and by systematically jointing together pairs in different layers in adjacent lengths. It also secures minimum resultant crosstalk by arranging that quads are jointed together in such a way that unbalances, both pair-to-pair and pair-to-earth, are self-compensating as far as possible.

Since 12-circuit carrier telephony works on a 4-wire basis, the important crosstalks are:—

- (1) distant-end crosstalk between pairs carrying traffic in the same direction;
- (2) near-end crosstalk between pairs carrying traffic in opposite directions.

The former has been successfully dealt with in the manner described above, together with a certain amount of distant-end crosstalk neutralising by "networks" or admittances connected between pairs at a selected point, but the latter has been considered too severe to permit oppositely-going groups of pairs to be employed in the same cable. The outgoing signal on one pair and the incoming signal at the same frequency on another pair will have a level difference between them which might be as great as 60 or 65 db., and in order that crosstalk from the high level circuit into the low level circuit shall be, say, 65 db. below the low level signal,

it is necessary that the near-end crosstalk attenuation between the pairs concerned should be 125–130 db. at least. This result has been achieved by using separate cables for the two directions of transmission, the screening provided by the two (earthed) lead sheaths being adequate even when the cables are drawn into the same conduit for the whole of the length of the repeater section.

Multiple twin cables—which were standard for trunk cables until about 1927, when they were superseded by star quad—have greater space factors than the present standard audio star quad trunk cables. The mutual capacitances were in the range 0.0475 $\mu\text{F}/\text{mile}$ to 0.062 $\mu\text{F}/\text{mile}$, which are comparable with the specified value of 0.057 $\mu\text{F}/\text{mile}$ for carrier quad cable, and this suggested that those factors which are influenced by wire spacing would be similar in the two types of cable. For example, the attenuation of the multiple twin cable should be sufficiently low over the whole 12-circuit carrier range to permit the operation of normal carrier repeater section lengths. On the other hand the measures taken to secure uniformity of characteristics and to reduce crosstalk between pairs would not, in general, be so thorough as those outlined above in connection with the special carrier cable. It was, therefore, to be discovered whether the crosstalk at carrier frequencies in a multiple twin cable was satisfactory for carrier operation or whether it could be brought to the requisite level without unreasonable expense. This could only be investigated by direct experiment on a group of pairs in a multiple twin cable deloaded for the purpose. A first experiment on a group of pairs in the Derby-Leeds No. 1 multiple twin cable, between Leeds and Sheffield, gave satisfactory results and led to a larger-scale experiment between Derby and Leeds. This produced some interesting crosstalk problems which are discussed in subsequent paragraphs.

Cables Selected for Experimental Operation.

The Derby-Leeds No. 1 multiple twin cable has 212 pairs in six layers and the group selected and deloaded comprised thirty 40 lb. pairs in the fourth layer. One reason for choosing 30 pairs was that this is the maximum number of pairs which can be accommodated on one standard distant-end crosstalk neutralising frame. The selected pairs were all in one layer and were separated from the cable sheath by two further layers. This condition is the most suitable for carrier operation since it provides, as far as possible, pairs of uniform electrical characteristics and also eliminates any effect on pair-to-pair crosstalk which the close proximity of a lead sheath might have. The attenuation of this deloaded group was approximately 2.7 db./mile at 60 kc/s, which is of the same order as that offered by carrier quad cables. The impedance at carrier frequencies varied irregularly with frequency, but the return loss of the mean impedance with the non-reactive 140 ohm terminal impedance was better than 20 db. at all frequencies above 20 kc/s. As described in more detail later, the distant-end crosstalk problems associated with this group of pairs were solvable by standard means.

To work in the other direction of transmission a group of 30 deloaded pairs was provided in certain smaller 70 lb. multiple twin cables, viz., the Leeds-Barnsley-Sheffield No. 1 50/70 P.C.M.T., the Chesterfield-Leeds 54/70 P.C.M.T., and the Birmingham-Derby-Chesterfield 54/70 P.C.M.T. cables. These cables are all relatively old cables. The 50/70 cable from Leeds to Barnsley was laid in 1913, at what might be considered to be the beginning of the first extensive scheme of main trunk cable provision. The Sheffield to Barnsley cable was commenced in 1913 and completed in 1914 and was one of the only two main cables completed in that period. The cables from Sheffield to Derby followed within a few years. A scheme of cable balancing by test-selected joints was introduced in 1913, but the Leeds-Barnsley-Sheffield cables were laid without this. The three layers of the cable, comprising three quads, eight quads, and fourteen quads respectively, were kept separate throughout and at each joint a quad was jointed to the quad in the corresponding layer one space ahead, i.e. instead of jointing marker quad to marker quad and all others in succession, the marker quad was jointed to the second quad in the same layer of the next length, and so on. There was little information available about the electrical characteristics of these cables, and by contrast with the remarks regarding carrier quad cable, it will be seen that some very difficult crosstalk problems were anticipated in seeking to apply 12-circuit carrier systems to them.

The attenuation of both sets of multiple twin cable was low enough for the length between Leeds and Derby to be operated as four repeater sections with intermediate repeater stations at Barnsley, Sheffield and Claycross.

Difficult problems were encountered in the within-cable distant-end crosstalk in the older cables, but before describing these an interesting second order near-end crosstalk problem will be described. This problem will be common to all schemes in which carrier frequency pairs and audio frequency pairs are contained within the same cable.

Second Order Crosstalk due to Association of Audio and Carrier Circuits.

A crosstalk problem is introduced at carrier repeater stations by the presence in the multiple twin cables of pairs used for audio-frequency transmission, and different methods of solving the problem are available according to whether or not the carrier-frequency pairs for both GO and RETURN directions of transmission enter the same repeater station, and again according to whether or not audio frequency pairs from one or both cables are also led into the same building. Because of the closer spacing of carrier frequency repeater stations it will often be necessary to lead the carrier frequency pairs into a building and provide them with amplifiers, when there will be no necessity to lead in the audio frequency pairs. This is one aspect of the second order crosstalk problem and the situation is illustrated in Fig. 3(a). The second order crosstalk path is built up of two near-end crosstalk paths in series; crosstalk is transmitted from the high level of the

carrier repeater output, through near-end crosstalk paths to all the surrounding audio frequency pairs and then again from these audio frequency pairs through their near-end crosstalk couplings into carrier frequency pairs on the low-level input side of the repeaters. The two near-end crosstalk paths in series will generally have quite a high attenuation,

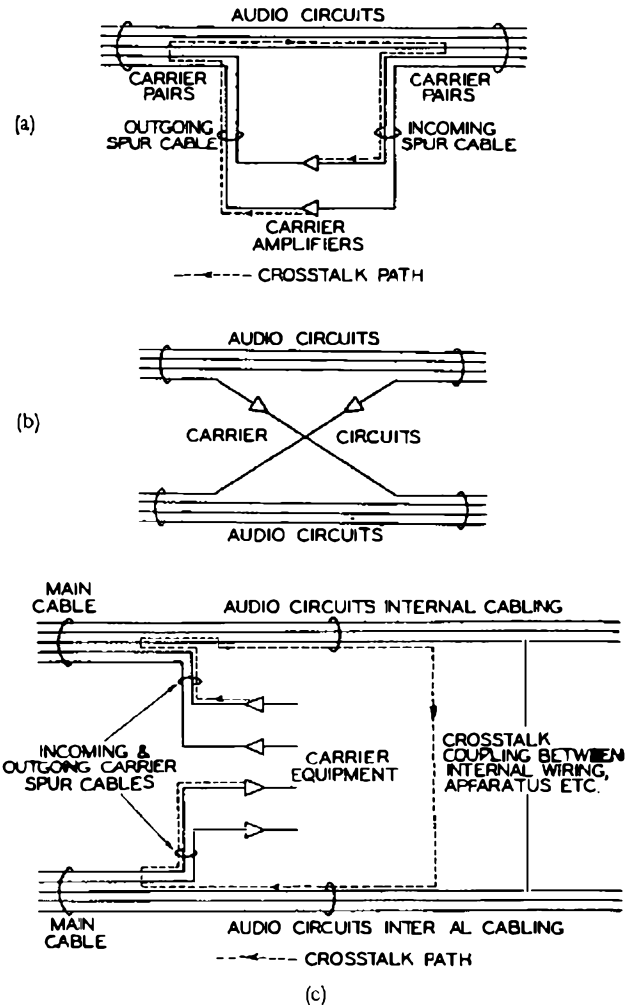

FIG. 3.—SECOND ORDER CROSSTALK PATHS BETWEEN HIGH AND LOW LEVEL CARRIER CIRCUITS.

but this is offset by the high gain of the carrier repeaters. This problem was encountered in the preliminary experiment when deloaded cable pairs from the Derby-Leeds No. 1 cable were led into and out of Barnsley exchange. The second order near-end crosstalk path had a worst value of 98 db. and a most probable value of 114 db. at 60 kc/s. This means that an unsatisfactory crosstalk level would be obtained (based on a desirable signal/crosstalk ratio of 65 db.), where the gain of the repeater exceeds 33 db. With a repeater section length equivalent to 58 db. the resultant crosstalk would be 40 db., which is intolerable.

When the two multiple twin cables carrying respectively pairs for the GO and RETURN direction of carrier transmission are so located that the two

groups of carrier pairs can be taken into the same amplifier station, a simple solution to the problem can be adopted, provided there is no necessity to lead in audio frequency pairs from either cable at this point. Crosstalk through the second order path indicated in Fig. 3(a) may be avoided by transposing the carrier-frequency pairs from one multiple twin cable to the other so that only high level carrier circuits are associated with one cable at the place considered and only low level carrier circuits are associated with the other cable, as shown in Fig. 3(b). The second order crosstalk path through near-end couplings is not now accentuated by the repeater gain, and thus is relatively unimportant; in the measurements mentioned above it would produce only a worst crosstalk of 98 db.

This very satisfactory simple method of overcoming the crosstalk problem is not applicable when the two multiple twin cables are not so located that the carrier frequency pairs can readily be taken into the same carrier repeater station. It is also insufficient in itself when audio frequency pairs from both multiple twin cables are led into the same building. These two aspects of the second order crosstalk problem are very similar, but it will be more simple to study the former first. Examining Fig. 3(a) there is seen to be a need for some simple means of preventing the transmission of carrier frequency signals over the audio frequency pairs or wires without interfering with the normal use of the pairs. Any device used must be of the simplest possible form, because it will be required in large numbers when very large multiple twin cables are involved.

Before producing a satisfactory crosstalk suppressor it was necessary to examine the manner in which this second order crosstalk is propagated in the audio portions of the cable; that is, to what extent it is transmitted over physical circuits and over derived circuits. An investigation into this was carried out at Leeds, using the deloaded pairs in two multiple twin cables, and the data collected was checked by measurement on unloaded pairs in two carrier cables. In this investigation pairs were strapped through from one cable to the other at the cable test tablets to produce, in effect, the "through" audio circuits of Fig. 3(a), and near-end crosstalk was measured between the deloaded groups of pairs in the two cables. Various forms of filter were inserted in the strapping connections and their effects on the crosstalk were observed. Having strapped across twelve consecutive pairs in the two cables, the near-end crosstalk between other pairs in those cables had a worst value of 106 db., and 50 per cent. of the combinations tested were worse than 125 db. These crosstalk levels would be intolerable in practice. Filters inserted in the pair circuits and designed to attenuate carrier frequencies transmitted over the pair circuit made no appreciable difference to the crosstalk, thus demonstrating that the crosstalk voltages and currents are not transmitted entirely over cable pairs in the normal manner. In fact, that part of the crosstalk which is propagated over the pair circuit must be very small compared with that transmitted on other paths. The greatest

improvement from a single measure resulted from the insertion of coil-and-condenser filters in the wire-to-earth circuits.

To block the wire-to-earth circuits without adding attenuation to the normal audio frequency transmission over the pair circuits, or phantom circuits, experiments were conducted with quad wound suppressor coils as illustrated in Fig. 4. These coils

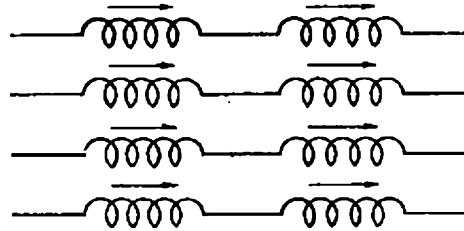

FIG. 4.—CROSSTALK SUPPRESSOR COILS, NON-INDUCTIVE TO PAIR AND PHANTOM CIRCUIT TRANSMISSION.

are wound so as to be non-inductive to loop currents over the pair circuits and also to loop currents over the phantom circuits, but they offer high impedance to the transmission of currents in the same direction in the four wires. Each winding was built of two sections to permit a certain amount of selection for the reduction of capacitance unbalances. A test of these quad wound suppressor coils showed that they effected an improvement of 28 db. at 60 kc/s in the worst near-end crosstalk, and a general improvement of 25 db. Inserting, in addition, other filters to give attenuation at high frequencies in the pair and phantom circuits improved the worst near-end crosstalk by another 12 db., and all the second order crosstalk was then better than 150 db. In a great many cables the quad wound suppressor coils would be sufficient in themselves. The results of the trial at Leeds on the two cables actually concerned in the main experiment are summarised in the curves of Fig. 5. There was a group of fifteen quads available in each of the two cables, and alternate

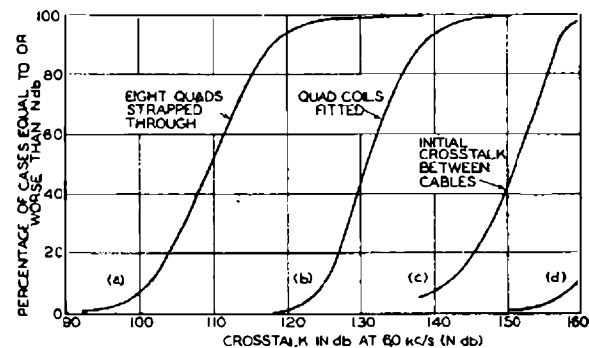

FIG. 5.—IMPROVEMENT IN SECOND ORDER NEAR-END CROSSTALK BY USING SUPPRESSOR COILS.

quads were strapped straight through to produce conditions as severe as any likely to arise in practice. The result of this was to set up in the remaining seven quads a second order crosstalk as given by the distribution curve (a). Inserting quad-wound suppressor coils in the straps improved the crosstalk to the levels shown in curve (b), giving an improvement of 26 db. in the worst case and a general

improvement of 22 db. Curve (t) does not indicate a crosstalk as good as would normally be desirable, e.g. no case worse than 125 db. and not more than 5 per cent. of possible combinations worse than 135 db., but since, generally, the initial state would be better than curve (a), the use of quad wound suppressor coils should be sufficient to overcome second order crosstalk of the type shown in Fig 3(a).

It will sometimes happen that the audio frequency pairs in the multiple twin cable are led in and out of the same building as the carrier frequency pairs and will be provided with amplifiers. These amplifiers will put attenuation into the wire-to-earth circuit and will in this way operate against the second order crosstalk. If the audio frequency amplifier operates in the opposite direction of transmission to the carrier amplifier and has a gain at the higher carrier frequencies, it will, of course, worsen that part of the second order crosstalk which is propagated over the pair circuits. Audio frequency repeaters tested at Leeds all had substantial losses at the higher carrier frequencies, e.g. greater than 40 db.

The simple transposition scheme shown in Fig. 3 (b) may also require some addition to it when pairs from the audio frequency groups in both cables are led into the same building as the carrier frequency groups, e.g. at common audio and carrier frequency repeater stations, exchanges, and terminal stations. At such places it will be possible to have direct connection of audio pairs in one cable to audio pairs in the other cable, either in the normal operation of trunk traffic or in diversion or re-routing of circuits. Second order crosstalk paths will thereby be set up. Apart from such connections the audio frequency circuits from both cables might become associated in the internal wiring of the building, so that carrier frequency couplings of low attenuation exist between them as shown in Fig. 3(c). When the two cables at Leeds were tested with no direct connection between them, the crosstalk distribution given in curve (c) of Fig. 5 was obtained. Four audio frequency pairs from the smaller cable are led into the repeater station, and this second order crosstalk was due to the coupling between the wiring of these circuits and other internal wiring. Suppressor coils were inserted in these pairs before they entered the repeater station, and the crosstalk was improved to the level shown in curve (d).

Cable-to-cable second order crosstalk at Derby, with suppressor coils inserted in all the audio

frequency pairs of the smaller cable had a worst value of 148 db. All the audio frequency circuits which it was possible to extend from one cable to the other were put through on the switchboard and the crosstalk was thereby degraded to 137 db. worst value, but the mean value was still not less than 150 db. The use of the quad-wound suppressor coils appears therefore to be all that is necessary in reducing this second order crosstalk.

The experimental scheme between Leeds and Derby was, therefore, laid out as shown in Fig. 6. The suppressor coils were provided in the smaller cable in each case and were required at Leeds,

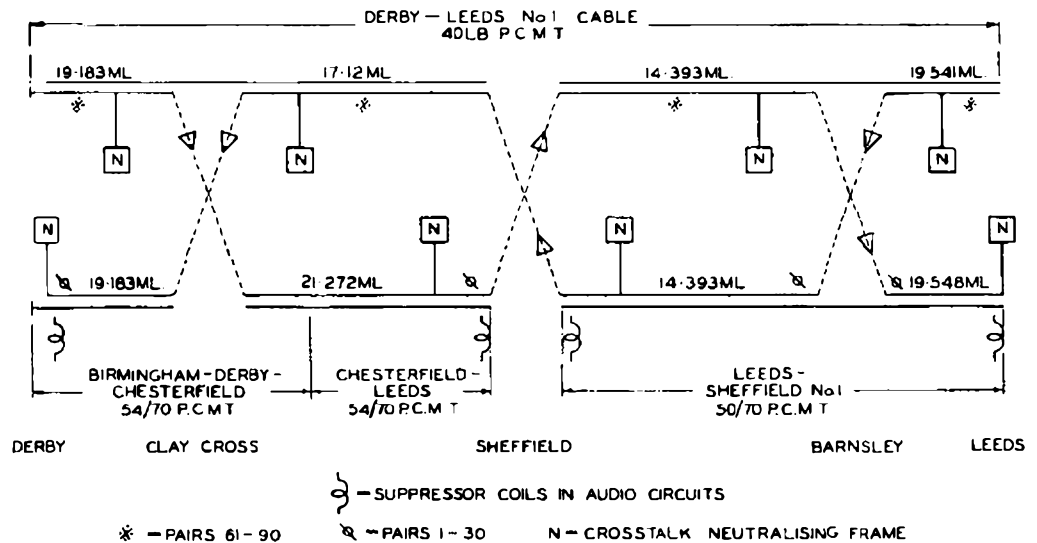

FIG. 6.—LAYOUT OF DERBY-LEEDS 12-CIRCUIT EXPERIMENTAL SCHEME.

Sheffield and Derby. Since the maximum number of coils required in one group was 12, they were panel mounted and installed as close to the terminations of the audio frequency pairs as possible.

The suppressor coils are individually small in size, but in dealing with cables having large numbers of audio frequency pairs, large numbers of coils will be required. They should be inserted as near as possible to the point where audio frequency pairs and carrier frequency pairs are associated in the same cable, and it will generally happen that the most satisfactory provision is the installation of the coils in a loading-coil pot in the cable chamber or exchange manhole.

Bad Crosstalk, and Poling Troubles, in the Leeds-Sheffield No. 1 Cable.

The first tests of distant-end crosstalk in the repeater section length of the Leeds-Sheffield No. 1 cable between Leeds and Sheffield revealed the cable to be unusable for 12-circuit carrier telephony unless considerable improvement could be effected in the distant-end crosstalk between pairs in the same quad, by some practical means, other than by distant-end crosstalk neutralisation by means of "balancing" networks. The distant-end crosstalk between pairs in the same quad was not only very bad in magnitude but also poled very badly, that is,

the effective distant-end crosstalk coupling or admittance unbalance measured at the receiving end of the cable was very different when measured from pair A to pair B than when measured from pair B to pair A. [The admittance unbalance between two pairs is that admittance which connected between two wires of two perfectly balanced pairs, at the testing end, would cause the same crosstalk between them—in magnitude and phase—as that normally existing between those pairs.] Fig. 7 gives two typical examples supplied by measurements on quads 1 and 7. The bad poling of the distant-end crosstalk imposes a severe limitation on the extent to which improvement can be effected by crosstalk neutralising networks between the pairs. These networks are, so far, simple reversible admittances and can, therefore, only neutralise completely a crosstalk which poles perfectly. It was estimated that the crosstalk within eleven of the fifteen quads could not be improved to a value of even 62 db., and eight quads could not be made better than 58 db. at 60 kc/s. A current specification for 12-circuit carrier cable required that the worst distant-end crosstalk after neutralising should not be worse than 65 db. and 95 per cent. of the combinations should be better than 70 db. in the range 12 to 60 kc/s, and a later specification has tightened up these limits by another 5 db.

against any selected termination. The reflected near-end crosstalk might, therefore, be close to the limit set for permissible distant end crosstalk, e.g. with a return loss of 16 db. and a near-end path of 49 db., the effective distant-end crosstalk would be 65 db., and since this would vary irregularly with frequency, and pole badly, it will add to the difficulties of neutralising crosstalk.

A single length of the multiple twin cable was isolated to ascertain its fundamental unbalance characteristics and to compare them with those in carrier quad cable. The following is a comparison of the capacitance unbalances in two equal lengths of cable:—

Unbalance characteristic	Side-to-side	Side-to-earth	Side-to-phantom
M.T. cable—			
average ..	40 $\mu\mu\text{F}$	240 $\mu\mu\text{F}$	132 $\mu\mu\text{F}$
maximum ..	123	820	380
Carrier quad—			
average ..	13	37	44
maximum ..	30	100	150

Distant-end crosstalk at 60 kc/s between pairs in the same quad of a single length of the M.T. cable was found to be approximately 14 db. worse than corresponding crosstalk in an equal length of carrier quad cable. Remembering that the satisfactory crosstalk levels attained in carrier quad cables are dependent on a careful test selection involving every joint, it was realised that the improvement of this old M.T. cable to a satisfactory level at a minimum expense would be extremely difficult.

Attempts to Improve the Poling of Distant-end Crosstalk.

It was found that the crosstalk couplings of within-quad pairs in the single length of M.T. cable poled quite well, and moreover the effective couplings of within-quad pairs in 2,000 yds. of the cable poled reasonably well, although the difficulties were just becoming apparent. It was decided, therefore, to ascertain what could be done by test-selected jointing at 1,000 yds. intervals, and 8,000 yds. of cable were examined in this way. Distant-end crosstalk measurements on the length of 8,000 yards before and after test selection showed no improvement at all in poling qualities, and thus it would not have been

possible to attain a satisfactory overall result by continuing this work over the whole cable. The unit length of 1,000 yds. is, therefore, too great for carrier frequency crosstalk neutralising by such means. A group of twelve consecutive cable lengths (total length 1,823 yds.) was, therefore, selected and test-selected joints made at all jointing points for reduction of audio frequency capacitance unbalances. When the selected jointing had been

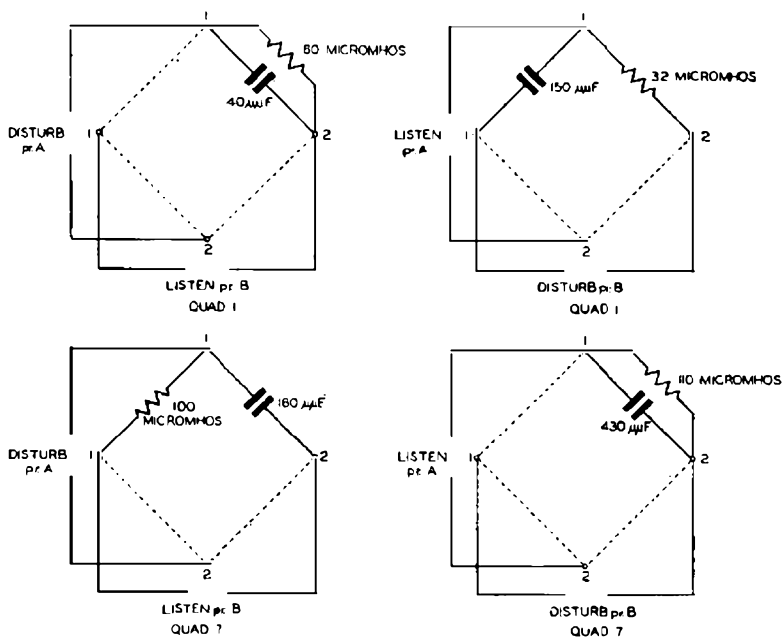

FIG. 7.—ILLUSTRATIONS OF BAD POLING OF DISTANT-END CROSSTALK (ADMITTANCE UNBALANCE).

Near-end crosstalk between pairs in the same quad was correspondingly bad, lying between 46 db. and 66 db. at 60 kc/s. The significance of this lies in the fact that power can be reflected at a terminal mismatch and can then operate through the near-end crosstalk path to appear as distant-end crosstalk in the other pair. Having an impedance which varies irregularly with frequency, it must be anticipated that some pairs will present poor return loss ratios

completed it was found that the distant-end crosstalk at 60 kc/s had improved only very slightly, but that the poling characteristics of the cable had improved considerably. Estimating the level to which the crosstalk could be neutralised by a simple network an improvement was found to have been made in 12 out of the 15 quads ranging from 3 db. to 20 db. Continuing this process over the whole repeater section length of the cable would possibly have given a resultant crosstalk which is satisfactory. The process would, however, have involved considerable expense and time, and it could not be stated positively at the start that the result would be entirely satisfactory. A much more satisfactory procedure was to operate the carrier systems over one pair only in each quad. The crosstalk levels then to be considered were only the between-quad crosstalks, which were more satisfactory and more amenable to treatment by standard neutralising methods. Having fifteen quads deloaded this gave fifteen pairs available for carrier systems, but by deloading one pair in each quad in the 50-pair cable and one pair in each of 25 quads of the 54-pair cables twenty-five systems could be operated, with much less expenditure than extensive test-jointing would demand.

There seems to be no reason why the other pair in each quad should not be used for an audio telephone circuit. It is thought, however, that suppressor coils or H.F. filters would be needed to prevent the introduction of noise into the carrier systems and to prevent any trouble arising from unbalanced signalling apparatus which might be applied to the audio circuits. Tests in this connection would obviously be desirable.

By selecting one pair only from each core a group of fifteen pairs was obtained in which the worst distant-end crosstalk before neutralising was 52 db. This just complied with the requirement for far-end crosstalk before neutralising given in the current specification for 12-circuit carrier cable. Crosstalk neutralising or "distant-end crosstalk balancing" was carried out in the usual manner. Balancing frames employing ceramic condensers were employed, using generally single capacitance networks with the addition of a few three-element networks. The final crosstalk values were within the specification limits for 12-circuit telephone cables then in force, the worst value being 66 db. These results were obtained on both the Leeds-Barnsley and Barnsley-Sheffield sections. On the Sheffield-Claycross and Claycross-Derby sections where the cable was of slightly later date, somewhat better results were obtained.

Crosstalk Neutralising on the Derby-Leeds No. 1 Cable.

The Derby-Leeds No. 1 cable was found to be much more suitable for carrier frequency working, and it was unnecessary to cut into the cable between repeater stations to make any rearrangements for the purpose of reducing crosstalk. This cable was laid in 1920 and was balanced on the usual basis of test selection for the reduction of capacitance unbalances. The cable was in every way much better than its

associated cables, although it was not up to the standard secured with the carrier quad cables.

The near-end crosstalk within the cable was found to have a worst value of 52 db. at 60 kc/s, and the cable thus just complied with the specification limits laid down for carrier quad cable. Distant-end crosstalk at 60 kc/s before neutralising had worst values of 42 db. and 44 db. in all four repeater sections. The distribution-of-crosstalk curves, however, started with quite a small slope, and in the four sections the total percentage of possible combinations below the limit of 52 db. specified for 12-circuit carrier cables was 5 per cent., 3 per cent., 2 per cent., 2 per cent. respectively. The worst result was obtained on a repeater section length which had been extended into Barnsley exchange on 500 yds. of quad trunk cable and was evidently influenced by the bad magnetic couplings between quads of the same lay in that cable.

The four sections of cable all gave very similar nett crosstalk values after distant-end balancing units had been fitted, viz., worst values of 66 db. or 68 db. and 5 per cent. to 8 per cent. of the total cases equal to or worse than 70 db. These results were obtained with the provision of between 179 and 221 neutralising networks in each frame, between 9 and 22 of these being three-element networks.

Overall Results.

Having dealt with all the repeater section lengths of cable individually, opportunity was found to measure the overall crosstalk from Leeds to De. by, using the intermediate amplifiers at Claycross, Sheffield and Barnsley. The result was somewhat lower than would be anticipated, the worst value being 60 db. and 10 per cent. of the possible combinations being 62 db. or below at 60 kc/s. It must be noted, however, that these figures would be associated with the top channel only and that channels lower in the frequency spectrum would give better results. Two 12-circuit systems were brought into traffic as soon as the cables were prepared and are still giving satisfactory performance.

Noise on the cable pairs was measured on the Derby-Leeds No. 1 cable at Leeds and Sheffield. At the former place the noise level was 120 db. below 1 milliwatt and at the latter place it was still better.

Conclusion.

It has been demonstrated that 12-circuit carrier telephony can be operated on a deloaded group of pairs in a multiple twin cable laid originally for audio circuits only. If the cable is of good quality and the group of pairs is suitably located, satisfactory crosstalk levels are obtainable without unreasonable expense, but if the cable is of an earlier type lacking uniformity in its characteristics, the carrier systems can be applied to only one pair in each quad. It is not necessary that the two cables for GO and RETURN circuits should follow the same route between terminal stations, but this is obviously very desirable.

Modern Materials in Telecommunications

U.D.C. 538 539 621.318.322

W. G. RADLEY, Ph.D., M.I.E.E.

C. E. RICHARDS, F.I.C.

E. A. SPEIGHT, Ph.D., D.I.C., A.R.C.S.

E. V. WALKER, B.Sc., A.R.S.M.

Part IV.—Magnetic Materials

The development of the theory of magnetism is followed from Ampère's idea of current whirls to the modern conception of spinning electrons. The conditions under which spin can confer ferromagnetic properties on a material are examined, with particular reference to the new magnetic materials now available which have exceptionally high permeability or coercive force.

Types of Magnetic Material.

IN the sense that certain peculiar phenomena associated with the mineral Lodestone have been known for at least 2,000 years, magnetism may be regarded as an ancient science. Owing largely to the intangible nature of magnetism, however, very formidable difficulties confronted the would-be scientific investigator, and no important progress towards even the classification of magnetic phenomena was made until the classic researches of William Gilbert in about the year 1600. During the next 200 years a slow accumulation of data took place, but little worthy of note emerged until the time of Ampère and Faraday. Both are remembered as brilliant experimentalists who added greatly to our knowledge of the facts of electromagnetism. Ampère, moreover, put forward a theory of magnetism which bears a remarkable similarity to present-day theories though, in his time, it was held to be too fantastic to receive serious consideration from the majority of scientists.

The known facts of magnetism at the close of the 19th century can be briefly summarised. The majority of substances belonged to one or other of two types, the paramagnetic and the diamagnetic. A rod of paramagnetic material, when placed in a strong magnetic field, would tend to set itself with its length parallel to the direction of the field, whereas a rod of diamagnetic material would tend to set itself at right angles to the direction of the field. In most materials these tendencies are slight and the forces brought into play are small. A more scientific basis for classification is the relationship between the magnetising force (usually indicated by the symbol H) applied to a specimen of the material, and the total magnetic flux density (B) produced thereby. The permeability (μ) of the material is the ratio of B to H . For the great majority of substances μ is practically independent of the absolute values of B and H ; being slightly greater than unity for paramagnetics and slightly less than unity for diamagnetics.

For some substances, however, notably the metals iron, cobalt, nickel and their alloys, the permeability varies considerably with the magnitude of the magnetising force applied and is usually much greater than unity. It is better, perhaps, to regard such substances as being qualitatively as well as quantitatively different from the majority of paramagnetic materials and to classify them separately. They are usually termed ferromagnetic, and practically all the technically important magnetic materials are of this type.

Properties of Ferromagnetic Materials.

The distinguishing features of ferromagnetics are most simply illustrated by the well-known "B-H curve," which is usually something like the full-line curve OS of Fig. 1.

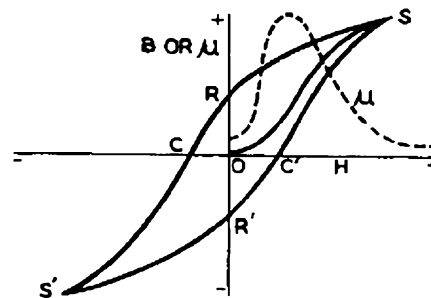

FIG. 1.—B-H CURVE OF A FERROMAGNETIC MATERIAL.

It will be seen that, for an initially unmagnetised specimen, as H is steadily increased there are three distinct stages in the corresponding change of B —a slow initial rise, then a phase where B increases rapidly and finally a state where the rate of increase of B with H becomes less and less rapid as saturation is approached. This is clearly seen from the dotted line which represents the variation of μ with H .

If, after saturation is reached, the magnetising force is reduced to zero, increased to an equal value in the opposite sense, reduced to zero again, and finally increased to its original maximum value in the first direction the original B-H curve will not be retraced. Instead, the condition of the specimen will be represented by a succession of points on the closed figure SRCS'R'C'S which, of course, is the well-known hysteresis loop. The value of B corresponding to the intercept OR (or OR') and the value of H corresponding to the intercept OC (or OC') are, respectively, the remanence and the coercive force (coercivity) of the material.

Properties Desirable in Commercial Magnetic Materials.

Although the magnitudes of the magnetic properties can and do vary widely for different types of magnetic material, the general shape of the figure is the same for all ferromagnetics. It is, therefore, possible to lay down, qualitatively, the relative magnitudes which are desirable in materials for various purposes. For example, a material intended for use in the manufacture of permanent magnets should obviously be characterised by high remanence. In the interests of stability the resistance to demagnetising influences, i.e., the coercive force, should also be high. The

value of the permeability, on the other hand, is usually relatively unimportant.

For alternating current applications a high value of the permeability is usually desirable and, particularly in communications engineering, the losses must be low. It can easily be shown, both theoretically and practically, that in passing round a hysteresis loop energy is consumed and that the amount of energy lost is proportional to the area of the loop. A low value of coercive force is, therefore, necessary. A further source of loss arises from the fact that, in a varying magnetic field, circulating currents—"eddy currents"—are generated in the material. To minimise eddy current losses the material should have a high electrical resistance.

For all applications of magnetic materials stability of properties is very important and the material should be capable of formation to the required shape reasonably easily, i.e. the mechanical properties must be borne in mind.

The State of Magnetic Theory in the 19th Century.

To the scientific historian the early theories of magnetism have many interesting features. Space does not permit a discussion of these, however, and we shall confine our attention to those hypotheses which have most resemblance to present-day ideas.

About 100 years ago Ampère suggested that the atoms of magnetisable substances contained minute whirls of current and were, in consequence, themselves minute magnets. Ordinarily the atoms in, say, a bar of material would be oriented entirely at random, so that their magnetic effects would cancel out, and the resultant external field would be zero. Under the influence of an applied magnetic field a more orderly atomic orientation would ensue, resulting in mutually aiding arrangements having a detectable external field. Owing to the difficulty in visualising the nature and origin of the "Ampèrian whirls," the theory was accepted only with reserve. The idea of the atomic magnet was extended by Weber and, especially during the years 1893-1900, by Sir James Ewing, although neither seriously attempted to explain why certain atoms should be magnets and others not.

In this form, the "molecular theory of magnetism," as it was called, was obviously an idealised conception. By taking into account the frictional forces which must undoubtedly exist in real materials, a qualitative explanation could, nevertheless, be given of the fact that soft iron had a higher permeability, lower remanence and lower coercivity than steel. Thus it appeared reasonable to expect that mechanically soft metals should also be "magnetically soft," and vice versa.

Early Development of Magnetic Materials.

All the important magnetic materials are metals. The controllable factors are, therefore, the purity and composition of the metals or alloys used and the nature of the heat treatment and working to which they are subjected during manufacture. Until quite recently magnetic theory was too incomplete to be valuable as a guide to practical development which, therefore, proceeded largely on hit and miss

lines. Further, the demand for highly specialised magnetic materials was too small to stimulate even empirical research on a large scale.

At the close of the 19th century Swedish iron was commonly used wherever a magnetically soft material was wanted. The maximum permeability was about 3,000, and, due to age-hardening brought about by precipitation of impurities in the space lattice, the metal was somewhat unstable, often showing a considerable increase in losses with continued use. The introduction of "Stalloy" (4 per cent. Silicon steel) by Hadfield and Bartlett was a considerable advance. The material was more stable, had appreciably greater permeability and lower hysteresis loss, and, having a much higher electrical resistivity, had much lower eddy-current losses. Improved manufacturing technique has led to still lower losses, while the permeability has been raised to 9-10,000 at the flux densities used in power engineering to-day. The improvement in magnetic properties is due to the fact that silicon renders the impurities less soluble in iron. These impurities, therefore, segregate at the crystal boundaries and are less likely to appear in the space lattice. This greatly reduces the liability to age-hardening.

During the last few years of the 19th century a considerable amount of attention was devoted to the nickel-iron alloys, but, with one exception, little of note was discovered, due as we know now mainly to lack of realisation of the great influence of heat treatment on these alloys. The exception was Hopkinson's discovery, in 1889, of a "non-magnetic" steel containing 25 per cent. nickel. Incidentally this discovery may, in part, have inspired the development of the relatively new "non-magnetic" cast irons containing about 10 per cent. nickel and 5 per cent. manganese.

In the permanent magnet field the main signpost along the investigator's road was mechanical hardness. As a result the early magnets usually consisted of 1-1.5 per cent. carbon steel. The beneficial effect of the addition of 5-6 per cent. of tungsten was noticed about 1880, but the scarcity of this metal prevented its general use until about 1910. About this time it was noticed that the addition of 1 per cent. of chromium increased the coercive force and yielded a steel which had satisfactory remanence when quenched in oil and which, therefore, was less liable to crack in manufacture. A few years later it was discovered that 4 per cent. of chromium could replace the tungsten, giving a cheaper steel having all the desirable properties of earlier tungsten-chrome steels. Where size and weight are not prime considerations such steels are still in use to-day.

MODERN MAGNETIC THEORIES

The last 20-30 years have seen the production of many new magnetic materials of striking properties and the rapid growth of a far-reaching theory of magnetism. It is beyond the scope of these articles to discuss the extent to which practical developments have arisen out of or independently of the new theory, and it is proposed, therefore, to outline this theory and indicate, as far as possible, the manner in which it is able to account for the outstanding properties

of the new alloys. First, however, it will be instructive to study some recently-discovered aspects of ferromagnetic phenomena which the earlier theories are incapable of explaining.

Magnetic Properties of Single Crystals.

In Part III of this series the fundamentally crystalline nature of metals was discussed. Now, thanks to the application of X-ray diffraction methods, we know the exact arrangement of the atoms in the space lattices of all the common metals and the various interatomic distances within the crystal units. Applying this knowledge to Ewing's theory of atoms behaving as magnets of minute but finite length, the most stable orientation of these magnets can be deduced. The results for iron and nickel are parallel respectively to the body-diagonals and the edges of the cube which constitutes the fundamental crystal unit of these metals. These should be "directions of easy magnetisation," i.e. directions in which a given intensity of magnetisation should be produced by the application of a smaller magnetising field than in other directions.

Obviously, in any ordinary piece of iron the constituent crystals will rarely, if ever, be oriented in perfect order, and the metal will appear to be as easily magnetised in one direction as in any other. During the last few years methods have been devised for enormously increasing the size of the ordinarily tiny crystals in most metals. By a carefully controlled degree of straining followed by suitable heat treatment, it is now possible to produce, for example, bars of iron and nickel several centimetres long which consist of one single crystal only. Experiments on such large crystals have revealed the existence of certain directions of markedly easy magnetisation in each. The surprising feature, however, is that these directions which, for iron and nickel, are shown in Fig. 2, turn out to be exactly opposite to those just mentioned.

The Nature of the Atomic Magnet.

These experiments on single crystals show that we cannot ascribe ferromagnetic properties to aggregates of atoms each having merely the properties of a tiny bar magnet. On the other hand, it seems clear that the origin of these properties must lie within the atom. What possibilities exist? One is the minute circular electric current or whirl suggested by Ampère, and calculations based on such a concept lead to just those directions of easy magnetisation found by the tests on single crystals. Is there, then, any feature of our modern ideas of atomic structure which suggests that such whirls of current really do exist? To answer this question it is necessary to digress into a field of science which, at first sight, appears to have little connection with magnetism.

Atomic Structure and Spectral Lines.

For many years it has been known that, under suitable conditions of excitation, the atoms of an element emit light which, when examined by the spectroscope, can be split up into a number of distinct lines, some of which are very sharply defined, others more diffuse, and all characteristic of that element

alone. Experiment showed that the wavelengths of the lines in any particular spectrum were not distributed in any random fashion, but bore certain simple arithmetical relationships one to another.

Many attempts were made to explain this fact in terms of the structure of atoms. It was soon realised, however, that something more exact was needed than the conception of a number of electrons revolving in orbits of unspecified size round a central positively charged nucleus. Classical electromagnetic theory, in fact, showed that such a system would be unstable—the electrons would move in ever-decreasing orbits, radiating energy continuously all the time, until the whole structure collapsed. This led Bohr, in 1913, to suggest that only certain definite, discrete orbits were possible, that, for some reason then unknown, an electron could remain in one such orbit without

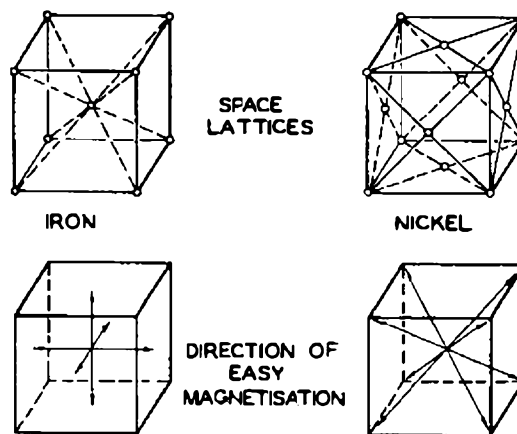

FIG. 2.—SPACE LATTICES AND DIRECTIONS OF EASY MAGNETISATION IN CRYSTALS OF IRON AND NICKEL.

radiating energy, and that, on moving from one permitted orbit to another, energy would be radiated, probably in the form of light.

On these assumptions Bohr was able to calculate the wavelengths that would be expected in the light radiated by excited hydrogen atoms, and these coincided with the measured wavelengths of the lines in the hydrogen spectrum. At least qualitative agreement was obtained for the spectra of more complicated atoms.

A direct connection between spectra and magnetism is the so-called "normal Zeeman effect," which was first noticed in 1896. The simplest manifestation of this effect can be observed by placing any source of light emitting a line spectrum (e.g. a sodium flame or a gas discharge tube) between the poles of a strong electromagnet and examining spectroscopically the light emitted along the direction of the magnetic field. Each single line is found to be split into two components equidistant from the position of the normal undisturbed line. The phenomenon can easily be explained in terms of the orbital motion of electrons.

The importance of these results lay not only in themselves but in the encouragement they gave to scientists to look for other consequences of the orbital motion of electrons. Now, we are all familiar with the conception of the equivalence of an electron

in motion to an electric current. It seems a simple and logical step from this to the idea that the electrons in their orbits are the modern realisation of Ampère's whirls of current.

During the last twenty years or so it has become possible to apply quantitative experimental tests to this theory—and these have shown unmistakably that it is inadequate to explain ferromagnetism. However, just as the science of spectroscopy led first to the conception, then to the abandonment of the electron-orbital theory of ferromagnetism, so, ultimately, did it lead to what is now thought to be the true explanation.

The Spinning Electron.

When the spectra of many elements were examined by spectroscopes of very high resolving power, it was found that the lines, instead of being merely broadened, were each split up into two or more finer lines, i.e. there were more lines than the Bohr theory predicted. A familiar instance is the doubling of the "D" line in the sodium spectrum. Related to this is the "anomalous Zeeman effect." By refined experimental technique this is observable under similar conditions to those of the normal Zeeman effect, and takes the form of a splitting of the spectral lines into many more than the two components produced in the normal effect.

To account for these phenomena an extension of the Bohr theory was necessary. This extension was provided in 1925 by Goudsmit and Uhlenbeck, who suggested that the electrons, as they moved in their orbits, were also spinning about their axes perpendicular to the planes of the respective orbits. The modern theory of wave mechanics shows that this mode of motion should give rise to a magnetic moment independently of the orbital motion.

Although it was not possible to measure independently the angular momentum and the magnetic moment due to spin, the theory could assign probable values. If these values were used, the calculated ratio of the magnetic moment to the moment of momentum—the "gyromagnetic ratio"—due to spin, agreed very closely with the measured figure and the positions of the spectral multiplets coincided exactly with positions predicted by theory. That such close agreement should be obtained in two so widely differing fields as magnetism and spectroscopy is very strong support for the theory, and provides ample justification for the spinning electron as the ultimate magnetic particle.

Spin and Magnetic Properties.

If some of the electrons within an atom possess spin, it is permissible to suppose that all do so. Some additional factor or factors must, therefore, be sought which determines the type of magnetic properties which spin can confer on any given element. To do this it is necessary to turn again to the modern conception of the structure of atoms and consider the arrangement of the electrons within the atom.

Every atom contains a central nucleus carrying a positive charge which is equal and opposite to the total negative charge of the surrounding electrons. The number of these electrons is equal to the atomic

number of the element which increases by one for each step along the periodic table in the direction of the heavier elements. These electrons are arranged in successive concentric shells which, when completed,¹ contain respectively 2, 8, 18, 32 electrons and so on. Within each shell the electrons can spin in two directions, opposite in sense, which can be called positive and negative. Within any completed shell half the electrons have positive spins and half have negative spins. The resultant magnetic moment of the shell will therefore be zero. In a single sodium atom there are eleven external electrons, ten of which just complete the first two possible electron shells, and, whose spins, therefore, give rise to no magnetic phenomena. The eleventh electron is known as the "valency electron," because to it may be ascribed the chemical properties of the element. This electron lies alone in the third—very incomplete!—shell and the atom as a whole should have a magnetic moment. This has been confirmed experimentally, and Gerlach and Stern have, in fact, succeeded in measuring directly the magnetic moment due to its spin.

Many other kinds of atom are built up on fundamentally similar lines—one or more complete inner shells of electrons, with an outer incomplete shell of valency electrons—and will show various magnetic properties, according to magnitude of the resultant magnetic moment when the free atom is considered. The majority of the elements are, however, solids in which the atoms are closely packed together. One result of this is that the valency electron shells are more or less completely disrupted and the outer electrons tend to wander from atom to atom. Prediction of the magnetic properties of such solid elements will obviously be a complex and difficult matter, but the experimental facts are simple and definite—no element of this type is ferromagnetic.

Magnetic Properties of Elements with Incomplete Inner Shells.

Not all the elements, however, are built on this simple plan; the maximum number of electrons in each

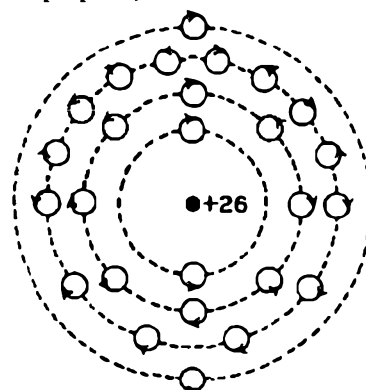

FIG. 3.—ELECTRON SHELLS AND DIRECTIONS OF ELECTRON SPINS IN AN IRON ATOM.

shell is not always reached before the next shell begins to form. In the iron atom, for example, there is a fourth shell of two electrons, although the third shell contains only fourteen instead of the maximum of eighteen. Moreover, nine of these fourteen have positive spins and five negative giving a resultant of four positive spins. These facts are depicted in a highly diagrammatic manner in Fig. 3, positive spin being shown clockwise. Similar conditions are found in all ferromagnetic elements.

¹ See, however, next section.

Although this is an essential condition for the occurrence of ferromagnetism, it is not, however, sufficient in itself. Thus, many other elements, such as palladium and platinum, have incomplete inner shells, but are only feebly paramagnetic. This is explained when the forces of thermal agitation² are considered. These forces, which tend to produce random orientation of the magnetic moments, can be calculated from the kinetic theory of matter. The results show that, if the atoms in a solid element were free to vibrate and rotate independently of one another, the strongest artificial fields would be incapable of causing more than a relatively small degree of magnetic alignment at ordinary temperatures. Further, on removal of the magnetising force, thermal agitation would completely break down the small degree of alignment produced. The orientation of the magnetic moments would become quite random and there would be no remanence. In short, the material would be paramagnetic.

Exchange Forces and Ferromagnetism.

Twelve years ago Heisenberg deduced, by the aid of quantum mechanics, that there should exist between neighbouring atoms in a solid certain forces, known as "exchange forces," which would be vastly more powerful than the magnetic forces between atoms. Provided certain relationships exist between the diameter of the incomplete electron shell and the interatomic distance in the crystal, the exchange forces will succeed in overcoming the thermal forces and will hold limited but relatively large groups of atoms in magnetic alignment. Recent investigations have shown that these relationships exist only in the ferromagnetic elements and certain alloys of manganese, such as the Heusler alloys (Mn-Cu-Al), which also exhibit ferromagnetism.

An estimate of the order of magnitude of the exchange forces can easily be made, for, while these forces will be substantially independent of temperature, the thermal forces depend entirely on temperature. This is borne out by the well-known fact that iron can be magnetically saturated by much smaller fields at the temperature of liquid air than are needed at ordinary room temperatures. Conversely, as the temperature is raised, the thermal forces become increasingly strong, saturation is attained with increasing difficulty, and finally a point is reached at which the two forces balance. This is the well-known Curie point (770°C for iron) at and above which the material is no longer ferromagnetic.

A further interesting deduction can be made. The maximum magnetisation possible in a material will depend both on the resultant electron spin and on the exchange forces. A measure of the saturation value might thus be expected by multiplying the resultant spin by the absolute temperature of the Curie point. If this is done for the series of consecutive elements chromium, manganese, iron, cobalt, nickel and copper the product increases from

chromium to iron, has almost the same value for cobalt, decreases again for nickel, and is zero for copper. It would, therefore, be reasonable to expect a maximum between iron and cobalt, and it is an experimental fact that the only known substances having a higher saturation value than chemically pure iron are the iron-cobalt alloys. A 50/50 iron-cobalt alloy to which 2 per cent. of vanadium has been added is the alloy "2V-Permendur," which is being used for the diaphragms of telephone receivers and the pole tips of electromagnets. The addition of vanadium, besides improving the mechanical properties, increases the electrical resistivity and therefore reduces eddy-current losses and, for certain alternating current applications, a valuable feature is that the permeability at high flux densities is several times greater than that of commercial pure iron under the same conditions.

The "Domain."

From the foregoing it appears that the magnetic unit of a paramagnetic substance is the independent atom in which there is some degree of resultant electron spin. In ferromagnetic substances the effective unit is a group of such atoms in which the magnetic moments of each are completely aligned, i.e. the group is magnetically saturated. Such groups were called by Weiss "domains." The change from an unmagnetised to a magnetised condition thus corresponds to the change from a random arrangement of domains whose magnetic moments cancel out to an arrangement in which the domains are more or less completely aligned. In each domain this change occurs by the simultaneous reorientation of the spins of the electrons of all the atoms therein, although the atoms themselves do not appreciably alter their relative positions in space.

The Role of the Domain in the B-H Curve.

A highly idealised picture of a minute piece of, say, unmagnetised iron would therefore resemble Fig. 4(a), in which the squares represent the domains and the arrows, circles and crosses the directions of magnetisation within the domains. These directions would be the six directions of easy magnetisation previously referred to. The other sections of this figure show pictorially the changes which occur in the domains at various points on the B-H curve.

When, say, a longitudinal magnetic field is applied the direction of magnetisation of some of the domains will be closer to the direction of the applied field than others. If the field is small it will be unable to change the orientation of any domain, and the result will be that the most favourably oriented domains will grow in size at the expense of less favourably oriented domains (Fig. 4(b)). Obviously, this will result in only a small degree of magnetisation of the whole piece of iron, i.e. the initial part of the magnetisation curve.

As the magnetising force increases, the orientations of the less favourably directed domains will change abruptly, one by one, to a more favourable direction of easy magnetisation (Fig. 4(c)). Such changes will make a greater contribution to the total magnetisation of the whole bar than the mere growth of domains,

² "Thermal agitation" may be defined as the movement of the molecules of all matter arising from the heat energy they possess. The average value of this energy is the quantity we measure as temperature.

i.e. the specimen is traversing the region of rapid rise of the magnetisation curve. This stage is completed when the crystal reaches the condition represented by Fig. 4(d), and is essentially one large domain. This is the knee of the magnetisation curve.

At this stage each crystal in the mass of iron will be magnetised completely in that particular direction of easy magnetisation which most nearly approximates to the direction of the applied field. In general, the effective intensity of magnetisation which is the vector sum, will be less than the arithmetic sum of the intensities due to the individual crystals. With further increase in the magnetising field, the magnetisation will change slowly and smoothly in direction until finally it is parallel to the field. The vector sum will then equal the arithmetic sum, no further change will be possible and the iron is then saturated as shown in Fig. (4e).

Size of Domains ; the Barkhausen Effect.

It is important to note that that part of the complete process which corresponds to the rapidly rising part of the magnetisation curve is a step-by-step or discontinuous process. This can be demonstrated experimentally. If a coil of wire wound round the specimen is connected to an amplifier and a telephone receiver, however slowly and smoothly the magnetising force is varied, a series of "clicks" will be heard in the receiver. These clicks correspond to the sudden changes in the direction of magnetisation of individual domains and their manifestation is called the "Barkhausen effect."

Experiments on this effect have enabled the size of the domains to be calculated. The results show that the average domain contains about 10^{14} atoms and occupies a volume of about 10^{-9} cc. There will thus be about 100,000 such domains in each of the 10,000 crystals present in a cubic centimeter of ordinary iron.

Mechanical Consequences of Magnetisation ; Magnetostriction.

It would be natural to expect that the changes just described in the condition of the domains would result in some mechanical effect. This is manifest in the Joule effect—the small change produced in the length of a piece of material as a result of magnetisation—and is one of the important phenomena known generally as "magnetostriction." Such changes in dimensions are opposed by the normal crystal forces, and energy must, therefore, be expended in producing them. There is little doubt that this is the main cause of hysteresis loss.

In iron the fractional change of length at saturation—the "saturation magnetostriction" has a positive value, whereas in nickel, owing to the different space lattice of the crystal, the value is negative. Alloys of these two metals show intermediate values, and, at about 80 per cent. Ni, after suitable heat treatment of the alloy, the effect practically vanishes. This is approximately the composition of one of the "Permalloys" introduced in 1921, the hysteresis

losses of which are very much less than those of either metal separately. The absence of magnetostriction effects would be most evident in allowing easy growth of domains during the first stages of magnetisation and would be reflected in the high value of the initial permeability.

It is not surprising, therefore, that the most outstanding feature of alloys of the permalloy type is the very high permeability shown at low magnetising forces—as much as 30 times that of commercially pure iron.

Following the discovery of these alloys an immense amount of work was done concerning the effect of addition of small amounts of other metals with a view to altering other properties of the alloys, such as machineability, constancy and uniformity and electrical resistance. Space permits the mention of one instance only, that of cobalt. The addition of this metal gives alloys of even lower hysteresis and eddy current losses, though at the expense of lower permeability and greater liability to loss of

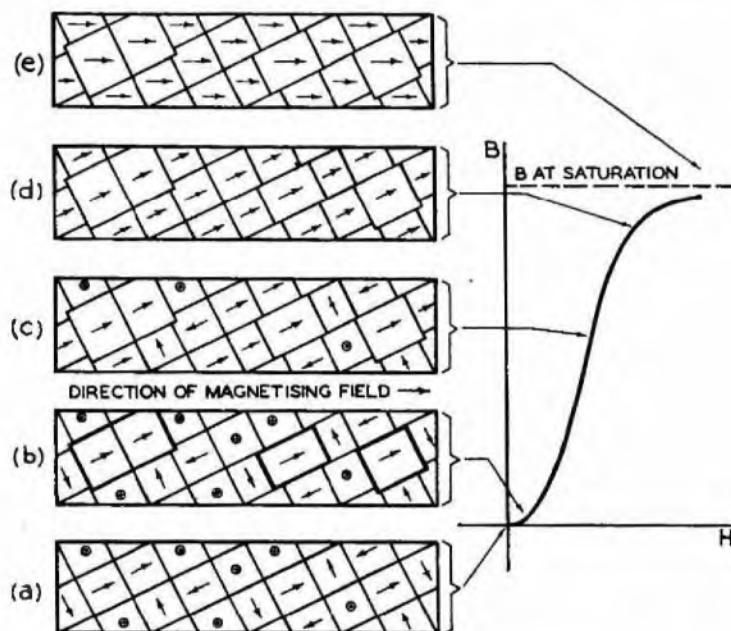

FIG. 4.—DOMAINS IN PART OF A SINGLE CRYSTAL OF IRON.

properties due to the application of too high magnetising forces. The permeability is, however, constant over a much wider range of (low) field strength than with the permalloys, and the tertiary alloys are, therefore, known as "Perminvars."

In all these alloys the purity of the constituents should be as high as commercially possible. Traces of carbon, especially, increase the hysteresis losses (by increasing the mechanical hardness) and reduce the permeability to a considerable extent.

Permanent Magnet Materials.

The modern theories of magnetism and the structure of metals have been particularly successful in explaining the properties of permanent magnet materials. At the present time there are, in fact, such well-established principles governing the design of permanent magnets in all their stages that great

advances in the near future can be confidently expected.

As previously mentioned, high remanence and high coercivity are desirable features of a permanent magnet material. It necessarily follows that the hysteresis will also be high. From what has just been said on the subject of magnetostriction, it is easy to see, therefore, why the best permanent magnet materials are those in which the crystal forces are large, i.e. mechanically hard materials. In Part III of this series it was shown that mechanical hardness is increased by distortion of the crystal lattice leading to the development of high internal strains and practically all the most modern developments in permanent magnet steels are, in effect, the outcome of new ways of producing, and retaining in the finished steel, those particular crystal rearrangements which lead to lattice distortion.

The first major advance after the development of tungsten and chromium steels was the introduction of the cobalt steels about 1917. Steel containing 35 per cent. of cobalt, for example, is much harder than, and has a coercive force about four times as great as that of the best tungsten steel. Although its remanence is about 10 per cent. lower than that of tungsten steel, the higher coercive force of cobalt steel permits a considerable reduction in length and leads to the production of much lighter magnets for such purposes as telephone receiver, loud-speaker, bell and magneto magnets.

With the introduction of alloys of the "Alnico" (Fe, Al, Ni, Co) type during the last 10 years or so, a further doubling of the coercive force has been achieved, and a further reduction has resulted in the volume of the magnet required for a given purpose. These advances are illustrated by the photograph in Fig. 5, which shows the relative sizes of bar magnet necessary in various alloys to produce a flux density of 5000 lines per sq. cm. in an air-gap 2 mm. long by 4 sq. cm. cross section.

The determination of the internal structure of Alni and Alnico by metallurgical and X-ray diffraction methods, has yielded a number of very interesting results. This structure may be described as consisting of tiny separate crystals of pure iron wedged in the lattice of the crystals of the main alloy. Since the lattice spacing in pure iron is about 0.5 per cent. less than the natural spacing in the alloy lattice enormous internal strains must exist. Very high fields are, therefore, required to magnetise these alloys, but, once magnetised, the magnetisation is very strongly retained.

Thus, in general, for a material to have outstanding permanent-magnet properties, it should consist of one homogeneous phase at some high temperature and, at a lower temperature, should tend to separate

into two phases with lattice spacings which differ as much as possible. This discovery has led to the investigation of the result of adding various other metals, e.g. copper and titanium, to the alloy to intensify these effects. Alloys containing platinum have also been studied. These last are, naturally, much too costly to be of commercial importance but, from the theoretical point of view, are striking in having a very much higher coercive force than, for example, Alnico.

It is obvious, from what we have just seen, that a careful study of methods of heat treatment is necessary before fullest advantage can be taken of the new alloy compositions, and much work has been done on the effects of slow cooling and the application of magnetic fields during cooling. The scope in these directions is wide, not only in the attempt to secure the best relationships between the various lattice spacings, but also in what may be termed "pre-orienting" the directions of easy magnetisation of the domains more nearly to coincide with the direction of ultimate magnetisation of the finished magnet.

The investigations mentioned in the last two paragraphs are, at present, only in their infancy,



FIG. 5.—RELATIVE SIZES OF BAR MAGNETS IN VARIOUS ALLOYS TO PRODUCE A SPECIFIED FLUX DENSITY.

and one cannot yet foresee the extent of future progress but, as an instance of the possibilities that exist, the new alloy Ticonal (Ti, Co, Ni, Al, Fe) can be mentioned, which not only has a coercive force nearly 50 per cent. higher than that of Alnico but also an appreciably higher remanence.

The Post Office and Public Address

E. J. CASTERTON

U.D.C. 621.395.623.8

The author reviews the methods by which the Post Office meets subscribers' public address requirements when these involve Post Office land lines or radio links. A brief description of the apparatus used is followed by details of some typical transmissions.

Introduction.

COMMENT passed in an article recently published in an electrical trade periodical concerning the efficient loudspeaker reproduction at a social function, of a conversation over telephone lines, has suggested to the writer that a brief review of the experience of eight years' work in this field may be interesting to readers of this Journal. It is not the intention to treat the subject technically or controversially, since the writer has not been in a position to develop the methods used, in a laboratory, but has merely been called upon to apply available apparatus to satisfy the demand of subscribers for this type of service. The particular transmission referred to above was a typical demand, arising from the inability, due to illness, of an important personage to speak at the function. The Post Office was approached, and in due course facilities were provided for two-way conversation between the invalid and the chairman, both sides of the conversation being made audible to the assembly by means of a public address system. Perhaps it would be as well, before proceeding with the description of how such work is carried out, to make a brief survey of the development of the subject.

The opening of the trans-atlantic radio-telephone service in January, 1927, between London and New York, was almost contemporary with the introduction of the "Talkies" which, in turn, produced the off-shoot we now term "Public Address" and which can be broadly defined as a means of addressing large or small assemblies of people by means of speech picked up by microphones, amplified, and reproduced on loudspeakers. All will, by this time, be familiar with the application of such systems.

It should be pointed out that the G.P.O. is interested in public address provision only when the use of Post Office lines, trunks or locals, or radio circuits is involved. Purely local public address facilities, such as indoor meetings or sports meetings, are deemed to be the province of firms who specialise in such service. In the main, Post Office facilities and installations are temporary, covering only the particular transmissions ordered.

The London-New York telephone service created a demand by big business executives in U.S.A. for facilities to address their staffs in this country. Publicity, novelty and prestige may have been incentives. Before acceding to such early requests, however, there was a certain amount of "feeling one's way" and these preliminaries came to a strikingly successful climax when a joint meeting between the Institute of Electrical Engineers in London and the American Institute in New York

was held in 1928. The entire proceedings were heard by the audiences on both sides of the Atlantic through the medium of loudspeakers, the intervening link being the long-wave radio telephony channel on 5,000 metres. This type of service having been successfully launched, demands by business concerns came along. In those early days equipment was scarce and costs were somewhat prohibitive. Practically the sole source of supply and type of high power loudspeakers and associated amplifiers was from firms manufacturing for the growing "talkie" demand, so that the early reproduction was from a "point" source, as from behind the screen of the cinema, utilising one or two huge loudspeakers which were distinctly ugly. These loudspeakers were the early examples of moving-coil pattern. They needed very careful handling lest the coil was jarred and knocked off centre. Great care had to be taken to avoid overloading the speaker, since it was an easy matter to rip the coil completely away from the cone.

Equipment Employed.

The only microphone available for what was high-quality in those days was the carbon type which was, of course, battery polarised. The weaknesses of this type, namely "packing" and "frying," are well known to-day. Also the amplifiers working with these microphones were battery driven, involving the usual troubles attending secondary cell batteries. There have been great strides in the development of high-quality microphones to such types as condenser, moving ribbon, moving coil and crystal microphones. Of these the moving coil type, as developed by the Post Office, has given highly satisfactory service since 1935, and is still preferred for public address work. In association with an all-mains amplifier, comprising three stages and triode valves, also developed by the Post Office, an output up to + 10 db. relative to 1 mW in 600 Ω is obtained from this pattern microphone. This amplifier, with its separate power pack, is readily portable, and can be put into service on 200-250 V A.C. mains in a matter of very few minutes. This type of microphone formed the subject of an article published in the POST OFFICE ELECTRICAL ENGINEERS' JOURNAL of January, 1935, and is shown together with a microphone amplifier, mixing box and power pack in Fig. 1.

The development of commercial main power amplifiers has not been so marked except, perhaps, that the rated undistorted output is now nearer its advertised value. There have been improvements, such as tone control and automatic volume control and possibly in frequency response. It is the writer's opinion that an amplifier with a rising frequency characteristic gives

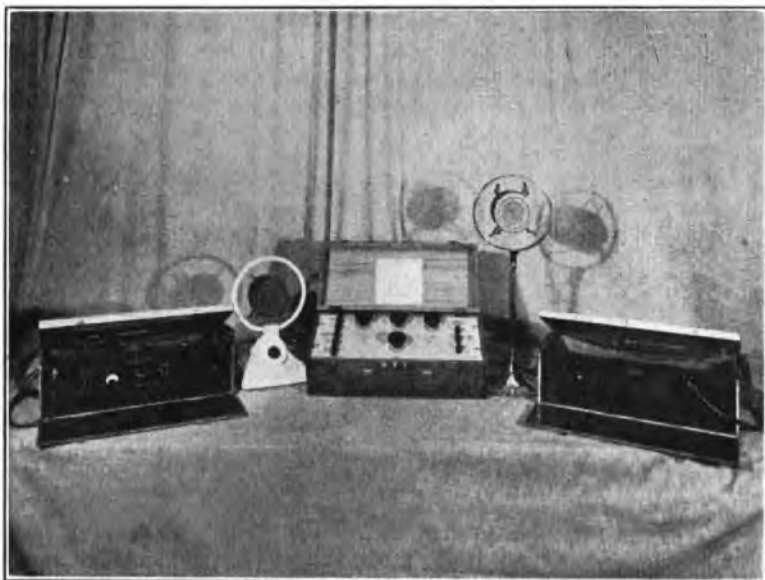

FIG. 1.—MOVING COIL MICROPHONES IN STANDS, MICROPHONE AMPLIFIER AND POWER-PACK, AND MIXING BOX.

better reproduction generally than an amplifier with a flat characteristic. The main power amplifiers used by the Post Office for this work are designed on the rising characteristic principle, being fitted with a bass control which commences a cut-off of the lower frequencies at 800 c/s as shown in Fig. 2. In the

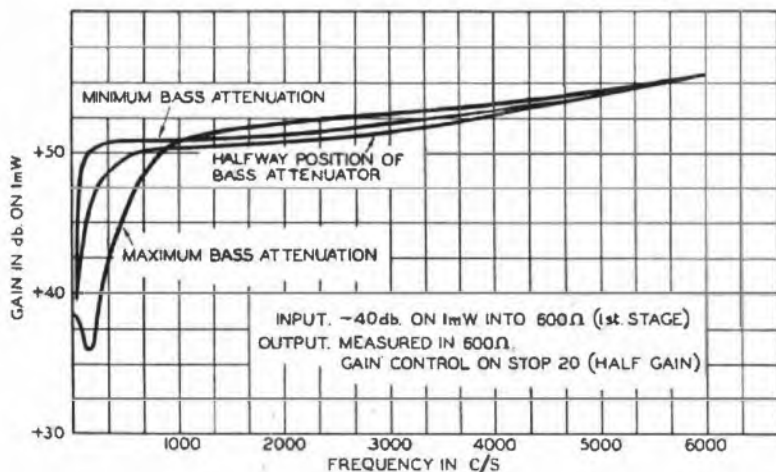

FIG. 2.—FREQUENCY CHARACTERISTIC OF 10 WATT AMPLIFIER SHOWING THREE SETTINGS OF BASS ATTENUATOR CONTROL.

main the power amplifiers and loudspeakers used on this public address service were supplied by Messrs. Parmeko, Ltd., Leicester.

The development of the box type loudspeaker capable of handling inputs up to 5 W resulted in a big improvement in indoor public address installations, and enabled a reproduction of speech more natural and more evenly distributed than was possible by straight horn loudspeakers. In regard to the diffusion of speech, the writer's experience indicates that reproduction by several loudspeakers placed with care around the hall and working at low volume gives a better distribution, a more even

volume and a higher degree of intelligibility to the audience than reproduction from one or more loudspeakers radiating from a single point. The use of several loudspeakers operating at low output level is frequently the only practical solution of acoustic difficulties, since it would be unreasonable to expect the patron to make the room acoustically ideal by drapery, and in any case the shortness of the average transmission would not justify such an elaborate precaution. In the course of experience several occasions have arisen when the company in one or other of the banqueting rooms of leading London hotels (which, incidentally, being carpeted are, therefore, well damped against echo) have been unaware that they have not heard the chairman directly but via a loudspeaker. It is a curious point that under the multi-loudspeaker arrangement, working at comfortably audible level, one appears to hear only one loudspeaker at a time

even though one should move carefully from place to place to test this effect. This does not obtain, however, if the volume from the loudspeakers is high enough to overlap each other considerably.

It should be understood that in assessing the efficacy of a public address system, one must regard the equipment as a whole, because, after all, it is a team effort, and one faulty or inferior part reflects upon the whole. For instance, a microphone is a single unit, and may be a fine piece of apparatus electrically and mechanically, but it is its matching with its input transformer and amplifier which produces the result we hear.

For a public address system within the scope of the Post Office activities, auxiliary apparatus is required such as motor generators for conversion of voltages other than 200-250 V A.C. Portable equalisers are required when lines of poor frequency response have to be corrected; combining amplifiers, for balancing levels of different pick-up points prior to passing to the main amplifier mixing boxes, for combining the simultaneous pick-ups of two or more microphones and attenuators for reducing levels which would be too high for input to the main amplifier. Testing equipment consists of voltmeters, volume indicators and variable audio-frequency oscillators, these being used to conduct frequency adjustment and to check the overload level of the lines to be used. All the apparatus used in conjunction with lines has input or output impedances of 600 ohms to conform with standard Post Office practice.

Procedure for Dealing with Enquiries.

Enquiries for this type of service usually reach the Telephone Manager, who obtains the main points of

the requirements; for example: "Mr. Jones, chairman of the XYZ Company, is addressing a meeting in the London office on Thursday, 2nd May, at 2.30 p.m., and he requires his address and the speeches of members of his board to be heard by executives in branches at Liverpool, Manchester, Norwich, Cardiff, Glasgow, and he wishes the managers at these centres to give their annual report in reply. Each meeting is to hear every speaker from each point. There will be a gathering of 200 persons in London and not more than 75 at each of the other points. The London office will be responsible for payment and Mr. Brown, the secretary, should be contacted for details." This represents quite a modest enquiry, and should not be regarded as an extravagant example, as later examples of jobs actually done will show. It is usual that the patron is completely unaware of what the service involves and what the charge is likely to be. Frequently the subscriber thinks it is necessary only to fit a loudspeaker across the telephone line at the distant end and he can proceed to address his audience by means of his telephone. The enquiry is passed by the Telephone Manager to Headquarters, Telecommunications Department, who, having given authority, request the Engineering Department, Radio Branch, to proceed. The lines and traffic branches are consulted as to the provision of high quality lines and their availability at the particular time required. The local engineers at the points concerned obtain particulars of the rooms in which the meetings will be held and of the facility of running-in separate local ends for the three circuits at each point which would be involved. Also details of available power supplies are sought. From the data thus obtained the amount of equipment involved can be visualised, and a reasonably close estimate is submitted to the patron often on the same day as the enquiry is received. If overseas radio links are involved the estimate is unavoidably delayed since overseas administrations have to be consulted as to their costs. Having received the concurrence of the patron, the lines and traffic branches are advised and provision thus made for the best available circuits to be taken up at a certain time; this means for approximately one hour on the day preceding the function for test purposes, and then 30 minutes before the scheduled starting time on the day of the function. The lines in this particular case would converge on the Radio Telephone Terminal, London, for reasons to be explained later. To each point there would be one uni-directional "go" circuit, one uni-directional "return" circuit and one both-way control circuit with ringing facilities. To such centres it is found very convenient to use a split 4-wire circuit, thus taking only one circuit from traffic for programme use. The control circuit will necessitate a second traffic line between the points concerned, but this need not be of the same high standard of transmission efficiency as the programme circuit. All 4-wire terminations and echo

suppressors are removed. The local ends or pairs referred to previously are the circuits run directly from the city's trunk exchange or repeater station to the room in which the function is to take place. For reasons of quality they must not pass through the ordinary exchange equipment or be bridged by any relays or coils; this, however, does not apply to the ordinary safety devices of the exchange main distribution frames. Headquarters furnishes all necessary equipment which travels to the various centres accompanied by a supervising officer who, with the assistance of the local engineering staff, carries out the installation, transmission and recovery. Although as much as 15 cwts. of apparatus have been taken in this way on passenger train, the cost is most reasonable, and the method has been found far preferable to the gear being crated and despatched separately. Surprisingly little damage has been caused in the eight years the writer has travelled with apparatus.

At a centre one may find a carpeted room 90 ft. by 40 ft., with the head table down the long side. An ante-room with door opening on main room makes a convenient housing for the apparatus. If no such room is available it is generally found convenient to screen off one corner of the main room. A portion 6 ft. by 6 ft. is usually ample. After examination it is considered that eight loudspeakers will suffice—two per side of the room. Three microphones are needed at the head table, where all talkers will be assembled. It is possible by careful adjustment of output level to bring a box loudspeaker within 10 ft. of a microphone and deliver satisfactory volume. Should this not be possible due to using many microphones, arrangement is made to switch out any loudspeaker likely to cause trouble. The trouble referred to discloses itself as a "howl" and is due to the output from the loudspeaker feeding back to the microphone at such a volume as to be comparable with, or in excess of, the actual talker's voice. This is another way of saying that to maintain the stability of a public address system, and to avoid

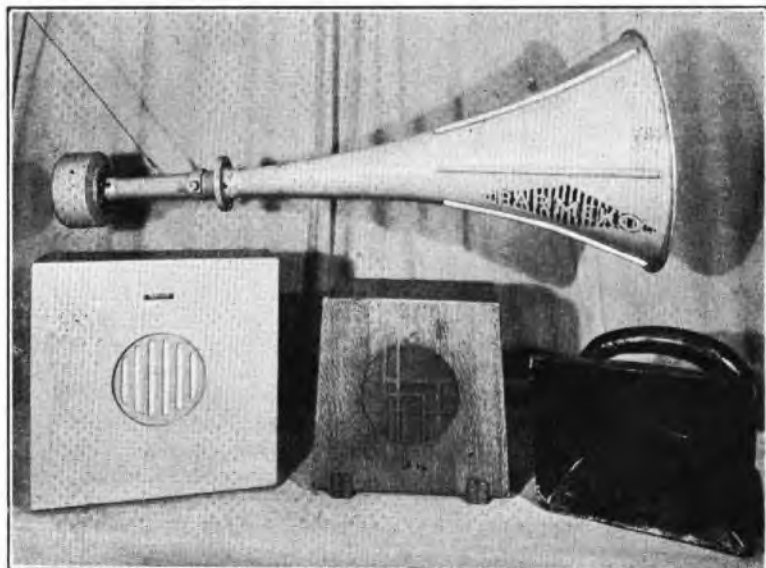

FIG. 3.—VARIOUS TYPES OF LOUDSPEAKER USED ON PUBLIC ADDRESS WORK.

this howl. the loss of energy in the acoustic path from the loudspeaker to the microphone must be of a higher value than the gain in the amplifiers in the rest of the transmission path. The loudspeakers used are of the box type permanent magnet moving-coil, fitted with a line transformer of $600\ \Omega$ impedance to line (Fig. 3). This impedance enables the loudspeakers to be wired up in parallel with light cabling—usually "jumper" wire 1 pair $12\frac{1}{2}$ lb.—thus making the wiring easy, since such wire can be readily passed under carpets. It has been found from experience that a suitable height for the loudspeakers is approximately 8 ft. from the ground, tilting slightly downwards. The microphone leads are of screened flex or lead-covered cable, the screening or lead-cover being earthed as a precaution against noise picked up from adjacent lighting or power cables. It is an advantage of the type of microphone adopted that distances up to 300 yards can separate microphone and amplifier without noticeable deterioration in speech quality. Also this type of moving-coil microphone not being sensitive to direction, permits quite a large latitude of movement by a talker without serious loss of pick-up. Directional microphones are not desirable for public address work. The loudspeaker installation in the room just examined would be satisfactorily operated from a 10 W output main amplifier, since the idea aimed at is to cover the room with a volume of speech comparable to a man's natural level of voice which makes listening comfortable. A mixing box enables the microphones to be brought smoothly into action as required.

Earlier on it was mentioned that all lines to each centre converged on the Radio Terminal, London. At this terminal are the means of control through a special broadcast control switchboard (Fig. 4), offering facilities and amplifiers to receive material from many sources and also for transmission to many sources simultaneously, adjustable to any desired volume. In the example under review, the outputs from the microphone amplifiers from all centres are brought to this terminal. Here they are combined and fed simultaneously to each centre on the line terminated by the main amplifier and so to the loudspeakers. Thus when the Glasgow man is speaking his voice travels to London and back to Glasgow before issuing from the loudspeakers in the same room. Under these circumstances there is no delay noticeable by a person in the audience. It must be admitted that this procedure could not be adopted over lines of considerable length such as New York-San Francisco. On such connections a combining amplifier is used for side-tracking part of the local speech into the local main amplifier.

It will also be seen that a focal point like Radio Terminal with its measuring, equalising, level adjusting, and control facilities is very useful in preliminary testing and ultimate operation of the transmissions, and it automatically comes into the picture whenever a radio channel is used for public address service.

Close proximity of the Radio Terminal to the Trunk Test Room is yet another important facility in grouping of lines.

Typical Transmissions.

Several types of request can be handled, viz. :—

- (a) One-way transmission only.
- (b) Two-way transmission and reproduction at both ends.
- (c) Multi-point pick-up for reproduction at one point.
- (d) Multi-point pick-up for reproduction at all points.
- (e) Single pick-up for reproduction at many points.

The largest transmission as yet undertaken was for a religious organisation whose leader, while addressing an assembly in Madison Square Gardens, New York, was simultaneously heard in halls and cinemas in 56 cities in the British Isles and also in Australia. A London-New York radio-telephone channel formed the connection between America and England, and the London-Sydney radio link the connection to Australia. This particular example emphasises the usefulness of the Radio Terminal as a distribution centre. For the sake of economical use of trunk circuits satisfactory sub-grouping was effected at points like Leeds, Manchester, Glasgow and Bristol. This transmission also illustrates the co-operation which exists between the Engineering Department and "Talkie" equipment engineers. By the provision of line matching transformers and attenuators talkie equipment has been used with great success as a medium of long distance public address. One of the first all land-line jobs undertaken was the opening of the 1,000th branch of Boots, Chemists, in Galashiels. This was performed

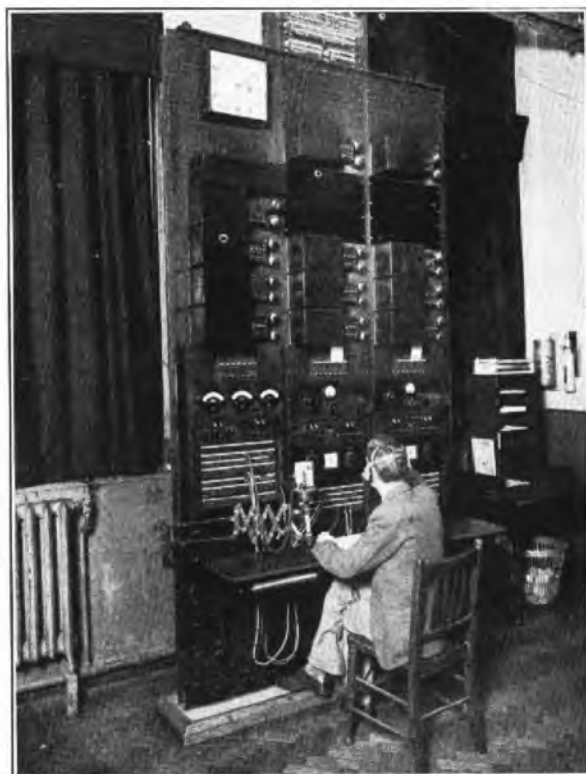

FIG. 4.—PUBLIC ADDRESS BROADCAST CONTROL SWITCHBOARD AT RADIO TERMINAL, LONDON.

by the Dowager Lady Trent from a banquetting hall of the Savoy Hotel, London. Speeches were relayed to and from the shop and hotel, much to the interest of the assembly of townfolk in Galashiels. The people gathered at the Savoy were highly amused to hear the first customer enter the shop and to hear her make the first purchases.

A job of great interest to the engineers concerned, and, indeed, one of world-wide scope, was carried out on behalf of a London firm. A joint conference of the firm's representatives in every continent was held, the chairman being seated at his office desk in London. Radio links to India, America, South Africa and Australia were simultaneously in use—every point heard every other point by loudspeaker installations—Perth, West Australia to Johannesburg via London, etc. With so many radio links in use, it was considered that the combined radio noise of all the circuits would mar the general transmission. This was obviated since the chairman in London engaged each point separately in conversation, the operation of a telephone key at the London Radio Terminal changing from, say, South Africa to India or Australia. By similarly throwing a key any point could "intrude" on the conversation. It was left to each distant point to reproduce its own portion of speech by "sidetracking" locally, since there would have been a marked deterioration in speech quality after the translations occasioned by a "double trip." Fig. 5 shows in schematic form the arrangement used on this occasion.

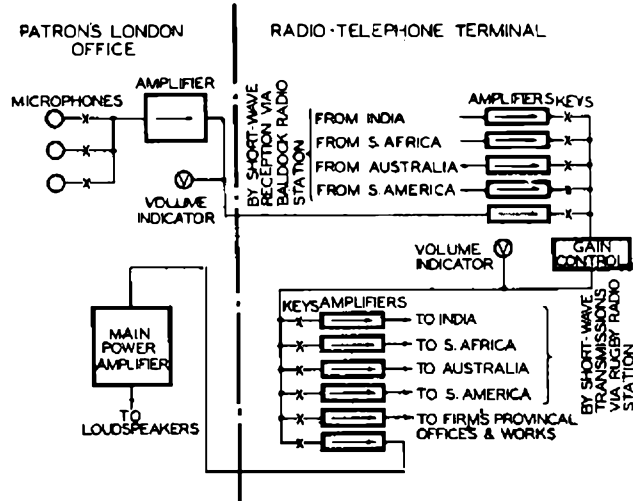

FIG. 5.—SCHEMATIC OF TYPICAL CIRCUIT ARRANGEMENTS.

Another transmission of novelty and interest was the relaying to a G.P.O. Exhibition of a well-known dance band under its equally famous leader, Jack Hylton, which was assembled in that comfortable old Pullman of the skies, the "Heracles," while flying high over London. Loudspeaker reproductions of free calls between members of the public to ships at sea, and various Empire centres, were a popular feature for some years at the Post Office stand at Olympia and elsewhere during certain exhibitions. Inaugural speeches and conversations between celebrities reproduced to the gathering by loudspeakers are a frequent feature at the opening of new automatic telephone exchanges. One particular occasion comes to mind when Sir Walter Womersley opened Barnsley exchange with a telephone call to a miner 5,000 feet underground in Barrow Main Pit. It was humorous to hear the miner's obvious chagrin at Sir Walter's quip that he had heard "that Barnsley's football team had been in every league except the League of Nations."

The microphone has been called to duty in many unusual circumstances, to wit, on one occasion the whole of a first night production of a play at Drury Lane Theatre was relayed to a lady at a nursing home. On another occasion a gentleman lying ill in a London hotel was intensely interested in the running of his horse in the South African Derby. He was supplied with a running commentary of the race, and to crown the success of the relay, his horse won—engineers run into champagne sometimes. Yet another example of uses to which long distance address can be put is the occasion when Gar Wood, of speed-boat fame, speaking from his home in Detroit, U.S.A., addressed the people at Oulton Broad, Norfolk, and started the competitors off on their out-board motor boat race for the "Daily Mirror" Trophy.

Even in war time we find a use for public address such as that furnished at various P.O. air-raid shelters. Here the P.A. installations are doing useful service in marshalling and passing instructions to the large staffs which perforce use the shelters. Also, by the addition of a gramophone turntable, a modicum of entertainment is available to relieve the tedium of waiting.

From the few foregoing examples it is hoped to have illustrated the wideness of the field of application of "Public Address." It certainly seems that distance is no deterrent.

An Impulse Generator

U.D.C. 621.395.342 : 621.396.615

B. M. HADFIELD, B.Sc., A.M.I.E.E., and
W. W. CHANDLER, B.Sc.

The authors describe an impulse generator which can produce a continuous series of impulses of any given speed and percentage break within the design limits, or a cyclic repetition of impulses of selected speeds and percentages. The generator was designed for use with an impulse measuring equipment to determine rapidly the failure points of automatic telephone apparatus.

DESIGN PRINCIPLES

THIS apparatus was designed as part of a complete equipment for impulse transmission testing, the associated measuring equipment having already been described.¹ It may, however, be used separately for general exchange testing, since its scope is much wider than previous types of impulse generators.

It comprises two units, one of which is the generator proper and the other a control unit which causes the generator to send either continuous impulses at any given speed and percentage, or a cyclic repetition of speeds and percentages. Consideration of the performance required of the generator to send the series of impulses corresponding to the combinations of permissible dial speed and ratio variations (known as the dial target), shows that any mechanical form would be extremely difficult of attainment, apart altogether from the resulting lack of flexibility. The generator has therefore been designed on the basis of a valve circuit which provides a current waveform for a relay, the impinging speed and break percentage of which can be practically instantaneously controlled by purely electrical methods.

Desirable Performance of Valve Generator.

An impulse generator capable of covering a speed range of 5 to 16 i.p.s., and a break percentage range of 50 to 85 per cent., will enable targets to be generated having an area greater than the normal dial target and approximately symmetrically disposed in relation to it. This range has therefore been chosen as the basis of design.

It is desirable that the method of control adopted should enable the speed and ratio to be varied independently. It is considered that the above ranges of speed and ratio will be adequately subdivided if steps of 1 i.p.s. and 5 per cent. are taken. Break percentages of 66.7 per cent. and 63.3 per cent. are also desirable, to provide the nominal system percentage and the lower dial limit percentage respectively.

If the diagram area to be depicted on the oscillograph screen of the measuring equipment is of the order indicated by the above ranges, the required order of accuracy of the test impulse times will depend partly upon the dimensions of the fluorescent spot, and an accuracy of 0.5 per cent. has been visualised. This should be maintained between individual impulses as well as for long-period variations due to other causes.

It is essential that no further error be introduced on successive impulses when these are different in character. In practice, this means that the controlling circuit must be such that the changes in the valve circuit conditions occur as closely as possible to the

instant when one impulse finishes and the next commences. Moreover, the changes must take immediate effect, since any delay would involve variations in the individual impulse characteristics which would be dependent upon the nature of the preceding impulse.

It is desirable that standard commercial valves be used throughout the generator, since this will facilitate subsequent maintenance.

Provision should be made in the circuit design to avoid fluctuations in impinging performance due to variations in ambient temperature and battery voltage. The latter is particularly desirable in view of the advantage to be obtained if the generator operates off the 50 V exchange battery.

So that the performance of the generator may be checked, a circuit should be provided to measure the speed and ratio of the impulses at any given setting. This circuit can then be used as a calibration standard for the generator.

Method of obtaining Variable Speeds of Impulsing without affecting the Percentage.

Suppose a relay (with negligible operate and release lags) to be energised by a current I of recurring waveform of the type shown in Fig. 1. If the relay

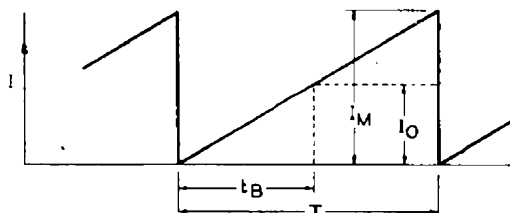

FIG. 1.—GRAPH ILLUSTRATING RELAY OPERATION.

operates when the current reaches the value I_0 , and the maximum value of the current is I_M , it will be clear from the diagram that the break percentage (on the make contact) $t_B/T = I_0/I_M$. Hence if the period T of the waveform is varied without altering its maximum value I_M , the speed of impulsing can be varied without affecting the break ratio of the contact.

The suggested type of energising waveform can be derived from any of the well-known linear time base circuits used in connection with cathode-ray oscillographs. The type chosen is shown in Fig. 2 in which V_1 is a gas-filled triode valve. When the circuit is switched on, the valve V_1 is non-conducting, and

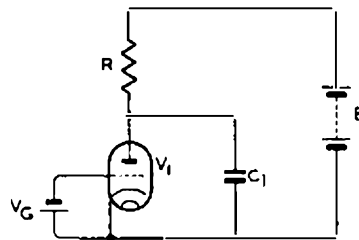

FIG. 2.—LINEAR TIME BASE CIRCUIT

¹P.O.E.E.J., Vol. 33, p. 149.

the condenser C_1 charges in series with the resistance R until the voltage across it reaches a value sufficient to cause ionisation of the gas within the valve. When this occurs the valve becomes effectively of zero impedance, thereby discharging the condenser C_1 until the voltage on the latter becomes just less than the de-ionisation potential of the valve. The latter then becomes non-conducting and allows C_1 to recharge. The ionisation or striking voltage of the valve is dependent upon the negative grid potential V_g , increasing almost linearly as V_g is made more negative. The de-ionisation or release voltage is dependent upon the gas pressure, heater current and ambient temperature, and is therefore not normally controllable. If the grid potential is maintained constant, variation in the charging resistance R will vary the speed of repetition without altering the amplitude of the waveform, since the striking and release voltages may be considered constant. The conversion of the voltage waveform on the condenser to a current waveform suitable for operating the relay is carried out by a valve circuit described later.

It will be clear from the foregoing that the rise of voltage on the condenser during the charging period is exponential in form and not strictly linear. If the striking voltage of the valve is kept small in comparison with the charging battery voltage, the condenser charge is confined to the initial portion of the exponential curve where the departure from linearity is small. Since the amplitude of waveform required is determined by the grid swing necessary on the succeeding valve, it may be restricted without disadvantage, so that the above requirement is met. This small non-linearity is corrected in the final circuit, in the valve stage operating the relay.

It can be shown that the frequency of the generated waveform and hence the speed of impulsing is inversely proportional to the charging resistance R , if the discharge time is made extremely small. It will be observed that, contrary to normal practice, no limiting resistance in the discharge circuit is used. This has been found necessary, as even small resistances of the order of 100 ohms were found to give unstable release voltages causing changes in speed and percentage. It is usually stated by the valve manufacturers that the discharge current must be limited to a maximum of about 1 A with this type of valve. No ill effects have ever been found with the present circuit, experience being based on several models which have been in continuous use in the laboratory for generation of impulses. The manufacturers have been approached on this matter, and agree that, provided the discharge voltage is of the order of 50 V, no harm is likely to be experienced. The discharge voltage with the present arrangement is some 20 V.

To provide for changes of speed in steps of 1 i.p.s., two methods are available. One method, used in the early forms of the generator, consists of choosing a suitable high value of R to attain the lowest required speed and then providing taps on this resistance, the values of the tapping points being evaluated from the inverse law. The complete tapping resistance is

then constructed from composition resistors or combinations thereof checked to have the calculated values. The disadvantage of this method is that the values of the taps required are all different and cannot be easily made up of standard values of composition resistors. The second method overcomes this difficulty by making use of the fact that the speed is directly proportional to the conductance in the charging circuit. Hence the various speeds can be attained by parallel combinations of resistors. Thus, by suitable design, each successive step can be produced by connecting a single standard value resistor in parallel with that already in the charging circuit. A value of 100,000 ohms or 10 μ mhos conductance per i.p.s. has been chosen for design purposes. Thus 5 i.p.s. would be obtained with 50 μ mhos or 20,000 ohms resistance, while 6 i.p.s. would be obtained with an additional 100,000 ohms in parallel with this. Due to the nature of the switching mechanism used for controlling the generator, it is necessary that separate resistance combinations be used for each speed tapping, so that the total number of resistors used is not much less than that of the simple tapped resistance, but it is considered that the advantage of being able to use convenient standard values based on the above method of design is sufficient to justify this method.

Having designed the charging resistance system on the above lines, the values of C_1 and V_g are chosen to give the required speed range and waveform amplitude. The circuit is set up by switching-in the value of R to give, say, 10 i.p.s. and adjusting V_g until this impulsing speed is attained. The other speeds then follow automatically when R is varied. It can be shown that the impulse time

$$T = C_1 R \log_e (E - V_1) / (E - V_2)$$

where E is the charging battery voltage, V_1 the release voltage and V_2 the striking voltage of the valve. Since E and V_1 can be considered constant, the method of adjustment ensures that V_2 , and hence the waveform amplitude, attains its correct value.

In the early experiments on this portion of the impulse generator, the mercury-vapour type (Osram GT.1) gas-filled triode was employed. This type was found to be unstable in operation as was also a later form (GT.1A) in which the gas was argon. More recently, the GT.1A type has been superseded by the GT.1C. Like the GT.1A, this type is argon-filled, but the electrode structure has been completely redesigned and is totally shielded by the anode. Experiments with this valve have been entirely satisfactory, since it is practically immune from temperature and photo-electric fluctuations, which were found to be the cause of the unstable performance of the earlier types.

Individual valves may show variations in release voltage. The method of calibration will result in a change of amplitude if a different valve is substituted. Since the variations of release voltage are fairly small, the changes in amplitude are not large, but are liable to affect the make percentage calibration. For this reason the speed calibration adjustment is best carried out before the latter.

Method of Obtaining Variable Percentage without affecting the Impulsing Speed.

The conversion of the saw-tooth waveform into a current waveform suitable for operating a relay is carried out by applying the voltage waveform to a type of trigger circuit indicated in Fig. 3. Earlier and more simple relay operating circuits were discarded

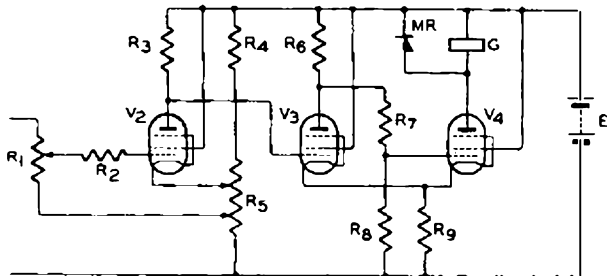

FIG. 3.—TRIGGER CIRCUIT.

because it was found that unless the relay current waveform was rectilinear, the relay distortion varied with the rate of change of current and hence no means for compensating the distortion at all impulsing speeds could be arranged. Conventional trigger circuits which operate by using an unstable condition were also found unsatisfactory on account of the very nature of such circuits.

The type of circuit finally adopted had been formerly devised for another investigation, and although using a number of valves has been found to be very reliable in action, because there is no unstable condition. In Fig. 3 V4 is the relay operating valve and V3 is of similar type; V2 is a pentode having a short grid base. Assuming that initially the bias on V2 is greater than that required for anode current cut-off, no current flows in V2, and the grid potential of V3 is slightly negative with respect to the cathode, being limited by the flow of grid current in R₃. A large anode current therefore flows in V3, producing voltage drops in R₆ and R₉. By means of the potentiometer R₇, R₈ the grid potential of V4 is maintained at a suitable fraction of the voltage between the anode of V3 and negative battery, while the voltage drop on R₉ applies a positive potential to the cathode of V4. R₈, R₇, R₈ and R₉ are chosen so that in this condition the net bias on V4 is sufficient to produce no current in the relay G.

When the time base voltage is applied to V2, and the grid potential of the latter reaches the point at which anode current commences to flow, an increased voltage drop is developed across R₃. By making R₃ very large the anode potential of V2 may be made to fall rapidly for a very small increase in its grid potential, so that the grid potential of V3 also falls rapidly to below the cut-off point. The fall in anode current in V3 reduces the voltage drop on R₆, causing the grid potential of V4 to increase until it is limited by the flow of grid current in R₇. V4 therefore passes maximum anode current, causing the G relay to operate. Since V3 and V4 are of similar type, the maximum anode currents are nearly equal so that the voltage drop on R₉ and hence the potential of the cathodes of V3 and V4 with respect to negative battery will be maintained constant during the changeover.

The change of anode current in V4 from zero to a maximum value determined by the limiting grid potential takes place with an extremely small change of input grid potential on V2. Hence, under impulsing conditions, a trigger effect is obtained, and the current waveform in the G relay is rectangular in shape.

It will be appreciated that the trigger effect is not obtained by any feedback action, and thus the circuit is perfectly stable. The trigger and de-trigger voltages are equal (within 0.01 V) and occur when the grid potential of V2 is just at the anode current cut-off point. Thus, most of the disadvantages of existing types of circuit have been overcome by this method.

Having attained a suitable relay current waveform, it is necessary to correct for the relay distortion. Since the make contact of the relay is used for feeding the ensuing circuit, owing to the transit time the operate lag of the relay is greater than the release lag. The relay distortion may be corrected by connecting a rectifier of suitable forward resistance across the G relay, as shown in Fig. 3. When the current is rising in the relay during operation, the induced E.M.F. on the relay is applied to the rectifier in the non-conducting sense. Hence no current flows in the latter, and the rise of current in the relay is unaffected. On release, however, the induced E.M.F. is applied to the rectifier in the conducting sense, and current flows round the relay-rectifier loop, so that the release of the relay is delayed. A resistance in series with the rectifier may be used to equalise accurately the operate and release lags, but it has been found by experiment that a W.4 type rectifier has the correct forward resistance to attain this condition with a high-speed type of relay where the distortion to be corrected is only some 1 mS.

With the development of the trigger action relay operating stage, a convenient method of controlling the make percentage is possible. The amplitude of the waveform applied to the trigger stage is maintained constant, and the initial bias on the first valve of the stage is varied so that the time interval t_n (Fig. 1) at which the relay operates is also varied. The range of control is very large; the output make percentage may be varied from zero to 100 per cent. by suitable choice of input amplitude and bias in relation to the trigger voltage of the first valve. Also, if the voltage waveform is assumed to be linear, the output percentage is directly proportional to the bias, and a linear control of make percentage is attained.

This method of control therefore facilitates the design of the make percentage control resistance network, since it is necessary only to choose a suitable standard value of resistance for a given change in percentage and arrange this as a potentiometer across the supply, calibrating adjustments being made at the upper and lower points of the network to give the minimum and maximum required percentages.

Compensation against Battery Voltage Changes.

A considerable amount of experimental work has been carried out on the question of stabilisation of the generator performance against changes in supply voltage. It was found that, if no provision is made for compensation, and as the whole of the impulse

generator is operated from the 50 V exchange battery, variations in supply voltage from 46 to 52 (i.e., normal limits) gave rise to changes in speed and percentage. These were of the order of ± 2 i.p.s. and in percentage of approximately ± 3 per cent. In view of the required accuracy of performance, it was evident that adequate compensation was essential if reliable results were to be obtained from the complete equipment.

At first, attempts were made to derive, by means of a barretter circuit, a substantially constant supply voltage and to use this derived voltage to feed the complete generator. This method involved a considerable waste of power and, in addition a barretter having suitable characteristics could not be found. It was therefore apparent that compensation would have to be effected separately on heater currents and anode and grid potentials. Heater current compensation has been arranged in the final circuit by means of a barretter. This barretter (Ediswan type BU 190/24) limits the current to 1.7 ± 0.3 A over a voltage range of approximately 20-35 V. It is therefore anticipated that when the supply voltage varies between 46 and 52 V the voltage of the valve heaters will be limited to 4 ± 0.2 V. Assuming the grid and anode potentials on V1 to remain constant, this will result in a speed variation of ± 0.15 i.p.s. at 16 i.p.s. The grid bias for V1 is derived from the heater circuits so that this varies by the same amount as the heater voltage.

Compensation against battery voltage variations in the relay operating stage is carried out as follows. It has been shown that the combined trigger stage operates at a point determined by the anode current cut-off potential of V2 (Fig. 3). It is known that in a pentode valve the negative grid voltage required for anode current cut-off is directly proportional to the screen voltage, and, in indirectly-heated types, the relation between these voltages includes a constant term, since even when the screen potential is zero a small bias is required on the control grid to reduce the emission to zero. If, therefore, the position of the trigger point in relation to the input waveform is to be kept constant with changes in supply voltage, the initial bias on V2 must consist of a constant amount together with a further voltage proportional to the supply. The required constant portion is derived from the controlled heater circuit voltage of V1. The remainder, proportional to the supply voltage, is obtained from potentiometer networks.

CONTROL UNIT FOR PRODUCTION OF CYCLIC SEQUENCES OF IMPULSES

Basic Features.

The production of a cyclic sequence of impulses from the generator unit is carried out in the following manner. The tappings on the resistances which control the speed and make percentage of the generator are selected by the wipers of uniselectors, the connections between the bank contacts and the resistance taps being arranged via a form of translation field of the crossbar type, which enables any tap to be associated with any desired bank contact. The uniselectors are stepped under the control of the impulses from the generator, and hence, at each step, select the desired speed and make percentage

taps for the next impulse. By suitable cross-connection at the translation field any desired target may be pre-arranged, and if all the bank contacts are not required for any particular target the pulses may be repeated at any given speed and percentage preferably at a high speed, since this enables the cycle to be repeated more quickly.

The following considerations have been observed in the design of the equipment :—

- (a) The uniselector must be able to step consistently on impulses which are at the limits of any possible target. The minimum operating pulse length, which is usually the determining criterion, corresponds to a speed of 16 i.p.s. and 15 per cent. make and is about 10 mS. The means by which this has been achieved have already been described².
- (b) The movement of the uniselector wipers must not produce any interruption in the time base charging circuit and the circuit must be arranged so that any new speed resistance is connected as near the end of the impulse as possible; otherwise the last portion of the impulse is inaccurate due to the connection, at some intermediate point, of a different charging resistance.
- (c) With reference to the selection of make percentage resistance taps, it is not necessary that the wipers move exactly at the end of the impulse. The movement may occur after the release of the generator relay, because a minimum time period of at least 30 mS is available for the selection of a new make percentage, if the maximum percentage at 16 i.p.s. is 50 per cent.
- (d) Since the generator relay has only one contact, it is necessary to provide a second relay to repeat impulses into either the generator or the apparatus under test. This impulse repetition must be distortionless.

The method by which the speed resistances are selected without causing appreciable errors in the speed of any impulse will be described in some detail. The methods by which the impulse repetition in the apparatus is made distortionless will be dealt with later, as this problem is common to the whole equipment.

Selection of Speed Resistances.

The circuit element adopted for speed-resistance selection is shown in Fig. 4. Two uniselectors are employed and a pair of high-speed relays B and C used to drive them. The operation is as follows: assuming that both switches are initially on the first contact and all the relays are normal, the charging circuit is completed via B1 and resistance R_1 , the drive magnet of switch 1 being energised via C1. When the generator relay contact closes at the beginning of the make period, relays B and C operate, C1 maintaining the charging circuit to R_1 via the wiper of the second switch, and releasing DM1 so that the first switch moves to its second contact. B1 energises the drive magnet circuit of switch 2. At the end of the impulse (i.e., at the end of the make period) relays B and C restore, B1 completing the

² Loc. cit.

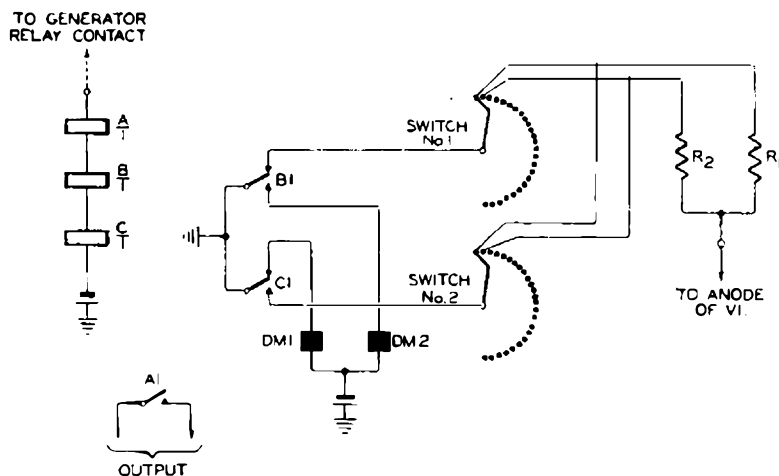

FIG. 4.—CIRCUIT ELEMENT FOR SPEED-RESISTANCE SELECTION.

charging circuit via switch 1 to R_2 and also causing the second switch to step forward. C1, on releasing, completes the circuit for energising switch 1.

To avoid interruptions in the charging circuit it is necessary to make the B1 break contact open and close at the same instant as the C1 make contact. This can be achieved by increasing the spring pressure and travel on the B relay and reducing the travel on the C relay, thereby increasing the operate lag and reducing the release lag of B with respect to C. This is termed synchronising the contacts and is only possible with relay adjustments close to normal because the lack of synchronisation is only due to the very short operate and release lags normally obtained with high-speed relays. Means for checking the synchronisation are provided in the equipment, but it is rarely found that any re-adjustment is needed after the initial check.

Due to the release lags of relays B and C on the generator contact, the actual changeover of the charging resistance takes place after the discharge of the gas-filled valve in the generator, and therefore the initial portion of the condenser charge takes place at a rate appropriate to the previous charging resistance. If the change of speed between two successive impulses is very large, this effect will give rise to considerable errors; to avoid these the necessary changes in speed should be carried in steps of not more than 1 i.p.s. In practice, there is little disadvantage in this procedure as such progressive changes were envisaged in this method of testing.

Distortionless Operation of Repeating Relays in the Equipment.

The equipment must of necessity include a number of relays the main function of which is to repeat the incoming impulses. For instance, the A, B and C relays in the generator control unit merely repeat the impulses from the G relay in the valve generator. Fortunately it is necessary that the repetition be distortionless on only one contact per relay, since if one portion of an impulse is correct (say the make period) then it follows that the other portion (i.e., the break period) is correct—the speed of the impulses being independently controlled. The use of high-

speed type relays facilitates the correction of distortion, because the operate and release lags are small—the distortion being caused by differences in these quantities. This is not the only reason for the use of this type of relay, since it is also desired that the least practical delay in the switching of the circuits be encountered.

Although the distortion with these relays, if the operating current is adequate, is about 1 mS on either contact, this would produce serious percentage distortion at high speeds. This order of distortion must therefore be reduced to something like 0.1 mS.

Relays such as A, B and C in the control unit and those in the measuring equipment which are used for charging the condensers, are energised from local contacts, and the latter must be prevented from sparking by a normal type of spark quench. These

spark quenches are designed so that in addition to being efficient from the point of view of preventing sparking, they also correct the appropriate contacts so as to produce minimum distortion.

The values for the series condenser and resistance of the quench are then quite different from those normally employed. In addition, the quench is always connected as close to the relays as possible, this being the correct position since it is designed to function with the inductances and resistances of the relays. Such connection also helps to minimise surge radiation, which might adversely affect the valve circuits.

For relays working on relatively low currents, such as the G relay in the valve generator and the telegraph relay in the measuring equipment, correction has been obtained by shunt rectifiers, which possess the advantage that no oscillatory currents are possible during the release of the relay.

General Use of the Impulse Generator.

For general exchange testing, the impulse generator can be used by itself in many tests where impulses of controlled characteristics are required. For example, tests can be made on selectors to determine if the switch steps satisfactorily on certain test impulses. For this type of test a subsidiary unit to select a train of, say, 10 impulses could be easily arranged and would prove useful.

The impulse generator can also be used as a source of impulses having a much wider range of characteristics than is available from the more normal types of mechanical generator, and is consequently of considerable value as a test instrument for general laboratory use. Models have been designed and constructed for this purpose, having a speed range of 5 to 25 i.p.s. and an independent continuous percentage variation from 0 to 100. Tests have shown that the variation between individual impulses is well within 1 mS and this is satisfactory for all normal test purposes. Satisfactory operation has been obtained over long periods of continuous use, and there is no reason to anticipate any serious deterioration in performance with life.

A Simple Introduction to the Use of Statistics in Telecommunications Engineering

U.D.C. 519.2 : 621.39

J. F. DOUST and
H. J. JOSEPHS, F.S.S., A.M.I.E.E.

The present article discusses the analysis of samples which obey the "Normal Probability Law," and shows how a simple test on prepared graph paper indicates whether or not statistical stability has been obtained and yields directly the required probability characteristics without laborious calculation. Later articles will deal with the treatment of samples which obey other probability laws and will describe a method of dealing with very small samples.

Introduction.

IT has been said that any fool can build a bridge which is strong enough but that only an engineer can build one which is just strong enough. In other words, it is not enough for the engineer to say merely how the work can be done; he must show how it can be done with the utmost economy of material and labour. The engineer is therefore also a good business man, and since accurate workmanship and detailed checking may be expensive, he has to judge, at each stage of the work, how far tolerances may be eased or testing time reduced without detriment to the finished product. Many engineering firms have found that statistical studies of the properties of the materials used, the performance of machines, and so on, have resulted in considerable economies and there is little doubt that an increase in the number of such studies in the field of telecommunications engineering would be equally profitable.

It is sometimes argued that the results of statistical investigations can be interpreted according to individual taste and are therefore unreliable, but if proper use is made of the statistics obtained this is not true. It should be remembered, however, that statistical studies provide only the most probable answer to questions which could not otherwise be answered without the expenditure of an altogether disproportionate amount of labour.

Engineers are often discouraged from using statistical methods because they have no time for the study of the mathematical theory of probability on which they are based. Many excellent mathematical weapons have been forged, however, which can be used in safety by those who have little or no knowledge of the underlying theory, and it is the purpose of these articles to show that the statistical weapon may be made equally easy and equally safe. Sylvanus P. Thompson in his famous "Calculus Made Easy" admitted that he had made it easy by leaving out all the difficult parts. The same course will be followed here, and it will be found that the method of solution of many important problems will have been given. In general, methods will be demonstrated by the use of examples, which will be examined in detail. Some of these examples have been used before but no excuse is offered since they provide excellent material for the purpose in view.

Types of Problem to be considered.

(1) A problem that frequently occurs concerns the acceptance of items in such large numbers that it is not possible to test them individually. Some of the questions that arise are:—

(a) What percentage must be tested to ensure that the sample is likely to be representative of the whole?

(b) How can we tell from the sample what percentage of the whole is likely to fall outside specified limits?

(c) How near is the average of the whole likely to be to the average of the sample?

(d) How are individual values likely to be distributed about the average?

(2) At the time when the present hand micro-telephone was developed the question arose as to what was the best length for the handle. It was therefore necessary to make measurements on subscribers' heads and the following questions arose:—

(a) How was a sample to be chosen that would be truly random and therefore likely to be representative of the whole population?

(b) How large must the sample be so that it is likely to be representative?

(c) How are the measurements likely to vary about the average?

(d) With a given length of handle, what percentage of subscribers are likely to be inconvenienced?

(3) Further questions are concerned with trunking problems. To decide the amount of equipment necessary to ensure a particular grade of service a number of facts must be determined about the length of telephone calls. For example:—

(a) Is the length of telephone calls likely to be dependent on the type of traffic?

(b) If so, how many calls in each class must be checked so that the sample is likely to be representative?

(c) How long is a call most likely to last?

(d) What percentage of calls are likely to exceed this length by certain definite amounts?

In all the above questions the word "likely" occurs. This is not accidental but is done deliberately to emphasise the dependence of statistical theory on the theory of probability. It is also intended to illustrate the statement made above that statistics can provide the most probable answer to questions which cannot be answered economically by any other method.

A Simple Telephone Problem.

For the first example consider the determination of the best length for the hand micro-telephone. The optimum length of handle must be deduced from data obtained from a random sample of head measurements.

It is apparent that the distance between the lips and the centre of the ear must be measured, as shown in Fig. 1, for a sample of the population. This distance will be denoted by x . It is essential that the people measured be collected as much at random as possible. The idea is to take the measuring stick and travel about the country in different directions taking measurements. It is no use concentrating on one section of the community and collecting all the data from, say, members of the Stock Exchange, as these measurements would probably not be representative of the population at large; in other words, it would not be a random sample. Suppose out of the x measurements of 10 persons two of the measurements are the same, three may approximate roughly to this value, and five may be very different. If these figures are plotted no sign of any statistical relationship results. It is obvious that the sample is far too small and more data must be collected. In general, the larger the number of items in the sample the more reliable will be the average value obtained from it. For determining the optimum x value a random sample of 1,945 heads was taken. In sampling problems in engineering it is convenient to partition the whole range of measurements into subgroups so as to show the number or frequency of measurements in each group. For example, from the 1,945 heads the following table may be constructed:—

TABLE 1
GROUPING OF DATA FROM 1,945 HEAD MEASUREMENTS

x Distances between lips and ear in cms.	f_x Frequency of occurrence	Cumulative Frequency number below upper group limit	Relative Frequency per cent. of occurrence
11.0 to 11.5	2	2	0.103
11.5 to 12.0	17	19	0.874
12.0 to 12.5	158	177	8.123
12.5 to 13.0	226	403	11.62
13.0 to 13.5	240	643	12.34
13.5 to 14.0	447	1,090	22.98
14.0 to 14.5	428	1,518	22.01
14.5 to 15.0	200	1,718	10.28
15.0 to 15.5	110	1,828	5.66
15.5 to 16.0	80	1,908	4.11
16.0 to 16.5	30	1,938	1.54
16.5 to 17.0	7	1,945	0.36

In the 1,945 measurements it was found that all the figures fell in the range from 11 to 17 cms. The first column (x) in Table 1 shows the range from 11 to 17 cms. arbitrarily divided into groups of $\frac{1}{2}$ cm. The second column (f_x) in the table gives the frequency with which the measurements were found to fall within the various groups. Thus only two of the measurements were found to fall within the group 11.0 to 11.5 cms., whereas as many as 447 were found to fall in

the group 13.5 to 14.0 cms. Such an arrangement of observations is called an "observed frequency distribution." The frequency distribution may also be



FIG. 1.—HEAD MEASUREMENTS.

specified if the number of heads having x values below (or above) any given x value is known. The third column of Table 1 gives the number of head measurements below the upper group limit shown. These figures in the third column are known as "cumulative frequencies."

The data tabulated in Table 1 is a random sample drawn from a much larger population or "universe." From the properties of this random sample inferences may be drawn about the larger population from which the sample was drawn. From the x measurements answers may be given to the following fundamental questions:—

- (1) What is the most probable value?
- (2) What is the frequency of occurrence of values within any two given limits?

With regard to the first question; it is common practice in engineering to assume that the average of the observations gives the most probable value or at least a measure of central tendency. It is also assumed that small deviations from the average are more likely to occur frequently than very large ones, and that positive and negative deviations with respect to the average are equally likely. But before considering the distribution of values around the average it is important to know if the average obtained from the sample is stable. In other words, will a second sample of the same size give the same average? If not, what is the magnitude of the error involved? This can be done by studying the curve obtained by plotting the frequency distribution of Table 1.

In order that the frequency distribution characteristics of samples of different sizes may be easily compared it is desirable that the curves should coincide as nearly as possible. The most convenient way of doing this is by expressing the actual frequencies, as percentages of the total number forming the sample.

The relative frequency figures are shown in the fourth column of Table 1 and are plotted as crosses in Fig. 2. The observed frequency distribution is shown by the dotted lines which join the crosses. The crosses have been joined by straight lines because of the difficulty of fitting a smooth curve to them.

The fact that the crosses appear in an irregular manner and cannot be joined by a continuous symmetrical curve shows that in this sample positive and negative deviations do not occur with equal regularity. It must be assumed that the sample is not large enough and that it does not give either a reliable indication of the average (or mean) of the population or of the frequency of occurrence among the population of values lying between particular limits.

To obtain a larger sample measurements were made on a further 1,945 heads and these were compounded with the first set to give a sample of 3,890 measurements. The actual and relative frequencies of the various groups of values are shown in Table 2.

TABLE 2

x Distance between lips and ear in cms.	f_x Actual Frequency of occurrence	Relative Frequency %
11.0 to 11.5	15	0.38
11.5 to 12.0	54	1.39
12.0 to 12.5	174	4.47
12.5 to 13.0	399	10.25
13.0 to 13.5	680	17.48
13.5 to 14.0	846	21.75
14.0 to 14.5	808	20.77
14.5 to 15.0	515	13.24
15.0 to 15.5	263	6.76
15.5 to 16.0	97	2.49
16.0 to 16.5	31	0.79
16.5 to 17.0	8	0.20

The relative frequency figures in the third column of Table 2 are plotted as dots in Fig. 2; it can be seen that most of these dots can be joined together by a smooth symmetrical curve as shown. This indicates that the assumptions as to the likelihood of the occurrence of positive and negative deviations and their distribution about the mean are justified, and the frequency distribution may be regarded as stable.

The bell-shaped curve illustrates what is known in statistics as the "normal probability law," some of the characteristics of which will now be discussed.

The Normal Probability Law.

As already stated, in engineering it is common practice to assume that the arithmetic mean or average gives a measure of central tendency. It is also assumed that small deviations from the mean are more likely to occur than very large ones and that positive and negative deviations with respect to the

mean are equally likely. The normal probability law satisfies these requirements. The first step therefore, in analysing the data obtained from a large

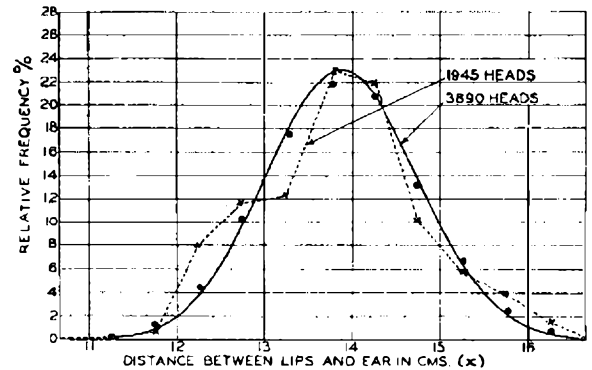

FIG. 2.—OBSERVED FREQUENCY DISTRIBUTION CURVES.

sample is to see whether or not the relative frequency points can be fitted by the bell-shaped normal characteristic shown in Fig. 3. In Fig. 3, y is a deviation from the arithmetic mean and the solid line is the curve joining the relative frequency points.

The probability that a deviation does not exceed y is given by the ratio of the area enclosed between the bell-shaped curve and the ordinates erected at $\pm y$, to

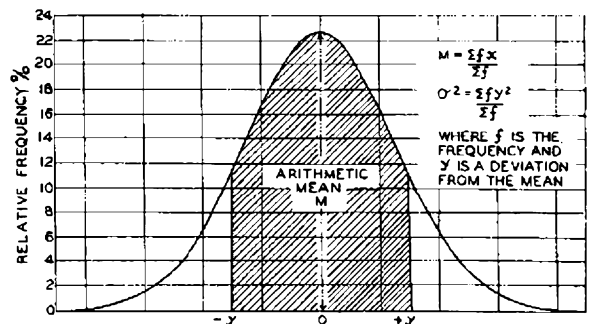

FIG. 3.—NORMAL PROBABILITY CURVE—DISTRIBUTION ROUND ARITHMETIC MEAN.

the total area under the curve. Since the total area under the normal probability curve is unity it follows that the probability that a deviation does not exceed y is proportional to the area shown cross-hatched in Fig. 3. It is shown in works on the theory of statistics that it is a simple matter to express percentages of the total area in terms of a quantity known as the standard deviation, which is defined as the root-mean-square value of the deviations of a set of numbers from their mean. The standard deviation measures the extent to which individual values are scattered and is almost as easy to calculate from the sampling data as the arithmetic mean. The calculation of the mean and the standard deviation involves only straightforward arithmetic, and the method of obtaining these quantities (or statistics) from the figures obtained from a small sample of head measurements is shown in Appendix I. It is usual practice to denote the mean and the standard deviation of a parent universe by the symbols M and σ respectively; the mean and the standard deviation of a small sample is usually denoted

by \bar{x} and s . Of course, as the number of items in a sample increases, then,

$$\begin{aligned} \bar{x} &\longrightarrow M \\ \text{and } s &\longrightarrow \sigma \end{aligned}$$

It can be shown that if the frequency distribution round the mean M follows a normal probability law, then,

- 50.00 per cent. of area lies within $M \pm 0.6745\sigma$
- 68.27 per cent. of area lies within $M \pm 1\sigma$
- 95.45 per cent. of area lies within $M \pm 2\sigma$
- 99.73 per cent. of area lies within $M \pm 3\sigma$

Reverting to the 3,890 head measurements the mean M is approximately 13.7 cms., and the standard deviation σ is 0.9 cms. Since Fig. 2 shows that the distribution of the relative frequency figures round the mean M appears to follow the normal probability law, it may be concluded that :

- 50 per cent. of the population will have heads lying within the range (13.7 ± 0.61) cms.
- 68.3 per cent. of the population will have heads lying within the range (13.7 ± 0.90) cms.
- 95.5 per cent. of the population will have heads lying within the range (13.7 ± 1.80) cms.
- 99.7 per cent. of the population will have heads lying within the range (13.7 ± 2.70) cms.

Since 95.5 per cent. of the heads lie within the range (13.7 ± 1.80) cms., it follows that 5 per cent. will be outside the range 11.9 to 15.5 cms. However, since there are equal numbers above 15.5 and below 11.9, the chance of a deviation exceeding the mean of 13.7 cms. by 1.8 cms. is $2\frac{1}{2}$ per cent. or 1 in 40. Thus it may be concluded that if the x value of the handset is made 15.5 cms., then all except about $2\frac{1}{2}$ per cent. of telephone users could use the hand-set by holding the receiver to the ear in the usual manner. The others could be accommodated by a slight shift of the receiver on the ear. The effect of such a slight shift on received speech, for a small number of persons, would be unimportant in comparison with the large improvement in transmitting performance for the great majority which would result from using an x value smaller than that required to accommodate all subscribers in comfort.

Probability Paper.

From the preceding discussion it may be inferred that the first phase of the numerical work involved in a sampling test consists in calculating the arithmetic mean \bar{x} and the standard deviation s from the test data. The next phase is to find whether the data obtained from the random sample does or does not depart significantly from the normal probability law. In Fig. 2 the goodness of fit between the theoretical and observed frequencies was tested by a process of trial and error. Since the goodness of fit is essentially a matter of personal opinion the difficulty of attaching the proper significance to deviations from the ideal bell-shaped curve is apparent.

The problem of attaching the proper significance to these sampling deviations was attacked some years ago by Allen Hazen¹, an American civil engineer, who

¹Trans. Am. Soc. C.E., Vol. 77, 1914.

was trying to develop a straightforward technique which would enable him to analyse in a few minutes the data obtained from a random sample. Hazen found that by plotting the cumulative frequency per cent. figures instead of the actual frequency figures he obtained curves which were nearly straight from 30 to 70 per cent. This fact is illustrated in Fig. 4 which has been obtained by plotting the cumulative frequency

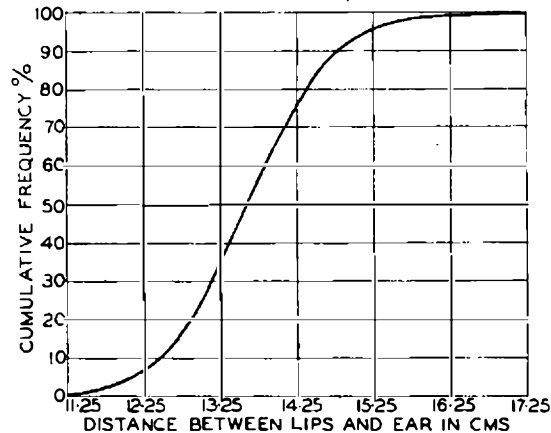

FIG. 4.—CUMULATIVE FREQUENCY CURVE.

figures for the 3,890 heads instead of the relative frequency figures of Fig. 2. These cumulative frequency figures can be readily obtained from the second column of Table 2. From Fig. 4 it can be seen that the curve is nearly straight from 30 per cent. to 70 per cent. Hazen found that by slightly altering the frequency scale he could readily transform the cumulative frequency curve into a straight line. It can be seen from Fig. 4 that the scale needs but little alteration for values from 20 per cent. to 80 per cent. Beyond these limits the greater the difference from the middle 50 per cent. value the greater must be the alteration to the scale.

Now a cumulative frequency curve is in effect an integral curve, and this led Hazen to produce a scale such that the integral of the normal bell-shaped probability curve of Fig. 2 would plot as a straight line. Consequently any series of observations which varied in accordance with the normal probability integral would also plot as a straight line if such a scale was used on co-ordinate paper. In constructing this probability scale, Hazen marked the centre of the scale 0.5. The other points on the scale are laid off in either direction from the centre point, so that the pairs of values 0.4 and 0.6, 0.3 and 0.7, 0.1 and 0.9, etc., are respectively equidistant from the centre. The distances from the centre are made proportional to the corresponding values of area under the normal probability curve (see Figs. 5 and 6). This type of paper² is known as "Arithmetic Probability Paper". The method of dealing with the figures for a "normality" test on probability paper will be illustrated by reverting to the first sample of 1,945 head measurements. The arrangement of the figures for a test is shown in Table 3.

²The various kinds of probability paper discussed in these articles can be obtained from the Research Branch of the E. in-C.'s Office.

TABLE 3

x Distance between lips and ear in cms.	f_x Frequency	Cumulative Frequency	Probability, or Cumulative Frequency per cent.
11.0 to 11.5	2	2	0.103
11.5 to 12.0	17	19	0.977
12.0 to 12.5	158	177	9.100
12.5 to 13.0	226	403	20.72
13.0 to 13.5	240	643	33.06
13.5 to 14.0	447	1,090	56.04
14.0 to 14.5	428	1,518	78.04
14.5 to 15.0	200	1,718	88.32
15.0 to 15.5	110	1,828	93.98
15.5 to 16.0	80	1,908	98.09
16.0 to 16.5	30	1,938	99.64
16.5 to 17.0	7	1,945	100

$\bar{x} = 13.86$ cms.

$s = 0.968$ cms.

It can be seen that with the exception of the fourth column, Table 3 is the same as Table 1. This fourth column merely lists the cumulative frequencies as percentages of the total number in the sample. In Fig. 4 the cumulative frequencies (as percentages) are plotted on the probability scale against the mid-points of the corresponding x groups (i.e., 11.25, 11.75, 12.25, etc.). These points are shown as crosses in Fig. 5. The cumulative frequency figures in the fourth column of Table 3 are really the percentage of people in the sample whose x measurements are less than that stated by the group limits in the first column. Consequently the probability scale is marked as the percentage of the population whose measurements are less than that given by the ordinates. It can be seen from Fig. 5 that the dotted line joining the crosses is not a straight line and consequently the sample does not appear to be quite stable. It will be recalled that the same conclusion was arrived at from a consideration of the frequency characteristic shown in Fig. 2.

Now consider the larger sample obtained by making measurements on a further 1,945 heads. The arrangement of the data for the probability paper test can be obtained from Table 2 in the same way as Table 3 was obtained from Table 1. Plotting the results a series of dots that can now be joined by the straight line shown in Fig. 5 is obtained. Since the data obtained from the 3,890 head measurements plots as a straight line and the calculated mean agrees approximately with the median value given by the 50 per cent. line, it may be concluded that the sample is now reasonably stable

and that the mean and the standard deviations obtained from it agree closely with the real values that exist in the parent universe from which the sample was drawn. The most probable value is given by the mean, and in a stable normal universe the mean and the median values are the same. On probability paper the standard deviation is approximately equal to the difference between the values of the ordinates at the 84 per cent. line and the median value at the 50 per cent. line. Thus, if the data plots as a straight line on arithmetic probability paper the most probable value and the standard deviation can be approximately determined by direct inspection. Thus, by referring to Fig. 5 it can be seen that the mean and the standard deviation of the parent universe are 13.7 cms., and 0.9 cms. respectively. Thus, the remarkable ease obtained from the use of probability paper is apparent.

Small Samples.

So far only a sample having a large number of items, namely, 3,890 heads, has been considered. If the number of items had been much smaller, the plotted points would not have fallen on a straight line. Fig. 4 shows the way the straight line is built up as the number of items in the sample is increased from 1,945 to 3,890 heads. It may be observed that 3,890 is a very large number of items to obtain for a sampling test. If, however, the number of items had been very much smaller, the stability test with probability paper would have been made in exactly the same manner.

As an example of the analysis of a sample with a relatively small number of items consider the results of tests made to see whether the D.C. Electric Motor

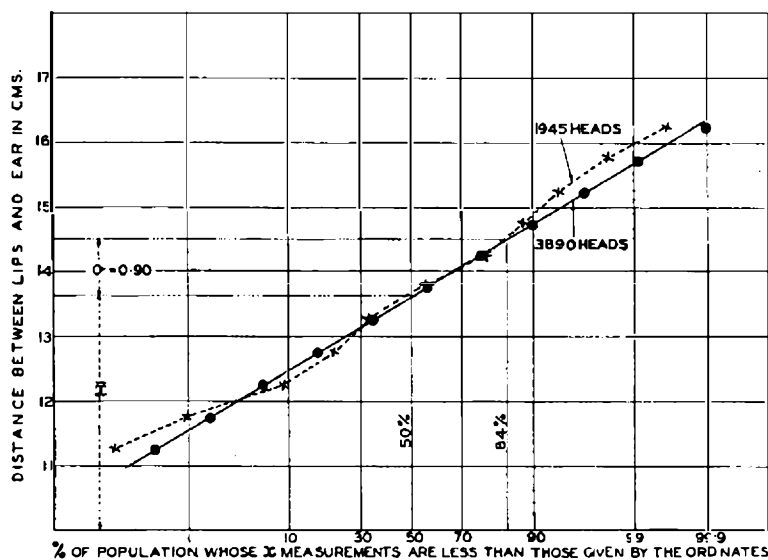

FIG. 5.—HEAD MEASUREMENTS (STABILITY TEST).

No. 13 would give adequate torque for driving a Teleprinter No. 7 with only 150 V applied to the 220 V tapping. This motor has a wide range of speed under ordinary working conditions and a preliminary test showed that speeds exceeding the required 3,000 r.p.m. can be obtained with an applied voltage of 150 V. Consequently a statistical analysis of test results obtained from a random sample of motors is necessary to

find what the chances are that a motor will fail to give a speed of not less than 3,000 r.p.m. when driving a load of 0.07 lb. ft. (the heaviest teleprinter load) with an applied voltage of only 150 V. An air brake was adjusted to provide a load of 0.07 lb. ft. when driven at 3,000 r.p.m., and this brake was attached to the shaft of each motor tested. In the first run 19 motors were taken as the sample. The results obtained are plotted as crosses in Fig. 6. It can be seen from these irregular crosses that the true distribution probably

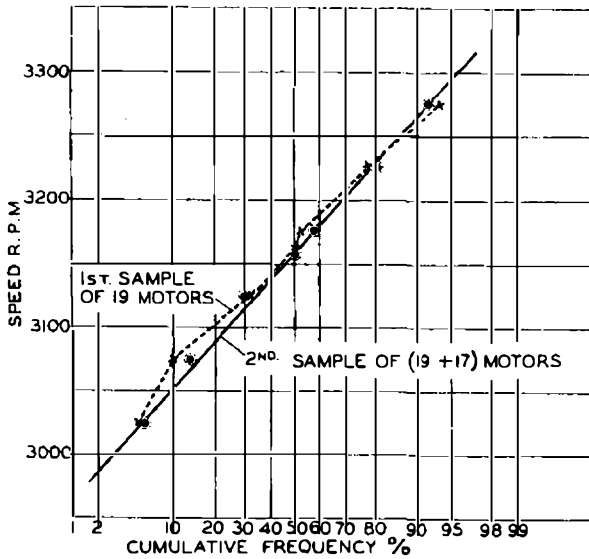

FIG. 6.—TESTS FOR STABILITY OF DATA.

follows a normal law but that the data was insufficient. Since the crosses fall in an irregular manner about a straight line it is apparent that a larger number of items is necessary. Consequently a further 17 motors were tested and additional results obtained. These results together with those previously obtained were taken as a whole and plotted as dots in Fig. 6. It can be seen that this second attempt closely approaches the straight line of the normal error law. This straight line gave the arithmetic mean at the 50th percentile and thus it can be concluded that the sample is large enough and the results are reasonably stable. From this data it was found that:—

Arithmetic mean = 3,158 r.p.m.

Standard deviation = 75 r.p.m.

Since the distribution follows the normal law, 95.5 per cent. of the speeds lie within the range $(3,158 \pm 150)$ r.p.m. Consequently approximately 5 per cent. will be outside the range 3,008 to 3,308 r.p.m. However, since there are equal numbers above 3,308 and below 3,008 r.p.m. and failures will occur only when the speed is below 3,000 r.p.m., it follows that the chance of failure is approximately $2\frac{1}{2}$ per cent. or 1 in 40. Since only one motor in 40 is likely to fail to give the required speed on a load of 0.07 lb. ft., and since it is known that only one teleprinter in 500 is likely to exceed this load at 3,000 r.p.m. it may be concluded that the likelihood of a slow running motor being associated with a heavy teleprinter is very remote. Consequently it may be concluded that in practice no difficulty will be experienced when using the 220 V tapping with an applied voltage of only 150 V.

Very Small Samples.

It often happens that the number of items forming a sample is very small indeed, say between two and ten. The above methods may not then be satisfactory. A simple technique, however, has been evolved for dealing with these very small samples. As this technique is based upon an analysis that is beyond the scope of the normal probability law, its discussion will be deferred to a later article.

APPENDIX I

Calculation of \bar{x} and s .

The first phase of the numerical work involved in the statistical analysis of a small sample consists in calculating the arithmetic mean \bar{x} and the standard deviation s from the test data. These two quantities (or statistics) may be calculated from the formulæ,

$$\bar{x} = \frac{\sum fx}{\sum f}$$

and

$$s^2 = \frac{\sum fy^2}{\sum f}$$

Where f denotes the frequency, x is an observed value, and y is a deviation from the mean \bar{x} . In calculating these two statistics it is helpful to set the work out in columns as shown below.

SAMPLE OF 10 OBSERVATIONS

x Measured values (cms.)	f Fre- quency of occu- rence	fx	y Deviations from the arithmetic mean	y^2	fy^2
12.5	1	12.5	- 1.44	2.0736	2.0736
13.0	1	13.0	- 0.94	0.8836	0.8836
13.65	2	27.3	- 0.29	0.0841	0.1682
13.7	1	13.7	- 0.24	0.0576	0.0576
13.75	1	13.75	- 0.19	0.0361	0.0361
13.8	1	13.8	- 0.14	0.0196	0.0196
14.5	1	14.5	0.56	0.3136	0.3136
15.15	1	15.15	1.21	1.4641	1.4641
15.75	1	15.75	1.81	3.2761	3.2761

$$\sum f = 10$$

$$\sum fx = 139.45$$

$$\therefore \bar{x} = 13.94 \text{ cms.}$$

$$\sum fy^2 = 8.2925$$

$$\therefore s^2 = 0.8293$$

$$\therefore s = 0.911 \text{ cms.}$$

Adding up the x column and then dividing by the total frequency $\sum f$, the arithmetic mean \bar{x} is obtained as shown. The y^2 column gives the squares of the deviations from the arithmetic mean \bar{x} . Dividing the sum of fy^2 column by $\sum f$, s^2 is obtained, the square of the standard deviation. Taking the square root the standard deviation s is found.

A Note on Amplitude, Phase, and Frequency Modulation

H. D. BICKLEY, B.Sc., Grad.I.E.E.

U.D.C. 621.396.619

The author analyses mathematically the waves produced when a carrier frequency wave is phase and frequency modulated by an audio frequency wave, and compares the results with the well-known analysis of an amplitude modulated carrier. The differences between phase and frequency modulation are also shown.

Introduction.

PHASE and frequency modulation, though not new, have not hitherto been employed to any great extent. However, recent developments, particularly in America, have shown that under some conditions they may be employed with advantage, and the purpose of this note is to point out some of the fundamental differences between them and the better-known principle of amplitude modulation. No attempt is made here to discuss the relative advantages realisable in practice.

AMPLITUDE MODULATION

The theory of amplitude modulation is well known, and is given here only to facilitate comparison with phase and frequency modulation.

Let the carrier wave be represented by the expression--

$i_1 = A \sin \omega t$, where A is the amplitude, ω is $2\pi \times$ carrier frequency, and t the time, and the audio frequency wave by

$i_2 = k_a A \sin \alpha t$, where k_a is the ratio of the amplitude of the audio wave to that of the carrier, and is usually less than unity, and α is $2\pi \times$ audio frequency. Then we have for the instantaneous value of the modulated wave

$$i = (A + k_a A \sin \alpha t) \sin \omega t \dots \dots \dots (1)$$

$$= A(\sin \omega t + k_a \sin \omega t \sin \alpha t) \dots \dots \dots (2)$$

$$= A[\sin \omega t + \frac{1}{2} k_a \cos(\omega - \alpha)t - \frac{1}{2} k_a \cos(\omega + \alpha)t] \dots \dots \dots (3)$$

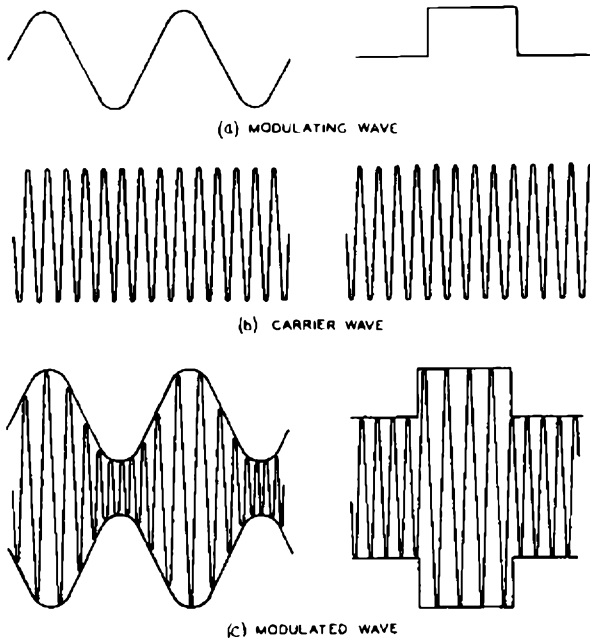

FIG. 1.—AMPLITUDE MODULATION BY SINGLE SINE WAVE AND BY RECTANGULAR PULSE. LATTER CASE MAY BE COMPARED WITH FIGS. 2 AND 3.

From these equations some useful information about the modulated wave can be obtained. Equation (1) gives the shape of the wave: it is a wave of radian frequency ω , having an amplitude of $(A + k_a A \sin \alpha t)$. In other words, the amplitude changes in sympathy with the audio frequency wave. This is shown graphically in Fig. 1. In equation (2) the wave has been split into two parts, (i) $A \sin \omega t$, the original carrier, and (ii) $A k_a \sin \omega t \sin \alpha t$. If a vector diagram is drawn and (i) represented by a straight line of constant length A , then (ii) will be represented by a straight line of varying length $A k_a \sin \alpha t$. By virtue of the term $\sin \omega t$, this line will be parallel to that drawn to represent the carrier. Equation (3) shows the modulated wave split into three parts, (i) $A \sin \omega t$, the carrier as before, (ii) $\frac{1}{2} A k_a \cos(\omega - \alpha)t$ and (iii) $\frac{1}{2} A k_a \cos(\omega + \alpha)t$. (ii) and (iii) are termed the side waves, and it will be seen that their frequencies are equal to the difference and sum of the carrier and audio frequencies respectively: further, their amplitudes are equal, and are one-half the amplitude of the audio wave.

The resultant of these two side waves is, of course, the varying vector $A k_a \sin \omega t \sin \alpha t$, which, as already pointed out, is in phase with the carrier.

For the present purpose, the points to be stressed are

- (1) The amplitude of the modulated wave is not constant, but the frequency is constant.
- (2) The modulated wave consists of three separate waves, namely, a carrier and two side waves: the amplitude of the side waves is determined only by k_a and A , and is independent of α .
- (3) The resultant of the two side waves is always in phase with the carrier.

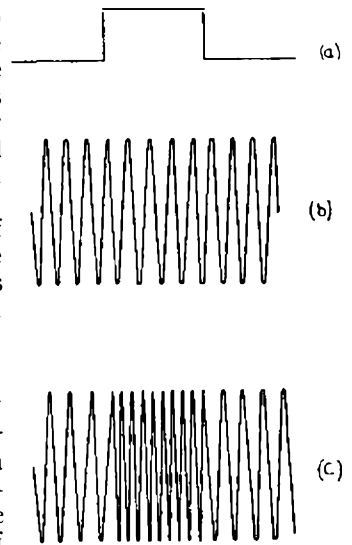

PHASE AND FREQUENCY MODULATION

In pure phase or frequency modulation the intelligence is conveyed by varying the phase or frequency of the carrier wave, its amplitude remaining constant. Since a variation in phase cannot be accomplished without varying the fre-

FIG. 2.—FREQUENCY MODULATION BY A RECTANGULAR PULSE. A POSITIVE PULSE IS SHOWN AS CAUSING AN INCREASE IN FREQUENCY. A NEGATIVE PULSE WOULD, UNDER THESE CONDITIONS, CAUSE A DECREASE IN FREQUENCY.

quency, it might at first be thought that the two systems are identical in nature, differing only in degree. That this is not so can be easily demonstrated by considering a very simple example, and the precise difference will be shown in the subsequent analysis.

Suppose it is desired to transmit a single rectangular pulse. If frequency modulation is employed, the frequency of the radiated wave must be changed at the commencement of the pulse, during the pulse it must remain at its new value, and at the end of the pulse it must revert to its original value. This is illustrated in Fig. 2.

If phase modulation is to be employed, the phase of the radiated wave must be changed during the transmission of the pulse, reverting to its initial value at the end of the pulse. This is illustrated in Fig. 3.

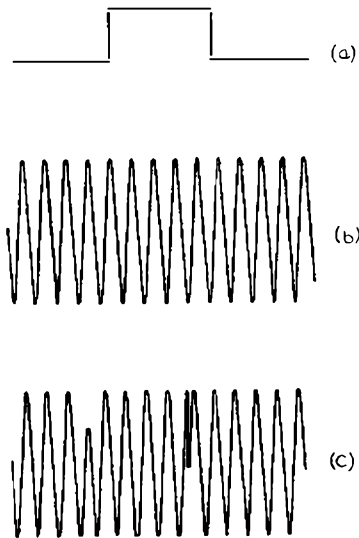

FIG. 3.—PHASE MODULATION BY A RECTANGULAR PULSE.

Comparing Figs. 2 and 3, it will be seen that there is a difference between the two systems, and the following analysis will help to realise the nature of this difference.

Phase Modulation.

Considering phase modulation first.

Let $i = A \sin \phi_0$ represent the carrier wave. If ϕ increases

linearly with time, then $\phi_0 = \omega_0 t$ and $i = A \sin \omega_0 t$.

Assuming the intelligence to consist of a single sine wave of radian frequency α and peak amplitude k_p , superposed on the linear function, i.e. :—

$$\phi = \omega_0 t + k_p \phi_1 \sin at$$

where ϕ_1 is the phase shift produced when the instantaneous value of the modulating wave is unity.

$$\begin{aligned} \text{Then } i &= A \sin (\omega_0 t + k_p \phi_1 \sin at) \\ &= A \sin (\omega_0 t + m_p \sin at) \dots \dots \dots (4) \end{aligned}$$

where $m_p = k_p \phi_1$. It represents the maximum value of the phase shift, and has been termed the modulation index.

Expanding equation (4) :—

$$A \sin (\omega_0 t + m_p \sin at) = A [\sin \omega_0 t \cos (m_p \sin at) + \cos \omega_0 t \sin (m_p \sin at)]$$

Now it can be shown that

$$\sin (x \sin r) = 2J_1(x) \sin r + 2J_3(x) \sin 3r + 2J_5(x) \sin 5r + \dots \dots \dots$$

$$\text{and } \cos (x \sin r) = J_0(x) + 2J_2(x) \cos 2r + 2J_4(x) \cos 4r + \dots \dots \dots$$

where $J_n(x)$ is a Bessel function of the first kind, of order n . It may be defined thus :—

$$J_n(x) = \frac{x^n}{2^n \Gamma(n)} \left[1 - \frac{x^2}{2 \cdot 2n+2} + \frac{x^4}{2 \cdot 4 \cdot 2n+2 \cdot 2n+4} - \dots + \dots \right]$$

$$\begin{aligned} \text{So } \sin (\omega_0 t + m_p \sin at) &= \sin \omega_0 t (J_0(m_p) + 2J_2(m_p) \cos 2at + 2J_4(m_p) \cos 4at + \dots \dots \dots) \\ &+ \cos \omega_0 t (2J_1(m_p) \sin at + 2J_3(m_p) \sin 3at + 2J_5(m_p) \sin 5at + \dots \dots) \end{aligned}$$

$$\begin{aligned} i &= A \left[J_0(m_p) \sin \omega_0 t + 2J_1(m_p) \sin at \cos \omega_0 t + 2J_2(m_p) \cos 2at \sin \omega_0 t + 2J_3(m_p) \sin 3at \cos \omega_0 t + \dots \dots \right] \dots (5) \end{aligned}$$

$$\begin{aligned} &= A \left[J_0(m_p) \sin \omega_0 t + J_1(m_p) \{ \sin (\omega_0 + a)t - \sin (\omega_0 - a)t \} + J_2(m_p) \{ \sin (\omega_0 + 2a)t - \sin (\omega_0 - 2a)t \} + J_3(m_p) \{ \sin (\omega_0 + 3a)t - \sin (\omega_0 - 3a)t \} + \dots \dots \right] \dots (6) \end{aligned}$$

Equations (4), (5) and (6) correspond respectively to equations (1), (2) and (3), and their significance will be discussed later.

Frequency Modulation.

Meanwhile, considering frequency modulation, let $i = A \sin \phi$ represent the radiated wave. When the radian frequency ω is not constant, the expression $\phi = \omega t$ becomes

$$\phi = \int \omega dt$$

If ω is such that it has a constant component (the carrier wave) with a superposed wave component proportional to the instantaneous magnitude of the modulating wave, then :—

$$\omega = \omega_0 (1 + k_f \cos at)$$

where a is the radian frequency of the superposed wave and k_f is its amplitude.

$$\text{Then } \phi = \omega_0 \int (1 + k_f \cos at) dt$$

$$= \omega_0 t + \frac{k_f \omega_0}{a} \sin at + \phi_2$$

ϕ_2 is an arbitrary constant. Putting $\phi_2 = 0$ and $m_f = \frac{k_f \omega_0}{a}$

$$i = A \sin (\omega_0 t + m_f \sin at) \dots \dots \dots (7)$$

This equation is similar in form to equation (4) and may be similarly expanded, giving :—

$$\begin{aligned} i &= A \left[J_0(m_f) \sin \omega_0 t + 2J_1(m_f) \sin at \cos \omega_0 t + 2J_2(m_f) \cos 2at \sin \omega_0 t + 2J_3(m_f) \sin 3at \cos \omega_0 t + \dots \dots \right] \dots (8) \end{aligned}$$

$$\begin{aligned} &= A \left[J_0(m_f) \sin \omega_0 t + J_1(m_f) \{ \sin (\omega_0 + a)t - \sin (\omega_0 - a)t \} + J_2(m_f) \{ \sin (\omega_0 + 2a)t + \sin (\omega_0 - 2a)t \} + J_3(m_f) \{ \sin (\omega_0 + 3a)t - \sin (\omega_0 - 3a)t \} + \dots \dots \right] \dots (9) \end{aligned}$$

Comparison with Amplitude Modulation.

Comparing equations (4), (5) and (6) with (7), (8) and (9), it will be seen that they are similar, except

that in (4), (5) and (6) the modulation index is given by m_p , whereas in (7), (8) and (9) it is given by m_f . m_f is the ratio of the maximum change in frequency to the audio frequency, whereas m_p , as has already been pointed out, represents the maximum phase shift and is not dependent on the frequency of the modulating wave: both m_p and m_f are, however, proportional to the amplitude of the modulating wave.

Equations (4) and (7) represent waves of constant amplitude A , which was the amplitude of the original carrier wave. Here is the first important difference between phase and frequency modulation on the one hand, and amplitude modulation on the other.

Equations (6) and (9) show modulated waves each composed of a carrier and an infinite number of side waves differing in frequency from the carrier by α , 2α , 3α , etc. That is to say that in phase and frequency modulation, a single modulating frequency sets up an infinite number of side frequencies. Generally the higher order side frequencies are small in amplitude. Equations (6) and (9) should be compared with equation (3), which showed that in amplitude modulation only one pair of side frequencies was set up by a single modulating frequency.

Another point of difference is that whereas in equation (3) the amplitude of the carrier is unaltered during modulation, in equations (6) and (9) it is seen to be multiplied by $J_0(m_p)$ and $J_0(m_f)$ respectively. Fig. 4 shows values of $J_0(x)$, $J_1(x)$, $J_2(x)$ and $J_3(x)$ for values of x from 0 to 7, and it will be seen that these are never greater than unity. Taking either equations (6) or (9) and putting the modulation index equal to x , these curves give the amplitudes of the carrier, and the first, second and third pairs of side frequencies respectively as a fraction of the unmodulated carrier amplitude.

It will be seen that when the modulation index is zero, $J_0(x)$ is unity, and $J_1(x)$, $J_2(x)$ and $J_3(x)$ are zero (actually all the higher order Bessel functions are also zero when x is zero, though this is not shown in the figure). This means that there are no side frequencies and the carrier is unchanged in amplitude: this is to be expected of any modulation system since it presupposes that the amplitude of the modulating wave is zero.

When the modulation index lies between 0 and 1 the carrier and the first two pairs of side frequencies predominate. As the modulation index increases, the carrier amplitude falls until at $x \approx 2.4$ the carrier amplitude is zero. Relative to an unmodulated carrier amplitude of unity, the side frequency amplitudes are 0.52, 0.44 and 0.21 for the first, second and third pairs respectively. In general, as the modulation index becomes higher, more and more of the radiated energy is vested in the higher order side frequencies.

The higher order side frequencies are attenuated by the tuned circuits at the transmitter and receiver, since the bandwidth of the modulated wave must be limited to prevent interference with other services, and this attenuation of the higher order side frequencies results in some amplitude modulation. To demonstrate this, it will be necessary to construct a vector diagram. On examining equation (5) it

will be seen that the carrier is given by $J_0(m_p) \sin \omega_0 t$, and the resultant of the first pair of side frequencies by $2J_1(m_p) \sin \alpha t \cos \omega_0 t$: this vector is, therefore, in quadrature with the carrier vector, as are those for the 3rd, 5th, 7th, etc., pairs of side frequencies. If all but the first pair of side frequencies are suppressed, there remain a carrier wave constant in amplitude, and a wave of varying amplitude in quadrature with it. The latter wave is the resultant

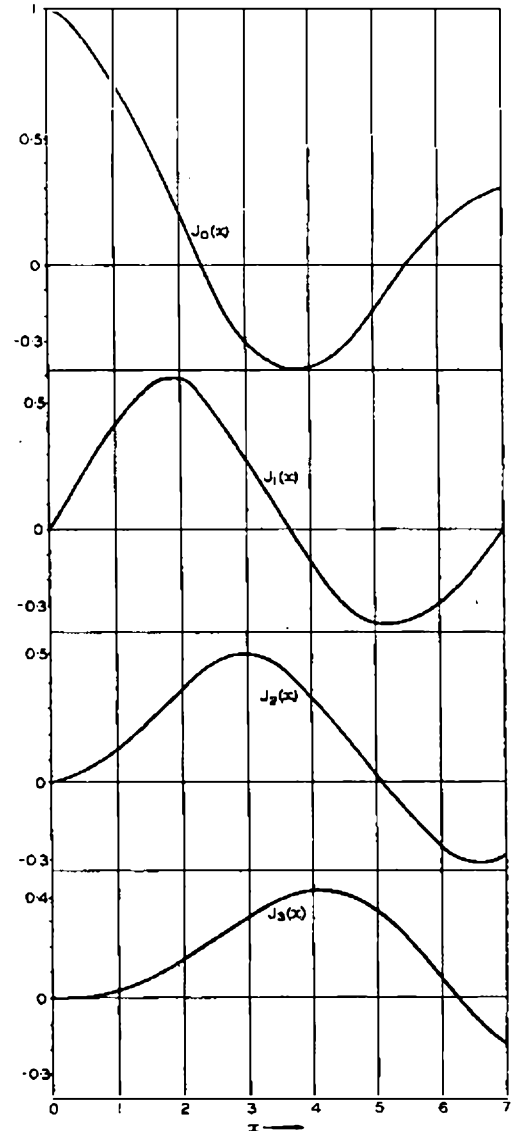

FIG. 4.

of two constant amplitude waves of higher and lower frequency respectively. Fig. 5 illustrates the point. OA represents the carrier, OC and OD represent the side waves, and the small arrows crossing them indicate that their frequencies are respectively higher and lower than that of the carrier. The vector AB represents the modulated wave, and it will be seen that it swings about the position occupied by the carrier vector, changing its amplitude at the same time. This change of

amplitude represents amplitude modulation, and it may be noted in passing that its frequency is twice that of the modulating wave. It is not possible to show true frequency or phase modulation as a sum of vectors as an infinite number are involved,

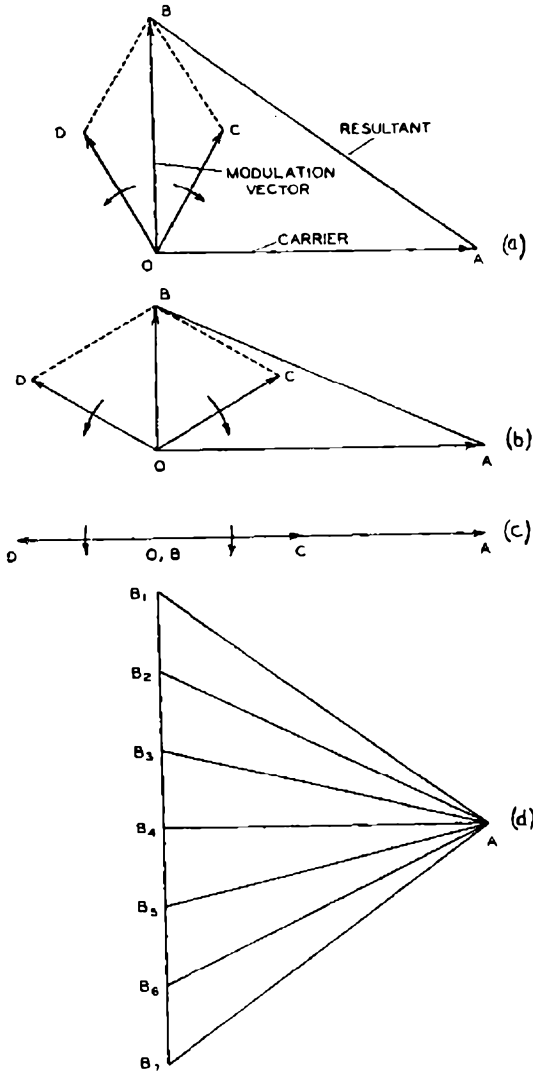

FIG. 5.—(a), (b) AND (c) REPRESENT CONDITIONS AT SUCCESSIVE INSTANTS OF TIME. (d) SHOWS AB, REPRESENTING THE MODULATED WAVE, AT SEVEN INSTANTS DURING A HALF-CYCLE OF THE MODULATING WAVE.

but if the modulation index is assumed to be small, so that the higher order side frequencies are very small in amplitude, an approximate vector diagram can be constructed. This has been done in Fig. 6, which shows the constancy of amplitude of the resultant wave.

Differences between Phase and Frequency Modulation.

So far only differences between amplitude modulation and the other two systems have been pointed

out. It is now necessary to show the difference between phase and frequency modulation. As has been shown, the equations representing the two systems are similar, except for the terms m_p and m_f . If a phase modulated transmitter is assumed to have in its audio amplification chain a stage of which the gain is inversely proportional to frequency, then the amplitude of an audio frequency wave at the modulator will be given by (say) $\frac{K}{\alpha}$, i.e. $k_v = \frac{K}{\alpha}$, and consequently,

$$m_p = \frac{K}{\alpha} \phi_1.$$

This may be compared with the expression for the modulation index in frequency modulation, and it will be seen that they are of the same form: the transmission can be received on apparatus designed for the reception of frequency modulated transmissions. If a normal phase modulated transmission is received on such apparatus, it is necessary to incorporate an equaliser to correct the upward slope of the audio frequency characteristic which would be obtained.

It is of interest to note that in experiments carried out in the U.S.A. by Armstrong, a frequency-modulated wave having a stable carrier frequency was desired, and a crystal oscillator was used to provide the stable carrier. It was not possible to modulate the frequency of this essentially fixed oscillator, but it is not difficult to arrange a network which will shift the phase of a carrier wave according to the amplitude of a modulating wave. This was done, and the modulating amplifier was corrected as described above, the result being a frequency-modulated wave: the modulation index was low, but was increased by feeding the modulated wave to a chain of frequency multipliers which had the effect of increasing the modulation index in addition to the obvious effect of increasing the carrier frequency. A further point of interest arises from the fact that the amplitude of a purely phase or fre-

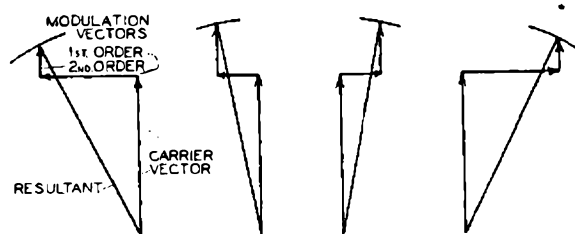

FIG. 6.—VECTOR DIAGRAM FOR PHASE AND FREQUENCY MODULATION (MODULATION INDEX SMALL). THE RESULTANT DOES NOT CHANGE IN AMPLITUDE.

quency-modulated wave is constant. Interfering signals in the transmission path modify this condition, and amplitude limiting stages in the receiving equipment have been used with a view to eliminating the effects of these amplitude changes.

Notes and Comments

Roll of Honour

The Board of Editors deeply regrets to have to record the deaths of the following members of the Engineering Department while serving with the Armed Forces:—

Belfast Telephone Area: Powell, G., Acting Inspector, Lance-Sergeant, Royal Corps of Signals.

Quincy, J., Skilled Workman, Class II, Signalman, Royal Corps of Signals.

Exeter Telephone Area: Endacott, C. B., Unestablished Skilled Workman, Sergeant (acting Company Sergeant-Major), Royal Engineers.

Glasgow Telephone Area: Hamilton, J., Unestablished Skilled Workman, Gunner, Royal Artillery. Reid, A., Unestablished Skilled Workman, Signalman, Royal Corps of Signals.

London Area: Dover, J., Motor Cleaner, Signalman, Royal Corps of Signals.

London Telecommunications Region: Clilverd, C. W., Labourer, Private, Royal Norfolk Regiment. Dimond, W. F., Unestablished Skilled Workman, Able Seaman, Royal Navy. Moore, A. G. C., Labourer, Stoker, Royal Navy. Tancock, F. W., Skilled Workman, Class II, Able Seaman, Royal Navy. Westwood, R., Unestablished Skilled Workman, Private, Royal Scots Regiment.

Manchester Telephone Area: Kay, R. E., Labourer, Private, South Lancs Regiment.

North-Western Regional Headquarters: Gates, R. E., Inspector, Lance-Corporal, Royal Corps of Signals.

Norwich Telephone Area: Nicholls, L. G., Labourer, Private, Royal Norfolk Regiment.

Southampton Telephone Area: Stevens, E. A., Unestablished Skilled Workman, Leading Seaman, Royal Navy.

Tunbridge Wells Telephone Area: Greenway, E. G., Unestablished Skilled Workman, Aircraftman, Class II, Royal Air Force. Pavey, A. W., Unestablished Skilled Workman, Lance-Corporal, Royal West Kent Regiment.

York Telephone Area: Gaul, G. L. G., Unestablished Skilled Workman, Signalman, Royal Corps of Signals.

Recent Honours

The Board of Editors offers its congratulations to all those Post Office servants whom the King was graciously pleased to honour in the list published on New Year's Day. Among these were the Director-General, Sir Thomas Gardiner, K.C.B., K.B.E., who received the Grand Cross of the Most Excellent Order of the British Empire, and the following members of the Engineering Department:—

To be an Officer of the Most Excellent Order of the British Empire: Mr. H. R. Harbottle, Assistant Staff Engineer, Engineer-in-Chief's Office.

To be Members of the Most Excellent Order of the British Empire: Mr. A. G. Cook, Area Engineer, Birmingham. Mr. F. Scott, Chief Inspector, Lincoln Telephone Area.

To be awarded the Medal of the Most Excellent Order of the British Empire: Mr. R. D. Crighton, Inspector, Aberdeen Telephone Area. Mr. T. S. Maginnis, Skilled Workman, Class I, Belfast. Mr. W. Mochrie, Skilled Workman, Class I, Rugby Radio Station. Mr. G. A. Rutland, Inspector, Gloucester Telephone Area. Mr. D. J. R. Traw, Unestablished Skilled Workman, Shrewsbury Telephone Area.

The Board of Editors has learnt with great pleasure that the following members of the Engineering Department, now serving with the armed forces, have been honoured for services rendered to their country. The Board tenders its congratulations upon the signal honour they have earned:—

Engineer-in-Chief's Office: Metson, G. H., Executive Engineer, Lieutenant, Royal Corps of Signals, Military Cross.

Engineering Department: Leigh, H., Leading Hand, Corporal, Royal Engineers, Medal of the Order of the British Empire (Military Division).

Burnley: Knowles, H., Unestablished Skilled Workman, Lance-Bombardier, Royal Artillery, Military Medal.

Gloucester Telephone Area: Trimmer, W. J., Chief Inspector, Lieutenant, Royal Corps of Signals, Mentioned in Despatches.

Newcastle-on-Tyne Telephone Area: Lathan, J. T., Unestablished Skilled Workman, Signalman, Royal Corps of Signals, Military Medal.

Scotland, West, Telephone Area: Kennedy, D. S., Skilled Workman, Class I, Sergeant, Royal Corps of Signals, Mentioned in Despatches.

The Board of Editors has also learnt with great pleasure of the honours recently conferred on the following members of the Engineering Department:—

Birmingham Telephone Area: Wright, F., Skilled Workman, Class I (Home Guard), Medal of the Order of the British Empire (Military Division).

Bristol Telephone Area: Giblett, K. G., Unestablished Skilled Workman, George Medal. Ashley, A. R., Skilled Workman, Class I, Medal of the Order of the British Empire.

Gambier, J. E., Area Engineer (Acting), Commended by H. M. the King. Long, K., Unestablished Skilled Workman, Medal of the Order of the British Empire.

Coventry Telephone Area: Griffiths, G. J., Assistant Engineer, George Medal. Williams, W. J., Skilled Workman, Class I, Medal of the Order of the British Empire. Wilkins, J. W., Unestablished Skilled Workman, Medal of the Order of the British Empire.

Manchester Telephone Area: Long, E., Skilled Workman, Class I, Medal of the Order of the British Empire.

North-Western Region Headquarters: Little, G. J. S., Chief Regional Engineer, George Medal. Whiteley, A., Inspector, Medal of the Order of the British Empire.

Mr. William Cruickshank, M.I.E.E.

Many of our readers, and old friends and colleagues, will deeply regret to learn of the death of Mr. William Cruickshank, who for the long period of eighteen years was Managing Editor of this JOURNAL. He died on the 26th December, 1940, in Glasgow, where he had lived since his retirement from service in the Research Branch of the Engineer-in-Chief's Department on 31st October, 1931.

Born at Keith, Banffshire, in 1871, he began his Post Office career in that town, and was transferred to Aberdeen in 1889, where for a time he was employed as special wire telegraphist for the *Aberdeen Journal*. At the same time he studied technical subjects at Gordon's College, and gained distinction at an early stage by winning the City and Guilds Silver Medal in Honours Telephony. He was selected for appointment to the Engineering Department in 1901, and the remaining 30 years of his successful official career—a period of great technical progress and discovery—were spent in that Department, where he was closely associated with most of the important developments in the design and improvement of telegraphs and telephones. Throughout most of that period he taught many hundreds of students, and lectured at the Northampton Institute, London. In the war of 1914-18 he was Chief Signal Instructor to the Eastern Command, and was subsequently in charge of the telephone exchange which he installed at Cologne for the Headquarters of the Army of the Rhine.

In 1924 he organised and managed the important Post Office exhibit at the British Empire Exhibition at Wembley. His long term of service in the Research Department, where from 1928 he was Assistant Staff Engineer in charge of the groups dealing with telephone transmission, telegraphs, and cable research, was fruitful of many revolutionary developments in

telephone and telegraph technique, and Mr. Cruickshank rendered a valuable service to his profession by continuously instructing its members, through the medium of articles and papers describing these developments which he wrote for this and other publications, and for the I.P.O.E.E. He was awarded the Senior Bronze Medal of the Institution for his paper on "Voice Frequency Telegraphs," and predicted the widespread adoption of that system with which readers are now familiar.

Mr. Cruickshank was a ready and talented writer of good English and possessed the gift of clear and concise expression of thought. These talents, combined with a capacity for conscientious work, contributed largely to the success and value of THE POST OFFICE ELECTRICAL ENGINEERS' JOURNAL, which he regarded as his own personal charge and which he elevated to its present high standard during his long period as Managing Editor. During his years of retirement he found scope for his literary interests in editing the journal, *Scotland*, the organ of the Scottish Development Council, but the advent of the war curtailed these activities and lately his health had been failing.

His many friends will remember the zest with which he participated in the foregoing and many other exploits, but they will also recall his strong physique and honest character, his cheerful and friendly disposition, his ready and imaginative sympathy, and his kindly good humour. Many younger men now prominent in the Service owe him much for guidance and inspiration in their earlier years, and they, with friends in this and other countries, feel deep sorrow at his passing. His home life was ideal and happy, and our deep sympathy is extended to Mrs. Cruickshank and her daughter in their great loss.

J. J. McK.

The Institution of Post Office Electrical Engineers

TECHNICAL PERIODICALS

In view of prevailing conditions it has been decided not to circularise each member to ascertain the periodical required for the year commencing 1st April, 1941. In a recent Library Bulletin members were requested to advise their local Secretaries if they wished to change to another periodical as from 1st April, 1941. Where no advice has been received it has been assumed that members will wish to continue to receive the publication circulated to them during the preceding year. Similarly, where a member purchased a periodical after circulation during 1940-41, it has been assumed that he will continue to do so, if advice has not been received to the contrary.

Flight has been added to the periodicals circulated by the Institution.

PROVISION OF P.O.E.E. JOURNAL

The Council has given consideration to the position which has arisen owing to the suspension of Centre meetings and the restricted supply of printed papers to the membership, and has arranged that members shall be supplied quarterly with the issue of the *P.O.E.E. Journal* as a supplementary facility to be provided by the Institution.

This free provision will commence with the April issue and will be maintained during the war period as long as the financial position of the Institution will permit.

Regional Notes

Home Counties Region

READING MOBILE FIRST-AID PARTY

The Reading Mobile First-Aid party, which was formed approximately 18 months ago, consists of one Clerical Officer and ten Engineering Officers. It recently staged a casualty case, arranged by a qualified member of the St. John Ambulance Association to obtain practical experience in rendering First-Aid in the field.

It was assumed for the purpose that a member of the staff had been knocked down by a motor vehicle, which caused the following injuries:—

Contusions of the face and head.

Broken tibia.

Cut tendons of the wrist, rendering the hand useless.

Severe shock which became evident during the dressing of the wounds.

The party was called upon to render emergency First-Aid on the spot and to bring the case to the nearest Departmental First-Aid post, which was assumed to be much nearer than the public First-Aid post.

In order that the fullest experience should be gained from the exercise, it was arranged for the casualty to be an officer fully qualified in First-Aid who was able to criticise the whole of the actions, for the benefit of those taking part.

The incident caused considerable interest, and the manner in which the various operations were carried out reflected great credit, not only to those taking part but to the Instructress from the St. John Ambulance Association, who gave very helpful constructive criticism.

A Departmental Radio Vehicle was used for transporting the casualty.

The members are very keen and hold frequent practices in First-Aid.

North-Western Region

MULTI-WAY THRUST BORINGS

In connection with the article appearing under the above heading in the Regional Notes, page 146 of the October, 1940, issue of the JOURNAL, it has been pointed out that asbestos-cement ducts should normally be used for thrust bores under railways.

In the case described steel pipe had to be used owing to the uncertainty of the depth of cover it would be possible to obtain, but the method of making parallel bores by means of the trihead would be equally applicable when using cement ducts.

Scottish Region

RETIREMENT OF MR. R. CURLING

His many friends in the Telephone Service will hear, with regret, of the departure of Mr. R. Curling, Area Engineer, Scotland West, who retired under the age limit on the 31st December, 1940.

Mr. Curling entered the telephone service 43 years ago as an apprentice with the late National Telephone Company at Canterbury. After passing through the various grades he was appointed local Manager at Eastbourne and Brighton, where he gained a splendid all-round experience of both the engineering and commercial sides of the telephone industry. On the transfer of the National Telephone Company's undertaking to the State he was transferred to the Engineering Department as a Chief Inspector, and in 1914 was promoted to Assistant Engineer at Glasgow. During the Great War he was in charge of the provision of war circuits under the control of the Superintending Engineer and was for a time Engineer-in-Charge of the telephone installation at the

great munitions factory at Greta, where he was responsible for several improvements in the service. In 1930 he was promoted Executive Engineer in charge of the Glasgow Internal Sections and latterly the External Section of Glasgow. When the Region was formed Mr. Curling was appointed Area Engineer in the Scotland West Area, in which capacity he served until his retirement.

At a function held in Sloans Rooms on the 7th February, Mr. Curling was presented in the presence of a large gathering of both the Scotland West and Glasgow Telephone Areas with a handsome display cabinet by the staff. The chair was occupied by Mr. R. Teasdale, Telephone Manager, Scotland West Area, and the presentation was made by Col. Carter, Deputy Regional Director, supported by Major Ashdowne, Chief Regional Engineer, Mr. H. G. Davis, Regional Engineer, Mr. A. E. Coombs, Telephone Manager, Glasgow Area, and various other Regional and local officers. In making the presentation Col. Carter paid high tribute to Mr. Curling's ability as a telephone engineer, to his devotion to duty and to the kindly interest he took in the staff under his control. Major Ashdowne and other officers also spoke very highly of Mr. Curling's work in the telephone service and the high standard he set in all work carried out under his direction.

Mr. Curling was well known in telephone circles in the West of Scotland both for his ability as an engineer, for the kindly interest he took in the welfare of the staff and for his work in connection with the social side of the telephone industry. He was for a number of years president of the Post Office Engineering Department's Sports Club and took an exceptionally keen interest in its various activities.

It is felt by all grades that in his departure the telephone service has lost a keen, loyal and capable officer and the staff a very good friend.

Welsh and Border Counties Region

MANHOLE CONSTRUCTION IN RUNNING SAND

Many difficulties may have to be surmounted when building manholes in wet situations, but none can be more troublesome than the existence of running sand. This fact was amply demonstrated during the construction of manholes on a section of the new Liverpool-Colwyn Bay duct line which necessitated the use of a dewatering system.

So far as is known, a dewatering system has not previously been employed on Departmental works. It provides for sinking into the waterlogged ground around the proposed excavation a number of tubes termed "wellpoints," each 14 ft. long, the bottom 3 ft. consisting externally of fine wire mesh, which permits the passage of water but not of sand.

The tubes are lowered into the ground by pumping through them water from an external source (operation termed "jetting") and the action is then reversed to drain the water from the immediate and surrounding areas, and the sand, thus drained, is in an ideal condition for excavation, which is effected in most cases without timbering being necessary. Six "well-points" were found sufficient for manholes of R.C.1 size and eight for R.C.2 size. The average time required to sink into position each "wellpoint" was 45 seconds.

The use of the device enabled four or five manholes per week to be completed as against a doubtful rate of one per week with ordinary construction methods.

It is hoped to describe the operations in more detail in an ensuing issue of the JOURNAL.

Staff Changes

Promotions

Name	Region	Date	Name	Region	Date
<i>From Exec. Engr. to Acting A.S.E.</i>			<i>From S.W.1 to Acting Insp.—continued</i>		
Swift, R. E. ..	E.-in-C.O. ..	1.12.40	Maile, J. L. ..	E.-in-C.O. ..	1.10.40
Doust, J. F. ..	E.-in-C.O. ..	5.2.41	McBain, A. ..	E.-in-C.O. ..	1.1.41
Barron, D. A. ..	E.-in-C.O. ..	9.1.41	Allen, E. G. (Unest.)	E.-in-C.O. ..	12.1.41
<i>From Asst. Engr. to Acting Exec. Engr.</i>			Welch, G. I. ..	E.-in-C.O. ..	9.12.40
Harmston, A. T. ..	E.-in-C.O. ..	9.1.41	Fleming, A. P. ..	E.-in-C.O. ..	12.1.41
Rusbridge, E. S. ..	Scot. Reg. ..	26.1.41	<i>From Chief Officer to Acting Commander</i>		
Lowe, J. ..	Mid. Reg. ..	7.2.41	Troops, A. E. ..	H.M.T.S. ..	To be fixed later
Wright, C. H. ..	E.-in-C.O. ..	7.2.41	Oates, J. G. B. ..	H.M.T.S. ..	To be fixed later
<i>From C.I. with Allowance to Acting Asst. Engr.</i>			<i>From 2nd Officer to Acting Chief Officer</i>		
Thornley, H. G. ..	N.W. Reg. ..	21.12.40	Jago, D. V. ..	H.M.T.S. ..	To be fixed later
<i>From C.I. to Acting Asst. Engr.</i>			Paines, A. V. ..	H.M.T.S. ..	To be fixed later
Duff, J. B. ..	Scot. Reg. ..	4.1.41	Elston, F. A. ..	H.M.T.S. ..	To be fixed later
Davidson, W. B. ..	Scot. Reg. ..	26.1.41	Wood, R. ..	H.M.T.S. ..	To be fixed later
Green, R. G. ..	N.W. Reg. ..	7.2.41	<i>From 3rd Officer to Acting 2nd Officer</i>		
Alston, G. J. ..	N.W. Reg. ..	To be fixed later	Evans, C. M. G. ..	H.M.T.S. ..	To be fixed later
Hopkinson, E. ..	E.-in-C.O. ..	7.2.41	Ramshaw, A. ..	H.M.T.S. ..	To be fixed later
<i>From C.I. to C.I. with Allowance</i>			<i>From 2nd Engineer to Acting Chief Engr.</i>		
Keown, W. S. ..	N. Ire. Reg. ..	To be fixed later	Thomson, A. J. ..	H.M.T.S. ..	To be fixed later
Moon, F. H. ..	N.W. Reg. ..	12.1.41	<i>From 3rd Engineer to Acting 2nd Engineer</i>		
<i>From D'man Class II to Acting Insp.</i>			Parker, C. ..	H.M.T.S. ..	To be fixed later
Wooler, A. E. ..	E.-in-C.O. ..	14.11.40	Sharp, A. E. ..	H.M.T.S. ..	To be fixed later
Newman, M. A. ..	E.-in-C.O. ..	1.12.40	<i>From D'man Class II to Acting D'man Class I</i>		
<i>From S.W.1 to Acting Insp.</i>			Jury, J. R. ..	E.-in-C.O. ..	1.1.41
Campbell, D. A. ..	E.-in-C.O. ..	1.10.40	Holt, J. V. O. ..	N. Western to Scot. Reg. ..	26.1.41
Marsden, S. ..	E.-in-C.O. ..	1.10.40	Davies, E. S. ..	W. & B.C. Reg. to S.W. Reg.	9.2.41
Marchant, H. J. ..	E.-in-C.O. ..	1.10.40			

Transfers

Name	Region	Date	Name	Region	Date
<i>Area Engineer</i>			<i>Inspectors</i>		
Ackerman, H. M. W.	E.-in-C.O. to J.T.R.	6.2.41	Barton, B. A. ..	E.-in-C.O. to N.E. Reg. ..	3.11.40
<i>Chief Inspectors</i>			Jones, J. R. ..	E.-in-C.O. to W. & B.C. Reg.	1.1.41
Barton, A. L. ..	E.-in-C.O. to N.E. Reg. ..	1.2.41	<i>Prob. Inspectors</i>		
Johnson, S. W. J. ..	E.-in-C.O. to S.W. Reg. ..	19.1.41	Blair, G. M. ..	Scot. Reg. to E.-in-C.O. ..	25.11.40
			Bassett, H. G. ..	S.W. Region to E.-in-C.O.	4.2.41

Retirements

Name	Region	Date	Name	Region	Date
<i>Asst. Staff Engineer</i>			<i>Chief Inspectors</i>		
J. Radford ..	E.-in-C.O. ..	31.12.40	Allsop, E. ..	S.W. Reg. ..	20.1.41
<i>Executive Engineers</i>			Wilson, W. ..	Test Section ..	31.12.40
Deane, W. ..	L.T.R. ..	8.2.41	Proudfoot, G. ..	Scot. Reg. ..	31.12.40
Clack, C. W. ..	E.-in-C.O. ..	31.12.40	Davidson, C. H. ..	S.W. Reg. ..	31.12.40
Roe, E. A. ..	Mid. Reg. ..	31.12.40	Standring, W. W. ..	N.W. Reg. ..	31.1.41
Curling, R. ..	Scot. Reg. ..	31.12.40	Hart, J. L. ..	N.W. Reg. ..	31.1.41
<i>Assistant Engineers</i>			<i>Inspectors</i>		
Bruce, R. ..	N. Ire. Reg. ..	31.12.40	Aldam, J. W. ..	H.C. Reg. ..	14.12.40
Gardner, A. J. ..	L.T.R. ..	31.12.40	Wickerson, H. A. ..	Test Section, London ..	31.10.40
<i>Chief Inspectors with Allowance</i>			Unthank, R. J. ..	Test Section, London ..	31.10.40
Lewis, A. F. ..	L.T.R. ..	31.12.40			
Partington, H. J. ..	N.W. Reg. ..	28.2.41			

Deaths

Name	Region	Date	Name	Region	Date
<i>Chief Inspector</i>			<i>Inspectors—continued.</i>		
Masson, D. J.	.. Test Section, London	.. 5.2.41	Thomas, R. A.	.. E.-in-C.O.	.. 2.2.41
<i>Inspectors</i>			<i>Senior Draughtsman</i>		
Powell, G.	.. N. Ire. Reg.	.. 31.8.40	Fraser, V. A.	.. E.-in-C.O.	.. 27.2.41
Gates, R. E.	.. N.W. Reg.	.. 2.12.40			

CLERICAL GRADES

Promotions

Name	Region	Date	Name	Region	Date
<i>From E.O. to Acting S.O.</i>			<i>From C.O. to Acting F.O.</i>		
Topley, W. de la C.	.. E.-in-C.O.	.. 16.1.41	Haley, M. R. (Miss)	.. E.-in-C.O.	.. 23.12.40
Meredith, C. T.	.. E.-in-C.O.	.. 16.1.41	Lane, N. (Miss)	.. E.-in-C.O.	.. 23.12.40
<i>From H.C.O. to Acting S.O.</i>			<i>From C.O. to Acting H.C.O.</i>		
Robbins, C. A.	.. N.W. Reg.	.. 9.2.41	Bradley, J. P.	.. N. Ire. Reg.	.. 20.12.40
			Scott, W.	.. Scot. Reg.	.. 13.1.41

Retirements

Name	Region	Date	Name	Region	Date
<i>Staff Officer</i>			<i>Higher Clerical Officer</i>		
James, W.	.. E.-in-C.O.	.. 3.2.41	Peck, H. W.	.. N. Ire. Reg.	.. 19.12.40

BOARD OF EDITORS

A. J. GILL, B.Sc., M.I.E.E., M.I.R.E., Chairman.
 F. E. NANCARROW, A.R.C.Sc., M.I.E.E.
 P. B. FROST, B.Sc., M.I.E.E.
 A. H. MUMFORD, B.Sc.(ENG.), M.I.E.E.
 C. W. BROWN, A.M.I.E.E.
 R. E. JONES, M.Sc., A.M.I.E.E.
 H. LEIGH, B.Sc.(ENG.), A.M.I.E.E., Acting Managing Editor.
 G. E. STYLES, A.M.I.E.E., Acting Assistant Editor.

Copyright

The entire contents of this JOURNAL are covered by general copyright, and special permission is necessary for reprinting long extracts, but Editors are welcome to use not more than one-third of any article, provided credit is given at the beginning or end thus: "From the *Post Office Electrical Engineers' Journal*."

The Board of Editors is not responsible for the statements made or the opinions expressed in any of the articles in this JOURNAL, unless such statement is made specifically by the Board.

Communications

All Communications should be addressed to the Managing Editor, *P.O.E.E. Journal*, Engineer-in-Chief's Office, Alder House, Aldersgate Street, London, E.C.1. Telephone: HEADquarters 1234. Remittances should be made payable to "The *P.O.E.E. Journal*" and should be crossed "& Co."

Binding Cases

Cases for binding are available, and may be obtained from the Local Agents for 1s. 9d. Subscribers can have their copies of Volumes bound, at a cost of 3s., by sending the complete set of parts to the Local Agents or to the *P.O.E.E. Journal*, Engineer-in-Chief's Office, Alder House, Aldersgate Street, London, E.C.1. Orders for binding for Vols. 1-19 should indicate whether the original binding case with black lettering, or the later pattern with gold, is required. Cases with gold lettering are the only type stocked from Vol. 20 onwards.

Back Numbers

The price of the JOURNAL, which is published quarterly, is 1s. (1s. 3d. post free) per copy, or 5s. per annum post free. Back numbers can be supplied, subject to availability of stocks, at 1s. each (1s. 3d. post free). Orders for back numbers may be sent to the Local Agents or to the Publishers.

Advertisements

All communications relating to space reservations should be addressed to the Advertisement Editor, *P.O.E.E. Journal*, Alder House, Aldersgate Street, London, E.C.1. Communications regarding advertisement copy, proofs, etc., should be addressed to the Publishers, Messrs. Birch & Whittington (Prop. Dorling & Co. [Epsom], Ltd.), 49 Upper High Street, Epsom, Surrey.

Mightier YET!

MUIRHEAD

Thanks to the Royal Navy an endless flow of materials and products to and from these shores, builds up our war strength at home, builds up our financial strength abroad. The ships of the Royal Navy use Muirhead components for their accuracy and for their reliability.

*

MUIRHEAD AND CO. LTD., ELMERS END, BECKENHAM
KENT. TELEPHONE: BECKENHAM 0041-0042



FOR OVER 60 YEARS DESIGNERS & MAKERS OF PRECISION INSTRUMENTS

C.R.C. 24

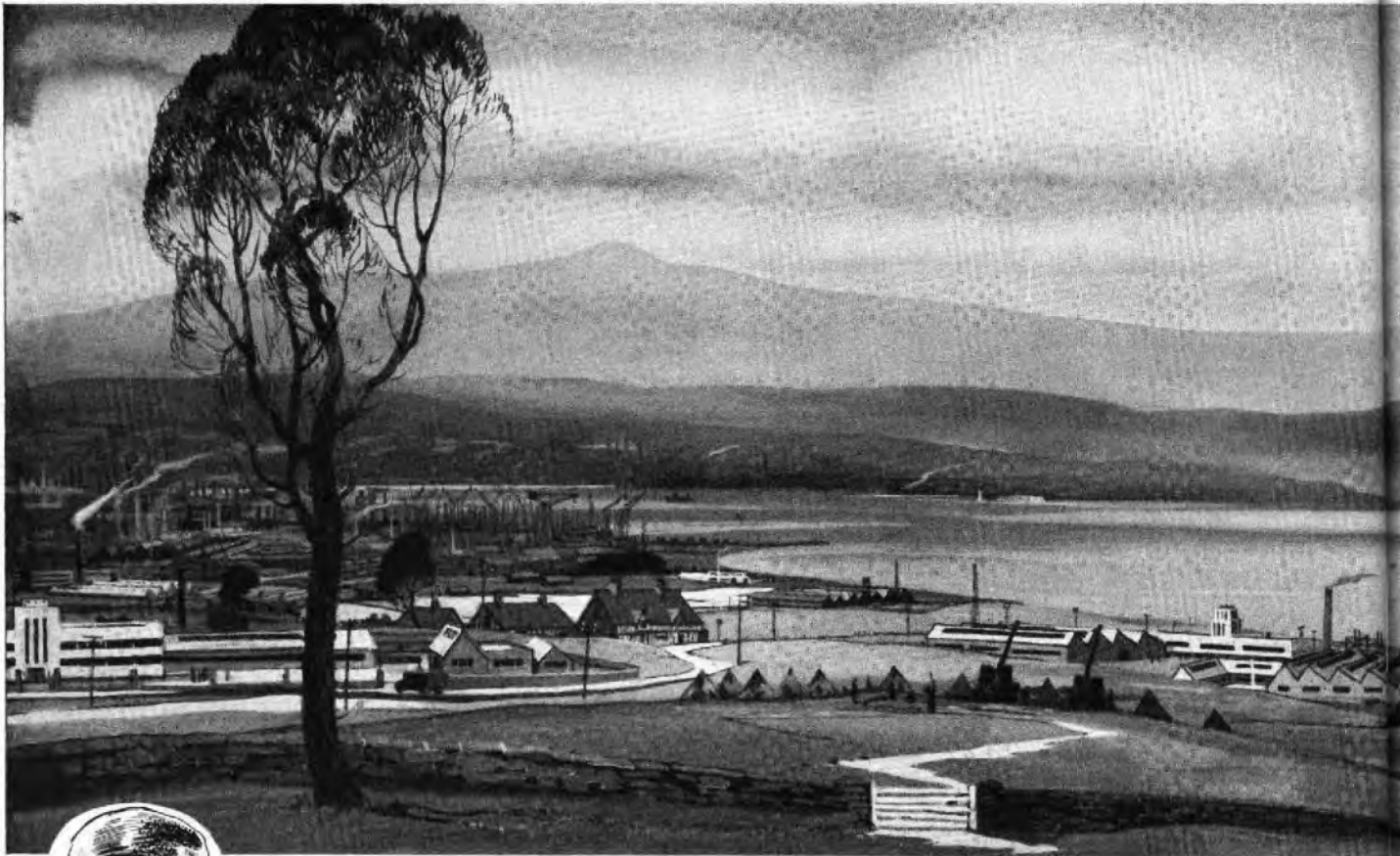

TELEPHONY



STROWGER AUTOMATIC TELEPHONE EQUIPMENT

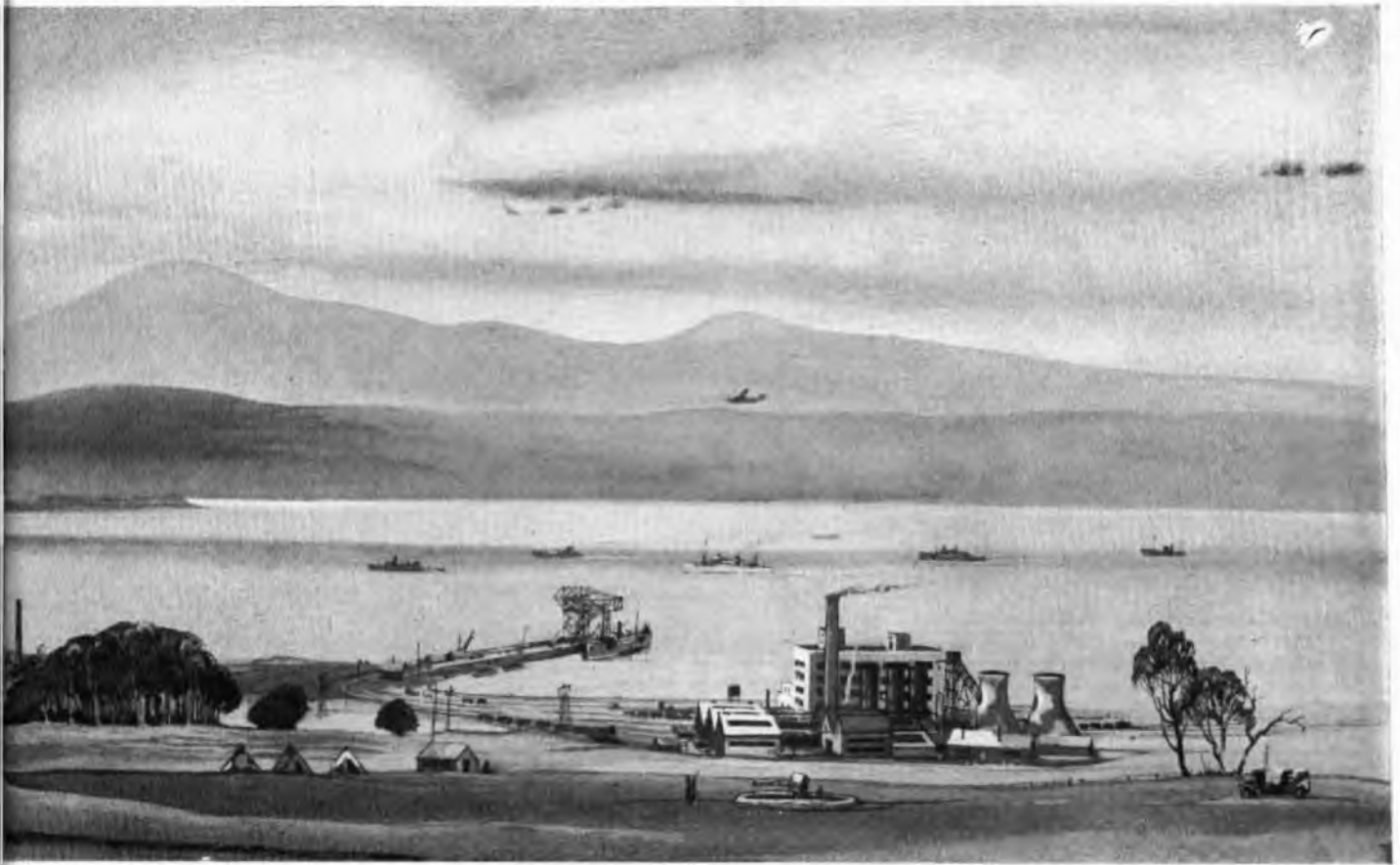

... VITAL TO THE VICTORY DRIVE

Communications are a factor of paramount importance and they affect every aspect of the Nation's War Effort. Military, industrial, commercial and civil requirements are being met, and in this hour of National need the advantages of telephone service are being appreciated as they have rarely been before. The provision and operation of adequate telephone service by the Post Office has been no light task and its maintenance may prove increasingly difficult in days to come, but it is certain that the effort will be made to accomplish the task as efficiently in the future as it has been in the past.

Automatic Telephone & Electric Co. Ltd., as manufacturers of Strowger Automatic Telephone Equipment for the Post Office are proud to feel that they are associated with the success of this enterprise.



AUTOMATIC TELEPHONE & ELECTRIC CO. LTD.

NORFOLK HOUSE, NORFOLK ST., STRAND, W.C.2.

Phone, Temple Bar 9262 • Grams, Auteko Estrand, London

STROWGER WORKS, LIVERPOOL, 7

Phone, Stoneycroft 4830 • Grams, Strowger, Liverpool



TRANSFORMING

THE SCENE



Here we have the bullock cart transporting to its destination one of the most essential forms of up-to-date communication. After travelling by road, rail and sea, our telephone equipment often completes the final stages of its journey by old traditional Eastern methods of transport. It is because overseas administrators have realised that modern science can, perhaps more than anything else, improve the conditions of the tropical countries, that we get such scenes as the old carrying in the new
 Engineers of the

General Electric Company's Telephone Works have made a specialised study of the hot climates thus ensuring production of telephone equipment which will withstand the effects of heat and humidity and the ravages of insects. At the present time, this organisation is largely occupied on National Work, but we are still manufacturing, exporting and installing improved means of communication in large cities, towns, and for small isolated communities overseas. The G.E.C. hope soon to be able to serve their customers to an even greater degree and look forward to that future, but meanwhile ask you to remember that Britain still delivers the goods!

G.E.C.

REGD. TRADE MARK

THE GENERAL ELECTRIC COMPANY LIMITED OF ENGLAND
 HEAD OFFICE — MAGNET HOUSE, KINGSWAY, LONDON, W.C.2

High Quality mouldings

Ebonestos have produced many of the finest mouldings manufactured in compositions, Bakelite, Urea, Diakon, and other synthetic resins. For the past 42 years, our reputation for finish and accuracy has been second to none.

Let us know your moulding requirements, and we shall be pleased to send one of our technical experts to discuss the matter with you, or, if you prefer it, meet you at our factory. Moulders to the General Post Office, Admiralty, Air Ministry and other Government Departments.

EBONESTOS
INDUSTRIES LIMITED
 EXCELSIOR WORKS, ROLLINS STREET,
 LONDON, S.E.15 Telephone: New Cross 1913 (6 lines)

FOR HEAVY FIXING WORK RAWLBOLTS take the strain!

When there is a fixing with bolts to be made, use Rawlbolts. With the aid of Rawlbolts anything can be bolted in position with the minimum of time, labour and tools. No waiting for cement to dry—no big holes to be drilled.

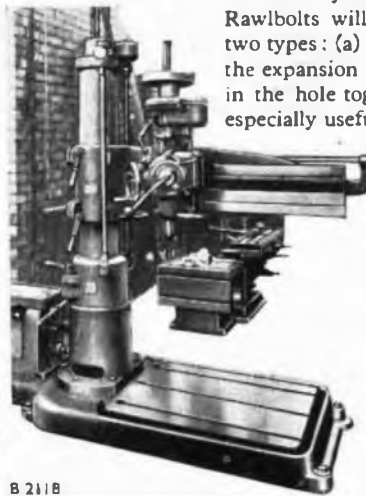

B 211 B



Whatever your "bolting" problem Rawlbolts will solve it. There are two types: (a) Bolt Projecting where the expansion shell and bolt can be inserted in the hole together, and (b) Loose bolt type especially useful where there is no crane to lift the machine over projecting bolts. When fixed to hard material and tested to destruction the bolt will break before the expansion shell can be dislodged! Stock sizes from $\frac{1}{16}$ " to $\frac{3}{4}$ " Whit.

Write for fuller particulars and a free sample.

The Rawlplug Co. Ltd.
 Rawlplug House,
 Cromwell Road, London, S.W.7

The illustration shows a Radial Drill fixed to concrete floor by Rawlbolts. Photo by courtesy of the Wayne Tank & Pump Co. Ltd., London.



Clip-on
HERE...

Clip-on
THERE...

Clip-on
 almost
EVERYWHERE



The range of the instrument is changed by a half turn of the switch.

Comprehensive Ranges		Available
0-100-500	0-7.5-75	0-20-100
0-100-1000	0-10-50	0-25-150
0-200-1000	0-15-75	0-50-250
0-300-1500		

Write for List IN.11.

FOR CHECKING CURRENT IN
 BUSBARS, FUSES & CABLES

FERRANTI
 DUAL RANGE
 Clip-on **AMMETER**

FERRANTI LTD., HOLLINWOOD, LANCs.
 London Office: Bush House, Aldwych, W.C.2.

Solder THE MODERN AND SPEEDY WAY

USE ERSIN MULTICORE

THE SOLDER WIRE
WITH 3 CORES OF
NON-CORROSIVE
ERSIN FLUX



- Avoids Dry Joints
- Increases Electrical Efficiency of Joints
- Speedily makes Sound Joints on Dirty or Oxidised Surfaces
- Always Correct Proportions of Flux and Solder
- No Additional Flux Required
- Low Melting Point (190° C. for 60/40 alloys)
- Approved by Air Ministry & G.P.O.
- All-British and acknowledged by the Leading Manufacturers to be the finest Cored Solder in the World.

FREE Two informative publications on soldering have been issued by Multicore Solders Ltd. Executives are invited to send for copies and a free sample of Multicore Solder.

MULTICORE SOLDERS LTD., BUSH HOUSE, LONDON, W.C.2

Telephone: TEMple Bar 5583/4



The illustration shows one of many compact wavemeters expressly designed for the Services
by **H. W. Sullivan Limited.**

It is of the Absorption type with an accuracy of 0.1%, the scale being engraved direct in frequency—this saves much valuable time by eliminating all references to calibration curves and dispenses with troublesome computations.

An advertisement of H. W. Sullivan Limited, London, S.E.15. Telephone: New Cross 3225 (Private Branch Exchange)

For New Telephone Developments—Technical, Plant, Commercial, Traffic, as well as late news affecting use of telephones—**READ**

TELEPHONY!

The weekly journal of the telephone industry. In these changing times the best investment a telephone man can make is to invest in himself. Competent men—the men who are well informed about their particular work and the business as well—are the ones who win promotion.

"TELEPHONY" covers every department of the telephone industry. It is informative, factual, inspirational; it publishes the latest developments, tells the approved telephone practices and current telephone news.

READ TELEPHONY!

Subscription price, \$5.00 per year; 52 issues. Published since 1901.

Address: Odhams Press, Ltd., Technical Book Dept., 85 Long Acre, London, W.C.2 (Telephone: Temple Bar 2468) for a sample copy of TELEPHONY, or write direct to:

TELEPHONY PUBLISHING CORPN.
688 S. Dearborn Street, Chicago, Ill., U.S.A.

TUNGSTONE^{reg'd.} BATTERIES

Are being regularly used by

**G.P.O. Stores & Engineering Depts.
Empire Post & Telegraph Depts.**

**Admiralty
War Office
Air Ministry**

- Open or Enclosed types in Glass Containers.
- Large Capacities in Lead Lined Wood Boxes.
- **TUNGSTONE** High-pressure Die-cast Plates conform to British Standard Specification.
- **British Empire Lead** exclusively used.

TUNGSTONE PRODUCTS LTD.
SALISBURY SQUARE LONDON, E.C.4

STANDARD WITH THE BRITISH POST OFFICE

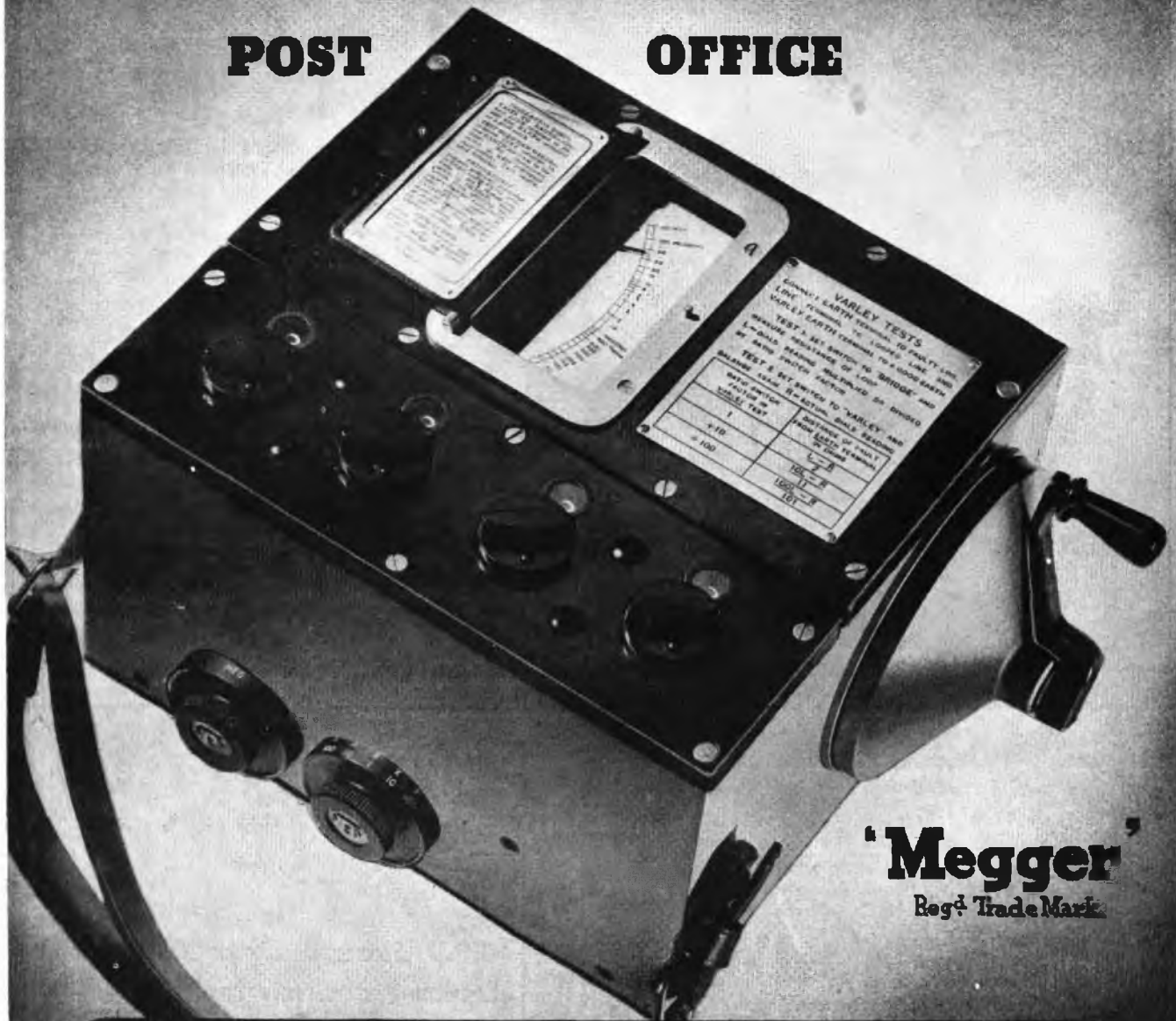

'Megger'
Regd Trade Mark

THE BRIDGE-MEG TESTING SET used by the British Post Office is a portable, self-contained instrument combining the functions of an Insulation Tester and a Wheatstone Bridge; it can be used for fault location by the Varley Loop method. Facilities can also be provided whereby, with the use of an external galvanometer and resistance box, the instrument may be used for making Murray Loop tests. Insulation range 100 megohms at 500 volts. Bridge range 0.01 to 999,900 ohms. Size 7x8 $\frac{3}{4}$ x12 ins. Weight 12 $\frac{3}{4}$ lbs. Mains operated instruments are also supplied to the British Post Office. Ask for list X 267.

EVERSHED & VIGNOLES LTD., CHISWICK, LONDON, W.4
TELEPHONE: CHISWICK 1370 * TELEGRAMS: "MEGGER" CHISK, LONDON

PORTABLE BOOST CHARGERS *for*

UNATTENDED AUTOMATIC EXCHANGES (U.A.X.)



U.A.X. Batteries are normally float-charged by a metal rectifier, but it sometimes happens that a sustained mains interruption causes the battery to become fully discharged. The portable equipment illustrated, which is divided into two sections for ease of handling, has been designed for transportation by one man by motor cycle and is used to boost charge the battery up to its full capacity. The output is 5 amperes at 48 volts, tapering to 61 volts when the charge is automatically cut-off.

Westinghouse

Represented in INDIA by
Saxby & Farmer (India) Ltd.,
Calcutta.

Write for full details to
Dept. P.O.E.J.

Represented in AUSTRALIA by
McKenzie & Holland (Australia)
Pty. Ltd., Melbourne.

WESTINGHOUSE BRAKE & SIGNAL CO. LTD., PEW HILL HOUSE, CHIPPENHAM, WILTS.

The New Star of the Telephone World

THE new Ericsson Automatic Telephone No. 1002 shown here has a casework of black moulded bakelite in a modern, distinctive and pleasing design. It incorporates a form of cradle or micro-telephone rest which is not readily damaged should the instrument get violently knocked or fall to the ground.

The whole of the interior apparatus which is mounted on a frame can be removed as a unit, the base plate which incorporates a useful sliding tray fitment being first removed. Dimensions, 6 by 9½ by 8½ inches ; weight, 6 lbs.

NOW AVAILABLE TO P.O. SUBSCRIBERS

Full particulars from makers :

ERICSSON TELEPHONES LTD.

HEAD OFFICE : 22 LINCOLN'S INN FIELDS, LONDON, W.C.2.

Works : Beeston, Notts.

(Telephone : HOLborn 0936)



CREATED BY

Ericsson

TELEPHONES LTD.

INDEX TO ADVERTISERS

Alton Battery Co., Ltd., The	iv	Institutional of Post Office Electrical Engineers, The ..	xxiv
Automatic Coil Winder & Electrical Equipment Co., Ltd.	iii	Muirhead & Co., Ltd.	xi
Automatic Telephone & Electric Co., Ltd. ..	xii & xiii	Multicore Solders, Ltd.	xvi
Bennett College	ix	Pirelli-General Cable Works, Ltd.	xxvi
Caplin Engineering Co., Ltd.	viii	Rawplug Co., Ltd., The	xv
Creed & Co., Ltd.	xxiii	Siemens Brothers & Co., Ltd.	vi & vii
Ebonestos Industries, Ltd.	xv	Smith, Frederick & Co.	xxv
Edison Swan Electric Co., Ltd., The	ii	Sullivan, H. W., Ltd.	xvii
Elliott Bros. (London), Ltd.	xxv	Telephone Manufacturing Company, Ltd.	x
Ericsson Telephones, Ltd.	xx & xxi	Telephony Publishing Corporation	xvii
Evershed & Vignoles, Ltd.	xviii	Tungstone Products, Ltd.	xvii
Ferranti, Ltd.	xv	Turner, Ernest	xxii
General Electric Co., Ltd., The	ii & xiv	United Insulator Co., Ltd.	v
Hall Telephone Accessories (1928), Ltd.	xxiii	Westinghouse Brake & Signal Co., Ltd.	xix

TURNER DIFFERENTIAL MILLIAMMETERS G.P.O. No. 17 & No. 18

Meet the most
exacting demands
for balancing currents
In multiplex telegraph circuits.

————— A quality
product of outstanding
merit —————

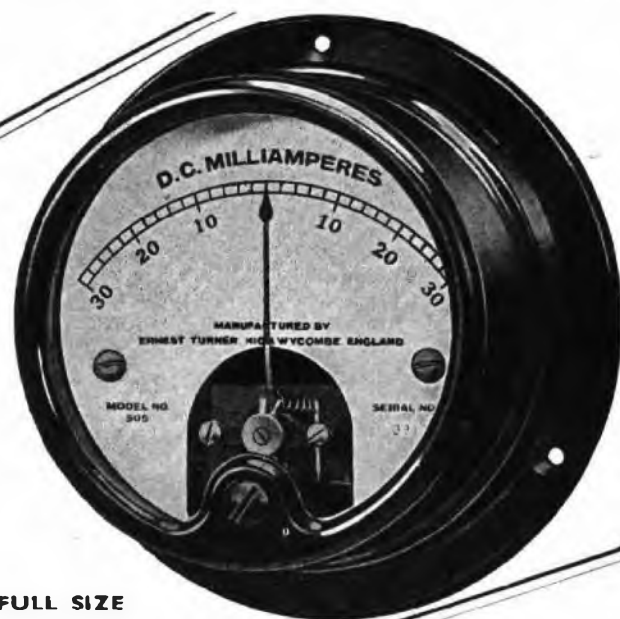

FULL SIZE

Also manufacturers of G.P.O. Detector No. 4, and a comprehensive line of instruments for precision electrical measurements.

ERNEST TURNER ELECTRICAL INSTRUMENTS, Ltd.

**CHILTERN WORKS,
49-73 TOTTERIDGE AVENUE,
HIGH WYCOMBE,**

BUCKS, ENGLAND

Telephone : High Wycombe 1301, 1302
Telegrams : Gorgeous High Wycombe.

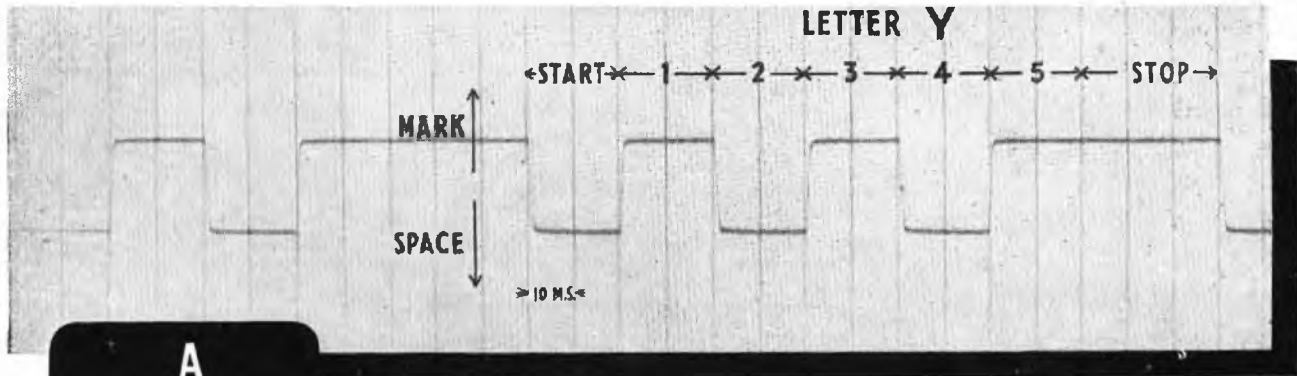

**A
NOTEWORTHY
ADVANCE IN**

TELEGRAPH TRANSMISSION

IN the Creed Laboratory efforts are constantly directed towards effecting further progress in Printing Telegraph Communication. A new Teleprinter Transmitter designated Transmitting Unit S.2184, is a recent Creed development of considerable importance. Some of its outstanding features are :—

The provision of high quality Transmission with greatly reduced maintenance.

The Transmission performance is attained without critical adjustment and remains constant over extended periods without readjustment.

Accurate timing, complete freedom from contact rebound and the almost imperceptible transit time will be noted from the above reproduced oscillogram of actual Transmission.

Transmitting Unit S.2184 is now standardized on all Model 7 Creed Teleprinters, and is interchangeable with the previously fitted Transmitting Unit S.1842.

CREED & CO. LTD., TELEGRAPH HOUSE, CROYDON. Telephone: CROYDON 2121 (6 lines)

Hall Telephone Accessories (1928) Limited

Suppliers to the British Post Office, Air Ministry, Admiralty, War Office and Foreign Government Departments.

Manufacturers of prepayment telephone multi-coin collectors, gas leak indicators, precision instruments, automatic stamp selling and ticket selling machines, automatic slot machines and fire alarm apparatus.

Registered
**Office & Works: 70, DUDDEN HILL LANE,
WILLESDEN,**

LONDON, N.W. 10
Tel. WILLESDEN 5141/2/3.
Also GUEST WORKS, DOWLAIS, STH. WALES

Order Your Next JOURNAL Now!

THE Post Office Electrical Engineers' Journal is, like all other publications, subject to paper rationing. It is therefore essential to reduce to a minimum the margin of the number of copies printed over those ordered in advance. If you have not previously given a standing order please do so now, and if you are a regular subscriber please advise your local agent or the publishers, as early as possible, of any change in your requirements. In this way you will assist in eliminating waste and also ensure that your copy of the Journal is available each quarter.

THE INSTITUTION OF POST OFFICE ELECTRICAL ENGINEERS

PRINTED PAPERS

The following papers contributed to the proceedings of the Institution have been printed by authority of the Council and may be obtained, if still in print, from

"THE LIBRARIAN, The Institution of Post Office Electrical Engineers, G.P.O. (ALDER HOUSE), LONDON, E.C.1."

The prices do *not* include postage, and in every case, Members, Associate Members and Associates have the privilege of purchasing copies at two-thirds the stated price.

No. 121	"X-RAYS, AND THE STRUCTURE OF SOME ENGINEERING MATERIALS."—W. G. RADLEY, B.Sc. 1929	9d.
No. 122	"THE MEASUREMENT OF RELAY TIMES."—R. W. PALMER, A.M.I.E.E. 1929	9d.
No. 123	"MODERN ELECTRICAL ILLUMINATION."—J. J. EDWARDS, B.Sc.(Eng.), A.C.G.I., D.I.C. 1928	9d.
No. 124	"THE MEASUREMENT OF SOUND AND ITS APPLICATION TO TELEPHONY."—A. J. ALDRIDGE, A.C.G.I., A.M.I.E.E. 1929	9d.
No. 125	"THE DEVELOPMENT OF AUTOMATIC ROUTINERS IN THE BRITISH POST OFFICE."—A. SPRIGHT, A.M.I.E.E. 1929	9d.
No. 134	"SOUND AND HEARING."—Capt. N. F. CAVE-BROWNE-CAVE, B.Sc., A.M.I.E.E. 1930	1s.
No. 136	"SOME DEVELOPMENTS IN TELEGRAPH TECHNIQUE AS APPLIED TO RADIO CIRCUITS."—H. FAULKNER, B.Sc., A.M.I.E.E., and G. T. EVANS. 1931.	1s.
No. 139	"DISTRICT ACCOUNTING."—T. FEWSTER. 1931	9d.
No. 140	"SOME NON-METALLIC SUBSTANCES AND THEIR CHARACTERISTICS."—Capt. N. F. CAVE-BROWNE-CAVE, B.Sc., A.M.I.E.E. 1931	9d.
No. 142	"PRIVATE BRANCH EXCHANGE INSTALLATIONS."—R. T. A. DENNISON. 1932	1s. 3d.
No. 146	"LAYING ARMOURD CABLE BY MEANS OF A MOLE-DRAINER."—L. G. SEMPLE, B.Sc.(Eng.), and R. O. BOCOCK, B.Sc.(Eng.). 1932	9d.
No. 147	"DESIGN AND CONSTRUCTION OF ELECTRIC WAVE FILTERS."—R. J. HALSEY, B.Sc., etc. 1932.	1s. 3d.
No. 148	"STORES SPECIFICATIONS AND ACCEPTANCE TESTING."—Capt. J. LEGG, B.Sc., A.M.I.E.E. 1933	9d.
No. 149	"RECENT DEVELOPMENTS IN UNDERGROUND CONSTRUCTION, LAYING AND LOADING ARMOURD CABLES."—J. E. Z. BRYDEN, B.Sc.(Eng.), A.M.I.E.E., and T. HARREAVES, A.M.I.E.E. 1933	1s.
No. 150	"TELEPRINTERS."—E. S. RITTER, M.I.E.E. 1933	1s.
No. 151	"RECENT REPEATER STATION INSTALLATIONS."—Major F. E. A. MANNING, M.C., B.Sc.(Eng.), M.I.E.E., A.M.I.Mech.E. 1933	1s.
No. 152	"SOME NOTES ON EXCHANGE EQUIPMENT FACTORY COSTING AND THE ECONOMICS OF PRODUCTION."—S. J. HUSBAND, Assoc.I.E.E. 1933	1s. 3d.
No. 153	"MODERN DEVELOPMENTS IN TELEPHONE TRANSMISSION OVER LINES."—J. STRATTON, A.C.G.F.C., and W. G. LUXTON. 1933	1s. 3d.
No. 154	"THE TELEGRAPH POLE."—W. H. BRENT, B.Sc., A.M.I.E.E. 1933	1s.
No. 156	"MODERN TENDENCIES IN THE SUPPLY OF POWER TO TELEPHONE EXCHANGES."—H. C. JONES, B.Sc.(Eng.). 1935	9d.
No. 158	"ULTRA SHORT WAVE RADIO TELEPHONE CIRCUITS."—D. A. THORN, B.Sc.(Eng.), A.M.I.E.E., and H. T. MITCHELL, A.M.I.E.E. 1935	1s.
No. 159	"MODERN ELECTRIC PASSENGER LIFTS."—R. S. PHILLIPS, A.M.I.E.E. 1935	9d.
No. 161	"MODERN TELEPHONE REPEATER STATION POWER PLANT."—F. W. G. DYE. 1936	6d.
No. 162	"VOICE FREQUENCY SIGNALLING ON TRUNK CIRCUITS."—T. H. FLOWERS, B.Sc., A.M.I.E.E., and B. M. HADFIELD, B.Sc., A.M.I.E.E. 1937	1s.
No. 163	"AUTOMATIC EXCHANGE DESIGN."—H. E. FRANCIS. 1936	1s. 3d.
No. 164	"THE LONDON-BIRMINGHAM COAXIAL CABLE SYSTEM."—A. H. MUMFORD, B.Sc.(Eng.), A.M.I.E.E. 1937	1s. 3d.
No. 165	"PROPERTIES AND TESTING OF DI-ELECTRIC MATERIALS."—J. F. DOUST and W. J. SULSTON, M.Sc., A.Inst.P. 1938	1s.
No. 166	"CHEMISTRY AND COMMUNICATIONS."—D. W. GLOVER, M.Sc., A.I.C. 1937	6d.
No. 167	"TWELVE-CIRCUIT CARRIER TELEPHONE SYSTEMS."—G. J. S. LITTLE, B.Sc., A.M.I.E.E. 1938	6d.
No. 168	"THE DEVELOPMENT OF MAGNETIC MATERIALS."—C. E. MORGAN, A.M.I.E.E. 1938	6d.
No. 169	"CROSSTALK."—H. C. S. HAYES, A.M.I.E.E., R. A. SEYMOUR and P. R. BRAY, M.Sc.(Eng.), Grad.I.E.E. 1938	1s. 3d.
No. 170	"SUBSCRIBERS' CABLE DISTRIBUTION—RECENT DEVELOPMENTS."—L. MEEK, A.M.I.E.E. 1939	6d.
No. 171	"MULTI-CIRCUIT CARRIER TELEPHONY."—E. M. RICHARDS, A.C.G.I., B.Sc. (Eng.), M.I.E.E., and F. J. D. TAYLOR, B.Sc. (Eng.). 1938	1s. 6d.



ANACOS

REGD.

WIRES

in

BRONZE AND CADMIUM-COPPER

AS SUPPLIED TO H.M. POST OFFICE
FOR TELEPHONE LINES

SEND US PARTICULARS OF YOUR JOB
AND OUR TECHNICAL ENGINEERS WILL
PROVIDE YOU WITH THE DATA YOU NEED

TELEPHONE
EXCHANGES
R.F. 19 (1922)

FREDERICK SMITH & COMPANY

INCORPORATED IN GREAT BRITAIN
ANACONDA WORKS, SALFORD, LANC.

TELEGRAPH
ANACONDA
WORKS

★
TELEGRAPH APPARATUS
for
MORSE SYSTEMS

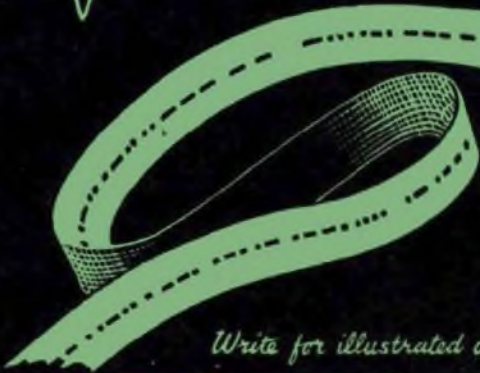
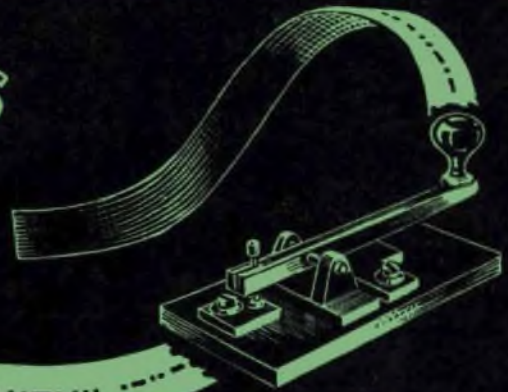

Makers of:

GALVANOSCOPES · INKERS
RESISTANCES · RELAYS
SOUNDERS · DETECTORS
KEYS · MILLIAMMETERS
AUTOMATIC RECEIVERS
& TRANSMITTERS ETC

Write for illustrated catalogue

ELLIOTT BROTHERS (LONDON) LTD. CENTURY WORKS,
LEWISHAM, S.E.13

MAINTAINING EFFICIENCY



THE HIGH STANDARD OF EFFICIENCY OF
PIRELLI GENERAL TELEPHONE CABLES IS
MAINTAINED BY THE CONTINUOUS
RESEARCH WORK OF AN EXPERIENCED
TECHNICAL STAFF.

TELEPHONE
SOUTHAMPTON
2141 (5 LINES)

PIRELLI-GENERAL
CABLE WORKS, Ltd., SOUTHAMPTON.

TELEGRAMS:
"PIGEKAYBEL,
SOUTHAMPTON."