

THE POST OFFICE ELECTRICAL ENGINEERS' JOURNAL

VOL. 31

JANUARY, 1939

PART 4

CONTENTS

	PAGE
THE PRODUCTION OF QUARTZ RESONATORS FOR THE LONDON-BIRMINGHAM COAXIAL CABLE SYSTEM—C. F. Booth, A.M.I.E.E., and C. F. Sayers	245
CHANNEL FILTERS EMPLOYING CRYSTAL RESONATORS—H. Stanesby, A.M.I.E.E., and E. R. Broad, B.A.	254
SULPHATE ATTACK ON CONCRETE—H. E. Morrish	265
THE LADDER DERRICK FOR OVERHEAD WORK—H. Trussler, A.M.I.E.E.	267
FROM SATELLITE TO MAIN EXCHANGE—W. D. Gray, B.Sc.(Eng.), A.M.I.E.E.	271
MUSIC CHANNELS—F. J. D. Taylor, B.Sc.(Eng.)	276
THE PROVISION OF MUSIC CHANNELS ON 12-CHANNEL CARRIER CABLES—R. J. Halsey, B.Sc.(Eng.), A.C.G.I., D.I.C., and D. G. Tucker, B.Sc.(Eng.)	280
TELEPHONE TRANSMISSION TESTING BY SUBJECTIVE METHODS—W. West, B.A., M.I.E.E.	286
HIGH SPEED CINEMATOGRAPHY—R. W. Palmer, A.M.I.E.E.	293
A METHOD OF EQUALISING THE FREQUENCY CHARACTERISTIC OF A TELEPHONE TRANSMITTER—D. McMillan, B.Sc., A.M.I.E.E.	299
THE NEW ST. PAUL'S TUBE STATION—J. Prescott	301
STATISTICAL THEORY APPLIED TO THE TESTING OF MASS-PRODUCED ARTICLES—K. L. Parker	305
NOTES AND COMMENTS	310
RETIREMENT OF CAPTAIN B. S. COHEN, O.B.E., M.I.E.E., F.Inst.P.	310
RETIREMENT OF MR. F. G. C. BALDWIN, O.B.E., M.I.E.E.	311
W. D. SCUTT, M.I.E.E.	311
H. W. FULCHER, M.I.E.E.	312
W. G. RADLEY, Ph.D.(Eng.), M.I.E.E.	312
LOCAL CENTRE NOTES	313
JUNIOR SECTION NOTES	314
DISTRICT NOTES	318
BOOK REVIEWS	304, 327
STAFF CHANGES	328
INDEX TO VOLUME 31	331

Price 1/- net

THE INSTITUTION OF POST OFFICE ELECTRICAL ENGINEERS

A 28 RANGE TEST SET

FOR A.C. AND D.C. MEASUREMENTS

G.E.C.

MULTI-RANGE TEST SET

A compact and easy-to-use instrument for measuring all electrical quantities commonly met in laboratory and workshop

DIMENSIONS (APPROX.)

$7" \times 3\frac{1}{4}" \times 2\frac{1}{2}"$

Net weight 2 lbs. 4 ozs.

Twenty-eight current and voltage ranges

·2 mA to 5 A.

60 mV to 500 V.

Resistances up to 500,000 ohms.

2,000 ohms per volt.

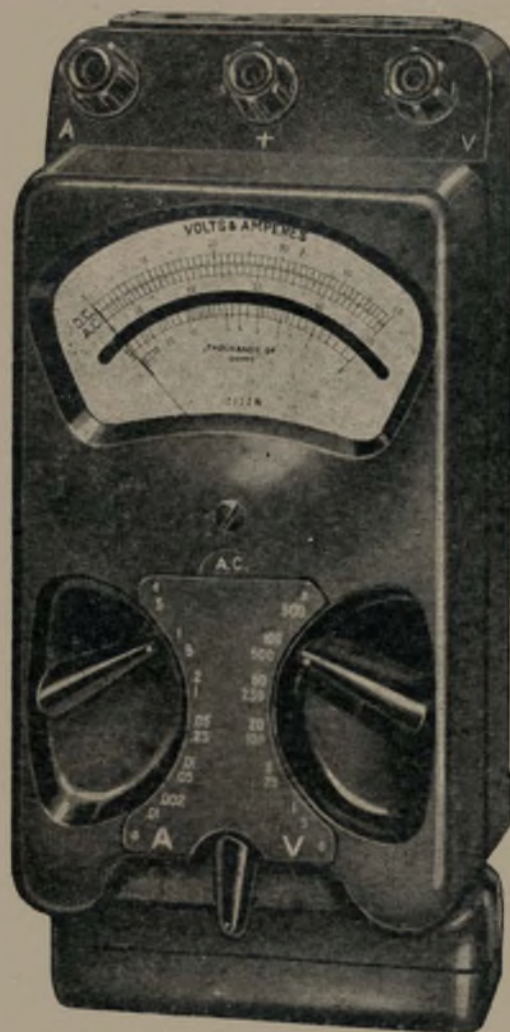

Write for full particulars to

SALFORD ELECTRICAL INSTRUMENTS, LTD., SILK STREET, SALFORD

The Salford Electrical Instrument Works of

THE GENERAL ELECTRIC CO. LTD., MAGNET HOUSE, KINGSWAY, LONDON

Branches throughout Great Britain and in all principal markets of the world

SIMPLIFIED

SERVICING MAINTENANCE & FAULT FINDING



BRITISH MADE

DESIGNED by technicians who have made a special study of the service and maintenance engineers' problems, the Model 7 Universal AvoMeter is acknowledged throughout the world as the one indispensable combination testing instrument. A single meter, yet at the touch of two simple switches it provides for any one of the 46 ranges of measurements for testing and tracing all electrical faults.

Entirely self-contained, the Model 7 Universal AvoMeter is essentially portable, and, above all, simple to use. It is dead-beat in action, has a 5-inch hand-calibrated scale with anti-parallax mirror, and conforms to B.S. 1st grade accuracy requirements. It is fully protected by an automatic cut-out against damage through overload.

16 Gns. Model 7 Resistance range Extension Unit (for measurements down to 1/100th ohm.) ... 12/6

Also the 36-range Universal AvoMeter ... 13 Gns.
22-range D.C. AvoMeter 9 Gns.
Leather Carrying Case ... 25s.

• Write for fully descriptive pamphlet.

Sole Proprietors and Manufacturers:

The Automatic Coil Winder & Electrical Equipment Co., Ltd.,
Winder House, Douglas Street, London, S.W.1. Telephone: Victoria 3404

16 Ranges
of
Direct
Readings

A.C.		D.C.	
Range.	Value per division.	Range.	Value per division
0- 5 Volts	50 mV.	0- 50 mV	0.5 mV
0- 10 "	100 "	(1 mA range)	1 "
0- 50 "	500 "	0- 100 mV	5 "
0- 100 "	1 Volt	(2 mA range)	10 "
0- 200 "	2 "	0- 500 mV	50 "
0- 400 "	4 "	0- 1 Volt	100 "
0- 500 "	5 "	0- 5 "	500 "
0-1,000 "	10 "	0- 10 "	1 Volt
		0- 50 "	2 "
		0- 100 "	4 "
		0- 200 "	5 "
		0- 400 "	10 "
		0- 500 "	5 "
		0-1,000 "	10 "

A.C.		D.C.	
Range.	Value per division	Range	Value per division
0- 5 mA	50 μ A	0- 1 mA	10 μ A
0- 10 "	100 "	0- 2 "	20 "
0- 50 "	500 "	0- 5 "	50 "
0-100 "	1 mA	0- 10 "	100 "
0-500 "	5 "	0- 50 "	500 "
0- 1 Amp.	10 "	0-100 "	1 mA
0- 5 "	50 "	0-500 "	5 "
0- 10 "	100 "	0- 1 Amp.	10 "
		0- 5 "	50 "
		0- 10 "	100 "

RESISTANCE	
Range.	First indication.
0-10,000 ohms	0.5 ohms
0-100,000 "	5 "
0- 1 megohm	50 "
0-10 "	500 "
0-40 "	2,000 "

using internal 1½-volt cell.
using internal 9-volt battery.
using external source of A.C. or D.C. voltage.

CAPACITY	POWER	DECIBELS
0 to 20 mFd.	in 4,000 Ω internal resistance	reference level 50 mW
First indication 0.01 mFd.	0 to 4 watts First indication 1 mW	-10 Db. to -15Db.

The 46-RANGE UNIVERSAL

AVOMETER

Regd Trade Mark

Electrical Measuring Instrument

Model 7

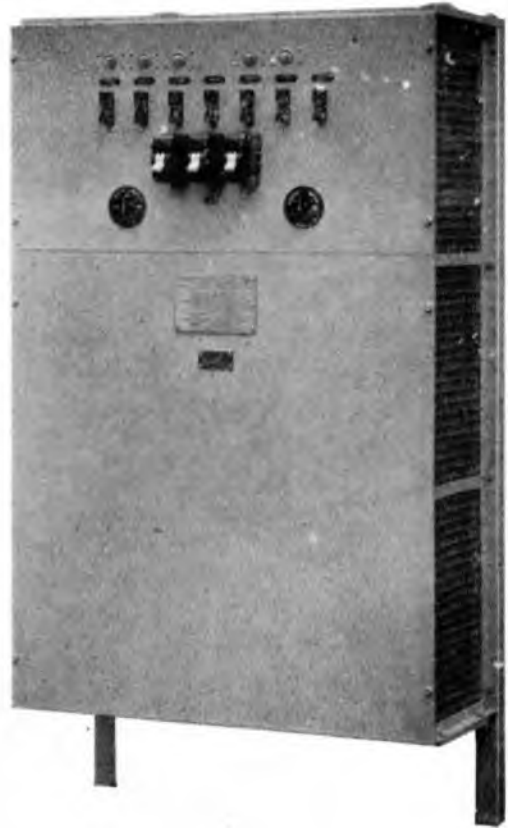

Westinghouse
**METAL
 RECTIFIER**

POWER SUPPLY UNIT

**FOR THE NEW BROADSTAIRS (NORTH
 FORELAND) MEDIUM-WAVE TRANSMITTER**

OUTPUT

1250 V. 0.15 A. for buffer stage H.T.

300 V. 0.15 A. for modulator and crystal oscillator H.T.

750 V. 0.75 A. for amplifier S.G. H.T.

250 V. 0.2 A. for amplifier and suppressor G.B.

230 V. 0.75 A. for control circuits operating contactors.

Full details and many circuits relating to the use of Westinghouse Metal Rectifiers in Telecommunication Engineering are given in booklet D.P. 11 H. Write for a copy to Dept. P.O.E.E.

**WESTINGHOUSE BRAKE & SIGNAL CO., LTD.,
 82 York Way, King's Cross, London, N.1.**

**IN THE SWITCHROOM OF A
MODERN NEWSPAPER
OFFICE**



We are indebted to Messrs. William Lucy & Co. Ltd., of Oxford, the Electrical Manufacturers, and Messrs. Rankin, Phipps & Co. Ltd., the Electrical Contractors, for permission to publish this photograph.

"Sindanyo"

Asbestos Electrical
INSULATING BOARDS
EBONY GRADE

The illustration above shows part of the main power and lighting board at Carmelite House, the headquarters of Associated Newspapers, Ltd.

This control board, which is 55'10" long x 6'6" high, consists of approximately 350 square feet of "SINDANYO" Asbestos Electrical Insulating Board (Ebony Grade) built up in 50 panels varying in thickness from 3/4" to 1 1/4". Of particular interest are the large Air-break main Circuit Breakers and Isolating Switches designed to carry a maximum of 2,500 amperes. In addition, the installation includes a number of English Electric High-Rupturing Capacity Fuse Handles, similar in type to the one illustrated. These are moulded in "SILUMINITE" Asbestos Electrical Insulating material, grade 2. Write for particulars of these and other similar products.

"Siluminite"

Asbestos Electrical
INSULATING MOULDINGS



SOLE MANUFACTURERS

TURNERS ASBESTOS CEMENT CO.
A BRANCH OF TURNER & NEWELL LTD
TRAFFORD PARK, MANCHESTER 17
Asbestos House Southwark St. LONDON S.E.1



CARRIER AND EQUIP

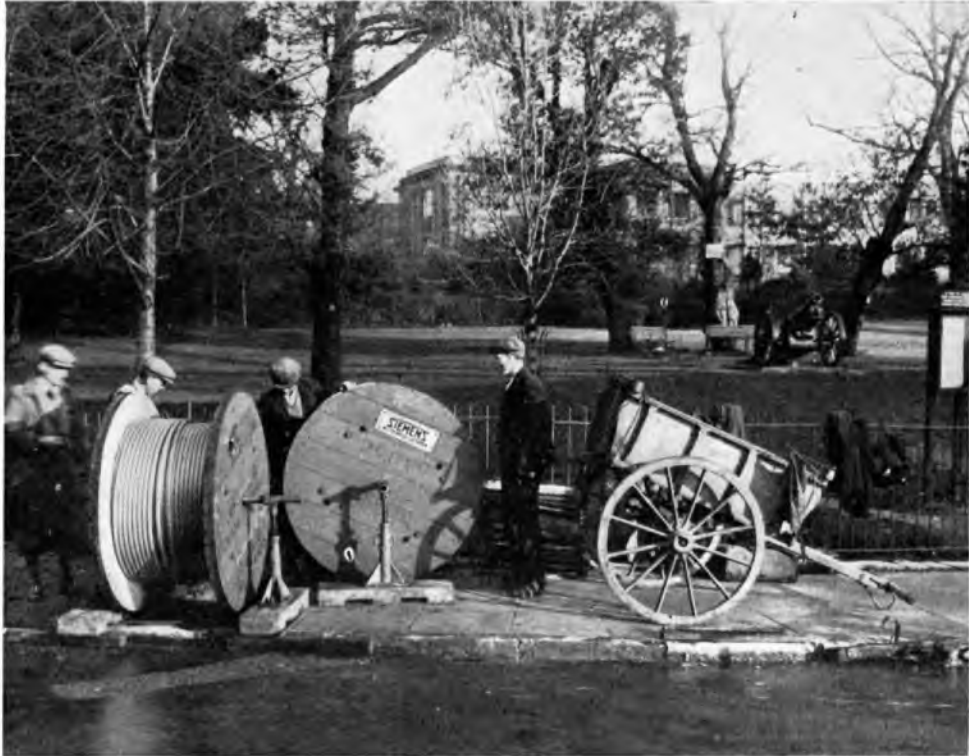

*Contractors for the
manufacture and installation
of all types of
Carrier Cables and Equipment*



Established 1858.

SIEMENS BROTHERS
WOOLWICH, LONDON

MENS

R CABLES

AND

PMENT

INSTALLATION OF 12-CHANNEL
CARRIER CABLE

SALISBURY—EXETER

TO THE ORDER OF

THE BRITISH POST OFFICE



RS & CO., LIMITED,
LONDON, S.E.18.

Telephone: Woolwich 2020.



Just Published

TELEPHONY Vol. II.

(AUTOMATIC TELEPHONY)

By T. E. HERBERT, M.I.E.E.,

*former Superintending Engineer to the G.P.O. : and W. S. Procter,
A.M.I.E.E., Regional Engineer, Post Office Engineering Department.*

The first volume of this work is now universally regarded as the standard textbook on manual systems of telephony. The new Volume II deals with Automatic Telephony, providing an exhaustive account of modern practice in this more recent branch of the subject. Electrical engineers and all concerned with telephony will find it invaluable for reference, and it is an indispensable textbook for candidates for the Post Office Engineering Department. Together with the first volume it covers the complete syllabus of the Preliminary and Intermediate examinations of the City and Guilds of London Institute, and provides much of the information required for the Final Grade. 738 pages. 440 illustrations. 20/- net (by post 20/7).

Volume I : MANUAL SWITCHING SYSTEMS AND LINE PLANT. 1,212 pp. 20 - net.

Order from a bookseller or direct from

SIR ISAAC PITMAN & SONS, LTD., Parker Street, Kingsway, London, W.C.2

ILFORD LIMITED

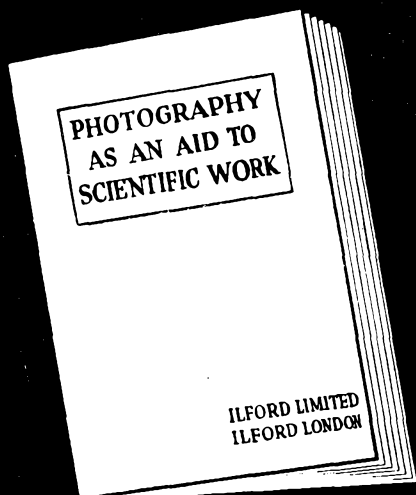

Write for a free copy
of "Photography as an
aid to Scientific Work"

**FREE to Post Office Engineers
a concise guide to sensitised
material for scientific uses.**



REGISTERED
TRADE MARK

As an aid to engineers and research workers, Ilford Limited have prepared a practical book of reference containing particulars of their full range of photographic plates and films for Field and Survey Work, Laboratory Research and all Scientific Purposes.

These materials are the outcome of some sixty years of specialised study and are world famed for their consistency and reliability.

ILFORD

PLATES - FILMS - PAPERS

MADE IN ENGLAND BY ILFORD LIMITED, ILFORD, LONDON



LET ME HELP
YOU
INTO A KEY
POSITION

DO ANY OF THESE SUBJECTS INTEREST YOU ?



Accountancy Examinations
Advertising and Sales Management
A.M.I. Fire E. Examination
Applied Mechanics
Army Certificates
Auctioneers and Estate Agents
Aviation Engineering
Banking
Boilers
Book-keeping, Accountancy, and Modern Business Methods
B.Sc. (Eng.)
B.Sc. (Estate Management)
Builders' Quantities
Building, Architecture, and Clerk of Works
Cambridge Senior School Certificate
Civil Engineering
Civil Service
All Commercial Subjects
Commercial Art
Concrete and Structural Engineering

Draughtsmanship. All Branches
Engineering. All Branches, subjects and examinations
General Education
G.P.O. Eng. Dept.
Heating and Ventilating
Industrial Chemistry
Insurance
Journalism
Mathematics
Matriculation
Metallurgy
Mining. All subjects
Mining. Electrical Engineering
Motor Engineering
Motor Trade
Municipal and County Engineers
Naval Architecture
Novel Writing
Pattern Making
Play Writing
Police, Special Course

Preceptors, College of
Press Tool Work
Pumps and Pumping Machinery
Radio Service Engineering
Radio Communication
Road Making and Maintenance
Salesmanship, I.S.M.A.
Sanitation
Secretarial Exams.
Sheet Metal Work
Shipbuilding
Shorthand (Pitman's)
Short Story Writing
Structural Engineering
Surveying
Teachers of Handicrafts
Telephony and Telegraphy
Transport Inst. Exams.
Weights and Measures Inspector
Welding
Wireless Telegraphy and Telephony
Works Managers



If you do not see your own requirements above, write to us on any subject. Full particulars free.

Study at Home in your Spare Time



CAN YOU CHANGE MY EXPRESSION ?
IF SO, YOU MAY BE THE ARTIST THAT COMMERCE IS WAITING FOR.

Just try it for yourself. Trace or draw the outline and then put in the features.

There are hundreds of openings in connection with Humorous Papers, Advertisement Drawings, Posters, Calendars, Catalogues, Textile Designs, Book Illustrations, etc.

60 per cent. of Commercial Art Work is done by "Free Lance Artists," who do their work at home and sell it to the highest bidders. Many Commercial Artists draw "retaining fees" from various sources, others prefer to work full-time employment or partners' arrangement. We teach you not only how to draw what is wanted, but how to make buyers want what you draw. Many of our students who originally took up Commercial Art as a hobby have since turned it into a full-time paying profession with studio and staff of assistant artists; there is no limit to the possibilities. Let us send full particulars for a FREE TRIAL and details of our course for your inspection. You will be under no obligation whatever.

John Dewar ART DEPT. 24

YOU CANNOT MAKE MONEY BY SAVING

If you save 10s. per week for 10 years you have only got £260, but if you spend 2s. 6d. per week for 12 or 18 months on a correspondence course, you give your brains a chance to earn thousands of pounds; then there is no need to save.

Savings are likely to vanish, but earning capacity is a permanent investment.

I HAVE HELPED THOUSANDS OF OTHERS

And when I say thousands, I do not exaggerate, as I can produce well over 10,000 unsolicited testimonials from grateful students who, through our Postal Training, have achieved their life's ambition.

J. Bennett



Dept. 24,
THE BENNETT COLLEGE, SHEFFIELD

EVERY DEPARTMENT IS A COMPLETE COLLEGE: EVERY STUDENT IS A CLASS TO HIMSELF

JOURNALISM

Short Story, Novel and Play Writing
There is money and pleasure in Journalism and in Story Writing. No apprenticeship, no pupilage, no examinations, no outfit necessary. Writing for newspapers, novels or pictures, is not a gift; it is a science that can be acquired by diligent application and proper guidance. It is the most fascinating way of making pastime profitable. Trained ability only is required; we do the training by post. Let us tell you all about it.

DEPARTMENT OF LITERATURE 24

If you attend to this now, it may make a wonderful difference to your future.

COUPON—
CUT THIS OUT

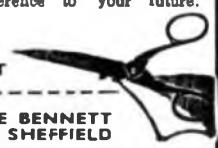

To Dept. 24, THE BENNETT COLLEGE, LTD., SHEFFIELD

Please send me (free of charge)

Particulars of
Your private advice about
(Cross out line which does not apply.)

PLEASE WRITE IN BLOCK LETTERS

Name

Address



South American **DEVELOPMENT**

Development in South America is more marked than in any other part of the world, and it naturally follows that *Standard Telephone Cables* should prove to be an important factor in this development. We supply millions of conductor feet of telephone cable to South

America annually. Installation in what was until comparatively recently virgin country is often a difficult task, but it is carried out with the same efficiency which characterises cable laying installations by this Company the world over.



Lead-covered Cable about to be drawn into duct.



Joining operations in progress.

Standard Telephones and Cables Limited

NORTH WOOLWICH, LONDON, E.16

Telephone: Albert Dock 1401

BRANCHES & REPRESENTATIVES THROUGHOUT THE WORLD

Sullivan-Griffiths
**DIRECT READING
 LOGARITHMIC
 CAPACITANCE BRIDGE**



List No. C.3000

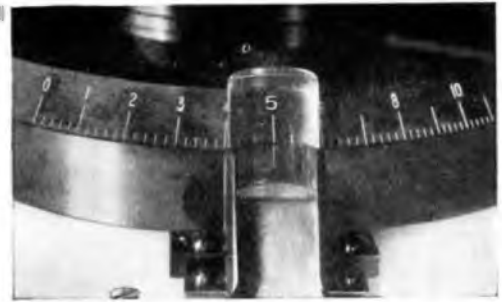

Illustrating the great openness of scale and the simple magnifier employed on this bridge to facilitate rapid reading with accuracy.

Range $1\mu\mu\text{F}$ to $100\mu\text{F}$.
 Accuracy 0.1% to 0.2% throughout.
 Visual and Aural indication of balance.

Full particulars of this and other bridges of higher or lower accuracies on application.

H. W. SULLIVAN LIMITED

LONDON, S.E.15

Telephones :
 NEW CROSS 2911 (3 Lines)

Telegraphic Address :
 "STANDELECT, PECK, LONDON"

"Sullivan" guarantees accuracy

**The 1937 Factory Act makes
 this instrument essential**



The extract with regard to lighting conditions in factories is as follows:

"Effective provision shall be made for securing and maintaining sufficient and suitable lighting, whether natural or artificial, in every part of a factory in which persons are working or passing."
 For the measurement of illumination at the point of work—on bench, desk, etc.—a Ferranti Light Tester is now an essential part of your equipment.

**FERRANTI
 LIGHT TESTER**

FERRANTI LTD., HOLLINWOOD, LANCs. London Office: Bush House, Aldwych, W.C.2.



SIEMENS

TELEPHONE TESTING SET

For objective sensitivity tests on telephone receivers and transmitters of every type. The attenuation of transmitters and receivers can be easily obtained from the incorporated meter. Furthermore, the equipment also enables subscriber connection attenuation to be measured.

The complete equipment, including mechanical noise generator and test microphone, is housed in a handy carrying case together with the flash lamp batteries providing the operating voltage. Operation is so simple that tests can be carried out by untrained personnel.

SIEMENS SCHUCKERT (GREAT BRITAIN) LTD.
30-34 NEW BRIDGE STREET, LONDON, E.C.4

Telephone : CENTRAL 8461.2.3
Telegrams : WERNERWERK
LUD. LONDON

TURNER DIFFERENTIAL MILLIAMMETERS G.P.O. No. 17 & No. 18

Meet the most
exacting demands
for balancing currents
in multiplex telegraph circuits.

A quality
product of outstanding
merit



FULL SIZE

Also manufacturers of G.P.O. Detector No. 4, and a comprehensive line of instruments for precision electrical measurements.

ERNEST TURNER ELECTRICAL INSTRUMENTS, Ltd.

**CHILTERN WORKS,
55-73 TOTTERIDGE AVENUE,
HIGH WYCOMBE,
BUCKS, ENGLAND**

Telephone : High Wycombe 301.
Telegrams : Gorgeous, High Wycombe.

JUST PUBLISHED—

AUTOMATIC TELEPHONY

by

CHARLES W. WILMAN, M.I.E.E.

ENTIRELY NEW AND ENLARGED EDITION

This widely praised book has now been completely revised and brought up to date. We have no doubt that in its new form it will prove of still greater value to all who wish to acquire a clear idea of basic principles and their relationship to present-day practice.

220 pages. 5½ × 8½. 103 illustrations.

10/6 from any bookseller

or 11/- post free from the publishers—

THE TECHNICAL PRESS LTD.

5, AVE MARIA LANE,
LUDGATE HILL, LONDON, E.C.4

who will be glad to send a free prospectus to any reader
of the P.O.E.E. Journal



The largest and most successful Institution in the world devoted to spare-time training by post, offers thoroughly sound Courses of Instruction to cover the following Examinations :

G.P.O. Probationary Assistant Engineer (Limited).
G.P.O. Probationary Inspector (Engineering Dept.).
Assistant Traffic Superintendent, Telephone Service.
P.M.G. Certificate for Wireless Operators.

Provisional Certificate in Radio Telephony and
Telegraphy for Aircraft.

Graduateship, I.E.E.

City and Guilds Electrical Engineering Practice.

Electric Installation and Telecommunications.

Institute of Wireless Technology.

Other Courses meet the requirements of all who desire to qualify for responsible positions in Electric Power, Light and Traction Stations. Equally successful is our instruction for Telegraph and Telephone Engineers, Telegraphists and Telephonists, Radio Engineers, Radio Servicemen, and those who wish to study Television.

Instruction is by correspondence from textbooks specially prepared by many experts in tuition by post.

WRITE FOR OUR SPECIAL BOOKLET and state the particular subject or Examination in which you are interested.

INTERNATIONAL CORRESPONDENCE SCHOOLS, LTD.,
Dept. 108, International Buildings, Kingsway, London, W.C.2



MODEL NO 3A TAPE TELEPRINTER



MODEL NO 5 PM.
MURRAY KEYBOARD PERFORATOR

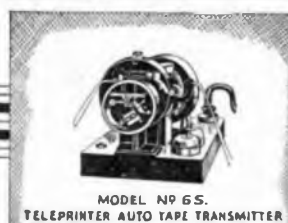

MODEL NO 6 S.
TELEPRINTER AUTO TAPE TRANSMITTER

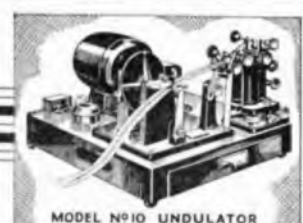

MODEL NO 10 UNDULATOR

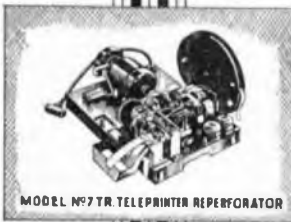

MODEL NO 7 TR. TELEPRINTER REPERFORATOR

ILLUSTRATED are some of the instruments manufactured to provide printing telegraph machines to meet all modern communication requirements.



MODEL NO 9
MORSE KEYBOARD PERFORATOR

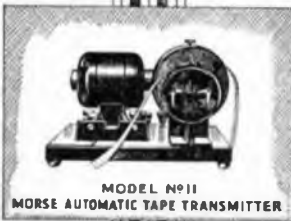

MODEL NO 11
MORSE AUTOMATIC TAPE TRANSMITTER



MODEL NO 7
PAGE TELEPRINTER
WITH COMMERCIAL TYPEWRITER KEYBOARD

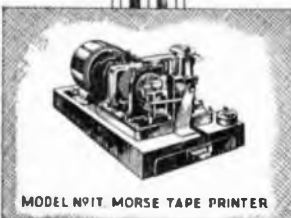

MODEL NO 1T. MORSE TAPE PRINTER



MODEL NO 27 CREED RELAY (Cover removed)

CREED & CO. L^{TD}.

Telephone :—
Croydon 2121

Telegraph House
CROYDON

Telex :—
Croydon Telex 1002



It is fascinating to trace the decimal system of numeration back through the ages, for it has been known to the peoples of many lands. Its exact origin is hidden in the mists of antiquity, but we know that it was used when man walked the earth with mastodon and dinosaur . . . and it has persisted till to-day. It is the logical system ; a simple principle which is ideally capable of application to science and mechanics.

Therefore Strowger engineers planned wisely in basing the operation of the Strowger selective switching mechanism upon the decimal system. Continued improvements in design and construction have since been possible without need for departing from the original operating

◀ **THE STROWGER TWO-MOTION DECIMAL SYSTEM STANDS SUPREME**



1902

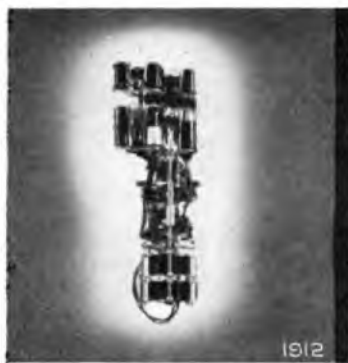

1912



1927

.. FOR CHANCE WILL NOT ACCOUNT FOR THE SAME THING HAVING BEEN DONE ALWAYS' ...

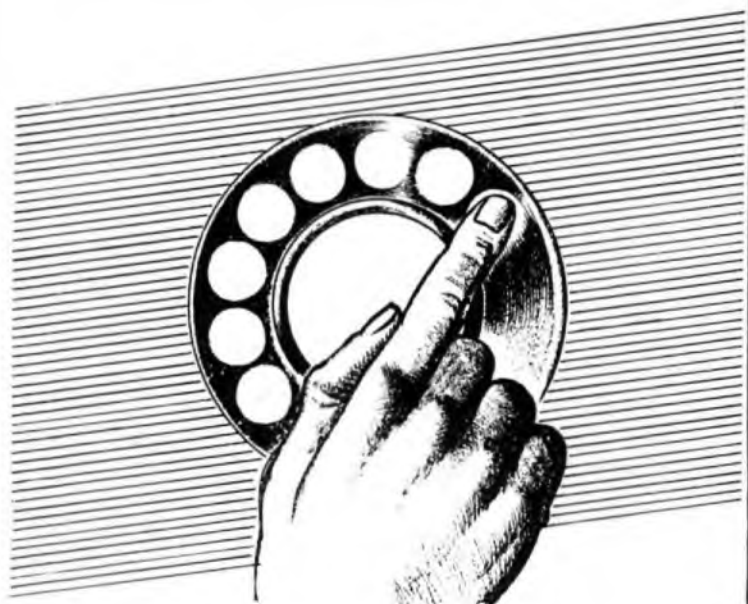

THE STROWGER 32A SELECTOR

principle employed, and in the march towards perfection the greatest step yet has been made with the introduction of the Strowger 32A Selector.

The 32A Selector hunts at a speed almost twice that of its speedy predecessor. It operates over wider limits of impulse speed and ratio variation. Improved arrangements for the return of the wiper carriage to normal after contact selection have removed the need for a separate release magnet. The cubic capacity of the Selector is only just over half that of the previous model, yet the Selector can accommodate three times as many contact banks and is even more robust. It can be "jacked-in" with a single movement and can be removed or replaced without disturbing the banks or bank wiring and without need for re-adjustment of the wipers.

AUTOMATIC TELEPHONE & ELECTRIC CO. LTD.

MELBOURNE HOUSE, ALDWYCH, LONDON, W.C.2

Phone Temple Bar 4506

'Grams "Strowger, Estrand, London"

Export Sales: NORFOLK HOUSE, NORFOLK ST., STRAND, W.C.2

Phone Temple Bar 9262

'Grams "Autelco, Estrand, London"

STROWGER WORKS, LIVERPOOL, 7

Phone Old Swan 850

'Grams "Strowger, Liverpool"



Power from **Exide-Ironclad** speeds up material-handling

YOU SAVE time, save trouble *and* save money when you install Exide-Ironclad Batteries. The reason?—because Exide-Ironclads have more vitality, and never lose their drive. They do tremendously hard work year after year without loss of power. That's why Exide-Ironclads are such a dependable aid to smooth production. And, moreover, they have very long life in relation to price — they *reduce* maintenance cost.

And don't forget that Exide-Ironclads are made by Chloride — the biggest battery makers in the British Empire, with experts stationed all over the country to give free service to Exide-Ironclad users.

EIT756b



Bale Stacking with a B.F.V. Truck

Exide-Ironclad BATTERIES

RELIED ON BY 600 BRITISH FIRMS IN 50 INDUSTRIES

- If you want further details about electric vehicles please write to The Chloride Electrical Storage Co. Ltd., Battery Traction Dept., Exide Works, Clifton Junction, near Manchester, or 137 Victoria Street, London, S.W.1

AUTHORITATIVE CORRESPONDENCE TRAINING for ENGINEERING QUALIFICATIONS

- POST OFFICE EXAMINATIONS —
Probationary Inspectors
Assistant Superintendents
Assistant Engineers
- A.M.Inst.C.E., A.M.I.E.E., A.F.R.Ae.S.,
B.Sc.(Eng.), C. & G., etc.

17 FIRST PLACES

and HUNDREDS of PASSES have been gained by T.I.G.B. students in the above examinations. The T.I.G.B. Guarantees training until Successful for the one fee.

Write to-day for "The Engineer's Guide to Success" — Free — which alone gives the Regulations for Engineering Qualifications and contains the world's widest choice of engineering courses — over 200 — including Electrical Engineering, Telephony, Telephonic Transmission, Telegraphy, Radio Engineering, Wireless and High Frequency Engineering, Sound Reproduction, Television, etc. Mention branch, post or qualification that interests you.

Free!



THE TECHNOLOGICAL INSTITUTE OF GREAT BRITAIN

115 Temple Bar House, London, E.C. 4

FOUNDED 1917

20,000 SUCCESSES

Fit
"TripleX"
Rapid

and be safe

THE

G.P.O.

DO

THE "TRIPLEX" SAFETY GLASS CO. LTD.,
1 ALBEMARLE STREET LONDON W.1

For All the Latest News and
Technical Data about the
Telephone Field—READ

TELEPHONY

Published every week for the past 37 years. This magazine is of interest and incomparable value to telephone people throughout the world. There is no other magazine covering every department of the telephone business as comprehensively. Contains timely, vital news and technical data that telephone people in almost every country in the world are finding of value and help to them in their daily work.

TELEPHONY

Address: Odhams Press, Ltd., Technical Book Dept., 85 Long Acre, London, W.C.2 (Telephone: Temple Bar 2468) for a sample copy of TELEPHONY, or write direct to:

TELEPHONY PUBLISHING CORPN.
608 S. Dearborn Street, Chicago, Ill., U.S.A.



SELENIUM *Metal* RECTIFIERS

BATTERY CHARGING SETS FOR ALL PURPOSES



The illustration shows a typical Battery Charging Unit (with and without covers) for charging 24 cells. Maximum current 6 amperes. Simplicity of design and elimination of complication in use are features of this charger, which includes the Selenium Metal Rectifier, the ideal medium for charging batteries from A.C. mains. Small, light-weight, strongly built without mechanical switching devices or moving parts, this type of charger is being increasingly used.

Bulletin No. 150, giving full details of the Selenium Rectifier which is now manufactured in our New Southgate Works, will gladly be supplied upon request.

**THESE SETS ARE MANUFACTURED IN
THE NEW SOUTHGATE WORKS OF**

Standard Telephones and Cables Limited

OAKLEIGH ROAD, NEW SOUTHGATE, LONDON, N.11

Telephone : ENTERPRISE 1234

THE POST OFFICE ELECTRICAL ENGINEERS' JOURNAL

Vol. XXXI

January, 1939

Part 4

The Production of Quartz Resonators for the London-Birmingham Coaxial Cable System

C. F. BOOTH, A.M.I.E.E.
and C. F. SAYERS

In this article, which will be continued in subsequent issues of the Journal, the authors describe the nature of quartz crystals with particular reference to the imperfections affecting their use as resonators in electric wave filters.

Introduction.

THE high order of frequency discrimination required in the initial modulation and the final demodulation stage in the London-Birmingham Coaxial Cable System¹ is achieved with the aid of lattice filters employing quartz resonators, the present design being such that 32 resonators are required for each speech circuit, i.e., 1,280 per supergroup of 40 circuits. It is true to say in fact that the system is based on the application of the quartz resonator to the filter problem.

Although considerable experimental work had been carried out by the British Post Office on quartz oscillators and resonators prior to 1935, when the design of the coaxial repeater and terminal equipment was commenced, little or no work had been done on large scale production and no published papers on the subject were available. In consequence of this almost total lack of authentic information, it was necessary for the authors, who were given the task of supplying the resonators for the first supergroup, to carry out a comprehensive investigation before the actual production could be considered. This investigation of necessity covered every phase of the work, and included the drawing up of a specification for the raw material, the development of cutting machines, of lapping systems, of electrode plating equipment, of testing equipment and the solution of the several other problems required to complete a process in which a gold plated quartz resonator mounted in a sealed holder and of resonant frequency within ± 10 c.p.s. of the specified value was produced from the natural crystal.

It is not possible in the space of this article to discuss in detail, either the theoretical aspect of the subject, on which much has already been written, or the many and varied difficulties which the authors encountered in setting up the Crystal Laboratory. It is proposed only to consider the solutions in broad outline so far as the resonator is concerned; the problem of oscillator production is much more difficult and will, it is hoped, form the subject of a later contribution. To enable the reader to obtain a fairly complete picture of the subject, the natural quartz crystal will be briefly described before the specification, cutting and lapping of the raw material and the testing, mounting and electrode plating of the resonators are considered.

¹ P.O.E.E.J., Vol. 30, pp. 206, 270, and Vol. 31, pp. 51, 132.

THE QUARTZ CRYSTAL

Crystal Structure.

Quartz, SiO_2 , is one of the commonest crystalline substances known to the crystallographist. The crystal form is a hexagonal prism terminated at each end by apparent hexagonal pyramids and it is clearly illustrated by Figs. 1 and 2. Close examination shows, however, that the development and characteristic

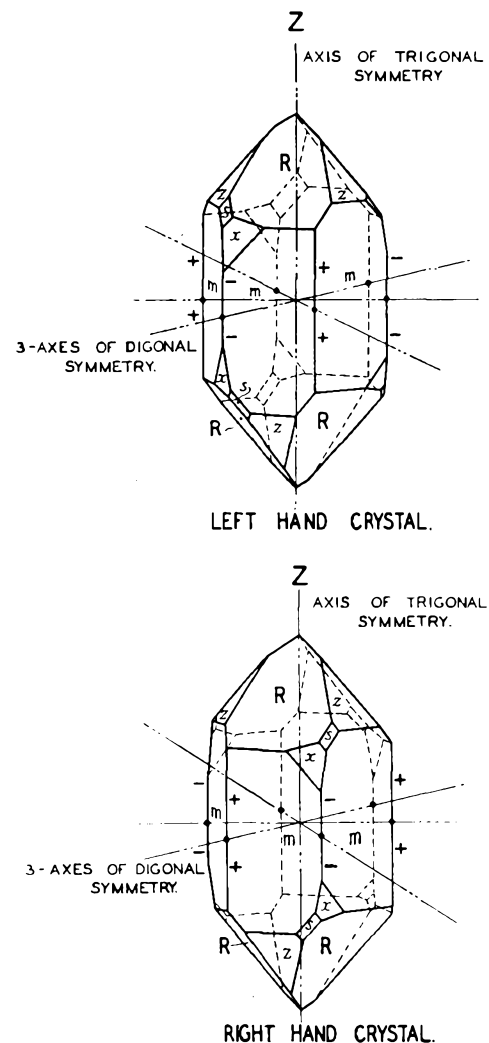

FIG. 1.—RIGHT AND LEFT HAND CRYSTALS.

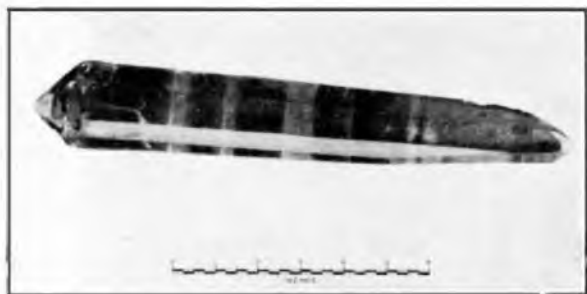

FIG. 2.—CRYSTAL WITH DOUBLE TERMINATION.

features of three alternate pyramid faces are similar and that they differ from those of the three remaining faces which in themselves are similar. In general, the "R" faces are bright and the "z" faces dull, due to unequal rates of natural etching on the two sets of faces, also the opposite faces of the two terminations belong to the two different types. In fact, as will be observed later, the crystal does not possess hexagonal symmetry as the apparent hexagonal pyramid terminations really comprise a pair of complementary rhombohedra. These are referred to as the direct and indirect rhombohedra, the corresponding pyramid faces being the R and z faces respectively. The prism faces are known as the "m" faces and here again the two sets of three alternate m faces frequently differ in development and characteristics. In addition to the six m, six R and six z faces, a doubly terminated crystal sometimes possesses small facets, "s" and "x," which, in a homogeneous crystal, appear on alternate prism edges. These facets occur in a fixed relation to the R faces and consequently are to be found on opposite edges at the two ends of the crystal.

It is apparent therefore that the symmetry about the axis joining the vertices of the pyramids is not hexagonal but trigonal, i.e., it is necessary to rotate the crystal 120° and not 60° about this axis before the pattern is repeated. The only other axes of symmetry are three axes of digonal symmetry which in a perfect crystal of regular form connect the middle points of opposite prism edges. The trigonal axis is known as the principal or optic axis, so called because of the property possessed by quartz of rotating the plane of polarisation of plane polarised light traversing the crystal parallel to this axis. The name Z axis has been given to this axis by workers concerned with the piezo-electric application and will be used in this article.

Since the crystal possesses neither plane nor centre of symmetry it belongs to the enantiomorphous class, i.e., it crystallizes in two forms, one of which is the mirror image of the other. The two types are called right hand, R.H., and left hand, L.H., crystals respectively, Fig. 1. In this connection it should be observed that the point system of a crystal is of a helical nature; in other words the molecular structure is of helical form. The axis of the helix is parallel to the Z axis and the "hand" of the helix is opposite for the two varieties. The presence of the s and x facets on a crystal provides a ready means of determining its hand. Thus, in a R.H. crystal, the x facet is below the right corner of an R face and in a

L.H. specimen is below the left corner of an R face. In the former, mxsz is in the form of a R.H. screw and in the latter of a L.H. screw. The s facet is also covered with striae which are parallel to the sR edge. It is probable that the conditions obtaining during the initial growth determine the variety. The experience of the authors indicates that the two varieties are more or less equally distributed in nature.

Although very big crystals have been mined, examples are known some 2 metres long and 0.5 metres across the flats of the cross section, they are usually much smaller and a crystal 25 cms. long by 10 cms. across the prism flats is considered a good specimen. Very few crystals possess the double termination; the average sample has one termination and one rough end, Fig 3, where it has grown from the rock. A crystal is usually of irregular form, in so much as the prism is not a regular hexagon and also as the cross section perpendicular to the Z axis varies appreciably in area throughout the prism length, the m faces being stepped. In addition, the areas of the



FIG. 3.—GROUP OF CRYSTALS, SINGLE TERMINATIONS.

R and z faces differ considerably and the s and x facets are generally not developed. It must be remembered, however, that despite the irregular form of the average specimen the quartz crystal possesses its own set of interfacial angles which are constant for all specimens. Thus the included angle between adjacent m faces is 120° and the angles which the R and z faces subtend to the Z plane, the plane perpendicular to the Z axis, are both $51^\circ 47'$.

Lack of homogeneity of the molecular structure of a crystal is referred to as "twinning" and the quartz crystal is subject to two primary twinning forms. The "orientational" type, in which one part of a crystal has suffered a 180° rotation about the Z axis with reference to the remainder and the "chiral" type in which part of the crystal comprises the structure associated with the L.H. variety and the remainder that associated with the R.H. variety, both parts being on a common Z axis. The former will be referred to as "electrical" twinning, so called because the two parts of the crystal develop their electric axes in opposite senses, and the latter will be known as "optical" twinning, as its presence is detectable by an optical system. The presence of extensive twinning in a crystal normally precludes its use for the piezo-electric application, although of

course the untwinned portions are serviceable. Unfortunately for the engineer concerned with the production of quartz oscillators and resonators almost all crystals are twinned to some extent by one or both varieties, or even by a combination of the two. Although classical examples are obtained of twinned crystals in which the twinning is readily detected from the external crystal form, this is the exception rather than the rule and in the great majority of crystals the presence and extent of twinning is not obvious unless recourse is made to an internal examination rendered possible when the crystal is cut.

Quartz crystals are found in all parts of the world but, owing to their smallness, twinning and other imperfections, the main sources of supply of good quality material are Brazil, Madagascar and Japan. The material employed for the quartz resonators described, is Brazilian crystal.

Piezo-electric properties.

When a quartz crystal is subjected to mechanical stress in the direction of any one of the three digonal axes, electric charges equal in magnitude and opposite in sign are developed at the extremities of the three axes, the magnitude and sign of the charges being dependent upon the magnitude and sign of the mechanical stress. Thus, if a compressional stress occurs along a digonal axis, equal negative and positive charges are released at opposite ends of this axis and reversal of the stress causes the sign of the charges to reverse, the magnitude of the charge being dependent upon the stress magnitude. Similarly a compressional stress applied in a direction perpendicular to a digonal axis and to the Z axis will produce equal and opposite charges at the extremities of the digonal axis, the charge polarities being opposite to those obtained when a compressional stress is applied along the digonal axis. The signs of the released charges in terms of compressional forces applied along the digonal axes are indicated in Fig. 1, the three prism edges bearing the sx modifications become negative and the remaining edges positive. This phenomenon, which is known as the "direct" piezo-electric effect, is reversible, as a difference of potential applied along a digonal axis will produce a mechanical strain along the axis. This is known as the "converse" effect. The relation between the signs of the strain and the potential difference is in agreement for the two effects.

Crystal Axes and Types of Cut.

In consequence of the piezo-electric effects along the digonal axes these axes are called the "electric" or X axes. Reference will be made to a third system of axes, the Y axes, of which there are three mutually at right angles to both the X and Z axes. To summarise, three systems of axes will be referred to, the Z, X and Y axes, of which there are one, three and three respectively. The three sets of X and Y axes occur due to the trigonal symmetry of the crystal about the Z axis. In a crystal of perfect form, one comprising a regular hexagonal prism doubly terminated by a pair of complementary rhombohedra, the Z axis is parallel to the prism axis and the X and Y axes are parallel to lines which are perpendicular to the

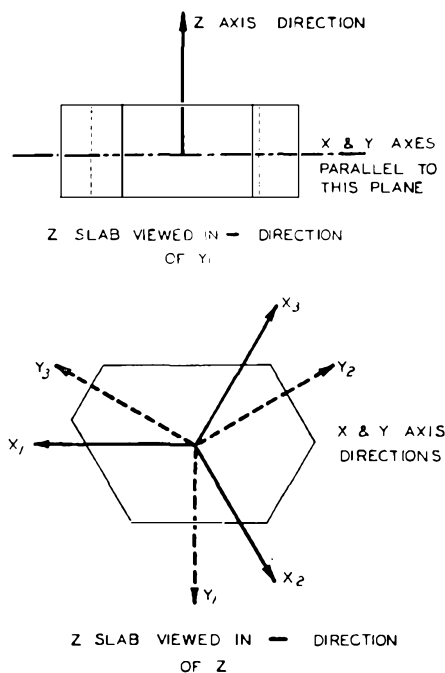

FIG. 4.—Z SLAB SHOWING DIRECTIONS OF X, Y AND Z AXES.

Z axis and respectively bisect the prism angles and the prism sides. In general, however, the prism is irregular and the axes are parallel to the dotted lines shown in Fig. 4 which is a view of a slab cut from a natural crystal, the cutting planes being perpendicular to the Z axis. It must be remembered that the X, Y and Z axes respectively refer to directions and not to unique axes.

The notation used in this article is in accordance with the findings of the sub-committee set up by the Department of Scientific and Industrial Research² to clarify the confusion which arose on quartz nomenclature. Space does not permit of reference to the many types of cut employed in the quartz art; the commonest cuts are, of course, the X and Y cuts, i.e. cuts respectively perpendicular to the X and Y axes, the dimensions of the plate parallel to the three axes being x, y and z. The X, Y and Z planes refer to planes respectively perpendicular to the X, Y and Z axes.

Applications to Frequency Stabilisation and to Filters.

When a quartz plate is subjected to an alternating electric stress, of which there is a component along the X axis of the plate, the plate is set in mechanical vibration at the frequency of the electric stress. The amplitude of vibration is small unless the frequency of the applied potential approaches coincidence with one of the natural vibration periods of the plate when the amplitude is increased many hundreds of times. To apply the alternating electric stress, it is necessary to mount the crystal between two metal electrodes, each of which may or may not be in intimate contact with one of the plate surfaces. For analytical purposes the plate with electrodes contiguous to the crystal surfaces may be represented

² The National Physical Laboratory. "Notation for Piezo-electric Quartz." 1938.

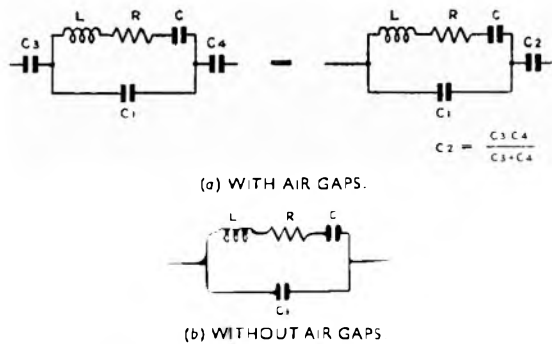

FIG. 5.—EQUIVALENT CIRCUIT OF A CRYSTAL.

by an equivalent electrical circuit, Fig. 5b, in which the series chain L, C and R represents the vibrator and C_1 represents the quartz dielectric, i.e., the electrostatic capacitance between the electrodes. When the electrodes are not contiguous to the surfaces the equivalent circuit is as Fig. 5a, where C_2 is the resultant capacitance between the crystal surfaces and the electrodes.

The performance of the crystal when associated with an electrical circuit is determined by replacing the crystal by its equivalent circuit. The natural vibration period of the plate is that of the resonant frequency of the series circuit L, C, R, the values of which are dependent on the plate orientation with reference to the crystallographic axes, the plate dimensions and the oscillation mode. It is apparent, therefore, that a quartz crystal may be associated with an electrical circuit and caused to self oscillate on one of its natural frequencies by virtue of the piezo-electric coupling which exists between the mechanical vibration and the electrical circuit. In consequence of the large value of L/C and the small value of the decrement, the oscillation frequency of a quartz controlled oscillator is determined primarily by the elastic constants of the quartz and by its dimensions, being affected only to a secondary degree by the constants of the associated electrical circuit. In view, therefore, of the durability of quartz and of its low thermal-elastic and thermal-linear expansion coefficients, the frequency stability of the quartz controlled oscillator is of an order unobtainable with the tuned circuit oscillator at the present state of the art. The high Q and L/C values also make practicable the design of filters operating on radio frequencies with band width and frequency characteristics which are even better than those of the highest grade coil and condenser filter designed for low frequency operation, and this application, which bids to become even more widely employed than the oscillator application, is considered in this article.

To clarify the difference between the oscillator and resonator it might be said that the former is associated with a valve system to maintain a continuous oscillation, the energy being obtained from the electrical system and the oscillator frequency being determined primarily by the crystal constants, whereas the resonator is driven by an electrical system but does not affect the frequency of the applied oscillation.

The Quartz Resonator.

The natural vibration frequency of an infinitely

$$\text{long bar is given by } f = \frac{1}{2l} \sqrt{\frac{c}{\rho}}$$

where c is the elastic constant in the direction of vibration in dynes/cm²

ρ is the density in grams/cm³

and l is the length of the bar in cms.

When the ratio of l to the larger of the other two dimensions is greater than 20 the error due to the finite length of bar is very small. The oscillation frequency of a finite bar is thus proportional, to a first approximation, to the length of the bar. The constant, k , is known as the frequency constant and is expressed in kilocycle-millimeters.

$$\text{Thus } f = 10 \frac{k}{l}$$

where f is the oscillator frequency in kc.p.s.

k is the frequency constant in kc.mm.

and l is the length of the bar in cm.

From a knowledge of the value of k the approximate length of a vibrator for a given frequency may be calculated.

The type of cut used for the resonators employed in the equipment of the first 40 circuits of the London-Birmingham coaxial cable is the X cut, the Y wave, which is a longitudinal vibration due to the transverse piezo-electric effect, being employed. The frequency constant and the frequency-temperature coefficient vary according to the values of x , y and z . When z and x are comparable and each is less than $y/10$ then k approximates to 2,700 kc.mm. and the frequency-temperature coefficient to $-2 \times 10^{-6}/1^\circ\text{C}$. If x is kept small and z is increased to approach y , then the constant decreases and the coefficient increases. Thus for the ratios $y/z = 2$ and $y/z = 1$ they are of the order of 2,650 kc.mm., $-10 \times 10^{-6}/1^\circ\text{C}$ and 2,400 kc.mm., $-50 \times 10^{-6}/1^\circ\text{C}$ respectively.

A y/z ratio of 2 is employed and the series resonant frequencies of the bars, i.e., resonant-frequency of series circuit L, C, R, lie in the range 62·389 to 99·222 kc.p.s. The corresponding values of x , y and z are 0·734, 42·51, 21·25 mm and 1·690, 26·73, 13·36mm. The specified dimensions and frequencies of typical examples of the 32 sets each of 40 plates produced for the first supergroup are detailed in Table 1. It should perhaps be stated at this stage that due to the fact that the elasticity surface of quartz is not a sphere, the direction of propagation of the Y wave is not coincident with the Y axis, the angle which this direction subtends to the Y axis being dependent on the ratio y/z . For the ratio $y/z = 2$ the angle is some 19° and the nodal plane of the Y wave is rotated about the X axis by that amount and is perpendicular to the X plane.

TABLE 1
Dimensions of Quartz Resonators.

Resonator	No. required	Dimensions in mm			Series Resonant frequency of Y wave in kc.p.s.
		x	y	z	
201	40	0·734	42·51	21·25	62·389
211	40	1·031	36·69	18·35	72·280
221	40	1·410	30·34	15·17	87·404
231	40	1·829	27·26	13·63	97·291
232	40	1·690	26·73	13·36	99·222

SPECIFICATION OF THE NATURAL CRYSTAL

Crystal Faults.

The accumulation of a stock of suitable raw material was of primary importance and before the specification is detailed, the chief faults which render the crystal useless for the piezo-electric application and the methods which have been developed for the inspection of both cut and uncut crystals will be discussed.

In addition to twinning faults, the quartz crystal is subject to internal flaws which also more or less impair its use for the production of oscillator and resonator plates. These flaws are of two distinct types; in one, they appear in the form of needle-like fractures which radiate from a common point in straight lines in all directions, and these are thought to be crystals of rutile which have grown with the quartz crystal. The second type, the most common variety, consists of cracks which do not occur in straight lines and planes, and have been caused by mechanical strain set up directly by mechanical shock or indirectly by thermal gradients in the crystal. When an unflawed crystal is subjected to sudden temperature changes numerous "strain" cracks appear throughout the crystal and it has been observed that a small "strain" fracture in a crystal will grow until it spreads through the crystal.

Another common defect in quartz is the inclusion of foreign matter of a sub-microscopic nature which gives rise to "smoky" quartz. It has been stated that the included matter is a hydro-carbon or other organic material. Two varieties of smoky quartz are found, in one the coloured bands of a Z slab are parallel to the m faces, whereas in the other they are curvilinear. The former appears to have been caused by inclusion during the crystal growth and the latter to diffusion from the crystal faces after the completion of crystal growth. A discontinuity in the growth of a crystal often produces what is known as a "ghost" crystal. It would appear that the crystal growth has stopped temporarily, and a deposit of foreign matter has formed on its faces before the growth has recommenced. With a transparent crystal the halt in the growth is clearly visible by reflection from the surfaces of the kernel crystal. It frequently happens by the denuding action of water that crystals are washed from the "parent" source into river beds and become worn to such an extent that all trace of the original crystal faces are lost; such specimens are known as waterworn crystals.

When it is realised that the resonator plate should be free of the defects which have been indicated, of which the twinning forms and the needle fractures often are undetectable from an exterior examination of the natural crystal, it will be appreciated that the specification and selection of crystals from an external examination is a difficult and almost impossible task, and for a positive test recourse must be made to cutting.

Etching Tests.

It was known that the natural etch patterns which are frequently observed on the m, R and z faces of a crystal indicate the presence of one or both of the twinning varieties. Because of the simplicity of the

process a comprehensive examination was carried out to determine the practicability of laboratory etching in the detection of twinning.

Quartz solvents are aqueous hydrofluoric acid (HF acid) and solutions of the alkaline hydroxides and carbonates, and the tests to be described employed hydrofluoric acid, strength 30 parts acid to 70 parts water, at room temperature. Specimens for microscopic examination were etched for several days although it was found that visual indication of twinning faults could be produced in some 20 minutes. It is not proposed to describe in detail the photo-micrographs which were obtained during the investigation, as this work will be published elsewhere. It can be stated, however, that the work was complete and characteristic etch patterns for the natural crystal faces and the X, Y and Z planes of both untwinned quartz and of each form of twinning were determined. The characteristic etch patterns which are described have been adopted by the authors as representing the best graphical interpretations of the patterns observed by microscopic examination with transmitted light. Early experiments proved that although crystals frequently possess natural etch patterns only very poor results are obtained when attempts are made to etch unprepared surfaces, and it is advisable to give the surface a fine matt finish.

Pure Electrical Twinning.

The twinned portion of the crystal has suffered 180° rotation about the Z axis with reference to the remainder of the crystal, both parts being of the same hand. In consequence, the twinned and untwinned parts develop their electric axes in opposite senses. The harmful effect of this twinning on the plate performance is obvious, thus on the application of a mechanical stress along the X axis of an X cut plate, Fig. 6a, the electric charges released on the twinned and untwinned parts of the X planes are of opposite sign. The resultant piezo-electric effect is therefore diminished, approaching zero when the two areas are identical, and the magnitude of the necessary piezo-electric coupling between the mechanical

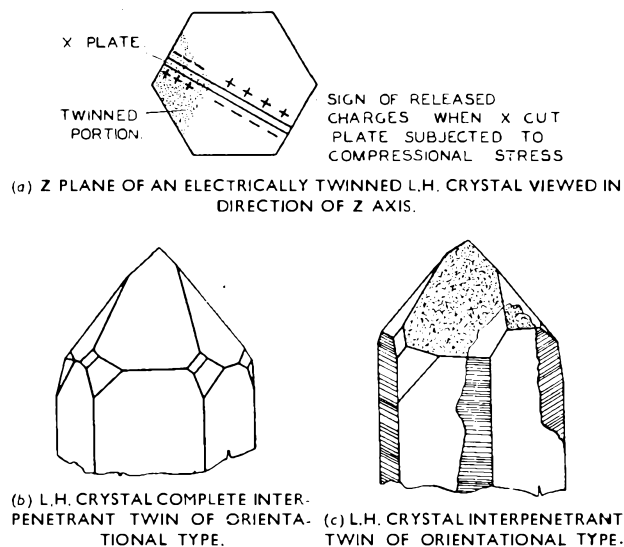
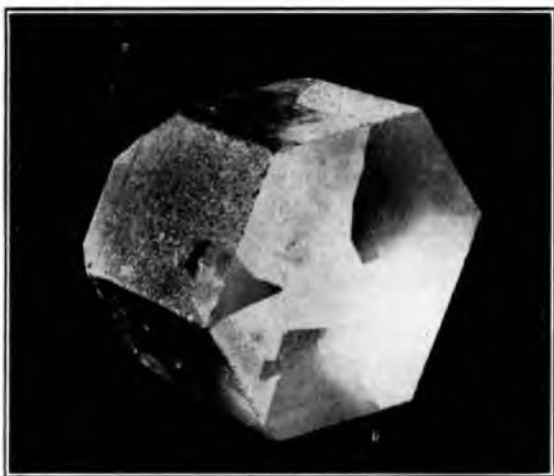

FIG. 6.—EXAMPLES OF PURE ELECTRICAL TWINNING.



(a) NATURAL ETCH PATTERNS ON PRISM AND PYRAMID FACES.



(b) ETCH PATTERN ON PREPARED Z PLANE OF THE CRYSTAL.

FIG. 7.—ETCH PATTERNS OF CLASSICAL EXAMPLE OF CRYSTAL CONTAINING ELECTRICAL TWINNING.

vibration of the plate and the associated electrical circuit is seriously impaired.

The presence of the twinning is sometimes reflected in the external appearance of the crystal. The classical example of the interpenetrant twin of the orientational type, i.e. one crystal completely interpenetrating a crystal of similar hand which has been rotated 180° about the Z axis so that the R faces of the latter coincide with the z faces of the former, is illustrated in Fig. 6b. The figure illustrates a L.H. crystal in which the developed edges and corners are those which carry the s and x facets. Such specimens are of extreme rarity and a more common variety is indicated in Fig. 6c, in which the twin structure is easily recognisable. Thus a pyramid face may comprise in

part an R face and in part a z face, similarly a prism face may be made up of part of an m face immediately below an R face and part of an m face immediately below a z face, with the result that the boundary between the two portions is clearly shown both for the prism and pyramid faces. An actual example of this twinning is given in Fig. 7. It should be pointed out that if the boundary of the twinned parts does not meet the external crystal surface the presence of twinning is not reflected in the external appearance of the crystal.

The detection of this twinning from the crystal's exterior is possible in only a proportion of crystals and more definite methods of detection are necessary. Its presence is not shown by direct optical examination because the hand of the molecular helix, which produces the optical phenomena for plane polarised light parallel to the Z axis, is not reversed by the 180° rotation of part of the crystal about Z. The apparatus developed by the late Dr. D. W. Dye provides a method whereby the presence and extent of the twinning may be observed. In this instrument a small area of the test plate is subjected to a known mechanical stress and the sign and magnitude of the released electric charges are determined with an electroscope and the extent and boundaries of the twinning may be found by exploring the whole area of the test specimen. Unfortunately the apparatus does not lend itself to ready application in a commercial production process.

The presence of electrical twinning in a specimen is clearly shown by the etching process, as fine and coarse X plane patterns are associated with the faces which are respectively positively and negatively charged when the slice is subjected to a compressional stress along the X axis. If the etch patterns on the X, Y and Z planes of a twinned plate are considered, the discontinuity of the pattern at the twinning boundary on each plane are both distinct and obvious. The characteristic X, Y and Z plane etch patterns of a plate from a twinned R.H. crystal are illustrated in Fig. 8a. In the Z plane the rhombohedra suffer a reversal at the twin boundary; the twinned and untwinned parts of the X planes show the fine and coarse patterns and the curvilinear triangles characteristic of the Y plane are reversed in the two parts. Similar patterns are obtained for a twinned plate from a L.H. crystal, but the Y plane patterns are mirror images of the corresponding ones for a plate from a R.H. crystal and the fine and coarse X plane patterns of the plate from R.H. quartz are replaced by coarse and fine patterns respectively.

Pure Optical Twinning.

The crystal is formed in part of R.H. and in part of L.H. quartz on a common Z axis. The electric axes of the two portions are in the same sense and the R face of one part is coincident with the z face of the other part. The twinning is sometimes apparent from the external appearance of the crystal, and an example of a perfect interpenetrant "chiral" twin is shown in Fig. 9b. Such specimens are of extreme rarity and in the average crystal external twinning indications are indistinct and difficult to find. Twin-

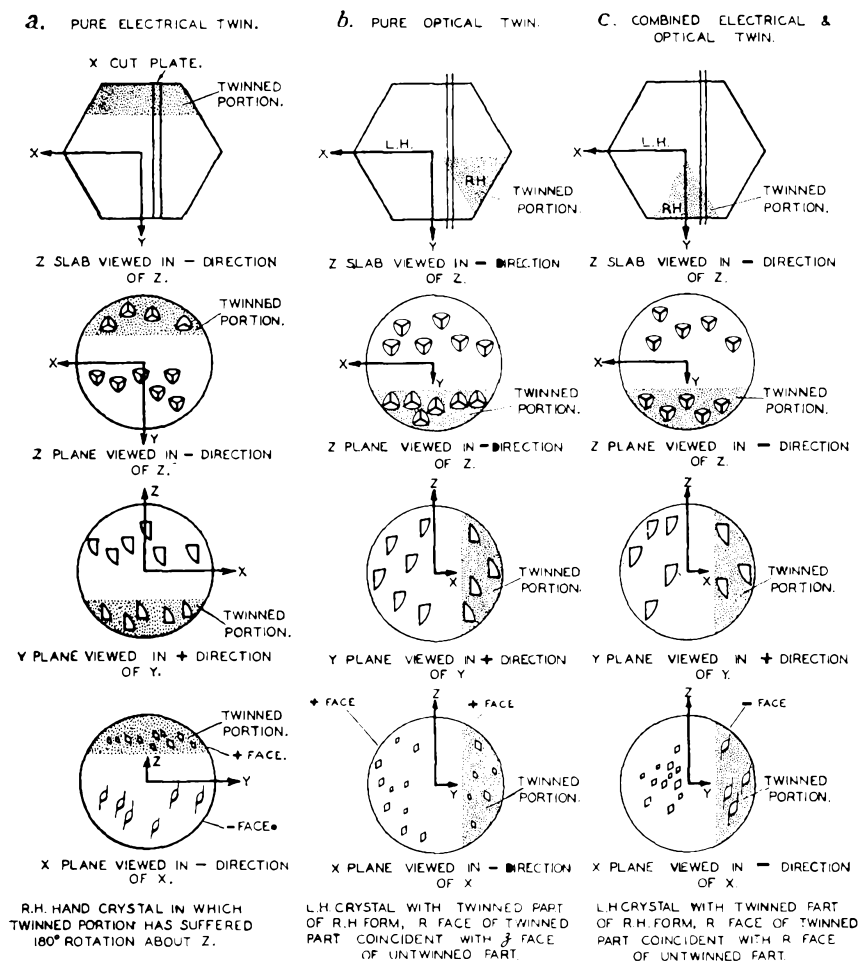

FIG. 8.—CHARACTERISTIC X, Y AND Z PLANE ETCH PATTERNS.

ning clues normally consist of natural etch figures on the m faces but in many crystals no external evidence is present.

A more certain test than is afforded by the superficial examination of the crystal is essential for the positive identification of the presence and extent of this twinning form. It is clearly shown by an etching test of a prepared specimen, but there is another simple and ready means whereby this may be accomplished in prepared samples. The method is an optical one, and takes advantage of the "rotary power" of quartz. When plane polarised light is transmitted through a Z slab in a direction parallel to the Z axis, the plane of polarisation is rotated by the quartz, the amount of the rotation is a function of the radiation employed and is directly proportional to the thickness of the slab. If an optical system employing plane polarised parallel monochromatic light is set up, Fig. 10, the nicols being crossed to give total extinction, then when a Z slab is inserted in the light field it shows a uniform coloration, and it is necessary to rotate the analyser to obtain total extinction.

Replacement of monochromatic light by white light results in colour effects which are both brilliant and beautiful, particularly for slabs between 3 and 10 mm thick, the specimen is uniformly coloured, and rotation of the analyser causes the colour to

change. The order of colour change is decided by the hand of the quartz and the direction of analyser rotation; for a R.H. crystal and anti-clockwise rotation, viewed in the direction from the analyser to the light source, the colour order is towards the blue end of the spectrum, and is reversed for clockwise rotation. With a L.H. crystal the order is reversed for corresponding analyser rotations. These colour effects are due to the variations of the rotary power with the radiation. The colour obtained when the slab is inserted in the light field, the nicols being crossed, is decided by the slab's z dimension and is the complement of the colour of the extinguished rays. Rotation of the analyser causes the latter to change and in consequence the observed colours undergo a complementary change.

Should the test slab be made up of L.H. and R.H. quartz on a common Z axis, i.e. be optically twinned, the twinning plane completely penetrating the slab parallel to the Z axis, then the extent and boundary of the twinning is clearly demonstrated, for as the analyser is rotated, the colours of the two parts are complementary, except for two positions 180° apart, in which they are identical. With monochromatic light the definition

of twinning is distinct but the colour effects associated with white light are replaced by mere intensity

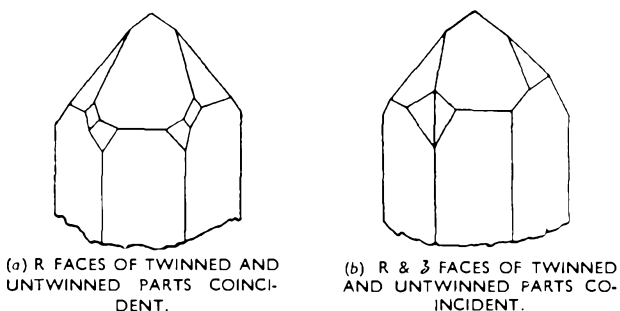

FIG. 9.—TWO TYPES OF PERFECT INTERPENETRANT CHIRAL TWIN.

variations, and, in general, increased sensitivity of detection is obtained with white light.

Two polariscopes for parallel white light analysis are available, one is a precision instrument for experimental work and the other is a workshop tool employed in the production process. In the workshop instrument the first polarisation is obtained by reflection and the second with a polar screen. The design of the second instrument is illustrated in Fig. 10. Nicols are used for both analyser and polariser

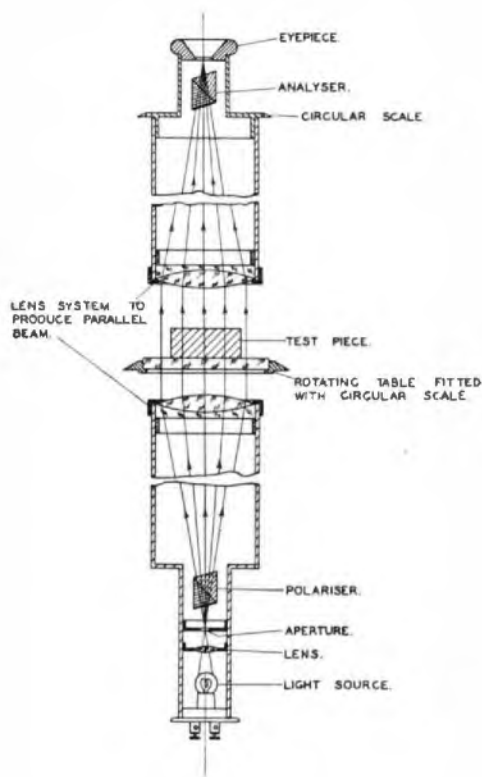

FIG. 10.—POLARISCOPE.

and high grade angular scales are fitted on the analyser and the rotatable specimen table to facilitate the precise measurement of plane of polarisation rotation.

The normal method employed to render a specimen transparent for optical examination is to polish the Z surfaces. This procedure, however, is both laborious and expensive, and as an alternative, an immersion bath is employed with the workshop polariscope. The bath is of glass, its base is flat and polished and it is filled with a liquid whose refractive index approximates to that of quartz. The matching of the two indices is not particularly critical, an imperfect match does not seriously affect the definition of the optical pattern. Employment of the bath enables unprepared slabs, i.e. slabs direct from the saw, to be tested for optical twinning. The type of pattern obtained with twinned slabs is shown by the actual photographs of Fig. 11.



FIG. 11.—Z SLABS IN PLANE POLARISED PARALLEL LIGHT.

Etching provides a ready means of determining the presence of optical twinning in a prepared specimen. Characteristic X, Y and Z etch patterns of a plate from a twinned L.H. crystal are given in Fig. 8b. Consideration of the Z plane shows that the rhombohedra are reversed at the twinning boundary but in the X plane both parts are fine or coarse although the patterns on each side of the boundary are mirror images of each other. Thus a reversal of the rhombohedra is not an infallible proof of electrical twinning. In the Y plane the curvilinear triangles suffer inversion in the twinned portion.

Combined Optical and Electrical Twinning.

Combined twinning is a special type of optical twinning inasmuch as the crystal contains both R.H. and L.H. quartz on the same Z axis. It differs from the pure optical variety because the electric axes in the two parts are developed in opposite senses, and is produced when the R faces of the two parts are coincident, the appearance of a perfect interpenetrant chiral twin is shown in Fig. 9a. Its effect on the performance of a plate may be serious for the reasons already given.

As with the other types of twinning, positive detection is not always possible from the external examination of a crystal. The etch method may be employed and, because the crystal contains both L.H. and R.H. quartz, the optical method is suitable. It will be appreciated that it is not possible to differentiate between pure optical and combined optical and electrical twinning with an optical system. With combined twinning the characteristic etch patterns of the X, Y and Z planes are as illustrated in Fig. 8c. The rhombohedra are not reversed at the Z plane twinning boundary, but in the X planes the fine and coarse patterns are found on opposite sides of the boundary, and mirror image patterns are obtained on opposite sides of the Y plane boundary.

Occurrence of Twinning Types.

The authors' experience of the types and extent of the twinning of a large number of Brazilian crystals which were selected in accordance with the specification, is no doubt representative of the twinning of high quality quartz. This experience has shown that almost all crystals contain some twinning, in fact the untwinned crystal is so rare as to become of

value for a museum specimen. It has been found that the most common twinning in material which has been roughly graded at the source is of the combined optical and electrical variety, pure electrical twinning is less common, and the pure optical variety is exceptional.

Pure electrical twinning occurs in two distinct forms. In the first, the twin boundaries approximate to planes which do not bear a fixed relation to the crystallographic axes. This form is illustrated by Fig. 12c which shows part of an etched Z slab; the twin boundaries are inclined to all three crystal axes. Fig. 12b is of interest for it shows successive X slices from a twinned Z slab and illustrates how the twinned area decreases in extent. A classical example of the natural etching of an electrically twinned crystal is illustrated in Fig. 7. The Z face of the crystal has been prepared and artificially etched to demonstrate the manner in which the twinning is distributed through the crystal. In the second variety, the twin boundaries do not approximate to planes but occur in a haphazard way through the crystal. The extraordinary complexity of the twinning of this

Fig. 11b, it will be observed that the boundaries indicated in this view, the Z plane, are definitely related to the axes, being in fact parallel to the X axes.

Specimens of pure optical twinning are rare and it has not been found possible to select a suitable specimen for reproduction. The twin boundaries occur in planes related to the crystallographic axes similar to the combined optical and electrical twinning described above.

The optical patterns of three Z slabs in plane parallel polarised light are shown in Fig. 11. The first, Fig. 11a, is a good specimen slab for it contains only a small amount of twinning. The second, Fig. 11b, is an average specimen and the third, Fig. 11c, is so full of twinning as to be almost useless.

It frequently happens that a mixture of all the twinning varieties are present in one crystal; in fact it is the exception rather than the rule to find a slab which contains only one of the fundamental forms.

Cracks, Flaws and Discoloration.

All these irregularities are more or less identified by examining the crystal, which has been made transparent by immersion in a liquid bath, in a strong arc light.

SPECIFICATION OF QUARTZ

It is not possible to enter into a detailed description of the specification in this article but merely to discuss it in broad outline. It must always be remembered that although the engineer concerned with the production of plates and bars is anxious to obtain perfect natural crystals, and consequently is inclined to tighten the specification, such crystals are extreme rarities in nature, and should he become too rigid in his demands then his natural crystal contracts will never be fulfilled.

The first consideration is the economical size and shape of crystal which is bound up with the method of production and the type of plate. Whereas comparatively long thin crystals are suitable for 25 mm square plates of frequency above 500 kc.p.s. the short fat crystal is best employed in the manufacture of low frequency bars. In both cases it is usual to specify a minimum ratio of say 2 or 3 to 1 for the total length of the crystal to the vertical height of the crown; again, to eliminate the uneconomical cross section a maximum value of 2 or 3 to 1 for the ratio of opposite prism faces is desirable. To facilitate cutting the crystal should possess a minimum of two pyramid and two prism faces.

The crystal should be free of all the normal twinning indications, such as discontinuities in the texture of adjacent parts of any of the crystal faces, irregular growth lines on the prism faces and serious natural etching on the faces.

The crystal should be free of cracks, flaws, ghosts and discoloration for the greater part of its volume.

As already stated, however, it is not possible to make the specification too rigid, and it should be freely translated by the selector in accordance with the amount and quality of the available material.

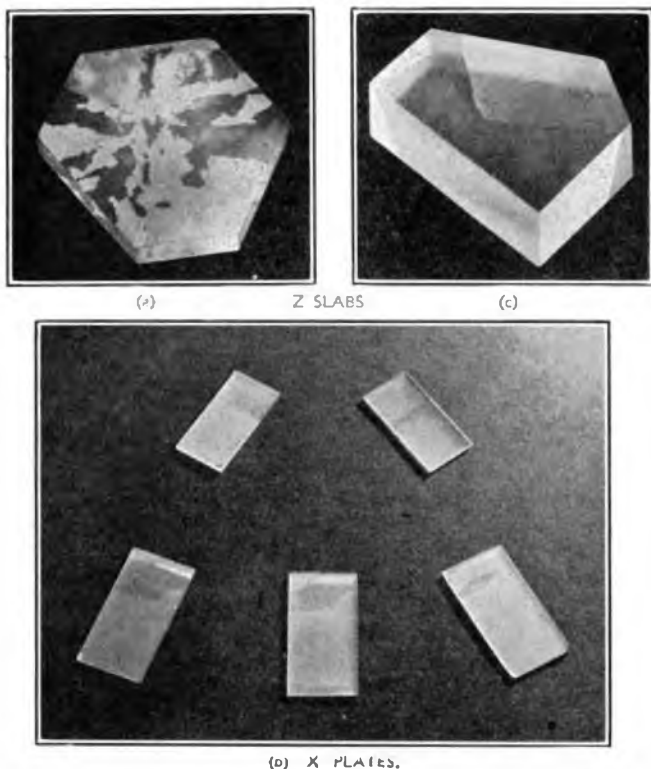

FIG. 12.—ETCH PATTERNS OF Z SLABS AND X PLATES CONTAINING ELECTRICAL TWINNING.

variety is clearly illustrated in the etch pattern, Fig. 12a of a specimen Z slab.

The twin boundaries of the commonest twin form, combined optical and electrical twinning, are usually planes which are related to the crystallographic axes. From the optical pattern of a twinned Z slab for the plane polarised parallel light analysis shown in

Channel Filters Employing Crystal Resonators

H. STANESBY, A.M.I.E.E. and
E. R. BROAD, B.A.

By replacing some of the elements in certain wave filters by crystal resonators it is possible to realise attenuation characteristics which approach closely to the ideal. The article analyses the properties of a band-pass filter in which this substitution may be carried out. When quartz crystal resonators are used this type of filter may, with advantage, be employed on 12-channel and broad-band carrier systems. It is shown that in the general case there are three parameters governing the propagation constant of each filter section. Attention is given to a case of particular interest in which only one parameter remains and a symmetrical propagation constant characteristic is obtained. Charts are reproduced which facilitate the computation of the attenuation and phase constants and the necessary design formulae are developed. A method of computing the total insertion-loss of a multi-section filter is stated and an example is given showing the agreement between the computed and measured characteristics of a typical channel filter.

Introduction.

IT is now approximately two decades since the development of the electric wave filter first made carrier telephony a practical proposition; indeed, one of the first applications of wave filters was to this branch of telecommunications. Until recently the performance of filters has been limited seriously by the dissipation of the inductors incorporated in them. However, within the last year or two this limitation has largely been removed. For many filters it has been found possible to replace the more important inductors and some of the condensers by electro-mechanical resonators having very low dissipation factors, with the result that the filter performance can be made to approach much more nearly to the ideal.

During approximately the same period, but not necessarily as a result of this development of electric wave filters, carrier telephone technique has been applied to very much higher frequencies and wider frequency bands. Perhaps the most notable example is to be found in the London-Birmingham broad band telephone system, already described in some detail in this JOURNAL.¹ This system, like the experimental system set up by the Bell Telephone Laboratories between New York and Philadelphia², employs channel filters incorporating quartz crystal resonators.

Since the type of crystal filter employed is likely to find application in various branches of telecommunications, it has been considered desirable to present a more detailed study of its properties than has hitherto been published.

The filter following a channel modulator in a multi-channel carrier telephone system has several outstanding requirements to fulfil. It has to introduce uniform and relatively low attenuation to the desired side-band over a frequency range governed by the audio-frequency response it is desired to realise. Outside this range the attenuation must rise rapidly in order that the opposite side-band shall be eliminated and other frequencies present in the output from the modulator shall not interfere with adjacent channels. Further, if complication is to be avoided, the filter must be suitable for operating in parallel with the other channel filters with which it is associated. Similar properties must be possessed by the filter preceding a channel demodulator.

For certain reasons which will not be discussed here, in such a system as that adopted on the London-Birmingham coaxial cable it is not desirable that any

of the side-bands be located below about 60 kc.p.s. If, in addition, the audio-frequency band to be transmitted is approximately 3 kc.p.s. wide and the channels are to be spaced at intervals of 5 kc.p.s. or even 4 kc.p.s., it is clear that the attenuation just outside the pass-band must rise to a high value for a very small percentage change in frequency.

When the London-Birmingham system was first projected, Mason's now classical introduction to crystal filters³ had just been published, and in view of the extraordinary performance claimed for them it was decided that the channel filters should if possible be of that type.

Preliminary Description.

In order to avoid unnecessary duplication of published information, those interested in the properties of quartz crystal resonators and in a general survey of some of the filter sections in which these resonators can with advantage be used, are referred to Mason's original paper and to later contributions to these subjects.⁴ For the sake of completeness, it is desirable, however, to include some of the information already presented in these articles.

Before considering in detail the filter that has been adopted, it is helpful to have some qualitative ideas relating to quartz crystal resonators and indicating the way in which they may be introduced into the filter network. By cutting a resonator according to certain well-defined rules it is possible to make it have a primary resonance of a predetermined frequency and fairly well removed in frequency from other natural modes. As consideration will be restricted to frequencies in the neighbourhood of the primary resonance, the presence of other natural frequencies will therefore be ignored.

As is well known, for frequencies in the neighbour-

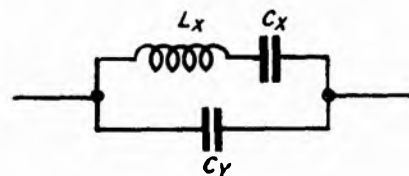

FIG. 1.—ELECTRICAL EQUIVALENT OF A QUARTZ CRYSTAL.

hood of a natural mode of vibration the equivalent circuit of a quartz crystal resonator may be represented as shown in Fig. 1. Owing to the fact that

¹*P.O.E.E.J.*, Vol. 30, pp. 206, 270; Vol. 31, pp. 51, 132.

²*B.S.T.J.*, January, 1937, p. 1.

³*B.S.T.J.*, July, 1934, p. 405.

⁴*B.S.T.J.*, October, 1937, p. 423; and January, 1938 p. 125.

the internal friction losses and the electrical power-factor of quartz are both remarkably low, as far as is known they are lower than in any other substance, the resistance of the elements in the equivalent circuit is usually neglected. The equivalent circuit has a reactance-frequency characteristic of the general form shown in Fig. 2 in which the two critical

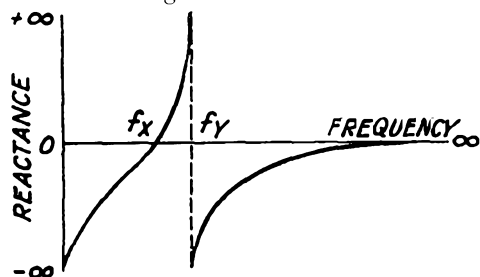

FIG. 2.—REACTANCE FREQUENCY CHARACTERISTIC OF RESONATOR.

frequencies f_x and f_y , never differ by more than about 0.4 per cent. By virtue of this equivalence some of the inductors and condensers in a filter may, in certain cases, be replaced by resonators.

If all the advantages that may be derived from using resonators in a filter are to be realised, all the inductors must be displaced by resonators, or alternatively, those inductors which remain must not modify the shape of the transmission-frequency characteristic. Frequently this cannot be done, but fortunately in the present case it is possible to approach the ideal closely.

The filter section upon which the design of the channel filters has been based is that shown in Fig. 3.

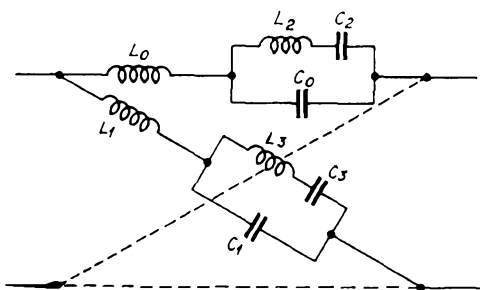

FIG. 3.—FILTER SECTION.

Subject to certain limitations which will be considered later, in each of the series arms a resonator may replace L_2 , C_2 and part or the whole of C_0 . Similarly L_3 , C_3 and part or the whole of C_1 may be replaced by a resonator in each lattice arm. The inductors L_0 and L_1 , with their accompanying dissipation remain. As it is impossible to dispense with these inductors, it is necessary to arrange that their dissipation does not affect the shape of the attenuation characteristic adversely.

By separately equating their short-circuit and open-circuit impedances it can be shown that the two networks, A and B, in Fig. 4, are equivalent. This demonstrates that if the resistances of the inductors L_0 and L_1 are equal they may be regarded as directly in series with any impedances with which the section may be terminated. It is then possible to regard these resistances as forming part of the terminating impedances of a resistanceless section, the external

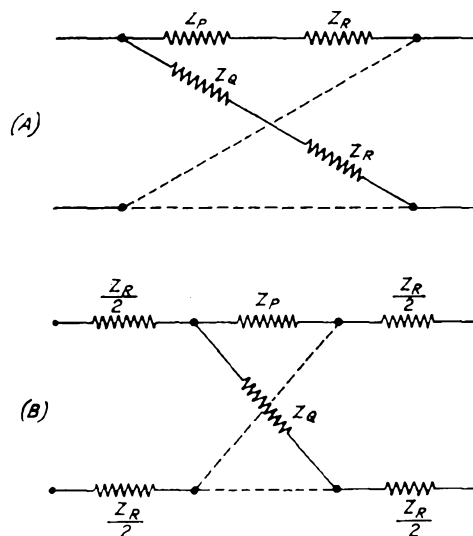

FIG. 4.—EQUIVALENT NETWORKS.

impedances forming the remainder. If the section is designed to allow for the fact that the effective terminating impedance includes this extra resistance, the only effect of the latter will be to increase the loss uniformly over the whole of the pass-band. In practice it is often convenient to make the inductances L_0 and L_1 equal and to replace them by inductances in series with the terminals of the network as shown in Fig. 5.

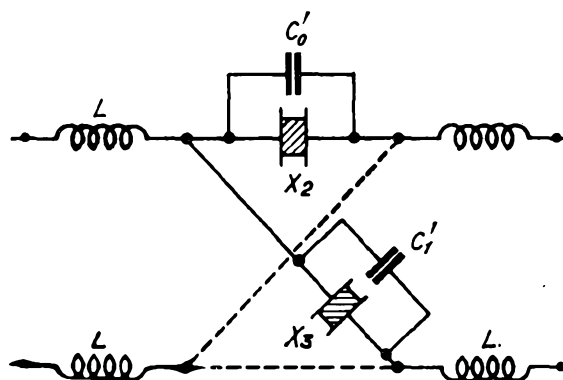

FIG. 5.—CHANNEL FILTER SECTION.

General Properties of Filter Section.

Lattice Section. Until comparatively recently practically all electric wave filters were based upon the familiar ladder structure, filters of this type having been developed to a high degree by Campbell, Zobel and their associates. Within the last few years, however, the theory of filters utilising the more general lattice or bridge structure has been developed to a considerable extent, notably by Cauer⁵ and Bode⁶; but at present the published information relating to these lattice filters is highly mathematical and generalised, and is not therefore suitable for use in determining the properties of any one particular type of section in detail.

⁵ *Physics*, 1932, p. 242.

⁶ *B.S.T.J.*, April, 1935, . 15

The filter section it is proposed to consider in connection with the application of resonators is one of the simpler types of lattice section.

It is desirable to recall some of the fundamental properties of the lattice network. Let Z_x and Z_y be the total impedances in each of the series and each of the lattice arms respectively. The characteristic impedance⁷ Z_k and propagation constant P of the network are given by :

$$Z_k = \sqrt{Z_x Z_y} \dots\dots\dots(1)$$

$$P = 2 \tanh^{-1} \sqrt{\frac{Z_x}{Z_y}} \dots\dots\dots(2)$$

It will be assumed that Z_x and Z_y are pure reactances.

From an inspection of these expressions it can be seen that when Z_x and Z_y are reactances of the same sign Z_k will be reactive and P will be real ; the network will attenuate ; in particular when Z_x and Z_y are equal the attenuation will be infinite.⁸ When Z_x and Z_y are of opposite sign Z_k will be resistive and P will be wholly imaginary ; the network will not attenuate but will merely alter the phase of currents flowing through it. In fact, it is quite easy to sketch the general shape of the characteristic impedance and attenuation constant characteristics from curves showing the way in which Z_x and Z_y vary with frequency.

Crystal Filter Section.—The properties of the filter section shown in Fig. 3 will now be considered.

The series and lattice arms will have reactance characteristics of the form shown in Fig. 6. In

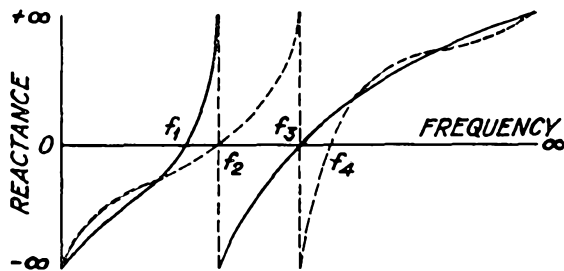

FIG. 6.—REACTANCE-FREQUENCY CHARACTERISTIC OF FILTER ARMS.

general the critical frequencies will, however, be different for the two arms, i.e. anti-resonance in one arm will not coincide with resonance in the other. At very low frequencies and very high frequencies the reactance of both arms will be of the same sign, the section will therefore attenuate and, if none of the critical frequencies coincides, there will be six intermediate points at which the reactance of one arm changes sign relative to that of the other. There will therefore be six frequencies at which the network changes from attenuation to free transmission or vice versa, and three discrete transmission bands.

If the disposition of the critical frequencies is

⁷ A lattice network is essentially symmetrical; the image and iterative impedances are therefore identical. It is convenient to denote both by the term "characteristic impedance."

⁸ If the network is regarded as a balanced bridge this is immediately apparent.

altered so that a critical frequency in the series arm coincides with one in the lattice arm, the following changes will occur in the attenuation characteristic. Every time two resonant or anti-resonant frequencies are made to correspond two adjacent attenuation-bands will coalesce. Every time a resonant frequency is made to coincide with an anti-resonant frequency two adjacent pass-bands will coalesce.

The only conditions that can be considered are those in which a single band-pass results. Of these two are of interest. In one the section can be made to have a relatively constant characteristic impedance in the pass-band, but yields only a narrow band-width when used with crystal resonators ; this occurs when the upper and lower pass-bands are made to vanish. The other arises when all three transmission bands are confluent ; this yields a wider pass-band and a characteristic impedance which is desirable when operating a number of filters in parallel. The conditions under which this occurs are indicated in Fig. 6, in which the full curve represents the reactance characteristic of one arm and the dotted curve that of the other. This case will now be considered in detail.

ANALYSIS OF CRYSTAL FILTER SECTION.

In this section it is proposed initially to show that the characteristic impedance of the section is identical with the mid-series image impedance of a "constant k " ladder filter. The manner in which the propagation constant varies with frequency will then be studied with particular reference to the frequencies of infinite attenuation. The results will be related to the insertion-loss characteristic. Finally the design formulæ will be developed.

Characteristic Impedance.

Let the elements of the series and lattice arms be designated as indicated in Fig. 3 and the critical frequencies numbered as in Fig. 6, in which the full curve relates to the series arm and the dotted curve to the lattice arm. It can be seen by inspection that f_1 and f_4 are the two cut-off frequencies.

If Z_x and Z_y denote the impedances of the series and lattice arms respectively, it can be shown by applying Foster's Theorem⁹ that :

$$Z_x = -j L_0 \frac{(\omega_1^2 - \omega^2)(\omega_3^2 - \omega^2)}{\omega(\omega_2^2 - \omega^2)} \dots\dots\dots(3)$$

$$Z_y = -j L_1 \frac{(\omega_2^2 - \omega^2)(\omega_4^2 - \omega^2)}{\omega(\omega_3^2 - \omega^2)} \dots\dots\dots(4)$$

$(\omega_n = 2 \pi f_n)$

Substituting in equation (1) the characteristic impedance is given by :

$$Z_k = \frac{-j}{\omega} \sqrt{L_0 L_1} \sqrt{(\omega_1^2 - \omega^2)(\omega_4^2 - \omega^2)} \dots\dots\dots(5)$$

It will be noticed immediately that the characteristic impedance is independent of ω_2 and ω_3 .

⁹ B.S.T.J., April, 1924. p. 259.

If Z_o be the value of the characteristic impedance at the mid-band frequency f_m where :

$$f_m^2 = f_1 f_4$$

then

$$Z_o = -j \sqrt{L_o L_1} \sqrt{\frac{(\omega_1^2 - \omega_1 \omega_4)(\omega_4^2 - \omega_1 \omega_4)}{\omega_1 \omega_4}}$$

$$= (\omega_4 - \omega_1) \sqrt{L_o L_1} \dots \dots \dots (6)$$

Z_o will be called the Nominal Characteristic Impedance.

From equations (5) and (6) :

$$\frac{Z_k}{Z_o} = \sqrt{\frac{(\omega^2 - \omega_1^2)(\omega_4^2 - \omega^2)}{\omega^2(\omega_4 - \omega_1)^2}}$$

$$= \sqrt{\frac{\left(\omega - \frac{\omega_1^2}{\omega}\right)\left(\frac{\omega_4^2}{\omega} - \omega\right)}{(\omega_4 - \omega_1)^2}}$$

$$= \sqrt{1 - \frac{\omega^2 - 2\omega_4\omega_1 + \frac{\omega_4^2\omega_1^2}{\omega^2}}{(\omega_4 - \omega_1)^2}}$$

$$= \sqrt{1 - \frac{\left(\omega - \frac{\omega_4\omega_1}{\omega}\right)^2}{(\omega_4 - \omega_1)^2}}$$

Dividing top and bottom of the fraction by ω_m^2 and remembering that $\omega_1/\omega_m = \omega_m/\omega_4$:

$$\frac{Z_k}{Z_o} = \sqrt{1 - \frac{\left(\frac{\omega}{\omega_m} - \frac{\omega_m}{\omega}\right)^2}{\left(\frac{\omega_4}{\omega_m} - \frac{\omega_m}{\omega_4}\right)^2}} \dots \dots \dots (7)$$

This expression is of the same form as that for the mid-series image impedance of a "constant k" ladder type band-pass filter¹⁰.

Propagation Constant.

Let the ratio of the impedances of the series and lattice arms be denoted by K. The propagation constant P will be given by the equation :

$$P = 2 \tanh^{-1} \sqrt{K} \dots \dots \dots (8)$$

where $K = \frac{Z_x}{Z_y}$

Hence provided Z_x and Z_y are purely reactive, K will be a positive or negative real quantity.

Let the attenuation constant and phase constant be denoted by A and B respectively, whence :

$$P = A + jB \dots \dots \dots (9)$$

When K is positive its square root will be real and the solution of the equation (8) may be shown to have the following results. (See Appendix I.)

(a) $0 < K < 1$.

$$A = 2 \tanh^{-1} \sqrt{K} \dots \dots \dots (10)$$

$$B = \pm 2 n \pi$$

(b) $K > 1$.

$$A = 2 \coth^{-1} \sqrt{K} \dots \dots \dots (11)$$

$$B = \pi \pm 2 n \pi$$

(c) $K = 1$.

$$A = \infty \dots \dots \dots (12)$$

B is indeterminate.

This condition corresponds to a discontinuity in the phase characteristic.

When K is negative the square root will be imaginary and the solution of the equation (8) is shown in Appendix I to give the following root only :

(d) $0 > K$.

$$A = 0$$

$$B = 2 \tan^{-1} \sqrt{-K} \dots \dots \dots (13)$$

From equations (3) and (4) the value of K is given by the expression :

$$K = \frac{L_o}{L_1} \frac{(\omega_1^2 - \omega^2)(\omega_3^2 - \omega^2)}{(\omega_4^2 - \omega^2)(\omega_2^2 - \omega^2)} \dots \dots \dots (14)$$

which is positive when $\omega < \omega_1$ and $\omega > \omega_4$, but is negative when $\omega_1 < \omega < \omega_4$, i.e. when the frequency under consideration lies in the pass-band.

Attenuation Constant.

The general conditions governing the attenuation constant are given in equations (10), (11), (12) and (14). It will be seen from equation (12) that the attenuation constant becomes infinite when the value of K is + 1. The frequencies f_{∞} at which this occurs are therefore given by :

$$\frac{L_o}{L_1} \cdot \frac{(\omega_1^2 - \omega_{\infty}^2)(\omega_3^2 - \omega_{\infty}^2)}{(\omega_4^2 - \omega_{\infty}^2)(\omega_2^2 - \omega_{\infty}^2)} = 1 \dots (15)$$

$$\text{Let } \frac{L_o}{L_1} = k^2 \dots \dots \dots (16)$$

Equation (15) may then be written in the form :

$$a \omega_{\infty}^6 + b \omega_{\infty}^4 + c \omega_{\infty}^2 + d = 0 \dots \dots \dots (17)$$

where

$$a = 1 - k^2$$

$$b = - [(\omega_4^2 - k^2 \omega_1^2) + 2(\omega_2^2 - k^2 \omega_3^2)]$$

$$c = (\omega_2^4 - k^2 \omega_3^4) + 2(\omega_2^2 \omega_4^2 - k^2 \omega_1^2 \omega_3^2)$$

$$d = -(\omega_2^4 \omega_4^2 - k^2 \omega_1^2 \omega_3^4)$$

It will be observed that odd powers of ω_{∞} are absent and that the equation has the form of a cubic in ω_{∞}^2 . The roots of equation (17) will therefore be of the form : $a, -a, \beta, -\beta, \gamma, -\gamma$. When a, β and γ are all real there will be three positive real roots and three frequencies at which the attenuation constant becomes infinite. The number of real roots depends upon the values of k, $\omega_1, \omega_2, \omega_3$ and ω_4 . There will always be at least one frequency at which the attenuation constant is infinite ; this may, however, be located either at zero or infinity.

When designing a filter the cut-off frequencies and the frequencies at which maximum attenuation must occur are usually fixed by the performance requirements. It is therefore proposed to obtain expressions for the critical frequencies f_2 and f_3 , and the ratio, k^2 , of the inductors L_o and L_1 , in terms of the cut-off frequencies f_1 and f_4 , and the frequencies f_{∞} at which the attenuation constant becomes infinite. An explicit solution of equation (17) is therefore unnecessary.

¹⁰ "Transmission Networks and Wave Filters," by T. E. Shea, p. 315.

Expressions for f_2, f_3 and k . Equation (15) may be rewritten in the form:

$$k^2 (\omega_3^2 - \omega_\infty^2)^2 = \frac{\omega_4^2 - \omega_\infty^2}{\omega_1^2 - \omega_\infty^2} (\omega_2^2 - \omega_\infty^2)^2 \quad (18)$$

each side of which can be made to take the form of a perfect square by putting:

$$y^2 = \frac{\omega_4^2 - \omega_\infty^2}{\omega_1^2 - \omega_\infty^2} \quad (19)$$

This substitution is permissible because $\omega_2 < \omega_\infty < \omega_4$ is a forbidden region for ω_∞ , and the expression on the right-hand side of (19) is therefore always positive.

Expressing ω_∞^2 in terms of y^2 :

$$\omega_\infty^2 = \frac{y^2 \omega_1^2 - \omega_4^2}{y^2 - 1} \quad (20)$$

Substituting for ω_∞^2 in equation (18):

$$k^2 \left(\omega_3^2 - \frac{y^2 \omega_1^2 - \omega_4^2}{y^2 - 1} \right)^2 = y^2 \left(\omega_2^2 - \frac{y^2 \omega_1^2 - \omega_4^2}{y^2 - 1} \right)^2 \quad (21)$$

On taking the square root of both sides of this equation¹¹ and expanding, the expression has the form:

$$y^3 (\omega_2^2 - \omega_1^2) - y^2 (\omega_3^2 - \omega_1^2) k + y (\omega_4^2 - \omega_2^2) - k (\omega_4^2 - \omega_3^2) = 0 \quad (22)$$

Since $\omega_1 < \omega_2 < \omega_3 < \omega_4$, and k can be taken as positive, this equation has three positive roots.¹² If d_1, d_2 and d_3 are the roots of the equation, D, E and F may be defined as follows:—

$$D = d_1 + d_2 + d_3 = k \frac{\omega_3^2 - \omega_1^2}{\omega_2^2 - \omega_1^2} \quad (23)$$

$$E = d_1 d_2 + d_2 d_3 + d_3 d_1 = \frac{\omega_4^2 - \omega_2^2}{\omega_2^2 - \omega_1^2} \quad (24)$$

$$F = d_1 d_2 d_3 = k \frac{\omega_4^2 - \omega_3^2}{\omega_2^2 - \omega_1^2} \quad (25)$$

Taken together these last three equations are the implicit solution for y , which is a function of ω_∞ .

From equation (19), d_1, d_2 and d_3 are given by:

$$d_n = \sqrt{\frac{\omega_4^2 - \omega_\infty^2}{\omega_1^2 - \omega_\infty^2}} \quad n = 1, 2, 3 \dots (26)$$

Using equations (23) to (26), ω_2, ω_3 and k may be expressed in terms of ω_∞, ω_1 and ω_4 . This can be carried out by assigning values to ω_∞ and hence to d_n , using (26); this in turn fixes the values of D, E and F , and it can be shown that:—

$$\omega_2^2 = \frac{\omega_4^2 + E \omega_1^2}{1 + E} \quad (27)$$

$$\omega_3^2 = \frac{D \omega_4^2 + F \omega_1^2}{D + F} \quad (28)$$

$$k = \frac{D + F}{1 + E} \quad (29)$$

Parameters D, E and F. The only restrictions imposed upon the parameters D, E and F , when electrical elements are used, are that they shall be positive and real and that $D \times E$ shall be greater than F , conditions which are met by taking the positive root of equation (26). The frequencies at which the attenuation constant becomes infinite may all be arranged on one side of the pass-band or distributed in any manner; in fact, two of the frequencies can be made to disappear by assigning them complex values.¹³

The quantities D, E and F are more convenient design parameters than ω_∞ although obtained therefrom. The final design formulae will therefore be developed in terms of the former together with the cut-off frequencies and the nominal characteristic impedance. The significance of these parameters becomes apparent by considering equations (27) and (28); it will be seen that ω_2^2 divides the interval between ω_1^2 and ω_4^2 in the ratio $1 : E$, and ω_3^2 divides the interval in the ratio $D : F$.

It is interesting to examine the conditions under which one or more of the parameters can be eliminated. Certain important cases arise under these conditions which will now be discussed. If the ratio of the inductances L_0 and L_1 is fixed, D, E and F bear a definite relationship; in particular, if L_0 equals L_1 , k becomes unity and:

$$E = D + F - 1 \quad (30)$$

This imposes the restriction that one of the roots of equation (22), say d_3 , is equal to unity. Interpreting this in the light of equation (26), one of the frequencies $f_{3\infty}$ must be infinite. Mention was made of this earlier when discussing the effect of coil dissipation.

If a further relationship be fixed between D, E and F , only one independent parameter remains. Since one of the three frequencies $f_{n\infty}$ has receded to infinity, it is convenient to arrange the remaining two in some symmetrical manner about the pass-band. Equation (26) indicates that the most suitable distribution is based on an arithmetical symmetry of the squares of the frequencies involved. Thus it is convenient to make:

$$\omega_1^2 - \omega_{1\infty}^2 = \omega_{2\infty}^2 - \omega_4^2$$

$$\text{whence } d_1 = \frac{1}{d_2}$$

and furthermore, since d_3 is unity,

$$D = E, \quad F = 1 \quad (31)$$

Equations (27) and (28) for ω_2^2 and ω_3^2 respectively, become:

$$\omega_2^2 = \frac{\omega_4^2 + D \omega_1^2}{1 + D} \quad (32)$$

$$\omega_3^2 = \frac{D \omega_4^2 + \omega_1^2}{1 + D} \quad (33)$$

It will be seen that ω_2^2 divides the interval between ω_1^2 and ω_4^2 in the ratio $1 : D$, while ω_3^2 divides the interval in the ratio $D : 1$. The whole attenuation

¹¹ This step is justified in view of the fact that equation (21) is an equation in y^2 only. The square root taken yields the positive roots of y and the other the negative roots. It is only necessary to use the positive roots of y in view of equation (19).

¹² If k is taken as negative the other square root of equation (21) yields an equation with positive roots.

¹³ If d_1 and d_2 are chosen as complementary complex quantities and d_3 is real, D, E and F will be real and the network may still be realised.

characteristic and the critical frequencies are symmetrical when plotted against the square of the frequency. The axis of symmetry f_p^2 is given by :

$$\left. \begin{aligned} 2 f_p^2 &= f_1^2 + f_4^2 \\ &= f_2^2 + f_3^2 \\ &= f_{1\infty}^2 + f_{2\infty}^2 \end{aligned} \right\} \dots\dots\dots(34)$$

Computation of Attenuation Constant. Having introduced suitable design parameters it is proposed to indicate a convenient method of calculating the attenuation constant.

It has been shown that the attenuation constant A is given by :

$$\begin{aligned} A &= 2 \tanh^{-1} \sqrt{K} \quad (K < 1) \\ A &= 2 \coth^{-1} \sqrt{K} \quad (K > 1) \end{aligned}$$

Substituting in equation (14) using equations (27) to (29), K may be expressed as a function of $D, E, F, \omega_1, \omega_4$ and ω .

$$\begin{aligned} K &= \frac{(D+F)^2}{(1+E)^2} \cdot \frac{\omega_1^2 - \omega^2}{\omega_4^2 - \omega^2} \cdot \frac{[D(\omega_4^2 - \omega^2) + F(\omega_1^2 - \omega^2)]^2}{[(\omega_4^2 - \omega^2) + E(\omega_1^2 - \omega^2)]^2} \\ &\quad \cdot \frac{(1+E)^2}{(D+F)^2} \\ &= \frac{\omega_1^2 - \omega^2}{\omega_4^2 - \omega^2} \cdot \frac{[D(\omega_4^2 - \omega^2) + F(\omega_1^2 - \omega^2)]^2}{[(\omega_4^2 - \omega^2) + E(\omega_1^2 - \omega^2)]^2} \dots(35) \end{aligned}$$

$$\text{Let } p^2 = \frac{f_4^2 - f^2}{f_1^2 - f^2} \dots\dots\dots(36)$$

$$\text{Then } K = \frac{(F + D p^2)^2}{p^2 (E + p^2)^2} \dots\dots\dots(37)$$

When the conditions set out in equation (31) obtain, K may be written in terms of one parameter only :

$$K = \frac{(1 + D p^2)^2}{p^2 (D + p^2)^2} \dots\dots\dots(39)$$

$$\left. \begin{aligned} A &= 2 \tanh^{-1} \frac{1 + D p^2}{p (D + p^2)} \\ &\quad \frac{1 + D p^2}{p (D + p^2)} < 1 \\ A &= 2 \coth^{-1} \frac{1 + D p^2}{p (D + p^2)} \\ &\quad \frac{1 + D p^2}{p (D + p^2)} > 1 \end{aligned} \right\} \dots(40)$$

Expressions (38) and (40) are specially adapted to computation. The use of the variable p instead of f renders the expressions independent of the absolute values of the cut-off frequencies and makes it possible to construct curves which are of general application.

When D is equal to E and F is unity is most important in view of the symmetry of the attenuation constant characteristic. Curves have therefore been computed for this condition which show the relationship between A and p with D as parameter. These are reproduced in Fig. 7.

Phase Constant.

In a number of applications it is desirable to ascertain the manner in which the phase constant B varies in the pass-band.

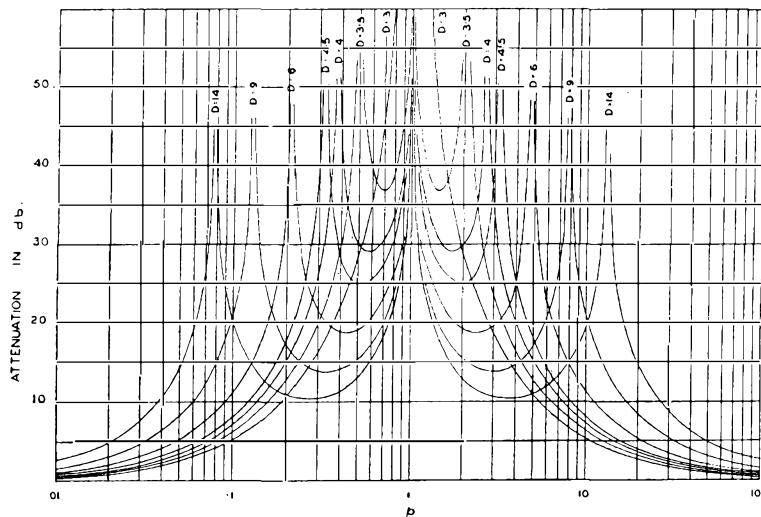

FIG. 7.—CHART FOR DETERMINATION OF ATTENUATION CONSTANT.

$$\left. \begin{aligned} \text{and } A &= 2 \tanh^{-1} \frac{F + D p^2}{p(E + p^2)} \\ &\quad \frac{F + D p^2}{p(E + p^2)} < 1 \\ \text{or } A &= 2 \coth^{-1} \frac{F + D p^2}{p(E + p^2)} \\ &\quad \frac{F + D p^2}{p(E + p^2)} > 1 \end{aligned} \right\} \dots(38)$$

From equation (13), the value of B in the pass-band is given by :

$$B = 2 \tan^{-1} \sqrt{-K}$$

Substituting in the expression for K given in equation (37) using the relationship :

$$q^2 = -p^2 = \frac{f_4^2 - f^2}{f_1^2 - f^2} \dots\dots\dots(41)$$

$\sqrt{-K}$ may be written as :

$$\sqrt{-K} = \frac{F - D q^2}{q (E - q^2)} \dots\dots\dots(42)$$

In the pass-band q^2 is positive and q is therefore real.

The phase constant B is then given by :

$$B = 2 \tan^{-1} \frac{F - D q^2}{q (E - q^2)} \dots \dots \dots (43)$$

This expression is a convenient one for calculation.

It will be observed that B depends upon the three design parameters D , E and F . These may therefore be used either for adjusting the attenuation constant or the phase constant characteristic.

The important case in which D is the only remaining parameter yields the following expression for the phase constant :

$$B = 2 \tan^{-1} \frac{1 - D q^2}{q (D - q^2)} \dots \dots \dots (44)$$

Curves showing the relationship between B and q with D as parameter are reproduced in Fig. 8.

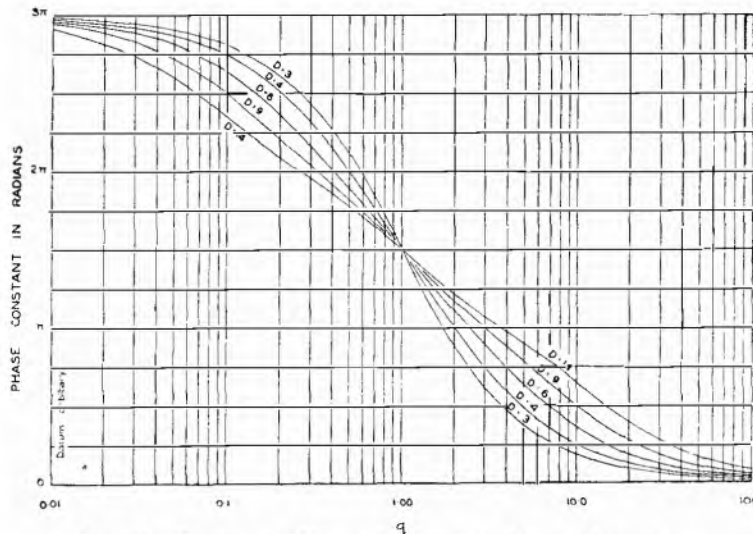

FIG. 8.—CHART FOR DETERMINATION OF PHASE CONSTANT.

Values of Electrical Elements.

The properties of the filter have been studied, first of all in terms of one element of each arm and the critical frequencies. These may be regarded as the fundamental constants of the filter. Later, certain parameters, more closely allied to the performance of the section, were introduced. Before the electrical network corresponding to the filter section can be fully defined it is necessary, however, to obtain expressions for the values of the individual elements. These expressions will first be derived in terms of the fundamental constants referred to above. The design parameters D , E and F and the nominal characteristic impedance Z_0 will then be introduced. Finally these expressions will be simplified to correspond to the condition where parameters E and F are eliminated.

The series and lattice arms of the filter section both have the configuration shown in Fig. 9a. Such a network cannot be regarded either as a combination of anti-resonant circuits in series or resonant circuits in parallel, as is required for the direct application of the second part of Foster's Theorem. It may, however, be transformed into the form shown in Fig. 9b,

by using one of the well-known network equivalents.

The elements of the original network may be expressed in terms of those of the second network :

$$L_A = L'_4 \dots \dots \dots (45)$$

$$L_B = L'_2 \left(1 + \frac{C'_2}{C'_0} \right)^2 \dots \dots \dots (46)$$

$$C_B = \frac{C'_0{}^2}{C'_0 + C'_2} \dots \dots \dots (47)$$

$$C_C = \frac{C'_0 C'_2}{C'_0 + C'_2} \dots \dots \dots (48)$$

The second network may be considered as consisting of three anti-resonant circuits in series where $C'_4 = 0$ and $L'_0 = \infty$. The reactance-frequency

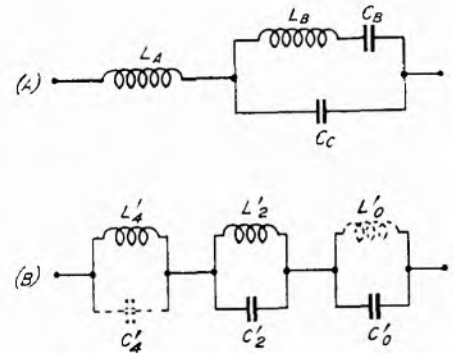

FIG. 9.—ILLUSTRATION OF NETWORK TRANSFORMATION.

characteristic is shown in Fig. 10 where the critical frequencies are numbered in accordance with the requirements of Foster's Theorem. Applying the

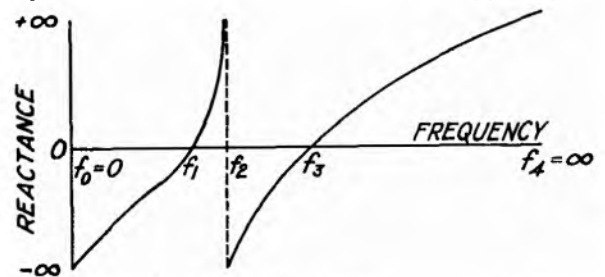

FIG. 10.—REACTANCE-FREQUENCY CHARACTERISTIC.

theorem the values of the elements of the second network are given by :

$$C'_0 = \frac{1}{L'_4} \cdot \frac{\omega_2^2}{\omega_1^2 \omega_3^2}$$

$$C'_2 = \frac{1}{L'_4} \cdot \frac{\omega_2^2}{(\omega_3^2 - \omega_2^2)(\omega_2^2 - \omega_1^2)}$$

$$L'_2 = L'_4 \cdot \frac{\omega_2^2}{\omega_2^4}$$

Substituting these values in equations (45) to (48) :

$$L_{\bullet} = L_A \cdot \frac{(\omega_1^2 - \omega_2^2 + \omega_3^2)^2}{(\omega_3^2 - \omega_2^2)(\omega_2^2 - \omega_1^2)} \dots (49)$$

$$C_B = \frac{1}{L_A} \cdot \frac{(\omega_3^2 - \omega_2^2)(\omega_2^2 - \omega_1^2)}{\omega_1^2 \omega_3^2 (\omega_1^2 - \omega_2^2 + \omega_3^2)} \dots (50)$$

$$C_C = \frac{1}{L_A} \cdot \frac{1}{\omega_1^2 - \omega_2^2 + \omega_3^2} \dots (51)$$

These expressions may be used to give the values of the elements in the original filter section shown in Fig. 3 in terms of the original critical frequencies f_1 , f_2 , f_3 and f_4 , indicated in Fig. 6, and the inductances L_o and L_1 :

$$L_2 = L_o \cdot \frac{(\omega_1^2 - \omega_2^2 + \omega_3^2)^2}{(\omega_3^2 - \omega_2^2)(\omega_2^2 - \omega_1^2)} \dots (52)$$

$$C_2 = \frac{1}{L_o} \cdot \frac{(\omega_3^2 - \omega_2^2)(\omega_2^2 - \omega_1^2)}{\omega_1^2 \omega_3^2 (\omega_1^2 - \omega_2^2 + \omega_3^2)} \dots (53)$$

$$C_o = \frac{1}{L_o} \cdot \frac{1}{\omega_1^2 - \omega_2^2 + \omega_3^2} \dots (54)$$

$$L_3 = L_1 \cdot \frac{(\omega_2^2 - \omega_3^2 + \omega_4^2)^2}{(\omega_4^2 - \omega_3^2)(\omega_3^2 - \omega_2^2)} \dots (55)$$

$$C_3 = \frac{1}{L_1} \cdot \frac{(\omega_4^2 - \omega_3^2)(\omega_3^2 - \omega_2^2)}{\omega_2^2 \omega_4^2 (\omega_2^2 - \omega_3^2 + \omega_4^2)} \dots (56)$$

$$C_1 = \frac{1}{L_1} \cdot \frac{1}{\omega_2^2 - \omega_3^2 + \omega_4^2} \dots (57)$$

It has been shown earlier that the nominal characteristic impedance Z_o is given by :

$$Z_o = (\omega_4 - \omega_1) \sqrt{L_o L_1}$$

Also, the ratio of the inductances L_o and L_1 has been defined as k^2 , whence L_o and L_1 may be written :

$$L_o = \frac{k Z_o}{\omega_4 - \omega_1} \dots (58)$$

$$L_1 = \frac{Z_o}{k (\omega_4 - \omega_1)} \dots (59)$$

From equations (23) to (25) defining the design parameters D , E and F respectively, it may be shown that :

$$\omega_2^2 - \omega_1^2 = \frac{1}{1+E} (\omega_4^2 - \omega_1^2) \dots (60)$$

$$\omega_3^2 - \omega_1^2 = \frac{D}{D+F} (\omega_4^2 - \omega_1^2) \dots (61)$$

$$\omega_3^2 - \omega_2^2 = \frac{DE-F}{(D+F)(1+E)} (\omega_4^2 - \omega_1^2) \dots (62)$$

$$\omega_4^2 - \omega_3^2 = \frac{F}{D+F} (\omega_4^2 - \omega_1^2) \dots (63)$$

$$\omega_1^2 - \omega_2^2 + \omega_3^2 = \frac{\omega_1^2(DE-F) + \omega_1^2(D+2F+EF)}{(D+F)(1+E)} \dots (64)$$

$$\omega_2^2 - \omega_3^2 + \omega_4^2 = \frac{\omega_1^2(DE-F) + \omega_4^2(D+2F+EF)}{(D+F)(1+E)} \dots (65)$$

Finally, substituting in equations (52) to (59) using the above expressions, together with equations (27) to (29), the values of the filter elements may be expressed in terms of the cut-off frequencies, the nominal

characteristic impedance and the parameters D , E and F :

$$L_o = \frac{Z_o}{\omega_4 - \omega_1} \cdot \frac{D+F}{1+E} \dots (66)$$

$$L_1 = \frac{Z_o}{\omega_4 - \omega_1} \cdot \frac{1}{D+F} \dots (67)$$

$$L_2 = \frac{Z_o}{\omega_1 - \omega_1} \cdot \frac{[\omega_1^2(DE-F) + \omega_1^2(D+2F+EF)]^2}{(1+E)(DE-F)(\omega_4^2 - \omega_1^2)^2} \dots (68)$$

$$L_3 = \frac{Z_o}{\omega_4 - \omega_1} \cdot \frac{[\omega_1^2(DE-F) + \omega_4^2(D+2F+EF)]^2}{F(D+F)(DE-F)(\omega_4^2 - \omega_1^2)^2} \dots (69)$$

$$C_o = \frac{\omega_4 - \omega_1}{Z_o} \cdot \frac{(1+E)^2}{\omega_4^2(DE-F) + \omega_1^2(D+2F+EF)} \dots (70)$$

$$C_1 = \frac{\omega_4 - \omega_1}{Z_o} \cdot \frac{(D+F)^2}{\omega_1^2(DE-F) + \omega_4^2(D+2F+EF)} \dots (71)$$

$$C_2 = \frac{\omega_4 - \omega_1}{Z_o} \cdot \frac{(DE-F)(\omega_4^2 - \omega_1^2)^2}{\omega_1^2(D\omega_4^2 + F\omega_1^2)[\omega_4^2(DE-F) + \omega_1^2(D+2F+EF)]} \dots (72)$$

$$C_3 = \frac{\omega_4 - \omega_1}{Z_o} \cdot \frac{F(DE-F)(\omega_4^2 - \omega_1^2)^2}{\omega_4^2(\omega_1^2 + E\omega_1^2)[\omega_1^2(DE-F) + \omega_4^2(D+2F+EF)]} \dots (73)$$

In the important case in which D is equal to E and F is unity the above formulæ reduce to the form :

$$L_o = L_1 = \frac{Z_o}{\omega_4 - \omega_1} \dots (74)$$

$$L_2 = \frac{Z_o}{\omega_4 - \omega_1} \cdot \frac{[\omega_4^2(D-1) + 2\omega_1^2]^2}{(D-1)(\omega_4^2 - \omega_1^2)^2} \dots (75)$$

$$L_3 = \frac{Z_o}{\omega_4 - \omega_1} \cdot \frac{[\omega_1^2(D-1) + 2\omega_4^2]^2}{(D-1)(\omega_4^2 - \omega_1^2)^2} \dots (76)$$

$$C_o = \frac{\omega_4 - \omega_1}{Z_o} \cdot \frac{1+D}{\omega_4^2(D-1) + 2\omega_1^2} \dots (77)$$

$$C_1 = \frac{\omega_4 - \omega_1}{Z_o} \cdot \frac{1+D}{\omega_1^2(D-1) + 2\omega_4^2} \dots (78)$$

$$C_2 = \frac{\omega_4 - \omega_1}{Z_o} \cdot \frac{(D-1)(\omega_1^2 - \omega_1^2)^2}{\omega_1^2(D\omega_4^2 + \omega_1^2)[\omega_4^2(D-1) + 2\omega_1^2]} \dots (79)$$

$$C_3 = \frac{\omega_4 - \omega_1}{Z_o} \cdot \frac{(D-1)(\omega_4^2 - \omega_1^2)^2}{\omega_4^2(D\omega_1^2 + \omega_4^2)[\omega_1^2(D-1) + 2\omega_4^2]} \dots (80)$$

Limitations Imposed by Resonators.

A complete discussion of quartz crystal resonators is beyond the scope of the present article. It is desirable, however, to draw attention to certain limitations in design that are imposed by the use of resonators.

In the equivalent circuit of a resonator shown in Fig. 1 the ratio of the capacitances C_y to C_x can rarely be made less than about 125, but it may, of course, be increased artificially by the addition of capacitance

in parallel with C_v . In the electrical equivalent of any filter into which resonators are to be introduced, the capacitances which correspond to C_x and C_y must therefore conform to this limitation.

For the introduction of quartz crystal resonators to be possible in the present case the following relationships must obtain:

$$\frac{C_o}{C_2} = \frac{(1 + E)^2 \omega_1^2 (D \omega_4^2 + F \omega_1^2)}{(DE - F) (\omega_4^2 - \omega_1^2)^2} > 125 \dots (81)$$

$$\frac{C_1}{C_3} = \frac{(D + F)^2 \omega_4^2 (\omega_4^2 + E \omega_1^2)}{F (DE - F) (\omega_4^2 - \omega_1^2)^2} > 125 \dots (82)$$

These conditions will be satisfied if either the band-width or $(DE - F)$ are small enough.

In the important case when D is equal to E and F is unity these conditions may be restated as:

$$\frac{C_o}{C_2} = \frac{(1 + D) \omega_1^2 (D \omega_4^2 + \omega_1^2)}{(D - 1) (\omega_4^2 - \omega_1^2)^2} > 125 \dots (83)$$

$$\frac{C_1}{C_3} = \frac{(1 + D) \omega_4^2 (\omega_4^2 + D \omega_1^2)}{(D - 1) (\omega_4^2 - \omega_1^2)^2} > 125 \dots (84)$$

Using these expressions it may be shown that D is not restricted when the band-width is less than about 13 per cent. of the mid-band frequency. For a wider pass-band D must exceed a limit which may be determined by inserting numerical values in expressions (83) and (84). The two remaining frequencies at which the attenuation constant becomes infinite, tend to approach the cut-off frequencies as the band-width is increased beyond 13 per cent.

In practice the properties of quartz crystal resonators and the problems associated with their manufacture impose limitations on the values of the elements in the equivalent circuit. To a first order these limitations affect the reactances of the three elements all in the same ratio. It is clearly indicated in expressions (66) to (73) that the reactances of all the elements in the filter network have the common factor $Z_o!(\omega_4 - \omega_1)$. The limitations imposed by the resonators can therefore be met by assigning a suitable value to this factor. Since the cut-off frequencies corresponding to ω_1 and ω_4 will usually be fixed by other considerations the value of the nominal characteristic impedance will therefore be restricted.

Termination of Filter.

It has been shown that the characteristic impedance of the section is identical with the mid-series image impedance of a constant k ladder type band-pass filter. X-series terminations may therefore be used with the former section in the same way as they are with the latter type, when operating filters in parallel. The necessary extra impedance can be introduced by increasing the series inductors and adding series condensers, using formulæ appropriate to the corresponding ladder structure.

For normal terminations the characteristic impedance will vary considerably over the pass-band, rising from zero at f_1 , to Z_o at f_m , and falling to zero again at f_4 . Reflection and interaction losses near the edges of the pass-band may be reduced at the expense of some slight loss in the middle of the pass-band, by making the total effective impedance R_o terminating the section rather less than Z_o . The optimum ratio

of R_o to Z_o depends upon the requirements to be fulfilled by the filter. A value of R_o in the neighbourhood of $0.8 Z_o$ is often used.

Compensation for Dissipation of Inductors.

Mention was made earlier of a method of compensating for the resistance of the inductors L_o and L_1 . It will be recalled that if the resistances of the two inductors are both equal to R their effect will be that of a total resistance R in series with each of the terminating impedances. If it is desired that the total effective terminating impedance of a section shall be R_o , the external circuit connected to the section must present a resistive impedance R_T given by:

$$R_T = R_o - R \dots \dots \dots (85)$$

If two or more sections were joined directly in tandem, each section would be terminated at a junction by a total effective impedance $Z_k + 2R$. This may be avoided by connecting a resistance R_s in shunt across each junction of such a value that the resistances R and R_s form an H section having a characteristic impedance R_o . It is easy to show that the required value of R_s is given by:

$$R_s = \frac{R_o^2 - R^2}{2R} \dots \dots \dots (86)$$

Loss Introduced. At both the input and output terminals of a complete filter, the loss A_T , in decibels, introduced by the resistance of the inductors, will be given by:

$$A_T = 20 \log_{10} \frac{R_o}{R_o - R} \dots \dots \dots (87)$$

At each of the junctions between sections the loss, A_s , in decibels, will be given by:

$$A_s = 20 \log_{10} \frac{R_o + R}{R_o - R} \dots \dots \dots (88)$$

The total loss, A_R , due to the effect of inductor dissipation, in a filter comprising n sections, will therefore be given by:

$$A_R = 2 A_T + (n - 1) A_s \dots \dots \dots (89)$$

Total Insertion-Loss.

It is well known that the total insertion-loss of a filter differs from its attenuation constant owing to the fact that reflection gives rise to additional loss components, namely, reflection and interaction losses. Certain unusual conditions arise in the present instance which make it desirable to give the matter some consideration.

It will be seen from the previous section that the method of compensating for dissipation in the inductors makes it impossible for perfect matching to obtain at the junctions between sections. This makes the precise evaluation of all the interaction components arising in a multi-section filter a difficult matter. In most practical cases where the loss per section due to resistance is small, it is, however, usually sufficient to neglect the mismatch between sections and to compute the reflection and interaction components for the whole filter on the assumption that reflection arises only at the input and output terminals. The approximation involved will affect the insertion-loss primarily in the neighbourhood of the pass-band, and then only

to a small extent. Fig. 11 compares the total insertion-loss computed in this way, with the measured characteristic of a channel filter.

In connection with the determination of reflection loss, another point is of interest. In the particular type of filter being studied, although the characteristic impedance becomes infinite at zero and infinite frequency the attenuation constant need not neces-

K Positive.

If \sqrt{K} is real the imaginary part of the last expression must vanish, i.e. :

$$\frac{\tan \frac{B}{2} \left(1 - \tanh^2 \frac{A}{2} \right)}{1 + \tanh^2 \frac{A}{2} \tan^2 \frac{B}{2}} = 0 \quad \dots \dots \dots (93)$$

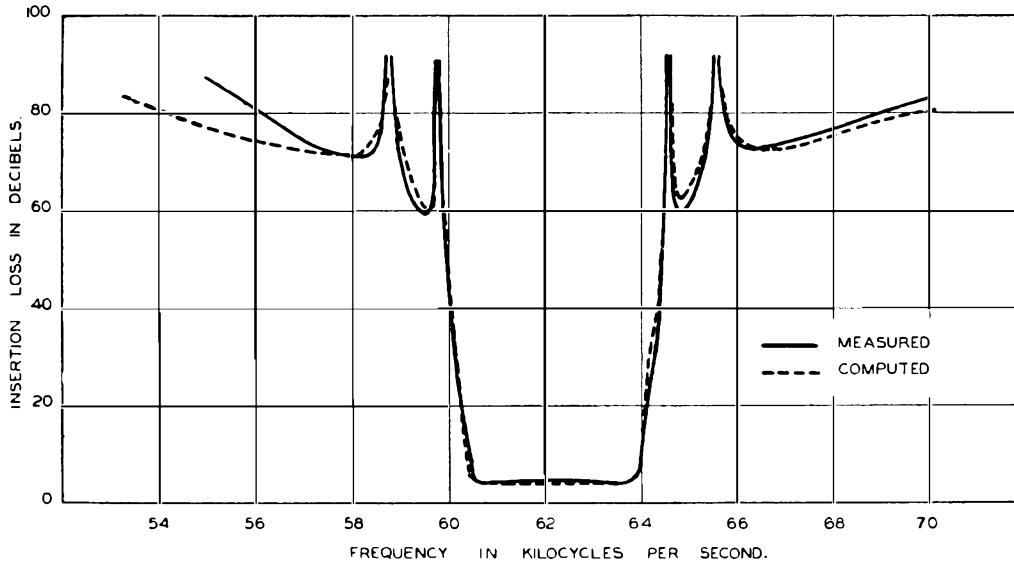

FIG. 11.—COMPARISON OF MEASURED AND COMPUTED INSERTION LOSS.

sarily be infinite. Hence despite the fact that the attenuation constant may be finite, the total insertion-loss will become very high at these frequencies owing to the infinite reflection loss. For narrow-band filters this is a factor of some importance, since in these cases the characteristic impedance will rise rapidly to high values outside the pass-band.

Acknowledgment.

In conclusion the authors have pleasure in acknowledging their indebtedness to Mr. G. Gray, who rendered valuable assistance in preparing the data incorporated in Figs. 7, 8 and 11.

APPENDIX I.

SOLUTION OF EQUATION (8).

Equation (8) for the propagation constant is given as:

$$P = A + j B = 2 \tanh^{-1} \sqrt{K} \dots \dots \dots (90)$$

where A, B and K are real. It is desired to solve this equation for A and B.

Equation (90) may be rewritten :

$$\tanh \frac{A + j B}{2} = \sqrt{K} \dots \dots \dots (91)$$

The expression on the left-hand side may be expanded into the form :

$$\begin{aligned} \tanh \frac{A + j B}{2} &= \frac{\tanh \frac{A}{2} \left(1 + \tan^2 \frac{B}{2} \right)}{1 + \tanh^2 \frac{A}{2} \tan^2 \frac{B}{2}} \\ &+ j \cdot \frac{\tan \frac{B}{2} \left(1 - \tanh^2 \frac{A}{2} \right)}{1 + \tanh^2 \frac{A}{2} \tan^2 \frac{B}{2}} \dots \dots (92) \end{aligned}$$

There are three ways of satisfying this equation, namely:—

$$\tan \frac{B}{2} = 0 \dots \dots \dots (94)$$

$$1 - \tanh^2 \frac{A}{2} = 0 \dots \dots \dots (95)$$

$$1 + \tanh^2 \frac{A}{2} \tan^2 \frac{B}{2} = \infty \dots \dots \dots (96)$$

(a) Solving equation (94):—

$$\begin{aligned} \frac{B}{2} &= \pm n \pi \\ B &= \pm 2 n \pi \dots \dots \dots (97) \end{aligned}$$

Whence from equation (92) :

$$\tanh \frac{A + j B}{2} = \tanh \frac{A}{2} \dots \dots \dots (98)$$

and the solution of equation (90) is of the form :

$$A = 2 \tanh^{-1} \sqrt{K}, \quad B = \pm 2 n \pi \dots \dots \dots (99)$$

Since $\tanh A/2$ cannot be greater than unity, this solution holds only for the region $0 < K < 1$.

(b) From equation (96), since $\tanh A/2$ cannot be greater than unity :

$$\begin{aligned} \tan \frac{B}{2} &= \infty \\ \frac{B}{2} &= \frac{\pi}{2} \pm n \pi \\ B &= \pi \pm 2 n \pi \dots \dots \dots (100) \end{aligned}$$

whence from equation (92) :

$$\tanh \frac{A + jB}{2} = \coth \frac{A}{2} \dots\dots\dots(101)$$

and the solution of equation (90) is of the form

$$A = 2 \coth^{-1} \sqrt{K}, \quad B = \pi \pm 2n\pi \dots\dots\dots(102)$$

Since $\coth A/2$ cannot be less than unity, this solution holds only for the region $K \geq 1$.

(c) Solving equation (95) :

$$\begin{aligned} \tanh^2 \frac{A}{2} &= 1 \\ A &= \infty \dots\dots\dots(103) \end{aligned}$$

whence from equation (92) :

$$\tanh \frac{A + jB}{2} = 1 \dots\dots\dots(104)$$

and B is indeterminate.

The solution of equation (90) is therefore of the form :

$$A = \infty, \quad B \text{ is indeterminate} \dots\dots\dots(105)$$

a solution which holds only for $K = 1$.

K Negative.

If K is negative, \sqrt{K} is imaginary and the real part of the expression (92) must be equal to zero. Again, there would appear to be three ways in which this might occur, but of these only one is admissible, namely :

$$\tanh \frac{A}{2} = 0 \dots\dots\dots(106)$$

whence from equation (92) :

$$\tanh \frac{A + jB}{2} = j \tan \frac{B}{2} \dots\dots\dots(107)$$

and the solution of equation (90) is of the form :

$$B = 2 \tan^{-1} \sqrt{-K}, \quad A = 0 \dots\dots\dots(108)$$

This solution only holds for the region $K < 0$.

APPENDIX II.

DESIGN FORMULÆ.

In view of the large number of equations involved in the text of the article, it is desirable to indicate the location of those expressions which are often required when designing a filter. These equations are therefore indicated in the tables below, as far as possible in the order in which they are likely to be used. The

first table refers to the case in which the three design parameters D, E and F are independent, and the second table indicates those expressions which are peculiar to the case in which D is the only remaining parameter.

TABLE I.
GENERAL CASE.

Function	Symbol	Variables	Equation
Roots for Infinite Attenuation ..	d_n	f_1, ∞, f_1, f_4	26
Design Parameter ..	D	d_n	23
Design Parameter ..	E	d_n	24
Design Parameter ..	F	d_n	25
Limiting Conditions for the use of Quartz Resonators ..	C_0/C_2	f_1, f_4, D, E, F	81
	C_1/C_3	f_1, f_4, D, E, F	82
Frequency Function Attenuation Constant ..	p	f, f_1, f_4	36
Frequency Function Phase Constant ..	A	p, D, E, F	38
Characteristic Impedance ..	q	f, f_1, f_4	41
Element Values ..	B	q, D, E, F	43
	Z_K	f, f_1, f_4, Z_0	7
Critical Frequency ..	L_0, L_1, L_2, L_3	f_1, f_4, D, E, F, Z_0	66-73
Critical Frequency ..	C_0, C_1, C_2, C_3	f_1, f_4, E	27
Shunt Resistor ..	f_2	f_1, f_4, D, F	28
Loss introduced by Resistance of Inductors ..	R_s	R_0, R	86
	A_R, A_S, A_T	R_0, R	87, 88, 89

TABLE II.
SPECIAL CASE.

Function	Symbol	Variables	Equation
Relationship between Parameters ..	D, E, F	—	31
Limiting Conditions for the use of Quartz Resonators ..	C_0/C_2	f_1, f_4, D	83
Attenuation Constant ..	C_1/C_3	f_1, f_4, D	84
Phase Constant ..	A	p, D	40
Element Values ..	B	q, D	44
	L_0, L_1, L_2, L_3	f_1, f_4, D, Z_0	74-80
Critical Frequency ..	C_0, C_1, C_2, C_3	f_1, f_4, D	32
Critical Frequency ..	f_2	f_1, f_4, D	33
	f_3		

Sulphate Attack on Concrete

H. E. MORRISH

A description is given of some recent cases of sulphate attack on concrete ; the cause is explained and the use of aluminous instead of Portland cement recommended in areas liable to sulphate corrosion.

Introduction.

THE question of the stability of Portland cement concrete when used underground has arisen and is of vital importance to all external engineers. It has been known for several years that Portland cement is liable to sulphate corrosion but until recently the possibility that this occurrence might be widespread has not been realised, and it is thought the experiences obtained in the North West Area of the London Region will be of interest and use to engineers in other areas.

During the inspection of manholes it was reported that two roadway manholes in Northwood Road,

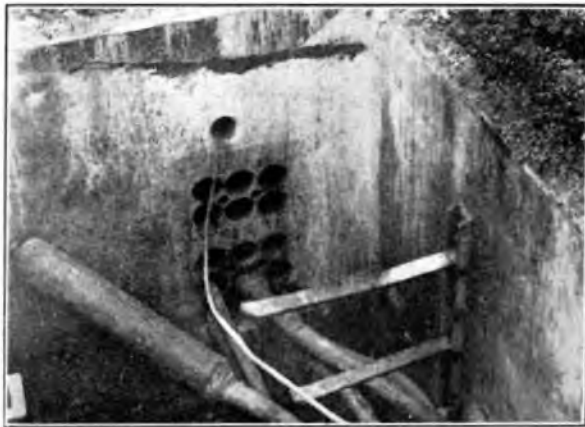

FIG. 1.—MANHOLE AFFECTED BY SULPHATE CORROSION.

Pinner, were in a bad condition. An examination of these showed that the whole fabric of the manholes was disintegrating. In one manhole the floor had nearly disappeared when the loose material was cleared away. The walls were bulging and when the cement rendering was knocked away the concrete was practically loose shingle. Similar trouble was found in manholes in the Colindale, Harrow and Harlesden areas. Sulphate corrosion was suspected from previous reports on the presence of selenite (calcium sulphate) crystals in the Edgware area and this was confirmed by analysis. Fig. 1 shows the effects of the corrosion as first seen from the inside of the manhole. The walls are liable to bulge and sound hollow when tapped. A white-grey deposit or sludge is generally found where the sulphate solution percolates through the concrete. Figs. 2 and 3 show the state to which the concrete is reduced after being attacked by the sulphate.

Causes of Sulphate Attack.

This sulphate attack on Portland cement concrete is caused by the action of any sulphates in the soil water on the calcium aluminate present in the cement. This

causes the formation of calcium aluminosulphate in the pores of the concrete and, as the compound contains a great deal of water of crystallisation, gives rise to a disruptive bursting stress within the concrete. The formation of this compound is only the first stage in the decay of the concrete, for the compound itself, when the chemical balance is slightly changed, is decomposed by the earth water and may be to a large extent washed away. This stage is, however, reached only after the damage has been done, and it is generally accepted that if the soil water contains more than about 350-400 parts per million of sulphate it is liable to cause deterioration of Portland cement concretes.

Most soils contain small amounts of calcium, magnesium and sodium sulphates, all of which may cause trouble if present in sufficient quantity. One of the more striking ways in which sulphate may be found in soil is as selenite ($\text{CaSO}_4 \cdot 2\text{H}_2\text{O}$) crystals. These crystals are liable to occur wherever clay occurs, especially the brown Middlesex clay. Fig. 4 indicates a sample of the crystals found on a recent job. Their formation appears to be due to the presence of clay stones occurring together with iron pyrites. The clay stones are calcium carbonate and the ferrous sulphate formed by oxidation of the pyrites acts on the former producing the calcium sulphate.

This knowledge forms a valuable guide to the liability of sulphate corrosion as the presence of selenite is readily detected when digging. In sunlight the crystals often sparkle and can be readily identified by inspection. When clean the crystals are transparent and flake similar to mica, for which they may be mistaken on first inspection.

Remedial Measures.

There remain two problems for the engineer dealing with this problem :—(1) does the presence of crystals in even minute quantities constitute a



FIG. 2.—EFFECT OF SULPHATE CORROSION.



FIG. 3.—FURTHER EFFECTS OF SULPHATE CORROSION.

liability to corrosion of Portland cement? and (2) what is the liability of a corrosive solution being carried into the manhole by ducts from a distance? Where water is encountered in an excavation intended for a manhole it is possible to obtain a quantitative analysis of this to ascertain whether the fluid is sufficiently strong to form a corrosive solution, but many cases occur where water accumulates only after the ducts have been laid and the manholes built.

The present examination of the London North West Area indicates that liability to the trouble can be expected wherever the brown clay sub-soil exists, i.e., North Paddington, Cricklewood, Colindale, Edgware, Harrow, Pinner; and no doubt it occurs throughout the area of the Middlesex clay sub-soil.

Where the existing manholes have failed to a dangerous extent, they have existed for seven to ten years, but a manhole less than one year old is under observation as effects of corrosion are already appearing. On existing work it is necessary to examine all concrete manholes and this is being done as inspections are made. On new work all works supervisors have been instructed to examine carefully all excavations made in clay and a number of samples have already been submitted for test and instructions. It would, however, be more satisfactory to be able to



FIG. 4. SELENITE CRYSTALS.

test on site, and the development of a convenient and simple field test would be of great assistance.

The remedy at present being applied in places affected by concrete corrosion is to employ concrete made with aluminous cement. Although slightly more expensive than Portland, aluminous cement is immune from the effects of sulphate. The extended use of aluminous cement will bring with it the need for the study of its peculiarities. It sets hard in a few hours and, due to its rapid chemical action, produces considerable heat. This characteristic necessitates mixing quantities which can be used or placed in position immediately, and the generation of heat requires more water to compensate for that lost by evaporation. The manufacturers warn users against too rich a mixture of their product, and the following specification has been issued in advance of an Engineering Instruction on the subject:

(1) The grading of the mixture for manholes and similar structures will be 1-2-4 when Cement Fondu is used.

(2) The water added to this mixture is of importance and the specified amount is a minimum of 4.5 and maximum of 5.5 gallons to each cwt. bag of Cement Fondu.

(3) To secure adequate setting and waterproof finish it is necessary to give water treatment to the concrete as follows:—Floors and walls, remove shuttering after 10-12 hours from mixing, spray or wash with water or line with wet sacks. Roofs or suspended spans should receive similar treatment after 16 hours from mixing.

Conclusion

The appearance of some of the damaged manholes is so bad as to make one wonder whether it would not be better, in areas where damage is known to occur, to cease using Portland cement and to make all underground structures in aluminous cement. This pessimistic view does not, however, appear to be warranted, for when the problem is viewed in its proper perspective it is realised that only a very small proportion of concrete manholes and other buried structures has been damaged. Some comfort may also be derived from the fact that fresh cement concrete is much more liable to damage than that which has been aged, so that structures which have shown no signs of trouble for some years may, for the most part, be regarded as immune. This leads also to the thought that provided aggressive earth waters can be kept away from the cement until it is decently aged, less trouble may be anticipated.

There is also the other thought, that even in the Middlesex clay there are a fair number of buildings with concrete foundations which do not, as yet, show signs of tottering!

The Ladder Derrick for Overhead Work

H. TRUSSLER, A.M.I.E.E.

IN a previous issue of the JOURNAL, Vol. 28, April, 1935, a simple travelling derrick for overhead work was described. At that time the derrick had been used very successfully in an experimental form. An improved model differing slightly from the original experimental one is now available, and will no doubt be in general use shortly. A short description of the improved fittings and the experience gained in the past three years may therefore be of interest.

General Description of Fittings.

Fig. 1 illustrates the derrick erected on a 30-cwt. W.D. type Morris vehicle in readiness to commence operations in the erection of aerial cable. The ladders are part of the normal tool kit of an overhead construction gang, and the remainder of the apparatus necessary is as follows:—

- (a) 1 set of fittings for the ladders.
- (b) 1 set of fittings for the stay.
- (c) 17 lbs. of 2-in. hemp rope.
- (d) 2 lbs. of $\frac{1}{2}$ -in. swivel stays.
- (e) 2 $\frac{3}{8}$ -in. screw pin D shackles.
- (f) 2 chimney irons.



FIG. 1.—THE LADDER DERRICK

Ladder Fittings.—This item consists of a channel steel base of generous dimensions which is made adjustable for use with either a 30-cwt., 2-ton or 3-ton type open body vehicle. At each end of the base a strong hinged clamp is fitted to hold the ladders. The base is secured across the body of the vehicle by four steel bolts, the heads of which fit into two channel steel members which extend underneath the body and for the width of the vehicle. These bolts are fitted with wing nuts for simplicity in handling, and they clamp a short hard wood beam over the base on each side of the lorry.

Stay Fittings.—In order that there shall be no undue strain on the fixings that hold the body to the chassis of the vehicle, a wire stay is provided for each side with a claw fitting for attachment to the chassis,

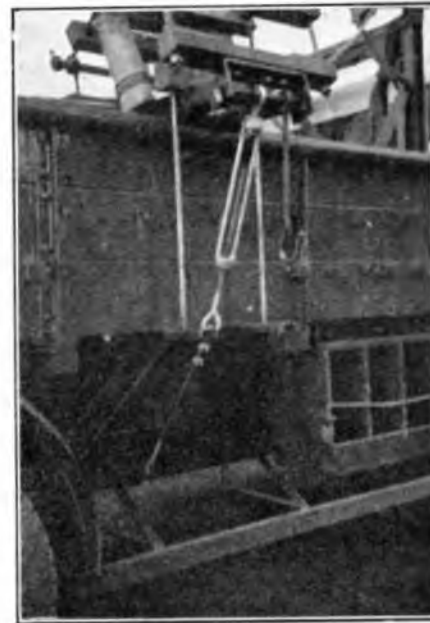

FIG. 2.—FITTINGS ON ONE SIDE OF THE VEHICLE.

and a swivel stay for attachment to the hinge of the base clamp.

Hemp Rope.—The 2-in. rope is to provide the necessary fore and aft stays from the tops of the ladders to the pole stanchions of the vehicle.

Chimney Irons.—These are arranged to prevent the wire stays chafing the bodywork of the vehicle.

Shackles.—Two screw pin D shackles are intended for use when the erection of aerial cable is to be carried out.

Included in ladder fittings is a double-hinged clamp of high tensile steel which is used to couple the tops of the ladders together. This type of steel, a high manganese alloy, has been used for all highly stressed parts to achieve reduction in overall weight. Fig. 2



FIG. 3.—TOP CLAMP IN POSITION.



FIG. 4.—ERECTION OF DERRICK.

shows one side of a vehicle with the fittings in position, but omitting the chimney iron for protection of the body.

Erection of Derrick.

The base is fitted across the body of the vehicle and clamped at a point approximately 3 ft. from the rear of the driver's cabin. The side stays may then be attached and adjusted. Two stout ladders of a length suitable for the work to be undertaken are selected and laid side by side in the road at the rear of the vehicle. The top clamp may then be fitted to hold one ladder between the 5th and 6th rung from its top, and to hold the other or tie ladder between its top and second rung. A bight of the 2-in. rope should be made off to the clamp so that it will form the fore and aft stays later.

Fig. 3 illustrates the attachment with ladders 21 ft. 6 in. long. Three men and the lorry driver should be capable, using ladders of medium length,

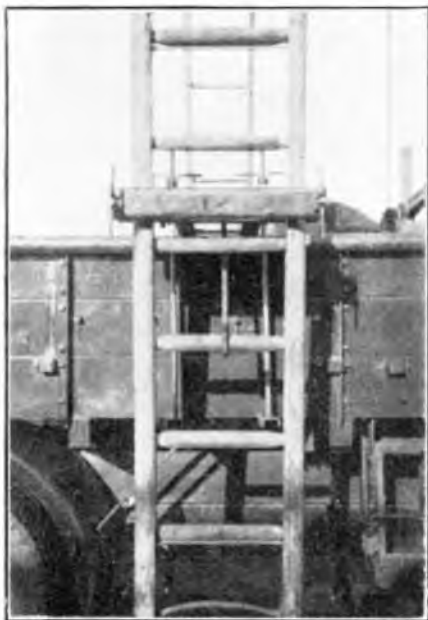

FIG. 5.—USE OF HOOK ON BASE CLAMP.

to erect the ladders, similar to a painter's trestle, astride the lorry and opposite the clamps at the base, Fig. 4.

The ladders may then be fitted into the base clamps and secured one at a time, and to facilitate this operation a hook is fitted on each base clamp to engage with and hold the ladder rungs in position while the clamps are tightened. It will be apparent from Fig. 5 that this hook also fulfils the important function of a guide to ensure that the clamps bear on the stiles of the ladders midway between rungs, which is the strongest part of the stiles.

Adjustments for Height and Overhang.

Adjustments for the height and overhang of the working position without changing the ladders, by moving the ladders up or down as may be necessary in the base clamps, are made possible within the limits of 5 ft. 6 in. for height, which is the approximate



FIG. 6.—DERRICK USED WITH MAXIMUM OVERHANG.

height of the base from the ground, and by inclining the vertical ladder to an angle up to 25° from the vertical position, which enables work to be reached at 8 ft. from the side of the lorry in a horizontal direction when there is average road camber. Fig. 6 indicates a typical example where aerial cable was erected using marline suspenders which are now obsolete.

In places where a route crosses the road it may be advantageous to adjust the ladders to "A" formation or extend the vertical ladder upwards in the clamp until it becomes in effect the tie ladder as in Fig. 7.

General Uses of Derrick.

The derrick may be used with advantage on many works which are near the roadside to effect a considerable saving in time, material and effort on the part of the men concerned where the road is not unduly obstructed by its use. One obvious disadvantage is that a considerable amount of road width may be taken up by the foot of the tie ladder projecting from the side of the lorry. This difficulty can be overcome by using a double clamp similar to the one used to couple the ladder tops together, rearranged to hold the foot of the tie ladder to the base within the body of the vehicle. This, however, necessarily

limits the adjustment to some extent; for overhang, the adjustment is obtained by moving the foot of the tie ladder towards the centre of the base, or, in other words, by shortening the base of the triangle (Fig. 8). This modification and others designed to reduce the danger due to road traffic are under consideration.

Examples of works that have been satisfactorily completed in the South Western District using the derrick as a mechanical aid are as follows:—

(1) Placing game guards on wires already erected. The guards may be secured to the wires as they are when new wire is erected.

(2) Tree cutting (Fig. 9). When the derrick can be used tree growth may often be removed by using shears or a small saw. Less cutting is necessary and it may usually be done without removing limbs from the tree. The necessity for men to climb the trees and work in precarious positions is avoided, and many of the serious accidents attending tree



FIG. 7.—DERRICK USED IN VERTICAL POSITION.

cutting activities can be avoided. All necessary tools are carried in the lorry and little time is spent in moving from point to point along a route. Generally speaking, short ladders are the most satisfactory for this work—16 ft. 6 in. to 18 ft. 6 in. long. One pruning rod with the shears or saw then gives a man a wide field for work.

(3) Aerial cable may be erected by the following method in suitable circumstances. The steel suspending strand is first erected by mounting the drum of wire in the lorry and using the derrick to enable a man to bore the poles and fit the suspender in the clamp at each pole. After the suspending strand is erected the cable drum may be mounted in the lorry and the end of the cable passed from the bottom of the drum forward, over the cab of the lorry, and through a snatch block attached to the steel suspender by the screw pin D shackles. This allows the snatch block and shackle to be drawn along the suspender



FIG. 8.—MODIFICATION TO REDUCE WIDTH OF BASE.

by a man on the ground with a sash line in front of the lorry. With the cable end made off fast to a pole, and two men on the derrick placing rings, the erection may proceed as one continuous operation without the use of petroleum jelly, each man continuously employed but by no means overworked. Five men in addition to the driver are required, one to take care of the revolving drum of cable, two placing rings, one if required to attend to the bight of the cable at the driver's cab, although he may be dispensed with if a pulley block is attached to the front pole bolster on the lorry. The fifth man draws the snatch block along the steel suspender, keeping it approximately 8 ft. in front of the men ring-



FIG. 9.—DERRICK IN USE FOR TREE CUTTING.

placing. This man may draw the steel suspender towards the men on the derrick if necessary as mid-span is approached. It is an advantage if a joiner is a member of the party so that any necessary cable joints can be made in the lorry or on the ground, while the remainder of the gang are engaged in



FIG. 10.—DERRICK USED TO ERECT AERIAL CABLE

getting a new drum of cable into position in the lorry ready for the next section. Fig. 10 shows a typical work in progress in the Exeter Section. The lorry driver can be of great assistance if he is provided with a driving mirror attached to the radiator cap of the vehicle to enable him to observe the work on the top of the derrick. The mirror is of no value in rainy weather, of course. It is advisable to arrange that, wherever possible, the derrick travels in a forward direction down any inclines encountered in order that the clutch of the vehicle is not subjected to undue wear.

A small cable has been replaced with a larger cable by a similar operation, the cable rings being taken off, fitted to the larger cable and the small cable left in temporary marline ties. After the circuits had been diverted to the larger cable the smaller one was recovered.

(4) Replacing perished marline suspenders on older aerial cable routes by cable rings can be rapidly accomplished.

(5) Aerial cable maintenance and fault location and clearance is simplified. Many faults and breakdowns of aerial cable have been due to punctured lead sheaths as a result of rings chafing or by being damaged by pellets from sporting guns. Numerous examples are on record of such faults being located and cleared within four or five hours in inclement weather by the following method.

At a convenient point, say, midway in a one-mile length of aerial cable, a nozzle from a joiner's portable dessicator has been introduced to the cable sheath and coupled up to the pump by two lengths of hose. With air pressure applied and maintained in the cable a man mounted on the derrick is able to ascertain the position of the puncture or fracture by listening for an escape of air as he travels along the route. The fault can then be cleared by drying out the cable, using an oven experimentally designed for the purpose.

(6) Observations on the behaviour of certain items of overhead plant by supervising officers and others under actual working conditions is facilitated. The writer was enabled to observe the behaviour of a small aerial cable in an exposed situation during a gale. The cable sheath had been badly chafed by the cable rings and it was desired to obtain some information on the cause if possible. It was observed that the cable was actually vibrating up and down in the rings as a result of the vibrations set up by bronze wires on the same route being transmitted to the steel suspender via the pole heads. Two methods of damping the vibrations were tried, one was to slacken the steel suspender and the other to fit a catenary wire. Sufficient experience has not yet been obtained to determine which is the better method, but the latter is preferred if it is as effective as it promises to be.

Conclusion.

Mild steel was mainly employed for the bolts in early fittings and these have been substituted by high tensile steel. Nevertheless, it was desired to confirm that the derrick was sufficiently strong and rigid and Fig. 11 shows a rough test applied to determine the safety of the outfit, in which four



FIG. 11.—DERRICK SUPPORTING THE WEIGHT OF FOUR MEN.

men whose total weight is 52 stones were suspended by ropes from the top of the derrick set to an angle of 25° before the weight was applied.

Acknowledgments with thanks for the facilities and assistance given in producing this article are due to officers in the South Western District and the Engineer-in-Chief's Construction Branch.

From Satellite to Main Exchange

W. D. GRAY, B.Sc. (Eng.), A.M.I.E.E.

A description is given of the method adopted at the conversion of Radlett exchange, Watford, from satellite to main exchange working.

Introduction.

RADIETT exchange, which had worked as a discriminating satellite on Watford (non-director) since June, 1931, was successfully converted to main exchange working on 16th October, 1938.

The writer wishes to take this opportunity of recording that this result was in no small part due to the close co-operation of the contractor (Messrs. General Electric Co.) with the several groups at the London Telecommunications Region headquarters, and to the clear grasp of the requirements by the contractor's and Post Office representatives on site.

Owing to the urgency with which the change was required and the limited accommodation available, a method of carrying out the conversion by modifying the existing equipment, and providing the minimum of new plant, was adopted.

This was the first occasion on which a conversion of this type had been effected in this country (or in any other country as far as the writer is aware), and in view of the likelihood of similar changes being required in other multi-exchange areas in the near future, a description of the problems met with and of the method adopted at Radlett will probably prove of interest.

Watford Multi-exchange Area.

To appreciate the considerations which led to the decision to change the method of working at Radlett, a brief description of the Watford area is desirable.

Watford automatic exchange was opened on June 13th, 1931, with two discriminating satellites, Radlett and King's Langley. A further exchange, Garston, was planned to be converted from manual to satellite working at a later date, but, when the time came to design that exchange it was decided, for reasons which will be given later, to make it an independent non-director exchange.

From the original numbering scheme for the Watford area, shown in Table 1, it will be seen that 4-digit numbers were to be allotted initially, with the introduction of 5-digit numbers later. Conditions have, however, changed considerably in the meantime. The London director area now occupies a circle of 12½ miles radius, as against 10 miles previously, and the volume of traffic between London and the Watford area is such that, to facilitate completion of calls from the director area to Watford subscribers, it has been found preferable to restrict the digits comprising a subscriber's number in the Watford area to four.

Accelerated development in this area has resulted in the four-digit numbers becoming exhausted at a

TABLE 1.
Watford M.E. Area.

Exchange	Multiple Range	
	Initial	Ultimate
Watford ..	2,000-5,599	2,000-5,899 59,000-59,999 80,000-81,999
Radlett ..	6,100-6,899	6,100-6,899 69,000-69,999
King's Langley Garston ..	7,100-7,599	7,100-7,999 89,100-89,999

Dialling Codes	
Garston	81
Bushey Heath ..	82
Elstree	83
Hatch End	84
Northwood	85
Pinner	86
Rickmansworth ..	87
Stanmore	88
Service levels ..	91-93, 95-90
Trunks	94
Assistance, etc. ..	0

date much earlier than was anticipated when the numbering scheme was prepared. At Radlett the 800 multiple (6,100-6,899) required increasing as early as possible. There was no other level available at Watford for this purpose—in fact, similar difficulties were being experienced with the Watford multiple—and as the alternative to the use of 5-digit numbers, the proposal to free Radlett from the Watford numbering scheme was put forward. In favour of this was the

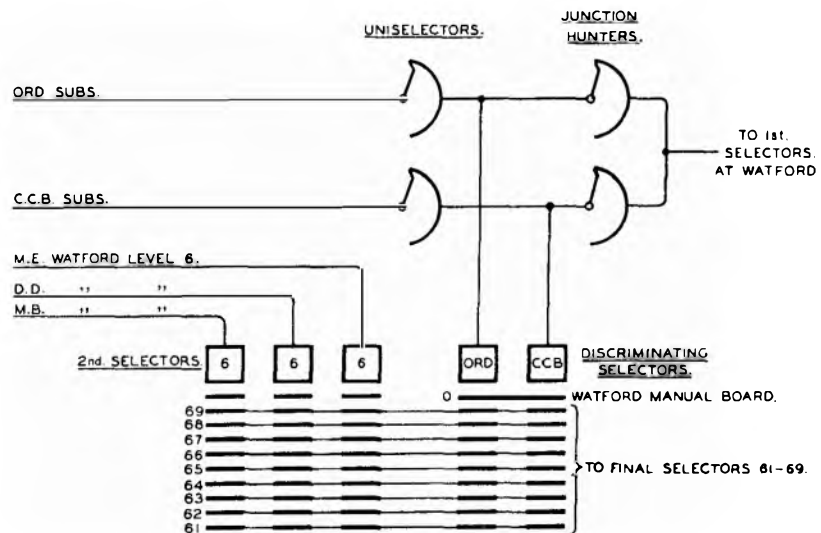

NOTE. THE DISCRIMINATING SELECTORS ABSORB "6" AS A FIRST DIGIT.
FIG. 1.—TRUNKING DIAGRAM OF RADLETT SATELLITE EXCHANGE

fact that its adoption would allow level 6 at Watford to be used for an additional 1,000 multiple there. In addition, it was found on investigation that, in the light of present standards, satellite working would not now be provided at an exchange like Radlett. In fact, the other proposed satellite, Garston, which remained manual until October, 1938, was then opened as a main non-director exchange.

The foregoing were the chief considerations which led to the decision to convert Radlett to a main exchange. The same conditions apply to Kings Langley, and conversion of this exchange will take place in the near future.

Conditions Before and After Conversion.

Fig. 1 gives the trunking arrangements at Radlett just prior to its conversion to main exchange working. Until recently, level 9 was trunked direct to 2nd selectors at Watford for trunk demand traffic, etc., but as an expedient to give an additional 100 multiple it was found practicable to pass trunk traffic over the multi-exchange junction group and to utilise level 9 for multiple.

The discriminating selectors were arranged to absorb the digit "6" as a first digit, and all traffic, other than local and level "0" traffic, was routed via the junction hunters to 1st selectors at Watford.

Fig. 2 is a trunking diagram showing the conditions at Radlett immediately after the conversion. With the following exceptions this is in accordance with standard non-director practice:—

- (1) Level 9. The direct route from this level to 2nd selectors at Watford has been restored, so that Radlett subscribers may continue to dial 94 for trunk demand and also to obtain the usual level 9 service without change of dialling code.
- (2) Manual board group. Access to the outgoing levels 2, 3 and 4, which is desired for testing and emergency purposes, has not been given to this group. The reason for this will be seen later when the method of conversion is dealt with.

From the subscribers' point of view, the conversion involved changes in dialling codes, or the use of codes for calls which had previously been completed by dialling the subscriber's number only. The old and new codes are shown in Table 2.

Schemes of Conversion.

It was originally envisaged that the discriminating selectors would be replaced by 1st selectors and a new rank of 2nd selectors introduced. Although this at first sight appears attractive, there are several points which must be considered. The standard 1st selector for a uniselector exchange of "pre-2,000" type provides for booster metering over the private wire, whereas the normal method in use at a discriminating satellite exchange is earth-metering over a fourth wire. It is thus not possible to provide standard 1st selectors in

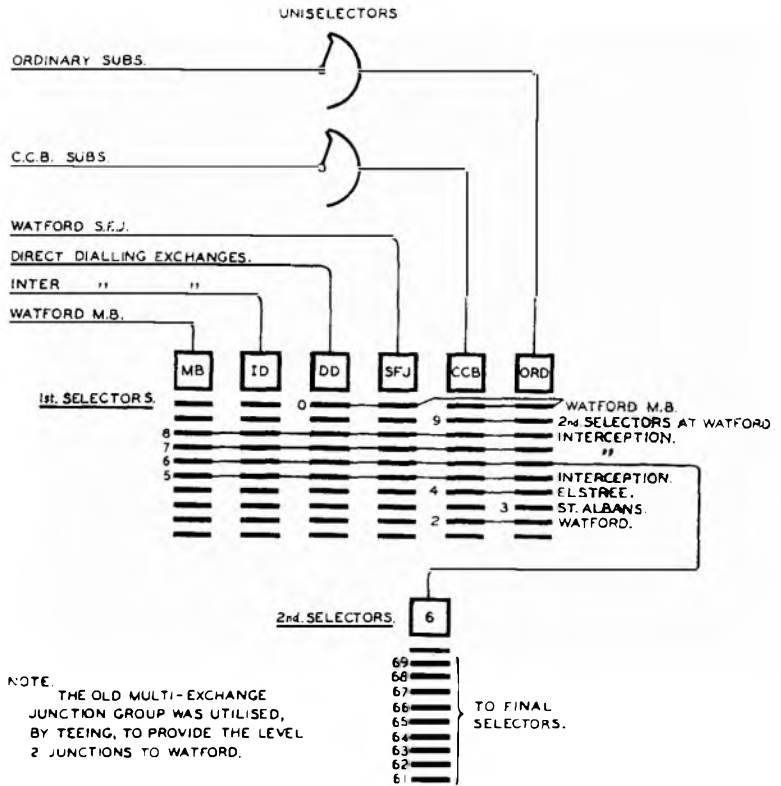

FIG. 2.—TRUNKING DIAGRAM OF RADLETT MAIN EXCHANGE.

place of the discriminating selectors without making other major changes.

The following is a brief account of some of the methods which were considered:—

- (a) Provide standard 1st selectors and replace existing line and final units.

This is practically equivalent to replacing the entire automatic equipment and where suitable accommodation is available has everything to commend it. At Radlett there was not sufficient space for this, and in addition the large amount of new plant required would have prevented the conversion being carried out as early as was necessary.

- (b) Provide standard 1st selectors and modify existing line circuits.

TABLE 2.

	Codes dialled by Radlett subscribers	
	As a Satellite	As a Main Exchange
Radlett ..	Sub.'s number	Sub.'s number
Watford ..	" "	2 + " "
King's Langley ..	" "	2 + " "
Elstree ..	83 + " "	4 + " "
Garston ..	81 + " "	281 + " "
Bushey Heath ..	82 + " "	282 + " "
St. Albans ..	0	3
Hatch End ..	84	284
Northwood ..	85	285
Pinner ..	86	286
Rickmansworth ..	87	287
Stanmore ..	88	288
Trunk demand ..	94	94
Assistance and other exchanges	0	0

The writer is not prepared to say that this is completely impracticable, but the obvious difficulties (i.e., two methods of metering in use at the same time, or else some form of change-over scheme for metering) were such that no detailed investigation was made.

(c) Provide non-standard 1st selectors.

These would be designed to work with the existing line circuit. It is obviously undesirable that development work should be carried out on a non-standard circuit. Even if it were done the time required for this development work and for manufacture would be considerable.

(d) Modification of discriminating selectors to function as 1st selectors.

Simple modifications to the shelf wiring only for the "ordinary" selectors, with slight changes to the wiring of the coin-box selectors, can be made to cut out the junction hunter and to render inoperative the absorbing and junction discriminating features. These modifications will allow the existing line and final units to be retained and used without any changes whatever. The only additional equipment required specifically for the conversion, by this method, is a new rank to serve as 2nd selectors. A minor point in favour of this scheme is that, as a transmission bridge exists in the modified selector, outgoing routes to automatic exchanges need not be provided with the usual relay set. This results, however, in the manual board selectors, which are of the ordinary group selector type, having to be barred access to these outgoing levels, as the transmission bridge in the modified discriminating selector is not then in circuit.

The fact that this method results in an exchange with non-standard local 1st selectors is a point against its adoption, but as a means of alleviating numbering scheme difficulties, and thus increasing the possible life of an exchange, the scheme has much to commend it. It was considered to be the one best suited to the conditions at Radlett and was therefore adopted.

The remainder of this article deals with the application of this method at Radlett.

DETAILS OF THE RADLETT CONVERSION

General.

Referring back to Table 2, a comparison of the codes to be dialled by subscribers under the two methods of working shows that it is essential for the conversion to take place at some predetermined time, and not piecemeal. Subscribers must receive notification that, at the specified time, their new dialling codes should be used, and from that time the exchange equipment must respond correctly to the new codes.

Subscribers on Watford and its remaining satellite (King's Langley) were also concerned. Instead of dialling the subscriber's number only for a call to Radlett, they must be notified to precede it by a dialling code from the advertised time of change-over.

At nearby director exchanges the dialling codes for Watford and Radlett were previously given the same translation and the calls routed to Watford 1st selectors. Under the new conditions the Radlett translation required amendment to include the digits necessary at Watford to route the call to the level outgoing to Radlett.

The problem was thus to maintain service up to a specified time under satellite working and then, with the minimum possible break, to bring into use modified equipment which would function as a main exchange. To attain this a portion of the equipment had to be withdrawn from service several hours before the change-over, and the whole of the plant could not be restored to service until several hours after the conversion. These considerations led to the choice of midday on a Sunday (the day of lightest traffic) as the time of cut-over.

The total amount of equipment available at the exchange thus has an important bearing on the conversion arrangements. At Radlett a contract extension was in progress; in fact the conversion was embodied as part of the extension, and the additional plant thus provided enabled a satisfactory grade of service to be maintained during the day of cut-over.

The racks in service before and after the conversion, together with their designations, are shown in Table 3.

TABLE 3.
Racks at Radlett before and after the Conversion.

Before	After
D.S. A	1st A (modified discriminating selectors) 1st B (new rack of modified discriminating selectors)
6 A (incoming 2nd selectors)	1st C (incoming 1st selectors) 6 A (new rack of 2nd selectors)
Line and final units	No change

Discriminating Selectors.

As mentioned previously, the scheme adopted included modifications to the discriminating selector circuits to cut out the absorbing and junction discrimination features and to render inoperative the junction hunters. In addition, it is necessary for dialling tone to be given as soon as a selector is seized. It is not proposed to give details of these circuit changes, which will naturally vary at different exchanges, dependent on the circuit of the existing discriminating selectors. There is, however, one point worthy of special note, as neglect to make the requisite changes will not be revealed by the ordinary tests made before the cut-over. Dialling tone from a discriminating selector is usually supplied only when all the multi-exchange junctions are in use, i.e., on a small percentage only of the total calls; at other times it is furnished by the main exchange 1st selectors. The dialling tone supply circuit to the discriminating selectors is, therefore, not designed to carry the load which will be imposed after the selectors have been modified to work as 1st selectors and supply dialling tone on all calls. This difficulty was overcome at Radlett in the first instance by replacing the 0.02 microfarad condenser, which was fitted on each shelf, by one of 0.5 value. Later the dialling tone was fed direct from a transformer on each rack.

The change-over from the old to the modified discriminating selectors was carried out as follows :—

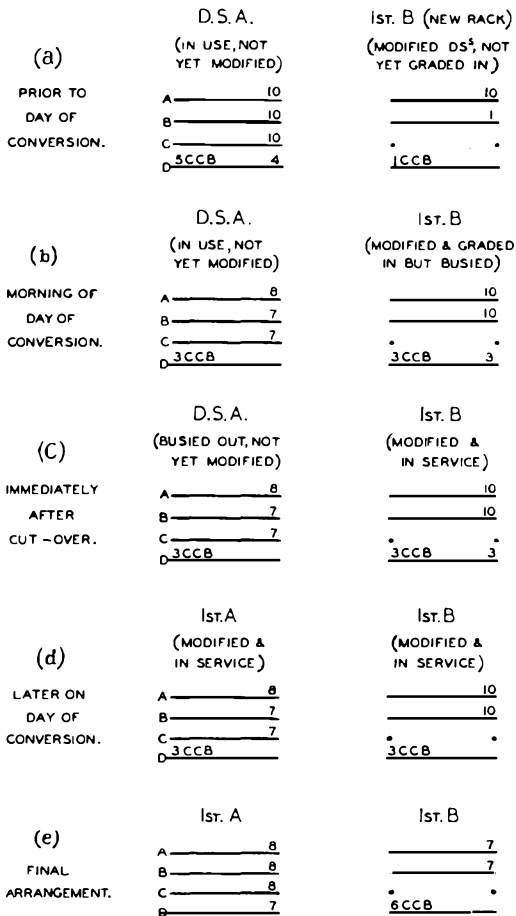

FIG. 3.—EQUIPMENT OF D.S. (1ST SELECTOR) RACKS AT VARIOUS STAGES.

As shown in Fig. 3 (a), a new rack, 1st B, equipped with eleven ordinary and one C.C.B. (coin collecting box) selectors fitted on shelves with modified wiring, was supplied as part of the extension. These selectors were not included in the uniselector grading until a few hours before the change-over, service being given by the thirty-four ordinary and five C.C.B. discriminating selectors existing on rack A.

On the morning of the change-over the selectors were rearranged as shown in Fig. 3 (b) and the uniselector grading modified to include all the selectors, those on rack B, however, being busied out. This reduced the selectors in service for ordinary subscribers from 34 to 22, a number ample for carrying the Sunday load.

At the cut-over (mid-day) all selectors on rack A were busied out and those on rack B brought into use. This arrangement is shown in Fig. 3 (c), and gives 23 selectors available for ordinary subscribers.

The shelf wiring of rack A was then modified and wiring changes made to the C.C.B. selectors. This rack was then restored to service, see Fig. 3 (d).

The next stage was to re-arrange the selectors, as shown in Fig. 3 (e) and to modify the uniselector grading to suit. The object

of this was to equalise the traffic per shelf and also to concentrate the C.C.B. selectors on shelf D of rack B. This shelf was then cut out of level 3 grading, to bar the C.C.B. subscribers from having access to the exchange served from this level (St. Albans CB exchange.)

TABLE 4.
Levels of Discriminating Selectors.

Level	Before Conversion		After Conversion	
	Access to	Ccts	Access to	Ccts
0	Watford MB	26	Watford MB ..	26
9	Final selectors	8	Watford 2nd selectors	5
8	" "	8	Interception ..	5
7	" "	8	" ..	5
6	" "	8	2nd selectors ..	44
5	" "	8	Interception ..	5
4	" "	8	Elstree ..	3
3	" "	8	St. Albans ..	3
2	" "	9	Watford ..	16
1	" "	8	N.U. tone ..	—

1st Selector Levels.

Table 4 shows the requirements before and after the conversion. With the exception of level "0" it was necessary for each level to be switched from a final selector group to one of the following :—

- (1) Outgoing junctions
- (2) 2nd selectors
- (3) Service interception
- (4) N.U. tone.

On most levels it was also necessary either to increase or to decrease the number of outlets.

This was achieved by grading each level for the larger of the two numbers of circuits, and by cabling from the outgoing blocks on the grading frames to keys specially provided for the change-over. With the keys normal the required number of outlets to final selectors was obtained, and throwing of the keys changed over the outlets, at the same time giving the desired change in the number of circuits by suitable commoning of the key springs.

Fig. 4 shows the arrangement adopted for level 6,

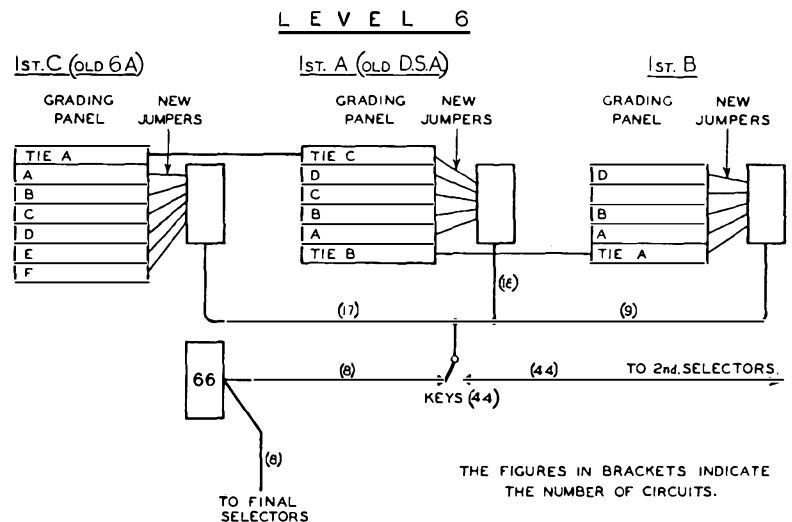

FIG. 4.—CHANGE-OVER ARRANGEMENTS FOR LEVEL 6.

which had to be changed over from 8 final selectors to 44 2nd selectors. The existing terminal block on rack C, with its cabling to the final selector unit, was utilised, but the block was temporarily displaced to allow the new block to be fitted in its permanent position. This block and the new ones on racks A and B were cabled as shown to the 44 keys for this level. The outlets from the resting springs were cabled back to the unit 66 block on rack C, and the make springs cabled to the new 2nd selectors. The level 6 grading for 44 outlets was then made, and the existing jumpers to the unit 66 block recovered.

The other 8 levels were treated similarly, but with the exception of level 2, which required 16 outlets, all levels had less than 10 outlets and cabling to the keys was therefore necessary from only one of the racks.

The method of wiring the keys for level 2 is given in Fig. 5. The change required was from 9 final selectors to 16 junctions.

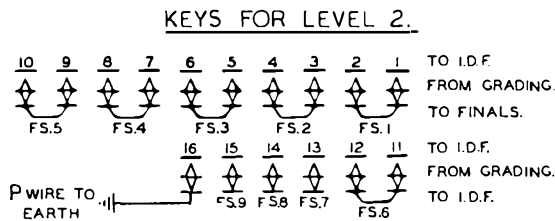

FIG. 5.—METHOD OF WIRING KEYS FOR LEVEL 2.

On all full-availability groups access was given to all the circuits during the periods when modifications were in progress on the day of change-over. On other levels, however, this was not possible. While rack B alone was in use for 1st selectors, 10 only of the 16 outlets from level 2 were available; on level 6 only 29 of the 44 2nd selectors could be used, and only 14 out of the 26 level "0" circuits. These quantities were quite sufficient for the Sunday traffic.

Level 5 is shown in Fig. 2 and Table 4 as connected to service interception. This was done in case Radlett subscribers omitted to use their new dialling code when making calls to the Watford 5000 series of numbers, but a few weeks after the conversion this level was trunked out to a further group of 2nd selectors, thus opening up additional multiple.

2nd Selectors (Level 6).

These were new selectors, fitted on a rack provided by the Contractor, who also installed a standard type trunk distribution frame to serve their levels. The outlets were jumpered to terminal blocks cabled direct to the final selector units, so that there were two cables incoming to each unit. As the incoming side of the 2nd selectors was disconnected at the keys, this arrangement in no way interfered with the normal working of the exchange.

Incoming Selectors.

Under satellite conditions these functioned as 2nd selectors as their levels were trunked out with the

discriminating selector levels. After the conversion these selectors remained in use for the incoming junctions, but under the new conditions they became 1st selectors.

Change-Over Operations.

The actual change-over consisted of the following three simple operations, carried out in the order shown:—

- (1) Insertion of busying markers in all selectors on rack A.
- (2) Throwing of the change-over keys.
- (3) Withdrawal of busying markers from the selectors on rack B.

These operations occupied about one minute. Tests carried out immediately afterwards proved that all the desired changes had been effected and that the equipment was functioning correctly as a main exchange.

The only work remaining, apart from the recovery of all temporary cabling etc., was the modification and subsequent restoration to service of rack A, which has already been described.

Other Points of Interest.

Although Radlett exchange was known to subscribers under its own name the conversion had the same effect, in some respects, as would have resulted from the establishment of a new area. For instance, a new route from Toll "A" exchange to Radlett (via S.F.J. keysending position at Watford) had to be introduced and all toll control manual boards notified that calls to Radlett must be passed over this new route and not via the Toll "A"—Watford route as hitherto. Similarly a new route from Trunks to Radlett was necessary.

Coin-box lines on Watford and Kings Langley, which had previously obtained Radlett in the same manner as ordinary lines by the dialling of the number only, had now to be given access to the level at Watford outgoing to Radlett, so that they could obtain Radlett by using a dialling code. At the same time they had to be barred other outgoing levels to which, as coin-box lines, they should not be given access.

At Watford it would have been possible to have retained Radlett on level 6 (see Table 1), but as this level was required for multiple, and the amount of traffic to Radlett was not sufficient to justify a level of the 1st selectors, change-over keys were provided at Watford to switch Radlett from level 6 to level 89.

Conclusion.

Although details of all the grading changes and the connections of all the levels to the change-over keys have not been included, it is hoped that sufficient detail has been given to illustrate the method used, and that this will assist in preventing from being overlooked, in other conversions of this nature, the large number of items requiring attention.

Music Channels

F. J. D. TAYLOR, B.Sc. (Eng.)

The author surveys the performance required from music channels and the existing and contemplated methods of meeting these requirements.

Introduction

THE term music channel is used in this article to mean a channel which may be of considerable length and which is used as a main distributing link; this article is not concerned with the provision of links between a central point and subscribers such as may be used in wire broadcast systems. Music channels are rented by the B.B.C., by wire broadcast and re-diffusion services, and by subscribers requiring special circuits for public address purposes. They may also be required for high definition picture telegraphy transmission. A network of such circuits has been provided in this country, some maintained on a permanent basis, whereas others are set up as and when required.

Circuit Requirements.

As is well known, normal telephone channels produce considerable distortion in the transmitted speech wave-form but, provided the distortion does not exceed certain limits, the intelligibility of the received speech is adequate for commercial purposes. If, however, the circuit is required to transmit music or speech for entertainment purposes it is essential that the distortion introduced by it shall be very small; hence circuits provided for such purposes differ very considerably in construction and performance from those provided for purely telephone purposes. The principal requirements of a music channel may be summarised as follows:—

- (1) It must transmit effectively frequencies ranging from at least 50 c.p.s. to 6,400 c.p.s.
- (2) Such frequencies must be transmitted with very little frequency, amplitude and harmonic distortion.
- (3) Noise and cross-talk interference must be negligibly small.
- (4) If used for high definition picture telegraphy the phase distortion must be small.
- (5) It must not be subject to interruptions.

In the past it has been customary to provide music channels of considerable length on special screened pairs which have been provided in a number of main underground cables, or on specially selected unshielded pairs. Generally the loading when used has been 16 or 22 mH at 2,000 yard intervals, these loadings producing cut-off frequencies of approximately 9,300 and 7,900 c.p.s. respectively. (Transmission may be considered effective up to some 80 per cent. of the cut-off frequency.) Using unshielded pairs a selection has been made to find pairs subject to a suitably small degree of interference, and having the required transmission band width. In exceptional circumstances unloaded pairs or unloaded phantoms are used; this applies particularly to short links required for special occasions such as outside broadcasts by the B.B.C. When unloaded phantoms are used it is usual to stop the circuits working on the sides during the period of the broadcast.

Frequency distortion, which is that due to change of line attenuation with frequency, is corrected at suitable intervals either by networks incorporated in

the special "music repeaters" or by 2- or 4-element networks inserted in the line at a point preceding the repeater. Equalisation within the repeater is effected by resonant circuits placed usually in the input circuit of the repeater. Two-terminal resonant networks which are usually used as a shunt across the line, have the disadvantage that the equalisation produced is due partly to the impedance mis-match, and this may cause difficulty when making line measurements. The most common form of equaliser used on present-day circuits is of the 4-terminal constant impedance type, and this arrangement has much to commend it.¹ Design is relatively straightforward and does not upset any impedance match arrangements.

As presented to a renter a circuit is usually equalised to within about ± 1 db. For circuits required for special events by the B.B.C. (Outside Broadcasts) each requirement is considered on its merits and, when possible, the Post Office undertakes the necessary equalisation. When the required degree of equalisation cannot be effected by the Post Office, the B.B.C. carry out equalisation on their own equipment. It is sometimes found that the local line and terminal equipment also introduce frequency distortion, and in this case the renter arranges for the provision of the additional equaliser.

Amplitude and harmonic distortion may be caused in loading coils and in repeaters. They are kept small by ensuring that the loading coils are called upon to carry currents of small amplitude only, so that saturation effects are eliminated, and in repeaters by reducing the effect of valve characteristic curvature and effects due to iron cored coils.

Cross-talk interference is kept at a minimum

- (a) by care in layout and screening of equipment in repeater stations and
- (b) by using screened or specially selected unshielded cable pairs.

A circuit which is satisfactory from the point of view of cross-talk interference is usually satisfactory from the point of view of induced noise such as electric power interference, etc.

Special care is taken in the design of decoupling circuits to ensure that any battery noise which may be present does not affect the music repeaters.

Repeaters.

The music repeaters in most common use in the past have been known by the Post Office designations Repeaters No. 24A and 29B. These repeaters are very similar in general design detail, each consisting of two resistance-capacitance coupled push-pull stages. In these repeaters, particular care was taken in the design of transformers and interstage couplings to avoid frequency distortion, and push-pull stages were employed to keep to a minimum harmonic distortion caused by the curvature of the valve characteristics.

Separate low and high frequency equalisers are provided, the two forming a separate unit known as

¹ P.O.E.E.J., Vol. 29, p. 302.

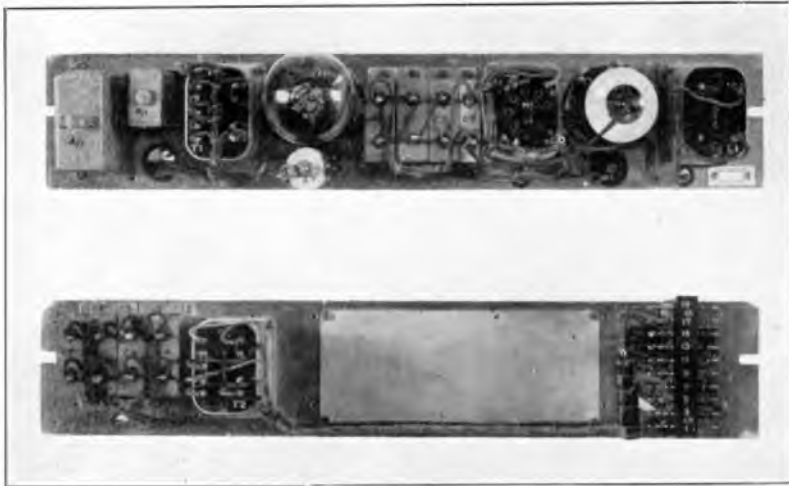

FIG. 1.—UNIT AMPLIFYING No. 24.

the Attenuation Equaliser No. 3A. It is of interest to note at this point that a single standard 10 ft. 6 in. repeater bay can accommodate 10 repeaters No. 29B and associated equipment whereas 20 music amplifiers of the latest design occupy the same space.

The performance characteristics of the 29B repeater are stated briefly below :—

- (a) Its gain is from 9.5—50 db. in steps of $1\frac{1}{2}$ db.
- (b) Frequency distortion does not exceed 1 db. over the range 50-8,000 c.p.s.
- (c) Amplitude distortion is such that the gain when measured at any frequency between 50 and 8,000 c.p.s. and with the output power of the repeater raised from 1 mW to 80 mW does not change by more than 0.5 db.
- (d) A change of $\pm 3\%$ in filament current does not change the gain by more than 0.3 db.
- (e) Monitoring does not reduce the gain by more than 0.3 db.
- (f) The real component of input or output impedance approximates closely to 600 ohms, and the reactance component does not exceed 100 ohms.
- (g) The associated attenuation equaliser No. 3A provides high frequency equalisation such that

the gain at 6,000 c.p.s. may be up to 2.6 db. in excess of that at 2,000 c.p.s., and low frequency equalisation such that the gain at 50 c.p.s. may be as much as 20.7 db. below that at 2,000 c.p.s.

Units of this and similar types are wired using screened pairs direct to the office side of the cable test tablets and not via a repeater test rack and repeater distribution frame. This helps to avoid crosstalk due to station wiring and also interruption due to testing or the changing of jumpers.

A new amplifier designed for use on music channels is now being introduced and is known by the title, Unit Amplifying No. 24. It is

so designed that it may be used in place of ordinary 4-wire units on standard amplifier bays (Equipments Amplifying); it is also available in the form of bays carrying 10, 14 or 20 units (Equipments Amplifying No. 24). The components forming a unit have been mounted on both sides of a $3\frac{1}{2}$ -in. panel of standard width (19 in.) (Fig. 1), but it is possible that a unit of components mounted on one side only of a $5\frac{1}{4}$ -in. panel will be produced for use where single-sided mounting is desirable (i.e. on the standard repeater station type of bays).

Fig. 2 is a schematic diagram of the Unit Amplifying No. 24. It will be observed that the unit uses two pentode stages, resistance-capacitance coupled, the output transformer being fed by a choke capacitance arrangement. Negative feed-back from the output of the second to the input of the first stage is effected, the gain of the unit being adjustable by varying the amount of feed-back employed. The use of a large amount of negative feed-back has resulted in a unit of extremely stable characteristics. Equalisation is obtained when required by providing a constant impedance equaliser immediately before the input transformer.

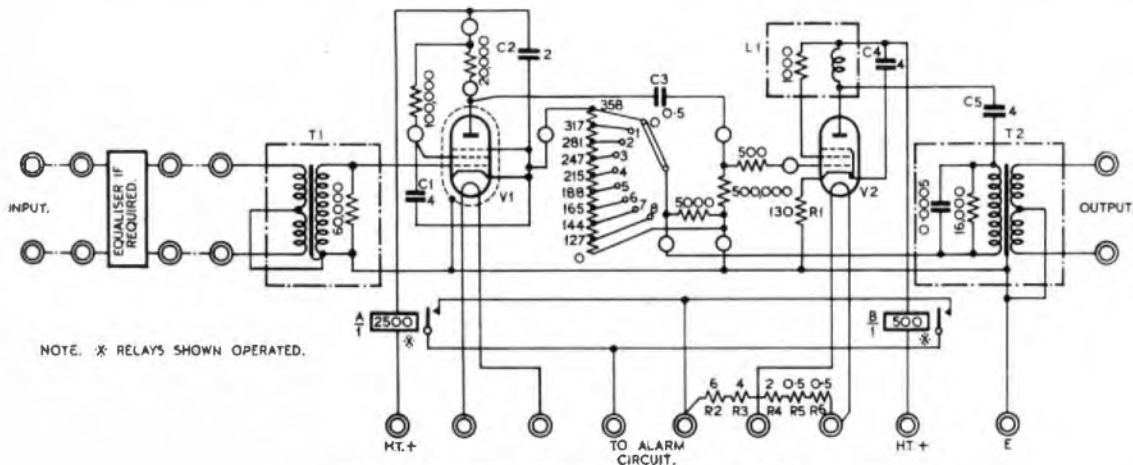

FIG. 2.—CIRCUIT OF UNIT AMPLIFYING No. 24.

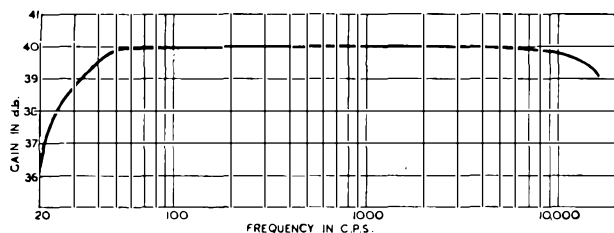

FIG. 3.—GAIN-FREQUENCY CHARACTERISTIC.

A space of approximately 7 in. \times 2.7 in. is left blank on the mounting plate for the accommodation of such an equaliser; should this space prove inadequate, it will be necessary to mount the equaliser on a subsidiary rack. The heater circuit arrangements are such that an L.T. voltage of either 6 or 24 can be employed, so that normal amplifier or repeater station type power plant can be used.

The performance of the unit is summarised below :—

- (a) The nominal maximum gain is 40 db. and this is reducible in steps of 1 db. to 32 db.
 - (b) The gain-frequency response with an output power of 10 mW (+10 db.) is flat to within ± 0.1 db. over the frequency range 50-8,000 c.p.s. (Fig. 3). With an output power of 158 mW (+22 db.) the 50-8,000 c.p.s. performance is degraded to ± 0.15 db. only.
 - (c) Amplitude distortion is such that the gain when measured at any frequency between 50 and 6,000 c.p.s. and with the output power raised from 1 mW to 100 mW does not change by more than 0.1 db.; with 158 mW output, this increases to 0.3 db.
 - (d) Harmonic distortion is not measurable when the output power is between 1 and 10 mW. With an output power of 100 mW, the percentage harmonic present is in the order of 0.37%.
 - (e) Input Impedance.
Resistance component = 600 ohms $\pm 2\%$.
Reactance component = 10 ohms approximately.
- Output Impedance.
Resistance Component = 600 ohms $\pm 9\%$.
Reactance component not greater than 32 ohms.
- These impedances are as measured at frequencies between 300 and 6,000 c.p.s.
- (f) For a change of $\pm 5\%$ heater current or $\pm 10\%$ change in anode voltage the gain stability is better than 0.1 db.

From the above it will be appreciated that the Unit Amplifying No. 24 has characteristics more than adequate for the purposes concerned. The use of valves of improved performance and of negative feed back has resulted in the production of a smaller and cheaper unit than that previously available.

Music Channels on Submarine Cables

In the past it has been customary to select on any particular submarine route cable pairs capable of transmitting the required frequency band and having the necessary freedom from interference. Frequently

this selection has been a matter of some difficulty. Equalisers and music repeaters have been installed at the terminal stations, special switching circuits being provided when necessary in order that the transfer from normal telephone to music transmission conditions may be effected, and in certain instances to reverse the direction of transmission.

The advent of carrier submarine cables of the coaxial types has involved the introduction of a special technique for providing music channels on such cables. Application of this technique has been described in this JOURNAL.²

Recent Developments.

Sub-carrier Working.—The rapidly expanding network of 12-channel carrier cables has led to attention being paid to the problem of providing music channels on such cables. An unused frequency band from 0 to 12 kc.p.s. is available. To use this band, it has been necessary to design suitable filtration equipment, for at each amplifying point the music channel and group of carrier channels must be amplified separately; this is essential as the carrier amplifier does not amplify effectively frequencies much below 10 kc.p.s.

Equalisation is a matter of some difficulty owing to the small overall frequency distortion permissible and the fact that, over the band concerned, the distortion introduced by the cable pair is very considerable.

An experimental installation providing two "music under carrier" channels has been completed on the Bristol-Plymouth 12-circuit carrier route. Details of this and the design consideration involved are given in another article in this JOURNAL.³

Carrier Working.—Consideration may be given in the future to the provision of music channels by carrier working. So far, it has not been necessary to consider providing such channels in this country; they have, however, been provided abroad, a notable example being that on the Bass Strait submarine cable.⁴

Transmission of music on a carrier basis involves relatively close synchronism between the carrier frequency at the transmitting and receiving terminals, a minimum asynchronism of 7 c.p.s. only being tolerable. This is due to the fact that lack of synchronism means that frequencies which are harmonic at the transmitting end are inharmonic at the receiving end.

Split-band Method.—Providing music channels by what might be termed an inversion of normal carrier working has recently been the subject of practical trial. This arrangement, known as split-band working, makes use of two or more telephone channels of normal band-width for the transmission of the wide band of frequencies required for a single music channel. The music frequency band to be transmitted is filtered into two or more bands, and the upper band or bands modulate carriers to produce frequencies within the normal telephone circuit band. Each band is then transmitted on a telephone channel

² P.O.E.E.J., Vol. 31, p. 23.

³ P.O.E.E.J., Vol. 31, p. 280.

⁴ Electrical Communication, Vol. XV, p. 284.

of normal type, and at the distant end placed by filtration and demodulation into its original position in the frequency spectrum.

The split-band system is attractive from the point of view that it does not involve the provision of special line plant. However, it does involve giving up temporarily a number of telephone channels, is likely to be expensive, and means transporting equipment of a bulky and somewhat fragile nature. It is probable that this will prevent it coming into general use. A description of the equipment used and the practical trial of split-band working will be dealt with in a later issue of this JOURNAL.

Conclusion.

The number of channels required for music purposes is increasing, and this factor, the extensive use of carrier cables, and the introduction of new amplifier design technique are resulting in special attention being paid to the design of such channels.

It is hoped that the foregoing will be considered as a survey of music channel requirements, of the existing and contemplated methods of providing such channels, and as an introduction to other articles to be published in this and subsequent issues of the JOURNAL which deal in detail with particular features of newly-developed equipment.

Wiring of Subscribers' Premises

THE Post Office has recently developed and brought into use a number of improvements in the means of wiring telephone subscribers' premises. In the writer's opinion reduced fault liability, enhanced appearance and simplification of fitting have been attained.

Cable—Standardisation of IRV Types.

Until recently two types of cable have been available, the one with a lead sheath (Cable E. & C.C.) and the other with a white braided covering (Cable E. & F.P.). Both had enamelled conductors which were found to be prone to faults originated in the stripping operation. The enamelled and flameproof cable was somewhat susceptible to damp and was, consequently, so unpopular that in some districts the lead-sheathed cable with enamelled and cotton covered conductors was used exclusively. The more expensive lead-covered cable, which is still available for use in really damp situations, is rather unwieldy and, moreover, is liable to cause damage by marking decorations, etc.

These circumstances have led to the introduction of a new cable with 12½ lb. tinned copper conductors having vulcanised india rubber insulation 20 mils thick, coloured in accordance with the standard colour scheme and finished with an overall glacé cotton braiding. The latter is so tensioned that it may be pushed back a matter of two inches from a freshly cut end. After the conductors have been stripped of their insulation and connected to the apparatus, the outer covering may then be returned towards its original position without fraying, thus making a neat termination. In stripping the conductors the VIR insulation comes away easily in one operation and a clean tinned surface is immediately available for soldering. The colours of the outer braided covering have been designed to harmonise with the general run of modern interior decoration, the cable being obtainable in brown or cream.

This type of cable has now superseded Cable E. & F.P., 1 pr., 3-wire and 4-wire, and reports already show that the cable is clean and easy to handle and results in a lower fault liability. Its insulating

properties render it suitable for use in all situations that are not abnormally damp.

A quantity of tough rubber-sheathed cable has been manufactured for trial in the under-floor duct system installed in the new Telephone Manager's Office at Coventry. The aim is to produce cable of similar properties to that described above, but with the required number of IRV covered conductors embedded in an overall covering of tough rubber intended to withstand a considerable amount of rough treatment and moisture and suitable for running in under-floor ducts, troughs, cellars, etc.

In view of the success of the VIR conductor in the braided cable, this principle is also being extended experimentally to lead-sheathed cable which is at present undergoing field trial.

When these types of VIR cable are finally available, Cable E. & C.C. will become obsolete and the new lead-covered VIR cable should only be used in extremely damp or deleterious conditions or where the mechanical protection or electrical screening of a lead sheath is required.

Terminal Blocks.

New 2-, 4-, 8- and 12-wire terminal blocks in moulded plastic have been introduced in place of the wooden connection strips and early types of terminal blocks. In addition to their superior electrical and mechanical qualities the new blocks are of improved appearance and are available in black, Chinese red, jade green and ivory.

Plugging Material.

A new product consisting of asbestos fibre mixed with cement, etc., is now available for plugging holes in walls, etc., to take fixing screws. The plugging material is moistened and rolled in the hand into a billet which is rammed down well into a hole cut in the usual way. While still moist a central hole is made in the compressed material in order to give the screw a start. The screw is then driven home and can take the load immediately. Interesting results have been obtained in test, e.g., a No. 8 wood screw used in a hole cut with a No. 18 bit was capable of withstanding a direct pull of up to 280 lbs. G. H. C.

The Provision of Music Channels on 12-Channel Carrier Cables

R. J. HALSEY, B.Sc.(Eng.), A.C.G.I., D. C.,
and D. G. TUCKER, B.Sc. (Eng.).

Music channels on carrier cables may be provided either within the range of the carrier system or, without modulation, below this range. The latter is thought to be preferable, and the necessary equipment is described, together with test results obtained on the Bristol-Plymouth route.

Alternative Schemes.

IN planning the provision of music channels on 12-channel carrier cables, two major alternatives were considered. The music channel may be located in a frequency band within the normal transmission range of the carrier system, when it will be transmitted through the normal line repeaters. This involves no additional plant at repeater stations beyond that normal to the carrier system. The crosstalk normally associated with the carrier channels, both inter-system and within system will also apply to the music channels and this may compare unfavourably with the very low noise and crosstalk at present obtained with screened pairs. Moreover, the problem of transmitting frequencies down to 35 c.p.s. presents considerable difficulty in the matter of filter design and a high degree of carrier stability is essential. Against this, however, must be offset the advantage of very low velocity distortion due to the cable.

Alternatively, the music frequencies may be transmitted over the cable without modulation, below the range of the carrier system, but with this scheme the provision of filters, special equalisers and music repeaters is necessary at each repeater station. It

mediate repeater station, it is obviously undesirable to work very close to the cut-off frequencies. Cut off frequencies of 11,500 c.p.s. for the high-pass filter and 10,500 c.p.s. for the low-pass filter give a reasonable design and permit of equalisation up to at least 9,000 c.p.s. on the music channel. The arrangements described are based on this allocation, but if new carrier systems are installed, embodying the Oslo recommendations of the C.C.I.F.,¹ the cut-off frequencies must be reduced by 1,000 c.p.s.

Filters.

Attenuation Requirements.—It will be seen from Fig. 1 that at a repeater station, a signal on either band is offered two alternative paths:

- (a) Through its own filters, equaliser and repeater.
- (b) Through the complementary system.

The signals via the two paths will re-combine on the line, but not necessarily in phase. Thus the signal which traverses the wrong path must be attenuated sufficiently to have only a small effect on the overall transmission, otherwise this will be irregular, owing to the phase characteristics of the system. This consideration determines the necessary

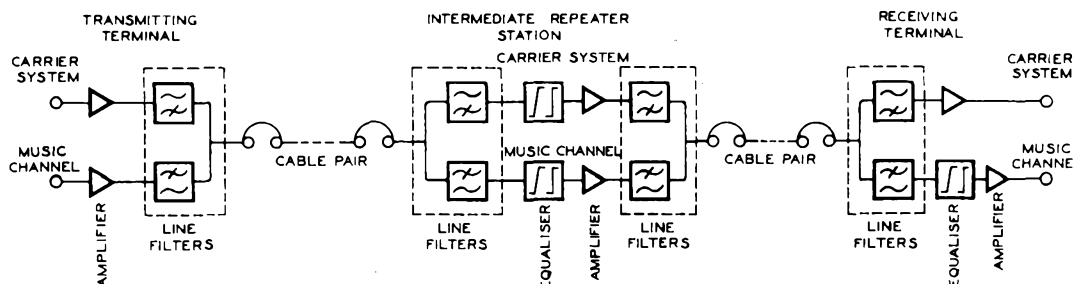

FIG. 1.—MUSIC CHANNEL ON 12-CHANNEL CARRIER CABLE. BLOCK SCHEMATIC.

will be appreciated that the carrier repeaters are not suitable for the transmission of frequencies below 12 kc.p.s. which is also the lower limit to which the line is equalised. It is expected that the noise and crosstalk level will be lower with this arrangement and should approach that obtained with screened pairs.

The second alternative has been explored and the results obtained are the subject of the present article. It gives potential music channels at the rate of one per pair, i.e. 24 channels in each direction over a normal carrier route. Fig. 1 is a schematic arrangement of terminal and intermediate repeater stations.

Frequency Allocation.

All 12-circuit carrier systems at present installed transmit the lower sidebands of carrier frequencies 16, 20, . . . 56, 60 kc.p.s. and the lowest frequency effectively transmitted is about 13,300 c.p.s. Since it is necessary to insert two filter units at each inter-

mediate repeater station, it is obviously undesirable to work very close to the cut-off frequencies. Cut off frequencies of 11,500 c.p.s. for the high-pass filter and 10,500 c.p.s. for the low-pass filter give a reasonable design and permit of equalisation up to at least 9,000 c.p.s. on the music channel. The arrangements described are based on this allocation, but if new carrier systems are installed, embodying the Oslo recommendations of the C.C.I.F.,¹ the cut-off frequencies must be reduced by 1,000 c.p.s.

Impedance Requirements. The filtration is complicated by the system of distant-end crosstalk balancing which is employed on 12-channel cables. This requires that the cable pairs shall be terminated in impedances which are not greatly different from their characteristic impedances. When the music channels are added, the lines are terminated by the filters, hence the filter input impedance is of major importance at the higher frequencies.

¹ The C.C.I.F. decided at Oslo (1938) that international circuits on 12-channel carrier cables shall transmit upper sidebands of carrier frequencies 12, 16 . . . 52, 56 kc.p.s.

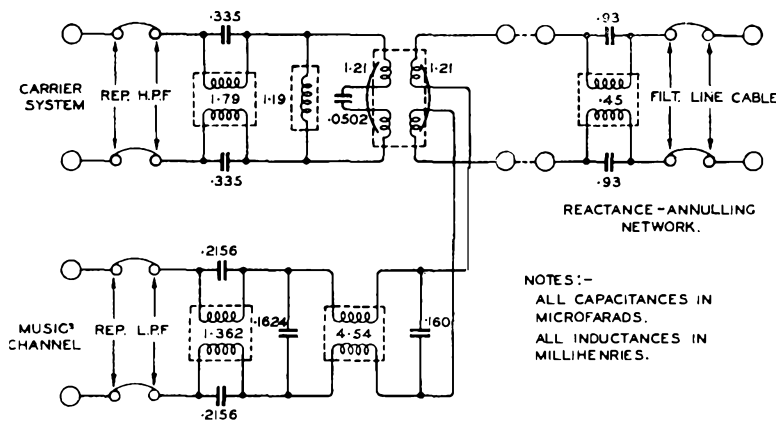

FIG. 2.—LINE FILTERS—CIRCUIT DIAGRAM.

The line terminal impedance of a line filter set of the usual type (parallel connection of the high-pass and low-pass filters) is quite unsuitable for terminating cable pairs in a multi-channel carrier cable. The device usually employed, of increasing the impedance of the first series element in each filter by about 50 per cent. (so called x-termination), gives a terminal impedance at the higher frequencies which is conveniently expressed as a parallel combination of resistance and inductance. The latter can be reduced by the addition of a shunt-connected susceptance-annulling network, but the final impedance-frequency characteristic then slopes the opposite way to that of the cable.

By using a series connection of the high-pass and low-pass filters a much more satisfactory result is obtained. The filter sections facing the line have mid-shunt constant-k impedances instead of mid-series as with parallel-connected filters. The equivalent of the x-termination is obtained by increasing the admittance of the terminal shunt arms by about 50 per cent., and the residual reactance is reduced by a series-connected reactance-annulling network. By this means it is possible to obtain a filter impedance which closely matches the line impedance over the range of the high-frequency system; it is not practicable to match the cable over the low-frequency band, owing to the rapidly changing cable impedance.

The impedance of 12-channel carrier equipment is specified to be approximately 138Ω (the return loss against 138Ω must be at least 20 db. at 60 kc.p.s.), and the impedance of the low-frequency equipment is about 150Ω .

Specification.—The circuit arrangement of the filters is shown in Fig. 2. The coils are specified as dust cored toroids with Q values in excess of 160. For much of the experimental work non-toroidal "ironclad" coils have been employed, but these have caused certain difficulties in connection with inter-system carrier crosstalk. Tests have been made using unbalanced high-pass filters (i.e., the circuit to the

left of the high frequency transformer was earthed on one side), but this also gave rise to carrier crosstalk difficulties. The condensers are clamped mica with the exception of those in the reactance-annulling network, which are clamped paper. Each filter unit is mounted on one side of a standard 7-in. panel.

Performance. The insertion loss of a line filter unit is shown in Fig. 3 and the input impedance, together with specified and measured cable impedances, is shown in Fig. 4. It will be observed that the filters are suitable for use with carrier systems transmitting up to at least 150 kc.p.s. and they will therefore fit in with new developments

which aim at the addition of one or two further 12-channel groups above 60 kc.p.s. The cable impedance curve shown was measured on the Guildford-Southampton route, these cables being of the latest quad type. The Bristol-Plymouth cables, which are of pair construction, have a lower impedance.

Installation of Experimental Systems.

Two music channels of an experimental nature have been installed on carrier cables between Bristol and Plymouth. Although they were finally set up to work in opposite directions, most of the experimental work was carried out with both circuits transmitting from Bristol to Plymouth. As indicated above, the filters used were not completely in accordance with the final specification and their shortcomings will be evident from some of the results which follow. The Bristol-Plymouth route is 125 miles in length and includes six intermediate repeater stations: Rooksbridge, Taunton, Willand, Exeter, Moretonhampstead and Tavistock.

The music amplifiers used for the tests are of a new type (Unit Amplifying No. 24) employing negative

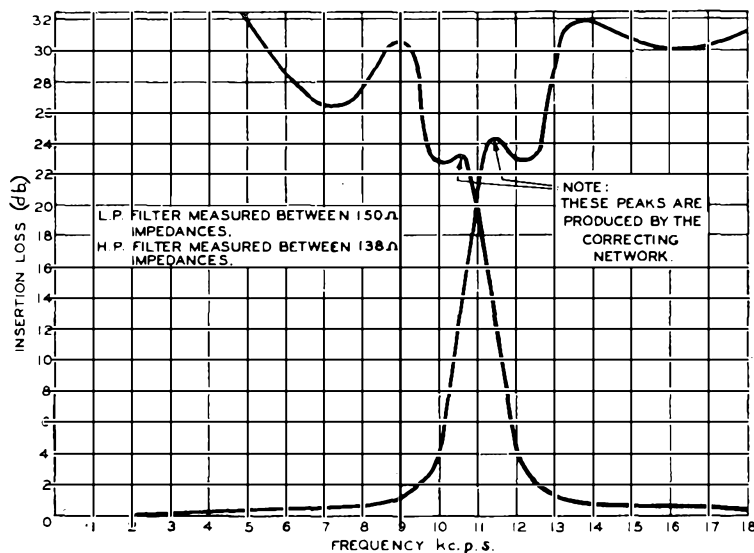

FIG. 3.—ATTENUATION OF LINE FILTERS.

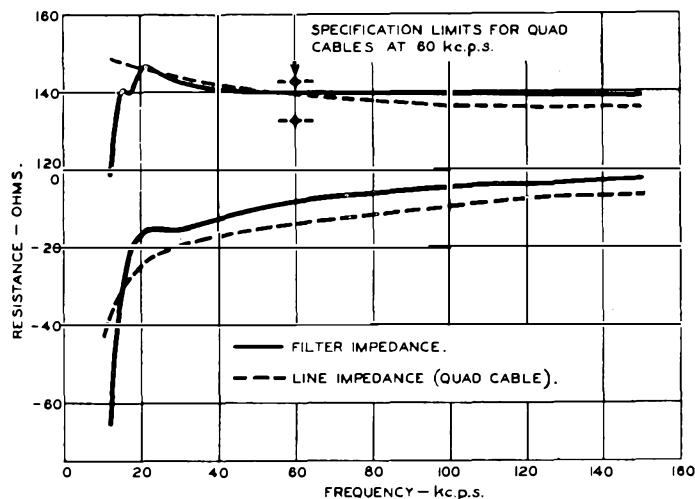

FIG. 4.—LINE FILTER AND CABLE IMPEDANCES.

feedback. These amplifiers are described in another article in this JOURNAL.²

Effect on the Carrier Systems.

Equalisation. The insertion of the line filters causes a considerable loss in the lower carrier channels, and in Channel 1 especially the frequency response is seriously affected. The pass-band attenuation of the high-pass filter (Fig. 3) varies from 0.15 db. at 60 kc.p.s. to about 1 db. at 13 kc.p.s., these two frequencies being approximately the limits of the 12-circuit carrier system. Between Bristol and Plymouth there are inserted 14 filters and the losses introduced into Channel 1 are as in Table 1.

TABLE 1

Voice Frequency c.p.s.	Sideband Frequency kc.p.s.	Loss of 14 Filters db.
300	15.7	7.2
800	15.2	7.7
1,500	14.5	8.3
2,000	14.0	8.7
2,400	13.6	10.0
2,600	13.4	11.2

On this route the frequency response of the whole system, and in particular, that of Channel 1, can be

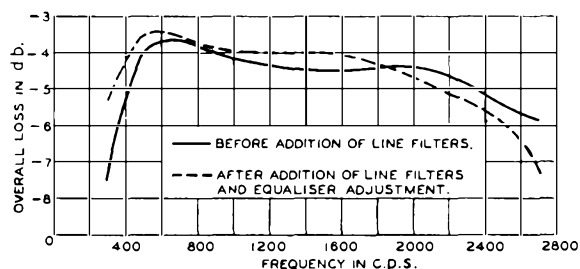

FIG. 5.—EFFECT ON CARRIER CHANNEL NO. 1

² P.O.E.E.J., Vol. 31, p. 276.

restored very nearly to its original degree of flatness by disconnecting the first section of the 12-channel equaliser at two intermediate repeater stations only. The change of level at the other repeaters is not serious and no re-adjustment of repeater gains is necessary. The frequency response of Channel 1 before and after insertion of music equipment on one of the Bristol-Plymouth systems is shown in Fig. 5.

Inter-system Crosstalk. The insertion of the filters in the carrier systems can cause crosstalk between the systems in two ways (a) by coupling between the high-level filter on one system and the low-level filter on another and (b) by disturbing the balance of the terminal crosstalk balancing networks, where fitted.

(a) With unbalanced filter circuits using "ironclad" inductors which rely on screens and panels for shielding, the crosstalk takes place chiefly by virtue of the common earth connection in the circuit. Crosstalk due to this cause is worst at Exeter, and Table 2 shows measured values. That this crosstalk is due to common earth resistance is shown by tests (see Table 2) carried out at

TABLE 2
EFFECT OF FILTERS ON CARRIER CROSSTALK

Crosstalk occurring at	Conditions	Crosstalk ratio at 60 c.p.s. db.
Exeter Due to coupling between high and low level filters.	No filters in circuit	72
	Unbalanced filters, "ironclad" inductors, no earth connections.	72
	Ditto, with earth connections.	59
	Balanced filters, "ironclad" inductors, no earth connection to panels.	72
	Ditto, with panels earthed.	67
	Balanced filters, toroidal inductors. No earth connection to panels.	72
Moreton-hampstead Due to coupling between high and low level filters.	Ditto, with panels earthed.	72
	No filters in circuit.	77
	Unbalanced filters, "ironclad" inductors, connected to earth through zero additional resistance.	77
	Ditto. 0.5 ohm additional resistance.	69
	Ditto. 2.0 ohm. additional resistance.	61
Tavistock. Due to disturbing conditions of terminal crosstalk balancing.	No filters in circuit.	75
	Ditto. Insert A-B cross in one pair on Moretonhampstead side.	68
	Unbalanced filters in circuit on Moretonhampstead side only.	71
	Ditto. Insert A-B cross in one pair on Moretonhampstead side.	52-64 according to point at which cross inserted.
	Balanced filters in circuit on Moretonhampstead side only.	75

Moretonhampstead, where the earth connection is normally good, and consequently, crosstalk of this type does not normally occur. When resistance is added in the common earth lead the crosstalk increases.

Filters using similar inductors in balanced circuits avoid crosstalk due to a common earth connection to the filter circuits proper, but there is still a fairly serious crosstalk due to the common earth connections to the panels. This is due, no doubt, to currents induced in the panels by the external fields of the coils, which are insufficiently self-screening. Balanced filters using toroidal inductances, which have no appreciable external field, cause no measurable crosstalk at any repeater station.

(b) Terminal crosstalk balancing networks are fitted only at Tavistock on the "Go" cable (i.e., Bristol-Plymouth) and at Moretonhampstead on the "Return" cable. On all other sections, intermediate balancing frames are used. Tests made at Tavistock, and given in Table 2, show that the insertion of unbalanced filters increases the crosstalk rather badly,³ and also that any A-B crosses in the wiring have a similar effect. The insertion of balanced filters, however, has no effect on the crosstalk if A-B crosses are avoided.

In view of these test results, balanced filter circuits using toroidal inductors have been specified and when these are employed it can be expected that the existing intersystem crosstalk will not be sensibly degraded by the addition of the music channels.

Line Attenuation, Reflection Losses and Equalisation of the Music Channel.

Before it was possible to design the equalisers for the Bristol-Plymouth music channels, it was necessary to determine the cable attenuation, and, more particularly, the insertion and reflection losses including the filters. These values were obtained by measuring overall insertion loss, through filters and appropriate terminating impedances, of two loops of cable of different lengths. By taking the differences

³ That this effect is not due to unbalance capacitance to earth was proved by obvious tests.

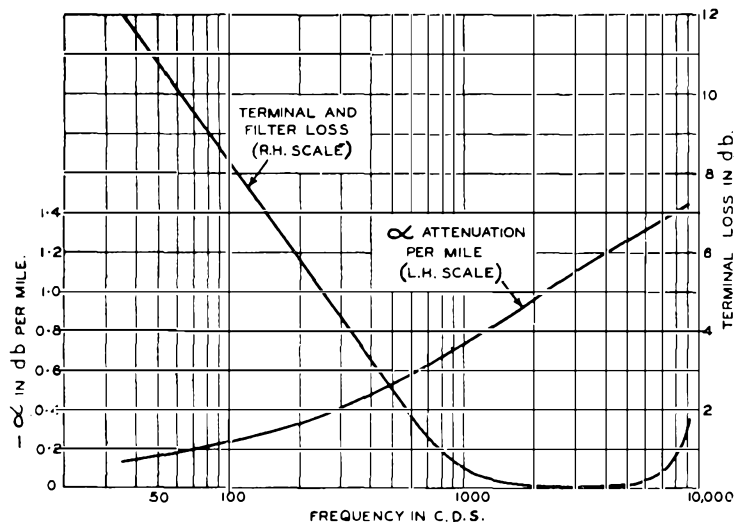
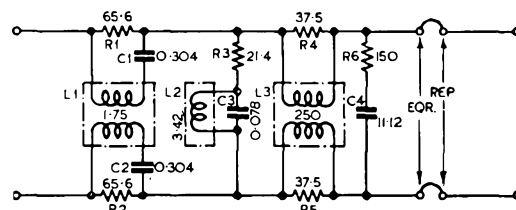

FIG. 6.—CABLE AND TERMINAL LOSSES PER CABLE SECTION.



NOTES. ALL CAPACITANCES IN MICROFARADS
ALL INDUCTANCES IN MILLIHENRIES.

FIG. 7.—TYPICAL EQUALISER CIRCUIT.

between the two sets of measurements, losses due to the filters and reflections are eliminated, and the attenuation constant of the cable can be evaluated on the assumption that interaction losses⁴ are negligible. This is shown in Fig. 6, for the frequency range 35 to 9,000 c.p.s. Using these values of the attenuation constant, values can be determined from the original measurements for the terminal losses (which include filter and reflection losses) which are very nearly the same for any cable section. These losses are also shown in Fig. 6. From these two curves the overall insertion loss of each cable section was determined and constant impedance equalisers⁵ were designed. It was not considered necessary to equalise correctly each individual cable section but the circuit has been equalised as a whole, the different types of network being so chosen and placed in the circuit that the levels at intermediate points do not vary unreasonably over the frequency range. A typical equaliser circuit arrangement is shown in Fig. 7.

The overall equalisation of the music circuits is quite satisfactory, frequency response curves for the two directions being shown in Fig. 8, together with the limits recommended by the C.C.I.F. for international circuits. It will be seen that except at the very low frequencies (below 100 c.p.s.) the overall loss lies within a range of ± 1 db. However, owing to the large difference in the cable attenuation between the extremes of the frequency range, temperature changes throughout the year will undoubtedly cause a poorer response to be obtained at some seasons. The exact extent of the seasonal variation and its correction have not yet been investigated.

Crosstalk and Noise on the Music Channels

The C.C.I.F. requirements with regard to interference with music channels in cables are as follows:

- Crosstalk.** The crosstalk from a speech circuit or from another music channel shall not be worse than 78 db, signal to crosstalk ratio.
- Noise.** The ratio between the useful maximum signal voltage (corresponding to 50 mW at the output of the repeaters) and the psophometric voltage (noise and crosstalk) shall be at least 60 db. The frequency weighting curve for the psophometer is specified.

⁴ See, for example, *Transmission Networks and Wave Filters*, by T. E. Shea, p. 120.

⁵ *P.O.E.E.J.*, Vol. 29, p. 302.

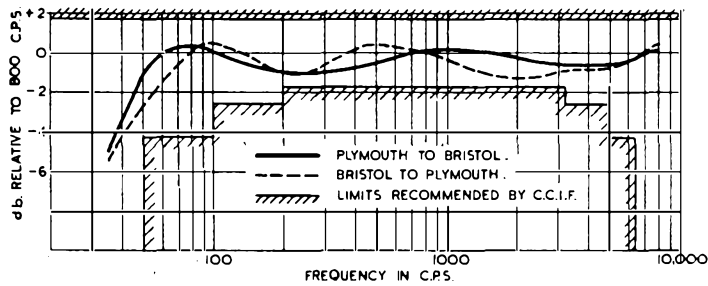

FIG. 8.—OVERALL FREQUENCY RESPONSE.

On the Bristol-Plymouth experimental music channels a certain amount of interference occurs from the carrier system. This is due to audio-frequency intermodulation products produced in the carrier repeaters.⁶ Since, however, high-pass filters separate the carrier repeater from the line, only a small amount of this noise reaches the music channel and this could be further reduced by filtration if necessary. In addition there is a small amount of power noise due to mains equipment at the unattended repeater stations. There is no intelligible crosstalk from the carrier systems. The total noise on the music channels was measured during a peak traffic period with an unweighted psophometer and also in conjunction with a weighting network designed for speech circuits. Weighting networks in accordance with the C.C.I.F. recommendation for music channels were not available, but the unweighted condition is clearly more severe. The channels were lined up so that the repeater output levels were +5 db. relative to the input of the channel and in Table 3 the noise is expressed in two ways:

- a, In db. below 1 mW at a point of zero relative level,
- b, In db. below the useful maximum signal, corresponding to 50 mW at the repeater outputs (C.C.I.F. method).

TABLE 3.

Condition	Signal/noise ratio db.	
	a	b
No weighting	70	82
Speech weighting network	85	97

Interference from the music channels to the carrier systems and also crosstalk between music channels is >80 db.

Transmission Time Over Music Channel.

The limits recommended by the C.C.I.F. for differences of transmission time on music channels are as follows:

“For music channels transmitting effectively a band of frequencies of 30 to 10,000 c.p.s. the difference in the times of propagation between 8,000 and 800

⁶ The extent to which negative feedback reduces the magnitude of a modulation product depends on the amount of feedback at the modulation frequency. Thus the carrier repeaters generate low frequency products of considerable magnitude.

c.p.s. shall not exceed 10 mS., and between 30 and 800 c.p.s. shall not exceed 200 mS.”

The transmission times at frequencies within the transmitted band of 50 to 8,000 c.p.s. were determined in two ways. The first method was by a measurement of the phase shift-frequency characteristic of the loop formed by joining the channels in tandem at Plymouth and determining with the aid of a cathode ray oscilloscope, the frequencies of complete phase rotations over the transmitted range. This characteristic is shown in Fig. 9. From the value of the slope of this curve ($d\beta/d\omega$) at various frequencies⁷, the times of propagation have been determined and are given in Fig. 10, Curve A.

The transmission times on the same loop (25 miles in length) were also measured directly by oscillograms of sent and received signals obtained on a Duddell oscillograph. From these oscillograms two times have been measured (a) the time of first arrival of the received wave and (b) the time when the received wave reaches approximately 80 per cent. of its steady state amplitude. These two times are given in Table 4 with the corresponding values of $d\beta/d\omega$.

TABLE 4.

Frequency c.p.s.	Transmission Time mS.		
	$d\beta/d\omega$	a	b
80	14.4	—	—
100	10.0	—	—
200	5.6	4.0	8.9
500	4.3	3.6	5.1
1,000	3.7	3.5	5.0
2,000	3.5	3.5	4.0
3,000	3.6	3.6	4.0
6,000	3.9	—	—
7,500	4.3	—	—

The measurements fail at very low frequencies but it is possible to calculate the propagation time due to the cable from the fact that $\beta = \frac{\sqrt{\omega CR}}{2}$, whence

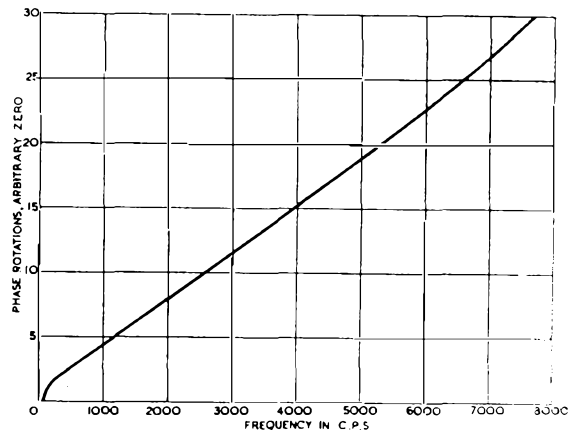

FIG. 9.—BRISTOL-PLYMOUTH-BRISTOL LOOP, PHASE SHIFT.

⁷ β = wavelength constant.

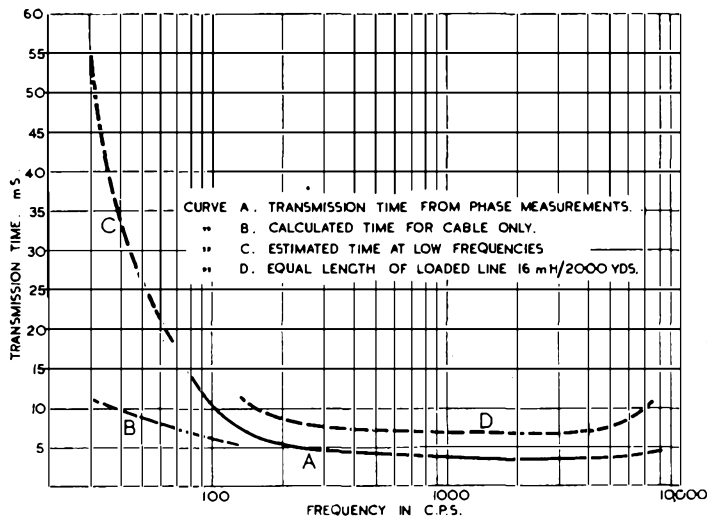

FIG. 10.—BRISTOL-PLYMOUTH-BRISTOL LOOP, TRANSMISSION TIME.

$d\beta/d\omega = \sqrt{CR/8\omega}$. This gives times as shown in Fig. 10, curve B. Assuming that the difference in the transmission time at 100 c.p.s. is due to shunt inductances at the repeater stations (e.g. repeater transformers), the corresponding times for lower frequencies can be estimated. The total times thus obtained are

shown in Fig. 10, curve C, and it will be seen that these are well within the C.C.I.F. limits. For comparison, Fig. 10 also shows the transmission time obtained on a music channel on an equal length of coil-loaded cable.

Conclusions.

To provide music channels on 12-channel carrier cables by direct transmission of the music frequencies in the frequency band below that of the carrier system appears to be a satisfactory solution of the problem. Line equalisation can be carried out accurately by constant impedance networks, but these are rather complicated and cannot be made up at short notice. Noise and crosstalk features are satisfactory and velocity distortion at high frequencies is superior to that of circuits on loaded cables; at low frequencies it is of the same order, being determined mainly by the amplifiers. Subjective tests of distortion over the music channels described will be the subject of a further article.

Inauguration of the First Mobile Unit Automatic Exchange

On Wednesday, December 7th, 1938, the Postmaster General, Major G. C. Tryon, made the first public call ever to have been completed through an automatic telephone exchange on wheels. This vehicle has been designed by the Post Office Engineering Department, and a full technical description will be published in the next issue of this JOURNAL. The ceremony took place in the postal yard of King Edward Building, London, and attracted considerable interest from the press, the cinematographers and the B.B.C.

While the 6-ton trailer van was hidden from view behind a curtain, the Postmaster-General made a statement outlining the functions of the vehicle, and mentioned its future usefulness in meeting occasional delays in supplying buildings or equipment where telephone service in small towns or villages is urgently required. The equipment as used on the vehicle is capable of serving 90 subscribers, and will have the usual facilities of access to other exchanges and to the trunk network.

Curtains were then drawn aside to reveal the large green van bearing the G.P.O. monogram and the inscription "Mobile Automatic Telephone Exchange." With a standard U.A.X. key, the Postmaster-General, accompanied by the Engineer-in-Chief, Sir George Lee, opened the main door on the inside of which had been fitted a special telephone instrument for his use. He then inaugurated this novel exchange by dialling a call which was extended over a trunk line to Mr. Hugh de Haviland, the Chairman of the Essex

County Council at Chelmsford, in which area the vehicle is first to be employed. After an exchange of greetings and congratulations from Chelmsford, a recording of which was made by the B.B.C., the Postmaster-General inspected the interior of the vehicle and the signal was then given for the mobile telephone exchange to be moved to North Weald, Essex, for the urgent replacement of a rural manual exchange.

While Post Office engineers cut away the telephone cable, a tractor was manoeuvred into position and was coupled up to the trailer. Within a few minutes the exchange was threading its way through the usual London traffic, on its way to North Weald, where it was later brought into service.

The bodywork of this experimental mobile exchange is of all-steel construction with cork insulation, and contains a standard U.A.X. No. 12 equipment for 90 subscribers, and is complete with duplicate batteries, A.C. charging rectifier and a standard petrol engine charging set with radiator cooling instead of the usual water tank. Connection to the cable network is effected by a demountable joint fixed on the inside wall of the vehicle, and space is allocated for meters and main fuses to be mounted by the supply company when A.C. mains are available. Every available space has been utilised, but there is still enough room in the van for all maintenance operations on the telephone equipment, or on the associated apparatus of this novel telephone exchange.

R. W. P.

Telephone Transmission Testing by Subjective Methods

W. WEST, B.A., M.I.E.E.

Some simple general rules for subjective, or listening, tests of telephone transmission are enunciated. Examples of the application of the rules to various tests lead to discussion of some factors affecting transmission. The article has as a background the possibility of change of the standard for this country from volume efficiency to effective transmission.

Introduction.

IN spite of the fact that the facility, scope and demand for objective tests of the electro-acoustic apparatus used in telephony has increased enormously during recent years, subjective testing still occupies a position of basic importance.

Although there have been many contributions to the technical literature dealing with objective electro-acoustical measurements, comparatively little has been written about subjective testing as applied to transmission systems rather than to the sense of hearing. Yet a great deal of subjective testing has been and is being carried out, not only at research laboratories, but also, in rather less refined forms, as listening tests carried out in the field. The functions of objective and subjective tests are, in fact, complementary; thus, for example, in designing a new type of telephone, measurements of frequency-characteristics by objective tests show exactly the effect produced by any modification of construction, but subjective tests are still required for assessing the value of such effects in terms of improved transmission.

There are a few generalisations concerning subjective tests which, though simple, are of fundamental importance. In the first place, since aural impressions or perceptions can be given no absolute value, subjective tests are essentially comparative. Before drawing up a testing programme it is necessary to consider what comparison should be made and how the tests can best be organised to yield a maximum of reliable information for a minimum of testing time. The comparison should be direct and without bias towards either of the systems being compared; this means, in effect, that all possible influences external to these systems should be common to both, i.e. direct switching from one system to the other and listening to each alternately for equal periods of time with negligible delay in the change-over. The control or variation of external influences must also be considered in order to avoid bias; thus, for example, in comparing loudspeakers for quality, it is desirable that all the comparisons should not be made at the same position in the same room, because the acoustical characteristics particular to the room may fit the reproduction by one loudspeaker better than the other.

It is also important to recognise that each single subjective observation is simply an expression of a single human perception or opinion. Where the comparison is at all difficult to make, it will be found, not only that the opinions of different individuals differ quite widely, but also that the opinion of any one individual varies when the same test is made on different occasions (if it is recorded, as it should be, in such manner that he cannot himself know what result is being recorded). This means, of course, that

many tests, involving several observers, are required to obtain a reliable "average opinion"; the minimum number of tests or observers required cannot be expressed in general form, it depends on such considerations as the importance of the decisions for which the results of the tests are required. It follows also that the result of a subjective test should not be regarded as a definitely repeatable fact, as should be the result of an objective test. This may seem to be, and for some purposes it is, a fundamental disadvantage of subjective testing, but it is unavoidable and inherent in the actualities of practical use; for if the two systems being compared are brought into service, it is only to be expected that different users will react differently towards them.

When an observer is required to make a judgment in a subjective test, it is most important that there should be no misunderstanding of the nature of the comparison that he is to make, and the issue at stake should be presented in as straightforward a manner as possible. Thus, in a judgment test, the instruction might be:—"Of the two transmissions, A and B, which you will hear, record which is the louder" or "which you can hear the more distinctly," as the case may be, rather than "which you consider is better." Where it is required to obtain a balance, i.e. a judgment of equality by degrading or upgrading the transmission on one of the systems in a controlled manner until it is judged to be equal to the other, the control is generally varied in steps and an observation is made on each step. The steps should cover a wide range round the estimated balance point and should be presented in a random sequence. It is to be preferred that the test be made without repetitions of observations on any one step and that the observer be asked to repeat the whole test on another occasion, rather than that attempt be made to verify the result by many tests repeated near his "balance point" at one sitting.

Although it is clearly legitimate to make some preliminary selection of observers on such grounds as discarding known abnormalities of hearing or intelligence, or obtaining representative relative numbers of the different sexes or ages, the placing of more weight on the opinion of one individual, however distinguished he may be, than on those of the others, is generally to be avoided. In cases of doubt it is better to bring more observers into the test.

Volume Efficiency Tests.

Although, in the absence of a suitable agreed alternative, volume efficiency (i.e. loudness) remains as the standard of transmission for international telephony, it is recognised that volume is by no means the only factor required for good transmission. Where there is little or no tone difference between the systems compared, little difficulty in making volume comparisons arises; but such comparisons are

generally more suitably dealt with by objective measurements. This is done in acceptance testing, for transmission, of telephone instruments, comparison being made on a voltmeter against a standard instrument of similar type. When there is tone difference, as for example in comparing a commercial circuit with a high quality circuit, difficulties of a similar nature to those involved in noise measurement are encountered.

The question of comparing loudnesses of different noises has been fully discussed elsewhere.¹ Probably the best of the possible methods of obtaining a judgment of equality of loudness is that described by Dr. Harvey Fletcher and W. A. Munson.² Certain features incorporated in this technique which the writer considers desirable may be noted:—

The observer hears the two tones alternately, for equal short periods of time. These are only twice repeated and he then records his impression of which is the louder; absolute certainty of opinion is, of course, not expected of him in any one such comparison. Then he makes a similar comparison, but with the intensities of both tones received at different levels, and so on. The levels are preselected, but are applied to the observer in a random sequence. When the observations of all the observers have been collected, they are plotted in such manner that average judgments of equality at two or more different levels of the standard tone are determined and each individual observation plays some part in the determination. Such a method is to be preferred to one which attempts to ascertain “accurately” the balance point of an individual observer, by a number of tests repeated at levels in the neighbourhood of what appears to be his balance point. An observer will be able to confirm his judgment of immediately preceding tests at similar levels with surprising accuracy, but this judgment may differ widely from that of the same individual on another occasion, or if approached by a different sequence of applied levels.

Investigations are proceeding with the object of selecting a more relevant standard of telephone transmission than that of volume efficiency, i.e. a standard of “effective transmission.” The method to be described later originated in the U.S.A. as a direct attack on this problem. Without in any way attempting to anticipate any future standards, we may visualise a conception of “effective volume efficiency” as the attenuation, relative to that of a standard circuit, at which the intelligibility on the two circuits (under otherwise similar testing conditions) is equal. Any assessment of such a quantity must be made under difficult listening conditions, such as faint reception in the presence of noise, since it is only under such conditions that volume efficiency is, in fact, a significant factor.

Effective volume efficiency is not, by itself, a measure of effective transmission, but it has a very direct bearing thereon. Attempts to assess effective volume must be made by some kind of quality test in some such manner as will be indicated in the next section.

Articulation Efficiency Tests.

In an art such as telephony, which is primarily concerned with the transmission of sounds of speech, it is only natural that tests should be made using synthetic speech sounds. Each of such sounds is, in general, made up by “initial consonant, vowel, final consonant” to form a syllable (usually meaningless) to which the international name logatom has been applied. In the most usual practice of articulation testing, a speaker transmits logatoms over a circuit, a listener (or listeners) records the sounds heard, and the result of the test is computed as the percentage number of logatoms which were correctly recorded. This is known as the articulation percentage.

This result is, of course, dependent, to some extent at least, on the technique and on the individuals employed, their method of articulating the sounds, etc., as well as on the system under test. It is tempting to endeavour to control or correct for the unwanted variables³ in order to obtain a result which can be regarded as an absolute value, applicable to the system under test alone. The writer prefers to adhere to the principle that the test should be used for comparison only.

Detailed accounts of articulation testing methods have been given elsewhere.⁴ Some details of the present practice of the Post Office Research Branch may be noted, particularly in connection with the emphasis that is placed on obtaining a fair comparison. Lists of logatoms (25 to a list) are obtained from a machine which maintains, on the average for a large number of lists, the correct proportions for the frequency of occurrence of the different sounds in the language. From any one list a second list, of equal difficulty, can be obtained by interchanging the three components of each logatom (initial consonant, vowel, final consonant), to produce 25 different logatoms. Both lists thus contain exactly the same components of speech, and the lists are paired and used, one on each of the two transmission systems to be compared. For some tests it is practicable to divide the transmission circuit and to include the item under test in one branch and the corresponding item in the other branch; identical logatoms are thus transmitted over both branches. To guard against the possibility of slight inequality as between the two branches, the items concerned are interchanged at intervals during a complete test. The speaker introduces the logatom into a standardised short sentence and he adjusts his speaking volume on this sentence (not on the logatom) by observing the reading of a meter connected to an independent moving-coil microphone.

In the practice here referred to, an isolated comparison test is completed when 100 logatoms have been sent on each of the two systems being compared, 25 logatoms by each of four speakers, generally two male and two female. A list of 25 logatoms on one system is immediately followed by the balanced list, with the same speaker and listeners, on the other system. If, as is often practicable, the terminating receiver can be replaced by four similar receivers, in

¹ *I.E.E.J.*, Vol. 81, p. 57, July, 1937, and others.

² *J. Acou. Soc. of America*, Vol. 5, p. 103 (Appendix A).

³ *P.O.E.E.J.*, Vol. 23, p. 25.

⁴ *Bell System Technical Journal*, Vol. 8, p. 806; and *I.E.E.J.* Vol. 71, p. 605.

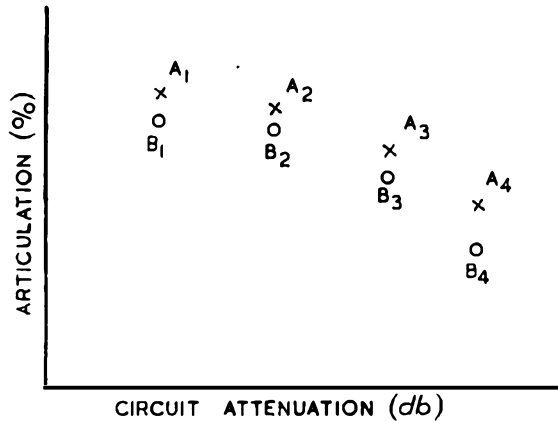

FIG. 1.—COMPARISON OF TWO TRANSMISSION SYSTEMS.

series-parallel, four listeners record simultaneously, so that the isolated test result is an average of 400 logatons received on each of the systems.

Usually information should be obtained on the relative transmission properties of two systems at different levels of received volume. This information would be shown by test points plotted as indicated in Fig. 1, where points A_1 , A_2 , A_3 and A_4 refer to the articulation percentages obtained on one system (A) at four different levels (controlled by adjustment of circuit attenuation at a convenient part of the circuit), and points B_1 , B_2 , B_3 and B_4 refer to articulation percentages on the other system B. Smooth curves drawn through the points A and the points B, then purport to give a true representation of how both systems perform at different levels.

But if the comparison has been made in the form of isolated tests comparing A_1 and B_1 , A_2 and B_2 and so on, the shape of the curves depends on comparison of the different points A with each other and of the different points B with each other, and these comparisons have not been directly made.

In order to make the comparison between the curve A and the curve B more direct the following procedure has been used:—The whole test series is first planned as a group of isolated tests each comparing a point on curve A with a point on curve B, taken in random sequence, such as A_2 and B_2 , A_1 and B_4 , A_4 and B_3 , A_3 and B_1 , A_1 and B_2 , A_4 and B_4 and so on, the number of such combinations depending on the amount of testing considered necessary. When all the tests have been completed the average is found for each of the separate points, and the difference of each individual test result from the corresponding average value is noted. Each isolated test includes two individual test results, and the mean of the differences of these from the corresponding average values is applied as a correction to both. For example, suppose that an isolated test of A_1 and B_1 gave 88 per cent. for A_1 and 42 per cent. for B_1 , and that the average of all the tests for A_1 was 87 per cent. and for B_1 , 39 per cent. The two differences are -1 and -3 (the average value taking the $+$ sign), and the mean, applied as a correction of -2 , makes the corrected values for this test 86 per cent for A_1 and 40 per cent. for B_1 . The average of all the corrected values for each point is then plotted.

Applications of Articulation Tests.

The nature of the problems for which articulation tests may be required is so varied that overmuch generalisation would be unwise. Some specific examples of very general interest follow.

The Effect of Noise on Conversation by Telephone.—From general considerations it may be concluded that the principal effects of noise on a listener are due to masking of the wanted sound and to distraction. The latter effect is not measured by articulation tests; it is attributable more, perhaps, to the subject than to the noise. The masking effect, however, may properly be studied by articulation tests.

That the masking effect of noise, either circuit noise or room noise, is in effect a limitation of the range of volume levels which can be effectively received by the ear is generally recognised. For a given type of telephone connection and a given noise condition, the extent of the volume limitation or "impairment" due to the noise can be assessed, in db., by a series of articulation tests made with and without the noise. The effect is illustrated in Fig. 2

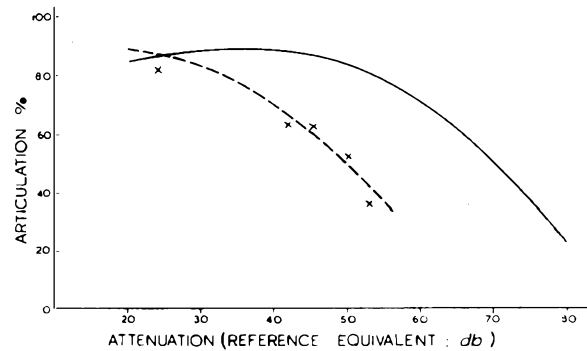

FIG. 2.—EFFECT OF NOISE

where the full curve is the articulation-attenuation curve for a commercial circuit, as measured with no noise at the listening end. The broken curve has the same shape as the full curve, but is displaced by 20 db. towards the left, i.e. it represents the articulation percentage on the same circuit but with 20 db. of added attenuation introduced at some point in the circuit. The points show observed articulation percentages on the circuit, without added attenuation, but with a certain steady circuit noise applied instead.

It is clear that the impairment due to the noise is, for all practical purposes, the same as that due to 20 db. of attenuation when no other noise is present.

The impairment due to a noise is logically equivalent to a loss of effective volume. It can be assessed in similar terms (db.) and by a similar technique, and if this is done the result is directly additive to the effective volume efficiency. But though the impairment due to a noise is substantially independent of the amount of attenuation in the circuit and of the loudness at which the sender is talking, it is not independent of the amount of other noise which may be present. Thus a small noise may introduce a substantial impairment when compared with no noise, but, if added to a much larger noise, the smaller noise, being itself masked, would be negligible. Even so, it seems that if sufficient assessments are

made of a single noise, when other noises of usual magnitudes and very different character are present, a single average impairment, attributable to this noise, can be used for most practical purposes.

Although a particular noise can produce a masking effect with frequency discrimination, it seems reasonable to assume that noise in general covers the useful range of audible frequencies uniformly, i.e. that the impairment due to the noise is equivalent to non-reactive attenuation.

Effect of Frequency Limitation on Conversation by Telephone.—It is well known that for long-distance telephony the wider the band of frequencies effectively transmitted, the more expensive are the circuits, hence the question of the effect of frequency limitation on transmission is one of very general interest. For purposes of design and planning it is desirable, if not essential, to reduce all relevant assessments of transmission to a common quantity, and this quantity is attenuation, or relative sensitivity, in db. Now the introduction of a frequency distortion, such as frequency limitation, is not, logically, equivalent to a uniform attenuation at all. Hence any assessment of frequency cut-off in terms of the added attenuation to give equally good transmission will produce an answer which is particular to the testing conditions employed (such as the frequency-characteristics of the circuit, the speaker's volume, room noise, etc.). A generalised answer is obtained if these conditions are constantly varied during the assessment in a random manner comparable to service conditions; this is the repetition rate technique.

Laboratory tests, under controlled conditions, supply more detailed information for the particular conditions used. An example is given in Fig. 3 which shows the results of a comparison, by articulation tests, of a certain commercial circuit with and without the frequency limitation caused by introducing a low-pass filter with a cut-off frequency near the upper limit of what is ordinarily regarded as the useful frequency range for commercial telephony. Some points of interest may be noted from the curves of Fig. 3. Where the attenuation is high an

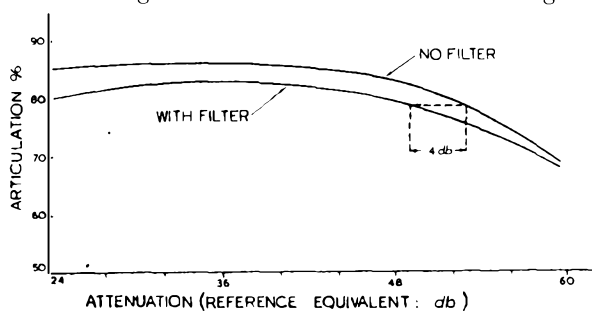

FIG. 3.—EFFECT OF FREQUENCY LIMITATION.

assessment can be made of the reduction of "effective volume" due to the filter; this is indicated in the figure at a particular point on the curve as equal to 4 db. Unlike the noise example, however, it cannot so readily be assumed that this quantity necessarily applies at greater attenuation levels. Also, unlike the noise example, at smaller attenuation levels there is a loss of articulation efficiency due to the filter

which cannot be made good by reducing attenuation.

One can visualise the received sounds as consisting of components at different frequencies and different intensity levels, ranging from the strong vowel sounds (generally in the mid-frequency range) to the weak, unvoiced consonants (at somewhat higher frequencies). While there is sufficiently low attenuation, all are transmitted (within the limitations imposed by the distortions of the system), but as attenuation is increased to the point where some of the weaker components are entirely lost, the articulation efficiency is reduced, and any further increase of attenuation augments this effect. A similar process applies when the filter is in circuit, but, in addition, the components at frequencies cut off by the filter are lost at all volume levels.

It can also be seen that with small attenuations, i.e. louder received sounds, the articulation efficiency is slightly less than the maximum, and that this effect is somewhat more pronounced when the filter is in circuit. The combination of two well-known influences may be sufficient to account for the effect. First, the sensitivity of the telephone instruments is very much greater at some frequencies in the mid-frequency range than it is at the more extreme frequencies, and secondly, the masking effect of a single frequency tone on the ear not only becomes greater as the strength of the tone is increased, but it also extends over a wider range of frequencies, especially towards higher frequencies. It is not unexpected therefore that the loud mid-frequency sounds received by the listener should produce sufficient masking of weak sounds at other frequencies to reduce articulation efficiency, and that this effect is augmented by a restriction of the frequency range.

Intelligibility Tests.

With the object of avoiding some of the artificiality involved in articulation testing, intelligibility tests have sometimes been used instead. The technique is generally similar, but short sentences, each containing a simple idea, are sent, instead of logatoms, and records are made of the number of ideas correctly received.

There are obvious practical difficulties in the selection of sufficient sentences suitable for intelligibility tests, if the observers remain unchanged. A continuous supply of fresh lists must be available to avoid the chance of aid by memory. It is not feasible to balance lists for difficulty, and the possibility of differences in degree of simplicity of the ideas, relative to the intelligence of observers, is introduced, a factor which is absent from articulation testing.

Another interesting method of test, immediate appreciation testing⁵, has recently been described. Simple sentences are also employed in this technique.

These methods can be applied for comparison tests in ways similar to those used for articulation testing.

Judgment Tests.

This title covers a wide variety of possible applications ranging from a complete testing series, devised to give a definite and reliable result, to a simple "snap" test by a single observer only, made with the object of confirming that the results of other

⁵ *Siemens' Magazine*, January, 1937.

tests are essentially reasonable. No subjective snap test should really be regarded as a test at all; variations between individual observations can generally be so wide that it is not safe to rely on the results of a few observations only, and this fact can easily be overlooked if record is made in the form of a test result.

Quantitative comparisons can sometimes be made between two transmission systems A and B by judgment tests, for example by the method of Fletcher & Munson mentioned earlier. A specific example of a comparison, in terms of relative attenuation (db.) may be quoted to illustrate, not only the method, but also some general considerations concerning the use of attenuation as a criterion of merit for a system:—

Two microphones, A and B, are to be compared on similar circuits. A is regarded as the standard and B as the microphone under test. The circuit includes in the junction connection a non-reactive attenuator which can be varied to control the overall attenuation. Switching arrangements are provided at the microphone termination so that changing over the microphones on the circuit also changes over attenuators in the junction. Different junction attenuations for circuits A and B, as shown in the table, are applied in turn. For each of these applied conditions the speaker reads from some text of a simple nature, switching over from A to B or

TABLE
COMPARISON OF MICROPHONES A AND B
(+ indicates judgment in favour of B, — in favour of A)

Observer	Attenuation in Junction for A (db.)											
	30						36					
	Attenuation in Junction for B (db.)											
	24	27	30	33	36	39	30	33	36	39	42	45
X	+	+	+	+	-	-	+	+	-	+	-	-
Y	+	+	-	+	-	-	+	+	+	+	-	-
	and so on for, say, 20 observations											
Percentage in favour of A	0	5	25	55	70	95	5	15	55	80	90	100

vice-versa after equal intervals of a few seconds duration. The observer signals which of the transmissions A or B he can hear more clearly and the record is made, e.g. by + or - sign as shown in the table. For the particular test illustrated each observer makes twelve judgments at a sitting. The conditions are, of course, applied in a random sequence and a reversing key at the sending end is used to interchange conditions A and B at will in a manner unknown to the observer. The test includes any desired number, say twenty such observations, either with twenty different observers or with, say, five observers each making four observations, for different speakers.

The results are then counted as a percentage of votes recorded in favour of one of the transmissions A or B, and points are plotted as shown in Fig. 4.

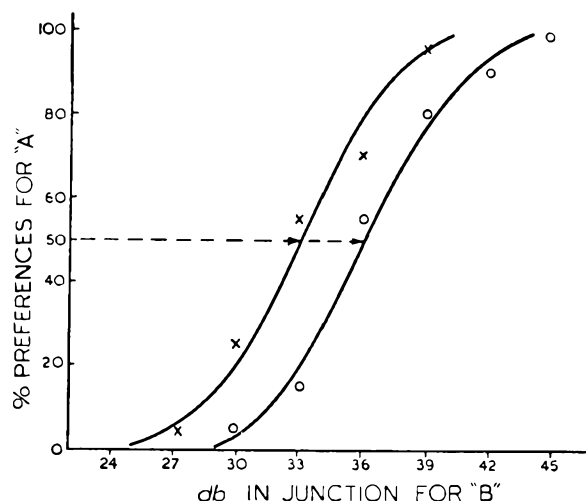

FIG. 4.—PERCENTAGE PREFERENCES FOR ONE OF TWO MICROPHONES.

The smooth curves drawn for these points intersect the line for 50 per cent. at points which are taken as indicating equality between the systems. Thus, under the conditions of the test and with 30 db. in the junction for A, balance is obtained with 33 db. and 36 db. respectively in the junction for B.

Since the criterion of the test was "which transmission can be heard more clearly," the test is one of effective volume efficiency. If the criterion had been "which transmission is louder" the test would have been one of volume efficiency, and generally a different result would have been obtained.

The effective volume efficiency of B in terms of A is thus + 3 db. with 30 db. in the junction for A and 0 db. with 36 db. in the junction for A, for the test conditions used, which would include certain levels of room noise and speaking volume. Differences of attenuation in the junction may be interpreted to include any changes of condition which are really equivalent to changes of attenuation, e.g. changes of noise or of speaking volume.

The difference of 3 db. in the test result at the two different levels may be due to subjective variations, or it may be an indication of a real effect. Suppose, for example, that microphone A is an ordinary commercial telephone transmitter and microphone B is one of relatively high quality, and that articulation tests under conditions similar to those of the judgment tests resulted as shown in Fig. 5. The curves

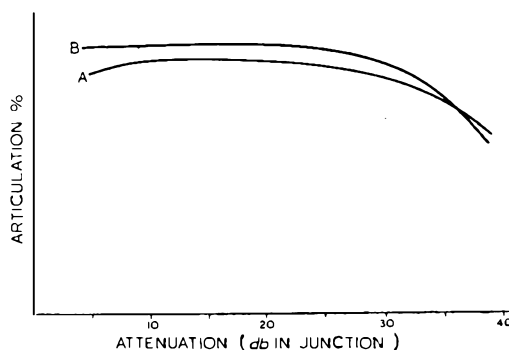

FIG. 5.—COMPARISON OF TWO MICROPHONES.

in this figure are drawn to correspond with the results quoted above for the judgment test, viz., the effective volume efficiency of B in terms of A is zero with 36 db. in the junction for A. For smaller values of attenuation, the effective volume efficiency of B in terms of A is a gain, and for larger values it is a loss. In the region where the curves are practically horizontal the concept of effective volume is meaningless, because in this region the transmission is not affected by change of attenuation. We may suppose that for attenuations less than the critical value (36 db. in the junction for the particular conditions of the test) the relative superiority of B is due to the wider range of frequencies effectively transmitted by microphone B; also that for greater values of attenuation the resonance of microphone A enables it to give a greater output than B over a restricted range of frequencies, and that at these high attenuation values frequencies outside this range are in any case inaudible.

Which then is the better microphone, A or B? Obviously in the majority of circumstances B shows a marked superiority over A. Some listeners, however, may be partially deaf or may suffer from a severe combination of adverse circumstances such as noise, attenuation and weak speaking, and in such circumstances preference for microphone A is understandable.

Repetition Rate Tests

The considerations touched upon in the preceding paragraph, and the fact that circuit performance can react upon the telephone user, differently for different users, in manners not accountable with certainty by laboratory tests, point to the necessity for collecting data from service observations to obtain direct assessments of effective transmission. The repetition rate method⁶ serves this purpose; it is based on a count of the number of repetitions required in ordinary telephone conversations and on the principle that if two interchangeable circuit components are directly compared by this method, they have equally effective transmission if they give equal repetition rates, the repetition rate most commonly used being the number of repetitions per unit of conversation time.

This is essentially a subjective test and no absolute figure of merit should be attributed to any measured value of repetition rate. The test is properly a comparison test, and the more directly the comparison is made the more reliable will be the result. There is evidence that the repetition rate is influenced by the proportions of types of conversation (e.g. business or social calls), sexes of the speakers, duration of the calls, etc. At the same time a repetition rate test cannot be made so direct a comparison as a laboratory test, since identical calls do not occur on the two circuits which are being compared. The assumption must therefore be made that, with a sufficient number of calls observed, the irrelevant influences have an equal effect on the repetition rates of both circuits.

Since the object of repetition rate testing is to obtain data for replacing existing volume efficiency ratings by effective transmission ratings, and since

it is desired to retain the useful and successful features of the existing scheme, it is clearly desirable that the test results shall be capable of interpretation in similar terms, viz. as distortionless attenuation in decibels. The first step is therefore an observation of the effect on repetition rate of a change in attenuation. From such observations it appears that a useful empirical finding has emerged, which can be expressed, in terms of the increase in repetition rate from R_1 to R_2 due to an added attenuation of X db., as:—

$$X = C \log \frac{R_1}{R_2}$$

where C is a constant. By means of this relationship, the value of C having been established, it is possible to assess in db. of effective transmission the value of any circuit change for which the relative repetition rates have been observed by direct comparison. Absolute invariability of the constant C cannot be assumed, which means that the fundamental relationship requires periodical verification by experiment.

An outstanding disadvantage of the repetition rate method is the length of observation time that is necessary to obtain a single reliable result. For this reason the test cannot, by itself, be used as a direct substitute for volume efficiency measurements, because the number of types of circuits and combinations thereof is too great. When taken in conjunction with laboratory tests, however, the results of repetition rate tests can be used to provide sufficient data for planning on an effective transmission basis.

Comparison of Laboratory and Field Tests.

The contrast between repetition rate and laboratory tests lies in the fact that whereas the latter can result in a number of different answers, according to different conditions of test, the former gives a single result in which the different conditions (e.g. of room noise, circuit attenuation, etc.) are automatically weighted, on a statistical basis, in accordance with their occurrence in the service conditions of the test. Moreover, the repetition rate answer includes psychological reactions, which may not be capable of simulation in the laboratory, and also abnormalities of hearing and speaking.

It should not, however, be too lightly assumed that a result obtained directly from a repetition rate test is necessarily more representative than an estimate based on laboratory tests. For practical reasons the callers involved in a repetition rate test are restricted in numbers and generally in locality, and the types of user and types of call may not be truly representative of those included in the service as a whole. In general, therefore, it is not desirable to lay down any hard and fast rule for evaluating the effect of a change of circuit or apparatus in terms of effective transmission. Relevant existing data must be reviewed and further tests planned, possibly on a basis of allocation of testing time in accordance with the importance of decisions for which the test results are required.

The formula $X = C \log (R_1/R_2)$, quoted above, was obtained by repetition rate tests under service conditions for local calls, but with artificial junction lines of distortionless attenuation X which were

⁶ *B.S.T.J.*, Vol. 10, p. 116; and Vol. 12, p. 331.

introduced for the test. The formula appears to be as applicable for quite small values of X as for larger values, i.e. the repetition rate increases with increasing attenuation even when there is a minimum of attenuation in the junction. This seems to be a different story from that given by articulation tests (see for example Fig. 3). An obvious difference between the two tests is that, whereas each point on the curve for articulation efficiency represents a single set of listening conditions, the repetition rate is always the combined result of a large number of different conditions. These differences of conditions are, one may presume, predominantly differences of noises, transmitter feed current, efficiency of instruments and of hearing and speaking, rather than tone differences on the circuit. In general, all such factors are impairments equivalent to attenuation, and some of them, e.g. noise and imperfect hearing, can have very large impairment values indeed. The comparison of repetition rate with articulation test results is therefore a comparison, not with any single point on the articulation-attenuation curve, but with the whole of an indeterminate but very wide range of attenuation values on the curve.

In so far as this comparison is reasonable, it follows that, for a given type of telephone instrument and local connection, the repetition rate is influenced mainly by the relatively few calls for which the listening conditions are exceptionally unfavourable, and that for these calls volume efficiency is a critically important factor. This does not mean that a considerable improvement in repetition rate cannot be effected by reducing the distortions introduced by the telephone instrument, but it does indicate that there is little room for sacrifice of effective volume efficiency in the design of instruments to give improved quality.

One further consideration which would be involved in establishing the telephone system on a basis of effective transmission deserves attention. For many years it has been a routine practice to line up circuits by tests at a single frequency of 800 c.p.s. This

frequency is probably well chosen for volume efficiency, but, for effective transmission, there are indications that a frequency of about 1,600 c.p.s. is to be preferred where tests at a single frequency only are justifiable. The middle point of the frequency range for articulation lies at about 1,600 c.p.s., that is to say that articulation is degraded by about the same percentage by the loss of all frequencies above as by the loss of all frequencies below this value. It is significant that the result of a repetition rate test has shown that one mile of a 20-lb. cable (88 ohms and .075 μ F per mile) is equivalent to about 1.6 db. for effective transmission; the same equivalence holds, for attenuation, at a frequency of about 1,600 c.p.s.

Conclusion.

Only certain subjective tests of very general interest in telephone transmission have been mentioned in this review. Other kinds of test have sometimes to be devised to deal with special circumstances, for example where voice operated switching devices may affect transmission.

For all major problems of telephone transmission it is useful to employ a variety of different tests. In any case such problems, involving subjective tests, require the expenditure of much testing time to establish sufficient reliable data. There is, however, room for ingenuity in the planning of the tests to yield information of the most general and comprehensive kind.

From the experience which is now accumulating of the combination of objective measurements with subjective assessments, it may be possible to rely more and more in the future on the former alone.

Subjective tests are themselves a compilation of records of human perceptions or opinions; as a subject of discussion or comment they readily acquire a highly controversial character. In this article the writer has endeavoured to avoid comment on the more controversial issues. Even so, the reader is warned that some of the statements which have been made may not be universally accepted.

TELEGRAPH AND TELEPHONE PLANT IN THE UNITED KINGDOM TELEPHONES AND WIRE MILEAGES. THE PROPERTY OF, AND MAINTAINED BY, THE POST OFFICE IN EACH ENGINEERING DISTRICT AS AT 30th SEPTEMBER, 1938.

Number of Telephones	OVERHEAD WIRE MILEAGES					Engineering District	UNDERGROUND WIRE MILEAGES					
	Telegraph	Trunk	Junction	Exchange*	Spare		Telegraph	Trunk	Junction†	Exchange†	Telephone Trunk	Junction ‡
1,147,480	324	760	1,774	56,483	5,832	London Reg.	24,723	313,400	886,072	3,207,783	90,716	322,206
143,001	1,657	1,466	10,990	56,296	13,066	S. Eastern	5,503	135,550	22,802	384,570	58,494	22,734
169,627	1,847	10,626	25,782	109,334	10,733	S. Western	19,862	144,902	13,593	341,214	70,858	16,120
120,503	2,558	10,276	24,118	88,257	19,355	Eastern	7,727	159,042	16,688	250,595	110,478	16,696
139,543	3,158	11,328	18,351	71,062	27,233	N. Midland	8,691	219,918	21,437	282,639	88,180	24,755
156,099	1,730	6,006	19,622	80,215	19,612	S. Midland§	9,836	197,212	31,984	399,901	77,696	30,531
81,939	1,138	5,448	17,068	58,195	12,025	S. Wales	5,725	82,688	15,862	158,256	58,746	16,300
205,433	1,518	9,477	23,485	88,647	20,009	N. Wales	12,779	215,114	103,842	434,808	112,544	37,798
243,048	971	1,485	3,262	36,020	5,656	S. Lancs.	10,591	125,898	108,952	685,934	55,050	54,611
102,124	706	2,048	5,154	37,195	15,422	N. Western	6,275	119,840	20,468	271,531	85,232	14,534
40,347	2,891	6,438	6,237	18,393	1,105	N. Ireland	1,516	13,962	7,908	87,844	26,784	4,520
291,711	4,692	13,251	22,905	97,207	29,759	N.E. Region	17,050	252,118	70,444	716,785	167,490	42,224
270,017	6,402	24,477	32,055	102,640	25,478	Scot. Region	10,459	214,208	35,833	516,157	149,692	37,288
3,110,872	29,622	103,086	210,803	899,944	205,285	Totals	140,737	2,193,882	1,355,915	7,738,017	1,151,960	640,317
† 3,070,606	29,842	103,241	208,983	882,757	204,085	Totals as at 30 June, 1938	140,313	2,115,870	1,332,970	7,672,630	1,063,794	594,178

* Includes low gauge spare wires, i.e. 40 lb.

† Includes all spare wires in local underground cables.

‡ Wholly Junction cables.

§ Figures for Overhead Trunks and All Junctions are as at June 30th, 1938, those for September 30th, 1938 not being available.

High Speed Cinematography

R. W. PALMER, A.M.I.E.E.

After some comments on the shortcomings of stroboscopic devices for studying fast-moving mechanisms, the theory, development and current practice of cinematography at high speeds are described together with a description of some recent slow motion films of automatic telephone mechanisms taken by the Post Office at 2,500 pictures per second. Mention is made of the possible applications of films taken at even higher speeds.

Introduction.

THE reason for the intrusion of an article on photography in this telecommunications journal is that the slow motion film is one of the many unusual tools which have recently played an important part in telephone engineering. The need is mainly for the electro-mechanical devices used in automatic telephony where the movements of small details, often at high speed, require special study during the design and development stages. Simple linear movements are comparatively easy to see and to measure, but mechanical details that bend, vibrate, move in jerks or move in more than one plane present a problem with which this article is specially concerned, and the particular example on which the experiments have been mainly conducted by the Post Office up to the present is the two-motion selector mechanism used in automatic telephony.

For many years the most effective methods of causing an oscillating or rotating object to appear stationary, or moving very slowly, have been based on stroboscopic principles. In these devices the illumination is interrupted at a frequency related to the speed of the object, or alternatively the vision of the observer is obstructed intermittently and at high frequency by a special shutter in front of an eyepiece. Apart from the problem of providing a sufficient magnification and intensity of illumination particularly for small compact mechanisms, the stroboscope is not well adapted to the observation of non-cyclic movements nor can it provide information on the first and last of a series of movements where they differ from the remainder.

A photographic record or "trace" of rapid movements can be obtained by reflected light from a very small mirror attached to a moving part, the trace being obtained on a moving strip of photographic paper as in the commercial oscillograph, and a variation of this principle, described in this Journal¹, involves the recording of the shadow of the moving part, thus avoiding the possible disadvantages of attaching a mirror. These systems are often not applicable owing to the difficulty of knowing what part of a mechanism to select for observation, which plane of movement to observe, or how to obtain optical accessibility without altering the conditions under which the mechanism normally works. There is no doubt that the type of record obtained has many advantages, such as ease of measurement and subsequent filing, but it has been due to the other limitations that attention has been diverted to the high speed cinematograph as an engineering tool.

Principles of High Speed Cinematography.

So far as projection of a moving picture is concerned, there is no real difference between ordinary and slow motion films. In both a chronological series of pictures,

or "frames", is projected on to the screen at such a frequency that the natural persistence of vision of the human eye covers up the intervals between frames and so gives the impression of a single picture which moves. The minimum commercial speed of projection is 16 frames per second, but this figure has been raised to 24 for sound films, not because any better picture is obtained, but because the higher speed of the film through the camera or projector allows the sound track to be drawn out to more practical proportions. Thus, 24 frames per second must be taken as the present standard film speed both for photography and subsequent projection. If, however, the separate frames are photographed at closer time intervals than 1/24 second, but are reproduced at the standard frequency, an illusion of slow motion is obtained on the screen, and the extent of this time magnification is limited only by the physical and photographic capabilities of high speed cameras.

The ordinary cinematograph camera is required to have facilities for taking each photograph on the sensitised negative while the film is stationary (Fig. 1a and 1c). The film must therefore be moved as rapidly as possible between successive photographs (Fig. 1b), and the lens aperture must be masked during this period to avoid the blurred image which otherwise would be recorded. This period of acceleration, movement and retardation, repeated many times every second, represents a considerable physical stress on

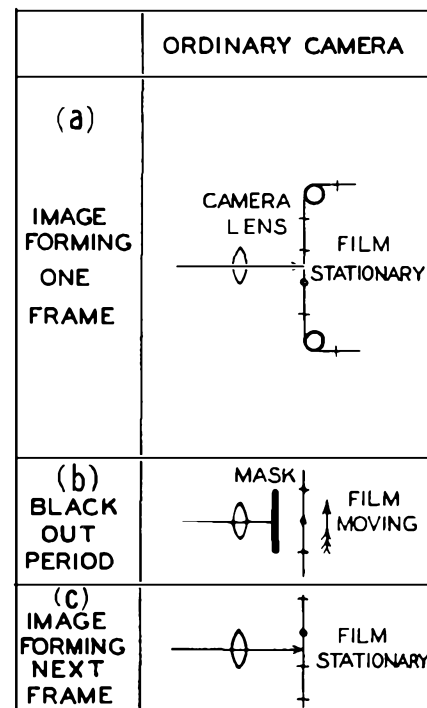

FIG. 1.—OPTICAL PRINCIPLE OF ORDINARY CINEMATOGRAPH CAMERA.

¹ P. E. E. J., Vol. 31, p. 112.

the celluloid or other material of the film, especially as it is driven only through the engagement of sprockets into perforations at the edge of the film itself. This is the first of the problems to be met in high speed cinematography.

Nevertheless, the Post Office and others have had some success with cameras in which the film was accelerated and decelerated 240 times per second, thus providing a time magnification of $\times 10$ when projected at the standard 24 frames per second. The cameras employed have been those commonly used by the news reel organisations for slow motion pictures of sporting events, the standard film 35 mm. wide being used, but perhaps it was the fact that 240 frames per second is the extreme upper limit of performance of this type of camera that very careful adjustment and lubrication was found necessary if stripping of the sprocket holes in the film was to be avoided during the shots. At this speed the time magnification was sufficient to reveal, for example, the unsuspected existence of a 2° horizontal twist of a selector shaft at each vertical step of the mechanism. Such results are important, if only to lead to investigations by other methods, and this success led the British Post Office to pursue the subject into the realms of ultra-high speed (or ultra-slow motion) photography.

Ultra High Speed Photography.

Provided that the physical problems of camera design can be solved, there is no real photographic difficulty in taking several thousand successive pictures in a single second, and it is even within the capability of the amateur to take flash-gun photographs in one thousandth of a second to obtain still pictures of such fast-moving objects as a jet of soda water halfway between syphon and glass.²

So far as has been ascertained, the first camera to take a continuous series of pictures at a speed of over 1,000 frames per second was the Chronoteine camera designed by C. Francis Jenkins (U.S.A.) and described in 1923³. Another early type was the Zeitlupe,⁴ ("time-magnifier"), the first model of which was produced by the Ernemann works in Germany. In these and in all other ultra-high speed cameras, the essential principle of operation is that the film shall travel continuously through the camera (instead of intermittently) and the image must be made to move in phase with the film movement and at exactly the correct speed. The Chronoteine camera employed a rotating disc 13 in. in diameter, on the periphery of which were 48 separate lenses which moved in turn across the aperture in the camera in order to follow the movement of the film. Fig. 2a shows in diagrammatic form how a single picture is being taken while both lens and film are moving (3 positions are shown). After a predetermined exposure time for the recording of one picture, there may be a brief "black-out" period (Fig. 2b) after which the next lens in the sequence will be providing a focussed

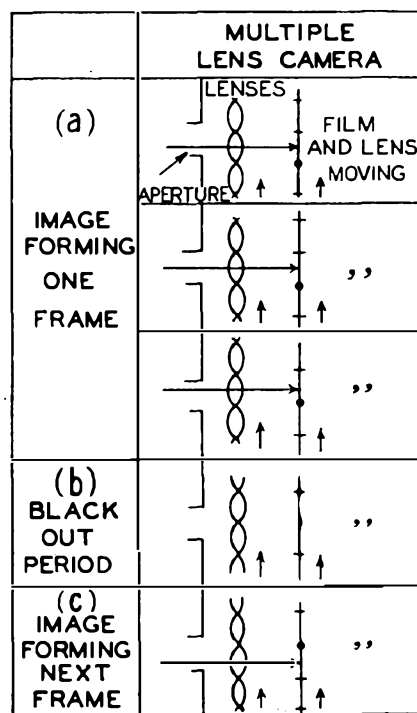

FIG. 2.—OPTICAL PRINCIPLE OF MULTIPLE LENS CINEMATOGRAPH CAMERA.

image on the next frame of the film (Fig. 2c). This lens again will synchronise the image with the film and by this means the complete film is taken at speeds of 3,000 to 10,000 frames per second without any serious strain on the film other than that caused by friction. A similar result is obtained in the Zeitlupe camera with 30 mirrors mounted on a drum in place of the multiple lens system, a speed of 1,500 frames per second being the standard adopted for the latest design (Model II) manufactured by Zeiss Ikon A.-G. of Dresden.

Other cameras, mostly using standard 35 mm. film stock, have been designed and used by research organisations in several countries with considerable success, in spite of the fire risk when passing standard celluloid film through the camera at phenomenal speeds, and one of the most interesting applications in this country has been the examination of air flow around aeroplane wings and struts, the air being rendered visible by the Schlieren effect. This is an optical phenomenon by which variations of air density are reproduced as shadows⁵, so that a flow of air can be seen, provided that local heating is supplied either continuously or by a series of sparks in order to produce local density variations in the air. Sparks produce variations which look like small puffs of smoke carried along in the wind.

Modern practice in ultra-slow motion pictures is now favouring the use of 16 mm. film instead of the standard 35 mm. thereby reducing the size of the cameras and the linear speed at which the film must travel for a given time magnification. Such a camera has been used with marked success in the tele-

² *Amateur Photographer*, 1st Dec., 1937.

³ *Trans. Soc. Motion Pict. Engrs.* No. 17, Oct., 1923.
Journal S.A.E. No. 25, Feb. 1928.

⁴ *British Journal of Photography*. Sept., 1935.

⁵ *Proc. Royal Society* (1931), Vol. 132.

Journal Franklin Inst. (1931), Vol. 211.

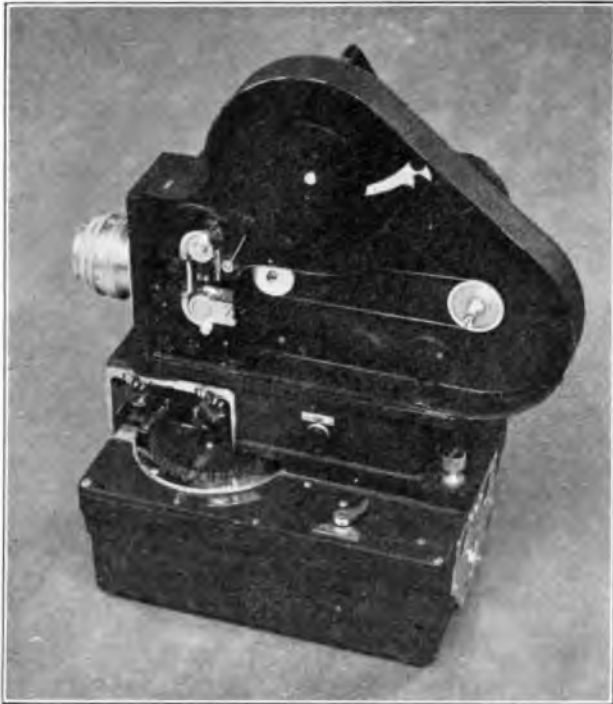

FIG. 3.—WESTERN ELECTRIC 16 MM. HIGH SPEED CAMERA.

communications field by the Bell System Laboratories (U.S.A.)⁶, and it was a camera of this type, manufactured by the Western Electric Co., that was used by the British Post Office for the ultra-slow motion films described later in this article.

The Western Electric 16 mm. High Speed Camera.

This compact precision instrument, shown in Fig. 3, has a maximum film speed of the order of 2,500 frames per second, and the mechanism for synchronising the image with the continuously moving film consists of a single small glass prism or plate which rotates at 1,250 revolutions per second (75,000 r.p.m.) for the maximum film speed. A beam of light from the object first passes through the fixed lens system of the camera and is then displaced vertically according to the position of the rotating prism at any instant. Fig. 4a shows by three successive sketches how the image follows the film movement as the prism rotates for one half-revolution. A black out is provided while the prism is in the position indicated in Fig. 4b, and then the next frame begins, in Fig. 4c, to receive its image during the next half-revolution. This represents the ideal, but in practice the exposures each last for only 80° revolution of the prism.

Provision is made for daylight loading and unloading of the film on reels taking 50 feet at a time, and as this length of film is used up in a single shot lasting about 1½ seconds it is extremely important to obtain rapid acceleration of the film to the maximum working speed. Here the use of 16 mm. film stock has not only enabled the whole of the camera to be kept small in size, but has made it possible for the rotating prism to be accelerated from rest to 75,000 r.p.m. in only 1½ seconds. The camera motor is permanently

coupled to the film drive, and the speed of the film therefore varies from zero to maximum in each shot. For this reason, a scale of time is essential in accurate slow motion studies.

The timing device in the W.E. Co. camera is integral with the transportable camera unit, and the edge of a graduated timing disc is photographed automatically side by side with the slow motion picture. This has been omitted from the reproductions of films which appear in this article but the contour of the timing disc is seen on the lower portion of the camera assembly in Fig. 3. The timing disc is graduated in hundredths of a second with a vernier scale allowing readings to 1 millisecond, and is driven by a synchronous motor in conjunction with a thermostatically controlled tuning fork. The whole system is entirely self-contained and includes the necessary lamps for the illumination of the disc to be photographed.

Apart from the camera itself which is mounted on a rigid tripod (Fig. 5) there are other items of equipment such as transformers and switch-fuses for the camera, and also the lighting equipment together with its controlling devices. The intensity of illumination required for photographic exposure times of the order of 1/3000th second is very great, and, for the close-ups such as are reproduced in this article, it was necessary to have two 1,000 watt spotlights placed with their lenses about 2 ft. from the object. The lamps were then considerably overrun for the short duration of the shot and Fig. 6 shows the set-up when photographing a portion of a teleprinter mechanism. Although the intensity of illumination was ample, it was necessary to apply a little make-up to the small mechanical details, and this was provided by aluminium paint to improve definition or to assist

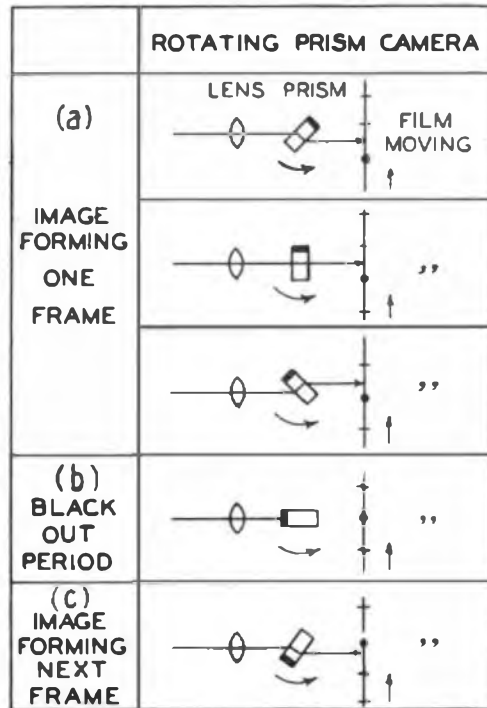

FIG. 4.—OPTICAL PRINCIPLE OF ROTATING PRISM CINEMATOGRAPH CAMERA.

⁶Bell System Tech. Journal. July, 1938.



FIG. 5.—CAMERA READY FOR OPERATION.

the penetration of the light into deep mechanisms rather than by dull black paint to prevent dazzle. The heat radiated by high intensity lighting is liable to present a problem, but it was not found necessary to provide water filters for the lighting units so long as focussing was carried out with reduced voltage on the lamps. Even with this precaution, the telephone equipment being filmed became very warm to the touch after 15 minutes' continuous illumination for focusing, and the wax on exposed wiring was melted, but a cooling period was allowed before each shot, and the shot itself did not last long enough to cause appreciable heating.

For reasons of temperature and of conservation of the life of the lamps, a sequence of operation of camera and lighting was arranged as follows. When all was ready, the photographer in charge counted "one," "two," "three," with about 1 second spacing, and the action taken at these counts is indicated in this schedule, which also shows approximate time intervals from the word "one."

- (0 sec.) At "one," an assistant switched on the lamps at normal voltage.
- (1 sec.) At "two," the assistant changed over the lamps to the greater voltage.
- (2 secs) At "three," the photographer operated a switch to start the camera motor which drives the film and this also started the

- operation of the apparatus under test.
- (2½ secs.) The photographer operated another switch applying more than the rated voltage to the camera motor in order to reach maximum speed in the shortest possible time.
- (3¼ secs.) The photographer released both camera switches, the motor and film having reached full speed.
- (3½ secs.) The 50 ft. reel of film has been fully exposed and rewound and the shot was finished.
- (4 secs.) The assistant disconnected the lamps.

For most shots a pre-arranged automatic time lag was provided by slow releasing relays between the closing of the camera starting switch and the starting of the apparatus under test, in order that the maximum interest in the shot should coincide with maximum speed of the camera. Another item of practical importance was the rigidity of the table or stand on which the apparatus was mounted. This was necessary to avoid small vibrations which would have been confusing especially in the short focus views.

Editing and Projection.

When the action to be photographed lasts only for about $\frac{1}{3}$ second out of the total $1\frac{1}{2}$ seconds duration of the shot, there is some waste film which must be cut out in order to avoid considerable ineffective time when watching the projected film. This cutting can be done on a rewinding bench using a magnifying lens to examine the individual pictures which are only $\frac{1}{3} \times \frac{1}{4}$ in., but the process is greatly simplified by erecting an optical bench giving a projected image about 9 in. square for each frame. A short length of waste film must be left so that the eye can be focussed on the screen picture before any important movement takes place.

A single shot may take about 2 minutes to show on the screen and it is convenient to collect a related series of shots into a complete reel having a showing



FIG. 6.—TAKING HIGH SPEED FILM OF A TELEPRINTER MECHANISM.

time of 15-20 minutes. A few general titles can then be incorporated to identify the reel as a whole and to identify each separate shot before it is shown. The process of joining individual lengths of film is very simple but a complete film without joins can be produced, if necessary, by obtaining a positive print after the negative has been pieced together in the desired sequence. As, in practice, shots might be regrouped frequently for study purposes, the Post Office has found it convenient to give each shot a code number which appears on a small paper label in each picture, and which is also quoted in every title. (The pictures reproduced in Figs. 7 and 8 were trimmed slightly and the code labels are just out of sight.)

Projectors to take 16 mm. film are available at reasonable cost, and the larger commercial models give a screen picture that can be seen comfortably by an audience of 200, but there is a definite advantage in a small bright picture for slow motion studies of technical subjects. A projector capable of speed variation down to 12 frames per second is also desirable in order to obtain the maximum time magnification, and it is found that the amount of flicker of the picture at this low frequency is negligible, especially with a 4-bladed shutter, unless there is a large area of white in the picture. In choosing a projector it is well to remember that the 16 mm. silent film type drives the film by means of two sprockets, one on each side of the picture, whereas the projectors with sound reproducing equipment drive on one side only because of the space taken up by the sound track. Hence, for slow motion experimental work where joins in the film are frequent, there is less liability of film fracture with the silent projectors. A further useful facility for experimental purposes is that of producing a stationary image of a single frame when required, and also a reversing gear is invaluable when it is desired to study any individual shot repeatedly.

Technical Films.

Ultra-slow motion films that have been taken on a large variety of technical subjects have given striking proof that this technique provides data that is not otherwise obtainable. For example, a film produced by the Massachusetts Institute of Technology, and appropriately entitled "Seeing the Unseen," contains many amazing pictures of the movement of liquids in gently floating cascades or in queer droplets that must be seen to be believed. Even on more serious subjects, an audience of telephone engineers has been known to give audible evidence of surprise on seeing for the first time the slow-motion antics of a telephone mechanism with which they had thought they were entirely familiar. It is difficult, if not impossible, to convey in a series of still pictures the vibrations, the uneven accelerations or the curious hesitations of a mechanism as revealed on the screen, but the reproductions in Figs. 7 and 8 will at least provide illustrations of the type of study which has so far been found most useful by the Post Office.

Fig. 7 is a picture taken for the purpose of examining the behaviour of a particular type of pawl assembly which engages with the teeth on a selector shaft on an ordinary Strowger selector. The pawl tip is behind the shaft, but an extension arm, the tip of which is

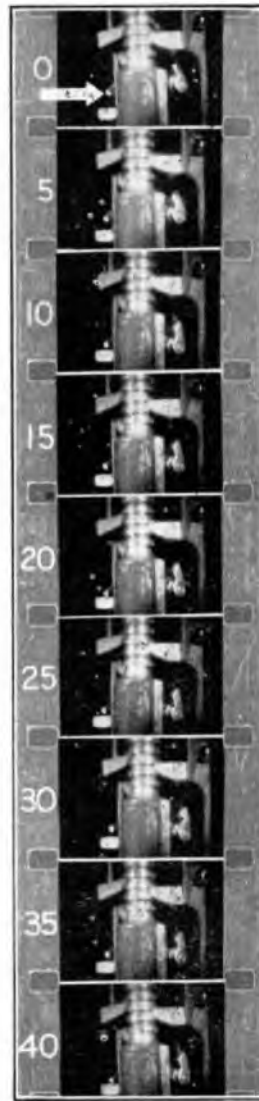

FIG. 7—EXTRACT FROM FILM SHOWING REBOUND OF AUTOMATIC SELECTOR PAWL.



FIG. 8—EXTRACT FROM FILM SHOWING OSCILLATION OF AUTOMATIC SELECTOR WIPER.

indicated by an arrow in the first picture, is integral with the pawl and moves in relation to a fixed stop which appears immediately below it. This, then, is a convenient measure of the pawl movement and the information gained by the series of pictures is given in tabular form below.

The pictures are approximately $2\frac{1}{2}$ milliseconds apart and are actual reproductions of every fifth frame of the film.

Frame 0 Shows the pawl when it has just completed its upward stroke and has lifted the shaft from the 7th to the 8th position.

Frame 5 The vertical magnet armature, at the end of which the pawl is pivoted, is beginning

to return downwards to the normal position, and the pawl itself is seen to be returning to normal as indicated by the tip of the pawl arm which is approaching the fixed back stop immediately below it.

Frame 10 The armature has returned to normal, and the pawl tip is seen to be almost touching the back stop.

Frame 15 The pawl tip has now struck the back stop and is bouncing away from it. The armature itself has also bounced upwards slightly, but this is not easily visible in the reproductions.

Frame 20 The pawl has returned to normal a second time.

Frame 25 A second bounce is seen to be commencing.

Frame 30 A continuation of this slow rebound is seen.

Frame 35 The pawl has not yet returned to normal.

Frame 40 The pawl has finally come to rest with the pawl tip against the back stop.

Fig. 8 is a picture of a new type of two-motion selector and is part of a study of the rotary motion of the selector wiper as it moves from one bank contact to the next. The photograph was taken almost vertically upwards from underneath the selector, and the time interval between the pictures reproduced was approximately $1\frac{1}{2}$ milliseconds, i.e., every 3rd frame in the actual film.

Frame 0 The wiper is leaving contact No. 5, under the action of the rotary magnet.

Frame 3 The wiper has reached the insulating gap between contacts 5 and 6.

Frame 6 Connection with contact No. 6 is established.

Frame 9 The mid-position of contact 6 is reached.

Frame 12 The wiper is continuing to travel across contact 6 under the momentum of the moving parts.

Frame 15 The wiper is now returning from the over-throw.

Frame 18 The return motion is seen to continue until the wiper has reached the leading half of the contact again.

Frame 21 The wiper is now travelling forward once more in the course of the oscillation which has been set up.

Frame 24 The forward motion continues past the central position of the contact.

Frame 27 The wiper has now reached a point nearly off the contact and it is apparent from the complete film that from this position (as in Frame 0) the rotary magnet takes up the drive again to move the wiper on towards

the next contact. This occurred in spite of the correct adjustment of the wipers to rest centrally on the contacts when operated by hand.

These illustrations are only examples of the simplest kind of information obtained from slow-motion film studies, but vibration of wipers, irregular operation of relay springs, drag on loosely fitting parts due to friction and oscillation in loose bearings are also included among the items of information which were obtained from the first Post Office film taken with a 16 mm. camera at 2,000 frames per second.

Future Use of Slow Motion Films.

The introduction of ultra-slow motion films into experimental work on telephone equipment has already produced an unexpected difficulty in keeping a proper sense of proportion. The magnification of time is so unfamiliar that there is a tendency to condemn a mechanism for irregular operation without realising that the slow irregularities seen on the screen are really negligible in their effect at normal high speeds. The best way to counteract this tendency might be to exhibit a brief slow motion film of a familiar object such as a clock, whose reliability is accepted, before showing any technical slow motion film to a new audience.

There is no doubt that many more ultra-slow motion films will be made by the British Post Office. Even with a time magnification of $\times 200$, an oscillation at 800 cycles per second (speech frequency) is reproduced as only 4 cycles per second and can be followed on the screen with comparative ease. It is therefore possible that high speed cinematography will enter the field of speech transmission, and films the action of the vocal chords have already been made⁷.

Practical cameras have been produced to take photographs at 10,000 per second (magnification, $\times 800$) and, although this is the present limit for continuous cinematography, an article was published⁸ in 1937 describing the Cranz-Schardin system of photography of a brief series of nine consecutive pictures at intervals of one ten-millionth of a second. The need for such an instrument for telephone work has not yet arrived, but there is still a great deal of unseen which has yet to be made visible by time microscopes of less ambitious proportions.

It is hoped that these notes will have been a useful record of the slow motion film work being undertaken by the British Post Office. Grateful acknowledgement is made to manufacturers and users of high speed cameras for information and assistance which has been freely given, and particularly to the Western Electric Co. for the reproductions in Figs. 3 and 5.

⁷*Radiography and Clinical Photog.* (U.S.A.), June, 1938.
⁸*Photography.* Dec., 1937.

A Method of Equalising the Frequency Characteristic of a Telephone Transmitter

D. McMILLAN,
B.Sc., A.M.I.E.E.

A modification to a Transmitter Inset to equalise its frequency characteristic is described and a formula developed to assist in the design of the transmitter.

Introduction.

IN the course of some recent experimental work it was found desirable to equalise the frequency characteristics of a number of experimental transmitter insets constructed in the laboratory. It is not intended here to describe a new type of inset but merely

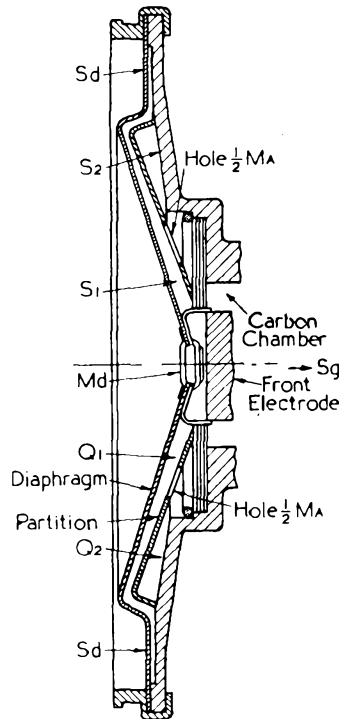

FIG. 1.—CROSS SECTION OF EQUALISED INSET.

to record the simple method of equalisation which was adopted and which has been found to be effective. The experimental insets incorporated the standard diaphragm and case of a Transmitter Inset No. 10 and, as at first constructed, exhibited the single resonance frequency characteristic which is typical of this type of transmitter¹. The resonance usually occurred at about 2,000 c.p.s. This simple form of construction was modified by the introduction of a rigid partition which divided the volume of air enclosed between the diaphragm and the case into two parts, small holes being cut in the partition to permit communication

Design Formula.

If M_d = Effective mass of diaphragm and granules —grams.

S_d = Effective stiffness of diaphragm —dynes/cm.

S_g = Effective stiffness of granules — dynes/cm.

$S_1 S_2$ = Effective stiffnesses due to enclosures —dynes/cm.

M_A = Total effective mass due to holes in the partition —grams.

and $\omega = 2\pi \times$ frequency of impressed force —radians/sec,

then, neglecting resistance, the mechanical system may be represented by the equivalent electrical circuit diagram shown in Fig. 2 and the total mechanical impedance of the system is given by

$$Z = j\omega M_d - \frac{j(S_g + S_d)}{\omega} - \frac{jS_1}{\omega} \left[\frac{S_2 - \omega^2 M_A}{S_1 + S_2 - \omega^2 M_A} \right] \quad (1)$$

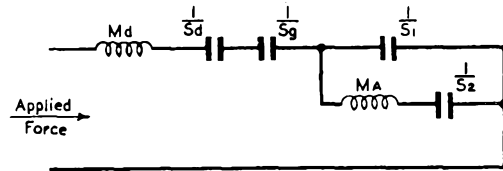

FIG. 2.—EQUIVALENT CIRCUIT OF EQUALISED TRANSMITTER.

Consider the third term of this equation. Its value will be

—ve and falling with increasing frequency when $\omega^2 M_A < S_2$,

$$0 \text{ when } \omega^2 M_A = S_2,$$

+ve and increasing with frequency when $\omega^2 M_A > S_2 < (S_1 + S_2)$,

$$\infty \text{ when } \omega^2 M_A = S_1 + S_2,$$

—ve and decreasing with frequency when $\omega^2 M_A > (S_1 + S_2)$.

Hence an anti-resonance, resulting in a minimum of response of the system, occurs when $\omega^2 M_A = S_1 + S_2$.

In the design of the actual insets under discussion, $(S_g + S_d)/\omega$ was always small in comparison with ωM_d for all frequencies above about 700 c.p.s.

Thus the negative reactance due to the third term of equation (1) may be adjusted by design to resonate with the positive value of reactance due to the mass of the diaphragm at some frequency above 700 c.p.s. and in the range $\omega^2 M_A < S_2$. Also a second resonance will occur in the frequency range where $\omega^2 M_A > (S_1 + S_2)$.

Summarising there is:—

A resonance in the range $\omega^2 M_A < S_2$,

An anti-resonance at the frequency given by $\omega^2 M_A = (S_1 + S_2)$,

A resonance in the range $\omega^2 M_A > (S_1 + S_2)$.

If, in designing the inset, the anti-resonance is arranged to occur at, or about, the frequency of the peak of resonance of the transmitter as originally

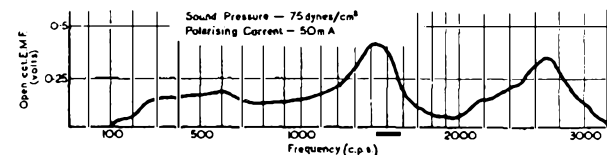

FIG. 3

constructed, this peak will be replaced by two others, one at a lower frequency and one at a higher frequency. Such a procedure will tend to flatten the characteristic and will certainly result in a better response at frequencies substantially above the peak of resonance of the original transmitter. Fig. 3 shows the frequency characteristic of a transmitter designed on these lines. The resonances may be

¹ P.O.E.E. J., Vol. 28, p. 3, and Vol. 31, p. 3.

critically damped in a convenient and simple fashion by fixing small pieces of material (e.g. Swiss silk, muslin, etc.) over the holes forming the mass M_A . A characteristic such as that shown in Fig. 4 is then obtained. This curve shows that the original single

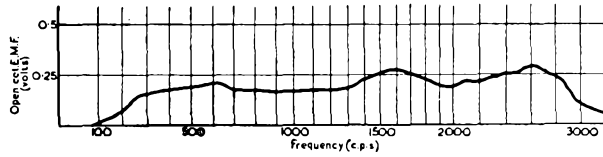

FIG. 4

peak type of response has been replaced by a more or less uniform sensitivity over the range of frequencies from 300 to 2,800 c.p.s.

Numerical Example of Design.

A numerical example of design may serve to illustrate the effects involved.

The effective mass of the diaphragm of an Inset No. 10 is about 0.7 grams and the effective stiffness is about 12×10^6 dynes per cm. These values may be used for M_d and S_d respectively for the experimental inset. The effective piston area of the diaphragm is about 15 sq. cms. In the particular experimental inset under discussion S_g was about 8×10^6 dynes per cm. The total volume of air enclosed between the diaphragm and the case of an Inset No. 10 is about 3.5 c.c. In the experimental transmitter this was divided into two parts, Q_1 c.c. immediately behind the diaphragm and Q_2 c.c. between the partition and the case such that $Q_1 = 2$ c.c. and $Q_2 = 1.5$ c.c. Two holes, each of about 0.14 mm. radius, were cut in the partition.

Then the acoustical reactance (stiffness) due to the volume of air $Q_1 = S_1^{-1}$ where

$$S_1^{-1} = \frac{\rho c^2}{Q_1} \text{ where } \rho = \text{density of air} \\ c = \text{velocity of sound in air.}$$

The mechanical reactance due to this stiffness = S_1 where $S_1 = A^2 S_1^{-1}$ in which equation A = effective piston area of the diaphragm (15 sq. cms.).

$$\text{Thus } S_1 = 15^2 \times \frac{0.0012 \times (34000)^2}{2} \\ = 156 \times 10^6 \text{ dynes/cm.}$$

Similarly $S_2 = 210 \times 10^6$ dynes/cm.

The acoustical reactance (mass) due to the two holes in the partition is given by $M_A^{-1} = 2 \left[\frac{\rho}{2r} \right] = \frac{\rho}{r}$ where r cms. is the radius of a hole. The mechanical reactance due to this mass = $M_A = A^2 M_A^{-1}$.

$$\text{Hence } M_A = \frac{225 \times .0012}{.14} = 1.87 \text{ g.}$$

If these various values are substituted in equation (1), with $\omega = n \times 1,000$

$$\frac{Z}{j} = 700n - \frac{20,000}{n} - \frac{225}{n} \left[\frac{5.6n^2 - 371}{.0083n^2 - 1.63} \right].$$

This equation has been evaluated over the range $n = 5$ to $n = 25$ and the resulting values of Z/j are shown plotted against n in Fig. 5.

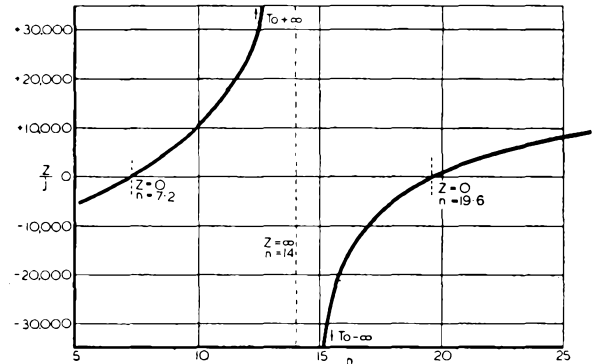

FIG. 5

It will be seen that $Z/j = 0$ when $n = 7.2$ or 19.6 and $Z/j = \infty$ when $n = 14$.

i.e., resonances occur at 1,160 and 3,100 c.p.s. and an anti-resonance at 2,200 c.p.s. In practice values ranging from 1,300 to 1,600, and 2,400 to 3,100, have been obtained for the two resonances and values ranging from 1,900 to 2,200 for the anti-resonance.

Conclusion.

Since the calculation ignores the effects of resistance and includes a large number of measured values of component impedances (each liable to an error) it is thought that the agreement between calculation and practice is quite good. It must be remembered also that the actual frequency characteristics were not measured with a constant applied force. For these measurements the transmitter was exposed to a uniform free field sound pressure and the actual force operating the instrument thus depended to some extent (and particularly at the higher frequencies) on the size and shape of the transmitter. Despite these restrictions and inaccuracies the calculation yields reasonable results and is sufficiently accurate to allow of a preliminary choice of Q_2 and r if M_d and $(Q_1 + Q_2)$ are known. The final adjustment of the design must necessarily be made experimentally. This is not really a disadvantage since the experimental method is usually quicker than a complete calculation including the effects of resistance and of the overall shape and size of the complete transmitter.

The New St. Paul's Tube Station

J. PRESCOTT

A description is given of the diversion of Post Office plant entailed by the construction of a subway and booking hall for the new St. Paul's Tube Station, London.

Introduction.

IN an endeavour to cope with the ever increasing traffic in inner London, the London Passenger Transport Board, in conjunction with the road authorities concerned, have remodelled many tube stations and constructed escalators and subways, all with the object of providing a steady and uninterrupted flow of passenger traffic.

In 1935 the first plans were made to afford relief to the passenger traffic at St. Paul's station (late Post Office station) on the Central London Railway, known to late Victorians as the "Twopenny Tube." At this station the Board are providing a new booking hall and escalators in place of the old booking hall

of entrance to the railway. Extensive underpinning of buildings was necessary, and under the roadway a 5 ft. \times 3 ft. City Corporation sewer had to be diverted before excavations for the escalator could be commenced.

Diversions to Post Office Plant.

These proposals involved shifting one of the main routes running from the Trunk and Toll A Exchange in Faraday Building to the north and the plant affected is shown in Fig. 1. It will be seen that this is considerable, but when sewers, gas, electric light, Water Board and hydraulic company's mains are added it will be realised that hardly a more difficult spot in which to construct a subway in the city could be found. To

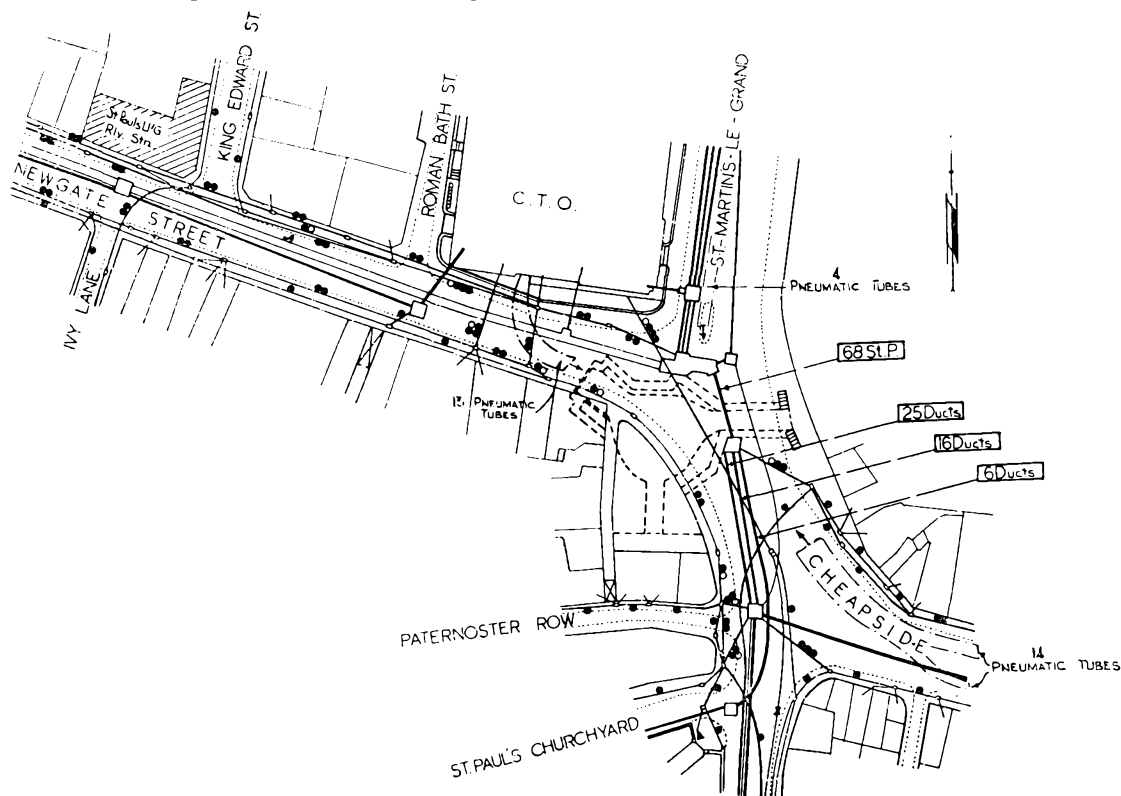

FIG. 1.—PLAN SHOWING POST OFFICE PLANT AFFECTED.

and lifts in Newgate Street. The new booking hall is partly under the roadway at the junction between Cheapside and Newgate Street, and partly under the adjacent buildings on the west side. It is connected with the station tunnels by a 22 ft. 9 in. diameter upper escalator tunnel, an intermediate chamber giving access to the west-bound platform, and a lower escalator 25 ft. in diameter terminating in a chamber which gives access to the east-bound platform. The new booking hall has an entrance on the east side of Cheapside, and another within the buildings opposite at the corner of Newgate Street, thus providing a passenger subway or road crossing as well as a means

add to the congestion the old parcels despatch tube, purchased by the Post Office for a cable run in 1922, runs under Newgate Street and terminates at this point.

Messrs. Mott, Hay & Anderson, the Railway Company's engineers, held several conferences with the various undertakers concerned before the final plans were drawn up. As far as the Post Office were concerned the proposals entailed diverting three nests of octagonal ducts of a total capacity of 47 and carrying 44 main cables. Most of the street pneumatic tubes in London radiate from the Central Telegraph Office (C.T.O.) and several of these were also affected by the

work and required shifting. The existing manhole at the north of the area concerned was undisturbed but advantage was taken of the operations to provide a doorway entrance from the Booking Hall and thus avoid entering by the roadway cover, the guard of which has hitherto created an obstruction to the road traffic.

A new manhole, Fig. 2, was built by the Board to the Post Office's design on the existing route and the two were joined by a nest of 68 steel tubes over the roof of the subway at a depth of two feet from the roadway

and only allowed when no other means exist. The manhole was constructed with a doorway direct from the subway and, since the locality is of loose sub-soil and water is always present, the manhole was waterproofed by asphalt sheeting. The steel pipes were laid after the subway roof had been completed and were grouted with concrete of fine aggregate. The work could only proceed at night and at week-ends and in order to facilitate matters the "set" on the pipes was inserted during the day by means of a template.

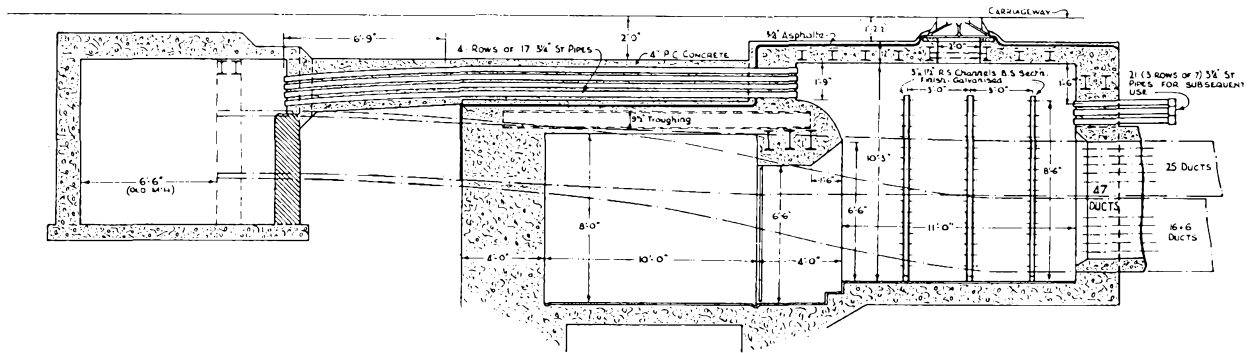

ENLARGED SECTION ON A-A.
SHOWING ARRANGEMENT OF 68 3/4" TUBES.

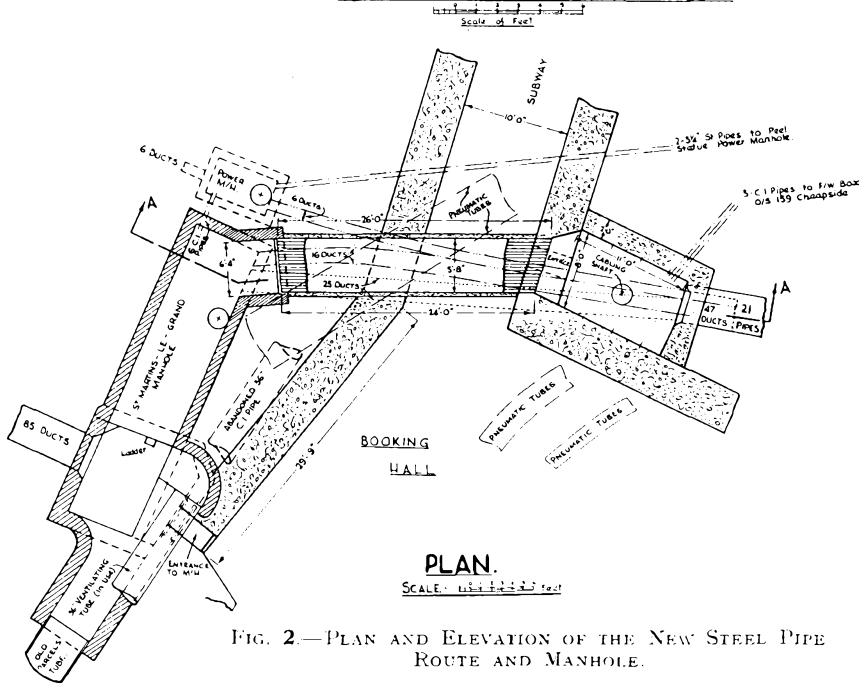

FIG. 2.—PLAN AND ELEVATION OF THE NEW STEEL PIPE ROUTE AND MANHOLE.

to the top layer. The presence of other undertakers' plant and also several of our own tubes was at first thought to be an insuperable barrier to the addition of these steel pipes but the happy relations between the various companies concerned and the willingness to help displayed by all enabled sufficient space to be obtained for the Post Office plant. The only alternative would have been to lay at a deeper level below the subway but experience (very dearly bought) has shown that deep manholes and ducts should be avoided

Cable Arrangements.

As will be seen from Fig. 2 the manhole was not of standard design and therefore the layout of the cables and positions of the joints required careful consideration. A plan was prepared showing the position of each cable and the particular bearer it was to occupy. Provision was also made for future cables and it will be seen that positions for all these have been allotted to the full capacity of the ducts. A print of this drawing which was supplied to the men engaged on

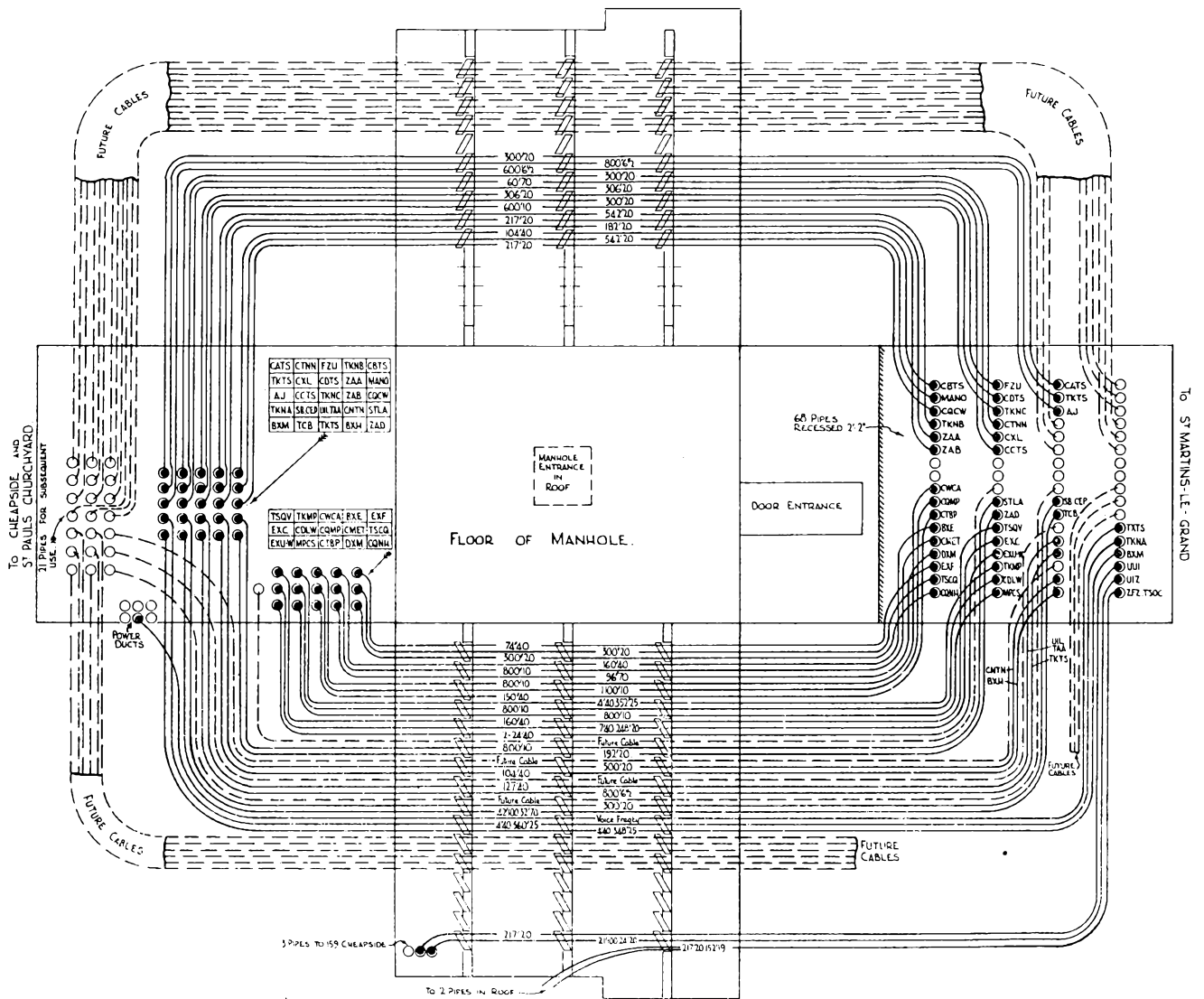

FIG. 3.—CABLING PLAN OF NEW MANHOLE.

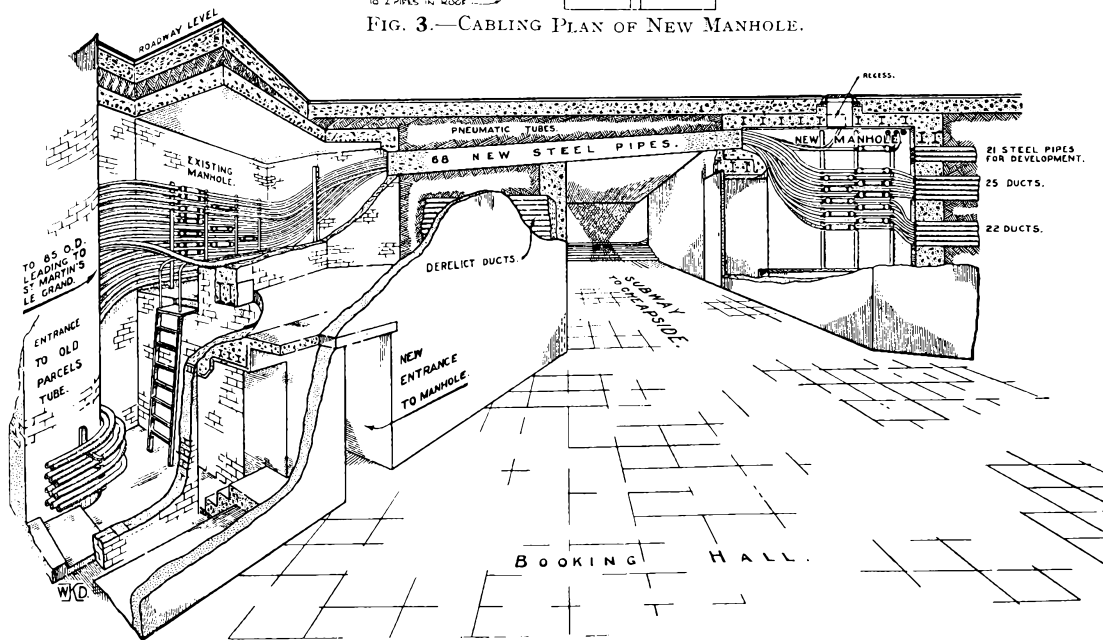

FIG. 4.—PERSPECTIVE VIEW OF THE WORK INVOLVED.

the work is shown in Fig. 3. Forty-four cables required diversion and four of these were carried over the Subway by two cables, a bifurcated joint being made at each end. Several cables were of obsolete type, others were of special specification, including both copper and lead screen, etc. One paper core twin type encountered was particularly interesting, the wires of each pair being wrapped in a single layer of paper. The majority of the circuits handled were long distance, trunk, junction and those carrying voice frequency channels. By careful measurement it was often found possible to avoid piecing the old cable so that on completion of the joint the cable was set back to its final position on the wall. The work of diversion proceeded continuously and occupied three months. Great credit is due to the jointers concerned for the care exercised and the entire absence of working faults.

In addition to the telephone cables it was necessary to divert 2 L.T. 3 core, 240 V. 200 kV.A. power cables; these cables were laid by the Department in 1910 between the C.T.● and Faraday Building. They provide an alternative power supply to be brought into use in the event of a breakdown of the public electricity supply to the latter building. As the position of the pipes containing these cables interfered with the Board's operations it was necessary to lay two new steel pipes, at a shallow depth, for a distance of 75 yards between two manholes on the power route. In order to economise in material the cables were cut away in the manholes and the lengths withdrawn without redrumming as it was feared that the waxed paper insulation of the cores would be damaged. The cables were then pulled

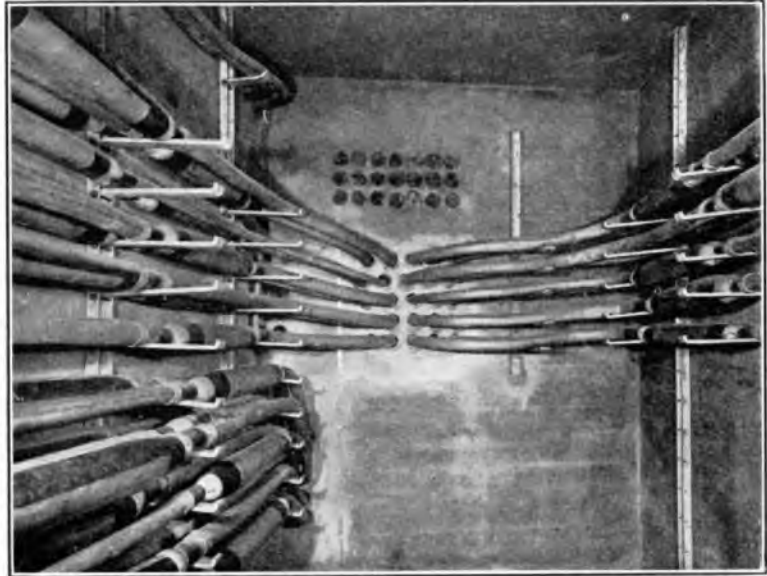

FIG. 5.—THE NEW MANHOLE.

into the new pipes and rejoined, the work being carried out by the telephone cable jointers.

Conclusion.

During a long period of several months while the work of underpinning adjacent buildings and the excavations were in progress the whole of the Post ●office plant, including a large nest of pneumatic tubes and cables from the C.T.●, was suspended for a distance of several yards in the excavations while the traffic passed overhead and apart from a few minor delays no inconvenience or interruption was caused to any of the services throughout the whole period of the operations.

A perspective sketch giving a general view of the work is shown in Fig. 4 and a photograph of one side of the new manhole is reproduced in Fig. 5.

Book Review

"Wireless Direction Finding" R. Keen, B.Eng. Third Ed. 803 pp. 549 ill. Iliffe. 25s.

Although the sections dealing with directional aerials for commercial wireless stations have been omitted in the third edition of this well known work, the increase from 409 to 803 pages is an indication of the amount of new material that has been included. It is pleasing to note that it has been found possible to retain and to bring up-to-date the very extensive bibliography, which has been such a useful feature of previous editions.

A useful, but brief, chapter on the propagation of electric-magnetic waves followed in due course by a chapter dealing with polarisation errors, night effect and freak phenomena leads one to a complete chapter on the Adcock aerial, the most popular method of eliminating

such errors. In view of recently published work it is interesting to note that a short statement on the possibilities of lateral deviation has already found its way into the text. Chapters are included on Shore, Ship and Aircraft Installations, containing accounts, copiously illustrated, of commercial apparatus with circuit and performance data as well as on Aircraft Approach and Landing Systems and the Cathode Ray Direction Finder.

The general treatment is essentially descriptive and mathematics, having been reduced to the absolute minimum, the book can be confidently recommended to the student as well as those responsible for the operation of such equipment, while the more advanced student will find the bibliography of great value. A.H.M.

Statistical Theory Applied to the Testing of Mass-Produced Articles

K. L. PARKER

The article describes how analysis of the deviations of a mass-produced article from the average may give a manufacturer useful information concerning the degree of control exercised in its production. Conversely, the consumer, by the same analysis, is helped to compare the products of different manufacturers.

Introduction.

ALL action is due to a cause. A billiard ball moves because it is struck, a piano wire sounds because it is struck, and planets rotate due to the interaction of forces which are described under the general term, "gravitational laws." The general reference is "cause and effect," while philosophers speak of "mechanical causation." Causes may be either "assignable" or "unassignable."

A marksman may be shooting at a target, a few of the shots hitting the bull's-eye, but the majority clustering around it more or less uniformly. After a time he notices that they are persistently tending to go to one side, although as far as he can see he has made no alteration in his aiming. He then discovers that although he himself is in a sheltered spot, a strong wind which has just arisen, is blowing across the range and is deflecting the shots away from their normal course. The wind in this case is the assignable cause.

Nevertheless, one may ask, why was he unable to hit the bull's-eye previously, instead of putting the shots in a cluster around it? It was evidently due to a cause, or system of causes which operated in such a manner that the shots went as often to one side as the other. Had they all tended to go to one side only, a correction could have been made in the aiming. Such a system of causes is known as unassignable or chance.

On throwing a die which has been accurately made the factor determining whether a particular face would fall uppermost is pure chance. Out of a large number of throws one would expect all faces to come uppermost more or less the same number of times. Should, however, the die be weighted causing one face to come uppermost the majority of the times, then this would be an assignable cause.

Chance is said to operate when anything results from the complete absence of controllable or governable factors or, if such factors exist, when they balance or nullify each other. There is no dominant force or systematic error to disturb the operation of chance.

Chance is not, however, mere randomness, and does not mean that things happen without rhyme or reason; for any event which is a chance happening conforms to certain laws.

If the marksman aims consistently at the bull's-eye his shots do not continually go into the edges of the target. He may only occasionally hit the bull's-eye, but the shots will tend to cluster around. Similarly, if a die is thrown several thousands of times, each number will appear approximately one-sixth of the total number of throws. In other words, chance entails control.

It is important to note, however, that the terms assignable and unassignable when applied generally are only relative. Causes which are classed as unassignable may become assignable upon the

acquisition of fresh knowledge of the phenomenon in question.

Distribution Curves.

It is not the purpose of this article to give detailed mathematical proofs (which may be found in the standard text-books mentioned in the bibliography), but rather to give a general outline of statistical method. It will be sufficient to say that if a very large number of items subject to chance variations, known statistically as a "population," be measured (as for instance the number of times the face of a die comes uppermost, the distance away of a shot from the bull's-eye, or the height of a species of a plant) and the results plotted with the values as the abscissæ and the number of cases as the ordinates, a distinctive type of curve known as the "Normal" or "Gaussian" curve as shown in Fig. 1 is obtained.

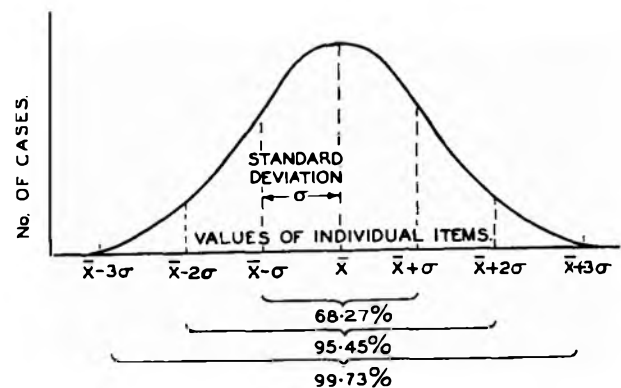

FIG. 1.

The curve is symmetrical, rising to a peak in the centre and tailing off asymptotically in both directions. The centre value \bar{X} is the arithmetic mean of all the readings taken.

In such a series of readings, however, it is not only desirable to know the value of the average but to have a measure of the amount by which the individual tends to deviate from this value. One way would be to find the amount by which each individual deviated from the average and then to take the arithmetic average of the sum of these deviations. This is known as the "mean deviation." Modern theory, however, tends to take the square root of the average of the squares of the individual deviations, or in other words, the root mean square of the deviations. This value is termed the "standard deviation" and is represented by the greek letter " σ ." Referring to Fig. 1, if the average value \bar{X} is taken as an origin and the values, σ , $-\sigma$, 2σ , -2σ , etc., be marked, it will be seen that the values σ and $-\sigma$ coincide with the points of inflection of the curve. More important, however, is the fact that approximately two-thirds of the cases lie within these limits, 95 per cent. within $\pm 2\sigma$, and 99.7 per cent. within $\pm 3\sigma$. 6σ , therefore, may be

regarded in practice as the length of the base of the curve. Half the total number of cases lie within the limit $\pm 0.6745\sigma$, or in other words the chances are even whether a reading lies within or without the limits $\bar{X} \pm 0.6745\sigma$.

Sampling.

In dealing with a case where the statistical population is very large (as, for instance, in determining the average length of an oak leaf or the average efficiency of a delivery of telephone transmitters) it is obviously impracticable to measure each individual case, and therefore it is necessary to be content with a comparatively small number of cases forming a sample batch¹, or several sample batches. Suppose, therefore, that the sample consists of 20 items taken at random, it may happen that the values would be distributed over the same range as the population, and more or less proportionately, i.e. two-thirds would fall between the limits \pm the standard deviation of the whole, and 95 per cent. within the limits \pm twice the standard deviation of the whole as shown in Fig. 1. In this case the average and standard deviation of the sample batch would be approximately equal to those of the population. More often than not, however, the distribution of the items would be irregular and in no way agree with that of the whole. This is illustrated in Fig. 2. The

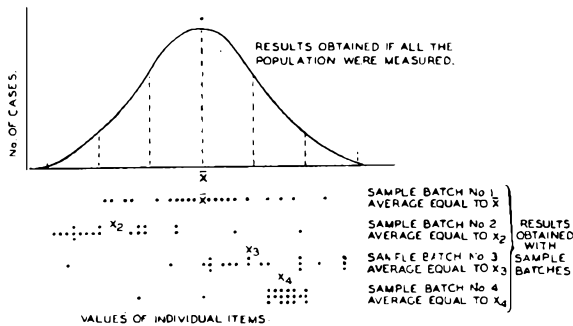

FIG. 2.

normal distribution curve of a population is shown together with the values of the individual items of four hypothetical samples. The items composing sample No. 1 have a distribution similar to the population. In none of the other cases, however, does the average or standard deviation coincide with that of the whole. Generally speaking, therefore, one sample batch is seldom truly representative of the population from which it is chosen. Statistical theory is able to show, however, that the arithmetic means of samples of n pieces chosen at random will themselves be closely represented by a normal curve with a mean of the same value as the population (\bar{X}) and a standard deviation of σ/\sqrt{n} , where σ is the standard deviation of the population as shown in Fig. 3. \bar{X} therefore will be also equal to the average of a large number of the sample averages, i.e. equal to $(x_1 + x_2 + \dots + x_p)/p$ where x_1, x_2, x_3 , etc., are the averages of different samples and p the number of samples taken.

¹ For the purpose of this article, a number of individual items taken and measured at any one and the same time for some characteristic will be termed a sample batch.

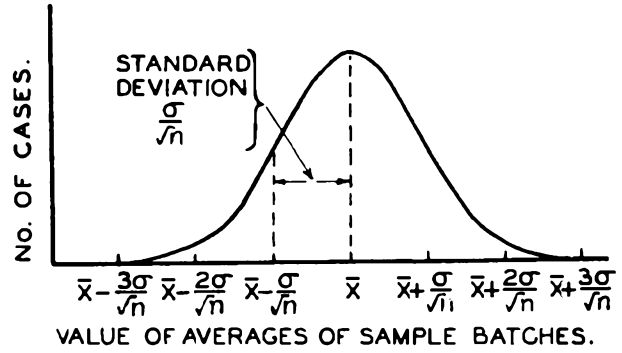

FIG. 3.

Likewise the standard deviation (S) of the sample will be normally distributed about the standard deviation (σ) of the population. This distribution having a standard deviation $\sigma/\sqrt{2n}$ (Fig. 4), σ is equal to $\sqrt{n}Ss^2/p(n-1)$. Since both the averages

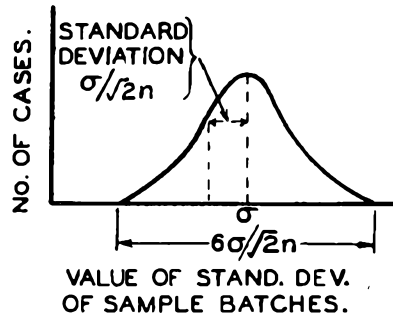

FIG. 4.

and the standard deviations are normally distributed, the same percentage of readings will fall within the limits one, two and three times the respective deviations from the averages, as shown in the figures.

A still more important aspect of all the above is that the converse holds true. If a large population were to be sampled and the values of the averages and standard deviations were distributed as discussed above, then this indicates that the population is statistically uniform, and that the different values of the separate items is due solely to chance causes, and not through the operation of any external factor. The average and standard deviation of the population can be calculated from the above formulæ. The importance of this point will be shown in what follows.

The above would also apply if, instead of being given the whole of a population together, it were given gradually and sampled over a period of time.

Aims of Mass Production.

In order to see how the above applies to acceptance of supplies, it is necessary to consider the circumstances under which mass production occurs.

The philosophy of mass production is the breaking down of the fabrication of a product into its elements so that one workman or machine performs a single operation over and over again. It involves the manufacturing of parts at the rate required for assembly. The factory layout is carefully planned and a good deal of one purpose machinery and expensive jigs and fixtures are employed. Processing and assembly are carefully timed. Large quantities

of a small number of standardised parts are produced during long runs of special machines—capstans, automatic multiple-spindle drills, milling machines, shapers, grinders, etc. Jigs, fixture dies and pattern plates are widely used. Each operation is performed by one person who probably carries it out until he is expert. More important still, however, the product is rigorously inspected at all stages, from the raw material to the finished article, expensive limit gauges and testing machines often being employed.

Against this may be contrasted the product of the craftsman. Different supplies of raw materials are tested in a rough and ready manner. One article, or at the most only a few, are made together at any one time, so that other factors may occur to alter the quality of those made subsequently. Moreover, since little, if any, machinery is used, the quality of the product depends almost entirely on the individual skill of the craftsman. This again is not necessarily constant but will depend on subjective influences. In a batch, therefore, of several thousand items, the output, say, of several individuals, one would anticipate a considerable divergence between the items.

In mass production, however, constancy of quality is aimed at in each element of the manufacture, so that in the finished product any two items taken at random should be more or less identical. The production is spoken of as “controlled” and the amount of variation as the “degree of control.” Nevertheless, despite the methods used and precautions taken, complete identity of items is seldom if ever achieved. One feels justified, therefore, in attributing the variation to “chance causes.” These, however, may be reduced by improvements in methods and machinery just as a marksman’s aim may be improved by practice.

Application of Statistical Theory.

If, therefore, a large number of mass-produced items, made under an efficient production system, were measured for some particular characteristic as, for instance, the efficiency of transmitter insets, the results would give a normal curve as shown in Fig. 1. The average of the product would be given by the value of \bar{X} . The standard deviation of the curve would indicate the degree of control exercised. Where high quality machinery and testing are used the variation between items would be small and consequently the standard deviation also would be small. On the other hand, where a lower standard of control was exercised, due to the use of less efficient plant, a greater variation between items would ensue, and the standard deviation would be larger.

Similarly, if samples were taken from the production at intervals, then, providing the production was constant in time, the averages and standard deviations would be distributed as shown in Figs. 3 and 4.

If, say, one sample per day were taken from the production for 50 consecutive days, and the averages put in graphical form, the results should be as shown in Fig. 5. The majority would fall within the limits $\bar{X} \pm \sigma/\sqrt{n}$, rapidly falling away outside them.

This at once indicates a fairly accurate method of

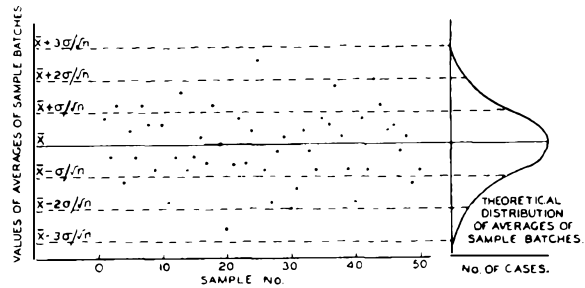

FIG. 5.

discovering whether a production is uniform or not. Samples of the product are taken at intervals and tested. The frequency and size of the sampling naturally depends on the conditions prevailing, such as rate of output, ease of testing, and whether or not testing destroys the article. It is obvious, however, that the more samples that are taken the more reliable are the results. The averages and standard deviations of the samples are calculated, and from these are obtained the average and standard deviation of the product. Finally the limits $\bar{X} \pm \sigma/\sqrt{n}$, $\bar{X} \pm 2\sigma/\sqrt{n}$, $\bar{X} \pm 3\sigma/\sqrt{n}$, are drawn. If the percentages lying within these limits are approximately as those shown in Fig. 3, then the product may be taken as uniform.

Non-Uniformity of Production.

Very often, results such as that in Fig. 6 are obtained. Looked at as a whole, the distribution is obviously not symmetrical about a fixed value, and

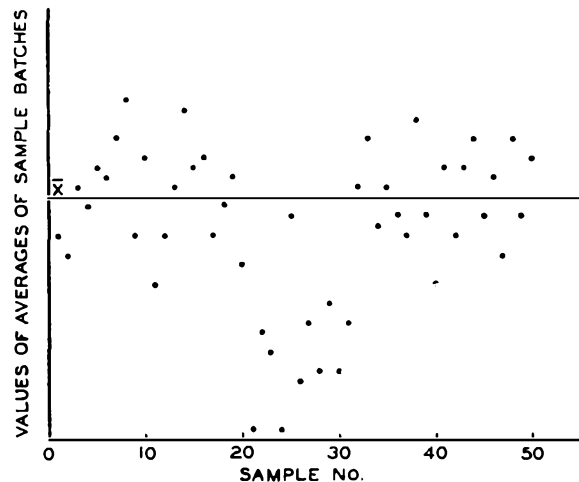

FIG. 6.

consequently the product is not statistically uniform. It has been shown, however, that on the basic principles of mass production there is no reason why uniformity should not be obtained. The conclusion therefore follows that there must be some factor or factors operating in the production system causing this non-uniformity; factors which were not intended to be present and which, therefore, should be eradicated.

It is obviously desirable to see how far the statistical data available will help to reveal the source of the trouble and consequently it is necessary to look at

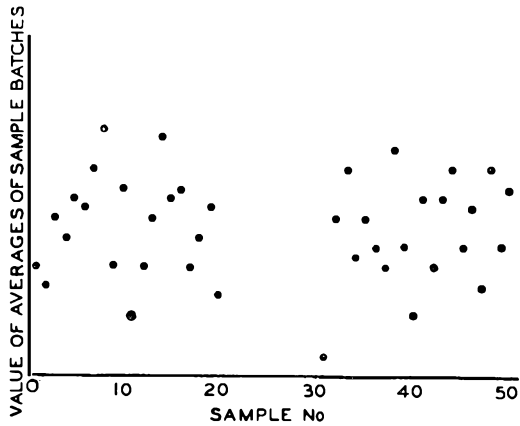

FIG. 7.

the results a little more closely. It will be noted that the values in the centre are decidedly lower than at the outsides. If the centre be eliminated and the results be regarded as in Fig. 7, they appear far more promising. The average and standard deviation can then be calculated, and when the limits are

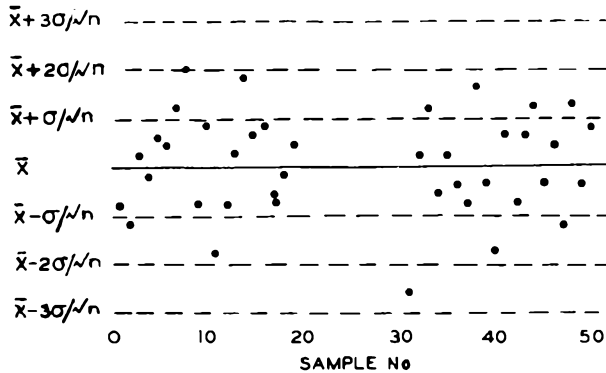

FIG. 8.

drawn Fig. 8 is obtained. This shows immediately that these two sub-sections are more or less uniform, since both fall between the proper limits. It, therefore, appears that the unknown factor was operating only between the 20th and 30th readings.

Next, calculating the average and standard deviation of the middle section, Fig. 9 is obtained. It will be seen that there is uniformity here also, and

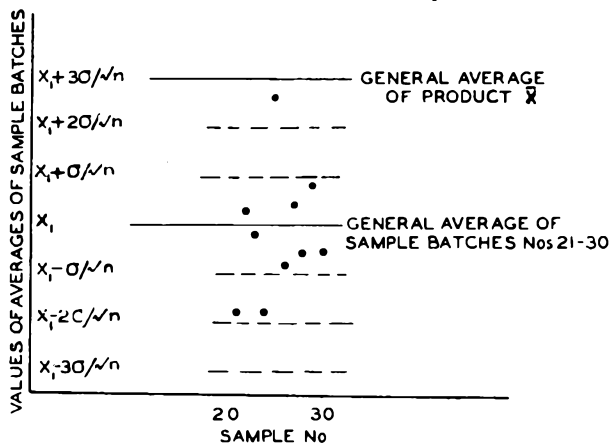

FIG. 9.

that the standard deviation is very nearly equal to that of the other two groups: in all probability it will not be exactly equal on account of the smaller number of samples taken. The consistency or "control" of the product has not been altered, but the unknown factor has caused a lowering of the general average of the product. It may be likened to the marksman who, after shooting at the bull's-eye for some time, begins to aim at a point, say, on the outer edge of the target for a few rounds, and then moves back again to the centre. By this analysis the manufacturer has narrowed down his investigation to a particular period, and also knows that it is something that has affected all items alike. By consulting his production records he is then able to see whether, for example, it is likely to be due to a fresh supply of raw material that was used during that period only or to a new machine that was being tried out.

Another problem that might be met is that illustrated in Fig. 10. Here a product which has been

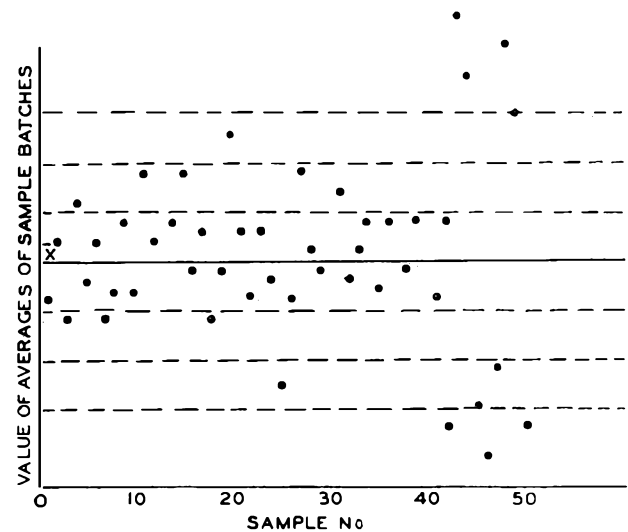

FIG. 10.

uniform over a fairly long period of time suddenly becomes erratic while still maintaining its general average. Since it was said that mass production is uniform by virtue of the fact that elements of manufacture were designed to give items of uniform quality, it would appear that this principle has failed to act at one or more stages. An indication where to investigate might be given, for instance, by the existence of a tool which is known to be old, or the recent employment of a new operator.

The two examples given indicate the principles of analysis of test data. In practice the results may be far more irregular, and the analysis correspondingly far more difficult.

Comparison of Production Methods.

Besides helping the manufacturer to locate trouble in his production, statistical analysis is also of help to the consumer in comparing the product of different manufacturers. This is best illustrated in Fig. 11.

Suppose that the specification to which the manufacturer is asked to work states that no item should

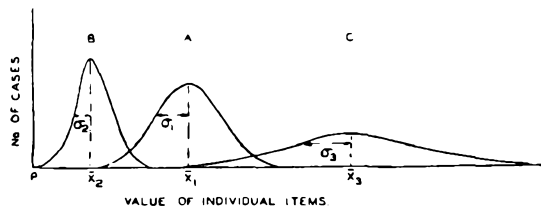

FIG. 11.

be below a certain value P , and that three contractors are all turning out uniform production.

The product of Contractor A has an average \bar{x}_1 and standard deviation σ_1 . The average \bar{x}_2 of B is considerably lower, but at the same time the standard deviation σ_2 is also considerably less, whereas C has a higher average and greater deviation σ_3 .

Interpreted in more practical terms, B, owing to employing a better technique, gets much nearer to the value that he is aiming at than does C, and consequently he is able to work much nearer the specified minimum. C, on the other hand, knows that a percentage of his product will vary by a fairly large amount from the value that he is actually aiming at, and consequently he must aim fairly high to ensure that his lowest values will meet the specification requirements. The dispersion, therefore, is a measure of the degree of control which a manufacturer has over his production.

Method of Sampling.

The efficiency of the foregoing method of analysis depends essentially on every sample reflecting as far as possible the quality of the whole from which it is taken. Correct sampling involves two important factors. First randomness in choosing the items for test, and secondly the size of the sample taken.

Randomness in choosing means that every item in the consignment stands the same chance of being chosen as another. That is to say that the person making the selection is not influenced in any way to choose from one part of the consignment and ignore another, for should the part chosen from be of a different quality from that ignored the sample will not be representative of the whole.

Even randomness, however, will not ensure that the sample is truly representative, for, as was shown in connection with Fig. 2, it is very seldom that the items chosen will be uniformly distributed on either side of the average of the product. In spite of every precaution to secure randomness slight variations must emerge due to the elements of chance present in every selection. Statistical theory shows, however, that the reliability of a sample batch is proportional to the square root of the number of items it contains. Obviously, the more items that are tested the higher the cost of inspection becomes, and consequently a compromise has to be made between accuracy and economy. This will depend very largely on the cost and quality of the product sampled.

Simplification of Calculations.

Up to the present the mean value of a sample or consignment has been represented by the arithmetic mean. Although this is the most accurate figure to use, a considerable amount of work is involved in obtaining it. Consequently, where conditions are

such that extreme accuracy is either not necessary, or that the data itself is known to be only approximate, the median M may be used instead.

The median is that value which divides the group into two equal parts, one part comprising all values greater and the other all values less than the median. The results of the tests are arranged in order of value, the middle one representing the median. Where an even number of readings has been taken, the median is the average of the two middle terms.

Similarly with the dispersion, the tedious work involved in subtracting each individual value from the average value of the whole, squaring, adding them and finding the square root of their average may be eliminated where accuracy can be sacrificed by taking the "semi-interquartile range." Just as the median divides the distribution into two equal parts, the lower quartile Q_1 divides the lower half into two equal parts, and the upper quartile Q_3 divides the upper half similarly. Q_1 , M and Q_3 , therefore, divide the distribution into four equal parts. The semi-interquartile range is then defined as equal to $(Q_3 - Q_1)/2$. Where a distribution is statistically uniform, the semi-interquartile range is approximately equal to two-thirds of the standard deviation. These measurements, however, are not sufficiently accurate for algebraic manipulation as described above, and consequently they are only suitable for a more or less general comparison between distributions. Where this is sufficient, the ease with which they can be obtained commends them.

Conclusion.

Summarising all the foregoing, it is seldom possible to do exactly what is intended. The ideal is not achieved owing to innumerable unknown or chance causes. Nevertheless, these act in such a way as to cancel one another out more or less, and for a large number of events the ideal is achieved on the average. Consequently, since the sum total of these causes tends to operate within limits, it is possible to speak of them as controlled. Events happening under such a system can be subjected to mathematical analysis from which the degree of control may be calculated. Moreover, it is unnecessary to know all the events happening under any given system, because, by taking a few only, it is possible to arrive at a reliable estimate of the whole. Conversely, given any system of events, it is possible by analysis to determine whether it is subject to chance causes only.

Mass production aims at the elimination of all disturbing factors in manufacture, and for all operations to be performed under identical conditions. Owing to chance causes, complete identity of articles in the final or intermediate production is impossible. Nevertheless, by using the same method of analysis it is possible to determine to what extent the ideal of identical items is being achieved, and whether or no unwanted or controllable factors are present.

Bibliography.

- Bowley, A. L. "Elements of Statistics."
- Connor, L. R. "Statistics in Theory and Practice."
- Yule, G. Udy. "Introduction to the Theory of Statistics" (11th edition).
- B.S.S. 600. "Application of Statistical Methods to Industrial Standardisation and Quality Control."

Notes and Comments

Post Office Telecommunications Convention, 1939.

We are pleased to announce that the third Telecommunications Convention is to be held this year during the period June 24th—July 1st. Again, the venue is to be "The Hayes," Swanwick.

The arrangements are in the hands of a small Committee under the Chairmanship of Mr. A. J. Gill, Asst. Engineer-in-Chief.

The field to be covered is extensive and the Committee fear that there may be some who through inadvertence fail to receive invitations. Any member who is interested and who has failed to receive an invitation by the end of the first week in February, is asked to make application to the Hon. Secretary, Mr. C. W. Gerrard, I.T.R., Union House, E.C.1.

Intending visitors are asked to signify their intention to be present at the earliest possible date, as the accommodation is unfortunately limited to about 300 persons.

Recent years have seen considerable development of the Post Office services and there seems every prospect of continued development. Changes in organisation have taken place during the past few years and these conditions have brought about a much closer association between the various branches of the Post Office. As time goes on the need for co-operation on the part of individual members of the service will increase. Co-operation can be most effective if based on friendly

relationships between individuals. The Convention will provide a unique opportunity for members of all branches to meet socially and to cultivate these personal relationships.

We take this opportunity of wishing the organisers of the scheme success in their third venture.

City & Guilds of London Institute Examiners' Report.

The report of the City & Guilds Examiners in Telecommunications subjects is contained in the Supplement issued with this Part. It is thought that this report will be of particular interest to those now studying for the next City & Guilds Examinations.

District Notes.

The attention of readers is drawn to the record of activities in the Districts as shown in each issue of the JOURNAL under the heading of District Notes. It is thought that there is a particularly interesting series of notes in this issue and it is hoped their perusal will be an incentive to readers to provide notes concerning similar interesting events, past or present, which have occurred in their Districts.

Binding.

This issue is the last of Volume 31 and readers are reminded that binding facilities are available. Full details will be found on page 330.

Retirement of Captain B. S. Cohen, O.B.E., M.I.E.E., F.Inst.P.



Capt. Cohen, Staff Engineer in charge of the Research Branch, retired on December 31st, 1938. He was educated at the City of London School and the Finsbury Technical College and joined The National Telephone Co. in May, 1897. In 1904 Capt. Cohen was placed in charge of the newly-formed Investigation Department. In 1907, in association with the late Mr. G. M. V. Shepherd, he read the first paper on telephone transmission at the Institution of Electrical Engineers for which he received the Fahie Premium. Among his earlier achievements the invention of the barretter resistance bridge and the vibrating wire audio frequency oscillator deserve special mention. On the transfer of The National Telephone Co.'s undertaking to the Post Office in 1912, Capt. Cohen was attached to the Research Section of the Engineer-in-Chief's office, served in the R.A.F. during the War, and in 1926 was promoted Staff Engineer of the Test Section. In 1929, he returned in charge of the Research Section.

Capt. Cohen has been associated with the C.C.I.F. since its inception and was Chairman of its 4th Commission.

Besides his many activities in the field of telecommunications, Capt. Cohen is an enthusiastic rock gardener and a collector of alpine plants. In addition he is an expert in the art of ornamental tuning and some of his work in connection with the new plastic materials has been exhibited at the British Industries Fair.

Those who have worked with Capt. Cohen will miss his helpful criticism and sustained enthusiasm and also the great interest which he always took in the welfare of his staff. His many friends at home and abroad extend to him and to his wife their best wishes for continued prosperity and long life.

F.C.M.

Retirement of Mr. F. G. C. Baldwin, O.B.E., M.I.E.E.



Mr. Francis G. C. Baldwin, Chief Regional Engineer of the North Eastern Region, retired on November 30th, 1938.

Mr. Baldwin entered the service of the late National Telephone Company at Sheffield as a draughtsman in January, 1896, and three years later was appointed Engineer.

In October, 1906, he became District Engineer, Birmingham, where he remained until September, 1909, when he was made Assistant Metropolitan Engineer and later Acting Metropolitan Engineer.

In 1912 Mr. Baldwin was appointed Sectional Engineer, City External Section, and in December 1913 he became Assistant Superintending Engineer of the Northern District and in August 1930, Superintending Engineer. On November 1st, 1935, Mr. Baldwin was appointed Chief Regional Engineer for the North Eastern Region, where he played an important part in setting up the organisation for Regional and Area conditions.

Mr. Baldwin has read several papers before the Centres of the Institution of Electrical Engineers and his paper in 1918 on "Telephone Exchange Transfers and their Organisation" gained for him the Fahie premium. He has contributed numerous technical and scientific articles to the press and his book "The History of the Telephone in the United Kingdom" is well known as a standard. He was awarded the O.B.E. in June of this year for his meritorious service in the telephone world.

Mr. Baldwin's geniality and kindness has endeared him to all his staff, and he will be long remembered. His many friends wish him and Mrs. Baldwin many years of health and happiness. His pursuits are so many and varied that he will not lack an interesting subject to pursue.
C. E. M.

W. D. Scutt, M.I.E.E.

Mr. W. D. Scutt, promoted to Chief Regional Engineer, North Eastern Region, took up duty in his new post at Leeds on December 1st, 1938. At the time of the transfer of the National Telephone Company's undertaking to the Post Office, Mr. Scutt, after passing through minor grades, held the position of Chief Electrician at Leeds. He was selected for special duties on behalf of the Company in connection with the arbitration proceedings and subsequently returned to the Leeds Engineering Section under the Post Office regime. He took a prominent part in the installation of the Leeds automatic exchange which up to that time was the largest exchange of its kind in the country. After further service in Leeds he was transferred to the Engineer-in-Chief's Office in 1924 and was actively engaged in the Telephone Section of that Office in the solution of many of the difficult problems arising out of trunk development and conversion to automatic switching. Returning to Leeds in 1928 he became Sectional Engineer of West Yorkshire Internal Section and later of Leeds External Section where he developed the works control system with successful results. In 1934 he was promoted Assistant Superintending Engineer, North Eastern District, and in December 1935 he was appointed Telephone Manager of the Bradford Area. The latter appointment conferred upon Mr. Scutt the honour of being the first Telephone Manager in the history of the Post Office, as Bradford was the first Telephone Area to be established under the new Regional organisation. His great abilities and experience as a successful Telephone Manager, his engaging personality and keen Yorkshire brain will all contribute to enable him to discharge his new responsibilities with distinction.
J. J. McK.

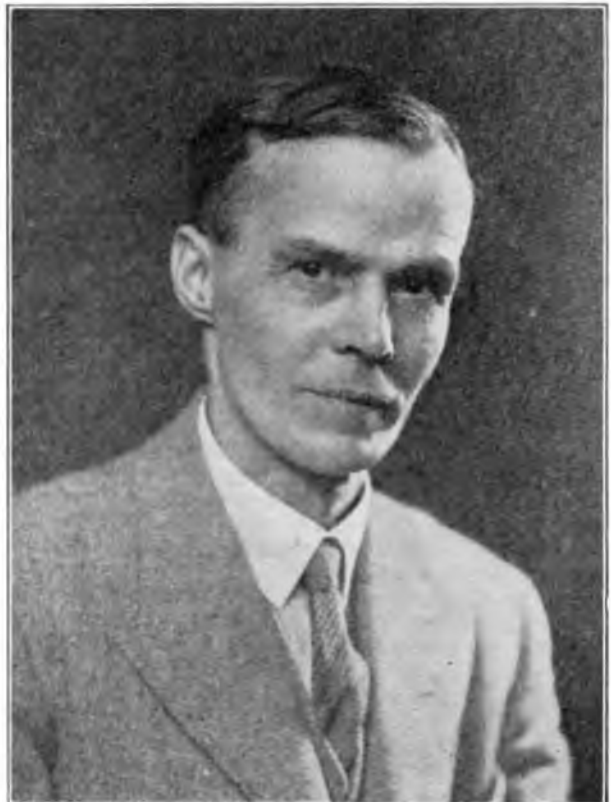

H. W. Fulcher, M.I.E.E.



Mr. H. W. Fulcher was appointed Staff Engineer of the Power Branch on September 19th. He received general education at Owen's School and technical education at the Northern Polytechnic, coupled with a three years' apprenticeship in a mechanical and electrical engineering workshop, entering the Post Office under the then Superintendent of electric lighting.

Mr. Fulcher was successful in the open competition examination for Second Class Engineers in 1905 and was appointed to the Power Section, Engineer-in-Chief's office, being transferred later to the Mount Pleasant section which, at that time, controlled the steam generating station, and was also responsible for testing electric lighting and power stores.

After promotion to Executive Engineer in 1911, he was in charge successively of each of the Sections of the Metropolitan Power District and was responsible for the Post Office (Blackfriars) Power Station and its associated sub-stations at the time of its closing down in 1926.

He was appointed Assistant Superintending Engineer in the London Engineering District in 1929 and in that capacity was in close touch with the electric light and power services in telephone exchanges and post offices, including the mechanisation schemes in sorting and telegraph offices.

Mr. Fulcher has taken an active interest in the Institution of Post Office Electrical Engineers since its inception and served as vice-chairman of the London Centre in the 1936/7 session. He is a keen lawn tennis player and has played for Buckinghamshire on many occasions. His promotion is welcomed by his friends and colleagues.

H. R. M.

W. G. Radley, Ph.D.(Eng.), M.I.E.E.

Dr. Radley, who now becomes the head of the Research Branch in succession to Capt. Cohen, completed a year on heavy electrical engineering with Messrs. Bruce Peebles, Ltd., after leaving Faraday House, where he gained the Gold and Silver Medals although his college training was interrupted by military service. He entered the Department as a temporary Inspector and passed the open competitive examination for Probationary Assistant Engineers in 1922, remaining in the Research Branch where he was largely concerned with spectography.

Dr. Radley was awarded the Silver Medal of the Institution of Post Office Electrical Engineers in 1929 for his paper "X Rays and the Structure of some Engineering Materials." Soon after, he was engaged upon a series of extensive field investigations, in collaboration with the Electrical Research Association, concerning electrical interference with communication circuits. His work on the calculation of the induced voltage on telephone lines arising from power system fault currents is recorded in several papers of the Institution of Electrical Engineers and various E.R.A. publications. He was awarded his Ph.D. degree in Engineering by London University for work in connection with interference between power and communication circuits.

Dr. Radley is a member of the Commission Mixte Internationale and of the 1st and 2nd Commissions of the C.C.I.F. He visited the United States in 1930 and again in 1937, when he was invited to take part in an international conference on the corrosion of underground plant arranged by the Bureau of Standards, Washington.

Dr. Radley's appointment is welcomed by his colleagues who have a high appreciation of his genial personality and distinguished achievements. F. O. B.



Local Centre Notes

North-Eastern Region Centres

JOINT MEETING

It is the practice of the North Eastern Region to hold a joint meeting of the two Local Centres at the opening of a session and this year the Region was particularly fortunate as the meeting held at York on October 12th was graced by the presence of the Council of the Institution headed by the Deputy Engineer-in-Chief, Col. A. S. Angwin, Vice President of the Institution. The visitors present also included members of the Royal Corps of Signals, the London and North Eastern Railway and the York Corporation Electricity Department, the total attendance being 340.

Mr. Baldwin chose for his Chairman's address an account of the early development of telephone switching, a subject on which he is probably the leading authority in this country. The slides with which Mr. Baldwin illustrated his lecture caused the older members present to become reminiscent of the good old days and the younger members to ruminate on the queer ideas they held in those early times, although many of the younger generation received a shock on hearing that a plug was originally a jack. In spite of the author's forecast that manual switching would become obsolete and be replaced by automatic methods in the near future, one was left with the impression that the pioneers of our art would not have been found wanting in ideas if they had been available to contribute to modern developments.

The vote of thanks, proposed by Col. Angwin and seconded by Capt. Berry, Telephone Manager, York, was warmly acclaimed.

In view of Mr. Baldwin's pending retirement (by a happy coincidence, October 12th was Mr. Baldwin's 60th birthday), Colonel Angwin took the opportunity of thanking Mr. Baldwin for the many services he had rendered the Institution. The enthusiasm maintained in the North-Eastern Region in I.P.O.E.E. affairs was attributed very largely to Mr. Baldwin's efforts.

In a typical reply Mr. Baldwin laid the "blame" for success on others and then delighted the audience with a display of lantern slides in colour photograph which he had produced as a hobby 20 years ago. The results, judged by present day standards, were truly amazing.

North-Eastern Centre

A most enjoyable and instructive visit was paid by nearly 100 members on September 12th and 14th, 1938, to the Lamp and Glass factories of Messrs. Crompton Parkinson, Ltd.

The Company, which has been associated with electric lighting since the arc lamp days of 1878, does not appear to be just living on history and reputation, if one may judge from the magnificent modern factory (air-conditioned) which we were privileged to inspect. The modern coiled coil lamp is anything but a simple, robust piece of equipment, but the machines which are employed to fashion glass stems and supporting wires, hang the coiled filaments (the coils of which are almost too small for the naked eye to detect) on hooked wires, and connect the whole ensemble together so that eventually we have the well known lamp, lead one to the belief that there is nothing in the mechanical side of life which is beyond the wit of man.

The staff are well cared for even in these days of holidays with pay, short working week, no Saturday morning work, etc., for in addition to these, they have a palatial dining room with a magnificent dance floor, and surrounding sports ground. The accommodation

officers of the Department had their attention drawn to these features but no results have appeared as yet!

The visit concluded with a delightful tea, after which the appreciation of members was suitably expressed and an invitation extended to the Company's servants to visit a telephone exchange in the Region.

Northern Centre

There was a touch of sadness about the second meeting of the session, because this was the last occasion on which Mr. F. G. C. Baldwin as Chief Regional Engineer would take the Chair, due to his retirement. As befitted such an occasion there was a bumper attendance and many distinguished visitors—engineering, postal and electrical.

In opening the meeting the Chairman made happy reference to the fact that the Region had gained first prize in the Junior Section Essay Competition, for a paper by K. Stephenson on "Television" and that R. J. Parsons had been specially commended for his paper on "Trunk Demand Working."

Mr. C. E. Morgan, Regional Engineer, gave a very interesting paper on "The Development of Magnetic Materials." The author covered a very wide range in discussing magnetic materials and their properties, illustrating his lecture throughout with a generous supply of lantern slides. He had also on view a very comprehensive display of apparatus, manufactured from many of the materials which had formed part of the subject matter of his paper. The ensuing discussion was cleverly debated by both members and visitors.

In proposing a vote of thanks the Deputy Regional Director, Mr. J. W. Atkinson, paid a very warm tribute to the author for his paper and concluded by congratulating the Centre on the very high level of its discussion.

The Chairman made a passing reference to the fact that this would be the last occasion on which he would occupy the chair of this Centre and took the opportunity of introducing the Chief Regional Engineer elect—Mr. W. D. Scutt. Mr. Scutt expressed his pleasure at being present and referred to the very favourable opinion he had formed of the Centre's work. He felt sure that that quality would be maintained by the Vice-Chairman—(Mr. F. Hopps) and he personally would use his best endeavours to maintain the high standard set by Mr. Baldwin.

Mr. Hopps made a feeling reference to the fact that this was the Chairman's last meeting in his official capacity. After an association extending over a period of 25 years with the Centre, he felt there would be a gap it would be very difficult to fill, concluding by expressing what he considered two salient characteristics—Mr. Baldwin's courtesy and efficiency. Mr. Ryland (Telephone Manager) supported the Vice-Chairman in his sentiments and made happy allusions to the very warm spirit which had always obtained between Mr. Baldwin and the Commercial Staff.

Mr. Baldwin replied briefly, thanking the speakers for their kind sentiments. He referred to the very important part played by the I.P.O.E.E. over a long period in the education and training of the engineering staff. Referring to the very loyal support Mr. Ryland had afforded the Institution, he thanked all present for the work they had done in the formation of the North Eastern Region, attributing much of its success to the members of the Institution. Concluding with his congratulations to the Centre on its 100 per cent. membership, Mr. Baldwin sat down amidst loud and prolonged applause.

A truly memorable meeting!

North Wales Centre

SESSION 1938-1939

The first meeting of the 1938-1939 Session was held in the assembly hall of the new Technical College, English Bridge, Shrewsbury, at 2.45 p.m. on Thursday, October 6th, 1938. The Chairman, Mr. H. Faulkner, Superintending Engineer, presided over an attendance of 233 members and visitors from the various District Manager's traffic staffs encompassed by the District. The Chairman first welcomed Mr. A. E. White, Principal of the Shrewsbury Technical College, through whose good offices the use of the new hall was obtained. The meetings of the North Wales Centre of the Institution in years gone by had been held in the old Technical College which the present building had replaced, while the hall in which the meeting was being held was of the most modern type and furnishing.

The Chairman warmly welcomed 57 new members enrolled since the last general meeting in March, 1938, and stated that as a result the membership of the Centre now stood at 370. The Chairman then gave his Inaugural Address "A Review of Progress" in which was reviewed the progress made in the District during the past twelve months.

A number of slides were shown giving the relative positions of the Districts and Regions with regard to Construction and Maintenance expenditure, Completion of Works, Performance Ratings, etc.

With regard to faults per telephone per annum the Chairman thought that the figure for this District could be greatly reduced by the active co-operation of the staff. Tribute was paid by the Chairman to the good work done during the year by the new Inspectors and encouraged them for the coming year. This concluded the first part of the afternoon's activities and a programme of G.P.O. Films then followed in conjunction with the P.O. Film Unit who were in the District. The films shown were "Cable Ship," "Big Money," "Book Bargain," "We Live in Two Worlds," "Calendar of the Year" and a telephone construction cartoon film "Getting Together," kindly loaned by our American contemporaries The American Telephone and Telegraph Co., Ltd.

The meeting concluded at 5.0 p.m. with a vote of thanks to the operators and organiser, carried unanimously in the approved manner.

The second meeting of the Session was again held in the Assembly Hall at the Technical College, Shrewsbury, on the 3rd November, 1938, at 2.45 p.m.

Owing to the absence of the regular Chairman, Mr. H. Faulkner, on official business, the Chair was taken by the Vice-Chairman of the Centre, Mr. H. G. S. Peck, who presided over an attendance of 238 members and visitors, the latter including Major Harris (S.E., N. Midland District), Colonel Reid (Headquarters), Mr. H. W. Green (Asst. Telephone Manager, Manchester), etc., representatives of the Traffic Staffs of the various District and Area Managers, and numerous retired officers. The Chairman welcomed a further two new members, bringing the Centre membership up to 372.

Owing to the size of the Hall and the assembly it was necessary on this occasion to use two microphones and P.A. equipment so that the paper and following discussion could be heard throughout the hall.

The Chairman then called upon Mr. S. F. Hill, A.M.I.E.E., Birmingham Maintenance Engineer, to read his Paper "The Other Things that Matter," 250 copies of which had been duplicated and previously circulated. Mr. Hill, with his characteristic humour, gave numerous anecdotes to illustrate points in the lecture and produced sketches of planning and misplanning with the aid of blackboard and chalk. At the conclusion of the reading the Chairman asked Mr. J. H. Watkins to open the discussion. Mr. Watkins first congratulated the Author on an excellent Paper and gave Mr. H. Faulkner's contributions to the discussion, in his absence, and went on to further Mr. Hill's illustration of the serpent in the garden of Eden "planning" to get Eve to accept the apple which was ultimately the cause of the formation of the first "Works Section," by pointing out that in that case Adam must have been the first maintenance man. Many members and visitors took the opportunity to discuss the paper but each was limited to five minutes owing to lack of time.

The Chairman closed the discussion, speaking on the value of co-operation and reliability, and saying that every man should have some ideal in life other than an ambition. After Mr. Hill had replied to the discussion and a hearty vote of thanks had been passed to the author in the usual way, the meeting terminated at 4.40 p.m. in order that members might have suitable time in which to prepare for the Annual District Dinner which was to follow at 7.0 p.m.

S. T. S.

Junior Section Notes

Birmingham Centre

In order to maintain the enthusiasm which was proved last session by a record membership, the Committee now in office have endeavoured this year to include in the programme, in addition to papers to be read by members, a number of talks on technical subjects to be given by professional men outside the Department. It is believed that in this way, in addition to providing a well balanced programme and assisting to our field of knowledge, members who have had little opportunity of preparing papers or public speaking will gain considerably from studying the methods of men of experience in these matters.

The events of the Centre to date include—

1938—

September 26th.—"Talkie Film Display. G.P.O. Film Unit.

October 19th.—"Broadcasting Generally. J. A. Cooper, B.Sc., A.M.I.E.E. (Engineer-in-charge B.B.C. Midland Regional).

November 15th.—"Television." S. T. Stevens.

November 28th.—"Plan Numbers and Cordless Switchboards." J. Meredith.

December 14th.—"Railway Signalling." P. G. Jacobs (G.W.R. Technical Staff, Signal Section).

Forthcoming events include :—

1939—

January 19th.—"Teleprinters." J. H. Rafe.

February 14th.—"City and Guilds Examinations." C. F. Partridge, B.Sc., M.I.E.E. (Head of Electrical Engineering Dept., Birmingham Central Technical College.)

March 16th.—"Humours of Librarianship." H. M. Cashmore, F.L.A. (Birmingham City Librarian).

March 27th.—“ The Drawing Office and its Relationship to External Plant.” C. D. Macklow.

May 16th.—“ Earthquakes and How They Are Recorded.” J. J. Shaw. (The well-known West Bromwich Seismographer).

May 24th.—Annual General Meeting.

The Committee of this Centre is fully representative of all sections and grades. In this way, together with the particularly interesting and instructive programme outlined above, it is hoped this year to eclipse easily the membership figure of approximately 200 attained last year.

All the junior staff, particularly youths-in-training and external members are urged to enrol now and avail themselves of the opportunity which awaits them to further their technical knowledge by attending the meetings and taking advantage of the library facilities.

The Annual Dinner has been arranged for February 11th, 1939, when it is hoped that S. F. Hill, Esq., the retiring Area Engineer will be the guest of honour.

G. W. B.

Hereford Centre

The new Hereford Junior Centre of the I.P.O.E.E. was launched at a very successful meeting held at St. Martin's Hall, Hereford, on Friday, October 7th, 1938; 112 persons were present.

The new Centre was fortunate in that both the Superintending Engineer, Mr. H. Faulkner, and the Sectional Engineer, Mr. G. F. Bolton, were present, and their addresses of approval and guidance were followed by an hour and a half's programme of really excellent films by the G.P.O. Film Unit.

The Centre, with an initial membership of 52, started its session on November 7th and can be considered to have made an excellent start as, in addition to the seven interesting papers to be read during the session, it has secured, free of charge, a lecture hall in a local school for its meetings.

The Secretary has also been fortunate in securing the use of two film projectors, 9.5 and 16 mm, and a lecture lantern, and has made arrangements for the projection of one or two G.P.O. films at each meeting throughout the session.

The Officers for the present Session are :—

Chairman—Mr. H. Pritchard.

Hon. Secretary—Mr. A. H. Rantell.

Treasurer—Mr. W. E. Jones.

Isle-of-Wight Centre

The new Centre was inaugurated at a meeting held on October 29th last with a membership of thirty-three, of whom all but two attended, these two being kept away by work in connection with the crisis.

The Centre received an enthusiastic send-off, the following officers being elected :—

Chairman—Mr. A. Kidd.

Treasurer—R. L. Cooper.

Secretary—R. A. Yeatman.

Committee—Messrs. W. C. French, S. Harrison, F. Longyear, M. A. Squibb.

The Committee were fortunate in having fourteen papers volunteered and these have been arranged in a programme designed to cover, progressively, as much as possible of the Department's activities and kindred subjects.

This session's programme is :—

1938—

October.—“ The Lineman.”

November.—“ Underground Construction and Development.”

December.—“ Clerk of Works' Duties in Auto. Construction.”

January.—“ Transport.”

February.—“ Auto. Exchange Maintenance.”

March and April have been left open at the moment since rearrangement of the existing programme may become necessary.

Now that the Centre has at last got going, the Committee hope that more and more members will be obtained, and ask all those on the Island staff to join and help build up a successful Centre.

R.A.Y.

King's Lynn Centre

The 1938-39 session has commenced and it is most gratifying to see the keen interest which the members are taking in the Junior Section. The officers elected for the 1938/39 session are as follows :—

Chairman—W. H. Brown.

Secretary—H. C. W. Norton.

Treasurer—F. W. J. R. Cameron.

Committee—A. H. Triscott, J. Hayes, T. Hall, K. W. Dutton, P. Carter.

The first meeting was held on October 26th, 1938, with a very good attendance, including Mr. Millar, the Telephone Manager, and several members of the Senior Section. The paper given by Mr. C. E. Riley was very instructive and a number of debatable points were discussed.

The second meeting took place on November 9th, 1938, and took the form of a discussion on overhead construction, based on the five sets of questions which have been prepared for the benefit of Youths in the Cambridge Area. The questions are based on :—Overhead, Underground, Dual Maintenance, Auto-Non-Director and Internal Construction.

Model answers were given after the reading of the questions and both internal and external members discussed them until each aspect had been dealt with. The remainder of the programme is as follows :—

November 30th.—“ Simple Auto Principles.”

K. W. Dutton.

December 8th.—Discussion Night. “ Under-ground.”

1939—

January 12th.—“ Repeater Stations ” G. Huke.

January 26th.—Discussion Night. “ Non-Director Exchange Maintenance.”

February 16th.—“ General Power.” S. E. Fincham.

February 23rd.—Discussion Night. “ Subs. Fitting.”

March 9th.—“ O/H Construction—Lead's In.” T. Hall, and “ U/G Construction—DP's.” J. Hayes.

March 23rd.—Discussion Night. “ Dual Maintenance.”

Lancaster Centre

On September 6th, a well-attended Meeting of all members of the staff was held, and a Centre was inaugurated. Mr. S. Fisher had kindly undertaken the preliminary work associated with the forming of the new Centre.

Mr. Carr, Sectional Engineer, opened the meeting and explained the objects of the Junior Section. Mr. C. G. Faulkner also mentioned the work of the Junior Centres in the Eastern District. Mr. A. A. Kilgour, being elected Chairman, then took the Chair and the various Officers and Committee were elected.

The meeting closed with a vote of thanks to the engineers for their interest in the matter.

The programme for the rest of the session is as follows

1939—

January 3rd.—“Overhead Construction.” T. Higginson. “Jointing.” S. Holmes.

February 7th.—“Unit Automatic Exchange No. 12.” J. Newsham.

March 7th.—“Photography.” F. Acton.

April 4th.—“Railway Signalling.” M. N. Denny.

The meetings will be held at 37a King Street, Lancaster.

Norwich Centre

The 1938 Session was opened on the 7th November, when members met for the Annual Supper at the Festival House, Norwich.

Prizes for the best papers read by members of the Junior Section during the 1937-38 Session were presented as follows :—

Awarded by the Institution.

Mr. C. W. Roe—Trunk Routing and Operation.
£2 2s. od. and Certificate.

Awarded by Eastern Centre Committee.

Mr. H. R. B. Lowne—The Generation, Distribution and Utilisation of Electricity.
£1 and Certificate (1st Prize).

Mr. P. G. Hay, the Telephone Manager, when presenting these prizes commented upon the high standard of the papers.

The awards should prove a splendid encouragement to the Centre.

The Officers appointed at the Annual General Meeting for the ensuing session are :—

Chairman—T. C. Loveday.

Vice Chairman—V. J. Nelson.

Secretary—R. B. Hoult.

Treasurer (pro tem)—E. W. Mason.

Committee—E. G. Hill and J. S. Fletcher.

The following programme has been arranged :—

1938—

November 28th.—“Single-battery Float System at U.A.X.s” Mr. E. W. Mason.

December 20th.—“Automatic Telephone Exchange. Non-Director System.” Mr. R. B. Hoult.

1939—

January 23rd.—“A Talk on the Slide Rule.” Mr. J. W. Sursham.

February 21st.—“Police Telephone and Signal System.” Mr. J. Parfitt.

March 20th.—The Preparation of Development Schemes.” Mr. H. W. Storey.

April 18th.—“From C.B. to Zuto.” Mr. C. W. Roe.

April 24th.—Annual General Meeting.

Oxford Centre

On October 5th, the Oxford Junior Section held the first meeting of the 1938-1939 session.

Previous to this, the Committee had met and discussed the possibilities of interesting all classes of workmen during the one evening. Suitable men were approached and asked to contribute to the paper. In the end, four people were chosen for their varying experience. The result of this experiment was highly satisfactory. The papers were of 10 minutes' duration, and the discussions that ensued at the end of each would most certainly not have allowed for any extension of that time.

The first paper was given by Mr. G. W. Harris on on “U.A.X. Development in Rural Areas.” Next, Mr. ● Tyrell on “7.45 to 5.30.” A lineman who covered in 10 minutes his complete working day ;

followed by Mr. E. Jones on “Overhead Construction” ; and, lastly Mr. F. Liddiard on “Patrol Duties.” So it will be seen that most duties were covered which could, and did, interest the thirty members present. I. M.

Portsmouth Centre

The annual General meeting of the Portsmouth Centre, I.P.O.E.E., Junior Section, was held at the Y.M.C.A., High Street, Portsmouth, on October 20th, 1938, at 7.15 p.m. At the conclusion of the financial statement the election of the Officers for the 1938-1939 session was proceeded with and the result of the elections were as follows :—

Chairman—Mr. H. G. Crook.

Vice-Chairman—Mr. A. J. Stainer.

Hon. Secretary—Mr. C. H. Hishon.

Hon. Treasurer—Mr. L. Dutson.

Committee—Messrs. G. Bowring, N. H. Hishon, A Short, W. Salter, P. H. Edwards, R. Greaves and F. Whittle.

The following programme for the ensuing session was then prepared as follows :—

1938—

November 17th.—“Radio Interference.” F. Waters.

December 15th.—“U.A.X. Development.” E. Downer.

1939—

January 19th.—“V. F. Telegraphs.” C. H. Hishon.

February 16th.—“Radio Transmitters.” H. McTrusty.

March 16th.—“Teleprinters.” N. L. Fletcher.

April 20th.—“Faults and Maintenance.” N. H. Hishon.

May 18th.—“Main Works Control.” E. C. Blake.

The first meeting of the 1938-1939 session was held at the Y.M.C.A., High Street, Portsmouth, on November 17th, 1938, and the paper read by Mr. F. Waters dealt with “Radio Interference,” and a warm vote of thanks was accorded the speaker at the conclusion of a very interesting evening.

Arrangements are now in progress for the further meetings to be held at the Y.M.C.A., and members are asked to make every effort to ensure that we shall have the most successful session since the inauguration of the Portsmouth Centre in 1934.

A word to the Committee—a little effort and our membership could be 150, and with a still further effort we could ensure larger and more representative attendances. C. H. H.

Preston Centre

The programme for the remainder of the session is as follows :—

1939—

January 18th.—“Internal Combustion Engines.” A. Marginson.

February 15th.—“Local Lines Development.” W. H. Eaton.

March 15th.—“Police Signalling Systems.” L. Hall.

May.—Annual General Meeting.

Meetings are held in the H.P.O. Commence 7.30 p.m. prompt.

Rugby Radio Centre

The programme for the second half of the session has been arranged as follows :—

1939—

January.—“Aerials and Transmission Lines.” Mr. L. L. Hall, B.Sc.

February, 1939.—“ Amateur Radio.” Mr. H. S. Norris.
 March.—“ Demountable Valves, and Associated Equipment.” Mr. H. J. Thwaites.
 April.—“ The Evolution of Naval Signalling.” Mr. S. R. Keen.

Salisbury Centre

A Supper and Smoker was held on October 8th at the Rendezvous Café, Salisbury, to inaugurate the fourth session of the Local Centre of the Junior I.P.O.E.E.

The guests of the evening included :—

Mr. F. W. Friday (Sectional Engineer)
 Mr. W. Bell (I.P.O.E.E. Secretary, South
 Midland District)
 Mr. E. Weaver (Asst. Engineer)

and eight local inspectors, the total attendance being 43.

It was very gratifying to have such a good attendance, also to see so many members of the external staff, who hitherto have been somewhat reticent in attending meetings. The committee hopes for a continuance of their support at forthcoming meetings.

Following some interesting and amusing speeches by our Chairman and visitors, the entertainment for the evening proceeded under the direction of the versatile Mr. J. L. Cox, with Mr. King at the piano, and Mr. Read, whose very fine amplifying arrangements contributed to a very pleasant evening's entertainment. Numerous “ turns ” were given by various members, notably by Mr. Clubb, whose monologue “ The day of Salisbury change-over,” were it not for its length, would be worthy of publication in these notes.

It is sincerely hoped that everyone will endeavour to attend the meetings this session in the same spirit as that displayed at our first social event, which we hope will be the forerunner of many more.

Scarborough Centre

At a meeting held on October 10th it was unanimously agreed that a centre be formed at Scarborough, and the following officers were elected :

Chairman—Mr. F. Cowper.
 Vice-Chairman—Mr. D. S. Goy.
 Secretary—Mr. A. B. Clarke.
 Treasurer—Mr. P. Mitton.
 Committee—Mr. T. G. Purt.
 Mr. K. Megginson
 Mr. J. Sherwin.

Auditors—Mr. J. Pickering, Mr. S. Stubbs.

The meeting was well attended, and three papers were promised, namely :

Mr. D. S. Goy—“ V.F. Telegraphs.”
 Mr. F. Cowper—“ Long Distance Communication and its Development.”
 Mr. T. G. Purt.—“ Unit No. 14.”

The dates when the above papers will be read together with the other three papers, will be announced later.

Slough Centre

The Slough Junior Section was successfully launched on October 13th when a paper on “ Fault and Maintenance Procedure ” was read by the President, H. Mortimer, Esq., A.M.I.E.E. The paper gave rise to a very spirited but enjoyable discussion. The meeting was honoured by the presence of a sprinkling of supervising officers, including the Superintending Engineer, who contributed in no small way to the success attained at the first session by his observations on the subject. If this meeting can be taken as an indication of future

meetings then we can look forward to a very successful season. The Chairman of the Branch is Mr. Hillard, Inspector, Taplow Repeater Station, and the Hon. Secretary, Mr. S. W. Wiltshire, who will be pleased to give any information required by members.

Southend-on-Sea Centre

A meeting of the staff was held in October with the object of reforming a Junior Section. Members of the staff were enthusiastic to the extent that the following officers were elected for the session :—

Chairman—A. W. Rance.
 Vice-Chairman—R. Foulsham.
 Secretary—A. W. Smith.
 Committee—T. Carthew, J. Garlick, R. Hoisnell,
 R. N. Risby.

Every effort is being made by the committee to compile a list of suitable papers.

It is hoped that with so much keenness we shall be able to show a steady increase in the membership.

Southport Centre

The programme for the second half of the session is as follows :—

1939—
 January 2nd.—“ Underground.” Mr. W. H. Ward.
 February 6th.—“ Aspects of Local Line Records.”
 Mr. J. H. Todd.
 March 6th.—“ U.A.X.s.” Mr. H. Lowe.
 April 3rd.—“ Secondary Cells.” Mr. G. Haley.
 E. M. S.

Torquay Centre

The second Annual Meeting of the Torquay Branch was held on Wednesday, June 15th, 1938, the Chairman, Mr. Davidson, presiding. The business included the election of officers for the ensuing year as follows :—

Chairman—Mr. E. J. Travers.
 Vice-Chairman—Mr. W. G. Seward.
 Hon. Secretary and Library—Mr. P. W. Crouch.
 Treasurer—Mr. W. E. Colwell.
 Committee—Messrs. Gill, Mogridge, Lightfoot and Skinner.

H. Trussler, Esq., A.M.I.E.E., was unanimously elected Vice-President.

A vote of thanks was accorded the President, W. E. Walton, Esq., A.M.I.E.E., Sectional Engineer, also Mr. Davidson, who had been chairman of the Branch since its inception and had resigned owing to his appointment to the position of Inspector.

The first meeting of the Session 1938-39 was held at the Electric Hall, Electric House, Torquay. The meeting opened with a short description by Mr. P. Swann of the more important internal and external engineering works, illustrated by lantern slides which have been completed in the Torquay and Newton Abbot areas since the 1937-38 session.

A lecture was then given by Sir Ambrose Fleming Kt., F.R.S., entitled “ The Work of Some Notable Telegraphists.” Sir Ambrose and Lady Fleming were introduced by Mr. Somerville, Assistant Superintending Engineer, South Western District. Sir Ambrose described the work of the earliest telegraphists, commencing with an essay by Oersted in 1825, and continuing with the work of such pioneers as Ampere, Morse, Wheatstone, Hughes, Lodge, Crooks, Faraday, Kelvin and Baudot. The history of the telegraphs was thus dealt with from the time of the discovery of the simple electromagnet to the modern teleprinter.

It is hardly necessary to record that the meeting was

well attended. Over 100 members were present, together with some 50 visitors from other districts. At the conclusion of the lecture a sincere vote of thanks to Sir Ambrose Fleming was proposed by Mr. L. A. Mogridge which was seconded by the whole of the audience with great enthusiasm.

The second meeting was held on Wednesday, September 28th, 1938. A paper by the Sectional Engineer, W. E. Walton, Esq., A.M.I.E.E., was unavoidably cancelled. This was substituted by a paper given by H. Trussler, Esq., A.M.I.E.E. entitled "Insulating Materials and Protective Surfaces." This meeting was also well supported and a lively discussion followed.

The third meeting of the Session proved a very interesting lecture by F. H. Mullett, Esq., entitled "A brief History of the Telegraphs."

Other features of the programme are lectures by December.—"Ships Power Supplies." W.L. Bartlett. January.—"Underground Maintenance."

February.—"Television Receivers" by a well-known Manufacturer. P. E. Swann.

March.—"Teleprinters." W. G. Seward.

The membership of the Branch is now well over the hundred and new members are being enrolled.

P. W. C.

District Notes

London Region

NEW AUTOMATIC EXCHANGES

Garston. This exchange of non-director type installed by the General Electric Company was opened on Saturday, October 15th, at 1.30 p.m. Installed multiple capacity 600 with an ultimate of 2200 and 304 subscribers' lines were transferred from the CBS2 manual exchange. The auto-manual board centre is Watford and the power plant is of the automatic parallel float type with two 300 ampere hour batteries fully plated. This transfer was of particular interest as it was linked with the change of Radlett non-director satellite on Watford to main non-director working. This conversion was effected at 12 noon on Sunday, October 16th.

On account of inter-dialling difficulties which would be experienced it was decided that the two conversions could not take place on the same day and as a result it was necessary that the ultimate dialling arrangements for Garston subscribers should be introduced at the opening of Garston and the ultimate dialling arrangements for Radlett, Watford, the main exchange, and Kings Langley, another satellite on Watford, at the opening of Radlett.

While Garston was manual, Watford, Kings Langley and Radlett subscribers dialled 81 to obtain the Garston operator and on the opening of Garston automatic exchange it was necessary to intercept level 81 at Watford on the Watford manual board till the Radlett transfer.

As a satellite exchange, Radlett occupied level 6 at Watford with a 4-figure numbering scheme. Garston dialling-out code for Radlett is 589 one of 8 dialling-out codes in the 58 series at Garston, Radlett being obtained through level 89 at Watford. It was therefore necessary for the latter level to be brought back temporarily to 1st selectors at Watford to route the call to the Radlett number which would be obtained from level 6.

Radlett. The conversion of Radlett to separate non-director working had to be carried out for two reasons:—

- (1) Radlett number range 6100 to 6999 was practically exhausted;
- (2) An additional 1000 numbers had to be freed at Watford to meet development for the next few years. Watford is due to be converted to director working in 1943. The introduction of the numbering range 6100 to 6999 as a separate range for Radlett only involved conversion of the D.S.'s to 1st selectors and the provision of a rack of 2nd selectors. Level 2 of 1st selectors to be used for obtaining Watford numbers and through Watford—Kings Langley, 2 plus number; Garston, 281 plus

number; Bushey Heath, 282 plus number; Hatch End 284 plus number; Northwood, 285 plus number; Pinner 286 plus number; Rickmansworth 287 plus number; Stanmore, 288 plus number.

It was decided that the existing D.S.'s should be modified to 1st selectors rather than by installing replacing 1st selectors. Opportunity was taken of an extension of the exchange to install an additional rack of D.S.'s already modified to work as 1st selectors and a new rack of 2nd selectors. All D.S. levels except "0" were, prior to the transfer, trunked direct to final selectors and in order to introduce the 2nd selectors the levels were taken through change-over keys to 2nd selectors, the outlets being teed to the final selectors.

On Sunday morning, October 16th, prior to the cut-over at 12 noon a proportion of the unmodified D.S.'s were taken out of service and modified to 1st selectors leaving half the total number of D.S.R.'s available to subscribers. The modified switches were busied when the modification was completed. At 12 noon the unmodified switches were busied, the modified switches unbusied and the change-over keys thrown to introduce 2nd selectors.

In addition the directors at Bushey Heath and Elstree, which previously routed calls to Radlett via Watford, had their Radlett translations altered to route calls over direct routes to Radlett. Radlett subscribers were also instructed from the time of transfer to obtain Elstree direct by dialling 4 plus the number, whereas previously they obtained Elstree via Watford by dialling 83 plus the number. A direct route to St. Albans was also established from level 3 whereas St. Albans was previously obtained by dialling "0" to the auto-manual board at Watford.

All the arrangements were carried out without a hitch and Radlett is now functioning as a separate non-director exchange. Arrangements were also made for level 6 at Watford to be intercepted at the manual board in order to free this level of traffic as early as possible. Subscribers at Watford and Kings Langley whose calls were intercepted were instructed to use the new code 89 plus the number to obtain Radlett subscribers. Levels 5, 7 and 8 at Radlett were extended over external circuits to the Watford auto-manual board thus trapping calls for Watford, Kings Langley and Garston on which the subscribers had omitted to prefix the digit 2. The attached schedule indicates the dialling arrangements at the various stages of the conversion. This conversion, which was the first of its kind to take place in this country, was of a very complicated nature and credit is due to the

staff engaged on the transfer whose interest and efforts ensured that it was a success. Fuller details of the Radlett conversion are given in an article by Mr. W. D. Gray published in this issue.

Markyate U.A.X. No. 13. This exchange which replaced the old manual C.B.S. 2 exchange was opened with 88 subscribers at 1.30 p.m. on October 19th. The initial equipped capacity is 150 lines.

Ravensbourne Exchange. 4,933 subscribers were transferred from the Ravensbourne manual exchange to the automatic exchange at 1.30 p.m. on November 2nd. The automatic equipment was installed by the General Electric Company Limited and has initial capacity of

5,900 lines, ultimate 10,000. The power plant is of the new parallel battery float type with batteries of 1,200 ampere hour capacity fully plated. These latter were installed by the D.P. Battery Company Limited.

Richmond Exchange. 3,600 subscribers were transferred from the Richmond manual to the new automatic exchange at 1.30 p.m. on November 16th. The equipment was installed by Messrs. Ericssons Telephones Limited and the power plant is of the parallel battery float type with two batteries with 1,200 ampere hour boxes plated to 600 ampere hours. These latter were installed by Messrs. Pritchard and Gold and E.P.S. Company Limited. The auto-manual board for Richmond is at Prospect exchange.

SUBSCRIBERS' DIALLING ARRANGEMENTS

FROM	BEFORE GARSTON TRANSFER			AT GARSTON TRANSFER			AT RADLETT TRANSFER		
	Watford and Kings Langley	Garston	Radlett	Watford and Kings Langley	Garston	Radlett	Watford and Kings Langley	Garston	Radlett
TO									
Watford	Subs. dial No.	Manual	Subs. dial No.	No change	5 and No.	No change	No change	No change	2 and No.
Kings Langley	Subs. dial No.		Subs. dial No.		5 and No.				5 and No.
Garston	81		81		Subs. dial No.				No change*
Radlett	Subs. dial No.		Subs. dial No.		589 and No.†				No change
Bushey Heath	82 and No.		82 and No.		582 and No.				No change
Elstree	83 and No.		83 and No.		583 and No.				No change
Hatch End	84		84		584				No change
Northwo	85		85		585				
Pinner	86		86		586				
Rickmansworth	87		87		587				
Stanmore	88	88	588						
St. Albans	via A.M.B.	via A.M.B.	6						
	Bushey Heath and Elstree subs. dial code and subs. No. on calls to Watford, Kings Langley and Radlett.			Bushey Heath and Elstree subs. dial code and sub's. No. on calls to Watford, Kings Langley Radlett and Garston. Garston calls intercepted at Watford M.B. till Radlett transfer.			No change in respect of dialling arrangements for Bushey Heath and Elstree subs. 1		

NOTES.—* All calls on 81 level at Watford to be intercepted at Watford M.B. and completed by operator.
 † Connected back to 1st selectors.
 ‡ Change in translation of codes from Bushey Heath and Elstree to Radlett will be necessary.

INAUGURATION OF THE BRIGHTON TELEPHONE AREA

An inauguration ceremony in connection with the Brighton Telephone Area took place at 3.45 p.m. on November 14th, 1938, at Telephone House, Brighton. To this 9-storey building have now come more than 300 of the telephone staff who were hitherto housed in a number of different buildings.

The gathering took place on the third floor of the building when Mr. McIntyre, Surveyor of the South Eastern District, introduced the Telephone Manager, Mr. G. Edward, to the company, many of whom did not know him. Mr. Edward then took the Chair and first offered greetings to the 1,100 men and women who come under his control. He then welcomed the guests and gave interesting particulars of the new area just established. After telegrams and messages of good wishes had been read, a further welcome to the new Telephone Manager was extended by Alderman Marks on behalf of the Advisory Committee, Mr. Harvey Smith (Superintending Engineer, S.E. District), Mr. F. R. Perris (Area Engineer), Mr. H. A. Stokes (Chief Clerk), Mr. A. A. Atnell (local Whitley Committee), Mr. S. T. Welch (Post Office Engineering Union) and Mr. P. Martin (Engineering Whitley Committee).

The pleasant proceedings were brought to a close by a tea, and a staff dance followed in the new building in the evening.

Eastern ELECTRICAL PANEL HEATING

During 1937 the Sub Post Office at Davey Place, Norwich, was enlarged. Extensive alterations to the premises were made to convert the old public office and the next door shop into one large public office. As no space was available for the accommodation of a central heating boiler it was decided to employ electrical heating.

In the mails room, accounts offices and supervisors' room, tubular heaters were installed, and in the staff retiring room an ordinary wire element radiator was employed. Both tubular heaters and radiators are extensively used by the Department, and it is not proposed to make further reference to these fittings.

In the public office, "Unity" panel heaters were provided, and some reference to these might prove of value to others faced with a similar problem.

Two types of these panels are made for:—

- Flush fitting into finished surface of wall.
- With moulded surround for fitting on finished surface.

The latter type was employed in the case described.

In an office of 40 ft. × 20 ft. × 10½ ft. high, panels to a total loading of 12.75 kW were installed. This may appear to be heavy loading for such an office, but the frequency at which public office doors are opened adds a very uncertain element in calculations for heating

schemes. It was, therefore, decided to make generous provision of panels to maintain a temperature of 60° when the outside temperature is 32° Fahr. As the total designed loading could not be accommodated on the available wall space by the use of standard panels, three of the panels were specially loaded by the makers.

Thermostatic control is employed which is capable of adjustment between 50° and 70° Fahr.; the circuits being arranged throughout the office for direct switching through bi-metallic thermostats. Two sizes of thermostats were used, one having a current carrying capacity of 5 amperes, and the other 15 amperes.

It should be mentioned that the main switch is thrown off when the staff leave at night, the cleaner switching on early in the morning. The office is up to standard temperature when the staff arrives. A cupboard was built around the main switches which were accommodated in the mails room.

The panels in a surround of Australian walnut have a pleasing appearance. The office has a very clean appearance and the paint surface of the panels still appears very bright and fresh.

As the chief criticism of electrical heating schemes centres around running costs, these notes have been withheld until such costs, based on actual consumption, could be given. With a total installed load of 23 kW actual and estimated consumption for the year 1938 is as follows:—

	Units
January-March	11,387
April-June	5,515
July-September	Nil.
October-December (Estimated)	7,500
Total	24,402

The anticipated total cost for the year 1938 is:—	
Consumption 24,402 units @ 3d.	£76
Interest at 3½% on capital cost of £200	£7
Depreciation at 3½% on £200	£7
Maintenance (say)	£1
Total	£91

Actually the cost of maintenance has been negligible to date.

In making any comparison of costs between electrical systems and hot water systems, something should be added on the credit side of electrical heating schemes for saving on cleaning and decoration costs. It is thought that these figures may be of interest to those who have to consider the relative advantages of electrical and hot water systems.

North Eastern Region

LEEDS (NEW) REPEATER STATION

Duct Work. With the rapid growth of the long distance cable network, the latest additions to which include cables of the coaxial and carrier types, it was found that the space available at the present repeater station in the Head Post Office, Leeds, was inadequate, and, as extension of the existing building was impracticable, a new building had to be considered. The decision to provide a coaxial cable between Manchester and Newcastle via Leeds, made the matter one of urgency and it was fortunate that a site in Burley Street, acquired for other purposes, was found to be suitable, and available for a repeater station. The plan and photographs illustrate the work carried out in the provision of the ducts to link up the new Repeater Station with existing duct tracks.

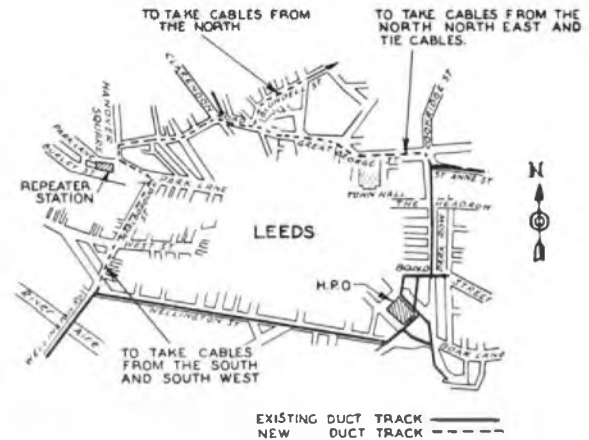

FIG. 1.—PLAN OF NEW DUCT ROUTE.

Fig. 1 shows the relative position of Burley Street to the Leeds Head Post Office, together with the existing and new duct tracks. The duct entrance to the cable chamber is in Park Lane and some difficulty was experienced in providing a nest of 54 octagonal ducts between the cable chamber and a specially designed manhole on the opposite side of Park Lane. Due to the general arrangement of the building and the level of Burley Street being approximately 10 ft. below that of Park Lane, the height of the cable chamber at the Park Lane side was limited to 10 ft. 3 ins. Enquiry of the local authorities and the excavations of pilot holes revealed that it would not be possible to lead into the cable chamber at a suitable distance from the floor without considerable alteration to the mains of other services in Park Lane. Co-operation of the various Undertakers was obtained for the lowering of a number of electric light mains, the raising of others, and by slight modification of the manhole it was found possible to get the track in, between a water main and a main sewer.

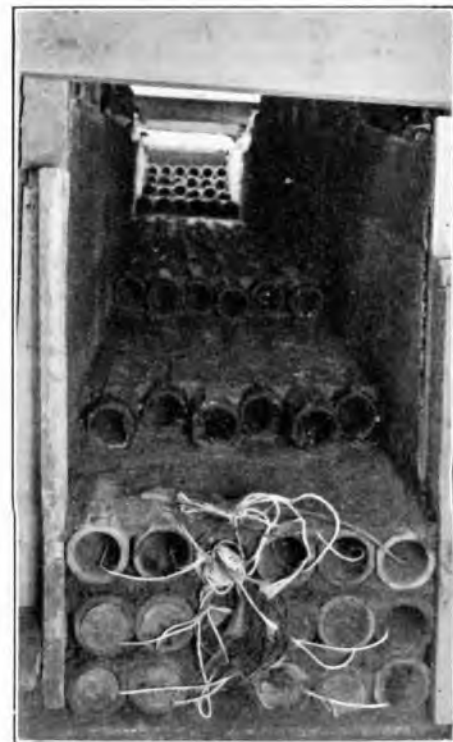

FIG. 2.—DUCT LAYING IN TUNNEL UNDER PARK LANE.

Fig. 2 gives a view of the 54-way octagonal duct being laid in a tunnel under Park Lane and open trench near the entrance to the cable chamber.

Fig. 3 is a photograph taken during the laying of a 28-way octagonal duct in an open trench in Hanover Square.



FIG. 3.—DUCT LAYING IN OPEN TRENCH IN HANOVER SQUARE.

Earthing System. A novel feature so far as the North Eastern Region is concerned is the earthing system which has been designed on the earth electrode principle. The system is composed of 15 tubular spikes driven into the earth at 8 ft. intervals and connected by stranded copper encased in lead piping. The presence of rock gave rise to some misgiving as to the probable efficiency of the system, and opportunity was taken to provide a lead strip earth consisting of 80 feet of lead strip laid under the leading-in ducts. These misgivings were fortunately unfounded since a test of the systems gave the following results:—

Electrode Earth	0.7 ohms.
Lead Strip Earth	0.25 ohms.
Both systems in parallel	0.2 ohms.

South Eastern

INAUGURATION OF THE TUNBRIDGE WELLS TELEPHONE AREA

An inauguration ceremony took place on November 7th, 1938, at the Ritz Cinema Café, Mount Pleasant, Tunbridge Wells. The company assembled at 3.45 p.m. when Mr. Langlands, in the absence through illness of Mr. McIntyre, Surveyor, S.E. District, introduced the Telephone Manager, Mr. W. E. Chinn, to the staff, many of whom had not previously met him.

Mr. Chinn then took the chair and, while tea was served, he welcomed the guests and read a number of telegrams conveying good wishes. Brief speeches of welcome to

Mr. Chinn were made by the Chairman of the Advisory Committee, Mr. Harvey Smith (Superintending Engineer, S.E. District), Mr. G. Edward (District Manager, Brighton), Mr. G. Casemore (Area Engineer), Mr. E. B. Jempson (Clerical Staff Association), Mr. F. W. Scott (Post Office Engineering Union) and Mr. R. L. Fagg (Engineering Whitley Committee).

After the ceremony full use was made of the opportunity for social contacts between the members of the staff of the new Telephone Area and a very cordial spirit prevailed throughout the whole proceedings.

South Midland

RETROSPECTIVE—AUTO-TELEPHONY IN THE PROVINCES

Some twenty-two years ago the Portsmouth automatic exchange was brought into service. Nothing very wonderful in that, the sophisticated "line-finderite" or "directorophil" will say, but it is hoped that some reminiscences of these early days may not be without interest, if only to show how far we have progressed in the science of automatic telecommunication since.

The installation of the equipment in specially built accommodation in the Head Post Office, Portsmouth, commenced early in 1914, and proceeded in the teeth of innumerable difficulties in stalling and equipment occasioned by the War. The installation staff consisted mainly of expert "switchmen" specially imported from Chicago, and they were largely responsible for training this Department's staff in the then practically new art of automatic exchange maintenance. This led to the adoption of a sort of pseudo-Yankee jargon, which, the writer remembers, used to infuriate the more conservative among our supervising officers. For instance, we used to say "grounded" instead of "earthed," "open" for "disconnected," "hook-up" for "temporary connection," while a faulty inter-switch circuit would be described as "bum link" or "phony trunk." The portable telephone used by exchange faultsmen was "butt-in-ski," and our Trans-Atlantic instructors would refer to the Test Clerk as the "Wire Chief" and the men on switch-adjustment duties as "Trouble-shooters."

The king-pin of the old installation was the Keith line switch. Most of the neophyte staff were apprehensive of this feature. It seemed so fragile in construction, and cumbrous in operation. The switch was (and is), a very light metal pointer shaped like a big clock-hand, with two tiny ebonite rollers at the business end of the pointer. The pointer was attached at right angles to the armature of a simple electro-magnet operated by the subscribers "loop" on removing the telephone receiver, when the rollers on the end of the pointer or "plunger" operated a set of very thin spring brass contacts arranged in an arc-shaped bank of ten sets of contacts opposite each "line-switch," thus extending the connection to the next class of switch. Local contacts in the bank completed the "master-switch" circuit, which was the component responsible for the selection of a disengaged outlet for the primary line-switches. This was a most fascinating piece of apparatus in those early days, as it was so different from anything that had previously been used in manual switching. The motive power consisted of a serrated arc which was oscillated from side to side in the horizontal plane by a solenoid in one direction, and by a flat steel spring, compressed by the pull of the solenoid, in the other. On this oscillating member were mounted flat guide bars to engage in notches cut in the fan-shaped ends of the plungers, so that all the Keith line-switches in one group (usually 100), that were in the normal or disengaged position were lined up by the master-switch against disengaged outlets. When all the outlets were

engaged, the switch carried all the disengaged plungers backwards and forwards in a rhythmical motion, which was very impressive to the embryo engineers of that time.

The rest of the equipment consisted of two-motion selectors not so very different in essentials from those in use at modern installations at the present time. There were, of course, no dust-insulated relays, no eleventh step, no forward rotary release, to mention a few refinements introduced in the two decades that have passed since Portsmouth's master-switches started hunting.

To save a multiplication of group selectors, another Keith type switch, known as the secondary line switch, was interposed between the primary line-switch and the first numerical selector. This latter nomenclature has, at any rate persisted till the present day. The final selectors were first known as connectors, and they performed most of the functions proper to a modern final.

The connector banks were rather troublesome at first. The insulation between the layers of contacts on the line banks was of red compressed fibre, and the bank contacts were held in position on American cloth segments ostensibly by shellac, but, in reality, by the compression of the assembly bolts and nuts. The red fibre insulation was very prone to insulation faults probably due to its inherent instability in the excessively humid atmosphere that generally prevailed. There was no Plenum system in those far-off days, and the air temperature was nearer 70° than 60° for the greater part of the year. So very frequently banks had to be dismantled to renew contacts or insulation. It was very soon found that the factory assemblers had done their work only too well, for not only had they fitted lock-nuts on the bank bolts, but they had carefully burred up the ends of all the bolts, so that it was impossible to withdraw them by normal methods. It was necessary to overtighten them by brute force until the shank of the bolt sheared, and, unless the operator was very careful, the removal of the last bolt usually resulted in all the contacts and insulators falling in a hectic shower all over the place. The job of re-assembly was no sinecure.

The installation was quite toneless at the outset. The first extraneous noise to be introduced was the dead number tone, a queer wailing sort of buzz produced by a reed hummer and fed to levels out of service and unconnected subscribers' multiple. Ringing tone came next, and dialling tone quite a time after that. The ringing tone was produced from the silent period of the interrupted ringing via the old type of seven-terminal transformer, one of which was located in the ringing feed circuit at each final unit. Even now, the tones on these old installations are non-standard in tonal pitch and volume, but, as the lyric says, "you can't have everything."

Before the equipment was ready for service the selected staff were given the opportunity of some intensive training on a demonstration set brought from the Engineer-in-Chief's office. The Instructor knew his job. After the circuits had been thoroughly mastered (no one was considered "passed" until the essentials of the through circuit from one auto. subscriber to another could be drawn from memory), the trainee was given a first numerical selector to dismantle to the very last spring. Then he had to put it together again, *and make it work*. This was naturally a titanic struggle, but the seeker after knowledge had not finished yet. The instructor would then exercise the most fiendish ingenuity in putting faults on the equipment in the most unsuspected places. These had to be cleared by diagram and deduction, not by hit or miss or rule of thumb. The writer must admit that in his case these methods of tuition, though heroic when measured by Dollis Hill standards, were certainly efficacious. Most of us knew the equipment inside-

out *before* the exchange was opened for service.

The methods, or rather the absence of methods, of switch adjustment may, at this late date, hold some interest. The Americans adjusted the switches almost entirely by ear. They could tell by the sound of the vertical or rotary magnets if a switch was in reasonably good adjustment. It was an education to watch them at work, although a trifle disconcerting at first. Most of them chewed sweet plug tobacco and had a sawdust box for expectoration purposes within easy reach. They did sometimes check up relay contact clearances by the aid of a feeler gauge, but more often than not they relied on the sound of the switch in operation as a guide to its satisfactory operation. They obtained most of their adjustments by a few strokes of a pair of duck-billed pliers on the impulsing relay springs, coupled with some minor adjustment of the duration of hold of the B relay, and the pole-pieces of the vertical or rotary magnets. Tensioning of springs was arbitrary. They never used a tension balance, although they did have some incomplete data as to spring tension. For instance, a relay might require weak, medium or stiff spring tension, but the gradations were not more precise than that. Naturally, these methods were followed, to a large extent, by the Department's staff when they came to maintain the equipment, and, though they may seem rough and ready compared with present-day standards, it is not too much to claim that the foundation of modern switch adjustment technique was laid in the early days of installations such as I have described.

The old Portsmouth installation has now seen its best days. Already the site of its successor has been secured, and soon the old Keith switches will take their last plunge. The basic features of the original equipment are still there, although the selectors have been converted to eleventh step and traffic recorders, automatic routiners rotary preselectors and 11/20 P.B.X. units have been grafted on the parent trunk, not without incongruity in some respects. It is rather curious to an old hand to see these venerable old switches performing robot gyrations at the behest of an automatic routiner. I am told they did not take kindly to it.

In the intervening twenty years the writer has been privileged to attend many transfers to automatic working, but he has never been able to recapture that pioneer thrill of that April day in 1916, when, heralded by the rattle of the wedges withdrawn on the (then) new Main Frame, Portsmouth automatic exchange began its long, and, let us hope, useful life in the service of the great telecommunications industry.

North Western

STORM DAMAGE

Substantial periods of stormy weather and heavy line damage are normal events in this District during the winter months. The past summer and autumn months, however, have unfortunately also produced many stormy periods, with the consequence that efforts made in the District both for improvement of service and in costs have been annulled.

The worst cases of storm damage occurred early in October when over 4,000 subscribers, 150 trunks and junctions were placed out of order and 5 exchanges isolated. The repair works proved abnormally costly due to the widespread area affected.

TELEPHONE AREAS.

The opening of the Blackburn, Lancaster and Preston Telephone Managers' Areas took place on November 21st, November 28th, and December 12th respectively. These changes convert the whole of the District to Area Working.



LORRY VISITS TELEPHONE EXCHANGE

On the winding Salisbury-Shaftesbury road lies the sleepy village of Donhead, but motorists negotiating the road through the village require to be wide awake for Donhead's Brookwater Hill has claimed heavy toll from indiscreet drivers.

In the morning of August 25th, a few minutes after nine o'clock, the hill claimed yet another victim. A heavily-laden milk lorry, Salisbury-bound, ran down one side of the hill, and commenced the ascent of the other. A faulty front axle collapsed, a wild diagonal swerve from the crown of the road followed, and Donhead Post Office, nestling on the side of the hill was unduly disturbed from its usual tranquility as the helplessly careering lorry tore through its front wall into the telephone exchange, flinging the driver from his cab into the road, drenched in milk from the toppling churns, inflicting minor bruises on the telephone operator at the switchboard and isolating seventy-four subscribers from the world.

Engineering Department staff were immediately sent to the scene of the accident, but little could be done upon arrival. The wrecked lorry was firmly embedded in the crumbling building so the services of a motor breakdown gang and builders were speedily requisitioned to remove the motor and debris and to shore-up the weakened structure against further collapse.

The lorry was unceremoniously dragged away by noon, the builders then made their contribution to the task and pronounced the walls and eaves safe at three o'clock and the engineers at last had access to their plant. The concentration of many men on the work was difficult in the confined space of the tiny exchange, milk was everywhere and saturating everything, but the main distribution frame which had been displaced by the impact, fortunately without seriously damaging the cables, was reinstated, all "jumper" wires changed, and a large proportion of the carbons, heat coils and fuses dealt with similarly.

The last subscriber was informed that his service had been restored shortly after eight o'clock and the Engineering Department had added another striking chapter to its record of public service. F. G. S.

South Western

INTRODUCTION OF THE SPEAKING CLOCK SERVICE AT BRISTOL

An interesting event took place at the Bristol Central exchange on November 23rd, 1938, when the Lord Mayor of Bristol inaugurated the extension of the speaking clock service to Bristol.

The Lord Mayor opened the service after introductory remarks by Mr. Morgan, Superintending Engineer, and Colonel Dainton, Postmaster Surveyor, by dialling 952

at approximately 3.30 p.m. on the 23rd. The service was subsequently available to the general public.

The announcement of the time is received from the Speaking Clock in London over a trunk circuit. The announcements are in the following form:—

"At the third stroke it will be 11.20 and 40 seconds, pip, pip, pip." The trunk line is routed via Birmingham where the "TIM" service has recently been introduced and passes through several repeater stations on route, the circuit being arranged to have zero loss.

The equipment at Bristol consists essentially of:—

- (a) Two mains operated, 2-stage amplifiers, one working and one reserve together with automatic changeover equipment.
- (b) Terminating relay sets which enable any subscriber's line to be connected to the speaking clock after the normal routing through the automatic switches. One relay set is provided for each simultaneous call. Arrangements have been made initially for 10 simultaneous calls to be made to the speaking clock but this number will probably be reduced after the initial "curiosity traffic" has ceased.
- (c) Miscellaneous equipment for providing Number Unobtainable tone, engaged tone, for applying "forced release" and for giving "Alarms."

To prevent congestion should subscribers continue to listen to the time announcements, the "forced release" condition is applied at the end of a period which may vary from one to two minutes when the call is automatically disconnected.

It is not possible to give coin box subscribers direct access to the speaking clock and these calls have to be routed via an operator. This is due to the fact that in such installations the subscriber can hear the distant or called subscriber before pressing button "A" and would therefore hear the speaking clock without charge, since on pressing button "B" refundment could be obtained.

Meters have been fitted for recording the traffic made to the service. Some indication of the volume of traffic received initially will be gained from the following:—

Five hundred calls were received in the first half hour; 16,800 from 4 p.m. on the 23rd November until 8 a.m. on the 25th, and during the next eight hours a further 16,700 calls were received. A. J. C.

North Wales

BIRMINGHAM REGIONAL TRAINING SCHOOL

The Training School was established in March, 1936, with a staff of one Inspector, one Clerical Officer, three SW.1 instructors, and two assistant instructors.

Three courses were arranged at first with a total of 23 students, each course or class being located in separate buildings, with one, the underground jointing and plumbing, being as far away as Wolverhampton. It was at once realised that, if the Birmingham school was to be organised to function on lines similar to those obtaining at the London central school, the first essential thing to do was to try to get the whole school centralised in order to facilitate direct and constant supervision on standard lines by the Engineer-in-Charge. This was especially important in view of the fact that all training had to conform to the Engineer-in-Chief's Training School principles and regulations. Lectures had to be given to each class each day and, as the lecturing staff was limited, it was obvious that very little ineffective time could be allowed; so it was arranged that the jointing and plumbing school should be transferred to

Birmingham as soon as possible. This was accomplished before the end of April 1936.

The number of students trained has steadily increased from 23 in the first month of training to a total of 5,251 up to the end of September, 1938. During the period quoted the number of different courses has increased from 3 to 15. The maximum number of students receiving training at one time was 250, involving 13 courses.

The staff at this period had increased to the following authorised list :—

1 Chief Inspector, 3 Clerical Officers, 5 Inspectors, 19 S.W.I. instructors, 13 assistant instructors (U.S.W. grades), 3 general labourers and canteen attendants.

The decision to introduce training courses for Inspectors resulted in an additional interest being taken by the whole school staff, as this greatly enhanced the responsibility of the Regional School.

Including 8 Inspectors courses, 17,958 student-weeks have been completed during the period March 1936 to September 1938, with a total of 262 courses.



By Courtesy of the Birmingham 'Daily Mail.'

The illustration shows a group of students receiving instruction in overhead work. The overhead construction ground, although comprising only about 3,000 sq. yds. is used to full advantage, every available sq. yd. being occupied either for permanent demonstration work, or for practical training. Owing to so many trainees requiring tuition on overhead work, it has been necessary on many occasions to give instructions to as many as 110 students on one day in this one construction park. This training, consisting of either practical or demonstration work, has, of course, had to be done without any duplication of tools or plant, etc., and only with co-ordination and keen co-operation between all members of the school staff has this been possible.

It would not appear to be conducive to good training, attempting to teach 110 students at one time on one construction ground with an overhead school staff of only six, but by a systematic method of first training the internal school instructors on overhead construction work, it is possible to use such instructors for both

external and internal work. This arrangement also tends to avoid duplication of school instructors.

Altogether, 3,104 students have received instruction on overhead work at the construction ground during the period previously quoted.

In addition to the general practical operations performed by the students, standard series of lectures are given daily, such lectures being of course relevant only to the subject matter of the course concerned. These talks are, when considered necessary, amplified by lantern slides. To keep abreast of modern developments, and to ensure that the training facilities are adequate, the school apparatus and equipment is kept up-to-date and in proper working order.

Every endeavour is made to promote a happy and contented feeling among the students, as well as the staff. The lodging accommodation for the trainees demands special attention and control; only approved addresses are kept on the school's official list. Although the school's accommodation does not boast of any playing fields, every effort is made to provide some recreation during break periods. The staff and students have separate recreation rooms in which games of various kinds may be played, the cost of such games being met from the school canteen funds. Library books are also provided for the students' benefit, and all kinds of technical books are available for staff and students.

Owing to the recent restrictions it has been deemed necessary to curtail a certain amount of the Birmingham Regional School's activities, but it is hoped, that in the near future, the position will again improve.

H. C.

UNUSUAL DAMAGE BY LIGHTNING

During a severe thunderstorm in the Rcester, Staffordshire, exchange area at 5.45 p.m., 1st July, 1938, a local route consisting of two cad. cu.40 lb. wires on twenty 24 ft. L poles with swan neck spindles, and insulators No. 2 was damaged. The damage was of such a nature that it is thought the details may be of general interest.

The spur route is some $\frac{3}{4}$ miles in length and runs along a narrow country lane with tall trees dotted along each side at short intervals. The trees overhang the route in many places. In a few places the wires pass between the branches of a tree. There is a dip in the road between Morrey House Farm near pole 13 and Havenhouse Farm, Sub. 47. The distance between the two farms is approximately 500 yards. The whole of this road runs along a ridge some 400 yards above sea level which overlooks the village of Rcester and the River Dove in the valley below.

During the storm an elm tree opposite pole No. 11 was struck and a strip of the bark running from the top to the bottom, on the field side remote from the road and the telephone route, was ripped away near the top, the lower portion being blackened.

The lightning apparently struck the line at pole 11. A portion of the discharge took the direction towards the main Rcester-Marston road. Near the cross roads where this spur route joins the main road are two power crossings, one on the main road towards Rcester one span distant from the junction pole. The terminal block and cable on this side of the power crossing were damaged and had to be renewed. Similarly on the Roston road there is a power crossing three spans away from the junction pole. Here again the terminal block and cable on the pole nearer to the junction pole were damaged and had to be renewed. The wire in the spans from the junction pole to pole 5 on the subscribers' spur route was annealed and sagged. It had to be renewed. Between

poles 5 and 11 the wire fused into lengths varying from 6 inches to 2 feet. In many places pieces were picked up in which the two wires were firmly welded together along their whole length without any apparent deformation of their circular section.

At pole 11, opposite the elm tree which was damaged, the two wires to a length of some five feet were welded together and then curled round the pole in a spiral with turns spaced about 12 inches. From pole 11 the major portion of the discharge appears to have travelled to pole 20 and so to earth at Havenhouse Farm.

Mr. Clamp, Farmer, of Morry House Farm, the only man to see the phenomenon, described how the lightning travelled along the wires into the dip and up to Havenhouse Farm where it ended in a big flash followed by smoke and flames which obscured the whole of the farm from his view. He states that the lightning hissed along the wires between the poles. As it reached a pole it disappeared for a fraction of a second to re-appear travelling beyond to the next pole and so on to Havenhouse Farm.

The wire was a long bright line for a brief interval. The hedgerow then lit up and smoked as though the whole of the hedge was on fire. This was apparently due to the hot wire falling on to the damp trees. Since the storm Mr. Clamp has, while haymaking in the fields alongside the route, found a large number of short pieces of wire welded together and curled up into peculiar shapes. In one or two cases the binders, holding a short piece of melted wire, were still on the insulators, which had been discoloured.

At Havenhouse Farm the protector H.C. & F.2/2 was badly damaged. The tops of the two insulators No. 16 were cut clean away, the cable lead was burnt and the lead sheath splashed on to the windows. The earth wire was fused and the receiver earpiece and diaphragm cut clean away.

A radio set and an electric kettle standing on a dresser near to the telephone were both burnt out. C.L.T.

BIRMINGHAM SERVICE P.A.B.X.

On October 24th a P.A.B.X. to serve the telephones in the Birmingham Telephone Manager's Office was brought into service. The equipment installed is of the partial secondary linefinder system with a three digit numbering scheme and access to the Birmingham director system network. The following schedule gives details of the facilities provided :—

Allocation of 1st Selector Levels.

Level 2	} P.A.B.X. extensions ; initial equipment—400 lines.
Level 3	
Level 4	
Level 5	
Level 7	Service P.M.B.X., Superintending Engineer's Offices, Shrewsbury.
Level 8	Trunks.
Level 9	1st code Selectors on Birmingham Central Automatic Exchange.
Level 0	P.A.B.X. Manual Board.
Levels 1 & 6	Spare.

The circuits to Shrewsbury are bothway, with direct access from the P.A.B.X. manual board, and auto-signalling in both directions as far as the manual boards are concerned.

Six manual positions have been provided ; these are located in the Toll enquiry suite and are of the sleeve control type.

Prior to the opening of the P.A.B.X. the whole of the service lines in Birmingham, including those of the Postmaster-Surveyor's staff were terminated on a joint P.M.B.X., located on spare positions at Colmore exchange. Owing to the abnormal growth of the number of exten-

sions, it has not been possible to convert the Postmaster-Surveyor's lines to auto. working and these are still being worked on a manual basis at Colmore, pending the extension of the P.A.B.X. Intercommunication between the manual and auto-extensions is carried out over transfer circuits between the two P.B.X.'s, incoming calls to the manual extensions being routed via the P.A.B.X. manual board, since the introduction of separate telephone numbers for directory purposes would possibly have led to some confusion amongst that section of the public who have occasion to make calls to the Department.

The telephone number of the Service P.B.X.'s, is G.P.O. 3311. Incoming traffic is routed to the P.A.B.X. manual board via level 33 on the second numerical selectors of Central automatic exchange which is also located in Telephone House, the same director translation being used as for Central. Calls incoming via Trunks and Toll are extended to the P.A.B.X. manual board over transfer circuits, the P.A.B.X. operators completing all incoming calls to auto-extensions by dialling in to 1st numerical selectors.

An extension of the P.A.B.X. is being put in hand during 1939 and will increase the equipment to 800 lines ; this extension also covers the conversion to a four digit numbering scheme as far as intercommunication between extensions is concerned, access to the Birmingham Director system remaining as at present, while direct communication with extensions will be possible from outside telephones by dialling G.P.O. followed by the extension number, thus eliminating a considerable amount of manual board traffic.

TIM.

The speaking clock time service was introduced in the Birmingham Area on November 4th. The introduction was marred to some extent by a major failure of the public electric supply in the evening which put the service *hors de combat*, as the amplifying equipment is supplied direct from the mains.

The service is proving very popular ; over fifty thousand calls were recorded during the first week, including 4,600 calls made between 8.0 a.m. and 11.0 a.m. on Armistice Day.

CHEADLE EXCHANGE CONVERSION

The 1938/39 U.A.X. programme was brought a step nearer completion on October 26th, 1938, with the conversion of Cheadle exchange from C.B.S. to U.A.X. 7 working.

A total of 169 D.E.L.'s ; 1 C.B. line and 18 junctions were successfully changed over. The junctions are as follows :—

Stoke-on-Trent (Main)	Parent exchange	7 B/W, 1 I/C
Ipstones (U.A.X. 12)		4 B/W
Oakmoor (C.B.S.2)		2 B/W
Blythe Bridge (C.B.S.2)		2 B/W
Leek (C.B.10)		2 B/W

The Cheadle exchange is equipped with the following units 2-7A ; 2-7B ; 2-7D ; 1-7E. Power is obtained from 2 batteries of 250 ampere-hours charged by a tungar rectifier. A traffic recorder is installed.

Correct conditions as regards air and temperature are obtained by means of a Humidistat and tubular electric heaters.

Cheadle subscribers have access to the Stoke-on-Trent multi-Office area by dialling 9.

958 gives access to Silverdale (Magneto)

956 gives access to Kidsgrove (Magneto)

957 gives access to Endon (U.A.X.7)

Calls from the Stoke area to Cheadle pass via the auto manual board.

Scottish Region

TELEPHONING THE OUTER HEBRIDES

To many readers of this JOURNAL the Outer Hebrides will probably mean nothing more than a group of rocky islands located somewhere in the Atlantic Ocean, off the west coast of Scotland. They will think of these islands as tenanted by crofters and fisherfolk living a simple life and often completely isolated from the mainland. Perhaps however, these islanders have been neglected in the past, but the introduction of an air service and shortly of telephone service to the mainland will render their isolation one of space rather than of time.

The development within recent years of ultra-short wave radio links has made it practicable for the Post Office to embark on a communication scheme which would otherwise have been impossible on economic grounds. Such a scheme is not without its problems from an engineering point of view. Difficulties of design have now, however, been overcome and the actual work in the field commenced.

The scheme is based on the provision of tandem radio links Oban-Tobermory and Tobermory-Castlebay, extended on the mainland to Glasgow in the new Glasgow-Oban trunk cable, and northwards in the islands by submarine cables and overhead lines.

The radio and power buildings have been designed within the Region and are in course of erection. One would hardly realise in these days of highly developed mechanical transport that the builders have found it necessary to employ horses either carrying the bricks in panniers (Fig. 1) or hauling primitive sleds over the peaty hills.

The shipment of the very large quantity of poles and



FIG. 1.—HORSES CARRYING BRICKS TO SITE.



FIG. 2.—UNLOADING POLES AT BARRA.

line stores, together with vehicles, presents its own problems as the provision of the land lines on the islands involves the erection of about 50 route miles of overhead line built to stand against the full force of Atlantic gales. Moreover it will be necessary, possibly for the last time, for the construction staff to undertake the building of heavy main line trunk routes with "A" poles. The first shipment of 80 tons of poles had its adventures. Leaving Glasgow in the steamer "Kyle Rona" on October 24th, and after calling at Tobermory, Mull, where a few poles were left for the wireless arrays, the ship battled her way against a strong westerly gale to Barra, and all went well until the evening of the 31st. when, leaving her berth to allow the regular island steamer to call, the trouble began. The force of the gale caused the vessel to drag her anchors and as a result a sleepless night was spent by the crew, together with the crew of the Castlebay lifeboat and probably the entire population of the island watching her bounce like a cork and finally ground on the Castle rocks—the ancestral home of the MacNeills of Barra. It was not until the following day that she was again safely berthed and the remainder of the poles unloaded. (Fig. 2).

The linking up of the various islands has involved the laying by the cable ship "Monarch" of two 4-core submarine cables, and the Scotland West Area has yet to accomplish the crossing of the North and South Fords, which separate North Uist, Benbecula and South Uist.

It will be appreciated from the foregoing remarks that before the last wire is bound in many of the engineers will have made stormy crossings either by air or sea and perhaps have been storm-stayed for days, completely out of touch with Headquarters and home.

Book Reviews

"Engineering Electronics." D. G. Fink. 385 pp. 217 Ill. McGraw-Hill. 21s.

The author of this work is the Managing Editor of the American periodical "Electronics" and the book is stated to be written to meet the needs of the practising engineer who has a good foundation in electricity, but who has no specific training in electronic concepts and methods. The material in the book was originally collected for a lecture course to members of the Westinghouse Lamp Co.

The book is divided into three sections, Physical Electronics, Electron Tubes, and Electron Tube Application. The first section deals with the fundamental properties of the electron and the theoretical principles of thermionic and gaseous discharges. The second section deals with the practical design of thermionic vacuum tubes, gas filled thermionic electron tubes, photo-sensitive tubes and cells and specialised electron tubes. Part three deals with the elements of circuit theory applied to electron tubes, power transformation circuits such as rectifier and inverter circuits (mutators), electronic communication circuits and finally industrial control and measurement circuits.

A useful feature with each chapter is a bibliography and a selection of problems to which numerical answers are given. The book is not highly mathematical and mathematics is included only where the proper elucidation of subject demands it.

For the purpose for which it was written, viz, the general education and training of workers engaged on the manufacture of electronic devices the book appears admirably adapted as it covers the field of theory and practice sufficiently and without too much detail.

The book is also likely to be of use to the student and engineer interested in electronic applications. A. J. G.

"Telephony." Vol. 2 (Automatic Telephony). T. E. Herbert, M.I.E.E. and W. S. Proctor, A.M.I.E.E. 738 pp. Ill. Pitman. 20s.

This is the second volume of two which are designed together to give, in the authors' words, a detailed exposition of the telephone system of the British Post Office. The first volume dealt with manual switching systems and line plant while the volume now under review deals with automatic telephony.

The work is confined almost entirely to systems in use by the British Post Office, but a general description is provided in chapters 15 and 16 of certain other types of equipment.

The book does not deal with electrical principles, which are covered in the first volume, although the principles of relay operation and design are dealt with in some detail, certain of the fundamental matter being repeated from the earlier volume.

All the main types of automatic exchange equipment in use in this country—director, non-director, Siemens' No. 16 and U.A.X.'s—are described in detail and there are chapters on subscribers' apparatus, power plant, trunking and grading, and maintenance. Coded call indicator working and intercommunication between automatic and manual exchanges are dealt with.

The book has been compiled with great care, and contains a large amount of up-to-date information on the

Post Office system. It seems a pity, however, that the description of what is now the standard type of two-motion switch in use by the Post Office should have been relegated to an appendix. The description given is a reasonably full one as regards the selector, but certain features of circuit operation associated with the introduction of this switch might, with advantage, have been treated.

The chapter on power plant has been brought up to date by the addition of an appendix covering the newer plant now being introduced. The value of this portion of the book would be enhanced if the description of the modern arrangements could have appeared in the text.

There is a very large number of illustrations and diagrams which have been carefully prepared. Although some of the standard graphical symbols for telephony appear as an appendix, it is noted that these standards are not by any means universally used in the circuit diagrams in the text.

In the section on ringing machines, the commutator method of generation of tones is still described, without any reference to the inductor type machines which are now standardised.

The authors are to be congratulated on having brought together in one volume much information not hitherto accessible in this form. The work should prove extremely valuable to students of telephony and communication engineers, especially those interested in the British Post Office system. J. L.

"Radio Frequency Electrical Measurements." H. A. Brown, M.S., E.E. 384 pp. 177 Ill. McGraw-Hill. 2nd Edition. 24s.

This book is intended by the author to serve as a manual for the radio engineer and the experienced amateur. The present edition departs from the old in that exact instructions for the procedure to be followed in making the more difficult measurements are given.

The author in his preface disclaims any attempt to write a comprehensive treatise but claims that many important methods and techniques necessary in practical and research engineering are covered. The book reasonably fulfils the claims made for it and is a fairly comprehensive guide to laboratory technique, covering circuit constants, frequency, antennae, lines, fields, e.m.f., current and waveform.

A useful feature of the book is the inclusion of a paragraph in each description of the precision of measurements. This is a very important point frequently overlooked or avoided in text books on measurements.

It was noticed that the author attributes too high a sensitivity to the Dudell Thermo Galvanometer. In the description of the determination of the value of capacitance necessary to produce resonance in a circuit at a fixed frequency the author suggests taking the average of two values of capacitance giving equal currents on opposite side of the resonance curve; this procedure is not strictly correct although the error introduced is small in the case of low decrement circuits.

These are rather trivial points and on the whole the book is reasonably free from errors and can be well recommended. A. J. G.

Staff Changes

Promotions.

Name	District	Date	Name	District	Date
<i>From T.M. to C.R.F.</i>			<i>From Insp. to Chief Insp.—(continued)</i>		
Scutt, W. D.	N.E. Reg.	1.12.38	West, V. A.	N.E. Reg.	30.10.38
<i>From A.S.E. to S.E.</i>			Hannah, W. W.	S. Lancs.	28.10.38
Fulcher, H. W.	E.-in-C.O.	19.9.38	Gill, E. S. A.	E.-in-C.O.	To be fixed later
Radley, W. G.	E.-in-C.O.	1.1.39	Wilkinson, E. H.	E.-in-C.O.	13.10.38
<i>From Ex. Engr. to T.M.</i>			Everson, W. E.	Eastern	To be fixed later
Bentlett, W. J.	E.-in-C.O. to Middlesbro'	To be fixed later	Moody, W. R. N.	E. to E.-in-C.O.	To be fixed later
Owen, J. M.	N. Mid. to Peterboro'	do.	Farnworth, W. R.	N.W. to N.E.R.	To be fixed later
Chinn, W. E.	E.-in-C.O. to Tun. Wells	do.	Lowry, W. R. H.	E.-in-C.O.	1.11.38
Bewick, W.	N. Mid. to Coventry	do.	Burdick, C. A. R.	L.T. Reg.	28.10.38
Beard, A. T. J.	N. West to Preston	do.	Clarke, G. E.	E.-in-C.O.	1.11.38
<i>From Asst. Engr. to Ex. Engr.</i>			Kidd, C.	Rugby R.S to E.-in-C.O.	To be fixed later
Snell, W. S.	E.-in-C.O.	1.9.38	Sayers, C. F.	E.-in-C.O.	1.11.38
Stollard, A. E.	N. Wales	1.1.39	Gray, G.	E.-in-C.O.	1.11.38
Lister, B.	S. Eastern	1.9.38	Pitham, S.	E.-in-C.O.	1.11.38
Hargreaves, T.	E.-in-C.O. to N.W.	To be fixed later	Shrubsall, F. W.	E.-in-C.O.	To be fixed later
Brett, S. I.	L.P. Reg.	28.2.39	Morris, T. G.	E.-in-C.O.	1.10.38
Affleck, D. B.	N. Midland	To be fixed later	<i>From Asst. Physicist or Asst. Chemist to Phys. or Chemist</i>		
Pearson, A. W. C.	L.T.R. to E.-in C.O.	1.10.38	Shuter, F. C.	T.S. B'm.	29.9.38
Pate, H. S.	S.E. to N. Ire.	3.10.38	Rayner, L. W. W.	T.S. Ldn.	To be fixed later
Smith, V.	S. Mid. to (location to be fixed later)	To be fixed later	<i>From S.W.1. to Insp.</i>		
Boocock, R. O.	Eastern	10.9.38	Donahue, C. P.	Rugby	5.8.38
Knox, A. H. C.	S. Lancs. to L.T.R.	1.9.38	Styles, H. H.	L. T. Reg.	1.6.38
Tobin, W. J. E.	L.T. Reg.	1.9.38	Bendy, D.	L.T. Reg.	20.6.38
Leigh, H.	E.-in-C.O.	1.9.38	Squire, F. H.	L.T. Reg.	25.6.38
Cook, A.	E.-in-C.O.	1.9.38	Rogers, T.	L.T. Reg.	1.6.38
Caveley, C. E.	E.-in-C.O.	1.9.38	Bloss, B.	L.T. Reg.	27.5.38
Pitcairn, A. C.	E.-in-C.O. to N.Wa.	1.10.38	Rawlings, J. E.	N.E. Reg.	20.8.38
Mead, F. C.	E.-in-C.O.	1.9.38	Clewer, R. W. H.	N. Midland	2.1.38
Chapman, R. H.	E.-in-C.O.	7.11.38	Parker, J.	N. Midland	15.7.38
Brockbank, R. A.	E.-in-C.O.	2.9.38	Sanders, F.	N. Midland	19.9.38
<i>From Chief Insp. to Asst. Engr.</i>			Cragg, A.	N. Midland	1.10.38
Collett, W. A.	E.-in-C.O. to S.E.	To be fixed later	Dickman, R. W.	N. Midland	24.7.38
Osborne, W. V.	E.-in-C.O.	1.10.38	Stanfield, J. W. W.	N. Midland	1.10.38
Thomas, C. F.	E.-in-C.O.	13.10.38	Joyce, A. C.	N. Midland	17.10.38
Lee, A.	T.S. Ldn. to T.S. B'm.	To be fixed later	Leney, W. H.	N. Midland	1.10.38
London, T. G.	E.-in-C.O.	13.10.38	Gardiner, E. R. B.	N. Midland	1.10.38
Smith, G. W*	S. Eastern	13.10.38	Lancaster, G.	N. Midland	19.9.38
Brown, A. H.	N. Midland	To be fixed later	Evans, E. G. P.	N. Midland	1.10.38
Hogbin, A.	E.-in-C.O.	7.11.38	Rawson, J. R.	N. Midland	22.8.38
Proctor, F. H.	E.-in-C.O.	13.10.38	Syson, J. J. H.	N. Midland	21.11.38
Sharpe, H. T. A.	L.T.R. to E.-in-C.O.	28.10.38	Connor, J. R.	N. Ireland	19.4.38
Owne, W.	S. Lancs.	28.10.38	Prujean, J. E.	S. Wales	19.4.38
Britton, G. A. C. R.	E.-in-C.O.	9.11.38	Marks, J. S.	S. Wales	8.8.38
Loveday, T. C.	Eastern	To be fixed later	Knight, T.	S. Western	15.10.38
Broadhurst, S. W.	E.-in-C.O.	9.11.38	Mills, F. C.	S. Western	20.1.38
Roy, D. W.	Sc.R. to E.-in-C.O.	1.12.38	Thomas, E. L.	S. Western	19.4.38
Smith, R. C.	S. Western	1.1.39	Wensley, A. J.	S. Western	3.7.38
Lewis, C. H.	S. Western	1.1.39	Cross, R. J.	S. Western	30.10.38
Johnstone, W. S.	Cooling R.S.	15.11.38	Plummer, W. H.	S. Western	19.4.38
Brown, E. P.	E.-in-C.O.	29.11.38	Berry, A. F.	S. Western	2.10.38
Hawkins, C. F. W.	L.T.R. to E.-in-C.O.	To be fixed later	Atkins, H. C.	S. Western	20.10.38
*Indicates C.I. with allowance.			Pike, G. G.	Test. Sec.	7.8.38
<i>From C.I. to C.I. with allowance</i>			Dunning, W. H.	S. Lancs.	1.9.38
Cornish, G.	S. Eastern	To be fixed later	Howson, S. A. G.	S. Eastern	To be fixed later
<i>From Insp. to Chief Insp.</i>			Young, R. A.	S. Eastern	To be fixed later
Dixon, J.	N.W. to N.Wa.	1.9.38	Briscoe, H. R.	S. Lancs.	6.11.38
Holder, T. G.	N. Midland	To be fixed later	Smith, J. L.	E.-in-C.O.	1.11.38
Dommett, S. G.	N.E. Reg.	25.9.38	Vickery, F. D.	Test Secn. Ldn.	4.9.38
			Fay, H.	E.-in-C.O.	1.11.38
			Loveless, E. R.	E.-in-C.O.	1.11.38
			Hobbs, J. G.	E.-in-C.O.	1.11.38
			Thurlow, E. W.	E.-in-C.O.	1.11.38
			Wright, A.	E.-in-C.O.	1.11.38
			Moss, R.	E.-in-C.O.	20.7.38
			Thomas, R. A.	E.-in-C.O.	1.11.38
			Carter, G. G. F.	E.-in-C.O.	24.9.38

Promotions—continued.

Name	District	Date	Name	District	Date
<i>From S.W.1 to Insp. (continued)</i>			<i>From S.W.1 to Insp. (continued)</i>		
Evans, F. C. M. N.	E.-in-C.O.	18.6.38	Mitchell, A.	E.-in-C.O.	24.7.38
Bliss, S. W.	E.-in-C.O.	2.7.38	Berry, J.	E.-in-C.O.	1.9.38
Goodfellow, J. J.	E.-in-C.O.	17.7.38	Mangan, D. P.	E.-in-C.O.	21.8.38
Frost, P. C.	E.-in-C.O.	1.9.38	Ogden, R. S. I.	E.-in-C.O.	30.10.38
Stenning, F. A.	E.-in-C.O.	1.10.38	Organ, E. C. H.	E.-in-C.O.	11.11.38
Phillips, M. W.	E.-in-C.O.	22.9.38			
Gent, P. E.	E.-in-C.O.	22.9.38	<i>From U.S.W. to Insp.</i>		
Bishop, J. F.	E.-in-C.O.	22.9.38	Jones, P. F.	E.-in-C.O.	16.9.38
Robinson, H.	E.-in-C.O.	22.9.38	Booth, G. F.	E.-in-C.O.	20.9.38
Gibbs, C. H.	E.-in-C.O.	1.11.38	Cowan, R. T. B.	E.-in-C.O.	20.9.38
Jacob, J. A.	E.-in-C.O.	2.10.38	Howcroft, F. W.	E.-in-C.O.	16.9.38
Connell, D. R. W.	E.-in-C.O.	1.11.38	Seager, E. G.	E.-in-C.O.	20.9.38
Didcock, F. T.	E.-in-C.O.	1.11.38	Dilworth, R. A.	E.-in-C.O.	16.9.38
Secker, C. E.	E.-in-C.O.	1.11.38			
Eltringham, G. C.	E.-in-C.O.	1.11.38	<i>From Draughtsman Cl. II to Insp.</i>		
Clark, S. J.	E.-in-C.O.	1.11.38	Forrester, H.	N.E. Reg.	1.9.38
Robbins, R. A. D.	E.-in-C.O.	4.10.38			
Hume, T.	E.-in-C.O.	2.10.38	<i>From Asst. Cable Foreman to Cable Foreman</i>		
Howse, J. L.	E.-in-C.O.	2.10.38	Smith, W.	H.M.C.S. Alert	6.8.38
Walters, J. J. H.	E.-in-C.O.	To be fixed later			
Smith, R. G. T.	E.-in-C.O.	do.	<i>From Seaman Cable Hand to Asst. Cable Foreman</i>		
Pendreich, I. A.	Sc.R. to E.-in-C.O.	do.	O'Beirne, H. W.	H.M.C.S. Alert	6.8.38
Nottingham, L. C.	Rugby	do.			
Abbott, H. F.	E.-in-C.O. to Cooling R.S.	do.			

Transfers

Name	District	Date	Name	District	Date
<i>Exec. Engr.</i>			<i>Chief Insp.</i>		
Swift, R. E.	S.E. to E.-in-C.O.	18.9.38	Johnson, J. P.	E.-in-C.O. to S.E.	21.10.38
			Johnstone, W. S.	E.-in-C.O. to Cooling R.S.	1.11.38
<i>Asst. Engr.</i>			<i>Insp.</i>		
Pearce, C. A. R.	E.-in-C.O. to L.T.R.	28.9.38	Thirsk, R. D.	E.-in-C.O. to N. Wa.	2.10.38
			Long, W. J.	S.Wa. to S.W.	16.10.38
			Granger, S. B.	S.E. to E.-in-C.O.	23.10.38
			Walker, W. A.	E.-in-C.O. to N.E. R.	20.11.38

Appointments

Name	District	Date	Name	District	Date
<i>Proby. Asst. Engr.</i>			<i>Proby. Asst. Engr. (continued)</i>		
Goodwin, A. E.	Trg. Sch.	12.9.38	Phillips, S. A.	Trg. Sch.	26.9.38
Collins, P. T.	Trg. Sch.	29.9.38	Knox, J.	Scot. Reg.	7.11.38
Bickley, H. D.	Trg. Sch.	26.9.38			

Retirements

Name	District	Date	Name	District	Date
<i>Supt. Engr.</i>			<i>Asst. Engr.</i>		
Brocklesby, C.	N. Western	31.8.38	Winstone, E. J. N.	E.-in-C.O.	31.10.38
			Siddle, W. H.	N.E. Reg.	30.9.38
<i>Asst. Supt. Engr.</i>			<i>Chief Insp.</i>		
Osborn, W. M.	Eastern	2.10.38	Chambers, L. W.	S. Midland	14.11.38
<i>Exec. Engr.</i>			<i>Insp.</i>		
Atkins, W.	N. Wales	30.9.38	Chapman, E. A.	S. Eastern	25.9.38
Gean, W. J.	L.T. Reg.	30.9.38	Ryan, J. R.	E.-in-C.O.	29.9.38
			Bell, J.	S. Lancs.	11.9.38
			Morgan, S. J. W.	L.T. Reg.	13.11.38
			Mills, W. W.	S. Eastern	1.9.38

Deaths

Name	District	Date	Name	District	Date
<i>Ex. Engr.</i>			<i>Insp.</i>		
Meek, L.	E.-in-C.O.	11.11.38	Fox, L. A.	E.-in-C.O.	16.9.38
			Ross, T. C.	Eastern	29.9.38
			Wilcock, J.	E.-in-C.O.	11.11.38
<i>Asst. Engr.</i>					
McGregor, A.	E.-in-C.O.	5.9.38			
Oman, G. R.	E.-in-C.O.	6.11.38			

Resignation

Name	District	Date	Name	District	Date
<i>Proby. Insp.</i>					
Percival, F. V.	N. Western	30.11.38			

BOARD OF DIRECTORS

P. J. RIDD, M.I.E.E., Chairman.
 G. F. O'DELL, B.Sc., M.I.E.E.
 F. E. NANCARROW, A.R.C.Sc., M.I.E.E., M.Inst.R.E.
 P. B. FROST, B.Sc., M.I.E.E.
 A. H. MUMFORD, B.Sc.(ENG.), A.M.I.E.E.
 C. W. BROWN, A.M.I.E.E.
 J. STRATTON, A.M.I.E.E.
 J. READING, B.Sc.(ENG.), M.I.E.E., Managing Editor.
 H. LEIGH, B.Sc.(ENG.), A.M.I.E.E., Assistant Editor.

Copyright

The entire contents of this JOURNAL are covered by general copyright, and special permission is necessary for reprinting long extracts, but Editors are welcome to use not more than one-third of any article, provided credit is given at the beginning or end thus: "From the *Post Office Electrical Engineers' Journal*."

The Board of Editors is not responsible for the statements made or the opinions expressed in any of the articles in this JOURNAL, unless such statement is made specifically by the Board.

Communications

All Communications should be addressed to the Managing Editor, *P.O.E.E. Journal*, Engineer-in-Chief's Office, Alder House, Aldersgate Street, London, E.C.1. Telephone: NATIONAL 6321. Remittances should be made payable to "*The P.O.E.E. Journal*" and should be crossed "& Co."

Binding Cases

Cases for binding are available, and may be obtained from the Local Agents for 1s. 9d. Subscribers can have their copies of Volumes bound, at a cost of 3s., by sending the complete sets of parts to the Local Agents or to the *P.O.E.E. Journal*, Engineer-in-Chief's Office, Alder House, Aldersgate Street, London, E.C.1. Orders for binding for Vols. 1-19 should indicate whether the original binding case with black lettering, or the later pattern with gold, is required. Cases with gold lettering will be the only type stocked from Vol. 20 onwards.

Back Numbers

The price of the JOURNAL, which is published quarterly, is 1s. (1s. 3d. post free) per copy, or 5s. per annum post free. Back numbers can be supplied, subject to availability of stocks, at 1s. each (1s. 3d. post free). Orders for back numbers may be sent to the Local Agents or to the Publishers.

Advertisements

All communications relating to space reservations should be addressed to the Advertisement Editor, *P.O.E.E. Journal*, Alder House, Aldersgate Street, London, E.C.1. Communications regarding advertisement copy, proofs, etc., should be addressed to the Publishers, Messrs. Birch & Whittington (Prop. Dorling & Co. [Epsom], Ltd.), Station Road, Epsom, Surrey.

Post Office Electrical Engineers' Journal

Volume XXXI, April 1938—March 1939

INDEX

	PAGE NO.		PAGE NO.
A			
Anson, B. O., Retirement of	150	Endecott, A. H., and A. G. Freestone. Post Office Pavilion at the Empire Exhibition, Bellahouston Park	85
Application of a Constant Volume Amplifier to a Short Wave Single Sideband Transatlantic Radio Circuit, The	104	European Trunk Switching Plan, Echo Effects in relation to the	16
Arman, L. T., and P. R. Hutton-Penman. The Application of a Constant Volume Amplifier to a Short Wave Single Sideband Transatlantic Radio Circuit	104	F	
Australian Commonwealth Communications	62	First London-Birmingham Cable, The	147
Automatic Exchange Developments in South Africa: Automatic Repeat Metering	216	Freestone, A. G., and A. H. Endecott. Post Office Pavilion at the Empire Exhibition, Bellahouston Park	85
B			
Baldwin, F. G. C., Retirement of Mr.	311	Fulcher, H. W., Promotion to Staff Engineer	312
Barker, H., and M. R. Shearing. Telephone Communications with the Scilly Islands	101	G	
Beale, C. E. Automatic Exchange Developments in South Africa: Automatic Repeat Metering	216	Gerry, P. R. An Electric Wax Heater	225
Beastall, J. G. Bristol Station Sorting Office Conveyors	117	Gill, A. J. Promotion to Asst. E.-in-C.	151
Belfast-Stranraer Cable Carrier System, The	23	Gray, W. D. From Satellite to Main Exchange	271
Belfast-Stranraer 9-Circuit Ultra-Short Wave Radio Telephone System, The	33	H	
Board of Editors	84, 166, 244, 330	Haliburton, F. C. The Treatment of Displaced Plant in Engineering Economic Cost Comparisons	221
Book Reviews	68, 79, 224, 229, 241, 304, 327	Halsey, R. J., and D. C. Tucker. The Provision of Music Channels on 12-Channel Carrier Cables	280
Booth, C. F., and C. F. Sayers. The Production of Quartz Resonators for the London-Birmingham Coaxial Cable System	245	Hand Microtelephone and Bell Set, The New Combined	1
Bristol Station Sorting Office Conveyors	117	Harris, L. H. Promotion to Suptg. Engineer	67
Broad, E. R., and H. Stanesby. Channel Filters employing Crystal Resonators	254	Harrison, G. B. W., and A. Miller. A New 54-way Duct Route in Central London	142
Brocklesby, C., Retirement of Mr.	231	Haward, R. C. Somerset House P.A.B.X.	137
Brown, H. P. Australian Commonwealth Communications	62	Henk, A. J. C., and W. Clayton. The Unit Automatic Exchange No. 14	41
C			
Carter, F. C., and C. G. A. McDonald. Electrical Services in Large Buildings	183	High Speed Cinematography	293
Channel Filters Employing Crystal Resonators	254	History and Development of the 30-cwt. Utility Vehicle, The	12
Cinematography, High Speed	293	Hutton-Penman, P. R., and L. T. Arman. The Application of a Constant Volume Amplifier to a Short Wave Single Sideband Transatlantic Radio Circuit	104
Clayton, W., and A. J. C. Henk. The Unit Automatic Exchange No. 14	41	I	
Coaxial Cable System, The London-Birmingham	51, 132	Impulsing in Non-Director Areas, The Problems Associated with	191
Cohen, B. S., Retirement of Captain	310	Institution of Post Office Electrical Engineers	69, 154, 232
Cooper, W. H. B. A Differentiated Impulse System of Dialling over Long Junctions	108	International Conferences	204
Concrete, Sulphate Attack on	265	Introduction of Ultra-Short Wave Radio Links into the Telephone Network, The	93
Constant Volume Amplifier, Application to a Short Wave Single Sideband Transatlantic Radio Circuit	104	J	
Cornfoot, T., Retirement of Mr.	153	Jenkins, I. H., Retirement of Mr.	231
Crystal Resonators, Channel Filters employing	254	Jones, R. E., and L. E. Ryall. A Stabilised Repeater and its Application to Trunk Circuits	126
Cullum, J., and E. C. C. Stevens. Noise and Treatments for its Reduction in Telephone Exchange Manual Switchrooms	57	Junior Section Notes	71, 156, 233, 314
D			
Differentiated Impulse System of Dialling over Long Junctions, A	108	L	
District Notes	73, 157, 235, 318	Ladder Derrick for Overhead Work, The	267
Duddell Oscillograph, The Study of Small Mechanical Movements with the	112	Legg, Capt. J., Promotion to Staff Engineer	230
E			
Echo Effects in relation to the European Trunk Switching Plan	16	Little, G. J. S., Promotion to Superintending Engineer	230
Electric Wax Heater, An	225	Local Centre Notes	70, 154, 232, 313
Electrical Services in Large Buildings	183	London-Birmingham Cable, The First	147
Empire Exhibition, Bellahouston Park, Post Office Pavilion at the	85	London-Birmingham Coaxial Cable System, The	51, 132
M			
		Lynes, F. A. Simple Transmission Theory relating to the Matching of Radio Feeder Lines	210
		M	
		McDonald, C. G. A., and F. C. Carter. Electrical Services in Large Buildings	183
		McGregor, J. E. Pneumatic Despatch Tubes—Their Economics and Uses	64

	PAGE NO.		PAGE NO.
McMillan, D. A Method of Equalising the Frequency Characteristic of a Telephone Transmitter	299	Shearing, M. R., and H. Barker. Telephone Communication with the Scilly Islands	101
" The Telephone Transmitter: A Suggested Theory of Operation	167	Simple Transmission Theory relating to the Matching of Radio Feeder Lines	210
Method of Equalising the Frequency Characteristic of a Telephone Transmitter, A.	299	Slewing and Lowering existing Ducts and Cables	201
Miller, A., and G. B. W. Harrison. A New 54-way Duct Route in Central London	142	Somerset House P.A.B.X.	137
Mirk, D. B. The Belfast-Stranraer 9-Circuit Ultra-Short Wave Radio Telephone System	33	Soons, A. T. Slewing and Lowering existing Ducts and Cables	201
Morgan, J., Promotion to Superintending Engineer	152	South Africa, Automatic Exchange Developments in: Automatic Repeat Metering	216
Morrish, H. E. Sulphate Attack on Concrete	265	Stabilised Repeater and its Application to Trunk Circuits, A	126
Multi-Fee Call Dialling and Registration at Non-Director Exchanges	5	Staff Changes	82, 162 242, 328
Mumford, A. H. The London - Birmingham Coaxial Cable System	51, 132	Statistical Theory applied to the Testing of Mass-Produced Articles	305
" " Promotion to Staff Engineer	152	St. Paul's Tube Station, The New	301
" " and D. A. Thorn. The Introduction of Ultra-Short Wave Radio Links into the Telephone Network	93	Stanesby, H., and E. R. Broad. Channel Filters employing Crystal Resonators	254
Music Channels	276	Stevens, E. C. C., and J. Cullum. Noise and Treatments for its Reduction in Telephone Exchange Manual Switchrooms	57
Music Channels on 12-Channel Carrier Cables, The Provision of	280	Study of Small Mechanical Movements with the Duddell Oscillograph, The	112
N			
New Combined Hand Microtelephone and Bell Set, The	1	Sudell, G. R., and F. Wilson. Multi-Fee Call Dialling and Registration at Non-Director Exchanges	5
New St. Paul's Tube Station, The	301	Subjective Methods, Telephone Transmission Testing by Sulphate Attack on Concrete	286 265
New 54-way Duct Route in Central London, A.	142	T	
Noise and Treatments for its Reduction in Telephone Exchange Manual Switchrooms	57	Taylor, F. J. D., and E. M. Richards. The Belfast-Stranraer Cable Carrier System	23
Notes and Comments	66, 150, 228, 310	Taylor, F. J. D. Music Channels	276
Notes, District	73, 157, 235, 318	Telephone Communication with the Scilly Islands	101
Notes, Junior Section	71, 156, 233, 314	Telephone Transmission Testing by Subjective Methods	286
Notes, Local Centre	70, 154, 232, 313	Telephone Transmitter, The: A Suggested Theory of Operation	167
P			
Palmer, R. W. High Speed Cinematography	293	Thorn, D. A., and A. H. Mumford. The Introduction of Ultra-Short Wave Radio Links into the Telephone Network	93
Parker, K. L. Statistical Theory applied to the Testing of Mass-Produced Articles	305	Timmis, A. C. Echo Effects in relation to the European Trunk Switching Plan	16
Pearce, C. A. R. The New Combined Hand Micro-telephone and Bell Set	1	Tolley, L. L., and W. A. J. Paul. The Photographic Recording of Subscribers' Meter Readings	207
Photographic Recording of Subscribers' Meter Readings, The	207	Townsend, E. H. The Study of Small Mechanical Movements with the Duddell Oscillograph	112
Pneumatic Despatch Tubes—Their Economics and Uses	64	Transmission Theory relating to the Matching of Radio Feeder Lines, Simple	210
Post Office Pavilion at the Empire Exhibition, Bellahouston Park	85	Transmitter, A Method of Equalising the Frequency Characteristic of a Telephone	299
Prescott, J. The New St. Paul's Tube Station	301	Transmitter, The Telephone: A Suggested Theory of Operation	167
Problems Associated with Impulsing in Non-Director Areas, The	191	Treatment of Displaced Plant in Engineering Economic Cost Comparisons, The	221
Production of Quartz Resonators for the London-Birmingham Coaxial Cable System, The	245	Trussler, H. The Ladder Derrick for Overhead Work	267
Provision of Music Channels on 12-Channel Carrier Cables, The	280	Tucker, D. G., and R. J. Halsey. The Provision of Music Channels on 12-Channel Carrier Cables	280
Q			
Quartz Resonators for the London-Birmingham Coaxial Cable System, The Production of	245	U	
R			
Radley, W. G., Promotion to Staff Engineer	312	Ultra-Short Wave Radio Links, Introduction into the Telephone Network	93
Richards, E. M., and F. J. D. Taylor. The Belfast-Stranraer Cable Carrier System	23	Unit Automatic Exchange No. 14, The	41
Robinson, R. T. The History and Development of the 30-cwt. Utility Vehicle	12	Utility Vehicle, The History and Development of the 30-cwt.	12
Rudeforth, S., and H. Williams. The Problems Associated with Impulsing in Non-Director Areas	191	W	
Ryall, L. E., and R. E. Jones. A Stabilised Repeater and its Application to Trunk Circuits	126	Walmsley, T. Wire Broadcasting	213
S			
Satellite to Main Exchange, From	271	Wax Heater, An Electric	225
Sayers, C. F., and C. F. Booth. The Production of Quartz Resonators for the London-Birmingham Coaxial Cable System	245	West, W. Telephone Transmission Testing by Subjective Methods	286
Scilly Islands, Telephone Communication with the	101	Williams H., and S. Rudeforth. The Problems associated with Impulsing in Non-Director Areas	191
Scutt, W. D., Promotion to Chief Regional Engineer	311	Wilson, F., and G. R. Sudell. Multi-Fee Call Dialling and Registration at Non-Director Exchanges	5
Semple, L. G., Promotion to Superintending Engineer	67	Wire Broadcasting	213
		Wood, P. T., Retirement of Mr.	153
		Wright, A., Retirement of Mr.	68

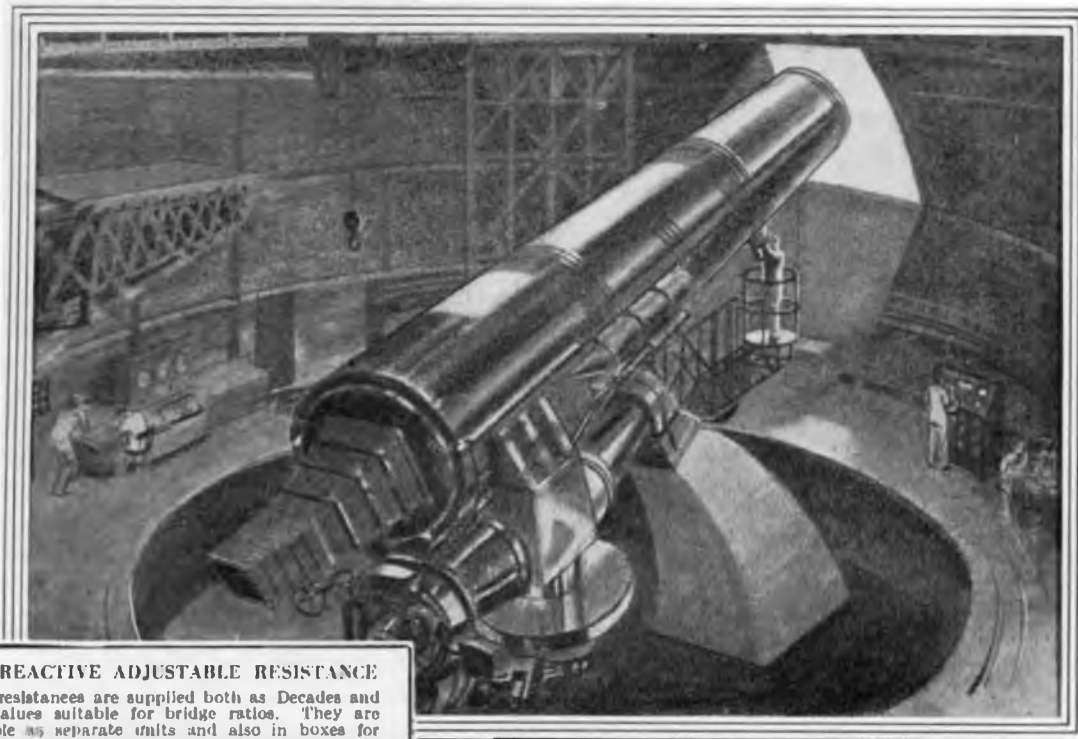

NON REACTIVE ADJUSTABLE RESISTANCE

These resistances are supplied both as Decades and with values suitable for bridge ratios. They are available as separate units and also in boxes for bench use.

- | | |
|--------------------------------------|--|
| 1. <i>Range.</i> | 0.1 ohm to 1 megohm. |
| 2. <i>Accuracy.</i> | ±0.1% above 1 ohm. |
| 3. <i>Frequency characteristics.</i> | Data on residual inductance is contained in our catalogue. |
| 4. <i>Screening.</i> | All units and boxes are completely screened. |
| 5. <i>Spindle.</i> | An insulated straight through spindle is fitted to provide for gangling. |



MUIRHEAD

We cannot say precisely!

When people ask us—"But exactly what do you make?"—it seems very inadequate to reply—"Well, it is difficult to be exact. Most of our products are concerned with communications, but we also do a great deal of other work." We can say, perhaps, that we undertake almost any kind of precision work that calls for the qualities we claim. Thus in 1887 we designed an Air Condenser for the British Association on Electrical Standards. Its capacity was 0.0031258 mfd. Three years later, after exhaustive tests to establish that this capacity remained constant, it was adopted as a standard. That was in 1887. Fifty years later we made an essential part of the control mechanism for one of the world's largest telescopes, now being installed at Pretoria University. How shall we set limits to what we will or will not undertake? The answer will be decided by what problems you ask us to solve. No matter whether it be electrical or mechanical, provided it demands a really high degree of precision, we shall make it for you if you ask us.

MUIRHEAD AND COMPANY LIMITED
ELMERS END, KENT. TELEPHONE: BECKENHAM 0041 0042

FOR OVER 60 YEARS DESIGNERS & MAKERS OF PRECISION INSTRUMENTS

C.R.C. 2

EDISWAN

TELEPHONE LINE PROTECTOR PANELS

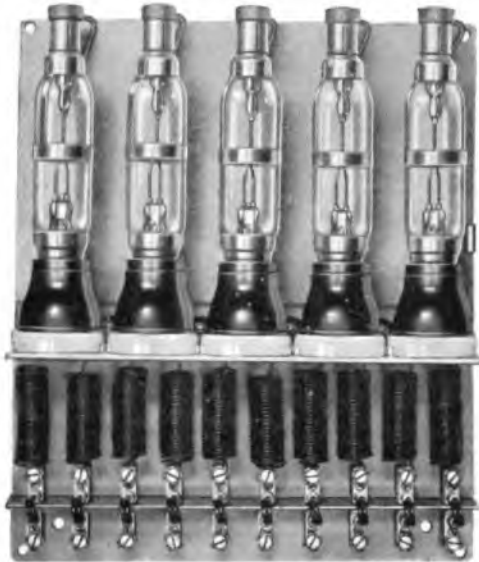

5-circuit panel for overhead lines incorporating choke coils, spark gaps, etc.

EDISWAN-SHOTTER-GREETHAM PATENT

(British Patent No. 353924)

for the protection of telephone systems against surges induced by faults on neighbouring power lines

Of the difficulties attendant upon the employment of overhead systems one of the most serious is to ensure uninterrupted working of the telephone system, by providing adequate protection against induced surges caused by switching or line faults in adjacent power lines or by lightning.

The Ediswan Patent Protectors provide the solution. They are inert at the normal working pressure of the telephone line, they keep the voltage on the line down to a pre-determined figure by providing a path of low resistance to earth whereby the surge is cleared and they again become inert immediately the surge is cleared.

They ensure simultaneous discharge of both lines and are capable of clearing heavy discharges without detriment to the system or the protector.

Ediswan Telephone Line Protectors have now been in use by Supply Companies for many years.

THE EDISON SWAN ELECTRIC CO. LTD.,  155 CHARING CROSS ROAD, LONDON, W.C.2

T.B.I.



TUNGSTONE

REGD. TRADE MARK

BATTERIES

PATENTED

Are being regularly supplied to the

GENERAL POST OFFICE

WAR OFFICE

AIR MINISTRY

MUNICIPAL CORPORATIONS

INTERNAL TELEPHONE SYSTEMS,
etc.

- Open or Enclosed types in Glass Containers.
- Large Capacities in Lead Lined Teak Boxes.
- **TUNGSTONE** High-pressure Die-cast Plates conform to British Standard Specification.
- **British Empire Lead** exclusively used.

TUNGSTONE PRODUCTS LTD.,
SALISBURY SQUARE, LONDON, E.C.4
Works: **MARKET HARBOROUGH, LEICS.**

G.E.C.



RURAL AUTOMATIC EXCHANGES

Set amidst tropic vegetation or where the snow crunches underfoot, G.E.C. rural automatic exchanges operate under a climatic range that is as wide as the range of facilities they provide. With capacities from 10 lines upwards, these unattended exchanges bring to subscribers outside towns and cities a telephone service in which there are :—

**NO OPERATORS ● NO DELAY ● NO WRONG NUMBERS
TWENTY-FOUR-HOUR SERVICE**

Catalogue No. 20 gives full particulars



THE GENERAL ELECTRIC CO. LTD. OF ENGLAND

TELEPHONE WORKS

COVENTRY

ENGLAND

Coventry 4111 (10 lines)

Springjack, Coventry

HEAD OFFICE : MAGNET HOUSE, KINGSWAY, LONDON, W.C.2

A SPOTLIGHT SHINES

RESTLESS energy, ceaseless research . . . keeping ahead . . . not just keeping in step with telephone progress . . . telephony problems being constantly probed — and solved. Such is Ericsson — serving the world's communication needs.

Here at Beeston, Nottingham, we are busy . . . making first class telephone material . . . famous all over the world for its wonderful quality and performance. Contractors to the Admiralty, War Office, Post Office, Railways, Mines, Colonial Govts., etc.

We manufacture, supply and instal complete automatic exchanges of the "director" and "non-director" types for any number of lines.



*Informative illustrated
literature sent post free.*

Ericsson

TELEPHONES LTD.,

Head Office : 22 Lincoln's Inn
Fields, W.C.2 Phone: HOLborn 6936
(FACTORY : BEESTON, NOTTINGHAM)

THE HOME OF A GREAT TELEPHONE SYSTEM . . .

ON *Ericsson* PROGRESS

2. *Testing the hardness of materials.*



INDEX TO ADVERTISERS

Automatic Coil Winder & Electrical Equipment Co., Ltd.	iii
Automatic Telephone & Electric Co., Ltd.	xiv & xv
Bennett College	ix
British Institute of Engineering Technology	xxv
Creed & Co., Ltd.	xiii
Ebonestos Industries, Ltd.	xxiv
Edison Swan Electric Co., Ltd., The	xx
Elliott Bros. (London), Ltd.	xxvii
Ericsson Telephones, Ltd.	xxii & xxiii
Exide	xvi
Ferranti, Ltd.	xi
General Electric Co., Ltd., The	ii & xxi
Hall Telephone Accessories (1928), Ltd.	xxiv
Iford, Ltd.	viii
Institution of Post Office Electrical Engineers, The	xxvi
International Correspondence Schools, Ltd.	xiii
McGraw-Hill Publishing Co., Ltd.	xxv
Muirhead & Co., Ltd.	xix
Pirelli-General Cable Works, Ltd.	xxviii
Pitman, Sir Isaac, & Sons, Ltd.	viii & xxiv
Siemens Bros. & Co., Ltd.	vi & vii
Siemens-Schuckert (Gt. Britain), Ltd.	xii
Smith, Frederick, & Co.	xxvii
Standard Telephones & Cables, Ltd.	x & xviii
Sullivan, H. W., Ltd.	xi
Technical Press, The	xiii
Technological Institute of Great Britain, The	xvii
Telephony Publishing Corporation	xvii
"Triplex" Safety Glass Co., Ltd., The	xvii
Tungstone Products, Co., Ltd.	xx
Turner, Ernest	xii
Turners Asbestos Cement Co.	v
Westinghouse Brake & Signal Co., Ltd.	iv

Just Published

THE RADIO AND TELECOMMUNICATIONS ENGINEER'S DESIGN MANUAL

By R. E. Blakey, D.Sc.

Invaluable data is provided in this book for designers and research engineers and all concerned with radio and telecommunications apparatus. It has been compiled by a research engineer as the outcome of his own experience, and much tedious "spade work" can be avoided by its use. In addition to basic calculations it includes numerous tables and practical examples.

142 pages. 15/- net (by post 15/6).

Order from a bookseller or direct from

PITMAN, Parker St., Kingsway, London, W.C.2

Hall Telephone Accessories (1928) Limited

Suppliers to the British Post Office, Air Ministry,
Admiralty & Foreign Government Departments.

Manufacturers of prepayment telephone
multi-coin collectors, precision instru-
ments, automatic stamp selling and
ticket selling machines, automatic slot
machines and fire alarm apparatus.

Registered

Office & Works: 70, DUDDEN HILL LANE,
WILLESDEN,

LONDON, N.W.10

Also GUEST WORKS, DOWLAIS, STH. WALES

High Quality mouldings

Ebonestos have produced many of
the finest mouldings manufactured
in compositions, Bakelite, Urea,
Diakon, and other synthetic resins.
For the past 39 years, our reputation
for finish and accuracy has been
second to none.

Let us know your moulding require-
ments, and we shall be pleased to send
one of our technical experts to discuss
the matter with you, or, if you
prefer it, meet you at our factory.

*Moulders to the General Post Office,
Admiralty, Air Ministry and other Govern-
ment Departments.*

EBONESTOS

INDUSTRIES LIMITED

EXCELSIOR WORKS, ROLLINS STREET,
LONDON, S.E.15 Telephone: New Cross 1913 (6 lines)

Radio Frequency Electrical Measurements

By Hugh A. Brown,

Associate Professor of Electrical Engineering, University of Illinois.

384 pages, 9×6, illustrated, 24 - net.

THIS combined laboratory textbook and manual for the student and practising electrical and radio engineer explains physical principles and procedures for making quantitative measurements. Sections on measurements of coil resistance, antenna resistance, condenser loss resistance, frequency by approximate and precision methods, vacuum tube parameters and performance, receiving set performance, have all been revised in the light of this advanced knowledge.

Electron Optics in Television

With Theory and Application of Television Cathode-Ray Tube.

By I. G. Maloff and D. W. Epstein.

299 pages, 9×6, illustrated, 21 - net.

IN this book the authors develop the theory of electron optics from its fundamentals and cover its application in the design of the television cathode-ray tube, including an account of that part of the subject with which the authors have had first-hand experience.

From the book the reader should get an understanding of electron optics and be able to use electron optics in various problems of pure and applied physics. He also should get the basic principle of the design of television cathode-ray tubes and associated circuits. Most of the material has never appeared in book form and some of it has not been published previously.

Practical Radio Communication

Principles—Systems—Equipment—Operation Including Short-wave and Ultra-short-wave Radio

By Arthur N. Nilson

Lieutenant (Technician) (Communications) U.S.N.R. (Retd.)

and J. L. Hornung

Formerly Radio Instructor, Guggenheim School of Aeronautics, New York University.

754 pages, 9×6, 435 illustrations, flexible 30/- net

A handbook for engineers and technicians on Radio station operation.

BESIDE providing the undirected newcomer to radio with complete, progressive material to prepare him to pass license examinations and to get a job in radio, this book presents much of value to the experienced operator and technician. Covering practical radio communication completely and its essential theory, the book is in effect a handbook, making available in concise, clear-cut form, adaptable for handy reference, a great deal of otherwise inaccessible material. The engineer and advanced technical worker will find here authoritative facts by which to check his familiarity with latest advances. Boiled down information is given on developments in systems and methods, the newer equipment and apparatus, advances in theory, the facts with which the radio technician will want to keep abreast.

Engineering Electronics

By Donald G. Fink,

Managing Editor "Electronics."

358 pages, 9×6, 217 illustrations, 21 - net.

Special Features Include :

- 1—A clear understanding and a working knowledge of electron physics.
- 2—A sound description of the engineering characteristics of all types of electron tubes.
- 3—An understanding and a comprehensive working knowledge of the application of these characteristics to electronic circuit design.
- 4—Gives descriptions of as many practical applications of electron circuits as could be included in one volume. These circuits have to do with power transformation, electrical communication, and industrial control and measurement problems.
- 5—In order to help the student in obtaining a working ability in the subject about one hundred problems of a strictly practical nature are included. Graphical and tubular methods of presentation are used freely and the book is written in a simple and descriptive style.

McGraw-Hill Publishing Co., Ltd.
Aldwych House London, W.C.2

LATEST EXAMINATION SUCCESSES

Since the B.I.E.T. was founded ten years ago, we have specialised in preparing candidates for leading Technical Examinations, and our success may be gauged from the following remarkable results :

FIVE 1st PLACES

In the Probationary Inspectors and Assistant Superintendent of Traffic Examinations held in 1932-1937, B.I.E.T. candidates obtained Five First Places.

FIRST THREE PLACES

In the 1937 Competitions for Probationary Inspectors, B.I.E.T. candidates secured First, Second and Third Places.

217 SUCCESSES

In the Probationary Inspectors and Assistant Superintendents of Traffic Examinations held in 1934-1937, 217 B.I.E.T. candidates passed the Examinations.

We teach successfully by correspondence and definitely guarantee—

“NO PASS—NO FEE”

You are advised to send for a copy of our General Prospectus “ENGINEERING OPPORTUNITIES.” This Handbook contains 268 pages of most useful information. It also contains particulars of all leading Engineering Examinations, including

Probationary Inspectors (Open and Limited Competitions).

Probationary Assistant Engineers (Limited Competition).

Assistant Superintendent of Traffic (Open and Limited Competitions).

City and Guilds, Special G.P.O. Examination, I.E.E., B.Sc., A.M.I.C.E., London Matric., etc., etc.

The Handbook also outlines “up-to-the-minute” courses of Home-Study in all branches of Engineering.

Special Courses are offered in Telegraphy, Manual Telephony, Automatic Telephony, Telephone Transmission, Electrical Technology, Wireless and High Frequency Radio Communication, Alternating Currents, etc., etc.

Our 268 pages Handbook should be on your Book-shelf. It will be gladly sent on request, FREE and without obligation. (Please state subject or Examination of most interest.)

British Institute of Engineering Technology

369 Shakespeare House,

17, 18 & 19 Stratford Place, Oxford Street,

London, W.1

THE INSTITUTION OF POST OFFICE ELECTRICAL ENGINEERS

PRINTED PAPERS

The following papers contributed to the proceedings of the Institution have been printed by authority of the Council and may be obtained, if still in print, from

"THE LIBRARIAN, The Institution of Post Office Electrical Engineers, G.P.O. (ALDER HOUSE), LONDON. E.C.1."

The prices do *not* include postage, and in every case, Members, Associate Members, and Associates have the privilege of purchasing copies at two-thirds the stated price.

No. 92	"TELEPHONE METERS AND COIN COLLECTING BOXES."—W. CRUICKSHANK, M.I.E.E., and F. McCLARENCE, M.I.E.E. 1923	1s.
No. 109	"THE PROBLEM OF FLEXIBILITY IN SUBSCRIBERS' CABLE DISTRIBUTION."—HARVEY SMITH. 1925	1s.
No. 110	"TESTING OF TELEPHONE CIRCUITS AND APPARATUS WITH ALTERNATING CURRENTS."—E. S. RITTER, D.F.H., A.M.I.E.E., and G. P. MILTON. 1926	1s. 3d.
No. 111	"SCIENTIFIC ORGANISATION AND THE POST OFFICE ENGINEERING DEPARTMENT."—F. G. C. BALDWIN, M.I.E.E. 1926	1s.
No. 116	"THE DIRECTOR IN AUTOMATIC TELEPHONY."—C. W. BROWN, A.M.I.E.E. 1927	9d.
No. 117	"THE SUBMARINE LINK IN INTERNATIONAL TELEPHONY."—C. ROBINSON, B.A., A.M.I.E.E. 1928.	1s.
No. 119	"THE PROBLEM OF THE P.B.X. CONNECTED TO AN AUTOMATIC EXCHANGE."—C. W. BROWN, A.M.I.E.E., and R. J. HINES, B.Sc. 1928	9d.
No. 120	"SATELLITE EXCHANGES IN AUTOMATIC AREAS."—F. I. RAY, B.Sc., D.F.H., A.M.I.E.E. 1927	1s.
No. 121	"X-RAYS, AND THE STRUCTURE OF SOME ENGINEERING MATERIALS."—W. G. RADLEY, B.Sc. 1929	9d.
No. 122	"THE MEASUREMENT OF RELAY TIMES."—R. W. PALMER, A.M.I.E.E. 1929	9d.
No. 123	"MODERN ELECTRICAL ILLUMINATION."—J. J. EDWARDS, B.Sc.(Eng.), A.C.G.I., D.I.C. 1928	9d.
No. 124	"THE MEASUREMENT OF SOUND AND ITS APPLICATION TO TELEPHONY."—A. J. ALDRIDGE, A.C.G.I., A.M.I.E.E. 1929	9d.
No. 125	"THE DEVELOPMENT OF AUTOMATIC ROUTINERS IN THE BRITISH POST OFFICE."—A. SPEIGHT, A.M.I.E.E. 1929.	9d.
No. 134	"SOUND AND HEARING."—Capt. N. F. CAVE-BROWNE-CAVE, B.Sc., M.I.E.E. 1930	1s.
No. 136	"SOME DEVELOPMENTS IN TELEGRAPH TECHNIQUE AS APPLIED TO RADIO CIRCUITS."—H. FAULKNER, B.Sc., A.M.I.E.E., and G. T. EVANS. 1931.	1s.
No. 140	"SOME NON-METALLIC SUBSTANCES AND THEIR CHARACTERISTICS."—Capt. N. F. CAVE-BROWNE-CAVE, B.Sc., A.M.I.E.E. 1931.	9d.
No. 142	"PRIVATE BRANCH EXCHANGE INSTALLATIONS."—R. T. A. DENNISON. 1932.	1s. 3d.
No. 146	"LAYING ARMoured CABLE BY MEANS OF A MOLE-DRAINER."—L. G. SEMPLE, B.Sc.(Eng.), and R. O. BOCCOCK, B.Sc.(Eng.). 1932.	9d.
No. 147	"DESIGN AND CONSTRUCTION OF ELECTRIC WAVE FILTERS."—R. J. HALSEY, B.Sc., etc. 1932.	1s. 3d.
No. 148	"STORES SPECIFICATIONS AND ACCEPTANCE TESTING."—CAPT. J. LEGG, B.Sc., A.M.I.E.E. 1933	9d.
No. 149	"RECENT DEVELOPMENTS IN UNDERGROUND CONSTRUCTION, LAYING AND LOADING ARMoured CABLES."—J. E. Z. BRYDEN, B.Sc.(Eng.), A.M.I.E.E., and T. HARGREAVES, A.M.I.E.E. 1933	1s.
No. 150	"TELEPRINTERS."—E. S. RITTER, M.I.E.E. 1933	1s.
No. 151	"RECENT REPEATER STATION INSTALLATIONS."—Major F. E. A. MANNING, M.C., B.Sc.(Eng.), M.I.E.E., A.M.I.Mech.E. 1933	1s.
No. 152	"SOME NOTES ON EXCHANGE EQUIPMENT FACTORY COSTING AND THE ECONOMICS OF PRODUCTION."—S. J. HUSBAND, Assoc.I.E.E. 1933	1s. 3d.
No. 153	"MODERN DEVELOPMENTS IN TELEPHONE TRANSMISSION OVER LINES."—J. STRATTON, A.C.G.F.C., and W. G. LUXTON. 1933	1s. 3d.
No. 154	"THE TELEGRAPH POLE."—W. H. BRENT, B.Sc., A.M.I.E.E. 1933	1s.
No. 156	"MODERN TENDENCIES IN THE SUPPLY OF POWER TO TELEPHONE EXCHANGES."—H. C. JONES, B.Sc.(Eng.). 1935	9d.
No. 158	"ULTRA SHORT WAVE RADIO TELEPHONE CIRCUITS."—D. A. THORN, B.Sc.(Eng.), A.M.I.E.E., and H. T. MITCHELL, A.M.I.E.E. 1935	1s.
No. 159	"MODERN ELECTRIC PASSENGER LIFTS."—R. S. PHILLIPS, A.M.I.E.E. 1935	9d.
No. 161	"MODERN TELEPHONE REPEATER STATION POWER PLANT."—F. W. G. DYE. 1936	6d.
No. 162	"VOICE FREQUENCY SIGNALLING ON TRUNK CIRCUITS."—T. H. FLOWERS, B.Sc., A.M.I.E.E., and B. M. HADFIELD, B.Sc., A.M.I.E.E. 1937	1s.
No. 163	"AUTOMATIC EXCHANGE DESIGN."—H. E. FRANCIS. 1936	1s. 3d.

Differential Moving Coil MILLIAMMETERS

For Telegraph Circuits

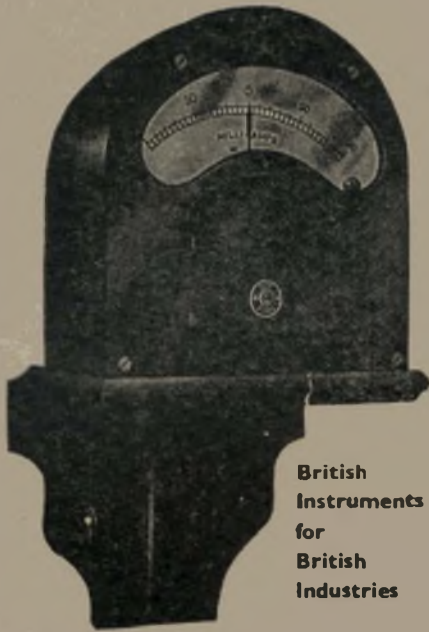

British
Instruments
for
British
Industries

T. 1098. WALL MOUNTING TYPE.



T. 1089. PANEL MOUNTING TYPE.

Frequency and many other Telegraph Systems, also for testing purposes in connection with Land Lines and Radio Communication.

Particulars will be sent on request.



T. 1097. TABLE MOUNTING TYPE

TABLE, WALL AND PANEL MOUNTING TYPES

INVALUABLE as fine Milliammeters on Differential Duplex, Sub-Audio

ELLIOTT BROTHERS (London) LTD., Century Works, Lewisham, S.E.13

Telephone :
Tideway 3232

in association with

SIEMENS BROTHERS & COMPANY, LIMITED, Woolwich, London, S.E.18

Telephone :
Woolwich 2020

ANACOS

REGD

BRONZE & CADMIUM COPPER WIRES

SEND US PARTICULARS
OF YOUR JOB, AND OUR
TECHNICAL ENGINEERS
WILL PROVIDE YOU WITH
THE DATA YOU NEED.

FREDERICK SMITH & CO.

INCORPORATED IN THE LONDON ELECTRIC
WIRE COMPANY AND SMITHS, LIMITED
Anaconda Works, Salford 3, Lancs.

Tel. : Blackfriars 8701 (8 Lines) Telegrams : "Anaconda Manchester."

AS SUPPLIED TO

H.M. POST OFFICE
FOR
TELEPHONE LINES

SILICIUM-BRONZE, COPPER

COPPER - CADMIUM

TAPES & BINDERS

OVER **ONE MILLION** YARDS

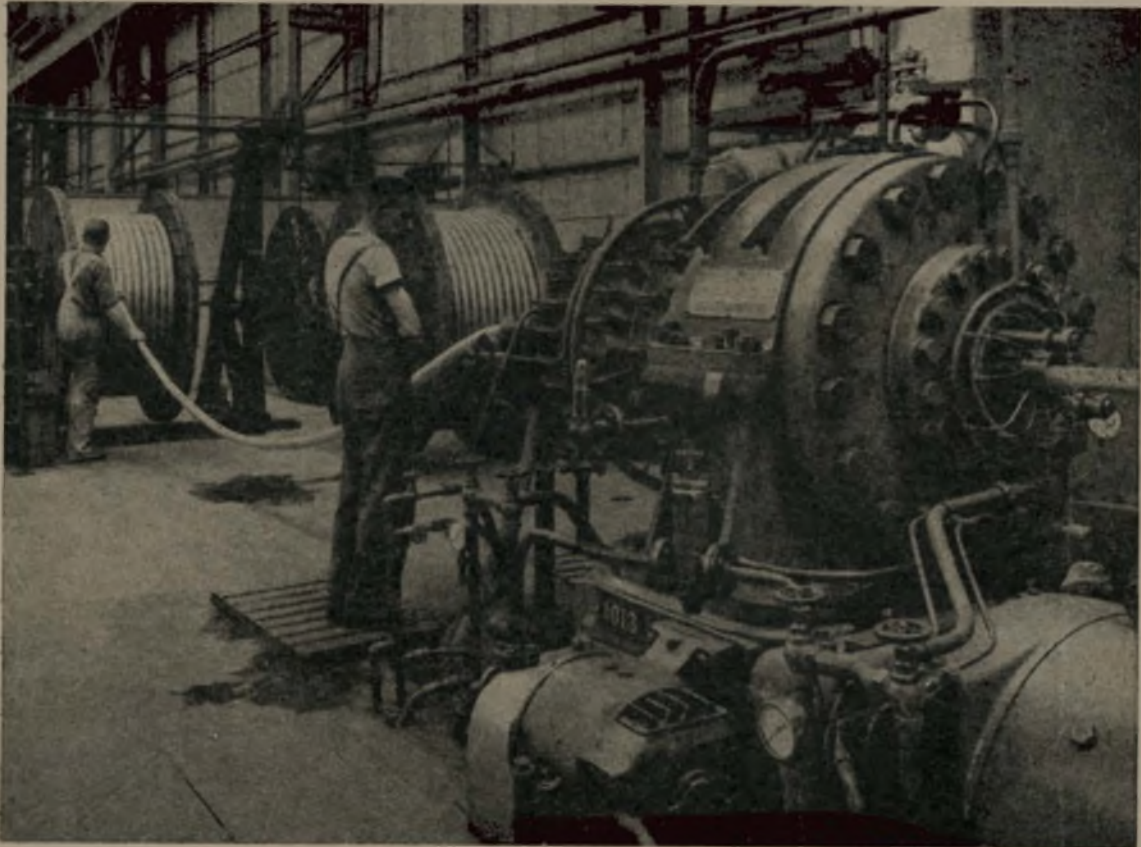

OF AIR SPACE TELEPHONE AND
SUPERTENSION CABLES HAVE
NOW BEEN SHEATHED ON THE
PIRELLI-GENERAL CONTINUOUS
LEAD EXTRUDING MACHINES.

TELEPHONE:
SOUTHAMPTON
2141 (5 lines).

PIRELLI-GENERAL

CABLE WORKS, Ltd., SOUTHAMPTON.

TELEGRAMS
"PIREKAYBEL"
SOUTHAMPTON."

Proprietors: PIRELLI, Ltd., and THE GENERAL ELECTRIC CO., LTD.