

THE POST OFFICE ELECTRICAL ENGINEERS' JOURNAL

Vol. 28

JANUARY, 1936

PART 4.



CONTENTS

	PAGE
THE POST OFFICE 2000 TYPE SELECTOR. ITS DEVELOPMENT AND MECHANICAL DETAILS—J. S. Young, A.M.I.E.E.	249
THE POST OFFICE 2000 TYPE SELECTOR. MOUNTING AND CABLING ARRANGEMENTS—W. H. Diack	257
TELEPHONE EXCHANGE EQUIPMENT STANDARDS—G. Brown, A.M.I.E.E.	263
TELEGRAPH AND TELEPHONE PLANT IN THE UNITED KINGDOM...	266
THE LONG DISTANCE TELEPHONE SYSTEM IN INDIA—N. F. Frome, D.F.C., M.Sc., A.M.I.E.E.	267
THE CALCULATION OF THE PRIMARY CONSTANTS OF A UNIFORM LINE FROM THE PROPAGATION CONSTANTS—A. Rosen, Ph.D., A.M.I.E.E.	274
RECENT UNDERGROUND DIVERSION WORKS IN LONDON—W. Boccock, A.M.I.E.E.	276
THE BELFAST AUTOMATIC AREA AND ZONE CENTRE EXCHANGE—M. C. Cooper, A.R.C.Sc.I., A.M.I.E.E., and C. E. Worthington ...	284
B.B.C. NORTHERN IRELAND REGIONAL STATION BROADCAST ON THE BELFAST AUTO TRANSFER	292
THE POST OFFICE 600 TYPE RELAY—C. W. Clack, A.M.I.E.E. ...	293
ASBESTOS-CEMENT DUCTS—C. F. Thomas	296
TRAFFIC CONTROL SIGNALS—A. H. Vause	301
METAL RECTIFIERS IN TELEPHONE CIRCUITS—B. Winch	310
NOTES AND COMMENTS	312
REGIONALIZATION—B. O. Anson, M.I.E.E.	318
RETIREMENT OF MR. T. E. HERBERT, M.I.E.E.	321
RETIREMENT OF MR. C. J. MERCER, M.I.E.E., M.I.R.E.	321
RETIREMENT OF MR. E. J. WILBY, M.I.E.E.	322
BOOK REVIEWS	323, 332
DISTRICT NOTES	324
INSTITUTION OF POST OFFICE ELECTRICAL ENGINEERS	328
JUNIOR SECTION NOTES	328
STAFF CHANGES	333
INDEX	337

Price 1/- net

THE INSTITUTION OF POST OFFICE ELECTRICAL ENGINEERS



PLASTIC

PERNAX

TAPE

Is Waterproof,
Highly Insulating,
Corrosion-resisting,
Lasting and
Inexpensive.

“ A Chip of the Old Block ”

Is Simple to Use,
Adhesive, but
Does not soil the
fingers.
Blow-lamps not
necessary.

SOME USES.

Insulating conductors exposed to weather to prevent Bird Contact, etc.

Insulating joints in manholes, between lengths of PERNAX sheathed cables.

Insulating purposes generally, where the usual type of sticky tapes have failed.

PERNAX is the only flexible insulating material that can be used in the open air without deteriorating more or less rapidly.

When first introduced it was not possible to make ordinary PERNAX TAPE (though in itself perfectly waterproof) adhesive enough to be waterproof between its lapping edges, without the use of a special adhesion process when using the tape.

Recent experiments, however, have developed PLASTIC PERNAX TAPE, whereby this difficulty has been overcome.

By lapping PLASTIC PERNAX TAPE on the cable without strain and by frictional pressure of the hand to assist adhesion a perfectly waterproof and highly insulating job will result.



(Actual photograph)

PERNAX cut away to show homogeneous result.

This should be of special value when replacing ordinary insulating tapes which have failed through moisture absorbence, perishing or unwrapping

PLASTIC PERNAX Sealing Ends have been totally immersed in water for long periods without any loss of insulation, which result is unobtainable with ordinary insulating tapes.

THERE IS NO OTHER INSULATING TAPE LIKE PLASTIC PERNAX
BECAUSE IT IS MADE OF PERNAX.

Manufactured only by

CROYDON CABLE WORKS LTD., MITCHAM ROAD, CROYDON

'Phone : THORNTON HEATH 2882 (4 lines)

G.E.C.

ALL-METAL LABORATORY APPARATUS

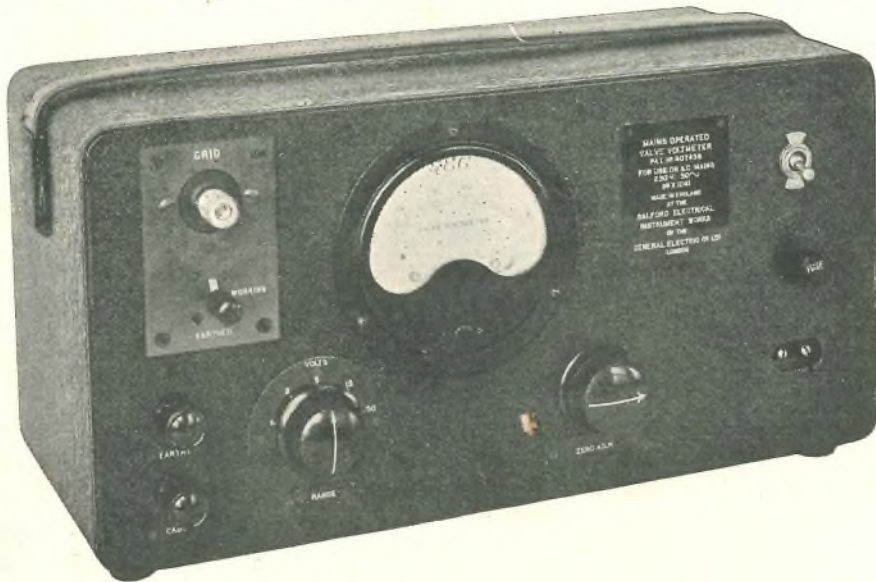

VALVE VOLTMETERS

(Patent No. 407458)

For Power, Audio and Radio Frequency Circuits
A.C. mains, 200-250 volts, 50 cycles per second.

A reflex anode-bend valve voltmeter with various ranges. The standard instrument has five ranges of one, two, five, fifteen and fifty volts with a very high impedance. It is not directly calibrated, but charts are supplied giving curves for each range. Calibration is performed on sinusoidal supply and a stabiliser which is incorporated makes the calibration independent of line voltage over the range of 200-250 volts.

Battery operated models are also available.

Made at the
SALFORD ELECTRICAL INSTRUMENT WORKS

of

THE GENERAL ELECTRIC CO., LTD.

Head Office: MAGNET HOUSE, KINGSWAY, LONDON, W.C.2
Branches throughout Great Britain and in all the principal markets of the World

A VALUABLE BOOK OF REFERENCE



The size of the above catalogue is 11 in. \times 8½ in. overall

Have you got **YOUR** copy?

SECTION 7 of our catalogue (*illustrated herewith*) is a comprehensive work devoted to Measuring and Testing Equipment for the Electrical and Communication Industries. It covers nearly fifty different precision instruments with full specifications, factors and descriptive matter.



A COPY OF THIS BOOK WILL BE SENT TO ANY BONA-FIDE ENQUIRER

MUIRHEAD & Co. Ltd.

MAKERS OF PRECISION INSTRUMENTS FOR OVER 50 YEARS
ELMERS END KENT

TURNER DIFFERENTIAL MILLIAMMETERS G.P.O. No. 17 & No. 18

Meet the most exacting demands for balancing currents in multiplex telegraph circuits.

— A quality product of outstanding merit —

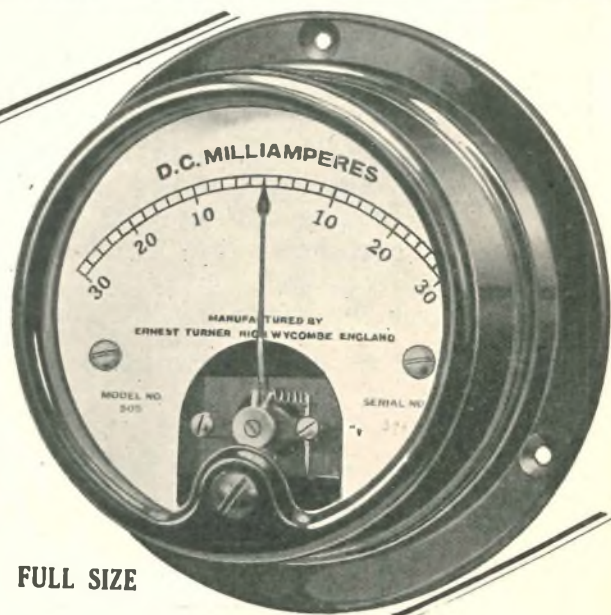

FULL SIZE

Also manufacturers of G.P.O. Detector No. 4, and a comprehensive line of instruments for precision electrical measurements.

ERNEST TURNER ELECTRICAL INSTRUMENTS, Ltd.

**CHILTERN WORKS,
55-73, TOTTERIDGE AVENUE,
HIGH WYCOMBE,
BUCKS. ENGLAND**

Telephone: High Wycombe 381.
Telegrams: Gorgeous, High Wycombe.

The Home of a Great Telephone System

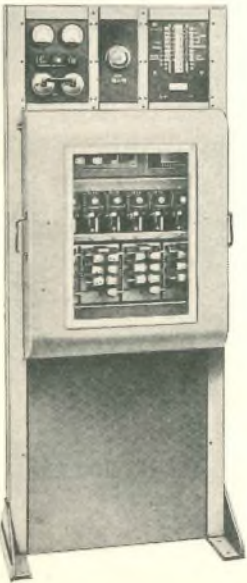
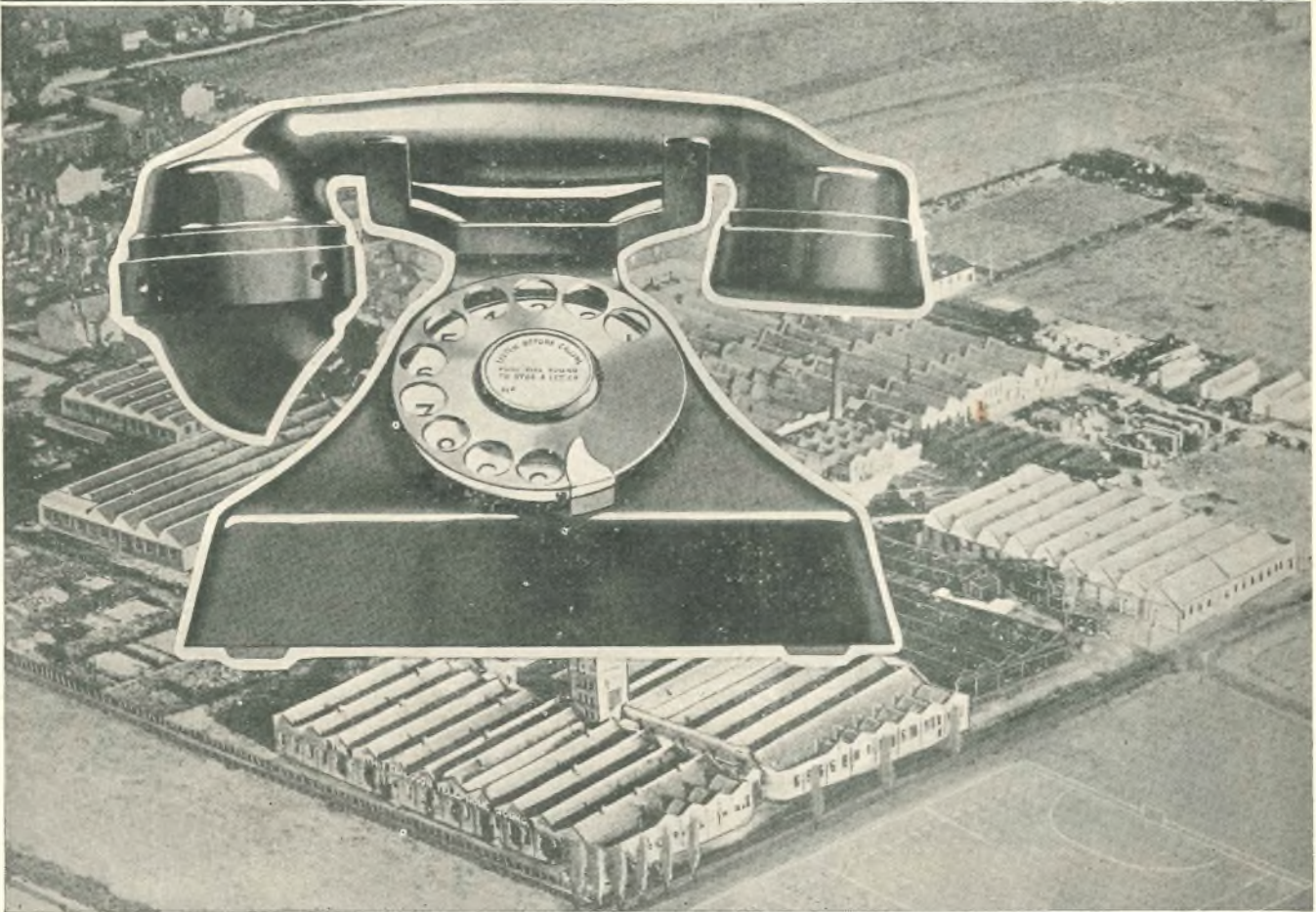

Ericsson Automatic Switch Board.

Ericsson Telephone Equipment is made at Beeston, Nottinghamshire. This fine factory keeps well ahead in telephone development and progress. A manufacturing and technical experience extending over 50 years is helping us all the time to maintain a high level of telephonic efficiency and reliability.

We manufacture, supply and instal complete automatic exchanges of the "director" and "non-director" types for any number of lines.

Informative Literature sent free.

ERICSSON TELEPHONES LIMITED

67/73, KINGSWAY, LONDON, W.C.2

Telephone: Holborn 3271/3

Works: Beeston, Notts

Ericsson

TELEPHONE
EXCHANGE
EQUIPMENT

SIEMENS

AUTOM

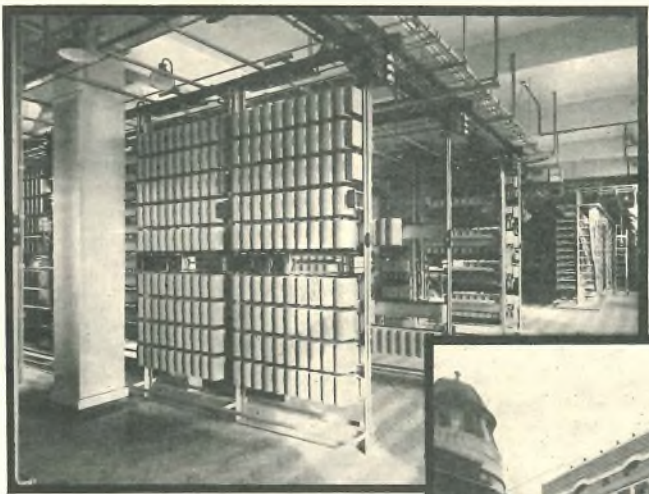

Central Exchange.
View of one of the Apparatus Rooms.



Telephone House, Belfast
(Central Exchange)



Belfast North Exchange, Apparatus



REPRESENTATION ABROAD : Winnipeg, Rio de Janeiro, Cairo, Cape Town, Johannesburg, Perth, Wellington, Auckland, Shanghai, Calcutta, Bombay, Madras, Colombo, Ipoh (Pe

ATIC TELEPHONES IN BELFAST

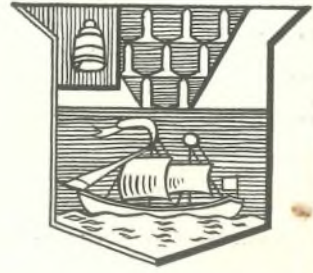

BELFAST, capital city of Northern Ireland, famous for shipbuilding and the centre of the Irish linen industry, has now the most up-to-date telephone system in the country.

The Belfast area has just been converted from magneto to automatic working, the official opening taking place on the 25th November last, in the presence of a distinguished company.

The system comprises 10 automatic exchanges providing a total of over 16,000 multiple lines. Belfast being the zone centre for Northern Ireland, manual switchboards consisting of 32 equipped positions are provided for dealing with junction, trunk and toll calls.

The complete exchange equipment was manufactured at our Woolwich Works and installed by us to the order of the British Post Office.

SIEMENS BROTHERS & CO. L^{TD.}
WOOLWICH, LONDON, S.E. 18

Telephone : Woolwich 1161

INSULATION AND CONTINUITY TESTER

Megger

REGISTERED TRADE MARK

A Two-in-One instrument which will measure the Insulation Worthiness of an electrical installation and, at a turn of the switch, the continuity of the conduit system.

Send for our leaflet X 254

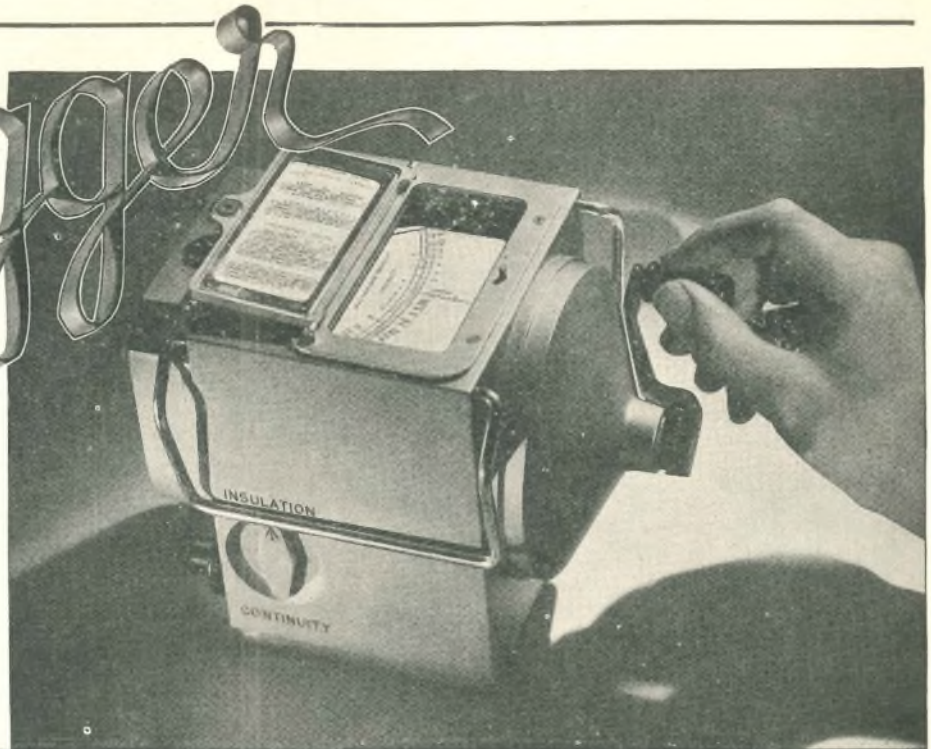

EVERSHED & VIGNOLES LTD

ACTON LANE WORKS, CHISWICK, LONDON, W.4.

Telegrams:—"Megger Chisk, London."

Telephone:—Chirwick 1370 (3 lines.)

4/151

E.W.G.

For quick and economical telegraph transmission

The

TELEPRINTER

The British Post Office, following their progressive policy, has been steadily replacing Morse Apparatus by Teleprinters during the last few years.

This change-over enables 100 telegrams an hour to be dealt with on each circuit as compared with approximately 30 by the Morse System.

Today there are over 3000 Teleprinters constantly at work handling telegrams with great efficiency and economy.

Model No. 3a
Tape Teleprinter

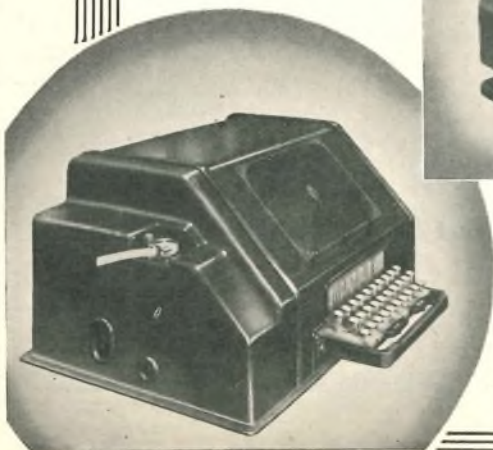

Model No. 7 Page Teleprinter

CREED & COMPANY, LTD.,

Telephone—
Croydon 2121

Telegraph House
CROYDON

Telex—
Croydon Telex 1082



LET ME BE YOUR
FATHER

35 YEARS
PRACTICAL
EXPERIENCE

W. Bennett

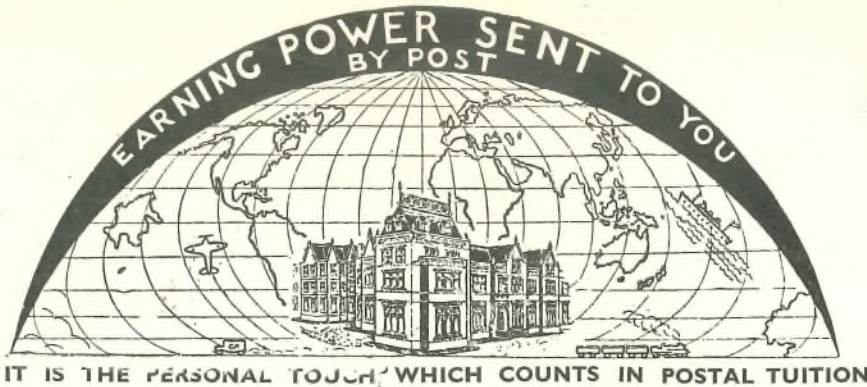

LET ME BE YOUR
BIG BROTHER

15 YEARS
HELPING HIM

W. Bennett

*Let us tell YOU
how to make a success of the
life before you - by using your
spare evenings wisely and
pleasantly*

THE MOST SUCCESSFUL AND MOST PROGRESSIVE CORRESPONDENCE COLLEGE IN THE WORLD



CAN YOU
CHANGE MY
EXPRESSION?

IF SO, YOU MAY BE
THE ARTIST THAT
COMMERCE IS
WAITING FOR.

Just try it for yourself,
trace or draw the out-
line and then put in
the features

Jim Duck

There are hundreds of openings in connection with Humorous Papers, Advertisement Drawing, Posters, Calendars, Catalogues, Textile Designs, Book Illustrations, etc.

60 per cent. of Commercial Art Work is done by "Free Lance Artists" who do their work at home and sell it to the highest bidder. Many Commercial Artists draw "retaining fees" from various sources, others prefer to work full-time employment or partnership arrangement. We teach you not only how to draw what is wanted but how to make buyers want what you draw. Many of our students who originally took up Commercial Art as a hobby have since turned it into a full-time paying profession with studio and staff of assistant artists; there is no limit to the possibilities. Let us send full particulars for a **FREE TRIAL** and details of our course for your inspection. You will be under no obligation whatever.

You Can have a College Training in almost
Any Career for a Few Shillings Monthly

Accountancy Examinations	Insurance
Advertising & Sales Management	Mathematics
A.M.I. Fire E. Exam.	Matriculation, Metallurgy
Applied Mechanics	Mining, all subjects
Army Certificates	Mining, Electrical
Auctioneers & Estate Agents	Engineering
Aviation Engineering	Motor Engineering
Banking	Motor Trade
Boilers	Municipal & County Engineers
Book-keeping, Accountancy &	Naval Architecture
Modern Business Methods	Pattern Making
B.Sc. (Eng.)	Police, Special Course
B.Sc. (Estate Management)	Preceptors, College of
Building, Architecture and	Pumps & Pumping Machinery
Clerk of Works	Radio Service Engineering
Cambridge Senior School	Radio Communication
Certificate	Road Making & Maintenance
Civil Engineering	Salesmanship
Civil Service	Sanitation
All Commercial Subjects	Secretarial Exams.
Commercial Art	Shorthand
Concrete and Structural	Shorthand (Pitman's)
Engineering	Structural Engineering
Draughtsmanship. All	Surveying
branches	Teachers of Handicrafts
Engineering. All branches;	Telephony and Telegraphy
subjects and examinations	Transport Inst. Exams.
General Education	Weights & Measures Inspector
G.P.O. Engineering Dept.	Welding
Heating and Ventilating	Wireless Telegraphy and
Industrial Chemistry	Telephony
	Works Managers

If you do not see your own requirements above, write to us on any subject

Also ask for our New Book (Free of Charge)

THE HUMAN MACHINE

Secrets of Success

SIGNS of the TIMES

The Budget has restored
POLICE OPPORTUNITIES

The Air Force is to be increased
AVIATION must DEVELOP

Pay Cuts have been restored
CIVIL SERVICE

Suitable to both sexes. Ages 15½ to 24.
G.P.O. ENG. DEPT.

CUSTOMS AND EXCISE; INSP. OF
TAXES, ETC. NO EXPERIENCE
REQUIRED. OPEN EXAMS.

MATRICULATION

There are many ways of commencing a career, but Matriculation is the jumping off board for all the best ones.

We prepare candidates for all

INSTITUTE EXAMS.

TECHNICAL, ACCOUNTANCY,
SECRETARIAL, INSURANCE, ETC.

Engineers and Draughtsmen

All Branches—Employers are advertising for them.

TELEPHONY, RADIO and MOTOR ENGINEERING are expanding rapidly. There are lots of vacancies. Our postal courses will make you eligible. Advice on all careers free.

THE MAN DOES NOT GO FAR WHERE ACTION LAGS BEHIND DECISION

YOUNG MEN

Young men physically fit and whose careers are not definitely fixed should join the Police Force. We have special Courses for Entrance and Promotion, 1/- per week brings success. Full Particulars Free.

Address:
POLICE DEPT. 24



Dept. 24 THE BENNETT COLLEGE, SHEFFIELD.

EVERY
DEPARTMENT
IS A COMPLETE
COLLEGE.

EVERY
STUDENT IS
A CLASS TO
HIMSELF.

Standard

Private AUTOMATIC TELEPHONE EXCHANGE

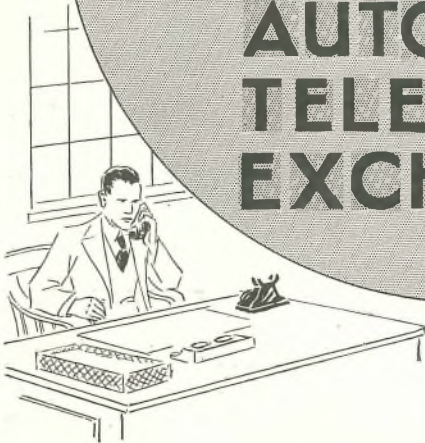

Realising the need for an up-to-date and thoroughly reliable Private Automatic Exchange for small installations, we have recently developed the apparatus shown in illustration.

This board caters for from 10 to 25 lines and is predominant in its sphere.

ADVANTAGES

Absolute secrecy on all conversations.
Great speed in operation.
Continuous service without attention.
Only two wires to each telephone.
Four conversations can be carried on simultaneously.

We shall be glad of the opportunity of sending you further details of this new Exchange without obligation

Standard

Telephones and Cables Limited

(COMMUNICATION ENGINEERS)

NEW SOUTHGATE, LONDON, N.11

Telephone

Palmer's Green 1101



THE POST OFFICE ELECTRICAL ENGINEERS' JOURNAL

Vol. XXVIII

January, 1936

Part 4

The Post Office 2000 Type Selector. Its Development and Mechanical Details

J. S. YOUNG, A.M.I.E.E.

Introduction.

SELECTORS of the two-motion type are used extensively for switching operations in automatic telephone exchanges. These selectors may be described as automatic switching devices serving to select vertically a particular level of contacts and horizontally a particular contact in that level. This article describes the development of a new design of such a selector known as the "Post Office 2000 Type Selector."

Trials of the new selector have been carried out by the Post Office at Regent Exchange, London, and at Ashton-in-Makerfield and these have afforded considerable experience in the maintenance of the selector and also resulted in certain improvements in design. Rugby Exchange, which is due for completion in September, 1936, will be the first exchange completely equipped with the new selector.

Limitations of the Present Type Strowger Selectors.

The circuit timing and operation of a selector are often vitally dependent upon the mechanical adjustment and where an adjustment cannot be definitely specified, but varies within wide limits, incorrect operation occurs. For instance, difficulties have been experienced in the past in the rotary magnet and rotary interrupter adjustments of selectors.

Failure of the present type of selector to release is sometimes caused by the shaft becoming bent. One end of the shaft being free makes it prone to such a fault. Excessive wiper pressure will also cause this trouble and hence it would be helpful to have a simple method of adjustment of wipers.

The above examples of the causes of some of the difficulties encountered with the present type Strowger selector are typical, but it should be remembered that, since the introduction, several years ago, of the Strowger selector a number of new functions have been required, necessitating the addition of operating levers, cams and mechanically operated spring-sets. These additions have been made to selectors which, as manufactured by the several Contractors concerned, differed fairly widely in design, and have resulted in a further lack of

uniformity, causing difficulties in adjustment and in the specification and maintenance of adjustments.

Need for Standardization.

In view of the difficulties encountered, it was imperative that a standard selector be produced, and the Post Office prepared, in collaboration with a Contractor, a redesign of the Strowger selector in such a manner as to keep manufacturing changes to a minimum.

This attempt at standardization was postponed while trials of new systems, employing uniselectors, were in progress. Meanwhile Messrs. Automatic Electric Company were developing a new type of two-motion selector, and, when it was decided by the British Post Office not to depart from the two-motion selector system as standard, this new type of selector was adopted.

ADVANTAGES OF THE NEW DESIGN.

The advantages claimed for the new type of selector may be summarized as follows:—

- (a) Reduced overall dimensions.
- (b) Reduced weight.
- (c) Reduced cost.
- (d) Greater magnet efficiency.
- (e) Similarity of design of components.
- (f) Improved mounting of mechanically operated springs.
- (g) Ease of removal and replacement of selector.
- (h) 2/10 P.B.X. facility on all lines in a 200 line final selector multiple.
- (i) Greater bank capacity.
- (j) Greater ease of adjustment.

The following details indicate how these advantages have been attained:—

(a) *Reduced Overall Dimensions.*

A separate release magnet is not provided, since the release action is obtained by automatically rotating the wipers to the 12th position, at which they first restore vertically to the normal level and then rotate in a reverse direction under spring tension. The vertical and rotary magnets are also smaller as mentioned later.

Fig. 1 shows a 200 Outlet Selector of the present Strowger type and a 200 Outlet Selector of the 2000 Type indicating the reduction in dimensions.

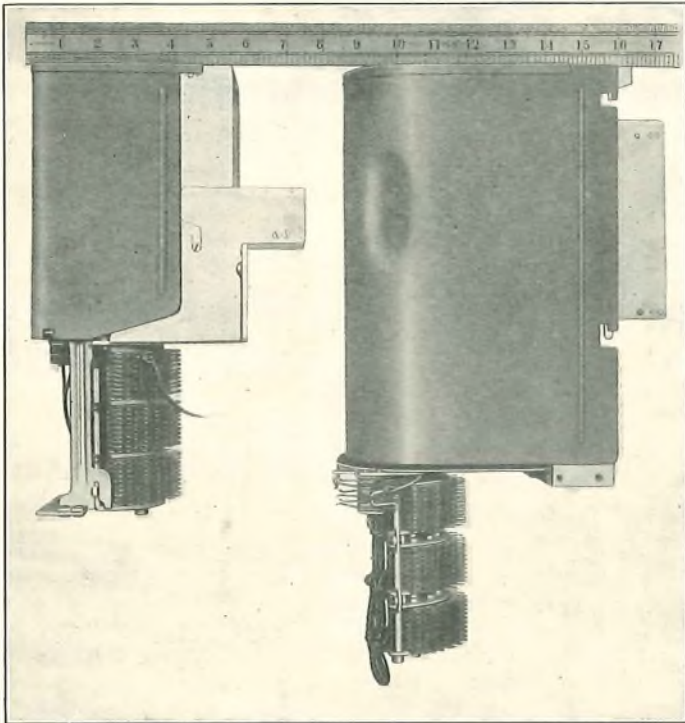

FIG. 1.—COMPARATIVE SIZES OF 2000 AND STROWGER SELECTORS.

(b) *Reduced Weight.*

A die-cast selector frame of 90% aluminium is employed and is of an I formation strengthened by a back piece. (The present Strowger selector has a sand cast iron frame which could not be cast to such close dimensions as the new frame). The points mentioned in (a) above also contribute to a reduction in weight.

Fig. 2 shows the selector frame.

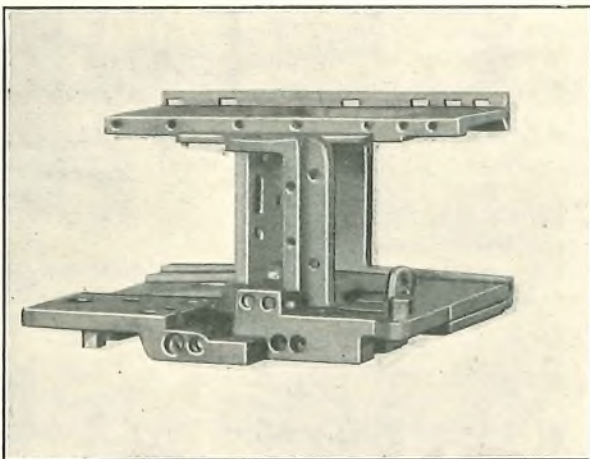

FIG. 2.—DIE-CAST SELECTOR FRAME.

(c) *Reduced Cost.*

The simplification of the casting and magnets has resulted in a cheaper construction and this saving will be augmented by savings in building costs, etc., due to the reduced dimensions and consequent greater rack capacities.

(d) *Greater Magnet Efficiency.*

The vertical and rotary magnets (Fig. 3) contained in the side recesses of the selector frame are of the single coil pattern with cores of rather generous dimensions of "H" formation. The armature in each case is parallel to the axis of the core and carries a heavy auxiliary plate designed to give rapidly a high density flux.

The efficiency of the magnets may be gauged by the fact that a model supplied to the British Post Office, fitted with ten 200 outlet banks and the same magnets as for the four bank models, gave a speed of stepping equal to the present Strowger selector.

(e) *Similarity of Design of Components.*

Wherever possible mechanical details of the same design have been employed, thus reducing the number of different piece parts and also making it possible to use the same adjustments for several items. The use of a greater number of repetition piece parts naturally reduces the manufacturer's tooling costs.

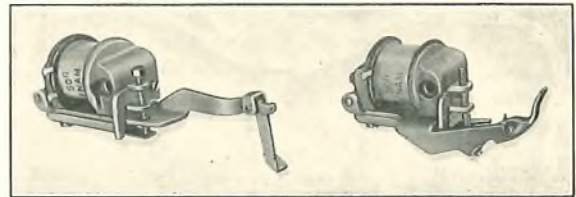

FIG. 3.—VERTICAL AND ROTARY MAGNETS.

(f) *Improved Mounting of Mechanically Operated Springs.*

All mechanically operated spring assemblies employ a uniform type of contact spring, bracket, insulator and clamp plate and are accessibly arranged across the top of the selector frame to which they are secured by means of one screw and a locating slot.

The springs are fitted with either twin silver or twin platinum contacts, as may be required by the circuit conditions, and the soldering tags of the springs project through to the rear so as to be accessible to the wiring forms which serve the relays.

A larger number of springs is available than with the present Strowger selector, thus allowing flexibility for circuit design purposes.

The maximum number of springs for the various functions, given in the order in which the assemblies appear from left to right on the front of the selector, are as follows:—

Vertical Interrupter Springset	V,	3 springs.
Rotary Off-Normal Springset	NR,	8 ..
Rotary Off-Normal Springset when V springs not fitted		14 ..
Off-Normal Springset ...	N,	9 ..
Off-Normal Springset when NR springs not fitted ...		14 ..
Cam (11th rotary step) ...	S,	9 ..
Cam when NP springs not fitted		14 ..
Level Springset	NP,	6 ..
Level Springset when two springsets fitted		3 .. each
Rotary Interrupter Springset	R,	3 ..

(g) *Ease in Removal and Replacement of Selector.*

The banks of the new type of selector are supported by a cradle which is fitted to the shelf. Thus the selector mechanism is independent of the banks and can be jacked into the cradle in a manner similar to that in which relay sets are jacked into the present type channel shelves.

Although the removal from, and replacement of a selector mechanism and wipers to the same bank position does not usually disturb the relative positions of wiper to bank contacts it is advisable to check these.

The ease with which the mechanism and wipers may be removed greatly facilitates the cleaning and lubricating of the bank contacts and should effect an improvement in the time taken for this operation.

(h) *2/10 P.B.X. Facility on all Lines in a 200 Line Final Selector Multiple.*

On the initial design of the 2000 type selector a P.B.X. 200 point bank arc was fitted in front of the ordinary banks and consisted of a double (20 outlet) pressed plate per level from which unwanted contacts could be clipped off. The bank was mounted on a hinge so that it could be swung out to provide adequate accessibility. This was an improvement on the present design in that double capacity, *i.e.*, all of the 200 lines, was available for the P.B.X. facility.

For the final design it has been decided to employ for the P.B.X. facility an additional bank (200 lines capacity) in the normal bank assembly, instead of the bank arc mentioned above, as there is no obstruction to the view when checking the wipers for alignment on the contacts or when checking the wiper position during fault tracing.

(i) *Greater Bank Capacity.*

Due to the higher magnet efficiency mentioned in (d) above and to the more rigid construction of the banks and selector shaft, more banks may be associated with the selector.

(j) *Greater Ease of Adjustment.*

The switch has been designed to simplify maintenance and all adjustments can be made from the front of the selector while it is in position on the shelf.

MICROPHONIC NOISE.

When a telephone conversation is in progress one sometimes hears a series of noises of mechanical

rhythm which are known as microphonic noise. Providing the noise is very small in comparison with the conversation it can be tolerated, but when it assumes such a proportion as to interfere even slightly with the conversation then methods must be sought to effect its elimination. Microphonic noise can start "frying" noises which are much more serious as they often persist for the duration of the call, whereas microphonic noise usually only synchronizes with some adjacent momentary mechanical vibration.

The two main causes of microphonic noise are:—

1. The transference of mechanical vibration from one selector to another when one is in motion and
2. Low wiper tension especially when this is coupled with dirty bank contacts.

To eliminate these noises three methods suggest themselves:—

- (a) Vibration insulation.
- (b) Wiper design to secure constant uniform wiper tension, together with suitable type of material.
- (c) Lubrication of Bank Contacts.

In connexion with lubrication it should be noted that this has also a very important bearing on the life of both wiper and bank contacts.

A series of tests carried out by the Department and the Contractor in collaboration to determine the most promising solution for the elimination of microphonic troubles has been carried on for some time, but no decision has yet been reached.

At first the comparison was made by aural tests under standard circuit conditions, later, noise meters were developed by the Research Station in order that definite measurements could be made and a standard of reference obtained by the Post Office and Contractor.

Investigations into means by which the noise can be reduced or eliminated are still in hand, and the most promising solution appears to be in the introduction of vibration damping devices between the selector and shelf. Several methods of effecting this are under test.

DESIGN DETAILS.

New Type of Wiper.

The design of an improved type of wiper has been given considerable attention in connexion with the new selector. Wipers are required to be non-bouncing, to have even pressures on upper and lower contacts throughout the bank, to retain their tension with minimum attention by the maintenance officer and, for most circuits, to be non-bridging. They should also be easy to adjust and to check for correct adjustment.

Many types were tried by the Contractor including variations of the present design as regards tip shape, *e.g.*, "V" shaped tips, spoon shaped tips, and combinations of these; also twin tip wipers having two points of contact with each individual bank contact and trailing edge wipers were tested.

Although the selector will normally rotate over the bank contacts in a forward direction only, the design allows for the wiper carriage to rotate backwards over a level under special conditions if required,

hence the use of a trailing edge wiper would somewhat restrict the application of the selector.

Due to the fact that normally the wipers rise vertically on one side of the bank and fall on the other side of the bank, and under these conditions must only be one rotary contact distant from the bank, the width of the wiper tip must be kept within small limits to avoid catching on the bank contacts under all tolerances of adjustment.

The objects of the design of the new type wiper are: (1) to brace the wiper tips together by means of a rectangular piece of fibre to ensure even pressure on both upper and lower contact of the level, even when the wiper assembly is not fitted in absolute alignment with the level; (2) to allow maximum flexibility between this point of bracing and the wiper carriage, by using the minimum width and thickness of material consistent with the required leverage tension—it will be seen from Fig. 4 that there is

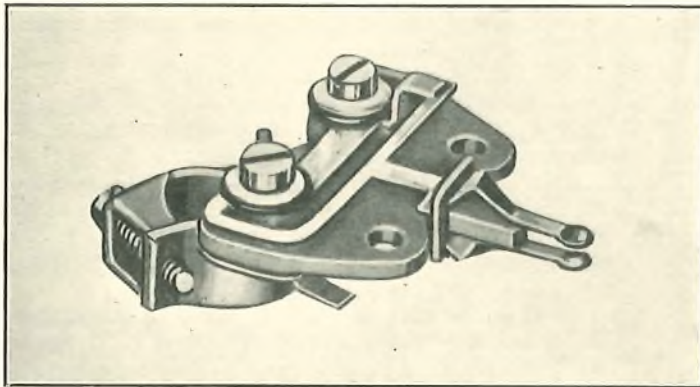

FIG. 4.—NEW TYPE OF WIPER.

a fair length of material between the wiper blade and the assembly clamping screws to assist in giving the flexibility required to prevent relative movement between carriage and bank contact and to assist in damping vibration at this point; (3) by means of the special shape and bracing, to obtain correct wiper tension by gauging the wiper tip clearance when out of the level instead of employing a pressure gauge—the use of a pressure gauge for testing wiper tip pressure is not entirely satisfactory; (4) to limit the amount of wiper whip, or bounce, during vertical stepping and release, by the extension of the insulating material separating the wiper blades—slow motion films taken of the selector in operation appear to confirm this point; (5) to reduce wiper wear and minimize the possibility of catching in the contacts of adjacent levels during rotary stepping and of fouling bank contacts during vertical stepping and release by employing a hemispherical wiper tip shape.

The wiper cord is taken through the wiper separating insulation to keep the cord from influencing the wiper operation. The assembly can be detached from the wiper carriage by unscrewing the fixing screw.

Spring Assembly Operating Levers.

The mechanically operated springs on the present Strowger selector give more trouble than any other

part of the selector. Having this in mind the springsets on the new selector are arranged together in alignment to allow adequate access. The springs being fitted with twin contacts should be more free from contact faults.

The operating levers are supported by fixed pins on the upper part, and adjustable pins with lock nuts on the lower part, of the selector frame. Oil holes are provided just alongside and above the fixed pins to facilitate lubrication of the bearings.

During the early stages of design the "Off-normal" lever was fitted with a roller to reduce friction with the cam attached to the upper part of the wiper carriage. Later the roller was dispensed with to ensure quick decisive action of the lever at the end of the first vertical step.

There is no normal post on the new selector, but the functions of the normal post springs are carried out by the level springs. Two independent level-springsets and levers are provided, which cater for operation on any or several levels irrespective of whether or not these are adjacent. The levers are tapped and drilled, and screws carrying rollers are fitted in the positions corresponding to the levels on which operation is required. As the rollers are relatively large, in order to obtain maximum leverage with the end of the swash plate with which they engage during operation, they overlap adjacent level positions, and cams are therefore fitted to the levers where operation is required on adjacent levels.

It might be criticised that lever No. 2 is a little difficult of access, but it must be remembered that changes in the level operating requirements are very seldom necessary and present circuits require only one set of springs.

Trouble was encountered during the initial tests due to the cam springs (11th step springs) becoming welded. Unlike the present selector the cam springs are momentarily operated every time the selector restores to normal and the flicking together of the springs, coupled with the circuit conditions applied to the springs, was responsible for the trouble. The type and spacing of the springs has now been altered.

All the operating levers for the mechanically operated springsets, except the vertical and rotary interrupters, are operated by the cam or swash plate which are located at the top of the wiper carriage.

Test Jack.

The test jack consists of one or more slotted rectangular blocks of moulded bakelite. A contact spring is placed in each of the six slots in the block. The springs are not rigidly fixed, but are kept in position by the soldering tag which projects downwards through the moulding. A set is given to the tag where it passes through the moulding to prevent excessive movement of the wired connexion when a test plug is inserted or removed. The horizontal part of the spring is normally bowed in the centre, and when the pin of a plug is pushed into the slot, the spring is flattened out making a very effective contact. In the majority of selectors two moulded

blocks (12 springs) are sufficient, but the design caters for a third, should it be required.

Above these blocks is mounted another of similar material which carries the supervisory lamp on the right, a label in the centre, and two springs in which the busying link is placed on the left. All the blocks are assembled together and secured by two screws below the left hand front corner of the selector frame. A stop is provided on the selector frame to ensure that the supervisory lamp always projects forward by about $\frac{3}{8}$ inch.

For busying purposes and to provide a change-over facility on the springs, "U" links with insulated handles are employed; the links being moved from one position to another as required. The handles are coloured red for the busying link and green for the release link.

Vertical and Rotary Interrupters.

One of the most important advances made on the new selector is the drive obtained by self interruption, which is now as positive as that previously obtained by relay inter-action. This is due to the design of the interrupters in which the instant of "break" can be made practically at the end of the armature operating stroke quite independently of the "re-make" which occurs practically at the end of the armature return stroke.

This independent timing of the "break" and "re-make" ensures absolutely complete armature strokes in both directions, without placing any reliance on armature inertia. With the old type of interrupter in which the "break" and "re-make" occurred at exactly the same point in the stroke, the armature inertia was the sole force upon which reliance had to be placed to complete the stroke after the current was switched off or on, and it was a matter of hit or miss as to whether it worked or not.

The new interrupters can be adjusted by gauging on the bench with the full knowledge that they will work perfectly when the current is applied. They have eliminated a relay from the group selector circuit.

Vertical Marking Bank and Wiper.

When a vertical marking bank is required on a selector, one of the inter-bank spacing plates is replaced by a vertical bank plate which has a projection to the right hand side of the bank, viewed from the front, to mount the vertical marking bank.

The bakelite insulation between the nickel silver bank contacts is raised to prevent the wipers from bridging the contacts during the vertical movement, and moulded so as to present an angle of 60° to the wiper in order to eliminate wiper bounce.

The wiper assembly is hinged by means of a very small bolt and nut to the lower part of the assembly fixing bracket and is secured under a thumb screw at the upper part of the bracket, so that the assembly can be swung clear of the vertical marking bank when the selector mechanism and wipers are about to be jacked-out of the cradle. The assembly fixing bracket swivels on a collar which is fitted on the selector wiper carriage.

The wipers are of phosphor bronze with a tip shape

of a combination of "V" and "spoon" shapes.

With the arrangement of vertical marking bank and wiper mentioned above, it has been found that unless due care is taken wipers become damaged, due to not being properly released from the bank prior to the selector being jacked out of the cradle. Also the arrangement is not suitable in its entirety for mounting on selectors having two ordinary banks (4 levels).

A further proposal which could be used in all circumstances is under consideration, and provides the vertical marking bank with a swivel mounting, so that when the selector is jacked out of the cradle the fluted side member of the selector moves the vertical marking bank forward out of engagement with the wipers without damage to the latter. Stops are provided for engaging the bank when in its normal or open position.

Selector Cover.

The design of a suitable cover is a difficult problem as there are so many requirements. It is not practicable to meet all these and, therefore, they have to be considered in the order of their importance.

It would doubtless save time and expense in the cleaning of contacts and incur less wear if the multiple banks could be covered, but it is essential that the position of the selector wipers in the bank may be quickly located. One type of cover submitted by the Contractor covered the whole of the selector including the bank, and embodied an indicator which showed the particular level and contact in the level on which the wipers were resting. The design did not meet with favour as the indicator could not readily be seen in all positions on a rack, and the cover was not sufficiently dust-proof.

To have a cover of insulating material would be ideal, if such a cover had the required mechanical strength without an increase in the thickness of the material and provided it could withstand the rough usage to which covers are sometimes subjected. The advantages of covers of insulating material are:—less weight, freedom from mechanical rattle and non-framing of electrical connexions with which they might come into contact. Such covers received serious consideration, but further investigation is necessary before a satisfactory cover of such material is produced.

Another consideration was whether the relays associated with the selector should be separately covered. It is argued that now the relays are of the 3000 type having twin contacts, they are more immune from faults than the mechanical parts of a selector, and hence the use of separate covers would avoid the relays being exposed when the mechanical parts require attention. Against this it appears very uneconomical to provide separate covers, and furthermore these would involve additional mounting space. It has been agreed that the one cover should cover both relays and selector mechanism, leaving the banks and wipers exposed.

In any cover design it is preferred that the same general design be employed throughout, for large as well as small selectors.

The design adopted (Fig 5) aims at a cover which is

practically dust-proof, rigid so as to avoid mechanical vibration and padded with cotton felt to reduce the amplification of mechanical sounds within the cover. The objection to a wool felt is that it assists in the propagation of moths which is becoming a serious matter in telephone exchanges. The cover is made of sheet steel and is approximately $4\frac{1}{2}$ " wide and 4" deep, the height depending upon the number of relays to be accommodated. Around the outside of the bottom is a stiffener to maintain rigidity when removed from the selector. In the front centre of the stiffener is rivetted a latch which locks the cover tightly in position. There are flutes towards the back of the sides to prevent any distortion. An inward bend is provided across the back of the top of the cover to engage in a slot between the selector base and rear cover. The cover fits between the selector base and cradle, the sides of which are slightly embossed to avoid undue friction.

To remove a cover the latch is undone and the fingers placed behind the projection immediately below the latch. The cover is pulled forward and then raised bodily to disengage at the top. The use of an upper lifting ring or handle was considered unnecessary.

Label Holder.

For a long time it has been felt that it would be an improvement to have more label space available on selectors, and opportunity has been taken to obtain this in the new design. The main label is accommodated in a label holder incorporated in the cover design and the small label on the test jack enables a cross reference to be made between the selector, its mounting position and the cover.

The label holder will accommodate 4 labels $\frac{1}{4}$ " high by 1" wide and of the usual thickness and can be seen in Fig. 5.

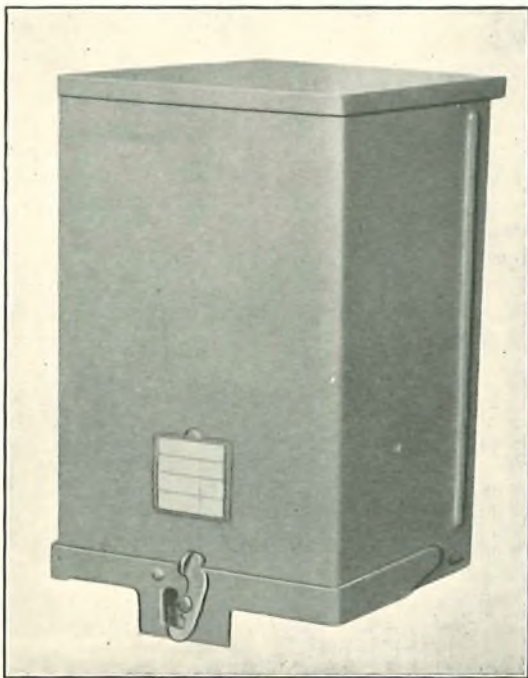

FIG. 5.—SELECTOR COVER.

Lubrication of Armature Bearings.

The magnets are located in the selector frame by the extension of the armature bearing pin and in consequence of this, the remote end of the armature bearing is inaccessible for lubrication in the normal manner without the removal of the spark quench condenser, which is mounted behind the selector frame. To obviate the necessity for the removal of the condenser, the bearing pin has been made of tubular metal and a wick passed through the centre to feed the remote bearing at which point the wick protrudes. The wick is saturated before assembly and provides a reservoir for a long period.

Rotary Pawl Projection and Stop.

With the earlier patterns of 2000 type selector, excessive wear was noticed on the 12th rotary ratchet tooth. This was due to the additional rotary interaction which occurred during release. It was not found possible to eliminate the trouble by circuit changes and so mechanical means were tried, and the difficulty was overcome by adding a projection to the rotary pawl and another projection, which acts as a stop, to the bottom of the comb. When the wiper carriage reaches the 12th rotary step, there are no further rotary ratchet teeth with which the rotary pawl can engage and hence the rotary pawl projection engages with the stop. The functioning of the rotary interrupter is thereby arrested and prevents the rotary interaction which previously existed.

Speed of Operation.

As a result of the improved design the adjustments are maintained for long periods without attention, thereby ensuring constancy of speed which is a valuable asset.

It is better to have one standard requirement for speeds than several depending upon the particular function of the selector. To obtain efficient operation, the following conditions must be met, but apart from these nothing has yet been specified:—

1. That the speed shall not be less than 40 steps per second on self-drive release.
2. That the speed shall not be more than 50 steps per second on hunting as a 200 Outlet-Group Selector.

This does not mean that the speed shall be between 40 and 50 steps per second, as the circuit conditions are different for the two speeds mentioned.

Wiper Carriage.

The selector wipers are supported by a wiper carriage which slides and rotates on a fixed shaft. The fixed shaft being supported at both ends serves as a guide for the carriage.

The wiper carriage, hub, cam and vertical ratchet constitute a single assembly and together with the shaft can be removed from the selector by removing four screws. To reduce its inertia and give a greater magnet operating margin, the wiper carriage is as light as possible, and, due to this, requires a vertical restoring spring. The shaft consists of a length of steel rod provided with a brass collar to which is secured one end of the helical restoring spring housed between the shaft and the wiper carriage. To the latter is fixed a bush which secures the other end of

the spring. The one restoring spring thus provides the restoring force for both the vertical and rotary motion and its tension is adjusted by undoing the bottom shaft fixing screw, rotating the shaft and then reclamping.

Distortion of the wiper carriage tube is prevented by ensuring a symmetrical fit of the wiper assembly bracket and clamp, which are forced around a mandrel and supplied as a combined item.

Fibre washers are placed at the bottom of the

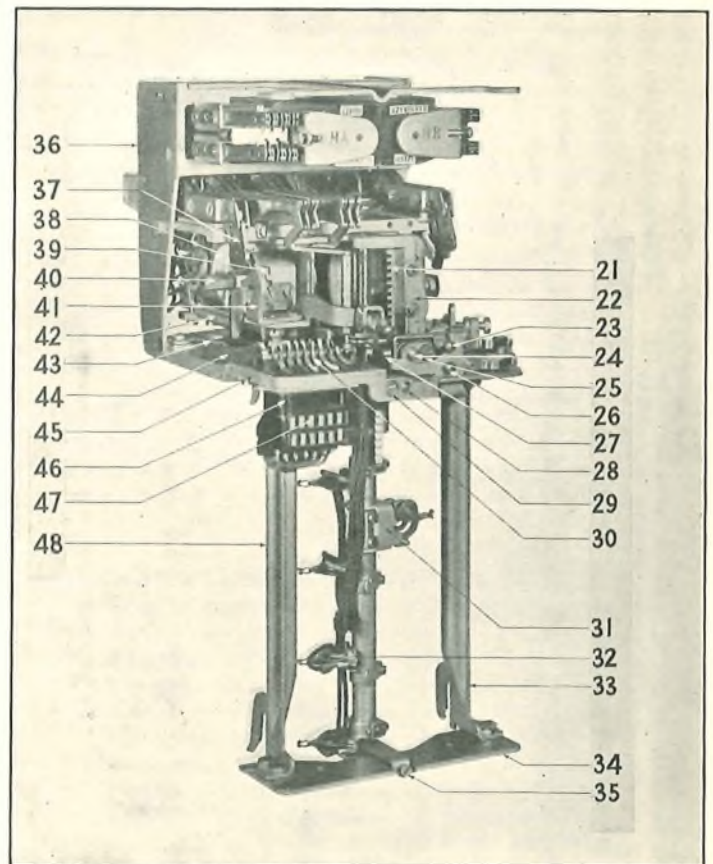
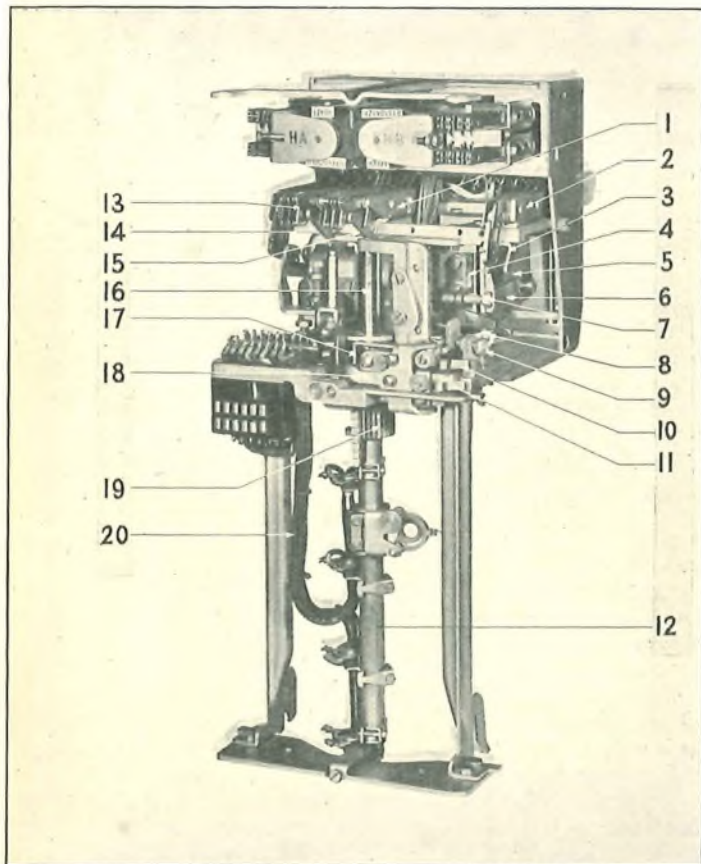

FIG. 6.—LOCATION OF MAIN ITEMS ON SELECTOR MECHANISM.

SCHEDULE OF MAIN DETAILS.

- | | |
|---|--|
| <ol style="list-style-type: none"> 1. Off-normal spring assembly. 2. Rotary interrupter spring assembly. 3. Rotary interrupter striker. 4. Rotary magnet. 5. Rotary armature. 6. Rotary armature restoring spring. 7. Rotary armature restoring spring adjusting screw. 8. Rotary pawl spring. 9. Rotary armature back stop. 10. Rotary detent restoring spring. 11. Vertical detent restoring spring. 12. Carriage tube. 13. Rotary off-normal spring assembly. 14. Rotary off-normal spring operating lever. 15. Vertical off-normal spring operating lever. 16. Shaft. 17. Rotary detent. 18. Vertical detent. 19. Hub. 20. Wiper cords. | <ol style="list-style-type: none"> 21. Comb. 22. Rotary pawl guide. 23. Rotary detent adjusting screw. 24. Rotary pawl front stop. 25. Rotary pawl front stop locking screw. 26. Vertical detent adjusting screw. 27. Vertical pawl spring. 28. Vertical pawl front stop. 29. Vertical pawl front stop locking screw. 30. Wiper cord terminal assembly. 31. Vertical wiper assembly. 32. Rotary wiper assembly. 33. Frame extension—right. 34. Bridge plate. 35. Shaft clamping screw. 36. Relay mounting plate. 37. Vertical interrupters. 38. Vertical interrupters. 39. Vertical armature restoring spring adjusting screw. 40. Vertical magnet screw. 41. Vertical interrupter striker. 42. Vertical armature. 43. Cable cleat. 44. Test jack wiring. 45. Frame. 46. Lamp jack moulding. 47. Test jack moulding. 48. Frame extension—left. |
|---|--|

shaft to take the shock of the falling carriage. At the end of the rotary release, the cam engages with the off-normal lever, thus affording a breaking action and preventing rebound, but as a precaution against the carriage being pushed off-normal by hand, a latch is also provided.

Location of the Selector in the Cradle.

A small block is incorporated on the selector die cast frame to ensure that the lamp projects a certain distance. The best indication that the selector is correctly seated in the cradle is to see that this block meets the bottom of the cradle.

Cover Guide.

The cover guide at the top of the selector, above the associated relays, is so shaped that in conjunction with the general external design no damage will result from a selector being rested on its front, back, side or top. Naturally the latter does not apply to selectors carrying a great number of relays.

A testing stand is being produced to facilitate the inspection and test of a selector at the repair bench. The stand allows the selector to be tilted in a vertical plane through an angle of 90° or rotated.

Provision for Adjustments.

It is claimed that all adjustable parts are accessibly arranged to make re-adjustments a simple matter. A point of interest in this connexion is that in most cases locking nuts on screw adjustments have been dispensed with on the grounds that they disturb the adjustment. The locking feature in such cases is provided either, by two tapped portions on a "U" bracket, sprung outward, so as to place a stress on the screw thread, or by two parallel tapped pieces pulled together by a second screw thereby causing stress on the adjusting screw.

Comb Plate and Disc.

As the vertical ratchet is fitted alongside the hub it moves out of engagement with the vertical detent

with the first rotary step of the wiper carriage. It is necessary therefore to provide some other means to prevent the carriage from falling. This is effected by the disc, which is located immediately below the cam, entering the appropriate level notch in the comb plate.

At the 12th rotary position a slot in the disc comes into line with the comb plate, thus allowing the carriage to fall. While the carriage is falling, the 12th rotary tooth of the hub slides along the rotary detent until it reaches the normal level when it is disengaged and free to release in the reverse rotary direction under the influence of the restoring spring.

Wiper Cords.

Owing to the lower end of the shaft being supported by a bridgepiece, the wiper cords cannot hang below the shaft as is the present practice, but must be fed *via* the centre of the carriage to the wipers above and below.

Position of the Items on the Selector.

Fig. 6, in conjunction with the schedule of the main details, shows how these are disposed with respect to one another on the selector.

CONCLUSION.

Life tests of models and semi-production switches have been conducted at the Post Office Research Station with very satisfactory results and tests of production models are now in hand. The Research Station is also carrying out rather exhaustive tests on the further reduction of microphonic noise. The Department is satisfied that the collaboration which has existed between themselves and the developing Contractor—Messrs. Automatic Electric Co., Ltd.—has been so intensive during the last twelve months that troubles, if any, will only be of a very minor character.

The author desires to express his thanks and appreciation to Messrs. A.E. Co. for the photographs kindly supplied by them.

The Post Office 2000 Type Selector. Mounting and Cabling Arrangements

W. H. DIACK

Introduction.

IN addition to the mechanical advantages claimed for the 2000 type selector, the reduction in the space occupied has increased the number of selectors which can be fitted on a rack.

The following schedule gives typical examples of the increased capacity of racks 10' 6½" high and 4' 6" wide:—

	Present Selector.	2000 type Selector.
Primary Finders	50	60
Group Selectors—200 outlet	60	80
Final Selectors—200 line ...	50	60

It has been calculated that the new arrangements will effect a floor space saving of 10%-15% in the average exchange.

The special wiring problem which was created with this concentration of equipment, and the contour of the new selector, necessitated the reconsideration of mounting arrangements generally, a fact of which advantage has been taken to introduce a greater degree of standardization of mounting details. This effort at further standardization has extended to items not intimately connected with the selector, e.g., mountings for miscellaneous apparatus fitted on the rack uprights.

Most telephone engineers are now familiar with the open type method of mounting exchange apparatus whereby the apparatus is mounted on racks, generally 4' 6" wide, and clear access is given to both the apparatus and the wiring sides of the equipment by gangways "open" at both ends. In making comparisons, therefore, illustrating the problems which had to be solved in connexion with the 2000 type selector, the writer has in mind the existing method of mounting selectors and relay sets on open type racks.

The following general principles of the open type rack arrangements remain unaltered:—

- (a) The rack design.
- (b) The selectors and relay sets are jacked-in and mounted at 4¾" centres on the shelf.
- (c) 10, 7, 5 or 2 jacked-in units may be mounted per shelf, the quantity depending on the standard rack widths used. By far the most common is a rack width of 4' 6" which accommodates 10 jacked-in units per shelf.
- (d) Condensers, resistors, rectifiers and barretters may be fitted on the rear of the selector or relay set base.
- (e) Cabling is fed down the rear of either rack upright and wired to the apparatus from supports at the rear of the shelf.
- (f) Cabling to banks is taken through connexion strips fitted on the rear of the shelves and cabling to shelf jacks wired direct to the tags of the jacks.

(g) The rack power feeders and fuses are fitted on the left hand upright of the rack and the miscellaneous apparatus on the right hand upright.

(h) Semi-cylindrical banks are retained and fitted below the mechanism of the selector.

Many details, however, have been altered. Before modifications were accepted detailed consideration was given to the possible use of existing items such as pressed steel channel shelves and standard connexion strips in order that the number of changes in design would be kept to a minimum. It is considered that the arrangements now made and, covered briefly by the following paragraphs, allow full advantage to be taken of the facilities and compactness of the 2000 type selector.

Method of Mounting Apparatus on Selector and Relay Set Bases.

The relays are mounted in two vertical rows, but as the arrangement is in accordance with well-known practice, no special remarks are necessary here. Resistors, rectifiers, condensers and barretters may be fitted in the relay positions if desired, and accommodation is provided for them on the rear of the selector or relay set. The condenser box is shown in Fig. 1 and a typical lay-out of a mixed equipment in the box in Fig. 2. The condenser box is fitted with a pin on a flat spring which retains the box perpendicular to the base when access to relay tags is required. Ridges in the wall of the box prevent movement of the condensers when the lid is closed. The condenser box acts also as a dust cover behind the relays, and therefore when a box is not required a less expensive form of cover is used. This cover is of similar dimensions to the condenser box in order that either will butt up to the shelf rear cover to assist in the exclusion of dust, and it will accommodate resistors, barretters and rectifiers. Barretters will normally be fitted in this position at the rear because of the greater protection it affords.

Shelf Construction.

The selector arrangement is such that the maximum permissible depth of the mounting bar is 2½". A deeper shelf would obscure bank contacts or locate the shelf jack in an awkward position. A shelf of rolled steel channel section 2½" x 1" has therefore been adopted.

It would have been preferable to follow orthodox design and fix the web of the channel bar directly to the rack upright, but the shape of the selector has necessitated the reversal of the channel so that the flanges point towards the upright. In order, however, that the bending moment on the shelf fixing bolts may be reduced to a minimum, a block casting has been added to fill the space inside the channel at each end. The casting also prevents the distortion

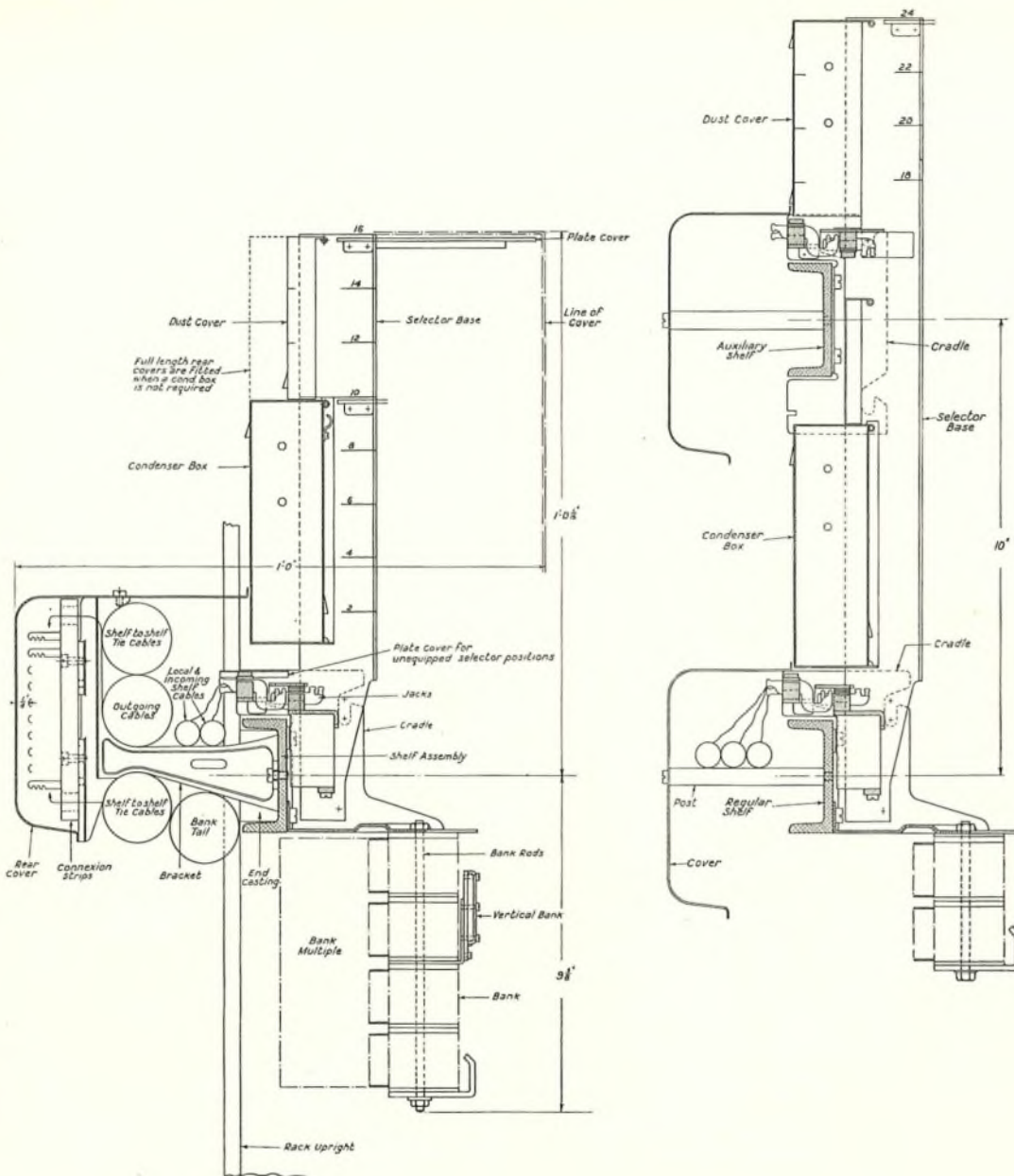

FIG. 1.—TYPICAL VIEWS OF SELECTOR MOUNTING ARRANGEMENTS.

of the web of the channel when the fixing bolt is tightened up.

A channel shelf $3/16''$ thick will safely carry a distributed load of 300 lbs., and it may be of interest to note that for racks $4' 6''$ wide the maximum longitudinal stress in the flanges of shelves carrying this weight has been calculated to be 3750 lbs. per square inch and the maximum vertical deflexion $.03''$. The latter figure has been verified by experiment. The vertical dimension, however, of a selector or relay set is large compared with the vertical distance between the fixings on the $2\frac{1}{2}''$ web, and it has therefore been necessary to introduce an auxiliary supporting shelf for the larger selectors and relay sets. In

the case of selectors this support is a channel bar similar to the regular shelf, but for relay sets it has been considered sufficient to use a sheet steel detail folded into angle section and fitted below the regular shelf. Pins in the horizontal portion of the angle engage with holes provided in the relay set base. The arrangements are such as to ensure that the regular shelf carries the load and that the auxiliary support simply prevents horizontal movement of the apparatus.

Cradles.

Along each shelf is a series of cradles—one cradle for each selector. The cradle is a pressed steel

Holes in side of condenser boxes & rear covers provide for mounting of resistors, metal rectifiers, barretters

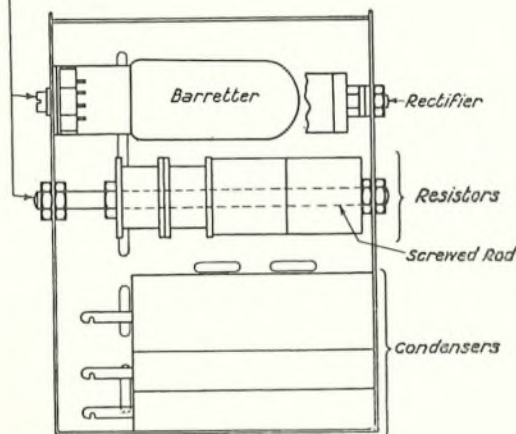

FIG. 2.—CONDENSER BOX—MIXED EQUIPMENT.

detail (Fig. 3) which is fixed to the web of the channel. The banks are rigidly bolted to the horizontal portion of the cradles. It is a useful feature of the new arrangements that the selector may be jacked in or out without the loosening of bank rods, a distinct advantage over the present scheme. No special support for the bank is required when a selector is not fitted. The cradle is rigidly fixed to the shelf, but this arrangement may be modified when microphonic tests with flexible supports are completed. It is a slight disadvantage that the cradle shape for selectors is not suitable for relay sets. A cradle has therefore been designed for mounting relay sets on the same principle as selectors and using the same type of channel shelf. It is possible to provide composite shelves of selectors and relay sets.

Shelf Jacks.

The shelf jack is mounted on a strip of mild steel forming a bridge at the top rear of the selector cradle (Fig. 4). The jack is an adaptation of the existing jacks No. 40 and No. 43, the only difference being that the depth of the ebonite block is reduced. Modification of jack design is at present being considered, and it is hoped to be able to introduce the improvements concurrently with the 2000 type selector. If a second jack per selector is required an additional bridge is provided at the rear of the cradle, or if an auxiliary supporting shelf is used, the second

jack is mounted on the auxiliary shelf cradle. On relay sets, the second jack is mounted at the rear of the cradle, but below the rolled steel channel shelf.

Rear of Shelf Arrangements.

Fig. 1 gives a view of the end of a typical fully wired shelf. The bank tail and outgoing cable forms are shown in their regular positions, but shelf to shelf tie cables may be above the outgoing cables if serving a shelf above, or below the bracket if serving a shelf below. This arrangement avoids the needless crossing of cable forms. Fanning holes are provided at both top and bottom of the connexion strips. The skimmers from the forms inside the brackets use the upper holes and the skimmers from below the bracket are fed through the lower holes.

The shelf rear cover is of sheet steel, in one piece per shelf, folded into the shapes shown in Figs. 1 and 5. The cover prevents dust from collecting unduly on the jack points and amongst the wiring and presents a plain surface for cleaning. It extends over the tags of the connexion strips, thus obviating the necessity for separate guards. In order to make the manufacture as inexpensive as possible, the ends

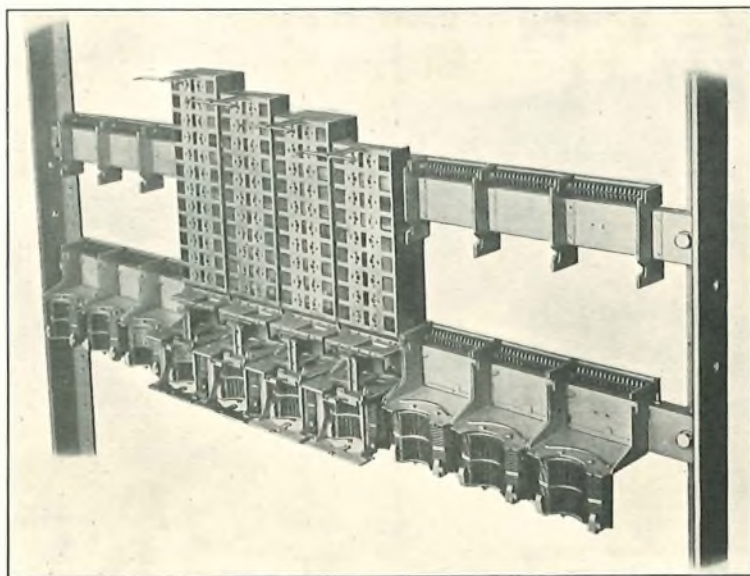

FIG. 3.—DOUBLE SHELF FOR LARGE SELECTORS.

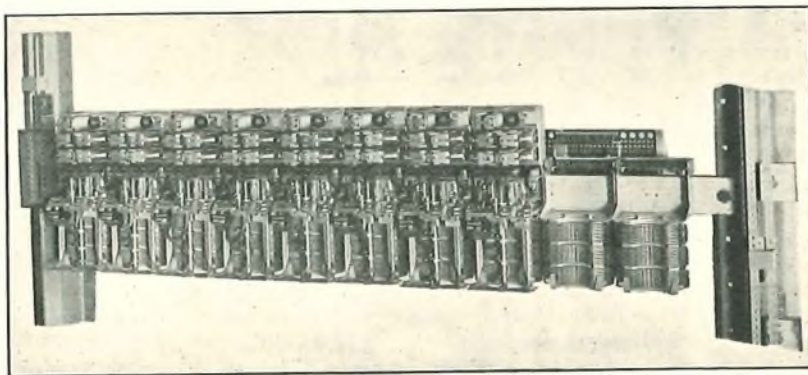

FIG. 4.—PARTIALLY EQUIPPED SHELF OF SELECTORS.

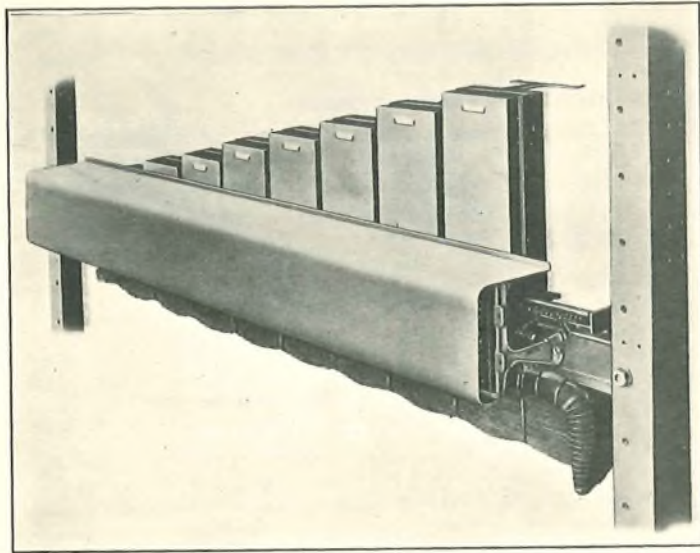

FIG. 5(a).—REAR OF SHELF WITH COVER.

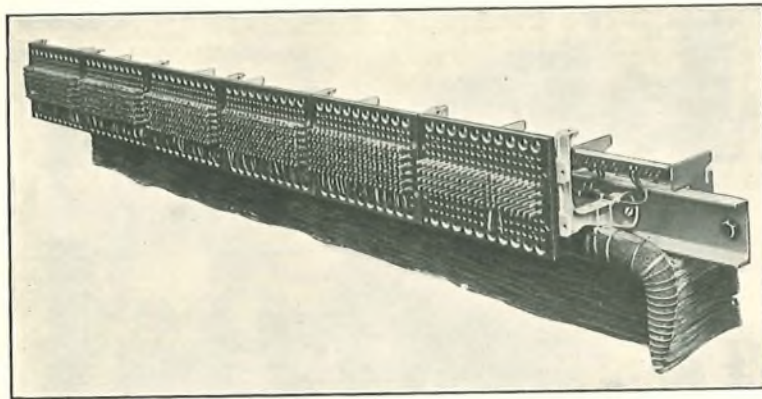

FIG. 5(b).—REAR OF SHELF WITH COVER REMOVED.

of the cover are sheared off straight, and as the cover must be short enough to allow for the turning of the cables, it does not shield the end shelf jacks completely; a small plate is therefore fitted over each of the end jacks. A tapped hole is provided in the jacks and a trapped screw in the plate. This plate when reversed may be used in any unequipped position on the shelf to cover jack points and so prevent interference with shelf commons while cleaning is in progress. The brackets at the rear of the shelf are steel castings. When connexion strips are not required, as in the case of one shelf of a 20 bank multiple, a simple post is used as shown in Fig. 1. The connexion strips consist of moulded bakelite blocks which are made in two sizes: one with capacity for 7 rows of 20 tags and the other with capacity of 10 rows of 20 tags. The 7 row connexion strip is used wherever possible as it provides clearer access to the tags of the shelf jacks. Although these capacities are provided, only the number of rows of tags necessary is fitted.

The Jacking-in-Arrangements.

Previous mention has been made of the fact that the selector may be jacked in or out without loosening the bank rods. A photograph of a selector in the first position of being jacked-in is shown in Fig. 6. The two tongues at the foot of the fluted side members of the selector carriage are placed over the projection on the bottom bank plate. Having located the selector in this manner, it is a simple operation to guide it into its vertical position in which the jack springs engage automatically, and then send it home by a firm downward pressure. A little care is necessary to ensure that the wipers, particularly if vertical marking banks and wipers are fitted, are in such a position that they will not foul the banks.

Line Finders and P.B.X. Final Selectors.

The rigid method of fixing the banks and the fact that the wiper shaft is supported at both ends has made it a practical proposition to fit more than the three banks normally fitted on 200-line line finders and final selectors. The Automatic Electric Company claim that a selector of the 2000 type with 10 banks and 10 pairs of wipers will give satisfactory service. Advantage has been taken of this rigidity to add a fourth bank to line finders to provide for 4th-wire metering, and to 2/10 P.B.X. final selectors to give the marking facility on first, intermediate and last lines of P.B.X. groups. The arrangement in the latter case dispenses with the auxiliary screw arc used at present. The conditions required for any P.B.X. group may therefore be set up at one point on the connexion strips behind the shelves, where the fourth bank is terminated with the other banks.

Banks.

The selector banks are essentially of the same construction as the existing type and the wipers have the same overall working radius. It will be seen in Fig. 7, however, that the bank sets are fitted closer together. This has been made possible by the use of counter-sunk screws fixing together the ten double layers of contacts in each set. The sets are bolted together by the same two bank rods which fix the banks to the cradle. This arrangement is comparatively rigid and the banks are not disturbed during withdrawal or replacement of a selector. It is anticipated, therefore, that bank wiring faults in working exchanges will be practically unknown.

It is perhaps generally known that the bank contacts are assembled on thin strips of tacky oiled linen and vulcanized paper treated with synthetic resin which insulates each contact from all others, and that each layer of contacts thus assembled is separated from its neighbour by a strip of aluminium for strength. Some time ago experiments, which were

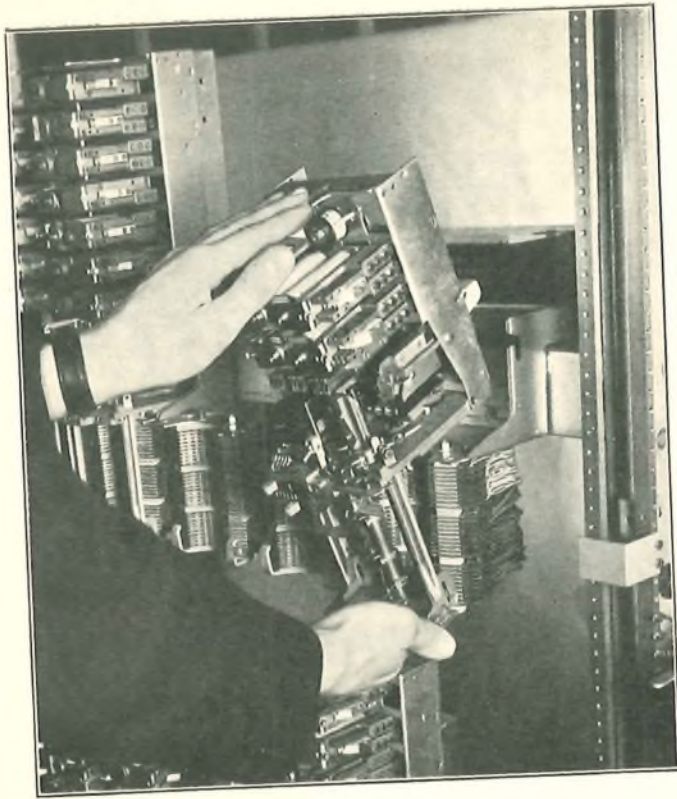

FIG. 6.—JACKING-IN A SELECTOR.

made to discover the cause of cross-talk, indicated that cross-talk caused by the adjacency of bank contacts was practically eliminated if approximately 80% of these aluminium spacers were connected together. To achieve this object one of the bank rods of each pair is slightly flattened before being pressed into the bank, thus making contact with the

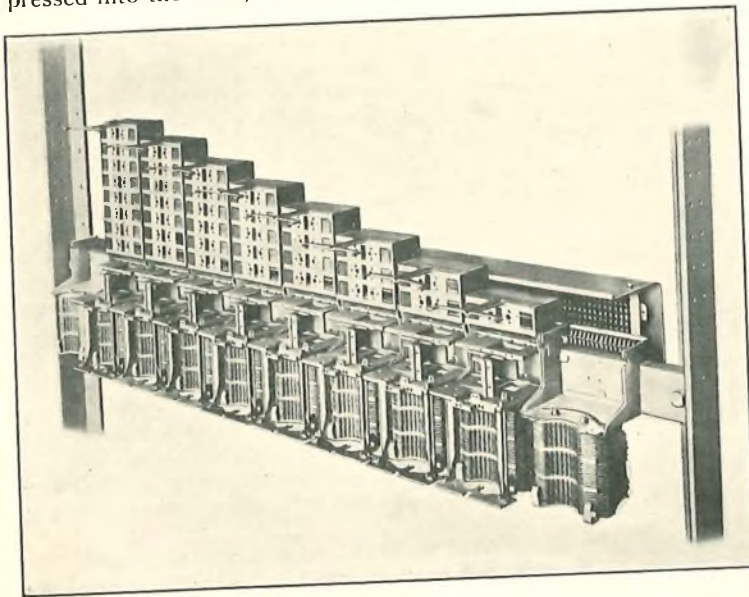

FIG. 7.—COMPARATIVE SIZES OF SELECTOR BASES.

edge of the round holes in the aluminium spacers. As pressure is necessary for this operation it follows that the rod is difficult to remove by hand, and although removal of bank rods is rarely required, provision has been made against such a necessity by the design of a suitable extracting tool, Fig. 8.

Re-design of Relay Sets.

Several reasons contributed to the decision to re-design jacked-in relay sets, directors, coders and senders concurrently with the development of the 2000 type selector arrangements.

For economic reasons it is desirable to be able to accommodate all jacked-in units on the same type of shelf and that as many as possible of the parts and tools used for the selector should be useable for the relay sets. In this connexion relay sets have been designed with a bottom plate, and so arranged that the covers designed for the 2000 type selectors are suitable also for the new relay sets.

Further, it will be seen from Fig. 9 that the existing equipment and the new equipment are in different positions relative to the rack upright. The overall measurement from front to back is the same in each case, 1' 2" to outside of guard rails, but the front of the new equipment is nearer the rack upright. Selectors and relay sets are frequently mounted on the same rack, and in the same suites, and it will be obvious that the two mounting arrange-

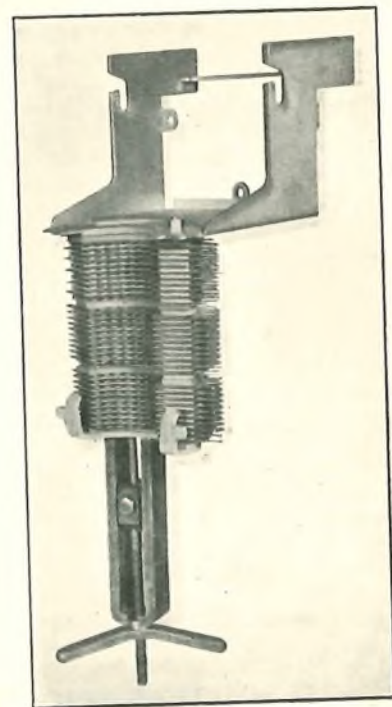

FIG. 8.—BANK ROD EXTRACTOR.

Telephone Exchange Equipment Standards G. BROWN, A.M.I.E.E.

THE stage reached with standardization of apparatus and equipment for telephone exchanges will, perhaps, be better appreciated after an impression of the position as it was 10 years ago, when the only available standards were those developed for manual exchanges.

At that time programmes were being arranged at Headquarters for the early introduction of the automatic system throughout the country and it was evident that extensive reconstruction of the Trunk system was imminent. Facilities, economics and traffic data had to be studied, automatic trunking schemes worked out and accommodation difficulties overcome. Visits abroad were made to study the communication systems of other administrations; circuits were designed; maintenance procedure was considered and plans made for training staff.

Many of the old exchange buildings were accommodating plant on every available square foot of floor space and in some exchanges no spare equipment existed; great difficulty was experienced therefore in many cases, in providing exchange apparatus for new subscribers' lines.

Contracts for extensions of existing equipment and for the provision of new exchanges were placed with the manufacturers. Works specifications for these had to be drafted under conditions of pressure; in some cases, the urgency was so great that work in the factories was commenced from scheduled information issued in advance of the specifications.

Under such conditions as these, it was not a simple matter to determine standards which could be followed immediately by all Contractors, especially as manufacturing methods and installation practice varied with the different Contractors. Nevertheless, the unremitting efforts of the Post Office and the manufacturers resulted after a time in the production of a number of equipment standards.

It is not proposed to deal in detail with all the items of exchange equipment in use, but rather to confine this article to a brief description of the outstanding changes to existing standards and to new standards which have been introduced within the past 10 years

Accommodation.

Four standard buildings are now available for Unit Automatic Exchanges. These have been classified according to size :—

Type	Capacity.
A	100 lines.
B	200 "
C.1	500 "
C.2	800 "

Several constructional details have been settled for larger exchange buildings such as the 10 ft. and 12 ft. clear height of apparatus rooms, subsidiary girder arrangements and leading-in cable trenches. Ven-

tilating systems are being adopted. Automatic control of humidity in certain unattended exchange buildings by means of electric heaters is under consideration.

Manual Switchboard Sections.

Three sections have been standardized for general use in Trunk and Auto-manual exchanges. These are (a) the three position, and (b) the single position section, both 6' 4" high, and (c) the single position section, 4' 8" high. A larger section, 7' 6" high, with greater cabling space, designed for London Trunk Exchange and large provincial zone centres, is also available. The C.B. No. 1 and C.B. No. 10 manual sections are obsolescent.

A comparison of the old and new key-shelves may be of interest :—

	Old C.B. Standard.	New Auto-manual and Trunk Standard.
Width of key-shelf ...	23 ins.	27 ins.
Depth from front edge of key-shelf to face of panel	15 $\frac{3}{4}$ "	18 "

The adoption of the 27" wide position gives seven 11 $\frac{1}{2}$ " jack panels for three operators positions.

Other changes in connexion with new switchboard standards are the use of the 30° angle sections for negotiating bends, giving greater elbow room and chair space for operators. The 22 $\frac{1}{2}$ ° angle section has been abandoned. Easier access to the interior of the sections has become possible by the use of rows of cable pin supports which have one end fixed in a stile bar and the other end resting in a link of a cycle chain suspended from the top of the section.

Key-shelves are now designed to take pneumatic tubes on the under side with inlet valves for tickets on the surface. They are also provided with transparent panels of "Rhodoid" recessed in the surface for displaying bulletins of traffic information.

The external appearance of the sections has been altered by the elimination of the heavy moulding above the frieze. The frieze itself is set at an angle and finished with a linoleum surface which may be used, if required, for designations or traffic notices.

Fireproof bulkheads and cable shelves are not included in the new designs.

These new arrangements of switchboard equipment were the immediate outcome of the introduction of the Trunk Demand system.

A few sections for special purposes have been designed, such as the Directory Enquiry Bureau now being installed at Manchester.

There are, of course, numerous well known miscellaneous items in common use, such as jacks, keys, plugs, condensers, etc., which are covered by standard drawings.

Apparatus Room Equipment.

With the exception of the main frame, all the

equipment normally installed in the apparatus room has undergone some change of design within recent years.

In the case of the intermediate distribution frame, horizontal mounting of the tag blocks on one side has been abandoned. Both sides of this frame are now designed for vertical mounting. This change has resulted in fewer faults from dust, wire cuttings and blobs of solder.

More radical changes have been made in the design of some of the other items. The apparatus racks, for instance, are now constructed on the open type principle, with channel shelves carrying jacked-in selectors or relay sets, which are accessible from one side of the racks only. The racks and frames are finished with light grey glossy paint, which is the standard finish for racks, frames and fittings in automatic and trunk exchanges.

Methods of mounting and lay-outs of apparatus on the racks are included in the Department's standard specifications. Approximately 1200 of these, together with drawings where necessary, have been issued.

Apart from the general racks for selectors, etc., important changes have been made in other directions.

Subscribers' Meters.

The new 100 type meter is smaller and weighs about 10 oz. less than the old meter. These new meters are assembled in panels of 100 and mounted 1000 on a rack with copper-oxide rectifiers for line-finder systems. When rectifiers are not required, 1200 meters may be mounted on a rack. Only 600 of the old type of meter could be mounted on similar racks.

Miscellaneous Apparatus.

The Special Apparatus Rack or S.A.R. has for many years served a useful purpose inasmuch as it was available for "after-thoughts" in the laying out of exchanges. The only special feature about the S.A.R. was its light construction—too light for present day requirements. Specified assemblies of jacked-in and strip mounted apparatus have now been drafted and the rack construction has been brought into line with standard requirements. This rack has been re-named the M.A.R. or Miscellaneous Apparatus Rack.

T.D.F. (Trunk Distribution Frame).

This frame provides a standard means of grading selector outlets. Bare cadmium-copper wire is used for strapping and the grading of any particular group may be readily inspected on the front of the frame.

Travelling Ladders.

Apparatus gangway ladders fitted with automatic brakes and capable of being reversed in the gangways, have been introduced.

Mezzanine Platforms.

A suitable light steel framework construction supporting a platform at mid-height and fitted with a system of strip lighting, has been developed for use with large main distribution frames. A specification will be available soon.

Lighting of Apparatus.

Electric light wiring and fittings are now provided as part of the equipment of apparatus racks, wiring gangways and distribution frames.

Unit Automatic Exchanges.

Equipment is being developed for three standard sizes of this type of exchange. They will be described as:—

U.A.X. No.	12	Capacity	100 lines
"	"	13	" 200 "
"	"	14	" 800 "

Relays.

The Post Office 3000 type standard relay is now being applied to circuit requirements wherever practicable. Up to the present, approximately 1300 separate designs of 3000 type relays have been dealt with for circuit purposes.

There is also the Post Office standard 600 type line and cut-off relay. This relay, besides being used for line and cut-off requirements, will be employed as a "donkey" relay when it can be applied in large quantities and mounted separately on strip mounted plates. A description of the 600 type relay appears elsewhere in this issue of the Journal.

Relay Sets.

Jacked-in assemblies of relays, resistors and associated items of apparatus have been developed in sizes varying from 10 to 32 relays per plate. Generally, it is arranged that one relay set plate will take apparatus for one circuit only, but suitable miscellaneous circuits are occasionally arranged two or more per plate. Approximately six hundred standard relay sets have been developed to date.

Selectors.

A new selector for automatic exchange purposes has been developed and is about to be introduced as standard. This new selector will be known as "Post Office 2000 Type Selector." Field trials have been proceeding for some time and arrangements have been made for equipping certain exchanges with it in the near future. A description of the proposed new standard selector and details of the changes resulting from its introduction, will be found in another part of this issue of the Journal.

Uniselectors.

A rotary 25 point uniselector, ranging from three to eight levels, has been specified as standard by the Department.

Directors, Coders and Senders follow recognized standard drawings.

Testing Equipment.

Improvements have been made in the design of the test desk, such as the increase in height and depth to allow greater capacity for apparatus and provide improved cabling space. Filing sections with their card records are no longer provided as part of the desk. The present lay-out for local exchanges over 900 lines capacity, is one miscellaneous section

to every two testing sections. This miscellaneous section accommodates a panel containing a decibel-meter, which supersedes the older arrangement of artificial cable and Bell receiver, for transmission testing. A horizontal type of voltmeter will be provided in the near future instead of the round type.

For automatic exchanges of 500/900 lines capacity, a 1' 4 1/2" rack equipped with the essential testing features of the test desk, is now a standard arrangement.

In exchanges below 500 lines capacity a portable tester (No. 25) is used.

Trunk exchange testing, with the advent of the Trunk Demand System and the general increase in volume of trunk testing, has demanded special arrangements. Standard racks are used for mounting the testing apparatus, which includes, besides the usual keys and horizontal voltmeter, a jack field with canopy for patching cords. Megger testing apparatus is provided and the necessary relays, resistors, etc., associated with the testing circuits, are mounted on the upper portion of the rack.

Cabling and Wiring.

It was realized in the early stages of development of large automatic equipments, that the available range of braided switchboard cables was inadequate. The following comparable tables show the changes made and the new types of cables which have been added to the list since 1925 :—

1925.			1935.		
No. of Wires.	Shape of Cable.	Weight of Conductor lbs./mile.	No. of Wires.	Shape of Cable.	Weight of Conductor lbs./mile.
11	Round	9.2	6		9.2
21	"	"	12	Round	36.8
21	"	12.5	12	"	9.2
22	"	9.2	20	"	"
22	"	12.5	21	"	"
24	"	9.2	22	"	"
33	Oval	"	30	"	"
42	"	"	33	"	"
42	"	12.5	40	"	"
59	"	9.2	42	"	"
63	"	"	44	Oval	20.7
63	"	12.5	52	Round	9.2
63	Flat	9.2	60	"	"
84	Oval	"	63	"	"
84	"	12.5	63	Oval	"
105	Round	9.2	75	Flat	"
154	"	"	80	"	"
			84	Oval	"
			100	Round	"
			105	"	"
			125	"	"
			154	"	"
			200	"	"
			300	"	"

Cables standardized for special requirements since 1925 :—

Signal and Tone Leads. (Cable Sw/Bd. I.R.).

6 wire—round—20.7 lb. per mile.
12 " " " " " "
24 " " " " " "

Voice Frequency Tone Leads. (Copper screened).

1 wire	9.2 lb. per mile.
1 " "	20.7 " " "
2 " "	9.2 " " "
2 " "	20.7 " " "
22 " "	9.2 " " "
63 " "	9.2 " " "

Cable for U.A.X. Equipment. (Enamelled and Flame-proof).

1 pair	9.2 lb. per mile.
3 wire	" " " "
4 " "	" " " "
4 pairs	" " " "
11 " "	" " " "
21 " "	20.7 " " "
25 " "	9.2 " " "

Switchboard Cable. (Lead covered).

For use in cable chases or conduit.

6 wire	9.2 lb. per mile.
12 " "	" " " "
20 " "	" " " "
21 " "	" " " "
22 " "	" " " "
30 " "	" " " "
33 " "	" " " "
40 " "	" " " "
52 " "	" " " "
60 " "	" " " "
75 " "	" " " "
80 " "	" " " "
100 " "	" " " "
105 " "	" " " "
125 " "	" " " "
154 " "	" " " "
200 " "	" " " "

Jumper Wire.

Serious trouble has been experienced for some time due to attacks from the cloth moth on the insulation of jumper wires in certain exchanges. Chemical treatment of the flame-proof jumper wire has been tried, but the extent of the trouble is such that it has been considered advisable to introduce a new type of jumper wire which will be immune from moth attack. Arrangements are being made for supplies of this new wire, which will be tinned, double acetylated cotton covered and cellulose acetate lacquered. Enamelled jumper wire of the same type will also be available in due course, for use where required.

Plate Wiring.

Wherever possible, apparatus plates and mountings are being wired with a type of wire known as "Cotopa," which is the trade name for a wire insulated with an acetylated cotton yarn.

Impregnation of Cables.

The possible use of "Seekay" wax for impregnating switchboard cable forms and wires, instead of beeswax, is under consideration. This is a material produced by chlorination of naphthalene. It is non-inflammable and resists attack from insects. Less

discolouration of the insulating material on wires is anticipated from its use.

Power Plant.

Power boards for large exchanges have been standardized in six sizes. By an arrangement of floating motor generators continuously on the exchange battery and trickle charging, it is anticipated it will be possible to standardize charging machines in five sizes.

Power Distribution.

A standard scheme of distribution over automatic exchange apparatus employing bus bars or cable feeders alternatively, with local fuses and alarms on the racks, has been prepared with the intention of introducing it concurrently with the standard 2000 type selector.

In conclusion, it may be mentioned that the closest possible co-operation between the Contractors' experts and Post Office Engineers has been maintained throughout the various stages of development connected with the introduction of new or modified items of apparatus and equipment. The large number of drawings and specifications which has to be amended by the Department and the manufacturers when changes are made to standards, is fully appreciated by the staffs concerned and every possible effort is made to keep these to a minimum.

Arrangements are also made to discriminate between minor non-urgent modifications to standards and important changes. A master list of standards applicable to current contracts is used to control such changes. This master list is reviewed and issued to the Contractors every six months.

Telegraph and Telephone Plant in the United Kingdom

TELEPHONES AND WIRE MILEAGES. THE PROPERTY OF AND MAINTAINED BY THE POST OFFICE IN EACH ENGINEERING DISTRICT AS AT 30TH SEPT., 1935.

Number of Telephones owned and maintained by the Post Office.	Overhead Wire Mileages.				Engineering District.	Underground Wire Mileages.			
	Telegraph.	Trunk.	Exchange*	Spare.		Telegraph.	Trunk.	Exchange. †	Spare.
908,978	434	5,374	49,653	6,717	London	37,902	230,440	3,920,879	86,607
114,522	2,067	15,684	49,794	8,255	S. Eastern	5,680	81,847	390,360	70,758
131,297	4,373	36,752	83,566	5,949	S. Western	24,732	71,224	306,904	70,592
91,134	4,218	37,921	76,586	13,078	Eastern	16,340	80,968	186,773	49,847
141,174	5,018	36,099	62,991	23,396	N. Midland	6,481	208,065	352,740	97,886
114,771	3,253	22,645	70,359	13,931	S. Midland	9,277	87,693	343,965	63,775
77,012	3,017	26,030	62,839	9,186	S. Wales	6,293	65,055	170,880	34,451
153,466	4,467	21,202	64,044	16,250	N. Wales	8,437	110,622	483,804	75,024
196,977	1,264	4,429	29,063	10,186	S. Lancs.	7,572	130,795	703,496	74,368
128,902	5,362	22,852	42,690	8,305	N. Eastern	12,088	105,253	364,056	40,657
84,012	1,122	12,890	30,395	15,857	N. Western	5,791	80,051	266,312	87,884
65,172	1,231	13,195	23,683	7,525	Northern	4,409	56,867	204,492	25,519
32,391	3,089	11,107	13,618	1,573	N. Ireland	412	7,580	83,002	21,652
94,539	4,571	27,180	44,847	9,038	Scotland E.	2,008	65,683	185,864	53,611
117,434	3,912	20,561	37,611	8,188	Scotland W.	10,516	86,041	288,585	100,221
2,451,781	47,398	313,921	741,739	157,434	Totals.	157,938	1,468,184	8,252,112	961,852
2,414,598	47,935	325,200	728,655	147,929	Totals as at 30 June, 1935	154,665	1,408,875	8,183,091	834,575

* Includes low gauge spare wires (*i.e.*, 40 lb. bronze on open routes and 20 lb. or less in aerial cables).
† Includes all spare wires in local underground cables.

The Long Distance Telephone System in India

N. F. FROME, D.F.C., M.Sc., A.M.I.E.E.,
of the Indian Posts and Telegraphs Department.

General.

THE Telephone System of the Posts and Telegraphs Department in India has expanded very rapidly during recent years. New exchanges have been, and are being, installed all over the country and a considerable mileage of trunk telephone lines linking these exchanges to the general long distance network has been erected. In addition, the rapid growth of trunk traffic has necessitated the provision of alternative routes and additional channels between main stations. The present state

of development of the long distance telephone system is illustrated in Fig. 1. The circuits of this network are all carried on overhead line wires mainly of 200 lbs. and 300 lbs. per mile copper, a 300 lbs. copper pair 300 miles from terminal station to terminal station being, more or less, a typical main trunk line in India. The shorter direct working trunks which occur throughout the network vary from some 30 to 150 miles in length, and are usually of 200 or 300 lbs. per mile copper conductors, or in some instances on short minor lines, 600 lbs. iron

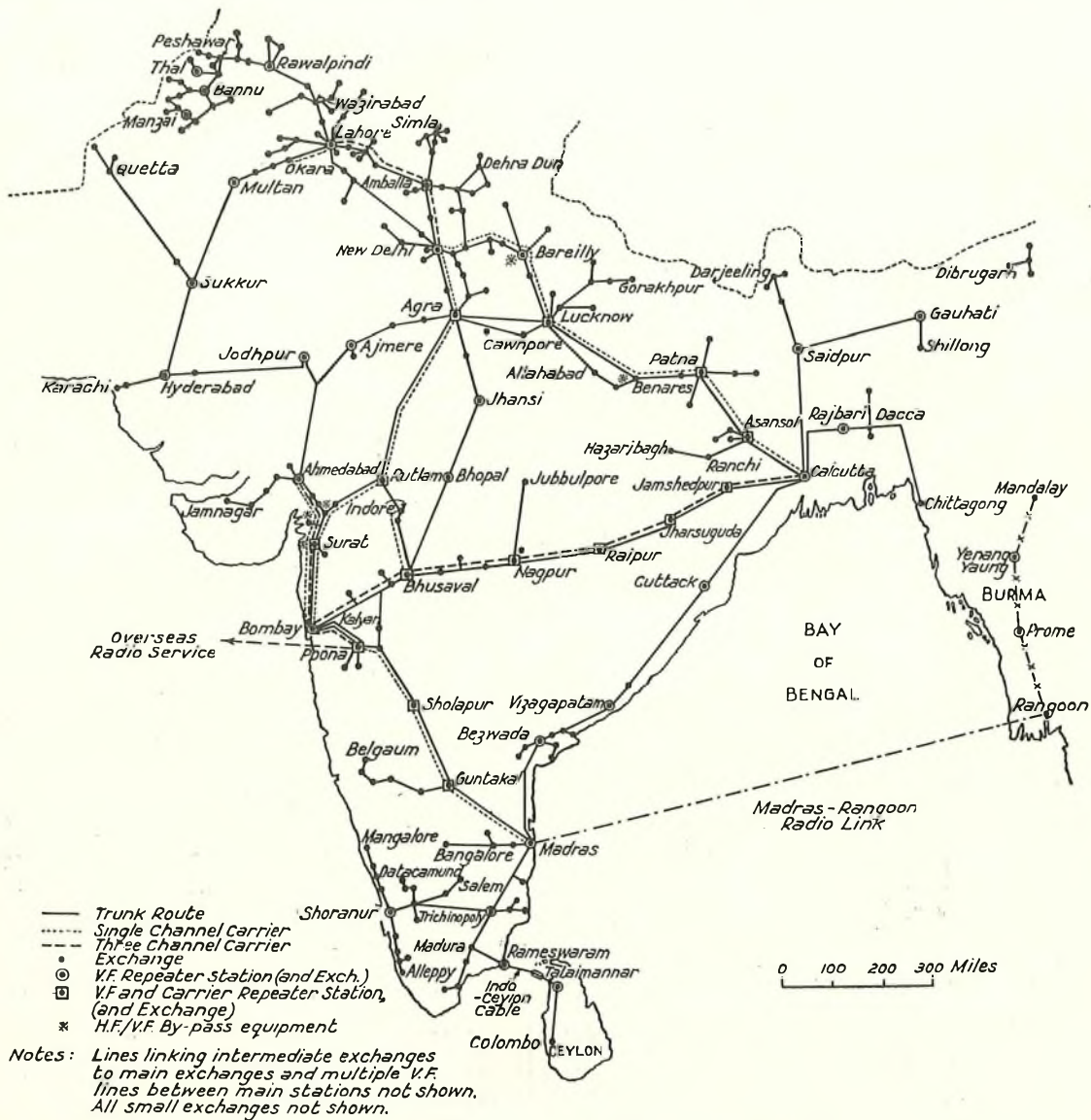

FIG. 1.—LONG DISTANCE TELEPHONE SYSTEM OF INDIA.

wires. All trunk circuits are transposed, using balanced physical or phantom transposition schemes of approximately 8 mile sections with 32 transposition points per section. Details of the line constructional methods employed in erecting these circuits have been given in a previous article.¹ The phantom circuits on trunk telephone pairs are normally operated as telegraph channels, where a balanced telephone quad is not in use, and, to a very limited extent, composite telegraph and telephone working on trunk circuits is also employed.

Long Distance Switching.

The trunk circuits are operated on a ring-down basis (16 cycle ringing), the lines generally being terminated on Departmental type Trunk Switchboards (Fig. 2). These units are designed to work

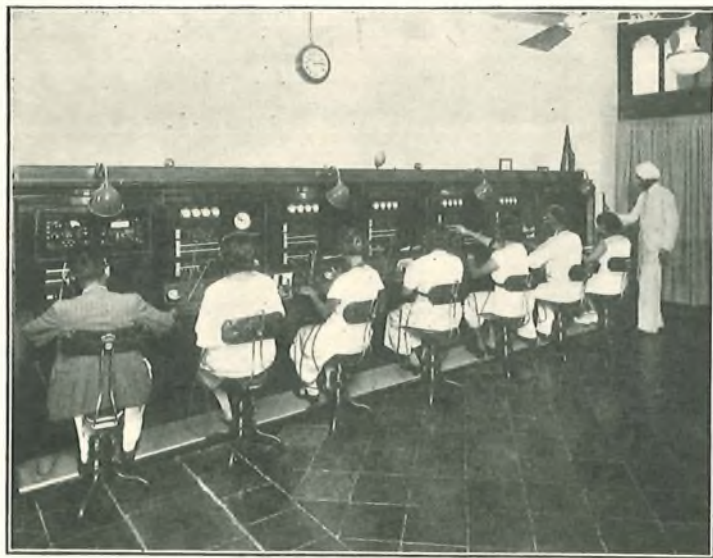

FIG. 2.—TRUNK SWITCHBOARD.

into all types of local exchanges, both manual and automatic; the trunk lines are multiplexed to all working positions and four to five circuits are allotted to each position as an operator's normal load. A feature of the cord circuits is the provision of low loss monitoring facilities which enable the operator to effect monitoring supervision on a call with the introduction of only a small transmission loss.

Record operating, trunk call booking and ticket procedure, and the methods of trunk line operating used in the Department follow normal delay practice. Trunk traffic is regulated by the main exchanges which act as controlling stations on the various circuits radiating from them, calls being completed in accordance with booking time priority.

Telephone Repeaters.

The long distance telephone repeater stations are spaced roughly 200-300 miles apart, circumstances

being such that repeater stations usually have to be situated at intermediate stations rather than at the ideal positions. The voice frequency channels are all worked as two-wire circuits, line repeaters with through (16 cycle) ringing being used on the long distance lines, and cord circuit repeaters for linking up two or three main line sections for shorter distance calls, or interconnecting the trunk lines radiating from a trunk centre. Gains up to 20 db. are available on both types of repeater, and fixed balancing networks of the type shown in Fig. 3 are used for the line balances. At one time it was considered necessary to use adjustable networks to deal with the variable line conditions which occur in India (the line insulation may vary from 0.5 megohms per mile in the rainy season to figures above 30 megohms per mile in the dry weather, and line temperatures range from just above freezing point to well over 120°F), but experience has shown that in spite of these variations stable working conditions can be obtained with fixed networks and fixed potentiometer settings.

It is now no longer the usual Departmental practice to design balancing networks from impedance bridge measurements of the lines, the components of the network being obtained instead by singing point tests made with balance simulators. This method has been found to give very satisfactory results and is quicker and more convenient than deriving a network from impedance bridge measurements particularly in the case of short lines. Singing points from 25-30 db. are normally obtained on all but very short trunk circuits and the tendency is now, for cord circuit repeater working, to add pads to short lines when connected to the repeaters to enable the latter to be worked at fixed gains on all lines. A level diagram of a typical long distance voice frequency circuit is shown in Fig. 3.

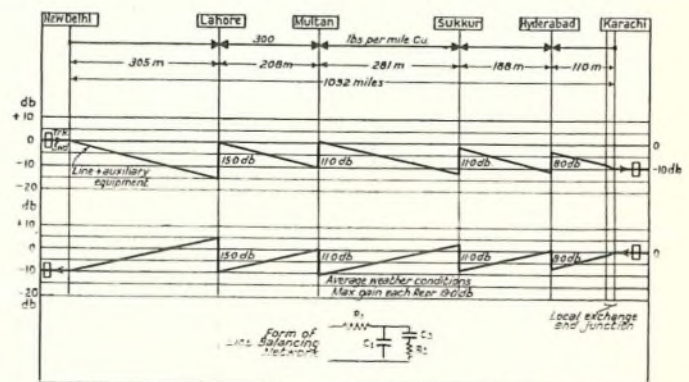

FIG. 3.—TYPICAL LEVEL DIAGRAM OF V.F. CIRCUIT.

The telephone repeaters themselves are of standard designs, but include features to suit the climatic conditions in India. These necessitate particular attention being paid to the insulation standards and wiring of the repeater components. The use of wiring forms is avoided as much as possible to overcome

¹ "Line Construction in India." *P.O.E.E. Journal*, Vol. 26, Part III., page 200.

low insulation troubles, and types of construction (such as that shown in Fig. 4), which permit of a large degree of open point-to-point wiring have been found the most satisfactory. The power supply for

Carrier Circuits.

The additional channels between main stations necessitated by the growth of trunk traffic have, in recent years, largely been provided by the installation of single and three channel carrier telephone equipments as indicated in Fig. 1.

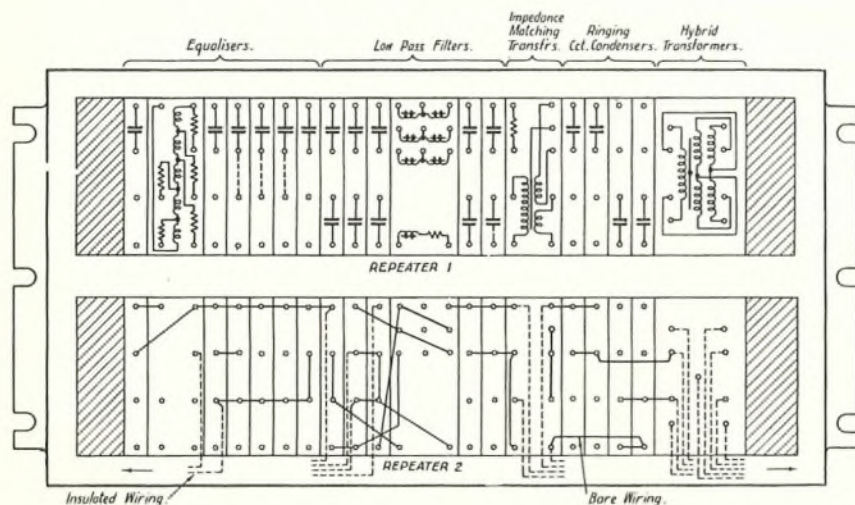

FIG. 4.—REPEATER PANEL, REAR VIEW.

repeaters is arranged according to the local facilities available—secondary batteries, direct supply from D.C. mains, or direct supply from A.C. mains through rectifiers are all used.

Points of interest in this design are the arrangement of the amplifying units (illustrated in Fig. 6), the adjustable attenuation equalizers, the means of ringing on the carrier channel and the level indicating scheme. Ringing is carried out by the 16 cycle ringing current from the switchboard operating a chain of relays which switch a condenser in and out of the oscillator circuit at 20 cycle periods, detuning the

(a) Details of the single channel carrier circuits in use are given in Table I; single channel carrier terminal equipments are shown in the centre of Fig. 5. This particular type of equipment is one which includes both carrier and voice frequency apparatus and is operated directly from D.C. or A.C. power mains supplies through resistances, or rectifiers, with ballast lamp control.

Points of interest in this design are the arrangement of the amplifying units (illustrated in Fig. 6), the adjustable attenuation equalizers, the means of ringing on the carrier channel and the level indicating

TABLE I.

SINGLE CHANNEL CARRIER INSTALLATIONS.

Route.	Total Length. Miles.	Line Conductors. (Copper).	Carrier Frequencies. Kc.p.s.	Side Band Frequencies Transmitted. Kc.p.s.	No. of Repeater Stations.	Overall Transmission Equivalent (db.).	Remarks.
New Delhi-Bombay.	905	300 lbs.	5.8	ND-BY 6.1-8.2 BY-ND 5.5-3.4	3	10.0	Suppressed carrier—one carrier frequency for both directions. Side band width 300-2400 cycles. Range without repeaters 38 db. Transmission output lower band +10.0 db. Transmission output upper band +11.3 db. HF gain control 16 steps of 1.74 db.
New Delhi-Calcutta.	970	300 lbs.	5.8	ND-CA 6.1-8.2 CA-ND 5.5-3.4	3	10.0	
Bombay-Ahmedabad.	306	300 lbs.	5.8	AM-BY 6.1-8.2 BY-AM 5.5-3.4	Nil	10.0	
Bhusaval-Indore.	167	300 lbs.	5.8	ID-BH 6.1-8.2 BH-ID 5.5-3.4	Nil	5.0	
Lahore-Okara.	80	200 lbs.	6.87 10.30	LH-OKR 6.67-4.17 OKR-LH 10.1-7.6	Nil	6.0	
Poona-Madras.	675	300 lbs.	6.87 9.60	PN-MS 6.67-4.17 MS-PN 9.8-12.3	2	4.0	Suppressed carrier. Side band width 200-2700 cycles. Automatic level control. When extended on a channel of Poona-Bombay 3 channel equipment over-all transmission equivalent Madras-Bombay 4.0 db.

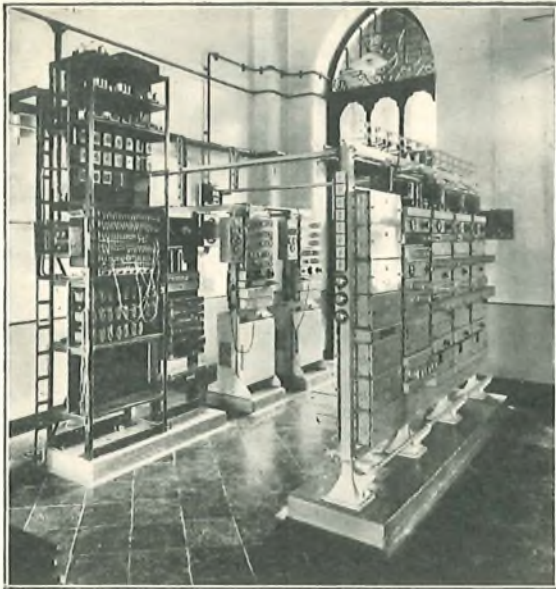

FIG. 5.—CARRIER TERMINAL EQUIPMENT.

oscillator plus or minus 500 cycles giving ringing frequencies of 6300 or 5300 cycles respectively. At the receiving end, after demodulation, the 500/20 cycle current is rectified, the direct current pulses operate a 20 cycle tuned relay and this, in turn, operates a relay to switch 16 cycles ringing current to the switchboard.

Level indication is given at all stations on the line from the output of standard 1500 cycle valve oscillators which are switched on automatically at the terminal stations when the circuit is not in use, the levels being recorded on indicating meters on the output side of the H.F. amplifiers (Fig. 6).

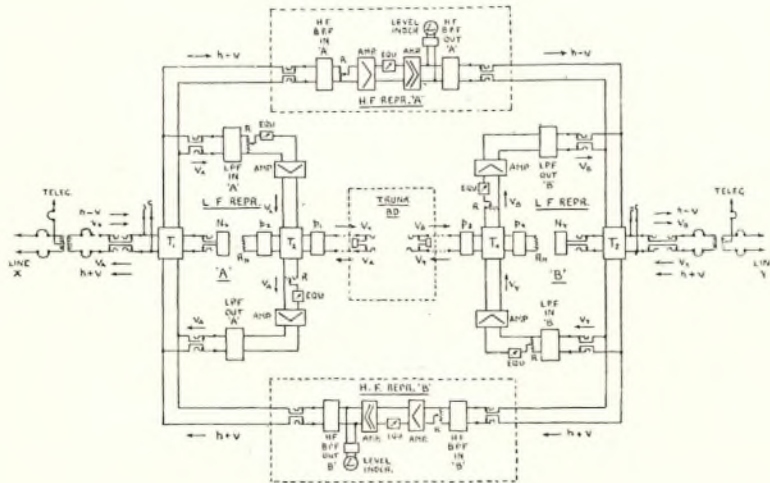

FIG. 6.—SCHEMATIC DIAGRAM OF INTERMEDIATE REPEATER EQUIPMENT H.F. AND V.F.

A level diagram of the combined V.F. and H.F. channels on the Bombay-New Delhi route is given in Fig. 7.

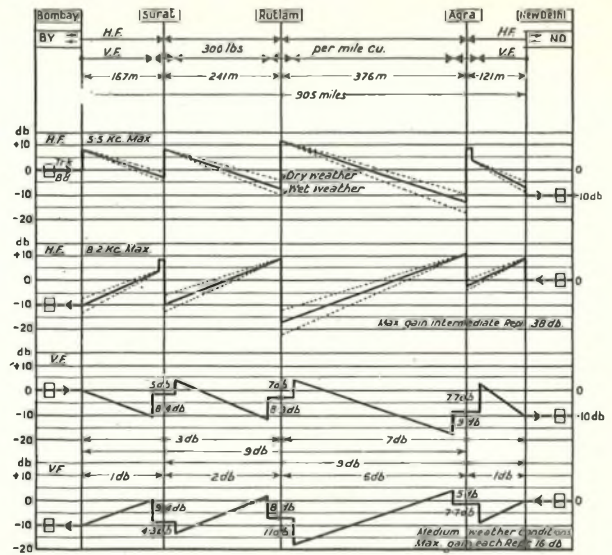

FIG. 7.—LEVEL DIAGRAM. SINGLE CHANNEL CARRIER AND V.F. CHANNELS.

On the Poona-Madras single channel carrier route automatic regulation is used to maintain a constant overall transmission equivalent. This is operated on the pilot channel system, pilot current being sent in one direction at 9.45 Kc.p.s. and the other at 6.8 Kc.p.s. The pilot transmitting circuits consist of single valve oscillators, and at the receiving end the pilot current, after amplification, is selected by a coupled tuned circuit and led to a valve rectifier with a pilot indicating meter in the anode circuit, the meter being calibrated in terms of change of pilot current above or below normal.

The automatic gain control is obtained by introducing attenuators in the amplifier circuits, the value of these being regulated (in 0.5 db. steps) by rotary switches operating according to the value of the received pilot current. The principle of the circuit operation is as follows:—

The rectified pilot current which operates the pilot indicator also passes through a marginal relay, which is actuated (when a change of line attenuation of 0.5 db. occurs) in a direction ready to give an increase or decrease of amplification as required. The marginal relay operates a second relay which closes the filament circuit of a delay valve. A condenser-resistance combination in the grid circuit of the latter, as well as the operating conditions of the relays concerned, provide a delay action before a relay in the anode circuit of the valve is operated, this delay feature ensuring that short line disturbances do not affect the gain regulation. Adjustment of the delay action also enables progressively longer delays at repeater stations

nearer the receiving terminal being used, to allow the control at the nearest receiving station to take precedence over the controls at later stations. When the delay circuit has operated, if the marginal relay is still responding to a change of pilot current, the regulating switches are stepped to alter the gain up or down as required, the control circuit returning to normal after the operation of the switch.

A pilot failure relay in series with the marginal relay is arranged to stop the operation of the regulating switches and give an alarm signal should the pilot current drop to more than 6-8 db. below normal, or when any abnormal conditions occur, as in the case of a line fault; the alarms are self-restoring when the trouble causing them is removed.

On this equipment ringing is performed by the 16 cycle ringing current from the switchboard actuating relays which (i) cause the carrier to be changed in frequency by 1000 cycles in the direction necessary to be passed by the band filter, (ii) unbalance the push-pull modulator allowing the altered carrier to pass at a definite energy value, and (iii) interrupt the transmitted current at 16 cycles. At the receiving end the interrupted 1000 cycle current is rectified in a tuned relay rectifier circuit and the

16 cycle component actuates a train of delay relays (to prevent operation of the ringing receiving circuit by speech) which ultimately switches 16 cycles ringing current to the switchboard indicator.

(b) Three channel carrier installations are in service, or are being installed, as shown in Fig. 1, details of these being given in Table II. A three channel terminal equipment is shown at the right hand side of Fig. 5 and a level diagram of one of the Bombay-Calcutta channels is given in Fig. 8.

On the Bombay-Calcutta route features of interest are the levels on the circuit, the method of operation of the automatic level control and the ringing arrangements. The automatic level control system used operates from the transmitted carrier, the received carrier controlling regulating equipment at the two terminal stations and the intermediate station at Nagpur. At the terminals each channel is regulated separately, but at the intermediate station the channel 2 carriers are selected from the common amplifier equipment to control the regulation.

The carriers are tapped after the H.F. amplifier units and led *via* a distributing relay chain to a common control repeater. The distributing circuit consists of a controlling condenser, relays, and neon

TABLE II.
THREE CHANNEL CARRIER INSTALLATIONS.

Route.	Total Length. Miles.	Line Conductors. (Copper).	Carrier Frequencies. Kc.p.s.	Side Band Frequencies Transmitted. Kc.p.s.	No. of Repeater Stations.	Overall Transmission Equivalent. (db.).	Remarks.
Bombay-Calcutta.	1223	300 and 400 lbs.	Ch. 1 12.2 Ch. 2 15.6 Ch. 3 19.0 Ch. 1 29.5 Ch. 2 32.8 Ch. 3 36.8	CA-BY 12.5-15.0 " 15.9-18.4 " 19.3-21.8 BY-CA 29.8-32.3 " 33.1-35.6 " 37.1-39.6	5	10	Ten channel duplex medium frequency telegraph system also carried on same pair Bombay-Calcutta. Partially suppressed carrier system. Automatic level control. Side band width 300-2800 cycles.
Bombay-Poona.	120	300 lbs.	Ch. 1 9.4 Ch. 2 16.2 Ch. 3 6.2 Ch. 1 24.4 Ch. 2 20.8 Ch. 3 28.3	BY-PN 9.6-12.1 " 16.0-13.5 " 6.4-8.9 PN-BY 24.2-21.7 " 20.6-18.1 " 28.1-25.6	Nil	4	On same alignment as Bombay-Calcutta system from Bombay to Kalyan (36 miles). Side band arrangements and levels specially allocated to minimise cross-talk with Bombay-Calcutta system. Totally suppressed carrier system. Side band width 200-2700 cycles.
Bombay-Ahmedabad.	310	200 lbs.	Ch. 1 15.0 Ch. 2 20.0 Ch. 3 25.0 Ch. 1 30.0 Ch. 2 35.0 Ch. 3 40.0	AM-BY 15.25-17.75 " 20.25-22.75 " 25.25-27.75 BY-AM 30.25-32.75 " 35.25-37.75 " 40.25-42.75	1	—	Extensible to 4 channels. Partially suppressed carrier. Side band width 250-2750 cycles. Automatic level control. Under construction.
New Delhi-Lahore.	320	300 lbs.	Ch. 1 12.2 Ch. 2 15.7 Ch. 3 19.2 Ch. 1 29.2 Ch. 2 33.2 Ch. 3 37.2 Ch. 4 8.7 Ch. 4 41.2	ND-LH 12.5-14.6 " 16.0-19.1 " 19.5-21.6 LH-ND 29.5-31.6 " 33.5-35.6 " 37.5-39.6 " 9.0-11.1 " 41.5-43.6	1	—	Extensible to 4 channels. Partially suppressed carrier. Side band width 300-2400 cycles. Equipment includes provision of 4 medium frequency telegraph channels New Delhi-Lahore. Under construction.

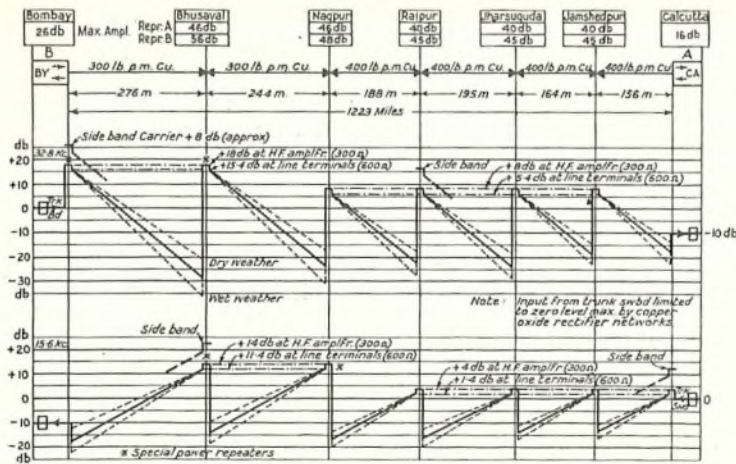

FIG. 8.—LEVEL DIAGRAM. THREE CHANNEL CARRIER SYSTEM.

lamp combination by means of which the common control repeater is regularly switched to test each amplifier circuit in turn, the frequency of the switching being regulated by prolonging or shortening the condenser charging time. At the terminal stations switching from channel to channel is arranged to occur at 12 second intervals and 1 min. 12 seconds is allowed for any gain control regulation. Shorter times are used at the intermediate station control to give the latter precedence over the terminal station controls.

When the common control repeater is switched to a particular channel the value of the anode current of the output valve of the repeater is regulated in accordance with the charge on a condenser in the grid circuit, the charge being controlled by the voltage of the carrier under test. Two relays in the anode circuit operate or remain unoperated, either singly or together, depending on the value of the anode current. The circuit conditions set up by these two relays are stored in a relay chain appertaining to the particular channel under test, and, if during the next cycle of testing the same circuit conditions are set up by the two control repeater relays, rotary switches to regulate the H.F. amplifier gain (in 0.9 db. steps) are operated. If the second test does not give a repetition of the first result the initial storing is released. The control is thus prevented from being operated by short line disturbances, or during ringing periods on the circuit. In the event of a sudden large drop of carrier level (8.7 db. or above) the automatic level control drops out of circuit and a special alarm is given indicating the occurrence of a line fault.

Ringing is also a function of the transmitted carrier feature and is performed as follows :—

Ringing current from the switchboard actuates an A.C. relay which in turn operates a switching relay. The latter prevents ringing current from directly affecting the modulator, alters the grid bias of the modulating valve raising the level of the carrier current by 22 db., and, at the same time, switches a 10 db. attenuating network into the output circuit giving a net increase of carrier current of 12 db. At

the receiving end a differential relay in the anode circuit of the demodulating valve, normally unoperated, is actuated by an increase of anode current from 3 to 6 milliamps, consequent on the reception of the increased carrier current. This relay operates others which connect the exchange line concerned to the ringing current supply, and short circuit the winding of a repeating coil on the transmitting side to prevent singing due to the unbalancing of the 4-wire termination.

The power supply to the equipments of this carrier installation is given directly from the mains with motor generator sets, ballast lamp control being used on the filament supply circuits and special carbon pile regulators at the terminal stations for the grid and anode circuits.

On the Bombay-Poona three channel equipment standard V.F. ringing is employed :—16 cycle ringing current from the switchboard is used to interrupt a 1000 cycle current supply from an oscillator common to all channels. At the receiving end the 1000 cycles is rectified by a valve and the 16 cycles component actuates a train of delay relays to operate the switchboard indicator.

Transmission Measurements.

Main trunk stations are equipped with attenuation and level measuring apparatus, volume indicators for speech level and noise measurements, and impedance bridges. With these, daily overall transmission measurements at 800 cycles on the through long distance voice frequency and carrier circuits are made; attenuation, noise, and speech level tests are taken on new circuits and check tests of circuit conditions for overseas calls carried out. The noise levels recorded are normally of the order of -40 db. under average weather conditions, and a difference of 20 db. between noise and speech levels is the limit which regulates the opening of a new circuit or connexion to the overseas link.

All important telephone centres are equipped with single or five frequency standard oscillators, attenuation indicators for routine line and exchange apparatus attenuation tests, and also with crosstalk meters. Tests on new circuits and routine tests on working pairs are taken with the latter, readings below 500 crosstalk units from any paralleling telephone or telegraph circuit being normally recorded on main trunk lines.

The impedance bridges are used for the investigation of suspected line irregularities which routine singing point tests (carried out monthly on all repeated circuits) may indicate.

Overseas Links.

(a) *Indo-Ceylon Telephone Cable.* Telephone communication between India and Ceylon has been rendered possible by the laying (1934) of a continuously loaded cable across the Palk Straits from Talaimannar to Rameswaram (see Fig. 1). This cable is 30 miles long and consists of four 200 lbs. per mile loaded copper conductors laid up in star

quad formation, insulated with gutta percha, brass taped and armoured. The cable carries India-Ceylon Baudot telegraphs on the phantom circuits in addition to the speech channels.

(b) *Overseas Radio Link.* India is also in communication with other countries of the world through the short wave radio telephone circuit operated between Kirkee and London. This link was opened for public service from Bombay in May, 1933, and the service has subsequently been extended to include the whole of the telephone system of India.

(c) *Telephone Communication to Burma.* In order that Burma may be linked to the trunk system of India a short wave radio telephone circuit between Rangoon and Madras is at present being installed.

Conclusion.

These notes indicate in a brief manner the growth

which has occurred in the long distance telephone system of India, and the working conditions on the circuits of the trunk network. Expansion is still continuing and it is anticipated that in the near future every town of importance in India will be connected to the trunk system with facilities for communication to any other part of India and to overseas countries, whilst the installation of other long distance three channel carrier equipment to give additional outlets between main stations is also contemplated. The extent to which development of the long distance telephone system has taken place in the last three or four years may be summarized by statistics from the Department's Annual Report :—

March, 1931	Trunk wire mileage ...	21,680	miles.
" 1933	" " "	30,700	"
" 1934	" " "	35,800	"
" 1935	" " "	44,900	"

“ Precut Poles ”

According to the Department's usual practice, poles are delivered to the scene of operations uncut in any way, and all drilling, slotting, and trimming at the tip, are carried out on site. It will be realized that such cutting and drilling penetrates the protective sheath of creosoted wood which forms the outer surface of the timber, and a system of preparing poles at the Pole Depot, before the pole is creosoted, would not only save time in the field, but also minimize the chances of decay.

The possibility of cutting slots in poles before issue has in the past been fully investigated, but it was found that, owing to variations in the extent to which poles and arms contract during seasoning, the proposal held out little promise of becoming a practical proposition. The original suggestion, therefore, underwent modifications and in its final form (as outlined by W. H. Brent in Paper No. 154, “ The Telegraph Pole ”) the proposal envisages the trimming of a “ flat ” on the pole of a length sufficient to accommodate the probable ultimate number of arms, having holes for the arm bolts accurately drilled and spaced down its entire line. The operations involved, together with the trimming of the apex at the top of the pole, are carried out prior to creosoting.

On the job, the arms are simply bolted against the flat and rigidity is assured by the use of Arm Braces extending from fixtures in the neighbourhood of the

inner insulator spindles to the arm-bolt securing the arm immediately below. The arm braces themselves are of galvanized mild steel, and in appearance are not unlike combiners, as used on 8-way arms. A good deal of experimental work has been carried out to determine the most suitable spacing and inclination of the arm braces for use on different types of arms, and the information so obtained has been crystalized into the design of a standard range of four braces.

As results obtained during trials indicate that a rigid arm assembly can be obtained at a cost certainly not greater than that of the existing method of slotting the poles, it has now been decided to meet the entire demands of certain areas for light poles of 24 ft. in length and over, with poles precut as described above. The Pole Depot selected is the one at Newport and the annual issue of light poles from this Depot will be sufficient to supply the whole of the needs of the South Wales Engineering District, and Bristol, Taunton and Plymouth Sections of the South Western Engineering District, which have accordingly been selected as the areas for the extended trial.

The pre-cutting scheme, although a considerable break-away from traditional methods, is considered to have every prospect of success and the large-scale trials in these two Districts will, it is hoped, give final confirmation of its suitability for general adoption.

R.M.

The Calculation of the Primary Constants of a Uniform Line from the Propagation Constants

A. ROSEN, Ph.D., A.M.I.E.E.
(Messrs. Siemens Bros. & Co. Ltd.)

INTRODUCTION.

IN a previous article,¹ the author discussed the calculation of the propagation constants, viz., the attenuation and phase constants and the characteristic impedance, from the primary constants, viz., resistance, inductance, capacitance and leakance, and gave short formulæ which lessen the labour of computation.

The reverse operation is required when measurements are made on completed lines and it is desired to find the values of the primary constants. It is well known that the propagation constants may be calculated from the impedances measured with the distant end open and closed: or the attenuation and phase constants may be obtained from a "Mayer" test, and the characteristic impedance by measuring the line with the far end extended to simulate the infinite condition.

The relations between the propagation and the primary constants are quite simple when expressed in terms of complex quantities, but the labour required to compute a series of tests by the usual methods may become very tedious. Furthermore, it is not obvious from the equations what relation exists between the precision of calculation and the accuracy of the final result, so that one cannot decide, for example, whether it is necessary to read angles closer than to the nearest minute, and whether 7-figure logarithms are preferable to 5-figure logarithms.

The simple formulæ given below permit a considerable saving of labour as no references to tables of angles are necessary, and the precision required in the calculations can be easily estimated; often, the slide rule can be used throughout. The equations are applicable to all types of uniform lines, loaded and non-loaded, and are valid for all frequencies.

RELATIONS BETWEEN THE PRIMARY CONSTANTS AND THE PROPAGATION CONSTANTS.

Let β be the measured attenuation in nepers per unit length,

α be the measured phase-shift in radians per unit length,

A be the measured resistance component of the characteristic impedance,

B be the measured reactance component of the characteristic impedance,

$\omega = 2\pi \times$ frequency.

To find R , the resistance in ohms per unit length,

L , the inductance in henries per unit length,

G , the leakance in mhos per unit length,

and C , the capacitance in farads per unit length.

The complex propagation constant, $\gamma/\Theta = \beta + ja$

where $\tan \Theta = \alpha/\beta$ (1)

and $\gamma = \alpha \operatorname{cosec} \Theta$ (2)

Similarly the complex characteristic impedance, $Z_0/\Phi = A + jB$

where $\tan \Phi = B/A$ (3)

and $Z_0 = A \operatorname{sec} \Phi$ (4)

Now $\gamma/\Theta = \sqrt{(R + j\omega L)(G + j\omega C)}$ (5)

and $Z_0/\Phi = \sqrt{(R + j\omega L)/(G + j\omega C)}$ (6)

Multiplying (5) by (6), we get

$$R + j\omega L = \gamma Z_0 / \Theta + \Phi$$

whence $R = \gamma Z_0 \cos(\Theta + \Phi)$ (7)

and $L = \frac{\gamma Z_0}{\omega} \sin(\Theta + \Phi)$ (8)

Dividing (5) by (6), we get

$$G + j\omega C = \frac{\gamma}{Z_0} / \Theta - \Phi$$

whence $G = \frac{\gamma}{Z_0} \cos(\Theta - \Phi)$ (9)

and $C = \frac{\gamma}{\omega Z_0} \sin(\Theta - \Phi)$ (10)

Thus the usual process of calculation is to derive γ , Θ , Z_0 and Φ using equations (1) to (4), and then to find R , L , G and C from equations (7) to (10).

ALTERNATIVE FORMULÆ FOR PRIMARY CONSTANTS.

The following relations are more convenient for computation, particularly if only one of the constants, e.g., resistance, is required:—

$$R = \alpha A(p + q) \dots\dots\dots(11)$$

$$L = \frac{\alpha A}{\omega} (1 - pq) \dots\dots\dots(12)$$

$$G = \frac{\alpha(p - q)}{A(1 + q^2)} \dots\dots\dots(13)$$

$$C = \frac{\alpha(1 + pq)}{\omega A(1 + q^2)} \dots\dots\dots(14)$$

where $p = \beta/\alpha$ and $q = -B/A$.

When q is less than 0.1, which is generally the case

¹ P.O.E.E. Journal, April, 1932.

for loaded cables, the following approximations are accurate to the ordinary limits of measurement:—

$$G = \frac{\alpha(p - q)}{A} \dots\dots\dots(13a)$$

error not greater than 1 per cent.

$$C = \alpha/\omega A \dots\dots\dots(14a)$$

error not greater than 0.1 per cent.

Example 1. At $\omega = 5,000$, the measured values are $\beta = 0.010$ nepers per mile, $\alpha = 0.2000$ radians per mile, $A = 500.0$ ohms and $B = -22.5$ ohms.

Then $p = 0.0500$ and $q = 0.0450$.

$$R = 0.2 \times 500 (0.05 + 0.045) = 9.5 \text{ ohms per mile.}$$

$$L = \frac{0.2 \times 500}{5000} (1 - 0.00225) = 19.96 \text{ millihenries per mile.}$$

$$C = 0.2/(5000 \times 500) = 0.080 \text{ microfarad per mile.}$$

$$G/C = 5000 \times 0.005 = 25.$$

Example 2. At $\omega = 5,000$, the measured values are $\beta = 0.10615$ nepers per mile, $\alpha = 0.11194$ radians per mile, $A = 416.0$ ohms and $B = -391.6$ ohms.

Then $p = 0.9483$ and $q = 0.9413$.

$$R = 0.11194 \times 416.0 \times 1.8896 = 88.0 \text{ ohms per mile.}$$

$$L = \frac{0.11194}{5000} 416.0 (1 - 0.8927) = 0.001 \text{ henry per mile.}$$

$$C = \frac{0.11194 (1 + 0.8927)}{5000 \times 416.0 (1 + 0.8861)} = 0.0540 \text{ microfarad per mile.}$$

$$G = \frac{0.11194 \times 0.0070}{416.0 \times 1.8861} = 1.0 \text{ micromho per mile.}$$

PROOF.

$$\text{Let } R/\omega L = \tan \theta$$

$$\text{then } R + j\omega L = \frac{\omega L}{\cos \theta} / \frac{\pi}{2} - \theta$$

$$\text{Let } G/\omega C = \tan \phi$$

$$\text{then } G + j\omega C = \frac{\omega C}{\cos \phi} / \frac{\pi}{2} - \phi$$

$$\begin{aligned} \text{Now } \beta + j\alpha &= \sqrt{(R + j\omega L)(G + j\omega C)} \\ &= \sqrt{\frac{\omega^2 LC}{\cos \theta \cos \phi}} / \frac{1}{2}\pi - \frac{1}{2}(\theta + \phi) \quad (15) \end{aligned}$$

$$\begin{aligned} \text{and } A + jB &= \sqrt{(R + j\omega L)/(G + j\omega C)} \\ &= \sqrt{\frac{L \cos \phi}{C \cos \theta}} \sqrt{\frac{1}{2}(\theta - \phi)} \dots\dots\dots(16) \end{aligned}$$

$$\text{Hence from (15), } p = \beta/\alpha = \tan \frac{1}{2}(\theta + \phi) \dots\dots(17)$$

$$\text{and from (16), } q = -B/A = \tan \frac{1}{2}(\theta - \phi) \dots\dots(18)$$

Further from (15)

$$\alpha = \sqrt{\frac{\omega^2 LC}{\cos \theta \cos \phi}} \cos \frac{1}{2}(\theta + \phi) \dots\dots\dots(19)$$

and from (16)

$$A = \sqrt{\frac{L \cos \phi}{C \cos \theta}} \cos \frac{1}{2}(\theta - \phi) \dots\dots\dots(20)$$

Whence multiplying (19) by (20)

$$L = \frac{\alpha A \cos \theta}{\omega \cos \frac{1}{2}(\theta + \phi) \cos \frac{1}{2}(\theta - \phi)} \dots\dots\dots(21)$$

and dividing (19) by (20)

$$C = \frac{\alpha \cos \phi \cos \frac{1}{2}(\theta - \phi)}{\omega A \cos \frac{1}{2}(\theta + \phi)} \dots\dots\dots(22)$$

From (17) and (18) it follows that

$$\tan \theta = (p + q)/(1 - pq)$$

$$\tan \phi = (p - q)/(1 + pq)$$

$$\cos \theta = (1 - pq)/\sqrt{(1 + p^2)(1 + q^2)}$$

$$\cos \phi = (1 + pq)/\sqrt{(1 + p^2)(1 + q^2)}$$

$$\cos \frac{1}{2}(\theta + \phi) = 1/\sqrt{1 + p^2}$$

$$\cos \frac{1}{2}(\theta - \phi) = 1/\sqrt{1 + q^2}$$

Substituting in (21), we obtain

$$L = \frac{\alpha A (1 - pq)}{\omega} \dots\dots\dots(23)$$

$$R = \omega L \tan \theta = \alpha A (p + q) \dots\dots\dots(24)$$

Substituting in (22), we obtain

$$C = \frac{\alpha (1 + pq)}{\omega A (1 + q^2)} \dots\dots\dots(25)$$

$$G = \omega C \tan \phi = \frac{\alpha (p - q)}{A (1 + q^2)} \dots\dots\dots(26)$$

Equation (25) may be written

$$C = \alpha/\omega A (1 - q \tan \phi) \dots\dots\dots(25a)$$

Now $\tan \phi = G/\omega C$ is the power factor of the dielectric; in communication lines it is of the order of 0.005. Thus in the approximate formula

$$C = \alpha/\omega A \dots\dots\dots(26)$$

the error will be of the order of $\frac{1}{2}$ per cent. in the worst case when $q = 1$, *i.e.*, for unloaded lines at low frequencies; when q is less than 0.1, *i.e.*, for loaded lines at any but the lowest frequencies, the error will be less than one part in two thousand.

The leakage has so little effect on the propagation constants that they have to be measured with very great accuracy in order to calculate it even approximately. When q is less than 0.1, the accuracy of one per cent. given by

$$G = \alpha(p - q)/A \dots\dots\dots(27)$$

is quite sufficient for practical purposes.

Recent Underground Diversion Works in London

W. BOCOCK, A.M.I.E.E.

Introduction.

DURING recent years the London Underground Electric Railways (now controlled by the London Passenger Transport Board) have modernized their tube stations by installing escalators and underground booking halls at Piccadilly Circus, Marble Arch, Hyde Park Corner, Chancery Lane and Leicester Square, etc. Chancery Lane Station was completed in June, 1934, and Leicester Square Station is expected to be completed early in 1936.

The majority of the tube stations are situated at road junctions and the additional entrances, subways, escalators and booking halls provided below the street level occupy a large portion of the roadway. In certain cases, as will be seen later, almost the entire width of the carriageway is required for these improvements. In consequence, diversion works of considerable magnitude were involved in moving the Department's plant in addition to the sewers, gas, water, hydraulic and electric supply mains. Details of the Chancery Lane and Leicester Square improvements are given below.

As the nature and extent of the removals were determined by the Railway Companies' civil engineering works a description of the main features of these works, so far as they affected the Department's plant, is included in these notes.

Incidence of Cost of the Work and Special Arrangements.

Detailed plans of the new subways, cable chambers, manholes and duct lines were agreed in the preliminary negotiations between the Department and the Railway Companies' representatives and their Civil Engineers.

The cost of the diversion of the Department's plant was wholly chargeable to the Railway Company concerned, and as the main Contractors responsible for the provision of the booking halls and escalators had previously carried out a large amount of Departmental contract work and were thus familiar with the Department's specifications, it was arranged that the main Contractors should build the manholes and cable chambers, and lay the conduits under Departmental supervision, their accounts for this work being rendered direct to the Railway Co's Civil Engineers.

By this agreement the Department was relieved of the responsibility of checking works diaries, paying accounts and claiming repayment for the aforementioned work.

The cabling charges account was submitted by the Accountant General on completion of the Works Order.

CHANCERY LANE STATION IMPROVEMENTS.

Fig. 1 is a plan of High Holborn by Gray's Inn Road, and shows the area affected by the Railway Co's operations and the general lay-out of the Department's manholes and main cable routes before the alterations.

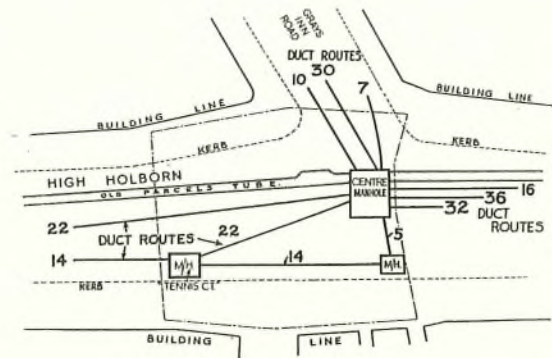

FIG. 1.—PLAN OF HOLBORN BEFORE THE DIVERSIONS.

Eleven main underground lines of a total capacity of 257 pipes and ducts connected to the centre manhole in High Holborn and containing 107 main cables were concerned in the diversion.

Fig. 2 is a cross-sectional view of High Holborn,

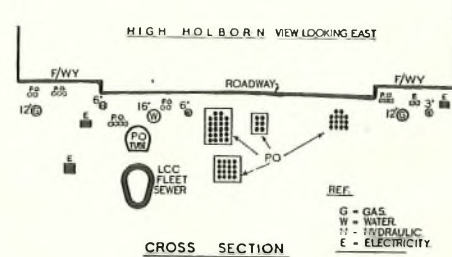

FIG. 2.—LAY-OUT OF PLANT BEFORE DIVERSION.

showing the relative positions of the various Undertakers' plant.

In addition to the Department's cables there existed 12" and 15" gas mains, a 6" hydraulic main working at 700 lbs. per square inch, two 6" and one 16" water mains, three sets of electric power supply cables and the 4' 6" diameter L.C.C. Fleet brick built sewer.

An item of particular interest is the old parcels tube, a metal tube 4' 6" x 4' 0", which was laid about 74 years ago for the transport of parcels on waggons propelled by atmospheric pressure.

Fig. 3 shows a cross-sectional view of the parcels tube. An interesting account of its early history was published in the July, 1934, issue of the *Post Office Magazine*. For many years the parcels tube, which was purchased from the original owners (the Pneumatic Dispatch Co.) has been used as a cable duct and in the section concerned carried 50 main trunk and junction cables and a 2 1/4" pneumatic tube, its ultimate capacity being 70 main cables. The tube gained considerable notoriety as it was involved in the explosion which occurred in High Holborn on 21st December, 1928, but it still functions very efficiently as a cable run in certain portions of the Centre and City Sections.

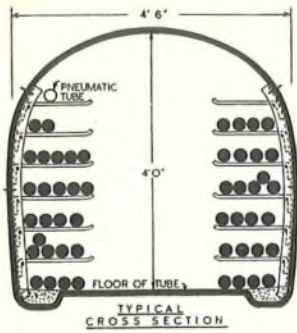

FIG. 3.—OLD PARCELS TUBE.

and south footpaths, resulting in improved access to the station platforms, and a new subway across Holborn for pedestrians.

To provide space for the new booking hall and passenger escalators, the parcels tube route and the north 22-way duct line were diverted to a new Post Office subway built under the north footpath. (See Figs. 4 and 5).

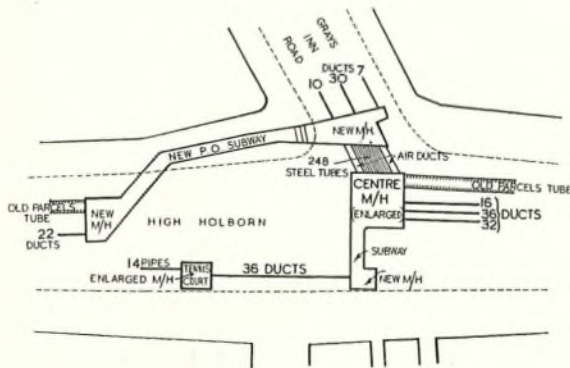

FIG. 4.—PLAN OF HOLBORN AFTER THE DIVERSIONS.

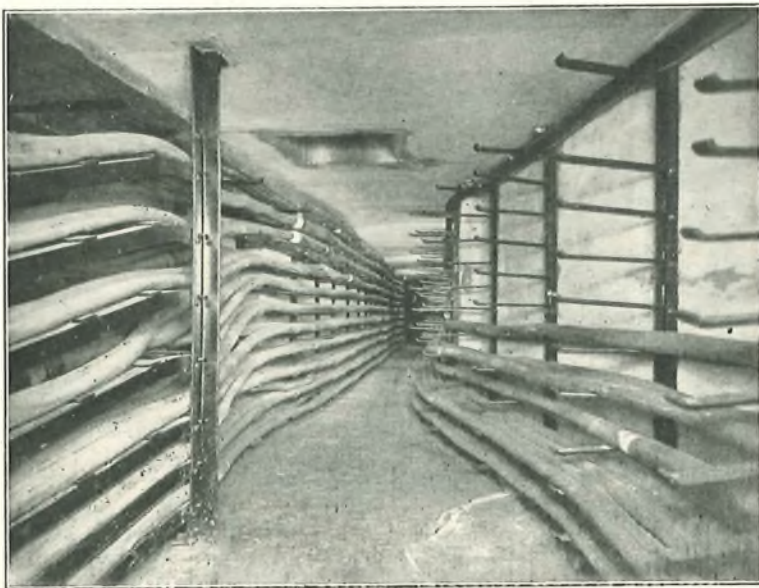

FIG. 5.—NEW POST OFFICE SUBWAY. (DIVERSION WORK IN PROGRESS).

Chancery Lane Station, on the Central London line, is situated about 150 yards west of Gray's Inn Road in High Holborn. Prior to the alterations, public entrances existed on the north foopath with lifts to the station platforms. The extension provided four new entrances from the street, two on each of the north

The subway, 6 ft. in height, 5 ft. in width and 40 yards in length, with an ultimate capacity of 110 main cables, at present carries 70 main and junction cables on channel iron and cantilever supports fitted on the side walls.

Fig. 6 is a cross-sectional view of High Holborn, showing the new street entrances, booking hall,

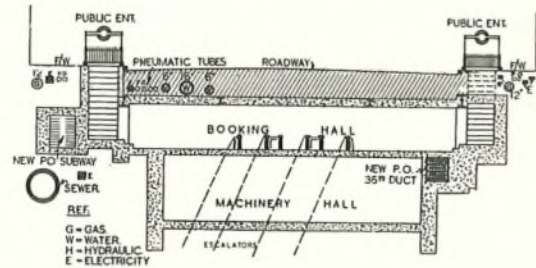

FIG. 6.—CROSS SECTION OF HOLBORN AFTER THE DIVERSIONS.

escalator and machine halls and, in addition, the relative positions of the various Undertakers' plant after the alterations (see also Fig. 4). A significant feature of this diagram is the large amount of space occupied by the entrances, booking and machinery halls. The roadway concrete bed extends down to the roof of the booking hall.

It was originally intended to connect the new subway on the north footpath direct to the centre manhole, but as a new passage from the street to the booking hall obstructed the subway at its east end it was necessary to terminate the subway, together with the Gray's Inn Road duct lines, in a cable chamber at that point and extend them to the centre manhole by fitting 248 steel pipes over the roof of the passage. (Fig. 7). The pipes, of solid drawn mild steel 13' 6" in length, 3 1/4" diameter, 1/8" thickness, are arranged in 4 bays. Owing to the limited space available it was necessary to place the pipes close together and after being firmly fixed in position to grout cement mortar between them. To dissipate any possible accumulation of gaseous vapour in the parcels tube, at regular periods during the day and night air is supplied under pressure by a motor-driven fan installed at the Holborn Exchange. As shown in Fig. 7, two air ducts have been provided to connect the west portion of the tube with the flow of air.

Grouting Steel Tubes.

Fig. 8 illustrates the method of cementing the pipes in position. The intervening spaces between the pipes were plugged with clay at the pipe ends and the pipes timbered as shown, inlet and inspection holes being left in the timbering. Cement and water, after being thoroughly mixed in a grouting pan, were forced between the pipes by compressed air at a pressure of 80 lbs.

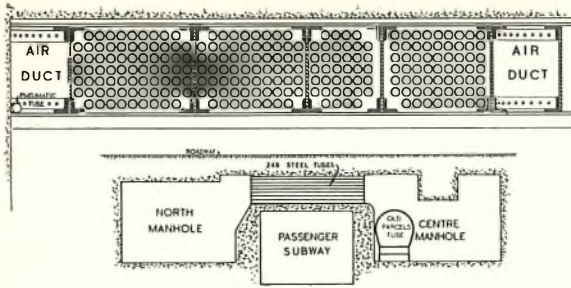

FIG. 7.—ACCOMMODATION OF STEEL PIPES OVER PASSENGER SUBWAY.

per square inch, the mixture being fed into the pipe spaces by a flexible hose terminating in a 1" wrought iron pipe fixed through the timbering. 3½ tons of cement were used to support the pipes.

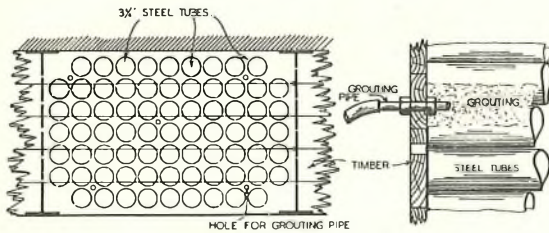

FIG. 8.—METHOD OF CEMENTING STEEL PIPES.

The south 22-way and 14-way duct lines were replaced by a new 36-way octagonal duct between the Tennis Court manhole and the centre manhole. (Fig. 4). As it was necessary to lay the duct line on the south side of Holborn below the railway booking hall at a depth of 18 feet, Tennis Court manhole was underpinned and deepened 10 feet. This section of duct line was tunnelled throughout. At the east end the duct was extended to the centre manhole by an inclined subway 7 ft. in height, 6 ft. in width and 30 ft. in length, the cables being carried on cantilever supports on the side walls. To accommodate the new subways and duct routes the centre manhole was extended to 24 ft. in length by 20 ft. in width.

The new manholes and subways are of concrete construction, the walls and roofs being finished on the inside by a 1" rendering of water-proofing cement. To prevent surface water leaking into the booking hall and station approaches a 2" layer of asphalt was provided between the road bed and the roof of the booking hall.

The cable supports are mainly of the channel iron and cantilever type, wall and centre standard-bearers being used as determined by the circumstances in each case.

Programme of Operations.

The first items of importance were

the provision of the new east-west cable subway on the north side of Holborn, the deepening of the Tennis Court manhole and the provision of the 36-way octagonal duct and subway on the south side of Holborn.

After the ground had been sufficiently excavated and while the aforementioned works were in progress the removal of the parcels tube was commenced.

Fig. 9 shows a view of the carriageway in High Holborn and the parcels tube being cut away by oxy-acetylene blowpipes. The tube metal is of special composition, not so brittle as cast iron, very durable and in some respects similar to crucible steel, but less porous. It has a high melting point and takes much longer to burn than cast iron or mild steel. As a precautionary measure before burning, the metal was carefully cleaned at the cutting point by removing the scale on the outer surface. In confined spaces, owing to the dense fumes generated, it was necessary for the workman using the oxy-acetylene blowpipe to wear a respirator. The tube was cut into pieces as large as possible having regard to the difficulty of handling in the excavation and the risk of physical damage to the cables. Fifty main cables were carried on cantilevers on the side walls and special precautions were necessary to prevent the cables being burned by the oxy-acetylene flame. To effect this the cables were moved away from the side of the tube to be cut and protected by asbestos sheets. As portions of the tube were removed timbering was provided for temporary support.

During this period the Railway Co's contractors were busy sheet piling to a depth of 30 ft. below the excavation and erecting stanchions for the support of the new booking hall. While these operations were in progress the contractors came across a very wet portion of ground, thought to be the old course of the River Bourn which in very early days flowed

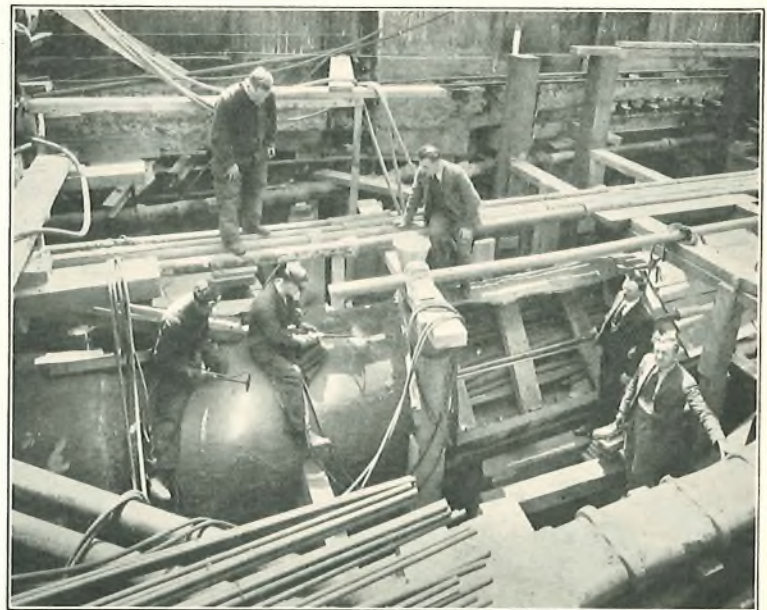

FIG. 9.—REMOVING THE OLD PARCELS TUBE.

across Holborn to the Fleet River. An 8 ft. head of water existed in the excavations, but fortunately for the Department's staff the water remained below the level of the cabling work.

One hundred and seven trunk, junction and main subscribers' cables were replaced in the affected area. The majority of the new cables were drawn in in single lengths, but, owing to the exigencies of the work, it was not possible to place them in their permanent positions until a later stage. Temporary substitution was effected and the lengths were finally adjusted by cutting out slack cable.

To facilitate the placing of individual cables in their correct positions in the subways and main runs, cross-sectional diagrams of the bearers were provided indicating the position of each cable. In addition a composite drawing of the centre manhole was prepared in such a manner that the drawing could be folded to show the duct lines in their respective positions on the walls, the various routes being shown in colour. The general lay-out was arranged to avoid cable crossings, but in exceptional cases, where this was impossible, the crossings were placed at convenient points away from the duct mouths.

The old cable section, approximately 35 yards in length, was replaced by a section length of 55 yards, and in consequence it was considered advisable to rebalance 18 of the longer and more important balanced and loaded trunk cables.

Included in the rebalanced cables are the London-Derby cable with 244 physical pairs, 91 phantom and 28 double phantom circuits, and the London-Bristol cable with 308 physical pairs, 84 phantom and 25 double phantom circuits. As these cables contain a large number of B.B.C. main station, newspaper picture transmission and other special circuits, great care was necessary to avoid interruptions to these services. Each operation involved in the diversion was studied and continuous working was effected by "strapping through" the wires at the changing-over points, the wires being identified, *i.e.*, pair numbered, at a suitable time when the circuits could be released by the Traffic staff.

Rebalancing Arrangements.

Rebalancing was effected by the "substitution" method, a full description of which is given in Technical Instruction Lines, Underground, G.1070. Using this method, a comparison is made of the capacity unbalances of the new length with those of the displaced length, suitable crosses being made in jointing the new cable to simulate as far as possible the old conditions. A replacing length was used as the interruption cable and this was pair numbered at the ends x and y . (Fig. 10). The old length (F)

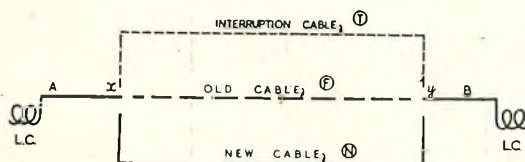

FIG. 10.—SUBSTITUTION METHOD OF REBALANCING.

was also numbered at the same points and the working cable then temporarily diverted to the interruption length. In the majority of the cases no joints existed at points x and y and in consequence the rebalancing of those cables was much simplified. The capacity unbalance of the old (F) and the new length (N) were measured, scheduled in order of magnitude and a selected joint prepared for point x , crosses being inserted at y to simulate the old conditions in the loading coil section. In the few cases where a crossed joint previously existed at x the principle embodied in Technical Instruction Lines, Underground, G.1070, method (3) was followed. Fortunately the same type of cable as that existing was available for rebalancing, and the core characteristics and magnitudes of the cable unbalances were similar. In view of the slight change in the cross-talk conditions and the very great saving of time, the employment of the "substitution" method appeared to be justified in this large scale diversion when compared with the alternative of rebalancing the loading coil sections.

Difficulties encountered and Measures taken to prevent Breakdown of Cables.

Throughout the progress of the work it was necessary to remove the original supports of the existing cables in the old routes and, prior to their recovery, to provide temporary bearers for the new cables. Considerable congestion was caused by having both new and old plant *in situ* and the situation was not made less difficult by the Contractors who simultaneously were excavating, pile driving, boring for the escalators and underpinning the street.

During the summer months of 1933 the temperature underground rose to an unprecedented figure and electric fans were temporarily installed for the jointers engaged on the diversions. Due to the high temperature and the large amount of timber and other inflammable material on the site, there was a considerable fire risk and as it was necessary to "piece-out" simultaneously several 800-pair cables by jumper wire, a plentiful supply of asbestos blankets, sand buckets and extinguishers was provided.

The Department's work was commenced on 3rd February, 1933, and completed on 13th April, 1934.

Four and a half miles of cable were drawn in, 60 tons of cable recovered and 120,000 pairs of wires changed over, the majority of which carried working circuits including, in some cases, phantoms and double phantoms.

At Chancery Lane a number of interruptions to junction circuits occurred due to the Railway Contractors puncturing a cable with a pneumatic drill. Having regard to the nature and extent of the work involved and the difficult and dangerous conditions existing, the fact that the whole of the working cables, with this single exception, were maintained intact throughout the operations reflects credit on the men engaged on the site, including the jointers of the Cable Balancing Group who were responsible for the diversion of the rebalanced cables.

LEICESTER SQUARE STATION IMPROVEMENTS.

Area of Railway Co's Operations.

Fig. 11 shows the central portion of the area of the Railway Co's operations, including the new circular booking hall, public entrances and escalators at the junction of Charing Cross Road and Cranbourn Street.

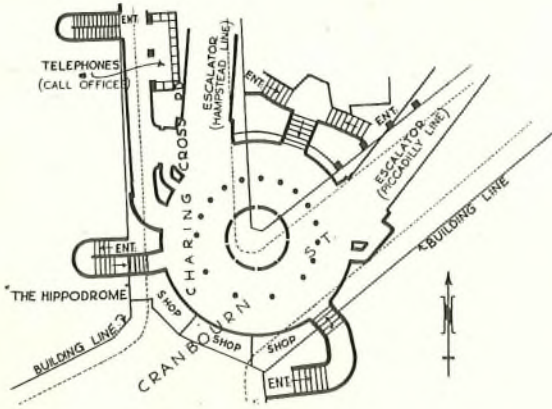

FIG. 11.—LEICESTER SQUARE TUBE STATION, NEW BOOKING HALL.

Leicester Square station connects the Hampstead and Piccadilly lines, and in place of the four passenger lifts previously existing, two escalator tubes have been provided, one 160 ft. in length serving the Piccadilly line being the longest escalator in the world.

The new booking hall extends across the carriage-way of Cranbourn Street and Charing Cross Road and under the building at the road junction. The circular dots represent the stanchions supporting the girders which carry the roadway.

Cross Sectional view of Charing Cross Road.

Fig. 12 is a cross sectional view of Charing Cross Road, the station booking hall and machine chamber. The diagram indicates the extent of the space

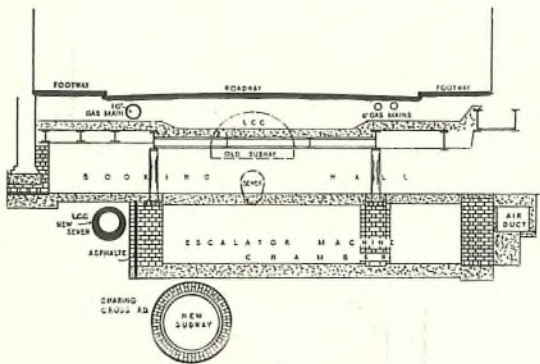

FIG. 12.—CROSS SECTION OF CHARING CROSS ROAD.

occupied by the station improvements, the position of the L.C.C. old subway, the new metal subway below, which replaces it and the air duct used for

railway ventilation. In certain sections the new subway is reinforced by external brick work.

Lay-out of the Department's plant in the vicinity of the station.

To provide space for the new booking hall, etc., it was necessary to remove the L.C.C. Charing Cross Road subway and its contents, together with the Department's 30-way and 12-way ducts on the east-west route and the 14-way duct and cables in Little Newport Street. (Fig. 13).

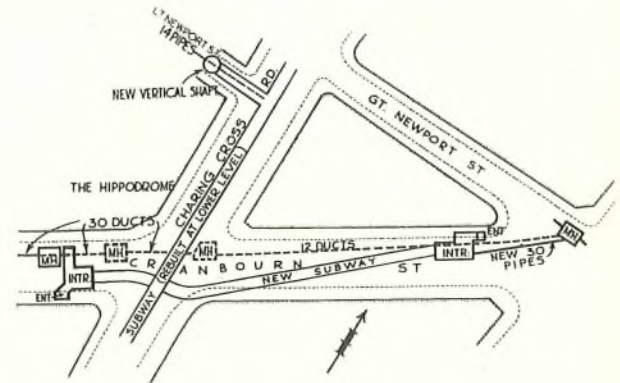

FIG. 13.—PLAN SHOWING DEPARTMENT'S PLANT, LEICESTER SQUARE STATION.

In Cranbourn Street several large water mains, a 4" diameter 700 lbs. per square inch hydraulic main and a very large number of high and low tension electric supply mains and feeders existed in the affected area. Fig. 13 shows the Department's existing plant (in broken line) and the two new subways and new duct line. To accommodate the large amount of plant displaced in Charing Cross Road it was decided to provide a 12 ft. diameter metal subway, 146 yards in length, parallel to and beneath the old subway, a sectional view of which is shown in Fig. 16. A branch metal subway from Charing Cross Road to Newport Street 8 ft. in diameter, 13 yards in length was built and connected to the Interceptor manhole in Little Newport Street by a vertical metal shaft 8 ft. in diameter, 30 ft. in height. Along Cranbourn Street a 12 ft. diameter metal subway 174 yards in length, similar to the Charing Cross Road subway, was provided 45 ft. below the street level.

To provide space for the diversion of a large number of electric supply cables at the east end of Cranbourn Street, the Department's 12-way duct in the carriage-way was removed, the cables were temporarily accommodated at a depth of 10 ft. in a stout wooden casing, and meanwhile the roadway was reinstated to allow traffic to proceed. At a later stage the Department's cables were diverted to a new 30-way octagonal duct laid under Great Newport Street, and the wooden casing was recovered.

Cross Sectional view of L.C.C. Old Subway. (Fig. 14).

The L.C.C. old subway of brick work construction, 12 ft. x 7 ft., contained, in addition to the Depart-

In the new subways the approaches to the street level are at an angle of 30° to the horizontal and in these sections tubular scaffold type support was pro-

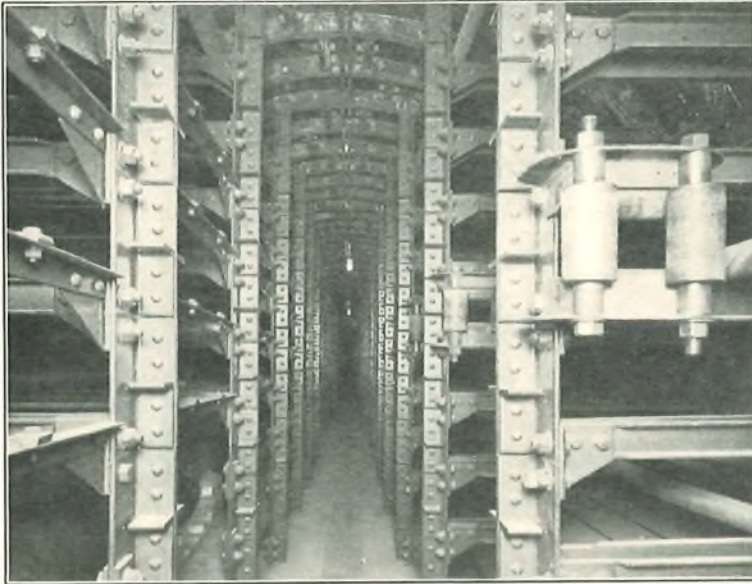

FIG. 17.—NEW L.C.C. SUBWAY.

vided (Fig. 18). This construction affords the valuable facility of raising or lowering the bearers by loosening the bolt on the coupling and sliding the coupling up or down the support. Vertical height space can thus be utilized to the utmost extent. In addition, the horizontal bearer, consisting of a flat steel piece clipped on the tube, may be tilted to any desired angle by slackening the set screws on the clip.

To enable the Charing Cross Electricity Supply Co. to carry out certain urgent diversions before the commencement of the winter load and to avoid delay to the Railway Contractors' work it was necessary to remove the Department's cables at the east end of Cranbourn Street at the earliest possible date. Six 800-pair, two 542-pair and one 300-pair junction cables were involved. Several of these cables were capacity balanced when first provided, but on account of the relatively small difference in length between the old and the new sections rebalancing was considered to be unnecessary.

In the L.C.C. Charing Cross old subway, in addition to a number of subscribers' distribution cables, 20 subscribers' main and junction cables, mainly of the 800-pair and 1000-pair type, were diverted. Careful consideration was given to the positions of the new cables on the racks to avoid unnecessary crossings at turning points and junctions along the subways. For

this purpose cross-sectional drawings of the racks indicating the position of each cable were prepared in advance for the use of the cabling gangs.

Novelty Heading and Vertical Shaft.

Fig. 19 shows a plan and elevation at Newport Street. The vertical shaft, 30 ft. in length, 8 ft. in diameter, is fitted with platforms 6 ft. apart. The term "Novelty Heading" was applied as segment plates for a 12 ft. diameter tube were used to form an 8 ft. subway, the joints between the plates being filled by a cast iron wedge. One half of the shaft was allocated to the Department, the remainder being reserved for Electric Supply Co's use. The Department's junction cables are supported at each platform level by being "tacked" to the horizontal W.I. bearers bridged across the platform girders.

Ventilation of Subways.

In both the old and new subways natural ventilation is relied upon. The interceptors at the east and west ends of the Cranbourn Street and the north and south ends of the Charing Cross subways terminate in large grid openings in the footpaths and carriageway refuges.

Drainage of Subways.

At a convenient point in the low level of the Cranbourn Street subway a sump is provided for drainage of flood water or possible leakage from water mains. To empty the sump, which calls for a lift of 35 ft. to the sewer, a hydraulic ejector is fitted, a cross sectional view of which is shown in Fig. 20.

A connexion from the hydraulic public service main



FIG. 18.—STREET APPROACH SHOWING TUBULAR CABLE SUPPORTS.

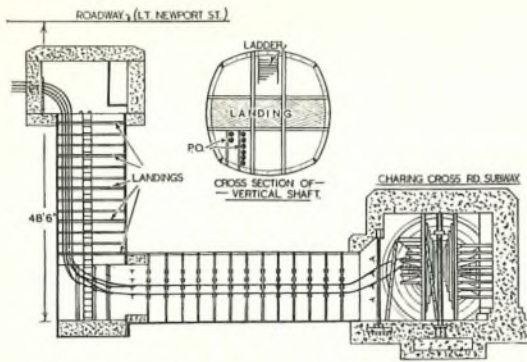

FIG. 19.—NOVELTY HEADING AND VERTICAL SHAFT AT LITTLE NEWPORT STREET.

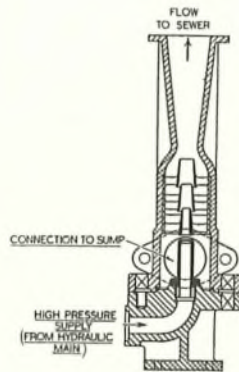

FIG. 20.—HYDRAULIC EJECTOR.

controlled by a hand operated valve near the street level is taken to the ejector, and a large bore pipe connects the ejector to the sump. On opening the hydraulic valve, water at a pressure of 700 lbs. per square inch is fed into the ejector nozzle, drawing the sump water into the flow pipe which is drained

into the adjacent L.C.C. sewer. The capacity of the ejector is 550 gallons per minute.

The L.C.C. new subways are electrically lighted throughout, the wiring being enclosed in screwed conduits and the circuits controlled by 2-way switches of iron clad pattern.

Organization of the work.

In dealing with large scale diversions such as those described, where gas, water, hydraulic, electric and telephone mains and services were involved, it was necessary to co-ordinate the activities of the various undertakers. For this purpose representatives of these supply services, including road traffic authorities, Metropolitan Police and Scotland Yard, met on the site at intervals to consider the programme of operations. The civil engineering contractors commenced excavating at Leicester Square in 1930. The Department's operations extended from October, 1932, to April, 1934.

Three and threequarter miles of telephone cable were laid and 51 tons of scrap cable recovered. 43,000 pairs of wires were changed over and 42,000 manhours spent.

CONCLUSION.

It is pleasant to record on the completion of the works at Chancery Lane and Leicester Square Stations that there were no casualties to report, *i.e.*, no accidents on duty, and in spite of the variety of the plant affected and the number of undertakers with occasionally conflicting interests, cordial relations were maintained by the Department's staff throughout the operations.

The author desires to express his thanks to Sir Harley Dalrymple-Hay, and Messrs. Mott, Hay & Anderson, Civil Engineers, for details of the new subways and to Mr. Lennon, of the Centre External Section (London District), for the preparation of the drawings.

The Belfast Automatic Area and Zone Centre Exchange

M. C. COOPER, A.R.C.Sc.I., A.M.I.E.E. and
C. E. WORTHINGTON

THE transfer to automatic working of the Belfast telephone area, which was carried out successfully at 2 p.m. on November 2nd, marks the opening of one of the largest and most up-to-date non-director systems in the United Kingdom. The scheme may be regarded as the first and greater portion of a plan for the complete mechanization of the telephone system of Northern Ireland.

A new trunk switchboard and repeater station, which were installed in the new Central Telephone Exchange building were brought into use two weeks in advance of the opening of the automatic system.

Prior to the opening, the Belfast area was served by five manual exchanges of the magneto type and these have been replaced by a multi-office system consisting of a main exchange, seven satellite exchanges, and two U.A.X's of the No. 7 or A.G.S. type. The following table gives details of the numbering scheme, the size of multiple, and the numbers of working lines and stations of the new exchanges at the opening date:—

dividual names of the Central and Satellite Exchanges will thus only be used for engineering purposes.

The conversion of this area to automatic working, which was due at least ten years ago, suffered many postponements for various reasons. This necessitated extension after extension to the old magneto system which latterly became completely top heavy and very difficult and expensive to maintain. The old system, known as the "magneto call, auto clear system," which obtained in the four big exchanges in the centre area, incorporated a method of working which was non-standard even for magneto exchanges. Earth was normally connected at the centre point of every subscriber's bell and was only removed when the receiver was off the hook. This earth on both legs operated the clearing supervisory signal in the telephonist's cord circuit. It had the effect of increasing the difficulties of jointing work when diverting the underground cables as it virtually put all lines normally in contact. It also necessitated special transfer procedure as will be described later.

The old Belfast Central Exchange consisted of

Exchange.	Numbering Scheme.	Multiple.	No. of Working Lines.	No. of Stations.
Central	20,000—27,199	7,200	5,943	11,015
Ormeau	41,000—41,799	800	553	671
North	43,000—44,399	1,400	1,108	1,608
Fortwilliam	46,000—47,299	1,300	927	1,071
Knock	53,000—54,699	1,700	1,183	1,451
East	57,000—57,999	1,000	789	1,190
Stormont	63,000—63,399	400	69	380
Malone	65,000—66,999	2,000	1,590	1,971
Dunmurry U.A.X. ...	{ 2,200—2,399 }	400	295	347
	{ 3,200—3,399 }			
Dundonald U.A.X. ...	{ 2,200—2,299 }	200	117	124
	{ 3,200—3,299 }			
Total		16,400	12,574	19,828

The new exchanges thus opened with a total multiple of 16,400 which, it is estimated, will increase to an ultimate of some 30,000 lines.

It can be seen from the map, Fig. 1, indicating the lay-out of the old and new exchange areas, that the scheme involved considerable re-arrangement of the exchange boundaries and the changing of a large number of subscribers into new areas. This necessitated very extensive re-arrangements of and, additions to, the existing underground line plant. The re-numbering consequent upon the re-routing of subscribers' lines did not, however, cause any public controversy as it was decided that all subscribers in the multi-office area, except those on the two U.A.X's, should be listed in the directory under the one general exchange name of Belfast. The in-

three separate manual switchboards in addition to the trunk suite, all in different rooms and widely separated. Board No. 1, the original, and some 35 years old, shown in Fig. 2, catered for a subscribers' multiple of 0 to 6399. Board No. 2, an early extension, provided for a multiple of 6400 to 9699, with a full multiple of 0 to 9699 over part of the suite; and here the height of the panel made it necessary for the telephonists to work standing. Board No. 3 was a comparatively recent extension, installed some nine years ago, having the low numbers multiplied over some positions and the high numbers over others. Calls for numbers not in the multiples available to the telephonists at the various boards were transferred by means of a local order wire system. The photograph of the old Belfast Central

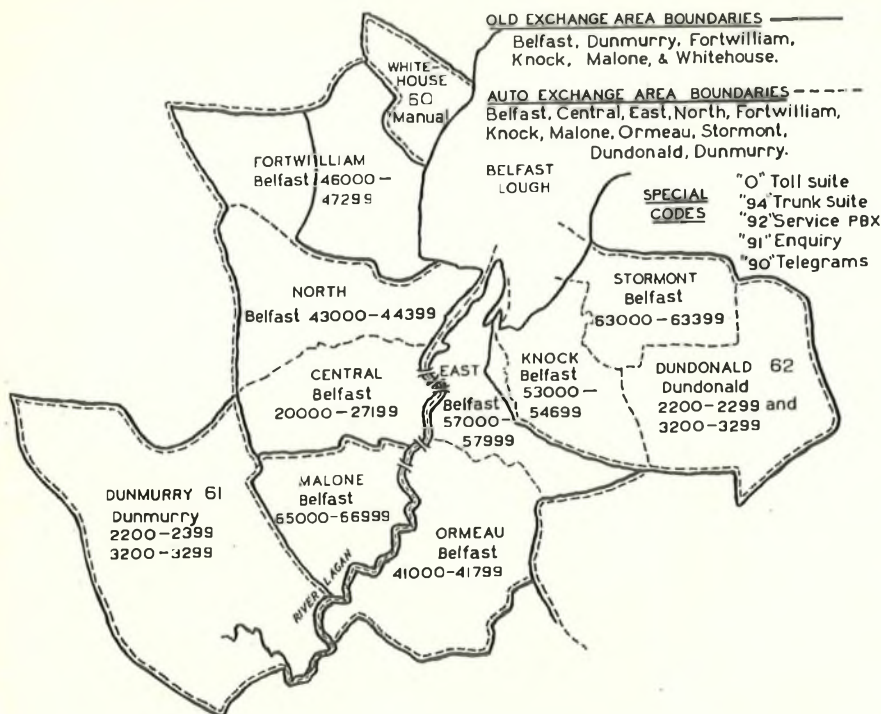

FIG. 1.—OLD AND NEW EXCHANGE AREAS.



FIG. 2.—OLD BELFAST CENTRAL EXCHANGE.

switchboards and the original M.D.F., Fig. 3, are of historical interest.

New Central Auto Exchange.

The Central, or Main Exchange, is accommodated in Telephone House, a new building, shown in Fig. 4, which stands on an island site about a quarter of a mile from the practical centre. The earliest map that can be traced shows the site of the new exchange

to have been a mill dam. Belfast is not a city of tall buildings due to the subsoil being composed of an estuarine deposit locally known as "sleech," and Telephone House with its six storeys and lantern lights, towers conspicuously above its surroundings. It was erected under the control of the Ministry of Finance for Northern Ireland, whose architects displayed no little talent in incorporating into the external aspect of the building that spirit of modern progress of which the automatic telephone is an outstanding example. The city stands partly on land reclaimed from the sea and partly on the beds of ancient rivers, several of which still run underground beneath the main streets. Into this "sleech" some 430 reinforced concrete piles were introduced, each to a depth of over 40 feet, to carry the foundations of Telephone

House. The method of "Pressure Piling" was adopted as it was felt that the patience of the neighbourhood would not have stood the driving of 430 piles 41 feet into the ground by the aid of a two-ton hammer. Accordingly the holes were bored with a hollow steel tubular borer, length after length being added, the cores of the boring removed, and reinforcement introduced. Into this borer concrete was forced, the pressure of the concrete gradually allowing the borer to be withdrawn, leaving the concrete pile *in situ*. The grouping of the piles has been so arranged that the load carried is uniformly distributed, each pile supporting not more than 32 tons. Local granite (Annalong, Co. Down) was used in the building up to the first floor, and thereafter silver grey facing brick with a dressing of reconstructed Portland stone.

The automatic switching plant is the Department's standard type employing the 200-outlet 2-motion line finder with partial secondary working. The busy hour calling rate of Central Exchange is high, being 1.2 calls per line, amounting to 10.432 traffic units per 200 line group, and this traffic is carried by 10 direct and 12 indirect primary line finders per group. These 22 line finders have a capacity of 10.75 traffic units. There are 32 ordinary and one coin box groups serving the Central Exchange. The apparatus is accommodated in two rooms, one on the first and the

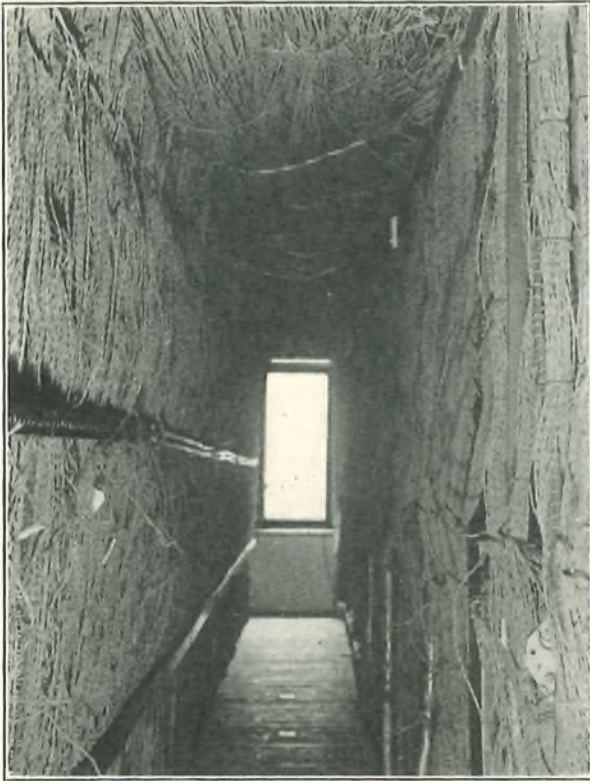

FIG. 3.—M.D.F., OLD BELFAST CENTRAL EXCHANGE.

other on the second floor. Figs. 5, 6, and 7 are views of the plant. The line finders, final selectors, I.D.F. and subscribers' meters are located on the second floor. The subscribers' meters, which are in a separate room, are of the new standard type, 1000 being mounted on each bay. The 1st, 2nd, and 3rd group selectors and M.D.F. are on the first floor which also accommodates the new repeater station in a separate room.

With the exception of the subscribers' line and cut off relays, and a small number of miscellaneous circuits, the new P.O. standard 3000 type relay has been used throughout.

The Auto-Manual and Trunk Switchboards, which are situated in a spacious room on the fifth floor, are of the very latest design, incorporating sleeve control cord circuits, free line lamp signals, multiple answering lamps, and pneumatic ticket tubes. Initially there are six 7-panel 3-position sections including two unequipped positions making up the auto-manual switchboard, while the trunk suite consists of five 7-panel 3-position sections and one cable storing section. A separate 14-position Monitors Desk is also provided. Fig. 8 is a view of the auto-manual switchroom.

Equipment is provided for centralized service observation facilities in respect of

Central Exchange and the six larger satellites. The observation panel is located in a separate room in Telephone House.

A detail of interest connected with the auto-manual switchboard is the mercury contact relay which serves as a master switch for the free line signal lamps, enabling them to be switched on or off by the operation of a single key on the cable turning section. This relay consists essentially of a small glass tube, slightly bent in the middle, which is sealed at both ends and contains a supply of mercury. The arrangement is such that if the tube is tilted slightly the mercury will run from one end to the other where it will complete the connexion between two electrodes; when tilted back the mercury returns to the original position and the circuit is broken. A small glass rod connected to the armature of a standard P.O. 3000 type relay serves as the lever to tilt the mercury tube, which can deal with currents of 20 amperes at voltages up to 250. The mercury contact relays are fitted on the lamp relay racks which are installed in a separate room on the 4th floor. Fig. 9 is a close up view of the relay.

The very unstable subsoil in the centre of Belfast would have rendered the construction of the usual cable chamber a matter of considerable difficulty. It was therefore decided to build the chamber as an annex abutting on the building and arranged as a mezzanine floor between the ground and the first floor. The underground cables enter *via* two shafts—one at the front and the other at the back of the building. These shafts connect the cable chamber with the underground manholes. From the cable chamber the cables are led into the cable trench at the rear of the main frame. The unusual features of the cable chamber with its associated vertical shafts complicated the design of the leading-in arrangements. A very workmanlike scheme was finally arrived at in which a separate space has been



FIG. 4.—TELEPHONE HOUSE, BELFAST.



FIG. 5.—1ST FLOOR, CENTRAL EXCHANGE.

allocated in the shafts and on the cable racking in the cable chamber for the cable, or cables, which are, or will be, associated with each individual duct. Fig. 10 shows the exterior of the chamber.

The M.D.F. standard cable trench is not deep enough to accommodate a circular type of solid plug containing the seven 200-pair E.S. and W. cables required for the termination of 1400-pair P.C. cables; the flat type solid plug, since adopted as standard and described in Engineering Instructions, Lines, Underground F.3340, was used. Figure 1 in the Engineering Instruction referred to is an illustration of the Belfast Central M.D.F. and Cable Chamber.

Central Exchange Power Plants.

Separate power plants are provided on the ground floor for the automatic exchange, including the trunk switchboard, and for the repeater station. The exchange power plant is of the standard 50 volt type employing two sets of "Chloride" secondary cells each of initial capacity of 3,200 Ah. capable of extension to 5,000 Ah. The charging sets are in duplicate.

The Repeater Station power plant is of the new continuously floating battery type described in a recent article.¹ There are two power sets each consisting of a mains operated motor driving two coupled D.C. generators of 24 V. 100 A., and 130 V. 10 A. respectively, and floating continuously on these are the A and B batteries. A 10-15 B.H.P. high speed diesel oil engine is provided for emergency such as a failure of the mains supply, and this can be coupled

to either charging set by an electromagnetic clutch operated from the power switchboard. The lay-out is shown in Fig. 11. The capacities of the "A" and "B" batteries are respectively 24 V. 400 Ah., and 130 V. 40 Ah., and each set is capable of maintaining the full power requirements of the Repeater Station for a period of 5 hours independently of the motor generator sets.

The two motor generator sets, together with the diesel engine, stand on a concrete bed some four feet thick which is supported by a separate group of 6 piles. The thickness of the concrete bed, and the fact that it stands on separate piles, will effectively prevent the transmission to the rest of the building of any vibration which may be set up by the diesel engine on the rare occasions on which it will be run.

Although not part of the multi-office area scheme the new repeater station and trunk switchboard, which are accommodated in Telephone House and were brought into use on the 20th October, are of interest. The trunk switchboard is of the standard type and has already been mentioned.

In the repeater station the incoming underground paper core main cables terminate directly on U-link test tablets, the terminations being sealed in wax. The transformer rack is of the latest pattern arranged for double sided mounting, and the repeater distribution frame is of very recent design and enables the line circuits to be cross connected to the repeaters, amplifiers, V.F. telegraphs, carrier current apparatus, or tariff A equipments as required.

The transmission testing rack is of the most up-to-

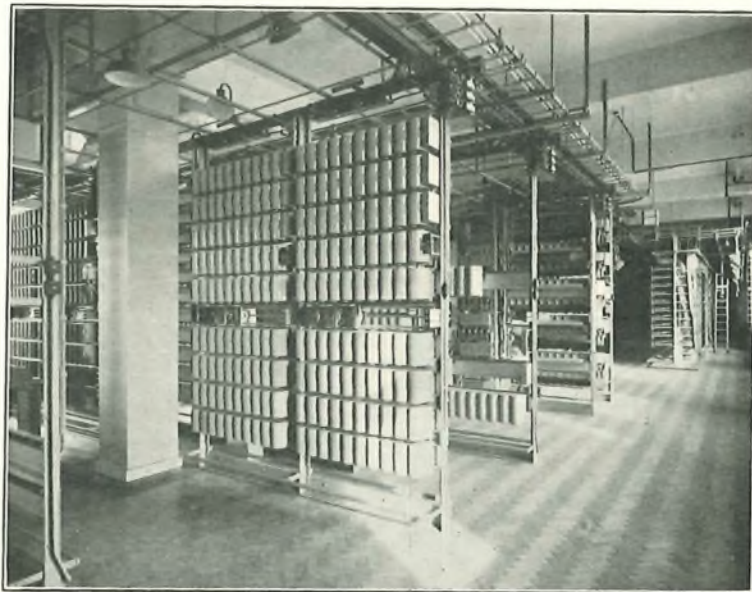

FIG. 6.—2ND FLOOR, CENTRAL EXCHANGE.

¹ P.O.E.E. Journal, Vol. 28, Pt. 2.

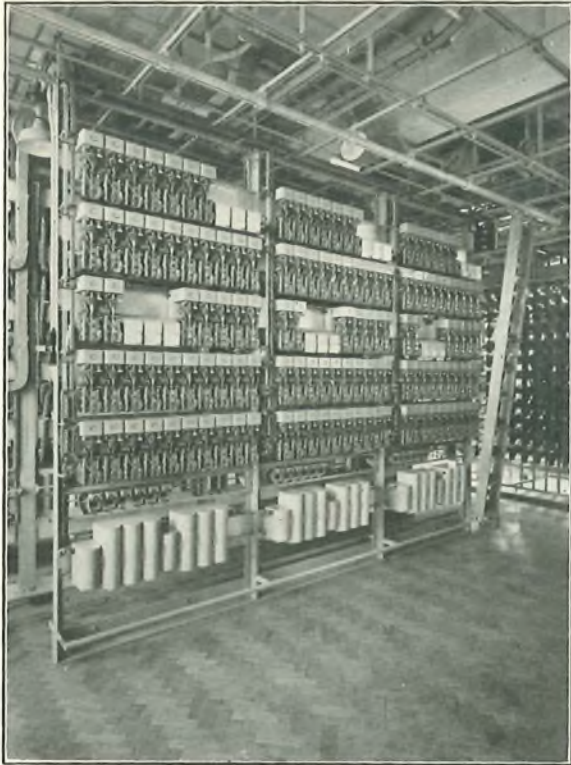

FIG. 7.—LINE FINDER RACKS, CENTRAL EXCHANGE.

date type and incorporates a Ryall-Sullivan oscillator with a new pattern direct reading transmission measuring set developed by the General Electric Company. The type of repeater test rack installed obviates the need of test jacks and permits any repeater to be connected for test by means of small cords and plugs, thereby accelerating the speed of testing.

The repeater rack is arranged for double sided mounting and accommodates the latest type repeater (No. 25A) which incorporates low consumption valves. One bay of repeaters No. 29A, also the latest type, has been installed for dealing with the B.B.C.'s various broadcasting circuits.

The amplifiers provided for short distance trunks are the Department's latest design, Unit Amplifiers No. 16.

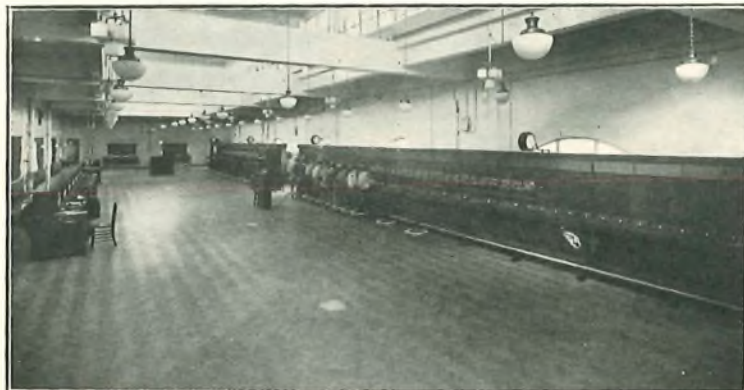

FIG. 8.—AUTO-MANUAL SWITCHROOM.

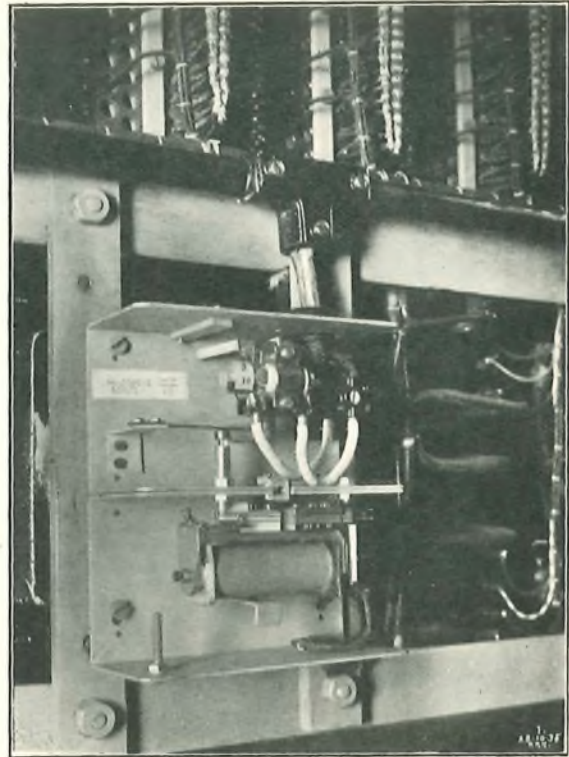

FIG. 9.—MERCURY RELAY SWITCH.

Satellite Exchanges.

The satellite exchanges are all of the discriminating selector type, the switching plant of each consisting of standard 200-point line finders, arranged for partial secondary working, discriminating selectors and junction hunters, 100-outlet 3rd group selectors, and 100-line final selectors. The first digit dialled is absorbed by the discriminating selector except in the case of "0," "9" or "2." Direct junctions are trunked from level "0" of the discriminating selectors to the manual board. There is sufficient traffic from all except one of the smallest satellites (Ormeau) to numbers on Central Exchange to justify a group of direct junctions from level "2" of the discriminating selectors to 2nd selectors (level "2") at Central. This not only effects a saving in 1st selectors, but permits lighter gauge junctions to be used for this "D" traffic. From Ormeau Exchange such traffic is routed in the normal way *via* junction hunters to Central 1st selectors.

The power plant at the satellite exchanges is the standard type comprising two sets of 50 volt secondary cells of the "Chloride" type with motor generator charging sets.

A view of one of the satellites, North Exchange, is shown in Fig. 12.

Dundonald and Dunmurry U.A.X's No. 7.

These exchanges are U.A.X's of the No. 7 or A.G.S. type, working into



FIG. 10.—EXTERIOR OF CABLE CHAMBER.

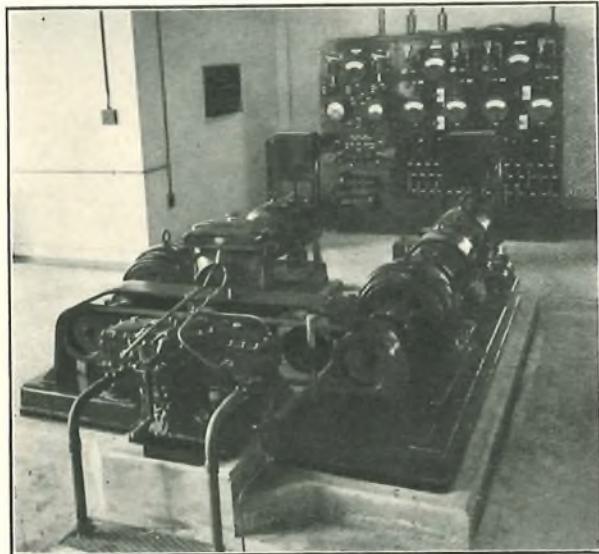

FIG. 11.—REPEATER STATION POWER PLANT.



FIG. 12.—NORTH SATELLITE EXCHANGE.

Central auto-manual board as their parent exchange. In addition these exchange subscribers can dial numbers in the multi-office network by using the code digit "9." Conversely multi-office subscribers can dial numbers on these U.A.X's by first dialling the code "62" or "61."

These U.A.X's are situated on opposite sides of the multi-office area and are consequently outside the unit fee (distance from each other, and under the present arrangement subscribers on one obtain calls to the other exchange *via* the manual board. When multi-metering is introduced, however, dialling through the multi-office network will be possible from one U.A.X. to the other.

This type of U.A.X. has been described in detail elsewhere,² but the following are the major points of interest:—

Line finders are of the 2-motion type, but have 100 outlets and are employed with secondary finders on a partial secondary basis. Direct junctions from adjacent exchanges can be connected to the banks of the secondary finders whence they obtain access to indirect 1st selectors.

The 1st selectors are of the 100-outlet type and are fitted with a vertical bank for discriminating on all calls. On local calls the 1st selector absorbs the first digit and provides the transmission bridge. Levels "0," "1," "2" and "3" have access to four groups of 200-line final selectors giving a capacity of 800 lines, and the first digit, which is absorbed, decides to which wiper set and hundreds bank of the 200-line final selector the call will be routed. Levels "4," "5," "6," "7," and "8" are available for direct junctions to other exchanges or for increasing the capacity for subscribers' lines.

Outlets from level "9" are used for junctions to the main exchange, both for calls into the automatic network and for "0" level calls to the auto-manual board. If "0" is dialled the 1st selector will cut into the 9th level and an appropriate signal is sent over the junction to operate a discriminating relay at the parent exchange and route the call to the auto-manual board. A subscriber dialling "9," however, will be routed over one of the same group of junctions to a 1st selector at the main exchange for dialling into the multi-office network. The 1st selectors at the U.A.X. will only step to the "0" level if the 1st digit of a local number ("2" or "3") has already been dialled, and will then search for an outlet to a local final selector as already explained.

Dialling Facilities.

The trunking arrangements cater for dialling to some 33 exchanges outside the area. The auto-manual board has joint access, *via* the O.J.M. to these

² P.O.E.E. Journal, Vol. 28, Pt. 3.

junctions which are also available to the outlying exchanges themselves where the telephonists can both dial into the multi-office network and "through dial" to any of the other exchanges. The trunking diagram for Central exchange, Fig. 13, indicates the extent to which this facility has been provided.

flooded and the workmen only just getting out of the manholes in time.

All subscribers' circuits were teed to the new and old exchanges. Some of the tees were made in the underground cables, but where the disposition of the plant permitted this to be done, the tees were made

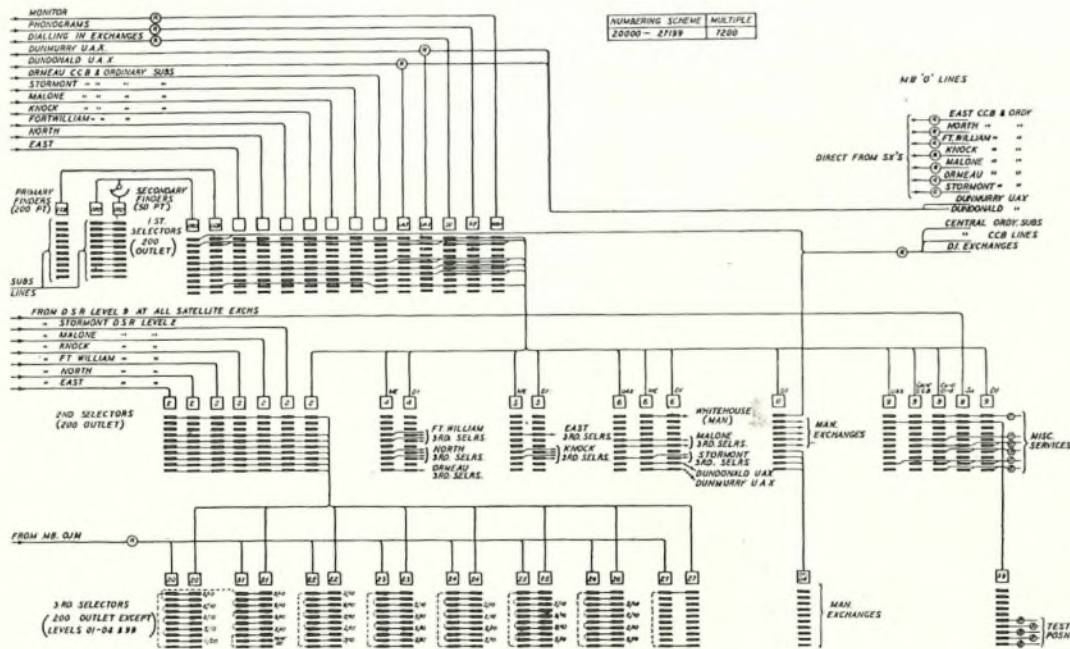

FIG. 13.—TRUNKING DIAGRAM, CENTRAL EXCHANGE.

Conversion Work, External.

The subsoil conditions at Belfast are definitely unstable, being affected by high tides and underground rivers in an area constantly liable to flooding by storms. The city lies at sea level at the foot of a range of hills. These conditions increased the difficulties in carrying out such an extensive underground re-arrangement. When heavy rains were followed by a high tide, the water draining from the hills increased the pressure of the water in the underground rivers and much of this water found its way into the Department's duct lines and manholes. Flooding from surface water was also experienced, and when these conditions were cumulative one or two serious breakdowns occurred, while the number of times serious breakdowns were narrowly averted was much more numerous. Unfortunately, that portion of the Belfast area where most trouble was experienced from flooding coincided with the area where the number of underground cable diversions was greatest.

It is interesting to note that the only satisfactory method of preventing water entering the manholes from the duct lines proved to be the lead seal. The interception chamber alone, whether using clay or petroleum jelly, proved quite useless, the pressure of water being too great. In more than one instance the water pressure suddenly forced the packing completely out of position and allowed the full head of water to flood the manhole. This occurred during working operations, the cable joints being completely

on the M.D.F. of the new exchanges by means of temporary jumpers which were all cut away shortly after the transfer.

A new multi-office cable scheme was provided between the Central and Satellite Exchanges. The scheme is interesting as the cables are of the composite type, consisting of 6½ lb., 10 lb., and 20 lb. conductors arranged in quad formation and designed to meet the usual transmission limits. Loading coils have been inserted where necessary to provide the required transmission efficiency.

Conversion Work, Internal.

The non-standard nature of the existing system necessitated the fitting of the automatic instrument side by side with the magneto instrument, together with a change over switch, at every subscriber's premises terminating a direct exchange line. Subscribers were asked to operate this switch at the time of the transfer and thenceforth use the automatic instrument. The magneto instruments were recovered after the transfer.

All P.B.X.'s were replaced by the auto area type of board prior to the transfer, temporary units being fitted at the old exchange to enable these P.B.X.'s to operate on a C.B. basis and at the same time return magneto call, auto clear conditions to the old manual board. For the carrying out of the conversion work some 200-odd men were recruited from the Belfast Labour Exchange and given suitable training in batches of 20 at a special school set up locally for the purpose. A records staff of approximately 15

was required throughout in connexion with the conversion work which gives some estimate of the magnitude of the operations. Some 20,000 stations and 800 Private Branch Exchanges were converted.

Fig. 14 is a view of the racks carrying the relays and repeating coils forming the temporary units

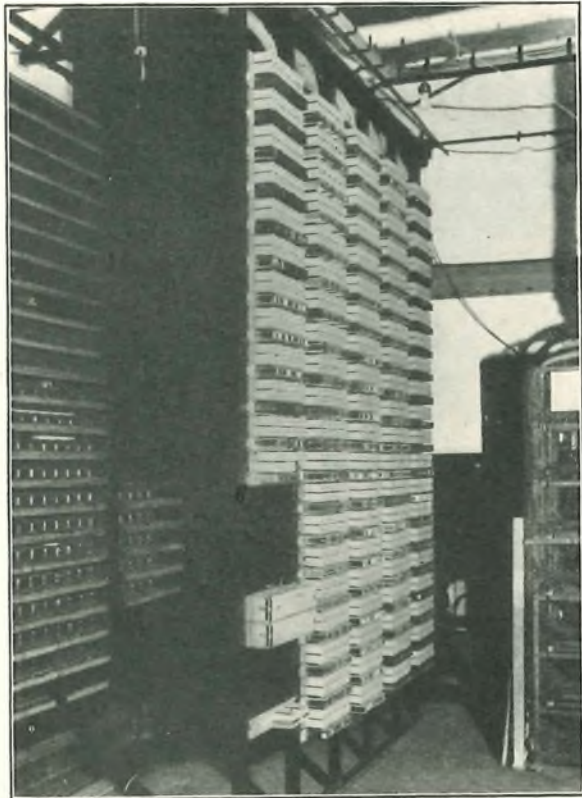

FIG. 14.—TEMPORARY P.B.X. UNITS.

required on Private Branch Exchange lines. It is noteworthy that these units were installed entirely by locally recruited and locally trained labour.

Coin boxes in the area were converted to automatic working in advance of the main transfer, the conversion being commenced as soon as the new auto-manual board was brought into use, some four weeks before the main transfer. The number of these installations was considerable, being some 400, but anything in the nature of a last minute rush was avoided by having all new equipment mounted on base boards and thoroughly bench tested before fitting. Temporary notices instructing users to dial "0" for all calls were placed in front of the permanent notices and these were removed very shortly after the transfer when the new directories were provided.

Transfer Arrangements.

As already stated the unavoidable use of change-over switches at subscribers' premises necessitated special transfer arrangements. To cut in all lines regardless of whether the change-over switches had been operated or not would have invited disaster. Failure on the part of the subscriber to operate the switch would result in the old condition of earth on

both legs, and if the line were cut-in to the automatic exchange this earth would operate the line finder start circuit. Even a relatively small proportion of such failures would give rise to serious congestion of the line finders, and accordingly it was decided to test all lines immediately before cutting-in, and only cut-in those on which the switch had been operated.

Subscribers were warned by every possible means to be sure and operate the switches half-an-hour before the transfer. To make assurance doubly sure all subscribers' lines were tested during this half-hour from the old exchange switchboards, and those who had failed to operate the switch were rung and asked to do so. Although complicated by the fact that it was necessary for any subscriber making or receiving a call during this half-hour to re-set the switch and revert to the magneto instrument, these measures proved quite effective, the number of failures being under 4%.

A simple test for earth was made on all direct exchange lines at the main frame of the new exchanges before cutting them in. The wedges in the negative line were withdrawn singly, and any line testing earth, indicating that the switch had not been thrown, was not cut-in. Such lines were re-tested and rung, and where necessary the subscribers were visited. This initial test for earth and the withdrawal of the wedges were carried out in 10 minutes 12 seconds, during which time 12,500 lines were dealt with.

The engineering test of subscribers lines after the transfer at each automatic exchange was carried out from special test panels, in accordance with the new method described in a recent article.³ The method was found to be very satisfactory and to possess all the advantages claimed for it by the author of the article quoted.

Contractors.

The Contractors who carried out the various works to the Department's specifications were as follows :—

Automatic switching plant, power plant, and auto-manual and trunk switchboards :—Messrs. Siemens & Co., who kindly supplied photographs for this article.

Pneumatic ticket tube system, the carrier telephony and V.F. telegraph apparatus :—Messrs. Standard Telephones & Cables, Ltd.

Repeaters and associated plant :—Messrs. General Electric Co., Ltd.

Repeater Station Power Plant :—Messrs. Austen-lite, Ltd.

Conclusion.

There is no doubt that the Belfast telephone public has benefited greatly by the inauguration of the new automatic system, which, as before stated, is a big step towards the complete automatization of telephones throughout Northern Ireland. This programme will be carried on during the next five years, by the end of which all, or very nearly all, the manual exchanges in Ulster will have been replaced by the automatic system.

³ *P.O.E.E. Journal*, Vol. 28, Pt. 3.

B.B.C. Northern Ireland Regional Station Broadcast on the Belfast Auto Transfer

THE Northern Ireland Regional Station of the B.B.C. has the distinction of being the first B.B.C. Station to use the telephone service as the motif for a purely entertainment broadcast. Prior to the change over to automatic working of the Belfast Multi-Office area, the B.B.C. Regional Director suggested that a "telephone" broadcast should be included in the Northern Ireland Regional programme on the evening preceding the transfer. The time assigned for this item was 9 p.m. to 9.30 p.m., probably the most popular half hour of the day for listeners.

The local staff co-operated enthusiastically with the local B.B.C. officials in the preparation of the script for the broadcast which was entitled "Contact," a title which sounds rather ominous to telephone engineers, but which was intended by the B.B.C. officials to convey the impression that their listeners were being brought into contact with the new automatic telephone system.

The programme consisted of two parts, the first eight minutes being allocated to a dramatized version of the opening of the first telephone exchange in Belfast in 1880, the public reaction to the innovation, and a reproduction of the conversation over the first trunk circuit between Belfast and Dublin and between Belfast and London. For the preparation of this portion of the script the B.B.C. officials obtained from old newspaper files and elsewhere the actual conversations which took place between the civic and other dignitaries who took part in the official opening of the services referred to. This portion of the programme was broadcast by the B.B.C. entertainers from the B.B.C. Studio.

The last 22 minutes were broadcast from Telephone House, after the Studio had been faded out to a cue of "Dial 0" and Telephone House was faded in to the call of a magneto bell in the well known sound of the interrupted ringing. The B.B.C. outside producer gave a racy description of the Auto Manual Switchroom, followed by a "questions and answers" conversation between himself and Mr. Froom, Traffic Superintendent, and then left the latter to talk for about one minute while he (the B.B.C. producer) rushed from the fifth floor to the automatic apparatus room on the first floor where a

dialogue, designed to explain in non-technical language the intricacies of the automatic system, was held between the B.B.C. official and Mr. Cooper, Sectional Engineer. This was followed by a short rehearsal of the actual transfer arrangements when the public of Northern Ireland had an opportunity of listening to the "cut out" and "cut in" instructions given over the circuits between the Central Automatic Exchange and the various old and new exchanges.

While the rehearsal was broadcast the producer ran from the Apparatus Room to the Power Room on the ground floor where, after giving his general impressions, he indulged in a dialogue with Mr. Metson, the show closing with Mr. Metson referring to the "Ticket Blower" saying "I will start it up and if it doesn't blow you away it will drive you away." To co-ordinate the talks from the three different rooms in the exchange, a control panel was established in Telephone House by the B.B.C.

Into the making of that half an hour's broadcast went an enormous amount of work. Rehearsals were numerous and the local staff who had speaking parts will not readily forget these and the intensive coaching in "B.B.C. elocution." Bearing in mind that the staff concerned in the production were also engaged in the final preparations for the largest non-director transfer that has yet taken place, it is a tribute to their zeal that they should have been so willing to shoulder the additional burden imposed by these rehearsals and coaching.

The author, who assisted the B.B.C. officials in the production, will carry pleasant memories of the occasion, as will, I am sure, all those who assisted in staging such a successful show.

On the same evening Mr. T. T. Partridge broadcast an appeal to subscribers to throw the switches which had been fitted at each subscriber's premises. These switches were necessary to disconnect the old Magneto Call, Auto Clear telephone and cut-in the new Automatic instrument, at the time of the transfer.

The exceptionally large percentage of subscribers who operated their switches is largely attributed to this broadcast appeal.

C.E.W.

The Post Office 600 Type Relay

C. W. CLACK, A.M.I.E.E.

Introduction.

SEVERAL articles have appeared in the Journal¹ and elsewhere describing the P.O. 3000 type relay and the present article is intended to give some general particulars of its "little brother," the P.O. 600 type relay. The two can conveniently be termed the "Major" and the "Minor" standard types of relay.

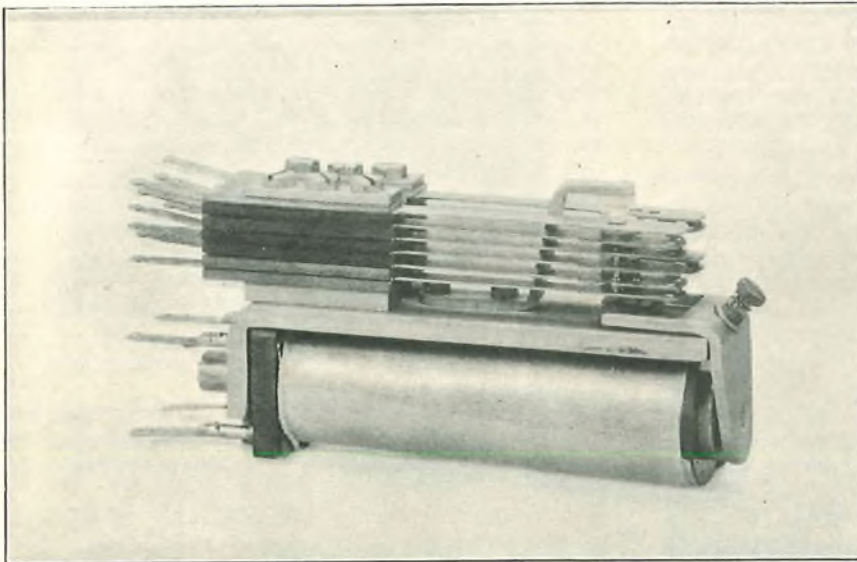

FIG. 1.—TYPICAL RELAY ASSEMBLY.

Whereas the major or 3000 type has been designed primarily to meet the exacting and complex requirements of automatic telephone circuits, the minor is intended for more general and simpler service, and should have a wide field of application. It is expected that together they will cover all ordinary relay requirements, leaving only very special functions to be met by relays of entirely different designs.

The minor or 600 type is, as might be expected, considerably smaller and less costly than the major. It is somewhat similar in general appearance (allowing for the difference in size), and has many desirable mechanical features in common with the latter.

¹ "The Proposed Post Office Standard Telephone Relay for Automatic Exchanges." R.W.P. Vol. 24, Pt. 3.

"Design of Relays for Automatic Telephone Equipment Circuits with special reference to Relay Type 3000." R. Barker, B.Sc. Vol. 26, Pt. 1.

"The Introduction of the Standard Telephone Relay." R. W. Palmer, A.M.I.E.E. Vol. 27, Pt. 1.

Mechanical Features.

Fig. 1 shows a typical relay assembly, and Fig. 2 the parts. The coil cheeks are of bakelite, and the rear cheek can accommodate a maximum of four tags. The annealed soft iron core has an enlarged pole face at the armature end, as in the major type. The winding space, although small compared with the major, is ample for the maximum armature load permitted. Taking, for example, the smallest size of wire used, viz., .002 enamel insulated, the number of turns which could be accommodated is 52,500; and the resistance of the copper wire would be 17,500 ohms.

The annealed iron yoke is an elongated L shape, and the coil is clamped thereto by a slotted circular nut screwed on a threaded extension of the core. Two screws in the heel of the yoke serve to fix the relay to its mounting. In this way independent provision is made for the fixing of the coil, which can consequently be removed and replaced without dismounting the relay. The front end of the yoke is machined to a slightly acute angle, so that it can serve as a bearing edge for the armature.

The armature is of slightly opened and rounded L shape, and has a machined groove in the bend to

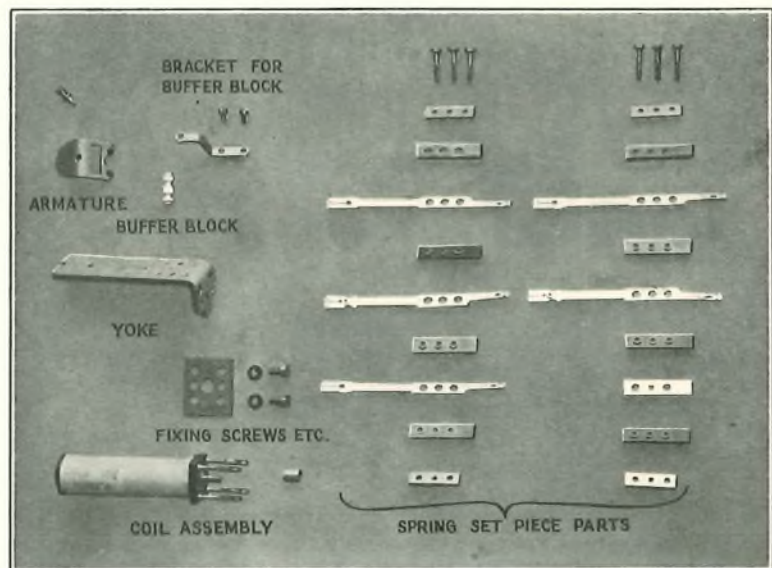

FIG. 2.—COMPONENT PARTS.

enable it to sit and rock snugly on the end of the yoke. It is held in position by the pressure of a spring loaded washer on a locating screw fitted obliquely in the end of the yoke. A phosphor bronze stud rivetted to the part of the armature facing the pole piece controls the residual gap. There are three sizes, giving projections of 4, 8, and 12 mils respectively, but the 8 mil stud is the one generally used. No provision is made for an adjustable residual screw mainly on account of the small size and thickness of the armature.

The contact springs are very similar in shape and dimensions to those on the major relay, and are arranged in two piles or assemblies. Twin dome shaped contacts are fitted throughout. The springs are of spring-hard nickel silver and the insulating spacers of bakelite. Each pile of springs, when assembled, has three screws, the centre one securing the springs between their clamping plates, and the other two serving to fix the assembly to the yoke. Each pile can therefore be detached as a unit.

As in the major type, a buffer device is provided to position the springs. It is, however, of simpler construction and consists of a turned pillar of white insulating material with the necessary steps on which the springs rest. One end fits directly into the yoke; the other is held by a bracket which is secured to the yoke by two screws.

The transmission of motion from the armature to the springs is by means of pins rivetted in the moving springs and insulated from the resting springs and armature.

The maximum number of springs in a spring pile on the minor relay is six, including two moving springs, *i.e.*, springs operated directly by the armature. The two piles together therefore provide up to four contact actions, which may be make, break, break before make, or make before break, in various combinations, providing a total of 69 possible contact functions for this relay.

The standard armature travel is 25 mils which gives the same contact movement (approximately 40 mils) as with the major type. The nominal contact pressure is 20 grammes for springs of standard thickness, *viz.*, 14 mils. For specially sensitive relays it may be necessary to use 12 mil springs, in which case the nominal contact pressure will be 15 grammes.

The standard contact metal is silver of 99.9% purity, and this is fitted for normal service. Platinum is reserved for cases of light contact pressure, extra heavy duty, or extra reliable service.

The small size of the minor relay renders it unsuitable for functions involving timing or sequence of contact operation, and a double winding reduces the available winding space by 8% due to inter-winding insulation. As already mentioned the purpose of the relay is to meet simple and straightforward circuit requirements.

Application to Circuit design.

The tolerances on dimensions are of the same

order as for the major relay. The effect on the smaller relay is bound to be greater, producing a higher percentage variation in performance. This has to be taken into account in the factors of safety.

The principles and procedure adopted for the application of the relay to circuit design are the same as for the major relay. Standard values of factors of safety have been determined, and tables prepared of test ampere-turns for various spring combinations and residual studs with standard armature travel; also a table of the number of turns and resistance which can be obtained by fully winding the spool with wires of various diameters. There is also a table of turns and resistance for percentages of fullness.

The test ampere-turns are those which provide a proper factor of safety over the design ampere-turns, and make allowance for variations due to materials and bulk manufacture. Circuit factors of safety in the form of multipliers or percentages are applied to the test ampere-turns to take care of adverse conditions of voltage and resistance. The present standard factors, expressed as percentages of test ampere-turns, are:—

Operate	140% minimum.
Non-operate	80% maximum.
Hold	150% minimum.
Release	70% maximum.

It is, of course, desirable to design relays well within the limits and allow larger margins wherever possible, the relay being then less liable to fail under unusual circumstances.

The maximum watts rating for the minor relay is 4 for half an hour's continuous application.

Mounting Arrangements.

With regard to weight and size, the average weight can be taken as 4 ounces. The minimum space required is $1\frac{1}{8}$ " \times $\frac{7}{8}$ ". It can be mounted at the following centres, which should be regarded as minimum:—

	Vertical Centres.	Horizontal Centres.
Under common cover	... $\frac{7}{8}$ inch.	$1\frac{1}{8}$ inches.
Individual covers	... 1 "	$1\frac{3}{4}$ "

The length, measured from the mounting, is 3 inches, or $3\frac{5}{16}$ inches with the individual cover. The mounting plates are of pressed steel, flanged type, with standard zinc finish.

It will be evident that the minor relay is admirably suitable for line and cut-off relays in subscribers' line circuits at telephone exchanges, and this is in fact the first use to which it has been put by the Department. Fig. 3 shows a strip of 20 such relays arranged for vertical mounting. Fig. 4 shows a strip arranged for horizontal mounting, and Fig. 5 the individual cover provided when required. It should be mentioned that this latter cover is secured by friction grip on the edges of the relay yoke.

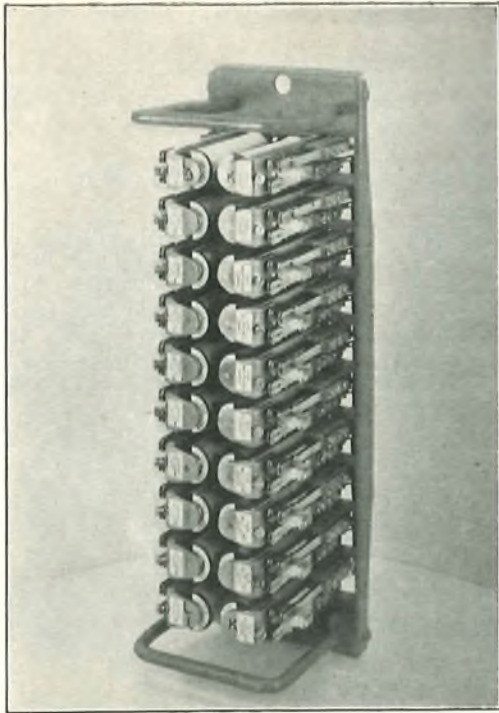

FIG. 3.—VERTICAL MOUNTING.

As the minor relay is not intended to usurp the position held by the major relay in meeting the exacting requirements of automatic switching circuits, it has been decided that the two types of relay shall not be indiscriminately mixed on the same mountings.

Maintenance.

It will have been seen that the major and minor relays are very much alike in all essential features, and the same maintenance technique can therefore be applied to both, which is obviously an advantage. Adjustments to "current" values are seldom required in normal maintenance procedure with these relays, the standard practice being to adjust to specified contact and spring pressures. For this purpose the same tools serve for both types. With standard initial adjustments, very little maintenance readjustment is needed.

The development of the 600 type or minor relay is the result of collaboration between engineers of the Department and the General Electric Co., Ltd., Coventry. The author is indebted to this Company for the supply of the diagrams which illustrate this article.

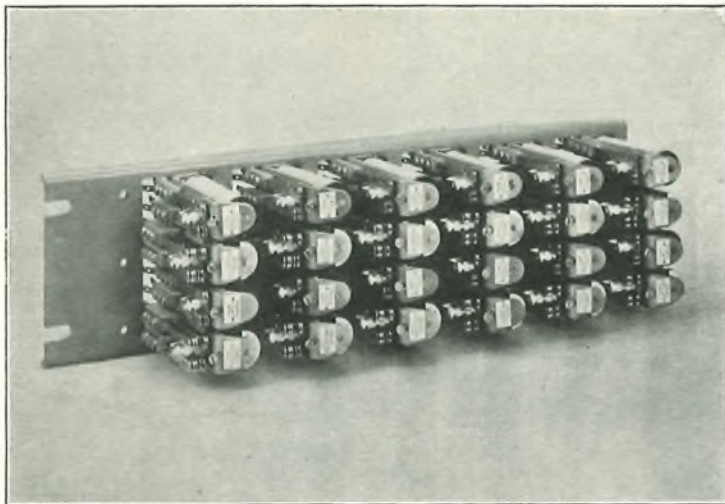

FIG. 4.—HORIZONTAL MOUNTING.

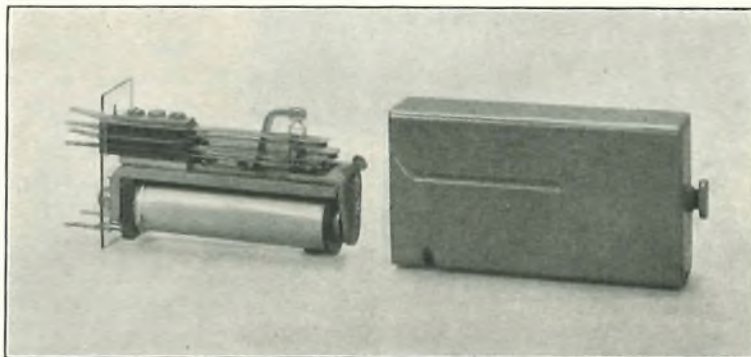

FIG. 5.—RELAY WITH INDIVIDUAL COVER.

Asbestos-Cement Ducts

C. F. THOMAS

Asbestos, its Origin and Properties.

WHEN "asbestos" is spoken of by many people visualize it as "a non-inflammable packing" and if "asbestos-cement" is mentioned their imagination turns to fireproof garages for urban villas or pink roofing tiles for the desecration of rural England. The use of asbestos-cement in the building industry is well known, but its employment in engineering is not so self-evident in every day settings. The manufacture of asbestos-cement pipes capable of withstanding water or gas pressure was begun in Italy in 1913 and had reached a commercial basis by 1916. Great progress had been made by 1921 and the process patented in the principal industrial countries, and in 1928-29 the manufacture of such pipes was commenced in this country. In April, 1933, a B.S. Specification, No. 486, "Asbestos-Cement Pressure Pipes," was issued, followed in December, 1934, by B.S.S. No. 582, "Asbestos-Cement Soil, Waste and Ventilating Pipes and Fittings." Pipes made under B.S.S. 582 have adequate strength for use as cable conduits.

Before proceeding with a description of asbestos-cement ducts it is desirable that a clear idea of the nature and function of the asbestos should be held. Fig. 1 illustrates raw asbestos fibre. Fortunately

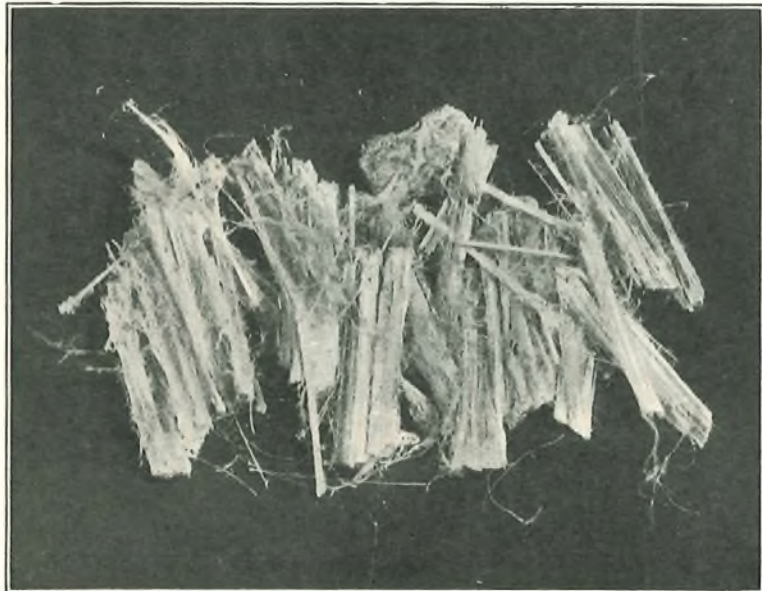

FIG. 1.—RAW ASBESTOS FIBRE.

many of the sources of asbestos lie within the British Empire; white asbestos or "Chrysotile" is found in Canada, Rhodesia, the Transvaal and in Russia. "Chrysotile" is the basis of most asbestos-cement ware, but there is also a blue asbestos which, although inferior to the white variety as a heat resist-

ing material, is superior where acid-resistance is important.

There is nothing uncommon about a non-combustible mineral; iron ore and mica might be cited similarly. Asbestos is, however, the only mineral occurring naturally in a fibrous state and that property is valuable when asbestos is used in combination with other fire-resisting materials, e.g., Portland cement, to make asbestos-cement ware.

Function of Asbestos as a Reinforcing Material.

The function of steel rods for conferring tensional strength upon concrete will be well known to most readers, but probably few will have considered the uses of asbestos fibre for a similar purpose. It is true that asbestos fibre mixed intimately with cement does not confer a high degree of tensional strength, but it is adequate for the purposes for which asbestos-cement products are required. In practice the material consists of

Asbestos Fibre	75-80%
Portland Cement	20-25%

Manufacturing Process of Asbestos Pipes.

The production of pipes, as seen at the works of a leading British firm of asbestos-cement ware manufacturers, may be described as follows: The pipe former is a polished steel mandrel of the correct diameter for forming the required bore. The mandrel is mounted horizontally and while rotating picks up a plastic film of asbestos-cement from an endless band or blanket rotating in the same direction and squeezed continuously against the mandrel along its length under great pressure. As the mandrel coating increases, dial gauges indicate its thickness and when the desired thickness has been built up the machine is stopped and the mandrel swung out bearing the newly formed pipe. The pipe is gently eased from the steel mandrel, and is then set aside with a wooden mandrel inserted in the bore in order to guard against deformation. While in the "green" condition the ends are trimmed squarely and a socket may be moulded on by hand.

When the pipes have hardened sufficiently to allow the wood mandrels to be withdrawn the pipes are "cured" under water for two weeks. Upon completion of the water curing process the pipes are washed very thoroughly in order to remove lime scum, after which they are set aside for a further period of hardening and finally dipped in a bituminous emulsion.

The formation of a pipe in the machine is a matter

of a few minutes, but about 5-6 weeks for hardening must elapse before the pipe is ready for service.

General Properties of Asbestos-Cement Ducts.

Five per cent. of the pipes made under B.S.S. 582 are required to pass a hydraulic test for soundness of 6 lbs. per sq. inch (or about 14' 0" head) maintained for one minute without sweating, leakage, or defect of any kind.

The bore tolerance for 3" pipes used as cable ducts is $+0, -0.04"$. (For earthenware ducts the tolerance is $\pm \frac{1}{8}"$).

The pipes conform to the same crushing test as 3" self aligning (s.a.) ducts, viz., $1\frac{1}{2}$ tons concentrated load per foot length. Lengths of 10' 0" and 6' 0" can most conveniently be produced by the standard machines.

No data is held relative to their strength as beams, but as a rough-and-ready test a man weighing 196 lbs. stood upon a 10' 0" pipe at midspan and rocked it vigorously for several seconds before fracture occurred.

The weight of 3" asbestos-cement ducts is about 19.7 lbs. per 6' 0" socketted duct or 227 yards per ton; the weight of 3" s.a. earthenware duct is about 29 lbs. per yard or 102 yards per ton.

Design of the Duct Joint.

Asbestos-cement pressure pipes intended to resist internal pressures up to a 300 ft. head of water are normally aligned and jointed by means of malleable cast-iron collars drawn together until rubber rings that furnish the actual seal are fully compressed. A special jointing jig is essential for the work.

Telephone conduit construction does not demand a joint that will resist high pressures and, as a simplified method of jointing in which the advantages of rubber rings are retained, it was suggested that two rings might be placed upon the spigot end of an asbestos duct, one ring poised upon the spigot-tip, the other about $2\frac{1}{2}"$ distant along the barrel. Upon thrusting this assembly home in the socket of another duct, the rubber rings travel naturally a little distance along the barrel before reaching their final positions, the amount of travel depending upon the sectional circumference of the rubber rings.

Airtightness is ensured by choosing rings whose sectional diameter is slightly greater than the annular space between spigot and socket, and thus the rings when in position are permanently under compression.

It was known that a certain municipal authority was laying several miles of power cable duct employing this method of jointing, but upon full consideration it did not appear wise to follow the same practice for telephone work as some danger of misalignment occurs and the overall diameter of the sockets (standard rainwater size) was considered too great for situations where nests or clusters of asbestos ducts might be required.

Accordingly the joint shown in Fig. 2 was designed, and it will be seen that it resembles the joint of spigot and socket steel pipes, the clearance between spigot and socket being only $1/32"$. The sockets were manufactured from cut pieces of asbestos pipe cemented on to the barrels.

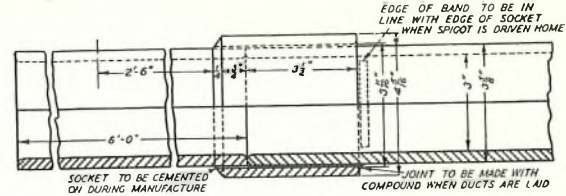

FIG. 2.—JOINT BETWEEN TWO PIPES.

No provision of "bends" was made, it being anticipated that the amount of "set" obtainable at each joint would suffice for all ordinary curvatures. Alternatively, ducts could be cut to shorter lengths in order to increase the number of "set" joints. About $1\frac{1}{2}"$ maximum deviation can be given to a 6' 0" asbestos duct.

As a jointing mixture a proprietary roof repairing compound was specified; it is a tar compound containing asbestos shreds, and is applied cold.

Experiences in laying Asbestos-Cement Ducts.

One mile of asbestos-cement ducts was included in the Bletchley development scheme carried out in August last year, the actual site being the Simpson Road from Fenny Stratford to the village of Simpson. The route was laid mainly in grass margin with a small amount of tarmacadam at road crossings, etc.

At the commencement of the work a few ducts were found to leak slightly at the cemented-on socket joint, but this defect was overcome by means of a smear of the compound applied around the seam and thus further trouble was avoided.

These leakages may be dismissed as "teething troubles" in view of the improvements in design and manufacture devised in the light of experience. Watertight construction had been specified in the contract for laying the ducts and a standard drain testing machine was employed for testing completed work. For the first few days smoke testing was employed, after which air-pressure alone was used. Smoke testing requires about 15-20 minutes per 176 yard section, but leakages, if any are present, can be detected by the appearance of smoke at the point of leakage. Air pressure gives a practically instantaneous reading. If the air pressure cannot be maintained a smoke test must follow for visual location of the leakage. The pressure applied was equal to a 4" column of water or .14 lbs. per sq. inch.

Several tests were necessarily made in the course of constructing each 176 yard section in order to prove every part of the work before filling in. Thus a 40 yard length might be laid, tested, and covered in, followed by the laying of another 40 yard run. The test of this second length would impose another test upon the work already covered and so on to the end of the section. There was no instance of leakage developing subsequently in work already covered in, although a mechanical rammer was used and carriageway crossings were included in the route.

Fig. 3 shows a 6' 0" asbestos-cement duct.

Figs. 4 and 5 show ducts in process of compounding and Fig. 6 shows the drain testing machine; the U-tube pressure gauge is reading about 4" water column.

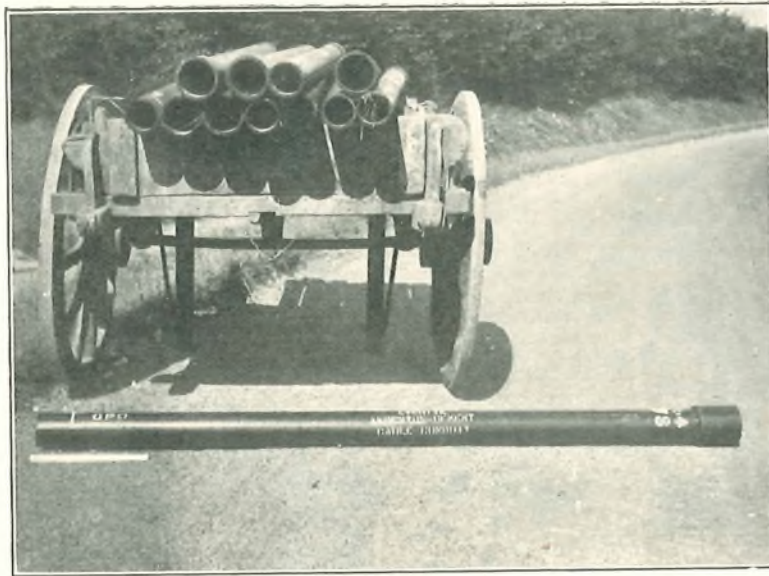

FIG. 3.—SIX FOOT LENGTH OF ASBESTOS-CEMENT DUCT.



FIG. 4.—JOINTING COMPOUND BEING APPLIED.

Curvatures in Route. The greatest deviation was an arc about 200 feet in length at a radius calculated to be 232 feet. This was negotiated without any necessity to shorten ducts for the purpose of increasing the number of "set" joints. It may be considered therefore that ducts in six-foot sections meet the average requirements of rural highway curvatures.

Breakages. There were no accidental breakages of asbestos ducts on rail or during progress of work.

Rate of Progress. The average rate of duct laying for the mile of route was 18 yards per hour and the best performance was 212 yards in 10 hours. Had the ductlayer been following a larger digging gang

progress would doubtless have been still better. It can be said that the laying of asbestos ducts is at least as rapid as the laying of earthenware ducts. Tests require about 30 minutes daily, assuming that faults do not occur. Once the ductlayer had settled down to the new methods faults were very few indeed.

Jointing Compound.

The compound had undergone lengthy tests at the Research Station with the object of ascertaining its behaviour towards lead-covered cables and its degree of flexibility. The compound cannot be applied by brushing, but is spread by means of a trowel or spatula. It was proved to be unharmed to lead and to remain sticky for two days and still flexible after

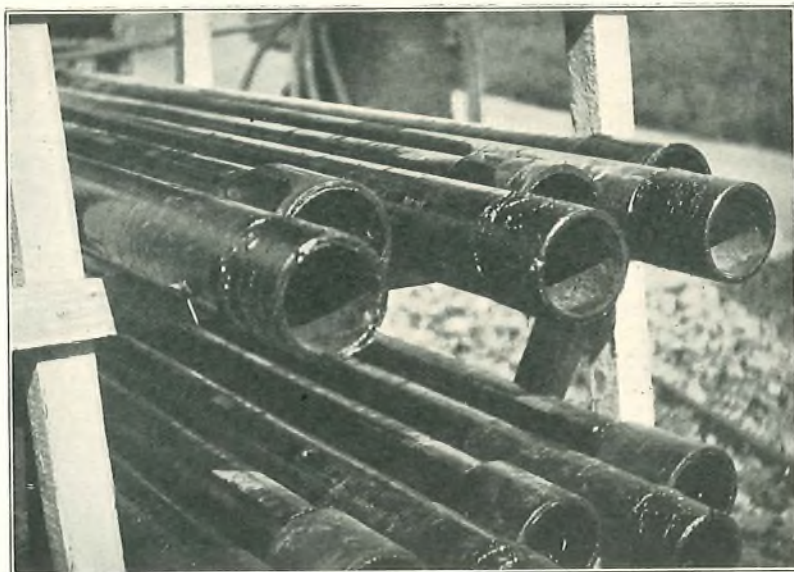

FIG. 5.—DUCTS WITH JOINTING COMPOUND APPLIED.



FIG. 6.—DRAIN TESTING MACHINE.

six months. The use of the new luting compound is not limited to asbestos ducts, but it was convenient to associate the two materials on this job.

Some small-scale trials of the compound have been made with s.a. ducts with complete satisfaction and it appears likely that the performance of the compound will lead to some simple acceptance test for airtightness of s.a. duct lines as well as asbestos ducts.

Extra Cost of Asbestos Duct Work, and Freight Charges.

It would be unfair at this stage to draw comparisons between the purchase price of asbestos ducts and earthenware ducts; the former have been made

under one contract only for a single mile, earthenware ducts have been purchased by competitive tender for many years.

But in regard to the cost of laying, the extra expense in the Bletchley scheme was only £10 per mile more than 3" s.a. duct, this figure includes the additional charge per yard run for laying and the extra cost of the compound. Freight charges for a 150 mile journey show a saving of 1.04 pence per yard in favour of asbestos ducts.

Probable lines of Development in Asbestos-Cement Ducts.

Reference has been made already to the rubbering method of jointing and although there are

definite objections to a clearance necessitating the use of rubber rings as large as $\frac{3}{8}$ " in diameter there is no doubt whatever that the method is astonishingly quick, and quite watertight. It is being used not only for asbestos-cement pressure pipes designed for 300 feet head of water, but for patented flexible joints in cast-iron mains.

Experiments now in hand support the view that rubber rings $\frac{1}{8}$ " in diameter and compressed by being rolled into a joint having a clearance of $\frac{1}{16}$ " between spigot and socket, will prove satisfactory. By limiting the spigot and socket clearance to $\frac{1}{16}$ " the correctness of alignment is assured under all conditions. There is no room for doubt as to the useful life of rubber joints when used in underground positions. Records are available of joints in position and still sound after 40 years of life. The B.S. Specification 486, previously referred to, requires that rubber used for joints shall be proof against water and sewage.

The process of manufacture does not lend itself to the production of multi-way ducts, but that need not be regarded wholly as a disadvantage. Each "way" is independent of its neighbours and leakage or damage to a single way does not waterlog the whole route as with multiple self-aligning earthenware ducts. The value of a nine-way earthenware duct is reduced from about twelve shillings to zero by an accidental blow, but if an asbestos duct is broken the damaged part may be sawn off and some part of the duct salvaged.

Storekeeping is simplified very greatly when single-way ducts alone require to be kept in stock, and capital is not "frozen" in stocks of "n" way ducts which must be kept on hand in sufficient quantities to meet anticipated demands in all multiples.

In any case, however, it would not be impossible to arrange for the manufacture of multiple asbestos-cement ducts, and if these were manufactured in circular formation a much more effective sealing could be obtained than is obtained with present multiple earthenware ducts.

General.

It has been stated already that the asbestos-cement ducts passed the Department's standard crushing test, viz., $1\frac{1}{2}$ tons per foot run. Fig. 7 shows a practical test in progress in which a 16-ton steam roller had spent several hours rolling the surface of the trench shown. Afterwards the 15-ton tractor illustrated crossed the trench several times and finally



FIG. 7.—TRACTOR STANDING ON ASBESTOS-CEMENT DUCTS.

stood for two hours with its heavy axle immediately over the top row of pipes. The pipes shown are heavier than cable ducts, but the test is convincing as regards the elasticity of asbestos-cement, since the uppermost pipes have a covering of only 9" of clay soil and no damage to any of the pipes occurred.

Although the experimental work described in this article was initiated independently in the Engineer-in-Chief's Office in 1933 it is fitting that reference should be made to a paper read before the I.P.O.E.E., South Western Centre, in October, 1930, by Mr. D. A. Barron, on the subject of "Revolutionary External Construction," in which the case for the asbestos-cement cable duct was first presented.

The writer is indebted to Messrs. Turners Asbestos Cement Co., Ltd., Asbestos House, Southwark Street, S.E.1, at whose Widnes factory the ducts were made, for the loan of the tractor illustration and for technical details of the properties of asbestos. He has also particular pleasure in acknowledging the friendly co-operation of Col. S. F. Newcombe and Mr. C. J. Stone, of Messrs. Turners staff, throughout the course of the experimental work.

Traffic Control Signals

A. H. VAUSE

TRAFFIC Control is a problem that has been with the Authorities for many years. In the days of slow moving horse drawn vehicles it was capable of easy solution, but the evolution of the motor vehicle, with its greater speed, and the increased number of vehicles using the public roads have made the problem both urgent and complex. The method generally adopted in the days of horse drawn traffic was to post at important points, usually at places where two or more busy thoroughfares crossed, police officers, who by means of hand signals, gave the "right away" or "stop" to the traffic. This was fairly successful as most drivers understood the signals and with good humour on either side no serious congestion of traffic was experienced.

The present day disadvantage of a police officer as traffic controller is that with a long line of traffic the rear drivers cannot see his signals, but must be guided by the movements of those vehicles in front. This difficulty can be partially overcome by the erection of a platform from which the officer can direct the traffic, but this arrangement is not entirely satisfactory.

In the early days of the motor vehicle it was realized that other means of control must be devised. It has been calculated that a large stationary motor vehicle in the City of London occupies space valued at £40,000 and an average sized stationary motor car occupies space valued at £20,000. Further, if 100 vehicles per hour in both directions traverse an intersection and the average delay is 30 seconds per vehicle the total annual cost for this section alone will be £416, assuming each vehicle is worked for 2,000 hours per year and that the average cost for each vehicle is 2/6 per working hour. These figures alone justify any attempt to keep traffic in a fluid state. As traffic congestion is a function of average speed, any improvement of this will reduce congestion.

So that traffic circulation at intersections could be improved, the traffic officer was at first provided with a hand controlled signal which gave unmistakable and definite indication to large groups of traffic. This experiment was followed by the introduction of an officer controlled signal light, which was in its turn replaced by a timing mechanism arranged to change the lights automatically and to give fixed periods of right-of-way to each highway in turn and so avoid the need of a traffic officer.

The fixed time system is now being superseded by vehicle actuated systems and in some instances a series of signals at successive road junctions is interlinked, using wires provided by the Post Office. The essential

features of all vehicle actuated systems are the Detectors, Signal Lamps and Controller.

VEHICLE ACTUATED SYSTEMS.

Detectors.

The Detector may be roughly described as a vehicle operated press button and represents the eyes of the traffic policeman. Two types are made, one by the Automatic Electric Co. and one by the Siemens & General Electric Co., the general features of each are shown in Figs. 1 and 2.

The construction of each type is such that when fitted in its position in the carriageway the working parts are adequately protected from damage by dirt, water, etc.

The Detector illustrated in Fig. 1, when used in certain localities where there is a possibility of vehicles passing over them in the reverse direction, has the upper plate split longitudinally and each plate separately connected to a relay fitted at the Controller. By discriminating according to the order in which they make contact with the lower plate, vehicles are only accepted as they approach an intersection and those leaving are ignored.

The Detector in Fig. 2 presents some novel features. It is unidirectional and the electrical circuit is actuated by an electro-pneumatic relay fitted under the pavement, allowing access to the contacts for examination at any time without obstruction to traffic or danger to the observer. Each electro-pneumatic relay includes two small bellows mounted at right angles to each other in such a manner that only one can be inflated at a time. They have a very small air capacity and are thus sensitive to the pressure of the lightest vehicle. Only the bellows associated with that side of the indiarubber mat which is normally first depressed is fitted with an electrical contact.

Small air leaks are provided to prevent damage by the pressure of heavy vehicles and to allow self adjustment to changing atmospheric conditions. Approaching vehicles inflate the contacting bellows

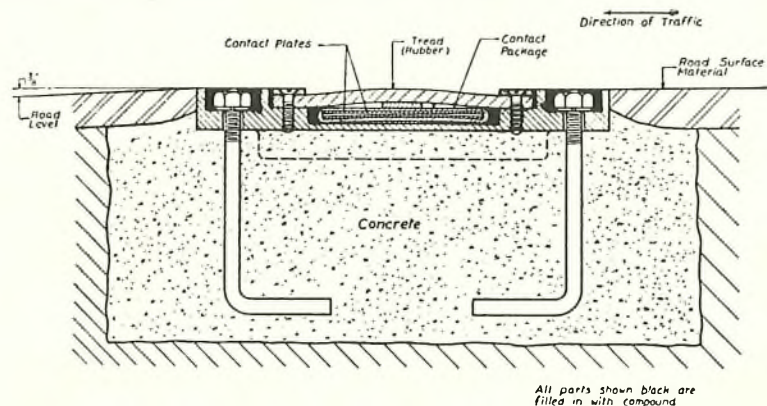

FIG. 1.—CONTACT PLATE DETECTOR.

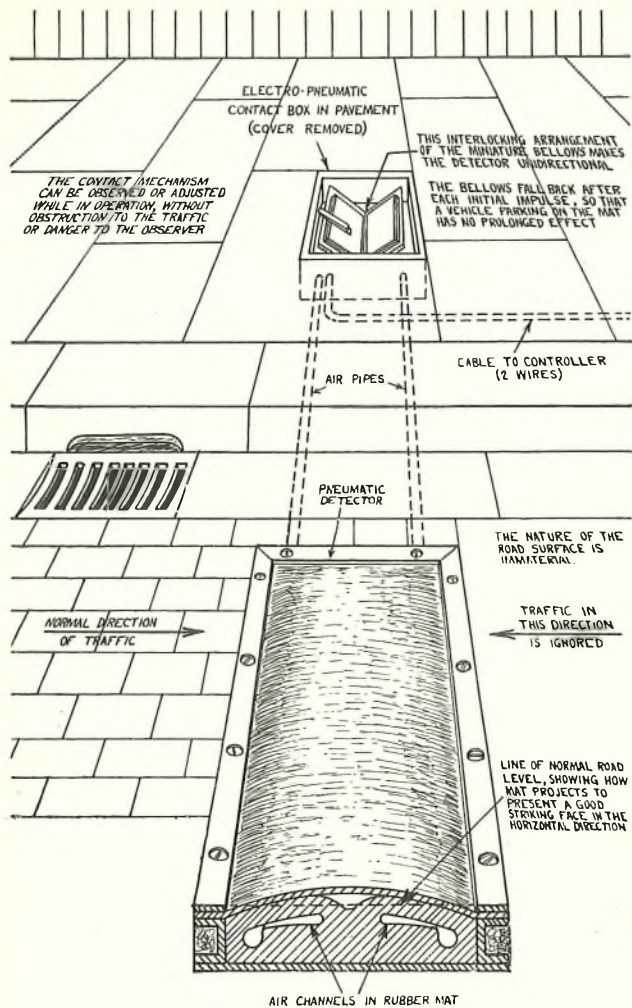

FIG. 2.—PNEUMATIC DETECTOR.

for periods proportional to the times of occupancy of the mat, thus transmitting impulses to the controller. The air leaks also restrict the inflated state of the bellows to the actual duration of the air movement, thus restricting the signal to vehicles actually in motion and ignoring any vehicle that may have "parked" on the mat.

Detectors are situated at some distance from the intersection, depending on the nature and average speed of the traffic. This distance is never less than 80 feet for average speeds up to 25 m.p.h., but is greater for higher speeds and for down gradients towards the intersection and is always fixed to allow sufficient braking space and to cover the reaction time of an average driver to a change of signal.

Signal Lamps.

Signals are made in pillar and bracket form suitable for fixing in any convenient position. The lamps are of the 60 watt pattern provided with an Edison screw fixing or bayonet holder. If screw fixings are used the light centre length must be 62 mm and that with bayonet holder 85 mm. The bulb must in all cases be of clear uncoloured glass.

Glass or metal reflectors may be used. The metal

must be non-ferrous chromium plated upon a nickel plated foundation.

Silvered plated glass reflectors must be protected by a deposit of copper and a moisture and heat resisting backing.

Details of design vary slightly as between manufacturers, but the main features are covered by British Standards Specification No. 505.

Controllers.

The controller is normally accommodated in a specially constructed signal post and is built on the demountable principle used in modern telephone exchanges and in one system the whole of the switching is carried out by means of relays of the telephone type.

The impulse circuits are novel. Apart from the relays the components are static and depend for their action mainly on the charge of a condenser and ionization of a neon tube (Fig. 3).

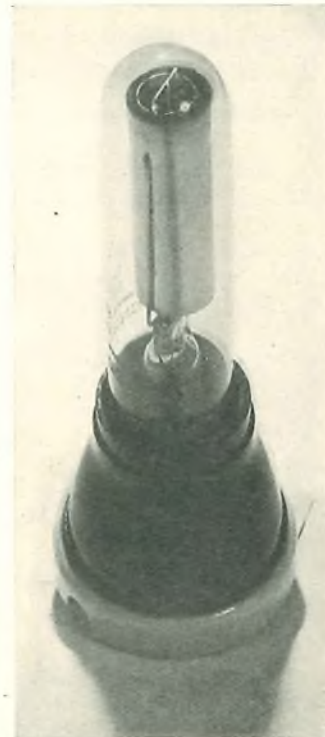

FIG. 3.—NEON TUBE.

ELECTROMATIC SYSTEM.

Timing Principle.

The principle of the Automatic Electric Co's electromatic timing circuit is illustrated in Fig. 4. A variable resistance V.R. is in series with a condenser and a source of E.M.F. In parallel with the condenser is a neon tube, F, and an electromagnetic relay A, which is of the type used in telephone installations.

FIG. 4.—PRINCIPLE ELECTROMATIC TIMING CIRCUIT.

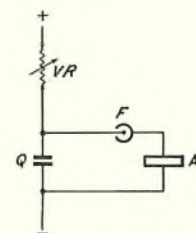

The operation of the circuit depends upon the charging

rate of the condenser Q and the "flash over" voltage of the neon tube, which is practically non-conducting until a certain voltage (63.2 per cent. of the applied voltage) is applied to its terminals. The charging rate of the condenser varies inversely as the resistance $V.R.$ and is expressed by Helmholtz's well known equation $E_c = E \left(1 - C \frac{-t}{RC} \right)$ where E_c = condenser voltage t seconds after application of the potential E , R = resistance in ohms, and C = capacity of condenser in farads.

When the voltage applied to F is sufficient to ionize the gas, it becomes conductive and sufficient current is passed to operate relay A , which in turn operates the Controller by means of a solenoid-operated cam switch. The operation of the relay reduces the condenser potential to zero by means of the additional contacts $S1$ and $S2$ (Fig. 5).

In practice the constants of the circuit are chosen so that the interval in seconds is numerically equal to the product of the condenser capacity in farads and the resistance of $V.R.$ in ohms. The condenser value is fixed so that a variation of the resistance $V.R.$ by 200,000 ohms represents a time interval of one second; the resistance $V.R.$ therefore acts as a time switch.

The practical timing circuit is shown in Fig. 5. A source of high voltage (412 v.) is connected across

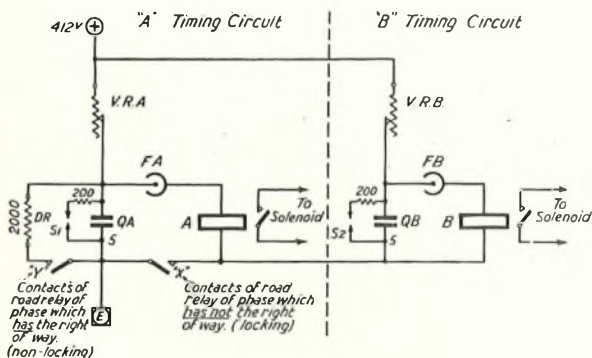

FIG. 5.—ELECTROMATIC TIMING CIRCUIT.

the points marked (+) and E . After an interval depending upon the value of the resistance $V.R.A.$, the potential across the condenser QA will equal that of the applied voltage.

Connected in parallel with the condenser are two circuits, one a discharge resistance DR and the other a neon tube FA and relay A in series, each circuit being normally open at the contacts X and Y . The contacts in the Y position are always associated with the road relay of the route which has the right of way in its favour and are only operated while the detector contact is closed. Those in the X position are associated with the route on which the right of way is closed and once operated they remain closed until the right of way is transferred to that route. When this is accomplished the contact functions are transferred on the two relays.

It will be seen that the contacts X are in series with the neon tube and relay. Though the condenser is free to charge, no discharge can take place

until a vehicle, faced with a stop signal, indicates its desire for a right of way by crossing the detector and so operating the relay, which in turn operates the solenoid and controller cam switch.

The Y contacts are in series with the discharge resistance DR , which is also connected in parallel with the condenser. Each time a vehicle with a right of way crosses the detector, these contacts operate and discharge the condenser to a greater or lesser degree, depending upon the speed of the vehicle and the length of time for which the contacts remain closed. In any case the condenser voltage is lowered below that of the neon tube flashover point and a further charge interval is necessary to raise it to this point and so permit of the right of way being transferred.

It will be noticed that if a succession of vehicles should cross the Y detector, the time intervals may be less than those necessary to charge the condenser to the "tube" flashover voltage, and a waiting vehicle, although having crossed the "X" detector, will be unable to proceed. In order to avoid this and to set a pre-determined time limit for which any route can hold the right of way, the circuit to the right of the dotted line is provided. This circuit is not affected by the operation of Y contacts and begins to charge immediately contacts X close. The condenser QB charges steadily and if a sufficiently long interval does not occur between the operations of contacts Y to charge condenser QA and so operate relay A , tube FB flashes and relay B operates, changing the right of way arbitrarily.

Whichever relay operates, the condenser is completely discharged by the operation of the solenoid contacts $S1$ or $S2$, thus ensuring that each new charge interval begins at zero.

These two circuits perform all the timing functions of the control system, and are loaned from phase to phase by the operation of the controller cam shaft.

A typical condenser charge and discharge curve is shown in Fig. 6. The inset shows the general form of graph relating vehicle speed and the time of wheel contact with the road detector. If the circuit diagram, Fig. 5, is considered in conjunction with these curves it will be seen that a vehicle travelling at 5 miles per hour closes the detector contacts for 70 milliseconds and at 30 miles per hour the contacts are closed for 12 milliseconds.

The "charge" graph is based on a 5 microfarad condenser in series with a 1 megohm resistance. With the condenser at zero potential and otherwise undisturbed, 5 seconds are required for it to charge to the flash-over voltage. The discharge curve is also based on a 5 microfarad condenser, but the series resistance is only 2000 ohms, the rate of discharge is therefore rapid. A vehicle passing over the detector Y at 5 miles per hour will almost completely discharge the condenser from the maximum voltage, whereas vehicles travelling at higher speeds will discharge the condenser by correspondingly smaller quantities. If the right of way has been extended to a line of traffic, the time spacing of which enables the condenser to be charged up to, or beyond, the flash-over voltage of the neon lamp prior to the next

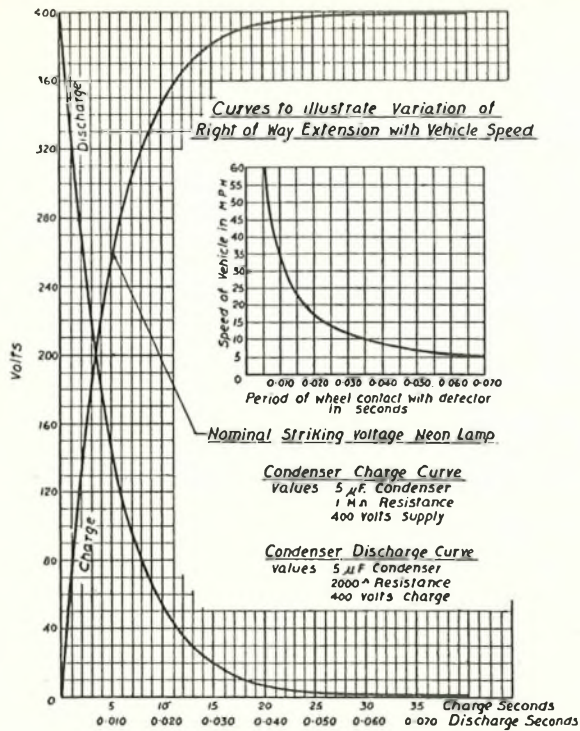

FIG. 6.—CONDENSER CHARGE AND DISCHARGE CURVES.

operation of the contacts Y, each succeeding faster or slower vehicle will actuate the contacts Y for shorter or longer periods, causing smaller or greater discharges of the condenser QA. If the condenser is fully charged, a vehicle crossing the detector at 30 miles per hour would close the contacts for 12 milliseconds and reduce the charge to approximately 115 volts. This voltage is attained in about 1.5 seconds, leaving 3.5 seconds of undisturbed charging time before the flash-over voltage is again reached.

A vehicle crossing the detector at 15 miles per hour will close the contacts for about 22 milliseconds, reducing the charge to approximately 40 volts, and now requiring 4.5 seconds to reach flashing point. It will thus be seen that the right of way is granted to vehicles for longer or shorter periods in accordance with their speed.

Should the condenser reach the flash-over voltage, denoting a lull in the stream of traffic having the right of way, then, if a vehicle on the other phase causes contacts X to close the right of way would immediately change over.

Circuit Diagrams.

The controls of the Electromatic Controller are shown in Fig. 7 and the circuit is given in Fig. 8. The controller consists of a solenoid operated cam shaft (Fig. 9), with which are associated two groups of 11 sets of spring contacts, four relays, two neon tubes, two 5 μF condensers and a group of resistances connected to regulating switches. The cam shaft is operated step

by step by the solenoid S, which has three sets of springs and is energized by the paralleled contacts of relays A and B.

The complete cycle is made in six steps, as shown in the schedule with Fig. 8. Various spring contact combinations are set up according to its position. Relay A operates when the neon lamp FA flashes and relay B when the maximum timing lamp FB flashes. At each operation of the solenoid, the condensers QA and QB are completely discharged via the 100 ohm resistances YA and YB and the operated contacts S1, S2, S3 and S4, thus ensuring uniformity in the charging times by commencing each charge from zero voltage.

It will be seen that the various timing adjustments are controlled by rotary switches which are connected to the various resistances, and that when the cam shaft is stepped round, the particular timing resistance is automatically introduced.

The various timing functions are eight in number as follows:—

1. Phase A Initial right of way interval.
2. Phase B " " " " " "
3. Phase A " " " " " "
4. Phase B " " " " " "
5. Phase A " " " " " "
6. Phase B " " " " " "
7. Phase A " " " " " "
8. Phase B " " " " " "

Phase A is usually referred to N – S and Phase B to E – W traffic.

A unique feature is the amber extension, which enables several seconds to be saved at each signal change since it allows a shorter period of amber signal normally than would otherwise be possible. When the signals change because of a gap in the stream of moving traffic, the vehicle of that stream nearest the intersection has not yet entered the controlled zone, and a very short warning period only is necessary before changing the signal indications, since there is ample braking distance between the boundary of the zone and the stop line. There are

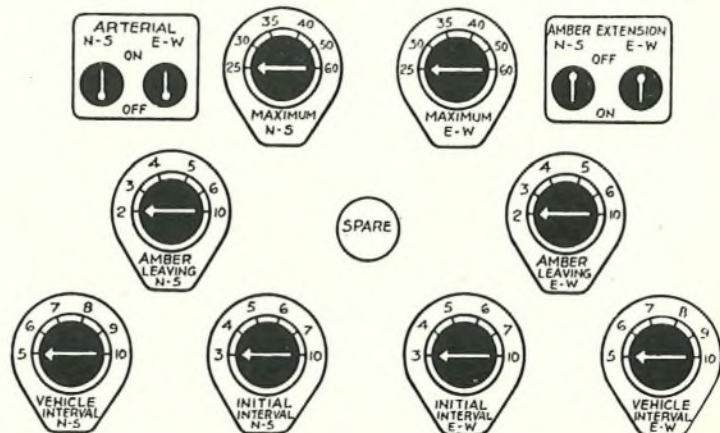

FIG. 7.—ELECTROMATIC CONTROLLER.

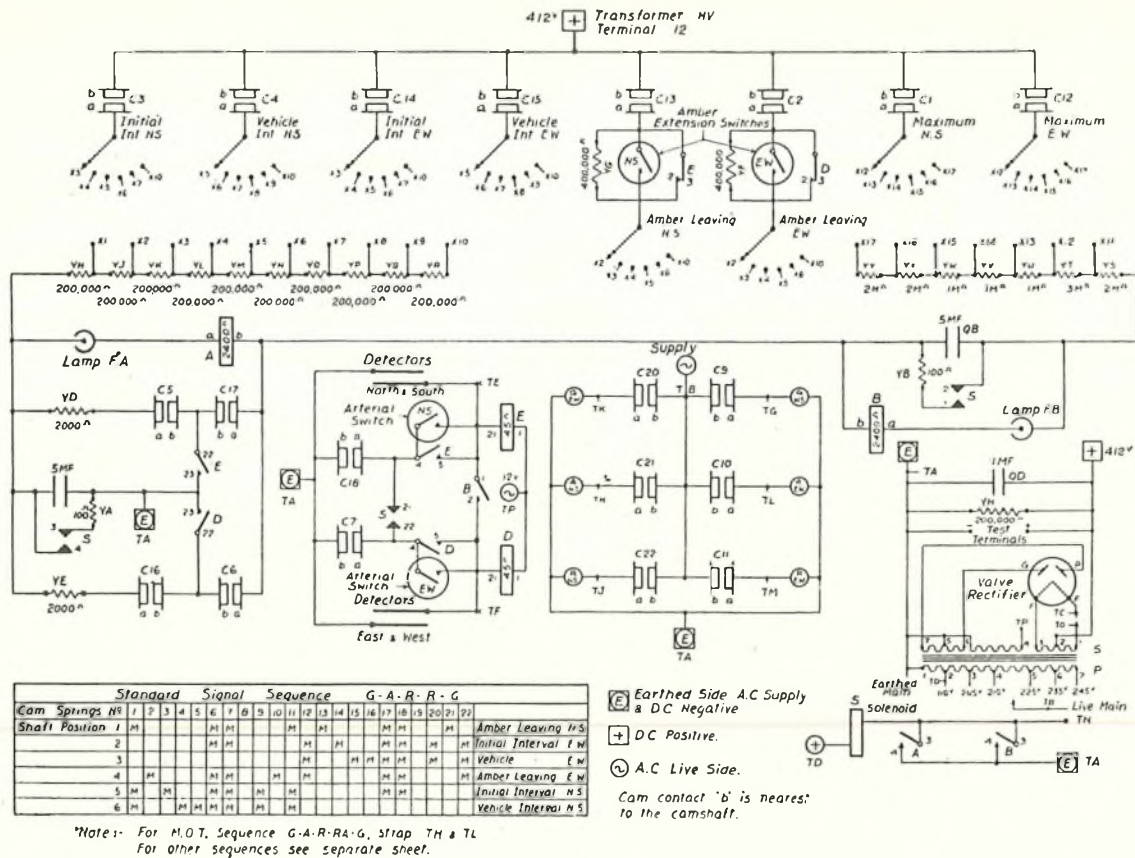

FIG. 8.—ELECTROMATIC CONTROLLER CIRCUIT.

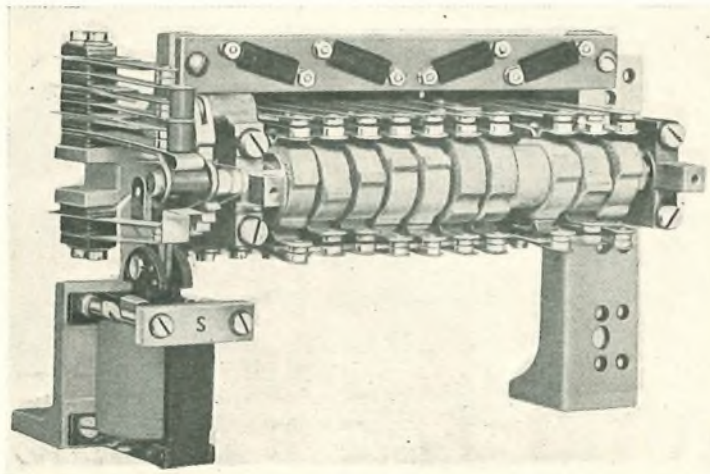

FIG. 9.—SOLENOID OPERATED CAM SHAFT.

occasional drivers who endeavour to "beat the signals," and "cross on amber" and therefore have to be protected against themselves. Conditions also arise when a moving stream is arbitrarily interrupted at the end of a maximum period of flow. In the latter case there may be a number of vehicles already beyond the stop line but not clear of the intersection and which therefore require protection. The amber

extension automatically covers these cases by allowing an extra two seconds amber period.

Fig. 10 shows in simplified form the conditions that prevail at the instant the "go" signal for the N - S traffic has been changed to the warning (amber) signal. If, now, another vehicle on the N - S stream enters the zone, relay E operates and locks, introducing an additional 400,000 ohms in series with condenser QA and so increasing the charging time. The normal amber period is thus increased by two seconds, or less, depending on how long after the signal change the relay was operated. A vehicle rushing to cross on "amber" is thus amply protected.

Reference has already been made to the unidirectional feature considered necessary in certain locations. This is accomplished by connecting the pair of relays shown in

Fig. 11 between the special detectors and the controller.

If a vehicle crosses the detector from left to right, the left hand upper strip will be depressed first and relay UA will operate. At springs UA 1 and 2 the circuit of UB is opened and as the vehicle passes from the left to the right hand upper strip UA is maintained in the operated condition via its operated con-

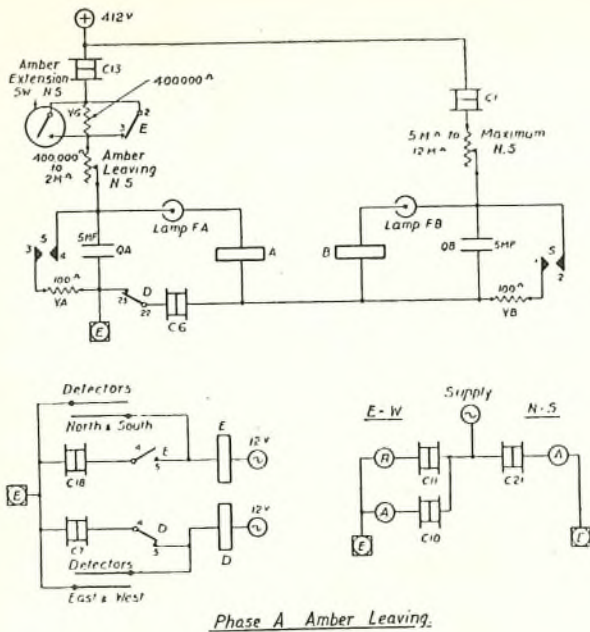

FIG. 10.

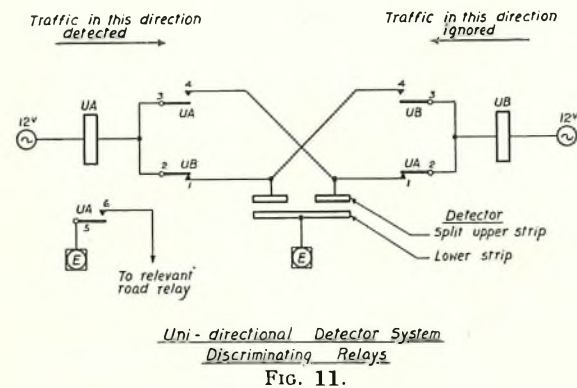

FIG. 11.

tacts UA 3 and 4 and contacts UA 5 and 6 close the contacts of the relevant road relay. Should the vehicle have approached from right to left, however, the circuit of UB would have been closed first and in operating have opened the circuit of UA at UB 1 and 2, thus preventing the operation of UA and the closing of the road relay circuit.

AUTOFLEX SYSTEM.

Timing Principle.

The Autoflex basic time circuit shown in Fig. 12 also employs a condenser for its operation, but the method of application differs from that previously described.

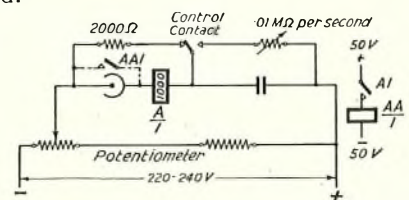

FIG. 12.—AUTOFLEX BASIC TIMING CIRCUIT.

The neon valve consists of a glass tube with two electrodes immersed in neon gas at low pressure and is designed to "strike" when the applied E.M.F. is 170 volts and so permit sufficient current to flow and recharge the condenser and operate a series relay.

When it is desired to measure a time interval the control contact is operated and the condenser discharged through a resistance. As the discharge proceeds the condenser potential is lowered and that across the neon tube gradually increased until it reaches a sufficiently high value to ionize the gas and operate the impulsing relay, which has a resistance of 1000 ohms, and is designed to operate with a current of 4 milliamperes. Should impulses of a longer period than those due to the valve be required, a single contact, provided on the impulse relay and controlling a relief relay, operates and so enables the impulsing relay to remain operated until the voltage drops so low that holding is no longer possible.

When the circuit is calibrated, the condenser charge voltage can be readily adjusted to suit the particular tube by means of a potentiometer. The condenser capacity is 5 microfarads and the discharge resistance is variable through 100,000 ohm values, each 100,000 ohms representing a time variation of one second, the discharge resistance in this case also acting as a time switch. The impulses have a duration of from 40 to 80 milliseconds with the arrangement and apparatus described.

It has been found that neon tubes have photoelectric properties and that the striking potentials are slightly greater in darkness than in daylight. Direct current at 220 to 240 volts for the valve operation is provided by a "jacking-in" power unit. A transrector, incorporating Westinghouse rectifiers, is used when the supply is AC and a dynamotor when the supply is low voltage DC.

Controller.

The controller is contained in one of the signal posts or in a pillar, and may be fitted at any convenient position. Each controller contains a framework fitted with control switches, shelves for demountable relay sets, and other apparatus, and is proof against damage by bad weather conditions when the doors are opened.

All relays except the right-of-way relay (RW) are of the Department's 3000 type which was described in this Journal in October, 1931, and April, 1934, further information is also available in the Department's Technical Instructions Telephones General Z1001 and Telephones Automatic B5144. Twin contacts are provided as they have been proved to prevent faults due to dust and it is of interest to note that an article on "Double contact springs for signal circuits" appeared in the Strowger Journal for June, 1935.

The "right-of-way" relay is of a type specially developed for use in automatic exchange circuits requiring rapidity of action, and is illustrated in Fig. 13. This relay has an operating and releasing lag of only 0.6 milliseconds, and is able to transmit signals from high or low speed vehicles with equal accuracy.

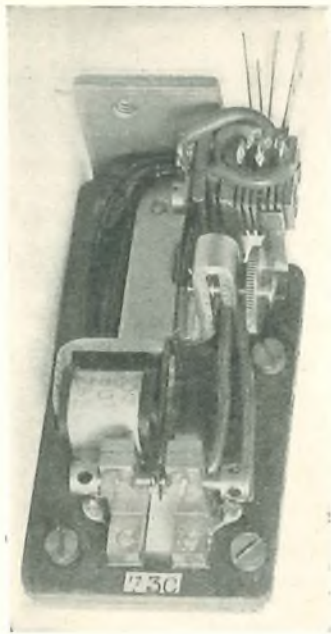

FIG. 13.—" RIGHT-OF-WAY " RELAY.

The lamp relays are fitted with heavy tungsten contacts and have an extra heavy spring tension with a slight rubbing action to prevent trouble due to dirty contacts. A special feature associated with these relays is the spark quenching circuit illustrated in Fig. 14.

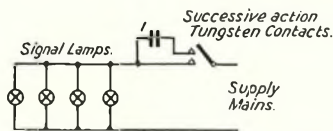

FIG. 14.—SPARK QUENCHING CIRCUIT.

The general principle of the Autoflex two part cycle controller is shown in Fig. 15 and a pictorial view of the complete controller is given in Fig. 16.

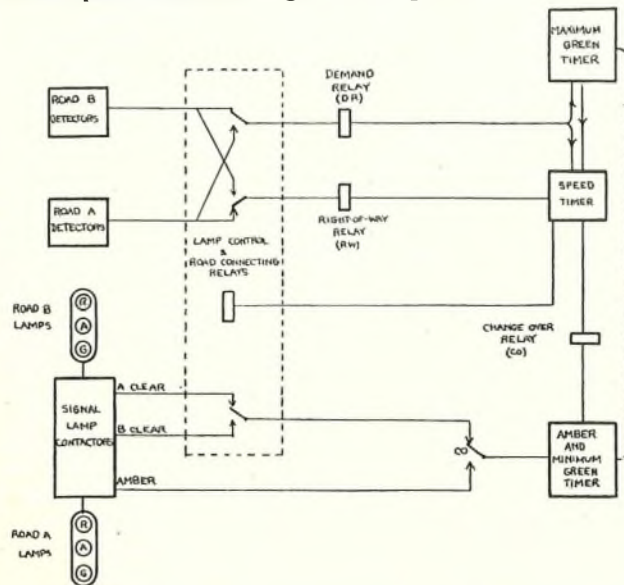

FIG. 15.—PRINCIPLE OF AUTOFLEX CONTROLLER CIRCUIT.

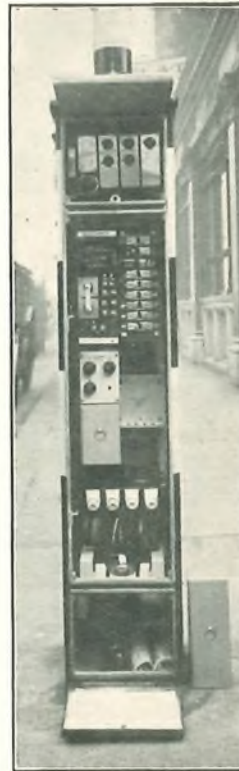

FIG. 16.—AUTOFLEX CONTROLLER.

The "right of way" road detectors (Fig. 17) are connected to the right-of-way relay (RW), by the road connecting relay (RC), and the road not having right of way is similarly connected to the demand relay (DE). Vehicles passing over the right - of - way detectors signal to the right-of-way relay which in turn signals the speed timer, where the speeds of all passing vehicles are noted and the right-of-way period extended. Should a vehicle operate a detector in the road on which the right of way is closed, an indication that a change-over is required is given by the demand relay to the speed timer and to the maximum green timer; a change-over condition is then set up by the speed timer and the change-over relays operated at the end of the right-of-way period. If the traffic stream is continuous, the normal right-of-way period does not expire and the speed timer is then forced by the maximum green timer to initiate a change-over. The demand relay is also retained in the operated condition by the maximum green timer in order to register a request for the right of way to be returned to the road from which it has been taken, and at the same time an indication is given to the amber timer that an extended amber period is required. The settings of the road connecting and lamp control relays are also changed by the speed-timer; the change-over relays extinguish the green lamps, connect the amber lamps and cause the amber period to be measured off. When the amber period has expired, the change-over relays are released and the minimum green period measured, the procedure can then be repeated when required. The correct phasing of the road relays and signal lamps is ensured by the working together of the lamp control and road connecting relays. Facilities are provided for converting the controller to fixed time operation and for operating all red lamps together. The fixed time operation is convenient if for any reason, such as road repairs, the detectors are inoperative and the all red facility if it is necessary for all normal traffic to be stopped.

Circuit Description.

A brief description of some of the main circuit operations will perhaps illustrate the general principles in greater detail. The right-of-way (RW) and demand (DE) relays (two main control relays) are connected to the moving springs of the road control

(RC) relay (Fig. 17) and are thereby connected to the detector contacts of roads "A" and "B" in the normal position of this relay. When the road control relay is operated the road contacts are changed over. A contact of the right-of-way relay (RW) is normally connected so as to discharge the

denser does not discharge, the maximum green timer condenser discharges and operates relay MT, thus completing the maximum green period. Relay MT operates relay MTA, which locks and holds the demand relay in the operated condition ready to register a demand for the right of way to be returned to the road from which it has been taken.

The operation of relay MTA also rapidly discharges the speed timer condenser through a resistance of $10,000\Omega$ causing the appropriate neon tube to strike and operate relays ST and STA as before. Relay MTA also removes the short circuit from the $20,000\Omega$ resistance in the amber timer circuit in order to increase the amber period by 2 seconds. This protects drivers who endeavour to "beat the signals" as referred to in the Electromatic system.

Controller Operated Systems using Post Office Wires.

The systems requiring the use of Post Office wires will be of special interest to readers of this Journal. These are governed by conditions laid down in British Standard Specification No. 505 of 1933 and the Department's Technical Instruction, Lines General A 6388. Among these conditions are the following:—

"The line shall be used for direct current or suitably smoothed rectified alternating current-working. There shall be no direct connexion between a public supply main and a Post Office line.

"Where an alternating current supply is concerned the supply main shall be separated from a Post Office line by a transformer having an efficiently earthed screen between the primary and secondary windings or the primary and secondary windings on separate limbs of the core shall be efficiently connected to earth. If more than one line is required

between any two points separate metallic loops must be rented. The use of a common return circuit is not permitted and connexion to 'earth' of any part of a Post Office line is prohibited."

Post Office lines for traffic signals may be provided in the usual telephone cable network, or, if circumstances justify, separate cables may be provided to accommodate the circuits. Several London Systems have been installed to which Post Office wires have been connected, amongst which are the Piccadilly and Finsbury installations provided by the Automatic Electric Co., and a brief description of the Piccadilly system will perhaps serve to illustrate the use of Post Office plant for linking purposes. This is probably the first occasion on which a series of fully vehicle actuated controllers has been provided with a system of automatic linking which, under certain conditions of traffic density on the main thoroughfares, superimposes a flexible programme plan of operation. This prearranged plan is not constantly superimposed, but each controller is brought into operation or dropped out entirely in

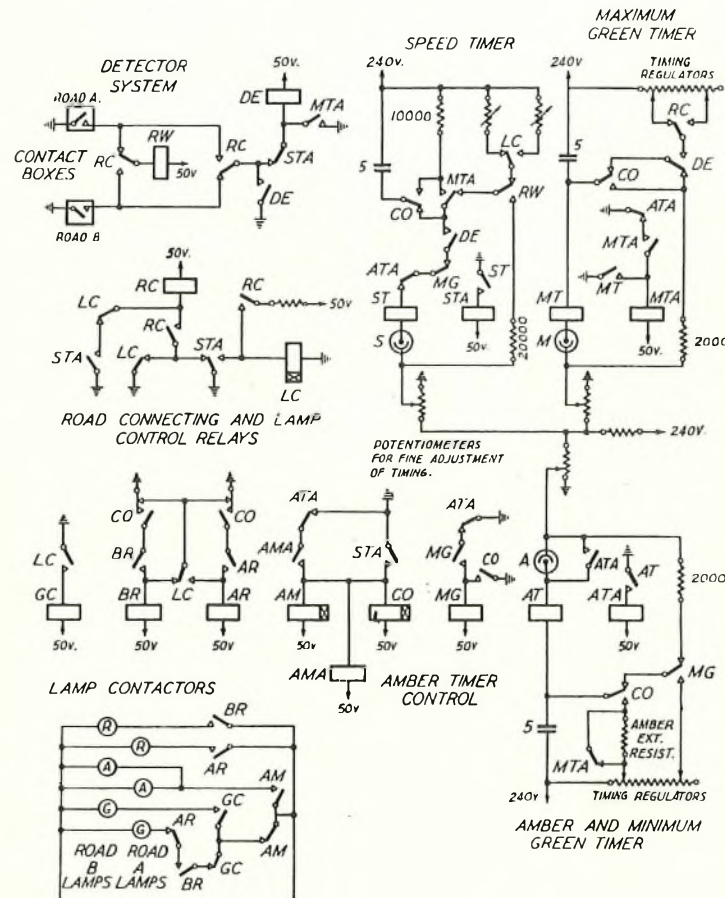

FIG. 17.—BASIC CIRCUIT OF AUTOFLEX TWO-PART CYCLE CONTROLLER.

speed timer condenser via contacts of relays MTA and CO and the appropriate resistance and on each impulse from the detector RW operates and recharges the condenser via an appropriate resistance to an extent dependent upon the speed of the vehicle.

The discharge time of the condenser thus depends on the volume of traffic and vehicle speed and is calculated so that the neon tube associated with the speed timer circuit cannot strike until sufficient time has elapsed to allow the last vehicle to clear the intersection. An exception to this is on the operation of the maximum green timer.

On receipt of a demand from a vehicle, the demand relay operates and is locked by one of its own local contacts. This relay also prepares the striking circuit of the speed timer and begins the discharge of the maximum green timer circuit. Should no further vehicles pass along the road having right of way, relay ST is operated by the striking of the speed timer tube, and in turn operates relay STA.

Should the traffic stream be continuous along the road having right of way so that the speed timer con-

accordance with the traffic conditions. The section of Piccadilly is shown in Fig. 18 and has been described as one of the traffic black spots of London, for both the main and cross roads, at certain hours of the day, carry traffic to their maximum capacity.

detector to signal its own intersections and the next one in the direction of travel. This is known as repeat pulsing and ensures that a momentary gap in the main road traffic at any intersection will not cause the right-of-way to change to the side road if

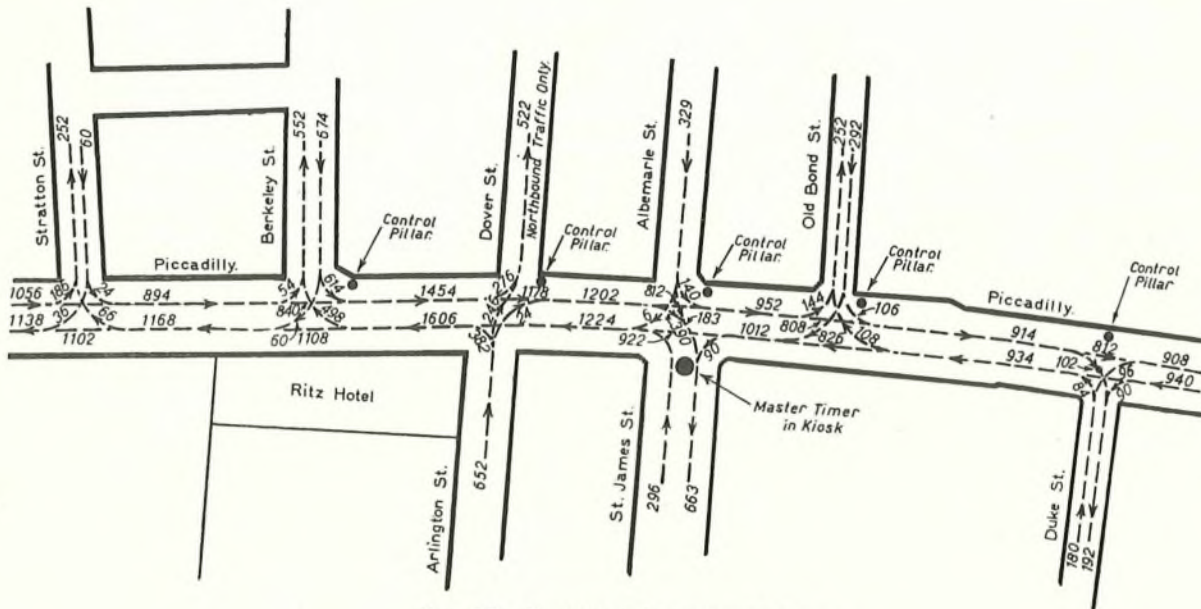

FIG. 18.—PICCADILLY INTERLINKED SYSTEM.

The drawing shows the volume and direction of traffic and the positions of the controllers, which are six in number and similar to those in Fig. 8.

A pair of Post Office wires is provided from the Master Controller to each local controller. Two relays L1 and L2 are also provided and the cam contacts ensure that the maximum time for the N-S phase is dependent on the operation of relay L1 and for the E-W phase on the operation of relay L2. Both relays are operated over the Post Office lines from the Master Timer, which is situated in the centre of the system and is a timer stepping a rotary switch.

The rotary switch wiper contacts are connected to sockets and the Post Office lines to the L1 and L2 relays and the sockets by means of plugs. In this way the maximum periods at the local controllers can be regulated as required, in relation to each other, by plugging into the appropriate socket in the rotary switch bank.

A complete cycle of the system is made when the rotary switch has stepped twenty-five contacts, and by adjusting the timer and causing the switch to step slower or faster, the cycle time can be lengthened or decreased.

An additional feature of the Electromatic interlinked system is provided by arranging for each

heavy traffic is approaching from neighbouring intersections, and provides progressive movement during periods of light traffic.

A comprehensive Autoflex system, using Post Office link wires, has recently been completed. This installation consists of three groups and a total of 50 points. A separate pair of wires is provided from each group Master Controller to each local controller in the group and a pair of wires in each group for a common telephone circuit. In addition private wire circuits have been provided connecting the Master Controller in each group to the Police Station and to a Borough Council Office.

Conclusion.

It will be seen that considerable ingenuity and technical skill have been displayed in the design of traffic signals, and there is no doubt the systems will continue to develop to meet new problems. A recent announcement states that experiments are being made with invisible rays for the protection of pedestrians. In conclusion, thanks are due to Messrs. The Automatic Electric Co. (Electromatic System) and Messrs. Siemens & General Electric Co. (Autoflex System) for their assistance and permission to reproduce illustrations and in particular to Messrs. Renshaw and Edwards of these Companies.

Metal Rectifiers in Telephone Circuits

B. WINCH

Introduction.

THE fact that certain metal plates held in firm contact with similar plates coated with the oxide of the metal have vastly different resistances to an electric current measured from metal to oxide and from oxide to metal, has been known for many years, but it is comparatively recently that this type of rectifier has been in commercial production. To-day rectifiers employing copper plates, coated on one side with copper oxide, are used for a multitude of purposes, perhaps the most well known of which are for charging secondary cells from A.C. mains and for eliminating batteries in wireless sets.

The size and number of the plates used in these rectifiers depend upon the current to be carried and the potential to be applied. For telephone purposes where the currents and voltages are small, copper-oxide rectifiers can be made in an extremely compact form, eminently suitable for mounting in relay sets, etc.

Such a rectifier is shown in Fig. 1. It is made by the Westinghouse Brake and Saxby Signal Coy. and consists of six copper discs, $\frac{3}{4}$ " in diameter, oxidized on one side and held tightly together on an insulated spindle by lock nuts and spring washers. Between each pair of plates is interposed a soft lead washer to improve the electrical contact by taking up the irregularities of the surfaces of the copper discs.

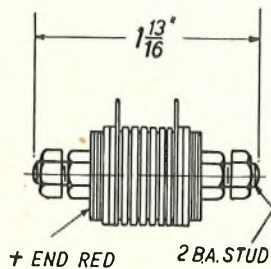

FIG. 1.—WESTINGHOUSE RECTIFIER.

Typical voltage-current curves of this rectifier are given in Figs. 2 and 3, the former curve showing the low resistance offered to a current in the conducting direction and the latter the high resistance to a current in the reverse direction. This high ratio of resistance, which makes it efficient as a rectifier, has been applied in a variety of ways to solve telephone circuit problems.

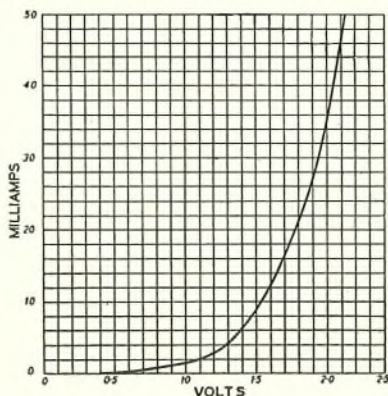

FIG. 2.—VOLTAGE-CURRENT CURVE, FORWARD DIRECTION.

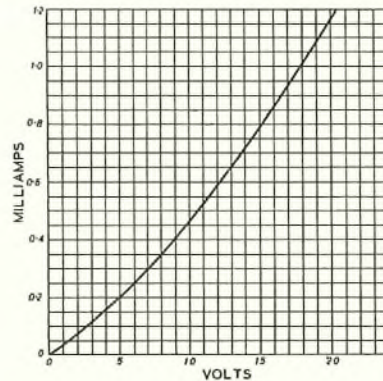

FIG. 3.—VOLTAGE-CURRENT CURVE, BACKWARD DIRECTION.

APPLICATIONS.

Re-Ring Facility.

One of the applications is that enabling the "re-ring" facility to be given on first code selectors and repeaters. Owing to the necessity of adding this facility to working equipments, it was desirable that the changes to existing circuits should be small. With this in view various schemes were tried for passing ringing, or a signal to control ringing, over the transmission bridge of the first code selector. The arrangement shown in Fig. 4 was found satisfactory and has been adopted.

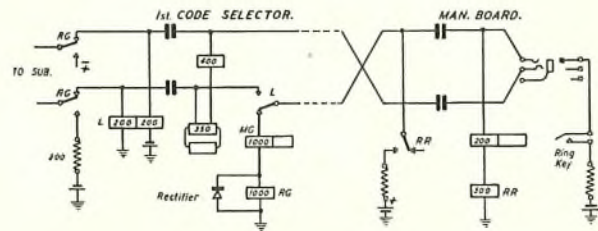

FIG. 4.—RE-RINGING FACILITY.

The rectifier allows the introduction of relay RG in series with relay MG without undue increase of series resistance, by providing a low resistance path across RG when the current is flowing in the normal direction in the circuit. When the operation of RG is required a negative earthed battery is applied to the line, reversing the flow of current. The rectifier no longer acts as a shunt and RG operates.

Both-way Loop Signalling.

With the development of both-way junction working between automatic exchanges it was found imperative to provide facilities for loop signalling in both directions. Similar conditions must therefore exist at both terminations when the circuit is idle, i.e., battery and earth through the coils of the line relays on the negative and positive lines respectively. It would appear that, as the two conditions oppose, no current will flow in the circuit but, for two reasons, this is not true, owing to:—

- (a) difference of battery voltages, which exists between batteries at different stages of discharge;
- (b) difference of earth potentials at the two exchanges.

The current flowing as a result of one or both of these conditions existing is sufficient to cause false operation of the line relays. Previously where signalling was effected over one line, false operation of the line relays was met by marginal adjustment, but with the introduction of loop signalling the magnitude of the currents rendered such a remedy impracticable, if not impossible.

It is obvious therefore that the remedial measures necessary to overcome this difficulty are in preventing the flow of current, and not in minimizing its effect. Fig. 5 shows how this can be effectively

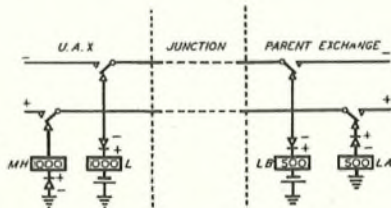

FIG. 5.

accomplished by means of rectifiers, the arrangement being such that current through one relay cannot affect the other, and *vice versa*.

Subscriber's Metering Circuits.

Advantage has been taken of the high resistance of the rectifier when current is applied in the reverse direction, to prevent the positive battery, connected to the private during metering from interfering with the operation of the circuit. A typical case is illustrated in Fig. 6. The line finder wipers

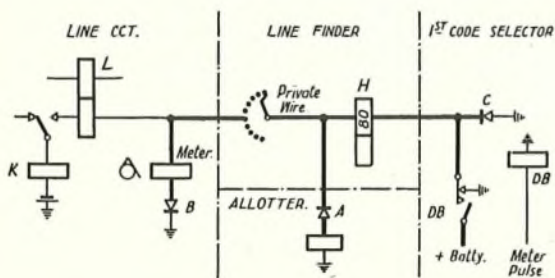

FIG. 6.—SUBSCRIBER'S METERING CIRCUIT.

rotate over the private bank until a negative battery operates the testing relay, thereby stopping the switch. As the private bank is also used for metering it is possible for a positive potential to exist on contacts passed over, thus giving rise to false operation of the testing relay, resulting in double connexion. The rectifier (A), however, obviates this by offering a high resistance to a positive battery. The rectifier (B) allows positive current to flow and operate the meter, but prevents earth, *via* the meter, holding relay K when earth is removed from the private.

During the progress of a call, selectors are held by an earth on the private wire. When metering occurs this earth is replaced by a positive battery,

which in operating the meter also maintains the selectors during the metering period. As a disconnection or failure of the positive battery would result in releasing the connexion, precautions must be taken, should this occur, to substitute an earth on the private wire during the metering period. This can be achieved by the use of a special circuit, but a rectifier (C) connected as shown in the private circuit of all selectors which apply metering conditions, affords a simple solution. It will be seen from the arrangement that the rectifier offers a high resistance to the positive battery, in order not to shunt the meter, but supplies a low resistance earth to the private if battery failure occurs.

A.C. Relays.

Fig. 7 shows a method of associating a rectifier with an ordinary relay to enable the relay to be operated by ringing current. Use is made in this case of both high and low resistance characteristics of the rectifier. When the negative half cycle of ringing is received, the rectifier shunts the relay and no current passes through it. The effect of this shunt, however, is to make L slow

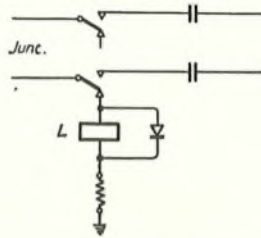

FIG. 7.—A.C. RELAY CIRCUIT.

to release, and thus remain operated while ringing is connected to it.

Discriminating Circuits.

The Country Satellite scheme¹ provides an example of the usefulness of rectifiers for discriminating purposes and part of this circuit has been extracted and shown in Fig. 8.

It will be seen that, by the location of rectifiers in series with each pair of relays, four distinct signals can be sent over the A line, relays A and B operating to light and heavy positive, C and X to light and heavy negative, respectively.

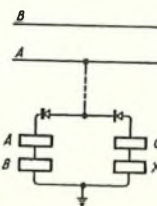

FIG. 8.—DISCRIMINATING CIRCUIT.

Quench Circuits.

One further example is given in Fig. 9, the rectifier serving as a quench to inductive surges in the sleeve circuit so preventing shocks being received by operators when withdrawing plugs from jacks. Here, owing to the high resistance of the rectifier to the normal flow of current and low resistance to any "back" E.M.F. generated, a marked advantage is apparent when compared with a non-inductive shunt across the relays.

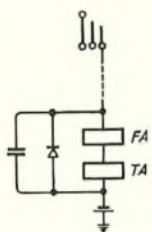

FIG. 9.—QUENCH CIRCUIT.

In conclusion, it can be said that the foregoing examples are by no means exhaustive, but serve to illustrate a few of the many ways in which rectifiers have been utilized.

¹ P.O.E.E.J., Vol. 26, Part 2.

Notes and Comments

The Telecommunication Journal of Australia

UNDER the title of *The Telecommunication Journal of Australia*, the Postal Electrical Society of Victoria has inaugurated a technical journal with the object of increasing the knowledge of its members and pooling the results of its investigations and researches so that others may benefit.

In welcoming and wishing good luck to the venture, Mr. J. H. Crawford, the Chief Engineer, says:—

"I well remember, as Secretary of the Institution of Post Office Electrical Engineers, helping to launch a Journal which, at its inception, was equally modest, and which we sent forth with equal trepidation. Its first issue was on All Fools' Day, 1908, and there were some who facetiously connected the date with the venture; but to-day that Journal is probably the premier Telecommunication Journal of the World—*The Post Office Electrical Engineers' Journal*. It also started from small beginnings and from a sense of the need which British Post Office Engineers were then feeling of some vehicle by which they could pool and share their engineering knowledge and experience. For the true Scientist and Engineer is never selfish or exclusive. He is glad to bring his contribution into the common hive of knowledge and place his observed data at the disposal of his fellow-workers, whether they be workers in the realm of inductive thought, research or practical engineering. The value of a Journal of this kind to our Engineers is emphasized in another article in these pages, but may I stress one vital truth—it is only possible to achieve success in a Journal of this kind by wide-spread and consistent support!"

We have pleasure in adding our quota of good wishes for the success of this enterprise, and can assure our Australian colleagues that its progress will be watched with interest by many in the Mother Country.

"Nippon Electrical Communication Engineering"

The *P.O.E.E Journal* has pleasure in extending a welcome to another new publication in the field of communication engineering. It is *Nippon Electrical Communication Engineering*, a quarterly journal, the first English edition of which appeared in September, 1935. It is the Japanese counterpart of our own Journal, and is the organ of The Institute of Telegraph and Telephone Engineers of Japan, which has 5000 members. A Japanese edition of the Journal is, of course, also issued.

The present number of 87 pages contains a Foreword by Mr. T. Akiyama, the President of the Institute, in which it is recorded that the number of telephones in Japan has reached nearly one million and that two million radio broadcast receiving sets

are in use. Mr. Akiyama pays tribute to the extent to which Japanese technique has benefited from information obtained from abroad and states, in justification of the English issue, that it is the duty of Japanese engineers to bring their own achievements in research to the notice of foreign countries, in order to repay the friendship shown to them over many years.

The subjects dealt with cover an interesting range and the opening article, on "Recent Development of Communication Networks and Engineering in the Nippon Teishinsho," by Mr. Takeshi Kajü, Director General of Engineering at the Ministry of Communications, forms a very complete synopsis of the present state of telegraph, telephone and radio development in Japan.

An Interesting "Wire" Broadcast

On Tuesday, October 8th, meetings were held by the Junior Section of the Institution of Post Office Electrical Engineers at their Eastern District Centres in Cambridge, Norwich, Ipswich, Colchester, Fenny Stratford, and Bury St. Edmunds, and these meetings were addressed simultaneously by the aid of the cable network and loud speakers, by Capt. N. F. Cave-Browne-Cave, the Superintending Engineer of the Eastern District, speaking from his home. Capt. Cave was followed by Mr. W. M. Osborn, the Assistant Superintending Engineer, and by Mr. C. W. Brown, of the Engineer-in-Chief's Research Section, who is the President of the Junior Section.

This event provided a good example of the ease with which several scattered audiences can nowadays be addressed simultaneously by a single speaker, a facility which is likely to appeal to many other organizations.

10 Years Index

It has been felt for some time that, in view of the frequent reference made by subscribers to back numbers of the Journal, a comprehensive index covering all recent articles would be of considerable advantage and would enhance the value of the Journal as a reference work. The Board of Editors has pleasure, therefore, in distributing gratis with this issue an index covering the articles which have appeared in the last ten volumes. Additional copies can be obtained at a price of 6d. per copy.

The Board wishes to express its thanks to Mr. W. S. Procter, the late Assistant Editor, for the work done in preparing the initial draft for this index.

Binding

This issue is the last of Volume 28 and readers are reminded of the binding facilities which are available, full details of which will be found on page 336.

Portraits of the Great Men of Telecommunications

The Bureau de l'Union Internationale des Télécommunications has advised us that it is publishing at the end of each year an engraving of some well known figure in Telecommunications. These engravings will be undertaken by well known artists and the issue limited to 600 copies. They will be printed on high quality paper 23 cm by 18 cm.

The first portrait is that of Morse and is now available. Copies can be obtained from the Union at Effingerstrasse No. 1, Berne, Switzerland, at a price of two Swiss francs, post and duty free.

Correspondence regarding Campbell's Formula

The Managing Editor.

Dear Sir,

I find that my note in the October issue of the Journal¹ contains an omission that calls for correction.

The complete series expansion for β , obtained from the asymptotic development of (6), which was omitted from the note, is,

$$\beta = \sqrt{2\pi} \sum_{m=0}^{\infty} (K_0 \beta_1) \{ \text{II}(-\frac{1}{2} - m) \text{II}(m) \}^{-1} (1 + K_0^2 \beta_1^2 y^{-2})^{-\frac{m}{2}} \dots \dots \dots (A) \quad (0 < y < 1)$$

The notation is the same as in the note. II denotes Gauss's P_i function. L and R_c are multiplied by the parameter ω , where ω is $1 - y^2 s L_m (1.5L)^{-1}$. K_0^2 is $(1 - y^2)^{-1}$ and f_c is v/π . The curves in the enclosed diagram show the calculated and measured characteristic of the Ashford-St. Margarets Bay cable. The difference between the measured and calculated curves is due to small differences between the nominal and the actual primary constants of the cable.

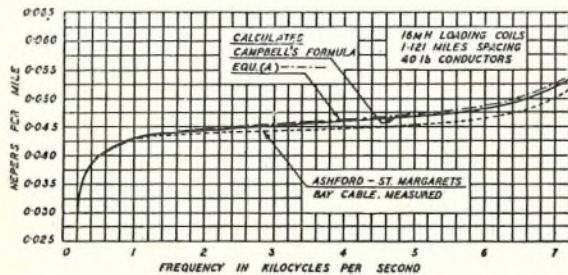

The working formula (7) in the note, which I formulated some years ago, was obtained from (A) by making a simplifying assumption based on curves showing the results of actual measurements. It has now been found that these curves were not representative. Consequently (7) has a limitation not stated in the note. To remove this limitation over

¹ Vol. 28, Pt. 3, page 194.

the transmission range ($0.25 < y < 1$), replace K_1 by K_0 , and multiply L and R_c by ω . The deviation between the critical frequency f_c of a very lightly loaded line and the cut-off frequency given by the usual formula, has a negligible effect in the range ($0 < y < 0.25$). Consequently, for low frequencies, β can be calculated from the formula for a line with uniformly distributed constants.

Yours faithfully,

H. J. JOSEPHS.

Correspondence regarding the Subscribers' Transmitters

The Managing Editor.

Dear Sir,

Mr. McMillan's extensive and careful research on the properties of the Transmitter Inset No. 10, published in your issue for October, 1935, has naturally interested me greatly.

It is especially interesting to note how the results recorded in Part I of his article supplement, and in a large degree confirm my own analysis of the performance of this transmitter, published in the Engineering Supplement to the Siemens' Magazine for March, 1935, to which Mr. McMillan makes a brief reference.

Our Magazine does not, of course, Sir, enjoy the same large circulation among specialists, nor possibly is it read with the same close attention, as your own Journal. It may therefore be of interest to set out a consideration of Mr. McMillan's results in the light of the more quantitative analysis made in the earlier article.

When analysing the operation of a carbon transmitter I have always assumed that the change of resistance of the granule brought about by a given amplitude of displacement of the moving electrode is independent of frequency, over the range of frequency which is of importance for commercial speech. There is evidence that this is not strictly true, but that it is a safe assumption within the limits of accuracy at present necessary. On such an hypothesis the shape of the frequency characteristic must be determined solely by the mechanical and acoustic quantities involved in the transmitter construction. Consequently the direct line of attack on the problem is to measure these quantities individually and to ascertain their general *modus operandi*.

The components of the Inset No. 10 which affect its acoustic-electric performance may be enumerated as follows:—

- s_0 Stiffness of the granule; mechanical resistance neglected.
- m_d Effective mass of moving electrode and metal diaphragm.
- s_d Stiffness of diaphragm edge.
- s_1 Effective stiffness of cavity between diaphragm and back of case.
- m_2 Equivalent mass of mouthpiece cavity and silk membrane together.
- s_2 Effective stiffness of cavity between silk membrane and diaphragm.

(The holes in the metal guard which covers the silk membrane and those in the mouthpiece moulding

are so numerous that their acoustic effect may be neglected).

All these quantities are "referred" to the rivet at the centre of the diaphragm; *i.e.*, the equivalent reactance of each of them at that point is measured and used in calculation.

In the first place each quantity was measured on a specially designed vibrometer. Then certain of them were checked by an independent method. Finally a theory of operation was derived, and the measured values used to predict the frequency characteristic of the assembled transmitter. Such a good agreement with the observed characteristic was obtained that the analysis was shown to be substantially accurate.

The numerical results of the vibrometer measurements were as follows:—

$$\begin{aligned} m_d &= 1.1 \text{ gms.} \\ s_d &= 15 \times 10^6 \text{ dynes/cm.} \\ s_0 &= 90 \times 10^6 \text{ " } \\ s_1 &= 95 \times 10^6 \text{ " } \\ s_2 &= 70 \times 10^6 \text{ " } \\ m_2 &= 0.82 \text{ gms.} \end{aligned}$$

The indirect method referred to above consisted in loading the centre of the diaphragm of an Inset No. 10 with various known masses and taking frequency characteristics of the inset without case, metal guard or silk membrane. A series of resonance peaks, similar to the single one shown in Fig. 15 of Mr. McMillan's article, ranging from 700 to over 2000 c.p.s., was thus obtained (see Fig. 2(a) of my article *loc. cit.*). By plotting $1/f_0^2$ to a base of mass added to the diaphragm, it is seen that the stiffness and mass of the unloaded system are as follows:—

$$\begin{aligned} m_d &= \text{approx. } 1 \text{ gm.} \\ s \text{ total} &= 197 \times 10^6 \text{ dynes/cm.} \end{aligned}$$

In the present case $s \text{ total} = s_0 + s_1 + s_d$, and from the vibrometer results this equals 200×10^6 dynes/cm.

Bearing in mind that granule stiffness varies very considerably with the "pattern" taken up by the granule at any given time, the agreement between two measurements made by such diverse methods is most satisfactory.

Taking the values $m_d = 1.1$ gms. and $s_d + s_0 + s_1 = 200$ dynes/cm, the resonance frequency corresponding to the conditions of the test for Fig. 15 of Mr. McMillan's article, is $= \frac{1}{2\pi} \frac{200 \times 10^6}{1.1} = 2150$ c.p.s.; which is in good agreement with his 2100 c.p.s. It may be remarked in passing that the mass of a complete diaphragm and moving-electrode assembly is 0.8 gms. Moreover, when clamped by the rim of the case, some of the diaphragm mass itself becomes ineffective in loading the vibrating system. One would therefore, at first sight, expect the effective mass to be somewhat less than 0.8 gms. (Actually, measurements have shown the "equivalent piston" to have a diameter midway between that of the conical portion of the diaphragm and that of the inner edge of the clamped surface). The effective mass deduced from vibrometer measurements is, however, 1.1 gms.; and

from the added mass test about 1.0 gms. A possible, indeed probable, explanation is that the layers of granule immediately in contact with the moving electrode move bodily when a vibromotive force is applied, and consequently increase the effective mass of the system. Time has not yet permitted further investigation of this point.

On page 172 Mr. McMillan is searching for an explanation of the resonance peak of Figs. 15, 16 and 17, which I have just discussed, and for which, it would seem, I had already given the complete reason. He, however, appears to conclude that none is yet forthcoming. Has he some difficulty in accepting that the granule mass between a fixed and a moving electrode possesses mechanical reactance of negative sign?

Let us turn to another source of information on this point. In the Bell Laboratories Record, July, 1935, J. R. Haynes has published some information on the behaviour of single carbon contacts. I have reproduced below his Fig. 7, which gives the force/displacement relationship for a single contact. The stiffness of the contact (*i.e.*, the inverse of the slope of the characteristic in Fig. 7) is seen to vary

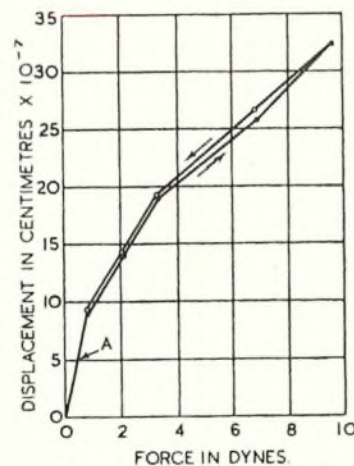

FIG. 7. (J. R. HAYNES).

quite widely over the range of 0 to 10 dynes. In order to calculate from the curve the granule stiffness of an Inset No. 10 it is therefore necessary to estimate, in the first place, the position of the point on the curve which is representative of the conditions under which a single granular contact normally operates.

The Inset No. 10 contains, approximately, 110,000 granules, each weighing, on the average, 0.000015 gms. When held with the diaphragm in the vertical plane, each granule on the axis of the inset will be supporting 32 other granules immediately above it. Consequently the "fluid" or static force to which this granule is normally subjected is 0.5 dynes.

When an acoustic pressure of 30 dynes/cm² is applied to the diaphragm of the inset the total force (alternating) developed at the moving electrode surface is 376 dynes, and since there are approximately 1500 granules in contact with the electrode, the force per granule is 0.25 dynes.

The representative point for the granule on the No. 10 axis is marked A on Mr. Haynes' curve, and the effective stiffness, for the appropriate amplitude of alternating pressure, is approximately 1×10^6 dynes/cm.

There are 8 granules in line between the electrodes, and, therefore, 9 contacts. Consequently the stiffness of the granule column is—

$$\frac{1500}{9} \times 1 \times 10^6 = 170 \times 10^6 \text{ dynes/cm.}$$

The figures, as measured on the vibrometer, quoted in my article of March, 1935, are "from 83×10^6 to 177×10^6 dynes/cm."

The value of 170×10^6 just calculated is, doubtless, higher than the average, for the following reason. It has been assumed in the calculation that the column of granule between the electrodes expands and contracts without deformation of its imaginary cylindrical containing surface. The Inset No. 10 as normally produced is not quite full of granule, however, and there will therefore be some measure of "bulging" of the cylindrical surface under the compression half of the pressure wave. Consequently the effective stiffness as measured may be expected to be appreciably less than that calculated above. The agreement between the result which has just been calculated from the measured stiffness of a single contact, and that obtained by direct measurement of the stiffness of the column of granule between the electrodes of an assembled inset (both by vibrometer and by the method of loading the diaphragm), is far too close to be dismissed as fortuitous. Personally, having made vibrometer measurements of the stiffness of a steel needle point bearing on a glass surface, and of other simple assemblies, I find no difficulty in picturing a quantity of granules as a mechanical stiffness of low power-factor. Without such an introduction, however, the conception may be more troublesome.

Now let us turn to the frequency characteristic of the assembled transmitter. Mr. McMillan states on p. 170—"The curves of Fig. 8(a) are generally similar in shape to curves obtained from a system of two resonators closely coupled." What, then, are these resonators? In my article I have shown that, if they are taken to be m_2, s_2 , on the one hand and $m_d, (s_d + s_g + s_1)$ on the other, the frequency characteristic of the assembled transmitter may be very accurately predicted. (Vide Fig. 10 of my article). I may add that the method of measuring mechanical and acoustic impedance has been materially improved since my article was written. In particular it is now possible to obtain a very useful degree of accuracy up to 3000 c.p.s. Using the improved method has only confirmed the general accuracy of the previous measurements, however.

Considerable advance has been made in recent years in the means for rapidly and accurately taking microphone frequency characteristics. To this advance Mr. McMillan's moving-coil reproducer is a contribution of major importance. The characteristics obtained are still materially dependent on the actual method employed, however. A little more detail in the description of Mr. McMillan's method

would therefore have been helpful, since it would have enabled other workers to compare their results with his with greater certainty.

It is to be presumed that Fig. 2 and onwards were taken under the conditions described in Fig. 1; that is, at a distance of 1" from the loudspeaker diaphragm. If this is the case, the curves obtained are neither "free-space" characteristics nor yet "pressure" characteristics, but something between the two. At such a short distance sound reflection between the inset or H.M.T. mouthpiece under test and the face of the loudspeaker, would materially affect the sound pressure at the higher frequencies.

At first sight the dip at 1500 c.p.s. in the characteristic of a No. 10 inset without mouthpiece, which Mr. McMillan has shown in Figs. 2, 3 and 4, and which he attributes at the bottom of p. 171 to the oiled silk membrane, appears to be identical with one which we have found to occur when the membrane is too tightly stretched in assembly. We regard this latter dip as an abnormality and if it is revealed by the frequency characteristic test to which all our production is subjected immediately after assembly, steps are taken to rectify it.

Since first reading Mr. McMillan's paper I have looked into the matter a little more carefully, however, and my present conclusion is that the two dips are not identical.

Fig. 1 shows the characteristic of a recently manufactured inset (16.8.35) which we should regard

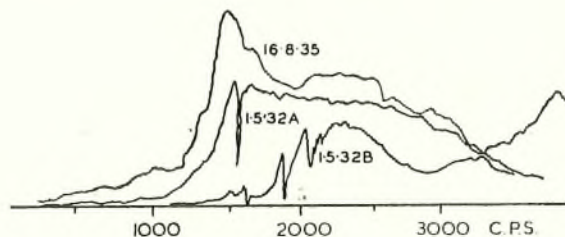

INSET NO.10, NOT IN MOUTHPIECE.

- 16.8.35 NORMAL
- 1.5.32 A OLDER INSET WITH DIP AT 1500 C.P.S.
- 1.5.32 B THE SAME AFTER REMOVAL OF SILK MEMBRANE.

FIG. 1.

as being perfectly normal. It also shows one from a much older inset (1.5.32)A in which the dip noted by Mr. McMillan shows itself. (1.5.32)B is the curve for the same inset after removal of the silk and guard. Three sharp dips are evident here between 1500 and about 2200 c.p.s. After taking this curve the silk was carefully stretched in the fingers and replaced, with the guard, on the inset. This treatment ensured that the silk was slack and that its mechanical constants were materially different from their initial values. The characteristic was found to be practically identical with A however; the 1500 c.p.s. dip was no less sharp and occurred at the same frequency as before.

This experiment indicates that the primary reason for the dip must be sought elsewhere than in the silk, although, of course, its position on the frequency

scale and its amplitude and decrement may be profoundly affected by the silk.

Three insets which had been shown by the curve-tracer used for checking production to have a "tight silk" dip, were then obtained. Their characteristics are given in Fig. 2. The true "tight-silk" dip is seen in each of them at 900 c.p.s. (point *x*). It may be mentioned that the curve-tracer just referred to, operates between limits of 700 and 1800

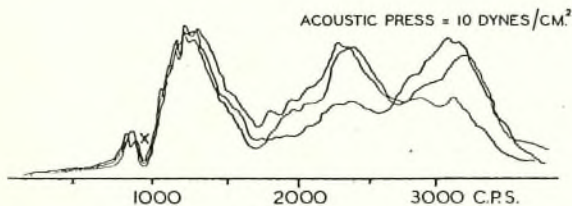
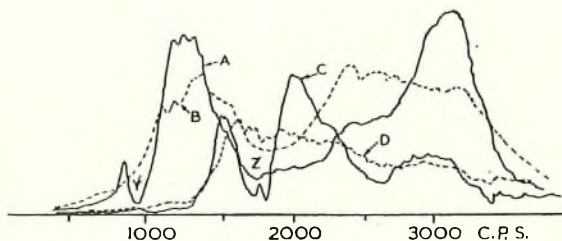

FIG. 2.

c.p.s., and the dip in Fig. 2 therefore appears much more prominently in its trace than in the curves of Fig. 2.

Fig. 3 will be found to be self-explanatory. It shows that, on the inset alone, an abnormally tight silk does resonate at 1500 c.p.s., and that it produces



A. NO.10. INSET. SILK TIGHT. IN H.M.T.
 B. NO.10. INSET. SILK NORMAL. IN H.M.T.
 C. NO.10. INSET. ALONE. SILK TIGHT.
 D. NO.10. INSET. ALONE. SILK NORMAL.

FIG. 3.

what might be described as an "energy absorption kink" at 900 c.p.s. (point *y*) in the characteristic of the completely assembled transmitter. New insets appear to be free from the dip discovered by Mr. McMillan, however.

Although Mr. McMillan hesitates to use granule stiffness as a factor in explaining his experimental observations in the earlier part of the paper, he is led to suggest that it probably plays a part in the production of sub-harmonics (vide the last two paragraphs of Section II, p. 174). I have found, when measuring granule stiffness by means of the vibrometer, that sub-harmonics of mechanical displacement are very readily produced with certain values of steady and of alternating pressures in the granule. The electrical equivalents of these harmonics, particularly the half-frequency component, appear in the A.C. potentiometer circuit, which is not electrically connected with the microphone itself. They are

attributable, with very little doubt, to the non-linearity of the pressure-displacement characteristic of the granule.

It has been observed, when making measurements of the stiffness of steel needle-point bearing on a hard, plane surface, that the half-frequency of the fundamental can be readily produced, and that, under more critical conditions, a three-quarter-frequency also consistently appears.

Reverting to the question of the influence of granule stiffness on the frequency characteristic, I have recently found that the effective stiffness of the granule is much more dependent upon the amplitude of the applied alternating force than I had previously supposed. In the case of one No. 10 inset, for instance, S_g fell from 154×10^6 dynes per cm at an alternating force corresponding to a pressure of 10 dynes per cm^2 on the diaphragm, to 77.7×10^6 at 69 dynes per cm^2 ; and to 37×10^6 at 260 dynes cm^2 . This may quite well account for—

- (a) the increase of sensitivity of the microphone with pressure, shown in Mr. McMillan's Figs. 2, 3, 4 and 8, and
- (b) the decrease in the value of the resonant frequency shown in the same figures.

Although there is no doubt, as Mr. McMillan points out, that the performance of Inset No. 10 still leaves room for improvement in several directions, this transmitter has one property which distinguishes it markedly from other insets. I refer to its constancy or stability. It is this property which has made practicable such an examination as Mr. McMillan has carried out. It has been realized for some years, as Mr. McMillan says, that modern methods of measurement make it possible for the physical characteristics of a transmitter to be defined fairly accurately, but unless these characteristics are in themselves reasonably constant and definite, little can be usefully done in the way of measurement. It is no unimportant advantage of the design of Inset No. 10 that its characteristics are stable, so that it permits intensive study by modern methods of measurement.

We have been engaged for some years in applying such study to the elimination of the remaining sources of distortion in subscribers' transmitters and hope shortly to be able to make available the concrete results of this work.

Yours faithfully,
 G. W. SUTTON.

The Managing Editor.

Dear Sir,

I find Dr. Sutton's communication to be of great value and interest. I am familiar with his excellent paper—printed in the March 1935 Supplement to *Siemen's Journal*—in which he describes measurements of the acoustical and mechanical reactances associated with the Inset 10 transmitter. In this publication Dr. Sutton uses his results to predict the general form of the frequency characteristic of the transmitter with great success. He also makes an analysis of the effects of individual components of

the inset and the transmitter case upon the shape of this generalized characteristic.

My own investigation was undertaken with a view to defining the various distortions introduced by the Inset 10 transmitter. Determinations of the actual frequency characteristics of the transmitter for different operating conditions had necessarily to be made. The fact that any one frequency characteristic for this form of transmitter represents only a very small part of the complete story cannot be too strongly stressed.

It would appear, from the above-mentioned communication, that Dr. Sutton's measurements have been extended considerably since the time of publication of his paper. I must confess to having felt that the interpretation of his measurements at that time as completely representing the mechanical performance of the inset rather precluded the observation of unexpected phenomena influencing the mechanical "constants." As instances of this possibility I would cite the following points:—

- (1) The somewhat remarkable effects of a varying mechanical resistance are not easily observed by the method.
- (2) The fact that the stiffness factor is probably dependent upon the instantaneous direction of motion of the force may be overlooked.

In this connexion I find Dr. Sutton's observation of a varying stiffness factor, with resulting sub-harmonics of displacement, of great interest. I believe that this effect was not mentioned in his publication of last March.

In reply to Dr. Sutton's direct question I should like to say that I have no difficulty in visualizing a negative reactance between the fixed and moving electrodes of the inset. In fact I have no doubt but that the column of granules introduces mass, stiffness and resistance into the system. I am of the opinion, however, that the stiffness in question is not a simple "constant." I would suggest that the evidence advanced by Dr. Sutton together with the results published in my recent paper do not allow us to assume a single mass reactance and a single stiffness reactance in the case of the small "button" transmitter discussed on page 172. The overall effect may be simulated by such a system with accuracy, but we may easily overlook important physical effects by being too definite at this stage. Dr. Sutton's uncertainty as to the amount of mass added to the diaphragm by the granules forms a good illustration of this possibility. Recent work by Madia (*Electriche Nachrichten Technik*, Oct., 1934) and Hara (*E.N.T.*, July, 1935) must be taken into account and the possibility of a form of wave transmission in the granule column has to be considered. It should also be noted that the curves of Fig. 17 include any effect which may be due to the Swiss silk washers. It may well be that a direct measure of impedance at the rivet of an elementary button transmitter yields, in effect, the components of the input impedance of a complex network.

Considering now the frequency characteristic of the

assembled transmitter I regard the two resonators concerned as being:—

- (1) The resonance of the effective mass and stiffness of the inset itself.
- (2) The resonance of the mass of the "horn" or "flare" plus the grid of 21 holes (to which must be added a mass due to the silk membrane) with the volume of air trapped between the mouthpiece grid and the metal diaphragm of the inset.

In this respect it will be noted that I am not entirely in agreement with Dr. Sutton. I find it a little difficult to understand why such a large proportion of the actual mass of the membrane should be effective mechanically. If the silk is supported at the edge and acts as a membrane—then surely the effective mass should be only $\frac{1}{3}$ of the total mass and not almost the whole mass of the unsupported area. A little calculation, in conjunction with the data given in Figs. 12 and 13 of my article, will reveal that the frequency characteristic of the transmitter may be equally well predicted from a postulation of the coupling of the above-mentioned resonators. The effective mass of the oiled silk membrane is found to be very close to the ideal value of $\frac{1}{3}$ of the total mass when such a calculation is made. In any case, it is probable that either conception represents only an approximation of the true system. It is merely a matter of which represents the better approximation.

Dr. Sutton's recent investigations to determine the cause of the sharp "dip" observed at 1500 cycles per second when an Inset 10 is tested alone are illuminating. The inset used for most of the tests recorded in my paper was selected from thirty new insets and all thirty showed the dip referred to in one form or another. It is possible that the effect becomes manifest only after slight ageing of the insets since those which were "new" to me had been made about a year previously.

The frequency characteristics of Fig. 2 and onwards were taken at about 1" from the loudspeaker—the sound pressure at the input to the transmitter being measured by means of the probe tube microphone. The relative values of sound pressure over the frequency range observed by the probe microphone were practically unaltered by the presence of the transmitter under test for any frequency below about 4000 c.p.s.

I agree with Dr. Sutton when he says that it is the marvellous stability of the modern telephone transmitter that has made possible an investigation of its characteristics. The fact that the success of modern telephony is entirely dependent upon the remarkable properties of a column of carbon granules commands for the instrument the respect of all who work with it.

In conclusion, I should like to thank Dr. Sutton for the valuable information given in his communication. I look forward with great interest to his promised description of the results of his recent work.

Yours faithfully,

D. McMILLAN.

Regionalization

B. O. ANSON, M.I.E.E.

THE late Postmaster-General, Sir H. Kingsley Wood, M.P., appointed a Committee consisting of The Right Hon. The Viscount Bridgeman, LL.D. (Chairman), The Lord Plender, G.B.E., LL.D., and Sir John Cadman, G.C.M.G., D.Sc., with A. Earl, Esq., C.B.E., as Secretary, to enquire and report as to whether any changes in the constitution, status, or system of organization of the British Post Office would be in the public interest. The Committee reported in August, 1932, and amongst other recommendations provided that a larger measure of decentralization should take place and that all Post Office activities in a given territory should be controlled from the administrative point of view by a Regional Director, assisted by the necessary administrative officers and staff. The Committee also recommended that there should be a greater measure of interchangeability between Administrative Officers located at Headquarters and officers serving in the Provinces and proposed that engineers should have an opening to administrative posts.

In January, 1935, the 1st report of the Gardiner Committee on reorganization was issued after full consideration of the practical steps that would be necessary to give effect to the Bridgeman Committee's proposals. This Committee is known as the Gardiner Committee as the Chairman is Mr. T. R. Gardiner, the Deputy Director General of the Post Office. It was then recommended that two experimental Regions should be established in the Provinces to test out in detail the practicability of the scheme. It was decided that these two Regions should be located in Scotland and the North East of England respectively and Lt.-Col. F. N. Westbury, O.B.E., and Lt.-Col. T. P. Hobbins, C.B.E., were appointed Regional Directors with Headquarters at Edinburgh and Leeds respectively in September last.

The appointments of the following officers then serving in this Department were announced in November last:—

Mr. J. W. Atkinson, Deputy Superintending Engineer, London, to be Deputy Regional Director of the North Eastern Region.

Mr. C. A. Taylor, M.C., Superintending Engineer, North Eastern District, to be Deputy Regional Director, Scottish Region.

Mr. F. G. C. Baldwin, Superintending Engineer, Northern District, to be Chief Regional Engineer, North Eastern Region.

Mr. J. J. McKichan, O.B.E., Superintending Engineer, Scotland East District, to be Chief Regional Engineer, Scottish Region.

Mr. J. Darke, Assistant Superintending Engineer, Manchester, to be Principal in the Telecommunications Department at Headquarters.

Mr. Atkinson had considerable experience at Headquarters during the period 1900-1907 and came into close contact with the various problems associated with the pre-1912 London Telephone System. In 1907 he took charge of the Sutton and

Epsom Section and in 1910 was promoted to a First Class Engineership in charge of the Bristol Section. In 1911, he was promoted Assistant Staff Engineer at Headquarters (Construction Section) and in March, 1926, was transferred to the London Engineering District as Assistant Superintending Engineer. In June, 1928, Mr. Atkinson became Superintending Engineer of the North Eastern District with Headquarters at Leeds and in 1933 was appointed Deputy Superintending Engineer, London. Mr. Atkinson

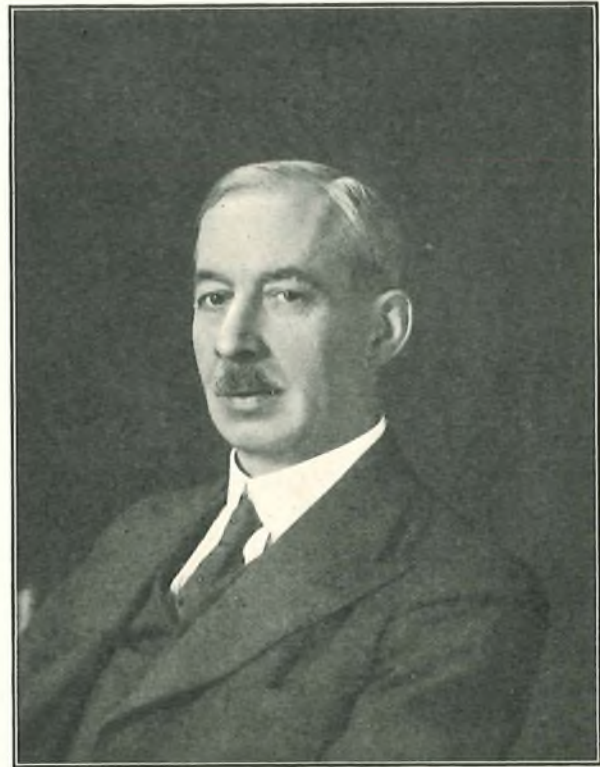

Photo by

Elliott and Fry.

MR. J. W. ATKINSON.

has done much to raise the prestige of the British Post Office communication services in the eyes of other Administrations and has always been one of the greatest supporters of the Institution of Post Office Electrical Engineers. He acted as Secretary to the Institution Formation Committee and for the first two years was Secretary to the Institution. Since then, he has served as Hon. Treasurer of the Institution and as a member and Chairman of the Board of Editors of this Journal. Mr. Atkinson's previous experience at Leeds will prove to be of great value in connexion with the inauguration of the North Eastern Region.

Mr. C. A. Taylor entered this Department in October, 1907, having been successful at the Open Competition for the post of 2nd Class Engineer. Mr. Taylor spent the first three years of his service in Scotland, mainly in the Scotland East District, after which he was transferred to Headquarters

where he remained until his appointment as Superintending Engineer in May, 1933. Mr. Taylor specialized for many years in the study of Telephone Transmission problems and was actively concerned with the provision of the present trunk network, including Telephone Repeater Stations. Mr. Taylor was sent to U.S.A. in 1933 in charge of a Commission to enquire into telephone engineering practice in the Bell System of America and many important developments followed. Since his appointment as Superintending Engineer, Mr. Taylor has made a close study of District procedure and has done much fundamental work in connexion with the setting up of the experimental Regions.

Mr. Baldwin was appointed Sectional Engineer, City External Section, on his transfer from the National Telephone Company, with which Company he latterly served as Acting Metropolitan Engineer; in December, 1913, he was promoted to the rank of Assistant Superintending Engineer, Northern District. His promotion to the Superintending Engineership of that District followed in August, 1930. During his long service in the Northern District Mr. Baldwin has acquired an intimate knowledge of the plant and has become personally acquainted with most members of the staff. Mr. Baldwin has taken a great interest in the work of the Institution of Electrical Engineers and served on the Committee of the Northern Centre for a number of years. He was Chairman of the Centre during 1922. Mr. Baldwin is a well known writer on communication engineering subjects and has read several papers before the Institution of Electrical Engineers and the Institution of Post Office Electrical Engineers. He is the author of "The History of the Telephone in the United Kingdom," a notable volume in the bibliography of the profession. Mr. Baldwin has also delivered lectures on geology and colour-photography. The experience gained in his long service at Newcastle will be particularly useful in connexion with the changes involved in setting up a trial Region in the North Eastern Area.

Mr. McKichan was appointed Probationary Sub-Engineer in 1911 and was promoted Assistant Engineer, South East District in 1914. In 1920 he was transferred to the Telephone Section and was promoted Executive Engineer in 1929. Promotion to Assistant Superintending Engineer, Scotland East District, followed in 1932 and Mr. McKichan became Superintending Engineer of that District in 1934. While at Headquarters, Mr. McKichan was engaged on re-organizing the telephone communications of the Air Force, particularly in connexion with the "Defence of London Scheme." He was also mainly responsible for the introduction of the loose-leaf series of Engineering Instructions and served on many important committees, including the Engineering Telephone Development Committee of 1930. Mr. McKichan was Assistant Editor of this Journal during 1926-32 and, for a short time, was Secretary of the Institution of Post Office Electrical Engineers. Since his transfer to Edinburgh, Mr. McKichan has become a member of the Scottish Centre Committee of the Institution of Electrical Engineers and of the Executive Committee of the Scottish National Development Council. Mr. McKichan's experience



MR. C. A. TAYLOR, M.C.



MR. F. G. C. BALDWIN.

and his knowledge of conditions throughout Scotland will be of material value under the new régime.

Mr. Darke entered the late National Telephone Company in 1907 and served in the Head Office under the late Mr. W. M. France. He was employed largely on switchboard equipment work and allied matters. On being transferred to the Post Office he served under the late Mr. A. W. Martin in the Telephone Section and during the War saw a considerable service in Egypt, Palestine and, later, in France. After the War, he was transferred to the Research Section where he specialized in cable testing and cable balancing operations. During this period a very large amount of pioneer work was being done and Mr. Darke was employed in most parts of the country in endeavouring to improve the cable technique in order to cater for the more stringent requirements consequent upon telephonic repeater development. In 1926, Mr. Darke was transferred to the Lines Section to work on the design and installation of long distance cable plant. In August, 1930, he was promoted to Sectional Engineer, Coventry, this being followed by a promotion to the grade of Assistant Superintending Engineer in Manchester in November, 1932. Mr. Darke was a member of the Commission which visited the United States in 1933 under the leadership of Mr. C. A. Taylor. He succeeded Mr. Innes as Joint Secretary of the Engineering Devolution Committee and was later transferred on loan to the Personnel Department in connexion with the reorganization necessary under the Regional Scheme.

The following appointments of other officers then serving with this Department were also announced :

Mr. W. D. Scutt, Assistant Superintending Engineer, Leeds, to be Telephone Manager, Bradford.

Mr. F. I. Ray, Executive Engineer, London District, to be Telephone Manager, Glasgow.

Mr. C. O. Horn, Executive Engineer, Coventry, to be Telephone Manager, Leeds.

Mr. G. Manning, Executive Engineer, Lancaster, to be Telephone Manager, Sheffield.

Mr. R. B. Rae, Executive Engineer, Edinburgh, to be Telephone Manager, Dundee.

Mr. W. R. Tyson, Executive Engineer, Cardiff, to be Telephone Manager, Lincoln.

It is, of course, a matter of much satisfaction to the members of the Engineering Department that their colleagues have been selected for these important posts and the Board of Editors extends to them its best wishes for every success and happiness in their new spheres.

The Board of Editors feels that, although the changes proposed under Regionalization are drastic, they are a necessity and should promote the efficiency that is essential to such rapidly growing services as those of the Post Office. As regards the Telephone Services in particular, the changes should permit of the maximum co-operation possible between officers responsible for the various phases of the work.

The question of effecting any changes in Post Office organization in London was reserved for separate consideration by the Gardiner Committee in its 1st report and as we go to press the 2nd report by that committee on the Metropolitan Telephone Organization is to hand. This report will receive notice in the Journal in due course.



Mr. J. J. McKICHAN, O.B.E.

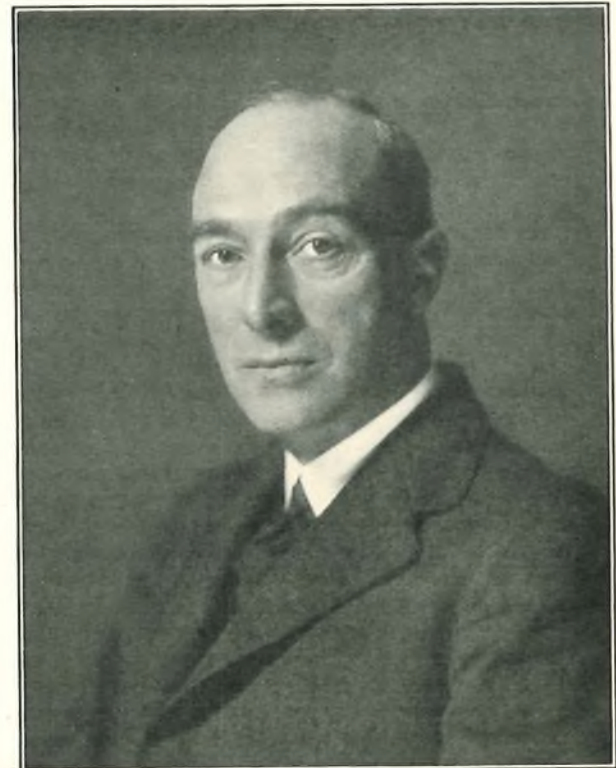
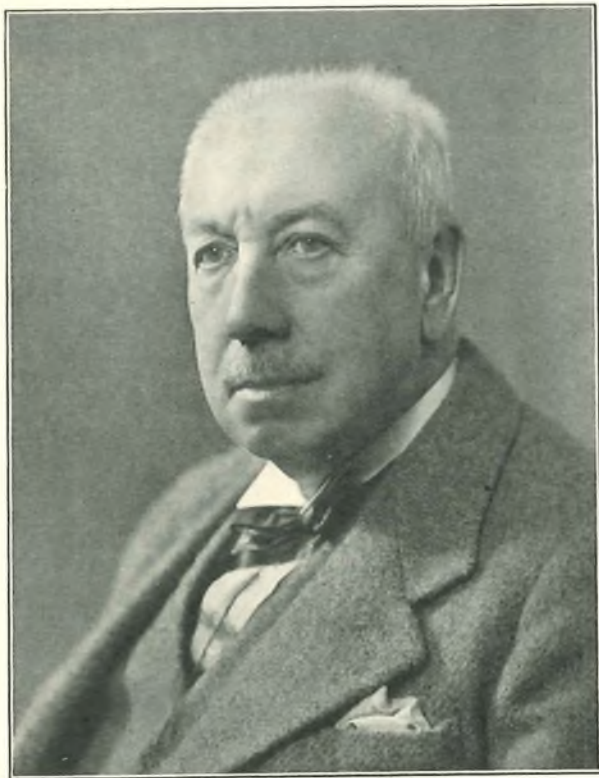

Photo by

Elliott and Fry.

MR. J. DARKE.

Retirement of Mr. T. E. Herbert, M.I.E.E.



The close of the year 1935 saw the removal from active participation in the Department's work of Mr. T. E. Herbert, Superintending Engineer, South Lancashire District, who retired on December 31st with a reputation which has made his name well known wherever Telegraph Communications exist.

Mr. Herbert was the son of Birmingham's first Superintendent of Telegraphs and entered the service as a Telegraph Learner. In 1891 he was appointed a Telegraphist at Manchester and while so serving he obtained medals in the Honours grade of both Telegraphy and Telephony and 1st class Honours in Magnetism and Electricity.

By successive stages of promotion Mr. Herbert became an Assistant Superintending Engineer at Glasgow in 1919,

was transferred to Manchester in the following year and succeeded Mr. Medlyn as Superintending Engineer in 1930.

During his long official career T. E. Herbert has taken an active part in the various changes which have been made in the service, such as the transfer of the trunk telephone lines, followed later by the co-ordination work involved by the transfer of the Telephone Service to the State in 1912, and culminating in the long series of transfers necessitated by the Manchester Automatic conversion. This work, in addition to all the difficulties normally experienced with a conversion of this size, necessitated huge duct routes and special underground work, presenting many problems in civil engineering of a major character all of which were successfully surmounted under Mr. Herbert's guidance.

His sympathetic understanding of men's difficulties and his practical advice and assistance, which was always so readily available to any member of his staff, have endeared him to all. Few, however, know the trouble he took, often at considerable personal inconvenience, to assist men who had fallen by the wayside or had experienced loss or illness.

While carrying a full official load, Mr. Herbert played an important part in promoting Technical education. In 1894 he published articles under the title of "Electricity in its application to Telegraphy" which were subsequently embodied in book form and which exercised a considerable effect in the teaching of Telegraphy.

In 1898 he wrote "The Telephone System of the British Post Office," which was followed in 1906 by the issue of his treatise on "Telegraphs," the standard work on the subject from that day to this, a work which has deservedly won international repute. It has passed through many Editions and its re-writing to include all modern developments will be one of Mr. Herbert's first tasks in his retirement.

In 1923, he published a work on Telephony which was re-written subsequently in collaboration with Mr. W. S. Procter. A second volume dealing with Automatic Telephony is at present in the press.

His many interests have led to a busy life and it is certain that he will find no lack of congenial occupation in his retirement. It is understood that he will not be leaving Manchester and his many friends who wish him many years of good health and happiness will hope to see him in the future and hear some of his characteristic speeches at functions associated with the South Lancashire District.

R. G. de W.

Retirement of Mr. C. J. Mercer, M.I.E.E., M.I.R.E.

Mr. C. J. Mercer, M.I.E.E., M.I.R.E., Staff Engineer Telegraph Branch, retired on the 31st December after forty-three years' service in the Post Office. He entered the service in 1892, was transferred to the Engineering Department in 1899 and in 1903 became a Second Class Engineer attached to Headquarters Telegraph Section.

In 1909, Mr. Mercer was transferred to Inverness as Sectional Engineer. Here he was in charge of a widely spread Section and upon him fell the responsibility of devising and providing, during the war years, all the

communication needs arising from the location of the battle fleet in the northern waters of the Orkney Islands. That all those needs, urgent and onerous as they were, were met to the fullest extent is exemplified by the fact that tributes were paid to the Engineering service and to Mr. Mercer in particular, by all the Admirals Commanding the Orkneys and Shetlands during the war and that an official appreciation of his personal work was received from the Admiralty at the termination of hostilities.

In 1923, Mr. Mercer was transferred to Liverpool as



Sectional Engineer Internal and two years later was transferred to the Radio Section at Headquarters as Assistant Staff Engineer. To him fell the arrangements for the carrying out of the trials of the Beam Services and the responsibility of obtaining staff and later the task of the maintenance of the various Transoceanic Telephone Services including the service given by the Radio Terminal at Faraday Building.

In 1931, Mr. Mercer was promoted Staff Engineer and transferred to the Telegraph Branch where he introduced and guided changes which have resulted in the complete metamorphosis of the engineering structure of Telegraphs, including the complete change over from direct current to alternating current operation by means of the voice frequency telegraph system. These changes have, moreover, resulted in large savings to the Service as a whole and in efficiency of operation undreamt of in the previous era.

Mr. Mercer attended the C.C.I.T. meeting in Prague in 1934 as Head of the British delegation and was elected President of the Technical Commission.

Mr. Mercer has served on the Council of the I.P.O.E.E. as E.-in-C's Office representative and as Treasurer and also on the Board of Editors of this Journal to the date of his retirement.

Mr. Mercer has many interests outside those connected with his official duties. He has a fine taste in literature, maintains an active interest in the French language, and has been a life long devotee of archaeology. In the combat with Father Time he has come off exceedingly lightly and retains an enthusiasm which we hope will continue undimmed for many years to come.

F.E.N.

Retirement of Mr. E. J. Wilby, M.I.E.E.



The retirement, on the 31st of December, of Mr. Ernest John Wilby, Staff Engineer in charge of the Efficiency and Organization Branch of the Engineer-in-Chief's Office, may well be regarded as the close of a chapter in the history of the Post Office Engineering Department—a chapter short in years, but very rich in content.

Mr. Wilby entered Leeds H.P.O. as a telegraph learner in 1890, and by successive stages of promotion became an Assistant Staff Engineer in 1926, and a Staff Engineer on the 30th December, 1931.

The chapter of history already mentioned opened with the assignment to Mr. Wilby in 1921 of the duty of revising and expanding the meagre lists of construction "items" and "descriptions of work" which then constituted the Unit Construction Cost System and rendered it unsuitable for post-war requirements.

The next task followed the report of the "Leech" Committee on the organization of the Engineering Department, when Mr. Wilby was selected to visit the Districts for the purpose of examining the organization of the Sectional Supervising Staffs and of eliminating all avoidable clerical work and enabling the engineering staff to devote more time to supervision of work in the field.

Mr. Wilby was a member of the Swedish Commission of 1927, and in 1930 accompanied Mr. E. Gomersall, O.B.E., to the United States to examine the organization of the Bell Telephone Companies. One of the sequels was the adoption of the "Installation system" under which one Sectional Engineer only is concerned with the provision of any new subscriber's service, other than an extensive P.B.X. installation. It fell to Mr. Wilby to

apply the system to the Provinces and, where it was unsuitable, to improve existing procedure in other ways. The result can best be indicated by saying that the proportion of orders executed within one week throughout the Provinces has risen from 39% to 86%.

Mr. Wilby has been a member of many Committees and of the Engineering and Stores Departmental Whitley Council and the Engineer-in-Chief's Promotion Board: in addition, he acted as chairman of the four Annual Conferences of Efficiency Engineers during the period 1932-1935.

It would be a mere platitude to say that the duties entrusted to Mr. Wilby during the past fourteen years have called for the exercise of tact: they have required a combination of tact, patience, good humour and persistence for which there can have been but few parallels

in the Home Service. It must suffice to say here that step by step, the ground was cleared of obstacles, and one aspect of the success with which Mr. Wilby has accomplished his formidable task is best illustrated by the numerous evidences of goodwill which his farewell visits to the Districts have evoked.

And now the chapter is closed. The good work will go on, but others will do it and they will be encouraged by the deep regard with which in all quarters they find "E.J.W." is held. He leaves us in better health than even he dared to hope until recently and it will be the wish of his many friends that he may enjoy, and share with his wife and family, a very long spell of the leisure which he may be trusted to use with wisdom and true profit.

J.W.A.

Book Reviews

"Radio Data Charts." R. T. Beatty, M.A., B.E., D.Sc. Second edition. 77 pp. 30 ill. Hiffe and Sons. 4/6.

Readers of the "Wireless World" will be familiar with data charts which have been published from time to time by that periodical. A collection of 77 of these charts were published in book form some years ago and the present edition is a re-issue with a few minor additions and deletions. The charts consist of a series of abacs mostly of the alignment type giving a variety of data on all radio matters from frequency wave-length values to design data on iron cored chokes and transformers.

The new edition contains particulars of decibel values with the corresponding power ratios and also a chart for the design of attenuator elements. The scope of some of the earlier charts has been extended while a few of doubtful interest have been deleted.

The collection is of definite utility to persons making computations in the subject and can be recommended as an obvious time saver for a large number of routine calculations.

A.J.G.

"Elementary Electrical Engineering." A. E. Clayton and H. J. Shelley. 462 pp. 318 ill. Longmans, Green & Co. 7/6.

This volume is the second edition of the text-book first published in 1927. The A.C. section of the book has been extended, considerably more attention being given to parallel grouping of A.C. circuits, three phase 3-wire and 4-wire systems, and to the static transformer. The book deals very lucidly with the theory of D.C. and A.C. machines and their windings, as well as covering the theoretical aspect of electro-technology. A number of numerical examples, together with the answers, is included at the end of the book.

The subject covers the syllabus of the Ordinary National Certificate in Electrical Engineering, and the book is strongly recommended to all students taking this course and also to others desiring a general knowledge of electrical engineering principles.

I.R.

"Wireless Telegraphy." W. E. Crook. 189 pp. 228 ill. Pitman. 7/6.

The sub-title of this book, viz., "Notes for Students," explains its purpose. The volume is intended to be a student's note-book, to be supplemented by written notes

made during lectures, and should be used as an accompaniment to suitable text-books.

The first few chapters deal briefly with Electricity and Magnetism and alternating currents, and provide sufficient matter for the revision of basic principles before dealing with their application to the radio aspect. Elementary mathematics only have been introduced, and the student should have no difficulty if he is equipped with a knowledge of the trigonometric functions of an angle, and is able to manipulate simple algebraic expressions. The ground covered is that required for the P.M.G.'s Air Licence for W/T operators, but students studying for the City & Guilds Examinations in radio will find the volume helpful.

J.R.

"Electrical Measurements in Principle and Practice." H. Cobden Turner, M.I.E.E., M.I.Mech.E., and E. H. W. Banner, M.Sc., A.M.I.E.E., F.Inst.P. 354 pages, 219 illustrations. Chapman & Hall. 15/-.

The authors of this book have set out to present the theory of measurement and a description of measuring instruments and methods in a reasonably elementary manner, and in doing so have almost entirely avoided the use of mathematics.

After a short introduction on units, standards and accuracy considerations, the authors devote about one-third of the book to descriptions of measuring instruments with notes on the theory of their operation. The range of instruments covered is extensive, so that the descriptions are necessarily brief.

The next two parts deal with the measurement of Electrical Quantities and Electrical Properties respectively and contain, in concise form, the methods available for the measurement of E.M.F. current, power, inductance, capacitance, etc. The final section contains notes on miscellaneous measurements, the subjects covered ranging from noise measurements to the measurement of fruit acidity. The diagrams in these sections do not all fulfil the authors' claim that the symbols used are in accordance with the B.S.I. standards.

It is inevitable that a book covering such a vast subject as Electrical Measurements should leave the reader wanting to know more about the particular instrument he is interested in, but, although the book will not be of any great use to the research worker, the engineer, and above all the student, will find it a mine of information.

H.L.

District Notes

South Eastern District

BRIGHTON TELEGRAPH REARRANGEMENTS.

Modernization of the telegraphs at Brighton has recently been completed, and included the provision of 2-12 channel V.F. systems London to Brighton and the installation of new equipment in the Instrument Room. The V.F. terminal equipment was installed by Messrs. Standard Telephones and Cables, Ltd., and is located at the telephone exchange. Physical conductors are provided to the Head Post Office which is approximately 600 yards distant. The control and test boards are located in the Instrument Room together with a concentrator for local circuits. Physical 2-wire extension circuits are provided to Bognor, Eastbourne, Hastings, Littlehampton and Worthing. Rack mounted apparatus has also been installed to extend V.F. channels over single wire circuits for special services.

The phonogram and telephone-telegram suite has been accommodated in the Instrument Room and is built up of desk-type units. The associated switchboard is of the continuous panel type with sixteen operating positions. A new telegraph table to accommodate 10 teleprinters is arranged parallel with, but remote from, the phonogram and telephone-telegram suite. "Vee" band conveyors run down the centre of the operating positions in each case. The Instrument Room has been redecorated and the artificial lighting brought into line with present day standards.

Telegraphically, the slogan "Brighter Brighton" holds good!

Northern Ireland District

POSTMASTER-GENERAL'S VISIT TO BELFAST.

The Postmaster-General, accompanied by Mr. H. Napier, Principal Private Secretary, and Lieut.-Col. E. T. Crutchley, C.B.E., C.M.G., paid an official visit to the new Automatic Exchange at Belfast on the 25th November, 1935, when a very pleasant ceremony took place in the Auto Manual Switchroom. The ceremony was attended by Lord Craigavon, Prime Minister of Northern Ireland, accompanied by several members of the Northern Ireland Cabinet, the Lord Mayor of Belfast, and a number of other distinguished guests, representing the various public bodies in Belfast.

The Prime Minister commenced the proceedings with a brief speech in which he welcomed Major Tryon as the first member of the new Imperial Government to visit Northern Ireland. He also welcomed the Postmaster-General as an old friend with whom his association began in the Imperial Parliament of 1910.

The Postmaster-General, in reply, said he was deeply conscious of the kindness with which he had been received. Telephone House was the finest exchange he had yet seen in the course of his official duties. It was probably the best exchange in the service and it was completely up to date. He congratulated Mr. Partridge and his staff on the technical work in preparing for and carrying out the transfer; Mr. Ingleby Smith, Chief Architect to the Ministry of Finance, Government of Northern Ireland, on the beautiful building he and his staff had designed to house the equipment and staff; and the Postmaster-Surveyor and the District Manager and staffs on their fine staff organization.

The Lord Mayor (Councillor Sir Crawford McCullough,

Bart.) extended in the name of the citizens of Belfast a most cordial welcome to the Postmaster-General.

After the Postmaster-General's party had been shown around the Auto-Manual Switchroom, the members of the District Automatic Committee comprising representatives of the Engineering and Traffic staffs, were presented to the Postmaster-General.

The Postmaster-General and his guests were then conducted through the Automatic Apparatus Rooms by Mr. T. T. Partridge, M.I.E.E., M.I.Struct.E., who described the Automatic System and explained its working.

In the afternoon the Postmaster-General was the guest of honour at a luncheon given by the Government of Northern Ireland under the Chairmanship of Lord Craigavon. The gathering included Ministers of the Northern Ireland Cabinet and distinguished representatives of public bodies and the commercial life of Ulster. In the after-lunch speeches some very kind things were said about the Post Office as a whole and the Engineering Department in particular. This evidence of the esteem and respect in which the Post Office is held in Northern Ireland was much appreciated by the staff.

The Postmaster-General visited His Grace, the Duke of Abercorn, Governor of Northern Ireland, during the afternoon, and, at night, closed a very busy day by speaking over the B.B.C. Northern Ireland Regional Transmitter. The staff of the Northern Ireland District hope the Postmaster-General will repeat the visit at a not too distant date.

Scotland West District

STORM DAMAGE, 18TH TO 19TH OCTOBER, 1935.

The worst gale the District has experienced for 10 years occurred during the night of Friday, the 18th October. It raged over the entire District, no locality escaping its effect. Gusts of wind reaching at times a velocity of 100 miles an hour were accompanied by continuous, heavy rain, no less than half an inch falling during the night.

Floods, fallen trees and branches, flying chimney pots and roof slates contributed to wholesale dislocation of the telegraph and telephone services to the many localities relying upon open lines for communication.

On the morning of the 19th all overhead main lines radiating from Glasgow were down. The west highlands including Oban, Fort William, Inveraray, Lochgilphead and Campbeltown were isolated and severe dislocation was reported from the Island of Mull. In the southern portion of the district wires in every main overhead route were broken in various places, isolating all exchanges having no underground outlet.

At the outset many of the roads were impassable owing to floods caused by the failure of the drains and sewers to cope with the accumulation of storm water and also by debris of fallen trees and branches. As instances of the force of the gale, poultry huts in the Dumfries area were blown with their contents a distance of 70 yards away. Whole rows of trees flanking the roadside were felled like ninepins. In Greenock roofs were stripped, doors and windows blown in and chimneys crashed into the streets. On the main overhead route at Upper Greenock a heavy galvanized iron roof attached to its framework of timber was blown a distance of 30 yards right through a bay of wires on the main pole line. A

wooden shed was found draped over the top of a telephone pole at Dalmally. In fact every town and village and main thoroughfare showed the effect of the gale by damaged buildings, fallen trees and debris strewn thoroughfares.



The storm isolated 228 exchanges and caused faults on 776 trunks and junctions and 9000 subscribers' lines. Almost the entire damage consisted of trees or branches falling on to the overhead lines and bringing them down. Only in a few isolated cases were poles actually broken and the number of deflected poles was extraordinarily small, indeed had it not been for trees and branches, the overhead routes would have weathered the storm without any abnormal effect. The close attention given in the past few years to line and wind staying obtained its reward.

The restoration was energetically undertaken, every available man being diverted to the work. It speaks well for the intensive efforts and zeal displayed by all the District staff concerned that by Monday night, that is, within 48 hours, communication had been re-established to 175 exchanges, while some 550 trunks and junction circuits, and 5000 subscribers' lines had been repaired. Owing to storm damage in other parts of the country practically no outside assistance could be obtained and in the circumstances it is a matter for satisfaction to record that by the end of the week the work of restoration had advanced so much that communication could be regarded as having reached normal conditions.

The public and the press were very appreciative of the difficulties to be overcome by the Engineering staff and of their sustained efforts under severe weather conditions to restore services. Some newspapers paid special tribute to the speed with which the restoration was being effected.

As is to be expected the aftermath of a storm such as this, involving overhauling the open lines to complete the permanent restoration, is severely taxing the resources of the staff which is barely sufficient at present to cope with its normal activities. For a month or two there may be an adverse effect on the speed of connexion of new subscribers and in completing new construction work, but it is hoped to get back to normal conditions before very long.

North Wales District

ANNUAL STAFF DINNER OF THE NORTH WALES ENGINEERING DISTRICT.

The Sixth Annual Staff Dinner of the North Wales Engineering District was held at Morris's Cafe, Shrewsbury, on the 6th November, 1935. A representative gathering, numbering over 160, was present including guests from the Postal, Stores and Traffic Staffs. The Guest of Honour was the Deputy Engineer-in-Chief, Colonel A. S. Angwin, D.S.O., M.C., T.D.

After the Chairman had proposed the healths of the King and of the Postmaster-General, the "P.O. Engineering Department" was proposed by Mr. J. T. Foxwell, Surveyor, G.P.O., North Wales District, and Colonel A. S. Angwin replied. The health of the "Visitors" was proposed by Mr. H. G. S. Peck, Assistant Superintending Engineer, North Wales District, and the response was made by Mr. T. B. Braund, Postmaster-Surveyor, Birmingham, and Mr. A. W. Burt, P.O. Stores Department, Birmingham. The health of "The Chairman" was proposed by Mr. P. G. Hay, Executive Engineer, Technical Section, and Mr. Faulkner's reply closed the official toast list.

Between the speeches a most excellent musical programme had been provided. Mr. A. C. Smith, the Staff Officer and the Dinner Committee are to be congratulated on a well organized and thoroughly enjoyable evening.

RETIREMENT OF MAJOR G. A. BLACKWELL.

On 30th September, 1935, Major G. A. Blackwell, Assistant Engineer, Technical Section, North Wales District, retired at the age limit. On the 7th December, 1890, he was appointed a Telegraph Messenger, passing subsequently through the stages of Lineman, Unestablished Lineman (Prov.), Senior Lineman, First Class Lineman, Inspector, Senior Inspector, and Chief Inspector. In February, 1925, he was appointed Assistant Engineer in the Shrewsbury Section. Subsequently he transferred to the Superintending Engineer's Technical Section where he had charge of the group dealing with Automatic Construction and Maintenance, and he was closely associated with the trunking work in the District since it was devolved upon the Superintending Engineer. In addition to the ordinary standard Provincial Systems, there is in Birmingham a large Multi-Office Director Area and the trunking work to be handled is therefore heavy.

During the Great War he held a commission in the Royal Engineers' Signal Section and he served with the Northern Command. Later he was attached to the Australian Corps in France, attaining the rank of Major.

Throughout his career Major Blackwell's interest in his work and his unflagging energy and zeal were always most noticeable.

In the presence of a representative gathering of his colleagues, the Superintending Engineer presented Major Blackwell with an all-mains wireless set which had been subscribed for by the Staff of the District as an earnest of their good wishes.

LONDON-BIRMINGHAM CO-AXIAL CABLE.

This cable consists of 4 tubes, each of approximately 0.45" internal diameter and each containing a single copper conductor insulated and supported centrally. In addition the centre interstice contains two 25 lb. quads and each of the four outer interstices one 25 lb. quad and one 40 lb. screened pair. A little over 11 miles of this cable has been pulled in from Great Charles Street to the District Boundary, and the jointing work is in hand. Arrangements are being made for the provision and termination of the final length from Great Charles Street to Telephone House and for the leading in to the Repeater Station which will be located in the Sheldon Automatic Exchange building.

OPENING OF HAGLEY AUTOMATIC EXCHANGE.

On October 5th, 1935, Hagley Automatic Exchange was brought into service, 362 working lines were transferred from the old exchange which was one of the six remaining magneto exchanges in the Birmingham Section.

The exchange which is situated eleven miles from

Institution of Post Office Electrical Engineers

CITY AND GUILDS OF LONDON INSTITUTE EXAMINATION.

The Council is pleased to record that the prizes presented by the Institution on the results of the City and Guilds of London Institute examinations held in the Intermediate Grade in Telephony, have been awarded for the year 1935 to the following Youths in Training of the L.E.D.:—1st prize of £3 0s. 0d. to Mr. R. N. H. Nidd, Student, Northampton Polytechnic Institute; 2nd prize of £2 10s. 0d. to Mr. W. A. Humphries, Student, Polytechnic, Regent Street.

ESSAY COMPETITION.

Sixteen papers were received, and the Adjudication Committee reported that the papers were all good, but there was no difficulty in selecting five of outstanding merit, well worthy of the award. These are listed below in alphabetical order of the authors' names.

C. L. Andrewartha (Testing Branch).

"The Clay Industry: its Application to the Manufacture of Earthenware Ducts."

A. G. Burgess (Dollis Hill).

"Some Applications of Metal Rectifiers to Transmission Problems."

T. D. Juden (London District).

"External Construction Difficulties and how overcome."

H. Yeatman (S. Midland District).

"Television."

D. L. G. Bartlett (S. Wales District).

"Unit Automatic Exchanges, No. 5 System."

DOCUMENTS OF HISTORICAL INTEREST.

The Council acknowledges with thanks the receipt of various documents of historical interest forwarded during the past year by members of the Engineering Department.

With the impending changes in the areas scheduled for experimental regionalization it is thought possible that many documents of historical interest may come to light, and the Council desires to remind members that arrangements have been made for the filing and indexing of any such memoirs or information which may be offered to the Institution.

CORRESPONDING MEMBERS.

The following have been elected:—

W. J. Parker, Trujillo, Peru.

A. W. Maile, Georgetown, British Guiana.

Junior Section Notes

Eastern District Centres

The general excellence of the papers submitted for consideration in connexion with the Institution's general competition, for the best papers read, by junior members, at Junior Section meetings, has been such as to render the selection of two, by the local Committee, for submitting to the Judging Committee, a task of some difficulty. For the further encouragement of the junior members of the centres in the East District, therefore, a District prize fund, subscribed by the senior members of the Eastern Centre, has been introduced. The awards are made to the authors of the papers which fail to obtain a prize in the Institution general competition, but which are adjudged to be the best submitted to the Eastern Centre. The result of the competition for the session 1934-5, which has just been decided, is as follows:—

District prizes value 10s. 6d. each and certificate.

(1) A. R. Redhouse, Cambridge. Paper entitled "Television."

(2) C. W. Reeve, Fenny Stratford. Paper entitled "The Chargeable Time Indicator."

Local Centre prize value 7s. 6d. and certificate.

R. Foulsham, Southend-on-Sea. Paper entitled "Trunk Demand Working at Southend-on-Sea."

Certificates.

(1) A. L. Challis, Technical Section, Cambridge. Paper entitled "Some Notes on Graphical Statistics."

(2) F. Palin, Fenny Stratford. Paper entitled "General Outline of Heat, Light and Sound."

The local prize scheme will be continued, in a similar form, in subsequent sessions.

Aberdeen Centre

Our opening meeting on the 15th October, when Mr. J. P. Haines gave a paper on the "Telex," was marked by a good attendance. There was an interesting discussion. Our thanks are due to the Post Office Research Station for the use of slides.

"The Faultsman and the Subscriber" was the title of a paper given by Mr. A. E. Wilson at our November meeting. Mr. Wilson also gave an account of the new House Exchange System. The discussion on this portion of the paper turned principally on a comparison of the facilities as compared with a P.B.X.

Birmingham Centre

The Birmingham Centre would appear to have taken on a new lease of life, following the election of Officers and Committee for the ensuing Session on 14th August.

It should be appreciated, of course, that the past session was an unfortunate one, inasmuch as staff changes affecting office holders, together with the extremely heavy programme of construction work in progress, seriously affected the efficient working of the Centre. Happily the situation has improved and we may expect to rely on the following for at least 12 months' good service:—

Chairman—Mr. C. N. Cartwright.

Vice-Chairman—Mr. H. Johnson.

Treasurer—Mr. A. Lanc.

Secretary—Mr. D. M. Laing.

Committee—Messrs. L. Cartwright, A. E. Crofts,

L. H. C. Grafton, E. S. Johnson, W. Meredith,

B. N. Martin, A. E. Nevey, and L. G. B. Newey.

An interesting programme has been arranged, copies of which have been supplied to members and circulated

wooden shed was found draped over the top of a telephone pole at Dalmally. In fact every town and village and main thoroughfare showed the effect of the gale by damaged buildings, fallen trees and debris strewn thoroughfares.



The storm isolated 228 exchanges and caused faults on 776 trunks and junctions and 9000 subscribers' lines. Almost the entire damage consisted of trees or branches falling on to the overhead lines and bringing them down. Only in a few isolated cases were poles actually broken and the number of deflected poles was extraordinarily small, indeed had it not been for trees and branches, the overhead routes would have weathered the storm without any abnormal effect. The close attention given in the past few years to line and wind staying obtained its reward.

The restoration was energetically undertaken, every available man being diverted to the work. It speaks well for the intensive efforts and zeal displayed by all the District staff concerned that by Monday night, that is, within 48 hours, communication had been re-established to 175 exchanges, while some 550 trunks and junction circuits, and 5000 subscribers' lines had been repaired. Owing to storm damage in other parts of the country practically no outside assistance could be obtained and in the circumstances it is a matter for satisfaction to record that by the end of the week the work of restoration had advanced so much that communication could be regarded as having reached normal conditions.

The public and the press were very appreciative of the difficulties to be overcome by the Engineering staff and of their sustained efforts under severe weather conditions to restore services. Some newspapers paid special tribute to the speed with which the restoration was being effected.

As is to be expected the aftermath of a storm such as this, involving overhauling the open lines to complete the permanent restoration, is severely taxing the resources of the staff which is barely sufficient at present to cope with its normal activities. For a month or two there may be an adverse effect on the speed of connexion of new subscribers and in completing new construction work, but it is hoped to get back to normal conditions before very long.

North Wales District

ANNUAL STAFF DINNER OF THE NORTH WALES ENGINEERING DISTRICT.

The Sixth Annual Staff Dinner of the North Wales Engineering District was held at Morris's Cafe, Shrewsbury, on the 6th November, 1935. A representative gathering, numbering over 160, was present including guests from the Postal, Stores and Traffic Staffs. The Guest of Honour was the Deputy Engineer-in-Chief, Colonel A. S. Angwin, D.S.O., M.C., T.D.

After the Chairman had proposed the healths of the King and of the Postmaster-General, the "P.O. Engineering Department" was proposed by Mr. J. T. Foxwell, Surveyor, G.P.O., North Wales District, and Colonel A. S. Angwin replied. The health of the "Visitors" was proposed by Mr. H. G. S. Peck, Assistant Superintending Engineer, North Wales District, and the response was made by Mr. T. B. Braund, Postmaster-Surveyor, Birmingham, and Mr. A. W. Burt, P.O. Stores Department, Birmingham. The health of "The Chairman" was proposed by Mr. P. G. Hay, Executive Engineer, Technical Section, and Mr. Faulkner's reply closed the official toast list.

Between the speeches a most excellent musical programme had been provided. Mr. A. C. Smith, the Staff Officer and the Dinner Committee are to be congratulated on a well organized and thoroughly enjoyable evening.

RETIREMENT OF MAJOR G. A. BLACKWELL.

On 30th September, 1935, Major G. A. Blackwell, Assistant Engineer, Technical Section, North Wales District, retired at the age limit. On the 7th December, 1890, he was appointed a Telegraph Messenger, passing subsequently through the stages of Lineman, Unestablished Lineman (Prov.), Senior Lineman, First Class Lineman, Inspector, Senior Inspector, and Chief Inspector. In February, 1925, he was appointed Assistant Engineer in the Shrewsbury Section. Subsequently he transferred to the Superintending Engineer's Technical Section where he had charge of the group dealing with Automatic Construction and Maintenance, and he was closely associated with the trunking work in the District since it was devolved upon the Superintending Engineer. In addition to the ordinary standard Provincial Systems, there is in Birmingham a large Multi-Office Director Area and the trunking work to be handled is therefore heavy.

During the Great War he held a commission in the Royal Engineers' Signal Section and he served with the Northern Command. Later he was attached to the Australian Corps in France, attaining the rank of Major.

Throughout his career Major Blackwell's interest in his work and his unflagging energy and zeal were always most noticeable.

In the presence of a representative gathering of his colleagues, the Superintending Engineer presented Major Blackwell with an all-mains wireless set which had been subscribed for by the Staff of the District as an earnest of their good wishes.

LONDON-BIRMINGHAM CO-AXIAL CABLE.

This cable consists of 4 tubes, each of approximately 0.45" internal diameter and each containing a single copper conductor insulated and supported centrally. In addition the centre interstice contains two 25 lb. quads and each of the four outer interstices one 25 lb. quad and one 40 lb. screened pair. A little over 11 miles of this cable has been pulled in from Great Charles Street to the District Boundary, and the jointing work is in hand. Arrangements are being made for the provision and termination of the final length from Great Charles Street to Telephone House and for the leading in to the Repeater Station which will be located in the Sheldon Automatic Exchange building.

OPENING OF HAGLEY AUTOMATIC EXCHANGE.

On October 5th, 1935, Hagley Automatic Exchange was brought into service, 362 working lines were transferred from the old exchange which was one of the six remaining magneto exchanges in the Birmingham Section.

The exchange which is situated eleven miles from

Institution of Post Office Electrical Engineers

CITY AND GUILDS OF LONDON INSTITUTE EXAMINATION.

The Council is pleased to record that the prizes presented by the Institution on the results of the City and Guilds of London Institute examinations held in the Intermediate Grade in Telephony, have been awarded for the year 1935 to the following Youths in Training of the L.E.D.:—1st prize of £3 0s. 0d. to Mr. R. N. H. Nidd, Student, Northampton Polytechnic Institute; 2nd prize of £2 10s. 0d. to Mr. W. A. Humphries, Student, Polytechnic, Regent Street.

ESSAY COMPETITION.

Sixteen papers were received, and the Adjudication Committee reported that the papers were all good, but there was no difficulty in selecting five of outstanding merit, well worthy of the award. These are listed below in alphabetical order of the authors' names.

C. L. Andrewartha (Testing Branch).

"The Clay Industry: its Application to the Manufacture of Earthenware Ducts."

A. G. Burgess (Dollis Hill).

"Some Applications of Metal Rectifiers to Transmission Problems."

T. D. Juden (London District).

"External Construction Difficulties and how overcome."

H. Yeatman (S. Midland District).

"Television."

D. L. G. Bartlett (S. Wales District).

"Unit Automatic Exchanges, No. 5 System."

DOCUMENTS OF HISTORICAL INTEREST.

The Council acknowledges with thanks the receipt of various documents of historical interest forwarded during the past year by members of the Engineering Department.

With the impending changes in the areas scheduled for experimental regionalization it is thought possible that many documents of historical interest may come to light, and the Council desires to remind members that arrangements have been made for the filing and indexing of any such memoirs or information which may be offered to the Institution.

CORRESPONDING MEMBERS.

The following have been elected:—

W. J. Parker, Trujillo, Peru.

A. W. Maile, Georgetown, British Guiana.

Junior Section Notes

Eastern District Centres

The general excellence of the papers submitted for consideration in connexion with the Institution's general competition, for the best papers read, by junior members, at Junior Section meetings, has been such as to render the selection of two, by the local Committee, for submitting to the Judging Committee, a task of some difficulty. For the further encouragement of the junior members of the centres in the East District, therefore, a District prize fund, subscribed by the senior members of the Eastern Centre, has been introduced. The awards are made to the authors of the papers which fail to obtain a prize in the Institution general competition, but which are adjudged to be the best submitted to the Eastern Centre. The result of the competition for the session 1934-5, which has just been decided, is as follows:—

District prizes value 10s. 6d. each and certificate.

(1) A. R. Redhouse, Cambridge. Paper entitled "Television."

(2) C. W. Reeve, Fenny Stratford. Paper entitled "The Chargeable Time Indicator."

Local Centre prize value 7s. 6d. and certificate.

R. Foulsham, Southend-on-Sea. Paper entitled "Trunk Demand Working at Southend-on-Sea."

Certificates.

(1) A. L. Challis, Technical Section, Cambridge. Paper entitled "Some Notes on Graphical Statistics."

(2) F. Palin, Fenny Stratford. Paper entitled "General Outline of Heat, Light and Sound."

The local prize scheme will be continued, in a similar form, in subsequent sessions.

Aberdeen Centre

Our opening meeting on the 15th October, when Mr. J. P. Haines gave a paper on the "Telex," was marked by a good attendance. There was an interesting discussion. Our thanks are due to the Post Office Research Station for the use of slides.

"The Faultsman and the Subscriber" was the title of a paper given by Mr. A. E. Wilson at our November meeting. Mr. Wilson also gave an account of the new House Exchange System. The discussion on this portion of the paper turned principally on a comparison of the facilities as compared with a P.B.X.

Birmingham Centre

The Birmingham Centre would appear to have taken on a new lease of life, following the election of Officers and Committee for the ensuing Session on 14th August.

It should be appreciated, of course, that the past session was an unfortunate one, inasmuch as staff changes affecting office holders, together with the extremely heavy programme of construction work in progress, seriously affected the efficient working of the Centre. Happily the situation has improved and we may expect to rely on the following for at least 12 months' good service:—

Chairman—Mr. C. N. Cartwright.

Vice-Chairman—Mr. H. Johnson.

Treasurer—Mr. A. Lane.

Secretary—Mr. D. M. Laing.

Committee—Messrs. L. Cartwright, A. E. Crofts,

L. H. C. Grafton, E. S. Johnson, W. Meredith,

B. N. Martin, A. E. Nevey, and L. G. B. Newey.

An interesting programme has been arranged, copies of which have been supplied to members and circulated

wooden shed was found draped over the top of a telephone pole at Dalmally. In fact every town and village and main thoroughfare showed the effect of the gale by damaged buildings, fallen trees and debris strewn thoroughfares.



The storm isolated 228 exchanges and caused faults on 776 trunks and junctions and 9000 subscribers' lines. Almost the entire damage consisted of trees or branches falling on to the overhead lines and bringing them down. Only in a few isolated cases were poles actually broken and the number of deflected poles was extraordinarily small, indeed had it not been for trees and branches, the overhead routes would have weathered the storm without any abnormal effect. The close attention given in the past few years to line and wind staying obtained its reward.

The restoration was energetically undertaken, every available man being diverted to the work. It speaks well for the intensive efforts and zeal displayed by all the District staff concerned that by Monday night, that is, within 48 hours, communication had been re-established to 175 exchanges, while some 550 trunks and junction circuits, and 5000 subscribers' lines had been repaired. Owing to storm damage in other parts of the country practically no outside assistance could be obtained and in the circumstances it is a matter for satisfaction to record that by the end of the week the work of restoration had advanced so much that communication could be regarded as having reached normal conditions.

The public and the press were very appreciative of the difficulties to be overcome by the Engineering staff and of their sustained efforts under severe weather conditions to restore services. Some newspapers paid special tribute to the speed with which the restoration was being effected.

As is to be expected the aftermath of a storm such as this, involving overhauling the open lines to complete the permanent restoration, is severely taxing the resources of the staff which is barely sufficient at present to cope with its normal activities. For a month or two there may be an adverse effect on the speed of connexion of new subscribers and in completing new construction work, but it is hoped to get back to normal conditions before very long.

North Wales District

ANNUAL STAFF DINNER OF THE NORTH WALES ENGINEERING DISTRICT.

The Sixth Annual Staff Dinner of the North Wales Engineering District was held at Morris's Cafe, Shrewsbury, on the 6th November, 1935. A representative gathering, numbering over 160, was present including guests from the Postal, Stores and Traffic Staffs. The Guest of Honour was the Deputy Engineer-in-Chief, Colonel A. S. Angwin, D.S.O., M.C., T.D.

After the Chairman had proposed the healths of the King and of the Postmaster-General, the "P.O. Engineering Department" was proposed by Mr. J. T. Foxwell, Surveyor, G.P.O., North Wales District, and Colonel A. S. Angwin replied. The health of the "Visitors" was proposed by Mr. H. G. S. Peck, Assistant Superintending Engineer, North Wales District, and the response was made by Mr. T. B. Braund, Postmaster-Surveyor, Birmingham, and Mr. A. W. Burt, P.O. Stores Department, Birmingham. The health of "The Chairman" was proposed by Mr. P. G. Hay, Executive Engineer, Technical Section, and Mr. Faulkner's reply closed the official toast list.

Between the speeches a most excellent musical programme had been provided. Mr. A. C. Smith, the Staff Officer and the Dinner Committee are to be congratulated on a well organized and thoroughly enjoyable evening.

RETIREMENT OF MAJOR G. A. BLACKWELL.

On 30th September, 1935, Major G. A. Blackwell, Assistant Engineer, Technical Section, North Wales District, retired at the age limit. On the 7th December, 1890, he was appointed a Telegraph Messenger, passing subsequently through the stages of Lineman, Unestablished Lineman (Prov.), Senior Lineman, First Class Lineman, Inspector, Senior Inspector, and Chief Inspector. In February, 1925, he was appointed Assistant Engineer in the Shrewsbury Section. Subsequently he transferred to the Superintending Engineer's Technical Section where he had charge of the group dealing with Automatic Construction and Maintenance, and he was closely associated with the trunking work in the District since it was devolved upon the Superintending Engineer. In addition to the ordinary standard Provincial Systems, there is in Birmingham a large Multi-Office Director Area and the trunking work to be handled is therefore heavy.

During the Great War he held a commission in the Royal Engineers' Signal Section and he served with the Northern Command. Later he was attached to the Australian Corps in France, attaining the rank of Major.

Throughout his career Major Blackwell's interest in his work and his unflagging energy and zeal were always most noticeable.

In the presence of a representative gathering of his colleagues, the Superintending Engineer presented Major Blackwell with an all-mains wireless set which had been subscribed for by the Staff of the District as an earnest of their good wishes.

LONDON-BIRMINGHAM CO-AXIAL CABLE.

This cable consists of 4 tubes, each of approximately 0.45" internal diameter and each containing a single copper conductor insulated and supported centrally. In addition the centre interstice contains two 25 lb. quads and each of the four outer interstices one 25 lb. quad and one 40 lb. screened pair. A little over 11 miles of this cable has been pulled in from Great Charles Street to the District Boundary, and the jointing work is in hand. Arrangements are being made for the provision and termination of the final length from Great Charles Street to Telephone House and for the leading in to the Repeater Station which will be located in the Sheldon Automatic Exchange building.

OPENING OF HAGLEY AUTOMATIC EXCHANGE.

On October 5th, 1935, Hagley Automatic Exchange was brought into service, 362 working lines were transferred from the old exchange which was one of the six remaining magneto exchanges in the Birmingham Section.

The exchange which is situated eleven miles from

Birmingham is of the Non-Director type, the parent exchange being Birmingham Central. Dialling-Out facilities are provided to Dudley Auto-manual Board and to several other exchanges in the surrounding district.

The initial equipment, which was installed by Messrs. Standard Telephones and Cables, Ltd., provides for 480 lines, and is the Department's Standard Line-Finder System with partial secondary working.

ABERYSTWYTH AUTOMATIC EXCHANGE.

This exchange was brought into service on the 21st August, 1935, with 505 stations, 335 D.E.L's and 30 junctions. The equipment consists of 400 L and K relays, 24 ordinary and 5 coin box line finders, and 10 secondary finders, 75 group selectors with 32 ordinary and 5 P.B.X. final selectors. There is an auto-manual board.

An unusual feature in connexion with the exchange is that it is accommodated on the upper floor of the centre portion of the Railway Station buildings.

It may be of interest to add that Aberystwyth is supplied with a single channel carrier current circuit and that the provision is contemplated of three-channel carrier equipment with channels to Swansea and Birmingham.

CONDUIT LAYING DIFFICULTIES OVERCOME.

Considerable difficulty was met recently in laying conduits for the provision of the Wolverhampton-Bilston cable, when a railway bridge at Ettingshall Road, Bilston, had to be negotiated. The arrangements made for carrying eight 3½" steel pipes over the bridge may be of interest to readers.

It was found on excavating on the bridge that the depth of cover both in the roadway and footway was only a few inches and would not allow the pipes to be laid over the bridge along the line of the public road in the usual manner. It was seen that some means would have to be devised for carrying the pipes on the outside iron-work structure of the bridge. It was decided that this

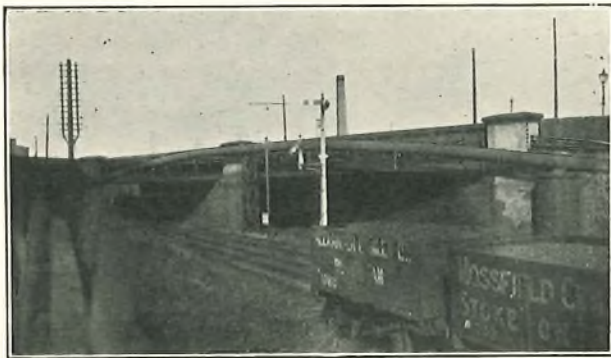

could best be done by accommodating the pipes on galvanized angle iron brackets fixed to the larger fins of the bridge. The length of the brackets, necessary to clear the three buttresses, would have given rise to vibration, and to shorten the brackets and set the steel pipes to clear the buttresses would have entailed considerable difficulty in drawing in cables, owing to the sharp angles which would be necessary. The railway company agreed, however, to the brickwork buttresses being cut away to allow the eight pipes to pass through and link up with the duct track in manholes on either side of the bridge, giving practically a continuous alignment, except at either end where the pipes enter the manholes. Detail drawings were prepared in the Sectional Engineer's office and the 72 brackets 1' 10" long made by a local con-

tractor. Scaffolding was slung over the bridge and the cutting away of the buttresses, drilling of the fins and fitting the brackets was carried out by the railway company to the Department's instructions. The pipes were



then clamped in position in four groups of twos, and, where passing through the buttresses, concreted in position. The photographs show the final result.

It will be noticed that a Mond gas main of 24" diameter crosses the railway in close proximity to the bridge and would not allow scaffolding to be erected. The difficulty of carrying out the work will be appreciated when it is considered that this section of railway track carries a considerable amount of main line traffic.

NANTWICH UNATTENDED AMPLIFIER STATION.

During October and November the Nantwich Unattended Amplifier Station was brought into service on the Northern underground route.

The equipment consists of two totally enclosed racks each capable of mounting fifteen Unit Amplifiers No. 6. Twenty amplifiers are fitted initially, and the station is thus capable of repeating 20 physical circuits, plus 20 carrier wave circuits. Present arrangements give one carrier channel per four-wire physical circuit. L.F. correctors are fitted in the input circuits and harmonic compensators are used in the anode output circuits.

The building closely resembles that used for U.A.X's, now so common all over the country. Internally the resemblance is also very close, the power plant and layout of equipment following U.A.X. practice. The amplifiers are rack mounted and are totally enclosed with pressed steel doors. The valves and input transformers are accommodated in the lower half of the rack and the main transformers in the upper portion.

South Western District

BRISTOL MAINTENANCE EXPERIMENT.

An experiment has been started in Bristol which is of considerable interest to the Telephone Service. The object of the experiment is to investigate the possibility of the reduction of the fault liability on all classes of telephone plant by a large percentage. The experiment is not new in nature, but is unprecedented in point of magnitude inasmuch as it covers the whole of the Bristol Section. The Bristol Section was chosen for the experiment on account of its varied character—it comprises Urban, Industrial, Suburban and Rural Areas and in the Rural Area the topography is again of varied character.

The method to be adopted in the experiment can be divided under three main headings:—

1. *Fault Analyses.*

Fault analyses of great particularity are being undertaken under the following subheads:—

- (a) Automatic Exchange plant.
- (b) Subscribers' apparatus.
- (c) Overhead line plant.
- (d) (At a later date) Underground line plant.

This may be followed by an analysis of Manual Exchange plant if thought to be desirable.

The outstanding features of these analyses are the detailed nature of the investigation and the number of faults which will be taken into account.

2. *Staff Training.*

Emphasis is to be placed on the necessity for good construction work in order to reduce the fault liability of new subscribers' services. Meetings of the Construction and Maintenance Staff have been held with the object of arousing their interest and enthusiasm for the experiment and special leaflets of "Hints to Workmen" have been issued in octavo size pocket folders.

Special steps are also being taken to train Fitters and Linemen in Instruction Classes which will later be continued on a larger scale at the South Western District Training School which it is hoped to open at Bristol early next year.

3. *Action on Result of Analyses.*

Special steps will be taken to deal with plant items or construction methods found by the analysis to be particularly faulty and increased efforts are being made to raise the general standard of work. In connexion with this, special supervising posts have been authorised, on a temporary basis, for supervision of the maintenance work in the Section for the period of the experiment. It will be obvious that no important results will be obtained immediately, but it is thought that after a few months certain features will emerge from the analyses which will give information of great value and enable the engineering service to be greatly improved, and at the same time to indicate those directions in which economies can be effected.

The results of the analyses will be watched with great interest.

PLYMOUTH—ANCIENT AND MODERN.

After the defeat of the Spanish Armada, Sir Francis Drake, the greatest of the Elizabethan seamen, spent his next few years ashore and during this period he contracted with the Corporation of Plymouth

"to bring the river Meavy to the town which, being in length twenty-five miles, he with great care and diligence effected."

Drake cut an open leat from the watershed, situated in the middle of Dartmoor, to the outskirts of Plymouth thence constructing a tunnel about a mile in length to Drake's Place reservoir. From the reservoir a tunnel, following a tortuous line, was provided to discharge surplus water into the sea. During the intervening period houses have been erected and streets laid out over the whole of the land in which the tunnels were built.

On August of this year when excavations were being made in Tavistock Road, Plymouth, in order to lay a 5-way duct, primarily to accommodate the experimental Bristol-Plymouth, multi-channel, multi-conductor carrier-on-cable system, an unrecorded stone built structure was encountered which formed an effective barrier to the placing of the required duct route.

Inquiries to various Corporation Departments were made and the obstruction proved to be Drake's waste leat which is still in occasional use for its original purpose

although the supply leat was superseded some years ago by a pipe line. Owing to the considerable number of services of other undertakers in position above and at the side of the tunnel, a deviation of the Post Office new duct route would have involved substantial extra expense. It was ascertained from the City Water Engineer that no objection would be raised to the placing of the Post Office plant in the tunnel provided that its roof was not disturbed and that the conduits were kept close to the soffit. An inspection of the tunnel from the interior disclosed it to be about 4' 6" wide and 5' high with walls of stone, the arched roof being of brick reinforced with a concrete-like composition of great durability. A feature of the tunnel is its remarkable state of preservation. Vibration caused by the great volume of traffic by which the roadway is constantly used appears to have had little effect on the structure.

It was decided that the tunnel, which is curved at the site of the obstruction, could be used to accommodate an overall length of 43 feet of the Post Office route. The requirement was met by means of five 3½" steel pipes, in formation 2 over 3, being placed close to the roof, support being given by the tunnel walls at the points of entry and exit of the pipes with three intermediate R.S. joists, 4" x 3", fixed across the tunnel, the ends of the joists taking a bearing on the side walls.

When Sir Francis Drake in 1590

"With fresh strams refresh this Towne that first

Though kist with waters yet did pine with thirst "

it is safe to assume that he did not foresee that nearly 350 years later a small portion of his enterprise would be of use in the provision of a telephone cable.

South Lancs District

RETIREMENT OF MR. A. W. FIELD, A.M.I.E.E.

Mr. A. W. Field, Sectional Engineer, Manchester West Section, retired on the 31st July, 1935, after 44 years' service. He entered the Post Office in 1891 as Counter Clerk and Telegraphist in the Metropolitan Western District, and in 1901 was appointed Junior Clerk in the Metropolitan South Engineering District.

In 1903 he was promoted Sub-Engineer in the same District, and was transferred to Blackburn in 1909 as Engineer, Second Class, in the North Western District. He was promoted Assistant Engineer in 1914 and transferred to Manchester in 1930 as Sectional Engineer, Manchester West Section. During the war from 1916 to 1918 he was loaned to the Army Scottish Command as Instructor in Field Telegraphy and Telephony. The period between 1930 and 1935 as Sectional Engineer was a particularly arduous term of office as this was the time of peak load in connexion with the conversion of the Manchester Area to Automatic working, and the able and efficient manner in which he controlled the activities of the Section was an inspiration to the whole of his staff. The kindness and courtesy with which he treated all his officers and his readiness at all times, despite his manifold preoccupations, to assist his subordinates with valuable advice in cases of difficulty will be remembered with gratitude for many years. The general esteem in which he was held was evidenced by the remarkable gathering of over 200 colleagues and friends from all branches of the Service which attended a farewell social function held on the 7th September, at which opportunity was taken by the Superintending Engineer, Mr. T. E. Herbert, M.I.E.E., to present to Mr. Field a Radio Gramophone and to Mrs. Field a Nest of Tables as concrete expressions of the good wishes of the Staff for their future health and happiness.

S.G.P.

Institution of Post Office Electrical Engineers

CITY AND GUILDS OF LONDON INSTITUTE EXAMINATION.

The Council is pleased to record that the prizes presented by the Institution on the results of the City and Guilds of London Institute examinations held in the Intermediate Grade in Telephony, have been awarded for the year 1935 to the following Youths in Training of the L.E.D. :—1st prize of £3 0s. 0d. to Mr. R. N. H. Nidd, Student, Northampton Polytechnic Institute; 2nd prize of £2 10s. 0d. to Mr. W. A. Humphries, Student, Polytechnic, Regent Street.

ESSAY COMPETITION.

Sixteen papers were received, and the Adjudication Committee reported that the papers were all good, but there was no difficulty in selecting five of outstanding merit, well worthy of the award. These are listed below in alphabetical order of the authors' names.

C. L. Andrewartha (Testing Branch).

"The Clay Industry: its Application to the Manufacture of Earthenware Ducts."

A. G. Burgess (Dollis Hill).

"Some Applications of Metal Rectifiers to Transmission Problems."

T. D. Juden (London District).

"External Construction Difficulties and how overcome."

H. Yeatman (S. Midland District).

"Television."

D. L. G. Bartlett (S. Wales District).

"Unit Automatic Exchanges, No. 5 System."

DOCUMENTS OF HISTORICAL INTEREST.

The Council acknowledges with thanks the receipt of various documents of historical interest forwarded during the past year by members of the Engineering Department.

With the impending changes in the areas scheduled for experimental regionalization it is thought possible that many documents of historical interest may come to light, and the Council desires to remind members that arrangements have been made for the filing and indexing of any such memoirs or information which may be offered to the Institution.

CORRESPONDING MEMBERS.

The following have been elected:—

W. J. Parker, Trujillo, Peru.

A. W. Maile, Georgetown, British Guiana.

Junior Section Notes

Eastern District Centres

The general excellence of the papers submitted for consideration in connexion with the Institution's general competition, for the best papers read, by junior members, at Junior Section meetings, has been such as to render the selection of two, by the local Committee, for submitting to the Judging Committee, a task of some difficulty. For the further encouragement of the junior members of the centres in the East District, therefore, a District prize fund, subscribed by the senior members of the Eastern Centre, has been introduced. The awards are made to the authors of the papers which fail to obtain a prize in the Institution general competition, but which are adjudged to be the best submitted to the Eastern Centre. The result of the competition for the session 1934-5, which has just been decided, is as follows:—

District prizes value 10s. 6d. each and certificate.

(1) A. R. Redhouse, Cambridge. Paper entitled "Television."

(2) C. W. Reeve, Fenny Stratford. Paper entitled "The Chargeable Time Indicator."

Local Centre prize value 7s. 6d. and certificate.

R. Foulsham, Southend-on-Sea. Paper entitled "Trunk Demand Working at Southend-on-Sea."

Certificates.

(1) A. L. Challis, Technical Section, Cambridge. Paper entitled "Some Notes on Graphical Statistics."

(2) F. Palin, Fenny Stratford. Paper entitled "General Outline of Heat, Light and Sound."

The local prize scheme will be continued, in a similar form, in subsequent sessions.

Aberdeen Centre

Our opening meeting on the 15th October, when Mr. J. P. Haines gave a paper on the "Telex," was marked by a good attendance. There was an interesting discussion. Our thanks are due to the Post Office Research Station for the use of slides.

"The Faultsman and the Subscriber" was the title of a paper given by Mr. A. E. Wilson at our November meeting. Mr. Wilson also gave an account of the new House Exchange System. The discussion on this portion of the paper turned principally on a comparison of the facilities as compared with a P.B.X.

Birmingham Centre

The Birmingham Centre would appear to have taken on a new lease of life, following the election of Officers and Committee for the ensuing Session on 14th August.

It should be appreciated, of course, that the past session was an unfortunate one, inasmuch as staff changes affecting office holders, together with the extremely heavy programme of construction work in progress, seriously affected the efficient working of the Centre. Happily the situation has improved and we may expect to rely on the following for at least 12 months' good service:—

Chairman—Mr. C. N. Cartwright.

Vice-Chairman—Mr. H. Johnson.

Treasurer—Mr. A. Lane.

Secretary—Mr. D. M. Laing.

Committee—Messrs. L. Cartwright, A. E. Crofts,

L. H. C. Grafton, E. S. Johnson, W. Meredith,

B. N. Martin, A. E. Nevey, and L. G. B. Newey.

An interesting programme has been arranged, copies of which have been supplied to members and circulated

for exhibition on staff notice boards. Any officer or member of the committee will be pleased to advise prospective members as to entrance, etc. The potential membership is 800 and it is hoped that a large percentage of this number will shortly be enrolled in active membership.

Interest in the centre's activity received a most welcome stimulant when it was made known that at the inaugural meeting the Superintending Engineer, together with his Assistants and the Sectional Engineers, would take part in a discussion on "The Causes of the High Percentage of Faults on Subscriber's Apparatus." When it was announced that the Superintending Engineer desired the attendance of all Skilled Workmen, Class I, Gang Foremen, Installation Group Fitters and Subscriber's Line and Instrument maintenance men at a general staff meeting immediately prior to the first meeting of the centre the occasion became unique. Never before in the history of the Birmingham Section, and rarely, if ever, in that of any other Section, can such a meeting have been convened. The meeting commenced at 4.45 p.m. on 15th October, with Mr. H. Faulkner (the S.E.) in the chair, supported by Messrs. H. G. S. Peck and J. H. Watkins. The Superintending Engineer first addressed the meeting, and he was followed by the two Assistant Superintending Engineers. The position, so far as the staff was concerned, was made abundantly clear, and in giving way to the Chairman of the Junior Centre Mr. Faulkner confessed that it was with a keen interest that he awaited the views of the staff.

Mr. Cartwright on taking the Chair at once announced that attendance at this stage of the meeting was entirely optional, but few availed themselves of the opportunity to leave the meeting. The discussion which followed was very frank, and the following spoke on the difficulties affecting their particular groups: Messrs. B. N. Martin, A. E. Nevey, T. Carver, and A. Robinson (Sub's Inst. and Line Mtce.). Smart, Newey, Poyton, Kimberley and Gaskin (Installation and Fitting). G. Arundel (Auto Exch. Mtce.) and several Gang Foremen. Mr. A. Hudson (Sectional Engineer, External) and Mr. E. H. Williams (Asst. Engr.) also contributed to the discussion. In closing the discussion, the Centre Chairman, on behalf of the members of the staff, moved that a vote of thanks be accorded to the Superintending Engineer for providing the opportunity for so full and frank a discussion. This was seconded by the Secretary, Mr. D. M. Laing, and carried unanimously. In replying, Mr. Faulkner thanked the staff generally for the manner in which the meeting had been carried on, and the committee of the centre for the arrangements which had been made for the meeting. From his point of view, he said, the discussion had been most helpful, and he hoped that the satisfaction was mutual. From the standpoint of the centre we should like to pay tribute to the splendid spirit and entire lack of destructive criticism which was a feature of all the speeches. We are truly grateful to all the members of the senior institution who were with us and who spoke, and we hope that on future occasions we shall have the pleasure of their company.

Blackpool Centre

The 1935-36 session is now in full swing, and we have already had two very interesting and well attended meetings.

On November 12th our colleague Mr. N. C. Armitstead delivered an instructive paper on "Carrier Telephony." The lecturer explained the theory of carrier working, and after tracing its development, gave a description of some systems now in use. The paper aroused keen interest, particularly in regard to the latest multi-channel systems, and many points were raised by the members, to which the lecturer suitably replied.

Mr. J. Kirtlan in proposing a vote of thanks to Mr.



Armitstead for the very clear manner in which he had delivered the lecture, compared the valve and metal rectifiers. Mr. G. D. Gable, in seconding the proposition, thanked the lecturer for making a difficult subject so very lucid and interesting.

After the meeting the members inspected the experimental carrier equipment which is now in use in the Blackpool Apparatus Room.

The photograph of the members of the Centre is by kind permission of the "Blackpool Gazette and Herald."

Bristol Centre

The 1935/36 session of the above opened on October 7th with a paper read by Mr. T. G. Clayton on "The Setting-Up of a 4-Wire Repeater Circuit."

Our Sectional Engineer—Mr. E. J. C. Dixon, B.Sc., A.M.I.E.E., kindly consented to give a paper on November 4th, the subject he chose being "The Wireless Branch of the Post Office and its Activities." Mr. Dixon hoped that his lecture would be taken as an encouragement to the junior members to come forward and give papers during the next session.

These two interesting papers have therefore given our session a good start and we hope that the members will continue to show their interest and their appreciation of the work done by their colleagues in preparing papers, by attending the meetings.

The remainder of the programme contains some very attractive subjects.

Don't forget our competition night on March 2nd, 1936.

Cambridge Centre

On the 8th October some 60 members and visitors clearly heard, by means of amplifiers and loudspeakers, the opening address of the session given by Capt. Cave-

Browne-Cave, who was speaking from his home. The address was also relayed to meetings at Norwich, Ipswich, Bury St. Edmunds, Marks Tey and Fenny Stratford.

Capt. Cave surprised his unseen audience by introducing the new Assistant Superintending Engineer, Mr. W. M. Osborn, and Mr. C. W. Brown, our President, who took the opportunity to point out the value of the work carried on by the Junior Section and the importance of keeping in touch with the rapid developments in telephone practice. Mr. J. E. Pidgeon, the new Sectional Engineer, who was present at the meeting, was introduced to the membership by the Chairman.

A very interesting and instructive paper was read by Mr. A. J. Thompson entitled "Cambridge Line Finders."

The remainder of the items on the programme for the session have been arranged as an approach to the problem of Carrier Systems and the first paper of this series, entitled "Underground Cables," was read by Mr. T. Heath on the 8th November.

The further programme is as follows:—

- Dec. 6. "Cable Testing and Balancing."
Mr. A. J. Coulson.
- 1936.
- Jan. 10. "Teleprinters." Mr. I. H. Wallis.
- Feb. 14. "Thermionic Valves." Mr. A. R. Redhouse.
- Mar. 13. "Voice Frequency Carrier Telegraph System."
Mr. A. J. Stearn.

Dundee Centre

The session commenced on the 25th October, when Mr. J. W. Cameron gave us an interesting paper on "Logarithms."

Mr. W. S. Procter, the Sectional Engineer, gave an address at our November meeting on "Recent Developments in Telecommunication" which covered the history of the telephone up to Auto Systems of working, Repeaters, Television and coaxial cables. There was a record attendance and the paper evoked very great interest.

Edinburgh Centre

The session's activities began on the 21st September with an interesting visit to the Forth Bridge.

At our opening meeting in October, Mr. W. S. Procter, A.M.I.E.E., gave us an excellent paper on "Recent Developments in Telecommunication." The construction of typical coaxial cables whereby frequencies up to 1,000 kilo-cycles can be transmitted was dealt with, amongst other technical developments.

Mr. J. Wright read a paper on "Standard Auto Systems" at the November meeting and a good discussion ensued.

London Centre

One is glad to report, in retrospect, that with two regrettable exceptions, the lectures during the past three months have been reasonably well attended, and in each case the lecturer succeeded in imparting a wealth of valuable information in a manner which held our attention and sent us away glad to have been present.

The following programme will cover a total of 27 meetings during the period January to April, and promises a further series of important lectures:—

Formal Meetings.

- Jan. 22. "Train Describers"—as installed by G.E.C. and Siemens Bros. C. A. R. Ashdown.
- Feb. 18. "Modern Tendencies in the supply of Power to Telephone Exchanges."
A. C. Jones, B.Sc.Eng. (Hons.).

Mar. 17. "Underground Diversion Works."

W. Boccock, A.M.I.E.E.

Apr. 8. *To be fixed.* Annual General Meeting.

Informal Meetings.

- "Automatic Traffic Signals." J. R. L. Burchell.
- "Cable Testing and Localization of Faults."
W. Boccock, A.M.I.E.E.
- "Picture Transmission Systems."
G. Carr (E.-in-C's Office).
- "Outline of Voice Frequency Keysending."
E. Gardner.
- "Cable Corrosion." F. A. W. Pyman.
- "The Functions of the Drawing Office in the London District." C. E. C. Skuse.
- "Radio Interference and Suppression Devices."
F. W. Newson.
- "Police Box Systems." D. J. Castro.
- "The Growth of a Telephone System: Factors Governing the Provision of Internal and External Plant." J. N. Hill, A.M.I.E.E.
- "Stamp Vending Machines." W. A. H. Venus.
- "Photometers." G. M. Mew, B.Sc. Eng.
- "Preparation of a Water Tube Boiler for Inspection."
F. H. Bennett, A.I.Mar.E.
- "Low Pressure Water Heating System. Annual Inspection." A. E. Sharp.
- "Emergency Procedure in cases of Breakdown on H.T. at Sub-Stations." (Conducted visit).
A. H. Payne.
- "Conveyors." (Conducted visit).

In conclusion, we would remind the membership of the amount of work involved preparing papers and request that there may be a large increase in the attendance at meetings during the second half of the session.

Manchester Centre

Up to date we have had a successful session, the following programme having been carried out:—

- Oct. 12. Visit to the A.E. Co's Works, Liverpool.
- „ 14. "Telephone Engineering in America."
J. Darke, A.M.I.E.E.
- Nov. 4. "The Faultsman and the Subscriber."
H. Miles.
- „ 16. Visit to the Central Fire Station, Manchester.
- „ 25. "Traffic Records." W. Owen, S. Lancs. Tech. Section.

Mr. J. A. Barrass, of Main (Oldham) Exchange, was successful in our last Essay Competition, his essay "Conducting Visitors" gaining an award of one guinea and certificate of merit. The presentation was made by T. E. Herbert, Esq., Suptg. Engineer, at our meeting on November 25th.

A further competition is being held, closing date February 29th next. Three prizes of one guinea are offered for the best essays on any subject. We have also instituted a prize, value one guinea, for the member making the most valuable contributions to discussions during the session. Members are reminded that it is not too late to begin qualifying for this prize.

The monthly journals "Armchair Science" and "Practical Mechanics" have been added to the circulation list.

The committee desire to place on record their appreciation of the interest taken in Junior Section matters by Mr. T. E. Herbert. They thank him for his many acts of courtesy and assistance, and most sincerely wish him a long and happy retirement. C.W.

Northampton Centre

A meeting to examine the possibility of establishing a Local Centre of the above Institution was held at the

Head Post Office, Northampton, on Wednesday, November 20th, 1935, Mr. E. G. Mills presiding.

The attendance was very encouraging having regard to the inclement weather and the proceedings throughout were followed with the keenest interest and enthusiasm.

After the Chairman had outlined the objects of the meeting, Mr. D. S. Arundel (Assistant Superintending Engineer, North Midland District), who had kindly arranged to be present, addressed the meeting, explaining the aims and objects of the Institution and indicated the many ways in which it would be helpful to the members.

Mr. Arundel's address was much appreciated and after several questions had been put and answered, it was moved and carried unanimously, that "A Local Centre of the Institution of the Post Office Electrical Engineers, Junior Section, be established in Northampton."

The election of officers for the ensuing year resulted as follows:—

Chairman—Mr. E. G. Mills.

Secretary—Mr. W. A. Tait.

Treasurer—Mr. A. D. H. Tull.

Committee—Messrs. P. E. Brown, A. B. Cooper, S. Kirk, J. Smith, Junr., A. C. Homer, and H. C. Leabon.

Thirty-two members were enrolled at the meeting and it is believed that others will follow.

It was resolved that an effort be made at an early date to transmit a lecture from Northampton to Kettering by means of microphone and loudspeaker.

It happened that the date of the meeting coincided with the departure from the Section of our Sectional Engineer, Mr. C. O. Horn, who is taking up duty at Leeds as Telephone Manager,¹ and it was moved and carried unanimously that a letter from the meeting be sent to Mr. Horn congratulating him upon his promotion and wishing him happiness and success in his new sphere of labour.

At the termination of the meeting a hearty vote of thanks to Mr. Arundel for attending and addressing the meeting was moved and carried with acclamation.

¹ North Eastern Region.

Nottingham Centre

The Annual General Meeting was held on November 12th, 1935. The following officers were elected for the forthcoming session:—

Chairman—Mr. T. Bagley (Assistant Engineer).

Vice-Chairman—Mr. E. R. B. Gardiner.

Hon. Secretary—Mr. L. C. Topham.

Treasurer—Mr. F. Frost.

Committee—Messrs. H. W. Fox, F. Jeacock, J. Lee, W. Banham, W. Trafford, and A. E. Clarke.

PROGRAMME, 1935-6.

Dec. 10. "Satellite Working," by T. A. Bish.

Jan. 3. "An External Point of View," by F. Jeacock.

„ 28. "Short Wave Telephony," by G. C. Ashmore.

Feb. 25. "Underground Development," by J. W. Parker.

Mar. 24. "Relay Auto Systems," by F. Frost.

Apr. 21. "Rectifiers and their Uses," by W. Trafford.

The Committee thank those members whose papers were unavoidably deferred until the next session.

In compiling the above syllabus the Committee has

endeavoured to cover a wide range of subjects and also to maintain the high standard set in previous years.

We are glad to note a further increase in the membership, the total now exceeding 40 members.

Preston Centre

Mr. F. C. Bond gave an intimate study of Plant Life on November 20th.

The object of the lecturer was to trace by the examination of a series of type-plants, the gradual advance towards complexity of the organs embodied in the propagation and dispersal of the various species. As examples of the lower cellular plants, *Haematococcus Pluvialis* and *Spirogyra* were selected and their life histories described. These were followed by algae of rather higher development, such as *Vaucheria* and *Ulothrix*. It is to be noted that, with the exception of *Spirogyra*, a free-swimming stage is represented in the life cycle of each of these plants. The mosses and ferns were then dealt with and the principle of alternation of generations emphasized. To represent the higher vascular cryptogams, *Selaginella Kraussianana* was selected and comparisons were drawn between the microspores and macrospores of this plant, and the floral organs of such plants as the Rock rose, Orchid, etc.

The lecture was illustrated by means of the lantern and microscopes. The members thoroughly enjoyed this new scientific investigation of how the world goes round.

Scotland West Centre

Programme for the second half of session:—
1936.

Jan. 20. "Auto Exchange Design."

H. E. Francis (E.-in-C.O.).

Feb. 3. "Police Signals."

W. C. Smith and R. C. Birnie.

Mar. 2. "Precision Testing and Fault Localization."

N. McKinnon.

Taunton Centre

At the annual meeting of the centre, held on 26th September, 1935, the following officers were elected for the forthcoming session:—

Chairman—Mr. R. E. Holt.

Vice-Chairman—Mr. H. Trussler.

Hon. Secretary—Mr. E. O. Bewick.

Treasurer—Mr. W. C. Paul.

Committee—Messrs. R. P. S. Davey, G. Stoneman, L. Gibbs, J. Elliott, and W. J. Durant.

Our programme for the session 1935-36 is as follows:—
1935.

Oct. 10. "Unit Amplifiers." Mr. A. D. Knowers,
E.-in-C's Office.

Nov. 7. "Cable Balancing." Mr. W. C. Paul.

Dec. 12. "A.N. Surveys." Mr. H. Hunt.

1936.

Jan. 9. "Underground Aspects of Taunton Auto.
Conversion." Mr. C. Westlake.

„ 30. "Faults, their Cause and Remedy."

Mr. W. J. Durant.

Feb. 13. "Submarine Cable Working."

Mr. W. R. A. Fagg.

„ 27. "Auto. Exchanges." Mr. O. A. K. Ferguson.

Mar. 12. "U.G. Cabling." Mr. E. J. T. Simmonds.

„ 26. "Repeaters." Mr. R. E. Holt.

Book Reviews

PUBLICATIONS OF THE INTERNATIONAL TIN RESEARCH AND DEVELOPMENT COUNCIL.

The International Tin Research and Development Council was established a few years ago with the objects of discovering and developing new industrial uses of tin, improving the existing products and processes and giving advice to tin consumers on technical problems relating to tin. The Council issues frequent publications, and the five most recent are very briefly reviewed below.

"Tin and its Uses," by D. J. Macnaughtan, Director of Research.

This publication opens with a short historical survey of the growth of the use of tin in industry and a description of the sources of tin. An interesting account is given of industrial tin-containing alloys, *e.g.*, bronze and white metal bearing alloys, solders and die casting alloys. Many other applications of tin are also dealt with.

"Tin and Civilization," by D. J. Macnaughtan, Director of Research.

In modern civilization tin plays a great part in the transmission of power both as a constituent of bearing metals and of solders for jointing electrical conductors. Food is transported and stored in "tinplate" steel cans, while news and information are disseminated by newspapers and periodicals, in the printing of which, tin alloys are used as type metal.

"Improvement in the Quality of 'Tinplate' by Superimposed Electrodeposition of Tin," by A. W. Hothersall and W. N. Bradshaw.

The tin coating formed on steel in the manufacture of "tinplate" used in the making of cans and boxes has invariably been found to be discontinuous and porous.

This paper concerns an investigation of the patent of D. J. Macnaughtan for reducing the porosity of the tin coating on "tinplates" by the superposition of an electrodeposited tin layer. When plating is carried out in an alkaline stannate bath, as recommended, small thicknesses reduce the porosity, while larger ones eliminate it entirely. An acid bath was found ineffective. This work will undoubtedly be of great value to the "tinplate" industry.

"Electrodeposition of Tin Alloys from Alkaline Stannate Baths," by R. G. Monk and H. J. T. Ellingham.

For some purposes it is an advantage to have a coating rather harder than pure electrodeposited tin while retaining this metal's properties of protecting others against corrosion. Preliminary work has been carried out in co-depositing tin and nickel and tin and antimony from modified alkaline stannate baths. The coatings thus formed have been found to be much harder than pure electrodeposited tin. Within certain limits of chemical composition, the tin-nickel deposits are generally satisfactory; those of the tin-antimony, however, even when they are within certain limits of chemical composition, are brittle if of thickness as great as 0.0005 in.

E.V.W.

"Solder," Bulletin No. 2 of the International Tin Research and Development Council, which has recently been published, is of outstanding interest to everyone concerned with the wiping of joints.

The historical development of the process is described and reference is made to the fact that the alloy consisting of one part of tin to two of lead, largely used to-day, was

in common use by the Romans. It appears, however, that the invaluable property of this alloy, its plasticity over a considerable temperature range, was not made use of fully until a much later date. The introduction of wiped joints is stated to date from the 15th Century. Prior to that date the jointing of lead piping seems to have been effected solely by means of lead castings.

The processes for jointing lead, steels, aluminium, etc., are described in the bulletin and much valuable information is given concerning the usefulness and plastic ranges of the various lead-tin alloys and the properties and functions of the Eutectic and of fluxes.

P.J.R.

Copies of these publications can be obtained free of charge from the International Tin Research and Development Council, Manfield House, 378, Strand, London, W.C.2.

"Mercury Arc Rectifier Practice." Frederick Charles Orchard, A.M.I.E.E. 224 pp. 106 ill. Messrs. Chapman & Hall, Ltd. 15/- net.

This book has been written essentially for the practical engineer dealing with the actual installation, operation and maintenance of Mercury Arc Rectifiers. Sufficient theory has been included for the practice to be applied intelligently, and has been set out in an easily understandable form.

The construction of these rectifiers, both in the glass bulb and steel tank forms, together with the auxiliary exhausting plant required to maintain the vacuum when the steel tank type is used, is dealt with fully, and the necessity of employing smoothing circuits to prevent interference with communication circuits, owing to the ripple in the rectified supply, has not been overlooked.

The design of rectifier substations as a whole is also considered in detail, and chapters are included on the testing out and maintenance of the apparatus and the methods of grid control, chiefly used for varying the D.C. voltage or protecting the apparatus against back fire. Finally, the comparative costs and merits of mercury arc rectifiers as against rotating converters are dealt with very fairly.

Taking the book all round it fulfils its purpose admirably, and should prove of considerable assistance to anyone interested in obtaining D.C. supplies from an A.C. system.

J.McG.

"Hutchinson's Technical and Scientific Encyclopedia." 4 Vols., 2468 pp. The Library Press. £5.

This work contains over 25,000 definitions and descriptions of the terms, processes and data used in pure and applied science, construction, engineering and the principal manufacturing industries. The fourth volume also contains a useful bibliography giving references to 3000 books and other sources of information from which more detailed information on the subjects covered by the encyclopedia can be obtained.

The list of the principal contributors is itself sufficient to guarantee the high and accurate standard of the subject matter and the information given under each heading is well illustrated and is much more than a bare summary.

The encyclopedia can be thoroughly recommended as a sound up-to-date reference work for all branches of science and industry. We know of no similar work which is so comprehensive in its scope and there is no doubt that the work is worthy of a place in every reference library.

Staff Changes

PROMOTIONS.

Name.	From.	To.	Date.
Innes, J.	Actg. Asst. E-in-C.	Asst. E-in-C.	20-11-35
Taylor, C. A.	Suptg. Engr., N. Eastern	Deputy Reg. Director, Scotland	1-11-35
Atkinson, J. W.	Deputy Suptg. Engr., London	Deputy Reg. Director, N. Eastern	4-11-35
Baldwin, F. G. C.	Suptg. Engr., Northern	Chief Reg. Engr., N. Eastern	1-11-35
McKichan, J. J.	Suptg. Engr., Scot. East	Chief Reg. Engr., Scotland	1-11-35
O'dell, G. F.	Actg. Staff Engr., E-in-C.O.	Staff Engr., E-in-C.O.	20-11-35
Darke, J.	Asst. Suptg. Engr., S. Lancs.	Principal, Telecommunications Dept.	17-11-35
Scutt, W. D.	Asst. Suptg. Engr., N. Eastern	Tele. Manager, Bradford	To be fixed later.
Ray, F. I.	Exec. Engr., London	Tele. Manager, Scot. West	"
Horn, C. O.	Exec. Engr., N. Midland	Tele. Manager, Leeds	"
Rae, R. B.	Exec. Engr., Scot. East	Tele. Manager, Dundee	"
Tyson, W. R.	Exec. Engr., S. Wales	Tele. Manager, Lincoln	"
Manning, G.	Exec. Engr., N. Western	Tele. Manager, Sheffield	"
Osborn, W. M.	Exec. Engr., Eastern	Asst. Suptg. Engr., Eastern	1-10-35
Millard, W.	Asst. Engr., S. Eastern	Exec. Engr., S. Eastern	1-1-36
Bewick, W.	Asst. Engr., N. Midland	Exec. Engr., N. Midland	1-12-35
Jones, F.	Asst. Engr., S. Lancs.	Exec. Engr., S. Lancs.	1-1-36
Hodge, G. W.	Asst. Engr., S. Eastern	Exec. Engr., S. Wales	1-1-36
Cox, H. E.	Asst. Engr., London	Exec. Engr., London	1-11-35
Rumley, B. C. H.	Asst. Engr., S. Western	Exec. Engr., S. Western	4-11-35
Strachan, L. D.	M.T.O.II., E-in-C.O.	M.T.O.I., E-in-C.O.	21-10-35
Unitt, A. T. G.	A.T.O., London	M.T.O.II., E-in-C.O.	21-10-35
Mills, C. F.	E.O., E-in-C.O.	M.T.O.III., E-in-C.O.	To be fixed later.
Green, G. A.	C.O., E-in-C.O.	M.T.O.III., E-in-C.O.	"
Hunt, E. F.	Mechanic I/C, Wandsworth	Tech. Asst., Leeds	"
Lakey, J.	Supt. Warehouseman, Reading	Tech. Asst., London	"
Doe, F. J.	Supt. Warehouseman, E-in-C.O.	Tech. Asst., E-in-C.O.	"
Gibson, J.	Mechanic I/C, Bristol	Tech. Asst., Manchester	"
Petrie, W.	Chief Insp., Scot. East	Asst. Engr., Scot. East	30-9-35
Biddlecombe, A. W.	Chief Insp., E-in-C.O.	Asst. Engr., E-in-C.O.	21-11-35
Clarke, H. V.	Chief Insp., E-in-C.O.	Asst. Engr., E-in-C.O.	30-9-35
Platt, F.	Chief Insp., S. Wales	Asst. Engr., S. Wales	5-11-35
McNeill, A.	Chief Insp., Eastern	Asst. Engr., Eastern	11-11-35
Tetlow, F. E.	Chief Insp., E-in-C.O.	Asst. Engr., E-in-C.O.	5-11-35
Davidson, G. N.	Prob. Asst. Engr., E-in-C.O.	Asst. Engr., E-in-C.O.	2-10-35
Barker, H.	Prob. Asst. Engr., London	Asst. Engr., London	1-10-35
Jackson, G.	Prob. Asst. Engr., E-in-C.O.	Asst. Engr., E-in-C.O.	1-10-35
Harnden, A. B.	Prob. Asst. Engr., London	Asst. Engr., London	1-10-35
Roberts, J. H.	Prob. Asst. Engr., S. Eastern	Asst. Engr., S. Eastern	1-10-35
Styles, G. E.	Prob. Asst. Engr., E-in-C.O.	Asst. Engr., E-in-C.O.	1-10-35
Hawking, W.	Prob. Asst. Engr., London	Asst. Engr., London	1-10-35
Cooper, W. D.	Prob. Asst. Engr., E-in-C.O.	Asst. Engr., E-in-C.O.	1-10-35
Ingram, C. P.	Prob. Asst. Engr., E-in-C.O.	Asst. Engr., E-in-C.O.	1-10-35
Smith, G. E.	Prob. Asst. Engr., London	Asst. Engr., London	1-10-35
Morley, J. E.	Prob. Asst. Engr., E-in-C.O.	Asst. Engr., E-in-C.O.	1-10-35
Creighton, J. L.	Prob. Asst. Engr., E-in-C.O.	Asst. Engr., E-in-C.O.	1-10-35
Prickett, W.	Prob. Asst. Engr., E-in-C.O.	Asst. Engr., E-in-C.O.	1-10-35
Oman, G. R.	Prob. Asst. Engr., E-in-C.O.	Asst. Engr., E-in-C.O.	2-10-35
Barnett, H. E.	Prob. Asst. Engr., E-in-C.O.	Asst. Engr., E-in-C.O.	2-10-35
Adley, A. G.	Prob. Asst. Engr., E-in-C.O.	Asst. Engr., E-in-C.O.	2-10-35
Taylor, F. J. D.	Inspr., S. Wales	Prob. Asst. Engr., S. Wales	1-10-35
Swain, E. C.	Prob. Insp., Scot. East	Prob. Asst. Engr., Scot. East	1-10-35
Fogg, G. H.	Inspr., E-in-C.O.	Prob. Asst. Engr., N. Eastern	1-10-35
Adam, S. A. F.	Inspr., N. Western	Prob. Asst. Engr., N. Western	1-10-35
Crook, H. G.	Inspr., E-in-C.O.	Prob. Asst. Engr., Trg. School	1-10-35
Stanbury, H. C. O.	Inspr., N. Wales	Prob. Asst. Engr., N. Wales	1-10-35
Cooper, W. H. B.	Prob. Insp., S. Midland	Prob. Asst. Engr., S. Midland	1-10-35
Jago, W. B.	Inspr., London	Prob. Asst. Engr., Trg. School	1-10-35
Dolbon, H. J.	Inspr., E-in-C.O.	Prob. Asst. Engr., Trg. School	1-10-35
Trott, L. J.	Inspr., S. Western	Prob. Asst. Engr., S. Western	1-10-35
Jeffs, H.	Prob. Insp., N. Western	Prob. Asst. Engr., E-in-C.O.	1-10-35
Shepherd, J.	Inspr., E-in-C.O.	Prob. Asst. Engr., E-in-C.O.	1-10-35
Burton, J. P.	Inspr., E-in-C.O.	Prob. Asst. Engr., S. Lancs.	1-10-35
Sheppard, J. A.	Inspr., E-in-C.O.	Prob. Asst. Engr., Trg. School	1-10-35
Mayne, E. A.	Inspr., E-in-C.O.	Prob. Asst. Engr., N. Midland	1-10-35
Matthews, C. J.	S.W.I., St. Albans Radio	Inspr., St. Albans Radio	7-5-35
Harrison, H. G.	S.W.I., S. Western	Inspr., S. Western	21-7-35
Taylor, I.	S.W.I., S. Lancs.	Inspr., S. Lancs.	11-4-35
Smith, J. P.	S.W.I., Northern	Inspr., Northern	11-8-35
Saberton, A.	S.W.I., Eastern	Inspr., Eastern	23-8-35
Noble, J.	S.W.I., N. Ireland	Inspr., N. Ireland	21-8-35
Edmonstone, J. M.	S.W.I., Scot. East	Inspr., Scot. East	19-9-35

PROMOTIONS (continued).

Name.	From	To	Date.
MacManus, G. L. H.	S.W.I., Portishead Radio	Inspr., Portishead Radio	6-10-35
Jones, J. E.	S.W.I., S. Lancs.	Inspr., S. Lancs.	4-8-35
Carroll, T. H.	S.W.I., S. Lancs.	Inspr., S. Lancs.	13-11-35
Baldwin, A. W. T.	S.W.I., E.-in-C.O.	Inspr., E.-in-C.O.	11-7-35
Birss, R. R.	S.W.I., E.-in-C.O.	Inspr., E.-in-C.O.	7-9-35
Branch, H. T.	S.W.I., E.-in-C.O.	Inspr., E.-in-C.O.	22-9-35
Bull, W. H.	S.W.I., E.-in-C.O.	Inspr., E.-in-C.O.	15-9-35
Campbell, A. D.	S.W.I., E.-in-C.O.	Inspr., E.-in-C.O.	12-10-35
Chapman, S. D.	S.W.I., E.-in-C.O.	Inspr., E.-in-C.O.	27-7-35
Cleary, E. J.	S.W.I., E.-in-C.O.	Inspr., E.-in-C.O.	10-10-35
Counsel, A. J. T.	S.W.I., E.-in-C.O.	Inspr., E.-in-C.O.	27-7-35
Day, J. V.	S.W.I., E.-in-C.O.	Inspr., E.-in-C.O.	17-8-35
Doherty, G.	S.W.I., E.-in-C.O.	Inspr., E.-in-C.O.	13-7-35
Edwards, A. G.	S.W.I., E.-in-C.O.	Inspr., E.-in-C.O.	27-7-35
Fox, W. H.	S.W.I., E.-in-C.O.	Inspr., E.-in-C.O.	27-7-35
Fytche, W. H.	S.W.I., E.-in-C.O.	Inspr., E.-in-C.O.	11-8-35
Gray, G.	S.W.I., E.-in-C.O.	Inspr., E.-in-C.O.	21-9-35
Green, L.	S.W.I., E.-in-C.O.	Inspr., E.-in-C.O.	4-8-35
Helm, S.	S.W.I., E.-in-C.O.	Inspr., E.-in-C.O.	26-8-35
Heron, K. M.	S.W.I., E.-in-C.O.	Inspr., E.-in-C.O.	4-8-35
Hudson, F. S.	S.W.I., E.-in-C.O.	Inspr., E.-in-C.O.	11-8-35
Lawton, J.	S.W.I., E.-in-C.O.	Inspr., E.-in-C.O.	20-7-35
Marchant, P. A.	S.W.I., E.-in-C.O.	Inspr., E.-in-C.O.	21-7-35
May, R. H.	S.W.I., E.-in-C.O.	Inspr., E.-in-C.O.	1-6-35
Missen, L. A.	S.W.I., E.-in-C.O.	Inspr., E.-in-C.O.	1-6-35
Pitham, S.	S.W.I., E.-in-C.O.	Inspr., E.-in-C.O.	21-9-35
Rackham, W. A.	S.W.I., E.-in-C.O.	Inspr., E.-in-C.O.	1-6-35
Raffles, H.	S.W.I., E.-in-C.O.	Inspr., E.-in-C.O.	12-10-35
Scholes, W.	S.W.I., E.-in-C.O.	Inspr., E.-in-C.O.	27-7-35
Searle, R. F. J.	S.W.I., E.-in-C.O.	Inspr., E.-in-C.O.	3-5-35
Thompson, S.	S.W.I., E.-in-C.O.	Inspr., E.-in-C.O.	2-9-35
Tyler, H. H.	S.W.I., E.-in-C.O.	Inspr., E.-in-C.O.	10-8-35
Utting, A. P.	S.W.I., E.-in-C.O.	Inspr., E.-in-C.O.	29-9-35
Walker, H.	S.W.I., E.-in-C.O.	Inspr., E.-in-C.O.	31-8-35
Watters, E. W.	S.W.I., E.-in-C.O.	Inspr., E.-in-C.O.	4-8-35
Worthington, A. G.	S.W.I., E.-in-C.O.	Inspr., E.-in-C.O.	21-7-35
Yeatman, H. G.	S.W.I., E.-in-C.O.	Inspr., E.-in-C.O.	7-9-35
Nicolson, P.	S.W.I., Scot. West	Inspr., Scot. West	19-4-35
McHugh, G. P.	S.W.I., N. Eastern	Inspr., N. Eastern	6-11-35
Mead, J.	S.W.I., N. Midland	Inspr., N. Midland	11-4-35
Green, F.	S.W.I., N. Midland	Inspr., N. Midland	11-4-35
Henson, F. B.	S.W.I., N. Midland	Inspr., N. Midland	30-6-35
Evans, D. O. M.	S.W.I., S. Wales	Inspr., S. Wales	27-10-35
Evans, W. H.	S.W.I., S. Wales	Inspr., S. Wales	11-4-35
Field, A. H. G.	S.W.I., S. Wales	Inspr., S. Wales	1-10-35
Goodwin, E. W.	S.W.I., S. Wales	Inspr., S. Wales	1-8-35
Rees, J. W.	S.W.I., S. Wales	Inspr., S. Wales	18-8-35
Sutton, C. J.	S.W.I., S. Wales	Inspr., S. Wales	23-7-35
Lewis, H. V.	S.W.I., S. Midland	Inspr., S. Midland	To be fixed later.
Inwood, F. W.	S.W.I., S. Midland	Inspr., S. Midland	To be fixed later.
White, A. W.	S.W.I., S. Midland	Inspr., S. Midland	To be fixed later.
Lees, W.	S.W.I., Scot. West	Inspr., Scot. West	6-10-35
Scott, E. F.	S.W.I., S. Western	Inspr., S. Western	1-12-35
Morris, H. M.	S.W.I., N. Eastern	Inspr., N. Eastern	To be fixed later.
Johnson, H.	S.W.I., N. Wales	Inspr., N. Wales	To be fixed later.
Manners, W.	S.W.I., N. Wales	Inspr., N. Wales	To be fixed later.
Shepherd, C.	S.W.I., N. Wales	Inspr., N. Wales	To be fixed later.
Crump, S. G.	S.W.I., S. Eastern	Inspr., S. Eastern	To be fixed later.
Cudmore, D. W.	S.W.I., S. Eastern	Inspr., S. Eastern	To be fixed later.
Abraham, H. E.	S.W.I., S. Eastern	Inspr., S. Eastern	To be fixed later.
Granger, S. B.	S.W.I., S. Eastern	Inspr., S. Eastern	To be fixed later.
Kemp, F. G.	S.W.I., S. Eastern	Inspr., S. Eastern	To be fixed later.
Lamper, F.	S.W.I., S. Eastern	Inspr., S. Eastern	To be fixed later.
Larkin, A. J. S.	S.W.I., S. Eastern	Inspr., S. Eastern	To be fixed later.
Lillywhite, A. G.	S.W.I., S. Eastern	Inspr., S. Eastern	To be fixed later.
Muller, P.	S.W.I., S. Eastern	Inspr., S. Eastern	To be fixed later.
Squelch, J. H. A.	S.W.I., S. Eastern	Inspr., S. Eastern	To be fixed later.
Thorpe, H. V.	S.W.I., S. Eastern	Inspr., S. Eastern	To be fixed later.
Willard, R.	S.W.I., S. Eastern	Inspr., S. Eastern	To be fixed later.
Norton, W. A.	S.W.I., Oxford Radio	Inspr., Oxford Radio	1-11-35
McClements, J. S.	S.W.I., E.-in-C.O.	Inspr., E.-in-C.O.	26-10-35
Wright, J. H. R.	S.W.I., E.-in-C.O.	Inspr., E.-in-C.O.	28-7-35
Ashworth, W.	S.W.I., N. Eastern	Inspr., N. Eastern	To be fixed later.
Harvey, H. C.	S.W.I., N. Eastern	Inspr., N. Eastern	To be fixed later.
Mantle, A. L.	S.W.I., N. Midland	Inspr., N. Midland	To be fixed later.

PROMOTIONS (continued).

Name.	Rank.	District.	Date.
Ellis, W.	S.W.I., N. Eastern	Inspr., N. Eastern	To be fixed later.
Major, A. S.	S.W.I., N. Eastern	Inspr., N. Eastern	"
Whiteley, H.	S.W.I., N. Eastern	Inspr., N. Eastern	"
Tapscott, H. F.	S.W.I., S. Western	Inspr., S. Western	"
Benyon, H. T.	S.W.I., S. Western	Inspr., S. Western	"
Page, W. F.	S.W.I., Test Section, London	Inspr., Test Section, London	11-4-35

RETIREMENTS.

Name.	Rank.	District.	Date.
Wakefield, J. H. M.	Asst. Suptg. Engr.	S. Eastern	30-9-35
Hart, J. H.	Exec. Engr.	London	31-10-35
Cockshott, W. J.	Exec. Engr.	S. Western	3-11-35
Jack, J. A.	Exec. Engr.	Northern	30-11-35
McMullen, J. F.	Exec. Engr.	S. Midland	30-9-35
McCormack, W.	Exec. Engr.	S. Eastern	30-9-35
Innes, G.	Asst. Engr.	Scot. East	5-9-35
Wilson, L.	Chief Insp.	N. Western	9-9-35
Stokes, G. W.	Chief Insp.	S. Eastern	13-10-35
Herbert, T. E.	Suptg. Engr.	S. Lancs.	31-12-35
Mercer, C. J.	Staff Engr.	E.-in-C.O.	31-12-35
Wilby, E. J.	Staff Engr.	E.-in-C.O.	31-12-35
Blick, F.	Asst. Suptg. Engr.	London	31-12-35
Leigh, C.	Asst. Staff Engr.	E.-in-C.O.	31-12-35
Arundel, D. S.	Asst. Suptg. Engr.	N. Midland	31-12-35
Pratt, A. J.	Exec. Engr.	S. Lancs.	31-12-35
Ogden, E.	Exec. Engr.	S. Wales	31-12-35
Crocker, J. R.	Exec. Engr.	S. Eastern	31-12-35
Hopper, E.	Asst. Engr.	N. Western	31-12-35
Laidlaw, J. B.	Asst. Engr.	E.-in-C.O.	23-12-35
Nicholson, W. A.	Chief Insp.	Northern	31-12-35
Cairns, J.	Inspr.	Scot. East	18-9-35
Beveridge, J. G.	Inspr.	London	30-9-35
Nichols, J.	Inspr.	S. Lancs.	12-11-35
Bunten, B.	Inspr.	E.-in-C.O.	14-11-35
Brett, W. H.	Inspr.	S. Western	12-11-35
Hyder, C.	Chief Cook	H.M.T.S. "Alert"	3-10-35
Campbell, J.	2nd Steward	H.M.T.S. "Monarch"	5-10-35

TRANSFERS.

Name.	Rank.	From	To	Date.
Gravill, W. E.	Asst. Suptg. Engr.	Eastern	S. Eastern	1-10-35
Friday, F. W.	Exec. Engr.	Scot. West	S. Midland	1-10-35
Graham, C.	Exec. Engr.	London	S. Eastern	1-10-35
Davis, H. G.	Exec. Engr.	E.-in-C.O.	Scot. West	14-10-35
Collman, E. L.	M.T.O.III.	E.-in-C.O.	A.T.O., London	21-10-35
Mayne, E. A.	Prob. Asst. Engr.	N. Midland	Seconded to Malaya	22-11-35
Jeffs, H.	Prob. Asst. Engr.	E.-in-C.O.	N. Midland	11-11-35
Barker, P. L.	Asst. Engr.	E.-in-C.O.	Eastern	1-12-35
Stovold, A. T.	Inspr.	E.-in-C.O.	Test Section, London	3-9-35
Freshwater, R. A. A.	Inspr.	London	E.-in-C.O.	27-8-35
Stowell, L. T.	Inspr.	E.-in-C.O.	S. Eastern	22-9-35
Wheeler, L. K.	Inspr.	N. Wales	E.-in-C.O.	6-10-35
Buckley, G.	Inspr.	E.-in-C.O.	N. Wales	6-10-35
Ware, W.	Inspr.	Portishead Radio	Test Section, London	7-10-35
Seymour, R. A.	Inspr.	London	E.-in-C.O.	1-10-35
Wood, R.	Inspr.	London	S. Western	19-10-35
Middleditch, E. G. H.	Inspr.	Oxford Radio	E.-in-C.O.	1-11-35
Beaumont, E. B. M.	Inspr.	S. Lancs.	E.-in-C.O.	5-11-35
Moore, G.	Inspr.	E.-in-C.O.	S. Western	1-12-35

APPOINTMENTS.

Name.	From.	To.	Date.
Button, G. E.	Inspr., London	Asst. Supt. Traffic, Glasgow	8-9-35
Amos, A. J.	Inspr., E.-in-C.O.	Asst. Supt. Traffic, L.T.S.	15-9-35
Whitehead, W. S.	Inspr., E.-in-C.O.	Asst. Supt. Traffic, Salford	22-9-35
Sulston, W. S.	Asst. Supt. Traffic, Scot West	P.A.E., Trg. School	1-10-35
Floyd, C. F.	New entrant	P.A.E., Trg. School	1-10-35
Fairweather, A.	New entrant	P.A.E., Trg. School	1-10-35
Smith, P. E. C.	New entrant	P.A.E., Trg. School	1-10-35
Mabe, W. S.	New entrant	P.A.E., Trg. School	1-10-35
Dodsworth, E. J.	New entrant	P.A.E., Trg. School	1-10-35

CLERICAL GRADES.

PROMOTIONS.

Name.	From.	To.	Date.
Johnson, P. B.	C.O., E.-in-C.O.	Actg. Exec. Officer. E.-in-C.O. ...	4-10-35
Dabbs, S. E.	C.O., E.-in-C.O.	Actg. Exec. Officer. E.-in-C.O. ...	4-10-35
Bourn, H. T. B.	C.O., E.-in-C.O.	Actg. Exec. Officer. E.-in-C.O. ...	4-10-35
Kirby, V. A. W.	C.O., E.-in-C.O.	Actg. Exec. Officer. E.-in-C.O. ...	23-10-35
Starkley, E. A.	C.O., S. Midland	Actg. H.C.O., S. Midland	25-11-35
Watkins, C. H.	C.O., Eastern	Actg. H.C.O., Eastern	To be fixed later.
Dobson, A. W.	C.O., S. Lancs....	Actg. H.C.O., S. Lancs.	28-11-35
Garland, H. N.	C.O., S. Wales	Actg. H.C.O., S. Wales	25-11-35
Suttle, E. C.	Actg. Staff Officer, E.-in-C.O. ...	Staff Officer, E.-in-C.O.	4-10-35
Johnston, A. E.	Exec. Officer, E.-in-C.O.	Actg. Staff Officer, E.-in-C.O. ...	4-10-35
Knightbridge, H. T.	Actg. Exec. Officer, E.-in-C.O. ...	Exec. Officer, E.-in-C.O.	4-10-35
Topley, W. D.	Actg. Exec. Officer, E.-in-C.O. ...	Exec. Officer, E.-in-C.O.	4-10-35
Meredith, C. T.	Actg. Exec. Officer, E.-in-C.O. ...	Exec. Officer, E.-in-C.O.	23-10-35

RETIREMENTS.

Name.	Rank.	District.	Date.
Ennis, J. A.	Exec. Officer	E.-in-C.O.	15-11-35
Wilson, E.	H.C.O.	S. Midland	11-12-35
Gain, P. G. W.	H.C.O.	S. Wales	25-10-35
Dell, A. H.	H.C.O.	S. Midland	1-11-35

BOARD OF EDITORS

- B. O. ANSON, M.I.E.E., Chairman.
 J. INNES, B.Sc., M.I.E.E.
 C. J. MERCER, M.I.E.E., M.I.R.E.
 P. J. RIDD, M.I.E.E.
 A. J. GILL, B.Sc., M.I.E.E., M.I.R.E.
 G. F. O'DELL, B.Sc., M.I.E.E.
 F. E. A. MANNING, M.C., B.Sc. (Eng.), M.I.E.E.,
 A.M.I.Mech.E.
 J. READING, B.Sc. (Eng.), A.M.I.E.E., Managing Editor.
 H. LEIGH, B.Sc. (Eng.), A.M.I.E.E., Assistant Editor.

Copyright

The entire contents of this Journal are covered by general copyright, and special permission is necessary for reprinting long extracts, but Editors are welcome to use not more than one third of any article, provided credit is given at the beginning or end thus: "From the *Post Office Electrical Engineers' Journal*."

The Board of Editors is not responsible for the statements made or the opinions expressed in any of the articles in this Journal, unless such statement is made specifically by the Board.

Communications

All Communications should be addressed to the Managing Editor, *P.O.E.E. Journal*, Engineer-in-Chief's Office, Alder House, Aldersgate Street, London, E.C.1. Telephone: NATIONAL 6321. Remittances should be made payable to "*The P.O.E.E. Journal*" and should be crossed "& Co."

Binding Cases

Binding cases and copies of the Contents for Vols. 3 to 28 are available, and may be obtained from the Local Agents for 1s. 9d. Subscribers can have their copies of Volumes bound, with index included, at a cost of 3s., by sending the complete sets of parts to the Local Agents or to the Managing Editor. Orders for binding for Vols. 3-19 should indicate whether the original binding case with black lettering, or the later pattern with gold, is required. Cases with gold lettering will be the only type stocked from Vol. 20 onwards.

Back Numbers

The price of the Journal, which is published quarterly, is 1s. (1s. 3d. post free) per copy, or 5s. per annum post free. Back numbers can be supplied, subject to availability of stocks, at 1s. each (1s. 3d. post free). Orders for back numbers may be sent to the Local Agents or to the Publishers.

Advertisements

All communications relating to space reservations should be addressed to the Advertisement Editor, *P.O.E.E. Journal*, Alder House, Aldersgate Street, London, E.C.1. Communications regarding advertisement copy, proofs, etc., should be addressed to the Publishers, Messrs. BIRCH & WHITTINGTON, 10, Station Road, Epsom, Surrey.

	PAGE		PAGE
M		S	
McMillan, D. Some Performance Characteristics of the Subscriber's Telephone Transmitter	167, 313	Secondary Cells, The Effects of Anti-Spray Oil Layers on the Performance of	179
Mercer, C. J. Retirement of	321	" Seekay " Wax, Uses of	207
Metal Rectifiers in Telephone Circuits	310	Selector, P.O. 2000: Its Development and Mechanical Details	249
Method of Locating High Resistance Faults in Loaded Cables, A	117	" " " : Mounting and Cabling Arrangements	257
Mitchell, C. W. A. A Four-Channel Duplex Voice-Frequency Telegraph System	182	Shackleton, J. M. Retirement of	74
Modern Developments in South African Telephone Exchange Design	12	Slingo, Sir William	71
Morris, T. G., and W. Lowne. The House Exchange System	135	Some Notes on Glass and its Manufacture	186
Mumford, A. H., and P. L. Barker. A Field Strength Measuring Set using Thermal Agitation Noise as the Calibrating Source	40	" Performance Characteristics of the Subscriber's Telephone Transmitter	167, 313
N		South African Telephone Exchange Design, Modern Developments in	12
New " Feed-Back " Repeater, A	225	Staff Changes	81, 162, 246, 333
" Method of Testing Subscribers' Lines after Transfer to an Automatic Exchange, A	205	Stewart, A. D. A New Method of Testing Subscribers' Lines after Transfer to an Automatic Exchange	205
Newcastle-Carlisle Cable and the Roman Wall, The	150	Stieltjes, F. H., and G. H. Bast. A New " Feed-Back " Repeater	225
Newcastle-on-Tyne New Sorting Office, The	236	Suffocating Gases and their Detection	201
Note on the Extension of Campbell's Formula to Lightly-Loaded Music Pairs	194, 313	T	
Notes and Comments	70, 153, 241, 312	Telegraph and Telephone Plant in the United Kingdom	36, 99, 204, 266
" District	77, 159, 244, 324	" System, A Four-Channel Duplex Voice-Frequency	182
" Junior Section	75, 156, 243, 328	Telephone Exchange Equipment Standards... ..	263
" Local Centre	156, 242	" Line Insulators of Various Types	120
O		" Tester for Service Officers, A New	39
O'dell, G. F. Promotion to Staff Engineer	155	" Transmission V.	48
P		" " VI.	131
Phillips, R. S. Liverpool New Parcel Post Office	147	Teletprinter, Automatic Message Sender	47
Plymouth Automatic Area, The	196	" Broadcast System, A	10
Portishead Radio Station, Recent Modifications at	216	Testing Subscribers' Lines after Transfer to an Automatic Exchange, A New Method of	205
Post Office Telephone and Telegraph Convention	142	Thomas, C. F. Asbestos-Cement Ducts	296
" " 600 Type Relay, The	293	Traffic Control Signals	301
" " 2000 Selector: Its Development and Mechanical Details	249	" Recorder, The Automatic	1
" " " " : Mounting and Cabling Arrangements	257	Trailer, A Combined Cable Drum and Pole	213
Potts, E. Recent Modifications at Portishead Radio Station	216	Transmission, Telephone, V	48
Pre-cut Poles	273	" " VI... ..	131
R		Transmitter, The Subscriber's Telephone, Some Performance Characteristics of	167, 313
Radio Telephone Circuits, Ultra Short Wave, to Northern Ireland	121	Tufnail, M. E., and D. W. Glover. The Effects of Anti-Spray Oil Layers on the Performance of Secondary Cells	179
Recent Developments in Electrical Lighting	85	U	
" " " Telephone Repeater Station	125	Ultra Short Wave Radio Telephone Circuits to Northern Ireland	121
" " Power Plant	125	Unit Automatic Exchange No. 12, The	105
" " Modifications at Portishead Radio Station	216	Use of a Surveyor's Level to Solve an Engine Problem... ..	104
" " Underground Diversion Works in London	276	V	
Rectifiers, Metal, in Telephone Circuits	310	Valveless Differential Echo-Suppressor, The	27
Regionalization	318	Valve-Maintained Tuning Fork, 50 c.p.s.	143
Relay, The Post Office 600 Type	293	Vause, A. H. Traffic Control Signals	301
Renton, R. N. A Teletprinter Broadcast System	10	Verbal Announcement, The Replacement of Busy Tone by	208
Repeater, A New " Feed-Back "	225	W	
" Station Power Plant, Recent Developments in... ..	125	Warren, A. C. Broadcast Interference Investigation—" Post Office Radio Service "	23
Replacement of Busy Tone by Verbal Announcement. Trial in the Folkestone Area, The	208	Wilby, E. J. Retirement of	322
Richards, C. E. Suffocating Gases and their Detection... ..	201	Williams, H., and W. A. Hibberd. The Replacement of Busy Tone by Verbal Announcement	208
Ridd, P. J. Gas Explosions: Precautionary Measures	144	Winch, B. Metal Rectifiers in Telephone Circuits	310
Rosen, A. A Method of Locating High Resistance Faults in Loaded Cables	117	Worthington, C. E., and M. C. Cooper. The Belfast Automatic Area and Zone Centre Exchange	284
" " The Calculation of the Primary Constants of a Uniform Line from the Propagation Constants	274	Y	
Ryall, L. E. The Valveless Differential Echo-Suppressor	27	Young, J. S. The Post Office 2000 Selector: Its Development and Mechanical Details	249

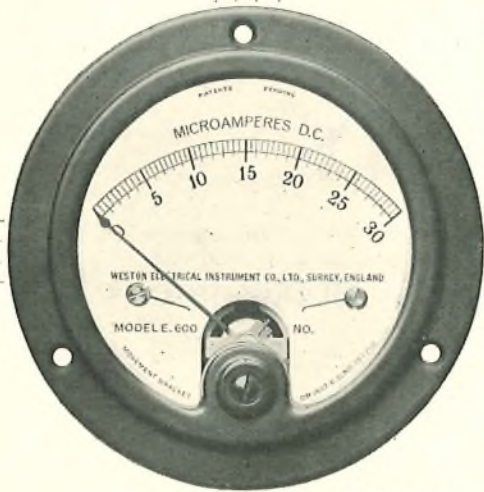

Model E 600

THE reliability and durability of WESTON instruments have been famous the world over for nearly half a century.

As a wide variety of WESTON British-made models is now available, you can now specify British-made WESTON instruments for your requirements, and thus be assured of having the best.

You are invited to write for particulars, mentioning the class of instrument in which you are interested.

WESTON
Standard the World over
PIONEERS SINCE 1850

Announcement of the Weston Electrical Instrument Co. Ltd.,
Kingston By-pass, Surbiton, Surrey. Tel.: Elmbridge 6400-01.
Telegrams: "Pivoted, Surbiton."

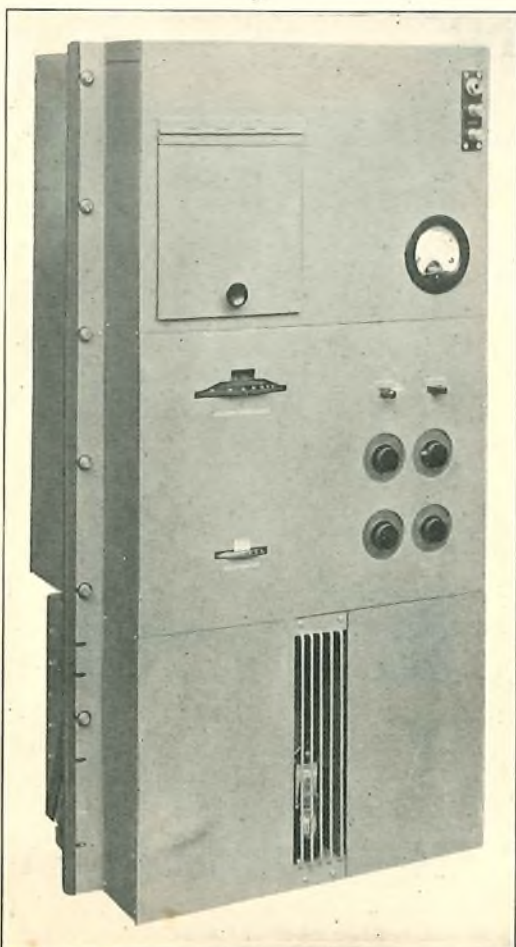

PRECISION

BEAT TONE OSCILLATOR

Sullivan-Griffiths Patents 326190 and 425329. Ryall Patents 408391 and 409360

THE MOST STABLE, ACCURATE AND PURE YET PRODUCED

Scale—C.C.I. (Internationally adopted). Linear to 100 c.p.s. Logarithmic 100 to 10000 c.p.s. Linear above 10000 c.p.s.

Scale Accuracy $0.2\% \pm$ c.p.s. (much better below 100c.p.s.)

Stability from immediately upon switching on ± 1 c.p.s. per day including changes due to temperature.

Harmonic Content less than 0.3% for powers up to 0.5 watt

0 TO 16000
CYCLES PER SECOND

Constant Output Voltage throughout range to less than ± 0.1 db. and independent of supply voltage fluctuations (**Neon Supply Stabiliser** has recently been added to this design.)

Reasonably Pure Output up to 2 watts.

Output Impedance of 600 ohms, very nearly non-reactive and output balanced with regard to earth potential for repeater station work.

Total Output 4 watts.

Mains or Battery Operated.

H. W. SULLIVAN, LIMITED

72, LEO STREET,

LONDON, S.E.15

"Sullivan" guarantees accuracy

AT THE TELEPHONE WORKS OF

THE GENERAL ELECTRIC COMPANY

automatic equipment for approximately 90000 lines is in course of manufacture, including exchanges for the British Post Office and for service in Palestine, Siam, India, New Zealand, China and other countries. To this total is now added equipment for an initial capacity of 6000 lines for:—

CITY WEST EXCHANGE MELBOURNE

which will be equipped with the new

BRITISH POST OFFICE TYPE 2000 SELECTOR

(Manufactured throughout at Coventry)

G.E.C.

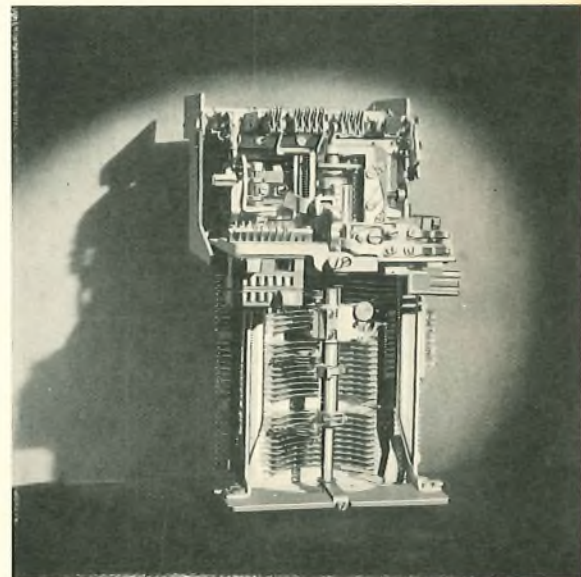

TELEPHONE

Coventry 4111 (8 lines)

Head Office: Magnet House

Temple Bar

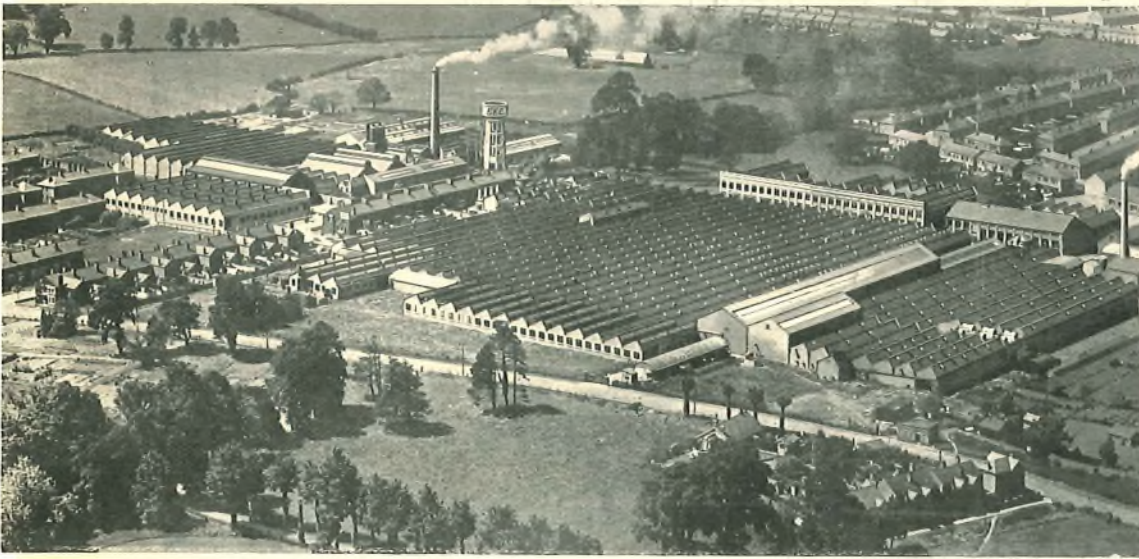

Nearly 6000 employees are engaged at this factory in the manufacture of communication equipment.

FEATURES

- **REDUCED OVERALL DIMENSIONS**

In some instances over 40% more selectors accommodated on a given rack.

Average of 15% saving in exchange floor space.

- **IMPROVED OPERATING CHARACTERISTICS**

Increased operating speed.

Wider permissible limits of variation in impulse ratio.

- **SIMPLIFIED MOUNTING SHELF**

Shelf consists of single angle iron.

- **EASIER MAINTENANCE**

All adjustments made with selector in position on shelf.

- **NO RELEASE MAGNET**

Selector restores to normal by completing arc, dropping to normal level and rotating in reverse direction. In addition to dispensing with release magnet, wear on bank contacts is equalised.

- **BANK CAPACITY OF 100 TO 800 CONTACTS**

WORKS, COVENTRY, ENGLAND

'Springjack, Coventry.'

se, Kingsway, W.C.2.

00 (70 lines); "Electricity, Westcent, London"; "Polyphase, London" (Cables)

New Standard; A.B.C. (5th Edition); Western Union; G.E.C. Private.

Branches and Agencies throughout the World

INDEX TO ADVERTISERS.

	PAGE		PAGE
British Institute of Eng. Technology	xvi	Muirhead & Co, Ltd.	iv
Creed & Co, Ltd.	viii	Pirelli-General Cable Works, Ltd.	xviii
Croydon Cable Works, Ltd	ii	Standard Telephones & Cables, Ltd.	x
Ebonestos Insulators, Ltd.	xiv	Siemens Bros. & Co., Ltd.	vi & vii
Elliott Brothers, Ltd.	xvii	Sir Isaac Pitman, Ltd.	xv
Ericsson Telephones, Ltd.	v	Smith, Frederick & Co	xvii
Ernest T. Turner	iv	Telephony Publishing Corp.	xiv
Evershed & Vignoles, Ltd.	viii	The General Electric Co., Ltd.	iii, xii & xiii
Ferranti, Ltd.	xvi	The Bennett College, Ltd.	ix
Hall Telephone Accessories (1928), Ltd.	xiv	Weston Elec. Instrument Co., Ltd.	xi
H. W. Sullivan, Ltd.	xi		

Moulders to the Trade

*Established
30 Years*

**MOULDINGS
IN WHITE OR
COLOURS.
BAKELITE —
BEETLE
AND OTHER
SYNTHETICS**

PLASTIC MOULDINGS HAVING
HEAT — ACID — OIL — ALKALI —
WATER RESISTING QUALITIES.

EBONESTOS INSULATORS LTD

Excelsior Works,
Rollins Street,
Canterbury Road,

Telephone
NEW CROSS 1913 (5 lines) **LONDON, S.E.15.**

Hall Telephone Accessories (1928) Limited.

Suppliers to the British Post Office and
- Foreign Government Departments. -

Manufacturers of prepayment telephone
multi-coin collectors, pre-selecting auto-
matic dials, automatic stamp selling and
ticket selling machines, automatic slot
machines and fire alarm apparatus.

Registered
Office & Works : 70, DUDDEN HILL LANE,
WILLESDEN,
LONDON, N.W. 10

Tel.: WILLESDEN 5141/2/3.



OF INTEREST TO ALL TELEPHONE ENGINEERS

Articles on every conceivable subject having to do with telephone engineering, design, construction and maintenance are published in the weekly issues of TELEPHONY. That is why this journal is read by progressive telephone men throughout the world. TELEPHONY has been the leader in its field for over thirty-three years. Subscription price \$5.00. U.S. money, for 52 interesting and instructive issues

Address : Electrical Trading and Electricity Technical Book Dept., 85,
Long Acre, London, W.C. 2, for a sample copy of TELEPHONY.
TELEPHONY PUBLISHING CORP., 608, S. Dearborn St. Chicago, Ill., U.S.A.

A Selection of Books for Engineers and Students

OUTLINE NOTES ON TELEPHONE TRANSMISSION THEORY

By W. T. PALMER, Wh.Ex., B.Sc., A.M.I.E.E., Member of the Institute of Post Office Electrical Engineers. These notes originally appeared in *The Post Office Electrical Engineers' Journal* as a series of short papers. They cover the syllabus of the City and Guilds of London Institute Examination in Telephone Transmission, and will also prove useful to students taking the Final B.Sc. (Eng.), of the University of London, the Institution of Electrical Engineers' Examinations, and the examinations for Inspectors and Assistant Engineers in the Post Office. 165 pp. 4s. net.

THE DIRECTOR SYSTEM OF AUTOMATIC TELEPHONY

By W. E. HUDSON, B.Sc., Wh.Sch., A.C.G.I., Engineer-in-Chief's Department, G.P.O., London. A book for traffic officers and telephone engineers requiring a knowledge of the theory of the director system. 166 pp. 74 illustrations. 5s. net.

THE CALL INDICATOR SYSTEM IN AUTOMATIC TELEPHONY

By A. G. FREESTONE, of the Automatic Training School, G.P.O., London. This book enables the student to understand the working of the new automatic exchanges with the present manual exchanges. 124 pp. Illustrated. 6s. net.

PRIVATE AUTOMATIC BRANCH EXCHANGES

By R. T. A. DENNISON, Engineer-in-Chief's Department, G.P.O., London. A special treatise for telephone engineers, dealing in detail with this particular branch of automatic working. 304 pp. Illustrated. 5s. net.

TELEGRAPHY

By T. E. HERBERT, M.I.E.E., Superintending Engineer, Post Office Engineering Department. A standard text-book. 1224 pp. 750 illustrations. Fifth Edition. 20s. net.

Order from a Bookseller or direct (postage extra) from

PITMAN HOUSE, PARKER ST., PITMAN KINGSWAY, LONDON, W.C.2

THE INSTITUTION OF POST OFFICE ELECTRICAL ENGINEERS.

PRINTED PAPERS.

The following papers contributed to the proceedings of the Institution have been printed by authority of the Council and may be obtained, if still in print, from

"THE LIBRARIAN,

The Institution of Post Office Electrical Engineers,
G.P.O. (ALDER HOUSE), LONDON, E.C.1."

The prices do *not* include postage, and in every case, Members, Associate Members, and Associates have the privilege of purchasing copies at two-thirds the stated price.

- | | |
|--|--|
| <p>No. 144. "SOME NOTES ON THE DESIGN AND MANUFACTURE OF TELEPHONE CABLES."—F. H. BUCKLAND and R. H. FRANKLIN, B.Sc. 1932 1s.</p> <p>+No. 145. "ROOM NOISE AND REVERBERATION AS PROBLEMS IN TELEPHONY."—W. WEST, B.A., A.M.I.E.E. 1932 9d.</p> <p>+No. 146. "LAYING ARMoured CABLE BY MEANS OF A MOLE-DRAINER."—L. G. SEMPLE, B.Sc.(Eng.) and R. O. BOCOCK, B.Sc.(Eng.). 1932 9d.</p> <p>+No. 147. "DESIGN AND CONSTRUCTION OF ELECTRIC WAVE FILTERS."—R. J. HALSEY, B.Sc.(Hons.), etc. 1932 1/3</p> <p>No. 148. "STORES SPECIFICATIONS AND ACCEPTANCE TESTING."—Capt. J. LEGG, B.Sc., A.M.I.E.E. 1933 9d.</p> <p>No. 149. "RECENT DEVELOPMENTS IN UNDERGROUND CONSTRUCTION, LAYING AND LOADING ARMoured CABLES."—J. E. Z. BRYDEN, B.Sc.(Eng.), A.M.I.E.E., and T. HARGREAVES, A.M.I.E.E. 1933 1s.</p> | <p>No. 150. "TELEPRINTERS."—E. S. RITTER, M.I.E.E. 1933 1s.</p> <p>No. 151. "RECENT REPEATER STATION INSTALLATIONS."—Major F. E. A. MANNING, M.C., B.Sc.(Eng.), M.I.E.E., A.M.I.Mech.E. 1933 1s.</p> <p>No. 152. "SOME NOTES ON EXCHANGE EQUIPMENT FACTORY COSTING AND THE ECONOMICS OF PRODUCTION."—S. J. HUSBAND, Assoc.I.E.E. 1933 1/3</p> <p>No. 153. "MODERN DEVELOPMENTS IN TELEPHONE TRANSMISSION OVER LINES."—J. STRATTON, A.C.G.F.C., and W. G. LUXTON. 1933 1/3</p> <p>No. 154. "THE TELEGRAPH POLE."—W. H. BRENT, B.Sc.(Hons.), A.M.I.E.E. 1933 1s.</p> <p>No. 155. "A FEW RECENT DEVELOPMENTS IN TELEPHONE TRANSMISSION APPARATUS."—L. E. RYALL, Ph.D. Eng. (Lond.), A.M.I.E.E. 1934 1s.</p> |
|--|--|

+ The Council have awarded Institution Medals for these papers.

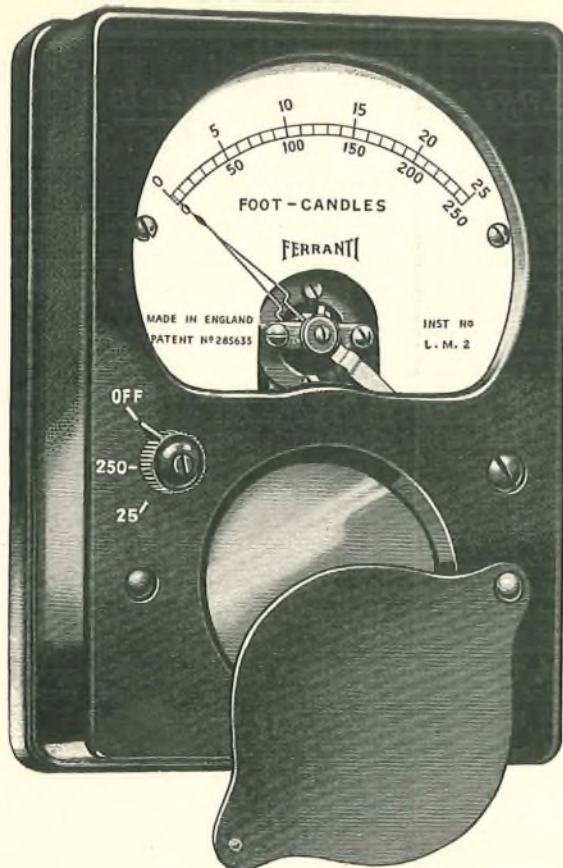

LIGHT... on the subject of LIGHT!

Intensities of illumination from 0-250 foot candles accurately measured by direct reading on a small robust portable instrument entirely self-contained. The instrument comprises a light-voltaic cell and a highly sensitive moving-coil indicator.

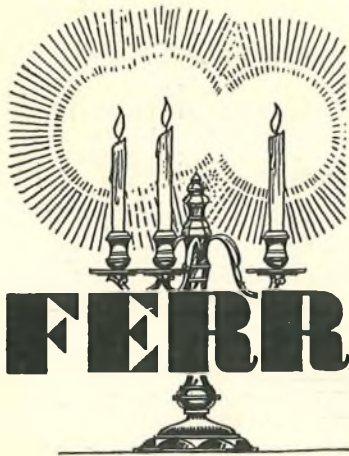

Double range
0 - 25 | foot
0 - 250 | candles

PRICE
£5 - 15 - 0
complete with case.

FERRANTI LIGHT- TESTER

FERRANTI LTD., Hollinwood, Lancs.
London Office: Bush House, Aldwych, W.C.2

LATEST EXAMINATION SUCCESSSES

Since the B.I.E.T. was founded several years ago, we have specialised in preparing candidates for leading Technical Examinations, and our success may be gauged from the following remarkable results:

FOUR 1st PLACES!

In the 1932 and 1934 Probationary Inspectors' Examinations, and in the 1933 & 1934 Assistant Superintendent of Traffic Examination, a B.I.E.T. Student obtained First Place in each case.

FIRST TWO PLACES.

In the Asst. Superintendent of Traffic (Limited Competition) Examination, 1934, the candidates placed 1st and 2nd in the list were trained by the B.I.E.T.

In the Probationary Inspectors' Examination held in December 1934, 71 B.I.E.T. candidates passed the Examination.

In the Assistant Superintendent of Traffic Examination held in 1935—24 B.I.E.T. candidates passed the Examination.

We teach successfully by correspondence and definitely guarantee—

“NO PASS—NO FEE”

You are advised to send for a copy of our General Prospectus “ENGINEERING OPPORTUNITIES.” This Hand-book contains 268 pages of most useful information. It also contains particulars of all leading Engineering Examinations, including

Probationary Inspectors (Open & Limited Competition)
Probationary Assistant Engineers (Limited Competition)
Assistant Superintendent of Traffic (Open and Limited Competition)

City and Guilds, Special G.P.O. Examination, I.E.E., B.Sc., A.M.I.C.E., London Matric., etc., etc.

The Hand-book also outlines “up-to-the-minute” courses of Home-Study in all branches of Engineering.

Special Courses are offered in Telegraphy, Manual Telephony, Automatic Telephony, Telephone Transmission, Electrical Technology, Wireless and High Frequency Radio Communication, Alternating Currents, etc., etc.

Our 268 page Hand-book should be on your Book-shelf. It will be gladly sent on request, FREE and without obligation. (Please state subject or Examination of most interest).

British Institute of Engineering Technology

Recently removed to greatly enlarged premises at—
370, Shakespeare House,
17-19, Stratford Place, Oxford Street,
London, W.1

Differential Moving Coil **MILLIAMMETERS** For Telegraph Circuits

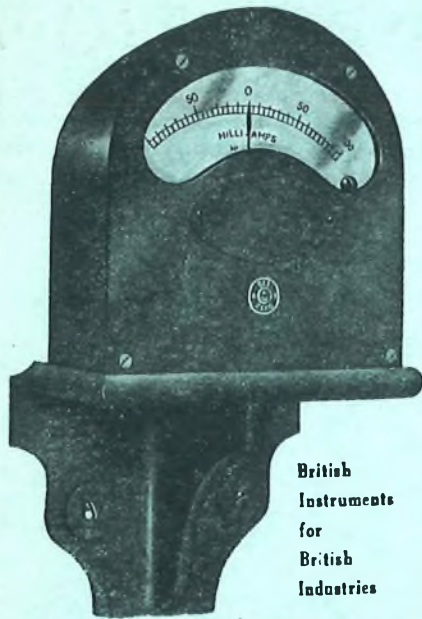

T. 1088 WALL MOUNTING TYPE.

British
Instruments
for
British
Industries



T. 1089. PANEL MOUNTING TYPE.

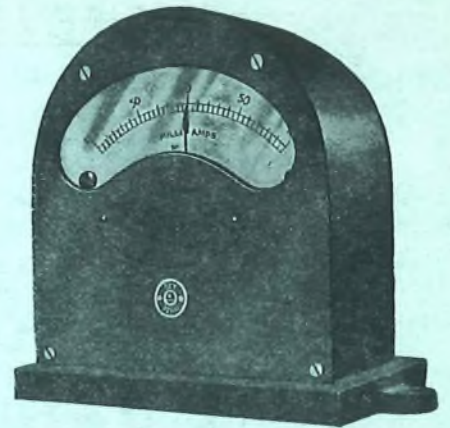

T. 1097. TABLE MOUNTING TYPE.

TABLE, WALL AND PANEL MOUNTING TYPES

INVALUABLE as line Milliammeters on Differential Duplex, Sub-Audio Frequency and many other Telegraph Systems, also for testing purposes in connexion with Land Line and Radio Communication.

Particulars will be sent on request.

ELLIOTT BROTHERS (London) LTD., Century Works, Lewisham, S.E.13

Telephone:
Lee Green 4640

in association with

SIEMENS BROTHERS & COMPANY, LIMITED, Woolwich, London, S.E.18

Telephone:
Woolwich 116f

ANACOS

REGISTERED

BRONZE & CADMIUM COPPER WIRES

SEND US PARTICULARS
OF YOUR JOB, AND OUR
TECHNICAL ENGINEERS
WILL PROVIDE YOU WITH
THE DATA YOU NEED.

as supplied
to H.M. Post Office for
TELEPHONE LINES

SILICIUM-BRONZE, COPPER
COPPER - CADMIUM
TAPES & BINDERS

FREDERICK SMITH & COMPANY

INCORPORATED IN THE LONDON ELECTRIC WIRE
COMPANY AND SMITHS. LIMITED
ANACONDA WORKS SALFORD 3, LANCS.
Telephone: Backfriars 8701 (8 lines) Telegrams: Anacoda, Manchester.

PIRELLI-GENERAL TELEPHONE CABLE

ADDITIONS TO A LONG & SUCCESSFUL CONTRACT LIST

**SHEFFIELD
— LINCOLN —**

67 MILES OF
122 PR/20 AND
104 PR/20 P.C.Q.
MINOR TRUNK
CABLE

GUILDFORD

— ALTON —

22 MILES OF
104 PR/20 AND
60 PR/20 P.C.Q.
MINOR TRUNK
CABLE

**MODBURY
— SALCOMBE —**

14 MILES OF
60 PR/40 AND
38 PR/40 P.C.Q.
MINOR TRUNK
CABLE



TELEPHONE:
SOUTHAMPTON
2141 (3 LINES)

PIRELLI-GENERAL
CABLE WORKS, Ltd., SOUTHAMPTON

TELEGRAMS
"PIGEKAYBEL,
SOUTHAMPTON."

Proprietors: PIRELLI, LTD., and THE GENERAL ELECTRIC CO., LTD.