

Eric Simpson

THE POST OFFICE ELECTRICAL ENGINEERS' JOURNAL

VOL. 27

OCTOBER, 1934

PART 3.



CONTENTS

	PAGE
THE AUTODIAL—W. A. Collett	161
SEVEN-DIGIT A.C. KEYSENDING—M. G. Holmes, B.Sc. (Hons.), A.M.I.E.E. and P. J. Sard, A.M.I.E.E.	166
TELEGRAPH AND TELEPHONE PLANT IN THE UNITED KINGDOM ...	172
PNEUMATIC TUBE FACILITIES AT CENTRAL TELEGRAPH OFFICE— J. E. McGregor, A.C.G.I., A.M.I.E.E. and N. W. Lewis, B.Sc. (Eng.)	173
PARCEL CONVEYERS—D. P. Gilbert	179
THE LONDON TRUNK CENTRE—S. Birch	187
FREQUENCY CHARACTERISTICS OF A WESTERN ELECTRIC MOVING COIL MICROPHONE	198
TELEPHONE TRANSMISSION—IV.—R. M. Chamney, A.K.C., B.Sc., A.M.I.C.E.	199
CARRIER TELEPHONY IN UNDERGROUND CABLES	203
RECENT DEVELOPMENTS IN CONCRETE KIOSK CONSTRUCTION— A. J. Amos	204
CARRIER TELEPHONY ON AERIAL LINES	206
A TRANSMISSION TEST SET FOR SUBSCRIBERS' INSTRUMENTS, LOCAL LINES, AND EXCHANGE APPARATUS—E. J. Barnes, A.C.G.I., A.M.I.E.E. and R. E. Swift, B.Sc., A.M.I.E.E.	207
A PRECISION HETERODYNE OSCILLATOR—L. E. Ryall, Ph.D. (Eng.) A.M.I.E.E.	213
MODERNIZING TELEPRINTER DIAGRAMS—C. D. Lipscombe	222
AN ANTI-SIDETONE COIL FOR LOCAL BATTERY CIRCUITS	224
E.H.T. SWITCHGEAR WITH AUTOMATIC CHANGE-OVER DEVICE— L. E. Williams, B.Sc., A.M.I.E.E.	225
A NEW ELECTRIC MAILS LIFT—A. E. Penney	228
NOTE ON THE SINGING POINT OF TWO-WIRE REPEATERS	231
NOTES AND COMMENTS	233
THE INSTITUTION OF POST OFFICE ELECTRICAL ENGINEERS ...	233
JUNIOR SECTION NOTES	234
BOOK REVIEWS	178, 232, 236
DISTRICT NOTES	237
STAFF CHANGES	238

Price 1/- net

THE INSTITUTION OF POST OFFICE ELECTRICAL ENGINEERS





ON TIPTOE

The very nature of the contracts awarded to Alton Batteries of Merit keeps us ever on top of our form. For to-day, so many great names, Institutions and Governments are associated with Alton installations that never for one moment is our diligence relaxed to preserve the trust placed in us.

Against enormous and organised competition;

against an early prejudice—Alton Batteries of Merit have, through no other reason than outstanding and exemplary performance, won their way to the top.

And so, to continue to deserve this success, we remain always on tiptoe—abreast of any means or method whereby we can improve our products.

BATTERIES OF MERIT

THE
ALTON BATTERY COMPANY
 LTD.

ALTON HANTS

Telephone: Alton 67. Telegrams: "BATTERY, ALTON."

LONDON OFFICE:
 DONNINGTON HOUSE, NORFOLK STREET, STRAND

Telephone: Temple Bar 9266.6.
 Telegrams: "BATTERICOL ESTRAND LONDON"

The Telephone Subscriber of Tomorrow



Provision for future development is perhaps the telephone engineer's greatest problem. The British Post Office, The South African Government, the Polish and Lithuanian State Telephone Administrations are among those who have found their plans for improved and extended service materially assisted by having adopted:—



AUTOMATIC ELECTRIC CO. LTD.
STROWGER WORKS, LIVERPOOL

iii.

$$Turns/volt = \frac{100,000,000}{F \times 4.4 \times N}$$

Where $F = \sim$

$N = 50,000 \times \text{area of core in sq. ins.}$

This giving a max output of 50 Watts/□" core.

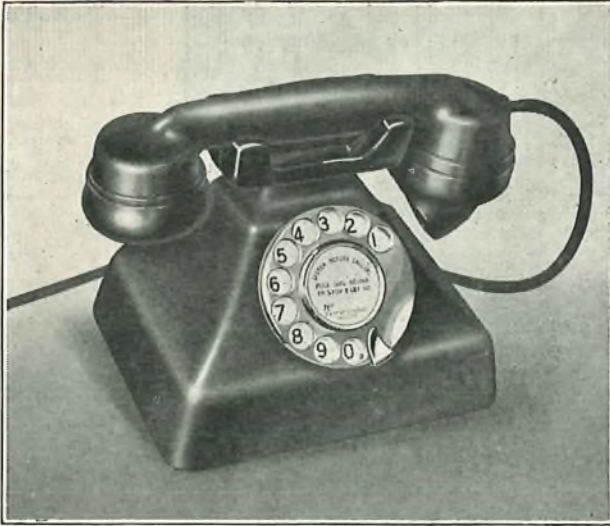

THE IMPROVED
GEOPHONE
 SUBSCRIBER'S SET

—the standard self-contained bakelite instrument for public service. Unique in design, unsurpassed in performance, this telephone possesses every feature demanded by the discriminating user. Of those qualities important in the light of modern developments, the most outstanding is improved intelligibility resulting from the maximum suppression of side tone. This instrument is unequalled for tropical service and has been adopted by Administrations in all parts of the world.

G.E.C.

TELEPHONE WORKS
 COVENTRY

Telephone: Coventry 4111 Telegrams: "Springjack, Coventry"

London Office: MAGNET HOUSE, KINGSWAY, W.C.2

BRANCHES AND AGENCIES THROUGHOUT THE WORLD

SHENLEY HOSPITAL

*has an Ericsson Telephone System
— of course!*

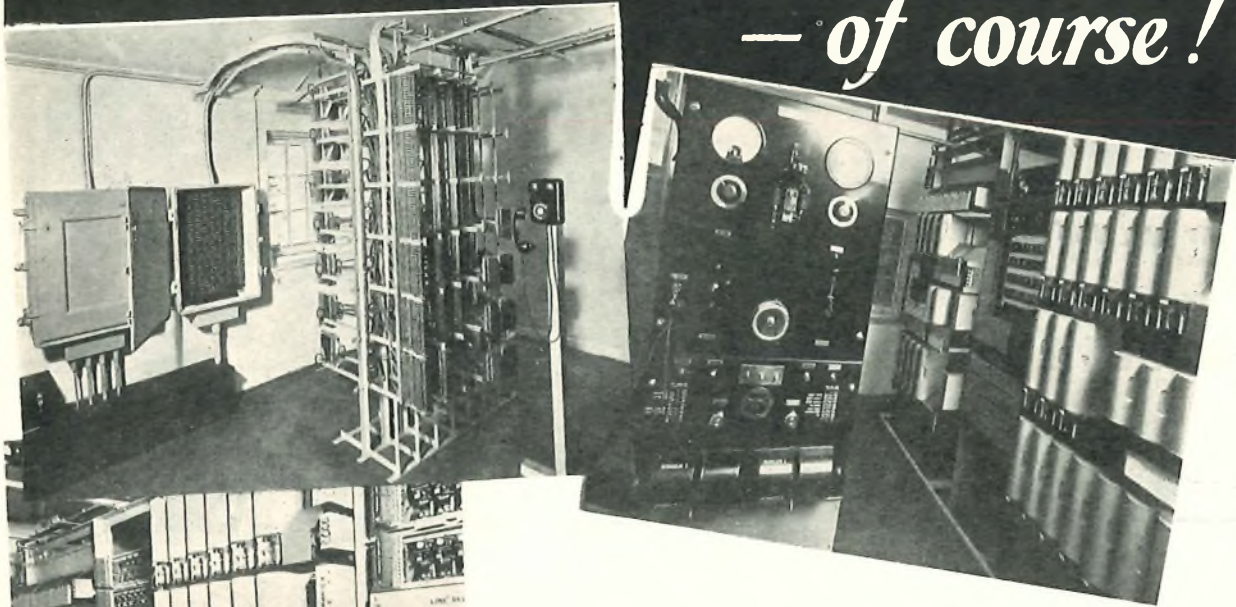

ONLY the very best in internal telephone equipment would satisfy the authorities responsible for SHENLEY HOSPITAL and they chose the Ericsson Intercommunication System.

Every development in telephone research and progress has been incorporated in this fine system, the illustrations of which are shown here.

Ericsson's manufacture, supply and install complete automatic exchange equipment of the 'director' and 'non-director' types for any number of lines.

May we send you informative literature—post free?

ERICSSON TELEPHONES LIMITED

67/73, KINGSWAY, LONDON, W.C.2
Telephone: Holborn 3271/3 Works: Beeston, Notts

Ericsson

**TELEPHONE
EXCHANGE
EQUIPMENT**

Photographs, Shaw

- The Front View of Power Board and Auto Units.
- The Main Frame.
- The Front View of Auto Units.
- The Battery Room.

The Telephone for noisy situations

SIEMENS NEOPHONE TYPE 300

Can be supplied for :
Automatic, Central Battery,
Magneto, & Battery Call systems,
to meet practically all requirements.



In the "Neophone" Type 300 the unrivalled transmission efficiency and articulation of our original "Neophone" has been rendered still more effective by the addition of our new "Anti-sidetone Induction Coil." Under all conditions the side tone control of this new instrument produces a delightful sense of naturalness.

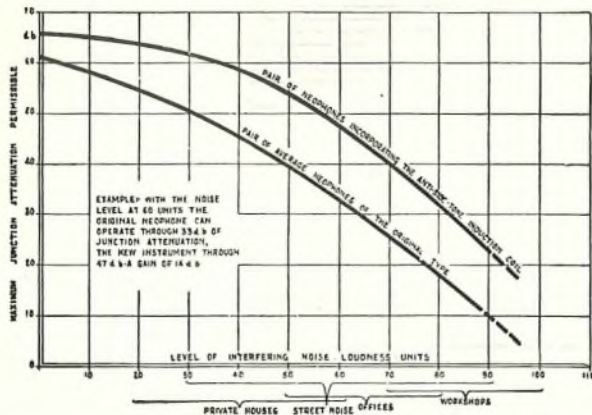

Curves showing improvement effected by the use of our new patent 'ASTIC' circuit in various situations.

The Type 300 "Neophone" solves the difficulty of telephoning in noisy offices, engine rooms, railway stations and factories where an ordinary telephone is almost useless.

It is used by the British Post Office, and after exhaustive practical tests has been adopted by many important Electricity Supply Authorities, Railways, Traction Companies, Collieries, etc.

Full particulars on request

SIEMENS BROTHERS & CO., LTD. WOOLWICH, LONDON, S. E. 18.

Telephone: Woolwich 1161

SIEMENS

AUTOMATIC CHARGING TRANSRECTER

for

**TELEPHONE, TELEGRAPH
& SIGNAL SYSTEMS. EMERGENCY
LIGHTING & POWER
BATTERIES Etc.**

ELIMINATES NEED FOR
SKILLED MAINTENANCE
AND ENSURES MAXIMUM
RELIABILITY AT MINIMUM
COST

ENTIRELY AUTOMATIC—
NO RELAYS, CONTACTORS
OR MOVING PARTS OF
ANY KIND

HIGH ELECTRICAL
EFFICIENCY AT ALL
LOADS

ENSURES MUCH LONGER
BATTERY LIFE, AND
REPAIRS AND RENEWALS
PRACTICALLY
ELIMINATED

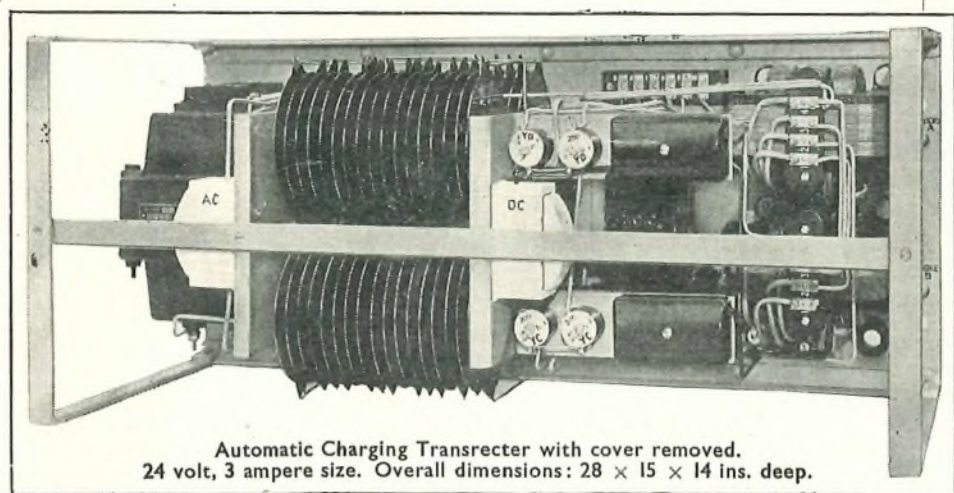

Automatic Charging Transrecter with cover removed.
24 volt, 3 ampere size. Overall dimensions: 28 × 15 × 14 ins. deep.

Siemens Automatic Charging Transrecter (incorporating Westinghouse Metal Rectifier), in conjunction with a suitable accumulator battery, provides the most efficient and economical method for obtaining an ABSOLUTELY RELIABLE D.C. SUPPLY FROM A.C. SUPPLY MAINS.

Current is supplied as required to meet the load conditions, the battery being automatically recharged at the proper rate to maintain it in its highest state of efficiency, and is always ready should the supply mains fail.

SIEMENS BROTHERS & CO., LIMITED
WOOLWICH, LONDON, S.E.18.

PUBLISHED BY PITMAN

A Selection of Books for P.O. Engineers and Students

TELEPHONY.

Vol. 1. MANUAL SWITCHING SYSTEMS AND LINE PLANT. By T. E. HERBERT, M.I.E.E., Superintending Engineer, P.O. Engineering Department, G.P.O., London, and W. S. Procter, A.M.I.E.E. Demy 8vo, cloth gilt, 1200 pp. Second Edition. 20/- net.
(Vol. 2. AUTOMATIC TELEPHONY, in preparation).

TELEGRAPHY.

By T. E. HERBERT, M.I.E.E. A detailed exposition of the Telegraph System of the British Post Office. Crown 8vo, cloth gilt, 1224 pp. Fifth Edition. 20/- net.

RELAYS IN AUTOMATIC TELEPHONY.

By R. W. PALMER, A.M.I.E.E. Crown 8vo, cloth gilt, 190 pp. 10/6 net.

ALTERNATING CURRENT BRIDGE METHODS.

By B. HAGUE, D.Sc.(Lond.), Ph.D., D.I.C., A.C.G.I., M.I.E.E., M.A.I.E.E., F.P.S.L. Demy 8vo, cloth gilt, 424 pp. Third Edition. 15/- net.

ACOUSTICAL ENGINEERING.

By W. WEST, B.A., A.M.I.E.E. Demy 8vo, cloth gilt, 352 pp. 15/- net.

PRIVATE AUTOMATIC BRANCH EXCHANGES.

By R. T. A. DENNISON, of the Engineer-in-Chief's Department, G.P.O., London. Crown 8vo, cloth gilt, 304 pp. 12/6 net.

PRACTICAL TELEPHONE HANDBOOK AND GUIDE TO THE TELEPHONIC EXCHANGE.

By J. POOLE, A.M.I.E.E. Crown 8vo, cloth gilt, 870 pp. Seventh Edition. 18/- net.

THE DIRECTOR SYSTEM OF AUTOMATIC TELEPHONY.

By W. E. HUDSON, B.Sc., Wh.Sc., A.C.G.I., Engineer-in-Chief's Department, G.P.O., London. Crown 8vo, cloth gilt, 166 pp. 5/- net.

THE CALL INDICATOR SYSTEM IN AUTOMATIC TELEPHONY.

By A. G. FREESTONE, of the Automatic Training School, G.P.O., London. Crown 8vo, cloth gilt, 124 pp. 6/- net.

MODERN RADIO COMMUNICATION.

By J. H. REYNER, B.Sc., A.C.G.I., D.I.C., A.M.I.E.E. Crown 8vo, cloth, 318 pp. Fourth Edition. 5/- net.

Write for details of these books, post free on request:

SIR ISAAC PITMAN & SONS, LTD., Parker Street, Kingsway, London, W.C.2

Morning Post,
September 15th, 1934.



Model No. 3a Tape Teleprinter



A MILESTONE IN TELEGRAPH HISTORY

TELEPRINTERS COMPLETELY SUPERSEDE MORSE APPARATUS IN THE CENTRAL TELEGRAPH OFFICE



Model No. 7 Page Teleprinter

The British Post Office, following their progressive policy, has been steadily replacing Morse Apparatus by Teleprinters during the last few years.

This change-over enables 100 telegrams an hour to be dealt with on each circuit as compared with 34 by the Morse System.

CREED & COMPANY, LTD.,

Telephone—
Croydon 2121

Telegraph House
CROYDON

Telex—
Croydon Telex 1082

Telephone Cables and switchboard wires

As with all other Henley Products, the manufacture of Telephone Cables, Switchboard Wires and auxiliary conductors is governed by the accumulated experience of years of specialised production.

Before delivery is made to you their behaviour in actual installation is computed as near as human ingenuity can compute it. Our Research Laboratories at Gravesend deal with the practical problems of installation as well as those of manufacture. May we be of service to you?

HENLEY



Laying-up Machines for Dry Core Cables.

W. T. HENLEY'S TELEGRAPH WORKS COMPANY, LTD.
HOLBORN VIADUCT — LONDON, E.C.1

TURNER DIFFERENTIAL MILLIAMMETERS G.P.O. No. 17 & No. 18

Meet the most exacting demands for balancing currents in multiplex telegraph circuits.

— A quality product of outstanding merit —

Also manufacturers of G.P.O. Detector No. 4, and a comprehensive line of instruments for precision electrical measurements.

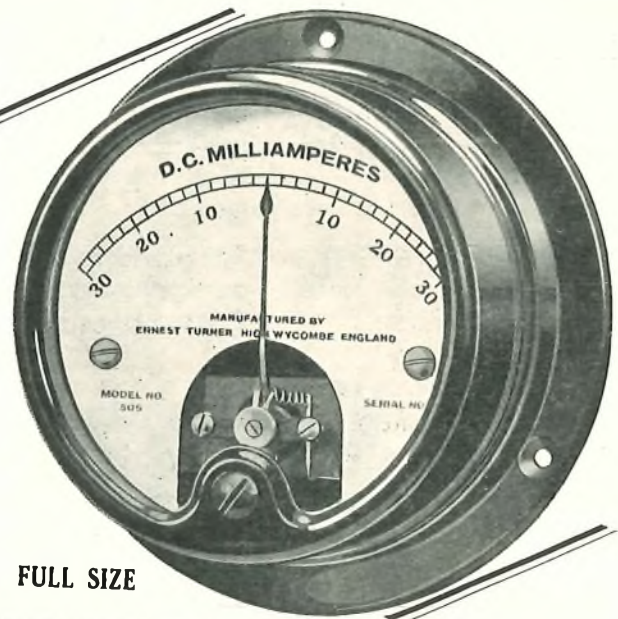

FULL SIZE

ERNEST TURNER ELECTRICAL INSTRUMENTS, Ltd.

CHILTERN WORKS,
55-73, TOTTERIDGE AVENUE,
HIGH WYCOMBE,
BUCKS, ENGLAND

Telephone : High Wycombe 301.
Telegrams : Gorgeous, High Wycombe.

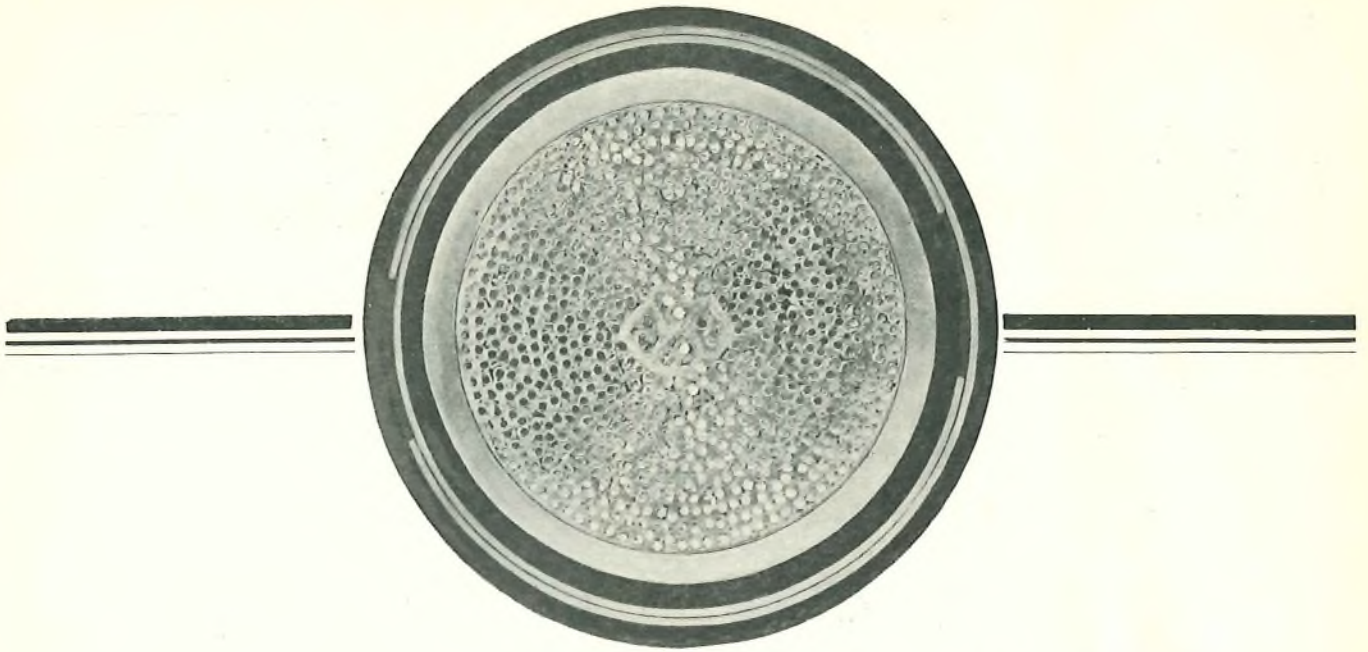

NO DELAY!

1. The Post Office ON DEMAND telephone service which has recently been introduced is proving of inestimable benefit to business men in all phases of industry.
2. Many of the additional telephone cables required in order to provide this standard of service have been manufactured by us at our North Woolwich factory.
3. The standard of service we set ourselves to give our customers for all classes of telephone cable, is a first class product, and NO DELAY.

Standard *Telephones and Cables Limited*

NORTH WOOLWICH, E. 16

Telephone : ALBERT DOCK 1401



THE POST OFFICE ELECTRICAL ENGINEERS' JOURNAL

Vol. XXVII

October, 1934

Part 3

The Autodial

W. A. COLLETT

Introduction.

NOTWITHSTANDING the very extensive telephone network and the tremendous volume of traffic carried, the telephone communications of the average subscriber are in the main limited to a comparatively small "circle" with whom his business and private interests are mostly concerned. Telephone communication with other subscribers outside this circle constitute a small proportion of the total calls made. It will be found that in a large majority of cases, the number of other subscribers with whom he is in more or less regular communication does not exceed 25, while with few exceptions 50 will cover nearly all cases. That being so, it becomes readily apparent that the process of dialling subscribers within that small "circle" can be reduced considerably, leaving subscribers outside that "circle" to be obtained by means of the normal dial.

The Autodial has been designed to meet this need. It reduces the process of gaining the attention of another subscriber, in so far as the caller is concerned, to the simple operation of selecting the name of the person required and pressing a lever. Nothing more. The Autodial is at once both a directory and a dial machine.

The Autodial is available in two sizes. The smaller, which is known as Autodial No. 1, has a capacity for 25 numbers and the larger, known as Autodial No. 2, has a capacity for 50 numbers. One number on each type is, however, reserved for test purposes, leaving 24 and 49 numbers, respectively, available to the subscriber.

The external appearance of the Autodial—Fig. 1—is a rectangular black japanned metal box, on the top of which are two labels bearing the names and telephone numbers of the subscribers obtainable. Between the two labels is a sliding pointer, which frames the name and number of the required subscriber. The names printed on the labels will be supplied by the renter and will usually be the colloquial name by which the person or firm is known. The telephone number, by the way, is required only in the case of any particular subscriber who for the

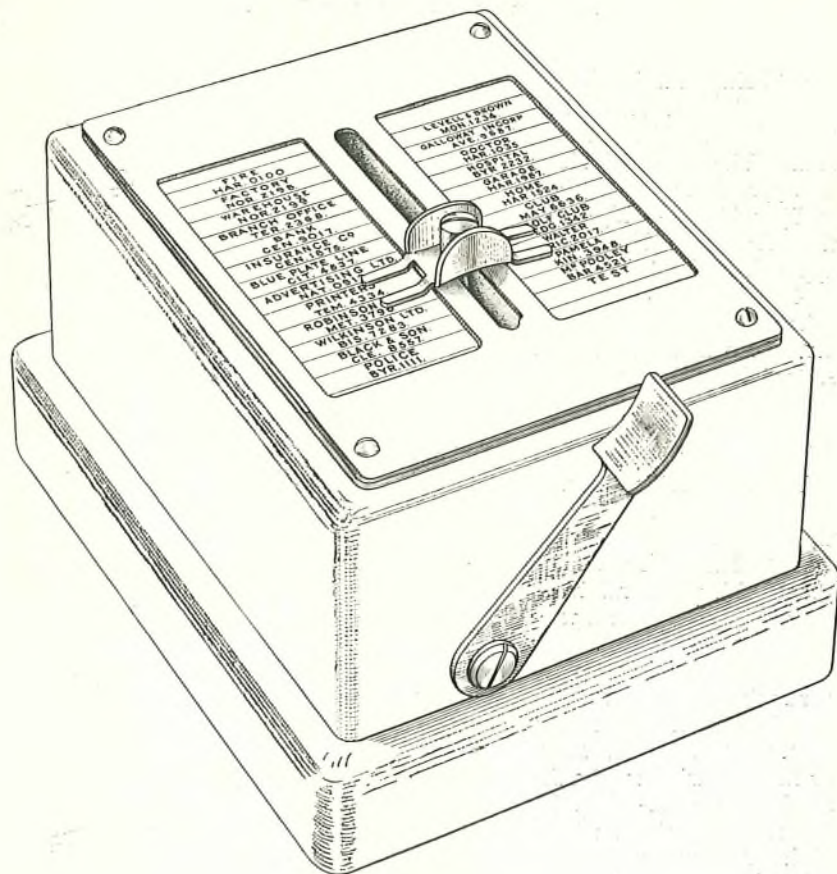

FIG. 1.—THE AUTODIAL.

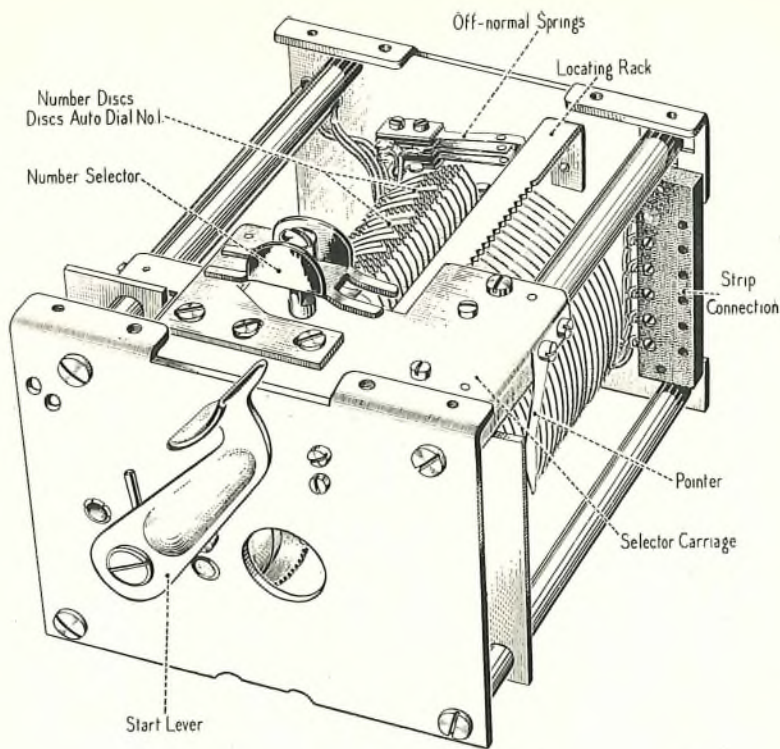

FIG. 2.—MECHANISM, VIEWED FROM FRONT.

time being might be on interception service and for the guidance of the faultsmen. The Autodial No. 1 is approximately 7" long x 5½" wide x 4" high, and the Autodial No. 2 is approximately 10" x 5½" x 4".

Two views of the complete mechanism of the Autodial are shown in Figs. 2 and 3.

The Number Discs.

The Autodial consists of a number, 25 or 50, as the case may be, of castellated discs. Each disc is prepared with what might be termed a code corresponding with the trains of impulses necessary to call a particular subscriber. The function of the disc is to control the impulses set up by the impulsing mechanism so that only the impulses necessary for the particular digits making up the called subscriber's number are transmitted to the line. The

disc may therefore be regarded as taking the place of the impulse wheel on the normal dial. The disc, however, is capable of controlling the complete number of trains of digits necessary for the various systems of automatic working, Unit Auto, Non-Director, with a maximum of seven trains for the Director System. In addition, the disc provides for the necessary inter-digit pause between each train of impulses.

The disc, which is known as Disc Autodial No. 1, is used in both Autodial No. 1 and No. 2.

The disc as issued has 120 castellations or teeth. Each castellation may be regarded as representing an impulse. In preparing the disc therefore, the object is to cut away all the teeth excepting where it is required to transmit an impulse to the line.

The disc is prepared by means of Tool Instrument No. 273 and the manner of doing so is illustrated in Fig. 4. The disc is inserted in the Tool Instrument No. 273 in the manner shown and it will be observed that the disc retaining spring is uppermost.

Commencing from the slot, the disc is rotated in a clockwise direction and the first four teeth are cut off. This is

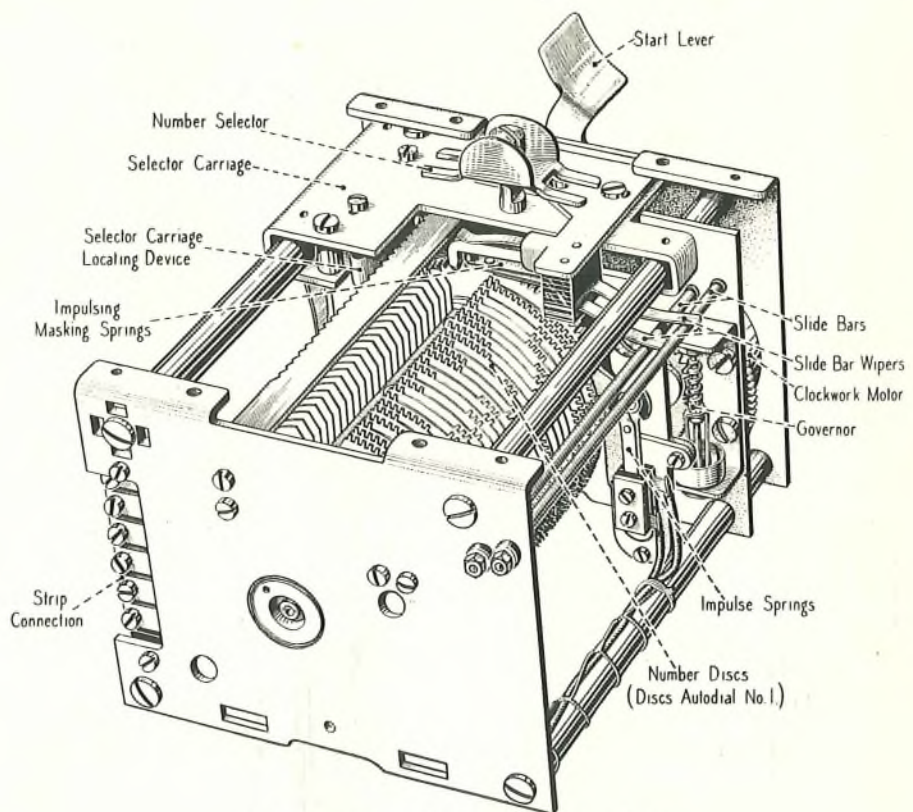

FIG. 3.—MECHANISM, VIEWED FROM REAR.

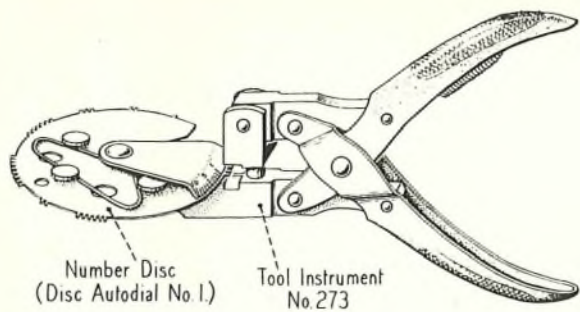

FIG. 4.—METHOD OF PREPARING THE NUMBER DISC.

necessary in all cases, irrespective of the telephone number, to ensure that the off-normal springs adequately guard against clicks throughout the range of adjustment of the impulse-masking springs.

Proceeding to cut the number, the disc is rotated until the first tooth past the cut stands opposite the number on the gauge corresponding to the last digit. If, for instance, the number NAT. 6321 is to be cut off, then the first tooth will stand against the numeral 1 on the gauge. By operating the "Tool, Instrument No. 273," eight teeth are then cut off the disc, forming an inter-digit pause of 800 milliseconds. The disc is then rotated until the first tooth past the cut stands against the numeral on the gauge corresponding to the last digit but one—in the telephone number taken as an example, this will be the numeral 2—and a second series of eight teeth are cut off forming the second inter-digit pause. The remaining digits are set up in a similar manner proceeding always from the last digit backwards in the correct order, to the first digit and an inter-digit pause of 800 milliseconds being cut out between each.

All the teeth remaining after the last digit has been cut, should be cut off. The finished disc will present the appearance of a toothed wheel having a series of sets of teeth. Each set of teeth will be separated by a space equivalent to eight teeth where the teeth have been cut off and the number of teeth in each set will be equivalent to the number of the digit it is required to dial. The illustration shows the telephone number NAT 6321 already set up and the unwanted teeth at the end being cut off.

It will be observed in practice that a short length of each tooth remains after cutting. This is in order and has been allowed for in design. It would require a much more powerful tool than Tool Instrument No. 273 to cut off the teeth clean at the base. Nevertheless, it is extremely important that the tool should cut off as much of the teeth as is possible, otherwise dialling difficulties are likely to arise.

The disc used for test purposes is prepared in the following manner. Commencing from the slot and rotating the disc in a clockwise direction cut out 10 teeth, leave 10 teeth, cut out 40 teeth, leave 10 teeth, cut out 40 teeth, leaving the remaining 10 teeth. This disc will therefore send out three trains of 10 impulses with a pause of 4 seconds between each of them.

The whole of the discs are carried on a common

spindle which is coupled through a train of reduction gears to a clockwork motor.

The Clockwork Motor and Control Mechanism.

The clockwork mechanism is controlled by means of a lever, termed the Start Lever, situated on the front of the Autodial. This lever has two functions. In the first place, depression of the lever to its fullest extent further tensions the main spring of the clockwork motor (which is already partly wound up) equal to the tension lost in driving the drum of discs one revolution.

The second function of the start lever is illustrated in Fig. 5. As the lever is depressed, it rotates an

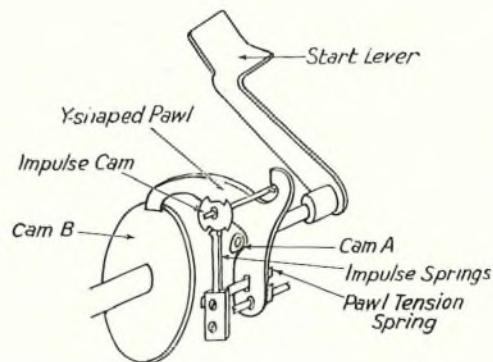

FIG. 5.—CONTROL MECHANISM.

eccentric cam A on the opposite end of the main spindle. This eccentric cam operates a Y-shaped pawl. In its normal position one arm of this pawl engages in a slot in the cam B on the drum of discs, so preventing the drum rotating. The other arm engages a pin on the impulsing cam spindle.

The purpose of this engagement is to ensure that when the drum of discs comes to rest after dialling, the impulsing cam will be definitely stopped in the position in which the impulse springs make contact. Reference to the circuit explanatory diagram, Fig. 6, will show that if this were otherwise, the line would be disconnected.

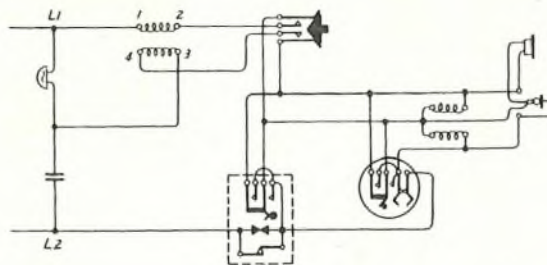

FIG. 6.—CONNEXION OF AUTODIAL WHEN USED WITH HANDMICROTELEPHONE.

The Y-shaped pawl is normally maintained in position under tension provided by a light spring mounted on the impulsing spring bank.

When the start lever is fully depressed, the eccentric cam A lifts the Y-shaped pawl clear of the

slot in cam B and upon the release of the start lever the drum of discs is free to rotate. At the same time, the other arm of the Y-shaped pawl lifts clear of the pin on the impulsing cam spindle and the impulsing cam is also free to rotate.

During the rotation of the discs, the Y-shaped pawl rides on cam B and is so kept out of engagement.

When the drum of discs has made one complete revolution, the Y-shaped pawl falls into the slot on cam B and further rotation of the discs is stopped. At the same time, the other arm of the Y-shaped pawl locks the impulsing cam.

The start lever returns to its normal position during the rotation of the discs, and must not be retarded or interfered with in any way during this return. If it be interfered with, the speed of the rotating discs is varied and the dialling impulses will be mutilated. The start lever must return to its normal position freely and unaided. The design of the start lever mechanism so that the clockwork motor is released only after the start lever has been fully depressed, obviates two difficulties. In the first place, it will be realized that the main spring of the clockwork motor must always be kept nearly fully wound up, in order to maintain a relatively constant speed. If the clockwork motor could be released after the start lever had been only partly depressed, then, as the drum of discs must make one complete revolution, the condition would arise where more tension was taken out of the main spring than was put in. Consequently after a few such operations the clockwork motor would be completely unwound, in all probability coming to rest with the drum of discs left in a position other than normal. Moreover for a number of operations before the clockwork motor had become completely unwound, the speed would have been so much reduced as seriously to mutilate the impulses and render them useless.

The second difficulty which has been obviated by the design adopted is that of over-winding. It will be appreciated that with operations each resulting in a little over-winding, the condition would eventually arise where the main spring would refuse to be wound up any more, (apart from the risk of breakage) and the mechanism would lock. Release of the mechanism could then be effected only by taking the mechanism out of the case and releasing the retaining pawl.

The speed of the Autodial is governed by a governor similar to that on the normal dial and is such that the standard impulsing speed of 10 impulses per second is maintained. The method of adjustment of the governor on the Autodial is similar to that for the governor on the normal dial, the governor springs being bent inwards to increase speed and outwards to decrease speed. One difference will be observed on inspection of the Autodial governor, that is, the governor springs are set slightly inward, whereas in the normal dial correctly adjusted for speed, the governor springs are roughly

parallel. The setting inward of the governor springs on the Autodial is in order that the inertia of the mass of discs may be more quickly overcome and correct speed reached as soon as possible.

The Impulsing Spring Assembly. Fig. 7.

A butterfly cam of insulating material continuously rotating between two contact springs is employed in this device. The butterfly cam rotates at 5 revolutions per second, providing in that time 10 complete

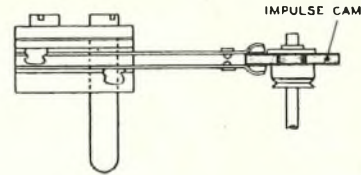

FIG. 7.—IMPULSE SPRING ASSEMBLY.

cycles of break and make of the impulse contact springs. The cutting of the butterfly cam is such as to provide the standard break to make ratio of 66 and 33 milli-secs. respectively.

The Impulse Masking Spring Assembly. Figs. 8 and 9.

The impulse masking springs are controlled by the impulse masking pawl. Tension is applied to the impulse masking pawl by the pawl tension spring.

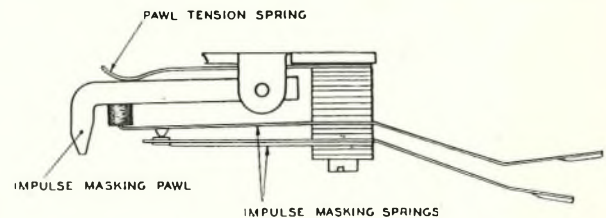

FIG. 8.—IMPULSE MASKING SPRINGS.

The impulse masking contact springs are extended in the form of wipers travelling over the wiper bars which are in turn wired in parallel with the impulsing springs. The impulse masking contact springs are

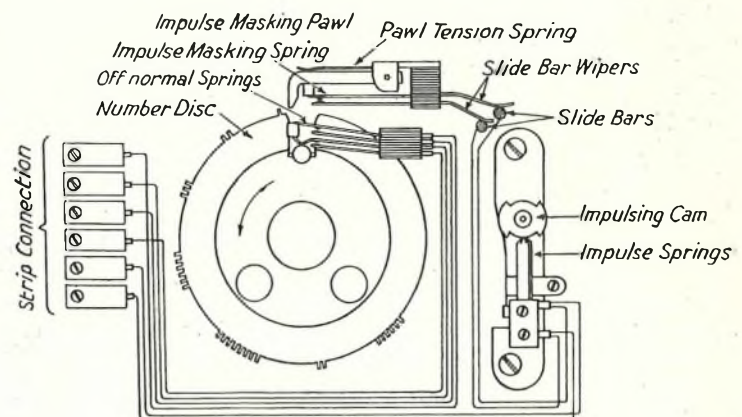

FIG. 9.—ELECTRICAL CONNEXIONS OF AUTODIAL.

normally making and they also make when those portions of the number disc where the teeth have been cut away are passing the impulse masking pawl. When the impulse masking pawl is riding on a castellation on a number disc, the contact springs are opened and the phase relationship between these springs and the impulsing springs is arranged so that the latter are open at the same time. By the special shaping of the impulse masking pawl, it is arranged that, when a slot between two consecutive castellations on a number disc forming part of a digit train is passing the impulse masking pawl, although the pawl, in following the contour of the discs, reduces the clearance between the contact springs, they do not make contact.

It will be seen, therefore, that the impulse masking springs short-circuit the impulsing springs at all times excepting during the digit trains as set up on the particular disc selected.

The impulse masking spring assembly is carried on a bracket secured to the number selector.

Provision is made in the method of securing the impulse masking spring assembly to the number selector to provide for adjustment to ensure the correct phase relationship between the impulsing springs and the masking springs previously referred to. Referring to Fig. 10, it will be seen that the

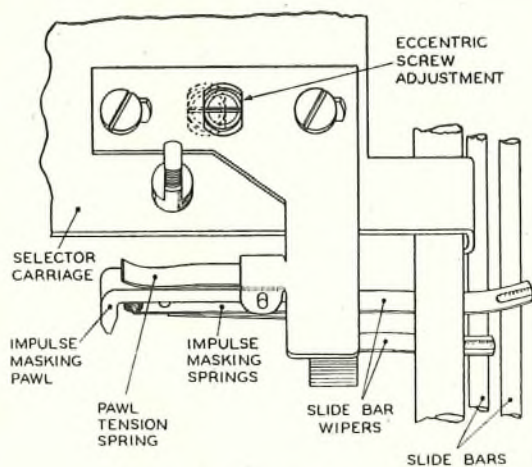

FIG. 10.—NUMBER SELECTOR.

bracket carrying the impulse masking spring assembly is secured to the number carriage by two screws through drawn holes. By slacking off the fixing screws and rotating the eccentric screw, the position of the bracket can be varied. This varies the position of the impulse masking pawl in relation to the castellations on the number disc.

When in correct adjustment, the masking springs should break during the closure of the impulse springs prior to the first break of the digit train and remake during the closure of the impulsing springs immediately after the last break of the digit train.

The Number Selector.

The number selector is illustrated in Fig. 10. It takes the form of a sliding carriage which may be

moved longitudinally over the drum of number discs. The number selector carries on its upper side a pointer which frames the name of the wanted subscriber on the label on the top of the Autodial.

Also, as previously described, on this carriage is fitted the impulse masking spring assembly. By moving the pointer on top of the Autodial to the name of the called subscriber, the impulse masking spring assembly is positioned over the corresponding number disc.

Sliding Carriage Locating Device.

Fig. 11 illustrates the method whereby it is ensured that the number carriage will not stay in an inter-

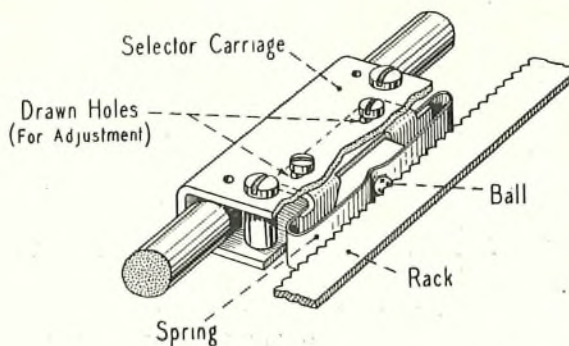

FIG. 11.—SLIDING CARRIAGE LOCATING DEVICE.

mediate position between two discs. A steel ball is held in tension against a rack by means of a flat steel spring. The steel spring should be tensioned sufficiently to ensure that the sliding carriage will not stay in an intermediate position, but not so heavily tensioned as to make movement of the pointer too stiff.

The flat steel spring is mounted on a small angle bracket which, being secured to the sliding carriage by two screws through drawn holes, provides a means of adjustment of the sliding carriage in relation to the rack.

Off-normal Springs Assembly. Fig. 12.

The off-normal springs serve precisely the same function as those on the normal dial. Normally they

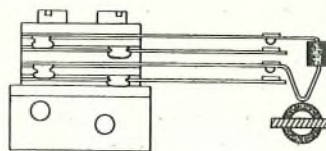

FIG. 12.—OFF-NORMAL SPRING ASSEMBLY.

are resting on an ebonite collet forced on to the end of the number disc locating bar. They operate immediately the Autodial moves off normal and remain operated until the Autodial again comes to rest.

Seven-Digit A.C. Keysending

M. G. HOLMES, B.Sc. (Hons.), A.M.I.E.E., and
P. J. SARD, A.M.I.E.E.

Introduction.

S EVEN-DIGIT A.C. Keysending is a development of the Four-Digit Keysending scheme which has been described in previous articles in the Journal and is a further step in the elimination of the B-operator in the setting up of exchange connexions in the London telephone network. Since the introduction of automatic working, the Tandem exchange has been the only routing centre for indirectly routed traffic originated at manual exchanges to other exchanges in the 10-mile ring. Under the Semi-mechanical Tandem routing scheme, the A-operator at the manual exchange orders the call on an order-wire to the Tandem B-operator, who keys the required code and number into the sender, which then routes the call to the automatic or manual exchange required. In the Seven-Digit A.C. Keysending scheme, the control of the call is solely in the hands of the A-operator, who keys seven digits, *i.e.*, the exchange code followed by the four numerical digits, over a junction to a suitable nearby automatic exchange where the call, after being set up in a sender, is routed *via* the normal director equipment to the objective exchange. The exact routing arrangements are described later, but the essence of the scheme is that each manual exchange adopting direct seven-digit keysending utilizes a suitable automatic exchange as a routing centre for the whole of its indirectly routed traffic. 71 manual exchanges, including 22 in the 10—12½ mile ring, have been selected and 33 automatic exchanges in the 10-mile ring are to be used as routing centres for the indirect manual traffic. Each automatic exchange, in general, acts as the centre for two or three manual exchanges, as determined by the junction cable lay-out.

The decision to adopt this system in the London area was made for three main reasons:—

- (1) The improvement in service to be anticipated by the fact that only one operator handles the call.
- (2) The saving in operating costs by the recovery of approximately 80 Keysender B-positions in the Tandem exchange, Holborn building, by the beginning of 1935.
- (3) The fact that the recovery of the K.S.B.-positions at Tandem will free space, which by certain re-arrangements will enable the new Chancery automatic unit, which must be opened in 1936, to be accommodated in the Holborn-Tandem building and thus obviate the provision of a new site and building in that area, the cost of which would, it is estimated, not be less than £100,000.

Outline of Method of Working.

Fig. 1 illustrates the method of routing calls under seven-digit keysending conditions, Fig. 1(a) illustrating a call from a manual exchange to an automatic exchange *via* the keysending centre and mechanical Tandem, and Fig. 1(b) illustrating a call from one manual exchange to another manual exchange *via* the same channels.

As regards the manual-auto call, the A-operator plugs into the outgoing jack of a junction to the keysending centre; the junction relay-set causes the associated sender hunter to search for a free 7-digit sender, the V.F. hunter of which searches for and finds a free V.F. tuned relay-set. These relay-sets are used indiscriminately in conjunction with the 4-digit system and the 7-digit system, *i.e.*, the 4- and 7-digit V.F. hunter multiples are common. Pip-pip tone is given back over the junction to the A-operator, and the calling supervisory lamp darkens indicating that keying may proceed. The A-operator then depresses the start and cancel key, as in the 4-digit system, to "clean-up" the sender, and then keys the exchange code followed by the four numerical digits. The single or mixed frequencies are received on the V.F. sets and the corresponding digits are stored in the sender storage relays. On the completion of keying, the operator's keysend lamp goes out, the V.F. set having been released.

Each 7-digit sender has associated with it an A-digit selector fitted on the same rack as the A-digit selectors for automatic subscribers' traffic, thus having access to the whole of the exchange directors. The seven digits stored in the sender are transmitted as Strowger impulses to the A-digit selector and then to a free director on the particular level selected, the director pulsing out the necessary translation *via* the sender and junction relay-set to route the call from the 1st code selector (group selector type) to Tandem, through first and second Tandem selectors and the auto-auto repeater to the automatic exchange required. The four numerical digits follow and select the particular subscriber required at the automatic exchange. When the director has completed its sending, the Sender is released for further calls and the A-operator's calling supervisory lamp re-lights till the called subscriber answers, when it is again darkened till the end of the conversation.

The same operations apply for a call to a manual exchange (see Fig. 1(b)) except that when the director has sent the translated impulses, a C.C.I. repeater is picked up at Tandem and prevents the director pulsing the numerical digits until a free coder has been connected to the junction. The numerical digits are then stored in the coder until

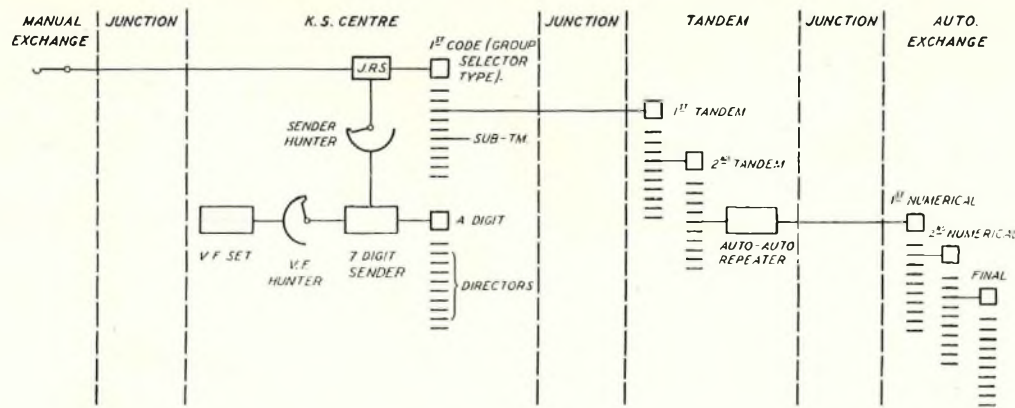

(a) Manual-Auto Call via K.S. Centre and Tandem.

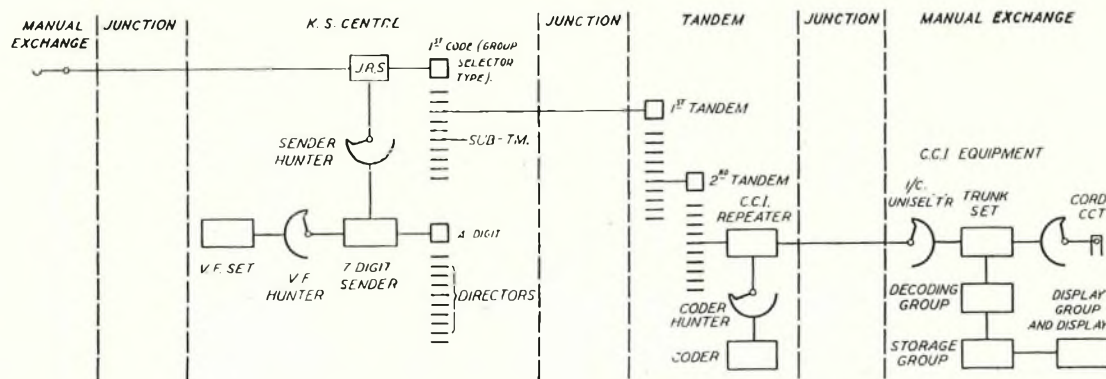

(b) Manual-Manual Call via K.S. Centre and Tandem.

FIG. 1.—METHOD OF ROUTING CALLS.

the junction to the manual exchange has found a free C.C.I. position, with its associated decoding, storage, and display relay groups, and display panel. When the required number is displayed, the operator connects it with her cord circuit and the A-operator's calling supervisory lamp remains alight until the subscriber answers.

Owing to the small quantity of common apparatus, the circuit is arranged so that the 6-12 second time pulse on the V.F. sets throws the sender out should an incomplete number of digits be set up. Pulsing to the director does not commence till all seven digits have been set up, but directly the pulsing out has commenced the sender is dependent upon the A-digit and director time pulses.

The majority of 7-digit keysending calls are routed via Tandem or Sub-Tandem exchanges after leaving the automatic keysending centre, although in a few cases certain calls may be routed over direct junctions from the keysending centre off 1st, 2nd or 3rd code selectors. In general, the outlets from the keysending 1st code levels are commoned to the outlets from the subscribers' 1st code levels, so that the 7-digit calls and subscribers' calls use the same junctions, but in certain instances, to meet transmission conditions, a higher grade of conductor to Tandem or Sub-Tandem is required for the 7-digit traffic and the keysending 1st code tandem and sub-tandem

levels have separate access to the higher grade junctions.

Development of 7-Digit Scheme through its various Stages: Preliminary Design.

Immediately the decision to adopt 7-digit keysending had been made, a considerable amount of work had to be carried out to determine the most suitable routing centres for the manual exchanges at which keysending was to be adopted. It was considered uneconomical to adopt 7-digit keysending at manual exchanges which would be converted to automatic working before the beginning of 1936 and one or two manual exchanges to be converted in 1936 were eliminated owing to the absence of suitable economic routing centres. As mentioned previously, 71 manual exchanges and 33 automatic exchanges are involved.

To determine the most suitable routing centre for the manual exchanges, it was necessary to study each case individually from the point of view of the lay-out of the junction plant to adjacent automatic exchanges, the availability of junction plant from these exchanges to Tandem and the area Sub-Tandem, and also the necessity of providing high-grade junctions to the keysending centres and also to Tandem and Sub-Tandems to meet the transmission design figure used for London connexions.

Consideration had also to be given to the number of junctions required; the calls were converted to traffic units, combined with that of other associated manual exchanges, and added to that of the key-sending centre. The total traffic thus obtained was routed on an economic basis for direct, Sub-Tandem, or Tandem routing. Fig. 2 is a diagram of the

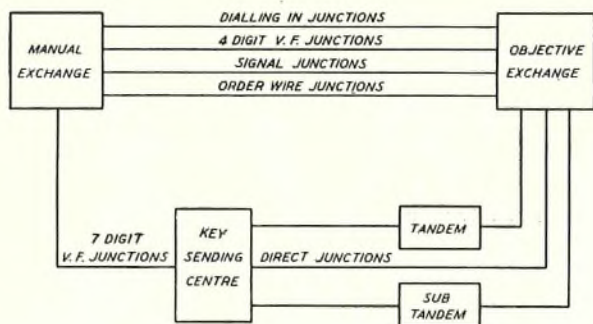

FIG. 2.—METHODS OF ROUTING MANUALLY ORIGINATED TRAFFIC.

possible routings for manually originated traffic. Locally situated automatic exchanges were not available for a number of manual exchanges situated outside the 10-mile circle and it has been decided to cater for this traffic at Holborn exchange by providing a separate group of directors, with access to the Holborn outgoing routes where transmission conditions will permit. In other cases, direct access to the outgoing Tandem network will be provided.

Line Plant Work.

The work of providing new cables, involving in some cases new ductways and manholes, loading and balancing, has been a task of no small magnitude for the external engineers in the London Engineering District, but in spite of initial difficulties in obtaining supplies of the new type of loading coil, good progress has been made and the due dates for completion of certain cables have been anticipated by several weeks. The following approximate total quantities of material have been provided, viz., 44 miles of cable ranging in size from 100-pr/40-lb. to 540-pr/20-lb.; 24,500 loading coils in 166 loading pots; 8 miles of additional duct-line. In a number of cases the loading, which has been provided to meet the 7-digit key-sending requirements, would have been necessary at a later stage for the routing of Sub-Tandem traffic upon conversion of the key-sending manual exchange to automatic working.

Design and Provision of the Automatic Equipment at Keysending Centres.

Traffic data giving the estimated quantities to be handled at each keysending centre as at 1935, and

the distribution and routing of the traffic from the keysending centre to the various exchanges in the London area, was obtained to enable the specifications for the equipment to be prepared and issued to the equipment Contractors.

Each work, which is carried out by the Contractor who originally installed the main exchange, involves the provision of junction relay-sets, sender hunters, 7-digit senders and V.F. hunters, 1st code selectors (group selector type) and A-digit selectors together with automatic routiners for junction relay-sets and senders. As regards 1st code selectors and A-digit selectors, it has been found possible in a large number of cases to utilize spare selectors existing in the exchange, the group selectors being taken from their original positions and mounted on an existing rack in proximity to the 7-digit equipment.

The senders and junction relay-sets with their associated V.F. hunters and sender hunters are mounted on standard open-type racks 10' 6" high and 4' 6" wide. Fig. 3 illustrates the junction relay-sets, senders, and 1st code selectors: it will be noticed that the senders are in two parts, one part containing the storage relays and uniselectors, and the other the control relays. To give an idea of the quantities involved, 2,400 junction relay-sets and 400 senders are being installed in 33 exchanges.

It has been necessary at a few exchanges to provide additional directors on existing racks to cover the increase of traffic quantities, and a few additional V.F. sets have also been provided by the Department, although, in general, the number originally fitted for 4-digit keysending has sufficed, the holding time being very short indeed.

During the installation of the equipment the standard automatic equipment tests such as insulation resistance, resistance of relay coils, mechanical and relay adjustments, inspection, and functional tests are carried out by the local staffs. A call-



FIG. 3.—TYPICAL EQUIPMENT AT A KEYSENDING CENTRE.

through test is made, usually during a week-end, calls being keyed from a manual exchange into the automatic exchange, every exchange and special service in the London area being covered, the usual figure of 1% or less faults being the determining factor for acceptance of the equipment. In this way every junction relay-set and every possible set-up on the senders is checked. As regards special services, it may be of interest to know that it is necessary to key up a series of four digits after the code to cause the sender to pulse into the director. The four digits are not always completely pulsed to the director as the latter will drop out on completion of the translated code digits. The set-up for Telegrams is, for example, TEL 2211. Furthermore, certain special services which are reached *via* Tandem are non-registering to automatic subscribers calling; there is therefore no reversal of the polarity of the speaking wires incoming to the repeater at Tandem when the special service operator answers and hence if 7-digit traffic were routed over the same channels, no darkening of the A-operator's calling supervisory lamp would occur. It is therefore necessary for a separate code to be allotted for special services obtained *via* the 7-digit keysending route and translated to route the traffic *via* a separate level in Tandem, with a repeater designed to give a reversal when the special services operator answers. The outgoing side of this repeater is tied to the outgoing side of the normal repeater. A typical case is the Foreign Telegram Enquiry 559; an automatic subscriber dials 559 and the Tandem translation is 919 and C.O.; a keysending operator will key 578 + 2211 and the Tandem translation is 618 and C.O.

Another important feature of the installation work at the automatic exchanges is the measurement of the attenuator resistances to be inserted in the junction relay-sets to maintain a uniform value of input voltage to the V.F. sets. The present method of measuring the required values is by means of a measuring set similar to a Moullin voltmeter inserted across the input terminals to the V.F. set and provided with a scale in which the voltage limits are clearly marked. The measurement is taken by sending out each frequency W-900 cycles per second, X-750, Y-600 and Z-500 in turn from the manual exchange, inserting an adjustable resistance box between the "pad" terminals and choosing a resistance value which will maintain the voltage within the proper limits for all four frequencies. The output level at the manual exchange is calculated to be 7.5 db. above 1 milliwatt through 600 ohms and the input level to the V.F. sets should be between 5 and 8 db. below 1 milliwatt through 600 ohms. On certain routes, in which, owing to loading, the calculated decibel loss is very low, it is not possible to maintain the voltage limits for all four frequencies with a series "pad" and it becomes necessary to insert three-element or "T-pads." A 2 μ F condenser is fitted in series with the shunt resistance to obviate shunting of the D and I relays in the junction relay-set.

Re-arrangements at Keysending Centres.

Owing to the combination of 7-digit traffic from

the manual exchanges with the traffic originated by the automatic subscribers, it has been necessary at certain keysending centres to re-arrange a number of levels to give a more economical use of code selectors under the new conditions and, in addition, the augmenting of the routes to Tandem and Sub-Tandem has entailed the regrading of those levels, throwing a large quantity of work upon the local staff before the introduction of keysending at the particular exchange concerned. The new codes for special services mentioned in the previous portion of this article have also had to be brought out on the directors.

Re-arrangements and Additional Equipment at Main Tandem Exchange.

A very considerable amount of work has been done and is still being done at Main Tandem Exchange in order to meet the new conditions introduced by 7-digit keysending. The augmentation of the incoming routes from the automatic keysending centres, together with the provision, in certain cases for transmission reasons, of a separate high-grade route to Tandem, has entailed an increase in the number of 1st and 2nd tandem selectors to carry the traffic through the purely automatic side of Tandem. Before the inception of 7-digit keysending, 2,880 1st tandem selectors, including 110 just fitted on spare shelves, existed and 2,500 were in use. It is estimated that by the middle of 1935 when the scheme, it is hoped, will be fully completed, approximately 3,500 1st tandem selectors will be required to carry all traffic including 7-digit traffic.

As the initial routes were thrown over to 7-digit keysending, a number of keysender B-positions with their associated 1st code (group type) selectors were thrown spare. In order to utilize these selectors as 1st tandem selectors, it was necessary for the outlets, which were incorporated in the portion of the grading proper to 2nd code selectors, to be regraded so as to be included in the portion proper to 2nd tandem selectors. Code selector boards U/V and W/X which have 480 selectors equipped were thrown spare of junctions, and each level was regraded so that the outlets from the shelf multiples were connected to 2nd tandem selectors of which 250 new selectors had been fitted on existing racks at the same time as the 110 1st tandem selectors were added. Similarly 2nd code selectors thrown spare from this regrading were picked up for use as 2nd tandem selectors and the 100 levels so treated were regraded in approximately two months, a task of no small magnitude. Concurrently with this work, the larger outgoing junction groups which consist of two portions, *i.e.*, one portion from tandem selectors and the other portion from code selectors, have had to be altered so that the tandem selector portion has been increased and the code selector portion correspondingly reduced, to cater for the transfer of incoming traffic from the Keysender B (code switch) side of Tandem to the Automatic (tandem switch) side of Tandem. Further alterations in this direction will have to be made as the number of 7-digit keysending exchanges increases, and further regrading of code selectors to become tandem selectors will also be necessary as



FIG. 4.—TANDEM SWITCHROOM, 1927.

they are thrown spare by the closing of keysender B-positions.

It may be mentioned here that additional 3rd stage selectors are being installed on the third floor of the Holborn Building so that levels may be available for new automatic exchanges to be opened up to the year 1940. At this date, the Tandem equipment will be dealing almost wholly with traffic originating from automatic exchanges, the number of keysender B-positions remaining being well below ten.

One effect of the transfer of the originated manual traffic from the keysender B-positions to the 1st tandem selectors is that calls to manual exchanges must now be handled by C.C.I. repeaters and coders at Tandem, whereas previously the senders associated with the K.S. B-positions pulsed out the C.C.I. impulses to the manual exchange. Although the number of manual exchanges is decreasing gradually year by year, it has been found necessary to install an additional 600 C.C.I. repeaters and associated coder hunters, and 35 additional coders to cater for this transfer of traffic. The 600 C.C.I. repeaters have been installed by the London District engineers, 60 on an existing rack and 540 on 6 racks thrown spare by the recovery of keysender B-positions and their associated junction relay-sets and position apparatus. The coder hunters have been installed by the Contractors, and as regards coders 24 have been released from Monument exchange and have been fitted on an existing rack, whilst the balance of 11 are being

obtained from spares at Holborn exchange.

Owing to the necessity for opening Chancery automatic exchange early in 1936, the equipment Contractors are scheduled to start operations early in 1935, the Office of Works building re-arrangements commencing early in August this year. Fig. 4 indicates the Tandem switchroom as it existed originally and Fig. 5 as it will exist when Chancery exchange has been installed. It will be seen that the information desk and four suites of K.S.B-positions will have been recovered, leaving Holborn and Chancery A-positions, 3 K.S. B-positions for Holborn and Chancery, and 33 Keysender B-positions for Tandem. It was not possible to free enough positions from 7-digit keysending transfers to clear the whole of the space for welfare accommodation by August 1st, hence it has been necessary to shift 51 K.S.B-positions to the

Holborn end of the switchroom, *i.e.*, 3 suites of 18 less 3 Holborn K.S.B-positions, to cover the traffic requirements at this date. The suite nearest the welfare portion will be recovered when further 7-digit routes are introduced, in time for the installation of the A-positions shown on Fig. 5, and further positions on the other two suites will become spare by 7-digit or manual to automatic conversions. Fig. 6 is a photograph of the Tandem switchroom towards the close of the shifting operations.

The work of shifting the 51 K.S.B-positions has

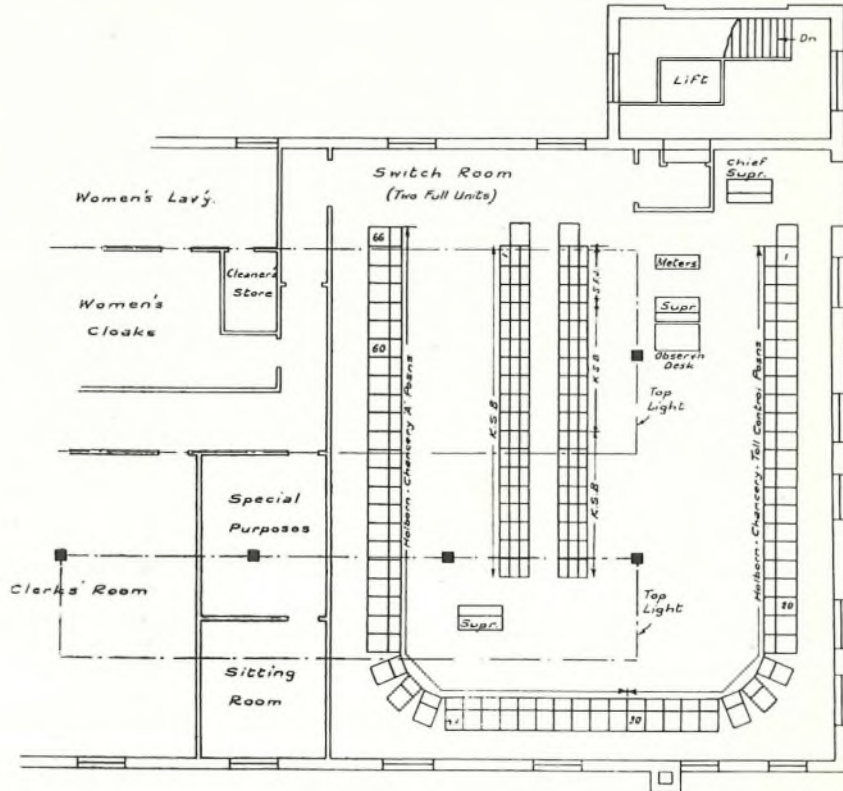

FIG. 5.—TANDEM-HOLBORN-CHANCERY SWITCHROOM, 1936.

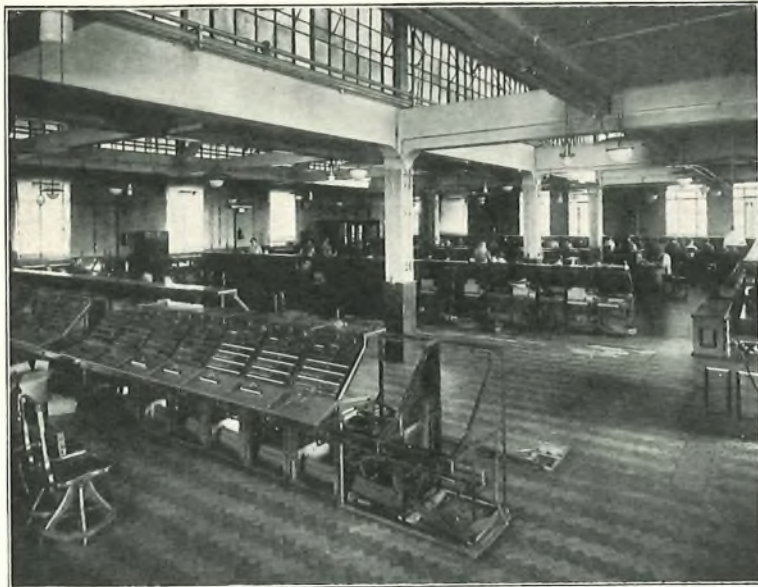

FIG. 6.—TANDEM SWITCHROOM, 1934.

been a heavy task occupying a period of five months and has entailed close co-operation throughout between the local engineering and traffic staffs in diverting junctions from one position to another to free the positions in correct order in batches of four for shifting. The positions which will remain are the high-numbered positions 108 downwards and the recovery of all the low-numbered positions will free rack space in the apparatus room which can and no doubt will be used for further extension of the Tandem automatic equipment. The reduction in positions will also enable a large number of 7-digit senders to be recovered, freeing further space.

Additions and Re-arrangements at Reliance Sub-Tandem Exchange.

At the above exchange, 600 additional Tandem selectors with associated banks have been fitted to cater for development and to take a certain amount of traffic which was originally routed *via* the Tandem keysender B-positions; a number of levels have been re-arranged and regraded to the revised requirements. In addition the Reliance Exchange-Reliance Tandem link has been regraded, as also the Reliance-Main Tandem link. Reliance Exchange is the key-sending centre for Brixton, Rodney and Sydenham, and Reliance-Tandem is a main routing centre for the following keysending centres:—Bermondsey, Tulse Hill, Beckenham, Macaulay, Liberty, Fairfield, etc.

Provision of Keysending Equipment at Manual Exchanges outside the Ten-mile Ring.

All manual exchanges inside the ten-mile ring were equipped with keysending equipment for the 4-digit scheme in 1932-33 and 22 exchanges outside this ring are being fitted with similar equipment for the 7-digit scheme. The modification of the cord circuits, provision of key-sets and installation of

the V.F. generators is being carried out by the District staff. At four of the exchanges, the V.F. generators are being driven by motors fed from the exchange battery, which is being plated to full capacity in each case, but at the remaining exchanges the motors are to be driven from the supply mains, either through a rectifier or, in the case of frequency - controlled mains, direct. Where necessary, the exchange battery capacity will be increased so that in the event of a mains failure the batteries will feed the stand-by generator for at least 12 hours during which emergency arrangements can, if necessary, be made.

Organization of Work and Cut-over of 7-Digit Routes.

A programme of this magnitude necessitates special organization and attention at the District headquarters. On the equipment side three officers, one of whom is occupied solely on 7-digit work, supervise and assist the local staffs in the testing out of the equipment and the call-through tests, confirm that everything is ready for handing over for traffic trials, watch the progress of traffic trials (for which the accepted figure for opening with public traffic is 89% O.K. calls), and assist with maintenance in the early stages. These officers report progress on the various works day by day to the engineer in charge of the group; difficulties are thus brought to light early and given special attention. Discussions are held frequently to maintain close contact with the work. Two skilled workmen are also fully employed in measuring V.F. junctions for pad values.

In addition, one officer on the equipment side and one on the trunking side deal with the equipment re-arrangements and regrading at the Main and Sub-tandem Exchanges and thus ensures continuity and co-operation in this important aspect of the work. Close touch is maintained between the engineers in the District headquarters dealing with grading and traffic routing, equipment and line plant—also the headquarters engineers in the Engineering Department. As a result of the efforts made by all staffs, local and headquarters, on this very complicated job, 30 manual exchanges working into 18 keysending centres have been put into public service between the beginning of January and the middle of May this year. Fig. 7 is a graph of the busy hour traffic handled at the Tandem keysender B-positions and shows clearly the decline in traffic from January, 1934, to the end of May, due to 7-digit keysending.

It will be of interest to note that an appreciable improvement in service has been realized. The "follow-up" observation results on calls 7-digit keysent *via* 13 automatic exchanges, available when this article was prepared, indicate that the percentage of calls completed on first demand averaged 69.7, while the corresponding percentage for calls com-

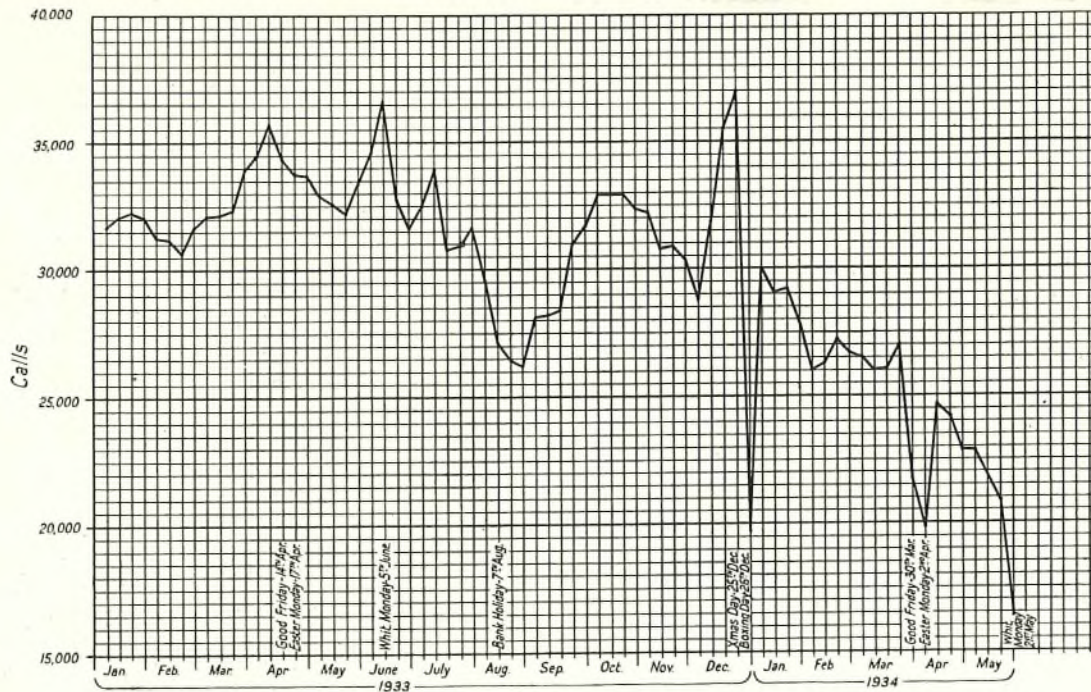

FIG. 7.—TANDEM EXCHANGE: KEYSENDER B-POSITIONS, BUSY HOUR LOAD, JAN.. 1933-MAY, 1934.

pleted via the Tandem Keysender B-positions was 66.1. It is anticipated that further improvement

will result as the A-operators at manual exchanges become more proficient in keying seven digits.

Telegraph and Telephone Plant in the United Kingdom

TELEPHONES AND WIRE MILEAGES. THE PROPERTY OF AND MAINTAINED BY THE POST OFFICE IN EACH ENGINEERING DISTRICT AS AT 30th JUNE, 1934.

Number of Telephones owned and maintained by the Post Office.	Overhead Wire Mileages.				Engineering District.	Underground Wire Mileages.			
	Telegraph.	Trunk.	Exchange*	Spare.		Telegraph.	Trunk.	Exchange*	Spare.
832,570	563	8,237	45,444	3,674	London	37,335	204,037	3,710,425	170,281
101,782	2,200	18,357	46,111	5,547	S. Eastern	4,631	58,393	370,188	60,830
116,566	3,934	37,221	72,924	5,207	S. Western	26,370	47,781	294,256	97,949
80,484	4,302	41,309	69,536	9,143	Eastern	15,475	65,465	169,654	58,315
127,585	6,218	49,318	56,590	10,004	N. Midland	9,940	166,736	337,390	124,020
102,656	3,683	30,466	64,807	5,425	S. Midland	17,062	64,384	319,428	65,596
69,860	3,161	28,683	56,632	6,347	S. Wales	6,575	54,696	166,870	43,288
139,453	4,898	28,507	59,219	9,441	N. Wales	8,867	80,622	453,212	114,675
182,426	945	9,486	26,668	7,103	S. Lancs.	8,888	122,578	667,622	82,265
117,338	5,105	24,459	39,414	9,103	N. Eastern	11,163	93,198	344,975	55,618
77,349	2,098	21,690	27,396	7,550	N. Western	4,312	46,621	252,546	57,082
59,791	1,628	14,212	22,140	7,114	Northern	3,858	52,789	190,826	33,178
29,602	3,317	11,231	12,399	894	Ireland N.	265	5,569	71,211	5,534
85,276	4,649	28,267	41,177	7,706	Scotland E.	1,230	54,978	179,307	44,454
107,099	4,404	22,937	33,258	4,727	Scotland W.	8,208	48,283	276,522	46,214
2,229,837	51,105	374,380	673,715	98,985	Totals.	164,179	1,166,130	7,804,432	1,059,299
2,202,723	54,462	388,156	665,040	84,209	Figures as at 31st March, 1934.	174,190	1,135,584	7,771,318	1,024,833

* Includes low gauge spares (i.e., wires of 20 lb. or less in cables and 40 lb. bronze on overhead routes).

Pneumatic Tube Facilities at Central Telegraph Office

J. E. MCGREGOR,
A.C.G.I., A.M.I.E.E. and
N. W. LEWIS,
B.Sc. (Eng).

VERY extensive alterations to the London pneumatic street tube system have now been completed by the conversion of the street tubes to automatic working. To appreciate the difference in working entailed the former method of handling telegrams on their arrival should perhaps be described briefly. Street tubes are used to transmit telegraph forms to and from the Central Telegraph Office and the various branch offices, cable companies' offices and newspaper offices, and radiate from the C.T.O. to these offices. There is also a small group of offices connected to a sub-centre in the War Office building connected to the C.T.O. by trunk tubes. (Incidentally a small automatic installation has been working at this War Office centre for some years and was described in the *P.O.E.E. Journal* for April, 1926. The design of the present installation has been based on the experience gained from this installation, but has been considerably improved in many respects). When a carrier was received at the C.T.O. it was withdrawn from the tube by means of a hand operated terminal in the Central Hall (Fig. 1), where the telegrams after sorting were inserted in fresh carriers and despatched to various parts of the building by means of the house tube system. From the delivery points of these tubes the messages were circulated by hand to the telegraph operators.

Under the new system the street tube carrier containing the messages is automatically transferred to a house tube extension terminating at a table in the Instrument Room, where it is automatically ejected and carried by a band conveyor to a point adjacent to the circulation table where the telegrams are sorted and delivered to the instrument tables by means of conveyors, thus cutting out much intermediate handling and many sources of delay. In the same way the outgoing messages are transmitted by conveyors to the circulation table where they are put into carriers which are inserted in the tubes through the open ends, automatically transferred to street tubes, and delivered through flap terminals at the out offices. Pneumatically operated electrically driven rotary switches have been introduced to transfer the carriers automatically from street tubes to house tube extensions and *vice versa*.

In consequence of the alterations, in addition to the saving of time and labour in handling the messages, valuable space has been released in the Central Hall while the transit time, and the time

interval between the carriers on the tubes themselves, have been reduced.

The house tube extensions are operated by centrifugal blowers instead of using the air supply from the main compressors for the street tubes, as was formerly the case, enabling a very considerable economy in power to be made.

Coming now to the actual details of the alterations it is simplest to deal first with the street tubes entering the building. These have been diverted into the old Pneumatic Container Room in the basement which has been cleared for the installation of the

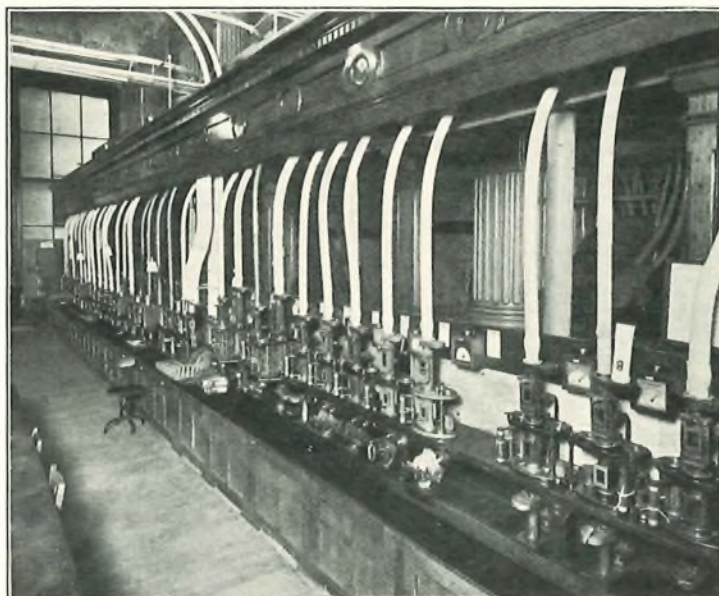

FIG. 1.—OLD TUBE TABLE, CENTRAL HALL.

pneumatic apparatus. This is erected in four banks along which run air headers for the high pressure and vacuum, and low vacuum and pressure air supplies (Fig. 2). The high pressure and vacuum headers and ducts connecting to the main compressors are of heavy cast iron, while galvanised iron is used for the low pressure and vacuum ducts and headers. "Up" carriers are brought to the C.T.O. by vacuum and delivered to the Instrument Room by low pressure, outgoing traffic being drawn to the switches by low vacuum and despatched through the street tubes under high pressure. For this purpose the main compressors deliver air at 10 to 12 lbs. pressure and $6\frac{1}{2}$ lbs. vacuum gauge while the blowers deliver the air at about 24 inches water gauge pressure and vacuum, these pressures and vacua

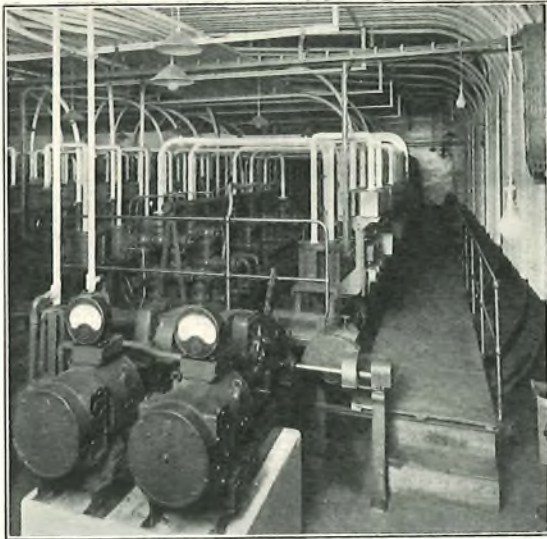

FIG. 2.—AUTOMATIC SWITCH ROOM.

being reduced as required for the shorter tubes, having regard to the required carrier velocity. The street tubes are fanned out to their respective switches which are connected to the various air supplies required and to the relative house tube extensions. The latter are collected in runs and leave the switch room by means of a gantry running up the light well to the 3rd floor which they enter through the tops of the windows, and are carried across the ceiling to the tube table (Fig. 3) where the incoming tubes are terminated in flap terminals and the outgoing tubes in bell mouths.

The transfer of the carrier from the street to the house tube is carried out by a rotary switch (Fig. 4) driven from continually revolving shafting by means of a magnetic clutch. The switch, which is mounted on an angle iron framework containing the driving gear, consists of a fixed open cylindrical frame with top and bottom plates having orifices to which the street and house tubes and the air supply pipes are connected. Inside this frame is a rotating body



FIG. 3.—NEW TUBE TABLE.

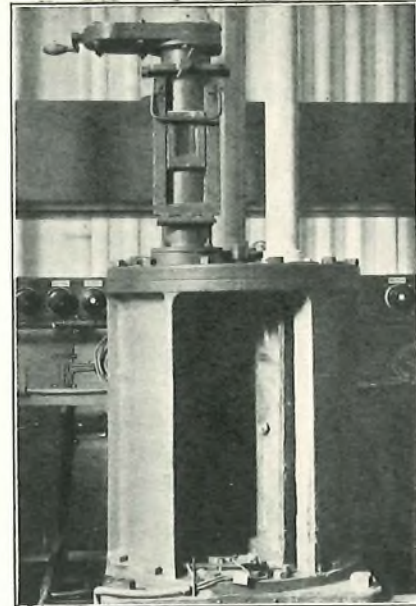

FIG. 4.—ROTARY SWITCH.

consisting of three tubular sections welded to top and bottom plates similar to those on the outside frame. Packing rings are inserted round the orifices to prevent leakage of air. The pipework connexions are shown in Fig. 5 and the electrical connexions in Fig. 6. When a carrier arrives in one of the compartments of the switch, it is held by a perforated grid covering the vacuum supply pipe. The flow of air is thus interrupted causing a considerable

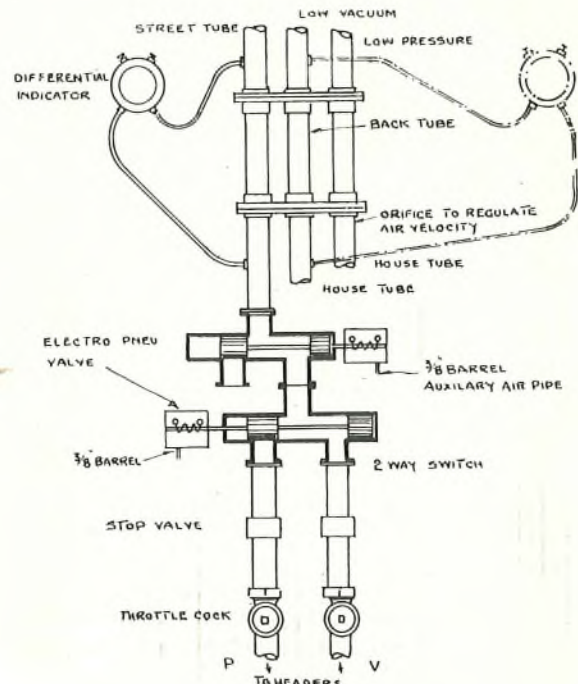

FIG. 5.—PIPEWORK CONNEXIONS OF ROTARY SWITCH.

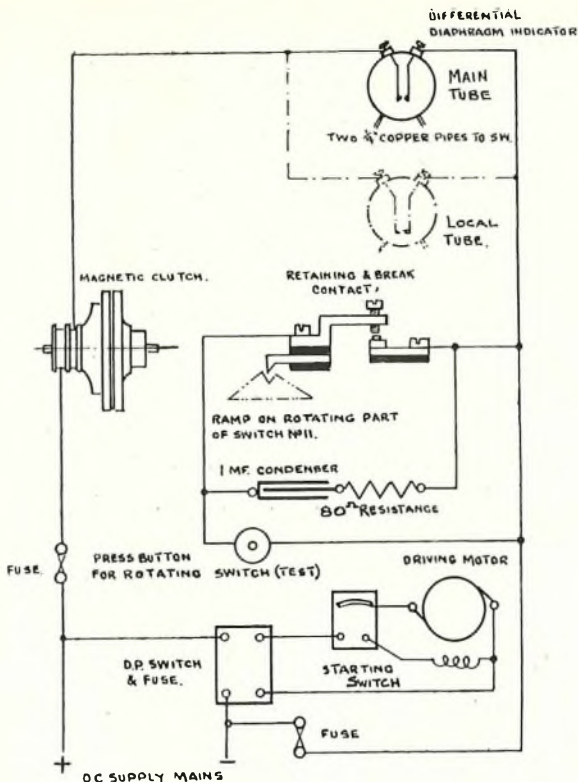

FIG. 6.—ELECTRICAL CONNEXIONS OF ROTARY SWITCH.

difference of pressure before and behind the carrier. Small pipes, led from above and below the switch, transmit these pressures to a piece of apparatus called a differential indicator consisting of a case divided into two compartments by a rubber diaphragm stiffened by aluminium discs. The movement of the diaphragm, caused by the relative change of pressure, is transmitted by an axial pin to a pair of contacts completing the magnetic clutch circuit, the clutch is energised and couples the switch to the shafting. When the switch leaves its normal position the circuit through the contacts in the differential indicator is broken and a retaining contact is therefore provided on the switch to maintain the electrical circuit. When the switch has made one third of a revolution the retaining contact is broken by means of a ramp on the rotating portion of the switch which then stops in a position where the carrier is blown out of its compartment into the house tube extension. The latter is operated by pressure, and the carrier is discharged at the tube table.

The outgoing carriers are transferred in a similar manner, being drawn to the switch by low vacuum and despatched through the street tube under pressure, and discharged through a flap terminal.

The switch always moves in the same direction, the various tubes and air supply pipes being arranged accordingly.

The supply of air to the house tube extensions is continuous, butterfly valves being provided in the various headers so that these may be isolated, or cut off at night when only a few street tubes are worked. These tubes are concentrated in one of the four banks. Quick-acting hand-operated valves are installed to isolate each switch from the main vacuum and/or pressure headers, while the air supply to working switches is controlled by electro-pneumatic switches. These are controlled by the despatch of the carrier and its arrival at the switch, or by means of signal impulses as described later. Where the tubes are worked in one direction the valves are arranged only to open and shut off the air supply, but where the tubes are worked both ways, a second valve determines whether the supply is pressure or vacuum. The valve is a form of slide valve operated by an auxiliary supply of compressed air, the admission of which is controlled by a solenoid.

The terminals for delivering the carriers, both at the C.T.O. and at the outside offices, are of the flap type in which the carrier by striking the flap opens it and is automatically ejected.

The main compressors, which are of the reciprocating pump type, electrically driven (Fig. 7) are in an adjoining room, in which the blowers of the single stage centrifugal fan type have also been installed. The blowers are also used to supply the other house tubes in the building (Fig. 8).

The shafting for the switches is driven by one of two alternative motors, the speed being gradually stepped down by gearing at various points from 1000 r.p.m. to 10 r.p.m. The drive from the motors to the shafting, and from the shafting to the magnetic clutches, is by chain, while mechanical clutches have been included to isolate the driving motors and the

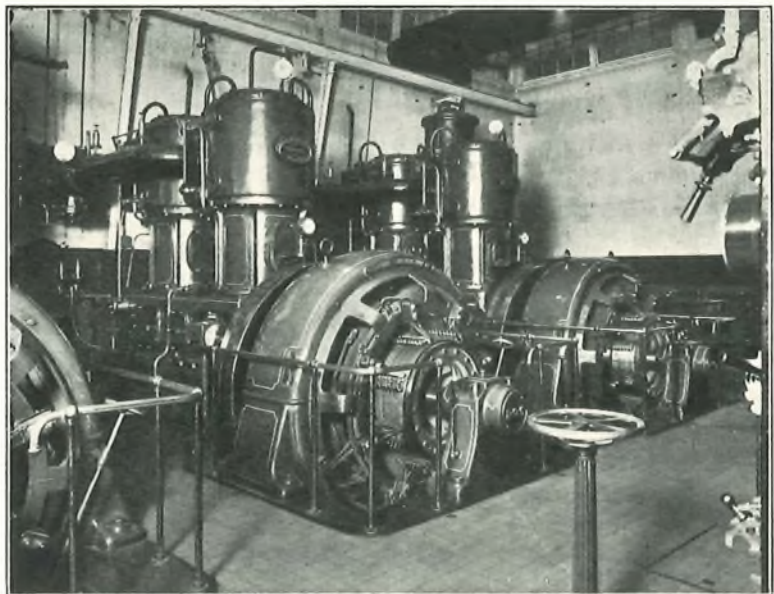

FIG. 7.—MAIN COMPRESSORS; HIGH PRESSURE AND VACUUM.

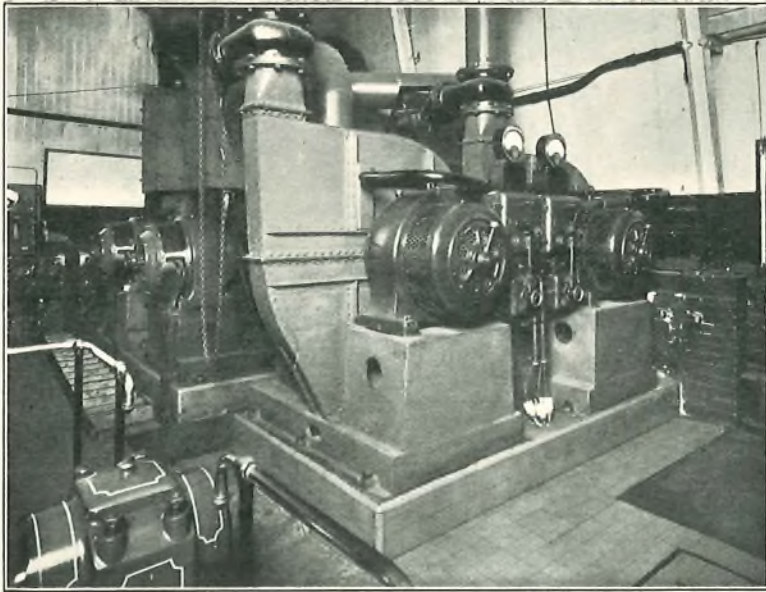

FIG. 8.—CENTRIFUGAL FANS; LOW PRESSURE AND VACUUM.

individual switches from the shafting for maintenance purposes.

In common with the mechanical side of the carrier-switching equipment the electrical side has been largely re-designed on the basis of the experience gained with the War Office installation. Briefly, the old method of announcing the despatch and arrival of carriers by means of block instruments and a code of bell signals has been replaced by a semi-automatic combined signal and control system in which use is made of apparatus of modern automatic telephone type.

The adoption of the new system has made it possible to simplify the work of the tube attendant, at the same time eliminating certain traffic delays. In the case of the both-way type of tube, for example, the control of both "pressure" and "vacuum" air services was formerly vested in the C.T.O. attendant. It was therefore necessary for an out office attendant wishing to despatch a carrier to signal a request for "vacuum" to the C.T.O. The introduction of a simple reservation facility has enabled the responsibility for the air supply to be divided equally between the C.T.O. and the out office, the former controlling the application of "pressure" and the latter the application of "vacuum." Further, the number of electrical controls required by the C.T.O. attendant has been reduced from four to one, while lamp signals enable the state of the tube as regards traffic conditions to be seen at a distance from the terminal. These two features are especially valuable during slack periods, when several tubes are operated by one attendant. Another facility which should be mentioned is that afforded by a timing device applied to the longer, more heavily loaded tubes. This allows trains of carriers to be sent with a relatively short interval between each carrier, and without the need for identification of the last carrier of each train by the operating staff.

In order to allow of speedy restoration of service in case of a fault on the signal equipment, the essential items for each tube are mounted in the form of a jacking-in relay-set, and spare relay-sets of each type are kept available. Standard uniselectors and 3000-type relays are employed throughout together with mercury-tube relays for controlling the magnetic clutches and electro-pneumatic valves from the 220-volt D.C. mains. The relay-set and differential indicators used for long and both-way tubes are illustrated in Fig. 9, which shows the control panel. The corresponding circuit arrangement is shown in schematic form in Fig. 10; relays A, P, V, PR, and VR are normally operated, but in accordance with the detached contact convention their contacts are shown in the un-operated position.

The general principles of the new system will be indicated by describing briefly the operation of this "long both-way" circuit. The electrical equipment associated with the despatching point at the C.T.O. terminal consists merely of one press-button (labelled "Send or Reserve") and three lamps coloured red, white and green. One or other of these lamps must glow while the tube is in service. The green and red signals indicate respectively that a carrier may or may not be inserted into the tube.

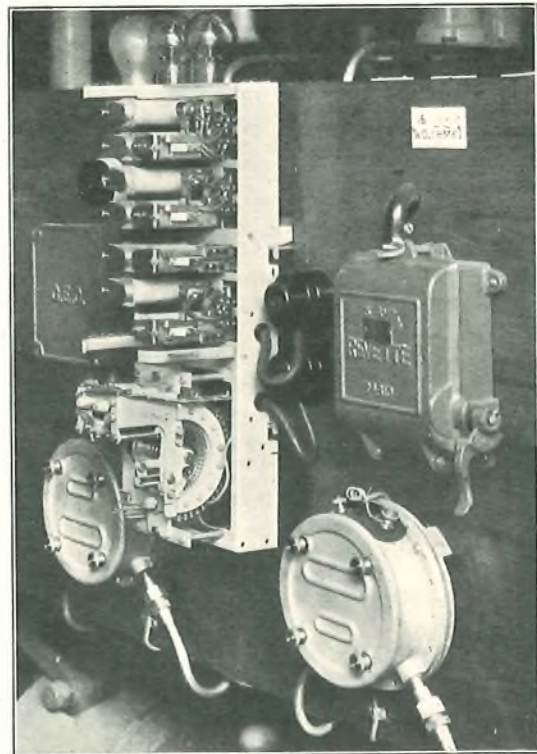

FIG. 9.—CONTROL PANEL OF A LONG BOTHWAY TUBE.

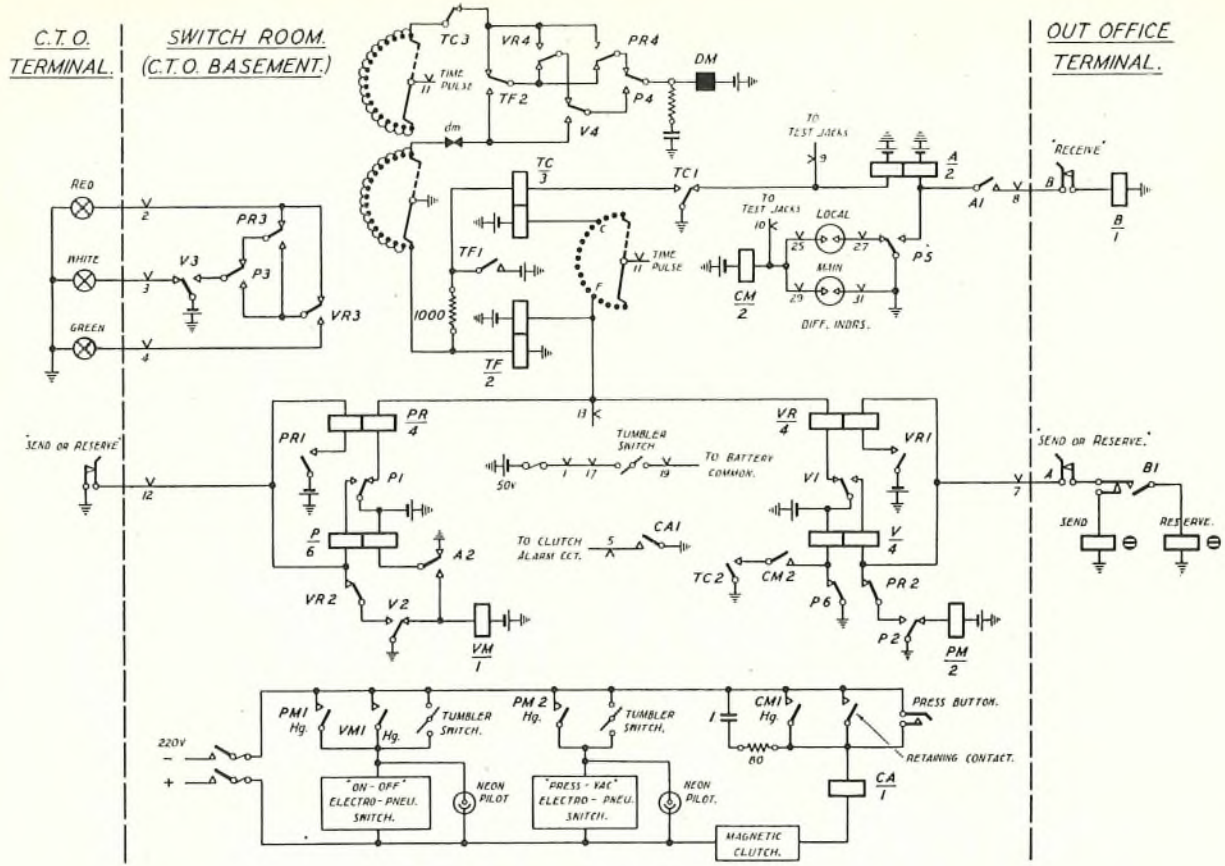

FIG. 10.—SIGNAL CIRCUIT FOR LONG BOTHWAY TUBES.

The white signal indicates that a carrier is on its way from the out office, with "vacuum" being applied to the main tube for the purpose. At the out office, a "Send or Reserve" press-button and a pair of doll's eye indicators fulfil functions similar to those of the apparatus at the C.T.O. terminal. An additional press-button is provided for acknowledging the receipt of carriers; its replacement by an automatic carrier-operated device is under consideration.

Normally, when the tube is empty of carriers, the green signal is shown at the C.T.O. To send a carrier, the attendant merely inserts it into the open end of the tube after pressing the button once. The green signal is thereby changed to red and the appropriate electro-pneumatic valves operated so as to cause "pressure" to be applied to the main tube. At the same time the uniselector is stepped off its home position and allowed to rotate at the rate of one step in 6 seconds (30 seconds in the case of a very long tube) under the control of a master clock. When the contact marked F in the diagram is reached, the green signal is restored thus indicating to the attendant that another carrier may be despatched. If traffic is waiting, the button is therefore again pressed and a second carrier inserted. The green signal is again changed to red, and the uniselector caused to "home" rapidly and then to

recommence its slow rotation under clock control. In the absence of any traffic in the opposite direction this process may be repeated indefinitely, resulting in the transmission of a train of carriers. The time required for the uniselector to travel from home to the F contact is known as the "feeding interval" and is adjusted for each tube to a value such that a maximum of from six to eight carriers may travel in the tube at a time.

If, however, no traffic is waiting, the uniselector steps on past the F contact and continues until that marked C in the diagram is reached. At this point it stops and prepares a circuit for the restoration of normal conditions, including the cutting-off of the "pressure" supply. The actual restoration signal is given by the out office "Receive" button, which is pressed by the attendant on receipt of each carrier. The C contact is selected for each tube so that its distance from the home contact corresponds to a "clearing interval" rather less than the transit time of the tube. It will be seen that the function of the uniselector is thus to render the clearing circuit ineffective until a short time before the last carrier of the train is due to arrive at the out office.

By means of the reservation feature, the attendant at either terminal is empowered to reserve the tube for the next "turn" at any time while a carrier is on its way towards him from the other terminal. For

instance, at any moment during the transmission of a train of carriers from the C.T.O., the out office attendant is able, by pressing the "Send or Reserve" button once, to maintain the red signal at the C.T.O. and so prevent the despatch of further carriers for the time being. As soon as the last of the train has arrived at the out office and been acknowledged, the attendant may take up his reservation by pressing the "Send or Reserve" button again and inserting a carrier. Similarly, the C.T.O. attendant may reserve the tube at any instant while the white signal is being shown, merely by pressing the button. It will be clear that the reservation feature ensures that the tube is worked on a strictly "carrier-for-carrier" basis during periods of heavy traffic in both directions.

Full attention has been paid to the question of the provision of adequate testing and alarm facilities. The miscellaneous apparatus rack (Fig. 11) includes a field of break jacks for the line and relay circuits, two test panels for testing relay-sets either separately or *in situ*, and a voltmeter test set for diagnosing line and apparatus faults. A delayed alarm, functioning on the S- and Z-pulse principle familiar in the "forced release" circuits of automatic telephone practice, is provided for drawing the attention of the maintenance staff after a few seconds to any rotary switch which becomes jammed by a damaged carrier or allowed to rotate continuously by a faulty differential indicator. In addition to giving visible and audible warning, the alarm throws the tube out of service by cutting off the air supply and disconnecting the signals at both ends.

For the rapid exchange of operating data and instructions, a telephone order wire system is provided. This consists of a central switchboard located near the C.T.O. terminals, with lines radiating to the out offices at each of which a hand-micro-telephone is installed. Owing to the importance of the signal line associated with each both-way tube, a special key is included in the equipment at the out office for crossing over the signal line and order wire

in the event of a fault on the former. This key may be thrown by the tube attendant in co-operation with the C.T.O. maintenance officer and so enable service

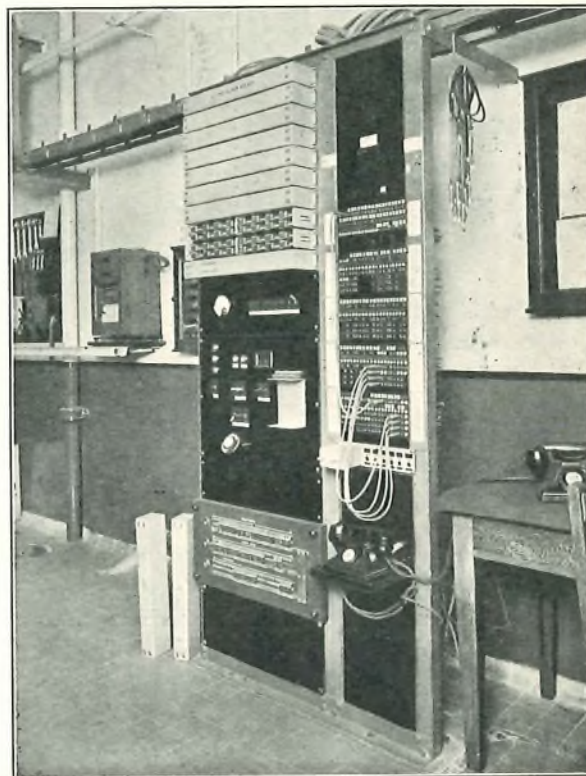

FIG. 11.—MISCELLANEOUS APPARATUS RACK.

to be promptly restored. A further emergency facility is, however, available for affording the C.T.O. attendant full control of any both-way tube in the rare case of failure of both lines.

Book Review

"Radio Receiver Measurements." By Roy M. Barnard, London. Oliffe & Sons, Ltd., 116 pp., price 4/6.

This work is described as being a concise handbook for the radio service engineer, giving up-to-date methods of receiver testing with full descriptions of commercial signal generators and their application to the adjustment of modern superheterodynes and "straight" receivers.

The above claims are fully justified and the book admirably fulfils its purpose. There is much information in this book which, although fairly well known among radio laboratory workers, has not hitherto been published in a collected and orderly arrangement and the work should therefore be a most useful reference book.

One of the most attractive features is a tabular summary at the end of the more important chapters where the various tests previously described are concisely reviewed for ready reference.

The book does not attempt to describe the design and construction of testing apparatus, but rather its applica-

tion to actual measurements. There is one point, however, where some additional information might be of advantage and help in the avoidance of errors and wrong methods. In dealing with the use of attenuators, the conditions of termination of the various types do not appear to be as clearly established as they might have been and it is suggested that this matter might be amplified when opportunity occurs.

The author has had considerable experience in the subject on which he writes with one of the leading radio engineering firms in this country, not only on broadcast receivers but also on super-sensitive and superselective commercial telephone and telegraph receivers and his views and recommendations may be accepted as authoritative.

In view of its modest price the book is excellent value and can be thoroughly recommended to all persons interested in or engaged on the measurement of performance of radio receivers.

A.J.G.

Parcel Conveyors

D. P. GILBERT

THE first conveyor to be used in the British Post Office was installed in 1902, and since that date there has been a great development in their use as a means for transporting and handling postal matter. In this article, it is proposed to give a description of the application of the latest developments in a conveyor system that has recently been installed for handling parcel mails.

Introductory.

The cost and difficulties of transporting parcels into an office for sorting, and out again for despatch by means of manual labour have been increasing for some years past. Whatever the number of parcels to be dealt with, the sorting must be completed and the parcels despatched to the various railway stations in time to be placed on board the mail trains which depart at specified times.

It has been necessary to maintain and store a large number of hand trucks, to have an ever increasing

and elastic force of porters, to maintain wide gangways throughout the sorting offices and to provide storage space on the sorting office floors, threatening to encroach, and in some cases actually encroaching upon valuable and limited sorting space, especially at Christmas time.

In the '90's, parcels were carefully packed in strong wicker baskets, some 5 ft. x 2ft. x 2 ft., provided with runners and each basket was locked and sealed with sealing wax. These baskets were dragged by porters across the floor of the sorting office to the sorters who unpacked, sorted the contents and repacked them for despatch, but owing to the increasing numbers to be dealt with, bags were substituted for the baskets, and lead seals for sealing wax. The bags were loaded on hand trucks and wheeled to a primary sorting table. To-day, the numbers dealt with are such that it has become necessary, in order to obtain the greatest saving in floor space and labour costs, to dispense with bags



FIG. 1.—LOADING PLATFORM CONVEYORS.

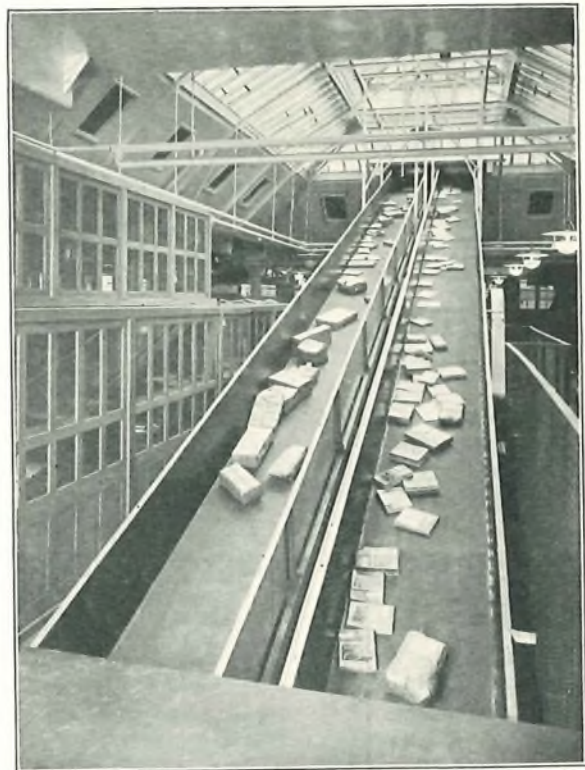
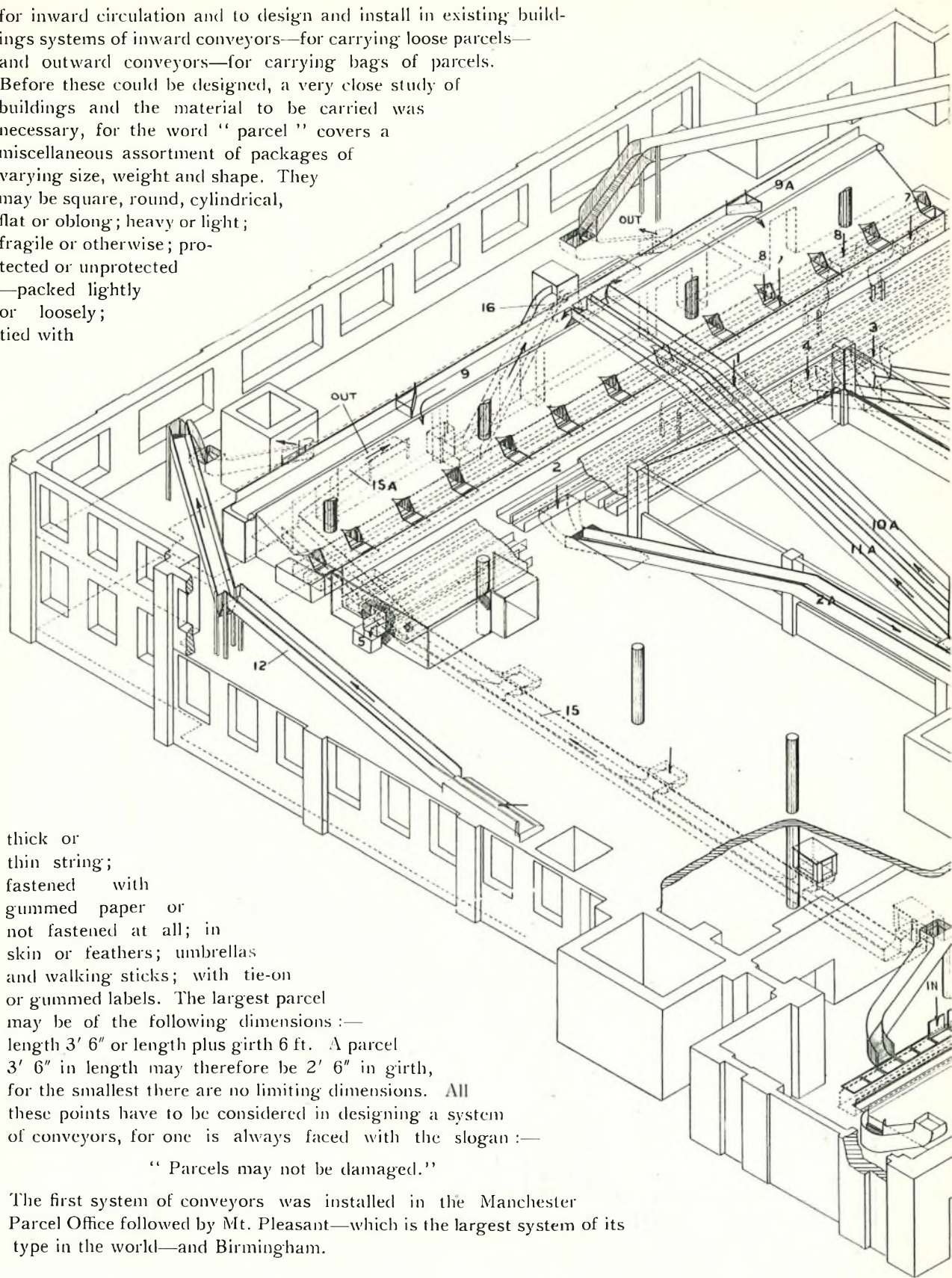

FIG. 2.—RISING CONVEYORS.

for inward circulation and to design and install in existing buildings systems of inward conveyors—for carrying loose parcels—and outward conveyors—for carrying bags of parcels. Before these could be designed, a very close study of buildings and the material to be carried was necessary, for the word “parcel” covers a miscellaneous assortment of packages of varying size, weight and shape. They may be square, round, cylindrical, flat or oblong; heavy or light; fragile or otherwise; protected or unprotected—packed lightly or loosely; tied with



thick or thin string; fastened with gummed paper or not fastened at all; in skin or feathers; umbrellas and walking sticks; with tie-on or gummed labels. The largest parcel may be of the following dimensions:—length 3' 6" or length plus girth 6 ft. A parcel 3' 6" in length may therefore be 2' 6" in girth, for the smallest there are no limiting dimensions. All these points have to be considered in designing a system of conveyors, for one is always faced with the slogan:—

“ Parcels may not be damaged.”

The first system of conveyors was installed in the Manchester Parcel Office followed by Mt. Pleasant—which is the largest system of its type in the world—and Birmingham.

FIG. 3.—LAY-OUT OF CONVEYOR SYSTEM AT

Conveyors.

The system dealt with in this article was installed in the South Eastern District Parcel Office, London, in 1933; it is the most up-to-date and efficient system installed in any Post Office to-day.

Fig. 3 shows the complete system. It will be noted that the main conveyors from the loading platform, including the glacia conveyors, are in duplicate; in this way an alternate path is provided in the event of a breakdown on any one of these conveyors. The figure also indicates the flow of parcels

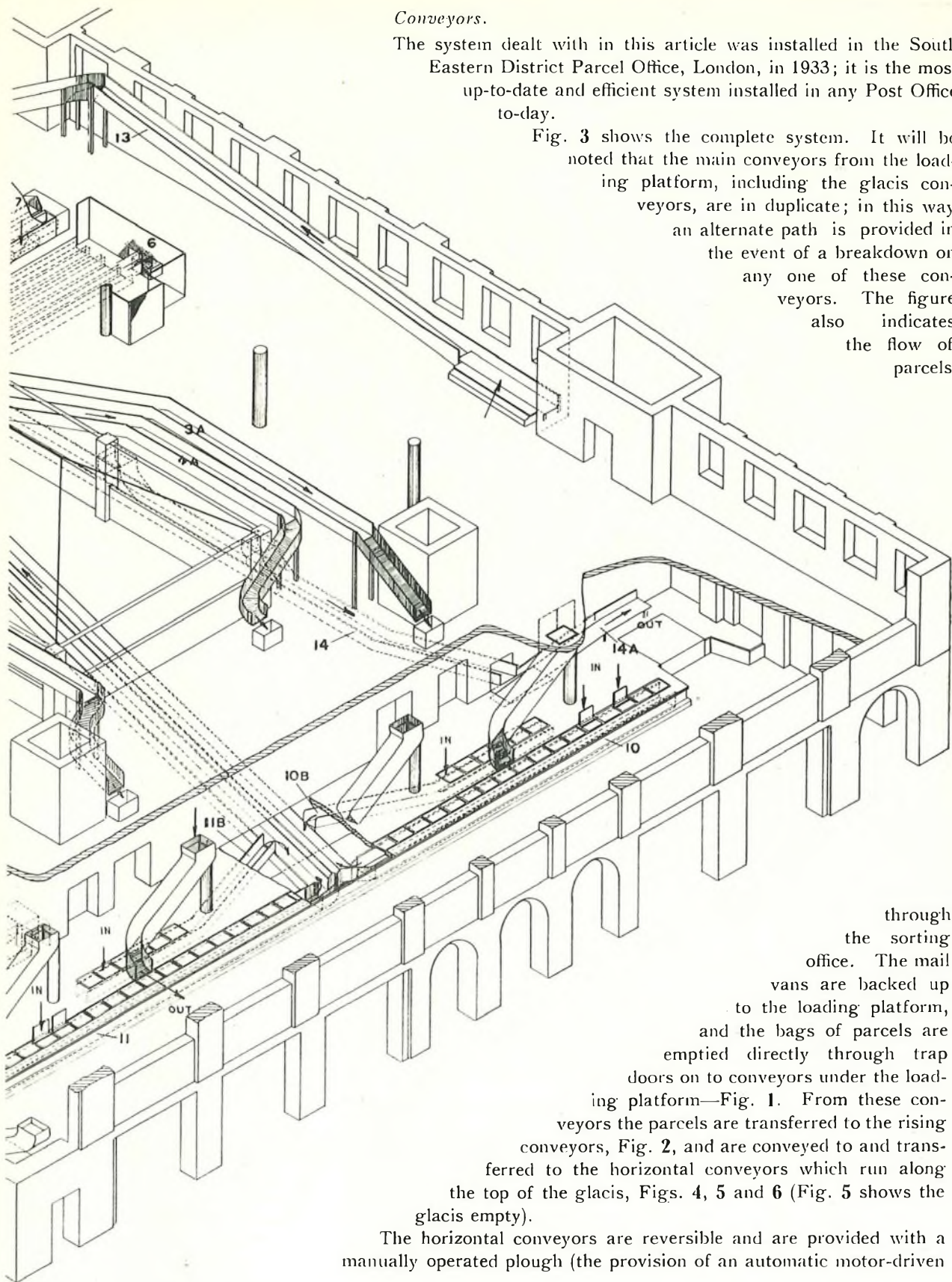

through the sorting office. The mail vans are backed up to the loading platform, and the bags of parcels are emptied directly through trap doors on to conveyors under the loading platform—Fig. 1. From these conveyors the parcels are transferred to the rising conveyors, Fig. 2, and are conveyed to and transferred to the horizontal conveyors which run along the top of the glacia, Figs. 4, 5 and 6 (Fig. 5 shows the glacia empty).

The horizontal conveyors are reversible and are provided with a manually operated plough (the provision of an automatic motor-driven



FIG. 4.—THE GLACIS.

plough is under consideration), which ploughs the parcels from the conveyor band to the glacis down which they slide to the sorters. At this point the primary sorting is carried out. The parcels are sorted into eight divisions—each division consisting of a conveyor shown in section in Fig. 7 and in Fig. 8.

The sorting fitting (Fig. 9) 122 feet in length is divided into nineteen sections, and will accommodate a maximum of 45 sorters. Each sorter has



FIG. 5.—GLACIS CONVEYOR, SHOWING PLOUGH (UPPER CENTRE).



FIG. 6.—ANOTHER VIEW OF THE GLACIS.

access to the eight conveyor bands through the medium of chutes or subsidiary conveyor bands—Fig. 7. The eight conveyor bands convey the primary sorted parcels to eight different points in the sorting office floor (Fig. 10 shows one of these points) where the secondary sorting is carried out.

After the secondary sorting has been completed and the parcels bagged, the bags are placed on the outward conveyors (Fig. 11) and are discharged through a balanced chute at the loading platform (Figs. 12 and 13) from which they are passed into the mail van.

Elevator.

A feature of the installation is the elevator, shown in Figs. 14 and 15. It is of the twin band type and will raise both loose parcels and loaded bags from floor to floor at an angle of 60°. It has a band speed of 200 feet per minute and may be used for fragile parcels without risk of damage to them. It has the great advantage of requiring less floor space than other systems and on that account is of great value for Post Office work. The elevator was recently developed and introduced by Messrs. Sovex, Ltd., Southwark,

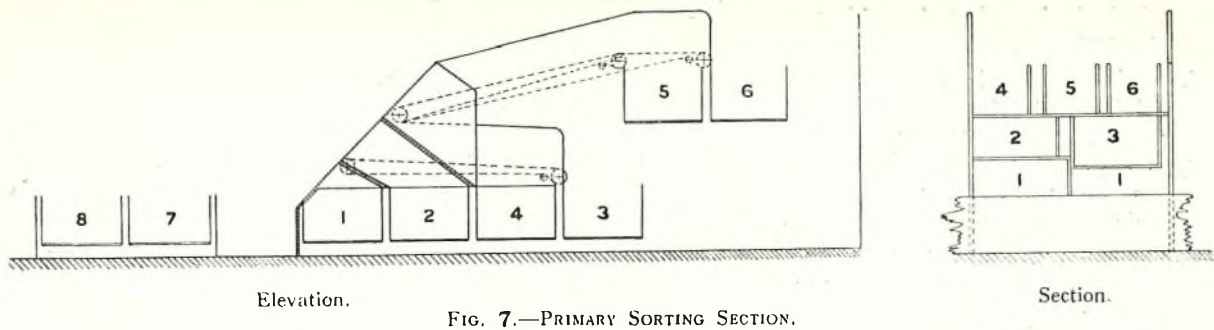

London, E.C.1, who manufactured and installed the system.

In designing conveyors, the nature of the postal matter demands careful consideration as anything in the nature of force in the handling of letters, packets, or parcels is out of the question, and only plant that will handle the matter gently and deliver it safely and without damage can be used.

The system is liberally provided with dust traps to collect dust and with shock absorbers to prevent damage to parcels. Grease-gun lubrication is provided.

Conveyor Bands.

The bands are of solid woven cotton,

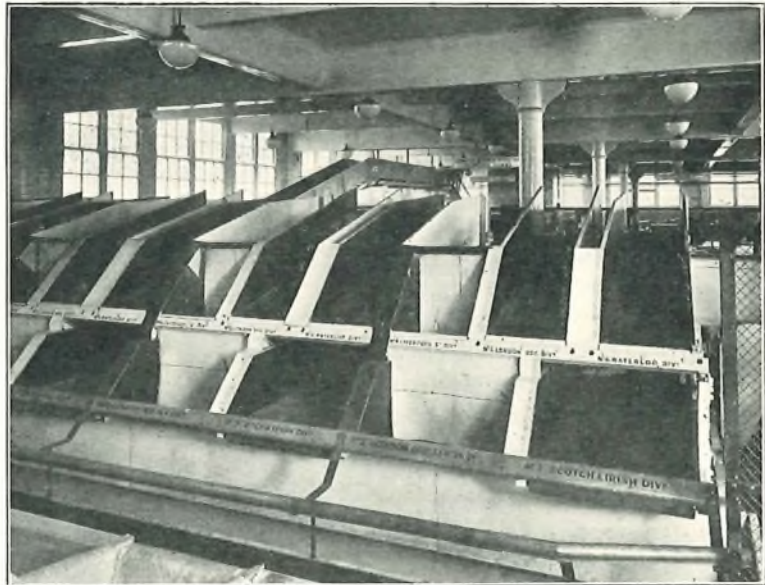

FIG. 8.—PRIMARY SORTING SECTION.

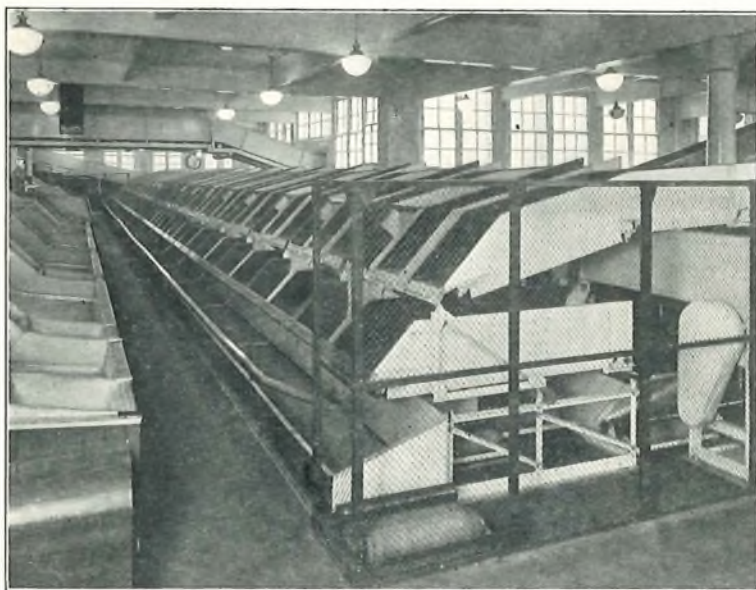

FIG. 9.—PRIMARY SORTING FITTING.

3/16" in thickness, and those on the sorting fitting are of finely woven cotton to reduce noise; they run at speeds varying from 120 to 200 feet per minute.

In any installation the conveyor bands are a most important factor and the general design should be such as to ensure for them a long life. Some points for consideration in this connexion are :—

The nature of the material to be carried.

The number of feed points for any particular conveyor should be arranged in order to avoid surface wear on the band.

The number of reverse bends to

which the band is to be subjected should be as few as possible.

The diameter of the rollers. Both driving and driven rollers should be of generous dimensions.

The amount of tension should be only sufficient to provide adequate driving effort.

The relation between the load to be carried per foot run and the width of the band.

The bands should be of ample thickness.

Conveyor bands generally work under severe conditions and are the most expensive item for renewal; it is most economical to employ bands of the finest quality.

In regard to the rising bands and for conveying generally it is not desirable to have a band too inclined. If the incline is steep the parcels slide back on themselves abrading the band and reducing its life. The maximum permissible incline varies from 12° to 26° according to the size and shape of the material to be conveyed; 18° is regarded as the critical angle for parcel work, but some parcels tied with string are liable to slide back even at this angle.

The bands are jointed by means of "Alligator" steel belt fasteners. These are easily fixed and hold well under very heavy loads and are suitable for both light and heavy drives.

Power Plant.

There are 17 motors totalling 95 H.P. Each motor is provided with a remote control heavy duty starter, the controls being interlocked in such a manner that a failure of one conveyor or section of a conveyor cannot cause damage to other conveyors through overloading. Further the control and motor circuits are interlocked in such a manner that it is impossible to leave the controller in the "on position" if the motor supply has failed from any cause.

Signalling.

A system of signalling by means of lamps has been installed in order to regulate the loading of the conveyors. No light means cease loading.

Conclusion.

In conclusion, it is desired to say a few words as to the usefulness of the conveyor system. It will be obvious that it saves an immense amount of manual

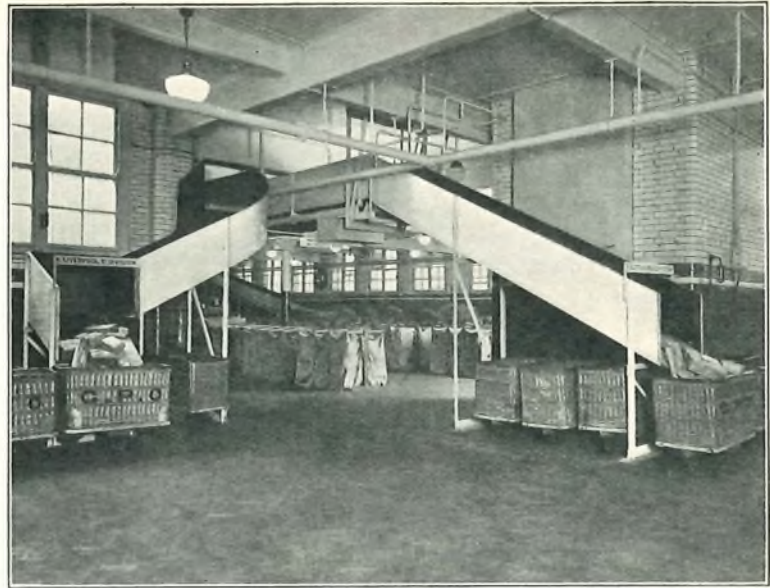

FIG. 10.—PRIMARY SORTING CONVEYOR
TERMINAL POINT.

labour, a type of labour, too, which in this enlightened age it is desirable to reduce as far as possible. The drudgery of porters' work in dragging or handling heavy bags of parcels has been released

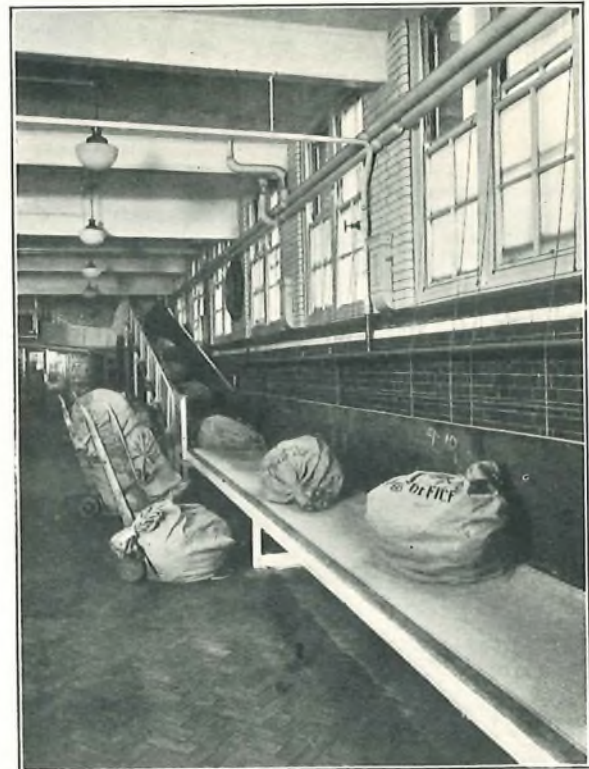

FIG. 11.—OUTWARD CONVEYOR.

of the greater part of its burden by the machine and may, as increasing experience and further development takes place, be done away with altogether. But there are other and equally important benefits which the Post Office derives from using conveyors. For one thing, they save a good deal of floor space as they usually run either overhead or underneath the floor and, in addition, they reduce the amount of traffic, such as the wheeling of basket trolleys and trucks, across the office and eliminate traffic congestion which at very busy periods may sometimes occur. Supervision is also facilitated. But the most important advantage is probably the reduction of the time lag between receipt of the parcel bags at the inward loading platform and the delivery of the parcels at the primary sorting position as well as in the subsequent movements to their final despatch. The conveyors reduce this time very greatly and, moreover, ensure an even and smooth flow of work from stage to stage. This

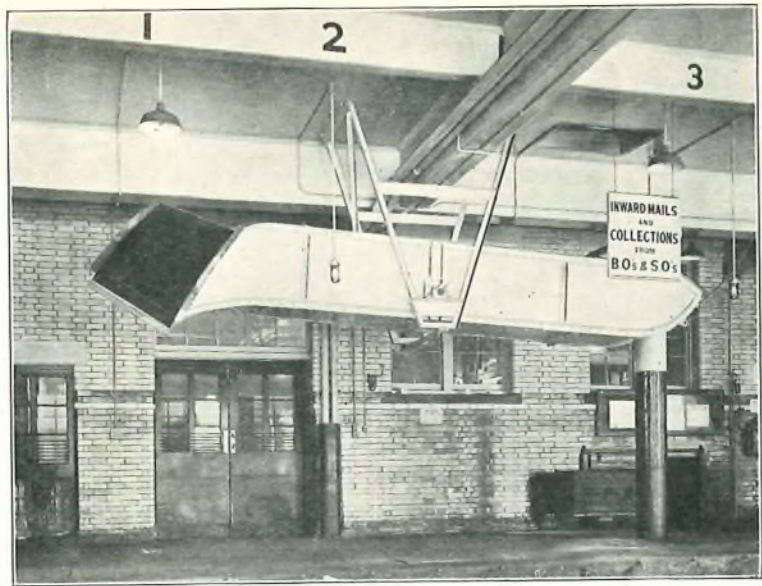

FIG. 12.—BALANCED CHUTE.

regularity of treatment enables a rhythmic movement to be given to the parcel sorting and ensures a steady and even output per man. Peak loads, whether daily



FIG. 13.—LOADING PLATFORM.



FIG. 14.—ELEVATOR.

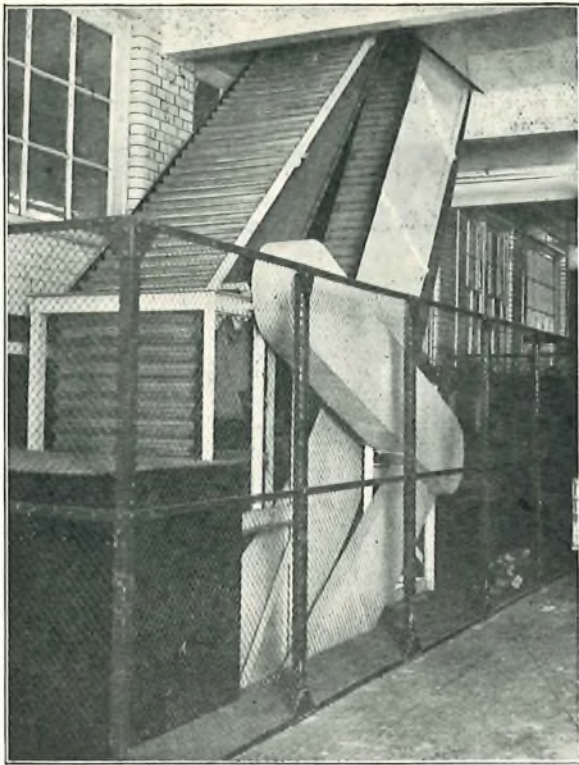

FIG. 15.—ELEVATOR.

or seasonal, all bow to the unrelenting efficiency of the organization and the machine.

The schedule reproduced below gives details of the various individual conveyors used in the system; the conveyor numbers are the same as those used in the isometric view of the lay-out shown in Fig. 3. Some conception of the volume of material which is handled smoothly and efficiently by this conveyor system may be gained from the details given in the schedule of the loading and lengths of the various conveyors. All this movement of material has been regularized and accelerated to the advantage of the staff responsible for the handling and sorting of that bewildering variety of packages which comprises the Parcel Post. The material saving in floor space resulting from the considerable reduction in the amount of wheeled traffic on the floor of the sorting office and the unobtrusive location of the various conveyors will be apparent from the photographs.

The introduction of mechanical conveyors in the sorting of parcel mails has reduced the amount of physical labour involved in the operation, with a consequent increase in the efficiency of the system to the advantage of the service rendered to the Public.

SCHEDULE OF DETAILS.
SOUTH EASTERN PARCEL OFFICE.

Conveyor No.	From	To	Remarks.	Width of Band or Chute.	Length Approx. feet.	Speed ft. per min.	Load in Lb.	
							Max.	Average.
1	Primary Sorting Position.	Secondary Sorting Position.	Via Chute to Ground Floor	2' 6"	145	200	2000	1200
2	" " "	" " "	First Floor	2' 6"	123	"	"	"
2A	" " "	" " "	" " "	3' 0"	100	"	"	"
3	" " "	" " "	" " "	2' 6"	123	"	"	"
3A	" " "	" " "	" " "	3' 0"	95	"	"	"
4	" " "	" " "	" " "	2' 6"	123	"	"	"
4A	" " "	" " "	" " "	3' 0"	90	"	"	"
5	" " "	" " "	" " "	2' 6"	123	"	"	"
6	" " "	" " "	" " "	2' 6"	123	"	"	"
7	" " "	" " "	Via Chute to Ground Floor	2' 6"	123	"	1600	"
8	" " "	" " "	" " "	2' 6"	123	"	1600	"
9	From 11A Conveyor Position.	Glacis	" " "	3' 0"	60	120	900	600
9A	From 10A Conveyor Position.	10A	" " "	3' 0"	65	120	900	600
10	Loading Platform	10A	1st Floor	3' 0"	60	200	1200	1000
10A	9A	Glacis	" " "	3' 0"	133	"	2000	1200
10B	Basement	10A	" " "	2' 0"	46	"	600	400
11	Loading Platform	11A	1st Floor	3' 0"	72	"	1200	1000
11A	9	Glacis	" " "	3' 0"	133	"	2000	1200
11B	Basement	11A	" " "	2' 0"	46	"	600	400
12	First Floor	Loading Platform	Via Chute 7	3' 0"	80	"	1600	1120
13	" " "	" " "	Via Chute 6	3' 0"	117	"	2000	1200
14	Sorting Office	" " "	" " "	3' 0"	105	200	2000	1200
14A	Loading Platform	" " "	" " "	3' 0"	27	120	600	400
15	Sorting Office	" " "	" " "	3' 0"	135	200	2200	1200
15A	Loading Platform	" " "	" " "	3' 0"	27	120	600	400
1 to 6 chutes	First Floor	" " "	" " "	3' 0"	—	—	—	—
16	Ground Floor	First Floor	Elevator	3' 0"	—	200	—	—

The London Trunk Centre

S. BIRCH

THE introduction of the Trunk Demand System with the attendant adoption of an entirely new exchange equipment has necessitated the reconstruction of practically all the Zone Centre Exchanges in Great Britain.

London was the first centre to be dealt with and the final arrangements developed for the whole country are based on experience obtained from the original installation, in London, of 66 positions from which Demand working was first introduced.¹

Work on the complete change-over to Demand equipment in London has progressed rapidly and there are at present 5 new switchrooms in use with a total of 435 positions, whilst others are in course of construction.

All the trunk switchrooms are housed in the Faraday Building, North Block (originally known as G.P.O. South, but renamed to form part of the new Faraday Building adjacent).

In addition to the Trunk exchanges, there are at present the City and Central manual exchanges in the building, but with the transfer of these two exchanges to automatic units in the new South Block the whole of the North Block will be devoted to the long distance services.

Fig. 1 shows an external view of the building which contains basement, ground floor and five upper floors. The various floors have accommodation as follows :—

Basement. Cable chambers and Power Plant.

Ground Floor. M.D.F. Line transformer racks.

Trunk and Toll Test positions.

First Floor. International exchange, Radio Telephony Terminal room and main I.D.F.

Second Floor. Central manual exchange and suite of Delay positions.

Third Floor. Inland and Main Trunk exchanges. Repeater station.

Fourth Floor. City manual exchange. Trunk Provincial exchange.

Fifth Floor. Toll manual exchange. Trunk Country exchange.

The lay-out of the floors is given in Fig. 2 and each will be considered in detail.

Basement.

The cable chamber is extensive and the cabling and ductwork entering the building are most intricate. Apart from the subscribers and junction cables serving the two manual exchanges there are some 96 junction cables with an aggregate of over 27,000 pairs serving trunk junctions, Toll junction circuits, local circuits to Toll B exchange for the extension of Toll circuits and through junctions. The main Trunk cables are fewer in number. There are 37, including the main Toll routes. The total number of pairs is approximately 5,000, but this

does not represent the true number of circuits as some are 4-wire circuits using two pairs whilst others are phantom circuits.

In addition to the cable chamber, the power plant for the building is accommodated in the basement. A general view of the plant is given in Fig. 3. Two motor generator sets are installed. The motors are synchronous induction machines of 104 H.P. and are supplied from 400v 3-phase mains. The output from the generators on full load is 1200 amps at 57v. There are two sets of batteries each of 7,800 Ah capacity. The power board is included in the illustration. The usual meters and switchgear for charging



FIG. 1.—FARADAY BUILDING, NORTH BLOCK.

ing either battery from either generator are provided. Facilities for "floating," *i.e.*, running a generator in parallel with the battery on discharge, are given. At the same time the switching would allow the spare machine to charge the idle battery if this were necessary.

The City and Central manual exchanges and the Toll exchange are supplied jointly from two interconnected 22v plants. The Repeater station filament battery is supplied from one of these 22v plants and the anode battery, 150v, is charged direct from 200v D.C. mains, the charging current being regulated by an adjustable resistance.

Ground Floor.

The ground floor is occupied mainly by the test room, including the Main Distribution Frame, Trunk Test Racks, Toll Test Desks and Transformer and Apparatus Racks.

The M.D.F. is fitted entirely with type 4028 fuse mountings and consists of 165 verticals with a possible extension to 177.

The trunk test racks were the first to be installed in this Country" and consist of 7 line testing

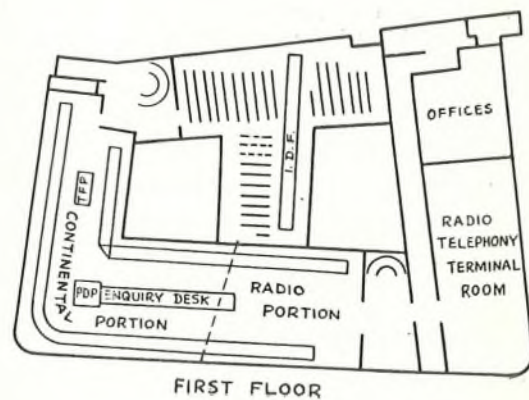
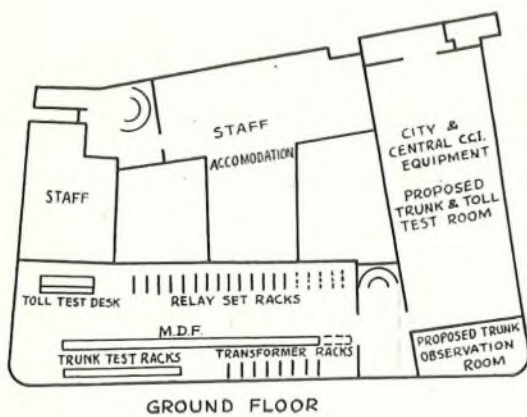
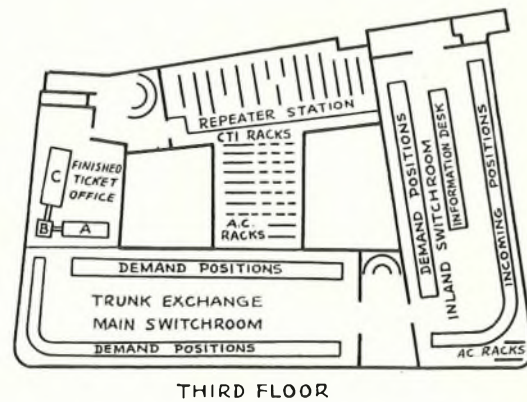
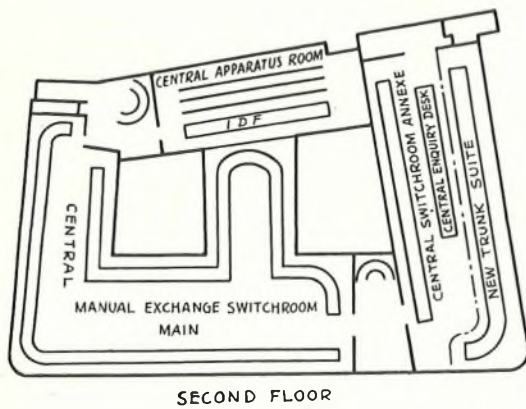
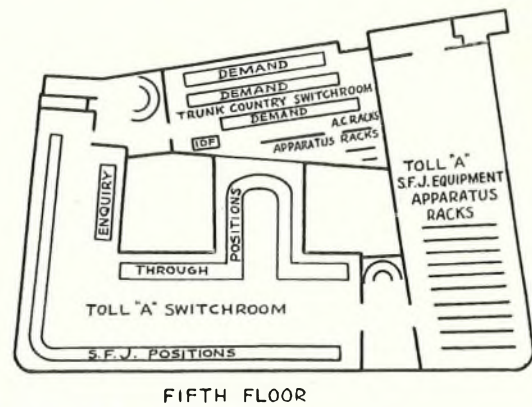
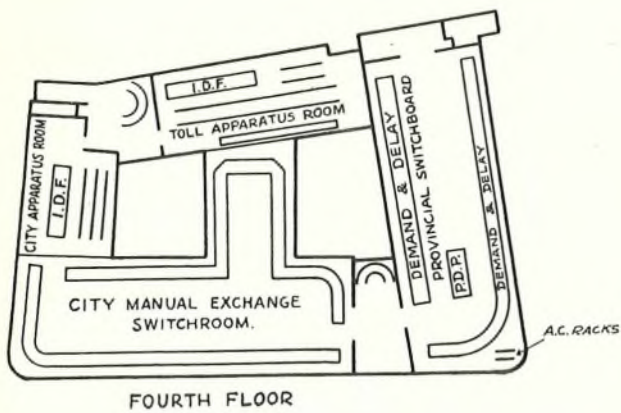

FIG. 2.—PLAN OF FLOOR LAY-OUTS.



FIG. 3.—GENERAL VIEW OF POWER PLANT.

positions, 2 megger panels, 1 junction test position, 1 fault control position and 1 telegraph speaker position. Fig. 4 is a photograph of the front equipment of the racks.

The Toll testing positions are 4 in number and are of the older desk type. When the City and Central manual exchanges are recovered test racks of the latest type will be installed in the space now used for the C.C.I. equipment and the Trunk and Toll testing will be combined.

Considerable space is taken up by transformer racks as most of the Trunk cables are repeatered and require transformers to match the line with the terminal impedances and also for phantom circuits. Altogether there are 27 racks existing and as these are being moved shortly, the new position has been shown in Fig. 2. Ample additional space for further racks will be available when the trunk test racks are recovered. The cable chamber is immediately beneath the M.D.F. and transformer racks. The majority of the cables terminate on the M.D.F. and are extended by V.I.R. leads to the transformer racks, but the new Birmingham and Liverpool cable and the latest St. Margaret's Bay cable terminate direct on the transformer rack test tablets.

Junction relay set racks are also accommodated on the ground floor. 31 racks are equipped and space is available for an additional 7. There are 10 relay sets per shelf and 9 shelves per rack.

The remainder of the ground floor is utilised for various staff purposes.

First Floor.

On the first floor is the International

Exchange and a complete description of this exchange was given in an article in the last issue of this Journal.³ The switchroom contains both Radio and Continental suites. In all 121 positions have been provided of similar type to the Inland Trunk positions, but altered in detail on account of the special character of the working involved.

The Radio Terminal Room on the same floor contains the control equipment and technical operator's positions for the Radio channels.

The first floor apparatus room is the largest in the building and contains trunk line relay set racks, C.T.I. racks, miscellaneous apparatus racks and the Intermediate Distribution Frame. The latter is of standard type and has a total of 106 verticals. The frame is in one straight run approximately 60 ft. in length. Space is available for 95 apparatus racks of the standard type 4' 6" wide. Each rack has capacity for 7 shelves in the case of bothway

trunk relay sets, or 8 shelves for unidirectional relay sets. The shelves are the standard channel type and accommodate 10 relay sets per shelf. At present only 55 racks are equipped as follows:—

Bothway Generator Signalling Trunks...	24 racks.
Outgoing Generator Signalling Trunks...	3 "
Automatic Signalling Trunks ...	4 "
Chargeable Time Indicator equipment ...	6 "
Multiple cut-in relay equipment ...	5 "
Group engaged tone relays ...	4 "
Miscellaneous equipment ...	9 "

These figures are interesting and, together with the junction apparatus on the ground floor, indicate the relative proportions of the various equipments.

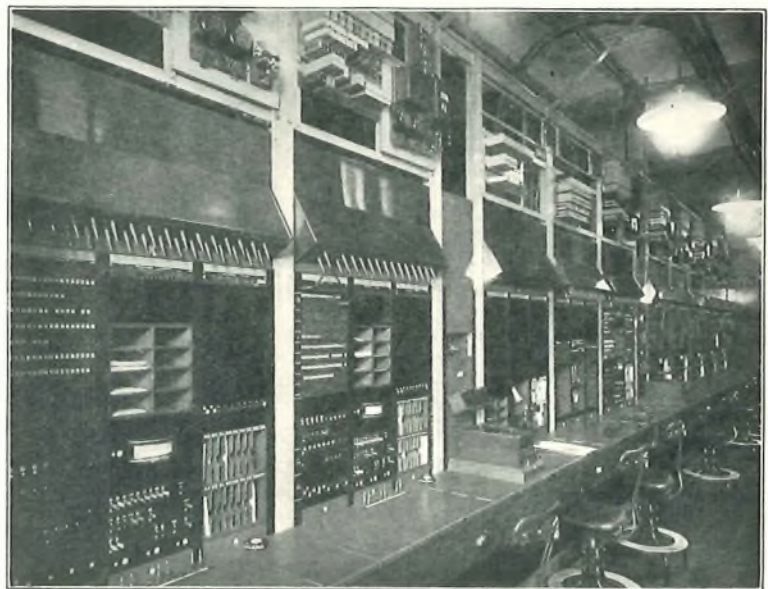

FIG. 4.—TRUNK TEST RACKS.



FIG. 5.—THE OLD TRUNK SWITCHROOM.

Second Floor.

The second floor is still mainly occupied by the Central manual exchange and apparatus room. When the exchange has been replaced by the new automatic unit in April, 1935, the space will be used for additional trunk switchrooms and equipment. The annexe switchroom is already being equipped with one suite of 42 new trunk positions.

Third Floor.

The third floor of the building has been associated with trunk working for many years. The original trunk exchange was installed here in 1904. The sections were of the 2-position 3-panel Helsby type as used at most trunk exchanges until recent years and the equipment was typical of the old trunk signalling system, although many modifications had been made at various times particularly on positions controlling Continental and Radio traffic. Fig. 5 shows the old switchroom as it appeared in September, 1929. The demolition of this switchroom in September, 1933, after over 29 years' service, marked the end of the old trunk regime so far as London is concerned. The new switchroom which has taken its place is fittingly equipped entirely with Demand positions. Standard large type sections are used and the 89 positions are installed in two suites. Fig. 6 shows the new switchroom as it is to-day.

Adjoining the switchroom is a ticket filing office where completed call tickets are received *via* pneumatic tubes from the various switchrooms. Referring to Fig. 2, 3rd floor plan, the tickets are

ejected from the tube terminal heads A on to a travelling band which carries them to a table B. Here a preliminary sorting takes place and the tickets are then sent on *via* another band conveyor to the desk C for final sorting into exchange name order to facilitate accounting work.

There is an additional switchroom in the annexe of this floor, known as the Trunk Inland Exchange. It contains three suites, one of 34 Demand positions, another with 45 incoming positions and a centre suite of double sided enquiry positions. The A.C. lamp racks for this switchroom are fitted at the rear of the end sections. The apparatus room adjacent to the main switchroom contains C.T.I. and A.C. lamp racks for that switchroom. The Repeater Station is also contained on this floor, but will shortly be transferred to the new South Block building.

Fourth Floor.

The fourth floor main switchroom contains the City manual exchange with its apparatus room adjacent. This space will be vacated when the new City automatic unit is brought into use in July, 1935. In the annexe switchroom of this floor is the Trunk Provincial exchange consisting of two suites, one of 35 positions and another of 45 positions, all equipped for Demand or Delay working. (Demand positions require only the addition of incoming tubes from the P.D.P. to make them suitable for Delay working). The main pneumatic distribution position (P.D.P.) for the trunk exchanges is also installed in the centre of this switchroom. The remainder of the



FIG. 6.—THE NEW MAIN TRUNK SWITCHROOM.

floor is taken up by the Toll A apparatus room which also contains racks for the C.T.I. equipment of the Country and Provincial Exchanges.

Fifth Floor.

On the fifth floor is the London Toll "A" exchange which deals with traffic from London exchanges to Provincial exchanges in the Toll area, and through traffic in this area which circulates *via* London. Traffic from the Toll area to London exchanges is dealt with by Toll "B" exchange situated near Holborn.

The control of calls at Toll "A" is being transferred to the manual boards of the London local exchanges and the calls are routed *via* through positions at Toll "A" working on a straight-forward junction basis. Forty positions have been converted from control to S.F.J. working and the remaining 31 will shortly be completed. Each S.F.J. position has 36 cord circuits and automatic coupling on a 6 position basis is provided. The S.F.J. equipment is fitted in the apparatus room adjacent, in which there is space for 114 racks. The other 53 positions are equipped partly for order wire working and partly for J.E.J. working for through Toll traffic. An enquiry suite of positions of the usual type completes the Toll switchroom.

The Trunk Country switchroom is also situated on the fifth floor. The switchroom contains three suites totalling 66 positions all of the smallest type, *i.e.*, 4' 6" in height. This type was necessary because of the restricted floor loading for this particular room. These are the positions from which Demand working was first introduced and originally differed in detail from the present standard. They have since been modified to conform to later design. A subsidiary I.D.F., apparatus racks and A.C. lamp racks are also contained in the switchroom. The equipment of the racks is identical in type to that of the other trunk apparatus rooms.

It will be seen that the general scheme of the building allows for two switchrooms (a main and an annexe) on each floor together with various apparatus rooms and offices.

A numbering scheme for the switchboard positions has been adopted for the building. Four figures are used for all positions, the first figure indicates the floor and the final three figures the actual position. The main switchroom on each floor is allocated numbers up to 500 and the annexe switchroom commences at 501. For example, position 3001 would be the first position in the 3rd floor main switchroom and position 3510 would be the 10th position in the annexe switchroom on the same floor.

The trunk switchrooms have specially treated ceilings to reduce the noise produced by echo and reverberation. The International exchange has a ceiling fitted with Sanacoustic tiles, consisting of perforated sheet iron containers in which are laid pads of sound absorbing material known as "Banroc Wool."

The 3rd and 4th floor annexe switchrooms have a surface layer of "Paxfelt" stuck to the existing plaster ceiling. The "Paxfelt," a proprietary

material, is in slabs 2' square and consists of an asbestos fibre in a number of layers held together with a special fixing solution and built up to about 1" in thickness. The surface is covered with three coats of distemper.

The 3rd floor main trunk switchroom has a suspended ceiling of $\frac{3}{4}$ " pumice plaster on expanding metal. The plaster surface is covered with "May Acoustic" material. This is a proprietary article somewhat similar to Paxfelt, but the surface is subjected to additional treatment as follows. The material is glued to the plaster with dextrine and then has a muslin sheet pasted over the surface. The muslin is distempered and then finely pricked to break up the surface and expose the sound absorbent material.

The use of various sound absorbing materials will enable a comparison to be made of the relative merits of the different systems.

With the exception of the Country exchange, all the switchrooms are fitted with the largest type of Demand Section. These sections are 7' 6" in height, 6' 8 $\frac{1}{2}$ " long and consist of three operating positions with seven jack panels per section. They are built on the lines of a CB1 type of section, but B gauge jacks are used and the keyboards are wider and deeper to allow more operating space. The construction of these boards was described in detail in a recent article.⁴ Fig. 7 shows a front view of a complete section as installed in the London Provincial exchange. A rear view of a section showing the multiple wiring and cord and position circuit

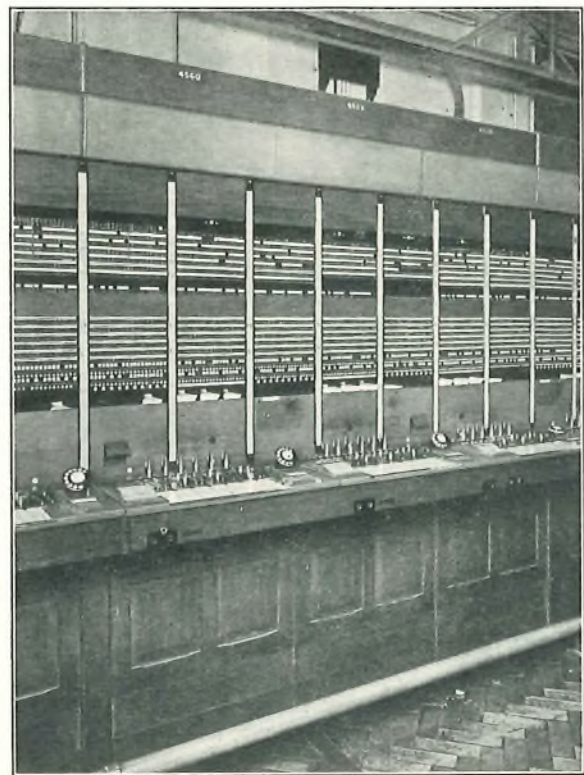

FIG. 7.—TRUNK DEMAND SECTION, FRONT VIEW.

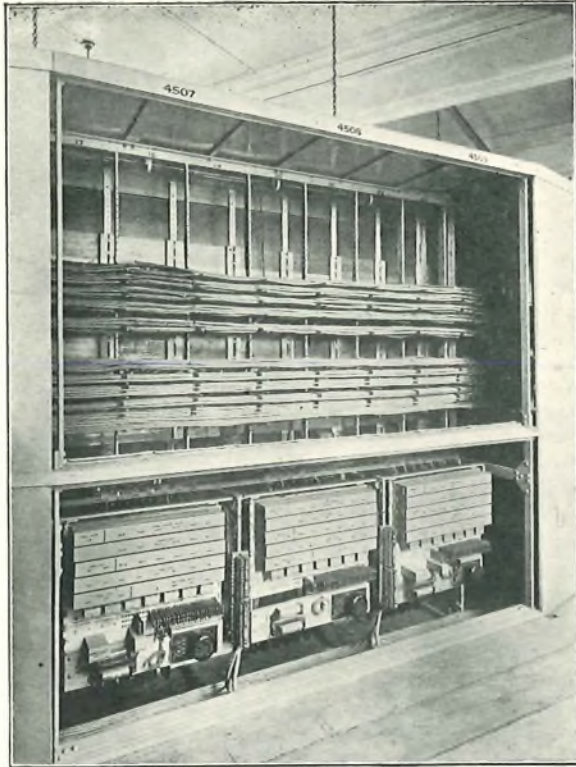

FIG. 8.—TRUNK DEMAND SECTION, REAR VIEW.

apparatus is given in Fig. 8. A general view of the Provincial exchange is given in Fig. 9 and this is typical of a Demand installation. All positions, whether used as Demand, Delay or Incoming, are similar as regards dimensions and construction and only differ in such details as the number of cords, etc. The Demand positions deal with "No delay"

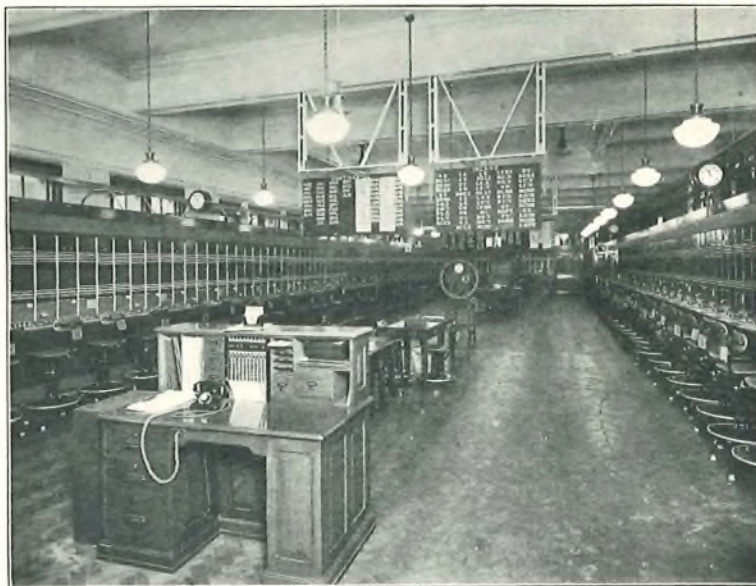

FIG. 9.—PROVINCIAL EXCHANGE SWITCHROOM.

outgoing traffic, *i.e.*, calls from local subscribers to distant exchanges over trunk routes on which there is no delay. The positions are fitted with incoming junctions from local exchanges, and a multiple of outgoing trunks and junctions.

Delay positions are similar except that they have no incoming junctions, they have only the outgoing multiples. Their function is to complete outgoing calls over trunk routes on which delay working is in force. Both Demand and Delay positions have six cord circuits each with a chargeable time indicator equipment. A card file on each keyboard gives information regarding routing, charges, etc.

Incoming positions deal with calls incoming from other distant trunk exchanges, either for connexion to local subscribers (terminated calls) or for connexion to other trunk lines (through calls). Incoming and through working is thus combined. The positions are fitted with incoming trunk lines and outgoing multiples of trunks and junctions. They are not equipped with timing devices as the timing and control of a call is always at the originating trunk exchange. The work per call is therefore less and 12 cord circuits per position are fitted so that a maximum of 12 calls may be connected simultaneously.

All incoming lines, whether trunks or junctions, are multiplied on either a 7- or 14-panel repetition basis. This provides for the distribution of incoming traffic over a number of positions and allows an operator to concentrate on the call in hand, an essential feature of the Demand System.

All outgoing multiples are wired on a 6-panel basis. The trunk multiples are equipped with the visual idle indicating feature in which a lamp shining through the designation strip indicates the first free circuit in a group of lines. A red lamp at the beginning of each route indicates when delay working is in force. These two features were dealt with in greater detail

in an article previously mentioned.⁴ The outgoing junction multiples have the standard group engaged tone equipment fitted. Special multiple cut-in relay equipment has been provided for multiples which are common to a number of switchrooms. With this equipment, only the switchroom from which the circuit is picked up is connected to the line, the multiple jacks in other switchrooms being left disconnected but testing engaged.

The multiple answering lamps and V.I.I. lamps are fed from the public supply mains to relieve the exchange battery of this load. The mains supply is stepped down by a transformer to 13 volts. Low consumption lamps taking approximately 50 milliamps at 6 volts are used. They are wired on a three-wire system with the centre wire earthed. The output voltage from the transformer thus allows one volt drop and the A.C. lamp racks are fitted near

the line of switchboards to avoid long heavy-gauge leads. Typical A.C. lamp racks are shown in Fig. 10.

It is imperative that there should be no interruption in the supply of current to the answering lamps and to guard against failure of the public mains a stand-by plant has been provided. This comes into operation automatically if the mains fail and supplies A.C. at 230v to the input of the lamp rack transformers. The emergency motor generator set is driven from the 50v exchange battery and is thus independent of an outside source of supply. Facilities for testing the plant are provided and this is done as a daily routine. A pilot lamp on the power board is bridged across the load to indicate that the standby plant is functioning correctly.

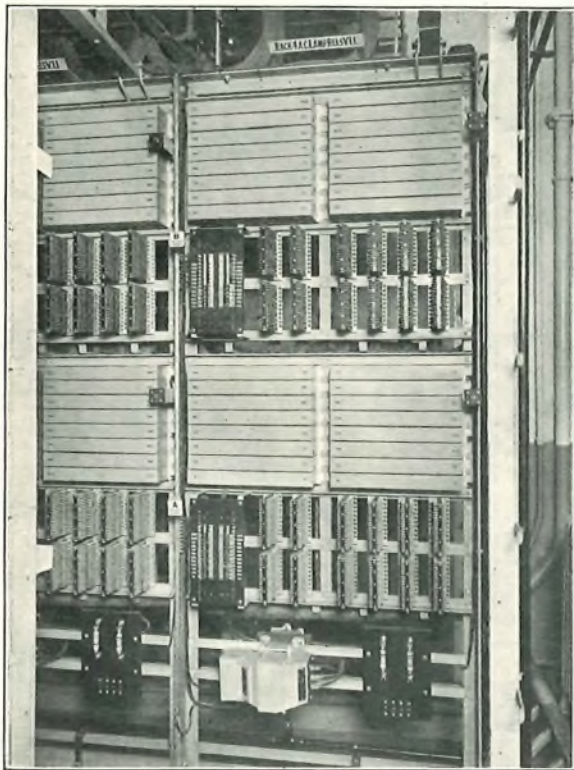

FIG. 10.—A.C. LAMP SUPPLY RACKS.

The line relay-sets for trunks and junctions are all jacked-in equipments and mount on the standard channel-type shelves. The circuit arrangements are based on the Sleeve Control system and the operation of typical relay-sets will be dealt with in detail as the equipment is representative of that installed at main trunk exchanges throughout the country.

The basic principle of the system is that one type of cord circuit only is used and this is of universal application. The varying requirements of the different line circuits to be interconnected are met by inserting a suitable relay-set in each line. The relay-sets vary in type according to the circuit on which they are connected, but the conditions sent out from the cord and position circuit are standard.

The cord and position circuit diagram is given in

Fig. 11. The position circuit is common to the position and any number of cord circuits may be associated. The cord circuit is normally a straight-through connexion from the answering to the calling plugs with no transmission element or bridging equipment in circuit. The straight-through connexion of the cord circuit is broken when the speaking key is thrown and the cord circuit connexion is then completed *via* the position circuit.

The circuit operation is as follows :—

The throwing of the speaking key operates relay SK. Contact SK1 operates relay SL. Contact SL4 short-circuits the 1300-ohm winding of relay SK which now holds on the 15-ohm winding. The battery connexion for the SK relay is *via* a 400-ohm resistance common to the position circuit and if, with one speaking key operated, a second key is thrown the associated SK relay will not operate as its high resistance coil will be shunted by the 15-ohm winding of the previously operated SK relay. This feature prevents the two cord circuits from being brought into contact.

Relay SK at contacts 2, 3, 4 and 5 diverts the cord circuit *via* the position circuit. The operator's telephone circuit is bridged across the position circuit for speaking purposes. The "speak call" and "speak ans" keys separate the answering from the calling cord and allow either side to be spoken on separately if required. The transfer keys connect positive battery to the ring of the plug and thence into the line unit. This facility allows a calling line to be transferred to another position, but is not at present in use at London.

The "dial ans" or "dial call" keys operate relays DA or DC to connect the dialling or key sending circuit to the cord circuit. Relays DK and DA or DC are held by earth from the off-normal springs of the dial to guard against restoration of the key before the dial has returned to normal. A guard lamp is also fitted and this glows whilst the dial key is thrown.

Coupling between positions in one direction is provided. The engaged test is obtained from a separate transformer which connects the operator's telephone circuit to the tip of both plugs. Ringing keys are individual to each cord circuit and connect a battery *via* 100 ohms to the tip of the answering or calling cord to operate an RR relay in the line relay-set.

There is also an individual monitoring key which, when thrown, connects a high impedance monitoring coil across the cord circuit. At the same time relay M in the position circuit connects the operator's receiver to the secondary winding of the monitoring transformer. When a speaking key is thrown the monitoring circuit is disconnected by relay MN. Listening-in taps are normally bridged across the tip and ring of the operator's circuit to preserve balance, but during monitoring the tap is connected directly across the receiver by contact M3.

It will be noticed that a 600-ohm resistance and series condenser is always bridged across the cord circuit when the circuit is not otherwise terminated. This feature also occurs in the Trunk line relay-set circuits and is essential where "Zero Loss" trunk lines are in use.³

The sleeve circuits are connected to battery *via* the respective supervisory lamps. An 85-ohm earth on the plug sleeve will light the lamp to indicate a clear, a high resistance earth will dim the lamp for the engaged condition, and the two intermittently will flash the lamp for a recall signal. These conditions are given over the sleeve circuit from the line relay-sets.

When the speaking key is thrown the lamps on the sleeve circuits are replaced by relay combinations (FA and TA in series and FC and TC in series). The lamps are then controlled by the FA and FC relays and the normal

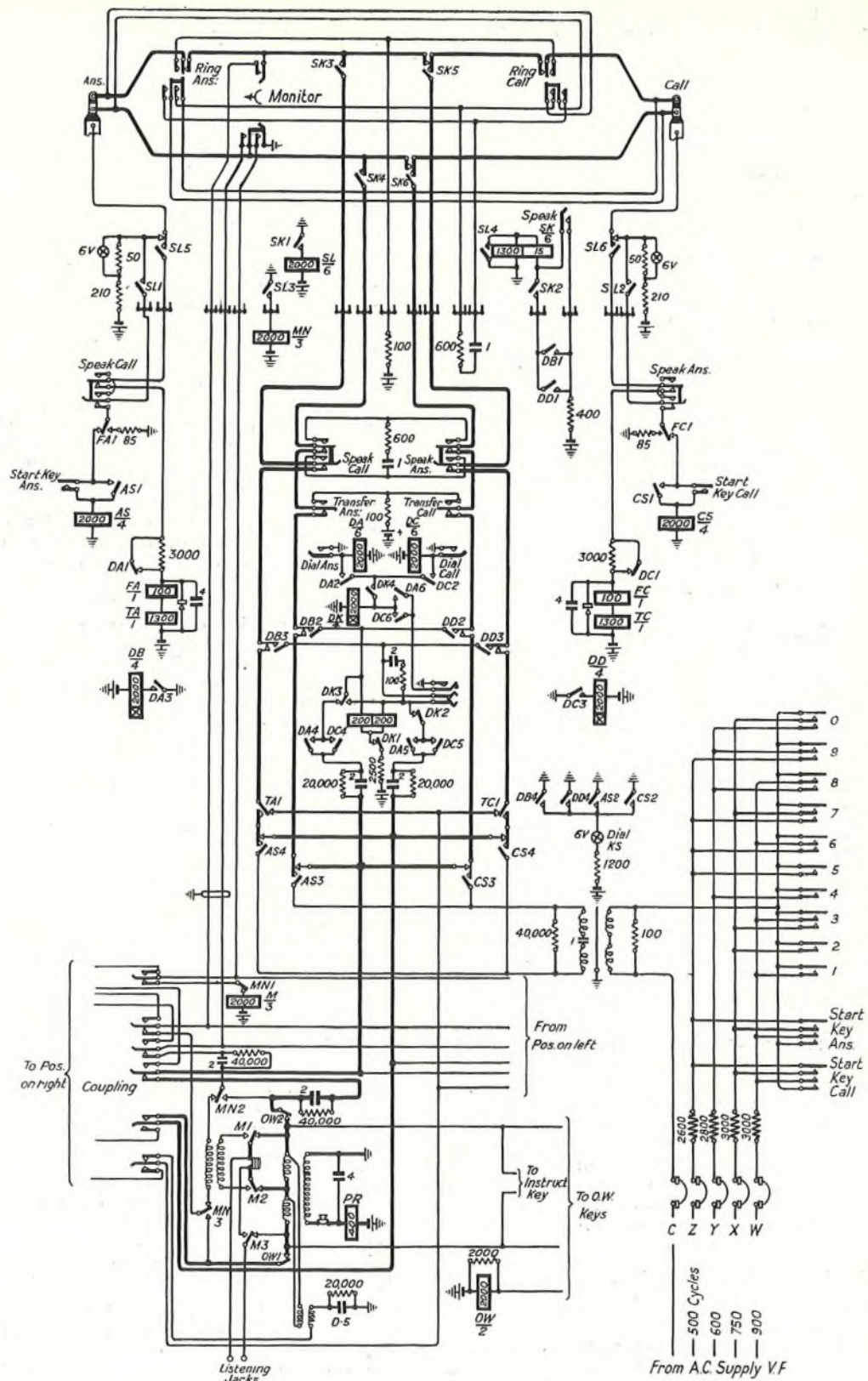

FIG. 11.—CORD AND POSITION CIRCUIT.

supervisory signals retained, but the sleeve circuit is increased from 240 ohms to 1400 ohms and this operates a DR relay in the line relay-set (as will be seen later).

These are the main features of the cord and position circuits and are not special to the London installation, but are standard at all sleeve control trunk centres.

Of the line relay-sets, those for junctions incoming from London automatic exchanges will be described first. The circuit arrangement is shown in Fig. 12.

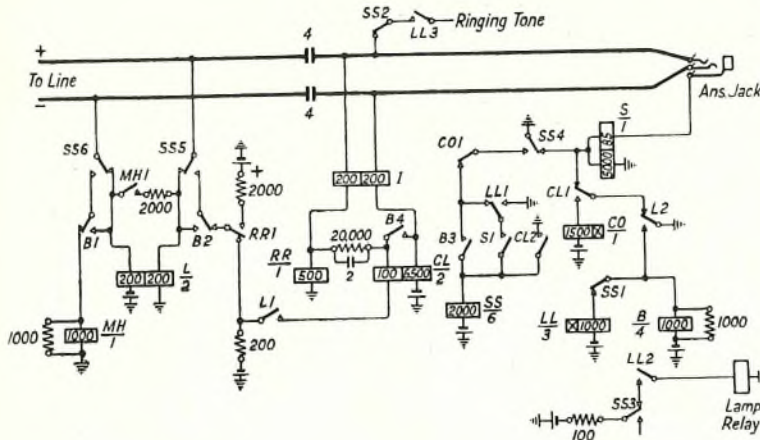

FIG. 12.—INCOMING JUNCTION FROM AUTO EXCHANGES.

The selector at the automatic exchange extends a loop to operate L relay. Contact L2 operates relays LL and B. Contact LL2 operates the answering lamp relay to light the multiplied answering lamps and LL3 returns ringing tone over the junction to the automatic subscriber. The trunk operator answers and relay S operates via S1 and LL1. Relay LL is disconnected by relay SS at SS1 and releases. Relay SS is held by SS4, CO1 and B3. Ringing tone is disconnected at SS2 and the lamp relay released at SS3. Contacts SS5 and SS6 operate, but relay L remains connected to line via B1 and B2.

If there is delay in setting up the call, the auto subscriber may hang up his receiver and wait to be rung. The subscriber's line and the junction are held by the trunk operator as follows:—

Relay L is released when the subscriber hangs up. Relay B is disconnected at L2 and releases. B1 and B2 connect battery via 200 ohms to positive line to hold the auto switches and earth via MH relay to the negative line. When the trunk line is ready, the trunk operator can call the auto subscriber by operating the answering plug ringing key. This extends battery to RR relay. Contact RR1 connects a positive battery to the positive line and operates a relay in the first code selector at the automatic exchange. This relay is shunted by a metal rectifier and does not operate with normal current, but only when a positive battery is used. When operated, the relay applies ringing to the subscriber's line. When the subscriber answers, a loop condition is given from the automatic exchange and relay MH at the trunk exchange operates from battery via 200-ohm resistance, contact RR1 normal, B2 normal, SS5 operated, positive line, auto exchange loop, negative line, SS6 operated and B1

normal. Contact MH1 operates relay L which re-operates relay B, relay L is again connected to line and the call is established in the normal way. When the auto subscriber clears, relay L releases and earth via L2 normal, CL1 normal and 85-ohm winding of S relay lights the supervisory lamp. Relays CL and CO are special to the London circuits and control the clearing signal when the junction is extended by the Demand operator to the Continental exchange. Relay CL operates when the Continental exchange operator answers. If the L relay is operated, i.e., the subscriber is on the line, L1 connects a low resistance battery to the Continental position and the Continental supervisory lamp is darkened. When the auto subscriber clears, relay L releases and at L1 gives a clear to the Continental operator. Relay CL remains operated on its high resistance winding and the release of L2 operates relay CO. Contact CO1 disconnects the earth via SS4 operated from the SS relay which remains operated, but is now dependent solely on CL2. When the Continental operator clears, relay CL releases and at CL2 disconnects relay SS which restores and lights, at SS4 normal, the supervisory lamp of the Demand position. Relay CO is slow to release in order that relay SS should not hold on contact SS4 when CO is restoring.

Circuits outgoing from the Trunk exchange to automatic exchanges may be either loop or battery dialling. The

former are more common in London and only this type will be considered.

Fig. 13 shows the circuit arrangement of an outgoing loop dialling relay-set.

When the line is picked up by an operator, relay S operates on the 85-ohm winding and a clear is received on the supervisory lamp. Contact S1 operates relay SS which operates the group engaged tone relay and connects flicker earth to low resistance winding of relay S. This flashes the supervisory lamp as an indication that the operator must dial.

When the dial key is thrown, battery from the position dial circuit operates relay RR. Contact RR1 operates relay DT which locks via DT contact operated, LR2 normal, and SS2 operated. Contact DT2 disconnects RR relay and short circuits the condenser in the tip circuit. Contact DT3 disconnects the through signalling battery circuit and shunts the condenser in the ring circuit. DT4 disconnects the flashing earth and connects

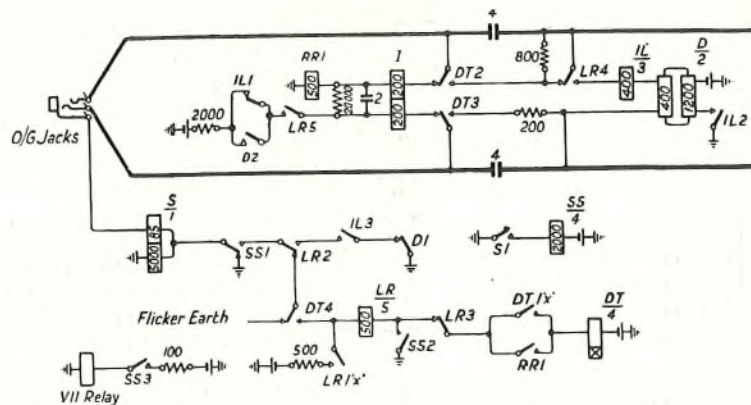

FIG. 13.—OUTGOING JUNCTION TO AUTO EXCHANGES.

the LR relay in parallel with the 5,000-ohm winding of relay S. Dialled impulses may now be sent direct to line from the position dial circuit. Loop impulses are sent out as the battery is disconnected by relay DK, Fig. 11, when the dial is off normal.

When the dial key is restored, the 3,000-ohm resistance in the cord circuit sleeve wire is short-circuited and relay LR now receives sufficient current to operate. Relay LR locks at LR1. Contact LR3 disconnects relay DT which restores the transmission bridge. Contact LR2 switches the control of the clearing signal to IL and D relay contacts and contact LR4 connects IL and D relays to line to hold the selectors and receive supervisory signals from the automatic exchange. Relay IL completes the circuit for the polarizing winding of relay D, gives the busy back flash signal at IL3, and relays this signal at IL1.

Clears are given by the reversal of current from the auto exchange selector circuit. This releases relay D which, in turn, connects earth to the 85-ohm winding of relay S to light the supervisory lamp. The clear is relayed as a through signal on incoming trunk lines by contact D2.

Junctions from and to manual exchanges are also provided at London, but these are comparatively simple and have not been described in detail as they work on a normal C.B. junction signalling basis, but of course incorporate sleeve control principles of design.

Relay-sets for trunk lines are of two main types and depend on the signalling system employed on the line, viz., automatic signalling or generator signalling.

Automatic signalling is similar to and gives all the facilities afforded by D.C. junction working, but is limited to lines up to approximately 50 miles long. It is not reliable over greater distances as in the case of overhead lines the insulation loss acts as a shunt to the supervisory relays and on underground cables, although the insulation loss is small, the conductor resistance becomes too high. Generator signalling is therefore used on long lines and also repeated circuits.

The disadvantage of generator signalling is that it is necessary to operate a key to call or clear and operating work is increased. Automatic signalling is therefore always to be preferred and voice frequency signalling systems at present being developed aim at giving full automatic signalling facilities on repeated circuits.

In the following description of trunk relay-sets, bothway circuits are considered as these combine the features of both incoming and outgoing circuits.

The bothway automatic signalling trunk circuit is given in Fig. 14.

Taking first an incoming call, battery and earth are connected to line at the distant end and L relay operates from the battery on the B line. Contact L1 operates relay LL. This in turn operates the answering lamp relay, VII lamp relay and en-

gages the bush of the outgoing multiple jack. The operator answers and operates S relay. Contact S1 operates relay SS. Contact SS1 disconnects the terminating impedance from the line to avoid transmission loss under speaking conditions. SS2 operates relay LO which locks via LO2 and LL2 to prevent a false signal if the incoming operator clears first. Contact SS3 provides an alternative earth to engage the outgoing multiple jack when the distant end clears first.

Contact LO1 disconnects the answering lamp relay and holds the VII lamp relay operated if the distant end clears. When the speaking key is thrown relay DR operates as follows:—Battery is connected on one winding of DR via a 300-ohm resistance and SS5 and LL4. The other winding has battery from the cord circuit sleeve via 240 ohms plus the 85 ohm S relay. The currents in the two windings of the DR relay are thus practically equal and as they are wound in opposition the relay does not operate. When the speaking key is thrown the sleeve circuit resistance is increased from 240 to 1400 ohms and relay DR operates on the out of balance current. DR1 operates relay TS which connects battery to the A-wire to dim the distant supervisory.

When the call is established via an outgoing circuit through signalling is given by TS relay.

On outgoing calls relay M operates from battery on sleeve of plug and at M1 operates relay MM. Contact MM4 connects relay SS which also operates. MM1 and MM2 reverse the battery and earth conditions to line (note that TS1 contact does not now control the battery connexion as no through signalling is required on outgoing calls). Contact MM3 connects battery via LL3 to the ring wire to give through signalling to the incoming line connected on the answering cord. It will be seen that LL3 controls the battery connexion on the ring wire.

Clears are received by the release of relays L and LL. For incoming calls LL2 connects earth via S relay direct to the answering jack sleeve and for outgoing calls the earth is via M relay and MM6 to the outgoing jack sleeve.

A flashing signal, to recall the distant operator on an established call, may be sent on either incoming or outgoing calls by operating intermittently the cord circuit ringing key. This operates intermittently relay RR which controls the battery connexion to line.

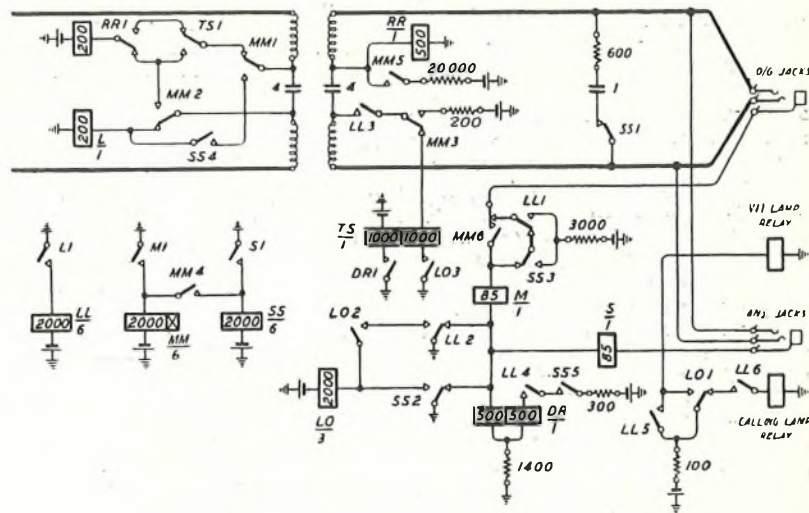

FIG. 14.—BOTHWAY AUTOMATIC SIGNALLING TRUNK.

The generator signalling bothway trunk circuit is shown in Fig. 15.

On incoming calls, relay L operates whilst ringing current is applied to line from the distant end. Contact L1 operates relay LL which locks *via* DR1 and operates the answering lamp relay, the VII lamp relay and engages the bush of the outgoing jack. The operator answers and operates relay S from the battery on the sleeve of the plug. S1 operates relay SS which disconnects the terminating impedance from the line, releases the answering lamp relay to disconnect the answering lamps, holds the VII lamp relay and engages the bush of the outgoing jack against the release of LL. The locking circuit of relay LL is broken by the operation of relay DR from the out of balance current when the cord circuit speaking key is thrown. When the speaking key is restored DR relay releases, but LL is now dependent again on relay L.

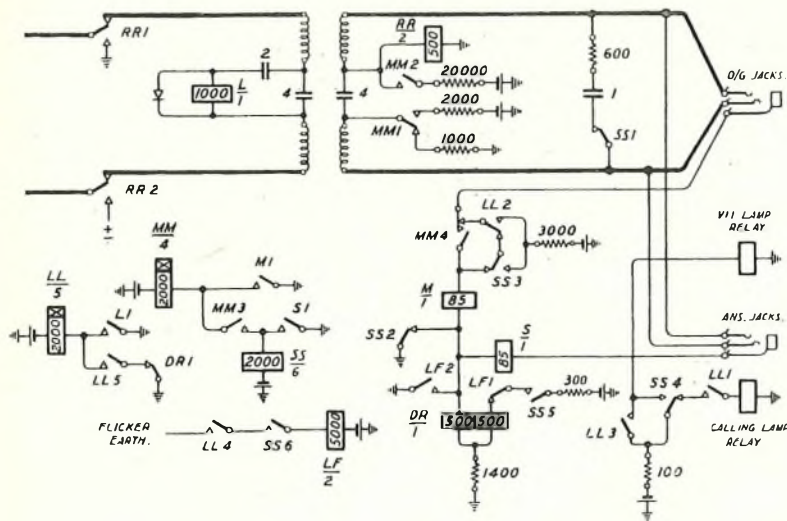

FIG. 15.—BOTHWAY GENERATOR SIGNALLING TRUNK.

If a ringing current is received on an established connexion, relay L operates and reoperates relay LL which again locks as DR1 is normal. LL4 completes a circuit for LF relay to operate intermittently from the flicker earth. LF2 connects earth *via* 85 ohms to light the supervisory lamp intermittently. In order to prevent premature operation of relay DR when one coil is short-circuited by LF2, contact LF1 is arranged to disconnect the other coil. The flicker signal on the cord circuit supervisory lamps acts as a signal to recall the operator into circuit. When the speaking key is thrown, relay DR operates and disconnects LL as before.

On outgoing calls relay M operates from battery on sleeve circuit, and operates relay MM. This relay at MM3 completes a circuit for relay SS, changes earth for battery for through signalling at MM1, connects high resistance battery at MM2 to avoid dry contacts in the speaking circuit and at MM4 connects relay M direct to the outgoing jack sleeve against operation of relays SS and LL. A calling signal is sent out by the operation of the ringing key which connects battery to operate relay RR and connect at RR1 and RR2, ringing current to line. A recall signal is received in a similar manner to that on incoming calls, *i.e.*, by the operation of L, LL and LF relays. The flashing signal is released by the operation of relay DR as before.

No mention has so far been made of cord circuit repeaters. There are only 8 cord repeaters in use and 100 lines only are balanced for use with the repeatered cord circuits. The repeater equipment is installed in the Repeater station and the line jacks and cords are fitted on an angle section in the International exchange.

The cord repeaters are of the semi-automatic type, in which the C.C.R. operator connects two trunks *via* a cord repeater at the request of a controlling operator. All controlling positions have access by order-wire to the C.C.R. position operator whose only function is to insert the cord repeater and clear down when required. The control is left with the original controlling operator, who retains all signalling and monitoring facilities. Full details and circuit description of these repeaters have been published in a printed paper of the Institution.⁶ This type of repeater was originally intended to provide additional amplification on through trunk connexions, but the introduction of zero loss circuits has rendered them unnecessary.

The timing device used on all Demand and Delay positions is the Chargeable Time Indicator (C.T.I.). Each cord circuit has associated with it a uniselector controlled by a lever key with start, stop and reset positions. In the start position of the key, the uniselector is operated by 12 second impulses from a master clock and rotates slowly for a maximum period of 18 minutes. A red lamp on the keyboard is connected to the uniselector and lights for 12 seconds every three minutes to indicate to the operator that the duration of the connexion must be announced. At any point the uniselector may be stopped from the cord circuit supervisory relay when the calling subscriber clears. The operator, by throwing the key into the stop position, connects in circuit a lamp display. One display consisting of a strip of lamps numbered 1 to 18, is fitted in a panel on each position. A lamp lights corresponding to the position of the uniselector and the actual time for which the call must be charged is indicated. The display is disconnected and the uniselector brought to the home contact by throwing the key to the reset position. The complete circuit arrangement of this device has recently been described.⁷

The call tickets are distributed in the building by the standard pneumatic ticket tube system of the Post Office. Outgoing tubes worked on a vacuum basis carry the tickets for completed calls from all positions to the ticket filing room. Tickets for calls to be completed on a Delay basis are sent from the Demand positions to the pneumatic distribution position (P.D.P.) from which they are sent by individual pressure tubes to the Delay positions. The complete system for the London trunk building is

extensive and has already been described in this Journal.⁸

With the exception of the Power Plant and the tube blowers the whole of the manufacture and installation of the telephone equipment has been carried out by Messrs. Standard Telephones and Cables, Ltd., to Post Office design.

The change over from the old to the new system of working in London is now complete, although additional equipment is being installed for development of the services and there is still considerable work yet to be done.

The task of reconstruction has been most difficult because of the congestion which existed in the building and this was accentuated during the demolition and rebuilding of the South Block.

Many schemes were discussed in conference before a satisfactory solution was reached, and the programme adopted required rigid adherence to the various dates to avoid dislocation of the trunk service.

The Demand System is now well established and in the London Trunk Centre the Post Office has a fine example of modern long distance communication equipment.

REFERENCES.

- 1 "Demand Trunk Service," by I. H. Jenkins, M.I.E.E. *P.O.E.E. Journal*, October, 1931.
- 2 "Trunk Exchange Test Racks: New Design," by G. Brown, A.M.I.E.E. *P.O.E.E. Journal*, April, 1933.
- 3 "The British Post Office International Exchange," by S. Birch and C. H. Hartwell. *P.O.E.E. Journal*, July, 1934.
- 4 "Some Recent Developments in the Design of Manual Switchboards," by J. H. Douglas. *P.O.E.E. Journal*, January, 1934.
- 5 "Modern Telephone Trunk Lines," by R. M. Chamney, B.Sc., A.K.C., A.M.I.C.E. *P.O.E.E. Journal*, January, 1933.
- 6 "Recent Repeater Station Installations," by Major F. E. A. Manning, M.C., B.Sc. (Eng.), M.I.E.E., A.M.I.Mech.E. I.P.O.E.E. Printed Paper No. 151.
- 7 "Acceptance Testers used on Sleeve Control Equipment," by E. J. Harrold and C. N. Smith. *P.O.E.E. Journal*, October, 1933.
- 8 "Pneumatic Ticket Tube System at G.P.O. (South)," by J. E. McGregor, A.C.G.I., A.M.I.E.E. *P.O.E.E. Journal*, January, 1934.

Frequency Characteristics of a Western Electric Moving Coil Microphone

The type 618A moving coil microphone is an instrument particularly suited to studio uses. Details of the design have been published by E. C. Wente and A. L. Thuras (*Journal Acous. Soc. Amer.* Vol. 3, p. 44, 1931) and by W. C. Jones and L. W. Giles (Bell System Monograph B-630).

An arched duralumin diaphragm carries a small coil, having an impedance of about 30 ohms, in the annular airgap of a permanent magnet. Small cavities and air release slots behind the diaphragm are designed to improve the uniformity, at different frequencies, of the sensitivity, which otherwise would be mainly controlled by the mechanical constants of the diaphragm.

The figure shows the results of calibrations made on one of these instruments at the Research Station; the full line curve is a pressure calibration (in terms of the sound pressures applied at the diaphragm)

and the broken curve is a field calibration (in terms of sound pressures in free air, for sound incident normally on the diaphragm). The curves have been

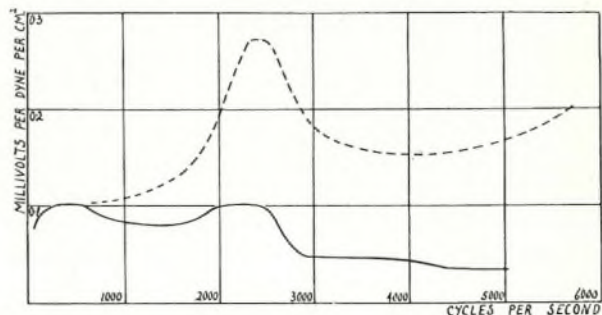

drawn ignoring such minor irregularities as cannot easily be determined exactly by a point-to-point method of calibration.

Telephone Transmission—IV.

R. M. CHAMNEY, A.K.C., B.Sc., A.M.I.C.E.

FORMULÆ for the study of telephone transmission over lines were developed in the article which appeared in the July issue of this Journal. These formulæ gave expressions for the attenuation constant (β) and the wave-length constant (α) as follows:—

$$\beta = \sqrt{\frac{1}{2}\sqrt{(R^2 + \omega^2L^2)(G^2 + \omega^2C^2)} + \frac{1}{2}(RG - \omega^2LC)} \dots (1)$$

$$\alpha = \sqrt{\frac{1}{2}\sqrt{(R^2 + \omega^2L^2)(G^2 + \omega^2C^2)} - \frac{1}{2}(RG - \omega^2LC)} \dots (2)$$

As by definition the primary constants R, L, G and C are expressed per unit length, formulæ (1) and (2) give the attenuation and wave-length constants in similar terms. Thus if the primary constants are given per mile the attenuation and wave-length constants will also be per mile.

The wave-length constant, to which reference will be made later, is the angle in radians by which the current at the end of a unit length lags behind the current impressed at the beginning of this length; *i.e.*, the lag is " α " radians per unit length. When the lag attains a value of 2π radians (360°) a wave-cycle has been completed and a repetition of the wave will commence. Clearly the length of the wave will be $\frac{2\pi}{\alpha}$ units of length. The symbol λ is used to signify the wave-length and

$$\lambda = \frac{2\pi}{\alpha} \dots (3)$$

An examination of these formulæ brings to notice

Under this condition G becomes zero and equations (1) and (2) can be written

$$\beta = \sqrt{\frac{1}{2}\sqrt{(R^2 + \omega^2L^2)\omega^2C^2} - \frac{1}{2}\omega^2LC} \dots (4)$$

$$\alpha = \sqrt{\frac{1}{2}\sqrt{(R^2 + \omega^2L^2)\omega^2C^2} + \frac{1}{2}\omega^2LC} \dots (5)$$

Table I shows the values of the attenuation and wave-length constants for a 20-lb. cable calculated on the assumption that the inductance is varied irrespective of the other primary constants. The inductance in this case is taken as resistanceless and as being distributed, not lumped as in a loading coil. The values of R and C have been taken as 88 ohms per mile and 0.065×10^{-6} farads per mile while the frequency selected is 800 cycles giving a value for $\omega = 2\pi f = 5000$.

In order to simplify the column headings the following notation has been used:

$$\begin{aligned} (R^2 + \omega^2L^2) &= X \\ \omega^2C^2 &= Y = .1056 \times 10^{-6} \\ \omega^2LC &= Z \end{aligned}$$

$$\text{and } \beta = \sqrt{\frac{1}{2}\sqrt{XY} - \frac{1}{2}Z}$$

$$\alpha = \sqrt{\frac{1}{2}\sqrt{XY} + \frac{1}{2}Z}$$

It will be apparent from an examination of the values of $X = R^2 + \omega^2L^2$ that as L increases the effect of R^2 becomes of increasingly less importance as compared with ω^2L^2 . Whereas at 1 mH, ω^2L^2 is

TABLE I.

L	ω^2L^2	X	\sqrt{XY}	Z	$\frac{1}{2}\sqrt{XY} - \frac{1}{2}Z$	β	$\frac{1}{2}\sqrt{XY} + \frac{1}{2}Z$	α	λ
0	0	7744	.0286	0	.0143	.1196	.0143	.1198	52.5 miles.
0.001	25	7769	.0286	.00163	.01347	.116	.01512	.123	51.1
0.002	100	7844	.02875	.00325	.01276	.1128	.01601	.126	49.7
0.005	625	8369	.0297	.00813	.01075	.1038	.01893	.137	45.7
0.01	2500	10244	.0329	.01625	.00833	.0912	.02457	.156	40.3
0.02	10000	17744	.0432	.03250	.00535	.0731	.03785	.194	32.4
0.03	22500	30244	.0565	.04875	.00388	.0622	.05262	.229	27.4
0.04	40000	47744	.0710	.06500	.00300	.0547	.068	.261	24.1
0.05	62500	70244	.0860	.08125	.002325	.0482	.08367	.289	21.7
0.06	90000	97744	.1016	.09750	.002050	.0452	.09955	.315	19.9
0.07	122500	130244	.11736	.11375	.00176	.0419	.1155	.340	18.5
0.08	160000	167744	.13309	.13000	.001545	.0390	.1315	.363	17.3
0.09	202500	210244	.14900	.14625	.001375	.0370	.14762	.384	16.4
0.10	250000	257744	.16498	.16250	.001240	.0352	.16385	.405	15.5

a number of interesting factors which assist in the elucidation of transmission problems. The leakage in unloaded underground cables is so small that it can be neglected without causing appreciable error,

less than 1% of R^2 , at 100mH the position is completely reversed. In other words the resistance has become of little importance. If R becomes negligible then

$$\begin{aligned} \beta &= \sqrt{\frac{1}{2} \sqrt{\omega^2 L^2 \cdot \omega^2 C^2} - \frac{1}{2} \omega^2 LC} \\ &= \sqrt{\frac{1}{2} \sqrt{\omega^4 L^2 C^2} - \frac{1}{2} \omega^2 LC} \\ &= \sqrt{\frac{1}{2} \omega^2 LC - \frac{1}{2} \omega^2 LC} \dots\dots\dots(6) \\ &= 0. \end{aligned}$$

$$\text{and } \alpha = \sqrt{\omega^2 LC} \dots\dots\dots(7)$$

Thus, in a line containing inductance and capacity but no resistance or leakance we have a system where there is no attenuation and only a wave propagation of short wave-length. Unfortunately there is always resistance and leakance present and a minimum value of attenuation only can be reached.

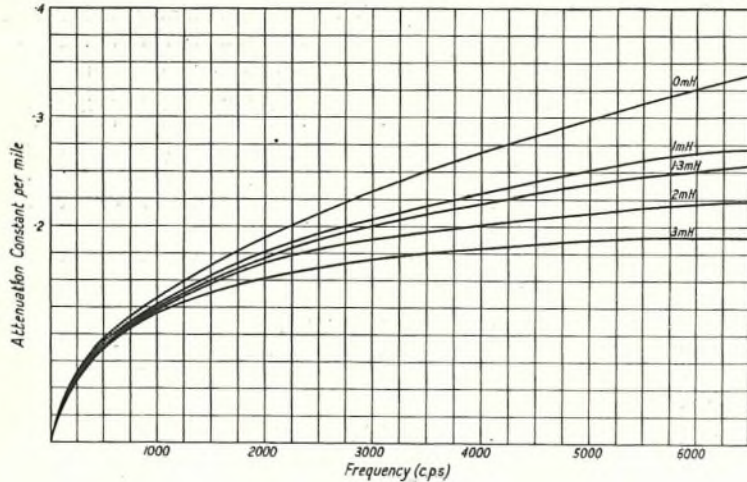

FIG. 1.—VARIATION OF ATTENUATION CONSTANT WITH FREQUENCY.

It will be of interest also to study the effect of various values of distributed inductance on the attenuation constant at different frequencies. The 20-lb. cable ($R = 88$ ohms per mile and $C = 0.065 \mu\text{F}$ per mile) will be taken for this example with various assumed values of inductance. In the multiple twin cable, the natural inductance of a pair may be taken as 1 millihenry, while in the star quad type the greater separation between wires gives a natural inductance of 1.3 millihenries. Fig. 1 has been prepared to show the effect on the attenuation constant of such a cable where the distributed inductance is assumed to be 0; 1; 1.3; 2, and 3 millihenries per mile.

Clearly the effect of even a very small inductance is marked as the frequency rises. At a frequency of 5000 cycles the 3 millihenry curve is becoming flat whilst the other curves where inductance is present show the same tendency, but in a lesser degree. The 2 and 3 millihenry curves are never met with in practice as no cables having these constants are manufactured. The curves have been drawn to demonstrate the effect of inductance in the attenuation formula. The

frequency range taken is larger than that necessary for the normal telephone circuit. It has been taken to show that as ωL increases the attenuation rise with frequency becomes less.

Fig. 2 shows the attenuation constant plotted against inductance. In this graph it will be noticed that as the value of inductance is increased the attenuation decreases, but at a diminishing rate. Actually the minimum attenuation is reached when the inductance and capacity are in such relation that $\beta = \sqrt{RG}$ (see Hill's "Telephonic Transmission," Appendix V). When sufficient inductance is introduced to balance the loss due to capacity the attenuation reduces to the D.C. case, *i.e.*, where inductance and capacity are zero. This is sometimes referred to as the distortionless case.

The wave-length is decreased as the inductance increases. This is shown very clearly in Table I and is illustrated graphically in Fig. 3. The effect of increasing the inductance of a line is therefore to decrease both attenuation and wave-length. This fact led naturally enough to attempts to introduce "loading" by adding to the natural inductance of the line to increase its transmission efficiency.

There is another point of interest to note from the examination of the figures in Table I. As the inductance increases and the value of R^2 becomes less important $R^2 \omega^2 C^2$ becomes relatively small. Since this is the determining factor in the equation, the effect of frequency on attenuation is small. Put in another way, one very considerable advantage of loading is to render the attenuation less dependent upon frequency. The diminishing influence of $R^2 \omega^2 C^2$ is seen by comparing the differences between the columns headed \sqrt{XY} and Z in Table I.

Returning to formula (7) for the wave-length constant, this formula is approximately true for all loaded lines since it depends on the addition of the

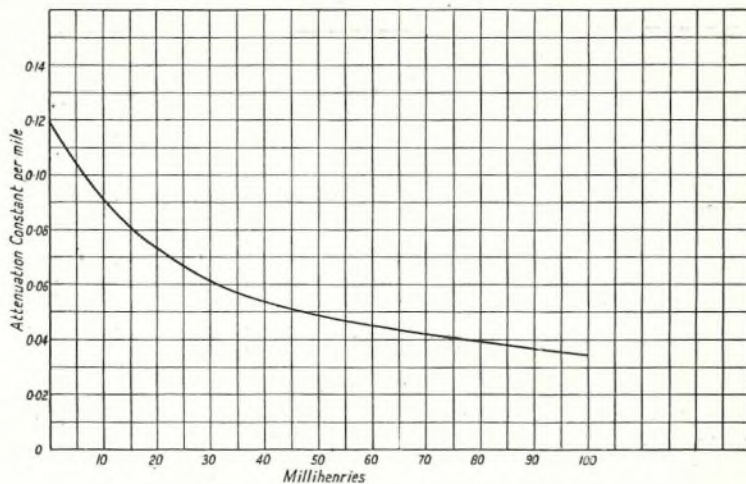

FIG. 2.—VARIATION OF ATTENUATION CONSTANT WITH INDUCTANCE; FREQUENCY = 800 C.P.S.

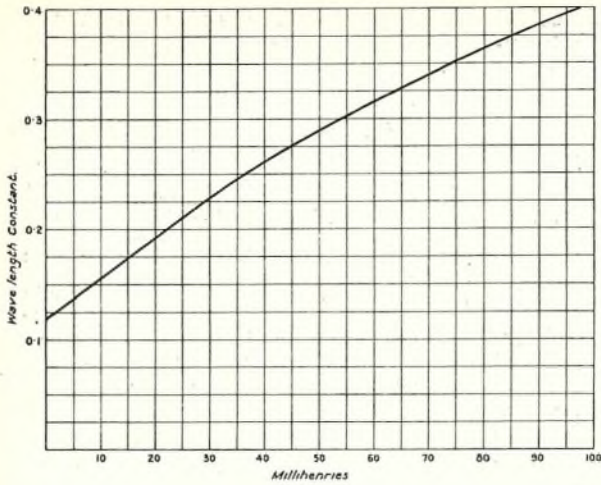

FIG. 3.—VARIATION OF WAVE-LENGTH CONSTANT WITH INDUCTANCE; FREQUENCY = 800 C.P.S.

two factors not their difference. R, therefore, in a loaded line, has small influence on α .

Consider now the transmission of a tone of 800 cycles along a line. When the current has travelled a distance equal to a complete wave-length of transmission the current is exactly in phase with the transmitted current, but 360° or 2π radians behind. The wave has progressed a distance λ in the time taken to complete one cycle or $1/800$ th of a second. That is, the speed of propagation of the wave is

$$\frac{\lambda}{\frac{1}{800}} = 800 \lambda.$$

In the general case

$$\begin{aligned} f\lambda &= \frac{2\pi}{\alpha} \lambda \\ &= \frac{2\pi f}{\omega \sqrt{LC}} \\ &= \frac{1}{\sqrt{LC}} = V \dots\dots\dots(8) \end{aligned}$$

If L and C are taken per mile the velocity V is calculated in miles per second.

The time of transmission on a loaded circuit is therefore dependent on $\frac{1}{\sqrt{LC}}$ and the heavier the loading the greater the time of transmission.

The characteristic impedance of a line is given by the expression

$$Z_0 = \sqrt{\frac{R + j\omega L}{G + j\omega C}}$$

Assuming again that in a loaded line the resistance and leakage are negligible in comparison with ωL and ωC ,

$$Z_0 = \sqrt{\frac{L}{C}} \dots\dots\dots(9)$$

and this may be taken as a reasonable approximation in all cases.

We are now in a position to sum up the effects of loading a transmission line by increasing its inductance.

1. Attenuation is decreased.
2. The length of propagation waves is decreased.
3. The time of transmission is increased.
4. The impedance is increased.

1. This is of immense importance since transmission efficiency is increased. By adding 100 millihenries as in Table I the cable could be extended to about 3.5 times its length for the same overall attenuation.

2. This is not of itself of great importance.

3. This factor becomes serious when very long lengths of circuits are involved since if the time of transmission becomes sufficiently great subscribers would not be able to reply to each other with sufficient rapidity and conversation would become difficult.

4. This is of importance because the effect of raising impedance is to raise the voltage on the circuit and this in turn increases cross-talk due to out of balance capacity.

Loading.

In actual practice loading may take one of two forms. A method was patented many years ago by Krarup, a Danish Engineer, consisting of wrapping a fine soft iron wire or tape round each conductor in a cable. The method is expensive and not very efficient, but has great advantages for sea cables where loading coils are difficult to deal with. A further disadvantage is that the effective resistance introduced by the iron losses causes the attenuation to rise rather rapidly with frequency.

The second and commoner method is to introduce coils of inductance at intervals along a cable. This can be done more cheaply and the addition of resistance to the circuit can be kept within reasonable limits. There is, however, another factor which needs to be explained.

Fig. 4 shows a coil loaded line without resistance, but having capacity and inductance and made up in sections.

This diagram will be obvious to all radio enthusiasts as a filter having several sections. Formula (6) shows the attenuation as zero, which is attained only with the perfect filter made of components having no losses. A filter made up as in Fig. 4 is

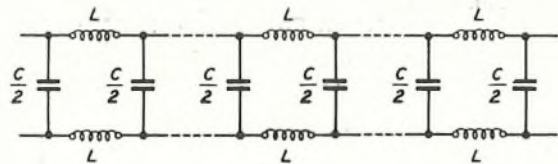

FIG. 4.—EQUIVALENT DIAGRAM FOR COIL-LOADED LINE WITHOUT RESISTANCE.

known as a "low pass" filter inasmuch as for low frequencies the series inductance and shunt capacity have but small effect. At high frequencies ωL being large and $\frac{1}{\omega C}$ being small, attenuation becomes very high and no current passes. Attenuation is there-

fore only "zero" over a certain range beyond which the filter cuts off all transmission. The filter "cuts off" when resonance occurs, and since the sections can be seen to be a series circuit of inductance L in series with two capacities each equal to $\frac{C}{2}$, the resonance frequency is found as follows:—

$$\omega L = \frac{1}{\frac{C}{4}}$$

$$\text{or } \omega^2 = \frac{1}{LC}$$

$$\text{or } \omega = \frac{2}{\sqrt{LC}} = 2\pi f$$

$$\therefore f = \frac{1}{\pi\sqrt{LC}} \dots\dots\dots(10)$$

where L and C are values of inductance and capacity per loading coil section.

The cut off frequency is usually written f_0 . If resistance be added there is still a filter, but one which may be described as "damped." Its attenuation will have a value depending on the resistance and shunting capacity at low frequencies and it will rise gradually until the cut off point is approached, nearing which the rise will become very rapid.

A typical curve of attenuation for a coil loaded line is shown in Fig. 5.

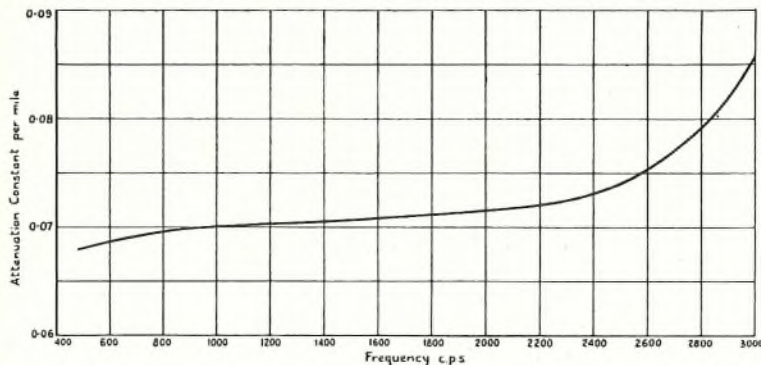

FIG. 5.—ATTENUATION CONSTANT OF 10-LB. CABLE LOADED WITH 120 mH COILS SPACED AT 1.136 MILES.

A coil loaded line therefore suffers from the difficulty that it only transmits a certain band of frequencies and it is necessary to determine the degree to which loading may be carried so as to avoid cutting off the important upper harmonics of speech.

Referring again to Fig. 4, the filter is made up of sections each containing capacity and inductance. The cut off point is determined by formula (9). Examining this formula it will be noticed that the frequency of cut off drops as the product of LC increases. In a telephone cable the capacity per mile is fixed, therefore the greater the inductance per loading coil section the lower will be the cut off frequency.

Putting it another way, if it is desired to add a certain amount of inductance per mile this can be done by, say, a 500 mH coil every five miles or a 400 mH coil every four miles or a 100 mH coil per mile. In the first case the filter section contains a product of 5 times the inductance with 5 times the capacity compared with the last case. In the first case the cut off frequency will be only one fifth that of the last case.

Table II gives the calculated cut off frequency (f_0) for various inductances spaced at different distances apart in a cable having an assumed capacity of $0.065 \mu F$ per mile.

The results have been shown in Fig. 6.

When loading was first introduced it was considered that articulation was satisfactory if frequencies up to about 2200 cycles were transmitted. Having in mind the cost of loading coils and man-holes and also the variation of copper weight required in order to get a desired attenuation with the loading chosen, it was decided that the most economical spacing of coils was about 2.5 miles. Under this condition the loading should be about 136 mH per coil.

When repeaters became a practicable proposition, the economic aspect of line provision changed as much lighter conductors could be used. Heavier loading became more economical since the added resistance of loading coils was of smaller import, while in order to get the same cut off the spacing was reduced to 1.6 miles. The corresponding inductance used was 177 mH. Later the cut off frequency was raised by reducing the spacing to 1.125 miles.

TABLE II.

Spacing (miles)	L = 20 mH. f_0	L = 50 mH. f_0	L = 100 mH. f_0	L = 150 mH. f_0	L = 200 mH. f_0	L = 250 mH. f_0
0.5	12500	7900	5600	4550	3950	3550
1.0	8850	5600	3950	3230	2790	2500
1.5	7230	4550	3230	2630	2270	2040
2.0	6250	3950	2790	2270	1980	1770
2.5	5600	3530	2500	2040	1770	1580
3.0	5100	3230	2280	1860	1610	1445

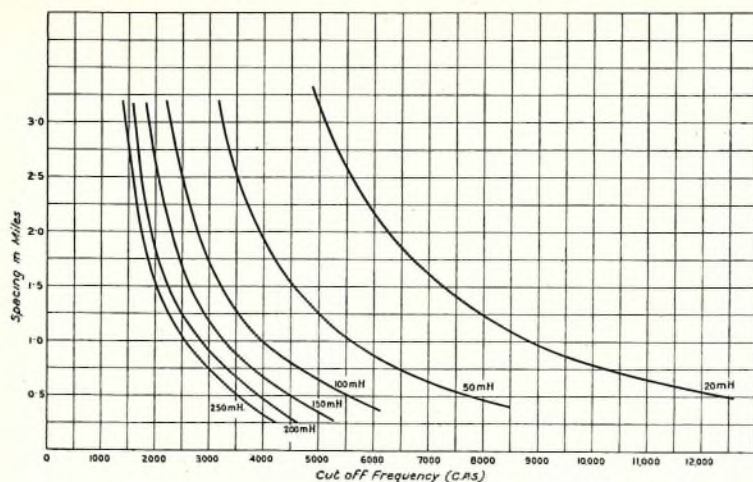

FIG. 6.—VARIATION OF CUT OFF FREQUENCY WITH LOADING SPACING; $C = 0.065 \mu\text{F}$ PER MILB.

As repeaters advanced in technique, long underground lines became possible and articulation had to be reconsidered from a new aspect. Since a repeater has a straight line law of amplification with frequency, it follows that a distortion due to a rise of attenuation with frequency in the first section would give a distorted input into the first repeater. This naturally became further distorted at the second and subsequent repeaters. It was therefore necessary to restrict the band of frequencies at its upper limit to 0.7 times the theoretical cut off point. By Inter-

national agreement the limiting value has been placed at 2400 cycles, thus giving a theoretical line limit of 3450 cycles. This condition is met by 120 mH spaced at 1.136 miles. This may explain to many the reasons for varying loading spacings in the past. The decisions have been based on the most economical method of loading to give the desired cut off.

The formula developed for attenuation assumes that inductance is distributed. It is not completely true for a line where loading is inserted at intervals along a cable, since the filter action completely cuts off transmission above a certain frequency. The formula for the case where the constants are not uniformly distributed is somewhat complex and will be found by those interested in Malcolm's "Theory

of the Submarine Telegraph," Chapter VI. The proof of a formula giving correct results for frequencies well below the cut off value is given in Hill's "Telephone Transmission," Appendix VI. The formula is as follows:—

$$\beta = \frac{R}{2} \sqrt{\frac{C}{L}} + \frac{G}{2} \sqrt{\frac{L}{C}}$$

Leakance which cannot be ignored, due to the higher impedance of loaded cables, is taken into account. R in this case includes the resistance of the loading coils as well as the line.

Carrier Telephony in Underground Cables

With a view to carrier working, certain pairs in several cables have been loaded or reloaded, the cut-off frequency being not less than 7 kilocycles per second. The reconditioned "East Coast" cable, London-Derby-Edinburgh, with 40-lb. conductors, has loading coils of 20 mH spaced at 1.6 miles between London and Derby, and coils of 27 mH spaced at 1.136 miles between Derby and Edinburgh. On the West Coast, the old "Northern Underground" cable has been reloaded with 10 mH coils at $2\frac{1}{2}$ miles. In these cases, the coil inductance chosen has been determined by the use of the old loading chambers with existing spacing. In Wales, the new cable laid between Carmarthen and Haverford West was provided with 30 mH coils at 1.136 miles. Similarly, the Liverpool-Glasgow cable to be laid this year has lightly loaded and unloaded quads in each of two layers with a view to the audio carrier scheme being applied.

Experiments have been in progress on the completed cables with their associated repeaters or unit amplifiers. The cross-talk problems between carrier and carrier and between carrier and audio have necessarily received special attention. On the Carmarthen

route, with unit amplifiers at Carmarthen and Haverford West, a very good performance was obtained. On the East Coast cable circuit, terminal carrier equipment has been tried starting with one repeater section and adding section by section, finally testing between London and Edinburgh. The circuits were equalized up to nearly 80% of the cut-off frequency. Carrier to carrier cross-talk tests showed that about half of the quads could be used. To ensure good cross-talk between carrier and audio due to a common repeater being employed, a small compensating resistance was necessary in the output circuit of each repeater. This operates in a way equivalent to making the valve characteristic curve similar on the two sides of the normal priming voltage. An additional simple and effective means whereby the input speech voltage to the trunk circuit is limited was also provided. It employs a biased metal rectifier circuit and operates only on the large peaks of speech when the volume of the latter is considerable. No degradation in speech quality occurs, whilst in general the volume of speech on the trunk will be lower than that used in the trials. By these means the circuits can be made very satisfactory in all respects.

Recent Developments in Concrete Kiosk Construction

A. J. AMOS

CONCRETE was first used by the Post Office as the material for constructing Telephone Kiosks when, in 1920, the Kiosk No. 1 was introduced. As a structure, this kiosk gave every satisfaction, and paved the way to the continued use of concrete in later designs. From an appearance point of view, however, it left much to be desired, and this feature led to the receipt of numerous requests from local authorities for designs more suited to local architecture. It was obvious that, on economic grounds, all these requests could not be met, and the Post Office invited Sir Giles Gilbert Scott, R.A., to prepare a design which could be standardised. The design of the Kiosk No. 3 which the architect prepared, and which is illustrated on the left of Fig. 1, followed closely the lines of the existing iron Kiosk No. 2, and a more imposing structure would have been difficult to imagine. The

fact that thousands of these kiosks are now erected in settings varying from the wooded lanes of the countryside to the heart of a busy city, shows how Sir Giles, in a masterly way, fashioned a kiosk in keeping with the dignity of the Post Office and which could be erected anywhere without drawing complaint from local authorities.

The original Kiosk No. 3 design.

The kiosk consists of seven separate concrete sections, viz., two side sections, one back section, till, floor slab, dome, and a transom section, with a Columbian pine door hung in a steel door frame (see Fig. 2). The two sides and the door are glazed, and the transom section provides for four opal glass TELEPHONE signs. The sides and back are screwed together, the door frame is fixed to the sides with nuts and bolts, while the transom section with its associated steel frame adds much to the rigidity of the structure.

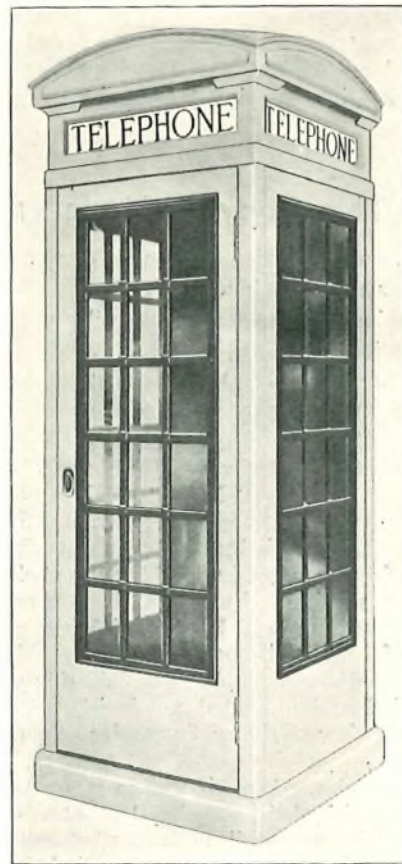
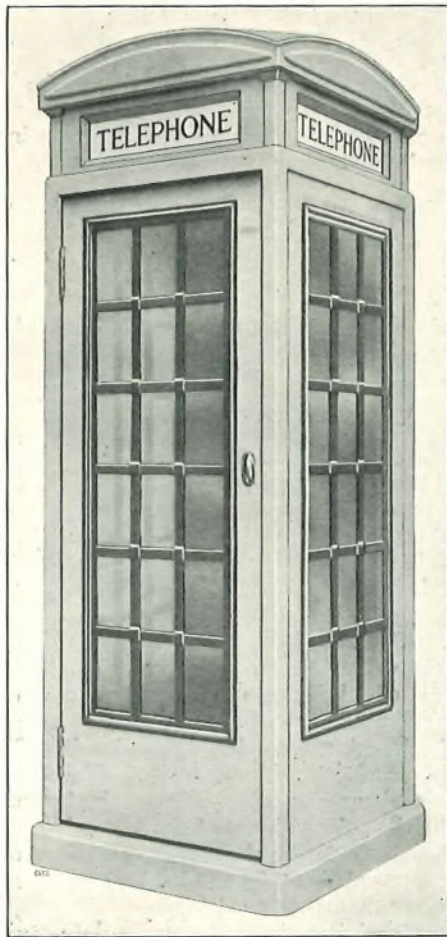
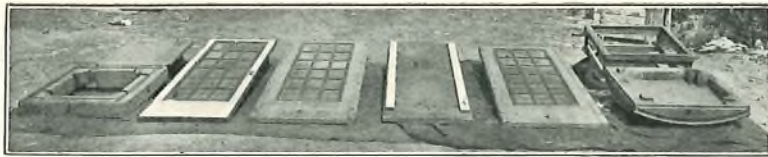

FIG. 1.—OLD AND NEW TYPES OF KIOSK NO. 3.



CILL FLOOR SLAB DOOR SIDE PANEL BACK SIDE PANEL TRANSOM DOME ROOF

FIG. 2.—SECTIONS OF OLD TYPE KIOSK.

The concrete used consists of an approved aggregate, graded into coarse and fine, with aluminous cement. The coarse aggregate varies between $\frac{1}{4}$ " to $\frac{3}{8}$ ", while the fine aggregate consists of clean, sharp washed sand $\frac{1}{8}$ " down. Not more than 5% of the fine aggregate must pass the 100-mesh sieve when subjected to the test laid down by the British Standards Institution. The concrete is mixed in the following proportions:—Cement 100 lb., fine aggregate $1\frac{3}{4}$ cubic feet, and coarse aggregate 3 cubic feet.

One of the most pleasing features of this kiosk is the finish, which is Clipsham stone colour with all the steelwork painted Post Office red. In the first instance, Portland Cement was used, but it was found impossible to obtain a suitable material, giving this specified finish, which would adhere or maintain a reasonably good appearance. It was because of this fact that aluminous cement was adopted, and to offset the disadvantage of the extra cost, there is the advantage that kiosks can be produced at three times the rate as with Portland cement. The aluminous cement coatings are treated with an oil-bound paint and lightly stippled. This paint, which is quick drying, is found to adhere to the concrete remarkably well.

Since the first contracts, in 1928, manufacturing difficulties have arisen from time to time, with resultant weaknesses in the castings and, while every effort was made to combat these difficulties, it was finally decided that the only satisfactory method of obtaining better castings was to make certain changes in structural design, and in the method of assembly. Against this, it had to be borne in mind that any change in outward appearance must be avoided as far as possible for two important reasons:—

- (1) The fact that the kiosk was prepared to the design of an eminent architect has proved an invaluable lever to the Post Office in dealing with local authorities.
- (2) The public are now thoroughly familiar with the appearance of a telephone kiosk.

Any changes that were made, therefore, should be such that external appearance should be almost unaffected.

Manufacturing difficulties and their cure.

Fig. 3 shows the transom section. It will be clearly seen from this illustration that the section is built up of a number of delicate members. The

mould for this casting is necessarily complicated and difficult to fill with concrete of a consistency which will produce reasonable strength. Even with considerable vibration of the mould and "rodding" of the concrete, it is almost impossible to remove trapped air.

In pre-cast concrete work, it is an advantage if moulds are open and flat on the top surface so that they can easily be filled and "vibrated" and the concrete "struck off."

With this in mind, it was decided to split up the transom section into four parts, casting three of these parts integral with the sides and the back, and letting the fourth side form a small panel to fix over the door frame. In doing this, two slight alterations to appearance were introduced. By splitting the section into four, surface joints were exposed on two sides, at points where they were most noticeable. Sir Giles Scott, in his design, had cleverly masked all joints by the shadow produced by a pilaster, and the same procedure was followed here by introducing pilasters on the corners at the top of the extended sides.

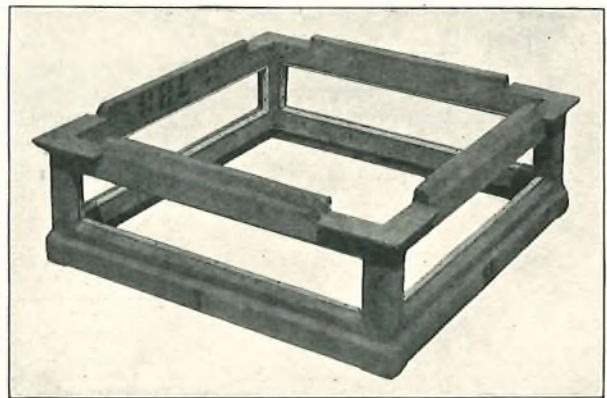

FIG. 3.—TRANSOM SECTION.

The second alteration resulted from the fact that, to produce a large enough section to give adequate strength, it was necessary to reduce the length of the TELEPHONE signs by $5\frac{1}{4}$ ".

Reference to Fig. 4 (a) will show that pilasters were cast on both sides of the side sections of the kiosk. To do this it was necessary to build up the shaded portion above the striking off surface of the mould with consequent difficulty in obtaining adhe-

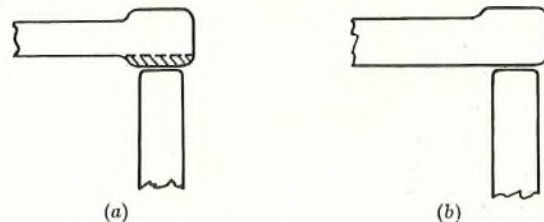
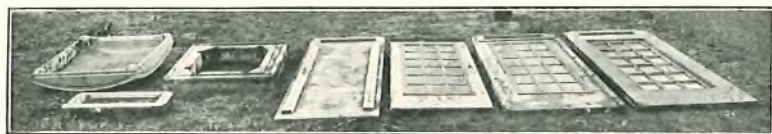

FIG. 4.—DETAIL OF PILASTERS.

sion. Structurally, the pilaster on the inside of the section serves no useful purpose and, as shown at Fig. 4 (b) it can be eliminated without altering the external appearance.

The new Kiosk No. 3 design.

Combining these two modifications, a kiosk can be produced, still consisting of seven separate concrete sections, but such that six of these sections can be cast in flat, open moulds. These sections (with the exception of the floor slab) are shown separately in Fig. 5, and the assembled kiosk is shown on the right of Fig. 1.



DOME ROOF CILL BACK DOOR SIDE PANEL (OUTSIDE (UPPERMOST)) SIDE PANEL (INSIDE (UPPERMOST))
TRANSOM PANEL

FIG. 5.—SECTIONS OF NEW TYPE KIOSK.

Difficulties due to other causes.

During the hot weather in the midsummer months, reports were received from a number of contractors that kiosks, after assembly and while awaiting inspection by the Department's inspecting officer, cracked under the influence of the sun. In examining this problem, it must be borne in mind

that the Department specifies rapid hardening aluminous cement, the behaviour of which is appreciably different from that of Portland cement. With a rapid hardening cement, very great care has to be taken to ensure that there should be sufficient water present during the setting process to produce complete hydration of the cement. If the kiosks are exposed to the sun, some of the water may evaporate and there will be insufficient water to bring about complete hydration, with consequent cracking of the castings. To overcome this, the moulds, when filled, are covered with wet sacking for a period of 24 hours, and a clause to this effect has been added to the specification. At the end of this time, the castings are ready for handling.

It was found that in many cases, the cracking of the concrete sections took place at those points where wooden plugs were inserted to enable the sections of the kiosk to be screwed together. The wood, in contact with the wet concrete, swelled appreciably and produced a bursting action. Wooden plugs have been replaced on the new design by metal inserts.

Before the new design was finally standardized, Sir Giles Scott was invited to inspect two kiosks incorporating the modifications. In expressing his approval, Sir Giles stated that, in his opinion, those few alterations which had been introduced, made the appearance of the kiosks more suitable for a structure constructed in concrete.

Carrier Telephony on Aerial Lines

A description of the mains-operated equipment designed for use on aerial lines was given in the July, 1933, issue of the *P.O.E.E. Journal*. Supplies of this equipment for providing 12 carrier circuits have been received and tested. Installation and lining up in various districts, especially in Scotland, have taken place and the performance of the circuits on traffic has been reported as very satisfactory.

In the Glasgow area, four circuits are in operation, viz., Glasgow-Oban, Glasgow-Fort William, Glasgow-Lochgilphhead, and Glasgow-Campbeltown. For 63 miles all the circuits are on the same pole route, whilst two circuits are together for 98 miles. The cross-talk between circuits is commercially satisfactory in all cases, but to provide additional margin in this respect additional transpositions will be introduced.

From Aberdeen, two carrier circuits are in operation to Inverness and one to Wick. In this case, satisfactory cross-talk was ensured by an adjustment

of levels. The Wick circuit has been especially appreciated by the subscribers and enables a very high grade of communication to be obtained from the Orkney Islands to London. It is understood that a favourite call for tourists on this route is from John O'Groats to Lands End.

A circuit is also in use between Swansea and Aberystwyth.

In all cases, the overall transmission has been made 3 db. Radio interference is almost completely absent whilst other line noise on the carrier circuit is generally, though not always, less than that on the associated physical circuit. This is quite satisfactory in view of the fact that the efficiency of the carrier circuit is everywhere better than that of the audio. The lines are 150 or 200 lb. copper, the longest length is 137 miles, and underground cable up to a total of 3½ miles occurs on some routes. The audio frequency attenuations of the physical circuits are between 8.5 and 10.5 db.

A Transmission Test Set for Subscribers' Instruments, Local Lines, and Exchange Apparatus

E. J. BARNES, A.C.G.I., A.M.I.E.E.
and
R. E. SWIFT, B.Sc., A.M.I.E.E.

SEVERAL attempts have been made in the past ten years to devise a means of testing the transmission efficiency of subscribers' instruments, including the transmitter, by a simple test capable of being made quickly by the maintenance officer in conjunction with the telephone exchange test clerk. This article describes simple and inexpensive testing equipment with which subscribers' apparatus, including the local line and transmitter, may be tested in a routine manner.

The apparatus consists of three units, namely:—

- (1) Noise Generator No. 1.
- (2) Oscillator No. 8A.
- (3) Tester T.L. 1635. (If mounted on a test desk—a Panel Test A.T. 2635.)

The Oscillator No. 8A and the Tester T.L. 1635 are portable units used for measuring the attenuation in lines or apparatus at 300, 800 or 2,000 c.p.s. The Noise Generator No. 1 and a modified form of the Tester T.L. 1635 may be used for obtaining the overall efficiency of a subscriber's circuit, including the transmitter, in terms of a standard circuit. A feature of both tests is that the results may be read on the meter of the Tester T.L. 1635 directly in decibels.

TESTING OF SUBSCRIBER'S INSTRUMENTS.

Three methods of measuring the efficiency of subscribers' instruments have previously been tried and it is thought a brief outline of the three methods will illustrate some of the difficulties that are met with.

(a) *The Artificial Cable Test.* In this test, which was used in telephone exchanges soon after the introduction of C.B. working, no quantitative measurements are made, but a listening test was made by an officer at the telephone exchange to a talk from a maintenance office at the subscriber's telephone over a circuit consisting of the subscriber's line plus thirty miles of artificial cable. It will be realised that with this test the number of transmitters described as faulty and changed will depend, amongst other factors, on the strength of the lineman's voice, the distance from the transmitter at which he speaks, the acuteness of hearing of the listener, and the amount of extraneous noise in the test room where the listener is located.

(b) *The Subscriber's Station efficiency Tester*¹ An obvious step from the artificial cable test was to provide the listener with a measuring instrument and the talker with a standard transmitter for com-

parison with the test transmitter. Such an equipment has been used at Willesden Exchange with useful results. This equipment, however, provided for the quantitative testing of receivers and for this purpose included a high gain amplifier which increased the cost out of proportion to the advantages obtained from the receiver test.

(c) *The Palmers Green Test Set.* In this test set the receiver test was abandoned and a two-valve amplifier rectifier employed in conjunction with the test desk voltmeter for comparing the output from a standard transmitter carried by the lineman and the subscriber's transmitter. It will be apparent that this method of testing relies for its accuracy on the judgment of the lineman in talking with equal volume into and at the same distance from both the standard and the test transmitters. There is the additional manipulative difficulty of connecting the standard transmitter to the circuit.

The introduction of the Noise Generator No. 1 by the Research Section, Dollis Hill, and the commercial development of the sensitive copper oxide rectifier A.C. voltmeter enabled the present test set to be evolved. It surmounts the main difficulties present in previous test sets and makes possible for the first time the routine measurement of transmitter efficiencies in the field, with known maximum errors.

GENERAL REQUIREMENTS OF A SUITABLE TEST.

It is now the practice in the Post Office to design each subscriber's plant and line so that the transmission is up to a certain standard grade. The standard grade of transmission is that given by a standard Microtelephone No. 162 with a Bell Set No. 1, connected through a non-reactive line of 300 ohms, to a standard 22-volt C.B. cord circuit.² The distance of the average speaker from the transmitter mouthpiece has been assessed from actual measurements and as this distance is different in the cases of pedestal and microtelephone type instruments, this difference is allowed for when estimating the efficiency of any circuit in terms of the standard circuit.

When the new basis of plant design has been in use for a sufficient period, we shall reach the condition where theoretically no subscriber's circuit, if the apparatus is in order, will have a worse efficiency than that of the standard circuit if the circuits were compared, by means of a speech test,

¹ "Routine Transmission Testing of Subscribers' Instruments at the Subscriber's Office." A. Hudson. *P.O.E.E. Journal*, Vol. 21.

² "Modern Developments in Telephone Transmission over Lines." J. Stratton and W. G. Luxton. A paper read before the London Centre of the I.P.O.E.E. on October 10th, 1933.

with the talker speaking at constant volume, but at the correct average distance for the type of telephone. Any routine test of subscribers' circuits, therefore, should be capable of measuring its efficiency in terms of the standard circuit and of giving results in agreement with speech tests.

As a satisfactory test would be used by thousands of linemen any equipment to be used by them should be inexpensive, stable, robust, light and not complicated in operation.

STANDARD NOISE AND VOLTMETER TEST.

It will be noted that the previous methods of test described above have relied upon a lineman's judgment in talking correctly into the transmitter under test. It is extremely difficult for a speaker, without much practice, to keep his voice constant during a test, and it has long been realized that a device emitting a suitable noise to replace speech is desirable both in acceptance and field tests of transmitters. The Telephone Instrument Tester³ has been used now for some years for acceptance tests and a noise generator suitable for use by linemen has been designed to provide a constant source of sound for field tests.

To provide the necessary measuring equipment at the exchange, it was decided to use, if possible, an 0 - 1 volt metal rectifier instrument without any amplifier since this type and range of meter was standardized for use with an attenuation measuring set for local lines. This instrument is described later in this article, and the use of a common meter will greatly facilitate the complete testing of equipment.

NOISE GENERATOR NO. 1.

A photograph of the noise generator is shown in Fig. 1. The overall dimensions are $2\frac{13}{16}'' \times 2\frac{13}{16}'' \times 2\frac{1}{4}''$ and the weight 1 lb. The apparatus is readily carried about and can be applied to the transmitter under test with one hand.

In principle the generator consists of a light nickel silver cone rigidly clamped round the edge. The apex of the cone is fitted with a hard steel adjustable pip which is struck by a number of hard steel balls at irregularly spaced intervals. The balls are carried in slots in a wheel which is made to rotate by clockwork. The slots are not quite radial but are placed so that the balls which fly out to the edge of the wheel under centrifugal force, have the minimum restriction of movement on striking the cone; the wear on both the cone and the balls will hence be a minimum. The balls are spaced irregularly round the wheel, the pitch varying from 15° to 26.5° ; in this manner the sound radiated by the cone during one revolution of the wheel consists of a varying fundamental frequency which, with the harmonies, covers the speech range. The wheel rotates at 300 revolutions per minute.

The mechanism of the generator is enclosed in a die-cast zinc alloy box from which it is insulated by rubber to prevent the mechanical transmission of vibration to the transmitter. The speed of the

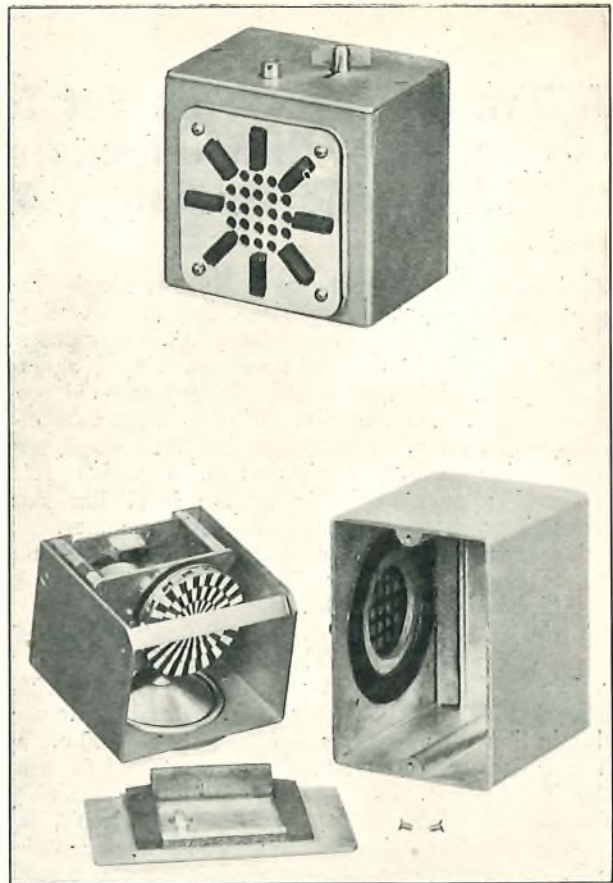

FIG. 1.—NOISE GENERATOR NO. 1.

wheel is kept constant by a governor similar to the one fitted in automatic dials. The wheel, which is set in motion by the depression of a button, rotates for 8 seconds, giving ample time for the test.

The noise generator is intended to radiate sound, the intensity of which will remain constant during the life of the apparatus. All noise generators will be adjusted before being put into service to give the same volume of sound output. This adjustment is made by setting the speed to 300 revolutions per minute and varying the distance of the cone pip from the rotating ball wheel. The speed adjustment is facilitated by the use of a stroboscopic disc designed for use with a lamp on a 50-cycle per second supply.

The moulded rubber guard on the front of the case is designed to place the generator in the correct position relative to the transmitters; it is suitable for either the curved mouthpiece of the Telephone No. 162 or the flat mouthpiece of the Transmitter No. 22, or Transmitter No. 1.

Noise generators manufactured under mass production conditions can readily be adjusted to give a maximum difference of plus or minus 0.7 db in sound output compared with a standard. There is no adjustment possible in regard to the natural frequency of vibration of the cone; this, however, is not of great importance provided that departures from

³ "Mechanical Testing of Transmitter and Receiver Efficiencies." A. Hudson. *P.O.E.E. Journal*, Vol. 22.

the standard are within defined limits. Actually cones are selected to a standard before assembly, but it is inevitable that small differences between cones will occur. These differences will not affect the accuracy beyond the 0.7 db. mentioned above.

DECIBELMETER NO. 1, TESTER T.L. 1635 AND PANEL TEST AT. 2635.

The common meter used as a receiving end for both noise generator tests of the efficiency of transmitters and for single frequency measurements of attenuation, is a 0 - 1 volt A.C. meter incorporating a copper oxide rectifier. The impedance of the meter is 2000 ohms at full scale deflection, but increases as the deflection decreases. The meter has been designed by instrument manufacturers primarily for this test and much research work has been done to provide an instrument with small temperature and frequency errors, with suitable damping and scale shape. The voltmeter measures the voltage across a non-reactive resistor of such a value that the impedance of the resistor-voltmeter combination is 600 ohms at full scale deflection. The resistor is attached to the meter case and the combination called a Decibelmeter No. 1. The decibelmeter has two ranges 0 - 15 db. and 5 - 20 db.; each meter is calibrated individually in decibels by inserting known losses between an oscillator and the meter in order to allow for the change of impedance of the meter.

The decibelmeter, with a condenser and inductor, is mounted as a portable unit called a Tester T.L. 1635, for making single frequency tests in conjunction with an Oscillator 8A. For noise generator tests the decibelmeter is associated with a transmission bridge; the combination is mounted on a test desk and is called a Panel Test A.T. 2635. By means of a key, this test desk equipment may be made identical with a Tester T.L. 1635 and used for the same purpose.

THE MINIMUM PERMISSIBLE NOISE VOLTAGE AT THE EXCHANGE.

In deciding the minimum permissible A.C. voltage at the exchange which should be produced by any type of transmitter when excited by a noise generator, the following considerations require attention.

The magnitude of the sound pressure on the transmitter diaphragm is important since the relative efficiency of two circuits will vary, depending on the volume of the sound used for testing; this effect will be particularly noticeable when one of the circuits is working C.B. and the other L.B. In order to be able to use a 0 - 1 volt instrument to measure the A.C. power at the exchange the volume of sound from the noise generator has been increased to a level of about 10 decibels above the level used by the average subscriber when making a trunk call; it is also at least 10 decibels above the volume used when making speech tests in the laboratory. It follows, therefore, that two circuits which have apparently the same efficiency when tested by speech may have different efficiencies when the noise generator test is applied. These differ-

ences are modified, however, because in practice a speaker talks at different distances from microtelephones and from transmitters of the pedestal type such as transmitters No. 22, and the noise generator is used at a common distance for transmitters of all types. It is impossible therefore to state a single figure for the minimum A.C. voltage that should be obtained at the exchange with a noise generator test of this type in order that all circuits should not be worse than the efficiency of the standard circuit when measured by means of a speech test. The differences, however, can readily be allowed for and a suitable value found for the minimum received voltage for each condition.

Tests have shown that an individual noise generator test of efficiency may be plus or minus two decibels different from the true speech efficiency so that in order to avoid the rejection of transmitters which are between 0 and 2 db. better than standard, it is necessary to allow a tolerance of 2 db. in practice. This means that transmitters which are on the maximum length of line allowed will be rejected if they are 2 db. worse than standard and may be rejected if they have an efficiency between 0 and 2 db. worse than standard.

When considering the case of L.B. instruments there is the complication of the transmitter battery. If the test were carried out when the batteries were in good condition, a circuit might pass the test, but the efficiency might fall below that of the standard circuit as the voltage of the battery falls to the limiting condition. It is necessary to ensure that the test is carried out when the batteries are in an average condition; and if the cells are renewed immediately prior to a transmission test the voltage of the battery is reduced during the test to that of the average battery by means of a shunt resistor. On long C.B. lines where L.B. instruments are fitted, the plant is designed to give standard transmission when the cells have the minimum permissible voltage of 1 volt per cell. With L.B. instruments in L.B. areas, the transmission efficiency is permitted to fall 2 db. below that of the standard circuit as the voltage of the cells drops from that of the average battery (1.2 volts per cell) to the limiting condition of 1.0 volt per cell.

These factors have been taken into account in preparing the table of rejection figures shown in Fig. 2 for use at Avenue Exchange where transmission tests are now in progress.

METHOD OF MAKING TRANSMISSION TESTS.

The test desk equipment necessary for transmission tests is a Panel Test A.T. 2635, a circuit diagram of which is shown in Fig. 3. The equipment consists of a Decibelmeter No. 1 connected to a transmission bridge, consisting of a two-winding inductor and a 1 μ F condenser. The exchange battery is applied through a resistor to the windings of the coil; the value of the resistor is adjusted for each type of exchange to give the same line current as the normal exchange cord circuit connected to a subscriber's line. The attenuation of the transmission bridge is 0.8 db. at 800 cycles

Type of Circuit.	Type of Telephone.	Bell Set No.	Max. Reading on Decibel Meter.
C.B.	Instruments fitted with Transmitters No. 1.	1	5
	Instruments with Transmitters No. 22, or H.M.T. Instruments fitted with Insets No. 10.		8
L.B.	Instruments fitted with Transmitters No. 2.	21	9
	Instruments with Transmitters No. 22, or H.M.T. Instruments fitted with Insets No. 10.		12
P.B.X. Operator's Circuit (using operator's induction coil).	Instruments fitted with Transmitters B.P. No. 5A.	—	10
	Telephones No. 184. ...		8

FIG. 2.—REJECTION FIGURES PREPARED FOR TRIAL AT AVENUE EXCHANGE.

per second and so compares with the loss in the average cord circuit. The operation of a key connects the apparatus to one of two test cords; a second key changes the range of the meter and a third key disconnects the exchange battery, short-circuits the $1 \mu\text{F}$ condenser and prepares the equipment for use with an Oscillator No. 8A for making single frequency measurements.

To carry out a transmission test, the subscriber's instrument is connected *via* the local line and the test cord to the test panel. The lineman applies the noise generator to the transmitter and the test clerk determines whether the reading on the decibel-meter is above or below the appropriate maximum permissible reading for that type of instrument; if the reading is above, then the transmission is unsatisfactory and faulty apparatus must be sought.

Proposed method of testing where the parent exchange is not equipped with a test desk.

Where normal testing is done over junctions from a central exchange, the junctions are arranged to give a loop without intervening transmission bridges between the central exchange and the subscriber. In these cases the total resistance of the line between the subscriber's apparatus and the central exchange may be 1400 ohms. The high transmission loss of such a circuit, where the transmitter feeding current is received from the central exchange, makes a transmission test with noise generator and decibelmeter impracticable.

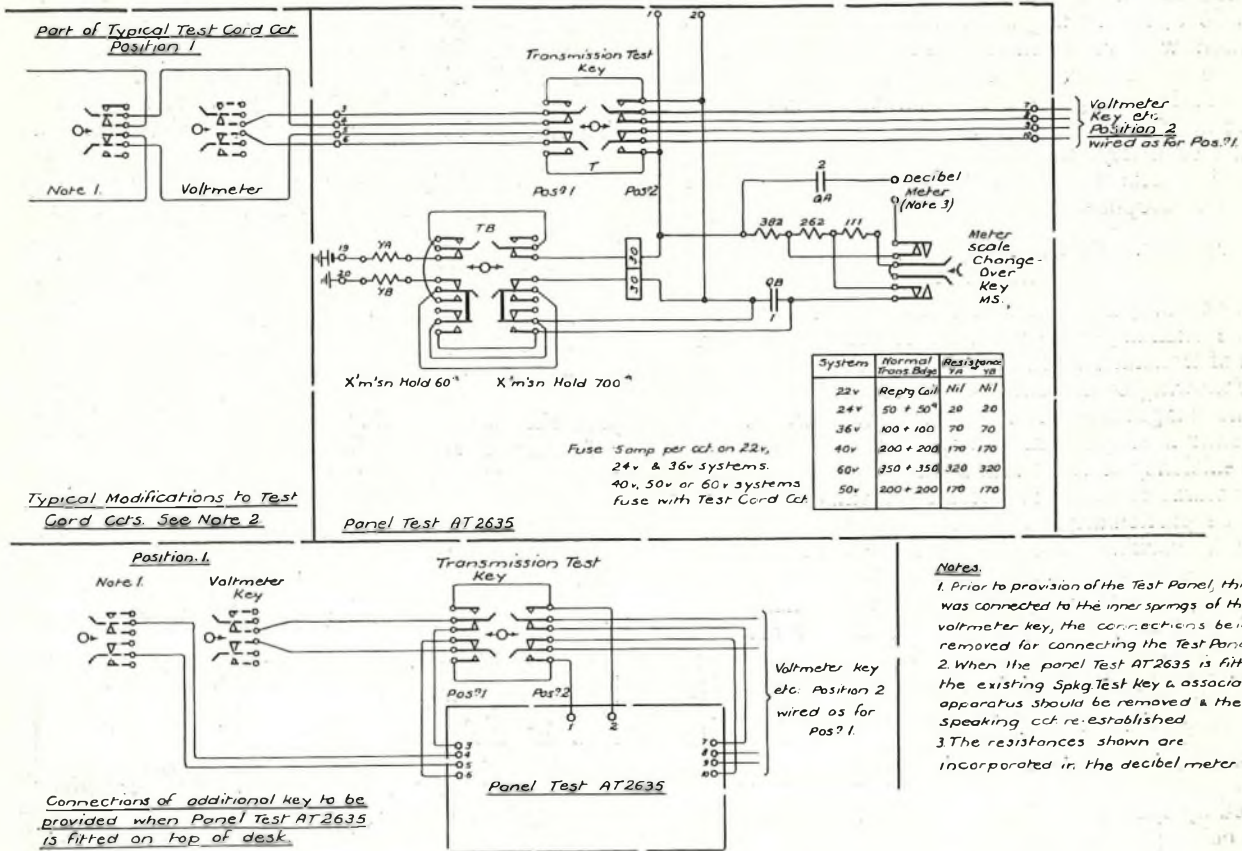

FIG. 3. TRANSMISSION TEST PANEL A.T.2635, SHOWING TYPICAL MODIFICATIONS TO TEST CORD CIRCUITS.

Alternative circuit arrangements which may be used are :

- (1) Extend the subscriber's circuit by an ordinary junction to the central exchange.
- (2) Provide facilities for switching a transmission bridge into the test distributor junction at the local exchange; the switching to be controlled at the central exchange.

Tests of the relative disadvantages of these two plans are in progress.

Proposed methods of measuring transmitter efficiencies at remote stations.

There are a large number of subscribers, estimated at 200,000, served by about 4,800 exchanges where it is economically undesirable and in many cases technically impracticable to install decibelmeters for the purpose of making transmission tests from subscribers' premises.

Alternative methods of test are :

- (1) Provide the lineman with a measuring instrument, a Tester T.L. 1635 may be suitable, and measure the output from the subscriber's instrument at the instrument terminals.
- (2) Extend the subscriber's circuit over a junction of known attenuation to the nearest exchange with transmission testing equipment.

Tests are in progress to determine the most suitable form of test.

MEASUREMENT OF ATTENUATION IN LINES AND APPARATUS.

In 1925 a junction test set was designed in the Research Section for measuring losses in lines up to 20 standard miles. The sending end consisted of a single valve oscillator giving a testing current at 800 cycles per second; the receiving end was a two-valve amplifier rectifier. The test set had the disadvantages of requiring an individual battery to supply the anode current and a calibration chart to show the relation between the meter reading and the loss in standard miles.

Portable, direct reading equipment, consisting of an Oscillator No. 8A and a Tester T.L. 1635, has been designed to measure attenuations up to 20 decibels. The circuit diagram of the new set is shown in Fig. 4 and a photograph of the apparatus in Fig. 5.

The oscillator has a single valve and is designed to work from any exchange battery from 25 volts to 60 volts. When a 22-volt battery only is available two or three additional dry cells may be used to enable sufficient output to be obtained. Three frequencies are available, namely, 300, 800 and 2000 cycles per second correct under all working conditions within plus or minus 10%. Any one of these frequencies can be selected by throwing a key. The voltage output from the oscillator is measured by means of a 0 - 6 volt metal rectifier voltmeter.

The oscillator is designed to give at least 3.6

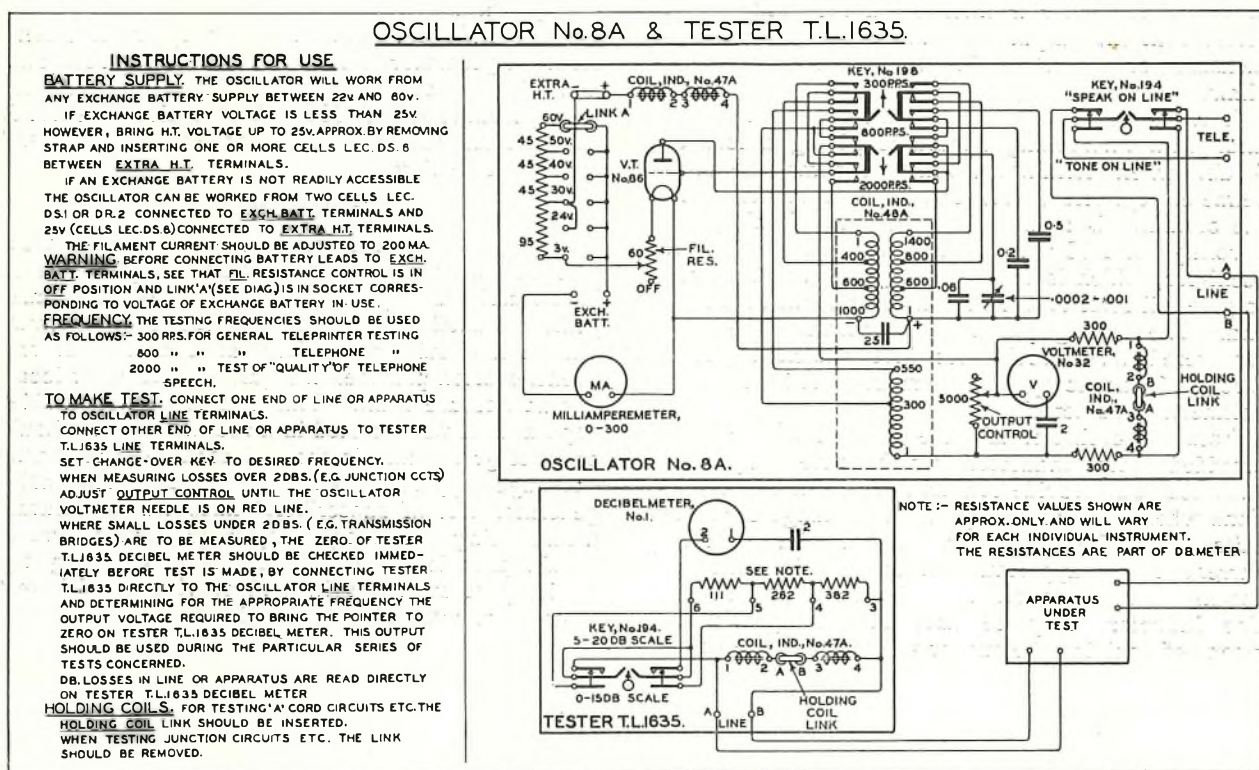

FIG. 4.—OSCILLATOR No. 8A AND TESTER T.L.1635.

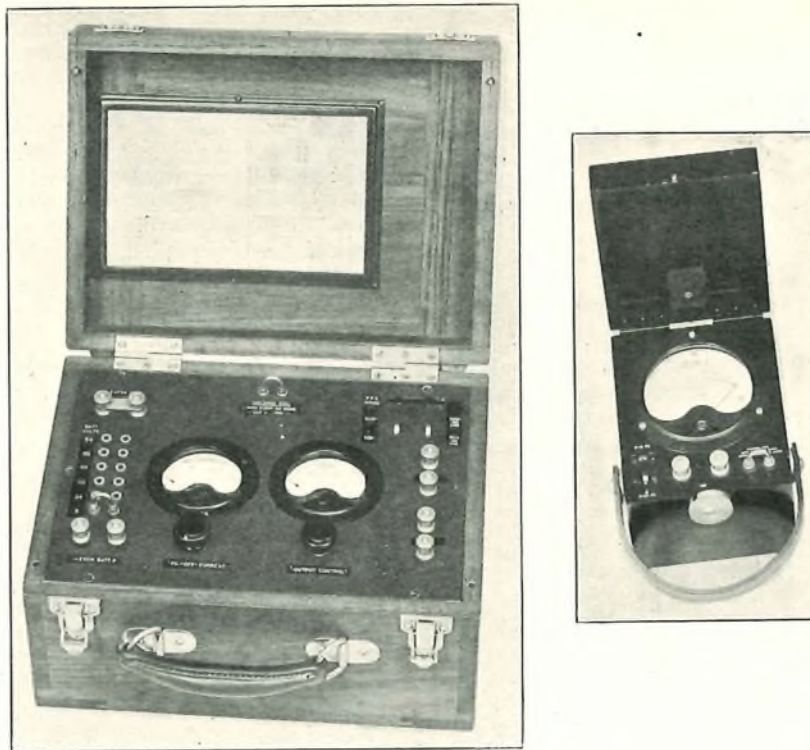

FIG. 5.—OSCILLATOR AND TESTER.

volts across a non-reactive output load of 800 ohms, of which 600 ohms is included in the oscillator in series with the output, so that at least 3.6 volts is measured on the meter with an external load of 200 ohms.

If the tester T.L. 1635 is connected to the oscillator with intervening apparatus giving a loss of 5 db. when terminated with 600 ohms, the decibelmeter registers 1 volt (full scale deflection) when the oscillator is adjusted to 3.56 volts. This gives a voltage of 1.78 volts on the line terminals of the oscillator, which is 5 db. above the 1 volt required to give full scale on the decibelmeter of the receiving end. The testing power of 1 milliwatt used for repeatered lines would not give sufficient power through 20 db. to operate the most sensitive rectifier voltmeter satisfactorily.

Both the oscillator and the tester T.L. 1635 are provided with inductors which have negligible A.C. loss but provide low D.C. resistance terminations where it is necessary, as in exchange cord circuits, to make measurements with large direct current in the apparatus under test in order to obtain the worst conditions which occur in practice. The inductors may be used also to provide a means of applying the exchange battery to the appa-

atus under test where this is necessary to operate the apparatus.

The Panel Test A.T. 2635 used by the test clerk for noise generator tests may also be used in conjunction with the oscillator for making tests over lines and apparatus at 300, 800 or 2000 cycles per second. This should prove a most convenient and useful method of testing.

CONCLUSIONS.

The apparatus described above provides an accurate and inexpensive means of analysing the losses in subscribers' apparatus, local lines and unrepeatered junctions. A measurement of the attenuation of a circuit, particularly at a number of frequencies often provides the quickest means of locating an obscure fault. This test set which enables apparatus to be so tested in a routine manner should prove of great value in the maintenance of telephone exchange apparatus and line plant. The noise generator test of subscribers' lines plus apparatus, whilst being inevitably subject to certain errors, should provide a valuable means of checking the efficiency of such circuits and provide a quick test in cases of transmission complaints.

A Precision Heterodyne Oscillator

L. E. RYALL, Ph.D.(Eng.), A.M.I.E.E.

ABSTRACT.

DESIGN details and the performance characteristics of a heterodyne oscillator with a frequency range from 0 to 15,500 c.p.s., which has been developed by the Post Office Engineering Research Section in conjunction with Messrs. H. W. Sullivan Ltd., are given. The remarkable frequency stability and calibration accuracy ensure that the frequency error is less than $0.2\% \pm 1$ c.p.s. The scale is truly logarithmic from 100 c.p.s. to 12,000 c.p.s. and the output voltage is constant to within ± 0.1 db. from 20 c.p.s. to 12,000 c.p.s. The wave form is particularly good with measured harmonic contents of less than 0.3% of the total signal voltage.

About three years ago the experience of the Department with the types of commercial heterodyne oscillators then available led to a decision being made that this form of signal generator was unsuitable for use in telephone repeater stations owing to frequency instability and to the poor calibration accuracy obtained. It was felt, however, that, in view of the other advantages which the direct reading, continuously-variable frequency heterodyne oscillator has over its rivals, an attempt should be made to produce an instrument as perfect in all respects as it was commercially possible to make. The co-operation of Mr. W. H. F. Griffiths, of Messrs. H. W. Sullivan Ltd., in the design of the components of the H.F. oscillators was obtained, and it is largely due to the stable inductance coils and condensers developed especially for this oscillator that the frequency accuracy has been achieved. The complete oscillator made to the Post Office design by Messrs. H. W. Sullivan Ltd. has now been adopted for general repeater station use.

PRINCIPLE OF THE HETERODYNE OSCILLATOR.

Any form of heterodyne oscillator, such as shown diagrammatically in Fig. 1, consists of two high-

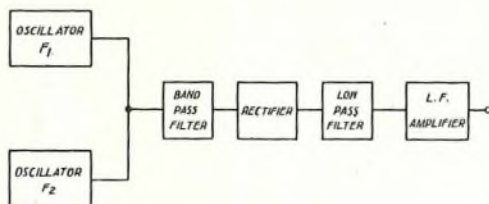

FIG. 1.—PRINCIPLE OF THE HETERODYNE OSCILLATOR (SCHEMATIC).

frequency oscillators having a fixed frequency F_1 and a variable frequency F_2 respectively. The frequency F_2 is changed by means of a variable air condenser calibrated direct in beat frequency, $F_1 - F_2$. The two high frequency signals are rectified and a signal

of frequency $F_1 - F_2$ is produced, which after suitable amplification passes to the output. If a pure beat note signal is required, one at least of the high frequency signals must be free from harmonic, and a band-pass filter (B.P.F.) should precede the signal rectifier. A low-pass filter (L.P.F.) should also follow the rectifier to prevent signals of the frequencies F_1 and F_2 from passing to the output.

The requirements of a good heterodyne oscillator are :—

- (1) A frequency range covering the audio-frequency spectrum.
- (2) A high accuracy of frequency calibration.
- (3) Very good frequency stability.
- (4) A pure output signal voltage free from harmonics and extraneous signals.
- (5) A constant output voltage over the frequency range.

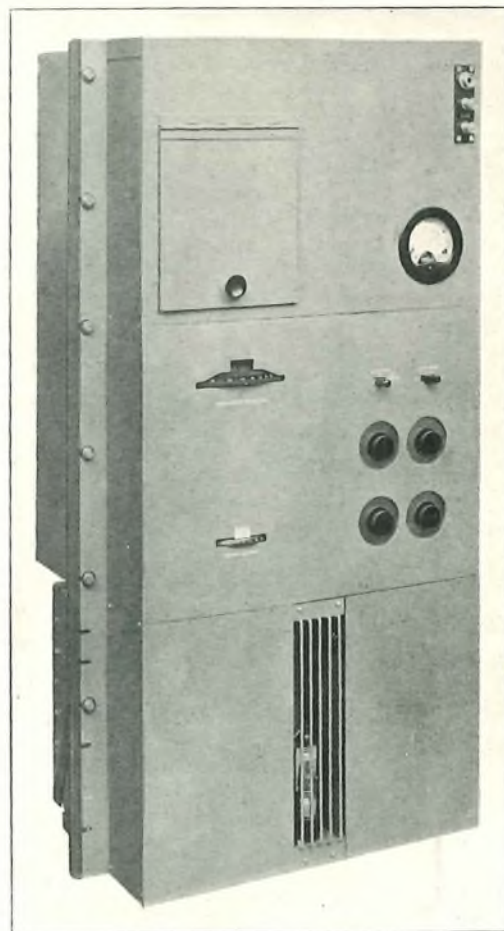

FIG. 2.—THE RYALL-SULLIVAN HETERODYNE OSCILLATOR—FRONT VIEW.

- (6) A scale beat frequency obeying some definite law, *e.g.*, a logarithmic scale of beat frequency.
- (7) For repeater station work, it is desirable that the output impedance should be constant over the frequency range.

The success with which these requirements have been met can best be judged by the following summarized performance characteristics of the final oscillator, shown in Figs. 2 and 3:—

- (1) Frequency range 0 to 15,500 c.p.s.
- (2) Scale — 0.2% accuracy ± 1 c.p.s.
- (3) Stability from immediately upon switching on — ± 1 c.p.s. per day completely unaffected by normal temperature changes.
- (4) Harmonic content less than 0.3%.
- (5) Constant output voltage from 20 c.p.s. to 12,000 c.p.s. to less than ± 0.1 decibel.
- (6) A perfectly logarithmic scale of beat frequency from 100 c.p.s. to 12,000 c.p.s. Below 100

c.p.s. and above 12,000 c.p.s., the scale is linear.

- (7) Output impedance of 600 ohms, very nearly non-reactive and output balanced with regard to earth potential for repeater station work.
- (8) The oscillator gives a pure output up to 0.2 watts with 130 V. H.T. supply or up to 2 watts with 350 V. H.T. supply, and can be made mains or battery operated.

OSCILLATOR DIMENSIONS, SUPPLY VOLTAGE, AND CIRCUIT.

The oscillator is designed for standard rack mounting. It is 35 inches high, 19 inches wide, and projects $4\frac{1}{4}$ inches in front of, and $8\frac{1}{2}$ inches behind, the rack.

The oscillator is normally supplied for operation from batteries standardized for telephone repeater station use.

Filament voltage:—19/22 volts, (2 amps).

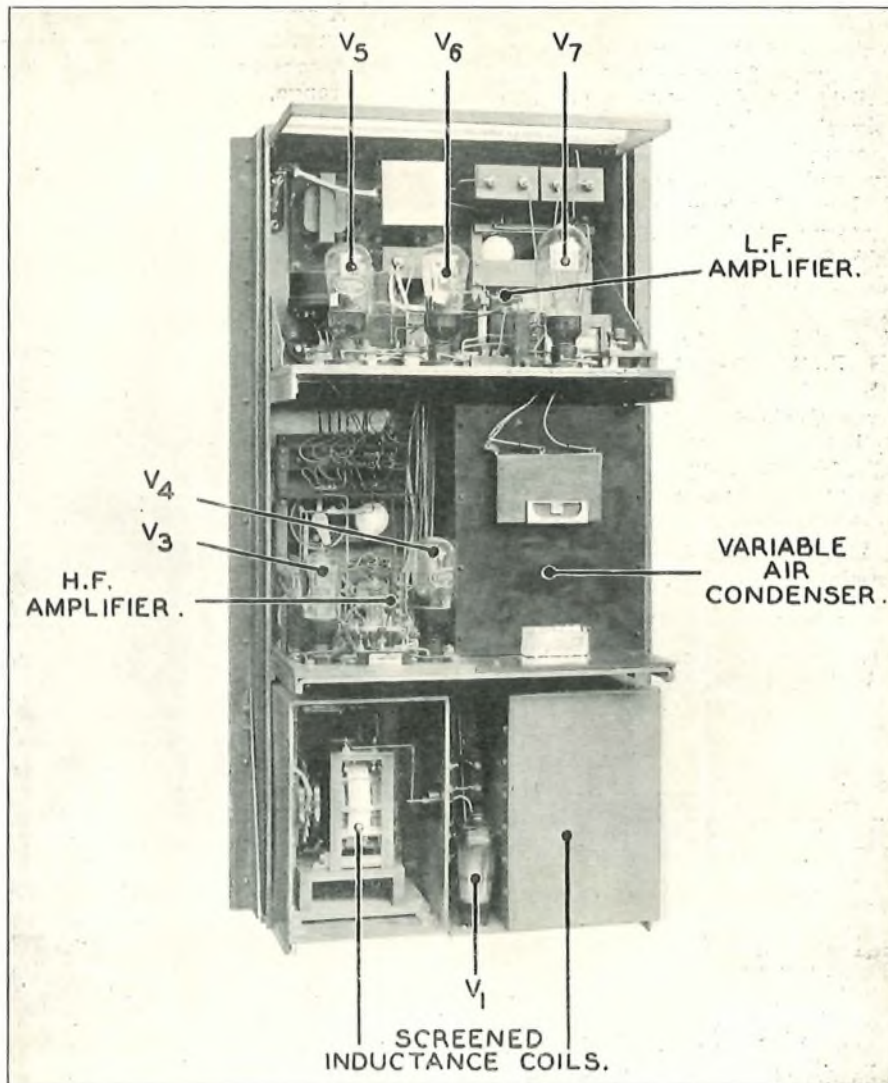

FIG. 3.—THE RYALL-SULLIVAN HETERODYNE OSCILLATOR—REAR VIEW WITH COVERS REMOVED.

Anode voltage :—130/150 volts, (50/60 mA).

The output is then limited to about 250 milliwatts.

With an anode supply of 350 volts, an output power of 2 watts can be obtained.

A mains supply panel for A.C. mains has been designed to supply the necessary anode and filament voltages. The panel is 19 inches wide and 15 $\frac{3}{4}$ inches high.

The simplified diagram of the oscillator is shown in Fig. 4. Dynatron oscillators are employed and their outputs are applied *via* potentiometers R_1 and R_2 to a common two-stage amplifier (valves V_3 and V_4) and then through a band-pass filter to the detector valve V_5 . This is followed by a low-pass filter C.O. = 20 kc.p.s.) and a stage of L.F. amplification V_6 incorporating a low-frequency corrector in the

10 times that required of the final calibration, since other factors will also influence the final beat frequency calibration. In order to obtain a frequency permanence over a period of years of the order of 0.01 per cent., dynatron oscillators incorporating the highest grade components in the oscillatory circuits are used. The coils used are Sullivan-Griffiths temperature compensated inductances of a small size developed especially for this oscillator. The inductances must be efficiently screened both

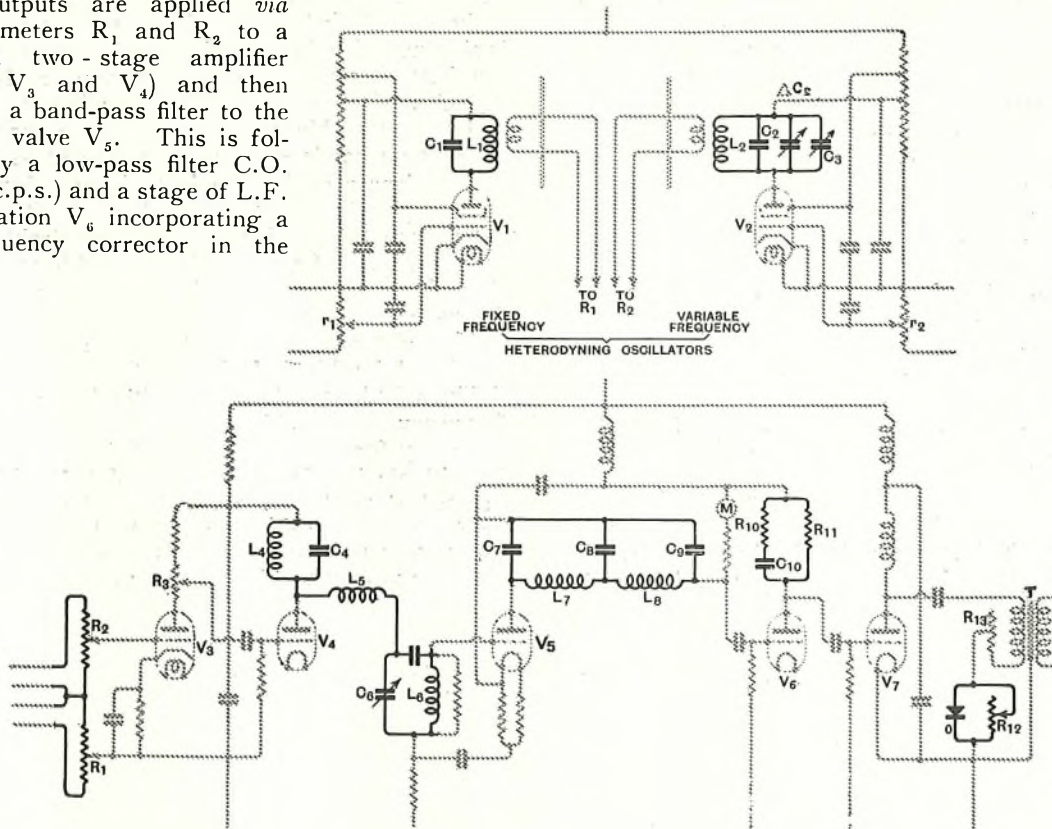

FIG. 4.—SIMPLIFIED CIRCUIT DIAGRAM.

anode circuit. The final output stage consists of a high-power valve V_7 feeding the balanced output transformer. A device for compensating for the amount of harmonic produced in the amplifier is incorporated in this output stage, and also means for controlling the output impedance.

FREQUENCY STABILITY AND CALIBRATION ACCURACY.

Probably the most striking features of the oscillator are the frequency stability and the scale accuracy, and so a few remarks on the factors influencing these features will not be out of place.

(a) A change in the frequency calibration will occur due to the fundamental frequency F_1 of the fixed frequency oscillator changing. It can be shown that the change of beat frequency f is proportional to the cube of the oscillator frequency F , so that it is very important that the permanence of F_1 over a long period should be as high as possible—at least

from one another and from external interference, but the screening must not unduly increase the coil losses, since the instability of oscillation is proportional to the square of the coil decrement. Since there is a commercial limit to the size of the screening box, it was necessary to design a special type of multi-layer temperature coefficientless inductance coil for the purpose. The condensers in the oscillatory circuits are temperature coefficientless fixed mica condensers and first grade air condensers. Long period stability of F_1 will be affected by valve replacement unless the capacity differences of the electrode system associated with the oscillatory circuit are negligible. Screen grid valves have a small anode to screen grid capacity, and with the type of screen grid valve used, *i.e.*, Mullard S4 VB, the capacity only varies very slightly from valve to valve due to the flat plate anodes, and the construction of the valve. When the calibration of the oscillator is

initially made, a screen grid valve having a mean capacity is employed.

(b) A change in the capacity calibration of the variable condenser will affect the calibration accuracy. Since the beat frequency f is small compared with the main oscillation frequency F_1 , it can be shown that changes of the variable capacity C produce proportional changes in f . It is extremely difficult to produce a logarithmic scale condenser having a high degree of permanence, particularly at the high frequencies where the capacity is large. A permanence of about 0.1 per cent. for a period of five years has been obtained, but it is essential that the condenser should be mounted with its spindle vertical to retain this calibration accuracy.

(c) Frequency instability occurs due to drift of the beat frequency. If the two frequencies F_1 and F_2 change relative to one another, except due to a change of the variable condenser, a corresponding error in the beat frequency f results. Any changes occurring in the frequencies F_1 and F_2 should therefore be similar and the oscillating circuits should be as nearly as possible identical. The inductance coils and fixed tuning condensers are matched with regard to temperature coefficient to within 0.00025 and 0.0003 per cent. per degree Centigrade, and are surrounded by similar substantially made copper screening boxes.

(d) Changes of supply voltages affects the oscillation frequency. The decrement of the oscillatory circuits must be low, otherwise the frequency F_1 will be affected by supply voltage changes, which would

also probably cause a frequency drift due to unequal changes of F_1 and F_2 .

SELECTION OF OSCILLATION FREQUENCIES F_1 AND F_2 .

The selection of these frequencies to give a beat frequency range up to 15 kc.p.s. is largely determined by the magnitude of the capacities necessary in the associated oscillatory circuits. Using 1,000 micro-henry inductance coils the tuning capacity is approximately 2,550 micro-micro-farads at 100 kc.p.s., increasing to 3,550 micro-micro-farads at 85 kc.p.s. This increase of 1000 micro-micro-farads is obtained with the variable air condenser controlling the beat frequency. Any reduction in these frequencies will necessitate larger tuning inductances and a considerably larger incremental capacity of the variable air condenser, which is difficult to obtain if the condenser calibration is to have a logarithmic frequency scale. On the other hand, increases in the heterodyne frequencies are also undesirable, as a greater degree of accuracy is required in maintaining these frequencies to give the same accuracy of beat frequency.

A special form of variable condenser has been developed by Mr. W. H. F. Griffiths, of H. W. Sullivan Ltd., to give a logarithmic law of beat frequency, and still retain the robustness that is necessary for the permanence of the calibration. A logarithmic law is usually associated with exaggerated plate shapes, occupying a large space and producing instability. Mr. Griffiths has obtained the desired law by varying the number of plates engaged in addition to shaping them. Fig. 5 shows

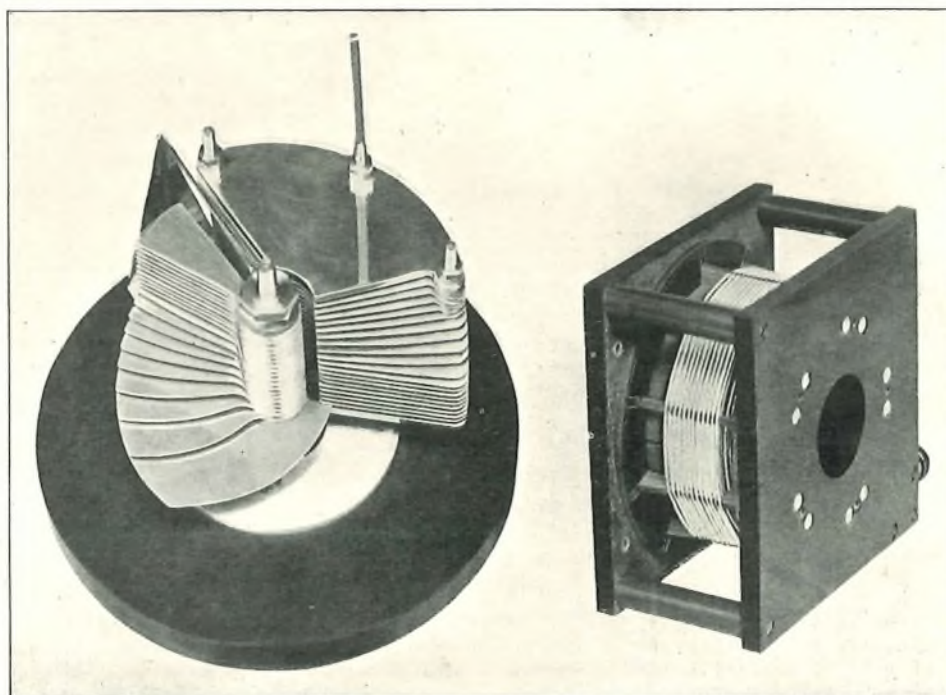

FIG. 5.—LOGARITHMIC LAW VARIABLE AIR CONDENSER AND TEMPERATURE COMPENSATED INDUCTANCE COIL.

the variable condenser¹ of robust design that is incorporated in the oscillator, and the temperature compensated inductance coil.

The scale is shown diagrammatically in Fig. 6. It will be observed that the total angular movement is 230 degrees and the scale is linear up to 100 c.p.s. and logarithmic from 100 to 12,000 c.p.s.

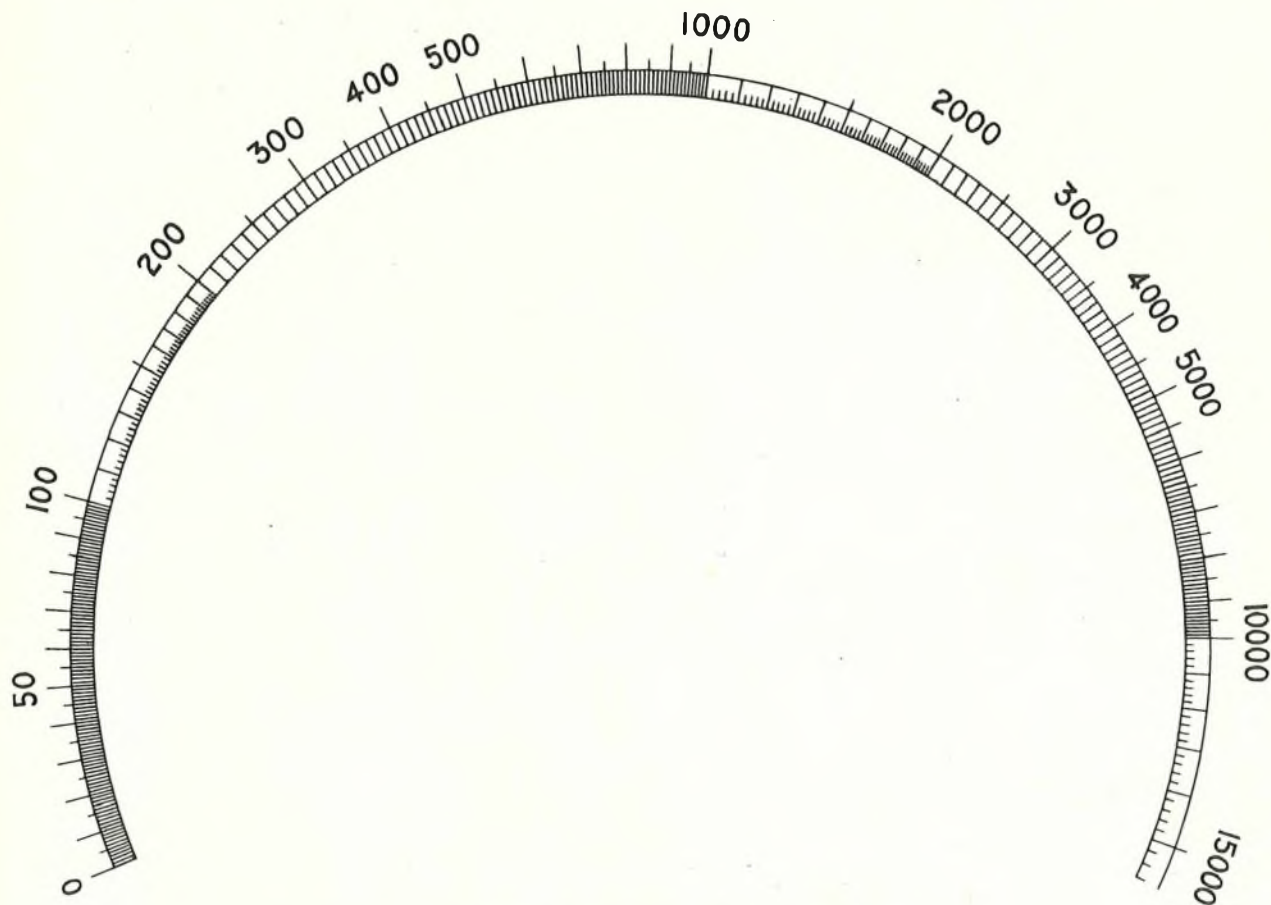

FIG. 6.—FREQUENCY SCALE OF RYALL-SULLIVAN HETERODYNE OSCILLATOR.

METHOD OF CONTROLLING THE OSCILLATING VALVES.

The valves used are Mullard screen grid, indirectly heated, type S4 VB. They are mounted just outside the coil screening boxes. The anode and screened grid voltages are obtained from potentiometer resistances connected across the H.T. supply. The voltages are approximately 35 and 80 respectively when the H.T. voltage is 130 volts. Separate potentiometers are used for each valve to prevent coupling between the two oscillators. The control grid voltage is obtained from variable potentiometers and can be varied between 0 and -4 volts with respect to

the kathode. The negative control grid voltage is increased until it is just below the value required to give maximum oscillation. The variable frequency oscillator is adjusted when the frequency is 88 kc.; *i.e.*, with the beat note condenser set at 12,000 c.p.s. The setting of the control grid voltage can be determined by noting the change in the rectifier anode

current when only the oscillator under test applies a signal to the rectifier valve.

The oscillating condition used is determined, not by frequency stability, but by output voltage stability. For a maximum frequency stability the negative resistance of the valve should be made only slightly less than the dynamic impedance of the oscillatory circuit. The amplitude of the oscillation will then vary considerably with the generated frequency and with supply voltage changes. To obtain a constant output at all values of the beat frequency, irrespective of slight changes in the supply voltage, is considered of greater importance than the maximum stability, provided that the stability otherwise obtained is in excess of normal requirements.

The effect of 5 per cent. supply voltage variations is to change the beat frequency approximately 0.15 c.p.s. when the common heater and grid bias battery changes, and less than 0.1 c.p.s. in the case of the supply to the anode and screened grid.

¹ Further details of the condenser design and a fuller description of the factors influencing the frequency accuracy and stability are given in two articles by Mr. W. H. F. Griffiths, "Precision Heterodyne Oscillators," *The Wireless Engineer*, May, 1934, and "Wide Range Variable Condenser for Special Laws," *The Wireless Engineer*, August, 1934.

"PULL-IN," FREQUENCY STABILITY AND CALIBRATION ACCURACY OBTAINED.

The oscillators are effectively screened from one another and there is practically no coupling *via* the coupling coils which have a mutual inductance with the main coil of about 3 microhenries. "Pull-in" between the two oscillators does not occur until the beat frequency is reduced below 0.2 c.p.s. A "zero beat" method of scale setting is employed in which the "zero beat" is recorded on a milliammeter in the anode circuit of the detector valve.

The stability is such that the frequency does not vary more than 1 c.p.s. over long periods of days and the change is less than 0.2 c.p.s. in a 15-minute period. Furthermore, the beat frequency obtained when oscillations commence after initially switching on the oscillator supplies, is within 1 c.p.s. of the normal value. Hence there is no time wasted in waiting for the oscillations to settle down before using the instrument.

The maximum calibration error after a period of years from all causes is 0.25 per cent.²

A difficulty arose in obtaining a satisfactory scale that could be set so that full use of the calibration accuracy could be made. It has already been pointed out that in order to retain the permanence of calibration the condenser must be mounted with the spindle vertical. The scale is consequently horizontal. The scale radius of 11 cms. is the maximum consistent with normal pressure on the edge of the milled circular scale, having no effect on the condenser calibration. With the special design of the condenser plates, the angular movement is extended over 230° instead of the more usual 170° giving a correspondingly more open scale, having a total length of 43.5 cms. The scale itself is finely engraved on bakelite and is initially calibrated at 60 cardinal points against a frequency standard.

The linear portions of the scale between 0 - 100 c.p.s. and 12,000 to 15,500 c.p.s. occupy lengths of 7.25 cms. and 3 cms. respectively, whilst the length of any octave between 100 c.p.s. and 12,000 c.p.s. is 4.8 cms., which represents 0.14 mm. change of scale length for a 0.2 per cent. frequency change. The engraved calibration lines are 0.1 mm. thick and it is possible to obtain alignment of the scale and the index at any calibration point to within .025 mm. or $\frac{1}{4}$ of the line width. This represents a scale setting accuracy having a maximum error of 0.06 per cent. Between calibrated points the error would be about doubled. At a recent meeting of the Institution of Post Office Electrical Engineers in London, the stability and scale setting accuracy of the oscillator were demonstrated during the course of the lecture by first switching on the oscillator some hours after setting it up and observing the "zero" beat, and then without adjustment setting the oscillator scale to 1,000 c.p.s. and comparing the note with that of a 1,000 c.p.s. frequency standard. In each case the beat frequency was well below one cycle per second.

² "Precision Heterodyne Oscillators." W. H. F. Griffiths. *The Wireless Engineer*, May, 1934.

PURITY OF OUTPUT—SOURCES OF POSSIBLE DISTORTION AND THEIR CORRECTION.

(a) *Distortion due to "Pull-in."* "Pull-in" between the two heterodyne oscillators will result in distorted wave form at frequencies considerably above the "pull-in" frequency, so that to obtain sinusoidal beat frequency signals at very low frequencies the "pull-in" frequency must be exceedingly low. It will be seen in Fig. 4 that there is no direct coupling between the two pick up coils which are connected across separate 1,000-ohm potentiometers. The variable potentiometer tapplings are connected in series in the grid circuit of an amplifying valve. The potentiometer connected to the variable frequency oscillator coil supplies the main high frequency signal; the potentiometer connected to the fixed frequency oscillator coil supplies the heterodyning signal, and this potentiometer controls the beat frequency output. "Pull-in" between the two oscillators does not occur until the beat frequency between them is less than 0.2 c.p.s. Fig. 7 shows

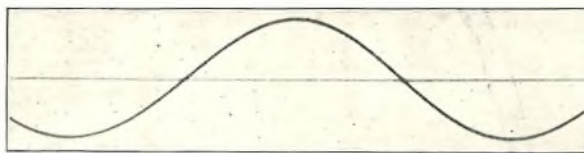

FIG. 7.—OSCILLATOR WAVE FORM—2 c.p.s.

the oscillator wave form at 2 c.p.s., and it appears sinusoidal.

(b) *Distortion due to impure high frequency signals.* An impure wave form of the high frequency signal when rectified will cause harmonics of the beat frequency to be produced. After two stages of amplification, the combined H.F. signals are passed through a single-section band-pass filter shown in Fig. 4. The shunt arms primarily have a resonant frequency of 95 kc., but an additional variable condenser is connected across the terminating impedance to provide high frequency equalization of the beat frequency signal. The series arm consists of a 5 mH dust-core coil designed to resonate by virtue of its self-capacity at approximately 200 kc.

(c) *Distortion in the rectifier.* Anode bend rectification is used with a steady grid bias voltage of 8.5 volts applied to the rectifier valve, V⁵, (P.O. type V.T. 82). The magnitude of the H.F. signal voltage (before heterodyning) applied to the grid is readily deduced from the increase of anode current it produces in the detector valve. Using valves of the same type, the applied signal voltage does not vary more than 10 per cent. when the corresponding equal increases in anode current are obtained. Grid leak rectification was also tried, but under the best conditions the harmonic produced for a given output is approximately 10 decibels above that obtained with anode bend rectification. The low frequency amplifier following the rectifier is such that 100 mW output is obtained with about 0.75 volt of the fixed frequency signal imposed on a variable frequency signal of 3.0 volts in the grid circuit of the rectifier valve.

(d) *L.F. Amplifier distortion.* Additional distortion will occur in the L.F. first stage amplifying valve, but by using an anode feed resistance of 50,000 ohms (equal to 10 times the normal valve impedance) and by reducing the grid bias voltage to a minimum, consistent with the absence of grid current at full output, this distortion is kept very small.

(e) *Distortion in the output stage.* The output stage can also produce considerable distortion. The valve distortion is kept small by using an LS6A type of valve capable of handling large powers. The output transformer is choke capacity coupled to the output valve so that no D.C. passes through the output transformer windings. The output transformer has a mumetal core. The inductance of the output (600-ohm) winding is about 15 henries and the leakage inductance is about 3.7 millihenries. The importance of this low leakage inductance is discussed later. The effect of the transformer distortion is not serious until the frequency falls below 50 c.p.s.

It was initially considered that a push-pull output stage would reduce the harmonic present and this was installed. An additional output valve is required and in addition a "para-phase" stage incorporating another amplifying valve, so that the signal voltage could be applied to the grids of both of the output valves in correct phase relationship. The introduction of a transformer to do this would mean additional distortion and a non-uniform frequency response. The push-pull stage only reduces the harmonic content of the output stage, but leaves the harmonic produced by the detector valve and the other L.F. amplifying valves. This residual distortion was found to be greater than that of the output stage, especially for small output voltages.

(f) *Correction of harmonic distortion.* A novel device for reducing the amount of harmonic present has been introduced into the output stage of the oscillator. This consists of a metal oxide rectifier in parallel with a resistance, the combination being connected in series with the output circuit. This rectifier combination produces harmonic distortion in the same manner as a thermionic valve, and by suitably choosing the type of rectifier and the value of the shunting resistance the valve distortion of the oscillator, including the anode bend rectifier distortion, can be compensated and reduced by at least 10 decibels. At small outputs practically no harmonic of any kind remains, especially for fundamental frequencies of 300 c.p.s. and above. Fig. 8 shows the relation between the harmonic content and the signal voltage for different outputs over the frequency range of the oscillator.

(g) *Distortion due to H.F. interference signals.* H.F. signals of frequencies from 100 kc. to 85 kc. may be superimposed on the oscillator signals due to "pick up" from radio stations unless the H.F. amplifier is adequately screened, including the connections to the oscillator "pick up" coils. Furthermore, when large outputs of a relatively high frequency beat signal are produced the harmonics present may themselves be introduced into the H.F.

amplifier and cause additional heterodyne signals, unless the H.F. amplifier is screened from the L.F. amplifier.

(h) *Distortion due to L.F. interference signals.* The band-pass filter is connected to the grid of the detector valve in the manner shown in Fig. 4 so that there is a high L.F. impedance between this grid and the H.T. supply of the prior H.F. amplifier and a very low L.F. impedance between the grid and the filament centre point of the detector valve.

UNIFORMITY OF OUTPUT VOLTAGE OVER THE FREQUENCY RANGE; SOURCES OF VARIATION, THEIR PREVENTION AND CORRECTION.

(a) *H.F. Oscillator amplitude variation.* A variation of the output voltage of the H.F. oscillator will occur when the frequency changes from 100 kc. to 88 kc. to give a beat frequency of 0 to 12 kc., due to a change in the dynamic impedance of the resonated coil in the anode circuit of the oscillator valve. This change is kept small by selecting the electrode potentials of the valve so that the negative anode-kathode impedance is much less than the dynamic impedance of the resonated coil. It is preferable that the minimum decrement of the oscillatory circuit should occur at a frequency greater than 100 kc. so that the output voltage of the oscillator tends to decrease as the frequency falls from 100 kc. to 88 kc., as this form of output-frequency characteristic readily lends itself to amplitude compensation in the band-pass filter.

(b) *Band-pass filter transmission losses.* The transmission loss of the H.F. band-pass filter can be

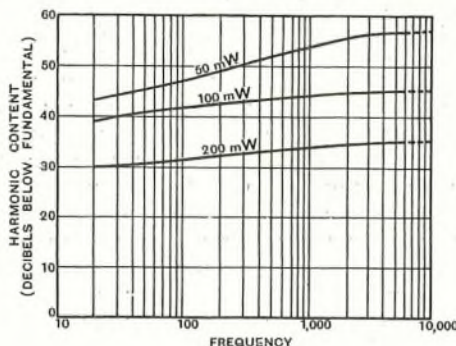

FIG. 8.—HARMONIC CONTENT OF OSCILLATOR WITH 130v. H.T.

controlled by varying the capacity C6 in shunt with the terminating impedance (see Fig. 4). Thus by increasing this capacity above the normal value the transmission loss is decreased at 88 kc. as compared with the loss at 100 kc. This results in a rising voltage beat-frequency characteristic of such a form that it can be adjusted to compensate the loss caused by capacity leakage and leakage inductance in the L.F. amplifier. The change in beat frequency output voltage due to a change in one of the H.F. signal voltages is reduced to a second order effect by making the varying signal voltages the larger of the two heterodyne voltages. Thus the relatively large changes in output of the variable frequency oscillator

needed to give small changes of beat frequency output are easily controlled, and the adjustment of the capacity C_6 in the band-pass filter is not critical. Fig. 9 shows the beat frequency output character-

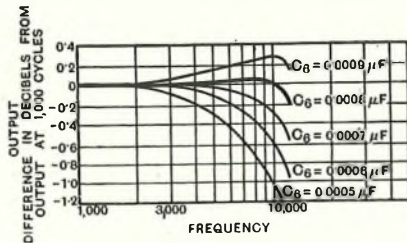

FIG. 9.—H.F. CORRECTOR CHARACTERISTICS.

istic with the capacity C_6 varied to give different amounts of compensation. When C_6 equals 0.00063 microfarads the variable signal voltage applied to the grid of the rectifying valve is constant and the loss of beat frequency output at high frequencies is due to the losses in the L.F. amplifier.

(c) *Low frequency amplifier losses.* At high frequencies, losses may occur in the low-pass filter as well as in the amplifier and output transformer, but as explained above these losses are less than 0.5 decibel at 10,000 c.p.s. and can be compensated in a very simple manner.

At low frequencies, transmission losses occur due to the impedance of the anode battery by-pass condenser rising and becoming comparable with the anode circuit impedance. Partly for this reason, and to separate the large A.C. output voltage from the anode battery as much as possible, the output transformer is capacity coupled to the cathode of the output valve, not to the anode battery. Serious loss in the inter-stage coupling is avoided by using coupling condensers and resistances with a time constant greater than 0.05 sec. Since it is also desirable to obtain the H.T. supply to the oscillator from a "mains unit" it is arranged that the amplification of the L.F. amplifier shall fall off below 20 c.p.s. so that very low frequency oscillation shall not occur.

The overall low frequency transmission loss of the oscillator is shown in Fig. 10. Suitable compensa-

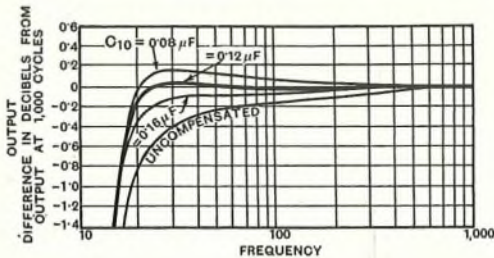

FIG. 10.—L.F. CORRECTOR CHARACTERISTICS.

tion is provided in the interstage L.F. amplifier. The effect of varying the value of the capacity C_{10} on the frequency equalization is also shown. It will be observed that the output does not vary from the value at 800 c.p.s. by more than 0.1 decibel when

C_{10} is 0.12 micro-farads until the frequency falls below 20 c.p.s. The values of C_6 and C_{10} for high and low frequency compensation are best selected by trial for each oscillator if the optimum constancy of output is required. The change in output voltage over the beat frequency range for different values of the load impedance is shown in the following table:—

Frequency, c.p.s.	Output variation from 1,000 c.p.s. value (db.).		
	300-ohm. load.	600-ohm. load.	1,000-ohm. load.
15	- 1.0	- 1.4	- 1.6
18	- .2	- .27	- .35
20	< \pm .05	- .09	- .2
30	"	< \pm .05	- .12
50	"	"	- .08
200	"	"	- .08
300 to 3,000	"	"	< \pm .05
4,000	"	"	+ .1
8,000	- .08	"	+ .15
9,000	- .13	"	+ .1
10,000	- .18	"	+ .05
11,000	- .23	- .06	< \pm .05
12,000	- .32	- .2	- .1
13,000*	+ .5	+ .75	+ .85
14,000*	+ .1	+ .2	+ .3
15,000*	- .3	- .25	- .2

* The frequency range in the original design was limited to 12,000 c.p.s., but has since been extended to 15,500 c.p.s. to meet future underground carrier telephone circuit requirements and to enable the highest audio frequencies to be obtained. No attempt has been made to maintain the output voltage absolutely constant above 12,000 c.p.s., but the change is less than 1 db.

The frequency range in the original design was limited to 12,000 c.p.s., but has since been extended to 15,500 c.p.s. to meet future underground carrier telephone circuit requirements and to enable the highest audio frequencies to be obtained. No attempt has been made to maintain the output voltage absolutely constant above 12,000 c.p.s., but the change is less than 1 db.

CONSTANCY OF OUTPUT IMPEDANCE.

For repeater station use the output impedance should be 600 ohms non-reactive. This value is determined by the output valve impedance. The output transformer ratio is such that the output impedance with normal valves is approximately 450 ohms, and can be varied by adjusting the resistance R_{13} in series with the valve impedance.

The reactive component of the output impedance is due to the inductance of the output transformer and the anode choke, together with the impedance of the coupling condenser. At low frequencies the shunt impedance of the output transformer, and at high frequencies, its leakage inductance affects the reactive component, and the resultant impedance between frequencies of 50 to 6,400 c.p.s. is shown in Fig. 11. The dotted curve indicates the limits within which the vector impedance must be to ensure that the error caused by the variation of the generator impedance from 600 ohms, when measuring the

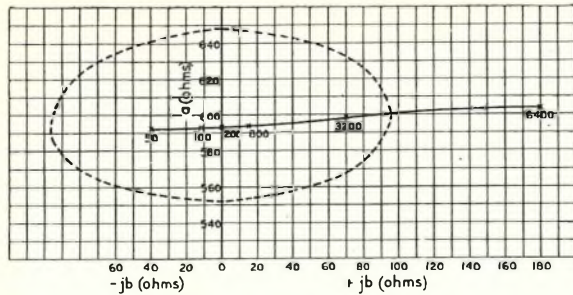

FIG. 11.—OUTPUT IMPEDANCE OF OSCILLATOR.

attenuation of circuits having re-active impedance with the angles up to 45° , shall not exceed 0.2 decibel. The small reactive component obtained is the result of a specially designed transformer having a ratio of leakage inductance to open circuit inductance of 1 to 4,000.

VARIATION OF OUTPUT VOLTAGE DUE TO SUPPLY VOLTAGE VARIATIONS.

One of the disadvantages of a multi-stage oscillator in which the output voltage amplitude is dependent on the A.C. voltage generated in the initial stages is that the output is liable to vary considerably when the supply voltage varies. The variation in output voltage of the H.F. generators is reduced by ensuring that the control grid voltage is such that the oscillation amplitude is a maximum.

The amplification variation of the intermediate amplifying stages is minimized by incorporating high resistances where possible in anode circuits. With the oscillator set up as described previously the output voltage variation is approximately 0.4 decibel when the filament voltage changes 5 per cent. and about 1.3 decibels when the anode supply voltage changes 5 per cent. It is desirable that rheostats should be fitted in series with the anode and filament supplies so that these supply voltages to the oscillator may be under control. A 3-range voltmeter-milliammeter is incorporated so that the anode and filament voltages can be measured. The third range is required to measure the anode current of the detector valve.

PROVISION FOR OBTAINING LARGE OUTPUT POWERS.

Whilst the oscillator has been designed primarily to give output powers up to 300 mW with an anode battery supply of 130 to 150 volts, output powers up to 10 times this value can be obtained by changing the LS6A output valve for a valve type PX25, and increasing the anode battery voltage applied to this valve to 350 or 400 volts. The harmonic content is then :—

- Less than 0.3% above 300 c.p.s. for outputs up to 0.5 watt.
- Less than 1% above 40 c.p.s. for outputs up to 1.0 watt.

Less than 2% above 20 c.p.s. for outputs up to 2.0 watt.

These harmonic contents are obtained using an A.C. mains unit designed to supply the L.T. and H.T. supplies to the oscillator.

SETTING OF THE OSCILLATOR CONTROLS.

In setting up the oscillator, the grid potentials of the screen grid oscillator valves are first adjusted, then the correct magnitude of the variable frequency oscillator signal is obtained for application to the detector valve grid. The output impedance can also be corrected if necessary, and the harmonic reduced to a minimum by means of the harmonic compensator. These control adjustments, having once been made should not require re-setting for some months, or until valve replacements are made. The controls are accordingly normally covered in. The only adjustments necessary when in general use are to control output and supply voltage. The "zero beat" condenser does not require resetting unless extreme accuracy is required.

For general use, the volume controls are set to give the output level required and the condenser dial is rotated to give the desired frequency as indicated on the dial.

IMPORTANCE OF FREQUENCY STABILITY AND OUTPUT PURITY AND CONSTANCY IN TELEPHONE TRANSMISSION MEASUREMENTS.

A high degree of frequency stability of a signal generator is required in order to measure the impedance irregularities of a telephone cable. It is impossible to obtain such characteristics if the frequency is unstable and drifting. The location of faults from a knowledge of the frequency changes between successive impedance "bumps" necessitates very accurate frequency measurements being made, and the stability and calibration accuracy of the oscillator are well worth the care and manufacturing precision that have been found necessary.

The oscillator purity greatly facilitates bridge balancing and becomes useful as a source of pure tone when measuring the harmonic distortion introduced by amplifiers. The purity of the oscillator signal at very low frequencies is of particular importance in measuring the transmission frequency characteristics of apparatus and circuits used for music transmission. If the attenuation of the network rises rapidly at low frequencies, any signal harmonics will pass through the network with relatively low attenuation and the resultant measurement of signal attenuation will be inaccurate.

Absolute constancy of output is essential where speedy and accurate attenuation-frequency characteristics of circuits are required. The introduction of an output correction factor at certain frequencies may lead to errors due to the sign of the correction factor being changed between gain and attenuation measurements.

Modernizing Teleprinter Diagrams

C. D. LIPSCOMBE

DURING the last seven years the Baudot and Wheatstone telegraph systems have been almost entirely replaced by start-stop teleprinters for the working of the Inland Telegraph Service. As was natural with a change-over of this type, it was accomplished office by office, and the varying circuit requirements, together with the differing power and battery supplies available, led to a multiplicity of diagrams covering Teleprinter No. 3A table circuits.

a duplex circuit in the earliest form of teleprinter diagram. It will be seen that although the conventions used were cumbersome and full of detail, thereby requiring excessive time in drafting, their electrical functions were not always clearly indicated and therefore, from a telegraphic point of view, the clarity of the diagram was greatly impaired.

Three years ago, efforts were made to simplify the conventions, and the extraction of those portions of the diagrams which could be considered as common

circuit requirements, such as the teleprinter connexions and the power supply for the teleprinter motor, was accomplished. By the adoption of the approved British Standard Institution symbols this year, a further simplification was rendered possible and the first attempt to produce these diagrams on a schematic basis was made. By this time circuit design had become standardized to a large degree and the power arrangements at the various offices had been collated. This led to a circuit being reproduced with its power supply connexions suitably designated, and alternative power arrangements were drawn as separate figures of another diagram, each of the figures being arranged for

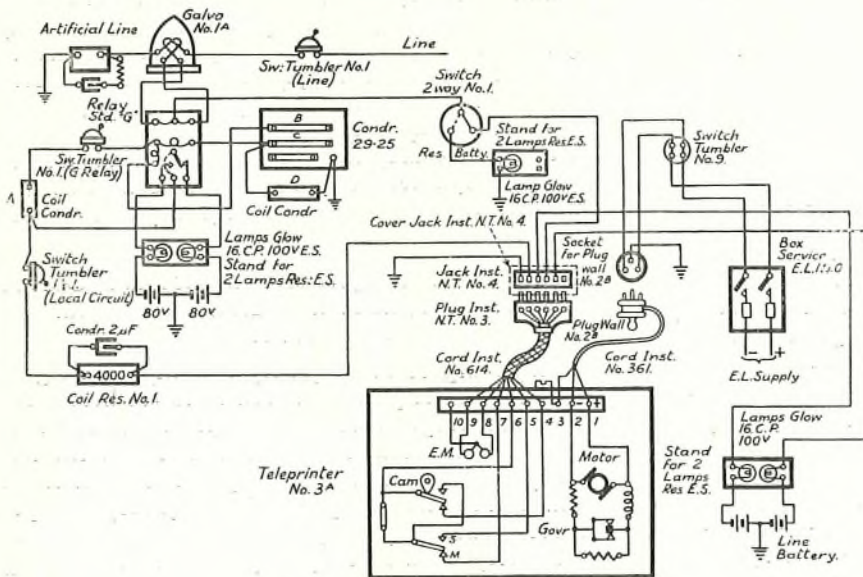

FIG. 1.—TELEPRINTER DUPLEX CIRCUIT.

After the completion of the change-over, the circuits had to be modified to suit modern requirements and conditions—for instance, the alternative morse facility was dispensed with and, later, 2-line or 2-pair simplex working was introduced to a considerable extent; these changes tended still further to add to the number of diagrams.

The diagrams were not produced on schematic lines, but attempted to portray the table lay-out and to picture the apparatus in order to show the relative positions of terminals, etc., as an aid to wiring. Fig. 1 illustrates

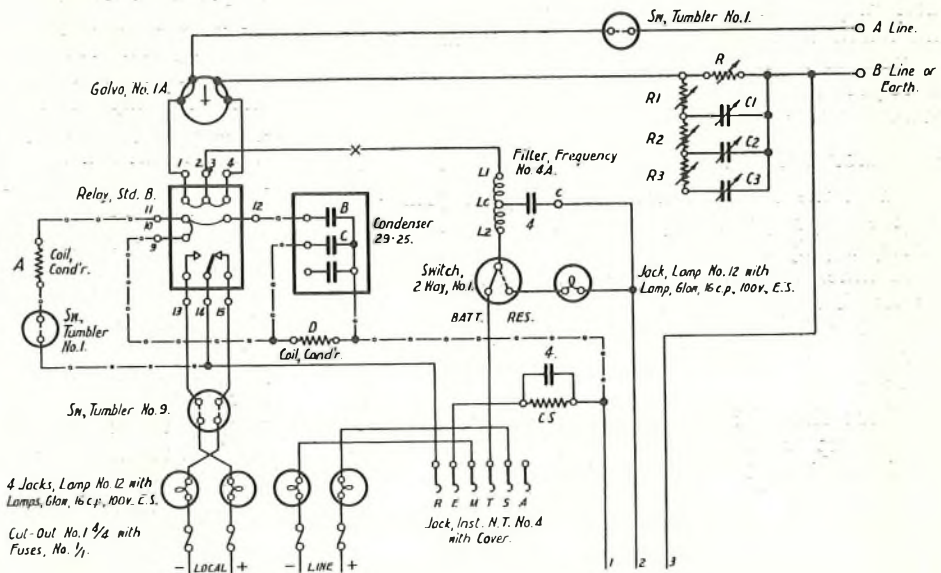

FIG. 2.—TELEPRINTER DUPLEX CIRCUIT.

placing adjacent to the circuit diagram, thereby linking up the latter with any power supply desired. Thus a basic circuit could be designed and standardized and all varying power supplies dealt with as occasion demanded.

Now that teleprinter table circuits, or, as they are now known, circuits for non-rack mounted offices, are being produced for loose-leaf issue, the final step in modernizing these diagrams has been made. A greater degree of clarity has been achieved by a further simplification of those conventions not covered by British Standard symbols, by drafting more on a straight line schematic basis, and by the segregation of all installation instructions from the individual diagrams to a separate loose-leaf sheet, to which all circuits will be referred. By combining, on a basic circuit diagram, the alternative connexions for non-relay, "B" relay, and "G" relay arrangements, and indicating the tag numbering for Relays Standard BN and GN, all variations of the circuit and all types of telegraph relay are embodied in the one diagram. This innovation has made possible a considerable reduction in the number of diagrams required. Fig. 2 illustrates a duplex circuit as drafted in the new style of teleprinter diagram and Fig. 4 shows three power arrangements as reproduced on a separate diagram. These power arrangements apply also to the 2-way simplex and YQ circuit diagrams.

In the new form of diagram the circuit may not appear to have been drafted in the clearest manner when compared with telephone practice, but it must be appreciated that these diagrams are mainly for use in the Districts where teleprinter circuits are required to be installed *in situ*; consequently the fullest information as regards terminal numbering or lettering had to be given and no detaching of associated parts of apparatus therefore was attempted. This meant that strictly straight line diagrams could not be produced; but every effort has been made to draft on the clearest lines possible having due regard to the three main purposes of the diagrams, viz., installation, maintenance and schematic record.

The new loose-leaf issue comprising some twelve diagrams will cover all common teleprinter circuits and power requirements for non-rack mounted offices and will replace about twenty diagrams of the old form, which were far from complete in covering all circuits and power supplies. With a scheme of this nature it can be made to embrace only common circuits and will cover Duplex, Simplex and YQ circuits and Duplex and Simplex circuits with switch to reserve facility, with the following line and local power arrangements:—

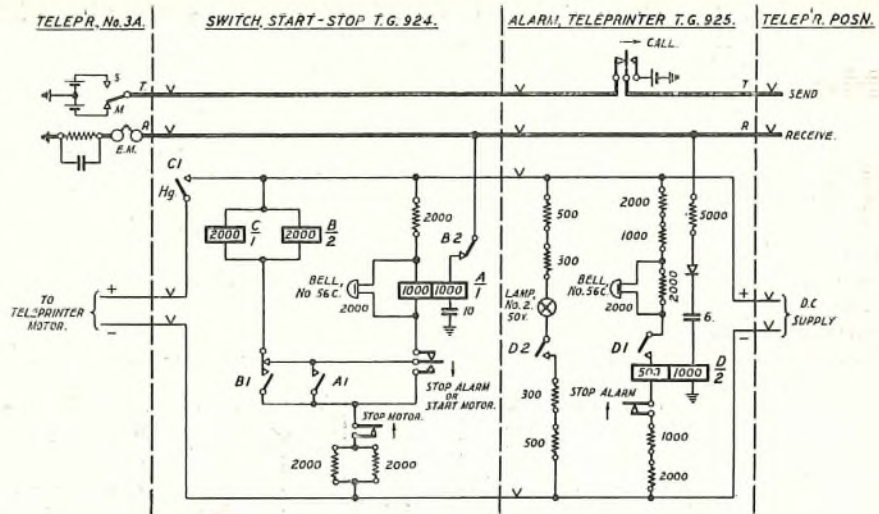

FIG. 3.—TELEPRINTER POSITION CIRCUIT.

- (a) Universal battery for line and local power.
- (b) One battery for line and local power.
- (c) Separate batteries for line and local power.
- (d) Rectified A.C. supply for line and local power.
- (e) Rectified A.C. supply for local power and battery for line power.
- (f) D.C. supply for local power and battery for line power.

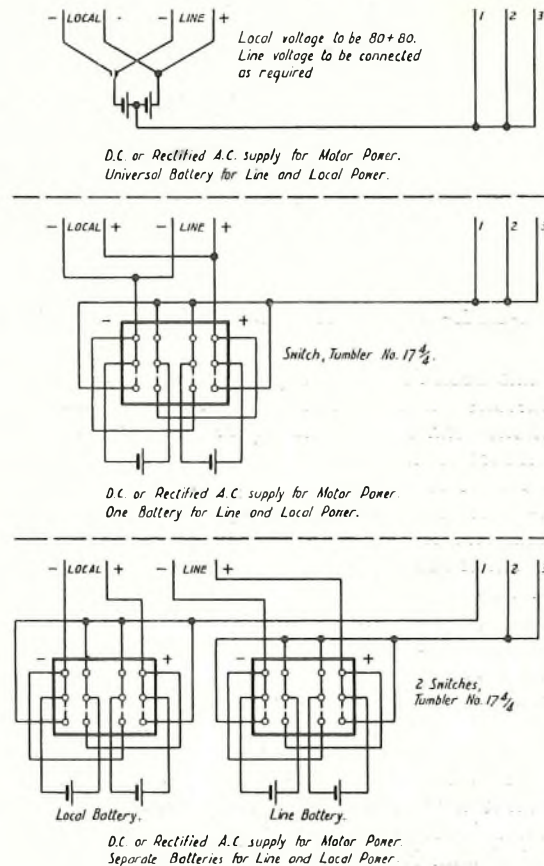

FIG. 4.—ALTERNATIVE POWER ARRANGEMENTS.

(g) Secondary cells, with gas or petrol engine charging set, for line and local power.

Special circuits, such as 2-way Simplex C.B. working and V.F. extensions, will be dealt with on the same general lines of simplification, but will not be related to the common power arrangements.

Diagrams covering the segregated common portions of the basic circuits are also being prepared for loose-leaf issue and include the teleprinter connexions, both internal and schematic, teleprinter motor power circuits, line and local power arrange-

ments, artificial line connexions for duplex circuits and installation instructions.

For schematic auxiliary teleprinter circuits, strict conformity with telephone diagram practice is observed; the diagrams being drawn on purely straight line and detached contact principles. Typical examples of these are illustrated by Figs. 3 and 5, which show a teleprinter position equipped with alarm, automatic calling and motor start facilities, and a head office teleprinter connected to two distant stations, respectively.

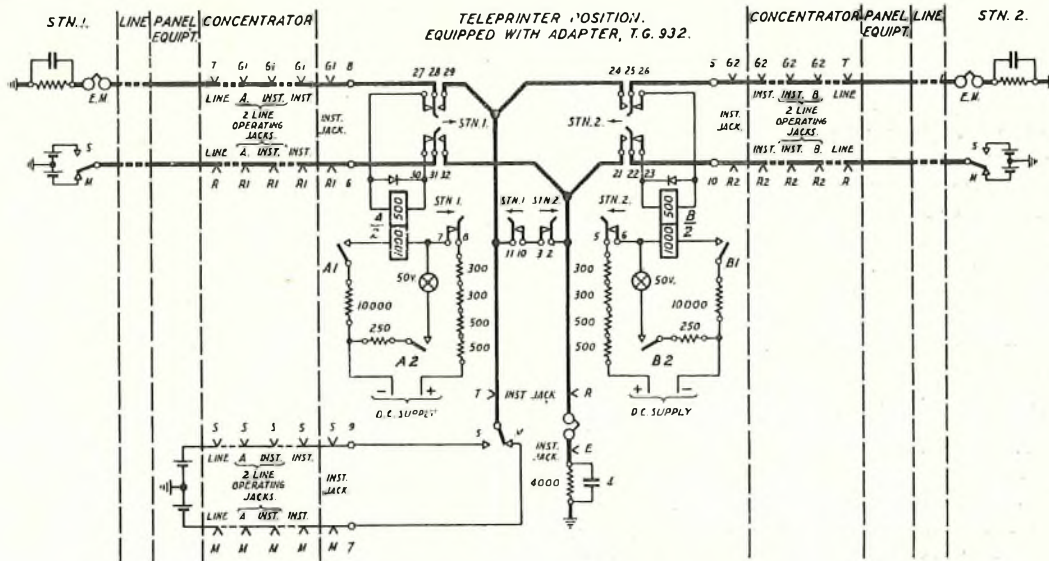

FIG. 5.—HEAD OFFICE TELEPRINTER CONNECTED TO TWO DISTANT STATIONS.

An Anti-Sidetone Coil for Local Battery Circuits

It has been found by experiment that the amount of sidetone which obtains at present with almost all telephones can be considerably reduced with increase in comfort to the user, and improvement in transmission. The speaker using an instrument with reduced sidetone will tend to speak louder, so that transmission from his end of the circuit is improved; also, if there should be noise in the room at his end, this noise, not being transmitted so loudly *via* the sidetone path to his receiver, will not interfere so much with his reception.

The instruments hitherto used for local battery working have in general a much greater level of sidetone than the standard central battery instrument using a Telephone No. 162. For instance, a Telephone No. 164 with a local battery Bell Set No. 21 and three new cells has about 10 db. more sidetone than a Telephone No. 162 with a C.B. Bell Set No. 1 on a 300-ohm local line.

For these reasons, a new induction coil with anti-sidetone properties has been developed in the Research Section. It has been found difficult to meet the requirements of high transmission efficiency and low sidetone combined with low loop resistance at the line terminals. The last requirement is necessary in order that signalling conditions shall not limit the length of line on which the telephone may be used. To overcome these difficulties it has been necessary to provide two coils each on a closed iron core. The coils are mounted side by side on the same stampings, which are so shaped that the coupling between the coils is reduced to a negligible amount. In this manner it has been possible to reduce the overall size of the two coils sufficiently to enable them to be fitted into standard apparatus.

The transmission efficiency compares favourably with that of a Bell Set No. 21 and the sidetone level is about 7 db. less.

E.H.T. Switchgear with Automatic Change-over Device

L. E. WILLIAMS, B.Sc., A.M.I.E.E.

THE E.H.T. supply to King Edward Building is taken from two companies—the City of London Electric Lighting Company and the Charing Cross Electricity Supply Company. The incoming supply is alternating current, 3-phase, 50 cycles at 10,500 volts. The voltage is reduced in the Companies' sub-station to 6,600 at which pressure it

teries or by means of the motor convertors at G.P.O. West running inverted from the batteries so as to maintain the E.H.T. supply to the remaining sub-stations except those supplying the Post Office Railway. Under this scheme considerable delay occurred before the main supply was again restored and it was decided to install new switchgear with automatic change-over device in the King Edward Building sub-station, the load being divided between the two companies. In the event of a failure of one supply, that portion of the load is automatically changed over to the other supply after a predetermined interval.

Description of Switchgear.

The new switchgear is of the metal-clad, compound-filled type, manufactured by Messrs. A. Reyrolle & Company.

The fixed portion consists of the bus bar chamber and the current transformer chamber. The conductors, which are insulated with empire cloth to withstand the full working pressure, are mounted on insulators and run in solid with compound. Each chamber is provided with three orifice insulators with sockets so arranged as to prevent accidental contact with live conductors.

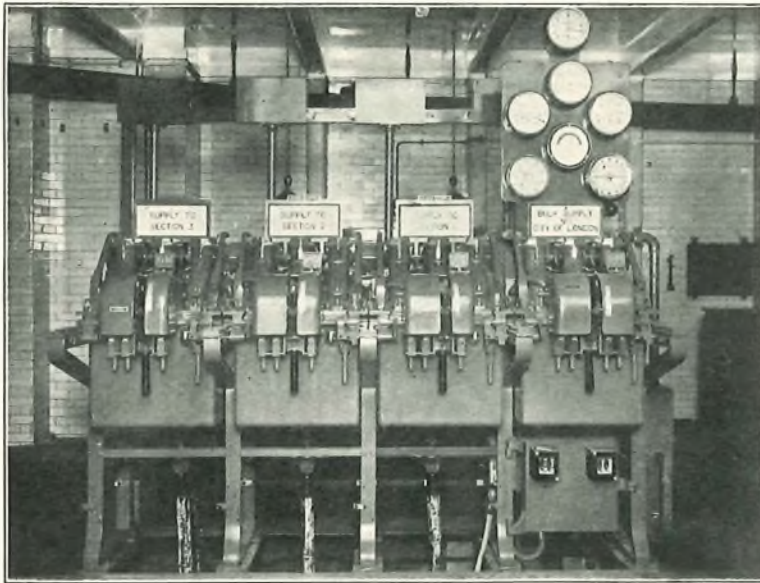

FIG. 1.—CONTROL PANEL.

is distributed to the various Post Office sub-stations. Feeders are run direct from King Edward Building to all the sub-stations except the Western Parcel Office and the West Central District Office which are fed from the Mount Pleasant bus bars.

A photograph of the control panels for the supply incoming from the City of London Electric Lighting Company, and for the outgoing cables to feeder sections is reproduced in Fig. 1, whilst a photograph of the feeder section at Mount Pleasant appears in Fig. 2.

When the Post Office Power Station at Blackfriars was closed down, the whole supply was taken from each Company every alternate month. When a failure of supply occurred some of the more important services such as lighting and conveyors were maintained either direct from the bat-

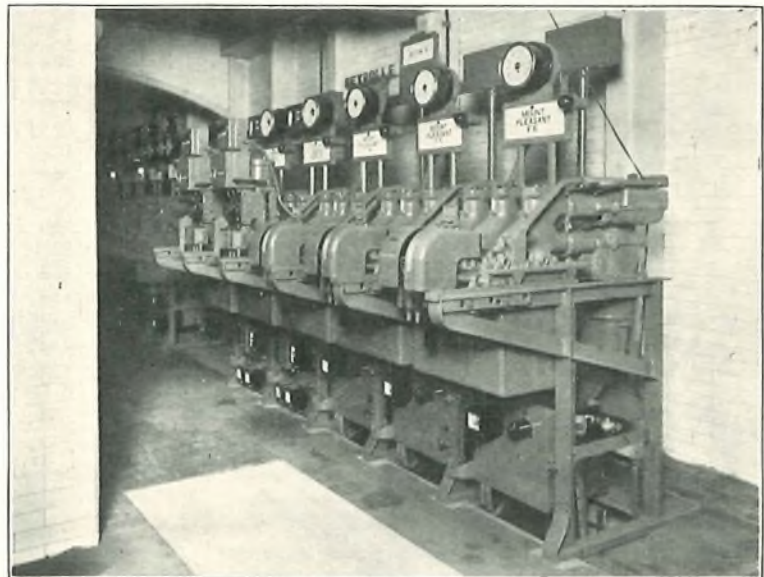

FIG. 2.—MOUNT PLEASANT FEEDER SECTION.

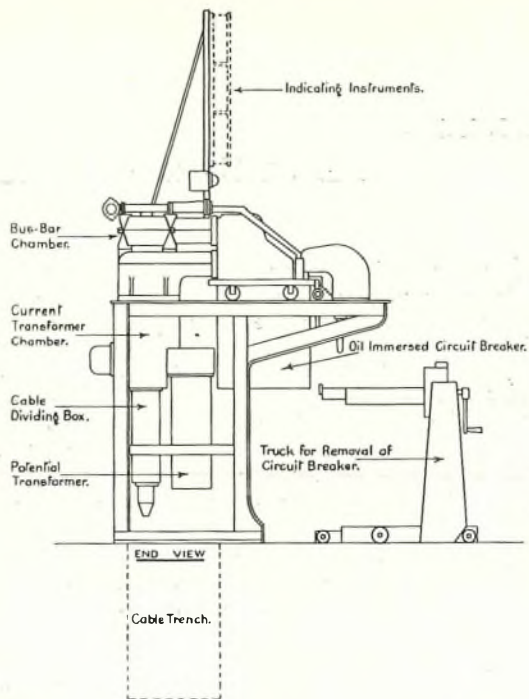

FIG. 3.—TYPICAL REYROLLE CIRCUIT BREAKER PANEL.

The removeable portion consists of the potential transformer (where required) and the oil-immersed circuit breaker with operating mechanism. The

circuit breaker is provided with a racking device for plugging in and out, and when it is withdrawn the feeder is isolated from the live bus bars. The withdrawal of the circuit breaker also closes doors over the orifices in the bus bar and transformer chambers.

The breaking capacity of each circuit breaker is 150,000 K.V.A.

Interlocks are provided to prevent the following operations :—

- (a) The plugging-in or withdrawal of the circuit breaker when closed.
- (b) The closing of the circuit breaker when not plugged-in.
- (c) The removal of the oil tank before the circuit breaker is isolated.

Fig. 3 shows a typical Reyrolle circuit breaker panel.

Arrangement of Switchgear.

The 6600-volt supplies are led into separate sets of bus bars situated at opposite ends of the sub-station.

The arrangement is shown diagrammatically in Fig. 4. A and A¹ are the control panels for the incoming supplies and B, C, D, B¹, C¹ and D¹ the control panels for the outgoing supply cables to the Feeder Sections.

The circuit breakers controlling the two supplies on each feeder section are mechanically and electrically interlocked so that one only can be closed at one time. They are provided with operating mechanism

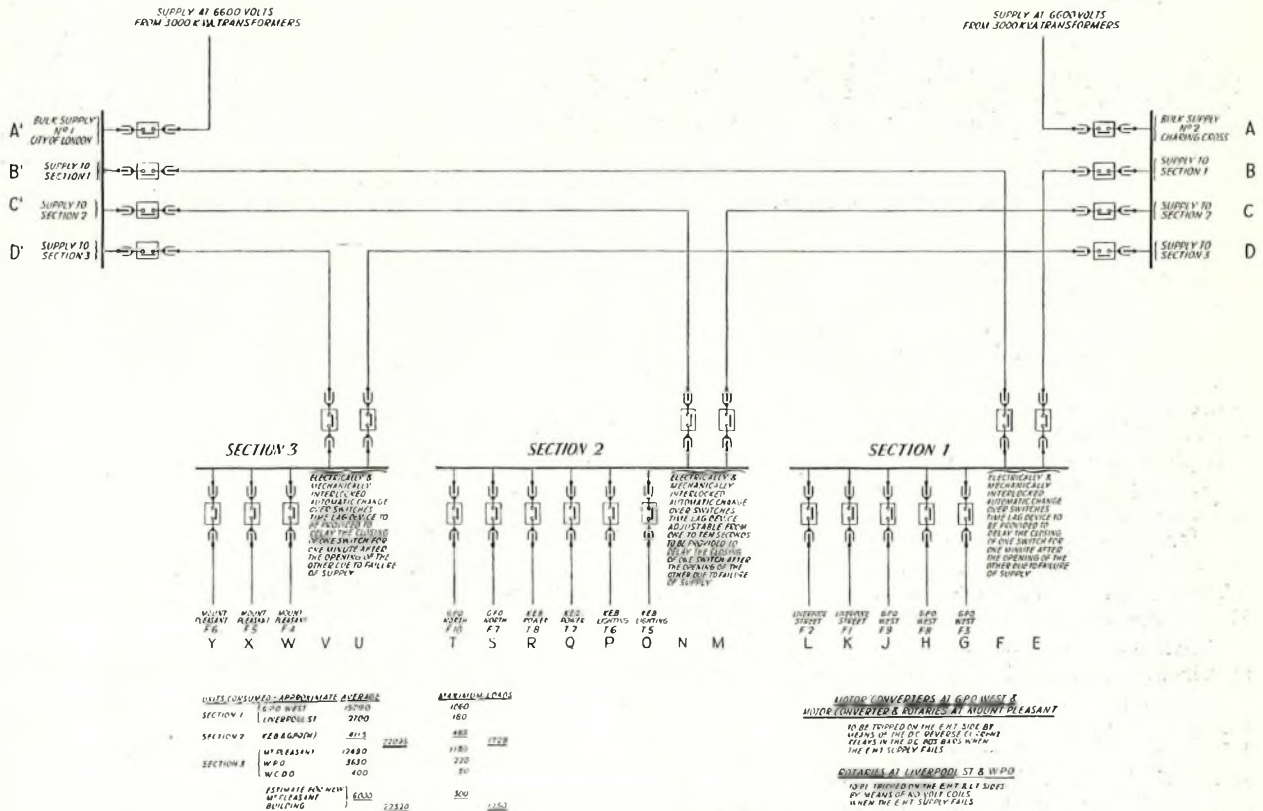

FIG. 4.—CONNEXIONS OF E.H.T. SWITCHGEAR.

- 1 FEEDER E OR F CANNOT CLOSE UNLESS ITS RESPECTIVE SUPPLY OIL CIRCUIT BREAKER IS CLOSED.
- 2 ONLY ONE FEEDER CAN BE CLOSED AT ANY TIME.
- 3 IN THE EVENT OF A FEEDER TRIPPING DUE TO FAILURE OF SUPPLY THE OTHER FEEDER CLOSES AUTOMATICALLY AFTER A TIME LAG.
- 4 IF IT IS DESIRED TO RECLOSE A FEEDER AFTER TRIPPING (AS 3) PRESS SELECTOR SW.

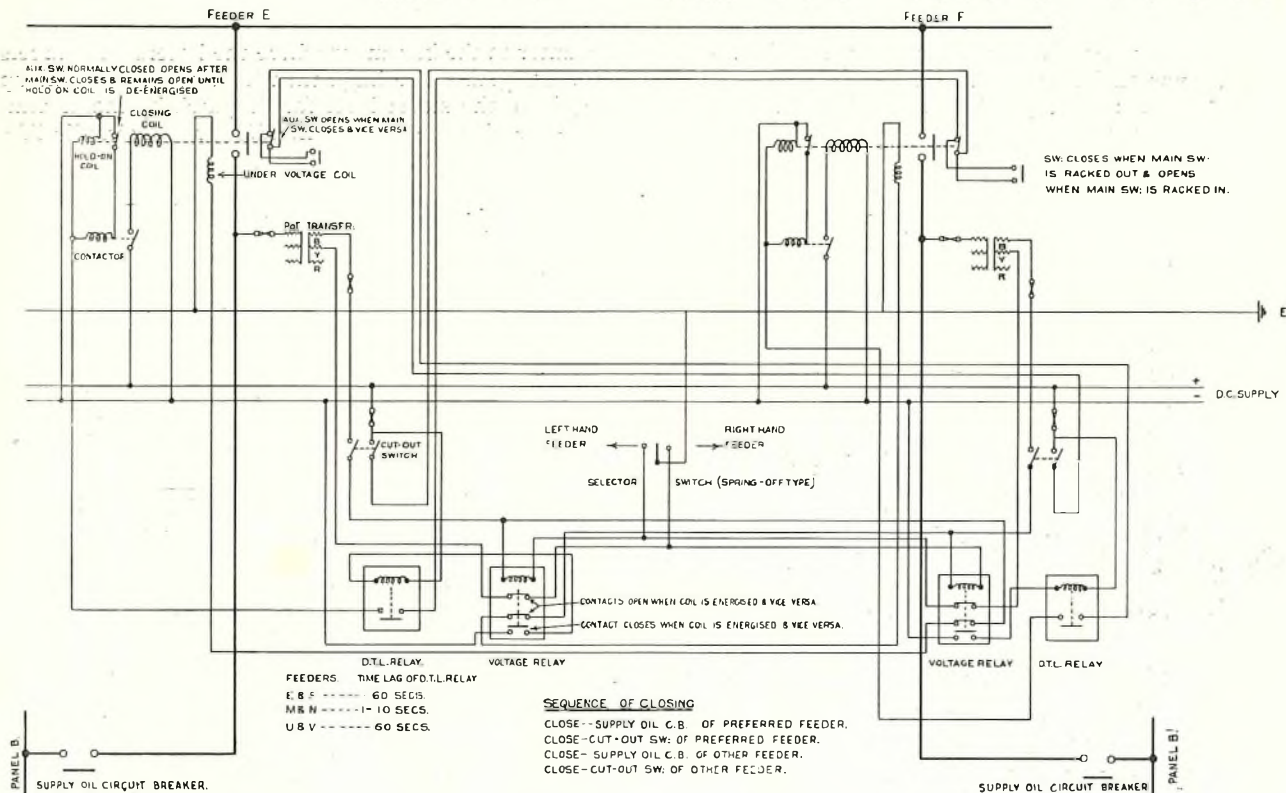

FIG. 5.—AUTOMATIC CHANGE-OVER SCHEME.

and discriminating time relays so that in the event of a failure of the supply one circuit breaker will open and the other will close automatically. If a failure of supply occurs, the synchronous machines at G.P.O. West and Mount Pleasant sub-stations are tripped on the E.H.T. side by means of reverse current relays in the D.C. bus bars and those at Liverpool Street and Western Parcel Office by means of "No-Volt" trips. To allow for the possible failure of these trips to work, which would necessitate the E.H.T. circuit breakers of the machines being operated by hand, the automatic change-over circuit breakers on Sections 1 and 3 have a time lag of 60 seconds. As no synchronous machines are connected to Section 2, the time lag is adjustable from one to ten seconds.

Fig. 5 shows the diagram of the automatic change-over scheme.

An indicating lamp board and alarms have been installed at G.P.O. West. A lamp on the board lights when its associated circuit breaker at King Edward Building is in the open position.

Metering Equipment.

The E.H.T. supply is paid for on the basis of kilovolt ampere-hours with further payment or rebate due to the varying price of fuel; also during the months of December, January and February there is an additional charge per k.V.A. of maximum demand

in excess of 2800 k.V.A. if this occurs between the hours of 9 a.m. and 5 p.m.

The Supply Companies' meters consist of two "Trivectors" and one "Summation Meter with Maxigraph." The "Trivector" consists of a cosine meter (kilowatt hour meter) and a sine meter (reactive component meter) coupled together by a system of gearing in such a manner that a true integration of kilovolt ampere hours is obtained at all power factors. A maximum demand indicator, which gives the maximum mean load in K.V.A. averaged over a definite time period, is also embodied in the Trivector.

The "Summation Meter and Maxigraph" summates the total number of kilovolt ampere hours that are registered on the Supply Companies' two Trivectors. It also indicates the arithmetic sum of the maximum demand on the two companies in the same half hour, and records graphically this value during each resetting period.

Check meters of similar type have been installed by the Department.

The switchgear, cabling, etc., were installed to the Department's specification by the City of London Electric Lighting Company and the work of changing over from the old gear to the new was carried out without interruption of supply. Exhaustive pressure tests were carried out during the progress of the work.

A New Electric Mails Lift

A. E. PENNEY

AT Branch Offices where large volumes of posted items are received it is usual for chutes to be provided from the letter-posting apertures and the parcel-accepting point at the

counter to the basement where the letters and parcels are bagged. The bags then have to be brought up again to the street level for despatch by motor van. At several offices in the London area hydraulic lifts

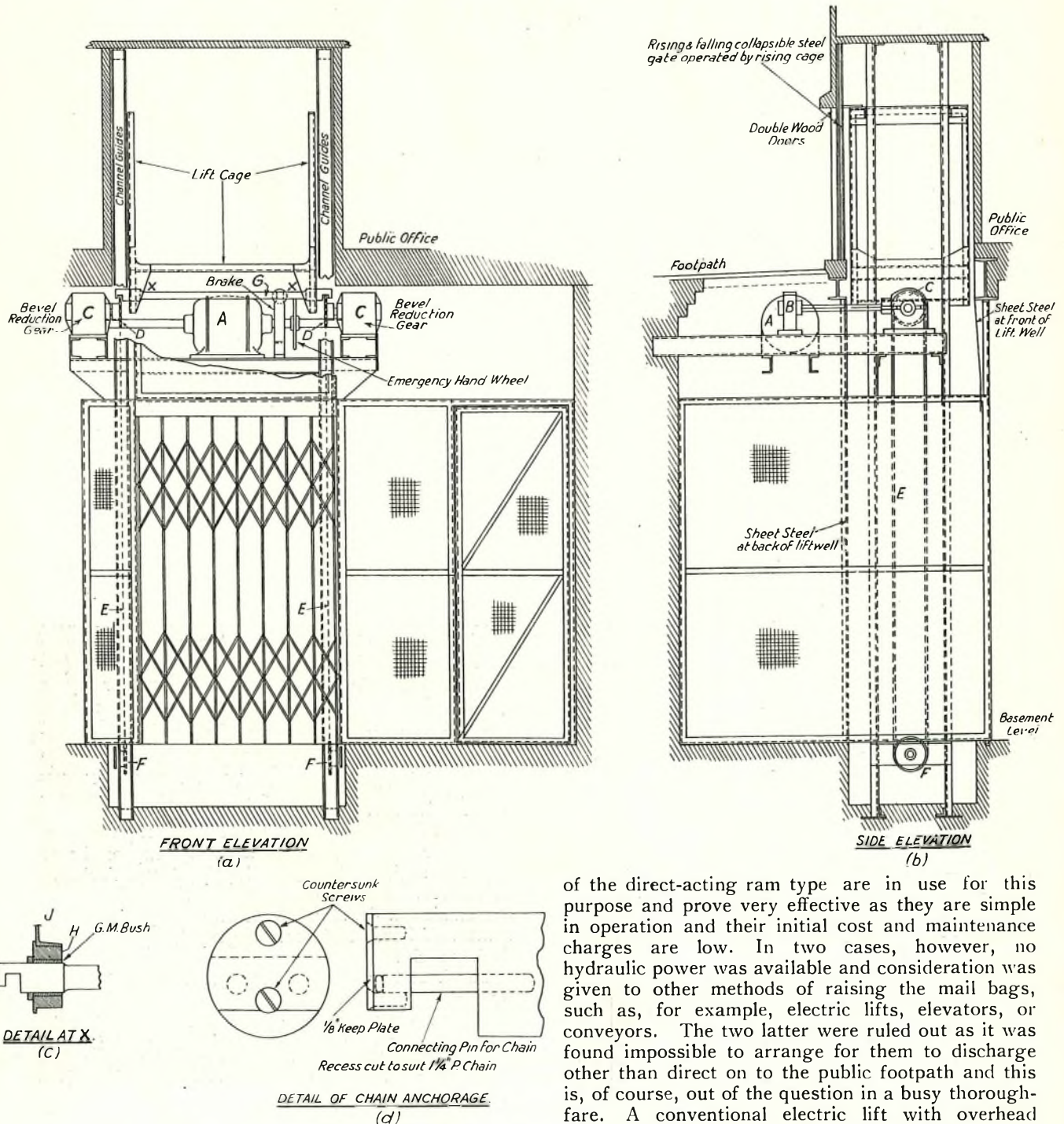

FIG. 1.—DETAIL OF ELECTRIC MAILS LIFT.

of the direct-acting ram type are in use for this purpose and prove very effective as they are simple in operation and their initial cost and maintenance charges are low. In two cases, however, no hydraulic power was available and consideration was given to other methods of raising the mail bags, such as, for example, electric lifts, elevators, or conveyors. The two latter were ruled out as it was found impossible to arrange for them to discharge other than direct on to the public footpath and this is, of course, out of the question in a busy thoroughfare. A conventional electric lift with overhead sheaves and balance-weight could not be installed

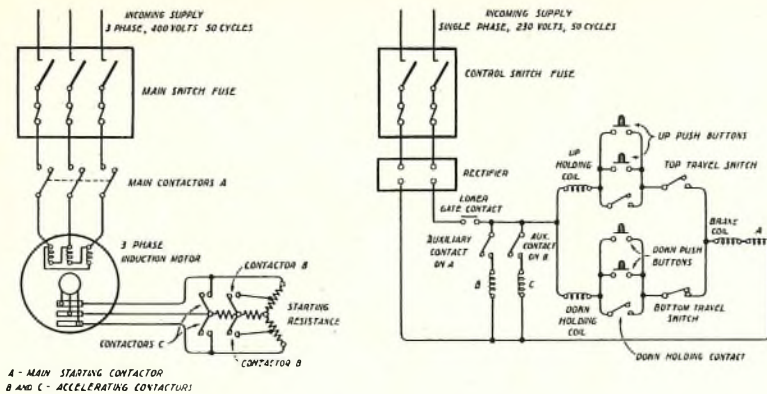

FIG. 2.—WIRING DIAGRAM.

in either case for the following reasons. The upper part of the lift well, which is concealed in a bulkhead in the Public Office, had to be of the smallest possible dimensions and even a few inches over-travel, which in the ordinary way is essential to prevent damage in the event of the brakes failing to operate normally, could not be obtained. The restricted space would also have necessitated the use of a number of diverting sheaves to carry the lift ropes and the life of the ropes would then have been very short owing to the large amount of bending to which they would have been subjected during every journey.

When the first case was put to the London Engineering District tenders were invited and lift makers were asked to put forward their own designs and some interesting schemes were submitted. The design finally accepted was that of Messrs. The Hoisting Appliance Co., Ltd., who installed the first lift at Hatton Garden Branch Office. Following the experience gained with this installation, a simplified design was adopted for Sloane Square Branch Office where the second lift has been installed by the same firm. The photographs are of the second lift and the following is a brief description of it.

Referring to Fig. 1, "A" is the driving motor supported on channel steel girders which also serve to brace the lift structure to the wall of the building. The motor shaft is extended at either end of the motor and carries a brake drum and also a handwheel to enable the gear to be turned by hand in an emergency. The shaft is coupled through two worm reduction gears, one of which is shown at "B" in the figure, to two bevel gears "C." The final bevel gear shafts, which have a common centre line, carry on their ends overhanging the lift-well, chain sprockets "D" which support and drive the two chains "E." These chains are of the bicycle type, but of a much heavier pattern. The idle sprockets "F" serve to keep the chains vertical. The motor is not reversible and the two chains move in one

direction only in step with one another.

The shaft "G" is attached at each end to a chain by the two connecting pins shown in Fig. 1(d). These connecting pins replace two consecutive chain rivets. Thus, if the motor is running, the shaft "G" in end elevation follows the path of a link of a chain, the shaft always remaining horizontal and parallel to the sprocket shafts. The transverse slot in each end of "G" is essential to enable it to pass round the sprockets "D" and "F." A roller "H" (Fig. 1(c)) is mounted on each end of the shaft "G" and is free to rotate on it. The side members "J" of the frame of the

lift cage rest on the rollers and the latter therefore transmit the weight of the cage and its load to the shaft "G" and consequently to the lifting chains "E."

As the shaft passes round the sprocket at each end of the lift's travel, the rollers "H" move at the same time along the tracks "J," a distance approximately equal to the pitch diameter of a sprocket. It will be seen therefore from Fig. 1(b) that the thrust between the cage and the rollers is out of centre both when raising and lowering, but this is not important as the cage is adequately guided and the eccentricity of the thrust is relatively small.

The "floor hitting" of this type of lift is extremely good. This is, of course, due to the fact that although the shaft may stop a few inches from the dead centre of the top or bottom sprockets the difference in level between the cage and landing is small.

As the cage is not balanced, its weight is kept down to a minimum. The sides consist of wire mesh panels in angle iron frames and there is no back or



FIG. 3.—LOWER ENTRANCE TO LIFT.



FIG. 4.—VIEW OF PAVEMENT LEVEL ENTRANCE.

front. To prevent articles which may have been loaded in such a manner as to overhang the edge of the cage, being caught up during the travel of the lift, the back and front of the well are finished smooth.

An ordinary collapsible steel gate 6' 6" high and 4' 0" wide is fitted at the lower opening, but at the street level there is a gate which opens like a portcullis collapsing into a space of a few inches above the upper opening. The lower gate is mechanically and electrically interlocked with the movement of the cage, but in the case of the upper gate the sides of the cage pressing against beaks attached to the gate open and close it as the cage approaches and leaves the upper landing. A pair of wooden doors outside the upper collapsible gate provide protection from the weather, etc., but these doors are not interlocked in any way with the lift.

The wiring diagram is shown in Fig. 2 and it will be seen from this that the controls are very simple. This is due in a large measure to the motor having

no reversing gear. This is no disadvantage as the occasions on which it is desired to recall the lift after it has moved away from a landing should be very few. The "Up" and "Down" push buttons are therefore starting buttons which are switched into and out of circuit by two travel switches in the well. The cage opens one of these switches as it arrives at a landing and allows it to close when it leaves, the actual movement of the switch mechanism being performed by a ramp attached to the cage. Assuming the cage is at the lower landing, the bottom travel switch is open and the "Down" buttons are therefore inoperative. The operation of an "Up" button, however, closes a circuit through the brake solenoid and main contactor "A." When the button is released the "Up" holding coil maintains the circuit until the lift arrives at the upper landing when the cage ramp opens the top travel switch and stops the lift. The bottom travel switch closes as soon as the lift leaves the lower landing and the lift is therefore ready for a journey in the downward direction.

The supply to the lift is 400 volts A.C. 3 phase 50 c.p.s., but to avoid having the controller on alternating current a metal rectifier is installed and the control circuits and brake are supplied with direct current at 180 volts.

The photographs (Figs. 3, 4, and 5) show the lower entrance to the lift, a view from the footpath with the cage approaching the landing, and a general view of the Public Office. This view indicates how successfully the lift has been concealed in the bulkhead under the window.



FIG. 5.—INTERIOR OF PUBLIC OFFICE.

Note on the Singing Point of Two-Wire Repeaters

H. J. JOSEPHS

WHERE two long distance telephone lines are connected by the usual type of two-wire repeater, a state of perfect balance would exist at the repeater if the two lines and their associated apparatus could be made identically alike, and there would be no tendency for the repeater to sing. As a result of random manufacturing variations, however, perfect balance is unattainable, and thus the amplification obtained from the repeater is limited by the production of reflected currents and singing. A statistical examination of the inductance of large numbers of loading coils and of the pair capacities in many drums of cable, shows that the deviations of these elements from their nominal values, follow Gauss's "normal" law for the distribution of errors. It follows, therefore, that by applying the methods of two-dimensional probability to steady-state transmission theory, it will be possible to calculate what restrictions must be placed on the manufacturing deviations of the elements, to ensure that a given transmission characteristic will have a preassigned probability of being within a specified range. The mathematical theory involved in the application of two-dimensional probability to A.C. transmission systems and networks has been worked

out by R. S. Hoyt, and is discussed in his paper, "Probability Theory and Telephone Transmission Engineering," which appeared in the "Bell System Technical Journal" for January, 1933. This note is concerned with a specific application of Hoyt's theory, namely, to determine the limits that must be placed on the inductance and capacity deviations of 20 lb. coil loaded telephone lines with the coils spaced at 2000 yard intervals, to ensure that the singing point of a two-wire repeater will fall between known limits.

Fig. 1 contains a set of six curves showing the probability ranges for the circuits in a 44 mH., coil loaded telephone cable. The vertical scale gives the singing point in decibels, whilst the horizontal scale expresses the (R.M.S.) loading coil inductance deviations. Because the distribution of deviations is "normal," the representative deviation is taken as the square root of the mean of the squares of the deviations, (R.M.S., deviations), i.e.,

$$\text{R.M.S. deviation} = \sqrt{\frac{d_1^2 + d_2^2 + d_3^2 + \dots + d_n^2}{n}}$$

The probability curves in Fig. 1 have been drawn for six frequencies from 500 to 4000 cycles per

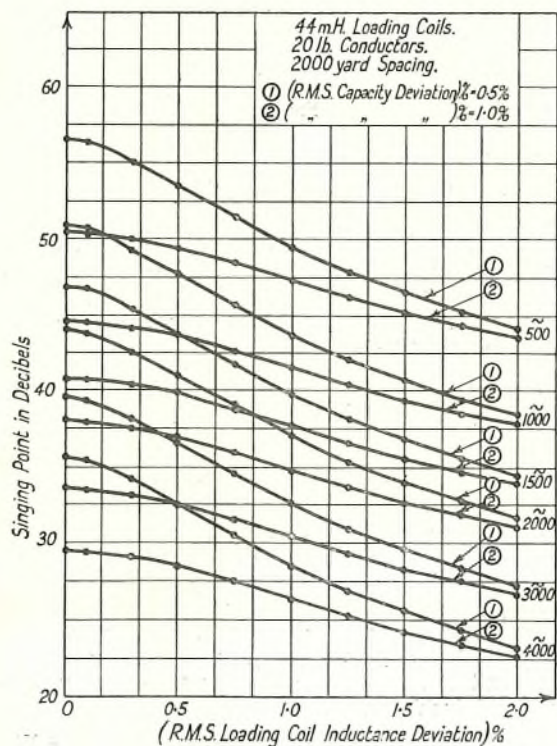

FIG. 1.

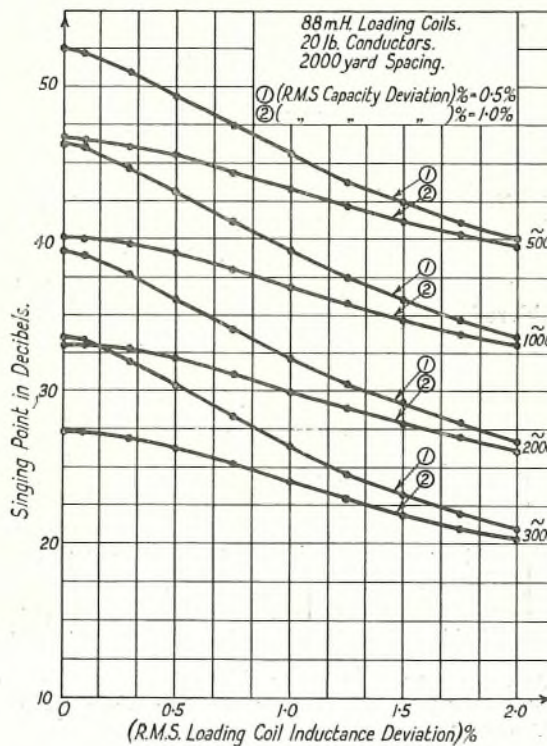

FIG. 2.

second, *i.e.*, from 500 cycles to approximately 0.75 of the cut-off frequency. The probability zone for a particular frequency is the area included between the curves marked ① and ② respectively. The curves marked ① have been calculated for the case of a R.M.S. capacity deviation of 0.5%, whilst the curves marked ② have been drawn for the case of a R.M.S. capacity deviation of 1.0%. In practice most

177 mH., coil loaded lines are given in Figs. 2, 3 and 4 respectively.

To understand more clearly the meaning of the curves, imagine that a large number of coil loaded 20 lb. circuits are to be built with a predetermined singing point at a particular frequency. Then the curves may be used to determine the permissible deviation of inductance and capacity, so that 90%

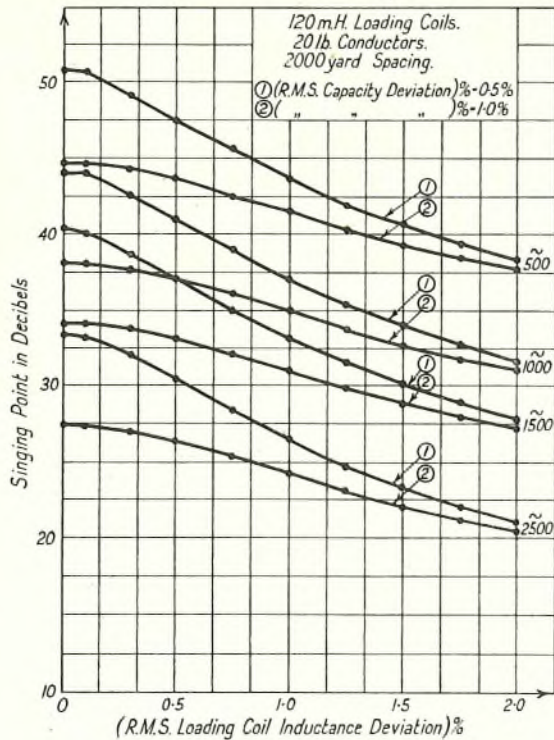

FIG. 3.

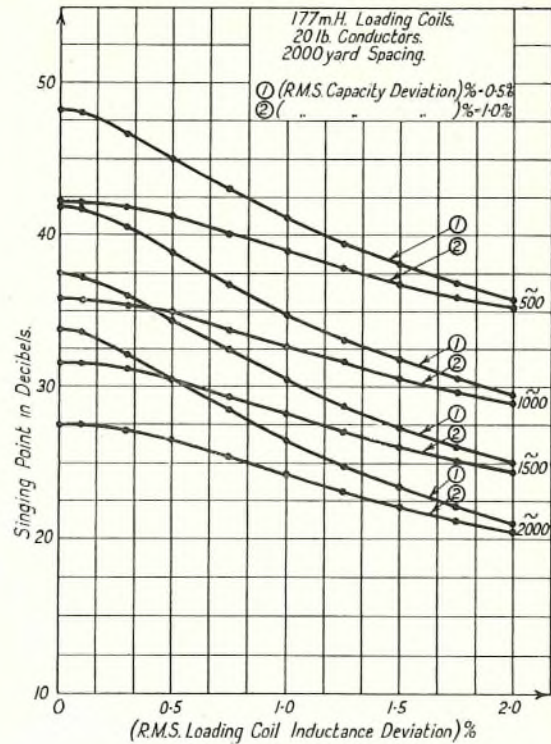

FIG. 4.

capacity deviations will be found to fall between these limits, and in any particular case, the singing point may be determined by taking a proportional part of the ordinate range (0.5 to 1.0) enclosed by the limiting curves ① and ②, at the inductance deviation considered.

The probability ranges for 88 mH., 120 mH., and

of the circuits may be expected to have a singing point somewhat greater, and 10% of the circuits a singing point somewhat less, than the predetermined value. Thus the curves may be used to determine what restrictions must be placed on the deviations of the elements, so that the singing point of a two-wire repeater will have a given probability of being within specified limits.

Book Review

"Wireless for the Man in the Moon." By Columbus and Decibel, 1934, 128 pages. Price 2/6. Published by George Newnes.

The authors, both of whom are well known contributors to World Radio, describe this book as "intended primarily for the Man-in-the-Moon" and as "perhaps a text-book or a fairy tale." The publishers admit that it is perhaps neither. Naturally they hope it will be read by the Man in the Street.

This exposition of how Wireless really works will provide an amusing relief for both student and expert and will be appreciated by the "Wireless Fan," his wife and children.

Wireless is treated from an entirely original view point and if at the conclusion the reader knows little about atoms and electrons he will certainly know all about ducks and ducklings.

A.W.

Notes and Comments

The British Standards Institution

READERS will be interested to hear that, at the Annual General Meeting of the British Standards Institution held on 13th July, 1934, Col. Sir T. F. Purves, O.B.E., was elected to a seat on the General Council. Sir Thomas, now Managing Director of United Telephone Cables, Ltd., was Engineer-in-Chief to the Post Office until his retirement on 30th November, 1932.

Management Courses for Executives

Advance information has reached us to the effect that at the beginning of November next, Loughborough College will inaugurate a series of intensive management courses under the whole-time direction of Mr. E. T. Elbourne, M.B.E., F.I.I.A., the well known exponent of management training. This marks an important development in placing at the disposal of industry the means whereby executives or prospective executives can be specially trained or "refreshed" in particular functional aspects of modern management practice on lines comparable with Army courses in signalling, the Engineer-in-Chief's Training School, etc.

Loughborough College is a large residential college with a complete range of productive engineering workshops. These conditions in combination are unique in this country, and make possible the attainment of a high standard of efficiency in the ten days allotted to each course. Particular emphasis will be placed on demonstrations of the best British

practice brought together from various industries. Lectures will follow in the main the sectional syllabuses of the Institute of Industrial Administration's Diploma, and subscribers to any course may, on completion, sit for the Institute's examination accordingly. The courses as planned are as follows:—

- (1) The Management Function.
- (2) Office Organization and Method.
- (3) Personnel Administration and Incentives.
- (4) Drawing Office Practice and Quality Control.
- (5) Process Planning and Progress Control.
- (6) Estimating and Ratefixing.
- (7) Industrial Accounts and Costing.
- (8) Specification, Purchasing and Tendering.
- (9) Sales Organization and Service.
- (10) Budgetary and Higher Control.
- (11) Factory Lay-out and Equipment.

Each of the eleven courses is complete in itself, and any one may be taken independently. The treatment in each will be consistently directed to show the interrelation of particular functions with one another and with the whole problem of management, as focussed in Course No. 1.

The tuition fee for any ten-day course is five guineas, including the loan of books and demonstration materials. Board residence at the College, with its many amenities, works out at half-a-guinea per day, *i.e.*, five guineas for the ten-day period. Inquiries should be addressed to the Registrar, Loughborough College, Loughborough, Leics.

The Institution of Post Office Electrical Engineers

INSTITUTION PAPERS.

Institution Papers, of which synopses are given below, have been added to the Library and are available on loan to members.

"Telephone Traffic in Automatic Exchanges."—F. M. McDougald.

A paper giving a comparison of manual and auto exchange problems, definition of traffic unit and representations, and dealing with grade of service, nature of traffic, full and limited availability conditions, methods of interconnecting and principles of grading construction, comparison of theoretical and actual traffic carried, cabling and terminal assemblies, traffic meters and traffic records.

"Awards Under Workmen's Compensation Acts and Injury Warrants."—Chas. H. Barrett.

This paper deals with the statutory provisions relating to compensation to workmen for personal injuries suffered in the course of their employment; the legal liability of the employer in cases of industrial diseases; references to legal decisions; the causation of industrial accidents; third party accidents; and Departmental procedure. The

paper also contains information in regard to awards to Civil Servants under the Injury Warrants.

"Cable and Cable Pair Distribution."—Capt. W. Cowburn.

This paper advocates the liberal provision of ducts, suggests alterations in design, ventilating and lighting of manhole and lay-out of cables in same; the adoption of Cable Distribution areas, centralized jointing points at selected manholes; the introduction of distributing centres in:

- (a) rooms in Post Offices or other buildings,
- (b) specially erected buildings,
- (c) specially constructed distribution chambers,

and illustrates the proposal by means of a specific example.

"Labour Costs."—H. W. Powell.

A paper dealing with observations made on works in Post Office Engineering Sections, with special reference to costs, and the extent to which they are affected by the use of transport and special tools, and the employment of Installation Groups.

RECENT ADDITIONS TO THE INSTITUTION LIBRARY.

- 1058 Reduction of noise in buildings: recommendations to architects.—Dept. of Scientific & Industrial Research. (1934, Brit.).
- 1059 The physical principles of electricity and magnetism.—R. W. Pohl. (1930, Cont.).
- 1060 Automatic street traffic signalling.—H. H. Harrison and T. P. Priest. (1934, Brit.).
- 1061 Modern electric clocks.—S. F. Philpott. (1934, Brit.).
- 1062 The world of modern science.—L. Infield. (1934, Brit.).
- 1063 Design of alternating-current machines.—K. Aston. (1934, Brit.).
- 1064 Theory of machines.—L. Toft and A. T. J. Kersey. (1932, Brit.).
- 1065 Loud speakers: theory, performance, testing and design.—N. W. McLachlan. (1934, Brit.).
- 1066 An elementary course of infinitesimal calculus.—Sir Horace Lamb. (1934, Brit.).
- 1067 Magnetism and electricity for beginners.—H. E. Hadley. (1929, Brit.).
- 1068 Alternating currents.—L. T. Agger. (1934, Brit.).
- 1069 Elementary practical mathematics.—E. W. Golding and H. S. Green. (1934, Brit.).
- 1071 Telephony theory and practice: manual switching and sub-station equipment.—K. B. Miller. (1933, Amer.).
- 1072 Telephony theory and practice: automatic switching and auxiliary equipment.—K. B. Miller. (1933, Amer.).
- 1073 Fundamentals of industrial administration.—E. T. Elbourne. (1934, Brit.).

North-Western Centre

PROGRAMME—SESSION 1934-35.

- 1934.
- Oct. "Some Notes on Radio Developments and the Interference Problem."
W. C. Ward, B.Sc. (Eng.).
- Nov. "Faults—mainly Internal." J. G. Robinson.
- Dec. "Some Engineering Workshop Processes."
H. R. Brown.
- 1935.
- Jan. "Research in the British Post Office."
B. S. Cohen, O.B.E. (E.-in-C.O.).
- 12 Feb. "The Provision and Maintenance of Repeated and Amplified Circuits."
A. T. J. Beard (E.-in-C.O.).
- Mar. "Reinforced Concrete Work." H. J. Allies.

Junior Section Notes

London Centre

A spirit of expectant optimism pervades the Committee. The Summer months have been busy ones, but they have resulted in the accompanying programme together with a reorganization which is already showing results in an increasing and more virile membership.

PROGRAMME 1934-5.

CITY AREA.

- Oct. 9. Tue. Farm St. Commentary by D. WADESON. An evening of films on many subjects.
- Nov. 9. Fri. Holborn. J. A. STRETTON. An outline of Telephone Transmission.
- Dec. 7. Farm St. R. W. PALMER, A.M.I.E.E. The Story of the Standard Relay.
- Jan. 11. Fri. Holborn. W. BOCOCK, A.M.I.E.E. Cable Testing and Localization of Faults.
- Feb. 15. Fri. Farm St. H. T. BLISS and D. P. STAGEMAN. Teleprinters No. 3A and their associated V.F. Equipment.
- Mar. 20. Wed. Holborn. J. N. HILL, A.M.I.E.E.. The Growth of a Telephone System, the Factors governing the advance provision of External and Internal Plant.
- Apr. 24. Wed. Holborn. D. E. WADESON. The Latest Developments in Two Motion Selectors.

CENTRE AREA.

- Oct. 10. Wed. Monument. Commentary by J. STRETTON. An evening of Films on many subjects.
- Nov. 2. Fri. Circuit Lab. Debate, Leaders: D. WADESON and J. STRETTON. That the Introduction of Automatic Switching Plant constitutes a practical advance over all previous Systems of Telephonic Communication.
- Dec. 11. Tue. Mount Pleasant. H. M. YELLS. A Modern Power Station, its Running and Control.
- Jan. 3. Thu. Faraday Building. R. W. PALMER, A.M.I.E.E. The Story of the Standard Relay.
- Feb. 8. Fri. Hop. H. M. YELLS. The How and Why of a Wireless Set.
- Mar. 8. Fri. Metropolitan. W. B. LISLE and W. J. DRISDALL. The Telex Service and its associated Private Wire Equipment.

- Apr. 5. Fri. Circuit Laboratory. W. BOCOCK, A.M.I.E.E. Cable Testing and Localization of Faults.

WEST AREA.

- Oct. 8. Mon. Kensington. Commentary by D. WADESON. An evening of Films on many subjects.
- Nov. 2. Fri. Flaxman. R. W. PALMER, A.M.I.E.E. The Story of the Standard Relay.
- Dec. 4. Tue. Bayswater. H. M. YELLS. A Chat on Television.
- Jan. 9. Wed. Acorn. T. D. JUDEN. External Construction, Difficulties encountered and overcome.
- Feb. 8. Fri. Acorn. P. R. GERRY. The Subscribers' Group Service.
- Mar. 22. Fri. Hounslow. J. A. STRETTON. Cables, Cabling and Jointing. (Illustrated by a Film).
- Apr. 10. Wed. Sloane. Debate, Leaders: J. L. W. MORGAN and R. C. W. WALKER. That the Introduction of Automatic Switching Plant constitutes a Practical Advance over all previous Systems of Telephonic Communication.

SOUTH EAST AREA.

- Oct. 12. Fri. Denman Street. Commentary by D. WADESON. An evening of Films on many subjects.
- Nov. 16. Fri. Tulse Hill. W. BOCOCK, A.M.I.E.E. Cable Testing and Localization of Faults.
- Dec. 14. Fri. Bexley Heath. P. R. GERRY. Subscribers' Group Service.
- Jan. 18. Fri. Hithergreen. J. A. STRETTON. An Outline of Telephone Transmission.
- Feb. 13. Wed. Beckenham. H. M. YELLS. A Tour of a Contractor's Factory.
- Mar. 29. Fri. Rodney. T. D. JUDEN. External Construction, Difficulties encountered and overcome.
- Apr. 29. Mon. Brixton. D. WADESON. The latest developments in Two Motion Selectors.

SOUTH WEST AREA.

- Oct. 15. Mon. Battersea. Commentary by D. WADESON. An evening of Films on many subjects.
- Nov. 23. Fri. Fairfield. R. W. PALMER, A.M.I.E.E. The Story of the Standard Relay.

- Dec. 7. Fri. Elmbridge. W. BOCK, A.M.I.E.E. Cable Testing and Localization of Faults.
 Jan. 23. Wed. Putney. P. R. GERRY. Subscribers' Group Service.
 Feb. 1. Fri. Battersea. J. A. STRETTON. An Outline of Telephone Transmission.
 Mar. 1. Fri. Liberty. H. M. YELLS. A Chat on Television.
 Apr. 3. Wed. Wandsworth (North Side). R. T. ROBINSON. Motor Transport and its Part in Telephone Engineering.

NORTH WEST AREA.

- Oct. 16. Tue. Hampstead. Commentary by D. WADESON. An evening of Films on many subjects.
 Nov. 14. Wed. Willesden. H. T. BLISS and D. P. STAGEMAN. Teleprinters No. 3A and their associated V.F. Equipment.
 Dec. 5. Wed. Arnold. J. A. STRETTON. Cables, Cabling and Jointing. (Illustrated by a film).
 Jan. 25. Fri. Primrose. H. M. YELLS. A Modern Power Station, its Running and Control.
 Feb. 22. Fri. Hampstead. R. W. PALMER, A.M.I.E.E. The Story of the Standard Relay.
 Mar. 29. Fri. Maida Vale. H. M. YELLS. A Tour of a Contractor's Factory.
 Apr. 10. Wed. Gladstone. J. N. HILL, A.M.I.E.E. The Growth of a Telephone System, the factors governing the advance provision of External and Internal Plant.

NORTH EAST AREA.

- Oct. 17. Wed. Leytonstone. Commentary by D. WADESON. An evening of Films on many subjects.
 Nov. 7. Wed. Ilford. J. A. STRETTON. An Outline of Telephone Transmission.
 Dec. 12. Wed. Advance. J. N. HILL, A.M.I.E.E. The Growth of a Telephone System, the factors governing the advance provision of External and Internal Plant.
 Jan. 16. Wed. Cannonbury. P. R. GERRY. The Subscribers' Group Service.
 Feb. 22. Fri. Grangewood (New). T. D. JUDEN. External Construction, Difficulties encountered and overcome.
 Mar. 13. Wed. Bowes Park. Debate, Leaders: J. L. W. MORGAN and R. C. W. WALKER. That the introduction of Auto Switching Plant constitutes a practical advance over all previous systems of Telephonic Communication
 Apr. 12. Fri. Stamford Hill. H. M. YELLS. A Chat on Television.

ANNUAL GENERAL MEETING.

- May 17. Fri. Denman Street. Subject and Speaker to be announced later.

VISITS.

- Oct. 13. Sat. Croydon Air Port.
 Nov. 24. Sat. Dollis Hill Research Station. Not yet fixed. National Physical Laboratory.

Gloucester Centre

On Friday, June 22nd, 1934, a large gathering of members met in Gloucester to show their appreciation of the services rendered by the Branch Officers of last session. A group photograph of the Local Centre had been taken some weeks previously, and it had been agreed that a framed copy be presented to each retiring officer.

W. Day, M.I.E.E.—who was leaving the Section on promotion to the Engineer-in-Chief's Office. Other Branch members expressed their thanks to the retiring officers, and it was very evident from these commentaries that the work done by the officials was fully appreciated.

The Superintending Engineer then made the presentations. His references, particularly to Mr. Day, were



MEMBERS OF THE GLOUCESTER CENTRE.

We were honoured by the presence of our Superintending Engineer—Mr. H. S. Thompson, M.I.E.E.—who had very kindly consented to make the presentations. The Chairman—Mr. F. W. Gill—after welcoming Mr. Thompson, made pleasing remarks about each officer and especially spoke sincerely of the retiring Chairman—Mr.

marked by touches of humour and sincerity and were appreciated on every hand. Each recipient suitably replied, and it was very gratifying to the membership to know that all had taken pleasure in the work they had done for the Branch.

Mr. Thompson was then asked if he would accept a

photograph from the Branch as a memento of the occasion. This he did, and expressed his appreciation amid loud applause.

A vote of thanks was expressed to Mr. Thompson by the Vice-Chairman (Mr. A. J. Hodgson), seconded by Mr. J. A. Chiswell, and a very enjoyable meeting was thus brought to a close.

The forthcoming session will soon be in full swing, and there is promise of another interesting series of papers for already quite a number of members have offered papers.

A visit to a Radio Station is being arranged to take place in the near future. This trip will take the form of a combined educational and social outing.

Cambridge Centre

The Committee thank those members who have promised to read papers during the ensuing session.

The subjects chosen cover a wide range, including Television; Telephone Transmission; Call Timing Devices; Fault Control; Radio Interference Suppression; Graphical Statistics; Overhead Construction.

A good sign for the future is the interest taken by younger members who are contributing towards the programmes and assisting in the management of the Branch.

We are glad to record a further increase in the membership: There are now 48 members on the books.

There is reason to believe that the session 1934-35 will be as successful as 1933-34, when six papers read before the membership were considered by the Committee under the prize scheme. We were very gratified to receive the commendation of the Superintending Engineer and Committee of the parent body in connexion with these papers.

During the summer a visit was made to the Post Office

Tube Railway, by kind permission of the Controller, London Postal Service.

Edinburgh, Dundee and Aberdeen Centres

The number of offers of papers for the ensuing session is very satisfactory and no difficulty is being experienced in the preparation of programmes. The subjects cover a wide field and it is felt that the standard of excellence reached during the past sessions will be more than maintained. Visits to places of interest will again be a special feature of our activities on account of their educational value.

The Edinburgh Centre has decided to award £1 1s. 0d. to the reader of the best paper which does not receive a prize from the Council of the I.P.O.E.E.

Bury St. Edmunds Centre

The forthcoming session of the Bury St. Edmunds Junior Centre is looked forward to with interest. A number of papers have been promised, including Unit Auto No. 6, by Mr. E. P. Shelbourne; The Daily Routine of a Lineman, by Mr. A. K. Giddings; and Teleprinter No. 3A, by Mr. F. N. Shildrick, with "subjects later" from Messrs. R. G. W. King and E. Turner.

Membership has now increased to nineteen. Whilst this is very pleasing, there is ample room for improvement, a number of our external staff not having yet grasped the advantages of belonging to the society.

A Junior Library has been inaugurated from which an abundance of technical literature may be borrowed free of charge. This, with the generous opportunity presented by the Senior Institution's Library, makes the membership of those who are keen to further their interests in the daily work, very advantageous.

Book Review

"Modern Acoustics." By A. H. Davis, D.Sc. G. Bell and Sons, Ltd., London. Price 26/- net.

Although Acoustics is generally regarded as a highly specialized study, it has in fact many ramifications and it touches the modern social structure at many different points. The subject offers scope to both the theorist and the empiricist, and it is difficult for one individual to avoid bias towards one or another of its different branches. The entire absence of such bias and the authority which one associates with the National Physical Laboratory are alone sufficient to mark the publication of "Modern Acoustics" as an event of some importance. I confess, however, to a wish that the author had somewhat relaxed his impartial attitude and given us the benefit of more of his personal comment and opinion.

The mathematical theory of sound, which is so important to a proper understanding of the subject, is inserted unobtrusively, mostly in the form of summaries of formulæ and conclusions, supported by appropriate references to the classical literature. In many cases, and particularly where impedance methods are used, the line of argument by which conclusions are reached is also indicated. For the rest the book deals with the practice and apparatus—from transformers to auditoriums—associated with all branches of acoustics, and with the work of investigators in this field, among whom Dr. Davis is himself an eminent contributor. Nor are the works of the earlier experimenters neglected; the justification for the word "Modern" in the title lies in the fact that,

in the realm of applied acoustics, they now constitute so very small a minority.

A summary of the contents of the book would occupy too much space for this review. It is difficult to think of anything pertaining to acoustics which does not receive at least mention or reference. There is even a chapter devoted to electrical apparatus, and summaries of useful mathematical formulæ and electrical data are inserted as appendices. By means of an excellent index the reader can readily find his way to whatever interests him and read on, without reference to what goes before. Thus the arrangement of the subject matter and the grouping of the chapters are of little consequence.

In the matter of units Dr. Davis introduces two ideas which deserve the serious attention of telephone engineers. The name "phon" is suggested as a unit of noise—as is now the German practice, and the names "brig" and "decibrig" are suggested for a system of logarithmic units, analogous to the bel and decibel, but relating to numbers only and not necessarily to the magnitudes of powers. It seems to me that there is a place for this terminology in telephone engineering; do we not, for example, use voltmeters ("volume indicators") for measuring watts—choosing to misuse our voltmeters rather than our decibels.

The text of the book is contained in 334 pages and there are more than 100 illustrations including some excellent photographic reproductions. A more important indication of size is the fact that Dr. Davis has the gift of clear expression combined with economy of words.

W.W.

District Notes

London Engineering District

MILEAGE STATISTICS.

During the three months ended June 30th, 1934, the following changes occurred:—

Telephone Exchange.—Nett increase in overhead and underground respectively of 574 and 11,685 miles.

Telephone Trunks.—Nett decrease in overhead, 1,305 miles. Nett increase in underground, 3,312 miles.

Telegraphs.—Nett decrease in overhead, 48 miles. Nett decrease in underground, 899 miles.

The total single wire mileage at the end of the period under review was:—

	<i>Overhead.</i>	<i>Under-ground.</i>	<i>Total.</i>
Telephone Exchange ...	46,225	3,711,327	3,757,552
Trunks	8,958	204,037	212,995
Telegraphs	1,131	37,336	38,467
Spare Wires	3,794	170,281	174,075
Total	60,108	4,122,981	4,183,089

Scotland West

GLASGOW-CARLISLE MAIN TRUNK CABLE.

The provision of the Glasgow-Carlisle Section of a new telephone trunk cable, ultimately to form part of a London-Liverpool-Glasgow additional artery, was commenced in the Scotland West District as an urgent matter on the 25th June last. In this District alone the work involves the provision of 106 miles of cable (95 miles of 4 pair/40 lb. + 270 pair/25 lb. and 11 miles of 4 pair/40 lb. + 360 pair/25 lb., 86 miles of the former being armoured); 13 miles of new duct; the building of 178 manholes and joint boxes, together with the installation of repeater equipment at Glasgow, Beattock and Dumfries. Pending the erection of a permanent building at Beattock, the equipment is to be accommodated in a temporary wooden hut adjacent to the site of the permanent building. The aim is to complete the laying and jointing of the cable and installation of the equipment by the 31st of October so that the final testing can be carried out before the end of the year and the cable brought into use early in January next. The whole of the duct work and approximately 40% of the cable has been laid up to the time of writing (mid August) and the marked activity of the Department's Contractors, Messrs. The Standard Telephones and Cables Co., Ltd., and the Southern United Cable Co., Ltd., is resulting in the cable being laid at a rate approximating to 1½ miles per day. A full description of the cable as a whole will form the subject of an article to appear in a later issue of the Journal.

MULL. EXTENSION OF TELEPHONE SERVICE FROM THE MAINLAND.

The opening of the Mull-Mainland telephone trunk service on the 21st June last marked a further step in the telephone development of the Western Isles of Scotland. Hitherto service was confined to local telephone communication between call offices and the Tobermory Ex-

change with no outlet to the mainland, except by means of telegraph. The installation of a switching Exchange at Craignure and the provision of a 4-core submarine cable across the Firth of Lorne from Craignure to Oban has enabled full trunk facilities to be afforded to telephone subscribers on the Island of Mull. Unit Automatic Exchanges are in course of erection at Dervaig and Aros (Mull) and on the Island of Iona which will extend the service from Craignure to distant parts of Mull and Iona.

In addition to the seven miles of submarine cable laid by the Submarine Department (H.M.T.S. "Alert") the scheme has involved the erection of over 1000 poles and 200 miles of wire on the Island. Special arrangements for transporting these stores from the mainland were made by chartering three vessels of the steam barge type which loaded at Oban and off-loaded, one at the small pier at the South end of Mull, and the other two by beaching at high tide at Loch Spelve and Loch Scridian, the cargoes being discharged at low tide and distributed by lorry to the scene of operations. To cope with the rocky nature of the sub-soil, rock drilling plant was also shipped to the Island together with the requisite motor transport for the conveyance of men and stores from point to point. Intercommunication by telephone is now made possible for residents and visitors on both sides of the Firth of Lorne and telephone subscribers in Mull can enjoy the full advantage of modern telephone service.

South Western

A Post Office Exhibition was held at Plymouth from 9th July to 11th August.

Some 108,000 people attended in all—about half the population of Plymouth. The Exhibition was opened by the Mayor of Plymouth who, as part of the opening procedure, held a conversation with the Captain of the "Empress of Britain" which was then on its way to America. At the time the vessel was about 750 miles west of Cornwall. The necessary arrangements for this conversation were carried out by the Engineering Department within a few hours of the opening of the Exhibition, and the speech, as the Mayor remarked, was as clear, if not more so, as any local telephone call. Sir Stephen Tallents was also present at the opening.

The Exhibition was an undoubted success, great interest being shown in the Automatic Demonstration which was no doubt occasioned by the pending transfer to auto. working.

Brixham auto. transfer took place on the 15th August without a single hitch. The exchange is the second of the A.G.S. type to be opened and contains developments over the apparatus installed at the original exchange of this type, *i.e.*, East Kirby, arising from the experiments which have been carried out at the latter. Three Units, each equipped with 80 "L and K" relays have been provided, together with a multiple for 300 lines. The exchange works into the Torquay Multi Exchange area and is equipped for Multiple Metering. It has Adjacent Exchange Routing Facilities for Dartmouth.

The Multi-Channel V.F. System has been extended and the Western Scheme which includes V.F. terminal equipment at Bristol, Exeter and Plymouth has now been completed and brought into use.

Staff Changes

PROMOTIONS.

Name.	From.	To.	Date.
Jenkins, I. H.	Assistant Staff Engineer, Equipment Section, E.-in-C.O.	Staff Engineer, Telephone Section, E.-in-C.O.	20-8-34
Ryder, W. V.... ..	Executive Engineer, Scot. East District.	Assistant Superintending Engineer, Scot. East District.	1-1-35
Scutt, W. D.	Executive Engineer, N. Eastern District.	Assistant Superintending Engineer, N. Eastern District.	1-1-35
McEwan, M. R. K.	Assistant Engineer, Scot. East District.	Executive Engineer, Scot. East District.	22-10-34
Farnes, G. H.... ..	Assistant Engineer, Scot. East District.	Executive Engineer, Eastern District.	1-1-35
Parker, T.	Assistant Engineer, N. Eastern District.	Executive Engineer, N. Eastern District.	1-1-35
Gemmell, W. T.	Assistant Engineer, Northern District.	Executive Engineer, Northern District.	1-12-34
Barlow, T. F.... ..	Assistant Engineer, N. Eastern District.	Executive Engineer, Scot. East District.	1-1-35
Stretch, W.	Assistant Engineer, S. Lancs. District.	Executive Engineer, S. Lancs. District.	1-12-34
Owen, J. McA.	Assistant Engineer, N. Mid. District.	Executive Engineer, N. Mid. District.	1-1-35
Tyson, W. R.	Assistant Engineer, S. Wales District.	Executive Engineer, S. Wales District.	1-1-35
Jones, H. C.	Assistant Engineer, E.-in-C.O.	Executive Engineer, E.-in-C.O.	1-8-34
Cooper, M. C.	Assistant Engineer, N. Ireland District.	Executive Engineer, N. Ireland District.	1-8-34
Kemp, A.	Assistant Engineer, S. Lancs. District.	Executive Engineer, S. Lancs. District.	13-8-34
Hedges, E. W.	Chief Inspector, E.-in-C.O.	Assistant Engineer, E.in-C.O.	7-8-34
Sturgess, H. E.	Chief Inspector, Rugby Radio Station.	Assistant Engineer, E.in-C.O.	7-8-34
Bevis, W. F.	Chief Inspector, E.-in-C.O.	Assistant Engineer, E.in-C.O.	7-8-34
Gray, G.	Chief Inspector, London District.	Assistant Engineer, London District.	1-8-34
Logan, B. G.	Chief Inspector, S. Eastern District.	Assistant Engineer, S. Eastern District.	2-8-34
Christie, G. C.	Chief Inspector, N. Wales District.	Assistant Engineer, N. Wales District.	12-8-34
Vause, A. H.	Chief Inspector, London District.	Assistant Engineer, London District.	2-8-34
Preston, S.	Chief Inspector, S. West District.	Assistant Engineer, N. Eastern District.	1-11-34
Millington, S. J. T.	Inspector, N. Wales District.	Chief Inspector, N. Wales District.	1-7-34
Fotheringham, S. D.	Inspector, Scot. East District.	Chief Inspector, Scot. East District.	12-7-34
Spiers, J. C.	Inspector, N. Wales District.	Chief Inspector, N. Wales District.	12-8-34
Jones, C. E.	Inspector, N. Wales District.	Chief Inspector, N. Midland District.	15-6-34
Footell, T. E.... ..	Inspector, N. West District.	Chief Inspector, S. West District.	1-7-34
Watkins, L. E.	Inspector, N. Midland District.	Chief Inspector, London District.	1-8-34
McNeille, J. L.	Inspector, N. Midland District.	Chief Inspector, London District.	1-7-34
Rogers, H.	Inspector, E.-in-C.O.	Chief Inspector, Testing Branch.	26-6-34
Pullen, L.	S.C. & T., Birmingham.	Repeater Officer, Class II., N. Wales District.	17-5-34
Penfold, C. A.	S.W.I., S. East District.	Inspector, S. East District.	26-6-34
Houghton, C. W.	S.W.I., S. East District.	Inspector, S. East District.	16-6-34
Burke, R.	S.W.I., Testing Branch, London.	Inspector, Testing Branch, London.	To be fixed later.
Holloway, A.	S.W.I., S. Lancs. District.	Inspector, S. Lancs. District.	5-5-34
Bent, G. P.	S.W.I., S. Lancs. District.	Inspector, S. Lancs. District.	8-7-34
Hanrahan, P.	S.W.I., Scot. West District.	Inspector, Scot. West District.	1-2-32
Armstrong, C.	S.W.I., N. Wales District.	Inspector, N. Wales District.	4-8-34
Douglas, A. S.	S.W.I., N. Wales District.	Inspector, N. Wales District.	4-8-34
Myatt, J. W.	S.W.I., N. Wales District.	Inspector, N. Wales District.	4-8-34
Dolman, L. F.	S.W.I., N. Wales District.	Inspector, N. Wales District.	6-8-33
Perks, H.	S.W.I., N. Wales District.	Inspector, N. Wales District.	24-6-34
Bradley, H.	S.W.I., N. Midland District.	Inspector, N. Midland District.	1-8-34

APPOINTMENTS.

Name.	From.	To.	Date.
Johnson, L. P.	Probationary Inspector, S. West Dist.	Inspector, S. West District.	1-5-31
Moody, W. R. N.	Probationary Inspector, East Dist.	Inspector, East District.	1-5-34
Adam, S. A. F.	Probationary Inspector, N. West Dist.	Inspector, N. West District.	2-5-31
Stanbury, H. C. O.	Probationary Inspector, N. Wales Dist.	Inspector, N. Wales District.	2-5-34

APPOINTMENTS—Continued.

Name.	From.	To.	Date.
Colledge, T. A. P. ...	Probationary Inspector, London Dist.	Inspector, London District.	1-6-34
Crossley, J. ...	Probationary Inspector, E.-in-C.O.	Inspector, E.-in-C.O.	4-5-34
Shepherd, J. ...	Probationary Inspector, E.-in-C.O.	Inspector, E.-in-C.O.	19-5-34
Taylor, F. J. D. ...	Probationary Inspector, S. Wales Dist.	Inspector, S. Wales District.	2-5-34
Coombes, R. H. ...	Probationary Inspector, N. Wales Dist.	Inspector, N. Wales District.	2-5-34
Tucker, D. G. ...	Probationary Inspector, E.-in-C.O.	Inspector, E.-in-C.O.	2-5-34
Drinkwater, M. ...	Probationary Inspector, S. Lancs. Dist.	Inspector, S. Lancs. District.	2-5-34
Waumsley, L. V. ...	U.S.W., St. Albans Radio Station.	Probationary Inspector, E.-in-C.O.	1-6-34
Lovegrove, L. W. ...	S.W.II., E.-in-C.O.	Probationary Inspector, E.-in-C.O.	1-6-34
Weaver, E. W. ...	U.S.W., London District.	Probationary Inspector, E.-in-C.O.	1-6-34
French, E. J. ...	U.S.W., S. West District.	Probationary Inspector, E.-in-C.O.	1-6-34
Cheetham, H. ...	S.W.II., N. West District.	Probationary Inspector, E.-in-C.O.	1-6-34
Tuck, R. O. ...	Unest. Draughtsman, N. East Dist.	Probationary Inspector, E.-in-C.O.	1-6-34
Maybank, E. W. ...	U.S.W., London District.	Probationary Inspector, E.-in-C.O.	1-6-34
Crowthier, L. R. ...	U.S.W., N. East District.	Probationary Inspector, E.-in-C.O.	1-6-34
Horner, G. H. ...	U.S.W., London District.	Probationary Inspector, E.-in-C.O.	1-6-34
Goford, R. ...	S.W.II., London District.	Probationary Inspector, E.-in-C.O.	1-6-34
Medcalf, L. W. ...	U.S.W., London District.	Probationary Inspector, E.-in-C.O.	1-6-34
Lamb, W. H. ...	S.W.II., London District.	Probationary Inspector, E.-in-C.O.	1-6-34
Nordh, P. W. F. ...	U.S.W., London District.	Probationary Inspector, E.-in-C.O.	1-6-34
Dickenson, C. R. ...	U.S.W., S. West District.	Probationary Inspector, E.-in-C.O.	1-6-34
Selby, C. H. ...	S.W.I., Portishead Radio Station.	Probationary Inspector, E.-in-C.O.	1-6-34
Hulcoop, G. J. ...	U.S.W., Testing Branch.	Probationary Inspector, E.-in-C.O.	1-6-34
Bennett, H. V. ...	S.W.I., Baldock Radio Station.	Probationary Inspector, E.-in-C.O.	1-6-34
Rule, F. T. ...		Probationary Inspector, E.-in-C.O.	1-6-34
Kirkpatrick, F. E. ...		Probationary Inspector, E.-in-C.O.	1-6-34
Scowen, F. ...		Probationary Inspector, E.-in-C.O.	1-6-34
Revell, H. J. ...		Probationary Inspector, E.-in-C.O.	1-6-34
Beniston, S. ...	From Open Competition.	Probationary Inspector, E.-in-C.O.	1-6-34
Martin, B. R. ...		Probationary Inspector, E.-in-C.O.	1-6-34
de Jong, N. C. C. ...		Probationary Inspector, E.-in-C.O.	1-6-34
Swain, E. C. ...		Probationary Inspector, E.-in-C.O.	1-6-34
Freeman, J. S. ...	Unes. Draughtsman, E.-in-C.O.	Draughtsman, Cl. II., E.-in-C.O.	11-4-34
Nichols, D. J. ...	Unest. Draughtsman, S. Mid. Dist.	Draughtsman, S. Mid. District.	21-3-34
Hawke, C. ...	Unest. Draughtsman, S. West Dist.	Draughtsman, S. West District.	2-5-34
Fry, A. M. ...	Unest. Draughtsman, S. West Dist.	Draughtsman, S. West District.	23-5-34

RETIREMENTS.

Name.	Rank.	District.	Date.
Hedley, J. ...	Staff Engineer.	E.-in-C.O.	19-8-34
Horner, F. H. ...	Assistant Staff Engineer.	E.-in-C.O.	31-7-34
Scarr, W. ...	Assistant Superintending Engineer.	N. Wales.	11-8-34
Aspinall, H. O. ...	Executive Engineer.	London.	30-6-34
Escott, H. ...	Executive Engineer.	S. Lancs.	12-8-34
Ray, J. W. ...	Assistant Engineer.	S. Eastern.	30-8-34
Milne, J. D. ...	Chief Inspector.	Scot. East.	11-7-34
Freeman, C. F. ...	Chief Inspector.	London.	31-7-34
Lane, T. H. ...	Inspector.	London.	24-6-34
Pearson, M. ...	Inspector.	London.	30-6-34
Goolding, T. S. ...	Inspector.	London.	30-6-34
Pigg, P. H. ...	Inspector.	N. Eastern.	15-5-34
Ralph, A. W. ...	Inspector.	London.	31-7-34
Thompson, C. ...	Inspector.	S. Midland.	6-7-34
Dotterill, F. ...	Inspector.	S. West.	4-8-34
Horobin, J. H. ...	Senior Draughtsman.	E.-in-C.O.	31-8-34

TRANSFERS.

Name.	Rank.	From	To	Date.
Jacquest, A. H. ...	Executive Engineer.	N. Ireland.	E.-in-C.O.	8-7-34
Ellson, F. A. ...	Executive Engineer.	E.-in-C.O.	Testing Branch, London.	9-7-34
Bryden, J. E. Z. ...	Assistant Engineer.	E.-in-C.O.	N. Eastern District.	1-7-34
Tyson, W. R. ...	Assistant Engineer.	London District.	S. Wales District.	1-8-34
Phillips, R. S. ...	Assistant Engineer.	E.-in-C.O.	S. Lancs. District.	1-8-34
Beastall, J. G. ...	Assistant Engineer.	S. Lancs. District.	E.-in-C.O.	15-8-34
Jones, F. ...	Assistant Engineer.	E.-in-C.O.	S. Lancs. District.	19-8-34
Millard, C. W. ...	Assistant Engineer.	N. West District.	S. East District.	19-8-34
Hodge, G. W. ...	Assistant Engineer.	E.-in-C.O.	S. East District.	26-8-34
Irwin, A. ...	Assistant Engineer.	St. Albans Radio.	N. West District.	1-9-34
McIntosh, H. B. ...	Chief Inspector.	N. Midland District.	Scot. West District.	7-8-34
Roberts, H. T. ...	Inspector.	London District.	E.-in-C.O.	7-8-34
Ingram, C. S. ...	Inspector.	Baldock Radio.	E.-in-C.O.	18-8-34

CLERICAL GRADES.

PROMOTIONS.

Name.	From.	To.	Date.
Eachus, R. S.	Acting Higher Clerical Officer, S. Midland District.	Higher Clerical Officer, S. Midland District.	3-7-34
Barker, E. W. M.	Clerical Officer, N. Midland District.	Higher Clerical Officer, N. Midland District.	15-8-34
Riddell, A. B.	Clerical Officer, Scot. West District.	Higher Clerical Officer, Scot. West District.	3-7-34
Bagshaw, H. M.	Clerical Officer, S. Lancs. District.	Acting Higher Clerical Officer, S. Lancs. District.	18-7-34
Franks, G.	Higher Clerical Officer, S. Eastern District.	Staff Officer, S. Eastern District.	19-8-34
Bagshaw, H. M.	Acting Higher Clerical Officer, S. Lancs. District.	Higher Clerical Officer, S. Lancs. District.	19-8-34
Sanders, T.	Clerical Officer, S. Western District.	Higher Clerical Officer, S. Western District.	30-11-34
Clayton, F. B.	Clerical Officer, S. Western District.	Higher Clerical Officer, S. Western District.	To be fixed later.
Hoare, A.	Clerical Officer, S. Wales District.	Higher Clerical Officer, S. Wales District.	1-9-34
Dall, C. A.	Clerical Officer, Scot. East District.	Higher Clerical Officer, N. Eastern District.	To be fixed later.
Thrush, G.	Clerical Officer, S. Eastern District.	Higher Clerical Officer, S. Eastern District.	To be fixed later.
Blower, A. W.	Clerical Officer, N. Midland District.	Acting Higher Clerical Officer, S. Midland District.	To be fixed later.
Gravett, E.	Clerical Officer, London District.	Higher Clerical Officer, London District.	19-8-34

RETIREMENTS.

Name.	Rank.	Location.	Date.
Taylor, G.	Higher Clerical Officer.	Scot. West District.	2-7-34
Carder, A.	Higher Clerical Officer.	S. Lancs. District.	17-7-34
Cooke, J.	Higher Clerical Officer.	N. Midland District.	14-8-34
Hardcastle, J. R.	Higher Clerical Officer.	N. Eastern District.	8-7-34
Allin, J. T. A.	Staff Officer.	S. Eastern District.	18-8-34
Morris, F. J.	Higher Clerical Officer.	S. Wales District.	26-8-34
Hills, A. M.	Higher Clerical Officer.	N. Ireland District	23-9-34
Lyons, J. C.	Higher Clerical Officer.	S. Eastern District.	30-9-34
Hilton, J. E. T. S.	Higher Clerical Officer.	London District.	1-9-34

BOARD OF EDITORS

- B. O. ANSON, M.I.E.E., Chairman.
 C. J. MERCER, M.I.E.E., M.I.R.E.
 P. J. RIDD, M.I.E.E.
 A. J. GILL, B.Sc., M.I.E.E., M.I.R.E.
 H. G. S. PECK, B.Sc., M.I.E.E.
 J. INNES, B.Sc., M.I.E.E., Managing Editor.
 W. S. PROCTER, A.M.I.E.E., Assistant Editor.

Copyright

The entire contents of this Journal are covered by general copyright, and special permission is necessary for reprinting long extracts, but Editors are welcome to use not more than one third of any article, provided credit is given at the beginning or end thus: "From the *Post Office Electrical Engineers' Journal*."

The Board of Editors is not responsible for the statements made nor the opinions expressed in any of the articles in this Journal, unless such statement is made specifically by the Board.

Communications

All Communications should be addressed to the Managing Editor, *P.O.E.E. Journal*, Engineer-in Chief's Office, Alder House, Aldersgate Street, London, E.C.1. Telephone: NATIONAL 3440. Remittances should be made payable to "*The P.O.E.E. Journal*" and should be crossed "& Co."

Back Numbers

The price of the Journal, which is published quarterly, is 1s. (1s. 3d. post free) per copy, or 5s. per annum post free. Back numbers can be supplied, subject to availability of stocks, at 1s. each (1s. 3d. post free). Orders for back numbers may be sent to the Local Agents or to the Publishers.

Advertisements

All communications relating to space reservations should be addressed to the Advertisement Editor, *P.O.E.E. Journal*, Alder House, Aldersgate Street, London, E.C.1. Communications regarding advertisement copy, proofs, etc., should be addressed to the Publishers, MESSRS. BIRCH & WHITTINGTON, 10, Station Road, Epsom, Surrey.

FERRANTI

A.C./D.C. CIRCUIT TESTER

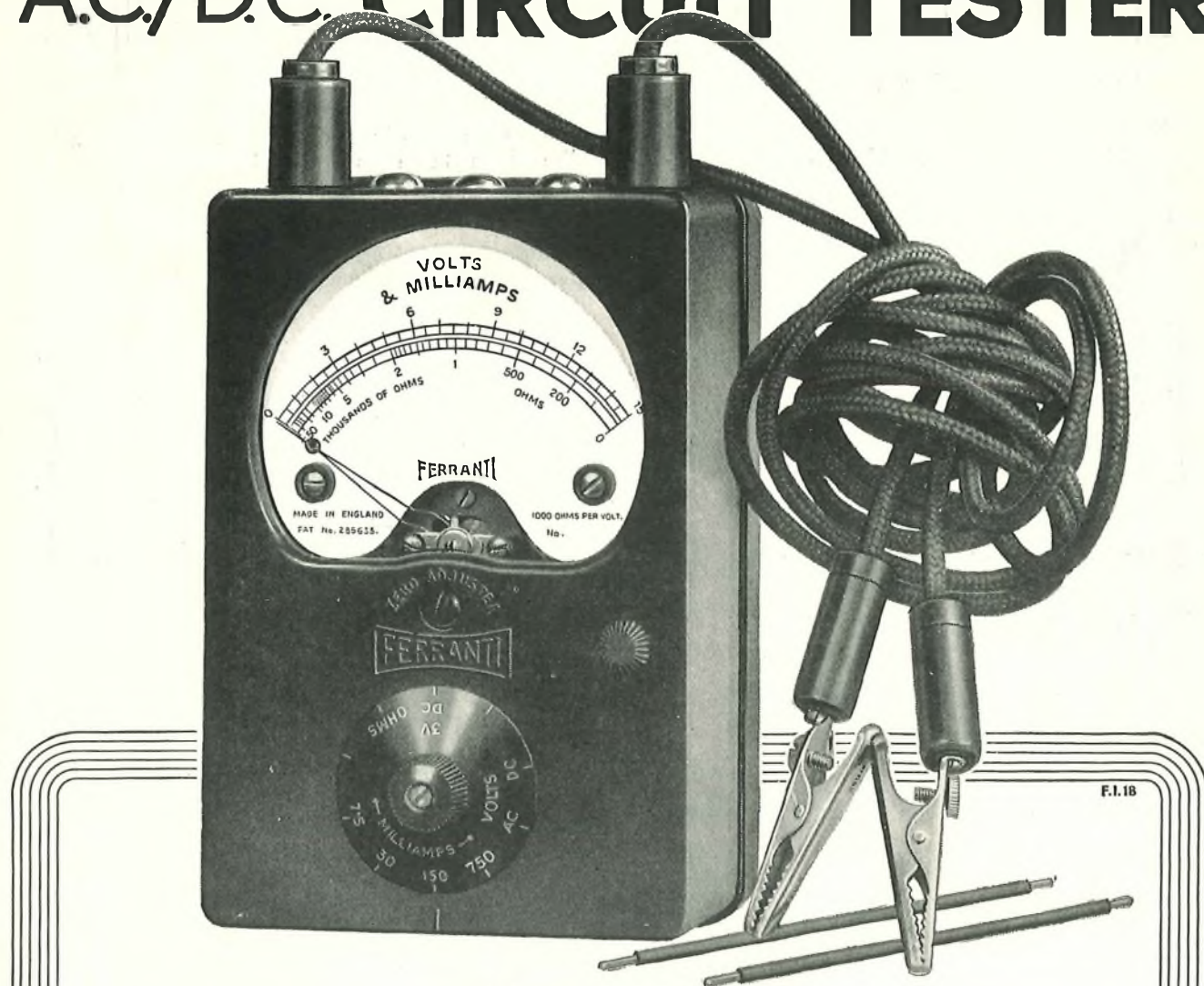

This new moving coil instrument measures D.C. milliamperes, D.C. volts, A.C. volts and ohms. D.C. readings are first grade in accordance with B.S.I. No. 89 and A.C. readings are correct within 3 per cent. at full scale reading. The instrument is complete with self-contained $1\frac{1}{2}$ -Volt cell.

RANGES

- | | | |
|----------------|---|-----------------------------|
| D.C. MILLIAMPS | 0-1, 7.5, 30, 150 and 750. | |
| D.C. VOLTS | 0-3, 15, 150, 300, 450 and 600. | } 1000 ohms
per
volt. |
| A.C. VOLTS | 0-15, 150, 300, 450 and 600
20 to 4000 cycles per second. | |
| A.C. MILLIAMPS | 0-1. | |
| RESISTANCE | 0-50,000 ohms self-contained
and up to 0-30 megohms with
external D.C. source up to 600V. | |
| DIMENSIONS | 3 $\frac{3}{8}$ " x 4 $\frac{1}{2}$ " x 2 $\frac{1}{4}$ " | |
| PRICE | £5 15s. including substantial case and
all accessories. | |

Write for list In. 1.

INDEX TO ADVERTISERS.

	PAGE		PAGE
Automatic Telephone Mfg. Co., Ltd. ...	iii	Pirelli-General Cable Works, Ltd. ...	xvi
British Institute of Eng. Technology ...	xiii	Pitman & Sons, Ltd. ...	viii
Creed & Co., Ltd. ...	viii	Standard Telephones & Cables, Ltd. ...	x
Ebonestos Insulators, Ltd. ...	xii	Siemens Bros. & Co., Ltd. ...	vi & vii
Elliott Brothers, Ltd. ...	xv	Smith, Frederick & Co. ...	xv
Ericsson Telephones, Ltd. ...	v	Telephony Publishing Corp. ...	xii
Ernest T. Turner ...	ix	The General Electric Co., Ltd. ...	iv & xiv
Ferranti, Ltd. ...	xi	The Bennett College, Ltd. ...	xiii
Hall Telephone Accessories (1928), Ltd. ...	xii	The Alton Batteries Co., Ltd. ...	ii
Henley's, W. T., Telegraph Works, Co., Ltd. ...	ix		

Hall Telephone Accessories (1928) Limited.

Suppliers to the British Post Office and
- Foreign Government Departments. -

Manufacturers of prepayment telephone multi-coin collectors, pre-selecting automatic dials, automatic stamp selling and ticket selling machines, automatic slot machines and fire alarm apparatus.

Registered
Office & Works : 70, DUDDEN HILL LANE,
WILLESDEN,
LONDON, N.W. 10

Tel.: WILLESDEN 5141/2/3.

Moulders to the Trade

Established
30 Years

MOULDINGS
IN WHITE OR
COLOURS.
BAKELITE —
BEETLE
AND OTHER
SYNTHETICS

PLASTIC MOULDINGS HAVING
HEAT — ACID — OIL — ALKALI —
WATER RESISTING QUALITIES.

EBONESTOS INSULATORS LTD

Excelsior Works,
Rollins Street,
Canterbury Road,

Telephone
NEW CROSS 1913 (5 lines) LONDON, S.E.15.



OF GREATER VALUE

Progressive telephone people who read TELEPHONY are of greater value to their employers. Each issue of TELEPHONY, which has been the telephone industry's leading journal for over thirty-three years, contains valuable information on engineering, construction, commercial and maintenance subjects. Enter your subscription today—you will not regret it. Subscription price \$5.00, U.S. money, for 52 interesting and instructive issues.

Address: Electrical Trading and Electricity Technical Book Dept., 85,
Long Acre, London, W.C. 2, for a sample copy of TELEPHONY.
TELEPHONY PUBLISHING CORP., 608, S. Dearborn St. Chicago, ILL, U.S.A.

STUDY
AT
HOME

YOU CAN HAVE A
COLLEGE TRAINING IN
ALMOST ANY CAREER
FOR A FEW SHILLINGS
MONTHLY.

IN YOUR
SPARE
TIME

Founded
1900



33
YEARS
OF
SUCCESS

THIS IS THE BENNETT COLLEGE—ALL OF IT

The Bennett College is not a Rented Room in a well known street—it is a College, with over 30 years of unbroken success.

The Bennett College Courses for the G.P.O and C.G.I. examinations have been prepared in close collaboration with P.O. Officials. The Courses combine the knowledge of technical experts and teaching specialists; the tuition is kept constantly in touch with modern progress.

**THE MOST SUCCESSFUL AND MOST PROGRESSIVE
CORRESPONDENCE COLLEGE IN THE WORLD**

- Aivan
lager we have
over all other colleges
1. All Text-books are supplied FREE.
 2. All our Text-books are compiled especially for the examination.
 3. The Text-books are sent to the Student immediately he joins the College.
 4. A small Monthly payment brings you exactly the same privileges as if you paid the fees in advance.
 5. All lessons are corrected on the College premises and returned the same day as they arrive. This means No Delay.

SPECIAL COURSES PROVIDED FOR:

- P.O. Probationary Inspectors (Open & Limited)
- P.O. Superintendents of Traffic (Open & Limited)
- P.O. Probationary Asst. Engineers (Limited)
- C.G.I. Telephony Examinations (All grades)
- C.G.I. Telegraphy Examinations (All grades); B.Sc. (Eng.); A.M.I.F.E., etc.

The Bennett College is the principal Postal Training Centre for P.O. Engineers, and special consideration is given to their requirements.

WE GUARANTEE TUITION UNTIL SUCCESSFUL

Particulars and Advice on Studies, FREE.

**P.O. Dept. 24,
The Bennett College Ltd., Sheffield.**

EXAMINATION SUCCESSSES

Since the B.I.E.T. was founded several years ago, we have specialised in preparing candidates for leading Technical Examinations, and our success may be gauged from the fact that over all this period of time, our candidates have returned the remarkable average pass record of

OVER 93% SUCCESSES.

Here are some recent results:—

In the Probationary Inspectors' Examination held in December 1931, 7 out of our 8 candidates were selected for interview.

In the Probationary Inspectors' Examination held in December 1932, one of our students obtained 1st. place.

In the I.E.E. Examinations held in 1932, 37 out of our 37 candidates passed successfully. Not one failed.

In the Assistant Superintendent of Traffic (Limited Competition) Examination held in April, a student of the Institute obtained 1st. place.

We teach successfully by correspondence and definitely guarantee—

“NO PASS—NO FEE”

You are advised to send for a copy of our General Prospectus “ENGINEERING OPPORTUNITIES.” This Hand-book contains 256 pages of most useful information. It also contains particulars of all leading Engineering Examinations, including

Probationary Inspectors (Open & Limited Competition)
Probationary Assistant Engineers (Limited Competition)
Assistant Superintendent of Traffic (Open and Limited Competition)

City and Guilds, Special G.P.O. Examination, I.E.E., B.Sc., A.M.I.C.E., London Matric., etc., etc.

The Hand-book also outlines “up-to-the-minute” courses of Home-Study in *all branches* of Engineering.

Special Courses are offered in **Telegraphy, Manual Telephony, Automatic Telephony, Telephone Transmission, Electrical Technology, Wireless and High Frequency Radio Communication, Alternating Currents, Talking-Picture Engineering, etc., etc.**

Our 256 page Hand-book should be on your Book-shelf. It will be gladly sent on request, FREE and without obligation. (*Please state subject or Examination of most interest.*)

British Institute of Engineering Technology

369, Shakespeare House,
29/31, Oxford Street, London, W.1

G.E.C. INSTRUMENTS

**SPECIALLY APPLICABLE TO
TELEPHONE MEASUREMENTS**

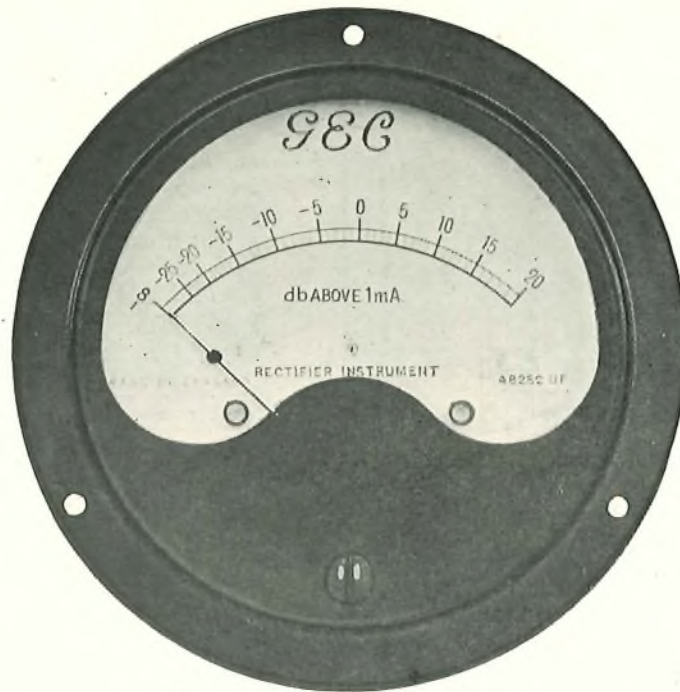

The DECIBEL METER

3¼ in. INSTRUMENT, METAL CASE, FLUSH MOUNTING

A direct reading instrument used either as a milliammeter or as a voltmeter, indicating DECIBELS above or below a given level.

The instrument has a linear decibel scale and is best suited to ranges of 10 milliamperes or 50 volts.

The total decibel range is about 45 decibels over the audio frequency range.

PRICES ON APPLICATION.

Enquiries are welcomed for instruments of all types including those for special purposes.

Made at the SALFORD ELECTRICAL INSTRUMENT WORKS of

THE GENERAL ELECTRIC CO., LTD.

Head Office: MAGNET HOUSE, KINGSWAY, LONDON, W.C.2

Branches throughout Great Britain and in all the principal markets of the World

Differential Moving Coil MILLIAMMETERS

For Telegraph Circuits

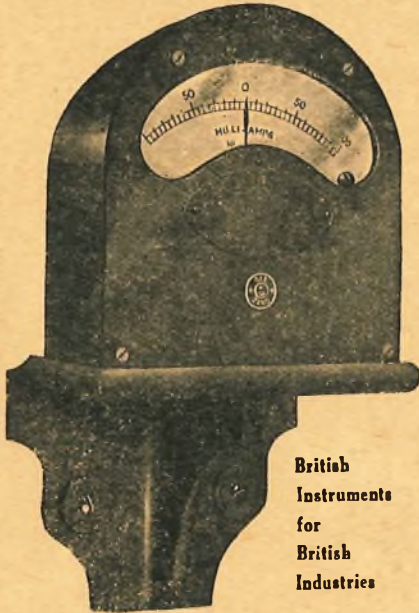

T. 1098 WALL MOUNTING TYPE.

British
Instruments
for
British
Industries

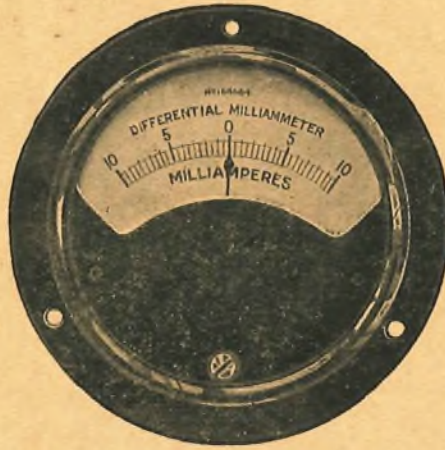

T. 1089. PANEL MOUNTING TYPE.

Frequency and many other Telegraph Systems, also for testing purposes in connexion with Land Line and Radio Communication.

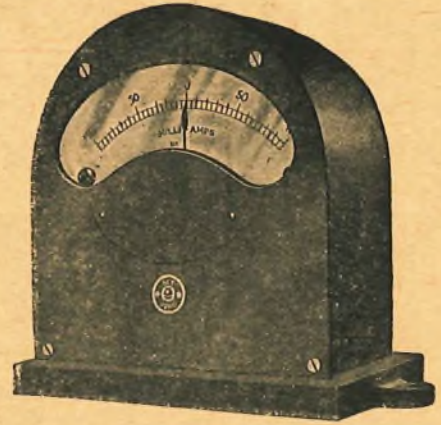

T. 1097. TABLE MOUNTING TYPE.

TABLE, WALL AND PANEL MOUNTING TYPES

INVALUABLE as line Milliammeters on Differential Duplex, Sub-Audio purposes in connexion with Land Line and Radio Communication.

Particulars will be sent on request.

ELLIOTT BROTHERS (London) LTD., Century Works, Lewisham, S.E.13

Telephone:
Lee Green 4848

in association with

SIEMENS BROTHERS & COMPANY, LIMITED, Woolwich, London, S.E.18

Telephone:
Woolwich 1161

ANACOS

REGISTERED

BRONZE & CADMIUM COPPER WIRES

as supplied
to H.M. Post Office for
TELEPHONE LINES

SILICIUM-BRONZE, COPPER

COPPER - CADMIUM

TAPES & BINDERS

SEND US PARTICULARS
OF YOUR JOB, AND OUR
TECHNICAL ENGINEERS
WILL PROVIDE YOU WITH
THE DATA YOU NEED.

FREDERICK SMITH & COMPANY

INCORPORATED IN THE LONDON ELECTRIC WIRE
COMPANY AND SMITHS, LIMITED

ANACONDA WORKS

SALFORD 3, LANCs,

Telephone: Blackfriars 8701 (8 lines)

Telegrams: Anaconda, Manchester."

MAINTAINING EFFICIENCY

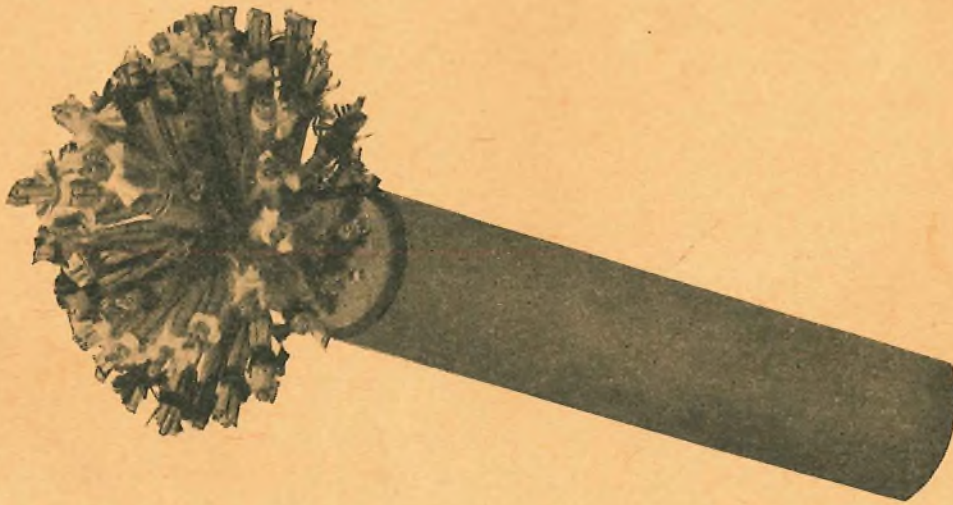

The high standard of efficiency of **Pirelli - General Telephone Cables** is maintained by the continuous research work of an experienced **Technical Staff**.

TELEPHONE :
SOUTHAMPTON
2141 (3 LINES)

PIRELLI-GENERAL
CABLE WORKS, Ltd., SOUTHAMPTON

TELEGRAMS:
"PIGEKAYBEL,
SOUTHAMPTON."

Proprietors : PIRELLI, LTD., and THE GENERAL ELECTRIC CO., LTD.