

## A Telegraph Converter for Tariff "Y" Service

H. G. DAVIS, B.Sc., A.M.I.E.E., and J. A. S. MARTIN, A.M.I.E.E.

### Introduction.

EVER since the introduction of public Telex Service into this country, the Department has had in view the provision of facilities for long-distance teleprinter communication at rates lower than the corresponding trunk telephone charges. Up to the present time, Telex subscribers have been offered, under Tariff "X," alternative speech or teleprinter facilities between Telex centres at the same rates as for trunk telephone calls. Under Tariff "Y," teleprinter communication, without speech alternative, will be offered between all the large towns at rates which show a substantial reduction on those prevailing under Tariff "X." The cheaper Tariff "Y" rate is made possible by the use of by-product trunks between Telex centres. As is generally known, by-product circuits, suitable for teleprinter transmission but not for speech, are made up from double-phantoms in multiple twin cables or phantoms in the newer star quad cables. Large numbers of these by-product lines have already been taken up for private teleprinter service, but there still remains a number available for Tariff "Y" development. Where by-product trunks between Telex centres are not available or are unsuitable on account of composition or length, the links will be formed by channels of the new multi-channel V.F. telegraph system described in Volume 26 (pages 163 to 170) of this Journal. As, in this system, eighteen teleprinter channels are obtained from one four-wire telephone circuit, the cost per teleprinter channel will be small compared with that of the normal telephone trunk.

### General.

Fig. 1 shows schematically a typical Tariff "Y" connexion between subscribers in distant Telex areas. The subscriber's equipment is the normal Telex installation

and therefore transmission over the "local" ends, *i.e.*, between a subscriber and the near Telex centre, is by single tone voice frequency, which is 300 p.p.s. for normal Telex working. On the main link between Telex centres, transmission is either by D.C. methods over by-product circuits or by V.F. telegraph channels. In either case, a conversation from D.C. to A.C., or *vice versa*, is necessary at the terminals of the main link. The functions of this terminal equipment are as follows:—

(1) To receive 300 p.p.s. teleprinter signals over a subscriber's junction or trunk line and to re-transmit them as double current signals at a voltage of  $\pm 20$  over a main by-product link or as double current signals at a voltage of  $\pm 80$  for operation of the transmitting relay of a V.F. telegraph channel.

(2) To receive double current signals at a voltage of  $\pm 40$  from the receiving relay of a by-product main link or at a voltage of  $\pm 80$  from the receiving relay of a V.F. telegraph channel, and pass them on as 300 p.p.s. signals over a junction or trunk to operate a subscriber's teleprinter.

While operation (2) is being carried out, and 300 p.p.s. tone is being sent out to the subscriber's line, it is necessary to disconnect the transmitting side of the Tariff "Y" converter in order to avoid repeating the incoming signals back on the main link and causing signal mutilations at the sending end. A telegraph relay is provided to do this.

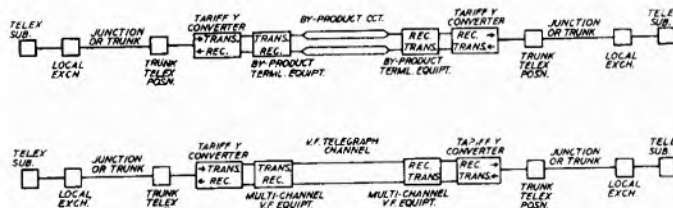

FIG. 1.—SCHEMATIC TARIFF "Y" CONNEXION.

In considering the design of the Tariff "Y" converter, the following main points have to be borne in mind:—

(a) A Tariff "Y" connexion, as shown in Fig. 1, involves a number of items of converter and other equipment as well as two junctions or trunks and a main by-product circuit or V.F. telegraph channel. Every item of equipment inevitably introduces some distortion of the signals and, as the maximum practical overall distortion allowable on a teleprinter connexion is 35 per cent., it will be seen that the distortion due to individual items must be as small as possible. The subscriber's Telex equipment is standard and cannot be specially improved as regards distortion for Tariff "Y" purposes. In a like manner, the by-product circuit or V.F. telegraph channel is also standard and cannot be specially improved for

storing time not less than twice the transmission time of the subscriber's line. This is necessary in order that echoes from the distant end shall not cause false operation of the transmitting side of the Tariff "Y" converter. As, in many cases, the subscriber's line will be a trunk, a restoring time of not less than 30 milliseconds has been found necessary.

(c) A special system of signalling must be provided, to enable a Telex operator to gain attention at the distant Telex service position. As the time of a teleprinter signal is normally 150 milliseconds per letter, the Telex operator's signal has to be long in comparison with that time. This involves the use of thermally-controlled relays, which send out a signalling impulse of at least 500 milliseconds duration over the main by-product or V.F. telegraph channel to operate slow-release re-

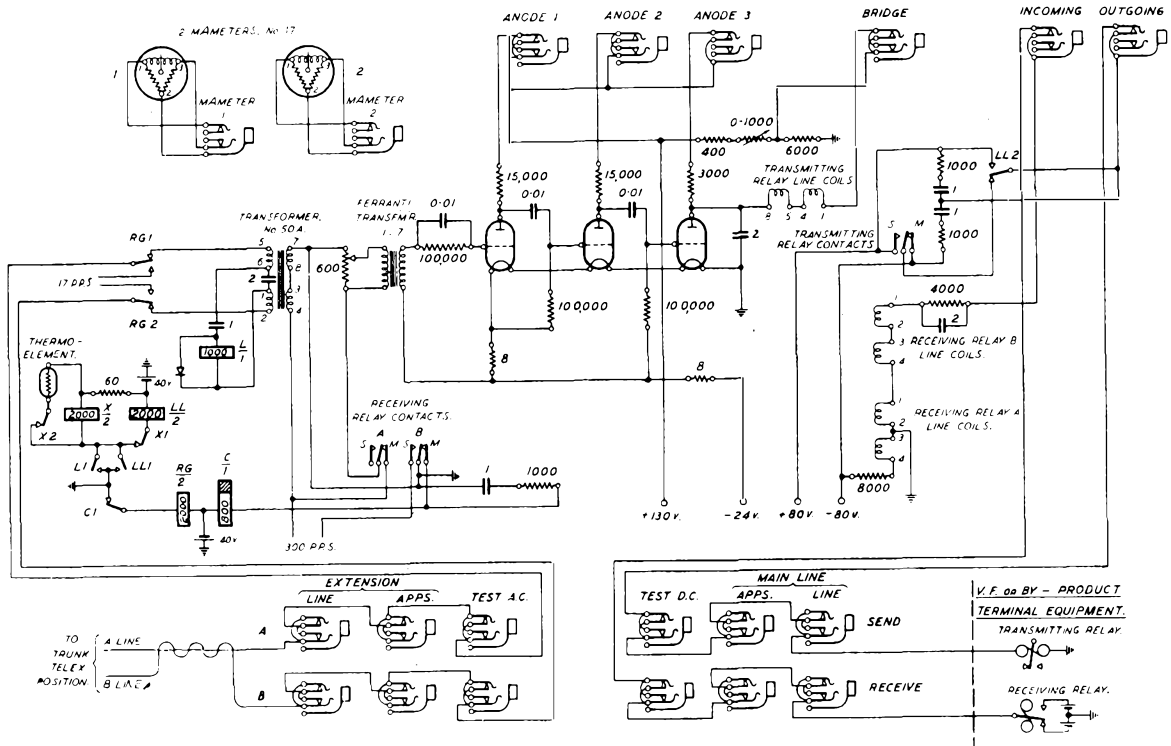

FIG. 2.—CONNEXION OF TARIFF "Y" CONVERTER.

Tariff "Y" work, even if such improvement were possible. The Tariff "Y" converter had therefore to be designed to operate within the limits of distortion remaining after the requirements of other portions of the circuit had been satisfied. To this end, every possible cause of distortion has been carefully considered and special measures taken for its reduction

(b) The relay which disconnects the transmitting side of the converter when sending 300 p.p.s. tone to a subscriber's line must have a re-

lays at the distant Tariff "Y" converter, thereby giving a visual signal at the distant Telex operator's position.

Practical details of a Tariff "Y" converter, designed in accordance with these considerations, are given in the following paragraphs.

*Details of Tariff "Y" Converter.* Fig. 2 refers.

The converter is essentially a three-stage resistance-capacity coupled unit, the first two stages being low frequency amplifiers and the third stage a rectifier. The input transformer has a ratio of 1/7. Be-

tween the secondary of this transformer and the grid of the first valve, a voltage limiting device is introduced consisting of a 100,000 ohms resistance shunted by a condenser of 0.01  $\mu$ F. Coupling between the valves is by means of a condenser 0.01  $\mu$ F and 100,000 ohms resistance. The anode resistances of the two amplifying valves are 15,000 ohms. The time constant of the voltage limiting device and of the coupling circuits is, therefore, approximately the same, namely, one millisecond. This fact has an important bearing on the small distortion that is caused to Teleprinter signals by the converter. The filaments of the valves are heated in series from a 24-volt battery and the grids are auto-primed from the filament circuit.

It will be seen that the rectifying circuit is arranged on the well-known " Bridge " principle, the valve itself forming one arm of an unbalanced bridge. The other arms of the bridge are resistances, two of which are fixed and one variable. The four line coils, in series, of a telegraph relay, type 299AN, are connected across the bridge. The valve, which is normally non-conducting, is made conductive by incoming signals. When the valve is non-conductive, current from the anode battery passes through the relay in the direction 8 to 1, and when conductive in the direction 1 to 8. Positive current passing through the relay coils in the direction 8 to 1 causes the relay tongue to rest on the negative battery contact (marking). Obviously positive current through the coils in a direction 1 to 8 will move the tongue over to the opposite battery contact which is positive (spacing). It will be seen, therefore, that the relay is operated by double current means. The variable arm of the bridge permits adjustment of the relay to working conditions.

The performance of the converter is such that the rectified output only varies by approximately 0.5 mA over a range of 0 to 28 decibels. This is considerably more than the range over which the converter will be required to function. With such a flat output over a wide range of working, bias distortion in the relay 299AN due to variations in the transmission equivalents of different subscribers' lines, junctions, or trunks, will not occur.

Two telegraph relays, type 320AN, labelled A and B in Fig. 2, connected in series, are used for transmission to the subscriber. The tongue and spacing stop of one relay connects the oscillator across the converter side of the line transformer, whilst the input circuit of the converter, which is normally closed through the tongue and marking contact of the other relay, is disconnected when this relay tongue is moved to the spacing contact. As previously mentioned, this is necessary to prevent the signals that are being transmitted to the subscriber's line from passing into the converter. Another function of this relay is to keep the input circuit of the converter disconnected for such a period of time that the echoes from the line and distant apparatus have dissipated their energy before the input circuit is closed again. To accomplish this, an electrical bias is given to the relay, in a spacing direction.

*Reception of a 300 p.p.s. signal by the converter and transmission of that signal to the by-product Circuit or Voice-Frequency Telegraph channel terminal by direct current. Fig. 2 refers.*

The 300 p.p.s. signals from the subscriber's Telex equipment reach the input of the Tariff " Y " converter via a Trunk Telex position. These signals are amplified and rectified by the converter, the rectified signals causing the tongue of the telegraph relay 299AN to be moved from the negative (marking) to the positive (spacing) battery contact. The tongue of this relay is connected to either the line relay of a by-product circuit, or the transmitting relay of a Voice-Frequency Telegraph channel.

*Reception of a direct current signal by the converter from either the by-product circuit or Voice-Frequency Telegraph channel and transmission of that signal to the subscriber's line by 300 p.p.s. A.C. Fig. 2 refers.*

Direct current signals coming from the tongue of the by-product circuit line relay, or the tongue of the Voice-Frequency Telegraph channel receiving relay, operate the two relays 320AN, connected in series. The tongue and spacing contact of one of these relays connects the output of a 300 p.p.s. oscillator across the converter side of the line transformer, whilst the tongue of the other relay disconnects the input circuit of the converter, and, by virtue of its spacing bias, keeps the input circuit open for a time sufficient for the circuit echoes to dissipate their energy.

*Signalling arrangements. Fig. 2 refers.*

In order that Tariff " Y " calls can be properly controlled, it has been necessary to provide signalling arrangements such that when a 17 p.p.s. ring is applied from the Trunk Telex position at one end of the main link, an indication is given on the supervisory lamp at the distant Telex position. The signalling equipment about to be described provides this facility.

Ringling current from the Trunk Telex position operates relay L, which has a metal rectifier No. 1/6A across its coil, via RG1 and 2 contacts and the primary winding of the line transformer, 50A. Relay LL operates via L1 contact and locks via its own contact LL1 as the operation of relay L only takes place whilst ringling current is actually passing. Contact LL2 breaks the circuit between the tongue of the telegraph relay 299AN and the main by-product circuit or Voice-Frequency Telegraph channel, and at the same time applies positive battery to the main link. The time for which this is applied, i.e., 500 milliseconds, is controlled by the relay X which is associated with a thermal element shunt. Until the thermal element has been heated for 500 milliseconds, the current through the relay coil is not sufficient to operate the relay. After 500 milliseconds, however, the current through the relay X operates it, and the circuit of LL is broken at contact X1, the thermal element being disconnected at contact X2. It is necessary to time the operation

of relay LL to ensure that the signalling device at the distant end is not operated by Teleprinter signals, the longest of which is 150 milliseconds.

At the distant end of the circuit, the positive current from the by-product circuit line relay, or Voice-Frequency Telegraph channel receiving relay, operates the two relays 320AN in a spacing direction. The circuit of slugged relay C, with a releasing lag greater than 200 milliseconds, which is made *via* the marking contact and tongue of one of the relays 320AN, is therefore broken for approximately 300 milliseconds and C releases. The release of relay C breaks the circuit of relay RG and 17 p.p.s. ringing current is applied to the line reading to the Trunk Telex position.

No calling lamp is provided at the Trunk Telex position. The operator does not ring nor can a ring be received until a plug has been inserted into the

between 0 and + 30 p.p.s., and a harmonic content not exceeding 15%. The output will be adjusted to give 3 volts on half load (60 ohms), and a variation of not more than  $\pm 12\%$  between no load and full load will be permitted.

*Monitoring and Testing Facilities.* Figs. 3(a) and 3(b) refer.

The rapid and accurate localization of faults depends to a great extent upon the facilities that are afforded for testing and monitoring purposes. Reference to Fig. 2 will show that a jack field is provided on both the A.C. and D.C. sides of the Tariff "Y" Converter. Two pairs of jacks on either side are for patching out purposes, whilst the third pair labelled "Test," connected up so as to give "make before break" facilities, is to provide a point of entry into the circuit for testing and

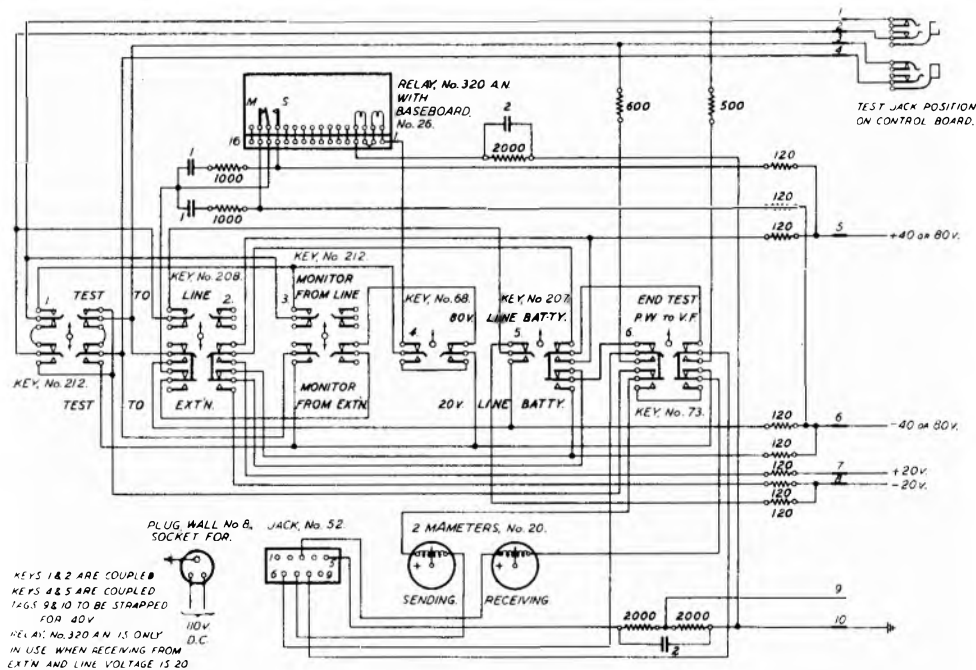

FIG. 3(a).—CONNEXIONS OF MONITOR AND TEST SET (D.C.).

"Y" jack. On ringing in this way, the signal is given to the distant operator by a flicker on the supervisory lamp associated with the distant operator's cord circuit.

#### Oscillator.

The oscillator required to supply 300 p.p.s. current for transmission to the subscriber from the Tariff "Y" Converter has been designed to feed 20 circuits. The filament current can be supplied from any standard exchange battery from 22 to 50 volts, and the anode voltage from batteries of 120 volts to 150 volts.

As regards performance, the oscillator will have a frequency of 300 p.p.s. with permissible variation

monitoring purposes without interrupting the working.

The connexions of the set are shown in Figs. 3(a) and 3(b). It is divided into two distinct and separate sections; one section is for testing from the A.C. side of the circuit, and the other for testing from the D.C. side. The latter is so arranged that it can also be used for testing private wire circuits worked over Voice-Frequency Telegraph channels.

The A.C. tester consists essentially of a Teleprinter 7A, a V.F. converter complete with a telephone, and several telephone-type keys for setting up the various test conditions. An A.C. voltmeter is incorporated in the set, so that measurements of sent and received voltages can be made for making

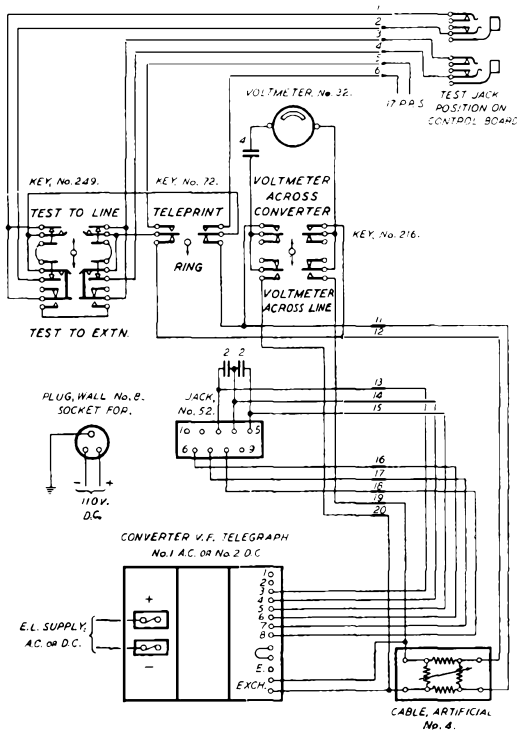

FIG. 3(b).—CONNEXIONS OF TEST SET (A.C.).

approximate transmission tests. With all the keys at normal, the circuit is through. The operation of Key No. 249 gives the following facilities:—

- (a) Holds the main "Y" link normal, and connects the test V.F. converter and Teleprinter 7A to the subscriber's line.
- (b) Holds the subscriber's line, and connects the test V.F. converter and Teleprinter 7A to the input of the Tariff "Y" Converter.

In both cases, a variable artificial line, 0-40 db's, is in circuit between the test V.F. converter and the circuit under test.

By these means, the attendant can test either to the subscriber and hold the main "Y" link, or to the main "Y" link and hold the subscriber's line. Listening or leak monitoring facilities are not provided. Key No. 72 applies 17 p.p.s. ringing current to test the ringing to either the home or distant Trunk Telex positions.

The D.C. tester consists essentially of a Teleprinter 7A, telephone-type keys for setting up the various test conditions, and milliammeters for measuring and indicating the outgoing and incoming currents. As in the A.C. tester, with all keys at normal the circuit is through. The operation of Keys No. 1 and 2 gives the following facilities:—

- (a) Holds the subscriber's side of the circuit

normal by connecting negative battery to the relays 320AN, therefore holding their armatures over to the marking contacts. Connects the tongue of the test Teleprinter to either the line relay of the by-product circuit, or transmitting relay of the Voice-Frequency Telegraph channel. At the same time, the electro-magnet of the test Teleprinter is connected to the tongue of the by-product line relay or the tongue of the Voice-Frequency Telegraph channel receiving relay. It will be seen, therefore, that under these conditions the attendant can test over the main "Y" link and at the same time hold the near subscriber's line.

- (b) Holds the main "Y" link normal by connecting negative battery to the line relay of the by-product circuit, or to the transmitting relay of the Voice-Frequency Telegraph channel. Connects the tongue of the test Teleprinter to the two relays 320AN on the "Y" converter, and the Teleprinter electro-magnet to the tongue of the relay 299AN in the output circuit of the "Y" converter. With these conditions, the attendant can test to the near subscriber and at the same time hold the main "Y" link normal.

The operation of Key No. 3 connects the test Teleprinter electro-magnet so that either the D.C. signals from or to the "Y" converter, according to the position of the key, can be observed by the attendant.

Keys No. 4 and 5 makes the necessary battery changes for testing to either a by-product circuit or a Voice-Frequency Telegraph channel.

*Rack Mounting of Tariff "Y" Equipment.*

The apparatus has been designed on a rack-mounted basis. Six circuits will be accommodated on an 8' 6" rack. The patching and test jacks will be mounted on a separate panel on the same rack as the apparatus so as to form a control point for a number of circuits. In the case of London, the jacks will be mounted separately from the racks on a special control board, which will be situated near the monitor and test sets.

*Scope of Service.*

At the outset, Tariff "Y" facilities will be provided between London and the following Telex centres:—Birmingham, Manchester, Liverpool, Leeds, Newcastle, Glasgow, Edinburgh, Bristol and Nottingham. The service areas of these centres will not be restricted to the local fee areas, but will extend over considerable distances. Extension of service, by opening up new centres, will gradually be made until a complete national network, inter-connecting all the large towns, is established.

## An Outline of Siemens No. 17 System of Automatic Telephony

S. W. BROADHURST and A. F. E. EVANS, A.M.I.E.E.

**A** NEW system using uniselectors exclusively and embodying common control principles has recently been introduced by Messrs. Siemens & Co., of Woolwich.

The main points of interest in the system are the use of a high speed (16-level) uniselector stepping at 200 steps per second and the flexibility of trunking achieved with its aid.

A view of the uniselector is shown in Fig. 1 and

Allowing four wires per circuit, the bank arrangements provide for 200 outlets. The wipers may be divided into two sets of eight and be used in the same way as a Post Office 50-point uniselector or divided into four sets of four so that two sets enter the bank when the other two sets leave. A combination of single- and double-ended wipers may also be used. Generally, the arrangement is to use four sets of four wipers and always each set is dis-

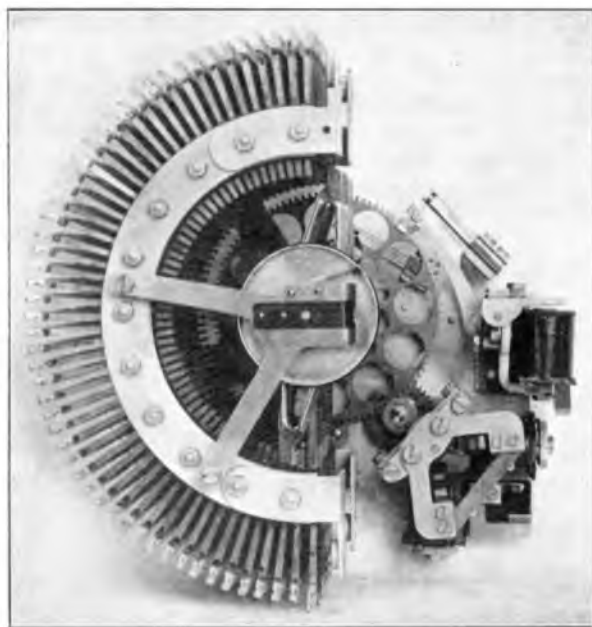

FIG. 1(a).—MOTOR UNISELECTOR: LEFT SIDE VIEW.

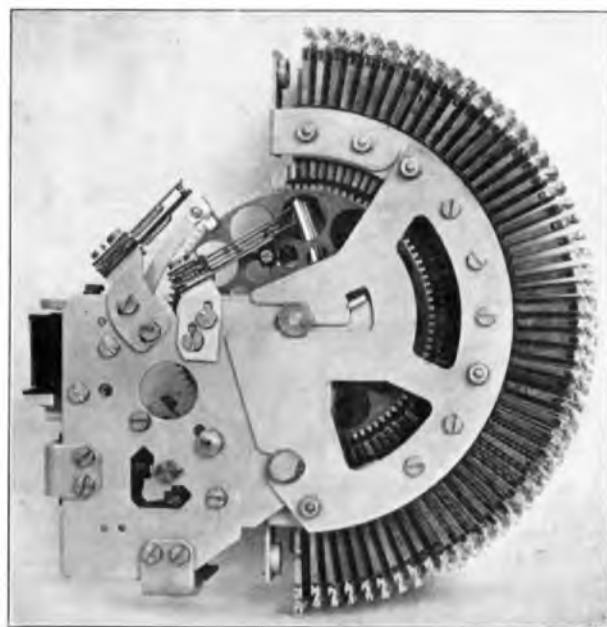

FIG. 1(b).—MOTOR UNISELECTOR: RIGHT SIDE VIEW.

its method of operation in Fig. 2. A large gear wheel coaxial with the wipers is normally held by a toothed latch engaging with the gear wheel under the pressure of a spring. On receipt of a start signal the latch magnet is energized, the latch disengages the gear wheel and closes contacts which complete a circuit for the motor. The motor consists of two magnets displaced at  $90^\circ$ , the magnets being energized alternately by a cam and interrupter springs. An iron rotor influenced by the magnets is geared *via* intermediate gearing to the large gear wheel carrying the wipers. The gear ratios are such that the wipers pass over 200 contacts in one second. The specially-shaped rotor is designed to give the shaft an even turning movement.

The switch carries a maximum of sixteen wipers, each wiper passing over 52 contacts in one half revolution of the switch. Contact O on each bank segment may be used as the normal contact and contact 51 for busy or wiper-selecting operations.

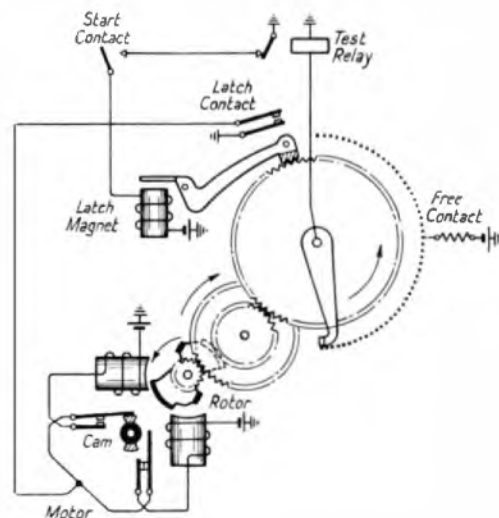

FIG. 2.—MOTOR UNISELECTOR; ELECTRICAL CONNEXIONS.

tinguished by a code letter. The letters adopted are W, X, Y and Z.

Referring to Fig. 2, it will be seen that once the unselector has been set in motion it can only be stopped by the release of the latch magnet. The current for this magnet is derived *via* a contact of a test relay. This relay is joined to the testing wiper of the switch and operates to battery when a free outlet is reached. Its operation releases the latch magnet and the latch spring causes the latch teeth to re-engage with the large gear wheel and so stop the switch.

Owing to the high speed of the unselector, the test relay used is specially designed to have a very short operating lag, actually about 0.5 milliseconds.

In size the relay is approximately equal to a horizontal relay and is designed to be fitted into an ordinary relay plate as shown in Fig. 3.

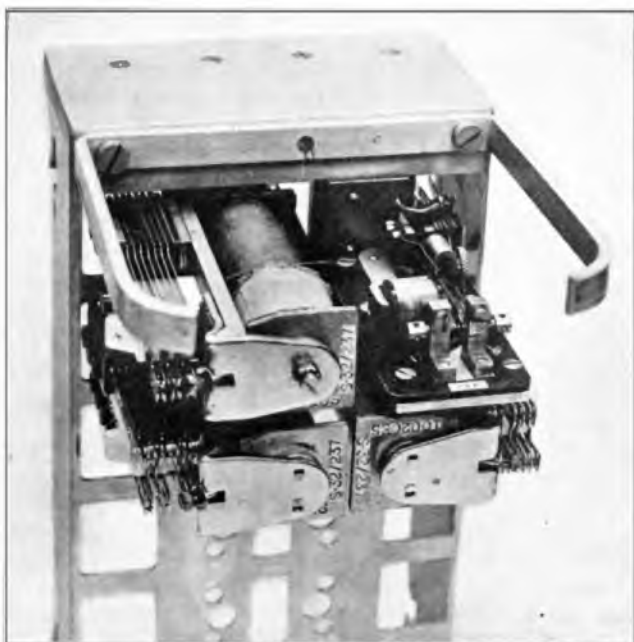

FIG. 3(a).—HIGH-SPEED RELAY MOUNTED IN JACKABLE RELAY UNIT.

The contact spring, which is made of phosphor bronze, is fitted in the usual way to the wiring tag assembly and is provided with platinum contacts that rest between two fixed contacts, the latter having screw adjustments.

The yoke is U-shaped with a coil winding over one leg and is placed at right angles to the spring so that its pole-pieces both face the spring approximately at its centre. The distance between the pole pieces is  $7/16$ " and the length of the spring is  $2\frac{1}{2}$ ".

That part of the spring immediately facing the yoke has a piece of soft iron welded to it and hinged on to the unwound leg of the yoke, thus forming the armature. The pressure on the armature is obtained by a buffer spring which is screw-tensioned. Fig. 3(b) shows the mechanics of the relay.

*Elements of Selector Operation.*

As previously stated the selectors in this system are common-controlled; the ratio of selectors to controls being about 8 to 1. Any selector, when seized, associates itself with its control by means of a coupling relay. The control contains a Post Office standard unselector, which steps to the dialled impulses, and a high speed testing relay. An elementary circuit is shown in Fig. 4. Assuming the selector to give access to 100 outlets in two groups of 50 and that 10 outlets are allotted for each "level," then levels 1-5 would appear on the W bank and levels 6-0 on the Y bank of the selector. As the final position of the digit switch indicates the required level, control of the wiper switching relay WS to select the correct bank, can easily be effected at the appropriate time. At this time, also, the control may energize the selector latch magnet under the control of a contact of the fast testing relay T. This relay is joined *via* a wiper of the digit switch to a wire which is strapped to contacts

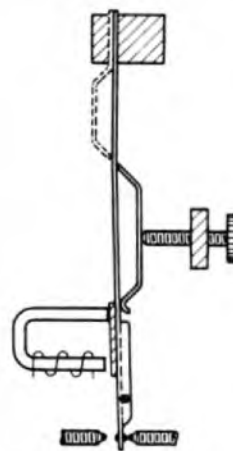

FIG. 3(b).—ELEMENTS OF HIGH-SPEED RELAY.

on one of the G banks of the selector corresponding to outlets on the P banks in the required level. Thus only while the selector wipers are passing outlets in the correct group can T operate.

If the digit received is, say, four, the digit switch will mark the fourth group on the G<sub>1</sub> bank and as the G<sub>1</sub> wiper is connected to the P<sub>1</sub> wiper a circuit is established when the wipers reach the marked contact from relay T in the common control to the P-wire of the first outlet in the group. The free condition is a negative potential and if this outlet is disengaged, relay T will operate and stop the wipers by disconnecting the latch magnet.

Should the first outlet be engaged the wipers continue to search over the group until a free outlet is found, the equivalent bank contacts on G<sub>1</sub> being commoned together to maintain the continuity of the testing circuit.

Should all outlets be engaged the wipers rotate to contact 51 or 101 as the case may be, and busy

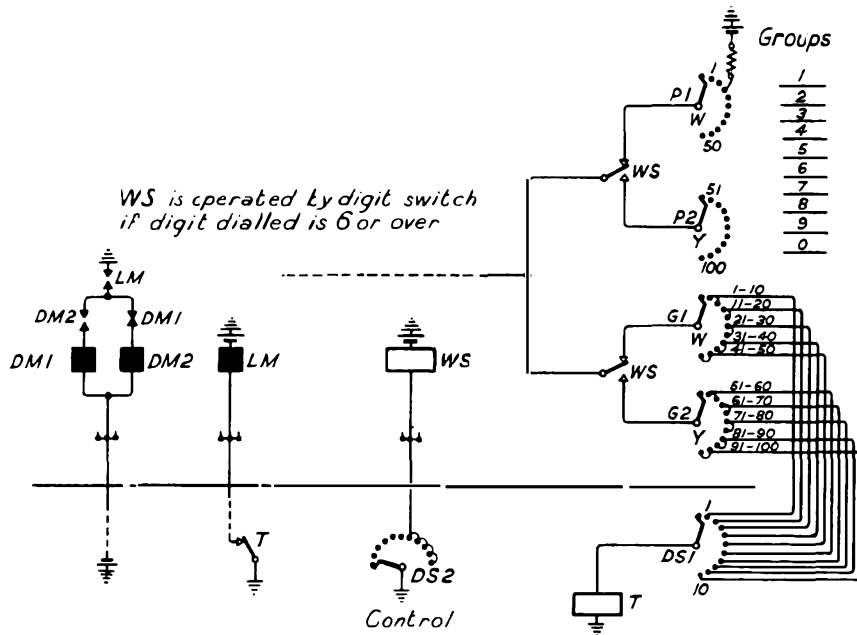

FIG. 4.—GROUP SELECTOR (100-OUTLET): TYPICAL EXAMPLE SHOWING METHOD OF SELECTING A FREE OUTLET IN A MARKED GROUP.

tone is connected from the common control equipment, which is held until the caller clears.

The selection of an outlet must occur in the intertrain pause period and although the selector travels at high speed its search must always be restricted to 50 contacts in any intertrain pause. That is to say, the use of a WS relay is an integral part of the system. Where the selector wipers are divided into four sets of four and the selector gives access to 200 outlets, it is necessary either to preposition the wipers on receipt of a signal from the preceding stage or to dial two digits into the selector control and, depending upon the first digit, to rotate the selector through 180° during the intertrain pause between the two impulse trains.

*Trunking: 4-digit system.*

Fig. 5 shows a typical example of a four-figure system of 10,000 lines.

The first numerical selector of 100 outlets is arranged in, say, five groups of 20, each group being a channel over which calls to 2,000 subscribers via ten groups of final selectors.

The first digit passes into the common control equipment (C.C.) and, as explained previously, the selector wipers rotate and find the first free outlet in the marked group.

Relay WS is operated on the termination of the digit if the required group is to be found on bank section Y, this being determined by the position of the digit switch, as shown in Fig. 4.

When the required pre-final selector is found, it is necessary immediately to decide on the banks required for the next stage of the call, i.e., W and Y or X and Z, depending upon the thousands digit dialled. If the X and Z banks are required, the wipers will rotate through 180° as the result of a discriminating signal passed from the first stage into the C.C. equipment of the pre-final stage.

This pre-positioning of the wipers takes place when the selector is seized and thus allows the inter-train period that follows the second digit to be available for the actual selection of an outlet in the final stage.

When the final selector is seized, there are two groups each of 100 subscribers available and the operation of WS is effected in the usual way if the pre-final digit indicates it to be necessary. The line on the final selector bank is marked by a combination of the digit switch position and storage relays after the two digits have been received.

It will be clear that if an exchange has just 2,000 lines capacity, it is only necessary to employ pre-finals and finals. The common control of the pre-final selector is in this case designed to receive two digits, the first digit determining the particular 1,000 required and the second digit marking the group in the usual way. The wipers are rotated through 180° during the intertrain period between

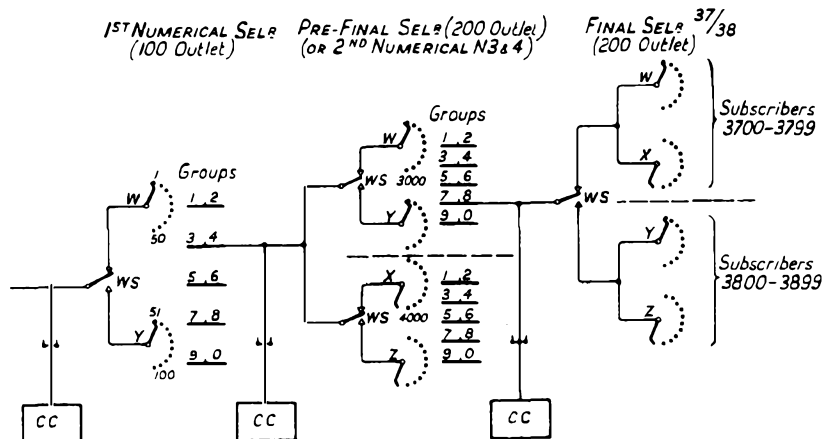

FIG. 5.—GENERAL SCHEMATIC.



the first and second digits if the thousands digit indicates it to be necessary.

*Use of Selector to Accommodate Large Numbers of Groups of Outlets.*

The flexibility of trunking which may be achieved by the uniselector is indicated in Fig. 6, which repre-

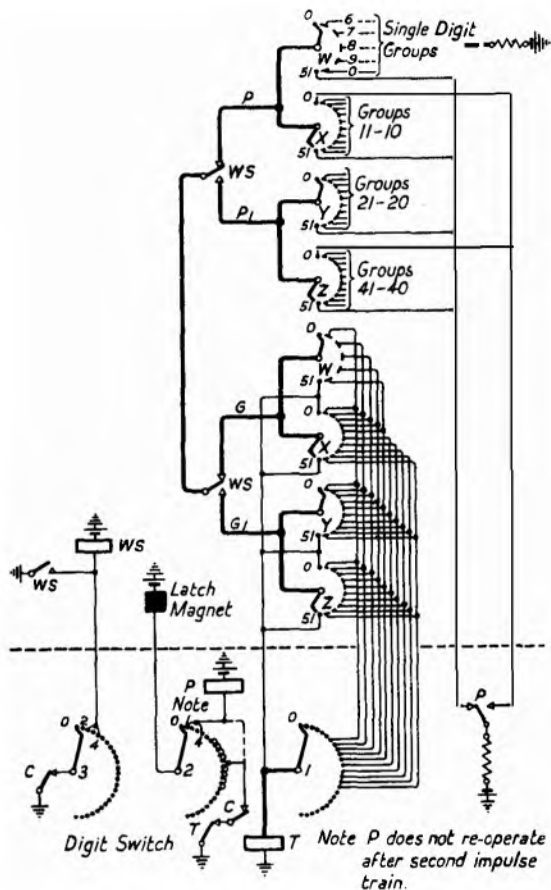

FIG. 6.—SCHEMATIC GROUP SELECTOR—200-OUTLET—1 OR 2 DIGITS (PROVIDING FOR 35 GROUPS).

sents a selector used to gain access to a large number of outgoing junction groups, the switch being capable of receiving one or two digits and searching within the correct group either after the first or second digit.

With the arbitrary numbering scheme chosen, if any digit greater than six is dialled, and assuming relay C performs its usual functions, the latch magnet is energized on the release of C and the switch commences to rotate. As WS is normal, search is only possible within the W section of the bank (50 contacts), the required group being marked by the digit switch on the W (G) bank of the selector. Should all the outlets be engaged, the switch rotates to its 51st contact and T operates via a normal contact of P. This is arranged to give the busy condition.

Should the digit 1 be dialled, relay P operates at the end of the first impulse train and the switch

latch magnet is operated. The switch must now rotate until the X wipers come to rest on contact O, as relay T can only operate to cut the drive when this contact is reached. No contact other than XO is marked on the G banks, as the digit switch arc 1 has its first five terminals unwired. Relay P releases and, although the circuit is not shown, the digit switch drives to contact 5.

The second train of impulses steps the digit switch beyond contact 5; and, on the release of C, the selector latch magnet is again operated and the selector searches over the X portion of its bank, driving to contact 51 if all outlets are engaged.

If the digit 2 is dialled as a first digit, WS operates but P does not. Hence the selector does not drive at all until the end of the second train of impulses, when the digit switch is beyond contact 5. In this case, search is restricted to the Y bank of the selector.

Should 4 be dialled, relays P and WS both operate and the latch magnet is energized. As the digit switch is not yet in a position to mark any outlets, the selector drives until the O contact on its Z bank is reached and T operates. P releases and, after the second digit, the selector searches for the required group with its Z wiper.

In Director areas, the number of possible groups on a selector of this type is 55, the selector being controlled by a Director capable of sending 15 impulses in any one train.

*P.B.X. Final Arrangements. Use of Auxiliary Numbers.*

In the normal case ordinary final selectors serve 200 subscribers' numbers and if the selector is not stepped until after the units digit, no question of hunting in an intertrain pause period arises. The necessary wiper discrimination in the W, X, Y or Z group may be effected in a straightforward manner. A particular contact may be marked by the control circuit and if the selector finds the line engaged, it may rotate to a special last contact to return busy tone.

Hitherto, except in the case of large P.B.X. groups, it has been necessary to allot numbers proper to the exchange numbering scheme for all P.B.X. lines, although only the first number appears in the Directory. In Siemens No. 17 exchanges, P.B.X. final selectors may be of the 200-outlet type accommodating 100 numbers and 100 auxiliary lines. The general scheme is shown in Fig. 7. In this scheme, the W bank of the selector is wired to 50 ordinary numbers having tens digits 0, 1, 2, 3 and 4, and the Y bank accommodates 50 ordinary numbers with other tens digits. In a similar manner, the X and Z banks are wired to 100 auxiliary numbers. As the final selector will only be reached from one level of the preceding stage, the number dialled into the control will always indicate a circuit on the W or Y bank of the selector, relay WS determining the correct wiper.

The digit switch (D.S.) takes up its final position at the end of the units digit and marks the same terminal on the selector G bank for two numbers

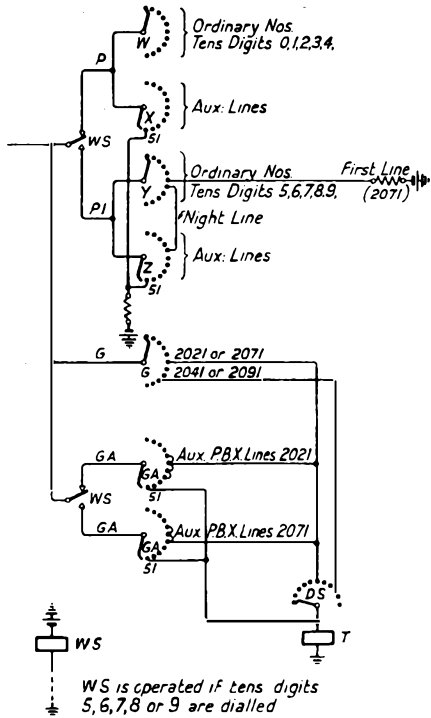

FIG. 7.—P.B.X. FINAL ARRANGEMENTS.

with similar units digits but in different tens groups, for instance, numbers 71 and 21. When the units train has ceased, the latch magnet of the selector is

energized and the selector rotates. If 21 has been dialled, WS will be normal and the only possible operate circuit for T will be in series with subscriber's circuit 2021 on the W bank. If 71 had been dialled, WS would have connected the testing circuit to the Y wiper of the selector.

Should T fail to operate when the selector reaches the required line, the switch continues to drive. The W, Y and G wipers leave the bank and the X, Z and GA wipers start to enter, the digit switch remaining stationary. If, therefore, the terminal previously marked on the G bank is connected to terminals on one of the GA banks corresponding to circuits in the auxiliary numbers allotted for the extra P.B.X. lines, T has a fresh possible operate circuit as the X or Z wipers are passing over auxiliary lines. If all these are engaged or if none are allotted to the exchange number previously dialled, the selector will drive to contact 51 or the V or Z bank and bring about busy conditions.

As night service lines must be allotted numbers in the exchange numbering scheme, it is necessary to strap the P-wire of the auxiliary line concerned to the P-wire of the Directory number to provide access to the night line under day service conditions.

*Graded Line Finder Scheme.*

As is now standard practice, a line finder scheme is employed and the partial secondary method has been adopted. Another interesting line finder scheme is available and is illustrated in Fig. 8.

A number of 200-point uniselectors up to a maximum of 48 is provided for each group of 200

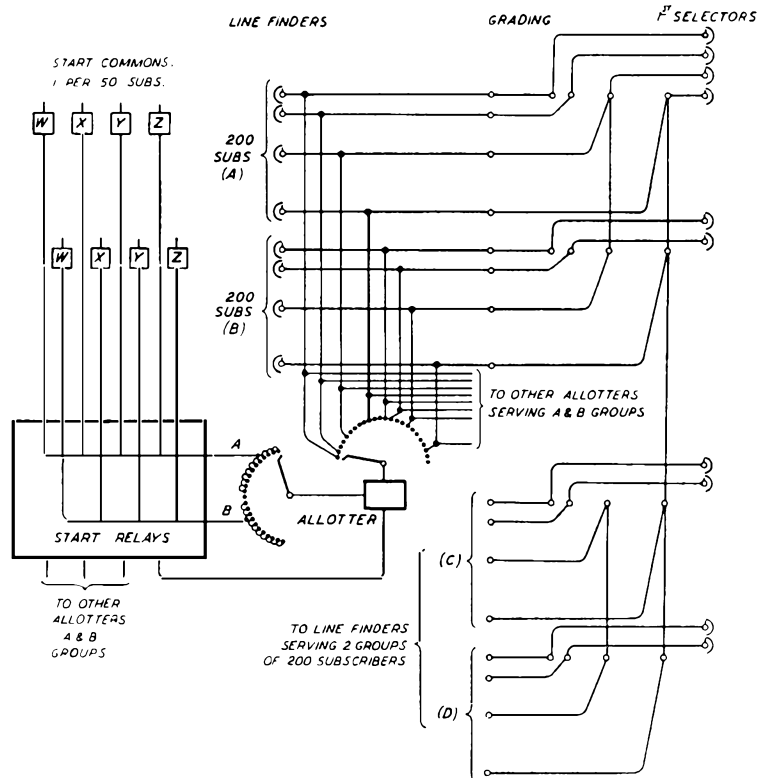

FIG. 8.—SCHEMATIC OF GRADED LINE FINDER.

subscribers' lines. Each group of line finders is served by a number of allotters. Should there be 24 or less line finders in each group of 200 subscribers, one set of allotters may serve 400 subscribers. With a reduced number of line finders the allotters may serve up to 800 subscribers. In the figure, an allotter is shown controlled by a start circuit available to 400 subscribers in two sets of four sections of 50 (W, X, Y, Z).

On receipt of a start signal from any one of the eight sections of subscribers, the allotter drives in search of a line finder tied to a free 1st selector. The allotter is a 50-point homing switch, and is only allowed to search over the line finders in the correct A or B group, as indicated by the start circuit. When a line finder is found, it is driven to find the calling subscriber's line and the allotter is freed.

The use of fast homing uniselectors as allotters enables the line finders to be graded and the allotter, in effect, searches over trunks to 1st selectors in a similar manner to the familiar subscriber's unselector in the Strowger system, and thus a number of 1st selectors may be common to line finders in many groups. To avoid unnecessary travel of the allotter, it is arranged that if an allotter has to pass ungraded outlets on its return to normal, it tests the start lead to see if another call has been originated and if this is the case the allotter takes up the call. Should all line finders in any group be engaged, the allotter makes a second search after a brief pause.

*Director Arrangements.*

In general, apart from the use of the high speed unselector, the trunking arrangements on this system follow Post Office standard practice. Directors and coders are employed in the normal way and the coders are actually of P.O. standard pattern. In the director circuit, Messrs. Siemens employ a 16-level motor unselector as a "BC" switch and each director can handle 100 exchanges. For this reason, the common control of the 1st code selector receives the "A" digit on its digit switch and causes a director hunter to hunt for a director (Fig. 9). As the same director may be seized for a pair of "A" digits, a discriminating signal is passed forward to the director from the 1st code control. In the case of "O" level calls, the position of the digit switch causes the 1st code selector to search for a manual board circuit at once.

On receipt of the first routing train from the director, the digit switch in the 1st Code control is stepped to a position marking the correct group of outlets on the selector banks. The director pulsing-out circuit is extended stage by stage and at the end of sending the director releases the 1st Code control. Should an outgoing junction call be originated, it is arranged that the transmission element of the junction relay-set is not inserted until the director releases. This saves needless impulse repetition.

The director itself varies from standard in that the "BC" switch is not stepped, but searches for the exchange code marked as a result of the receipt of the "B" and "C" digits by the sender and

control switches respectively. Twelve wipers of the "BC" switch are available for translation and, providing that the combined translations for any two exchanges do not exceed twelve, both exchanges may be accommodated on the same position of the BC switch bank. The sending control is suitably arranged to test the exchange terminals in the correct sequence. The sender switch is capable of sending 15 impulses in any one train.

Alternative routing is provided for and, owing to the large number of translating wipers available on the "BC" switch, the new translation necessary for any exchange when the direct route is congested is wired to exchange terminals following what would have been the DC terminal on ordinary translations.

*Other Features.*

*Interpolation of Transmission Bridge.*

Instead of the transmission bridge being part of a selector circuit, in the Siemens No. 17 system the transmission and ringing feeds are arranged in the form of relay-sets which may be placed between

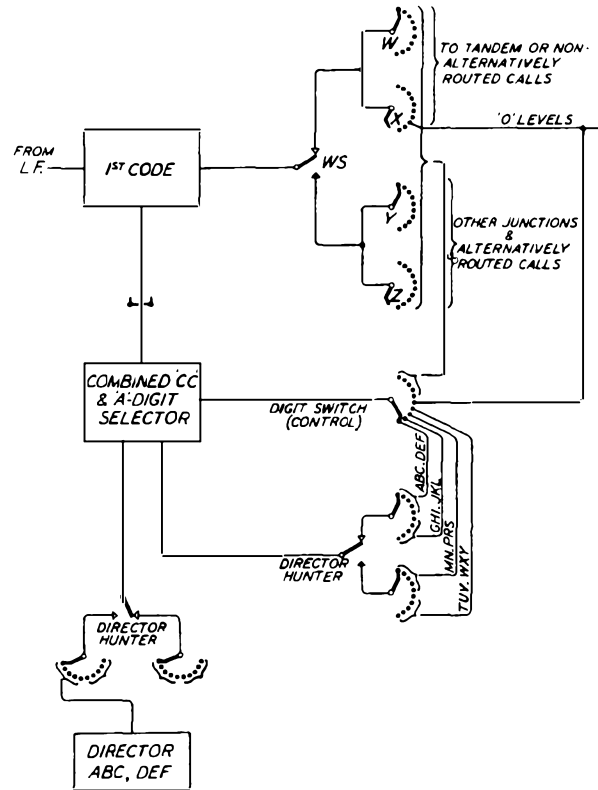

FIG. 9.—SCHEMATIC 1ST CODE AND DIRECTOR.

successive selectors anywhere in the call. The relay-sets require three incoming and four outgoing wires. Normally while the call is being set up, the relay-sets merely provide a straight-through circuit between the selectors concerned but, on receipt of signal from the selector ahead, the transmission and ringing feeds are placed in circuit and relays in the

relay-set take over the hold of the connexion. The arrangement may be briefly described with reference to Fig. 10. Assuming the relay-set to be placed between the first and second numerical selectors; then normally the negative, positive, and private wires form a three-wire through path. As is the case in the Post Office standard system, each succes-

the calling junction. When the junction is found, the distant director is allowed to send.

#### *Incoming Trunk Circuits.*

These are terminated on special relay-sets associated with common-controlled first selectors. The call is passed over the normal exchange routes, but

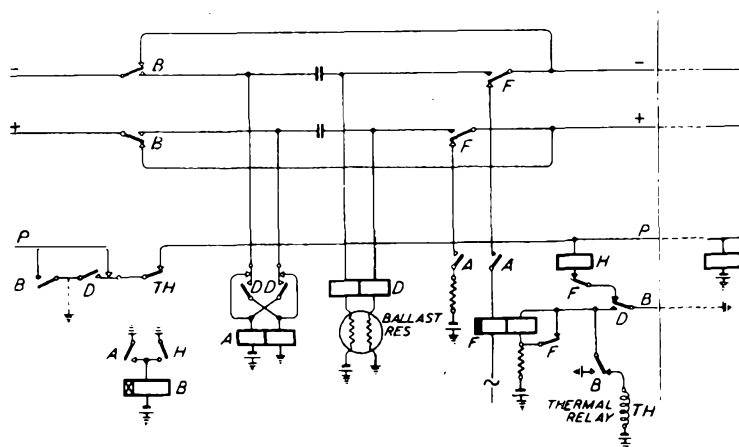

FIG. 10.—TRANSMISSION BRIDGE.

sive stage places an earth on the P-wire to hold the H relays of the various selectors previously operated, this earth also serving to short-circuit the H relay of the relay-set. It is arranged that when the final selector has found a free subscriber's line, this earth is removed and that the H relays on the P-wire hold in series with the relay-set H relay, which now operates.

Subsequent operations will be apparent from the figure. Calling subscriber release is provided and the object of the thermal relay is to provide a delay period before the called subscriber is made a caller in cases where the calling subscriber clears first.

Relay-sets are also provided on outgoing junctions and in these cases the A relay is fed through ballast resistances.

#### *Excess Fee Metering.*

Director control of metering is provided and a special impulse train is absorbed by the outgoing junction relay-set to prepare for subsequent metering. The maximum number of meter pulses provided for is five.

#### *Incoming Junctions.*

In general, the designers of this system do not use common control for incoming selectors. For junctions from automatic exchanges in director areas, a special form of common control is used for the incoming selectors, as it is possible with such junctions to restrain the distant director from sending until the circuit is ready. Each junction terminates on a selector and any selector when seized causes a cyclic start to be energized and a control circuit preselected by the cyclic start searches for

the circuit arrangements prevent the ordinary transmission feed from being cut into circuit. Should the subscriber be engaged and busy conditions be reverted from the final common control, the operator is enabled to signal the final control to cause the final selector to step again to the subscriber's line. If the line is still engaged, the final selector does not rotate to its last contact, but provides a bypass circuit through its control to enable the call to be offered. If the call is accepted and the subscriber clears, the operator receives a clearing signal and may ring over the circuit. The control is then released and the connexion established.

If the wanted subscriber is already engaged on a trunk call, it is arranged that a special tone is reverted should an attempt be made to offer a second trunk call. Arrangements may also be made to vary the tone received, depending upon the type of trunk call on which the subscriber is engaged.

#### *Rack Arrangements.*

As no exchange has yet been completely equipped with Siemens No. 17 apparatus, no photographs of fully-equipped racks are available. The capacity of a standard single-sided rack is given as 80 selectors and 10 common control relay-sets.

In conclusion, the authors wish to express their thanks to Messrs. Siemens Bros. and Co., of Woolwich, for the loan of photographic blocks and for their courtesy in supplying information on their system.

#### *References:*

"Recent Developments in Automatic Telephone Systems," by H. E. Humphries.  
Siemens Engineering Society Publication.

# Some Recent Developments in the Design of Manual Switchboards

J. H. DOUGLAS.

## Introduction.

THE evolutionary — almost revolutionary — changes that have taken place throughout the whole field of telephone engineering and service during the last decade have, as might be expected, also influenced the design of manual switchboards. These changes have extended to the details of automatic switching plant, line plant, and subscribers' apparatus, methods of construction, systems of switching, and ideas and methods of battery maintenance; but comprehensive changes in operating procedure have also contributed in no small degree to the drastic departures from what, only a few years ago, was standard practice.

## New Trunk Sections for Demand Working.

The first of six new types of switch section was designed three years ago for the new Trunk Record and Demand exchange in London, and is shown in Fig. 1. This section is known as the Small or Island type of trunk section and is 4 ft. 6½ ins. high, being designed primarily for island suites. This was followed by the Large or London type of section designed for a jack capacity larger than that of any of the older boards; this type is illustrated in Fig. 2. The section is 7 ft. 6½ ins. high and, amongst other new features, incorporates a new design of cornice which, if less ornate than the old standard pattern, is more useful and less conducive to the accumulation of dust. The lower portion functions as a notice board and, being removable, permits of extension of the jack field if required. The accom-

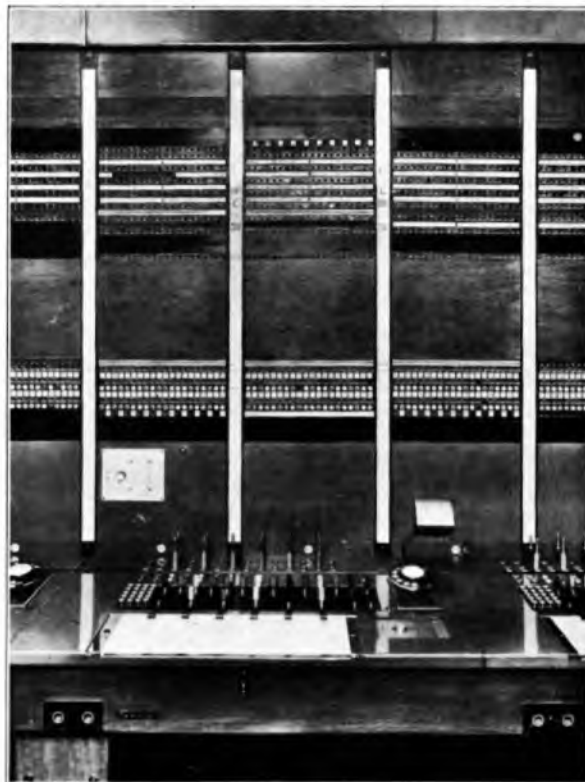

FIG. 2.—" LONDON " TYPE.

modation of pneumatic ticket despatch tubes is catered for in both panels and keyshelves whilst, on Delay positions, delivery tubes are also fitted in the panels when required. Keyshelf despatch valves are fitted one per position, and panel valves (despatch and delivery) are fitted one per two positions.

It was impossible to accommodate on keyshelves of the old standard dimensions the additional operating aids necessitated by the introduction of Demand working, and the additional equipment required for the new sleeve control cord circuits and chargeable time indicators. The depth of the keyshelves was therefore increased by 2¼ ins. to 18 ins. The length was increased to 27 ins. by the decision to standardize three-position seven-panel sections with No. 10 type jacks. The additional aids and equipment included the despatch valves already mentioned, routing and rating files, bulletin charts, monitoring keys, and C.T.I. keys and lamps. The introduction of sleeve control working with ancilliaried

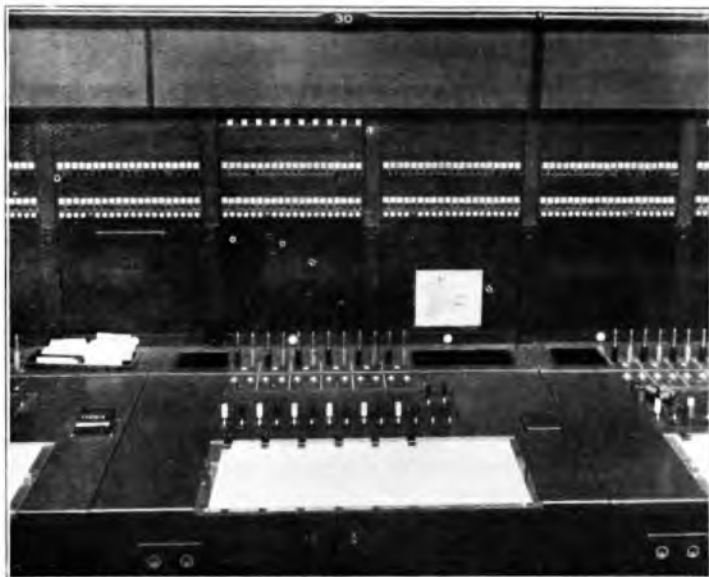

FIG. 1.—" ISLAND " TYPE.

answering equipments eliminated the use of line pilot lamps and the pilot lamp rails as such. Space on the keyshelves had therefore to be found for Instruction circuit and Dial Guard or Keysend lamps in addition to the Tube Alarm lamp.

Another important innovation was the multiple answering equipment with lamps fed from the A.C. mains through a transformer. This very materially affected the design of the sections, as the method of cabling ultimately decided upon for ancillared answering equipments and for multiplied outgoing circuits with visual idle indicating lamps necessitated much longer cable pins which, in turn required rear supports. On the introduction of a third type of section 6 ft. 4½ ins. high, known as the Intermediate or Provincial type and shown in Fig. 3, a suggestion to support the cable pins by means of standard cycle chain was adopted, and is now standard practice.

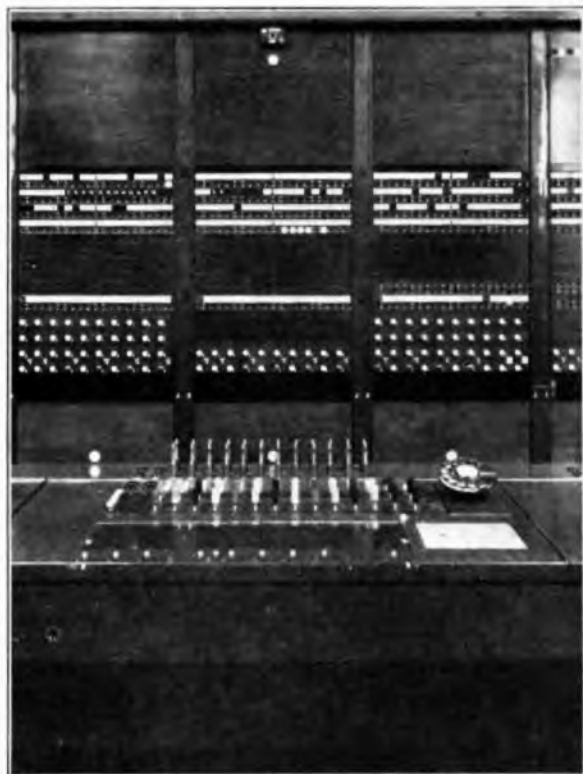

FIG. 3.—" INTERMEDIATE " TYPE.

#### Evolution of Present Standard Designs.

It may first be of interest to review some of the salient features of past standards. One of the primary considerations in the design of manual switchboards is the relation between the operator's position and the multiple field. Two standard types of jacks—usually distinguished as C.B. No. 1 type and C.B. No. 10 type—have been used in British practice. The former are mounted on 8½ ins. centres and the latter on 11½ ins. centres. In American practice, jacks mounted at approximately 10½ ins. centres are used, thus accommodating five panels on

two positions approximately 25½ ins. long—a very convenient arrangement from an operating point of view. With British standard equipment, however, the sections in use do not lend themselves so conveniently to traffic requirements although three-panel one-position sections using No. 1 type jacks would constitute an ideal arrangement from the traffic standpoint as a six-panel multiple could be accommodated within two positions 25½ ins. long. With the introduction of visual idle indicators or the extended use of visual engaged signals, lamp jacks to accommodate 20 lamps are required and, whilst this is standard practice where No. 10 type jacks are used, there is no standard lamp jack of No. 1 dimensions to take 20 lamps, and it was not considered desirable to introduce such a jack which would also necessitate the design of a much smaller lamp than the present standard. This, with other considerations, led to the decision to standardize No. 10 type equipment for these new sections. These three sections are of the seven-panel, three-position type with an overall length of 6 ft. 8½ ins., the heights being 4 ft. 6½ ins., 6 ft. 4½ ins., and 7 ft. 6½ ins., whilst the overall depths are approximately 3 ft. 3 ins., 3 ft. 7 ins., and 4 ft. 3 ins., respectively, for the small, intermediate, and large types. It will be seen from Fig. 4 that the new sections are a com-

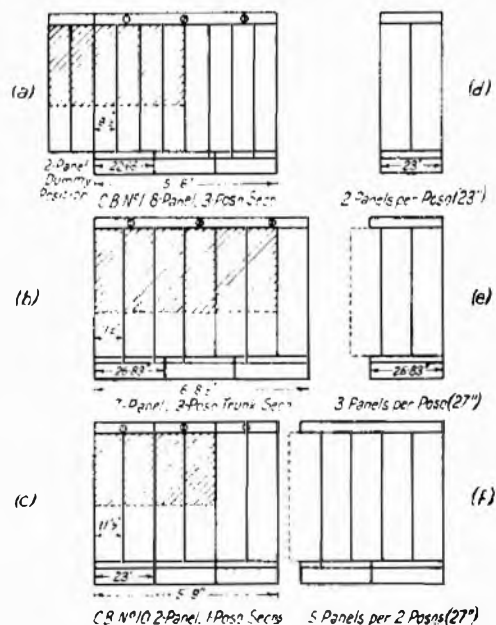

FIG. 4.—TYPICAL LAY-OUTS OF ONE-POSITION AND THREE-POSITION SECTIONS, SHOWING RELATION BETWEEN MULTIPLE PANELS AND POSITIONS.

promise between the old C.B. No. 1 and C.B. No. 10 standards.

#### Modified One-position Section for Provincial Exchanges.

Whilst jack capacity is of prime importance, floor space is scarcely less important and, where the instal-

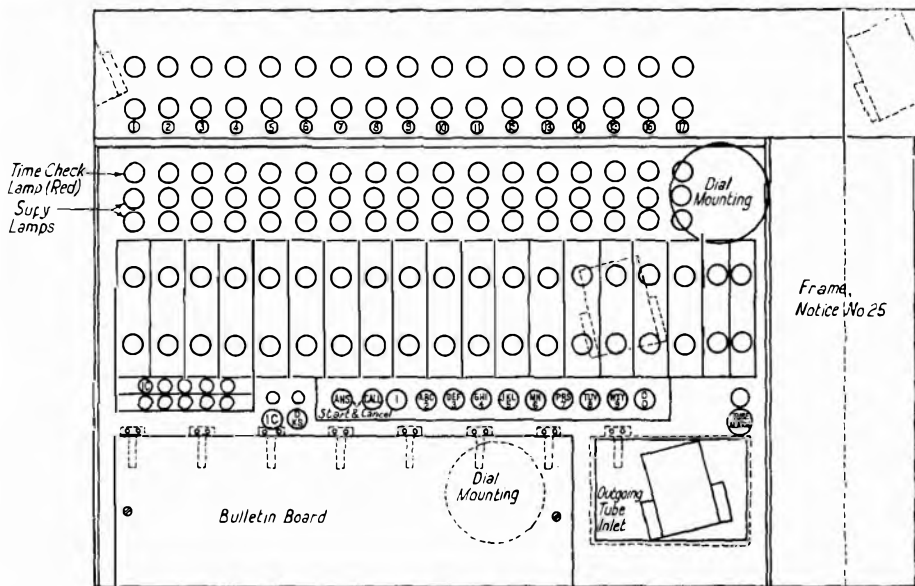

FIG. 5.—KEYSHELF, 23 INS. BY 18 INS.

maximum stretch may exceed 50 inches when the boards are fully equipped. In C.B. No. 10 exchanges the installation of 4-panel multiples was normal practice and in a few cases 6-panel multiples were installed. In C.B. No. 1 practice, 6-panel, 8-panel, and 9-panel multiples were employed, the panels being thinner than those of the No. 10 type. With the introduction of 7-panel sections, 6-panel outgoing multiples and 7- or 14-panel ancillared answering equipments were standardized. This has now been modified to 4-panel outgoing multiples with 6- or 12-panel answering multiples, except in special

cases where the ultimate number of lines to be accommodated does not permit of such an arrangement. It will be seen from Fig. 4 that with the new one-position (27 ins.) section, a panel arrangement of three or five panels per one or two positions respectively is catered for—a distinct advantage from the traffic point of view over the old one-position sections with a corresponding arrangement of two or four panels. Apart from the engineering difficulties involved with 23-inch positions, chair space was somewhat

lation of new exchanges in existing non-standard buildings is concerned, the available floor space may preclude the use of these standard sections. It was principally for this reason that, in certain Zone centres, a modified standard provincial auto-manual section was installed. A fourth new section was, therefore, designed which was similar in construction to the intermediate type, but was only 23 ins. wide and had two No. 10 type panels with keyshelves 18 ins. deep. This type of section is being installed in over thirty automanual exchanges (Group centres) but, in future, the standard 27-inch positions will be fitted either with three-position sections or a combination of three-position and one-position sections. Whilst the use of one-position sections 23 ins. wide eased the situation with regard to the provision of a specified number of positions in a given floor area, considerable difficulties arose due to the limited space available for cabling keyshelves and sections, and for accommodating pneumatic tubes. The keyshelf lay-out is shown in Fig. 5.

Multiple Repetitions; Past and Present Standards.

*Multiple Repetitions; Past and Present Standards.*

In a C.B. No. 1 exchange with 10,000 lines and a 9-panel repetition, the maximum "stretch" is 56 inches. This is measured from the centre of the front edge of the keyshelf to the most distant multiple jack. Whilst the increase of 2½ inches in the depth of the keyshelves is negligible as far as "stretch" is concerned in low-type sections, or intermediate type sections with low multiples, it will be readily appreciated that with the 7 ft. 6 ins. type of section equipped with a 6-panel repetition the

cases where the ultimate number of lines to be accommodated does not permit of such an arrangement. It will be seen from Fig. 4 that with the new one-position (27 ins.) section, a panel arrangement of three or five panels per one or two positions respectively is catered for—a distinct advantage from the traffic point of view over the old one-position sections with a corresponding arrangement of two or four panels.

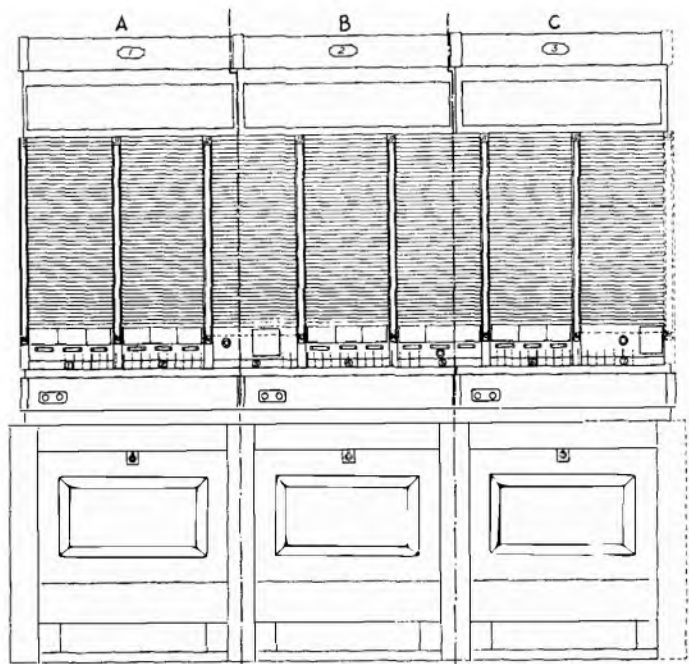

FIG. 6.—THREE ONE-POSITION SECTIONS.

limited, particularly at bends, and the introduction of 27-inch positions as standard practice met both engineering and traffic objections. The problem of constructing a new one-position section to accommodate standard keyshelves 27 ins.  $\times$  18 ins. and at the same time permit the use of No. 10 type jacks with a minimum loss of space in the multiple field has been solved by the introduction of the section shown typically in Figs. 6 and 7. By means of multiple drillings on the section details, the necessity for stocking a multiplicity of types of section has been eliminated, and the standard section can be supplied as any of the four types A, B, C, or D, and, moreover, in the event of recovery and re-use, can be readily converted from one type to another by changing the position of the stile bars and, when necessary, fitting an additional stile bar, *i.e.*, when the conversion of a B section to an A or C section is required. A typical front view of the three sections A, B, and C is shown in Fig. 6, whilst the cross-section and the D section are shown in Fig. 7.

suite) were equipped with book racks and docket distributors. Three-compartment pigeon holes and two-compartment docket distributors on alternate panels will now be provided on these positions.

#### *Application of the New Sections.*

To avoid any misapprehension as to the application of the new one-position section, it may be useful to point out the general principles to be followed. D sections are to be used exclusively for bends. The two panels are placed centrally in the section so that half of the lost space of  $2\frac{1}{2}$  inches is at each end of the section, but, as all angle sections will be equipped with outgoing and answering multiples, the gaps will be negligible from the point of view of stretch. To eliminate this loss when A or C sections are used, end panels and cable turning sections will be equipped with stile bars and casings to complete the panel space when necessary. It will be seen from Fig. 9 that this loss will only arise in certain cases, where the number of positions between

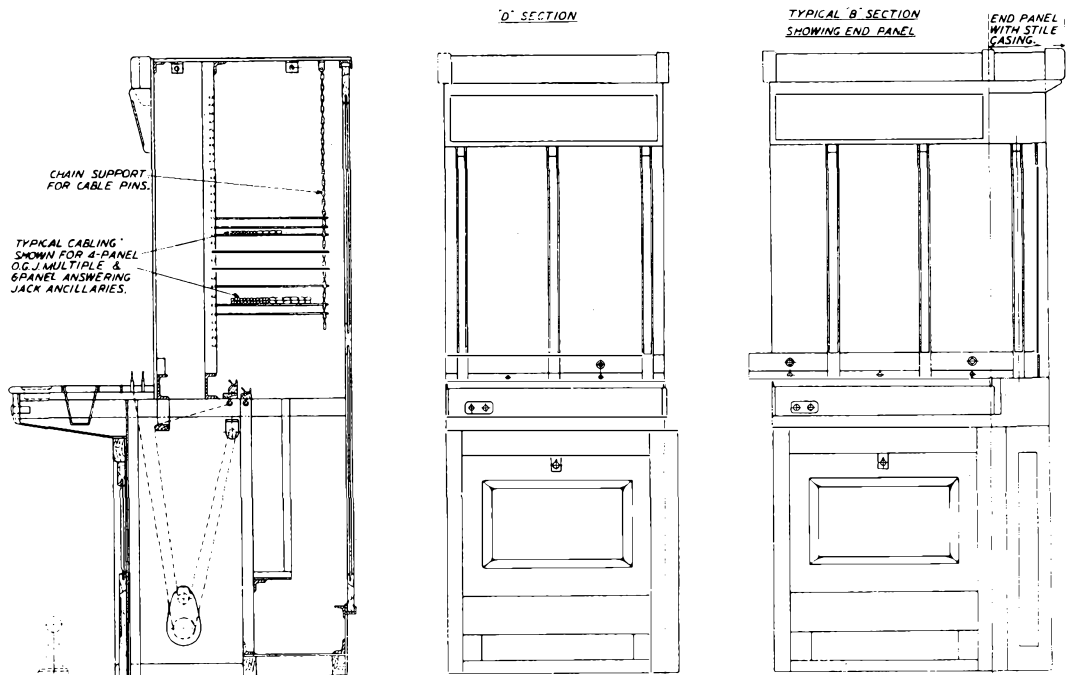

FIG. 7.—CONSTRUCTION OF SECTION, D SECTION, AND END PANEL.

#### *Standard Keyshelf for Trunk Exchanges or Automatic Switchboards.*

Fig. 8 shows the keyshelf lay-out, and it will be observed that there is little or no spare space. An additional new feature has been introduced on this keyshelf in respect of Enquiry Positions (*en suite*). A special card trough, for accommodating "Information" cards, can be fitted in place of eight of the ordinary keys. The conversion of positions to or from Enquiry positions can be readily accomplished by recovering the keys and fitting the card trough or *vice versa*. Formerly, Enquiry positions (*en*

two bends exceeds a multiple of three by one or two positions. In the latter case, care is required to ensure that the two one-position sections are placed one at each end of the straight line of boards and not together at one end, which would place a B section with a gap of 7 ins. adjacent to an angle section. With the standard arrangement of a C section at one end and an A section at the other, there is a gap of approximately 3 inches at each end of the straight line of boards. When a B section is used at the end of a suite, the adjacent end-panel cable turning section will be equipped with a set



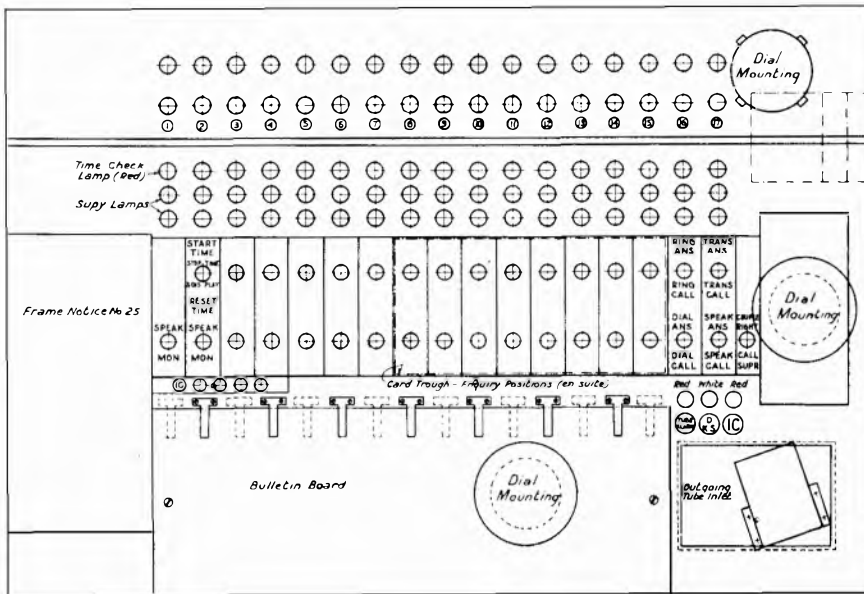

FIG. 8.—KEYSHELF, 27 INS. BY 18 INS.

native arrangement. With the introduction of the 27-inch positions as standard, however, it has been decided to standardize 30° angle sections with multiple equipment. The “elbow room” with the arrangement is much greater than with the old standards, whilst there is a decided economy in floor space as compared with the use of 22½° angle sections with three positions in a bend.

*Modified Type of Auto-manual Section.*

Fig. 9 shows typical layouts with 27-inch one-position sections, 4 ft. 8½ ins. high. This section is a modification of the type at present in use in London auto-manual switchboards. The modified

stile bar and casing as in the case of the A or C sections.

*Face Equipment.*

To reduce the stretch difficulties to a minimum, the arrangement shown in Fig. 7 has been standardized. Reduction of stretch has been achieved by—

- (i) Adopting a 4-panel outgoing multiple as standard.
- (ii) Fitting pigeon holes in the removable panel one inch lower than in the original sections, and omitting them in panels where delivery valves are fitted.
- (iii) Eliminating the blank spaces originally left in the panel equipment for “ultimate” requirements, where practicable.
- (iv) The introduction of a combined lamp jack and designation strip, thus effecting an economy of ½ inch (designation strip) per 20 answering equipments. (The standard arrangement provides for strips of 20 answering equipments, with strips of 10 in special cases).
- (v) The re-arrangement of pneumatic tube valves.

*Standard Angle Sections.*

Two standard angle sections have been used in the past, viz., 22½° and 30° sections. Where 90° bends were necessary in a suite, three positions with four 22½° angle sections or two positions with three 30° angle sections were used. These angle sections were installed either with or without multiple equipment. With 23-inch positions, the seating accommodation in bends was obviously better with three positions and 22½° angle sections than with the alter-

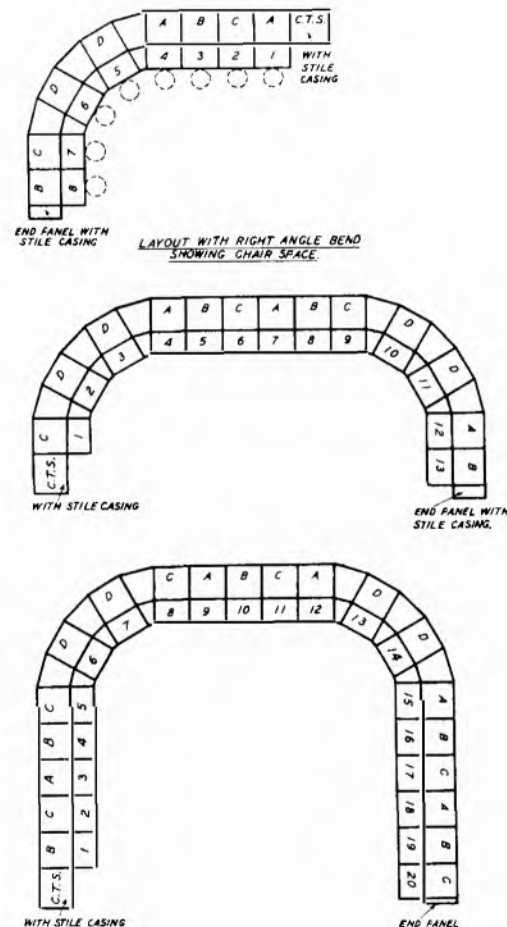

FIG. 9.—TYPICAL SWITCHROOM LAY-OUTS WITH ONE-POSITION SECTIONS

type will be used in London and Provincial exchanges where the capacity of the section meets traffic requirements.

The lay-outs shown in Fig. 9 may also be applied to the 6 ft. 4½ ins. sections where it is decided to install one-position sections throughout the exchange. This may be desirable in non-standard buildings where a small number of positions is required and where exceptional difficulty would be experienced in getting three-position sections into the switchroom.

#### *Miscellaneous Implications.*

The size of apparatus entrances and strength of jibs are controlled by the design of manual sections, apparatus racks, etc., but the introduction of these new sections does not necessitate any revision of the existing standards laid down for C.B. No. 1 exchanges in respect of these facilities. With regard to transport and handling, however, the weight of the large type of section may exceed that of the old type according to the amount of equipment fitted in the sections before shipping.

## A Device for Measuring Sound Pressures in Free Air

W. WEST, B.A., A.M.I.E.E.

A FAMILIAR difficulty in the measurement of sound pressures in free air is due to the fact that the microphone used for the purpose has dimensions which are not small as compared with the wave-lengths of the sounds. As a consequence, the presence of the microphone distorts the sound field and the actual pressures which actuate the diaphragm are not the same as the pressures which it is desired to measure.

With the object of overcoming this difficulty, Harrison and Flanders have designed a miniature condenser microphone, an account of which is given in *The Bell System Technical Journal*, Vol. XI., p. 451, 1932.

An alternative method is available by the addition, to an ordinary condenser microphone, of a suitable "mouthpiece." Such a device, constructed at the Post Office Research Station, is illustrated in the photograph.

diameter. For the last four feet of its length the tube is filled with about 20 strands of knitting wool, drawn in before coiling. There is a small slit in the side of the tube where it passes immediately over the diaphragm.

A sound pressure at the open end causes a sound wave to pass along the tube and to actuate the diaphragm of the condenser transmitter. Reflection of sound, and hence resonance in the tube, is prevented by the complete absorption provided by the filling of wool.

The device is essentially the same as the "Artificial Ear" described in this *Journal* (Vol. 22, p. 260, 1930), except that instead of terminating at a cup, the tube is continued for a length of about one foot.

The obstruction due to the transmitter is thus removed to a distance of one foot from the point where the pressures are measured. This distance is



MOUTHPIECE ATTACHMENT TO CONDENSER TRANSMITTER FOR MEASURING SOUND PRESSURES AT A POINT.

The mouthpiece has the form of a tube, one quarter of an inch internal diameter, which is straight for about one foot of its length, and then dips into a brass fitting, covering the diaphragm and in close proximity to it. Thereafter the tube extends for a further five feet and is coiled on a convenient

sufficient for most uses, but possible effects of reflections from the transmitter can be avoided by covering the transmitter with felt or cotton wool. Such a covering effectively prevents reflections at high frequencies, and at low frequencies the obstruction effect is in any case very slight.

# Burton-on-Trent Multi-Exchange Area: Transfer to Automatic Working (Bypass System)

A. G. LYDDALL and J. H. RUSSEL.

**B**URTON-ON-TRENT Automatic Exchange and its two automatic satellite exchanges, Swadlincote and Tutbury, were brought into service on April 22nd, 1933. Bypass switching equipment is provided at each exchange; thus the second portion of the experimental trial of this system is now in operation, the first being at Advance Exchange, London.<sup>1</sup>

shown in Fig. 1, is practically self-explanatory. Coin-box lines are served by a separate group of 1st line finders and share the regular 1st Paths and Bypasses, discrimination in access to a separate group of O-level lines being effected in the Bypass by a signal sent forward *via* an additional wiper of the coin-box 1st line finders. The incoming junctions from the satellite exchanges have access to the Burton sub-

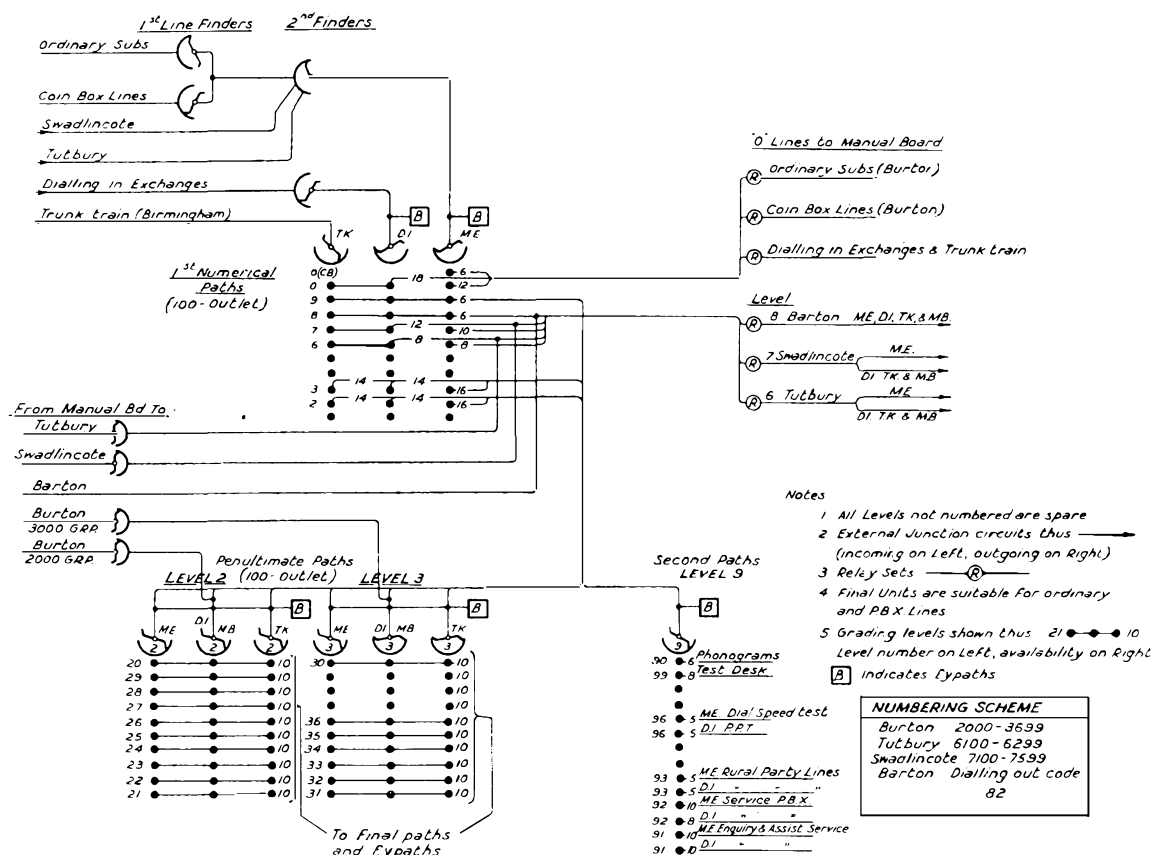

FIG. 1.—TRUNKING DIAGRAM, BURTON AUTOMATIC EXCHANGE.

The equipment provides equivalent standard arrangements as required by the British Post Office in a Multi-exchange Non-director Area, and, in addition, several new facilities. These are:—Trunk train for incoming Trunk calls. Assisted Service scheme; Busy subscribers Recorder; Combined automatic Dial speed tester and Faultsmen's ring back; Intermixing of P.B.X. groups and lines on all Final Selectors.<sup>2</sup>

The trunking diagram of the main exchange,

scribers' 2nd finders and therefore the 1st Paths and Bypasses and associated outlets.

Level 8 is allocated to dialling-out exchanges, but only one manual exchange, Barton, is within the multi-exchange area and the code 82 applies. Level 8 2nd path switches are not provided, however, the second digit being absorbed in the outgoing relay-set.

Level 9 2nd Paths and Bypasses are arranged in one group, common to both M.E. and D.I. traffic; the choice of outlets being dependent upon the first stage through which the call passes.

The Trunk train consists of separate 1st and

<sup>1</sup> P.O.E.E. Journal (Vol. 26, Part 1; Vol. 24, Part 3).

<sup>2</sup> Ibid.

Penultimate paths, but shares the regular bypaths of the Penultimate stage and the regular Final paths and bypaths. Trunk train access to the satellite exchanges is given over the group of junctions serving the manual switchboard and dialling-in exchanges, and a discriminating signal is sent over the junctions to the incoming relay-set to effect access to trunk offering Penultimate paths at the satellite exchanges.

The transmission feed and ringing control for local calls is located in the Penultimate switching stage.

#### *Calls to satellite exchanges, Automatic and Manual.*

Automatic calls to satellite exchanges are trunked directly from the 1st Stage *via* outgoing junction relay-sets which include the transmission feed. The Swadlincote and Tutbury (automatic satellites) junctions terminate at the distant end on junction line circuits which are searched for by second finder switches associated with the regular satellite Penultimate switches.

The junction relay-set repeats the dialled impulses forward to the automatic satellites and holds the forward and backward circuits.

The manual satellite relay-set, as previously mentioned, absorbs the second digit and signals the manual exchange operator.

#### *Calls to Manual Board O-level.*

The O-level relay-sets include, on the calling subscriber's side, a transmission feed of low D.C. resistance in which is included a marginal relay. This relay operates and switches into the feed a series resistance if the transmitter current reaches an excessive figure. As the O-level circuits carry the long-distance traffic, the scheme provides for regulation of the subscriber's transmitter current on long and short lines in order to give maximum transmission efficiency.

#### *Grouping Arrangements at 1st Stage. Burton Exchange.*

The following are the grouping arrangements of the 1st Line Finders, 1st Paths (comprising a 2nd Line Finder and an outlet switch, S), and the 1st Bypaths.

At Burton Exchange 11 1st line finders per group of 100 subscribers' lines are provided, these finders being available to the total number of 108 1st Paths and 12 1st Bypaths.

The bank capacities of these switches are:—

	1st Line Finders	...	...	102
1st Paths	2nd " "	...	...	51
	S Switches	...	...	102

The 1st Bypaths are arranged in pairs, each pair controlling 18 1st Paths. One bypath of a pair is taken into use alternatively for successive calls, the changeover being effected by a sequence relay termed CO.

The wipers of the 1st Line Finders are cross-connected to the banks of the 2nd Line Finders and multiplied over the banks of the group finders in the bypaths, *e.g.*, taking the case above of 18 1st

Paths, the 2nd finders of this group of paths have a multiple which is common to the banks of the two group finders in the pair of bypaths.

Fig. 2 shows the Line Finder grouping scheme.

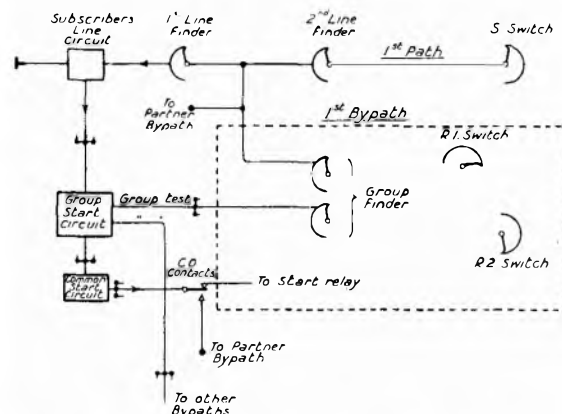

FIG. 2.—MAIN EXCHANGE, LINE FINDER SCHEME.

The following description summarizes the major operations from the subscriber's line circuit up to and including the selection of an outlet to the 2nd selecting stage:—

The subscriber's line relay operates to extend a calling battery potential from the cut-off relay to a bank contact of the 1st Line Finder. The line relay also energizes the group start circuit, which extends two battery potentials *via* the group test leads to the banks of the group finders.

#### *The group start circuit.*

A common start relay operates, which extends start conditions to the 1st bypaths whose group finders hunt for the calling group, as indicated by the two battery potentials.

Two group finders seize the calling group, the unsuccessful group finders are stopped, and two 1st line finders then hunt for the calling line as indicated by the calling battery potential.

Dial tone is extended from the Bypass *via* the successful 1st Line Finder to the calling line, and when the subscriber dials, the impulses step R1 switch.

R2 switch steps to find the marked digit group as indicated by one of 10 marking wires from R1 switch.

R2 switch hunts for a free outlet within the digit group.

R1 switch then steps past the remaining digit contacts and associates itself with a free 1st path. These paths are disposed on contacts 12 to 29 of the R1 switch.

The 2nd line finder of the selected 1st path drives to the 1st line finder, which has already been chosen by the group finder.

Path (S) switch drives to the outlet already chosen and marked by the R2 switch.

The next digit is pulsed over the impulsing

positive and negative wires *via* the 1st Stage Bypass to the 2nd Stage Bypass. After the R<sub>1</sub> switch of the latter finds the outlet from the 1st Stage marked *via* the 1st Path S switch, the 1st Stage Bypass is released.

It can be seen, therefore, that the 1st Bypass has two major functions, (a) to control the line finding operations, (b) to receive a digit and select an outlet to the next stage.

Subsequent selecting stages, *i.e.*, the Penultimate and Final stages have only to perform the second function; therefore, the Bypasses of these stages comprise an R<sub>1</sub> and R<sub>2</sub> switch only and the Paths comprise an "S" Switch only. From 8 to 10 Paths are under the control of one such Bypass.

**Outlet selection.**

When the R<sub>2</sub> switch hunts for a free outlet to the next stage, it seeks a free Path and Bypass indicated over a single test wire by a battery potential from a disengaged bypass *via* the normal contacts of the path switching relay.

Fig. 3 is a schematic diagram of this feature.

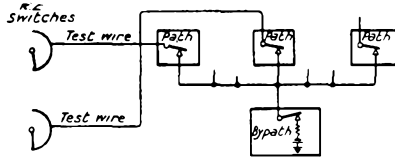

FIG. 3.—OUTLET TESTING PRINCIPLE.

The various outlets in each digit group are cabled to a number of different Bypasses at the next stage. This arrangement is essential, as during the time that a Bypass is in use, its "test" battery potential is disconnected. The associated disengaged Paths, therefore, are artificially "busied," and if one group of Paths provided outlets from the same S switch multiple, a high percentage of "busy" calls would result, due to one call engaging several outlets from the one switch.

**Marking.**

To drive the R<sub>2</sub> (outlet selecting) switch to the beginning of the digit group indicated by the position of R<sub>1</sub> (digit receiving) switch, and also to associate the S (path conversational) switch with the outlet selected by the R<sub>2</sub> switch, "Marking" banks are used on each of the three mentioned switches.

Fig. 4 shows the arrangement of the marking multiple. Relay M controls the stepping of both R<sub>2</sub> and S switches. When R<sub>2</sub> is positioned, so that a free outlet in the required group marked by R<sub>1</sub> is chosen, a relay H in the bypass operates, and M then controls the S switch which steps to the outlet marked by R<sub>2</sub>.

**Partner Bypasses.**

The bypasses are arranged in pairs, so that if one is withdrawn from service its partner may take over control of both groups of paths.

To achieve this, it is necessary that the marking multiple should be common to both bypasses. An M relay controls the stepping of switches and to prevent an M relay switching to a contact marked by the partner bypass, the battery and earth connexions for the M relays in the two bypasses are interchanged. In the one case the M relays requires an earth-marking for completion of its circuit, whilst in the other case a battery-marking is necessary. This ensures that an M relay operates only to its own bypass marking.

**The Final Stage Circuit.**

The Final bypass receives two digits, the tens on the R<sub>1</sub> and the units on the R<sub>2</sub> switch. The R<sub>2</sub> switch has no connexion to the subscribers' line circuits, but "marks" the position particular to the line required. The bypass has control of two groups of final paths, each serving one hundred subscribers in consecutive "hundreds," that is, odd and even, but the bypass does not require to have direct access to 200 lines since the choice of the hundreds group is made *via* the path. If subscriber 3,251 is dialled, the penultimate stage seizes a final path in the 3,200 group, and the bypass marks line 51 on the path switch. If 3,351 is dialled, a bypass also marks line 51, but in this case a path in the 3,300 group has been seized by the penultimate stage.

Up to this point, the bypass is indifferent as to whether the "two" or "three" hundreds group has been dialled, and the usual pair of MK banks only is required on R<sub>2</sub>, *i.e.*, 50 contacts each bank.

In the case of P.B.X. working, however, this would require the grouping of P.B.X. lines to be exactly the same in both final path groups. To avoid this, four banks are required on R<sub>2</sub> for P.B.X. discrimination, two for each group. R<sub>1</sub> switch provides the means for discriminating between these two pairs of banks. If it is resting on a path (say in the odd hundreds group) it provides access to the

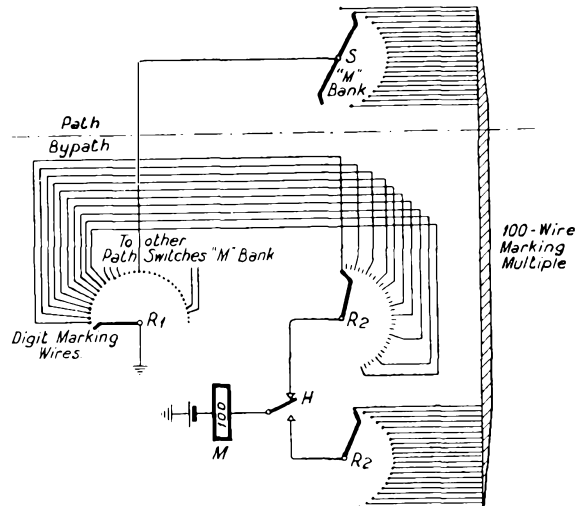

FIG. 4.—SCHEMATIC DIAGRAM OF "MARKING" PRINCIPLE.

odd hundreds pair of P.B.X. discriminating banks, and *vice versa*.

It should be noted that R<sub>2</sub> is a 51-point switch, and has to indicate to two groups of paths (each serving a hundred subscribers) the relevant marked number. For this reason two marking banks are provided, each bank having 50 marking wires to the path switches.

The R<sub>2</sub> switch tests *via* C bank for the marking from the T bank of R<sub>1</sub>. R<sub>2</sub> marks the outlet chosen *via* its M<sub>1</sub> or M<sub>2</sub> banks to the M bank of the path switch.

The tens digit marking contact on R<sub>1</sub> T<sub>1</sub> bank are strapped in pairs so that whether the subscriber's tens number is 3 or 4, for instance, the same wire to the R<sub>2</sub> C bank will be marked. A relay is joined to the even digit contacts on R<sub>1</sub> and provides the discrimination between the two subscribers marking banks on R<sub>2</sub> and between the two sets of P.B.X. indication banks. The marking contacts for the tens digit on R<sub>2</sub> C bank are each ten steps apart, and because R<sub>2</sub> has later to step to the units digit, these contacts precede by one the first line of the dialled tens group. The R<sub>2</sub> switch does not step off its home contact if the digit 1 or 2 is dialled. When any other digit is dialled, the R<sub>2</sub> switch steps to a position corresponding to the last contact of the preceding tens group, this contact being marked from the T<sub>1</sub> bank of R<sub>1</sub>.

Fig. 5 illustrates this arrangement.

		<i>Actual physical number of contact on R<sub>2</sub> Switch Banks M<sub>1</sub> and M<sub>2</sub>.</i>																					
	Home.	1.	2.	3.	4.	5.	6.	7.	8.	9.	10.	11.	—19.	20.	21.	—29.	30.	31.	—39.	40.	41.	—49.	50.
		<i>Numbering of Subscribers' lines on contacts of R<sub>2</sub> Switch.</i>																					
	X.	11.	12.	13.	14.	15.	16.	17.	18.	19.	10.	31.	—39.	30.	51.	—59.	50.	71.	—79.	70.	91.	—99.	90.
Odd Tens.	X.	21.	22.	23.	24.	25.	26.	27.	28.	29.	20.	41.	—49.	40.	61.	—69.	60.	81.	—89.	80.	01.	—09.	00.
Even Tens.																							
		<i>Bank.</i>																					
		M <sub>1</sub>																					
		M <sub>2</sub>																					
		The "Tens" digit marking wires from R <sub>1</sub> Switch T <sub>1</sub> Bank are wired to contacts on R <sub>2</sub> Switch C Bank as follows:—																					
		Tens digit																					
		R <sub>1</sub> Switch.																					
		1 and 2 to physical contact X.																					
		3 and 4 " " " 10.																					
		5 and 6 " " " 20.																					
		7 and 8 " " " 30.																					
		9 and 0 " " " 40.																					

FIG. 5.—ARRANGEMENT OF CONTACTS OF R<sub>2</sub> SWITCH, FINAL STAGE.

#### *Use of circuit as a 200-outlet, Final Stage.*

Final bypaths are arranged in partner pairs and serve two groups of paths having access to subscribers in two separate hundreds groups. The path is preselected by a Penultimate bypath and, as all paths served by any bypath have a common marking multiple irrespective of the hundreds group they serve, the Final bypaths merely have to set a path switch in accordance with the tens and units digit after finding the marked path in the correct hundreds group.

#### *Manual Exchanges. Dialling-in 1st Stage.*

Dialling-in exchanges, other than Birmingham

Trunk exchange whose junctions terminate on Trunk Train 1st digit switches, have their junctions terminated on the banks of Line Finders.

The Path circuit of this 1st Stage served by Junction Line Finders includes a repeating coil transmission bridge and provides for battery dialling and repeated impulsing. The Penultimate Stage Paths are therefore without a transmission bridge, but use the regular Penultimate Bypaths.

Line Finding for a calling junction is effected in a similar manner as in a subscriber's call.

#### *Satellite Exchanges. Trunking arrangements.*

At the satellite exchange the 1st Stage is distinct from the main exchange 1st Stage, in that means for discriminating are essential as in the standard system.

Fig. 6(a) shows the discriminator scheme and Fig. 6(b) completes the trunking diagram for Swadlincote exchange.

A discriminator is associated with every call made by a satellite subscriber. When the start signal is received from the line circuit, all discriminators drive their group-finders in search of a free 1st line finder having access to the calling subscriber. A free 1st line finder, when found, is driven in search of the calling subscriber, (the unsuccessful discriminators being stopped) and at the same time the successful 1st line finder is marked on the banks of the 2nd finders. Start conditions are then applied by the

discriminator to the relay-sets having access to junctions to the main exchange auto equipment.

The idle main exchange relay-sets drive their 2nd finders towards the position marked by the discriminator. The subscriber is then extended *via* the successful main exchange relay-set to a first stage at the main exchange, from which dial tone is given.

The train of impulses representing the 1st digit is received in the main exchange relay-set, being repeated to the discriminator and the first stage at the main exchange. The 1st digit indicates to the discriminator whether the call is local, *via* the main exchange, or *via* the manual switchboard.

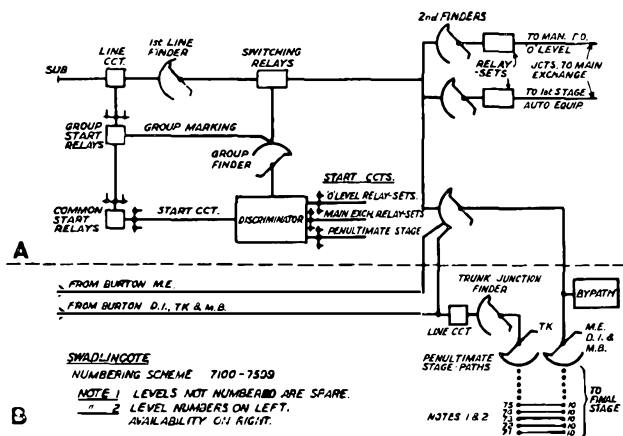

FIG. 6.—SATELLITE EXCHANGE; DISCRIMINATION AND TRUNKING SCHEME.

If the call is to the main exchange the discriminator releases and leaves the call under control of the main exchange relay-set.

If the call is local, the discriminator releases the main exchange relay-set and junction, etc.; start conditions are applied to the local penultimate stage which drive their idle 2nd finders in search of the 1st line finder marked by the discriminator. This search takes place during the inter-digit pause, and when the marked 1st line finder has been found by a penultimate stage, the discriminator releases. To

reduce the finding time of the penultimate 2nd finders, the switches are normally evenly spaced on the banks by means of "ghost" home positions. Every switch in use leaves a "ghost" position vacant, and at the termination of the call, the released switch drives and stops at the first free "ghost" position encountered, where it awaits the next call. This ensures connexion during the inter-digit pause, as the number of steps taken by a switch to the marked position is thereby reduced to a minimum.

Should the call be intended for the manual switchboard, the discriminator releases the main exchange relay-set and applies start conditions to the o-level relay-sets which drive their 2nd finders in search of the marked line finder. The O-level relay-sets provide connexion with high-grade junctions to the manual switchboard at the main exchange, and when an O-level 2nd finder has found the marked 1st line finder the discriminator is released, and the successful relay-set extends the calling subscriber to the manual switchboard.

When all junctions to the main exchange are engaged, the discriminator supplies dial tone and receives the 1st digit dialled. Should the call prove to be *via* the main exchange, busy tone is returned to the subscriber. Otherwise the call will proceed normally.

Similar conditions obtain when other routes are engaged.

## Telegraph and Telephone Plant in the United Kingdom.

TELEPHONES AND WIRE MILEAGES. THE PROPERTY OF AND MAINTAINED BY THE POST OFFICE IN EACH ENGINEERING DISTRICT AS AT 30TH SEPT., 1933.

No. of Telephones owned and maintained by the Post Office.	Overhead Wire Mileages.				Engineering District.	Underground Wire Mileages.			
	Telegraph.	Trunk.	Exchange†	Spare.		Telegraph.	Trunk.	Exchange†	Spare.
798,611	597	8,659	44,190	3,117	London	39,799	192,664	3,575,324	156,111
96,943	2,012	19,205	44,793	5,277	S. Eastern	4,354	50,842	349,436	44,536
112,168	3,852	36,521	69,066	5,260	S. Western	25,254	39,586	284,179	63,425
77,052	4,564	40,921	66,826	8,666	Eastern	16,976	58,292	161,112	56,474
122,767	7,521	50,056	54,328	7,945	N. Midland	21,311	148,795	330,171	129,571
98,411	3,966	31,440	63,302	4,019	S. Midland	17,410	58,835	303,972	70,525
67,730	3,013	30,708	54,374	6,219	S. Wales	6,594	49,838	165,330	43,595
134,043	6,093	30,636	56,937	5,727	N. Wales	13,637	72,271	442,005	116,783
178,359	1,016	11,359	25,741	6,459	S. Lancs.	11,878	118,920	631,406	80,483
113,264	5,304	28,602	37,776	8,107	N. Eastern	12,968	82,570	337,463	64,874
75,033	3,479	22,108	26,327	6,344	N. Western	4,956	48,976	249,591	53,115
57,758	1,980	16,029	21,882	5,358	Northern	3,752	42,764	188,588	39,470
28,301	3,248	11,239	11,835	990	Ireland N.	511	4,858	69,758	5,746
82,381	4,576	32,430	40,004	3,191	Scotland E.	5,104	44,380	178,185	35,534
103,805	5,429	23,128	31,807	3,088	Scotland W	8,921	46,495	264,602	37,810
2,146,626	56,650	393,041	649,188	79,767	Totals.	193,425	1,060,086	7,531,122	998,052,
2,129,840	57,666	395,022	641,096	75,598	Figures as at 30 June, 1933	221,147	1,041,210	7,467,875	986,740

† Includes low gauge spares (*i.e.*, wires of 20 lb. or less in cables and 40 lb. bronze on overhead routes).

# Delay Probability Formulae

C. D. CROMMELIN, M.A.

(of Messrs. Siemens Brothers & Co., Ltd.).

## (1) INTRODUCTION.

THIS article is an addendum to the previous one on the above subject which appeared in a previous issue of the Journal.<sup>1</sup> An unavoidably inadequate footnote reference<sup>2</sup> was there made to the extensive work of Pollaczek. The author has had further opportunities of examining the theory in question, and thinks that it may be of interest to draw a comparison between it and his own work. This is done in what follows. Pollaczek's assumptions are outlined and these are shown, under the limiting condition which he introduces to obtain most of his practical formulæ, to become identical with the assumptions underlying the author's theory. The exact agreement between the sets of formulæ is thus consistent and satisfactory. Particular attention is called to two of Pollaczek's formulæ, giving respectively the probability for no delay, and the average delay, which were not obtained by the author. They are especially convenient because they only involve the initial parameters of the problem, *i.e.*, the switch quantity and the traffic density. On the other hand, they only deal with part of the problem and are not of much help in obtaining  $P(> t)$  the probability for a delay exceeding  $t$ , for which purpose formula (19) of the author's article is in general the most convenient. Section (3) of the present article describes practical methods of dealing with the  $P(> t)$  problem. Some numerical results are presented.

## (2) OUTLINE OF POLLACZEK'S ASSUMPTIONS AND RESULTS.<sup>3</sup>

Pollaczek's fundamental assumption is that exactly  $N$  calls originate in the busy hour of length  $T$ .<sup>4</sup> These are independent of one another and are distributed in a random manner: they are served in the order of their arrival by the  $n$  switches provided

for this purpose. Thus calls arriving when  $n$  are simultaneously in progress must wait their turn for the use of one of the switches becoming free later. In most of his work leading to practical formulæ, Pollaczek further assumes that the holding times of calls are constant and equal to  $t_0$ .

The methods of procedure used in obtaining the average delay  $M$ , and the probability for a delay less than  $t$  [ $P(< t)$ ], are similar in their general aspects. We shall outline the initial steps in the derivation of  $P(< t)$ .

The  $m^{\text{th}}$  call is considered and the probability  $\rho_m(t)$ , that it is delayed for a time  $< t$  is put down as

$$\rho_m(t) = \frac{\int_0^T dx_1 \int_{x_1}^T dx_2 \dots \int_{x_{N-1}}^T dx_N}{\int_0^T dx_1 \int_{x_1}^T dx_2 \dots \int_{x_{N-1}}^T dx_N}$$

$\tau_m \leq t$

where the integrals in the numerator are taken subject to the condition that the delays  $\tau_m$  of the  $m^{\text{th}}$  call implied by particular sets of  $x$ 's shall  $\leq t$ .

The denominator reduces to  $\frac{T^N}{N!}$  and the last

$(N - m)$  factors of the numerator to  $\frac{(T - x_m)^{N-m}}{N - m!}$

So we get

$$\rho_m(t) = \frac{N!}{T^N} \cdot \underbrace{\int_0^T dx_1 \int_{x_1}^T dx_2 \dots \int_{x_{m-1}}^T dx_m}_{\tau_m \leq t} \frac{(T - x_m)^{N-m}}{N - m!} dx_m \dots \dots \dots (1)$$

as given by Pollaczek.<sup>5</sup>

$\tau_m$  is specified in terms of the  $x$ 's by the formulæ

$$\tau_m = (x_{m-n} + \tau_{m-n} + t_0 - x_m) \left( \begin{matrix} n + 1 \leq m \leq N \\ 1 \leq m \leq n \end{matrix} \right) \quad (2)^6$$

and  $\tau_m = 0$

where the thick brackets denote that zero or the numerical value indicated is alternatively to be used, according as the latter is negative or positive. The basis for this formula is the fact that when the  $m^{\text{th}}$  call is delayed, the ending of the  $(m - n)^{\text{th}}$  call gives it service. This applies in all circumstances, *i.e.*, whether or not the  $m^{\text{th}}$  call finds others waiting when it arrives.

Applying this formula successively we get

$$\tau^m = (a_1 + (a_2 + (a_3 + \dots + (a_n) \dots)))$$

= Maximum of the  $\mu + 1$  numbers

$$0, a_1, a_1 + a_2, \dots, \sum_{v=1}^{\mu} a_v \dots \dots \dots (3)^7$$

<sup>1</sup> "Delay Probability Formulæ, when the Holding Times are Constant," by C. D. Crommelin. P.O.E.E.J., Vol. 25, page 41. Referred to as C.D.C. in this article.

<sup>2</sup> C.D.C. footnote 4, p. 41.

<sup>3</sup> Pollaczek's theory is contained in the following articles:—*Mathematische Zeitschrift*. 32. S. 64-100 und S. 729-750, 1930; *Electrische Nachrichten-Technik*: June and July, 1931; *Telegraphen und Fernsprech-Technik*: S. 71-78, 1930: the last is a summary of results. The articles will be referred to as M.Z.I and II, E.N.T.I and II, and T.F.T. respectively. A further article in *Math. Zeitschrift*. 35 (1932), S. 230-278, deals with the lost call problem by methods analogous to those used for the delay problem. It is not considered in the present article.

<sup>4</sup> Pollaczek's notation has been modified so as to be consistent with that of the author's article. Thus the  $N, n, a, P(< t), M$  here used correspond to Pollaczek's  $n, s, \eta, e(t), v$  respectively. Also in the statement of the formulæ,  $t_0$  has been put equal to 1 so that  $t^*$  becomes identical with  $t$ .

<sup>5</sup> M.Z. II, formula (2), p. 730.

<sup>6</sup> M.Z. II (3) and (3a).

<sup>7</sup> M.Z. II (4) and (5).



where  $a_v = x_{m-vn} - x_{m-(v-1)n} + t_0$  ( $v = 1, 2, \dots$ )  
 and  $m = \mu n + s$  ( $1 \leq s \leq n$ )

This formula is obtained by considering the  $(m-n)^{\text{th}}$ ,  $(m-2n)^{\text{th}}$ , . . . calls in succession and applying (2) to each. The argument is obvious so long as the call in question is delayed. Suppose that  $r$  is the smallest number such that the  $(m-2n)^{\text{th}}$  call is not delayed. Then the 1st of the  $\nu n$  calls preceding this must have originated at least  $\nu t_0$  previously, i.e.,—

$$x_{m-rn} \geq x_{m-(r+\nu)n} + \nu t_0,$$

$$\text{and } \sum_{\tau=1}^{r+\nu} a_\nu = x_{m-(r+\nu)n} - x_{m-rn} + \nu t_0 \leq 0$$

This shows that the contributions to  $\sum_{v=1}^{\mu} a_v$  by calls prior to the earliest of the  $(m-n)^{\text{th}}$ ,  $(m-2n)^{\text{th}}$ , . . . calls belonging to the batch of delayed calls under consideration, is at most zero, and justifies the final statement formula (3), for  $\tau_m$ .

The probability in which we are interested is

$$P(< t) = \frac{n}{N} \sum_{\mu=0}^{\frac{N}{n}-1} \rho \mu n + s(t) \dots \dots \dots (4)^8$$

which is given when  $\rho_m(t)$  has been determined.

The problem is now reduced to the purely mathematical one of evaluating the series of integrals in formula (1) subject to the conditions implied by (3). The investigation will not be considered here. It is described in detail in the article M.Z. II and leads to the formula (31) appearing on p. 737 of that article. It should be noted that the expression involves  $\eta = \frac{N t_0}{n T}$ . This is the occupancy of the group; it is here denoted by  $a$ . An extension to the case of variable holding times need not concern us, as the formulæ obtained do not lend themselves to practical application.<sup>9</sup>

In obtaining the practical formulæ of the next section<sup>10</sup>, Pollaczek distinguishes three cases. From our point of view the first case, in which  $a < 1$ , is by far the most important. It leads to the formula (47) in which  $P(< t)$  is expressed as a term independent of  $N$  added to another of order  $\frac{1}{N}$ . In other words the first term becomes increasingly accurate as  $N$  increases, and we may say that it is the limiting value of  $P(< t)$  as  $N \rightarrow \infty$ .

Now this condition involves us in an infinite busy hour in which the finite traffic density  $n a$  is contributed by an infinite number of subscribers (since it is independent of the number of calls in progress). This is precisely the condition of statistic equilibrium, assumed as the basis for the formulæ obtained in

the author's article.<sup>11</sup> The identity of the resulting formulæ which had been partially noticed by the author<sup>12</sup> is therefore perfectly consistent, and provides a valuable check on the accuracy of the two investigations.

Pollaczek's practical deductions from his formula (47) and the corresponding one for the average delay, are most concisely set forth in his T.F.T. article. Here formula (14) for the average delay  $M$  is identical with the author's (24); formulæ (19), (21) are respectively identical with the author's (17), (32) for  $P(< t)$  in the special case of  $n = 1$ ; formula (27) for  $(P = 0)$  is identical with the author's (10). Pollaczek gives some additional formulæ for  $P(= 0)$  and  $M$  which we shall consider later. But for  $P(< t)$  in the general case he contents himself with (18) which is identical with (47) mentioned above. From it, the author's (17) may be deduced by an extension of the method used by Pollaczek<sup>13</sup> in the case of  $n = 1$ , and (19) follows by the method described in Appendix I.<sup>14</sup>

The remaining cases distinguished by Pollaczek in obtaining his asymptotic formulæ<sup>15</sup> may be discussed together. They correspond respectively to  $a$  approximately equal to 1 and  $a > 1$ . The resulting formulæ are to be interpreted as approximations applying when  $N$  is large but finite. In each case there would be an indefinite pile up of the calls if an infinite number were under consideration. If we consider  $N$  finite, the inappropriateness of Pollaczek's assumption as applied to telephone traffic becomes apparent. His theory would apply to the case in which an attendant was present who only allowed  $N$  calls to pass during each busy hour. But this condition is never realized in practice. The maximum possible number of calls per busy hour, which would be the number resulting from each subscriber using his instrument continuously, is certainly much greater than what Pollaczek would use for  $N$ ; moreover the calls do not satisfy Pollaczek's independence condition, for those originated by the same subscriber must occur successively and cannot overlap with one another. Pollaczek's  $N$  rather corresponds with the average number of call originations per busy hour. Now the busy hour is usually long enough for this number not to vary very much. The formulæ are thus valuable as approximations, particularly since they are the only ones available for these cases.

It should be noted that in the  $a < 1$  case, where we can take  $N$  infinite, our assumptions are much less drastic, and in fact may be summed up in the statement that we are dealing with an infinitely long period during which the traffic density—contributed by an infinite number of subscribers—is constant. The lack of independence of calls from the same subscribers now becomes a negligible consideration,

<sup>8</sup> M.Z. II (1a), p. 734.

<sup>9</sup> M.Z. II, Sections 2 and 4. However a formula for the single case of  $n = 1$  is given for the average delay  $M$  in T.F.T. (32), p. 188.

<sup>10</sup> M.Z. II; Section 3, p. 739.

<sup>11</sup> C.D.C. 1st paragraph of Section (2), p. 41.

<sup>12</sup> C.D.C. Footnote 4.

<sup>13</sup> M.Z. II, Section 5, bottom of p. 747.

<sup>14</sup> C.D.C. Appendix 1, p. 49.

<sup>15</sup> T.F.T. Formulæ (10), (11), (16), (23), (25) and (26).

for each subscriber contributes only an infinitesimal portion of the traffic.

We have next to consider some mathematical simplifications of the original formulæ, effected by Pollaczek. The most important of these are two remarkable series expressions, involving only  $n$  and  $a$ , for  $P(=0)$  and  $M$  respectively. They may be derived from the formulæ for these quantities mentioned above, which were obtained both by Pollaczek and the author. The manner of derivation is given in the Appendixes to the present article.

The formulæ in question, stated in their most convenient forms, are as follow :—

$$\log [P(=0)] = - \sum_{w=1}^{\infty} \frac{e^{-wy}}{wy} \sum_{\mu=wn}^{\infty} \frac{(wy)^{\mu}}{\mu!} \dots\dots\dots (5)$$

$$\text{and } M = \sum_{w=1}^{\infty} e^{-wy} \left\{ \sum_{\mu=wn}^{\infty} \frac{(wy)^{\mu}}{\mu!} - \frac{n}{y} \sum_{\mu=wn+1}^{\infty} \frac{(wy)^{\mu}}{\mu!} \right\} \dots\dots\dots (6)^{16}$$

where  $y = an$  is the traffic density.

Their importance rests on the fact that they do not involve the  $\lambda$ 's or the  $a$ 's which respectively appeared in the corresponding original formulæ for  $P(=0)$  and  $M$ . The  $\lambda$ 's are complex numbers, while the  $a$ 's are functions of the  $\lambda$ 's. The computation of both sets of quantities, described in Section (10) of the author's previous article, is a tedious matter. The derivation of the  $a$ 's is particularly laborious when  $n$  is at all large. The above simple formulæ consist of series of Poisson probabilities, for which extensive tables exist; in most practical cases they converge quite rapidly. They were, no doubt, used by Pollaczek in obtaining his numerical results.<sup>17</sup> The author has found formula (5) useful in his  $P(>t)$  work described in the next section. He would use formula (6) if he required the average delay in any case not evaluated by Pollaczek.

In T.F.T. formula (20), Pollaczek states, for the case of  $n = 1$ , the complete expression to which the Erlang asymptotic formula for  $P(>t)$ , derived by the author,<sup>18</sup> is an approximation. An analogous expression holds for  $n > 1$ . It has not been used by the author, although the simple Erlang formula has been found very useful. Pollaczek gives other asymptotic formulæ for  $P(>0)$ ,  $M$ , and  $P(>t)$  applicable for large values of  $n$ .<sup>19</sup> One of these, namely,

$$P(>0) = 1 - P(=0) = \frac{1}{1-a} \frac{(ae^{1-a})^n}{\sqrt{2\pi n}} \dots\dots\dots (7)$$

is worth quoting as it is very easy to evaluate, and is often a fair approximation, applicable when only a rough result is required.<sup>20</sup> But the author did not find either this or the other formulæ mentioned sufficiently accurate for the cases up to  $n = 20$  for which he carried out the computation described in the next section. (See Fig. 1).

(3) METHODS OF COMPUTING  $P(>t)$  FOR VARIOUS VALUES OF  $n$ ,  $a$ , AND  $t$ .

The author has carried out a computation of  $P(>t)$  for the cases  $n = 2, 3, 4, 5, 8, 10$  and  $20$ , and  $a$  at intervals of 0.1 between 0.1 and 0.8, only occupancies making  $P(>0) > .0001$  being considered. (See Figs. 2-8 inclusive). The results of Erlang,<sup>21</sup> Fry,<sup>22</sup> and Pollaczek<sup>23</sup> for  $n = 1$  were collected and some additional low occupancies and large values of  $t$  computed to complete the collection. Low occupancies for  $n = 2$  were also dealt with.

For most of the cases, the author's formula (19) used as described in the latter part of his section (10)<sup>24</sup> was found to be most convenient. As regards the determination of the  $a$ 's: in the cases of  $n = 2$  and 3, these were read from a table given by Erlang<sup>25</sup>; for greater values of  $n$  an approximate device was used which it is believed can introduce very little error. This is a refinement of the suggestion made in the author's previous article—namely, of taking the  $a$ 's equal to 1 (this was found to be too inaccurate except for the lower occupancies). It consists in the use of the  $a$ 's appropriate to an Exponential Distribution of holding times. These are given immediately as

<sup>20</sup> It is interesting to note that this is the limiting form as  $n \rightarrow \infty$  of the well known Molina lost calls formula:

$$P = \sum_{r=n}^{\infty} \frac{y^r}{r!} e^{-y}. \text{ The result is a consistent one, for when the switch quantities are large, the probable delays are small fractions of the holding time, and the call distribution does not differ much from that involved in a system with unlimited switch quantities.}$$

<sup>21</sup> Annales des Postes Telegraphes et Telephones. July, 1922. Table IV, p. 808. Table V corresponding to  $n = 2$  was used for checking the author's arithmetic.

<sup>22</sup> Table IX of an unpublished memo. referred to in C.D.C. footnote 2, gives  $P(>t)$  very accurately for  $a$  at intervals of .01, but only for integral values of  $t$ .

<sup>23</sup> T.F.T. Fig. 2.

<sup>24</sup> C.D.C., p. 48. It may be well to draw attention to an unfortunate error in the statement of the formula in the middle of the 2nd column of this page. The expression inside the square bracket should read:—

$$\left[ \frac{\{4(1-\tau)\}^{19-v}}{19-v!} \cdot e^{-4(1-\tau)} + \frac{\{4(2-\tau)\}^{29-v}}{29-v!} e^{-4(1-\tau)} + \dots \right]$$

There are other errors and misprints, rather too numerous to set forth here. It is hoped that they will not prove misleading.

<sup>25</sup> "Revue Generale de l'Electricite": 21st Aug., 1926, p. 277.

<sup>16</sup> T.F.T. formulæ (29) and (13) respectively. The Pollaczek statements differ slightly from the above, but the equivalence is easily established.

<sup>17</sup> E.N.T. II, Figs. 1, 2, 5a and 6. T.F.T., Figs. 1 and 3, cover the same ground as E.N.T. Figs.; Fig. 2 is new.

<sup>18</sup> C.D.C. Appendix 2, Formula (32).

<sup>19</sup> T.F.T. Formulæ (30h), (15), (31) constitute the simple set. A more elaborate set applicable for a wider range of  $a$  are summarized in E.N.T. II formulæ (11) and (12). Numerical values of the functions involved are given in Figs. 3 and 4. Figs. 7 and 8 give some idea of the range of accuracy.

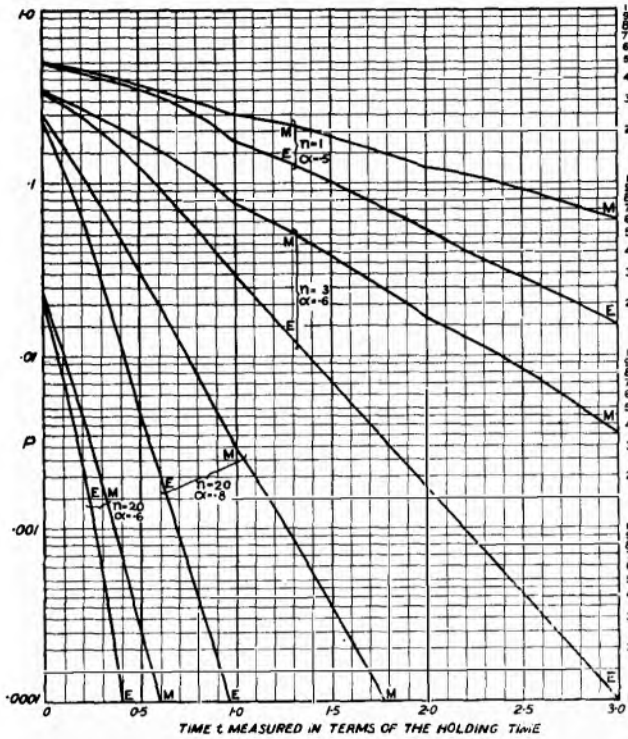

FIG. 1.—PROBABILITIES  $P$  FOR A DELAY EXCEEDING  $t$  HOLDING TIMES WHEN THERE ARE  $n = 1$  SWITCHES WITH OCCUPANCY  $a$ . SOME COMPARISONS BETWEEN RESULTS OF THE MOLINA APPROXIMATE FORMULA (M) AND THE ERLANG ACCURATE FORMULA (E).

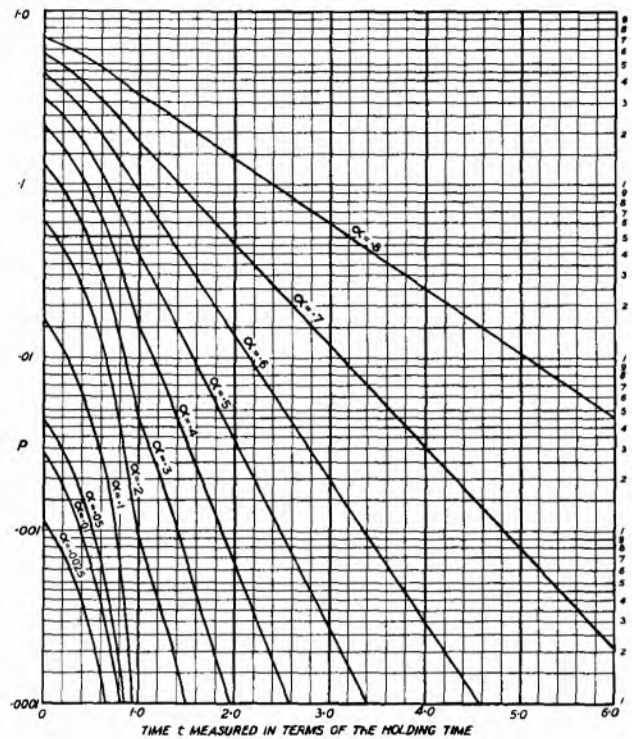

FIG. 3.—PROBABILITY  $P$  FOR A DELAY EXCEEDING  $t$  HOLDING TIMES WHEN THERE ARE  $n = 2$  SWITCHES WITH OCCUPANCY  $a$ .

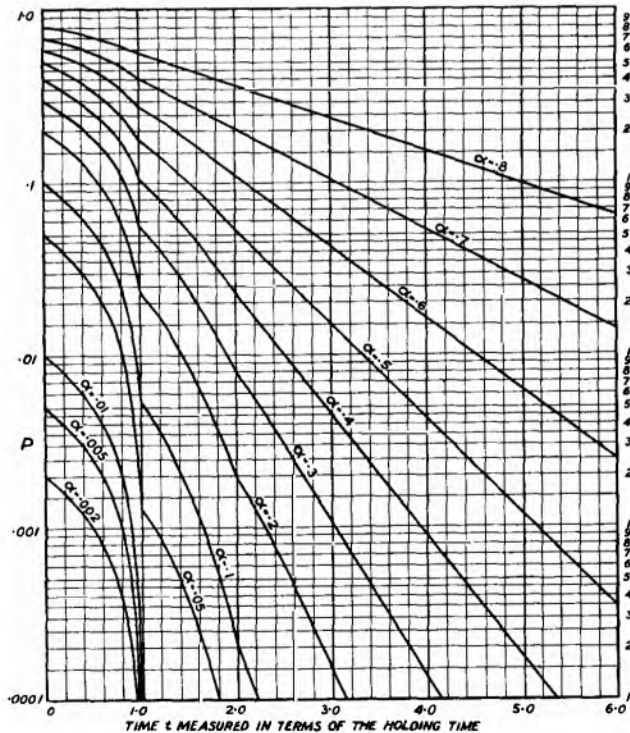

FIG. 2.—PROBABILITY  $P$  FOR A DELAY EXCEEDING  $t$  HOLDING TIMES WHEN THERE ARE  $n = 1$  SWITCHES WITH OCCUPANCY  $a$ .

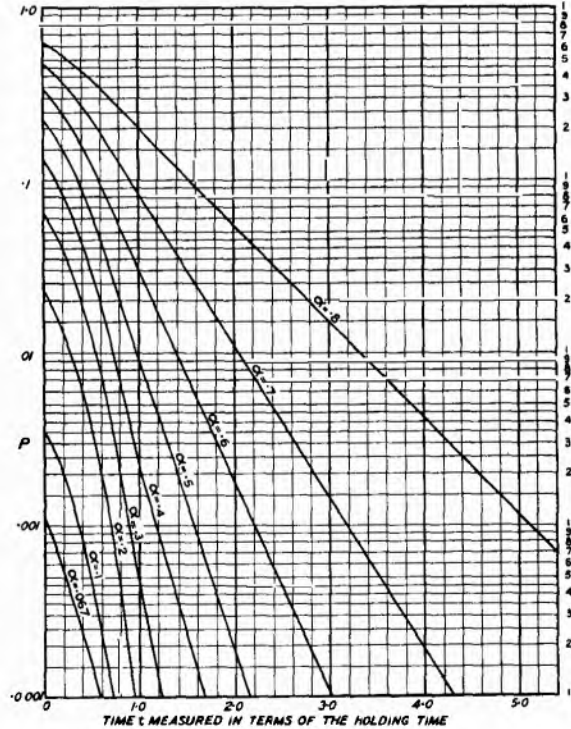

FIG. 4.—PROBABILITY  $P$  FOR A DELAY EXCEEDING  $t$  HOLDING TIMES WHEN THERE ARE  $n = 3$  SWITCHES WITH OCCUPANCY  $a$ .

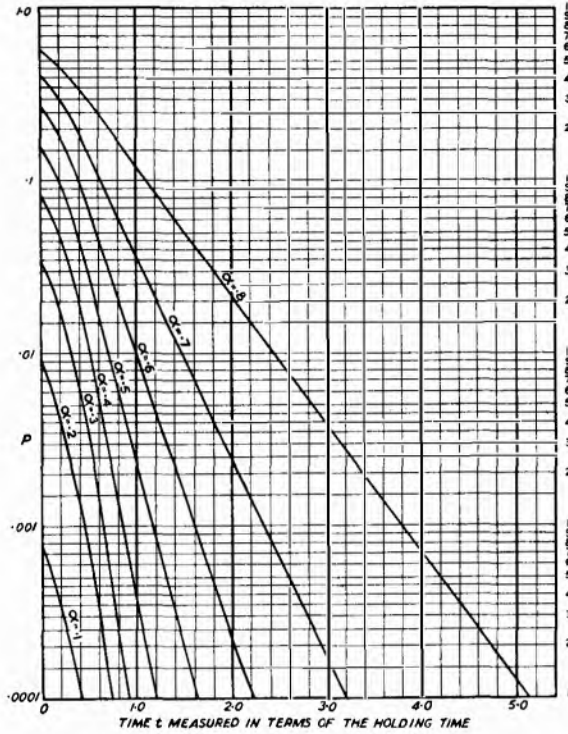

FIG. 5.—Probability  $P$  FOR A DELAY EXCEEDING  $t$  HOLDING TIMES WHEN THERE ARE  $n = 4$  SWITCHES WITH OCCUPANCY  $a$ .

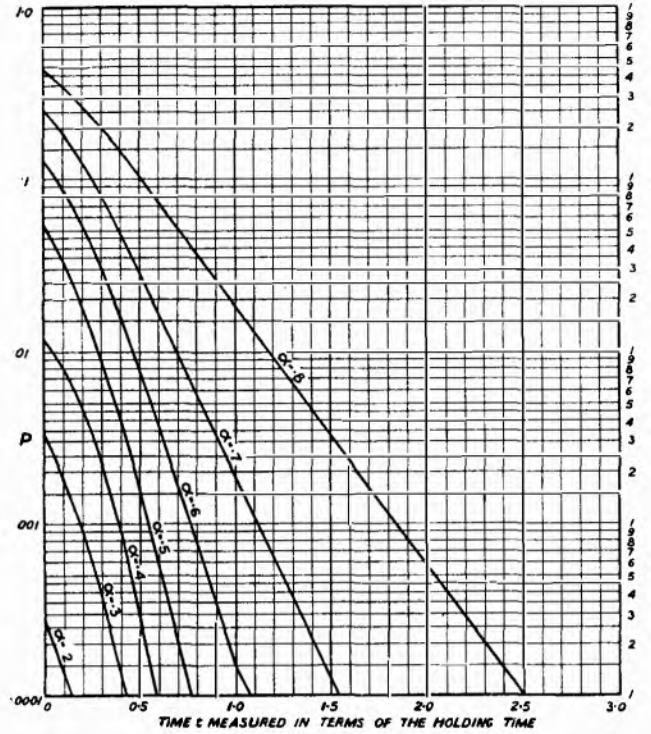

FIG. 7.—Probability  $P$  FOR A DELAY EXCEEDING  $t$  HOLDING TIMES WHEN THERE ARE  $n = 8$  SWITCHES WITH OCCUPANCY  $a$ .

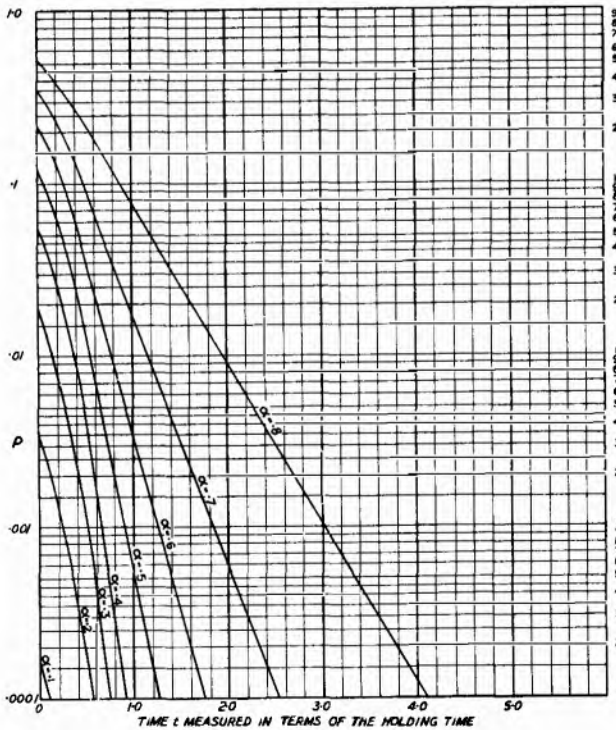

FIG. 6.—Probability  $P$  FOR A DELAY EXCEEDING  $t$  HOLDING TIMES WHEN THERE ARE  $n = 5$  SWITCHES WITH OCCUPANCY  $a$ .

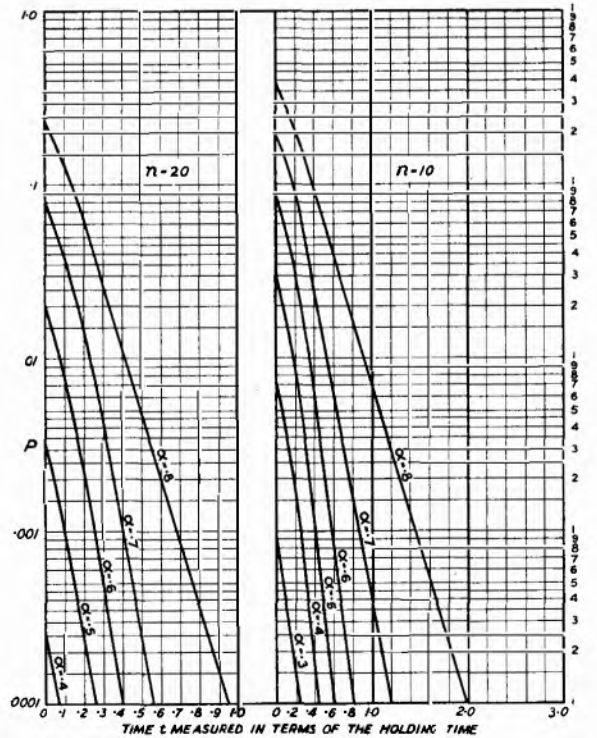

FIG. 8.—Probability  $P$  FOR A DELAY EXCEEDING  $t$  HOLDING TIMES WHEN THERE ARE (i)  $n = 10$  AND (ii)  $n = 20$  SWITCHES WITH OCCUPANCY  $a$ .

$$a_v = \frac{E_v(y)}{E_{n-1}(y) + \frac{y^{n-1}}{n-1!} \frac{y}{n-y}} \dots\dots\dots(8)^{26}$$

where  $E_v(y) = 1 + y + \frac{y^2}{2!} + \dots + \frac{y^n}{n!}$

The resultant  $a_{n-1}$  is invariably slightly less than that appropriate to the constant holding time problem. The remaining  $a$ 's have varying relative sizes, the ones corresponding to small values of  $v$  being usually longer in the exponential case than in that of constant holding times. But in all the cases where direct comparisons have been made, the differences are quite small. Two checks enable us to get a definite idea of the probable inaccuracy of the method.

The first is the evaluation of  $P(>0)$  direct by Pollaczek's formula (5) of the present paper). The terms required in this are for the most part identical with those required as the coefficients of the  $a$ 's in formula (19) (though they have to be arranged differently); hence the computation is by no means difficult. This gives us the correct value of  $a_{n-1}$ . Using now the remaining  $a$ 's as given by (8), we obtain  $P(>0)$  from (19). In the author's computations, the result never differed from the true value,  $1 - P(=0)$ , by as much as 2%. From the nature of formula (19) we are justified in saying that this percentage error is unlikely to be exceeded in the determination of  $P(>t)$  where  $t$  differs from 0.

But another valuable check presents itself for larger values of  $t$ . This is the use of the ratio between the probabilities corresponding to different values of  $t$  indicated by Erlang's asymptotic formula.<sup>27</sup> We have:—

$$\frac{P(>t_1)}{P(>t_2)} = e^{-y(r_0-1)(t_1-t_2)} \dots\dots\dots(9)$$

The two final values of  $P(>t)$  evaluated by formula (19) were in each case checked in this way, and again the error did not exceed 2% except in a few cases where the requisite range of  $t$  (to make  $P(>t) < .0001$ ) was too small for the asymptotic formula to become accurate. In these cases, the probability is so low that a greater percentage error can be tolerated though actually there is no reason to suspect such increased error.

A more direct comparison between the asymptotic formula and formula (19) is possible, and was used in some cases. The former formula may be written

$$P(>t) = - \frac{a_{n-1}}{n-r_0y} \left( 1 - \frac{u_1}{r_0} + \frac{u_2}{r_0^2} - \dots \dots + (-1)^{n-1} \frac{u_{n-1}}{r_0^{n-1}} \right) e^{-y(r_0-1)} \dots\dots\dots(10)$$

where  $u_r = \sum \lambda_1 \dots \lambda_r$ , the  $\sum$  including all the  ${}_{n-1}C_r$  ways of selecting  $r$   $\lambda$ 's from the  $n-1$ .

$$\text{Now } u_r = (-1)^r \cdot \frac{a_r}{a_{n-1}} \dots\dots\dots(11)^{28}$$

Taking the  $a$ 's to be determined by the "Exponential Holding Times" formula (8), we find the  $u$ 's and hence the absolute value of  $P(>t)$ .

As implied above, the 2nd check on  $P(>t)$  as evaluated by formula (19), is also a check on the asymptotic formula. The results show that the latter becomes accurate for smaller and smaller values of  $t$  as both  $n$  and  $a$  increase.

- Thus for  $n=1, a=0.4$  the formula may be used for  $t > 3$  (approx.).
- $n=1, a=0.8$  the formula may be used for  $t > 2$  (approx.).
- $n=20, a=0.6$  the formula may be used for  $t > 0.5$  (approx.).
- $n=20, a=0.8$  the formula may be used for  $t > 0.25$  (approx.).

This fact is a fortunate one as it means that the asymptotic formula becomes increasingly useful the larger the switch group, and it is large switch groups that probably offer most difficulty by other methods. There is a consideration tending to counterbalance the latter statement. This is the fact that the ratios of successive terms of the coefficients of the  $a$ 's in formula (19) become smaller and smaller for a given occupancy, the larger we make  $n$ .

This ratio for the coefficient of  $a_v$  is readily expressed as

$$\frac{\{y(r+1-\tau)\}^{(T+r+1)n+n-1-v} e^{-y(r+1-\tau)}}{\{(T+r+1)n+n-1-v\}!} \div \frac{\{y(r-\tau)\}^{(T+r)n+n-1-v} e^{-y(r-\tau)}}{\{(T+r)n+n-1-v\}!}$$

where  $t = T + \tau \dots\dots\dots(12)$

By approximating to the factorials by Stirling's formula, we find that the limiting value of this ratio is

$$\left(\frac{y}{n}\right)^n e^{n-y} = (ae^{1-a})^n \dots\dots\dots(13)$$

Now since  $ae^{1-a} < 1$ ,  $a$  being  $< 1$ , the above ratio decreases as  $n$  increases. In other words for a given occupancy, the series of coefficients of  $a_v$  converge more and more rapidly as  $n$  increases. For instance when  $a = 0.8$ , the ratio is 0.6295 for  $n = 20$  and 0.3963 for  $n = 40$ . It seems therefore that for moderately high occupancies the work of evaluating formula (19) for large values of  $n$  will not be excessively tedious. If  $a$  is very near 1, the Erlang asymptotic formula becomes a fair approximation throughout the whole range of  $t$ .

Actually the most difficult cases are those in which  $a$  is large and  $n$  only moderately large. For instance, the author found the cases of  $n = 8$  and

<sup>26</sup> For a derivation of this see for instance an article by Vaultot: Annales des Postes: 1925, Vol. 14, p. 136.

<sup>27</sup> C.D.C. formula (32), p. 50. A table for  $r_0$  is given in Erlang's Rev. Gen. article already cited (p. 278). The quantity is not difficult to compute if this is unavailable.

<sup>28</sup> This follows from C.D.C. formula (16), p. 45.

10,  $\alpha = 0.8$  extremely laborious. For the former, and for other cases when  $n$  is small, he actually returned<sup>29</sup> to the original Erlang formula for  $P(< t)$  where the series involved are terminating ones so that the convergence difficulty does not arise. This formula suffers from the disadvantage previously pointed out, that it consists of the sum of nearly equal quantities of opposite sign, so that much accuracy is lost in the final result. But this is not a fatal objection if it is possible to carry out the earlier stages of the calculation with increased accuracy. And this is possible for a certain range of  $t$ , thanks to some admirably accurate tables, computed by Erlang,<sup>30</sup> giving the Poisson function  $\frac{Y^r}{r!} e^{-Y}$  for negative values of  $Y$ . In the case of  $n = 8$ ,  $\alpha = 0.8$ , the highest value of  $t$  which can be dealt with by the help of these tables is  $t = \frac{5}{8}$ . For this and larger values of  $t$ , the asymptotic formula becomes applicable, so that the complete range of  $t$  can be covered. Of course, the  $a$ 's have to be calculated to a corresponding accuracy, and for this purpose the Exponential Distribution  $a$ 's given by formula (8) are useless. It is therefore necessary to return to some such formula as (16) of the author's previous article. Here again tables of Erlang, appearing in the article just cited, are extremely useful.<sup>31</sup> These give the real and imaginary parts of  $\frac{\lambda_r}{\alpha}$  for occupancies at intervals of 0.1. To make use of them, an alternative method of evaluating the  $a$ 's is found to be preferable to that detailed in the numerical section of the author's previous article.<sup>32</sup>

This introduces the quantities

$$\left. \begin{aligned} H_r &= \lambda_r + \lambda_{n-r} = 2 \frac{R_r}{\alpha} \\ \text{and } K_r &= \lambda_r \cdot \lambda_{n-r} = \frac{R_r^2 + I_r^2}{\alpha^2} \end{aligned} \right\} \dots \dots \dots (14)$$

where  $R_r$  and  $I_r$  are the quantities tabulated by Erlang in his respective tables (14) and (15), and  $r < \frac{n}{2}$ .

When  $n$  is even, we need the additional quantity

$$H_{\frac{n}{2}} = \lambda_{\frac{n}{2}} = \frac{R_{\frac{n}{2}}}{\alpha} \dots \dots \dots (14a)$$

The formulæ being somewhat more complicated when  $n$  is even than when  $n$  is odd, we shall describe the former case, putting  $\frac{n}{2} = n'$ .

Then we have :—

$$\begin{aligned} u_1 &= \sum_{r=1}^{n'} H_r \\ u_2 &= \sum_{r_1, r_2=1}^{n'} H_{r_1} \cdot H_{r_2} + \sum_{r=1}^{n'-1} K_r \end{aligned}$$

and in general

$$\begin{aligned} u_s \leq n^s &= \sum_{r_1, r_2, \dots, r_{s-1}=1}^{n'} H_{r_1} \cdot H_{r_2} \dots H_{r_{s-1}} + \\ &\quad \sum_{\substack{r_1, r_2, \dots, r_{s-2}, \rho=1 \\ r_1, r_2, \dots, r_{s-2}, \rho=1}}^{n'} H_{r_1} \cdot H_{r_2} \dots H_{r_{s-2}} \cdot K_\rho \\ &\quad + \sum_{\substack{r_1, r_2, \dots, r_{s-4}, \rho_1, \rho_2=1 \\ r_1, r_2, \dots, r_{s-4}, \rho_1, \rho_2=1}}^{n'} H_{r_1} \cdot H_{r_2} \dots H_{r_{s-4}} \cdot K_{\rho_1} \cdot K_{\rho_2} + \dots \\ &\quad + \sum_{\substack{\rho_1, \rho_2, \dots, \rho_s=1 \\ \rho_1, \rho_2, \dots, \rho_s=1}}^{n'} K_{\rho_1}, K_{\rho_2} \dots K_{\rho_s}, \text{ when } s \text{ is even} \\ \text{or } &+ \sum_{\substack{r_1, \rho_1, \rho_2, \dots, \rho_{s-1}=1 \\ r_1, \rho_1, \rho_2, \dots, \rho_{s-1}=1}}^{n'} H_{r_1} \cdot K_{\rho_1} \cdot K_{\rho_2} \dots K_{\rho_{s-1}}, \\ &\quad \text{when } s \text{ is odd} \end{aligned} \quad (15)$$

In the  $\Sigma$  terms only distinct combinations of the  $H_r$ 's are to appear in the summations; for instance, of the identical terms  $H_1 H_2$  and  $H_2 H_1$  only one will appear.

When  $n$  is odd, we use  $n' = (n - 1)/2$  as the upper limit in every case. For  $s > n'$ , the modification to the above general form is simply that terms containing more than  $n'$  factors cannot appear. Thus the first  $\Sigma$  and some of the subsequent ones must be omitted.

In the case of  $n = 8$ , the total number of terms requiring evaluation is about 54, excluding the calculation of  $a_{n-1}$  by formula (10) of the author's previous paper.<sup>33</sup> Since this number increases rapidly with  $n$ , we could scarcely deal with larger values of  $n$  by this method.

We find that with a calculating machine and the Erlang tables, we can calculate the  $a$ 's to 7 decimal places, the 7th being slightly doubtful. For  $\alpha = 0.8$ , the worst case  $\tau = \frac{5}{8}$  now leads to a loss of accuracy of 3 significant figures, so that we get  $P(< t)$  to 4 significant figures. A further loss of 1 significant figure is then involved in obtaining  $P(> t)$ . In spite of this, the result agreed with that given by the asymptotic formula, (10) of the present article, to within 0.5%.

In general it may be said that this method is suitable for the case of high occupancies and small values of  $n$ . It should not be used when  $n$  is greater than about 8.

<sup>29</sup> C.D.C. formula (17), p. 45. Note that there should be a bar over the T-w in the factorial in the denominator.

<sup>30</sup> Annales des Postes Telegraphes and Telephones. July, 1925. Table 13 (a, b, c and d).

<sup>31</sup> A.P.T.T., July, 1925. Tables 14 and 15.

<sup>32</sup> C.D.C. Formula (27), p. 48.

<sup>33</sup> C.D.C., p. 44.

APPENDIX I.

DERIVATION OF FORMULA (5) FOR LOG (P(=0)).<sup>34</sup>

In formula (10) of the author's previous article it was established that

$$P(=0) = \frac{n-y}{(1-\lambda_1) \dots (1-\lambda_{n-1})} \dots \dots \dots (16)$$

where  $\lambda_1, \dots, \lambda_{n-1}$  are the  $n-1$  roots of  $1-z^n e^{y(1-z)}$  whose moduli  $< 1$ .

This is the starting point of the present investigation.

We have immediately

$$\log [P(=0)] = \log (n-y) - \sum_{r=1}^{n-1} \log (1-\lambda_r) \dots (17)$$

The sigma term on the right hand side suggests the use of Cauchy's Integral<sup>35</sup> which states that

$$\frac{1}{2\pi i} \int_C f(z) \cdot \frac{\phi'(z)}{\phi(z)} \cdot dz = \sum r_1 \cdot f(a_1) - \sum s_1 \cdot f(b_1),$$

where  $f(z)$  is analytic on and inside  $C$  and so is  $\phi(z)$  except at the poles at a finite number of points  $b_1, \dots$  of respective multiplicity  $s_1, \dots$ . The zeros of  $\phi$  are at  $a_1, \dots$  of respective multiplicity  $r_2, \dots$ .

Taking

$$\phi(z) = 1 - \frac{e^{y(z-1)}}{z^n} = - \frac{e^{y(z-1)}}{z^n} [1 - z^n \cdot e^{y(1-z)}],$$

we note that  $z = \lambda_1, \dots, \lambda_{n-1}$  each gives us a zero of multiplicity 1, while  $z = 0$  gives us a pole of multiplicity  $n$ .

Hence

$$\begin{aligned} \frac{1}{2\pi i} \int_C \log (z-1) \frac{\phi'}{\phi} dz &= \sum_{r=1}^{n-1} \log (\lambda_r - 1) - n \log (-1) \\ &= (n-1)\pi i + \sum_{r=1}^{n-1} \log (1-\lambda_r) - n\pi i \\ &= -\pi i + \sum_{r=1}^{n-1} \log (1-\lambda_r) \dots \dots (18) \end{aligned}$$

where  $C$  is the complete contour shown in the figure, which excludes the singularity at  $z = 1$ , and also the external zeros of  $\phi(z)$  (at  $r_n$  etc.). The small curve round the point 1 is a circle, radius  $\rho \rightarrow 0$ .

To simplify  $\int_C \log (z-1) \frac{\phi'}{\phi} dz$ , we split it into two parts :

- (i) The integral along the large curve  $\Gamma$  surrounding the point 1.
- (ii) The integral along the straight portions length  $R - \rho$ , and the small circle.

For (i) we integrate by parts, obtaining :

$$\begin{aligned} \frac{1}{2\pi i} \int_{\Gamma} \log (z-1) \cdot \frac{\phi'}{\phi} dz &= \\ \frac{1}{2\pi i} [\log (z-1) \cdot \log \{\phi(z)\}]_{\Gamma} &- \frac{1}{2\pi i} \int_{\Gamma} \frac{\log \phi}{z-1} \cdot dz \end{aligned}$$

The square brackets of the 1st term on the left hand side indicate that the values of the expression within have to be taken at the extremities of  $\Gamma$ , that at  $\arg z = 0$  being subtracted from that at  $\arg z = 2\pi$ .

Now on  $\Gamma$ ,  $z = re^{i\theta}$  where  $r > 1$  :

$$\begin{aligned} \text{So } \log (z-1) &= \log [(r \cos \theta - 1) + i r \sin \theta] \\ &= \log (r^2 - 2r \cos \theta + 1) \\ &\quad + i \tan^{-1} \frac{r \sin \theta}{r \cos \theta - 1} \end{aligned}$$

At  $\theta = 0$ ,  $r \cos \theta > 1$  and we can take  $\arg [\log (z-1)] = +0$

At  $\theta = \text{some value } \theta_0$ ,  $r \cos \theta_0 = 1$  and  $\arg [\log (z-1)] = \frac{\pi}{2}$

As  $\theta$  increases from  $\theta_0$  to  $\pi$ ,  $r \cos \theta - 1$  is  $-$ , and  $\arg [\log (z-1)]$  increases from  $\frac{\pi}{2}$  to  $\pi$ .

For  $\theta > \pi$ , the expression under the  $\tan^{-1}$  becomes  $+$  again, and  $\arg [\log (z-1)]$  still increases.

Next at  $\theta = \theta_0^1 < 2\pi$ , we again have  $r \cos \theta_0^1 = 1$  and  $\arg [\log (z-1)] = \frac{3\pi}{2}$

When  $\theta > \theta_0^1$ , the expression under the  $\tan^{-1}$  becomes  $-$  again, and  $\arg [\log (z-1)]$  still increases.

Finally at  $\theta = 2\pi$ , we have  $\arg [\log (z-1)] = 2\pi$ .

We next treat  $\log \phi(z)$  in a similar way.

$$\begin{aligned} \text{We have } \log \phi(z) &= \log \left[ 1 - \frac{1}{z^n} \cdot e^{y(z-1)} \right] \\ &= \log (1 - re^{i\theta}) \text{ where } r < 1 \\ &= \frac{1}{2} \log (1 - 2r \cos \theta + r^2) \\ &\quad - i \tan^{-1} \frac{r \sin \theta}{1 - r \cos \theta} \end{aligned}$$

This time there can never be an infinity in the expression under the  $\tan^{-1}$ , for  $1 > r \cos \theta$ . So  $\arg [\log \phi(z)]$  returns to its initial value 0 as  $\theta$  changes from 0 to  $2\pi$  round  $\Gamma$ .

Altogether then  $[\log (z-1) \cdot \log \phi(z)]_{\Gamma} = 2\pi i \log \phi(1+R)$  and  $\frac{1}{2\pi i} \int_{\Gamma} \log (z-1) \frac{\phi'}{\phi} dz = \log \phi(1+R)$

$$- \frac{1}{2\pi i} \int_{\Gamma} \frac{\log \phi}{z-1} dz$$

(ii) We next consider the integrals along the straight portions and the small circle.

Taking the two straight pieces together, we have

$$\int \log (z-1) \frac{\phi'}{\phi} dz = \int_{1+\rho}^{1+R} -2\pi i \frac{\phi'}{\phi} dz$$

(for only the imaginary part of  $\log (z-1)$  does not cancel out)

<sup>34</sup> For the method of this and the subsequent Appendix, the author is again indebted to D. P. Dalzell.

<sup>35</sup> Whittaker and Watson, Modern Analysis, 6.3, p. 119. The integral is easily deduced from the fundamental residue theorem.

$$\begin{aligned}
 &= -2\pi i [\log \phi]_{\rho+1}^{R+1} \\
 &= -2\pi i [\log \phi(1+R) - \log \phi(1+\rho)] \\
 \text{On the small circle, } z &= 1 + \rho e^{i\theta} \\
 \text{Also } \phi &\rightarrow -\frac{(z-1)e^{y(z-1)}}{z^n} \left( y - \frac{n}{z} \right) \\
 &\quad \rightarrow (n-y)(z-1) \\
 \text{So } \frac{\phi'}{\phi} &\rightarrow \frac{1}{z-1} = \frac{1}{\rho} e^{-i\theta} \text{ and } dz = i\rho e^{i\theta} \cdot d\theta \\
 \text{So } \int \log(z-1) \frac{\phi'}{\phi} dz &\text{ along small circle} \\
 &= \int_{-\pi}^{\pi} (\log \rho + i\theta) id\theta [1 + o(\rho)] \\
 &= 2\pi^2 - 2\pi i \log \rho, \text{ for } \rho \log \rho \rightarrow 0 \text{ as } \rho \rightarrow 0. \\
 &= 2\pi^2 - 2\pi i [\log \phi(1+\rho) - \log(n-y)], \\
 &\quad \text{for } \log \phi(1+\rho) \rightarrow \log(n-y)(z-1)_{z=0} \\
 &\quad = \log(n-y) + \log \rho
 \end{aligned}$$

Combining the results of (i) and (ii) we have :-

$$\begin{aligned}
 \frac{1}{2\pi i} \int_C \log(z-1) \frac{\phi'}{\phi} \cdot dz \\
 &= -\frac{1}{2\pi i} \int_{\Gamma} \frac{\log \phi}{z-1} dz - \pi i + \log(n-y)
 \end{aligned}$$

and from (17) and (18)

$$\log [P(=0)] = \frac{1}{2\pi i} \int_{\Gamma} \frac{\log \phi}{z-1} \cdot dz \dots \dots \dots (19)$$

Pollaczek gives the form (19).<sup>36</sup>

$$\text{Now } \log \phi = \log \left( 1 - \frac{e^{y(z-1)}}{z^n} \right) = - \sum_{v=1}^{\infty} \frac{e^{vy(z-1)}}{z^{vn}}$$

For on  $\Gamma$   $\frac{e^{y(z-1)}}{z^n} < 1$ , justifying the expansion.

$$\begin{aligned}
 \text{So } \log [P(=0)] &= -\frac{1}{2\pi i} \int_{\Gamma} \frac{dz}{z-1} \cdot \sum_{v=1}^{\infty} \frac{e^{vy(z-1)}}{z^{vn}} \\
 &= - \sum_{v=1}^{\infty} \frac{1}{v} \cdot \frac{1}{2\pi i} \int_{\Gamma} \frac{e^{vy(z-1)}}{z^{vn}} \cdot \frac{dz}{z-1}
 \end{aligned}$$

We integrate term by term. For the  $v^{\text{th}}$  term we have to consider a pole of the 1st order at  $z=1$  and one of the  $vn^{\text{th}}$  order at  $z=0$ . To obtain the latter,

we expand  $\frac{1}{z-1}$  as  $-\sum_{\mu=0}^{\infty} z^{\mu}$  and take the coefficient of  $z^{n-1}$  in  $\frac{e^{vy(z-1)}}{z-1}$ .

Hence altogether

$$\begin{aligned}
 \log [P(=0)] &= - \sum_{v=1}^{\infty} \frac{1}{v} \left[ 1 - \sum_{\mu=0}^{\mu=vn-1} \frac{(vy)^{\mu}}{\mu!} e^{-vy} \right] \\
 &= - \sum_{v=1}^{\infty} \frac{1}{v} \sum_{\mu=vn}^{\infty} \frac{(vy)^{\mu}}{\mu!} e^{-vy}
 \end{aligned}$$

which is formula (5).

<sup>36</sup> E.N.T.I. Formula (1). The subsequent reduction follows Pollaczek's method, op. cit. p. 259.

APPENDIX 2.

DERIVATION OF FORMULA (6) FOR THE AVERAGE DELAY M.

In this case we start from formula (23) of the previous article, viz. :-

$$M = \frac{1}{y} \sum_{r=1}^{n-1} \frac{1}{1-\lambda_r} + \frac{y^2 - n^2 + n}{2y(n-y)} \dots \dots \dots (20)$$

The first term suggests the use of  $\int_{\Gamma} \frac{1}{z-1} \cdot \frac{\phi'}{\phi} \cdot dz$

where  $\phi$  has the same meaning as in Appendix 1, and thus has zeros at  $\lambda_1 \dots \lambda_{n-1}, 1$ ; and  $\Gamma$  is as in the previous figure without the indentation, i.e., is closed at  $z=1+R$ .

At  $z=\lambda_r$  we have  $\phi \rightarrow (z-\lambda_r)\phi'$

$$\therefore \frac{1}{z-1} \cdot \frac{\phi'}{\phi} = \frac{1}{\lambda_r-1} \cdot \frac{1}{z-\lambda_r}$$

The residue at this pole is therefore  $-\frac{1}{1-\lambda_r}$

The pole at  $z=1$  gives some trouble as it is of the 2<sup>nd</sup> order. By expanding in powers of  $z-1$  and neglecting  $o(z-1)^3$  we find

$$\frac{\phi'}{\phi} \rightarrow \frac{1}{z-1} - \frac{1}{2(n-y)} \{ (n-y)^2 + n \}$$

So the residue of  $\frac{1}{z-1} \frac{\phi'}{\phi}$  at  $z=1$  is  $-\frac{\{ (n-y)^2 + n \}}{2(n-y)}$

At  $z=0$ ,  $\frac{\phi'}{\phi} = \frac{yz-n}{z[1-z^n e^{y(1-z)}]} \rightarrow -\frac{n}{z}$

So residue of  $\frac{\phi'}{\phi} \cdot \frac{1}{z-1} = +n$ .

Altogether then

$$\frac{1}{2\pi i} \int_{\Gamma} \frac{1}{z-1} \frac{\phi'}{\phi} \cdot dz = - \sum_{r=1}^{n-1} \frac{1}{1-\lambda_r} - \frac{(n-y)^2 + n}{2(n-y)} + n$$

And from (21)

$$\begin{aligned}
 M &= \frac{1}{2\pi i} \int_{\Gamma} \frac{1}{z-1} \frac{\phi'}{\phi} \cdot dz \\
 &= -\frac{1}{2\pi i y} \int_{\Gamma} \frac{\log \phi}{(z-1)^2} dz \dots \dots \dots (21)^{37}
 \end{aligned}$$

It will be noted that in this case we dispense with the indentation used in Appendix 1, the reason being that  $z=1$  is here merely a pole of the 2<sup>nd</sup> order and not an essential singularity.

The reduction of (21) to the series formula (6) proceeds on similar lines to the method given in Appendix 1 for obtaining (5) from (19). The details need not be given here.

<sup>37</sup> Pollaczek's E.N.T.I. Formula (2).



# Automatic Chart Analyser

E. A. SPEIGHT, Ph.D., A.R.C.S., B.Sc., and H. J. JOSEPHS.

THE automatic chart analyser described below has been designed and constructed in the Research Section to obtain a rapid analysis of records of the operation of apparatus in connexion with trunking investigations.

The records are made by pens which draw lines on a paper chart, operation of the apparatus being indicated by interruptions of the lines, and the times of operation by the lengths of the interruptions.

In the analyser, a spot of light is focussed on the line record and the variation in the amount of light reflected from the surface of the paper at any interruption of the line is utilized to operate a photo-electric cell which, in turn, actuates the counting and integrating apparatus associated with it.

The analyser consists of three main portions, viz., the winding gear, the optical system, and the electrical circuit. These can with advantage be discussed separately.

The winding gear is designed to draw the chart to be analysed past the optical system at a suitable constant speed. For this purpose, a pair of sprocket wheels (A), see Fig. 1, mounted on one shaft is employed, the pegs on which engage with holes punched in the edge of the chart. Curved guides (B) are provided to maintain the paper in close

contact with the cylindrical surfaces of these wheels and prevent slipping. (The distance between the sprocket wheels is adjustable in order to accommodate different widths of paper.) The sprocket shaft is driven from a small gramophone motor (C), see Fig. 2, of the induction type *via* a spring-operated dog-clutch and reduction gearing (D). An adjustable centrifugal governor, integral with the motor, maintains the speed of the latter constant. Setting of the motor speed to its correct value is facilitated by the use of a stroboscopic disc (E) viewed by the light of a neon lamp (F) fed from the 50-cycle alternating current mains from which the whole apparatus is operated. Alternative sets of inter-changeable gears permit the chart to be passed through the analyser at speeds of 6", 2" or 1" per second. In operation, the spool (G) of chart to be analysed is supported in a bearing bracket at the extreme right-hand end of the apparatus, see Fig. 3. Its path thence is across the top of the cabinet containing the amplifying apparatus,<sup>1</sup> below the optical system (H), over the sprocket wheels and on to a take-up spool (I) driven by means of a spring belt

<sup>1</sup> This permits the operator to prevent the analyser functioning on any false operations shown on the record.

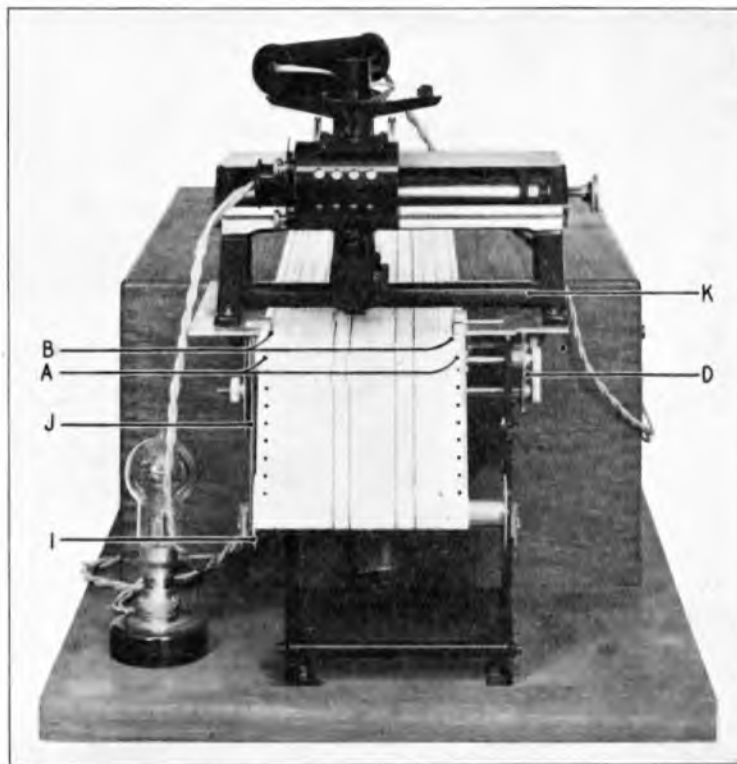

FIG. 1.—LEFT-HAND END OF CHART ANALYSER.

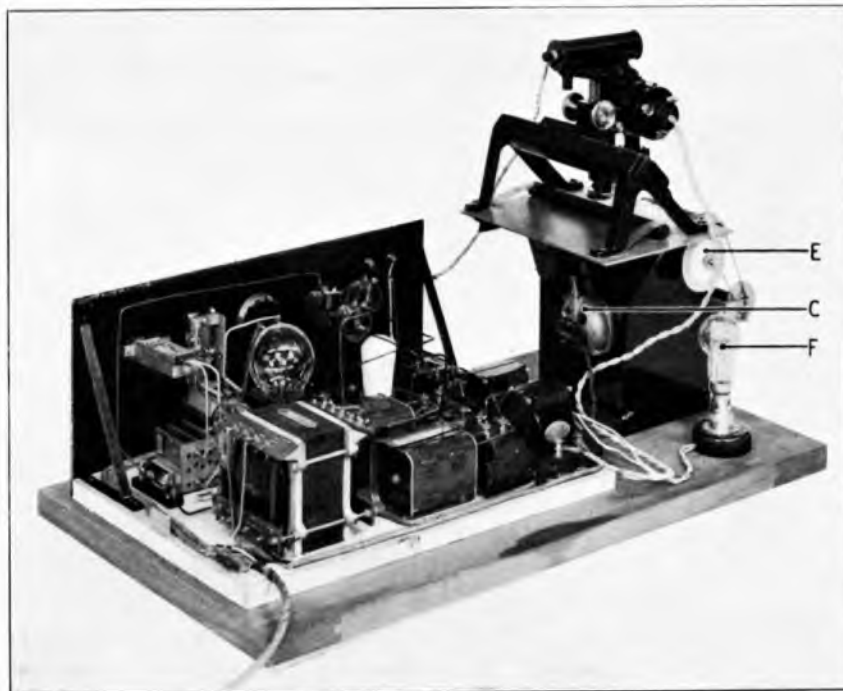

FIG. 2.—CHART ANALYSER.

(J) from a pulley integral with one of the sprockets. A polished ebonite rod (K) rests on the chart immediately before it passes under the optical system, keeping it flat on the plate carrying the latter and ensuring accuracy of focus.

The complete optical system including lamp-housing (L), lens-system (M) and photocell tube (N) is carried on a saddle moving on a vee slide (O) transversely to the chart. Coarse and fine traversing adjustments are provided in order to locate the system accurately over the record to be analysed.

The source of light used is a 60-watt automobile-headlamp-type bulb running on 12 volts A.C. Adjustments are provided to permit placing the filament at the centre of curvature of, and at right angles to, the axis of a small spherical mirror which increases the useful illumination. By means of a lens system, the light is concentrated into a "vertical illuminator" and thence by means of a large aperture microscope objective to form a real image of the filament in the plane of the paper. A cylindrical lens preceding the vertical illuminator elongates this to form a uniform band of light, about 2 mm.  $\times$  0.3 mm., transversely to the line of the record. A secondary image of the small portion of the chart so illuminated is formed, by means of the same objective lens, on the cathode of a gas-filled caesium photocell contained in a light-tight tubular holder mounted on top of, and at right angles to, the microscope body. The photocell holder can be swung in a horizontal plane to bring

a ground glass screen vertically over the microscope body for focussing the images.

The amplifying equipment is entirely mains-operated using indirectly-heated valves, the various high-tension supplies being obtained from two metal rectifiers in a half-wave rectifying circuit, see Fig. 4. A two-section choke-condenser filter smooths the H.T. current to the first valve whilst the supply to the photocell (Osram type CMG8) is smoothed by a two-section resistance-condenser filter which also smooths the grid bias supply for the first valve. Coarse and fine adjustment (the latter has been added subsequently to taking the photographs) are provided for the standing bias in the condition of no illumination of the photocell. The photo-electric current passed through a 5 megohm grid leak controls the effective bias under working conditions. The valve used (Mazda type AC2,HL,  $\mu = 6.5$ ) is worked on the linear portion of its characteristic. By means of a resistance in the anode circuit of this valve, variations in photocell output control the effective bias on the grid of a gas-filled relay (Osram type G.T.r). The overall sensitivity of the amplifier is controlled by means of a sliding contact on this coupling resistance, the control being mechanically coupled to a variable potentiometer by means of which the standing grid bias on the gas-filled relay is kept constant in spite of sensitivity variations. The main coupling resistance is shunted by a condenser to minimize spasmodic operation of the

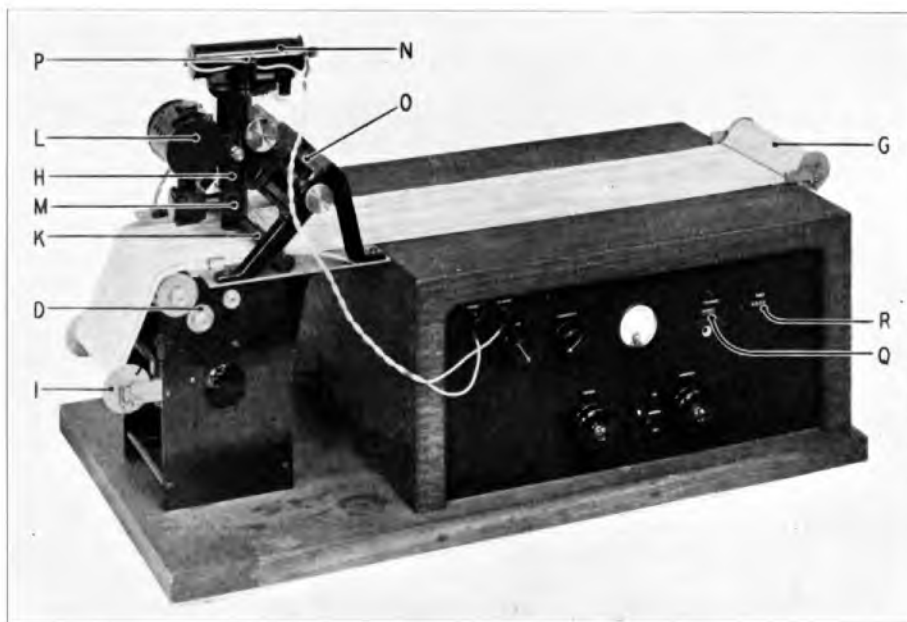

FIG. 3.—CHART ANALYSER; SIDE VIEW.

counting mechanism due to random fluctuations in illumination.

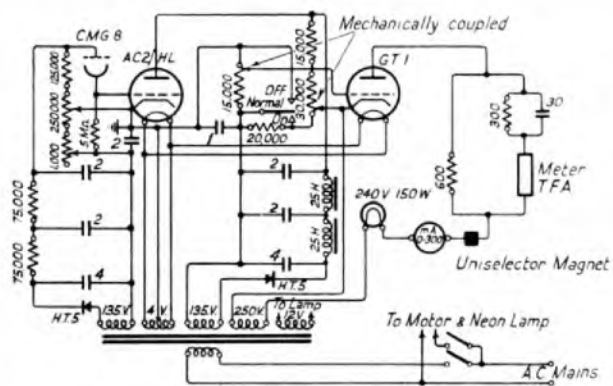

FIG. 4.—CONNEXIONS OF CHART ANALYSER.

The anode circuit of the gas-filled relay, which is fed with alternating current, contains a gas-filled lamp (as stabilizing resistance), a milliammeter and the integrating and counting mechanisms. The integrator consists of a standard uniselector, with contact bank removed. On the main spindle, carrying the 50-tooth ratchet wheel is a small drum engraved 0, 1, 2 - - - - 9 and a striking arm which operates a revolution counter (Q). In view of the rectifying action of the gas-filled relay, when the latter discharges, 50 unidirectional impulses are passed through the anode circuit thereby causing

rotation of the uniselector spindle at the rate of one revolution per second.

The counter is a standard telephone subscriber's meter (R) shunted to reduce the operating current to a suitable value and fed *via* a resistance condenser impulsing circuit to ensure operation on the shorter " off-normal " periods of the record. The circuit constants are chosen to produce operation for impulses of 30 milliseconds or longer. The condenser shunting the coupling (valve to relay) resistance prevents operation for impulses of shorter duration and the mechanical inertia of the meter is sufficient to eliminate any tendency to follow the 50-cycle impulses.

The actual operation of the device is as follows. When a break in the normal line of the record appears under the scanning spot, the photocell is subjected to increased illumination. The increased photo-electric current reduces the bias on the first valve and therefore on the gas-filled relay. The latter therefore discharges until such time as the illumination on the photocell is again reduced by the reappearance of the normal line under the scanning spot. During this period the integrator rotates, thus finally indicating the total length of time taken by the " off-normal " parts of the record to pass the scanning spot, whilst, as above explained, the counter merely indicates the number of such periods. The average duration of an " off-normal " period, and therefore of a single operation of the device under examination, is obtained by simple arithmetic. The complete analysis of one chart (60 feet long) can be made in a few hours as opposed to two or three days by manual analysis.

## Subscribers' Group Service.

H. O. ELLIS AND B. WINCH.

PROBABLY one of the greatest difficulties experienced by sales officers in canvassing for subscribers is to convince the potential subscriber that the benefits conferred by his use of a telephone line will justify the rental of a direct line. The use of party lines in which a number of subscribers share line plant has been adopted, with certain restrictions regarding the relative geographical position of subscriber and exchange, for many years and has enabled a rental less than that of a direct exchange line to be offered to subscribers.

For party line working the subscribers' lines are teed across the exchange pair; hence, no secrecy is given. In addition, code ringing is employed. The disabilities of the arrangement from the service point of view have been elaborated in the article on Country Satellite Exchanges in the *P.O.E.E. Journal* for July, 1933.

To overcome the disabilities of code ringing many schemes have, from time to time, been evolved necessitating various types of special apparatus such as frequency generators and ringers at the Exchange or subscribers' premises.

A scheme providing a service at a rental considerably lower than that of a direct line but without the disabilities of the old Party line arrangement has been developed by the Department's engineers and will shortly be introduced to the public.

With the new scheme the subscribers are arranged in groups, as shown in Fig 1; hence, the

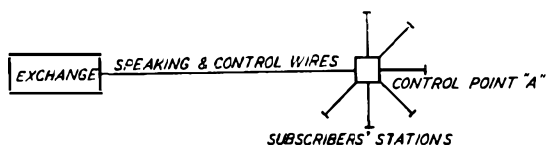

FIG. 1.—GROUP SERVICE.

scheme is known as "Subscribers' Group Service." The lines from the main exchange terminate on a small relay-set, situated at a point "A" which is the centre for a group of subscribers. Each subscriber is provided with a pair of wires to this relay-set. Line economics indicate that the subscriber's spurs should not exceed one tenth of a mile, and this limit has therefore been adopted. The operations of all the relays in the relay-set at the control point A are controlled over the exchange pairs, so that no provision has to be made for a battery at this point. This fact enables the relay-set, which is of small dimensions, to be contained in a weather-proof box capable of being mounted on a telegraph pole or in a street pillar.

Each subscriber is given an individual number which may be any number in the Exchange numbering scheme. For the purpose of catering for originating traffic in the C.B. case, one calling lamp

and answering jack common to all subscribers in a group is provided, whilst for automatic working, one subscriber's line circuit supplies the necessary outlet.

It will perhaps be of interest briefly to describe the operation of the circuits for the main Automatic and Manual cases.

### Manual Exchanges.

For Manual Exchanges, the Central Battery Exchange case is taken as typical, and is shown in Figs. 2 and 3. It will be observed from Fig. 3, that when the control point relays are normal, all the subscribers in the group are connected in parallel to the exchange speaking wires. When a subscriber removes his receiver, relay L operates *via* this subscriber's loop, and lights the calling lamp. Relays G and GG are also operated to provide engaged test on all multiple numbers in the group. When the operator answers, relay CO is operated from the sleeve of the plug and operates relay CR which disconnects the L relay and earth from the B- and A-wires respectively, and at the same time maintains relays G and GG operated. The operator ascertains the calling subscriber's requirements and also his own number, say 1471. She then inserts the answering plug of a second pair of cords into the multiple jack of the calling subscriber, disregarding the engaged test, and removes the first plug from the common answering jack. The removal of this plug releases relay CO, which allows relays G and GG to release. It will be seen that when G1 makes on release, a circuit for KA is completed from battery on the sleeve of the plug. KA operates to re-apply earth to relays G, GG, and CR. The former two relays again apply engaged test to the multiples. Relay CR is designed to hold, in virtue of its slow-release slug, during this cycle of operation, so preventing relay L from re-operating and causing the re-operation of relays G and GG before relay KA has had time to operate.

Relay KA also applies negative potential to the C controlling wire, and in virtue of the metal rectifiers at the control point (Fig. 3) relay A operates. The contacts of this relay are so arranged that all subscribers, other than subscriber 1471, are disconnected from the speaking circuit, so that secrecy is assured to the calling subscriber.

The operator completes the call to the required number in the usual manner. As the calling subscriber is now directly connected to the cord circuit just as in the case of a direct exchange line subscriber, normal cord circuit supervision is obtained.

On a call incoming to, say, subscriber 9321, the operator completes by inserting a calling plug in the multiple of this number, after making the usual engaged test. Relay KE operates, followed by relays CR, G, and GG. Engaged test is thus im-

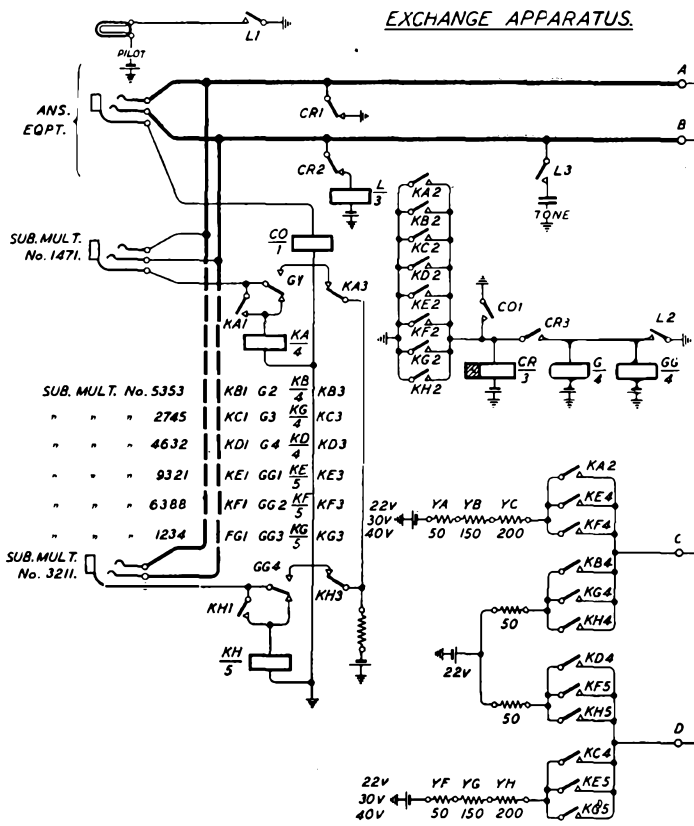

FIG. 2.—C.B. MANUAL EXCHANGE; CONTROL UNIT.

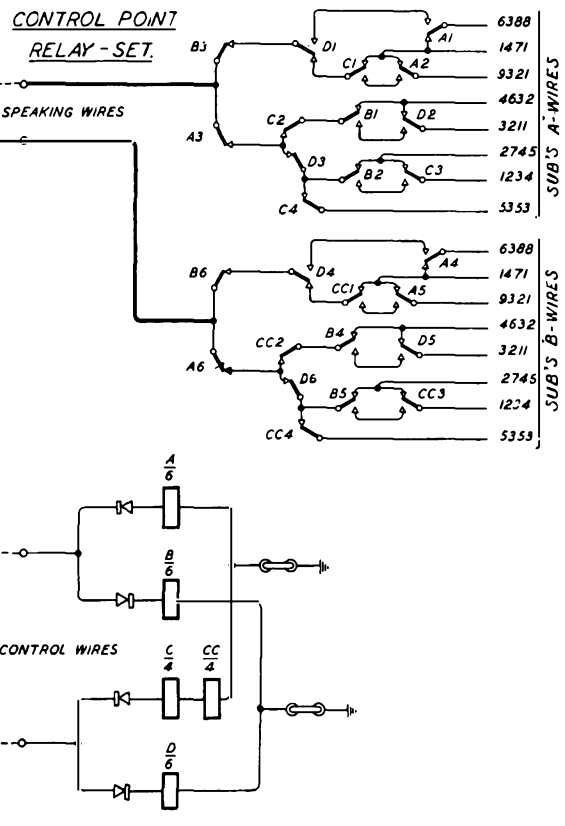

FIG. 3.—C.B. MANUAL EXCHANGE; CONTROL POINT RELAY-SET.

mediately applied to the remaining multiple jacks in the group. Contacts KE 4 and 5 connect negative potential from the normal exchange battery to the C and D wires and relays A, C and CC are operated at the control point. This action disconnects all subscribers, other than 9321, from the speaking pair. When the ringing key is thrown, therefore, ringing current is directed only to the bell of subscriber 9321 and normal supervision obtains from this subscriber's gravity switch.

On either incoming or outgoing calls, the relays at both exchange and control points return to normal when the operator withdraws her plug from the multiple jack.

*Automatic Exchanges.*

The design involved in the case of Automatic Exchanges is necessarily more complicated than that of the Manual counterpart, as no operator's service is involved in controlling the Control Point equipment and also automatic meter discrimination is necessary.

As in the Manual case, the subscribers' numbers may be anywhere in the Exchange numbering scheme. The P-wire connexion to each of these multiple numbers is associated with discriminatory control relays. As a higher voltage than in the Manual case is available, it is possible to arrange for six of these relays to control the eight discriminations. Thus relays KA and KG serve three subscribers. The restriction of the maximum contact

units which can be accommodated on relays precludes the extension of this principle to the control of more than three discriminations by two relays.

The diagram shown in Figs. 4 and 5 illustrates the circuit suitable for use in Director Exchanges equipped for multi-meeting. As a battery of 50 volts is used at Automatic Exchanges, and to simplify the circuit conditions to give meter discrimination, marginal relays are used at the control point for selecting the required subscriber.

As may be expected, the circuits function rather differently in respect of incoming and outgoing calls, and the operations involved in switching through to a line circuit of subscriber 4632 will be taken as typical.

When the subscriber removes his receiver, a circuit is completed from earth at the control point, coil of relay DD, subscriber's spur and telephone, DD2, CN1, HH3, etc., to battery via relay L on the negative wire, Fig. 4. Relay L operates, and operates relays G and GG which apply engaged conditions to the P-wires of all multiples in the group. Contact L2 operates relay B which, at B1, completes the circuit prepared by L1 to the line relay of the common subscriber's line circuit.

Relay DD, Fig. 5, commences to operate in series with relay L and on the closure of contact 4 completes its operation from battery via relays P and Q. Relay DD, at DD3, disconnects the negative wire from all subscribers' spurs and, at DD2, connects the negative spur of subscriber 4362 to the

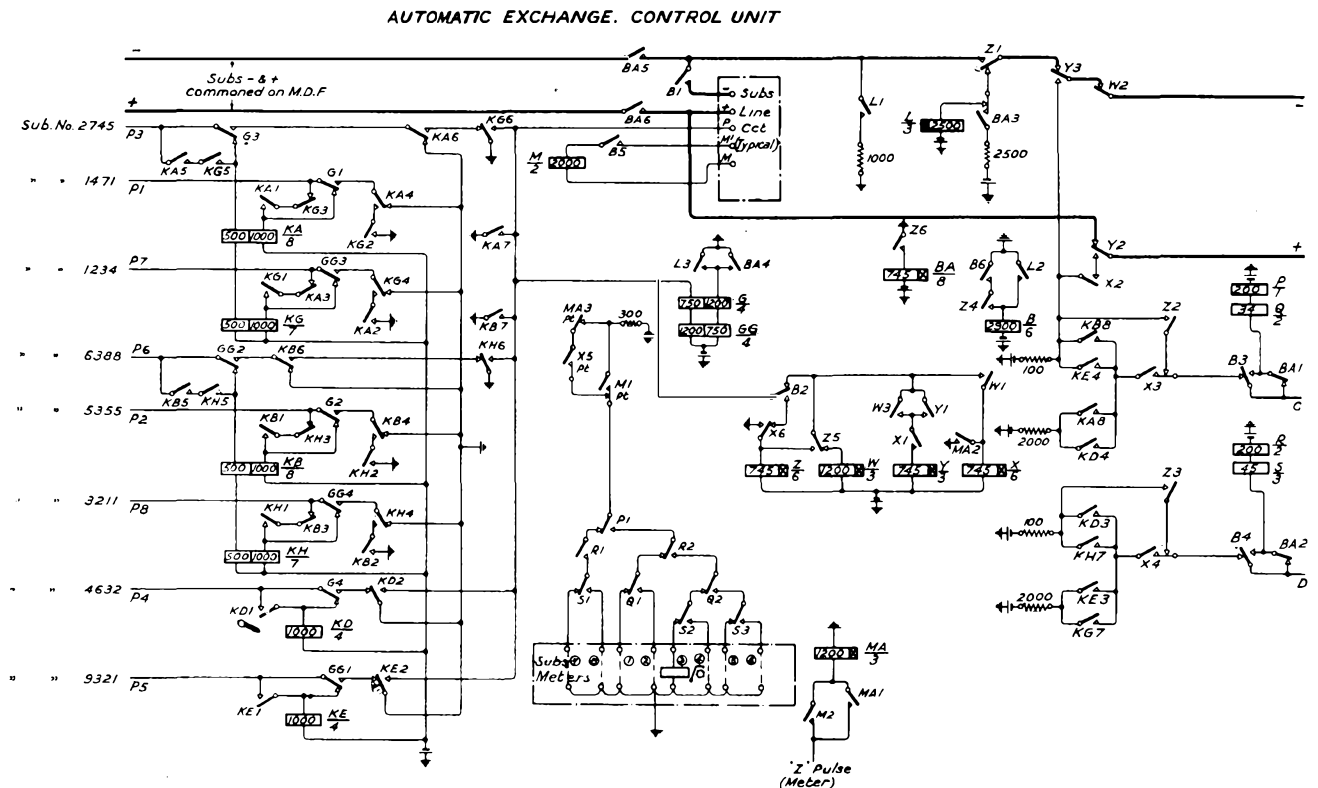

FIG. 4.—AUTOMATIC EXCHANGE; CONTROL UNIT.

negative wire, and, at DD5, disconnects relay CN from the positive wire. The resistance of the second coil of relay DD is of such a value as to operate only relay P at the Exchange end of the C wire, while the resistance earth applied to the D wire *via* contact DD6 operates both relays R and S. The contacts of relays P, R, and S are arranged so that the simultaneous operation of the three relays connects the meter associated with subscriber 4632 to the metering circuit.

Meanwhile, the completion of the earth connexion to the negative wire of the subscriber's common line circuit *via* B and L operated, results in the seizing of a first selector and consequently the return of earth on the P-wire. This earth operates relay Z *via* B2 which, at contact Z1, disconnects relay L and switches the negative of the speaking loop through to the line circuit. It will be noticed that relays G and GG are maintained by the earth on the P-wire. Contact Z4 takes over the control of relay B, after the release of L2. Contact Z6 operates relay BA, the function of which will presently be considered.

The subscriber receives dialling tone from the 1st selector and dials the required number in the usual manner.

When metering conditions are returned from the 1st code selector, relay M responds to meter pulses from the Exchange meter pulse machine. Relay MA is operated *via* M2 to the Z pulse from the pulse machine and is held operated for the duration of this pulse, *via* its own contact. Contact MA2 operates relay X which, at X6, maintains the circuit for relay Z.

The calling subscriber's meter is operated by the closure of contact M1, the number of operations being determined by the fec value of the call as interpreted by the 1st code selector. Upon completion of the metering cycle, relay M is released, and MA releases when the Z pulse terminates. Contact MA3, on release, re-connects a circuit for the subscriber's meter *via* X5, while contact MA2 releases X. Thus, during the release lag of relay X, the meter is re-operated and an extra unit is recorded on any type of metered call.

Normal calling subscriber's gravity switch control of the connexion is retained, and when the receiver is replaced the train of switches is released, and the earth is removed from the P-wire, thus releasing relay Z. Relay Z, at contacts 2 and 3, disconnects the C and D wires, so releasing relays DD at the control point, and P, R, and S at the Exchange end. Contact Z4 on release, releases relay B, and at Z6 releases BA. The G and GG relays maintain engaged conditions on the multiples until BA has released. On the release of Z1 contact BA3 applies battery to the negative wire to charge the subscriber's condensers, so that, on BA3 releasing to re-apply relay L to the line, the latter relay is not flicked up by any condenser surge.

Incoming calls to the group are routed over ordinary final selectors, which test the multiple of the called line in the usual way. Thus, a final selector testing to multiple No. 2745 would, providing no other subscriber in a group was engaged on a call, switch in to the coils of relays KA and KG in series, and both these relays operate. Contacts KA5 and

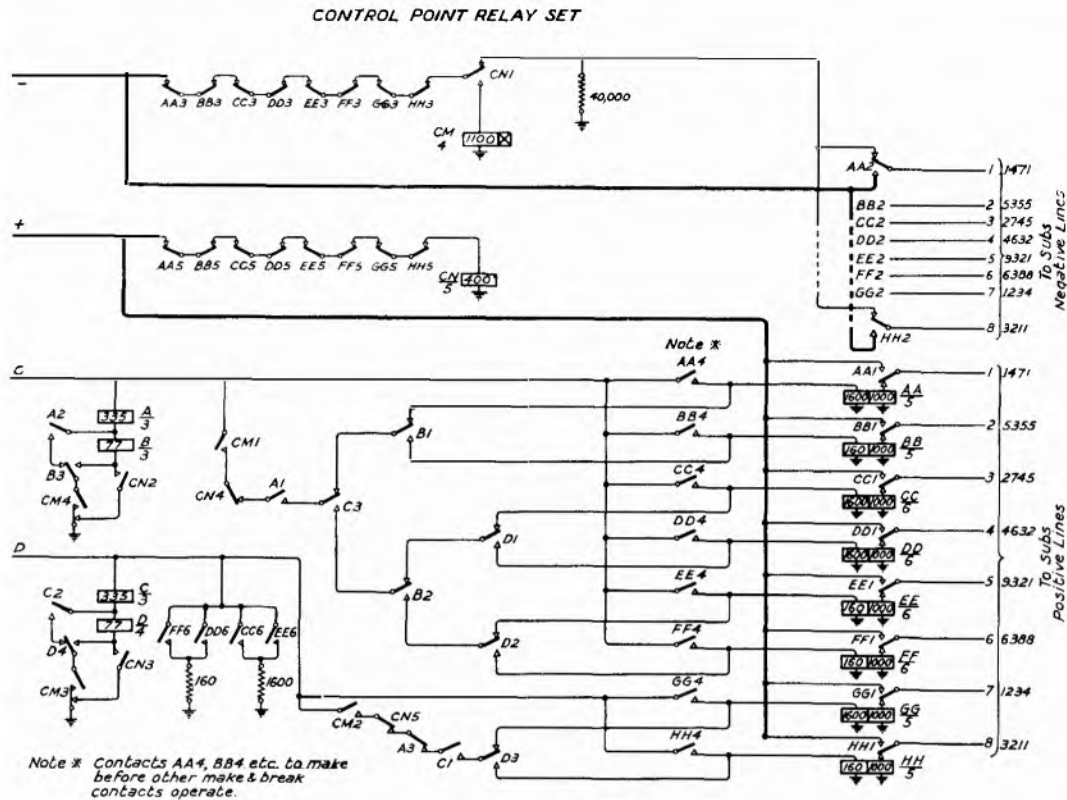

FIG. 5.—AUTOMATIC EXCHANGE; CONTROL POINT RELAY-SET.

KG5 provide a locking circuit for their parent relays under control of the H relay of the final selector which has seized the line. Relays G and GG are operated by KG6, and apply earth to the remaining private wires associated with the group. The operation of KG6 and KA7 in parallel with it, also operates the K relay in the line circuit, and completes a circuit for the group of relays W, X, Y, and Z.

Relay W operates relay X which completes a circuit for both Y and Z. The operation of Z5 releases relay W, which, in turn, after a delay period, releases relay X; contact X1, on release, releases relay Y. During this cycle of operations, conditions are applied to the wires which effect the selection of the calling party. Thus, during the releasing lag of relay W, with X and Y operated, battery is applied to the positive wire to operate relay CN, Fig. 5, which at contacts 2 and 3 completes circuits to the discriminating relays. As subscriber 2745 is being called and KG and KA are operated, a 2,000-ohm battery is applied to the C and D wires via contacts X3 and X4. These high resistance batteries operate only relays A and C, which at A1 and C3 prepare an operating circuit for relay CC. Contacts A2 and C2 prepare alternative circuits for relays A and C, such that when CM operates, relays B and D are disconnected.

When the W relay releases, and during the releasing lag of relay X, relay CM is operated on the negative wire via CN1 contact. The function of contacts CM3 and 4 is to prevent the operation of

any other discriminating relays when a low resistance battery is applied at a later stage to the C and D wires. When relay X has released, and during the release lag of relay Y, battery is disconnected from the positive wire and relay CN releases. At CN1 the circuit of relay CM is disconnected, but this relay, in virtue of its slug, remains operated for a short period during which a circuit is completed from the low resistance battery applied to the C wire on the release of X3, via contact CM1 operated, CN4 normal, A1, C3 operated, B2, D1, to relay CC, which operates and holds at CC4. On the release of CM, the discriminating relays and the operating circuit for relay CC are disconnected, but the latter relay is maintained via its own contact, CC4. The selection and operation of relay CC connects the spur of subscriber 2745 to the positive and negative wires while disconnecting the remaining subscribers.

The negative and positive wires are connected through to the final selector multiple when relay Y releases, since relay BA is operated by contact Z6.

On the release of the connexion by the calling subscriber relays KG and KA release, thus releasing relay Z and the K relay in the line circuit. The release of relay Z disconnects the negative, C, and D wires, thus accomplishing the release of relay CC at the control point, and also relay BA at the Exchange end. The release of BA connects the wires through ready for another call, and releases relays G and GG to remove the guard from the final selector multiple.

# Voice Frequency Signalling for Trunk Circuits

T. H. FLOWERS, B.Sc. (Eng.).

THE difficulties of signalling by means of direct currents over long repeatered telephone circuits are well known and the advantages of using alternating current within the frequency range efficiently transmitted by such circuits have been recognized for some considerable time. Generator (500/20) signalling has been used extensively on the trunk line system of this country, but the facilities given by this method are very limited and the need for a rapid signalling system giving full supervision has long been felt. The introduction of On-Demand working of trunk lines and the growing tendency to repeater even short lines has accentuated this need. The advantages of having a signalling system which gives full automatic supervision of calls, including dialling and keysending, are considerable; the revenue-earning capacity of the lines is increased, chiefly because of quicker clearing; tandem working, which facilitates alternative routing of calls, becomes much easier; and operating time is saved by making overlapping operations possible and, in the case of automatic set-ups, by reducing the number of operators required.

This article describes a voice-frequency signalling system which has been developed with the object of providing on long lines signalling as nearly as possible the same as the d.c. signalling at present given on junctions. It differs from junction signalling only in minor respects, so that the operating procedure in the two cases is practically uniform, with obvious advantages.

## Principles.

The basic requirements may be regarded as two signals to be given from each end of the circuit, viz., calling and clearing signals from the calling end, under the control of an operator, answering and clearing signals to be given from the incoming end of the circuit under the control of an operator and of the called subscriber's gravity switch. These requirements are common to all circuits, and involve apparatus being permanently connected to each end of the line. All other signals, e.g., dialling and keysending, can, in general, be most efficiently provided by using common apparatus which is associated with a particular line only so long as it is required to fulfil its function. The simplest way of meeting these requirements is to use A.C. of one frequency to signal in one direction and of another frequency to signal in the reverse direction. In the system about to be described, two frequencies are used in this manner, the frequencies being 600 and 750 p.p.s., usually referred to as Y and X respectively. They are the same as the Y and X frequencies used for keysending from A positions and were in fact chosen so that the same generator could be used for both purposes.

For purely manual working, the following procedure has been adopted. When an operator originates a call, by inserting a plug into an outgoing jack, an X frequency signal is sent forward, causing the calling lamp to be lit and a Y frequency signal to be returned. At the outgoing end the receipt of the Y frequency signal causes the X frequency to be cut off. The called end answers by cutting off the Y frequency, which is re-applied to give the clearing signal. The Y frequency signals are controlled by the operator's speaking key and the called subscriber's gravity switch. Clearing from the outgoing end when the operator pulls out the plug is accomplished by sending an X frequency signal forward. The circuit releases completely, i.e., all relays release and all tones are cut-off from the line, when the plugs at both ends have been removed. This sequence of events has to be modified slightly when the call is to be set up automatically, but the principles remain the same.

Echo suppressors on 4-wire lines are intended to prevent transmission in both directions simultaneously. In order to be able to signal in both directions simultaneously, it will be necessary to make the echo-suppressors ineffective at the signalling frequencies.

The power which can be transmitted by a repeatered line is too small to operate a telephone-type relay. Valve detectors, with relays in their anode circuits, are therefore used in the V.F. receiver, which has two valve-relay circuits, one for each of the frequencies used. One circuit responds to X frequency signals, the other to Y frequency signals: speech currents which may have components at the signalling frequencies must be prevented from actuating the signalling apparatus. Immunity from speech operation is attained in the following manner. On the X side is a relay X which by electrical tuning is made less sensitive to A.C. at frequency Y than at other frequencies: it will not operate with Y frequency signals, but will operate readily with X frequency signals and with speech currents, since the latter are in general of complex wave-form and if a component at frequency Y is present, to which the relay X does not readily respond, components at other frequencies are present to operate relay X. Relay X controls another relay, P, which is operated when relay X is in its normal position. In a similar manner on the Y side is a relay Y which controls a relay Q and which is made less sensitive to A.C. at frequency X than at other frequencies. Relay Y therefore is not operated by X frequency signals, but is readily operated by Y frequency signals and by speech. When Y frequency signals are being received, relay Y operates and Q releases. Speech, operating and releasing the X and Y relays approximately in unison as the speech level rises and falls, is prevented





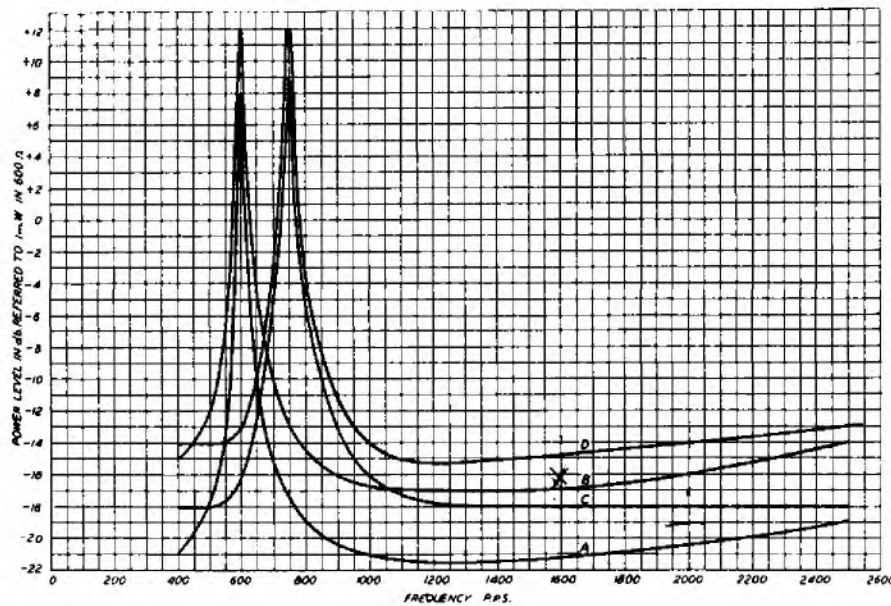

FIG. 2.—FREQUENCY CHARACTERISTIC OF V.F. RECEIVER.

frequency which it is required to receive. This method results in maximum sensitivity, but slows up the normal release of the relay. But, due to the property of rectified reaction noted above, that the device is much more sensitive once operated than before operation, a swamping resistance can be connected across the rectifier after the relay has operated without impairing efficiency. In the circuit diagram, resistances YD and YH are the swamping resistances, connected when the relief relays XX and YY operate. It has been found advantageous to make the swamping resistances small enough to ensure that the release level is higher by a few db. than the operating level. This means that at input levels just greater than those necessary to operate the anode relays, the X and XX, or Y and YY, relays vibrate, the relief relays being slugged to make the rate of vibration fairly slow, about 5 per second. The condensers QG and QH are necessary for the vibration to occur at the higher frequencies.

Fig. 2 shows a typical frequency characteristic of a receiver. At all power levels below curve A, relay X is unoperated; at all levels above curve B, relay X is permanently operated; at levels between curves A and B, relays X and XX vibrate. Curves C and D are similar to A and B, but refer to relays Y and YY. The usefulness of the vibration feature can be seen from these curves. Without the swamping resistance, curve A represents the levels at which relay X, and curve C the levels at which relay Y, would permanently operate. An input level of -19 db. at 2000 p.p.s. would operate relays X and XX, but not Y and YY, and relay P would release. But when relays X and XX, or Y and YY, vibrate as just described,

neither of the relays P or Q is released. Hence, it is impossible to release relays P or Q with A.C. at 2000 p.p.s.

Fig. 3 is a photograph of a V.F. receiver. It is made up as a complete unit on a standard jack-in type baseplate, with a cover over everything except the valves. A complete line termination is made up of one V.F. receiver, which is universal for all circuits, and a relay-set which varies according to the facilities required.

#### Relay-Sets.

Typical relay-set circuits are shown in Figs. 4 and 5. These are suitable for unidirectional manual - to - manual working with sleeve-control circuits<sup>2</sup>; bothway working is also possible.

<sup>2</sup> *P.O.E.E. Journal*, Vol. 24, Part 3, October, 1931.



FIG. 3.—V.F. RECEIVER.





# Pneumatic Ticket Tube System at G.P.O. (South)

J. E. MCGREGOR, A.C.G.I., A.M.I.E.E.

IN view of the importance of the pneumatic tube systems installed in modern trunk telephone exchanges to deal with the call record tickets, the following notes on the pneumatic ticket tube system installed at the London Trunk Exchange will probably be of interest as this installation, when extended and completed, will be the largest in this country. In these tubes no carriers are used, the tickets being inserted directly into the tubes through which they are carried by a current of air.

The original installation of tubes at this Exchange—which consisted of rectangular tubes of smooth bore, operated by means of Roots' Blowers "working through" from the vacuum to the pressure tubes—has been done away with during the remodelling of the exchange, together with the old despatch valves on the vacuum tubes which required two-handed operation and could only be installed on a keyboard tube, and the old motor-operated double roller discharge valves.

The new system consists of rectangular tubes with a slightly ribbed surface to reduce friction, a new design of despatch valve on the vacuum tubes suitable for single-handed operation on either keyboard or panel, and improved despatch valves on the pressure-operated tubes. A few motor-operated discharge terminals of the Mix and Genest double-chamber type were installed temporarily on the vacuum-operated tubes, but these now have been replaced by the discharge terminal designed for the Department by the Author (Patent 379544. Foreign Patents pending). It should be noted in passing that whilst all other vacuum-operated ticket tube systems require hand operation or mechanical or electrical devices to discharge the ticket, in this standard P.O. system the tickets are freely discharged without any auxiliary device and without any delay. This terminal is constructed with a door hinged about the centre line and so balanced against the forces acting, *e.g.*, vacuum, atmosphere pressure, etc., that the impact of the ticket is sufficient to cause the door to be opened and the ticket to be discharged. It thus becomes unnecessary to provide for any mechanical or electrical means of forming an air lock to enable the ticket to be discharged against the vacuum in the tube, and whilst the terminal has many advantages over other types it is simple in construction and cheap to install. The system is operated by means of independent pressure and vacuum turbine blowers so that the degree of pressure or vacuum maintained is practically constant, irrespective of the number of tubes used, instead of

varying between wide limits as was the case with the original plant. The old type of ticket with a folded arrow head has also been superseded by a new ticket with a short sail formed by turning up the back. The result of these alterations in design has been to provide a tube system of very high efficiency, whilst the new pattern of tube and tickets have enabled considerable economies to be made in the power required owing to lower degrees of pressure and vacuum being required to transmit the tickets as compared with the old system.

A satisfactory feature of the system now installed is that whereas in the past the tubes and fittings all had to be obtained from Germany, the whole of the apparatus has been made in this country by Messrs. Standard Telephones and Cables, Ltd., who have carried out the installation, the tubing being made by Messrs. Booth. At the beginning it was necessary to obtain a few discharge terminals for the vacuum-operated tubes from abroad, but as stated above these have been replaced by the new standard terminal which is being manufactured by Messrs. Standard Telephones and Cables, Ltd.

A diagram of the complete system to be installed is given in Fig. 1. Actually it will be seen that

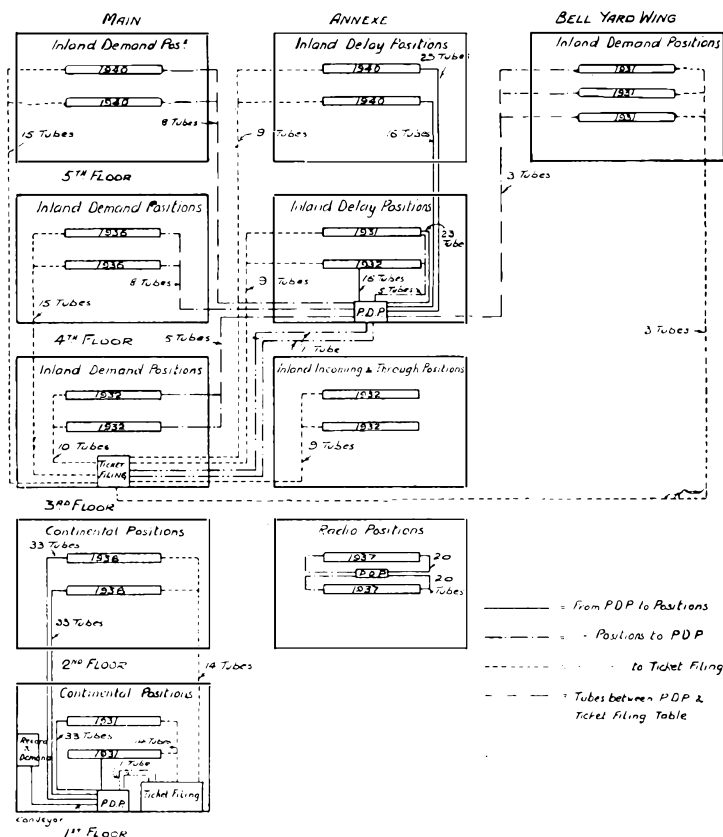

FIG. 1.—G.P.O. SOUTH TICKET TUBE SYSTEM PROPOSED AT 1950.



FIG. 2.—DESPATCH AND DISCHARGE VALVES ON TICKET TUBES AT OPERATOR'S POSITION.

there are two complete systems dealing independently with the Inland and Overseas Exchanges, both being supplied with air from a common air-duct system fed from the blowers which are installed in the basement. Owing to the shape of the building, considerable care has had to be taken to arrange for the runs of the tubes so as to keep their lengths to a minimum. Separate tubes are installed to deal with tickets bearing details of completed and uncompleted calls, the former being taken from the Demand positions direct to the Ticket Filing Positions (T.F.P.) and the latter to the Pneumatic Distribution Positions (P.D.P.) whence they are distributed to the Delay positions to be dealt with. After the completion of the calls, these tickets are tubed on to the T.F.P.

The collecting tubes, which are operated by rarefied air (or vacuum) have each, on an average, nine despatch valves connected to them. Those for the completed call tickets are run along the keyboards with a despatch valve for each operator, while the tubes for uncompleted call tickets are run behind the jack panels with a valve between every pair of operators. The tubes for the redistributed tickets from the P.D.P. to the operators' positions are pressure-operated and discharge the tickets through the open ends of the tubes on to the keyboard. Fig. 2 shows the despatch and discharge valves fitted at an operators' position.

Fig. 3 shows the P.D.P. in the Overseas Exchange in which it will be noted that the despatch valve panel for

the distributing tubes has been placed at an angle for convenience in operation. In this case the tickets are brought from the record positions, which are adjacent to the P.D.P., by means of a silent conveyor band running along the top of the positions, the tickets being posted on to the band through the slots shown. The tickets are delivered by the band on to chutes at the sides of the P.D.P. where they are sorted and sent on to the proper operator. The vacuum-operated tube shown is for transmitting tickets which have been miscirculated, or not completed, from the Filing positions. This photograph gives a good idea of the method of running the tubes overhead and shows the small space taken up by a large number of these tubes. Generally, when feasible, the tubes are run in the floor, but this was impossible here. The ultimate capacity at this position will be one vacuum-operated and 126 pressure-operated tubes.

Fig. 4 shows the P.D.P. for the Inland Trunks. The collecting tubes from the positions are connected to a vacuum header running along the top, the terminals discharging the tickets on to a glass tray from which they are removed by the operators and redistributed by means of the pressure tubes, the despatch valves of which are grouped in a horizontal panel underneath. The ultimate capacity of this position will be 28 vacuum-operated and 96 pressure-operated tubes.

As a matter of interest the same P.D.P. is shown in Fig. 5 as it was before the change over from Mix & Genest to McGregor terminals and it will be seen by how much it has been possible to improve



FIG. 3.—P.D.P. IN THE OVERSEAS EXCHANGE.



FIG. 4.—P.D.P. IN INLAND TRUNK EXCHANGE CONVERTED FROM MIX AND GENEST TO MCGREGOR TERMINALS.

the design by doing away with the motor-operated cam drive for the terminals.

Fig. 6 shows the Ticket Filing Position for the Overseas Exchange which is similar in design to the Inland P.D.P. except that, in place of the pressure tubes, duplicate removable aluminium trays, fitted with compartments into which the tickets are sorted,



FIG. 5.—P.D.P. FOR INLAND TRUNK EXCHANGE AS EQUIPPED ORIGINALLY WITH MIX AND GENEST TERMINALS.

are used. Equipment is provided on the keyboards so that the operators can answer enquiries as to the cost of calls, etc., from the details given on the tickets held in the trays. As the trays are filled they are replaced in turn by empty trays, the most recently-filled trays being held for enquiries. The ultimate capacity of this position will be 28 vacuum tubes.

Fig. 7 shows the new Ticket Filing Position which is about to be installed for the Inland Exchange. In this case, owing to the very large number of tubes to be dealt with, the tickets will be discharged from the terminals on to a moving band which will carry them to a primary sorting point. There they will be sorted on to a 4-channel conveyor which will distribute the tickets to the various positions where the final sorting is to be carried out. These positions are to be equipped with duplicate sorting trays as described above and also equipped to deal with enquiries. The ultimate

capacity of this position will be 78 vacuum-operated tubes.

Power for operating the tubes is provided by means of turbo blowers driven by 3-phase induction motors, each main set consisting of one vacuum and one pressure blower direct driven by a common motor. These have each a capacity of 1,000 cu.



FIG. 6.—T.F.P. IN OVERSEAS EXCHANGE.

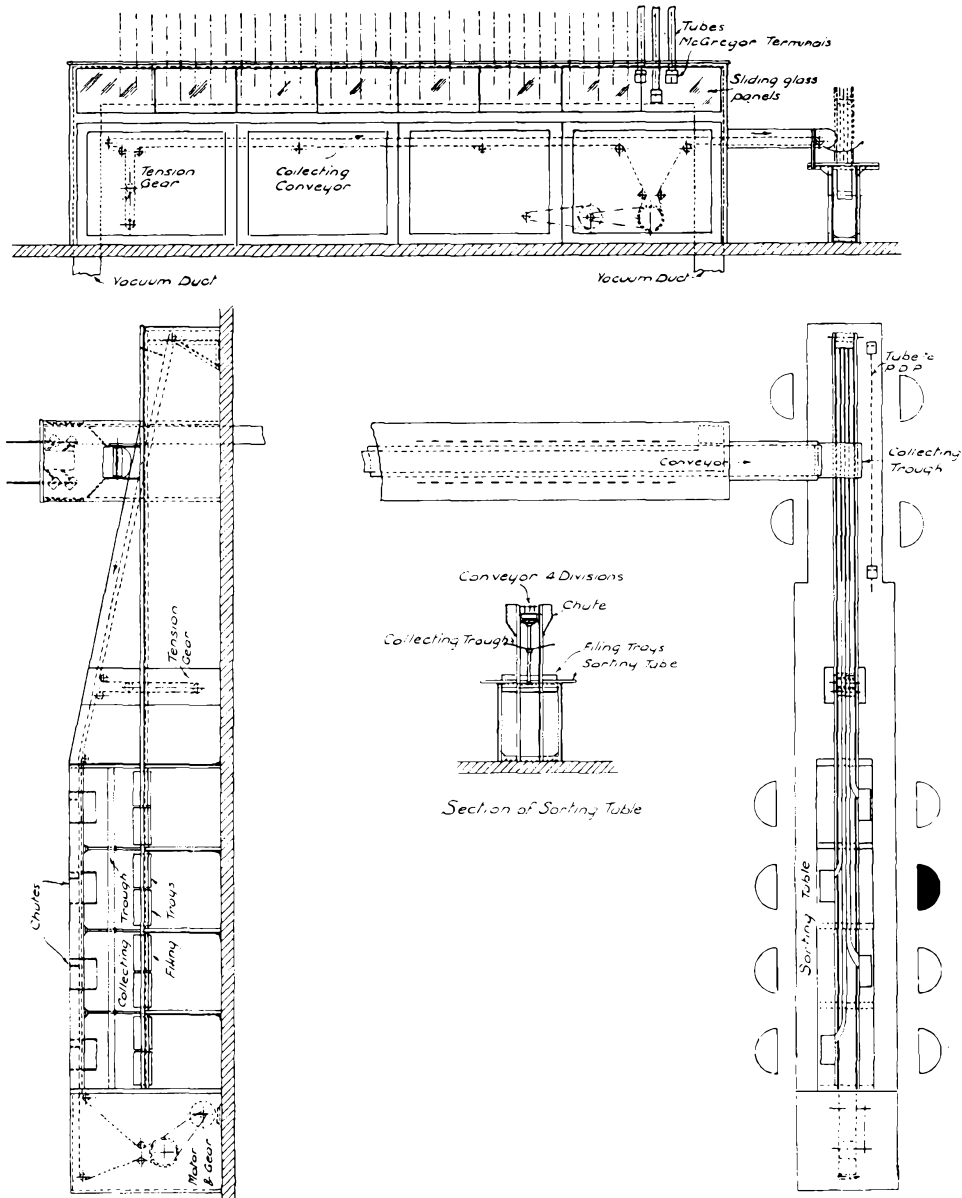

FIG. 7.—G.P.O. SOUTH INLAND TRUNK EXCHANGE: TICKET SORTING AND FILING POSITIONS.

feet per min. at 24 inches water gauge vacuum and pressure respectively. Two additional independent blowers are being installed to meet the increasing load and to provide a margin of safety in view of the importance of the service given by the tubes, and the disorganization which would result in case of failure. The various tube centres are connected to the blowers by heavy galvanized iron trunking of ample area to minimize the pressure drop between the basement and the upper floors. The normal water gauge drop along the tubes when the air is flowing freely is regulated to about 10 to 14 inches, depending on the length, but the transit of the ticket is also affected by the total pressure or vacuum available from the blowers, as when the air flow in the tube is restricted by tickets tending

to stick at bends or form blocks, the resistance to the air flow of the control valves and bypass holes in the terminals is automatically reduced, and in consequence the pressure or vacuum acting on the ticket is increased until the air and tickets are again moving normally.

Similar systems of ticket tubes on a smaller scale have been or are being installed at Birmingham (temporary), Bristol, Cardiff, Edinburgh, Glasgow, Leeds, Leicester, Liverpool, Manchester, Newcastle, Nottingham and Sheffield. Of these Bristol and Leeds have been equipped with Mix and Genest vacuum tube terminals, all the other Exchanges being equipped with the standard P.O. system which will also be installed at the new Birmingham Exchange, Belfast, etc.



# The Anglo-French (1933) Submarine Telephone Cable

E. M. RICHARDS, A.C.G.I., B.Sc.(Lon.), M.I.E.E.

ON Sunday afternoon, September 10th, 1933, the "Dominia," the world's largest cable laying ship, left Greenwich with 29 nauts. of submarine cable aboard her—the Anglo-French (1933) Telephone Cable—to be laid between St. Margaret's Bay (Kent) and Calais.

Increase of traffic on trunk lines to the Continent is the *raison d'être* of the new cable, which was manufactured to the order of the British Post Office. Messrs. Telegraph Construction and Maintenance Co., Ltd., Greenwich, were awarded the contract. The sub-contractors were Messrs. Standard Telephones and Cables, Ltd., Woolwich, who manufactured the paper-core cable and applied the lead sheath. The rubber tape covering, armouring and jute servings were applied by the T.C.M. Co., who also laid the submarine section of the cable. Whilst it is designed to give 19 audio and 19 carrier circuits, additional circuits may be obtained by the use of phantoms.

## Description of the cable.

Fig. 1 shows the construction of the submarine section and the English and French land sections.

wires of a quad are marked with 1, 2, 3 and 4 ink lines respectively on the insulating paper, the lines being coloured red and blue in alternate quads, beginning with red on each marker quad (*i.e.*, quads Nos. 1, 2, and 8). Paper quad lappings are coloured red and blue alternatively, with orange for the markers and green for the reference quads.

One ternary lead alloy sheath is used, the composition being that which gave the most satisfactory results in vibration tests carried out by the P.O. Research Section. A rubber tape covering 0.25 inch in thickness is applied throughout the whole length of the submarine section. The English land section is not armoured and is drawn into ducts; the French land section is double steel-tape armoured and laid in sandy soil; the sea section is armoured with No. 2 wires.

The weight of the cable is about 30 tons per naut.

## Balancing.

Test selected joints to reduce side-to-side and side to phantom interference were made in works at intervals of 0.5 nautical mile. All crosses were made within quads only.

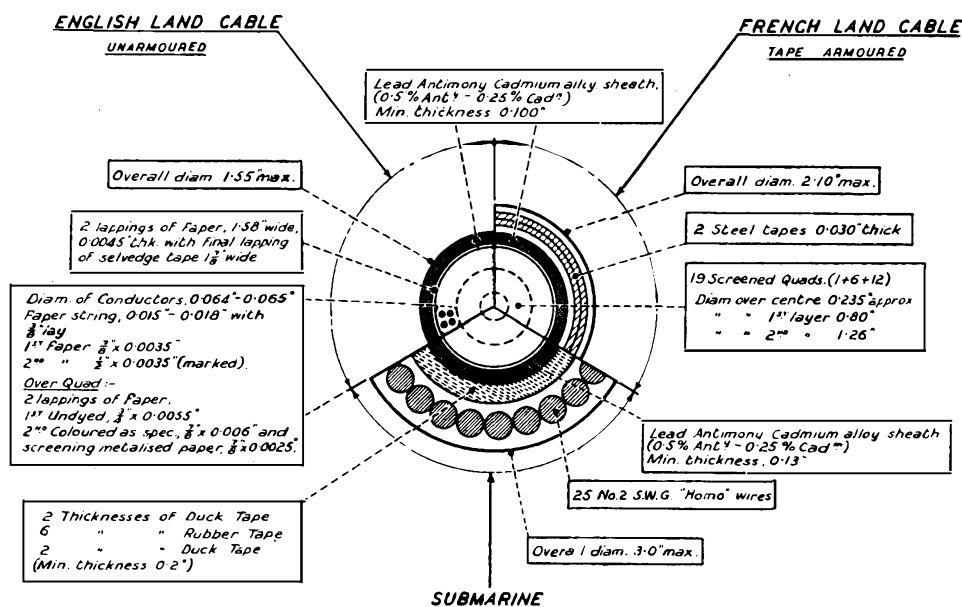

FIG. 1.—CROSS-SECTION OF SUBMARINE, ENGLISH, AND FRENCH LAND SECTIONS; SCALE  $\frac{1}{2}$ .

It will be seen that there are 19 star quads, containing conductors of 66 lb. weight per statute mile, each quad being electrostatically screened by paper coated on one side with aluminium to a thickness of about 0.5 mil. The metallized paper is applied with the metal on the inside. The A, B, C and D

## LAYING OPERATIONS.

The English land section (0.321 naut.) from St. Margaret's Bay Repeater Station to a manhole near the beach was laid and jointed during July, 1933. The French land section (1.309 nauts.) from the newly built repeater station at Calais to a manhole



FIG. 2.—C.S. "DOMINIA."

in the sand dunes near high water mark was laid and jointed during August, 1933. This work was carried out by Messrs. S. F. & C., Ltd. Tests made by the Post Office Research Section in conjunction with the Contractors proved these lengths of cable to be satisfactory, and they were insulated and capped.

Figs. 2 and 3 show the "Dominia" at anchor off St. Margaret's Bay. A heavy swell held up operations on the 14th, but on the 15th the end of the cable on the "Dominia" was paid into the motor barge "Lais" without being cut. The "Lais" moved away from the "Dominia" paying out cable as she moved, and on reaching shallow water she anchored and the remainder of the cable was floated ashore as shown in Fig. 4. The "Dominia" began laying when the end was near the shore at St. Margaret's Bay, a continuous watch being kept on insulation resistance and conductor



FIG. 3.—THE "DOMINIA'S" BOW SHEAVES.



FIG. 4.—FLOATING THE CABLE ASHORE AT ST. MARGARET'S BAY.

resistance. Figs. 5 and 6 show the arrival of the end of the cable on the beach. Fig. 7 shows a later stage in the operations, the "Dominia" then being well on the way to Calais.

On September 16th, the "Lais" crossed to Calais and laid the shore end of 2.5 nauts. The joint to the land section at St. Margaret's Bay was made on the 17th, that to the land section at Calais on the 18th and the final sea splice was completed early on the 18th. The cable was then through between the repeater stations at St. Margaret's Bay and Calais. Jointing and plumbing on the sea joint (excluding splicing of the armouring) occupied seven hours.

#### *Length.*

The complete length of cable between repeater stations is 26.31 nautical miles (1 nautical mile = 2026 linear yards).



FIG. 5.—LANDING THE ENGLISH SHORE END.



FIG. 6.—THE END OF THE CABLE AT ST. MARGARET'S BAY.

ELECTRICAL TESTS AFTER LAYING.

On completion of the final joint the acceptance tests were begun. The principal measurements made and the results obtained were as follows:—

(1) *Insulation Resistance.*

This was measured after one minute's electrification with 150 volts. The value was specified to be



FIG. 7.—PREPARING TO HAUL THE CABLE UP THE BEACH.

TABLE I.  
INSULATION RESISTANCE.

	Red Ink Line Quads. (Excluding Quad 1).	Blue Ink Line Quads.	Quad 1. Red Ink line quad.	
Maximum	43,000 megohms per naut.	26,000 megohms per naut.	A. Wire	370 megohms per naut.
			B. ..	42,000 megohms per naut.
Minimum	37,000 megohms per naut.	22,000 megohms per naut.	C. ..	43,000 megohms per naut.
			D. ..	43,000 megohms per naut.

not less than 15,000 megohms per naut. Table I. gives the results.

All wires, except the A wire of quad No. 1, were satisfactory. This wire had an insulation resistance to all other wires earthed of 14 megohms. Localization tests showed a fault to exist at 9.0 nauts. from St. Margaret's Bay repeater station. It was decided to continue with the tests as the fault was obviously not due to the ingress of moisture but to a contact to one or more of the screens. (Subsequent tests confirmed this view.)

It will be observed that the blue ink lines cause considerably more leakage than the red ink lines.

Owing to the low insulation resistance on wire 1A, test results on the pair have been excluded in all the Tables following (except Table IV.).

(2) *Conductor Resistance.*

The minimum and maximum single wire D.C. resistances per naut. were 14.754 and 14.845 ohms respectively, and the specified maximum 15.44

ohms. The conductors of the centre quad were 0.3% lower in resistance than those of the first layer. The maximum resistance unbalance was 0.019% of the loop resistance.

(3) *D.C. Capacity.*

Values measured by a ballistic method are given in Table II.

TABLE II.  
D. C. CAPACITY.

	Microfarads per naut.		
	Min.	Mean.	Max.
Side Circuits ... ..	0.1028	0.1035	0.1045
Phantom Circuits ... ..	0.2475	0.2545	0.261
Ratio $\frac{\text{Phantom Capacity}}{\text{Side Capacity}}$ ... ..	2.48	2.46	2.495

The D.C. capacity of a single wire to all other wires earthed was measured on 25 conductors, including at least one wire from each quad. The maximum was 0.2007 and the minimum 0.1870 micro-farads per naut. The values would prove useful in locating a disconnection fault.

(4) *Near End Crosstalk.*

The specified requirements were as follows:—

Mean of values at 640, 800, 1100 and 1900 p.p.s. :—

- (a) Between any two pairs to be greater than 8.5 népers (73.8 db.).
- (b) Between any two pairs in different quads to be greater than 11.8 népers (102.5 db.).

Values at 5,000 p.p.s.

- (c) Between any two pairs to be greater than 7.4 népers (64.3 db.).
- (d) Between any pair in 1st layer and any pair in

2nd layer to be greater than 10.0 népers (86.85 db.).

- (e) Between any two pairs not in the same quad, not in adjacent quads and not in adjacent layers to be greater than 10.4 népers (90.4 db.).

All pair-to-pair and side-to-side cases (703 in number) were measured at each end of the cable with frequencies of 1,100 and 5,000 p.p.s. The worst cases at Calais were also measured at the other three specified audio frequencies, and at St. Margaret's Bay all side-to-side and 25% of the pair-to-pair cases were measured at 640, 800 and 1,900 p.p.s. The mean of the values at the four audio frequencies agreed very closely with the value at 1,100 p.p.s. in all cases. This will be seen from Table III. which gives the value obtained. There is actually one pair which just fails to meet the limit of 11.8 népers, its value being 11.77 népers—a negligible difference. Apart from this, all values meet the specification.

TABLE III.  
NEAR-END CROSS-TALK.

(a) *Side-to-Side at Audio and Carrier Frequencies.*

		At St. Margaret's Bay.			At Calais.	
		Frequency p.p.s.	Népers.	No. of cases.	Népers.	No. of cases.
Average	...	1100	11.20	18	11.20	18
Worst	...	1100	10.30		10.34	
Average	...	5000	9.85	18	10.14	18
Worst	...	5000	9.04		9.58	

Mean of the values at 640, 800, 1,100 and 1,900 p.p.s. (worst quads only at Calais.)

		At St. Margaret's Bay.		At Calais.	
		Népers.	No. of cases.	Népers.	No. of cases.
Average Mean	...	11.22	18	—	4
Worst Mean	...	10.27	18	10.37	

(b) *Pair-to-Pair at audio frequencies.*

		At St. Margaret's Bay.			At Calais.	
		Frequency.	Népers.	No. of cases.	Népers.	No. of cases.
Average	...	1100	14.04	648	14.07	648
Worst	...	1100	12.11		11.95	

Mean of the values at 640, 800, 1,100 and 1,900

	At St. Margaret's Bay.		At Calais.	
	Népers.	No. of cases.	Népers.	No. of cases.
Average Mean ...	13.17	120	—	16
Worst Mean ...	11.99		11.77	

(c) Pair-to-Pair at Carrier Frequency (5,000 p.p.s.)

	At St. Margaret's Bay.		At Calais.		
	Népers.	No. of cases.	Népers.	No. of cases.	
Average ...	12.13	288	12.55	288	Between any pair in the 1st layer and any pair in the 2nd layer.
Worst ...	10.94		10.80		
Average ...	12.48	276	12.85	276	Between any two pairs NOT in adjacent quads and NOT in adjacent layers.
Worst ...	11.32		10.57		
Average ...	10.97	72	10.9	72	Between pairs in adjacent quads in the same layer.
Worst ...	10.11		9.52		

Table IV. gives cross-talk values between pair 1AB and all other pairs in the cable. The values for pair 1CD are added for comparison, and since 1CD is better than an average pair, values for the rest of the pairs are added. At audio frequencies pair 1AB gives three cases outside the specified value of 11.8 népers, viz., 11.53, 11.72 and 11.73 népers, but these values are not, of course, sufficiently bad to render the pair unserviceable. At 5,000 p.p.s. the values are within specification.

At audio frequencies pair 1AB is considerably

worse than other pairs, but the difference is less marked at higher frequencies. At Calais the values are normal as the fault is further from that end of the cable.

Table V. shows how pair-to-pair cross-talk between quads in the outer layer improves as the number of quads separating the pairs concerned is increased. The best value is obtained with two or three separating quads; beyond this the cross-talk becomes worse again, probably due to increase of electromagnetic interference.

TABLE IV.

NEAR END CROSS-TALK IN NÉPERS BETWEEN CENTRE QUAD PAIRS AND REST OF THE CABLE.

(a) Side-to-Side.

	Frequency p.p.s.	At St. Margaret's Bay.		At Calais.	
		Quad 1.	Rest of the cable.	Quad 1.	Rest of the cable.
Average ...	1100	—	11.20	—	11.20
Worst ...	1100	9.04	10.30	10.35	10.34
Average ...	5000	—	9.85	—	10.13
Worst ...	5000	9.86	9.04	9.38	9.58

(b) *Pair-to-Pair.*

	At St. Margaret's Bay.				At Calais.		
	Frequency p.p.s.	Pair 1AB v. the rest.	Pair 1CD v. the rest.	All other cases.	Pair 1AB v. the rest.	Pair 1CD v. the rest.	All other cases.
Average ...	1100	12.48	14.47	14.04	13.63	13.99	14.07
Worst ...	1100	11.44	13.17	12.12	12.13	12.16	11.95
Average Mean	Mean at four audio frequencies ...	12.45	—	—	13.48	—	—
Worst Mean ...		11.53	—	11.99	12.00	—	11.77

TABLE V.

## NEAR END PAIR-TO-PAIR CROSS-TALK IN NÉPERS.

Frequency p.p.s.		Between adjacent quads.	Between quads separated by				
			1	2	3	4	5
1,100	Average ...	13.12	14.32	14.74	14.51	14.17	14.17
	Worst ...	12.11	13.07	13.34	13.56	13.07	12.98
5,000	Average ...	10.93	12.15	12.68	12.68	12.34	12.38
	Worst ...	10.11	11.33	11.46	11.61	11.33	11.53

(5) *Impedance-Frequency.*

About 20 pairs were measured at each end of the cable over the frequency range 300 to 6,000 p.p.s. and some pairs from 200 to 60,000 p.p.s. All pairs (except 1AB) are well within the specified

maximum deviation of not more than 7.5% from a smooth curve obtained during manufacture. Table VI. gives mean values of impedance at various frequencies and maximum deviations from the specimen curve.

TABLE VI.

## IMPEDANCE OF SIDE CIRCUITS.

Frequency p.p.s.	$Z_0 \sqrt{\phi_0}$ Vector Ohms			
	At St. Margaret's Bay.		At Calais.	
200	474.5 $\sqrt{42^\circ 52'}$	Mean of 3 pairs	473.8 $\sqrt{42^\circ 55'}$	Mean of 19 pairs
300	390.7 $\sqrt{41^\circ 52'}$	" " 21 "	390.4 $\sqrt{42^\circ 15'}$	" " "
800	244.5 $\sqrt{37^\circ 56'}$	" " " "	242.9 $\sqrt{38^\circ 5'}$	Mean of 18 pairs
2,000	164.8 $\sqrt{29^\circ 26'}$	" " " "	164.1 $\sqrt{29^\circ 57'}$	" " "
6,000	124.1 $\sqrt{13^\circ 44'}$	" " " "	125.5 $\sqrt{16^\circ 6'}$	" " "
60,000	88 $\sqrt{0^\circ 35'}$	Pair 13 AB	—	—

MAXIMUM IMPEDANCE DEVIATIONS OF SIDE CIRCUITS FROM THE MEAN.

Frequency p.p.s.	At St. Margaret's Bay.	At Calais.
300	1.6%	1.8%
800	1.4%	1.6%
2,000	1.6%	1.3%
6,000	2.0%	1.8%

NOTE.—In all cases these maximum deviations occur on the centre quad, CD pair, which has lower resistance and capacity than all other pairs (except 1 AB).

Fig. 8 shows the effective resistance and reactance of pair 1CD and Fig. 10 the modulus of the impedance.

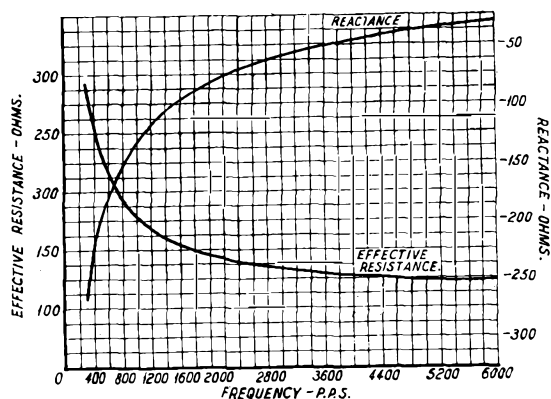

FIG. 8.—IMPEDANCE CHARACTERISTICS.

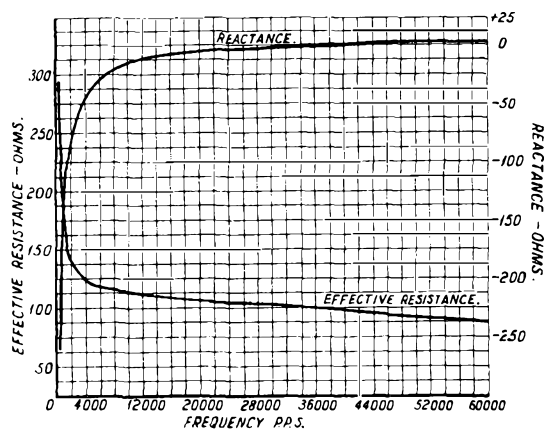

FIG. 9.—IMPEDANCE OF SIDE CIRCUIT UP TO 60,000 P.P.S.

Figs. 9 and 11 give the impedance of a side and a phantom circuit respectively up to 60,000 p.p.s.

(6) Attenuation.

The attenuation of each pair looped to a pair in another quad was measured at 800 and at 5,000

p.p.s. The results, together with the specified values, are given in Table VII.

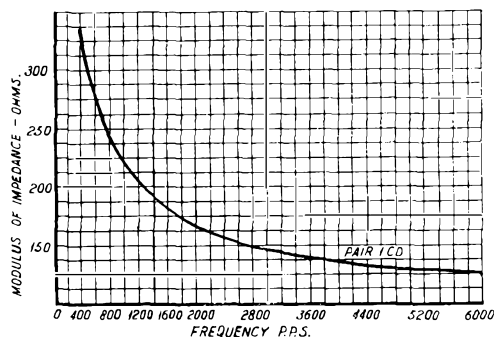

FIG. 10.—MODULUS OF IMPEDANCE.

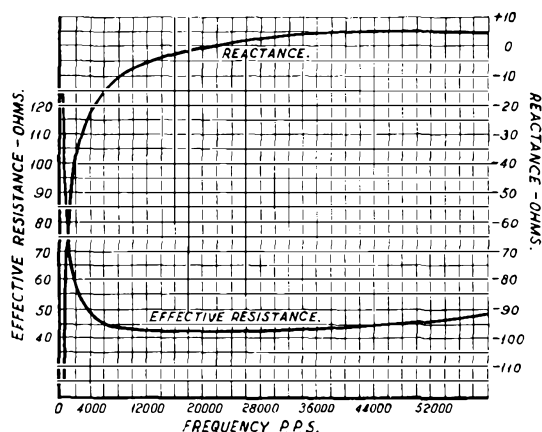

FIG. 11.—PHANTOM CIRCUIT IMPEDANCE UP TO 60,000 P.P.S.

Fig. 12 gives the attenuation-frequency curve of an average side circuit up to 9,000 p.p.s. Fig. 13 gives similar curves up to 6,000 p.p.s. for pair 1 CD and a pair in the first layer, the difference between them being due to the slightly lower resistance and capacity of the former.

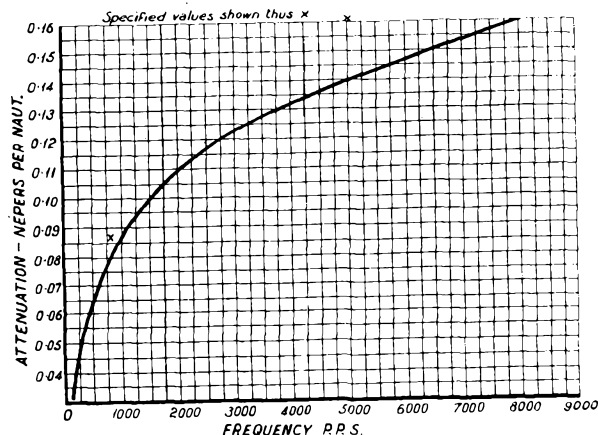

FIG. 12.—ATTENUATION OF A SIDE CIRCUIT UP TO 9,000 P.P.S.

TABLE VII.  
ATTENUATION OF SIDE CIRCUITS.

Frequency p.p.s.	800.		5, 00.	
	Népers.	Decibels.	Népers.	Decibels.
Minimum per Naut ...	0.0792	0.688	0.1355	1.177
Mean per Naut ...	0.0794	0.690	0.1383	1.201
Maximum per Naut ...	0.0796	0.691	0.1404	1.209
Specified values ...	0.087	0.756	0.162	1.407

TABLE VIII.  
SIDE AND PHANTOM CIRCUIT ATTENUATION PER NAUT. AT HIGHER FREQUENCIES.

Frequency p.p.s.	9,500.		10,000.	
	Népers.	Decibels.	Népers.	Decibels.
Pairs 17AB & 13AB ...	0.1699	1.475	0.1731	1.503
Phantom Quads 9 and 7	0.196	1.702	0.200	1.737

Table VIII. gives attenuation values at some higher frequencies for side and phantom circuits and Fig. 14 shows a phantom circuit attenuation-frequency curve up to 9,000 p.p.s. (The undulations above 6,500 p.p.s. are due to phantom-to-phantom cross-talk.)

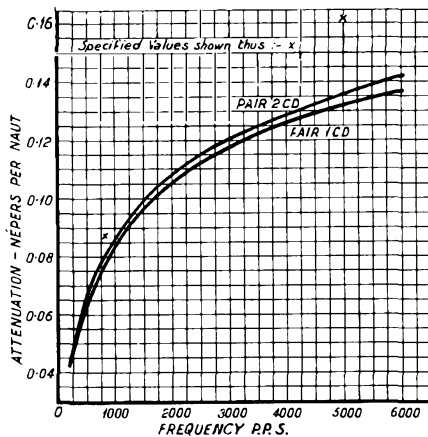

FIG. 13.—SIDE CIRCUIT ATTENUATION.

As the cable is not loaded attenuation-frequency distortion is high. A comparison with other paper-core cables to France is drawn in Table XI.

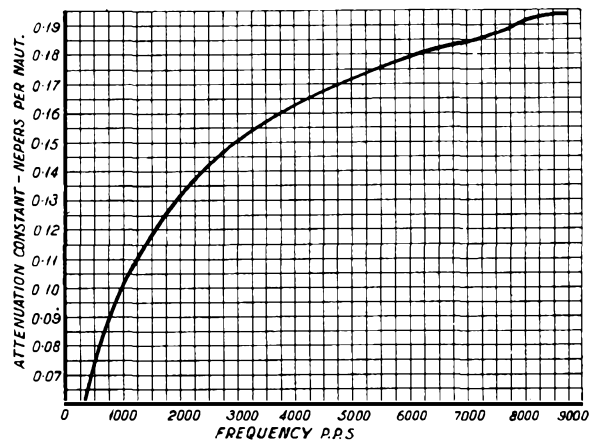

FIG. 14.—PHANTOM CIRCUIT ATTENUATION.

(7) Phase Constant and Propagation Time.

Fig. 15 gives the phase constant of two side circuits and one phantom circuit, measured by the Mayer method, and the propagation time of a side circuit for the overall length. It will be seen that the time is very small, being about 0.2 milli-second.

(8) Near End Cross-talk Frequency.

The way in which near end cross-talk varies with frequency is shown in Fig. 16. Circuits which have the same cross-talk attenuation at certain fre-



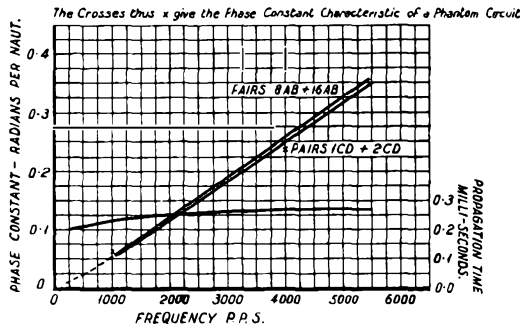

FIG. 15.—PROPAGATION TIME FOR OVERALL LENGTH, AND PHASE CONSTANT PER NAUT.

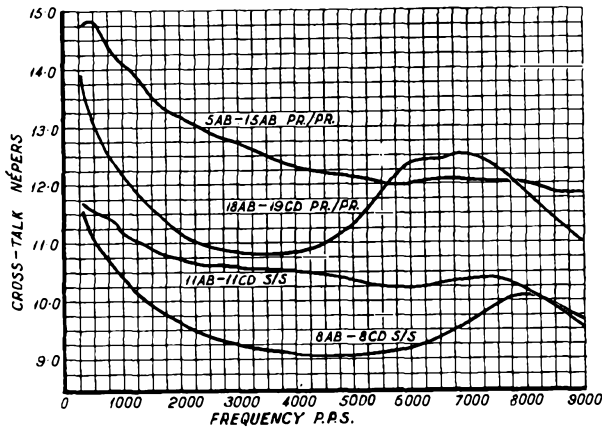

FIG. 16.—NEAR-END CROSS-TALK—FREQUENCY CHARACTERISTICS.

quencies differ by nearly 2 népers at other frequencies. Similar results were obtained at Calais, the difference in one case being 3 népers (at 9,000 p.p.s.).

(g) Phantom-to-Phantom and Side-to-Phantom Cross-talk.

In order to examine the possibility of the use of phantom circuits in the cable all near end +/s and +/+ and all distant end +/s cross-talk cases were measured at 1,100 p.p.s. The values are given in Tables IX. and X.

TABLE IX.

(a) NEAR END PHANTOM-TO-PHANTOM CROSS-TALK.

At 1100 p.p.s.

	At St. Margaret's Bay.		At Calais.	
	Népers.	Decibels.	Népers.	Decibels.
Mean	16.00	138.9	14.73	128.0
Worst	13.28	115.4	12.72	110.5

(b) NEAR END PHANTOM-TO-SIDE CROSS-TALK.

At 1100 p.p.s.

	At St. Margaret's Bay.		At Calais.	
	Népers.	Decibels.	Népers.	Decibels.
Mean	9.40	81.68	10.20	88.7
Worst	8.17	71.0	9.34	81.2

TABLE X.

DISTANT END PHANTOM-TO-SIDE CROSS-TALK AT 1,100 p.p.s. CORRECTED FOR ATTENUATION LENGTH OF SENDING CIRCUIT (SIDE CIRCUIT).

	Népers.	Decibels.
Mean ...	11.19	97.3
Worst ...	9.70	84.3
Next Worst ...	10.25	89.1

All near end +/+ values are very good. At St. Margaret's Bay the centre quad is appreciably worse than the rest, but is normal at Calais. The +/s values on quad 1 would prevent the phantom circuit being used.

From the point of view of distant end side-to-phantom cross-talk on the cable all phantoms except that on the centre quad should be serviceable, the worst signal to noise ratio being 60.3 decibels at 1,100 p.p.s. Hence it may be possible to set up 18 phantom circuits.

(10) A.C. Fault Localization Constant.

This was measured on two side circuits, one in each layer. The points of zero difference between a normal circuit and the circuit with an artificial fault at the far end were as follows:—

Pair 2 AB.	Pair 13 AB.
181 p.p.s.	180 p.p.s.
860 "	856 "
1697 "	1686 "
2558 "	2556 "

Neglecting the interval between the first two points in each case where the difference curve is obviously distorted, the frequency intervals for a complete wave are 1698 and 1700 for pairs 2 AB and 13 AB respectively. This gives for the constant the values

$$1698 \times 26.31 = 44,680$$

$$\text{and } 1700 \times 26.31 = 44,720$$

(11) A.C. Inductance.

A measure of the A.C. inductance of side and phantom circuits was obtained by Mayer method

tests. The frequency interval in p.p.s. between consecutive balance points in the tests is

$$n = \frac{1}{4l\sqrt{CL}}$$

Where "l" is the length and C and L are capacity and inductance per unit length. With C in micro-farads and L in milli-Henries, we have

$$L = \frac{10^9}{16n^2l^2C}$$

The values of "n" were 883, 894 and 888 p.p.s. for the three side circuits and 991 p.p.s. for a phantom circuit. This gives for L the values 1.12, 1.10 and 1.13 mH. for the side circuit and 0.36 mH. per naut. for the phantom; calculated values are 1.35 and 0.42 mH. respectively.

#### Tests after 30 days.

A number of the above tests were made again 30 days after laying.

Insulation resistance was about 13% higher due to the lower temperature. The value for wire 1 A had increased from 14 to 15.9 megohms. D.C. con-

ductor resistance was 0.78% lower, indicating a mean reduction in temperature of 1.9° C (in 29 days). Attenuation was correspondingly lower. All cross-talk and capacity tests, including those on pair 1 AB, gave the same values.

#### Conclusion.

The electrical characteristics of the cable have remained constant during the 30 days' maintenance period. At least 18 audio and 18 carrier frequency circuits, and possibly 18 phantom circuits will be obtained.

The earth noise on pair 1 AB, due to the very large capacity unbalance to earth between the A and B wires, will probably be the deciding factor as to the suitability of the centre quad for use as a public circuit. The noise arises from power cables at St. Margaret's Bay which run parallel with the telephone cable for short distances.

Table XI. gives an interesting comparison between the principal features of the three Anglo-French paper-core cables now existing. In particular, the high attenuation-frequency distortion of the 1933 cable should be noticed.

TABLE XI.  
ANGLO-FRENCH PAPER-CORE CABLES.

Date.	1926.	1930	1933.
Manufacturer ... ..	Siemens, Ltd., Woolwich.	Siemens & Halske.	S.T. & C., Ltd., & T.C.M. Co., Ltd.
Landing points ... ..	Seabrook & Audrecelles.	Seabrook & Le Portel	St. Margaret's Bay and Calais.
Lengths—Nauts. ... ..	23.92	32.11	26.31
Weight—Tons per naut. ...	26.5	19.7	30
Number of quads ... ..	7	7	19
Loading mH. per naut. ...	11.8	18	Nil
Conductor weight lb. per naut.	117.5	92.5	75
Attenuation length of side circuits at 800 p.p.s.—Népers (db.) ... ..	0.653 (5.67)	0.900 (7.81)	2.09 (18.1)
Attenuation—frequency distortion from 300 to 2,000 p.p.s. ...	0.177 Néper (1.54 db.)	0.151 Néper (1.31 db.)	1.513 Népers (13.1 db.)
Best specified cross-talk attenuation Népers (db.) ... ..	8.12 (70.5)	8.5 (73.8)	11.8 (102.5)

# Telephone Transmission Problems

## I. FEATURES OF THE ESSENTIAL FACTORS IN TELEPHONE TRANSMISSION

R. M. CHAMNEY, B.Sc., A.K.C., Assoc.M. Inst.C.E.

A GREAT deal of matter has been published in recent years on the subject of telephone transmission. The majority of standard works are devoted to one particular phase or another of the problem and are replete with elaborate mathematical explanations as a guide to enable students to follow the underlying physical conceptions. There is a need, however, for some descriptive material in order that engineers, other than specialists, may appreciate the many varied aspects of transmission problems and a series of articles has been designed to afford a comprehensive view of the subject. The present article deals with the more or less preliminary matters which are essential to the reader and subsequent articles will deal with :—

Simple transmission theory.  
Lines.  
Repeaters.  
Testing apparatus and maintenance of long lines.  
Applications to the present day telephone network.

### *General.*

The energetic research work of telephone engineers throughout the world has brought the transmission of speech to such a pitch of perfection that one is inclined to overlook many important and fundamental details and to lose sight of basic principles in view of the interesting nature of modern developments.

Fundamentally the telephone exists for the transmission of speech with sufficient volume and intelligibility to enable conversation to be carried out between any two points. Geographical distance has, in these days, lost a large part of its significance where telephone transmission is concerned and it is safe to say that in a very few years any two telephone subscribers in the world will be able to converse with ease.

Already a subscriber in this country can be put into communication with nearly 95% of the total telephone subscribers in the world. Not only is the connexion possible, but speech can be carried out with comfortable volume and good intelligibility. These two qualities necessitate the design of telephone systems on definite standards. It is useless to provide a standard which is beyond the price which the customer will pay and, on the other hand, it is unsound to provide such a cheap construction that the resulting service is poor and thus largely useless. A compromise between these two extremes is obviously essential and efforts have been directed for many years towards the setting up of not only national, but international standards which will take due regard of the requirements of satisfactory com-

mercial speech and at the same time take cognisance of the economic factor. There are many difficulties as apart from the human element, necessitating the reconciliation of opinions based on the senses, a common basic standard is not easy to achieve where the observers use different languages. The efforts have, however, met with a considerable measure of success, and a good commercial standard is now available.

It will not be out of place to refer at this stage to the effect of broadcasting on the transmission engineer's problem. As every broadcast enthusiast knows, the volume of reception of wireless signals over large distances can be made of sufficient strength to give the listener no difficulty in hearing. The broadcasting microphone also is now such a fine instrument that the intelligibility is really marvellous. Telephone subscribers accustomed to the broadcast standard are, therefore, much more critical than formerly. They do not always appreciate the fact that one broadcasting microphone may be talking to millions of listeners and the Authorities have only to provide a very limited number of these instruments. Again, broadcasting receivers are expensive items, but are paid for cheerfully, whereas a telephone receiver is demanded at a very much cheaper rate. The critics are apt to overlook the very different conditions to be fulfilled by the two services.

A microphone and line used for broadcasting must be able to pick up and transmit music of the highest class. This is a much more drastic test than speech and can only be provided at an enhanced cost. It is not surprising, therefore, that the equipment gives superlative conditions for the transmission of the spoken word.

Telephone transmitters and receivers have been designed which give results strictly comparable with the best broadcast service. The cost of production and maintenance, together with the lines giving equivalent conditions, entails such a prohibitive rental that their commercial application is extremely limited.

Before the perfection of the telephonic repeater and consequent extensive use of underground cables, a subscriber was accustomed to a degree of volume in transmission which was roughly proportional to distance, and he was quite prepared to shout his loudest in order to make himself understood by the listener at the distant end. The intelligibility was reduced also to a marked degree due to parasitic noises such as telegraph and power induction. It is hard perhaps to realize that less than ten years ago it was almost an adventure to call from London to Aberdeen. The best overall equivalent was roughly 25 db. on the lines, which figure was increased in

effect to at least 30 db. by various extraneous noises. These figures may be better appreciated when it is realized that a drop of 30 db. means that the received power is only 1/1000th of the transmitted power.

Under present day conditions, there is no transmission loss in the London-Aberdeen lines and no induction. That is to say the speech received at Aberdeen has the same volume as that put into the line in London. It is thus possible to provide transmission of good volume, not entirely governed by geographical considerations or the weight of copper used in the lines, and of good intelligibility since induction on cable circuits can be kept under control.

#### *The characteristics of Speech.*

The spoken word, as is well known, is made up of a large number of frequencies combined into a complex wave. The effect of volume is given by the lower frequencies or undertones whilst the higher frequencies give the character to the sound. The main part of vowel sounds of most speakers is similar in general outline. The overtones vary according to the shape of the individual's vocal passages, mouth, and method of delivery. The overtones give to the words those particular characteristics which are, as it were, the personal peculiarity of the speaker and enable one to recognize individuals by their speech.

The frequency range covered by the human voice lies approximately between 100 and 10,000 p.p.s., but the majority of this range is relatively unimportant for the transmission of commercial speech. The most effective range starts at about 250 p.p.s. and extends up to 2,500 p.p.s. A circuit which will transmit this restricted range will give good and intelligible speech. If the frequency range of the line and apparatus be increased to cover the full extent, a gain in articulation of only about 15% will accrue. Translated into intelligibility this percentage becomes too small to be of real importance. Since the expense of extending the range is very great, it is obviously unnecessary to give a better standard for such a small gain. If, however, a restriction below 2,500 p.p.s. be attempted it will be found that the intelligibility begins to suffer very rapidly. It is important, therefore, that the frequency range between 250 p.p.s. and 2,500 p.p.s. should be picked up by the transmitter, passed over the line, and reproduced by the receiver so that speech can not only be heard but also interpreted accurately by the listener.

The next point to be noted is that to convey a natural sound it is necessary to think of the conditions underlying speech transmission in a room. It must be clearly understood that no speech is normally transmitted without distortion through air. The chief causes of distortion are echo effects produced by reflection of speech, sounds from walls and furniture reaching the ear at slightly different time intervals. A room completely "dead" as regards echo may perhaps have been experienced by readers and, if so, it will be realized at once that this condition is usually classed as most unnatural.

In the early days of broadcasting every endeavour

was made to avoid echo with the result that the speaker's voice was noticeably displeasing and dull to the listener. Elaborate tests were made by using a "dead" studio and mixing a small amount of speech with a definite time delay to give a more natural effect. The studios in Broadcasting House are arranged to have varying amounts of echo so as to give desired effects for particular items.

Speech delivered to the microphone, therefore, is not distortionless and in cases where rooms are unsuitable the distortion may be considerable. This is not the fault of the microphone and those whose duty it may be to investigate transmission complaints should note this point. A badly-placed telephone may give rise to much dissatisfaction and trouble.

In cases where speeches in a room or large hall have to be picked up, transmitted over telephone lines, and reproduced on loud speakers, elaborate care has to be taken to achieve a reasonable freedom from the longer echoes so that the result is intelligible. Where proper precautions have been taken, intelligibility is often better over the electrically transmitted links than in parts of the hall itself.

There is another problem in telephone communication which is often overlooked. If two people converse in the ordinary way, they pay little attention to anything but the main words in each sentence. To put it another way, a man listening to observations will take note of the salient points about which he will be thinking and he will neglect a large proportion of the words spoken to him. This is seen when a conversation takes place between two people who are both interested in the same subject and both know within a small amount what the other person will be likely to say. If a telephone conversation be observed and the subscribers are people who are speaking continually to each other, conversation will be easy and without repeats on even a difficult line. If, however, subscribers unknown to each other are put into communication, and are not conversant with each others' views, difficulty frequently ensues even on a very good line. In judging transmission over lines it is necessary, therefore, to make certain of the conditions of test. In carrying out speech tests two men well known to each other will find the line perfect, whereas two strangers will report that the line is not good. This entails practical difficulties for those engaged in assessing commercial conversation. In making laboratory measurements standardized monosyllabic tests are usually made. This method gives good results, but is not applicable in the same way to commercial work.

#### *Telephone Instruments.*

Although the telephone instrument itself is very important as a part of the transmission system, it is not proposed to deal with it in detail in this article apart from certain fundamental requirements.

Reference should be made to a paper read before the Institution of Electrical Engineers in 1926, by Cohen, Aldridge and West, whilst a further paper read before the same Institution in 1932 by Harbottle gives further information.

If a transmitter or a receiver is to be a perfect instrument, it must be able to function as a converter uniformly for the whole of the frequency range to be transmitted. The ordinary commercial instruments are far from being perfect.

Both transmitters and receivers depend for their action on the vibration of a diaphragm. In transmitters, the diaphragm is usually of light metal such as aluminium, and in receivers the diaphragm is of a magnetic material. Since a diaphragm is involved, the elasticity of the material will take a large part in determining the characteristics of the instruments. Every diaphragm has a definite natural frequency which may be modified within limits by the manner in which the diaphragm is clamped or loaded mechanically.

The transmitter is most efficient at about 1,000 p.p.s., and falls off very rapidly below 700 and above 1,400 p.p.s. The ordinary Bell receiver has an efficient performance between 800 and 1,100 p.p.s., and one or two other efficient periods up to about 300 p.p.s. It would appear, therefore, from a perusal of the curves, that the distortion would be so great as to render accurate speech impossible. This, however, is not the case, since the ear is very accommodating and quite comfortably fills in blanks without appreciable strain.

The immersed electrode transmitter which is now in use has a rather better frequency response than the older solid-back transmitter. Particulars of this are given in an article by Aldridge, Barnes and Foulger in this Journal for October, 1929.

(To be continued.)

## Miscellaneous Facilities at Automatic and Manual Telephone Exchanges

### METER OBSERVATION EQUIPMENT

A. HOGGIN.

IN the preceding article reference was made to the comparatively rare occasion when a subscriber disputes his telephone account. If the complainant persists, his line may be associated with meter observation equipment in order that continuous watch can be maintained on the number of debited calls.

Broadly speaking this equipment consists of apparatus connected at the Main Distribution Frame

and the meter rack, for tapping an observation circuit across one subscriber's line. The other end of this circuit is terminated on monitorial positions on a key so that one of two monitors can connect her receiver to the observation circuit for listening purposes. Associated with this key are lamps and a check meter which within view of the observer operates in synchronism with the subscriber's meter.

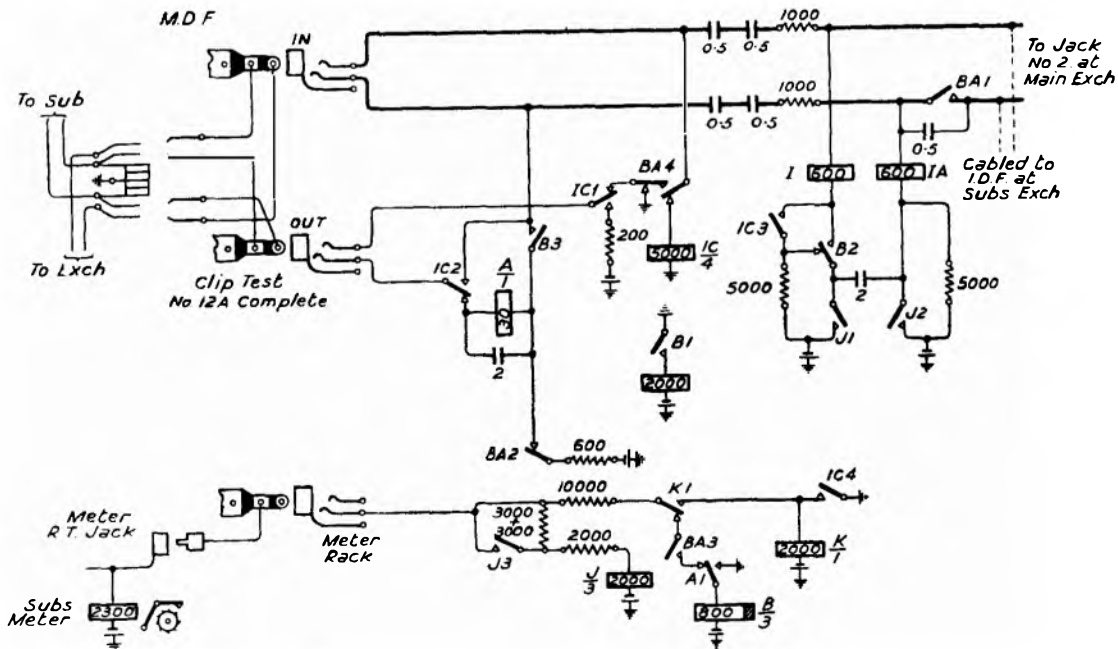

FIG. 1.—TAPPING AND OUTGOING JUNCTION CIRCUIT.

### Basis of Provision.

The basis on which meter observation circuits are provided is at present under review, but in the past it, has been as follows:—

At exchanges with 10,000 or more lines or having two monitorial positions staffed normally, one circuit is provided for each 10,000 lines or part thereof. In sub-exchanges in a non-director area which have at least 1,000 lines a tapping circuit is fitted at each exchange, but it is connected, *via* double-ended plugs and jacks at the main exchange, (Fig. 2) to a common incoming junction and position circuit on the central Auto Manual Switchboard.

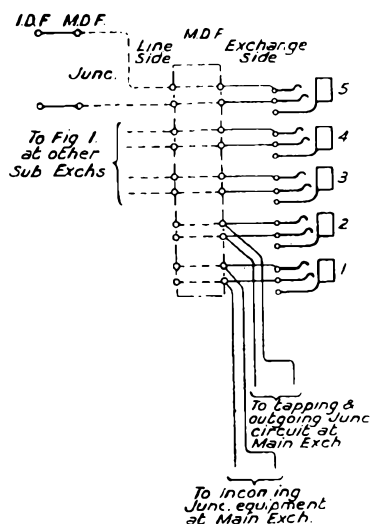

FIG. 2.—MAIN EXCHANGE JACKS.

### Facilities Provided.

- (1) Glowing of a "white" lamp on the monitorial position when the subscriber connected to the observation circuit originates a call.
- (2) Listening by one of two monitors by the throwing of a key in the appropriate direction.
- (3) Disconnexion of the "white" and the "red" lamps when the key is thrown in either direction.
- (4) When metering takes place glowing of another white lamp marked "R" and operation of the check meter.
- (5) On a call incoming to the subscriber concerned, a "red" lamp lights and a monitor observes the call to see that the subscriber's meter and therefore the check meter, do not operate irregularly.

### Brief circuit description.

The meter wire connexions on meter observation circuits differ slightly in accordance with the type of automatic equipment as, for instance, at exchanges having 4th wire earth or 4th wire battery metering, booster metering, etc. Otherwise the subscriber's tapping and the outgoing junction circuits and the equipment at the monitorial positions are the same in all cases. Fig. 1 shows the tapping and outgoing junction circuit used at exchanges with booster metering, and Fig. 3 depicts

the circuit and equipment at the incoming end.

When the subscriber associated with the observation equipment lifts his receiver, relay A (Fig. 1) operates from battery *via* contact BA<sub>2</sub>, the subscriber's loop and the earth at BA<sub>4</sub>. Contact A<sub>1</sub> operates relay B, and B<sub>1</sub> operates BA, thus connecting A in series with the subscriber's loop and exchange equipment *via* B<sub>3</sub> and BA<sub>4</sub>. A 5,000 ohm battery *via* BA<sub>1</sub> and one wire of the junction circuit operates relay LA (Fig. 3). The white lamp is connected at LA<sub>1</sub>. When the key is thrown by either "observer" so as to connect her receiver to the junction circuit, relay CO disconnects the lamp.

When the called subscriber answers, "booster" metering current operates the subscriber's meter as well as relay J, *via* 8,000 ohms. Contact J<sub>1</sub> connects battery *via* B<sub>2</sub> and the retard coil to the other wire of the junction circuit and operates M. The check meter connected at M<sub>1</sub> lights the white "R" lamp.

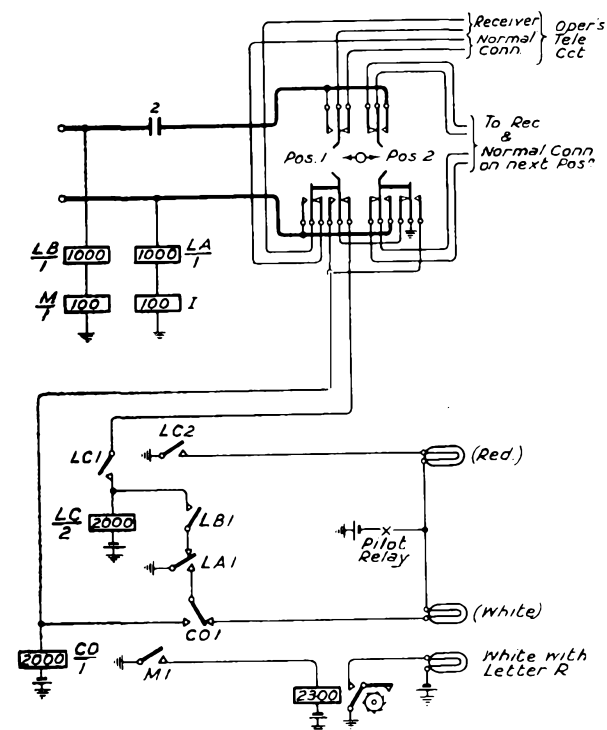

FIG. 3.—INCOMING JUNCTION AND MONITORIAL POSITION CIRCUIT.

When a call is made incoming to the subscriber relay IC is operated by the ringing return battery. Contact IC<sub>1</sub> connects a substitutory ringing return to the subscriber's line and IC<sub>2</sub> extends the ringing current on the negative line, whilst IC<sub>3</sub> connects battery over the junction to operate LB and light the red lamp at LB<sub>1</sub>. The throwing of the key disconnects LC and the red lamp.

After the tripping of the ringing when the subscriber answers, earth is connected at the final selector to the positive line thus releasing IC and connecting relay A at IC<sub>2</sub>. The operation of A *via* the subscriber's loop causes relays B and BA to switch the lines through at B<sub>3</sub> and BA<sub>4</sub>.

# Voice-Frequency Relay-set Routiner

J. S. YOUNG, A.M.I.E.E.

TO obtain maximum benefit from Voice-Frequency operation of the junctions from Manual to Automatic Exchanges in London, it was essential that the scheme be introduced as early as possible. The maintenance of the Voice Frequency (V.F.) relays and their polarized relief relays presented something quite new and consequently it was necessary that some testing arrangements should be available at the outset.

Photographs of these relays accompany the article by Mr. H. A. Ashdowne on "Voice Frequency Keysending from Manual A-Positions," in Vol 25, Part 4, of this Journal. It might be mentioned here that the article also gives details of the procedure for determining the attenuation and feed resistance values required for the routiner.

In view of the great amount of traffic to be carried by each V.F. relay-set, it was considered desirable to provide facilities for frequent testing of the relay-sets. Consequently, a manual tester was out of the question and a routiner was decided upon.

The original machines used for deriving the voice frequencies are costly items and although considerable economy has been effected in the latest type, their provision at an Automatic Exchange for the use of one routiner could not be justified. The most promising alternative was to receive the frequencies for testing by the routiner over a junction from a Manual Exchange. It was decided that one, and in some cases two, conveniently situated Manual Exchanges in each Engineering Section should provide the frequencies for testing at each Automatic Exchange in that Section. Naturally an endeavour was made to keep the apparatus and circuit at the Manual end as simple as possible.

At this time tests were being carried out on sample V.F. relays and associated equipment at National Exchange by means of artificial traffic from Clerkenwell Exchange. From the preliminary results of these trials, it appeared essential to make two tests on each V.F. relay, one for operation and another for non-operation, viz. (1) To send each frequency singly over a junction degraded to 17 db. and (2) To send all frequencies, except that corresponding to the relay under test, over a junction degraded to 9 db. An important factor in these tests is the duration of the pulse of frequency. The normal minimum and maximum pulse time as keyed by operators was believed to be 30 mS and 250 mS respectively. (A further reference to this is made later.) To maintain simplicity at the manual end of the junction, only one period of pulse could be used and the period chosen was 200 mS.

The maximum junction loss in service was considered to be 14 db. and, in order to obtain uniform signal strength, which reflects upon relay sensitivity and adjustment, it was decided to pad all junctions used for V.F. working from 12 db. to 14 db. This

appeared to indicate that the test junction to be used for the routiner might be anywhere within the range of 0 db. to 14 db. As it was necessary to test at the equivalent of 9 db. over a junction of perhaps 14 db., some means of amplifying the signal strength had to be considered. It was felt that the delay of producing a suitable valve amplifier, to be stable and standard for all jobs, could not be tolerated at this stage. There were no V.F. relays and frequency generating machines available for independent investigations to be carried out. Consequently the Contractors were requested to produce a suitable transformer for the supply at the Manual Exchange to give a gain of 5 db. The transformer was produced in due course, but a change of circuit at the supply end was recommended for use with the new transformer. Hence the circuit arrangements of the feed resistances are different from those in the A-operator's position circuit, and also the bank contacts of the Frequency Supply Uniselector are connected direct to the supply, which may prove to be an undesirable feature although no trouble has been experienced yet.

The signal strength at each frequency supply set is raised by 5 db. and then degraded at the routiner to the required level.

It will have been noticed that the signal level has so far been referred to junction losses, *e.g.*, 9 db. and 17 db. for the test levels. This was found to be difficult to measure as a separate entity and as it was necessary also to know the overall loss, the signal level indication was transferred to the equivalent received level. The keys in the routiner marked 2.5 db., 5 db., 7.5 db., and 10 db. therefore refer to the received level as measured and averaged for the four single frequencies.

In order that apparatus may function efficiently in service and also that the associated routiner may detect faulty apparatus before it causes trouble in service, the routiner aims at imposing a slightly more onerous test condition than the worst practical condition. The V.F. relays were reputed to function satisfactorily over a range of 0 db. to 14 db. (received level) and consequently junctions were padded to a range of 5 db. to 9 db. which with a reasonable margin gives a working range of 4 db. to 10 db. The routine test range was made  $2\frac{1}{2}$  db. to  $12\frac{1}{2}$  db. After tests had been made at several exchanges installed with V.F. apparatus it was observed that the routiner was showing a greater percentage of failures than occurred in the trials; in other words, the routiner was too severe. It was then discovered that the reliable range of the relays in practice was  $2\frac{1}{2}$  db. to 10 db., so, to permit of the necessary margins, the ranges were revised to be 5 db. to 8 db. for padding, 4 db. to 9 db. working, and  $2\frac{1}{2}$  db. to 10 db. for testing.

It will be seen from the accompanying diagram,

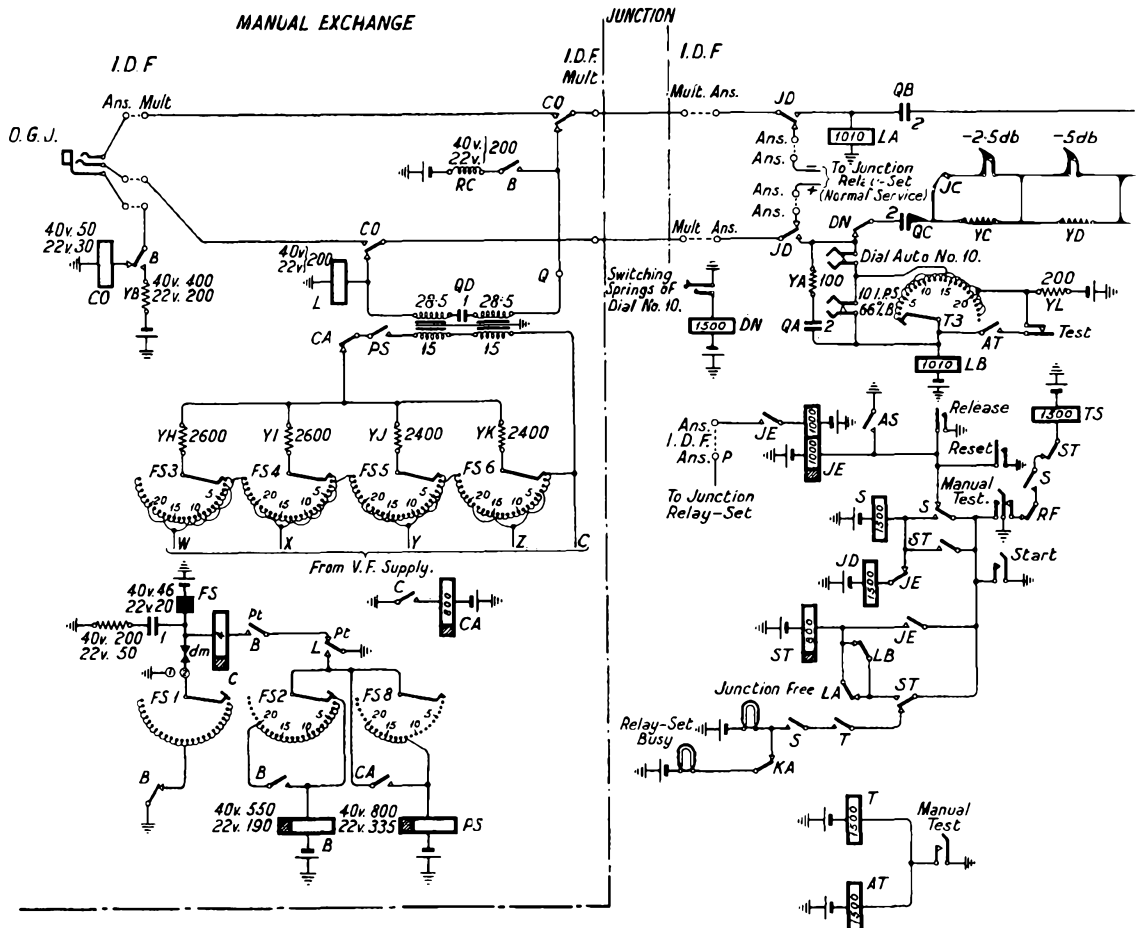

showing the elements of the Voice Frequency Relay-set Routiner Circuit, that condensers and relays are so arranged in the negative and positive lines to simulate the transmission bridge of the junction relay set to permit of testing under similar conditions to those in service.

Before testing of the V.F. relays is commenced, it is necessary to ascertain that the junction relay set associated with the test junction is free; that the junction is free and has no plug inserted in the distant end; and also that the V.F. selecting uniselector, F. S., is in the "home" position. This is accomplished by, firstly, associating relay JE with the private of the junction relay-set; secondly, testing for the earthed relay L on the positive wire *via* relay LB; and thirdly, testing for battery on the negative wire by means of relay LA. Relay B cannot operate to connect battery to the negative wire unless the uniselector is at the "home" position.

The frequencies and combinations of frequencies are connected to the bank contacts of the frequency selecting uniselector and, as the testing proceeds, the uniselector progressively applies the required frequency or combination for the test being made. The

uniselector is stepped by impulses from the routiner, which are passed over the positive wire of the test junction. The impulsing was found to be rather erratic due to the inductance of relay LB and consequently a 200-ohm non-inductive resistance has been arranged to be connected across the relay during impulsing.

Any changes of the line conditions cause surges which operate the V.F. relays and hence a delay period is provided by the slow release of relay SA before the V.F. relay-set is connected to the routiner, to allow sufficient time for the effects of the surges to die away before the test is made. Even the removal of the 200-ohm shunt just mentioned will cause such surges.

The impulse, previously referred to, charges the line and condensers and should a combination of frequencies be passed over the line before this charge has dissipated, the frequencies, have additional energy imposed upon them which causes "overlap," *i.e.*, the operation of the relay under test for which the frequency has not been sent. Consequently a sufficient period must elapse before the frequencies are connected and this is catered for by the release of relays C and CA. Relay CA was



UTILIZING VOICE FREQUENCY SUPPLY FROM A DISTANT EXCHANGE.

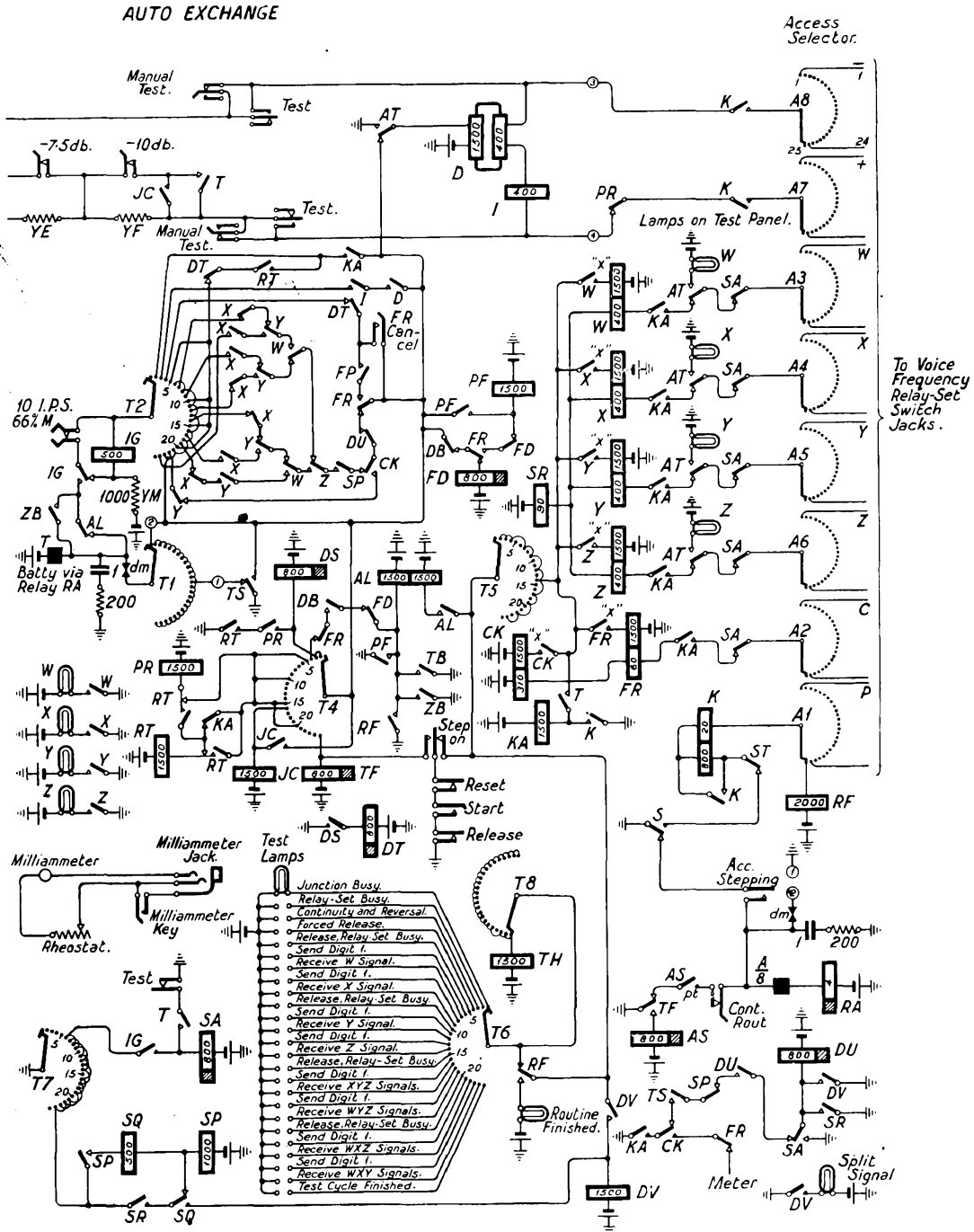

added after the relay-sets for the manual exchanges had been manufactured as the period was found, during tests, to be insufficient.

The incorporation of these various delays increased the time of the tests and to prevent false fault alarms operating in the routiner the test cycle had to be sub-divided so that the relay set is released and re-seized several times during a complete cycle of test.

At the completion of each test cycle, the frequency selecting uniselector must return to its "home" position in readiness for the succeeding tests. This is effected by releasing the test junction with a re-applicator of the busy test before again seizing it, as during this released period the junction may be taken into use for normal service.

Like most new schemes, one or two minor weaknesses were discovered subsequent to the field

trials. During the investigation of these it was found that when the V.F. relays were reaching failure point, due to dirty contacts, etc., the relief relay contacts gave "flicks" or "split signals." It became necessary, therefore, to include in the routiner a test for "split signals" such that the test would reveal a possible failure before it occurred in service. This presented some difficulty as under service conditions a failure could occur if the period of break of the signal was sufficiently long to allow release of the DS relay and the stepping of the digit distributor in the sender. This period varied from 14 mS to 36 mS with different Contractors' apparatus. Relay SR in the routiner simulates relay DS in the sender, whilst the operation of relay SQ in the routiner takes the place of the stepping of the digit distributor. Due to this variation in timing, no standard time could be laid down but it has been stipulated that the releasing lag of SR plus the operating lag of SQ in the routiner is to be less than the releasing lag of DS plus the stepping time of the digit distributor in the sender.

In view of the short time required for this operation, it will be appreciated how difficult it is to maintain an efficient test in the routiner, when it is remembered that no means of measuring such periods are available for maintenance officers. The testing circuit can only be checked by ensuring that the relays are within the specified adjustments which usually provide such wide tolerances as to make the test doubtful.

Before the incorporation of the Split Signal test it was possible for the routiner to function satisfactorily from a pulse which was too short to operate the sender DS relay and step the digit distributor. Relay SR, which simulates DS, due to its quick release is a little slow in operation and this results in the detection of short pulses. As the release of SR enters into the test, the failure of a V.F. relief relay to release is also noted.

A peculiar fault was brought to light during the installation of a V.F. Relay-set Routiner. The tip of wiper 6 of the test switch was badly burnt. This was found to be due to a test lamp being short-circuited and although the series relay, TH, was of low resistance the period, *i.e.*, 100 mS, which the test switch was in that position was too short to allow the fuse to function. Relay TH is now connected to level 8 of the switch.

Some tests carried out recently on V.F. installations show that the operators' key depressions are, in general, between 80 mS and 150 mS, hence the routiner tests are somewhat inefficient as the testing pulses are between 200 mS and 300 mS. The testing pulse was changed temporarily to 100 mS and was then capable of detecting faults not otherwise noticed.

When a fault has been located by the routiner it is necessary to ascertain whether it is due to the V.F. relay or the relief relay. The routiner is used for obtaining frequencies for making manual adjustment and localizing tests in connexion with the relays. Associated with the routiner is a test panel, mounted on one of the V.F. Relay Set racks. The

panel has a Milliammeter, Dial Auto No. 10, Milliammeter Jack and Key, Rheostat, Lamps for W, X, Y, Z signals, "Junction Free" and "Relay Set Busy," Test Key and Release Key. The frequencies are obtained for manual testing as follows: The Access Selector is stepped to the particular Relay-set by means of the Stepping key. The Manual Test key is thrown and indication is given on the test panel if the relay-set is busy and when the test junction is free. The required frequency is obtained by using the dial on the panel in accordance with the following table:—

Dial 01	for W	frequency	
" 02	" X	"	"
" 03	" Y	"	"
" 04	" Z	"	"
Dial 05	for XYZ	frequencies	
" 06	" WYZ	"	"
" 07	" WXZ	"	"
" 08	" WXY	"	"

The test key must be thrown to allow the frequency to pass into the relay-set. A Release key is provided to release the equipment as required. The frequency so supplied from the manual exchange is continuous to allow of adjustments and tests being made of the relief relay while the frequency is applied.

Before taking any action in connexion with the V.F. relay in a faulty relay-set, the polarized relay must be checked for operation and release. The Manual Test key is restored thus placing the routiner in a normal condition. Connected in the circuit of each polarized relay is a test jack and this is associated with the milliammeter jack by means of a double-ended cord. The rheostat is turned to give the necessary variation of current for the test. The relay should operate at 5 mA and release at 2.5 mA, each test being made after saturation at 12 mA. The appropriate lamp on the test panel indicates the operation and release of the relay.

The relief polarized relay depends for its operation upon the removal of a short-circuit by the bobble contact of the V.F. relay. This contact is operated when the tuned reed responds to the relevant frequency. If the relay is out of adjustment, the reed will not respond faithfully and the short-circuit will only be removed intermittently. A milliammeter placed in series with the polarized relay indicates whether the removal of the short-circuit is continuous or intermittent by the value of the current passing. Arrangements are provided for associating a milliammeter with the relief relay circuit as follows: Throw the required attenuating key, 10 db. for operating test and 2.5 db. for non-operating test, then the Manual Test key and obtain the necessary frequency as previously mentioned. With the relevant test jack connected to the milliammeter jack as above and the Milliammeter key thrown, operate the Test key. Provided the rheostat is at zero the milliammeter will show the current flowing through the polarized relay.

Should the V.F. relay be indicated as faulty, the bobble contact should be cleaned. If, then, the relay

is still faulty, the relay-set should be jacked out for return for re-adjustment.

In the initial design of the routiner it was essential that the busy key of the relay-set be thrown before making a manual test. It was considered that such manual tests would only be made on faulty relay-sets and by having the busy key operated there was no chance of the relay-set being taken into use for normal traffic during any slight unguarded period that might otherwise have occurred.

After some experience had been gained of the performance of the V.F. relay-sets, it was deemed advisable to include certain manual tests in the normal maintenance routine. To have to operate the busy key of each relay-set prior to making the tests was thought to be laborious. The lamp associated with the key is a guide as to whether the set is engaged, but, even so, the key might be operated at the moment when the relay-set was seized. It was therefore decided to associate the busy test by the routiner with the manual testing arrangements. The P-wire connexion to the relay-set was changed so that this test could be made irrespective of whether or not the busy key was operated and, hence, in the

case of faulty relay-sets, they can be tested without being freed for even the slightest period.

The test key connexions were arranged to short-circuit the negative and positive leads to prevent the application of frequencies to the relay-set. This caused a quick discharge of the V.F. relay-set condenser when associated with the routiner and consequent violent movement of the bobble contact. The connexions of the key have now been re-arranged to complete, instead of short-circuiting, the circuit for the frequencies.

It is essential when making manual tests that one of the attenuating keys be operated to prevent abnormal movement of the bobble contact. Such movement sometimes results in a dirty contact.

It will be noticed that lamp-indication of the relay-set being tested is not provided in this routiner and that there is no "homing" circuit for the access selectors. Consequently the access selectors are mounted in such a position on the routiner rack that the selector indicators can be readily seen. When the routiner is not in use, the access selectors should be left in position 25, and prior to commencing a test they should be stepped to position 1.

## Book Reviews

"Proceedings of the International Consultative Committee on Long Distance Telephony." (English translation issued by the International Standard Electric Corporation. 350 pages. 21s. net).

The "Comité Consultatif International des Communications Téléphoniques à Grande Distance" (C.C.I.) was formed at a preliminary meeting held in Paris in 1923.

During the ten years of its existence an efficient system of international telephone circuits has been built up which enables, for example, subscribers in Great Britain to speak to about 95 per cent. of the 35 million subscribers in the World's telephone network. This system has been built up, so far as the European network is concerned, in accordance with the recommendations drawn up by the C.C.I. The recommendations are formulated by sub-committees and confirmed by the full Committee, on which 34 Telephone Administrations are represented. The recommendations deal with questions affecting telephone transmission, protection, operating and tariff problems.

The publication under review deals with the proceedings of the last full meeting which was held in Paris in September, 1931.

It contains all the recommendations of the C.C.I. in practically all fields of long-distance telephone practices. Under the general heading of Transmission, definitions of principles and rules pertaining to standards are given as applicable to wire, carrier and radio-broadcast circuits. Similar rules and regulations for telephone apparatus, over-head and underground lines and maintenance thereof are also given.

A valuable feature of this publication is a series

of 26 typical specifications for cables, apparatus and systems in a modern telephone plant. One section is devoted to a bibliography of English, French and German publications in the communication art. The extent of this bibliography is indicated by the fact that 728 references are given to such publications.

Another important feature is the section on the protection of telephone lines against high tension disturbances and electrolytic corrosion with a description of modern methods to combat these troubles. In this connection three articles by eminent telephone technicians are included in the publication for reference purposes.

A complete list of delegates, together with verbatim reports of the opening and closing sessions of the plenary meeting complete the subject matter.

The volume includes a good index of contents with references to the page numbers both in the French and English editions.

This publication may be said to represent an up-to-date compendium on international telephony and should be of interest to all telephone engineers.

C. R.

"Worked Examples for Wiremen and Students." H. Rees, Grad.I.E.E. Sir Isaac Pitman and Sons, Ltd., London. 3/6 net.

This small book on D.C. Calculations covers the more elementary calculations required in the City and Guilds Examinations in Telegraphy and Telephony, and, while intended primarily for the power engineer, should also prove useful to students of these subjects.

W. S. P.

## Notes and Comments

### The "Post Office Magazine"

**T**HROUGH the courtesy of the Editor, we have been privileged to read the proofs of the "Post Office Magazine," which is to make its debut on January 5th, 1934. Judging from the contents, it should have an enthusiastic reception and it is not our intention to indulge the curiosity of our readers by giving a detailed review of its contents. We can, however, assure them that they will find its 48 pages of great interest; they are filled with brightly written articles, and accounts of social and sporting activities from all parts of the country. The articles are lavishly illustrated and range from a description of the Post Office Research Station to a humorous survey of the various means which members of the Staff taking part in the Staff Salesmanship may (or may not!) adopt in persuading members of the public to become subscribers to the telephone. In regard to District News, the Editor has worked wonders with the space at his disposal, and it is doubtful whether any part of the country remains without representation.

The Magazine will be on sale to members of the Staff and to the public at one penny. It will appear regularly on the first Friday of each month, and it can be heartily recommended to our readers as filling a niche in the social activities of the Post Office Staff which has hitherto been deplorably vacant.

### Inductive Interference from E.H.T. Lines

28th November, 1933.

The Managing Editor,  
*Post Office Electrical Engineers' Journal,*  
Alder House, E.C.1.

Dear Sir,

I have read the article on the above subject by Mr. A. J. Jackman in the July issue of the P.O.E.E.J., and the subsequent correspondence between Messrs. Josephs and Jackman with considerable interest. Having done so, I only venture to occupy further space in your columns because I feel that it has not yet been made perfectly clear to the ordinary reader why engineers no longer use the equivalent earth plane theory for computing the coefficient of mutual induction between the power and the telephone line.

The equivalent earth plane theory visualizes the coupling as being that between two loops, the vertical distance between the go and return conductors forming the inducing loop being twice the height of the power line above the equivalent earth plane, and variable at will. This is not in accord with physical fact as the real coupling is partly resistive and partly reactive. When the two circuits are close together the mutual reactance predominates, when they are

far apart the coupling is almost entirely due to the existence of a mutual resistance between them. For practical engineering purposes the inadequacy of the picture would not matter much—if the size of the inducing loop could be so fixed that for a given site the calculated coupling would always be numerically equal to the true coupling. Unfortunately this cannot be done, and the depth of the equivalent ground plane has to be continuously adjusted as such factors as frequency, separation and resistivity of the earth are varied.

On the other hand, the—so called—coefficient of mutual induction, as calculated from the Carson or Pollaczek formula, includes within itself both the resistive and the reactive part of the coupling. When the earth is approximately homogeneous it has been found to give the true result over a wide range of all the variables. To the uninitiated the formula may appear terrifying, but tables of  $\text{ker}'$  and  $\text{kei}'$  functions are available which reduce the evaluation of the true coupling between the lines to a simple arithmetical process.

Yours faithfully,

W. G. RADLEY.

### Rules of Golf

The Royal Insurance Co., Ltd., 1, North John Street, Liverpool, has sent us a copy of their booklet setting forth the revised Rules of Golf, which come into operation on January 1st, 1934. The Company informs us that they will be happy to forward a copy to any of our readers who care to apply for it.

### The Imperial Patent Service

Mr. M. E. J. Gheury de Bray, well known to our readers as the Author of "Exponentials Made Easy" and a similar work on hyperbolic functions, informs us that he has commenced a patent service under the above title, with offices at First Avenue House, High Holborn, London, W.C.1. In connexion therewith, he has prepared a booklet on "Practical Hints on the Patenting and the Development of Inventions" and is prepared to supply a copy to any of our readers who may be interested.

### Telephone Transmission

In this issue, we commence the first of a series of articles from the pen of Mr. R. M. Chamney, who needs no introduction to our readers as an authority on telephone transmission. In this series, it is Mr. Chamney's intention to treat his subject practically

non-mathematically and to give a comprehensive view of the subject of telephone transmission in order that engineers, other than specialists, may appreciate the many varied aspects of transmission problems.

### Trunking

Readers who are concerned with Trunking Problems in Automatic Telephony will be interested to hear that Mr. G. S. Berkley, of the Engineer-in-Chief's Office, has written a book on this subject and it is to be published in some two months' time. We hope to include a review of the book in our next issue.

### Location of Faults in Armoured Cables

P.O. Research Station,  
Dollis Hill,  
28-10-33.

The Managing Editor,  
*P.O.E.E. Journal.*

Dear Sir,

The necessity for quickly and accurately locating the position of a breakdown in the case of armoured telephone cables laid directly in the ground was emphasized in a recent article.

The usual methods can be used to locate the actual faulty length of cable, but it is very desirable that the exact position of the fault in that length should be determined. In the case of contact and earth faults the Varley or Murray tests can be employed for this purpose, a good wire external to the cable being used in the case of a complete breakdown.

The object of this letter is to bring to more general notice a very simple method of locating contact or earth faults. This method was described in *The Electrical Review* of July 28th, 1933, "Finding a Multi-core Cable Fault," by "A.A.I.E.E."

The arrangement is shown in the diagram below.

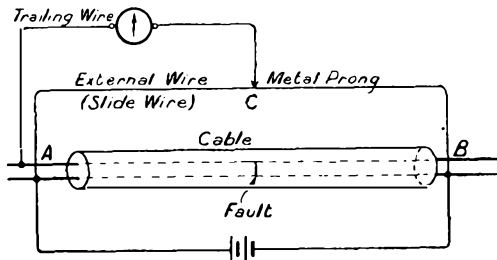

For the sake of simplicity only two wires in the faulty cable have been shown.

It will be seen that two insulated wires are run external to and over the line of the cable from one

end of the length to the other. One of these wires feeds a battery of about 4 or 6 volts into one of the faulty wires, the other external wire, in parallel, acts as a slide wire. A third or trailing wire is connected to one end of the other faulty wire then through a galvanometer to a pointed metal prong. This prong is used to make contact with the wire used as a slide wire.

The method of locating the fault is to balance the galvanometer, i.e., find the position on the slide wire at which no current flows through the galvanometer. This position transferred to the main cable gives the position of the fault.

When the galvanometer is balanced the voltage drop across AC is equal to that across AF.

If desired the connections can be reversed and the voltage drop BC found, which will be equal to BF and the mean of the two positions taken.

A wire whose resistance is uniform with length should be used for the slide wire.

The arrangement, when all the wires in the cable are faulty, has been shown in the diagram. If a good wire exists in the cable then this wire can be used for the battery wire.

An accuracy of plus or minus two inches was given in the original article.

In two recent trials of this method on actual faults the following results were obtained:—

(a) On a length of cable of 143 yds. using one cell the fault was found three inches from the point indicated by the prong method. An ordinary Varley test gave a location two feet away from the actual position.

(b) On a length of cable of 261 yds. using two cells the fault was found two feet from the point indicated. The error in the case of an ordinary Varley test was 2 yds. In the case of this fault it should be mentioned that the cable was soaked with water for a distance of 4½ yds. and that the location as given by the prong method was almost at the centre of the wet patch.

Yours faithfully,  
G. W. HODGE.

### Delay Probability Formulae

In this issue we publish an article on this subject from the pen of the late C. D. Crommelin, to whose tragic death we referred in our last issue.

### Binding Cases

As this issue marks the completion of a Volume, it is opportune to remind readers that red cloth binding cases, lettered in gilt, are available for binding the four parts of each Volume. Details will be found on page 320.

## Mr. C. Robinson

It is with extreme sorrow that we have to record the death of Charlie Robinson, which took place at his residence, "Wroxham," Reigate, on October 31st last. He left on leave early in September in comparatively good health and there was no indication to assume but that he would return at the end of his leave period. Unfortunately, he developed thrombosis of the veins of the leg and a slight touch of dry pleurisy followed. No complications ensued, however, and he was making good progress towards recovery when suddenly he collapsed and died of cardiac embolism in the afternoon of the 31st October.

Mr. Robinson was born in July, 1882, and was, therefore, just over 51 years of age at his death. He was educated at Clifton and Pembroke, and was a B.A. of Cambridge. He entered the Post Office Engineering Department by the first Open Competitive Examination held for University graduates for posts in that Department, held in 1904, and was attached to the old North Metropolitan district. In 1909, he was transferred to the Research Section of the Engineer-in-Chief's Office and was promoted to Assistant Staff Engineer in that Section in 1923, a post which he held until his further promotion in 1930, to Head of the Test Section as Staff Engineer.

His work on telephone transmission and telephonic repeaters is well known. In 1922, he was awarded the I.P.O.E.E. Senior Silver Medal for his

paper on "Gas Discharge Relays and Development of Telephone Repeaters" and from the same Institution in 1925, and 1928, he was awarded the Senior Bronze Medal for papers on "Recent Research Work on Telephone Repeaters" and "The Submarine Link in International Telephony," respectively.

Mr. Robinson was a member of the Comité Consultatif International des Communications Téléphoniques, and his work on International Committees was highly esteemed in scientific and technical circles throughout the world. Those who had the privilege of working with him did not take long to appreciate his charming manner and the ease with which his active brain elucidated any difficulties which his less brilliant fellows appealed to him to solve.

Words cannot be found to express in adequate terms the sorrow which his early death has caused in the Engineering Department, and in particular in the Testing Branch.

He was laid to rest on Friday, November 3rd in the family grave in Reigate Churchyard adjoining the grounds attached to the house where he resided in his youth. The large and representative gathering at the obsequies was indicative of the high regard in which he was held.

To his wife and relatives we extend our heartfelt condolences.

R. T. K.

## District Notes

### South Lancs

#### TELEGRAPH AND TELEPHONE TRUNK ROOM REARRANGEMENTS. LIVERPOOL.

H. M. TURNER, A.M.I.E.E.

Early in 1932 work was started on the rearrangements of the Telegraph Room at Liverpool Head Post Office in connection with the introduction of Teleprinter working, and very shortly afterwards work was started on the replacement of the Telephone Trunk Room by the new Demand Suites. Both these alterations are now practically completed and a few notes on the work may be of general interest.

The area of the Telegraph Room was considerably in excess of that required after the installation of Teleprinters and rack mounted apparatus, whilst the Telephone Trunk Room required to be increased by a considerable area to accommodate the new Demand Suites. At the same time the old Phonogram Room situated at one end of the Telephone Trunk Room was to be replaced by a new room

using double tier equipment and situated in the Telegraph Room. The fact that these alterations had to be carried out at one and the same time made the work extremely difficult, particularly as most of the floor required strengthening by the



FIG. 1.—TELEGRAPH INSTRUMENT ROOM.



FIG. 2.—TELEGRAPH ROOM; RACK-MOUNTED APPARATUS.

Office of Works in order to withstand the additional weights imposed.

Fig. 1 shows the Telegraph Instrument Room with the Phonogram Room enclosed in the partition on the right of the picture. The whole of the old apparatus had to be concentrated in the space now occupied by the Phonogram Room, whilst the whole of the floor was relaid, and the tube system moved from the near end of the room to the distant end where they may be clearly seen. The teleprinter tables were then installed, together with the rack mounted apparatus, and the work transferred back to the new tables.

Fig. 2 shows the bays of rack mounted apparatus.

Fig. 3 shows the new Phonogram Room which consists of one double sided phonogram suite, one double sided telephone-telegram typewriter suite, and to the right of the picture can be seen the third double sided suite used for Outgoing purposes. Space is left for the installation of a fourth suite. A 2-hand Convevor Svstem is used for the circulation of messages to and from the Telegraph Instrument Room. The two drop chutes formed of light chains are clearly seen in the illustration.

Before work could be proceeded with the installation of the new Telephone Trunk suite the



FIG. 3.—PHONOGRAM ROOM.



FIG. 4.—TELEPHONE TRUNK SWITCHROOM.

operating on the old suite which was "U" shaped was concentrated to the two ends of the suite, whilst the central portion was recovered to enable the first stage of the new suites to be installed. The cutting of the multiple cables was avoided by the erection of a structure spanning the room and forming a trough into which the cables were lifted as the old suite was dismantled. The first stage was then installed, and opened for service in June last, after which the second stage was commenced consisting of the erection of a further number of Demand positions and this was brought into use in October.

Fig. 4 shows the new Trunk Room, the positions on the right being those for Incoming and Through working, numbering 21, those on the left being the 67 Demand and Delay positions. The pneumatic tube distributor is seen at the far end of the room.

Fig. 5 shows some of the bays in the Apparatus Room, a portion of the Chargeable Time Indicator Racks being visible on the left. The wide spacing of the racks was necessary on account of the floor strength.

The new Trunk Room was longer, but narrower, than the old one, and this enabled the Repeater

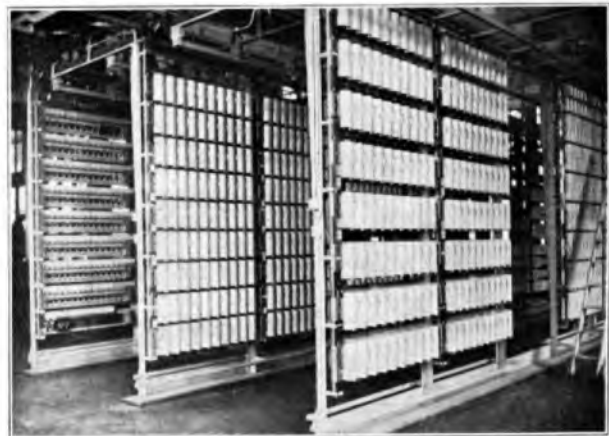

FIG. 5.—TRUNK APPARATUS ROOM, SHOWING RELAY-SETS AND CHARGEABLE TIME INDICATORS.

Room to be widened for the ultimate accommodation of additional equipment.



FIG. 6.—REPEATER ROOM, INCLUDING V.F. TELEGRAPH AND TARIFF "A" PRIVATE WIRE RACKS.

Fig. 6 shows a portion of the Repeater Room. The room extends, however, considerably to the left of the picture, this portion including 40 additional Repeaters recently installed, the main cable terminations and transformer racks, and the R.D.F. In the far distance can be seen the Voice Frequency telegraph apparatus recently installed, and immediately in front of them the Tariff "A" Teleprinter racks installed during the last year.

## Northern Ireland

### REARRANGEMENT OF TELEGRAPH ROOM AND NEW PHONOGRAM ROOM.

The old Telegraph Instrument Room at the H.P.O. Belfast has now been entirely rearranged. This work included the provision of the new type of teleprinter tables and Vee conveyors, and the installation of an apparatus rack for accommodating the latest type voice frequency equipment and associated control board. The work also involved the complete rearrangement of the pneumatic tube system and, as a result of these changes, Belfast Instrument Room is now equipped on the most up-to-date lines. The space formerly occupied by the old instrument room now accommodates the new Phonogram Board in addition to the telegraph instruments.

The new T.T.T. and Phonogram Switchboard, which was brought into service on the 9th August last, practically completes the scheme for replacing Morse working at Belfast by Typewriter Telephone-Telegram working, and it is hoped that the completion of the new Belfast-Portadown Banbridge cable will bring about the final abolition of Morse in the district.

The switchboard, which is of the standard design described in a recent article,<sup>1</sup> consists of two main

suites, one for T.T.T. traffic and the other for phonograms, situated on opposite sides and forming the main line of boards with eleven working positions and one distribution position in each suite. A belt conveyor, running in the centre between the two suites and accessible to operators on both sides, is used to convey received messages to the circulation point for appropriate distribution. The return side of the conveyor carries forwarded messages from the circulation point to a drop point on the distribution positions at the commencement of the T.T.T. and phonogram suites, whence they are distributed by hand.

The circulation point is situated in the main telegraph instrument room which adjoins the phonogram room and wherein are accommodated the teleprinters for all circuits linking Belfast. All telegrams and phonograms outgoing and incoming, including those received at the H.P.O. public counter, pass through this circulation point for distribution.

Special position lamps are provided in connexion with the T.T.T. suite, two lamps, a red and a green fitted under a dome on top of the board, being installed for each position. There is no glow when the position is unstaffed, but with an operator's instrument in circuit the dome glows green if the operator is engaged and red if the operator is not busy.

A Distribution Panel is provided at the commencement of the T.T.T. suite in connexion with the offices served by direct T.T.T. junctions. Depressing the key associated with the name of the required office indicates by the lighting of a lamp the position already engaged with that office or, if no lamp lights, will show that the junction to the office is free.

Separate outgoing junction multiples are provided on the Phonogram and T.T.T. suites with ordinary single-tier ancillary calling equipment of the 5-panel two-position type. The telephone-telegram circuits from Belfast are multiplied on both suites, but normally call only on the T.T.T. side. By means of controlling keys mounted in the panel, these circuits can be transferred individually to the phonogram side during pressure on the T.T.T. suite. Similarly the incoming phonogram circuits from Belfast normally call on the phonogram board, but, by the operation of a key, any circuit can be transferred to calling equipment ancillared on the T.T.T. side.

A flashing system of calling assists in the answering of calls in order of priority. On the phonogram side when a subscriber is calling the lamp glows steadily for a minimum of 15 seconds and between 15 and 20 seconds commences to flash and continues flashing until answered. On the T.T.T. side the lamp calls steadily for a period of 30 to 45 seconds before flashing sets in.

The typewriters used are equipped with continuous roll-feed message forms.

The switchboard is separated from the apparatus room and from a passage-way by a partition, and as this partition did not extend to the ceiling the top was used to support a local cable rack connecting the apparatus room with the switchboard.

<sup>1</sup> "Modern Developments in Phonogram and Telephone-Telegram Working," by G. Spears, P.O.E.E.J. Vol. 26, page 7.



# Retirement of J. Sinclair Terras, Esq., M.I.E.E.

Superintending Engineer, South Wales District



" For our sincere, though haply weak endeavours,  
 " With grateful pride we own your many favours;  
 " And howsoe'er our tongues may ill reveal it,  
 " Believe our glowing bosoms truly feel it."

*Burns.*

On the 11th September, over 200 members of the South Wales District Engineers staff, as well as representatives from all grades of the Postal, Telegraph, Telephone and District Manager's staff assembled at the Royal Hotel, Cardiff, to pay a farewell tribute to Mr. Terras who, through the age limit regulation, retired on the 30th September. During the evening Mr. Terras was presented with a 7-Valve All-Electric Radio set, and Groves "Complete Dictionary of Music and Musicians." Mrs. Terras was also asked to accept, as a token of esteem, a pair of solid silver Electric Table Standards. Mr. Herbert J. Hunter, M.I.E.E.,

Assistant Superintending Engineer, South Wales District, who made the presentation on behalf of the staff, referred to the happy relationship that had always existed between all grades of the staff and their departing chief, and to Mr. Terras's judicious administration whereby the public telephone system in South Wales had been advanced in efficiency and service. Speeches of appreciation were also made by representatives of the various grades and departments. Mr. C. A. Jackson, Surveyor of the South Wales District, specially referred to the great help and consideration his Department had always received during Mr. Terras's term of office. Mr. H. C. A. White, M.A., Head Postmaster of Cardiff, also spoke of his happy official experiences and the assistance which had always been given without reservation.

Mr. Terras was educated in Glasgow and entered the service of the late National Telephone Company in 1899. He held the successive posts of District Manager at Galashiels, Greenock and Reading until 1909, when he was made District Engineer at Birmingham. He held this post until the acquisition of National Telephone Co. by the State in 1912, when he was appointed to the position of Executive Engineer for Birmingham City. In 1913 he was appointed to the post of Assistant Superintending Engineer, North Western District, at Preston, where he remained until 1928, when he was promoted to the rank of Superintending Engineer, South Wales District, Cardiff.

Apart from his Engineering attainments, Mr. Terras is a musician of outstanding ability. For a long period he held the post of Organist in an important Church in Greenock. He also took a prominent part under Sir Landon Ronald in the last festival of the Preston Guild Merchant which is held once in twenty years. In 1925, the first prize was awarded to Mr. Terras's Instrumental Trio at the Lytham annual festival. Mr. Terras rendered very valuable help to the movement for retaining the National Orchestra of Wales which the B.B.C. had decided to disperse, although the local industrial situation was very acute. For this reason the movement suffered, but the B.B.C. would not alter or modify this decision which was a severe blow to Welsh Instrumental music.

Mr. Terras possesses a charming personality and as Chairman of the South Wales District Whitley Committee, he never failed to bring about harmony where discord seemed inevitable.

Being in the prime of life and in perfect health, it is the wish of his many friends that there will be no "age limit" to a very happy retirement amongst those who are near and dear to him.

H. J. H.

## Junior Section Notes

### Intermediate Telephony Examinations

The City and Guilds of London Institute have approved the publication of the following notice relating to the conditions under which candidates possessing a Final Certificate in Section 1—Automatic Telephony—may enter for the Intermediate Examination. The concession relates to the year 1934 only.

“The City and Guilds of London Institute, at the request of the Post Office Engineering Department and upon the recommendation of its Advisory Committee on Telephony, Telegraphy and Radio Communication, is prepared, as an exceptional measure, to allow candidates who obtained the Institute's Final Certificate in Section 1—Automatic Telephony—in 1932 or prior thereto without having passed the Institute's Intermediate Grade Examination in Telephony, to enter for the last-mentioned examination in 1934. Such candidates will not be eligible for any prize or medal awarded in respect of the Intermediate Examination. They should make application to the Superintendent, Department of Technology, City and Guilds of London Institute, 31, Brechin Place, London, S.W.7, on or before February 28th, 1934, in order that the College or Institution at which the candidate desires to be examined may be duly informed as to the above permission.”

### Telephone Transmission

Members of the Junior Section will be interested to hear that the Board of Editors has asked Mr. R. M. Chamney to write a series of articles on this subject with the object of indicating to the non-specialist engineer the practical implications of the various aspects of telephone transmission theory. The first of these articles is published in this issue, and the Board feels that the series will form a useful adjunct to the more theoretical series of articles by Mr. W. T. Palmer which was published some time ago, and subsequently reproduced in book form. Mr. Chamney is eminently fitted to deal with his subject in a lucid manner, for his work on telephone transmission problems has won international reputation. His object will be to present his subject devoid of that mathematical aura with which it is surrounded in the majority of text-books.

### The Current Issue

For some time, the Board of Editors has considered the possibility of introducing a Student's Section in the Journal and segregating thereto all those articles which are primarily of interest to the student. If this were done, however, the Student's Section would contain nearly 75% of the material published in the Journal, for the great majority of the articles are of interest to the student as well as to the technician. In the present issue, for instance, the first article by Messrs. Davis and Martin describes the telegraph converter required as the

link between a telex subscriber's teleprinter, which utilizes voice frequency currents for its operation, and the by-product circuit between Telex centres. Although this article is complete in itself, it forms one of the series on Telex working which have appeared in the pages of the Journal.

Then, too, to complete the series in the Bypass system of Automatic Telephony, we publish the article on Burton-on-Trent Exchange, which is the first of the Provincial exchanges to work on this system. The two articles already published give details of the system as a whole, and its application to a Director exchange.

Subscribers' Group Service is described by Messrs. Winch and Ellis who were responsible for the circuit design. This service is entirely new, and is likely to be very much to the fore in the coming year.

Voice Frequency Signalling for Trunk circuits is described by Mr. Flowers, who has been mainly responsible for the Research work in connexion with the system. Its application to two typical circuits is described.

Then, Messrs. Evans and Broadhurst, who should be well known to a large number of Junior Section members, for they are lecturers at the Training School, Dollis Hill, tell us about the Siemens No. 17 system of Automatic Telephony and describe the principle of the remarkably fast-operating relay and the high-speed uniselector which form the basis of the scheme.

Similarly, other articles in this issue are of direct interest to members of the Junior Section. All of these articles are of educational value and, as such, are intended for the student, but it is undesirable to place them in a special student's section. Members of the Junior Section may rest assured that the Board has their interests at heart, and makes every endeavour to ensure that a due proportion of the articles published shall be of interest to its readers among the Junior Section.

### Edinburgh Centre

The Session commenced in October when Mr. J. Lockie read a paper on “Telegraphy, Old and New.” Lantern slides were used, and a good discussion ensued. At the November Meeting, Mr. T. Henry took for his subject the “Application of the Telephone Repeater.” Slides and diagrams illustrated the subject.

Members were privileged to spend an interesting and instructive Saturday afternoon in November, in a visit to the Arniston Coal Company's Midlothian mine. Our thanks are due to Mr. J. A. Philips, General Manager of the Company, for permission to visit the mine, and to Mr. A. Hall, the Colliery Manager, who so ably conducted the party. The visit was happily terminated by tea, to which we were kindly entertained by the Colliery Authorities.

### Research Centre

The enthusiasm with which the inauguration of the Research Centre was received has continued throughout the past year. By the kind permission of Captain B. S. Cohen, we have been enabled to maintain interest by organized visits of members to all sections of the Research Station. These visits were arranged to take place on Saturday mornings and lasted for a period of 10 weeks, thus materially assisting in keeping the members together during the summer months.

Many promises of papers were received at the commencement of the present session. The following have been read before an average attendance of sixty members and visitors (the latter representing students attending the Engineer-in-Chief's Training School):—

Oct. 19th. Strength of Materials, by Mr. K. L. Beak.

Nov. 29th. Oscillographs and Oscillograms, by Mr. T. C. J. Kerwin.

These papers and those to be read during the remainder of the session, deal with the various phases of the department's activities from a Research standpoint, and should be of great interest to all members.

### Dundee Centre

The first paper given in October, by Mr. W. Batchelor, was on the main cable recently brought into use between Dundee and Perth. As Mr. Batchelor was left to deal with Precision Testing, the paper was carried forward and completed at the November Meeting. Good attendances were recorded, and the discussions keenly maintained.

### Aberdeen Centre

Our new Chairman, Mr. J. McLeod, opened the first meeting with appropriate remarks. Papers on "The Keystone of Telephony" by Mr. J. M. Cowie, and "Stray Currents," by Mr. W. C. Kelly, were read. At the November meeting, a paper on "Teleprinter No. 2A" was read by Mr. G. B. Ritchie. Lantern slides were used, and a working Teleprinter was subsequently inspected. The attendances and discussions were very satisfactory, and the interest shown by the Members indicates that the success of the first session is assured.

### Birmingham (Testing Branch Centre)

The 1933 programme made a highly successful debut with a visit to the B.B.C. Broadcasting Station at Daventry on September 23rd, and on October 16th, a "Technical Film Exhibition" opened our series of lectures. At this lecture we were pleased to have with us our Chairman, Capt. E. E. Fenn, O.B.E., and several other members of the Senior Section.

This film exhibition needs special mention as it

was given with our own Projector, and the Programmes for the evening turned out on our own Duplicator, both of which were recently acquired by the Branch.

Special mention should be made of the fact that a member of this branch, Mr. S. Stevens, with a paper read before this branch, came out No. 1 in the Annual Award for Papers, and although we did not have the privilege of seeing the certificate presented at one of our own meetings, we nevertheless tender to him our hearty congratulations.

### Chester Centre

By the courtesy of the Superintending Engineer of the South Lancs. District, several members of the newly-formed branch at Chester visited Manchester Toll and Blackfriars Exchanges on Saturday, September 23rd. Members of the Manchester Centre explained the different features of the exchange and the operation of the apparatus; altogether, an enjoyable and instructive afternoon was spent. Having the opportunity of visiting such a large exchange gave us, in a smaller area, some idea of the vastness of the present-day telephone service.

### Brighton Centre

The first meeting of the session, held on October 4th, was historic on account of the visit of the President, Mr. C. W. Brown M.I.E.E., who gave us details of the training of staff at Dollis Hill, a general outline of the developments that are taking place in the field of Automatic Telephony, and a demonstration of apparatus dating back to 1912, which was greatly appreciated by a large and enthusiastic audience which included the Superintending Engineer, Mr. G. F. Greenham, M.B.E., M.I.E.E., and the Assistant Superintending Engineer, Col. Carter, M.I.E.E.

The programme arrangements for the remainder of the session include a "talk" by the Assistant Engineer-in-Chief, Mr. A. B. Hart, O.B.E., M.I.E.E., and papers from Messrs. C. E. Calvelev, B.Sc., H. V. Thorne, A. V. Miles, C. A. Penfold, C. J. Wright, and H. Lee.

### Manchester Centre

On Saturday, October 28th, a party of members visited the works of Messrs. Oldham and Son, Battery Makers, Denton, and a most interesting and profitable time was spent in viewing the different processes of manufacture of this firm's products. Particular interest was evinced in the miner's lamps and dry battery sections. As a fitting conclusion, the members were entertained to tea by the firm, when the opportunity was taken of expressing thanks for the courteous and cordial reception afforded us.

The complete syllabus is now in the hands of members and augurs well for a most successful session.

# Staff Changes

## POST OFFICE ENGINEERING DEPARTMENT.

### PROMOTIONS.

Name.	From.	To.	Date.
Barralet, F. O. ... ..	Assistant Staff Engineer, Research Section, E.-in-C.O.	Staff Engineer, Test Section, E.-in-C.O.	13-11-33
Heil, H. ... ..	Chief Inspector, Telegraph Section, E.-in-C.O.	Assistant Engineer, Telegraph Section, E.-in-C.O.	30-11-33
Campbell, P. J. ... ..	Chief Inspector, Lines Section, E.-in-C.O.	Assistant Engineer, Lines Section, E.-in-C.O.	29-11-33
Martin, P. G. ... ..	Inspector, Scot. E. District.	Chief Inspector, Scot. E. District.	16-3-33
Knott, L. F. H. ... ..	Inspector, Eastern District.	Chief Inspector, Eastern District.	2-8-33
Brown, J. ... ..	Inspector, Scot. E. District.	Chief Inspector, Scot. E. District.	1-1-34
Baxter, F. J. ... ..	Inspector, N. Wales District.	Chief Inspector, Eastern District.	1-9-33
Thomson, A. ... ..	Inspector, Scot. W. District.	Chief Inspector, Scot. W. District.	7-12-33
Bridges, J. T. ... ..	Inspector, S.E. District.	Chief Inspector, S.E. District.	15-6-33
Burrell, G. E. ... ..	Inspector, Northern District.	Chief Inspector, Northern District.	3-8-33
Evans, G. E. ... ..	Inspector, N. Wales District.	Chief Inspector, N. Wales District.	4-10-33
Faulkner, C. G. ... ..	Inspector, Eastern District.	Chief Inspector, Eastern District.	1-1-34
Bird, F. T. ... ..	Inspector, N. Mid. District.	Chief Inspector, N. Mid. District.	6-10-32
Woodhouse, T. ... ..	Inspector, N. West District.	Chief Inspector, N. West District.	1-1-34
Wood, J. ... ..	Inspector, Research Section, E.-in-C.O.	Chief Inspector, Research Section, E.-in-C.O.	18-6-33
Keown, W. S. ... ..	Inspector, N. Ireland District.	Chief Inspector, N. Ireland District.	28-5-33
Stone, A. E. ... ..	S.W.I., S. Wales District.	Inspector, S. Wales District.	28-11-32
Wood, R. ... ..	S.W.I., London District.	Inspector, London District.	18-12-32
Turner, H. E. ... ..	S.W.I., London District.	Inspector, London District.	1-1-33
McCloud, J. H. ... ..	S.W.I., N. Ireland District.	Inspector, N. Ireland District.	18-3-33
Lee, S. H. ... ..	S.W.I., S. Lanes. District.	Inspector, S. Lanes. District.	9-7-33
Warburton, E. ... ..	S.W.I., S. Lanes. District.	Inspector, S. Lanes. District.	30-7-33
Lancaster, A. E. ... ..	S.W.I., N. East District.	Inspector, N. East District.	29-5-33
Dodd, O. W. ... ..	S.W.I., London District.	Inspector, London District.	9-6-31
Chisholm, H. ... ..	S.W.I., Scot. W. District.	Inspector, Scot. W. District.	2-9-33
Cooper, H. L. ... ..	S.W.I., S. Mid. District.	Inspector, S. Mid. District.	22-2-33
Morse, F. H. ... ..	S.W.I., E.-in-C.O.	Inspector, E.-in-C.O.	27-8-33
Sherwin, E. ... ..	S.W.I., S. Lanes. District.	Inspector, S. Lanes. District.	11-7-31
Whitmore, L. H. ... ..	S.W.I., S. Lanes. District.	Inspector, S. Lanes. District.	21-10-33
Groves, E. J. ... ..	S.W.I., S. West District.	Inspector, S. West District.	3-9-33
Boyd, W. J. ... ..	S.W.I., N. Ireland District.	Inspector, N. Ireland District.	28-3-33
Stewart, R. J. ... ..	Draughtsman, Cl. II., Scot. W. (vice W. G. Robertson, Dsmn., Cl. I)	Draughtsman, Cl. I., Scot. W. (Scot. W. reverted to Cl. II.)	14-8-33 8-8-33
Clark, E. A. ... ..	Draughtsman, Cl. II., E.-in-C.O.	Draughtsman, Cl. I., E.-in-C.O.	9-11-33
Palk, E. ... ..	Unest. Draughtsman, S. Mid.	Draughtsman, Cl. II., S. Mid.	14-9-33
Wharmby, L. C. ... ..	Unest. Draughtsman, N. Mid.	Draughtsman, Cl. II., N. Mid.	15-10-33
Roberts, H. E. ... ..	Unest. Draughtsman, N.E.	Draughtsman, Cl. II., N.E.	23-10-33
Brown, W. D. ... ..	Unest. Draughtsman, E.-in-C.O.	Draughtsman, Cl. II., E.-in-C.O.	6-9-33
Morris, W. A. ... ..	Unest. Draughtsman, E.-in-C.O.	Draughtsman, Cl. II., E.-in-C.O.	9-10-33
Cole, F. ... ..	Unest. Draughtsman, E.-in-C.O.	Draughtsman, Cl. II., E.-in-C.O.	12-11-33

### APPOINTMENTS.

Name.	From	To	Date.
Barker, H. ... ..	Inspector, London District.	Probationary Assistant Engineer, Research Section, E.-in-C.O.	1-10-33
Jackson, G. ... ..	Inspector, Research Section, E.-in-C.O.	Probationary Assistant Engineer, Research Section, E.-in-C.O.	1-10-33
Harnden, A. B. ... ..	Inspector, London District.	Probationary Assistant Engineer, London District.	1-10-33
Roberts, J. H. ... ..	Inspector, London District.	Probationary Assistant Engineer, Research Section, E.-in-C.O.	1-10-33
Styles, G. E. ... ..	Inspector, London District.	Probationary Assistant Engineer, Research Section, E.-in-C.O.	1-10-33
Hawking, W. ... ..	Inspector, Telegraph Section, E.-in-C.O.	Probationary Assistant Engineer, Research Section, E.-in-C.O.	1-10-33
Cooper, W. D. ... ..	Inspector, Radio Section, E.-in-C.O.	Probationary Assistant Engineer, Research Section, E.-in-C.O.	1-10-33

## APPOINTMENTS—Continued.

Name.	From	To	Date.
Ingram, C. P. ... ..	Inspector, Equipment Section, E.-in-C.O.	Probationary Assistant Engineer, Research Section, E.-in-C.O.	1-10-33
Smith, G. E. ... ..	Probationary Inspector, London District.	Probationary Assistant Engineer, London District.	1-10-33
Morley, J. E. ... ..	Inspector, Test Section, E.-in-C.O.	Probationary Assistant Engineer, Research Section, E.-in-C.O.	1-10-33
Creighton, J. L. ... ..	Inspector, London District.	Probationary Assistant Engineer, Research Section, E.-in-C.O.	1-10-33
Prickett, W. ... ..	Inspector, Lines Section, E.-in-C.O.	Probationary Assistant Engineer, S. Mid. District.	1-10-33
Oman G. R. ... ..	Open Competition.	Probationary Assistant Engineer, Research Section, E.-in-C.O.	2-10-33
Barnett, H. E. ... ..	" "	Probationary Assistant Engineer, Research Section, E.-in-C.O.	2-10-33
Adley, A. G. ... ..	" "	Probationary Assistant Engineer, Research Section, E.-in-C.O.	2-10-33
Davison, G. N. ... ..	" "	Probationary Assistant Engineer, Research Section, E.-in-C.O.	2-10-33

## RETIREMENTS.

Name.	Rank.	District.	Date.
Lamb, J. F. ... ..	Superintending Engineer.	Eastern District.	22-9-33
Terras, J. S. ... ..	Superintending Engineer.	S. Wales District.	30-9-33
Hook, G. H. J. ... ..	Executive Engineer.	Lines Section, E.-in-C.O.	5-10-33
Balcombe, R. C. ... ..	Executive Engineer.	S. West District.	25-10-33
Gillespie, J. T. ... ..	Executive Engineer.	Scot. East District.	9-10-33
Wynne-Jones, A. ... ..	Assistant Engineer.	S. Lancs. District.	7-9-33
Woodhouse, M. D. ... ..	Assistant Engineer.	S. Lancs. District.	31-10-33
Edwards, W. B. ... ..	Assistant Engineer.	S. Wales District.	14-10-33
Catto, M. ... ..	Chief Inspector.	Scot. E. District.	30-10-33
Hailes, S. E. ... ..	Chief Inspector.	S. Wales District.	28-10-33
Dawson, J. W. ... ..	Chief Inspector.	Testing Branch, London.	25-10-33
Hulse, W. J. ... ..	Chief Inspector.	S. Lancs. District.	2-12-33
Evans, J. ... ..	Inspector.	S. Wales District.	8-9-33
Morgan, J. W. ... ..	Inspector.	N. Wales District.	23-10-33
Eason, W. S. ... ..	Inspector.	N. Mid. District.	13-10-33
Dimond, G. ... ..	Inspector.	London District.	31-10-33
Isherwood ... ..	Inspector.	London District.	31-10-33
Yeates, H. T. F. ... ..	Inspector.	S. Mid. District.	30-11-33

## TRANSFERS.

Name.	Rank.	From	To	Date.
Bagley, T. ... ..	Asst. Engineer.	Sect. W. District.	N. Mid. District.	
Perris, F. R. ... ..	Asst. Engineer.	Telegraph Section, E.-in-C.O.	S.E. District.	
Dixon, E. J. C. ... ..	Asst. Engineer.	Radio Section, E.-in-C.O.	S. Mid. District.	1-12-33
McDonald, A. G. ... ..	Asst. Engineer.	Radio Section, E.-in-C.O.	Northern District.	28-12-33
Ward, W. C. ... ..	Prob. Asst. Engineer.	London District.	N. West District.	1-12-33
Hall, L. L. ... ..	Prob. Asst. Engineer.	N. Wales District.	Radio Section, E.-in-C.O.	8-10-33
Summers, F. ... ..	Prob. Asst. Engineer.	S. Mid. District.	S. Wales District.	15-10-33
Swindlehurst, R. J. K. ... ..	Prob. Asst. Engineer.	S. West District.	Radio Section, E.-in-C.O.	1-11-33
Lee, W. H. ... ..	Prob. Asst. Engineer.	Scot. W. District.	Radio Section, E.-in-C.O.	1-10-33
Coates, A. G. ... ..	Inspector.	S. Mid. District.	Research Section, E.-in-C.O.	4-10-33
Mays, S. G. ... ..	Inspector.	S. Wales District.	Equipment Section, E.-in-C.O.	24-7-33
Beatby, G. ... ..	Inspector.	Scot. E. District.	Equipment Section, E.-in-C.O.	8-10-33
Arnold, A. F. ... ..	Inspector.	S. Mid. District.	Equipment Section, E.-in-C.O.	10-10-33
Tucker, D. G. ... ..	Inspector.	Northern District.	Lines Section, E.-in-C.O.	22-10-33
Shepherd, J. ... ..	Inspector.	S. Lancs. District.	Designs Section, E.-in-C.O.	13-11-33

## STAFF CHANGES

## DEATHS.

Name.	Rank.	District.	Date.
Robinson, C. ... ..	Staff Engineer.	Test Section, E.-in-C.O.	31-10-33
Dixon, W. ... ..	Chief Inspector.	N. Mid. District.	30-10-33
Reid, A. ... ..	Chief Inspector.	Scot. W. District.	6-12-33
Langley, J. H. ... ..	Inspector.	S. Lancs. District.	16-8-33
Marshall, J. E. ... ..	Inspector.	London District.	8-11-33
Kenneth, A. P. ... ..	Inspector.	Scot. W. District.	2-12-33

## CLERICAL GRADES.

## PROMOTIONS.

Name.	From.	To.	Date.
Picken, C. C. ... ..	Clerical Officer, S. Wales District.	Higher Clerical Officer, S. Wales District.	22-11-33
Dick, J. ... ..	Clerical Officer, Scot. W. District.	Higher Clerical Officer, Scot. W. District.	27-11-33
Alexander, R. G. ... ..	Clerical Officer, S. West District.	Higher Clerical Officer, S. West District.	24-10-33
Woodland, T. H. ... ..	Clerical Officer, S. West District.	Higher Clerical Officer, S. West District.	5-1-34
Tulloch, J. J. ... ..	Clerical Officer, N. Wales District.	Higher Clerical Officer, N. Wales District.	25-10-33
Robbins, C. A. ... ..	Clerical Officer, Test. Branch, Birmingham.	Higher Clerical Officer, N. West District.	8-10-33
Hoole, G. H. ... ..	Higher Clerical Officer, N. Eastern District.	Staff Officer, N. Eastern District.	1-2-34
Hall, G. W. ... ..	Higher Clerical Officer, N. West District.	Staff Officer, Eastern District.	1-1-34

## RETIREMENTS.

Name.	Rank.	District.	Date.
Careless, E. D. ... ..	Higher Clerical Officer.	S. Wales.	21-11-33
Brown, R. ... ..	Higher Clerical Officer.	Scot. W.	26-11-33
Brown, H. H. ... ..	Higher Clerical Officer.	S. Western.	23-10-33
Bartlett, J. W. ... ..	Higher Clerical Officer.	S. Western.	4-1-34
Waller, R. E. ... ..	Higher Clerical Officer.	N. Wales.	24-10-33
Rowbotham, A. ... ..	Higher Clerical Officer.	N. West.	30-9-33
Hogsum, A. E. ... ..	Higher Clerical Officer.	London Engineering District.	31-10-33
Denton, J. C. ... ..	Staff Officer.	N. Eastern.	31-1-34
Adams, T. ... ..	Staff Officer.	Eastern.	31-12-33

## BOARD OF EDITORS.

- B. O. ANSON, M.I.E.E., Chairman.  
 P. J. RIDD, M.I.E.E.  
 C. J. MERCER, M.I.E.E., M.I.R.E.  
 A. J. GILL, B.Sc., M.I.E.E., M.I.R.E.  
 H. G. S. PECK, B.Sc., M.I.E.E.  
 J. T. KELLY.  
 J. INNES, B.Sc., M.I.E.E., Managing Editor.  
 W. S. PROCTER, A.M.I.E.E., Assistant Editor.

## COMMUNICATIONS.

All Remittances and Communications should be addressed to the MANAGING EDITOR, P.O.E.E. JOURNAL, Engineer-in-Chief's Office, Alder House, London, E.C.1. Telephone: NATIONAL 6321 (P.B.X).

Binding covers and copies of the Contents for Vol. 3 to 25 are available, and may be obtained from the local agents for 1s. 6d. and 3d. respectively. Subscribers can have their copies of Vol. 25 bound, with index included, at a cost of 3s., by sending the JOURNALS to the local agents. Orders for bindings, Vols. 1—19, should indicate whether the original binding with black lettering, or the latter pattern in gold, is required. Covers with gold lettering will be the only type stocked from Vol. 20 onwards.

The price of the JOURNAL is 1s. (1s. 3d. post free) per copy, or 5s. per annum, post free. All back numbers 1s. each, (1s. 3d. post free).

# Post Office Electrical Engineers' Journal

Volume XXVI--April 1933--March 1934

## INDEX

A	PAGE	D	PAGE
Acceptance Testers used on Sleeve Control Equipment. E. J. Harrold and C. N. Smith ... ..	185	Davis, H. G., and J. A. S. Martin. A Telegraph Converter for Tariff "Y" Service ... ..	243
Advance Automatic Exchange. M. C. Cooper and A. G. Lydall ... ..	48	De Wardt, R. G. Teleprinter Private Wires on By-product Circuits ... ..	83
Agreements for Wayleave and Maintenance of P.O. Plant on Railways, The New. H. M. ... ..	114	Delay Probability Formulae. C. D. Crommelin ... ..	266
Anglo-Belgian (1932) Submarine Telephone Cable. E. M. Richards ... ..	193	Design of Relays for Automatic Telephone Equipment Circuits, with Special Reference to Relay Type 3,000. R. Barker ... ..	15
Anglo-French (1933) Submarine Telephone Cable. E. M. Richards ... ..	291	Determining the Transmission Efficiency of Telegraph Circuits. E. H. Jolley ... ..	1
Angwin, Col. A. S. Appointment as Asst. E.-in-C. ... ..	66	Device for Measuring Sound Pressures in Free Air. A. W. West ... ..	260
Automatic Chart Analyser. E. A. Speight ... ..	275	District Notes ... ..	68, 153, 234, 312
Automatic Gain Control for Radio Receivers. I. J. Cohen ... ..	58	Douglas, J. H. Some Recent Developments in the Design of Manual Switchboards ... ..	255
Automatically Controlled Power Plants, Small. H. C. Jones and H. S. Waters ... ..	437		
		<b>E</b>	
<b>B</b>		Edwards, J. J. Trailer Handcarts and Pumps ... ..	222
Ballast Resistance in Transmission Bridges, The Use of. F. B. Chapman ... ..	140	Electrode Testing Methods Applied to Telephone Cables. W. T. Palmer and Major F. E. A. Manning ... ..	36
Barker, R. Design of Relays for Automatic Telephone Equipment Circuits, with special reference to Relay Type 3,000 ... ..	15	Electrode Method of Locating an Earth Fault on Submarine Cables, and the Development of Apparatus for Use on Cables. S. Hanford and L. Voss ... ..	180
Board of Editors ... ..	82, 162, 242, 322	Ellis, H. O., and B. Winch. Country Satellite Exchanges ... ..	125
Book Reviews ... ..	78, 158, 239, 309	Ellis, H. O., and B. Winch. Subscribers' Group Service ... ..	278
Brent, W. H. Continuous Suspension of Aerial Cables ... ..	219	Evans, A. F. E., and S. W. Broadhurst. An Outline of Siemens No. 17 System of Automatic Telephony ... ..	248
Brent, W. H., and A. O. Gibbon. Recent Development in the Design of Loading Equipment for Junction Cables ... ..	107		
Broadhurst, S. W., and A. F. E. Evans. An Outline of Siemens No. 17 System of Automatic Telephony ... ..	248	<b>F</b>	
Brown, G. Trunk Exchange Test Racks; New Design ... ..	53	Flowers, T. H. Voice Frequency Signalling for Trunk Circuits ... ..	282
Burton-on-Trent M.E. Area (Bypass System). A. G. Lydall and J. H. Russel ... ..	261	Frome, N. F. Telegraph Line Construction in India ... ..	200
Bypass System (Advance Automatic Exchange) ... ..	48		
Bypass System (Burton-on-Trent M.E. Area) ... ..	261	<b>G</b>	
<b>C</b>		Gibbon, A. O., and W. H. Brent. Recent Development in the Design of Loading Equipment for Junction Cables ... ..	107
Carrier Telephone System for Open Lines. A Simplified. R. J. Halsey ... ..	90	Gilbert, D. P. Telegram Conveyors ... ..	208
Chamney, R. M. Telephone Transmission Problems ... ..	301	Gill, A. J. Appointment as Staff Engineer ... ..	67
Chapman, F. B. The Use of Ballast Resistance in Transmission Bridges ... ..	140	Gill, A. J. Privacy Systems for Radio Telephony ... ..	224
Christmas Day Broadcast. A.J.G. ... ..	56	Gracie, A. J. A. Music Transmission over Short Wave Commercial Radio Telephone Circuits ... ..	60
Cohen, I. J. Automatic Gain Control for Radio Receivers ... ..	58		
Common Control System (Wigan Exchange) ... ..	145	<b>H</b>	
Communications ... ..	82, 162, 242, 322	Halsey, R. J. A Simplified Carrier Telephone System for Open Lines ... ..	90
Considerations in the Installation of Telephone Cables. C. F. Street ... ..	43	Hanford, S., and L. Voss. Electrode Method of Fault Location ... ..	180
Continuous Suspension of Aerial Cables. W. H. Brent ... ..	219	Harrold, E. J., and C. N. Smith. Acceptance Testers Used on Sleeve Control Equipment ... ..	185
Converter for Tariff "Y" Service. A Telegraph. H. G. Davis and J. A. S. Martin ... ..	243	Hines, Capt. J. G. The Snow Storm of February, 1933 ... ..	133
Cooper, M. C., and A. G. Lydall. Advance Automatic Exchange ... ..	48	Hogbin, A. Miscellaneous Facilities at Automatic and Manual Telephone Exchanges ... ..	21, 131, 303
Country Satellite Exchanges. H. O. Ellis and B. Winch ... ..	125		
Crommelin, C. D. Delay Probability Formulae ... ..	266		

	PAGE		PAGE
<b>I</b>			
Inductive Interference from Fault Currents on E.H.T. Power Lines. A. J. Jackman ... ..	97	Recent Developments in the Design of Loading Equipment for Junction Cables. A. O. Gibbon and W. H. Brent ... ..	107
Installation of Telephone Cables, Considerations in the, C. F. Street ... ..	43	Regenerative Repeater for Teleprinter (Start-Stop) Systems. E. H. Jolley and J. A. S. Martin ... ..	171
Institution of P.O. Electrical Engineers ... ..	76, 156, 237	Relay Type 3,000, Design of. R. Barker ... ..	15
<b>J</b>			
Jackman, A. J. Inductive Interference from Fault Currents on E.H.T. Power Lines ... ..	97	Repeater, The Toll. A. C. Timmjs ... ..	29
Johnson, H. A. The Witwatersrand Automatic Telephone System ... ..	116	Research ... ..	63, 150
Jolley, E. H. Determining the Transmission Efficiency of Telegraph Circuits ... ..	1	Richards, E. M. Anglo-Belgian (1932) Submarine Telephone Cable ... ..	193
Jolley, E. H., and J. A. S. Martin. Regenerative Repeater for Teleprinter (Start-Stop) Systems ... ..	171	Richards, E. M. Anglo-French (1933) Submarine Telephone Cable ... ..	291
Jones, H. C., and H. S. Waters. Small Automatically Controlled Power Plants ... ..	137	Robinson, A. K. Two Aids in the Study of Telephone Transmission ... ..	175
Junior Section Notes ... ..	77, 158, 237, 316	Russel, J. H., and A. G. Lyddall. Burton-on-Trent M.E. Area ... ..	261
<b>L</b>			
Loading Equipment for Junction Cables, Recent Developments in. A. O. Gibbon and W. H. Brent ... ..	107	<b>S</b>	
Local Centre Notes ... ..	76, 157	Siemens No. 17 System of Automatic Telephony, An Outline of. S. W. Broadhurst and A. F. E. Evans ... ..	248
Lyddall, A. G. Wigan Exchange ... ..	145	Simplified Carrier Telephone System for Open Lines. R. J. Halsey ... ..	90
Lyddall, A. G., and M. C. Cooper. Advance Automatic Exchange ... ..	48	Smith, C. N., and E. J. Harrold. Acceptance Testers for Sleeve Control Equipment ... ..	185
Lyddall, A. G., and J. H. Russel. Burton-on-Trent M.E. Area ... ..	261	Snow Storm of February, 1933. Capt. J. G. Hines ... ..	133
<b>M</b>			
M.H. The New Agreements for Wayleave and Maintenance of P.O. Plant on Railways ... ..	114	Spears, G. Modern Developments in Phonogram and Telephone-Telegram Working ... ..	7
Manning, Major F. E. A., and W. T. Palmer. Electrode Testing Methods Applied to Telephone Cables ... ..	36	Speight, E. A. Automatic Chart Analyser ... ..	275
Manual Switchboards, Some Recent Developments in the Design of. J. H. Douglas ... ..	255	Staff Changes ... ..	80, 160, 241, 318
Martin, J. A. S., and E. H. Jolley. Regenerative Repeaters for Teleprinter (Start-Stop) Systems ... ..	171	Subscribers' Group Service. H. O. Ellis and B. Winch ... ..	278
Martin, J. A. S., and H. G. Davis. A Telegraph Converter for Tariff "Y" Service ... ..	243	<b>T</b>	
McGregor, J. E. Pneumatic Ticket Tube System at G.P.O. (South) ... ..	287	Telegram Conveyors. D. P. Gilbert ... ..	208
Mercer, C. J. The New Inland Telegraph Service ... ..	163	Telegraph and Telephone Plant in the U.K. ... ..	14, 106, 207, 265
Miscellaneous Facilities at Manual and Automatic Telephone Exchanges. A. Hogbin ... ..	21, 131, 303	Telegraph Converter for Tariff "Y" Service. H. G. Davis and J. A. S. Martin ... ..	243
Modern Developments in Phonogram and Telephone-Telegram Working. G. Spears ... ..	7	Telegraph Line Construction in India. N. F. Frome ... ..	200
Music Transmission over Short Wave Commercial Radio Telephone Circuits. A. J. A. Gracie ... ..	60	Telegraph Service, The New Inland. C. J. Mercer ... ..	163
<b>N</b>			
New Inland Telegraph Service, The. C. J. Mercer ... ..	163	Telephone Transmission Problems; Features of the Essential Factors in Telephone Transmission. R. M. Chamney ... ..	301
Notes and Comments ... ..	65, 152, 231, 310	Teleprinter Private Wires on By-product Circuits. R. G. DeWardt ... ..	83
Notes, District ... ..	68, 153, 234, 312	Timms, A. C. The Toll Repeater ... ..	29
.. Local Centre ... ..	76, 157	Trailer Handcarts and Pumps; New Design. G. Brown ... ..	53
.. Junior Section ... ..	77, 158, 237, 316	Two Aids in the Study of Telephone Transmission. A. K. Robinson ... ..	175
<b>P</b>			
Palmer, W. T., and Major F. E. A. Manning. Electrode Testing Methods Applied to Telephone Cables ... ..	36	<b>V</b>	
Phonogram and Telephone-Telegram Working, Modern Developments in. G. Spears ... ..	7	Voss, L., and S. Hanford. Electrode Method of Fault Location ... ..	180
Pneumatic Ticket Tube System at G.P.O. (South). J. E. McGregor ... ..	287	Voice Frequency Signalling for Trunk Circuits. T. H. Flowers ... ..	282
Power Plants, Small Automatically Controlled. H. C. Jones and H. S. Waters ... ..	137	Voice Frequency Relay-set Routiner. J. S. Young ... ..	305
Privacy Systems for Radio Telephony. A. J. Gill ... ..	224	<b>W</b>	
<b>R</b>			
<b>S</b>			
<b>T</b>			
<b>V</b>			
<b>W</b>			
<b>Y</b>			