

Eric Simpson

THE POST OFFICE ELECTRICAL ENGINEERS' JOURNAL



**VOL. 25
PART I**



**APRIL
1932**

Price 1/- net.

ADVERTISEMENT INDEX
see page xii.

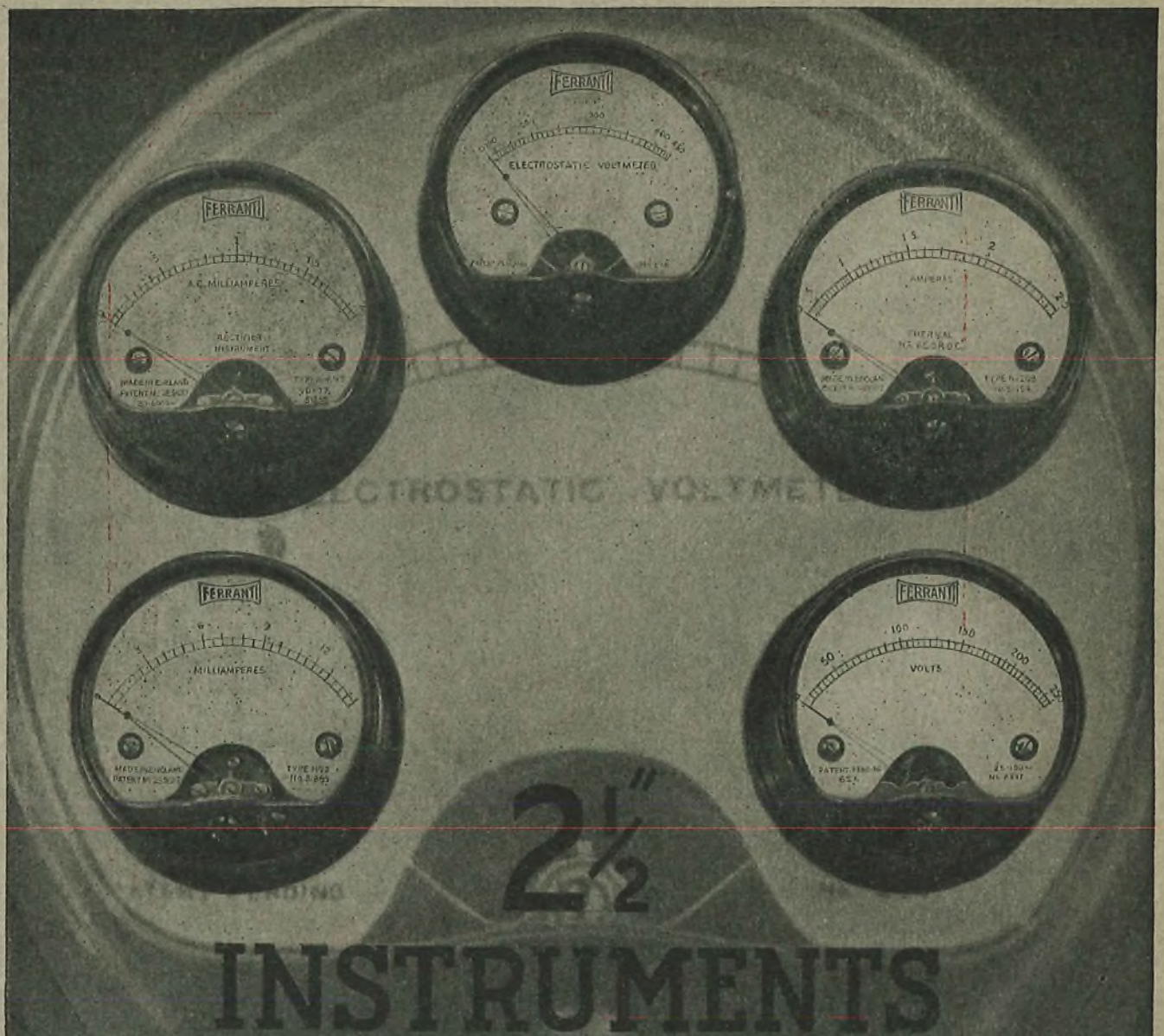

MOVING COIL RECTIFIER
 ELECTROSTATIC THERMAL
 AND MOVING IRON instruments fitted in cases
 of moulded insulation and having high torque, excellent
 damping and attractive finish. Robustness with
 precision character. Write for list In.1.

FERRANTI

HOLLINWOOD ENGLAND.

THIS IS THE AGE OF SPEED !



STROWGER AUTOMATIC TELEPHONES

AUTOMATIC ELECTRIC CO., LTD.

(formerly Automatic Telephone Manufacturing Co., Ltd.)

STROWGER WORKS, LIVERPOOL.

Telephone

Old Swan 830

LONDON OFFICE:

MELBOURNE HOUSE, ALDWYCH, STRAND, W.C. 2.

Telephone

Temple Bar 4506

The Post Office Electrical Engineers' Journal.

A QUARTERLY JOURNAL.

COPYRIGHT.—The entire contents of this Journal are covered by general copyright, and special permission is necessary for reprinting long extracts, but Editors are welcome to use not more than one third of any article, provided credit is given at the beginning or end thus: "From the 'Post Office Electrical Engineers' Journal.'"

The Board of Editors is not responsible for the statements made nor the opinions expressed in any of the articles in this Journal, unless such statement is made specifically by the Board.

CONTENTS FOR APRIL, 1932.

	PAGE
AUSTRALIAN CARRIER SYSTEM	1
A VOICE FREQUENCY MULTI-CHANNEL TELEGRAPH SYSTEM—J. M. OWEN, A.M.I.E.E., and J. A. S. MARTIN	8
TELEGRAPH REPEATER DEVELOPMENTS—R. P. SMITH, A.M.I.E.E., and F. T. CATTELL	17
RECENT DEVELOPMENTS IN AUTOMATIC TELEPHONE EXCHANGE EQUIPMENT—G. BROWN, A.M.I.E.E.	23
A GRAPHICAL METHOD OF DETERMINING THE IMPULSING PERFORMANCE OF TWO- MOTION SELECTORS—C. G. GRANT	28
ACORN EXCHANGE—B. HOUGHTON BROWN	32
MISCELLANEOUS FACILITIES AT AUTOMATIC AND MANUAL TELEPHONE EXCHANGES —A. HOGBIN	33
LINE PLANT ECONOMICS AS APPLIED TO JUNCTION TRAFFIC ROUTING—L. F. SALTER, B.Sc.	35
DELAY PROBABILITY FORMULÆ WHEN THE HOLDING TIMES ARE CONSTANT—C. D. CROMMELIN, M.A.	41
BRISTOL AREA AUTOMATIC TELEPHONE EXCHANGES—J. EMLYN-JONES	51
YOUNG PEOPLE'S TELEPHONE EXHIBITION	57
500 KILOWATT DEMOUNTABLE VALVES	61
TELEGRAPH AND TELEPHONE PLANT IN THE UNITED KINGDOM	64
A RESISTANCE THERMOSTAT WITH LIGHT-SENSITIVE CELL OPERATION—E. J. C. DIXON, A.C.G.I., B.Sc., D.I.C.	65
THE CALCULATION OF THE PROPAGATION CONSTANTS OF UNIFORM LINES—A. ROSEN, Ph.D., A.M.I.E.E.	67
OUTLINE NOTES ON TELEPHONE TRANSMISSION THEORY—W. T. PALMER, B.Sc., Wh.Ex., A.M.I.E.E.	72
NOTES AND COMMENTS	79
HEADQUARTER'S NOTES	82
MR. P. J. RIDD, M.I.E.E.	83
MR. C. J. MERCER, M.I.E.E., M.I.R.E.	83
MR. E. J. WILBY, M.I.E.E.	84
DISTRICT NOTES	84
THE INSTITUTION OF POST OFFICE ELECTRICAL ENGINEERS	95
LOCAL CENTRE NOTES	96
BOOK REVIEWS	100
STAFF CHANGES	101
COMMUNICATIONS	104

All communications with regard to advertisements to be addressed to:

The Advertisement Manager,

Post Office Electrical Engineers' Journal,

4, Ludgate Hill, London, E.C.4.

PUBLISHERS:

THE ELECTRICAL REVIEW, 4, LUDGATE HILL, E.C.4.

Single copy 1/- net, post free, 1/3.

Annual Subscription, postage
inclusive, 5/-, payable in advance

v.



INSTANT CONNECTION!

Through to your man AT ONCE no waiting, no "cross-talk." That's the job of the Ericsson Intercommunication System — and it does it well.

An Ericsson Telephone on your desk places your organisation at your finger tips—directors, secretary, accounts, warehouse. Clear-speaking, efficient, foolproof, a really faithful servant earning its keep all the time.

Our new instrument is handiness itself—a wonderful improvement on the older "candlestick." It looks well on the orderly desk too.

We are supplying this system to progressive firms everywhere. Can be supplied in delightful colours to match your interiors. May we quote for installation? *Write for quotations and particulars of our moderate rental and maintenance service terms.*

ERICSSON TELEPHONES LTD.
67/73, KINGSWAY LONDON, W.C. 2

Telephone—HOLBORN 32713.

Ericsson



ENTIRELY BRITISH MADE

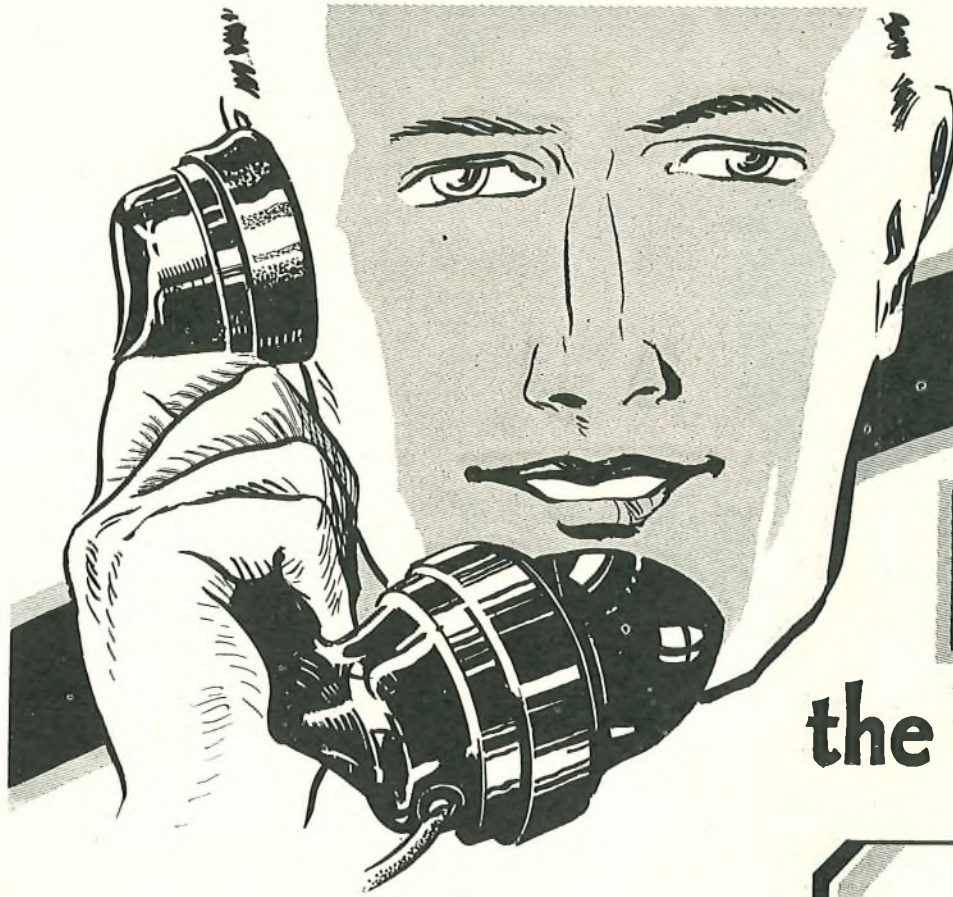

NEOF

the World's most

The desk pattern can be supplied either with the combined bell set as illustrated, or with a separate bell set.

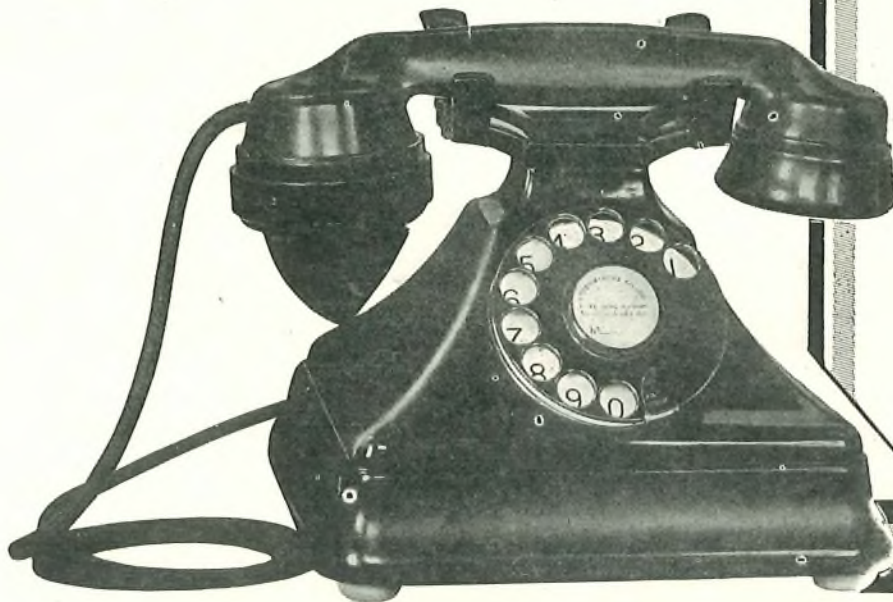

Standardized by the
BRITISH POST OFFICE
*after exhaustive tests of all the
available microtelephone instru-
ments.*

*Adopted by many important
Telephone Administrations,
including those of
South Africa,
Southern Rhodesia,
New Zealand,
Hong Kong,
Canada,
India*

The PHONE efficient Telephone

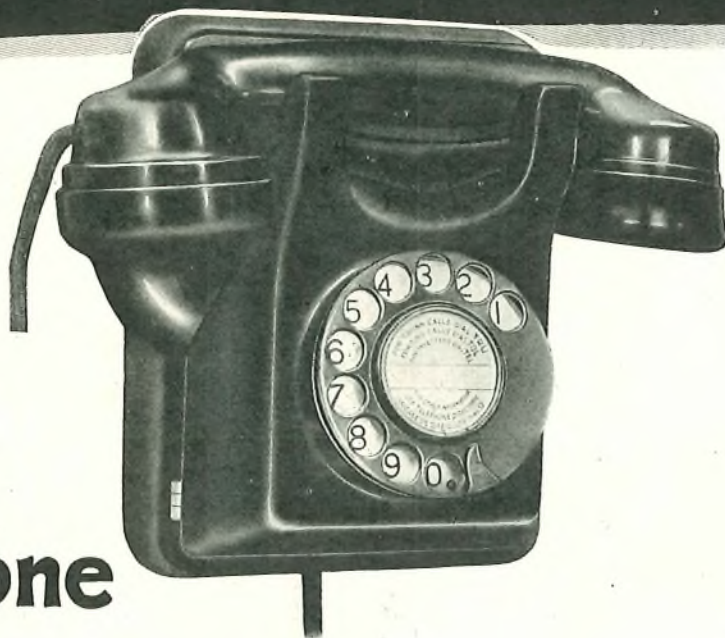

*Wall pattern "Neophone" as supplied to
South African and Canadian Telephone
Administrations.*

The "Neophone" embodies many exclusive and patented features, including the Siemens "Immersed Electrode" inset transmitter and special anti-side tone circuit.

It is not only exceptionally handsome in appearance and convenient to use, but is definitely superior to any other telephone as regards speech transmission efficiency and articulation.

SIEMENS
AUTOMATIC TELEPHONES

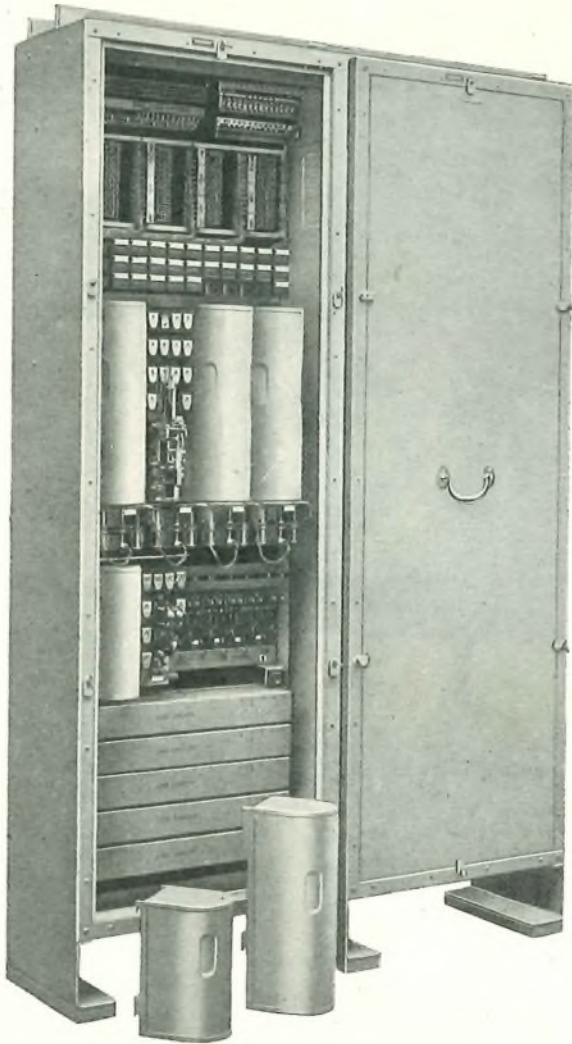

**AUTOMATIC
AND
SEMI-AUTOMATIC
TELEPHONE
EXCHANGES
FOR
RURAL
DISTRICTS**

The General Electric Company specialises in the design and manufacture of modern rural telephone exchanges of all sizes and for every class of service. The above illustrates two Units Auto No. 5 as supplied in large numbers to the British Post Office. In addition to this and other standard types, the Company manufactures a complete range of rural automatic and semi-automatic exchanges of special design for use in tropical countries.

**THE GENERAL ELECTRIC CO. LTD.
TELEPHONE WORKS - COVENTRY**

TELEPHONE: COVENTRY 4111

TELEGRAMS: "SPRINGJACK, COVENTRY"

London Office: MAGNET HOUSE, KINGSWAY, W.C. 2

BRANCHES AND AGENCIES THROUGHOUT THE WORLD.

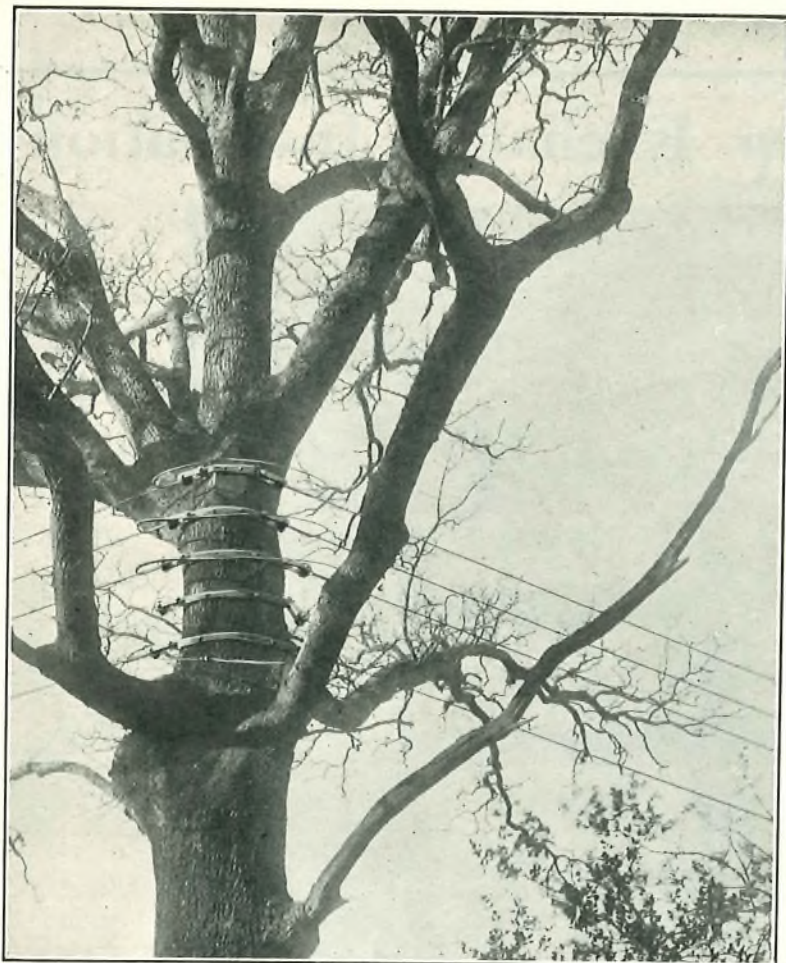

For rural schemes

Henley Class P.B.J. Cables are supplied finished in Green and Chocolate Brown in addition to the usual Red finish. These colours blend with foliage and harmonise with rural surroundings.

The Green and Chocolate Brown finishes will often help to solve your problems, and from the point of view of insulation and lasting properties the cables are unique.

As we are on the Post Office List of Approved Manufacturers of P.B.J. Cables, we are able to despatch supplies to you without the delay of having to submit samples to the G.P.O.

Send us your enquiries for Class P.B.J. Cables finished Red, Green or Chocolate Brown.

HENLEY P. B. J. CABLES

W. T. HENLEY'S TELEGRAPH WORKS, CO., LTD.,
Holborn Viaduct - - - - - London, E.C. 1

Telephone: CITY 2271

Telegrams: "Henletel, Cent, London

G.P.O. Detector No. 4.

D.C. Voltammeter
Model 55

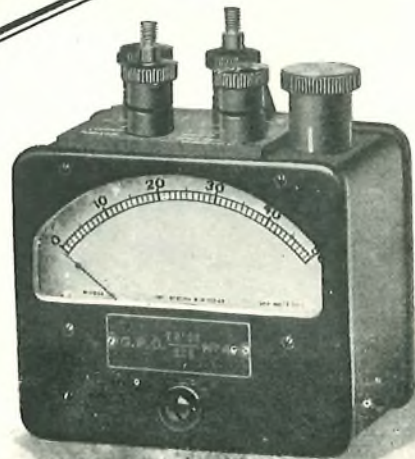

This instrument was designed by us for the British Post Office, and is now a standard instrument in that service and the majority of the Dominion and Colonial P. & T. Services, with the Post Office designation "Detector" No. 4.

*Sole Manufacturers under
Patents 217738 and 299247.*

With Set of Shunts and Resistances, Tests from 200 Microamps to 50 Amps, and from 2 Millivolts to 500 volts can be made.



EXT. RESISTOR.

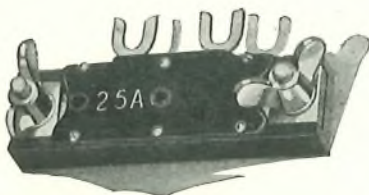

EXT. SHUNT.

ERNEST TURNER,

CHILTERN WORKS,

55-73, TOTTERIDGE AVENUE,

HIGH WYCOMBE,

BUCKS, ENGLAND

Telephone: High Wycombe 301.
Telegrams: Gorgeous, High Wycombe.

An Innovation in Exchange Installation



ACORN EXCHANGE

This Exchange, which we manufactured and installed for the Post Office, embodies two interesting innovations in installation practice.

It is the first exchange to be installed utilising throughout the new Standard Open Type Racks, and it is the first on which the "piece-meal" method of installation was employed.

The chief advantages of this method of installation are:—

1. The framework can be shipped to the exchange in advance of the apparatus, and the installers can start work on it immediately.
2. Handling is simplified by dispensing with haulage tackle, as each unit can be lifted manually.
3. Ceiling and wall supports can be fixed before the apparatus is in the building.

Standard Telephones and Cables Limited

CONNAUGHT HOUSE, ALDWYCH, LONDON, W.C. 2

TELEPHONE: HOLBORN 8765 (24 LINES)

Home Branches: Birmingham, Glasgow, Leeds, Liverpool, Manchester.

Overseas Branches: Cairo, Calcutta, Dublin, Johannesburg, Singapore.

which was brought to the shore at Cottesloe near Perth. These three lines were each equipped with duplex repeaters at Port Augusta, Cook, and Kalgoorlie, and the difficulties in maintaining sufficiently accurate duplex balances to permit maximum working speeds over the 24-hour cycle will, no doubt, be readily appreciated by the reader.

The degree of maintenance required to maintain an efficient service became more and more exacting as the traffic increased over the last few years; and, as commercial activities between the two settlements increased in volume, the need for telephonic facilities became a very real one. In consequence, to meet the public demand, it was decided to investigate the methods available for, and the economics of providing a telephone link.

The scheme decided upon as the most economical was to provide one voice-frequency channel operating over a band of 100-3,000 cycles per second, a carrier telegraph system operating over a band of 3,300-10,000 cycles, and two composite hand speed duplex telegraph channels operating over the remaining band of 0-100 cycles per second.

Description of Line.

In order to minimise interference it was necessary first to re-arrange the wires on the route. For nearly the whole distance between Perth and Adelaide the route followed the trans-continental railway. Between Adelaide and Port Augusta—259 miles—the three available wires were run on wooden poles and formed part of a normal trunk route. From Port Augusta to Kalgoorlie—across the desert area of 1,051 miles—they were run on iron poles (spaced 25 to the mile), the property of the Commonwealth Railway Department, which had on the same poles a number of telegraph and telephone wires; and from Kalgoorlie to Perth the wires again formed a portion of a normal 400-mile trunk route through country which is now largely under cultivation for the production of wheat.

Standard E, L, and X transposition sections were provided between Adelaide and Port Augusta, and between Kalgoorlie and Perth. The transpositions over the desert section between Port Augusta and Kalgoorlie were provided in the manner shown in Fig. 2, which is a photograph of a typical transposition pole. A plan of one section is shown in Fig. 3. It will be seen that, although there are only three wires actually in position, provision has been made for the erection of a fourth wire which, when it becomes necessary to do so, can be erected with minimum interference to the existing services.

Repeater Station Location.

The repeater stations at the Eastern and Western ends of the line were not difficult to locate because of the existence of small townships at suitable points. The Adelaide end of the circuit was perhaps slightly more difficult to decide upon than the Perth end, but it was finally decided to establish the stations at Gladstone and Port Augusta at the Adelaide end and



FIG. 2.—TYPICAL TRANSPOSITION POLE.

at Merredin and Kalgoorlie at the Perth end of the line. Small townships with populations ranging from 1,000 to 5,000 inhabitants existed at each of these points, and generally it was necessary only to add to the existing buildings under the control of the Postmaster-General's Department. This left a distance of approximately 1,000 miles to be bridged between Port Augusta and Kalgoorlie, and on this long section there were no townships existing although there were several small settlements of railway employees along the route. At one station—Cook—there was already in existence a building which was suitable for use and which had been erected in 1926 to house the duplex telegraph repeaters. Subsequently Tarcoola and Rawlinna were found to be the most suitable of the other railway settlements to choose as repeater stations, and the lay-out of the lines on the basis of these stations provided that the longest section between repeaters was—that between Cook and Rawlinna—a distance of 303 miles. The attenuation of this section at

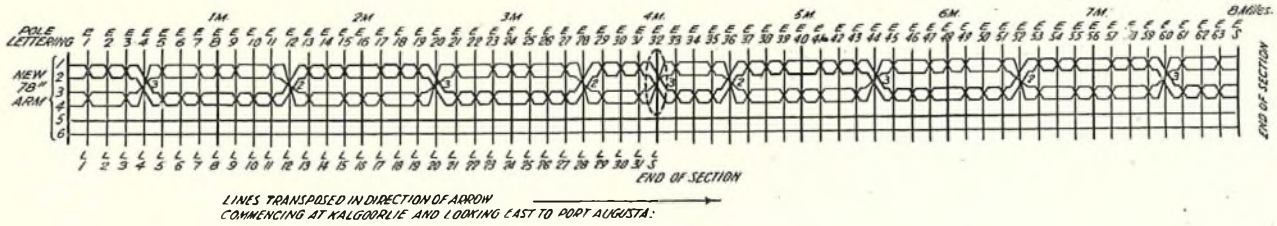

FIG. 3.—PLAN OF ONE TRANSPOSITION SECTION.

1,000 cycles is within the limits of the voice frequency repeater, and also at 10,000 cycles of the repeater on the carrier telegraph system. It was necessary both at Tarcoola and Rawlinna to erect repeater buildings and cottages for the staff which was to be employed. It was necessary also, at the repeater stations, to provide for the postal and telegraphic business originating at these centres. Fig. 4 is a photograph of a repeater station building.



FIG. 4.—REPEATER STATION BUILDING: TRANSCONTINENTAL ROUTE.

Line Measurements on Repeater Sections.

When the repeater sections had definitely been decided upon, and prior to the installation of the equipment, the electrical characteristics of the line on each repeater section were measured at frequencies up to 10 Kc. The conditions existing over these lines vary widely from section to section. At the two ends of the line and for the two repeater sections from each end the wires are on heavily laden pole routes, and they are exposed to many types of interference. As frequent serious interruption had been caused to the telegraph services due to earth currents when these lines were working as earth return circuits it was anticipated, and has ultimately proved to be the case, that the electrical storms so common in this part of the country would cause serious interference to the channels provided on the carrier telegraph system should any unbalance be present on the pair now being used to provide service. It has been found, however, that over the carrier system the telegraph working is immeasur-

ably superior to what it had been previously over the physical circuits.

Fig. 5 shows the impedance-frequency curve of the 256-mile section of line between Cook and

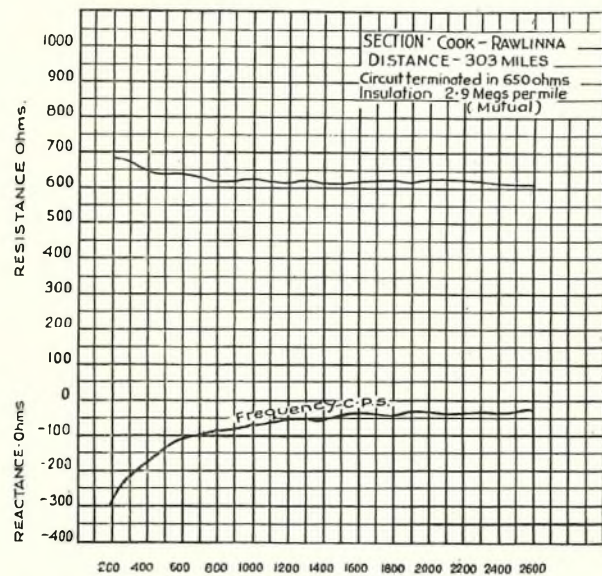

FIG. 5.—IMPEDANCE V. FREQUENCY.

Rawlinna. The attenuation characteristics of this section plotted against frequencies are also shown in Fig. 6. It was thought that the conditions on this line would be almost ideal because of the dry climate, but it has been found in practice that the insulation varies over wide limits and that the attenuation over the channels must be watched carefully during the day. The reasons for this wide variation are now the subject of investigation, but it would appear that mists which blow over the plains from the sea, a distance of perhaps 60 to 100 miles, and also the formation of heavy dews, seriously reduce the insulation resistance between wires to values as low as 0.7 megohms per mile.

Power Supply.

In carrier terminal offices and small repeater stations the battery voltages have been standardized and are:—

- (a) For filament current supply ... 24 volts.
- (b) For plate current supply ... 130 ,,

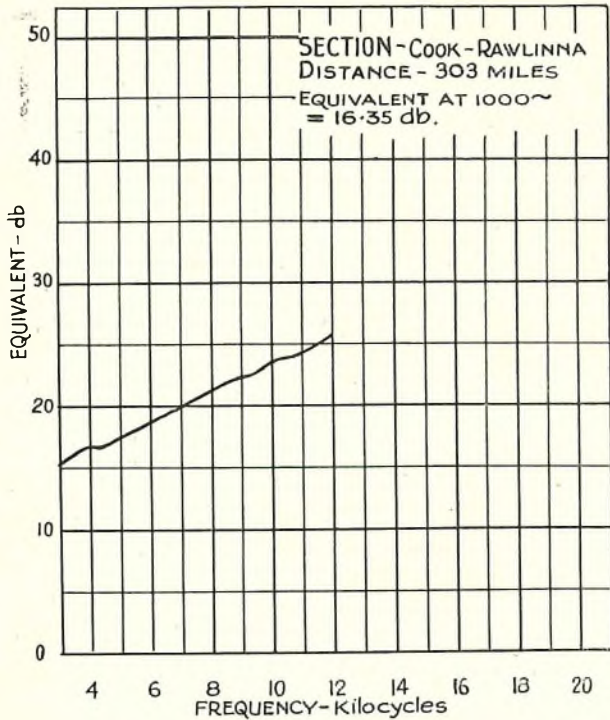

FIG. 6.—ATTENUATION V. FREQUENCY.

Generally speaking, two batteries of each voltage are installed in order that a regular charge and discharge routine may be arranged. The batteries are installed with sufficient capacity to provide some measure of insurance against breakdown in the service in the event of a failure in the main supply or in the battery charging plant.

Motor generators are installed at Gladstone, Port Augusta, Kalgoolie and Merredin to convert the main supply for battery charging. At each of these

towns there is a satisfactory supply available. At Tarcoola, Cook and Rawlinna, where there is no local power supply, prime movers direct coupled to generators were installed. These machines each consist of a petrol engine direct coupled to two generators, one supplying current up to 25 amps. at 35 volts and the other up to 10 amps. at 180 volts, and were supplied by the New Pelapone Engineering Company (England). This supply is also used to light the repeater station itself and the homes of the attendants. The 24 volt batteries have an initial capacity of 300 ampere hours at the 10 hour rate. The 130 volt batteries at Tarcoola, Cook and Rawlinna are Exide type (CZG 6) cells, while at the other stations the cells are the Exide DFG type. In the case of the open top cell there is considerable evaporation at the desert stations although the surface of the electrolyte is covered with battery oil. The cost of sending distilled water to these stations was estimated at 3/- per gallon, so, in order to avoid such high cost, small stills operated with kerosene heaters have been installed at these stations.

Telegraph System.

The carrier telegraph system provides at present for eight duplex channels and is capable of extension to ten channels. The system installed is that of Standard Telephones & Cables, Ltd., and was manufactured in England. In this system one group of frequencies from 3,330 cycles to 5,500 cycles is used in one direction, while another group from 6,500 cycles to 10,000 cycles is used in the opposite direction. At the sending end each of these carrier frequencies is controlled by a relay in the sending loop, so arranged that the carrier current flows for a marking signal but no current flows for a spacing signal. At the receiving end the carrier currents of different frequencies are separated from each other by selective tuned circuits. The received currents are then amplified and rectified and the

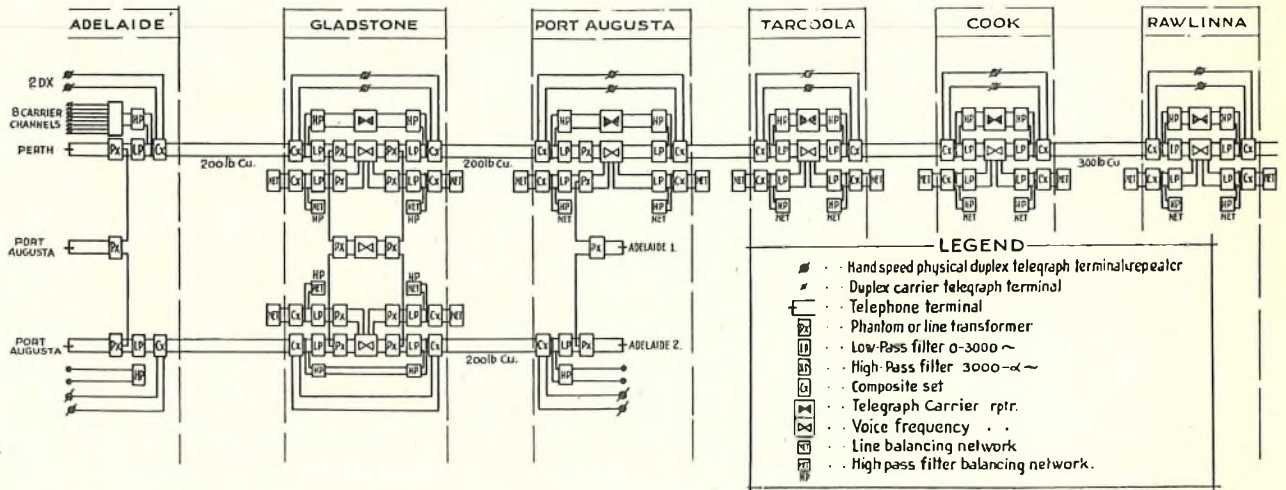

FIG. 7.—LINE

telegraph instrument in each receiving loop is controlled from a relay in the plate circuit of the rectifier valve.

At the repeater stations the group of carrier currents transmitted in one direction is separated from the group transmitted in the opposite direction by directional filters, and amplifiers are provided for each group of frequencies, *i.e.*, one amplifier for the east to west direction and one for the west to east direction. When the carrier system was first opened the telegraph channels were operated by Wheatstone Creed, the system which was previously used on the physical channels, but, subsequently, direct multiplex systems were provided between Perth and Adelaide, Perth and Melbourne, and Perth and Sydney. It will be appreciated that the introduction of these direct systems has meant a very considerable saving to the Department when it is considered that the need for re-transmission of Perth-Sydney traffic, which previously was required to be done at Adelaide, has now been entirely eliminated. The Perth-Adelaide multiplex link consists of a quadruple-duplex Murray system working at 270 revolutions per minute (45 words per minute per arm). The links between Perth and Melbourne and Perth and Sydney are Murray triple-duplex systems also working at 45 words per minute per arm, the latter working through rotary regenerative repeaters at Adelaide. These three systems are working quite satisfactorily and in the near future it is proposed to provide another Murray system between Perth and Brisbane after the carrier telegraph system, now being provided between Sydney and Brisbane, has been made available. This Brisbane to Perth system will operate over carrier channels for a distance of 3,500 miles.

One channel of the Perth-Adelaide carrier system is used by the Eastern Extension Cable Coy., who operate over it a Wheatstone Creed system, linking up with their submarine cable at Cottesloe, near

Perth. The remaining channels are used for circuits between Perth and the other capital cities as the traffic justifies.

Composite telegraph equipment is fitted on the wires and duplex composite repeaters are installed at each repeater station. One of the composite channels is used to handle the telegraph business originating at the railway stations on the trans-continental railway line, and the second is equipped with selective "calling-in" equipment of local manufacture. This "calling-in" equipment is designed to enable the repeater station attendants to be recalled to their stations when required by either of the terminal stations. Normally, attendance is provided at these stations from 7 a.m. until 11 p.m., and should the necessity to have any testing carried out arise outside of those hours, the repeater attendants can be recalled from their homes by the attendant at either terminal station.

Telephone Channel.

The telephone channel is operated throughout at voice frequencies. The carrier frequency currents are separated from the voice frequency currents at repeater points and at the terminals by filter sets, each comprising a low and a high pass filter which are connected in parallel across the line and have nominal cut off frequencies of 3,000 cycles. The repeaters are the ordinary two-wire type of Standard Telephones and Cables' manufacture.

The line diagram is shown in Fig. 7, from which it is seen that the circuit is part of a phantom group for two repeater sections at each end of the line and for the other sections is a single pair only.

This channel is normally worked at an equivalent of 12 db. between terminals, but when required for through traffic it is switched through cord circuit repeaters on to the remainder of the trunk line system to Melbourne, Sydney and Brisbane. The channel is equipped with 1,000 cycle signalling which has been standardized in Australia for use on repeated lines and carrier channels.

Due to the long open wire circuit and the consequent variation in line conditions, it was found necessary to provide very accurate balancing networks at the repeaters, and all filter sets, line transformers and composite sets were balanced in pairs while four element networks closely simulating the lines were designed.

A third wire formerly used as one of the physical telegraph circuits is available and the question of its use to form, with the other two wires, a second telephone channel is being investigated. In the meantime, however, this spare wire

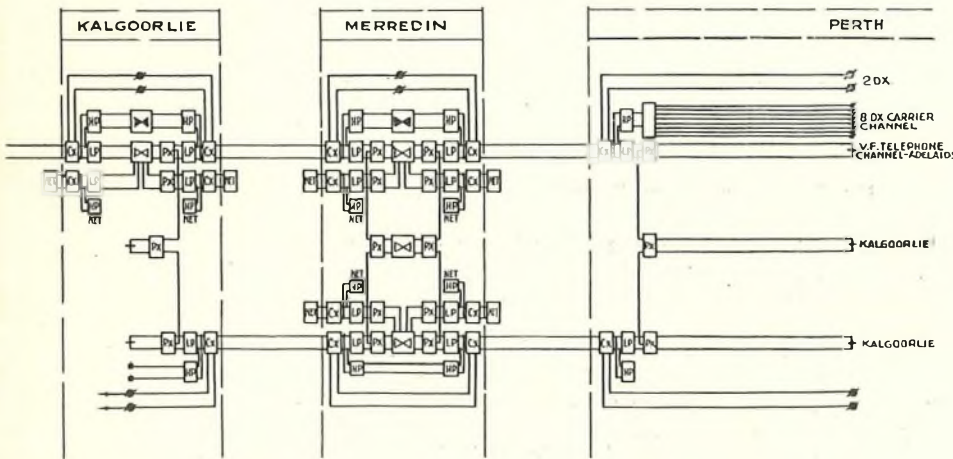

DIAGRAM.

is used as an emergency telegraph channel in the event of a carrier failure and also as a patching wire for use when a fault occurs on one wire only of the trunk line. Use has been made of this wire for patching purposes, and when in use it has been possible to operate the carrier system. The degree of unbalance, however, brought about by its use has prevented the voice frequency channel from being put into service, the noise induced from the Railway Department's circuits being too great to allow of commercial speech.

Maintenance.

Facilities for ordinary direct current measurements and for open circuit location are provided on trunk test boards designed and supplied by Standard Telephones & Cables, Ltd. The terminals at each repeater station are equipped with variable frequency oscillators and transmission measuring sets capable of measuring either equivalents or levels.

The maintenance routine provides for a complete line-up of the voice frequency channel and the carrier telegraph system between terminals at 7 a.m. daily. Fig. 8 shows the power level diagram for the

have been plotted and are shown in Fig. 9. During the test period no alterations were made to the repeater gain settings. The variation in the line equivalent does not seriously affect the value of the rectified current on the telegraph channel due, generally, to the characteristics of the detector circuit. It is practicable to work through the variation met with on a normal day without alteration to the repeater gain and, generally speaking, with very little necessity to alter the gain at the terminal station.

It was anticipated that many difficulties would arise in the operation of these long channels, and perhaps the most interesting of these was encountered in operating the Murray multiplex systems. For some considerable time after multiplex working was introduced over the carrier systems in Australia difficulty was experienced in obtaining satisfactory operation. The difficulty was brought about by a certain type of distortion introduced mainly by the rectifier circuit of the carrier system. The effect on the multiplex signals could be described as positive characteristic distortion and was felt particularly by the synchronising or correcting impulse.

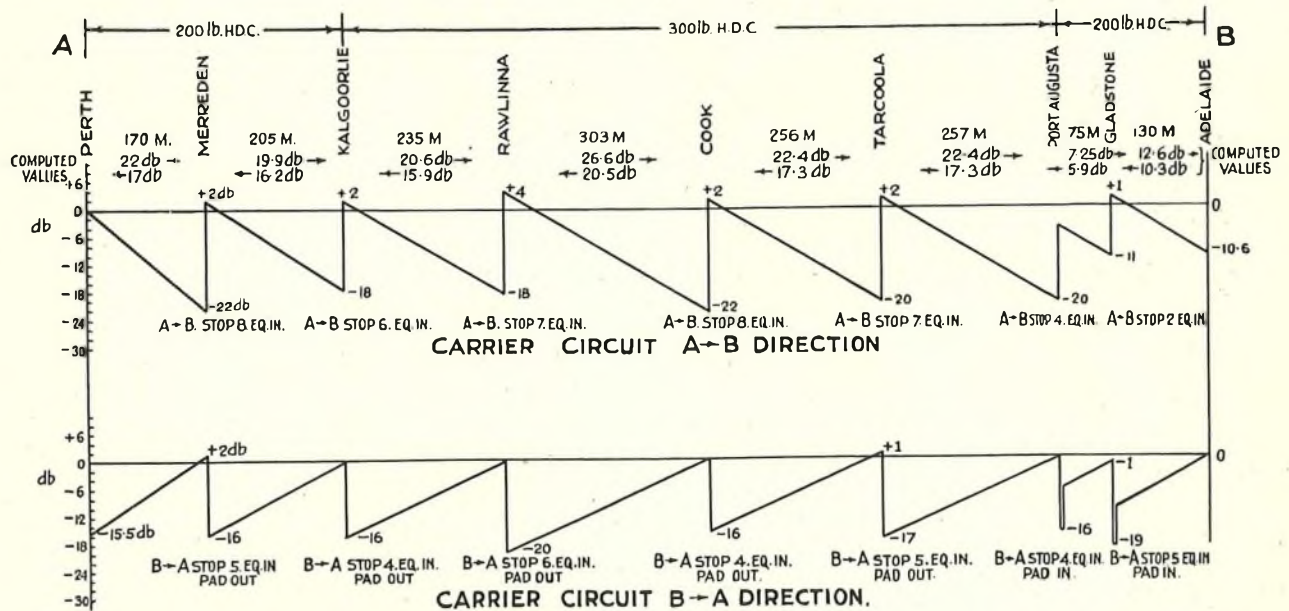

FIG. 8.—POWER LEVEL DIAGRAM.

carrier telegraph system and an endeavour is made each morning to return all stations to their normal setting and to have provided the levels laid down in that diagram.

It has been found necessary, in addition to the early morning line-up, to have an adjustment of repeater gains on the telephone channel occasionally during the day in order to maintain a constant equivalent. As an indication of the variations which occur in the equivalent on the voice frequency line, measurements made at 1,000 cycles over a test period during one day between Adelaide and Perth

On a triple Murray system the distributors used have on each of the sending and receiving rings 17 segments—five signalling segments for each of the three arms and two others, the 16th and 17th, which are employed in the synchronising system. Briefly the method of synchronisation employed is as follows:—

The distributor at one terminal is run at a speed approximately .3% faster than that at the other terminal. (For reference purposes the former will be called the "correcting" distributor and the latter the "corrected" distributor). The correcting dis-

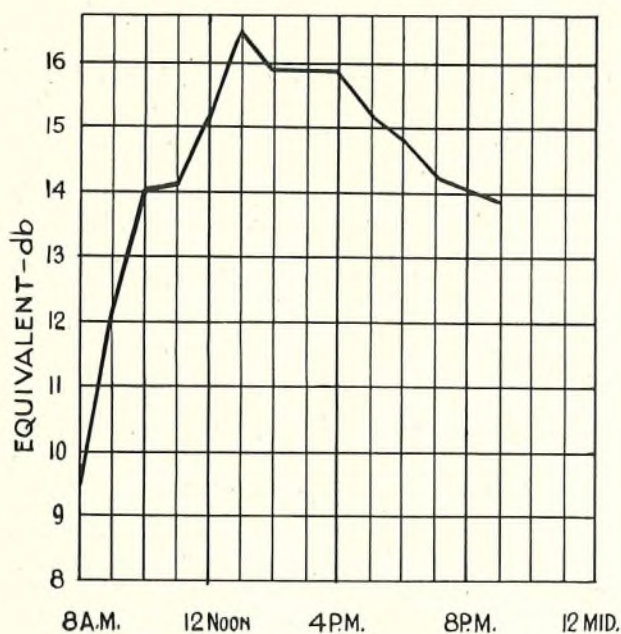

FIG. 9.—VARIATION IN ATTENUATION AT 1,000 C.P.S.

tributor transmits on each revolution of its brushes a correcting impulse from the 16th sending segment, and when the two distributors are in exact phase this impulse is received by the corrected distributor on its 16th receiving segment which is in fact a vacant space on the receiving ring. As the brushes of the corrected distributor advance in relation to those of the correcting distributor, however, this correcting impulse is impressed on the corrected distributor's 17th receiving segment. The latter is connected to a correcting magnet which, when it energises, operates an epi-cyclic gearing arrangement and steps the brushes back $1\frac{1}{2}^\circ$ in relation to the brush spindle. It will be seen that should the tail-end of the correcting impulse be distorted, instability of synchronism would result.

In actual practice when operating the Murray system over carrier channels, it was found that the correcting impulse was on certain channels considerably distorted. When the correcting impulse was immediately preceded by a signalling impulse, the correcting impulse was foreshortened and instability of synchronism, combined with resultant phenomena, into which it is not proposed to enter in this article, was the result. Investigation into the cause of this distortion disclosed that the bulk of it occurred in the carrier rectifier circuit and was more evident on the lower frequency channels than on the higher. Two stages of amplification are employed and the rectifier is biased back to 51 volts negative and is swung by the applied carrier to a point towards the upper flat portion of its curve. In effect the rectifier tube is overloaded and an appreciable value of grid current is caused to flow.

This grid current impresses a negative charge upon the grid condenser, but does not build up to a

maximum during the time of one multiplex impulse. The charge does build up to a maximum, however, during the time of two impulses and the result is that when a double impulse is received the negative charge on the grid condenser reduces the magnitude of the positive potential applied to the grid by the incoming carrier current and consequently the rectified current value. The effect of this is that when the input is cut off the rectified current drops to zero more quickly and the signal is foreshortened. Between signals, of course, the charge on the condenser leaks away through the $\frac{1}{2}$ megohm grid battery resistance. It was found that, without doubt, it was this phenomenon which was causing the difficulty in operating the multiplex systems, and where two or more channels were operated in series the trouble, being cumulative, became more serious.

Several remedies were tried, among which were a reduction of the capacity of the grid condenser, and the use of transformer coupling, but so far the most satisfactory method of overcoming the trouble has been by making use of a device attached to the corrected distributor.

The average amount of phase displacement brought about by the distortion was determined in terms of millimeters measured on the receiving ring of the distributor. A small segment of the required length was attached to the leading edge of the 17th (correcting) segment but insulated from it. This extra segment could be connected to the correcting segment proper through the contacts of a polarized relay, the operating coil of which was placed in series between the fifth signalling segment of the third arm and the fifth magnet of the printer on this arm. When a fifth impulse is received (the impulse immediately preceding the correcting impulse) this relay operates and connects the extra piece of segment to the correcting segment proper. Thus when the tail-end is clipped from the correcting impulse, the correcting segment is actually brought back to meet the brush and so is not lost.

Although every effort had been made to provide for the more likely contingencies, occasional troubles have occurred which have caused serious inconvenience. Perhaps the most unfortunate instance occurred when drizzling rain set in along the line after a dust storm had been experienced. For some four or five hours until the dust had been washed away from the surface of the insulators by the rain, telegraph service was seriously interfered with and hand working only could be maintained. Speaking generally, however, it has been possible to maintain a high grade of service both on the telephone and the telegraph channels, and an analysis of the faults which occurred during the three months ended March 31st, 1931, showed that the average daily interruption to the circuit during this period was 37 mins.; 28 mins. being due to line troubles. So far indications are that this amount of interruption will be lower for the current quarter, and, as experience is accumulated, it is anticipated that methods will be devised to avoid the consequences of most of the troubles which may arise.

A Voice Frequency Multi-channel Telegraph System.

J. M. OWEN, A.M.I.E.E., and J. A. S. MARTIN.

A DESCRIPTION of "A Voice Frequency Multi-channel Telegraph System" was given by the authors in the *P.O.E.E. Journal*, Vol. 21, Part 4, in January, 1929. Considerable progress has been made in the development of voice frequency telegraph systems since then, and several important improvements have been effected in multi-channel working. The present article describes the system developed by Messrs. Standard Telephones & Cables, Ltd., which embodies many new features and improvements. It will be of interest to consider these new features before describing the system in detail.

In the first place, the almost universal use of teleprinter working with its relatively low transmission speed has enabled a much closer frequency band width to be used, and this has in consequence permitted a larger number of channels to be accommodated in the frequency range. The frequencies used are odd multiples of 60 p.p.s. In a twelve channel system the lowest and highest frequencies are 420 p.p.s. and 1740 p.p.s. respectively, whilst in an eighteen channel system they are 420 p.p.s. and 2460 p.p.s., the frequency spacing between channels being 120 p.p.s. These figures are in accordance with the agreement issued by the Comité Consultatif Internationale des Communications Télégraphiques (C.C.I.T., Berne, May, 1931, Avis No. 9, "Normalisation des fréquences porteuses dans la Télégraphie Harmonique").

The use of odd multiples of the fundamental frequency is no new arrangement, but it may be of interest to give the reasons for this selection. When odd multiples of the fundamental frequency are used inter-channel interference due to amplifying valves at the repeaters is practically eliminated. It will be appreciated that the valves at intermediate telephone repeater stations are common to all channels, and that in the normal course of events, considerable interference between the channels would arise due to modulation between the frequencies used. Modulation usually occurs because the valve characteristics are not always exactly linear, and this being so, a number of new frequencies will be introduced into the circuit. The most serious of these new frequencies are naturally those whose currents have the greatest magnitude. Fortunately, the frequencies with these high current values occur at points in the frequency range which are equal to the sum and difference of the carrier frequencies taken in pairs. If therefore carrier frequencies are used which are all odd multiples of some fundamental frequency, the interfering sum and difference frequencies will be even multiples of the fundamental, and consequently will lie midway between the carrier frequencies. This simplifies the problem considerably, since it is

at these midway points that the filters exercise the greatest discrimination against the undesirable frequencies.

Another improvement in the present system is the use of a multi-frequency generator for producing the carrier frequencies. This machine is capable of generating eighteen frequencies. In former systems the frequencies were either generated by means of a valve oscillator, or by the use of a valve-maintained tuning fork. Both of these methods necessitated a considerable amount of rack space, and for that reason alone, the present arrangement justifies its use.

A multi-channel voice frequency telegraph system similar to the one about to be described, has recently been installed at the Central Telegraph Office, London, and at Dundee, in order to provide communication between London and Scotland. It is not improbable that more units will be installed between the larger towns in the near future. The present system provides twelve channels in each direction. Where, however, the line conditions permit (cut-off, etc.), the channel capacity can be increased to eighteen. The equipment is so constructed that these extra channels can easily be added to the present set when the traffic conditions warrant their use. In order that the system may be worked at its maximum capacity, that is to say twelve or eighteen channels in each direction, a four-wire telephone circuit is necessary. If for some reason a two-wire circuit must be used, only half the number of channels, *i.e.*, six or nine, can be used in each direction.

The working speed for which the channels have been designed is 66 bauds (*i.e.*, 33 p.p.s.), subject to the proviso that the lines only vary within certain defined limits. Under these conditions the signals will not suffer a distortion of more than 25 per cent. Actually the channels can be worked at a speed of 70 bauds. Any type of telegraph apparatus can be used on a channel, provided of course that its transmission speed does not exceed 66 bauds. When a four-wire telephone circuit is used, the voice frequency equipment takes the place of the termination sets used in telephony, although the terminal repeater is retained. In the case of the two-wire circuit, however, a telephone repeater with its associated balancing equipment is necessary.

The average repeated telephone circuit is usually maintained to a specified overall transmission equivalent to within ± 2 db. A feature of this particular voice frequency equipment is that the receiving circuit of each individual channel is so designed that variations of as much as ± 8 db. can be suffered without interrupting the working of the system.

On the telegraph local apparatus side of the equipment the following circuit arrangements can be established.

- (a) Full duplex conditions (two directions simultaneously) for either double current, or single current working.
- (b) Half duplex for single current working. This arrangement provides for working in two directions alternately, but with the added facility that the receiving operator can interrupt the sending station.

The telegraph relays used for linking the telegraph apparatus to the voice frequency equipment are the well known Polar relays. In the case of the receiving relay, the tongue, pole-pieces, and yoke are made of permalloy. At the sending end the transmitting relays are known as the 215 A type, and are fitted with line coils only. This type has no permalloy in the magnetic circuit. The receiving relays are of the 209 F.A. type (Post Office 299 A type), and have vibrating windings in addition to the four line coils.

Transmitting Circuit.

Reference has already been made to the choice of frequencies used and Table No. 1 gives the details for an eighteen channel system.

TABLE NO. 1.

Channel.	Frequency p.p.s.	Channel.	Frequency p.p.s.	Channel.	Frequency p.p.s.
1	420	7	1140	13	1860
2	540	8	1260	14	1980
3	660	9	1380	15	2100
4	780	10	1500	16	2220
5	900	11	1620	17	2340
6	1020	12	1740	18	2460

The essential features of the transmitting circuits are the multi-frequency generator, and the line transformer common to all transmitting channels, and the telegraph relay and sending-end filter individual to each particular channel.

The generator is an inductor alternator, and is designed to produce currents of eighteen different frequencies in eighteen magnetic circuits which are electrically independent of each other. It consists in effect of eighteen different alternators with common field excitation. The exciting current for the field windings is supplied by a 24 volt battery through a rheostat. The design of the generator is such that the reluctance of the magnetic circuit through each stator and rotor remains constant as the rotors move, and by this means inductive effects from the separate circuits on the common field exciting current are prevented. It should be noted, however, that the flux in each individual stator tooth varies as the rotor moves, and is a maximum when a rotor tooth is opposite to it. As the rotor moves, this variation in flux induces the voltage in the generator windings round the tooth. All the windings of a given stator are connected in series, so

that the total voltage generated in each circuit is the sum of the separate voltages in the several windings. The terminal voltage of each generator circuit is 2 volts \pm 0.1 volt. Adjustment of the voltage can be made by varying the field current, but final adjustments are made by means of resistances in each alternator output. The energy for the driving motor, which is compound wound, is supplied from a 24 volt battery, and in order to maintain the speed accurately at 3600 revs. per minute a centrifugal type of governor is fitted. This governor is adapted to control the amount of current flowing through the shunt field winding. In the first trials a tuning fork in conjunction with a stroboscopic disc was used to check the speed of the motor generator, and consequently the frequencies of the generator currents, but it is probable that this arrangement will be discarded in favour of a neon lamp used with an oscillator.

The present equipment is provided with two motor generators, one for the normal supply, and the other as a spare. By the operation of suitable keys, current can be taken from either generator as required. A schematic diagram of the generator supply system is given in Fig. 1 and is more or less self explanatory. When the generator is first started, and during the first hour of running, these machines are a trifle fast, and for this reason the machine in use is kept running more or less continuously. During the trials the actual figures obtained were as follows:—At start 0.5% fast; after 60 hours, normal, and then a very gradual slowing effect, the figure being 0.08% after 120 hours.

The frequency for a particular channel is fed through resistance pads. In addition, resistance pads are also connected in the output side of the filter, so that it is possible to adjust the power output of a channel by varying these resistances. The values of the several resistance pads are fixed during the installation trials, so that further adjustment is unnecessary unless it is required to alter the power level at which the system is operating. The carrier, or voice frequency, is normally short-circuited at the input side of the transmitting filter *via* the locals of a telegraph relay. Direct current telegraph signals operating the relay, cause the short-circuit to be removed when a marking signal is transmitted from the telegraph office, and conversely, the short-circuit will be restored when a spacing current is transmitted. The voice frequency current is therefore passed to line for the period that the transmitting relay is on the marking contact.

The sending-end filters serve a dual purpose. They offer a high impedance to the outgoing signals of other channels, and therefore ensure that any one channel will not take appreciable energy from the others. In addition they prevent the transmission to line of currents of undesirable frequencies which are present in the supply. These frequencies are produced by the short-circuiting, and opening of the carrier frequency at the relay contacts. Further, the telegraph signal which operates the telegraph

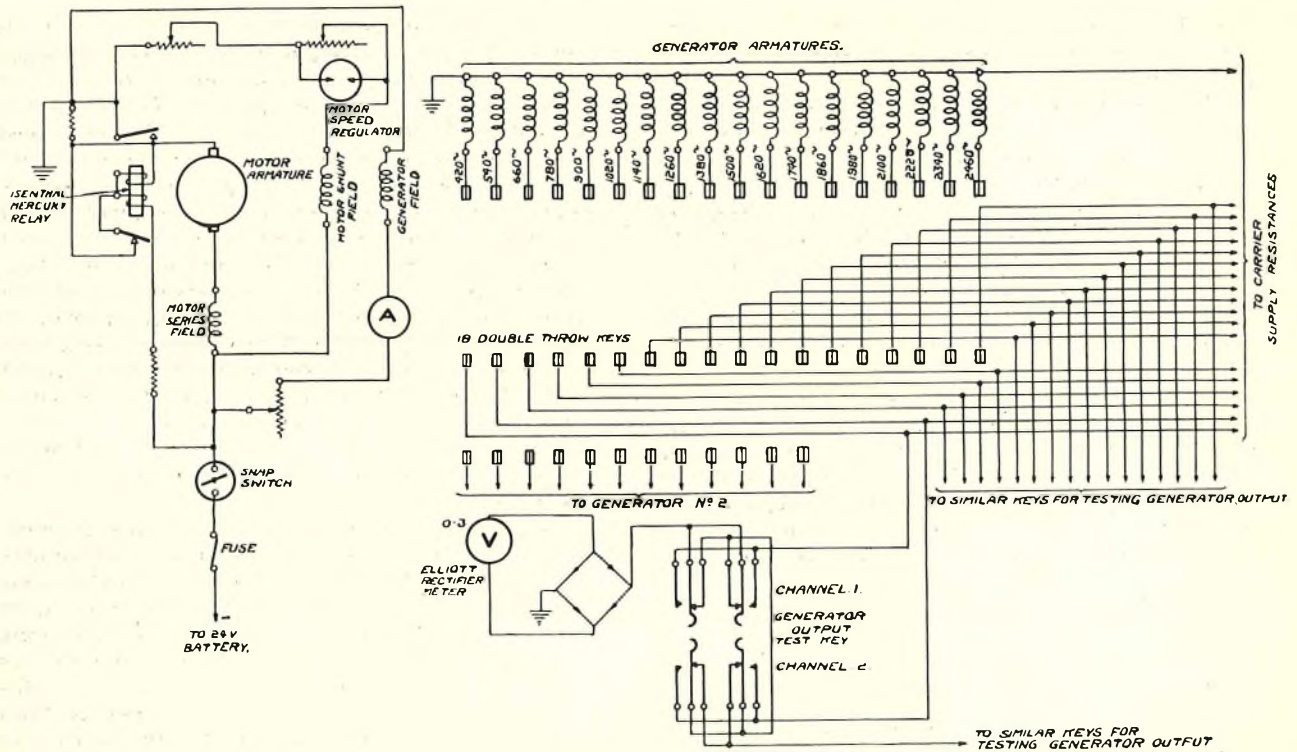

FIG. 1.—SCHEMATIC DIAGRAM OF CARRIER CURRENT SUPPLY.

relay is composed of a range of frequencies. Some of these will modulate the carrier frequency current, and produce frequencies which will lie in the ranges or bands proper to other channels. The provision of sending-end filters is thus a decided advantage. The transmission frequency characteristics of the sending-end filter associated with channel 6 (1020 p.p.s.) are shown in Fig. 2, and this curve is typical of all the transmitting filters. These filters are designed to transmit the range of frequencies necessary to secure the desired range of transmission, whilst at the same time excluding undesirable frequencies. The resistances which are inserted on the input side of the sending-end filters serve the purpose of a terminating impedance during the short-circuiting period at the relay contacts. Fig. 3 shows a sending-end filter, and the compactness of the unit will be appreciated by comparison with the rule.

The outputs of the sending-end filters of all channels are connected in parallel to the primary of a line transformer, the secondary of which is connected *via* the terminal repeater to line. It will be seen therefore that the terminal repeater takes the place of the common amplifying valve of previous systems. When all channels are sending a marking signal at the same time, in other words the condition of maximum output, the power supplied to the line is less than that which would normally be accepted during speech transmission.

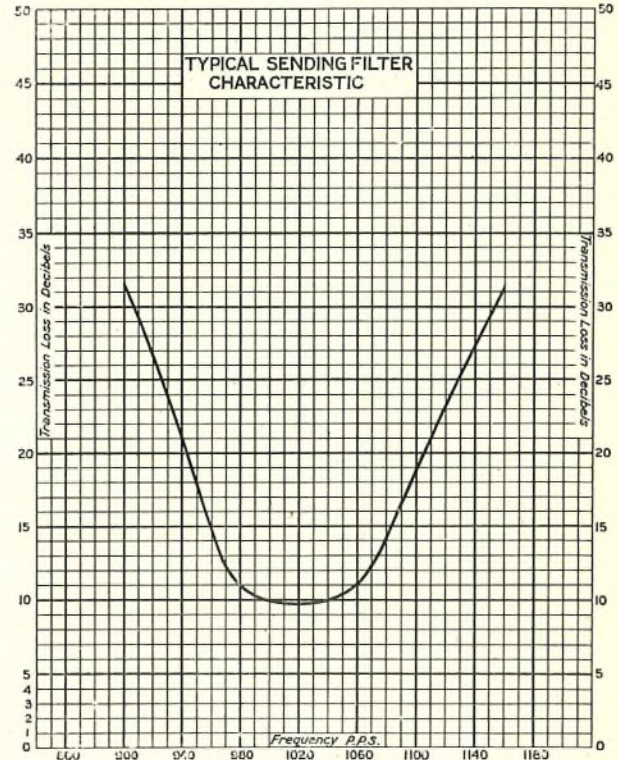

FIG. 2.—TYPICAL SENDING FILTER CHARACTERISTIC.

Receiving Circuit.

The receiving circuit consists essentially of a band-pass filter, amplifier-detector unit, and a telegraph relay for repeating the signals to the telegraph apparatus. Voice frequency currents pass from the end repeater through a line transformer, and thence to the respective band-pass filters which are connected in parallel across the local side of the transformer. Fig. 4 shows a receiving end filter and the compactness of the unit will be apparent.

The transmission frequency characteristics of the receiving end filter associated with channel 6 are shown in Fig. 5, and the curve is typical of all the receiving filters. If the curve shown in Fig. 5 is compared with that in Fig. 2 it will be seen that the receiving end filters are more efficient than those inserted at the sending end. Each receiving filter passes a band of frequencies proper to the particular channel with which it is associated, and currents at these frequencies suffer but small attenuation. In the case of frequencies outside this range, however, the particular filter offers a high impedance to such currents.

The amplifier detector unit, which is connected to the output of each receiving band-pass filter, reproduces direct current signals, which in turn operate a telegraph relay. Fig. 6 gives a schematic diagram of a sending and receiving channel, and from this, the path of a sent and received signal can be traced. The action of the amplifier detector unit, a photograph of which is given in Fig. 7, will now be briefly described. The voltage which is applied to the unit from the output of the receiving filter can be varied by means of an input potentiometer. This potentiometer—marked "Gain," Fig. 7—can be adjusted in steps of 1 db. up to a maximum of 30 db. The input voltage is then stepped up by means of an input transformer, the secondary of which is connected to the grid of the amplifying valve V₁. This valve has a high amplification factor. Coupling between the amplifier and detector valves is made by means of an intervalve transformer. The receiving

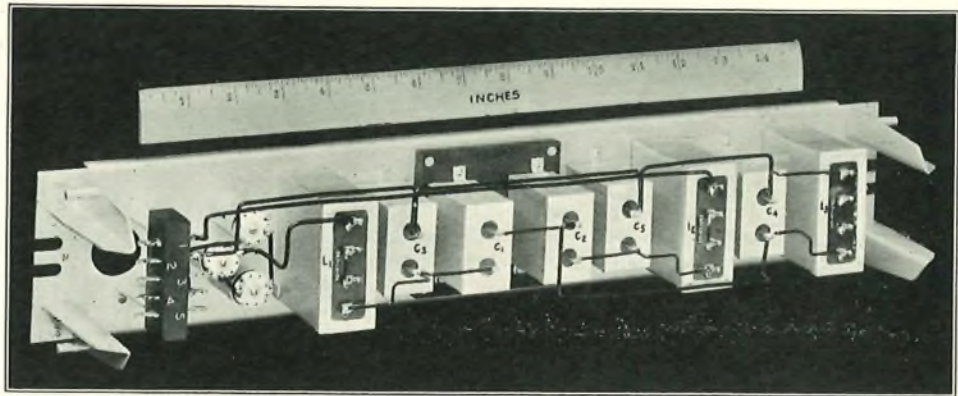

FIG. 3.—SENDING-END FILTER.

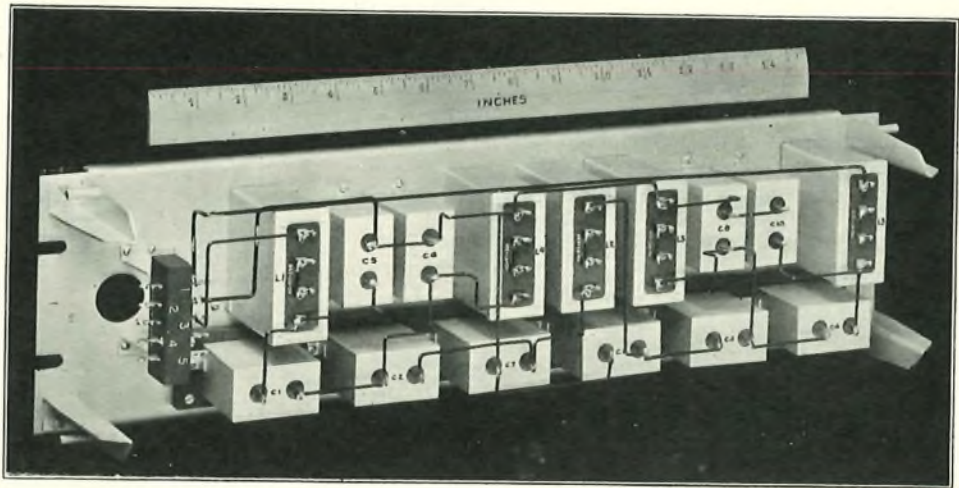

FIG. 4.—RECEIVING-END FILTER.

telegraph relay is connected in the anode circuit of the detector valve, and is operated by the rise of current when the valve becomes conductive. As this is single current operation of the relay, a bias must be provided in order to ensure that the relay tongue will be returned to the opposite contact when the emission of the detector valve is suppressed, in other words when there is no incoming signal. In order to produce this bias, current from the anode battery is passed through the vibrating windings of the relay *via* a variable resistance. This method of biasing is to a certain extent self-adjusting, because if the anode battery voltage varies, then the bias current will be affected to the same degree as the valve current. In Fig. 7 this resistance, which is marked bias, can be seen in the centre of the photograph just below the input gain potentiometer.

For the purpose of measuring the anode current in any particular channel, a milliammeter is so arranged that it may be inserted into that circuit without interrupting the working. When the voice frequency current is on the line, that is to say during a marking signal, the rectified current is normally between 5 and 7 mAs.

The grid bias voltage necessary for both the amplifier and rectifier valves is obtained from the voltage drop in the filament circuit. In the case of the detector valve, however, the grid bias can be obtained from a second source, the change over from one to the other being effected by means of a link (top right hand corner in Fig. 7) which is fitted on the panel; the bias is taken from a potentiometer circuit across the telegraph battery, and this permits the use of the amplifier detector panel for testing purposes. Under normal conditions any variations in the level of the received signals is compensated for by a corresponding change in the amplifier output. By this means a variation in the level of the received signals over a range of ± 8.0 dbs. can be tolerated. This is accomplished in the following manner. A signal amplified by valve V_1 is passed to the grid of valve V_2 , which is thus made slightly positive. Grid current flows, and condenser C_1 is charged by the voltage produced due to the flow of current through resistance R_1 . As a result of this the grid of V_1 is made more negative, and naturally the amplification of the valve is reduced. The bias on the grid of V_1 will, however, be reduced as the condenser C_1 discharges through R_1 . It is essential therefore, that the value of R_1 should be large enough to enable C_1 to hold its charge for a time at least equal to the time length of the maximum spacing signal. The grid bias of V_2 will also be affected by the flow of grid current through R_1 , but

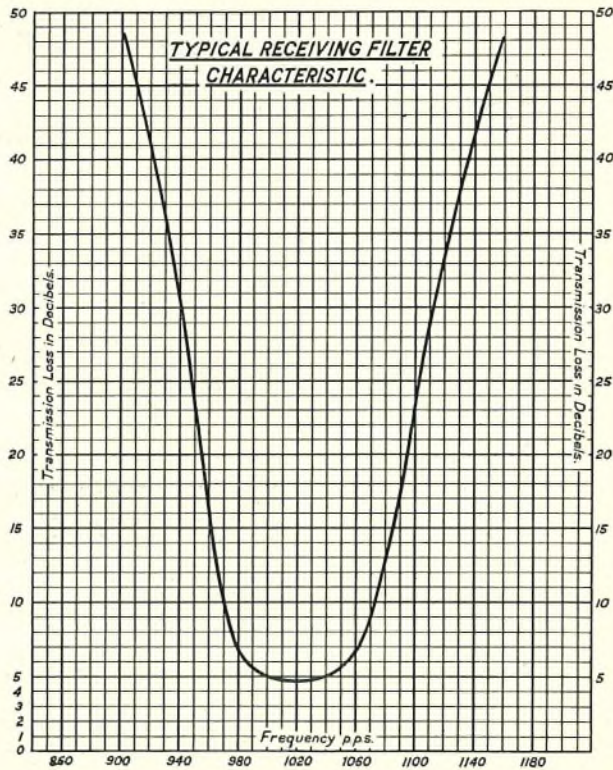

FIG. 5.—TYPICAL RECEIVING FILTER CHARACTERISTIC.

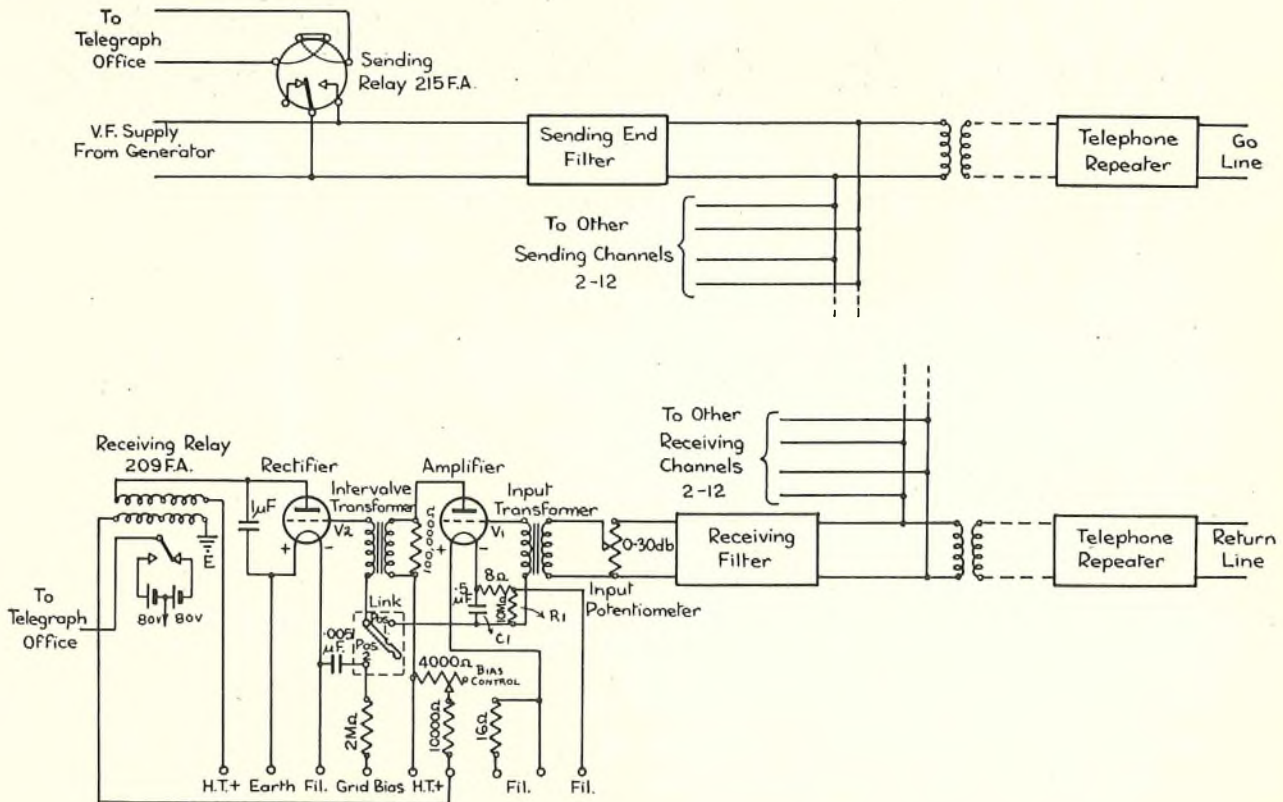

FIG. 6.—SCHEMATIC DIAGRAM OF A SENDING AND RECEIVING CHANNEL.

in this case the change in the grid priming voltage is not sufficient to affect the operating point appreciably. It will thus be seen that if the attenuation of the line decreases, thus raising the level of the input signals, the increase of grid bias produced in valve V₁, as just described, reduces the gain accordingly. Conversely, if the attenuation of the line increases, thus lowering the level of the input signals, the reduced grid current flowing through R₁ will cause condenser C₁ to discharge slightly, and thus, by reducing the negative volts on the grid of valve V₁, the gain or amplification of the valve will be increased to normal. It will be seen therefore that over a predetermined working range, a constant output can be maintained from valve V₂.

Apparatus details.

All apparatus other than the multi-frequency generators is mounted on steel panels. These panels are then mounted on racks similar to those used in telephone repeater equipment. A rack so equipped forms a bay 10 ft. 6 ins. high and occupies a floor space of 1 ft. 8½ ins. by 1 ft. 3 ins. Table No. 2 below, gives the floor space and the number of bays

the overall length of the equipment is increased by about one foot. It will be of interest to note that five complete eighteen channel systems, that is to say a total of ninety channels, would only occupy seventeen bays.

The panels are made from special thin steel and all the apparatus is mounted on the front, thus leaving the backs entirely free. It is therefore possible to mount the panels on both sides of the racks. Dust covers are provided on all panels except those which carry telegraph relays, keys, and jacks. Every cover is of the same height, and the bay is therefore given a neat and flat appearance. All the apparatus associated with one circuit is located together on one side of the rack. This point is important as it considerably facilitates the maintenance of the system both as regards the daily setting up of the channels, and the tracing of faults. Bay cable forms run down the inside of the rack channel iron and are thus completely hidden. On the other hand the panel wiring is easily accessible as it is carried out in front of the panel. This point can be clearly observed if reference is made to the wiring of the amplifier detector panel shown in Fig. 7.

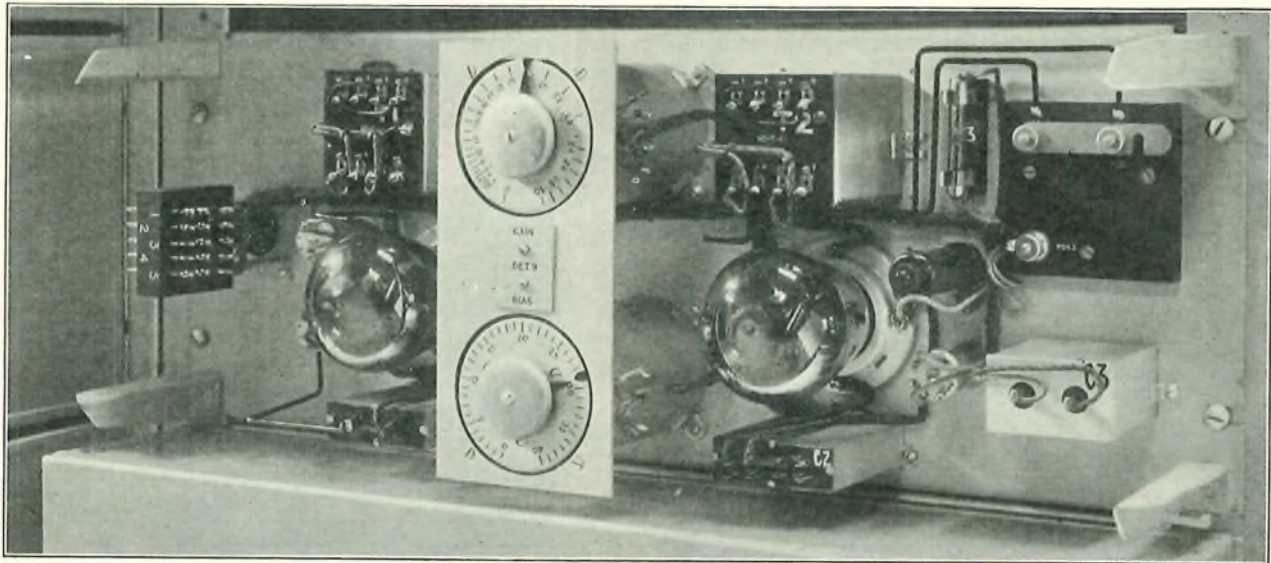

FIG. 7.—AMPLIFIER-DETECTOR UNIT.

required for a six, twelve, and eighteen channel system.

TABLE NO. 2.

Number of Channels.	Number of Bays.	Floor Space.
6	3	5' 1½" × 1' 3"
12	4	6' 9" × 1' 3"
18	5	8' 5½" × 1' 3"

In cases where the installation is fitted with a guard rail, and this is the case in the present set,

A typical twelve channel equipment is shown in Fig. 8. A similar view is given in Fig. 9, but in this case the covers have been removed from a channel bay. Fig. 10 is a rear view of the complete installation; the two motor generators can be clearly seen.

The system comprises three types of bays:—

- (1) Channel bay which provides equipment for six channels, three on each side of the rack.
- (2) Battery supply and generator bay, which is capable of providing equipment for ten eighteen channel systems.

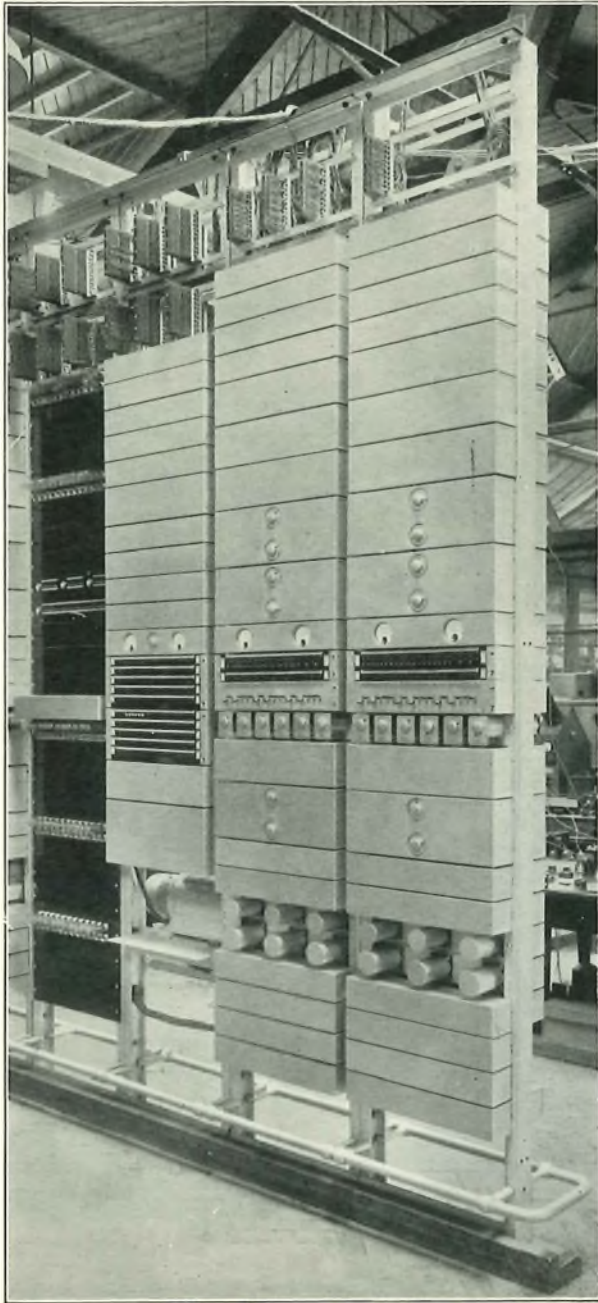

FIG. 8.—TYPICAL 12-CHANNEL EQUIPMENT.

- (3) Fuse bay capable of providing equipment for five eighteen channel systems.

In Fig. 8 the two bays on the right are channel bays, and the next two are respectively the battery supply, and fuse bays. Each channel bay carries the transmitting, receiving, and testing apparatus. A channel bay is made up of the following apparatus :

- (a) A panel carrying the amplifier detector and

gain control apparatus for the receiving circuit.

- (b) Filter panels carrying the sending and receiving end filters.

- (c) Relay panel carrying the transmitting and receiving relays, three relays being accommodated on one panel. The spark quench circuits for these relays are mounted on a separate panel. Each channel is provided with jacks in order to test the filters, receiver, etc.

- (d) Meter panel common to three channels, and carrying the telegraph galvanometers and meters for testing purposes.

The battery supply and generator bay carries the apparatus for the supply of current at eighteen different frequencies for any number of systems up to ten. It accommodates the following apparatus :

- (a) Alarm relay and lamp panels carrying the alarm relays and lamps for the filament circuit of each channel.

- (b) The multi-frequency generator sets which are mounted on rubber feet on the other

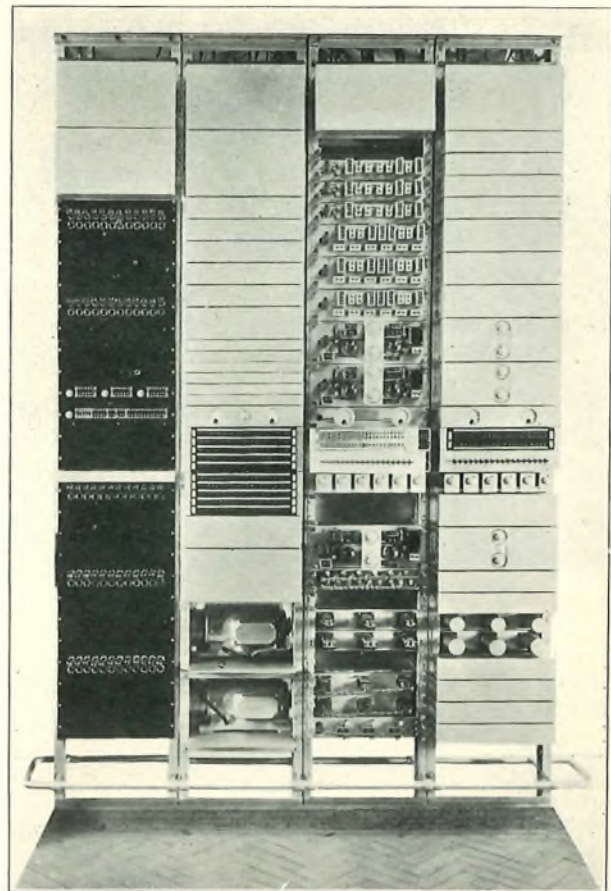

FIG. 9.—FRONT VIEW, SHOWING CHANNEL BAY COVERS REMOVED.

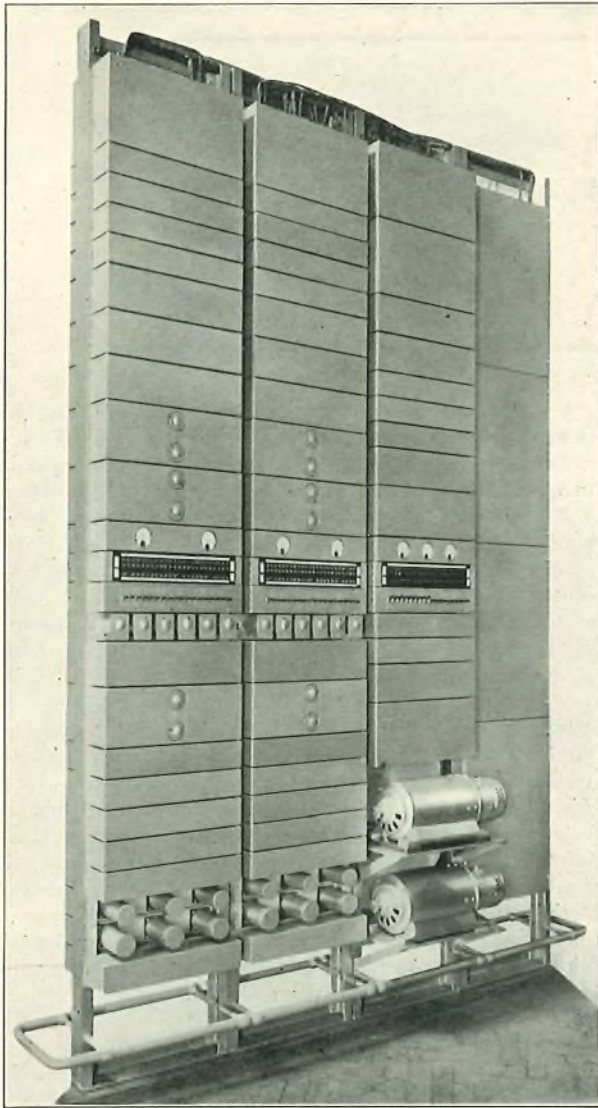

FIG. 10.—REAR VIEW OF RACK.

side of the panel to that shown in the figure.

- (c) Jack panels which carry the jacks whereby the meters can be inserted for measuring the filament current of each pair of channels.
- (d) Filament and grid resistance panels carrying the resistances for the correct adjustment of these particular circuits.

The fuse bay which is shown on the extreme left of the figure mounts the protective resistance lamps for the local telegraph battery circuits, and also for

the 130-volt anode battery circuits. This bay can accommodate equipment for five eighteen channel systems.

Power for the motor generator sets, filament circuits, and alarm relays is supplied from a 24-volt battery, whilst the anode circuits are supplied from a 130-volt battery. The power for the local telegraph circuits is supplied from a positive and negative 80-volt battery. The plate battery supplies a current of 20 mAs per channel; the motor generator requires a maximum current of 12 amperes; and the filament circuit takes 0.25 ampere for each pair of channels. Grid priming, as already explained, is supplied from resistances in the filament circuit and is normally about 23 volts.

Maintenance and Operating.

The maintenance of the system should present no serious difficulty. Perhaps the most important considerations, apart from the usual valve maintenance, are the constancy of the frequencies generated, and the proper adjustment of the transmitting and receiving relays. For the latter purpose a relay test panel has been provided with the equipment. This set provides for the following tests:—

Sensitivity, using 0.3 mA through relay coils; neutrality test at 25 p.p.s.; percentage contact test; and in the case of the sending relays, a differential test. In addition the sending relays should be adjusted to have a gap of 4 mils, and the receiving relays should have a 2 mils gap. With regard to frequency variations, it is not expected that much trouble will be experienced, as the multi frequency generators have proved reliable throughout most exhaustive trials.

In addition to the relay test unit a distortion measuring set has been provided with each equipment. This instrument measures the percentage distortion suffered by a signal during transmission from one end of the circuit to the other, or through apparatus. It therefore affords a guide as to the allocation and appropriation of the distortion due to the line, apparatus, etc. Space does not at present permit of a description of this set, but it will be of interest to quote some of the results obtained during the trials on the system between London and Dundee. Five types of perfect signals were sent from one end and the distortion was recorded at the other end of the circuit. These signals were (a) 1 mark 1 space; (b) 1 mark 5 space; (c) 5 mark 1 space; (d) the word "Paris"; (e) the word "Paris" inverted.

Further, in addition to the above, measurements were made at three different levels, zero, -8 dbs. and + 8 dbs. Table No. 3 gives the minimum distortion on the best channel, and the maximum distortion on the worst channel, for the signals and the levels under consideration.

TABLE NO. 3.

Signal.	Level.					
	- 8 db.		Zero.		+ 8 db.	
	% Distortion.		% Distortion.		% Distortion.	
	Min.	Max.	Min.	Max.	Min.	Max.
1M, 1S	12	24	6	20	12	24
1M, 5S	10	24	8	16	10	22
5M, 1S	8	20	6	16	10	24
" Paris "	10	20	8	20	15	22
" Paris " (Inverted)	10	26	8	17	14	24

The allocation of the channels on the present voice frequency installation between London and Dundee is as follows:—

Channels 2 and 3 carry London-Dundee circuits; channels 4, 5 and 6 are used for London-Aberdeen circuits, the extensions from Dundee to Aberdeen being on normal telegraph lines; channels 7, 8 and 9 are used for London-Edinburgh circuits. The London-Edinburgh circuits are worked voice frequency between London and Dundee, and extended back on a normal telegraph basis to Edinburgh. Channel 10 takes a Birmingham-Aberdeen circuit, and is on normal telegraph lines between Birmingham and London, and between Dundee and Aberdeen. The remaining three channels (1, 11 and 12) are at present spare, but it is expected that an additional London-Dundee circuit will be allocated to channel 1 in the near future.

The linking of the voice frequency channels to the longer telegraph extensions is carried out by using a simplified telegraph repeater. As these local circuits are worked on a two-line simplex basis there is no need for a duplex balance. The telegraph repeater units are very neatly mounted on panels telegraph No. 13. Relays standard G.N. with base-board No. 26 are used, and facilities for inserting a "G" circuit are available if required. In addition to the above a filter frequency 4A is incorporated in the sending leg. As the whole arrangement is a fundamental one it is not proposed to describe it here. Seven of these units are fitted at Dundee for the Aberdeen and Edinburgh extensions, and one at London for the Birmingham extension.

A useful monitoring set has been made up by the Telegraph Section for use at the voice frequency terminals. It is a neat arrangement both as regards the design and the facilities provided. The operation of the set may be briefly described thus. A teleprinter and Morse unit are joined up to three telephone keys, the operation of which can set up the following conditions:—(1) Leak on channel from or to voice frequency with teleprinter in circuit. (2) Speak on teleprinter to local or distant end. (3) Either teleprinter or Morse as in (2) or (3). In the second condition when the monitoring set is speaking to the local end, the channel under test is looped back, so that the distant operator, if he should send during such a testing period, receives his own signals, and is thus informed that the local end is under test. Conversely if the test is being carried out with the distant operator, the home operator will receive his own signals if he sends during such a testing period. The whole unit is mounted on a trolley and a seat, attached to the trolley, is provided for the testing operator. Battery power for the unit is picked up from the voice frequency frame.

The present voice frequency installation is functioning satisfactorily, and it is not unlikely that considerable progress will be made in the near future in adapting existing circuits to voice frequency operation.

In conclusion, the authors tender their thanks to the S.T. & C., Ltd., for the loan of photographs, etc., and also to those of their colleagues who have been associated with them in the above mentioned trials.

Telegraph Repeater Developments.

R. P. SMITH, A.M.I.E.E., and F. T. CATTELL.

A TELEGRAPH circuit on a long overhead line, or a small gauge underground conductor, cannot be worked direct by means of the Post Office Standard Relays. Owing to the effects of defective insulation, resistance, capacity, and inertia of the apparatus, only a portion of the sent current is effective at the distant office. The actual speed at which a circuit may be worked is inversely proportional to the square of the length of the circuit. To improve reception and allow an increased speed of working, apparatus is introduced at an intermediate point which, by its action, transmits amplified currents to the second section of the circuit.

Repeaters performing this function have been in use in the Telegraph Service since it was transferred to the State in 1870. The wiring of a repeater is shown in the Telegraph Diagram Book of 1886, and the first record of Construction at the P.O. Factory, Holloway, is dated 1888. The amount of apparatus and its lay-out have varied from time to time to meet circuit requirements, but Repeaters, in their main features, have remained unaltered down to the present time. The apparatus is mounted on a Base-board through which the wiring is taken and secured by staples on the under side. The board, measuring approximately 3' 6" in width and 2' 4" in depth, is then hinged to a stouter sub-base.

The following types of Repeater have been issued :—

- (1) Key speed, duplex or simplex.
- (2) Fast speed simplex.
- (3) Fast speed, duplex or simplex.
- (4) Fast speed, duplex or simplex, for cable circuits.
- (5) Forked news repeaters.
- (6) Hughes, simplex, cable on down side.
- (7) Hughes, duplex or simplex.
- (8) Fast speed, duplex or simplex, " Bridge " or " Differential " both sides.
- (9) Duplex, " Differential " both sides, for Baudot submarine cable circuits.

The chart shows the location of the telegraph repeater stations in this country, those enclosed in a rectangle being employed on routes between London and abroad.

About 130 repeaters are in use at the present time, all types being represented with the possible exception of (1) and (2). A fast speed repeater arranged for simplex or duplex working is illustrated in Fig. 1.

The introduction of Teleprinter working on practically all long distance Inland circuits gave rise to difficulties at the repeater stations, viz. :—

- (1) A teleprinter circuit has a marking current on the line during idle periods, whereas other systems in use send out a spacing current. Consequently, the Alarm unit in

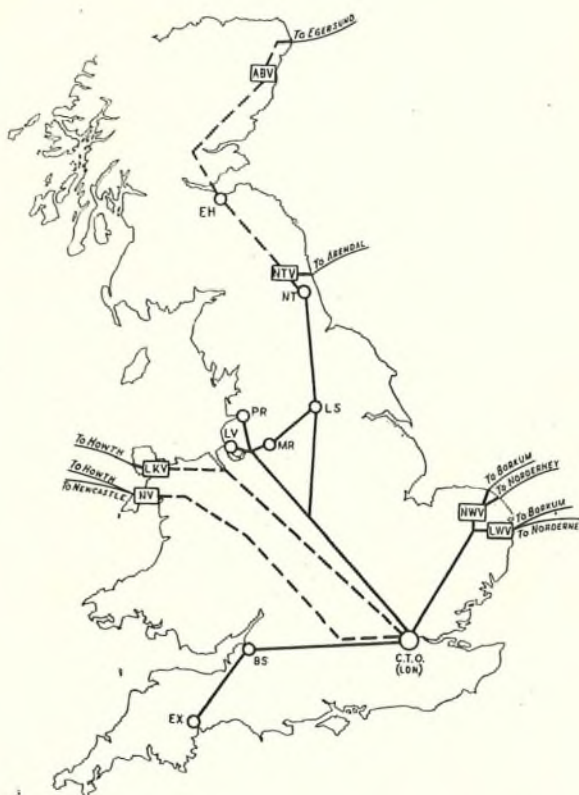

CHART SHOWING LOCATION OF TELEGRAPH REPEATER STATIONS.

use with repeaters, which operates with a marking current of 12 to 15 seconds duration, will not function.

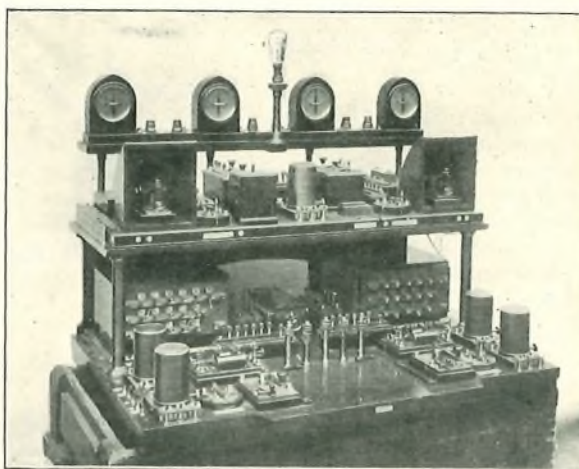

FIG. 1.—REPEATER, SIMPLEX AND DUPLEX.

- (2) The leak circuit of a repeater is provided with a Wheatstone Receiver by means of which the accuracy of the duplex balance and the character of the passing signals may be checked. This provision is adequate for Wheatstone and Baudot circuits as, in the latter case, Morse signals can be transmitted by arranging and locking certain combinations on the transmitters, auto or manual, at the terminal offices. This method cannot be adopted with Teleprinters, neither can a sequence of reversals of the same length be given, owing to the additional length of the stop signal.
- (3) A general demand arose for facilities to enable a Teleprinter to be used in the leak circuit and, also, to enable either side of the repeater to be terminated and worked teleprinter for testing purposes.

Temporary measures have been taken to overcome these difficulties. Fig. 2 shows the method of obtaining teleprinter signals in the leak circuit.

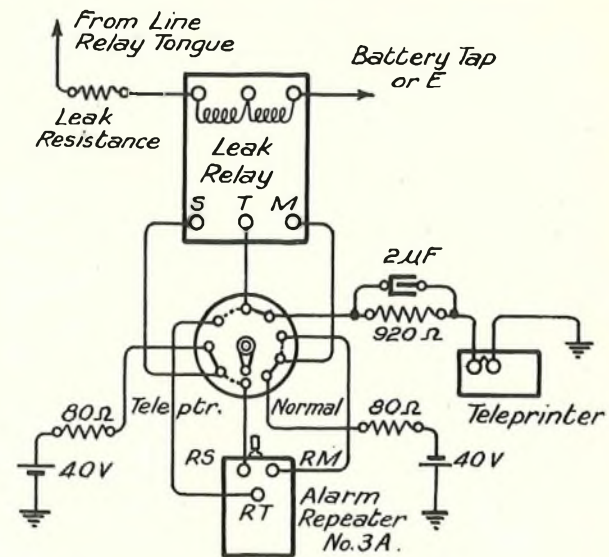

FIG. 2.—LEAK TELEPRINTER CIRCUIT.

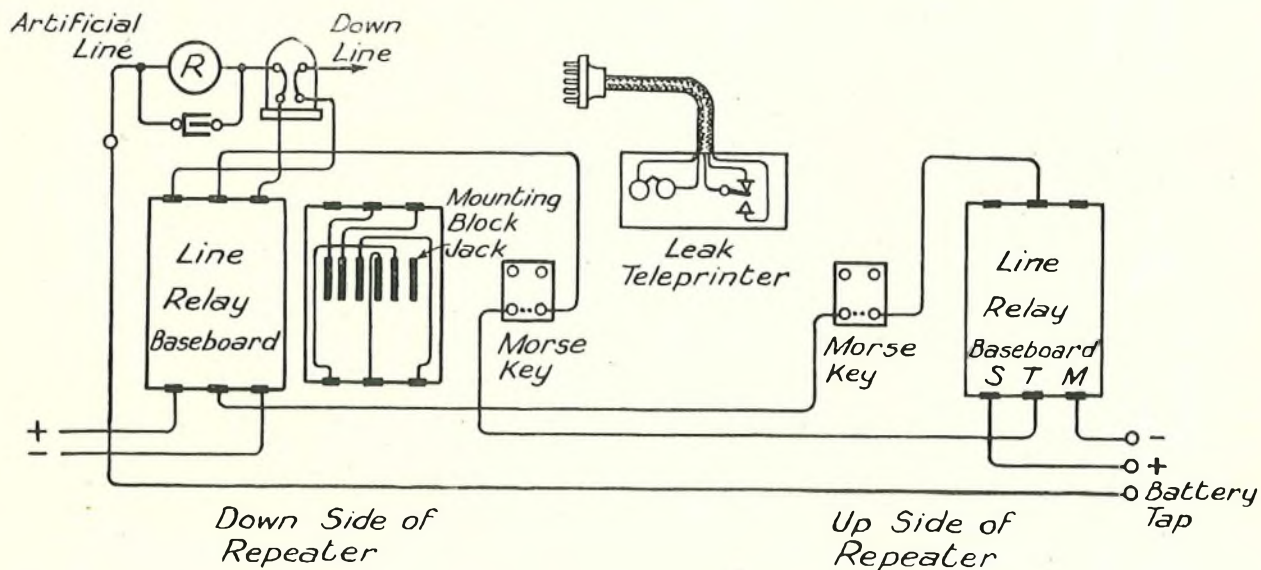

FIG. 3.—REPEATER TERMINATED FOR TELEPRINTER WORKING.

The 2-position switch enables the Alarm unit to be disconnected and substituted by a 40v positive and negative battery connected to "S" and "M," respectively, of the leak relay. The tongue of this relay repeats signals through a shunted condenser to the teleprinter electro-magnet. The leak teleprinter is introduced by means of a jack, placed in proximity to the repeater.

Fig. 3 shows the method of terminating either side of a repeater and working a teleprinter to the distant office. A jack to accommodate the teleprinter plug is attached to a mounting block. When necessary, the line relay is removed from its Baseboard and the mounting block inserted. It will be seen from Fig. 3

that the tongue of the up side line relay is joined to the teleprinter electro-magnet which is in series with the down side artificial line. The values of the latter can be altered, if necessary, to give a good teleprinter signal. The line battery on the down side relay is joined through to the teleprinter, the tongue of which is connected to the split of the up line relay. These circuits, devised by the Preston Repeater Station staff, have been introduced pending provision of the new form of repeater. The Alarm unit has been re-modelled for use on teleprinter circuits and is issued as Alarm, Repeater No. 3A.

A complete description of the racks, apparatus and wiring for the initial scheme of rack-mounted

terminal equipment at Leeds was given in the *P.O.E.E. Journal* in January, 1931. The success of this initial scheme led to the design of a section of repeaters embodying the same principles, and provision was made for four repeaters, each to accommodate either duplex or 2-loop simplex circuits. The apparatus required for each repeater is mounted on an Apparatus Bay as shown in Fig. 4. Two Apparatus Bays are placed at each side of a Test Bay, Fig. 5, and a Power Bay, Fig. 6, is placed at the right hand end of the group of bays.

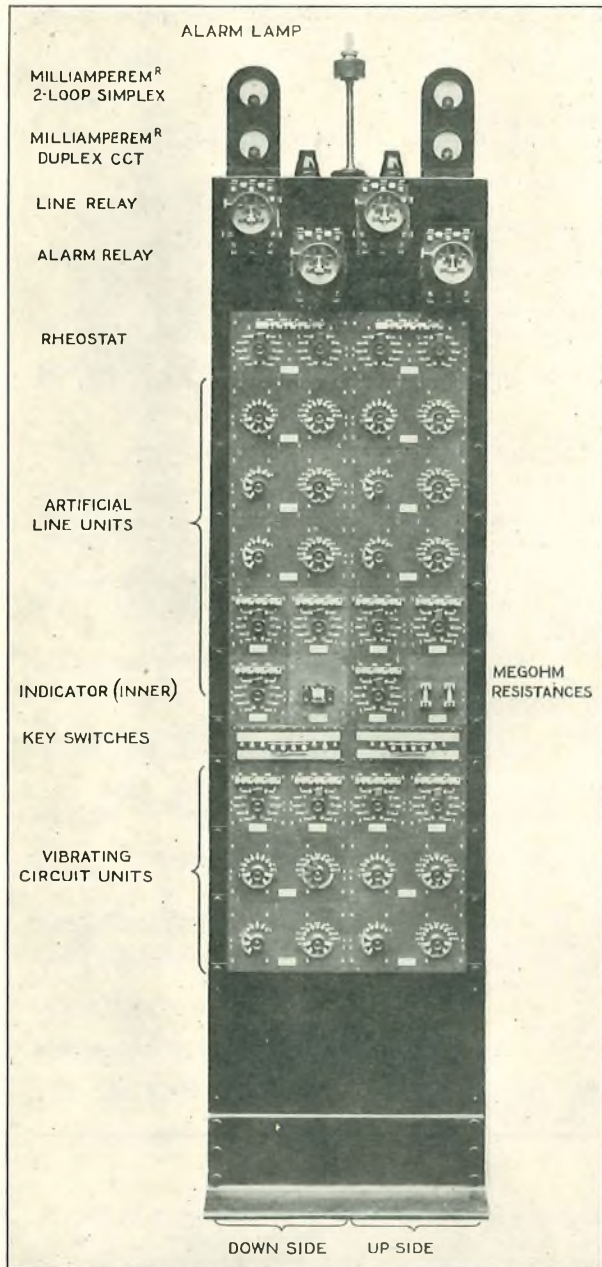

FIG. 4.—APPARATUS BAY.

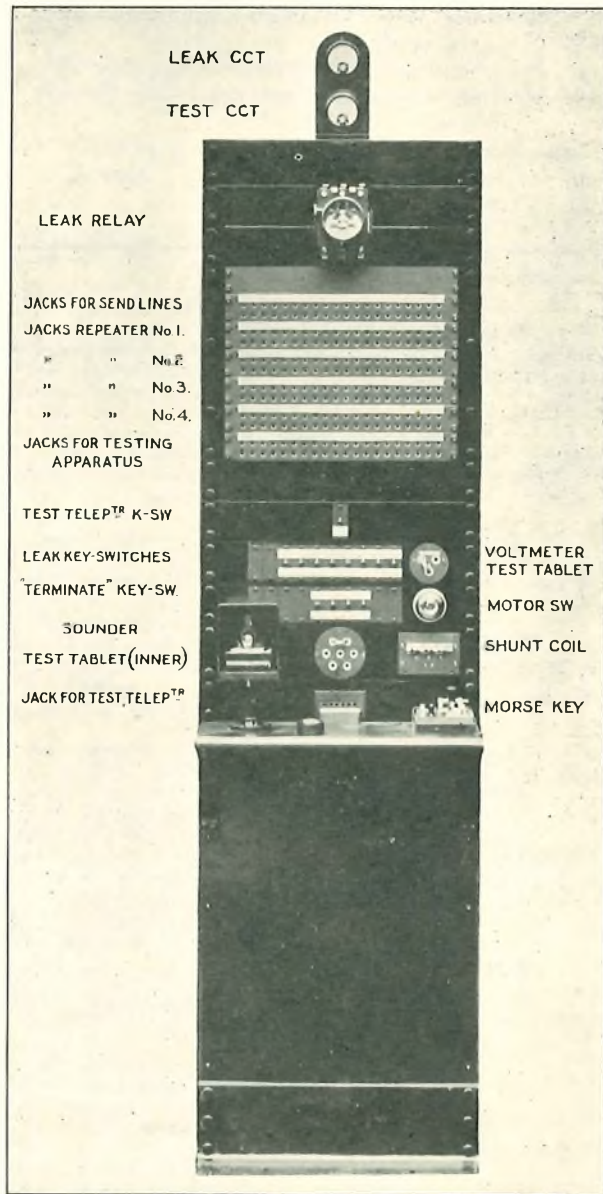

FIG. 5.—TEST BAY.

The apparatus is similar to that described for the initial scheme, but the Differential Galvanometers have been replaced by Differential Milliamperemeters and additional apparatus is provided for the Alarm circuit. Key switches are provided to enable either, or all, of the repeaters to be terminated and the two sides worked to Leeds as independent duplex or 2-loop simplex circuits. The value of this provision is that, should the line circuit on one side of the repeater fail, the other side can be terminated at Leeds and thus enable the office concerned to dispose of its traffic to Leeds without the further delay involved in transferring the line, and balancing a

second apparatus set. The four Apparatus Bays may be used to provide :—

- (1) 8 terminal sets for teleprinter duplex circuits.
- (2) 8 terminal sets for teleprinter 2-loop simplex circuits.
- (3) 4 teleprinter duplex circuits in repeater.
- (4) 4 teleprinter 2-loop simplex circuits in repeater.

- (5) A combination of terminated and repeater circuits as required.

Against the practical value of the dual function must be set the additional key-switches and somewhat complicated wiring which are involved. Ten key-switches are required on the "Down" side of the repeater and eight on the "Up" side. Details of their operating functions are as follows :—

<i>Type of key, and label.</i>	<i>Position of key, and function.</i>
Two-position key. "Teleprinter receive or repeater through."	<i>Normal position.</i> Circuit disconnected. <i>Operated position, set terminated.</i> Tongue of line relay connected to Teleprinter electromagnet at Instrument Table. <i>Operated position, set in repeater.</i> Tongue of line relay connected to line relay coils on opposite side of Repeater.
Two 3-position keys coupled. Above keys. "Test set to line." Below keys. "Test set to local."	<i>Key lever horizontal.</i> Normal working position. <i>Key lever depressed.</i> Testing officer works Teleprinter to Instrument Table. Required for terminated condition. <i>Key lever raised.</i> Testing officer works Teleprinter to terminal Office.
Two 3-position keys coupled. Above keys. "Morse." Below keys. "Resistance."	<i>Key lever horizontal.</i> Normal working position. <i>Key lever depressed.</i> Testing officer cuts off the line battery, for balancing purposes. <i>Key lever raised.</i> Testing officer works Morse to the terminal Office.
Three-position key. Above key. "G on, Repeater." Below key. "G on, terminated."	<i>Key lever horizontal.</i> Vibrating circuit of relay disconnected. <i>Key lever depressed.</i> Vibrating circuit arranged to operate with positive voltage on marking contact of relay. <i>Key lever raised.</i> Vibrating circuit arranged to operate with negative voltage on marking contact of relay.
Two-position key.* "Alarm Bell cut-off."	<i>Normal position.</i> 80v positive battery connected to Alarm circuit. <i>Operated position.</i> Alarm circuit disconnected.
Two-position key. Right hand set. "Terminate up." Left hand set. "Terminate down."	<i>Normal position, set in repeater.</i> (1) S contact of line relay to line battery, positive voltage. (2) Vibrating circuit of relay to earth, or battery common, as required. (3) Alarm relay circuit to earth, or battery common. (4) M contact of line relay to line battery, negative voltage. <i>Operated position, set terminated.</i> (1) S contact of line relay to 80v negative voltage. (2) Vibrating circuit of relay to earth. (3) Alarm relay circuit disconnected. (4) M contact of line relay to 80v positive voltage.
Two-position key.* "Terminate alarm."	<i>Normal position, set in repeater.</i> (1) M contact of alarm relays connected to megohm resistances. (2) Tongue of alarm relays connected to condensers. <i>Operated position, set terminated.</i> All circuits are disconnected.
Two-position key. "2-loop simplex."	<i>Normal position, set in repeater.</i> Tongue of line relay connected to line relay coils on opposite side of Repeater. <i>Operated position, set in repeater.</i> Tongue of line relay diverted to "send" line. <i>Normal position, set terminated.</i> Instrument Table Teleprinter connected to line relay coils. <i>Operated position, set terminated.</i> Instrument Table Teleprinter connected to "send" line.
Two-position key on Test Bay. Above key. "Repeater No. (1 to 4)." Below key. "Terminate Repeater No. (1 to 4)."	<i>Normal position, set in repeater.</i> (1) Down side relay tongue to Up side line relay coils. (2) Up side relay tongue to Down side line relay coils. <i>Operated position, set terminated.</i> (1) Line relay tongue, both sides, to Teleprinter sets. (2) Teleprinter to line relay coils, both sides.
Two-position key on Test Bay. Above key. "Leak (1 to 8)." Below key. "Term: A1 outgoing, Repr: A2 incoming."	<i>Normal position.</i> Circuits disconnected. <i>Operated position, set in repeater.</i> Line relay tongue operates leak relay giving incoming signals to leak Teleprinter. <i>Operated position, set terminated.</i> Teleprinter at Instrument table operates leak relay giving outgoing signals to leak Teleprinter.

* These keys are provided on Down side only.

It is probable that the terminated condition will be dispensed with for future installations, in order to simplify the circuit connexions. The skeleton connexions of a duplex circuit with key-switches

arranged for repeater conditions are shown in Fig. 8.

The leads connected to Jacks number 4, 5, 6, 7, and 8 (Down side of repeater), and number 14, 15, 16, 17 and 18 (Up side of repeater), Fig. 8, are

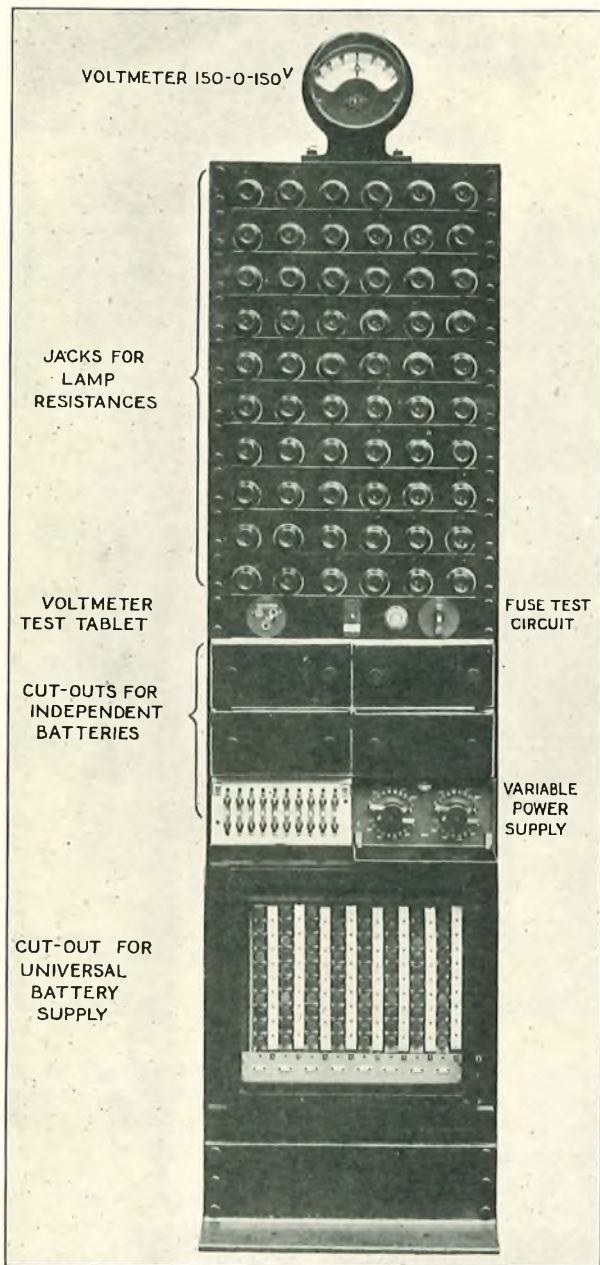

FIG. 6.—POWER BAY.

taken to the Concentrator panel by means of T connexions at convenient points. This provides a means of connecting the two line sets to teleprinter positions in the Instrument Room when the repeater is terminated. The connexions at the Concentrator are shown in Fig. 7. The 6-point Jacks, and flat-spring Plugs used with them, have been designed specially for use on Concentrator panels. The Jacks are mounted in strips of 20, and are fixed upon a Bay of the standard type. For normal circuits a line and instrument jack is provided, the inner

springs being connected, but for the repeaters a line jack only is wired. The alarm circuit of the repeater is shown in Fig. 8. Either terminal station may

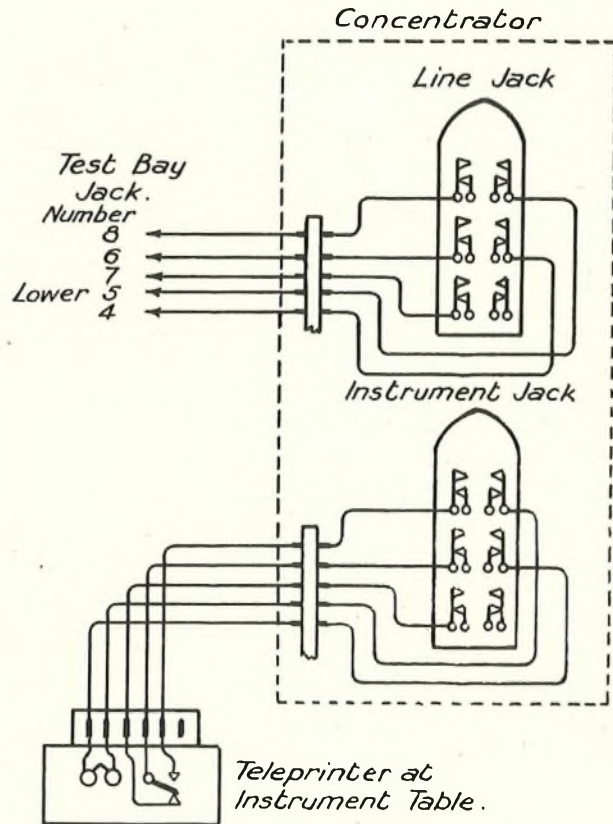

FIG. 7.—CONCENTRATOR CONNEXIONS.

call Leeds by sending a positive current to line for 12 to 15 seconds. To do this the terminal station withdraws the teleprinter plug and replaces it by a plug connected to a Morse key and sounder mounted upon a portable Baseboard. The tongue of the line relay is connected, through a fixed resistance of 2,500 ohms, to the coils of the alarm relay. The effect of a positive current upon the line relay is to place the tongue on the spacing contact. This, in turn, causes the alarm relay tongue to connect with the marking contact. The tongue of the alarm relay is connected to a $2 \mu\text{F}$ condenser; the marking contact is connected to an 80v earthed battery through a resistance of 5 megohms, and the spacing contact is joined to earth through one coil of a drop indicator. When the tongue connects with the marking contact for the specified period of time, the condenser is charged sufficiently to operate the indicator by discharging through the coil when the relay tongue returns to the spacing contact. The drop-shutter of the indicator, when released, closes the circuit of a bell fixed behind the Apparatus Bay and a lamp mounted upon a pillar placed above the bay. The

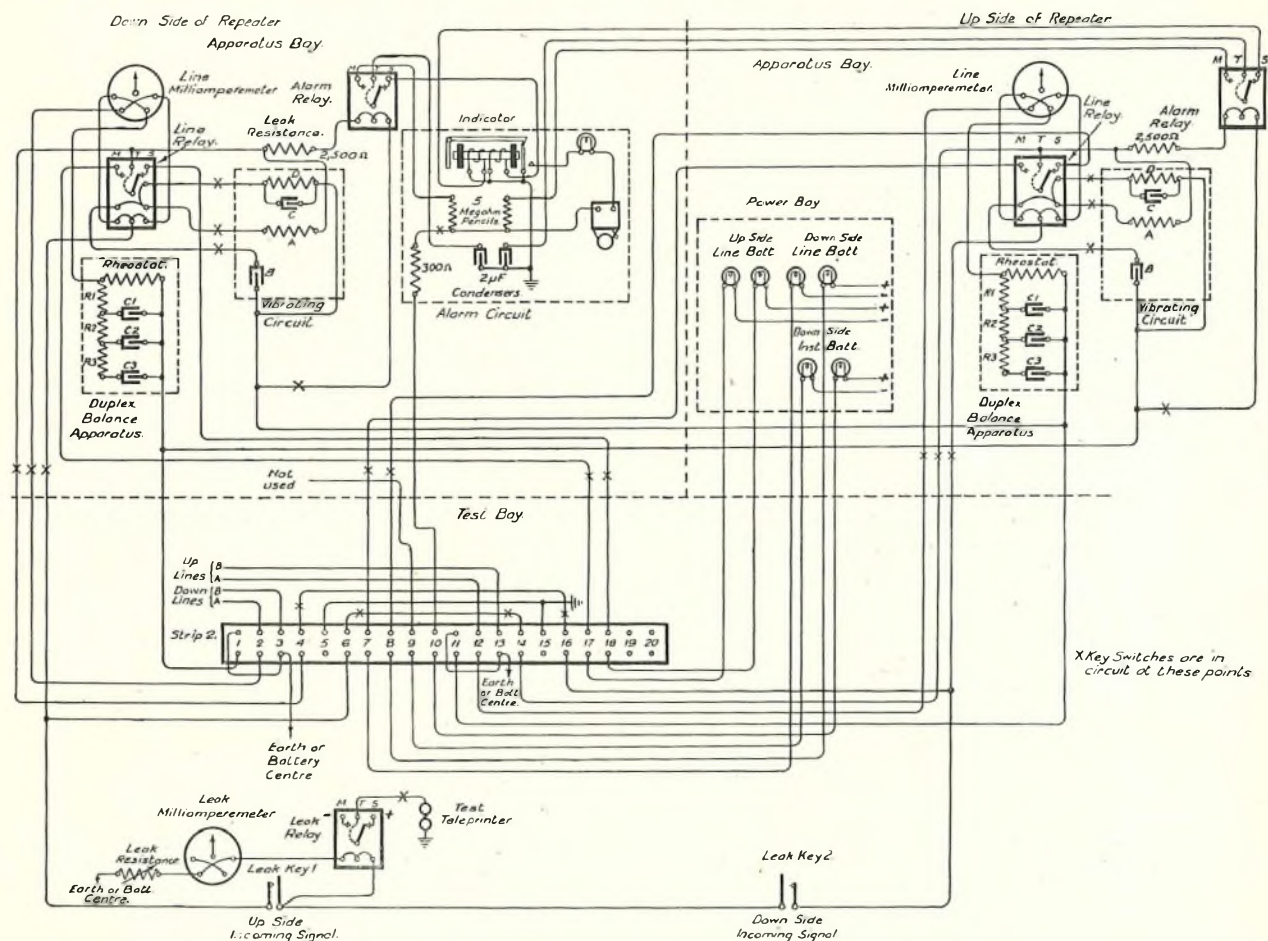

FIG. 8.—CIRCUIT CONNEXIONS—REPEATER THROUGH.

attendant thus has visual and aural warning. By operating the appropriate key-switch a polarized sounder and Morse key are brought into circuit for speaking purposes, whilst by means of another key-switch the alarm circuit is disconnected until through working is again established.

Rack-mounted repeaters have proved entirely satisfactory and arrangements are in hand for their introduction at other stations. Further supplies will, however, follow the general design of the rack-mounted telegraph apparatus now being installed at London and other large offices where the space required for a Section of Bays has been reduced by half.

The demand for telegraph repeaters may be

modified in the near future as the result of an experimental double-phantom circuit between London and Glasgow, a distance of 447 route miles. This circuit has been specially loaded and is working at teleprinter speed without a repeater in circuit; there is sufficient margin of adjustment to allow the use of a non-vibrating relay. Further steps in this direction would allow all the double-phantom circuits in use to be worked direct.

There is also the probability that multi-channel voice-frequency telegraph circuits will be installed in the near future to provide for all long distance circuits. This system is operated through the normal telephone repeater station equipment so that telegraph repeaters will be released from service.

Recent Developments in Automatic Telephone Exchange Equipment.

G. BROWN, A.M.I.E.E.

IN a description of the Department's standard automatic equipment which appeared in the April, 1930, issue of *The Post Office Electrical Engineers' Journal*, it was mentioned that Bristol and Acorn Exchanges would be provided with the new open type racks. Those two Exchanges have now been completed and brought into service and the open type rack for automatic selectors is being installed generally throughout the country by all Post Office contractors.

As work proceeded on the new equipment, close observation was made in the factories and on site, with the result that several minor improvements were effected. When it is realised that the change over from the line switch and final unit type of equipment to open type racks meant extensive changes not only in floor plans and apparatus arrangements but also in methods of wiring selectors and banks, and in the capacity and routing of cables between racks and frames, it will be appreciated that there was ample scope for suggestion in the early stages.

It is the purpose, however, of this article to give some information regarding the following new items which have been developed since that date:—

- (1) Travelling ladders with brakes.
- (2) Flood lighting of racks and frames.

(1) Ladders.

It was recognised in the early stages of the development of the open type equipment that ladders would be necessary to give access to the apparatus on the upper shelves of the 10' 6" racks. The possibility of using portable ladders was investigated, but it was considered that a travelling ladder provided with a brake and arranged to serve two faces of a 2' 6" wide apparatus gangway would best meet the conditions.

Particulars of a number of different types of ladder brakes were considered, including brakes used by American and German Telephone Administrations.

Ultimately, it was decided to use a brake designed to meet Post Office requirements by the General Electric Co., Ltd., at their Coventry works. This brake is now specified as an inherent part of the Post Office standard travelling ladder.

Fig. 1 is a side view of the ladder extended at an angle of 60° to the horizontal, ready for use. The vertical support is a cylindrical steel tube with its head welded to a malleable cast bracket which in turn is securely attached to a double bogey carriage with roller bearing wheels. A collar fixed to the steel tube acts as a stop and the ladder is maintained firmly in the extended position by a pair of slotted

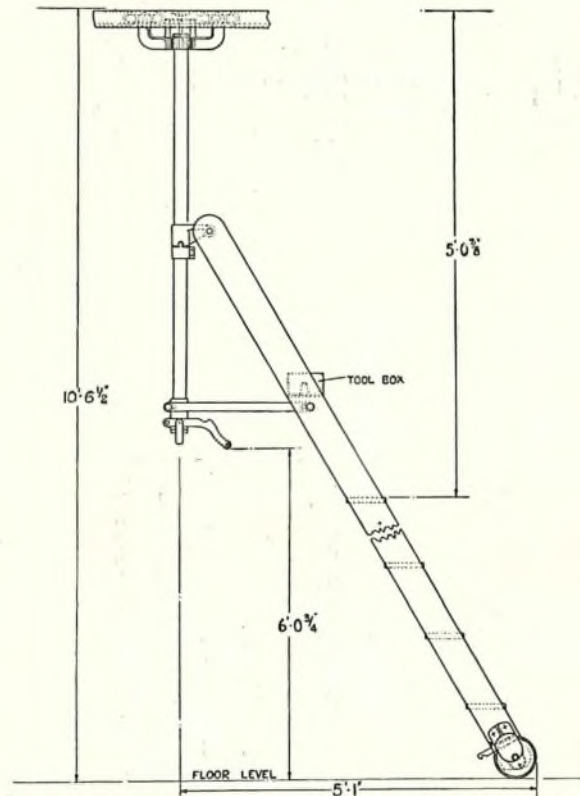

FIG. 1.—SIDE VIEW OF LADDER READY FOR USE.

horizontal arms attached to the bottom end of the tube and to the ladder stringers.

The brake control handle at the bottom of the vertical support is connected to a spring-loaded rod

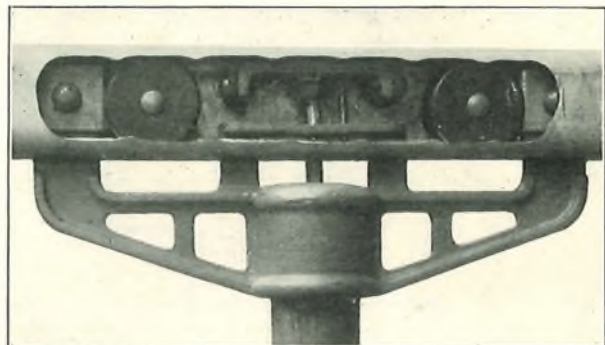

FIG. 2.—BRACKET, BRAKE, AND TRACK.

which extends up the interior of the tube and terminates on a brake shoe, pressing firmly against the top inside face of the track. The ladder in the extended position is therefore normally braked. The brake is released by depression of a control handle which may be effected, if necessary, without descending the ladder.

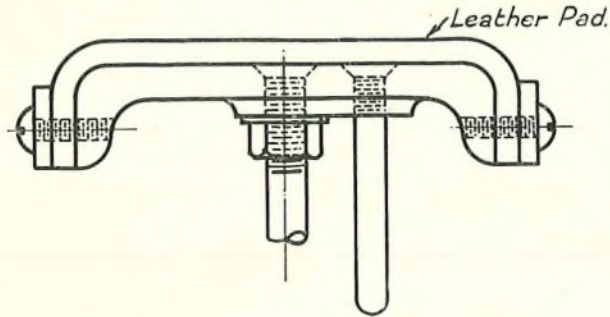

FIG. 3.—BRAKE SHOE.

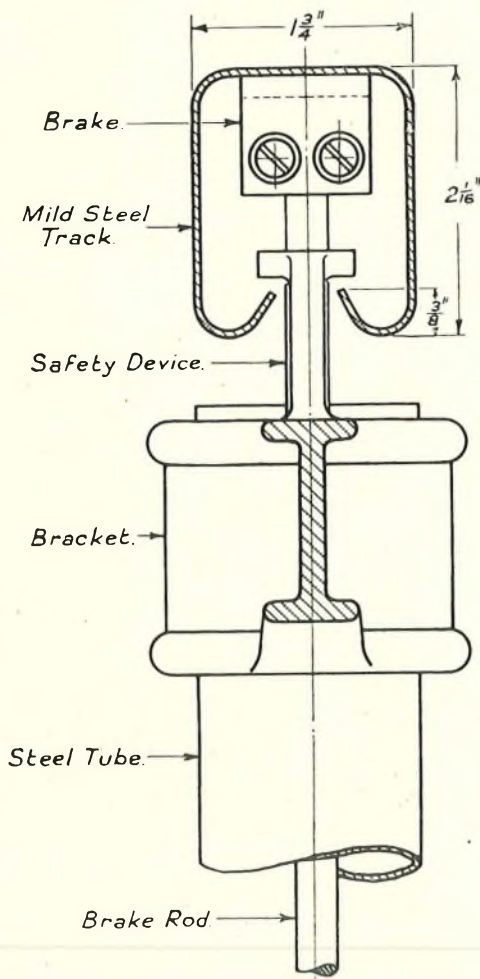

FIG. 4.—SECTIONAL VIEW OF TRACK AND BRAKE.

In Fig. 2 a view of the malleable cast bracket at the head of the vertical support is given with a section of one side of the track removed to show the wheels and the brake with guide pin and safety device. The brake shoe is seen detached in Fig. 3, and in Fig. 4 a sectional view of the track is given together with the brake and its associated parts.

Fig. 5 is a view of the ladder as it would appear

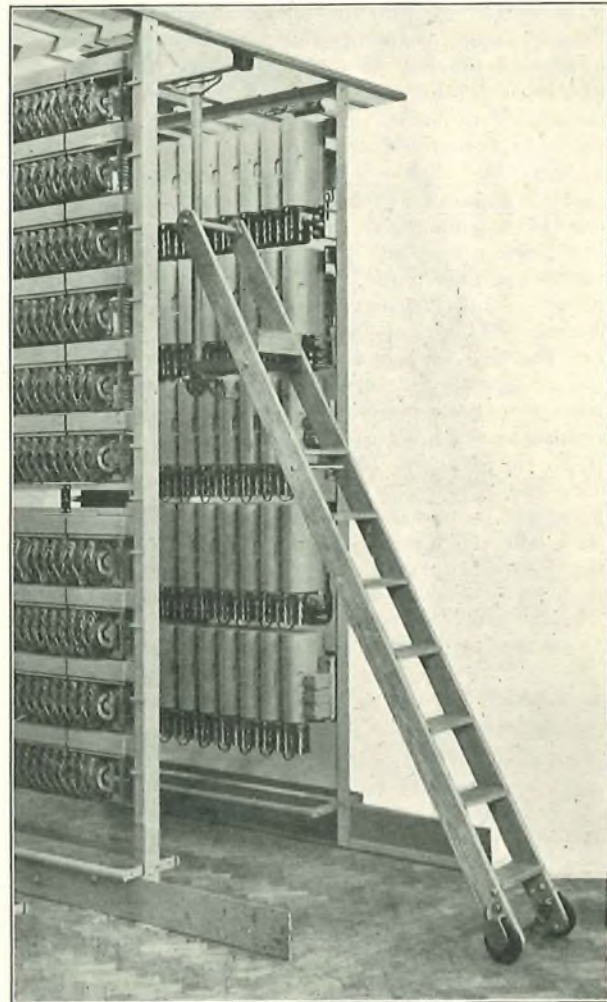

FIG. 5.—LADDER AT END OF APPARATUS GANGWAY.

in an apparatus gangway. The overhead track which is of galvanized steel can be seen supported by cast brackets bolted to the inter-suite stays. Guard rails at the bottom of the racks prevent damage to selectors, etc., when the lower part of the ladder is moved aside to give passageway.

The view in Fig. 6 shows the ladder turned through an angle of 45°. This is a position which may be required to give access to power distribution fuses when these are fitted at the end of a suite of racks.



FIG. 6.—LADDER TURNED THROUGH 45°.

In the vertical position, illustrated by Fig. 7, the ladder is suspended clear of the floor and parallel to the line of racks. The weight of the ladder when suspended in this manner rests on the brake control, compresses the brake spring and releases the brake so that the ladder may be freely moved along its track in either direction. It may also be rotated through 180°, a facility which makes it possible to reverse the angle of inclination, thus obviating the necessity for extending the overhead track beyond the limits of the equipment served and providing a choice of working from the ladder to right or left as desired.

When out of use the ladder may be secured to either side of the gangway by means of a spring hook which engages with the guard rail. With the ladder thus secured the least possible obstruction is caused in the gangway. (See Fig. 8).

In addition to the brake and the mobile features described, the new ladder will have a few refinements such as a tool tray, a spring clip for soldering irons

and a grease feeder on the wheels. It is intended that all travelling ladders for future exchanges will be of the new type.

(2) *Flood Lighting of Racks and Frames.*

The effective lighting of equipment in Automatic Telephone Exchanges has been under consideration for some time. Ordinary general lighting is unsatisfactory for high racks with narrow gangways and hand lamps with shot loaded counterweights have several drawbacks, not the least of which is the trouble that follows if the contract for the electric lighting is completed in advance of the installation

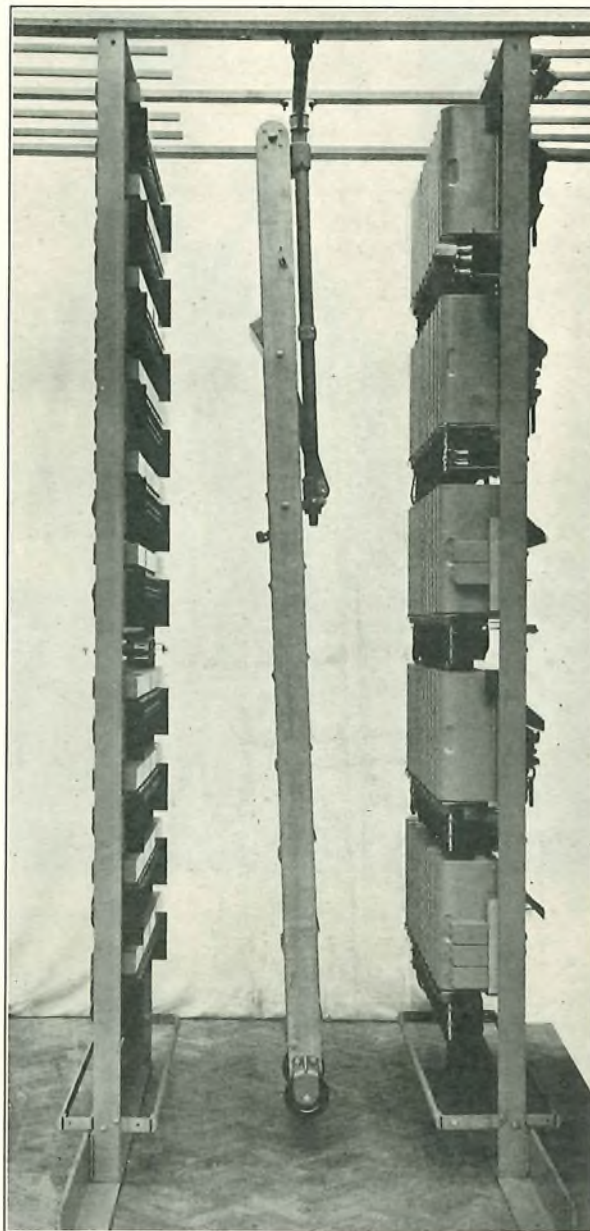

FIG. 7.—LADDER IN VERTICAL POSITION.

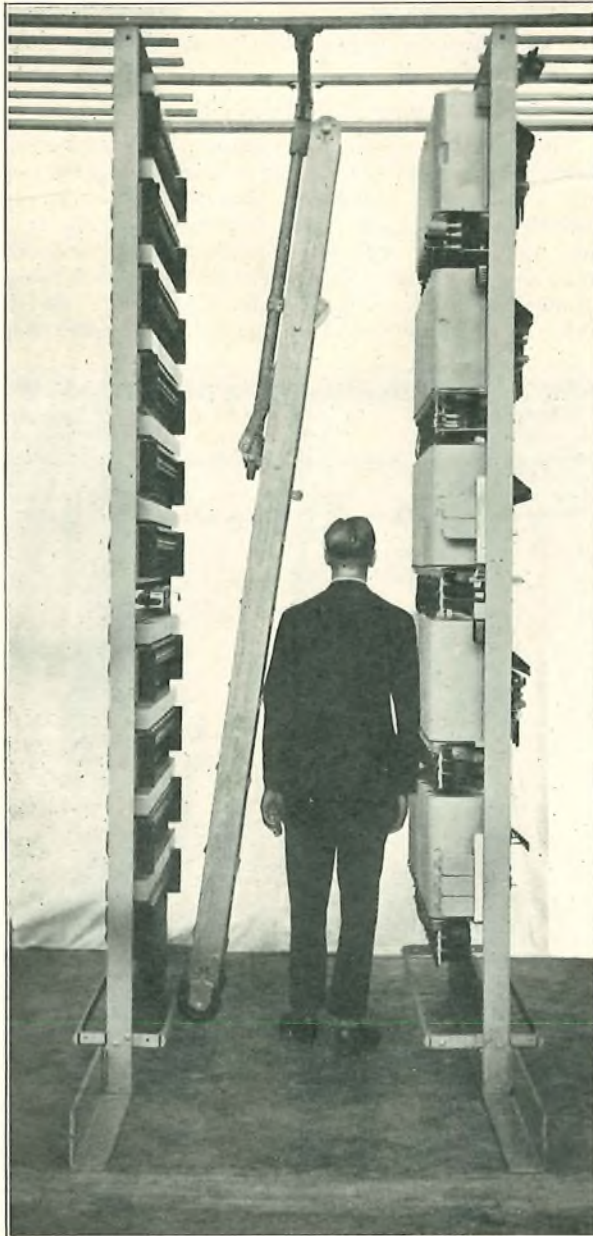

FIG. 8.—FOOT OF LADDER SECURED TO ONE SIDE OF GANGWAY.

of the Exchange equipment, and some unavoidable change in the floor plan causes a rearrangement of, say, two thirds of the lighting points, with consequent risk of grit and dust lodging on the relay contacts. Apart from this, the introduction of travelling ladders in narrow gangways with overhead ladder tracks and cable runs made it apparent that the use of pendant light fittings of any type was no longer practicable.

In co-operation with the Department's Power and Maintenance engineers, experiments were carried out at Sloane Exchange early in 1931 with a form of

flood lighting for the racks and the main frame. As a result of these experiments, it was decided to standardise rack lighting for future Exchanges which would ensure the projection of a serviceable light on the apparatus sides of all racks with good general lighting in the wiring gangways—all lights to be controlled by two-way switches fitted to the rack uprights at the ends of the gangways. For work such as rewiring, a hand lamp connected to a plug and socket fitted on the base angle will be within reach of every rack. 50 volt head lamps plugged into battery jacks equipped on the racks will continue to be used for close up inspections and adjustments of apparatus on site.

At Bristol, Acorn and certain other new London Exchanges where installation had already commenced, arrangements were made for the rack lighting to be carried out by the Post Office staff.

As it is intended that the rack lighting for future Exchanges will be included as part of the equipment provided by the Exchange contractor and will be subject to the general conditions governing the contract as a whole, an outline of the arrangements may be of interest to engineers concerned with the construction or maintenance of Automatic Exchanges.

Racks 10' 6" high are now laid out in parallel suites of varying length, with the apparatus sides face to face forming apparatus gangways 2' 6" wide and wiring gangways 1' 8½" wide. It was found that satisfactory lighting of the apparatus was obtained from 40 watt lamps in parabolic angle reflectors fitted at the top of every alternate rack so as to project light on the opposite side of the gangway.

Fig. 9 is a plan view of an apparatus and a wiring gangway formed by 4' 6" racks, five racks per suite, showing the approximate positions of the lighting points. Such an arrangement constitutes a wiring group for rack lighting purposes.

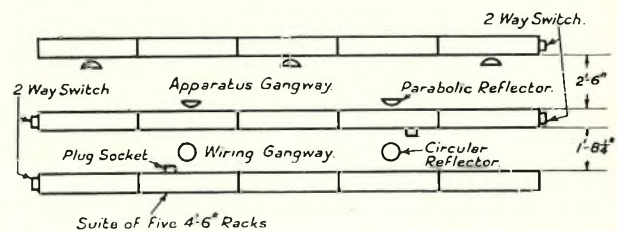

FIG. 9.—PLAN OF APPARATUS AND WIRING GANGWAYS.

Fig. 10 shows a typical wiring arrangement for a complete group of three parallel suites.

Varying conditions of exchange equipment lay-out will, of course, affect the wiring of the lighting points. For instance, if only two racks of an ultimate six per suite are installed initially, the wiring should be terminated and strapped in a conduit box fitted near the second rack and only one singleway switch provided instead of a two-way switch at each end of the gangway.

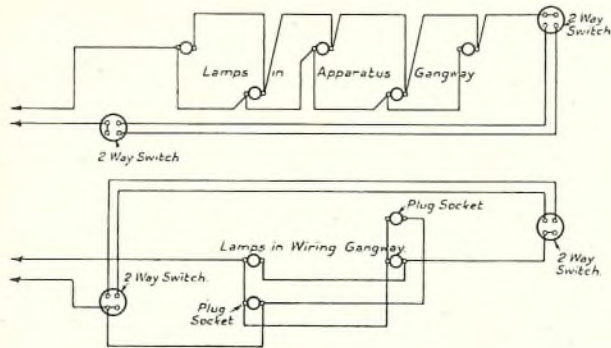

FIG. 10.—WIRING OF GROUP OF THREE PARALLEL SUITES.

The wiring would be extended as racks are added and the ultimate arrangement of wiring and switches would be that required for a complete group.

3/.036 V.I.R. Cable will be used for groups having over 300 watts and under 600 watts. Groups having 300 watts or less will be served by 3/.029 V.I.R. Cable.

Fig. 11 is an end view of the upper portion of two adjacent gangways showing the relative positions

of the reflectors, travelling ladder tracks and automatic selectors.

In the January, 1932, issue of the *P.O.E.E. Journal* (pages 274-275) illustrations of Acorn Exchange are given which show the lights in position.

British Standard heavy gauge screwed conduit will be used throughout and will be required to form a continuous metallic circuit earthed by means of 7/.029 V.I.R. Cable.

Arrangements are being made for lighting main frames with 100 watt lamps in elliptical angle steel reflectors attached to travelling carriers at the top of the frame. Each carrier will travel horizontally over a length of eight feet, and will be controlled by a drop handle attached to the end of a chain within reach of the floor. Pendant switches will be provided for controlling the lights. This applies to main frames which have travelling ladders installed.

For large main frames with mezzanine platforms, it is intended to flood light the upper and lower portions of the frame from two separate sets of reflectors, the bottom set being equipped on the under side of the platform.

The writer is indebted to the General Electric Coy., Ltd., for the photographs of the travelling ladder.

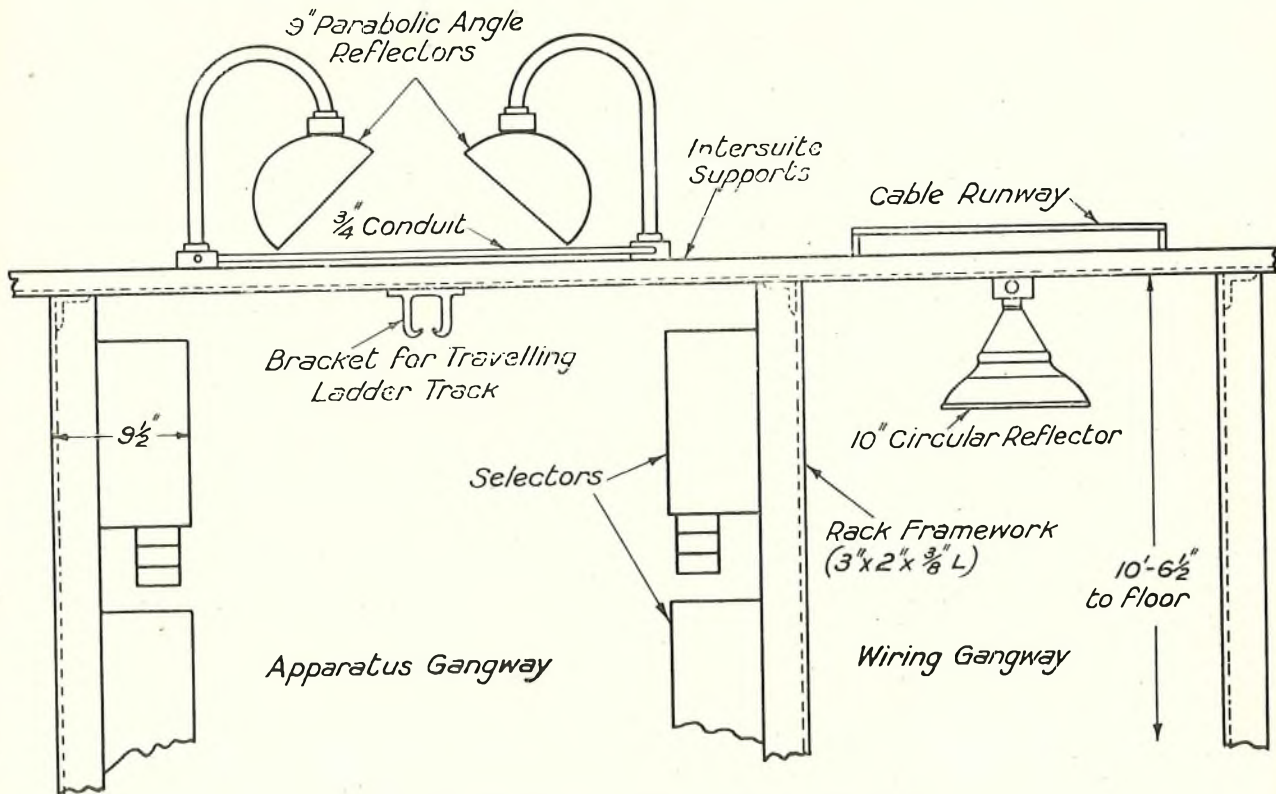

FIG. 11.—END VIEW OF UPPER PORTION OF GANGWAYS.

A Graphical Method of Determining the Impulsing Performance of Two-Motion Selectors.

C. G. GRANT.

A METHOD of expressing graphically the results of impulsing tests on auto apparatus has already been described in a previous article, "Aids to the Study of Impulsing in Automatic Telephone Systems," by W. H. Grinstead and D. A. Christian, which appeared in Part 4, Vol. 20, Jan., 1928, of the *P.O.E.E. Journal*. This method has been in use for some time and experience has shown how great is the convenience of being able to express impulsing test results in graphical form, so that the factors of safety of the apparatus under the varying test conditions can be read from the curves obtained.

In fixing the test conditions one has, however, to consider a number of variable factors, the four main variables being as follows:—

- (a) Exchange battery voltage.
- (b) Line conditions.
- (c) Speed of impulsing.
- (d) Ratio of impulsing.

For the graphical representation of a series of tests it is only possible to have two of these factors variable for a given curve. It will therefore be seen that there are a number of possible variations, of which the following four alternative combinations have been given consideration:—

- (1) Line and speed constant, voltage and ratio variable.
- (2) Voltage and ratio constant, speed and line variable.
- (3) Line and voltage constant, speed and ratio variable.
- (4) Voltage and speed constant, line and ratio variable.

It now remains to be decided from which of these combinations can be gained the most useful data, when the results obtained are plotted graphically.

The first method is of little practical value as it is known that for long line working the minimum allowable voltage on the system is the most severe testing condition, as both relays and selector magnets are then receiving their minimum current. Therefore tests should be made with the minimum voltage of a system as one of the fixed conditions.

The second method of testing in which a fixed ratio is used is subject to the following criticism. An in-

crease in line resistance reduces the current received by the impulsing relay, causing its operating lag to increase and its releasing lag to decrease. Ultimately a line value is reached at which failure occurs owing to relay B not being retained by the shortened pulses from the make contact of the impulsing relay. An increase of the break ratio of the dial accentuates the long line effect and therefore decreases the maximum permissible length of the line.

Line to line leak has the opposite effect on the impulsing relay and tends to maintain it during the break periods. Therefore a shortening of the break periods on the dial will still further decrease the time of closure of the impulsing break contacts so that ultimately magnet failure will occur.

The permissible range allowed by the Department, on a dial, is from 63% to 70% break, and as this range is considerably widened by the distortion introduced by circuits using repeating relays, it is not desirable to have the ratio as one of the fixed test conditions.

In the third method, which is the one dealt with in the article mentioned in the first paragraph, the impulsing speed and ratio are the two variable factors. The results obtained from tests of this nature give certain useful information regarding the performance of the apparatus under test, when they are plotted on a suitably prepared chart, the curves shown in Fig. 1 being typical for a normal group or final selector in good adjustment. The factors of safety for both the leak and long line conditions at which these tests were made are indicated at a glance by the spacing of the curves from the "target."

From considerable experience gained in the testing of the impulsing performance of auto apparatus, it was realized that none of the three above methods of testing gave the necessary information unless repeated sets of test results, covering a wide range of conditions, were taken and separately plotted. Therefore attention was given to the fourth alternative method in which tests are made with voltage and speed constant, while line conditions and ratio are varied, as this scheme appears to have advantages over others.

Tests were made and a chart of the form shown in Fig. 2 was developed for the recording of results. This chart is divided into two sections, the left hand side being used for leak test results and having its

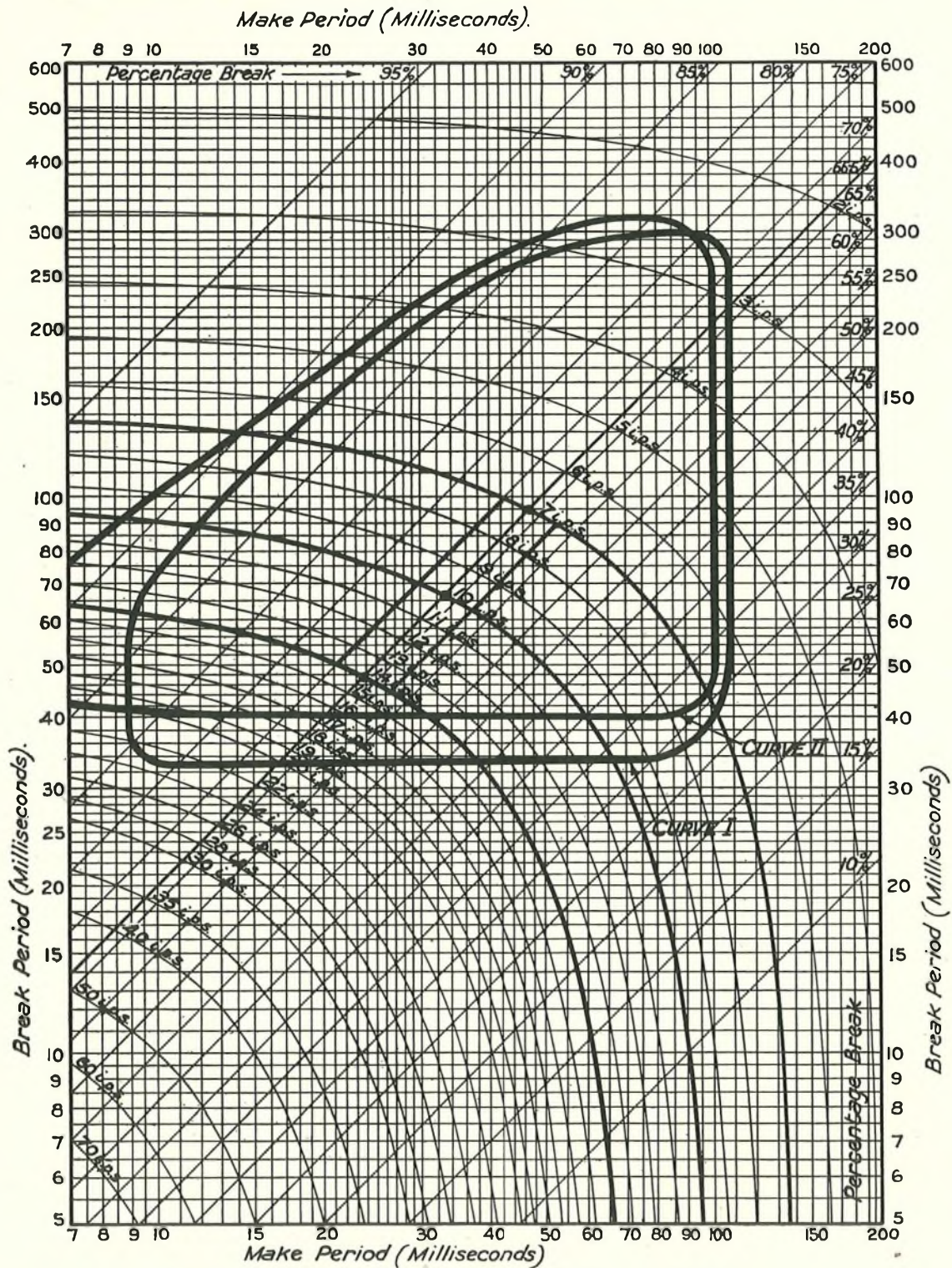

CURVE I. Line Resistance 1800Ω, Leak ∞, 46 Volts.
 CURVE II. Line Resistance Zero, Leak 20,000Ω, 52 Volts.

FIG. 1.—TARGET DIAGRAM.

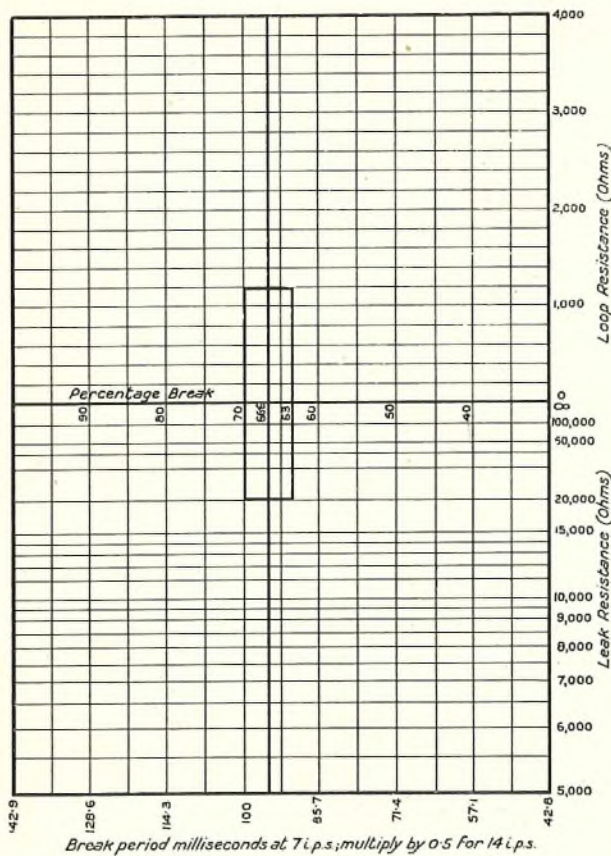

FIG. 2.—PERFORMANCE CHART.

abscissa divided by a scale with a reciprocal spacing, to cater for infinity or no leak conditions, while the right hand section is used for long line test results and has a plain scale. The centre ordinate is calibrated in percentage break, which may also be read as milliseconds break when 10 i.p.s. curves are plotted. Further the left hand ordinate is marked in milliseconds at 7 i.p.s. which when multiplied by the factor 0.5 also gives milliseconds at 14 i.p.s. The rectangle in the centre of the chart encloses an area which is bounded on two sides by the dial ratio limits specified by the Department of 63% to 70% break; and on the other two sides by the test line limits of 20,000 ohms leak and 1,200 ohms loop resistance.

Tests were made on a number of selectors at 7, 10 and 14 i.p.s. and at 46 and 52 volts, the results obtained for a typical selector being shown in Fig. 3. The boundary lines of these curves have a definite significance, the lower portions of the 10 and 14 i.p.s. lines indicating magnet failure owing to an insufficient make or energisation period, and it will be

noted that the higher speed of 14 i.p.s. imposes the most severe test condition. The lower portion of the 7 i.p.s. line indicates the failure of relay C to hold over long break periods when receiving only short make pulses, while the top lines at all three speeds indicate the failure of relay B from the same cause. The left hand boundaries of the curves are fixed by the magnitude of the leak current being such that relay A failed to release during the break periods. The practical working limit of the selector will, however, be to the right of the ordinate which indicates a value of leak which allows the full release of relay A. The right hand boundary indicates the failure of relay A to operate owing to the high value of loop resistance.

It will be observed that the upper lines of the three curves cross, so that under leak conditions with high percentage break ratios, 7 i.p.s. is a more severe test condition than 14 i.p.s., but within the normal working range of the selector the 7 i.p.s. line does not come below the point touched by the 14 i.p.s. curve at 1,200 ohms loop resistance. Therefore at high percentage break ratios 14 i.p.s. is the most severe test condition for the selector.

From a curve taken at 14 i.p.s. and plotted on a chart of the above form, the factors of safety under various line conditions can be read off in milliseconds break from the lengths of the ordinates between the curve and the centre rectangle. It will thus be seen that it is possible to read from the graph the maximum permissible junction or leak resistance for a given impulse ratio, or the maximum impulse distortion, outside the normal range of 63 to 70 per cent., for a given junction or leak resistance. In the course of testing a selector it would, however, be as well always to take a portion of the upper and lower lines at 7 i.p.s. in order to check the holding properties of relays B and C at low speeds. Therefore full information as to the impulsing performance of the apparatus under test can be gained from one curve taken at 14 i.p.s., with the possible addition of two portions of the 7 i.p.s. curve.

The following important point becomes prominent when this form of testing is used and concerns the voltage at which leak tests should be taken. Selector performance on zero line is worse at 46 volts than at 52 volts; this is owing to the relays and selector magnets receiving less current at the lower voltage. When leak is applied to the A relay the break period decreases and the higher the exchange voltage the greater is the effect of the leak, but the higher voltage improves the performance of the selector magnets.

Therefore as these two factors are opposite in their effects there is usually a point at which they neutralize and beyond which the effect of the leak at high voltage predominates. This effect can be seen in Fig. 3, where the dotted lines cross the full lines of the same speed in the lower left hand portion

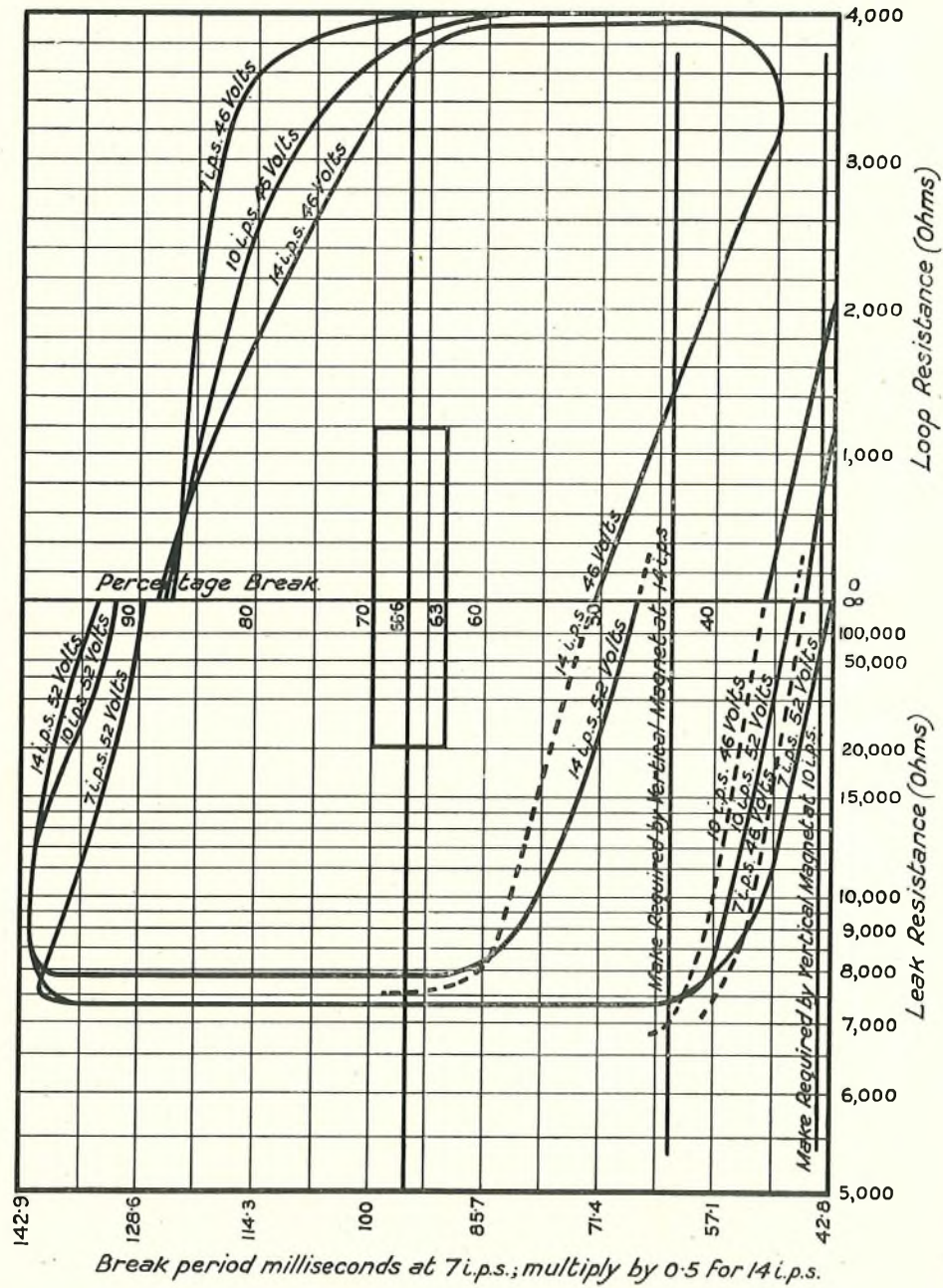

FIG. 3.—SELECTOR PERFORMANCE CHART.

of the chart. Therefore up to this point the most severe test condition is 46 volts and beyond this 52 volts should be used. It will be noticed that on the curves for the selector under consideration the cross-over does not occur until the value of leak applied is far beyond that met under practical conditions.

The varying distortion of the A relay with differing line conditions is shown by the contour of the lower sides of the curves in Fig. 3. The amount of make in milliseconds required by the selector magnets for the speeds of 10 and 14 i.p.s. can be expressed by two abscissæ. Therefore the distortion in milliseconds of the A relay for any line condition is given by the length of the ordinate between the lower line of the curve for the impulsing speed under consideration and the relative abscissa.

This method of testing readily disclosed a defect in a certain selector, which was not apparent from tests made with fixed leak and long line values, the impulsing speed and ratio being varied. A portion of the curve taken for this selector is shown in Fig. 4 and it was found upon further investigation that the upwards bend in the centre of the line was caused by contact bounce occurring on the A relay break contact in varying amount with differing line conditions.

It is thought that the scheme, outlined above, will form a useful addition to existing methods of determining the impulsing performance of auto apparatus, as it enables considerable information to be obtained from a minimum of test results.

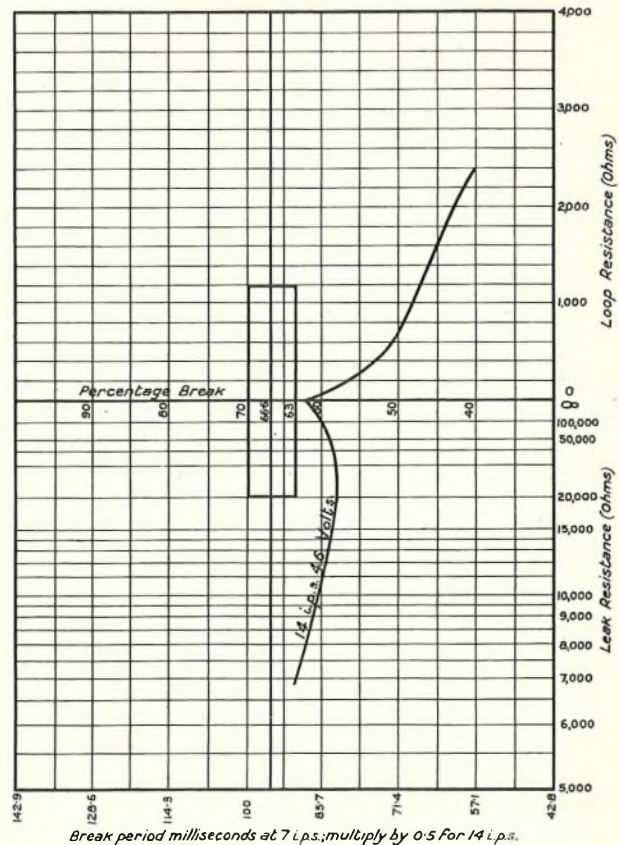

FIG. 4.—PORTION OF PERFORMANCE CURVE.

Acorn Exchange.

Progressive Installation of the New Standard Open Type Rack and Shelves.

B. HOUGHTON BROWN,

Engineering Division, Standard Telephones and Cables Limited.

THIS Article concludes the series dealing with the installation of the first exchange to be installed incorporating throughout the British General Post Office "open type racking scheme." The exchange was successfully cut into service at 2.30 p.m. on Thursday, the 7th January, 1932.

Until the reports have been received and tabulated, it is difficult to determine whether all the advantages claimed for the "piecemeal" method of installation have been realised, but the information to hand is sufficient to show that this system has numerous advantages over bulk installations

particularly where the distance between the contractors' works and the exchange is relatively small.

In conclusion, the Author wishes to thank Messrs. A. B. Eason and G. Brown of the Engineer-in-Chief's Office who have so untiringly fathered the introduction of the "open type racking scheme," the seeds of which have now developed and are being used throughout the country.

"The Acorn which scatters great hopes in the seed field of man."—*Browning*.

Miscellaneous Facilities at Automatic and Manual Telephone Exchanges.

A. HOGBIN.

THE chief engineering and traffic facilities for giving automatic service to telephone subscribers were decided when automatic working was first introduced into this country. Since then, many additional facilities have been devised but owing chiefly to the diversity of the automatic equipment it has not been practicable to standardize many of these.

Within the last three or four years, however, the degree of equipment uniformity which has been obtained has made the standardization of certain facilities possible. The more important of these, *e.g.*, the straightforward method of working and voice frequency key-sending, soon became comparatively well known; but there are a number of minor facilities which, though of considerable importance, have not received the same amount of attention. These facilities have been introduced or modified without very much publicity, with the result that the majority of engineering officers are unaware of the latest and best methods of providing the various facilities required.

It is thought that readers of the Journal will be interested in a description of these engineering and traffic facilities and in this series of articles it is proposed to give outline descriptions of some of them. When existing facilities are modified or eliminated the reasons for this action will be stated briefly: when new ones are devised for general application they will receive a brief introduction. There are certain facilities which have been in use for some years, but have only recently been standardized; these will also be reviewed.

Director Time Pulse Arrangements.

The control of calls passing through an automatic telephone exchange in a director area is just as important to a telephone engineer as the control of vehicular traffic is to a city traffic policeman. People who "break down" along the route must not be allowed to impede the smooth flow of other traffic and in a similar way subscribers must not be allowed to hold common equipment, such as directors, while they spend leisured minutes in dialling their numbers. In the past, therefore, a period varying from 30 to 60 seconds has been allowed after the dialling of *each* digit and at the end of this period number unobtainable tone has been connected to the calling subscriber's line.

Now-a-days it is considered that a subscriber is justified in replacing the receiver if a tone is not received within 30 seconds of the completion of dialling and if for some reason he is still connected to a director at the end of this period, he will

abandon the call without knowing the reason why the call was unsuccessful. Such "no tone" calls are unsatisfactory and to reduce them as much as possible the director circuit has been modified. Number unobtainable tone is now connected to the calling line from 30 to 60 seconds after the dialling of the *first* digit, *i.e.*, after the director has been seized.

Fig. 1 shows the part of the director circuit concerned. Previously, contact C₁ disconnected the holding circuit of the time pulse relay when each digit was dialled, but with the elimination of this

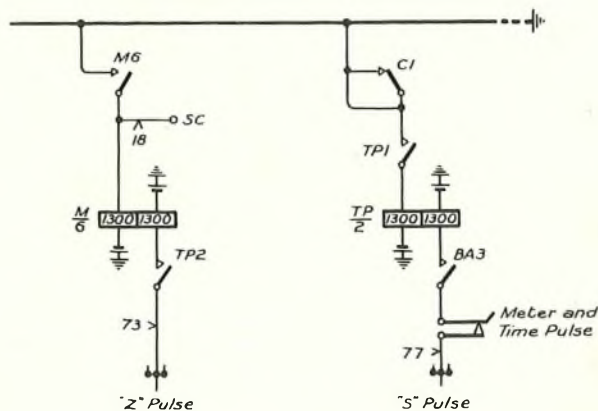

FIG. 1.—PART OF DIRECTOR CIRCUIT.

contact relay TP is now independent of the impulsing circuit. It operates when the first time pulse is received, *i.e.*, from 1 to 30 seconds after the director has been seized. Relay M operates via TP₂ when the next time pulse is received 30 seconds later and transmits the forced release condition to the first code selector which then connects number unobtainable tone to the calling subscriber's line.

Dialling-out Equipment at C.B. Exchanges.

Duplicate answering equipments have hitherto been associated with each dialling-out junction incoming to a C.B. exchange in order to cater for "following-on" calls. As soon as the outgoing end of the circuit is freed from one call, a subsequent call can seize the junction even though a plug still remains in the answering jack. When this occurs, the alternative calling lamp glows and connexion is effected through the associated answering jack.

A new circuit has recently been devised which provides for following-on calls but, as will be seen

from Fig. 2, requires only one answering equipment. If a second call arrives while a plug is in the jack, the calling lamp glows and to answer the call an operator must withdraw and then re-insert the plug.

ringing current is connected to the line while the adjustments are being made. It is desirable, therefore, that ringing current should be available to faultsmen.

For this purpose, a faultsmen could obtain

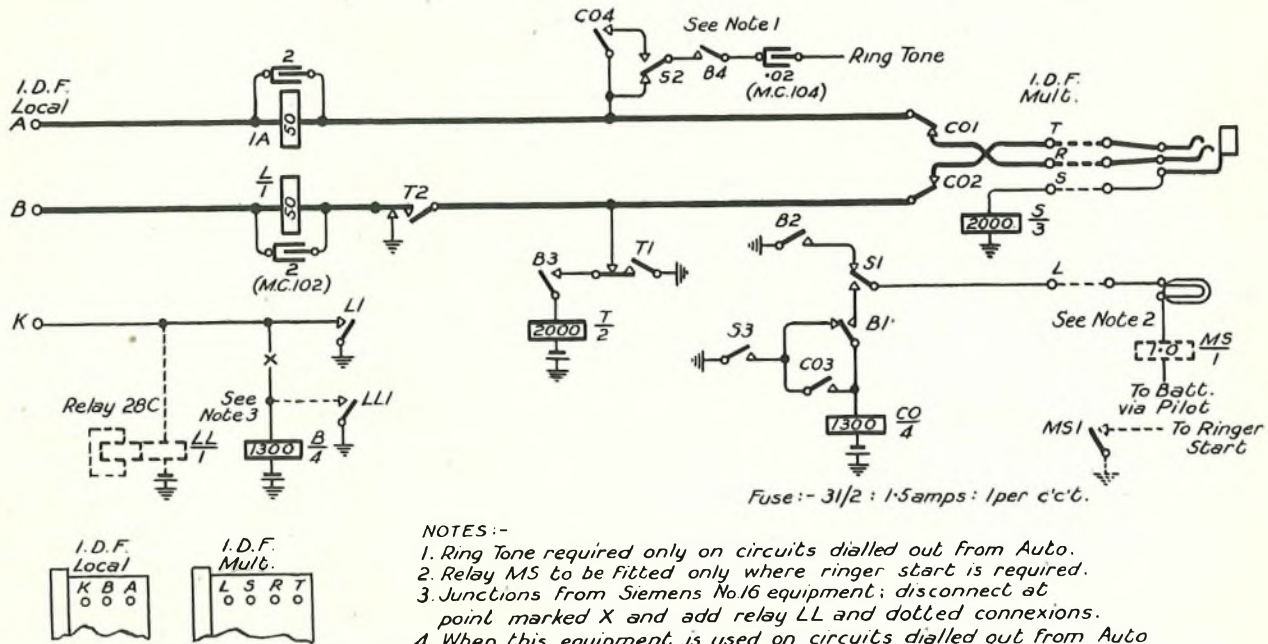

- NOTES:-
1. Ring Tone required only on circuits dialled out from Auto.
 2. Relay MS to be fitted only where ringer start is required.
 3. Junctions from Siemens No.16 equipment; disconnect at point marked X and add relay LL and dotted connexions.
 4. When this equipment is used on circuits dialled out from Auto the cord circuit to be modified to prevent through signalling from the Speak Key.

FIG. 2.—JACK-ENDED JUNCTION CIRCUIT WITH CALLING SIGNAL ARRANGED FOR FOLLOWING-ON CALL.

Normally an incoming call operates relay L and L₁ operates relay B to light the calling lamp at B₂. Ringing tone is connected at B₄. When the call is answered, relay T operates from the cord circuit and completes the speaking circuit at T₂. Contacts S₁ and S₂ disconnect the calling lamp and the ringing tone respectively, and prepare circuits for a following-on call. As soon as the outgoing end of the circuit is cleared down, relays L, B and T release and relay CO operates via S₃ and B₁.

If another call seizes the circuit before the answering plug is withdrawn, relays L and B operate as before. The calling lamp is connected via S₃, CO₃ and B₁, and ringing tone is returned to the calling subscriber via B₄, S₂ and CO₄. The operator, seeing the calling lamp glowing, withdraws the plug, thus releasing S which disconnects relay CO at S₃. The re-insertion of the plug again operates relay S and S₁ disconnects the calling lamp. Relay T re-operates from the cord circuit in order to complete the speaking circuit.

Faultsmen's Ringing Back Circuit.

It is difficult to "tune-in" a radio receiver to a station unless signals are being transmitted from that station. Similarly, it is difficult to adjust the magneto bell of a subscriber's telephone unless

access to a test clerk over the normal channels and ask him to connect ringing current to the line but to save time the faultsmen's ringing back equipment shown in Fig. 3 is provided at the majority of main exchanges, in non-director areas. In Siemens No. 16 and director exchanges, the presence of a transmission bridge in the first selector does not permit of ringing current being connected to a calling line in this way.

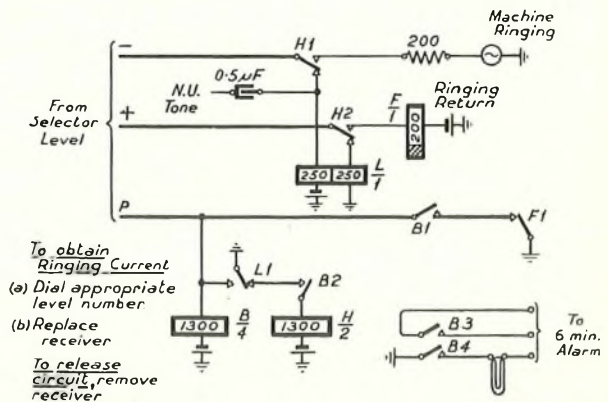

FIG. 3.—FAULTSMEN'S RINGING-BACK CIRCUIT.

The equipment is connected to a spare level on the 9-level second selectors, *e.g.*, level 98, and when a faultsman requires ringing current he dials this number. Relay L in the equipment is operated by the loop from the subscriber's circuit and L1 operates relay B. Contact B1 connects a guarding earth to the private wire, and B2 prepares a circuit for relay H. Number unobtainable tone is connected via H1 to the subscriber's circuit and, on hearing this, the faultsman replaces the receiver. The release of relay L operates relay H through L1 and B2, relay B being held at F1, and ringing current is connected at H1 and H2.

Having adjusted the bell, the faultsman lifts the receiver momentarily, so operating relay F. Earth

is disconnected from the private wire at F1, thus releasing the selectors and relays B and H.

On account of the possibility of relay B being locked through B1 and F1 after accidental operation by hand, contacts B3 and B4 are associated with a 6-minute delayed alarm.

When this equipment was first designed, there was a possibility that it might be useful as a general source of ringing current. For this reason, relay F was connected in the ringing return side of the circuit instead of the more usual connexion direct to the ringing supply. But the equipment is now used only for its primary purpose, *i.e.*, the adjustment of subscribers' bells.

Line Plant Economics as applied to Junction Traffic Routing.

L. F. SALTER, B.Sc.

JUNCTION line plant in common with all other apparatus involved in the construction of telephone circuits has been subjected to detailed study with the object of obtaining the maximum economy in its use. This study has involved a complete investigation into the costs of providing circuits of different weights of conductor and it has been decided that the annual charges on external cables can be taken as a percentage of their capital cost. With this as a basis an investigation into the average costs of junction cables in London was undertaken and figures giving the annual charge per circuit per mile for the different weights of conductor were deduced. They include the proportionate cost of duct and make an allowance for unuseable spares.

In certain of the larger towns Tandem junction lending centres have been installed in conjunction with the introduction of Director automatic working. With a Tandem centre it is not essential to have a group of direct junctions from each exchange to every other, and it is necessary to devise a method by which it can be ascertained when direct junction groups are economically justified.

The transmission allowance on junction circuits and the route mileage between the exchanges determines the weight of conductor required to give standard transmission and thus the annual charges on a junction circuit can be calculated.

The efficiency of the tandem method of working is largely due to the fact that each exchange in the area has a comparatively large group of junctions to and from this switching centre. The traffic carrying efficiency of large groups is well known and is illustrated by the curve (Fig. 1) which indicates the increase in the average traffic per circuit as the

number of junctions in the group increases. In this figure the junctions have been assumed as coming from a level of 10 contact per level 1st selectors, as nearly all groups to Tandem are routed from 1st code selectors. The curves for groups of circuits from other selector levels are similar in character and it can be seen that when the group of circuits is numerically in excess of 40 the average traffic

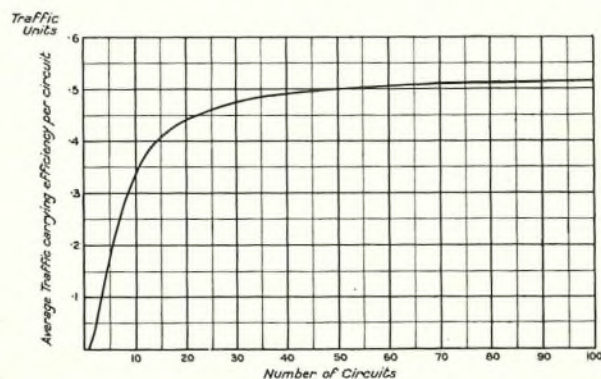

FIG. 1.—TRAFFIC CARRYING EFFICIENCY OF LARGE GROUPS.

carrying efficiency of each circuit in the group is not materially increased. If then an approximate estimate of the number of junctions in the usually large tandem groups can be made, the efficiency can be assessed with a fair degree of accuracy.

The traffic to tandem centres is made up of a number of small quantities of traffic which is distributed at Tandem to the various receiving exchanges. Similarly, the traffic from Tandem to an

exchange is made up of a large number of small amounts of traffic from other exchanges. As a preliminary step in comparing costs, therefore, it is necessary to determine what proportion of the total number of junctions to Tandem is absorbed by traffic to a particular exchange. It is also necessary to assess the proportion of the group from Tandem to the receiving exchange absorbed by traffic from the particular originating exchange. Consider the traffic from an exchange X to another exchange Y *via* Tandem. This traffic absorbs, on an average, a proportion of the total number of junctions provided from X to Tandem equal to the ratio which the traffic from X to Y bears to the total traffic routed from X *via* Tandem. Similarly, a proportion of the group of junctions from Tandem to Y is absorbed by traffic from X. By considering existing similarly situated exchanges of similar size, a good estimate of the number of junctions which will be required to and from the tandem centre can be made. It follows that in the case of existing exchanges more accurate figures can be obtained.

Fig. 2 indicates a hypothetical case and it will be seen from this that the Annual Charge per Traffic Unit routed *via* Tandem from X to Y is $(2r + 2.33s) = \text{say } t$.

ANNUAL CHARGES PER CIRCUIT TO TANDEM FROM X . . . r.	ANNUAL CHARGES PER CIRCUIT FROM TANDEM TO Y . . . s.
NUMBER OF JUNCTIONS . . . SAY 50	NUMBER OF JUNCTIONS . . . SAY 60
TRAFFIC CAPACITY OF GROUP . 24.91 TU	TRAFFIC CAPACITY OF GROUP . 25.73 TU.
A/C ON GROUP . . . 50r.	A/C ON GROUP . . . 60s.
A/C PER T.U. TO TANDEM . . . 2r.	A/C PER T.U. FROM TANDEM . . . 2.33s

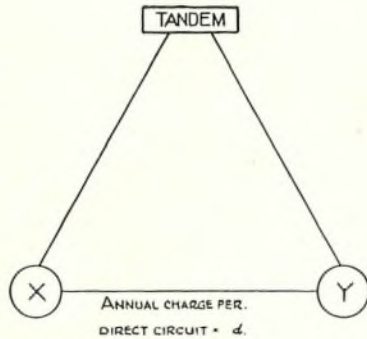

FIG. 2.—ANNUAL CHARGES FOR TRAFFIC ROUTED *via* TANDEM.

In the following, two methods are described, each method being applicable solely to those originating exchanges at which the necessary conditions are fulfilled. The descriptions only indicate the methods of economic junction routing and although in this explanation the traffic carrying efficiency of groups of circuits and the traffic carried per circuit have been taken according to Erlang's theory, the methods can be applied to any systems of working for which comparable data is available.

Exchanges, such as existing automatic exchanges, in which traffic to another exchange is routed wholly

over direct junctions or wholly *via* a tandem centre, necessitate the use of the following method :—

Method A.

The standard grade of service to be given between consecutive ranks of selectors, as laid down in Technical Instruction 25, Part 12A, is 1 lost call in 500 and tables are there given of the number of circuits required to effect this.

If we assume that A traffic units requiring N direct junctions are originated at X for Y, and that this traffic would cost the same in annual charges whether routed over direct junctions or *via* Tandem, then

$$At = Nd \text{ and } \frac{A}{N} = \frac{d}{t}$$

There is, of course, an algebraic relation between A and N, but the relation as given by the Theory of Erlang is too complicated to admit of easy solution. The solution for various numbers of circuits is given in the Technical Instruction previously referred to

and values of $\frac{A}{N}$ can be calculated for various values

of A. It will be realised that the graph of $\frac{A}{N}$ on a base of A will be a series of straight lines as the graph of N to a base A consists of a series of steps. Fig. 3 gives such a graph.

Having thus determined the value of $\frac{d}{t}$ for the two exchanges, the corresponding values of A can be determined from the curve.

Allowance can be made for the difference in apparatus annual charges whether the calls are routed *via* Tandem or direct. Fig. 4 indicates the main items of apparatus used in calls from one automatic exchange to another. The switching equipment which is used equally whichever routing is adopted has been ignored.

The 2nd Tandem selectors and 3rd Tandem, if used, are in large groups and the Annual Charge per traffic unit can be estimated when the size of the groups, the capital cost of the selectors and the work unit maintenance costs are known. The 1st Tandem selectors associated with the incoming junctions at Tandem and the 1st numerical selectors at the receiving exchange associated with the junctions incoming from Tandem are also in large groups and the Annual Charge per Traffic Unit can similarly be estimated. The 2nd code selectors used in the direct routing can also be assessed in Annual Charges per Traffic Unit, but on the direct route the number of 1st numerical selectors used is equal to the number of direct junctions required, so that for these the Annual Charge per selector is used.

The equation

$$At = Nd$$

must therefore be modified to make allowance for the apparatus charges. To the annual charges on the

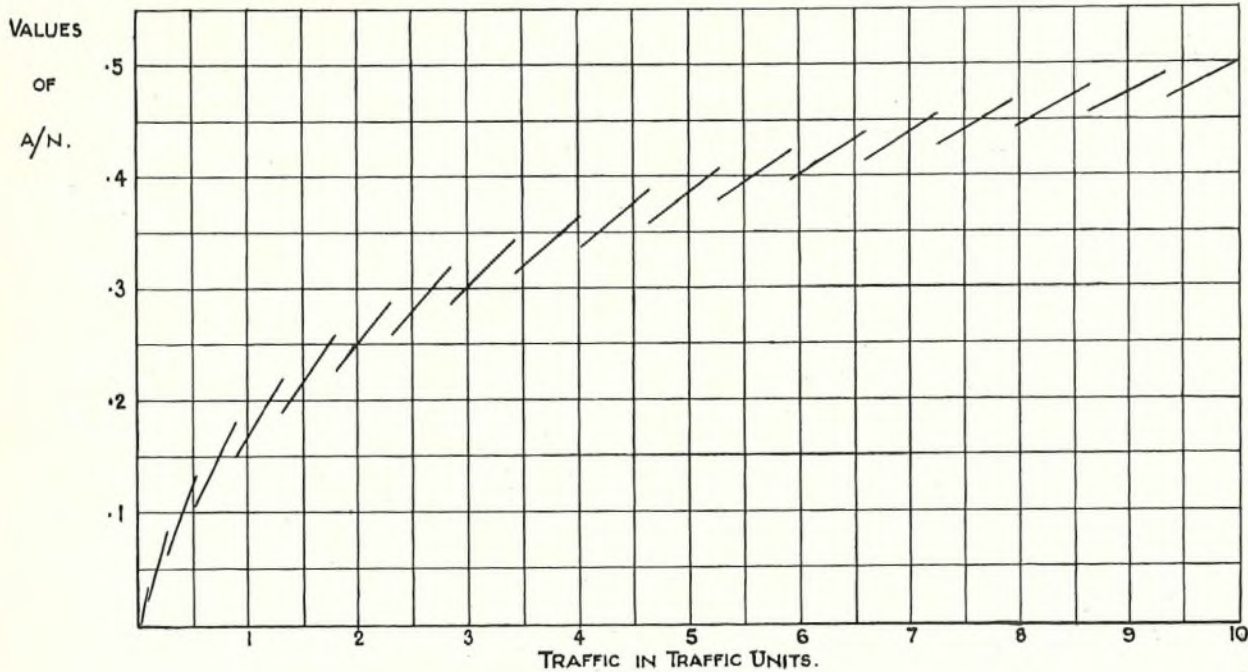

FIG. 3.—RELATION BETWEEN TRAFFIC PER JUNCTION AND TOTAL TRAFFIC.

junctions *via* Tandem must be added the annual charge on the apparatus involved. Since this apparatus is all in large groups the total annual charge *via* Tandem will now be—

$$A(t + b)$$

where *b* = the sum of the Annual Charges per Traffic Unit on the 1st and 2nd Tandem and the 1st numerical selectors.

The annual charges on the direct group will

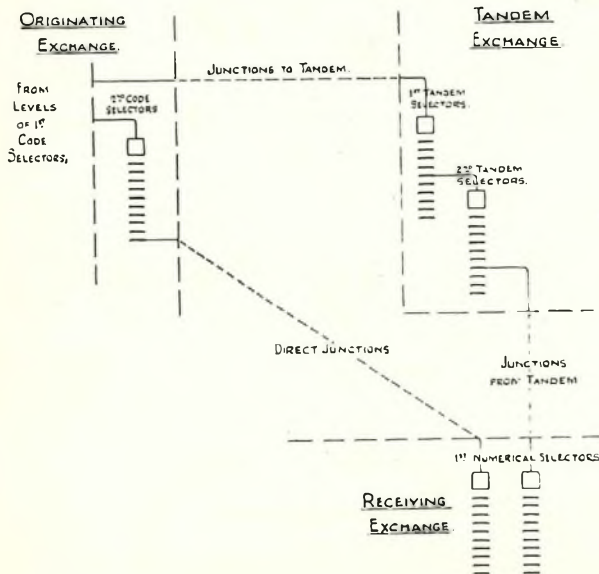

FIG. 4.—APPARATUS REQUIRED FOR DIRECT AND TANDEM-ROUTED TRAFFIC.

require similar modifications and in this case the annual charges will be

$$N(d + e) + Ac$$

where *c* = the Annual Charge per Traffic Unit on the 2nd code selectors and *e* = the Annual Charge per 1st numerical selector.

For equal costs *via* Tandem or direct the equation now becomes :—

$$A(t + b) = N(d + e) + Ac$$

$$\text{and } \frac{A}{N} = \frac{d + e}{t + b - c}$$

and the traffic which will cost the same whether routed direct or *via* Tandem can be found as before.

If, then, the actual traffic to be routed is more than the value thus obtained, a direct route will be justified as in this case,

$$A(t + b) \text{ is greater than } N(d + e) + Ac$$

Conversely, if the traffic be less than the value found, Tandem routing will be more economical.

Example.

For the purpose of this example the following figures will be assumed :—

- Route distance from X to Y of direct circuits and weight of conductor = 11 mls. of 20 lb.
- Route distance from X to Tandem and weight of conductor = 9 mls. of 40 lb.

Route distance from Tandem to

Y and weight of conductor... = 4 mls. of 20 lb.
Annual Charges per circuit per mile—

20 lb. conductors—£1 : 40 lb. conductors—£1.8

The groups to and from Tandem will be taken as those shown in Fig. 2.

Annual Charge per direct circuit

$= d = 11 \times £1 = £11$
 „ „ per circuit to Tandem from X
 $= r = 9 \times £1.8 = £16.2$
 „ „ per T.U. to Tandem from X
 $= 2r = £32.4$
 „ „ per circuit from Tandem to Y
 $= s = 4 \times £1 = £4$
 „ „ per T.U. from Tandem to Y
 $= 2.33s = £9.32$
 „ „ per T.U. from X to Y *via* Tandem
 $= £(32.4 + 9.32) = £41.72$

$$\frac{A}{N} = \frac{d}{t} = \frac{11}{41.72} = .26$$

From Fig. 3 it will be seen that two values of A correspond to this value of $\frac{A}{N}$, viz., 2.07 and 2.33, and these will be the quantities of traffic which will cost the same to route either *via* Tandem or direct.

The reason for the two values is that although the average traffic carried per circuit of the Tandem group remains practically constant, that of the small groups of direct junctions varies extensively as the traffic offered continuously increases.

For values of A between the two values obtained, the direct route would be the cheaper between 2.07 and 2.31 traffic units as although more traffic would be carried than the first critical value of A no additional junctions are required to give the standard grade of service. Between 2.31 and 2.33 traffic units an additional junction would be necessary, so far reducing the average efficiency of the direct group as to render Tandem routing the more economic. Under the present system of defining traffic terms and measuring traffic quantities it is not possible to state exactly what traffic is being sent between any two points and it is only necessary therefore to obtain an approximate value for A. The writer's system of applying the method is to take the mean of the two values as the quantity required, viz., 2.21 traffic units.

Annual charges on apparatus have been neglected in this example for the purpose of simplicity in explanation, but no difference in the use of the curves is caused thereby.

Method B.

The development of switching arrangements in automatic telephony, whereby calls which were un-

successful in obtaining a disengaged direct junction were routed *via* a Tandem centre, necessitated a method being devised by which the full economic value of this feature could be obtained.

The principle of the method is that each direct junction is justified on its merits as a traffic carrying agent.

It has been proved both experimentally and mathematically that the amount of traffic carried by a junction is not affected by the number of later choice junctions, provided that lack of junctions does not cause repeated calls. With automatic selection it is therefore possible, although in the case of graded groups exceedingly tedious, to ascertain with any given traffic offered to the group the amount of traffic carried by each circuit. This has been done in the case of full availability groups by the use of Erlang's Theory, Fig. 5 showing the results obtained.

Using the same conditions as shown in Fig. 2, we have, if an individual direct junction of a group carried p traffic units, the annual cost of routing p traffic units on this junction is d . The annual charges for routing this traffic *via* Tandem would be

$$pt$$

Since the annual charges per traffic unit *via* Tandem cannot be materially decreased, the most economic provision of direct circuits is that in which

$$d \text{ is less than } pt$$

$$\text{or } \frac{d}{t} \text{ is less than } p$$

for all direct junctions provided. As many circuits as will satisfy this condition should be provided, as each will be more economic as a traffic carrying agent than circuits *via* Tandem. If the traffic to be routed from X to Y be known and the ratio $\frac{d}{t}$ be determined for these two exchanges a point on Fig. 5, corresponding to this value and the traffic offered, can be obtained. All circuits whose "curve of traffic carried" intersects the ordinate of "traffic offered" above this point can be economically provided.

Fig. 6 shows the traffic left after particular quantities of traffic have been offered to certain numbers of circuits, and from these curves the traffic to be routed *via* Tandem can be ascertained.

Allowance for apparatus annual charges can be made as follows:—

Assuming the same meaning for b , c and e , the annual cost of routing p Traffic Units *via* Tandem including apparatus which is not common to a direct route

$$= pt + pb$$

The annual cost of routing this traffic direct would be

$$d + pc + e$$

and for most economic routing

$$d + pc + e \text{ must be less than } p(t + b)$$

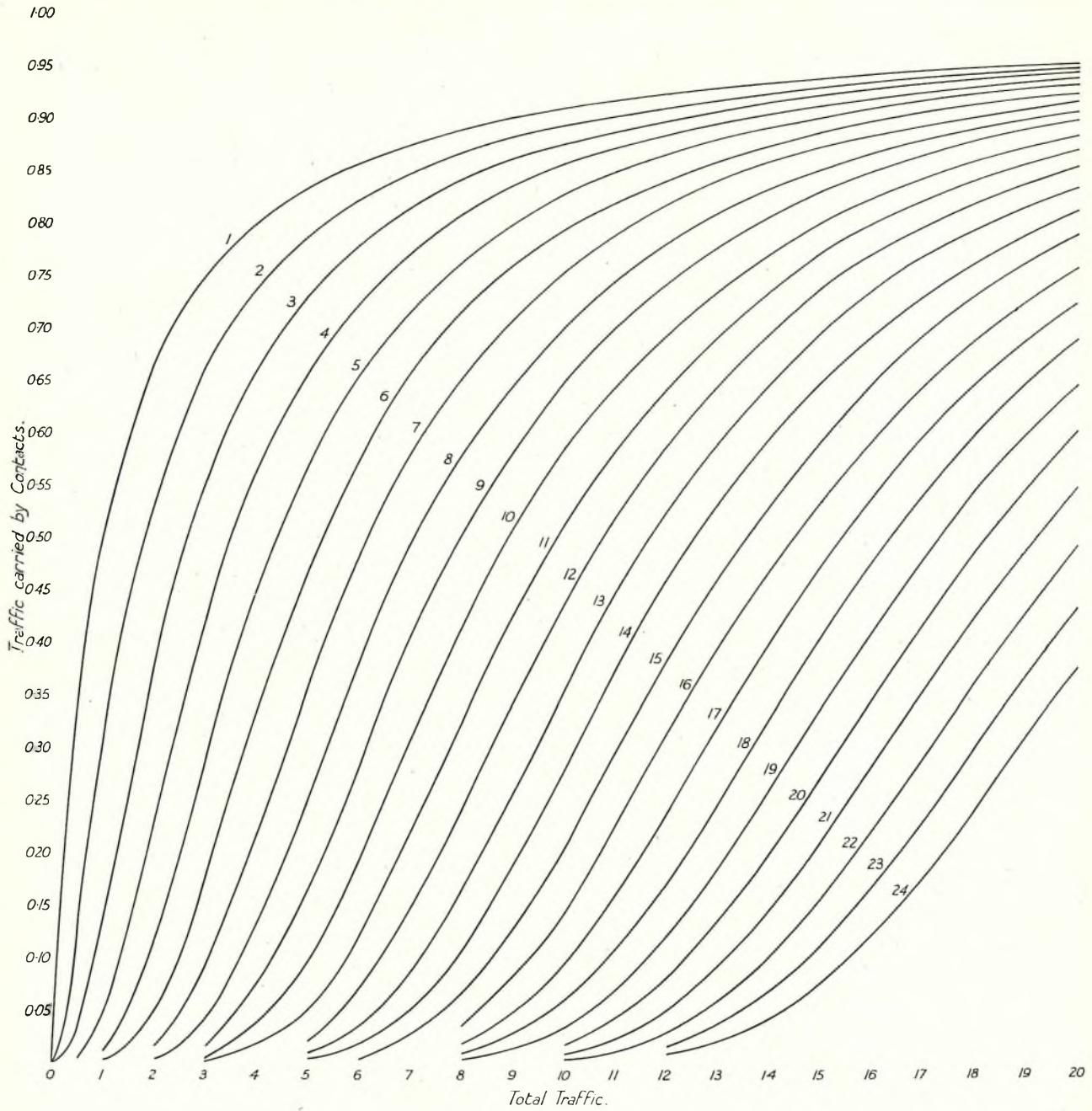

FIG. 5.—TRAFFIC CARRIED BY EACH CONTACT IN A FULL AVAILABILITY GROUP.

for every direct junction.

Thus

$$d + e \text{ must be less than } p(t + b - c)$$

$$\text{and } \frac{d + e}{t + b - c} \text{ is less than } p$$

In the same way as before the number of direct junctions and the traffic to be routed *via* Tandem can be found.

Example.

Using the same ratio of $\frac{d}{t}$ as that found in the previous example and assuming that the traffic from X to Y is 4 traffic units we can see, by locating a point on Fig. 5 whose abscissa is 4 and ordinate .26, that 6 direct circuits can be provided economically. From Fig. 6 it can be seen that .47 traffic units will be routed *via* the tandem centre.

It is, perhaps, made clearer that this number of

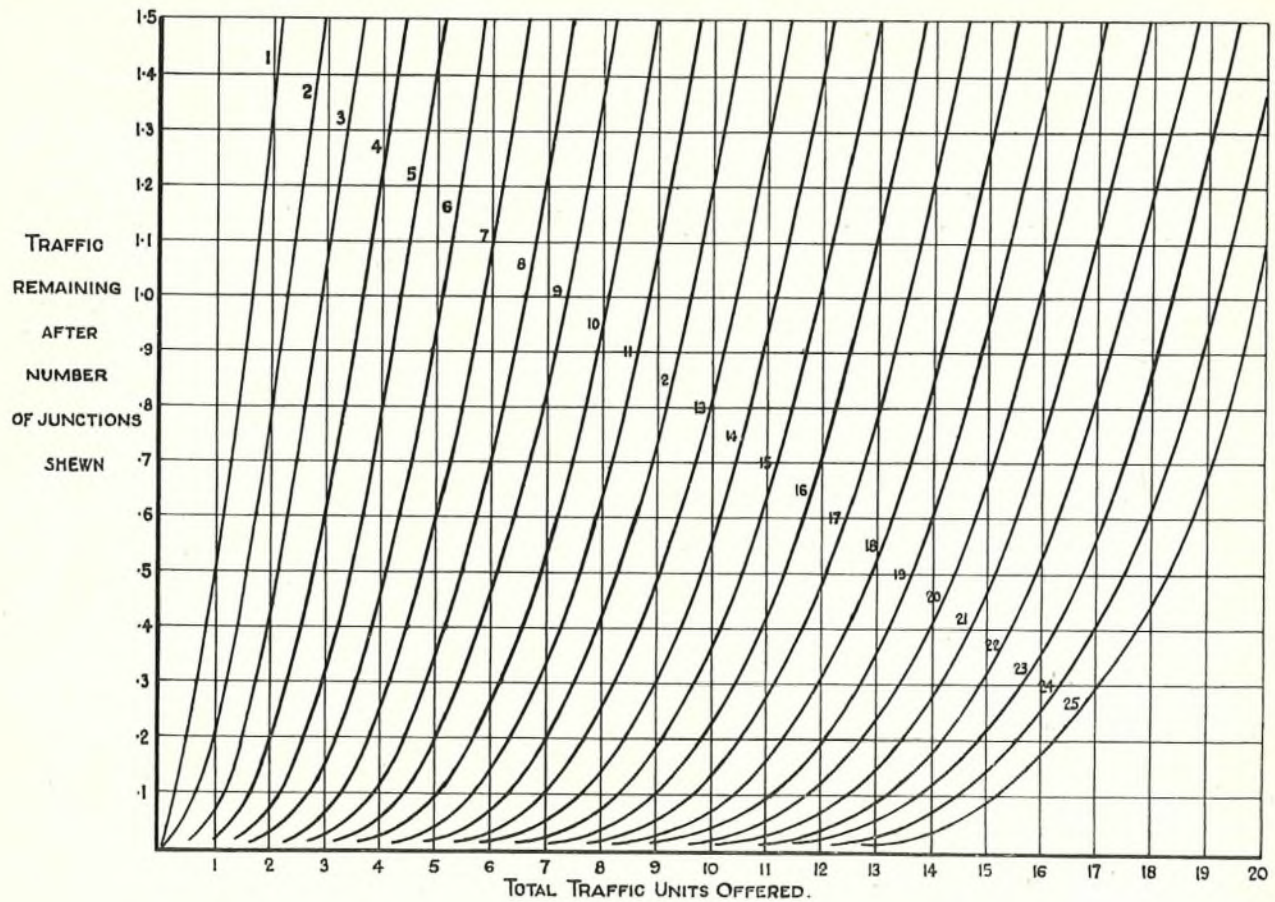

FIG. 6.—TRAFFIC LEFT WHEN PARTICULAR QUANTITIES OF TRAFFIC ARE OFFERED TO JUNCTION GROUPS.

direct circuits is the most economic, if one additional and one less circuit than this number be taken and the annual charges calculated.

Number of direct circuits	5	6	7
Annual Charges on direct circuits in £	55	66	77
Traffic <i>via</i> Tandem in Traffic Units	.8	.47	.36
Annual Charges <i>via</i> Tandem in £	33.4	19.6	15.
Total Annual Charges for routing 4 traffic units	88.4	85.6	92.

It can be seen quite easily that any increase or decrease of the number of direct circuits beyond the

figures taken will merely increase the total annual charges and that 6 circuits is therefore the economic number to provide.

The methods described in the foregoing article were developed in London to enable the very large quantities of junction traffic to be routed with a minimum expenditure on junction cables. Forecasts of the junction traffic anticipated at definite dates for the whole of the London Telephone Area are received and by the application of the above processes to these forecasts data showing the most economic lay-out of junction cables is obtained.

Delay Probability Formulae When the Holding Times are Constant.

C. D. CROMMELIN, M.A.,
of Messrs. Siemens Bros. & Co., Ltd.

(1) INTRODUCTION.

THERE are two methods of handling the surplus calls in the switching stages of automatic exchanges. In the first method the call is lost and has to be repeated subsequently: in the second it is delayed until a sufficient number of the calls already in progress (or waiting) have ended to provide it with a free switch. The probability problem involved by the first method has been satisfactorily solved for the case of fully available switch groups. The problem involved by the systems with delay arrangements has, however, attracted less attention, partly because it only arises directly in one stage of exchanges designed by the British Post Office, and still more because it has proved much harder to solve than the lost calls problem. It happens, as several writers have pointed out, that the distribution of call holding times affects the results in the delay problem though not in the lost calls problem. The easiest type of distribution with which to deal theoretically is the exponential distribution, the solution of which has been published more than once and will not be described in the present article. The other apparently simple case, that of constant holding times, has however given great difficulty. Molina¹ attempts a solution which he admits is only approximate. It aims at giving the probability for delays exceeding a specified time. No formula is given for the average delay. Fry gives an accurate treatment of the problem for the special case of single switches.²

Erlang, the author of the "lost calls" theory, has published a set of formulæ about delays.^{3,4} Un-

fortunately he has presented his remarkable solution in a very obscure and not sufficiently general manner. Moreover he gives few hints about the numerical evaluation of his rather formidable formulæ with the result that most subsequent investigators have formed the mistaken opinion that they are quite intractable.

The present article gives a general proof and statement of the fundamental Erlang formulæ. A numerical example is then evaluated in sufficient detail to enable the processes to be grasped. The author is deeply indebted to the friendly collaboration of D. P. Dalzell, to whom are due the method of solution of the main equations and many details of the mathematical work.

It may be pointed out that the constant holding time problem corresponds approximately with many occurrences outside telephony, for instance the probable delays in waiting for tickets at booking offices.

(2) DERIVATION OF THE FUNDAMENTAL EQUATIONS.

We assume that statistic equilibrium has been established, that the traffic, *i.e.*, the average number of call originations per holding time, is y , and proceeds from an infinite number of subscribers, and that the number of switches in the group is n which $> y$. We further assume that subscribers wait until their calls are successful and then talk for the full holding time (unit time).

Let P_v denote the probability for a state of v simultaneous calls and let a_v denote the probability for not more than v simultaneous calls, so that

$$a_v = \sum_{r=0}^v P_r.$$

Then we have the following set of equations⁵ :—

ing articles :— "Über eine Aufgabe der Wahrscheinlichkeitstheorie," I. u II. Teil. Math. Zeitschrift. 32. S. 64-100 and S. 729-750, 1930; "Über zwei Formeln, aus der Theorie des Wartens vor Schaltergruppen." Electricische Nachrichten-Technik (E.N.T.), June, 1931; and "Gesprächsverluste und Wartezeiten," E.N.T., July, 1931. Pollaczek's theory is very voluminous and the author has not yet had time to study it in detail. It is, however, clear that the present paper overlaps with it to a considerable extent: for instance, the formula here obtained for the Average Delay is given by Pollaczek. It seems, however, that the present treatment is simpler and more straightforward than Pollaczek's, and it will in any case call attention to the prior work of Erlang on the subject.

¹ Bell System Technical Journal, Vol. 6, 1927, pp. 461-494.

² "Probability and its Engineering Uses." Macmillan & Co. 1928. Chapter X., Sections 134-136. An unpublished memorandum which forms No. 5 of "Some Fundamental Studies in Telephone Probabilities," written for the Bell Telephone Laboratories, gives a more extended treatment than the book. The fundamental equations of the problem are derived. The subsequent treatment, though differing widely from that given in this article, has been helpful to the author.

³ Most of the formulæ are collected in Table 5, facing p. 628, of an article in the "Annales des Postes, Telegraphes et Telephones," July, 1925. This table will be subsequently referred to as A.P.T.T. Erlang has published several more or less equivalent accounts of his methods of derivation of the formulæ. Of these the latest and probably most accessible is that contained in the "Revue Generale de l'Electricite," 21st August, 1926, pp. 270-278. This will be subsequently referred to as R.G.E.

⁴ Since writing this article, the author has been introduced to the work of F. Pollaczek which is contained in the follow-

⁵ Introduced to the author by Fry's unpublished memorandum mentioned earlier.

$$\left. \begin{aligned} P_0 &= a_n \cdot e^{-y} \\ P_1 &= a_n y \cdot e^{-y} + P_{n+1} \cdot e^{-y} \\ \dots & \\ P_v &= a_n \cdot \frac{y^v}{v!} \cdot e^{-y} + P_{n+1} \cdot \frac{y^{v-1}}{v-1!} e^{-y} \\ &\quad + \dots + P_{n+v} \cdot e^{-y} \end{aligned} \right\} \dots(1)$$

These equations express that the probability for the state specified by the suffix on the left-hand side at the beginning of a unit time interval is identical with the probability for the existence of the same state at the end of the interval. For instance, considering P_v , the right-hand side expresses the probability that one of the following alternative conditions occurs :

- not more than n simultaneous calls at the beginning of the interval and v call originations within the interval :
- exactly $(n+1)$ simultaneous calls (n of which are being served) at the beginning of the interval, and $(v-1)$ originations within the interval, etc. :
- and, finally, $(n+v)$ simultaneous calls at the beginning of the interval and no originations within the interval.

These are an exhaustive account of the ways of getting v simultaneous calls at the end of interval.

(3) METHOD OF SOLUTION OF THE EQUATIONS.

Our main problem then is the solution of the set of equations (1). The following method is that of generating functions. It is a mathematical device by which we replace the successive quantities $P_0, P_1, \dots, P_v, \dots$ by the single function $f(z)$

$$\equiv \sum_{v=0}^{\infty} z^v \cdot P_v. \text{ The function has no probability}$$

significance except when $z=1$. We then have $f(1) =$

$$\sum_{v=0}^{\infty} P_v = 1. \text{ But owing to the fact that } P_v \text{ is a}$$

probability and is therefore such that $0 \leq P_v \leq 1$, we know that $f(z)$ is regular and bounded, *i.e.*, has no infinities or other singularities, so long as $|z| < 1$, where z can be any complex number satisfying this condition. This fact enables us to determine P_0, \dots, P_v, \dots as we shall show.

Multiply each of the equations (1) by the power of z specified by the suffix of the P of which its left-hand member consists, and add; then

$$\sum_{v=0}^{\infty} z^v P_v = a_n e^{y(z-1)} + z P_{n+1} \cdot e^{y(z-1)} + z^2 P_{n+2} e^{y(z-1)} + \dots$$

$$= e^{y(z-1)} \left\{ a_n + \sum_{v=1}^{\infty} z^v \cdot P_{n+v} \right\}$$

or again $z^n \sum_{v=0}^{\infty} z^v \cdot P_v = e^{y(z-1)} \left\{ z^n \cdot a_n + \sum_{v=n+1}^{\infty} z^v \cdot P_v \right\} ;$

whence, if $Q_n(z) = \sum_{v=0}^n z^v \cdot P_v$, so that $Q_n(1) = a_n$,

$$z^n \cdot f(z) = e^{y(z-1)} \{ z^n \cdot a_n - Q_n(z) + f(z) \}$$

or $f(z) = \frac{Q_n(z) - z^n \cdot a_n}{1 - z^n e^{y(1-z)}} \dots\dots\dots(2)$

The requirement that $f(z)$ is regular within the unit circle (defined by $|z| \leq 1$) can be satisfied by choice of P_0, P_1, \dots, P_n if the function $1 - z^n e^{y(1-z)}$ have exactly n zeros in and on the unit circle. Probability considerations force us to conclude that this condition must be satisfied, for the system of equations (1) is completely descriptive of the state of statistic equilibrium, and the probabilities P_v are known to exist and to be uniquely determinate. We can, however, give an analytical justification for the condition. We proceed to do this for the sake of completeness, and because the method helps in our subsequent numerical procedure.

(4) PROOF THAT THE DENOMINATOR OF $f(z)$ HAS EXACTLY n ZEROS IN AND ON THE UNIT CIRCLE.

Define β as any number satisfying the equation $\beta e^{-\beta} = \omega \cdot a e^{-a} \dots (3)$ where $a = \frac{y}{n}$ and ω is a number specified below.

Then, raising each side of (3) to the power n and transferring factors we find that $\omega^n \left(\frac{\beta}{a} \right)^n e^{y \left(1 - \frac{\beta}{a} \right)} = 1$.

In other words $\lambda = \frac{\beta}{a}$ is a root of the denominator of (2) if $\omega^n = 1$; and we require to prove that there are exactly n values of β satisfying the equation

$$\beta e^{-\beta} = \sqrt[n]{1 \cdot \omega} \cdot a e^{-a} \dots\dots\dots(4)$$

and such that $|\beta| < a < 1$.

In general the roots of (4) are complex; we therefore set $\beta = r e^{i\theta}$ where $0 < r < 1$.

Then $\beta e^{-\beta} = r \cdot e^{-r \cos \theta} \cdot e^{i(\theta - r \sin \theta)}$ and so, equating real and imaginary parts in (4), we have :—

$$r e^{-r \cos \theta} = a e^{-a} \dots\dots\dots(5)$$

and $\theta - r \sin \theta = \frac{2p\pi}{n} \dots\dots\dots(6)$

where p is in turn $1, 2, \dots, n-1$.

(6) shows us that if $p < \frac{n}{2}$ we must have

$$0 < \theta < \pi, \text{ while if } p > \frac{n}{2}, \pi < \theta < 2\pi.$$

Moreover, if (r, θ) is a solution of (5) for a particular integer p , we have

$$\begin{aligned} 2\pi - \theta - r \sin(2\pi - \theta) \\ = 2\pi - (\theta - r \sin \theta) = \frac{2\pi}{n} (n - p) \end{aligned}$$

So $(r, 2\pi - \theta)$ is a solution of (6) for the integer $n - p$.

This fact entitles us to consider merely the values of $p \leq \frac{n}{2}$.

The case of $p = \frac{n}{2}$ only arises when n is even.

We then have $\theta = \pi$ as the only possible solution of (5).

From (5), for $\theta = \pi$, we have immediately $r = a$:

$$\text{for } \theta = \pi, (5) \text{ becomes } re^r = ae^{-a}$$

The left-hand side of this equation increases steadily with r . It is $< ae^{-a}$ for $r = 0$ and $> ae^{-a}$ for $r = a$. Therefore there is one root $r = a'$ where $0 < a' < a$.

We next consider the general case where $\theta < \pi$.

$$\text{We may write (5) as } \cos \theta = \frac{1}{r} \log \frac{r}{a} e^a \dots\dots(7)$$

$$\text{Hence } \frac{d\theta}{dr} = - \frac{1}{r^2 \sin \theta} \left(1 - \log \frac{r}{a} e^a \right)$$

After a little reduction we now find

$$\frac{d}{dr} (\theta - r \sin \theta) = - \frac{\left(1 - \log \frac{r}{a} e^a \right)^2 + r^2 \sin^2 \theta}{r^2 \sin \theta}$$

which is always negative.

Therefore $\theta - r \sin \theta$ decreases steadily as r increases.

But at $r = a, \theta - r \sin \theta = 0$;

and at $r = a', \theta - r \sin \theta = \pi$,

so between these values of $r, \theta - r \sin \theta$ must take the value $\frac{2p\pi}{n}$ where $p < \frac{n}{2}$.

This proves that there is one and only one pair (r, θ) satisfying (5) and (6) simultaneously for given $p < \frac{n}{2}$.

Whether n is odd or even, $(a, 0)$ is a solution. When n is odd, the total number of solutions is therefore $1 + 2 \frac{(n-1)}{2} = n$. When n is even, (a', π) is a solution, and the total number of solutions is $2 + \frac{n-2}{2} = n$. Thus in either case there are

exactly n solutions of (4), and we have proved the required result.

(5) COMPLETION OF THE SOLUTION OF EQUATIONS (1).

From (2), we may then write

$$Q_n(z) - z^n a_n = k (z - 1) (z - \lambda_1) \dots (z - \lambda_{n-1})$$

where $\lambda_r = \frac{\beta_r}{a}$ is a root of $1 - z^n e^{\gamma(1-z)} = 0$ such that $|\lambda_r| < 1$, and k has to be determined so that $f(1) = 1$.

$$(2) \text{ becomes } f(z) = \frac{k (z - 1) (z - \lambda_1) \dots (z - \lambda_{n-1})}{1 - z^n e^{\gamma(1-z)}}$$

We require to find the limit of the expression on the right-hand side as $z \rightarrow 1$. To do this we use the 1st mean value theorem which states that under certain conditions satisfied here $\phi(z-1) = \phi(1) + (z-1)\phi' \{1 + \epsilon(z-1)\}$ where $\phi(z)$ stands for the denominator of $f(z)$, z is real, $0 < \epsilon < 1$, and the dash indicates differentiation with respect to z for the value inside the curly bracket.⁶

In our case $\phi(1) = 0$, and we get

$$f(z) \rightarrow \frac{k (1 - \lambda_1) \dots (1 - \lambda_{n-1})}{\phi'(1)} \text{ as } z \rightarrow 1.$$

Hence we find

$$k = - \frac{(n-y)}{(1-\lambda_1) \dots (1-\lambda_{n-1})}$$

$$\text{and } f(z) = - \frac{(n-y)}{(1-\lambda_1) \dots (1-\lambda_{n-1})} \cdot \frac{(z-1)(z-\lambda_1) \dots (z-\lambda_{n-1})}{1 - z^n e^{\gamma(1-z)}} \dots\dots(8)$$

We deduce that the P's are the coefficients of the powers of z in the expansion of the right-hand side as an infinite series when $|z| < 1$.

(6) THE PROBABILITY FOR NO DELAY, WRITTEN⁷
P(=0).

This is the probability that a call will find not more than $n-1$ calls in progress, i.e., it is a_{n-1}

$$\text{where } a_r = \sum_{v=0}^r P_v.$$

⁶ For further details see Hardy. A Course of Pure Mathematics, 5th Edition, pp. 226-7 and pp. 268-9. The extension to the case of z complex is straightforward.

⁷ This rather clumsy notation is that introduced by Erlang, except that with a view to accuracy " $= 0$ " is written in place of " < 0 ." The symbol may be regarded as an abbreviation of $P(\delta=0)$ which stands for the probability corresponding to the event of zero delay. Similar remarks apply to the symbols $P(< t)$, $P(> t)$ occurring later.

We can find a_r conveniently by the method of generating functions : for let $F(z) \equiv \sum_{v=0}^{\infty} a_v z^v$ where $|z| < 1$.

$$\begin{aligned} \text{Then } F(z) \cdot (1-z) &= \sum_{v=0}^{\infty} z^v (a_v - a_{v-1}) \\ &= \sum_{v=0}^{\infty} z^v \cdot P_v \text{ from the definition} \\ &= f(z) \text{ of } a_v \end{aligned}$$

$$\text{So } F(z) = \frac{f(z)}{1-z} = \frac{n-y}{(1-\lambda_1) \dots (1-\lambda_{n-1})} \cdot \frac{(z-\lambda_1) \dots (z-\lambda_{n-1})}{1-z^n e^{y(1-z)}} \dots \dots \dots (9)$$

a_{n-1} is the coefficient of z^{n-1} on the right-hand side of (9).

$$\text{So } P(=0) = a_{n-1} = \frac{n-y}{(1-\lambda_1) \dots (1-\lambda_{n-1})} \dots \dots \dots (10)$$

Using the fact that $\lambda_r = \frac{\beta_r}{\alpha}$ we deduce the forms for a_0, a_1, a_2 given by Erlang for the special cases $n=1, 2, 3$ respectively.⁸

(10) may be readily evaluated by use of the fact that λ_s, λ_{n-s} are conjugate complex numbers, being⁹ $\left(\frac{r_s}{\alpha}, \pm \theta_s\right)$

$$\begin{aligned} \text{We have } \frac{1}{(1-\lambda_s)(1-\lambda_{n-s})} &= \frac{1}{1-2\left(\frac{r_s}{\alpha}\right) \cos \theta_s + \left(\frac{r_s}{\alpha}\right)^2} \end{aligned}$$

We note that (8) can now be written :—

$$f(z) = -a_{n-1} \cdot \frac{(z-1)(z-\lambda_1) \dots (z-\lambda_{n-1})}{1-z^n e^{y(1-z)}} \dots \dots \dots (11)$$

(7) THE PROBABILITY FOR A DELAY LESS THAN $t, [P(<t)]$.

In order to solve this problem we introduce the assumption that calls are served in the order of their origination.

We consider the general case in which $t = T + \tau$, where T is an integer and τ a proper fraction.

Define b_r as the probability for the state of

⁸ A.P.T.T. Table.

⁹ $\left(\frac{r_s}{\alpha}, 2\pi - \theta_s\right)$ is identical with $\left(\frac{r_s}{\alpha}, -\theta_s\right)$. The latter, more convenient, notation is used here and subsequently.

occupation of the group at a given instant such that not more than v of the calls then in progress, will be in progress at time τ subsequently.

Taking the given instant to be that of the origination of the call whose delay we are investigating, and considering the state corresponding to b_{Tn+n-1} , we see that the above definition implies that not more than $Tn+n-1$ of the calls preceding the given call will be in progress at time τ later, and consequently not more than $n-1$ of them at time $\tau+T=t$ later. This is precisely the condition for a delay $< t$. In other words $P(<t) = b_{Tn+n-1}$.

To determine b_r we note first that

$$\begin{aligned} a_r &= \left. \begin{aligned} &\frac{(y\tau)^r}{r!} e^{-y\tau} b_0 + \frac{(y\tau)^{r-1}}{r-1!} e^{-y\tau} b_1 + \dots + e^{-y\tau} b_r \\ &= e^{-y\tau} \sum_{v=0}^r b_v \frac{(y\tau)^{r-v}}{r-v!} \end{aligned} \right\} \dots (12) \end{aligned}$$

This is true for all values of r . The argument is that, to get a_r , we take the probabilities for the various numbers of call originations within the interval τ preceding the instant used for defining a_r , multiply each by the probability for the corresponding state at the beginning of the interval which gives not more than r simultaneous calls at its end, and add the products.

We now again make use of generating functions,

$$\text{introducing } G(z) \equiv \sum_{v=0}^{\infty} b_v \cdot z^v \text{ where } |z| < 1.$$

From (12) we have

$$\begin{aligned} F(z) &= \sum_{r=0}^{\infty} a_r z^r \\ &= e^{-y\tau} \sum_{r=0}^{\infty} \sum_{v=0}^r z^v b_v \frac{(y\tau)^{r-v}}{r-v!} \\ &= e^{-y\tau} \sum_{v=0}^{\infty} z^v b_v e^{y\tau z}. \end{aligned}$$

The last step follows by fixing v and letting r take all its possible values, namely, the integers from v to ∞ .

$$\text{So } F(z) = e^{y\tau(z-1)} \cdot G(z)$$

$$\text{or } G(z) = F(z) \cdot e^{y\tau(1-z)} \dots \dots \dots (13)$$

$$= \frac{a_{n-1} (z-\lambda_1) \dots (z-\lambda_{n-1}) e^{y\tau(1-z)}}{1-z^n e^{y\tau(1-z)}} \dots (14)$$

$$\begin{aligned} &= a_{n-1} e^{y\tau} (z-\lambda_1) \dots (z-\lambda_{n-1}) \\ &\quad \sum_{s=0}^{\infty} z^{sn} e^{sy\tau} e^{-y\tau(s+\tau)} \dots \dots \dots (15) \end{aligned}$$

Now for $r < n$, we have :

$$\begin{aligned} &\text{Coefficient of } z^r \text{ in } a_{n-1} (z - \lambda_1) \dots (z - \lambda_{n-1}) \\ &= \text{Coefficient of } z^r \text{ in } F(z) = a_r \end{aligned}$$

$$\text{and also } = a_{n-1} \cdot (-1)^{n-r-1} \sum \lambda_1 \dots \lambda_{n-1-r} \dots \dots (16)$$

where the \sum includes all the ${}_{n-1} C_{n-1-r}$ ways of selecting $n-1-r$ λ 's from the total $n-1$ λ 's.

A convenient way of evaluating (16) will be explained and illustrated in the numerical section (10).

From (15), by taking the coefficient of z^{Tn+n-1} and expressing the result in terms of a_r , we find

$$P(< t) = b_{Tn+n-1} = \sum_{w=0}^T \sum_{r=0}^{n-1} a_r \frac{\{-y(w+\tau)\}^{T-wn+n-1-r}}{(T-wn+n-1-r)!} \cdot e^{y(w+\tau)} \dots \dots \dots (17)$$

It is worthy of note that if $\tau=0$, $G(z)=F(z)$, and $P(< t) = a_{Tn+n-1}$.

This is a consistent result as may be seen directly. (17) is the form given by Erlang for the special cases $n=1, 2, 3$ respectively.¹⁰ From the point of view of computation it suffers from the defect that the terms alternate in sign and in general are larger than their sum. This may be predicted theoretically from (14), for the left-hand side of the latter has a unit radius of convergence, while the right-hand side is the product of a polynomial and a function of z whose radius of convergence = $\min. |\lambda_r|$, i.e., < 1 .

Later, Erlang realised this difficulty and suggested a way out, though he did not give an alternative formula explicitly. We do this in the next section.

(8) FORMULA FOR $P(> t)$, THE PROBABILITY OF A DELAY EXCEEDING t .

The formula of this section can be obtained from (13) by expanding $G(z)$ in powers of z and $\frac{1}{z}$ by Laurent's Theorem in an annulus outside $|z|=1$. The method, which involves complex function theory, is given in Appendix 1. Here we give a direct probability argument which is, we believe, equivalent to the very vague argument given by Erlang for a special case.¹¹

$$\text{Consider } q_{w,v} \equiv \frac{\{y(w-\tau)\}^{w+Tn+n-1-v}}{(w+Tn+n-1-v)!} \cdot e^{-y(w-\tau)} \dots (18)$$

where $0 \leq v \leq n-1$.

Where there is no danger of confusion we shall drop the v suffix and write q_w simply.

q_w is the probability for a number of call originations within the interval $w-\tau$ preceding the instant (denoted by A) of arrival of the call whose delay probability we are investigating, sufficient to give a delay $> T+\tau$.

If now we can multiply q_w by the probability for

the state of occupation of the group at the beginning of the interval in such a way that the resultant probability is not included in the corresponding q products obtained for larger values of w , we shall obtain $P(> t)$ as the sum of all the w products.

We find that we can secure this unique statement for a given $q_{w,v}$ by associating $q_{w,v}$ with a_v , the probability for not more than v calls at the beginning of the $(w-\tau)$ interval. Under this condition there cannot have been more than $w+Tn+n-1$ call originations within the $(w+1-\tau)$ interval preceding A. But for the cases belonging to the q_{w+1} class there must have been at least $w+Tn+n$ call originations within the same $(w+1-\tau)$ interval. So there is no overlapping between $q_{w,v}$ and q_{w+1} .

On the other hand, if $n+v > \rho > v$ where ρ is the number of calls in progress at the beginning of the $(w-\tau)$ interval, $q_{w+1, v+n-p}$ gives ρ more originations within the $(w+1-\tau)$ interval than $q_{w,v}$ gives within the $(w-\tau)$ interval. In some arrangements of $q_{w+1, v+n-p}$, these ρ extra calls occur within the $(w+1-\tau)$ to $(w-\tau)$ interval preceding A; and therefore $q_{w+1, v+n-p}$ includes $q_{w,v}$ within it.

Similarly for $2n+v > \rho > n+v$, $q_{w+2, v+2n-p}$ gives ρ calls more than $q_{w,v}$; and in some arrangements of the former the ρ extra calls occur within the $(w+2-\tau)$ to $(w-\tau)$ interval preceding A. Again there is overlapping. This argument is evidently general. So altogether we have

$$P(> t) = \sum_{w=1}^{\infty} \sum_{v=0}^{n-1} a_v \cdot q_{w,v} \dots \dots \dots (19)$$

In this formula a_v is given by (16) and $q_{w,v}$ by (18).

(9) THE AVERAGE DELAY.

We can again dispense with the assumption that calls are served in the order of origination. Our method is an extension of that given by Fry in his book.

$$\text{We require to determine } \sum_{v=1}^{\infty} v \cdot P_v.$$

To do this, we return to the original equations (1)

$$\text{and form } \sum_{v=1}^{\infty} v^2 P_v.$$

For this purpose it is convenient to write p_r for

$$\frac{y^r}{r!} e^{-y}$$

It is quickly verified that $\sum_{r=1}^{\infty} r p_r = y$,

$$\sum_{r=1}^{\infty} r^2 \cdot p_r = y^2 + y.$$

¹⁰ A.P.T.T. Table.

¹¹ R.G.E. Article: p. 272, column 2: also p. 274, column 2.

Hence
$$\left. \begin{aligned} \sum_{r=0}^{\infty} (r-n) p_r &= y-n \\ \sum_{r=0}^{\infty} (r-n)^2 p_r &= y^2 - y(2n-1) + n^2 \end{aligned} \right\} \dots\dots(20)$$

So we have

$$\begin{aligned} \sum_{v=1}^{\infty} v^2 P_v &= a_n \sum_{v=1}^{\infty} v^2 p_v + \sum_{r=0}^{\infty} \sum_{s=n+1}^{\infty} (r+s-n)^2 P_s p_r \\ &= a_n \cdot y(y+1) \\ &\quad + \sum_{r=0}^{\infty} p_r \left[\sum_{s=n+1}^{\infty} s^2 \cdot P_s + 2(r-n) \right. \\ &\quad \left. \sum_{s=n+1}^{\infty} s \cdot P_s + (r-n)^2 \sum_{s=n+1}^{\infty} P_s \right] \\ &= a_n y(y+1) + \sum_{s=1}^{\infty} s^2 \cdot P_s - \sum_{s=1}^n s^2 \cdot P_s \\ &\quad + 2(y-n) \sum_{s=n+1}^{\infty} s \cdot P_s + (y^2 - y(2n-1) + n^2)(1-a_n) \end{aligned}$$

by the help of (20).

$\sum_{v=1}^{\infty} v^2 P_v$ cancels out, and after re-adjustment we get

$$\begin{aligned} 2(n-y) \sum_{s=n+1}^{\infty} s \cdot P_s &= y^2 - y(2n-1) + n^2 + a_n \cdot n(2y-n) - \\ &\quad \sum_{s=1}^n s^2 \cdot P_s \dots\dots\dots(21) \end{aligned}$$

The next step is therefore to determine

$$\sum_{s=1}^n s^2 \cdot P_s.$$

From (11) we have

$P_s = (-1)^{n-s-1} a_{n-1} (u_{n-s-1} + u_{n-s})$ where $s < n$, and $u_r = \sum \lambda_1 \lambda_2 \dots \lambda_r$, the summation including all the ${}_{n-1} C_r$ ways of selecting r λ 's from the total $n-1$.

Also $P_n = -a_{n-1} + a_n$

So
$$\sum_{s=1}^n s^2 P_s = a_{n-1} \left\{ \sum_{s=1}^{n-1} (-1)^{n-s-1} s^2 (u_{n-s-1} + u_{n-s}) - n^2 \right\} + a_n \cdot n^2$$

$$\begin{aligned} &= a_{n-1} \left\{ \sum_{s=1}^n (-1)^{n-s-1} (s^2 - s - 1^2) u_{n-s} \right\} + a_n \cdot n^2 \\ &= a_{n-1} \left\{ 2 \sum_{s=1}^n (-1)^{n-s-1} (s-1) u_{n-s} + \sum_{s=1}^n (-1)^{n-s-1} u_{n-s} \right\} + a_n \cdot n^2 \\ &= a_{n-1} \left\{ -2[(n-1) - (n-2)u_1 + (n-3)u_2 - \dots + (-1)^{n-2} u_{n-2}] - [1 - u_1 + u_2 - \dots + (-1)^{n-1} u_{n-1}] \right\} + a_n \cdot n^2 \\ &= a_{n-1} \left\{ -2 \Delta \sum_{s=1}^{n-1} \frac{1}{1-\lambda_s} - \Delta \right\} + a_n \cdot n^2 \end{aligned}$$

where $\Delta = (1-\lambda_1) \dots (1-\lambda_{n-1}) = \frac{n-y}{a_{n-1}}$ from (10).

Again, by definition,

$$\begin{aligned} y &= \sum_{s=1}^n s \cdot P_s + n \sum_{s=n+1}^{\infty} P_s \\ &= \sum_{s=1}^n s \cdot P_s + n(1-a_n) \dots\dots\dots(22) \end{aligned}$$

Substituting these results in (21), we find that the a_n terms cancel out, and after a little reduction we get

$$\sum_{s=1}^n s \cdot P_s - y = \sum_{s=1}^{n-1} \frac{1}{1-\lambda_s} + \frac{y^2 - n^2 + 1}{2(n-y)} \dots\dots\dots(23)$$

Now $\lambda_s = \frac{\beta_s}{\alpha}$ and $y = n\alpha$

$$\sum_{s=1}^{\infty} s \cdot P_s - y$$

So Average Delay $M = \frac{\sum_{s=1}^{\infty} s \cdot P_s - y}{y}$

$$\begin{aligned} &= \frac{1}{n} \cdot \sum_{s=1}^{n-1} \frac{1}{\alpha - \beta_s} \\ &\quad + \frac{n\alpha^2 - (n-1)}{2n\alpha(1-\alpha)} \dots\dots\dots(24) \end{aligned}$$

This is the form given by Erlang for the special cases $n=1, 2, 3$ respectively.¹²

¹² A.P.T.T. Table.

From the point of view of numerical evaluation we note that $\frac{1}{\alpha - \beta_s} + \frac{1}{\alpha - \beta_{n-s}} = \frac{2(\alpha - r_s \cos \theta_s)}{\alpha^2 - 2\alpha r_s \cos \theta_s + r_s^2}$ (25)

where $\beta_s = r_s \cdot e^{i\theta_s}$.

When the probability for delay is small this formula suffers from the defect of formula (17)—namely, that the average delay consists of the sum of terms of opposite signs greater than itself. An alternative method is very convenient when the $P(> t)$ curve has been plotted over a sufficiently wide range.

We have: Probability for a delay between t and $t + dt$.

$$= P(> t) - P(> t + dt)$$

$$= - \frac{dP}{dt} \cdot dt \text{ the argument of } P \text{ being now}$$

dropped.

$$\text{So average delay} = \int_0^\infty -t \cdot \frac{dP}{dt} \cdot dt$$

$$= \left[-t \cdot P \right]_0^\infty + \int_0^\infty P \cdot dt$$

$$= \int_0^\infty P \cdot dt \dots\dots\dots(26)$$

We have, therefore, simply to find the area between the $P(> t)$ curve and the axes, by counting squares or some equivalent method.¹³

(10) NUMERICAL EXAMPLE.

We take the case of 10 switches subject to a traffic density of 4.0, i.e., $n=10, y=4, \alpha=.4$. In this example $P(> t)$ diminishes very rapidly as t increases, and in fact becomes negligible by $t=1$. We thus cannot exhibit the discontinuities in the slope of the $P(> t)$ curve which occur at $t=1, 2 \dots$. Moreover the average delay is too small to be evaluated accurately by formula (24). The example was chosen as being typical of traffics passing between large P.B.X's and the main exchanges to which they belong. In spite of the defects mentioned above, it illustrates the use of the formulæ sufficiently clearly, and the results indicate a noticeable departure from those given by the theories at present in use.

We start by finding α' , the real solution of $re^r = \alpha e^{-\alpha} = .2681$. By trial we have:—for $r=.2$, L.H.S. = .2443, and for $r=.22$, L.H.S. = .2748. Interpolation suggests $\alpha'=.2160$ which turns out to be nearly right.

The four conjugate pairs of complex solutions

$(r_s, \pm \theta_s)$ of equation (4) are therefore all such that $.4 > r_s > .2160$.

Equation (5) expressed in the most convenient form gives

$$\cos \theta = \frac{1}{r} [\log_e r - \log_e (\alpha e^{-\alpha})]$$

$$= \frac{1}{r} [\log_e 10 r - .9862]$$

We now give r different values and evaluate $\cos \theta$ and hence θ in radians, choosing the angle between 0 and π in every case. It is useful here to plot $\theta - r \sin \theta$, the left-hand side of (6), against r (Fig. 1).

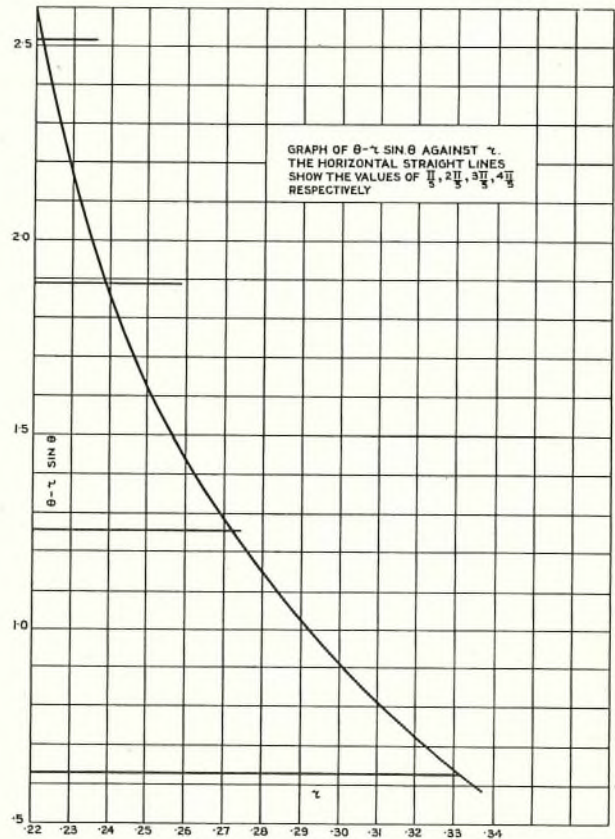

FIG. 1.—CURVE USED FOR OBTAINING THE NUMERICAL SOLUTIONS OF EQUATIONS (5) AND (6).

We then find for what values of r the function takes the values $\frac{2\pi}{10} = \frac{\pi}{5}, \frac{2\pi}{5}, \frac{3\pi}{5}, \frac{4\pi}{5}$ in turn. For the sake of accuracy it is desirable to return to interpolation for the final step. We give the calculation in the last case.

$$\text{With } r=.2214, \cos \theta = \frac{.7948 - .9862}{.2214} = -.8645$$

$$\theta = 3.1416 - .5266 = 2.6150,$$

¹³ As the curve extends to infinity a rule is required for giving the error due to the portion omitted. It is easy to ensure that this error is negligibly small in practice. A rough guide to its magnitude is that it is of the order of the value of P terminating the portion included in the measured area. This follows from the asymptotic formula for $P(> t)$. (See Appendix 2).

$\theta - r \sin \theta = 2.6150 - .1113 = 2.5037$ which just $< \frac{4\pi}{5} = 2.5133$

So r is a little too great.

We try $r = .2212$: this gives $\theta - r \sin \theta = 2.5152$ which just > 2.5133 . Interpolation gives $r = .22124$, for which $\theta = 2.6227 = 150^\circ 16'$.

The other solutions are similarly determined, and we obtain the complete set of λ 's which according to our definition are $\left(\frac{r}{a}, \theta\right)$ and occur in conjugate

pairs except for the real value $\left(\frac{a'}{a}, \pi\right)$. The results are: $-(.55310, \pm 150^\circ 16')$, $(.59535, \pm 119^\circ 50')$, $(.67822, \pm 87^\circ 31')$, $(.82670, \pm 50^\circ 39')$ and $-.5400$ respectively.¹⁴

The next problem is to work out expressions of the form $\sum \lambda_1 \dots \lambda_s$ required in formula (16) for deter-

mining the a 's. The best way of doing this is to use the formula

$$u_s = \frac{1}{s} [u_{s-1}v_1 - u_{s-2}v_2 + \dots + (-1)^{s-1}v_s] \dots \dots (27)$$

where $u_s = \sum \lambda_1 \dots \lambda_s$, and $v_s = \sum_{v=1}^{s-1} \lambda_v^s$

The v 's are easily evaluated, for λ_v and λ_{n-v} form a conjugate pair and $\lambda_v^s + \lambda_{n-v}^s = 2 \left(\frac{r_v}{a}\right)^s \cos s\theta_v \dots (28)$

by De Moivre's theorem $\frac{r_v}{a}$ and θ_v are the quantities whose numerical values have just been given.

So we obtain the v 's from (28) and hence the u 's in succession from (27), it being noted that $u_1 = v_1$.

The results are:—

s =	1	2	3	4	5	6	7	8	9
$v_s =$	-.9859	-.9400	-.8183	-.5742	-.19505	+.2246	+.4739	+.3731	+.0016
$u_s =$	-.9859	+.9560	-.8959	+.7907	-.6330	+.4362	-.2396	+.0920	-.0185

We note as a check that $u_9 = \lambda_1 \lambda_2 \dots \lambda_9$
 $= \left(\frac{r_1 r_2 r_3 r_4}{a^4}\right)^2 \times \frac{a'}{a}$
(29)

which on evaluation gives $-.0184$.

We now evaluate a_9 straightforwardly from (10), the result being $.99218$.

Hence we find a_s from (16) which may be written,

$$a_s = a_{n-1} \cdot u_{n-1-s} \cdot (-1)^{n-s-1}.$$

The results are:—

$$a_8 = .9782, a_7 = .9485, a_6 = .8889, a_5 = .7845, \\ a_4 = .6280, a_3 = .4328, a_2 = .2377, a_1 = .0913, \\ a_0 = .0183$$

We can now evaluate formula (19) for different values of T and τ . We find that $T = 0$ covers the practical range sufficiently.

The formula becomes

$$\sum_{v=0}^9 a_v \left[\frac{(4-\tau)^{19-v}}{19-v!} e^{-4} + \frac{(8-\tau)^{29-v}}{29-v!} e^{-8} + \dots \right]$$

The series in the square bracket converge rapidly, so that direct computation is short and straightforward. Pearson's tables of the Poisson formula will be found helpful. The following table exhibits the results, comparison being made with those following from other formulæ:—

$t = \tau$	0	.05	.15	.30	.50	.80	1.0 ($T=1, \tau=0$)
From (19)008227	.005876	.002756	.000680	5.13×10^{-5}	2.14×10^{-7}	1.23×10^{-8}
from (19) with a_v put = 1	.008392	.005989	.002803	.000689	5.19×10^{-5}	2.17×10^{-7}	1.25×10^{-8}
from Erlang's asymptotic formula ¹⁵ (See Appendix 2)01065	.000939	3.69×10^{-5}	2.87×10^{-7}	1.30×10^{-8}
from Molina's formula00878	.0065	.0035	.00120	.00024	1.37×10^{-5}	
from Accurate formula for exponential holding time distributions00878	.0066	.0035	.00145	.00043	7.1×10^{-5}	

¹⁴ Erlang in his A.P.T.T. article gives tables ((14) and (15)) from which the values of the λ 's may be obtained for certain values of n and a . The figures specified for our case agree closely with ours.

¹⁵ R.G.E. Article, p. 277.

The comparative results are also shown in Fig. 2. It will be noted that $P(> 0)$ should reduce to $1 - P(=0) = 1 - a_{n-1} = .00782$. At first sight this check does not seem to work very well, but we must remember that we lose two significant figures by this

second method, and some of our calculation is only worked to four significant figures. So the agreement is satisfactory. Incidentally, the above discrepancy illustrates the unsuitability of formula (17) as a means of calculating $P(> t)$.

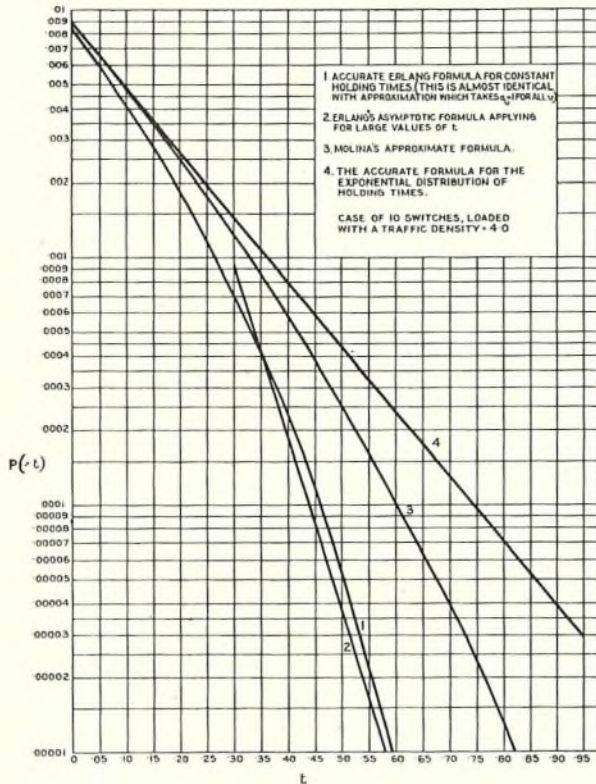

FIG. 2.—CURVES SHOWING THE PROBABILITIES FOR DELAYS, EXCEEDING VARIOUS SPECIFIED TIMES.

A striking and important feature of the above table is the closeness of the approximations obtained by taking all the a 's = 1. The difference is in fact so small that it could scarcely be shown on the curves. The reason for the effect is the fact that, as shown by our results, a_9, a_8, a_7, \dots differ comparatively slightly from 1. It seems that this approximation will generally hold for groups subject to traffics which only allow a small congestion. It would not of course apply to heavily loaded groups in which long delays are probable. The approximate formula is extremely easy to evaluate as it does not require the determination of the λ 's.

There remains to calculate the average delay. This follows from (24) and (25). It turns out that the terms under the sigma in (24) are all positive, while the last term is a negative quantity nearly equal to the sum of the positive ones. So we lose three significant figures in the process and the final answer is not very accurate. We obtain .00106 for the average delay. This may be verified from (26) by computing the area between the $P(> t)$ curve (plotted

on uniform squared paper, not shown here) and the axes. The result agrees precisely with the above figure which may therefore be assumed to be fairly accurate. It indicates that the average delay of delayed calls = $\frac{.00106}{.008227} = .129$. This may be compared with the figure $\frac{1}{n-y} = .167$ resulting from an exponential distribution of holding times.

APPENDIX I.

DERIVATION OF FORMULA (19) FOR $P(> t)$ FROM THE GENERATING FUNCTION $G(z)$.

We have found in Section 7 that $P(< t)$ is the coefficient of z^{Tn+n-1} in $G(z)$

$$\equiv \frac{a_{n-1}(z - \lambda_1) \dots (z - \lambda_{n-1})e^{yr(1-z)}}{1 - z^n e^{y(1-z)}}$$

The problem before us is to obtain an alternative expression for this coefficient consisting of terms of the same sign. We proceed by expanding $G(z)$ within a wider area than the unit circle, thereby taking into account the pole at $z = 1$. The limit of this area is fixed by the pole of next lowest modulus, which turns out to be real. To prove this, we note

first that $\frac{d}{dx} \{ x^n e^{y(1-x)} \} = x^{n-1} e^{y(1-x)} (n - xy)$ is positive at first as x (real) increases from 1. In other words $x^n e^{y(1-x)}$ begins by becoming > 1 : but at infinity it vanishes. So there is a value r_0 at which it becomes 1. Now $z^n e^{y(1-z)}$

$$= r^n e^{y(1-r \cos \theta)} \cdot e^{i(n\theta - yr \sin \theta)} \text{ where } z = r e^{i\theta}$$

So $|z^n e^{y(1-z)}| > r^n e^{y(1-r)} > 1$ for $1 \leq r \leq r_0$.

In other words r_0 is the next lowest pole or singularity of any sort in $G(z)$.

Owing to the pole at $z = 1$ where the residue is -1 , we can write $G(z) \equiv -\frac{1}{z-1} + H(z)$ where $H(z)$ is now regular in the circle $|z| < r_0$.

$H(z)$ may be expanded in a convergent series

$$\sum_{v=0}^{\infty} A_v \cdot z^v \text{ when } |z| < r_0. \text{ For Cauchy's in-}$$

equality¹⁶ tells us that $A_v \leq \frac{M \cdot r!}{r^v}$ where M is the upper bound of $H(z)$ in the circle radius $r < r_0$. Hence A_v is of the order $r^{-v} \rightarrow 0$, as $v \rightarrow \infty$.

Now for $1 < |z| < r_0$, the original function $G(z)$ may be expanded in a Laurent series,¹⁷ by taking :—

$$G(z) = \frac{a_{n-1}(z - \lambda_1) \dots (z - \lambda_{n-1})e^{yr(1-z)}}{-e^{y(1-z)}z^n \left\{ 1 - \frac{1}{z^n e^{y(1-z)}} \right\}}$$

¹⁶ Whittaker & Watson, "Modern Analysis," 5.23.

¹⁷ Whittaker & Watson, loc. cit. 5.6.

$$\begin{aligned}
 &= -a_{n-1}(z-\lambda_1) \dots (z-\lambda_{n-1})e^{y(r-1)(1-z)} \\
 &\quad \sum_{v=0}^{\infty} z^{-v+1n} e^{-y(1-z)} \quad 18 \\
 &= -a_{n-1}(z-\lambda_1) \dots (z-\lambda_{n-1}) \cdot \\
 &\quad \sum_{v=0}^{\infty} z^{-v+1n} e^{-y(v+1-r)} \cdot e^{zy(v+1-r)} \dots \dots \dots (30)
 \end{aligned}$$

So for $|z| < r_0$,

$$\begin{aligned}
 \sum_{v=0}^{\infty} A_v z^v = H(z) = G(z) + \frac{1}{z-1} &= \text{expansion (30)} \\
 + \sum_{v=1}^{\infty} \frac{1}{z^v}
 \end{aligned}$$

But this is valid for all $|z| < r_0$ and therefore for $|z| < 1$.

$$\text{So for } |z| < 1, G(z) = -\frac{1}{z-1} + \sum_{v=0}^{\infty} A_v \cdot z^v$$

$$= \sum_{v=0}^{\infty} z^v + \text{expansion (30)} + \sum_{v=1}^{\infty} \frac{1}{z^v}$$

$$\text{And } P(<t) = 1 - \sum_{v=0}^{n-1} a_v$$

$$\sum_{v=0}^{\infty} \frac{[y(v+1-\tau)]^{T+v+1n+n-1-v}}{(T+v+1n+n-1-v)!} \cdot e^{-y(v+1-r)}$$

using (16) and taking the coefficient of z^{T+n-1} in (30). This gives $P(>t) = 1 - P(<t)$

$$= \sum_{v=0}^{n-1} a_v \cdot \sum_{w=1}^{\infty} \frac{[y(w-\tau)]^{T+wn+n-1-v}}{(T+wn+n-1-v)!} \cdot e^{-y(w-r)}$$

which is identical with (19).

APPENDIX 2.

ERLANG'S ASYMPTOTIC FORMULA FOR $P(>t)$.

This is a generalisation of the method of Appendix 1; it proceeds by taking into account the further poles in $G(z)$, beginning with that at r_0 .

The fundamental residue theorem¹⁹ gives :—

$$\frac{1}{2\pi i} \int_c \frac{G(z)}{z-x} \cdot dz = G(x) + \sum_r \frac{d_r}{C_r-x} \dots \dots \dots (31)$$

where C_r denotes the various poles of $G(z)$, d_r the residues at these poles, and C any circle including these poles which does not pass through any of them,

¹⁸ This is the binomial expansion, valid since $|z^ne^{y(1-z)}| > 1$ in the region in question.

¹⁹ Whittaker & Watson, loc. cit. 6.1.

i.e., is such that $G(z)$ is bounded on its circumference.

It is shown in Whittaker and Watson²⁰ that (31) leads to :—

$$\begin{aligned}
 G(x) &= G(0) + \sum_{r=1}^{\infty} d_r \left(\frac{1}{x-C_r} + \frac{1}{C_r} \right) \\
 &= G(0) - \frac{x}{x-1} + \frac{d_1}{x-r_0} + \sum_{r=2}^{\infty} \frac{d_r}{x-C_r} \\
 &\quad + \sum_{r=1}^{\infty} \frac{d_r}{C_r},
 \end{aligned}$$

where d_1 denotes the residue of $G(x)$ at the pole r_0 . This applies for all x , and we therefore have for $|x| < 1$

$$\begin{aligned}
 G(x) &= G(0) + \sum_{r=1}^{\infty} x^v - d_1 \sum_{r=0}^{\infty} \frac{x^v}{r_0^{v+1}} + \sum_{r=2}^{\infty} d_r \sum_{r=0}^{\infty} \\
 &\quad \frac{x^v}{C_r^{v+1}} + \sum_{r=1}^{\infty} \frac{d_r}{C_r}
 \end{aligned}$$

We require the coefficient of x^v in this expression. We note that the larger v becomes, the smaller becomes the importance of the contributions of the further poles in $G(x)$ relative to those at 1 and r_0 . We therefore obtain an approximation which improves the larger we make v , by merely considering these first two poles.²¹ We then require the residue at r_0 .

This is given by an application of the first mean value theorem, as in Section 5.

We have :—

$$d_1 = \frac{a_{n-1}(r_0-\lambda_1) \dots (r_0-\lambda_{n-1})}{-(nr_0^{n-1}-yr_0^n)e^{y(1-r_0)}} e^{yr_0(1-r_0)}$$

So to our order of approximation :—

$$\begin{aligned}
 P(<t) &= \text{Coefficient of } x^{T+n-1} \text{ in } G(x) \\
 &= 1 + \frac{a_{n-1}(r_0-\lambda_1) \dots (r_0-\lambda_{n-1})}{(n-r_0y)r_0^{n-1}} \cdot \frac{e^{y(1-r_0)}(r_0-1)}{r_0^{(T+1)n}}
 \end{aligned}$$

Now $r_0^n = e^{y(r_0-1)}$, from the definition of r_0 ; also $t = T + \tau$

So $P(>t) = 1 - P(<t)$

$$\begin{aligned}
 &= -\frac{a_{n-1}}{n-r_0y} \left(1 - \frac{\lambda_1}{r_0} \right) \dots \\
 &\quad \left(1 - \frac{\lambda_{n-1}}{r_0} \right) e^{-y\tau(r_0-1)} \dots \dots \dots (32)
 \end{aligned}$$

Noting that a_{r_0} is identical with Erlang's a^t , we easily deduce the forms given by Erlang for the special cases $n=1, 2, 3$ respectively.²²

²⁰ loc. cit. 7.4.

²¹ A progressively better approximation for given v is obtained by taking in more and more subsequent poles, which occur in conjugate complex pairs.

²² R.G.E., p. 277.

Bristol Area Automatic Telephone Exchanges.

J. EMLYN-JONES.

THE telephone system of the Bristol Multi-Exchange Area was successfully changed over to automatic working at midnight on the 28th November, 1931. A transfer of 75 per cent. of the short trunks and junctions took place on the same evening, but these lines carried no traffic until midnight.

On the 10th October, 1931, 261 long distance trunk circuits, which were accommodated at a separate trunk exchange at the Head Post Office, Small Street, Bristol, were transferred to the auto-manual suite in the new Central Automatic Exchange at Telephone Avenue, Baldwin Street.

A transfer of 200 service lines was also effected on the 14th November, intercommunication between the old and the new systems being maintained by means of transfer circuits from the auto-manual switchboard to the old Central Battery exchange until the general transfer of subscribers' lines at the end of November.

The manual exchanges which have been closed are :—

Bristol.	C.B. No. 1 exchange.
Westbury-on-Trym.	Magneto „
Stoke Bishop.	„ „
Kingswood.	„ „
Whitchurch.	C.B.S. No. 1 „

Bristol is a standard 5-digit step-by-step system with discriminating selector repeaters at each satellite exchange and ten automatic exchanges have been installed in the area by The Automatic Electric Company. The present equipment and ultimate capacities are given in the following table, which also shows the initial numbering scheme for the area and the number of lines and stations connected to each exchange at the date of opening.

Exchange.	Dialling-out code.	Ultimate lines when Automatic.
Pill	85	300
Filton	89	400
Frenchay	88	200
Fishponds	84	2,300
Keynsham	87	700
Long Ashton...	86	400

The transfer affected 61 other exchanges, and the short trunks and junctions of all types number 1732.

Fig. 1 is a diagram of the Bristol Multi-Exchange Area.

The first telephone exchange in Bristol was opened in November, 1879, and it is a coincidence that in the same month 52 years later, Bristol was converted to automatic working. The original exchange at 16, High Street, approximately 300 yards from Telephone Avenue, was equipped for 70 lines and had 20 subscribers initially. The rental was £20 per annum for a circuit within a radius of one mile from the exchange and unlimited local service was given between the hours of 7 a.m. and 6 p.m. on weekdays, but the exchange was closed on Sundays! Some old residents of Bristol still remember the inconvenience of such restricted telephone service.

The Central exchange building was erected in Telephone Avenue in 1899 to accommodate the first central battery exchange in Europe. The building has been extended to accommodate the new automatic equipment and a new repeater station is at present being installed.

As a matter of historical interest, it may be mentioned that the original C.B. No. 1 exchange was opened for traffic on 25th May, 1900, and was

Exchange.	Multiple.		Numbering Scheme.	No. of Lines at opening date.	No. of Stations at opening date.
	Initial.	Ultimate.			
Central	5,900	9,600	20,000—25,899	3,790	8,209
North	2,400	4,300	44,000—40,399	1,439	1,736
South	1,300	2,600	76,000—77,299	769	1,078
Easton	1,800	3,000	56,000—57,799	880	1,330
West	3,700	5,400	33,000—36,699	2,284	2,957
Bedminster	1,100	2,000	63,000—64,099	650	1,237
Westbury-on-Trym	1,400	2,700	66,000—67,399	801	891
Stoke Bishop	700	1,200	81,000—81,699	481	548
Kingswood	700	1,400	73,000—73,699	412	563
Whitchurch	100	300	41,100—41,199	51	53

Access to the following exchanges, at present worked manually but due for conversion to automatic working later, is obtained by dialling a two-digit code. This places the Bristol automatic subscribers in communication with the sub-exchange operator, who completes the call in the usual manner.

designed to have an ultimate capacity of 6,300 lines. The growth of the system necessitated the erection of a relief exchange in another part of the building, bringing the total capacity of the exchange to over 11,000 lines. Subscribers' meters were not provided when the exchange was built and register keys were

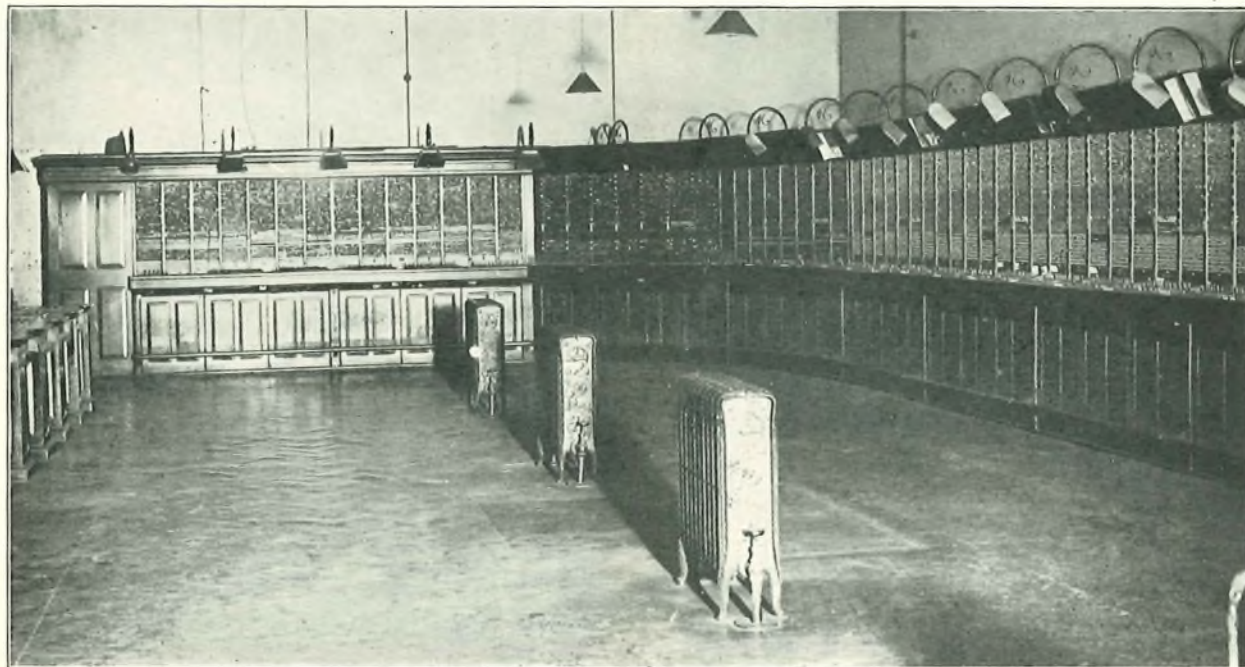

FIG. 2.—BRISTOL CENTRAL BATTERY EXCHANGE, LOOKING NORTH.

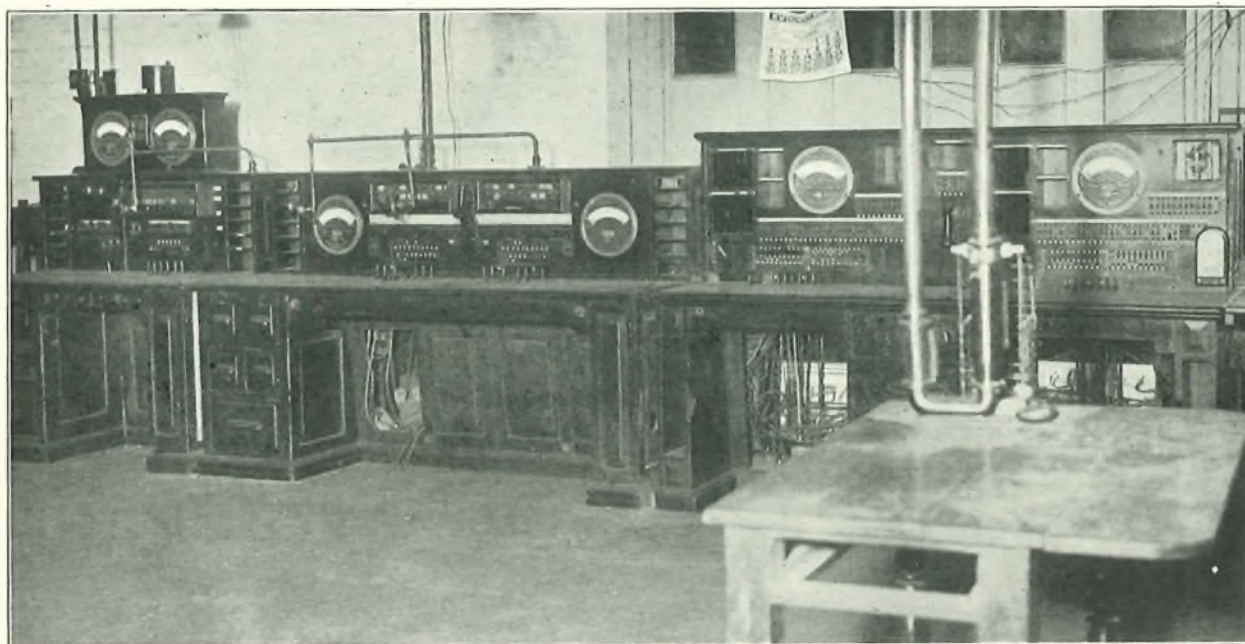

FIG. 3.—OLD TEST DESKS, BRISTOL C.B. EXCHANGE.

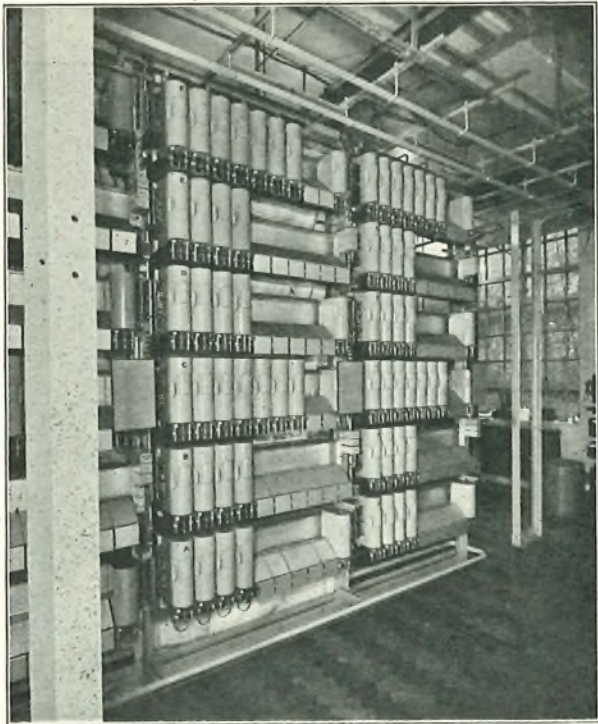

FIG. 4.—3RD SELECTORS, CENTRAL EXCHANGE.



FIG. 5.—FINAL SELECTORS, CENTRAL EXCHANGE.

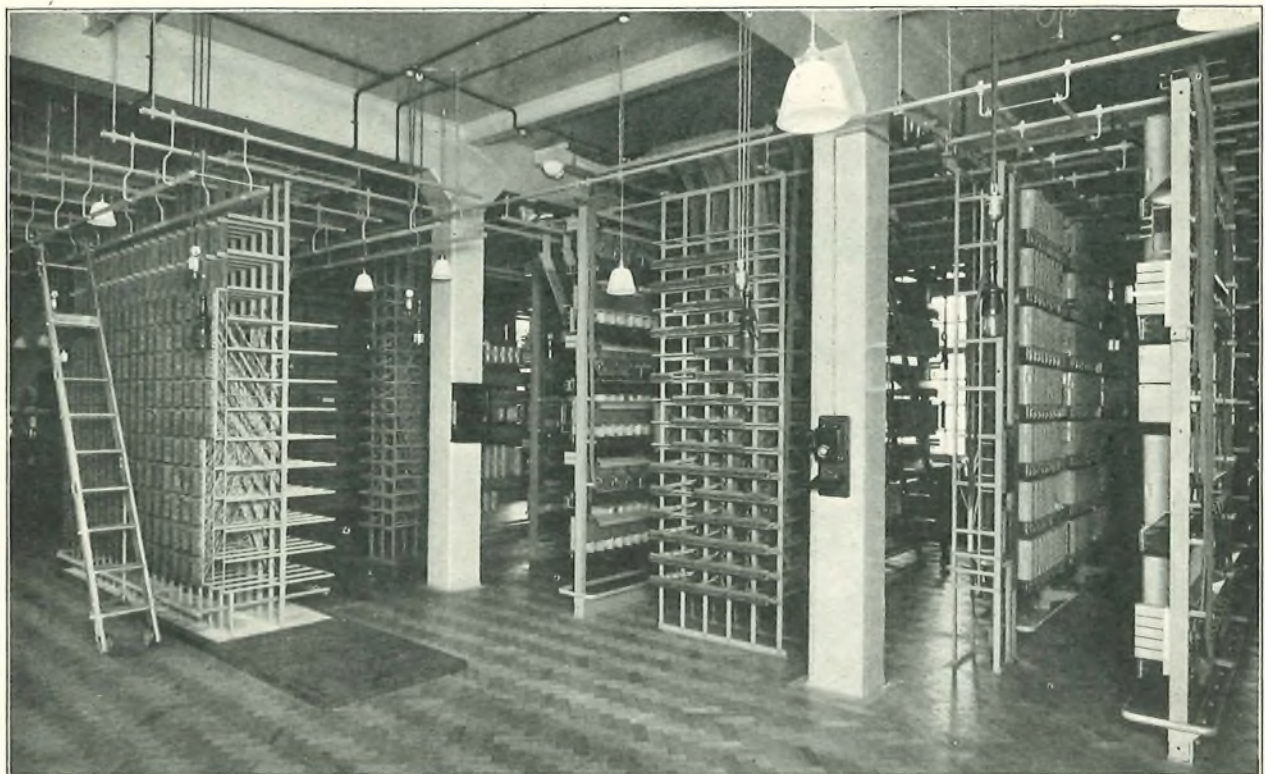

FIG. 6.—WEST EXCHANGE.

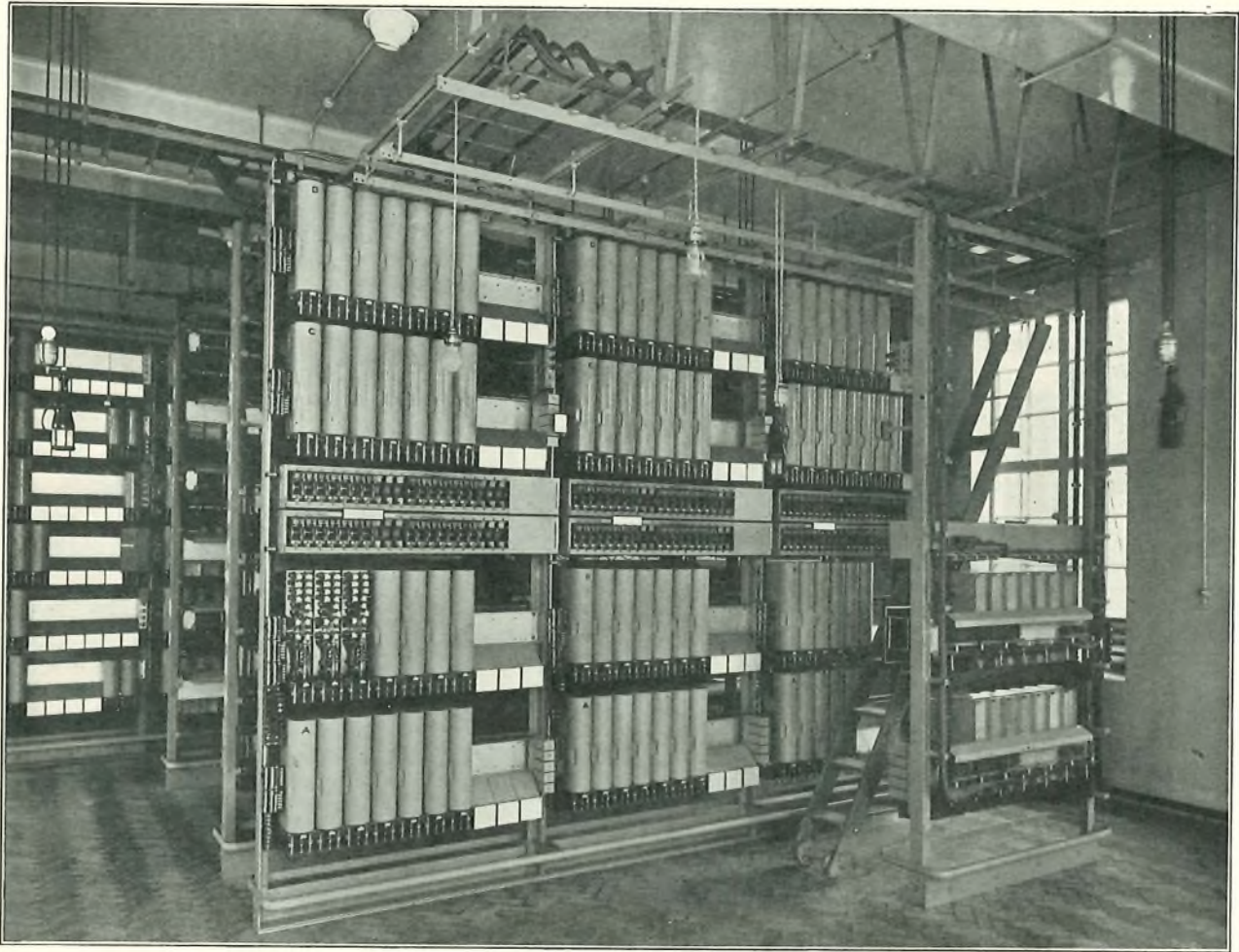

FIG. 7.—NORTH EXCHANGE.

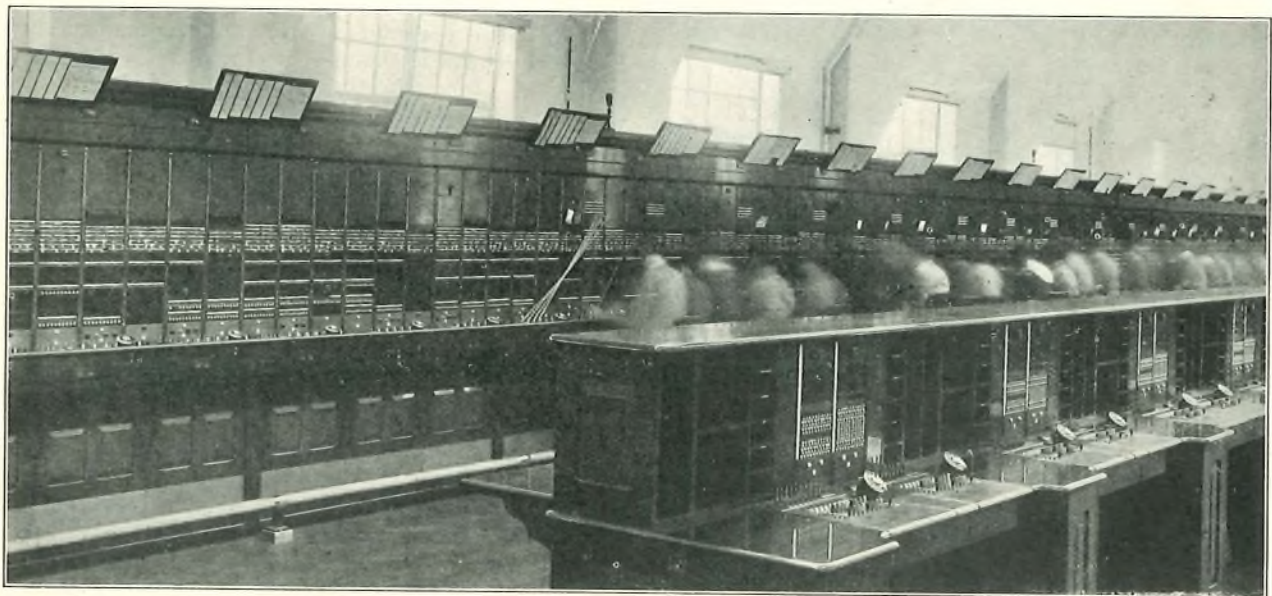

FIG. 10.—AUTO-MANUAL SWITCHBOARD, CENTRAL EXCHANGE.

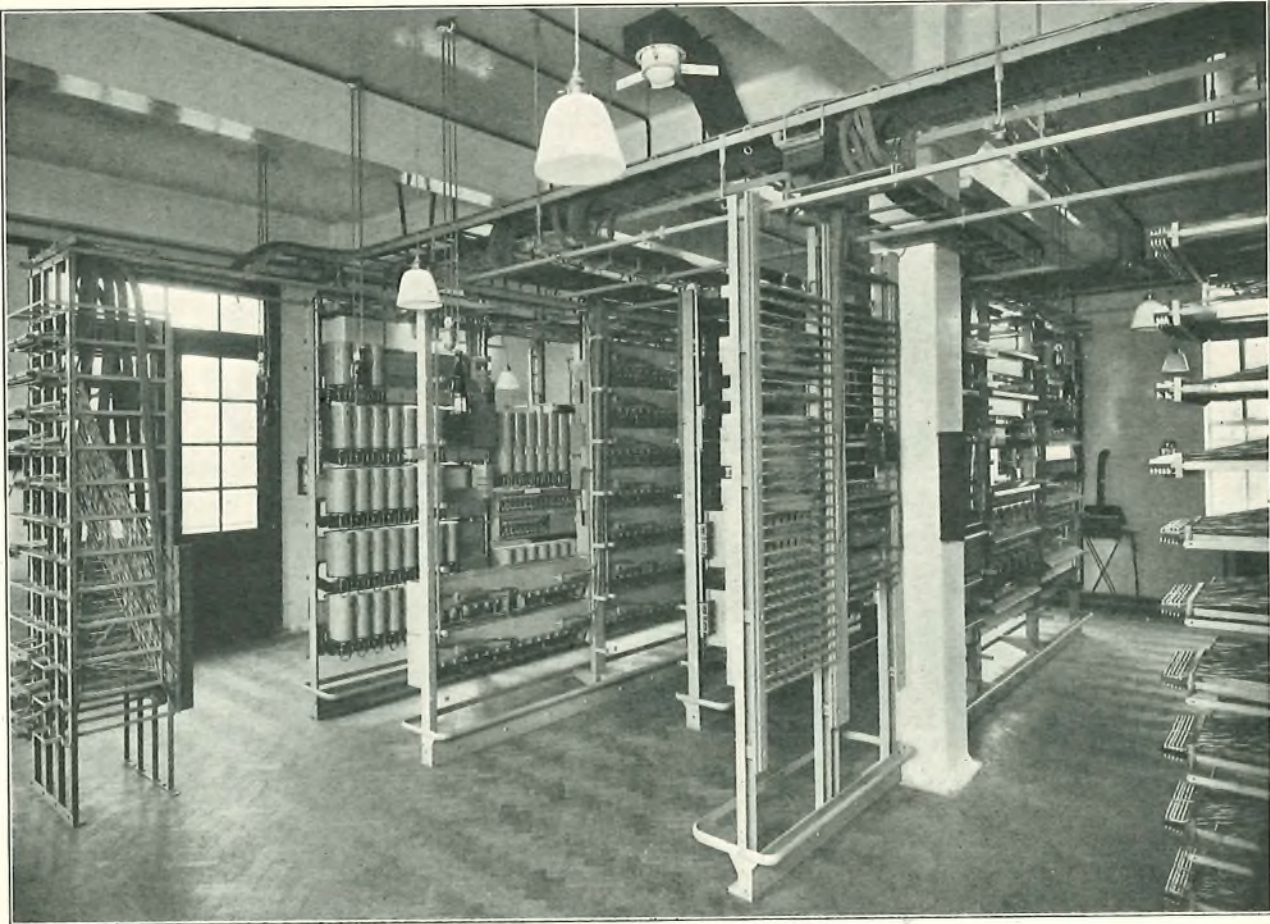

FIG. 8.—STOKE BISHOP EXCHANGE.

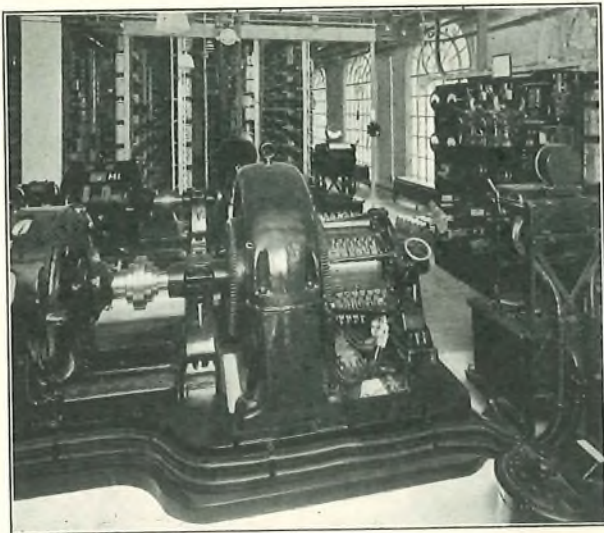

FIG. 9.—POWER PLANT, CENTRAL EXCHANGE.

The power distribution consists of bare aluminium bus bars with circuit breakers mounted at the top of the selector racks. The negative bus bar is protected

where necessary. These features can be clearly seen at the top of Fig. 9.

Fig. 10 is a view of part of the new manual suite at the Central exchange. It comprises:—

15—3-position sections of the C.B. No. 1 type for ringing trunks and junction signalling circuits.

1—section for cord circuit repeaters.

33—positions at which short trunk and junction calls from subscribers are handled, the operator being obtained by dialling 0, 92 or 93 for the particular service required. Incoming calls from Manual exchanges, Phonograms, Service P.B.X., and Rural Party Lines are also completed at these positions.

The Monitors' desks can be seen in the foreground of the photograph.

Centralized observation desks have been installed and preparation has been made for a suite to deal with Trunk Demand working and for Automatic Routers, but these have not yet been installed.

The author is indebted to the Automatic Electric Company for the photographs of the new automatic equipment given in this article.

Young People's Telephone Exhibition.

THE recently commenced Telephone Publicity Campaign was lifted from comparative obscurity to a prominent position by the extremely successful Young People's Telephone Exhibition, which was held at the Imperial Institute, South Kensington, from January 5th to 23rd. Although primarily designed for the entertainment and education of youngsters, the idea being to sow seeds of telephone knowledge in the minds of the coming generation which will produce a hoped for prolific crop in a few years' time, the needs of those of maturer years were not overlooked.

In designing the exhibition, it was desired to bring to the notice of the public the full range of the Department's activities. Every phase of Communication Engineering was fully represented, and endeavours were made to indicate the development of each branch from its beginnings to the most up to date equipment, and also to show the principles on which the working of the equipment is based.

Fig. 1 is a general view of the Exhibition hall, which had an area of 8,000 square feet. The space was divided into blocks, each block comprising some 400 square feet. To each block was allocated one branch of Communication Engineering, the exception being Telephony, which needed two blocks for its adequate representation.



FIG. 1.—GENERAL VIEW OF THE EXHIBITION.

In order that the main design could be carried out effectively, it was necessary to seek the co-operation of every Technical Section in the Engineer-in-Chief's Office, of the London Engineering District and also of Contractors to the Department. This co-operation was enthusiastically accorded in every case. The Department of Overseas Trade was responsible for the design and

provision of the properties and lighting effects, and is to be congratulated on the very effective result.

Fig. 2 is a photograph of the Telegraph block. There were numerous exhibits of historical and modern equipment, but the main interest centered around the Teleprinters 3A and the Telewriters, which were working. Visitors could hand in telegrams for transmission within the exhibition hall, and these were accepted and stamped in the



FIG. 2.—TELEGRAPH BLOCK.

usual way, and passed for transmission from one Teleprinter to another situated at the distant end of the stand. 37,500 telegrams were passed in this way, the final one being sent to the Postmaster General with greetings from the exhibition staff. Other working exhibits were single and double current sounders, Wheatstone Automatic Transmitter and Receiver, a Baudot Printing Telegraph System and Phonogram working. The historical exhibits were a source of delight to many of the veteran engineers and telegraphists who visited the exhibition, and many were the references to the good old days overheard in this corner of the hall. A specimen of the recently designed vertical rack for mounting telegraph equipment also excited much comment.

The Radio Block (Fig. 3) contained a number of extremely interesting items illustrating the progress of modern radio-communication. A section of the long-wave telephony equipment used on Transatlantic talks, a telephony channel working on 5 metres, modern valves (including the new Heptode), and a Ship's Terminating Equipment were in great contrast to Marconi's magnetic coherer and other relics of pioneer days.

The Power Block was adjacent to the Radio stand, and contained the Power Plant necessary for



FIG. 3.—RADIO BLOCK.

running the working exhibits. A 96 Ah. battery and Charging Equipment, and the necessary ringing and tone equipment was installed. As a contrast to the working cells, a battery box of a 10,000 Ah. cell was placed in the Battery room.

Fig. 4 is a view of one of the Telephony Blocks. The back of the first block was devoted to a display of historical equipment and exhibits showing the make-up of various items of manual and automatic Telephone Equipment. Most of the front of this block was allocated to an arrangement for demonstrating the principles of automatic telephony in Director Areas—the passage of calls between Automatic Exchanges and from Automatic Exchanges to Manual Exchanges being indicated. The second Telephony Block was wholly concerned with modern Telephony, and contained, among other things, a model Director Type Automatic Exchange, and full equipment for passing calls between Automatic Exchanges from Automatic to Manual Exchanges (C.C.I. working) and from Manual to Automatic Exchanges (Keysending); a



FIG. 4.—SECOND TELEPHONY BLOCK.

Rural Automatic Exchange, Private Branch Exchange, and a Manual A-position (C.B. 10 type) with a bothway junction to the Rural Automatic Exchange and an order wire to the keysending B-position.

The next block (Fig. 5) was devoted to miscellaneous items, and, somewhat to the surprise of the organisers, proved one of the most popular of the whole show. Here were, a working plenum ventilating unit, such as is now standard for the smaller Automatic Exchanges, with outlet ducts terminating in revolving Punkah louvres; a Game-well fire alarm box; an automatic letter stamping machine, a model kiosk containing a Radio Visor equipment, which controls the lighting of the Kiosk by means of a selenium cell; an automatic Traffic Control Equipment (working on Automatic Telephony principles), Venner Time Switches, and a master clock controlling all the clocks in the Exhibition, and supplying the time pulses for exhibits on the Telephony stand.

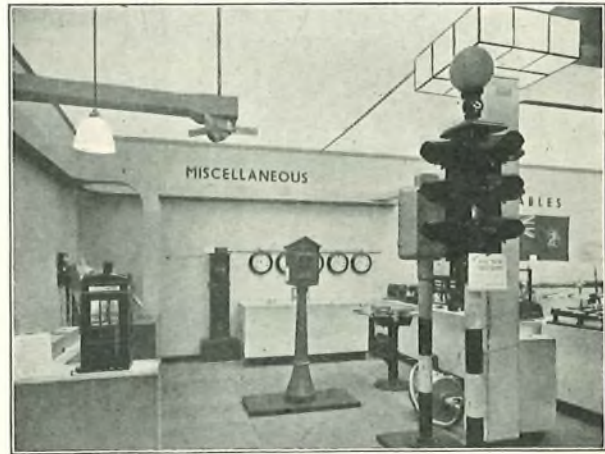

FIG. 5.—MISCELLANEOUS BLOCK.

Adjacent to the miscellaneous block was housed an exhibit of underground and submarine cables and equipment. The place of honour was given to a model of the P.O. cable ship "Monarch," kindly lent by the Engineer-in-Chief, and grouped around this were specimens of the submarine cables ranging from the first Transatlantic Telegraph Cable, laid in 1858, to the most up-to-date continuously-loaded, paper-core, Anglo-Continental Telephone cables. A fine range of specimens of underground cables was displayed at the back of this block. Fig. 6 is a photograph of the arrangement. Over this stand ran the latest type of trunk ticket tube, designed by the Department; this is a great advance upon all previous arrangements for this work.

Between the Cable Block and the Speech Transmission Block were the Radio Control Cabin and the Exhibition office, both of which were centres of intense activity throughout the Exhibition.

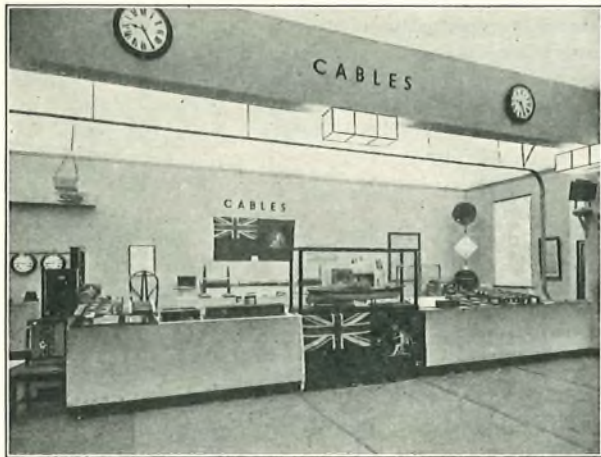

FIG. 6.—CABLE BLOCK.
Above the Front Bench runs the Trunk Ticket Distributing Tube.

Arrangements had been made with the Continental and Overseas Administrations to place telephony channels at the disposal of the Department at stated times, and visitors to the Exhibition were chosen at random and allowed to speak to an operator at the distant end. Talks with Sidney, New York, Buenos Ayres, and Rio de Janeiro were made over radio channels; talks to cities in practically every European country, except Russia and the Balkans, were made over the Continental channels. These conversations were made from a silence chamber, containing a high quality microphone, which was specially fitted up in the Radio Control Cabinet, and were broadcast throughout the hall by means of equipment kindly lent by Messrs. Standard Telephones and Cables, Ltd. The same equipment was used for broadcasting announcements and music from gramophone records.

The speech transmission block (Fig. 7) contained many interesting items, principally designed to indicate the principles of speech transmission and



FIG. 7.—SPEECH TRANSMISSION BLOCK.

amplification. The Kathode Ray Oscillograph proved a great attraction—this instrument was labelled "See your own voice"—and showed on a screen, the wave shape of different sounds. The apparatus consists of a highly evacuated tube, into which a trace of argon (10^{-5} atmospheres) is passed after evacuation. The end of the tube is enlarged to form a screen upon which a stream of electrons may be focussed, the electrons passing from a heated filament through a hole in a positively-charged anode. The pattern traced by the electron stream is made visible by a deposit of a mixture of calcium tungstate and zinc silicate.

A diagrammatic sketch of the arrangement is shewn in Fig. 8. On the side of the anode remote from the filament are placed four small plates, as shewn, and these plates are used for controlling the direction of the electron stream. In the arrangement at the exhibition, the varying potential of a condenser discharging through a neon lamp was placed across one pair of plates; this deflected the electron stream by a continuously varying amount as the condenser charged decayed, producing a

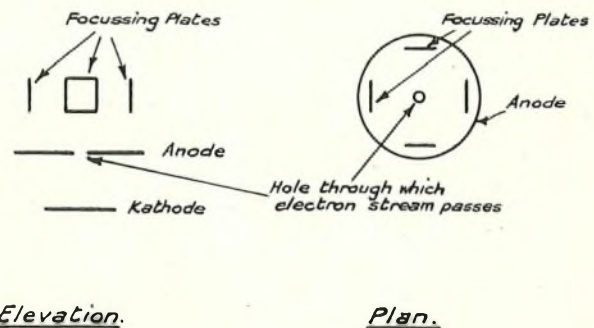

FIG. 8.—ARRANGEMENT OF KATHODE RAY OSCILLOGRAPH.

luminous line on the screen, the line being approximately straight. Across the other pair of plates was connected a telephone transmitter, and the varying P.D. across the plates due to the vibration of the diaphragm under the influence of sound waves produced a transverse deflection of the electron stream. Hence the waveform of the diaphragm vibrations was accurately produced on the screen of the tube—in other words, by speaking or humming into the transmitter, and looking at the screen, a visitor could "see his own voice." This extremely attractive exhibit was loaned by Messrs. Standard Telephones and Cables, Ltd.

Other interesting items in this block were a speech frequency indicator, by means of which the various wave frequencies present in speech were indicated by a number of neon lamps, each in a circuit tuned to a particular frequency; a model repeater; a gramophone with a frequency cut-out equipment, by means of which the effect on speech and music of suppressing certain frequency bands could be observed, and a schematic model of four-wire repeater working over long distances. All

these were designed and fitted by the Research Section.

The middle of the hall was devoted to external construction plant. A model cable chamber (Fig. 9) in which exhibitions of jointing were given, proved extremely interesting to all visitors. Between two poles at opposite ends of the hall were run overhead wires and a section of the London-Brighton aerial cable. A jointer's tent near to a footway jointing box was also shown. To complete this exhibit, the two side lockers of a Utility motor van, completely fitted with tools and equipment, were placed in a prominent position; this was to give the public an idea of the facilities provided by the Department for the rapid undertaking of any piece of work. A working model of a Travelling Post Office was also installed and attracted great interest.



FIG. 9.—MODEL CABLE CHAMBER.

The exhibition was opened by the Postmaster General, Sir Kingsley Wood at 11.0 a.m., on January 5th, 1932. Part of the opening ceremony consisted of a call to New York, and this was broadcast through the hall. A movietone photograph was taken of the speakers, and also of many of the exhibits; this was subsequently shown in various cinemas throughout the country.

The attendance exceeded all expectations. A member of the Secretariat intimately connected with publicity had been told by an expert that we should be lucky to get an attendance of 10,000 during the three weeks the Exhibition was open. The total attendance was 328,000! There were many anxious moments during the first day, as the layout of the hall had been designed so that all items of equipment were readily accessible to visitors. This was reckoning without the hosts of children who stormed the place; and who lost no time in climbing on racks, helping selector shafts and wipers with their fingers, and scrambling one over the other to reach telephones and hand in telegrams. Ropes were produced in the afternoon and the inside of every

stand temporarily closed; visitors being allowed inside the stands a few at a time. The number of staff was doubled. The following morning wooden barriers were placed round every stand, and messengers placed in position for controlling the crowds. These measures proved successful, and little difficulty was experienced thereafter in keeping the children in order. The average daily attendance during the first week—including 4,000 who arrived on the day before the exhibition opened—was over 27,000. The record attendance was 37,500—on Saturday, January, 23rd, the last day—a sure sign of the Exhibition's popularity.

There were many incidents of an amusing nature. Here is one conversation that was overheard:—
 1st small boy. "You telephoned yet, Bill?"
 2nd " " "No, but I'm going to."
 1st " " "Who to?"
 2nd " " "My Grandma—in Japan."
 1st " " "Garn! You haven't got a grandma in Japan!"
 2nd " " "Course I haven't! But they don't know—do they?"

There was no official record of a request for a call to Japan.

There were many lost children during the first week, and broadcast appeals of the following nature were frequent:—

"Will Charlie Jones please come to the office where his brother Wilfred is waiting for him. Charlie Jones, please!" Meanwhile the tears of Wilfred were being dried by one of the staff. Some light was thrown on a mysterious increase in the number of lost children by the following fragment which was overheard: "Go and tell them you're lost, George—I'll come and fetch you!"

During the second week a young genius of ten was unearthed. One of the demonstrators came to the Engineer-in-Charge and said "Have you seen him?"—"Seen who?" was the reply. "The kid who knows all about everything!—he's a marvel! Wants to know what the impedance of relays in the selector is!" Polite incredulity was expressed, but the truth prevailed. This boy had sufficient technical knowledge to understand the working of the Kathode Ray Oscillograph and the Radio Visor, and was actually able to explain the interaction of the condenser and induction coil in a subscriber's telephone set. He came to the Exhibition every day during the second week, and examined every working exhibit. Towards the end of the week he was observed explaining, quite correctly, the working of the model London Automatic Exchange to a grown-up friend. He said he was going to be an electrical engineer, and if he lives, he should make a distinctive mark on the profession.

One of the most gratifying things about the Exhibition was the way in which the demonstrating staff worked under the most trying conditions. With every excuse for frayed tempers, everyone maintained a cheerful demeanour and adopted a

EARLY TELEPHONES.



By courtesy of the *Evening Standard*.

FIG. 10.—Low's IMPRESSIONS OF THE EXHIBITION.

helpful attitude to the most obstreperous visitor. There was not the slightest friction between members

of the staff, and the most cordial relationships existed throughout.

In addition to the distinguished visitors who attended the opening ceremony, the exhibition was honoured by visits from Sir Austen Chamberlain, Sir Evelyn Murray, Sir Thomas Purves, Sir William Noble, Mrs. Lees-Smith and other notabilities.

The imagination of the Press was attracted, and scarcely a day passed but news of the Exhibition appeared in one or other of the big national newspapers. Fig. 10 shows some cartoons of the Exhibition which appeared in the *Evening Standard* for Saturday, January 9th.

The Department is indebted to the following contractors for the loan of apparatus and help for the Exhibition:—Standard Telephones and Cables, Ltd., General Electric Co., Ltd., Siemens Bros. & Co., Ltd., Automatic Electric Co., Ltd., Ericsson Telephones, Ltd., Salford Electric Instruments, Ltd., W. T. Henleys Telegraph Works, Creed and Co., Ltd., Radio Visor Parent, Ltd., R. K. Webster & Co., Chloride Electrical Storage Co., Sir Isaac Pitman & Sons, Ltd., Visco Engineering Co., Ltd., Venner Time Switches, Ltd. Throughout the whole period the staff of the Imperial Institute were most helpful and considerate.

A social gathering of the demonstrators to celebrate the success of the undertaking was held after its close on Saturday, January 23rd, and was voted a complete success by all.

The exhibition was under the control of Mr. W. J. Beale, of the Secretary's Office and Mr. W. R. Tyson of the Engineer-in-Chief's Office. Mr. McCarthy and Mr. Wakeman collaborated for the Central Telegraph Office and the London Telephone Service respectively.

W. R. T.

500 Kilowatt Demountable Valves.

ONE of the most interesting of recent developments has been the production of a new type of demountable transmitting valve. The idea of a demountable valve is not new and some years ago a valve was produced in France which was demountable and continuously evacuated by means a special type of mechanical pump.

There are two serious problems in the production of a satisfactory demountable valve. Firstly, the attainment of perfectly air-tight joints in the assembly and secondly the provision of satisfactory pumping equipment, since a demountable valve must of necessity be continuously evacuated. Even with the most perfect mechanical joints the use of a jointing compound is essential in order to achieve airtightness and it is a matter of difficulty to obtain a jointing material which has a sufficiently low vapour pressure to allow of its use.

Secondly, in order to obtain a sufficiently good vacuum in a reasonable time, it is necessary to use some type of molecular pump. The molecular pumps in general use are of the mercury vapour type and in order to prevent impairment of vacuum due to the entry of mercury vapour in the valve, it is necessary to use traps cooled by liquid air. Such an arrangement is too complicated for use on a commercial transmitter. Both of these problems are solved by the discovery in the Research Laboratories of the Metropolitan Vickers Electrical Co. of a group of oil distillates having remarkable properties. These oils could be boiled at low pressures without decomposition and yet at normal temperatures their vapour pressure was so low that their presence inside a valve assembly did not cause loss of vacuum. This company approached the Post Office, as one of the largest users of

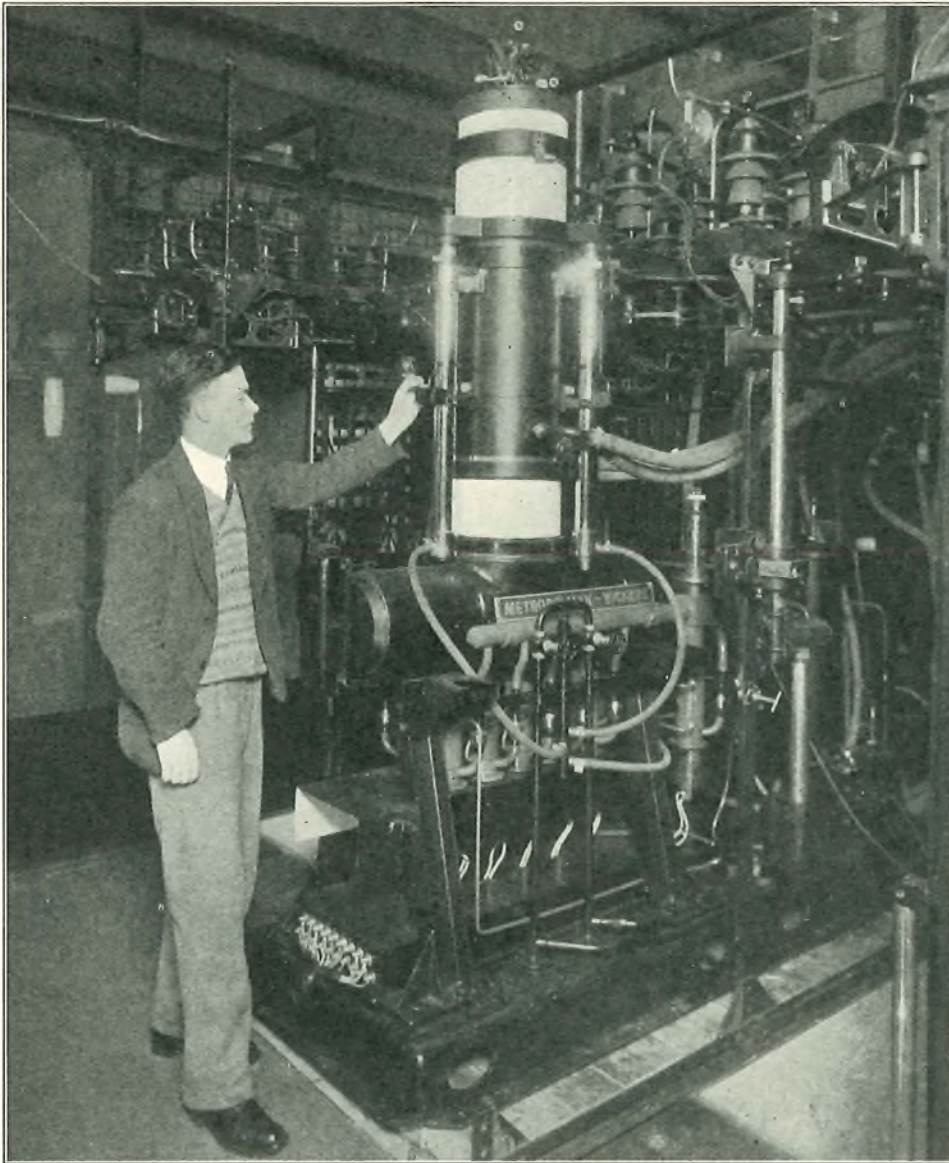

FIG. 1.—500 KILOWATT DEMOUNTABLE VALVE.
The attendant is holding a receiving valve for comparison.

transmitting valves and as a result an order was placed for an experimental valve of approximately 25 kW input. This valve was installed in a drive stage of the main telegraph transmitter at Rugby and gave satisfactory service, displacing three water-cooled 10 kW sealed valves. In the meantime an order was placed with the Company for a larger valve of 500 kW input. This valve, Fig. 1, was built and subjected to preliminary test in time to permit it being exhibited at the recent Faraday Exhibition.

The valve assembly consists of a pumping system which terminates on the high vacuum side in a large reservoir on which is mounted the valve itself. This reservoir is a large horizontal cylindrical

drum with a large opening at the top. This top surface is accurately ground and on it is mounted a 12" diameter porcelain insulator providing insulation between the reservoir and the anode. The anode is of steel and is approximately 24" long. Its internal section is in the form of a polyfoil consisting of 9 petals approximately $2\frac{1}{4}$ " diameter on a pitched circle of 9". Each foil has its own grid and filament. The anode is cooled by circulating water through holes drilled lengthwise, each hole having $\frac{1}{8}$ " of metal between it and its neighbours and a similar thickness of metal between it and the inside of the anode. Above the anode is a second porcelain insulator on the top of which is mounted a flange carrying the grid system. A

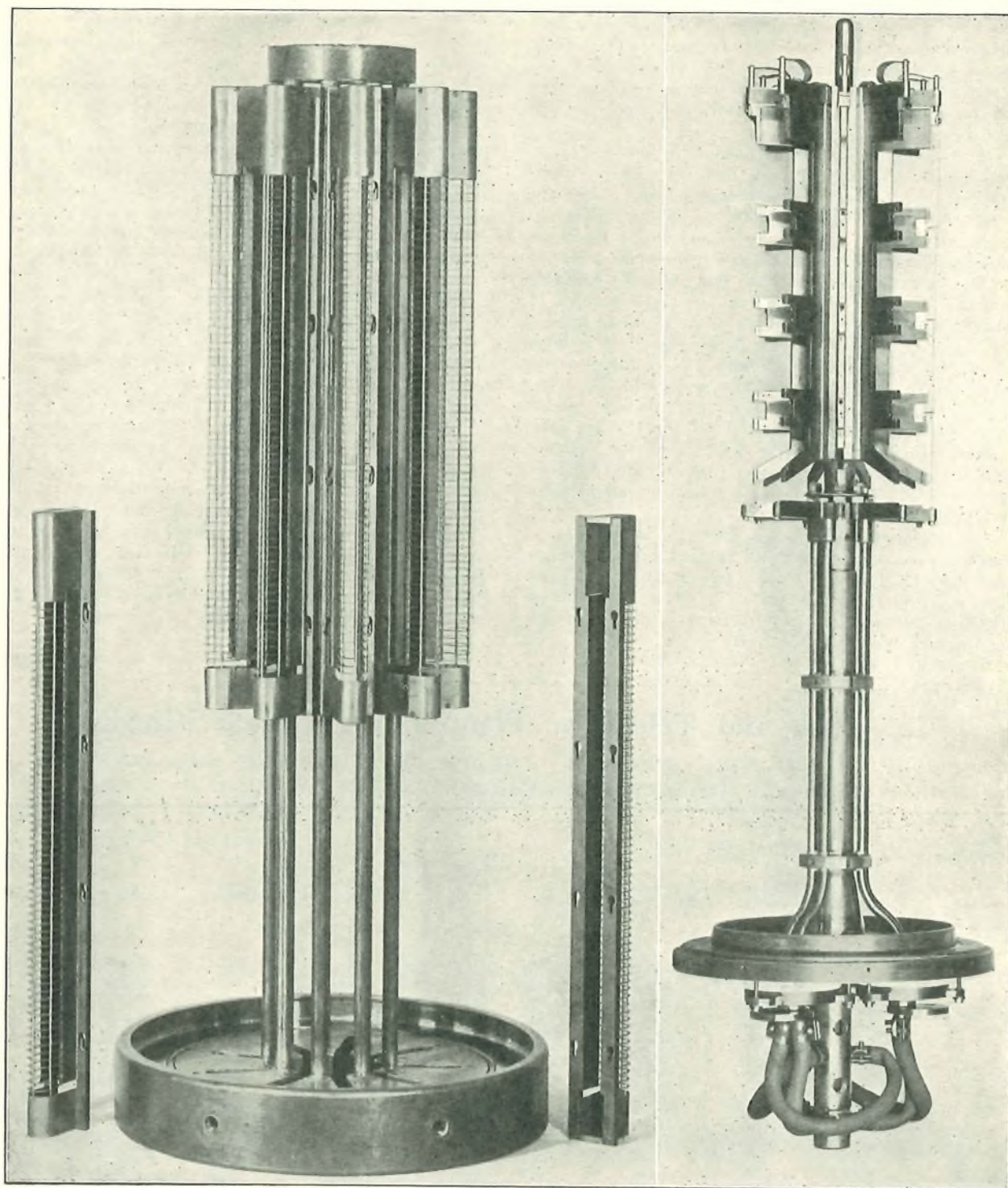

FIG. 2.—GRID STRUCTURE.

FIG. 3.—FILAMENT SYSTEM.

third porcelain insulator insulates this from the flange carrying the filament assembly. The filament system, Fig. 3, is three-phase, star-connected, the bottom of each filament being connected to neutral.

The grid structure shown inverted in Fig 2 is water cooled and is made of copper. On this is mounted the grid elements made up in the shape of flat horse-shoe washers of molybdenum clamped

to their respective copper supports and held rigid by two longitudinal molybdenum rods. The anode is provided with three hydraulic jacks which are used to lift the grid and filament assemblies clear of the anode and to serve 2-position electrodes when the valve is re-assembled.

The pumping system consists, firstly, of a mechanical backing pump followed by a high-capacity, low-speed, oil-vapour pump. The 3rd stage consists of 2 high-speed oil-vapour pumps in parallel and the final stage consists of 10 high-speed oil-vapour pumps in two groups of 5.

The final side of the last 10 pumps is the working vacuum for the valve. There are two vacuums in the pumping system to give a greater cubic capacity of vacuum. This serves the purpose of a high degree of vacuum longer under bad conditions and also acts as a cushion for the pumps in the event of a sudden large leak. The time taken to obtain a working vacuum after initial assembly is approximately 90 minutes. The valve can be opened, minor repairs carried out and re-evacuated without excessive absorption of gas by the internal metallic structure.

All the joint surfaces are planes. Some of these surfaces are semi-permanently sealed with a bitumen compound. Joints, which are normally broken when dismantling are sealed by means of special vacuum grease having properties similar to those of the oils used in the pumps.

In order to test the valve it was installed in one of the power panels of the GBR main telegraph transmitters at Rugby and was provided with excitation and power supply normally used on the final stage of this transmitter. Owing to the fact that it was desired to exhibit this valve at the Faraday exhibition, only a short time was available to carry out these preliminary tests, but the results obtained were very gratifying. The valve was found capable of taking an input of 521kW and was able to deliver to the antenna current of over 700 amperes. The valve, thus, was capable of carrying out the duties normally carried by 54 sealed-off valves in this stage of the transmitter. The capabilities of the valve however have not yet been fully explored and final tests have yet to be carried out. Although the possibilities of utilising valves of this size for wireless purposes are relatively limited, the development appears to have great possibilities for industrial purposes in connexion with high frequency electric furnaces where powers of thousands of kW could probably be utilised. The fact that the most vulnerable portion of the valve, *i.e.*, the filament, can be replaced at comparatively nominal cost permits the running of the filament at a higher temperature than is economically possible in a sealed-off valve. As a result the filament power is more economically utilised and the output of the valve increased.

Telegraph and Telephone Plant in the United Kingdom.

TELEPHONES AND WIRE MILEAGES. THE PROPERTY OF AND MAINTAINED BY THE POST OFFICE IN EACH ENGINEERING DISTRICT AS AT 31ST DEC., 1931.

No of Telephones owned and maintained by the Post Office.	Overhead Wire Mileages.				Engineering District.	Underground Wire Mileages.			
	Telegraph.	Trunk.	Exchange.	Spare.		Telegraph.	Trunk.	Exchange.	Spare.
730,642	211	3,554	26,827	1,088	London	37,067	126,797	3,153,326	104,345
98,950	2,059	18,753	45,402	4,135	S. Eastern.	4,702	60,809	358,917	47,367
104,125	4,420	36,557	58,038	3,057	S. Western.	24,062	25,620	242,175	62,767
84,243	5,232	42,790	61,945	7,433	Eastern.	24,154	66,516	184,638	76,520
115,638	7,286	52,554	48,645	4,698	N. Mid.	33,299	105,172	301,612	94,866
103,902	4,183	34,201	65,358	2,973	S. Mid.	17,518	51,048	289,199	91,051
65,870	3,270	31,794	49,582	3,745	S. Wales.	6,749	37,117	157,983	55,713
127,100	6,874	31,055	50,857	3,809	N. Wales.	15,274	44,981	383,621	134,808
178,018	957	14,040	24,190	3,793	S. Lancs.	12,600	99,644	563,787	84,863
107,601	5,200	32,652	35,656	4,439	N. Eastern	20,357	65,408	299,622	54,155
73,012	3,299	24,862	24,842	3,485	N. Western.	8,785	40,604	222,723	49,570
55,901	2,208	17,870	20,201	2,533	Northern.	10,233	31,347	169,943	41,422
26,326	3,618	10,667	10,542	716	Ireland N.	198	3,959	57,537	2,781
78,264	4,198	32,628	37,147	1,739	Scotland E.	8,049	27,145	170,928	49,108
100,763	4,532	24,974	28,405	1,616	Scotland W.	11,101	35,364	248,591	30,714
2,050,355	57,547	408,951	587,646	49,259	Total	234,157	821,531	6,804,602	980,050
2,029,613	68,832	388,673	839,937	48,898	Figures as at 30 Sept., 1931	223,740	758,565	6,493,239	950,743

The mileage figures for December, 1931, include adjustments consequent on the Re-valuation (31.3.1929).

A Resistance Thermostat with Light-sensitive Cell Operation.

E. J. C. DIXON, A.C.G.I., B.Sc., D.I.C.

Abstract

A METHOD of using a resistance thermostat with a reflecting galvanometer and a light-sensitive cell to control the operation of the heater relay is described and practical circuits are given for working from A.C. or D.C. mains. The sensitivity of the device as used in practice is $\pm 0.1\%$, but can be increased by using a more sensitive galvanometer.

The thermostat described in this note was developed for use with ovens containing oscillators determining the carrier frequencies of radio transmitters. The chief requirements in thermostats for this service are reliability of operation over long periods of time with a minimum of attention, robustness of design and a sensitivity of the order of $\pm 0.1\%$ at temperatures of the order of 50°C .

The Oven and Thermometer.

The size of the oven varies with the number of oscillators required and a typical oven is approximately a 12 inch cube of aluminium sheet to the inner faces of which are fixed heater mats sandwiched between thin sheets of mica. An attenuating layer of heat insulating material is placed between the heating surface and the apparatus in the interior of the oven, while the exterior surface is covered with several layers of similar material and finally a casing of highly polished aluminium.

A controlling resistance of nickel is wound on strip mica sandwiched between mica sheets and fixed to the heating surface adjacent to one of the heater mats. The mica sheets between the heater and the heater surface and between the controlling resistance and that surface are made as thin as possible and are perforated in order that the transfer of heat from the heater to the control shall be as rapid as possible.

The nickel resistance forms one arm of a Wheatstone Bridge, the other arms of which are equal resistances of Manganin wound on porcelain or mica, annealed at 140°C . for 24 hours and coated with shellac or other protecting varnish. All joints are made with silver solder as soft solder affects the resistance of Manganin. The bridge arms are usually of 50 ohms resistance, the nickel resistance having that value at 50°C . which is commonly used as the working temperature of the oven. A potentiometer of about two ohms resistance and preferably constructed with switch-controlled Manganin bobbins may be included in one side of the bridge as a convenient means for adjusting the operating temperature of the thermostat.

In early experiments with this type of resistance thermometer a moving coil relay working in the grid circuit of a valve was used in the manner described by Cooke & Swallow.¹ Various types of relay were tried with some success, although the use of an impulsing circuit was found to be essential to prevent stiction at the relay contacts. It was not found possible, however, to obtain high sensitivity and reliability of operation with the types of moving coil relay tried, particularly in the practical design which necessitated a lead to the moving contact independent of the moving coil circuit. It was decided, therefore, to try a reflecting galvanometer in conjunction with a light-sensitive cell operating a relay through the medium of a valve. A device of this nature, described in the *Journal of Scientific Instruments* in 1927², was used as a cable signal magnifier operating a relay directly from the light-sensitive cell. In this device a powerful source of light and a large selenium bridge were used and it is interesting to note the vast improvement in the performance of light-sensitive devices since that date.

Description of the Selenium Thermostat.

A convenient galvanometer was available in the "Portable Galvanometer" of Messrs. H. Tinsley and the "Selenium Bridge" manufactured by Messrs. Radiovisor Parent, Ltd., was chosen as a suitable light-sensitive device. The portable galvanometer may be obtained in the form of a wooden box containing the light source and a reflecting galvanometer of $10\text{ mm}/\mu\text{a}$ sensitivity. The selenium bridge has the advantage of a large sensitive area $50 \times 25\text{ cm.}$, a sensitivity sufficient to operate a relay through the medium of a single valve and a life which is theoretically not limited by deactivation. It is constructed of a thin glass surface on which a gold grid in the form of two interdigitated combs is fused. The surface is covered with a layer of selenium of the order of $2.5 \times 10^{-3}\text{ cm.}$ in thickness and is contained in a gas-filled glass envelope fitted with a standard valve base.

The scale of the portable galvanometer was removed and the selenium bridge fixed horizontally in a light-tight housing so that the sensitive surface extended from the centre to one end of the galvanometer scale, the surface being inclined so that its whole width was illuminated by the reflected light spot. Using a 4 volt lamp (or a twelve volt lamp run on 8 volts to give a long life) as the source of light, illumination of 1 cm. length of the sensitive

¹ *Journal Scient. Instr.* 6 (1929) 287.

² *Journal Scient. Instr.* 4 (1927) 420.

surface was sufficient to reduce its resistance from about 5 MΩ to half that value. When the selenium bridge is included in the grid circuit of a valve the change of its resistance causes sufficient change in anode current to operate a small relay. A convenient relay circuit is manufactured by the Radio-visor Company in the form of a "Lighting Unit" which may be obtained to work from A.C. or D.C. Mains and is designed for use with their standard selenium bridge.

Circuits and Adjustments.

Fig. 1 shows the circuit employed for a thermostat worked from A.C. mains. The fixed bridge arms are shown at R_1 , R_2 , and R_3 , while R_4 represents the nickel thermometer fixed adjacent to the heater resistance on the heating surface of the oven. The

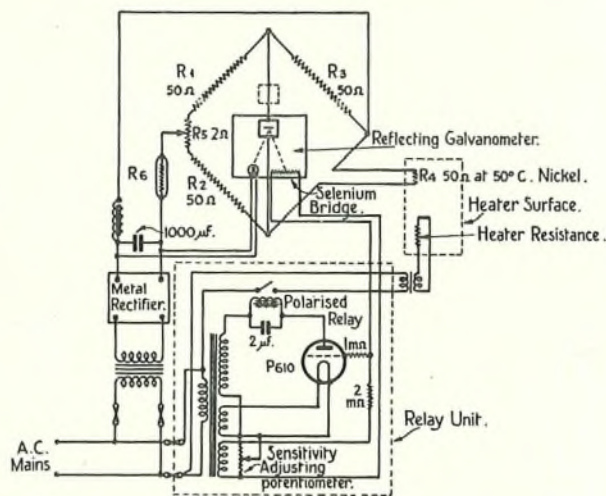

FIG. 1.—CONNEXIONS OF THERMOSTAT WORKED FROM A.C. MAINS.

P.D. applied to the bridge is usually 4 volts and is obtained from a metal rectifier giving 9 volts through the series resistance R_6 and the potentiometer R_3 . R_6 may be in the form of a barreter lamp, but this was found unnecessary in practice as a variation of the supply voltage of $\pm 10\%$ affected the control device only to a slight degree. The voltage from the rectifier is also used for the illuminating source.

The A.C. lighting unit has a transformer giving about 140 volts for the anode supply, 5 volts for the filament of the valve and about 70 volts across the grid potentiometer. The anode relay has a magnetic bias which maintains the heater contacts closed until the rectified anode current rises to 2 or 3 mA. The anode current is controlled by the effective positive potential of the grid with regard to the filament which in turn is controlled by the resistance of the selenium bridge and the setting of the grid potentiometer. Thus when the selenium bridge is illuminated the heater circuit is broken and the connexions of the thermometer bridge are therefore arranged so that the light sensitive surface is illuminated when the nickel resistance becomes

greater than 50 ohms in value. It is desirable to arrange a stop to the galvanometer mirror to prevent the reflected light traversing the sensitive surface and leaving it at the end of the scale owing to inertia in the transfer of heat from the heater to the thermometer causing the thermometer to continue rising in temperature after the heater has been disconnected. The selenium bridge has a higher sensitivity for weak than for strong illuminations and for this reason it is desirable not to expose the sensitive surface to daylight. If, for any reason, the cell is flooded with light it becomes "polarised" and a slight adjustment of the grid potentiometer is necessary to cause normal operation of the relay.

Where an indication of the temperature of the oven heater is required a second galvanometer may be placed in series with the controlling galvanometer and calibrated in degrees Centigrade. (See Fig. 2).

An alternative circuit working from D.C. mains and using a separately heated cathode valve on the lower bend of the characteristic is shown in Fig. 2. A Mazda D.C./H.L. or Osram D.L. valve is suitable and its filament can be wired in series with the potentiometer R_7 of about 400 ohms. In this case the variation of the resistance of the selenium bridge alters the negative potential of the grid with regard to the filament and varies the anode current from zero to 2 or 3 mA's which is sufficient to operate a telephone type relay in the heater circuit.

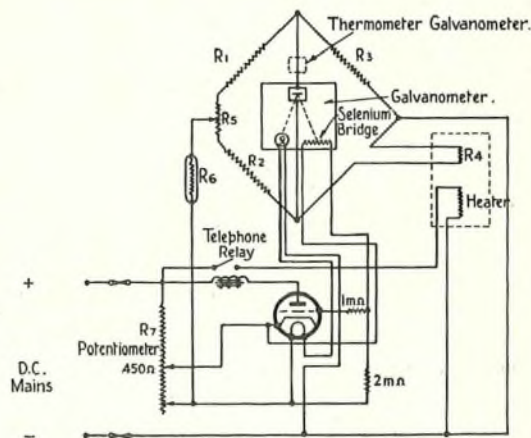

FIG. 2.—CONNEXIONS OF THERMOSTAT WORKED FROM D.C. MAINS.

In using the selenium bridge on D.C. it is desirable to keep its polarity constant and of the same sign as that used by the makers in the ageing process.

Sensitivity of the Light-Sensitive Cell Thermostat.

Using a 50 ohm thermometer bridge, a four volt input with a resistance of 10 ohms, a 300 ohm Tinsley Galvanometer with a sensitivity of 10 mm/ μ a and taking an operating illumination of 20 mm. width the theoretical sensitivity for a nickel thermo-

meter is $\pm 0.085^\circ\text{C}$. In tests carried out under working conditions an actual sensitivity of $\pm 0.06^\circ\text{C}$. was recorded. This was sufficient for the purposes for which the thermostat was designed and this constancy of temperature in the actual oven can only be realised by the use of vigorous air circulation since the thermal lag of the heater system itself causes its temperature to vary as much as $\pm 0.15^\circ\text{C}$.

The theoretical sensitivity may be greatly increased by using a more sensitive galvanometer with an adequate light source, *e.g.*, a D'Arsonval galvanometer with a sensitivity of $2500 \text{ mm}/\mu\text{a}$ at one metre gives a theoretical sensitivity of the order of $\pm 0.0004^\circ\text{C}$. With sensitivities of this order it would be necessary to control the temperature of the Manganin bridge arms, *e.g.*, by enclosing them in the oven if space permitted.

Alternatively, the sensitivity might be increased by the use of an A.C. input and a "push-pull" valve rectifier across the output in the manner described by F. T. McNamara.³

³ Review Scient. Instr., June, 1931.

Practical Tests.

A set-up, as shown in Fig. 1, has been in continuous operation controlling the outer oven of the reference standard of frequency at the Dollis Hill Radio Laboratory for some time. The device operated satisfactorily without any attention for six months, after which difficulties arose owing to apparent shifting of the sensitive region of the selenium bridge. Two new short wave transmitters have been equipped with the device and further data on the effective life of the selenium bridge will become available. The superior sensitivity of the photo-emitting types of light cell may make their use preferable, in some applications of the thermostat device, to the selenium resistance type, but no experience has so far been gained by the Radio Section with cells other than the Radiovisor type. A further alternative cell is the cuprous oxide-copper type, described by Professor Hill⁴, which has the advantage that it may readily be adapted to a differential arrangement.

⁴ Journal Scient. Instr. 8 (1931) 262.

The Calculation of the Propagation Constants of Uniform Lines.

A. ROSEN, Ph.D., A.M.I.E.E.
(Siemens Bros. and Co., Ltd.).

INTRODUCTION.

THE secondary constants of a uniform transmission line, viz., the attenuation constant β , the wave-length constant α and the characteristic impedance Z_0 can be derived from the primary constants, viz., the resistance R , inductance L , leakage G and capacitance C by means of equations which have a simple form when expressed in terms of vectors or complex numbers, *e.g.*,

$$\beta + ja = \sqrt{(R + j\omega L)(G + j\omega C)}.$$

Calculations using these expressions become somewhat tedious as they necessitate reference to tables of angles; on the other hand, when the equations are converted into forms in which angles and complex numbers are avoided, *e.g.*,

$$\beta = \sqrt{\frac{1}{2} \{ \sqrt{(G^2 + \omega^2 C^2)(R^2 + \omega^2 L^2)} + (GR - \omega^2 LC) \}}$$

they are unsuitable for calculation. Simple expressions have been derived by assuming that the leakage is very small, which is always true in practice, and (a) that the inductance is small, when

$$\beta = \alpha = \sqrt{\frac{1}{2} \omega CR}$$

$$Z_0 = \sqrt{\frac{R}{\omega C}}$$

or (b) that the inductance is large, when

$$\beta = \frac{1}{2} \left(R + \frac{G}{C} L \right) \sqrt{\frac{C}{L}}$$

$$\alpha = \omega \sqrt{LC}$$

$$Z_0 = \sqrt{\frac{L}{C}}$$

and these are the ones which are generally used for computation. There are however a number of cases for which neither of these assumptions holds good, *e.g.*, a lightly loaded line at low and medium audio-frequencies, a loaded line at telegraph frequencies or a non-loaded line at carrier frequencies. In this article the simple expressions are extended to cover all values of inductance, and the equations are left in a form suitable for rapid calculation. The method of treatment is more direct than those given in textbooks, and as an example of its simplicity, the equations of the Heaviside Distortionless Line are derived.

GENERAL.

Let R be the resistance in ohms per unit length,
 L be the inductance in henries per unit length,
 G be the leakage in mhos per unit length,

C be the capacitance in farads per unit length,
 $\omega = 2 \pi \times$ frequency in cycles per second,
 $\gamma =$ propagation constant per unit length,
 $\beta =$ attenuation constant in nepers per unit length,
 $\alpha =$ wave-length constant in radians per unit length,

$Z_0 =$ characteristic impedance in vector ohms,

$$\theta = \tan^{-1} \frac{R}{\omega L},$$

$$\phi = \tan^{-1} \frac{G}{\omega C}.$$

It is well known that

$$\gamma = \beta + ja = \sqrt{R + j\omega L} (G + j\omega C) \dots\dots(1)$$

$$Z_0 = \sqrt{\frac{R + j\omega L}{G + j\omega C}} \dots\dots\dots(2)$$

THE LOADED LINE.

Writing $R + j\omega L = \frac{\omega L}{\cos \theta} \left| \pi/2 - \theta \right|$

and $G + j\omega C = \frac{\omega C}{\cos \phi} \left| \pi/2 - \phi \right|$

equation (1) may be put in the vector form

$$\gamma = \sqrt{\frac{\omega^2 LC}{\cos \theta \cos \phi}} \left| \frac{\pi - \theta - \phi}{2} \right| \dots\dots\dots(3)$$

(i) Wave-length constant.

$$\alpha = \sqrt{\frac{\omega^2 LC}{\cos \theta \cos \phi}} \cdot \cos \frac{\theta + \phi}{2} = \omega \sqrt{LC/K_1} \dots\dots\dots(4)$$

where $K_1 = \frac{\sqrt{\cos \theta \cos \phi}}{\cos \frac{\theta + \phi}{2}} \dots\dots\dots(5)$

(ii) Attenuation Constant.

$$\begin{aligned} \beta &= \sqrt{\frac{\omega^2 LC}{\cos \theta \cos \phi}} \cdot \sin \frac{\theta + \phi}{2} \\ &= \omega \sqrt{LC} \cdot \frac{\sin \frac{\theta + \phi}{2} \cos \frac{\theta + \phi}{2}}{\cos \theta \cos \phi} \cdot \frac{\sqrt{\cos \theta \cos \phi}}{\cos \frac{\theta + \phi}{2}} \\ &= \frac{\omega \sqrt{LC}}{2} \cdot \frac{\sin(\theta + \phi)}{\cos \theta \cos \phi} \cdot K_1 \\ &= \frac{\omega \sqrt{LC}}{2} (\tan \theta + \tan \phi) K_1 \end{aligned}$$

$$= \frac{K_1}{2} \left(R \sqrt{\frac{C}{L}} + G \sqrt{\frac{L}{C}} \right) \dots\dots\dots(6)$$

$$= \frac{K_1}{2} \left(R + \frac{G}{C} L \right) \sqrt{\frac{C}{L}} \dots\dots\dots(6a)$$

In a modern telephone cable, $\frac{G}{\omega C}$ is of the order of $\frac{1}{250}$ and therefore ϕ is a very small angle. Hence in equation (5) $\cos \phi$ can be put equal to 1 and $\phi/2$ can be neglected in comparison with $\theta/2$ without serious error.

Whence $K_1 = \frac{\sqrt{\cos \theta}}{\cos \frac{\theta}{2}} \dots\dots\dots(7)^1$

It will be seen that K_1 is dependent only on θ , i.e., on $R/\omega L$. In Table I. values of K_1 corresponding to $R/\omega L$ from 0 to 1 and $\omega L/R$ from 1 to 0.1 are given and the relationship is plotted in Fig. 1.

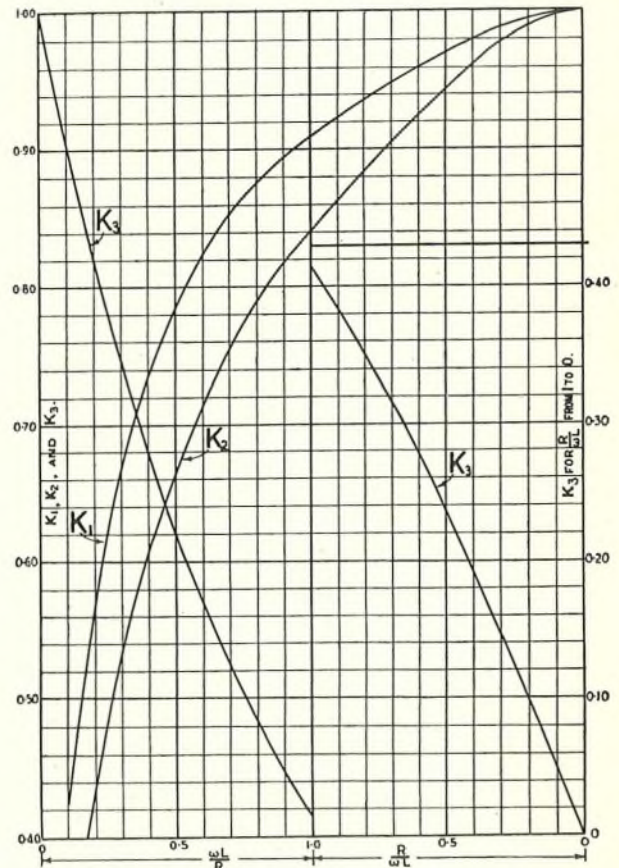

FIG. 1.—CORRECTION FACTORS FOR LOADED LINES.

¹ This equation is given in another form by H. F. Mayer: "Telegraphen und Fernsprechtechnik," Part 6, 1927.

(iii) Characteristic Impedance.

Equation (2) may be written

$$Z_0 = \sqrt{\frac{\omega L}{\cos \theta} \cdot \frac{\cos \phi}{\omega C} \left| \frac{\pi/2 - \theta - \pi/2 + \phi}{2} \right|}$$

$$= \sqrt{\frac{L}{C} \cdot \frac{\cos \phi}{\cos \theta} \left| \frac{\theta - \phi}{2} \right|} \dots \dots \dots (8)$$

When ϕ is very small

$$Z_0 = \frac{1}{K_2} \sqrt{\frac{L}{C} \left| \frac{\theta}{2} \right|} \dots \dots \dots (9)$$

where $K_2 = \sqrt{\cos \theta} \dots \dots \dots (9a)$

$$\text{Further } Z_0 = \frac{1}{\sqrt{\cos \theta}} \sqrt{\frac{L}{C}} \left(\cos \frac{\theta}{2} - j \sin \frac{\theta}{2} \right)$$

$$= \frac{\cos \frac{\theta}{2}}{\sqrt{\cos \theta}} \sqrt{\frac{L}{C}} \left(1 - j \tan \frac{\theta}{2} \right)$$

$$\text{Whence } Z_0 = \frac{1}{K_1} \sqrt{\frac{L}{C}} (1 - j K_3) \dots \dots \dots (10)$$

$$\text{where } K_3 = \tan \frac{\theta}{2} \dots \dots \dots (11)$$

The values of K_2 and K_3 are shown in Table I. and they are likewise plotted in Fig. 1.

The formulæ given apply to lines with either uniformly distributed inductance or with coil loading. For coil-loaded lines, there is in addition a correction due to the "lumpiness" of the loading, but at the frequencies at which K_1 , K_2 and K_3 have to be considered, the "lumping" correction is in general negligible.²

Whence $R/\omega L = \frac{50}{100} = 0.5$, and $K_1 = 0.972$, $K_2 = 0.946$, $K_3 = 0.236$. Applying equation (6a),

$$\frac{1}{2} \left(R + \frac{G}{C} L \right) \sqrt{\frac{C}{L}} = 0.0504$$

i.e., $\beta = 0.0504 \times 0.972 = 0.0490$ neper per mile.

$$\omega \sqrt{LC} = 0.200$$

i.e., $\alpha = 0.206$ radian per mile.

$$\sqrt{\frac{L}{C}} = 500, \text{ i.e., modulus of } Z_0 = 529 \text{ vector ohms}$$

$$Z_0 = 514 - j121 \text{ ohms.}$$

THE DISTORTIONLESS LINE.

When $\theta = \phi$, i.e., when $\frac{R}{L} = \frac{G}{C}$, we have from equation (5), $K_1 = 1$

$$\text{whence } \beta = \frac{R}{2} \sqrt{\frac{C}{L}} + \frac{G}{2} \sqrt{\frac{L}{C}}$$

which is independent of frequency and is the well-known equation for the Heaviside Distortionless Line.

Further, from equation (4), $\alpha = \omega \sqrt{LC}$

$$\text{and from equation (8), } Z_0 = \sqrt{\frac{L}{C}} |0$$

TABLE I.

$\frac{R}{\omega L}$	K_1	K_2	K_3	$\frac{\omega L}{R}$	K_1	K_2	K_3
0	1	1	0	1.0	0.910	0.841	0.414
0.1	0.999	0.998	0.050	0.9	0.895	0.818	0.445
0.2	0.995	0.990	0.099	0.8	0.877	0.790	0.481
0.3	0.989	0.979	0.147	0.7	0.854	0.757	0.521
0.4	0.981	0.964	0.193	0.6	0.824	0.717	0.566
0.5	0.972	0.946	0.236	0.5	0.786	0.669	0.618
0.6	0.961	0.926	0.277	0.4	0.736	0.609	0.677
0.7	0.949	0.905	0.315	0.3	0.668	0.536	0.744
0.8	0.936	0.884	0.351	0.2	0.573	0.443	0.819
0.9	0.923	0.862	0.384	0.1	0.426	0.316	0.905
1.0	0.910	0.841	0.414				

Example : In a continuously loaded line at $\omega = 5000$ radians per second, $R = 50$ ohms per mile, $L = 20$ millihenries per mile, $C = 0.08$ microfarad per mile and $\frac{G}{C} = 20$.

THE NON-LOADED LINE.

When the inductance or the frequency is small so that $\omega L/R$ is small, the corrections to the loaded line formulæ become large; it is preferable then to regard the line as non-loaded and to put the equations in another form.

² F. Breisig: "Theoretische Telegraphie," Brunswick, 1924. p. 424.

Writing $R + j\omega L = \frac{R}{\sin \theta} \left| \frac{\pi/2 - \theta}{2} \right|$

and $G + j\omega C = \frac{\omega C}{\cos \phi} \left| \frac{\pi/2 - \phi}{2} \right|$

equation (1) becomes

$$\gamma = \sqrt{\frac{R}{\sin \theta} \frac{\omega C}{\cos \phi} \left| \frac{\pi - \theta - \phi}{2} \right|} \dots\dots\dots(12)$$

and equation (2) becomes

$$Z_0 = \sqrt{\frac{R \cos \phi}{\sin \theta \omega C} \left| \frac{\phi - \theta}{2} \right|} \dots\dots\dots(13)$$

(i) Wave-length constant.

From equation (12)

$$\begin{aligned} \alpha &= \sqrt{\frac{\omega RC}{\sin \theta \cos \phi}} \cdot \cos \frac{\theta + \phi}{2} \\ &= \frac{1}{k_1} \sqrt{\frac{\omega RC}{2}} \dots\dots\dots(14) \end{aligned}$$

where $k_1 = \frac{\sqrt{\frac{1}{2} \sin \theta \cos \phi}}{\cos \frac{\theta + \phi}{2}}$

As above, since $\frac{G}{\omega C}$ is always a small quantity, $\cos \phi$ can be put equal to 1 and $\cos \frac{\theta + \phi}{2}$ equal to $\cos \frac{\theta}{2}$.

$$\begin{aligned} \therefore k_1 &= \sqrt{\frac{\frac{1}{2} \sin \theta}{\cos^2 \frac{\theta}{2}}} \\ &= \sqrt{\frac{\sin \frac{\theta}{2} \cdot \cos \frac{\theta}{2}}{\cos^2 \frac{\theta}{2}}} \\ &= \sqrt{\tan \frac{\theta}{2}} \dots\dots\dots(15) \end{aligned}$$

(ii) Attenuation Constant.

From equation (12)

$$\beta = \alpha \tan \frac{\theta + \phi}{2}$$

When ϕ is small $\alpha\theta$ is large, $\tan \frac{\theta + \phi}{2} = \tan \frac{\theta}{2}$

$$\therefore \beta = \alpha X k_1^2 = k_1 \sqrt{\frac{\omega CR}{2}} \dots\dots\dots(16)$$

(iii) Characteristic Impedance.

When ϕ is small compared with θ , equation (13) becomes

$$\begin{aligned} Z_0 &= \sqrt{\frac{R}{\omega C \sin \theta} \left| \frac{\theta}{2} \right|} \\ &= k_2 \sqrt{\frac{R}{\omega C} \left| \frac{\theta}{2} \right|} \dots\dots\dots(17) \end{aligned}$$

where $k_2 = \sqrt{\operatorname{cosec} \theta} \dots\dots\dots(17a)$

$$\begin{aligned} \text{Further } Z_0 &= \sqrt{\frac{R}{2\omega C \sin \frac{\theta}{2} \cos \frac{\theta}{2}} \left(\cos \frac{\theta}{2} - j \sin \frac{\theta}{2} \right)} \\ &= \sqrt{\frac{R}{2\omega C} \left(\frac{1}{\sqrt{\tan \frac{\theta}{2}}} - j \sqrt{\tan \frac{\theta}{2}} \right)} \\ &= \sqrt{\frac{R}{2\omega C} \left(\frac{1}{k_1} - j k_1 \right)} \dots\dots\dots(18) \end{aligned}$$

Values of k_1 and k_2 corresponding to $\frac{\omega L}{R}$ from 0 to 1 are shown in Table 2, and the relationships are plotted in Fig. 2.

TABLE 2.

$\frac{\omega L}{R}$	k_1	k_2
0	1	1
0.1	0.951	1.002
0.2	0.905	1.010
0.3	0.863	1.022
0.4	0.823	1.038
0.5	0.786	1.057
0.6	0.752	1.080
0.7	0.722	1.105
0.8	0.693	1.132
0.9	0.667	1.160
1.0	0.644	1.189

Example: The constants of the "Standard Cable" per mile loop at $\omega = 5000$ radians per second are:— $R = 88$ ohms, $L = 0.001$ henry, $G = 1$ micro-mho, $C = 0.054$ microfarad.

Whence

$$\omega L/R = 5/88 = 0.0568, k_1 = 0.972, k_2 = 1.001.$$

$$\sqrt{\frac{\omega RC}{2}} = 0.1090, \beta = 0.1060 \text{ neper per mile.}$$

$$\alpha = 0.1121 \text{ radian per mile.}$$

$$\sqrt{\frac{R}{\omega C}} = 570.9, \text{ i.e., modulus of } Z_0 = 571.5 \text{ vector ohms.}$$

$$\sqrt{\frac{R}{2\omega C}} = 403.8, \text{ i.e., } Z_0 = 415.4 - j392.4 \text{ ohms.}$$

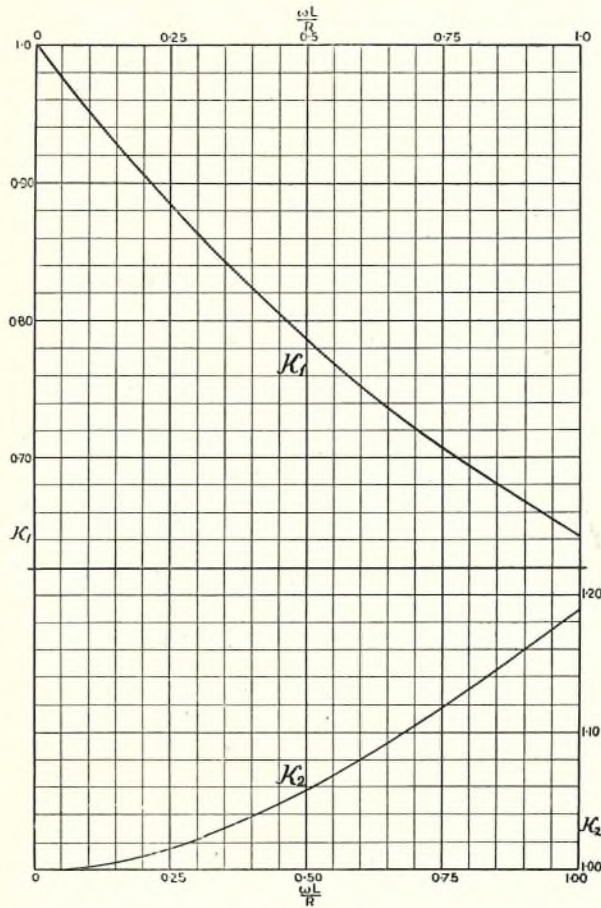

FIG. 2.—CORRECTION FACTORS FOR NON-LOADED LINES.

The exact values of β and α are 0.10616 and 0.11193 respectively, whilst $Z_0 = 416.3 - j391.7$ ohms. It will be seen that the error introduced by neglecting the leakance in the short formulæ given above is of the order of 2 parts in 1000; on the other hand the error caused by neglecting the inductance in the uncorrected short formulæ is about 3%.

SUMMARY OF EQUATIONS.

Loaded Lines.

Attenuation Constant

$$\beta = \frac{K_1}{2} \left(R + \frac{G}{C} L \right) \sqrt{\frac{C}{L}}$$

Wave-length constant

$$\alpha = \omega \sqrt{CL} / K_1$$

Characteristic Impedance

$$\begin{aligned} Z_0 &= \frac{1}{K_2} \sqrt{\frac{L}{C}} \left| \frac{\theta}{2} \right| \\ &= \frac{1}{K_1} \sqrt{\frac{L}{C}} (1 - j K_3) \end{aligned}$$

where $K_1 = \frac{\sqrt{\cos \theta}}{\cos \frac{\theta}{2}}$

$$K_2 = \sqrt{\cos \theta}$$

$$K_3 = \tan \frac{\theta}{2}$$

$$\theta = \tan^{-1} \frac{R}{\omega L}$$

Non-loaded Lines.

Attenuation Constant

$$\beta = k_1 \sqrt{\frac{\omega RC}{2}}$$

Wave-length constant

$$\alpha = \frac{1}{k_1} \sqrt{\frac{\omega RC}{2}}$$

Characteristic Impedance

$$\begin{aligned} Z_0 &= k_2 \sqrt{\frac{R}{\omega C}} \left| \frac{\theta}{2} \right| \\ &= \sqrt{\frac{R}{2\omega C}} \left(\frac{1}{k_1} - j k_1 \right) \end{aligned}$$

where $k_1 = \sqrt{\tan \frac{\theta}{2}}$

$$k_2 = \sqrt{\operatorname{cosec} \theta}$$

$$\theta = \tan^{-1} \frac{R}{\omega L}$$

Outline Notes on Telephone Transmission Theory.

W. T. PALMER, B.Sc., Wh.Ex., A.M.I.E.E.

[The complete series of notes will be published, with some additions, in book form soon after the July issue.]

SECTION 13.

Telephone Repeaters—Cross-Talk and "Echo" Effects.

The earliest form of telephone repeaters followed, naturally, the lines of the telegraph repeaters and were more or less mechanical in design. Such repeaters suffer from inherent disadvantages such as mechanical resonance (resulting in speech distortion) and also instability of action. With the advent of the three-electrode thermionic valve (or vacuum "tube," in American terminology) came very soon its application to communication engineering, since the valve can be made to reproduce exactly any alternating currents which enter the grid circuit and also amplify them. (See end of Section for references concerning the action of the thermionic valve). When used in this way, to amplify received speech and transmit to a further distance, the valve is said to be a telephone "repeater," and the simplest amplifying circuit associated with a line for *one-way operation* is shown in Fig. 47.

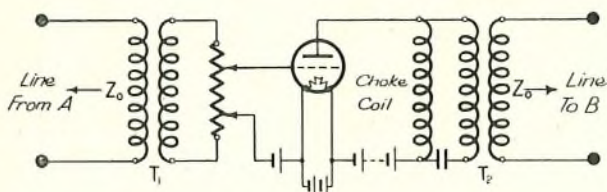

FIG. 47.—ONE VALVE AMPLIFICATION—ONE WAY—ONE ELEMENT "REPEATER."

For commercial use, however, in connection with telephone lines, an amplifying circuit must be capable of *operation in both directions* intermittently, since either end of a given line requires to be sending or receiving depending on the conversation in progress. The circuits used in repeater stations for such amplification of speech can be divided into three main types:—

(a) The two-way one-element circuit—commonly called the "2-1" type.

(b) The two-way two-element circuit—called the "2-2" type.

(c) The four-wire circuit, using type "2-2" circuit for terminal stations and a number of one-way amplifying circuits in tandem as required in the two transmission paths.

A brief description of each type is given in the following, but the student is strongly advised to consult the references, given at the end of the Section, for further details.

(a) The Two-Way One-Element Repeater Circuit—"2-1" Type.

Can be only used for a uniform line of such a length that a single repeater station can be placed just midway between the terminal stations since successful operation of the circuit depends on the equality of impedances on either side of the repeating element.

The input circuit (See Fig. 48) is connected in parallel with the line at CD through the potentiometer (adjusting the input voltage to the grid) and step-up transformer T_2 . The output is in series with the line through the step-down hybrid transformer T_1 (or "repeating coil").

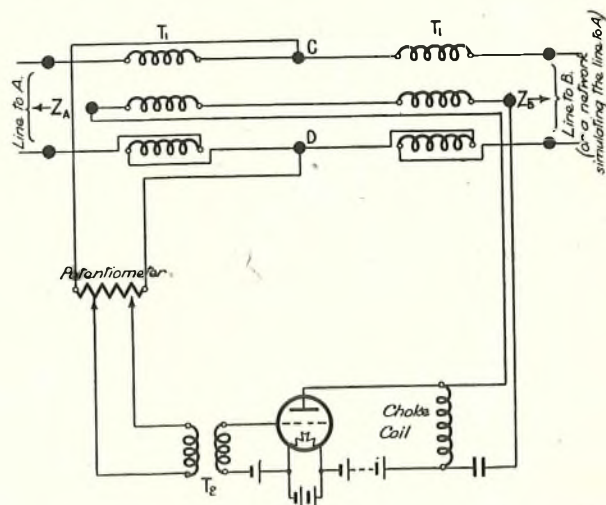

FIG. 48.—PRINCIPLE OF TWO-WAY ONE-ELEMENT "REPEATER" (2-1 TYPE).

Let Z_A , Z_B be the impedances as measured at CD, I_L be the current in the primary of the transformer T_1 , then the p.d. of the line to B is $I_L \cdot Z_B$ and the p.d. across the line towards A is $I_L \cdot Z_A$. Since to prevent circulating current due to the amplified current the p.d. at CD must be zero it follows that $I_L Z_A$ must equal $I_L Z_B$, i.e., $Z_A = Z_B$.

If Z_A is not equal to Z_B then a p.d. exists at CD due to the amplified current and the valve may act as an oscillator, depending on the phase relations existing, since this p.d. is fed back to the grid and becomes again amplified. When such oscillation or "howling" is produced the repeater is said to be "singing."

Only one-half the amplified energy is useful, viz., that towards the receiving end, the other half being dissipated in the line towards the sending end.

repeater station midway between the terminal stations thus "balancing" the two halves of the line against each other. With the "2-2" circuit, however, it will be observed that each line is "balanced" by an artificial line or network Z_N . This balancing network should thus be designed to have an impedance equal to the corresponding line impedance for all frequencies within the range it is desired to transmit, but owing to the extreme difficulty of so designing a network it is usual to construct one which gives a smooth mean curve through the line impedance-frequency curve. For this reason specifications for loaded lines, which are required to work with "two-wire" repeaters, include a clause which limits the deviation of the line-impedance to $\pm 5\%$ of a mean impedance-frequency curve drawn through the actual curve—this smooth mean curve representing the curve which will

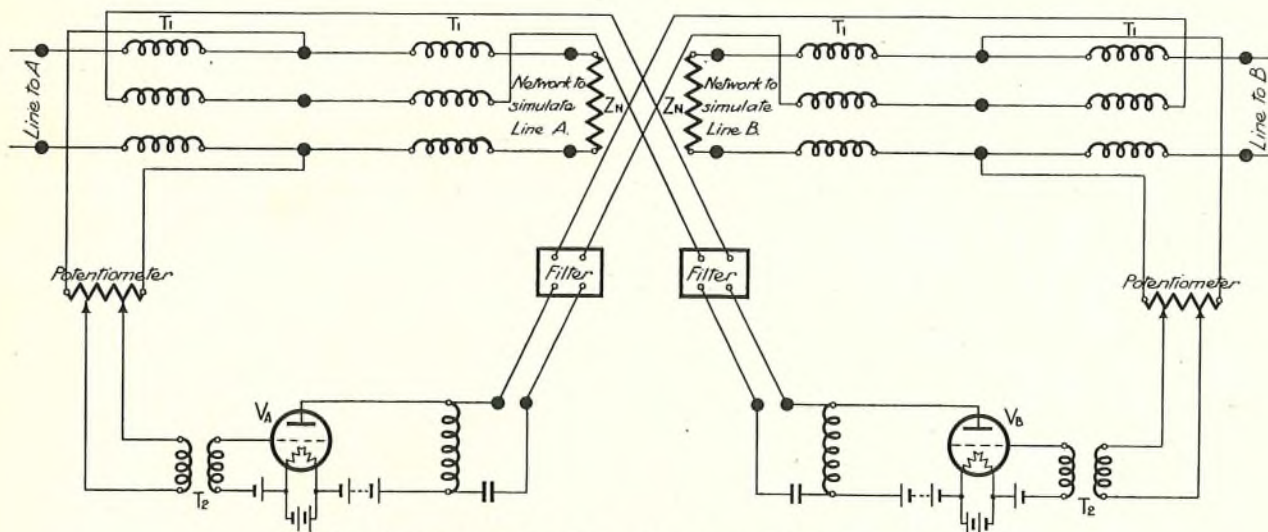

FIG. 49.—PRINCIPLE OF TWO-WAY TWO-ELEMENT "REPEATER" (2-2 TYPE).

(b) **The Two-Way Two-Element Repeater Circuit — "2-2" Type or Two-Wire Repeater-Balancing Networks.**

Consists of two of the foregoing type circuits each amplifying in one direction and universally used in connection with lines requiring more than one repeater station, except for very long circuits, some hundreds of miles in length, when "four-wire" working is adopted—see pp. (c). (See Fig. 49).

With the "2-1" circuit, oscillatory action of the amplifier is prevented by locating the

eventually be used as a basis to construct the relevant simple balancing networks having similar characteristics to the line. (See references for the design of balancing networks, etc.).

The useful amplified volt-amperes energy for each harmonic of a speech wave is again one-half of the total amplified energy for that harmonic, the other half being dissipated in the network.

(c) **"Four-Wire" Repeater Circuit.**

Used for very long circuits, when a large number of repeater stations are involved, in

preference to "two-wire" working since the latter requires two line balances and filter circuits, etc., at each station. The "four-wire" circuit, as the name implies, requires two two-wire transmission paths (See Fig. 50). In each two-wire path there are a number of simple one-way amplifiers (See Fig. 47) in tandem and only at the terminal stations are "2-2" type circuits installed, with balancing networks, etc.

Further, unbalance of the network and line towards A can cause the same speech to travel back again along V_1, V_2, \dots etc., and be received at B, the listening end, also as an echo.

Elimination of such echo effects can be obtained by use of an **Echo Suppressor**, the principle of one type being shown in Fig. 51. In this circuit the grid of the A_1 amplifier is made so negative by speech transmitted along the loop of the V_1

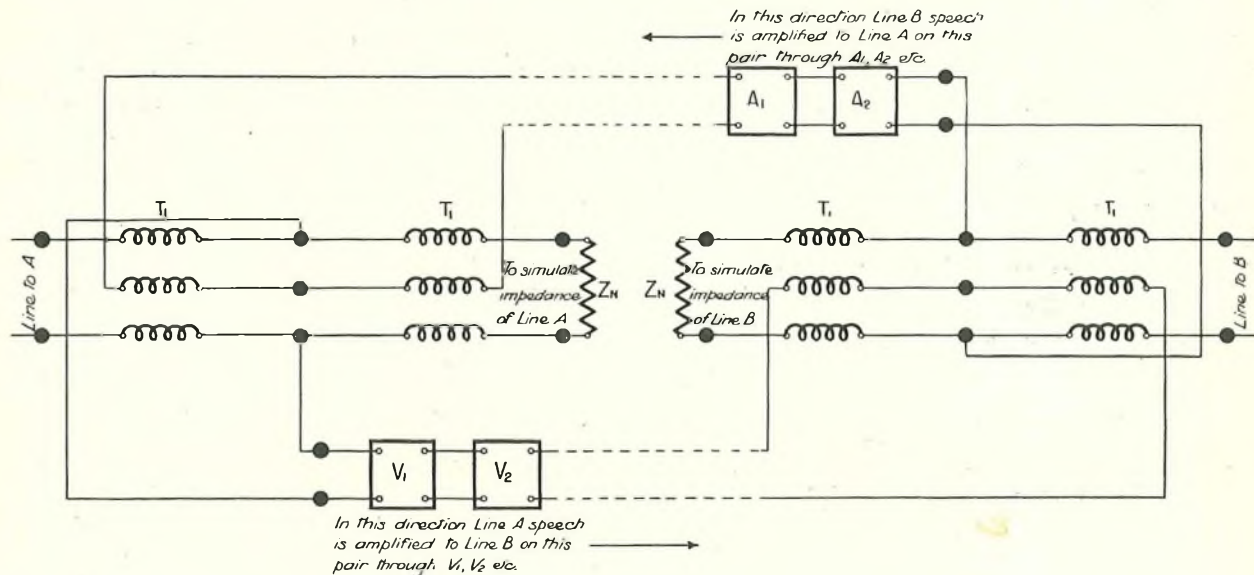

FIG. 50.—"FOUR WIRE" REPEATER CIRCUIT.

Long Distance Cable Circuits—"Echo" Effects, Cross-Talk, etc.

In "echo" effects are included all disturbing effects which are produced by speech currents arriving at the speaking or listening end with a time lag due to traverse of the speech along other paths. The chief cause of echo lies in the deviation of the line impedance from that of its simulating network and can be reduced either by use of a more complicated network which simulates the line more closely or by use of "echo-suppressors," (See paragraph below). Considering Fig. 50, for example, speech coming from A arrives at B through the amplifiers V_1, V_2, \dots etc., but owing to unbalance between the network and the line towards B, some volume of the same speech is transmitted back along the amplifiers A_1, A_2, \dots etc., and is heard at A with a time lag (which is greater the longer the line) and in the semblance of an "echo."

amplifiers that no current can flow in the plate circuit: hence any reflection towards the A-line is blocked. The speech from V_1 is amplified, then rectified and smoothed and slowly built-up as a negative potential on the grid of the A_1 amplifier. A similar suppressor acting on one of the V_1 amplifiers by speech in the opposite direction is installed in another station along the line.

Another type of echo suppressor employs a slow-acting relay which short-circuits the line along which reflection is undesired. (See references).

In addition to the main speech currents, the repeaters in circuit will amplify the cross-talk and the greater the distance between repeater stations, with a given intensity of cable cross-talk, the greater will be the disturbing effect of the cross-talk owing to the greater amplification employed. To keep the cross-talk experienced at

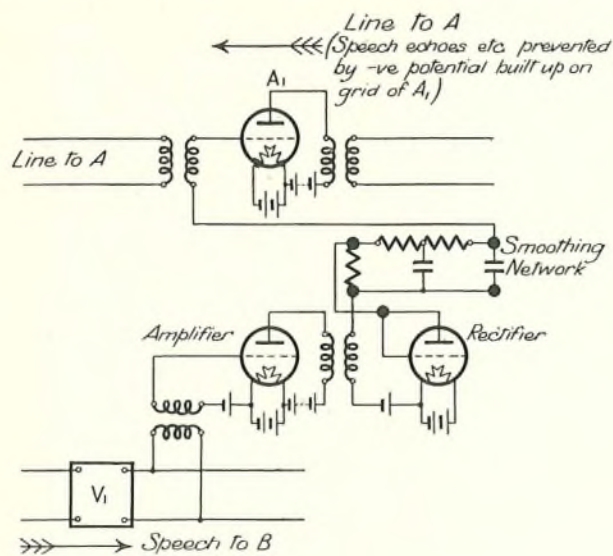

FIG. 51.—PRINCIPLE OF ECHO SUPPRESSOR.

the trunk terminals within a definite limit (about 55 or 60 decibels) it is necessary to keep the amplification down and the line attenuation between repeater stations below a correspondingly low value (not greater than about 30 decibels) in order to avoid too great an amplification of the repeaters, and thus for long repeated circuits cross-talk considerations set the limit to the distance between repeater stations.

For four-wire working it is usual to ensure the minimum amount of cross-talk from "Go" circuits to "Return" circuits by grouping the "Go" circuits together and separating them, by some such means as a metallic screen, from a corresponding group of "Return" circuits. Another important cross-talk consideration is obviously then the *distant-end* cross-talk (See Section 10, pp. 3) between two "Go" or two "Return" circuits and steps must be taken during cable installation and balancing operations to reduce this as much as possible in addition to the normal procedure adopted for reducing the "near-end" cross-talk by capacity balancing operations. (See Section 15).

References for Section 13.

Repeaters.

"The Thermionic Vacuum Tube," by H. T. Van Der Bijl.
 "Telephone Repeaters," by B. Gherardi and F. B. Jewett, A.I.E.E. 1919.

"Phase Relations in Unbalanced Two-way Telephone Repeaters," by A. R. A. Randall and C. S. White, Electrical Communications, July, 1929, p. 34.
 "A Telephone Repeater with Remote Control," by A. C. Timmis and H. G. Davis. P.O.E.E. Journal, January, 1927, p. 351.
 "Limitation of the gain of Two-way Telephone Repeaters by Impedance Irregularities," by G. Crisson. Bell System Technical Journal, July, 1925, pp. 15-25, also Bell Monograph E.22.
 "Negative Impedances and the Twin 21-type Repeater," by G. Crisson. Bell System Technical Journal, July, 1931, pp. 485-513, also Bell Monograph E.512.
 "Recent Research Work on Telephone Repeaters," by C. Robinson and R. M. Chamney. I.P.O.E.E. Paper No. 99.
 "Telephonic Repeaters," by A. B. Hart. I.P.O.E.E. Paper No. 75.
 "Telephonic Repeaters and their Maintenance," by C. Robinson. I.P.O.E.E. Paper No. 112.

Echo Suppressors.

"Echo Suppressors for Long Distance Circuits," by A. B. Clark and R. C. Mathes. A.I.E.E. Journal, June, 1925, pp. 618-626, also Bell Monograph E.65.
 "Trans-Atlantic Telephony," by C. A. Beer and G. T. Evans. P.O.E.E. Journal, April, 1927, pp. 65-72.
 "Recent Advances in the Communication Art." A.I.E.E. Journal, December, 1925, p. 1302.

SECTION 14.

Line Measurements, etc.

In addition to the necessity for the ability to calculate the electrical characteristics of the parts of a complete telephone system, after the design of the system comes the necessity for the ability to measure its characteristics. Amongst the most frequent of measurements is that of *impedance*—of lines, transformers, receivers, transmitters, relays, etc.—and this measurement is usually carried out by means of an A.C. bridge in conjunction with a valve oscillator as the source of supply. The A.C. measurement of inductance and effective resistance, of capacitance and leakage, etc., is dealt with fully by Hague in an

excellent text-book on " A.C. Bridge Methods " (published by Pitman's), to which the student is referred for further details.

An A.C. Bridge for Impedance Measurement of a Telephone Cable Circuit is shown in Fig. 52. This bridge is suitable for long lengths of line (from about five miles) and for positive or negative angles of impedance. The solution for the unknown impedance, $Z_{e^{j\phi}}$, is the same in either the full or dotted position of the capacity C, viz.,

$$Z = \frac{R}{\sqrt{1 + \omega^2 C^2 R^2}} \dots\dots\dots(1)$$

and $\tan \phi = \omega CR \dots\dots\dots(2)$

where $\omega = 2\pi \times$ frequency of supply, R is the balancing resistance required, and C is the balancing capacity required, being adjusted simultaneously with R until silence is obtained in the telephone. Proofs of the solution are given below. The following points are important (many of which apply to all A.C. bridges for audio frequency measurements):—

- (a) The resistances, P, Q, R, should be non-reactive (negligible residual inductance and capacity) and the condenser, C, must have negligible power-factor (practically zero leakage).
- (b) The transformer T should have a secondary winding balanced on each side and screened to earth to minimize unbalances (and thus errors) in the bridge due to the testing equipment itself.
- (c) The current measuring device should be inserted in the *middle* of the secondary winding, at I, so avoiding dissymmetry. If $P = Q$ then the current in the unknown impedance is *one-half* the reading at I.
- (d) The frequency measuring device and the current regulating resistance should be included in the *primary* circuit of supply.

Solution of Bridge for +ve Angles.

(Dotted position of C).

Let $Z_{e^{j\phi}} = A + jB$. Then the condition for balance is:—

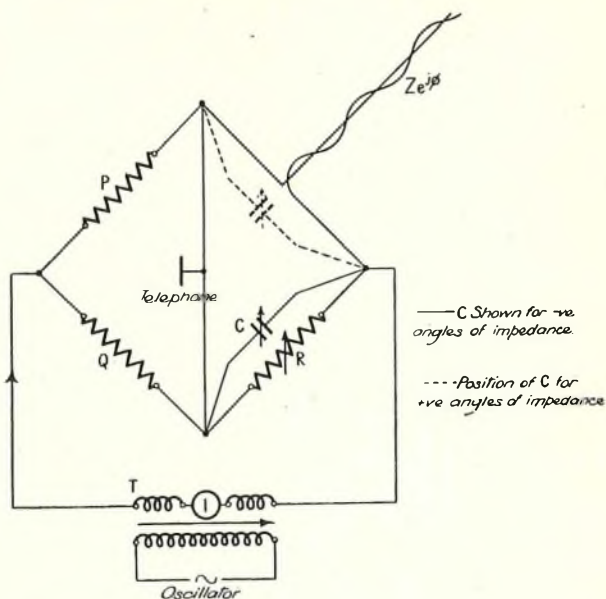

FIG. 52.—A.C. BRIDGE FOR LINE IMPEDANCE MEASUREMENT.

$$P \times R = Q \times \left\{ \frac{I}{\frac{I}{A + jB} + j\omega C} \right\}$$

If $P = Q$

$$\therefore A + jB = R - \omega BCR + j\omega ACR$$

Equating real parts:

$$\therefore R = \frac{A}{1 - \omega BC} \dots\dots\dots(1)$$

Equating imaginary parts:

$$A = \frac{B}{\omega CR} \dots\dots\dots(2)$$

Hence from (1) and (2)

$$A = \frac{R}{1 + \omega^2 C^2 R^2} \text{ and } B = \frac{\omega CR^2}{1 + \omega^2 C^2 R^2}$$

Since $Z = \sqrt{A^2 + B^2}$ and $\tan \phi = B/A$.

$$\therefore Z = \frac{R}{\sqrt{1 + \omega^2 C^2 R^2}}$$

and $\tan \phi = \omega CR$

Solution of Bridge for -ve Angles.

(Full position of C).

With $P = Q$, the condition for balance is:—

$$Z \cdot e^{j\theta} = \frac{1}{\frac{1}{R} + j\omega C} = \frac{R}{1 + j\omega CR}$$

$$\therefore Z = \frac{R}{\sqrt{1 + \omega^2 C^2 R^2}}$$

and by multiplying numerator and denominator by $1 - j\omega CR$

$$\therefore \tan \phi = -\omega CR$$

which is the same magnitude as the solution above.

Determination of R, L, G, C, $Z_0 e^{j\theta}$, β and α from Test Data.

All these constants can be derived from two impedance measurements on the line. The A.C. bridge already described is employed and the procedure is as follows:—

- (1) Measure the closed impedance of the line (distant end short-circuited). This is calculated from the bridge readings according to the solution given in the foregoing. Let the closed impedance be $Z_c \cdot e^{j\theta_c}$.
- (2) Measure the impedance with the distant end of the line open-circuited. Let the open or "free" impedance be $Z_f \cdot e^{j\theta_f}$.
- (3) The characteristic impedance is then obtained from the relation:—

$$Z_0 = \sqrt{Z_c Z_f} e^{j\frac{1}{2}(\theta_c + \theta_f)}$$

(See Section 5, equation 17).

- (4) The propagation constant, γ , is given by the relation:—

$$\tanh \gamma l = \sqrt{\frac{Z_c}{Z_f}} \cdot e^{j\frac{1}{2}(\theta_c - \theta_f)}$$

(See Section 5, equation 18).

To separate γl into its real and imaginary components, in order to obtain the attenuation and phase constants, write:—

$$\tanh (\beta + ja)l = \sqrt{M} e^{j\mu}$$

where $\sqrt{M} = \sqrt{\frac{Z_c}{Z_f}}$ and $\mu = \frac{1}{2}(\theta_c - \theta_f)$

$$\therefore \tanh (\beta + ja)l = \sqrt{M} \cos \mu + j\sqrt{M} \sin \mu$$

Write now $\sqrt{M} \cos \mu = x$

$$j\sqrt{M} \sin \mu = jy$$

$$\therefore \tanh (\beta + ja)l = x + jy \dots\dots\dots(1)$$

$$\text{and } \tanh (\beta - ja)l = x - jy \dots\dots\dots(2)$$

Since $\tanh 2\beta l = \tanh (\beta l + ja + \beta l - ja)$

$$= \frac{x + jy + x - jy}{1 + (x + jy)(x - jy)}$$

$$\therefore \tanh 2\beta l = \frac{2x}{1 + x^2 + y^2} = \frac{2\sqrt{M}}{1 + M} \cdot \cos \mu$$

$$\therefore 2\beta l = \tanh^{-1} \frac{2\sqrt{M}}{1 + M} \cdot \cos \mu$$

Similarly $2\alpha l = \tan^{-1} \frac{2\sqrt{M}}{1 - M} \cdot \sin \mu$

Hence both β and α can be obtained when \sqrt{M} (i.e., $\sqrt{\frac{Z_c}{Z_f}}$) has been calculated from measurements taken in pps. (1) and (2) above.

$$\text{Then } \gamma \cdot e^{j\theta} = \sqrt{\beta^2 + \alpha^2} e^{j \cdot \tan^{-1} \alpha/\beta}$$

- (5) To calculate the primary constants R, L, G and C.

Since $\gamma e^{j\theta} \times Z_0 \cdot e^{j\theta}$

$$= \sqrt{R + j\omega L} (G + j\omega C) \times \sqrt{\frac{R + j\omega L}{G + j\omega C}}$$

[See Section 2, equations (6) and (8)]

$$\text{Then } R + j\omega L = \gamma \cdot Z_0 \cdot e^{j(\theta + \phi_0)}$$

$$= \gamma \cdot Z_0 \cdot \cos (\theta + \phi_0) + j\gamma \cdot Z_0 \sin (\theta + \phi_0)$$

$$\therefore R = \gamma \cdot Z_0 \cos (\theta + \phi_0) \dots\dots\dots(1)$$

$$\text{and } \omega L = \gamma \cdot Z_0 \sin (\theta + \phi_0) \dots\dots\dots(2)$$

Similarly

$$\frac{\gamma_0 \cdot e^{j\theta}}{Z_0 \cdot e^{j\theta_0}} = G + j\omega C = \frac{\gamma}{Z_0} \cdot e^{j(\theta - \phi_0)}$$

$$\therefore G = \frac{\gamma}{Z_0} \cdot \cos (\theta - \phi_0) \dots\dots\dots(3)$$

$$\text{and } \omega C = \frac{\gamma}{Z_0} \cdot \sin (\theta - \phi_0) \dots\dots\dots(4)$$

Example.—(Using the bridge shown in Fig. 52). The bridge readings for an open test of a submarine cable circuit 50.6 nautical miles in length, between Canterbury and Boulogne, were

$R_f = 397.0$ ohms and $C_f = -0.0126 \mu\text{F}$. The corresponding closed circuit bridge readings were $R_c = 411.6$ ohms and $C_c = -0.140 \mu\text{F}$. Calculate the mean inductance and capacity per naut. loop of this circuit and the attenuation constant per naut. loop, if the frequency of the testing current corresponds to an angular velocity ($2\pi f$) of 5000 radians per second. It is known that the D.C. loop resistance of the circuit is 19.7 ohms per naut. loop.

Following the procedure given in the foregoing paragraphs:—

$$(1) \text{ The closed impedance } Z_c = \frac{R_c}{\sqrt{1 + \omega^2 C^2 R^2}}$$

$$\text{Tan } \phi_c = \omega C R_c$$

where $\omega = 5000$, gives:—

$$Z_c e^{j\phi_c} = 395.5 e^{-j16^\circ 44'} \text{ or } 395.5 \angle 16^\circ 44'$$

(2) The open impedance is similarly given:—

$$Z_f \cdot e^{j\phi_f} = 396.9 e^{-j1^\circ 26'} \text{ or } 396.9 \angle 1^\circ 26'$$

(3) The characteristic impedance $Z_0 e^{j\phi_0}$ is:—

$$\sqrt{Z_c Z_f} e^{j\frac{1}{2}(\phi_c + \phi_f)}$$

$$\text{i.e., } Z_0 = 396 e^{j80^\circ 45'}$$

$$(4) \sqrt{M} = \sqrt{\frac{Z_c}{Z_f}} e^{j\frac{1}{2}(\phi_c - \phi_f)}$$

$$\sqrt{M} = 0.99823 \angle 7^\circ 19'$$

$$\therefore 2\beta l = \tanh^{-1} \frac{2 \times 0.99823}{1.99655} \cos 7^\circ 19'$$

i.e., $2\beta l = 2.750$ (from tables or curves of hyperbolic tangents) and since $2l = 101.2$ nauts,

$$\therefore \text{Attenuation Constant} \left. \vphantom{\begin{matrix} \text{Attenuation} \\ \text{Constant} \end{matrix}} \right\} \beta = 0.0272 \text{ (nepers) per naut loop}$$

$$2\alpha l = \tan^{-1} \frac{2 \times 0.99823}{0.00345} \sin 7^\circ 19'$$

$$\therefore 2\alpha l = 4.726 \text{ radians} + 4\pi^*$$

$$\text{Constant } \left. \vphantom{\begin{matrix} \text{Constant} \\ \text{i.e., Phase} \end{matrix}} \right\} \alpha = 0.1707 \text{ radians per naut loop}$$

$$\therefore \gamma e^{j\theta} = \beta + j\alpha = 0.0272 + j0.1707$$

$$\text{i.e., } \gamma = 0.1728 e^{j80^\circ 57'}$$

(5) To calculate the resistance:

$$R = \gamma \cdot Z_0 \cos(\theta + \phi_0)$$

$$= .1728 \times 396 \cos(80^\circ 57' - 8^\circ 45')$$

$$\therefore \text{Resistance} = 20.9 \text{ ohms per naut loop}$$

To calculate the inductance:—

$$\omega L = .1728 \times 396 \times \sin(80^\circ 56' - 8^\circ 45')$$

$$L = 65.2 \div 5000 \text{ henries per naut loop}$$

$$\therefore \text{Inductance} = 13.0 \text{ millihenries per naut loop}$$

To calculate the capacity:—

$$\omega C = \frac{\gamma}{Z_0} \sin(\theta - \phi_0)$$

$$= \frac{.1728}{396} \sin(80^\circ 57' + 8^\circ 45')$$

$$C = (436.5 \times 10^{-6} \div 5000) \text{ farads per naut loop}$$

$$\therefore \text{Capacity} = 0.0874 \mu\text{F per naut loop}$$

* The number of π 's to be added to the numerical value given by the formula can be readily obtained by trial calculation for R which must be of the order of the D.C. resistance if the correct number of π 's be added.

SECTIONS 15, ETC.—CABLE "BALANCING," ETC.

[Notes to be concluded in next Issue, and the complete Series in Book form will be published before the Autumn.]

Notes and Comments.

REFERENCE is made elsewhere in this issue to the establishment of a Junior Section of the I.P.O.E.E. A number of centres have already been created and it is apparent that the junior grades will take full advantage of this development towards fostering interest in technical knowledge. In this connexion, during the past year we have issued a free supplement giving typical answers to the City and Guilds examination papers, on Magnetism and Electricity, Telegraphy, Telephony, and Radio Communication and the present issue completes the series for 1931. The supplement has been issued primarily as an aid to the junior grades for the examinations. Its object, however, is to interest such readers in the study of the various subjects in order that the standard of efficiency in every respect may be improved. The subject of communication engineering is daily becoming more and more highly technical and a proper groundwork in the elementary stages is essential to future advancement in the profession. We feel that such good service is being done by the publication of the supplement that it will be continued during 1932. Space will be given also to report the activities of the Junior Section to which we offer our best wishes.

Royal Corps of Signals.

We have been asked to bring to the notice of our readers that many Territorial Army Signal units are below strength, and that many vacancies exist in these units throughout the country.

The association of the Post Office with the Territorial Army Signal units has always been of the closest nature. In fact at their inception and during the war some of the units were entirely composed of linemen, telegraphists, etc., recruited from the Department. The more active interest of the many officers in the Engineering Department who have served with these units in the past, would go far towards improving the position of the units now below strength, and by whom an acquisition of suitable Post Office men would be welcomed. For

these reasons we have thought it not inappropriate to bring the matter to notice in this Journal.

Our attention has also been directed to the considerable number of vacancies for Officers in category B (not in units) of the Supplementary Reserve. The technical qualifications required are those generally possessed by the engineering supervisory staff, but candidates should not be more than 35 years of age.

Recruiting for category C of the Supplementary Reserve is also being opened for Electrician Fitters; Instrument Mechanics; Morse Telegraph Operators and Linemen. In the case of these four classes, applicants must be over 19 and under 40 years of age, but men living within a 10 mile radius of the headquarters of a unit will not be eligible.

Details regarding conditions of service, bounties and allowances are given in recent circulars and readers desiring more detailed information can obtain particulars from their Superintending Engineer. The link between the Post Office Engineering Department and the Royal Corps of Signals is historical, and we feel sure that the younger generation will see to it that the tradition is maintained.

Staff Sales Scheme.

It is too early to comment at length on the success of the Staff Sales Scheme which was introduced recently. The figures available to date, however, indicate that a new field of development is being reached by the Engineering staff, and which may yet grow considerably. The total number of orders received under the scheme during the last quarter was 2,854, of which 70% was obtained by the Engineering staff. We propose to publish the details from time to time in the hope that they may encourage men who may not yet have participated in the scheme, to bring about even better results.

Readers of the Journal will be interested in the following extracts from Svensk Trafiktidning, of 21st November, 1931, dealing with the Swedish Telephone Department's Budget for 1932-33. The statistics of income and development are as follows:

Year.	Fee Junctions & Trunk Calls.			Income from Subscribers' rentals (includes local calls) millions 1/-.	Telephones Number.	Telephones % Increase per year.
	Calls millions.	Income in 1/- millions.	Cost per 1/-.			
1926	37.05	28.8	.78	51.0	438,059	3.6
1927	38.37	30.0	.78	53.0	453,513	3.5
1928	39.69	31.5	.79	55.0	472,205	4.1
1929	41.82	34.0	.82	56.0	495,312	4.9
1930	43.62	35.7	.82	58.5	522,454	5.5
1931	44.18	36.7	.83	60.0	546,500	4.6

(1931 figures estimated on 9 months returns).

" The Department anticipates the continuation of the increase and to assist it they are easing the conditions to be fulfilled before erecting exchanges; reducing subscriptions on smaller exchanges; increasing the areas in which free calls can be made, and increasing the length of subscribers line allowed free in Exchange Areas.

" For capital expenditure in extending the local network an amount of £510,000 is allowed. For increasing the trunk and junction lines £128,000 is allowed and for radio stations £16,700."

Automatic Electric Company, Ltd.

We have been advised by the Automatic Telephone Manufacturing Co., Ltd., that the Company has decided on a change of name to Automatic Electric Co., Ltd. It has been felt that the original name was not sufficiently indicative of the Company's manifold operations whereas the new name will convey a better idea of the extent of the Company's activities.

Line Finder Developments.

Some doubt has been expressed in regard to our readers being able to follow the circuit operations covered by Fig. 3 in the article on Line Finder Developments which appeared in the January 1932 issue. The Automatic Electric Company has placed a large scale print of the diagram at our disposal and a copy is issued as a loose leaf with this issue.

The following letters have been received regarding details given in the article :—

18th January, 1932.

The Editor,
P.O.E.E's Journal.

Dear Sir,

I have read with interest the instructive description by Messrs. W. A. Phillips, A.M.I.E.E., and R. Taylor, on Line Finder Developments in the British Telephone System published in the *P.O.E.E. Journal* for January, 1932. The text is clear and concise and it is with something of a shock at the finish to find the authors closing on a note which gives a somewhat misleading picture of the comparative values of switching data made with the Uniselector System.

The new Finder System, it is stated, employs 513 selectors where formerly 3,163 were necessary. One thinks with some alarm of a famous scientist's dictum that automatic telephone communication had reached the high water mark of human ingenuity. Faced with such sweeping economies, one is driven to doubt.

I am re-assured, however, by a remark made to me recently by a colleague of the authors. This gentleman had been defending his costs for certain similar classes of equipment and he finished by saying that two animals, each with four legs, might be

described as similar. But if the animals in question happened to be elephants and rabbits, the similarity stopped well short of equality.

I suggest to Messrs. Phillips and Taylor that their comparison, if not quite one of elephants and rabbits, is, at least, one of foxes and rabbits.

For example, in Table I. on p. 288, it should be made apparent that though no preselectors (should it not be uniselectors?) are required in Col. 2, it is still necessary to provide the 3000 L and K relay combinations formerly associated with the subscriber's uniselectors.

Secondly, the 513 selectors include over 80% two-motion selectors which, together with relay-sets and bank cabling, have a cost ratio to uniselectors of something like 6 to 1.

Finally, the Allotters in Col. 2 are of the expensive 8-level type with controlling relay-sets.

I should be the first to recognise that the authors had no conscious intention of making a comparison that might be misleading. My remarks should therefore be taken as explanatory.

Yours faithfully,

L. J. HUSBAND.

26th February, 1932.

The Editor,
P.O.E.E's Journal.

Dear Sir,

We are somewhat at a loss to understand why the latter part of our article appears misleading to Mr. Husband since the summary given in Table I., which appears immediately above the paragraph he refers to, shows the quantities of single-motion and double-motion selectors contained in the totals of 3,163 and 513. Furthermore, the graph of comparative costs—Fig. 8—includes, of course, the L and C.O. relays—common to both systems—and also the higher cost of the heavy duty uniselector employed as allotters in the finder system. A simple calculation will show at once that the graph—Fig. 8—is substantially consistent with the approximate mounted cost ratio of 6 to 1, given by Mr. Husband, for the two types of selectors.

We are inclined to the opinion that Mr. Husband, whom we know to be an expert on costs, has naturally been tempted to consider the aspect of cost in preference to other considerations. He appears to have overlooked the technical and engineering advantages which accrue from the fact that a total of 513 mechanisms has been adapted to give precisely the same service as 3163 mechanisms, a fact which is obviously interesting and of considerable importance for a variety of reasons.

In the finder system not only is the total number of mechanisms employed very much less than in the uniselector system, but these are practically all of the two-motion type. The total contacts wiped per call is, therefore, correspondingly reduced, whilst maintenance routines are both simplified and facilitated by the self-routining provisions described.

We should like to take this opportunity to correct an error which appears in the first paragraph on page 288. The percentage should be 8% and not 30% as stated, the higher figure being for the finder system on single-sided racks as against the uni-selector system on units and trunk boards.

Yours faithfully,
W. A. PHILLIPS.
R. TAYLOR.

Exhibitions.

The Physical and Optical Society held its annual exhibition of Scientific Apparatus at the Imperial College in January. Opportunity was taken by the Department to exhibit some recent developments in the apparatus used in the field of communications research. The models shown included (1) an artificial ear; (2) a gain measuring set with a uniform scale in decibels; (3) a meter for measuring line noise and (4) a transmission time measuring set. These models were designed and built in the Research Section.

Five other exhibits were working models showing ideas developed in the Research Section. Two of the models were of signalling equipment which discriminated between a voice frequency signalling current and the normal speech currents. The third model demonstrated the effects of "Rectified Reaction" in increasing the sensitivity of valve operated relays. The two other models were respectively a "Logatom building machine" which prints chance combinations of "consonant-vowel-consonant" and is used in making articulation tests, and a "Mechanical Wave model" to demonstrate modulation of one sine wave by another.

One of the busiest spots at Olympia during the recent British Industries Fair was the Department's exhibit of telephone and telegraph equipment. Demonstrations were given of automatic and manual, public and private exchange working including long distance communication. In view of the development of the teleprinter service as an aid to business firms advantage was taken of this opportunity to demonstrate the facilities available with the teleprinter exchange and private wire services. A very satisfactory number of orders and enquiries was received.

One of the main attractions at the forthcoming Ideal Homes Exhibition at Olympia from April 5th to 30th will be the display of communication equipment and methods. The underlying motif of the exhibit will be "Every home needs a phone" and an endeavour will be made to interest the public by giving views of the Department's activities which are very little known. A suite of rooms is being arranged to show the facilities available by the installation of telephones, and methods of wiring will be shown to demonstrate that the amenities of the rooms are not interfered with. The display as a whole will occupy an area of about 18,000 square feet round the central staircase on the second floor.

Anglo-South African Radio Telephony Service.

On Monday, February 1st, 1932, a direct radio telephone service between London and Capetown was inaugurated by the Rt. Hon. J. Ramsay MacDonald speaking from the Cabinet Room, 10, Downing Street, when he held a conversation with General Hertzog at Capetown. The conversation was satisfactorily broadcast from all B.B.C. stations.

In the near future the service will be available to the whole of Europe, Australia, Canada and the United States.

Trans-Canada Telephone Link.

An interesting announcement has been received from the High Commissioner of Canada regarding the opening of the trans-Canada telephone system by the Governor-General in January of this year. The new line extends from Halifax, Nova Scotia, to Vancouver, British Columbia, a distance of 4,263 miles and has been provided at a cost of approximately £1,000,000. The scheme provides a complete Canadian route independent of the United States and has been made possible by the co-operation of the seven major telephone organisations which operate in the Dominion.

We have received advice also of the establishment of direct communication between Vancouver and Prince Rupert, British Columbia. Submarine cable is used from Vancouver to Nanaimo, from which a land line carries the circuit to Campbell River. Short wave radio is used from the latter point to reach Prince Rupert. The total circuit length is 545 miles.

We have received from Dr. Herr Felix Pollaczek, of Berlin, reprints of the following articles describing his work on telephone traffic:—

1. *Über eine Aufgabe der Wahrscheinlichkeitstheorie*, parts 1 and 2, from "Mathematische Zeitschrift," Volume 32, Nos. 1 to 5.
2. *Theorie des Wartens vor "Schaltern,"* from "Telegraphen- und Fernsprech-Technik," 1930, pages 71-78.
3. *Über zwei Formeln aus der Theorie des Wartens vor Schaltergruppen,* from "Elektrische Nachrichten-Technik," 1931, No. 6.
4. *Gesprächsverluste und Wartezeiten,* from "Elektrische Nachrichten-Technik," 1931, No. 7.

All the works treat the subject from the mathematical standpoint. As is well known, the treatment of traffic problems relating to automatic telephone exchanges varies according as the system is designed to test outlets only once and then give the busy signal if all are engaged—as in the Strowger group selectors, or to hunt continuously for disengaged outlets—as in the case of the Rotary system. The latter condition is usually present at the first stage of a call, but is assuming more importance in this

country owing to the development of line finders. Dr. Pollaczek's information on this phase of the work has therefore arrived at a very opportune moment.

Errata.

We regret that a number of errors appeared in Mr. N. A. Hawkins' article in the January issue. The errors occur in the mathematical portions of the article and will be sufficiently obvious to readers without complete details being given.

Mr. Woodhouse has called attention to the follow-

ing errors in his article on the Solution of the Wheatstone Bridge:—

Fig. 1 (b). The resistance of the conductor between the point A and the junction of "p" and "q" should be shown as "g" while "r" and "s" are identical with R and S in Fig. 1 (a).

On page 294 all the terms following (P + Q + G) in the denominator of the penultimate and last identities should be collected in brackets, and on page 295 the expression for the resistance of the bridge, when "G" has a maximum value, should be inverted.

Headquarter's Notes.

EXCHANGE EQUIPMENT.

The following works have been completed:—

Exchange.	Type.	No. of Lines
Stockport	New Auto	3000
Woodley	"	600
Hampstead	"	7100
St. Helens	"	2100
Prescot	"	400
Southall	"	1700
Abbey Hill	"	600
Sale	"	2900
Whitehall	"	8400
Longford (Manchester)	"	1100
Heaton Moor	"	1900
Shirley (Southampton)	"	900
Woolston	"	500
Hampton	"	1400
Prospect	"	5700
Denton (Manchester)	"	500
Edinburgh Central	Auto Extn.	1900
Linthorpe	"	300
Southampton (No. 4)	"	Manual Board
Manchester	"	Manual Board
Ilford No. 3	"	P.B.X. 11/20
Southampton	"	Manual Positions
Manchester	"	Operators' School
Newbury	New Manual	1080
Chislehurst	"	1300
Seven Kings	"	3000
Orpington	"	1700
London Trunk Exchange	Manual Extension	Pneumatic Tubes on Record and Demand Positions
Barnsley Fever Hospital	P.A.B.X.	20
Lee & Sons, Sheffield	"	35
L.T.S. Cornwall House	"	500
Thrift Stores (Leeds)	"	30
Manchester Telephone Service	"	480
Kendal Milne	Extension P.A.B.X.	Re-arrangements

Orders have been placed for the following:—

Exchange.	Type.	No. of Lines.
Belgrave	New Auto	700
Birchfields	"	1000
Bamber Bridge	"	300
Woodseats	"	600
Ranmoor	"	1200
Swinton	"	900
Lee-on-Solent	"	300
Haverton Hill	"	200
Shirley (Birmingham)	"	800
Warstock	"	300
Terminus	"	London Enquiry Bureau Positions.
Bishopsgate	Auto Extn.	Toll Control
Reliance	"	Toll Control
Archway	"	Toll Control
Chatham No. 1	"	500
West Hartlepool	"	200
Paignton	"	100
Cheltenham	"	700
Burslem	"	400
Trentham	"	200
Newcastle-under-Lyne	"	300
Longton	Auto Extn.	300
Stoke	"	300
Ilford No. 2	"	Manual Board
Blackpool Area	"	Observation Equipmt.
Manchester	"	Manual Board
Sloane	"	Toll Control
Fulham	"	Toll Control
Primrose	"	Toll Control
Amherst	"	Toll Control
St. Annes-on-Sea	New Manual	720
Stafford	"	900
Bangor	"	1200
Ardrossan	"	600
Norwich	Manual Extension	900

In addition to the foregoing, orders have been placed for 9 P.A.B.X.'s and for minor extensions of miscellaneous equipment at 7 Exchanges.

Mr. P. J. Ridd, M.I.E.E.

MR. P. J. RIDD, who was appointed Staff Engineer in charge of the Construction Section on the 1st March, 1932, joined the staff of the late National Telephone Company in 1895, and his early experience of telephone engineering was obtained on the exchange Construction Staff in London and the Provinces.

Amongst the work upon which he was engaged was the installation of one of the first C.B. Exchanges in this country, viz., Kensington, London, which was opened in 1901. Subsequently, he was employed on exchange construction work in Glasgow and Manchester Districts.



Elliott and Fry.

MR. P. J. RIDD.

In 1903, he was appointed Exchange Manager at Paddington Exchange and in 1905, on the separation of the Company's Traffic and Engineering Staffs, he became Divisional Electrician in the Northern and subsequently in the Southern Divisions of London.

In 1907, Mr. Ridd was appointed Metropolitan Construction Electrician, responsible under the Metropolitan Electrician for all exchange construction and subscribers' installation work in the London area. This position he held at the transfer of the Company's Undertaking to the State, when he was attached as Executive Engineer to the Technical Section of the Metropolitan Central District.

In 1915, he took charge of the London City Internal Section, where he remained until 1926, when he was appointed Assistant Staff Engineer in the Research Section. Mr. Ridd returned to the London District as Assistant Superintending Engineer in 1928 to take charge of the maintenance of the Internal and External plant in the District. He

now returns to Headquarters, as Staff Engineer in the Construction Section.

Mr. Ridd has been a member of the Board of Editors of the Journal since the 25th July, 1928.

F.W.

Mr. C. J. Mercer, M.I.E.E., M.I.R.E.

MR. C. J. MERCER was appointed Staff Engineer in charge of the Telegraph Section on 13th December, 1931. Joining the Engineering Department at Manchester in 1899, he was transferred to Headquarters in 1900 and spent several years under the late Mr. A. Eden and his successors in the Section



Elliott and Fry.

MR. C. J. MERCER.

of which he has now taken charge. During this period of his career he received the thanks of the Postmaster-General for "improvements in Central battery telegraph working" and reference was made to this work in the jubilee celebrations of the Institution of Electrical Engineers where Mr. Mercer was referred to as having made definite contribution to the art of telegraphy.

Appointed as Sectional Engineer at Inverness in 1909 Mr. Mercer was responsible for the extensive work entailed in the building up of the Navy's communications in the Orkneys and Shetlands and the North of Scotland during the war. His services in this respect were brought to notice on several occasions and at the end of the war he received the special thanks of the Admiralty. He was subsequently transferred to Liverpool, taking charge of the Internal Section in that city.

Mr. Mercer returned to Headquarters as Assistant Staff Engineer in the Radio Section in 1925, following the reorganization of the radio service and the

transfer of control of the point-to-point stations to the Engineering Department.

J.I.

Mr. E. J. Wilby, M.I.E.E.

MR. E. J. WILBY entered the Engineering Department at Leeds in 1898 and was transferred to London in 1904 to take charge of the new lamp signalling trunk exchange. This experience in the London trunk exchange from 1904 to 1907 brought about his transfer to Headquarters to deal with the extension of the trunk system and the introduction of lamp signalling throughout the provinces. He was appointed Sectional Engineer in charge of Dublin City Section in 1915 and spent four strenuous years in the Irish capital, on the re-building of the plant and equipment destroyed in the Irish Rebellion.

Returning to Headquarters in 1919, Mr. Wilby was engaged on the introduction and application of the Unit Construction cost system until his appointment as Assistant Staff Engineer in 1926.

Mr. Wilby visited Sweden as a member of a special commission to investigate costs and later visited the United States with Mr. E. Gomersall to enquire into possible improvements in organization for speedier provision of Subscribers' services.

The "Leech" committee recommended the appointment of an advisor to the Engineer-in-Chief on matters of District and Sectional organization and Mr. Wilby was selected for this appointment.



Elliott and Fry.

MR. E. J. WILBY.

The importance of such matters in minimizing costs and effecting improvement in service has been recognized by the up-grading of Mr. Wilby's post to the rank of Staff Engineer.

J.I.

District Notes.

London District.

UNUSUAL METHODS OF SUSPENSION OF PIPES AT HAYES BRIDGES.

D. E. BLAKE, D.I.C., A.C.G.I., B.Sc.

A brief description of the work being carried out by the Department in connexion with the road widening operations in the Uxbridge Road, Hayes, may be of some interest to readers, not so much because of the difficulties which have been and are being experienced as because of the unusual methods which have had to be employed to overcome them.

At the scene of the operations the Uxbridge Road runs east and west and crosses the Grand Junction Canal and Yeading Brook, which are about 170 yards apart at this point. The original brick bridges have been demolished in order to give way to modern ones of reinforced concrete which are now being constructed.

Post Office plant existed on both sides of the original road. On the northern side there was only a single duct containing several small cables

which carried subscribers', junction, and main telegraph circuits.

The plant on the south side of the road is, however, much greater in quantity and in importance, consisting as it does of six cables carrying trunks and main telegraphs to the West of England as well as a Tandem—Southall—Hayes junction cable.

Over the Grand Junction Canal Bridge these cables are carried in three C.I. pipes which were embedded in the concrete of the footway and four steel pipes which passed through the buttresses of the bridge and were carried on the outside of the wall. Over the Yeading Brook Bridge the plant on this side runs through five C.I. pipes which were buried in the concrete of the roadway (there being no footway at this point) and one steel pipe carried on the outside of the bridge.

The old bridges were rather humped and there was therefore a not inconsiderable dip between them. The opportunity is being taken in conjunction with the road widening and straightening to raise the levels between the bridges in order to eliminate this dip. It will be appreciated, there-

fore, that considerable alterations to the Post Office plant were rendered necessary by the widening of the bridges and the alterations to the kerb lines and levels.

The new bridges are being constructed in two portions for traffic reasons, the northern sides having been built first. A trough was provided in each bridge to accommodate the plant of various undertakers, and similar ones are to be provided on the south sides of the bridges. A new track was laid along the new footway on the north side and through these troughs. The small cables lying on that side of the original road had fortunately not been interfered with by the construction of the first half of the new bridges and they were now diverted into this new track over a section of some 320 yards.

Dealing with the plant on the south side was a very different matter and the straightforward way of getting all the pipes absolutely clear of bridge building operations by diverting the cables to the troughs provided on the northern sides of the bridges was out of the question on the grounds of expense. It was decided therefore to divert the existing plant to the new bridges and kerb line by slewing and raising as necessary. Having reached this stage, the next problem was how to support the pipes when the bridges were demolished. The Contractors building the bridges desired to complete the decking of each bridge in its entirety and refused to allow any under support for the pipes as they did not wish the continuity of the concrete broken. The only alternative was, of course, to support the pipes from above, and suspension from a beam or from a chain or steel hawser slung between two poles was suggested. As it was thought that they may prove suitable for this purpose, two lengths of heavy gauge tram rail were borrowed from the London United Tramways Company who were removing the rails which had been thrown out of commission by the diversion of the tram track to a different position over the new Canal bridge.

It would probably be as well at this stage to deal with the two bridges separately and first to detail, briefly, the operations on the smaller bridge over Yeading Brook. Here, as mentioned above, the cables are carried in five C.I. pipes, and one steel pipe. It so happened that these pipes were sufficiently high to be clear of the new deck so, until that was made, the question of slewing did not have to be considered. The only consideration therefore at this stage was the support of the pipes. One of the above-mentioned tram rails was brought into service, and was placed across the stream and above the pipes. However, the excavation for the new bridge had been extended and instead of a span of about 30ft. as originally anticipated, the rail had to span a gap of 46ft. As a result it developed an ominous sway and was considered to be too "free" to be safe. It was therefore removed and steps were taken to get the

necessary poles, etc., for an overhead suspension as originally proposed. The bridge contractors then changed their minds and allowed us to support the pipes from the top of the wooden shuttering on which the concrete deck was to be laid. The only condition was, that the vertical supports had to be small and had to be placed so that they came between the iron reinforcement bars of the deck. The holes thus made in the concrete were filled in subsequently. This support was adequate as the shuttering was itself supported on a number of substantial I-girders which were carried on timbers built up from two small coffer-dams. The photograph (Fig. 1) clearly shows the reinforcement bars and the vertical supports standing on the shuttering. This concession fortunately saved a lot of work and it only remains for the pipes to be slewed and lowered into the trough provided.



FIG. 1.—PIPES SUPPORTED ON SHUTTERING.

The suspension of the nine pipes over the Canal bridge presented rather more difficulty, because no under support could be given as the canal and towpaths had to be kept free for traffic. The span to be supported was about 60 ft. and this, coupled with the arched formation of the pipes and the fact that they have to be raised, rendered overhead suspension from a beam impracticable. A stout pole was then erected on each side of the bridge in such a position as to be suitably placed relative to the plant to be supported and as near as possible in line with the proposed trough in the new bridge. The poles were suitably stayed and two steel hawsers were slung between the tops of the poles and across the Canal. The central portion of the four steel pipes originally on the outside of the bridge was supported by several slings from one of these hawsers whilst the central portion of the three C.I. pipes was similarly slung from the other. The side portions of the spans were supported by direct stays from the tops of the poles (Fig. 2). These various stays

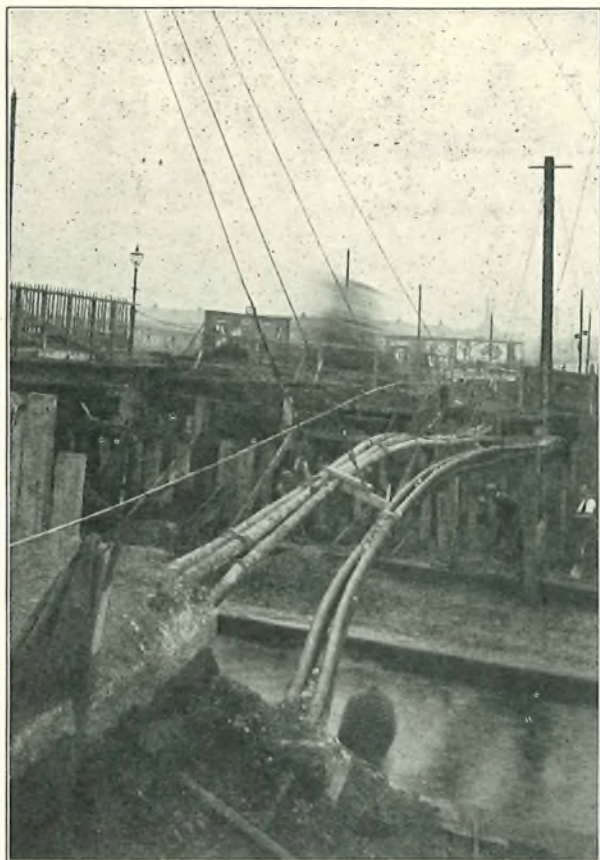

FIG. 2.—PIPES SUPPORTED BY SLINGS AND STAYS.

and slings were fitted with swivels and clamps to enable them to be used to assist in the lifting of the pipes which have to be raised over a foot in the centre and more than two feet at the ends of the span. The raising and slewing will necessitate stripping back the pipes for some distance and, unlike the job at the smaller bridge, this must be partially carried out in advance, as the pipes, if

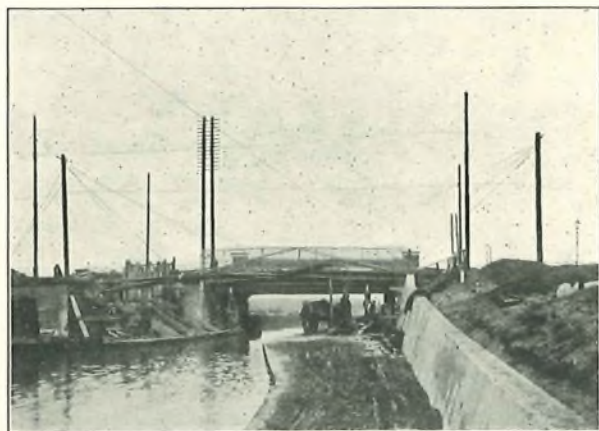

FIG. 3.—SIDE VIEW OF SUSPENDED PIPES.

left in their present position, would foul the deck of the new bridge. The final slewing and lowering into the trough to be provided will be difficult as the steel pipes are very much bent (as will be seen in the photograph) and enter a manhole immediately abutting the bridge where they become associated with a 12-way duct line. However, the initial stage of safely carrying the pipes which were left in mid-air after the bridge was demolished has been successfully accomplished and the photographs give a good idea of the form of suspension employed.

GROWTH OF TELEPHONE SYSTEM.

Direct Exchange Lines	423,677
Telephone Stations	714,220
Increase during Quarter : 2,869 exchange lines and 6,066 stations.	

L.E.D. MILEAGE STATISTICS.

The total single wire mileage under review at the end of December, 1931, was :—

Telephone Exchange	3,180,926
Trunks	131,419
Telegraphs	37,917
Spares	105,521

The additions since September, 1931, obtained by deducting the September totals from the December totals are :—

Telephone Exchange	195,768
Trunks	10,231
Telegraphs	11,146
Spares	48,676

These, however, cannot be taken as actual, as since 30th September, 1931, the inventory figures have been received and various adjustments have been made.

On 31st March, 1929, the figures in use were :—

Telephone Exchange	O	51,880
	U	2,444,897
Total		2,496,777
Trunks	O	3,985
	U	75,197
Total		79,182
Telegraphs	O	517
	U	24,891
Total		25,408
Spares	O	112
	U	119,009
Total		119,121

The figures obtained from the Inventory as at 31st March, 1929, were :—

Telephone Exchange ...	O	24,762
	U	2,609,752
Total ...		<u>2,634,514</u>
Trunks ...	O	3,615
	U	84,533
Total ...		<u>88,168</u>
Telegraphs ...	O	140
	U	36,468
Total ...		<u>36,608</u>
Spares ...	O	1,088
	U	150,458
Total ...		<u>151,546</u>

It will be seen that the additions due to the Inventory were:—

Telephone Exchange ...	O	2,634,514
	U	2,496,777
		<u>137,737</u>
Trunks ...		88,168
		<u>79,182</u>
		8,986
Telegraphs ...		36,608
		<u>25,408</u>
		11,200
Spares ...		151,546
		<u>119,121</u>
		32,425

The actual alterations therefore during the quarter ended 31st December, 1931, were:—

Telephone Exchange ...		195,768
		<u>137,737</u>
	+	58,031
Trunks ...		10,231
		<u>8,986</u>
	+	1,245
Telegraphs ...		11,146
		<u>11,200</u>
	-	54
Spares ...		48,676
		<u>32,425</u>
	+	16,251

SYNCHRONOUS TIME SWITCHES.

The introduction of frequency control by many of the Electricity Supply Authorities for technical reasons, has provided incidentally a means of securing accurate time. In place of ordinary clock mechanism a small synchronous motor, whose speed is directly proportional to the frequency can be used, suitably geared down, to drive the clock hands. Such a clock will show the time to an accuracy depending on the closeness with which the supply frequency is maintained at the standard. "Syn-clocks" made on this principle are now on the market and numbers of them are being fitted in public telephone kiosks in areas where the electricity supply is suitable, in place of spring driven clocks, to operate the time switches which control the lighting.

MERCURY ARC RECTIFIERS.

When the new 8-floor extension to the Money Order Office, Holloway, was contemplated, it was decided to instal a passenger and a service lift, each running at 200 feet per minute. In view of this speed and the nature of the supply it was considered preferable to use D.C. motors to drive these lifts.

As special rectifying plant was necessary it was decided that this should be of sufficient capacity to enable the automatic brush shifting single phase motors of the three large existing lifts to be replaced by D.C. motors. Two 85 kW Mercury Arc Rectifiers have therefore been installed. They are of the glass bulb fan-cooled type each of which is capable of carrying the total D.C. load of the building.

The rectifiers are connected to the 400v A.C. supply through oil-immersed circuit breakers, and supply an ironclad D.C. switchboard of standard pattern.

The rectifiers have an output of 187 amps. at 400v D.C. and in addition an auxiliary supply of 50 amps. at 200v is available for the control circuits of the passenger lifts and the main and control circuits of the small service lifts.

The 200v supply is obtained from auxiliary anodes connected to a tapping of the secondary winding of the oil cooled transformer associated with each rectifier.

BARTHOLOMEW HOUSE EXCHANGE.

Owing to the proposed demolition of Bartholomew House, it has been necessary to replace the private exchange situated in the building and leased by the Department to the Exchange Telegraph Company.

This exchange, which has no connexion with the public system, provides an interconnecting service between offices in the Stock Exchange Area, and also handles calls from suites of call office cabinets situated in rooms adjacent to the floor of the Stock Exchange. A member desiring to make a call enters one of these boxes and gives the number required to an attendant, who passes it over an

order wire to a telephonist at Bartholomew House Exchange, to whom he also states the cabinet which will be used. The circuits from these cabinets terminate on plugs in front of the telephonist, who is therefore able to complete the connexion. It will be appreciated that, at the Bartholomew House Exchange, this service from the call office cabinets amounts to B-position working.

Service between the ordinary subscribers is provided by A-positions, but, to enable a subscriber to speak to another who is actually at the Stock Exchange, each A-position is provided with order wire keys, by means of which the telephonist can inform an attendant at the Stock Exchange the name of the member required, and also the name of the caller. The attendant notifies the member required, who gets in touch with the caller *via* a call office cabinet and the B-position.

Several special facilities are required on the switchboards at Bartholomew House Exchange; automatic continuous ringing is provided on both "A" and "B" suites, and a break-jack multiple is fitted to render double connexions impossible. To speed up operation, ancillary working is used, and the A-position cord circuit is designed so that an engaged test may be made with any calling plug, without the necessity of throwing the associated speaking key. The latter facility permits the telephonist to carry out a practically continuous test of an engaged circuit while she is dealing with other calls, in cases where the calling subscriber has stated that he will wait until the required number is disengaged.

Thirteen A-positions and five B-positions of the No. 10A type, with a 1,000-line multiple, together with the associated equipment, M.D.F., batteries, power plant, etc., have been installed on the top floor of No. 7, Angel Court, the batteries and power plant being supplied by Messrs. Standard Telephones and Cables, Ltd. Extra care has been necessary in the distribution of the weight and in avoiding disturbance of the tenants of the offices below. Although the provision of the special facilities necessitated the complete re-wiring of the No. 10A switchboards, the whole exchange has been installed in 11 weeks. The new exchange was cut-over on the 12th March.

Scotland East District.

LAYING A NEW SUBMARINE CABLE ACROSS THE KYLE OF TONGUE.

JOHN ANDERSON, WICK.

In the Coast Communication Circuit from Wick Radio to Cape Wrath is included a short length of submarine cable across the Kyle of Tongue. This cable was laid in 1888, and was remarkable for its continuity of service, four breaks only having occurred during the 43 years of its useful life.

The fourth and final break which occurred on 22nd June, 1931, was located in the West channel of the Kyle, without much difficulty, by under-running from the West Shore End. Insulation Resistance tests proved this section electrically sound to its terminal pole test box. The sound end was therefore buoyed and attention directed to the missing end. Grappling operations commenced on the evening of 23rd June, with the assistance of the Tongue Ferry motor boat. At midnight, after five hours' zig-zagging across the track of the cable, operations were somewhat reluctantly suspended owing to the strong incoming tide. On the following morning operations were resumed and continued all day without success owing to the cable being too deeply sanded for the appliances available. Nevertheless, a further endeavour was made to recover the lost end with a special grapnel evolved from a $\frac{3}{4}$ " steel rod bound to an oar, and used by hand from the small boat at low water. This method also proved to be abortive. On the 25th June attempts were made to underrun from the East side where the cable was picked up on a sand bank at low water, after much digging and probing. Underrunning was continued with zest for about 200 yards when the incoming tide made it necessary to take to the boats. Further progress was arrested, however, when about half a mile from the break, owing to the great depth of sand over the cable. Four men exerting all their strength were unable to lift it inboard by hand, whilst, at the same time, the bow of the boat was being occasionally forced under water. Owing to rising wind and sea, further attempts had to be abandoned. On the following day it was decided to cut the cable in mid channel and test towards the East side in order to ascertain its electrical condition. The tests proved the East section to be faulty also. It was therefore decided to abandon further attempts to repair, and a new length of cable was requisitioned.

Meanwhile, the telegraph service was maintained by bridging the gap between Tongue and Talmine by messenger via Tongue Ferry.

The difficulty of transporting a 4 ton drum of cable from Lairg to Tongue Ferry over mountainous roads presented something of a problem. A local contractor was invited to tender; but on seeing the huge drum and learning its weight, discreetly withdrew. An Inverness contractor, however, undertook the job without seeing the drum and probably without any conception of the nature and condition of the roads. The consternation of the driver on his arrival at Lairg with a 5 ton lorry, on surveying the 8 foot drum, can perhaps be imagined. He loudly voiced his sentiments in Gaelic which, we presumed, were to the effect that he was certain he would never reach Tongue with such a load. Nevertheless, the load was picked up and the journey to Tongue successfully accomplished by slow and careful driving at

approximately 6 miles per hour. On arrival at Tongue it was anticipated that difficulty might arise in negotiating the notoriously dangerous Kinloch road round the Kyle, it being of comparatively recent and very light construction. The Resident Assistant County Road Surveyor was interviewed as a precautionary measure, re the condition and safe bearing weight of the three ferro-concrete bridges, culverts and road surface on this section. On learning that the total weight to be borne was approximately 8 tons he said that the breaking weight of these bridges was estimated at 20 tons, and that they should bear 8 tons without danger. He thought, however, that some of the culverts might prove too weak; but as they were only from 12" to 15" wide there would, in his opinion, be no danger. The journey round was therefore continued, the Road Surveyor accompanying the lorry on his motor cycle. No difficulty was experienced until the lorry reached a point on the road about $1\frac{1}{2}$ miles from the end, where the road surface gave way and the rear wheels went through the macadam crust down into peat moss over 12" deep. Fortunately the weather was dry and there were plenty of stay blocks and planking at hand. Stay blocks and stones were used to

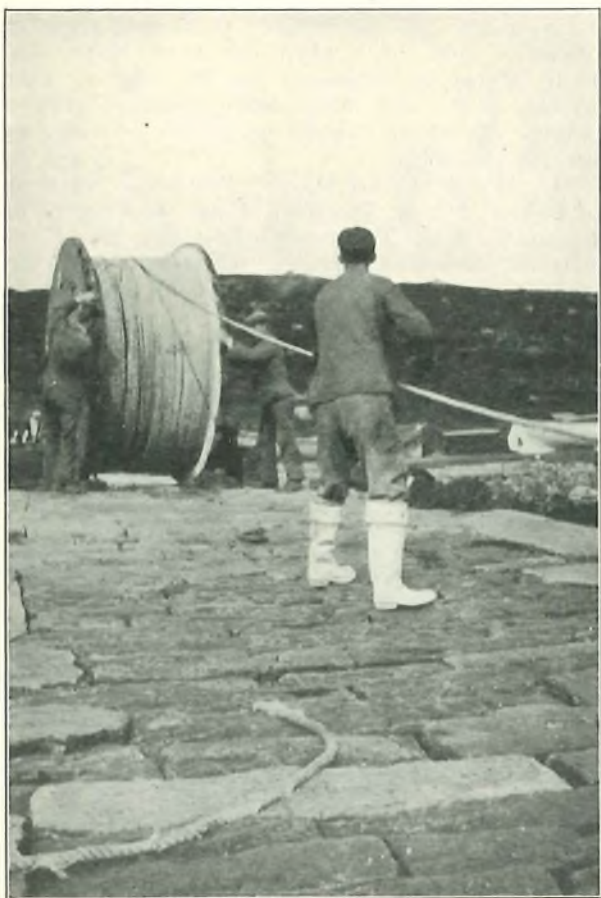

FIG. 1.—CABLE DRUM AT PIER HEAD.



FIG. 2.—COILING THE CABLE.

fill up the ruts and after several unsuccessful attempts to go forward or backward the lorry was at last backed clear of the ruts. After these were made good and planking laid over them, a Departmental lorry was hitched by a 3" tow rope to the load and successfully manoeuvred over the broken road surface. The remainder of the road to the pier was covered without difficulty with the heavy lorry in tow, although the load was seen from behind to cause a deep depression in the road surface which travelled in a wave with the car. On arrival at the pier, unloading difficulties were encountered; but by taking advantage of a high bank at the roadside the 4 tons of Cable were safely unloaded by means of railway sleepers and blocks and ropes. The drum was then rolled by hand into position at the head of the pier, as shown in Fig. 1.

Local yawl and motor boats were hired for the laying of the cable across the Kyle. Two 15' keel yawl boats were lashed together and a platform of battens was secured to them. The cable was then coiled pancake fashion on the platform (Fig. 2) and the motor boat hitched to the yawl boats by a 3" tow rope. The pier being about half a mile North of the West Cable End Pole Test Box, it was therefore arranged to leave the pier when the tide was flowing up the Kyle so as to arrive opposite the Pole Test Box at slack water. The tide at this stage would be less likely to deviate the

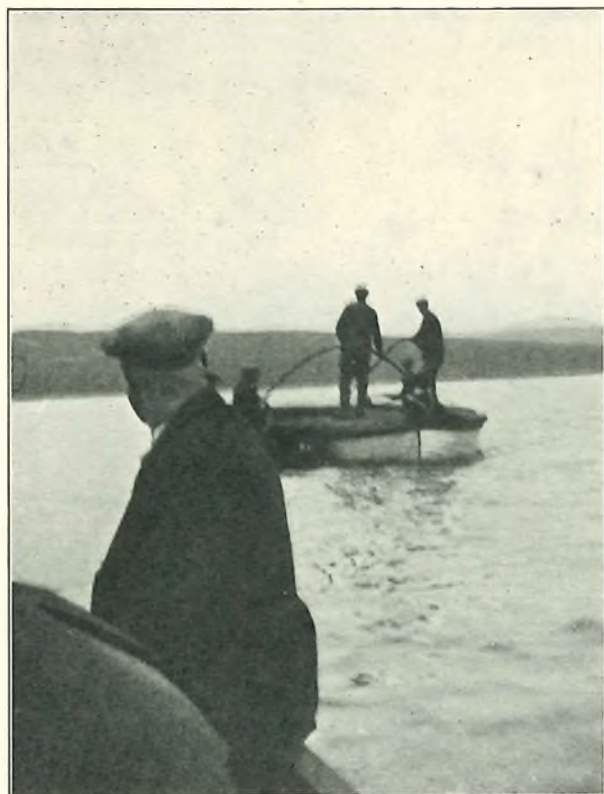

FIG. 3.—LAYING THE CABLE.

boats from their course, and this was found to be the case. Some doubt was expressed by local fishermen that the depth of water over the sand banks would be insufficient during the neap tides which happened to be prevailing at the time, but, contrary to local opinion there was a depth of over 7 feet at high water and the operations of laying were carried out without mishap. The actual work of laying the one nautical mile 4-core $42\frac{1}{2}/55$ 19/12 cable (Fig. 3) occupied only half an hour. The speed of the motor boat was about 2 miles per hour while paying out.

THE LATE J. T. TATTERSALL, Esq.

The Scotland East District mourns the passing of John Thomas Tattersall, Assistant Superintending Engineer, on 27th February, 1932, from a painful disease, which he had borne very patiently since September, 1931. We desire to tender our heartfelt sympathy with his wife, daughter, and relatives. He possessed a pleasing disposition and cheerful personality, and his good nature endeared him to his colleagues, and under all circumstances. A typical North Countryman—born in Lancashire—most of his active service was spent in Hull where he was Engineer to the National Telephone Co. at the transfer. A popular member of the Inventory Staff, he had what will probably prove the unique experience arising from the transfer of the Hull local telephone

plant to the Hull Corporation, of subsequently carrying out a local inventory at that place. He was a past Honorary Treasurer of the Hull Musical Union; and was interested in Masonic charities. The closing of the Hull Section in 1928 took him for a short period to the Exeter Section, and he was promoted to Scotland East District on 12th October, 1929.

In addition to members of his family, the funeral in Liberton Church Cemetery, Edinburgh, was attended by H. Kitchen, Esq., Superintending Engineer, and a large number of past and present representatives of the District Staff, including Mr. J. D. Taylor (Leeds), Captain C. Crompton (Edinburgh), retired Superintending Engineers, and Major J. Cameron (Glasgow) who also represented the Scotland West District Staff; wreaths were received from the Scotland (East), Scotland (West) and North Eastern District Staffs.

W.A.R.

South-Western District.

OFFICIAL OPENING OF BRISTOL AUTOMATIC EXCHANGE.

The Automatic System which came into operation on the 28th November, 1931, was given an official "send off" when the Lord Mayor and Lady Mayoress, supported by the Sheriff, Lord Apsley, M.P., and many other prominent Bristol citizens visited the Central Telephone Exchange on the 7th December.

Mr. W. Blandford Harris, Postmaster-Surveyor of Bristol, Mr. P. Thornton Wood, Superintending Engineer, South Western District and Mr. A. G. Bristow, District Manager, with their respective staffs, co-operated to give the visitors an insight into a system which marks the most modern phase of telephone science.



Bristol Evening World.
OFFICIAL OPENING OF BRISTOL AUTO EXCHANGE.

After the reception, which took place in the old switchroom, the party divided itself into groups under the escort of members of the P.O. Staff and made a tour of the building. The Cable Chamber, Main Frame, Test Desk, Power Plant, Selector Racks, Manual Room, Trunk Room and Observation Room were all visited in turn and from the interest evident and the many questions asked at each point it was clear that the visitors were intrigued by the intricate and complicated plant.

The guests again assembled in the reception room for refreshments and listened, by means of loudspeaker broadcast, to a conversation between Mr. Simon, The Director of Telegraphs and Telephones, London, and the Lord Mayor of Bristol.

Mr. Simon expressed the opinion that Bristol now occupied its rightful place in the telephone world. In reply the Lord Mayor said he and his party had viewed the exchange with delight and wonder.

Tribute was paid to the efficiency of the departments responsible for the achievement and the Lord Mayor said he was "filled with amazement at the ingenuity of man. Seldom, if ever, have I seen so much intricate and complicated mechanism in so small a space."

The Sheriff of Bristol then addressed the gathering and also expressed his wonder at what he had seen and appreciation of the efforts of the staff in initiating the visitors into the working of the exchange. Further, he stressed the importance of a good telephone service and asked the guests to try and visualise business conditions without such a rapid means of communication.

Lord Apsley was struck with the ease of the "change over," and the businesslike methods of the departments concerned. He also felt that a word of praise was due to the general public who had so whole-heartedly co-operated in the inauguration of the new system.

In conclusion Mr. W. Blandford-Harris thanked the visitors for the lively interest displayed and for their appreciation of the visit.

FARADAY CENTENARY CELEBRATIONS, EXETER.

Further to the brief reference made to this matter in the last issue of the Journal, great success attended the P.O. display at the Faraday Centenary Celebrations, which were held at Exeter University College, on December 10th, 11th and 12th, 1931. Considerable publicity was given to the Exhibition and flood-lighting and other special illuminations were provided to signalise the event.

On the evening of the opening day a meeting was held under the Chairmanship of Sir J. A. Fleming, D.Sc., F.R.S., when Sir William Bragg, O.M., K.B.E., F.R.S., delivered the Faraday Lecture. The exhibits ranged from the earliest types of electrical appliances and the simple apparatus originally used in Faraday's fundamental

experiments, to examples of the most modern technical applications of electricity, including automatic telephones, lighting equipment, recording instruments, control appliances, synchronised electric clocks, discharge phenomena, thermionic valves and a variety of up-to-date domestic and radio instruments.

The Post Office exhibit attracted a large number of visitors and was the subject of specially favourable comment in the local press. Particular interest was shown in the Automatic Demonstration Set, fitted with four sets of subscribers' apparatus, and a prepayment coin collecting box. Continuous demonstrations were given and the Engineering and District Manager's Staff were plied with questions from a keenly interested and inquisitive public. There seems no doubt that exhibitions of this nature have a high publicity and educational value and must inevitably result in increased telephone business and in a more proficient use of the service.

Other working models included two Teleprinters No. 3A, operated by rectified mains A.C., a Wheatstone Transmitter and receiver and a Morse set.

In addition there was a very comprehensive display of modern telephone apparatus, including pedestal instruments, cordless switchboards, automatic switches and dials, and various underground cables. The development of the telephone and telegraph systems in this country was exemplified by numerous types of telephone transmitters and receivers and a representative selection of telegraph instruments. Valves and other apparatus as used at Rugby Radio station were also featured.

D. A. B.

South Eastern District.

CAPTAIN F. H. WISE.

On the 31st March, 1932, Captain F. H. Wise retired from the post of Assistant Superintending Engineer, S.E. District, Croydon. He came to Croydon in 1929, having previously served in Cambridge, Luton, Tipton, Reading, Cardiff, Kensington, Richmond, Wandsworth, Notting Hill, Ilford and Exeter.

In May, 1884, he passed the Elementary Electricity and Magnetism Examination while still a schoolboy, and was presented with a prize, consisting of books, by the late Sir Wm. H. Preece, who, on the same day, gave a demonstration of the use of electric light in the Town Hall, Reading.

In June, 1913, Captain Wise was appointed Sectional Engineer of the newly-formed Ilford Section in the Eastern District. By reason of its geographical situation, the Section contained the North Eastern outposts of London and the war-time demands of the Naval and Military authorities were extremely heavy. These requirements included, apart from ordinary telegraphic and telephonic services, lines and special apparatus for height-

finders, position-finders, direction-finders, velocity-calculators, meteorological recorders, anti-aircraft gun and light controls, aerodrome services and communication with ships at sea. He was in almost constant consultation with officers of H.M. Forces with reference to the solution of their particular communication problems. It was only by the assistance of considerable contingents of troops, in addition to workmen loaned from other Districts, that it was possible to cope with the requirements at the time. He was also an Inspector of Special Police at Ilford during the War and had charge of the telephone operating staff during Air Raids.

In 1919 he was thanked for the valuable assistance which he had given in the Anti-Aircraft Defence of London in connexion with the Telephonic Communications of the Army and Air Force.

In 1922 the Ilford Section ceased to exist, and he was transferred to Exeter. The number of telephone subscribers in Devon, Somerset, Dorset and a part of Cornwall was 8,000. When he left the Exeter Section in 1929, the number was 22,000, the District having become so large that it was necessary to split up the Section, and establish an additional Section with Headquarters at Taunton. The original section covered an area of over 4,000 sq. miles.

In 1929 and 1930 the Engineer-in-Chief selected him as Vice-Chairman of the London Centre of the Institution of Post Office Electrical Engineers. In 1930 he assisted in the landing of the Anglo-Belgian Submarine cable at Dumpton Gap, and in 1931 he was largely responsible for the erection of the Aerial Cable between London and Brighton so far as the S.E. District was concerned.

Apart from an exceptionally keen interest in his official work, his special knowledge ranged over the following subjects: Architecture (Ancient and Modern), Chemistry, History and Natural History. His stalwart frame, characteristic manner of giving quick decisions, his cheery smile and confident air will be missed by his colleagues.

A presentation was made by the Superintending Engineer to Captain Wise on the day of retirement. The S.E. District at this function wished him, his wife and family, continued good health and happiness in his beloved Devon where he is settling down.

J.H.M.W.

Palmeria Stores, Hove, was the scene of a big fire on Sunday morning, February 14th, when the Private Branch Exchange was completely destroyed, and damage was done to various extensions throughout the building.

Reports of the disaster reached the P.O. Engineers about 9.30 a.m. Emergency Staff set about restoration as soon as conditions permitted. The General Manager of the Stores was greatly concerned about the loss of business that would ensue if the telephones were not effective at opening time on Monday morning. An undamaged room was put at our disposal

and a switchboard $\frac{10 + 60}{180}$ was quickly transported

to the spot. The main staircase and other easy means of access being impassable, and the only available staircase being too narrow to allow the passage of the board, it was necessary to lift it over roofs of outbuildings. These roofs had to be shored up with timber to bear the weight. Windows and doors had to be taken out, but all difficulties were overcome during the afternoon.

The Exchange lines cable and extension cables were diverted by means of cables run over the roofs. The temporary switchboard required modification for Automatic working by the fitting of dialling keys and wiring alterations. When darkness fell the work was continued under exceptional difficulty. The ordinary lighting supplies were cut off and recourse to hurricane lamps was necessary.

By 3 a.m. on the Monday morning the temporary installation was ready for service, and it is satisfactory to relate that this great Store was able to announce "Business as Usual." The firm quickly acknowledged their indebtedness to the Department in an appreciative letter and the local press gave publicity to the remarkable result achieved by the P.O. Engineers.

W.McC.

Northern District.

DISPLAY OF TELEPHONE AND TELEGRAPH APPARATUS AT FENWICKS, LTD., NEWCASTLE-ON TYNE.

In connexion with the publicity campaign now proceeding to foster the growth of the Telegraph and Telephone service, an exhibition was held at Fenwicks, Ltd.—one of the leading stores in the town—during the fortnight ended the 27th of February. The occasion was a Beauty Exhibition organized by the firm, and the Post Office stand, a photograph of which appears in this Journal, was situated among the stalls of the leading Beauty Specialists and Cosmetic Dealers of London and Newcastle. On an adjoining stand, the latest fashions were exhibited by mannequins.

In these surroundings it might be thought that an exhibition of Telephone and Telegraph equipment would be out of place, but in point of fact this was not the case. A number of coloured telephones, together with a well chosen design of decoration, was an effective means of blending the purely engineering exhibits and the more ornamental displays on the adjacent stands.

Prominently displayed on the stand was a working model of an automatic 4-digit exchange, to which four "exchange" lines were connected. This equipment was of great interest to a large number of visitors, and the demonstrators were kept busy explaining the details of the automatic system and the operation of the apparatus.

Two teleprinters, type 3A, were also installed and



FIG. 1.—POST OFFICE STAND.

connected in such a manner that telegrams could be transmitted either from one machine to the other for demonstration purposes, or to the H.P.O. for direct transmission to any part of the world. The public took advantage of this facility, and several telegrams were accepted and despatched without delay. A number of enquiries were also received regarding the hire of teleprinters and the facilities offered by them, and it is expected that agreements for these machines will be signed in the near future by several Newcastle firms.

Another attraction was the offer of free telephone calls in the Newcastle area, of which advantage was taken to the extent of about 350 calls. Two telephones were also connected *via* a circuit which simulated a line 500 miles in length, by means of a specially equalized repeater and a loss network. Conversations were invited over this circuit in order to enable visitors to appraise the quality and volume.

Among the other exhibits were the following:—

A replica of the 2,000,000th telephone that was presented to the King.

A model of the original Graham Bell Telephone.

A number of old fashioned type telephones and apparatus, including an Ivory and Gilt Switchboard and telephones, which at one time had belonged to Lord Rothschild.

A private branch exchange switchboard, the operation of which was demonstrated.

Sections of typical telephone cables.

Demonstration multi-coin box.

Maps showing the range of international telephone communication in 1920, and the extension achieved to date.

A series of cartoons illustrating the methods of communication used by man from the stone age to the present day.

In addition to the exhibition space, Messrs. Fenwicks, Ltd., were good enough to provide accommodation for a window display. The main theme was a series of pillars showing the growth

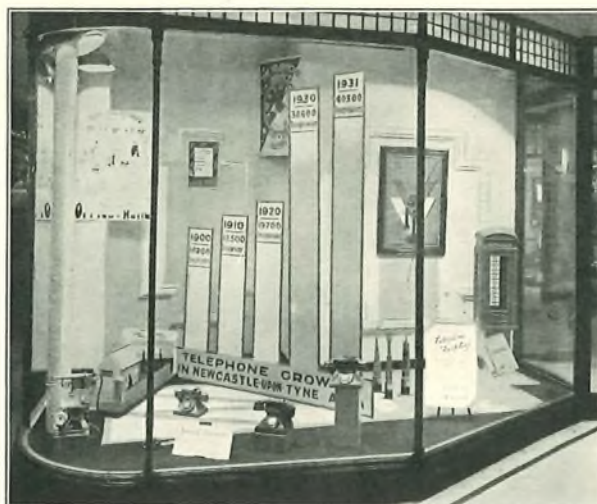

FIG. 2.—WINDOW DISPLAY.

of the telephone service in Newcastle. Prominent also in the window was a model of a kiosk No. 2 and of a rural automatic exchange, as well as a display of coloured hand micro telephones. A good deal of interest was shown by the public and the window was an excellent means of attracting visitors to the Exhibition itself.

There is no doubt the interest of the Newcastle public has been greatly stimulated, and a better appreciation of the activities and value of the telephone and telegraph services has resulted from this exhibition.

S.L.H.

Eastern District.

LOWERING A MANHOLE.

About three miles South East of Fenny Stratford, the Bucks County Council has widened Watling Street and lowered the surface about four feet in one part. This led to the Department having to lower the duct line and manholes, and gave rise to a most unusual and difficult engineering problem.

The Department's plant consisted of a 3-way multiple duct, containing the London-Manchester, London-Derby and the London-Birmingham-Liverpool cables, together with a 3-inch C.I. Pipe carrying the London-Birmingham telegraph cable. In addition, there was a large loading coil manhole type R.C.C. 11 containing eight loading coil cases, the coils being used for the London-Derby and London-Liverpool cables. This manhole weighed over 40 tons, including contents.

It was decided that the loading coils could not be cut out during the operations, and that it was undesirable to remove the roof and suspend the loading coils from barks while the manhole was practically rebuilt. It was finally agreed, in consultation with officers of the Engineer-in-Chief and Messrs. Standard Telephones & Cables, Ltd., that

the Company should undertake the work on the following plan:—

Excavate around the manhole, timber and shore up as required. Drive under the manhole floor sufficient steel joists to support the whole structure. Utilize eight screw-jacks (each 10-ton) to take the whole weight, these jacks to be used to effect the actual lowering operation.

It will be appreciated that the excavations were very extensive so that one of the first operations was the construction of a sump, 18 feet deep, seven feet away from the manhole. Fortunately the weather kept exceptionally fine during the whole work. Excavation round the manhole then proceeded, and, as shown by the photographs, full precautions were taken to support the manhole by proper timber framing.



FIG. 1.—MANHOLE READY FOR LOWERING.

Six rolled steel joists, 9 feet by 4 inches by 3 inches, were driven under the width of the manhole floor and spaced at equal distances of 2 feet 10 inches. Two rolled steel joists, 18 feet by 12 feet by 6 inches, were placed under the smaller joists to extend to the full length of the manhole. The jacks lifted direct on to these joists. The position of the 10-ton jacks was such that they could be operated in pairs, at each corner of the manhole. The jacks rested on $\frac{1}{4}$ -inch boiler plate under which were hardwood blocks of varying thicknesses. These blocks in turn rested on 10-inch balk timbers some 12 feet long. The soil was hard strong clay.

By 24th February, 1932, one jack under each

corner, extended some four inches, was screwed up simultaneously until the 40 odd ton weight was fully carried by the jacks. This was proved by a slight raising of the manhole, which showed all safe. Four feet of soil was then excavated from below the manhole, and all was in readiness for the lowering.

The four spare jacks in their extended position were placed one under each corner, and the manhole was lowered very slowly some $3\frac{1}{2}$ inches on to them, so slowly as to be almost imperceptible. Timber packing was removed from under the first four jacks, and the manhole was then again lowered on to these in their extended position and so on for the four feet.

An inspection of the interior walls of the manhole revealed no flaw whatever and there appeared to have been no movement of the cables. Concrete

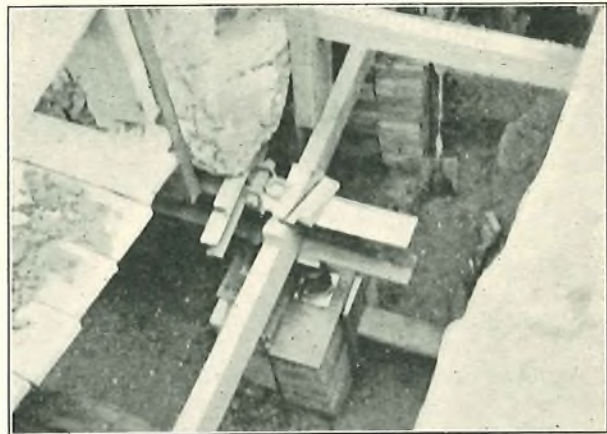

FIG. 2.—METHOD OF SUPPORTING MANHOLE.

was forced under the floor between the cross joists, and extended to fill in any excavations that had been made under and around the manhole below the new bottom level. The operation of withdrawing the two larger joists was then proceeded with and all timber was extracted and the excavation filled in.

The work involved anxious moments for those concerned, knowing the importance of the circuits, but so far as is known not a single fault has developed.

I am indebted to Mr. B. P. Holland, the Company's Resident Engineer in charge of the work, for the photographs.

W. J. STOREY, A.M.I.E.E.

The Institution of Post Office Electrical Engineers.

Essay Competition, 1931-32.

The Judges have reported to the Council that the Prize Winners in the recent Essay Competition, arranged in order of merit, are as follows:—

- H. Chapman, Testing Branch, Birmingham.
 " Timber Technology."
 F. W. Allan, North Eastern District.
 The Value of Private Study and its Application to Technical Training."
 J. Donaldson, Scot. East District.
 " From Overhead to Underground."
 A. D. Neate, Research Station, Dollis Hill.
 " The Corrosion of Lead Covered Cables."
 P. E. Fisher, Eastern District.
 " Internal Combustion Engines."

The Council has decided to award Certificates of Merit to the following five competitors who were next in order of merit:—

- E. H. Wilkinson, Research Station, Dollis Hill.
 " Rural Automatic Exchanges."
 A. H. Chance, Gloucester Repeater Station.
 " Outlines of Telephone Transmission."
 J. Lawton, South Lancs. District.
 " The Manchester Plug Ended ' B ' Suite."
 E. N. Clark, Eastern District.
 " Rural Automatic Exchanges."
 C. Wood, South Lancs. District.
 " Routine Testing in Automatic Exchanges."

There were 51 entries, and the Judges reported that the average marking of the essays received was considered satisfactory.

J. INNES,
 Secretary.

March, 1932.

Junior Section of the Institution of Post Office Electrical Engineers.

The Council of the I.P.O.E.E. last year decided to establish a Junior Section of the Institution in order that all ranks of the Post Office Engineering Department below the ranks of Inspector and Draughtsmen Class II. might enjoy facilities for the reading and discussion of papers and the interchange of ideas on telegraphic, telephonic and radio subjects similar to those enjoyed by members of the Institution. The scheme was definitely launched in January of the present year and local centres of the Junior Section are now being established in most of the larger towns throughout the country.

Credit is due to the London Centre of the parent Institution for originating the proposal and to the members of the I.P.O.E.E. Committee who examined the proposals and formulated without any delay a workable scheme which, it is believed, will

encourage the establishment of many local centres and form the basis of a successful organization.

The organization is of a simple character. Each local centre of the Junior Section is to be self-supporting and self-governing. The President of the Junior Section will be appointed annually by the Council of the parent Institution and it is intended that the President shall be the only direct link between the various local centres and the Council. He will watch over the interests of the Junior Section and be available to give advice and assistance to any local centre with a problem to solve. For the present session Mr. C. W. Brown has been appointed President.

The Chairman and Local Secretaries of the parent Institution will, of course, render what assistance they can to local centres of the Junior Section within their Districts and the Council has arranged for the following facilities to be afforded:—Loan of books from the Central Library; loan of lanterns and projectors; transmission of library books on the same conditions as those applicable to the parent Institution, and arranging facilities for meetings to be held on official premises.

Members of the I.P.O.E.E. are so familiar with the advantages which an organization of this kind affords that they will not be surprised to learn that the junior ranks warmly welcome the formation of the new Section and in several localities much enthusiasm is being manifested in the formation of centres. Although only one month of the present session has yet to run no time is being lost in holding meetings, and by the time these notes have gone to press meetings at which papers have been read and discussed will actually have been held. At one centre the opinion was expressed that the Junior Section had only one defect and that was that it should have been started ten years ago!

From accounts which reach us there will be no dearth of papers offered to Local Centre Committees for reading during next session, and it is to be expected that there will be keen rivalry among the centres for the five prizes of two guineas each to be awarded by the Council of the I.P.O.E.E. for the best papers read during the session.

There is undoubtedly a great wealth of hidden talent in the junior ranks which the new organization will assist to develop and reveal and, in course of time, as members of the Junior Section are promoted to ranks eligible for membership of the I.P.O.E.E. many of them will be well equipped to participate actively and usefully in the proceedings of the parent Institution. The educational standard of the junior ranks is higher to-day than at any time in the previous history of the Department, and the enthusiasm with which the new Section has been welcomed is a sure sign that some such organization had become a necessity.

Local Centre Notes.

North Wales Centre.

The British Broadcasting Corporation is, in many ways, a "close corporation," admitting, in its own publication, its policy of preserving the anonymity of its officials. So that, with the exception of the few highly placed gentlemen who, perhaps by design, bear upon themselves the fierce light of publicity and the Uncles of the Children's Hour, whose very names frequently hide the identity of the "relative," few of the numerous staff are known for whom they are. In North Wales, however, we can now claim more than passing acquaintance with at least one of them.

It was generally felt that the Committee had made a wise and popular decision in inviting Mr. Ernest Redpath, the Technical Editor of the B.B.C.'s Journal, "World Radio," to address the Centre on 11th December, 1931, on—"The Development of Short Wave Broadcasting."

Invitations to attend the meeting had been extended to the Shropshire Philosophical Society (of which the late Mr. T. Plummer, a former Superintending Engineer of the District, had been President), and the Headmasters and Staffs of the Shrewsbury School and the Shropshire County School, and an unusually large attendance gathered under the presidency of Mr. R. A. Weaver, M.I.E.E. Much pleasure was expressed at the attendance, for the first time at one of the Centre's meetings, of an Assistant Engineer-in-Chief, in the person of Major H. Brown, O.B.E.

In introducing the speaker the Chairman referred to Mr. Redpath's long association with Wireless investigation and to his work during the war in the Experimental Section of the Royal Naval Air Service, where he was closely connected with the late Professor Sir Erskine Murray, and at the R.A.F. Training Schools at Cranwell and Winchester.

Mr. Redpath reminded the meeting of the development of broadcasting on the medium and long waves, which are in general use in all countries, and of the small beginnings from which has grown the great organization in this country known as the B.B.C., and its kindred organizations in other countries.

Considerable interest was evoked in the theory, as introduced by the speaker, of the development of wireless in cyclic form, from the early experiments of Hughes, Hertz and Lodge in the production of very high frequency oscillations (and consequently extremely short waves), through the medium and long waves in present use, back to the ultra-short waves or micro-ray transmissions, a few years ago, began first to interest the amateur transmitter, and are now seriously engaging the attention of the B.B.C. and foreign radio administrations as a commercial possibility in the dissemination of broadcast programmes, and, to a lesser degree, of the Post Office and Wireless Companies for the purpose of radio communication.

Comparisons were given between the results obtainable by the use of waves falling within the well-known categories of short, medium and long, which included an interesting dissertation on range, fading and skip-distance effects, the influence on transmission of day and night, and the effects of the Kennelly-Heaviside and the more recently discovered Appleton layers.

Some remarkable instances were quoted of authenticated cases of the recording of wireless "echoes," which came as a revelation even to the many whose profession has made them quite familiar with the vagaries to be observed in the behaviour of electrical currents. Instances were given of the reception of waves that had travelled both ways round the earth from transmitter to receiver; of multiple signals that had travelled up to four times round the earth to be received as repetitions of the original signal, and of the reception of strong signals after as much delay as 4 minutes 20 seconds after their transmission, during which time a distance of 50 million miles must have been travelled. Such facts make it almost possible to believe in the apocryphal story of the proposed broadcast of the landing of Julius Cæsar on these shores and the Post Office Engineer must wonder whether he cannot envisage the possibility of adapting this phenomenon to the "timed call" trunk system!

On the practical side Mr. Redpath gave comprehensive details, to the delight of the hearts of the amateur constructors present, for the construction of short-wave receivers and of auxiliary apparatus for the conversion of an ordinary receiver for the reception of short-wave transmissions, at which stage there was much activity in the taking of copious notes.

The lecture was illustrated by a series of slides illustrative of the theories referred to and concluded with a pictorial tour of some of the World's principle short-wave broadcasting stations.

The fullest advantage was, naturally, taken in the subsequent discussion, of the speaker's ready offer to deal with questions on his subject.

Mr. Redpath was accorded very hearty thanks for his expert handling of a subject which is nowadays of universal interest, and which holds such immense possibilities for the future in the work of the Electrical Engineer.

J. T. W.

Scotland East Centre.

The Session was opened on the 13th October, 1931, when a visit was made to the Electrical Works of Messrs. Bruce Peebles and Co., Ltd., Granton, Edinburgh. The visit proved of great interest. A new system of rectifying to deal with heavy power loads, as well as transformer and winding coils, was

seen in course of construction. Motors of various sizes from the small fractional H.P. to 1000 H.P. were seen in the assembling stage, and processes of insulating laminations, windings, etc., were demonstrated.

A meeting was subsequently held in the Y.M.C.A. Building at which the Chairman gave an introductory address. Mr. Kitchen dealt with the work of the Institution and its objects. He earnestly hoped that all eligible members of the Staff would be persuaded to join up and take full advantage of the many excellent facilities offered in the form of lectures, papers, discussions, journals, library, etc., etc.

A lecture, entitled "The Control of Electrical Time Services in the British Post Office," was given by Mr. A. O. Gibbon, M.I.E.E., Engineer-in-Chief's Office, in the Goold Hall, St. Andrew Square, on the 10th November, 1931. It was illustrated by lantern slides, and a model master clock was in operation.

An interesting discussion followed in which members of the staffs of the Royal Observatory, Blackford Hill, and the City Observatory, Calton Hill, also took part.

At the December meeting the lecturer was Mr. J. Walker, of Annandale Street, Edinburgh. His subject was "Electrical Breakdowns and Repairs."

A large number of excellent slides were used to illustrate A.C. plant—Stators, Rotors, Transformers, Windings and Connexions: D.C. Plant—Armatures, Field Coils, Commutators, Brushgear as well as the maintenance of Shafts, Gears, Bushes, etc.

The items of general interest dealt with included Overhead Cables, Standards, Transformer Houses, Switchboards and Power Station Plant. Samples of Windings, Shafts, Bushes and Insulation were on view.

Some interesting points arose out of the discussion and were dealt with by Mr. Walker.

Northern Centre.

The Northern Centre was honoured at the February meeting when Professor W. M. Thornton, O.B.E., D.Sc., D.Eng., M.I.E.E., Professor of Electrical Engineering at Armstrong College, Newcastle-on-Tyne (University of Durham) gave a Lecture on "Transients." Dr. Thornton, whose name and work in the domain of research are well known to Electrical Engineers, very kindly placed at the disposal of the Centre his own Lecture Theatre for this occasion, a feature which added greatly to the interest of the proceedings. There were present 72 members and visitors. The Lecture was illustrated by lantern slides and blackboard demonstrations of the various circuits considered.

A few notes upon "Transients" have been kindly prepared by Dr. Thornton specially for publication in the Journal and, in view of the importance of the subject especially at the present

time when the Grid system is in course of Construction, the notes are printed in full below:

TRANSIENTS.

An electrical transient is defined as a momentary effect superposed on a normal electric circuit, which may arise from sudden changes of the circuit voltage, or from sudden induced or stray voltages such as atmospherics or in the phenomena of switching on or off the circuit. The current rush at switching on either a D.C. or an A.C. circuit is one form of transient. The equalisation of a charge along a conductor takes place not quite instantaneously but at the velocity of free electric waves. When a circuit is closed there is a rush of charge along it and the head of the charge or state of strain is called the wave front. If this is steep the Transient is dangerous for, on meeting an inductive part of the circuit, the charge piles up to a voltage which may be double that applied, and reflected waves run to and fro along the conductor until they are damped out by radiation of energy into space or by the resistance of the conductor.

The impedance of the circuit to these free transient waves is $\sqrt{\frac{L}{C}}$ where L is the inductance

and C the capacity of the circuit. This arises from the fact that when oscillations of this kind occur, their energy is at one instant all magnetic and at another all electro-static. The energy of the former is $\frac{1}{2}Li^2$ and of the latter $\frac{1}{2}CV^2$. Equating

these we see that the ratio $\frac{v}{i} = \sqrt{\frac{L}{C}}$

Transients, as their name implies, decay or pass away. If we are thinking of the magnitude of the starting current or voltage in a circuit, which may be much in excess of the steady current, we see a decay of the amplitude to that of the steady state. If again we fix our attention on one point of a line we may have a travelling transient pass it, with a high wave front tailing off to zero as the surge moves along. The calculation of the frequency of such oscillations is not always easy to make but when it is necessary to compare the performance of say two circuit breakers there can be no real standard of performance unless the surge impedance and free period of the waves in the circuit are known. Practice has shown that it is on these transient effects that most electrical breakdowns occur and in the testing of insulators it is very necessary to see that such surges do not arise. The so called "lightning generators" sometimes used in high tension testing, are designed for the purpose of making transients which imitate in their magnitude and frequency those introduced in the working of a circuit by atmospheric disturbances or instantaneous changes of the working conditions. All this applies equally well to light engineering

circuits where, however, the consequences are less severe.

In the era of high tension transmission now beginning in this country one of the difficulties to be faced is the possible interference in telegraph and telephone circuits arising from surges on neighbouring power lines or from harmonics in their voltage and current waves. Wherever these occur there is no temporary remedy possible; the disturbing causes must be minimised or suppressed by line chokes or surge absorbers or similar devices.

After the Lecture those present were entertained by Dr. Thornton with instructive and interesting practical experiments in the College Electrical Laboratory.

Scotland West Centre.

The opening meeting of the session was held on 5th October, 1931, when a paper on Wayleaves was delivered by Mr. F. W. Turner.

The lecturer acknowledged the work of previous writers in interpreting the Telegraph Acts and endeavoured to show the advisability of adhering strongly to the Postmaster-General's powers of construction in Public Roads as distinct from private property. The effect of the growth of overhead line distribution systems of Electric Light undertakers was referred to. A good discussion ensued.

For our November meeting the lecturer was Mr. A. McNeill, and the subject "Ayr Automatic Transfer." The paper was fully illustrated by lantern slides. The description given of the operations and of the difficulties encountered proved of great interest and led to considerable discussion and questions.

The December meeting was devoted to a paper on "Costing," by Mr. J. Dick. The purpose of the paper was to elucidate points which, from the evidence of the working of the system in the District, appeared to require some elucidation. The questions and discussion on the "Construction" section of the paper occupied so much time that the "Maintenance" section had to be postponed.

It was decided to bracket the "Maintenance" section of Mr. Dick's paper on "Costing" with Mr. M. Beattie's paper on "Telephones, Past and Present, Glasgow particularly," at the January meeting. Mr. Beattie led off with a most interesting review of the development of the telephone system in Glasgow, beginning with single wire and earth return Magneto, and tracing progress up to Automatic. The salient features of the several steps were dealt with. The nature of the paper did not lend itself to much discussion, but many expressions of appreciation were given and items of further information were contributed.

As copies of Mr. Dick's paper had, in the interval since the previous meeting been circulated

it was agreed that the "Maintenance" section be taken as read and the discussion proceeded with, after Mr. Dick had dealt with some points which had arisen since circulation of the paper. A good discussion followed.

At the February meeting Mr. R. Milne delivered a paper on Costing. The paper dealt with the plant records under the two heads of "Main" and "Local" and special mention was made of the points of difficulty which had arisen locally. The discussion which followed indicated that a keen interest had been aroused.

South Western Centre.

A meeting was held at Bristol on the 8th December, 1931, when two short papers were read by members of the Local Centre.

- (1) Mr. C. W. Bufton, on "Bridge Demolition affecting the Department's Plant."
- (2) Mr. R. C. Smith, on "Introduction to Cable Balancing."

The papers being of a practical character and very informative, were received by the members present with appreciation and good discussions resulted.

On the 12th January, 1932, Mr. J. S. Elston read a paper before a full Centre meeting at Bristol on "Trunk Telephone Re-organization Plan," there being over 100 members and visitors present. The lecture, which was freely illustrated with lantern slides, was much enjoyed and the discussion which followed the reading of the paper showed the keen interest and enthusiasm taken by the members in the subject.

Cinematograph films, shot during the progress of the London-Brighton Main Cable work, were exhibited under the direction of Mr. W. H. Brent. All present agreed that the films were an excellent series, educational and interesting.

At a meeting of this Centre held on the 9th February, Mr. W. E. H. Kennedy, M.C., delivered an exceedingly interesting illustrated lecture on "Industrial Psychology and its relation to the Post Office Engineering Department."

The paper provoked a very animated discussion which was marked by the differences of opinion on the value of the system in relation to the Post Office Engineering Department.

Inauguration of Junior Centres.

EDINBURGH.

A meeting, representative of all ranks of the Engineering Department eligible for membership of the Junior Section, was held in the Dining Room, Edinburgh Central Exchange, at 8 p.m., on 23rd February, for the purpose of establishing a Local Centre at Edinburgh. The Local Secretary of the parent Institution, Mr. J. Airey, was present to

assist in the formation of the Centre. Mr. J. J. McKichan acted as chairman. The aims and objects of the Junior Section were explained.

The proposal to establish a Centre in Edinburgh was carried unanimously. The draft Constitution and Rules were discussed and adopted, subject to slight modifications to suit local conditions.

Several members expressed a desire for meetings to be held during the remainder of the present session, and the meeting proceeded to appoint a Local Centre Committee. It was decided that the committee should be representative of the various interests and duties of the members, and the following were elected :—

Chairman—Mr. J. J. McKichan (Sectional Engineer).

Vice-Chairman—Mr. P. S. S. Biggers.

Treasurer—Mr. J. Edmonstone.

Secretary—Mr. M. Craig.

Internal Staff, Exchange and Repeater Stations—Mr. P. Quinn.

Internal Staff not in Exchanges—Mr. J. Macguire.

Overhead Staff—Mr. W. Robertson.

Underground Staff—Mr. W. Dickson.

Telegraph and Electric Light Staff—Mr. J. Lockie.

Over 70 members have been enrolled and an application for registration as an authorised Local Centre has been forwarded.

DUNDEE.

A similar meeting was held in the H.P.O., Dundee, at 7.30 p.m., on the 3rd of March. Captain H. G. Tissington took the Chair. After Mr. Airey had set forth the various objects of the Junior Section, it was unanimously decided to establish a Section at Dundee. The following Committee was appointed :—

Chairman—Captain H. G. Tissington (Sectional Engineer).

Vice-Chairman—Mr. J. Mathewson.

Secretary—Mr. J. Donaldson.

Treasurer—Mr. W. V. McWalter.

Internal Staff, Dundee Post Office—Mr. J. B. Soutar.

Maintenance and Fitting Staff—Mr. E. Rae.

Open Construction Staff—Mr. J. R. Simpson.

Underground Construction Staff—Mr. W. Batchelor.

25 Members have been enrolled and an application for registration as an authorised Local Centre has been forwarded.

THE INSTITUTION OF P.O. ELECTRICAL ENGINEERS.

Officers of Colonial and Foreign Telegraph Administrations who are engaged in Electrical Engineering Works may be admitted as Corresponding Members after application.

Subscription payable annually in advance on 1st April in each year:

Corresponding Members £1 0 0

This sum includes the Annual Subscription to the Journal of P.O. Electrical Engineers and the supply of all Professional Papers issued during the period covered by the subscription.

Forms of application for Corresponding Membership can be obtained on application to

The Secretary,
Institution of P.O.E. Engineers,
G.P.O. (Alder House), E.C.1,

or the undermentioned gentlemen who have kindly agreed to act as representatives of the Institution in their respective countries :—

R. Badenach, Esq., B.Sc. (Melb.),
Chief Engineer's Office,
Postmaster-General's Department,
Treasury Gardens,
Melbourne, C.2,
Australia.

H. C. Brent, Esq.,
District Telegraph Engineer's Office,
Wellington, N.Z.

N. N. Banerjee, Esq., A.M.I.E.E. (Ind.),
Divisional Engineer, Telegraphs,
Calcutta West Division,
8, Wellesley Place,
Calcutta,
India.

A. T. Kingston, Esq., M.B.E., A.M.I.E.E.,
Office of the Chief Engineer,
Telegraphs & Telephones,
C.T.O.,
Colombo,
Ceylon.

A. G. Kellaway, Esq.,
P.O. Box 1077,
Johannesburg,
South Africa.

E. L. Jephcott, Esq., A.M.I.R.E.,
Chief Engineer's Department,
G.P.O. Box 391,
Salisbury,
South Rhodesia.

Book Reviews.

"Submarine Telegraphy," by Ing. Italo de Giuli. Translated from the Italian by J. J. McKichan, O.B.E., A.M.I.E.E. Sir Isaac Pitman and Sons, Ltd., Parker Street, Kingsway, London, W.C.2. Price 18/-.

Apart from the transactions of the professional institutions of England and America and an occasional article in a technical publication, there is little published information in English on modern methods in submarine telegraphy. This is the more surprising in view of the acknowledged pre-eminence of these two nations in this field of engineering. The present work translated from the Italian is, therefore, a welcome addition to the literature of the subject. The author modestly describes the book as a collection of notes, and while this is, perhaps, true in regard to its treatment of the constructional and theoretical sides of submarine telegraphy, the book is a compendium of information on apparatus and methods of working cables much of which is not readily available elsewhere.

An introductory chapter contains a brief history of the subject and a variety of general information with descriptions of such well known features as the

bridge duplex and the make-up of artificial lines. The chapter on transmitting apparatus deals with automatic working in some detail and contains diagrams and descriptions of transmitter, phonic motor and vibrator control. The sections dealing with receiving apparatus and multiplex telegraphy, as applied to cables, form perhaps the most valuable portion of the book, the treatment being comprehensive and the text well illustrated by reproductions of photographs and numerous diagrams. The Huertley magnifier, Brown relay, regenerators, methods of synchronization and the Western Union and Muirhead systems of multiplex are all described in detail. The book also contains chapters on testing, the layout of a typical cable station and, finally, a section on loading in which history is combined with theory and the description of methods. Appendixes on the KR law and signalling speed, and the balanced sea earth, have been added by the translator.

The translation of a technical work is frequently not entirely successful as a text-book, owing to divergent practice, but the present book is British in nearly everything but authorship and Mr. McKichan has performed a useful task in making it

JUST
PUBLISHED

PITMAN'S
BOOKS

JUST
PUBLISHED

A Practical Manual for Students and Engineers

SUBMARINE TELEGRAPHY

By IN. ITALO DE GIULI.

Translated into English by J. J. McKICHAN, O.B.E., A.M.I.E.E.
With a Foreword by T. E. HERBERT, M.I.E.E., *Superintending Engineer, Post Office Department.*

THIS careful translation follows very closely the original Italian edition which is a recognized standard work in that country. It deals with the operation of modern telegraph apparatus and provides sound fundamental knowledge from a practical standpoint. A modest acquaintance with electrical phenomena is assumed so that students and engineers of all branches of telegraphic and electrical communication work may benefit from its practical and up-to-date information. Many insets, photographs and diagrams illustrate the text, and, together with numerous curves and tables, add to its reference value.

250 pages

18s. net

Illustrated

The Third Edition of a Standard Work

ALTERNATING CURRENT BRIDGE METHODS

By B. HAGUE, D.Sc., Ph.D., A.C.G.I., M.I.E.E., ETC.

A THEORETICAL and practical handbook for the use of advanced students and research workers. The fundamental principles are fully explained and the theory underlying the use of bridge networks is given in an able and easily understandable manner. The most up-to-date methods for the measurement of Inductance, Capacitance and Effective Resistance at low and Telephonic Frequencies are included, with practical and valuable suggestions on choice of bridges and the precautions to be observed. Supplementary Notes have been added in this revised edition.

THIRD EDITION. 15s. net. THIRD EDITION.

"No one who has to deal with a bridge can afford to be without this book." (*Jnl. Scientific Instruments*).

Write for Pitman's Complete Catalogue of Technical and Scientific Books

SIR ISAAC PITMAN & SONS, LTD., 39-41, Parker Street, Kingsway, London, W.C. 2

available for reference and study by the English reader.

C.J.M.

"The Motor Cyclist's Workshop." By "Torrens" of "The Motor Cycle." Iliffe & Sons, Dorset House, Tudor Street, E.C.4. 2/-, by post 2/3.

This book is a valuable guide to the rider who has a mechanical turn of mind, who is willing to tackle jobs beyond the scope of running repairs, and who does not begrudge the investment of a few shillings in additional tools.

The lay-out of an "ideal" workshop for an amateur motor cycle mechanic and the correct use and application of hand tools, *e.g.*, chisels, files, scrapers, drills, etc., are dealt with in a concise, interesting and instructive manner. The simple but often mishandled jobs of soldering, rivetting and brake relining are clearly described. Other sections deal with the renewal of such parts as bushes, bearings, sprockets and valve guides. Re-enamelling

and the fitting and removal of tyres are also adequately dealt with.

Whilst the author admittedly describes an "ideal" or dream workshop which is not within the reach of all riders, anyone who has space for a bench and vice could effectively undertake many of the operations described.

A section on "Tuning for Speed and Efficiency" is of special interest for the speedster rather than the tourist.

The book is clearly illustrated throughout by nearly one hundred simple drawings and is without doubt a sound investment for the rider who is practical and who seeks efficiency with economy.

R.M.

We have received from Messrs. Pitman a set of 12 books forming their Motor Cyclists' Library. The books are well printed and illustrated and form a useful aid to users of the various types of machines dealt with. The published price is 2/- per volume.

Staff Changes.

POST OFFICE ENGINEERING DEPARTMENT.

PROMOTIONS.

Name.	From	To	Date.
Ridd, P. J.	Asst. Superintending Engineer, London District.	Staff Engineer, Construction Section, E.-in-C.O.	1-3-32
Wilby, E. J.	Asst. Staff Engineer, E.-in-C.O. (Investigations).	Staff Engineer, E.-in-C.O. (Investigations).	30-12-31
Faulkner, H.	Executive Engineer, Radio Section, E.-in-C.O.	Asst. Staff Engineer, Radio Section, E.-in-C.O.	7-1-32
Gibbon, A. O.	Executive Engineer, Telegraph Section, E.-in-C.O.	Asst. Staff Engineer, Construction Section, E.-in-C.O.	1-4-32
Bell, J. H.	Executive Engineer, London District.	Asst. Suptg. Engineer, London District.	1-3-32
Morice, A. B.	Executive Engineer, Research Section, E.-in-C.O.	Asst. Staff Engineer, Lines Section, E.-in-C.O.	1-4-32
Eves, W. J.	Assistant Engineer, N. Wales, District.	Executive Engineer, Aberdeen Section, Scot. E. District.	20-2-32
Radford, J.	Assistant Engineer, Equipment Section, E.-in-C.O.	Executive Engineer, Equipment Section, E.-in-C.O.	12-12-31
Bates, A.	Assistant Engineer, Equipment Section, E.-in-C.O.	Executive Engineer, S.E. Internal Section, London District.	12-12-31
Hart, J. H.	Assistant Engineer, C.T.O. Section, London District.	Executive Engineer, S.W. Internal Section, London District.	1-1-32
Fraser, A. R.	Assistant Engineer, Test Section, E.-in-C.O.	Executive Engineer, Test Section, E.-in-C.O.	1-4-32
Armitage, D.	Assistant Engineer, Radio Section, E.-in-C.O.	Executive Engineer, Radio Section, E.-in-C.O.	28-1-32
Davis, H. G.	Assistant Engineer, Telegraph Section, E.-in-C.O.	Executive Engineer, Telegraph Section, E.-in-C.O.	28-1-32

STAFF CHANGES.

Name.	From	To	Date.
Little, G. J. S.	Assistant Engineer, Lines Section, E.-in-C.O.	Executive Engineer, Lines Section, E.-in-C.O.	1-4-32
Harris, L. H.	Assistant Engineer, Telegraph Section, E.-in-C.O.	Executive Engineer, Telegraph Section, E.-in-C.O.	1-4-32
Ray, F. I.	Assistant Engineer, Telephone Section, E.-in-C.O.	Executive Engineer, City Internal Section, London District.	1-3-32
Brown, C. W.	Assistant Engineer, Research Section, E.-in-C.O.	Acting Executive Engineer, Research Section, E.-in-C.O.	28-1-32
Dopson, F. W.	Chief Inspector, E.-in-C.O.	Assistant Engineer, E.-in-C.O.	12-1-32
Booth, C. F.	Chief Inspector, E.-in-C.O.	Assistant Engineer, E.-in-C.O.	3-12-31
Thatcher, C. H.	Chief Inspector, London District.	Assistant Engineer, London District.	3-12-31
Mitchell, T. A.	Chief Inspector, S. East District.	Assistant Engineer, E.-in-C.O.	22-1-32
Bocock, W.	Chief Inspector, London District.	Assistant Engineer, London District.	27-1-32
Boulton, J. D.	Chief Inspector, London District.	Assistant Engineer, London District.	To be fixed later.
Smith, J. G.	Chief Inspector, E.-in-C.O.	Assistant Engineer, E.-in-C.O.	To be fixed later.
Pricket, W.	Chief Inspector, E.-in-C.O.	Assistant Engineer, E.-in-C.O.	To be fixed later.
Haveron, T.	Inspector, Scot. W. District.	Chief Inspector, Scot. W. District.	1-1-32
Durkin, T.	Inspector, N.E. District.	Chief Inspector, N.E. District.	3-11-31
Baxter, F.	Inspector, S. Lcs. District.	Chief Inspector, S. Lancs. District.	1-1-32
Hayton, E.	Inspector, S. Mid. District.	Chief Inspector, S. West District.	10-1-32
Glenn, B.	Inspector, N. Mid. District.	Chief Inspector, N. Mid. District.	3-1-32
Read, A. J.	Inspector, N. Mid. District.	Chief Inspector, N. Mid. District.	17-1-32
Turley, T. G.	Inspector, S. Lancs. District.	Chief Inspector, London District.	3-1-32
Morphew, R. O.	Inspector, London District.	Chief Inspector, London District.	1-11-31
Pate, H. S.	Inspector, London District.	Chief Inspector, E.-in-C.O.	1-1-32
Gosney, G.	Inspector, London District.	Chief Inspector, E.-in-C.O.	1-1-32
Thwaites, J. E.	Inspector, St. Albans Radio.	Chief Inspector, E.-in-C.O.	10-1-32
Gill, O. W.	Draughtsman, Class I., E.-in-C.O.	Chief Inspector, E.-in-C.O.	24-11-31
Ivory, J.	Draughtsman, Class II., N.W. District.	Inspector, E.-in-C.O.	1-6-30
Buckingham, L. J.	} Skilled Workmen, Class I., E.-in-C.O.	} Inspector, E.-in-C.O.	1-1-31
Watts, G. D.			1-1-31
Davey, F. R.			11-7-31
Perkins, T. F.			13-5-31
Hartwell, C. N.	} Skilled Workmen, Class I., N. Mid. District.	} Inspectors, N. Mid. District.	12-12-31
Domett, S. G.			12-12-31
Greenbury, L. J.	} Skilled Workman, Class I., Testing Branch.	} Inspector, Testing Branch.	1-11-31
Hingley, H.			1-11-31
Gowland, J. W.	} Skilled Workman, Class II., N. District.	} Inspector, N. District.	1-1-31
Doughty, R. S.			1-1-31
McDonald, W.	} Skilled Workmen, Class I., Scot. E. District.	} Inspector, Scot. E. District.	14-2-32
Allen, A. T.			31-1-32
Loveday, T. C.	} Skilled Workman Class I., E. District.	} Inspector, E. District.	21-2-32
Thorpe, H. W.			7-2-32
Thorpe, H. W.	} Skilled Workman Class I., Scot. W. District.	} Inspector, Scot. W. District.	To be fixed later.
Borthwick, G.			To be fixed later.
Wallis, R. H. J.	Second Engineer, H.M.T.S. "Alert."	Chief Engineer, H.M.T.S. "Alert."	20-1-32
Jago, D. V.	Third Officer, H.M.T.S. "Alert."	Second Officer, H.M.T.S. "Monarch."	To be fixed later.
Jago, D. V.	Fourth Officer, H.M.T.S. "Alert."	Third Officer, H.M.T.S. "Alert."	To be fixed later.

STAFF CHANGES.

RETIREMENTS.

Name.	Rank.	District.	Date.
Turner, E.	Staff Engineer.	E.-in-C.O. Construction Section.	29-2-32
Pink, E. A.	Assistant Staff Engineer.	E.-in-C.O. Construction Section.	31-3-32
Wise, F. H.	Assistant Suptg. Engineer.	S.E.	31-3-32
Shea, J.	Assistant Suptg. Engineer.	N. East.	31-1-32
McNicol, A. J.	Executive Engineer.	London.	31-12-31
Cowling, G.	"	E.-in-C.O.	31-3-32
Taylor, J. L.	"	E.-in-C.O.	16-1-32
Morgan, J. A.	"	E.-in-C.O.	31-3-32
Glover, J. B.	"	Scot. E.	19-2-32
Mairs, J. B.	Assistant Engineer.	Scot. E.	3-1-32
Reddrop, W. H.	"	London.	31-1-32
Batty, J. W.	"	Scot. W.	31-1-32
Land, A. E.	"	S. Wales.	13-1-32
Martin, W.	"	London.	31-1-32
Lawson, R. J.	"	Scot. E.	31-1-32
Frost, G. H.	"	N. Wales.	31-3-32
Pugh, J. D.	Chief Inspector.	E.	31-12-31
Graham, W. A. T.	"	N. West.	11-2-32
Williamson, G. E.	"	S. West.	31-12-31
Ewing, J. G. A.	"	S. Lancs.	31-12-31
March, H.	"	N. Mid.	30-11-31
Brewin, G.	"	N. Mid.	30-12-31
Briggs, J. W.	"	Testing Branch.	31-12-31
Graham, J.	"	Scot. E.	16-1-32
Robertson, J. O.	"	London.	31-1-32
Houghton, C. H.	"	S. East.	5-2-32
Morrison, G. P.	"	S. Lancs.	16-3-32
Rushforth, J. A.	"	N. East.	12-2-32
Gatty, A.	"	N. Wales.	19-2-32
Nash, W. H.	Inspector.	Testing Branch.	21-12-31
Prentice, C. W.	"	London.	31-12-31
Smeed, H. C.	"	London.	31-12-31
Whiting, H.	"	London.	31-12-31
Allen, J. L.	"	S. East.	31-12-31
Chandler, W. C.	"	Scot. East.	31-12-31
Charlish, W. J.	"	S. Mid.	31-12-31
Gibbs, L. F.	"	S. Mid.	31-10-31
Lewis, B.	"	S. Wales.	3-1-32
Coates, J. W.	"	N. East.	31-12-31
Eager, F. C.	"	S. West.	31-1-32
Fitzpatrick, G. A.	Chief Engineer.	H.M.T.S. "Alert."	19-1-32

DEATHS.

Name.	Rank.	District.	Date.
Tattersall, J. T.	Assistant Suptg. Engineer.	Scot. E.	27-2-32
Ainsworth, F. G.	Inspector.	S. Mid.	21-1-32

TRANSFERS.

Name.	Rank.	From	To	Date.
Taylor, C. A.	Assistant Staff Engineer.	E.-in-C.O.	S. East. (Assistant Supt. Engineer).	1-4-32
Chinn, W. E.	Assistant Engineer.	E.-in-C.O.	Egypt (3 years loan).	23-2-32
Richardson, A. E.	Wireless Overseer (Inspector).	Cupar Radio.	E.-in-C.O.	21-2-32
Elden, F. A.	Fourth Officer.	H.M.T.S. "Monarch."	H.M.T.S. "Alert."	To be fixed later.

STAFF CHANGES.

CLERICAL ESTABLISHMENT.

PROMOTIONS.

Name.	From	To	Date.
Luxford, A. E.	Higher Clerical Officer, London District.	Staff Officer, London District.	1-4-32
Roberts, E. L.	Clerical Officer, London District.	Higher Clerical Officer, London District.	7-3-32
Edwards, C. A.	Clerical Officer, London District.	Higher Clerical Officer, London District.	1-4-32
Thornburn, W. H.	Higher Clerical Officer, North East District.	Staff Officer, South Mid. District.	23-1-32
Shadforth, F. J.	Higher Clerical Officer, Northern District.	Staff Officer, Northern District.	1-4-32
Powley, T.	Clerical Officer, North East District.	Higher Clerical Officer, North East District.	23-1-32
Austin, R. B.	Clerical Officer, North West District.	Higher Clerical Officer, Belfast.	31-1-32
Cunningham, J. H.	Clerical Officer, Scot. East District.	Higher Clerical Officer, Scot. East District.	30-11-31
Oliver, S. R.	Acting Executive Officer, E.-in-C.O.	Executive Officer, E.-in-C.O.	12-11-31
Dyson, C. E. J. C.	Clerical Officer, E.-in-C.O.	Acting Executive Officer, E.-in-C.O.	12-11-31
Peacock, T. L.	Clerical Officer, S. Wa. District.	Higher Clerical Officer, S. Wales District.	7-3-32
Portch, A. J.	Clerical Officer, S.W. District.	Higher Clerical Officer, N. Wales District.	Not yet fixed.
Campbell, T.	Clerical Officer, Scot. E. District.	Higher Clerical Officer, Scot. East District.	Not yet fixed.

RETIREMENTS.

Name.	Rank.	District.	Date.
Freeman, F.	Staff Officer.	London.	31-3-32
Burtles, G.	Higher Clerical Officer.	London.	6-3-32
Motyer, J. A.	Staff Officer.	Northern	31-3-2
Balcombe, W. O.	Higher Clerical Officer.	South Wales.	5-3-32
Dunnet, W.	Higher Clerical Officer.	North Wales.	14-4-32

BOARD OF EDITORS.

- B. O. ANSON, M.I.E.E., Chairman.
 P. J. RIDD, M.I.E.E.
 C. J. MERCER, M.I.E.E., M.I.R.E.
 A. J. GILL, B.Sc., M.I.E.E., M.I.R.E.
 J. D. BOULTON.
 J. T. KELLY.
 J. INNES, B.Sc., A.M.I.E.E., Managing Editor.
 W. S. PROCTER, A.M.I.E.E., Assistant Editor.

COMMUNICATIONS.

All Remittances and Communications should be addressed to the MANAGING EDITOR, P.O.E.E. JOURNAL, Engineer-in-Chief's Office, Alder House, London, E.C.1.

Binding covers and copies of the Contents for Vol. 3 to 24 are available, and may be obtained from the local agents for 1s. 6d. and 3d. respectively. Subscribers can have their copies of Vol. 24 bound, with index included, at a cost of 3s., by sending the JOURNALS to the local agents. Orders for bindings, Vols. 1—19, should indicate whether the original binding with black lettering, or the latter pattern in gold, is required. Covers with gold lettering will be the only type stocked from Vol. 20 onwards.

The price of the JOURNAL is 1s. (1s. 3d. post free) per copy, or 5s. per annum, post free. All back numbers 2s. each.

LONDON to BRIGHTON Aerial Telephone Line



The Standard adopted by the
BRITISH POST OFFICE

The first link in the Rural Trunk Telephone System of Great Britain (on-demand or no delay trunk service) has been forged by the successful LONDON-BRIGHTON Aerial Cable line, using Pirelli-General 74 pair/10 lb. star quad trunk cable

Loaded throughout with

G.E.C.

LOADING COILS

wound on

GEALLOY CORES

MADE IN ENGLAND

*Famous for the
Outstanding Characteristics*

Low Losses and High Stability

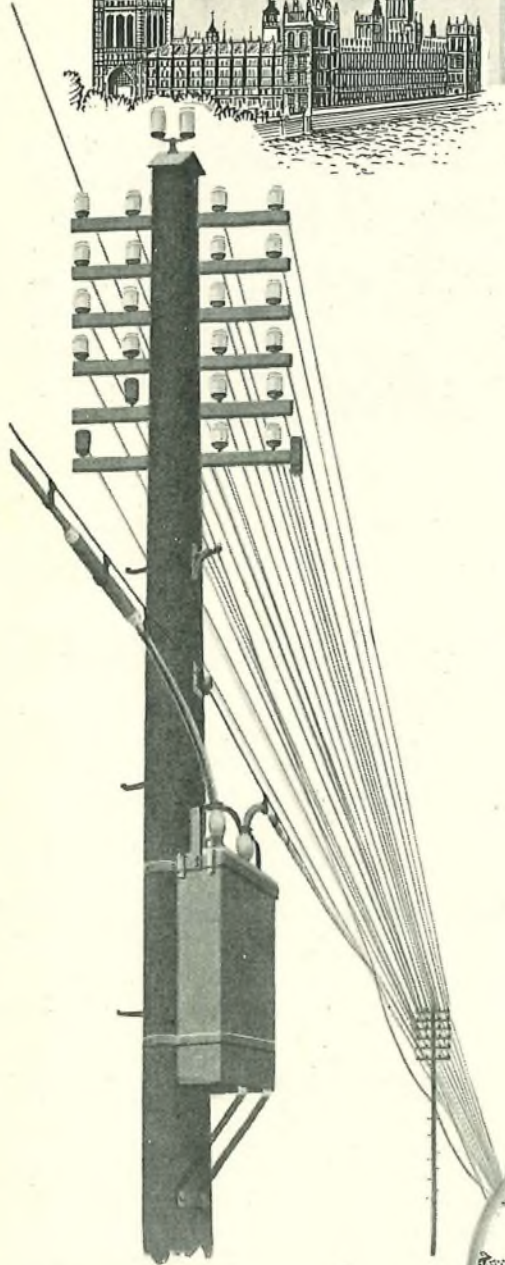

Made at
The Salford Electrical Instrument Works
of
THE GENERAL ELECTRIC CO., LTD.

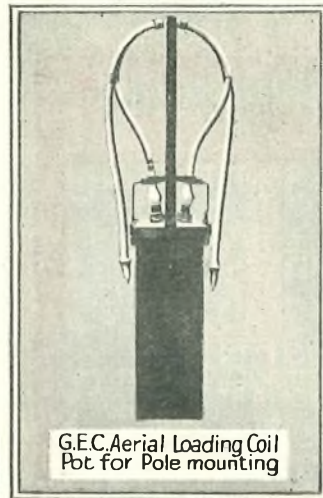

G.E.C. Aerial Loading Coil
Pot for Pole mounting

INDEX TO ADVERTISERS.

	PAGE		PAGE
Automatic Telephone Mfg. Co., Ltd.	iii	Henley's, W. T., Telegraph Works, Co., Ltd.	ix
British Institute of Eng. Technology ...	xiv	Pirelli-General Cable Works, Ltd. ...	xvi
Creed & Co., Ltd.	xiii	Pitman & Sons, Ltd.	100
Ebonestos Insulators, Ltd.	xii	Standard Telephones and Cables, Ltd.	x
Elliott Brothers, Ltd.	xv	Siemens Bros. & Co., Ltd. ...	vi and vii
Ericsson Telephones, Ltd.	v	Smith, Frederick & Co.	xv
Ernest T. Turner	ix	Telephony Publishing Corp. ...	xii
Ferranti	ii	The Electrical Review	iv
Hall Telephone Accessories (1928), Ltd.	xii	The General Electric Co., Ltd.	viii and xi

Hall Telephone Accessories (1928) Limited.

Suppliers to the British Post Office and
- Foreign Government Departments. -

Manufacturers of prepayment telephone multi-coin collectors, automatic stamp selling and ticket selling machines, automatic slot machines and fire alarm apparatus.

Registered
Office & Works : 70, DUDDEN HILL LANE,
WILLESDEN,
LONDON, N.W. 10

Tel.: WILLESDEN 5141/2.

Moulders to the Trade

Established 30 Years

MOULDINGS
IN WHITE OR
COLOURS.
BAKELITE —
BEETLE —
CELLULOSE
AND OTHER
SYNTHETICS.

PLASTIC MOULDINGS HAVING
HEAT — ACID — OIL — ALKALI —
WATER RESISTING QUALITIES.

EBONESTOS INSULATORS LTD

Excelsior Works,
Rollins Street,
Canterbury Road,

Telephone
NEW CROSS 1913 (5 lines) LONDON, S.E.15.

Telephony



TELEPHONY'S Engineering Data Sheets—

are contained in every issue and are so arranged that the sheets may be clipped and filed in binders. The subject matter covers everything pertaining to outside and inside plant design, construction and maintenance.

This feature constitutes only one of many reasons why TELEPHONY is so popular among telephone men all over the world. Subscription price £1. 5s. for 52 interesting and instructive issues.

Address: Electrical Trading and Electricity Technical Book Dept., 85, Long Acre, London, W.C. 2, for a sample copy of TELEPHONY.
TELEPHONY PUBLISHING CORP., 608, S. Dearborn St. Chicago, Ill, U.S.A.

The
NEW
CREED TELEPRINTER
For PAGE or TAPE
PRINTING.

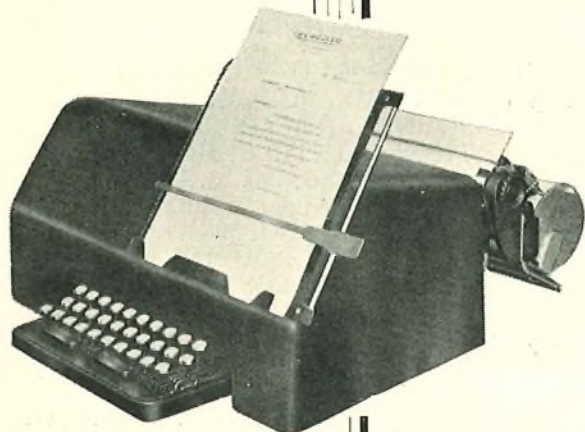

No. 7a MODEL
 (Front View)

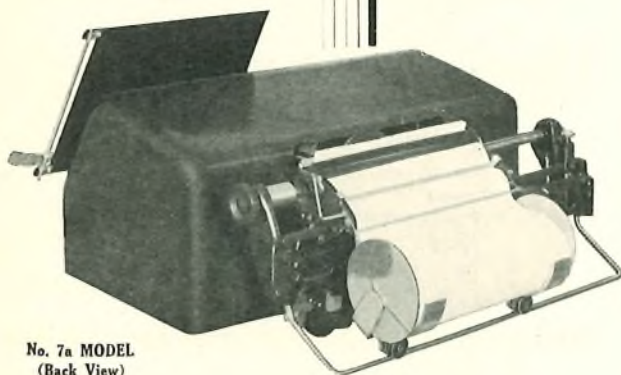

No. 7a MODEL
 (Back View)

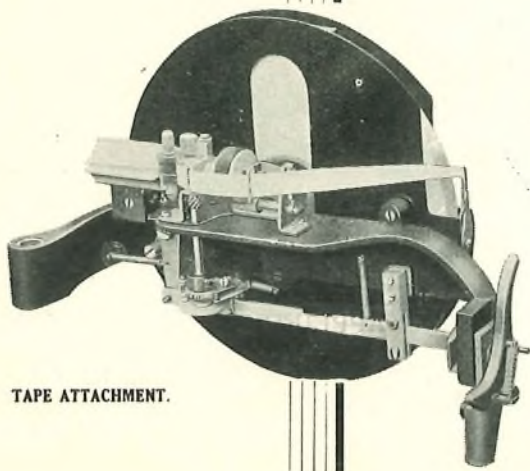

TAPE ATTACHMENT.

The new 7a model Teleprinter is similar as regards essential principles to the earlier Creed Teleprinters, but it incorporates numerous improvements in design.

One very important feature of this model is that it can be converted from page printing to tape printing without trouble.

The paper carriage, which is a self-contained unit, is readily movable by merely pressing a latch and then lifting it off a large pivot on the main base. The tape attachment (see lower illustration) can then be fitted on the pivot. The working of the machine is not altered by the change.

Creed Teleprinters are rapidly replacing the Morse Key and Sounder apparatus in Telegraph Administrations because they are faster and more economical.

Over 2,000 Teleprinters are already in service by the General Post Office throughout Great Britain.

For further particulars apply to :

CREED & CO. L^{TD.}

Telegraph House,

CROYDON - SURREY

Telephone : CROYDON 2121 (6 lines)

Telegrams : CREDO, PHONE, CROYDON.

GUARANTEED EXAMINATION COACHING

Since the B.I.E.T. was founded several years ago, we have specialised in preparing candidates for leading Technical Examinations, and our success may be gauged from the fact that over all this period of time, our candidates have returned the remarkable average pass record of

OVER 90% SUCCESSES.

Here are two very recent results :—

In the Probationary Inspectors' Examination held in December, 1931, 7 out of our 8 candidates were selected for interview.

In the I.E.E. Examination held in November, 1931, 13 out of our 14 candidates passed successfully.

In each of the above instances, the only unsuccessful candidate had not fully completed our course, and can hardly be termed a true "failure."

We teach successfully by correspondence and definitely guarantee—

"NO PASS—NO FEE"

You are advised to send for a copy of our General Prospectus "ENGINEERING OPPORTUNITIES." This Hand-book contains 200 pages of most useful information. It also contains particulars of all leading Engineering Examinations, including

Probationary Inspectors (*Open and Limited Competition*)

Probationary Assistant Engineers (*Open and Limited Competition*)

City and Guilds Special G.P.O. Examination, I.E.E., B.Sc., A.M.I.C.E., London Matric., etc., etc.

The Hand-book also outlines "up to the minute" courses of Home Study in *all branches* of Engineering.

Special Courses are offered in **Telegraphy, General Telephony, Automatic Telephony, Telephone Transmission, Electrical Technology, Wireless and High Frequency, Radio Communication, Alternating Currents, Talking-Picture Engineering, etc., etc.**

Our 200 page Hand-book should be on your Book-shelf. It will be gladly sent on request, FREE and without obligation. (*Please state subject or Examination of most interest*).

British Institute of Engineering Technology

369, Shakespeare House,

29/31, Oxford Street, London, W. 1

The Institution of Post Office Electrical Engineers.

PRINTED PAPERS.

The following papers contributed to the proceedings of the Institution have been printed by authority of the Council and may be obtained from

The Librarian,

The Institution of Post Office Electrical Engineers,

G.P.O., Alder House, London, E.C. 1.

The prices do *not* include postage.

- | | | |
|----------|--|-----|
| No. 124. | "THE MEASUREMENT OF SOUND AND ITS APPLICATION TO TELEPHONY."—A. J. ALDRIDGE, A.C.G.I., A.M.I.E.E. 1929 | 9d. |
| No. 125. | "THE DEVELOPMENT OF AUTOMATIC ROUTINERS IN THE BRITISH POST OFFICE."—A. SPEIGHT, A.M.I.E.E. 1929 | 9d. |
| No. 126. | "TELEPHONE CABLE CIRCUIT INTERFERENCE."—A. MORRIS, A.R.C.Sc., M.I.E.E. 1929 | 1s. |
| No. 127. | "SECONDARY CELLS (LEAD-ACID TYPE)."—H. H. TURNER. 1928 | 6d. |
| No. 128. | "CRITICAL METHODS OF INVESTIGATION AS APPLIED TO THE STUDY OF TELEPHONE AREAS AND PLANT LAY-OUT."—J. N. HILL. 1930 | 1/3 |
| No. 129. | "PICTURE TELEGRAPHY."—E. S. RITTER, D.F.H., M.I.E.E. 1929 | 9d. |
| No. 130. | "COMPOSITE TELEGRAPH AND TELEPHONE WORKING."—J. M. OWEN, A.M.I.E.E., and J. A. S. MARTIN. 1930 | 1/3 |
| No. 131. | "CARRIER CURRENT TELEPHONY."—Capt. A. C. TIMMIS, B.Sc., A.M.I.E.E. 1930 | 1s. |
| No. 132. | "THE HEATING AND VENTILATING OF POST OFFICES AND TELEPHONE EXCHANGES."—W. T. GEMMELL, B.Sc. (Hons.), A.M.I.E.E. 1930 | 9d. |
| No. 133. | "RURAL AUTOMATIC EXCHANGES."—J. C. DALLOW. 1929 | 9d. |
| No. 134. | "SOUND AND HEARING."—N. F. CAVE-BROWNE-CAVE, B.Sc., M.I.E.E. 1930 | 1s. |
| No. 136. | "SOME DEVELOPMENTS IN TELEGRAPH TECHNIQUE AS APPLIED TO RADIO CIRCUITS."—H. FAULKNER, B.Sc. (Hons.), A.M.I.E.E., and G. T. EVANS. 1931 | 1s. |

Differential Moving Coil MILLIAMMETERS FOR TELEGRAPH CIRCUITS

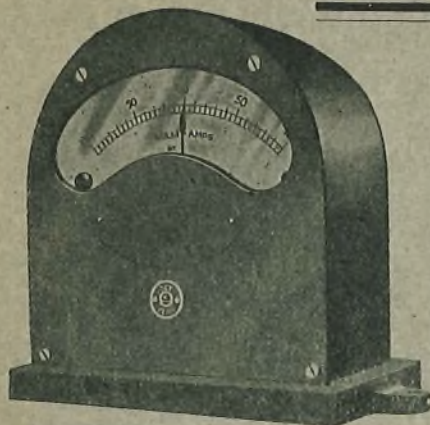

T. 1097. TABLE MOUNTING TYPE.

TABLE, WALL AND PANEL MOUNTING TYPES.

INVALUABLE as line Milliammeters on Differential Duplex, Sub-Audio Frequency and many other Telegraph Systems, also for testing purposes in connexion with Land Line and Radio Communication.

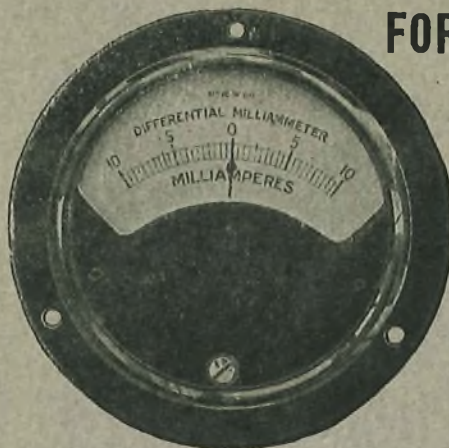

T. 1089. PANEL MOUNTING TYPE.

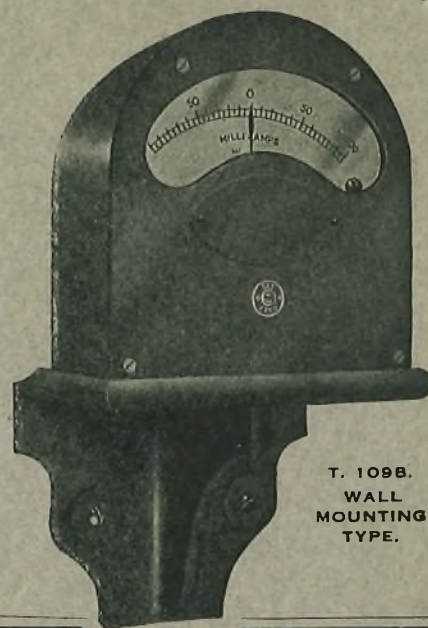

T. 1088. WALL MOUNTING TYPE.

Particulars will be sent on request.

ELLIOTT BROTHERS (London) Ltd., Century Works, Lewisham, S.E.13

Telephone:
Lee Green 4246

in association with

SIEMENS BROTHERS & Co., Ltd., Woolwich, London, S.E. 18

Telephone:
Woolwich 1161

FREDERICK SMITH & COMPANY

(INCORPORATED IN THE LONDON ELECTRIC WIRE COMPANY AND SMITHS, LIMITED)



BRONZE AND CADMIUM COPPER WIRES

As Supplied to H.M. Post Office for
TELEPHONE LINES

SILICIUM-BRONZE,
COPPER,

COPPER-CADMIUM
TAPES & BINDERS.

Anaconda Works

Telephone:
Blackfriars 8701 (8 lines)

SEND US PARTICULARS OF YOUR JOB,
AND OUR TECHNICAL ENGINEERS
WILL PROVIDE YOU WITH THE DATA
YOU NEED.

Salford, Manchester

Telegrams:
"Anaconda, Manchester"

Land Lines

PIRELLI-GENERAL are at present supplying the land lines for connecting Belfast to Glasgow. These cables contain circuits for Four-Wire Repeaters, Two-Wire Repeaters and Broadcasting;

whilst circuits are specially loaded for Carrier Current Telephony. Complete immunity from cross-talk between four-wire "Go" circuits and four-wire "Return" circuits is obtained by the insertion of screening fillets. Pirelli-General were the first to install a cable with this screening device some while ago and it is noteworthy that it is again being used on the important contract mentioned above.

TELEPHONE
SOUTHAMPTON
2141 (3 LINES).

PIRELLI-GENERAL

CABLE WORKS, Ltd., SOUTHAMPTON.

Proprietors: PIRELLI, LTD., and THE GENERAL ELECTRIC CO., LTD.

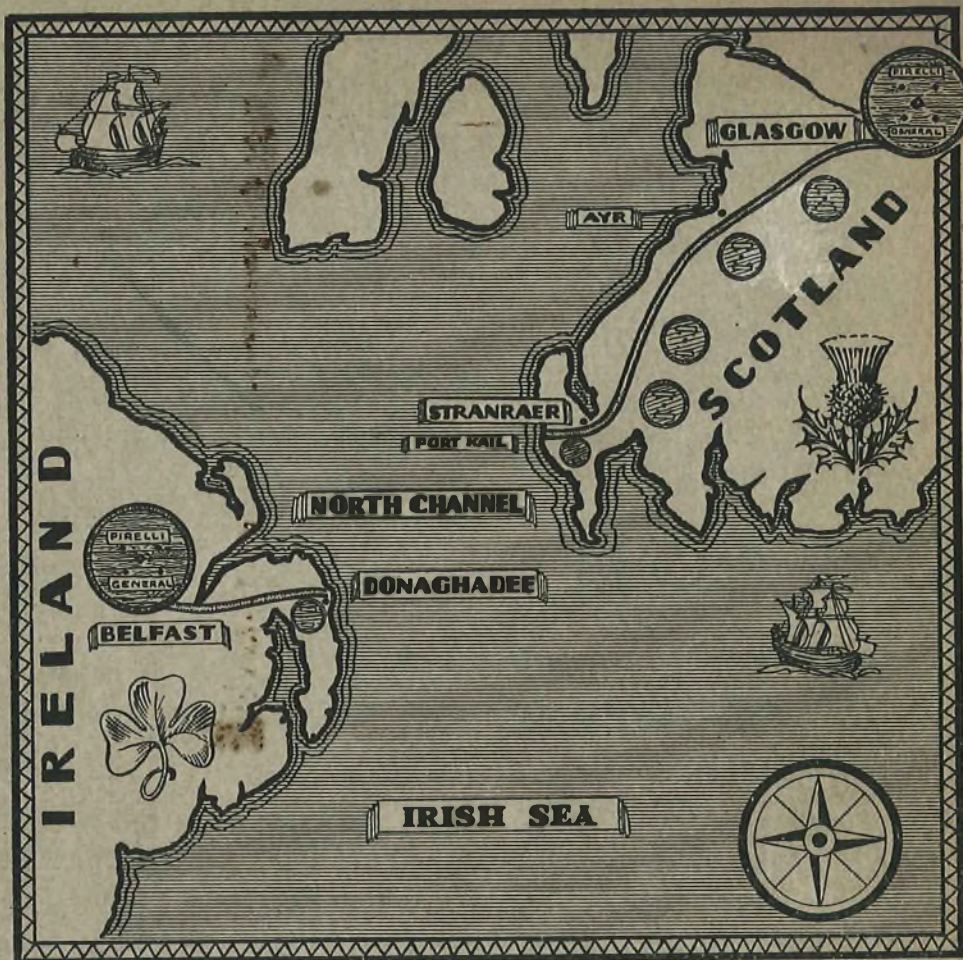

**ANOTHER
EXAMPLE OF
THE EFFICIENCY
OF PIRELLI-
GENERAL TELE-
PHONE CABLES**

TELEGRAMS:
"PIGEKAYBEL,
SOUTHAMPTON."

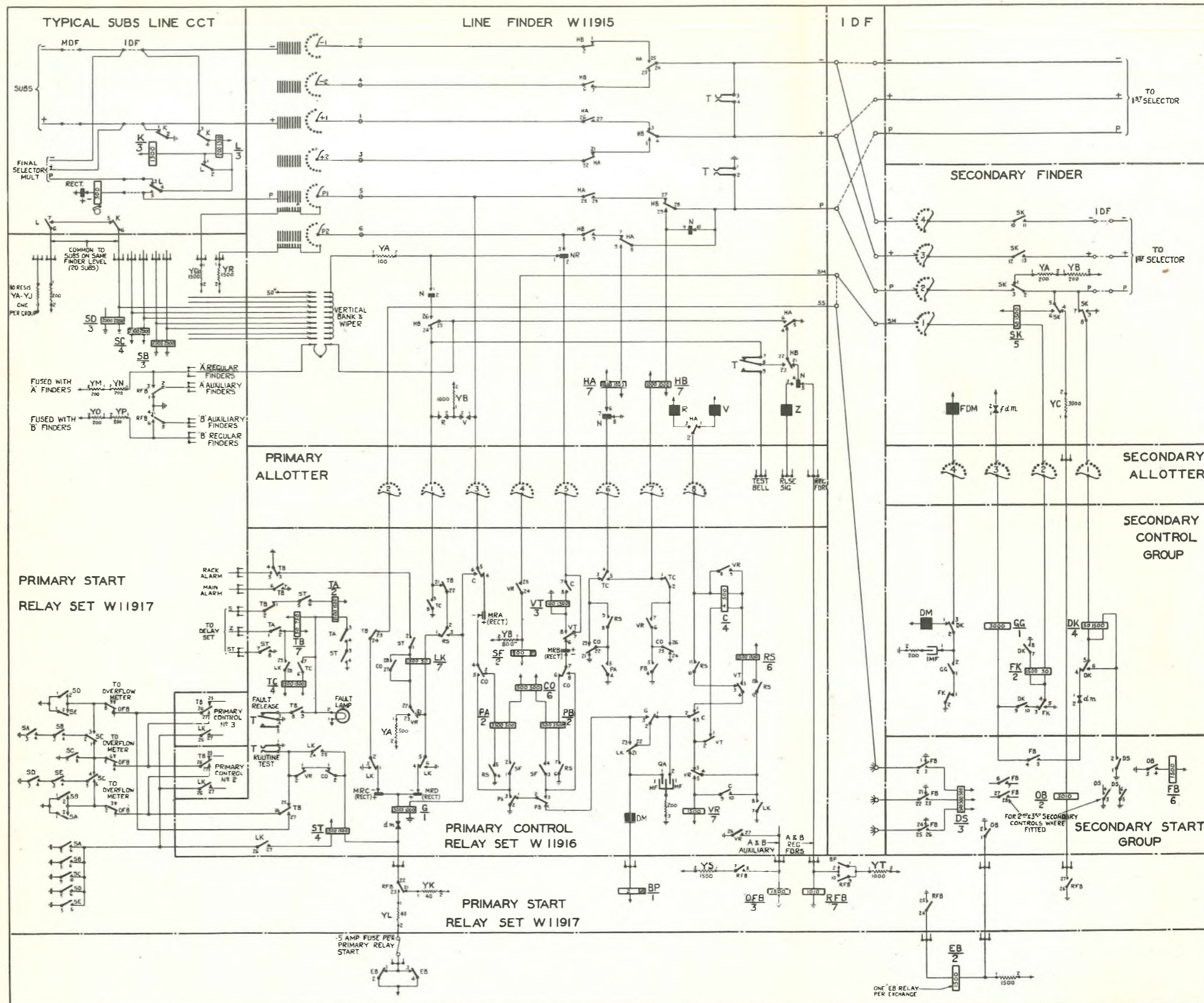

FIG. 3.—LINE FINDER CIRCUIT.

