

CONTENTS

Vol. XX. No. 80. MODERN WIRELESS. AUGUST, 1933.

	Page		Page
Editorial	87	Trouble Tracking	121
Broadcasting in Soviet Russia	88	"M.W.'s" Record Review	122
Coil-Matching at Home	91	At Your Service	123
The "Modern Wireless" LAND, SEA AND AIR SUPPLEMENT	93	On the Short Waves	125
Wherever-You-Go-Radio	94	Toulouse—The Unmuzzled Broadcaster	128
The "Auto" Three	96	Round the Turntable	130
On the Road with the "Auto" Three	101	My Broadcasting Diary	145
The "M.W." "Yachtsman's" Four	103	The New Leeds Studios	147
The "M.W." "Yachtsman's" Four	103	Tuning by Shadows	149
Afloat	107	Questions Answered	151
The "Airman" Two	109	When Time Counts in Radio	152
Preventing Ignition Interference	112	Spotlights on the Programmes	153
Flying with the "Airman" Two	113	The B.B.C. and British Composers	155
The "Classic" Portable on Tour	115	In Passing	157
Experiment House, Langham Place	117	Screened Down-Leads	159
On the Test Bench	119	Radio Notes and News of the Month	164

SPECIAL SECTION, "THE WORLD'S PROGRAMMES," PAGES 131-144
(See page 131 for Contents).

As some of the arrangements and specialties described in this Journal may be the subjects of Letters Patent the amateur and trader would be well advised to obtain permission of the patentees to use the patents before doing so.

Edited by **NORMAN EDWARDS.**
 Technical Editor: **G. V. DOWDING, Associate I.E.E.**
 Radio Consultant-in-Chief: **P. P. ECKERSLEY, M.I.E.E.**
 Scientific Adviser: **J. H. T. ROBERTS, D.Sc., F.Inst.P.**

COLVERN FERROCART COILS

ON LAND, SEA
or in the AIR

COLVERN FERROCART COILS
are PRE-EMINENT

YOU want the BEST—then fit COLVERN FERROCART COILS for outstanding selectivity, compactness and efficiency

FREE The Colvern Ferrocart Booklet R.L.12. Send for a Copy

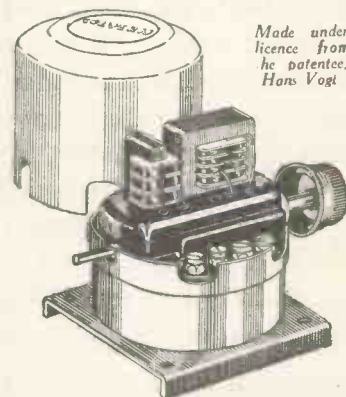

Made under licence from the patentee, Hans Vogt

FOR THE
AUTO-THREE
TYPES F6 and F3
25/- per pair.
Mounted on sub base with ganged wave-change switches

COLVERN LTD., ROMFORD, ESSEX

London Wholesale Depot:—
150, King's Cross Road, W.C.2

WHERE IS ITS EQUAL?

● FOR FULL
SUPERHET
PERFORMANCE,
TESTED
SELECTIVITY
AND FINE
APPEARANCE

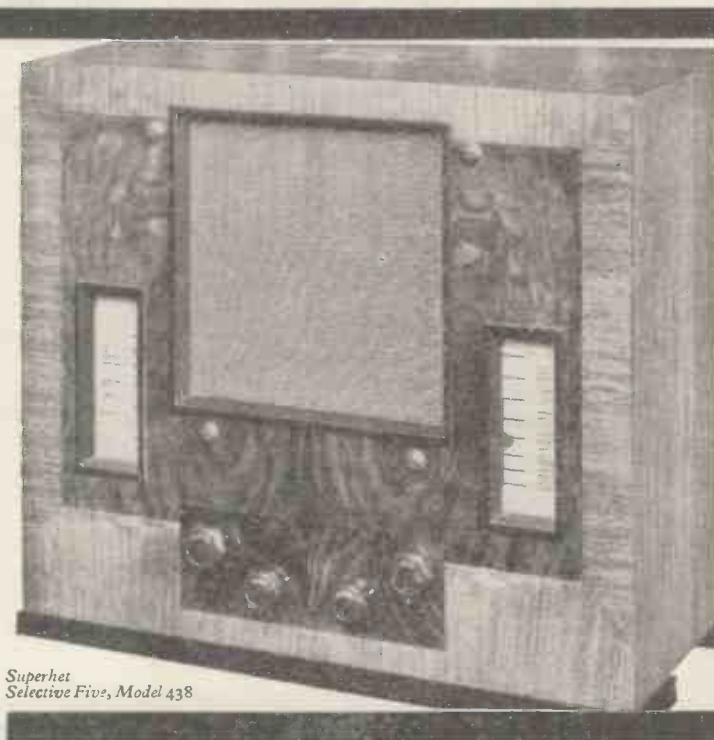

Superhet
Selective Five, Model 438

**SUPERHET
SELECTIVE FIVE
MODEL 438**

SPECIFICATION

Electrically operated. Five Marconi valves (inc. rectifier). Variable mu I.F. amplifier. New type energised moving coil speaker. Super-heterodyne circuit with band-pass tuning. Station names on illuminated wave-length scales. Mains aerial. Provision for gramophone pickup and high or low resistance extra speakers. 200-250 volts, 50-100 cycles (models for other voltages to order). Acoustically designed cabinet of finely figured walnut on ebonised base.

15 GNS. ONLY!

This five-valve superhet set, with nothing skimped, and bearing the world's most famous trade-mark (itself a guarantee of high quality throughout) costs you no more than fifteen guineas! At this price, unrivalled value for wireless that offers such performance.

The model is the latest and finest radio product of the famous Hayes factories. Before being catalogued for sale, it was taken to Prague, centre of the most congested ether in Europe, and to within sight of Brookman's Park, notorious for "second channel" interference, and subjected in both places to the most severe practical tests. No set of its type has ever before offered so wide a range of stations. "His Master's Voice" invite its comparison with any other similar receiver on the score of giving you each station absolutely *cut off* from immediate wave-length neighbours; of giving you that most important quality from the set you have to live with— "true-to-life" tone; and of allowing you all the volume you will ever need, entirely free from distortion.

Go to any "His Master's Voice" dealer and ask to hear it. You will recognise it instantly by its distinctive cabinet of finely figured walnut, carried out in that restrained "straight line" style which is the best of modern design.



"HIS MASTER'S VOICE"

'TRUE - TO - LIFE' RADIO AND RADIO - GRAMOPHONES

The Gramophone Co., Ltd., 98-108 Clerkenwell Road, London, E.C. 1

(Price does not apply in I.F.S.)

Modern Wireless

Vol. XX. No. 80.

BRITAIN'S LEADING RADIO MAGAZINE

August, 1933

The Radio Exhibition—Outstanding "M.W." Exhibits—Our Special Set Supplement— Another Million Listeners?

THE great Radio Exhibition which opens on the 15th of this month at Olympia is likely to prove one of the most successful of all the Radio Exhibitions organised by the Radio Manufacturers' Association.

Last year over 700,000 wireless sets and radio-gramophones were sold by hire purchase by the British radio industry, the business representing at least £9,000,000. This year, although the wireless season, in the real sense of the word, does not open until September, manufacturers are reported to be preparing to put 1,750,000 new sets on the market before next Spring, representing an outlay of something like £21,000,000.

Creating New Listeners

INCIDENTALLY, the trade is endeavouring to create one million new radio listeners, for it is estimated that there is a huge market for new set owners open to British manufacturers in this country.

Directly after Olympia, the Manchester and Glasgow Exhibitions follow on each others' heels, and there is every sign that, with the lifting of the clouds of economic depression, the radio industry will have one of the most successful seasons it has ever experienced.

Don't Forget to Visit Us

MEANWHILE, we can only urge every reader to take advantage of the remarkable Show to be seen at Olympia. All that is best and most up to date in British radio will be on view at this marvellous Exhibition.

And do not forget to pay a visit to the MODERN WIRELESS stand, where some of the most famous home-constructor sets of the last twelve months will be on view, including not only those which have been described in MODERN WIRELESS, but also those which have been described in our contemporaries, "Popular Wireless" and "The Wireless Constructor." Among the many fine exhibits on our Stand, you will see the first Cathode Ray television receiver for home constructors, and models of the famous "S.T.300" and "S.T.400" sets designed by Mr. John Scott-Taggart.

More Battery Sets

THE fact that visitors to Olympia will notice a great increase in the number of battery-operated sets this year will not come as a surprise to those who have looked into the statistics regarding electric light

supply in houses in this country. These figures show that of 12,000,000 homes in Great Britain, 2,900,000 are wired for A.C., 1,100,000 for D.C., while 8,000,000 are without any electric light supply of any kind.

It is quite likely that there are 5,000,000 to 6,000,000 potential purchasers of battery-operated sets for use in districts—and there are still a good many districts—where electric light supply is not available. For some years past British radio manufacturers have concentrated a good deal on the improvement of all-mains receivers, and there is evidence to show that the battery-operated set has been somewhat neglected. We feel sure, however, that this year the radio industry has made a move in the right direction in paying more attention to the potential purchaser of a set whose house is not equipped with electric light.

Despite the rapid progress of the grid scheme, there is no doubt that many districts have little chance of getting electric current for light or power for some years to come.

For Car, Boat, or Plane

THE special Land, Sea and Air Supplement which we include in this issue of MODERN WIRELESS tells you how to build and use new receiving sets for use in a car, a boat, or an aeroplane.

At very little expense, you can install in your car a set which will amuse you with radio, not only from British but from foreign stations, in any part of this country; and for equally little expense you can equip your motor-boat, or other sea- or river-craft with a light-weight set which will do a great deal to enhance the pleasures of your holiday or your week-end trips.

And if you own a Puss Moth, or any other sort of plane, "The Airman" Two is the ideal small-powered set for you to carry. This set has dimensions not in excess of those of a large novel, and it represents compressed efficiency to a very remarkable degree. The circuit is a simple S.G. and detector, having very few components, the whole being built into a light aluminium box.

Undoubtedly it is the ideal set for the plane.

Most owners of aeroplanes will agree that flying becomes monotonous at times and a radio receiver would seem particularly necessary to this rapidly developing method of transport.



BROADCASTING!



ably three-quarters of such points are situated in towns and the remainder in villages; but it is almost impossible to estimate the number of listeners served by such means, although I've heard it put as high as ten millions.

Spacious and Modern Studios

There is a great difference between the stations. In Moscow I talked with a director of artistic production—who was the widow of a Red Army general—in an office which might have been taken direct from Portland Place.

The studios, with their silver walls and austere grey velvet curtains, were spacious and modern. There was a magnificent concert hall which seated 800.

In the circle to the left is one of the small-power transmitters of which there are some thousands in the country attached to factories and institutions.

PROBABLY in no other country in the world does the radio play so large a part in the daily life of the people. In a previous article I tried to show how every hour of the twenty-four is at the mercy of the loudspeaker. Now let us consider how this dual existence is achieved, for in the Soviet Union the worker seems to live simultaneously on two planes, one of which is regulated by wireless.

A Million-Station Project

Apart from the large number of ordinary broadcasting stations, there are nearly 4,000 sub-stations, a number which every enthusiast hopes to raise to not far short of a million.

These sub-stations are of very small power, approximately 30 watts, and they are attached to factories, farms, clubs, houses of culture, rest-parks, clinics, prisons, labour communes and workers' flats. Prob-

Two Russian tailors listening on a crystal set while at work. Lectures connected with trades and the work of the people form a large part of the material broadcast.



SOVIET RUSSIA

by ROSITA FORBES

The famous traveller, who has recently spent considerable time in Russia, tells about the items which make up the broadcast programmes of the U.S.S.R., and of the free access to the microphone which almost anyone is permitted.

The filing system for the thousands of letters received reminded me of Whitehall and brought home to me the range of Soviet influence. For there were not only letters but telegrams from unknown islands within the borders of the Arctic Circle; from stone-built mountain strongholds in the Caucasus, where the last of the feudal warriors wear chain armour; from mining camps and oil-fields strung between the Caspian and the Northern Urals; from Siberian forts still snowbound, and from the new cotton farms of Central Asia; from the

SCIENCE IN THE VILLAGE



Practical education plays an important part in the life of Russian peasants, and here we see children in one of the villages watching an electrical demonstration.

tropics and the steppes; from universities studying the most recondite sciences, and from Moslem villages on the legendary road to Samarkand.

On the other hand, the average factory sub-station is a small, none-too-clean room tucked away in a corner, hung with the usual banners, posters and slogans of Red Russia, with a worker in a black blouse, sometimes unshaved, generally with a cigarette clinging to his lips, performing the manifold duties of director.

Relieving the Tedium of Queues

In the Red Giant rubber factory in the Krasny Bogater suburb of Moscow, which turns out 80,000 pairs of goloshes every 24 hours and employs 10,000 workers, 60 per cent of whom live in the neighbouring model settlement among fir woods and silver birches, loudspeakers are attached to posts in the yards.

A particularly powerful specimen dominates the *quichets* in the office where labour is engaged, paid,

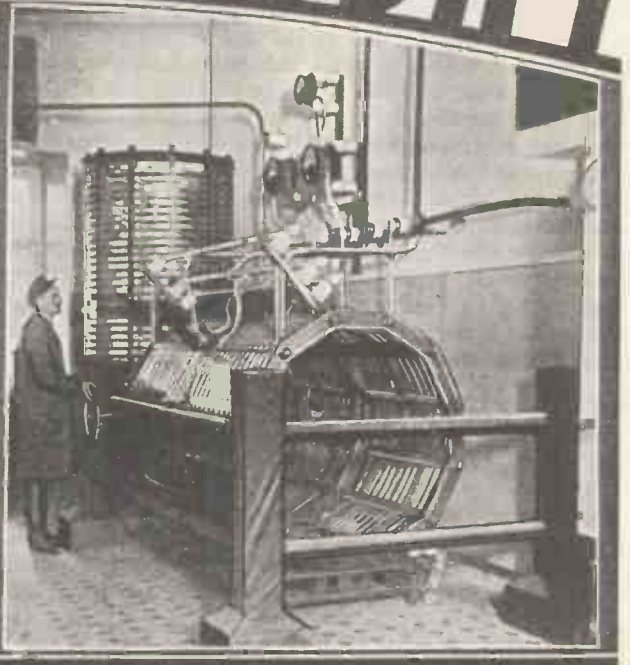

A view of some of the apparatus in the Moscow high-power transmitting station.

ticketed, listened to, and on occasion reprimanded. Another blares to the weary dray-horses in the public square. Still others administer information and culture to the queues waiting for food at the communal restaurant, cigarettes and newspapers at the kiosks, and trams in the middle of the road.

Radio Talks by Workers

All this vocal energy is supplied by the factory sub-station which is wired to more than 100 loudspeakers. Approximately three-quarters of the programme is received from central stations and is relayed over the wires to the above-mentioned loudspeakers; but the proportion varies. The director, in consultation with the elected Workers' Soviet Committee, and under the watchful eye of the factory representative of the Communist Party, selects and adjusts the local programme to suit the needs of the moment.

For instance, we visited the Red Giant in April when it was logically considered a matter of vital interest to the mass of industrial workers, dependent on food supplies from the state and communal farms, to follow the progress of the spring sowing. Consequently, a certain amount of time every day was allotted to agricultural reports, but these were followed by workers' speeches relayed from the factory studio.

The subjects ranged from suggestions for growing vegetables on the window-sills of the new blocks of flats, to the necessity of improving relations between peasants and artisans.

In every factory there are circles of art, drama, literature and music, the latter playing many different sorts of instruments and including choirs of both sexes, which

Airing Workshop Grievances Over the Radio

contribute to the local programme. But by far the most interesting aspect of factory, or indeed of any Russian broadcasting, is the freedom of speech allowed to workers.

Any man who has an idea or a complaint can submit it to the radio director, and in his turn he will be allotted five minutes on the air in which to explain the reason for his discontent or the elements of what may develop into an invention. During such workers' speeches, criticism, trenchant, barbed and very often constructive, pours out of the loudspeakers, and it may well be the first occasion on which the management has ever heard of the said problem or complaint. For the radio director is chosen by the "Arts and Politics Committee" of the factory which, in its turn, is elected by the workers. He has right of entry to, and of investigation in, any part of the factory, but he himself is as open to criticism as any other member of the staff.

From Behind Prison Walls

In a heavy industry plant we listened to a vigorous indictment of the system of payment in force on the conveyors, by which it was alleged two idlers who regularly held up the rolling belts were able to earn as much as shock-workers pledged to produce 107 per cent.

In one of the largest prisons we heard a man, convicted of stealing government money, proclaiming from the

between the managerial staff, the foremen and the operatives, but no lack of order, because the workers feel they own the factories.

Their growing efficiency and the practical suggestions they broadcast for the improvement of technical processes and economy in material or design are a tribute to the spectacular boldness of a scheme which puts control and criticism into the hands of the mass rather than the individual.

Programmes in Six Languages

The main stations, whose programmes supply the greater part of the material used by several thousand minor receiving and relaying points, devote a large proportion of their time to music. The huge Leningrad station (100 kw.) allots nearly two-thirds of its programme to "art," a generic term covering vocal and instrumental music, children's instruction, literature and the theatre, which latter, on the modern side, is, like the screen, an instrument of propaganda.

Anti-religious concerts are a popular item, and on the rest-day (one in six) ninety-five per cent of the programme is "artistic with a cultural bias."

Such big stations (including, naturally, the famous Moscow Trades Union, which gives an international programme in half a dozen different languages from ten

to twelve every night, "Attention, Comrades! Moscow speaking!") possess large symphony orchestras, military bands and folk instrument orchestras, although folk music, particularly appreciated in the villages and farms, is gradually giving way to more formal music, an eighth of which, perhaps, is Russian.

The Leningrad "Methods Committee," which gives auditions to ambitious youth, claims to have introduced to the air a sufficient number of new composers to justify the formation of the sharply differentiated schools of music labelled the New, of which Davidienko (author of the symphony entitled "Lifting a Railway Carriage") is the most famous, and the Old.

Politics and Hygiene

After 60 per cent of the main station programmes have been devoted to the broadest possible conception of "Art," which may well be precluded or concluded by a discourse on the Marxian theory, the remainder is divided between politics and physical culture, including hygiene, which appear to be closely allied since the Soviet endeavours to increase the physical as well as the intellectual stamina of the people (perhaps 20 per cent); news, the foreign with a pronounced political bias, including government information, and the weather forecast (about 10 per cent); and technical propaganda, which is possibly more carefully prepared than any other subject.

Under this heading we heard lectures on hydro-electricity, farming, sugar-beet, cotton-breeding, the use and misuse of tractors, metallurgy, transport, the

(Continued on page 163)

POWER IN PLENTY FOR RUSSIAN LISTENERS

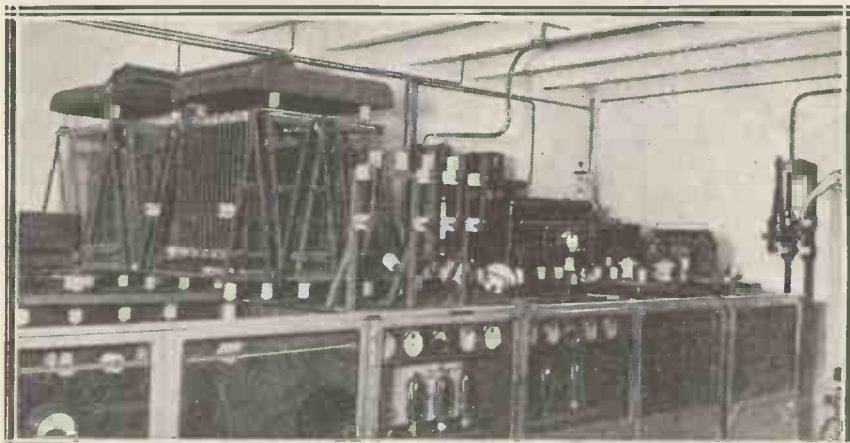

The Komintern station at Moscow, which radiates its 100 kw. of power on 1,481 metres, can fairly be described as all-Russian. The station was built entirely from materials manufactured in Russia, and was designed by Prof. Bench-Bruevich, a Russian radio expert.

Institute's sub-station, which also served the district, that the prisoners (to whom he referred as "workers temporarily isolated from their fellows") were hampered by an ineffective administration. "We want our boots mended and we want overalls, but the more we complain the less seems to happen. It is time the Governor took to early rising, lest there be a gap in the (Five Years) Plan for which we are all banded as comrades to work."

Freedom of Speech by Radio

This complete freedom of speech and of access to the air, in conjunction with the caustic and often humorously illustrated comments of the Wall newspapers, written and edited by the men themselves, gives a very large measure of control to the workers. The result is complete equality



BY
P. WOODWARD.

COIL MATCHING at HOME

THE rise to popularity of the gang-tuned set has brought one unfortunate consequence in its train, and that is the return of the element of mystery in regard to one of our more important components. "Matched" coils sound very much like something with which the amateur should on no account meddle. We all know in a general way that they are only coils which have had their inductances carefully adjusted to the same value, but very few amateurs have any idea how this really very simple operation may be carried out.

A False Impression

As a result, most people feel that a ganged set must necessarily be made

How to build a simple, inexpensive and efficient coil balancer—a unit which every radio enthusiast requires.

- One 1- or 2-meg. grid leak.
- One fixed condenser, .0002, .0003 or .0005 mfd.
- One fixed condenser, .0002 mfd.
- One fixed condenser, .001 or any larger capacity up to .01 mfd.
- One milliammeter, 3, 4 or 5 ma. full scale. Quite a cheap type will serve perfectly.
- One special coil (see text).

Small panel and baseboard, terminal strip and a few terminals, etc.

The circuit diagram of the "matcher" is shown in Fig. 1, and

kept just gently oscillating, and the coil for test is connected to the terminals marked Lx. If it is placed so that it is lightly coupled to the coil in the matching unit, it will be found that interesting things happen when the tuning of the oscillator circuit is varied. When it comes into resonance with the circuit formed by the coil under test and the .0002 fixed condenser wired across the Lx terminals, it will be noted that the milliammeter gives a sharp kick upwards, the resonance point being clearly indicated by this as you go through it.

Very Easy Matter

By substituting the other coils of the set for the one first tried and noting the dial readings at which the kicks occur, a basis for matching is obtained, and by removing turns from those which read high it becomes a very simple matter to get them all matched. A little adjustment of the degree of coupling between the coil under test and the one in the matcher is needed to get the sharpest possible indication of resonance, but once this has been done it is a very easy matter to match up a set of coils with considerable accuracy.

It is only necessary to keep carefully to this same amount of coupling throughout and you will be able to match coils quite as closely as the best commercial ones. Actually, if you like to take a little trouble over

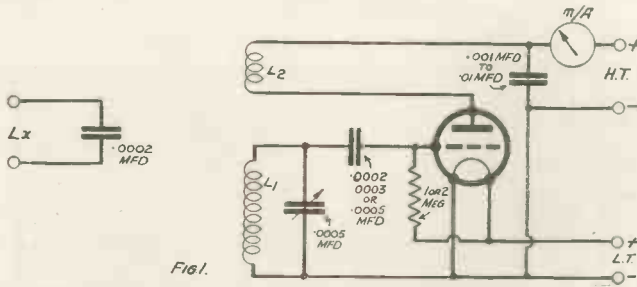

THE "MATCHER"
This is the circuit used by Mr. Woodward. The milliammeter in series with the anode of the valve is one having a fairly low maximum reading, say, three or five milliamps.

with bought coils, and so they are unable to try out any ideas they may get with the aid of the inexpensive home-made coils we all used for the purpose in days gone by. This seems to me a pity, and it shall be my endeavour in this article to explain how such coils may be "matched" at home with the aid of the simplest and most inexpensive of apparatus.

you should have no difficulty in wiring it up from this. No L.T. switch is shown, for it is hardly necessary, but one can easily be added if desired.

The way the device is used is very simple. The size of the reaction winding is adjusted so that the valve is

DUAL WAVEBAND

In this arrangement the circuit is suitable for both medium and long waves. The inductances are connected in series, the long-wave windings being "shorted" by switches when not required.

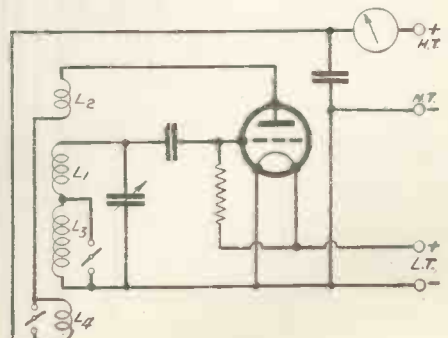
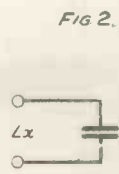

All You Need

All you require for the purpose is an instrument which calls for only the following parts:

- One .0005-mfd. variable condenser.
- One dial for above (not necessarily slow-motion, but good clear scale is essential).
- One valve holder.

A Simple Method of Inductance Balancing

the job you may be pretty sure that your matching is definitely better than that of most of the coils you can buy.

To make the unit you want first the winding data for the coil, and these follow. The grid winding L_1 should be of 50 turns of any gauge of wire from 26 to 30, cotton or silk covered. The reaction winding L_2 should be of 10 turns of the same wire, and this should later be reduced turn

DIFFICULTY OVERCOME

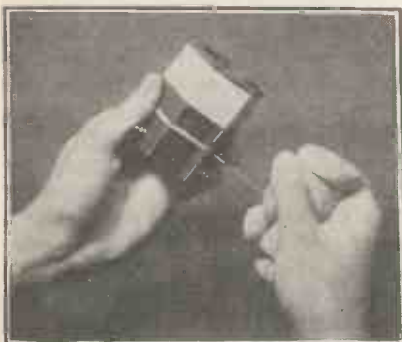

The simple matching device described in this article does away with what has hitherto been the chief difficulty in applying home-made inductances to the modern "ganged" receiver.

by turn until the valve just stops oscillating when the tuning condenser is turned right in.

The former for this coil should be 3 in. in diameter, and its length should really depend on the size of wire used, so get one 4 in. long and then you will be sure of having enough room. Start the grid winding close to one end, allow a space of about $\frac{1}{8}$ in., then put on the reaction winding (the direction of this is immaterial).

Testing the Unit

Fasten this coil down near one edge of the baseboard, so that it will be conveniently placed for coupling the coils under test to the grid winding. In use you will probably find that distances of from 3 to 6 in. will suit most cases, and it will facilitate matters if you mount the coil up an inch or so above the baseboard on small blocks of wood.

When the unit is finished insert a valve of the H.L. or special detector type in the holder, and give it about 40 volts H.T. Note the reading of the milliammeter, then short-circuit the tuning condenser with a bit of wire and see whether the milliammeter reading changes. It should jump up

to a new figure if the valve is oscillating. If it doesn't, reverse the leads to the reaction coil and try again.

Having found the correct connections for the reaction circuit, next proceed to reduce the turns on the reaction winding until the valve just stops oscillating when the tuning condenser is turned right in. Next increase the H.T. until the valve oscillates at the top of the dial again, which will usually occur with some 60 volts or less, and the unit is ready for use. Always use the same valve and voltages in future for the sake of uniformity of results.

Adjusting the Coupling

Now take one of your coils for test and connect it to the L_x terminals. Place it about 3 in. away from the coil in the unit, and turn the tuning condenser. The milliammeter should kick violently as you go through the resonance point. If it doesn't, put the coils a little nearer together. Once the kick is obtained, separate the coils until you are getting only the smallest needle movement which you can see with certainty. Having got the coupling so adjusted, you are ready to start matching, but there is one point I must explain before you begin.

It is very difficult to get the milliammeter kick down to an absolute point on the dial, so be content to get it down until it covers, say, a couple of degrees only. Suppose you find it occurs at about 60 degrees. Put the condenser at 50 degrees, then go upwards gradually until you find the first sign of the kick beginning, which will probably be at 59 degrees.

Taking Readings

Turn the dial a little farther, and you will find the milliammeter deflection beginning to subside again, finally disappearing at, say, 61 degrees.

In this case you would decide that the correct reading was 60 degrees. Always work in this way from low readings towards high ones, locate the beginning and end of the milliammeter kick and record the midway reading.

Now suppose one coil reads 59, the next 60, and the third 61 degrees. Discrepancies as big as this may easily occur even with coils carefully wound to the same number of turns. Now make the 59-degree coil your standard and proceed to pull turns off the others until they come down to the same reading. Suppose that in doing so you find that one of them is

(Continued on page 166.)

COMMERCIAL METHODS YOU CAN COPY



"Iron dust" coils of the Ferrocart type always undergo stringent matching tests. The engineer seen above is checking up the various coils with an oscillator unit and loud-speaker. The final inductance adjustment is made by altering the distance between the two halves of the coil.



WHEREVER-YOU-GO



RADIO

INTRODUCING OUR SPECIAL MOBILE-RADIO SUPPLEMENT

The most comprehensive work ever published dealing with the construction and use of receivers for on-the-move wireless.

THERE is an old nursery rhyme concerning a place called Banbury which might easily be parodied to fit exactly the spirit of our special set section this month. "They shall have radio wherever they go" is literally true for those who build receivers from the details provided in the next score or so of pages.

Was Ignorance Bliss ?

Nowadays we live at a greater speed than the fine lady referred to in the rhyme, and our demands from the entertainment world and our thirst after news and learning are rapidly increasing. And why not when our desires in these respects can so easily be gratified—by radio ?

A short while ago the radio receiver brought us entertainment and news with unfailing regularity, *but to our homes only.* Outside we were necessarily ignorant of what was happening in the ether, and no matter how tempting the programme, or how vital the news that was being broadcast, it passed us by unless we were at home listening on our sets.

Scope of the Portable

Nowadays we can be in radio touch with events of the moment no matter where we may be. At home, on holiday, travelling by land, sea or air, always can the ether be combed for radio fare. And at little expense and trouble, too !

The next few pages of this section

show in detail how this can be accomplished, with simple apparatus that can be built at home, and adapted to any and every daily radio need.

The lightweight portable set gives tremendous scope in this regard ; it enables listening to be conveniently carried out in a multitude of places, and is of infinite value to the traveller or holiday maker.

Such a set was detailed last month under the title of the "Classic"

Portable, and hereafter we describe how it was used by the Chief of our Research Department on a recent holiday jaunt—an ever-willing and companionable entertainer.

For all Travellers

But we can go farther. If you own a car, no matter how modest or elaborate it is, the advantages of full-blooded radio reception are yours while you travel. Whether the car is in motion or stationary, the

AMPLE ENTERTAINMENT FOR ALL ON BOARD

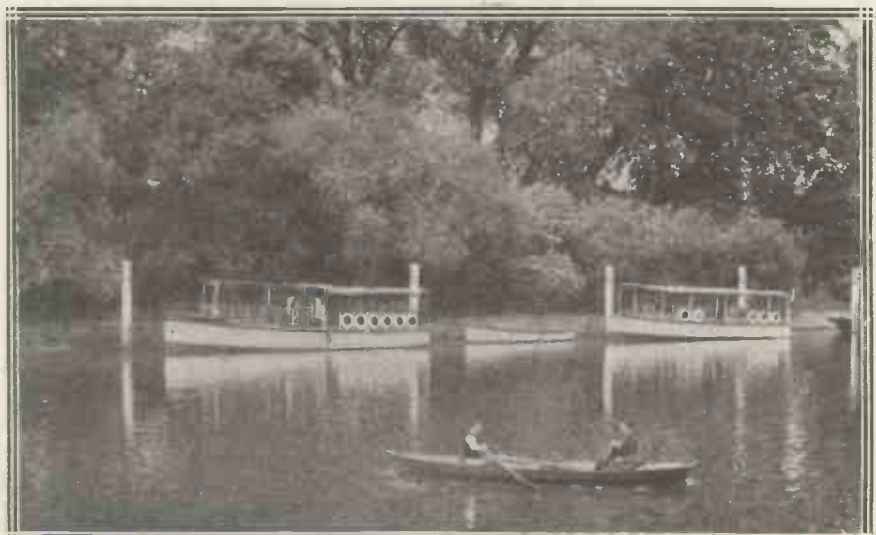

The special boat receiver described in following pages has "Class B" output and S.G. amplification, and tucks away neatly against bulkhead of yacht or motor-boat. Here is an "M.W." technician being rowed to a motor-boat to install the "Yachtsman's" Four.

Simple Apparatus that Can be Built at Home

"Auto" Three receiver will give full loudspeaker reception of a number of stations with its two indirectly heated mains valves and pentode output.

Leave the land for the water, river or sea, and radio is still ready to accompany you, this time in the form of a specially designed boat receiver, which tucks away neatly against the bulkhead of yacht or

As a matter of fact, whether flying, motoring or cruising, the reception of weather forecasts is a most valuable use of radio, and with the special sets we have designed, and describe in the following pages, this vital feature can be fully obtained without need for travel operations to be suspended, or any break made in the journey in any way.

For pleasure, business, or as a

In each case screened-grid amplification has been employed, so that the sensitivity and selectivity of the sets are well maintained.

In the cases of the boat set (the "M.W." "Yachtsman's") and the "Classic" Portable, battery operation is used, and the L.F. sections in each instance include a "Class B" stage. This enables economic running to be maintained.

The "Auto" Three uses one L.F. valve, but as this is of the pentode type it provides ample amplification and power, forming with the other two valves a very efficient valve team.

REMARKABLY COMPACT AND EFFICIENT

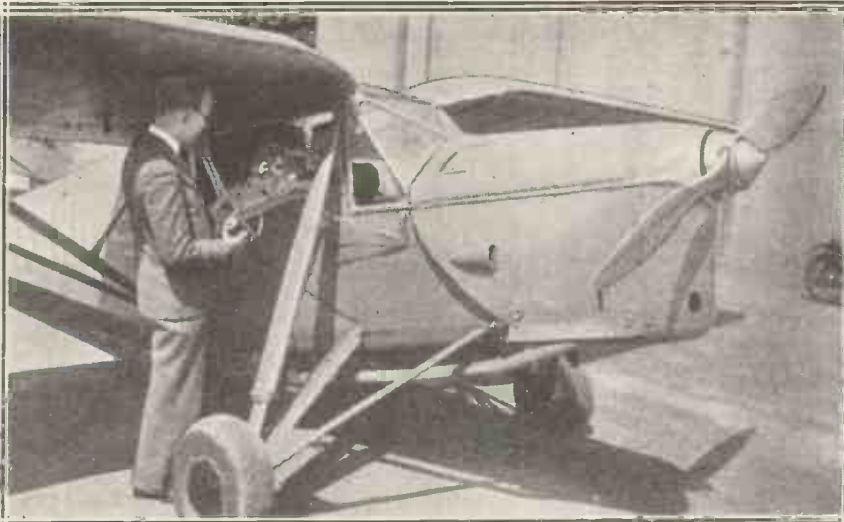

The "Airman" Two will stow away practically anywhere convenient in the cabin or cockpit, and provides reception on all wavelengths from 160 to 2,000 metres.

motor-boat, and which, with its "Class B" amplification, will provide ample entertainment for all on board.

Flying is rapidly becoming a national mode of travel, though in small private machines it is apt to be a little monotonous and lonely. Here again radio comes as a companion.

For Business and Pleasure

Size and weight are naturally vital considerations here, so we have designed a third set, remarkably compact, which will stow away practically anywhere convenient in cockpit or cabin, providing radio reception on all wavelengths from 160 to 2,000 metres, via radio headphones or the normal D.H. speaking tube.

The full waveband coverage of this set is particularly valuable to air pilots, for it takes in all the important stations that disseminate weather forecasts, whether by phone or Morse, including the Air Ministry and the various aerodrome broadcasts.

direct aid to travel, radio is brought into full use by these sets, which enable the very greatest use to be made of modern wireless facilities.

Suitable Outputs

The receiver used for the air (the "Airman" Two) is naturally a smaller powered arrangement so far as the strength of the output is concerned, for it would be unreasonable to expect to be able to listen to a loudspeaker while piloting or traveling as a passenger in an aeroplane. The external noise would normally be too great for comfortable listening.

So in this case the L.F. stage or stages of the receiver have been left out, and a simple screened-grid and detector design has been built, bearing in mind the convenience in many machines of being able to plug the standard de Havilland speaking tube fitted to a flying helmet into the set in place of the ordinary electric headphones, though the receiver is provided with facilities for the latter as an alternative.

LOUDSPEAKER RECEPTION OF MANY STATIONS



Whether the car is in motion or stationary, the "Auto" Three receiver will give full loudspeaker reception of a number of stations. This set, with its small loudspeaker, can be adapted to fit on any car.



THE AUTO-THREE

THE first receiver to be described in the special land, sea and air supplement this month is one expressly designed for use on a motor-car. Like the set designed for boat and 'plane use, it employs the latest in iron-cored coils, but differs from the other sets in that two of its valves are of the indirectly-heated mains type, thus providing an unusual degree of sensitivity; while a pentode output stage ensures plenty of power.

As explained in the following article, the set is intended to be used when the car is either in motion or stationary, and the receiver and the loudspeaker fit inside in convenient positions, with the generator that supplies the H.T. underneath the body.

With this arrangement no H.T. smoothing is required in the set, and the starter battery of the car provides ample L.T. To suit all makes of cars, we have chosen 6-volt valves throughout, so that with a small car having 6-volt lighting equipment the whole of the battery voltage is employed, and with a "larger" make having 12 volts half the battery is tapped off for use with the receiver.

Generator

The H.T. generator is driven from the same battery as the set, and is controlled with

The two most universally appreciated gifts with which our scientific age has endowed us are undoubtedly radio and the motor-car. What more natural, then, that there should be a growing desire for them in combination? An efficient set to meet this demand has been designed and is here described

By **K. D. ROGERS.**

the set by the on-off switch on the chassis.

The Circuit

The circuit is designed for use with the necessarily small aerial that is the best that is available with a car, and the efficiency of the tuning circuits has been one of the main considerations. It is because the very best must be made of every vestige of incoming impulse that we have picked iron-cored coils, the famous Ferrocart variety being used for

the receiver under consideration here. The aerial is a small affair—it is bound to be—and so we have no need to take special precautions as regards selectivity, and we can dispense with the band-pass input usually associated with Ferrocart inductance circuits.

The aerial, then, is fed direct into the usual tap of the first Ferrocart coil which is connected on the secondary side to the grid of the screened-grid amplifier. This valve is of the usual type, and not of the variable- μ variety. For this stage one of the 6-volt .5 amp. D.C. valves is used.

Tapped tuned-anode coupling is used between this valve and the detector, the anode coil being directly in the anode-feed circuit of the S.G. valve, no shunt-feed arrangement being employed. This assists in keeping

the size of the set down, for the 1-mfd. condenser used to allow the variable condenser moving vanes to be at earth potential takes up much less spacethan would the H.F. choke and condenser required for a shunt-feed scheme.

Shunt-Fed

A leaky-grid detector is employed, shunt transformer-fed into the pentode output valve. It might be imagined that to shunt-feed the

GIVES GOOD RESULTS ON A SMALL AERIAL

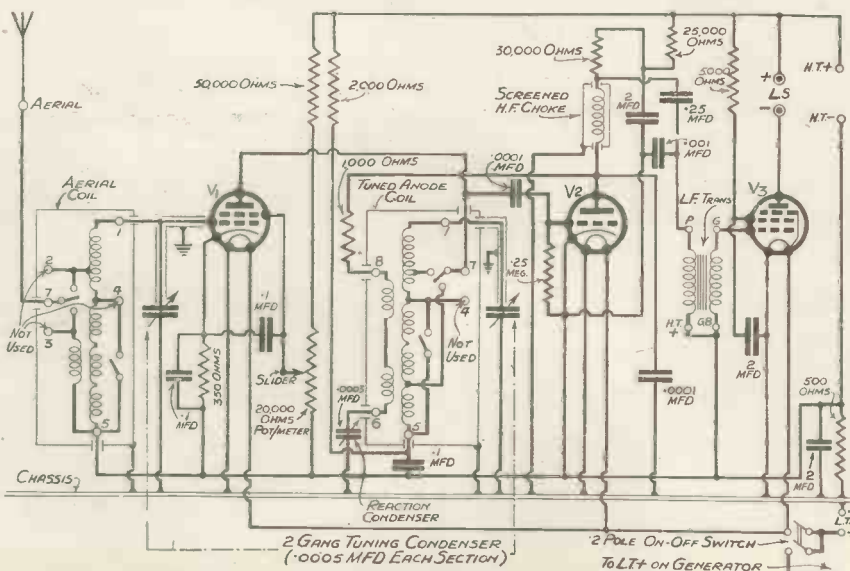

A travelling motor-car must necessarily employ a diminutive aerial with poor pick-up qualities calling for high efficiency in the set. Ferrocart coils, indirectly-heated valves, tapped tuned-anode coupling, and a high ratio L.F. transformer contribute to this amazingly sensitive design.

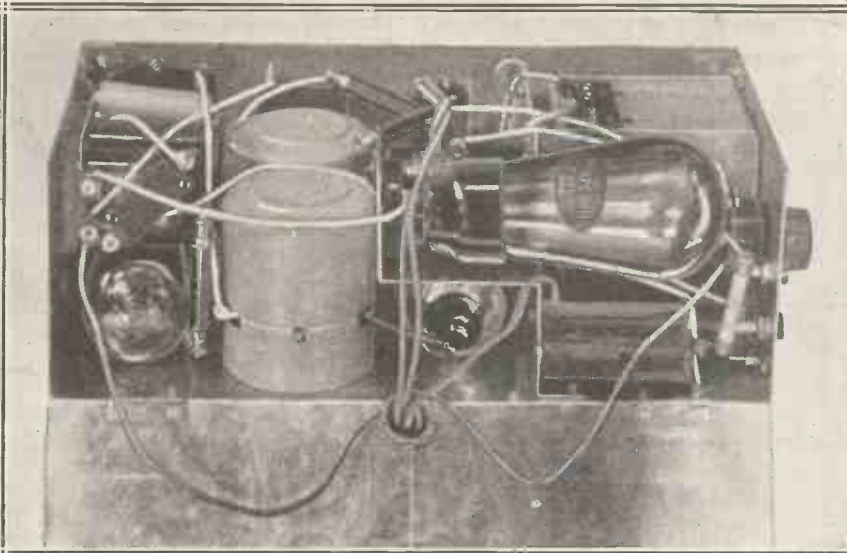

The extremely compact "layout" of the components is made feasible and constructionally simple by the expedient of a bent aluminium bracket which carries the pentode valve holder and a fixed condenser while helping to separate H.F. and L.F. parts of the set.

transformer is a waste of space and components in a design of this nature, but parallel-feed allows efficient L.F. coupling to be obtained with quite a small transformer. It must be remembered that the detector will take quite a considerable anode current—

the same throughout, we used a Marconi or Osram battery pentode, the P.T.625, which takes .25 amp. at 6 volts.

The usual parasitic oscillation stopper is inserted in series with the reaction feed of the tuned-anode Ferrocart coil, so that smooth and accurate reaction control on the long waves shall be obtained. Without

this resistance there is a possibility of two oscillation settings being reached with the reaction on the long waves, one point at which parasitic oscillation occurs and later the true reaction point. As the former completely masks the true setting, and also swamps any incoming reception, it has to be checked; hence the 1,000-ohm resistance.

Simple Volume Control

A potentiometer feed is arranged for the potential application to the screen of the S.G. valve, the lower half of the potentiometer system being a variable potentiometer itself, so arranged that it gives variable control of the voltage, this being used as a simple means of volume control.

Great care has been taken to ensure no H.F. gets through from the detector to the pentode stage, for, besides the H.F. choke and its .0001-mfd. condenser to earth, we have the .001-mfd. condenser connected between one end of the primary of the L.F. transformer and the detector cathode. This condenser undertakes a dual role, for not only does it remove the last traces of H.F., but it acts as a tone control, which is so often necessary with pentode receivers.

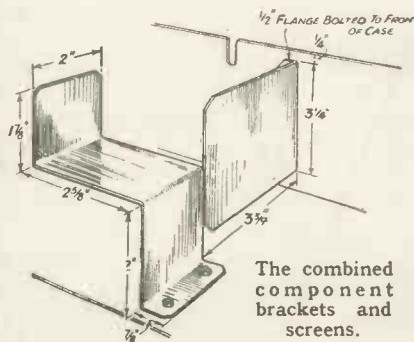

more than in the case of battery valves—and so the danger of spoiling the reproduction by transformer saturation is a very real one.

Careful Decoupling

Every circuit is carefully decoupled where there is the slightest possibility of inter-circuit reaction taking place, and automatic grid bias is applied to the two amplifying valves. The pentode, of course, is of the directly-heated variety, because the pentode belonging to the D.C. group of valves, while taking only half an amp. for the heater current, requires about 8 volts applied across the heater—two more than is needed for the rest of the family.

In order to keep the voltage

DISPENSING WITH PANEL AND BASEBOARD

Neither panel nor baseboard figures in the construction of the set. Components are mounted directly on to the metal of which the container is made, full dimensions and details of which are given below. Components are also carried by the brackets shown to the left.

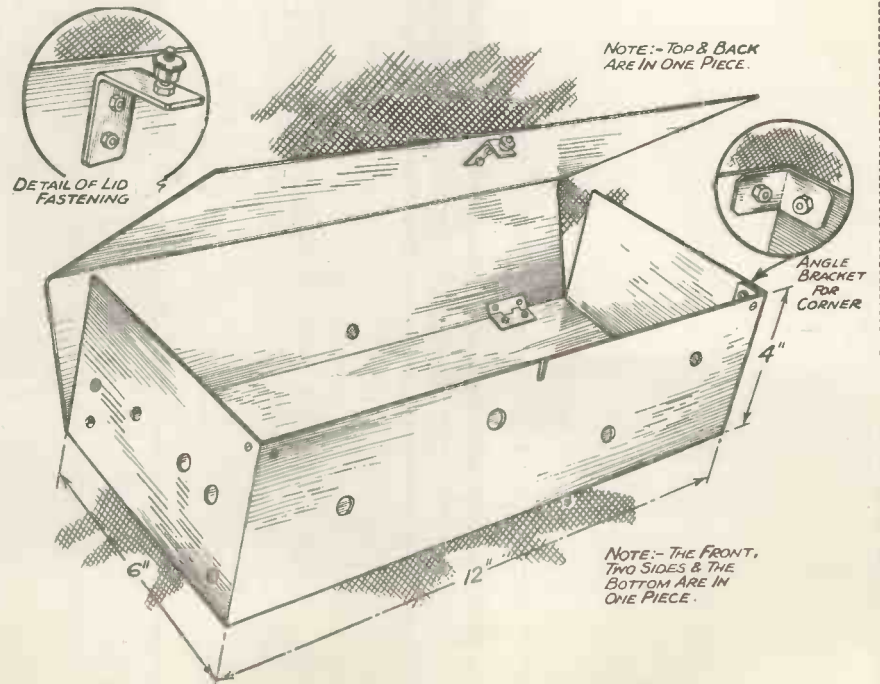

Car and Radio Make Good Road Companions

The design of the set in practical form necessitates several unusual features. One of these is the screened leads which run from the fixed vanes of the variable condenser. These leads are necessitated by the impracticability of getting the anode coil as near the condenser as is usual, owing to the compact nature of the receiver.

Direct Mounting

The whole set is housed in a metal box, specially made for it, and shown clearly in one of the diagrams, and the parts are mounted direct on the metal, there being no base-board.

A separate bracket consisting of a piece of bent aluminium is used to mount the pentode valve holder and one of the 2-mfd. condensers, and to act as a shield between H.F. and L.F. parts of the receiver.

Another metal bracket is used to mount the variable condenser, and, on the reverse side, one of the round Dubilier condensers, another 2-mfd. of the 9200 type.

The front and two sides, together with the bottom of the metal box,

SUITABLE VALVES FOR THE SET

S.G.—Mazda D.C./S.G. Detector—Mazda
D.C./H.L. Output—Marconi or Osram
P.T.625.

are made out of one sheet of metal, bent to shape. The angle brackets strengthen the chassis, while the lid and back are made from another sheet, and are hinged to the bottom.

There are several points in the construction that need special attention. The first is the method of mounting the tuning condenser and the 2-mfd. condenser on the metal

bracket made for them. The 2-mfd. condenser should be fixed in position first on the bracket before it is placed in position, and then the variable condenser should be mounted. After this the whole assembly can be mounted in the metal box.

The valve holder for the detector valve should be wired up before the mounting of the L.F. transformer is undertaken. Countersinking screws should be used for all mounting on the chassis, the holes being countersunk on the outside.

Insulated Control

The mounting of the two coils is a little bit awkward, for they have to be taken off their platform and mounted direct on the chassis, the switch-rod earthing spring being fixed to the chassis between the aerial coil and the control panel.

The sensitivity or volume control must be insulated from the chassis,

Constructional Simplicity Achieves Radio Efficiency

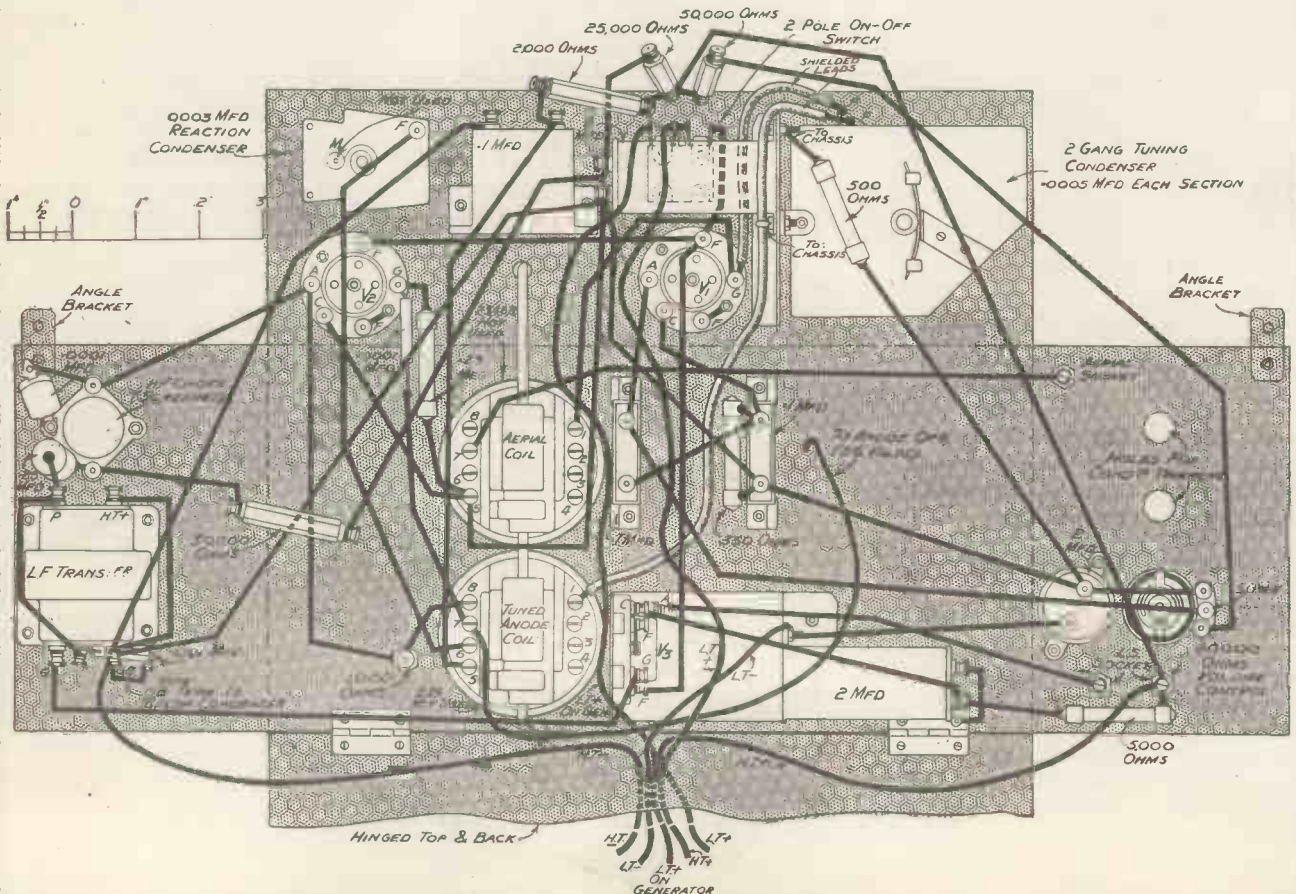

All wiring difficulties are removed by depicting the set "flattened-out" to one plane in this manner. Reference should, however, be made to the text which deals with the one or two constructional points which must be watched when assembling and wiring.

Programmes on All Your Journeys

or a short-circuit of H.T. will occur, and the screening grid of the S.G. valve will not receive any high-tension potential.

Five flex leads come out of the set, and these are to be attached to H.T. positive, H.T. negative, L.T. negative, L.T. positive on the battery,

The whole chassis is connected to the L.T. end of the set, and so any aerial that is used must keep as far away from the metal parts of the car as possible. In cases where a fabric body is in use the question of the aerial in the roof of the car is a simple one. It can be stretched along the

length of the automobile close under the roof, quite easily and efficiently, or it can be hidden under the cloth covering of the roof, a twin or single wire aerial being used.

Another possibility where a sunshine roof is fitted to a fabric body is the use of a copper sheet aerial

Remarkably Compact Design—Simple Controls Throughout

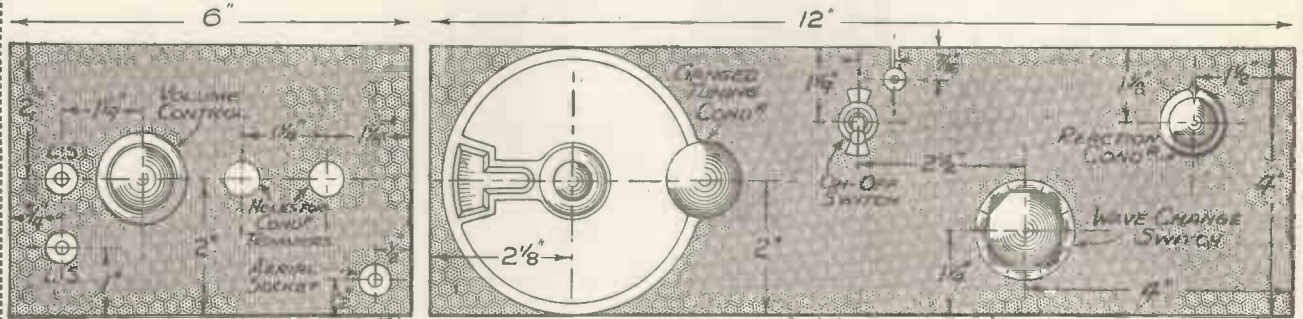

LAYOUT OF CONTROLS

and the last to L.T. positive on the generator.

The aerial plugs into the single socket on the end of the chassis; while the loudspeaker leads plug into the pair of sockets specially provided on the same end.

The question of a satisfactory aerial is one that has largely to be met in individual cases. It will depend upon the make and type of car as to what type of aerial is best, and how much aerial can be utilised.

Roughly, the aerial can be divided into three sections: above the chassis, below the chassis, and external to the car, such as one strung up on a tree or post. This latter, of course, limits the use of the set to periods when the car is stationary, but it may quite easily be tried during picnic intervals on a journey, as being better than the aerial available in the car.

Chassis Pick-Up

Of the other two, the better is undoubtedly that which is above the chassis, except on certain occasions when an all-metal saloon vehicle is used. It will naturally be a matter of experiment to decide which type and size aerial will be best for any particular case, but in all instances it must be remembered that the chassis of the car is acting to a large extent as a pick-up device for radio reception, and this fact should not be lost sight of.

How to mount the controls is indicated by the diagram; while the photograph below shows the ingeniously contrived layout.



under the cloth covering of the underside of the sliding roof.

Well Hidden

With the down-lead taken from the forward end this aerial is both efficacious and well hidden. It can be alternately arranged as two or three parallel wires running along the sliding portion of the roof.

Parallel wires are better than the rectangular aerial so often employed by set users having indoor aerials, and usually such set owners lose quite a lot of efficiency by making the aerial return along itself, so to speak. It is better to have the end remote from the down-lead completely free than to run it round back towards the down-lead end.

If the car is of all-metal construction the aerial should be kept as far away from the body as possible, and to avoid unsightliness it is sometimes better, from the result point of view, to run the wire along the length of the car from the front axle to the back. It will then be fairly clear of the chassis during most of its journey, though it will be very low and not a particularly good pick-up device.

Aerial on Roof

If it runs inside the car the chances are that it will be a very poor collector owing to the screening of the metal body, which is, of course, earthed to the chassis. One means of overcoming the trouble very well, if

PENTODE OUTPUT FOR POWERFUL RESULTS

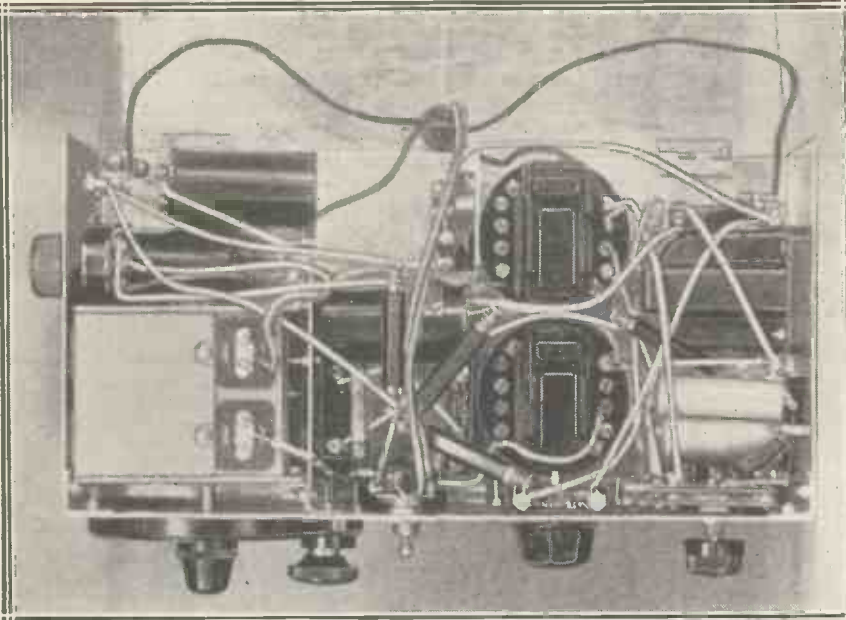

The manner in which the gang condenser is mounted on a metal bracket is clearly shown. The covers have been removed from the coils to display the connections.

you do not mind the aerial being visible from the outside of the car, is a neat aerial run along on small spacers on each side of the roof, along the edge, from front to back corner of the roof of the car.

This aerial can be of quite thin rubber-covered wire, and the down-lead can be brought in through a small hole either in the top of the windscreen where the wiper is, and the down-lead run along the inside of the car to the set, or it can be brought through at the back of the car through a small hole plugged with a rubber washer.

Other Entry Points

Other points at which the aerial can be brought into the car will occur to individual owners, for it is not a critical matter at all, the only thing

that has to be watched being that the entry does not cause any leaking of the car body in wet weather.

No earth is required if the car in which the set is to be installed is fitted with single-pole lighting equipment, but if the double-pole variety is used the L.T. negative pole of the car battery should be earthed (unless already done); or, alternatively, the chassis of the receiver.

Trimming the Set

The operation of the set is perfectly normal, but it should be trimmed fairly accurately while on the test bench before it is installed in the car. This is a precaution taken to ensure that the set is O.K. before it is finally mounted in position in the car.

The trimming should be done very carefully, the trimmers being slacked

off before commencing, and then the set should be tuned to a weak station on the lower end of the medium-wave scale. If no weak station is to be found at first, trim on the lowest station you can hear. Adjust the trimmers carefully until the best results are obtained, and then search round for a weaker station; this should easily be found, when the set is partly trimmed.

Use Reaction

With the weak station re-trim, using reaction to keep the tuning as sharp as possible, and keeping the volume to moderate proportions with the volume control. It should be found that the trimming is fairly sharp, and the whole aim of the process should be to find a sharp point of ganging with the trimmers set as far out as is feasible.

On no account should it be imagined that the object of a trimmer is to keep on adding capacity more or less haphazard until the circuits are matched, and that it does not, therefore, matter how much is added as long as they are matched.

How to Adjust

The trimmers are used for adding capacity to those circuits that have less initial capacity than the others, when the tuning condenser is at minimum. No more trimmer capacity should be added than is absolutely necessary to balance up to the capacity contained by the most loaded circuit. Keep the trimmers as far "out" as possible.

This is essential if the tuned circuits are to remain in gang over the full medium and long wavebands. Ferrocart coils are all accurately matched by the makers, so that there should be no difficulty in matching up the circuits.

COMPONENT INFORMATION IN TABULATED FORM

Component	Make used by Designer	Component	Make used by Designer
1 .0005-mfd. twin gang tuning condenser	Radiophone 805	1 screened H.F. choke	Wearite H.F.P.
1 .0003-mfd. reaction condenser	Peto-Scott	1 double-pole on-off switch	Bulgin S.104
1 slow-motion dial	Igranic "Indigraph"	3 five-pin valve holders	W.B. small type
1 pair matched coils	Colvern F.6 and F.3	3 insulated plugs and sockets	Belling-Lee
Fixed condensers :		Aluminium for chassis	(See diagram) Peto-Scott
3 2-mfd.	Dubilier 9200	2 hinges 1 1/4 x 1/2 in.	
1 .25-mfd.	T.C.C. type 250	5 yards 18 S.W.G. tinned copper wire	Goltone
3 1-mfd.	Telsen small type	3 yards insulated sleeving	Goltone
1 .001-mfd.	Dubilier type 870	1 ft. screened sleeving	Goltone
1 .0001-mfd.	Dubilier type 665	1 insulating bush for potentiometer	Sator
1 .0001-mfd.	T.C.C. type M.	Flex (to carry 5 amps), screws, etc., etc.	
1 20,000-ohm potentiometer	Sator	Rotary transformer with watertight container, 6 volts input, 220 volts/40 milliamps. output	Electro Dynamic (Car type)
Fixed resistances :		Loudspeaker	
1 25-megohm	Dubilier 1 watt		R. and A. "Bantam"; Ferranti, Rola, Epoch, Ormond, Atlas, Celestion, H.M.V., Marconiphone, B.T.H., W.B., Amphon, etc.
1 50,000-ohm	Graham Farish "Ohmite"		Dubilier (specify make of car when ordering).
1 30,000-ohm	Do. do.		
1 25,000-ohm	Do. do.		
1 5,000-ohm	Dubilier 1 watt		
1 2,000-ohm	Graham Farish "Ohmite"		
1 500-ohm	Dubilier 1 watt		
1 350-ohm	Do. do.		
1 1,000-ohm	Graham Farish "Ohmite"	Ignition interference suppressors (4 or 6 according to car)	



ON THE ROAD

*with the
Auto-Three*

HAVING built the "Auto" Three, you will now have to fit it to your car. Thanks to the design of the set this is not at all difficult, and whether the set is used in the smallest car on the road or a thirty-seater charabanc, the results will be equally good.

The accompanying photographs show the set installed in the writer's car, this being chosen as it was the smallest in the office, for if it could be made to fit satisfactorily in the limited space available, there was sure to be no difficulty with larger cars. Yes, it is sometimes very convenient being the owner of one of these really small cars, especially when there is a suitable radio set in the offing!

Ample Room

The actual position of the set does not really matter, but as a rule it will be found most convenient to fix it to the side of the car. In nearly every case there is a certain amount of more or less wasted space where it will fit without getting in the way.

As you can see from the photographs, the particular set described was screwed to the left-hand side of the car alongside the back seat. And although at first sight it might look as though it would come in the way of one's elbow, this is not so provided the set is mounted sufficiently forward. In this position it was found that there is ample room behind the receiver, and at times it makes a very nice arm rest.

Out of the Way

An alternative position is on one of the cross-pieces of the roof. Some readers may prefer it in this position, because owing to its comparatively

The car receiver described on preceding pages is suitable for fitting to any size car, a fact well illustrated by our installing it on an Austin Seven. How this was carried out and also the general aspects of fixing the set to any other car are described

By FRANK BRIGGS.

small size it is even more out of the way, being well clear of one's head except, perhaps, in the case of an exceptionally low-built car.

A couple of lugs, one on each end of the metal cabinet, are all that should be necessary to fix the receiver. It may even be possible to use existing screws in the interior bodywork if

BESIDE THE SEAT



A very good position for the set is on the side of the car just below one of the back windows.

the actual positions of the lugs are thought out carefully. This is certainly a great advantage, as nobody likes driving screws into the sides of his car, not even to fix such a valuable asset as a radio receiver.

Now, regarding the loudspeaker—this is mounted in a similar way to the set, except that it is detachable,

so that full use can be made of it for picnics, etc. In fact, if you provide a nice long length of twin flex you can take the loudspeaker almost anywhere you wish.

A good scheme is to carry a special long length for these occasions, and leave a short

piece permanently fixed inside the car for listening while under way. The loudspeaker connections on the receiver consist of a couple of sockets, so if you have a pair of wander plugs on the ends of the wire, connecting up becomes a very simple matter.

Aerial Arrangements

Now regarding the aerial, as mentioned in the preceding article there are three main methods: (1) Fix some form of aerial inside the car; (2) sling it between two insulators underneath the chassis, or (3) use an external aerial tied on to the nearest tree or post. This latter arrangement, however, is not to be recommended as it limits using the set to occasions when the car is stationary.

Single rubber-covered flex is the best wire to use for an aerial. It is nice and pliable, and can be tucked away out of sight.

You will have probably noticed by now that there is no earth terminal on the set. Now, even car receivers need an earth connection of one sort or another, and the one being described is no exception.

Earth Considerations

The rubber tyres prevent a real earth being used, so we use the next best thing—the chassis of the car. And, incidentally, connection is made to it via the L.T. negative lead from the receiver. This arrangement forms a very efficient aerial-earth system,

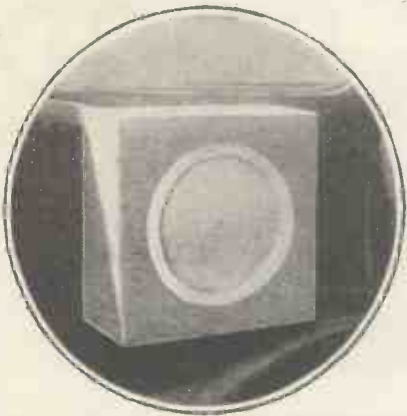

The cabinet for the speaker should be just large enough to house the unit chosen. On the side of the car, opposite the receiver, is a convenient spot for the loudspeaker.

and in use gives exceptionally good results.

The high-tension supply for the receiver is provided by a very neat little rotary transformer made specially for car radio by the Electro Dynamic Construction Company. The output is 200 volts at 40 milliamperes, the driving power being obtained from the car accumulator.

Water-Tight Container

The generator is supplied by the manufacturers for working from 6- or 12-volt lighting systems. The former type is the one required for the "Auto" Three. The machine is mounted in a special watertight case so that it can be screwed to the underside of the chassis (this was the scheme adopted in the writer's case), or, if preferred, it can be let into the floorboards.

If it is possible, this latter arrangement is better, as the generator can then be withdrawn from its box for inspection without difficulty. In many present-day cars, however, the floor is made of sheet metal, which makes letting-in a difficult business. In these cases the alternative is to bolt the whole outfit underneath.

There are five leads coming out from the receiver: H.T. plus, H.T. neg., generator plus, L.T. plus and L.T. neg. The first two go to their respective terminals on the generator, and the third one is connected to L.T. plus on the generator. The remaining two leads must now be joined to the positive and negative terminals on the accumulator—at least, in the case of 6-volt systems.

Six Volts Used

If the car accumulator is 12 volts, the L.T. plus tapping will have to be connected to a point half-way along

the battery. The set is designed for single wire lighting systems where the car chassis acts as an earth return; so if your car happens to be one with twin wiring and no "earth" it will be necessary to join the negative terminal of the accumulator to the chassis.

To some readers it might seem strange that full use is not made of the battery in the case of 12-volt outfits. The reason for this is that 6-volt valves are employed in the set, and it would be very difficult to get a resistance sufficiently robust to break down the extra 6 volts at the fairly heavy current that passes.

Alternative Scheme

Those who are sufficiently advanced in radio matters, however, could, by using a separate switch for the generator, run it from the full 12 volts. But if this arrangement is decided upon it would be necessary

GENERATOR HOUSING



The generator, run from the car battery, is fixed beneath the car floor. It is here shown opposite the accumulator of an Austin Seven.



Although next to the exhaust pipe, the generator is quite safe, being protected by a metal container, from which it is seen removed in the circle below.

to a nicety. The on-off switch controls both the valve filaments and the H.T. generator. But, as mentioned previously, a separate switch can be used if desired.

As regards range, using a small aerial 6 to 10 ft. long, it should be possible to receive several alternative programmes in almost any part of the country. Reproduction is clear and crisp, and the 1½-watts output of the pentode should give ample volume for all normal requirements.

The beauty of the set is that it will receive just as well while the car is in motion, as when it is at a standstill by the roadside. What could be better than a little dance music to relieve the monotony of a long run? Or, perhaps, listening to the news while travelling westward across Salisbury Plain. You might hear that an anti-cyclone was approaching the south-west coast of England, or would it be one of those depressions?

Outstanding Reception

On one occasion near London, North Regional was received at quite reasonable strength. And, what is more, it was broad daylight, and the aerial was only about eight feet long. Not at all a bad performance for a straight three-valver.

Of course, when conditions are good you should be able to receive quite a number of the higher powered foreigners. And, if you are lucky, many of the smaller fry as well. It is really surprising what can be achieved with three modern mains valves in a properly designed receiver.

PROTECTED BY CASING

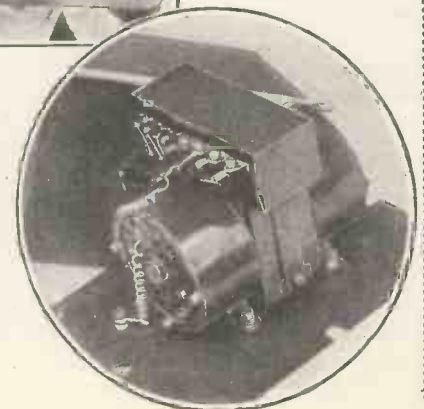

to specify a generator having a 12-volt input.

Elsewhere in this supplement there is a page dealing with interference problems from the ignition system. With car engines it is fairly easy to get rid of this.

The operation of the set is extremely simple, reaction is delightfully smooth, and the volume control on the end of the cabinet allows the sensitivity of the set to be adjusted



The M.W. "YACHTSMAN'S" FOUR

By
The "M.W." Technical Dept.

THOSE who are familiar with sailing yachts and motor-boats will realise the limitations that are imposed on a convenient radio-receiver design for use in any sort of small river or sea craft. They will know that whereas there seems to be plenty of room on board for ordinary things, and for passengers, that room becomes remarkably precious when the fitting of radio is considered.

Stowage Problems

In a two-berth cabin, for instance, there is hardly any space that can be spared, even for a console type of set, for the table must be kept clear for meals, or charts, and it is a terrible nuisance to have to clear everything away when radio is to be listened to, or to park the set elsewhere when the table is required for other purposes.

The set cannot be placed on the deck in such circumstances, for it will still be in the way, and a set of that description will only insist in rolling about with the motion of the vessel.

The only way to ensure really satisfactory radio on board ship is to use a design that can be fixed permanently in position on the bulkhead, or in a recess in the cabin, with the batteries or power pack (if a motor is carried) in a

convenient position. The speaker can then be fixed or movable as desired, for it takes but a moment to hook a speaker up in any convenient position either below or up on deck.

So in this part of our land, sea and air section we are giving a description of a simple battery radio receiver which can be used either in a recess, as shown in the photographs, or else actually screwed to the bulkhead, in which case the most convenient position is to have the set with the panel uppermost, when it will project but a short distance into the cabin.

It is rigidly constructed, and if the batteries are stored somewhere convenient, in a small box, everything will be ship-shape and immovable even in the roughest weather. A very important point, this!

In spite of its four valves, the "Yachtsman" Four measures only 7 in. x 14 in. x 10 in., so that it is a very easy matter to find space to stow it. The aerial and earth part, of course, as described in the next section, are extremely simple to

fix, and as a "water" earth is one of the most efficient, the results from the set should be particularly good.

Range and Power

"Class B" amplification has been employed so that the power obtainable from the loudspeaker leaves nothing to be desired, while the iron-cored band-pass coils provide ample selectivity with a sensitivity that is surprising.

A screened-grid valve of the multi-mu variety carries out H.F. amplification, giving a range of reception that is more than adequate for all ordinary listening

Here is a special set for a special purpose, but its efficiency makes it of great interest quite apart from its application as the ideal receiver for use in motor-boats and sailing yachts.

purposes. Varley alloy coils are employed, the band-pass section being coupled on the inductive link method, a 100,000-ohm resistance and .25-mfd. condenser being employed to decouple the bias control potentiometer.

From the screened-grid valve we go to a shunt-fed, tuned-grid circuit and the leaky-grid detector. This is later fed into an L.F. transformer coupling for the driver valve of the "Class B" stage, which latter is coupled to the "B" valve through the usual driver transformer.

Loudspeaker

No "Class B" output transformer is used for the last valve, as it is assumed that the loudspeaker chosen to work with the set will have a suitable transformer incorporated in its design. Nowadays nearly all makes of permanent magnet moving-coil speakers can be obtained with

BAND-PASS INPUT AND "CLASS B" OUTPUT

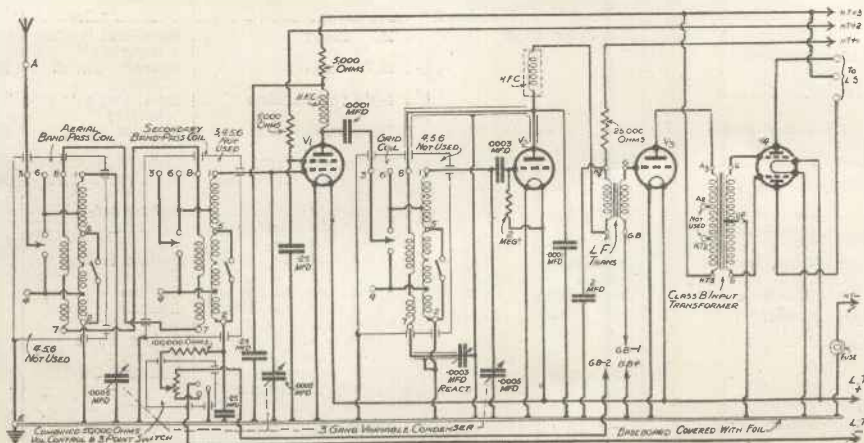

The circuit of our special receiver for use on boats starts off with a band-pass fed multi-mu S.G. stage. This is followed by a grid-leak detector and two L.F. valves, the final one being of the "Class B" type for giving powerful reproduction.

"Class B" input transformers suitable for matching the various "Class B" valves on the market, and one of these models from the makes specified in the list of alternatives will fill the bill to a nicety.

Transformer Ratios

It must be remembered, of course, that the output valve to be used should be specified when the speaker is ordered, and the valves shown in the accompanying list must be adhered to if the best is to be obtained from the set. This is because the various "Class B" valves have differing characteristics, and have to

be properly fed from the driver transformer in order that the maximum or any predetermined output power shall be obtained.

Thus with certain transformers and certain ratios of primary to secondary the power of the maximum output of a "Class B" valve can be predeter-

MODERN IRON-CORED COILS USED

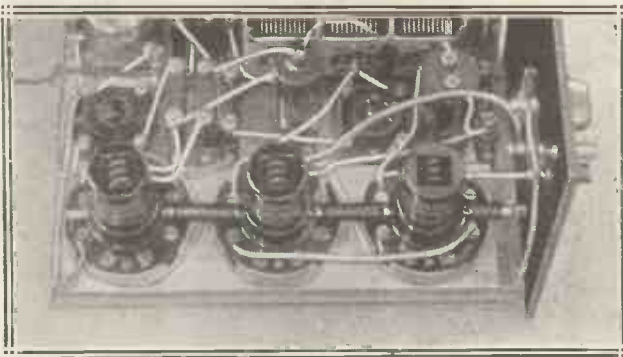

The screened coils are of one of the latest types, and their switching is ganged to a single knob. Two of the units form the band-pass input circuit, and the other, the parallel-fed grid circuit of the detector valve.

MADE COMPACT FOR EASY STOWING

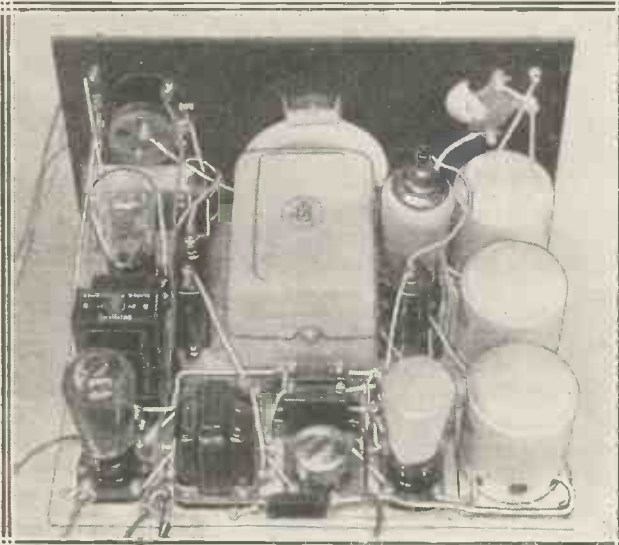

On a small boat, or any boat for that matter, space is an important consideration. But the "M.W." "Yachtsman's" Four does not require much, and gives good return in entertainment value for a place in some small nook or cupboard.

mined from about 1 to 2 watts, depending on the valve chosen. Furthermore, the driver valve also has to be chosen to suit the transformer ratio and the "Class B" valve, apparently another complication in the scheme of things

Actually, if you follow the details given in the list of valves and use the transformers specified, getting into touch with their makers or the manufacturers of the valves, if you

are at all in doubt, you will not go far wrong. The valves in the list given here are those suitable as teams for use with the transformer used by the designer of the set, and they should be adhered to absolutely.

Volume Considerations

Naturally, it is not economical to arrange a "Class B" set so that the full output wattage of which the valve is capable is obtained if the set is to be used by all and sundry, for it will be found that in most cases the set will be turned full on, and more or less left in that condition, which means that the H.T. battery will very soon run down, for it must be remembered that one has to pay in H.T. according to the strength of the reception.

In the case of a set of the description of the "Yachtsman," it will be

COMPONENTS and SUITABLE MAKES for BUILDING the "M.W." "YACHTSMAN'S" FOUR

Component.	Make used by Designer.	Alternative makes of suitable specification recommended by Designer.	Component.	Make used by Designer.	Alternative makes of suitable specification recommended by Designer.
1 Panel, 13 1/2 in. x 7 in.	Goltone	Peto-Scott, Becol	1 H.F. choke	Peto-Scott "Pilot Saperhet"	R.I., Goltone
1 Baseboard, 13 in. x 10 in., and foil	Peto-Scott	—	1 H.F. choke	Graham Farish H.M.S.	Telsen, Lewcos, Wearite
1 Triple-gang .0005 mfd. tuning condenser	J.B. Unitone	—	3 4-pin valve holders	Benjamin "Vibroldor"	W.B., Telsen
1 Triple-gang coil unit	Varley Nicore B.P.30	—	1 7-pin valve holder	Wearite	Ferranti, Benjamin, W.B. Lewcos
1 .0003-mfd. reaction condenser	Polar "Compax"	Lissen	1 L.F. transformer	Lissen "Hypernik"	R.I., Varley
Fixed condensers :			1 "Class B" input transformer	R.I. type D.Y.37	Sound Sales, Benjamin, Varley
1 2-mfd.	Dubilier B.E.	T.C.C., Telsen	1 Wander fuse	Belling & Lee 1028	—
1 .25-mfd.	Dubilier 9200	—	5 Safety shrouded plugs and sockets	Belling & Lee 1015	—
2 .25-mfd.	Telsen small type	—	6 Wander plugs	Belling & Lee	Clix
1 .0003-mfd.	T.C.C. type 34	Dubilier	2 Accumulator tags	Clix	Belling & Lee
1 .0001-mfd.	T.C.C. type 34	Dubilier	5 Yards insulated sleeving	Goltone	—
1 .0001-mfd.	Dubilier 670	Telsen, T.C.C.	7 Yards 18-gauge tinned copper wire	Goltone	—
1 Combined 50,000-ohm wire-wound volume control and 3-pt. on-off switch	Lewcos	—	1 Grid-bias clip	Eulgin No. 2	—
Resistances :			1 Yard screened wire	Goltone	—
1100,000-ohm and holder	Ferranti Synthetic	—	1 Anode connector	Felling & Lee 1030	—
125,000-ohm and holder	Ferranti Synthetic	—	Wire, screws, flex, etc.	—	—
2 5,000-ohm and holder	Ferranti Synthetic	—	Wood for Cabinet :	—	—
Grid leak :			2 pieces 10 in. x 6 1/2 in. x 1/2 in.	—	—
1 2-megohm with wire ends	Goltone	Dubilier 1 watt, Lissen	1 piece 7 in. x 13 1/2 in. x 1/2 in.	—	—
			1 piece 13 1/2 in. x 10 in. x 1/2 in.	—	—

THE VALVES WE SUGGEST

Make	S.G.	Detector	Driver	"Class B" Output
Mullard	P.M.12M.	P.M.1H.L.	P.M.1L.F.	P.M.2B.
Cossor	—	210 Det.	220P.A.	240B.
Mazda	—	H.L.210	P.220	P.D.220
Marconi	—	H.L.2	L.P.2	—
Osram	—	H.L.2	L.P.2	—

used mainly by the set builder, or the owner, and will not be likely to be employed in a haphazard manner by, say, an inexperienced family, as might a set at home, so we can afford to cater for the full output, or very nearly so.

Thus we have arranged for about 2,000 milliwatts as the maximum undistorted A.C. output from the "Class B" valve, varying a little according to make, employed with the R.I. transformer and the driver valves specified. In everyday use this wattage will rarely be required, for on board a ship the space is limited, and one's proximity to the loudspeaker is such that the full power of 2,000 milliwatts would be unbearably loud.

Thus it is probable that rarely would more than half this be exceeded except in the very peakiest of loud passages, and the average level will

most likely be of the order of about a quarter of that figure.

On occasion, however, it may be desirable to have a speaker

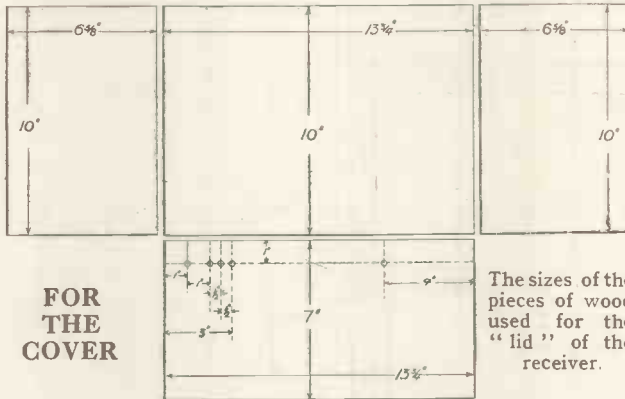

FOR THE COVER

A STRAIGHTFORWARD LAYOUT

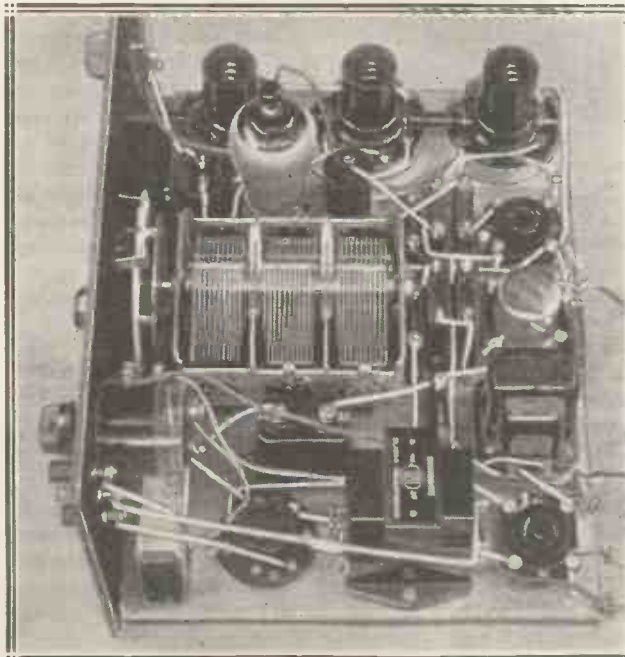

Freakishness has been entirely avoided in the layout, which, apart from its extra compactness, follows more or less along conventional lines, so that no difficulties should be met in its construction.

TERMINALS ARE ON THE PANEL

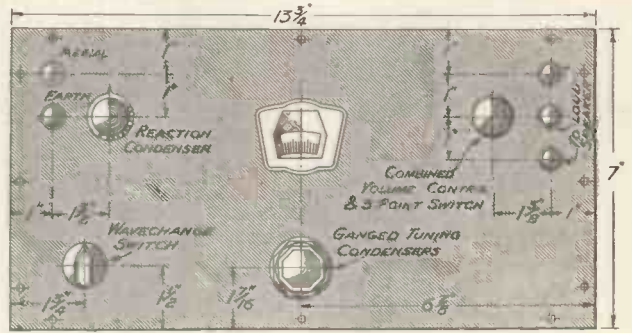

PANEL LAYOUT

So that the set may be used when desired with the panel horizontal, the aerial, earth and loudspeaker terminals are mounted on it instead of in their more usual position on a terminal strip at the back of the baseboard.

very badly in sea air, tinned iron would tend to rust, copper would be very expensive, and zinc would not be very satisfactory.

Everything is quite straightforward in the building of the "Yachtsman's," the layout being compact without being tricky in any way. A standard type of layout is employed, having the coils ganged and running down one end of the baseboard with the first two valves alongside. Next to

these comes the three-gang variable condenser, while the output from the detector is taken via the transformer to V_3 along the back of the set, V_4 being nearer the panel on the left-hand side looking from the back.

Battery Connections

This latter superposition of the last two valves makes the layout of this part of the set unusual, for we normally have the output valve near the back of the set. In this case, however, the loudspeaker terminals are mounted on the panel, and not the baseboard, there being no terminal strip.

The battery connections are made via flex leads running out of the back of the set, but aerial and earth connections go to two terminals on the panel. The circuits have been well

operating on deck, a pleasant way of spending a lazy summer evening, and then the full wattage will be welcome, for in the open air one needs very much more power to make a programme comfortably loud. The set is constructed on the normal baseboard and panel system, with the baseboard covered with metal foil, a simple wooden box being made to contain the whole receiver.

There is no need for an all-metal construction, and, indeed, this would be rather difficult to make, seeing that it would have to be made of some fairly non-corrosive metal, for aluminium, used normally for all metal sets, would soon oxidise

ACCESSORIES WE RECOMMEND

- H.T. Battery, 120 volts.—Pertrix ; or Ever Ready, Lissen, Ediswan, Marconiphone, Siemens, Drydex, etc.
- Grid-Bias Battery, 4.5 volts.—Lissen ; or Ediswan, Pertrix, Ever Ready, Siemens, etc.
- L.T. Battery, 2 volts.—Oldham ; or Exide, Ever Ready, Lissen, Ediswan, Block, etc.
- Loudspeaker.—Special "Class B" type. B.T.H., Rola, Celestion, R. & A., Magnavox, W.B.

HOW TO WIRE UP THE "YACHTSMAN'S" FOUR

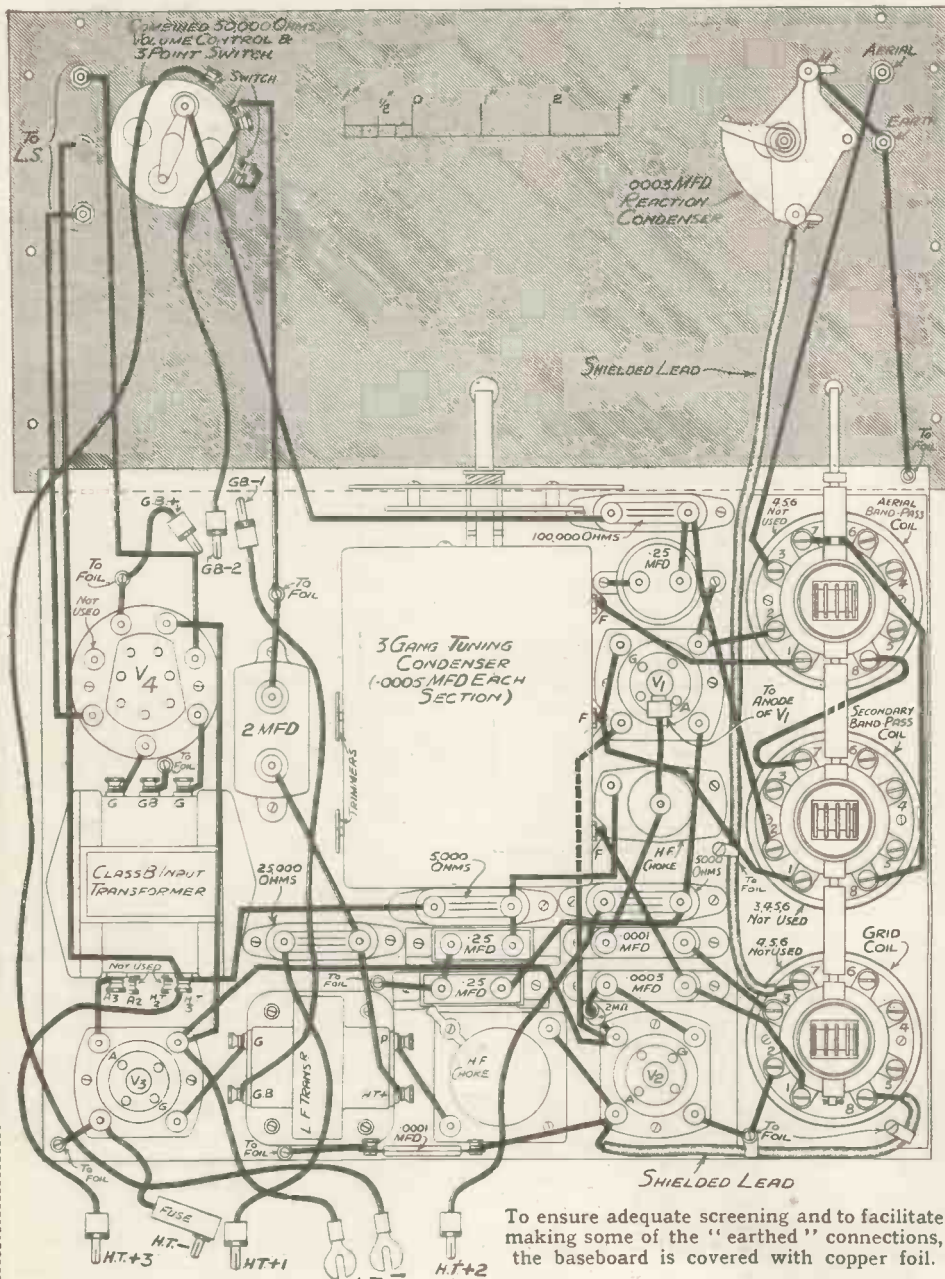

To ensure adequate screening and to facilitate making some of the "earthed" connections, the baseboard is covered with copper foil.

The operation of the receiver is perfectly normal. About 120 volts H.T. are required on H.T.3, 70 to 80 on H.T.2 and about 60 to 100 on H.T.1. This latter variation is required according as the strength of the received station varies, a lower H.T. voltage on the detector sometimes being an advantage if a lot of reaction is to be employed. This must be found out by experiment, but the voltage adjustment on this valve is not critical.

Grid Bias

The grid bias required is about 3 to 4.5 for G.B.—1, depending on the driver valve used, and from 4.5 to 15 for G.B.—2. This latter will depend on the variable-mu valve chosen, for instance, if the Mullard P.M.12M. is employed, the voltage can be either 4.5 or 6 volts, while with other makes a voltage of between 9 and 15 volts is advisable, the actual voltage being not in any way critical.

Trimming of the variable condenser is carried out in the usual way, by tuning in a station at the bottom end of the medium-wave band, and checking up the trimming with a little applied reaction and the reception of a weak station as low down on the wavelength scale as possible. In all cases of trimming the strength of the received station should be kept down by means of the variable volume control rather than by reduction of reaction, for the use of reaction assists in making the trimming more accurate.

A Trimming Tip

As often explained in these columns, it is of the utmost importance, in carrying out condenser trimming, that the absolute minimum of added capacity be applied. This means that one, at least, of the trimmers should be almost "out" when the trimming is completed; the trimmer corresponding, of course, with that circuit which has already the greatest added stray or minimum capacity of the three.

decoupled throughout so that the set can be used from either dry H.T. batteries or "Class B" mains units (when used ashore at any time), of which there are several makes now available. Normally, of course, the battery will be employed, for if one has mains it is usual to use mains valves rather than "Class B."

It is not advisable to try and operate the set from ordinary generators run from the lighting battery of the motor-boat, owing to the requirement of really first-class anode voltage regulation for feeding the "Class B" valve.

Such regulation can be obtained

from ordinary electric supply mains, but it is a little too much to expect from small generators designed to supply but 40 to 50 milliamps. from low-tension batteries. It is to be hoped, however, that the advantage of "Class B" for mobile sets of all types will prompt manufacturers to tackle this problem of suitably regulating small generators.

Voltage Requirements

Two screened leads are employed in the wiring of the "Yachtsman," and these are important if any chance of interaction between the leads and the rest of the set is to be obviated.



The m.w. "YACHTSMAN'S" FOUR AFLOAT

IF the reader's first reaction upon seeing a receiver designed especially for the yachtsman is to question the necessity for such a design, it will not be surprising.

Questions of space must, of course, limit the design of a set for an aeroplane or a motor-car to almost infinitesimal dimensions, but there are very few yachts afloat where a portable receiver would be an impossibility.

Special Requirements

The advantages of a special yachtsman's receiver are many, and the average seaman's desire for having all his gear suited to its purpose, well stowed away and shipshape, is certainly not the least of them! But it is certainly significant that two of the most important yacht architects in the country are including built-in radio in their designs—even, as I noticed a week or two ago, in the larger racing boats which boast cabin space of a sort.

The limitations of a portable are well known, but there is the additional snag, when going to sea, that it is not the easiest form of gear to stow securely. And to find one's radio rolling about the cabin floor is not the jolliest end to a wet and windy cruise.

Pointed Reminiscences

It must be several years now—although it seems but the day before yesterday—that I first installed a radio set in a five-ton sailing yawl. It was a makeshift affair, and I remember that a Primus stove, several plates, the bread tin and a pair of kippers had to be lumped together under the cabin table so that we could mount the components directly on to a shelf in the cupboard! Even then the owner, after a day's sailing, would

Installing our special boat receiver is a simple matter. Whether it is to be used in a small sailing yacht, or in a river steamer, there are many alternative places for its accommodation. These, together with other items of installation, are here dealt with

By **PATRICK CAMPBELL.**

dive down the hatchway to make quite sure that none of the valves had fallen out during the cruise.

However, results were all that we could have wished for, and the enthusiasm of the audiences at the little South Coast ports where we dropped anchor for the night often became embarrassing. We had a most

efficient aerial which stretched from the bowsprit, via the mast-head, to a makeshift lead-in at the stern. While sailing, the aerial was supposed to lie flat along the mast; unfortunately, a keen but inexperienced gentleman—a barrister of the Inner Temple—who was acting as "crew" in a particularly exciting race, mistook it for the jib halyard as we were rounding a mark buoy. We lost the race—and it also proved the end of the receiver, the owner having some strange preference for seamanship rather than "this new-fangled idea of entertainment."

A Sceptic Convinced

As a matter of fact, this particular owner, whose business allows him to take a summer holiday running into months, never got over his aversion to yacht radio until a few weeks ago, when I took the MODERN WIRELESS "Yachtsman's" Four aboard his new yacht for a trial under cruising conditions. The installation of this receiver proved so simple, thanks to a recess just behind the mast (the reader can see how easy it was from the photograph on the next page), that we spent two evenings trying out new ways of fixing it under less favourable conditions—many other craft, some of them perfect strangers, being roped in for experiments.

Easily Accommodated

The chief joy of this receiver is that it can be fastened with a screw or two on to almost any part of the cabin partition, or even—as we proved in one obstinate case of a boat which seemed to have crammed the luxuries of a five-roomed flat into a space of about 12 square feet—to the deck-head.

We fixed it to a cupboard door, to the floor (the ease with which it could

GOING ASHORE



One of the advantages of the "Yachtsman's" Four outfit is that it is easily taken ashore if the boat is to be out of commission for a period.

be operated in this position by the occupant of a bunk was astonishing!), to an ordinary partition door, the underside of the table, and a dozen other places, likely and unlikely.

The provision of a satisfactory earth on the boat's bottom presented no difficulties, although the owner—now a complete radio convert—has quite made up his mind that the job must be done properly and permanently on the keel when the boat is next on the slips for overhaul.

Novel Aerial

The aerial difficulty (which was, of course, no difficulty at all in the case of the motor cruiser we borrowed) was solved on the sailing vessel by running the wire round the rail at a height of about six inches from the gunwale. Besides being out of every-

USE IT ON DECK—



On a river boat, probably used mainly at week-ends, there are a number of points on deck where the "M.W." "Yachtsman" can be installed and be quite accessible. It is here seen on the fore-deck.

one's way and clear of all halyards and sheets, it turned out to be quite as efficient as the more imposing affair slung between the masts of the motor boat.

Speaker Extensions

Incidentally, we found one boat with a brass rail running round the deck, and in this instance a lead-in to the set was all that we needed. Taking it all round, the aerial question is probably easier on a yacht than anywhere else, for the variety of ways in which it can be erected seems never-ending. A wire hoisted to the mast-head of a racing boat of the 12-metre class at the end of each day's work is certainly much more efficient all round than the great majority of aerial systems' one meets with on land.

We found that the very short leads

needed to bring the loudspeaker on deck through the cabin skylight did not impair the efficiency of the "Class B" speaker in any way.

Stowing Batteries

The advent of a sudden downpour of rain, not an uncommon occurrence even on a July evening, made a hasty retreat below a matter of seconds. Certainly yacht radio is an all-weather business, and the boon which it offers to three or four tired and wet enthusiasts cooped up in a very small space is quite incalculable.

The battery question, too, is one which solves itself. There are those motor cruisers—and many of them will be proud to install the "Yachtsman's" Four—which boast the possession of an electric lighting system. In the matter of re-charging batteries such people will certainly score, but in other ways their advantage is not so great, for there are a hundred and one places in which battery and accumulator can be stowed. Clothes are not the only things which find their way underneath a bunk!

Power Supplies

As for those boats which use batteries for their engine or auxiliary motor, a 2-volt tap for low-tension supply is the easiest thing in the world, while high-tension supply can be taken from dry batteries.

—OR STOW IT AWAY IN THE CABIN



In the text, Mr. Campbell, seen here with the "M.W." "Yachtsman," tells how a friend of his found a neat place for his radio in a recess just behind the mast.

It was this very variety of supply which prompted the designers of the "Yachtsman's" Four to keep the batteries separate from the receiver, and the arrangement has had the incidental advantage of reducing the size of the receiver itself.

One might spend many hours and use many pages in describing the many ways in which a radio receiver can be installed and worked afloat.

For All Craft

But if I know anything of the ingenuity of yachtsmen, they will vie with one another in the simplicity, the oddity and the efficiency of their own installations. And owners of motor cruisers need have no fear of interference from their engines—for if they *do* get such interference at first, the cause and cure are pointed out in the article on "Preventing Ignition Interference."

So, whether you own a floating palace or a four-tonner that will "sleep three" (one under the table!); whether racing is your *métier* or whether you are just a fair weather sailor with white flannels and a brand new cap, I leave you to it with the certain knowledge that yacht radio permanently installed in your boat is going to bring you all the fun in the world besides keeping you informed via Daventry, as to what weather is in store.

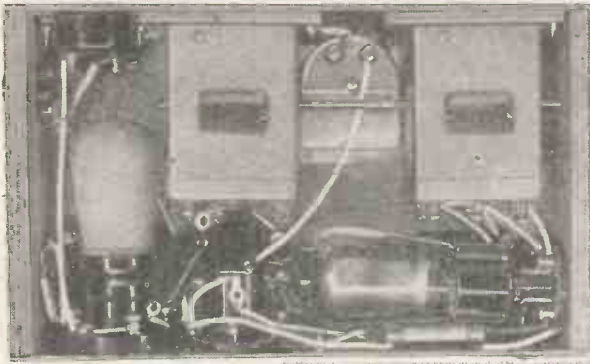

**A
PLACE
FOR
EVERYTHING**

By careful layout the components are given sufficient clearance without any space being wasted.

earth potential, so that there is no vestige of hand capacity; while the fact that iron-core coils are used allows the set to be compacted together in a way that would spell inefficiency if air-cored inductances were used.

Quite a plain tuning system is used, there being no need for band-pass or other more elaborate circuits, all the sharpening of tuning that may be required from time to time can be carried out by the reaction control, while the shunted tuned-grid circuit allows a high degree of sensitivity to be obtained.

The tuning is, in fact, extremely simple and has been so arranged that it is easily operated when the set is on the lap, the condensers being well up to one edge of the set, and not impeded in any way by the body of the listener.

The Wavechange Control

The wavechange control is on the side, so that it falls to hand quite readily when required, and this is important, for it must be remembered that there are three wavelength bands to be covered, and consequently three operations of the switch to select the bands.

It should be explained here that the coils are so designed that the total waveband covered is divided

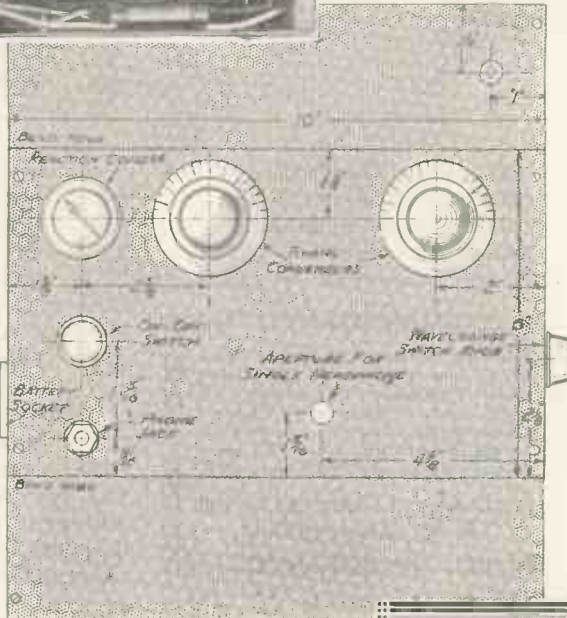

into three sections, with a certain amount of overlap between successive bands, and in operation the coils tune from about 160 to 450 metres, 350 to 850 and 800 to 2,000. This may seem complicated at first, but in a little while the operation becomes quite natural and selection is an easy matter.

No earth is used with the set, unless the user likes to connect the chassis to some metal portion of the plane. The metal-covered lead to the batteries, which will quite often be best housed in the luggage rack in the back of the cabin, will usually be found quite sufficient. The length of flex to the batteries should, of course, be decided in accordance with the position in which the battery box will be placed.

This box, by the way, need be

only a very simple affair, just sufficient to take the required H.T. and L.T. battery, tightly fixed so that they will not shake about, an unspillable L.T. accumulator being employed.

The actual shape of the battery box can be left to the individual constructor, for he will obviously build it to suit the requirements of the moment. It should be of metal, if possible, so that there is no danger whatever of fire, and it should be fitted with a valve-holder socket device for the plugging-in of the link to the set.

Preventing Shorts

It is essential that the flex link be detachable in order that the battery end of the connection can be disconnected before the set end, thereby preventing any possibility of battery short-circuiting should any of the pins on the battery plug touch the metal chassis of the receiver.

It is a good plan when the set and battery box are installed in the plane to fix the flex lead permanently into position, leaving enough slack at each end for any movement necessary

LINKED SWITCHING

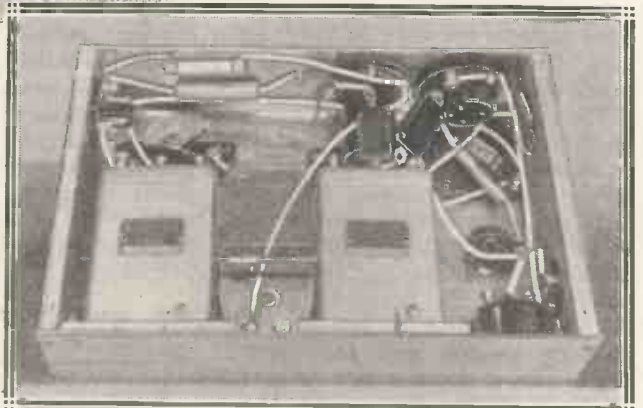

The wavechange switching of the coils is effected by one knob on the side of the set. This can be clearly seen in the diagram above and also in the top photograph.

of the box or the receiver when they are to be removed.

Remember to adjust the pins of the battery plugs so that they make a really tight fit in the battery box and the set valve holder sockets, for no chance of the flex becoming disconnected while the machine is in flight must exist.

If desired, it would be an easy matter to arrange a small clip or other locking device so that without the removal of a screw or wing nut the plugs could not possibly be

RUN THE SET ON THESE

- H.T. Battery, 99, 100 or 108-volt portable type, according to make (see text concerning battery box).—Siemens "Full O'Power"; or Ediswan, Lissen, Pertrix, Ever Ready, Marconiophone, etc.
- L.T. Accumulator, 2 volts.—Exide; or Ediswan, Ever Ready, Lissen, Oldham, Block, etc.

KEEP TO THESE PARTS WHEN BUILDING THE "AIRMAN" TWO

Component	Make Used by Designer	Component	Make Used by Designer
1 aluminium box (see text)	Peto-Scott	1 2-point on-off switch	Bulgin rotary QMB
2 tuning coils with ganged switch rods	Lewcos Triple Range	1 2-megohm grid leak with wire ends	Lissen
2 .0005-mfd. variable condensers	Lissen type No. LN5103	1 1/2-megohm " "	Dubilier 1-watt type
1 .0003-mfd. reaction condenser	Graham Farish	1 high resistance earpiece "	Electradix (maximum diameter 2 in.)
1 .0005-mfd. fixed condenser	T.C.C. type M	1 piece of metal for step bracket	
1 .0003-mfd. " "	Dubilier 670	1 1/2 in. wide x 2 1/2 in.	
1 .0002-mfd. " "	Igranic tag type	1 insulated aerial socket	Belling-Lee
1 .001-mfd. " "	Igranic tag type	Material for battery box (see text)	
1 .1-mfd. " "	T.C.C. type 250	2 4-pin plugs	Bulgin P9
1 4-pin valve holder	Lissen type LN5069	3 yards tinned twin-screened cable	Goltone R34/CT
1 4-pin " "	Ferranti baseboard type	1 wander plug	Belling-Lee, or Clix, Igranic, Goltone
2 5-pin " "	Ferranti chassis type	1 wander fuse	Belling-Lee
1 H.F. choke	R.I. "Quadastatic"	2 accumulator tags	Belling-Lee, or Clix, Igranic, Goltone
1 'phone jack	Peto-Scott "Midget Reaction"	1 1-in. length of brass tube, 1/2-in. internal diameter, to fit hole above earpiece.	
1 'phone plug	Igranic P72		
	Igranic P40		

SPECIAL NOTE.—Owing to the extremely compact nature of this receiver, it is not possible to use components of alternative makes to those specified except in the case of the 2-megohm grid leak, where Dubilier or Goltone may be used, and the 1/2-megohm grid leak, for which Lissen and Goltone are suitable.

withdrawn. This can be left to the ingenuity of the constructor, who will no doubt adapt a system, as he will the length of the battery flex, to the requirements of the machine in which the outfit is to be used.

The whole set is contained in a two-sided aluminium box with wood ends 3/8-in. thick. The bottom is of sheet metal, of the same thickness as the top and sides of the container, namely, 1/8-in.

In addition, a small piece of metal, 1 7/8-in. wide by 2 1/4-in. long, is bent to form a step bracket to hold the earpiece which is used when the De Havilland 'phone is employed for listening. This earpiece must be carefully fixed opposite the hole shown in the diagram, and between its edges and the inner surface of the box should be a small piece of felt to make a sound-proof "joint."

Into the hole and protruding outside is fixed, tightly, a short length of brass tubing, which should be split for about 1/2-in. at the outer end, to allow the headphone plug to fit tightly into it. Care must be taken here to make every joint as sound-tight as possible, so that no loss of strength shall occur owing to acoustic leakage.

A Wiring Tip

In the construction of a set that has to meet with varying conditions of operation, vibration and a certain amount of knocking about, it is, of course, most important that all the

connections be well and truly made. There must not be the slightest possibility of anything working loose or coming adrift, and this particularly applies to connections that are made by means of terminals.

There is nothing like terminals for coming undone if they are subjected to vibration of any kind. Gradually they will tend to work loose and the connection under them will become inconstant, with annoying results.

Be sure, therefore, that not only are all the terminals done up really tight, with pliers, but that the loops of wire under them are made in the correct way. They should so turn that in the process of tightening the terminals the loops will tend to close up. If they are made the wrong way they will tend to undo as the terminal is tightened, and this will make a very unsatisfactory connection.

CHOOSE TWO OF THESE
 S.G.—Mullard P.M.12A ; Cossor 215.S.G. ; Mazda S.G.215.
 Detector.—Osram H.L.2 ; Marconi H.L.2 ; Cossor 210.H.L. ; Mullard P.M.1.H.L.

FLATTENED OUT FOR SIMPLICITY

For the purpose of this wiring diagram the receiver case is drawn in plan form.

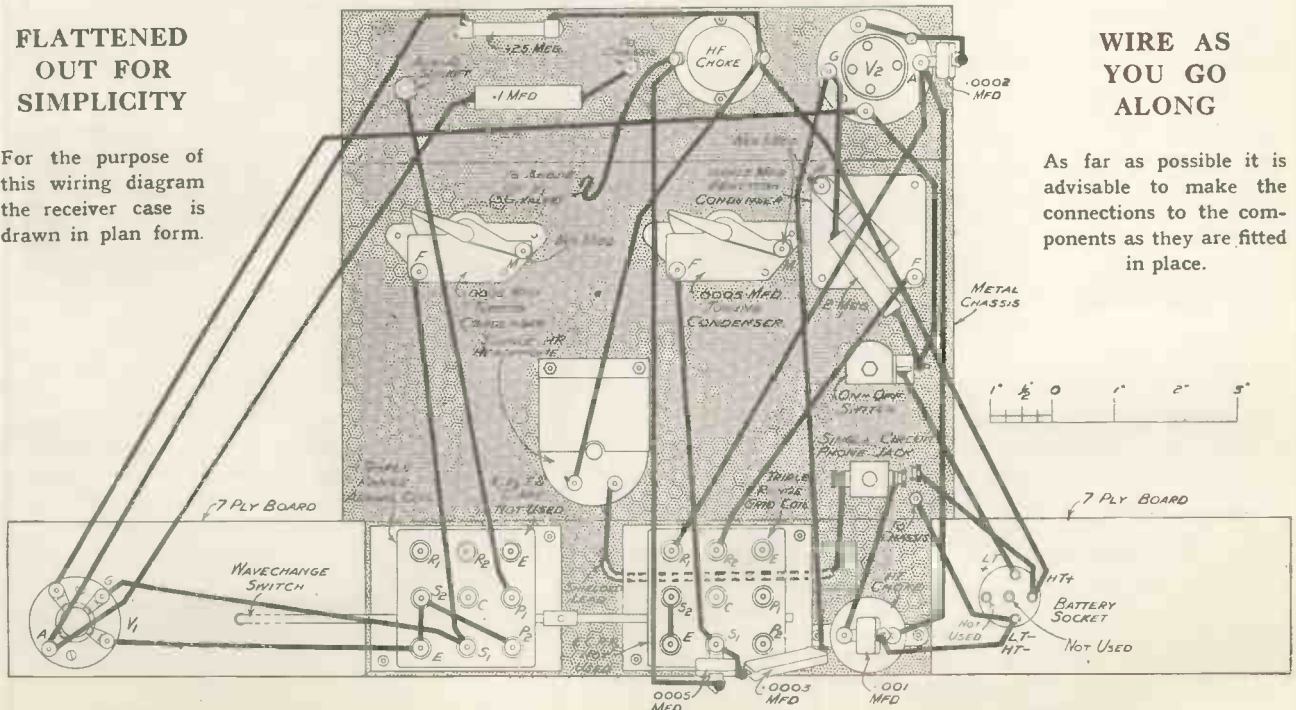

WIRE AS YOU GO ALONG

As far as possible it is advisable to make the connections to the components as they are fitted in place.

Preventing IGNITION INTERFERENCE

By An "M.W."
TECHNICIAN.

A SIMPLE spark transmitter consists of a spark jumping across a gap in a circuit which contains some inductance and capacity. These conditions are completely fulfilled in the ignition wiring and sparking-plugs of a petrol engine, whether it is used for driving a motor-car, motor-boat or aeroplane.

As you know, the tuning of a spark transmitter is always very flat, consequently a set working close to an ignition system is almost bound to pick up some interference. It will not necessarily, though; and in some cases users of the land, sea and air sets described in this supplement may not be bothered at all by ignition interference.

Applying Damping

The following suggestions are for those who do experience trouble, whether it be slight or rather bad. In only an extremely few, if any, cases, will they be found ineffective.

First of all we will deal with interference from the engines of motor-boats and cars. These are very similar cases, and the same method is suitable.

The high-frequency oscillations necessary in the spark circuit (to which reference has already been made) to produce radiation of radio waves, require the circuit to be fairly undamped. If the damping is great, an oscillatory current will be impossible and there will be no interference.

Such damping can be introduced into the circuit by adding resistance to it. So long as this resistance is kept reasonably low it will not be likely to interfere with the efficiency of the engine in any way whatever.

Adding Resistance

The most convenient way of adding the resistance is to connect fixed resistances in series with the sparking-plugs. Some value between 7,000 and 20,000 ohms will usually do the trick.

If you use anything higher than values between these figures the spark may be weakened, and you should keep an eye on the performance of the engine. With coil ignition

systems a further resistance in the main lead from the coil may prove beneficial.

The resistances should be special suppressor type such as Graham Farish or Dubilier. Special sparking plugs

The spark system of a petrol engine constitutes to all intents and purposes a miniature transmitter capable of interfering with a radio receiver in close proximity. But luckily it is possible to prevent any radiation from the ignition by the simple expedients described on this page.

incorporating the resistance are also obtainable in Champion make.

See that the resistances are firmly fixed into place.

With an aeroplane the question is rather different. Not because there

is any difference between the interference produced by an aero engine and a car engine, but because suppressors of the series-resistance type are not permitted by the Air Ministry on light aeroplanes.

Complete Screening

It thus becomes necessary to screen the ignition system completely. Metal-covered wire is used for the leads and a metal screen covers the magnetos (there are duplicate ignition systems on an aeroplane).

The question of the sparking-plugs is not quite so straightforward, for complete screening here might cause overheating. An open-work metal cover is effective, or special plugs are available in K.L.G. and Lodge makes.

All the screening should be connected at frequent points to the metal-work of the engine, and should be passed by an official of the Air Ministry.

WHERE THE NOISES COME FROM

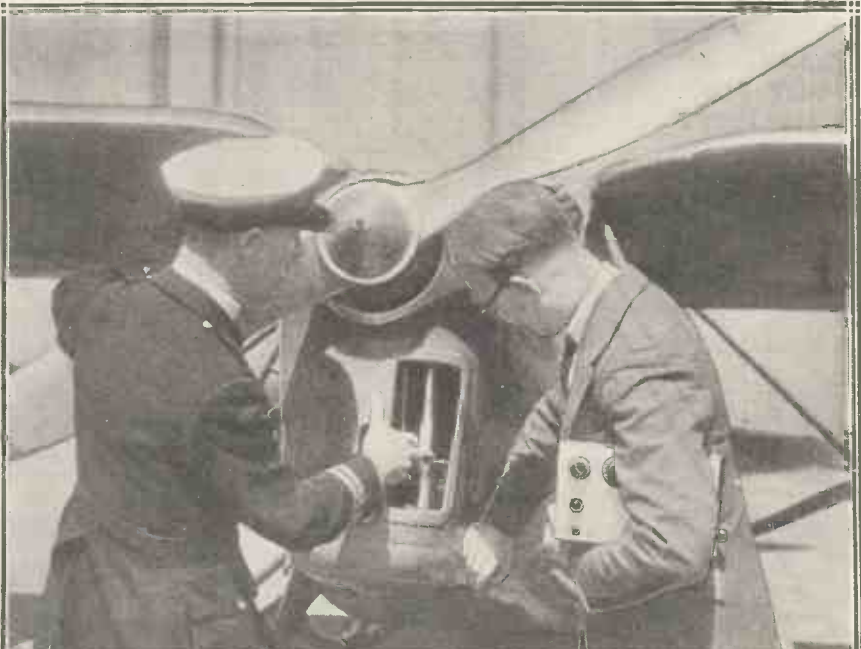

An official of Surrey Flying Services at Croydon Aerodrome points out the position of the ignition system on a Puss Moth aeroplane. Easily effected screening will prevent this interfering with reception.



SURPRISING though it may seem to many, flying from one place to another can be rather monotonous these days. If you want proof of this, you have only to remember that many of the passengers on the airliners sleep almost throughout their journeys.

So anything which provides a diversion, or helps to pass the time away, or in the case of the pilot wards off any tendency to sleepiness, is very welcome. And what better calculated to do this than radio?

But quite apart from this, it is real fun seeing what long-distance results can be obtained in the air, and how they differ from the results one obtains at home. Also a vital purpose is served when the receiver is able to tune into the special weather reports for aviators that are sent out at regular intervals by Heston on 833 metres.

An Essential

Of course, any receiver for use on a light aeroplane has got to have small dimensions and be designed on lines that make its use an easy and convenient matter. There is not a lot of room to spare in the modern light aeroplane for extras, after the pilot, passenger (or passengers) and luggage are aboard.

But these are items which were foremost in our minds when we designed the "Airman" Two. The set itself, as you will have gathered from the constructional details, is very small, and the battery container only a little larger.

Conveniently Designed

The dividing up of the outfit into these two sections makes it ideal for stowing away under all sorts of conditions. The two sections are

By A. S. CLARK.

The writer of this article, which deals with the "Airman" Two in practice, is himself a qualified pilot, and therefore fully understands the conditions under which the receiver will be called upon to operate.

joined by an armoured cable which can be of any desired length, so that the set and the batteries may be arranged some distance apart.

By making the set fairly flat, and placing the tuning controls on the top of the case, it is possible to rest the set comfortably on the lap, when the controls come conveniently to hand for adjustment. Alternatively

in of these automatically breaks the circuit of the high-resistance headphone that is normally permanently connected up inside the set.

This earpiece is clamped against an outlet tube on the side of the receiver by means of a metal bracket. To ensure a sound, tight joint a felt washer is inserted between the cap of the earpiece and the aluminium.

The outlet tube has an inside diameter of $\frac{5}{8}$ in., so that the tube of a pair of De Havilland telephones may be plugged into it. These telephones are usually fitted to flying helmets and used in open machines for purposes of communication between pilot and passenger.

A PRACTICAL DEMONSTRATION



The author explains to a fair companion how the ordinary aeroplane "speaking-tube" telephones can be plugged on to the set instead of radio headphones. An ordinary earpiece is actually incorporated inside the set for this purpose.

it will not take up any appreciable room on the side of the cabin or the cockpit, where it can be permanently fixed.

I write "cabin or cockpit," because, although the photographs show the receiver in a Puss Moth belonging to Surrey Flying Services, Ltd., of Croydon Airport, it is just as suitable for use in a two-seater

machine such as the Gipsy Moth.

In the case of the two/three-seater Puss Moth, where flying helmets are not used, ordinary radio headphones would be plugged into the jack provided. The plugging

automatically breaks the circuit of the high-resistance headphone that is normally permanently connected up inside the set.

This earpiece is clamped against an outlet tube on the side of the receiver by means of a metal bracket. To ensure a sound, tight joint a felt washer is inserted between the cap of the earpiece and the aluminium.

The outlet tube has an inside diameter of $\frac{5}{8}$ in., so that the tube of a pair of De Havilland telephones may be plugged into it. These telephones are usually fitted to flying helmets and used in open machines for purposes of communication between pilot and passenger.

The Batteries

To use the set, it is merely necessary to remove the De Havilland phone "plug" from its normal position and insert it into the tube on the receiver.

The battery box is as easily accommodated as the set. Since access to it is only necessary when the accumulator has to be removed for charging, the battery box can go almost anywhere.

In the case of a cabin machine, the luggage rack is quite a good place, and makes possible quite a short lead from batteries to set. You can see how little space it requires from the photograph on another page.

For Open Machines

Another very good place to fix the battery box is in the luggage locker, behind the rear seat. This

REQUIRES LITTLE SPACE



The set is so small it will not "get in the way" on even the smallest aeroplane. It may either be fixed to the side of the machine, or held on the lap in the care of a passenger.

applies specially to open machines. But if any stunting is to be indulged in, it is naturally advisable to secure it in position.

The metal-covered battery cable can be permanently fixed if a neat job is desired. The plugs on either end make it a simple matter to remove the battery box and the set without disturbing this wiring.

The Aerial

There are many other places where the battery box could be accommodated, such as behind one of the seats, care being taken to ensure it cannot foul any of the control wires. Its position is a matter that is best decided for each individual case.

The question of ignition interference is fully dealt with on another page, so we can go on to considerations of the pick-up system. This does not need to be large, as even on the ground the set will give very good results with a few feet of wire as aerial.

A trailing aerial, such as is used by air liners for transmission as well as reception, is unnecessary, and would restrict the use of the set when flying near the ground. Also reception on the ground would not be possible, and it is very interesting to compare the results while on the ground with those obtained in the air.

Like the positioning of the set and battery box, there are many alternative arrangements for an aerial, but it is a matter for decision with all the conditions of each particular case taken into account.

There will usually be no difficulty about running a wire from one wing tip to the tail of the machine, the lead-in being brought from either end according to which is the more convenient. On a Puss Moth one end of the wire may be attached to the strut which supports the wing.

Alternative Arrangements

In an open machine it may be found better to run the wire from the top wing, over the head of pilot, to the tail. In such a case the arrangement of the lead-in is particularly easy.

Wherever the aerial is arranged, it

THE BATTERY CONTAINER



The top of the battery box, apart from the hinged portion that gives easy access to the accumulator, is normally screwed into place. Twin armoured cabling is used for connections between the battery box and the set.

should be securely fixed and pulled tight. Tiny insulators should be employed and some strong, but not too thick, wire. When it is finally fixed, it is as well to get it passed by an Air Ministry official.

In some cases it would probably be possible to arrange the aerial internally, along the cabin or inside the fuselage.

An earth connection is not a necessity. The armouring of the battery lead is joined to L.T. negative, and if it is at all long, will act as quite a good counterpoise. There is, of course, no reason why an extra piece of wire should not be joined on. However, this is an item which should

be tried to see whether there is any improvement from it.

Similarly the metalwork of the engine can be treated as "earth" and a connection run to that. It must suffice to say that the Airman Two will work quite well without an earth connection of any sort.

Some Final Hints

Occasionally one of the special screened lead-ins is useful in severe cases of interference, when the screening of the ignition leads in a manner described on another page is not quite effective in entirely removing the trouble.

It is quite possible you will find when operating the set that a certain station will come in at two positions of the wavechange switch. In one case it will be at the top of the tuning dials, and in the other at the bottom. This

is quite in order, and is due to the wavelength of the ranges covered by the tuning coils with their three-point switches. Naturally it is immaterial on which range the set is worked for a given station so long as that station can really be tuned in properly.

Finally, let me advise you to have a nicely-fitting pair of 'phones, whether they be of the ordinary radio or De Havilland type. Sorbo rubber pads make an ideal method of ensuring a sound-tight contact between ears and 'phones without any discomfort for the wearer. Happy Landings!

ON THE LUGGAGE RACK



The battery box is easily accommodated on the luggage rack, in the locker, behind a seat, or anywhere convenient. The plug makes it quickly removable, if necessary, without upsetting the armoured cabling.



The "CLASSIC" PORTABLE ON TOUR

I LIKE to keep in touch with daily events whether I am at home in London or on holiday miles from that bustling centre of energy. So when recently I departed from Tallis House on a tour of the West country, I borrowed the "Classic" Portable described last month in "M.W." as a radio companion to be sure of entertainment or news wherever I might care to go.

An Ideal Set

The "Classic" was chosen for three reasons. It is compact and light, it is sensitive, and it will provide a good, powerful loudspeaker output. I dislike having to strain my ears to hear what a radio receiver is trying to say, and there is none of that with the "Classic."

So one Saturday three of us—the

Last month we gave full details for the construction of the "Classic" Portable, an extremely compact set with powerful "Class B" output. Since then, Mr. Rogers, Chief of the "M.W." Research Department, has taken the set with him on an extensive tour, and tells how he was never without good alternative programmes wherever he went.

set, my wife and myself—set out from London for the wide, open spaces. We had no definite destination, so we first wended our way to the Kent Coast, making for Herne Bay, Westgate, Margate and Broadstairs. Lunch-time music, during a picnic on the cliffs between Westgate and Margate, provided a preliminary taste of the entertainment value of the receiver.

A PORTABLE THAT IS PORTABLE



You don't *have* to use a car to enjoy the "Classic" Portable. As you can see, it is a set that is taken around as easily as a small case. Its universal utility is one of its great attractions.

Both London stations, 5 XX and Radio Paris were at full loudspeaker strength, in spite of the fact that the set was on the ground and it was a blazing hot day.

Reliable Daventry

Following lunch, we moved on via Canterbury through the heart of Kent to the South Downs behind Brighton. Here reception, as might be expected, was excellent, especially that of Daventry, which station, by the way, never lost reliability throughout the whole tour.

At the old village of Petworth, not far from Worthing, we stayed the night, listening to the dance band relay from London, until it was time to "put out the lights and go to sleep." The London Regional was coming in fairly well, but again Daventry was the best.

Sunday morning saw a late start for the coast route to Bournemouth, and as we pushed westward we noticed a rapid falling off of the London transmissions, our chief sources of entertainment throughout the day being Radio Paris and Daventry.

At Corfe Castle

Through the New Forest we went to Bournemouth, going on to Poole and Wareham in the evening, and eventually coming to rest at Corfe Castle, where we "turned-in" within a stone's-throw of the castle itself. A short selection of British and foreign programmes showed the willingness of the set to provide entertainment, and we closed down for the night.

The next day ancient and modern came together, for we took the set right into the castle, where the visiting shades of William the Conqueror, Stephen, King John, and the rest, who had at various times close association with the stronghold, would have been

Foreigners Heard in the Valleys of Wales

amazed, had they been present, at the black magical powers of the little box.

But we had to return to our 20th-century steed, and the car moved off again on its travels. A good exploration of the beautiful coves of Dorset was followed by a non-stop trek through Dorchester, Axminster to Honiton and Tiverton, at which latter town we pulled up for tea.

Consistent Reception

Here we found, in a café, a full-coded radiogram in operation, against which we set up a lively opposition show with "Maggie," as the "Classic" Portable had now been somewhat unclassically nicknamed, and very well she did considering the odds. The test transmission was that from the Western Regional, coming over the hills from some 60 miles away.

Leaving Tiverton, we made for South Molton and Barnstaple, thence proceeding to Ilfracombe, where we stayed several days. All this time the portable provided evening broadcast reception without fail, with the exception of one evening when its tiny L.T. battery was on charge at a local charging station.

In the Cheddar Gorge

The beginning of the second week found us packing up for Wales, which country we reached via Somerset and Gloucester again. Our route followed the picturesque course of the river from the main Bampton road to Tiverton, on the banks of which the photograph in the heading was taken.

Thence we went via Taunton to the Cheddar Gorge. Here a series of tests was carried out in the gorge itself and in the caves. The shielding of the caves against radio penetration was, of course, complete almost immediately we entered, for, though the carrier of the Western Regional, not far distant, could be faintly heard quite a long way underground, it could not be resolved into useful modulation.

Variations in Volume

In the gorge the reception strength varied almost from yard to yard as the tortuous path of the road was traversed, full reception of very fine strength from a host of stations being

obtained the moment the car reached the top of the climb up from Cheddar.

On to Bristol and Gloucester, and then sharp left for Wales. The next night was spent near Symonds Yat, where reception was mainly confined to Daventry, the Midland Regional and the Western Regional stations, with a few foreigners thrown in as alternatives.

Tenby was reached the next day, "Maggie" being tested at intervals on the journey through Brecon and

BY CORFE CASTLE



The "Classic" Portable providing modern entertainment under the shadow of the ancient ruins of the famous Dorset castle.

Carmarthen. Here reception was rather poor, Daventry holding the only hope of reliable programmes, and the Western Regional coming a somewhat unreliable second.

Athlone Excellent

The coast reached again, however, saw an immediate improvement in the picking-up powers of the set, and most of the old friends were back at good strength. I have forgotten to mention Athlone during the trip through Devon and Wales, but, as

might be expected, this station came roaring through at great strength nearly all the time.

Radio Paris deserves a pat on the back, for not once were we without him as some sort of pretty reliable alternative, and many a good musical programme was received from his aerial.

Plenty of Programmes

During the whole trip the companionship of a portable receiver was proved up to the hilt, for we were never without radio entertainment of some kind from early morning, when one or more foreigners were to be heard, till late at night, or even a. m. the next day, when Fécamp, among others, was busily engaged in filling the speaker. The directional effect of the frame aerial was a valuable feature in aiding selectivity, and the tuning and reaction controls were extremely easy to handle. Never was there any of that annoying verge of oscillation uncertainty that sometimes occurs with portables, for the stability of our little companion was unshakable.

There is little more to be told, except that the tour was completed some few days later with a long run through Wales back to Gloucester, Cheltenham and Oxford, a detour being made on the road to London to see some friends in Hertfordshire.

Here we had an opportunity to test the set close up to Brookmans Park, when the two stations were just separable close to the aerials of the London stations. They could be cut out for the reception of the Northern Regional, which came in at quite good strength after dark, but the Midland Regional, as was to be expected, was blanketed somewhat by the London Regional.

Not to be Dismantled

As a member of the technical staff of MODERN WIRELESS, I get my fair share of set testing and listening, and when the various designs built for publication have gone through their tests, and the usual retention period afterwards, and are finally dismantled, I usually regard the process of demolition quite dispassionately. In the case of "Maggie" I can assert quite definitely that this process will not be carried out. *I am keeping her myself for use on future tours!*



"EXPERIMENT HOUSE"

LANGHAM PLACE

By Radio Junius

"The B.B.C. is no longer an eager, responsive public service universally popular in this country, and deservedly praised abroad," says the writer of this trenchant article. And he suggests that the amiable security exuded by the "Palace of Langham Place" is not nearly so well founded as the pundits assume. You may not agree with this article—but you will enjoy it!

A CONTEMPORARY expresses alarm because of his discovery that the B.B.C. is flouting the public. This is a belated discovery. Its origin has not been properly analysed. The fact is that the B.B.C. has been undergoing almost a complete transformation. It is no longer the eager, responsive public service universally popular in this country and deservedly praised abroad. It is becoming clearer every day that the B.B.C. was at its best when as a Company it was under the control of the wireless industry. The change-over to the Corporation was a serious blunder, and one which may lead not only to the end of the monopoly, but also to the end of State broadcasting of any kind in this country.

A Changed Attitude

In the old days of the Broadcasting Company, with a board of experienced alert business men, there was an essentially business attitude. For instance, the Press was regarded as a potential ally and never as a natural enemy. Co-operation was the watchword. This attitude towards the Press is typical. It did not change at once, but it has changed steadily despite the efforts of those directly concerned to maintain it. There are those who argue that this change would have come in any event; that, as soon as broadcasting had reached the point of confidence with regard to its financial resources and stability, it would turn on its friends of the printed word. I do not share this view.

Publicity Discouraged

I am convinced the reason is to be found in the growth of dead-handed bureaucracy animated by a kind of introspective arrogance. In the past few months there has been an unmis-

takeable effort not only to discourage publicity for broadcasting, but also to spread the idea that the B.B.C. is wholly indifferent to public opinion. The censorship of Press statements has been tightened to a ridiculous degree. Members of the staff of the B.B.C. have been warned to have no contact with pressmen. The absurd bar against personal publicity has succeeded in contracting the area of comment. In a word, the attitude of Broadcasting House has become that of a "Close Syndicate" which appears to regard broadcasting as favourable ground for experiments in organisation. Where is all this going to lead? Is there a chance of reform?

BRIGHTENING THE TALKS



The talk during which this photograph was taken proved to be a very popular one—it was a discussion between an Italian and an English waiter.

I suggest that the amiable security exuded by the palace of Langham Place is not nearly so well founded as the pundits assume; that the farther broadcasting gets away from the realisation that its real job is to entertain the public, the nearer it approaches disaster. Let us proceed with the analysis.

Patronising Tolerance

It was about six years ago, just after the Company had become a Corporation, that the Director-General made his famous statement that the policy of the B.B.C. was to give the public not what it wanted but what the B.B.C. thought was good for it. There were strenuous attempts to explain away this pronouncement on various pleas, and these attempts did allay a certain amount of public anxiety. But it is now clear that, whatever was meant, the established policy is to treat the public with something of the patronising tolerance of a zealous missionary towards his flock of natives in West Africa.

What is the cause? Certainly there is no absence of good intention. Indeed, good intention is one of the troubles. The well-meaning amateurs and uplifters that constitute the Board of the B.B.C. care nothing for entertainment and know less about it. If recent appointments are any criterion, their chief concern would seem to be to produce a staff admirably adapted for a missionary college or an army school. Anyway, I suppose it is comforting to know that no one can contest the respectability of these new recruits.

The Real Owner

Meanwhile, information is being more and more withheld, and the attitude of possession becomes more and more obtrusive. I wonder if it ever dawns on the pundits of Langham Place that broadcasting belongs not to them but to the listener, who pays his licence fee in the hope of receiving entertainment in exchange. No, this

The Listener is the Owner of the B.B.C.!

simple fact has successfully escaped recognition.

And while I am on the subject of the average listener, who is the real owner of the B.B.C., I might just as well add that he or she is not a bit stirred by portentous declarations about organisation, "input" and "output," and all the other stock-in-trade of the new bureaucracy. The poor bewildered listener, having only common sense to guide him or her, can hardly be forgiven the view that in broadcasting the thing to organise is the programmes and nothing but the programmes.

Future Prospects

I am not condemning the B.B.C. lock, stock and barrel. I think the original B.B.C. approached as nearly to the ideal as is possible under human limitations. But, as a friend of the listener and as a friend and admirer of the B.B.C. in its right attitude, I am gravely concerned about recent and present tendencies.

Is the disease incurable? I profoundly hope not. Anyway, there is the prospect, in the absence of reform, of a major operation in 1936. After all, even the B.B.C. has a limited life. In the old days, the periods before a parliamentary enquiry were always times of great constructive activity and of the alignment of friends, particularly in the Press. There is little indication to-day that the B.B.C. is conscious of the significance of 1936.

Indeed, I have heard it said, with at least a show of authority, that the B.B.C. has already been promised indefinite continuance of its charter on the present basis and without any enquiry. If this promise has been

ARRANGING THEIR PROGRAMME



Jack Hulbert and his principals discussing a forthcoming vaudeville act.

made, it cannot be redeemed; and if the B.B.C. has invoked it, this is just another example of wrong tendency. The B.B.C. should invite parliamentary enquiry if only as an excellent

advertisement, that is, if it were sure of the goodwill and confidence of the listening public. But as these things are disregarded, it is perhaps not surprising that the "Close Syndicate" hopes to go amiably along from generation to generation of bureaucracy.

Now let us consider the alternatives for the future. First of all, if the B.B.C. does not recognise the danger signal and makes no effective attempt to revert to the attitude and policy of its former better self, it will have its wings clipped. Despite the obvious disadvantages and handicaps of commercial broadcasting, most people will agree that it is better than bureaucratic amateurism.

A Serious Menace

The present tendencies of Langham Place are a serious menace to the idea of public broadcasting. Also, the sense of aloofness and self-satisfaction, linked as they are to the notoriously bad morale of the working staff, are well calculated to spread a general and not unhealthy disgust with the whole idea of monopoly.

The next regime of broadcasting may be commercial and competitive. If it is to go on as a kind of public monopoly it will have to abandon bureaucracy and work amicably with outside interests such as the Press; deal with listeners as its owners, and get down to the rightful function of good entertainment on professional standards. There is the real picture.

FUSES are the cheapest form of insurance policy covering a wireless set against damage, and the further advanced an amateur wireless enthusiast becomes, the more indispensable he finds fuses to be.

These may be purchased in a number of forms, but they are all the same in principle. A fuse is a short length of wire so chosen that it will melt, and thus break the circuit, when more than a certain definite current is passed through it.

The fuse fitted in any circuit to safeguard other apparatus from excessive current should be chosen from the maker's list so that it will carry about 50 per cent greater current than that normally flowing through it. Thus in an anode circuit where normally 5 milliamps. will be passing, it would be wise to fit a fuse blowing at 8 milliamps.

PROTECT YOUR SET!

Fuses are a valuable precaution against accidental "shorts," and quite easy to fit.

Fuses should always be fitted so that in the event of mishap they immediately cut off the power supply. Thus in the case of a set using a high-tension battery the fuse should be fitted in the H.T. negative lead.

Mains-driven sets should invariably be well protected with fuses, and on no account should the job be left to the main house fuses, since considerable damage may be done to the set before these blow.

Since no hard and fast rule can be laid down as to the company's earthing of the electric supply wires, the

precaution of inserting fuses in both leads should be taken.

These may be fixed outside the set, if not already fixed within, and protected with an enclosing metal or wooden box covering.

The experimenter has obvious need of fuse protection, since his alterations to a circuit being tried out may well lead to an accidental "short" with disastrous consequences. If he finds himself without the necessary commercial fuse, he can easily improvise one with the tinfoil from a packet of cigarettes or chocolates and a couple of terminals.

A narrow strip of foil, cut with a pair of scissors and clamped between the terminals, makes an excellent improvised fuse, but a little experimental work is necessary before the best width to use is found. The narrower the strip the less current it will pass before fusing. M. L. H.

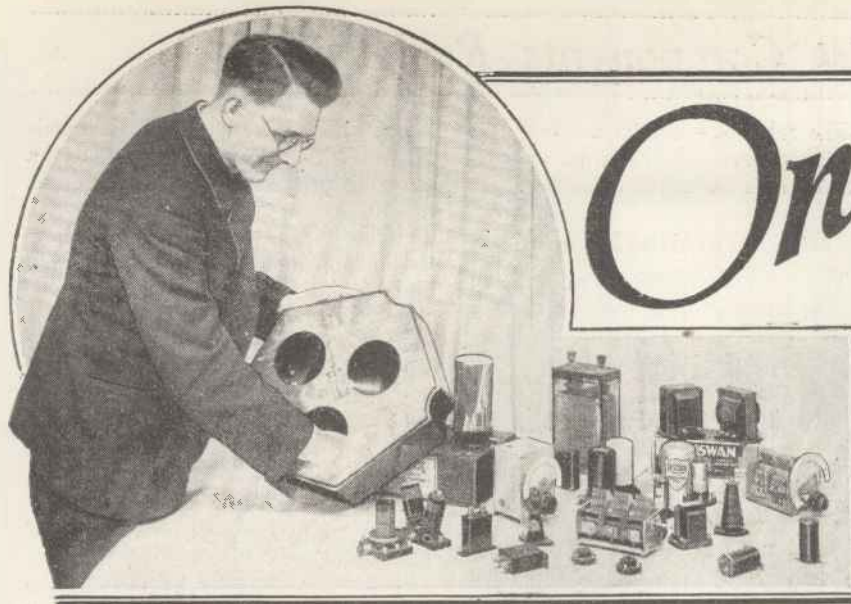

On the TEST BENCH

Our comments regarding some interesting new components.

Lissen "Class B" Transformer

WE have recently had the opportunity of testing the Lissen Hypernik "Class B" transformer.

This component embodies a special nickel-iron core which enables it to attain a high working inductance with a minimum of wire. By this means its self-capacity and resistance are kept low.

Actually, its primary resistance is less than 500 ohms, while that of the secondary is well below the 400 ohms which has been accepted as the desirable maximum for a good "Class B" transformer.

The primary inductance is 25 henries at zero current, and falls only by 10 henries when 5 milliamps. is flowing.

FOR "CLASS B"

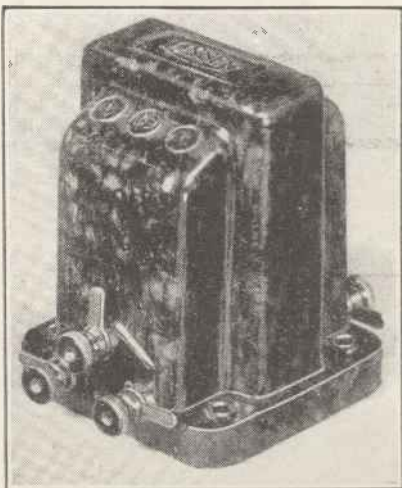

The Lissen Hypernik "Class B" transformer has a secondary D.C. resistance of well below 400 ohms.

These figures compare most favourably with many other makes.

On test we have found this transformer to be highly efficient, with none of that tendency towards thinness of response noticeable when a sub-standard transformer fails on bass.

Indeed, its response is highly satisfactory, and we can recommend it unhesitatingly to all constructors. The price is particularly reasonable in view of its quality. At the 12s. 6d. at which it is retailed it is within the reach of all.

New Varley Iron-Cored Coils

We have recently received several samples of the Varley Nicore coils. These are of the dust-iron-core type. It is no new thing for Varley to venture into the production of dust-iron-core components, for their experience of the method dates back to 1926.

But it is within only the last few months that the problems relating to the application of it to H.F. coils have been satisfactorily solved.

The Varley Nicore coils each comprise medium- and long-wave windings, and the compact assembly is completely screened.

A built-in wavechange switch is provided.

There are two distinct types of Nicores. B.P.30 is an aerial or tuned-grid coil with reaction, and B.P.31 is an H.F. intervalve transformer with reaction. Each of these lists at 10s. 6d.

Various standard arrangements of three- and four-ganged units of Nicores are available at 33s. and 44s. respectively.

We have tried the Varley Nicores in various circuits under varying test conditions, and find them to be very efficient productions.

There can be no doubt as to their great superiority over iron-cored equivalents.

Ferranti Moving-Coil Speaker

In nearly every case where a mains-energised moving-coil loudspeaker is used nowadays, the instrument is built into a cabinet of a

HIGHLY EFFICIENT

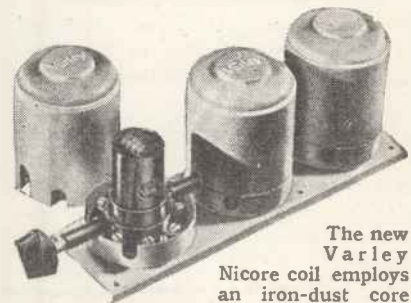

The new Varley Nicore coil employs an iron-dust core and is available in two distinct types.

mains set. Where a separate loudspeaker is desired it is usual to employ a permanent magnet type so that there need be no separate connection to the mains for the purpose of supplying the speaker.

If, then, the speaker is built into the set, it is wasteful if its field winding cannot be employed for smoothing as well, and thus allow a choke to be eliminated.

But hum is liable to creep in if steps are not taken in the design of the speaker to prevent it. This is done in the Ferranti D.3T chassis, which is, in other respects too, a very sound production.

The Latest Components Reviewed

It can be supplied with a field winding suitable for 100/125 volts or 200/250 volts, and the average coil impedance is 15 ohms.

Good matching between this and any type of output valve, including a pentode (but not "Class B") is given by the three-ratio built-in transformer whose ratios are 10/1, 20/1 and 30/1.

MAINS ENERGISED



The Ferranti mains-energised moving-coil speaker has a built-in transformer giving three ratios.

The Ferranti D.3T is designed for a maximum input of 3 watts, and it possesses an unusually high degree of sensitivity.

Its response is first-class, and there is an entire absence of objectionable resonances and peaks.

At 50s. it appears to us to be one of the soundest loudspeakers on the market.

Easy to Assemble

A very practical article which will appeal strongly to constructors is the Goltone Coil Chassis. This has been produced so that single Goltone Screened Coils can be assembled in gangs by the amateur himself.

As will be seen from the accompanying photo, there are no less than three types of chassis available, and these are for two-, three- and four-gang assemblies.

Each is sent out complete with all necessary screws, and it is a simple task to mount the coils. These automatically fall in their right positions, and all that the constructor has to do is to screw them into place.

The result is every bit as good as a manufactured unit both in appearance and in technical efficiency.

The "Terminal Cop"

This is an ingenious adaptation of the tubular condenser principle. It is quite small and is, in fact, barely larger than a grid leak.

But by varying the position of the plunger a range of from .00001 mfd. to .00015 mfd. is obtained.

The object of the "Terminal Cop" is, of course, to act as a series aerial selectivity and volume control device; but besides its convenient form and easy control, it has the further advantage over an ordinary variable condenser that it can be shorted out of action merely by pushing the plunger right in.

This is an important feature, because it so often happens, especially on the long waves, that it is all but essential that any such series capacity should be eliminated.

The Pressland "Terminal Cop" is

IMPROVES SELECTIVITY

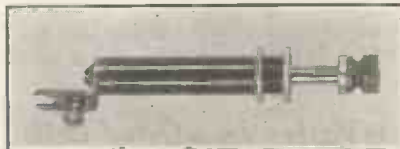

The Pressland "Terminal Cop" is a small variable condenser with a self-shorting position.

extremely easy to fit to any set; it can even be secured to the aerial terminal itself.

In operation it is smooth in action and provides a wide control of volume and selectivity. It costs only two shillings, and at that figure ought to prove very popular, for one can pay more for the less satisfactory compression type of condenser.

Clix Chassis Mounting Strips

Constructors of chassis sets should warmly welcome these new Lectro Linx products.

They are made in three-point types for mains aerial connections.

Easily fitted on any conventional metal chassis, one of these Clix mains aerial strips contributes a feature to a home-constructed outfit usually only to be found on commercial sets.

The strip, complete with terminals for screw connection, costs 6d., and a shorting plug for use with it retails at 3d.

When wired correctly, the mains aerial is switched in and out merely by moving the position of this plug.

It is a convenient, well made and neat device.

A New Screened Down-Lead

Messrs. Ward and Goldstone inform us that considerable success has been achieved by their now well-known multiple shell-type screened down-lead.

This success has led them to produce a less costly material designed to sell at a more popular price, though, of course, the other type is to be continued.

The popular one is known as "Metocel," and comprises in the main a cellular rubber construction of extreme robustness having first-class qualities. As an instance of these, it can be mentioned that its self-capacity does not exceed 20.1 micro-microfarads per foot.

"Metocel" is a most attractive selling proposition because it can be cut to any length by the dealer.

The list price is 8d. per foot and with its efficient and resilient rubber, metal and fabric structure it is thoroughly to be recommended to all who wish to try a screened lead-in at little expense.

SIMPLIFYING GANGING

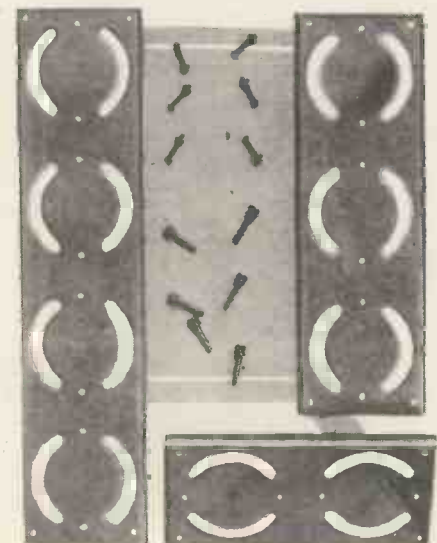

The constructor can easily assemble his own ganged coil units with the aid of the Goltone chassis.

TROUBLE TRACKING



At this time of the year there is a tendency for reception to fall off slightly owing to what are called "summer-time" conditions.

Now this is due partly to the extended hours of daylight which, of course, are unfavourable to long-range reception, and partly to the fact that waves seem to show a disinclination to travel so readily over the sun-baked surface of the earth.

Every listener knows that his results are better after dark than during daylight. There is, however, another point which has nothing to do with external conditions.

Little Losses

If the set is a powerful one, perhaps my remarks won't apply so much, because the margin of safety as regards range is fairly high with a sensitive design, and a small loss of efficiency is therefore not always apparent.

When the set is a moderate-sized one the question of aerial and earth efficiency counts. Probably the earth is the most likely cause of losses during the dry season—apart from the outside conditions I have already mentioned.

No matter whether the earth is a metal plate, tube, or even a water pipe contact, there is always the chance that the surrounding soil will become less moist and so increase the contact resistance.

A PRACTICAL TIP



Corroded accumulator terminals cause bad contact and may prevent the set from working. The cure for this is to smear the terminals with vaseline just after they have been cleaned.

In the case of the water pipe, however, the contact area is so large that the resistance variation throughout the season is not anything like so serious as that of a comparatively small plate or earth tube. In fact, the main water supply is a remarkably fine earth summer and winter provided the connection between the earth lead and the pipe is electrically sound.

I always plump for a proper sweated joint here, because the popular brass clip is not absolutely trouble-free unless precautions are taken

Under this heading the Chief of the "M.W." Query Department discusses some of the common difficulties which can often be so troublesome. This time he deals with aerial and earth faults.

to exclude the oxidising effect of the atmosphere on the metal pipe.

Periodical cleaning will overcome this possibility, but lots of us prefer to make the connection once and then to forget it.

A Good Earth

There is also the percolative chemical earth, which has the advantage of attracting moisture to itself, thus maintaining a low contact resistance, and so doing away with the need for the regular watering, which the soil round the ordinary plate or tube invariably requires during a particularly dry spell.

At any rate, it definitely pays to make the most of your earthing system at this time of the year, because undoubtedly its efficiency has a marked bearing not only upon the range but also often upon selectivity and stability.

Some receivers tend to oscillate when the resistance of the earth contact rises, and if you meet with this trouble always make sure that your earth is really up to standard.

About the Aerial

Then the aerial. Well, there is no reason why an aerial should show

any efficiency variation at all except for the fact that some of them contain joints that are not too good.

For instance, there is the twisted connection which one frequently sees at the point where the horizontal and vertical lead-in portions of the aerial are joined together (I am referring to outdoor aerials).

Twisted Joints

Now, a twisted joint gets dirty, and after a while usually develops a comparatively high resistance. In some cases this resistance may become so high that it is only the lead-in that remains effective, with the result that a loss of volume begins to show itself or, alternatively, more reaction has to be applied to produce the same effect as before.

Poor joints, not forgetting the lead-in tube connection, are things that need watching, and it behoves every listener who is suffering from weak reception to see that his aerial is not letting him down.

Also, with an outdoor aerial it is worth while to give the insulators a wash once a year. The amount of soot and filth generally that they accumulate in some localities is surprising, and bearing in mind that soot and similar deposits are partial conductors, it is easy to see why an annual cleansing pays.

A Final Point

And it is not only the outside connections that matter. Those inside the house often need a look over, and it is as well to check up the condition of those portions of the aerial and earth wires that actually go to the "A" and "E" terminals on the set. Also, make sure that the earthing switch (if one is fitted) is perfectly clean and free from high resistance contacts.

"M.W.'s" RECORD REVIEW



Some notes on the new numbers specially worth a trial, and hints by our expert upon the wise purchase of a library of records.

MANY of us are apt to fall into error in believing that during the summer months the record lists will contain little of real interest, and that the Companies are saving up all the best stuff for the long evenings of winter. True, the summer lists are always lighter, in quality and quantity, but it would be a pity for anybody to miss the monthly supplements of Mid-June and July, for there is something good for everybody in them.

From the big stuff down to the "odds and ends" category, there are one or two outstanding records which will certainly tax the monthly record "allocation" to the point of a debit balance! It is especially pleasant to find that there are so many which fall within the "library-builder's" demands—the records which everybody can enjoy for years to come. Let's begin with the big orchestral records. Here, then, are the plums.

Haydn—Rossini—Handel

First, *Haydn's Symphony No. 100 in G (The Military)*. Of all the symphonies written by the masters, there isn't one which is more straightforward and understandable, more essentially tuneful, more wholly pleasant than this. The reasons which caused it to be known as "The Military" are of the slenderest, for the whole composition is just full of kindly good nature. There are too many passages of delight to single out one except, perhaps, the Minuetto (3rd Movement). There are four records at half-a-crown each (Parlophone, R1537-40) of this performance by the Berlin Grand Symphony Orchestra, of which you will find it impossible to select only one or two.

Now for Rossini. On Columbia LX255 you will find the overture to *La Scala di Seta*. Again, effervescent,

light-hearted fare. If you have his "Barber of Seville," you may think this too nearly related; if not, you'll like it immensely. The London Philharmonic Orchestra (under Beecham) play it faultlessly. On part of side two is Handel's *Entry of the Queen of Sheba* (Solomon). Quite in the same vein (her majesty's entrance is by no means over-pompous!), it provides a delightful exercise in comparison between the composers.

Modern Light Music

Eric Coates' "descriptive" music is always interesting and attractive. His *London Suite* is done by a Symphony Orchestra (himself conducting) on Columbia DX470. Tone-pictures of Covent Garden, Westminster and Knightsbridge are the

three movements. Real summer music for a long time to come, with just enough grandiose orchestration to make it a winter record too.

Here is a modern dance record which is well worth a place for the exotic melody and brilliant performance. Hear *For You, Rio Rita* and *I Want Nothing But Your Love*. This Argentinian music as played by Marek Weber's Orchestra (H.M.V. B6342) is really splendid. The famous *Rhapsody in Blue* has been done again. This piece represents a school of contemporary music, and one should know something of it, however much "hot" jazz (at its extreme end) may offend. Gershwin's composition is undeniably a clever piece of work and Billy Cotton's Band play it well—with a sparkling pianoforte performance—on Regal-Zono MR957.

A Classical Gem

A transcription of the *Air From the Suite in D* (Bach) is played by the Léner String Quartet on Columbia DB1133. This fragment is an enchanting thing, and the intimate playing on this record even adds to its charm. The finale of the *Quartet in D* (Dittersdorf) is on the other side.

Songs of All Sorts

Tauber's offerings to his admirers are pretty certain to be popular. He gives vocal versions of Saint-Saëns' *Le Cygne* and Dvořák's *Humoreske*.

(Continued on page 165.)



THE NEO-BECHSTEIN piano is an instrument in which the reproduction has a similarity to that of an organ. The sounds from the strings are picked up by microphones, passed through an amplifier and then applied to a loudspeaker. Here we see John Hunt recording a Chopin prelude at the H.M.V. studios.

AT YOUR SERVICE

by
**OUR TRADE
COMMISSIONER**



Speakers in Exeter Cathedral

ONE of our photographs this month shows the latest piece of work done by the Marconi-phone public address engineers. This is the equipping of Exeter Cathedral with loudspeakers and microphones to enable the whole of the congregation to hear all the service without effort.

The installation is a masterpiece of harmonious design and unobtrusiveness, for every piece of apparatus is merged into its surroundings with the utmost care and skill.

When the cathedral was built between 1280 and 1350 the designers naturally were not particularly well up in acoustics, and it is not surprising that no provision was made for collective worship as we now know it.

More especially was that the case when it is considered that the original design catered for the inclusion in the building of a number of small chapels, and the subsequent use of the whole edifice for services naturally imposed a large strain on the officiating priest.

The new public address scheme that Marconi-phones have just fitted up should be of the utmost value, for now there is no need for the preacher to raise his voice above normal speaking strength.

Holbro Cabinets

A new departure is announced in the policy of Messrs. Holmes Bros. (London), Ltd., makers of Holbro products and cabinets. For some time this firm has been supplying cabinets to set manufacturers, but now they have decided to make their designs available to the general public, and I have received a leaflet illustrating some of their products.

All are the most reasonable in price and extremely attractive in appearance, walnut being the wood chosen, and used in contrasting grains with very picturesque effect. The question of box resonance has been carefully considered, and the greatest

Some trade news and views that will prove of interest to readers, whether or not they are connected with the radio industry. Members of the trade are invited to send items of interest or photographs to be included under this heading.

care has been taken to maintain a very high standard throughout. Full details of the styles available can be obtained from Messrs Holmes, at the Holbro Works, Billet Road, Walthamstow, E.17.

On Your Guard

This is the time of the year when nature's spark transmitter usually

AT EXETER CATHEDRAL

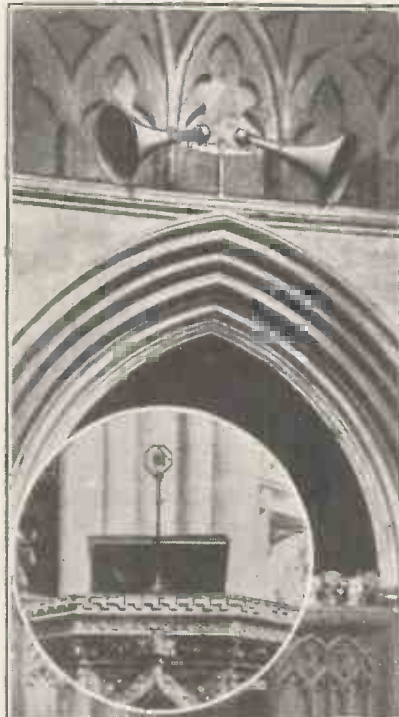

The Marconi-phone public address engineers have recently fitted Exeter Cathedral with microphones and loudspeakers so that the congregation in all parts of the cathedral can hear clearly without the preacher having to raise his voice above normal speaking strength. Our composite picture shows the microphone on the pulpit and two of the speakers above an archway.

gets to work on full power, and thunderstorms and lightning take their toll of damage to trees and buildings. Few houses are fitted in any way with protection against these giant sparks, though hundreds of thousands have aerials raised aloft on pole or chimney.

The aerial can be used as a very good protective device against a direct lightning strike if it is properly designed and well earthed, for it will tend to keep the surrounding atmosphere free from the large electric charges that culminate in the fearsome flash we all know so well. But it must be properly earthed either by a switch or a lightning "arrester," which latter acts as an automatic alternative for an earthing switch.

One of the most convenient of these little gadgets is the Graham Farish "Gard," which can be fitted in a few moments and is extraordinarily cheap—1s. 6d., to be exact. It carries a useful guarantee, too, and is well worth looking into.

Iron-Cored Coils

During the next "season" (why will everybody consider radio to be seasonal, I wonder?) we are going to hear a lot about iron-cored inductances, and rightly, too, I think, for these new coils are certainly efficient, and they are very compact.

But at first it is likely that the various differences in core material will not be easily recognised, or remembered, and already a certain amount of confusion seems to exist as to who uses such and such a core, and who makes use of this and that.

I am not going to attempt to put you wise as to the various patent names that exist in the iron-core world and to the firms who adopt them, but I must clear up a little error that appeared in this journal last month in a caption under one photograph of Varley iron-cored coils.

Here it was said that the Ferrocart core was employed. This is not so, for this material is used in the Colvern

Some Facts About Iron-Cored Coils

inductances (apart from certain manufactured sets), and so far no one else has been granted a licence by Colvern to use that type of core.

Varley have a core of their own made of an iron alloy, the elements of which are naturally not divulged, and this is quite different in characteristic and in appearance from the laminated core of the Colvern coils.

New Accumulators

I have received a small folder describing the new C.A.V. slow discharge and "Acton" glass batteries, which are obtainable in a wide range of capacities and voltages. The slow discharge types run from 20 to 90 ampere hours capacity at the 1,000-hour rate, and cost from 4s. 6d. to 14s. 6d., while the "Acton" types cover from 33 to 100 ampere hours at the same rate and cost from 8s. 6d. to 16s. 6d.

In addition, there is a new range of celluloid cells which run from 28 to 84 ampere hours at 100-hour rate, and cost from 9s. to 17s. Messrs. C. A. V. will be only too pleased to let those interested have full particulars concerning the batteries, with which, by the way, a free metal carrier is supplied with every cell.

A FINE "MIKE"



An exceedingly attractive B.T.H. microphone, ideal for use with amateur transmitters, recording purposes, making announcements via the loudspeaker, etc.

The Royal Visit

I hear from British General, the well-known radio manufacturers, that recently His Royal Highness Prince George paid a visit to their works at Brockley, Kent, when he was shown over the whole factory.

The various processes of manufacture and testing of radio components were explained to H.R.H.,

who was intensely interested in what he saw, and showed that even the commercial side of radio was no mystery to him.

Congratulations

I should like to take this opportunity of congratulating Mr. J. T. Mould, of the Igranic Electric Co.,

BATTERED BUT CLEAR



A Columbia radio set which received a severe testing in a recent explosion, in which it was buried under the debris of a house. Although being badly damaged, it still worked well—a true proof of strength.

Ltd., on his appointment to the board of that famous electrical firm. Mr. Mould has long been an active member of the Radio Manufacturers' Association, and his promotion will be welcomed as his just deserts by all his friends.

An Important Development

We are able to announce that an important development took effect when the marketing and sales of all Magnavox moving-coil loudspeakers were transferred to the care of The Benjamin Electric Limited, Tottenham, N.17.

It is, of course, well known that Magnavox speakers for sale on the British and certain overseas and continental markets have for the last two years been manufactured by the Benjamin Electric at their Tottenham works, and the striking success which these British-made speakers have achieved is an eloquent tribute to the quality of the materials and workmanship employed.

The many friends whose support in the past has resulted in so widespread an adoption of the Magnavox speaker

in radio receivers will be glad to know that the changed marketing conditions do not in any way make changes in the Magnavox Sales personnel.

Any communications relative to Magnavox loudspeakers should in future, however, be addressed to the Sales Manager, The Benjamin Electric Ltd., Tariff Road, Tottenham, N.17.

An Excellent Idea

In order to assist the purchasers of their sets who make use of the hire-purchase systems, Marconiphone have hit on an excellent scheme for simplifying the monthly or weekly payments.

Instead of the money having to be sent to the firm, it is deposited in regular instalments in a special home-safe which is provided for the purpose. The home-safes are emptied every month, on a stated day, so that regularity in payment becomes easy, and the collection is quite a simple matter. In practice it has been found that the scheme has resulted in very much better payments, with a great decrease in trouble.

Ferrocart Coils

I have just received the following list of Colvern Ferrocart coils that are now available for various purposes on the constructor market. The list shows how great has been the growth of these coils during the comparatively short time that they have been on the market.

Here are the types of coils available and the classes of circuit for which they are intended:

- F5. Aerial coil with reaction for detector L.F. receivers.
- F10, F3. Aerial and H.F. coil for 1 S.G. H.F. receivers.
- F10, F11, F12, F13. Tapped aerial coil with intervalve band-pass coupling for 2 S.G. H.F. stage receivers.
- F10, F14, F13. Suitable for 2 S.G. H.F. stage receivers without band-pass coupling.
- F1, F2, F8. Band-pass and oscillator coil for single-dial superhets.
- F1, F2, F14, F8. Band-pass preceding S.G. H.F. stage with H.F. and oscillator coil for superhet receivers.
- F10, F14, F8. For single-dial superhets with 1 S.G. H.F. stage without band-pass filter.
- F1, F2, F3. Band-pass filter with auto-transformer intervalve coupling, with reaction for 1 S.G. H.F. stage receivers.

ON THE SHORT WAVES

by
W.L.S.

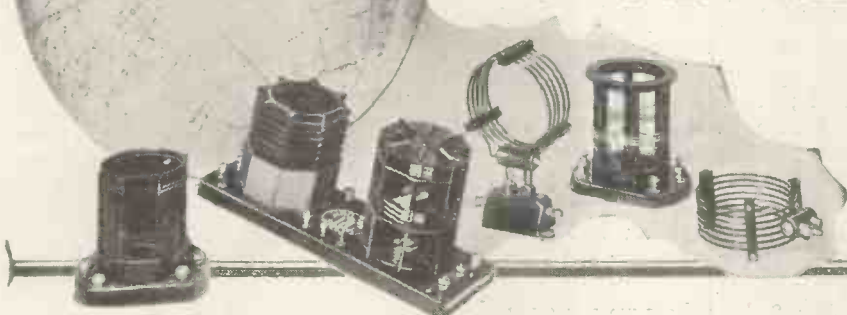

In the past two issues of "M.W." I have scattered abroad a large number of random thoughts on the two rather kindred subjects of circuits and layouts. As a result, I have received quite a number of letters asking me to air my views on one or two rather more narrow subjects connected with short waves.

I have no objection to airing my own views, as long as it is clearly understood that they are my own, and that I am not attempting to belittle the efforts of others, or to suggest that my method is the only correct one.

Unpopular Devices

The first subject I have singled out is "wavechanging," which is probably responsible for more trouble and bewilderment with the short-wave novice than anything else.

To the man descending from the broadcast waves, where he is absolutely spoilt in the matter of rapid, easy, and efficient wavechanging, it

Matters of interest in every branch of short-wave reception seem to flow from the pen of "M.W.'s" short-wave expert. This month he deals in a comprehensive manner with the subject of wavechanging on short waves and gives his own views on the matter. He also includes news of the stations and reception conditions.

is a gruesome business to have to fiddle about with plug-in coils. It is even worse when he finds out he has to change his coils for every 10 or 20 metres that he covers.

Naturally, if he would only think in kilocycles—and we all have to, sooner or later—he wouldn't be so annoyed about it, because he would find that each "range" was vastly wider than anything that he could possibly cover "in one sweep" on the broadcast bands.

The fact of the matter is, however, that labour-saving wavechange devices are not popular on short-wave sets, for the plain, straightforward reason that they do impair the efficiency of the set quite a lot.

Tackling the Problem

Let us examine the problem from the very root. If we take up short-wave listening as an extension to our hobby of broadcast reception, we very naturally want to hear everything that is going. We find, to our dismay, that the stations we want to hear are spread out, apparently at random, between Rome on 80 metres (3,750 kcs.) and Pittsburg on 13.93 metres (21,540 kcs.).

Although the spread of 66 metres appears to be nothing, when we regard

it in terms of nearly 18,000 kilocycles it is a different tale. (And remember that on the broadcast bands we only have to cover 1,000 kcs. on the "medium," and a mere 150 kcs. on the "long" band.)

We may as well give up all hope, right away, of covering the full range of 18,000 kcs. by using one coil with wavechange switching. To start with, some people are so "ham-handed" that they can hardly tune in foreign stations on the medium broadcast band, where they have a range of 1,000 kcs. on the dial.

Not Worth-While

Even if we make the tuning twice as difficult on our short-wavers, we shall still have to have *nine* complete ranges; and if we decide on ordinary broadcast tuning for the standard of difficulty in operation, we shall have to have eighteen of them.

No one is going to tell me that it is worth his while to devise a

QUEER EFFECTS

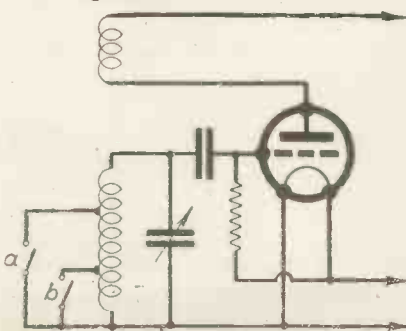

FIG 1

When both switches are closed, two parts of the inductance are in parallel, which W.L.S. says "may be guilty of all sorts of funny effects."

ANOTHER METHOD

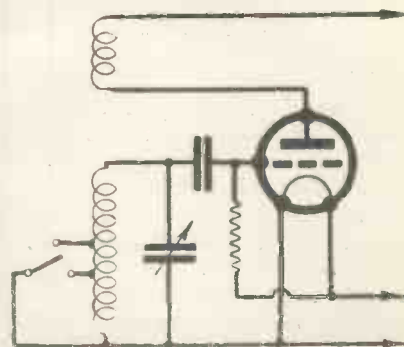

FIG 2

A three-position switch is sometimes used for a three-range coil, but has drawbacks on short waves.

wavechange scheme which uses (a) one switch with eighteen positions, or (b) eighteen different switches.

Even when we get down to more practical politics by making our tuning about four times as difficult as broadcast-band tuning and covering 4,000 kcs. or so on each sweep of the dial, we are confronted with a bit of a problem. Wavechanging for two ranges (like the well-known "medium" and "long") is easy; wavechanging for three ranges is "not so good"; but when we get to four or five of them, it's a positive nuisance.

Wavechange Methods

The time and thought given to the design of the thing in the first place, plus the inevitable drop in efficiency when it is put into action, definitely do not balance the slight trouble saved in the direction of coil-changing. And that is why most of us still go through the laborious process of lifting the lid off our receiver, removing the coil, groping all over the place for the other one, plugging it into a socket that isn't there, cursing, and eventually getting it into position.

We would sooner do *all* that than feel that we were losing something by having a lot of wire and dirty switch contacts taking up valuable space inside the "works."

FOR SHORTING TURNS

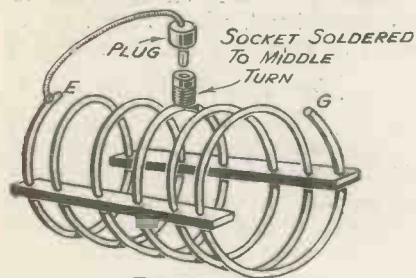

FIG. 3.

A short piece of wire, supplied with a plug, soldered to one end of a coil and a socket on the coil's centre turn is suggested in the article.

The diagrams illustrating this article go a long way towards explaining the trouble. Fig. 1 shows the most usual methods of making one coil cover two ranges; the switch simply short-circuits some of the turns of the grid coil.

One of the problems that arises at once is that of making the one reaction coil serve for the grid coil in its two different conditions—"all-in," and with half the turns out of action. This can be done easily enough for the two ranges.

Indeed, one can hardly quarrel with this arrangement, provided that

the switch is a good one and that the wiring to it is *very* short. But at the best, it must be admitted that the arrangement is not good, because the unwanted turns are not really "shorted," in the true electrical sense of the word, at all. We have really only succeeded in putting another tuned circuit in parallel with them.

A Queer Mixture

This circuit comprises the inductance of the wiring and the switch; the capacity of the whole affair to earth; and a certain amount of resistance, in the shape of (possibly) dirty switch contacts and (again possibly) doubtful soldered joints.

Shorted turns, in themselves, are not terribly harmful; but this queer mixture may be guilty of all sorts of funny effects.

Fig. 2 shows how we can expand it and provide three ranges by means of a switch giving three positions; and to this arrangement the same remarks apply with equal force.

Text for Experimenters

Perhaps I had better make it clear at this stage that the loss of efficiency, if the whole thing is well done, is not serious enough to worry us if we are only concerned with the reception of fairly strong broadcast stations. In other words, the "non-experimental" short-wave man will in all probability be perfectly satisfied.

It is my opinion, however, that most of the short-wave fraternity pride themselves on being experimenters; and an experimenter will *never* long continue to put up with any arrangement that he thinks might be improved. (That last sentence, by the way, might well be printed as a text and hung on our "shack" walls, for it might remind some of us occasionally that we *are* meant to be experimenters.)

Approximating to Perfection

So it happens that we decide that these half-caste wavechange schemes are not yet good enough, and we continue to change, and mislay, our coils from time to time.

Fig. 3 shows an arrangement that is, I believe, getting nearer to the state of things that we *can* tolerate. Soldered on to the centre turn of our coil we have a small socket; and soldered on to the earth end of the coil we have a short length of wire terminating in a plug suitable for the said socket. If we keep our wire short and our connections clean, we

have here a scheme which, though crude, will give us a real approximation to "shorted" turns.

Half-Way Measures

Candidly, I don't think it possible to evolve a really comprehensive wavechanging arrangement which will make it possible for us to cover the full short-wave band with one coil and a switch, or switches. But it is probably better to go half-way than not to attempt the thing at all,

TWO-RANGE COIL

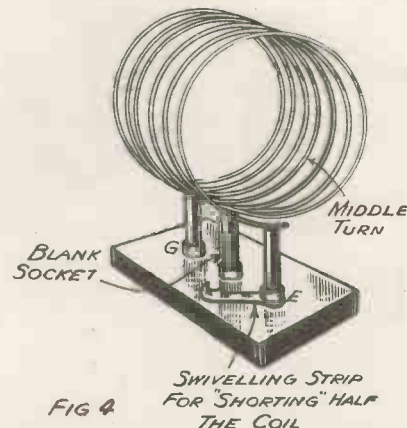

FIG. 4.

The shorting-strip on this holder enables two-range plug-in coils to be employed.

and we can cut down our coil-changing by half, if we are careful, without losing anything noticeable.

Fig. 4 shows what is, in my opinion, an even better scheme (although it's my own idea!) for those of us who use home-made coils. Perhaps it will go as far as becoming commercial; I make a present of it to anyone who would like to make up a coil and coil-holder on the lines suggested.

Recommended Arrangement

It is only necessary for our coil to have three plugs instead of two, the centre one being connected to the "key" turn, which will probably be somewhere near the centre. The base, likewise, has three good sockets, and the "earth" one is equipped with a swivelling strap which will make good contact with the centre socket. (We could easily extend this strap by means of a short rod protruding through a hole in the front panel.)

It should be possible, then, to arrange for the use of two coils only. One of them would cover a range of about 13 to 30 metres, split up into two halves of something like 13 to 20 and 18 to 30 metres.

Our other coil would have to give us something of the order of 28 to 60 metres, split into 28 to 42 and 40 to 60 metres. And Rome, on 80 metres,

Radio Waves that are 50,000 Years Old

would have to pass unnoticed! A third coil would do that job whenever he was wanted.

As I haven't tried it out fully yet, I cannot give turn-numbers, but in any case they would be largely a matter for experiment. I commend this arrangement to readers who want to give something new a trial.

Gaining Simplicity

About wavechange schemes involving a complete change-over, by switching, from one coil to another, I have nothing to say. They don't interest the home-constructor very much, because they fall in the category of large complications introduced to give a slight gain in simplicity!

Do let me make it clear once again that I am not criticising the existing commercial wavechange coils, which are quite good enough for the average short-wave broadcast listener. I write these notes primarily for the short-wave "fan" who delights in trying out new circuits and generally in improving his own gear from day to day.

Origin of Static

Having disposed of this month's "technical topic," I may as well say a little about the way things have been going during the summer. Conditions, as is usual for summers of late, have been "patchy." The short-wave stations seem to be conspicuously absent one day and rearing in the next. The 49-metre crowd, of course, are never as good at this time of the year as they are in the winter, although they come in quite well at 2 or 3 in the morning.

The 19-metre group are even more freakish than they are in the winter, although they are improving, on the whole, as the tide of the eleven-year cycle turns.

Easily the most interesting waveband is that between 31 and 33 metres. Sydney seems to be heard every morning that he transmits, and his best time is between 6 and 8 a.m.

The amateur 20-metre band is also good, with flocks of Central and South Americans coming in late at night, and West Coast U.S.A. stations in the early mornings. There's *always* something interesting to be heard in this band, summer and winter, except when we are really in the doldrums of "blank" conditions.

A fairly exciting discovery this

month hails from Professor Jansky, who has found that some of our "mush" (described as "the type of static that produces a steady hiss") emanates from far away in the galactic system. He places the source of these disturbances as the centre of the Milky Way!

This is a timely reminder that we have fallen into the habit of regarding radio waves as a product of man's brain. Just as the light waves radiated by the most insignificant star make all the light ever produced by artificial means seem merely ridiculous by comparison, it seems probable that the radio energy eman-

feel presumptuous in talking about the feeble radiations of earthly short-wave stations; but they *are* what we listen to, after all.

"Earthy" news includes the following items: W I X A L has settled down on 25.45 metres, and is heard no more on the 49-metre band.

Readers' Co-operation

H K E, Bogota, Colombia, is broadcasting now on 42.3 metres on Mondays and Tuesdays only. He may be heard between 11 p.m. and midnight, and is quite strong in London.

V Q 7 L O, Nairobi, has altered his

NEATLY ARRANGED 160-METRE TRANSMITTER

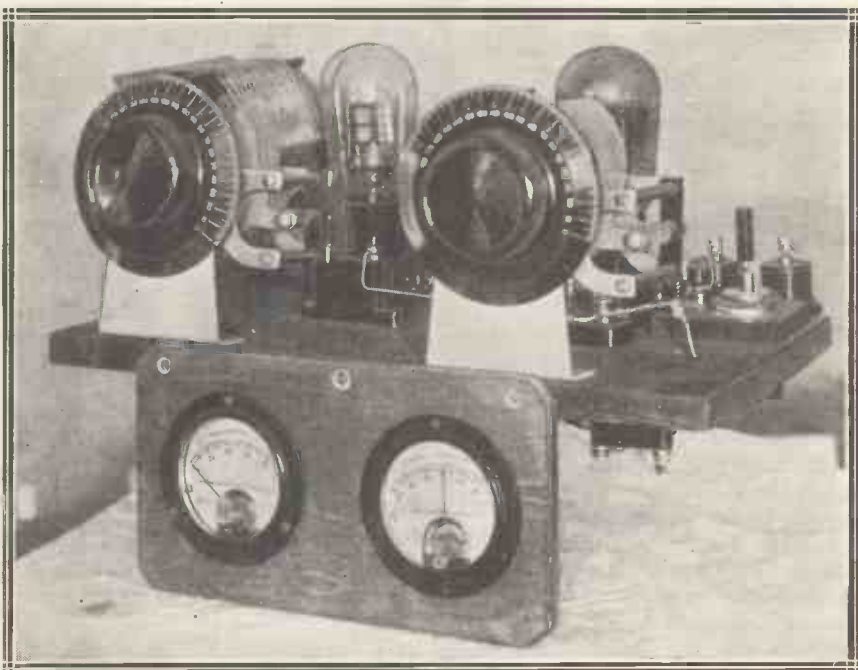

Were it not for the meters, this transmitter could quite easily be mistaken for a receiver. Note the crystal holder at the right-hand end of the baseboard.

ating from natural sources must amount to something right beyond the comprehension of mere man.

Important Discovery

The discoverer of these "natural" short waves points out that they take something like 50,000 years to reach us, and therefore must originally have had behind them an energy of more than a few kilowatts. This discovery of the existence of boundless natural energy, radiated at the wavelengths which we describe as "radio," may open up immense fields for exploration and research.

The mere thought of it makes one

times on account of the "rival concern"—none other than the Empire station at Daventry!

Will any readers who hear announcements "on the air" relating to changes of wavelength, changes of schedule, opening of new stations, etc., please notify me of them, so that I may keep these notes up-to-date? I can't listen to everything at once; much as I should like to, so that several interesting announcements may pass unnoticed, as far as I am concerned. The co-operation of a few readers is much appreciated, but I should like to see a few more of them. Thank you!

TOULOUSE-

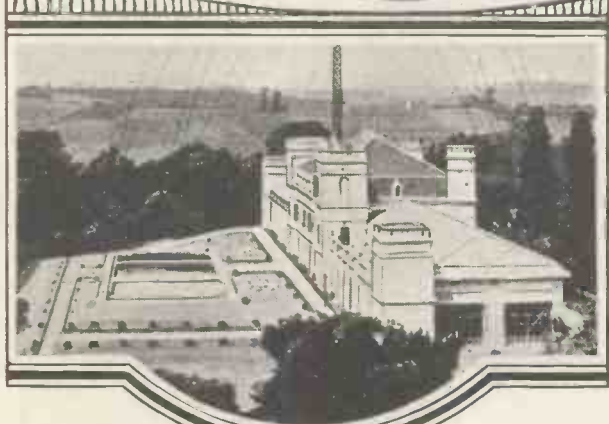

The Château St. Agnan, which houses the new Toulouse apparatus, is situated in beautiful park lands.

TOULOUSE—the new giant station which the French Government kept “muzzled” for months!

Even when the disastrous fire at the 8-kilowatt station burnt out the studios and part of the transmitter, the French P.T.T. officials wouldn't let the new station be run to maintain the programme service. They complained of “possible difficulties with the U.I.R. authorities,” even though the U.I.R. office at Brussels wasn't consulted. And when I went to the Château St. Agnan last month to see the new outfit, I found the chiefs highly indignant at the harsh treatment meted out by the French Government.

Can you imagine the engineers' disappointment, after the new Toulouse had been given a thorough testing, when they heard that the broadcaster would have to be muzzled, pending the removal of much governmental red tape!

They certainly have a fine station. The 60-kilowatt plant of the new Toulouse transmitter takes up much more space than at the old 8-kilowatt station. The new broadcaster is housed in the Château St. Agnan.

This is a large grey stone building surrounded by some of the most beautiful park land you could wish to see.

In Picturesque Surroundings

You couldn't imagine anything less like a broadcasting station, and the latticed masts standing out above the tree-tops seem bizarre in the extreme.

The château is reached by a twisting pathway from the gate to the park. The building is underneath the electrical shadow of the aerial, but is not midway between the masts. The masts are about 250 yards apart and stand high

above the poplar trees to the extent of about 400 feet. They are held up by banks of guy wires, each group coming from one of the four joined points in the mast latticed structure. These masts are in four sections, you see.

The château is a mass of curious turrets and towers, and the aerial down-lead comes straight to one of these. The new 60-kilowatt transmitter is housed in the left wing of the massive building.

More Modern than Radio Paris

Inside, the château is an impressive place. It has spacious tiled floors and lofty halls. The power section of the new Toulouse takes up the whole of one of these halls, the heavy transformer gear being fitted at the far end against the immense windows.

The Radiophonie du Midi apparatus has been built by the C.F.R. engineers—a French group of broadcasting experts who do the technical side of many European stations under French control, and, of course, most of the French home stations, as Radio Paris.

In many ways the power section of Toulouse is similar to Radio Paris. There are the same iron-clad chokes: the same oil-filled condensers.

The condensers, incidentally, are in large tanks of more than shoulder height. A great deal of the wiring is carried in channels along the tiled floors. There are also considerable numbers of the copper tubes which carry the H.F. energy at about head height at the power transformer end of the machine room. These bare copper leads are mighty dangerous fellows if you come in contact with them!

The main valves of Toulouse's 60-kilowatt outfit take roughly 12,000 volts on their anodes. This power comes from the local A.C. power supply mains, stepped-up to the requisite voltage by the tall transformers fitted with air-cooling fins, and then rectified.

A New Method of Lighting

This section of the Toulouse station comprises a lengthy control panel running down one side of the main transmitter hall, a 4,000-volt input transformer from the six-phase supply and then five separate groups of the big oil-filled condensers.

The transformers and condensers are for the power supply, each on its steel stand at the window end of the transmitter hall, while the regulating panel is about half-way down.

On the other side of it are two large and two small converters, each mounted on a concrete slab. There are the usual springs between the chassis of the rotary converter and the concrete slab to cut out any chance of vibration.

The popular “Radio Toulouse” station was destroyed by fire last April, and although a new Toulouse transmitter was already built, the Government has only just permitted it to be used. The “unmuzzled” apparatus has many interesting points, which are described in this article By OUR SPECIAL CORRESPONDENT.

the UNMUZZLED BROADCASTER

The transmitter hall is a spacious affair and is only separated by pillars from the other side of the next wing of the building where the H.F. panels are installed.

Incidentally, in the main transmitter hall there is a very modern style of indirect lighting, which strikes a new note in transmitter fashion!

At Toulouse the C.F.R. engineers have used some of the biggest valves yet tried in French broadcasting. You must bear in mind that this Toulouse plant is even more modern than the high-power Radio Paris transmitter on the outskirts of Paris.

No Wavelength Wobbles Likely

The familiar valve "tower" which is a feature of Radio Paris is not used at Toulouse, the valves instead being housed behind cabinets fitted with grilles at the top and looking really much more like a typical German transmitter than a French one.

All the wiring is kept behind these grilles, and there are even holes cut in the wire mesh so that the voltmeters and ammeters can be clearly seen. The wiring is carried from one cabinet to the next over the tops of the grilles, and the connections through to the main power panels are made by leads supported at almost ceiling height.

A view of the transmitter panels, which include some of the largest valves yet used in French broadcasting. The valves are situated behind the wire top part of the panels.

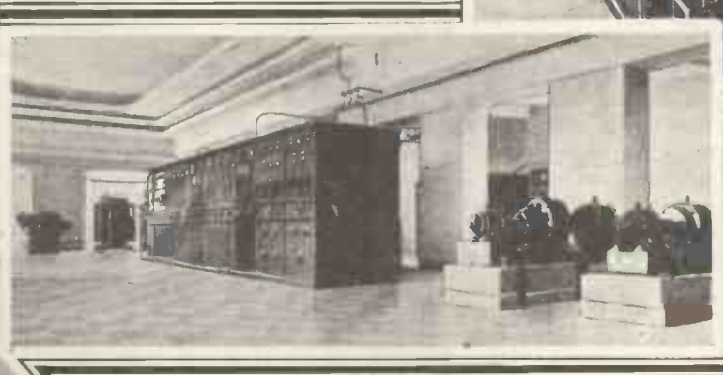
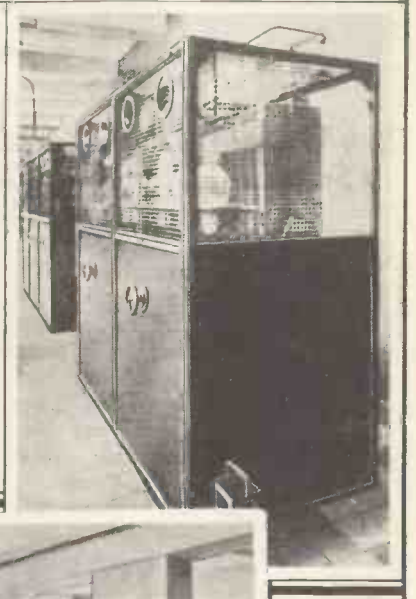

The main power switchboard and some of the generators are seen in this photo of the power section.

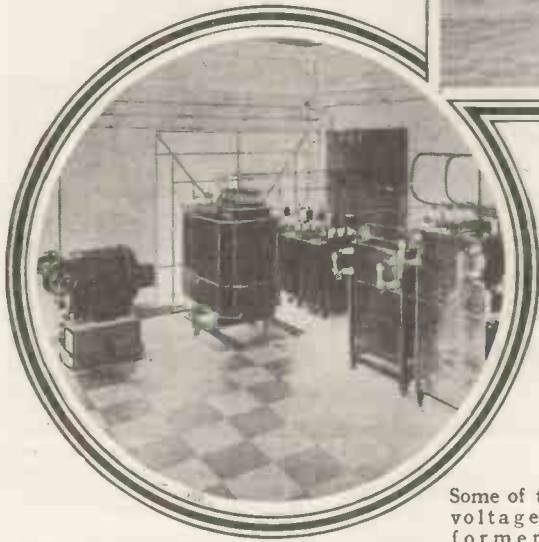

Some of the high voltage transformers and condensers. Note the head-high feed lines running from these instruments, and the ample spacing provided.

There are elaborate drive arrangements for keeping Toulouse on its wavelength of 385 metres during the tests. Toulouse is one of the several Continental stations provided with an official wavemeter by the technical committee at Brussels. The B.B.C. has several of them, of course.

As a result, the Toulouse engineers were able to check up for themselves the constancy of the transmitter's wavelength, and they can check their reports with those issued every month by the Brussels experts. But until the last few weeks the Government refused a permit in spite of this extreme accuracy—much better than that of the 8-kilowatt.

Listeners Approve the Quality

At present Toulouse is working on a very favourable wavelength, its nearest ether neighbour being Leipzig. Archangel, the Russian station now trying to find a new home "on the air," has once or twice interfered with Toulouse, but that has not been Toulouse's fault.

The engineers told me that the power is varied during the transmissions, and is increased up to the present maximum for the long-distance programmes, such as a special concert for listeners in Morocco. But at present only 8 kw. may be employed.

Listeners reported that during tests of the 60-kilowatt they found the quality of Toulouse is quite above the average of French stations, and this in spite of a fairly heavy modulation depth which causes a fine local signal.

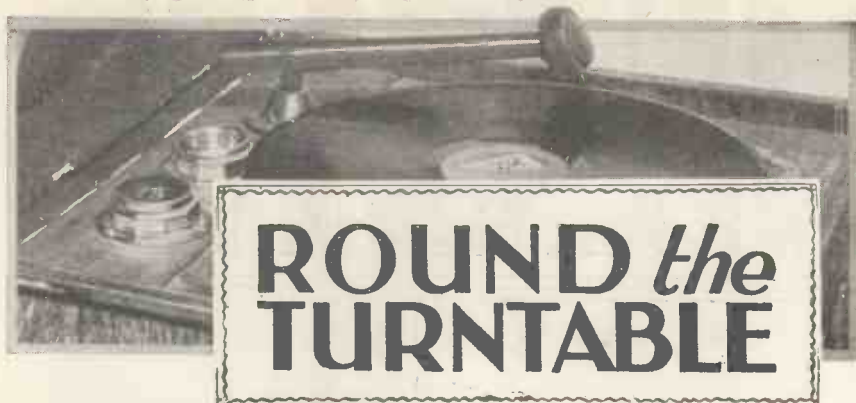

ROUND *the* TURNTABLE

*Pitch Variation of Piano Reproduction—Check Your Motor Speed—
Special Irish Records—A Brilliant Semi-Permanent Needle.*
By **TONE ARM.**

FOR some time recently I have been disappointed with the reproduction my radiogramophone has been giving from piano records. The tone itself has been good throughout, but the pitch constancy of the records has been very poor. You know the sort of thing I mean.

The record starts off, perhaps with a fairly heavy passage in the bass, and you sit back to enjoy things. Then the treble of the instrument comes to the fore, with some fairly sustained notes. At once instead of the pure piano tone one is treated to a sort of cross between the piano and the harpsichord. A tinniness has made itself known.

A Question of R.P.M.

After the first two or three new records that evidenced this pitch variation that I tried, I began to suspect that the trouble was not due to the discs, though the feature is well known as a likely fault in piano recordings, and I tried one or two old favourites that I had heard often enough on the same outfit with perfect results.

The same thing happened, and I began to see daylight. Everything else in the way of recordings seemed O.K., so I had previously failed to suspect the electric motor, especially as it had been carefully fitted to be level, was of good make, and had had the speed checked when installed.

The level was all right, but the speed—only 70. I had gradually become used to all records running a bit slow, and a steady and slow increase in speed diminution had been going on during a time when I had rarely been using piano discs. The net result was that the slight faults in the recordings, which would

not show up when the proper speed was used, and slight unevenness of rotation of turntable, which would affect only sustained notes, were being heard.

Once the speed was returned to normal the trouble vanished, and I can now enjoy my piano records as well as I have enjoyed the other types.

Righting a Wrong

I mention this at some length because many record users are apt to imagine that the peculiar metallic tone imparted to piano records by

of the turntable before you commence to condemn the recording. So, if your piano discs begin to play you up in the manner described, check your motor speed right away.

I am now busy running through all the new piano discs that I thought were erring in recording efficiency to put right the mental condemnation of them that had so unjustly occurred.

Worth Hearing

Those of my readers who are Irish will be glad to know of a special Irish issue of Regal-Zonophone records during the last few weeks. Sixteen records have been released, instrumental and vocal, containing characteristic Irish humour, reels, schottische airs, and so forth. The whole list is a most intriguing one, and the next time my Irish friends are at the local dealer's they should certainly make inquiries about these records.

I have been chasing around among the various needles again; I do that occasionally so that I shall not get into a groove (no pun intended) with one needle, and always consider that type the best.

Of course, there is no "best" for every use. The needle must be chosen to suit individual taste and individual pick-ups. But the search has made me change again. I have discarded the Columbia Chromium,

DUKE ELLINGTON AND HIS BOYS



At the time of going to press, Duke Ellington and his famous "hot" rhythm band are still touring Great Britain. Many listeners will no doubt have already heard his broadcasts and recordings on the H.M.V. and Columbia discs.

the recording faults of some time ago are still present. This is by no means the case except on rare occasions, and the trouble, which was at one time so difficult to solve, has been practically done away with.

Consequently if you experience any suspicion of pitch swing in the piano tone of your records, try the speed

which is a very fine needle, in favour of the same firm's "Duragold" type. This latter seems to give a little more brilliant and cleaner reproduction with my pick-up, and although it does not last so long (8 to 10 playings instead of some 40 or more), one gets about ten times the number for the same price, and they are excellent.



The WORLD'S PROGRAMMES

SPECIAL ILLUSTRATED SUPPLEMENT
FOR LONG-DISTANCE ENTHUSIASTS

CONTENTS OF THIS FOREIGN PROGRAMME FEATURE

Round the Long-Wave Dial

Reich Radio

A History of Berlin Broadcasting

For the Short-Wave Listener

The Month in Europe

Programmes from the Continent

Zagreb and the Slavs

Other People's Programmes
No. 8—America

Medium-Wave Listening

Overseas Items from Tun's to
Toulouse

The Announcers of Riga

The Ravages of Time





ROUND THE LONG-WAVE DIAL

With notes on atmospheric disturbances, the reliability of Luxembourg, and the wavelength re-shuffle.



ONE of the few disadvantages of the long waveband, as compared to medium wavelengths, is that above about 1,000 metres summer-time atmospherics are apt to prove more severe. And at this time of the year, when thunderstorms in Britain are frequent, the electrical crashes and rattles which accompany them are unavoidable on a sensitive set. (They may be just a faint mutter, almost inaudible; or they may rise to a strength that spoils enjoyment of the programme. But they are always there, in hot weather.)

* * *

Such electrical interference is usually more noticeable on long-waves. And when "X's" (as the noises are called) seem severe on those wavelengths, it is always worth switching over to the medium waveband, which may be enjoying immunity from them.

* * *

Apart from this, the long waveband has made a very good showing during July.

Even the more distant and the less highly-powered stations have been receivable. True, their programme value is apt to be negligible in summer, because when high amplification or reaction is necessary to receive a programme the ever-present background mutter of the "X's" gets magnified too. But the keen listener for distance, who has checked up his dial readings occa-

sionally, will have noted that most of the stations were recognisable even during the hottest weather.

* * *

So far as the transmissions of the main long-wave stations are concerned, "X's" have been very little trouble. Radio Paris, for instance, gets over at such good strength in the London area that usually only the approach of a local thunderstorm can mar his programme.

(At such a time, of course, the set should in any case be "off" and the aerial earthed, for it is unwise as well as useless to listen through a thunderstorm.)

* * *

Coupled with the name of Radio Paris we must mention Luxembourg as a permanently reliable station for the South of England listener. This summer has proved his merit, and for strength and consistency at all hours Luxembourg ranks definitely in the first-class.

* * *

Of virtually all the other favourite stations the summer takes toll in the form of variability. Motala, for

instance, may be excellent one night, and not worth tuning in a couple of nights later.

As a matter of fact this station has seemed so good on his good nights that it has been really interesting to note how fast and far he can fall from that condition.

* * *

Warsaw has been well worth watching, and Deutschlandsender (alias Berlin, alias Königs Wusterhausen, alias Zeesen!) has also repaid regular visits. Neither Oslo nor Kalundborg, on the other hand, have seemed in form, but Huizen at the top of the dial is always a possible stand-by.

* * *

Owing to the coming wavelength re-shuffle resulting from the Lucerne Conference, quite a number of strangers have strayed into the long waveband for test purposes. These transmissions are usually, for obvious reasons, carried out very late at night, or in daylight—usually morning—hours when the normal service is suspended.

We shall probably get a good deal of this test business on all wavelengths until mid-winter, when their newly-allotted wavelengths will be adopted by all stations.

By far the most interesting example at the moment is "Radio Kootwyk," the new high-powered Dutch long-wave station.

He is already testing outside programme hours on Huizen's wavelength, 1,875 metres.





KÖNIGS WUSTERHAUSEN transmitters, of which there are a whole host, are all used for commercial telephony and telegraphy within Europe and with the Near East. The broadcasting station has been erected some two miles away at Zeesen. I met Mr. Schwartzkopf down in the town, and he drove me over. I gather that the village of Zeesen must be near the transmitter, but I did not see it.



KÖNIGS WUSTERHAUSEN

The old Deutschlandsender still remains on this spot, despite the modern apparatus which has succeeded it.

My readers may wonder at the Deutschlandsender which stands at Zeesen being called Königs Wusterhausen. When the broadcasting station was removed to the new site

Continuing our brief history of broadcasting in its relation to the Berlin listener, this second special "World's Programme" article takes us to Beelitz, famous for its asparagus, and Nauen, the Station with a history.

By A. A. GULLILAND.

at Zeesen the old name was retained for tradition's sake. The two short-wave stations on the other hand, that stand on the same site and which are housed under the same roof, are officially termed "Zeesen."

Apart from the Deutschlandsender and its long aerial, there are a number of beam aerials for broadcasting to the North American continent, and one omnidirectional aerial for several short wavelengths.

A PIONEER'S LAMENT

Mr. Schwartzkopf sadly told me that he who had been the very first practical broadcasting pioneer in Germany was now even denied a microphone. I found out that this was a precaution against persons who might seize the transmitter in lonely Zeesen and start broadcasting on their own. But with a twinkle in his eye, Schwartzkopf said that after all if emergency arose there were always ways and means for an old engineer

like himself to make a short announcement, such as that of an approaching storm and probable close down, without a microphone!

A few days later saw me in another of those rather slow and tedious little steam-engine trains which take you from Berlin to nowhere in particular.

After about an hour and a half's journey I got out at Beelitz, famous for its asparagus, but otherwise insignificant except for the reason that the great German transatlantic radio receiving station is situated close to the town.

On leaving the station I found the bus which the officials in Berlin had told me I could use to



RADIO VETERAN

The first station house at Nauen, dating from 1906, still stands as a memorial to the early pioneering days of radio.

MASTS THICK AS TREES IN A WOOD

reach the radio station, which is about two miles away. But the conductor had received no instructions, and as it was a private bus only for the use of P.O. officials, I was only admitted on telephone permission from the chief who, seemingly, had forgotten that I was expected that day.

struction of Beelitz and Nauen, the famous German pioneer firm, the Telefunken Company, very kindly drove me out to Germany's historical station, Nauen.

Nauen is a station with a history. In 1906, Count Arco decided to have a station erected at Nauen; and Mr. Hirsch, who very kindly accom-

The engineer in charge at Nauen, which was recently bought by the German Post Office from the Transradio, rattled off a few details about the technical equipment, so here you are:

The highest mast (a guyed mast, unlike the self-supporting Königs Wusterhausen one) is 268 metres high. It weighs 360 tons, and five hundred people could stand on the top platform if they clambered up the vertical ladders. There are two of these giants masts, and they support the aerial for the long 18,130-metre wave.

NOTABLE VISITORS

In all there are 14 long-wave masts and 29 masts for short-wave aeriels and beam aeriels. Of these there are four beams for South American traffic, four for North America, three for Central America, two for Egypt and six for East Asia (Japan, etc.).

Nauen's visitors' book is an historic book in more senses than one. I found the signature of Amanullah, King of Afghanistan; the signature of the brother of the Emperor of Japan; names of B.B.C. engineers; the name of the former director of Radio Luxembourg; the name of an Abyssinian prince, of the Papal Legate Orsenigo, etc., etc.

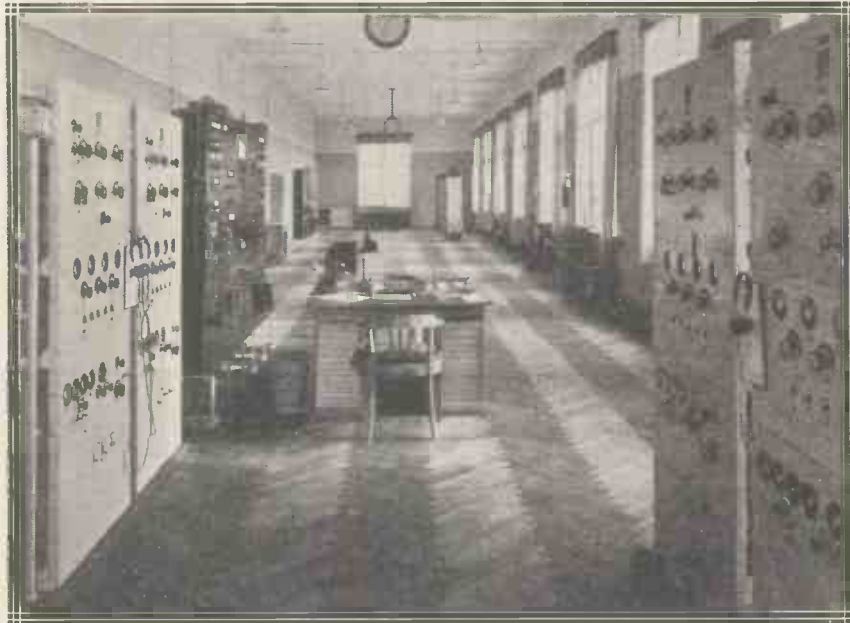

TRANSATLANTIC RELAYS are handled in this receiving station at Beelitz, where three aeriels are employed on each programme to obviate fading.

I saw Beelitz amidst cornfields, and the thirty-six masts which support the receiving aeriels for reception from all parts of the world seemed more like a wood than anything else. It is at Beelitz that U.S.A. stations are received when a transatlantic broadcasting relay from U.S.A. to Germany is in progress.

PREVENTING FADING

The engineers usually employ three aeriels and receivers, coupled together, as this greatly helps to cut out fading, which sometimes occurs on the short waves. All commercial S.W. telephony from overseas comes in via Beelitz, and so does telegraphy, for that matter.

My photos give a pretty good idea of the Beelitz station, and certainly a much better one than any word picture, so permit me to pass on to the last stage of my visits.

This was by far the pleasantest. The firm responsible for the con-

panied me out to Nauen, showed me the very spot where he, who was in charge of the work, had ordered the men to place the concrete foundation for the heavy gear.

The old, historic house, dating from 1906, has been left intact. The new building is now close by. Nauen was the only means of communication that Germany had during the war after her cable connection had been cut. It was Nauen that carried German telegrams across the ocean during the War.

A SUPER MAST

After the War the Transradio took over, and in 1922 the new Nauen buildings were opened by the first President of the German Republic, Friedrich Ebert. It is a long way from "Black Susie," the 35 h.p. locomobile of 1906, to the wonderful Diesel power-house of present days which has tanks to enable it to run for well-nigh a year without filling up!



THE ENGINEER in charge of the Nauen station makes a careful note of the photographs taken by our contributor.

I am proud to say that my name figures there, also.

From Nauen 16 telegraphy lines go out, and five telephony ones; of these, one to the Argentine, one to Brazil, one to Venezuela, one to Siam and one to the Dutch Indies. Apart from these five telephony lines, there are two picture telegraph lines, one to the Argentine and the second to New York.

Nauen witnessed the first German television demonstration on short waves some years ago. In Germany, Nauen is termed the historic cradle

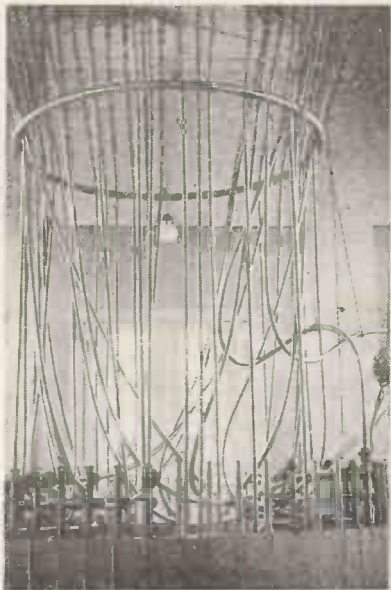

SOME GIGANTIC OCTOPUS is suggested by the Beelitz aerial system which allows any aerial to be connected to any receiver.

of German wireless, and I think it certainly is this. It only seems a pity that Count Arco, although still among the living, has severed his connection with the Telefunken Company and withdrawn into private life.

It seems even a greater pity that Mr. Hirsch, the man who built the old Nauen, should have had to leave in view of the National Socialist revolution.

BERLIN'S OWN

But, then, I am harking back, and in Germany everybody is straining forward to the new. But the steel masts of Nauen no doubt bear testimony to their designers.

My account is short, but I hope my reader has obtained a glimpse through my eyes of the wireless stations in and around Berlin which are, at the same time, Germany's most important.

To be complete, I should add a

few words on the Witzleben transmitter. This stands close by the new Broadcasting House, and operates with a mere 1.5 kw. It will shortly be superseded by the giant 120-kw. Berlin high-power station which is expected to open this autumn.

FUTURE DEVELOPMENTS

This latter station is being built on the outskirts of the town, close to the Tegel prison, on the grounds of the former artillery shooting ground. With the opening of this transmitter, the famous Berlin "Radio Tower" will lose its use as an aerial support, and will become merely decorative.

Also, the small relay station on the roof of a house in the Berlin East End in the Boxhagenstrasse will close down.

So that there remain the Fermant, the nerve centre, the Deutschland-sender Königs Wusterhausen at Zeesen, the commercial stations for European traffic at Königs Wusterhausen, the Beelitz transatlantic receiving post for broadcast relays, for telegraphy and telephony, the famous Nauen station, the Zehlendorf receiving post for European commercial traffic, and the new Berlin broadcasting station under construction at Tegel.

FOR THE SHORT-WAVE LISTENER

SOON the days will become shorter and conditions revert to their "autumn" level. Next month will be a more opportune time than the present to quote the "best times" for the autumn; just now we are going through the transition stage.

The chief characteristic of the month of August, in connection with short-wave work, seems to be that conditions are better than usual in the late evening. On the 19-, 25-, and 49-metre bands, strong signals are usually heard between 9 p.m. and midnight.

Both North and South Americans should be good, late at night, on practically all bands. Australians are unreliable; South Africa, if received at all, should come over best about 7 or 8 p.m.; and Asia is so uncertain that nothing can be said about it. These, at any rate, are the facts that emerge from an examination of detailed logs from the present time back to 1927.

Readers who follow amateur transmissions closely may be interested to know that during this time of the year it is not unusual for the South American amateurs to be heard early in the morning—at 6 or 7 a.m.—as distinct from their more usual time of 11 p.m. to midnight.

Conditions for European work on short-wave amateur bands can never be described as poor, but during the past two months there has been a notable scarcity of British stations on the 40-metre and 20-metre bands. With the approach of autumn the skip-distance usually undergoes a change, and we shall probably be hearing more British "phone" on Sunday mornings than of late.

RECEPTION THRILLS

Among the "station news" is the promise of a new short-wave station in the U.S.A. WOR, well-known to medium-wave listeners as Newark, N.J., is starting a short-wave transmission which should be "on the air" very shortly.

One of the most interesting aspects of short-wave listening is the constant arrival of new commercial telephone services. Once these are established, they cease to be a source of much interest, but while they are in the "testing" stage, using gramophone records and making adjustments, they are quite interesting.

After all, the biggest thrill that awaits the short-wave listener is the reception of a new and unidentified



OPENING A STATION for keeping German listeners in U.S.A. and Canada in touch with home. Zeesen is the station used (wavelength 49.58 metres).

station. Recently I found one of these "phones" that I could not place, and it turned out to be K K P, Kauhuku, Hawaii, on about 19 metres. Hawaii is one of the places on the globe that one doesn't hear very much from!

W. L. S.

THE MONTH in EUROPE

The progress of continental broadcasting told in pictures



FRANKFURT (Germany). The musical director of the Opera House has adopted the system of listening to his orchestra via a microphone and headphones. Any discrepancies in the broadcast can then be remedied in the orchestra instead of in the control room.



GERMAN STATIONS as a whole make a special feature of "on-the-spot" radio interviews. This is the special microphone which is used by the reporter and the notability being interviewed. It is portable and can be produced at any meeting of importance and used at once. On top of the microphone is incorporated a special signalling disc used by the engineers for control purposes.

HILVERSUM (Holland). The designers of the Workers' Amateur Transmitter—seen on the right—have managed to combine artistry with utility. The ornamental pool is used for supplying water-cooling to the transmitting valves.

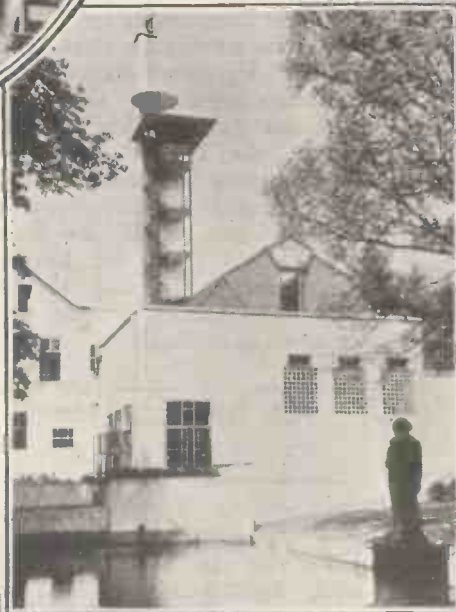

HAMBURG (Germany). A special radio news reel of topical events is included in the programmes every week, and below can be seen the special cutting-room for the gramophone records which supply this ingenious and tremendously popular feature.

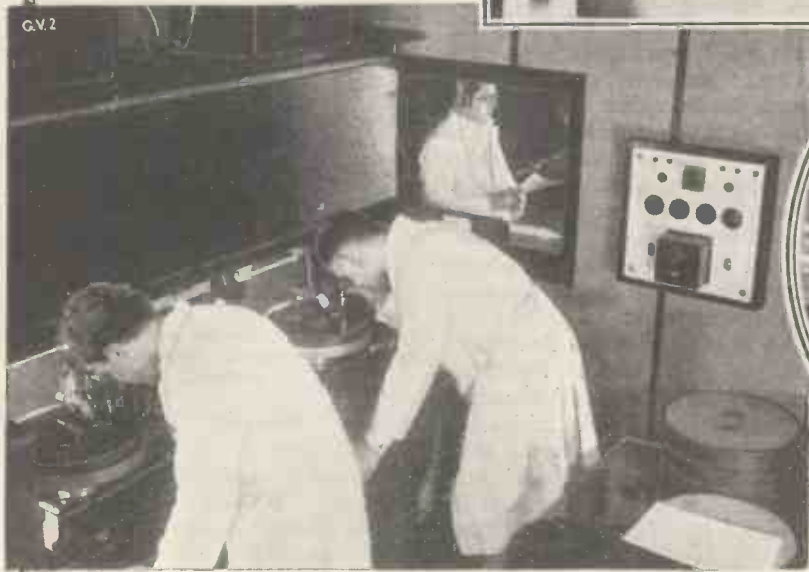

KAUNAS (Lithuania). The control engineer takes his job very seriously at this station on the top of the long-wave dial.

PROGRAMMES FROM THE CONTINENT

"AND the night shall be filled with the music of Johann Strauss" seems to have been the motto of the month, for summer music has, in almost every country, meant a repetition of the works of this composer. Fortunately they are works which bear repetition even to the extent of hearing "Morgenblatter" four times in an evening!

It is significant that in no country but Britain has the advent of the fine evenings meant any diminishing of programme time—or value. Quite the reverse in most cases.

Here are some of the outstanding programmes of the past month from the point of view of the English listener.

AUSTRIA

The Vienna Symphony Orchestra has now thrown its lot in with broadcasting, and a special radio section has been formed. British listeners heard a relay of this orchestra early in the month in a delightful programme of Viennese operettas, and since then there have been concerts twice, three times and even four times a day. Listeners to Vienna will now be assured of even more really good music than was their lot before.

Among the best of the Viennese programmes were the British relay and "A Walk in Vienna," which consisted of relays from the Symphony Orchestra itself, the People's Garden, the Municipal Park, and the Prater. Light and very jolly music—principally Strauss!

DENMARK

Denmark's contribution to the summer festivities took the form of a grand ball—from 8.30 to midnight—especially arranged by the Copenhagen studio for the old folks.

Brief comments on the programmes of other countries during the past month, showing that "foreign listening" is still worth while from an entertainment point of view.

Light music, dance music and songs of the eighties were prevalent, and made a welcome change to the modern café dance music.

FRANCE

Radio Paris has a genius for providing just the right breakfast-time music. What, for instance, could be more appropriate these mornings than the ballet music from "Coppelia," which I heard the other morning at 7.45? Incidentally, this station is copying the British idea of



THEY HAVE THEIR BACH

The Church of St. Thomas in Leipzig from which every Sunday Bach Cantatas are relayed throughout Germany.

long and properly arranged recitals of gramophone records. One of these recently lasted the whole morning, with an interval for the mid-day news.

Strasbourg, on the other hand, seemed to take up nearly all its time with commentaries on the Cycle Tour of France, which was a feature of July.

GERMANY

The martial spirit of the country still takes a prominent place in German programme organisation, so that we see in the programmes of the past month such announcements as "A U-Boat Commander Discusses His War Experiences with His Officer of the Watch"; "A Relay of the Unveiling of a Memorial to Two Murdered Nazis"; "A Call to Arms—a Military Band Concert of German Marches and War Songs"; etc.

However, even from these programmes the Strauss melodies could not be excluded; and I enjoyed a fine concert by a Quartet of French Horns which reminded me vividly of a thrilling performance I heard from the tower of the old imperial palace when I was last in Munich.

There was also a most enjoyable broadcast of the "Mikado."

ITALY

Just a mention of the Rome station to remind those listeners who are looking for an opportunity of learning or practising Morse, that this station has regular lessons twice a week round about 7.20 p.m.

NORWAY

General Higgins, of the Salvation Army, is not a regular broadcaster, and it was therefore rather a pleasant surprise to hear him during the month from Oslo.

COSMOPOLITE.



ZAGREB AND THE SLAVS

Now that the new British West Regional is working on 309.9 metres, it is doubtful whether many of you will be able to hear the transmitter at Zagreb which is situated only about 2 metres lower.

But to those in Yugoslavia it is a very important station and therefore worthy of inclusion in our "Visits to Foreign Stations."

"**G**OVORITE li engleski ili francuski?" I asked the military-looking engineer in charge of Radio Zagreb.

And, fortunately, he did! Speaking in very fluent French, he chatted readily about the transmitter, and I learned a great deal about this side of Yugoslav broadcasting.

First impressions of Zagreb had been very favourable.

After an experience of linguistic nightmares and misunderstandings with uncomprehending police, I found myself in a main street and right under the shadow of the aerial of the station I was searching for!

A TOWN AERIAL

As a matter of fact, the Zagreb transmitter is in the centre of the town, and the aerial masts stand high above the roofs. The guy wires are anchored to neighbouring rooftops, and the aerial itself crosses a main thoroughfare. A plain stone building is the house of the transmitter panels, and the main apparatus is right at the top floor of the building.

Zagreb is a self-contained station running off the local power supply. The power output is rated in Yugoslavia as 3 kilowatts, but according

to our style of power rating, the output is .75 kilowatts. So, of course, very elaborate apparatus is not to be expected. The main section of the broadcaster, as a matter of fact, is made up very much like an amateur transmitter.

HIS LONG DAY

But I do not want you to think that Zagreb is any the less efficient because it is small.

There is a very keen resident engineer in charge, and he personally

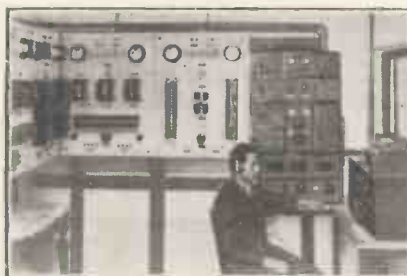

PROGRAMME CONTROL

The meter panels and control switch-board of the transmitter.

runs the whole transmitter for twelve hours a day from its opening at 10.30 a.m.

Zagreb's transmitter boasts a special form of choke modulation which it is possible to use owing to the comparatively low power. Incidentally, I noticed a number of what appeared to be British-made components in the H.F. section, particularly condensers.

SAFETY SWITCHING

For a small station there is a very clever one-knob control gear for the aerial and safety spark-gap switching.

Zagreb takes a good many outside broadcasts, especially from neighbouring restaurants and hotels. The

late night dance music, for instance, is frequently relayed from a big hotel known as the "Esplanade."

The volume regulation on the lines during these outside broadcasts is done in the speech control room, and I had the opportunity of seeing this done before I left the Zagreb broadcaster.

As the telephone lines are owned by the State, there is no difficulty about the switching.

The Zagreb engineer has an interesting postbag of letters which he gets from all over Europe, and many of them from Great Britain. As the Zagreb aerial is about 830 miles away from London, it is remarkable that the station can be heard in England at all!

Two studio matters at Zagreb which may interest you are the fact that an ordinary metronome is stood close to the studio "mike" to give the interval signal, and that an off-played gramophone record is responsible for the National Anthem which they switch on at the end of every programme.

ON 307 METRES

The greatest trouble in this part of the country is experienced from German stations, but this is only because of the inadequate wavelength separation, and not because of any frequency wobbling.

And I was shown the U.I.R. wavelength table for the previous month, in which the average and maximum wavelength variation of Zagreb was shown marked in blue. The average wobble is not more than .3, so Zagreb is nearly as constant on its 307 metres as are the leading B.B.C. and German stations.

B. N.



A FAMOUS QUARTET

This Zagreb quartet, besides being well known in its own country, has given recitals in Germany, Sweden, Norway and Hungary.



Other People's Programmes

No. 8—AMERICA

To attempt to deal with such a stupendous subject as American broadcasting in a single article would be little short of madness. But fortunately the matter divides itself very neatly into two distinct heads, so that in this issue we can look at the work of the National Broadcasting Company, leaving the Columbia Broadcasting System and a general summing-up of the position until next month's MODERN WIRELESS.

INTERESTING COMPARISON

In this way it will be interesting to compare not only American broadcasting with that of Europe, but also the two systems with each other, in so far as any comparison is possible.

There is no need to tell you that broadcasting in the United States is a private industry supported by "sponsored" programmes. These programmes are given by firms which are announced or whose products are mentioned during the broadcast.

POPULAR IMPRESSION

This fact has given rise to some belief in Europe that the American "air" is filled with a nerve-wracking conglomeration of intermingled jazz and sales exhortations. Unfortunately this entirely inaccurate impression continues because American broadcasting is rarely heard on this side of the Atlantic—except for isolated relays which are scarcely representative of the programmes as a whole.

Difference in time and the cost of transmission are big obstacles to extensive exchange of programmes, and it is, therefore, difficult to give a satisfactory picture to British listeners who, although interested, do not have the opportunity of hearing

Thanks to the co-operation of the European representatives of American broadcasting, "The World's Programmes" starts this month, in the series of Other People's Programmes, a brief summary of the system of broadcasting which obtains in the United States.

these programmes and of forming their own opinions.

Probably the most interesting way of approaching the subject would be to review the programme list of a normal National Broadcasting Company day.



THE FAMOUS CITY

New York, city of skyscrapers, has a programme of one thing or another throughout nearly the whole 24 hours of each day

We begin with "Tower Health Exercises" at 6.45 a.m. over one N.B.C. chain of stations and with a Musical Trio at 7.30 over another chain. From now on, over both chains, programmes succeed each other throughout the day, with no

intervals, for quarter, half or full hour periods, until 1 a.m. the following morning!

The American broadcaster's life is literally one of split seconds.

There are ninety-six items scheduled for this day—and if we had Columbia's schedule for the same day before us, we should probably find it equally full. This gives some idea of the quantity offered to American listeners.

TYPICAL ITEMS

To indicate the variety, we will glance at some of the listed items, without describing them in any detail.

We find that "Morning Devotions" recur daily at 9 o'clock just as the "Tower Health Exercises" item is a daily feature. We find "Your Child," a talk by a representative of the Children's Bureau of the Department of Labour. Market and Weather reports are given at 1 o'clock every day, and "To-day's News" at 6.45 p.m.

There is a musical programme called "Popular Varieties," and, peeping ahead, we see that at the same time two days later appears a programme called "Classic Varieties."

HUMAN INTEREST ITEMS

There are sketches—mystery, comedy, drama. There are human interest items such as "One Man's Family," in which the younger and older children of a typical family frankly discuss with their parents the various problems arising from their divergent viewpoints.

Of course, there is Ed Wynn, the inimitable comedian, beloved of stage and radio audiences from one end of America to the other. There are the Goldbergs who, each day, bring their now famous family before

750,000 LETTERS OF ENTHUSIASTIC APPROVAL

the microphone. I hear that, early in their broadcasting experience, at a loss to know whether the public enjoyed them, they one night bluntly asked listeners to tell them whether or not they wanted their programme to continue.

The reply to their query was in the nature of something like 750,000 letters of enthusiastic approval. Surely a record "fan mail"!



RADIO AND THE PRESS

Three of the leading newspaper men in the States are here seen with Mr. Aylesworth (left), President of the N.B.C. Walter Lippman, who recently broadcast to England, is second from the right.

In this same programme we find items like "A Forum for Political and Educational Problems," the "Mid-Week Hymn Sing" (what a delightful title!), "Nursery Rhymes" and "The Lady Next Door"—a children's programme. The Woman's Radio Review fills the half-hour from 3.30 to 4.0.

These titles readily suggest their character; but in the same list appear "Amos 'n Andy"—a by-word in America—who for four years now have broadcast their daily "black-faced" dialogue.

"MUSIC APPRECIATION"

The use of broadcasting for educational purposes is widely appreciated. To cite one instance, the National Broadcasting Company has the "Music Appreciation Hour" conducted by Walter Damrosch. This series is dedicated to "the schools and colleges of the United States," and special teachers' manuals and pupils' notebooks are used in conjunction with the broadcasts.

Through this series young people receive not only a grounding in music but a thorough knowledge of composers. I believe that something in the region of 6,000,000 children benefit from this weekly instruction—rather a terrifying thought.

Around and through these fixed

series occur not only broadcasts such as those I have taken from a day's lists, but also addresses by representatives of the professions, speeches by men and women in public life, talks on every kind of subject by special radio commentators, relays from other countries (graphically called "pick-ups"), feature and "stunt" broadcasts of unexpected events and so on.

PUBLIC VERDICT

Individuals who through personality or achievement, sympathy or controversy, have established themselves in the public interest are brought to the microphone. How often they are heard depends upon the public "reaction" to their broadcasts.

It can be no exaggeration to say that American broadcasting in the



A STUDIO NEWS ROOM

A studio at the National Broadcasting headquarters was turned into a news room for tabulating the election results at the Presidential campaign—an example of American thoroughness.

course of almost any hour offers, somewhere "on the air," some programme of interest to the listener.

It is, of course, generally known that American broadcasting pays its way through the sale of time to advertisers—and in that respect it stands alone. But this information, undoubtedly brings to many minds visions of antiquated gramophone records interrupted in their rounds of dismal gaiety to permit unwelcome and often nauseating announcements of somebody's wares.

LOW PERCENTAGE

In actual fact the time devoted to "sponsored" programmes is roughly 30 per cent of the total broadcasting time. For instance, out of 2,880 programmes last May, only 647, or less than 25 per cent, were sponsored.

For the rest, it probably is not known that more than two-thirds of the programmes in the United States are "sustaining" programmes, the cost of which is borne by the broadcasting organisation. In this category we find the bulk of the religious, cultural, literary and educational programmes—the talks, news, special commentaries, symphonies, operas.

On the other hand, the "sponsored" programmes provide the major part of the lighter entertainment and bring to the microphone such names as Will Rogers, Eddie Cantor, Ed Wynn and Al Jolson.

PROGRAMME VALUE

The advertiser, in his own interests, follows closely the changing demands of the public taste, and the general tendency seems to be towards decreasing the time allotted to mentions of firms and products.

Here is an example of the American method of handling a "special event." To cover the inauguration of President Roosevelt, fifteen microphone points, five mobile short-wave transmitters (two of them in the air), thirty-two engineers, ten announcers and twelve observers! This was, of course, an exceptional broadcast and possibly the most elaborate of its kind ever attempted anywhere. One of the portable transmitters was installed in an airship, another in an army aeroplane. A third was in a car which followed the President-



WINNING AN ELECTION

John A. Farley (left) campaign manager for President Roosevelt, is here being introduced to listeners by John W. Elwood, vice-president of the N.B.C., during the recent elections.

Elect, and the other two were carried on the backs of announcers who mingled with the crowds in the streets. The control engineer switched the programme back and forth from one position to another all the time. This broadcast was relayed to sixteen countries throughout the world.

(To be continued next month.)



MEDIUM-WAVE LISTENING

A report on conditions below 550 metres.

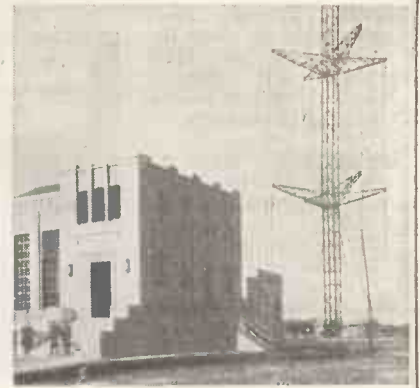

LONG-DISTANCE listening is always at its lowest ebb around this part of the year, when the out-of-door attractions are powerful, and few people care to be tied to a wireless set for long. But for those who hate to neglect the world's finest hobby even in bright weather there has been ample reward, for this is the best wireless summer ever experienced.

Even in the hottest and brightest weather the dials have been full of interest. That acid test, the breakfast-time reception of far-distant transmitters, has proved again and again that the owner of a good radio set has the world at his finger-tips.

One of the best of the "8 a.m. brigade," for whom daylight has no terrors, is Langenberg, on 473 metres. Another excellent one is Poste Parisien, on 328.2 metres, whilst Hilversum has to be heard fairly regularly to be believed, so consistent is the good reception possible from this station.

Incidentally he is at present, and until the end of September, radiating the "Huizen" programme, complete with a realistic cock-crow as an opening signal.

When night falls, of course, there is a host of programmes to choose from. But one of the advantages of

listening in the mornings is that one comes across quite low-powered stations, like Stavanger, Sweden, or Lille, France, which may be far more clearly received than at night, when there are dozens of other stations to be encountered.

Talking of out-of-the-way transmissions, there is now no limit to the surprises a skilled listener will be liable to hear. Owing to the fact that the Lucerne Plan comes into force on January 15th, and a great many readjustments will have to be made by then, much wavelength experimentation is taking place.

You may find a well-known long-wave station trying what the medium waveband is like, or some equally amazing misplacement. And as power is being altered in many cases, as well as wavelength, there is a constant element of surprise for those who have mapped out their dials more or less fully.

So far as the British stations go there will not be much change when the Lucerne Plan comes into force. But it will revolutionise our long-distance reception records.

Moscow will become the most powerful station working in Europe, and Luxembourg will be related to a medium-wave transmission, instead of possessing one of the coveted long waves with its superior carrying-power.

At the time of writing several of the most important radio interests have not agreed to the plan, being dissatisfied with their allotments. Great countries like Sweden, Poland, and Hungary, and important broadcasters like Holland and Luxembourg are among the malcontents.

Obviously, the success of the whole scheme is endangered unless they can be persuaded to co-operate with the satisfied signatories.

Although Moscow No. 1 (1,714 metres) will be allowed 500 kilowatts, on long waves, the tendency has been to limit power rather severely. In general, 100 kilowatts is the limit between about 550 and 270 metres. But Budapest, Leipzig, Paris P.T.T., Prague 1, Rennes P.T.T., Toulouse, and Vienna, will all be allowed to try up to 120 kilowatts.

They will be the super stations of the medium waves next year.

Between about 270 and 240 metres the limit of power is to be 60 kilowatts; whilst below 240 metres no station must use more than 30. In order to minimise interference there will be an increasing use of directional aerials and reflectors, designed to give strong service in some desired direction with a corresponding fall-off in neighbouring areas.

Nothing so ambitious as this has been tried before, and when the Lucerne Plan has had a good trial we may be using the wavebands to far better advantage than at present.

Hörby, Sweden, is to employ one of the new directional schemes (its aerial being directed towards the north if the power exceeds 60 kilowatts), so probably this old favourite will be seldom heard.

But plenty of new stations will be available for the long-distance enthusiast.

D.X.



TUNIS. The new Tunis station is to share the wavelength of 514.6 metres with Madona, Latvia, which at present is using 15 kilowatts.

DROITWICH. When the new B.B.C. long-waver at Droitwich is completed, and replaces 5XX, it will use a wavelength of 1,500 metres.

BISAMBERG, VIENNA. The engineers are now erecting a second "reflector" mast at Vienna, and when this comes into operation—probably in September—the Bisamberg high-power station will take over the daylight as well as the night programmes.

MOSCOW No. 1. In 1934 this will be the most powerful station in Europe, its rating being 500 kilowatts, as compared with the mere 200 kilowatts (now used by Luxembourg) which constitutes the present maximum.

IRISH FREE STATE. A better wavelength than the present 431 metres has been secured by Athlone under the wavelength scheme to be introduced in January next.

It will work on 531 metres, and increase its present power to 60 kilowatts if this proves to be necessary.

RABAT, MOROCCO. The main Rabat programme is usually relayed on 48 metres by C N 8 M C, a privately-owned station in Casablanca.

LEIPZIG. Germany has been granted 120 kilowatts for this station, provisionally, although 100 kilowatts is the nominal maximum for the medium waveband, under the Lucerne Plan which comes into force on January 15th, 1934.

PLYMOUTH. The B.B.C. has permission to raise the power of Plymouth from 2 to 5 kilowatts, when it operates on 203.5 metres next year.

TRONDJHEIM. The new Marconi station to replace the existing plant is to be a 20-kilowatt.

RENNES, FRANCE. The projected station is to have a power of 100 kilowatts (the maximum for its waveband), and special permission to increase this experimentally to 120 kilowatts, for a time.

MONACO. The Principality of Monaco was one of the new countries to enter European broadcasting under the Lucerne Plan. Its projected station has been allotted to the International Common Wavelength of 222.6 metres.

"HANNIBAL." The huge Imperial Airways liner "Hannibal" can pick up English broadcasting direct whilst flying between Baghdad and Basra.

VIENNA. The new station is to be permitted to work on the high power of 120 kilowatts—at least, for a time—until the Lucerne Wavelength Plan has been thoroughly tested in 1934.

CYRENAICA. This small state is planning to erect a radio station at Benghazi, and



THE N.P.L. The National Physical Laboratory has installed a transmitter for investigating the ionosphere.

It can send out 50-a-second impulses on any wavelength between 50 and 1,000 metres.

BRASOV, ROUMANIA. This station is to have Europe's longest wavelength—1,875 metres—next year, when the Lucerne Plan comes into force.

MALTA. Among the new stations to be working in Europe before the end of 1935 is a 5-kilowatt, at Malta.

REYKJAVIK, ICELAND. The present power of 16 kw. is shortly to be raised to 30 kw.

HUIZEN. This station has recently been putting out some specially good gramophone concerts in the mornings.

LISBON. The new "Portuguese North" station is to use a directional aerial towards the south, and reduce its power at night, if it interferes with Spanish and French listeners.

RADIO EXCELSIOR. This station is aptly named, for its two 700-ft. masts support the highest aerial in the world used exclusively for broadcasting. Its power is 20 kw.

MADRID. Spain is contemplating the erection of a new station at Madrid.

BOLZANO, ITALY. If it is found that this station's broadcasting interferes seriously with ship traffic, its aerial will be made directional to the land.

ATHLONE. If this station decides to use its full power of 100 kw. next year, on 531 metres, the Italian stations sharing this wavelength will also increase their power, and employ directional aerials to reduce interference in Ireland.

SYDNEY, N.S.W. A comprehensive scheme of school broadcasts has been in operation during the holiday season from the Sydney (2 F C) and Newcastle (2 N C) stations.

RADIO KOOTWYK. This is the name of the new Dutch long-wave station which has been testing 50 kilowatts on a wavelength of 1,875 metres.

MINSK KOLODISTCHI. One of the new Soviet stations is working on 1,107 metres under the name Minsk Kolodistchi. The power rating is 35 kilowatts.

NEW YORK. Some very interesting results have been obtained in the attempt to destroy insects by high-power radiation on 7 metres. At this wavelength the effect is to destroy the eggs of the pests.

TOULOUSE. Having been deprived of their programmes by the burning down of their once-popular station, Toulouse listeners have been gratified by the French Government's permission to use the St. Agnan transmitter. (An article on this station appears on page 128.)

OVERSEAS ITEMS

From Tunis to Toulouse.

has secured a share in the 222.6 metres wavelength.

830 METRES. This wavelength, together with 168 metres, is being used for standard frequency transmissions from the National Physical Laboratory, for the benefit of research workers.

MARRAKESH, MOROCCO. This new Moroccan station will share with Poznan, Poland, the wavelength immediately above that of London Regional, when the Lucerne Wavelength Plan comes into force on January 15th, 1934.

RIGA. This station, which was often heard in Britain last winter, is to have its power reduced from 15 to 10 kilowatts.

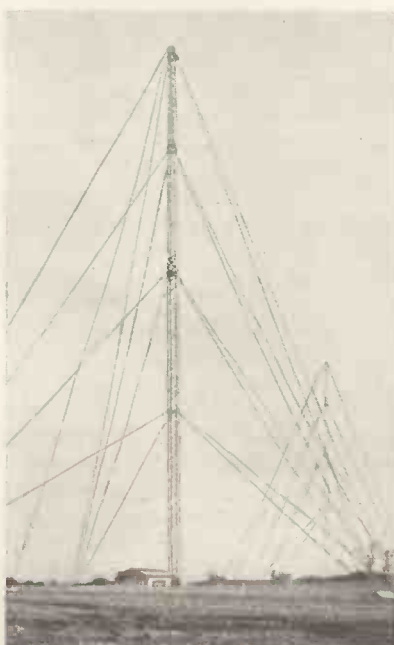

THE ANNOUNCERS OF RIGA

Some notes about the personalities behind the radio voices to be heard from this Latvian broadcaster, the imposing station building of which is shown to the left

By A. GULLILAND

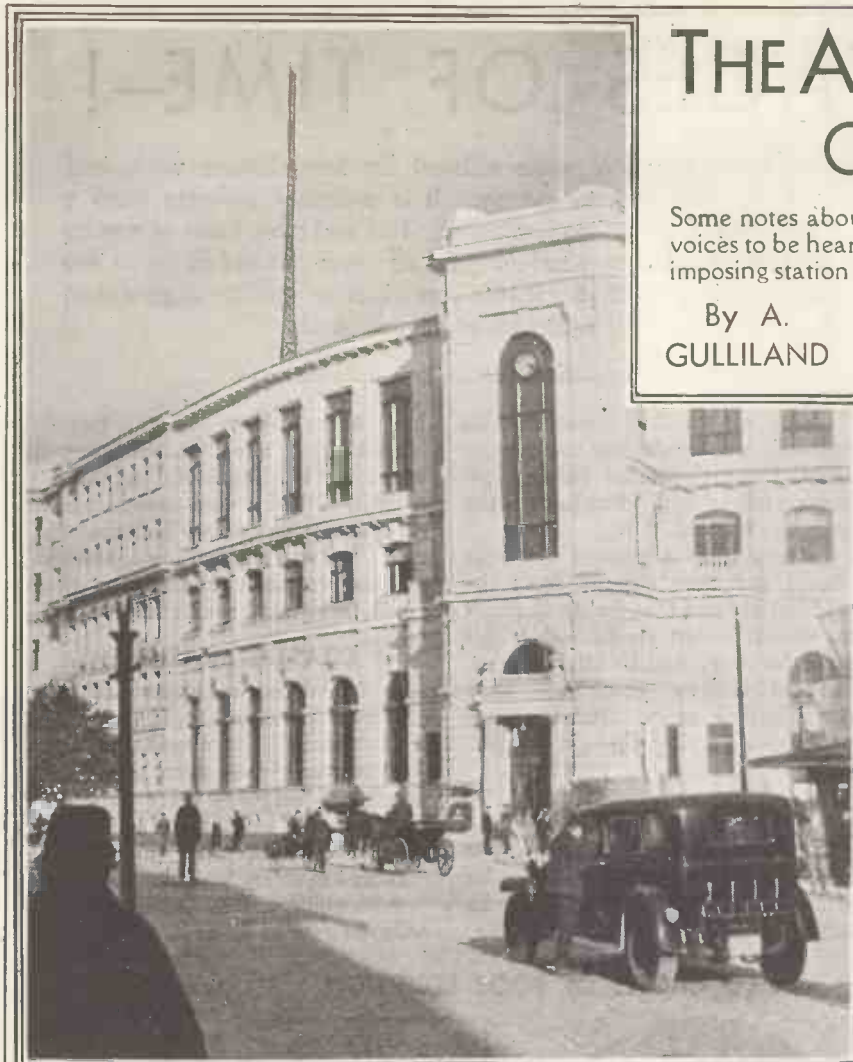

her help that I was able to converse with Mrs. Stein-Birkmann and her young colleague Baltpurvins. Alma Stein started announcing some three years ago. Her voice is true and clear, and very soon one of her most ardent admirers and listeners carried her off and married her. So she became Mrs. Stein-Birkmann.

After some persuasion she very kindly got her national costume—all Latvian women are proud of their national costume, which is worn on Sundays in the country—and permitted me to take her photo in it. We had a short controversy about the headdress. As an unmarried woman she wore the circular band, and as a married woman she wears the small white cap.

As I thought the band prettier than the cap she very kindly consented to my taking her with the cap and with

I WONDER if you have ever tried to listen for that far-off station on the Baltic Sea—Riga? The power is 15 kilowatts and the wavelength above 500 metres, so that you ought to have a try. You will then hear the voice of either Mrs. Stein-Birkmann or of Mr. Carl Baltpurvins.

When up in Riga I was astonished to find newly-opened, up-to-date studios on the third floor of the General Post Office. Here I met Mirdza Adamson. She was the first announcer at Riga, and only gave up some time ago owing to ill-health. She still does office work, and very kindly acted as my interpreter.

She speaks excellent English, and it was with

Mrs. Stein-Birkmann in her picturesque national costume. She had not been announcing long before she married one of her listeners. Her assistant announcer is Carl Baltpurvins, seen below in front of the microphone.



the band. I hope no good Latvian sees her with the band, as otherwise she may get into trouble with her husband.

Carl Baltpurvins is a typical native of the country. He has fair hair and blue eyes, and likes his work, which he has been doing since Miss Adamson left off.

He only speaks Latvian, whereas Mrs. Birkmann speaks fluent Latvian as well as the German and Russian languages.

THE RAVAGES OF TIME—!

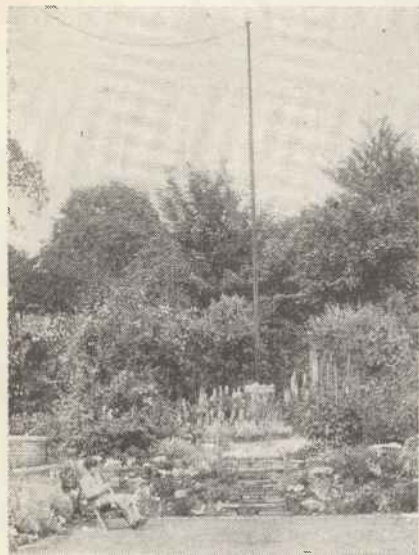

An aerial may look quite efficient for long-distance work, and yet be working very poorly. It is probably suffering from a collection of dirt on the insulators. This, and other items of a radio installation, which may be feeling the effects of time and corrosion, are covered in this article. It tells you which to look for when distant reception begins to fall off.

WHY doesn't a set always continue to give very good results? Why does it so often happen that after a set has been installed for about a year or so, the distant stations begin to get weaker and sometimes vanish altogether?

IS IT THE BATTERY?

It can't be put down to mechanical wear, the moving parts of a set are so few and consist of merely one or two condenser and potentiometer spindles and such-like. And, anyhow, there never seems to be the least little thing wrong with these when results have fallen off.

Of course, it could be the H.T. battery, but, then, this is one of the first things that gets suspected. And it must not be forgotten that mains sets are just as liable to exhibit this deterioration of distance-getting powers.

So, having decided that results are not so good as a few months or a year ago, and that it is not due to temporary poor conditions, what does one look for? I'll make a few suggestions.

WHAT A LIFE!

The fundamental item to remember is that time has an effect on radio as on all other things, and that radio receivers are not exempted from the ravages of dirt and corrosion. And that last word, "corrosion," will give the clue to the majority of troubles that crop up only after a considerable period of use.

Being such an obvious thing to suspect, we won't say any more about the high-tension battery, assuming one is used. But there is the grid-bias battery.

I know that a normal amplifier should not take current from the grid battery and that its life is really its shelf-life—but shelf-life does not go on for ever. And if G.B. batteries, like old soldiers, never die, they certainly fade away. And they are not above playing the old soldier, either!

VICIOUS HANDIWORK

The trouble is that shelf-life starts as soon as the battery is put into its cardboard case, and it may easily be largely spent on the dealer's shelf.

TWO CAUSES OF POOR RECEPTION

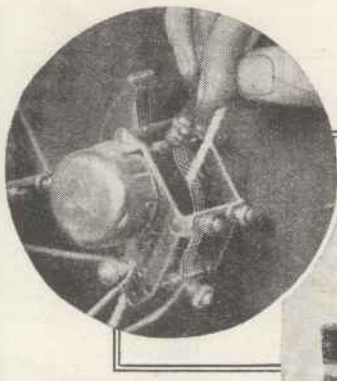

Keep all components free from dust, and battery connections free from corrosion, if you want to get real punch on foreigners.

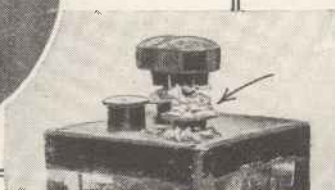

That is why you should always go to a fairly large stores for dry batteries, for stocks are then sure to be frequently changing.

Well, that's enough about G.B. What about L.T.? Here you will meet what is probably the most vicious handiwork of corrosion. Unless L.T. terminals are continually being cleaned and greased, they will manage to corrode—and corrosion means poor contact, and poor contact produces voltage drop and valves that are working below par.

A terminal does not have to be

half eaten away before trouble begins. Even a lead-coated terminal can get a hard coat of "sulphate" over it. I had a case once in which such a coating was so bad that the spade-tag was not making contact at all, and yet there was none of that green, messy stuff round the terminal.

DRASTIC MEASURES

Voltage drop due to corrosion may also take place in the H.T. circuit, so that all H.T. plugs need watching. As a matter of fact, every contact of this type, including valve pins, coil plugs, terminals, and so on, all require cleaning after a spell of "being forgotten."

And, going a step further, if the set's trouble is difficult to spot, all

soldered joints come under suspicion. If a joint will not stand rough banging and pulling with pliers, it will come apart, and that will be as well, for it will have to be re-soldered, and may have been a dry joint.

As a popular resort for corrosion, the earth probably comes

next to the L.T. terminals. The buried plate may no longer be attached to the earth lead (try pulling the wire hard), or the clip may be clamped round an oxidised surface on the water pipe.

GOING UP

Going a bit higher, if there's a joint in the aerial wire or lead-in, you may be losing a lot of stations there. And then there are the insulators, which brings us to the dirt that collects with time.

A. S. C.

MY BROADCASTING DIARY



Keeping a critical eye on the affairs of the B.B.C., Our Special Correspondent comments frankly and impartially for the benefit of listeners on the policies and personalities controlling British broadcasting.

"Free Trade in Music"

BEFORE Dr. Adrian Boult left Broadcasting House to go on his honeymoon he had the satisfaction of knowing that his music policy had been vindicated. For some weeks he had been defending it against repeated attacks, and now that he has triumphed, only those who are aware of what has been going on behind the scenes can appreciate the full extent of his victory.

Advisory Committee, Director-General, Governors—all express their approval of his work for the musical arts and heartily endorse his methods.

His policy may be summarised as "Free Trade in Music," for he believes that only by direct competition and example can British musical achievements maintain and, if possible, improve upon their present high standards. Thus (once and for all, it is to be hoped) the B.B.C. have laid it down that the world's best talent shall be made available to British listeners. It is recognised as only fair that British musicians shall, wherever possible, be granted priority, but this must not bar the foreign genius. Quality is to be the paramount consideration.

Sir John Reith

Those recurring rumours of Sir John Reith's impending resignation are rampant again just now. Recent staff changes at headquarters have all been designed to place the B.B.C. on a more smooth-running and permanent basis with the Director-General receding into the background. This alone encourages the belief that the day is not far distant when the "D.G." will leave the B.B.C.

Sir John has received some tempting offers, but the realm of commerce holds little attraction for him. There are those at Broadcasting House who say that nothing short of an ambassadorship—preferably Washington—would persuade him to leave the B.B.C.

Broadcasts from Olympia

Plans are now practically complete for the broadcasts that are to take place from the huge temporary studio at Olympia during the National Radio Exhibition. At

each performance about 1,500 of the public will be able to be seated in the studio so as to discover exactly what it is like behind the scenes at Broadcasting House. Even some of the announcers may show themselves.

John Watt, fresh from a long holiday on the Continent, is now busying himself with the variety programmes that are to be put over at Olympia; while John Sharman is arranging to drag back artistes from their holidays and from seaside concert parties so that they can appear in the Radiolympia revues.

The first night of the Exhibition (August 15th) will be marked by a revue programme at which visitors to the show will be able to form the biggest studio audience ever. This will be broadcast Nationally, as will Olympia variety on August 18th and 19th. There will then be another revue on August 22nd and more variety on August 24th.

This Year's Proms

The "Proms" will enter their thirty-ninth season, the seventh under the auspices of the B.B.C., on Saturday, August 12th. Sir Henry Wood, happily recovered from his

HEARD ON BERLIN'S WAVELENGTH



Military band music is very popular in Germany, and outside broadcasts from the various parks are not uncommon. Much of the military music heard from the Berlin stations is furnished by the Kröll-Garten band seen above.

Sir Henry Wood to Conduct Promenade Concerts

recent illness, will, of course, conduct throughout the season. The B.B.C. Symphony Orchestra, now returned from holiday, has been weeded out to a strength of ninety players, and is busily rehearsing.

The evenings during this year's "Proms" will be devoted as follows: Mondays will be given to works of Wagner, Wednesdays to Bach and Brahms, Fridays to Beethoven, Tuesdays and Thursdays will be mixed composers' nights, when many new works will be performed, in some cases with the composer conducting. Saturday, according to precedent, will be "popular night," There will be, of course, the usual distinguished list of soloists.

Forthcoming Gramophone Recitals

Continuing their policy of providing listeners with gramophone recitals of music which could not ordinarily be heard during the early afternoon, arrangements are being made by the B.B.C. for a number of recitals this month. Next Saturday, for instance, the gramophone recital will consist entirely of music by Gertrude Lawrence. On the following Saturday, August 12th, there will be a gramophone recital by Cortot, the pianist. On the 19th the gramophone recital consists of songs by Richard Tauber (tenor) and Marlene Dietrich (contralto).

There will be additional gramophone music—of dance records—at 10.20 p.m. on both August 14th and 17th. This, however, does not mean a change in the hitherto

KNOWN TO EVERY LISTENER



Mr. Christopher Stone, whose gramophone broadcasts have made his name familiar to every listener trying out a new record at his Sussex home. The large exponential horn shows that Mr. Stone believes in doing full justice to the bass notes.

accepted policy of late dance music by dance orchestras in the flesh, because immediately after the gramophone numbers listeners will as usual be taken over to one of the restaurants or night clubs for dance music until midnight.

"Songs from Dickens' Novels"

Fifty songs that Dickens mentioned in his works are to be broadcast in a new series which begins at 8 p.m. on Friday, August 4th, under the title of "Songs from Dickens' Novels." Harold Scott had the idea of wading through Dickens and digging out the names of these songs.

PRAGUE'S NEW HEAD-QUARTERS

Severely practical lines characterise this new Czechoslovakian "Broadcasting House," the completion of which coincides with the tenth anniversary of the Prague station. The building also forms the headquarters of the country's postal and telegraph systems.



most of which will be of the early or mid-Victorian period, reminiscent of the old drawing-room musical evenings.

Cyril Scott at the Piano

Cyril Scott "fans" must make a point of tuning-in to the National at 7.30 p.m. on August 9th, when this favourite composer will be at the piano playing some of his own works. During the recital Gertrude Johnson will sing some of Cyril Scott's songs.

Camp-Fire Relay

The microphone is being taken to one of the numerous Sussex Boys' Camps on August 11th, and again on the 15th, to relay an open air around-the-camp-fire sing-song.

Sir Landon Ronald

Everyone who knows how much Sir Landon Ronald has done for music in this country—and in particular broadcast music—will be delighted to hear that there is no question of his resigning from the B.B.C. Music Advisory Committee. Sir Landon regards his work on the Committee as of great importance, and is one of the few famous musicians in this country who can claim to have foreseen from the beginning what a profound effect the B.B.C. would have upon the musical arts.

The Tidworth Tattoo

Another Tattoo, the Tidworth, is to make a long outside broadcast during Saturday evening, August 5th. The broadcast opens with trumpet marches by trumpeters of the 2nd Cavalry Brigade, followed by guard mounting with massed drums and fifes by the Loyals, and St. George and the Dragon by the Royal Army Ordnance Corps. After an interval there will be a further relay from Tidworth consisting entirely of massed bands.



NINE years ago my friend, Philip Fox, was appointed B.B.C. Director at Leeds. I remember with what excitement we viewed the first studio in Basinghall Street, a coffin of a room swathed in curtains. That, as Chief Engineer Noel Ashbridge told a gathering of Pressmen in Leeds recently, was an era of "half-baked semi-scientific ideas in studio design," and nothing could display more effectively the advance to knowledgable technique than the magnificent Yorkshire Broadcasting House which has now taken the place of the old premises.

Astonishing Transformation

"The most modern broadcasting studios in this country—at the moment," was the proud description by Fox, who has by now become a B.B.C. institution in Yorkshire.

All the experience earned in building London's Broadcasting House has been invested in making this provincial centre a representative example of modern studio design.

The B.B.C. has taken an old Quaker Meeting House, practically gutted it, and built into it a suite of studios, offices, and control rooms—about as astonishing a transformation, from the quiet drabness of the worshipping place to the elegant

modernity of the Temple of Sound, as you could find.

In J. C. Proctor, a local architect, they have discovered an admirable exponent of modern decorative ideas.

The premises are a delight to the eye. Mr. Proctor well deserves the contract to design new studios at Bristol, which he tells me he has received.

There are two studios, and herein

At Leeds the B.B.C. have taken an old Quaker Meeting House and adapted it to be a modern Temple of Sound. In it they have incorporated many of the ideas and acoustic experiences gained in the building of Broadcasting House, London, and the result is interestingly described in this article

By Our Northern Correspondent

lies the one flaw in the Leeds enterprise.

Why the B.B.C. did not provide for a drama studio I cannot understand. The large orchestral studio is too "brilliant" for normal speech; the talks studio is too small for plays and, moreover, contains gramophone turntables often needed for effects.

I learn that an artistes' waiting-room is to be wired for a microphone and will be used for drama, but this

is an afterthought—at present the play producer at Leeds is having to adopt all kinds of artifices, such as herding the players into the announcer's cabinet in a corner of the big studio.

An Engineering Achievement

For concert purposes this studio is first class. It was the old Meeting Hall, and had galleries on three sides, supported by unlovely cast-iron pillars. Two of the galleries have been demolished.

Their pillars also supported the roof, so the B.B.C.'s Civil Engineer, Mr. M. T. Tudsbery, had to bring in a mammoth steel girder, to run the full length of the building. The third gallery has been re-stepped to seat 70 people and its pillars cased with fibrous plaster (filled with pumiced concrete to avoid any "hollow" sound), so that now they form two massive black columns and lend great dignity to the studio.

Colourful Decorations

Grey and biscuit walls, relieved with black and with chromium plating, and gay yellow furniture complete the decorative scheme, and an orange glow thrown upwards to the ceiling from six hanging lights gives the studio a cosy atmosphere despite

How the Walls were Prevented from "Drumming"

its size—50 ft. long, 37 ft. wide, and 27 ft. high.

Most of the wall space is covered with sound-absorbent composition board, and Mr. Ashbridge told me that the secure fixture of this to the walls is most important, for the smallest space behind the board causes "drumming" noises. Many adhesives have been tried; at Leeds pitch was used.

A novelty is the microphone suspension in the big studio. Proctor has designed a steel frame which hangs from a turntable concealed in the ceiling, so that the microphone can move anywhere within a 32-ft. circle; the chromium-plated arm to which the microphone is appended is provided with Ferodo-lined friction joints so that the microphone's movements are universal between 4 ft. 6 ins. from the floor, and 12 ft. high, anywhere within the circle.

Automatic Ventilation

The skirting boards are removable; behind them cables are run to the control room. This is at the front of the building, where three stories are divided into various purposes.

In the basement there's an echo-room, battery-charging machines, heating and ventilating apparatus. Air in the studios is completely exhausted five times every hour by an electric fan dealing with 5,580 cubic ft. per minute. On the ground floor a tasteful entrance hall is flanked by offices for the Leeds staff, a band room, and the waiting-room which is to be a part-time drama studio.

Upstairs the engineers have taken most of the space, for Leeds is an important junction in the B.B.C.'s landline network.

Dealing with O.B.

The move from Basinghall Street has provided an opportunity to renew entirely all the S.B. switchboards and amplifiers. The Leeds control-room is now a replica in miniature of the main control room in London.

Through it pass all programmes relayed between London on the one hand and the Northern, Scottish and Belfast transmitters on the other. Here the quality is checked, the volume raised in amplifiers; here the lines are "squeaked" daily to test their frequency response; to this room are brought the special lines rented for any Yorkshire O.B.—a service from York Minster, perhaps,

or an orchestra at Scarborough Spa; and here, of course, programmes in the Leeds studios are controlled.

Testing Quality

Adjoining, there is a quality testing-room, furnished with a moving-coil loudspeaker in one of those specially-padded B.B.C. cabinets. The same room does duty as dramatic control-

beration time of 1.2 seconds, the other only .3 second.

The decoration here is, again, what might be called "safe modernism"—the simple line and colour of modern decoration allied sanely to the practical functions of broadcasting.

Where Quakers sat in silent meditation, or leaned forward to attend to one of their number speaking from

DESIGNED ESPECIALLY FOR TALKS



Talks are a very popular feature in the North, and this studio is especially designed for the purpose. The modern furniture and plain lines give it a very attractive air.

room, with a six-channel control panel for the producer to exercise his multi-studio fancies.

The talks studio, also on this floor, is a small room, 13 ft. square, charmingly decorated and lighted. It is interesting to note how different the acoustic treatment is here, compared with the big studio. One has a rever-

beration time of 1.2 seconds, the other only .3 second. The decoration here is, again, what might be called "safe modernism"—the simple line and colour of modern decoration allied sanely to the practical functions of broadcasting. Where Quakers sat in silent meditation, or leaned forward to attend to one of their number speaking from

TUNING by SHADOWS



MANY modern super-selective receivers incorporate a device whereby it is possible to see when the set is exactly in tune with the incoming signal. This is often a great advantage as it enables the operator to be perfectly sure that the reproduction is not being marred by side-band losses, and hence allows him to enjoy a programme without having to make several readjustments to the tuning controls.

In sets which have a "post-detector" volume control, there is the additional advantage of being able to tune-in with the volume control at zero; this prevents the audible reception of "mush" and heterodyne whistles which is so disturbing to the more sensitive members of the household.

The Valve-Voltmeter

The method of obtaining this visible indication is an adaptation of the "valve-voltmeter"; although the type of "tuning picture" presented varies considerably with different makes of receivers, the "V.V." principle, plus a little ingenuity, is always responsible for it.

The "valve-voltmeter" circuit will be familiar to most amateurs, but a

"ANODE-BEND" CURVE

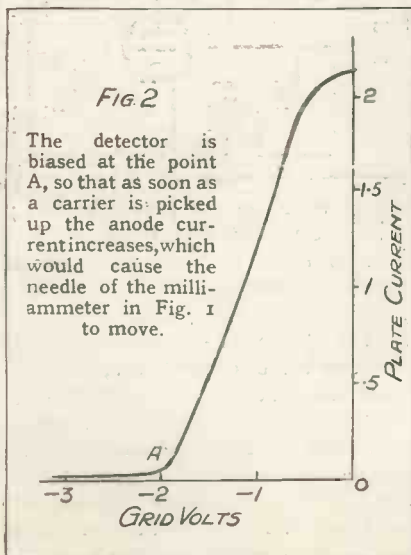

For accurate tuning an aural indication is far inferior to a "visual" dial reading, such as is afforded by a shadow falling across an illuminated scale. Some easily-applied and very interesting suggestions along these lines are given by our contributor,
J. AUSTIN.

brief description of it may prove a useful refresher to the memory.

If a milliammeter is connected in the plate circuit of a valve, as in Fig. 1, it will show us the current flowing through this circuit; this current is

THE BASIC CIRCUIT

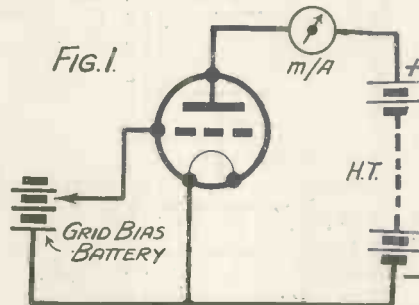

All visual tuning indicators are based on this simple valve-voltmeter circuit, though it is sometimes not easy to trace the connection.

the emission of the valve and can, of course, be controlled by the application of a voltage to the grid.

Suppose we apply such a negative grid voltage that the plate current is reduced to zero; then any further negative grid volts cannot produce a deflection of the metre needle; whereas any positive volts will start the plate current flowing once more and so give us a deflection.

This will be quite clear if reference is made to the characteristic curve shown in Fig. 2.

Anode Current Indicator

The application of -2 volts to the grid brings us to the point A on the curve, and it is quite obvious that at this point virtually no plate current is flowing. More negative volts will take us farther to the left of A and,

as the curve is flat, the current remains at zero.

Positive volts, however, move us to the right of A, and here the curve climbs steeply, indicating a steady increase of plate current for positive volts.

In this condition the valve can be used as an A.C. voltmeter; but, for our purposes, it is necessary to connect it up as a detector in a receiver.

The circuit will be something like that shown in Fig. 3. The signal voltage generated across the aerial tuning coil (which is drawn in lightly in the diagram), and amplified by the H.F. valve, will be applied to the grid of our biased detector.

Well-Known Principle

The signal voltage is rapidly alternating from positive to negative and, as we have seen, the negative impulses will produce no plate current, while positive impulses will cause current to flow.

The valve is therefore rectifying the signal voltages—i.e. producing a direct current for an alternating

SELECTIVE LIGHTING



An interesting application of lighting to tuning dials is instanced in the H.M.V. Superhet Ten Autoradiogram, the controls of which are seen above. The special selective lighting system only illuminates the scale that is actually in use.

"Room for Many More Ingenious Ideas"

voltage. It is, in fact, the well-known anode-bend detector.

Simplest Method

We are concerned, however, with the milliammeter, and from the foregoing it is quite clear that when no signal is being applied to the grid there will be no reading on the meter; when a signal comes along, the

Consequently, the milliammeter will give its maximum reading when we are "dead" on tune, and will fall back towards zero when the tuning condenser is rotated in either direction away from this position.

By this method, then, we can actually see when the set is exactly on the wavelength of the transmitting station.

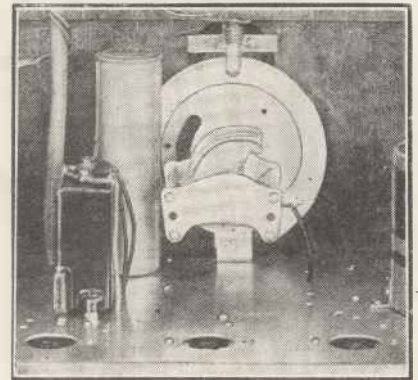

Illuminated scales are very popular, and it would not be difficult to make the visual-tuning light also serve for dial illumination.

The range of the meter should be in the neighbourhood of 0-3 milliamps., and should preferably be of the moving-coil variety.

Improved Scheme

The meter can be neatly mounted on the front panel, and, even if the selectivity of your set is not so great that it is imperative to tune to the exact position, you will find it a very interesting and informative addition to your receiver; since its readings will be proportional to the incoming signals, you will be able to measure, quite accurately, the relative strengths of the stations you pick up.

Set manufacturers have modified this system to such an extent that, in some cases, it is difficult to connect the "eye-tuner" fitted to their re-

THE STRONGER THE STATION THE WEAKER THE SHADOW

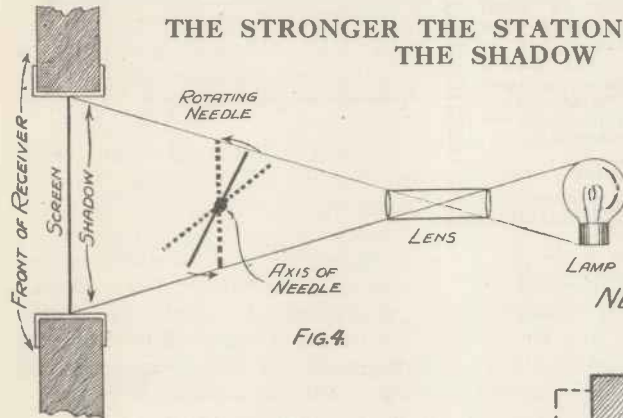

The amount of light falling on the screen from the lens is governed by the position of the flat needle, which rotates according to the strength of the received station.

FIG. 4

positive impulses cause a current to flow, and a deflection of the needle, proportional to the value of the current, results.

Now the plate current, so measured, is proportional to the signal volts on the grid (reference to the curve in Fig. 2 will show this clearly; as we alter the grid volts we get a corresponding change in plate current); therefore the deflection of the milliammeter needle will also give an indication of the value of the grid volts, or, in other words, the strength of the signal we are receiving.

WHERE IT SCORES

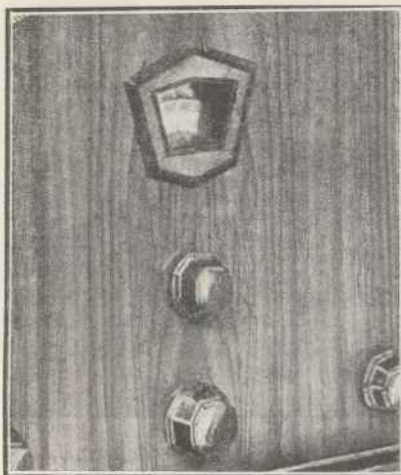

Visual tuning scores over the ordinary method in that it is easier to tell by vision when a station is tuned into its maximum.

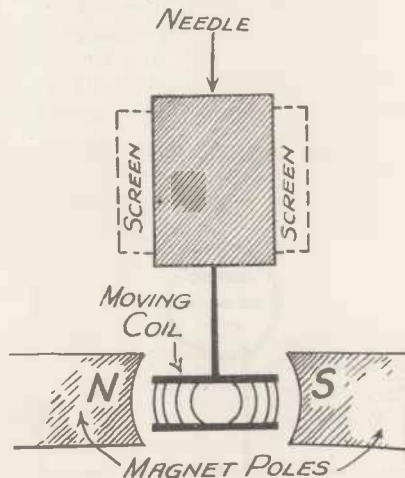

FIG. 5

Above, in Fig. 5, the arrangement of the flat needle and its screen in relation to the meter's armature is illustrated. To the right is the type of circuit which would be used to operate the needle. The two valves would, of course, form part of the receiver.

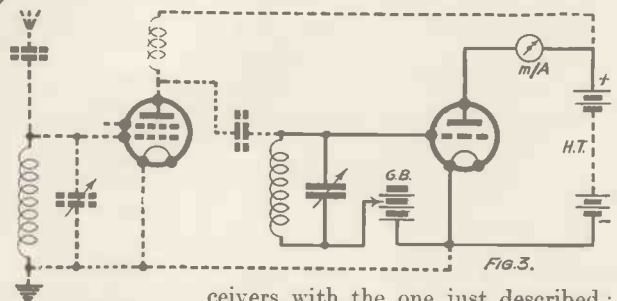

FIG. 3.

This is the simplest arrangement for "eye-tuning." If your set already incorporates an anode-bend detector it is an easy matter to insert a milliammeter in the plate circuit; you will probably find, however, that a small reading is obtained at all times; but, as most meters have a device for adjusting the "zero reading" (usually a small screw at the base of the needle), this residual current can be compensated and the meter made to register zero.

ceivers with the one just described; and in the matter of modifications, there is still room for many more ingenious ideas.

One clever arrangement is known as the "shadow-tuner." In this case the valve current is still made to actuate a meter needle; the needle, however, instead of showing a reading on a scale, is mounted on the same axis as the moving coil of the meter. The needle, therefore, instead of describing an arc, rotates through

(Continued on page 168.)



QUESTIONS ANSWERED

Parallel-Fed Transformers

S. L. C. (Caterham).—“Why do transformers with special alloy cores have to be parallel-fed? Is it an advantage to adopt this procedure with all transformers or only in those cases recommended by the makers themselves?”

The high-permeability core which has enabled manufacturers to produce instruments of good quality, adequate primary inductance, and small physical dimensions at an extremely reasonable price has a natural dislike to steady currents such as flow in the anode circuit of a valve.

The effect of this current, when it passes through the primary winding, is greater than a certain limiting value, is such that it reduces the effective inductance of the winding. The safe current value depends upon the design of the transformer, but the majority of the small commercial instruments are deliberately designed for parallel-feeding.

Isolating the primary winding from the steady anode current ensures a good frequency response, and has the further advantage that the windings may be connected to form an auto-transformer, so giving a choice of ratios.

There is little or no advantage in adopting the parallel-feed scheme with transformers designed for direct feed, since in these cases the inductance loss is almost negligible within the limits of normal working.

The best policy is to purchase a well-known make and follow the maker's instructions.

Poor Quality

H. N. (Folkestone).—“I have built a superhet, and although it is both sensitive and selective, thus fulfilling two of my chief requirements, I am disappointed with the

reproduction. I expected some loss of high notes and used a pentode with a suitable tone compensator to counteract this. But the quality is definitely “hissy,” as if the set is not stable, yet I will guarantee that the intermediate and preliminary S.G. stages are well below the oscillation point.”

Two possibilities are—overloading the second detector (this is liable to

TECHNICAL QUERIES DEPARTMENT

Are You in Trouble With Your Set?

The MODERN WIRELESS Technical Queries Department is in a position to give an unrivalled service. The aim of the department is to furnish really helpful advice in connection with any radio problem, theoretical or practical. Full details, including the revised scale of charges, can be obtained direct from the Technical Queries Department, MODERN WIRELESS, Fleetway House, Farringdon Street, London, E.C.4. A postcard will do. On receipt of this all the necessary literature will be sent to you, free and post free, immediately. This application will place you under no obligation whatever. Every reader of MODERN WIRELESS should have these details by him. An application form is included which will enable you to ask your questions so that we can deal with them expeditiously and with the minimum of delay. Having this form you will know exactly what information we require to have before us in order to solve your problem. London Readers, Please Note: Inquiries should not be made in person or by 'phone to Fleetway House or Tallis House.

happen on a powerful transmission) and H.F. leaking through into the L.F. side.

The use of a filter circuit consisting of a superhet H.F. choke or two good chokes in series in the anode circuit of the second detector, together with a fixed condenser connected between the anode and earth, is often a great help. A fixed condenser of the order of .001 mfd. or even more is sometimes necessary. Another scheme is to insert a .25-meg. resistance in the grid circuit of the L.F. or output valve.

Of course, you must also make quite sure that the output valve is not being overloaded.

Outdoor or Indoor?

A. C. (Honiton).—“I am rather puzzled about the question of aerial efficiency. Is there much difference between the results obtainable with an outdoor or an indoor aerial?”

To a large extent the answer to this question depends upon the type of set connected to the aerial. Generally speaking, a good outdoor aerial is definitely more efficient than a good indoor aerial. On the other hand, some indoor aerials give better results than the outdoor variety—but only because the latter are bad ones.

In addition, if the set is very sensitive the gain in efficiency due to the use of a good outdoor aerial may not be noticeable simply because the receiver brings in everything worth listening to at adequate volume on the indoor aerial.

In fact, in certain cases the better aerial may merely produce an increase in background noises. When the set is of moderate size it nearly always pays to erect the best possible aerial from the point of view of distant reception, except when trouble is caused by interference from a powerful local station.

It all depends upon the set and conditions, but in most cases the good outdoor aerial scores every time. While on the subject of aerials it may be as well to mention that most all-electric receivers are provided with a plug which can be inserted into either the mains or ordinary aerial sockets as desired; while the pick-up properties of a mains aerial do not compare with a good outdoor type, it possesses the advantage of making the set a true transportable.

WHEN TIME COUNTS IN RADIO

By C. PATERSON

This really enjoyable article raises some very unusual aspects of radio theory and practice. By means of familiar examples it makes a difficult subject seem perfectly clear and remarkably interesting.

WHEN the listener commences to study seriously the technical aspects of radio, one of the first facts which he learns is that radio waves travel at a speed of 186,000 miles per second. To the mind unaccustomed to deal with very large or very small quantities, 186,000 miles per second is near enough to instantaneous, and it is not surprising, therefore, that listeners are apt to imagine that the time factor plays but an insignificant part, if any, in radio technics.

This is far from the truth, however, for radio is indeed an exact science; all its phenomena are governed by exact laws, and all its reactions are capable of exact measurement.

A Simple Example

To take a familiar and simple example of the importance of the time element in radio, let us consider the operation of tuning. Each broadcasting station radiates its programme on a wave of a certain frequency, which may be some hundreds of thousands or even some millions of cycles per second.

POSITIVE AND NEGATIVE

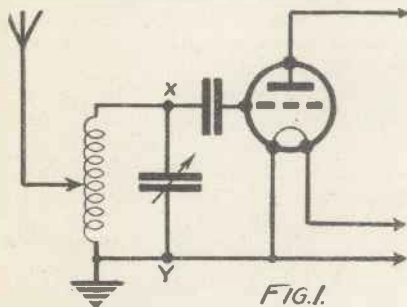

The points X and Y are subjected to varying pressures due to the impulses collected by the aerial.

Thus, the impulses radiated from a station operating on a wavelength of 300 metres follow each other at intervals of one millionth of a second. In tuning a receiver, therefore, it is necessary so to adjust one or more oscillating circuits that they respond accurately to impulses occurring every one millionth of a second.

What is more, if the circuit is to be

sufficiently selective to prevent the programme from one station being interfered with by that of its next-door neighbour on the wavelength scale, the tuning must be so accurate that while waves arriving at intervals of 0.000001 of a second are accepted and amplified, those arriving at intervals of 0.000001009 of a second are completely or almost completely rejected—or rather absorbed.

Minute Periods

Having in mind the extremely minute periods with which we have to deal, and the comparative crudity of even the best radio apparatus, it is really a matter for wonder that the standard of efficiency and selectivity achieved in radio sets with three or more ganged circuits is so high.

The above, of course, is a very elementary example, but as we go deeper into radio technics, we find that the time element assumes greater and ever greater importance.

An interesting case is presented by the familiar leaky-grid system of detection. There are a good many ways in which the operation of the leaky grid detector can be explained, but the following, although not the most simple, illustrates how the time element enters into the problem, and also throws some light on the importance of correct condenser and grid-leak values.

No Grid Leak

In Fig. 1 is indicated a detector valve with the usual tuned-grid circuit, the grid coupling condenser also being shown, but the grid leak is for the moment omitted. A radio-frequency voltage developed by the incoming signal in the tuned circuit exists between the points X and Y. During the positive half-cycle of any one wave, the grid coupling condenser will be charged, the grid itself becoming positive.

The effect of this is to decrease the effective impedance of the region between the filament and grid, and hence the impedance of the whole valve. During the first half of the positive half-cycle, therefore, decreasing valve

impedance results in increasing anode current. During the second half of the positive half-cycle, however, the positive charge decreases and the anode current will decrease in sympathy.

The Other Half-Cycle

Now consider what would be expected to happen during the negative half-cycle of the incoming signal. Owing to the high impedance of the grid-filament path of the valve, the condenser cannot be charged negatively. On the face of it, this would mean that the valve would give perfect rectification. But—and here is the snag—this is not the true state of affairs, for the discharge of the condenser during the last half of the positive half-cycle is not a simple dissipation of the charge.

The discharge is oscillating—as it dies away to zero it overshoots the mark, partly charging the condenser in the opposite direction. This charge dies away, too, but again overshoots

HOW THE DETECTOR WORKS

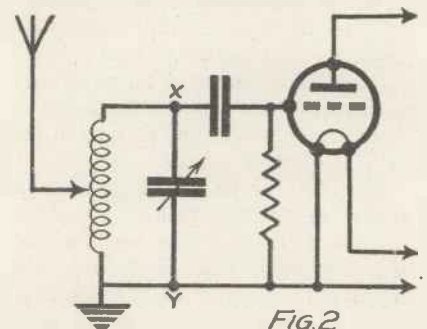

The typical detector circuit, the action of which is discussed by our contributor on this page.

the mark, charging the condenser to a still smaller degree in the original direction. This oscillation gradually dies down, but actually leaves the condenser with a slight negative charge, because the grid-filament path is of almost infinite impedance.

Familiar Trouble

So, if the circuit were operated as shown in Fig. 1, each successive wave would leave the condenser with a greater negative charge which would ultimately neutralise the positive half cycle of the incoming wave and no signals could get through. This is the familiar trouble of a "choked grid" which is experienced if an open circuit exists in the grid leak.

In Fig. 2 is shown the complete detector circuit with a high-resistance (the grid leak) connection from the grid to the filament circuit. Through

(Continued on page 167)

SPOTLIGHTS

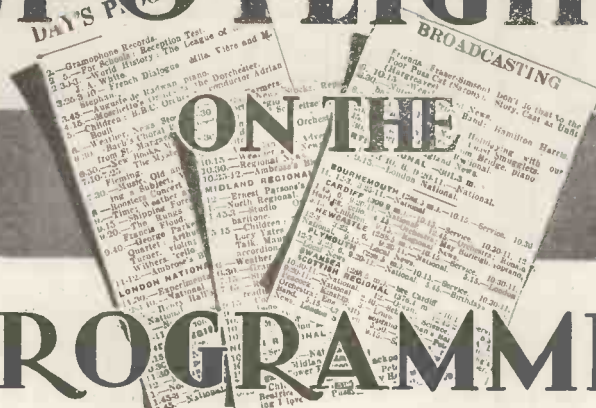
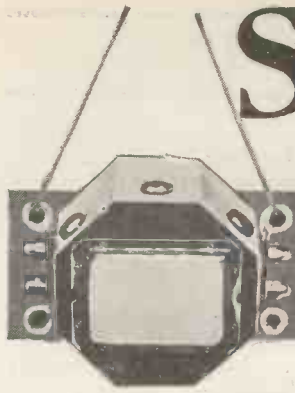

ON THE PROGRAMMES

"Dumb Drove of Oxen!"

RING LARDNER, radio critic for America's leading humorous weekly, seems to rate the ordinary listener as a pretty poor mutt—and the members of the studio audiences even lower!

"That a troupe can perform sixty minutes once a week," he says, "and hold the interest of even as dumb a drove of oxen as the great invisible audience (and the dumber drove that frequents the National Broadcasting Company's studio) is, I claim, proof of good showmanship."

Maybe he's right. Anyhow, the B.B.C. has now decided that the studio audiences at Broadcasting House need a bit of production, and the genius of the "effects" department has been transferred, most appropriately, for the purpose.

Certainly it was time something was done about it. Whether production in laughter and applause is better than total abolition remains to be seen. The first excursion into this new realm

of entertainment was definitely a success. Just in case you noticed it and wondered what was happening, it was the background to that amusing show "Cabaret."

Incidentally, this repeat performance of the vaudeville-cum-mystery show has proved the most successful light production of the month.

Here is Fame

To my colleague Garry Allighan goes the palm, biscuit, medal or what-not for having his remarks immortalised in the pages of *Punch*.

In reply to Garry Allighan's opinion that men were better broadcasters than women—"their voices have a rich clinging quality, more warmth of tone and more S.A."—*Punch* provided an apt little poem concluding:

"Heed not the sneers of misanthropic boobies
Who heap foul scorn upon the race of man;
Your price is far above the price of rubies—
You have been praised by Garry Allighan!"

Reviving Pleasant Memories

It has always surprised me that more radio plays are not published in book form. It would seem to be fairly obvious that plays intended only for the ears must—if we leave out "effects" and things—make good reading.

However, the lack of published radio drama makes it all the more exciting when a new book does come along.

Louis Goodrich—who is our radio personality of this month—was responsible for perhaps the most universally popular of all the radio plays, *Ann and Harold*, and George Allen and Unwin have just published the several episodes in the lives of this charming couple in one volume at 4s. 6d.

I know that there are many listeners who considered this the best of all the radio plays, and I advise them to get hold of the book, for it presents the play as it was originally intended to be produced—in twelve short episodes.



RIVER SPORT

"Surely such events as the final of the Thames Cup or the Grand at Henley are as suitable subjects for running commentaries as quarter-final matches at Wimbledon."

These pictures, taken at Henley last month, show one of the finals in progress, and part of the huge crowd which lined the booms.

Played Three Times in Ten Minutes!

Louis Goodrich maintains that a radio play of eighteen minutes is most suitable for broadcasting, and he arranged his own *Ann and Harold* accordingly. The B.B.C. thought otherwise—but despite the success of the play as produced, it would have been an interesting experiment in its original state.

Louis Goodrich dedicates the play "without permission to that dear Ann for whom it was written, to the actresses and actors who so kindly helped . . . and to Howard Rose," a tribute to the B.B.C. productions department which is highly deserved.

Radio Stars on Tour

The popularity of radio stars has never been in question since the first radio concert party appeared at certain London and provincial theatres. Listeners in their thousands seized the opportunity of seeing in person those artistes who had previously existed only as voices, and their enthusiasm must have been as gratifying to the stars themselves as it was to the theatre managers who had been led to believe that radio was killing the variety theatres.

again by a trio at about the same time, and lastly by Jack Payne at 8.2.

If this isn't song plugging, then it is pretty bad stage management!

This Sporting Controversy

My post-bag last month consisted almost entirely of letters from listeners who did or did not want (a) Tennis, (b) Cricket, (c) Racing, and (d) Rowing given a prominent place in the news.

It seems to be that the B.B.C.'s policy of commentaries should be "all or nothing."

Wimbledon and certain important

In the Programmes

LOUIS GOODRICH

Louis Goodrich, author of "Ann and Harold," and a regular actor for the microphone, is one of the most interesting of B.B.C. personalities.

Originally intended for the Army—he was born in the Royal Military College at Sandhurst—he has been farm hand, land surveyor and tea planter in all the most romantic story-book lands; officer in the Artists' Rifles from 1914 to 1919; playwright, actor and film artiste.

His work includes half a dozen or so one-act plays, several radio dramas, and numerous films—and he still finds time for golf and fly-fishing!

With visions of man-eating tigers, dawn attacks and fever-stricken swamps, we asked Louis Goodrich to tell us one of his most interesting experiences. This is what he wrote:

"London would be a dull place to a resident if it were not for certain quaint happenings. A few nights ago I had dined at a house in London's largest square, a neighbourhood utterly unknown to me, and was proceeding swiftly,



as is my healthy wont, in the direction where I imagined a taxi might be found.

I had gone some distance, listening to a summer gale rasping the leaves in the trees, when a door opened just ahead and an old lady stood framed in the light with a lace shawl over her head.

'Are you going as far as the pillar box?' she asked.

'Yes. Can I do anything for you?'

'Would you kindly post these letters for me?'

'With pleasure.'

She came close to me. Gave me the letters. Thanked me. Then suddenly put a frail hand on my arm.

'Are you better?' she inquired, solicitously.

'Much better, thank you,' as that seemed to be the expected reply.

'I'm so glad.' She patted my arm.

'So glad.' She turned and left me.

'So glad! So very glad!' She closed the door.

I posted the letters."

That is Louis Goodrich. In spite of his many adventures, he still retains his youthful illusions.

The Sally Complex

Have you noticed how our old friend Sally has been creeping into the variety programmes of late? This unfortunate young lady (and she can't be so young, either, after all this time) seems condemned to live in, leave or return to the alley until the end of time.

If all our lyric writers must write about Sally, they might at least be original, and allow her to make her home in a valley, dance in a ballet, or even—for North Country listeners—play in the Hallé!

I notice that the "Radio Times" has reprinted the ghastly "hacher-nacher" rhyme which I noticed here two months ago. I only hope that this may lead to something drastic being done at least about the worst of the dance tune words.

The latest news on the radio-theatre front comes to me from Philip Ridgeway, who is touring his famous "Ridgeway Parade" through the Provinces this summer. Packed houses at every performance show that Philip's reputation in the studio is standing him in good stead "on the boards."

Song Plugging or—

It is not very long before the new Controller of Output takes over his duties and I hope that one of his first jobs will be to supervise the construction of each day's broadcasting.

In a recent evening at Broadcasting House the same dance number was played no less than three times in five minutes on the two alternative wavelengths—once in a variety show at 7.57,

golf matches are picked out for running commentaries during the summer, while such events as the Henley Regatta are left more or less in the cold.

There are just as many people interested in international rowing as there are in international golf, although they are possibly not the same people. And surely events such as the final of the Thames Cup or the Grand at Henley—events in which England beats Germany or America beats England by the narrowest of margins—are as suitable subjects for running commentaries, or at least eye-witness accounts, as quarter-final matches at Wimbledon.

I am *not* a rowing man—and I *do* play tennis, so my comments are quite unbiased!

PATRICK CAMPBELL



ONCE upon a time the composers who were not employed by royalty lived and died in garrets. This, of course, was considerably before the broadcasting era. Nowadays, there's not so much musical neglect. Composers have every opportunity of fattening up—and the B.B.C. is to blame (or to praise!).

When the public have to be supplied with music for at least six hours a day, it stands to reason that talent in composition must be encouraged—if the flow of harmony is not to run dry.

Selecting Manuscripts

So the broadcasting authorities have set to work on the same lines as the Royal Academy of Art. Just as all hopeful artists submit their canvases to the Selection Committee, so the B.B.C. receive musical manuscripts from composers.

Naturally, the selection of budding genius is no light task. The commendable policy of Dr. Adrian Boult, Musical Director of the B.B.C., is to give

every inducement to British composers, both well known and inexperienced, to offer work for broadcasting and to give little or no encouragement to foreign writers of music. Hence, in the series of Queen's Hall concerts, of twenty-one works by

No one will deny that the B.B.C. is doing excellent work in helping British composers. What do the composers themselves think about it all? Here you will find representative opinions gathered from leading musicians

BY OUR SPECIAL
CORRESPONDENT

living composers, fourteen were "home-grown." Buying British with a vengeance!

Every manuscript submitted to the committee—on which Sir Landon Ronald, Sir Walford Davies, Sir Hugh Allen and several others figure—is

read by three members, each of whom is unacquainted with the reports of the others. Unanimous agreement on their part means submission of the work to the full committee—and they come to a final decision. So is the truth arrived at.

In doubtful cases, the work is given a special playing by an orchestra. In consequence our talented composers are not found languishing without approval in Montmartre, but living comfortably in country cottages and Chelsea flats, Mayfair apartments and St. John's Wood mansions.

Composers' Opinions

Yet there are always two sides to a picture. Listeners do not always enjoy being spoon-fed, no matter how much it may be for their own good. What do British composers themselves think of the Corporation's god-fatherly spirit? During the last week I have been acting as a roundsman—collecting, not milk-bottles but opinions.

They prove enlightening.



"Decidedly the B.B.C. has proved a great help to the cause of good music," is the opinion of John Ireland, whom you see on the left. Dame Ethel Smyth, Britain's most well-known woman composer, has conducted her own works at Broadcasting House, and her opera, "The Wreckers," has also been broadcast. In the centre is that popular master of music, Sir Edward Elgar.

“So Much Music of an Inferior Quality”—Sir Frederic Cowen

In the main the composers think well of the B.B.C. While some would appear timid in the presence of that august body. Roger Quilter could not be persuaded to say anything more than, “I think their work is wholly admirable!”; Constant Lambert was “very rushed—never been so busy in my life—can’t deliver an opinion!”; Albert Coates was “just leaving for abroad,” and William Walton simply would not answer at all. A shy crowd, these composers!

“A Great Help”

But Dr. John Ireland broke my streak of bad luck.

“Decidedly, the British Broadcasting Corporation has proved a great help to the cause of good music,” he said. “First and foremost, by training public taste. The broadcasting authorities do not have to think of box offices. They can present music for its intrinsic worth, knowing that it will be appreciated somewhere.

“Thus they render performances of much good work which would otherwise go unheard. They can enable us to hear not only all that is worth while in British music, but also all that is of interest on the Continent. And since a greater proportion of the public has acquired a musical ear, the scope of the musical world is widening.

Orchestras Aided

“We were once told that broadcasting would ruin the concert world; that it would put hundreds of musicians out of business. The contrary has proved to be the case.

“A few years ago most of the great orchestras were in parlous plight. Now they are playing to large audiences. The world of music is

flourishing. More than a hundred and sixty concerts have been announced for this season. We are marching ahead!”

With this view, Sir Edward Elgar concurs. “Broadcasting is widening the market for music. Not only in



DICTATOR OF BROADCAST MUSIC

Dr. Adrian Boulton, musical director of the B.B.C., whose firm and far-seeing policy has done much to enhance the reputation of broadcast concerts, orchestral and vocal.

itself, but also by promoting interest in concerts and composers. We are told that man cannot live by bread alone, and broadcasting is replenishing the composer’s table.”

To which Cyril Scott adds: “The B.B.C. is not so much educating the public as widening the public. A liking for music is inherent in most men, and no fault can be found in the

work of wireless in this direction—or in the work of the men behind the scenes. But, to my mind, while the house of the B.B.C. is in order, wireless instruments are not.

“We have still to perfect the system of transmission, still to eliminate the bugbears of atmospheric and other interference. Despite many improvements of recent months, we have still to perfect broadcast reception, too. Radio music is not yet natural, and will probably not be so for some time to come.”

Music-Hall Songs

In the early days of radio, Sir Richard Terry found broadcast music for the most part on the same intellectual level as the old penny dreadful. Now, doubtless, he has changed his mind. He is even in favour of more old music-hall songs.

“The tunes,” he writes, “are frequently obvious to the point of dullness, yet they are nearly always redeemed by a rollicking chorus with an infectious lilt. I would rather any day hear ‘Champagne Charlie,’ or ‘Hi-tiddle-ty,’ or ‘They’re All Very Fine and Large,’ than the sloppy sentiment of Tosti’s ‘Good-bye,’ or the fustian of Stephen Adams’ ‘Midshipmite.’”

But few men hold exactly the same opinions. Contrast with this the views of Sir Frederic Cowen, best known, perhaps, to the general public as the composer of “The Better Land.”

“I think the serious side of broadcasting is doing a great deal of good by creating a fuller knowledge of the best in the musical art. It is only a pity that there should be so much music of an inferior quality as well. Still, I suppose the B.B.C. has to appeal to all tastes—”

Stimulating Interest

I next put the question to that septuagenarian, Dame Ethel Smyth.

“I have expected broadcasting to stimulate interest in music and have thought that it *should*, but for myself I have only lately acquired a set—simply because I can’t go to and from London in winter if I want to hear new music—so I have not had time yet to study the programmes.

“These, *I am told*, are becoming less and less satisfactory for serious musicians, though of my own first experiences a few weeks ago I have no

(Continued on page 167.)



THE MEN WHO CHOOSE

Sir Hugh Allen, Sir Landon Ronald, and Sir Walford Davies are members of the B.B.C.’s selection committee for new works. Their efforts have discovered much in music which might otherwise have been lost in obscurity. Sir Walford Davies, of course, is known in every home in Britain where a wireless receiver is installed.



IN PASSING

A Story of "Life and Death"

ALTHOUGH the limits of human credulity are set extremely wide, Henry Hollip (hereinafter known as "Olly") has up to the present failed to secure even one believer in his story of the Benevolent Baboo, the Life and Death Ray and the Lost Flashlamp. His evidence, he complains, is either beyond reach or is brushed aside as merely circumstantial. Also, he is sorry for whoever stole the Flashlamp, and fearful for what may have been done with it.

Therefore I have agreed to lay the whole case before my impartial and scientifically-minded public, with whom the final verdict must rest.

Gifted with Mechanistic Skill

Olly is not a trained scientist, but some of his army wireless instruction stuck to him; he is not more than elementarily educated, yet gifted with some mechanistic skill, inherited from

AN AUTHORITY



"... Ohm's Law was revealed to him by a torpedo instructor in a third-class carriage . . ."

a grandfather who made a competence out of wire puzzles and mousetraps.

He seems to have picked up the current babble of radio amateurs without effort, and he told me that

the true inwardness of Ohm's Law was revealed to him by a torpedo instructor in a third-class carriage en route to Portsmouth.

Some of the things attributed to Ohm by the naval man are outrageous!

"Looking at Visions"

Olly left his lodgings in Dooley Street one foggy, drizzly, biting November evening last year, bound for Tuft's Radio Stores, where he hoped to exchange congenial gossip with Miss Tuft and negotiate the loan of a

A strange visitor from the mysterious East comes into Henry Hollip's life with consequences which will tax your credulity more than a little.

battery. Though his chin and nose were tucked for protection inside his coat collar and so might have drawn his eyes downward, the fellow was looking at visions of Miss Tuft with the mind's eye, leaving his physical eyes at "neutral." So he tripped over Chunder's feet.

Chunder was a bundle of rags and bones which had come all the way from Boondapore in Bengal, and was rocking itself to and fro to the accompaniment of a soft, childish, whimpering. And then this blundering sahib kicks a poor man's feet.

Olly Gives Advice

"Aie! Hai! Mai!"
"Sorry, mate," quoth the kind-hearted Cockney. "Hurt yer?"

The rags moved like the unfolding of petals and showed a thin, brown, face and a sparse grey beardlet. A thin, brown, hand was raised and Olly felt that he was being saluted or absolved or admonished.

"Aw right, dad," he said, in the tone he used for harmless "drunks"

who "orter go home ter bed." "Why aren't yer home?"

Out of the whimpering he caught intelligible scraps. "A poor man—no friend—over the black water—verree ongree—"

"'Ungry, eh? Why don't yer go ter the Seamen's Home, then? Rundle Street!"

The rags heaved and leapt and the bundle struck itself on its chest.

"Not Lascar! Chunder not Lascar," it said indignantly. "No being eshippee man."

"Well, dad, here's a bob. Go and get yerself some grub. And, if I were you, I'd look after meself a bit, dad."

There was kindness in every word; no condescension, no patronage. Olly had once been very near the gutter himself.

Chunder Speaks

A skinny hand took the shilling, bestowed it in some hidden reservoir, shot out of the rags and clutched Olly's coat.

"'Ere—what—" cried Olly. But the grip was as strong as steel, and

LOVE'S BLINDNESS



"... looking at visions of Miss Tuft with the mind's eye . . . he tripped over Chunder's feet."

like the Wedding Guest in "The Ancient Mariner," Olly "stood still and listened like a three years' child. The Baboo had his will."

The old man then told him of a strange mountain on the northern

"First Gives Life and . . . then Gives Death"

side of the Himalayas, a totally barren place whereon nothing grew; not a blade of grass, not a tiny insect. No birds were ever seen to alight there, and no animal would visit it, not even, because of its solitude, to lay down and die. It was a place not so much of death as of repulsion to life.

The Mountain's Secret

The secret of the mountain's sterility was the presence of a mineral which when subjected to strong light gave off remarkable influences—so Chunder described them. These rays first gave life. Then they gave death.

His own father had discovered the secret of the mineral and had died quickly. He had aged incredibly in a few weeks and passed away in apparent senility.

Chunder, after some years of meditation and prayer, had come to the conclusion that if he could sell the death-rays to the white sahibs he might lay comfortably back under his own fruitful vine and watch the unbelievers destroy themselves. Thus twice good might come of evil.

He had somehow or other made his way to London, where he had been ordered off the steps of the War Office, the Admiralty, Adastral House, and Scotland Yard, "by large men in the garb of maharajahs"—which is highly flattering to the commissionaires in question.

In short, he had failed to get a hearing, and he now proposed to

KILLED BY LIGHT



"He had seen this Thing before—in Mespot."

give Olly his precious piece of mineral and entrust him with the negotiations.

Interested but Incredulous

By the time the story had reached this point Olly was enormously interested but wholly incredulous. His interest was the more intense because he had spent several years in searching

for a Radio Death Ray, but had succeeded only in wasting a lot of time and money.

That much he knew. What he did not know was that he had unwittingly concentrated some very short waves on to the laboratory of Father Ignatius Restrepo, Chief of the Observatory at Aguas Calientes, in the South American republic of San Matador, to the excitement of that holy man, who began at once to write a famous monograph about messages from Mars.

"Well, well!" said Olly. "That's a good 'un, dad. Show us the lump of stuff."

"Look! I give it to you. You were kind to old Chunder. Remember thy servant when thou gatherest riches."

"You Have Killed Me!"

Chunder handed up a screw of black cloth from which he abstracted an object about as big as a marble. Olly bent forward, but saw nothing plainly because of the fog. He took from his pocket a shilling flashlamp and directed its beam steadily towards the finger and thumb and that which they held.

An eldritch scream arose from Chunder, who dropped the specimen and began to whine, "You have killed me! The light makes the wonder! *Hai mai! I die!*" He rolled backwards and his mouth opened.

"Crumbs!" gasped Olly. "'Ad a fit! 'Ere! Kim up, dad!"

He raised the bundle and then lowered it gently but hastily. He had seen this Thing before—in Mespot.

"Gorn!"

He stood for a moment or two appraising his situation. Then he wrapped the specimen in his handkerchief—and raised the alarm.

Trying it Out

A week had passed and Olly, locked in his bedroom at dusk, sat at a table with the specimen before him.

"Coo!" he muttered. "Didn't see much life when the old nigger went off. *Dangerous!* However, here goes!"

He fastened the fragment of stone to the lens of his flashlamp, stood the lamp upright, and switched on the battery. The beam of light, split by the interposed stone, shone upon the rafters of the ceiling. Olly thought that the stone sparkled all over its

surface, but he did not care to approach it closely enough to confirm the observation.

He was surprised, a little later, to notice that flies were buzzing about him. He switched off the lamp, lit the gas, and caught a fly.

The Result

"Coo! Flies in November, eh? Rummy! Came all of a sudden, too!" Then the truth broke upon him. "Must have gingered up their blooming eggs. They lay 'em in the corners. What did the old chap say? 'First gives life and . . . then gives death.'"

HORTICULTURAL MARVEL



"In a few days that garden blossomed like Eden . . ."

Oof! 'Spose I accidentally shone it on a funeral!"

The fly which he held was a slim, aristocratic-looking insect, very vigorous, and of cleanly habits. It washed itself assiduously with its two free legs and simultaneously performed its proboscis exercises.

Speeding Up Life

Olly put it under a glass tumbler and began to watch it closely. In five minutes it had grown to the size of a large bluebottle. Then it ceased flying and began to crawl weakly. It died shortly afterwards.

"Um!" said Olly. "Grew to a ripe old age pretty sharp and then snuffed it. First life and then death."

A scrap of a Bible text from the deeps of his memory floated to the surface. " . . . life, and have it more abundantly." The secret was out. These radiations speeded up life processes so greatly that an organism subjected to them lived the cycle of its life in a very small fraction of its normal duration.

Maturity succeeded adolescence, senility and final decay followed maturity with unnatural swiftness, and life failed before the sense of youth had faded. Olly saw all this.

(Continued on page 168.)



SCREENED DOWN-LEADS

By
GEOFFREY ELTRINGHAM

The use of a shielded aerial lead-in is often of considerable value in minimising or eliminating the programme-spoiling effects of "man-made static." In this article our contributor ably discusses the pros and cons of the method and also gives practical details of an efficient home-constructed screened down-lead.

IF one listened to the wails of some people it would appear that the problem of local electrical interference is getting worse every day, but the truth of the matter most probably is that sets are growing more and more sensitive, and so they tend to be more easily upset by stray disturbances. Perhaps, too, we are getting more knowledgeable in these matters, and so we can diagnose with more certainty the causes of the odd noises we hear.

Prevention

Be all that as it may, it cannot be denied that the problem of stray interference is one of the most serious which confronts us to-day, and calls for a determined attempt to improve things. Much can be done by the proprietors of such well-known noise-makers as tramcars, badly-maintained electric motors, flashing signs, and so forth, and no doubt they would be legally compelled to do something to abate the nuisance in a truly civilised state.

While this is certainly the proper way to deal with the trouble, there seems little hope of its being adopted just yet, and so we have to concentrate rather on methods of preventing interference from reaching or disturbing our sets so much. Fortunately a good deal of useful work has been done on the problem of late, and some quite helpful discoveries have been made.

One of the most interesting of these is that a large proportion of the miscellaneous noise we hear comes into our houses along the electric

light mains, and that the "field" spreads only a short distance around the building, as can sometimes be demonstrated very clearly with the aid of a portable set.

A Practical Test

This is a very hopeful discovery, because it indicates that if we can keep the noises from getting into our mains sets by means of suitable filters and prevent our down-leads from picking them up we shall have done much to reduce the nuisance.

The use of filters in the supply leads of mains sets is fairly well-known nowadays, but the prevention of

then go ahead and try screening your down-lead, for the result will probably be a marked improvement.

The ideal arrangement in these circumstances appears to be a good high aerial, well clear of the building, and a down-lead which is screened as completely as possible right from the point where it leaves the horizontal span to the aerial terminal of the set itself.

Value for Money

This perhaps sounds simple enough, but actually we must proceed with considerable caution, or we shall only succeed in reducing heavily the efficiency of our aerial system.

Screening incorrectly applied can introduce very severe losses, indeed, we must be prepared to pay a certain price for our reduced interference in any case. All that we can do is to see that we pay only a fair price, and get good value for it!

Avoiding Losses

The possibilities of heavy dielectric loss are obvious, and the point need not be laboured. The most acute difficulty arises in connection with the large capacity to earth which is so apt to exist between the aerial lead and the earthed screen surrounding it. Even with a receiver employing comparatively weak coupling between the aerial and the first tuned circuit, this is pretty sure to cause trouble, especially if the set has a ganged system of tuning.

Capacity Effects

Quite a number of elaborate schemes have been devised to overcome the difficulty, but they are mostly unsuitable for incorporation in an existing set, and they are very hard to adapt to a receiver which has to cover two

INVESTIGATING TRAMWAY NOISES



The G.P.O. has carried out a great deal of pioneer work on the elimination of "man-made static," and here we see Post Office engineers and tramway officials conducting midnight tests on a tramway conduit system with the aid of portable receivers.

interference pick-up by the aerial down-lead is a comparatively new subject, and so I think perhaps the readers of MODERN WIRELESS may be interested in some practical details.

The first thing to do in all these cases is to make sure that the interference is really coming in from the aerial, and this can be done in the usual way; just disconnect the aerial from the set and note whether the noise stops, or at any rate is much reduced. If this is found to happen,

wavebands. You see, wavechange switching is rather difficult to provide in a device which will normally be located at the top of one's aerial mast!

So far as the ordinary experimenter is at present concerned, it seems that the best course to adopt is to endeavour to keep down the capacity

AN AERIAL POINT!

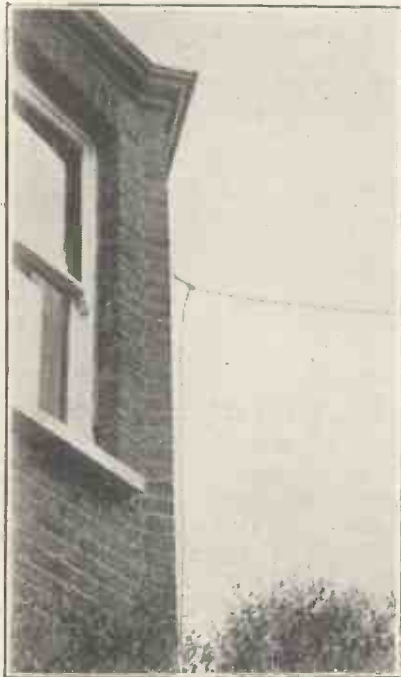

In many cases external interference is picked up by the aerial down-lead, and by suitably screening it the trouble is often considerably reduced, or even eliminated completely.

between screen and down-lead as much as possible, so that no alteration in circuits becomes necessary. If this can be done with any degree of success, the only change likely to be required in the receiver will be a slight re-adjustment of the trimmers in a ganged set.

This is a point which should never be forgotten when installing a screened down-lead, for there is sure to be a pretty considerable increase in the effective aerial capacity as a result, and this is most likely to have some effect on the tuning of the first circuit in the receiver. Neglect of this rather obvious precaution is probably the reason for the reports of ruined performance one sometimes hears from those who have tried this form of screening without due care.

Factors Involved

To get the desired low capacity to earth in our screened down-lead we must satisfy one simple requirement, whose nature we shall understand the more readily if we first see exactly what is involved in the matter. We

shall obviously have the usual lead-in wire, which will presumably be some sort of stranded conductor, and around this we wish to place a metal screen extending for its whole length and connected to earth. Now, the tubular screen and the insulated conductor inside can be regarded as the plates of a condenser, and the capacity between them will be considerable if we are not careful. Since this capacity will be shunted across the aerial and earth terminals of the receiver, it is evident that care is unquestionably called for.

Basic Principles

Again, a considerable fraction of the total voltage of the incoming signal will be developed across this capacity, and so any appreciable amount of dielectric loss therein will be most disastrous. We must, therefore, be extremely careful about the materials we use for insulation between the lead-in wire and the surrounding screen, air being obviously desirable here.

Our one simple requirement for efficiency, then, is that we must keep down the capacity between lead-in and screen, and keep a very watchful eye upon the possibility of dielectric loss in the insulating material in the space between, using air as far as possible.

I stress these points because at present the cost of the special materials offered for the construction of screened down-leads is rather high, and so most of us try to improvise suitable schemes for ourselves. If we understand the basic principles we have a good chance of doing this successfully, hence my rather detailed explanations.

Suitable Materials

It should by now be obvious that all such materials as lead-sheathed cable and the braided wire used for the heater circuits of mains sets are quite unsuitable for our present purpose. The capacity of all these is decidedly high, and they are far from satisfactory from the point of view of dielectric loss.

To get what we want we must be prepared to make up the lead and its screening from such materials as are available to us, and this is fortunately not difficult. For the conductor I suggest a single rubber-covered flexible of medium weight, *not* the very heavy type often used for the purpose, because it is rather unmanageable.

For the screen you want a suitable length of metal tube with a bore of about half an inch. You can, if you

like, use a thin gauge of brass or copper tube here, but it is rather expensive, and as good if not better results can be got with the rolled iron conduit material used in electrical installation work.

The main problem is to support the conductor approximately in the centre of the tube, and to maintain the highest possible insulation between the two. The rubber covering of the wire

EXTERNALLY SCREENED



One of the difficulties in screening the leading-in wire is that of keeping the capacity effects down to reasonable limits. In this Goltone screened down-lead the leading-in wire is carefully air-spaced from the external tubing.

is a help here, but it is not alone sufficient. What we want, in addition, is a means of spacing the wire in a central position, and this is quite easy. Obtain a small supply of ebonite tube of a size to slip easily inside the screening tube, and with a bore through which the rubber-covered wire will slip freely.

Making a Down-Lead

Cut this up into half-inch lengths and slide them on to the wire. Arrange them at intervals of a foot or thereabouts, and secure each in position

READY FOR USE



Screened down-leads, such as the Radio-phon type above, can be obtained ready for use in various lengths. The down-lead wire passes through the centre of the shielded tube, and the metal casing is joined to earth.

MATCHED PERFECTION in Miniature

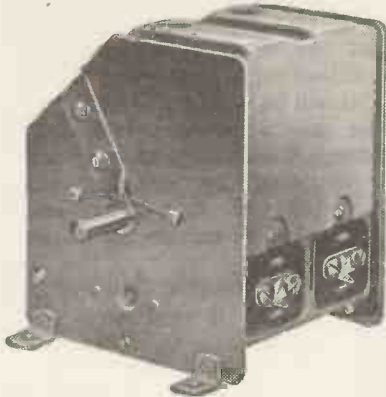

BRITISH RADIOPHONE MIDGET

THE vogue for midget receivers and compact layout has called the new Radiophone Midget into being.

But efficiency has not been sacrificed to size. The Radiophone Midget is just as everlastingly accurate, as perfectly matched, as soundly constructed as the standard size condensers which have climbed to such a high place in the esteem of the designers and constructors.

If you are planning or building a receiver where every inch is valuable you will find the British Radiophone Midget absolutely indispensable.



2-gang condenser with cover and disc drive (Type 605) **SPECIFIED EXCLUSIVELY FOR THE "M.W."**
 PRICE **20/-** COMPLETE "AUTO-THREE."

BRITISH RADIOPHONE LTD., ALDWYCH HOUSE, ALDWYCH, W.C.2

A British Radiophone Product

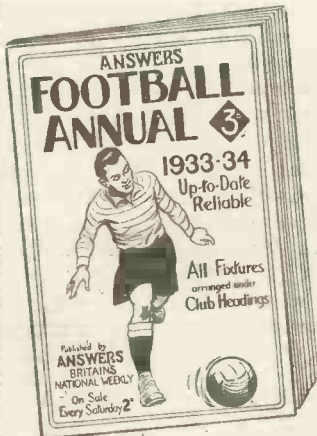

Everything You Want To Know About the New Football Season.

YOU must have ANSWERS FOOTBALL ANNUAL (now on sale). It is packed with facts and figures indispensable to the "Soccer Fan." All the English League and International fixtures, Cup Tie dates, and details about new players, are given clearly and concisely. This handy book is so arranged that you can fill in the results of your team's matches throughout the season.

ANSWERS FOOTBALL ANNUAL

Buy Your Copy To-day **3d.**

H.T. SUPPLY for CAR RADIO

THE **ELECTRO DYNAMIC**

ROTARY CONVERTER

USED IN THE **AUTO-THREE CIRCUIT**

DESCRIBED ON PAGE 96

TO get the best results from the Auto-Three use the converter specified by the designer. The ElectroDynamic Converter! It operates from 6- or 12-volt supply. Output 200-220v.40m/a. Efficiency 60%. Electrically and mechanically silent.

PRICE

CONVERTER AND FILTER

£5.14.0

CONVERTER AND FILTER MOUNTED IN METAL CASE AS ILLUSTRATED

£6.4.0

GUARANTEED 12 MONTHS

Write for full particulars and other sizes to:

ELECTRO DYNAMIC CONSTRUCTION CO. LTD.
Devonshire Grove, London, S.E.15.

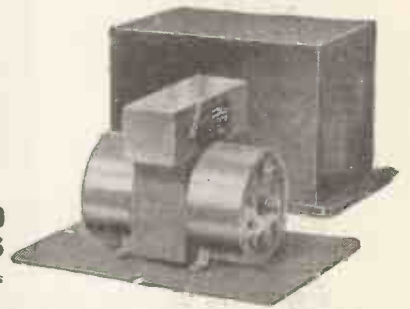

CONSTRUCTORS!

THE NEW RANGE OF CAMCO CABINETS WILL BE SHOWN AT **OLYMPIA STAND 83**

Be sure to call for Complete Catalogue, available August 15th.



CARRINGTON MFG. CO., LTD., Showrooms: 24, Hatton Garden, London, E.C.1. Holborn 8202. Works: S. Croydon.

If you cannot call at our Stand at Olympia, fill in and post coupon (½d. stamp) for the new Camco Catalogue.

NAME.....
 ADDRESS.....
 12 M.W.

Eliminating External Electrical Interference

with a dab of the invaluable Chatterton's Compound. Now thread the resulting string of ebonite "beads" into the metal tube and pull it tight. It won't stay tight, of course, unless you take steps to anchor the ends; but this is easily done.

If the spacers happen to be anything like a real fit in the tube, you can fix the end ones in position by daubing them freely with more Chatterton's; but, failing this easy solution of the problem, get a couple of small corks and fit them in the ends of the tube with a liberal coating of the same adhesive, having first threaded them on to the wire, which should be a tight fit in holes bored in them. It will tighten up, of course, as the corks are compressed by forcing them into the tube.

Separate Earth

This done, coat the projecting parts of the corks and the ends of the tube with still more Chatterton's, to seal up the whole job and ensure good insulation at the weakest point, namely, the exposed ends. Your screened down-lead is now complete, and it only remains to fix it in place, for you will naturally have taken care to see that it is of the correct length before finally sealing up the ends.

Such a down-lead, of course, is comparatively heavy, and it will usually be advisable to provide a system of stays to give it some support. Much depends on individual circumstances

here, however, and I cannot hope to give any very helpful suggestions. It is generally a fairly simple matter, and is not likely to call for anything beyond a single stay to take the weight and another to prevent undue sideways in high winds.

Having got the lead in place and

between the set and the leading insulator it may be advisable to screen this also, but I suggest that you try first the effect of the external screened lead only. You may well find that this will be sufficient, but if you consider that a further reduction in interference is necessary, then by all means try screening the part of the aerial lead which is outside the house.

SOMETIMES THE CAUSE OF CRACKLES

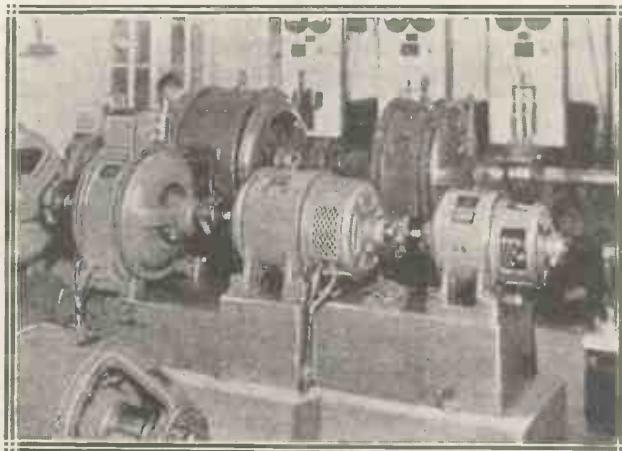

Dynamos and electric motors are sometimes the cause of background crackles, and where it is not possible to apply a cure at the source, a screened down-lead may be extremely valuable in overcoming the trouble.

A Simple Matter

Here it will often be permissible to earth the screening tube by connecting it to the earth terminal of the receiver, but this should not be done when the interference is really severe. In such cases it should be connected to the same separate earth as you employ for the screen of the down-lead proper.

One final point I must impress upon the reader, and that is that a screened down-lead system, such as I have just described, must be regarded as definitely perishable, and requiring

inspection at suitable intervals. It is such a simple matter, however, to renew the rubber-covered wire and the Chatterton's seals that it is no great hardship to have to do it at intervals of, say, twelve months.

Incidentally, the same objection applies equally to almost all the special materials offered for the purpose, even some of the most expensive—so the reader is really at no disadvantage if he decides to try the scheme I have suggested.

properly secured, there remains the important question of an earth for it. The screening tube *must* be earthed, and well earthed at that, or it will be almost useless. A separate earth is usually best, and if a water pipe is not available, then use not one but *two* earth pins, driven well home in a place where the soil can be watered in dry weather.

So much for the screening of the down-lead outside the house. If there is any considerable length of lead

EDINBURGH. The old Edinburgh relay station which closed down when the Scottish Regional was put into service has been re-erected at Plymouth.

NORTH PORTUGAL. For its long-wave station, Portugal has secured the 1,261-metre wavelength. Its power will be 20 kw.

HAIFA, PALESTINE. 307.1 metres is the wavelength reserved for this new Palestine station, which is to employ a power of 5 kw.

CAIRO. The new Egyptian station to be erected at Cairo will have a power of 20 kw. and will cost about £25,000.

OULU. The power of the Oulu (Finland) station is to be increased from 2 to 5 kw., provided it uses an aerial directional to the north.

STATION INFORMATION

Recent and forthcoming alterations and events.

ATHENS, GREECE. The wavelength earmarked for the new Athens station is 499.2 metres.

AMERICAN STATIONS. Even during the midsummer hot spell it was sometimes possible to pick up medium-wave American stations direct, on this side of the Atlantic, during the small hours.

Of particular note was WPG, the World's Play-Ground station, at Atlantic City

FINLAND. The Lahti station is to be permitted to use up to 150 kw. if an aerial directed towards the north is installed.

SOFIA, BULGARIA. The projected station at Sofia is to use a directional aerial to prevent interference with western areas.

SOUTH AMERICA. Although not as frequently as with the North American stations, many British listeners have reported that it was possible during mid-summer nights to receive medium-wave South American broadcasting stations.

KALUNDBORG. The new high-power station is situated on the island of Zealand. It has apparently been testing on high power, as reports of the programme being heard at great strength in Britain have been received.

BROADCASTING IN SOVIET RUSSIA

—continued from page 90.

industrialisation of the Urals, the Dnieper dam, physiology, psychiatry and ideology as a method of stimulating production.

Listeners' opinions on all subjects are eagerly solicited. Members of the Communist Party, which represents the driving-power of modern Russia, hold meetings in factories and prisons, on farms and in market gardens, in institutes, clubs and educational establishments to discuss programmes, complaints and suggestions.

"Interval" programmes for specialists are arranged to occupy free half-hours. For instance, the workers of the Ford plant at Ostroy may be encouraged by a special evening hour devoted to their particular interests.

Timing Programmes

There is a midnight radio for late shifts; and 11 p.m. news budget for the Arctic Circle, where receiving conditions are best at that hour; and a post-midnight selection for Eastern Siberia; while textile, rubber, metal, and other workers get their interim programmes in turn.

It is supposed that there are a quarter of a million radio sets in Leningrad, and considerably more in Moscow. As many of these belong to institutions, the majority of people can and do listen in, whether they want to or not, for just as long as they are concerned in any public business, even if the price of sets or the difficulty of obtaining them prevent private listening.

The Personal Element

If the Soviet system has eliminated from the Radio—as from Press, cinema, theatre and public platforms—sex, fashion, advertisement, competitive finance, crime, sport and sentiment, it has introduced, by means of workers' comments and proposals, so great and far-reaching a personal element that each listener feels he has a definite responsibility for the programme, just as he has a place in the Plan to which the programme contributes. Thus Radio is an organic part of the new system which, whatever its faults and however it breaks down under economic pressure, reaction, suspicion, and inefficiency, is leavening the inert softness of old Russia with something hard and strong as creation.

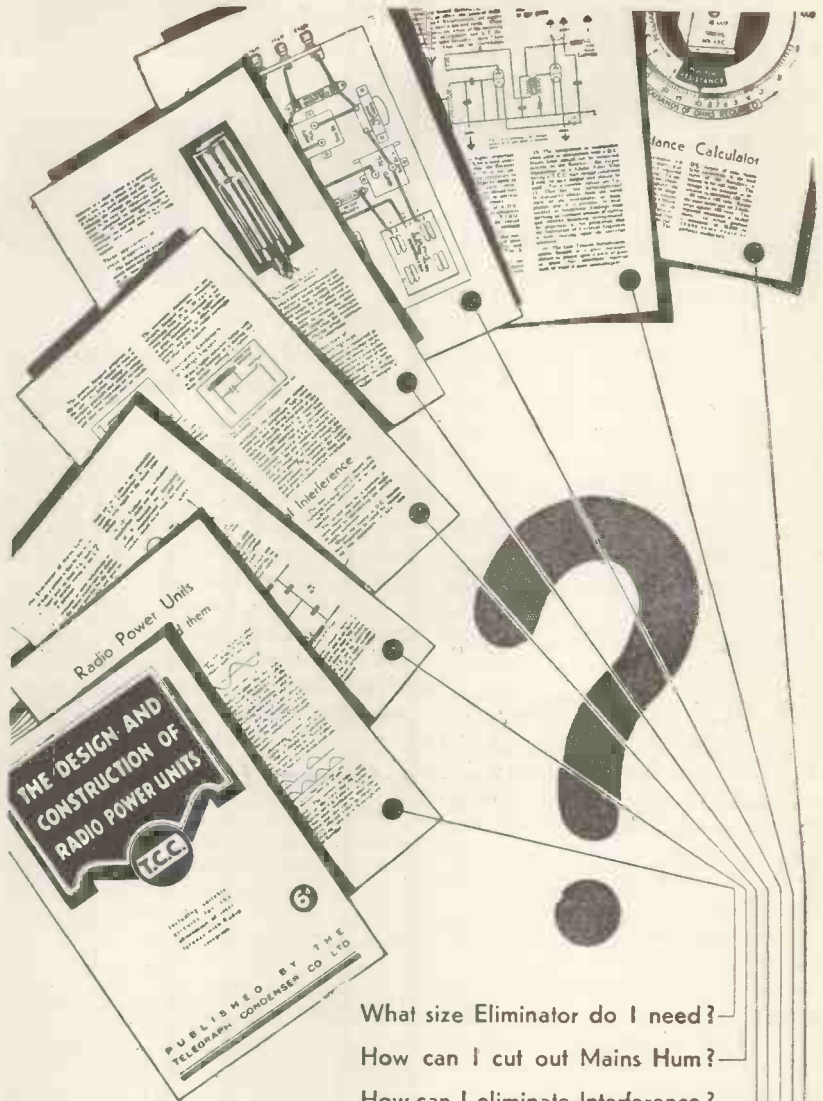

- What size Eliminator do I need?
- How can I cut out Mains Hum?
- How can I eliminate Interference?
- When should I use an Electrolytic?
- How do I build an A.C. Power Pack?
- What special precautions for D.C.?
- What resistance do I need?

YOUR MAINS PROBLEMS! — this Book answers them all

T.C.C.
ALL-BRITISH
CONDENSERS

GET YOUR COPY

COUPON To The Publicity Dept., The Telegraph Condenser Co. Ltd., Wales Farm Rd., N. Acton, London, W.3.

Please send me a copy of your book "The Design and Construction of Radio Power Units," for which I enclose six penny stamps to cover cost and postage.

NAME.....

ADDRESS.....

M.W. 8/33. Please write in block letters

RADIO NOTES and NEWS of the MONTH

By G.B.

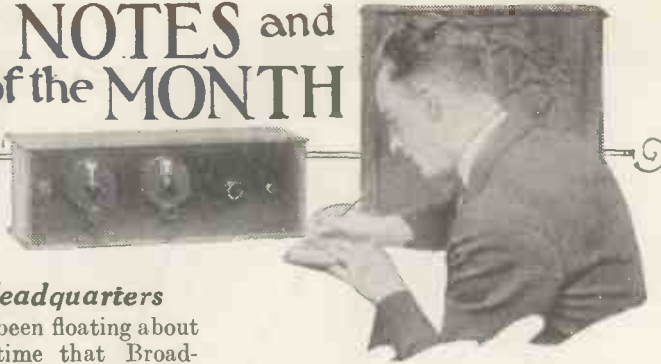

Extending Headquarters

RUMOURS have been floating about for some time that Broadcasting House, when completed, was found to be far too small for the Corporation's needs, and now it is understood the B.B.C. has definitely completed arrangements to take over the premises of No. 16, Portland Place, next door to Broadcasting House.

It is expected that the B.B.C. will take possession of its extra accommodation very shortly, and that certain reconstruction work will be undertaken so that the two buildings are linked up.

A Duel in the Ether

Did any of our readers hear the German-Russian wireless duel which was fought recently? The trouble seems to have been that the programmes from Moscow included denials that German settlers in the Volga region were starving.

German broadcasting had alleged that settlers were starving and, in fact, the German stations had been carrying on a campaign for some time, and on similar wavelengths to those used by the Russian stations. The result was that there was mutual interference and the duel turned into a battle as to who could drown the other.

Anyway, Moscow has declared that from August 1st important Soviet stations, staffed by expelled anti-Hitlerites, will begin to broadcast propaganda in German to counteract the propaganda sent out by German stations.

Towards Better Broadcasting?

An attempt has been made to blow up the Luxembourg and Strasbourg broadcasting stations with dynamite. Apparently the plot was discovered by French Secret Service men.

Luxembourg is certainly asking for it, for it is using an unauthorised wavelength of 1,191 metres with a power of 200 kilowatts. Luxembourg has made the excuse that it is merely testing, but Luxembourg had better look out!

Continuous Sunday Programmes

The B.B.C. has announced that from the beginning of September there will be a continuous Sunday programme from 12 o'clock midday to 10.30 p.m., which means that at last the gap between 6.30 and 8 in the evening will be filled.

Incidentally, however, there will be no alternative programme to the religious service, and there is little sign that the actual programme material will be lightened.

German Licence Figures

Much to everybody's surprise, German licence figures have not yet reached the five-million mark, as was done not so long ago in this country.

The latest figures for June from Germany were 4,521,106.

Marconi on the Next Step

It isn't often that Marchese Marconi grants an interview to the Press these days, but a little while ago the "Evening Standard" secured a nice little scoop by obtaining an interview on "Wireless—the Next Step." In the course of this interview, the Marchese pointed out once more the possibilities of the micro-wave.

Hitherto Unexplored

"If we could communicate on wavelengths, say, between 20 centimetres and 1 metre," stated the Marchese, "we should, at one stroke, open up a hitherto untapped field of wireless communication. We might then have as many wireless stations for our new wavelengths as to-day serve the present broadcasting channels.

"All fear of congestion would disappear, together with all risk of interference from those disturbances which exist within the present radio spectrum. None of these come within range of the micro-wave."

Pioneering Experiments

The Marchese went on to point out in the interview that the existence of micro wavelengths was realised as long ago as 1896, when it was demonstrated to the engineers of the General Post Office that waves of the order of 30 centimetres could be successfully adapted for telegraphic communication over a distance of 1½ miles; but following successful results obtained with larger wavelengths, the investigation of the very short waves was suspended, and, in fact, it was only last year that micro wavelengths were taken up again as a subject for further investigation.

A Regular Service

Last year successful communication up to 160 miles was established with micro-waves over sea, and as a result of tests carried out in April last year, a regular micro-wave telephone service is now in operation between the Vatican and the Pope's summer palace.

The Great Point

The Marchese also pointed out in the interview that during one test these micro-waves had to pass through the masts and aerials of a high-powered radio station; but whether these waves passed through or over a natural barrier like a hill is still uncertain. As the Marchese stated, the great point is that they do in some way surmount it.

The Ultimate Goal

The Marchese also revealed that at the moment he is busily engaged in constructing much more powerful micro-wave apparatus with which to carry out experiments this summer.

"If it proves successful," he remarked, "it is hardly too much to say that the resultant developments are likely to add enormously to practical wireless possibilities. . . It is logical that in the world of wireless research the ultimate goal of extended and improved communications should take precedence over every other consideration."

The West National

Preliminary tests have been successfully made with the West National transmitter at Washford, Somerset, and regular transmissions will begin on August 12th. The wavelength will be the same as that of London National and the same programme will also be transmitted.

(Continued on page 165.)

RADIO NOTES AND NEWS OF THE MONTH
—continued from page 164.

Licences Soaring

Licence figures are still increasing. At the end of June the figure stood at 5,598,000, representing an increase of 21,700 new listeners since May. An official of the B.B.C. stated in an interview the other day that it is anticipated that by the end of the year licence figures will be above the six-million mark.

Even then, however, he remarked, we shall still be a long way off saturation point. Saturation point need not begin to worry us until we are well over the seven-million mark.

Piracy Still Rife

But pirates are by no means dead. During June the Post Office brought 210 cases against pirates into Court,

all of which were successful. The amount collected in fines came to £168 12s.

The Prince's Compliments

Here's an interesting story about the Prince of Wales, who is a keen listener.

According to a correspondent in the "Daily Telegraph," a short time ago an ex-private soldier broadcast an account of his part in the Somme battle in 1916. Of course, as most of our readers know, the speaker was Mr. Derek McCulloch, who is one of the real geniuses of the Children's Hour.

Mr. McCulloch had a pretty thick time of it in the Somme battle in '16; he was wounded in several places, lost an eye, and since the Armistice has undergone goodness knows how many operations.

After the broadcast the Prince of Wales rang up the B.B.C. and asked the identity of the ex-private, expressing his warm appreciation of the broadcast.

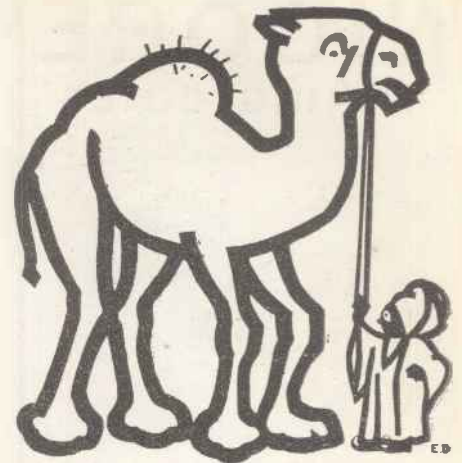

The CAMEL has the hump

He has a hump on at all times. If you do not get wise to the best in radio you will get like the camel and have the hump. Insist on Graham Farish components and you get the best in radio. They are precision made instruments, incorporated in any set and they provide Efficient Selectivity, High Tonal Quality, and Reliability.

LIT - LOS

Condensers

Compact and efficient. Accurately gauged bakelite dielectrics and solid brass pigtail connection to moving vanes. All capacities up to .0005 mfd. in tuning straight line capacity and differential types

2/- Each

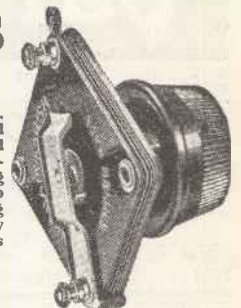

OHMITE Resistances

The most popular and efficient type of fixed resistance for all general purposes. "Better than wire-wound." All values 50 ohms to 5 megohms. Each

1/6

100° F. Temperature rise.

Ohms	Milliamps	Ohms	Milliamps
1,000	40	20,000	3
2,000	35	30,000	6-75
3,000	29	40,000	5-5
Other values pro rata.		100,000	3-5

Heavy Duty type, approximately double the above ratings, price 2/3.



L.M.S. Twin Screen H.F. Choke

In H.F. circuits where ultra efficiency is such a necessity you cannot do better than to fit L.M.S. Choke. Equally suitable for the long, medium and short wavelengths. Each 4/6

Where a cheaper screened choke is required use the H.M.S. Screened Choke. 2/6

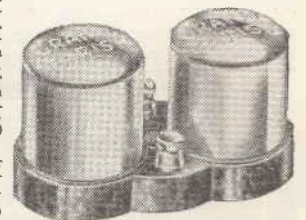

Graham Farish Components

Graham Farish Ltd., Masons Hill, Bromley, Kent. Export Office: 11/12, Fenchurch St., E.C.3.

"M.W.'s" RECORD REVIEW
—continued from page 122.

The first is much the better in every way, but perhaps my violent antipathy to the second piece may lead me astray. Anyway, I don't like the organ. Nevertheless, they, are sung with his usual easy, accomplished style, and I feel it would be a mistake not to mention this record—Parlophone R020220.

Now another Caruso record with new accompaniment—*Celeste Aida* and *Je Crois Entendre Encore* (Pearl Fishers). Not only is this a magnificent example of the versatility of this immortal singer, but each shows a different Caruso from the vocal viewpoint. Quite a triumph, this record—H.M.V. DB1875.

Ballads of Yesterday and To-day

Have you a liking for the old Cockney ballads? *The Ratcatcher's Daughter* and *Botany Bay* on Regal MR945, sung by the Victorian Quartette, are quite good. And then a very modern couple—from "Music in the Air," by Lawrence Tibbett. He sings *And Love Was Born* and *The Song is You*, on H.M.V. DA1313. The first is delightful, a fanciful titbit, exquisitely sung.

For the first—Anona Winn. She has made a very entertaining record (Columbia DB1138) of *Our Little Baby Boy* and *All Over Italy*. Now this very clever artiste from down under is a great wireless favourite—and deservedly. Her record shows off both her fine voice and excellent facility for imitation of widely divergent characters.

Humour and Sophistication

Then a gem of unusual brilliance, even for Stanley Holloway, on Columbia DX474. This has an all-wireless origin, having been written for him by Mabel Constanduros and Michael Hogan for a variety hour. The imperturbable Sam Small is not decorated on *Sam's Medal*, and the way in which the story is told shows the authors to be steeped in the love of this classic warrior. To use film adjectives one would say: "daring and devastatingly funny." *Many Happy Returns* is as good a piece as could be found to go with such a great monologue.

And, lastly, Ann Suter in *Jekyll and Hyde* on Parlophone R1529. Here are (a) a very clever artiste who will remind you of dear Sophie Tucker, (b) a jolly tune, (c) words which have a laugh (or at least an embarrassed titter) in nearly every line. *Actions Speaker Louder Than Words* follows at a respectful distance.

NICORE TUNING COILS

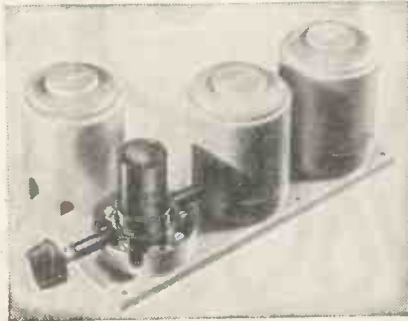

Varley NICORE Coils mark the biggest advance in radio tuning since the introduction of "Square Peak." Consistency has been the great aim, and has been attained with an even greater efficiency than was thought possible. Coils, 10/6 each (also supplied in 3 or 4 gang)



Write for FREE literature.

Varley

(Proprietors: Oliver Pell Control Ltd)

Advt. of Oliver Pell Control Ltd., 103, Kingsway, W.C.2. Tel.: Holborn 5303

HAVE YOU HAD?
particulars of the famous
"Magnum" Short Wave Adaptor,
which is now available for every type of receiver?
Full particulars, with a list of short-wave stations
and free trial offer, on request.

BURNE-JONES & CO. LTD.,
296, Borough High St., London, S.E.1.

Famous Maker's Offer! **£5** Radio-Gram CABINET for **65/-**
7 DAYS' FREE TRIAL
(OR 10/- MONTHLY.)
Polished Oak I and Piano built!
The Acoustic Tone brings a fine
thrill. Makers to (Radio-Press,
B.B.C., 3,000 clientele).
Other Models 35/- to £15.
Photographs and List FREE.
PICKETTS Piano-Tone
Cabinets.
10, W. Abbot Road, Bexleyheath.

PLEASE be sure to mention
"MODERN WIRELESS"
when communicating with
Advertisers. **THANKS!**

COIL MATCHING AT HOME

—continued from page 92.

giving a reading of 59½ degrees. If you take off another whole turn you will most likely discover that you have overdone things and gone down below the required 59 degrees, so instead push the end turn along the former away from the rest of the winding, until there is a space of, say, ¼ in. between it and the first turn of the winding proper. This will probably do the trick, but if the reading is still above 59 degrees repeat the process on the next turn. A little pushing back and forth of the end turns in this way will soon give you an accurate match.

Standard of Accuracy

As regards the accuracy at which to aim, it will be amply good enough if you get the coils within half a degree of one another, but if you like to spend a little time on the job you can get a good deal nearer than this, and then you can be sure you have a set of coils which are a little better than the average ones you can buy. To guard against possible shifting of the displaced end turns and consequent loss of match, by the way, it is as well to put a few dabs of Chatterton's Compound on them here and there when you have finished.

Those who have never done any of this sort of work before will be well advised to practise a little on some spare coils and get the hang of the method before they try to match up a set of coils intended for actual use.

Overshooting the Mark

Just a little experience is needed before one can estimate how many turns to take off at a time, and it is easy at first to overshoot the mark if one is not careful. As a rule, of course, if coils have been wound carefully they will come pretty close at the start, and it will be best to proceed turn by turn right from the beginning.

So far, it will be noticed, we have

dealt only with the matching of coils for the medium waveband, because it is usually only such coils that one troubles to make for experimental purposes. However, I dare say the reader may sometimes want to match long-wave coils as well when he discovers how easy it really is. Moreover, it is no bad idea to check up the matching of the commercial coils one uses for permanent sets sometimes, for even the most careful of coil makers must slip up occasionally.

For Long-Wave Coils

In Fig. 2 I show how the matching unit may be modified to include a long-wave coil if desired. For this you want a tube 3 in. in diameter and 6 in. long. The grid winding L₃ should consist of 180 turns of No. 34 D.S.C. wire, while the reaction winding L₄ should be of 30 turns of the same wire. Arrange this in series with the other coils as shown, with two ordinary L.T. switches connected across each winding to short them out when working on the medium waves.

Determine the correct connections and number of turns for this new reaction winding exactly as before, and the modified unit is ready for use. The method of matching is just the same on long waves, but it will be found that there is no longer any need to work any closer than a single turn. This will only shift the dial reading a fraction of a degree and will enable quite close matching to be obtained.

Reaction Modifications

One final point and then, I think, I can safely leave the reader to find out for himself just how easy this mysterious matching business can be made with the aid of even so simple a gadget as the one I have been describing.

The reaction windings I have given will suit the average modern freely-oscillating valve, but if it should happen that the one you are using does not spill over quite so easily, just increase them by, say, 25 per cent and try again. The important point is to see that the valve is only just oscillating when the tuning condenser is at maximum.



"J.B." SHORT WAVE "SPECIAL"

Designed in every detail for Short Wave work. Bearings carry no current. Special screened "pigtail" to rotor. Very small minimum capacity. Insulating material is carefully placed and proportioned so as to reduce H.F. losses. Design of frame minimises closed loop effects. Capacities .00005, .0001, .00015, .0002, .00025.

Price 5/9 each

Advertisement of Jackson Bros. (London) Ltd., 72, St. Thomas' St., London, S.E.1. Telephone: Hop 1837.

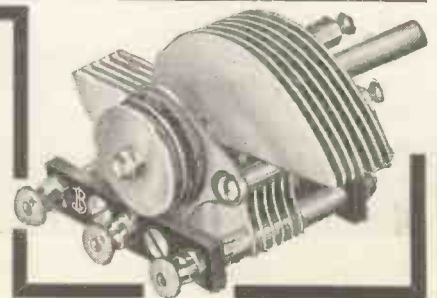

FOR THE SHORT WAVES

**WHEN TIME COUNTS
IN RADIO**

—continued from page 152.

this leakage path the slight negative charge left on the grid side of the condenser can be dissipated, leaving the valve free to deal with the positive half of the next wave.

It will be clear, therefore, that the necessity for a grid leak is due to the fact that the grid condenser takes a definite time to discharge. Note, also, that the value of the grid leak must be such that the condenser is discharged in time for the next positive half-wave. A resistance too great will prevent the complete discharge within the space of one half-cycle, and symptoms of choked grid will result.

What is a Farad ?

Speaking of condensers is a reminder that many listeners have but a hazy notion of what the capacity of a condenser is. A text-book on electricity will tell you that a condenser having a capacity of one farad is one in which a voltage of one volt will cause a quantity of electricity called one coulomb to flow into the condenser.

It should be explained that one coulomb is the amount of electricity represented by a current of one ampere flowing for one second—one ampere-second, in other words. And since a condenser of one farad would be an enormous piece of apparatus and would have a capacity far too big for practical radio purposes, we measure the capacity of radio condensers in millionths of a farad, or microfarads.

The Time Factor

So that a condenser of one microfarad, when charged by a pressure of one volt, will store a millionth of a coulomb of electricity, corresponding to one-millionth of an ampere-second.

Now, listeners who use battery sets know that the capacity of their low-tension accumulators is measured in ampere-hours, and an ampere-hour is 3,600 ampere-seconds. So it would

appear that the capacity of a condenser and the capacity of an accumulator are very much of the same nature, although, in practice, greatly differing in quantity.

At any rate, this examination of the meaning of condenser capacity has been sufficient to show that the factor of time does enter into the matter, and that a condenser does take an appreciable, if very small, time to charge and discharge. In some radio applications the time factor can be a distinct annoyance, but usually a condenser is employed because its time-lag can be turned to good account.

An extremely interesting example of this is found in television reproduction by the cathode ray. In this system it is necessary to divert the beam both upwards and downwards, and also sideways, the path of the beam being so controlled and timed that each upward movement takes a definite time and downward travel is to all intents and purposes instantaneous, the cycle of operations taking place 375 times in every second. The horizontal travel has to be timed at a slower speed, namely, 12½ times per second, the return journeys in each case being also instantaneous.

Deceiving the Eye

The actual deflection of the beam is caused by varying electric charges applied to plates on either side of the beam, one set of plates controlling the vertical, and another set controlling the horizontal movement. The varying charges are applied by condensers, which are charged up at the required rate by interposing some form of impedance—usually a diode between the source of supply and the condenser—while the “quick return” is arranged by connecting in parallel with the condenser a vapour-filled discharge tube which discharges the condenser very rapidly as soon as a certain voltage is reached.

So you see that in radio telephony, and also in television (where the eye is not nearly so readily deceived as the ear), accurate timing is all-important, and can be achieved by making use of the inherent time factor of electrical phenomena.

**THE B.B.C. AND BRITISH
COMPOSERS**

—continued from page 156.

complaints to make. Living in the country and seldom seeing musicians, I really am not in a position to say whether broadcasting has or has not the effect (as many maintain) of lessening zeal in concert-goers. From all I hear, I fear that audiences are getting smaller and smaller—but that may be the effect of severe financial depression.”

Chasing Opinions

Ketelbey thinks broadcasting a great ally to music, though if he had his way he would firmly forbid any “jazzed” version of the classics. It is noteworthy that he began as a composer of serious music, and then found himself compelled to write popular stuff because there was no market for his other works. The B.B.C., however, has given them a hearing.

And if posterity wants to know anything more about the opinions of our contemporary composers on the magic work of radio, they will have to seek it. I have been chasing Gustav Holst up and down Kensington High Street all the afternoon. And I am footsore.

**HONOUR FOR
SIR AMBROSE FLEMING**

THE Institute of Radio Engineers of New York, U.S.A., meeting in their Annual Convention at Chicago on June 26th, have awarded their Gold Medal of Honour this year to Sir Ambrose Fleming, F.R.S., for the conspicuous part he has played in introducing physical and engineering principles into the science of radio. Sir Ambrose was the inventor of the first form of thermionic valve, which is now the master weapon of wireless telegraphy and telephony, and without which there would have been no broadcasting as it exists to-day.

Build your **“M.W.” SET** with a

PILOT AUTHOR KIT

100% SUCCESS . . . exact to specification

YACHTSMAN'S 4 KIT “A” All first specified parts, including ready-drilled panel and foil-covered baseboard, less valves and cabinet. Or 12 monthly payments of 11/8. Set of Specified Valves, £2-5-3. **6 gns.**

AIRMAN TWO KIT “A” All first specified parts, including undrilled aluminium box with wood sides, less valves. Or 12 monthly payments of 5/6. Set of Specified Valves, £1-2-6. **£3**

IMPORTANT! MISCELLANEOUS COMPONENTS, Parts, Kits, Finished Receivers or Accessories for Cash, C.O.D. or H.P. on our own system of Easy Payments. Send us a list of your wants. We will quote you by return. C.O.D. orders value over 10/- sent carriage and post charges paid. **PETO-SCOTT CO. LTD. 77, CITY RD., LONDON, E.C.1**
Telephone: Clerkenwell 9406/7.

IN PASSING

—continued from page 158.

Then he quietly opened the window and deliberately trained the lamp upon the garden next door.

Enoch Gramp had some chickens and some chicks when that evening he retired from his backyard and made for the "Turk and Tumbler." On the following morning he found his chickens very peaceful but quite lifeless; they looked thin and worn, he thought. His chicks had been transformed overnight into outside cocks and hens and were "raising Cain," he said. By mid-day they had perished silently, aged and full of years.

These happenings had scarcely been the rounds of the local pubs when Olly had secretly turned his magic rays into the garden on the left, aiming at a bed of tulips.

In a few days that garden blossomed like Eden and its proprietor almost promised his wife to give up drink and become a regular church-goer. When the entire spring crop died in a single night, however, he rushed round and had the father-and-mother of a row with the nurseryman!

Resisting Temptation

Olly watched these marvels with ever-growing delight. Here was the means of wealth and power.

"Rightly used, o' course," he said, though once he flirted with the wicked notion of expediting the life-history of his Aunt Carrie, who was rising eighty and was known to have "quite a nice little bit put away." The temptation to speed up the performance of the seven ages of man in the odious person of Jim Barnsforth, his foreman at the works, became at times as poignant as an abscess in the ear.

Finally, he wrote out the whole story, intending to submit it to the War Office, though his thesis failed to contain any suggestion about what should be done during the period

when an enemy army corps of weedy conscripts was enjoying a lusty but premature prime!

And then some pickpocket took the flashlamp and its miraculous attachment from his overcoat.

Olly now lives a life devoted to the small paragraphs of the newspapers. He sees in imagination a country strewn with the corpses of old, old men and women, not to say dogs, cats, horses, with an elephant or so, who have died mysteriously.

And sometimes he thinks that he would do well to go and seek that barren hill beyond the Himalayas, but feels that the undertaking is too vast for him. The fare to India—*coo!*

TUNING BY SHADOWS

—continued from page 150.

about 90 deg., when maximum current is passing. (See Figs. 4 and 5.)

A bright light is focussed on the

surface is turned towards the light, and the operator, therefore, sees a broad shadow on the screen when no signal is being received. As soon as he tunes in a station, however, the needle rotates, a smaller surface of the needle shuts out light from the screen, and consequently a narrower shadow is seen; when the shadow is thinnest, he knows that he is exactly in tune with that particular station.

The construction of such a complicated device is beyond the capabilities of most of us, but several improvements on the ordinary milliammeter readily suggest themselves.

It should not be difficult to fix a new scale to the meter and to calibrate this in some units which are more suitable to a "signal meter." The usual method of denoting signal strength is the "R" scale, "R1" denoting just audible strength and "R10" full loudspeaker strength; the intermediate figures indicate corresponding increases.

For the ordinary listener who is not interested in relative signal

NEXT MONTH

The September issue of "M.W." will be our

Special Exhibition Number

It will contain a lavishly illustrated and comprehensive review—

ALL ABOUT THE GREAT RADIO SHOW AT OLYMPIA

ALSO

How to Build a 5-metre Transmitter and Receiver

On Sale August 15th.

Price 1/- as usual.

needle and a small screen is mounted on the front of the receiver which receives any light that gets past the needle.

The needle is so arranged that, when no current is flowing, its broad

strengths, there is no advantage in going to this trouble, but the enthusiastic amateur will undoubtedly think of many ways of adapting the "eye-tuner" to his own requirements.

INDEX TO ADVERTISERS

	PAGE
"Answers Football Annual"	161
Burne-Jones & Co., Ltd.	166
British Insulated Cables, Ltd. .. .	Cover ii
British Radiophone Co., Ltd. .. .	161
Carrington Manufacturing Co., Ltd. ..	161

	PAGE
Colvern, Ltd.	85
"Chums"	Cover ii
Edison Swan Electric Co., Ltd. .. .	Cover iv
Electro Dynamic Construction Co., Ltd. .. .	161
Graham Farish, Ltd.	165
Gramophone Co., Ltd.	86
Jackson Bros. (London), Ltd. .. .	166
"My Own Lawyer"	Cover iii

	PAGE
Peto-Scott Co., Ltd.	167
Picketts Cabinets	166
Telegraph Condenser Co., Ltd. .. .	163
Varley Products	166

All communications concerning advertising in "Modern Wireless" must be made to John H. Lile, Ltd., 4, Ludgate Circus, London, E.C.4. Telephone: City 7261.