

ALL THE LATEST VALVES CLASSIFIED

MODERN 1/- WIRELESS

VOL: XVII. N° 64

APRIL 1932

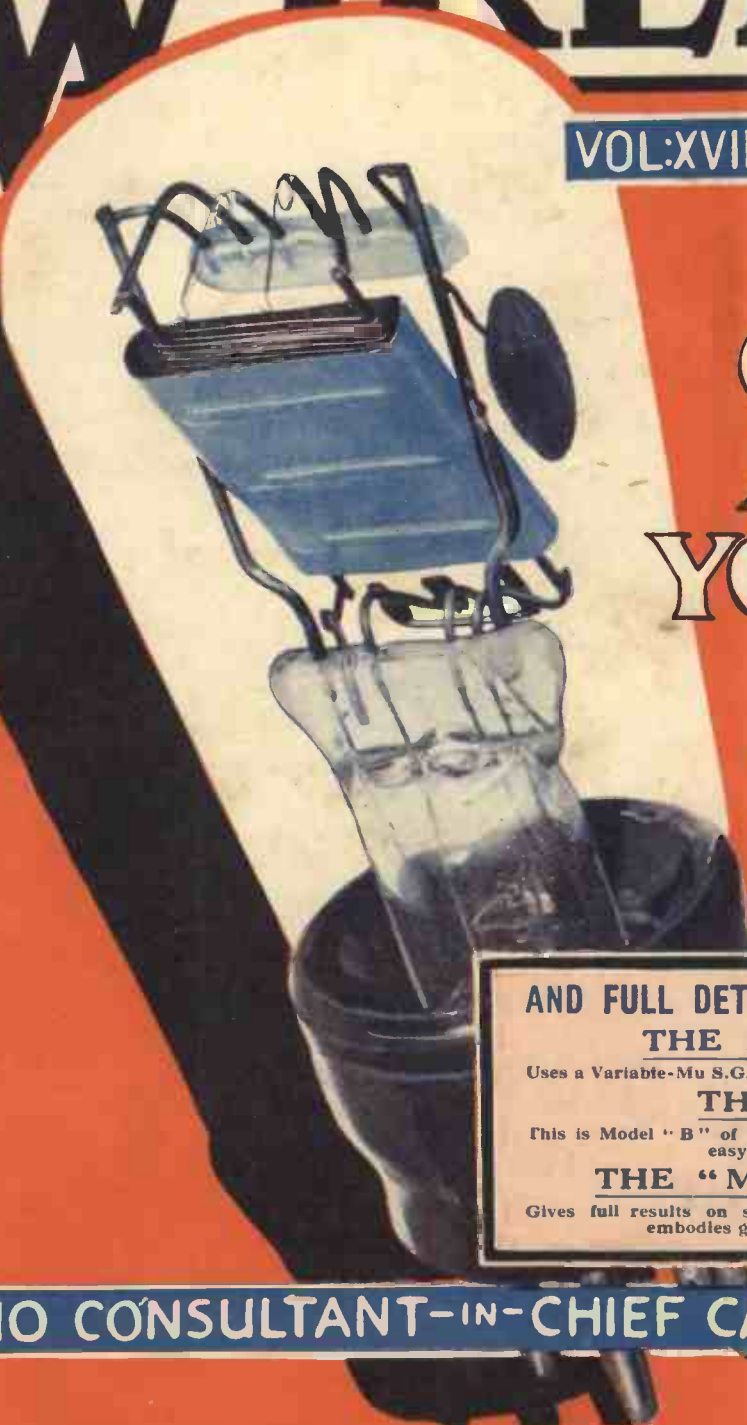

HOW TO CHOOSE AND USE YOUR VALVES

*See
Special
Supplement
Inside!*

AND FULL DETAILS OF THREE OUTSTANDING SETS: THE ECKERSLEY "VARMU"

Uses a Variable-Mu S.G. Valve, an Eckersley Tuner, and an Eckersley Intervalve Coil.

THE "CABINET" TWO

This is Model "B" of an artistic console set which is particularly inexpensive and easy-to-build. It uses a moving-coil speaker.

THE "M.W." "TRI-BAND" THREE

Gives full results on short, medium and long waves without coil-changing, and embodies gramophone switching and other modern features.

RADIO CONSULTANT-IN-CHIEF CAPT. P. P. ECKERSLEY M.I.E.E.

PRICES reduced

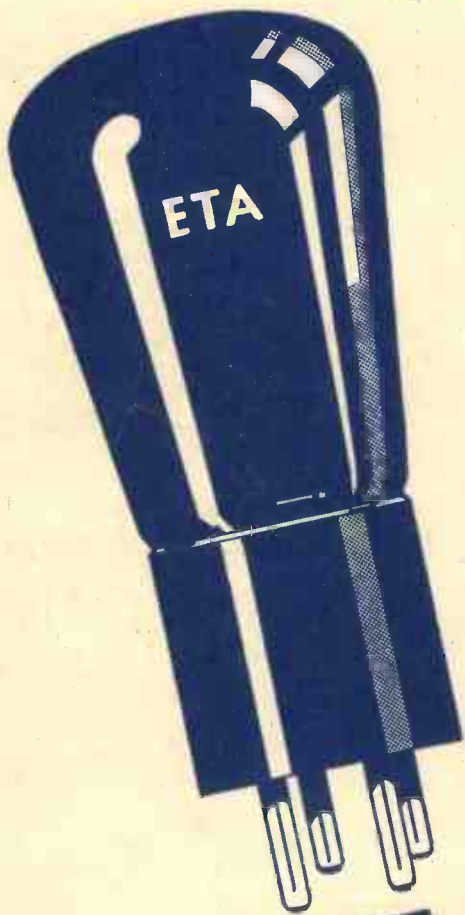

ETA
THE INTERNATIONAL VALVE

Increased sales and increased production have enabled us to reduce the prices of all types of ETA, the international valve.

The world produces no more efficient valves than ETA, no matter what you pay. Why then pay more than you need? ETA's price is the right price for the right valve.

THE ELECTRICAL TRADING ASSOCIATION LTD.

Aldwych House, Aldwych, London, W.C.2

**NEW
REDUCED PRICES
FROM**

6'3

CONTENTS

Vol. XVII. No. 64.

MODERN WIRELESS.

APRIL, 1932.

	Page		Page
Editorial	303	On the Test Bench	368
The B.B.C.'s Director of Radio Music	304	Trouble Tracking	370
The "M.W." "Cabinet" Two	307	"Power" Curves for Coils	372
Checking Distortion	312	On the Short Waves	373
Making Short-Wave Coils	327	Making the Most of Your Mains Unit	375
A Radio Reckoner	329	Questions Answered	376
What are Microfarads?	331	In Passing	377
The Eckersley "Varmu" Three	332	My Broadcasting Diary	379
Round the Turntable	340	Recent Record Releases	384
Improving S.G. Selectivity	357	At Your Service	385
An H.M.V. Mains Set	359	Readers' Researches	388
The "M.W." "Tri-Band" Three	360	Radio Notes and News	390
		Large Liner's Land-links	391
		A Simple "Super"	392

SPECIAL SECTION, "THE WORLD'S PROGRAMMES," PAGES 341-356
(See page 341 for contents of this comprehensive supplement).

A COMPLETE SURVEY OF MODERN VALVES, PAGES 313-326.

As some of the arrangements and specialities described in this Journal may be the subject of Letters Patent the amateur and trader would be well advised to obtain permission of the patentee to use the patents before doing so.

Edited by **NORMAN EDWARDS.**

Technical Editor: **G. V. DOWDING, Associate I.E.E.**

Radio Consultant-in-Chief: **Capt. P. P. ECKERSLEY, M.I.E.E.**

Scientific Adviser: **J. H. T. ROBERTS, D.Sc., F.Inst.P.**

EPOCH

PERMANENT MAGNET

**SPECIALLY CHOSEN FOR
THE "M.W." "CABINET" TWO**

REAL PIONEERS—YEARS AHEAD

in experience, research and design



MODEL J.1.

18 months before the many so-called pioneer claims to the production of the Permanent Magnet Moving-Coil Speakers, Epoch designed, developed and manufactured the first practical Permanent Magnet. Epoch's leadership in this class is definitely established by a new standard of comparison for performance and price set by Model J.1. The lowest price 9% cobalt steel Permanent Magnet Moving-Coil Speaker on the market. Comparable to instruments costing pounds more. The 3-Ratio Transformer fitted makes it ready to work instantly from any set with Pentode or Super Power output. When purchasing a Moving-Coil insist on EPOCH.

Send for Free Art Booklet P.S.5.

Complete with aluminium covered cobalt steel magnet, one-piece moulded linen diaphragm and 3-ratio input transformer. Ask your dealer for it. He will gladly demonstrate this or any Epoch Model. If you have any difficulty send for nearest dealer's name or call at our new showrooms and hear it.

45/-

(Complete with 3-Ratio Input Transformer.)

THE LATEST MODEL. 1 lb. HEAVIER MAGNET. EXTRA-ORDINARILY SENSITIVE. NO ADVANCE IN PRICE.
EPOCH RADIO MANUFACTURING CO., LTD., EXMOUTH HOUSE, EXMOUTH STREET, E.C.1

At the junction of Rosebery Avenue and Farringdon Road.

With 3-Ratio Input Transformer

COSSOR

—the valves with the

MICA BRIDGE—

THE development of the Cossor Mica Bridge system of construction has permitted the attainment of a much higher standard of valve efficiency. Under this method of construction the elements of every Cossor Valve are rigidly held in permanent alignment. All possibility of variation is eliminated thus ensuring life-long consistency and efficiency. By fitting Cossor Valves to your present Receivers a considerable improvement in performance can be effected at small cost.

COSSOR VALVES FOR THE "M.W." SETS DESCRIBED IN THIS ISSUE

"VARMU" THREE—*220V.S.G., *210H.F., 230P.T.

"TRI-BAND" THREE—*210H.L., 210L.F., 230X.P.

"CABINET" TWO (Model B)—*210H.L., 230H.P.T.

*Metallised

which ensures

EFFICIENCY and CONSISTENCY

A copy of the 72 page Cossor Wireless Book B11 will be sent you free on application to A. C. Cossor Ltd., Melody Dept., Highbury Grove, London, N.5.

Get one of the new Cossor Station Charts price 2d. Ask your dealer for a copy of this useful novelty or write to us enclosing 2d. stamp.

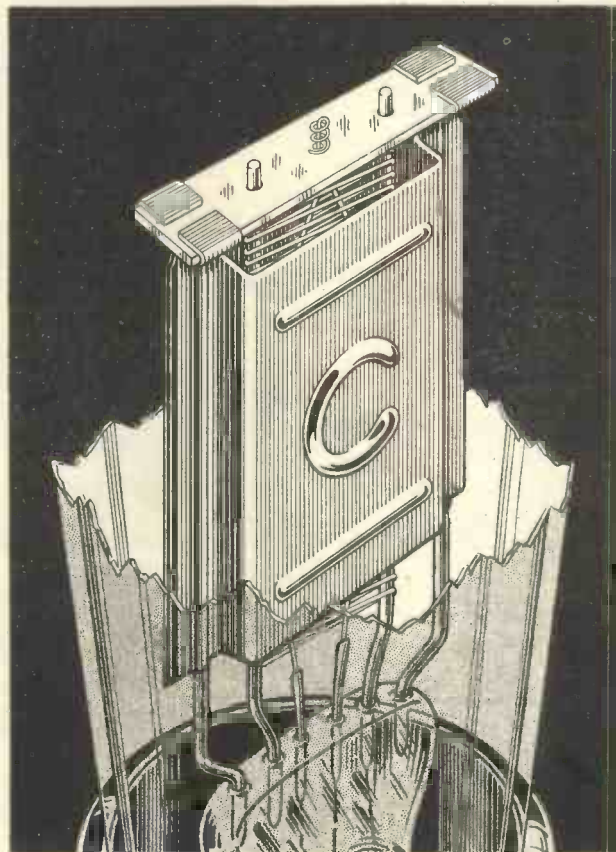

A. C. Cossor Ltd., Highbury Grove, London, N.5. Deposits at Birmingham, Bristol, Glasgow, Leeds, Liverpool, Manchester, Newcastle, Sheffield and Dublin.

MODERN WIRELESS



Vol. XVII. No. 64.

BRITAIN'S LEADING RADIO MAGAZINE.

APRIL, 1932.

Our Special Valve Section—Three Outstanding Sets—The Latest Demonstration of Officialdom as Applied to Radio.

WE are devoting a good deal of space in this special issue of MODERN WIRELESS to a complete survey of modern valves. We think our readers will find this section of considerable interest and importance.

For some time past, the technical staff have been carefully collecting data regarding all types of valves, and the result is that you have a classified review of information which should prove a valuable reference to all readers operating sets using valves—and, incidentally, we should like to hear from any reader who does *not* operate a valve set!

The crystal set has undoubtedly had its day—at least, as far as we can gather from the thousands of letters we receive from readers in the course of the year; but if there are any MODERN WIRELESS readers who are still making use of the old crystal—and a jolly good detector it was in its day!—we should be interested as a matter of curiosity to have details.

And in that event we advise crystal set users to keep this copy of MODERN WIRELESS by them, for the day will inevitably come when they will discard the crystal for the valve.

A Fine Set

THE Eckersley "Varmu" Three is the first Eckersley set of the powerful S.G., Det., Pentode variety.

Incidentally, it is also the first battery set to use a variable- μ valve.

In designing this set we have borne in mind the up-to-date requirements of the really modern home-constructor. Also in the special circuit you will find the now-famous Eckersley tuner and an Eckersley intervalve coil.

A cursory glance at the descriptive article will quickly demonstrate to readers the distinct originality of this receiver. Altogether it is a very notable production, and the results it gives are bound to attract widespread attention. The receiver has the selectivity of a super-het, but without the expense, complication and other drawbacks usually associated with a set of such distinctive character.

The other two receivers which we include in this issue of MODERN WIRELESS are: The "M.W." "Tri-Band"

Three, and the "M.W." "Cabinet" Two. The former is an all-wave set—short, medium and long waves are all available without coil-changing.

We think we are not exaggerating when we say that the "Tri-Band" achieves a maximum efficiency on each wave-length band. This is not a compromise set or, if you like it better, the sort of set where results are sacrificed in order to obtain a spectacular effect in design.

The "Cabinet" Two, Model B, is distinctly a simple but effective "M.W." console design. A moving-coil loud speaker of the inexpensive junior type is built in, and there is ample room for the batteries in this pleasing-to-the-eye cabinet set.

"What a Life!"

IN Germany before the War there was a craze which turned on the word "Verboten." In Berlin you were forbidden to do this, that and the other, until you had to memorise thousands of petty rules and by-laws which, if you broke them, might land you in for anything from a fine of five marks to five years' hard!

Luckily, in Germany to-day a good deal of this "verboten" business has gone by the board, but we are sorry to see in more than one way that it is creeping into this country. Readers don't need telling here the number of things they are forbidden to do in these post-war years, but perhaps the most amazing of all will be when the authorities who control our water supply issue the fiat that water-pipes must not be used for wireless earths.

Whether there is any real likelihood of this order coming into force we don't know as yet, but in a Sunday newspaper recently it was stated that after prolonged tests the Water Board authorities had come to the conclusion that the indiscriminate use of water-pipes for wireless earths was leading to a rapid deterioration of the pipes because of electrolysis being caused!

And if you switch over to a gas-pipe, I have no doubt that the Gas companies will in due course come to the conclusion that the gas-pipes are getting cancer or something, and in the end you will have to buy a large piece of tin, zinc, iron or steel and make a nice hole in the garden, fixing your earth that way.

What a life!





DR. ADRIAN BOULT

The B.B.C.'s of Radio

An intimate sketch of Dr. Adrian Boult.

WHAT a glorious opportunity! Who wouldn't like the chance to have absolute control of B.B.C. music, to broadcast just as much Jack Payne or as few Bach cantatas as you like?

That, in effect, is the Alpha and Omega of the job of Dr. Adrian Boult, the B.B.C. Musical Director, and I'll wager that although the average man would love to have this absolute control of the microphones for about twenty-four hours, there are few who honestly feel capable enough to take on the task for every day of the year.

A Very Busy Man

The Radio Plays Department does not have exclusive use of broadcasting hours, the Talks people appear only for a few hours out of every broadcasting day, and even the News Department can sometimes take a few hours off; but music goes on always. There is always some question of musical policy to be settled, some programme arrangements to be thought out, some concert details of the 114-member Symphony Orchestra to be dealt with,



A POPULAR TURN. The Stratton String Quartet broadcasting from London.

Director Music

By a Special Correspondent.

or some tricky personal question in the musical world to be settled amicably.

Dr. Boult is the man for all these jobs, some of them pleasant and many of them exceedingly irksome. He gets few thanks. He seldom "gets in the papers." It is not his business to do so.

He is our Musical Director and a virtual musical Mussolini, but he has perforce to sink part of his personality in the embracive scope of the Corporation. He is just one of those men who make the B.B.C. what it is without ever becoming conspicuous for doing so.

Thousands of listeners have seen him, tall and military, conducting at the Queen's Hall. A few have seen him conducting rehearsals in the studio.

"He Appears Impressive and Military"

To the vast majority he is just a name. "What does he do?" they ask. "What is he like?" "Is he qualified for the job?" "What was he before joining the B.B.C.?"

I did not know him personally before he came to the B.B.C. in March, 1930, but since his appointment I have had the pleasure of frequently coming into contact with him. That is not just politeness. It is a pleasure. His appearance belies his nature. He appears impressive (because of his height) and military and perhaps overbearing because of his manner.

A FAMOUS GUEST-CONDUCTOR



To the left, Dr. Richard Strauss is shown with Dr. Adrian Boult behind him, and Mr. Percy Pitt. At the top (circle) is Arthur Catterall, and below is a scene during a rehearsal of the B.B.C. Orchestra.

The Man Who Surprised the Pressmen!

It is a delusion which is dispelled immediately he speaks, in a soft, cultured voice very unlike the Licut.-Col. boom one naturally anticipates! He shares with Noel Ashbridge, the present Chief Engineer, the distinction of being admirably suited to the job, technically and socially.

"Is he qualified for the job?" they ask. I will tell you his life story as it was told to me.

He was born in Chester in April, 1889 (he is only 42, you see, despite the Shakespearean brow), and went to Westminster and Christ Church, Oxford. There he won his M.A., and is now, of course, a Doctor of Music. I do know that he had an early ambition to be something other than a musician, but at Oxford he settled all doubts.

An International Education

Immediately he came "down" he went off to the Leipzig Conservatorium to study music, and that is where he got his International education. Non-musical people may not understand how much Continental countries esteem him and what a favourable light it put upon the B.B.C. in musical circles of other countries when he was put in charge of the musical section.

Of course, he has travelled a great deal, in Munich, Vienna, Prague and Barcelona.

While he is at the B.B.C. he is tied to England alternating between London and Birmingham.

Friends of mine remember the days when he was President of the Oxford University Musical Club—that was somewhere about 1910—and he is still a member of the Oxford Union Dramatic Society. For six years he conducted the City of Birmingham Orchestra, the concerts of which were frequently broadcast before he joined the B.B.C. The Birmingham folk just went mad about him after the last concert, on March 27th, 1930, which he conducted before leaving for Savoy Hill.

Percy Pitt was the previous Musical Director, and Boulton took over at a very busy time. He is now in the throes of the Symphony Concert series, of which he is conducting twelve. Sir Henry Wood, Sir Landon Ronald, Richard Strauss and others are in charge at the other eleven.

In Absolute Control

Adrian Boulton is in absolute control of the 114-member Symphony Orchestra, which under his direction started life in the summer of 1930 and absorbed the Queen's Hall Orchestra and the old London Symphony Orchestra. An advance guard of ninety players ran the 1930 "Proms," Charles Woodhouse being the leader, and the full new orchestra of 114 made its debut on October 22nd at the Queen's Hall with the ever-popular Catterall as leader

All this was Boulton's work, and though there are many listeners who think that this giant orchestra is wasted on the average receiver, it must be remembered that it plays a very big part in the musical life of London, and Boulton's position socially is of the most vital importance

An Inherent Diplomat

He is the man who directs the "big policy." When there was trouble in the winding-up of the National Orchestra of Wales, and when there was dispute about the Manchester Hallé concerts, he had to step in as the diplomat; not too pleasant a job. Often because of the sheer magnitude of the B.B.C., and because of the knowledge that broadcast music could not be stopped by trivialities, he had to break with old friends in the musical world. A thankless job, and one meaning a whole lot of administrative work.

Last season he realised that he could not for ever go on spending worrying days in the office and then going off

to conduct heavy concerts at the Queen's Hall. So Owen Mase was appointed as Assistant Musical Director. He took over much of the administrative work, leaving Boulton more free to conduct. He is one of London's most popular conductors, and in stage parlance is a good box office "draw."

I vividly remember one Spring afternoon when there was an informal reception in the drawing-room at Savoy Hill, a few days after Boulton had had his appointment officially announced. About half a dozen of us, representing the British Press, sat down and frankly discussed with him his ideas about

B.B.C. music and orchestral policy.

"We Were Taken by Surprise"

We wanted to see what kind of a man he was, how he differed from the genial Percy Pitt and what he was going to do. We were prepared for something highbrow. We even dreaded that in a few days he might have become part of the B.B.C. "machine" and would say a lot without giving away secrets!

We were taken by surprise. "Gentlemen," he said, "don't be afraid that I intend cutting down the proportion of jazz music. I am going to be far too busy with big orchestral plans to do that!" Then he continued to reveal these plans, many of which (the big Symphony Orchestra, for instance) have since materialised, and he explained them in the intimate way of a man full of ambition, broad-minded enough to explain them to people who could not follow technicalities.

A National "Daily" man said to me as we left: "That man's going to do big things with the music of this country."

That is coming true.

THE CONFLICT IN THE FAR EAST



A picture of the first broadcast of Lieut.-General Araki, the War Minister of the Manchurian Expeditionary Forces.

The "M.W." "Cabinet" Two

(Model "B")



Last month we published details of Model "A" of this novel set, and now we are following it up with a second receiver of similar type, but employing a slightly different layout and several "extras." It is a very neat affair, and with the exception of aerial and earth is entirely self-contained.

THE "Cabinet" Two, Model A, that we have already described is a particularly easy set to build, but it may not be quite as ambitious from the cabinet point of view as many readers would like.

Extenser Tuning

Here, then, is a further model of the same set, using the same circuit, but housed in a much more elaborate cabinet, and with a moving-coil loud-speaker. The wave-change switching scheme also is different, being in this set controlled by an Extenser, thus eliminating all wave-change switches and simplifying the panel controls.

Naturally, the Model B is a little more expensive than the first model,

but the results are correspondingly better both in quality and in the number of programmes available.

The circuit is very similar to that employed in the first model, an ordinary grid-leak detector dual-wave stage being followed by a pentode output stage transformer-coupled to the detector.

The components used are different, for instead of the P.V. and P.J. coils, a dual-range coil of well-known make is employed, and provision for the use of a larger pentode valve is made by the use of a bigger output choke.

Selectivity control is obtained by a series variable condenser, which is mounted as standard on the top of the dual-range coil unit, though a choice is

offered of using or neglecting this condenser by the two aerial terminals on the coil unit itself. As you will see later, the connection of the aerial terminal of the set to terminal 1 on the coil unit cuts out the series condenser, while the use of terminal 2 places this component in circuit.

The first step in the construction of Model B is the building of the cabinet. This is entirely constructed of five-ply wood, which can be faced with a veneer of oak, mahogany, etc., as desired, or it can be merely stained to suit the likes of the constructor. The usual thickness of such plywood is $\frac{3}{8}$ th in., and the diagrams are drawn up to agree with that thickness.

Simple Cabinet

No back is made for the cabinet, as it would seriously interfere with the operation of the loud speaker, which is mounted on the sloping top of the cabinet.

Separate diagrams of the various pieces of wood are provided, and it is best to cut these and fit them together

EVERY COMPONENT YOU REQUIRE IS INCLUDED IN THIS COMPREHENSIVE LIST

PANEL

One 9-in. by 5-in. (Permoal, Becol, Ready Radio, Peto-Scott, Wearite, Goltone).

CABINET (See text).

VARIABLE CONDENSERS

1 .0001-mfd. differential reaction (Lotus, Telsen, Ready Radio, Peto-Scott, Polar, J.B., Cyldon, Ormond, Graham Parish).

EXTENSER

1 .0005-mfd. (Formo, Cyldon with plain dial, Wavemaster).

SWITCH

1 Push-pull on-off (Ready Radio, Telsen, Bulgin, Goltone, Peto-Scott, Graham Parish, Lissen, Igranice, Wearite, Colvern).

TRANSFORMER

1 L.F. (R.I. B.P. Telsen, Varley, Ferranti, Lewcos, Graham Parish, Igranice).

RESISTANCES

1 2-meg. grid leak (with holder, if necessary) (Graham Parish Ohmite, Igranice, Loewe, Dubilier, Telsen, Ready Radio, Ferranti, Watnet, Varley).
1 .15-meg. grid leak (Graham Parish, etc.).
1 25,000-ohm Spaghetti (Telsen, Lissen, Bulgin, Sovereign, Varley, Peto-Scott, Ready Radio, Igranice, Magnum).

VALVE HOLDERS

1 4-pin (W.B., Telsen, Wearite, Igranice, Bulgin, Clix, Graham Parish, Lotus).
1 5-pin (W.B., etc.).

FIXED CONDENSERS

2 .0003-mfd. (Ferranti, Dubilier, T.C.C., Telsen, Ready Radio, Lissen, Ediswan, Formo, Goltone, Sovereign, Watnet).
1 .01-mfd. mica (Dubilier, T.C.C., etc.).

1 2-mfd. (Dubilier, Telsen, T.C.C., Ferranti, Sovereign, Igranice, Lissen).

CHOKES

1 H.F. (Sovereign Senior, R.I., Wearite, Ready Radio, Telsen, Varley, Climax, Formo, Lewcos, Peto-Scott, Atlas, Dubilier, Magnum, Graham Parish, Tunewell).
1 L.F. pentode output (R.I. Pentamite, Tunewell, Atlas).

COIL

1 Telsen aerial dual-range.

MISCELLANEOUS

1 Terminal block and 2 terminals (Belling-Lee type B, Bulgin, Sovereign, Eelex, Igranice).
Glazite, Quickwyre, Jiffitinx, Lacoline.
Flex, screws, etc.
Battery plugs (Clix, etc.).

The Batteries Are Housed Inside the Receiver

before starting the construction of the set itself.

The base of the cabinet consists of a square piece of wood measuring $11\frac{1}{4}$ by $11\frac{1}{4}$ in. It fits inside the front and the two sides, hence its apparently peculiar dimensions.

Cutting the Wood

The front is made from a piece of wood measuring 12 by $8\frac{1}{2}$ in. This is the overall dimension before any chamfering is carried out.

After cutting the base and the front the two sides can be made. These should be carefully cut to size, otherwise the whole appearance of the cabinet may be spoiled. It is too easy in cutting such pieces to cut one a little bit too much, with the result that the top will be "cock-eyed," slanting either to the right or to the left.

Dead correctness of the slant of the two sides is essential to the final appearance of the cabinet, and so special care should be taken over this portion of the work.

There remains only the top on which the loud speaker is mounted. The dimensions of this piece of ply is 12 ins. square. We have not given the dimensions of the fret in the centre as this will depend upon the particular loud speaker used, and upon the constructor's own ideas upon the pattern he will employ for the fret.

Completing the Cabinet

In the particular set illustrated here an Epoch speaker (model J1) was employed, and this speaker can be recommended for the task, being sensitive and having quite a good response.

Before mounting the loud speaker, the sides, front and top should be fitted together, and the chamfering of the front and the top carried out carefully. When a good fit has been obtained the pieces can be taken apart again and the vignette in the front can be cut.

This is best carried out with a fret-saw, the dimensions being given in the diagram of the front piece of wood. A little beading can be fitted round the vignette if desired, and this would improve the appearance. Naturally, such moulding would, like the wood facing of the cabinet, be chosen to harmonise with the furniture of the room in which the set is to be used.

Behind the vignette is later fitted the panel, consisting of a rectangular

piece of ebonite, with the various components mounted upon it. The panel, of course, is fixed to the base of the cabinet, and the whole set is built and tested before the base is placed in position and the cabinet is screwed together.

We have seen how the various pieces of wood are cut to form the complete cabinet, now we must turn our attention to the building of the receiver proper.

This is done by screwing the panel to the front of the base, and treating the construction as if it were that of an ordinary receiver to fit into an ordinary cabinet.

If you turn to the wiring diagram

you will see that not quite all the components are mounted on the base, the aerial terminal block, the dual range coil and a fixed condenser are mounted on the one side of the cabinet. Nothing is fixed on the other side.

Normal Construction

We can, however, ignore this side mounting until quite a lot of the construction has been accomplished, and until nearly all the wiring has been carried out.

So we will proceed in the usual way. First the panel is drilled, and the reaction condenser, on-off switch, and the Extenser are fixed in position. Note that the Extenser is mounted

THE PARTS ARE ALL ASSEMBLED AT THE FRONT

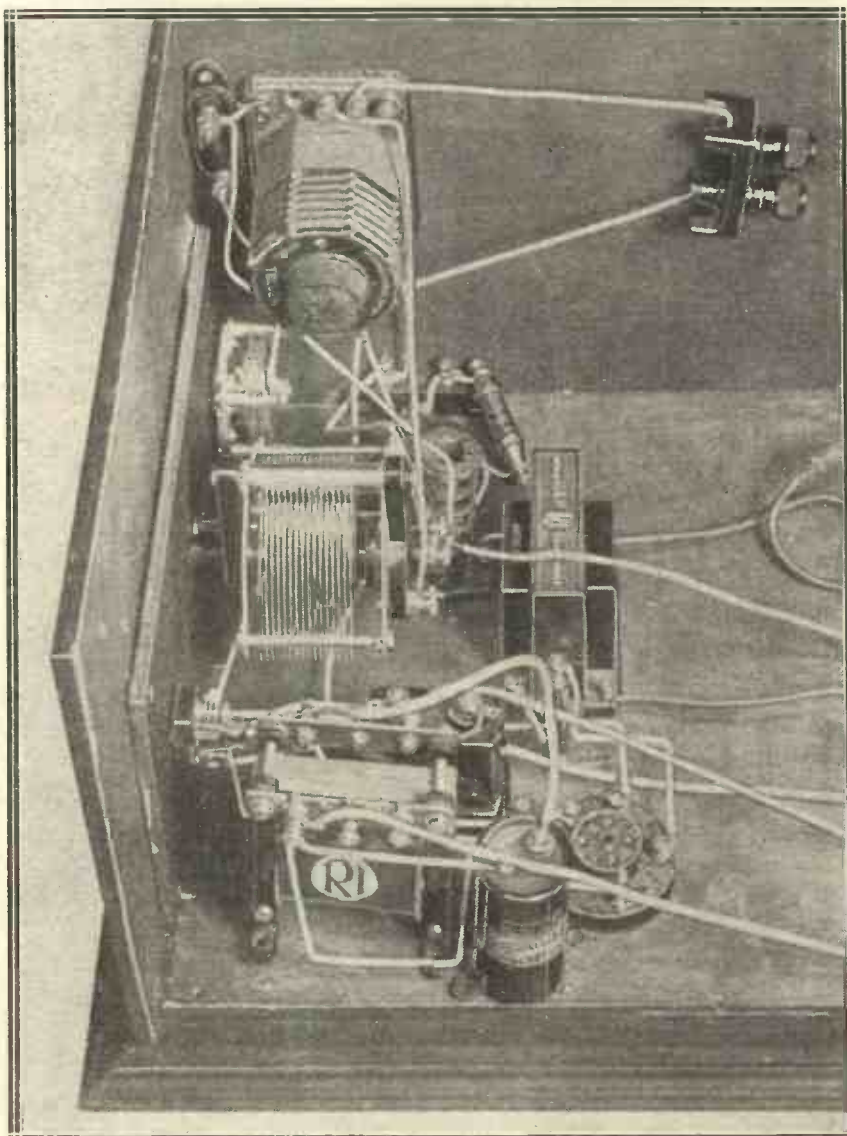

From this photograph you will get a good idea how all the components are mounted at the front of the baseboard. By employing this scheme there is ample space left for the H.T. battery and accumulator.

Ten Reasons Why You Should Build This Magnificent Two-Valver

- SINGLE-KNOB TUNING
- AUTOMATIC WAVE-CHANGING
- VARIABLE SELECTIVITY
- ECONOMICAL RUNNING
- SMOOTH REACTION

- MOVING-COIL LOUD SPEAKER
- VARIABLE RATIO OUTPUT FILTER
- TONE CORRECTION
- PENTODE OUTPUT
- SELF-CONTAINED

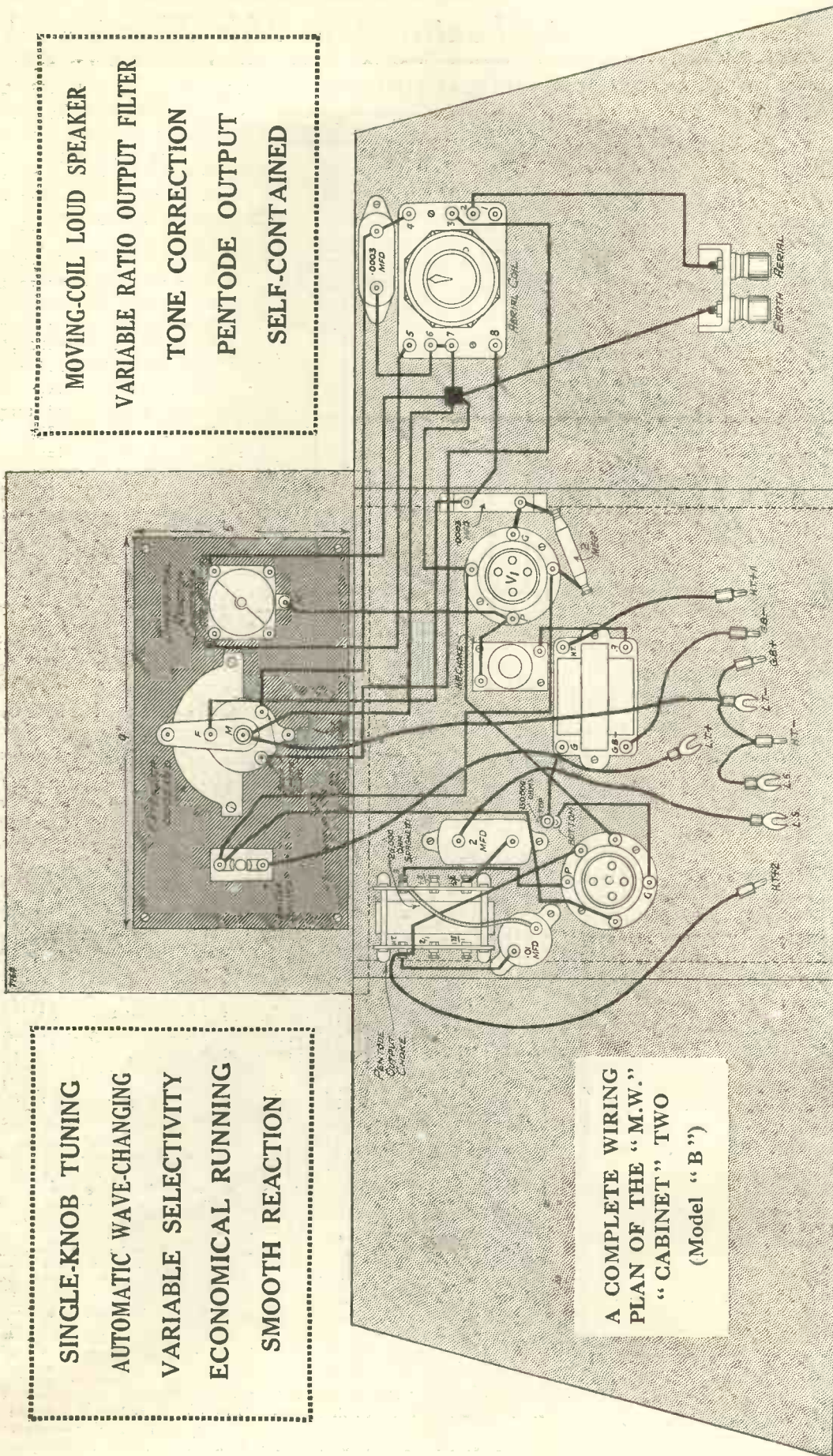

A COMPLETE WIRING PLAN OF THE "M.W." "CABINET" TWO (Model "B")

In this diagram you see the completed receiver as it would appear if the cabinet top were removed, and the two sides and front panel laid level with the baseboard. In a receiver of this type layout is not very critical, but it is as well to follow the original pretty closely in this particular set, otherwise difficulty might be experienced in accommodating the batteries. On the right of the diagram you will see the aerial tuning coil. This has a small variable condenser mounted on top which acts as a selectivity control. The reason it is not mounted on the panel is because once set to suit your own locality it need not be touched again.

Many Refinements Are Featured in This Fine Two-Valver

ALL WAVE-CHANGING ENTIRELY AUTOMATIC

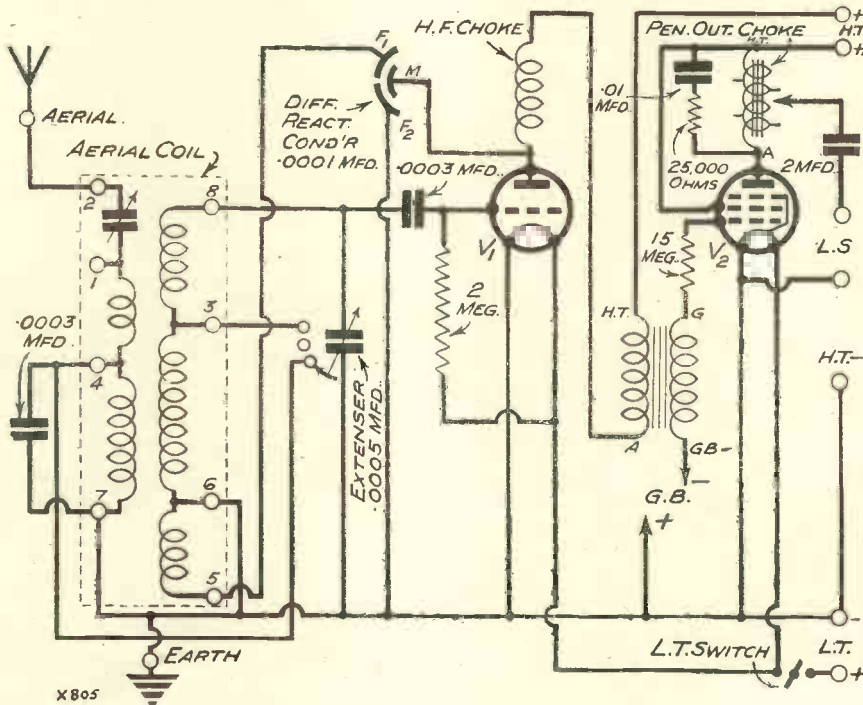

As the diagram shows, the set is a straight two, using a pentode valve in the output stage. Wave-change switches are dispensed with, the Extenser enabling the change from medium to long waves to be done automatically.

“upside down.” This is done for a purpose, so do not try and “right matters” by mounting it the other way up.

All the “baseboard” components can be mounted right away and the wiring commenced. This can be carried on quite a long way before you will find it necessary to fix the side to the base and to mount the last three components.

Regarding Wiring

For instance, the filament wiring can be done on both positive and negative sides, with the exception of the lead from V_1 to the junction between the earth terminal and terminal 7 on the coil unit.

The leads from terminal 7, earth, F_2 of the reaction condenser, and the moving vanes of the Extenser, need not be carried out exactly as shown in the wiring diagram. The easiest way to wire up these points is as follows:

Still leaving the side of the cabinet out of the picture, we can carry on in this wise. Take a lead from the negative terminal of V_1 to the moving vanes of the Extenser as well as to the filament of V_2 .

Later, when the side is fitted the remaining leads will be taken as follows: F_2 of reaction to earth terminal on the block, moving vanes of Extenser to terminal 7 on the coil, and a wire soldered on to join together both of these leads.

Battery Space

But we shall come to that part of the construction later on. Meanwhile we are busy with the wiring of the part on the base itself. This is perfectly straightforward, and no snags should be encountered. The layout should be carried out fairly closely to that shown, but at the same time it must not be forgotten that the set is completely self-contained and that this means that the H.T. battery and the L.T. accumulator have to be given space in the cabinet. Thus when mounting the various “baseboard” components it is a good plan to check up the amount of space that you are leaving for the batteries from time to time so that you shall not be disappointed later on.

A MOVING-COIL LOUD SPEAKER IS INCORPORATED

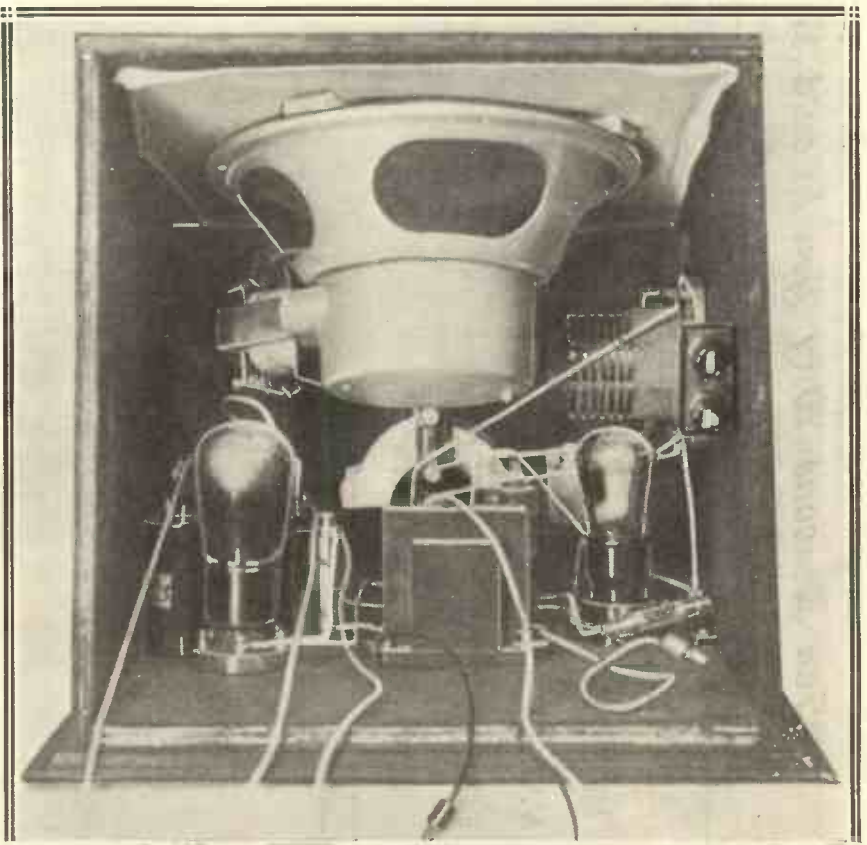

The loud speaker is mounted in the lid of the cabinet, and as it is of the moving-coil type, the highest quality reproduction is to be expected. The batteries are accommodated on that part of the floor of the cabinet in the foreground.

There is no danger of trouble occurring if the components are crowded a bit, provided that the packing is not carried too far. Obviously, the output choke must not be crowded on top of the detector circuit, otherwise reaction at low frequency is liable to take place.

The "Side" Components

When the wiring on the base has been carried out as far as possible the components on the side can be mounted and the side fitted on. Then the leads that we have already discussed can be connected up, and the few remaining connections to the coil, aerial terminal and the fixed condenser can be added.

The flex leads to connect the batteries can be added last, suitable size spade tags being connected to the leads for the loud speaker. One of

this state of affairs the tuning is very sharp, and if mechanical vibrations are transmitted to the Extenser, thus making the vanes vibrate, electrical vibrations in the tuning circuit are set up, with the result that a definite howl is generated.

Packing the panel a fraction of an

inch in which the set is to be used whether or not the series condenser on the coil is required. That will be decided by test, but if you are within twenty miles of a powerful station it is almost certain that you will want it.

In this case the lead from the aerial terminal is taken to terminal 2 on the coil, whereas if the condenser is not required the lead goes on to terminal 1.

Recommended Valves

The series condenser is turned to the right to increase selectivity, though at the same time the sensitivity is somewhat decreased, especially on the long waves.

The valves recommended for the set are an ordinary H.L., such as the H.L.2, and a pentode. Here we have a fair choice, dependent upon the requirements of the owner of

MAKE YOUR OWN CABINET

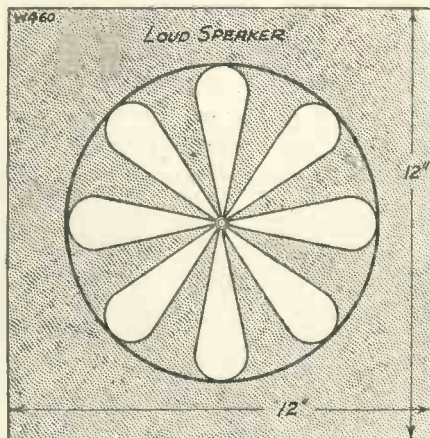

TOP

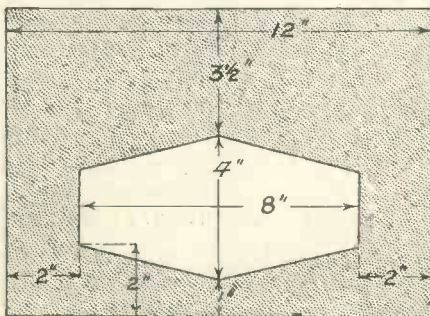

FRONT

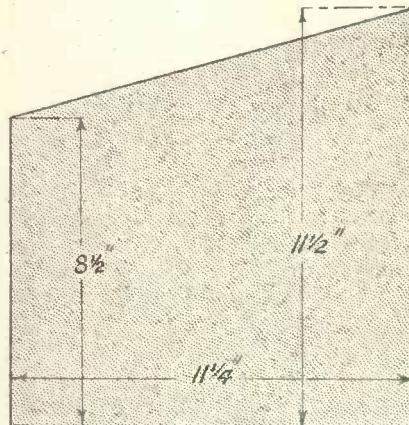

SIDE

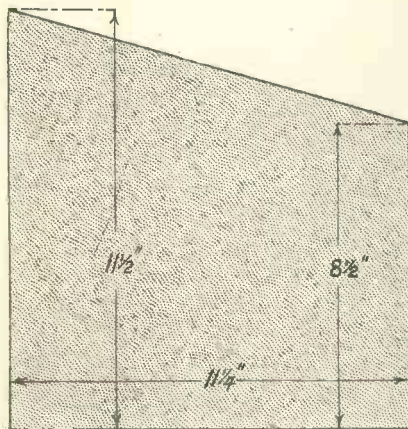

SIDE

The cabinet can be constructed throughout from the same sort of wood that is used for baseboards, namely, five- or seven-ply. If the job is carried out with due care quite a pleasing result can be obtained, especially if the wood is nicely polished.

The loud-speaker grill can best be cut out with a fretsaw, after which the rough edges should be cleaned up with sandpaper. The panel opening can be treated in a similar manner. All the necessary measurements are given in the accompanying diagrams

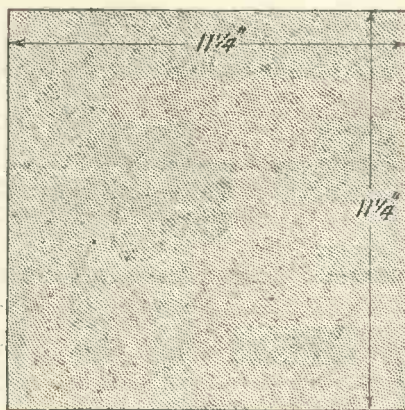

BASEBOARD

these it will be noted goes directly to the H.T.— plug.

It must be remembered that the panel must be fitted to the front before the side of the cabinet and its components can be fitted, and in this simple task there is an important point to watch. The panel must be packed a bit away from the front of the cabinet so that the vibrations from the loud speaker (which is screwed on the top of the cabinet) shall not be transmitted to the Extenser.

If this does take place there is a danger that the vibrations will cause a howl when the set is tuned in to a station and reaction is employed. In

inch by means of pieces of felt or cotton wool at the corners and not screwing up too tightly will obviate the trouble.

Series Aerial Condenser

When the wiring is completed the loud speaker should be rested on the top of the cabinet and the set tried out. It will depend upon the locality

the set. If he is desirous that all the batteries shall be right inside the cabinet, a small pentode of the order of the Pen.220 or the P.T.2 should be used. But if, as might easily be the case, the back of the set being open, the H.T. battery can be placed protruding a bit at the back, then a larger valve, such as the P.M.22, can be used.

This latter valve will, of course, give greater output and will work the loud speaker with more punch than the smaller valve, though, of course, it must be said that it will give a surprising output.

The bias battery will have to be chosen to suit the valve, and the

An Ideal Set for the Man with Limited Space

capacity of the H.T. battery will also depend on the output valve. If it is to be one of the larger pentodes, then a triple- or super-capacity battery should be employed. The Pen.220 needs only the ordinary capacity H.T. battery.

SUGGESTED ACCESSORIES

- Loud Speaker. (Epoch type J1.)
- Valves. 1 detector (Cosor, Mazda, Marconi, Mullard, Osram, Eta, Tungsram, Dario, Six-Sixty, Lissen).
- 1 pentode (Mazda Pen.220a, Mullard, Osram, Marconi, Six-Sixty, Tungsram, Cosor).
- Batteries. H.T., 120-volt (Pertrix, Ever Ready, Magnet, Drydex, Lissen, Ediswan).
- G.B., 9-volt (Pertrix, etc.).
- Accumulator. 2-volt portable type (Exide, Ever Ready, Lissen, Pertrix, G.E.C.).
- Mains Unit. To give 20 milliamps. at 120 volts (Regentone, Formo, Tannoy, R.I., Heayberd, Lotus, Ekco, Atlas, Tunewell).

There is little to be said about the operation of the set. It is quite straightforward. The Extenser dial should be placed in position with the vanes in full mesh, in which position the dial should read 200. Then the readings between 101 and 200 will tell you automatically that you are on the long waves, and readings between 0 and 99 that you are tuning on the medium band.

Adjusting the Tone

The taps on the output choke should be adjusted while the set is in operation, as should the various taps on the Epoch speaker, until the best quality and volume are obtained. The impedance equaliser (the resistance and condenser in series with each other and across the output choke) is for the

purpose of tone correction. It is adjusted as shown in the diagrams for most cases, but should you find the reproduction too high-pitched the resistance should be lowered in value; while if the tone is not brilliant enough the resistance can be increased.

Ideal for Locals

It should be remembered that the set is intended as a useful household

value, especially if the coil selectivity adjustment is towards the maximum position.

As a local-station set the receiver is extremely useful, for it is compact, and the quality and power are surprisingly good.

After tests have been carried out the set is ready for general use. The loud speaker is fitted permanently on the top board, the fret being covered

PLEASING PANEL PRESENTATION

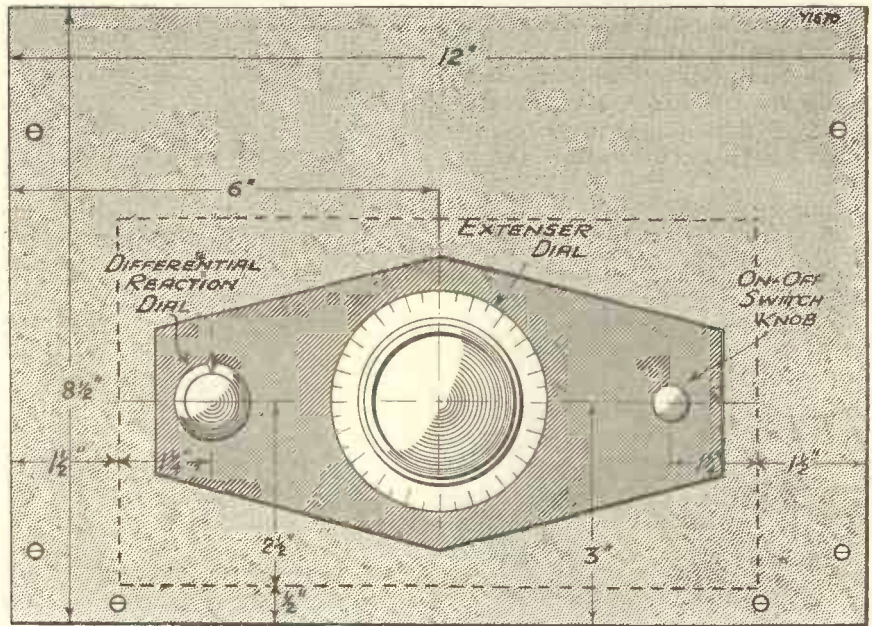

PANEL LAYOUT.

The controls of this receiver are very simple, there is a reaction knob, tuning dial and on-off switch—that's all. You will notice that there is no wave-change switch on the panel. This is because an Extenser is used for tuning, and this component enables the change from medium to long waves to be carried out automatically; 0-99 on the dial corresponds with medium waves, and 101-200 gives long waves.

local medium- and long-wave receiver, and is not intended as a distance-getter. It will get foreign stations under good conditions, but it is not to be expected that these will necessarily be of good programme

with some light silk, and the board is screwed down permanently, where its sloping position enables it to direct the sound upwards and forwards in a manner that is very valuable in the case of the average room.

Do you use a milliammeter to check up the presence of distortion in your set? If not, it is well worth trying, as much of the distortion encountered in radio reception is due to sheer overloading of one or other of the L.F. valves, or putting too much on the detector.

A certain amount of distortion is allowable, for it is on the cards that quite a measurable amount can be present before it is audible on the speaker. A milliammeter in the anode circuit of the last valve, however, will show up distortion long

CHECKING DISTORTION

How a meter can be made to tell you when your set is distorting.

before it makes itself felt by upsetting the reproduction from the loud speaker.

The meter should be capable of carrying the full anode current of the last valve, and it should have as light a needle movement as possible. A heavy needle will take a lot of shifting, and so the distortion will be

very pronounced before the needle kicks are noticed.

A meter with a total reading of 25 milliamps. is a size most usually useful, and it should have as wide a scale as possible. There is no need for it to be accurate if you are not going to depend on it for current measurement purposes, and a light movement meter of this description can be obtained for a few shillings.

The ideal reception would give no kick on the meter, but, as we said before, a certain amount of flicker does not matter.

A COMPLETE SURVEY OF MODERN VALVES

How to Choose and Use Your Valves for Best Results at Minimum Cost

The MAKES AND TYPES TO BUY

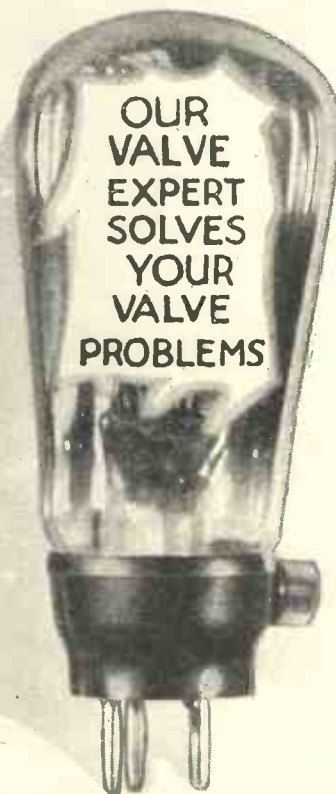
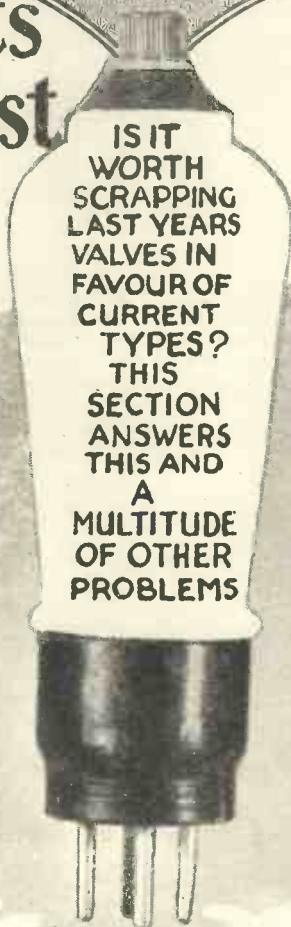

THE LATEST VALVES

In this article you will find an answer to many questions regarding that most important part of the receiver—the valve. From the tables you will be able to see the advantages the present-day types have over those of a year or two ago, and how you would be likely to benefit either by scrapping your old valves or re-arranging those you are now using.

By K. D. ROGERS.

QUITE recently we were asked by a confused reader why there were so many different types of radio receiving valves on the British market, and if they were really all necessary. Our answer, that

the number was the result of the policy of British manufacturers to keep the valve unstandardised, and therefore more or less uncontrolled as regards numbers of types, was at once met with another question that took some answering.

Practical and Complete

It is with the purpose of answering this latter query and similar queries that we are attempting to give in these pages a practical and complete survey

FOR THE DETECTOR STAGE.
Marconi, Mullard, and Cossor "detector" valves.

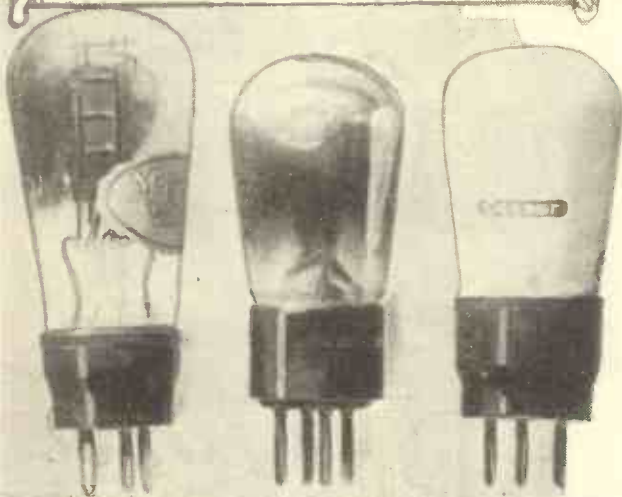

A MIXED QUARTET OF AMPLIFIERS.
Six-Sixty, Marconi, Dario, and Mullard output valves are seen here.



THE PENTODE PRESENTS CERTAIN PROBLEMS. BUT IT ALSO PRESENTS PLENTY OF POWER!
The valves below include the D.C./Pen. and battery valves, of Marconi, Osram, Mazda, and Cossor makes.

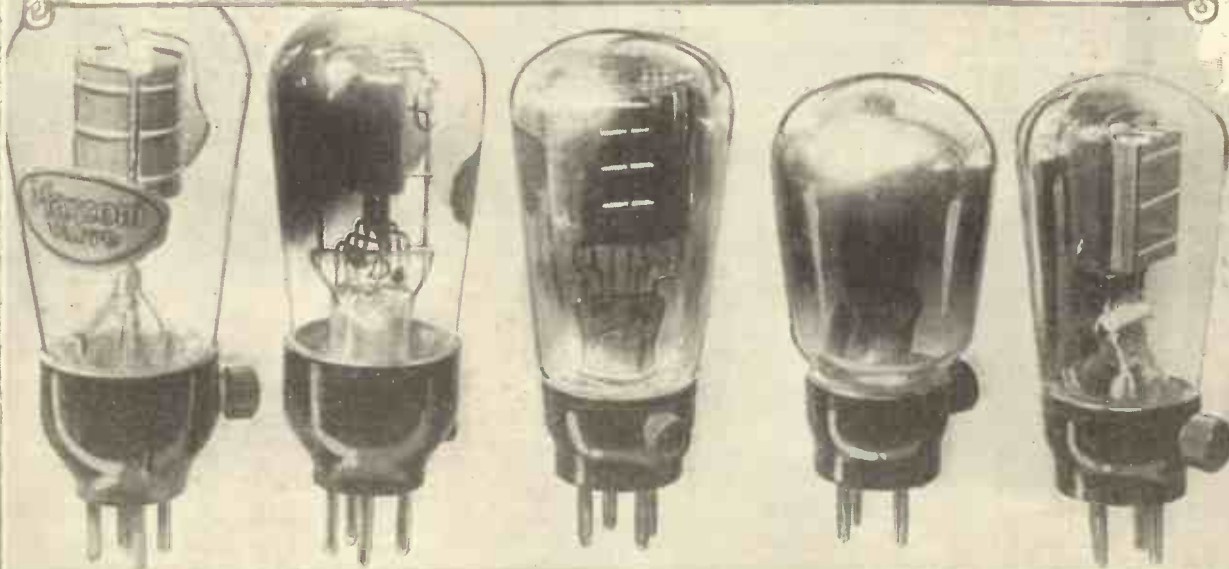

of the valve position as it affects the average set-user. It is not proposed to criticise or review the various valves, but to give their essential characteristics and explain briefly how they may be used.

A Tall Order

When you are asked how to differentiate between the hundreds of valves available, as we were in that second question to which we referred, it is impossible to give a definite answer in a comparatively few words.

Such a question demands a long discussion of the merits and demerits of the various valves, as operated in various circumstances.

For instance, it would be unfair to expect, say, one particular type of screened-grid valve always to function with full efficiency no matter what the constants of the circuit were.

In order that the very best may be obtained from a valve the circuit in which it is placed must be arranged to suit it. Or, conversely, if we want to get the most out of a circuit we must choose the right valve to operate in it.

The Better Plan

Of the two it is the better plan to choose one's valves first and arrange the circuits to suit them; that is what the set designer does. But as a rule the home constructor has the circuit all mapped out for him, and he is faced with the choice of valves to suit the set.

This is not difficult if he knows the

various types of valves from which he can make his choice, and it is the purpose of this section to throw some light upon the vexed question of "Which valve shall I choose?" by describing briefly the various types of valve on the market and showing how various makes and classes correspond or differ.

Six Main Divisions

To do this we must of necessity group them roughly, and having done so we will

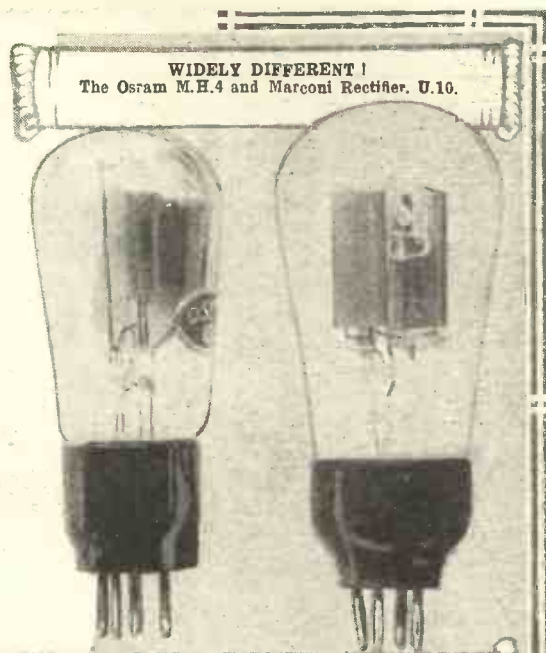

WIDELY DIFFERENT!
The Osram M.H.4 and Marconi Rectifier, U.10.

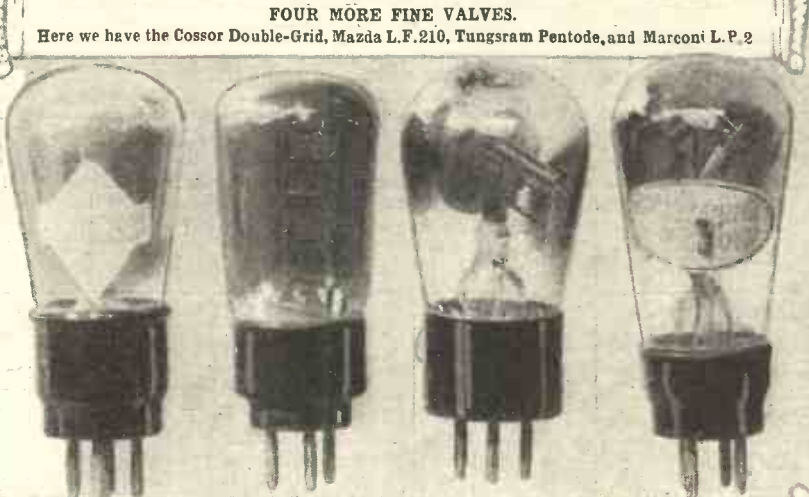

FOUR MORE FINE VALVES.
Here we have the Cosor Double-Grid, Mazda L.F.210, Tungram Pentode, and Marconi L.P.2

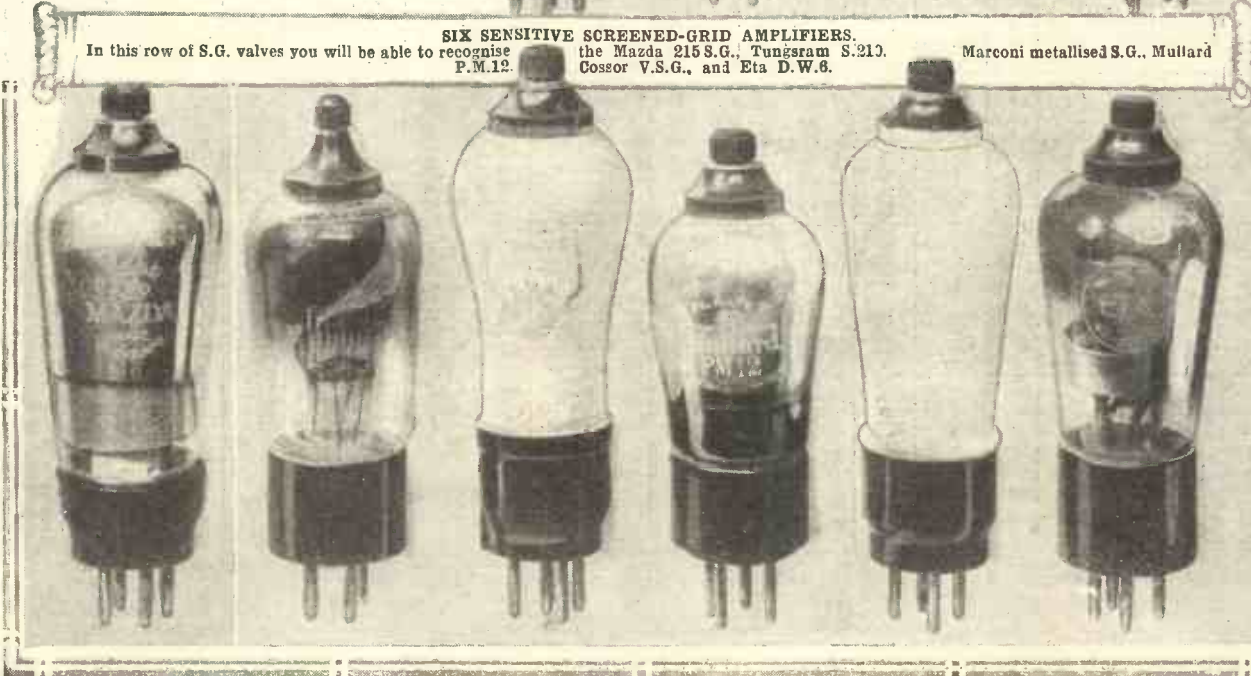

SIX SENSITIVE SCREENED-GRID AMPLIFIERS.
In this row of S.G. valves you will be able to recognise the Mazda 215 S.G., Tungram S.210, Cosor V.S.G., and Eta D.W.6. Marconi metallised S.G., Mullard

WHEN THE "TUBE" WAS OPENED

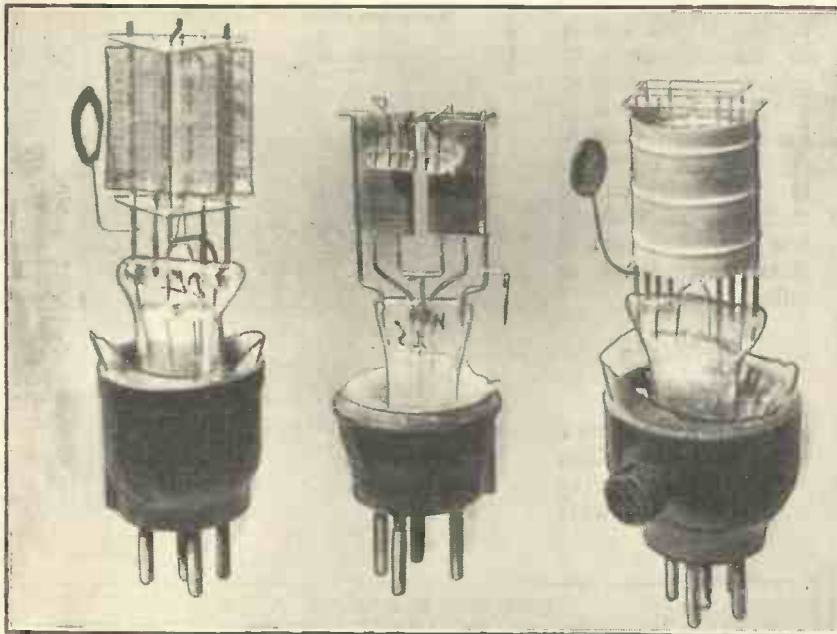

Here are three vastly different examples of internal valve structure. They belong to the Mains H.L. (Marconi), U.10 (Osram rectifier), and A.C./Pen. (Mazda) types.

endeavour in the space at our disposal to break up the groups into more closely accurate sections.

Taking the average radio set, there are six main divisions in the types of valves that can be used. They are: Screened grid, detector, low-frequency amplifier, power, pentode, and mains rectifier.

Alarming Overlap!

"Oh," you will say, "they have missed out the neutralised H.F. amplifier, super-het. oscillators, and so on."

True; but on examination you will find that immediately you begin to look at the classification you start to find that the types overlap in a most alarming way. S.G. valves can be used as detectors and as R.C. coupled amplifiers, as well as for their legitimate task. The

USEFUL BATTERY DETECTOR VALVES

Make	Type	Fil. volts.	Impedance.	Amp. fac.	Likely anode current with 60-80 volts and leaky grid rectification*	Usual coupling	Make	Type	Fil. volts.	Impedance.	Amp. fac.	Likely anode current with 60-80 volts and leaky grid rectification*	Usual coupling	
COSSOR ..	210H.L.	2	22,000	24	1.2	R.	MAZDA	H.L.210	2	18,500	26	1.25	R. or T.	
	210H.F.	2	15,000	24	1.8	R. or T.		H.L.2	2	21,000	32	1.25	R.	
	210Det.	2	13,000	15	2.5	R. or T.		L.210	2	10,000	17	3.2	R. or T.	
	210L.F.	2	30,000	14	3.5	T.		L.2	2	10,000	19	3.2	R. or T.	
	410H.F.	4	20,000	22	1	R.		H.L.610	6	20,000	22	1.2	R.	
	410L.F.	4	10,000	17	3	R. or T.		MULLARD ..	P.M.1H.F.	2	22,500	18	1.2	R.
	610H.F.	6	20,000	20	2.5	R.			P.M.1H.L.	2	14,000	28	1.5	R. or T.
610L.F.	6	7,500	15	2.5	T.	P.M.2D.X.	2		10,000	19	3	R. or T.		
DARIO ..	Super H.F.	2	20,000	32	1.2	R.	P.M.1L.F.	2	12,000	11	3.2	R. or T.		
	Super Det.	2	7,500	15	2.5	T.	P.M.3	4	13,000	14	2.5	R. or T.		
	Universal	2	8,000	10	2	T.	P.M.4D.X.	4	7,500	15	1.2	T.		
	Super H.F.	4	20,000	32	1.2	R.	P.M.5D.	6	20,000	26	1.2	R.		
	Universal	4	7,500	15	2.5	T.	P.M.5X.	6	14,700	17.5	1.2	R. or T.		
ETA ..	B.Y.2020	2	20,000	20	1.0	R.	SIX-SIXTY ..	S.S.210H.F.	2	25,000	19	1.2	R.	
	B.Y.1814	2	14,000	18	1.5	R. or T.		S.S.210H.L.	2	17,200	26	1.2	R.	
	B.Y.1210	2	10,000	12	1.5	T.		S.S.210L.F.	2	12,500	10.6	2.2	T.	
FOTOS ..	B.C.9	2	9,000	9	1.5	T.	S.S.210D.	2	10,600	17	2.7	R. or T.		
	B.C.18	2	20,000	16	1	R. or T.	S.S.4075H.F.	4	12,500	13.5	2	R. or T.		
	D.40	4	30,000	36	1	R.	S.S.410D.	4	7,250	14.5	2	R. or T.		
	D.15	4	7,500	15	2	T.	S.S.6075H.F.	6	15,200	17	1.5	R. or T.		
LISSEN ..	H.L.210	2	20,000	20	1.2	R.	TRIOTRON ..	H.D.2	2	21,000	15	1	R.	
	H.L.2	2	21,000	32	1	R.		S.D.2	2	10,000	20	2	R. or T.	
	L.210	2	10,000	12	2	R.		T.D.2	2	10,000	10	2.6	T.	
	L.2	2	10,000	20	1.5	R. or T.		W.412	4	21,000	25	1	R.	
	H.L.D.410	4	21,000	25	1	R.		H.412	4	7,500	9	2.5	T.	
	L.410	4	8,500	15	2	R.		A.420	4	7,500	15	1.2	T.	
	H.L.D.610	4	21,000	25	1.5	R. or T.		W.420	4	20,000	40	1.5	R.	
	L.610	6	8,000	16	2	T.		A.430	4	8,300	25	1	R. or T.	
MARCONI AND OSRAM	H.2	2	35,000	35	1	R.	TUNGSRAM	H.210	2	25,000	25	1	R.	
	H.L.210	2	23,000	20	1.5	R.		L.210	2	16,000	16	1.2	R. or T.	
	H.L.2	2	18,000	27	2.8	R. or T.		L.G.210	2	10,000	10	1.5	T.	
	L.210	2	12,000	11	3.2	R. or T.		P.D.220	2	10,000	16	1.2	R. or T.	
	L.2/B.	2	10,000	15.5	3	R. or T.		H.407	4	25,000	35	1	R.	
	(Marconi)	2	10,000	15.5	3	R. or T.		H.B.406	4	17,000	25	1	R. or T.	
	H.L.410	4	20,800	25	3	R.		H.B.410	4	17,000	25	1	R. or T.	
	L.410	4	8,500	15	3	R. or T.		R.406	4	21,000	25	1	R.	
	H.L.610	6	30,000	30	1.5	R.		L.D.408	4	8,500	17	1.5	R. or T.	
	L.610	6	7,500	15	3	T.		L.D.410.	4	7,500	15	1.8	T.	
						H.R.607	6	35,000	30	1	R. or T.			
						L.G.607	6	8,250	16.5	1.5	T.			

NOTE.—Other valves, such as those with impedances above 40,000 ohms, not mentioned here, can be used on occasion as detectors, but the above are those most generally suitable. Double-grid detectors for super-het receivers are made by Cossor, Marconi, Mullard, Osram, Six-Sixty, and Triotron, and Cossor and Triotron also have mains double-grid valves. Loewe valves are omitted as they are of the special multiple-stage variety. *Four- and six-volt valves should always be used with a potentiometer to control the positive bias, otherwise the bias will be too great and the anode current excessively large. The anode current drops when a station is tuned in, the drop being dependent on the strength of the station. The actual anode current will also be dependent on the resistance of the valve and the total resistance of the anode circuit. The figures given will show, however, that there is a real danger of transformer saturation unless the "size" of the transformer primary is carefully considered.

so-called H.F.-detector valve (the H.L. and det.) can also be used for L.F. amplification, or as a superhet. oscillator, to say nothing of a neutralised H.F. amplifier.

And so it goes on. It is convenient, but at the same time it can be misleading to classify valves in the conventional manner as S.G., Det., L.F., Power, and so on. They should be regarded as valves with no special purpose, but with certain characteristics that make them suitable for use in certain positions in a radio receiver, the position depending upon the characteristics of the circuit.

An Excellent Detector

For instance, it is better to look upon the average L.F. valve as one having an impedance of something like 10,000 ohms and a mutual conductance of 1.5, and therefore suitable for any job where the anode circuit is of suitable impedance for that valve to operate satisfactorily, than to say that it is an L.F. valve, and that there the matter ends.

Perhaps the better example is the P.M.2D.X., an avowed detector, but one that has characteristics that make it eminently suitable as a first-stage

L.F. amplifier. Whereas the Cossor 210 H.L., whose initials would lead one to suppose that it was an H.F. or L.F. amplifier, is really suitable only in limited cases for the last task, while as a detector it is excellent.

You will see from the lists accompanying this article how the various makes and types of valves compare, and what valves

are substitutes for what others, in a general sense, but further details of the different types will be of assistance, especially in the choice of S.G. and L.F. and power valves.

The S.G. Valve

The S.G. valve has been very greatly exploited during the com-

paratively short time that it has been in existence, and the number of so-called distinct types that are available make it very difficult to pick out one for any particular purpose.

Let us have a look at the battery screened-grid valves shown in the table. Here we see that

INDIRECTLY-HEATED DETECTORS

Make	Type	Fil. volts	Impedance	Amp. fac.	Anode current	Inter-valve coupling
COSSOR	41M.R.C.	4	19,500	50	1	R.
	41M.H.	4	18,000	72	2.5	R.
	41M.H.F.	4	14,500	41	1.9	R. or T.
	41M.H.L.	4	11,500	52	2	R. or T.
DARIO	Super H.F. Super Det.	4	20,000	40	—	R. or T.
ETA	D.W.4023	4	23,000	40	1.5	R.
	D.W.1508	4	7,500	15	2	T.
	E.Y.827	2.5	9,000	9	—	T.
FOTOS	S.440	4	7,500	15	—	T.
	S.415	4	20,000	40	—	R. or T.
	T.425	4	8,000	24	—	R. or T.
LISSEN	A.C./H.L.	4	11,700	35	2.5	R. or T.
MARCONI AND OSRAM	M.H.4	4	11,100	40	3	R. or T.
	M.H.L.4	4	8,000	20	3	R. or T.
	D.H. (D.C.)	16	10,800	40	4	R. or T.
MAZDA	A.C./H.L.	4	11,700	35	.3	R. or T.
	A.C.2/H.L.	4	11,500	75	3	R. or T.
	D.C./H.L.	6	13,000	35	2.25	R. or T.
	(D.C.)					
MULLARD	904V.	4	13,000	35	2.5	R. or T.
	354V.	4	10,000	35	4	R. or T.
SIX-SIXTY	S.84D.X.A.C.	4	17,700	85	2.5	R. or T.
	S.84G.P.A.C.	4	10,300	35	3	R. or T.
TRIOTRON	W.415N.	4	23,000	35	1.8	R.
	A.430N.	4	8,300	25	3.5	R. or T.
TUNGSRAM	A.R.4100	4	17,000	33	1.5	R. or T.
	A.R.495	4	17,000	85	2.2	R.
	A.R.4101	4	13,300	40	1.5	R. or T.
	A.G.4100	4	8,000	16	2.5	R. or T.

WOULD YOU LIKE TO MAKE THESE?

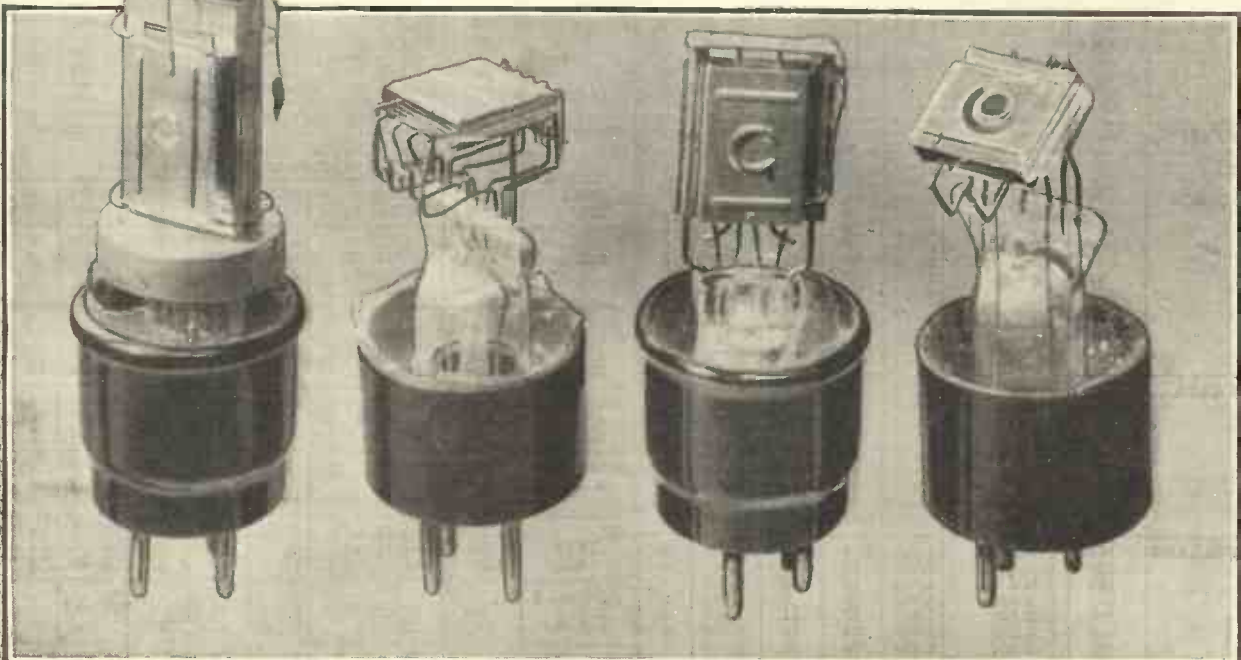

It takes highly skilled workmanship to turn out this sort of thing. The photograph shows the inside of the Cossor S.G., a typical H.L. valve, Cossor Det.210, and a small L.F. valve.

very efficient coils to match the high impedance of the valve.

The result in most cases is a low stage gain; not that this is a disadvantage if you are designing a set with several S.G. stages, or to be used near a powerful transmitter, for such a valve is not so likely to cause cross-modulation as is the higher-mu valve.

Classifying S.G.'s

Thus we see that, although there is no hard and fast division, we can roughly classify the S.G. valves into single- and multi-stage valves. Where we want the most out of a single stage we use one with as low an impedance as possible, but with a correspondingly high amplification factor (that is, a valve with as high a mutual conductance as possible), and for a two or more stage set we take a valve with a lower mutual conductance.

In the first case, of course, it is essential to have a valve with as low an impedance as possible,

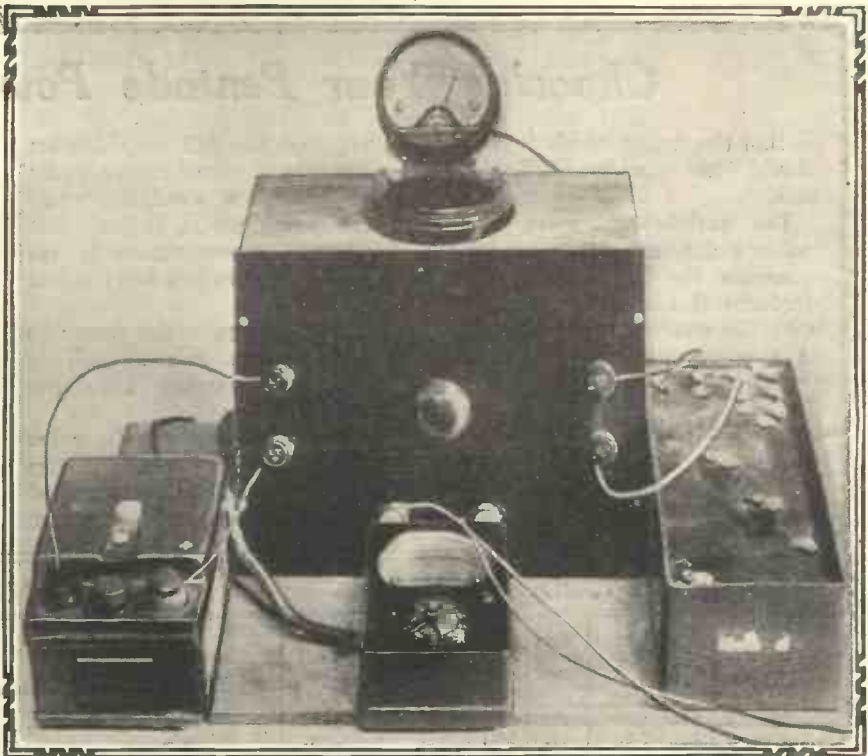

A simple valve voltmeter used to measure the H.F. input from a station, or the efficiency of a tuning system.

SCREENED-GRID H.F. AMPLIFYING VALVES

BATTERY TYPES

Make	Type	Impedance	Amp. factor	Filament volt
COSSOR	220V.S.G.	110,000	176 (Var. Mu.)	2
	220S.G.	200,000	320	2
	215S.G.	300,000	330	2
	410S.G.	200,000	200	4
	610S.G.	200,000	200	6
DARIO	S.G. (Two-volt)	200,000	200	2
	S.G. (Four-volt)	200,000	200	4
ETA	B.Y.6	300,000	300	2
FOTOS	B.C.150	170,000	170	2
	C.150	170,000	170	4
LISSEN	S.G.215	300,000	300	2
	S.G.410	200,000	180	4
MARCONI AND OSRAM	S.215	200,000	170	2
	S.21	200,000	220	2
	S.22	200,000	350	2
	S.410	200,000	180	4
	S.610	200,000	210	6
MAZDA	S.G.215	370,000	400	2
	S.215A	727,000	800	2
	S.215B	333,000	500	2
MULLARD	P.M.12	180,000	200	2
	P.M.14	230,000	200	4
	P.M.16	200,000	200	6
SIX-SIXTY	S.S.215S.G.	190,000	200	2
	S.S.4075S.G.	220,000	190	4
	S.S.6975S.G.	210,000	190	6
TRIOTRON	072	285,000	200	2
	084	310,000	250	4
TUNGSRAM	S.219	333,000	400	2
	S.407	330,000	330	4
	S.410	330,000	330	4
	S.X.2220	412,000	330	3-3

INDIRECTLY-HEATED VALVES

Make	Type	Impedance	Amp. factor	Heater	
				V.	A.
COSSOR	M.S.G.L.A. (A.C.)	200,000	750	4	1
	41M.S.G. (A.C.)	400,000	1,000	4	1
	M.S.G.H.A. (A.C.)	500,000	1,000	4	1
	M.S./Pen.A. (A.C.)	H.F. Special		4	1
		Pentode			
DARIO	A.C.4091 (A.C.)	1,000,000	1,000	4	1
ETA	D.W.2 (A.C.)	200,000	240	4	1
	E.Y.835 (A.C.)	350,000	385	2-5	1-75
	E.Y.824 (A.C.)	400,000	400	2-5	1-75
	D.W.6 (A.C.)	800,000	1,000	4	1
FOTOS	P.4150 (A.C.)	125,000	250	4	1
	S.4160 (A.C.)	425,000	400	4	1
MARCONI AND OSRAM	M.S.4B. (A.C.)	350,000	1,120	4	1
	V.M.S.4 (A.C.)	450,000	500	4	1
			(Var. Mu.)		
	M.S.4 (A.C.)	500,000	550	4	1
MAZDA	D.S.B. (D.C.)	350,000	1,120	16	0-25
	D.S. (D.C.)	500,000	550	16	0-25
MAZDA	A.C./S.G. (A.C.)	400,000	1,200	4	1
	A.C./S.2 (A.C.)	600,000	3,000	4	1
	D.C./S.G. (D.C.)	363,000	1,000	3	0-5
MULLARD	S.4V.B. (A.C.)	257,000	900	4	1
	M.M.4V. (A.C.)	300,000	900	4	1
			(Var. Mu.)		
	S.4V.A. (A.C.)	430,000	1,500	4	1
SIX-SIXTY	S.4V. (A.C.)	909,000	1,000	4	1
	S.S.4V.S.G.A.C. (A.C.)	257,000	900	4	1
	S.S.4M.M.A.C. (A.C.)	300,000	900	4	1
TRIOTRON	S.S.4X.S.G.A.C. (A.C.)	485,000	1,600	4	1
	S.S.4S.G.A.C. (A.C.)	1,000,000	1,000	4	1
			(Var. Mu.)		
TUNGSRAM	304A.C. (A.C.)	100,000	300	4	1-1
	104A.C. (A.C.)	150,000	150	4	0-9
	124A.C. (A.C.)	400,000	500	4	0-9
	S.2010N (D.C.)	150,000	150	20	0-18
	094 (D.C.)	350,000	310	4	1
TUNGSRAM	A.S.4100 (A.C.)	180,000	250	4	1
	A.S.X.:240 (A.C.)	400,000	400	2-5	1-75
	A.S.495 (A.C.)	428,000	1,500	4	1
	A.S.494 (A.C.)	667,000	1,000	4	1

Good Makes Mean Good Results



with the screening then in use, by using a valve with a lower mutual conductance. The variable- μ mains valve is also a useful friend in such a case, for then

one can get right up to the spill-over point without actually going into oscillation. But such treatment of what is really a fault in the design of the set is only a palliative. It does not remove the real cause of the trouble—inefficient screening.

The use of the S.G. valve is so common nowadays that there is no need for us to go into details of actual practice, other than to emphasise the necessity of correct adjustment of the screen and anode voltages, and to stress the importance of proper decoupling and efficient screening, especially where more than one stage of S.G. is employed.

The Detector

The detector is one of the most important valves in a set. And yet it is easily chosen, in spite of the multitude of suitable valves that are available.

They are not all the same, of course, and a certain amount of "savvy" is required if one is to get the very best out of the stage. But practically any H.L. valve "will do," and it is only when we think of such things as anode circuit impedance,

saturation current of small transformers, that we have to watch our p's and q's.

There are on the market something like 75 to 80 battery valves that are more or less suitable for use as detectors. From such a galaxy it should not be difficult to pick some really good ones.

An Important Factor

In a detector, as in the amplifier, the impedance is of paramount importance, and when the impedance has been roughly decided then the valve with the best mutual conductance is chosen.

Usually a valve with an A.C. resistance of between 10,000 and 20,000 ohms is chosen, for such values are low enough to enable a good percentage of the maximum amplification to be obtained, and high enough not to cause serious loss of anode-filament voltage (in the case of R.C.C.) or saturation of the transformer primary in the case of transformer coupling, especially where the nickel-iron-cored transformer is employed.

Just to see how one would pick out a valve for a set, let us take an imaginary case. The set is transformer coupled with a make of transformer that has a primary of quite good inductance, but a "small" core that allows no more than 3 milliamps. of primary current before saturation sets in.

We look out for a valve that has a fairly low impedance, so that the low-note reproduction shall be up to scratch. A high impedance valve would mean a rather serious falling off of the lower musical frequencies.

On Studying the Curves . . .

We also remember that as the valve is to be operated on the "leaky-grid" principle (on the grid-current-grid volts curve bend) the anode current must be carefully watched in order that it shall not exceed the 3-milliamp. safety mark.

On studying the curves we find that there are very many of the 75 that pass more than 3 milliamps. when operated at zero bias, the state of affairs that represents about the average condition of the valve when

operating under normal conditions (not power grid) on the local station. On distant transmissions the bias will be more positive, and so the anode current will be higher.

Taking into consideration the resistance of the anode circuit, which even with transformer coupling will make the voltage on the anode considerably less than that of the applied voltage from the H.T. battery, we look through the curves until we find a valve with a consumption of less than the 3 milliamps.

Continuing the Search

In fact, we pick out a number of such valves, noting their impedances and their mutual conductances. We then choose a valve with as low an impedance as possible and as high a mutual conductance.

You will see from the list of suitable detectors how this sorting will rule out some valves for the particular case we have in mind. In the case of a transformer that will stand more than 3 milliamps. the narrowing down of the valves need not be so severe, while for resistance coupling the anode current only comes into the picture when we are considering the drop in voltage across the resistance.

Obviously the greater the anode current required the less the per-

"TRI," "TET," AND "PENT"

A TRUSTWORTHY TRIO



How to Select a Detector Valve

centage of the applied voltage will the anode of the valve receive.

We are deliberately using the loose expression of "voltage on the anode," instead of the more correct "voltage across anode and filament," because it is easier to visualise for some reason or other.

Those "R.C." Valves

You will notice that we have kept the impedance of the valve as low as possible, and you will probably be wondering what will happen to such valves as the R.C. type with impedances of 50,000 ohms or so. These valves are not generally useful as detectors, because the anode resistances of modern radio technique are not usually very high.

Values of 100,000 ohms represent the general limit, and obviously it would be ridiculous to use a 50,000-ohm valve where a 20,000-ohm valve would do. Another reason lies in the fact that in most sets the detector is used also as a reactor valve, and the use of the high-impedance valve militates against the obtaining of smooth reaction.

So, except in special cases, you will not find the use of a detector having an impedance of more than 30,000 ohms at the most will be of advantage;

and in the case of transformer coupling it will be a very decided disadvantage, for the high impedance will mean a serious loss of low-note amplification.

We have referred to the list of detector valves. You will notice that this has been drawn up in a rather unusual form—with the impedance first, mutual conductance second, and the anode current at 100 volts (on the anode) third. These are the three most important considerations, the make and the price being minor details from a technical point of view, especially as the prices of the modern valves are more or less standardised.

Concerning "L.F." Types

You will therefore, we hope, find the list not only of interest, but of assistance, when you are on the lookout for a suitable detector for your next set, or when you want to check up the suitability of a particular valve you have in mind for that task.

As some of the "detector" valves are also useful as first-stage L.F. amplifiers, the list can be brought into service again when that part of the receiver is being considered.

Obviously the same remarks about impedance and anode current apply when dealing with the L.F. stage,

though here we also have to consider the available grid swing of the valve, and, if it is a last valve, its power output.

Suitable L.F. valves are almost as many as the detectors in the case of the first L.F. stage, and with the power stage added they probably outnumber the detectors quite easily.

"Grid Swing"

The remarks regarding impedance, etc., applied to the detector also apply to the L.F. valve. The same care must be taken that the transformer is not saturated and that the resistance is not too high in comparison with the impedance of the valve that it will drop the voltage too much.

And here we come up against the fourth important consideration—grid swing. We have discussed the questions of impedance, mutual conductance, and anode current; we now have to be sure that the valve will be able to take the input from the preceding stage without overloading.

The anode current in this case is the one passed when the valve is properly biased, and the grid swing is the number of volts that the grid can deal with on either side of the bias point before the valve is forced to operate off the straight portion of its anode current-grid volts curve.

THE SHIELDING OF SCREENED-GRID VALVES

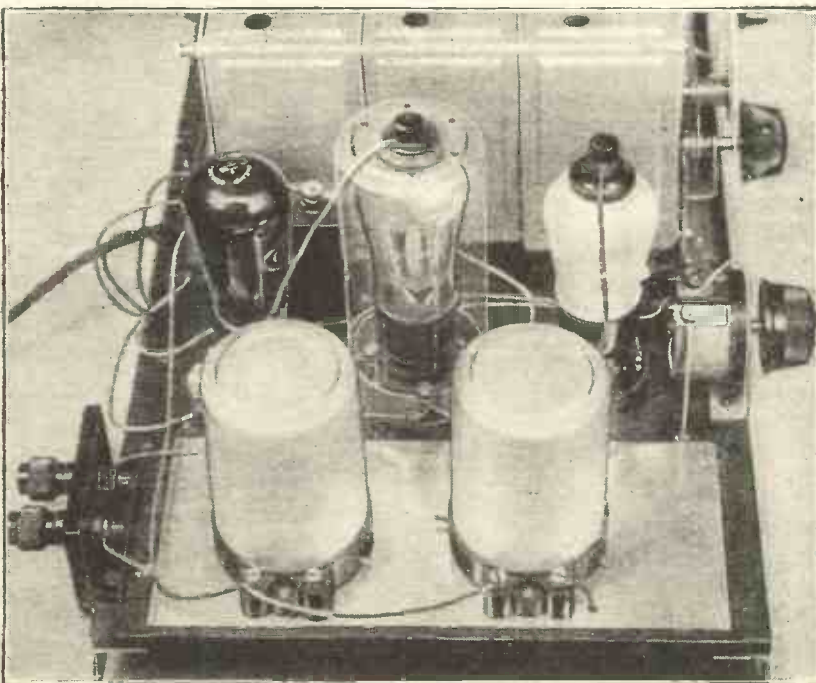

This photograph shows a couple of H.F. valves of the screen-grid type—one metallised and needing no "can," and the other shown in position inside the "ghost" of a screening can.

A Vital Question

Take any L.F. valve leaflet and have a look at the curve. You will see that it has a straight portion, and at the left end it has a bend, flattening out towards the left; while on the right it crosses the vertical line denoting no grid volts.

We set the valve to work on the straight portion of the curve by giving it an initial grid voltage of so many volts negative.

This voltage is the one denoted by the bottom set of figures on the curve that correspond with a point just below the centre of the valve curve taken at the H.T. voltage under which we are to operate the valve. (The point is somewhat indefinite in position because the curve is a static one and does not truly represent the state of affairs when the valve is in operation; it is, however, good enough for most purposes.)

The number of volts that are shown on the bottom line on either side of the bias point before we come under

How the Valves May Be Classified

the left-hand bend in the curve, or the upright line showing anode current, gives us an indication of how much input the valve can stand. That is the grid swing.

Now why do we want to know this? Because we are passing to the valve a certain number of volts (at maximum reception) from the preceding valve; in this case the detector.

Detector Amplification

We can assume that for average local reception, even on a selective set at a distance of 12 miles from the transmitter, we shall have something like a voltage of .5 volt

in L.F. impulses from the radio station on the grid of the detector. This valve amplifies these in a proportion dependent upon the valve's mutual conductance and the type of anode circuit coupling to the next valve.

The Maximum "Gain"

A simple formula tells us roughly the maximum we can possibly get. In practice this is not usually realised. It is $A = \frac{\mu Z}{Z + R_p}$, where μ is the amplification factor of the valve, Z is the external impedance of the anode circuit (we can take this roughly to be the ohmic resis-

tance of the anode resistance), and R_p is the impedance of the valve.

An Example

Thus if we have a 20,000-ohm valve with an amplification factor of 22, and we use it in a circuit that has an impedance of 100,000 ohms, we shall get the following stage gain:

$$A = \frac{22 \times 100,000}{100,000 + 20,000}; \text{ that is, } A = \frac{2,200,000}{120,000} = 19.3.$$

So that for every volt we put on the grid of the valve we should pass 19.3 volts to the grid of the next valve. With our assumed .5 volt we shall

USEFUL VALVE ALTERNATIVES

2-VOLT BATTERY VALVES

COSSOR	DARIO	ETA	FOTOS	LISSEN	MARCONI & OSRAM	MAZDA	MULLARD	SIX-SIXTY	TRIO-TRON	TUNGSRAM	CLASS
S.G.215 S.G.220	S.G.2-Volt	B.Y.6	B.C.150	S.G.215	S.22 S.21 S.215	S.G.215	P.M.12	S.S.215S.G.	072	S.210	S.G. valves.
210R.C.			B.C.40	H.210 H.2	H.210	H.210	P.M.1A.	S.S.210R.C.		R.208	R.C.C. valves.
210Det. 210H.L. 210H.F.	Super-Det. Super H.F.	B.Y.1814	B.C.18	H.L.2 H.L.210 L.2	H.2 H.L.2 H.L.210	H.L.2 H.L.210 L.2	P.M.2D.X. P.M.1H.L. P.M.1H.F.	S.S.210D. S.S.210H.L. S.S.210H.F.	W.D.2 S.D.2 H.D.2	H.210 P.D.220	Detector and general-purpose valves.
210L.F.	Universal	B.Y.210	B.C.9	L.210	L.210 L.2/B.	L.210	P.M.1L.F.	S.S.210L.F.	T.D.2	L.210 L.G.210	Small L.F. valves.
210D.G.					D.G.2		P.M.1D.G.	S.S.210D.G.	D.210		Bi-grid valves.
215P. 220P. 220P.A.		B.W.1304 B.X.604	B.D.9	P.220 L.P.2	P.215 L.P.2	P.220	P.M.2 P.M.2A.	S.S.220P. S.S.220P.A.	Z.D.2		Small power valves.
230X.P.	Super-power Hyper-power	B.W.303 B.W.602	B.D.5	P.220A. P.X.240 P.X.240A.	P.240 P.2 P.2/B.	P.220A. P.240	P.M.202 P.M.252	S.S.220S.P. S.S.240S.P.	U.D.2 S.P.2	P.215 P.220 S.P.230	Super-power valves.
230P.T. 23H.P.T.			B.D.100 B.F.100	P.T.225 P.T.220A. P.T.240	P.T.2	Pen.230 Pen.220 Pen.220A	P.M.22	S.G.230P.P.	P.215	P.P.230	Pentode valves.

4-VOLT BATTERY VALVES

COSSOR	DARIO	ETA	FOTOS	LISSEN	MARCONI & OSRAM	MAZDA	MULLARD	SIX-SIXTY	TRIO-TRON	TUNGSRAM	CLASS
410S.G.	S.G.4-Volt		C.150	S.G.410	S.410		P.M.14	S.S.4075S.G.	084	S.407 S.410	S.G. valves.
410R.C.			D.40	H.410	H.410		P.M.3A.	S.S.4075R.C.	W.D.4		R.C.C. valves.
410H.F.	Universal Super H.F. Super-det.			H.L.D.410	H.L.410		P.M.3 P.M.4D.4	S.S.4075H.F. S.S.410D.	W.412 W.420 A.430	H.407 H.R.406 H.B.410 R.406	Detector and general-purpose valves.
410L.F.			C.9 D.15	L.410	L.410				H.410 A.420	L.D.408 L.D.410	Small L.F. valves.
									D.410		Bi-grid valve.
415X.P. 425X.P. 4X.P.	Super-power Hyper- Mag-	D.X.502 D.W.702 D.W.302	D.E.5 F.5 F.10	P.425	P.415 P.X.4	P.P.5/100	P.M.254 A.C.104 A.C.064 A.C.044 D.024	S.S.420S.P. S.S.H.V.4/1 S.S.H.V.4/2	E.422 E.420 K.420 K.435/10 K.450/25 K.450/40	P.415 S.P.414 P.430 P.460 P.4100	Super-power valves.
415P.T.			D.100 F.100	P.T.425	P.T.425 P.T.4	Pen.425	P.M.24 P.M.24A. P.M.24B. P.M.24C. P.M.24D.	S.S.415P.P. S.S.4Pent.S.P.	P.420 P.425 P.430 P.440	P.P.415 P.P.416 P.P.430 P.P.4100	Pentode valves.

USEFUL VALVE ALTERNATIVES—(Contd.)

6-VOLT BATTERY VALVES

COSSOR	DARIO	ETA	FOTOS	LISSEN	MARCONI & OSRAM	MAZDA	MULLARD	SIX-SIXTY	TRIO-TRON	TUNGS-RAM	CLASS
610S.G.	—	—	—	—	S.610	—	P.M.16	S.S.6075S.G.	—	—	S.G. valves.
610R.C.	—	—	—	H.610	H.610	H.610	P.M.5B.	S.S.6075R.C.	—	—	R.C.C. valves.
610H.F.	—	—	—	H.L.D.610	H.L.610	H.L.610	P.M.5D. P.M.5X.	S.S.6075H.F.	—	H.R.607	Detector and general-purpose valves.
610L.F.	—	—	—	L.610	L.610	—	P.M.6D.	S.S.610D.	—	L.G.607	Small L.F. valves.
610P.	—	—	—	P.610	P.610	—	P.M.6	S.S.610P.	—	P.610 P.X.1120	Small power valves.
610X.P. 625P. 680P. 680X.P. 620T. 660T.	—	—	—	P.625 P.625A.	P.625 P.625A. L.S.5 L.S.5A. L.S.6A. D.A.60	P.625A. P.625B. P.650	P.M.256 P.M.256A. — — D.025 D.060	S.S.625S.P.A. S.S.625S.P. — — — S.S.H.V.6/3	—	P.615 S.P.614 P.X.1710	Super-power valves.

BATTERY VALVES (Not Standard)

COSSOR	DARIO	ETA	FOTOS	LISSEN	MARCONI & OSRAM	MAZDA	MULLARD	SIX-SIXTY	TRIO-TRON	TUNGS-RAM	CLASS
—	—	—	—	—	—	—	—	—	—	S.X.2220	S.G. valve (3.3 volts)
—	—	—	—	—	—	P.P.3/425	D.O./20	—	—	P.X.2100 P.X.2500	Super-power valves (7.5 volts)
—	—	—	—	—	—	—	D.O./75	—	—	—	Super-power valve (10 volts)
—	—	—	—	—	—	—	—	—	—	P.X.2450	Super-power valve (2.5 volts)
—	—	—	—	—	—	—	—	—	—	L.X.2260	Small power valve (1.5 volts)

INDIRECTLY-HEATED A.C. VALVES (4 Volts)

COSSOR	DARIO	ETA	FOTOS	LISSEN	MARCONI & OSRAM	MAZDA	MULLARD	SIX-SIXTY	TRIO-TRON	TUNGS-RAM	CLASS
11M.S.G. 11S.G./H.A.	A.C.4091	D.W.6	—	—	M.S.4B.	A.C./S.G. A.C./S.2	8.4V. 8.4V.A. 8.4V.B.	S.S.48.G.A.C. S.S.4X.S.G.A.C. S.S.4Y.S.G.A.C.	124A.C.	A.S.495 A.S.494	High-mag. S.G. valves.
M.S./L.A.	—	D.W.2	S.4150 P.4150	—	M.S.4	—	—	—	101A.C. 304A.C.	A.S.4100	Low-mag. S.G. valves.
M.S./Pen.A.	—	—	—	—	—	—	—	—	—	—	H.F. pentode.
—	—	—	—	—	V.M.S.4	—	M.H.4V.	S.S.4M.M.A.C.	—	—	Variable-mu S.G. valves.
41M.R.C. 41M.H. 41M.H.F. 41M.H.L.	Super H.F. Super-det.	D.W.4023 D.W.1508	S.440 S.415 T.425	A.C./H.L.	M.H.4 M.H.L.4	A.C./H.L. A.C.2/H.L.	904V. 354V.	S.S.4G.P.A.C. S.S.4D.X.A.C.	W.415N. A.N.4 A.430N.	A.R.4100 A.R.495 A.G.4100 A.R.4101	Detector and general-purpose valves.
41M.D.G.	—	—	—	—	—	—	—	—	D.410N.	—	Bi-grid valves.
—	—	D.W.Y.04 D.W.1003	—	—	—	—	164V.	—	E.430N.	A.G.495	Small power valves.
41M.P. 41M.X.P.	—	—	—	—	M.L.4	A.C./P. A.C./P.1	104V. 054V.	S.S.4P.A.C. S.S.4S.P.A.C.	—	A.P.495	Super-power valves.
M.P./Pen.	—	—	—	—	M.P.T.4	A.C./Pen.	Pen.4V.	S.S.Pen.A.C.	—	—	Pentode valves.

therefore load the L.F. valve grid with over 9 volts. So you see how easy it is to overload the receiver on the local.

So much for resistance coupling; what of the transformer method? Here we must take into account the voltage amplification of the transformer due to the step-up ratio between primary and secondary. This is usually about 1:3.

With a good transformer the impedance at medium music fre-

quencies is very much more than in the case of the resistance.

As a matter of fact, for the sake of what we may call "safety" calculations we can reckon the full amplification factor of the valve, multiplied by the transformer ratio, as the stage gain.

A Useful Formula

If you wish for a more elaborate formula here it is:

For any given audio-frequency

$$A = \frac{\mu Z}{(R_p + R)^2 + X^2}$$

where μ is the amplification factor of the valve, R_p is the valve impedance, R is the resistance of the anode circuit impedance (the transformer primary), X is the part of its impedance depending on its inductance and capacity, or its reactance, and Z is the impedance of the primary.

This is then multiplied by the step-up ratio to get the stage gain.

But from the first simple calcula-

How to Choose Your Output Valve

tion above it can be seen how very easily the output valve can be overloaded.

Take an input of two volts (plus and minus) as being the result of the reception by a detector of a more or less distant station, and of its subsequent amplification through a fairly low magnification coupling.

SMALL, BUT MIGHTY!



Here are two little giants in the pentode class—the Marconi P.T.2 and the Mazda 220Pen.

We have the two volts on the grid of the first L.F. valve, which, as is so often the case, we will assume is transformer coupled to the last valve.

What valve shall we use as the first L.F. valve? Obviously one that will suit the primary of the transformer; one with a lowish impedance, but not so low as to cause too great a primary current.

Round about 8,000 ohms is usually right unless the transformer is of the small nickel-iron-cored variety.

Output Valves

What about the output valve? We can choose this in two ways. One is to get the most out of the first L.F. stage and to suit the last valve to carry the input. The other is to limit the size of the output valve and to volume control, or limit the stage gain of the L.F. valve.

With a good 8,000-ohm valve and a 1:3 transformer we should get a stage gain of somewhere round about 40. So that 2 volts becomes 80.

Obviously on anything like local or strong distant reception we need vigorous volume-controlling.

You see how very easy it is to overload the last valve, and a glance at the lists will show how you will have to watch the grid swing in order that the chance of overloading is not too great. It must not be so big that you are limited so much by the last valve that you cannot get good speaker strength.

That sounds absurd, doesn't it? But the fact is that unless the last valve can take a fairly big grid swing, or alternatively has a high mutual conductance, you will not get enough current change in the anode circuit, and it is current change (that is, power) that you are after now, not voltage stage gain.

"Loud-speaker" Power

Thus we must pick a valve that has a fair anode dissipation, in order that with a good mutual conductance that dissipation may be turned to A.C. output large enough to operate the loud speaker properly.

As a rough rule it can be said that the undistorted output of an ordinary power valve is one-fifth of the anode dissipation. That is, it is one-fifth of the figure obtained by multiplying the anode current taken at a certain voltage H.T. (the voltage to be used) and that voltage.

Thus if the valve took 20 milliamps. at 150 volts it would have an anode dissipation of $20 \times 150 = 3,000$ milliwatts. The approximate undistorted output power will therefore be 600 milliwatts. This is sufficient to give moderate loud-speaker strength on a moving-coil loud speaker used in a small room.

Thus in choosing a power valve we have to consider the maximum undistorted output that we require, and that we are likely to get from the valve we think of using. Then we look at its grid swing and see if this is large enough to be reasonably capable of handling the output from the first L.F. stage.

Distant Station Reception

If not, and the valve gives us quite enough power output, we are wasting energy in having an L.F. stage that is so far above the required amplification fully to load the output valve. Here we have to take into account the reception of distant stations, where the L.F. valve will not have so much to deal with, and when it will be less likely to overload the last valve.

It is all a vicious circle in a way, and it is impossible to lay down fixed rules for the choice of valves. We hope, however, that the foregoing remarks will be useful, and that with the help of the various tables you will be able to pick out your valves with greatly increased ease.

Concerning Pentodes

We have so far said nothing about the pentode valve. This deserves a small section for itself, for it cannot be treated in quite the same way as the ordinary output valve.

In all output valves the matching of the anode load with the valve impedance is essential if the maximum output is to be obtained, but in the case of the pentode it is even more important than in the case of the three-electrode type.

In the output-valve tables we give the optimum load for the various valves, and it is important that this be approached if the maximum quality as well as output power is to be obtained.

CONSTANTLY VARIABLE!



These are the first variable-mu battery valves—introduced a few weeks ago by Cossor.

Speaker matching is another important business, especially in the case of the moving-coil type. This is not a difficult task really, for all the important loud-speaker manufacturers sell output transformers to suit their own speakers, and of different primary impedances to suit the various output valves on the market.

Thus if you decide to use so-and-

Where the Mains-Operated Valve Scores

so's speaker, and find that the such-and-such output valve will do you, all you have to do is to tell the speaker firm that you want to use that valve with a certain model of their speaker and they will supply the correct transformer. This may seem a troublesome and unnecessary bit of bother, but if you want the very best quality as well as power from your set that matching of the valve and speaker must be carried out.

Another Useful Formula

For those who are experimentally inclined here is the formula for matching the speaker to the valve, given the impedance of the coil on the speaker, and the optimum load of the output valve.

This, of course, applies to the pen-

practice to use a pentode output choke for average work, unless a special pentode output transformer is available.

Impedance Equalisers

With the output choke an impedance equaliser of some sort is usually employed. This can conveniently take the form of a resistance in series with a condenser, the whole being connected across the choke. The speaker is tapped down the choke to the right ratio, of course.

The value of the resistance in the impedance equaliser is dependent upon the valve and the condenser, a usual value being 15,000 or 20,000 ohms, with a condenser of .01-mfd. capacity.

The value of the equaliser can, of course, be set to suit the tastes of the individual listener; less resistance and/or larger capacity acting as a high-note reducer, and vice versa.

Pentodes

In choosing pentodes, as in the case of power valves of the triode variety, it is undistorted output that counts, and you should study the figures giving that essential factor before finally picking on any particular valve. We have given a rough rule to enable the power output to be determined at a glance from the

valve characteristics in the case of the triode.

With the pentode the same formula holds, but instead of the output being roughly one-fifth of the anode dissipation it becomes about one-third. So a pentode passing a current of 30 milliamps. at 250 volts (such as some of the A.C. pentodes) will have a maximum undistorted output (with a maximum harmonic distortion of 5 per cent) of one-third 7,500 milliwatts, or 2,500 milliwatts.

Mains Valves

The mains valve has almost invariably a better mutual conductance than its battery prototype. Consequently we may expect to get more out of it. As a general rule, this expectation is realised, partly because the valve is better and partly because we usually find that we have more H.T. available than in the former case, where the anode

supply as often as not comes from H.T. batteries, or from smallest mains units restricted to a maximum of 120 to 150 volts.

The mains valve often gets nearly its full voltage of 200 or 250 volts, and this increase cannot fail to have a beneficial effect upon the power and sensitivity.

Special care must be taken in the cases of mains S.G. valves, both of the A.C. and the indirectly-heated D.C. variety, that the screening is adequate. Many sets that have sufficient screening to act properly with battery valves will be insufficiently screened when mains valves are tried.

Where the mains valves score chiefly is in the output stage. With plenty of H.T. large valves can be employed, and a really fine margin of safety against overloading becomes a feasible thing. Also, the extra anode power input allows a larger undistorted power output, and you will find that the indirectly-heated and the directly-heated cathode mains output valves go up in what may be called the "ordinary receiver" sizes to a wattage of 5 watts undistorted power.

Some Interesting Types

During the last few months some very interesting valves, of battery as well as mains variety, have made their appearance on the market.

We should like to point out for special attention, however, such valves as the Mazda 215B; the Marconi and Osram D.S.B. (a D.C. counterpart of the M.S.B.); the new full-voltage mains valves for D.C. introduced by the Austrian firm, Ostar-Ganz; the wonderful little battery pentodes, the P.T.2, Pen.220, and the Pen.220A.

All the D.C. valves of the indirectly-heated cathode variety are worth notice. They fall into two camps: those with .25-amp. heaters, and the .5-amp. types. So far, three firms are making them; two doing the former and one the latter types. The .1-amp. valves are not yet reasonably far advanced to be placed on the general market.

Among the valves of special interest must also be mentioned the variable-mu valves, both the A.C. and the battery types. And we must not forget the A.C. double-grid detector brought out by Cossor. The battery D.G. is so well known as a super-het. oscillator mixer valve that the A.C. prototype is liable to be overlooked. So is the mains H.F. pentode. A wonderful advance on the ordinary screened-grid valve.

By the way, most of the battery, as well as mains, S.G. and det. valves, can now be obtained in the metallised form. This is a great convenience in many cases, but it must not be assumed that because the valve is metallised it is unnecessary to have any screening in the H.F. end of the receiver.

And talking about metallised valves of the battery variety, do not forget to look at the valve and see which filament pin is taken to the coating, and to wire up the valve holder so that that pin fits into the L.T. socket. The mains valve has the metallising taken to the cathode.

Robust Construction

Finally, remember that although the modern valve is a very robustly constructed article, it has its mechanical as well as its electrical limits, and should be treated with the consideration it deserves. Don't overrun it from the point of view of H.T. and L.T., and in the case of some of the larger output valves of the indirectly-heated type, do not underrun as regards the L.T.

Such process in either case will cause lack of emission, and consequent shortening of the life of the valve.

Also, in the cases of mains valves remember that they vary as regards the values of bias resistance required for automatic grid-biasing, and the correct value (if not given by the makers, or in our lists) should be worked out from a study of the characteristic curve of the valve at the H.T. voltage to be applied.

The operation is simplicity itself if you remember that a bias resistance of 1,000 ohms will give a bias of 1 volt for every millamp. of anode current. For you must not forget that the whole anode current of the valve in question flows through the resistance—that is how the bias is obtained.

If you want a formula, here it is. The resistance required in ohms is determined by

$R = \frac{\text{Volts required}}{\text{Anode current}} \times 1,000$. Thus in the case of a valve requiring 3 volts bias, and taking (according to the curves) 9 milliamps. at the necessary H.T. voltage, and at that bias, we find that the resistance required is $\frac{3}{9} \times 1,000 = 333$ ohms. Quite easy, is it not?

But the bias resistance is a most important factor, not only in the operation of the valve, but also in its life, and it should never be carelessly chosen.

TWO RECENT ARRIVALS

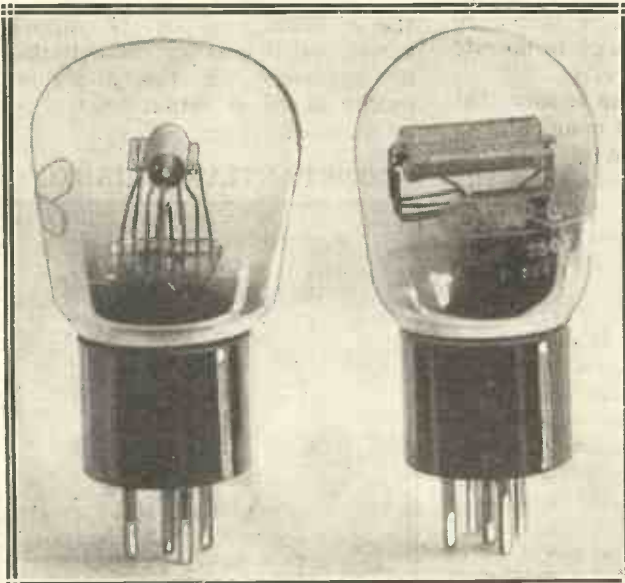

These unusual-looking "tubes" are Ostar-Ganz detector and L.F. full-voltage indirectly-heated D.C. valves that have recently been introduced into this country. They are not yet available to the public and so are not dealt with in this article. They take the full mains voltage and need no series break-down resistance.

tode valve as well as to the triode.

$R_s = \frac{2R_p}{T^2}$; where R_p is the optimum

load of the valve, and R_s is the impedance of the speaker, T being the required transformer ratio. Thus

if T is required we have: $T = \sqrt{\frac{2R_p}{R_s}}$

In the case of the pentode care must also be taken that the generation of harmonics does not upset the quality of the reproduction. It is a general

MAKING SHORT-WAVE COILS

By W.L.S.



READERS of MODERN WIRELESS who have studied short-wave work at all, even if they have only reached the "dabbling" stage, must have found out by now that the two important aids to success are the design of the set and the design of the components.

Component prices nowadays being very different from those in force in the early days of broadcasting, it does not pay to go in for too much home-made gear. In cold fact, the only components worth making at home for a short-wave set are the variable condensers and the coils. We will put the condensers out of consideration for the present, for two reasons.

For Very Low Wave-lengths

First, the advantage of making one's own is not concerned with efficiency so much as with the fact that short-wavers for special purposes require variable condensers of a type that our manufacturers have not, as yet, made available to us. Secondly, we cannot really make our own—it is a question of pulling old condensers to pieces and making something serviceable out of them.

Doubtless when the 7-metre broadcast business really gets going our leading component makers will turn their attention to the production of a variable condenser with a maximum capacity of the order of .00001. Until then we shall have to buy .0001's or .00005's and pull plates out of them when we want anything really small!

Using a Valve Base

But I shall not please the Editor if in an article "Making Short-Wave Coils" I begin a learned discourse on condensers, so, having explained the position, I will go ahead!

The short-wave coil is a component that we can all make ourselves

Our popular short-wave contributor passes on to "M.W." readers much interesting information concerning the construction of home-made coils, and tells how to get the best out of this vital component.

practically as well as anyone can make for us. Further, we can suit our own individual requirements very well, while the manufacturer, quite reasonably, caters for the majority only.

The photographs with which these pages are illustrated show some excellent types that can be made at home with very little trouble. I will deal first with the "valve-base" coil, because very little is heard of it in this country. One of the pictures shows a small, "tubby" ebonite former equipped with valve pins.

Anyone can make one of these after raiding the local shop, and a stock of them is extremely useful. They take two windings, which may be either "aerial" and "grid" for a screened-grid set, or "grid" and "reaction" for a detector affair. In the latter case the aerial is capacity-coupled to the grid circuit.

That Short Wiring

The advantage of this type is its compactness. It scores for this reason, because the coils themselves have a small field and are therefore suitable for all-metal sets. But another advantage is that the base itself—an ordinary valve holder—is so small that it can be mounted close up to the detector, making possible the very short wiring that is so desirable in short-wavers.

EFFICIENT FORMERS OF SIMPLE CONSTRUCTION

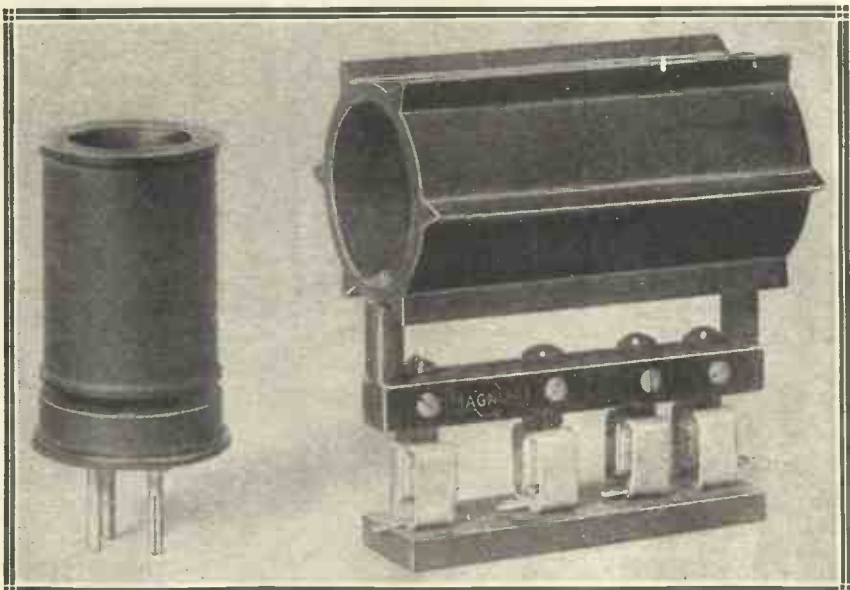

Coil units similar to the one shown on the left can be very conveniently made from the bases of old "burnt-out" valves. The one on the right is a commercial production. Either of these will form the basis for home-made coils of high efficiency.

Getting the Best From Your Short-Waver

I leave the constructional details to your particular fancy, except to pass on the hint that the windings should be "close-wound," and that the reaction, rather than using a lot of turns a long way away from the other winding, should be as close up as possible, and should consist of as

A POPULAR TYPE

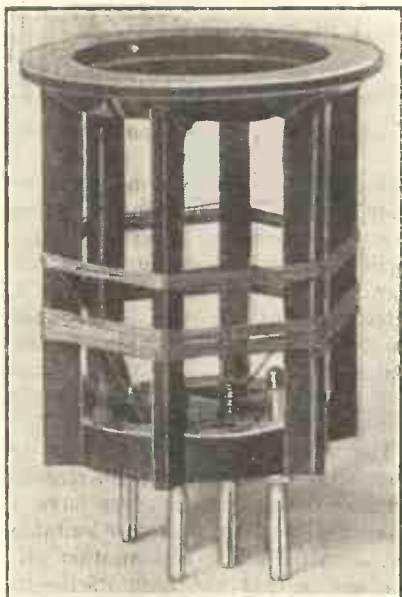

This extremely popular type of coil fits into a normal six-pin base, and is ideal for all-wave sets. The change to short, medium or long waves is effected simply by plugging-in the appropriate coil.

few turns as possible. This type may actually be wound on the bases of old and burnt-out valves.

It does not matter which pins you take the ends of your windings to, but *do* adhere to this rule with the windings themselves: Make the two "middles" the low-potential ends. That means that you *start* your grid coil with the grid end, go on to the filament end, and then carry on with your reaction coil, starting with the "H.T. positive" end and finishing up with the plate. These suggestions apply to all types.

For Close Coupling

Let us now consider the "basket-weave" type. This is made by knocking eleven nails into the *flat* surface of a wooden cylinder (near the edge) and winding wire on them, so that it passes inside one and outside the next. When the desired number of turns has been wound on, the nails are pulled out and the turns tied with cotton at the places where they cross.

The construction is very simple, the coil is quite "low-loss," and the mounting may take almost any form. The coil of this type in the photograph really comprises both grid and reaction coil. It has been wound with sufficient turns for both, and cut at the right point, the two ends being brought out. This ensures close coupling between the two and allows one to use very few turns for the reaction coil.

Skeleton Formers

Personally, I prefer the mounting shown to the "four-pin" variety—the lugs simply screw down under terminals, and the contact is therefore very good indeed.

Now we are left with the vast variety of coils on formers—formers of all kinds, whether ribbed, skeleton or solid. And the variety of windings and mountings must be almost inexhaustible.

I will, therefore, confine my remarks to the types that I know to be efficient, and commence with the skeleton former.

The coil shown in the photograph is wound on a "skeleton" made of bakelite and equipped with the ordinary "Southern Cross" six-pin base, and is, as a matter of fact, one of the best I have made.

Very Easy Indeed

The construction could not be simpler. One simply hitches the end of the wire round one of the pins, screws it down, makes a notch in one of the "ribs" with a penknife or hacksaw, and *winds*. It is advisable

to make the notches in such positions that the wire joins and quits the former at convenient places with relation to the pins it goes to, but no rules need be laid down.

A Reaction Tip

Three complete windings may be accommodated—aerial, grid, and reaction, for instance, each being kept entirely isolated and taken to its two pins. When I deal with turn numbers I shall have more to say about this, but no more need be mentioned now except that the reaction winding should preferably begin about $\frac{1}{4}$ in. from the point at which the grid winding finishes.

These are probably *the* easiest coils for the average amateur to make for himself, and I rather think they are about the most efficient as well. The only commercial type that I like as well is the rather similar type shown in the photograph.

The Coil Inside

This winding is very much like the home-made variety, but it has the advantage of a small (by which I mean physically small) reaction coil very tightly coupled and placed inside it. This operation is beyond the scope of most home constructors.

The first picture also shows a ribbed former. Possibly the presence of all the extra ebonite has a detrimental effect on the efficiency of the coil made in this way, but it is too small to notice by the actual results. Ribbed formers of this kind can be bought "by the yard" and cut up into

(Continued on page 396)

TWO EXAMPLES OF SHORT-WAVE COILS

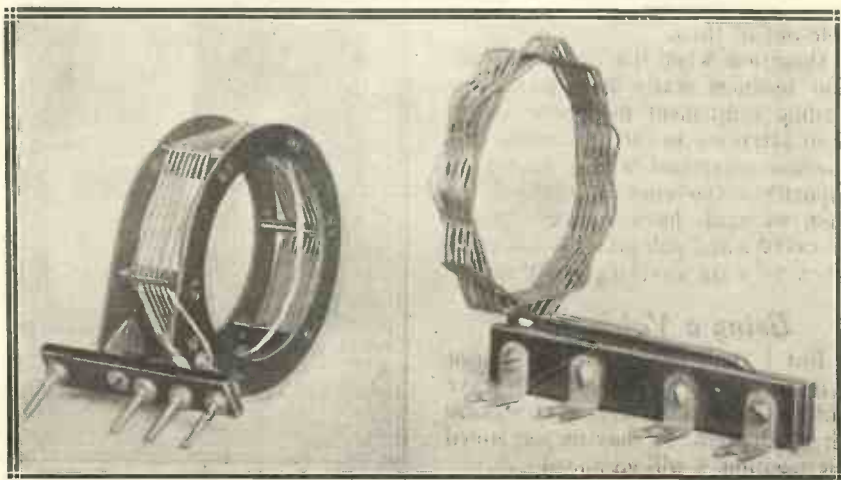

Here are two excellent examples of good short-wave coils. The one to the right is an air-spaced basket-weave coil, and the other is a factory-made job.

A RADIO RECKONER

By
W.A. BARCLAY
M.A.

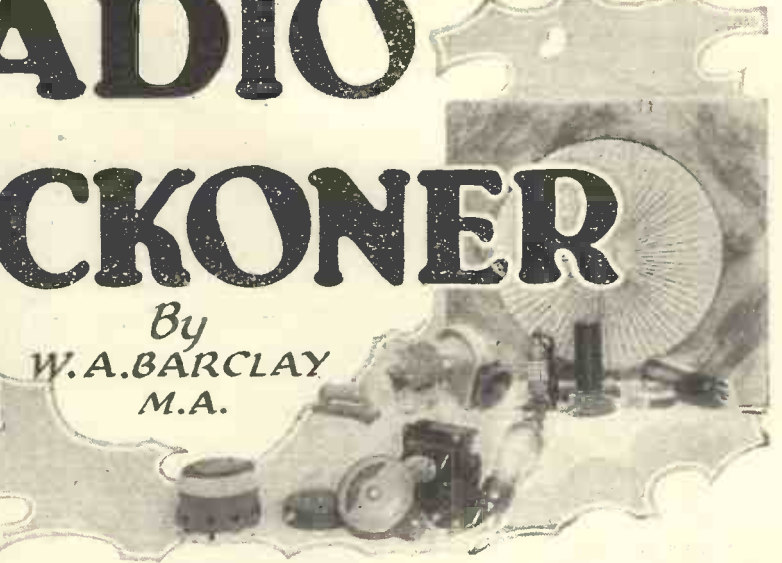

Continuing this interesting series of articles, we now publish details of an easy method of finding the effective capacity of two condensers in series. Two special diagrams are provided, one for cases where the two capacities differ considerably, and the other for when they are relatively close.

BEFORE leaving the subject of tuning and resonance it may be well to consider a little more fully than we have done the different effects which may be ob-

CONDENSERS IN SERIES

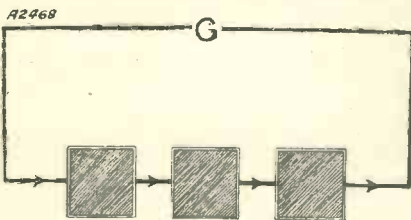

FIG. 1A

When a number of condensers are connected in series the current flowing from the generator G through each condenser at any given moment is the same.

tained by placing two or more condensers in series or in parallel.

It need hardly be said that a series arrangement is the name given to a circuit such as that of Fig. 1A, in which the different elements of the circuit follow each other in such a manner that at any given moment the current flowing through each element is the same.

Divided Current

A parallel arrangement, on the other hand, is shown in Fig. 1B, from which it will be seen that the total current from the source is divided up among the various elements, each taking its share. It is important to notice, however, that the potential difference, or voltage, across each member of Fig. 1B is the same, since one terminal from each member is

connected on one side, and the remaining terminals are similarly connected on the other.

We have already considered the behaviour of resistances when connected in series and in parallel to a source of direct current. We have now to inquire into the behaviour of condensers when similarly placed in relation to a source of alternating current.

Storing Electricity

A condenser, as its name implies, is a piece of apparatus for "condensing" or storing electricity. This is its fundamental meaning; actually, in radio work, the storing and discharging actions occur so quickly that one is often apt to lose sight of them, and regard the condenser as

merely some sort of special resistance to alternating currents.

We have seen in previous instalments how this special resistance—or "reactance," as it is called—depends upon the "capacity" of the

ALL IN PARALLEL

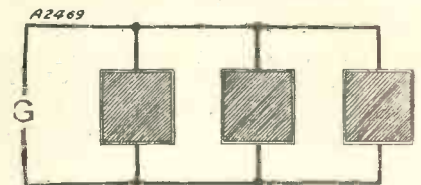

FIG. 1B

This shows three condensers connected in parallel. In this case the total current will be divided up among the various capacities.

condenser for storing electricity, while in the issue of MODERN WIRELESS for August last we showed how in turn the capacity of a condenser could be readily estimated when its dimensions were given.

Adding Capacities

Reference to that article will show that if the area of the condenser plates is doubled, the capacity rating of the condenser will be doubled also. In other words, the capacity of a condenser varies directly as the area of its plates.

Now, it is not at all difficult to see that if we connect two condensers in parallel—i.e. by the method shown in Fig. 2—what we are doing is merely to add the total areas under the dielectric "strain," and hence to add together the capacity values.

THE THEORETICAL EQUIVALENTS.

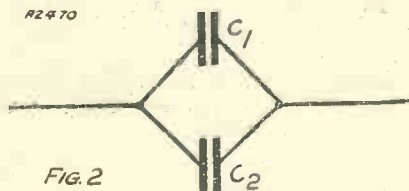

FIG. 2

CONDENSERS IN PARALLEL $C = C_1 + C_2$



FIG. 3.

CONDENSERS IN SERIES $\frac{1}{C} = \frac{1}{C_1} + \frac{1}{C_2}$

These two diagrams represent the theoretical equivalents of the parallel and series arrangements of condensers. Fig. 2 shows two condensers in parallel, and Fig. 3 two connected in series.

The resultant capacity obtained by placing any two condensers in parallel is thus simply the sum of their separate capacity values.

When in Series

Now let us place the two condensers in series, as shown in Fig. 3. For simplicity let us call them C_1 and C_2 . Is it possible to find the value of a single condenser which would in itself be the equivalent of this arrangement where alternating currents are concerned? The answer is "Yes." If we give to the resultant condenser the symbol C , it is always possible to find its value by means of the formula :

$$\frac{1}{C} = \frac{1}{C_1} + \frac{1}{C_2}$$

In this series of articles, however, we do not pay much attention to formulae, but are more interested in devising means to obtain practical working values without the aid of cumbersome mathematical symbols and arithmetic. Accordingly, we are giving this month two alignment charts designed to take the place of the above formula, and render very simple the task of finding the equivalent value of two condensers when placed in series.

The first of these (Fig. 4) is designed to meet the case when the two condensers concerned are not very different in size. The value of the larger condenser is found on the left-hand scale of Fig. 4, and the value of the smaller condenser in series with it is taken on the right-hand scale.

Finding the Value

On joining these values with a ruler or other index-line, the value of the condenser equivalent to the two in series is read off on the third, or centre, scale. The same procedure exactly applies in the case of Fig. 5, which is specially adapted to deal with those instances in which the two condensers differ appreciably in size.

As an example of the use of these charts, let us consider a "three-noughts-five" variable air condenser such as is used normally for tuning purposes in a radio receiver. Such a condenser may, irrespective of circuit conditions, be made to assume all capacity values between a maximum of .0005 microfarad and a minimum of .0001 microfarad, say.

Let us suppose that these values apply, and ask ourselves what would be the effect on the effective variable capacity if a fixed condenser

of .002 mfd. were placed in series with it?

By pivoting a ruler about the point .002 mfd. at the top left-hand corner of Fig. 4, this chart can readily be made to show the variation of the effective capacity in the circuit as the air condenser is made to vary between .0005 and .0001 mfd. The maximum resultant capacity is seen to be .0004 mfd., while the minimum is a little under .0001 mfd.

that employed for those coils which are tuned to the signal frequency.

However, the use of ganged condensers of uniform value for both H.F. tuner and oscillator is found to be unpractical, and the working solution adopted is to insert a fixed condenser of about .002 mfd. in series with the oscillator condenser. This has the effect of reducing its overall value in such a manner as to maintain practically constant the

WHEN THE CAPACITY DIFFERENCE IS SMALL

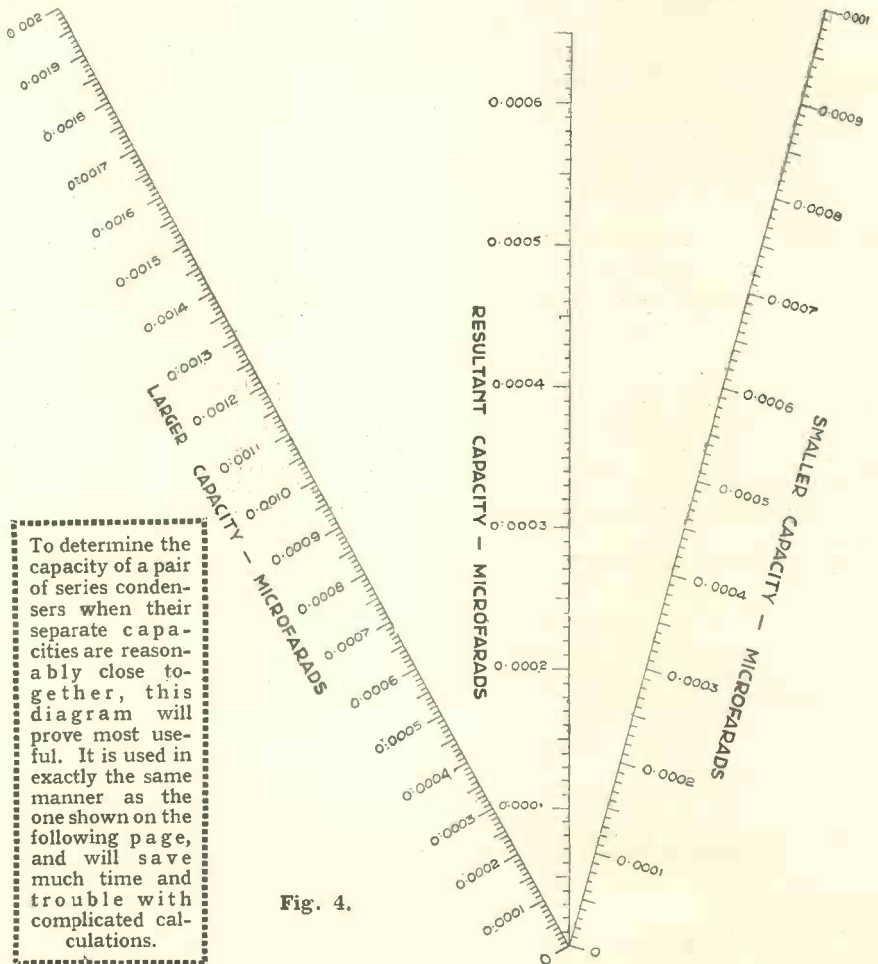

Fig. 4.

This example has a very practical application to one of the very latest types of super-heterodyne receiver. As is well known, one of the great disadvantages of the super-het. principle has lain hitherto in the necessity of providing separate tuning controls for both the H.F. tuning and the oscillating systems.

A Super-het Point

If the frequency difference between these two circuits is to be kept constant—i.e. if the oscillator circuit is always to be so many kilocycles above the H.F. tuner—the tuning inductance of the oscillator must necessarily be somewhat less than

required frequency difference between tuner and oscillator over the whole of the tuning range.

There are, of course, many occasions in radio work in which the use of two condensers in series is found to be advantageous. Perhaps the best-known instance is that of the series aerial condenser, in which a small capacity is introduced in series with the already existing natural capacity of the aerial. By this means the effective capacity of the aerial for tuning purposes is reduced, and higher frequencies—i.e. lower wave-lengths—attained. It is hoped to discuss the question of aeri-als and aerial tuning in a future article.

For Finding the Capacity of Condensers in Series

For the present it will be sufficient to notice one very important point about the connecting of capacities in series. This is, that the resultant capacity of the combination is always less than either of the two constituent capacities!

An Example

This fact provides us with a very useful means of lowering the value of any capacity incorporated in a set which may be found too great for its function. Indeed, we have already seen that the overall range of a variable condenser may be lowered by the inclusion of a condenser in series with it, and this principle may always be employed when capacities of very small value are desired.

The appropriate value of the series condenser which will be required in any given case can always be ascertained by means of the charts which accompany this instalment. Suppose, for example, we wish to know the size of condenser to insert in series with one of .001 mfd. in order to reduce its effective value to .0008 mfd.

By joining .001 mfd. on the outer right-hand scale of Fig. 5 with .0008 mfd. on the centre scale we immediately read .004 mfd. on the left-hand scale of the diagram. This, therefore, is the required value of the series condenser.

WHEN THE CAPACITY DIFFERENCE IS LARGE

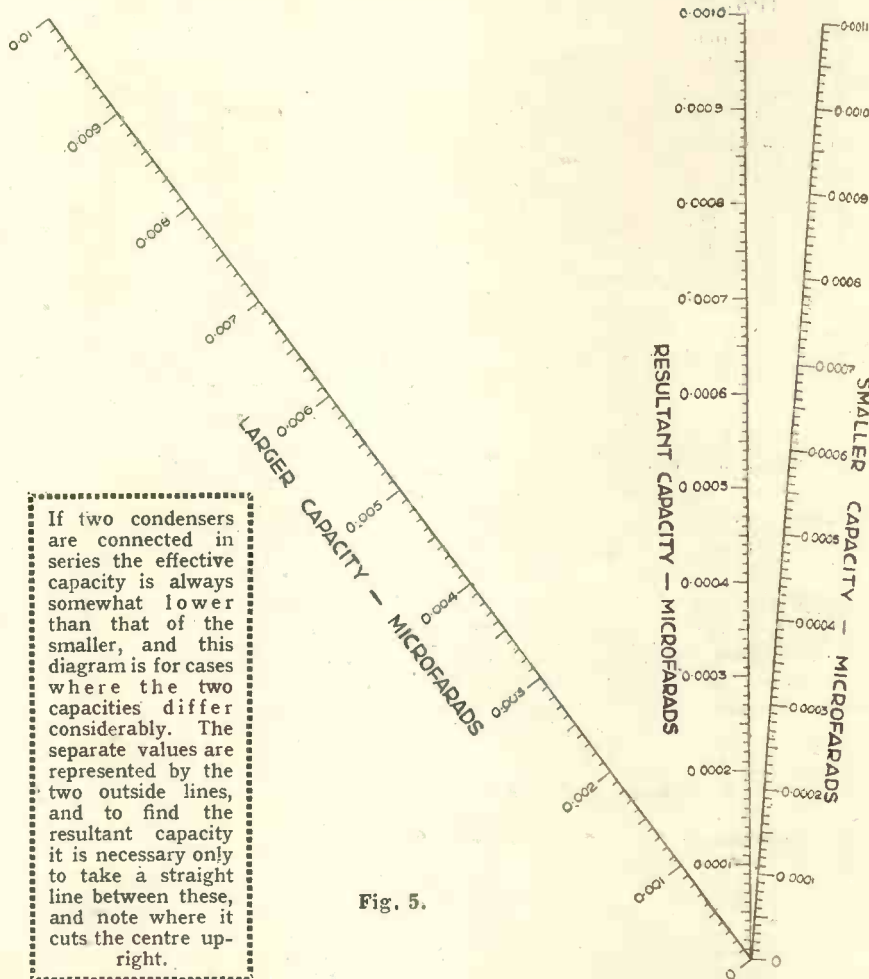

If two condensers are connected in series the effective capacity is always somewhat lower than that of the smaller, and this diagram is for cases where the two capacities differ considerably. The separate values are represented by the two outside lines, and to find the resultant capacity it is necessary only to take a straight line between these, and note where it cuts the centre upright.

Fig. 5.

MICROFARADS; we are continually meeting the term in radio. A variable condenser has a capacity of .0005 microfarad, a grid condenser is generally .0003 microfarad, and large 2-mfd. condensers are quite common.

But what is the value given in microfarads? What is a microfarad? These are questions that not everyone can answer who glibly uses the term almost every day.

Microfarads are millionths of a farad, because micro is the prefix indicating a millionth part. A farad is the unit.

A Useful Size

We use microfarad because a millionth part of a farad is much nearer to the value usually employed in radio than is a whole farad. Thus unnecessarily small decimals are avoided in the same way as when we use the term milliamps. instead of

WHAT ARE MICROFARADS?

An explanation of a term often used in radio.

thousandths of an ampere when talking of the plate current of valves.

And now, what is a farad? Technically speaking, a conductor has a capacity for electricity equal to one farad when a current flowing for one second at a rate of one ampere is able to raise the voltage of the conductor by one volt. So you see that the bigger the capacity of a condenser the more current that is required to impart a certain voltage to it.

As very small capacities can have large effects in radio circuits, it is quite the usual thing for the capacity, when it is of a particularly small value, to be specified as so many micro-microfarads. The reason for

the use of this term is the same as that for the use of microfarads. It is to save the use of very small fractions of microfarads.

A micro-microfarad is, of course, a millionth part of a microfarad. In other words, a billionth part of a farad.

Easily Converted

Unless one is accustomed to using the term, so many micro-microfarads do not convey much. We have no standard in our mind upon which to base the value and so must convert them into microfarads.

This is extremely easy. Just remember that one micro-microfarad is, in decimals, .000001, or five noughts 1.

Then all you have to do to convert micro-microfarads to microfarads is to divide the 1 by the number of micro-microfarads. Thus 50 micro-microfarads is the equivalent of .00005 (four 0's 5).

The First Eckersley S.G.-Pentode Three

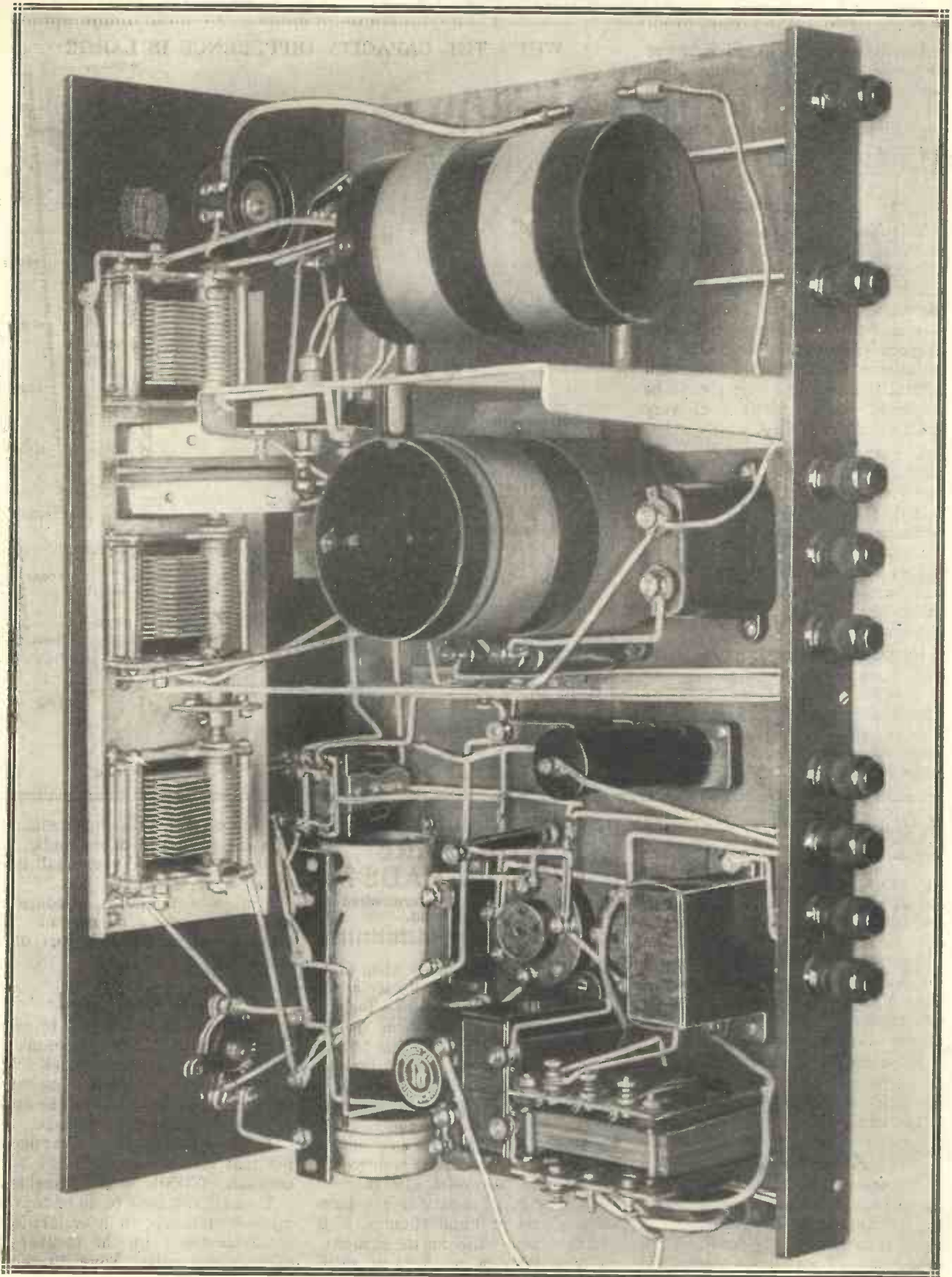

The Eckersley "Varmu" Three



WE wonder how many readers have written to us during the past few months—in fact, ever since the first set using an Eckersley tuner was described—asking for details of an S.G. model!

The number would probably surprise even ourselves, who are used to extremely heavy "fan mails"; for a truly amazing amount of interest has centred round the Eckersley tuner. Every post brings us letters discussing

It is no idle "boost" to claim that this set is the finest S.G. Three to date—but an absolute fact, as all who are well versed in modern reception technique will at once realise. Using one of the very latest "variable- μ " valves and a pentode, it provides a performance that is far and away ahead of all conventional standards. We are confident that the "Varmu" will appeal most strongly to all discriminating constructors.

the various sets incorporating that coil, and also inquiries for H.F. models.

An Interesting Debut

It may be asked why we did not give such details before, but we felt that remarkable as the Eckersley coil is in itself, it deserved something better than an ordinary S.G. circuit in which to make its H.F. debut.

We also knew that experiments

YOUR COMPONENT GUIDE FOR THE ECKERSLEY "VARMU"

PANEL

18 x 7 in. (Permeol, Becol, Peto-Scott, Wearite, Ready Radio).

CABINET

To fit, baseboard 10 in. deep (Pickett, Ready Radio, Peto-Scott, "Morco," Gilbert, Osborn, Camco).

CONDENSERS

- 1 Double-drum three-section .0005-mfd tuning (Cyldon Triple Syneratone Junior).
- 1 .0005-mfd. solid-dielectric variable (Ready Radio, Polar, Telsen).
- 1 .0001-mfd. differential reaction (Telsen, Ready Radio, Polar, J.B., Cyldon, Lotus, Igranic, Lissen, Graham Farish, Wave-master, Formo).
- 2 .0001-mfd. (max.) compression type (Formo, Sovereign, Lewcos, Polar, Telsen, Graham Farish, Goltone).
- 1 .0003-mfd. (Dubilier 670, T.C.C., Telsen, Ready Radio, Sovereign, Ferranti, Lissen, Formo, Graham Farish, Goltone, Igranic).
- 1 .001-mfd. (T.C.C., etc.).
- 1 .01-mfd. (T.C.C., etc.).

- 1 2-mfd. (Telsen, Dubilier, T.C.C., Ferranti, Sovereign, Helsby, Hydra, Igranic).
- 2 1-mfd. (Dubilier, etc.).

SWITCHES

- 1 4-pole double-throw rotary, without terminals (Wearite type I.24).
- 1 2-pole double-throw rotary (Wearite type I.22).

RESISTANCES

- 1 50,000-ohm volume control (Clarostat, Magnum, Wearite, Colvern, Igranic, Sovereign).
- 1 2-megohm grid leak, and holder if necessary (Graham Farish, Ohmite, Igranic, Loewe, Ferranti, Lissen, Varley, Ready Radio, Telsen).
- 1 25,000-ohm spaghetti (Telsen, Varley, Lewcos, Igranic, Sovereign, Tunewell, Bulgin, Lissen).

VALVE HOLDERS,

- 1 Horizontal type (W.B.).
- 1 4-pln. (W.B., Graham Farish, Wearite, Chix, Igranic, Telsen, Lotus).

- 1 5-pln. (W.B., etc.).

COILS

- 1 Eckersley Tuner (Wearite, Goltone, R.I., Sovereign, Melbourne, Formo, Lewcos).
- 1 Eckersley H.F. coil (Sovereign, etc.).

CHOKES

- 2 H.F. (Ready Radio and R.I. Quad Astatic, Varley, Lewcos, Telsen, Peto-Scott, Graham Farish, Tunewell, Sovereign).
- 1 Pentode output (R.I. Hypermite, Tunewell).

TRANSFORMERS

- 1 L.F. (R.I. Hypermu, Varley, Telsen, Graham Farish, Igranic, Ferranti).

MISCELLANEOUS

- 1 Terminal strip, 18 x 1½ in.
- 1 Screen, 8 x 6 in.
- 9 Indicating terminals (Belling & Lee, Bulgin, Eclax, Igranic).
- Glazite, Lacoline, Quickwyre.
- Flex, Battery plugs (Chix etc.), Screws, etc.

The First Battery "Variable-Mu" Receiver

were in progress on a battery-operated variable-mu screened-grid valve, and we decided that a set incorporating that valve would be the very thing for our first Eckersley S.G. set.

There were other reasons why the H.F. version of the Eckersley receivers could not be rushed through, even at the request of thousands of our readers. One is that it is our practice to test thoroughly every set, big or small, before we publish its description,

and to rush through a set would mean breaking that inflexible rule.

Another is that a great deal of experiment was necessary before a novel set of the description required could be offered to readers with every confidence.

Ganged Tuning

Obviously we could have tacked an ordinary screened-grid stage on to the "Eckersley" Three, enabling greater range of reception to be obtained, but

at the expense of having three tuning controls.

But with the selectivity that is the essential characteristic of the Eckersley coil that would have meant untold trouble in handling the set. (As a matter of fact, it would have been almost beyond the capabilities of even experienced constructors to get more than a few stations with it!)

Mere sharpness of tuning is one thing, but when high selectivity is coupled with a multi-tuning

Carefully Designed for Ease of Assembly

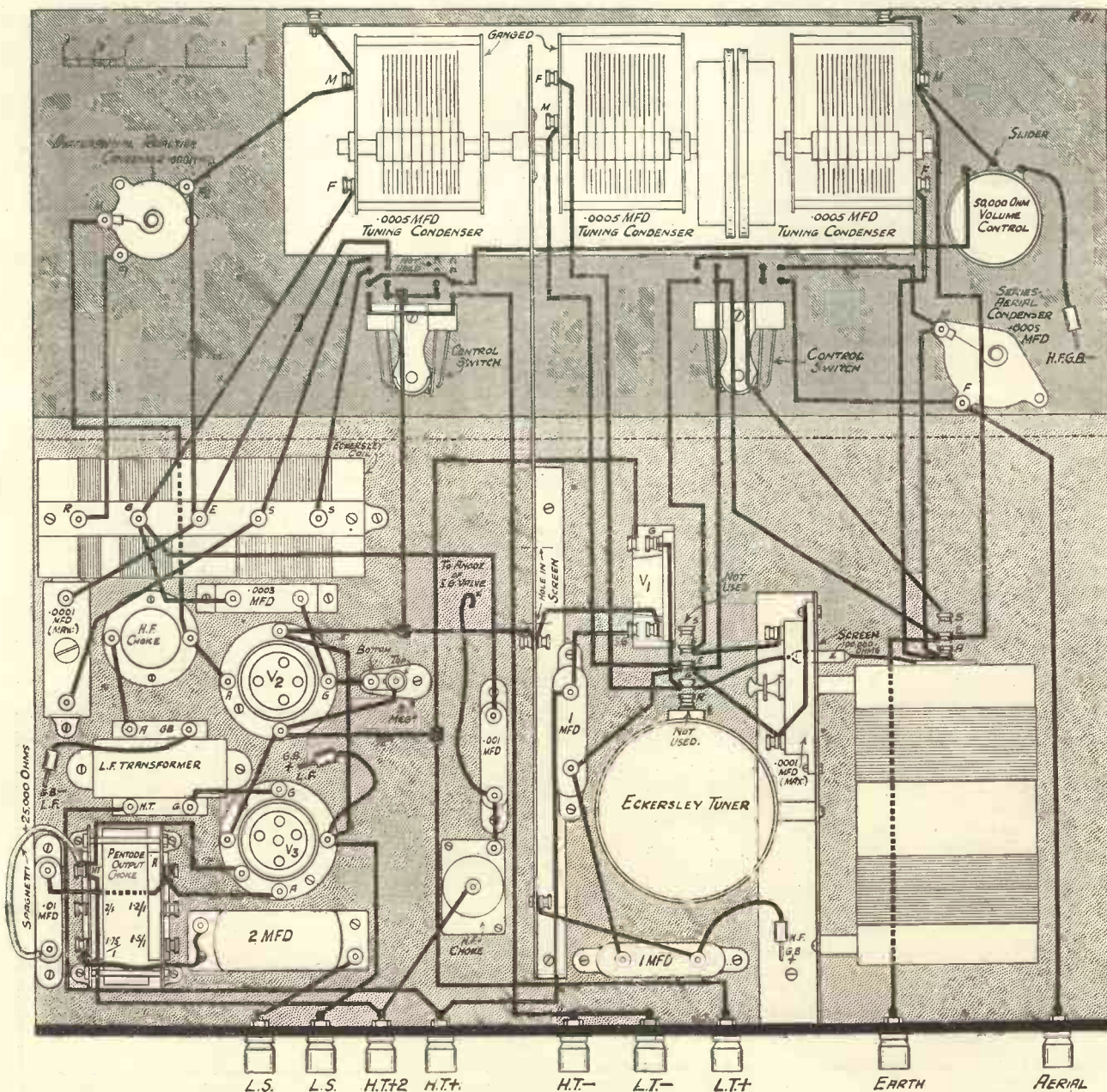

As you see, the "Varmu" is not a haphazard jumble of components and wires. Indeed, it has a decidedly attractive layout, making for ease of assembly as well as neatness.

Colossal Power—Flexible Volume Control

arrangement real trouble in handling the set commences.

We have said that the variable-mu valve was decided upon as desirable for the Eckersley "Varmu" Three, and you will by now have realised that ganged tuning was also decided upon as essential.

But you cannot merely link up any tuned circuits and call the result "ganged tuning." The coils have to be carefully matched, and commercial models have to be made and tested and passed before it is safe to place a set of this description before the public.

The "Eckersley" H.F. Coil

So a special H.F. coupling coil that would gang up with the Eckersley tuner had to be designed. And, moreover, it had to be small—there is no room for another unit of the same size as the tuner itself.

That coil has now been designed, and the various makes mentioned in the list of components have been tested in the original Eckersley "Varmu" receiver and have been passed as O.K.

Extensive tests with the first

models of the variable-mu valve also were carried out. So you will see that although the Research Department

ACCESSORIES RECOMMENDED

Loud Speakers. (Celestion, Amplion, H.M.V., B.T.-H., Marconiphone, R. & A., Blue Spot, Epoch, Undy, Graham Farish, W.B.)

Valves. 1 S.G. variable-mu (Cossor).
1 detector (Mazda H.L.2, Mullard, Marconi, Osram, Six-Sixty, Tungsram, Dario, Cossor, Eta, Lissen).
1 Pentode (Mullard P.M.22, Cossor 230P.T., Marconi or Osram P.T.240, Mazda Pen.230, Six-Sixty 230P.P., Tungsram, Dario).

Batteries. H.T., 120-150 volts, super-capacity (Pertrix, Drydex, Ever Ready, Magnet, Lissen).

G.B., 1 16½-volt G.B. for L.F. ;
1 9- or 18-volt (see text) for H.F. (Ever Ready, etc.).

Accumulator. 2-volt (Exide, Pertrix, Ever Ready, G.E.C., Oldham, Ediswan, Lissen).

Mains Unit. To give 25 milliamps at 150 volts (Regentone, Ekco, Tannoy, Forno, Heayberd, Lotus, R.I., Atlas, Tunewell).

has been silent concerning this development of the Eckersley tuner, it has not been idle.

And now, having explained the steps that have led up to the publication of the receiver under examination let us look more closely at the circuit and see exactly what happens.

Basically the set is an S.G., detector, and pentode design, but there is far more in it than such a terse description conveys.

For instance, we have a system of group and gang tuning that enables the very utmost to be obtained from the set, while the variable-mu valve allows perfect volume control to be effected without any upsetting of the quality or the tuning of the set.

A Special Valve

In normal receivers there are usually two ways of carrying out pre-detector volume control; each of which is efficacious, but not so sound theoretically as it might be. The series aerial condenser method has associated with it a more or less objectionable variation of tuning, while the screen-grid voltage control upsets the characteristics of the S.G. valve and is inclined to cause distortion due to the tendency of the valve under reduced S.G. voltage to rectify.

Ample Dimensions—No Space Wasted

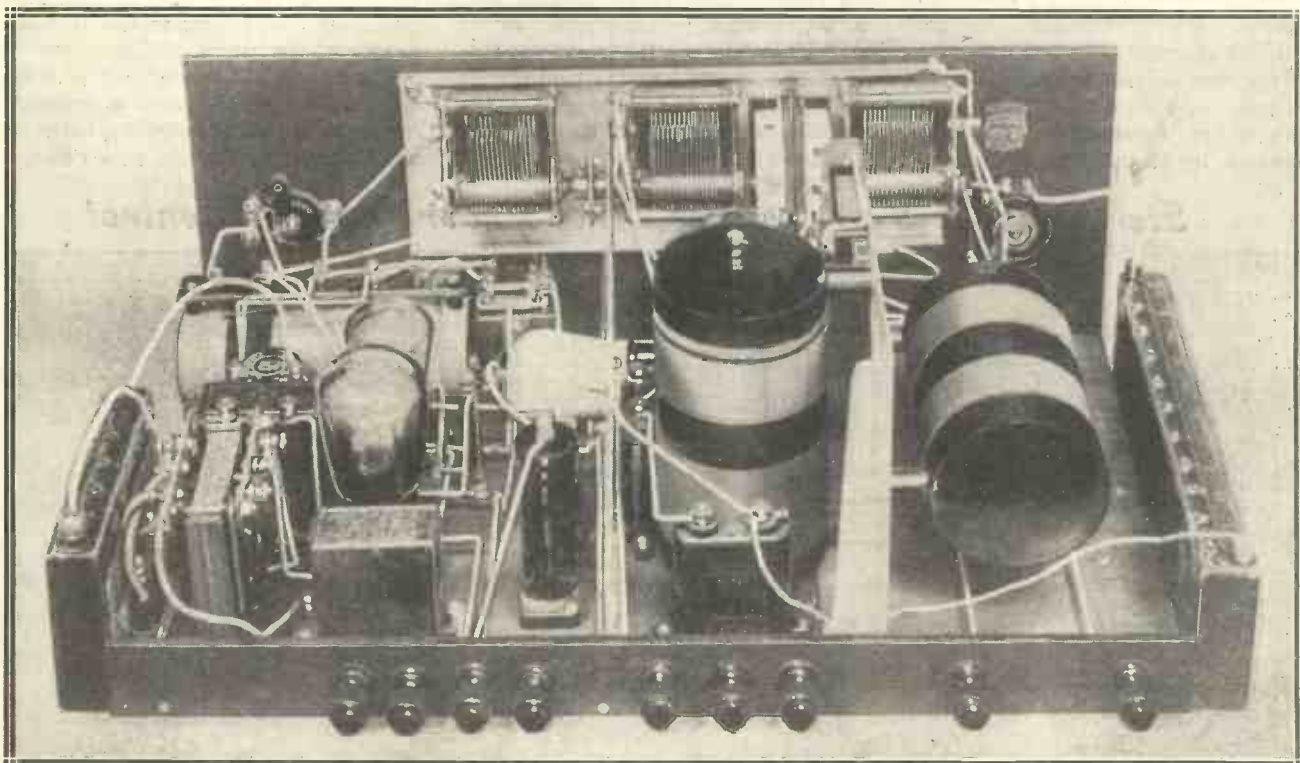

Capt. Eckersley said: "You cannot make an omelette without eggs," and proceeded to break away from conventional standards by designing a tuner of ample dimensions and high efficiency. But it packs away in the "Varmu" quite easily and enables this set to achieve a very high power-selectivity standard.

THE FAMOUS TUNER IN POSITION

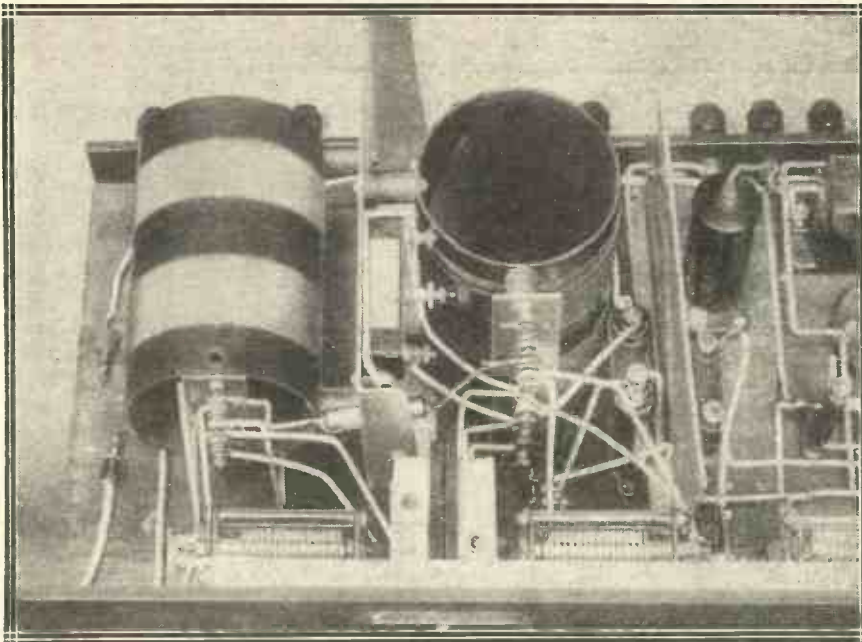

A close-up of the Eckersley Tuner and its terminal strips. Note the non-inductive resistance which is supported through a hole in the screen.

The use of a variable- μ screened-grid valve obviates such troubles, for unwanted alteration of the tuning cannot take place in either the grid or the anode circuits to any appreciable extent, while the fact that the valve is so designed that it allows the control of its amplification properties to be carried out without fear of rectification taking place, and thus introducing distortion.

What happens is that the grid bias of the control grid is varied, for the valve is so designed that it has a variable mutual conductance, this being reduced by an increase in bias, and

increased to maximum when no bias—or very little—is applied to the grid.

Applying Bias

The manner of applying the variable bias to the grid is perfectly simple. A grid-bias battery, its voltage depending on local conditions (this will be explained later), is connected with its positive pole to earth, and with a 50,000-ohm potentiometer across it. The slider of the potentiometer is then connected to the grid circuit of the valve, and variation of the position of the slider controls the applied bias to a nicety.

In order that the bias battery shall not be wasted by drainage through the potentiometer when the set is not in use, a three-point on-off switch is used for the filament circuit, the third point being employed to break the circuit between the bias battery and the potentiometer.

Such a volume control will enable you to cut down the strength from full blast on the local to almost inaudibility, the control being delightfully smooth and progressive.

Here, perhaps, it may be explained what was meant by the statement above that the voltage of the bias battery depended on local conditions.

How Many Volts ?

This is not so complicated as it sounds, for it merely means that whereas when you have the set in a location some miles from a powerful local a 9-volt battery will be sufficient to reduce the volume to the required degree, when the distance is smaller then 18 volts will probably be required to reduce the volume to the same extent when listening to the local programme.

Roughly, we would say that within 20 miles of the local the higher-voltage battery will be required, the 9 volts probably being sufficient at distances greater than that.

And now, having discussed fairly fully the action of the variable- μ valve, we will get on to the further details of the circuit.

The series aerial condenser that is so familiar in Eckersley sets is retained to control the aerial coupling, but it is not intended to be used as a volume

Its Unusual Potentialities Are Under Perfect Control

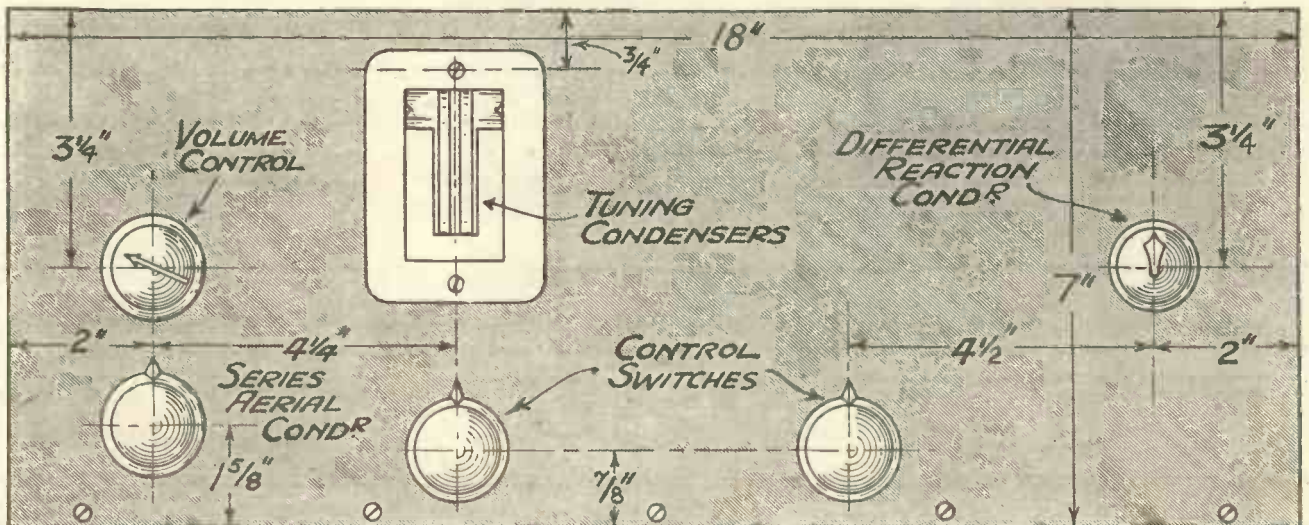

Y1650

PANEL LAYOUT

In the hands of a constructor who is prepared to handle this receiver methodically, the programmes available on the loud speaker can be numbered by the score.

A New System of Group Ganging

control; the S.G. valve looks after that.

From the first coil we go to the second coil of the usual Eckersley tuner in the normal way.

These two sections of the coil are tuned by means of a double-drum condenser, so that they can be tuned either together or separately. The second half of the drum condenser is fixed to a third series of vanes that are used to tune the third coil—the new one specially developed for this set.

S.G. Output

So from the second of the circuits we come to the grid of the S.G. valve. The anode of this valve is shunt-fed from a choke to the tuned-grid circuit of the detector; containing the new coil, and being tuned by the second section of the double part of the drum condenser.

This new coil is like the second section of the standard Eckersley coil in miniature. It has the same type of terminal strip with the same number of terminals, and the terminals are marked in just the same way.

The S.G. output is fed across the whole of the coil, it being unnecessary to tap down, as the selectivity of the tuner itself is sufficient to ensure good station separation, so that we can make full use of the coil to obtain the maximum amplification.

Like the Eckersley tuner, wave-change switching is carried out by means of a three-point switch, but in this set we have used rotary switches, making them do a variety of tasks.

Let us examine them next, for there is little to be said about the rest of the circuit, except to record the fact that the L.F. side is transformer coupled to the detector, and the output valve is a pentode.

About the Switches

The switches, we have said, are of the rotary type. They are, in fact, the normal Wearite two-way switches that can be used so that the middle position is an "off" one.

Two of these switches, with two poles in the one case and three in the other, are employed. They are used like this.

The two-pole one is so connected that in the one position it short-circuits the long-wave sections of the two parts of the Eckersley tuner,

while in the other position it shorts the series aerial condenser.

This latter action could have been omitted if a self-shorting series condenser had been used. But we consider that it is of additional advantage to be able to cut this condenser out with the same switch that wave-changes the coils rather than to have to alter the condenser position so that it shorts itself.

IN THIS SET:—

- An Eckersley Aerial Tuner.
- A Variable-Mu S.G. Valve.
- An Eckersley H.F. Coil.
- A Pentode with a balanced Output Circuit.

The other switch controls the filament circuit, the grid-bias connection of the S.G. valve, and the wave-changing of the H.F. coil. The centre position of the switch, of course, is the "off" one.

You will notice in the diagrams and the photographs two compression-type condensers across the second and the H.F. coils. These are long-wave trimmers that are useful in getting

the circuits exactly in tune, after which they do not have to be touched. Usually the yare set nearly at maximum. Incidentally, they enable you to increase the wave-range of the set by acting as loading capacities. But we shall have more to say about them later.

Some Constructional Points

The actual construction of the set is quite easy if one or two minor points are borne in mind, and there need be no apprehension as to the practical details. The wiring diagram shows how the layout is arranged, and if you follow that carefully there is no likelihood that you will go wrong anywhere.

Care must be taken in fixing the S.G. valve holder that room is left for easy removal of the valve (and insertion, too). Otherwise there are no nasty little points that need special care. Ordinary care, of course, must be used, but if this is taken you should not run against any difficulties.

Also the switches on the panel under the condenser should be wired and fitted with longish leads before the condenser is mounted, otherwise it will be difficult to get at them.

THE NEW ECKERSLEY COUPLING COIL

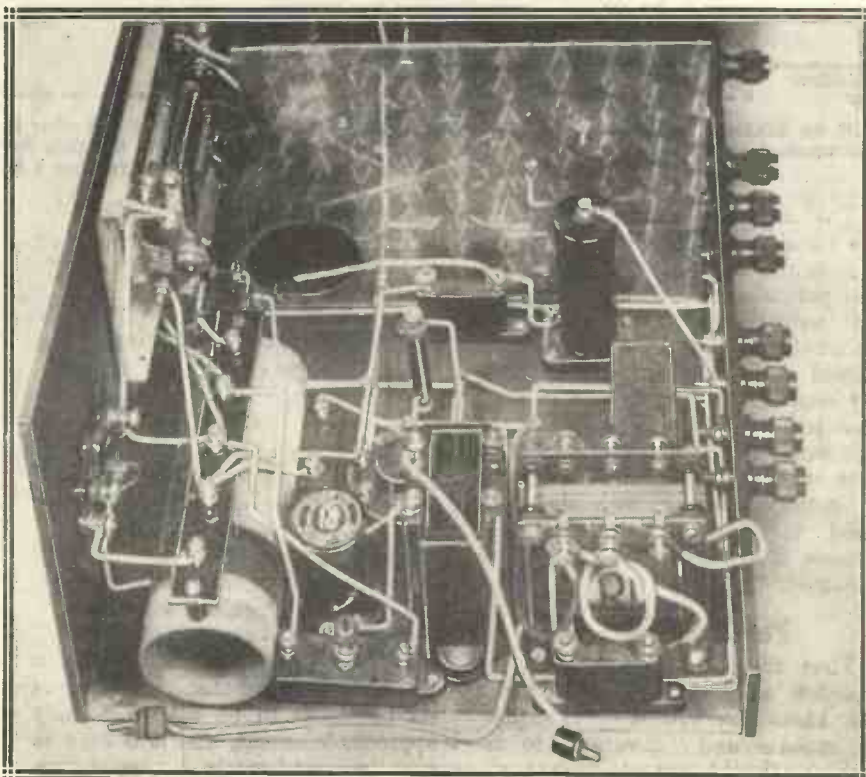

A new Eckersley Coil is introduced in the "Varmu," and you can see it above on the extreme left. It is an inter-stage coupler.

Razor-Edge Selectivity Without Losses

One point that should not be overlooked is the earthing of the back plate of the gang condenser. This is quite separate from the moving vanes, and so is not earthed automatically with the wiring of the set.

Also note that the second screen (the one through which the S.G. valve goes) is not earthed, but goes to

reversing the connections to the outside terminals.

When the set has been completed, it is the work of a minute or two to connect up and get things going.

There are two H.T. terminals—one for the screened-grid voltage, which should be about 80 volts, and the other for the anode of the S.G.

As a matter of fact, you will notice that they are connected across the long-wave sections of the coils, so that the trimming will only take place when tuned to the long-wave stations. It is neither necessary nor advisable to have the additional capacity when dealing with the medium wave-lengths.

A Powerful S.G. and Pentode Combination

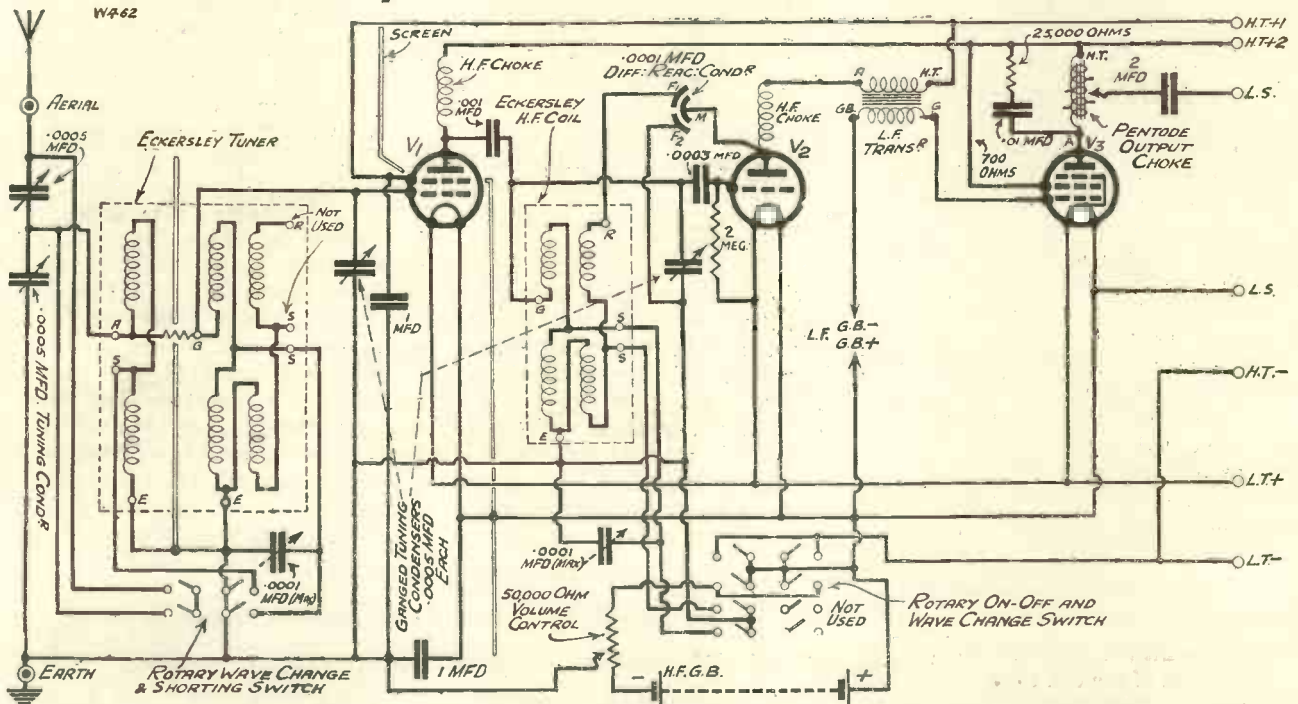

With an Eckersley aerial tuner, followed by a "variable-mu" H.F. valve, an Eckersley H.F. coil and a pentode, it is clearly obvious that unusual orders of power and selectivity must be achieved. The above circuit is worth examining in detail, and you will find it of great interest to compare this with the photograph on a following page.

L.T. —, and this screen *must not touch* the variable condenser screen.

Note also that the volume control—the potentiometer that controls the S.G. valve—is connected so that the volume increases as the knob is turned anti-clockwise. This is done for convenience, as it is a control that is likely to be operated by the left hand, and it is more natural to turn outwards to increase (as is done to increase reaction with the right hand operating the reaction condenser) than to turn in the reverse direction.

Varying Volume

Thus to vary volume either by reaction or by the potentiometer the knobs are turned "outwards" to increase and "inwards" to decrease. Should you desire the potentiometer to operate in the reverse direction this is easily achieved by

valve, the detector and the pentode.

This terminal should be connected to the maximum of the H.T. battery, a matter of 120 to 150 volts.

The G.B. Batteries

Two separate grid-bias batteries are advisable, to obviate long bias leads from the S.G. stage. The H.F. bias should have a maximum of either 9 or 18 volts, as explained earlier, while the L.F. bias should have about 16½ volts.

These batteries can conveniently be situated on the inside of the back of the cabinet, one at either end, so that the leads are reasonably short.

When the set is switched on you will probably find that the trimmers do not have to be altered to any appreciable extent, and it is easy to tune in a moderately distant station and adjust them for maximum sensitivity.

There is one further point about the trimmers that we should mention, for the benefit of those who have unusually short aerials.

In such cases it may be found that there is difficulty in getting up to wave-lengths above Radio-Paris. In this event, a .0002-mfd. fixed condenser may be connected permanently across terminals S and E of the first section of the tuner, and the trimming condensers, which, as we said before, were not critical in adjustment, set at maximum.

How to Handle It

It should then be found that the set will go up to well above Radio-Paris without any trouble.

The handling of the receiver is quite normal. The two drums of the condenser are rotated together, and the left-hand one is adjusted to keep the aerial circuit in tune. It will

not be in step on the long waves, though with adjustment of the series aerial condenser it can be kept so on the medium band.

This series condenser should be kept fairly low in value on wavelengths below 350 metres, but above this can be placed near the maximum.

Variable-Mu Adjustments

The adjustment of the variable-mu valve is simplicity itself. The full voltage of its grid-bias battery is used, and the turning of the potentiometer knob does the rest.

When near a local station you will not be able to use the potentiometer at maximum volume, due to the overloading of the S.G. and the detector valves, but you will be able to adjust it to get the maximum volume without distortion, with the knowledge that the S.G. valve is really operating under the proper conditions.

The maximum position of the potentiometer will be found to be fairly sharply defined, and you will probably notice that on either side of this there will be a decrease. The maximum position will be close to one end of the resistance and denotes the setting of bias voltage that enables the valve to give the greatest amplification.

The set is quite easy to handle and a few minutes' practise will enable

you to get the very best from it, when you will be surprised at the ease with which sensitivity and volume

can be controlled, and at the capabilities that the receiver has for bringing in stations.

A REVELATION IN STATION SEPARATION

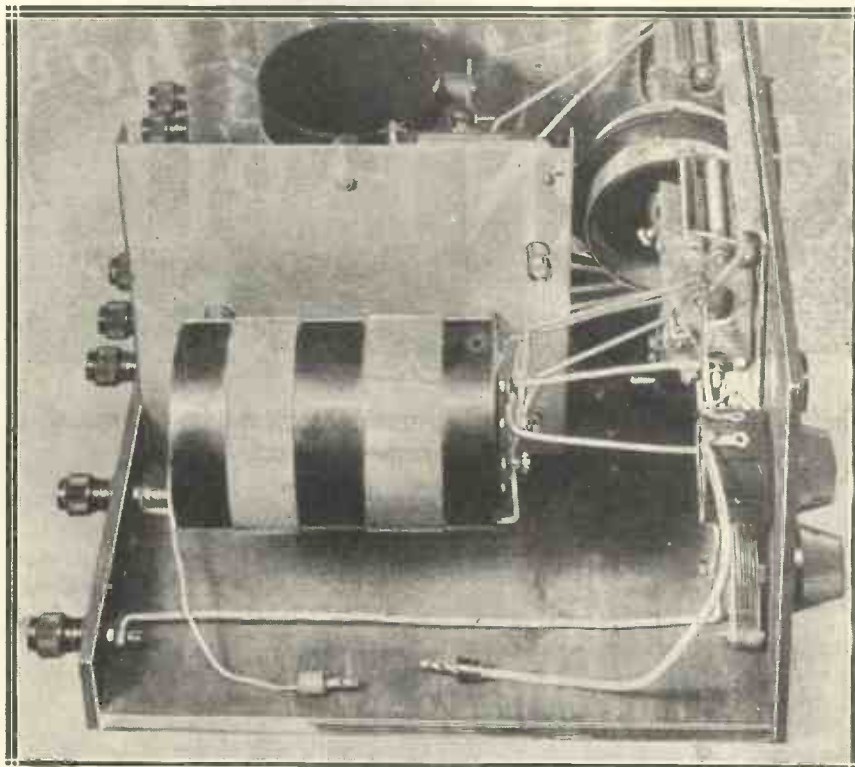

The Eckersley tuner above is able to provide exceptional selectivity, and where you have another tuned circuit as well . . .

Points to Note in this "M.W." Design

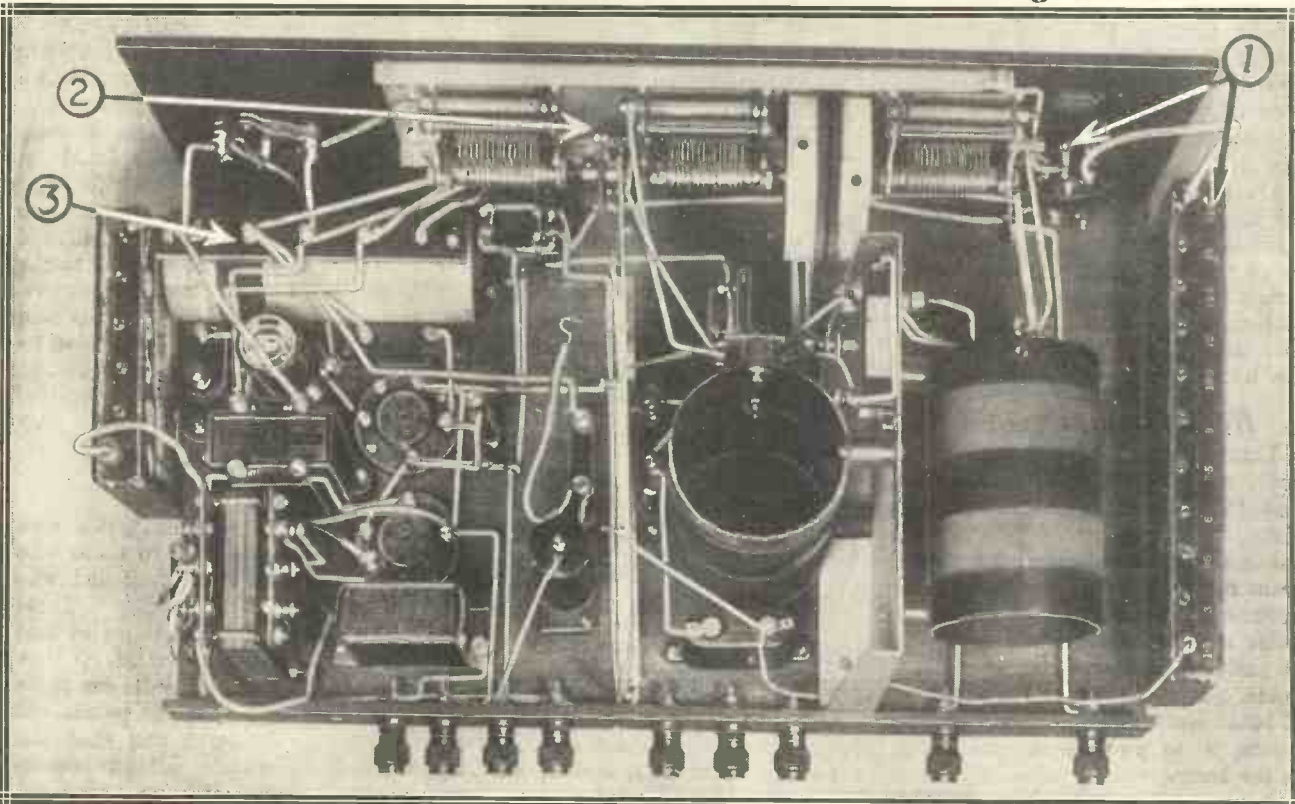

(1) The variable-mu control and bias battery; (2) the ganged tuner controls; (3) the new interstage coil unit.



Finding a "home" for your radio-gram—A neat needle-cup mounting that will appeal to home-constructors.

By "TONE ARM."

MANY of us are so keen on getting the very best out of our radio-grams, spending hour upon hour in various experiments in the quest for perfect quality, that we are apt to forget that, taken as an instrument, it deserves a really first-class home.

The True Ideal

There is something fascinating to the scientific mind in a bench full of lash-ups, a long table strewn in orderly disorder with the necessary gear that constitutes the latest in reproducers. But there is something even more attractive in the beauty that only a well "cabineted" outfit can give.

The lash-up may look (and it may be) scientific, but it is not the embodiment of the true radio-gram ideal. It may be said that the ideal is to obtain perfect reproduction, true realism, and so forth, but surely to that must be added the words "in the home."

Home Entertainment

That is the greater task, and in its quest one must take into consideration the final housing of the conglomeration of electrical components that go to make the ideal. A radio-gram receiver in the laboratory is of intense interest, but its practical value is absolutely nil unless it can be introduced into the ordinary home. For the whole *raison d'être* of broadcast radio, and of the gramophone, is to provide entertainment in the home.

As such, therefore, it is essential that the appearance of the outfit as a

whole shall be attractive; the scientific-looking receiver has no place in the drawing-room or lounge.

There are difficulties in combining appearance with electrical and acoustic efficiency, but a near approach can be obtained if care is taken with the choice of the home for the set—the cabinet.

Very many styles, both good and

AN ATTRACTIVE CABINET



This is a photograph of the "Pianotone" walnut cabinet described on this page.

bad, are available to the searcher for a radio-gram cabinet, but one of the most attractive that I have seen for a long time is the Pickett "Pianotone"

Grand De-luxe which can be obtained in a variety of woods.

The illustration shows the cabinet finished in highly polished walnut, and a very attractive job it is. The thickness of the wood is one of the fine points of the design, for thick wood means less resonance, and, in fact, this cabinet in use is remarkably free from that boxiness that is the bugbear of all radio-gram users who try to combine appearance with tonal quality.

Separate Baffle

A separate baffle, either detachable or not, as required, is provided a part from the actual speaker mounting, which is a strong thick piece of wood (provided cut for any speaker) with felt packing between it and the baffle proper. At 12 guineas for oak, 14 for mahogany, and 16 for walnut, the price is not excessive; while the piano finish and the design of the cabinet make it a very attractive piece of furniture.

And now I want to draw radio-gram fans' attention to a very inexpensive little gadget that will appeal to many of them. You all know how essential it is to have a needle box of some sort, and it is no less essential to have a used-needle receptacle in which to drop the duds.

A Useful Fitting

If you use a home-made instrument you will probably be rather chary about drilling a couple of large holes in the motor-board to take the two needle cups that are required.

But with the Bulgian needle cups that have recently been placed on the market there is no need for that rather tricky procedure, for the two cups are set in a very neat bakelite mounting that can be screwed to the motor-board with invisible screws. The colour matches most boards, and the ease with which the cups can be mounted will make the little gadget extremely popular. The price, too, is most reasonable, being only 2s. 6d.

Take Warning

Here, perhaps, I might give a word of warning and advice to those who use cups for their needles, and who also use tungstyle needles. These are provided in special boxes so that the points shall be protected. If they are turned out into a needle cup there is strong danger that the points will be seriously damaged, and when the slightest amount of bending is present in these needles they are rendered useless.

THE WORLD'S PROGRAMMES HOW, WHEN AND WHERE TO HEAR THOSE FOREIGNERS



THE FIRST ACROSS! In these days, when so many sets have delighted their owners by "landing" a programme from across the Atlantic, great interest attaches to this new portrait of Marchese Marconi—the pioneer of transatlantic radio reception.

CONTENTS OF THIS SPECIAL SUPPLEMENT

Radio in Pictures
Long-Distance Dodges
Flying-Squad Wireless
On the Medium Waves
Station Alterations
Radio City
Listen for Czechoslovakia

The Abolition of the Aerial
What the Distant Stations are
Doing
Short-Wave Shorts
Above 1,000 Metres
Here and There
Conducted Tours—Northern
Europe on Long Waves

RADIO IN PICTURES

*Some interesting items
caught by the
camera.*



This battery of microphones was used for broadcasting the speech by the Prince of Wales from the Albert Hall.



A wintry view of the B.B.C.'s listening station, at Tatsfield, Kent, which watches the wave-lengths of British and foreign broadcasting transmitters.

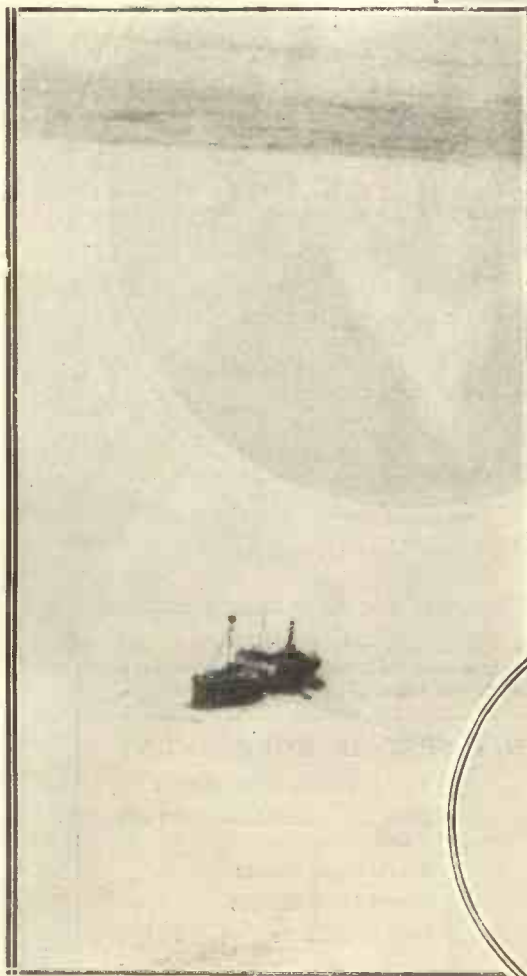

ICEBOUND! This ship was locked in the Arctic ice but radioed her plight to Alaska, whence help was dispatched, and the valuable cargo of furs was unloaded by dog-sleds (right).



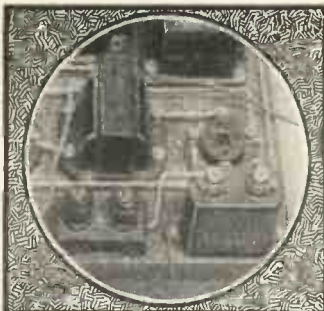

LONG-DISTANCE DODGES

Here are some really good practical hints that will help you in reception, and should enable you to pull in many stations that hitherto have eluded you.



MAKING sure the batteries are up all right and trying different H.T. voltages on the detector are typical of the various things that are naturally done when putting a set in tip-top condition for long-distance reception. They are among the obvious things to do when you are out to log the foreigners—but what about the "unobvious"?

Loud-speaker Adjustment.

There are quite a number of them which are overlooked again and again, and while any one of them by itself may be of little consequence, two or three can add up to have a distinctly detrimental effect on results. Let's take a look at one or two of them and you will see how easily they are passed by.

Take, for example, loud-speaker adjustments. "But," you say, "that's one of the obvious ones. I always see that mine is adjusted to the most sensitive point."

Yes, but I'll bet nearly everyone adjusts the speaker on the local and leaves it at that! If it's not a balanced-armature type, the armature can often go nearer the magnets for stations other than the local, with a decided increase in sensitivity.

Quite a small point, but it may make just that needed difference when you are trying to identify a station to fill up your log. And another point in connection with log-making:

Don't get exasperated because the blighters won't tell you who they are. Don't swish round and try and identify someone else instead, or go on to another wave-band.

Logging the "Landmarks"

You'll waste less time in the end if you stalk on that first station till you know who it is. It's like a jig-saw puzzle; one awkward piece may be holding up the positioning of many others which will fall into place with ease once you have settled the stubborn one.

Then with regard to reaction and oscillation. It is very easy to make a fetish of smooth control, and so carry it too far at the expense of sensitivity.

H.T. Voltages

Up to a point, the more H.T. you give to the detector the more sensitive it is; unfortunately, at the same time, the more suddenly you find the set goes into oscillation. Nevertheless, on quite a number of medium-distance stations you get better results by having more sensitivity due to a high voltage and then not working so near to the oscillation point.

Since you do not have to go so near to the oscillation point, the less smooth control doesn't matter.

is not obtained right at the positive end. But even so the advice still holds; don't go too negative.

A pernicious practice with small sets, but often used with sets employing H.F. stages, is to search for stations with the receiver oscillating. This is certainly a quick way of finding stations, afterwards resolving the carriers, but it can be carried too far on weak ones.

"Threshold" Reception

The stronger the set oscillates, the less marked will be the silent point, with the consequent effect that the carriers themselves will seem higher pitched and weaker. So if you use this method of searching, see that the receiver is only just oscillating.

Perhaps the next point is a little

which is not really meant for long-distance work, but which is often used for this purpose—the portable.

For Portables

Very often a small aerial, generally a length of wire "stuck" round the room somehow, is attached to the grid end of the frame.

This is quite O.K. so long as it does not introduce bad hand-capacity effects. Unfortunately, however, this often happens, although there is no such trouble with the frame alone, and often the change in tuning when the hands are removed is so difficult to overcome that better results can be attained without the assistance of the extra pick-up.

"A jerky dial means a blank dial," would be a good slogan for the manufacturer of a good condenser with nice, smooth bearings. Its truth is only too plain.

If your dials are stiff, or have backlash, or move in jerks, whether due to faulty slow-motion dials, bad spindle bearings, or dials touching the panel, you won't be able to get fine tuning. And without fine tuning you won't be able to get those weak "point-something" kilowatters.

A little vaseline and careful dial-setting before grub screws are tightened will prevent most of the trouble. Now, last but not least, dust and damp. When a set has been poked away for some time, or simply left idle, it seems to collect no end of damp.

Damp Windings

Although coils wound with cotton- and silk-covered wires (particularly the former) will absorb moisture if they have not a coating of wax, shellac, or similar "dope," the fact that they have done so is not patent by just looking at them. So the best plan, especially as coils are mostly undoped nowadays, when a set has been where it may absorb moisture is to stand it in front of a fire for several hours.

WIRELESS IN THE WILDS OF ABYSSINIA



Hayle Selassie, Emperor of Abyssinia, recently became so interested in radio that he decided to equip his own country with a service. This is how the new station to be erected at Addis Ababa will appear when completed.

Certainly, on really loud stations, where only a tiny spot of reaction is wanted, the higher H.T. method of boosting is better.

An almost parallel state of affairs exists in connection with the adjustment potentiometers that control detector grid-bias voltage. When the slider (connected to the grid leak) is at the negative end of the resistance, reaction is at its smoothest and results are weakest, or perhaps I should say least strong.

Obtaining Smooth Reaction

At the positive end the effect is strongest results and roughest reaction. So don't be tempted to go too negative.

Of course, that is a rather broad generalisation, sometimes loudest results or most sensitive detection

bit on the extravagant side, but of that you must judge for yourself. It concerns the type of output valve that you use.

Why Not Two Valves?

You can get small power valves that will handle what is best termed "small loud-speaking" without distortion, and which amplify quite a bit more than a valve of the super-power class. But quite likely you need one of the latter so as to get plenty of volume from the locals.

If you do, why not have two output valves and use the higher mag. one for distance work only? Naturally, though, you must remember to alter the G.B. suitably when changing from one to the other.

To turn now to a type of set

GOT A FRIEND OVERSEAS?

You can keep him in touch with radio by sending his name and address with 17s. to the Subscription Dept., Amalgamated Press, Ltd., The Fleetway House, London, E.C.4. He will then receive "M.W." every month for a year.

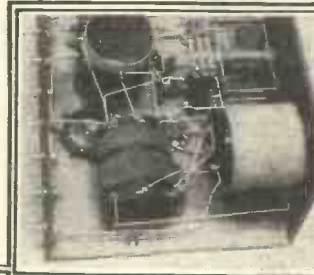
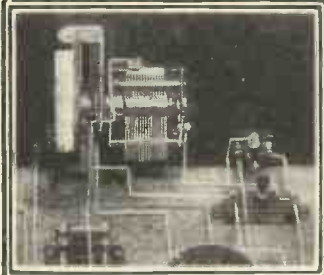

FLYING-SQUAD WIRELESS



A complete receiver with loud speaker and remote-control tuner.



Headquarters speaks to the driver and passengers through the loud speaker fixed to the roof of the car.

To aid in curbing crime, New York police have now installed new radio equipment in their Flying-Squad cars.



The picture above shows one of the valves at Police Headquarters, removed from the transmitter for inspection.



To the left is a typical police car on the road with the tuning gadget fixed to the steering column and connected to the set (below the dashboard) by a flex lead. About 65 cars can simultaneously pick up the messages broadcast from headquarters.

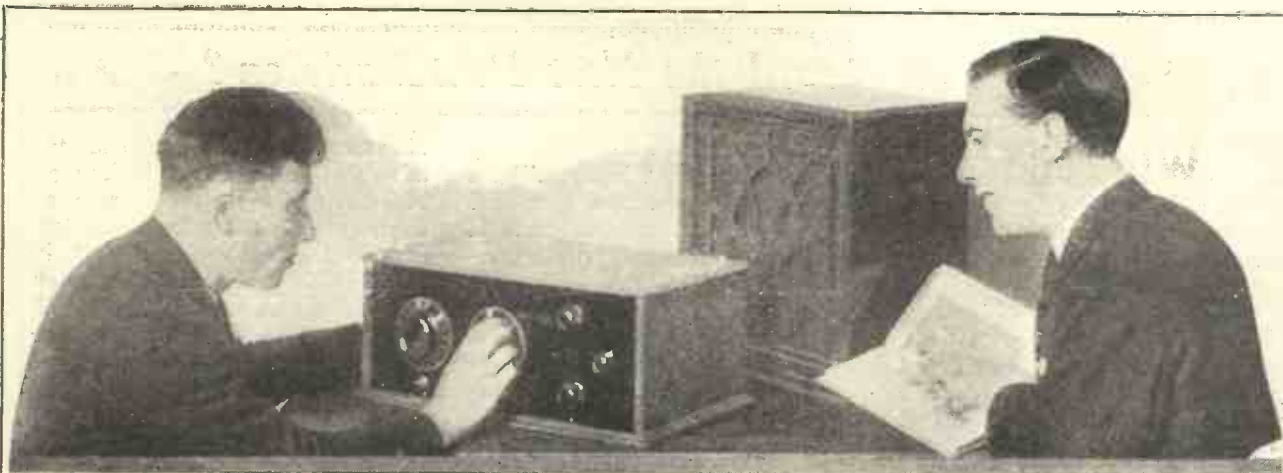

ON THE MEDIUM WAVES

THOSE listeners who maintain that there is no need to dive down to the short waves or climb up to the long waves for broadcast entertainment, when so many fine foreigners disport themselves on ordinary wave-lengths, have certainly had a strong case presented to them by reception conditions on 200 to 600 metres during the past few weeks. An air of feverish foreign activity pervaded the whole sweep of the dial, from Radio-Normandie at the bottom to Wilno at the top.

Sponsored Programmes

Radio-Normandie, who seems to have settled on 219.9 metres, is rated as a 1-kilowatt station; but there is a common impression that it is a very virile kilowatt, for the programmes are certainly very powerful in the London area.

Probably you know that the Radio-Normandie programmes are sponsored by advertisers, who pay for time on the air. These programmes from the Fécamp transmitter are not all of the gramophone record type, however. Some weeks ago the Fécamp announcer introduced not the usual Radio-Normandie programme, but a religious address—in fact, a sermon, although it was a weekday night. It certainly proved a somewhat striking programme in contrast to the jazz on adjacent dial readings.

The speaker was an American, who let his hearers have it in no uncertain terms. There is a great deal of paid religious propaganda in the U.S.A., but it was certainly a surprise to find

Notes regarding recent reception conditions and some details of interesting stations to look for.

such an evangelical item on the European ether. Listeners who wear the clergyman's collar will follow this development with interest.

* * *

Talking of advertising programmes at the bottom of the dial, reminds me that Radio-Normandie's nearest neighbour, Cork, on 224.4 metres, seems to spread his sponsored programmes with a very heavy hand. Despite the charming voice of Cork's lady announcer, there seems rarely much pleasure to be gained from this

FOR GOOD QUALITY



A control engineer sitting at the "monitoring" desk of a broadcasting station, with his eye on the tell-tale needle.

class of programmes, and instead of subtle suggestion the programmes come over as blatant, unashamed, have-at-ye advertising matter.

More Power from Paris

About the middle of the dial we have had an extremely interesting newcomer in the form of the Post Parisien station, who has been making trial runs of his new transmitter. This is going to be a really good station by all accounts, and the power output will be at least equal to one of our own Regional stations, so—in the south of England, anyhow—a visit to Paris will be an easy matter.

Post Parisien uses the wave-length of 328.2 metres, immediately above Breslau (Germany), and immediately below Milan. His setting is almost exactly half-way between that of the London Regional and that of the North National, and as English as well as French is spoken from this station there should be no difficulty in adding it to your log-if you look out for him.

The full power of the station is not being employed at first, and he shares a wave-length with Grenoble, at least for a time; so should they appear on together, bad quality is certainly going to be a result in this country.

"Radio Roma" Relapses

One curious effect worth noting on the debit side of the ledger is the strength of Rome. Not many weeks ago, "Radio-Roma" seemed to be sitting on my aerial, simply waiting for the dial to be anywhere near his true setting, when he would come in with a roar. For some reason this state of affairs has completely altered,

Have You Heard the New Post Parisien?

and the famous Italian has rather suddenly become comparatively coy. Is this a local effect or are other listeners experiencing similar situations from Rome?

Doing Their Best

Ever since the Spanish revolutions, the Dons appear to have brightened up considerably, and lately their programmes rank amongst the best received in Europe. Radio-Barcelona, for instance, just a degree or so below the London Regional, with call-sign of EAJ1 and a wavelength of 349 metres, has been coming in with some wonderfully good music late in the evening.

The Madrid stations on 424 metres, namely, "Unione Radio Madrid" and "Radio España," have placed themselves in the picture again. Radio España works on from 5 p.m. to midnight on Mondays, but on other days it closes down early, leaving the field to Madrid Unión Radio.

Enquiries as to who is the Frenchman working on a wave-length below Langenberg remind me that Lyons has been putting over an excellent programme for some weeks. The full name of this station is "Lyons La Doua."

Usually the announcer omits the Lyons and says "Ici La Doua";

spoken quickly, this sounds to English ears like "E.C. la do A." Its power is very much lower than that of Langenberg, but often there is little to choose between their comparative strengths.

For real vigour and virility there is no doubt that the Prague station on 488.6 metres is setting up some-

be interesting hearing; and the advocates of the use of high-power broadcasters have certainly received a powerful backing from the two super-stations which are now in action in Europe, namely, Prague on the medium waves and Warsaw on the long waves.

Those extra kilowatts seem to

WHERE IT ALL BEGAN!

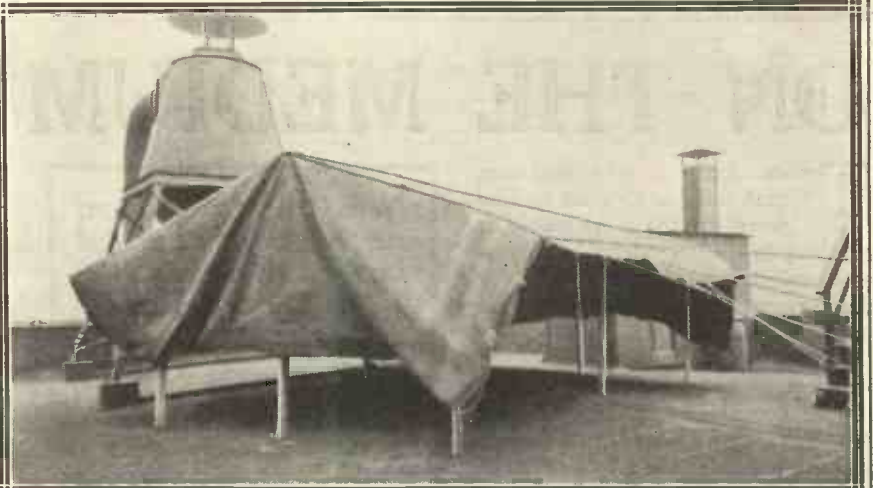

It was from this tent KDKA, "The Pioneer Broadcasting Station of the World," sent its first programme to radio listeners. And on the next night the tent blew down on the musicians, and the first "technical hitch" had to be explained away.

thing of a record. What the North Regional listeners with not very selective sets say of him, sitting right on top of their own "local," would

make the stations in question stand out from all their neighbours, though in neither case could the distance be called anything but tremendous, for Prague is 640 miles from London and Warsaw still farther.

A VIEW OF THE VATICAN

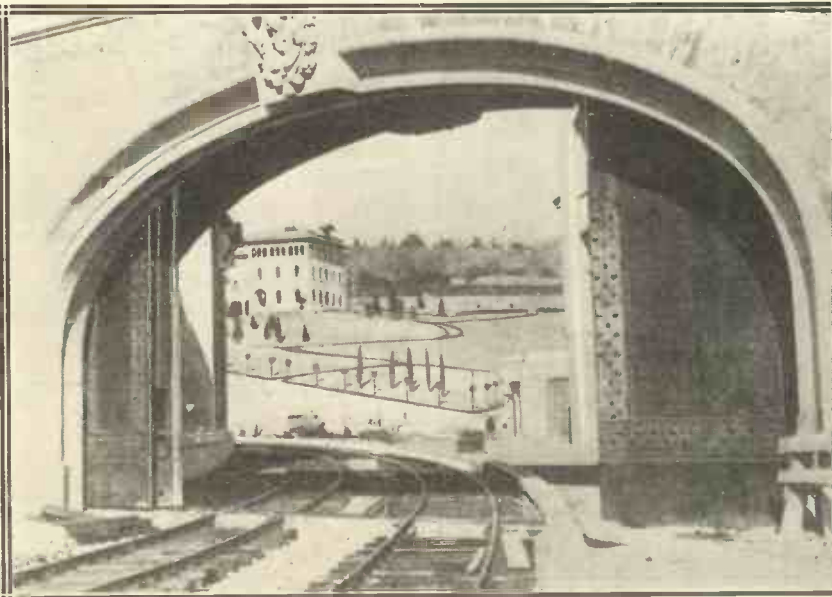

The Vatican now has its own railway station, and this view through the arch shows the Pope's radio station in the distance.

Wandering Wilno

Until a few weeks ago Prague's nearest neighbour towards the top of the dial was Wilno, Poland, but this well-received station folded up his tent one night and reappeared next day higher up the dial on 563 metres.

Wilno is a good station, well worth listening for, but it is probable that now he appears on the dial well above Budapest most British listeners will give his programmes a miss, preferring to have somewhat smaller coils which allow them the stations at the bottom of the dial.

Finally, mention must be made of Florence, the 20-kw. station now appearing on 500.8 metres. It is easily identified, for it is the next station downwards from Brussels No. 1, and is only a degree or so above Prague.



STATION ALTERATIONS

Items of interest to the long-distance listener, and news of the new stations on the air or in construction.

of about 50,000 licences in the past twelve months.

BERLIN. Some of the ambitious acoustic devices planned for Germany's Broadcasting House have had to be abandoned on account of enforced economies.

LUXEMBOURG. April 15th is the date provisionally named for the tests of the new high-power station to begin. Wave-length, 217.4 metres.

DAVENTRY. The cost of the New Empire Station at Daventry is estimated to be about £50,000.

BELFAST. The Northern Ireland Regional improvements are expected to take precedence over the long overdue power-increase and overhaul of the Daventry 5 X X station.

HONOLULU. The Honolulu K G U station was the one to which the credit must be

LYMPNE. The Kentish air-station is probably to be fitted with a Marconi-Adcock direction-finder in the near future, to give better service to aircraft needing direction at night.

CROYDON. An improved "visual" radio beacon for aiding air-navigation is shortly to be placed in experimental operation at the London air-port.

W G Y. The Schenectady station was the first to use a condenser microphone, and also the first to use crystal control of wave-length.

FALKIRK. The first experimental broadcasts from the new Scottish Regional station should be "on the air" on 376.4 metres about the time these lines appear in print.

RADIO SWISS ROMANDE recently gave a highly satisfactory running commentary from Mt. Goonergrat, 10,000 ft. up! This constitutes a record for broadcasting!

SCHWEIZERISCHER LANDESSENDER and Radio Suisse Romande, the two high-power Swiss regionals, have resulted in an increase

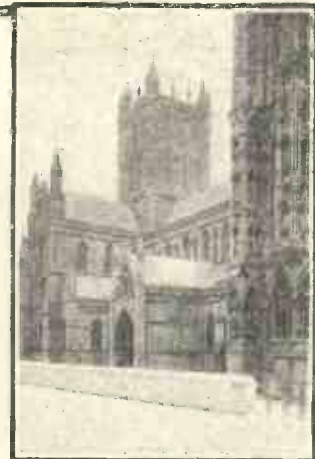

has been improved to give "music" quality, and is now available as an international relay circuit.

PULHAM recently installed a new direction-finding receiver system for aircraft which has important advantages.

HILVERSUM recently broadcast a successful version of "Macbeth."

BARCELONA has been running an interesting English lesson at 7.30 p.m. on Thursdays.

VILLA ACUNA, the powerful Mexican station operating under call X E R, is in great disfavour because it is said to be run on a "quack-medicine" basis, to advertise a goat-gland specialist. It is just over the border from the States and migrated there when the Federal authorities refused to renew the licence.

PARIS P.T.T. When this station celebrated its tenth birthday recently the Minister for Posts, Telegraphs and Telephones announced that work on its new high-power transmitter would begin immediately.

TURIN. The Italian broadcasting authorities have purchased the Turin Theatre for broadcasts of operas, etc.

MADRID. The great Wireless Conference, from which so much improvement in Europe's wave-length situation is expected, is to take place at Madrid in September.

LANGENBERG. The recently increased separation in wave-length from the North Regional has resulted in improved reception for Langenberg listeners.

WELL WORTH TRYING FOR

Some selected foreigners of more than ordinary interest.

Russian Stations	Metres.	Moscow Stalin	Metres.
(Testing on long waves, especially about 1,200 metres)		Barcelona	424.3
Wilno (Recently altered wave-length)	563	Poste Parisien (New Paris station)	349
Florence	500.8	Genoa	328.2
Schweizerischer Landesender (Bermunster)	459	(Same power as Trieste)	312.8
		Bordeaux Lafayette	304
		Nurnberg	239
		Fecamp ("Radio Normandie")	219.9

BOLZANO. The carillon at 11.30 a.m. is from the famous Gries Monastery.

5 H W. This is the call-sign of the transmitting station of the National Physical Laboratory, from which modulated test transmissions are radiated at specified times for calibration purposes.

given for a "broadcasting" volcano, the moving microphone being taken to Mt. Halemaunna.

POZNAN is still clearly receivable in this country at times, though a recent closing-up of wave-lengths brought it very near that of Milan.

STRASNICE, the old Prague transmitter, which for a long time took the morning transmissions, leaving the new (Liblice) transmitter to carry on the later programmes, is to be rearranged to work on 250 metres.

LILLE. The Paris-Lille-Brussels telephone circuit



"RADIO CITY"



Some Views of New York's Newest Marvel

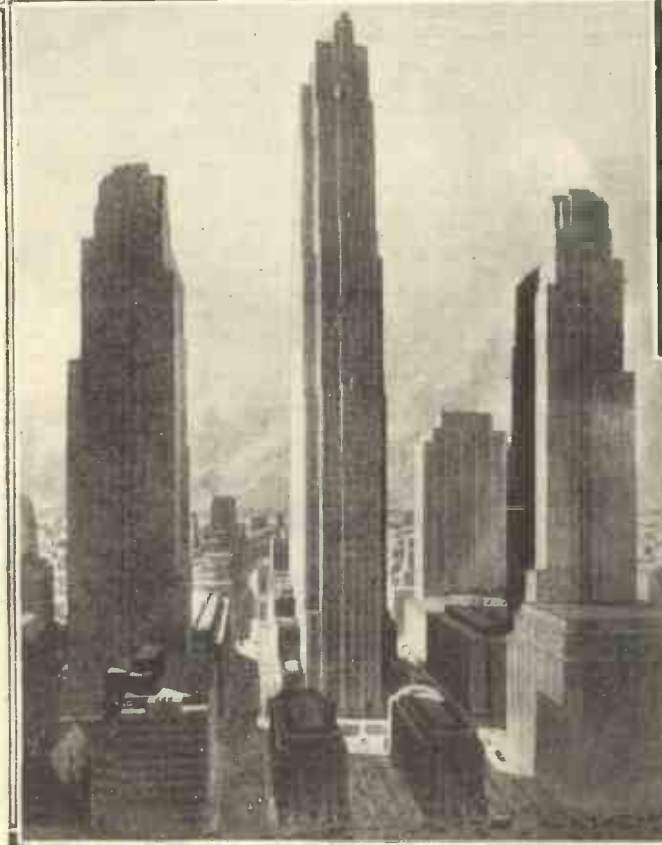

New York is to have the world's first Radio City—a \$100,000,000 project consisting of skyscrapers housing the headquarters of the whole radio and television interests of North America. Left, the architect's conception of the future Radio City.



The top left photograph shows a battery man about to blast a section of solid rock far below the street level to make room for the Radio City's foundations. In the photograph beside it workmen are shown setting more sticks of dynamite into a rock-hole.



In the lower photograph above, the dynamite has been planted and some of the workmen are hoisting into position a blasting mat to localise the effects of the coming explosion.

Countries to Listen for— CZECHO-SLOVAKIA

CZECHO-SLOVAKIA is one of the newest countries in Europe, for it arose out of the ashes of the Great War. Formerly it was included within the empire of Austria-Hungary, and it lies only a few miles north of Vienna and Budapest, with Prague as its principal city.

Czecho-Slovakia is a long, narrow country, about 700 miles from east to west, and nowhere much more than 100 miles across. Although existing as a separate country for only a few years, it comprises such famous historical places as the Plain of Bohemia, Moravia and Silesia.

On the west the boundaries (Bohemia itself) are more or less definite mountain ridges, but farther east the boundaries are not natural ones, but those determined largely by older treaty and tradition. The country is traversed by the upper courses of many famous rivers, including the Danube, the Elbe, the Oder, and the Vistula.

A rough estimate of the total number of inhabitants is 12,000,000. Most of the artisan and farmer class are found living in Bohemia and Moravia; that is to say, the western portion of Czecho-Slovakia, where there is a greater concentration of population than in the east.

The broadcasting service of Czecho-Slovakia is carried out by five stations, namely, Prague, Moravska-Ostrava, Brno, Bratislava, and Kosice, and all of these stations have been well received in this country. Prague, which works on 488.6 metres, is one of Europe's most powerful stations, with a transmitter located in the suburb of

Liblice, and rated at 120 kilowatts (Copenhagen rating). This is a figure which is equalled only by the Warsaw long-waver.

Identified With Ease

Prague itself is situated in Bohemia at the western end of Czecho-Slovakia, and its nearest broadcasting neighbour is Brno. The name of this station is pronounced "Birno," and its dial reading lies half-way between that of Brussels No. 2 (338 metres) and Strasbourg-Brumath (345 metres).

There is a pleasant-voiced man announcer who says "Radio Birno" when the programme originates locally, though, of course, it often comes from Prague.

Farther to the east and on the northern border near Poland lies Moravska-Ostrava, which has often been heard by Londoners when the National programme has closed down, because its wave-length is only about

two metres above that of the London National station. Although not a high-power station, it is often very clearly received in this country, and as, fortunately, the name happens to be pronounced as one would expect from the spelling, it is a station which is fairly easy to recognise.

About 100 miles away to the south and lying between Brno and Moravska-Ostrava, is Bratislava. This station again is well known to British listeners, its dial reading coming immediately above that of Heilsberg, the famous German regional.

YOUR OVERSEAS FRIEND—

Why not send him "Modern Wireless" every month, to keep him in constant touch with all the latest radio news and developments?

Post his name and address with 17s. to the Subscription Dept., Amalgamated Press, Ltd., Fleetway House, Farringdon Street, E.C.4, and "M.W." will be sent every month for a year.

THE NATIONAL THEATRE

A view of the famous building at Prague, from which broadcasts are often made by the Czecho-Slovakian stations.



Bratislava's wave-length is 279 metres and its name is frequently and clearly pronounced, exactly as it is spelt. The power employed is 14 kilowatts.

There is, by the way, a good deal of variation in the power employed at the different Czecho-Slovakian stations, partly owing to the district in which they are situated, and partly no doubt to the necessity of speaking up for themselves in the proximity of powerful neighbours. Bratislava, for instance, is only 25 miles or so from Vienna, and ringed round Czecho-Slovakia and but a little way outside her borders are such powerful broadcasters as Budapest, Cracow (Poland), and Breslau (Germany).

An Unlucky Station!

The most easterly station of Czecho-Slovakia is Kosice, which employs a power of 2.5 kilowatts and a wave-length of 293 metres. Kosice is certainly of the Czecho-Slovakian broadcasting stations the least known to listeners in this country, not so much because it lies farther away from us as that the geographical situation of its transmitter does not appear to be so good for reception over here, and its wave-length allotment is distinctly unlucky.

It shares a wave-length with Limoges, the French station, and immediately below it is another common wave on which three low-power Finnish stations are located. There are thus five stations using two wave-

lengths, and, as they come almost immediately above the whole group of British relay stations, this part of the wave-band generally sounds like an inferno of interference, and is normally given a very wide berth by the long-distance listener.

Announcements are frequently made from the Czecho-Slovakian stations in German, English and French, but the native tongue which is usually employed is a very difficult one to "place," for it is quite unlike German or Latin, and superficially resembles that heard from the Polish stations.

THE RADIO STATIONS OF CZECHO-SLOVAKIA



This map clearly shows the position of the various stations; these are printed in heavier type than the non-broadcasting towns.

THE ABOLITION OF THE AERIAL!

An extremely interesting development in which the mast comes into its own. It is being used not to support the aerial, but to supplant it altogether.

SOME very interesting experiments recently carried out in America have culminated in what is claimed to be a perfect aerial. And, curiously enough, the aerial in question is nothing more nor less than a tremendous mast, carrying no aerial at all, because the mast itself is acting as one.

The mast, of course, is not a wooden one. It actually is a steel tower, the entire surface of which is used for radio transmission.

Novel Method of Tuning

As developed by the Columbia Broadcasting System of America, and used in conjunction with a 70-kilowatt transmitter of station WABC, New Jersey, the mast towers up to some 665 ft. high. It is pointed at both ends, and looks something like a tremendous candle-flame in shape, the stay wires which support it being taken from a central thickened portion.

The upper point is free and the lower point rests on a large porcelain ball insulator, which is supported on a concrete foundation. At its widest part the mast is about 9 yds. square, this being at a height of approximately 270 ft. from the ground. Right on the tip of the mast is an enormous 75-ft. point of steel which can be raised or lowered as a tuning adjustment!

The final shape of the mast aerial was determined from experiments with balloons, which were sent aloft supporting a system of wires acting as an experimental radiator.

Engineers tested the results from this while the balloon was flown at different heights, and while the wire framework was altered to different shapes. They finally decided that much better results were obtainable from such a vertical aerial than from the types normally in use.

Reduces Fading Considerably

Not only does the use of such an aerial extend the non-fading area of a wireless station far beyond that secured by other types, but it controls the so-called "sky wave," and thus limits interference at a distance.

With a view to discovering what was the effect of vertical wire aeriels the B.B.C. employed one of these for the North National transmitter, which was opened in June last year. In this case the aerial is supported from a triatic slung between two of the 500-ft. high masts.

At the time of writing, evidence is still inconclusive as to whether indirect ray at great distances is seriously reduced by this form of aerial, which certainly gives greater efficiency for the direct ray, and a diminution of the indirect ray at distances round about 80 or 90 miles. Reports on this side of the B.B.C.'s research work are expected with interest.

Half-Wave Type Aerials

It is interesting to note that the American experimental mast aeriels, like that at the North Regional, are of the half-wave types; that is to say, the natural wave-length of the mass of metal is half that of the station wave-length which they are designed to radiate.

The latest American example (that mentioned above, at WABC, New Jersey) will work on 348.6-metre wave-length. A similar half-wave aerial is used also for station WAA B, at Squantum, Massachusetts, and it is possible that in time these will be regarded as the pioneers of mast aeriels of a type far superior to those with which the world is now studded.

WHY are medium-wave South American stations "coming over" with so much more reliability and consistency than North American stations? is a question that is uppermost in the minds of long-distance enthusiasts who have spent a night at the dials "trying their luck."

Unusual Reception

I have received reports from all over the country of reception of South American stations on the medium waves. This in itself is unusual, but what is more so is the fact that almost without exception the reports add that North American stations do not equal them in volume or reliability!

At first one is inclined to conclude that the South American stations have increased their power. In several instances this is the case. However, the most frequently received employ the same power and wavelength has they did last year, when North American stations came in at phenomenal strength.

Using my two-valve receiver, I have received L R 3 (Radio Nacional), L R 4 (Radio Splendid) and L R 9 (Radio Fenix), all located at Buenos Aires. In all instances L R 3 has been the best signal, whilst all stations have been heard at moderate strength on various occasions. Others have been more lucky than me, for I have reports of reception of L S 2 (Radio Prieto) and L R 3 (Radio Cino-Paris), both in Buenos Aires, besides reports of reception of the stations I have received.

A "mystery" Spanish-American station, L N, has been coming in well in many parts of the country. This station appears to be located in Buenos Aires, but no definite information is forthcoming regarding this station.

U.S.A. Stations

Though the North American stations have been less consistent than the South Americans, extremely good reception has been experienced from time to time. Indeed, whenever I have attempted reception I have received at least one U.S. station.

W T I C (Hartford, Connecticut) and W P G (Atlantic City, N.J.) are the two most consistent and powerful signals. On most occasions W P G is the stronger. This despite the fact that W T I C employs 50,000 watts and W P G only 5,000 watts!

W I O D (Miami Beach, Florida) and W N A C (Boston) are the next two most reliable signals. These stations might well be termed the "big-babies," for they each have a power of only 1,000 watts, but they are two of the best "caring" stations.

Newly Received

Several "new" American stations have been coming in (by "new" I mean newly-received on my two-valve receiver), including W J R (Detroit), W L W L (New York) and W R V A (Richmond, Va.).

W L W L was heard broadcasting on W P G's wavelength, and I can only presume it shares that wavelength with W P G, for no interference was experienced. W R V A came in at moderate strength relaying the N.B.C. programme.

WHAT THE DISTANT STATIONS ARE DOING

Further notes and news from a long-distance listener's log.

This station operates with a power of 5,000 watts on 270.1 metres. W J R has been extremely good on two occasions, but only a faint unintelligible signal was heard on his band on other occasions.

Dual Transmitters

The synchronised transmitters, W B Z-W B Z A (at Springfield and Boston), have come in well on several occasions. It will probably be of interest to readers who pick up this station to know that W B Z is in reality the half they are mostly picking up, for it employs a power of 15,000 watts, whilst

W J Z, like K D K A, put in poor signals considering their power.

On Low Power

Whilst on the topic of American broadcasting, I should like to give a few notes regarding an interesting Cuban station which commenced operations in December, 1931. This station uses the call letters C M C D, and operates on 323 metres. Despite its comparatively low power of 250 watts, this station has been heard well in Canada, the United States and Mexico, and it is not improbable that it will be heard in Europe before long if the good conditions continue.

BEHIND THE SCENES AT W E A F

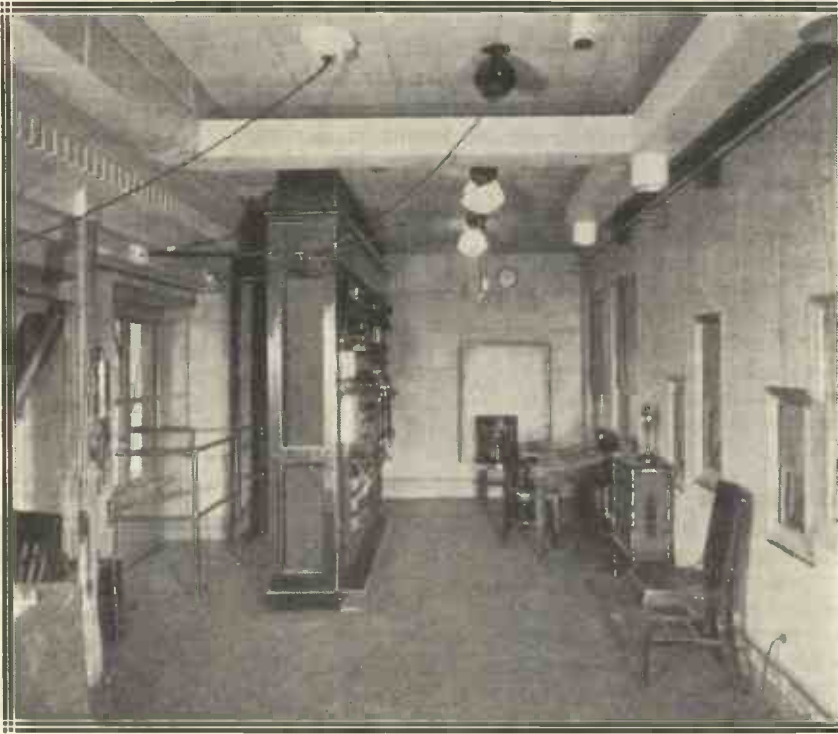

A view of one of the control panels of the famous New York Station showing where the microphone currents are amplified for their journey to the distant transmitter.

W B Z A, at Boston, uses a power of 500 watts.

Reference is frequently made to the 400-kw. transmitter of K D K A. This is misleading, for K D K A only employs 50 kw. However, a 400-kw. station does exist. This station is an experimental station of the Westinghouse Company, and is located in Saxonsburg, 10 miles from Pittsburg.

This station employs the same wavelength as the K D K A transmitter—305.5 metres—and broadcasts experimental transmissions after midnight, Eastern Standard Time (7 a.m. G.M.T.), using the call letters, W-8 X A R. To my knowledge this station has not, as yet, been heard in Europe.

At Moderate Strength

W G Y (Schenectady), W J Z (Boundbrook), W C A U (Philadelphia) and K M O X (Saint Louis) have been received by me at moderate strength. W G Y and

This station has "In a Clock Store" as its "theme." The ticking and chiming of clocks can be heard during intervals in the programme, from which one is led to conclude that the station is owned by a watch and clockmaker!

Some Europeans

Turning to out-of-the-way Europeans, I have found Russian broadcasting stations coming in at much greater strength than for some months past. Employing my larger receiver—(e.g. Det., 1 R.C.C., 1 P.P.)—I have heard Tiraspol on 358 metres at very good strength. This station is most readily heard when broadcasting concerts for the benefit of night workers at 3 a.m. or thereabouts.

Tiflis, Leningrad and Moscow (both Trade Union and Old Komintern) have also been received strongly.

Short-wave reception has improved enormously with me, particularly on the 49-metre band.

During the daylight reception has been extremely good from P L E, Bandoeng (31.86 metres); Zeesen; U O R Z, Vienna; Moscow (50 metres); Eindoven V L K, Sydney; and many others and other stations. V K-3 M E, Melbourne, on 31.28 and 31.55 metres, and V-K-2 M E, Sydney (broadcast), have come in well on Saturdays and Sundays. F 3 1 C T, Saigon; Radio Colonial, Paris; Chelmsford; Lyngby; H V J, Vatican City; and others have been well received in the evenings.

After 11 p.m. I can generally receive one or other American station on the 49-metre band. The "star" stations on my aerial have been V E-9 D R, Drummondville, and W-8 X A L, Cincinnati.

After Midnight

After midnight these stations reach tremendous strength. W-3 X A L and 3 X L, Boundbrook; W-9 X F, Chicago; W-2 X A L and 2 X F, New York; H R B, Tegucigalpa; H K D, Barinquilla, and various other American stations, have been heard at good volume on this band.

On February 29th reception of W-3 X A L and V E-9 D R was so powerful that I brought my recorder into action and made a good gramophone record of the popular fox-trot, "Home," from W-3 X A L, and of choral music of some sort from V E-9 D R. These records are extremely clear, and in recording V E-9 D R, I add a new station to those already recorded by me last year.

I had previously recorded W-3 X A L. L S X, Buenos Aires; Rio de Janeiro on 31.75 metres (commercial); W-2 X A F, 1 X A Z and 3 X A U have been heard on the 30-metre band, but at only poor strength.

W-8 X K has been heard on one or two occasions at moderate strength on 25.25 metres, but W-2 X A D has not been heard by me for some time.

L. W. O.

SHORT-WAVE SHORTS

An interesting "special programme" idea is being run by the Chicago station W 9 X A A on 25.34 metres. Every Sunday from 9 p.m. till 11 p.m. (G.M.T.) he is broadcasting a programme dedicated to some particular part of the world. The programmes are arranged in connection with the coming "Century of Progress" Exposition.

It is possible for the owner of a good short-wave receiver to tune in broadcasting from some forty-five different countries. If amateur telephony is included, the possible number is in the region of ninety!

An American station using the call-sign W 10 X A O is located on the world's largest airship, the "Akron." No reports have yet been received from the British Isles, but he has been heard in Europe on 48.5 metres.

A new country to look for is Venezuela. The Maracao station broadcasts on 16 metres odd at irregular times.



WITH HER LOVING CUP! This is Miss Winter, a singer who was recently "crowned" Radio Queen of Chicago.

SEVERAL readers who have been interested for the first time in daylight reception on the long waves have inquired who is the station using telephony and giving figures, etc., between 1,050 and 1,100 metres. The inquirers report that strength is very good in the East and South-east of England, which confirms the fact that this is undoubtedly Scheveingen Haven.

A Commercial Station

The wave-length used is 1,070 metres, and the station is not such a find as might be imagined on first picking it up, for it is not a real broadcasting station in the true entertainment sense of the word. The service is a commercial one, of stock exchange reports and market prices, and so forth, for the benefit of business men.

* * *

On one occasion recently, about noon, a fairly strong voice was picked up just about 1,000 metres, and although this is the wave-length of Leningrad, and the announcements bore a superficial resemblance to that station, it seems impossible that he should be getting over at such strength in daylight, unless power had been very greatly increased. Has anyone else picked up this mystery station?

Reliable "Regulars"

Of the regular stations there is nothing but good to report, except perhaps one most surprising excep-

ABOVE 1,000 METRES

A rapid review of recent happenings on the long wave-band, and notes on the way in which some of the interesting continentals have been coming over.

tion, Kalundborg, for on several daylight tests he has seemed distinctly weaker than he was last month. Although his aerial is a matter of 550 miles from my own, Kalundborg is probably the most reliable foreign station received, in spite of the fact that he employs only a power of 7.5 kw.

Even in the morning he has been coming over with quite a kick behind him, but so good is the usual standard of Kalundborg that a temporary fall from full power is recorded with regret.

Full Marks for Oslo!

Oslo deserves full marks for some very creditable results in daylight, and, of course, after dark he becomes a really big noise, though of the three long-wave Scandinavian stations—Kalundborg, Motala and Oslo—the latter is the least powerful. Probably this is due to the fact that his aerial is situated in difficult country from a radio point of view, both mountains and metallic ores playing their parts in screening him.

Kalundborg, on the other hand, with his aerial almost on the seashore, always achieves a good get-away.

* * *

Higher up the dial we come to the real big fellows, clustered around the Daventry National station. In my own case Radio-Paris is the best of these; while second place is tied for by the Eiffel Tower, only 200 miles away, and Warsaw, whose aerial is quite 900 miles distant.

This speaks volumes for the design and maintenance of the Polish giant, but as he is mentioned elsewhere in these pages we must resist the temptation to enlarge on his activities here.

Less Interference

On the whole, the interference situation has been a little easier than usual, though no doubt this will be modified in different localities, according to how the interfering stations happen to come over. One or two rather mysterious transmissions were heard and assumed to be Russian, and one of these succeeded in rather taking the edge off Radio-Paris for a time.

Perhaps the situation will become clearer when the various new Russian stations finally settle down on whatever wave-length they fancy, and announce their intentions of full power.

More Power from Moscow

The Moscow Trade Union, by the way, must be putting out a very powerful programme nowadays, as there have been several reports of harmonics of this being received in this country. At my own station it comes in reasonably well on long waves, but without nothing like the power of Warsaw.

Another curious fact is that the Moscow Trade Union, on 1,304 metres, comes in well enough to sometimes make a daylight showing, whereas the neighbouring Moscow station, Old Komintern, on 1,481 metres, using the same power and situated right in the same district, is an almost unknown quantity, in spite of its adjacent wave-length. Is that a common experience with these two stations?

"THAT REMINDS ME . . ."



This happy chap is a German announcer, telling listeners funny stories which he culls from the magazines.



HERE AND THERE

Condensed notes and news items about home and foreign radio.

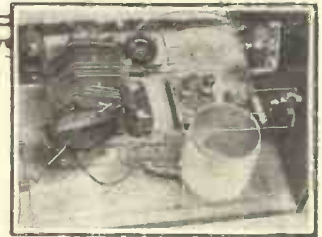

WINNIPEG was the first city in Canada to equip its police headquarters with short-wave radio.

RADIO NORMANDIE has recently been experimenting with television transmission.

MOSCOW has now caught the craze for big broadcasting headquarters and intends to have a huge radio palace built by the end of next year.

NEW YORK. The relayed programmes from America are now generally received over the Post Office commercial radio service route, the terminal station of which is Baldock, Herts.

DUBLIN. Although this station is more powerful than Cork, the Dublin programme is generally much more easily received in the London area from the relay instead of from Dublin itself.

CORK and **DUBLIN** usually send out the "six pips" at 11 p.m. on Sundays, so if the time signal is missed from the B.B.C. stations the clock can be put right from one of the Irish stations.

HILVERSUM sends an early-morning time-signal at 7.40 a.m., on 298.9 metres. (Dutch time is twenty minutes ahead of Greenwich.)

RABAT. This Moroccan station on 416 metres is shortly to double its power.

ASTRAKHAN—where the fur collars come from!—has recently treated itself to a new 10-kw. station, under the Russian Five-Year Plan. It has been heard broadcasting tests on 509 metres.

CT 1 A A, the famous Lisbon short-waver on 42.9 metres,

has a medium wavelength also—282.2 metres.

NORWAY has a receiving station on Jeløy Island for picking up broadcasting—on the lines of our own Tatsfield.

ALGIERS recently broadcast thrilling S.O.S. messages to some lost airmen, asking

adjacent wavelength! Surely one of the biggest radio mistakes ever made!

COLTANO, the Italian short-waver, has been testing with Rugby on 23.5 metres.

WILNO recently moved up to a new wavelength, and is now to be found on 563 metres.

length was originally allotted to the Budapest relay

PARIS. The new P.T.T. station is to be situated about 15½ miles from the centre of Paris. Its power will be about 70 kilowatts.

HILVERSUM, which for the past three months has been radiating the Huizen programme, reverts to its own transmissions again on April 1st.

TIRASPOLI, a new Russian station, has been working on 358 metres—a fraction above London Regional—in the very early mornings, about 3 a.m.

RADIO TOULOUSE observed a one-minute silence on the day that General Ferrie was buried, as a tribute to the great French radio pioneer.

RADIO NATIONS, the League of Nations station at Nyon, is to employ a beam type aerial carried on six 130-ft. pylons.

PRANGINS, just outside Nyon, Switzerland, is the actual site of the League of Nations transmitting station.

THE WORLD has an estimated total of 1,423 broadcasting stations, of which 617 are in the U.S.A. and possessions.

BUENOS AIRES and other South American stations, over 6,000 miles away, have now been received by several listeners in this country on ordinary—not short—wavelengths.

RABAT. Early next year this station is to increase its power a second time, bringing the output to 15 kilowatts.

WHEN USING A POTENTIOMETER

for the detector's grid return, remember it may need re-setting if a new valve is used.

them to send out their whereabouts on a wave of 27 metres, and to light flares to assist searchers to find them. The search was in the end completely successful.

K D K A, the famous American station at East Pittsburg, which proudly announces itself as "The Pioneer Broadcasting Station of the World," started life with the call 8 Z Z.

MONTREAL is considering a project for spending £6,000

LAHTI, the Finnish long-waver on 1,796 metres, would be picked up more often in this country if it were realised that owing to its difference of time the station closes very early—usually about 7.45 p.m.

WIEDERAU is the actual site of the new Leipzig station, the buildings of which are now virtually complete.

MARSEILLES. The Marseilles P.T.T. station recently announced a high honour for one of its staff—the Legion

YOU CAN OFTEN CURE A HUM

by inserting an old L.F. transformer primary in the detector H.T. + lead and by-passing it.

on a short-wave police broadcasting station.

RADIO VATICAN, the Pope's station, was recently "put on the air" by one of the big American "hook-ups," and after an hour's working somebody phoned and diffidently pointed out that the programme in question was not Radio Vatican's at all, but another station on an

of Honour, bestowed on the conductor of the station orchestra.

RADIO NORMANDIE regularly transmits a late programme—till 3 a.m. at the week-end and till 1 a.m. on other days.

CSEPEL is the name of the Hungarian station working on 210 metres. This wave-

NEXT MONTH

The May "M.W." will be on Sale April 30th.

ORDER NOW

and make sure of it!

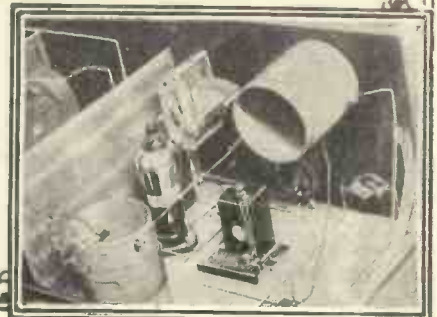
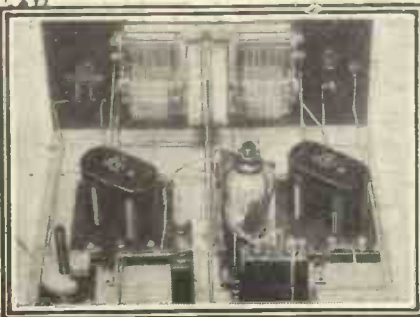

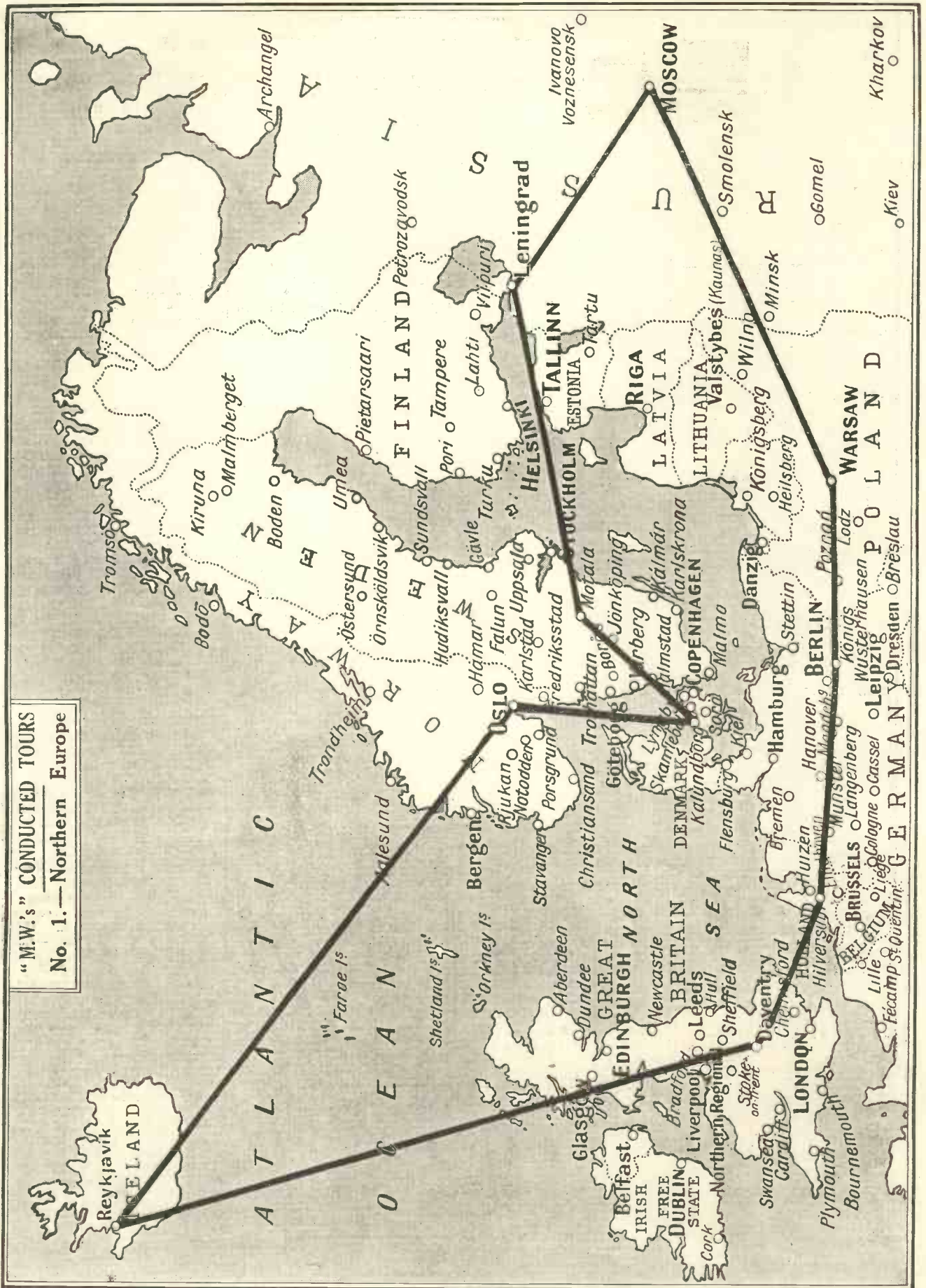

"M.W.'s" CONDUCTED TOURS
 No. 1.—Northern Europe

HAVE you ever dreamed of going abroad with all the sting taken out of the travelling? Most of us like to think of ourselves as adventuring far, but we are appalled with the prospect of long, cold journeys, strange speech, unknown beds, and exorbitant charges. But why not dodge all these discomforts?

It is not generally realised how accessible the rest of the world is becoming to the stay-at-homes by radio, nor how easy it is to make contact with country after country, enjoying the music and the culture of each, studying the language, appraising the people, and all without moving from your own cosy fireside.

Suitable Sets

This month "M.W." proposes that you should take a trip round Northern Europe on your set. There is no passport to bother about, no fare to pay, no getting up early, nor—unless you wish it—any sitting up late. Best of all, there are no tips to give; in fact, the only tips on the tour are those which we hope to be able to give you about getting the stations!

First, just a word about your set. It need not be an elaborate one, for many a well-handled one-valve set would think nothing of the tour which we propose. It would, however, need to be connected to a fairly good outdoor aerial in order to take this trip, for we shall cover many hundreds of miles, if not thousands, and with less than three valves it really needs a good aerial and earth system to do that!

Three-valve sets should not find it at all difficult, especially if one



**"M.W.'s" CONDUCTED TOURS
No. 1.—Round NORTHERN EUROPE
ON THE LONG WAVES**

of the valves is of the high-frequency type, or if all three valves are of the A.C. variety, which, owing to their high efficiency, should give results comparable with most battery fours. Anyhow, the beauty of the "M.W." conducted tour is that it costs you nothing to try, so let us see what we can do in the way of a run round Northern Europe on the long waves.

The first thing to decide is the time of starting. Can it be a day-light tour, or shall we wait till the evening? Undoubtedly, the better time is the evening, for it is only after dark that the distant stations seem to attain their full strength.

Moreover, mankind, whether he lives in Germany, Poland, Norway, Russia, or by the side of a dinky little dyke in Holland, usually thinks about "packing up" at 6 o'clock p.m., or soon after. Thus the main broadcasting programmes which are intended for his amusement are timed for the evening, somewhere between the hours of 7 and 10 p.m.

We Start

So let us switch over to long waves, and just to get our bearings and appoint a rendezvous we all know, let us first tune-in to Daventry National, 5 X X.

Got him? You are now in the centre of England, the Daventry station being only a few miles from the actual geographical centre-

point, which lies in the open some few miles from the station. And your tuning dial is a little more than half-way round in all probability.

Now tuning dials differ from one another in many ways, some being marked from 0 to 180, some being marked 0 to 100, and others, like the Extenser, having special long-wave readings from 100 to 200.

The First Hop

On such a dial as the latter, 150 is half-way round, 175 three-quarters of the way round, and so on. So, for the purposes of this tour, we will give the readings on such a dial, for the stations come in at about the same relative positions on all sets, and therefore these representative dial readings will afford a guide as to what the actual reading should be on your own set.

Our first jump is to be across the North Sea to Holland, and the easiest way to do this is to tune right up to the top of the dial. Apply a little reaction, keep the set nearly but not quite oscillating, and come slowly down the dial, listening for speech or music.

Probably the very first station you encounter in your journey downwards will be Huizen, Holland. Huizen works on 1,875 metres, and there is only one station in Europe with a longer wave-length, namely, Kaunas, Lithuania.

There are two peculiarities worth noting about Huizen. The first is that his time appears to be wrong. If you hear the Huizen clocks chiming you may be surprised to note that the hour is struck at twenty minutes to 1!

The reason for this is that Dutch time is different from all the other countries in Europe, being exactly twenty minutes ahead of Greenwich.

Another thing worth noting about the Huizen station is that he exchanges his aerial and transmitter with Hilversum on 298.8 metres. At the time of writing, for instance, Hilversum is sending out Huizen's programme on 298.8 metres, and Huizen is sending the programme of Hilversum on 1,875 metres.

Fine Broadcasts

Admirers of vocal music should look out for Huizen on Sundays, when many fine church broadcasts are to be heard, with particularly sweet singing and effective choral renderings. There is a quiet reverence about these Dutch services which is strongly reminiscent of a village church in England and simple services of that nature, and even although the words are not understood there is a quiet thrill to be gained by dropping into a Dutch church for a service on Sunday.

Holland is a lovely little country, but we must not stop to admire the beauties of Huizen too long, as it is a particularly easy station which we can come back to when there is more time to spare.

We have said that Daventry's reading will be a little over half-way

Poland's Capital—A Scene in the Heart of Warsaw



This is the Zamkowy Square—remarkably homelike, though nearly a thousand miles away.

Some Famous Stations That You Should Not Miss

round the dial, while Huizen will be near the top. On the 100-to-200 dial representative readings for these would be Daventry 170 and Huizen 178 or 179. It is just a little above the reading for Radio-Paris.

Our next move will be farther east, to the great Berlin long-wave station at Konigs Wusterhausen. Although quite a powerful station, it is not a particularly easy one to find, as it is overshadowed by our own Daventry.

The wavelength is 1,635 metres, and the dial reading in our representative case would be about 172—not more than 2 degrees above Daventry. Thus if you are near Daventry, or if your set is not very selective, it will be almost impossible to receive Konigs Wusterhausen whilst Daventry is transmitting, but he should come in strongly enough during the breaks in the programme.

Easily Recognisable

This station is sometimes called "Zeesen," because some year or so ago, when the original Konigs Wusterhausen station was remodelled with larger power, the new station was put up at the neighbouring hamlet of Zeesen. It relays the Berlin programme, and is easily recognisable by the appearance of this and other German words during announcements, and the "achtung" which precedes them. (Achtung means attention.)

Many of the programmes radiated on the Berlin long-waver are from Berlin itself, from Hamburg, or other station, but its own name, Konigs Wusterhausen, is quite frequently repeated. And another distinguishing sign is the interval signal, which takes the form of clock ticks, occurring about four times as fast as our own signal; that is to say, instead of one beat to the second, there are four.

Konigs Wusterhausen is situated about 500 miles from London, and our next step should be quite an easy one, although it will take us much farther eastwards. Our destination this time is Warsaw, the capital of Poland.

Warsaw has the most powerful long-wave station in the world, the power being nearly three times that of the B.B.C. Regional stations, which themselves are no weaklings. The Poland of to-day is a republic created by the Peace Conference at the end of the Great War, yet the country is admirably covered with a great broadcasting service that is conducted with quite unusual efficiency.

Beautiful Music

Both the language and the music of Poland are distinctively beautiful, and the fine quality of the Warsaw transmissions enable this to be judged by any who will attend closely to the programmes. The music of Chopin is, of course, particularly popular.

The wave-length of the Warsaw station is 1,411 metres, and on the representative dial we have referred to he will come in about 160. This dial-reading, by the way, will be almost the same as that of Eiffel Tower, which is separated from Warsaw by an unusually narrow separation of five kilocycles.

On a set with fairly flat tuning the adjustment would be almost exactly the same, but on a really selective set Warsaw would be found to be slightly lower than Eiffel Tower. Owing to this small wave-length separation it is best to try some time when the Eiffel Tower is not working, and listen quietly to the Warsaw programme, which is announced (by both men and women announcers) with great clearness.

As pronounced from there the word Warsaw sounds like "Varshova," and either this or the words "Polski-Radio" will serve to identify the station. Relays from other broadcasting centres in Poland are often taken, and thus various interval signals can be heard, including the very famous interrupted bugle call from Cracow.

Those who can read Morse will often hear the letter W (---) sent on this wavelength at the beginning of the programme, and as the station works all day and until very late at night it should afford plenty of opportunity for the zealous searcher to pay it a call.

Into Russia

Still travelling to the East we must next cross the border of Poland—country where much heavy fighting occurred during the last war—and advance into Russia. Unlike Warsaw, the Russian stations are not at all easy to get.

The best one to try for is Moscow Trades Union, which works on 1,304 metres. There is another Russian high-power station on 1,481 metres, namely, "Old Komintern," but for some reason this does not seem to get over to England so well as the Trades Union station.

The distance is a matter of almost 1,600 miles from London, so there is a real thrill to be got out of hearing the historic old clock strike in the famous city of the Tsars, which is now subject to the great Soviet experiment.

Moscow is the farthest point of our tour, and we can turn now to the North to make our way home by Leningrad. This station has a wavelength of 1,000 metres, which happens to be almost exactly the same wavelength as that adopted by the British and French direction-finding stations, which come in at great strength and work almost continuously.

Consequently, on many sets the background of Morse is far too steady and heavy to permit of the reception of Leningrad; but in some districts it may be heard quite clearly, the interval signal being the call of the cuckoo.

In English

This station also uses English sometimes, and when speaking in Russian the announcer (man) speaks so clearly that the word Leningrad can be picked up quite distinctly. English is sometimes used, and the station usually closes down at about 10 or 10.30 p.m.

YOU CAN'T CATCH HER!



Here is the owner of one of Warsaw's delightful voices, Miss P. Irena Wasiutynska. Notice that she keeps two watches on the desk, so if one of them stops she still finishes her announcements sharp on time.

One good way of finding Moscow Trades Union is to search for it a trifle above half-way between the Warsaw programme and that from Kalundborg, Denmark—both well-received stations, which are probably well known to owners of long-wave sets.

Many of the programmes are of foreign propaganda nature, sometimes being spoken in French, sometimes in German, and sometimes in English, in which case a very full announcement of wave-length, etc., is made, coupled with an invitation to write to this station reporting on your reception. If you butt in on a musical programme, you may note that the term "comrade" is used instead of those usually employed, and thus the announcement of "Comrade So-and-So will play" is sufficient to establish the fact that you are listening to Moscow.

Early Closing

Moscow time is three hours ahead of Greenwich, so usually you will find this station and its neighbours closing down about 10 p.m., which is 1 a.m. with them. Of particular interest are the chimes, which come from the famous Kremlin clock tower.

Our next step is right across the Baltic to Sweden. Instead of a cold journey in an icy, frost-bound train, all we have to do is to set our tuning dials a little below the reading for Warsaw, and adjust reaction to its most sensitive condition. All the Scandinavian countries are easily visited by radio, and Motala represents Sweden.

Easily Heard Station

Motala works on 1,348 metres, and although standing well inland, the well-watered Swedish country, with its many rivers and inland lakes, gives the Motala programmes an excellent send-off, with the result that the station is easily heard almost all over Europe.

The programmes are from Stockholm, the pleasant-voiced announcer giving the name clearly but rather quickly. Generally in the form of "Stockholm-Motala," though occasionally other programmes are relayed instead of Stockholm.

At Motala we are about 770 miles from London, and our next step is to Kalundborg, Denmark, which brings us under 550 miles from home. Kalundborg is well down below Motala, for whereas the latter's reading would be about 154, the former is about the 140 mark,

its wavelength being 1,153 metres. The name is generally given as "Kalundborg-Copenhagen," in one quick phrase, and at the end of the programme the station closes down with three strokes on a gong and a little Danish melody.

Noticeable "Homeliness"

From delightful Denmark we now strike north again to Norway. The Oslo reading will be found only a little above that for Leningrad, but unlike this latter station he is entirely removed from this Morse interference area, and therefore his signals are usually to be relied upon when once his correct adjustment for tuning-in is found.

Even in daylight Oslo can often be heard, but at night he comes into the easy-to-get class on a good set, the reception in England being, curiously enough, inferior to that of the other Scandinavian stations which use lower power.

Norway, with its deep ravines and scattered population, is a singularly difficult country to serve with broadcasting, but an excellent system is in force, backed up by many relays and presided over by Oslo, whose call is "Hallo, Hallo, Oslo Hier."

In contrast to those preceding them, the Scandinavian stations have a noticeable "homeliness" about their programmes. Their taste for news, talks, music, etc., is astonishingly like our own.

Oslo (whose reading, by the way, would be about 132 on the representative tuning dial) is a matter of about 720 miles from London, but before returning home the possessor of a really good set may be tempted to try one trek into the Far North.

Towards the end of last year Iceland acquired a high-powered long-wave station, namely, Reykjavik, on 1,200 metres, and as this wavelength can be very accurately known from Kalundborg's setting, which is just a little beneath it, a careful searcher may come across this interesting station in the evening.

North of London

During daylight the station changes over to work with ships, etc. The Icelandic authorities would be glad of reports from this country of reception, etc., as the service is still in the experimental stage, and they have more than once expressed a wish that British listeners would inform the Station Director, Reykjavik, of any interesting experience or reception they may have encountered in connection with this station.

Reykjavik is Europe's farthest-north long-waver, and this accounts for the fact that it is asked to share a wavelength with Istanbul or Constantinople, which is the big noise of the South. As neither station is easy to receive singly, the 1,200-metre mark will certainly repay the searcher for any success he may have thereon.

Even if Reykjavik proves elusive, we can now return to Daventry with memories of a wonderful tour in northern latitudes. Holland, Germany, Poland, Russia, Sweden, Denmark, Norway (and, of course, possibly Iceland), all lie to the north of London, and all are represented on the long-wave radio.

Their diverse speech, their music, their folk tunes, their church bells—these and many other characteristics of interest can be experienced at first hand by the possessor of a good long-wave set. And if the visit is oft-repeated, if the voices of the various announcers become familiar, if the tremble of the bells from the Kremlin, or that most poignant signal, the interrupted bugle call from Poland, become well-known to you, the radio link will have made you friends in many countries.



IMPROVING S.G. SELECTIVITY

The ordinary S.G. valve, although it has been remarkably successful, has always suffered from the drawback that it was easily overloaded, with disastrous results to the selectivity. This article tells how this apparently insurmountable obstacle has been overcome by the introduction of the new and improved type of S.G. valve.

By J. ENGLISH



THE screened-grid valve when it appeared at the Wireless Exhibition years ago produced something like a revolution in wireless reception. Until that time we had to be content with what we should now regard as a very modest amount of high-frequency amplification, unless we were prepared to go to a great deal of trouble in building sets or to spend large amounts in buying them ready made.

A single high-frequency amplifier with a three-electrode valve could be

The screened-grid valve cheapened and made much easier the construction of wireless sets, since neutralising became unnecessary, and excellent results could be obtained with quite simple components. Enormous strides have been made in these valves since Capt. H. J. Round's first tubular pattern made its appearance, and the modern S.G. types are amongst the most efficient wireless components that have yet been made.

made it much more difficult to obtain reproduction of the highest quality.

If you care to take for yourself the plate-volts plate-current curve of a screened-grid valve, or, failing this, if you examine one that somebody else has taken, you will find that there is actually no portion of the characteristic which is perfectly straight. That

ONE OF THE FIRST S.G.'s



This S.G. represents the very early types, and although they were not as good as present-day models, their efficiency was much greater than the ordinary three-electrode H.F. valve.

Asking for More

There are few scientific discoveries which do not contain "an if" or "a but" somewhere. At a very early stage it was realised that the screened-grid valve in its original form must be limited in its use to the high-frequency side of the set, owing to the peculiar shape of its characteristic curves. This led to the evolution of the pentode, which is in effect a low-frequency screened-grid valve.

Like Oliver Twist, all human beings having received something proceed to ask for more. The screened-grid valve has conferred incalculable benefits upon the high-frequency sides of our receiving sets, but as we make bigger and bigger demands upon it we realise that it falls somewhat short of perfection.

Effects of High Power

And, curiously enough, it is the growing efficiency of our broadcasting stations that has brought out an almost unsuspected weak point in the screened-grid valve. High-power transmission, in a word, has not been all milk and honey from the point of view of the designer of receiving sets. It was intended to make reception easier, but in many respects it has

part to which we refer as "the straight portion" is really a gentle curve.

This fact complicates matters considerably when we have two high-powered transmissions on neighbouring wavelengths, as for example those of Mühlacker and the London Regional station. Owing to this curvature of its characteristic, the valve is liable to introduce cross-talk between transmissions.

Even a year ago no one had started to pick holes in the performances of the screened-grid valve. But as time



Tremendous strides have been made in recent years with S.G. valves. This photograph shows a modern main "tube" of the metal-coated type.

made with special coils and delicate neutralised circuits to give a magnification of about 40. When two stages were used neutralising became a very intricate business, unless one was prepared to sacrifice a good deal of the magnification in return for stability.

A New "S.G." with Remarkable Characteristics

goes on we become more and more exacting in our demands and discover that what we at first regarded as tiny shortcomings are really matters of some moment.

Introducing Distortion

We have now discovered that it is by no means as easy as it might seem to obtain good reproduction from a powerful local station with a set which incorporates an ordinary S.G. high-frequency amplifier. The reason is that owing to the shape of its characteristic curve the screened-grid valve is liable to introduce a certain amount of distortion unless the magnitude of the voltage swings reaching its control grid are comparatively small.

confine themselves entirely to short-distance reception. Almost everyone wants to be able to bring in the best of the foreign stations if he feels so minded.

Variable-Mu Valves

Here, particularly in summer-time, a great deal of magnification is required. What we want is a kind of elastic valve which will provide a small amount of magnification and be able to handle considerable grid voltage swings when the local station is coming in, and yet will be capable of giving a high degree of magnification when we want to hear stations from distant places.

This is provided in the variable-mu

we can adjust the valve by means of grid bias to give precisely the right amount of magnification for a given transmission.

And there is a good deal more than this. Owing to the very satisfactory shape of its characteristic, the variable-mu valve can deal with grid-voltage swings about twenty times as great as those within the powers of the ordinary S.G. without distortion.

Cross-Talk

The shape of the characteristic again enormously cuts down cross-talk. If we reckon the cross-talk introduced by a normal S.G. as a hundred per cent, then the figure for one of the best types of variable-mu valve is one half of one per cent, or two hundred times as small.

Clearly, the variable-mu valve makes delicate volume control a comparatively simple business, and there is no reason why this control should not be automatic, the incoming transmission adjusting the valve amplification to its own requirements.

THEY MAKE AN INTERESTING COMPARISON

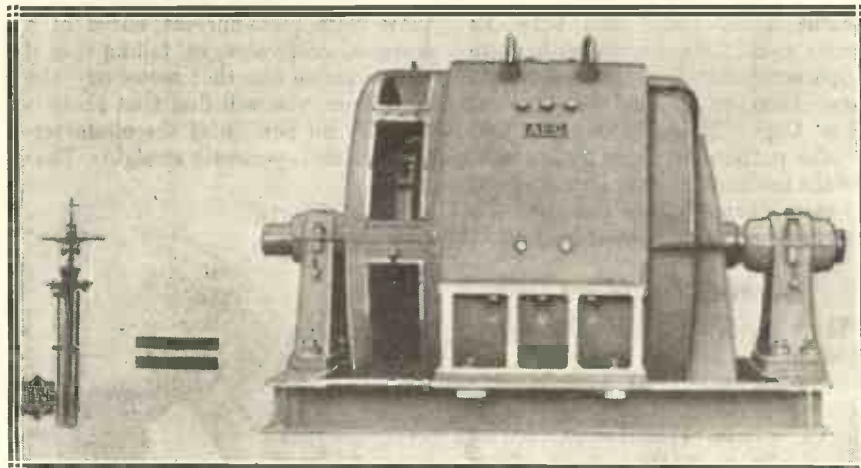

This photograph comes to us from Germany, and shows a 150-kw. water-cooled transmitting valve alongside a huge high-tension generator of the same power.

If we live within a few miles of a super-station it may be necessary, in order to obtain undistorted reproduction, to cut down the aerial to very small proportions or to introduce damping into the grid circuit in order to reduce incoming impulses to something that is really within the powers of the valve.

Less Magnification

In other words, we would be happier if the screened-grid H.F. valve gave us less magnification when we have tuned in the local station; and the higher the power and the shorter the distance of this the less is the amplification that we want.

What we then need is a screened-grid valve with a much lower amplification factor than that of the ordinary one. For local reception such a valve would be a distinct advantage, but comparatively few people nowadays

tube, which has recently appeared on the market.

What is the variable-mu tube exactly? It is one of those ingenious inventions whose utter simplicity makes everyone wonder why it did not occur to someone long before. Without going deeply into technicalities, I may say that the control grid of the variable-mu tube is divided into two sections with a small gap between them.

When a strong negative bias is applied to the control grid the two sections of it behave as if they were made of solid metal, and the only path available for electrons is that of low magnification between the two sections. With a small negative bias the control grid behaves quite normally.

In this condition, that is to say, the valve has just about the same magnification factor as the ordinary S.G. Point number one, then, is that

WHAT IS THE BEST SHORT-WAVER?
A difficult question that depends largely on the locality.

PEOPLE still do not seem to be able to realise that there is no answer to the question: "What is the best short-waver?" No one would expect an answer if that question related to broadcast waves, for it is common knowledge that the proverb "One man's meat is another man's poison" applies very well to radio receivers! But, as a general rule, I can suggest this. If you live in a "quiet" locality, out in the country, you are fairly free to choose.

Two Problems

You may have the most sensitive and powerful set you like, and your results will be accordingly good. But a set of that type will often be wasted on the town-dweller.

There are two separate problems to deal with. The country-dweller's is to pick up the very weakest signals; the town-dweller's is to keep his already noisy background down to reasonable proportions, so that he stands a chance of picking out the weaker signals through it. W. L. S.

AN H.M.V. MAINS SET



Some interesting details of the H.M.V. model 435 radio receiver, which has recently been undergoing tests in the "Modern Wireless" laboratory.

THERE is something about the appearance of a product of the Gramophone Co. that inspires the technical as well as the lay listener with confidence in the set's performance, even before he connects it up and switches on. Whether it is the unobtrusive excellence of the finish or the business-like layout we cannot say, but the fact remains that every time we have one of the H.M.V. products to test we feel that we are in for a really interesting and profitable time.

Unassailable Reputation

Undoubtedly the unassailable reputation for instruments that work, and work well, that has been enjoyed by that firm since the early days of the gramophone has something to do with it. But the feeling is undeniably there, and as we unpacked the H.M.V. radio receiver, Model 435, we knew we were not to be disappointed as regards results.

But our readers will not thank us for but a catalogue of stations heard, or mere praise concerning the selectivity and sensitivity of the set—these we can take as read. What is most interesting is the circuit of the set; in other words, how the fine results of which the receiver is capable are obtained.

Technical Details

So here goes for some brief technical data. The circuit shows at a glance that three valves are employed, an S.G., detector and a pentode, all being of the indirectly-heated cathode A.C.-mains variety.

The set is a three-circuit band-pass receiver, the anode circuit of the S.G. valve being choke fed. The detector acts on the power grid system, and is resistance-capacity fed to the L.F. transformer-coupled pentode. A special resistance has been fitted to the detector grid coil to prevent any section of this coil developing spurious

oscillations. This effectively stabilises the instrument without impairing its high sensitivity.

The L.F. transformer is of the nickel-iron-cored type, and has a ratio of 1:7. Finally, the loud speaker is transformer fed, it being of the low-resistance type. Provision for the use of a pick-up is included, and the undistorted output of the receiver is about 1½ watts.

Single-Knob Tuning

The high-tension supply is obtained through a full-wave rectifier, the U.10; the power transformer having, of course, in addition to the H.T. secondary, a 4-volt winding for the heaters of the valves and the pilot lamps for illuminating the scale.

The triple-gang condenser allows single-drive tuning to be carried out, and the drive to this instrument is particularly smooth, being carried out by a spring-loaded cord drive.

The radio-gram, wave-change and on-off switch is all in one, being continuously rotatable so that no trouble can occur through its being overrun. This cannot possibly happen.

A very ingenious longitudinal rotating tuning scale is fitted with semi-exterior lighting that perfectly illuminates the scale.

Ingenious Volume Control

The volume control, too, is very ingenious, for with one knob either radio or gramophone volume can be varied, and the method of the variation in the case of radio deserves special mention. The volume control starts off from the minimum position by increasing the potential applied to the screen grid of the S.G. valve. Then the final stages of rotation introduce shunt-fed-capacity reaction.

(Continued on page 396.)

THE THEORETICAL CIRCUIT OF THE "435"

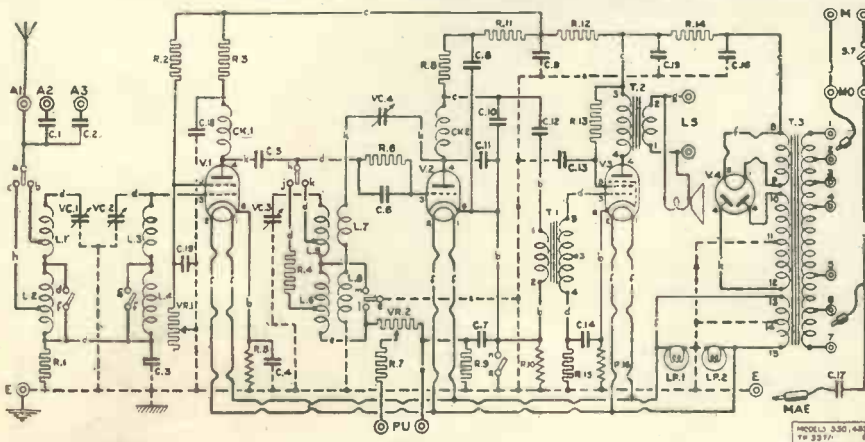

The circuit of the "435" is particularly interesting, special points to notice being the anti-parasitic resistance R₄, the method of tapping the detector grid down the coil, and the double H.F. shunt across the detector H.F. choke to earth. A photograph of the interior of the receiver will be found in another page.

Every Refinement for All-Wave Results

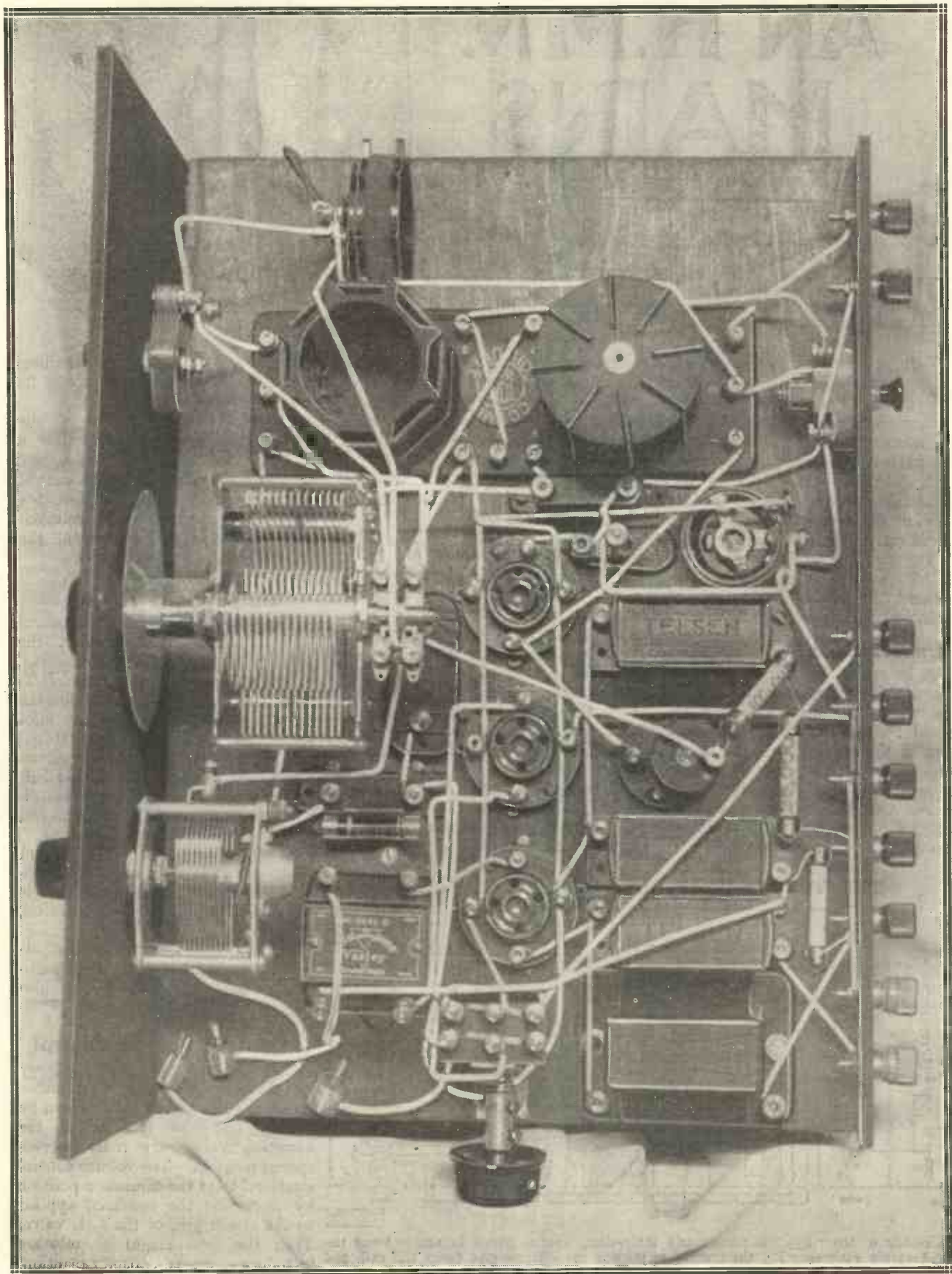

THE "M.W." "Tri-Band" Three

PACKED into a space of only just over one-half a square foot is a little set that holds the key to world-wide radio reception. Programmes from the distant East Indies, from our cousins down under in Australia and New Zealand, entertainment from the U.S.A.—all this in addition to the reception of such close stations as Rome, Moscow, and other Continentals—such is the fare open to the owner of the "Tri-Band" Three.

Records as Well!

But that is not all, for this remarkable three-band receiver is also a radio-gram, enabling you to reproduce gramophone records at full volume and with perfect purity.

Such is a very brief idea, a mere glimpse, of the set that is to be described in the following pages.

Many of our readers will remember the original "Cosmic" that was recently introduced to the public (the "Tri-Band" is a development of this). It was an instant success, and throughout the length and breadth of the country are three-band

sets combing the ether on wave-bands between 20 and 2,000 metres for programmes from all sorts of radio stations.

Based upon the now famous "Cosmic" circuit, this receiver embodies numerous entirely unique features. It is able to receive short-, medium- and long-wave stations without coil-changing, and there is not even any switching between the last two bands, yet the set is unusually easy to assemble and operate.

The "M.W." "Tri-Band" receiver is the outcome of much careful research into the problem of combining a highly sensitive broadcast receiver and an easily-handled short-wave set.

The short waves are peculiarly fascinating in that they hold out opportunities for the ordinary listener to range continents and oceans in successful endeavour to bring in programmes from the very ends of the earth.

There is nothing in the way of long-distance receivers to hold a

candle to the short-wave set when it comes to mere distance of reception, and the great beauty of the short-waver is that it need not be in the least expensive or complicated.

An All-Wave Set

Up to the last few months it has been necessary to have either two receivers or a receiver and an adaptor if one wished to cover both the ordinary wave-lengths and those below 100 metres. The old set with plug-in coils is, of course, as dead as the dodo.

The "Tri-Band" system enables the full advantages of both the ordinary wave-lengths and the short waves to be enjoyed on one set, and without any coil changing or circuit fiddling.

Instead the set covers with one go wave-lengths between 200 and 2,000 metres, automatic self-changing taking place between the medium and the long wave-lengths.

This, of course, is accomplished by the well-known Extenser, which obviates the need for wave-change switches between those two bands.

Quick Change-Over

The short waves are received on the same Extenser, the movement of a switch changing the wave-band to between 20 and 60 metres, thus embracing everything that is of real value in the way of short-wave broadcasting.

TUNE IN THE WORLD ON ONE DIAL

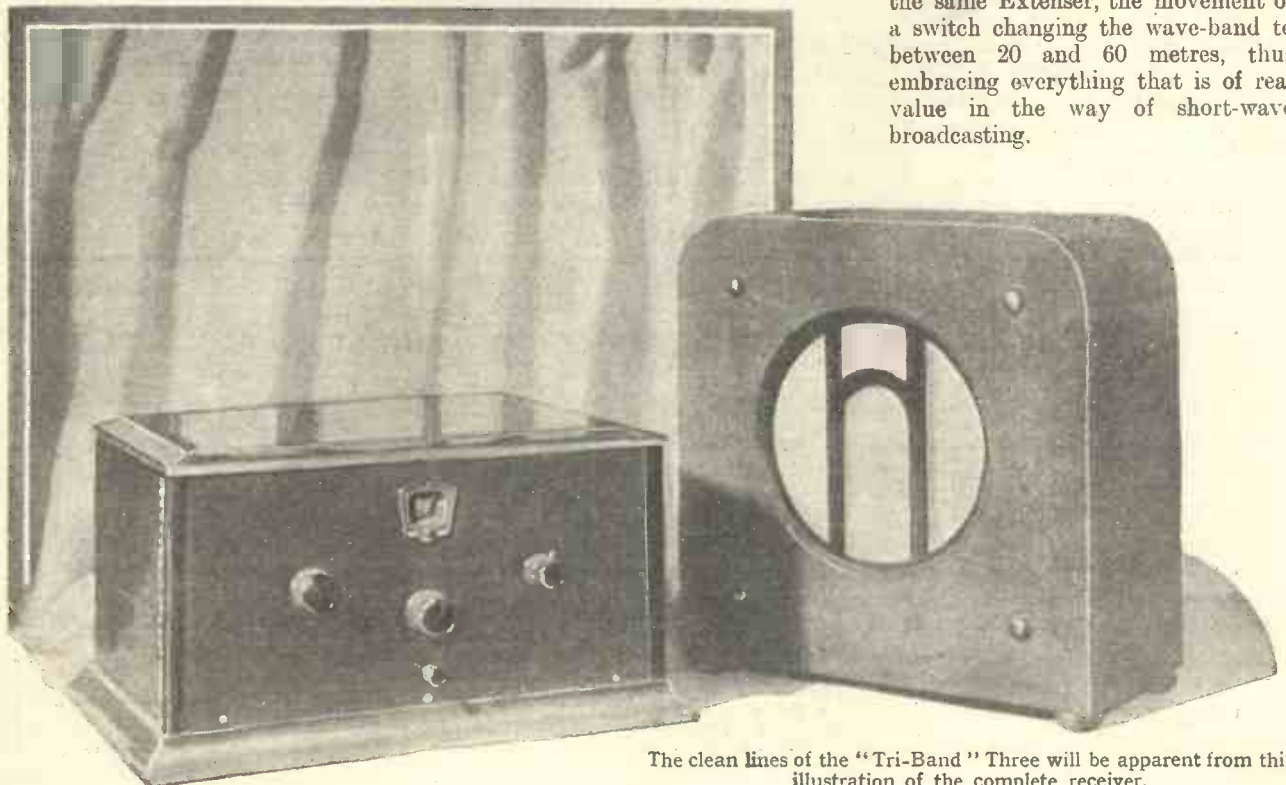

The clean lines of the "Tri-Band" Three will be apparent from this illustration of the complete receiver.

CONCENTRATED COIL EFFICIENCY

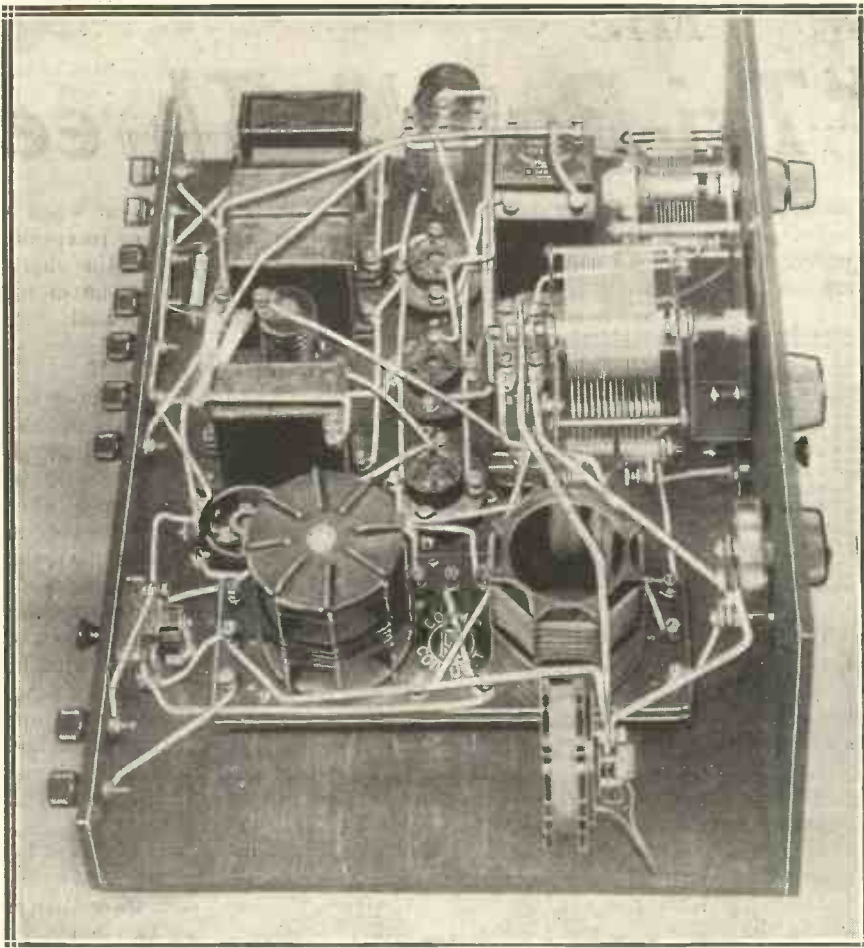

There is no coil-changing whatever—just a smooth and instantaneous change-over to whichever wave-band you wish.

A further ingenious feature about the set is that by the pressing of another button, so to speak, the Extenser is automatically converted from a .0005-mfd. tuning control to one much more suitable for easy short-wave tuning, namely, .00025 mfd.

It may sound as if the set is difficult to operate, or that it is

bristling with controls, but neither is the case. Take a look at the panel. You will see that there are the main tuning control, a switch under it, and one control on either side of it.

These latter are a selectivity device which we call a Moderator, and reaction. The switch is for the purpose of

altering the capacity of the Extenser as above mentioned.

The short-wave switch is placed in the best position both from the point of view of efficiency and from that of convenience—at the back on the terminal strip, next to the earth terminal.

Convenient Switch

You will probably ask why this position should be called convenient. But just think a while, and you will see that as the short-wave part of the set is not likely to be used so much as the ordinary broadcast department, and, at any rate, will not be used other than by the constructor, it is better to have the switch at the back out of harm's way; in a position where the family, who use the set in the daytime, will not be likely to want to fiddle with it.

The average family user, as distinct from the enthusiast, does not want to be confronted with a number of switches, even if they are not likely to be required during the time he or she is using the set. So with the short-wave transformation switch safely tucked away, though easily get-at-able when really required, this state of affairs is retained, together with a clean panel appearance.

The on-off combined radio-gram switch is also most conveniently placed—on the side of the set, so that it lies easy to the right hand when the set is to be switched on or off, or when a change from radio to gramophone or vice versa is contemplated.

About the Circuit

So much for the controls; now let us have a look at the circuit of the set and at the arrangement inside.

The circuit is a very carefully worked out one, every aid to successful

THE COMPONENTS WE RECOMMEND FOR THE "M.W." "TRI-BAND" THREE

PANEL

- 1 14 in. x 7 in. (Permcot, Becol, Peto-Scott, Ready Radio, Wearite, Goltone).

CABINET

- To fit above, with baseboard 10 in. deep (Gilbert, Pickett, Osborn, Ready Radio, Peto-Scott, Cameo, Morco).

EXTENSER

- 1 .0005-mfd. Duotunc (Ready Radio). Other makes of Extenser can be used provided slow-motion drive is employed, with a series .0005-mfd. condenser on the short waves (Formo, Cylden).

CONDENSERS

- 1 .00025-mfd. reaction with slow-motion control (Polar type QJ with small knob and pointer, or .0003-mfd. Ready Radio, Telsen).
- 1 .00075-mfd. solid-dielectric (Telsen, Ready Radio, Polar).
- 1 .0003-mfd. fixed (T.C.C., Dubilier, Telsen, Formo, Goltone, Graham Farish, Ready Radio, Sovereign, Lissen, Ferranti).
- 1 .01 (Dubilier type 610, etc.).
- 3 2-mfd. (Telsen, Dubilier, T.C.C., Ferranti, Hydra, Helsby, Sovereign, Lissen).

RESISTANCES

- 1 400-ohm potentiometer (Sovereign, Lissen, Igranic, Ready Radio, Wearite).
- 1 10,000-ohm (Dubilier 1-watt type, Graham Farish Ohmite, etc.).
- 1 25,000-ohm (Dubilier 1-watt type).
- 1 100,000-ohm (Dubilier do.).
- 1 1-meg. grid leak and holder (Dubilier, Telsen, Lissen, Graham Farish Loewe, Igranic, Ready Radio, Ferranti).
- 1 2-meg. grid leak and holder (Graham Farish Ohmite, etc.).

COILS

- 1 "Cosmic" coil unit (R.I.), or 1 dual-range and 1 short-wave "Cosmic" coil (Goltone, Wearite, Peto-Scott, Ready Radio, Sovereign, Bullphone, Tunewell, Telsen).
- 1 Moderator coil (Peto-Scott, Ready Radio, Sovereign).

TRANSFORMER

- 1 L.F. (Varley Nicore II, R.I., Ferranti, Graham Farish, Lewcos, Lotus, Formo, Sovereign, Climax, Igranic).

CHOKES

- 1 H.F. (Wearite, Lewcos, No. 11 Ready Radio, Tunewell, All-wave Sovereign, Senior Telsen Binocular).
- 1 Output (Ferranti B8, Igranic, Lotus, Graham Farish, Varley, Wearite, R.I.).

SWITCHES

- 1 Push-pull on-off (Ready Radio, Goltone, Peto-Scott, Bulgin, Graham Farish, Telsen, Wearite, Colvern, Sovereign).
- 1 Four-point push-pull (Telsen).
- 1 Two-way rotary with terminals (Wearite type I.22) and mounting bracket with 1-in. extension piece.

VALVE HOLDERS

- 3 Four-pin (Bulgin, Telsen, Graham Farish, W.B., Lotus, Wearite, Chx, Igranic, Formo).

MISCELLANEOUS

- Terminal strip, 14 in. x 2 in.
- 9 Indicating terminals (Belling-Lec type R, Elex, Bulgin, Chx, Igranic).
- Battery plugs (Igranic, etc.).
- Glazite, Quickwyre, Lacoline, Jiffilix.

Flexible Selectivity to Suit Your Requirements

FEW CONTROLS—BUT FULL CONTROL

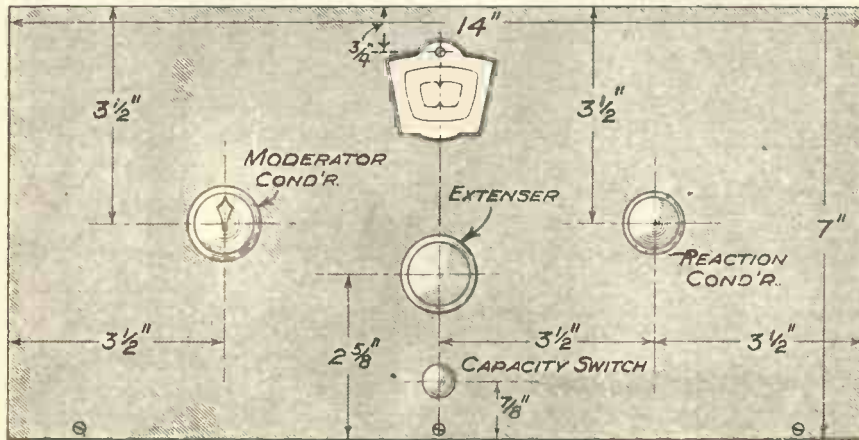

PANEL LAYOUT.

X811

All the tuning is done on the Extenser, on which long-wave stations all have 3-figure readings, and the medium-wavers come in on the 2-figure readings below 100. The other controls are all of the very-easy-to-set type, and full details for these will be found in the article.

station-getting that can be applied to a three-valve set having been included.

We have, for instance, what we call the Moderator control, a simple device that enables the best selectivity with power to be obtained in the simplest manner possible.

It consists of a coil quito wound with a few turns of wire and tapped at three points. This is tuned by a .00075-mfd. solid-dielectric condenser mounted on the panel.

This coil and condenser are used together on the medium wave-band, and serve to tune the aerial circuit so that the maximum selectivity and sensitivity shall be obtained.

On the long waves the coil is disconnected from the condenser, and the latter is used in series with the aerial as a selectivity control.

A Valuable Control

Incidentally, on both wave-lengths this Moderator condenser acts as a very valuable volume control.

By the three taps on the Moderator coil a very good control over the whole of the medium wave-band can be obtained when you are listening for distant stations. With the set in use as an ordinary broadcast programme receiver the taps do not have to be altered, the setting of the plug in the middle socket enabling most stations to be received by just altering the control on the panel.

The arrangement of the reaction condenser to avoid hand-capacity on the short waves is particularly interesting. With ordinary broadcast

wave-lengths there is no need for the moving vanes of a reaction condenser to be at earth potential. As a matter of fact, they are usually connected to the plate of the detector valve.

Avoiding Hand-Capacity

In the case of short waves, however, the importance of keeping the moving vanes at earth potential is paramount, and so in the design of the "Tri-band" the condenser is automatically changed from a condition of non-earthed moving vanes to the earthed condition when the set is switched for short waves.

This is carried out by the same simple four-pole switch that is used to earth the ends of the short-wave coil windings, and it has the effect of enabling extremely smooth reaction to be obtained with freedom from hand-capacity.

THE SET THAT SETS YOU ROAMING!

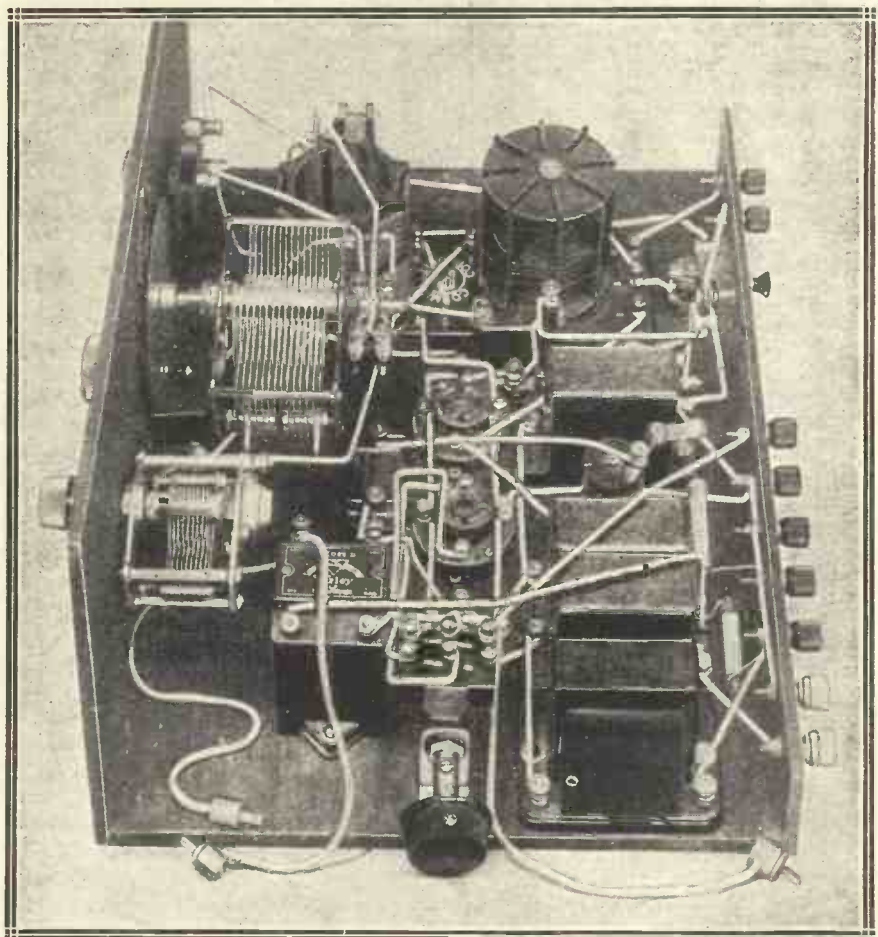

Its remarkable distance-getting properties do not mean that the "Tri-Band" Three is necessarily complicated, for as a matter of fact it is based on a detector and 2 L.F. combination of proved efficiency on all wave-bands. Where it scores heavily is in the high selectivity that is so easily obtainable, its flexibility, and in the ease with which it can be made.

By looking at the theoretical circuit you will see exactly how this is done—by placing the reaction condenser between the dual-range coil and the short-wave unit, with the moving vanes towards the earthed end of this latter.

The set is fully decoupled, and incorporates an output filter so that the bugbear of threshold howl shall not be given a chance, provided the

While at this stage we can perhaps explain how the change of capacity of the Extenser is obtained, for this is a very strong point in the design of the short-wave section of the receiver.

Novel Extenser

If you examine the Duotune type of Extenser (for this feature is not included in other types) you will notice that there are two tags brought

from one another. The two tags belong each to one of the sections.

Now it will be clear that as the moving vanes are kept as usual, the full capacity of the Extenser can only be obtained when the two sections of the fixed vanes are joined together.

In other words, when they are separate the condenser has a maximum capacity of only half that of its

Where the Circuit Breaks New Ground

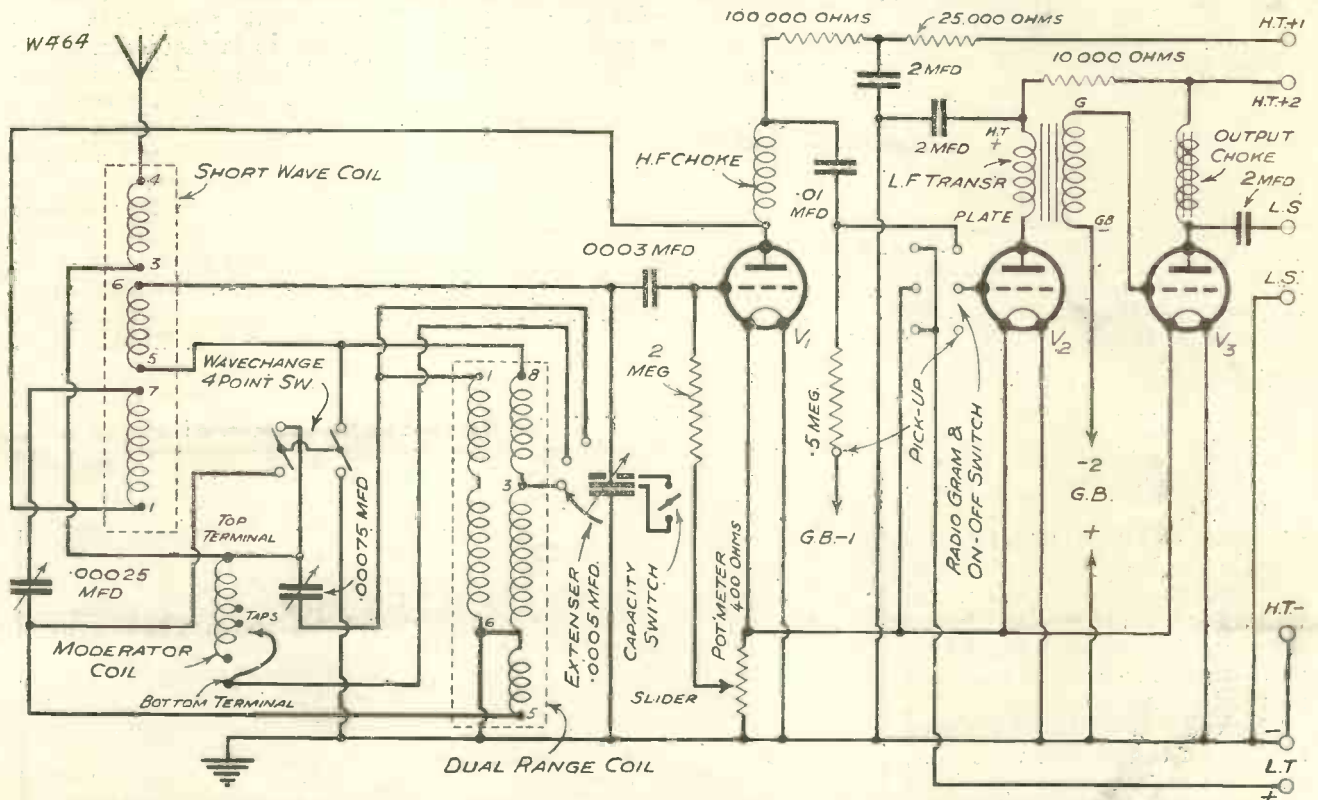

Preceding the dual-range coil is a complete short-wave unit, part of which is always in action as a novel selectivity system. Another unique circuit feature is Moderator control of selectivity and power, and yet another novelty is the switch for controlling the tuning capacity. Note also the simple change-over to radio-gram incorporated with the on-off switch.

constructor keeps to the list of components provided.

It should also be noted that the number of terminals has been kept down to a minimum, and the connections of the set to the least possible by arranging for the gramophone pick-up to be connected direct to the radio-gram switch, instead of to separate terminals on the strip at the back.

Easy to Build

The construction of the set is not at all difficult, but it must be done carefully if the best results are to be expected. It must not be forgotten that the set has to deal with frequencies of the order of four million or so, and to control H.F. impulses oscillating at that rate will be no easy matter unless due care to the copying of the layout of the set is given.

out from one side of the fixed vanes instead of the usual one.

RECOMMENDED ACCESSORIES

Loud Speaker. — (Epoch, W.B., B.T.-H., Celestion, Blue Spot, H.M.V., Graham Farish, Marconiphone, Amplion, R. and A.).

Valves.—Detector: Mazda H.L.2. 1st L.F.: Marconi L.2B., Cossor L.210, Mazda, Eta, Tungram, Osram, Mullard, Six-Sixty, Dario, Lissen, etc. Output: Cossor 230 X.P., etc.

Batteries.—H.T., 120 volts: Pertrix, Ever Ready, Lissen, Magnet, Ediswan, Drydex.

G.B., 16-18 volts: Ever Ready, etc. Accumulator.—2 volts: Exide, Pertrix, Ever Ready, G.E.C., Ediswan, Lissen.

Closer examination will evince the fact that the fixed vanes are divided into two equal sections, insulated

capacity when all the fixed vanes are in action.

So when the set is used for the broadcast wave-lengths the two sections of the fixed vanes are connected together by means of a simple push-pull shorting switch, and when the short waves are to be received this switch is opened, and immediately the Extenser becomes of .00025-mfd. max. capacity. Neat, is it not?

Constructional Details

Returning to the actual construction of the "Tri-Band" Three, the position of the coils with relation to one another is clearly shown in the diagram, and, in fact, if the make of coils employed in the original receiver illustrated here is used, absolutely no mistake on this score can be made, for the very simple reason that they are mounted on one base.

The Acme of Wave-Change Simplicity

Other makes of coil are available, however, and in this connection some detailed instructions as to the connections are necessary. The reason for this is that the various firms that have made the special coils have

the medium-wave stations being tuned in when the Extenser is reading on the 0-100 scale, and the long waves with the reading between 0-200.

But there is this difference between the "Tri-Band" and the ordinary

Extensered set. There is a fairly flat selectivity adjustment in the form of the Moderator control. This enables greatly increased selectivity (and increased sensitivity) on the medium waves to be obtained, with freedom from break-through, and also increased selectivity on the long waves.

You will notice that there are three taps on the Moderator coil. These are for rough adjustments of the inductance so that it may suit your individual aerial, and do not have to be constantly altered when the set is in normal use.

Tuning Procedure

The procedure of tuning the "Tri-Band" is this. With the Moderator coil tap on the top socket (if you are near London), and the Moderator condenser roughly three-quarters in, try for the London Regional. You will find him somewhere about 60 degrees on the Extenser. The capacity switch on the panel must be in the "out" position, and the short-wave switch at the back "in."

Having picked this station up and noted the position of maximum strength on the Extenser setting, vary the Moderator control until maximum strength is found here. You will find it is a fairly sharp, though not critical, setting.

Next try for the London National. The Extenser will probably read about 30, but without decreasing the Moderator condenser capacity you may have difficulty in picking up the

IT GIVES YOU "GRAMOPHONE" AS WELL

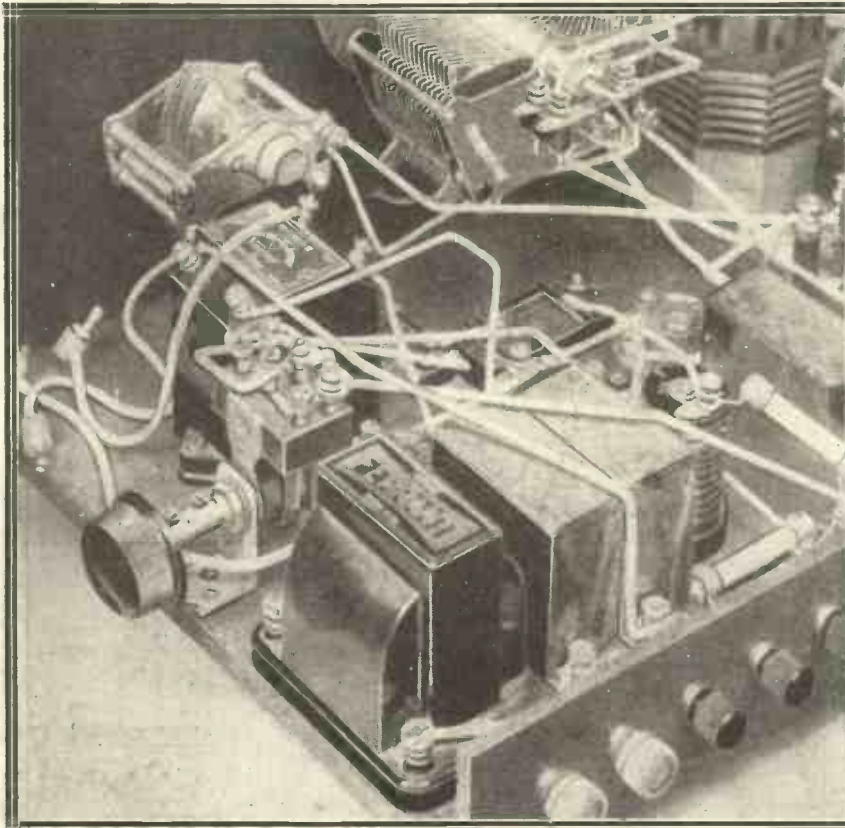

The neat switch near the grid-bias leads is of the combined type, and serves to switch the set on or off, and also to change it over to gramophone reproduction when desired.

to a large extent used their existing former mouldings.

This has had the effect that we have three differently marked coils as regards the numbering of the terminals, though the relative positions of the terminals are the same. Some, however, have eight terminals and some have six (though they are not all used, the numbering up to six or eight is retained), so in this article we are giving a table showing the corresponding numbers of the various makes of coils, so that whatever make you use you cannot possibly go wrong.

Testing Out

We can now assume that the set has been wired up and the connections checked, and that we are ready to give it a test.

The handling of the receiver is like any other using an Extenser,

CHOOSE YOUR OWN CONDITIONS WITH THE MODERATOR

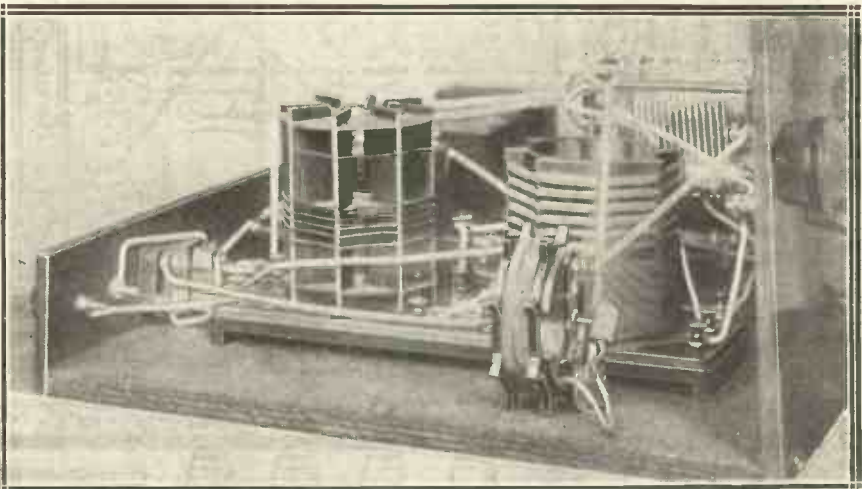

By means of the Moderator adjustment you can suit the set to your own local conditions, and attain the utmost selectivity for near-the-local stations or the maximum punch from stations that are comparatively clear. It is this flexibility that makes the "Tri-Band" so astonishingly fascinating to handle.

station. With the Moderator control near minimum, however, the London National should come in at fine strength.

Now for the upper end of the tuning scale. The North Regional is a good

one to practise on. He should be found on the Extenser at about 90, and with the Moderator about full in.

The Moderator setting will vary with different aerials, of course, and so you should try the effect of the

various taps on the different stations, retuning the Moderator condenser each time the tap is altered.

You will soon get into the way of handling the set, realising that the Moderator makes all the difference in

It's So Easy!

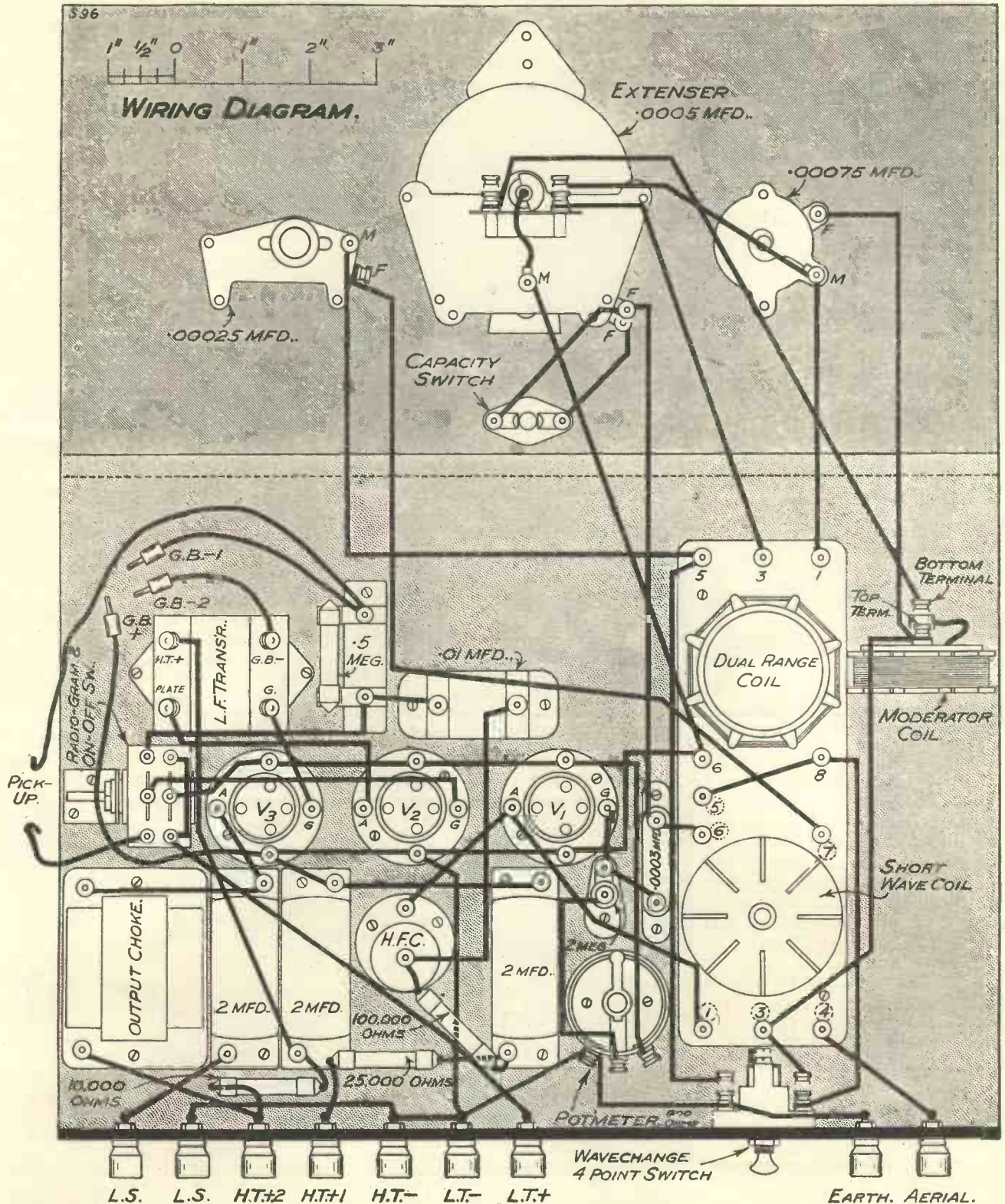

The heavy black lines show the connecting wires, and you will see that the wiring is quite straightforward, being simplified at the H.F. end by numbered terminals on the coil unit.

the powers of the receiver. On the long waves all you have to do is to operate the Extenser on the 0-200 scale, using the Moderator control as a means of getting variations of selectivity should this be desirable. The control does not in this case act

short-waver. The short-wave switch at the back, on the terminal strip, is pulled out, and the capacity switch under the Extenser is pushed in.

The art of successful short-wave reception must be learned gradually. The chief ingredients are very slow and patient tuning adjustments, with equally careful reaction control.

This latter is most important, because throughout the use of a short-wave set it must be kept in the condition of maximum sensitivity.

On Short Waves

That is, it must be kept just short of oscillation, and as the tuning control is handled it means a very careful corresponding control of the reaction condenser.

But you will soon get the hang of the set, and we feel we can with confidence leave it to you without any further directions except as far as H.T. voltages and the choice of valves are concerned.

The H.T. on the detector (plus 1) should be between 60 and 100 volts; you will naturally choose the voltage that gives maximum smoothness of reaction. The other tap can be from 100 to 150, and the grid bias should be

THE "TRI-BAND" COSMIC COIL GUIDE.

DUAL-RANGE COILS.
 *CLASS A COILS. *CLASS B COILS.
 TERMINAL No. 2 is equivalent to TERMINAL No. 3
 TERMINAL No. 3 is equivalent to TERMINAL No. 1
 TERMINAL No. 4 is equivalent to TERMINAL No. 8
 TERMINAL No. 5 is equivalent to TERMINAL No. 6
 TERMINAL No. 6 is equivalent to TERMINAL No. 5
 (Terminal No. 1 is not used in this class of coil) (Terminal No. 4 is not used in this class of coil)
SHORT-WAVE COILS.
 *CLASS A COILS. *CLASS B COILS.
 TERMINAL No. 1 is equivalent to TERMINAL No. 4
 TERMINAL No. 2 is equivalent to TERMINAL No. 3
 TERMINAL No. 3 is equivalent to TERMINAL No. 1
 TERMINAL No. 4 is equivalent to TERMINAL No. 7
 TERMINAL No. 5 is equivalent to TERMINAL No. 6
 TERMINAL No. 6 is equivalent to TERMINAL No. 5
 *NOTE.—Class A Coils have their terminals numbered from 1 to 6.
 Class B Coils have their terminals numbered from 1 to 8.

as a tuning control, and when set for the desired degree of selectivity it can be left set.

On the short waves the Moderator control is out of action, and the tuning of the set is like any ordinary

WHAT THE "TRI-BAND" DOES

Covers Three Wave-bands—Long, Medium and Short—Without Coil-changing.

Suits your own Locality and is Adjustable to your own Requirements.

Reproduces your Gramophone Records.

Changes from Long to Medium Waves—and vice versa—Without any Switching.

Brings in those elusive foreigners.

adjusted in accordance with the maker's instructions for the particular valves and the H.T. voltage used.

Some Paramount Points of a Distinctive Design

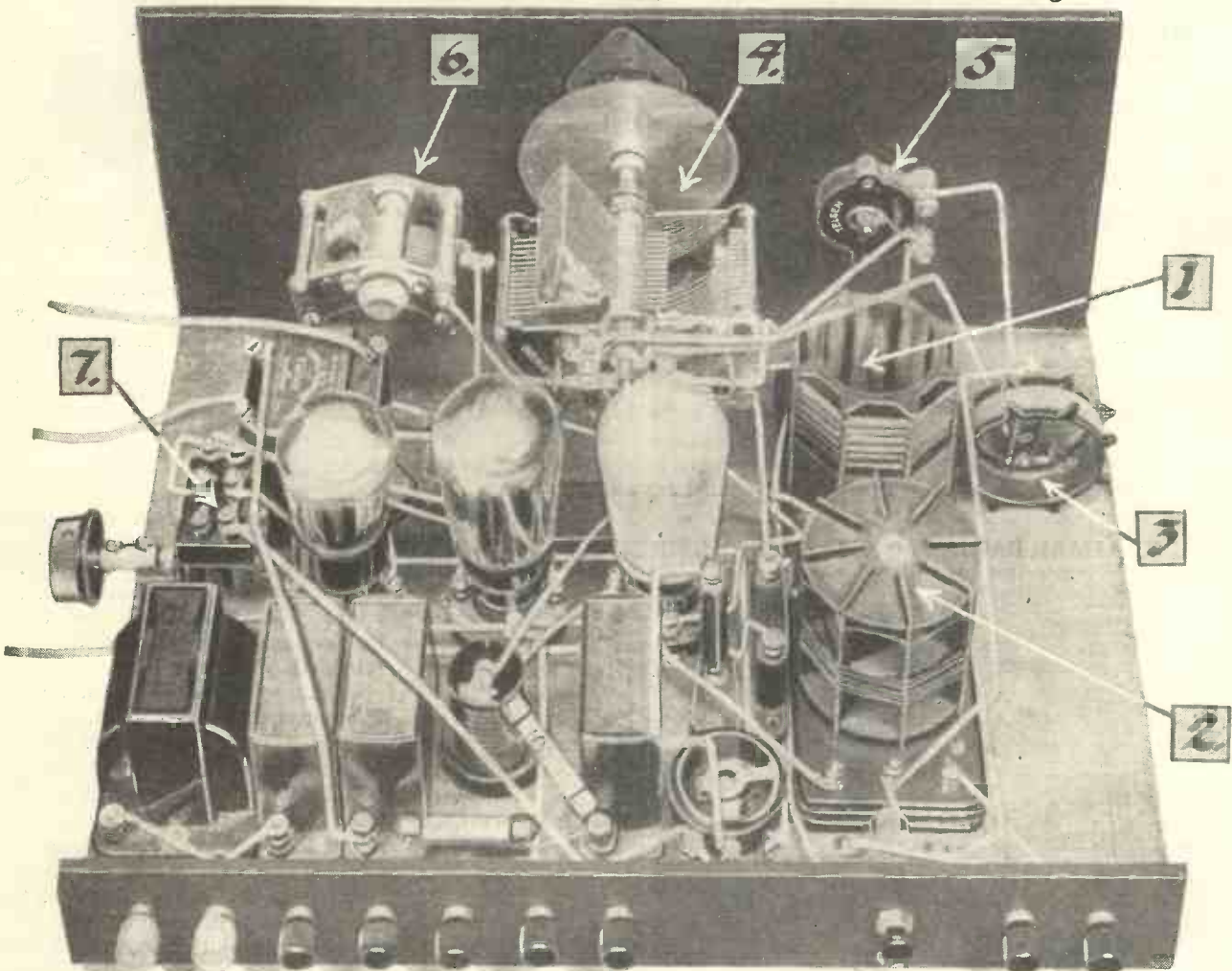

The coil unit indicated by (1) is the double-range winding covering ordinary and medium waves, while (2) is the short-wave coil that serves also for selective coupling; (3) is the famous Moderator; (4) the Extenser for automatic wave-change, and (5) the Moderator control. The reaction condenser is indicated at (6), and (7) is the on-off and radio-gram switch.

By the
**Technical
Editor**

On the

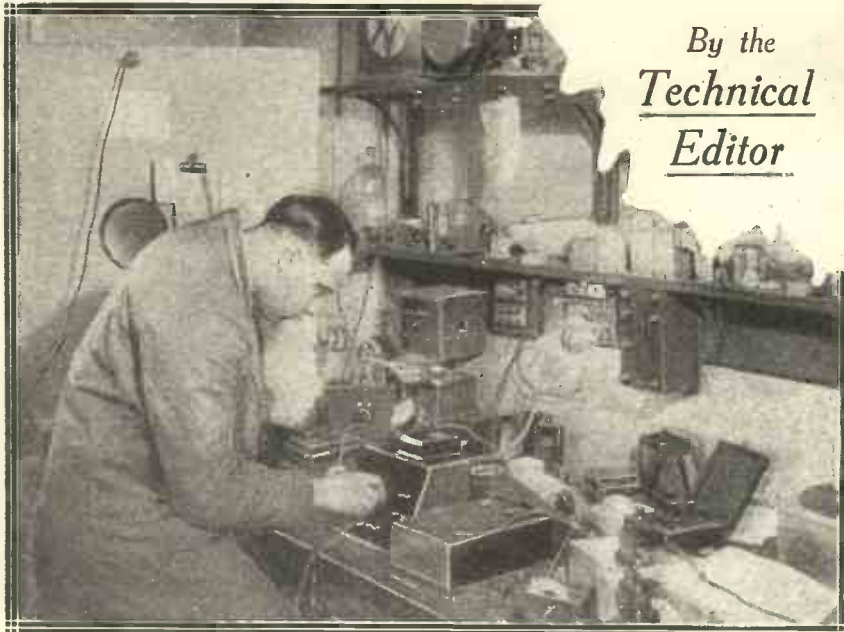

A New Kit Set

THE Graham Farish "Amazing" Three marks an important stage in the development of the commercial kit set, in that its chassis comprises a special bakelite moulding instead of the usual ebonite or metal panel and a piece of wood.

And the panel markings, dial readings, etc., are moulded in, while on that part which displaces a base-board, and which is, in fact, a "well" chassis, the positions of the components and fixing holes are all similarly treated.

The result is most attractive, and a neater, tidier appearance would be hard to visualise. Further, the assembly of the set is simplified to an extraordinary degree.

In short, for ease of assembly, compactness and polished appearance the "Amazing" Three is, we think,

superior to anything of the kind that has previously been attempted.

The circuit consists of an anode-bend detector and choke-coupled and transformer-coupled L.F. stages. A screened coil of new design providing a choice between two aerial taps is used.

We tested the little set in London on an outdoor aerial of fair proportions, and it gave a very good performance. The selectivity was adequate for the separation of the two London transmitters, and also for the separation of Daventry 5 X X and Radio-Paris. This last station and the North Regional could easily be received in daylight at full loud-speaker strength.

The price of the "Amazing" Three kit is 38s. 6d., and it is our considered opinion that at this figure it represents as good radio value as can be obtained anywhere to-day.

THE GRAHAM FARISH "AMAZING" THREE

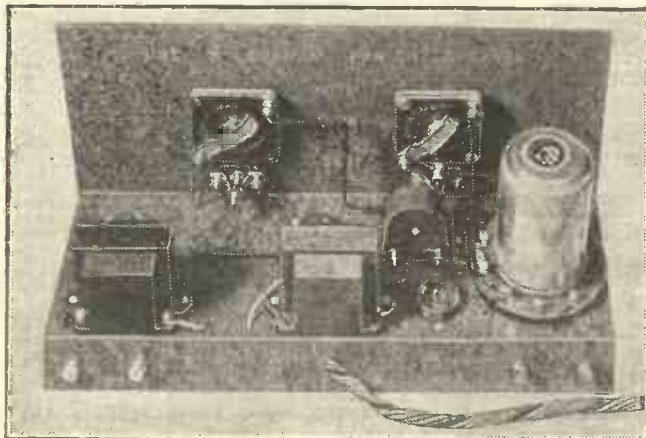

This receiver is unusually small in size and is particularly neat in appearance.

A Readirad Mains Unit

Constructors who are contemplating the "electrification" of their receivers would be well advised to bear in mind the Ready Radio mains unit.

It is a particularly attractive proposition, and although it retails at what is a most modest price for such a device, it is able to "feed"

the larger kinds of sets, including ambitious radio-gramophones as well as those of humbler calibre.

There are four H.T. tapings, including a useful variable giving from 0-100 volts, and trickle-charging for 2-, 4- or 6-volt accumulators is arranged for.

It is, of course, for use with A.C. mains, and complies with the official "safety first" requirements.

The Trix "Elasticator"

This is a particularly ingenious article for distant station identification and searching. There are three printed scales in a kind of large folding notebook. These scales are arranged in vertical columns and they

A GOOD UNIT



An H.T. and L.T.-trickle-charging A.C. unit made by Ready Radio.

show the separation of the medium-wave stations as given by the three different types of variable condenser in common use.

Then there is a length of white rubber having condenser degrees marked on it (0-100 one side for Extensers and 0-180 the other side).

The scheme is beautifully simple. You note the dial readings of three stations at spaced intervals on your tuning dial, and then stretch the rubber indicator along the side of the appropriate station scale and fix it in position with the drawing-pins provided.

Then the dial readings of all the other stations can be read off at a glance. We would suggest that a suitable slogan for the "Elasticator" would be "Station Searching Simplified," for so long as the various stations retain their present wave-lengths, and so long as your tuning condenser really does conform with one of the three "laws" (though we fear there are variables which have curious laws of their own!), the "Elasticator" does make the job of station finding a particularly simple one.

Test Bench

Graham Farish, Ready Radio, Burne-Jones, Standard Battery, and Blue Spot products are impartially dealt with this month.

The "Magnadenser"

It is good news that our old friends, Messrs. Burne-Jones and Co., Ltd., are making a solid-dielectric variable, for there is plenty of room for high-class components of this nature. Of course, that is providing the price is right, and at 2s. 6d. each, complete with knob, the "Magnadenser" readily fulfils this requirement.

SMOOTH IN ACTION

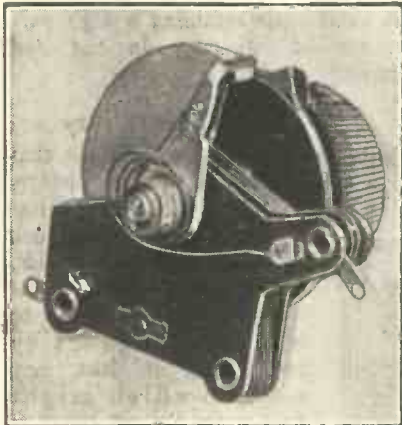

The Burne-Jones "Magnadenser."

It is available in .0002-mfd., .0003-mfd and .0005-mfd. capacities.

In both design and construction it is quite above criticism, for it is compact, robust, and cleanly finished. There is a direct connection to the moving vanes, and it is apparent that good materials have been used.

Its insulation resistance is high, and it is stated that each one undergoes a 500-volt A.C. test. Finally, we find the capacities of our samples close to their ratings (while the mechanical movement is unusually smooth and free from backlash and irregularity).

A Useful Testing Device

The Standard Battery Co. are pioneers in the provision of inexpensive test meters for wireless enthusiasts, and in their Wates Universal Test Meter they have made a notable advance. This latest product of theirs not only has L.T. and H.T. voltage and milliampere scales, but also enables direct readings of resistances to be taken in ohms.

Of course, the scale is somewhat restricted in size and the needle is thick, but the amateur does not need laboratory precision measurement in testing and maintaining a radio receiver.

For battery testing (G.B., H.T. and L.T.), continuity tests, H.T. current tests, and other such meter applications as are within the scope of the amateur, the Wates Universal Test Meter is perfectly adequate. And in that it is small in size and inexpensive in cost its popularity is assured.



The Wates Universal Test Meter.

Worthwhile Loud Speakers

We are delighted that "Blue Spot" have seriously embraced the inductor principle, for the inductor deserves the further expansion which will now inevitably follow. Let us consider the Blue Spot 100U Inductor Unit. This retails at 39s. 6d. complete, and all ready to fit on to a baffle or into a cabinet. (Don't try and use it alone or you will lose all the really good bass it is able to provide.)

Now we should be very surprised indeed if this unit failed to "get over," for it has all the attributes of previous "Blue Spot" successes, and, perhaps, a few more.

The same applies to the Blue Spot 100D Inductor Loud Speaker at three

guineas, which is a complete instrument built into a handsome oak cabinet.

We have had both on test and, particularly remembering their prices, we have no hesitation in styling their performances as impressive. They are exceptionally sensitive, and it is no exaggeration to say that they give better results than some moving-coil speakers.

As a matter of hard fact, it is dubious whether any "M.C." could give much better results on the average set!

Constructors contemplating the purchase of new loud speakers would certainly be well advised to make point of hearing demonstrations of these Blue Spot Inductors.

NEW BLUE SPOT INDUCTOR SPEAKERS

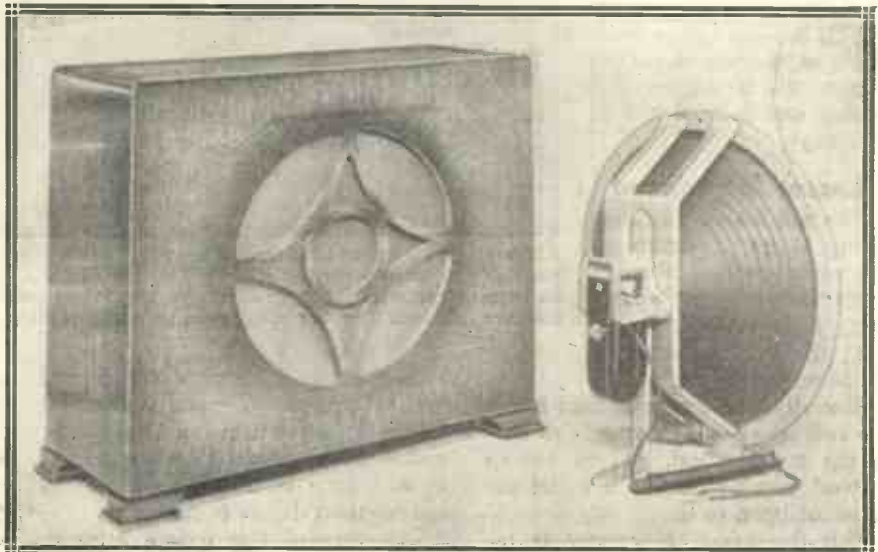

The 100D Blue Spot Speaker and the 100U Blue Spot Unit—both are of the Inductor type.

Trouble Tracking

On this page the Chief of the "M.W." Query Dept. discusses, month by month, some of the common difficulties and troubles which can be so perplexing. This month he deals with coil troubles.



I HAVE recently noticed that quite a number of my correspondents are having trouble with sets employing coils of their own construction.

Screened Coils

Some of them have made up their own dual-range coils, and these they have included in S.G. receivers, utilising either complete screening "cans" or vertical shields and metal-covered baseboards.

Now there is often a "snag" here which accounts for much of the trouble experienced. For instance, flat tuning is one of the complaints, and I have found that this occurs very frequently in these cases of home-designed coils and receivers.

One of the reasons is this. When a coil of wire is placed near a sheet of copper or aluminium it loses a certain proportion of its inductance, and in addition its high-frequency resistance increases.

This increase in the resistance of the winding is the factor which causes flat tuning, and is produced in two ways.

Losses Introduced

The coil loses inductance owing to its proximity to the metal sheet, and more turns have to be wound upon it in order to bring back the inductance value to its proper figure.

Secondly, the magnetic field round the coil causes eddy currents to flow in the metal shield, and so has to do work which otherwise it would not be called upon to do.

This dissipation of energy is reflected back into the coil in the form of losses, and so frequently we get a

high-loss instead of a low-loss winding simply because of the positioning of the coil in relation to the screen.

The remedy is to keep the coil as far away from the shield as possible.

In a set employing a metal baseboard, if the coil turns practically fill the former it is advisable to mount the former on a block of wood so that it is at least half an inch above the metal baseboard screen.

Similarly all coils should be posi-

On the other hand, the modern tendency is to employ small diameter windings for these "canned" coils, and if they are skilfully designed the diameter of the "cans" can be kept down to within reasonable limits, at the same time retaining a high percentage of efficiency in the coil windings.

Increasing Selectivity

Speaking of coils reminds me that

I have had dozens of letters asking me how the selectivity of a simple set such as a detector and two L.F. stages can be further increased without resorting to band-passing, Eckersley tuners, or, in fact, any method which might necessitate the scrapping of the existing tuning scheme. And, above all, these readers expect to get their desired increase in selectivity without any decrease in volume.

A Difficult Task

What an impossible task! It is quite beyond me. You can, for example, take an ordinary straightforward tapped coil and move the tapping nearer the earth end. This will decrease the number of turns in the aerial circuit, thus reducing the coupling between the aerial and grid circuits and therefore increasing the selectivity.

This is all very fine, but although you obtain better selectivity you only achieve this at the expense of signal strength, and there is no way of increasing the selectivity and retaining all of the volume.

A series aerial condenser does exactly the same thing, and so does a reduction in the size of the aerial. So there you are!

NO FAULTS HERE



Although home-wound coils sometimes give trouble, there is little possibility of faults occurring after rigid testing like this. Not only do these commercial coils each receive careful inspection and measurement, but they are also tested on actual signals in a set.

tioned at least an inch away from vertical screens. When we come to coil "cans" the problem is a bit difficult, and it is sometimes necessary to put up with some losses in order to achieve the required degree of screening.

Instances of this nature arise in cases where two high-frequency S.G. stages are employed.

HEAR

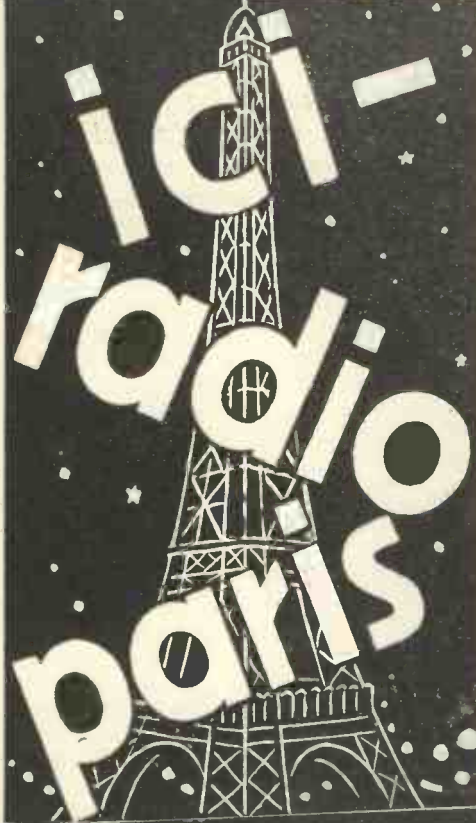

PARIS

tonight on

The

GRAHAM-FARISH

"AMAZING 3"

SCREENED COIL



When you have assembled your "AMAZING 3," then comes the happy hour. Switch on your new receiver. Tune in Radio Paris, most popular of Continental stations. How's that for volume—selectivity—tone? No other set—anywhere near the price—can beat it! That is what we say to all potential constructors—and the experts back us up. Listen to them—

"Broadcaster," February 27th. This Kit Set is among the most selective we have tested. With a long aerial, 10 miles from Brookmans Park, Midland Regional was received at reasonable volume without interference. On the long wave-band the performance was extremely good, and we received in daylight Huizen, Radio Paris, Eiffel Tower and 5 X X clear of interference.

"Amateur Wireless," March 19th. The "Amazing 3" has all the advantages of a good factory product. I was immediately struck with the neatness of the layout, and can see that this is a Kit Set that can give very good results, even in these days of congested wave-bands. The selectivity is indeed far above the average.

"Popular Wireless," March 12th. Much more polished and refined than the majority. The performance available is certainly quite attractive. It is superior to some commercial Kit Sets selling at higher prices.

EMERGENCY COUPON

In case of difficulty send this coupon for FREE Descriptive Leaflet to GRAHAM FARISH LIMITED, Bromley, Kent.



Name.....

Address.....

M.W.....

Use a Graham Farish Speaker for best results from your "AMAZING 3."
SENT POST FREE BY RETURN IF YOUR DEALER DOES NOT STOCK.

RETAIL PRICE

38/6

COMPLETE

"POWER" CURVES FOR COILS?



By G. V. DOWDING, Associate I.E.E.
A suggestion concerning which we would welcome the comments of our readers.

THE qualities of L.F. amplifiers are fairly easily judged from the circuit and the values and types of components used. Even the moderately skilled home constructor is able to gauge something of the potentialities of the L.F. end of the set.

But it is an entirely different matter when you go to the other side of the detector.

It is true that theoretical amplification figures can be worked out by the expert, but as yet there is little or no attempt at the standardisation or even, one might almost say, the rationalisation of the components employed.

I do not mean that there is an entirely haphazard "hit or miss" on the part of the designers, and that they are not able to work to closely defined standards.

They can, but the standards are not common property, as in a few instances are the standards laid down by L.F. transformer makers.

Comparing Coil Units

Admittedly, the issues are far from being as clear-cut. It is all very well saying that a coil—for that is the essential H.F. element I have in mind—should be as efficient as possible.

But how can you define a practical efficiency standard for a coil?

"H.F. resistance—dynamic impedance," I can hear some of you murmuring. But that won't take us far.

You see, although a simple single-winding coil with terminals at each end of its winding could possibly be dealt with in that manner, the fact is that simple constructions of this nature are not used in any appreciable numbers.

The "coil," so called, is generally a coil unit comprising primary and secondary, long- and medium-wave and reaction windings, and first of all we must pause and ask ourselves what it has to do.

It has to provide for a more or less wide range two-band tuning, and it also has to contribute towards the selectivity of the set in which it is used. Indeed, it may have to supply all the selectivity.

Definitions Demanded

Some such units are very compact and very nicely screened, others are larger and unscreened. And then there are those even more complicated units employing the band-pass method of coupling primary and secondary circuits.

be satisfied with Det.-L.F.'s—if they use one of the less conservatively designed coils!

You will now no doubt see what I am getting at. All the foregoing can be known to the experts without the public realising that it is in the hands of compromises.

And it seems clear that the time is ripe for some definite performance standardisation, or, rather, grouping, for all these different units.

It would be just as much to the benefit of coil manufacturers to have this, as can plainly be seen.

BIGGER TELEVISION PICTURES?

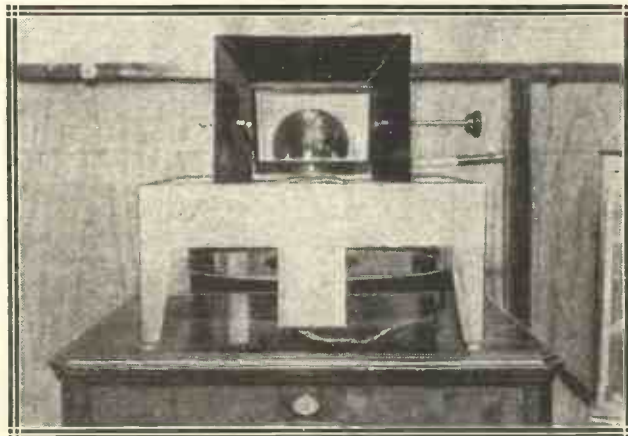

One of the latest American television receivers has a 5-in. square screen, but we have no information as to its practical effectiveness!

But someone must give the lead, and we are hoping that "M.W." can do this by "marking up" in some way such coil units as may be produced in our Research Department from time to time.

Fair Figures

Candidly, I don't quite see how a fair method of doing this can be evolved, and that is where readers may help with suggestions.

Obviously, the technical qualities of all these different types vary enormously.

We know that some are much less efficient than others when employed in the aerial circuit of a Det.-2 L.F. type of set. And that means overall efficiency, too.

But we might be told that in designing one of these coils, compactness and intervalve coupling purposes were more in mind than aerial circuit efficiency, and that people should know better than try and "make do" with Det.-L.F.'s these days.

All very well up to a point. But the fact remains that people can still

Kilocycle separation for selectivity might be one factor worth nailing down on some categorical unit method.

And for power (sensitivity) perhaps we could scheme out a system of measurement based on a millivolts per meter foundation—a standard input—standard output load, arbitrary frequency, etc.

But it must be remembered that we want simple and fair figures—a unit for selectivity and one for sensitivity which the inexpert can learn to appreciate.

What do you think? We'd like to know.

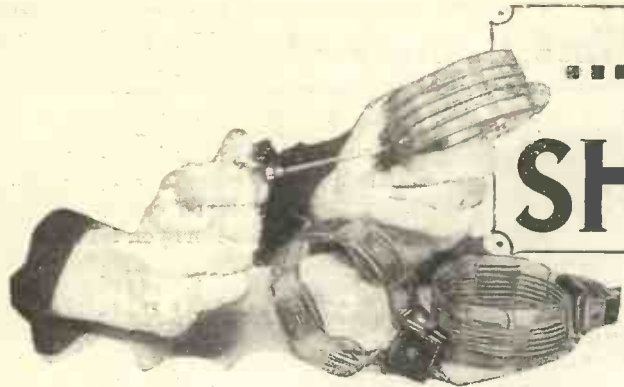

... ON THE ... SHORT WAVES

By W. L. S.

Who dwells on the many charms of this fascinating wave-band and gives some useful hints for newcomers.

I SEE from an Australian radio journal that a short-wave club out there has been subjecting its members to a questionnaire. One of the most interesting questions was: "What made you take up short-wave reception as a hobby?" The replies were many and various, but the two principal ones were: "Because the thought of hearing the whole world gives me a thrill," and "So as to get out of the rut of broadcast listening, which anyone can do."

An Excellent Reason

It seems to me that the combination of these two replies is an excellent reason for taking up short-wave reception. Personally, I believe the "urge" that sets us off in this direction is mildly comparable with the thought that sets a man off to drive an uncomfortable racing car instead of his draught-proof, cushioned "Family Seven."

Certain it is that short-wave listeners, as a body, are vastly more keen on the technical side of radio than those who never think in terms of less than 100 metres.

I myself fell into the short-wave habit in the very early days of broadcasting, when there were no foreign transmissions to listen to except the Eiffel Tower and "The Dutch Concerts." If one wanted novelty in those days one listened to the amateur transmitters; and as the amateurs were steadily wafted downwards by their discoveries that the real "DX" was awaiting them on shorter and shorter waves, we—the mere listeners—followed them.

And you certainly will not find a man that is keener on radio as a hobby than the amateur transmitter—whatever you say about him when he wipes out your pet programme!

For the Newcomer

As this is the time of year when thousands of listeners are trying out short waves for the first time, I want

to make one or two remarks especially for their benefit, and I hope the "old hands" will not grudge the space. First of all, you newcomers, you will probably find that short-wave work is not quite so "cut and dried" as you imagined it to be.

A Great Charm

That is its greatest charm, and the very thing that makes for enthusiasm. If you received every station you wanted to at "first go," I venture to suggest that you would soon become bored and blasé. It is the mere fact that you have to keep on improving your gear, and trying harder and harder, that keeps you at it.

There is that pleasant feeling of achievement when you have finally got a set that will do just what you want, and *when* you want it. None

of these break-downs when Uncle Charles calls and wants to hear America! When you have reached that desirable state, you begin to feel that you are a little farther up in radio than your next-door neighbour.

Secondly, you will find that "conditions" count for a tremendous lot. Certain stations fade out—unaccountably, you think—and others come in in a fashion that is quite bewildering. This, too (although you may not think so!), makes it all the more interesting and exciting.

How Conditions Vary

You never know what you are going to receive, or when. As a matter of fact, "conditions" vary on a regular cycle throughout the year, and you will find in "M.W." some fairly accurate details concerning

PIERCING THE HEAVISIDE LAYER.

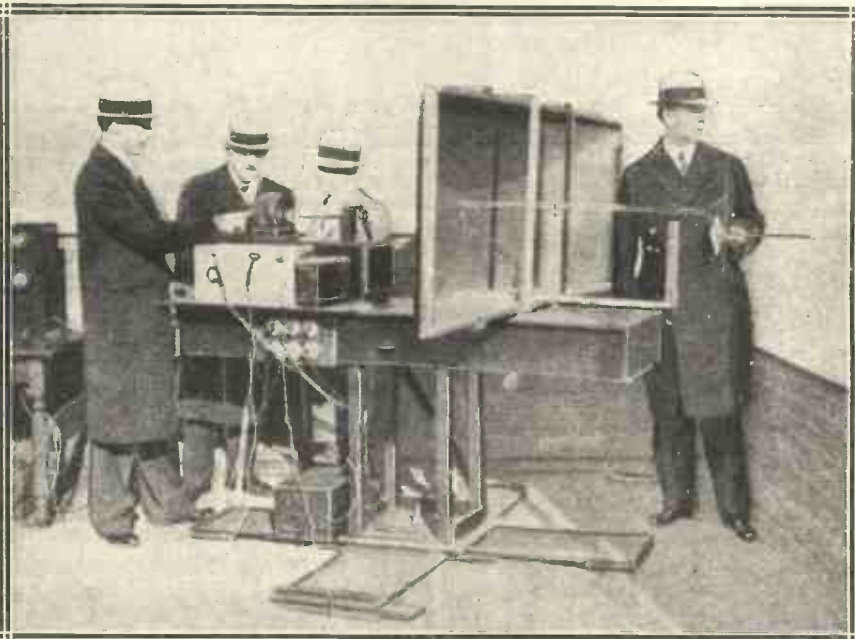

The photograph of this queer-looking apparatus comes to us from America, and shows engineers of the Westinghouse Company trying out a new ultra-short-wave transmitter. It is claimed that transmitters using wave-lengths of only a few metres have no reflected ray, the waves passing right through the Heaviside layer. The miniature vertical aerial can be seen to the right at the end of the pair of "feed" wires that come from the transmitter. The large object through which these wires pass is a special parabolic reflector.

"There's a Good Time Coming—!"

what you may reasonably expect to receive.

The general level of reception conditions is at the moment fairly bad, and has been for over a year. But that only means that you will have to make a better receiver than you would have done two years ago! And when conditions *do* improve again, you will be duly pleased to see, for the first time, what a fine set it really is.

don't take it up unless you are prepared to stick at it."

A Good Spring?

And now some news for the old-stagers. Comparison between my log so far this year with the five previous years leads me to suggest that we are in for a very good spring. Already the distant signals have been coming in in exceptionally good form, although February and March are

Broadcast, too, has been very good on the whole. W 2 X A D, unfortunately, still fades out early (although he should be coming in up till 9 p.m. by the time you read these notes).

The General Rule

W 2 X A F and the other 32-metre stations have been fairly consistent, but the Americans in the 49-metre region have rather let us down. When they come over at all they seem to be good, but there have been long patches when they have not been audible at all. Of course, the Europeans and the nearer stations like Rabat have been fairly uniform.

The general rule has been "East good, West bad." Never has there been any difficulty about finding the various stations in the Dutch East Indies; Saigon and Chi-Hoa also have been consistent. This same rule has applied to amateur reception, stations from Australia and the Far East having been better than the Americans, on the whole.

New European Station

Incidentally, although it will be ancient history by the time this reaches you, there is a new European on 49.4 metres—Radio-Wien (Vienna). He is at present transmitting in the afternoons and evenings on Tuesdays and Thursdays, and puts out a very good signal.

I have been taken to task by one or two readers for not writing the half-promised "continuation" article on the "1932 Short-Waver." The fact of the matter was that after a month with the set I could not find anything that had not been covered in the January article, and for that reason I did not burst into print again in February.

Insufficient H.T.

I have met two cases of minor troubles with the set, one due to insufficient H.T. and the other to a Spaghetti resistance that appears to have been wrongly labelled. In each case the result was that too low a voltage was applied to the screening grid of the detector valve, and that the set would not oscillate over the whole range.

That, of course, was quite natural, and also, of course, quite easily remedied. It is a point worth bearing in mind.

SHORT-WAVE RADIO IN THE FIELD



The American Army authorities are very keen on portable radio equipment, and here you see one of the special field short-wavers in operation. Note the handy loop-aerial, which can be easily folded for transport purposes.

Thirdly, you will find that instead of thinking in terms of "Europe," you will have the whole world opened up to you. This, in some respects, is rather a pity—it makes one expect so much. If you receive America on the broadcast waves, for instance, you are probably as pleased as Punch. But when you get it on the short waves, you murmur: "I should jolly well think so, with three valves!" and pass on to look for Australia.

Make the Decision

If these few remarks have given short-wave work a new aspect for you, think over it very hard and decide whether it sounds good or not. But (if I may borrow words from another's mouth). "Don't, please,

often dull. So just keep your ears in order for April and May—they ought to be good.

February was a month of tests, what with the British Empire Radio Union Contest at week-ends and the "International Good-Will Contest" for a week at the end of the month. Both series of tests were very successful, judging by the wonderful DX reception that seems to have been the rule.

Those readers who have never been tempted to learn Morse and listen to the amateurs will probably be surprised to hear that over a hundred different Australian amateurs were logged in this country during two week-ends. I heard well over fifty myself, with one valve.

MAKING THE MOST OF YOUR MAINS UNIT



A practical and extremely interesting article that will assist you considerably in getting the best out of your H.T. battery eliminator.

THERE is a widespread belief that, in practice, mains units are less satisfactory than batteries. They do not run down, nor do they have to be sent away to be recharged, and on that score give less trouble. But is their performance really all it is supposed to be?

Aiming At An Ideal

They should be like batteries that never drop in voltage, that never cause crackles, that continue to give an even flow of current. But they are not batteries! They don't even operate in the same way.

You can buy a 120-volt battery, but if you ask for a 120-volt mains unit the salesman will want to know what sort of set you have, what current the valves take. It is not mere inquisitiveness, because he cannot sell you a mains unit that will work satisfactorily with your set unless he knows these details.

If your valves take 8 milliamps. from an H.T. battery at a pressure of 120 volts, then this voltage will still be available when you have added an extra big output valve and brought the total current consumption up to, say, 14 milliamps.

Varying Loads

Not so an H.T. mains unit.

Suppose you have one rated to give 120 volts at 20 milliamps. You have a high-mag. output valve for long-distance work, but use a bigger one with low impedance and correspondingly low mag. for local station quality listening.

In the first case the total current for all valves is, say, 15 milliamps., but that when you use the bigger

valve this figure is brought up to 25 milliamps. Now, what voltage will the eliminator give in each case—120 volts? Unfortunately not.

The actual voltage will depend on the design of the mains unit, but as a rough approximation the first case will be—at 15 milliamps.—about 140 volts. At 25 milliamps. you would probably only obtain 100 volts.

REDUCING THE VOLTAGE

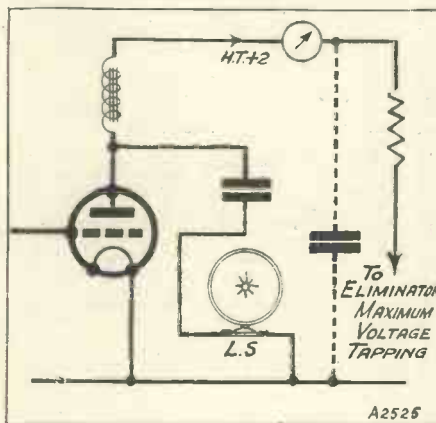

If your mains unit gives too high a voltage for the valves you are using it can be cut down very easily by inserting a resistance in the main H.T. lead. But care should be taken that it is properly decoupled by a large fixed condenser.

An estimate of the voltage given by the eliminator can be made by guessing, but this figure will be very rough. The best method to adopt is this. First, if you haven't a milliammeter, borrow one.

With a 20-milliamp. mains unit a 0 to 30 m.a. will be best, while for a larger mains unit one with a maximum of 50 m.a. should be used. The place to connect it is between

the 120-volt (or whatever the maximum value may be) mains unit tapping and the H.T. terminal on the set for the last valve, as in the illustration.

Checking the Current

The H.T. for other valves should be obtained by a separate connection, so that the current does not pass through the milliammeter.

If you switch on now the meter will indicate the current taken by the last valve only. To make sure that your grid bias is correct, temporarily remove any "free G.B." or mains unit G.B. connections and substitute a battery. Now read off from the meter the current passed by your output valve and compare the figure with that given by the makers.

If you find that, for a given grid bias, the current is too much, then you must drop the voltage by means of a resistance. One of the spaghetti type will do as long as it will handle the necessary current. You will probably need a condenser of about 2 mfd. in the position shown in order to avoid instability.

The Series Resistance

The value of this resistance to drop the voltage, and thus the current, to the correct value may be between 1,000 and 3,000 ohms. If you have a spaghetti with a value somewhere near, it should be tried, and then from the new meter reading it will probably be possible to guess the value likely to be required.

If you now replace the "mains G.B." you will be able to tell in a like manner whether the valve is getting its correct bias.

QUESTIONS ANSWERED

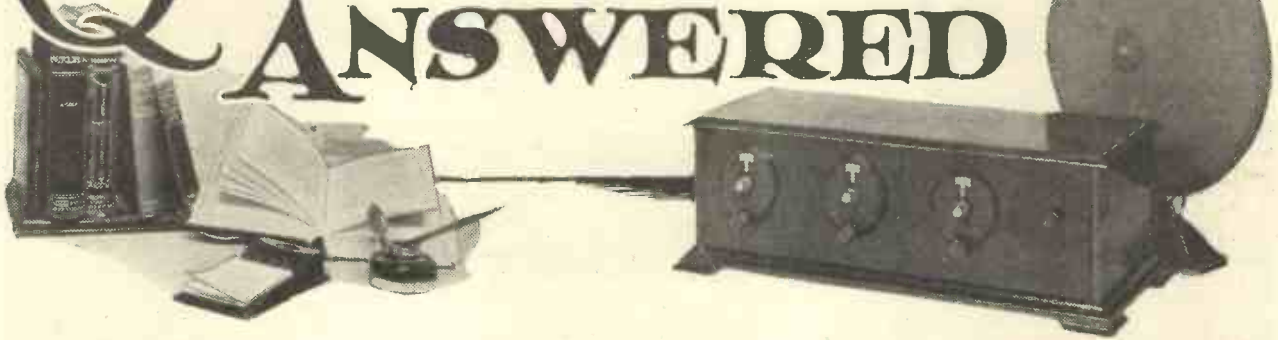

Aerial Screening

N. C. (Cambridge).—" Will you please settle an argument I have had with a friend? I maintain that if I try to work a set from an indoor aerial erected in a building composed of steel structures there is every likelihood of the results suffering owing to the shielding effect of these structures.

" My friend, on the other hand, does not consider that a few steel beams or struts will have any appreciable effects.

" Which of us is right? "

You are correct, N.C., because it is usually found that aerials erected in reinforced buildings give poor results.

In some buildings sets employing frame aerials, such as portables, will receive practically nothing and yet directly they are taken away from the buildings they give excellent reception. Of course, the degree of screening is largely affected by the amount of steel-work, but practical experience tends to indicate that in the modern reinforced building this is sufficient to upset things.

D.C. Mains Units

L. M. (London) wishes to know whether any special precautions should be taken when using a D.C. mains unit for H.T. He mentions that he is at present employing dry batteries in conjunction with an " Eckersley " Three, and doesn't want to do any harm to himself or his set when changing over to the mains supply.

There are certain precautions which are advisable. If the mains unit is of commercial type you will find a special earthing terminal on the case. Remove the earth lead from the earth terminal on the set and connect it to the earth terminal on the unit.

If, on the other hand, you intend to construct your own mains unit,

you must be careful to insert a large high-voltage type (about 2 mfd) condenser in series with the earth lead.

Moreover, it is as well also to isolate the aerial from the set itself by connecting a .005-mfd. condenser in series with the aerial lead.

Primary Inductance

A. C. (Sidcup).—" Why is it necessary for an L.F. transformer to have

and has a primary winding comprising a very large number of turns.

There are, of course, many other factors which also have to be taken into consideration and which cannot be dealt with here.

The golden rule is to choose a first-class make, and then you can rest assured that the design is right.

A Fault-Finding Tip

H. K. and others ask for a simple method of testing for faults, such as breaks in transformer windings and coils. Also for short-circuits in condensers, etc.

One of the easiest methods is to use a pair of telephones or a loud-speaker and a dry cell.

One tag of the 'phone or loud speaker should be connected to one terminal of the dry cell, and two flex leads should be connected, one to the remaining 'phone tag and the other to the remaining terminal of the dry cell (a flash-lamp battery is quite satisfactory).

These two flex leads, if now touched lightly together, will produce a strong double click in the 'phones; one click when they make contact with each other, and another when they are separated again. They may thus be used for testing for continuity in leads, etc., since the loud double click is ample evidence that everything is satisfactory.

Indicating a Break

A fault on the coil-holder, for instance, such as a break between the terminal and the plug or socket to which it is connected, may now easily be detected, since if one flex lead is connected to the terminal and the other to the side of the holder to which the terminal should make connection, absence of the double click is positive evidence that the component is faulty. But clicks would indicate all was O.K.

TECHNICAL QUERIES DEPARTMENT

Are You In Trouble With Your Set?

The MODERN WIRELESS Technical Queries Department is in a position to give an unrivalled service. The aim of the department is to furnish really helpful advice in connection with any radio problem, theoretical or practical.

Full details, including the revised scale of charges, can be obtained direct from the Technical Queries Department, MODERN WIRELESS, Fleetway House, Farringdon Street, London, E.C.4.

A postcard will do. On receipt of this all the necessary literature will be sent to you, free and post free, immediately. This application will place you under no obligation whatever. Every reader of MODERN WIRELESS should have these details by him. An application form is included which will enable you to ask your questions so that we can deal with them expeditiously and with the minimum of delay. Having this form you will know exactly what information we require to have before us in order to solve your problem.

London Readers, Please Note: Inquiries should not be made in person at Fleetway House or Tallis House.

a high inductance? Is it a question of magnification or quality of reproduction?"

Amplification and quality are both affected by the primary inductance. If a transformer primary has a low inductance value the low notes will not be amplified in the same proportion as the high notes. Consequently the tone balance will be poor and the resulting reproduction will sound high-pitched.

To ensure faithful reproduction, the high and low notes should be amplified equally, and this can only be achieved if the transformer is properly designed,



The Mystery of the Suitcase

*'Twas in the merry month of May
That our Aunt Julie came to stay,
All trim aloft and broad in beam,
A fat cheque-book, a kindly look ;
She caught a chill and took her hook,
But left us not a single bean.
Alas, things are not what they seem !*

THAT'S the dire result of reading all this poet's tripe about May and lamblins and hawthorns. I remarked to my landlady only this morning, as I looked out of the window and saw the blue sky and

DAY OF RECKONING



"I thought to-day seemed to be settling day, Mr. Jones."

brilliant sunshine, and the passers-by hunching themselves into their fur coats against the icy wind, that things are not always what they seem. She replied, with a certain percentage of nitric acid in her voice :

"Ye-es ! F'rinstance, I thought to-day seemed to be settling-day, Mis-ter Jones."

All for a Phrase

You know, that gave me a sort of uncomfortable feeling that I had become the slave of a phrase, because recollection flooded in upon me and

I remembered how I had once spent several strenuous minutes in trying to convince a casual acquaintance that he would do well to mistrust appearances.

Even in Radio

" Things are not always what they seem," I said, gravely wagging my forefinger at him.

" I know," he said dully. " I'm a professional illusionist."

All the same, what I say is true. You find it in women, the radio game, banking, thimble-rigging, dining in boarding-houses, and picking up purses. Oh, I've had some rare surprises in my time. I remember once, when I was voyaging to India to sell gold flat-irons to Indian rajahs, there was a rummy little fellow aboard. Looked like a wizened tailor's cutter. Always sat by himself and played chess—one hand against t'other. I took pity on him, told him tall stories of the jungle, and warned him of the water, bugs, and cholera.

Waits for the Charge

He was most grateful, and said that he would be sure to remember—and did I know where he could buy a " Hymns Ancient and Modern." Now, at some forsaken port half-way down the Red Sea my gentleman disembarked, on the African side—quite alone, loaded like a Chinese coolie, with gun-cases and all manner of shikari tackle.

" Who on earth is that funny little shrimp ? " I asked the second mate.

" Oh, that's Sir P— C—, the big-game hunter. We bring him out somewhere East every year. They

say he never shoots a tiger till it charges ! "

But that's nothing ! Just listen to this one. Last year I was booked to read a paper at the Annual Assembly of the All-Britain Amateur Radio Association, at York. By the way, I had chosen as my subject : „ Pseudo-signals : A Refutation of the Planctarian Cosmography." Rather strange, that !

A Near Thing

Owing to oversleeping and a traffic-jam, I caught the luggage van of the

THE KILLER !



" Who on earth is that funny little shrimp ? " I asked.

Scarborough Flier, and was lucky to have done that, considering that I had to be hauled aboard by the scruff of my neck. I sat down on a barrel and devoted several minutes to regulating the jolly old bellows and getting my heart back again on to its proper hook. By the time we slid through Hitchin I was feeling normal, and lit a pipe. I thought that I would stay awhile, pass the time of day with the guard, and then find my booked seat.

The Set That Turned Into a Shirt!

The guard, a brisk, nosey and efficient member of the N.U.R., told me that I must not smoke there—and altered his view of the proposition after I had chalked a diagram of his "Rodeo" Three on a barrel and explained to him how the set could be made to create more noise than the "Universal" Four of his neighbour, an "outside" porter of Paddington. Presently Bert—the guard—went along to see what he could snaffle from the kitchen, and just as I was on the point of staggering along the corridor, in barged a fellow laden with a biggish suitcase, which he lowered carefully into a corner of the van.

Something Secret

"How d'ye do?" he said genially.

"Oh, so-so!" I answered.

"I've got something pretty secret and valuable in this suitcase, and it's too big to go on the rack—and my compartment is full of little boys with hobnailed boots," he went on. "So I've brought my case here for safety. Got any pipe tobacco, by any chance? I left my pouch at home by mistake, and I'm nearly crazy for a draw."

"Well, I have, but it's a special mixture—"

"Latakia? Good man!" And he snatched my pouch like a monkey.

"I'm—puff, puff—a slave to tobacco," he said, with his head in a cloud of smoke.

"Well, I'm happy to have been able to help you out," I answered. "I'm off to find my seat now."

"Would you mind watching my suitcase while I polish off a spot of lunch. I had to give breakfast a miss. Overslept!"

"So did I. Right! Carry on, and I'll butt in and do likewise at the second sitting. — I overslept, too. Is there anything explosive or dangerous in the case?"

A Heavy Case

"No-o! Only a surprise—for the police—if they did but know it." Saying which, he wobbled out. I looked at the case. It was of good leather and neatly printed with the letters "H.W." I felt its weight—rather a hefty tonnage, and inclined to rattle, but at the same time I received the impression that it contained something wet and sticky.

While I was waiting for the luncher to return I pulled out my newspaper and nosed through the headlines.

Presently I noticed the account of a murder, the victim having been dismembered, only the trunk being found. How wet and sticky. I glanced at the suitcase.

Back he came, slightly mellowed by food and drink. Especially drink!

A RADIO ENTHUSIAST



"I chalked a diagram of his 'Rodeo' Three on the barrel."

I left him gazing happily at his suitcase and fled to the dining-car, where half-way through my after-lunch smoke I bumped along the corridor, impelled by an impulse probably related to the morbid.

"H.W." was still there, and received me with affection. He had been reading my newspaper and was chatty about corpses.

"They pack 'em in trunks generally," he observed. "Or big suitcases—such as mine."

"Yes," I said, "the police ought to keep an eye on luggage-vans and cloak-rooms."

"He! He!" chuckled "H.W."

THE MYSTERIOUS POOL

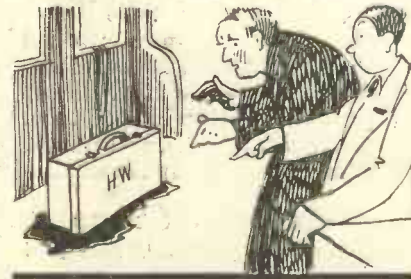

The dark pool in which it stood had grown bigger.

"They'd love to have a peep into mine. Shall I show you—?"

"No, no; I don't want to come between you and the police," I replied.

Presently he said that he would go along the Wobbly Way and try to get a cup of tea. Would I guard The Case? I agreed, and out he plunged.

I looked at the beastly case once more. Then my blood turned to ice-

water and my pulse registered about 127. Because, you see, there was a pool of blood around it, dark red, sluggish, and altogether horrible.

In popped "H.W."—the tea had done him a world of good.

"Hallo!" he cried "Behold my faithful watchdog." Then, seeing the look on my face, "Smatter? You look a trifle upset."

I pointed, without a word, to the Case. The dark pool in which it stood had grown bigger. He stared, his mouth gaped and his whole attitude expressed, "Discovered!" So I thought, anyhow.

An Inside View

"What's in the case? That's what I want to know," I said.

"I don't see what that has to do with the matter, but since you ask I don't mind telling you that— Good lor, *that's not my case at all!* My initials are H.N. I must have grabbed the wrong 'un at Euston."

"Yes," I thought, "now you're found out—it's neither your case nor name." Aloud: "Well, if it's not yours we can open it right here and now. Come on." I admit that I was surprised to see that he made no objection and, indeed, evinced no particular interest.

The Case was not locked. I snapped back the catches. A ghastly sight met our eyes—red-soaked shirts, pyjamas, handkerchiefs and collars, and over all a peculiar smell.

Trouble Tracking

"Look underneath," said H.N.

"Do it yourself," I answered. I was feeling strangely hollow in the middle and dizzy on top. He got one of Bert's flags and with the handle gently poked the stained garments about until he disclosed a "traveller's" sample case of test-tubes which apparently contained dyes. *Several of the tubes were smashed.*

* * *

"But what," I remarked to H.N. in the buffet at York station, "had you in your own suitcase which was so precious and which, as you said, would be a surprise for the police?"

"Aha! I see! Well, I was to read a paper at the Radio Assembly here on new applications of radio to police work. I am, as a matter of fact, a 'Yard' man—and I had in my case the best and smallest and lightest combined receiver and transmitter ever designed."

MY BROADCASTING DIARY



Our own Broadcasting Correspondent records the progress of the British Broadcasting Corporation, and frankly comments on the policies in force at B.B.C. Headquarters.

Special Season of "Proms."

It is great news that the B.B.C. has practically arranged to do a special season of Christmas "Proms," on the lines of the Queen's Hall "Proms." Dr. Malcolm Sargent will conduct.

The Roosters

The Roosters Concert Party is now firmly established in the affection of the vast listening public. I am glad, therefore, to hear that they are bringing out a book of reminiscences covering both their service in France and their work for the B.B.C.

I suggest that the B.B.C. should take on the Roosters as a permanent concert party on a permanent staff engagement. There are none too many ex-service men in the employment of the B.B.C. This is an added reason for doing the right thing about the Roosters.

Those New Governors

It was about a year ago now that I called attention to the beginning of negotiations for the change-over jobs on the B.B.C. Board. There was at one time considerable speculation. History is repeating itself.

The scramble has begun afresh. Those who believe they know declare there will certainly be two, and possibly three, vacancies on the B.B.C. Board at the end of this year.

I hear that Lord Gainsford and Dr. Montagu Rendall are unlikely to continue; Lady Snowden will offer herself for re-appointment, and it seems to be generally understood that the practical problem will be to find two new Governors. I shall tell you how the situation develops.

The Television Tangle

Although the Baird Company has now got an agreement with the B.B.C. which will run until at least March 31st, 1934, there is a great deal of hopeful activity in other television quarters. I hear confident accounts of the results of recent short-wave experiments conducted by the Marconi Company.

There are also about five new processes at various stages of development, but all still remote from reaching the microphone. Scientists interested seem to think we may be on the verge of a revolutionary new discovery—well, we shall see what we shall see. The Baird Company

is well dug-in politically and financially, and will take a lot of dislodging from the position they now hold.

I suppose that we can say the "age of television" is approaching.

Geneva Broadcasts

Pacifist circles were disturbed by the refusal of the B.B.C. to relay slabs of the speeches made by delegates at the Disarmament Conference at Geneva. They complained that while the American broadcasters were relaying practically the whole thing, the B.B.C. contented itself

GIANT RELAY SET FOR LONDON



This is the control panel of a 22-valve set which operates a relay service in one of the London suburbs. The subscribers simply connect up their loud speakers whenever they wish to listen to one of the alternative programmes.

with the opening speech and an occasional commentary from Vernon Bartlett.

For once in a way let me heartily commend the B.B.C. for its good sense. Interminable speeches translated afterwards, and all taken on inferior land-lines, with wretched quality, before ever reaching the broadcasting aerial, are no fare for the British public.

What can I expect from His Master's Voice Radio?

Let the Radio experts tell you — Read below!

HOW DOES THE QUALITY OF REPRODUCTION COMPARE WITH OTHER SETS?

Wireless Magazine says: "This is one of the best sets we have tried this season. Loudspeaker output is extremely well-balanced, top and bass notes coming out with a delightfully natural timbre."

Amateur Wireless: "The quality of reproduction from the self-contained loudspeaker is simply great. The deep bass and the clear-cut treble combine to give a balance of tone not often found in table sets."

And *Wireless World* reports: "The quality of reproduction is well up to the standard expected from an 'His Master's Voice' product, with the output nicely balanced and the bass well in evidence without being overpowering, or obscuring the upper register, the reproduction of which is good."

IS THE 435 SENSITIVE?

Wireless Magazine says: "Sensitivity is equally good at the top and bottom ends of the tuning scale, Cologne and Budapest were taken as the two extremities, and both came out well."

And *Wireless World*: "Sensitivity is well above the average for a receiver of this type."

IS IT SELECTIVE?

Wireless World: "When searching for distant stations, the characteristic sharp cut-off of band-pass tuning was quite evident by the way signals quickly attained maximum

intensity and the rapid decline to inaudibility beyond the normal setting. The long waveband provided eight alternative programmes, all at good volume. Königswusterhausen, between Daventry 5XX and Radio Paris, was not affected by the proximity of these stations, although the last mentioned was exceptionally strong."

And *Amateur Wireless* says: "Selectivity will satisfy most listeners even if they live quite close to the regional centre."

While the *Gramophone* says: "The sensitivity and selectivity are all that can be expected of a set of this calibre; in this respect, indeed, we should rate it well above the average."

IS IT SIMPLE TO OPERATE?

"Control is altogether delightful" says *Amateur Wireless*. "If you are a set buyer who likes simple operation, here is a set that is outstandingly attractive." *Wireless World* adds, "Practically every modern feature likely to enhance the performance of the set and simplify its operation has been incorporated."

AND OTHER OUTSTANDING FEATURES

"Its many technical points," says *Wireless Magazine*, "will interest the enthusiast, and its wonderful performance will thrill the ordinary listener. Model 435 incorporates many requirements not found in the usual straight set."

While *Amateur Wireless* says: "It would be difficult to overdo praise for this excellent table console set, which has a great many points that distinguish it from the ordinary run of sets... I am very much impressed with the meticulous care taken at every point to assure good results," and sums up by describing the instrument as "one of the most outstanding triumphs of the British Radio Industry."



COUPON

The Gramophone Co., 365 Oxford Street, London, W.1. Please send me full particulars of "His Master's Voice" Radio Set Model 435, and address of my nearest dealer.

Name.....

Address.....

M.W.1.



**THE SET
THE EXPERTS
RECOMMEND**

SPECIFICATION

3-valve radio receiver and moving coil loud-speaker in walnut cabinet Mains operated (A.C. or D.C.). Band-pass tuning. Marconi valves. One tuning knob. One volume control—new “His Master’s Voice” frictionless pattern. One operating switch—new continuous action pattern. Unique illuminated control scales, showing only what is in operation—long waves, medium waves or the playing of gramophone records from a pick-up. Mains aerial (A.C.). Plugs for additional loudspeaker. Model 435.



Note the clean layout of the interior of Model 435. Precision Engineering not at one point, but at every point.

42/- down and 12 monthly payments of **33/10**
 CASH PRICE 20 GNS.
Price does not apply in Irish Free State. (A.C. or D.C.)

Ask your “His Master’s Voice” dealer for demonstration and full particulars.

His Master’s Voice
Radio — “true to life”

Latest News Items for the Listener

"Rungs of the Ladder"

The B.B.C. is planning a new series of unusual interest. The idea is to get a number of representative successful men of various walks of life to come to the microphone and inspire the listening youth to go and do likewise. I hear Lord Reading, Lord Beaverbrook, and Mr. Gordon Selfridge are likely to participate. I look forward to this series.

A New "Vigilance Committee"

There was an informal "Broadcasting Vigilance Committee" among members of a former House of Commons. Now I hear of another kind of "Vigilance

THE AMY JOHNSON OF AMERICA



Miss Elinor Smith, the noted American aviatrice, photographed as she spoke from a New York studio of the N.B.C. of America.

Committee" concerned with broadcasting. This is supposed to consist entirely of ex-members of the staff who are still sufficiently interested in broadcasting to wish to help it.

I was given a circumstantial account of a dinner party presided over by Captain P. P. Eckersley, and among the party were reputed to be Captain Cecil Lewis, Mr. Rex Palmer, Mr. Alan Howland, Mrs. Callis, Mrs. Bussell, Miss Hilda Matheson, Captain West, Captain Gambier Parry, Mr. "Bim" Hodder, Mr. Philip Jordan, Mr.

Carruthers, Mr. Parker, Mr. Eric Dunstan, and about half a dozen ex-engineers.

If this jolly gathering did take place, it must have been a rare treat. It would indeed represent a kind of "alternative B.B.C." Captain Eckersley in charge; Captain West as chief engineer; Captain Lewis back in his old job of "O.C. Programmes"; Miss Hilda Matheson handling the spoken word; Rex Palmer, music; Eric Dunstan, chief announcer; Mr. Hodder, general editor; and Captain Gambier Parry, controller. I wish I could get hold of an account of the proceedings, but this is unobtainable.

Alarm at Droitwich

The announcement of the intention of the B.B.C. to move Daventry to Droitwich had a mixed reception locally. There was indignation among a certain section of the inhabitants, who pictured a menace to their amenities.

This found premature expression in the newspapers; then came the official reaction from the Mayor and Council, naturally concerned that the B.B.C. should not be frightened off. Anyway, the alarm was duly composed, and now relations are as cordial as they should be; Droitwich welcoming the advent.

Wireless Trade and the B.B.C.

The wireless trade is taking more interest in the organisation of the B.B.C. than at any time since the Company became a Corporation. There has been a feeling that the trade should be ready for the next Parliamentary inquiry, which cannot be delayed beyond 1935, just ten years after Lord Crawford's Committee.

Although liaison with the B.B.C. has been strengthened largely through the personal influence of Captain Gambier Parry, the resignation of the latter throws back the position a long way. There has been set up a new trade committee to study broadcasting and to safeguard the interests of the trade in that connection.

I would not be surprised to see Captain Parry identified with this activity. He is certainly in a position of unique opportunity, armed as he is with inside knowledge, and having at his back the goodwill of all parties concerned.

Women in the B.B.C.

There is a growing revulsion against the employment of women in important jobs at Savoy Hill. Some time ago there was an inquiry into the proportion of married women, and although nothing was decided about people already employed it was made pretty clear that women normally supported by their husbands would not be taken on the staff where there were other suitable candidates. Now there is a move to get in a larger proportion of men on clerical as well as administrative and specialist posts.

Has It Ever Occurred To You—

That modern wireless technique is a potent force, which is changing the world before your eyes?
That it is making history—moulding the destinies of new nations—creating contacts—breaking barriers?

- ☞ To keep you well informed of radio progress and possible development is the aim of "MODERN WIRELESS" for which purpose this journal is uniquely equipped.
- ☞ In "My Broadcasting Diary" you have, every month, an insight into British Broadcasting—its policies and personalities.
- ☞ In "The World's Programmes" we present the panorama of changing conditions as new stations open.

ONLY

"MODERN WIRELESS" can keep you really in touch with the progress of MODERN WIRELESS.

The only specified coils for the
BI-BAND THREE



British General Band Pass Units, Aerial and Anode models, 14/6 each, including non-inductive coupling condensers, from all dealers or direct from the Manufacturers.

BRITISH GENERAL

BRITISH GENERAL MANUFACTURING CO., LTD.,
 Brockley Works, London, S.E.4

An Ideal Gift for your gardening friends!

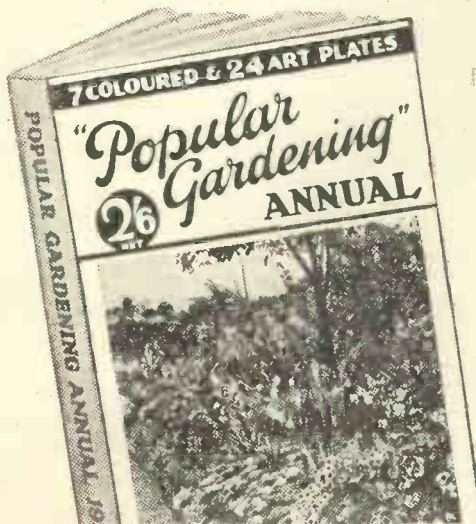

There is no happier gift for gardening friends than a copy of POPULAR GARDENING ANNUAL. This very useful book is an illustrated budget of useful advice for amateur gardeners. It contains an immense amount of information, seven coloured plates and twenty-four art plates from photographs and designs.

Popular Gardening Annual Now on Sale **2/6**

CHOSEN
 for the
TRI-BAND THREE

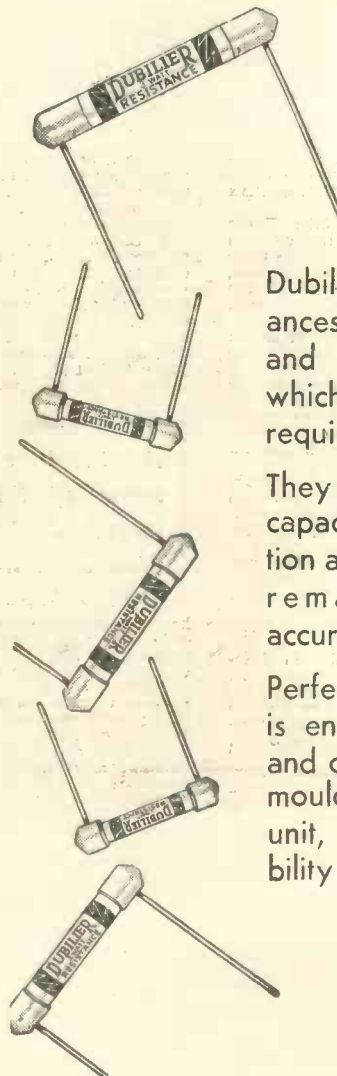

Dubilier Metallized Resistances are made in one, two and three watt ratings which cover every radio requirement.

They have a large overload capacity, are stable in operation and the resistance value remains permanently accurate.

Perfect mechanical contact is ensured by the filament and connecting wires being moulded together into one unit, eliminating any possibility of noise during use

PRICES

- One watt - 1/- each
- Two watt - 2/- each
- Three watt - 3/- each

DUBILIER METALLIZED RESISTANCES

DUBILIER CONDENSER CO. (1925) LTD.
 Ducon Works, Victoria Rd., N. Acton, London, W.3



BROADCAST

ALTHOUGH by the time this appears in print Easter will be over a few days, it is not too late to mention some of the special Eastertide records that have been introduced into the Vocation programme this month. They are essentially of a religious character, and take the form of oratorio selections or of abbreviated services.

One of these records that is well worthy of note is 3165, on a Broadcast Super-Twelve. It contains *He Shall Feed His Flock, and I Know That My Redeemer Liveth*, sung by the boy soprano, Frank Nichols. Recorded in the church of St. Mary-le-Bow, the atmosphere essential to the success of this type of record is fully captured, and the result is a very fine recording.

Another "Super" contains a brief Easter Service, including Hymns, Collects, Lessons, and is recorded at the same church. (3164.) This place of worship is also the scene for a "ten" recording of *Fight the Good Fight and Through All the Changing Scenes of Life*, by the full choir. (819.)

Coming to the secular type of record we have a wide variety from which to choose. A novel disc has been made on 816 (a "ten") by Archie Glen, who *Makes a Nuisance of Himself* in the Recording Studio. It is a breezy few minutes of utter nonsense that is quite refreshing after some of the more usual collections of more organised "humour" that have been creeping into the records during the last few months.

The *Impressions of Bird Life*, by Jim Sherry (813), include imitations of the canary, blackbird and nightingale on one side, while on the other is a record of *Actual Step-Dancing*, by the five Sherry Brothers.

The bird impressions are really excellent, and are certainly among the most skillful that we have heard. The second side is interesting, but not of true entertainment value. Step-dancing is very fine to watch, but it loses nearly all its attractiveness when "canned."

Monte Hunter is not really a "hit" in Halle-lujah, *I'm a Bum*, on 812; but he is a bit better on the other side, *I Don't Work for a Living*.

Slavonic Dance, by Dvorak, and *The Bee and Waltz in A flat*, by Brahms and Schubert respectively, played on the violin by Winifred Small, are good, but not inspiring. They are to be found on the "Twelve" No. 5266, with piano accompaniment by Maurice Cole. The recording is good.

The two selections from Grig's *Peer Gynt Suite*, played by the Berlin State Orchestra on 5265, are well recorded and, of course, their execution needs no description. The recording could have been a little sharper with advantage; but, on the whole, it is good. The items chosen are *Anitra's Dance* and *Morning*.

COLUMBIA

We have received a collection of ten-inch records from this famous concern; the variety being simply amazing. We cannot discuss all of them in the space at our disposal, but will mention those that seem to us to be the most interesting.

First, then, we will have that popular, but ridiculous, ditty that is now so well known: *He Played his Ukulele as the Ship Went Down*. It is recorded by the *Masqueraders* on CB416. It is perfectly recorded and most amusing. The sheer idiocy of the words make the number a real hit. You should get it.

And now, to switch over from the ridiculous to the sublime, we have DB749. On this disc are two recordings by the *Choir of St. George's Chapel, Windsor*. They are *Jesus Christ is Risen To-day*, and *Jesu, Lover of My Soul*, set to that magnificent Welsh tune, "Aberysweyth." The latter needs a little more of the Welsh fervour in its singing to bring out its wild minor qualities to the full, but it is tastefully if not vigorously sung. The choir is conducted by Sir Walford Davies.

Son O' Mine and *The Rebel*, sung on DB750 by Dennis Noble, forms an excellent disc that will find a home in many a gramophone's collection. Dennis Noble's diction is something that many vocalist recorders would do well to emulate. *The Rebel* is perhaps the better of the two recordings, being less hackneyed, while the singer's "top-note" climax is reproduced magnificently by a

good radio-gramophone. In the former item the singing is just as fine, but we found the accentuated rolling of the "r's" rather wor-r-rying. In fact, in the last verse the way the rolling is done on the word "halter" gives almost a comedy twist to the word.

Recently, a real gem in the form of *Binnie Hale* singing *You Forget Your Gloves* was released. Now we have another of her delightful three-minute entertainments in *You're Blasé*, and with André Randall in *Mona Lisa*; both from the popular show, "Bow Bells."

Binnie is one of those clear-cut vocalists that give the recording engineers the chance to show what their art can do with the wax, and in this record they succeed in producing a very lifelike representation of the famous musical comedy star. The disc is No. DB743, and it is a gem of light comedy artistry that should not be missed.

We cannot say quite the same of *Jessie Matthews* and *Sonnie Hale* in "Hold My Hand" selections (DB760.) These are recorded with the *Gaiety Theatre* chorus and the result is a little disappointing. *Sonnie Hale's* voice sounds very "doubtful" in both its tunelessness and its timbre. It is not a singing voice, while that of the lady is rather on the thin side for recording purposes. The chorus is just a typical chorus. The total result is a thin, lifeless record, without vivacity or body.

A brief selection from some of the records released during the month.

Rudy Starita is always an attraction, whether he is performing in person, by radio, or on disc. This month's Columbia releases include two of his numbers on DB742. He has chosen *When the Circus Comes to Town* and *Magic Notes*.

The best of all this month, from a recording point of view, would be hard to find, but it certainly could not beat the banjo solos by *Eddie Peabody* on DB713. He plays (and sings) *St. Louis Blues* and *Some of These Days* with a snap that is a sheer delight to the listener who is interested in syncopated music, and *Eddie's* syncopation is perfection.

Of the dance numbers we shall not say much, except that they are all good. The *Savoy Hotel Orpheans* are a fine recording combination, and their vocalist has either improved since their first record or has been changed.

H.M.V.

Naturally at this time of the year the attention of gramophone companies is drawn towards sacred music, and round about Eastertide we find a goodly selection of religious recordings. "The Messiah" is one of the usual favourites, as are certain well-known anthems, but in the H.M.V. list we are offered a very much more original selection.

First and foremost there is that world-famous contralto, *Florence Austral*, singing *Allerluia* and *The Vesper Hymn*. They are two contrasted records, one with a vigorous spirit of fervent joy and exultation, and the other a delicate representation of the sounds of a hymn borne softly over the waters. (B593.)

The choir of *St. Margaret's, Westminster*, give us another very fine disc in B4090, but the record that we liked most of all is the one by our old favourite, *Peter Dawson*. The two pieces thereon are war songs, but they are sung with that impressive firmness and delicacy that this fine baritone is so famous for. His "Menin Gate" of some time ago is a record that has always been prominent in our memory, and now *Ginchy Road* and *Christ in Flanders* rank among his very best. The latter tells the story of a vision in a way that only Dawson could tell it, with his fine sense of sympathy and his perfect diction. (B4089.)

Trees has sprung into fame as a dance number before it is properly known as a straight song. It is not a new song, having been included in the "straight" lists of the music publishers for some

time; but although originally written as a ballad, it has become known (some may consider unfortunately) far better as a dance number. In the H.M.V. list we have it sung in its proper fashion by *Derek Oldham*, on B4091, and it is well worth hearing. On the reverse side is *Song of Songs*, another general favourite; this time usually of the cinema organist, but once more treated as it was originally intended to be treated.

No H.M.V. release seems complete without one or more of *Gracie Fields'* records, although we realise that we cannot expect to get a new "Gracie" every time. This month, however, we are lucky once more, and two very fine items are perpetuated by that inimitable comedienne. Home, one of her numbers, is too well-known to need any introduction, and, as might be expected, full justice is done to its rather haunting melody. The second item is *He Forgot to Come Back*, a quite different type of piece, which gives one "the other side" of *Gracie* in perfect fashion. (B4101.)

Lovers of restaurant type of music will welcome the latest *De Groot* (B4092), in which the great violinist and *David Bor* and *Reginald Kilbey* record *Kisses in the Dark* and *Old Vienna Moon*. On the dance side we have the "King of Jazz," *Paul Whiteman*, and his Orchestra playing two numbers that will be very popular. He has chosen *Gettin' Sentimental* and *My Good-bye to You*, both foxtrots; and though we are not lovers of his band we must certainly acknowledge the perfection of the recording. (B6148.)

We mentioned above that *Trees* was more renowned as a dance number than as the straight song it was intended to be, and we have already given you the disc number of that ballad sung in its original form. Here we are going to draw your attention to the same thing in its more popular guise, as a foxtrot.

It is played by *Ambrose* and his Orchestra, and we must say that he really does do the rather haunting composition justice. It is doubled with one of the most tuneful waltzes of the moment—*Sleep On*, from "Helen," and those two together should make this particular disc one of the very best sellers. (B6142.)

Ambrose is certainly one of the finest of the recording dance combinations; he gives us enough of the very necessary brass, but never overdoes it, while during the whole of his recordslugs the balance of the orchestra is superb.

Another of his latest discs is B6137, a double-sided recording of that delightfully absurd comedy foxtrot, *He Played His Ukulele as the Ship Went Down*. *Goopy Geer*, the gentleman who played the piano, "and played by ear," is a third of the *Ambrose* selection, being coupled with a Negro number, *Open Up Dem Pearly Gates*. The number of this disc is B6143.

H.M.V.'s special dance combination, *Ray Noble* and his *New Mayfair Orchestra*, are always worth listening to, and here we have a couple of their latest recordings, B6146 and B6147. The items are *Good-night, Little Girl*, *Good-night*, with *Sweetheart in My Dreams To-night*; and *Blues in My Heart*, with *It's Great to be in Love*. You should hear them.

If you want something a bit "hotter" you should listen to *Victor Arden*, *Phil Ohman* and their Orchestra playing *Who's Your Little Who-Zis P*, on the reverse side of which are *Warning's* *Pennsylvanians* doing *Blue of the Night*. (B6149.)

There are, however, two of the recently introduced and frequently broadcast comedy numbers that we should like to suggest as both suitable and profitable items to record. We believe they have not yet been published by the Gramophone Company, but played by a combination such as *Roy Fox* and his Band (whose particular pets the numbers are) they would be sure of a very ready sale. We refer to those unusual but wholly delightful absurdities, *Kicking the Gong Around* and *There's Another Empty Saddle*. Let us hope they will soon be found among the famous "plum-labels."

ZONOPHONE

The popular green label records are now starring a great favourite in the person of *Elsie Carlisle*. She has recorded this month a couple of light and tuneful items that will be sure to have a large appeal. The first-mentioned, though perhaps more hackneyed item, is the well-known dance number, *You Try Somebody Else*.

Elsie Carlisle sings it with perfect diction, and with a neatness that in itself is half the charm of the number. On the other side we have *To Be Worthy of You*. (6069.)

Bud and *Joc Billings* are their own selves on 6063, whereon they give us *Missouri Valley* and *In the Cumberland Mountains*. This latter record is also notable for the fact that it contains an example of the playing of the *Carson Robison Trio*, which assist *Bud* and *Joc*. The record is, however, rather of the flat type, there being nothing outstanding if the rather out-of-tune whistling of the trio is excepted.

Les Allen, on 6066, is good in *Good-night, Little Girl*, if you are fond of the rather sickly sentiment provided by the average "moonlight blues" type of number. We prefer something with a little more originality. The other side is a little better, the *Starlight Serenade* having a bit more pep in it.

AT YOUR SERVICE



by
**OUR TRADE
COMMISSIONER**



Another "Winner"

WE are informed that Messrs. Ever Ready, the famous battery makers, have anticipated the summer selling season by placing on the market a portable "Winner" H.T. battery. The original "Winner" was always a good seller, and it is now available in a smaller size for portable sets. The voltage is 108, and the dimensions of the battery are such that it will fit most of the popular portables on the market.

Ferranti at 5s. 6d.

Ferranti have entered the cheap transformer market with a competitive priced component known as the A.F.10. It retails at 5s. 6d., and has a ratio of 1:3. Housed in an attractive bakelite case, its appearance recalls the A.F.8, except that it is finished in bright red. The primary is rated at 6 milliamps. maximum current-carrying power.

More Mains Clocks

People on time-controlled A.C. electric light mains are to have an even wider selection of electric clocks, for a number of new models at all prices have been placed on the market by Synchronous Electric Clocks, Ltd., of Great Portland Street. These are available in all sorts of novel designs, and in cases of onyx, malachite, marble and a variety of other materials.

Telsen Speakers

Telsen Electric, Ltd., are introducing two loud speakers, one in cabinet form and the other as a chassis. The prices are of the same astounding lowness that characterises all the products of this energetic firm, that of the first-named being 25s., and the chassis costing but 17s. 6d. or 22s. 6d., dependent upon which of two models is preferred.

Here is some varied news of the trade that should interest all readers, whether or not they are connected with the radio industry. Manufacturers, dealers, home constructors and general readers are invited to send items of interest to be included under this heading.

A four-pole magnet is employed, and the chassis is provided with either a 11-in. or a 14½-in. cone.

Another new line consists of improved types of solid-dielectric condensers.

Pertrix Prices

We have just received the latest leaflet describing the many Pertrix batteries and their prices. One does

not realise until such information arrives how many different types of dry batteries are made by this famous firm. Probably you would not guess that nearly thirty H.T. or G.B. batteries are described in that little folder.

All classes of wireless work are covered by the various capacities and sizes of these batteries, from small portable set operation to the power supply of large sets demanding 30 or 40 milliamps.

As a matter of fact, we did not fully realise the possibilities of the dry H.T. battery until we studied the Pertrix list and noted that there is a battery whose maximum output is rated at 45 milliamps.

INSIDE A MODERN RADIO RECEIVER

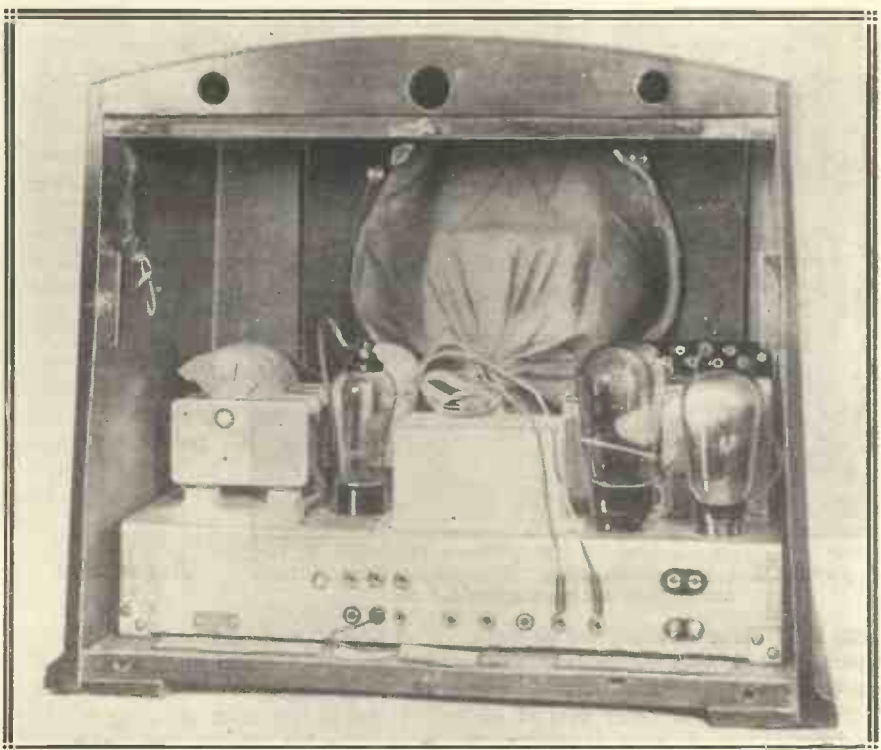

An interior view of H.M.V. receiver Model 435, described on another page. Note the particularly compact and well-screened layout.

H.T. Batteries for all Classes of Sets

This is the No. 3 Super Heavy, which is tapped at 22.5 volts, and can be obtained in 45-volt units. The price is extremely reasonable, for the 45 volts cost 19s. 6d.

The Heavy-duty No. 2 costs 13s. for the 45-volt unit and is capable of supplying, without undue strain, 24 milliamps. The grid-bias batteries, too, are very varied. The cost of the 30-volt battery is 4s. 6d., while the more usually used sizes of 9 and 15 volts cost but 1s. 6d. and 2s. 9d. respectively.

For the guidance of set constructors and dealers alike the following information concerning the capacities of Pertrix batteries may be of value. Ordinary capacity gives up to 9 milliamps, Ultra capacity up to 12, No. 1 Super 16 m.a., No. 2 and No. 3 Heavy-duty 24 and 45 milliamps respectively.

"As Good as New"

In response to an advertisement in our contemporary, "The Wireless Constructor," regarding the Igranic moving-coil speaker, the firm in question received the following interesting letter from a radio enthusiast in Ipswich.

"Dear Sirs,

"I thought it might interest you to know that I have one of your Type 'E' intervalve transformers

NOT THE NEW A.F.10!

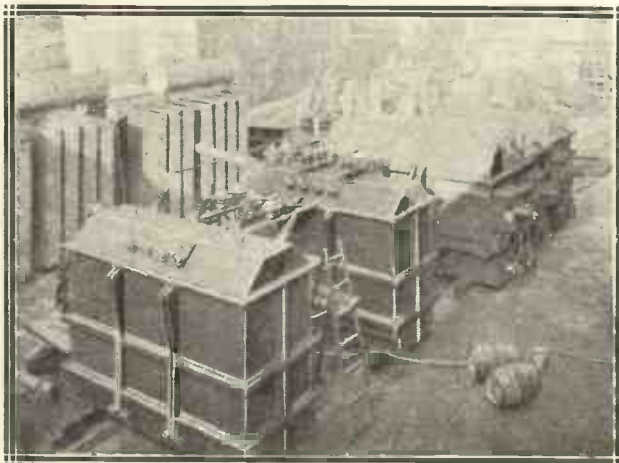

Some of the giant transformers built at the world-famous factory of Ferranti, Ltd., Hollinwood, Lancs. The smallest Ferranti transformer is, of course, the new A.F.10.

that has been in constant use for eight years, and is still giving the same excellent service as when new.

"I have done a great deal of experimenting with it in attempts to incorporate the use of 230-volt A.C.

mains, and more than once created the smell of burnt toast in my circuits; in fact, on one occasion I burnt several condensers and another transformer; the Igranic was well warmed up but suffered no harm. The bakelite terminal block is in a disreputable condition, due to frequent visits of a hot soldering iron.

"You may use this letter as you wish, as I always considered your components second to none, and recommend them to the numerous radio fans with whom I come in contact."

We need add nothing to such a whole-hearted testimonial.

An "Atlas" Alteration

We have received notice from Messrs. Clarke's "Atlas" that a slight error occurred in their information concerning the price of the "Atlas" D.C. mains unit type 15/25, which was recently reviewed in our columns. The price then stated was 35s. 6d., whereas it should have been 39s. 6d. We are asked, therefore, if we will make this known to our readers and extend to them the manufacturer's regrets, as the mistake has been causing some trouble to a number of their clients.

A Novel Radio-Gramophone

One of the smallest radio-gramophones has been produced by Climax Radio Electric, Ltd. Only 20 in. high, this instrument comprises a three-valve mains-driven receiver, complete with electric gramophone motor and a Climax pick-up.

The cabinet is finished in figured walnut, and with its moving-coil speaker, complete in every detail, costs only 22 guineas.

Ingenious Wire

A new type of "self soldering" wire has been introduced by Messrs. A. F. Bulgin & Co., Ltd.

It takes the form of a six-strand copper "cable" of small cross-section, with a centre core of pure solder

running through the whole of its length.

It is all twisted together to form a single conductor, the idea being that the wire is to be used in the usual way for wiring up radio receivers,

A SMALL "ECKERSLEY"

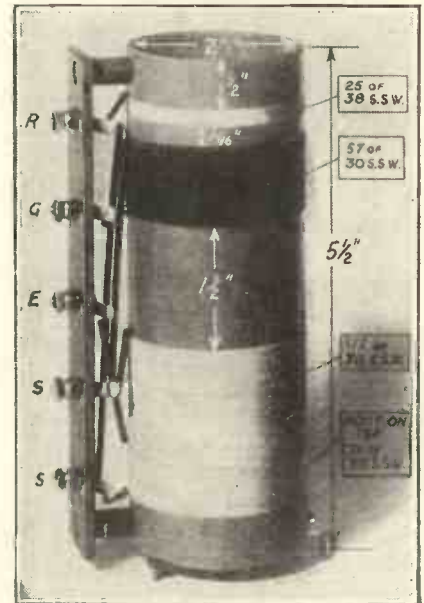

Here are the winding details of the new H.F. "Eckersley" coil used in the "Varmu" receiver.

and that with just the soldering iron and a little flux (preferably not killed spirits) the wire itself will supply the necessary solder for making the joints.

The insulation is easily slipped back, and remains in place so that there is none of the scraping to be done that is essential in other types of wire, thereby making "Soldawyre," as the new wire is called, especially handy for the home constructor.

The appearance of the new wire is very much like that of "Quickwyre," a product of the same firm. The price of "Soldawyre" is 6d. per length of 8 ft.

Simplifying the Set

An ingenious triple-task volume control has recently been introduced by Messrs. Burne-Jones & Co., Ltd. It takes the form of a ganged twin potentiometer that can be obtained in various resistance values, and used to control two different circuits.

In addition it is fitted with a filament control switch, so that turning the volume control off automatically turns off the set, and vice versa.

Such a component should find wide application, for it is specially useful in radio-gram receivers.



"Stands in a class by itself."
"WIRELESS WORLD."

The Incomparable "Type 40," chosen for use with the "Meteor III," the "Lotus Landmark 3," and many other Kit Sets. Remarkable for its quality and volume, and more than moderately priced at sixteen shillings and sixpence. Your radio dealer can supply.

"Wireless World" states:
"Speech exceptionally good, by comparison with moving-coil instruments... performance and workmanship bear all the marks of a thoroughbred. . . . Stands in a class by itself."

Descriptive Leaflet Post Free on request.

REPRODUCERS & AMPLIFIERS, LTD.,
FREDERICK STREET, WOLVERHAMPTON.

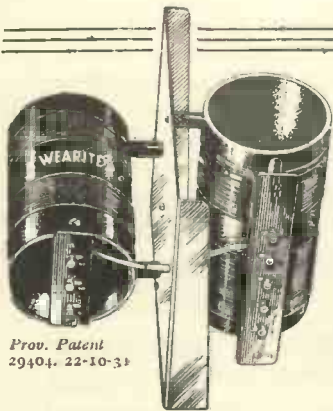
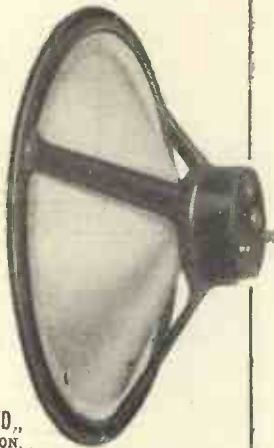

Prov. Patent 29404, 22-10-31

SPECIFIED
for the
ECKERSLEY
"VARMU" THREE

Wearite components again specified! Your "Varmu" Three will live "up to specification" if you insist on proven parts. The Eckersley Tuner illustrated is guaranteed to possess characteristics identical with the original "Eckersley" model. Make certain—and use Wearite.

PRICE 15/6 complete

IF YOU ARE MAKING THE "TRI-BAND 3"— here are the Wearite components you need:

- 1 pair "COSMIC" COLLS (Dual and S.W.I. Price 9/- per pair).
- 1 Universal H.F. Choke.
- 1 2-way D.T. Rotary Switch, 1.22, Price 4/- (with mounting bracket and extension piece).
- 3 Four-pin Valve Holders, S.1, Price 1/3 each.

—and these Wearite Switches

made by radio's first component manufacturers and backed by them!

4-pole D.T. Rotary Switch, 1.24	Price - - - 4/6
2-pole D.T. Rotary Switch, 1.22	Price - - - 3/6

—use the Wearite Volume Control, too—the Q35, 50,000 ohms. Price 4/-



HERE IS THE WEARITE EARTH TUBE
No Spanner, No Screwdriver - - - **PRICE 3/6**

WEARITE
COMPONENTS

WRIGHT & WEAIRE, LTD.,
740, High Road, Tottenham, N. 17.

Phone: Tottenham 3847/8/9.

B.I.
ENAMEL
COVERED
WIRES

B.I. Enamelled wires are unequalled for the field windings of small motors, measuring instruments, radio transformers, and other pieces of electrical apparatus where space is all-important. They are produced throughout in our own works, from the raw material to the finished wire, and every phase of manufacture is under the strictest control as regards quality of material and accuracy of gauge. B.I. Enamelled Wire is unexcelled for its high insulation, dielectric strength, flexibility of enamel, and general dependability. We regularly manufacture Enamelled wire as fine as '002" dia.



BRITISH INSULATED CABLES

LIMITED

PRESCOT-LANCS

Makers of B.I. Cables

Telephone No.: PRESCOT 6577.

London Office: Surrey House, Embankment, W.C.2

Telephone No.: Temple Bar 4793, 4, 5 & 6.

READERS' RESEARCHES

On this page two unusual items of great interest are dealt with, both of which originate in experimental work carried out by readers. The first, in the form of a letter, deals with gramophone records under the microscope, while the second is a short note on a scheme for overcoming static interference.

To the Editor, MODERN WIRELESS.

Sir,—I have been very interested of late in the gramophone articles appearing in MODERN WIRELESS, and having done a fair amount of research on the subject myself, I thought you might care to see some of my efforts. I have concerned myself mainly with the form, shape, and general structure of the sound tracks on commercial records.

Enclosed you will find two photomicrographs taken with a Watson's Mint Metallurgical Microscope, using vertical illumination and a linear

MECHANICALLY RECORDED

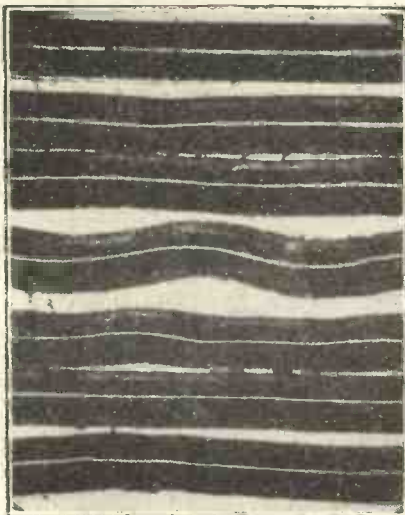

No. 1 The thin white lines indicate the bottom of the needle grooves of a mechanically recorded disc. The white spaces are the gaps in between the channels.

magnification of 60 diameters. The exposure in each case was 25 seconds.

The one marked (1) is of a well-known record, mechanically recorded. You will notice that the tracks are by no means equally spaced, the distance between tracks being from .0005 in. to .004 in.

An Average Figure

The latter figure is the average value. The width of the track averages .0072 in., about correct. One serious fault in the record, however, is over-cutting of the track, which causes the needle to run off one track into the next.

Photograph 2 shows an electrically-recorded track, and at once you will

be struck by the uniformity of spacing of the tracks. Here the widths are: Track, .0075 in.; spacing, .004 in. The depth is normally .0025 in., but varies in different makes. No over-cutting is noticeable in this record.

In regard to needle fitting of the tracks, I have discovered only one make of needle that really fits the groove. All the well-known makes I have tested do not reach the bottom of the groove, except one, which is finer pointed than any I have examined under the microscope.

With regard to the microscope with which I photographed these records, I might say that it is of the projection type, throwing the image on to a screen in a dark room.

It is illuminated by a Watson's Argus arc lamp of 3,000 candle-power. The plates used were Wellington anti-screen, 450 H.D.

Worn Grooves

In the photographs, the white line running down the middle of the track is the bottom of the groove, while the broad white bands are the flat ridges between the grooves. The grooves, being V-shaped, reflect the light only at the root of the angle.

The needle follows the thin white line, if it is fine enough; if not, it bears on the walls, with final destruction to the record. No. 1 has some abrasion at the curves of the sine waves, and has been played only by a soft-toned needle, with a Burndeft electric sound-box. The other record was played in a similar manner.

Yours faithfully,
WILFRED A. ATKINS.

Anfield, Liverpool.

JUST A REMINDER

Fidgeting with a crystal detector adjustment or continually altering the plugs of your high tension may cause no end of annoyance to neighbours by spoiling their reception.

Eliminating Static

PEOPLE who are driven frantic with electrical disturbances in their reception certainly ought to give the following notion a thorough trial, for in many cases it has been found to work wonders in curing static disturbances and interference.

Obtain a foot of 1/2-in. brass tubing, and run the down-lead wire from the aerial centrally through the tubing. The down-lead in its passage through the brass tube must on no account be allowed to make contact with the tube, the space between the

CERTAINLY WORTH TRYING

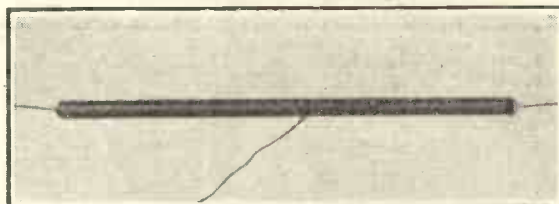

By varying the length of the tube it is possible to overcome static interference in many cases.

down-lead and the inner walls of the tube being filled up with candle-wax, tallow, Chatterton's compound, or any other convenient insulating material.

To the outside of the tube, about halfway down its length, is soldered (beforehand, of course) a single-strand connection leading to an earth-plate, or to some other earth connection other than the earth connection of the receiver.

ELECTRICAL UNIFORMITY



No. 2. Compare the evenness of the spacing of these grooves with those of No. 1. This record is electrically recorded.

Of course, specific cases of trouble need specific cures, and it is quite impossible to lay down any definite ruling regarding the length of the brass tube to be used. A foot length of tubing is about the average.

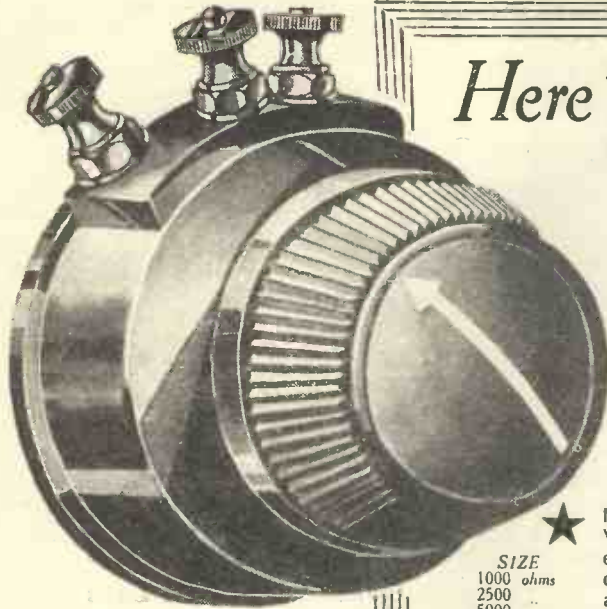

Here's a WIRE-WOUND VOLUME CONTROL

for every type of modern set



Make sure you specify IGRANIC when you buy a Wire-Wound Volume Control. Note these exceptional points: Smooth contact ensuring silent operation. Resistance wire wound on high-quality insulating former. Moulded Bakelite case, neat and attractive, to protect winding from mechanical damage. Definite travel stops. Single-hole fixing and two insulating washers supplied for mounting resistance on metal panel. Pointer control knob. Igranic workmanship. Igranic perfection. What more!

SIZE	
1000	ohms
2500	"
5000	"
10000	"
25000	"
50000	"
CURRENT CARRYING CAPACITY	
55	Milliamps
35	"
25	"
18	"
11	"
8	"



5/6

all sizes.

★ Write for descriptive leaflet No. J.1172.

IGRANIC ELECTRIC CO., LTD., 149, QUEEN VICTORIA STREET, LONDON

INTRODUCING A NEW MAGNUM PRODUCT

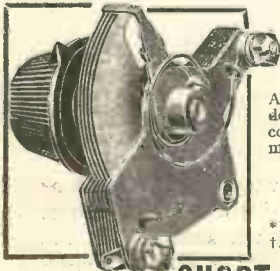

SOLID-DIELECTRIC VARIABLE CONDENSER

A really high-grade component (1) Every condenser is tested at 500 volts A.C. (2) Positive connections to the moving vanes. (3) Smooth movement. (4) Supplied complete with knob.

'0001, '0002, '0003, '0005*, 2/6 each.
'00075t, 3/-

*Recommended for the Eckersley "Varmu" 3.
†Recommended for the "M.W." "Tri-Band" 3.

SHORT WAVES ON A.C. MAINS or BATTERY SETS

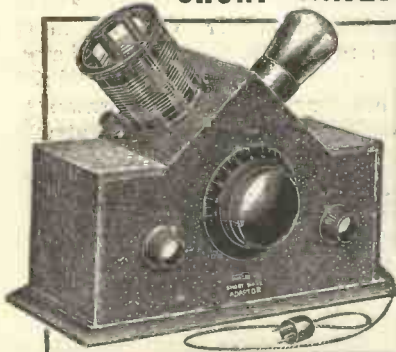

An entirely new design of amazing efficiency.

This short-wave adaptor can be used with any type of receiver (excluding D.C.), whether A.C. mains, battery operated or super-het., irrespective of the circuit or the number of valves. It is supplied complete with one special short-wave coil (40/80 metres), cord and plug. No extras whatsoever are required. Can be attached to your set in a few seconds. Write now for full particulars and free trial offer. Price complete 39/6

Extra coil if required, 18/40 metres 3/-

BURNE-JONES & CO. LTD.
"MAGNUM HOUSE,"
296, BOROUGH HIGH STREET,
LONDON, S.E.1.

Telephone: Hop 6257 & 6258.
Scottish Agent: Mr. Ross Wallace,
54, Gordon Street, Glasgow, C.1.

We specialise in the "Varmu" 3, "M.W." "Tri-Band" 3, and "M.W." "Cabinet" 2 which can be supplied ready wired and tested. Lists on application.

KIT-BITS SELECTED COMPONENTS CASH or C.O.D. FOR THIS MONTH'S "MODERN WIRELESS" SETS.

You pay the postman—We pay all Post Charges on orders over 10/-

"M.W." "TRI-BAND" THREE

- 1 Ready Radio Duotone Extender with Dial .. 18 6
- 1 R.I. Cosmic Coil Unit 12 6
- 1 Peto-Scott Moderator Coil 2 6

"M.W." "CABINET" TWO

- 1 Formo '0005-mfd. Extender, with Dial 14 6
- 1 Telsen Dual-Range Aerial Coil .. 7 6

"M.W." ECKERSLEY "VARMU" THREE

- 1 Cylidon Triple Synchronizing Junior '0005-mfd. Tuning Condenser .. £2 2 6
- 1 Wearite Eckersley Tuner .. 15 6

BUY RADIO BY POST—IT'S QUICKER. Detailed list of parts for above kits on application

PETO-SCOTT CO. LTD. 77, CITY ROAD, LONDON, E.C.1
Telephone: Clerkenwell 9406-7-8.

A NEW Super Paper of the FILMS All Photogravure with Pages in COLOUR

FILM Pictorial

Every Thursday

2d.

RADIO NOTES and NEWS of the MONTH

By G.B.

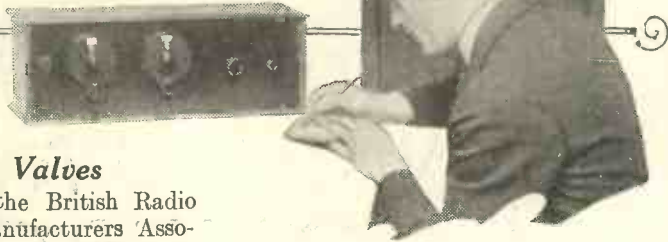

Cheaper Valves

MEMBERS of the British Radio Valve Manufacturers Association recently decided to reduce the prices of all well-known makes of wireless valves. The main alterations in prices are as follows:

8s. 6d. battery valves reduced to 7s.

£1 battery screen-grid types reduced to 16s. 6d.

£1 5s. mains pentode types reduced to £1.

£1 2s. 6d. mains screen-grid types reduced to 19s.

Corresponding reductions will be made in other types, and the firms affected are Marconi, Mazda, Osram, Mullard, Cossor and Six-Sixty.

Those Vaudeville Critics

The B.B.C.'s idea of having a vaudeville critic broadcast his impressions of the week's entertainment

once a week was a good one—theoretically; but in practice it hasn't worked out so well. For one thing, the critics who have so far appeared before the microphone seem to have jibbed at giving their candid impressions of what they have heard during the week, while in some cases the vaudeville artistes themselves have taken an entirely wrong viewpoint of the stunt.

"A Monstrous Insult"

Mr. Gillie Potter, for example, said that he would not appear in the broadcast vaudeville programme again—not even for £1,000—so long as the B.B.C. employed a vaudeville critic. In an interview, Mr. Potter said that he regarded the employment of any-

one to criticise vaudeville artistes immediately after their appearance as "a monstrous insult."

They Aren't Serious!

We don't know whether to take this seriously or not. After all, Mr. Potter is a famous humorist, and the idea of objecting to the B.B.C.'s critic on the grounds that it is "a monstrous insult" seems too fantastic for words.

Besides, so far these vaudeville critics, whose work is announced as "not serious," have supplied some of the best vaudeville turns of the week. Certainly, the two gentlemen we have already listened to have been miles ahead of some of the vaudeville artistes themselves in the humour and technique of "funny business."

What the B.B.C. Says

The B.B.C., when approached about the matter, were rather shy in their attitude. An official stated that "the vaudeville criticism included in the Saturday evening programmes is in the nature of a burlesque, and not intended to be serious criticism. And it is surprising," the official added, "to find an artiste, himself a prominent humorist, taking exception."

He Might Help!

It is surprising. But it is even more surprising to find the B.B.C. backing away from the original intention of having a vaudeville critic. Why should the critic burlesque his job? Why shouldn't he criticise seriously? He might help—and broadcasting humour to-day needs a lot of help!

More Power for 5XX

The new Daventry to be built at Droitwich will be one of the most powerful radio transmitters in the world. The power on both the long-wave National and the Midland Regional transmitter will be increased to at least three times what it is at present. A listener using the most ordinary sort of set in Cornwall will easily pick up the new Daventry when it gets on the air.

Some Licence Figures

The Postmaster-General stated in the Commons recently that the number of wireless licences taken out during 1931 was 4,329,170.

The number of prosecutions was 1,042, and the fines imposed amounted to £1,933, with about £240 in costs.

It was difficult to estimate with certainty the number of additional licences taken out as a result of the

(Continued on page 392.)

ACCURATE CONTROL MADE EASY



J.B. NEUTRALISING CONDENSER



J.B. DIFFERENTIAL REACTION CONDENSER

J.B. NEUTRALISING CONDENSER—extremely simple design, cannot go wrong. Minute capacity changes made with ease. The slotted knob can be adjusted with a screwdriver and hand-capacity effects eliminated. Maximum capacity, 20 m.mfd. Minimum capacity, 1.5 m.mfd. Price 3/6

J.B. DIFFERENTIAL REACTION CONDENSER, for smooth reaction control. Carefully shaped vanes ensure equal capacity changes for both halves. Insulated centre spindle. Bakelite dielectric between vanes makes short-circuits impossible. Pigtail to rotor. '0001, 4/- '00015, 4/- '0002, 4/3 '00025, 4/3 '0003, 4/6

PRECISION INSTRUMENTS





LARGE LINER'S LAND-LINKS

THE French liner s.s. Atlantique is a 40,000-ton boat, and one of the finest and most luxuriously appointed afloat. Her thousand-odd passengers can at any moment get in touch with the outside world by means of a very complete radio plant, one of the most efficient ever installed on board ship.

This comprises both long- and short-wave equipment as well as various auxiliary plant.

The long-wave transmitter used for telegraph work is a set with about 800 watts aerial power, designed for ten different wave-lengths in the 1,850-2,400-metre band, but which, for certain calls, can also be operated on 600 metres. The various parts of the set are housed in an angle-iron cabinet, closed in front by removable wooden panels and on the side by plywood panels, and a small door through which the plug-board of the oscillating circuit can be reached.

Modulated Signals

Keying takes place by cutting with a relay the grid resistance circuit. Modulated signals are obtained by adding to the grid voltage an alternating voltage at a musical frequency delivered by a small 500-cycle alternator.

By Dr. ALFRED GRADENWITZ
Radio has completed the co-ordination of the world's telephone systems, and it is now possible even for private calls to be made to ships at sea. Here is a description of the elaborate radio installation on a modern liner.

The long-wave part of the installation also comprises a 500-watt transmitter, enabling telegraphic transmission to be made on all wave-lengths between 600 and 800 metres. Seven wave-lengths can be adjusted for in advance by means of plugs on the plate-grid inductance and on the aerial inductance.

The modulated continuous-wave set has been supplemented with an emergency installation of reduced power, working on storage batteries.

The Control Desk

The following devices have been provided on an automatic controlling desk, thus speeding up operation:

(1) Starting and stopping of converters; (2) transmission to reception change-over; and (3) set to set change-over. A number of safety devices, judiciously chosen and arranged, avoid all damage liable to occur through omission or carelessness.

The same desk also controls the traffic receiver, designed to secure reception under normal service conditions (for waves intermediary between 400 and 8,000 metres), in addition to which there has been provided a special Press receiver, covering a wave-band between 200 and 24,000 metres.

TRANSMISSION ON ALL WAVES

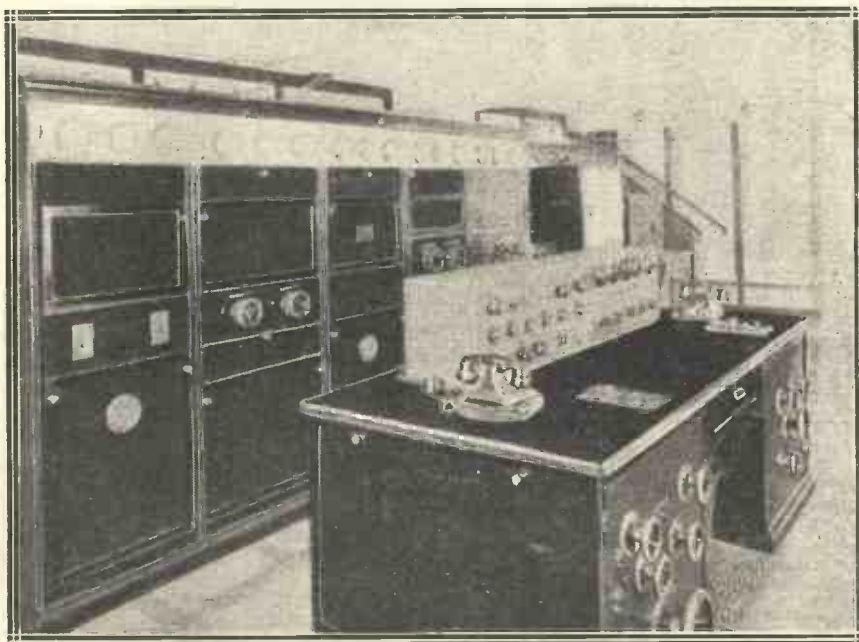

A view of the "Atlantique's" radio room, showing the operating table and, at the back, the long- and short-wave transmitters and crystal-control stabiliser.

Short Waves

The short-wave part of the plant comprises two entirely distinct transmitting sets, viz., an "F.C.50" transmitter and a radio-telephone set. The "F.C.50" set has an aerial power of 500 watts and can

Continued on page 394

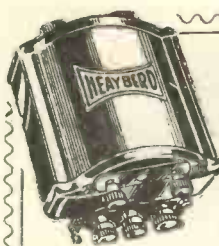

**60 m.a.
at 250 v.**

with the Heayberd model W.31 Mains Transformer—specially designed for the Westinghouse H.T.8 Rectifier. Just what you want for all-mains circuits—sturdy and thoroughly reliable.

Model W.31 MAINS TRANSFORMER RECTIFIED OUTPUTS
250 volts at 60 m.a., using tapping 200 v.
200 volts at 60 m.a., using tapping 175 v.
L.T., 4 volts 4 amps., for A.C. Valves

**PRICE
30/-
EACH.**

POST NOW
I enclose 3d. stamps for lists giving full range of Heayberd Transformers, with diagrams, also details of Mains Units, Kits, etc.

M.....
Address.....



10, FINSBURY STREET, LONDON, E.C.2.
(One minute from Moorgate Und. Station.)

**GET ALL YOUR
RADIO FROM
READY RADIO**

EASTNOR HOUSE, BLACKHEATH, S.E.3.
Lee Green 5678.

A "SOUND"

INVESTMENT!

"Sound"—in looks and performance. Camco Cabinets are in step with Set and Speaker and represent astonishing value. Write for the Camco Radio Cabinet Catalogue—FREE.



THE
"WINDSOR"



CABINET

CARRINGTON MFG. CO., LTD.
Showrooms:
24, Hatton Garden, London, E.C.1. Phone: HOLBORN 8202.
Works: S. Croydon.

ADVERTISEMENTS

As far as possible all advertisements appearing in "Modern Wireless" are subject to careful scrutiny before publication, but should any reader experience delay or difficulty in getting orders fulfilled, or should the goods supplied not be as advertised, information should be sent to the Advertisement Manager, "Modern Wireless," 4, Ludgate Circus, London, E.C.4.

**RADIO NOTES AND
NEWS OF THE MONTH**

—continued from page 390

detector van campaign begun last October.

It appeared from the total number of licences in force from September 30th last to January 31st that there had been an increase of about 544,000, a great part of which might fairly be regarded as directly or indirectly attributable to the campaign.

Broadcasting in Canada

The Canadian House of Commons has appointed a Committee to consider the situation of broadcasting in Canada, and especially to consider a report recommending a National system of broadcasting similar to that in force in this country. The Government has also announced that it intends to increase the cost of an annual licence for a wireless receiving set in Canada from one to two dollars.

This change will affect about six hundred thousand registered broadcast licences.

That Rake-Off

The B.B.C. will receive £1,366,000 in the coming financial year. The amount due under the agreements is £1,516,000, but this is reduced by £150,000—the amount which the B.B.C. agreed to give up as a contribution to the Exchequer in the National emergency.

Continental Opera

We understand that the B.B.C. is considering a regular broadcast of operas from the great theatres of the Continent.

When technical conditions permit these may include performances from Italian houses such as the Scala at Milan, the Teatro Reale at Rome, and the San Carlo at Naples.

No definite arrangements have yet been concluded, but it is hoped that a weekly broadcast may soon be possible.

News from Mukden

A three-times-a-week broadcast in English of Manchurian news was started a few days ago by the North-Eastern Radio Broadcasting Bureau at Mukden.

The wave-length is 27.4 metres, and broadcasting will be carried out on Tuesdays, Thursdays and Saturdays for twenty minutes from 3 p.m. The call-sign of the station is Zily.

A SIMPLE "SUPER"

An article which describes the various tribulations of trying to make a satisfactory set from old-fashioned components, and one that may spur others to try their hands at giving discarded apparatus a new lease of life and usefulness.

By H. M. SYMON

THE domestic powers had been spring cleaning. And, in that annual cyclonic upheaval, they fell upon my wireless junk-box, said that it cumbered the ground, and ordered me to get rid of it! So it came about that on one of the wetter days of an unpleasantly wet summer holiday, I spread several large newspapers on the floor and sat down to review my "radio career"! It began on a day in May, 1923, when I bought a complete crystal set and became a listener!

That over-sized sugar box, into which I had dumped from time to time such sets and parts as had been superseded by more efficient units, yielded up its "dead"—a marvellous collection. There were aged solenoid coils wound with hundreds of turns of thin enamelled wire (shades of "The Hague" and "Radiola"), there were almost equally prehistoric plain plug-in inductances—nineteen of them, of every make and size.

Many Useful Components

There was a vast array of crystal detectors—plain, fancy, enclosed, open, including several of the alleged permanent type. There were three ancient resistance-coupling units whose resistances had long ago burnt out, and there were nearly a dozen of the clumsy old variable condensers which a humorous friend of mine used to call "Round-law High-loss" (that was when we were tumbling over each other to fit square-law low-loss condensers at fifteen shillings or so apiece). And down in the dusty depths there were dozens of valve holders, grid leaks and small fixed condensers.

But among all the faded ebonite and dull tinned-copper wire, two small articles caught my eye and fired my imagination. They were a pair of oscillator units, made on the lines of the old barrel-type H.F. transformer. They had belonged to a commercial super-het. which I bought some time in 1926. That super-het. is still going strong, but it is now permanently connected up for the ultra-short waves.

(Continued on page 393.)

A SIMPLE "SUPER"

—continued from page 392

Long since a screened-grid five-valver took its place for work on the long and medium waves. And as changing the super-het. to the broadcast waves took the best part of a quarter of an hour, and meant using a separate frame aerial, those two oscillator units had gone into retirement.

An Inexpensive Experiment!

But, seeing them, the thought flashed to my mind—why not another super-het.—a portable? Here was a lovely chance for an interesting experiment without spending too much money, as befits these hard times! It was surprising, once the idea had been born, to find what a lot of the necessary parts were among the so-called scrap in the junk-box. In two or three minutes the following had been set aside:

A Marconiphone Junior transformer—1925, but with its windings intact.

A Lissenola loud-speaker unit—circa 1924, with a cone and reed of rather later vintage.

A Sterling square-law twin condenser—each section '00025—memories of the original famous "Transatlantic" receiver, and late nights in 1924!

An Ormond S.L.F. condenser of the most expensive slow-motion type.

A 4-volt general-purpose valve which though perfect had given way to still more modern 2-volters.

A 4-volt power valve, ditto, ditto.

Three 4-volt '06 type valves of prehistoric date and, so far as I remember, of Continental origin.

Designing the Set

In my mind's eye the set was growing apace. It would follow broadly on the lines of my commercial super-het. and give those oscillator units a job of work in the world once more. That general-purpose valve would make an excellent combined first-detector-and-oscillator. The 4-volt power valve, preceded by the Junior Ideal transformer, would easily handle as much power as I was likely to get from the second detector.

That accounted for three of my five valves, leaving two to spare for the intermediate-frequency amplifier. Two stages of I.F.—with old-fashioned triodes—was certainly not a very generous allowance, but I resolved to see what happened.

(Continued on page 394.)

WHY "M.W." DESIGNERS SPECIFY BULGIN

The reason is not far to seek. Bulgin Products are made up to a quality and not down to a price. They could be made cheaper by sacrificing quality, but they could not be made better, whatever the price charged. The construction of Spaghetti Resistances is typical of Bulgin thoroughness. The nickel chrome resistance wire is wound on a flexible insulated core and is **ELECTRICALLY SPOT-WELDED** to a heavy gauge copper winding to which the tag is secured. **NO OTHER FORM OF CONSTRUCTION HAS PROVED AS GOOD**, and no other Spaghetthis are built like Bulgin Spaghetthis.

Send 2d. postage for the 75-pp. Illustrated Catalogue and Manual

For the "Tri-Band 3"
3 Four-pin Valveholders each 9d.
9 Engraved Terminals each 3d.
De Luxe "On-Off" Switch, Type 8.22 .1/6
For the Eckersley "Varmu 3" 25,000-ohm Spaghetti. .1/6

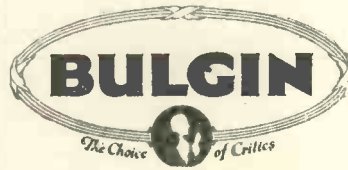

For the "M.W." "Cabinet 2"
De Luxe "On-Off" Switch, Type S.22 .1/6
25,000-ohm Spaghetti. .1/6
Four-pin Valveholder 9d.
2 Engraved Terminals each 3d.
Bulgin "Quickwyre" is specified for wiring all these sets. Price per 10-ft. Coil, Red or Black, 6d.

A. F. BULGIN & Co. Ltd., Abbey Rd., Barking, Essex

Telephones: Grangewood 3266 & 3267.

London Showrooms: 9, 10, 11, Cursitor Street, Chancery Lane, London, E.C.4. Telephone: Holborn 2072.

Electrically Spot-welded

Famous Makers' Offer! **£5 Radio Gram CABINET for 65/-**
7 DAYS' FREE TRIAL

10/- monthly if desired

Polished Oak, Piano Tone Cabinet (43 in. high, 24 in. wide) at makers' prices. Delivered FREE British Isles. PHOTOGRAPHS and LISTS FREE. All Models from 35/- to £15

Patent 8123 acoustic chamber yields mellow, rich, full volume that your speaker is really capable of. Makers to: Radio-Press, B.B.C., 3,000 clientele.

SEND FOR LIST!

PICKETTS Piano Tone Cabinets (M.W.), Albion Rd., Bexleyheath, Kent

SOLVE ALL H.T. TROUBLES

WET BATTERIES TAYLEX SELF GENERATING

Per doz.	No. 1	No. 2
	s.d.	s.d.
Jars (waxed)	1 3	1 6
Sacs	1 2	1 9
Zincs	10	11
Rubber Bands (24)	4	4
Terminals	8	10

Trade supplied.

LONG LIFE : SILENT : ECONOMICAL

Sample doz. (18 volts), complete with bands and electrolyte. No. 1, 4/1; No. 2, 5/-; post 9d.; terminals extra. No. 3, with terminals. 7/6 (10,000 milli-amps) sample unit 6d. Orders 10/- carr. paid. New illustrated catalogue post free.

FREE Bargain List of Receivers, Amplifiers and Components.

M. TAYLOR, 57, Studley Road, Stockwell, London.

Make **The DAILY SKETCH** YOUR Picture Paper

FREE!

MODERN SQUARE PEAK BAND-PASS CIRCUITS FOR EVERY REQUIREMENT

Varley

Use this **Coupon**

To Messrs. Varley, Kingsway House, 103, Kingsway, London, W.C.2.

Please send me, free and post free, the new Varley circuit booklet, MODERN "SQUARE-PEAK" BAND-PASS CIRCUITS, showing how to build up-to-date band-pass receivers—S.G. sets, simple Detector sets and Super-Hets.

Date.....

Name.....

Address.....

M.W.

LARGE LINERS LAND-LINKS

—continued from page 391

be used for telegraphy by pure continuous waves, and also for interrupted continuous-wave telegraphy. It transmits on three wave-lengths comprised in the range between 15 and 70 metres, which can be selected at will by means of a special controller.

For tonic train telegraphy the modulated signals are produced by an alternator supplying in the grid circuit a musical frequency current.

As regards, next, the radio-telephone transmitter, this has an aerial power of about 400 watts and is intended for telephone communication on short waves between the ship and the shore. In order to allow for variations of short-wave propagation, according to the actual location and time of day or night, this transmitter had to be able to send out any wave-length intermediary between 15 and 60 metres.

The multiplicity and quality of all these sets not only dispose of any risk of breakdown, but secure a wide range of traffic possibilities.

The ACME J. CRAFTSMANSHIP High-Grade RADIO-GRAMOPHONE CABINET

Of exclusive, modern design, hand made and polished on Queen Anne legs

Figured Oak £4.12.6
Figured Walnut or Mahogany £5 10.0.

Carriage paid
Illus. Catalogue Free. Cabinets made to order a speciality

GILBERT SWINLON
Cabinet Maker.
Estimates rec. Feb. 1896.



PERMGOL

Specified for "M.W." "TRI-BAND" "THREE, FOKERSLEY" "V.A.R.M.U." "THREE, "M.W." "CABINET" TWO.

Nothing looks worse than a dull and discoloured panel. Use mirror polished PERMGOL, the new Ebonite which is guaranteed never to discolour. Its beauty and polish will delight you, and its cost is less than 1d. per square inch (A 7" x 18" panel costs only 4/6)

Don't spoil that set, but insist on PERMGOL, the modern permanent colour Ebonite

From all dealers or direct. The British Hard Rubber Co., Ltd., Middlessex Ponders End.

A SIMPLE "SUPER"

—continued from page 393

Now, whatever else my junk-box held, it certainly could offer me no intermediate-frequency transformers, and for a day or two I contemplated spending thirty shillings or so on these apparently very necessary items. Until it came to me that they were not so necessary! A sudden twist of memory brought up two facts that were articles of faith to radio enthusiasts six or seven years ago.

Resistance Coupling

First, that the super-het. practically owed its invention to the fact that while the earliest valves were sadly inefficient H.F. amplifiers on 300-600 metres, they could put up quite a

square and about 5 in. deep. Appropriately, it had originally contained the product of a famous Scottish firm of cornflour makers!

An hour's careful work with the keyhole-saw produced in its bottom—or its front, as you please—a circular hole 10 in. in diameter crossed by two parallel bars. On these I purposed to mount my Lissenola unit—its reed towards the concave side of the cone.

Winding the Frame

Around the outside of the box, on four rough ebonite "combs," I wound twenty-two turns of single rubber-covered flex for a frame aerial. Before going farther, I mounted up the loud-speaker unit and cone in the case and tested it on my standard detector-and-pentode local station set. I found the volume and response quite adequate, although naturally rather below that

ABOUT YOUR LOUD SPEAKER!

—If you are thinking of a new one—If you have wondered how the various types would suit your requirements—If you are out for the best possible reproduction—Be sure to get next month's

"MODERN WIRELESS"

It will contain a long and comprehensive review of loud speakers of to-day and the methods of installing and operating them for best results.

¶ This will not be just a trade review of different models, but a practical and intensely interesting outline, invaluable to every set owner. Full of authoritative information, it will immediately assist in your search for quality reproduction. It will in fact be a

COMPREHENSIVE SURVEY OF LOUD SPEAKERS OF TO-DAY.

"MODERN WIRELESS"

Next Month.

On Sale April 30th.

One Shilling.

respectable show at the lower radio-frequencies. Second, that resistance-capacity coupling for H.F. circuits had nothing at all against it provided you didn't try to use it for wave-lengths of less than 1,000 metres.

I had lots of suitable coupling condensers and grid leaks. It only remained to buy a few Spagheti resistances of various values and my "supersonic" kit was ready for assembly!

I had made a stern resolve that the money laid out on those Spagheti resistances should be the last I would spend until I had discovered whether my projected set was a working proposition, and so I hunted through the family's stock of firewood to find timber for a "cabinet."

But my search had only begun when I lighted on the very thing—a stout wooden grocery box made of decent straight-grained deal, 15 in.

of a modern moving-iron unit and cone mounted on a respectable baffle-board.

The Layout

Not until the loud speaker had been tested and the batteries disposed inside the "case" did I consider the layout of the actual receiver.

A 60-dry battery was placed at the left-hand side with two glass mass-type accumulators on the right. The 9-volt grid-bias battery was arranged close to the right-hand end of the H.T.

This left a vacant space about 3 in. wide. It required only a little visualisation to see that this space could very usefully be filled by the L.F. transformer. I saw that if I put my baseboard above the H.T. battery, with the transformer hanging "head downwards," as it were, into that

(Continued on page 395.)

A SIMPLE "SUPER"

—continued from page 394

vacant space, I would just have room in the upper part of the case for the valves and the two tuning condensers.

The horizontal space available for mounting the oscillator unit, five valve holders, five condensers and three grid leaks was only 9½ in. wide by 5 in. from front to back. The centre of the cone overhung it at the right-hand end, and where it overhung I had to avoid mounting anything more than three-quarters of an inch high.

Limited Space

With so little space to play with, I decided to make my baseboard of ebonite. Thus, dispensing with terminal blocks and fitting grid-leak clips direct to the base, I was able to accommodate all the components

A SOUND SUGGESTION

Have you ever thought how difficult it is for a newsagent to order just the right number of copies of any particular paper each week? You can make his task much easier if you place a regular order with him. You will not only help him to order correctly and avoid waste, but you will make sure of getting your copy regularly each month.

without dangerous overcrowding or complicated super-imposing. To simplify the task of wiring and obviate the risk of accidental "shorts" later, I decided to run the filament and earth potential leads under the panel, leaving the top free for the grid and plate connections.

The circuit, except for the connections to the oscillator unit, is perfectly straightforward—even primitive. I know now, for example, that an H.F. choke in the anode of the second detector would be a help, though it is not essential.

Testing Out

So, when my soldering iron had cooled for the last time, I coupled up the batteries, put on a pair of headphones and turned the condensers—hoping against hope. To my joy I heard, amid a chorus of squeals, squeaks and hisses, first the Regional and then the National from the twin-wave station nearest to me.

The outfit was horribly unstable and hand-capacity effects were terrifying. Also those ancient '06 valves, even in

sprung holders, were terribly microphonic and, being close to the cone, the slightest touch started a hum which built up into a devastating howl.

How I finally stabilised the set by experimenting with various resistances, capacities and leaks, how I taught it to bring in not only the locals but a few strong foreigners, how I cured those old valves of "ponging"

half-past nine or ten, if the night is a good one, I shall be able to hear Milan or Heilsberg or Toulouse.

Out of the Ordinary

Admittedly there are simpler sets which would do as much even on this 15-in. frame, but it's pleasant to have been responsible for the creation of something little out of the ordinary, and, in spite of screened grids, band-

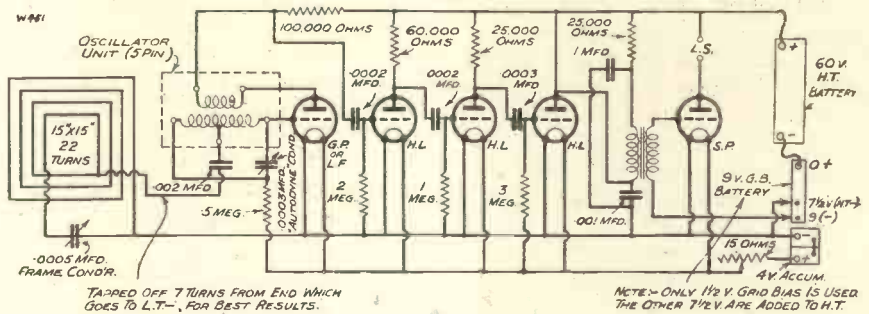

by swaddling them in cotton-wool, tinfoil and insulating tape, is far too long a story to be set down here.

Success at Last

Suffice to say that as I write my "super-het-from-junk" stands at my elbow. The Regional programme is coming in—not shouting, but, anyway, with the volume of a good two-valve set coupled to an outdoor aerial and a modern loud speaker. Later on, at

passing, ganged tuning and all the other super-modernities, nothing has come along yet to lessen my admiration for the ingenuity, simplicity and effectiveness of Edward H. Armstrong's supersonic principle.

The building of this set, with all the scheming and juggling necessary to get good results from what Mr. William Shakespeare calls "unconsidered trifles," has brought me endless interest and pleasure.

EVERY SET IN THIS ISSUE SPECIFIES BELLING-LEE TERMINALS

There's no "guessing" with Belling-Lee Terminals—no risk of costly mistakes. The heads are bakelite-insulated and clearly engraved in 37 indelible letterings. Non-removable, too, preventing all possibility of error.

TYPE "B." (Patent.) Non-rotating name. Extra large clamping area. Cross-hole for solid tags or wire. Slot and nut to eliminate soldering. 2B.A. stem. Price 6d. each.

TYPE "R." (Patent.) Rotating name. 4 B.A. stem. Price 3d. each.

BELLING-LEE TERMINAL MOUNT. (Patent.) Takes two terminals and mounts them anywhere, vertically or horizontally. Particularly suitable for use with Belling-Lee Terminal Type "B." Price 8d.

BELLING-LEE FOR EVERY RADIO CONNECTION

Adv. of Belling & Lee, Ltd., Queensway, Ponders End, Mdx.

AN H.M.V. MAINS SET
—continued from page 359

When the set is acting as an electric gramophone the same volume-control knob operates a potentiometer across the pick-up, so with the one control three kinds of volume control are handled.

The valves used in the 435 are the Marconi M.S.4, M.H.4 and the M.P.T.4. As stated before, a U.10 is employed as rectifier.

Special Loud Speaker

There is one other point that we would like to bring to the notice of readers. This concerns the loud speaker incorporated in the 435. This speaker has a specially doped cone, so that the very best shall be got out of it. The cone is made of a new material, and is sprayed in such a way that it is balanced. This is known as spray loading and is carried out so that the acoustic properties of the cone shall be right, especially with regard to the high frequencies.

A mains aerial device is fitted to the set, so that it can be used either on an ordinary aerial or without any aerial other than that provided by the electric light mains.

The set is available for mains voltages of 100 to 160 and 200 to 250 volts, and periodicities of 40 to 100

cycles. The consumption of power from the mains is only 35 watts.

On test our expectations of the set were fully realised, it was both selective and sensitive and the ease of handling was delightful. It is useless to give a list of the stations that were received for such lists mean little, suffice it therefore to say it is a set that we can thoroughly recommend to all who require an inexpensive (the price is only 20 guineas) but really first-class radio receiver. It is a set that with its special H.M.V. walnut finish, known so well to the radio public, will grace any scheme of furnishing, and fit in with any style and size of room. It is equally valuable to the flat-dweller or the owner of a spacious country home.

MAKING SHORT-WAVE COILS
—continued from page 328

suitable lengths, some mounting being improvised to suit one's own taste. The "knife-edge" mounting shown on the particular example used is not too hard to make and is very efficient.

Generally speaking, bakelite seems to be the best possible material for any of the types of former mentioned. Ebonite, being soft, is liable to do funny things in hot weather. The most noticeable of its crimes is

that the wire "bites" into it when the former expands slightly, with the result that when it contracts the winding is slack. For supreme accuracy—such as is required for coils intended for wave-meters—porcelain formers are often used. Bakelite is, however, more suited to the ordinary enthusiast.

Number of Turns

Concerning turn-numbers, there is a lot that I *could* say, and a lot that I *won't*. Everyone knows his own mind nowadays, and likes to please himself. I will therefore content myself with giving a rough indication of the turns necessary to cover the usual bands into which the short-wave range is divided up.

It is generally accepted that the whole range of "shorts" be taken as 10-100 metres. This divides nicely into 10-18 metres, 18-30 metres, 30-60 metres and 60-100 metres. The 30-60-metre range includes most of the stations of interest and is probably that which is most used by short-wave listeners.

Considering, all the time, "close-wound" coils of 2½ in. diameter, we shall need coils of the following sizes: Grid 2 turns, reaction 2; grid 4 turns, reaction 3 or 4; grid 9 turns, reaction 6; and grid 20, reaction 12. The last-mentioned will actually go up to about 130 metres with a .0001 condenser, which has been presumed all through.

"BETTER THAN WIREWOUND!"

OHMITE RESISTANCE

ALL values from 300 ohms to 5 megohms
1/6 Holder 6d.

GRAHAM-FARISH

Ohmite

Made by **GRAHAM FARISH** Bromley Kent.

INDEX TO ADVERTISERS

		PAGE		PAGE
Belling & Lee, Ltd.		395	Pickett's Cabinet Works	393
British Blue Spot Co., Ltd.	Cover iii		"Popular Gardening Annual"	383
British General Manfg. Co., Ltd.	383		Ready Radio, Ltd.	392
British Hard Rubber Co., Ltd.	394		Reproducers and Amplifiers, Ltd.	387
British Insulated Cables, Ltd.	387		Taylor, M.	393
Bulgin, A. F., & Co., Ltd.	393		Varley Products	393
Burne-Jones & Co., Ltd.	389		Wright & Weaire, Ltd.	387
Carrington Manfg. Co., Ltd.	392			
Cossor, A. C., Ltd.	302			
Dubilier Condenser Co. (1925), Ltd.	383			
"Daily Telegraph"	Cover iii			
Electrical Trading Assoon., Ltd.	Cover ii			
Edison Swan Electric Co., Ltd.	Cover iv			
Epoch Radio Manfg. Co., Ltd.	301			
"Film Pictorial"	389			
Gilbert, J. C. (Cabinets)	394			
Graham Farish Radio, Ltd.	371, 396			
Gramophone Co., Ltd.	380, 381			
Heyberd, F. C., & Co.	392			
Igranic Electric Co., Ltd.	389			
Jackson Bros.	390			
Peto-Scott Co., Ltd.	389			

All communications concerning advertising in "Modern Wireless" must be made to John H. Lile, Ltd., 4, Ludgate Circus, London, E.C.4. Telephone: City 7261.

AMAZING is the only word BLUE SPOT

1000



SUPERLATIVES are the only possible adjectives in describing this wonderful **BLUE SPOT** Loudspeaker Unit.

Nothing like it has ever been heard before. It is the nearest to natural that science has ever produced. Speech, music and song are made living realities full of colour and personality—the *real* thing at last.

Price complete
mounted to
chassis

39'6

This amazing inductor type speaker is as good as the most expensive dynamic speakers and costs but a fraction of their price.

It is the best of all speakers for use with any of the popular kit sets. Hear one and you will have nothing else. Write for Catalogue M.W.15U.

THE BRITISH BLUE SPOT COMPANY LTD.

BLUE SPOT HOUSE, 94/96 ROSOMAN ST. ROSEBERY AV. LONDON, E.C.1
Telephone: Clerkenwell 3570. Telegrams: "Bluospot, Isling, London."

Distributors for Northern England, Scotland and North Wales: H. C. RAWSON (Sheffield and London) Ltd., 100, London Road, Sheffield; 22, St. Mary's Parsonage, Manchester; 183, George Street, Glasgow.



Registered Trade Mark

Hutcheonad

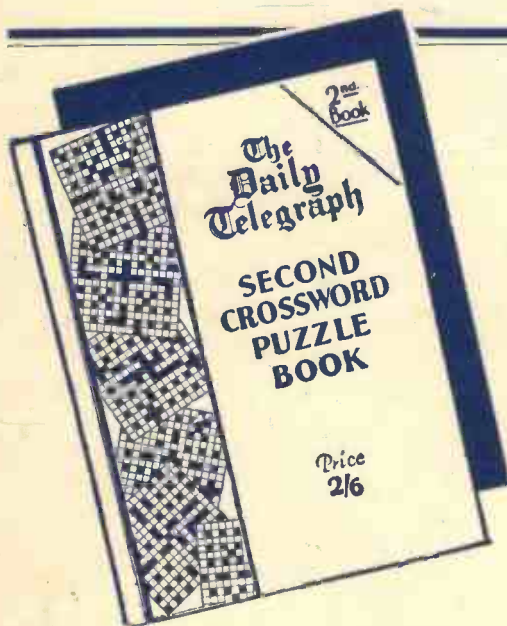

CROSSWORD PUZZLE BOOK

THE ingenuity of *The Daily Telegraph* Crossword Puzzles and their high standard have called forth for many years the appreciative comments of many thousands of its readers. Another fifty puzzles have been published in book form and have been eagerly welcomed by Crossword solutionists throughout the country. *The Daily Telegraph* Crossword Puzzle Book can be obtained from your local newsagent for 2s. 6d. or a copy will be sent for 2s. 10d. (post paid) by the publisher of the

On Sale at all
Newsagents

2/6

Daily Telegraph

FLEET STREET, LONDON, E.C.4.

2 VOLT MAZDA MASTERPIECES

TYPE	PRICE
H.210 - - -	7'6
★H.2 - - -	7'6
HL.210 - - -	7'6
★HL.2 - - -	7'6
★L.2 - - -	7'6
L.210 - - -	7'6
P.220 - - -	8'9
P.220A - - -	12'6
P.240 - - -	12'6
PEN.230 - - -	17'6
PEN.220 - - -	17'6
PEN.220A - - -	17'6
S.G.215 - - -	16'6
★S.215A - - -	16'6
★S.215B - - -	16'6

★ METALLISED



LOOK FOR
"EDDY" IN
YOUR DEALER'S
WINDOW

THE AMAZING

MAZDA PEN. 220

Characteristics:

Filament Voltage - - 2.0 volts Anode Current (Max) - 12 mA
 Filament Current - - 0.2 amps. Screen Voltage (Max) - 150 volts
 Anode Voltage (Max) - 150 volts Mutual Conductance - 2.5mA/V
 At $E_s = 100$; $E_s = 100$; $E_g = 0$.

PRICE 17'6

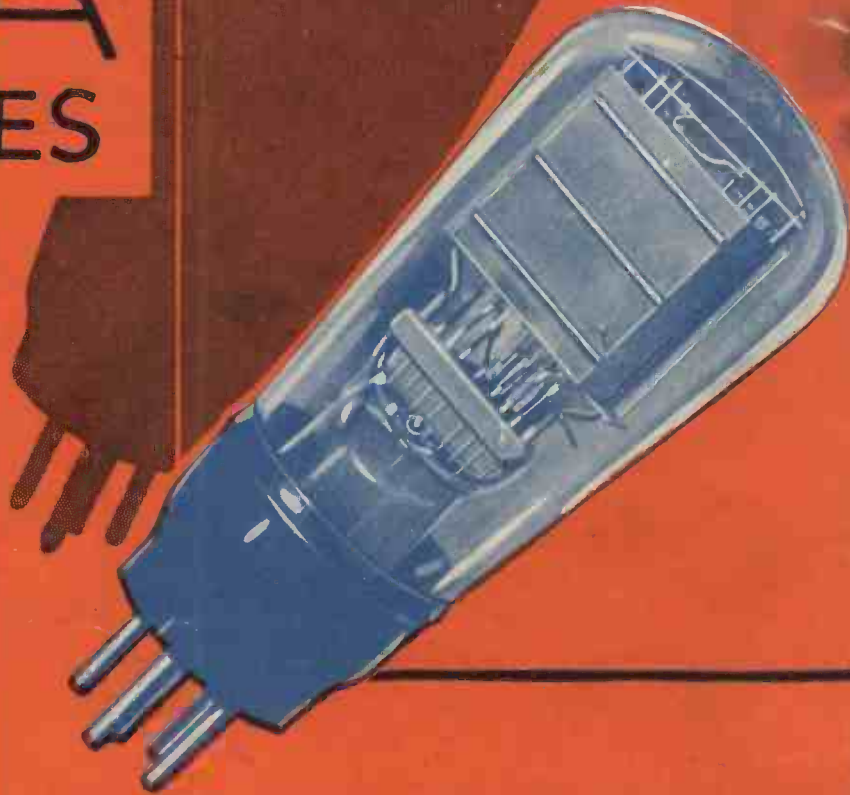

Never, in the history of 2-volt valves, has there been such an amazing range as this—so much evidence of brilliant engineering—so many valves with outstanding characteristics. Instance the Pen. 220; a pentode valve which at once presents the solution to the output stage problem in portable sets, giving an extraordinary large output for a combined screen and anode current of under 5 mA. It is a valve for which dry battery users have long waited.

Being typical of all Mazda valves, it is outstanding in its efficiency. Mazda 2-volt valves, both metallised and clear bulb types, are sold by all good radio dealers.

MAZDA

THE
BRITISH
VALVES

The Edison Swan Electric Co. Ltd.



155 Charing Cross Road, London, W.C.