

BRITAIN'S LEADING RADIO MAGAZINE

MODERN 1/- WIRELESS

Vol: XVI. N°55

JULY 1931

FULL CONSTRUCTIONAL DETAILS OF —

A FIVE-VALVE SUPER-HET

AS EASY TO BUILD AS A THREE VALVER

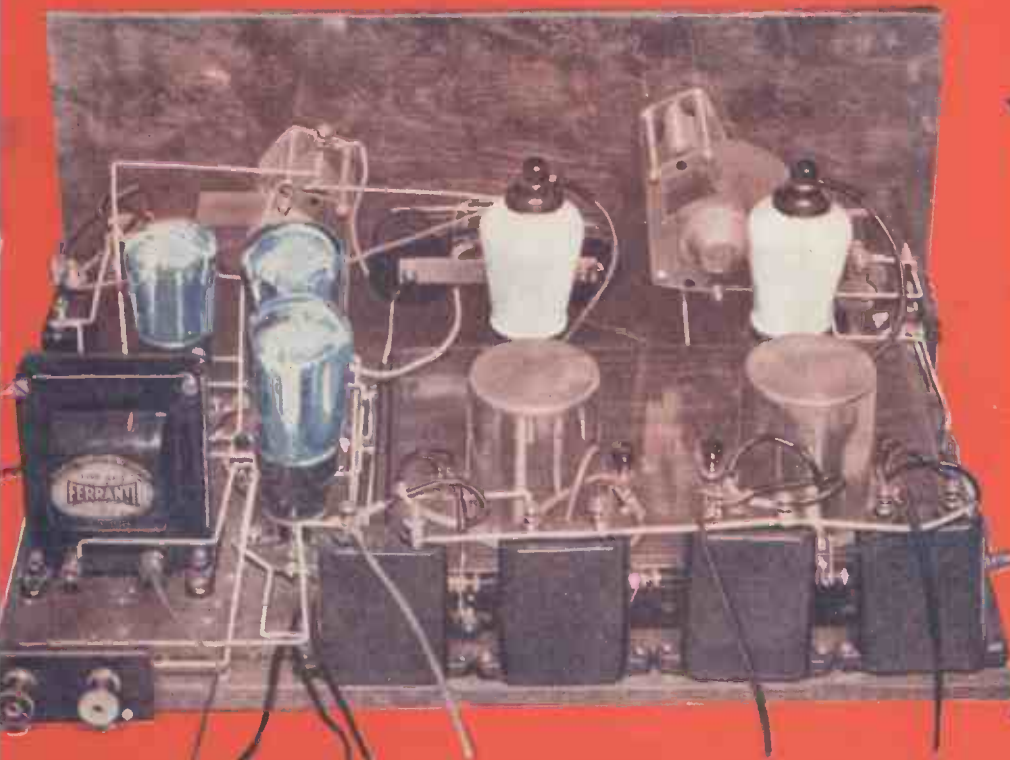

READ ALL ABOUT
THE
"SIMPLICITY"
SUPER

Which incorporates the following special features:—

- BAND-PASS TUNING
- SCREENED-AND-WIRED-UNIT CONSTRUCTION
- STAGGERING SELECTIVITY
- EASE OF ASSEMBLY

MANY OTHER FINE
ARTICLES INSIDE

RADIO CONSULTANT-IN-CHIEF CAPT P. PECKERSL

EVERYTHING **The G.E.C.** ELECTRICAL
your guarantee

A new era of radio enjoyment for the D.C. Mains user

with the *New*

GECOPHONE

D.C. ALL ELECTRIC RECEIVER

SPECIALLY DESIGNED AS A D.C. JOB

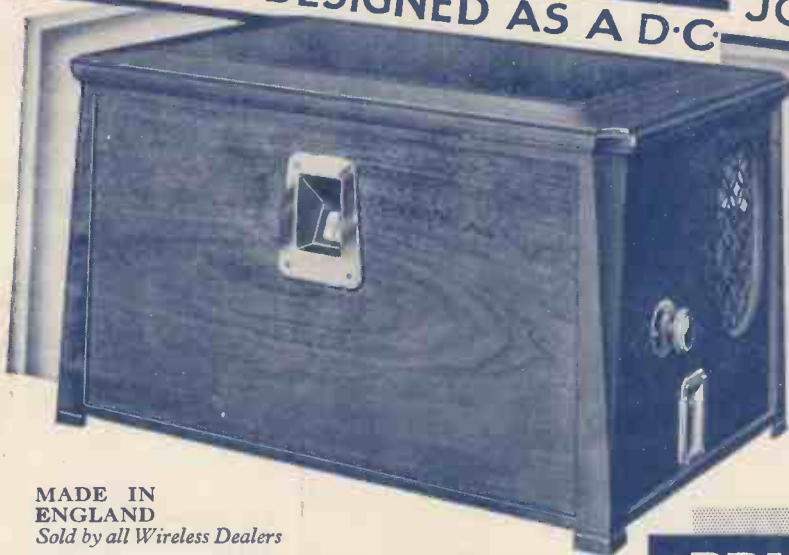

MADE IN ENGLAND
 Sold by all Wireless Dealers

With this new GECOPHONE all-electric receiver, those having a Direct Current electricity supply can enjoy radio reception equal to that given by the best A.C. mains receivers. Here, then, is a set that thousands have been waiting for—a D.C. all-electric receiver that excels in selectivity, range, power and purity of tone. Choose it because of its magnificent performance, its handsome appearance, its amazingly good value.

HIRE PURCHASE
 Terms: Deposit £2.10.0, 12 monthly payments of £1.19.5

Fill in and post this coupon for leaflet in full colour giving all particulars of GECOPHONE D.C. ALL-ELECTRIC RECEIVER.

4 VALVE
 ALL D.C.
 MAINS OPERATED
 WITHOUT HUM
 CONFORMS TO I.E.E.
 RECOMMENDATIONS

SINGLE DIAL TUNING
 2 MATCHED STAGES HIGH FREQUENCY AMPLIFICATION

TONE CORRECTED SUPER POWER PENTODE OUTPUT
 WILL OPERATE MOVING COIL LOUD SPEAKER

SELECTIVE AND SENSITIVE FOREIGN STATION RECEPTION WITH INDOOR AERIAL
 HANDSOME SOLID WALNUT CABINET

PRICE
£25
 INCLUDING OSRAM VALVES AND ROYALTY

COUPON
 Please send me particulars of the new GECOPHONE D.C. ALL-ELECTRIC RECEIVER

Name..... Address.....
 The General Electric Co. Ltd.
 Magnet House, Kingsway, London W.C.2.
 Cut out and paste on postcard, or enclose in unsealed envelope. Halfpenny postage in either case. M.W.

Advt. of The General Electric Co., Ltd., Magnet House, Kingsway, London, W.C. 2.

CONTENTS

VOL. XVI. No. 55

MODERN WIRELESS

JULY, 1931

	Page		Page
Editorial	3	An "Ekco" All-Electric Three	57
Eight Years of Radio	4	Modern Valves for Modern Sets	59
Choosing Coupling Values	6	At Your Service	61
Radio at the Paris Exhibition	7	On the Short Waves	63
New Wave-lengths for Broadcasting?	9	The "Compact" Two	64
The "Simplicity" Super	12	An Amplion Portable	69
Round the Turntable	20	Questions Answered	71
The Corsor "Commander"	33	On the Test Bench	72
My Broadcasting Diary	35	Is Band-Passing Worth While?	74
Pick-ups That Peak	37	Recent Record Releases	76
Those Amplification Curves	39	Making Metal Rectifiers	77
Taxing the Listener	42	In Passing	78
A Radio Reckoner	45	Trouble Tracking	82
The "M.W." "Hi-Mag" Four	48	Radio Notes and News	84
H. G. Wells Was Right!	56		

SPECIAL SUPPLEMENT, "THE WORLD'S PROGRAMMES," PAGES 21-32
(See page 21 for contents of this section.)

As some of the arrangements and specialities described in this Journal may be the subject of Letters Patent the amateur and trader would be well advised to obtain permission of the patentee to use the patents before doing so.

Edited by **NORMAN EDWARDS.**

Technical Editor: **G. V. DOWDING, Associate I.E.E.**

Radio Consultant-in-Chief: **Capt. P. P. ECKERSLEY, M.I.E.E.**

Scientific Adviser: **J. H. T. ROBERTS, D.Sc., F.Inst.P.**

HI-MAG 4

New Era in Radio affirmed by unparalleled success of CYLDON EXTENSER

- 1 Sturdy construction, a standard CYLDON feature, and more essential with the Extenser type than others.
- 2 Any number of CYLDON Extensers may be ganged end on end or side by side if desired.
- 3 Solid end plates give highly effective screening with provision for additional screening.
- 4 Absolutely foolproof and exclusive commutator contact system providing the very necessary adjustment for correctly timed change over from short to long waves, eliminating overlap or time lag.
- 5 Reinforced one-hole fixing bearing design makes loosening of bearings impossible by turning on the panel.
- 6 Six point insulation suspension.
- 7 Four pillar frame construction gives absolute rigidity.
- 8 Noiseless Brush wipe contact, superceding pig-tail, gives complete rotation through 360° in either direction.
- 9 Finally, the CYLDON Extenser is backed up by the famous CYLDON quality and name.

There's a whole of difference for the slight extra cost.

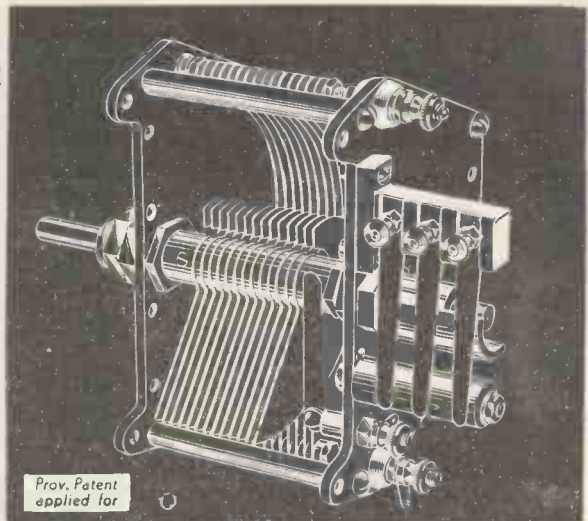

Prov. Patent applied for

From all dealers in the country. In case of difficulty send direct to the makers
SYDNEY S. BIRD & SONS LTD.
CYLDON WORKS,
SARNESFIELD ROAD,
ENFIELD, MIDDLESEX

Telephone: Enfield 2071-2
Telegrams: Capacity, Enfield S.F.B

CYLDON

FIVE YEARS GUARANTEE

Extenser as illustrated. (4" Bakelite 360° Dial 2/- extra) **15/-**

EX. 1.T.5. Single Drum Drive Extenser with Drum, Chassis, Bakelite Escutcheon, Steel Drilling Template, Fixing Screws and full instructions. **18/9**

EX. 2.T.5. 2 Extenser Condensers controlled by 2 Drums mounted on one Chassis. **39/6**

EX. 3.T.5. Triple ganged Extenser controlled by 2 Drums. Complete as Ex.1.T.5 **55/-**

Still lower inter-electrode capacity —still greater effective amplification

Cossor Metallised Valves are available in the following types at standard list prices:—

BATTERY OPERATED:

- 215 S.G. 220 S.G.
- 210 H.L. 210 DE7.

A.C. MAINS VALVES

- MSG - HA MSG - LA
- 41 MSG 41 MH
- 41 MHL MS/PEN.A

THE latest Cossor development—Metallised Valves—is a matter of the utmost importance to every user of a long-range Receiver.

The process of metallising, i.e., the depositing of a metal coating on the exterior of the glass bulb, forms an efficient screen and, in addition to reducing still further the very low inter-electrode capacity of the Cossor Screened Grid Valve permits even greater effective amplification.

At the same time selectivity is considerably improved due to the elimination of direct pick-up and of couplings between the valve and near-by components. This feature is of marked importance to users of super-heterodynes as it ensures freedom from stray couplings that frequently give rise to instability.

Cossor Metallised A.C. Mains Valves, in addition to the advantages outlined above, possess the further important

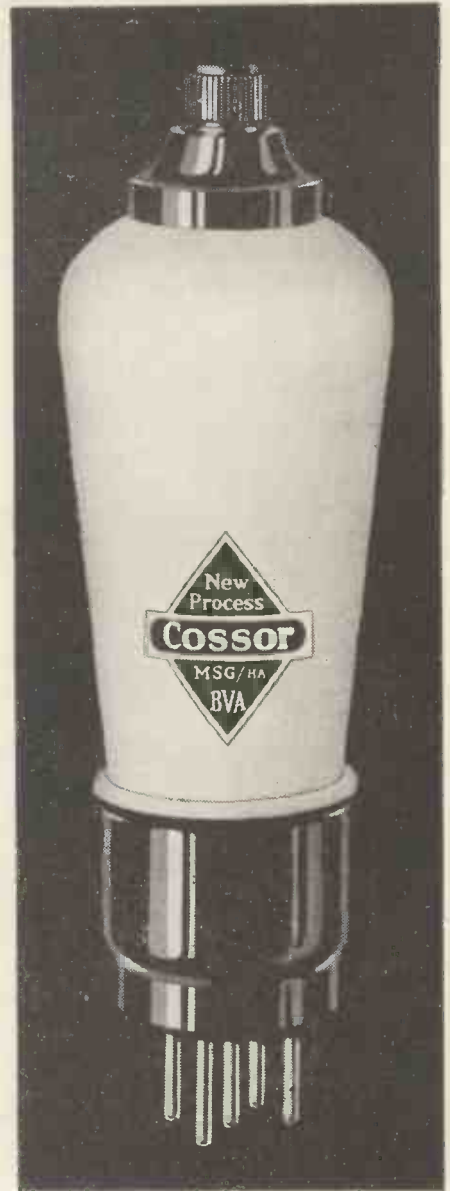

quality of reducing the tendency towards mains hum.

Cossor Metallised Valves in both Battery operated and A.C. Mains Types are obtainable from any Wireless Shop.

To Messrs. A. C. Cossor Ltd., Highbury Grove, London, N.5.
Please send me, free of charge, Leaflet L-31, giving interesting technical information on Cossor Metallised Valves.
Name.....
Address.....
M. W. 7/31.

COSSOR

METALLISED VALVES

MODERN WIRELESS

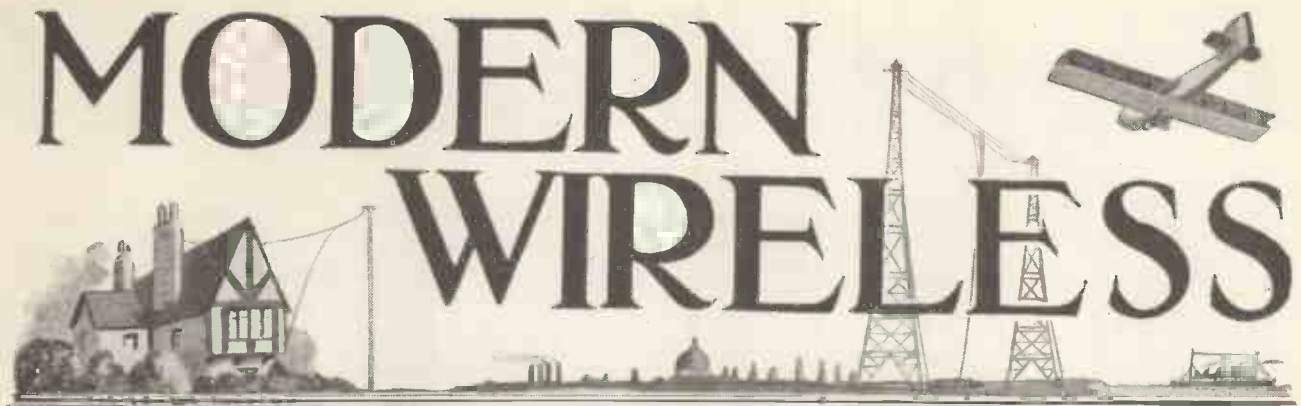

Vol. XV1. No. 55.

BRITAIN'S LEADING RADIO MAGAZINE

July, 1931

Our Five-Valve Super—The "Hi-Mag" Four—A Compact Design—B.B.C. and U.S.A.—The Copenhagen Conference

Our Five-Valve Super

WE present to our readers in this issue of MODERN WIRELESS a five-valve super-het.

Little need be said about it here, for much space is devoted to it on other pages of this issue; but we would emphasise this fact: this super-het is as easy to build and to wire up as any three-valver.

Five valves may at first glance intimidate you—not so much because of the intricacy of construction, but because of the expense involved. Naturally, a five-valve set is going to be a bit more expensive than most three-valvers, but in this super-het you have a set which is extremely selective as well as being extremely powerful.

It is no exaggeration to say that it gives you *scores* of programmes at full loud-speaker strength. And economically it is a sound proposition. Running costs, for example, you will find are very moderate indeed, and when you come to consider what this set will do for you the *total* cost may be said to be distinctly low.

The "Hi-Mag" Four

ANOTHER set which we think you will be interested in this month is the "Hi-Mag" Four. This set incorporates MODERN WIRELESS's latest contribution to coil design.

We have been paying a lot of attention lately to the question of economy in sets, and in this particular receiver you will notice that we have used foil on wood for screening. We have made several experiments with these home-made screens, and, judging by the reports from the Test Room, we have no hesitation in saying that you can now—by following our instructions—make your own first-class screens and, in the process, save a considerable amount of money.

A Compact Design

OUR third set, the "Compact" Two, lives up to its name. It is extremely small, and the aim of the designers has been to produce a really powerful two-valver in which our latest two-band wave-changing system figures.

Coil Quits are used, both to reduce the expense of the set and to make it as a whole more compact. This neat

little instrument is sure to prove one of our most attractive productions in view of its special features and low cost.

B.B.C. and U.S.A.

THE visit to America by the B.B.C.'s Director-General has been attended with conspicuous success. In fact, he was nicknamed by the newspapers in New York as the "Radio Czar of Great Britain."

Sir John made it clear that British sentiment and practice was utterly opposed to the American system of sponsored programmes by advertisers, and he gave it as his opinion that the broadcaster in America worked under an immense handicap for this very reason. "Ballyhoo" was the cry by which the antagonised listeners or readers vented their opinion of the broadcaster who thrust advertised wares upon their attention.

Sir John also emphasised the point that there was a risk of educational Ballyhoo, as well as of commercial Ballyhoo.

It is interesting for British listeners to note that Sir John is now of the opinion that the attachment of the word "educational" to any broadcast matter weighs heavily against its popularity. Sir John himself now admits that people object to any proposal forcibly to educate them by radio.

The Copenhagen Conference

IT is to be hoped that good results will come of the International Consultative Technical Committee which is now conferring at Copenhagen. The Committee has met in order to discuss subjects to be put forward at the International Radio Convention to be held in Madrid next year.

Naturally the question of the distribution of wave-lengths for broadcasting purposes occupies a very important place on the agenda, as does the question of whether the existing interval of 9 kilocycles between each wave-length will suffice for the next few years.

As we have pointed out time after time, the continual increase in new high-power stations in Europe, as well as the continual increase in the power of existing stations, tends to render the ether situation more and more unsatisfactory.

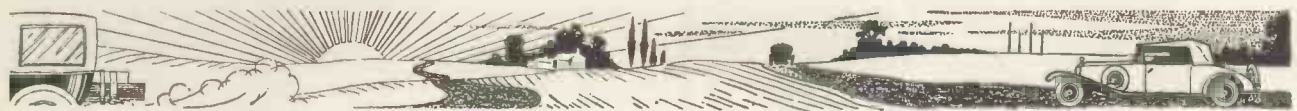

Eight Years of

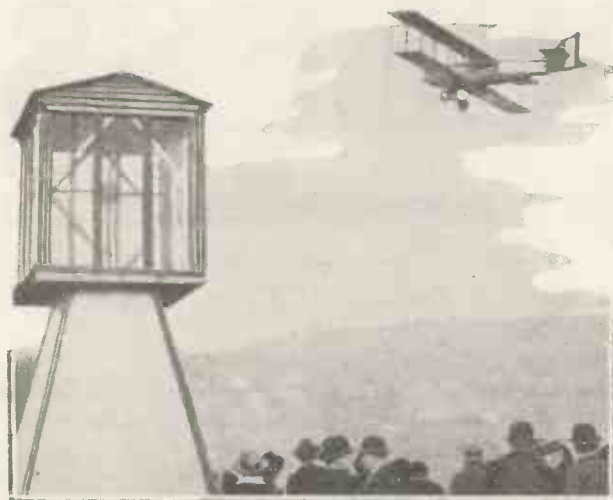

What luck we have to be living in the wireless age! Quite apart from broadcasting, it is one of the biggest factors in safe travel, both by air and water.

ONE wonders whether wireless will not eventually oust the weather as the universal topic of conversation. They have, of course, one thing in common. Everybody complains about them.

Yet there is a fundamental difference between them. Weather we must endure, whether we will or no. Wireless is more a matter of free will.

The Return for Your Money

When people grumble about the wireless, saying it is too cultured, too vulgar, too modern, too old-fashioned, I cannot help feeling the unreasonableness of their complaints. Whatever the wireless programme, YOU CAN ALWAYS SWITCH OFF. I write this simple state-

Broadcasting has been with us only a few years, yet we take it so much for granted that we are apt to expect it to be perfect in every way. In this thoughtful article the author reminds us of the rapid growth of radio, and the difficulties that attend such swift development.

ment in capital letters on purpose, since it seems to escape so many people's notice.

"All very well," you may say; "but, then, I pay a certain sum yearly for the privilege of using my wireless set. I expend further monies on buying new valves and having adjustments made to my set. Far from being willing to switch off, I expect something for my money."

A plausible argument, until you examine it. Wireless programmes nowadays are so varied that nobody could possibly dislike each and every item of an evening's broadcast. If madrigals appear on the programme, there is probably a comedian or two to cheer the less musical. A number of people obtain more amusement from the day's news than from any of the official "entertainment" numbers.

He Likes Time Signals Best!

An elderly gentleman I know practically lives for the moment each night when he can compare his watch with Greenwich Mean Time. The pleasure he obtains from knowing that his watch is absolutely correct makes the wireless worth while to him, if he never listened-in to another item.

No! Our case against wireless programmes is, I fear, not based on reason; an echo of our early schooldays persisting into adult life. Julius Cæsar, when he had invaded Britain, is reported to have said that the inhabitants were Gauls, but strangely barbarous.

"Certain to Become One of the Finest Orchestras"



That is the author's considered opinion of the B.C. Orchestra, which is here seen rehearsing at the huge No. 10 Studio.

Radio

By LORD BERNERS

This national characteristic has not, I suspect, altered greatly during the intervening centuries. The average Englishman or woman has a peculiar horror of any kind of edification. English common sense, character, backbone are all right. English culture is another thing altogether. We leave culture to foreigners and despise them, often, for their superior knowledge and social manners.

Away with Intellectual Uplift

Darkly we surmise that the B.B.C. is trying to educate us, to undermine this national shameless ignorance which we have all been taught to believe to be the foundation of our country's greatness. Hence we constantly attack the B.B.C.'s choice of programme. We will have none of this uplift, intellectual or musical. Give us something suitable to our childish minds is, in effect, what we said to the B.B.C.

We seem to be afflicted with a false modesty in respect to learning. The French readings broadcast each week provide a wonderful opportunity of learning to speak and understand everyday French. Yet how many English people, in the bosom of their family, would have

RADIATES EXCELLENT PROGRAMMES

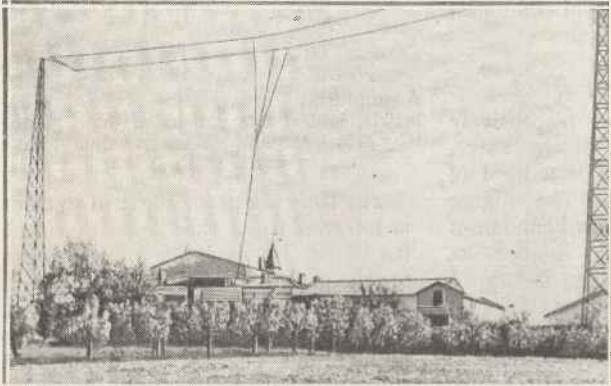

Quite a picturesque little station, Toulouse "puts out" some of the finest musical broadcasts that emanate from the Continent

the nerve to listen in to these regularly? We dare not label ourselves as being so peculiar as to wish to learn something, especially when that something is a foreign language.

According to the latest returns about three million homes are at present fitted with wireless, while some nine million houses are without radio. During the last few years the increase in the number of wireless users has been in the neighbourhood of 10,000 more users per month!

Wireless, then, is rapidly becoming more popular in these islands; which means that the deviser of wireless programmes has more and more to try to satisfy the taste of the greatest number of listeners.

You, possibly, would like to hear Mr. Woolley speak again on his fascinating discoveries while excavating Ur of the Chaldees. You should remember, however, that



Lord Berners.

to hundreds of your fellow listeners-in Ur is a name without meaning. If asked what it was, most of them would surmise that Ur was a racehorse, though they did not remember what races it had figured in particularly.

We cannot, therefore, expect the B.B.C. to bore thousands of wireless enthusiasts in order to interest a very small minority. If you wish for general knowledge on any subject, the wireless is a good teacher; but when you want special knowledge it is sometimes better to apply elsewhere.

I personally prefer music on a good gramophone to music on the wireless. The fear of little interrupting noises which occasionally sound in the middle of my wireless music sets me on edge before I begin listening-in.

Our Luck in Living Now!

Other musicians have possibly felt the same. Music being our particular province, we want the very best interpretation, where a person with less interest in music would be perfectly satisfied with the wireless.

Not that I wish to decry music on the wireless. The musical programme broadcast from Toulouse strikes me as excellent, while the B.B.C. orchestra is certain to become one of the finest in the world.

What luck we have to be living in the wireless age! Apart from the blessing it is to the blind, the bedridden and the sick, we able-bodied people have great cause to be thankful for it. When other trades are dull, wireless has absorbed about 300,000 persons directly into the industry.

Wireless protects and aids us in our daily life. A criminal's finger-prints can be transmitted by wireless in a few seconds. Aeroplanes in fog are guided to port by radio. And through their wireless, ships at sea can speedily summon help when in distress

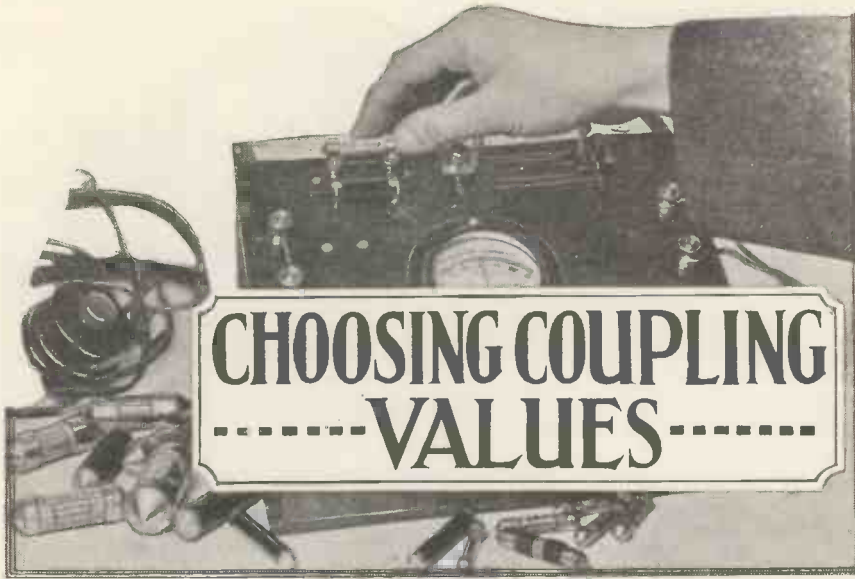

CHOOSING COUPLING VALUES

By H. A. R. BAXTER.

Practical pointers concerning the choice and use of certain vital components.

RADIO, as with many other things, is well stocked with compromises. For example, it is often necessary to sacrifice a little in the way of sensitivity in order to obtain the required selectivity. Particularly do you find this with crystal sets.

And in valve sets, too, a compromise of this kind is sometimes essential. But these are well-known facts. What may not be quite as well-known are the principles underlying the choice of grid-leak and condenser values.

In an ordinary detector circuit the most common values are .0003-mfd. for the grid condenser and 2 megohms for the grid leak. And these are exceptionally well-matched values.

Reducing Efficiency

If you decrease the capacity of the condenser you reduce the efficiency of the arrangement. But if you increase it or increase the resistance

WORKING TOGETHER

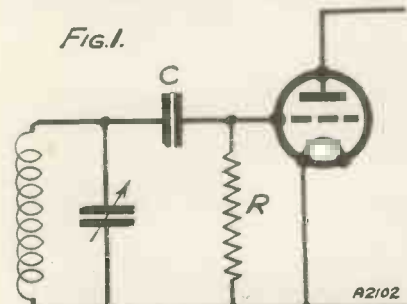

A grid leak and condenser should be considered together and not separately, for neither works independently.

of the grid leak the efficiency of the circuit may go up from a sensitivity point of view at the expense of some other quality.

A primary requirement is to transfer as much of the high-frequency energy from the tuning circuit to the grid of the valve as is possible. For explanatory purposes, Fig. 1 can be redrawn as Fig. 2, the grid condenser being shown as a resistance.

Potentiometer Effect

(2) and (3) represent respectively the grid and filament of the valve, and you can see there is a kind of potentiometer formed. The higher the resistance of C, the grid condenser (and that means the smaller its capacity), the less voltage is tapped off by the valve. And exactly the same happens when the resistance of the grid leak is reduced.

Now the resistance of a .0003-mfd. fixed condenser to frequencies such as we get in broadcasting will not be much more than 700 ohms. And that is not much in comparison with the 2,000,000 ohms of the grid leak. There is no point in making the condenser smaller given the same value of grid leak, and to increase the grid condenser capacity involves the possibility of losing some of the high notes through the by-passing of a proportion of the L.F. impulses set up across the grid-filament of the valve subsequent to rectification.

You see, the grid condenser is, in effect, right across the grid leak from an L.F. point of view. (The tuning coil will have negligible resistance to L.F. currents.)

If you glance at Fig. 3 you will see how the thing works out. Obviously to increase the grid condenser capacity unnecessarily would be far from wise.

But if you put up the resistance of the grid leak you are liable to cause a choking of the grid when greater degrees of energy are being dealt with. This effect is much more serious in the case of grid leaks and condensers employed in resistance-capacity-coupled L.F. amplifying stages.

The Time Constant

Here the grid of the coupled valve is kept at a negative potential by means of a biasing battery. But a strong burst of energy is liable to send the valve right over into grid current. And at the end of that burst the valve will be left with an overdose of negative potential. Until this has leaked away through the grid leak the operation of that valve will very seriously be impeded.

AT A GLANCE

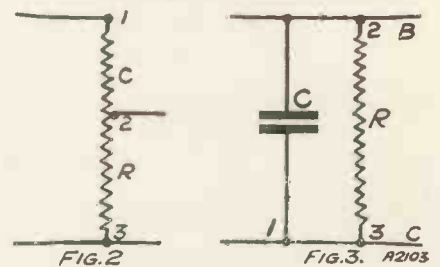

A simplification that, after you've read the article, will enable you to see at a glance why grid leaks and condensers should have certain values.

The time taken for the grid to clear is referred to as the Time Constant (to be precise, it is the time it takes for the grid to clear down to a certain small percentage of its initial charge).

You will clearly be able to see the implications of this, no doubt. In short, it means that a large condenser (able to store more energy), or a grid leak of considerable resistance, will slow down the grid clearing and tend to emphasise the blocking effect.

Careful Compromise

And because the condenser capacity cannot be increased to any great extent for this reason it will have some appreciable effect on amplification at the lower frequencies dealt with in the L.F. stages. Even a .01-mfd. grid or coupling condenser will have a resistance running into hundreds of thousands of ohms at the bass end of the audio scale of frequencies.

It's a matter of careful compromise all the time, isn't it?

Radio at the Paris Exhibition

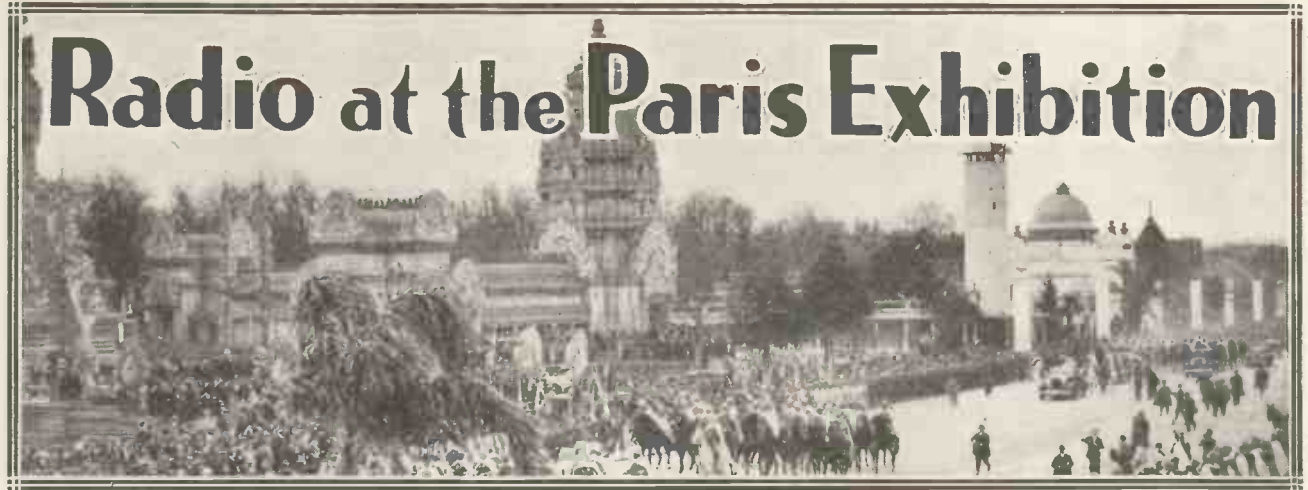

THE French are nothing if not artistic, and they have certainly managed to excel themselves both in the site they have chosen for their exhibition, as well as in the architecture and grouping of the main buildings, which form its nucleus.

The Bois de Vincennes lies in the south-east corner of Paris. As its name suggests, it is a well-wooded park with a lake, called the Lac Daumesnel, half-hidden amongst the trees. On this site a new city of quaint and varied architecture has arisen to house exhibits assembled from all parts of the world.

Searching for Radio

The place is, in fact, so vast that one is bewildered at first by the multitude of things to be seen. Stark towers and huge buildings, designed in the most ultra-modern style, are intermingled with the square red forts of ancient Africa, mosques and pagodas, and all the fantastic architecture of Indo-China and the East.

However, I had come to look at whatever was to be seen of French radio, and my first task was to find where this particular section was located. And right here came a slight check to my enthusiasm. I am as full of admiration as anyone for the artistic talents of the French nation, but I am afraid they do not shine so brightly in matters of organisation.

Lighting the Lamps

Naturally, I tried to buy a programme, but nothing so simple was to be procured. Possibly we overdo the programme-sellers in our own exhibitions, but the lack of any programme at all is distinctly disconcerting. The first official to whom I appealed most courteously conducted me to the central office, where, he

Our Special Correspondent here tells you of his experiences during a recent visit to the Paris Exhibition. Owing to the restrictions on the erection of outside aerials in Paris, the super-het. is about the most favoured type of set, a large number of these being on view on the stands.

said, I should be given all the information I desired.

At the central office I again demanded the location of "La Section de T.S.F.," and was at once given minute instructions to proceed to the

REALISTIC REPRODUCTION



Electrical gramophones are very popular on the other side of the channel, this being the latest production of a French factory.

Cité des Informations, where I should most certainly find exactly what I wanted.

Unfortunately, I must have fallen into the hands of one to whom the magic letters "T.S.F." (telegraphie-sans-fil) meant long-distance commercial wireless, and nothing so commonplace as broadcast receivers. However, it was just as well I met him, because otherwise I might have missed an exhibit which is well worth seeing by anyone who is interested in the wider aspects of wireless.

This is a huge map of the world, laid out on Mercator's projection, across one side of the central hall in the Cité des Informations. On the map are marked the principal commercial wireless centres of Great Britain, France, Holland, and the U.S.A., all distinguished by different-coloured lamps, together with the various subsidiary stations with which they communicate.

How They Work

One hears a loud call-sign in Morse, and immediately a red lamp flashes out in sympathy from the Rugby station. Simultaneously other red lamps flicker at various points on the map, ranging from Shanghai to Hobart, and, in fact, from every station throughout the world which receives the Rugby signals.

After a short interval another Morse call rings out, and this time the principal French radio centres, together with their distant associates, are shown on the map in lamps of a different colour. And so with the Dutch and American stations in turn.

To cut a long story short, the radio section was finally run to earth in the enormous Palais de la Section Métropolitaine. For the information of other English visitors it may be

France's Latest in Radio Receiver Design

mentioned that this is the largest block of buildings in the whole exhibition, and lies to the north of the Porte de Picpus, along one side of the Boulevard Soult.

Although, as will probably have been gathered from the absence of any programmes, the exhibition is not yet fully complete, the Radio Section contains a representative selection of broadcast receivers, chiefly of the super-het type, as well as loud speakers and elaborate radio-gramophone outfits.

Artistic Element

The display of component parts is at present somewhat disappointing, though a further large accession is to come in from the Paris Fair at Versailles, which closed down recently.

ALL-METAL CABINETS ARE POPULAR

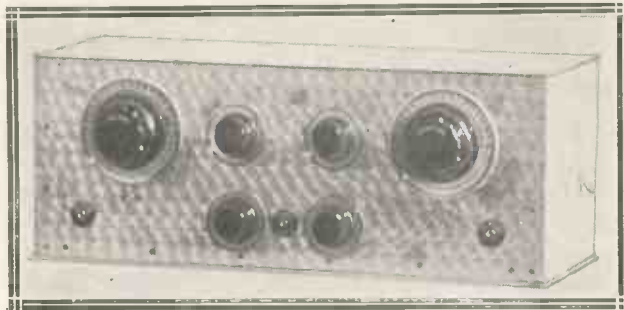

Receivers contained in metal cabinets are very much in vogue at the moment. The screening is very useful when receiving on the ultra-short waves, as it does a great deal to reduce body-capacity effects. Here is a typical French screened receiver

Most of the firms who showed at the Foire de Paris are to transfer their stalls to the exhibition.

Even here, in the Radio Section, it is the artistic element which strikes the English visitor most forcibly. There certainly seems to be a much wider range of inspiration in French cabinet design than is to be met with in England. The same also applies to loud speakers and to frame aerials, both of which are made to disguise their normal appearance in a number of pleasing and ingenious ways.

Elaborate Container

One manufacturer claims, for instance, that in making a small-sized cabinet he uses fifty-four pieces of hardened wood, each piece being treated by fourteen different machines. In assembly the cabinet is passed through the hands of no less than seventeen different workmen, each a specialist at his own particular task. The whole process of manufacture and assembly is deliberately designed to improve the acoustic qualities of the completed set.

On the other hand, our own manu-

facturers more than hold their own so far as circuit design is concerned. Unfortunately, few of the French exhibitors show the inside wiring of their "cabinets de luxe," but those that were visible seem to be more or less of orthodox type.

The favourite circuit appears to be a six-valve super-het, comprising a "bigrille" or screened-grid detector-oscillator, two intermediate-frequency amplifiers, one second detector, and two L.F. stages. In some cases the changes are rung by using an initial H.F. stage before the oscillator, or a "trigrille" (pentode) output stage, but there is no outstanding development that calls for comment.

This is rather surprising, because the super-het type of circuit has enjoyed a wide vogue in France for

WITHIN THE WORKS

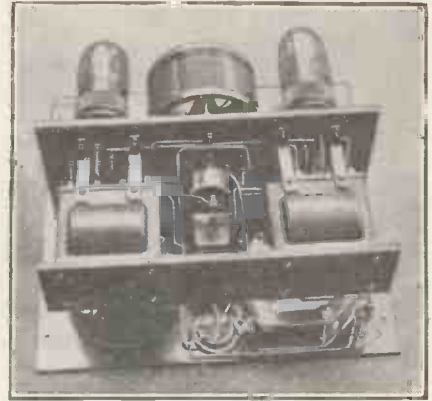

A back view of the inside of a small continental receiver. Note the method of mounting the valves on a shelf behind the panel.

of outside aerials is forbidden by law in the city of Paris. At least, they cannot be erected on any residential flat, which practically amounts to the same thing. Parisian listeners have, therefore, been compelled by force of circumstances to make use of comparatively small frame-aerials and powerful H.F. amplification if they wish to receive any programmes outside the local stations. So that the super-het reigns practically supreme in Paris; and where Paris leads, other listeners, who can afford to do so, follow suit.

There are one or two minor refinements that may be worth mentioning. Most of the better-class models are fitted with enclosed aerials, and various ingenious ways have been adopted to allow the frame to be "orientated," or set in any desired direction without moving the cabinet as a whole. In one case the spindle of the frame is mounted on pivots and is rotated by an outside control whilst in another the windings are supported on a hinged frame capable of universal movement independently of the main cabinet.

For Public Speakers

Another item of interest is a self-contained L.F. amplifying unit, driven from the mains and fitted with a separate microphone attachment (in addition to the usual gramophone pick up), so that it can be used, if necessary, as a portable "public address" system by a speaker addressing a large audience. This might be very useful to budding orators at election time, or on occasions when it is necessary for a speaker to try and "beat the band."

A PARIS PORTABLE



This exceedingly neat and compact instrument is a radio-gram portable of French design and manufacture

NEW WAVELENGTHS FOR BROADCASTING?

By R.L. SMITH-ROSE, D.Sc., Ph.D., A.M.I.E.E.

This is the second and concluding article on the very interesting and important problem of finding new bands of wave-lengths to relieve the present overcrowded state of the ether. In it the author describes receivers suitable for use on wave-lengths between 5 and 10 metres and the results obtained in experiments.



IN a previous issue an outline was given of the probable part which ultra-short wave-lengths would play in the future development of radio communication. A description was also given of some typical experimental transmitters which have been employed on wave-lengths below 10 metres.

Coils and Condensers

In the present article it is proposed to deal briefly with the design and operation of some simple receiving sets which are suitable for the reception of such short waves. During the past few years great progress has been made in the design and development of receivers for wave-lengths below about 50 metres, both in connection with short-wave broadcasting stations and for use at the commercial receiving stations operating on the beam systems.

This work has shown that there is nothing radically new in the design of receiving apparatus for use on very short wave-lengths. The fundamental technique of the subject remains sensibly the same as that employed in the construction of receivers for longer waves. Due consideration must, however, be given to the various effects which result from the large increase in frequency, and also from the fact that sizes of both the inductances and capacities required in short-wave receivers are considerably reduced.

A Fifty-Million Frequency!

For example, stray capacities become of the utmost importance at frequencies of the order of 50 million cycles per second (wave-length 6

BELOW 10 METRES

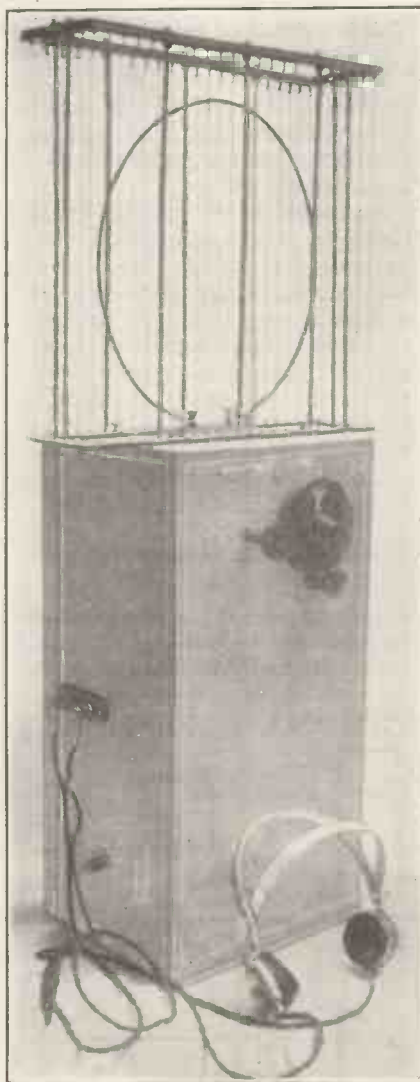

This is an ultra-short-wave directional receiver. It is entirely self-contained, and has a turntable mounted underneath on which the completed receiver can be rotated.

metres), and a very careful layout of the components of a receiver is necessary in order to avoid undue shunting of the currents through such stray capacities.

Standard Circuits

The simplest type of receiver which has found widespread use on wave-lengths below 100 metres is that employing a single-valve detector stage with variable capacity retroaction. For the reception of modulated continuous waves this retroaction can be set critically to a point just below that at which the valve oscillates, while at a point just above this the receiver is very sensitive for the reception of continuous waves.

Since any valve circuit which will oscillate freely at the working frequency can be controlled by suitable adjustment of the retroaction, it is evident that any of the various circuit arrangements which were described in the article on transmitters can be made to serve for reception purposes by a suitable modification.

S.G. and Super-Het.

Where additional sensitivity is required it is usual at frequencies within the medium of the broadcast band and below to employ one or more stages of direct radio-frequency amplification, and the recent rapid development of the screened-grid valve has considerably aided this object in improving the overall sensitivity of the receivers.

As the working radio-frequency is increased, however, it becomes increasingly difficult to obtain any appreciable amplification, and at the present time it appears that the

limiting frequency at which such direct radio-frequency amplification is worth while is found to be about 20 million cycles per second (wave-length 15 metres).

So far little work appears to have been done on the development of the supersonic heterodyne receiver for wave-lengths below 10 metres, although this would appear to offer the greatest possibilities.

While the supersonic heterodyne receiver does not appear to have found favour in this country for the reception of broadcasting, it is used to a large extent in commercial communication, particularly on the shorter wave-lengths, and for some years past the supersonic heterodyne has been quite a popular type of receiver in France among broadcast listeners.

A Practical Circuit

The advantage which this type of receiver possesses lies in the comparative ease with which it is possible to obtain considerable voltage amplification at an intermediate frequency of the order of 100,000 cycles per second (wave-length 3,000 metres). In order to use such an intermediate-frequency amplifier in a short-wave receiver it is necessary merely to precede it by a frequency-changing unit which generates oscillations of such a frequency as to heterodyne those of the incoming signals. By the substitution of different frequency-changing units it would appear possible to extend the range of such a receiver down to the shortest wave-lengths at which receiving valves may be made to oscillate, which, as has been stated in a previous article, is of the order of 1 metre.

The circuit diagram given in Fig. 1 illustrates the arrangement of a simple receiver employing one detector stage with capacity retro-

action, followed by one stage of transformer-coupled low-frequency amplification.

In this arrangement the tuning inductance is centre-tapped, as at this point there is no alternating potential, and by connecting the centre of the coil through a suitable battery to the negative end of the filament any required bias may be

poise connected thereto should be arranged to provide potential variations at these points.

It is, therefore, necessary to ensure that the length of the aerial is not an odd multiple of a quarter of the wave-length, since this would provide a potential node at the connection to the receiver. The condition for optimum reception with this type of

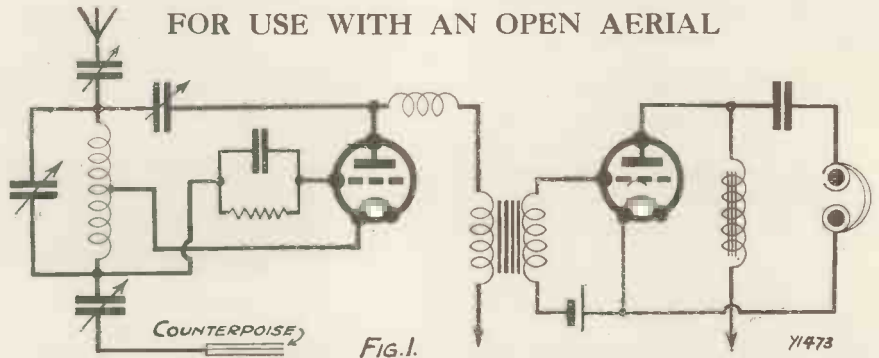

This is a circuit for reception on the very short waves, which makes use of an ordinary aerial and counterpoise. The latter replaces the usual earth connection.

applied to the grid of the detector valve without interfering with any alternating electro-motive forces in the tuned circuit.

An open aerial can be coupled through a small variable condenser to one end of the coil, as illustrated in the diagram. If a definite earth connection is employed it is preferable that this should be to the centre of the coil; that is, the negative end of the filament. If, on the other hand, an insulated counterpoise system is used, this may be connected to the other end of the coil by a variable condenser in the same manner as the aerial.

A. and E. Connections

The important point to observe is that in this circuit the two ends of the inductance coil are at high alternating potentials, and the aerial and counter-

poise involves the adjustment of the length of the aerial and all the controls of aerial coupling, retroaction and tuning.

The correct adjustment of aerial coupling is particularly important, since if this is too great the radiation resistance of the aerial would prevent the detector valve from oscillating, whereas if it is too small a loss of sensitivity would result.

One-Turn Coils

For an experimental investigation of the propagation of ultra-short waves it was considered desirable to dispense with the necessity for using an open aerial. The receiving antenna thus took the form of a closed loop which was mounted directly on a screened box containing all the receiving apparatus, as illustrated in the second photograph.

In this way everything except the pick-up loop can be efficiently screened, a great advantage for many signal intensity and direction-finding measurements. In order to avoid the central tapping at the top of the single-turn loop the circuit arrangement of this receiver was slightly modified, as shown in the diagram, Fig. 2.

The Tapping Point

This arrangement is sensibly similar to that shown in Fig. 1, employing one detector stage and one audio-frequency amplifying stage, but the connection to the negative end of the filament is taken from the centre

A RECEIVER FOR DIRECTIONAL RECEPTION

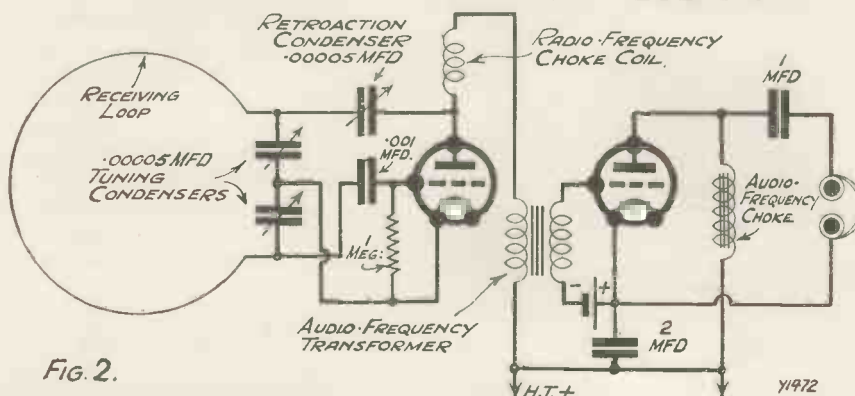

Here is the circuit used in the set seen on the first page of this article. Note how the filament lead is taken to the centre of the double condenser instead of to the coil, as in Fig. 1.

Loop Aerials for the Lower Waves

point of the two tuning condensers which are connected in series across the receiving loop.

In order to make the whole receiver as symmetrical as possible about the central axis of the loop, and also to shorten the length of the wiring to the first stage, the apparatus is arranged in three tiers, as indicated in the photograph on this page.

Interchangeable Inductances

The loop is held rigidly to the top of the box by its terminals, to the underside of which is connected the tuning condenser. The controls for this and the retroaction condensers are taken through the back of the box, and sockets are provided for interchangeable grid leaks and choke coils.

A single audio-frequency amplifying stage is mounted on the middle platform, while the necessary batteries are placed at the bottom of the box. The output terminals for telephones are placed as a shunt across an audio-frequency choke in the anode circuit of the second valve, as by this means the telephone leads and hence the observer are maintained at the screen potential, thus avoiding certain difficulties due to capacity changes.

With this type of receiver a series of interchangeable single-turn loops constructed of $\frac{1}{8}$ in. diameter copper tube are employed. The tuning condenser—which, as mentioned above, consists of two variable condensers in series—has a range of capacity of from 2 to 24 micro-microfarads. With a single-turn loop 5 in. diameter this gives a tuning range on the set of from 4.8 to 6.9 metres; with a 12-in. loop the wave-length range becomes 6.7 to 10.8 metres.

A Lower Limit

The lower limit of wave-length is determined by the minimum capacity across the tuning inductance associated with the valve cap, the valve electrodes, and the connections from the valve holder to the tuning condenser. Although a valve holder may be dispensed with, and a de-capped valve may be used in the receiver, it is extremely difficult to proceed in the direction of shorter

wave-lengths and still retain the flexibility of the receiver for tuning over any appreciable range.

The minimum capacity of the main tuning condenser is reduced as far as possible in the receiver under discussion, but this fact carries with it the fact that the maximum capacity of such a condenser must necessarily be small.

This limitation in capacity restricts the range of wave-lengths which it is possible to cover with any one coil, but, as indicated above, there is no difficulty in making the receiver operate at wave-lengths down to about 4 metres.

When it is desired to proceed to still shorter wave-lengths it is an advantage to remove the stray capacity due to the screened box. In this way the same receiver with the inductance coil reduced to a straight

wire of No. 16 S.W.G., 2 in. long, has been made to operate on a wave-length of 2.9 metres.

In the practical use of this receiver it has been found an advantage to surround the inductance coil by a screen of straight vertical wires insulated at their upper ends. This screen is shown mounted on the receiver ready for operation in the first photograph.

An 8-Mile Fade-Out

This receiver has been used in experimental work for determining the rate of decay of the field strength from an ultra-short-wave transmitter. As is to be expected from theoretical considerations, the absorption of energy from the waves due to the earth at such wave-lengths is extremely great, and signals which are very strong in the neighbourhood of the transmitter soon die away to such a low intensity as to be almost inaudible.

With the transmitter described in a previous article, feeding a current of about one-tenth ampere into a half-wave aerial on a wave-length of 7.5 metres, signals were just audible with the above receiver at a distance of about eight miles.

By increasing the current in the transmitting aerial this range has since been considerably increased.

By mounting the receiver illustrated on a suitable turntable it can be employed as a moderately good direction-finder, and bearings have been taken with this instrument to an accuracy of 2 deg. or 3 deg. at various ranges of from one to twenty miles.

Using Space Waves

All this experimental work has, of course, been done upon those wireless waves which are radiated horizontally along the earth's surface and which are subjected to the absorption effect mentioned above.

It is possible that the range of propagation of these very short waves through the upper atmosphere may enable reception to be carried out at much greater distances of the order of several thousand miles, but the definite settlement of this point must remain the subject of future investigation.

SIMPLICITY !

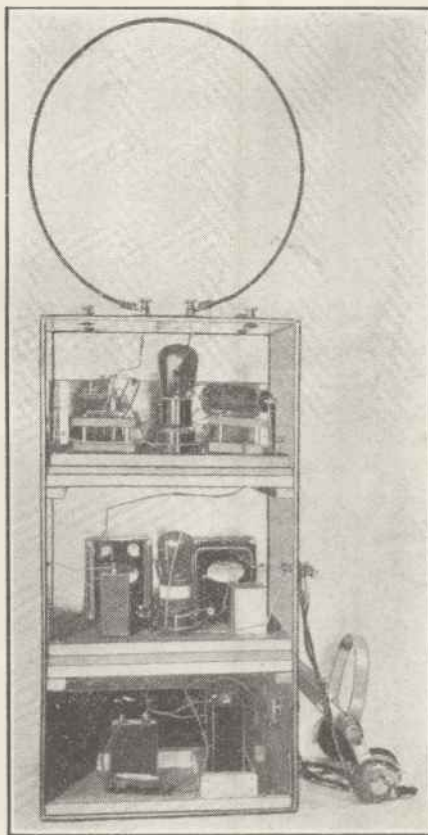

Another view of the directional receiver, showing the extremely simple construction. The loop seen on top serves the double purpose of aerial and tuning inductance.



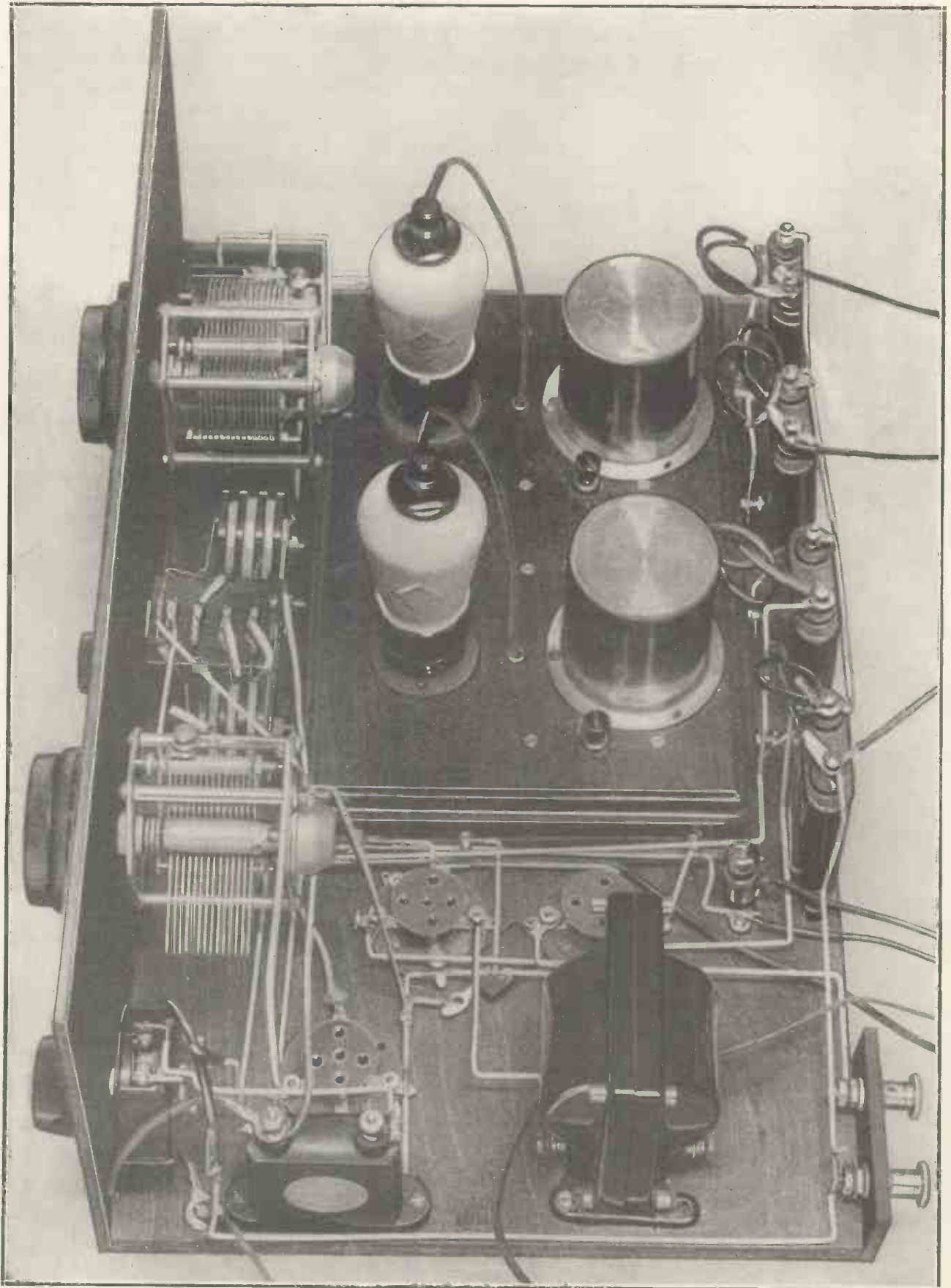

A Triumph of Inexpensiveness and Ease of Construction

The "Simplicity" Super

A Five-valve Super-Het that is as easy to build as an ordinary Three-valver, but will give you scores of alternative programmes and is extremely selective.

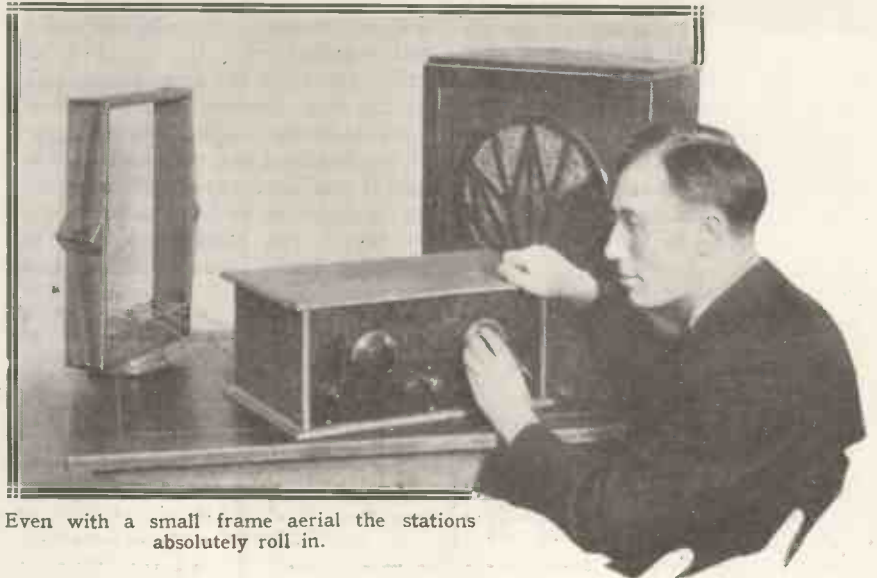

Even with a small frame aerial the stations absolutely roll in.

THE super-heterodyne receiver and economy have hitherto never been associated together, for it has always been thought that this type of receiver is inevitably expensive to build and expensive to run. Because it contained numerous valves, and involved a large anode consumption, the super-het was banned by the home-constructor unless he could operate the receiver from the mains.

Only Five Valves

Why has it been so difficult to design a super-het which would be economical to build and to run? Because with ordinary intermediates and H.F. valves several stages of I.F. amplification have always been necessary in order to get suitable selectivity and good volume. The coming of the screened-grid valve changed this somewhat, but even that did not cure the trouble, for although greater amplification was

obtained, at the same time a loss of selectivity was also apparent in most designs, and consequently two or more stages of intermediate amplification were still the order of the day.

That made the super-het practically useless to the man who could not run it from the mains, while the cost of building was no small item. So MODERN WIRELESS got down to it with the idea of producing a super-het that would give real "super" performance, but would not have more than five valves.

Enormous Efficiency

An apparently impossible task to tackle, you might say, for it seems absurd that one should take an efficient six- or seven-valve super-het

and set out to get the same results with only five valves. But that is what has been accomplished.

It has been done by altering the circuit somewhat from standard practice, if one can say there is a really standard practice in super-het design, and by making the one intermediate stage and the filter give really the last very ounce in efficiency.

Band-Pass Selectivity

So many super-hets which have quite high degrees of efficiency are only kept stable by having deliberate loss introduced into the intermediate stages. The "M.W." super-het which we present this month is so designed that every valve pulls its full weight, while the specially designed band-pass filter and band-pass intermediate enable a

THIS IS THE COMPLETE LIST OF PARTS REQUIRED

PANEL

16 x 7 in. (Becol, or Permcot, Keystone, Parex, Goltone, Wearite, etc.).

CABINET

To take panel and baseboard 10 in. deep (Camco, Pickett, Lock, Kay, Gilbert, Osborn, etc.).

VARIABLE CONDENSERS

2 .0005-mfd. with slow-motion (Polar, or Cydon, J.B., Lotus, Igranic, Ready Radio, Dubilier, Formo, Burton, Astra, Ormond, Wavemaster, Lissen, etc.).
1 .0001-mfd. reaction, with very low minimum (Polar).

SPECIAL UNITS

1 oscillator coupler and on-off wave-change switch (Rolls-Caydon).
1 filter-and-single-intermediate unit complete with valve holders and coupling components (Rolls-Caydon).

VALVE HOLDERS

3 four-pin holders, (Clix, or Telsen, W.B., Lotus, Lissen, Igranic, Magnum, Formo, Wearite, Junit, Bulgin, Benjamin, etc.).

L.F. TRANSFORMER.

1 medium ratio (Ferranti A.F.3, or R.I., Varley, Telsen, Lissen, Lewcos, Igranic, Lotus, Mullard, etc.).

FIXED CONDENSERS

1 .001-mfd. (T.C.C., or Telsen, Ready Radio, Dubilier, Mullard, Ediswan, Watmel, Formo, Lissen, Graham Farish, Ferranti, Igranic, etc.).
4 1-mfd. (Filta and Lissen, or T.C.C., Dubilier, Hydra, Igranic, Franklin, etc.).
1 2-mfd. (Filta, or Lissen, T.C.C., Dubilier, Franklin, Hydra, Ferranti, Igranic, Formo, etc.).

RESISTANCES

4 1,000-ohm Spaghetti (Lewcos, or Bulgin, Ready Radio, Sovereign, Keystone, Magnum, Graham Farish, etc.).

1 1,500-ohm Spaghetti (Ready Radio, or Lewcos, Bulgin, Sovereign, Keystone, Magnum, Graham Farish, etc.).

1 15,000-ohm Spaghetti (Magnum, or Bulgin, Lewcos, Ready Radio, Sovereign, Keystone, Graham Farish, etc.).
1 50,000-ohm potentiometer, wire-wound, with special on-off switch (Magnum).

MISCELLANEOUS

1 terminal strip, 3 x 2 in.
2 terminals (Eelex, or Clix, Igranic, Belling & Lee, etc.).
1 socket strip, 2 1/2 x 2 in.
3 sockets and plugs for same (Clix, or Eelex, Belling & Lee, Igranic, etc.).
1 fuse and holder (Ready Radio, Magnum, Bulgin, Keystone, Belling & Lee, etc.).
Spade terminals, H.T. plugs, G.B. plugs, etc. (Belling & Lee, or Clix, Igranic, Eelex, etc.).
Flex, screws, Glazite or "Lacoline," etc.

high degree of selectivity and magnification to be obtained with good quality reproduction.

Outstanding Points

As our readers are aware, it is not our practice to praise our designs up to the skies with extravagant and hackneyed phrases so well known in many branches of journalism. We prefer our sets to earn their praises in the hands of home-constructors, but we should just like to enumerate a few of the leading points in this receiver before going on to the details of its construction.

provided, together with generous de-coupling, so that even if your H.T. battery is not too good your results will not be spoiled by instability.

Then look at the size. An ordinary 16 in. by 7 in. panel is employed with a 10-in. baseboard, the whole lot being put together with the greatest of ease. Owing to the unit construction of the first detector and the intermediate stages simplicity in construction is obtained to a very high degree, and if you have never built a multi-valve set before we have no hesitation in saying you need have not the slightest qualm about building this

The super-heterodyne receiver as such is not new; it was many years ago that the first circuits were evolved for this extremely interesting type.

Changing Wave-length

The basis of the idea, as many of you probably know, is the changing of the frequency (or wave-length) of the received wave. It is well known that it is more difficult to get efficient high-frequency amplification on the ordinary medium broadcast wave-lengths than at the frequencies used by, say, 5 X X and stations on 2,000, 3,000, or 4,000 metres.

It is not Nearly so Complicated as it Looks From This!

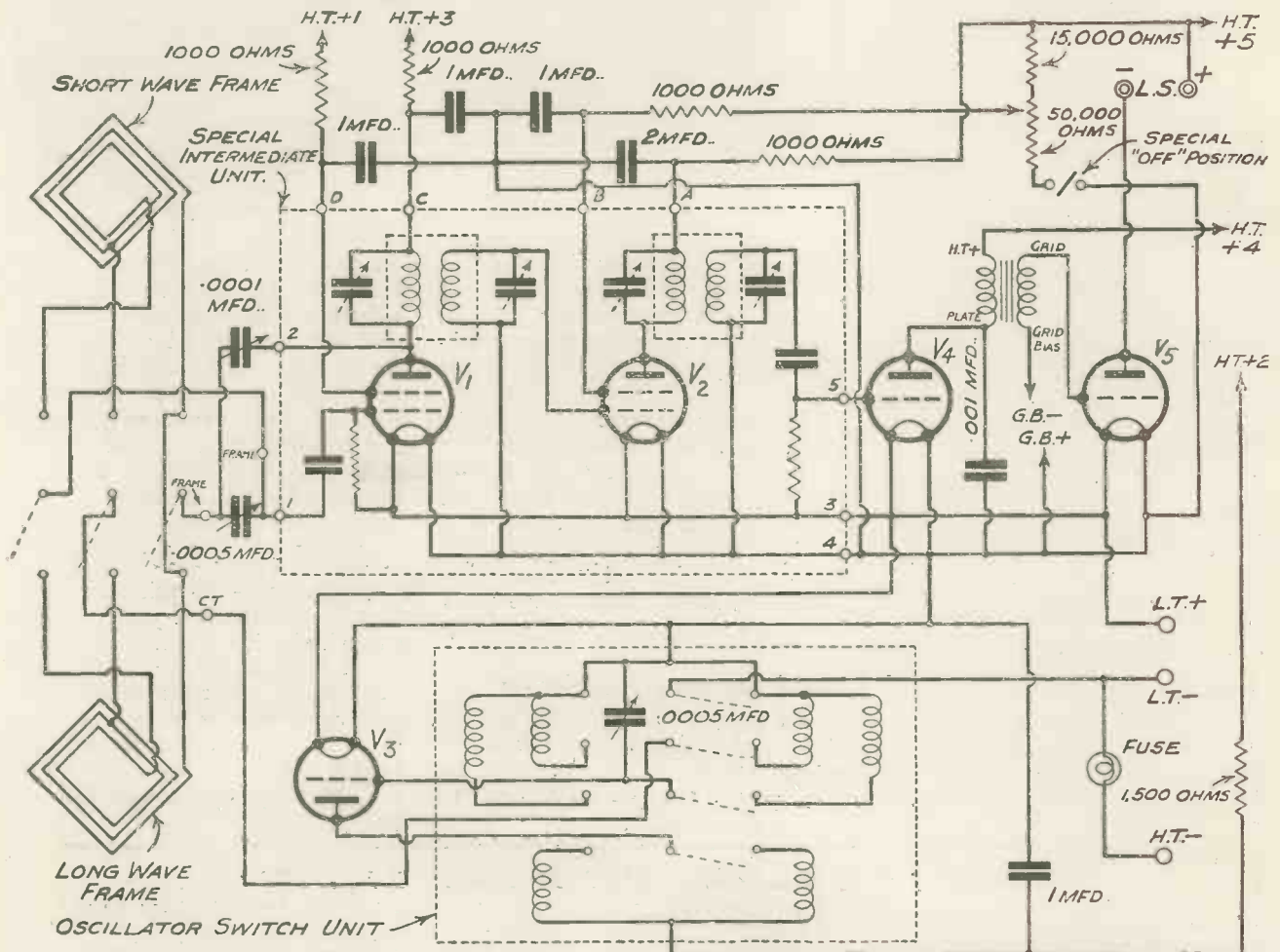

Here is the theoretical diagram of this wonderful set. It is not half so intricate as it appears at first sight, as a lot of the wiring is already done for you in the two special units.

In the first place we have a band-pass filter and a band-pass intermediate. A screened-grid detector is used with reaction on to the frame, which enables you to get from a far-distant station which is already coming in at moderate loud-speaker strength just that little bit more to enable you to get full volume. Completely controllable H.T. voltages in the main sections of the set are

receiver and getting first-class results straight away.

The Super-Het Principle

And then, finally, after you have got it working, if you should write in to us and tell us that it is definitely the finest five-valver that has ever been published, you must forgive us if, though we may blush, we are not surprised!

Much greater amplification per stage can be obtained on these lower frequencies. Obviously, then, if we could only change the wave-length of our local station and its fellows on the 200 to 500-metre band, and make them "transmit" on 3,000 metres or thereabouts, we should be able to get very much better results. But how can we do it?

Here is an analogy, incomplete, but

The Whole of Europe at Your Command!

useful as a basis. Suppose we have two aeroplane engines, and we listen to them as the machines wend their way through the sky. Every now and then we get a sort of droning beat note, which comes out louder than the ordinary steady roar of the two engines. That beat note is caused by the two notes from the engines clashing together and forming a new note every now and then.

Can You "Beat" It?

Again, take two loud speakers giving two single notes. Say, one about 1,000 and one about 1,500 cycles. When these two notes enter the ear we hear not only the two individual notes but also another note of 500 cycles. Now, if we superimpose yet another note on *one* of the two loud speakers, say, a very low, deep bass note, something like 50 cycles, the new 500-cycle note (which is the beat note between the two main loud-speaker notes) will also have on it this 50-cycle "modulation." Then if we could remove the 500-cycle note from the beat note we should have left the 50-cycle modulation.

Now that is a rough analogy of what happens in a super-heterodyne. We take an incoming station (say, 300 metres) and on it we have got L.F. modulation forming the programme. But we do not want the station to transmit on 300 metres; we want our station to be transmitting on 3,000 metres, howbeit we still want the modulation of the programme on it.

Modulation Methods

So what we do is to make a local tunable oscillator which can be made to turn out oscillations at, say, either 1,100 kilocycles or 900 kilocycles, that is, 100 kilocycles away from the 1,000 kilocycles of the 300-metre transmission. Suppose we choose to tune it to 900 k.c.

Now we have two H.F. transmissions, 1,000 kilocycles and 900 kilocycles; the 1,000-kilocycle one being modulated with the programme, and the 900 kilocycles a pure note. We turn these two signals into a "mixing" valve (known as the first detector) and out of it we get a beat note at a frequency of 100 kilocycles, now modulated with the same modulation as the incoming 1,000 kilocycles signal. So we have got out of the detector a 3,000-metre "station" with the same programme as the 300-metre transmission.

This is a rough explanation, but it will show briefly how the super-het works. The next step is to put that 3,000-metre "station" through an amplifier.

Filtered First

It must first be passed through a filter circuit to make sure that nothing but the 3,000 metres and its modulation is going through. Then we amplify it at H.F. and finally detect in the usual way as if we were receiving an ordinary 3,000-metre long-wave station, finally amplifying the results at L.F. in quite the normal manner.

So much for the bare bones of the super-het. It has little snags which appear in the practical form, but

theoretically it is an extremely good scheme. Unfortunately, as you have to have an oscillation generator (which we tune to be 100 k.c. away from the station to be received) and a special detector for "mixing" the two, if we do not look after things we find we get a set having an abnormal number of valves, and therefore being very costly to run as well as difficult to operate. And in keeping down the number of valves we have to be very careful that we do not lose efficiency and selectivity.

Anode Current Requirements

Many modern super-hets, especially the mains-driven types, have seven or eight valves, but, of course, this

WHERE TO MOUNT THE BASEBOARD UNIT

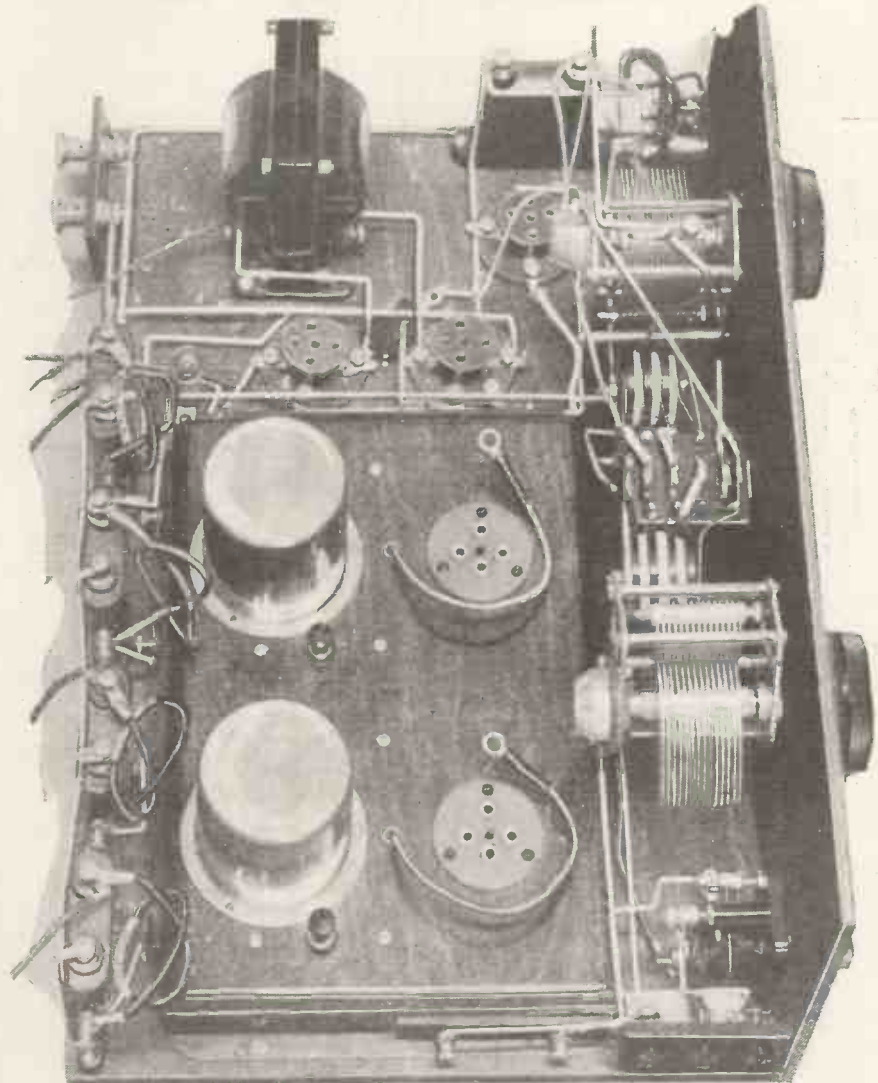

This shows how the special super-het unit is mounted. It carries the first detector and the intermediate-frequency amplifying valve, and all the associated coils are included in the one assembly.

number is practically hopeless for battery operation, owing to the tremendous anode current which would be required.

A Simple Super

Realising all this, the "M.W." Research Department therefore set to work a long time ago to see if it were possible to bring out a small super-het of very simple design so that it could be easily made up, and having not more than five valves. The result is the simple "super" you see in these pages.

There is a system in super-het practice of making the first detector or "mixing" valve act as its own generator of the local oscillation, but that is not a particularly good method for many reasons, which we need not go into here, and so in the design of the receiver we are presenting to you this month we have used a separate oscillator valve. But owing to the exceptional efficiency of the intermediate transformers we have done away with one intermediate stage and so we use only one instead of two, and we have employed a regenerative

screened-grid detector as a "mixer." The remaining two valves are the second detector and the low-frequency amplifier, which latter can be an ordinary L.F. valve or, if desired, a pentode.

Saving Work!

Now the main feature in building a super-het is, of course, the winding of the oscillator coils, the filter, and the intermediates, and it is usually far better for the constructor to buy these ready-made than to attempt to wind them himself; because if he does not

You Can Wire It All Up in One Evening

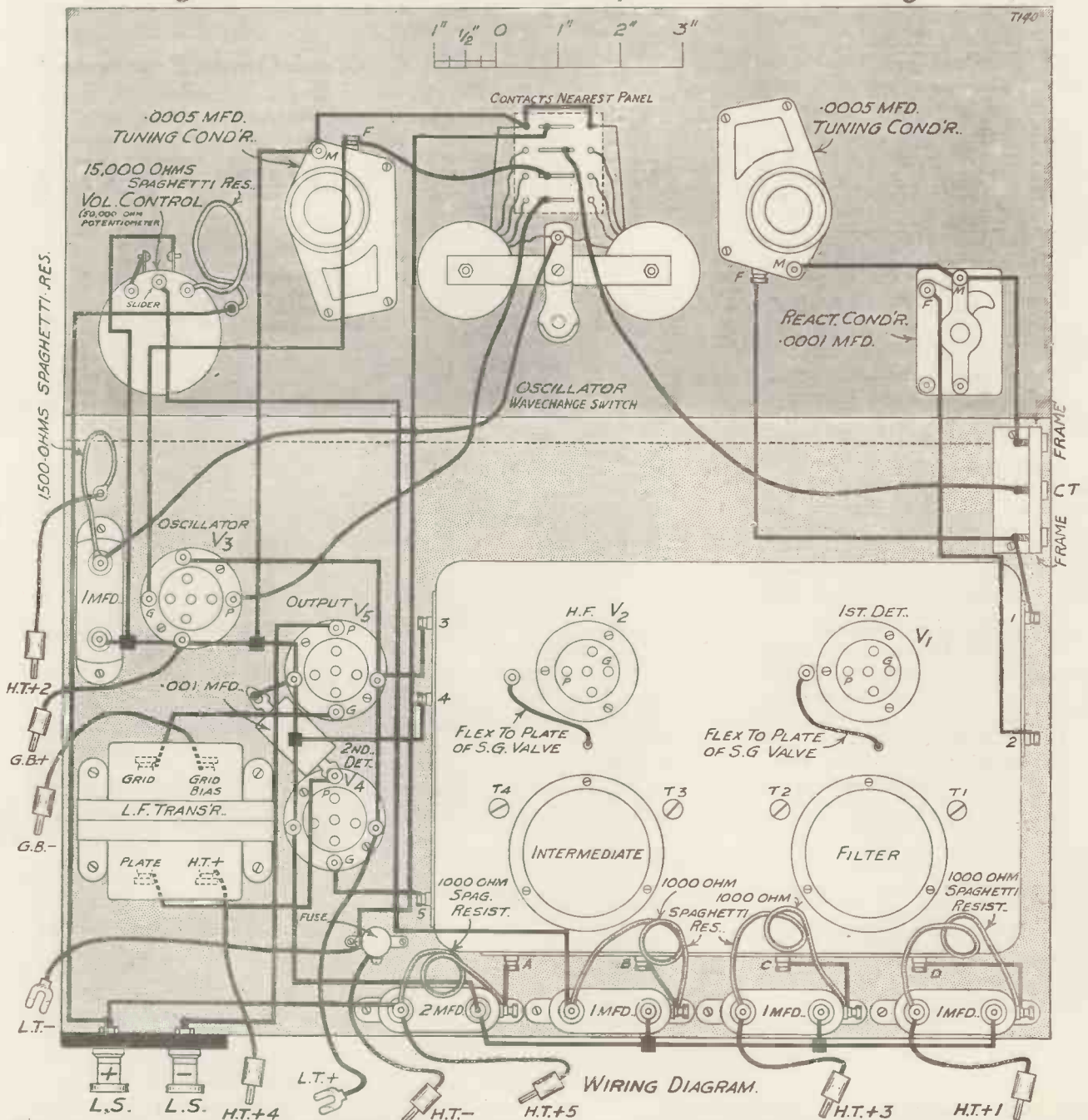

When you look at this diagram you will realise how very easy the job of wiring up will be. When finished it makes a very neat set, and there seems to be no limit to its programme-pulling powers.

A Super-Receiver which is Really Easy to Build

get them just right and get the filter and the intermediates dead in tune he is going to lose a tremendous amount of magnification, and the set as a whole is going to be a failure.

Consequently we strongly advise commercial oscillators and intermediate coils, and in the super-het described here we have used a form of filter and intermediate assembly which is extremely simple for the

covered. The receiver is used with the usual centre-tapped wave-change frame aerial, and any good make of aerial can be employed.

Matched and Ready

The intermediate unit is sent out by the firm in question (whose name you will see in the list of components) properly tuned and matched with the oscillator, all ready for mounting,

out the very signal you want in your intermediates. If, for instance, you are using an intermediate to amplify 100 kilocycles, and the filter is tuned to 150 kilocycles, you will not get very much through.

So these two must be dead in tune, and by obtaining an intermediate unit like the one we have used in this set one ensures that this is the case.

Showing the Main Features of this Wonderful Receiver

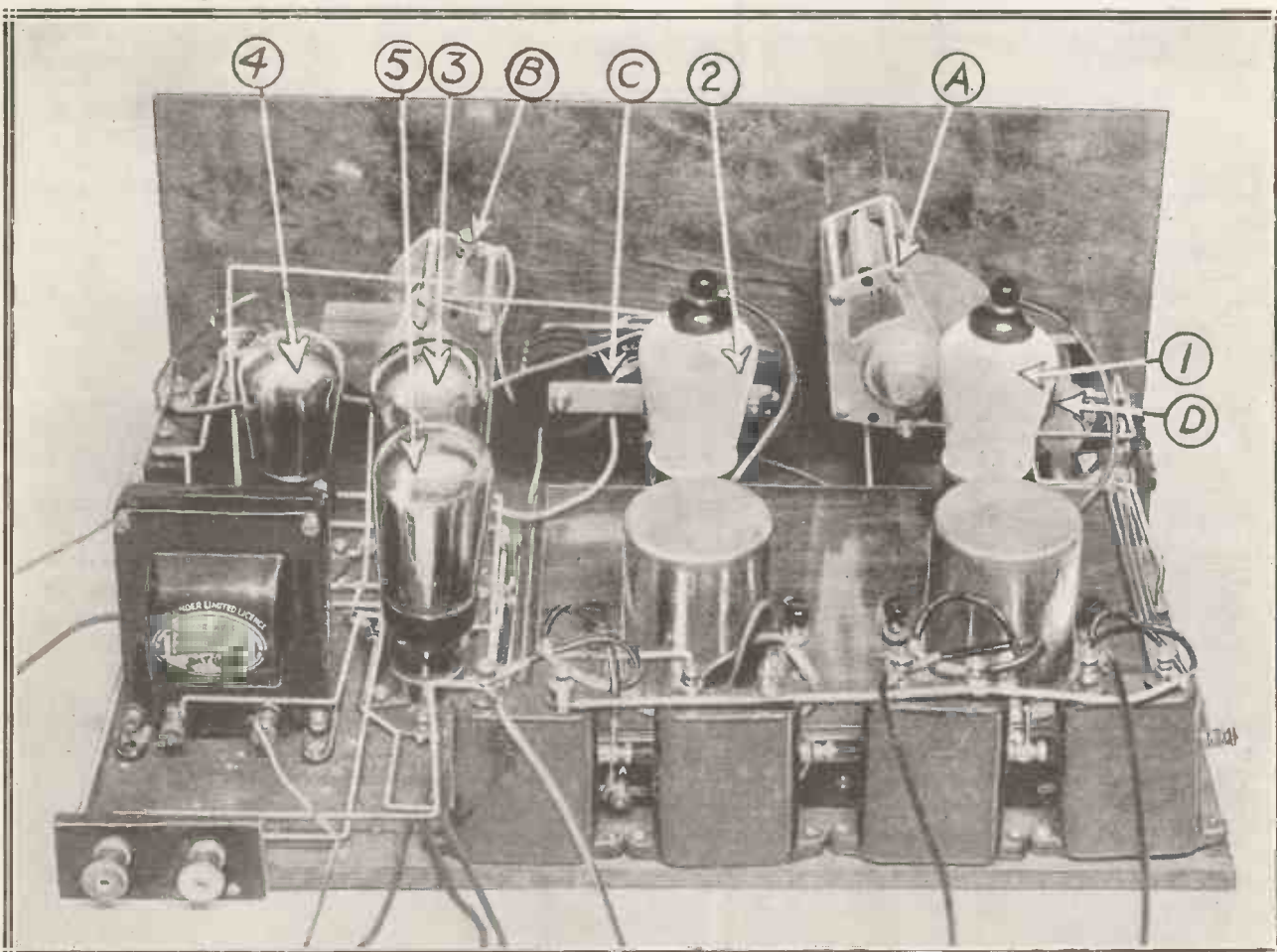

(1) First detector; (2) intermediate-frequency amplifier; (3) output valve; (4) oscillator; (5) second detector; (A) aerial tuning condenser; (B) oscillator condenser; (C) oscillator unit; (D) reaction condenser.

home-constructor, because it is supplied in one unit complete with the detector valve holder, all the coupling devices, and intermediate valve holder on one little baseboard, which is dropped directly into the set and wired up by means of terminals.

The Frame Aerial

The oscillator coil unit is extremely handy, being mounted integral with a wave-change on-off switch, so that either medium or long waves can be

and it is advisable not to touch the little pre-set condenser knobs which you will see on either side of the little copper pots enclosing the filter and the intermediate coils. Once you get these out of adjustment you are liable to have a lot of trouble getting them readjusted.

Obviously your filter circuit, which is in the right-hand foreground looking from the back of the set, must be dead in tune with the intermediate transformer, otherwise you will be filtering

The rest of the set is simple. On the left of the panel, at the bottom, you have a low-minimum reaction condenser (it is essential that this has a low minimum, because on most stations you do not have to use reaction at all, and when you do use some it is only very little).

Control Positions

Next is the aerial tuning condenser, which is fairly "flat" in operation, such as three or four degrees on many

A SUPER STATION-GETTER!

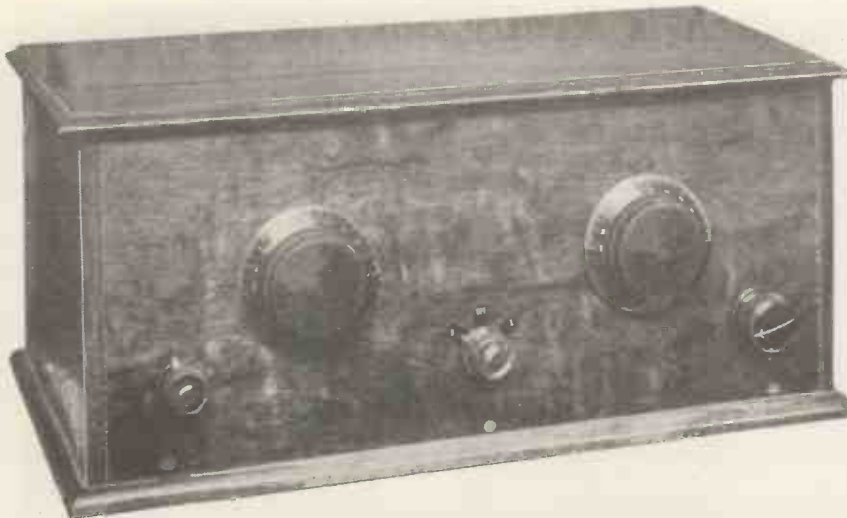

You will be surprised at the results obtained from this unobtrusive-looking set. So easy to tune, too! And stations will come in by the dozen.

stations in tuning; then the oscillator wave-change and on-off switch, the oscillator tuning condenser (which is dead sharp, and you will find that in very many cases half a degree is sufficient to completely cover and lose a station). Finally, on the right is a potentiometer screened-grid control which acts as a volume control, and which, when turned hard over to the left, has an off position, so that you do not lose any H.T. when the set is not in use.

Don't Forget It!

If this had not an off position you would have to remove the negative plug from your H.T. battery every time you were not using the set, in order to prevent a certain drain of H.T. taking place.

Careful de-coupling has been carried out in the receiver, as you will see, the oscillator and the screened-grid valves being thoroughly de-coupled, and transformer coupling between the second detector and the L.F. valve completes the circuit.

In construction it is best, after mounting the components on the panel and baseboard, to commence by wiring up the intermediate unit and oscillator. The actual connections are clearly shown in the wiring diagram, and provided care is taken you should not have any snags in the construction of the set.

Coloured Flex

The oscillator has different coloured flex leads running out from it, and you should be careful that these go to the right places. The white flex lead goes to the oscillator valve anode; there is a brown one which

goes to the centre tap of the frame aerial—that is, from the pick-up part of the oscillator, and there is another one (a yellow one) which goes to the oscillator tuning condenser and to the grid of the oscillator.

Good De-coupling

Finally there is a red one, which goes to H.T. supply for the oscillator valve. This is obtained through a Spaghetti resistance of 1,500 ohms, bypassed by a 1-mfd. condenser to ensure that the oscillator is properly de-coupled.

Three sockets just behind the panel on the left of the set, looking from

the front, are for the frame aerial, which, as we said before, must be of the centre-tapped variety.

The line of 1-mfd. condensers at the back, with de-coupling resistances of 600 or 1,000 ohms, are employed for de-coupling the screened-grid valves. You will note that the Spaghetti resistance de-coupling the oscillator valve is anchored to the baseboard, and a separate H.T. lead is taken from this to the H.T. battery.

Watch the Dummies!

The Spaghetti resistance attached to the potentiometer volume control is of the order 15,000 to 25,000 ohms, and merely acts as a voltage breakdown device, so that one does not need a separate H.T. tapping for the volume control potentiometer which controls the screening electrode of the second S.G. valve; and without resistances, of course, the potentiometer is right across the full H.T. supply, and one would be getting an unnecessarily large current through it.

As regards the row of condensers used at the back of the set, these are the filter type and, as you will notice, have three terminals, one of which is a dummy and is merely used for anchoring purposes. Looking at the condensers from the back of the set you will see that on the right there is a terminal projecting and two on top. The dummy terminal is the one farthest away from the projecting terminal, and is the one to which the H.T. positive leads are taken, and to which is anchored one end of the Spaghetti de-coupling resistance.

The operation of the set is not difficult, but requires a certain amount of practice before one can be sure of getting the best out of it. The H.T. voltages are not critical, with the exception of that going to the screening grid of the detector (first); that is, the H.T. plug attached to the first of the four condensers at the back. This should be placed somewhere about 60 volts and varied until the correct voltage is obtained.

L.T. and G.B.

The next H.T. lead, marked H.T. +3, can be taken direct to maximum H.T. up to 150, and the next H.T. along the back should also be at maximum. The second detector H.T., which is directly attached to the transformer, can be varied, but it will probably be found to work best in something like 100 to 120 volts.

The oscillator H.T. lead which we have already mentioned is anchored

- RECOMMENDED ACCESSORIES.**
- **• Loud Speakers.** (B.T.-H., Amphion, Celestion, Blue Spot, Undy, Mullard, Ormond, Donotone, Rolls Caydon, etc.).
 - **• Valves.** (Cossor, Mazda, Mullard, Osram, Eta, Marconi, Lissen, Six-Sixty, etc.).
 - **• In set:—**
 - 2 Cossor metallised S.G.
 - 1 Mazda H.L.210.
 - 1 Mazda P.220 (see text).
 - 1 Mullard P.M.1L.F. (oscillator).
 - **• Batteries.** H.T., 120 to 150 volts triple capacity (Drydex, Pertrix, Ever-Ready, Grosvenor, Lissen, Fuller, Siemens, G.E.C., National Oldham, etc.).
 - G.B., 9-18 volts (see text), as above.
 - L.T., 2-, 4-, or 6-volt, to suit valves (Exide, Ediswan, Fuller, Pertrix, Oldham, Lissen).
 - **• Mains Units.** Should be very carefully chosen, as good de-coupling and smoothing is essential (Westinghouse, Regentone, R.I., Varley, Tannoy, Ekco, Atlas, Junit, etc.).
 - **• Frame Aerial.** Wave-change centre-tapped (Ready Radio, or Rolls Caydon, Wearite, Keystone, Lewcos, etc.).

A Fine Combination of Simplicity, Selectivity and Power

to the baseboard by means of a screw, and should be placed in about 100 volts, and that concludes the H.T. connections with the exception of H.T.—

The accumulator can be either two, four, or six volts, according to the valves you use.

In the photographs two-volt metallised screened-grid valves are shown, and two-volt oscillator detector and output valves. Grid bias can be in accordance with the type of output valve employed. For average work, and where very large loud-speaker volume is not required from the local station, something of the order of the P.220 will do for the output valve, and

if one tunes to stations which are more powerful, including the local, one still cannot get more than that certain maximum. This, of course, is due to the fact that one gets a tremendous H.F. amplification, and so obtains the full input the detector will handle, and anything over this strength causes distortion.

Some Operating Details

This is one of the reasons why people are sometimes disappointed with super-hets, because they do not get a tremendous ear-splitting signal on the local, although they get just as powerful results from about twenty or thirty different transmissions.

The grid bias, of course, will be according to the maker's instructions for the output valve.

We used the P.220 type and found 9 volts sufficient, but if you use the P.220A. then you may want 10½ to 12. It is advisable to get a battery up to 18 volts if you are going to use valves as large as the 220A.

If you use a pentode, then an extra H.T. tapping must be taken from the side terminal of the pentode to the H.T. battery, or to the fifth terminal on a 5-pin valve holder, and this is placed at a few volts less than the maximum H.T. used on the pentode. We do not, however, advise the use of a pen-

A Very Attractive Panel Layout

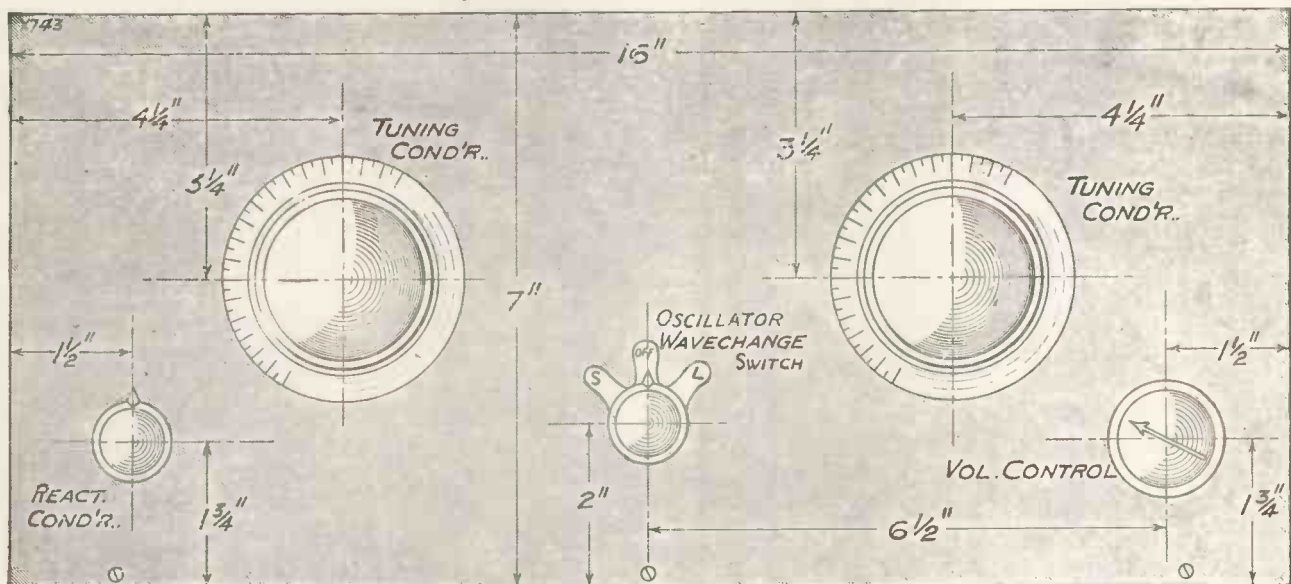

PANEL LAYOUT.

The drilling of this panel will not worry you! There are only five components to mount, and they are all one-hole-fixing.

this gives very good amplification on distant stations.

If a little more magnification is required on the L.F. side one can use a pentode valve, but one has to be very careful not to overload this on a powerful transmission.

Loading the Detector

One is, of course, limited in the size of the output valve and the number of L.F. stages to a certain maximum volume, which will be obtainable not only on the local station but on a great number of other stations as well.

It is a peculiarity of the super-het that one seems to reach the limit at a certain strength, and no matter

As regards the operation of the set, this is perfectly simple. You require an H.T. battery of 120 to 150 volts—the latter, of course, being preferable—and it should be of the triple-capacity type.

The milliamp. consumption of the set is not large, but if you want good, reliable service from your battery it is advisable to have the triple cells. You could use a mains unit, but it *must* be adequately smoothed.

During our tests the two-volters that we used (shown in the photographs) were two Cossor screened-grid metallised valves on the H.F. side, a Mazda H.L.210 for detector, with a P.220 (or, alternatively, 220A.) for output, and Mullard P.M.1L.F. for oscillator.

tode, as we think that probably you will get all you want without the need of the extra magnification available by the use of a five-electrode valve.

The First Test

On switching on the set, controlled by the oscillator switch, try the medium waves first, the oscillator switch going over to the left, and the frame-aerial switch being placed in the medium-wave position. The frame aerial, of course, is connected to the three sockets on the left of the receiver, looking from the front, the centre tap going in the centre socket. It does not matter which way round the other two taps go.

(Continued on page 92.)



The latest H.M.V. model—A good scheme—Some awkward questions—That safety factor.

By "TONE ARM."

I HAVE just been trying out the famous H.M.V. radio-gramophone, model 521. The one I had was of the A.C. type, though D.C. models are available at the same price, and give the same performance—and this is exceptionally good.

As the last valve is a pentode (P.T.625) care has to be taken that it is not easily overloaded on record playing. This is arranged by limiting the maximum input to the first "gramophone" valve to half the voltage output from the pick-up. Even then the pick-up is so sensitive that overloading on very loud passages does occur unless the volume control is "reduced" a little.

An Ideal Arrangement

This scheme is a very good one, and no doubt prevents a great deal of mis-handling and consequent misconception of the musical value of the instrument. The volume control on the radio side (operated by the same knob) is also very ingenious, and consists of a potentiometer across the H.T., which allows the cathode potential of the S.G. valves to be raised or lowered at will. A real brainwave on someone's part. As the 521 is an H.M.V. product nothing need be said about the appearance—it is perfect, and with the tonal quality that the instrument gives it is amazing value at 48 guineas.

And now I must deal with one or two querists' requests—and some of my good readers do ask some awkward questions. How's this for one?

"What output valve do you recommend for my A.C. radio-gram—it has three L.F. stages?"

How can I hope to answer this without half of the issue of "M.W." at my disposal? The Editor (and readers, too) would never stand for that.

Difficult to Answer!

It is a difficult question, and depends largely on the H.T. power supply. If only 200 volts are available, but plenty of milliamps., it is worth trying a P.X.4, or even two in push-pull if a large reserve of power is required, and plenty of volume.

With 250 volts one can try the P.625 or P.625A. valve—if a 6-volt L.T. winding is available on the power transformer.

If you have 400 volts—and I don't expect many people have—it is worth trying the new P.P.5/400 Mazda valve. It is a big "bottle," but gives one a very fine output and plenty to spare. Then, of course, there is the L.S.6A.—not to be sneezed at, I am sure.

"Safety First"

You may think I am a "safety-factor" fiend. Perhaps you are right, but I do like plenty "in hand." If you have to control volume very accurately in order to prevent occasional "blasting," then it is a sure sign that you need a different valve arrangement. The only safe way to avoid such distortion, due to sudden passages of heavy modulation, is to leave at least a quarter of the volume control "in," i.e. to have a quarter to spare *before* overloading normally commences on loud notes.

Then it is not likely that anything which is not really exceptional will ever cause that annoying harshness denoting an overloaded stage.

By the way, a great deal of the bother caused by mains hum in A.C. sets, and, indeed, in battery sets where an eliminator or long pick-up or speaker wires are employed, can be obviated by the use of metal-covered leads.

Useful Wire

I do not mean the heavy lead-covered cable used in house or car wiring, but flexible single or double rubber-covered wire over which a braiding of metal has been woven.

Such wire—obtainable, I believe, from the London Electric Wire Co.—makes valuable heater leads in A.C. sets, and is also very useful for pick-up and speaker cables where any distance has to be covered.

The casing is earthed, of course, and will prevent pick-up from the mains, or transformers, etc., or induction from the heater wiring of the set. Wire of this type is used by quite a number of commercial set makers, and is undoubtedly well worth the attention of the home constructor.

A NEW RADIO-GRAM



This is a general view of the new H.M.V. radio-gramophone which is discussed above.

THE WORLD'S PROGRAMMES HOW, WHEN AND WHERE TO HEAR THOSE FOREIGNERS

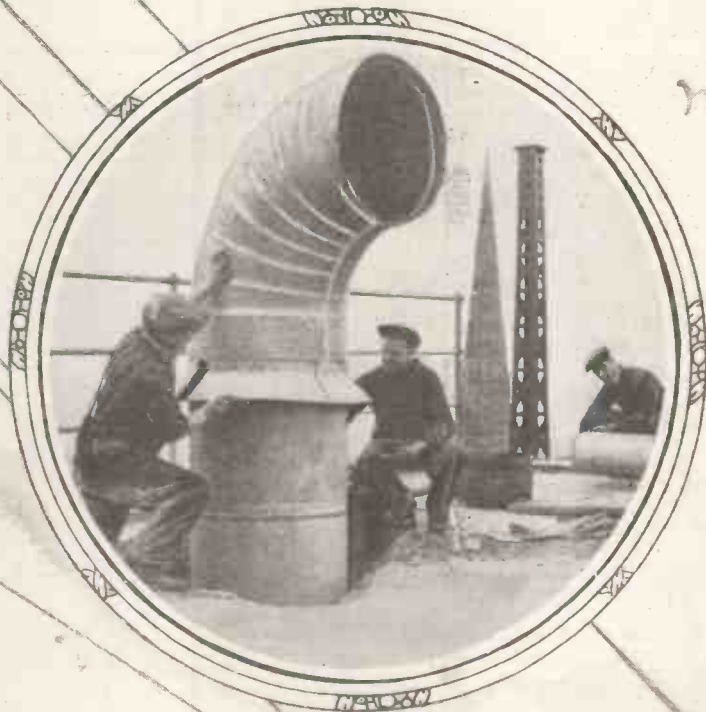

The photograph in the circle above was taken on the top of Broadcasting House, the B.B.C.'s new headquarters in Portland Place, London, W. The huge ventilating shaft is that for the studios.

CONTENTS OF THIS SPECIAL SUPPLEMENT

	Page		Page
News in Brief	.. 22	Here and There	.. 29
Countries to Listen for—		The Medium Waves	.. 30
Denmark	.. 23	Using a Frame Aerial	.. 30
Nauen	.. 24	Those Long-Distance Results	30
In the African Goldfields	.. 27	Short-Wave News and Notes	31
Radio in Other Lands	.. 28	Station Information	.. 32
On the Long Waves	.. 29		



NEWS IN BRIEF

A record of some of the more interesting radio events reported from all over the world.



MILAN is to have a really powerful new station ready by March, 1932. The power will be 50 or 60 kilowatts, in all probability.

ELBE-WESER-RADIO is the name of the German coast station by means of which ships of that nationality can get expert medical advice from the National Hospital at Cuxhaven.

BOLZANO, the low-power Italian relay on 453.2 metres, is reported to be contemplating a six-fold increase in power. The station is not at present heard in this country, its power being only .2 kw.

VIENNA students recently fêted Professor McCallum, who for the past six years has given the English lessons from that station.

FÉCAMP has changed its wave-length from 223 to 219.9 metres. It announces itself as "Radio Normandie."

GENOA has conferred the freedom of the city on Marchese Marconi.

MOSCOW (Trades Unions), on 1,304 metres, announces that the lectures in English are to be given on Sundays and Thursdays at 10 p.m. B.S.T.

RADIO BEZIERS, on 240 metres, has been coming on the air with a cock-crow for a distinguishing signal—and this unusual call is also used by Pontoise, on short waves.

SOTTENS, the first of the new Swiss stations (403 metres), uses a power of 32 kilowatts, which is a little less than half of that employed by Beromunster, on 459 metres.

STUTTGART and other German stations are occasionally relayed from Beromunster,

and it is planned to develop this service further.

FLORENCE is to have a 20-kilowatt station on the air by October next. The date given as likely to be the opening day is October 20th.

BARI (Italy) will be another link in the Italian broadcasting chain when it opens

BEROMUNSTER, which was not officially opened until June 11th, had made a great name for itself on 459 metres long before that date for strength and reliability.

YAMACHICHE, the Canadian short-wave listening post, reports unusually good reception of 5 SW in that country.

THE "NAUTILUS," Sir Hubert Wilkins' Polar Exploration submarine—which is to make a dash under the ice for the North Pole—will use wave-lengths of 800, 750, and 731 metres, as well as various short wave-lengths.

CHARLOTTENBURG, just outside Berlin, has been the scene of some successful very-short-wave reception experiments. The wave-length was only 7.05 metres!

LUXEMBOURG'S new superstation, which will be used as an advertising centre, is to be built by the Société Française de Radiophonie.

COLOMBO broadcasts, which are at present sent out by the coast station that works with ships, are shortly to be sent from a new transmitter specially for broadcasting.

MOSCOW announcements reveal that only about half of the 2½ million radio sets expected to be ready under the Five-Year Plan have been delivered.

KOSICE, on 293 metres, uses a metronome interval signal, ticking 80 to the minute.

DUNEDIN, like Wellington, recently organised a successful radio exhibition.

NABUEL TUNIS has been named as the site for a new North-African station. It is about 30 miles from Tunis, and is to be built by the same firm as Radio-Toulouse was.

RADIO LILLE (265.4 metres) has opened a studio in the Boulevard Haussmann, Paris.

ATHLONE, the projected high-power station of the Irish Free State, is hanging fire over the selection of a suitable site.

DOUBLE-DIAL DIFFICULTIES

These new drum-driven dials, thumb-controlled, hair-lined, and all the rest of it, are very easy to handle. But two ordinary plain dials are not quite the same thing, are they?

Especially if one of them is calibrated up to 100, and the other to 180! For then the guide of similar dial-readings—which is always a bit uncertain—is rendered quite useless.

But, in future, if ever you want to compare dial readings on two different scales, lay a ruler exactly straight across the two shown here. And simply read off the corresponding figure.

Suppose you want to know what number on a 180 dial corresponds with 20 on a 0-100 dial, for instance. The ruler laid across shows it to be 36.

Of course, you could have worked it out by proportion. Twenty being one-fifth of one hundred (the full scale), one-fifth of the full one-hundred-and-eighty would give the required figure. And so on.

But you always find awkward fractions cropping up, so the ruler is much better.

a 20-kilowatt station next April.

KONIGSWUSTERHAUSEN is now much more easily separated from 5 X X, owing to its power having been increased to 75 kilowatts. It uses a metronome, beating 40 times in ten seconds. Wave-length, 1,635 metres.

RADIO PARIS has not yet been able to effect its promised great increase in power, owing to certain difficulties over the land-line link between studio and station. Next October is now given as a likely date for the increase to take effect.

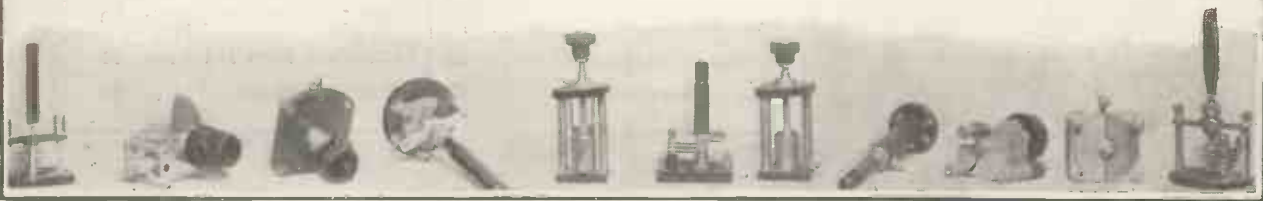

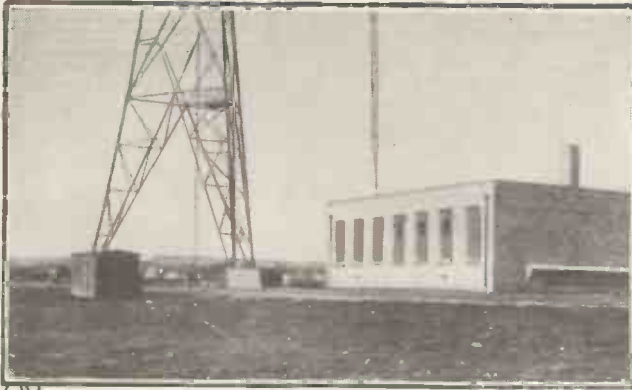

A view of Denmark's long-waver—Kalundborg.

Most radio men know how to get the Danish programmes. The easiest reception is from Kalundborg, on 1,153 metres, who relays the Copenhagen programmes which is sent out from that city on 281 metres.

The short-wave enthusiast knows Lyngby, too. This station again relays the Copenhagen programme, this time on 31.51 metres. These three stations constitute Denmark's broadcasting system.

The country they serve is a small one. Small, but remarkable.

Its population is about three-and-a-half millions. And half of this number live in the towns. Their climate is much like our own, but a little more extreme—colder in winter and warmer in summer.

Agriculture is the biggest industry, and radio reports are a great help in this. Excellent roads, telegraphs, telephones, railways and so forth knit the country districts closely to the towns.

Education is of a high order—English and other foreign languages are taught as a matter of course in many of the elementary schools. And the whole country is highly civilised.

Most of the country is well cultivated, but there are wide stretches of bog and moorland. Also large areas of beech forests. Very beautiful at this time of the year.

The towns—prosperous and well kept—tend to cluster thickest in the south, and on the islands. The constitution, like our own, is a limited monarchy.

“The Athens of the North” is what they call Copenhagen—and those who know Denmark well tell you it is a well-bestowed description. Queenly,

comely, and tranquil, the city enchants all who visit it.

Copenhagen was founded in the 12th century by Bishop Absalon, and its old moats and ramparts are now converted into boulevards. They enclose

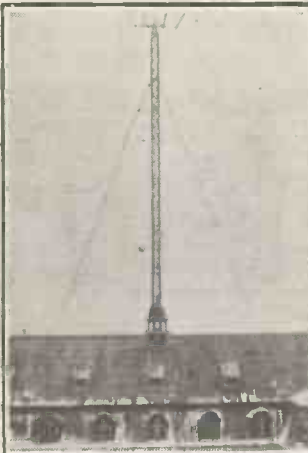

The mast of the Copenhagen station was erected on the roof of the State Telegraphs building.

but the nucleus of the present flourishing city, which with its suburbs has a population of getting on for three-quarters of a million.

It has recently been the scene of an important Radio Conference to which nearly all countries sent delegates.

This Conference was to pave the way to the much-anticipated Madrid Conference, where it is hoped that Europe's wave-length difficulties will be solved.

The Danish capital lies along the eastern shore of the island of Zealand, and on Amager, a smaller island. It is thus at the gateway of the Baltic.

Quaint streets, old buildings, bristling quays, modern business houses, promenades, parks and palaces—all crowded together into a lovable cluster called Copenhagen

COUNTRIES TO LISTEN FOR—

DENMARK

Nearby is Helsingør—or Elsinore, as Shakespeare called it when he painted his pen picture of its tragic prince, Hamlet. This and the whole surrounding country has the matured, well-lived-on aspect that comes with a past of which the present may be proud.

And the Danes are proud. They have cause to be. Britain knew that centuries ago when the Danes tempestuously invaded this country and left their mark upon it.

To Denmark belongs the honour of being the most radio-minded country of all in Europe; that is, the country with more broadcast listeners per thousand population than any other. (Britain holds the third place with about 77 per thousand.)

In Denmark the number of listeners works out at 119.5 per thousand population. Sweden, the nearest competitor, has about 80 listeners to every thousand, so that Denmark's lead is not likely to be challenged for a long time.

Recently the famous Lyngby short-wave station O X Y has moved to a new site at Shamleboek, but its wave-length remains unaltered. It uses rather low power (.5 kw.), and usually relays the Copenhagen programme from 8 p.m. till close-down.

Denmark has had her full share of great men, and to one of them, Oersted, wireless owes a great debt. He was a pioneer in the realm of electro-magnetics.

Oersted was a genius. But he could not have foreseen that electro-magnetic waves would one day link his lovable little country to the whole world.

Kalundborg, Copenhagen, Lyngby—places he knew. Now you know them, or can know them, for they will be on the air to-night.



The orchestra in the studio at Copenhagen.

NAUEN

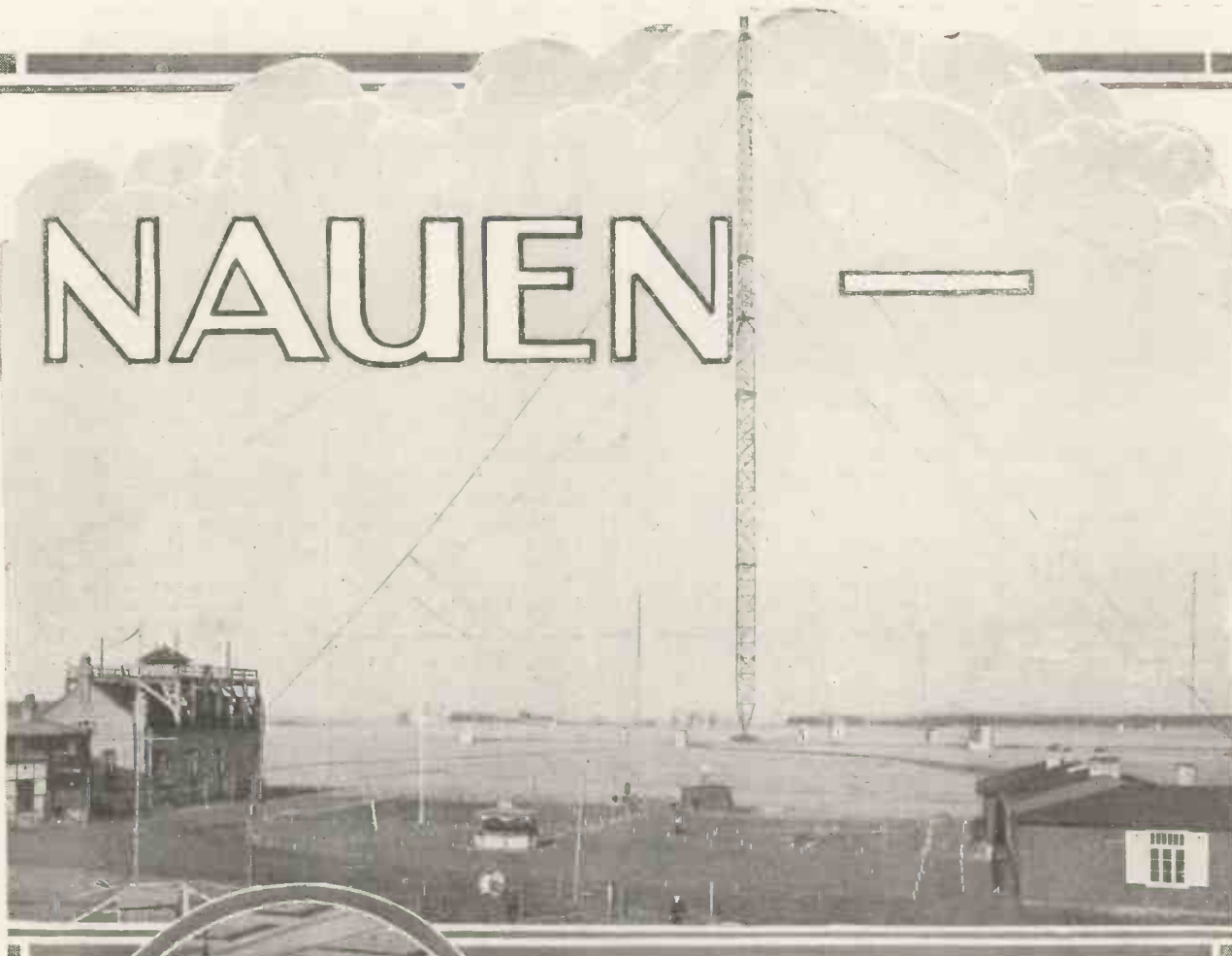

A general view of the famous German station.

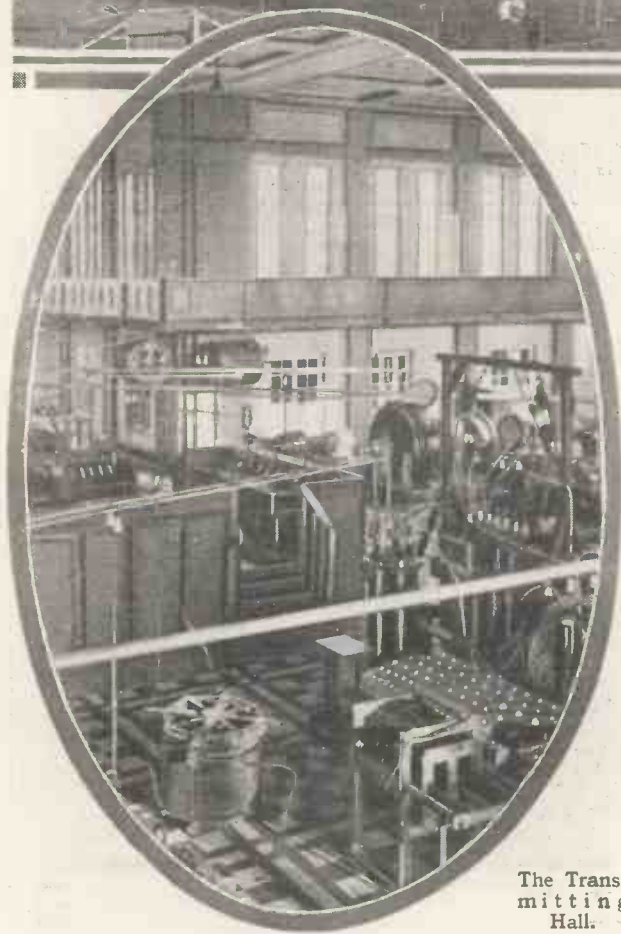

The Transmitting Hall.

I WONDER how many broadcast listeners can remember what a good spark note sounds like, know how a magnetic detector works, or remember ever having to heat the top "pip" of a valve with a match before it would work?

I was reminded of these early relics when recently I met in one of Berlin's side streets a man who was an official of the huge Nauen station—a transmitter colony corresponding somewhat to our Rugby.

Now, I have not been to Nauen since a compulsory visit just after the War, when I met my friend the official, and made pals. We fell a-talking about old times. It appears that celebrations have just taken place because Nauen has been going strong for a quarter of a century.

"You know," said the man from Nauen, "our station is really the grandfather of stations."

The Station's First Transmitter

"The start was really in 1906, in April, if I remember rightly. Of course, spark transmitters were the only things available then, and we were very proud of our huge discharge outfit. In a little wooden shed there were 360 large Leyden jars with cables (absolutely uncovered) leading off in the most dangerous fashion from the foil inner and outer linings of the huge glass pots.

"The frequency of the spark was about 8 or 10 alternations a second, and I suppose, frankly, the resulting note would now be deemed disastrous. It must have spread nearly 100 metres each way, but in those days we thought it wonderful!

"THE GRANDFATHER OF RADIO STATIONS"

Nauen, the huge German station which is as historic as the old Poldhu and Carnarvon stations in this country, has just celebrated its twenty-fifth year, and here our Special Correspondent in Berlin describes a chat with a Nauen official.

"There was a tall iron mast holding the aerial for the spark outfit, and the receiving gear was right underneath this. I dare say that in the light of modern 100-kilowatt broadcasting stations, Nauen's first spark gear would seem prehistoric, for there was no real way of measuring the high-frequency power, and the only figure I know is that of 35 h.p.

"I remember that a big 35-h.p. dynamo was driven by a steam engine—the sort of thing now used to pull roundabouts and other circus impedimenta along the road!

Early Transmissions of Speech

"1908 was a red-letter year, I remember, for in the autumn the station was visited by members of the Second International Radio Conference, and they were able to hear, for the first time, a demonstration of speech transmitted by wireless. You see, up to this time, everything had been done by Morse.

"Valves were not then thought of, and for this speech transmission we used a huge arc transmitter (several arcs in series, as a matter of fact), and for the first time at Nauen a crystal detector was used for receiving. This



The old Nauen station with its Leyden jars is shown here, while above are two of the huge modern valves used for transmission.

Rumour of "Hush-Hush" Generator Proves True

was necessary because coherers and magnetic detectors are no good for the reception of speech. This transmission, by the way, was only over a distance of thirty miles, but it did represent a milestone in radio progress.

"Then, for the next six years, until the outbreak of the War, things went on in a giant's stride. A year after this first speech transmission we were able to scrap the old spark gear and fit a new transmitter, still utilising the spark principle, but having a damped spark gap and

speaking, we felt that Nauen was by then a station to be reckoned with in the ether.

"All during that year the technical people were busy working on a new device which was then of a very 'hush-hush' nature—a new H.F. generator which rumour said would render all our spark gear obsolete; and shortly rumour proved to be true. With this new H.F. affair our signals were picked up in Togo, which is about 5,000 miles away.

"During the fatal year before the War we were in constant touch with New York, and feeling very proud about it, too!

"A year after the War we were once again in touch with America, and in order to get regular long-distance communication we decided to build a separate receiving station well removed from the transmitter, so that there would be no pick-up effects. A place known as Geltow was finally chosen, and when the transmitting gear was installed here we found that we could work in duplex fashion (that is, transmitting and receiving at the same time) to places even as far away as America.

THE NEW POWER HOUSE

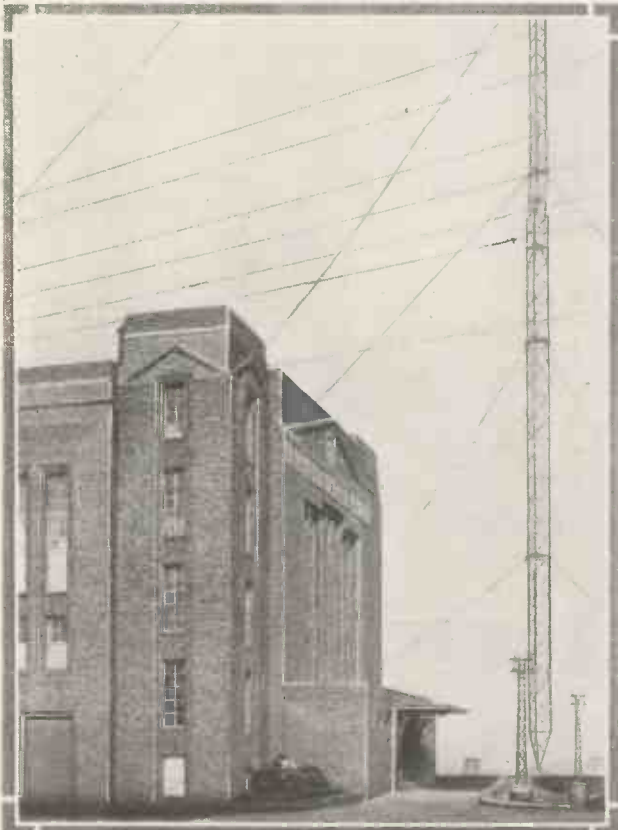

A corner view of the station building which gives a good idea of how big Nauen has grown.

therefore giving a wave having much less spread in the ether.

"We covered several hundreds of miles with this gear, and for the first time we were able to measure our high-frequency power in the aerial system. The magnificent figure was 30 kilowatts!

Reports from Ships' Operators

"In 1910 we had several reports from ships' operators who had picked up Nauen's transmission, and, of course, all the daily papers jumped at this. The possibility of using Nauen to increase the safety of ships at sea was first realised.

"A year later a new station was built at the side of the small hut housing the historic spark apparatus of 1906. The power was put up to 100 kilowatts in the aerial; a new mast, some 500 ft. high, was erected, and, generally

Short-Wave Press Service

"Then some Siemens' engineers came along with a novel idea for type-printing by wireless, and within a few months we had this new system working very satisfactorily.

"In 1924 we opened a new department for short-wave working, and for some fortunate natural reason Nauen proved to be a good centre for short-wave transmission. Within a few months we had a fine short-wave transmitter in regular working, and we opened a press news service to China and Japan and, a year later, to South America, covering the world in one stride.

"Short-wave working is now established as a permanent auxiliary to Nauen's long-wave transmissions, and there is, frankly, not any reception point on the whole of the earth's surface which Nauen cannot reach either by long- or ultra-short-wave transmissions."

And that is just exactly what the German official told me.

"PUFFING BILLY" OF THE PAST

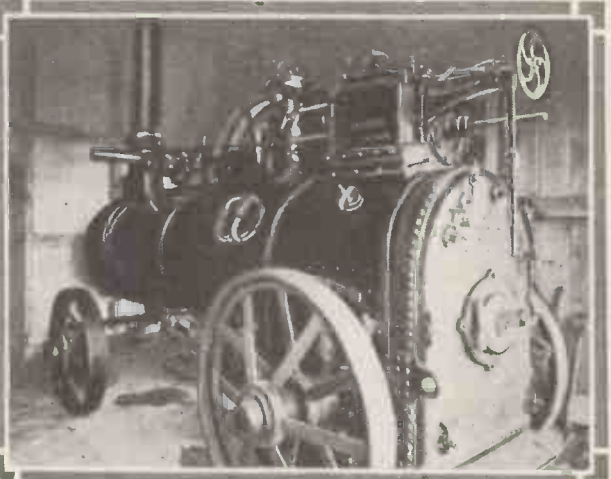

This is the old steam engine which supplied Nauen's power in 1906.



IN THE AFRICAN GOLDFIELDS

An "M.W." reader's experiences of short-wave radio reception.



Sir,—Whether you are interested in short-wave reception in Ashanti I do not know, but I take the liberty of forwarding to you a three-months' record of short-wave wireless reception in what is considered the *worst spot* in the country.

Now I wish you would carefully study the photograph I send you with the following remarks I make :

(1) Is the main shaft workings of the goldfields I am with, and the whole of the buildings near are full of motors, dynamos, etc., etc.

Very Bad Screening

(2) Is the gas plant department. A huge place which generates a D.C. approximating 250-260 volts, and is full of generators supplying power to the whole of the camp and bungalows. (The whole area is one network of heavy cables carrying current.)

(3) Types of hills and forests which surround us for many miles.

(4) My bungalow is on a level with the mines, and is surrounded on three sides with cables, besides having a corrugated iron roof.

(5) The tree from which my aerial is suspended to my bungalow.

Types of Aerials

Reference aerials: Short, long and medium. After experimenting, I find that: (a) In regard to my position and locality, a short aerial of 30 to 40 ft. is poor; (b) medium, 100 ft., first-rate; (c) long, 140 ft., good, but not equalling the 100-ft. supraerial.

My set is a straight three (not screened grid), coupled to a Burne-Jones short-wave converter.

I use 2-volt accumulators and an Ekco D.C. H.T. eliminator. I have the choice of three sets of valves, Mullard, Cossor, and Triotron.

I have heard so much about the rotten reception in this part of the country that I feel really pleased to be able to send you my report of experiments in the worst place one could be.

WHERE THEY GET THE GOLD!



This is the picturesque setting from which our correspondent wrote his letter dealing with his results this year on short wave-lengths. The figures were inserted to mark the various points referred to by him in the letter on this page.

These are stations which come in when conditions are favourable:

Pittsburg East; Rome (always at full power); Chelmsford (but I wish with more power); Schenectady; Bound Brook, N.J.; Nairobi (occasionally), and several other stations bounce in when reception is good.

I am overjoyed to hear Big Ben boom into my bungalow, but I do wish Chelmsford would equal Rome in power.

Wishing "M.W." and "P.W." the greatest of success,

I am, sir,

Yours faithfully,

(Major) F. W. SHARPE.

Obuasi, Gold Coast,
West Africa.

Editorial Note.—The three-months' log of stations picked up makes most interesting reading, but only a few extracts from it can be reproduced here.

We should, however, like to thank our correspondent for the opportunity of perusing it. It certainly shows what a wonderful link with the world is provided by a good short-waver!

Some Typical Entries

24.1.23. Erected aerial.
French station—concert.
German station—concert.
Roma-Napoli—Tango band.
Three other stations on speaker, giving talks and singing.

19.2.31.

At 5 p.m. tuned in Rome with delightful piano solos (L.S. strength).
11.3.31.

Rotten reception. Spoilt by lightning throughout the evening. America on L.S., also Rome. England for a minute. All poor.
23.3.31.

Rome loud, but "wavy."

Heard Big Ben strike 7 p.m. Chelmsford was good. A talk, music, and a group of songs by a lady.

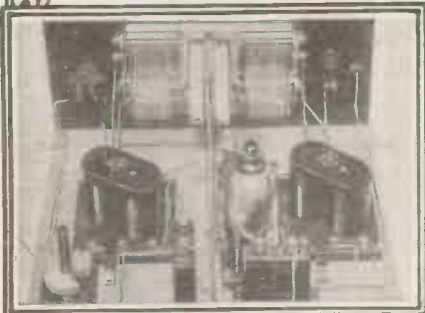

NEXT MONTH

The August issue of "M.W."
—another fine number—will be
ON SALE AUGUST 1st

ORDER NOW

if you want to make sure of it!

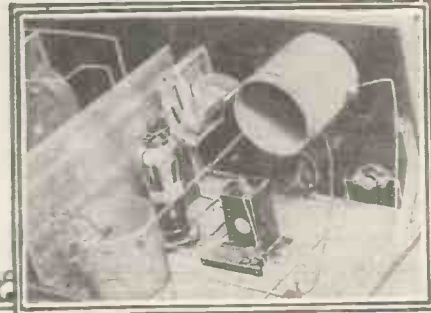

RADIO IN OTHER LANDS



The fancy striped trousers of the singers above are not for platform effect, but are the distinguishing marks of convicts! These four are singing from the Philadelphia Eastern Penitentiary, from which programmes by inmates are frequently broadcast.

On the right, Jumbo is taking exception to the Hamburg microphone, when interviewed during a touring circus broadcast, and in the centre of the page is some sheer happiness. (She is supposed to be "reporting" the scene on the beach at a popular Californian summer resort!)



Rome's new motor-road is the scene of the picture at the bottom of the page. Radio-equipped cars are tooting past the judges' stand, and Mussolini himself leads the procession, driving an Alfa-Romeo. The road was made solely for motor traffic.



Atmospherics have certainly been "playing up" on the long waves during the past few weeks. Even so reception has not been seriously hampered—at least not from the point of view of one who has heard the *real* atmospherics of the tropics! (There they sometimes seem to strip the ear-drums! So that the disgruntled tsssssszzz or fzzzz experienced in this country, or the occasional sharp crack of a not-too-distant lightning flash seems very small beer indeed.)

The big noise of the past month has certainly been the Berlin long-wave relay at Zeesen—or, if you like to call it by its older and longer name, "Königswusterhausen." At the beginning of June the power was advanced from 35 kw., and the station is now working on a maximum of 75 kw.

Reception has been very good since the change was made. Even in bright mid-day conditions the separation from 5XX has been comparatively easy, and the results after dark have been very gratifying.

Much of this station's charm in the past has been due to its orchestral music, in which the Berliners specialise. The greater power has generally enabled reception to be much better in quality, because reaction need not now be "pushed," as in the past. Altogether a very satisfactory change.

Higher up the scale, Radio Paris has been good in strength, though



the programmes appear to be falling off, and not quite up to the standard of last winter. Great interest will centre around this station shortly, when its promised big increase of power will bring it to much more familiar terms with British loud speakers.

Above Radio Paris my only pat on the back goes to Huizen, as Lahti has proved nothing more nor less than a wash-out. It was rumoured, by the way, that Lahti's beautiful wave-length (1,935 metres) was the subject of much covetous discussion at the Copenhagen conference.

On the lower half of the long-wave dial Kalundborg has been my best station for daylight

reception, though often marred by Morse interference. Eiffel Tower and Kalundborg are bracketed together as good programme providers, all the other competitors in this part of the scale being much inferior to these two.

Oslo does not seem to be the station it once was, so far as reliability goes. Although occasionally during the past month excellent programmes have been obtained, I should class the famous Norwegian as a temperamental programme provider on his recent form. Not to be compared to Kalundborg, for instance.

Warsaw Number 1—incidentally, the Number 1 station of Europe so far as power is concerned—has

been good. But not so remarkably good as one might expect from its power rating, which might lead the interested searcher to suppose that these programmes would stand out from among all others like a giant in Lilliput.

Warsaw is not a bit like that. It is just a good, clear station, not so very different from any other, even when distance is taken into account. Motala, on a neighbouring wave-length, and using only 40 kw. against Warsaw's 158, makes an uncommonly good showing by comparison, don't you think?

The question of Morse interference on long waves seems to be likely to cause considerable difficulty as time goes on. It is not so much that any particular gate-crasher butts in and spoils reception either here or there on the long waves, but it is rather a question of stray callers continuously dropping in to spoil the wanted programme.

At the bottom of the long waves the aeronautic activities around and above 900 metres tend to increase, but they have the merit of being interesting. The beacon stations, on the other hand, are anything but interesting. Infernal would be a better description!

These stations are like Tennyson's brook—they go on, on, on for ever! To give them their due one must admit that they are tireless; but having said that the entry on the credit side is finished, and all the rest is dead loss!

OVER THE FIVE-FIFTY-METRE MARK

A list of the European broadcasting stations with wave-lengths greater than 550 metres.

Wave-length in metres	Name of Station	Remarks	Wave-length in metres	Name of Station	Remarks	Wave-length in metres	Name of Station	Remarks
560	Kaiserslautern (Germany)	(Relays Munich)	800	Kiev (Russia)	—	1350	Kasbah (Tunis)	—
560	Augsburg (Germany)	(Relays Munich)	840	Nijni Novgorod (Russia)	—	1352	Motala (Sweden)	(Relays Stockholm). 40 kw.
565	Smolensk (Russia)	—	937.5	Kharkov (Russia)	—	1411	Warsaw No. 1 (Poland)	158 kw.
566	Hanover (Germany)	(Relays Hamburg)	1000	Leningrad (Russia)	—	1445.7	Eiffel Tower (FLE)	15 kw.
570	Freiburg-im-Breisgau (Germany)	(Relays Stuttgart). 0.3 kw.	1060	Tiflis (Russia)	—	1481	Moscow (Old Komin-tern) (RAI) (Russia)	—
574.7	Ljubljana (Yugoslavia)	2.5 kw.	1071	Oslo (Norway)	75 kw.	1538	Ankara (Turkey)	—
587.1	Hamar (Norway)	(Relays Oslo)	1073	Rostov-Don (Russia)	—	1554.4	Daventry, National Station (Gt. Brit.)	35 kw.
680	Lausanne (Switzerland)	—	1103	Moscow, Popoff (Russia)	—	1635	Königswusterhausen (Zeesen) (Germany)	(Relays Berlin). 75 kw.
700	Minsk (Russia)	—	1116	Novosibirsk (Russia)	—	1725	Radio Paris (CFR)	17 kw.
720	Moscow	(Experimental).	1153	Kalundborg (Denmark)	(Relays Copenhagen). 10 kw.	1796	Lahti (Finland)	(Relays Helsinki). 54 kw.
760	Geneva (Switzerland)	15 kw.	1200	Reykjavik (Iceland)	21 kw.	1875	Huizen (Holland)	—
770	Ostersund (Sweden)	(Relays Sundsvall). 0.75 kw.	1200	Istanbul (Turkey)	—	1935	Kaunas (Lithuania)	—
778	Petrozavodsk (Russia)	—	1229.5	Boden (Sweden)	0.75 kw.			
			1304	Moscow (Trades Unions)	—			

JOHANNESBURG. This station is now working every day from 4.30 to 9.30 p.m., on 49.4 metres.

ZEESEN. This famous German short-waver is usually on the air from 2 p.m. till after midnight, relaying attractive German programmes, on 31.38 metres.

HALIFAX (NOVA SCOTIA). A new transmitter is being

HERE AND THERE

installed by the Maritime Broadcasting Company, to work on the 49-metre band. Call-sign: VE9CF, relaying the programmes of CHNS. The times provisionally arranged are midnight to

4 a.m. (B.S.T.). Tuesdays, Thursdays, and Fridays.

SKAMLEBAEK. References to this station as a relay of the Copenhagen programmes sometimes give the impression that it is an additional

transmitter. Actually it is the new site of the Lyngby station, retaining the call-sign OXY, and working from 8 p.m. onwards daily.

MELBOURNE (VK3ME). This well-known Antipodean has extended its working hours, and now broadcasts on both Wednesdays and Saturdays from 11 a.m. to 12.30 p.m. B.S.T. Wave-length 31.56, power 5 kw.



THE MEDIUM WAVES

Some Notes on Reception Conditions.

Now that Great Britain has grappled with the Regional Scheme in real earnest, the Leeds transmission on 200 metres is a thing of the past. Cork is the first English-speaking programme that occurs when working up from the bottom of the dial, this transmission being on 224.4 metres.

Just how well or badly Cork has been coming over recently I have not noticed. The programme is hardly likely to entice one to tune down specially for it, and the strength has not been outstanding enough to be noticeable when the dials have been turned towards the nearly-all-out position.

CLIMBING UPWARDS

Ascending the wave-length scale, the next British programme is Belfast, on 242 metres. Rumour has it that this station is going to get a substantial increase in power before the Regional Scheme is considered complete. (The programme quality is certainly pleasing enough to make this welcome.)

The really powerful British programmes begin at 261 metres, where the London National resides; and except for the bunch of relays on 288.5 metres, Cardiff always came in next. Now this is altered, and the National version of the North Regional has been sitting immediately above Hilversum.

It is too early to speak with certainty about the effect of this change, but most South of England listeners will frown heavily at the Northern "National" if it interferes with Hilversum. They could always rely on a cheerful little earful from that station on 298.8, and anything that blankets it will be disapproved of most heartily.

According to the calendar this is the low-water period for radio reception conditions, but the results obtainable lately have been nothing to grumble about. Atmospherics have often been there, of course, but generally speaking they haven't been at all bad on the medium waves.

A REAL WANDERER!

At the lower end of the dial to which we have been referring, Heilsberg makes a firm bid as the best foreigner. Turin has been good, though it still commits the mortal sin of pushing out its programme on 296 metres or so, instead of the 274.2 metres allotted to it.

On the upper part of the medium-wave dial—appropriately enough not far from Lyons—the Swiss roll in! Sottens is very good indeed. His power is 32 kw., and Bero-munster, with 77 kw., is not much louder at his best, and sometimes not so good.

There are several stars clustered near Sottens. Hamburg (372 metres) and Toulouse (385 metres) are much in demand, being known as likely to put across a good concert any evening. Between them is one other foreigner, viz., Lv6w, the recently polished-up Polish station, now working with a power of 21 kw.

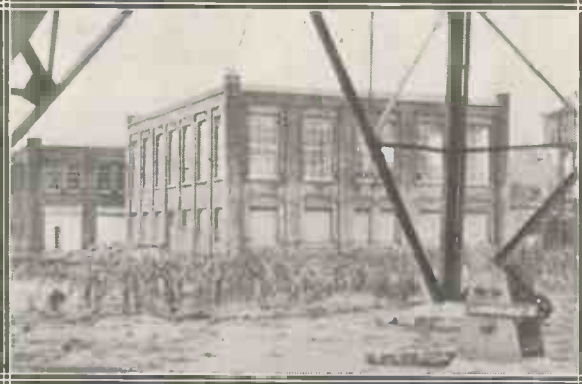

This is a view of one of the newly-erected station buildings at Brussels. That city is well served with radio, the main stations working on the following wave-lengths: 509, 338, 280, 246 and 216 metres.

BRITISH ITEMS OF INTEREST

LONDON long-distance listeners may be interested to know that a London branch of the Anglo-American Radio Society has now been formed. Inquiries should be addressed to Mr. W. A. L. Smith, 55, Cadogan Terrace, Victoria Park, London, E.9.

DAVENTRY 5XX sends out a check signal twice a week about 9.45 a.m., in the form of a note of 4,064 cycles, to enable the relays to check frequency.

BELFAST station will probably be moved outside the city and eventually have its power considerably increased, as a part of the B.B.C.'s Regional Scheme.

BRISTOL is to hold a radio week from September 21st to 30th this year. (At the same time there is to be a West of England Radio Exhibition in the Colston Hall.)

USING A FRAME AERIAL

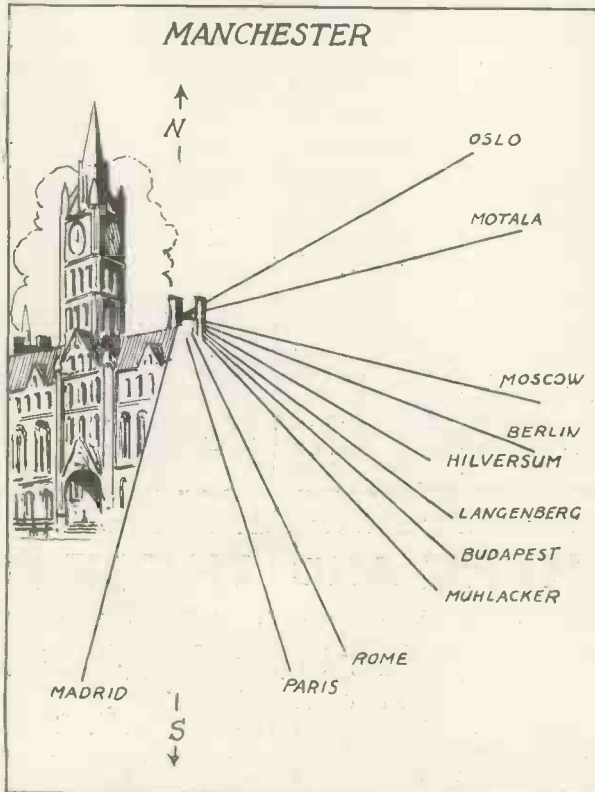

As you probably know, the strength of reception on a frame aerial largely depends on which way it is pointed. (The windings should be directed at the station desired.) Last month we gave bearings of some of the principal stations for London listeners' benefit. This month's sketch shows Manchester district listeners how to point the frame for various foreign stations.

THOSE LONG-DISTANCE RESULTS

A few further words about last month's challenge to DX men.

Dear Sir.—Upon perusing my June MODERN WIRELESS to-day I was rather amused and astounded to read "an earful" on DX fans in general, taken from the pen of a Mr. Jean d'Vincent, of Denham, Bucks.

This Mr. d'Vincent is not a stranger to me, as he recently challenged me to prove my reception when details had appeared in a local newspaper. After dealing with various questions he put to me in the Press, I invited him to visit me—Denham being only two miles from here—when I would certainly do my best to turn his scepticism into a reality of what radio could do.

After my invitation appeared in the Press I awaited for Mr. d'Vincent's arrival. He did not turn up! After waiting two weeks I wrote again to the paper a sort of S.O.S., and again inviting Mr. d'Vincent to turn up. From that day to this I have not heard or read a word from our friend, until I read his elaborate attack upon DX'ers in "M.W."

PROVING HIS POINT

Now I should like to know upon which particular point Mr. d'Vincent is wanting me to prove. I have letters and cards of verification from a large number of the farther stations I have received, including 100-watt Americans.

I have (as Mr. d'Vincent should know if he has read my communications to you carefully, and also the Editorial note at the end of one of the letters) gramophone records I have made of a number of American stations, including WIOD, WABC, WTIC, WPG, WJZ, WEA, WKBW, WTAM, WOR, WGY, KOA, XED, PLE, PLM, 31CD (Saigon), 1AB (Singapore), 2XAF, 2XAD, 1XAZ, 3NAU, 3XAL, 8XK, 9XF, and many others. Does Mr. d'Vincent consider that I say that and run the risk of persons asking to hear them when I have not received the stations?

Well, I can only assure him that it is not so, and also that I invite him a third time to visit me at my address, when he can hear my radio, "going it," when I know that he cannot honestly be otherwise than converted.

Yours faithfully,
LESLIE W. ORTON.
Kingsthorpe, Willowbank,
Uxbridge, England.

ESPERANTISTS

The broadcasting of Esperanto talks appears to be catching on in many European countries. During a recent week, for instance, Lille and Leipzig were giving Esperanto talks on Sunday; Vienna and Leningrad on Tuesday; and Paris (P.T.T.), Lyon-la-Doua and Kaunas on Thursday.

On Friday, Mühlacker and Leningrad were on the air with Esperanto, and on the Saturday there were six stations—Hilversum, Huizen, Heilsberg, Lyon-la-Doua, Kharkov, and Leningrad.

In nearly half the broadcasts took the form of an Esperanto course, the remainder being news.

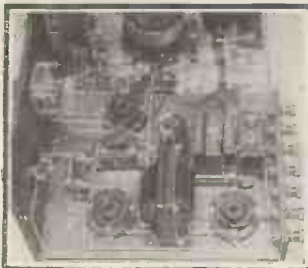

SHORT-WAVE NEWS AND NOTES

Interesting items from all over the radio world.

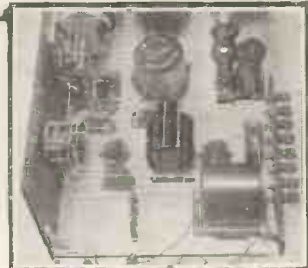

MEDELLIN (COLOMBIA). This station works on 50.6 metres every weekday from midnight on. It is situated in the Hotel Europa, which is frequently mentioned in the announcements.

"ILE DE FRANCE." This famous French liner uses the call letters FNTM, and wave-length about 180 metres.

SP3KYL. This call-sign belongs to Miss Helen Malinowska, a short-wave transmitter of Posen, Poland. She thinks she is the first European short-wave worker to be engaged as a result of radio, having first become acquainted with her fiancé "over the air."

KOOTWYK. This famous Dutch station is credited with an amusing record—that of waking up the inhabitants in the middle of the night by a cock-crow, accidentally sent out by Bandoeng, Java. This was so piercingly received in Holland that the local birds were awakened and thought the dawn was at hand!

THE EMPRESS OF BRITAIN. This wonderful new liner has an elaborate radio-telegraphic equipment as well as short-wave telephone apparatus for two-way conversations.

RADIO POZNAN. The Polish short-wave relay at Radio Poznan, which is crystal-controlled on 31.35 metres, works on Tuesdays from 7.45 p.m. to 10.45 p.m., and on Thursdays from 7.30 p.m. to 2 a.m. The power is 1 kw.

PERU. The thirty transmitting amateurs of Peru, who work under the prefix O A, were closed down in May due to political upheavals.

ALLAHABAD. The Univer-

VE9GW. This is the call-sign of Bowmanville, Canada (see above). This station would like reports on its 25.4-metre experimental transmissions.

ALLAHABAD. From this city amateurs are now working telephony on 150 metres.

H V J. The Vatican short-wave station works partly in English on Tuesday evenings, 7 to 7.30 p.m., on 50.26 metres.

"POSTE C 12,000." This is the (temporary) call of the Pontoise station, France.

MADRID. The Spanish capital has been carrying out single-side-band telephony tests with Buenos Aires and Paris on short waves.

HAWAII. Following the European example, the Hawaiians are constructing 5-metre radio-telephony links between the various islands.

K U K U. These four letters are the call-sign of the American expedition to the unhealthy Matto Grosso Jungle, Brazil, which has not been heard on the air since April, when the operator announced that he was beginning to feel ill. Considerable anxiety is felt in America for the safety of the expedition.

ASMARA (ERITREA). This neighbourhood is quoted as the probable site of an experimental station to relay the Italian colonial short-wave programmes.

LAHORE. A report from India says that the 100-watt amateur station is planning to duplicate its 340-metre programmes on 21 metres.

SINGAPORE. This station works on 41.7 metres on Sundays and Wednesdays, from 3.30 to 5 p.m. B.S.T

Where the Favourites are Found

19.56 metres.	Schenectady (U.S.A.)	W2XAD
25.25 "	East Pittsburgh (U.S.A.)	W8XX
25.4 "	Rome (Italy)	3RO
25.53 "	Chelmsford (Essex)	G5SW

city officials are reported to be experimenting with wireless in connection with a war on locusts and similar pests!

MADEIRA. The Funchal station (CT3AG) has now stopped transmitting on 47 metres, and opened up on 24 metres under the call-sign CT3AQ.

BOWMANVILLE (CANADA). A new transmitter has taken over the Bowmanville transmissions on 49.22 metres, working on weekdays from 11.45 a.m. to 3 p.m. and 8 p.m. to 3 a.m.; Sundays, 5.30 p.m. to 4.15 a.m.

AMERICAN SIGNAL CORPS. It is disclosed that A.S.C. engineers are using tiny transmitters, weighing about 1 lb., to broadcast from the upper atmosphere, on 130.5 metres. They are sent up attached to balloons, which rise to a pre-arranged height before descending to earth.

CEYLON. This island is installing a special aerial and receiver to receive the G5SW broadcasts.

PONTOISE, recently inaugurated, the new "5SW of France," having a power of about 13 kw.

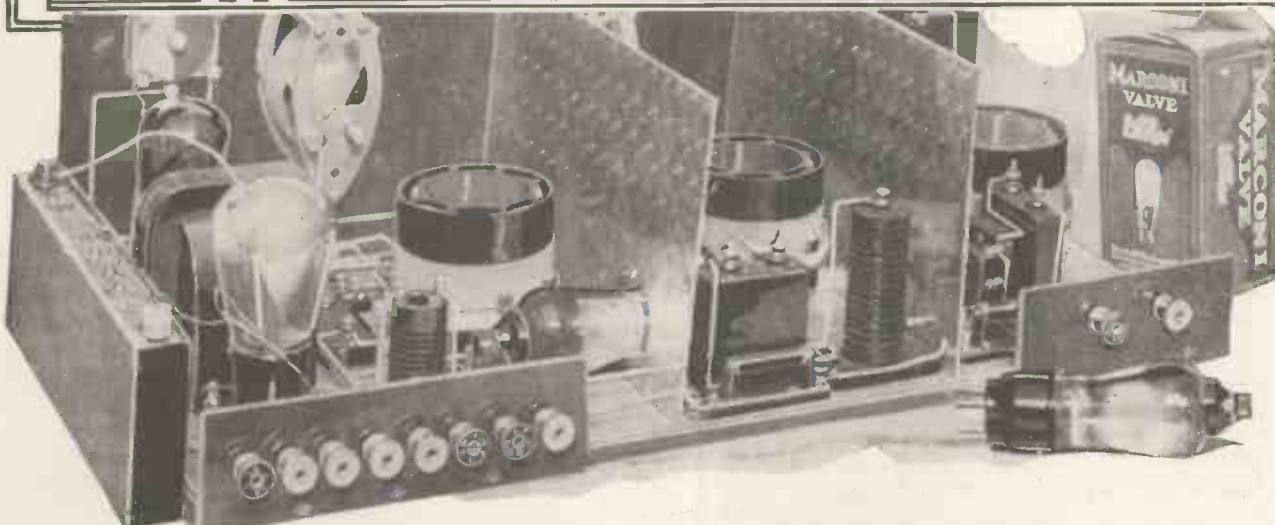



WARSAW No. II, which is "standing by" until the new long-wave Warsaw completes all its tests, will probably be turned into a short-wave relay when no longer needed for its old purpose.

WILNO has been sending out tests of its 22-kilowatt on 244 metres.

SOVIET authorities are trying to trace an anti-Bolshevik propaganda station which has been broadcasting on Tuesday, Thursday and Sunday afternoons. It closes down with the old Russian National Anthem—"God Save the Tsar."

KAMPALA. The new Air Ministry telegraphy station on Kololo Hill was due on the air in June. The power is 3 kilowatts, and local residents are hoping that, like other stations on the Cape Air Route, it will eventually be used for concerts as well as for plane messages.

VIENNA runs a radio-equipped motor-van to get running commentaries of sports and outdoor events through to listeners.

MANILA does not now broadcast on short waves, the only programmes going out being the one on 485 metres.

Station Information

News and Views of the World's Radio Activities and Interests.

HAMBURG gives an unusual broadcast early every Sunday morning in the form of a "Harbour Hour." It takes the form of a microphone visit to a ship in the port, descriptions of the scene, sirens, etc.

SAN SEBASTIAN, Spain, has recently been closing down with "La Marsellaise."

LILLE, France, arranged to broadcast the Lord Haig monument ceremony at Montreuil on June 28th—a day

the "benefit" of a silent night, now transmits nightly.

VIENNA recently broadcast a unique programme of ticks, tocks, and chimes from its famous Clock Museum, where many old, rare and beautiful clocks are housed.

DONGES is to be the site of a powerful French C.W. station to be used for communicating with French vessels anywhere on the North or South Atlantic. It will thus be the "Rugby of France."

THAT FRIEND OF YOURS ABROAD!

Why not send him "Modern Wireless" every month, to keep him in constant touch with all the latest radio news and developments?

Post his name and address with 17s. to the Subscription Dept., Amalgamated Press, Ltd., Fleetway House, Faringdon Street, E.C.4, and "M.W." will be sent every month for a year.

or so before this issue of MODERN WIRELESS is on sale.

BERLIN district listeners are benefiting greatly from the increased power used by their long-wave relay at Zeesen (Konigswusterhausen) which has more than doubled its power.

SPAIN has not adopted a summer-time this year.

WELLINGTON, which formerly gave New Zealand listeners

NEW YORK claims that in the Astoria Hotel, radio fans are better catered for than in any other in the world. Any one of its 2,000 rooms can have the choice of six programmes, but in 150 of the rooms provision is made for connection to an outside aerial, to enable DX enthusiasts to try for the distant stations.

ITALY has eleven female announcers, and only one male!

PARIS has been considering the holding of a Radio Con-

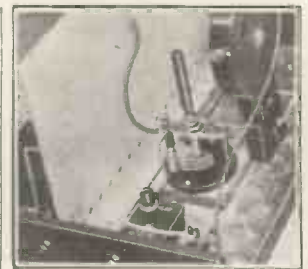

gress in connection with the Overseas Exhibition before it closes in November.

THE EMPRESS OF BRITAIN, which recently ran her maiden voyage for the Canadian Pacific, has a direction-finder and lifeboat sets, in addition to the main long and short-wave apparatus.

ESTONIA is the only country in Europe in which radio appears to be declining in popularity. The Tallinn station, which works on 296.1 metres, is situated in the town formerly known as Reval (Russia).

GENOA is due to increase its power this month (July). The new figure is 10 kilowatts, as against 1.5 kw. in use last month.

BUDAPEST is greatly interested in the probable developments of the recently introduced Radio Act, which calls for a 150-kilowatt station for that city.

LOS ANGELES has combined with **KANSAS CITY** in laying down a radio beam service between the two cities, so designed that it gives the pilot a visual indication of his route, and even in thick fog will show up any deviation.

HOW THE WORLD'S STATIONS PASS THE TIME

Clocks Abroad Compared with B.S.T.		
BARCELONA - 11 a.m.		MADRID - 11 a.m.
BERLIN - - 1 p.m.		NEW YORK - 7 a.m.
EAST PITTSBURG 7 a.m.		PARIS - - - Noon
FRANKFURT - 1 p.m.		SAN FRANCISCO 4 a.m.
Hilversum 12.20 p.m.		TOULOUSE - Noon
HEILSBERG 1 p.m.		TORONTO - 7 a.m.
LEIPZIG - - 1 p.m.		VANCOUVER - 4 a.m.
LYONS - - - Noon		VIENNA - - - Noon



A brief account of our experiences with the latest Cossor battery receiver—a four-valver of unusual merit.

COMMANDER! What does that name conjure up before you? A leader? A stately figure that will master opposition? One who has climbed to a high position, and reached a pinnacle well above the multitude?

All true pictures; and applicable no less to the radio receiver with which we are here dealing than to the responsible position attained by some relatively few members of the human race.

It was Well Chosen!

What does one expect of a person (or set for that matter) bearing such a title? A masterful display of power; energy that is directed along well-defined channels toward a definite goal that will undoubtedly be reached. The title is one that conveys a very real impression of mastery. And it is one which has very rightly been chosen for the Cossor four-valve battery receiver illustrated in these pages.

A mere description of a set usually conveys very little to the general reader—it is only of assistance to the technically-minded enthusiast, who revels in circuit designs and the whys and wherefores thereof.

Ganged Tuning Control

So suffice it to say that the Cossor "Commander" is a four-valve (2 S.G.) receiver having every modern refinement, including completely ganged tuning control, and enclosed in a compact cabinet which also houses the dry batteries.

The photographs give a fairly

good impression of the appearance of the set, and of how the general layout is arranged. It will be seen that the valves are mounted in a row, with the ganged condensers between them and the tuning coils.

A Preliminary Canter

Underneath is room for the H.T. and G.B. batteries, and marked flex leads to these do away with the need for a lot of bothersome terminals.

The on-off switch is at the back, between the low-tension terminals, and the other controls are accessibly and artistically arranged.

On receiving the set from the manufacturers we at once decided to give it a test in our London research room before taking it out into the country in order to carry out an examination of its distance-spanning power.

No directions were enclosed with the particular receiver we tested.

ON THE UPPER DECK



The set itself is on a shelf, with H.T. and G.B. below it.

A Set to Suit Every Family

probably because of the maker's confidence in the very simple arrangement of the receiver. Anyhow, the whole thing was so simple that it was but a very short time before it was hooked up and working. Naturally, full directions for operation are enclosed with each model placed on the market.

A few minutes after hooking up we counted the stations we had received on the loud speaker in full daylight. They numbered nine.

"Not very many for a four-valver,"

to be "sneezed at." It held great promise for future tests.

The Foreigners "Fall In"!

Four of the stations were on the long waves and were very well received (a fifth was just audible), while the other five included the two London stations, and the Midland and Northern Regionals—all at good loud-speaker strength.

And searching was so easy, too—the programmes seemed to be eager to

first brief tests in London. Station after station rolled in, and a very merry couple of hours were spent after sundown in picking out the stations by means of their interval signals, call "signs," and the various announcements.

Although the situation of the test aerial is only 7 or 8 miles from Brookmans Park, no trace of trouble due to this proximity was experienced, and the two stations were not only easily separated, but several foreigners who lie between the London National and London Regional wave-lengths were picked up perfectly clear of interference from the locals.

On Both Wave-Bands

The Midland Regional, too, was received clear of the London Regional—a feat that is not possible in that district on any but a really good set. The Northern Regional, of course, romped in, and so did Rome, Toulouse, Brussels, Mühlacker, Langenberg, Hamburg, Heilsberg, and dozens of other lesser known continentals.

After we had fairly exhausted the medium waves we went "upstairs," and had a good "look round" the long-wave band.

There they were, all the old favourites, at good strength. Radio Paris and Eiffel Tower perfectly clear of 5 X X, with Königswusterhausen not far away, and Huizen finishing off the top end of the long-wave band in fine style.

Polskie Radio was in fine fettle, too, and so was the Moscow station in the middle of the tuning scale. Of course, a certain amount of reaction had to be used on some of the stations, but it was perfectly easy to pick-up several dozen programmes at good strength without having to drag them out of the ether on the ends of attenuated threads of oscillation.

For the Old Folk

As a family set the Cossor "Commander" is likely to satisfy everybody. The old folks can tune in their local programmes without trouble, while the more adventurous can satisfy their radio wanderlust by touring the ether whenever they feel so inclined.

As an article of furniture, too, the receiver commends a high measure of respect, for its well-finished cabinet, with its artistic "panel" front, enables it to be included in the decorative scheme of any room without the least chance of its looking out of place.

THOROUGHLY WORKMANLIKE DESIGN

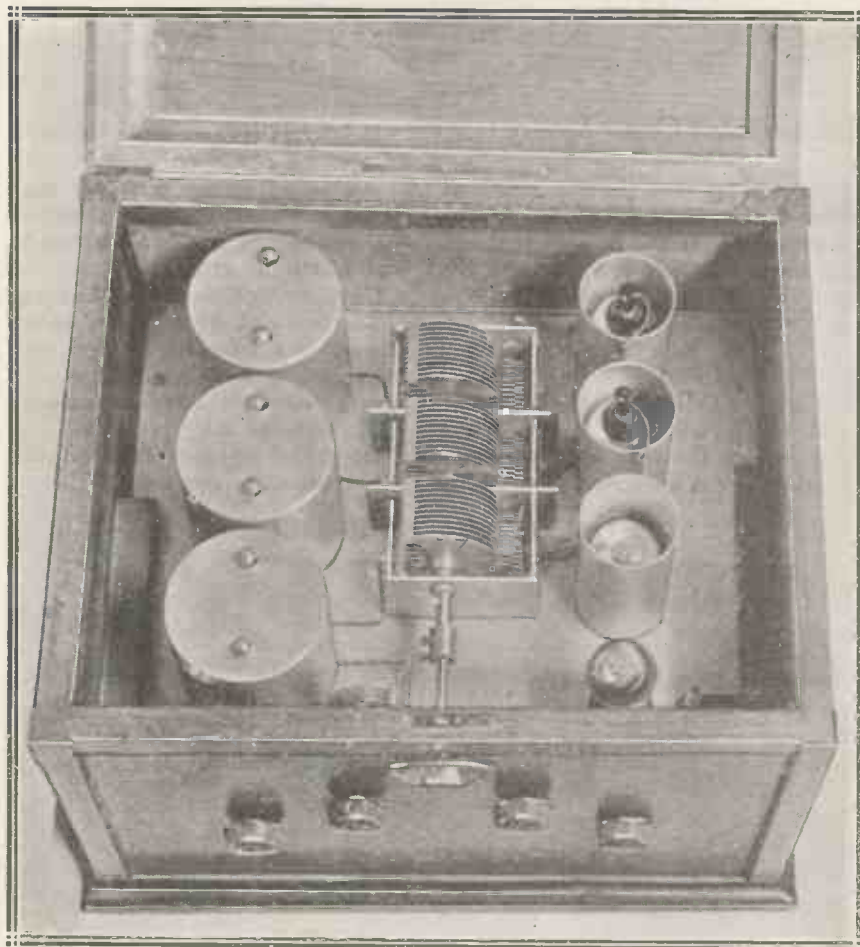

Extremely neat is the method of arranging the valves and the tuning coils, on either side of the ganged tuning condensers.

you say. Not at first sight, perhaps, but you must not forget that this test was being carried out under some of the worst possible conditions.

Very Promising

Right in the heart of London at 11.30 a.m., with a low aerial running over a lead-covered roof, and an earth system that was by no means perfect, such a performance was certainly not

obey the commands of the set to "fall in."

After this preliminary canter the set was packed up again and a few days later was taken out to "somewhere in Hertfordshire," where it was given much more stringent comparative tests against a standard receiver on a really decent aerial-earth system.

The results more than justified the confidence that had been born of the

MY BROADCASTING DIARY



Our own Broadcasting Correspondent records the progress of the British Broadcasting Corporation, and frankly comments on the policies in force at B.B.C. headquarters.

Future of Syncopation

THERE has been a good deal of public interest about the position of B.B.C. dance music, and in particular about the money which Mr. Jack Payne is making. I have been making inquiries about the remuneration for this very popular feature of the programmes, and I find the B.B.C. rather reticent about the arrangement with my friend Mr. Payne.

This, of course, is hardly to be wondered at, in view of the fact that for both quantity and quality these broadcasts are exceptional.

Religious Broadcasting

The attitude of the Roman Catholics towards broadcasting has been considerably stiffened of late. On the whole, the Catholics have taken a move which seems to me is an advance. Apparently what they have done is to suggest through their Cardinal, and other spokesmen, that the whole system of tolerant and compromising religion should give way to an era of definite competitive religion.

I wonder what the B.B.C. will do about it. I happen to know that Sir John Reith has been meeting a lot of Catholics (Romans) during his visit to America. But, even so, having regard to all the influences at work, I believe that the average view of the listener will prevail. Namely, a decent middle view of Christianity *without* a pronounced bias either way.

Studio Opera

Since I announced exclusively that Studio Opera had come to an end, there has been a certain amount of contradiction on the merits and demerits of the decision. That Mr. Filson Young should have objected goes without saying. I was surprised, however, to note that Mr. Stanton Jeffries continued to plead for the *status quo*.

In the end I am glad to accept the view of Mr. Mase, that the average listener is now getting much better value for his money in operatic transmission than ever before. Incidentally, Dr. Boulton's confirmation seems inevitable.

Mr. Hely-Hutchison

It is good to know that Mr. Hely-Hutchison is at last receiving some recognition. I remember him in the days in which he was merely an interval filler. Then one day

the power of concentrated correspondence, augmented by the recognition of his distinguished antecedents, worked a change.

But that was not the whole story. There were many more days of hard work and negotiation, and what is the result? Mr. Hely-Hutchison is now the most promising of the younger school of composing conductors, and is quite unspoil by the "modernist" virus.

Reviewing the Orchestra

Friends of mine in the new B.B.C. Symphony Orchestra tell me that Dr. Boulton and his staff are now busy with the first annual review of talent that either has declined or has not fulfilled expectations for one reason or another.

Several musicians are affected, and although, of course, there is bound to be individual hardship, it is obviously necessary for increased efficiency constantly to be reviewing the personnel of this orchestra.

I have not heard whether there is any compensation involved for the suspension or cancellation of these orchestral engagements.

A ONE-MAN AFFAIR!



The control desk of one of the transmitters at Moorside Edge. From this position the engineer-in-charge has complete control of the whole transmitter, the row of meters in front telling him exactly what is happening in the various circuits.

Latest News Items for the Listener

Miss Ursula Greville

There is a good deal of talk these days at Savoy Hill about Miss Ursula Greville and the possibility of getting her to take an extended series of microphone engagements to sing folk-songs, which she does remarkably well.

I hope the negotiations fructify, because Miss Greville undoubtedly would add to the pleasure and edification of the listening millions, and the pity is that she has not been heard often enough in the past.

The B.B.C. in Leeds

Very wisely, I think, the B.B.C. has decided to regard Leeds as one of its permanent centres for collecting programme material. It has been important technically for some years as the chief repeating station in the north; but its importance programmatically has not been so great. With the establishment of the North Region

A FIRE-FIGHTER'S RADIO !

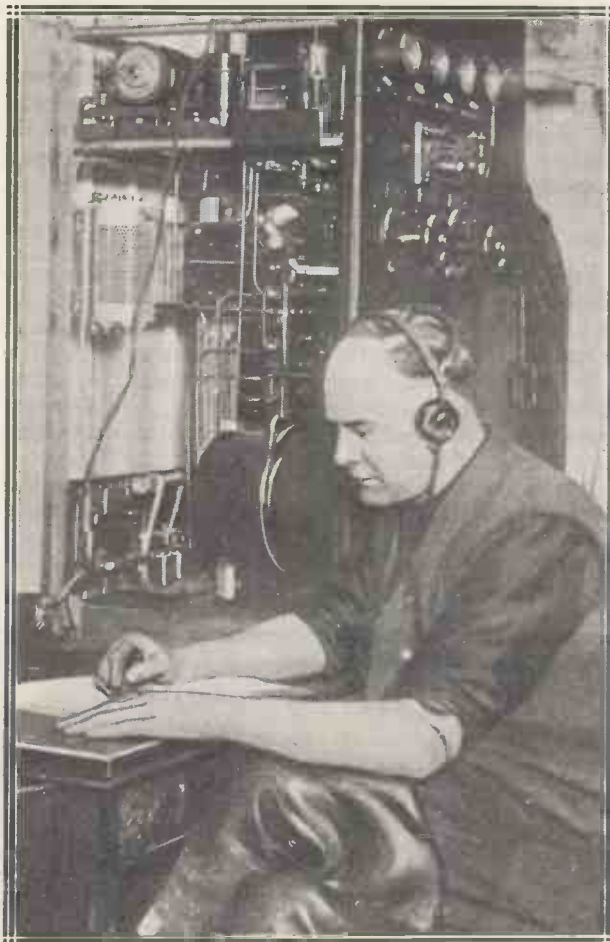

Here is the radio cabin on a New York fire-boat. By means of this equipment the vessel is in constant touch with headquarters, which saves a great deal of valuable time when a fire breaks out anywhere in the port.

there was a move at Savoy Hill to close down all programme work at Leeds, but wiser counsels prevailed.

Thus Yorkshire will have adequate facilities of representation in the programmes not only of the north, but also of the whole country. There is to be a good-sized studio and offices.

Empire Broadcasting

The present position about Empire broadcasting is most unsatisfactory. After endless parleys with Conferences, Imperial and Colonial, and continuous bickering with Government Departments, the B.B.C. is no nearer its goal of being provided with the money to go ahead and make a proper Empire station and put on a continuous and worthy service on short waves.

It's a matter of about £50,000 capital expenditure, and then a permanent service charge of about the same amount annually. This is about 10 per cent of the proportion of licence revenue taken by the Treasury in 1930.

The existing experimental service is costing the B.B.C. about £10,000 a year, and Savoy Hill naturally is reluctant to go on putting this out when the experimental period is over, as it now is. I hope Parliament gets a chance to deal with this subject of Empire broadcasting. It is enormously important to the United Kingdom and the Empire, and should be handled boldly and generously without delay.

Sir John Reith in America

I have been looking through a mass of newspaper cuttings on the subject of Sir John Reith in America. Apparently his visit made a great stir. He had over an hour with Mr. Hoover at the White House, and numerous theories were advanced as to what was discussed and how.

Of course, Sir John and Mr. Hoover are old friends and would have much to remind each other about. But apparently Mr. Hoover was very interested to hear more about the way broadcasting is organised and run in England. No doubt also the dole was touched upon; here Sir John would be in agreement with the United States President.

Those Bach Cantatas

There is a growing movement at Savoy Hill against the continuance of the Bach Cantatas, which now for several years have been a feature of the Sunday afternoon transmissions. No doubt Bach enthusiasts have enjoyed them, but many listeners, probably the majority, have become definitely restive.

It was noticeable, too, on the charts of those wireless exchanges where statistics of listening were kept that the load of current on the line during the Bach Cantatas on Sundays indicated that hardly anybody was listening. I think the B.B.C. went wrong in running the Bach Cantatas to death; if we had had them, say, once a month they would have survived.

B.B.C. Golfers

Several members of the staff of the B.B.C. have been annexing a good many golf trophies lately. Of course, Mr. Roger Eckersley, the head of Programmes, is the best golfer there. His experience as Secretary of the Stoke Poges Club gave him an excellent chance to perfect his game.

Then there is Mr. Lindsay Wellington, who is closing up on Mr. Eckersley, and took individual honours this season. Major Guy V. Rice is another noted golfer.

His achievements on the Herne Bay links made history there. He has a terrific drive, but is slack on the greens. There is a proposal that a team of these three players should tour America next year.

PICK-UPS THAT PEAK

A practical
article by
FREDERICK LEWIS

A "peaking" pick-up is a perfect plague. That is an expression with which, I think, most radio-gram enthusiasts will agree. Nothing is more trying than to attempt to get good reproduction from your electric gramophone when the pick-up—the source of the modulated energy—insists on emphasising some of the notes very much more than the others.

"Screeching" Sopranos

A soprano with a particularly virulent E, or a contralto to whom full justice is done only when she is on A, can be most exasperating. But such is the state of affairs we so often meet when trying to find the ideal pick-up.

I remember a few weeks ago testing a quite high-priced "electric sound-box" (the name must be kept secret, I am afraid), and I had run through what is usually a fairly searching orchestral record. Results were very good. And then I thought of trying the instrument on a particularly strenuous musical comedy selection ("Follow a Star," H.M.V.), and there I found a most villainous peak. It was accentuated a bit, because I have my suspicions about the "straight-lineness" of the record at that point; but not far in on the first side a soprano fairly hit it, and out it came three times louder than anything else.

Fitting a Filter

Further tests on constant-frequency records located the peak, and also one or two others of less serious characters. These were "sat on" to a great extent by using a semi-tuned filter scheme consisting of a .01-mfd. condenser and variable resistance of high value placed across the pick-up on the set side of an

H.F. choke in series with the pick-up. Inside the choke a number of small strips of iron had been placed. Rough and ready, perhaps, but it did the trick fairly well, although a certain falling-off of high-note response was also caused.

But pick-up peaks can sometimes be advantageous if they occur in the right place. No loud speaker yet devised has a straight-line reproduction curve. They all have humps and troughs, and as it is possible to design an amplifying system which is tolerably straight-line, it is sometimes found that a pick-up peak will coincide with a loud speaker trough and vice

versa. In such a case the peak is an advantage. If it coincides with a speaker peak, however, obviously there is a very bad patch in the reproduction curve.

A Good "Job"

But there are several pick-ups on the market (not all cheap ones, by any means) which are comparatively "peakless." One is the A.E.D., which was mentioned by "Tone-Arm" last month, and another is the Claude Lyons' "Audak."

This is an American job, and at first sight appears rather clumsy and heavy. But in use it is remarkably

RINGING THE CHANGES ON THE BELLS

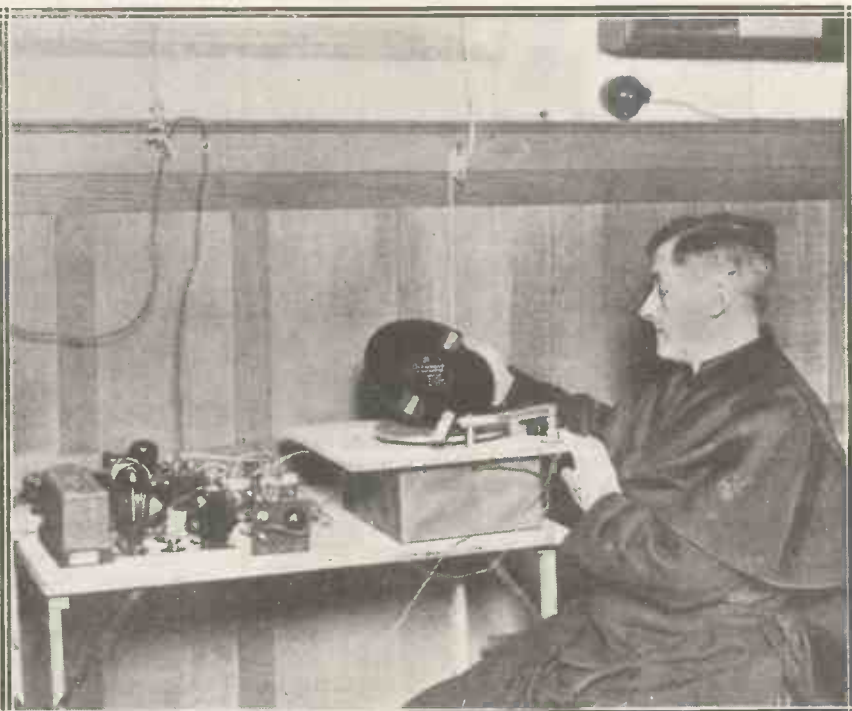

A loud speaker has been installed in the belfry of Totteridge Church, and gramophone records of various famous bells are broadcast by means of the radio-gramophone outfit you see above.

An Interesting Pick-Up of American Design

good. The bass is clearly reproduced—not woolly, like it is in so many pick-ups that have deliberate bass lifts in their curves—and the high notes are well balanced. A remarkable absence of peaks is noticed.

Record Wear Reduced

The weight of the head is somewhat greater than in most British models, but this does not seem to have any deleterious effect upon the record, nor does the fact that the arm has no offset scheme.

A cranked arm will enable perfect tracking to be obtained, but in the case of the "Audak" such cranking does not exist, and so the alignment of the needle is not tangential with the grooves all the way over.

One would think this was a great disadvantage, but it appears to cause no trouble, and, in fact, the wear on the record with the "Audak" is remarkably slight.

In reference to the absence of "offsetting," or "cranking," I received a long letter from Mr. Claude Lyons

wear on the record, and at the same time allow of the best quality results. Here is the letter:

"The fact that the carrier-arm of this pick-up is not 'cranked' has already been pointed out to us by one or two persons and firms as a bad feature. Because of this, we went to very considerable trouble to see whether, in practice, this makes any difference.

"After spending a good deal of money destroying large numbers of records of the same serial number by running them dozens of times with different pick-ups and tone-arms, we found that wear appeared to be less with the 'Audak' pick-up than with any other, and that our figures agreed almost exactly when the standard 'Audak' arm was used and when the 'Audak' pick-up was employed in a specially manufactured cranked arm.

Many Years Experience

"As a matter of fact, the writer has paid most particular attention

networks, properly arranged as a gain-loss measurement set.

"In connection with your belief—which I certainly respect—that for best results and longest life of records carrier-arms should be cranked, may I respectfully submit the following points for your further consideration?

"Straight" Carrier-Arms

"1. Records are *always* produced by the employment of an absolutely straight cutter.

"2. After the needle has been traversing the groove for only one or two revolutions of the turntable it assumes a certain shape and commences to be abraded along two definite and well-defined faces. With the cranked type of tone-arm the abrasion of these faces becomes very acute by the time the innermost groove is reached.

"This is because cranking does *not* give the usual effect of turning the needle in the groove slightly, as is accomplished by a straight arm. In other words, the needle becomes so worn on two opposite faces that it goes much deeper into the groove in the case of the cranked arm and thus causes excessive wear.

"The ideal needle-holder would be one in which the needle would be held by a chuck which would revolve noiselessly. In some slight measure this is obtained by the use of a straight arm, and I am therefore inclined to the belief that a straight arm is the best as regards wear.

Laboratory Tests

"3. In connection with the actual reproduction, I am of the belief that, theoretically, the cranked arm may, to a very slight extent, aid the needle to better tracking of the wave-form on the walls of the grooves. However, by most careful laboratory tests I have never been able to see any practical difference in the quality of reproduction, and I have come to the conclusion that the — Co. crank their arm more to produce an additional selling point which they could talk about than for any other reason."

The letter goes on to discuss the practical side of pick-up testing, and in particular the effect of the characteristics of the recording stylus upon the record, but the foregoing certainly gives one food for thought, and it would be interesting to hear the opposite "side," as it were, stating their case for offsetting.

THEY BRING OUT THE BASS!



Here we see Messrs. Flotsam and Jetsam, the broadcast and gramophone favourites. Records of these two are excellent for testing the naturalness of the bass reproduction of pick-ups, and frequently will show up nasty little peaks in the middle register.

pointing out the arguments in favour of non-cranking the pick-up tone-arm, and for the benefit of readers who may be interested in the subject I will quote the relevant part of that letter.

It was in answer to a criticism of mine in which I expressed the opinion that offsetting was a very decided advantage, and definitely did reduce

to pick-ups for some years, and he has designed for several of our leading companies pick-up testing equipment; some of a simple nature for rough comparison work, and some of a precise laboratory-measurement type. The former merely comprised the use of standard frequency records, standard amplifier, vacuum-tube voltmeter, and the usual attenuation

Those Amplification Curves!



It is the custom for manufacturers of intervalve transformers, choke couplings, and other amplifier components, to advertise the merits of their wares by means of "curves" showing the amplification at all the frequencies or musical notes which it is intended should be transmitted to the loud speaker.

ALMOST AN IDEAL

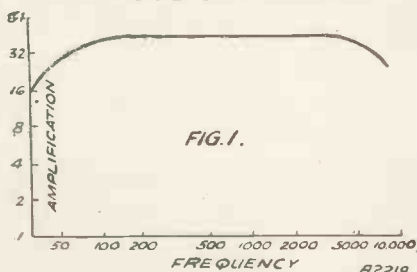

The curve of a perfect L.F. transformer would be absolutely straight. About the nearest we can get to it in practice, however, is illustrated above.

The ideal is a perfectly level straight line, indicating that the amplification is the same at all frequencies. Fig. 1 is about the nearest we can get to a curve of this sort and shows the amplification obtained by a good intervalve transformer used in conjunction with a suitable valve.

It will be noticed that over the greater part of the frequency range the curve indicates an amplification of about 50, but at the very low and high frequencies it falls off.

Increasing the Power

From a practical point of view this means that for every audio* volt that appears at the grid of the first valve 50 audio volts are supplied to the grid of the next valve, except when very low or very high musical

* That is to say, alternating or fluctuating voltage corresponding to sounds broadcast, as distinct from the steady voltages used for bias, etc.

Does the frequency response curve of a pick-up or transformer really tell us anything we want to know, or does it simply mislead us? There are many points about L.F. response curves which are completely overlooked, and their rights and wrongs are explained very clearly in this article.

By **MARCUS G. SCROGGIE**,
B.Sc., A.M.I.E.E.

notes are transmitted, in which case the amplified voltage is 40 or less for every volt at the input.

Logarithmic Scales

The actual voltages may be much lower than these figures, which merely indicate the ratio of one to the other, or "amplification."

In Fig. 1 the scale of frequency is not a uniform one, but is logarithmic, which means that the length of scale between any one frequency and double that frequency is the same at every part of the scale. The reason for this more complicated arrangement is that it corresponds with the way the human ear works.

THE MAG. PER STAGE

1ST. VALVE TRANSFORMER 2ND VALVE

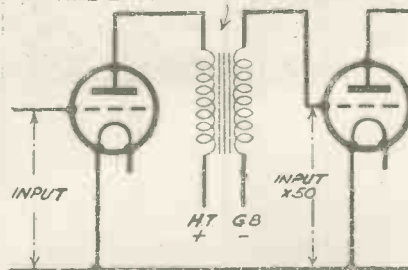

FIG. 2. If a transformer used in conjunction with a certain valve gives an amplification of 50, it means that 1 volt applied to the grid and filament of the valve would result in 50 volts across the grid and filament of the next valve.

If one were to ask why a transformer represented by Curve A (Fig. 3) is better than that corresponding to Curve B, it is most likely that the answer would be to the effect that for distortionless reproduction the amplification must be equal at all frequencies. In Curve A this is substantially so, but Curve B has an

COULD YOU HEAR IT?

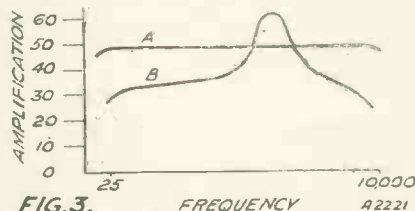

FIG. 3. Peaks which may look terribly bad on paper may not be very noticeable so far as the ear is concerned.

outrageous peak; therefore, distortion will be introduced.

This explanation dies hard because it is correct up to a point. It is true that uneven amplification is a form of distortion. It is also true that germs cause disease. But it does not follow that everybody becomes ill who breathes air in which germs are floating. Normally there are not enough of them to upset a healthy person.

Not Really Bad!

Similarly, the distortion introduced by the peak of Curve B does not upset the average ear. For one thing, if it were possible to listen to an absolutely perfect loud speaker, driven by a perfect amplifier, the reproduction would differ from the original as much as, and probably more than, B differs from A.

Now the reason for this is that the room in which the sound is being reproduced possesses resonances which

very greatly interfere with the perfection of our imaginary apparatus. And the strange and pleasant thing is that it does not produce the objectionable effect on the ear that the corresponding curve does on the eye.

Any reasonably musical ear is very sensitive to *pitch* or frequency, but is extraordinarily insensitive to variations of strength or loudness.

An Interesting Test

The ear will tolerate an immense amount of distortion.

If a listener goes out of the room and then returns after somebody has adjusted the receiver to increase (or decrease) the volume by 30 per cent, it is unlikely that he will notice it, and even trained observers might have an animated discussion on the point.

This statement may sound improbable to some, but it can easily be verified by means of simple measuring apparatus, remembering also that *twice* the audio voltage produces *four times* the volume. If the overall volume is left the same, the relative amplitude of the different frequencies can be altered about to an enormous extent without being seriously noticed. One hundred per cent difference will easily pass, unless it is all at one end of the scale.

Nothing to Worry About

So although it is quite true that Curve B indicates distortion, only the unwary attach much importance to it. It is quite possible that the peak shown might coincide with a hollow in the characteristic of the loud speaker used, in which case B would be superior to A, purely as giving a level output at all frequencies.

One could imagine a transformer with a curve the exact opposite to all the other distorting elements in the chain of apparatus between the original sound and the ear of the listener, and which would therefore compensate for them and produce a perfectly level output.

Such a transformer or other coupling device is rather outside the scope of practicability.

Tone Control Useful

In any case its curve would be so monstrously bad to look at that it would be very unlikely to sell on the strength of it, but there is a tendency to make use of tone controls or compensators, which may often be introduced at the part of the circuit occupied by the intervalve coupling; these will be dealt with at a later date.

Is there any good reason for preferring the straight-line A-type characteristic? Yes, there is, and it may be very important to listeners, particularly those with battery-driven

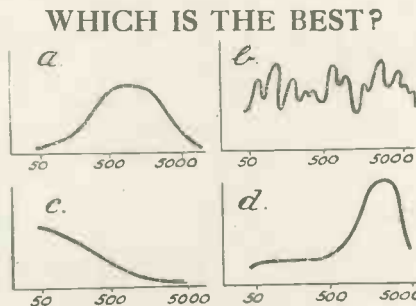

FIG. 4. Here is a selection of pick-up curves. Their merits and demerits are not so obvious as one might at first expect; they are described in the text.

sets. We have seen that the ear overlooks *amplitude* distortion. But it does not so easily tolerate *overloading* distortion.

THE OUTPUT COUNTS



It is the overall amplification that should be straight-line, peaks in separate stages may easily tend to cancel out. This is the mast of the Brighton Radio Relay Station which serves over 1,000 homes, a task requiring very carefully designed L.F. apparatus.

If any of the valves are driven seriously beyond their capabilities, such as by allowing the audio voltage supplied by the transformer secondary to exceed the grid-bias voltage of the valve following, the reproduction becomes horribly distorted and broken up, and the better the loud speaker the more evident this is.

Real Power Valves Essential

Now, unless very large valves are used and generous power is supplied to them, which is a costly business if the receiver is not run from the mains, the volume available without overloading is very small. Since broad casting started this fact has been responsible for more than all the other forms of distortion put together.

The difficulty is that there is always a tendency to overload a small set. Consequently one desires to be able to squeeze as much volume as possible through it, short of overloading. This is where Curve B deals us a nasty blow. Suppose the height of A from the base line represents not only the amplification but also the maximum voltage which the valves can handle properly.

An Explanation

For example, if the grid bias is 5 volts and everything else is satisfactory, one might divide the whole amplification scale by 10 and call it "volts." A certain volume of sound will issue from the loud speaker when a programme in which all the frequencies are present is being rendered. The volume will then be represented by the area of the space below line A. (If only a limited range of frequencies is present, as in a flute solo, the volume would be represented by the area under line A and as wide as the frequency range.)

If B is now examined it will be seen to protrude above the 5-volt mark, and so the whole line must be lowered in proportion so as to bring the peak down below the level of A. This lowering is, of course, carried out by means of the volume control.

Reduced Amplification

The average height of curve B above the base line will then be much less than A; in other words, the volume from the loud speaker, taken over the whole range of frequency covered by speech and music, will be much less. And both conditions (A and B) represent the maximum volume which can be obtained without overloading.

So the presence of a peak in the characteristic, standing, let us say,

The Higher Frequencies are the Most Indispensable

twice as high as the general level, does *not* cause serious distortion in the way that appears obvious at first sight, but it *does* limit the volume which the amplifier can handle. Or, looked at in another way, it causes distortion, which is very serious if the full normal volume is forced through.

The audio intervalve coupling, exemplified by a transformer, has been considered up to the present, but it may be mentioned in passing that there are other causes—and commoner ones in these days of good transformers—which cause the inability to obtain adequate volume without distortion.

Too Much Reaction

The excessive use of reaction is often blamed for distortion, but the reason is not always clearly understood. Provided that the circuit is properly tuned, the disproportionate increase in the strength of the lower frequencies caused thereby is not likely in itself to be bad, but rather otherwise; for except in the case of very perfect amplifiers and loud speakers the very lowest frequencies are cut off to such an extent that they can stand considerable boosting, to the extent, perhaps, of two or three times normal.

But as explained in connection with the transformer, this peak causes overloading. In a portable receiver, for instance, it is unlikely that frequencies much below 100 are reproduced appreciably by the small loud speaker, even after excessive emphasis due to extreme use of reaction. The effect of these "silent" impulses is to overload the power valve, and perhaps the detector valve, and to cause very bad distortion in this way.

Peaky Pick-Ups

Another common example is the gramophone pick-up. Published curves of pick-ups often show a bad peak at the principal resonance of the moving system, which in poorly designed instruments may be as low as 1,000 or 2,000 cycles. These are not always so enormous as to cause very unpleasant emphasis of that one particular frequency, unless it happens also to be a resonance of the loud speaker, but it is apt to limit volume.

Lest it should be supposed that the foregoing discounts entirely the distortion due to amplification, it may be as well to point out that this is

not so. Transformers of the type common 10 years ago, in conjunction with the high-impedance valves then used, cut off low tones almost entirely.

In the Early Days

This was not such a serious fault at the time, because contemporary loud speakers would not have reproduced them even had they been supplied, and the cut-off was, if anything, rather an advantage in that it counteracted the overloading distortion due to the excessive use of

set or to the whole, are shown in Fig. 4:

(a) is bad, because both high and low frequencies are cut off almost beyond repair;

(b) looks rather horrible, but is actually quite good, because the balance of tone, taken broadly, is fairly uniform, and the hollows and peaks are isolated and not so violent as to strike the ear;

(c) is extremely bad, and not so uncommon as might appear; an over-generous use of by-pass condensers is a common cause. All brilliancy

HEARD OVER THE WHOLE OF EUROPE



This is the interior of the studio of the Naples broadcasting station. Concerts from this studio have been heard near and far, for Naples practically always works in conjunction with Rome in sending out the same programme.

reaction that was necessary in the days before screened valves became available for H.F. amplification.

But such transformers used under modern conditions would certainly cause an easily perceptible falling off in low-note reproduction. So long as the ratio of maximum to minimum of the curve is more than 2 or 3 there is hope. It is an almost complete cut-off which is most ruinous, and owing to another peculiarity of the ear it is the higher frequencies which are the most indispensable. Low tones which are not reproduced can be heard by reason of their harmonics.

Some imaginary curves, which might apply to any part of a

and life is removed, and speech is difficult to follow.

(d) is a case where a peak, besides causing overloading trouble in a very marked degree, would really be noticeable to the ear; for it is very pronounced, and is, moreover, broad enough to upset the balance of tone entirely.

Our Old Enemy!

This sort of curve has been known to result from the use of a battery eliminator. This cause of distortion, usually known as feed-back, is still fairly common, and requires careful watching in the design of a receiver, so will form the subject of a separate article.

Taxing the



A recent portrait of the Author.

A trenchant attack on the present dispersal of the revenue from radio licences.

By Lt.-Commander the Hon. J. M. Kenworthy, R.N., M.P.

system is, the greater the number of licences taken out the larger is the share of the "swag" taken by the Chancellor of the Exchequer!

Thus in 1929 the B.B.C.'s share was 64.02 per cent, but in 1930 it was only 61.49 per cent of the gross takings. If the licences reach a total of 3,000,000, the share of the B.B.C. drops to 52 per cent!

The recent concession under which the Post Office now receives 10 per cent. instead of 12½ per cent. is not very substantial and still leaves insufficient to the B.B.C. for its legitimate work.

Against All Reason!

In ordinary business, increase of turnover spells greater profits. But the more the B.B.C. succeeds, the less it is to be allowed to reap the benefit.

Furthermore, the total money taken in licences is paid over in arrears; so that the Post Office and Treasury benefit by having this money in hand and the

PURELY POLITICAL PROGRAMME FEATURES

It is time there was public protest against the unreasonable taxation levied on broadcasting.

This great service is still in process of development and expansion, involving heavy capital expenditure in new Regional stations and the like. The science of broadcasting is marching forward with immense strides and wonderful new inventions are continuously being made; and to take advantage of them means spending money. *Yet out of gross receipts of £1,700,000, more than £600,000 was taken last year by the Post Office and Treasury, nominally for the minor service of issuing the licences, but actually as a hidden tax.*

Out of all Proportion

If it is urged that this is an entertainment tax, it is out of all proportion to any levy that the Government dare impose on the ordinary amusements such as theatres, cinemas, fairs and flower-shows. For at present the B.B.C. only gets 61.49 per cent of the gross revenue from licences.

It is only because it is a monopoly that it is able to survive this impost. "Wireless" is a public service, not managed for profit, and does much national and governmental work for nothing, as I shall presently show.

But the most objectionable feature of the present

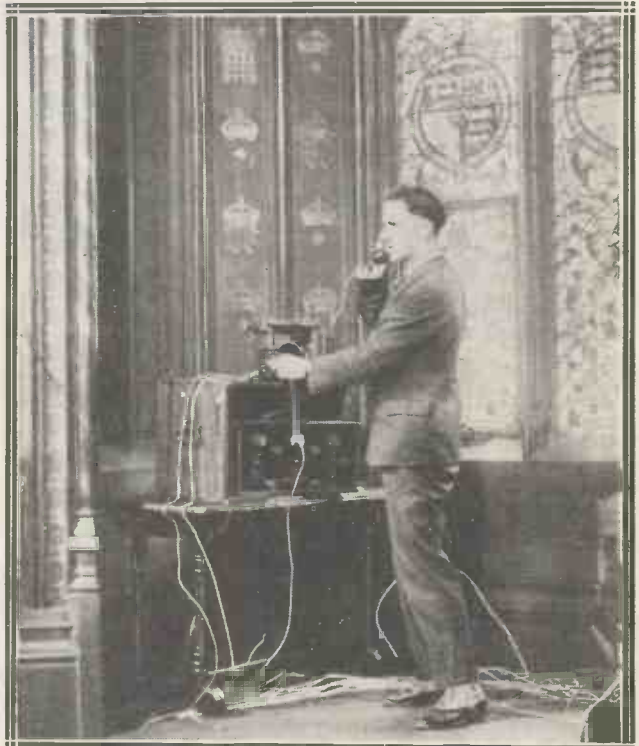

Lt.-Commander Kenworthy does not consider that the broadcasting of items like the speeches on the occasion of the Naval Treaty ratification constitute entertainment. Above you see the B.B.C. engineers testing the gear used for this historic event.

Listener

B.B.C. loses the interest. Five per cent on £1,000,000 is £50,000 a year; and this amount is lost by the B.B.C.

In the meantime, for the heavy capital expenditure on, for example, the Regional developments, the B.B.C. has to borrow money and pay interest on it. So instead of ploughing back its surplus into the service, and getting the interest on balance at the bank, the B.B.C. has to borrow on capital account for necessary expenditure and pay five per cent in interest on its loans!

It comes to this, therefore, that three-eighths of the revenue from wireless licences goes to the Treasury and Post Office, and this is, in reality, a tax on the subjects of this realm.

Charged Income Tax as Well!

All other taxes are discussed annually on the Finance Bill, but there is no opportunity of this kind for the House of Commons to protest against this tax on millions of families. And to make the picture of spoliation complete, this public Corporation has to pay £50,000 a year in income tax.

I referred above to the defence made that this is an entertainment tax; but only a portion of the B.B.C.'s activities can be classed as entertainment in this sense. The Corporation performs all manner of public services, such as broadcasting the opening speech of His Majesty the King at the London Naval Conference in 1930, and

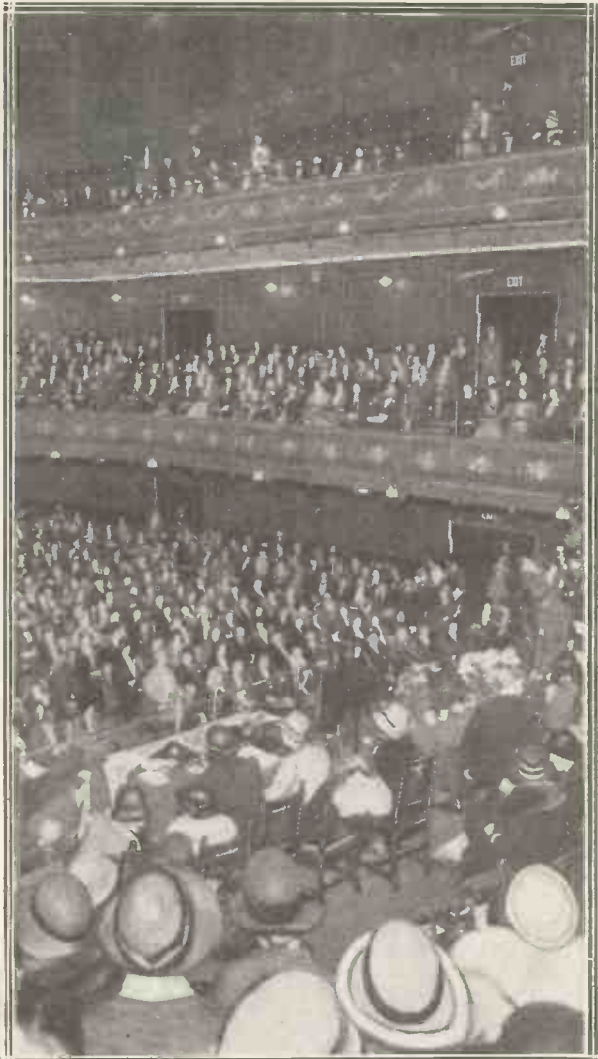

"We might just as well charge the crowds an entertainment tax who witness the parading of the King's Colours" is one of the points made in the accompanying provocative article.



the speech of His Majesty at the opening of the Round Table Conference on India later in the year.

This is no more "entertainment," within the meaning of the Act, than the King's Speech at the opening of Parliament. We might just as well charge the crowds an entertainment tax who witness the parading of the King's Colours by the Brigade of Guards on His Majesty's birthday, or have charged a fee to those who attended the last Coronation ceremony.

What Is "Entertainment"?

A certain number of political talks have taken place, when the microphone has been made available to the leaders of the organised political parties. These were for the guidance and enlightenment of the electors, and we have no more right to regard them as entertainment than an ordinary political meeting, for which tickets are frequently sold.

When Mr. Baldwin addresses the faithful in the Albert Hall, or the Prime Minister addresses a political meeting in the Manchester Free Trade Hall, at least half the seats are sold; and it would be just as logical to charge an entertainment tax here.

Again, when the Naval Treaty was ratified there was an international broadcast of speeches by the heads of Governments. The Prime Minister and the Japanese Ambassador in London spoke from Downing Street, President Hoover from Washington, and the Japanese Prime Minister from Tokio. By means of careful organisation all these speeches were relayed and broadcast.

The B.B.C. had no option in the matter, it could not possibly refuse facilities, and such public service naturally cut into the ordinary programmes. Again, a great deal of the programme is purely educational and under the auspices of the Ministry of Education.

Why should this be taxed?

So it is with the religious services. We don't tax the congregations in the cathedrals, churches and the chapels,

(Continued on page 88.)

QUEUEING UP TO PAY TAXES!



These people are lining up to see an entertainment which is definitely included in the entertainment tax schedule. But do you consider that a broadcast on Treaties, by the Japanese Prime Minister, is an entertainment? Yet you undoubtedly are taxed for the privilege of listening to such items.

A RADIO RECKONER

By
W. A. BARCLAY
M.A.



Here is another set of N-diagrams which should be really interesting to all who are keen on radio, and should prove particularly useful to those who construct their own coils. Read all about them, and you will save yourself much time and trouble.

WHEN an alternating current flows through a coil of wire it encounters an opposition to its passage over and above that of the resistance which the material of the coil would naturally offer to direct current.

This opposition is a kind of resistance, but nevertheless it is not a pure resistance of the kind we have been considering, for if a source of direct current be used instead of A.C. the effect is entirely absent.

Inductive Reactance

For this reason we call this kind of resistance by a special name, viz., "reactance," and though it is convenient to measure it in ohms as though it were a resistance, it must always be remembered that it is only in virtue of the alternating quality of the current that it exists at all!

However, that it does exist is very fortunate for the science of radio, as it is entirely due to this peculiar effect of coils of wire on alternating currents that we are enabled to receive wireless signals at all.

How to Measure It

Now, the quality in a coil of wire which exercises this reactive effect is called "inductance," and, in general, the greater the inductance of a coil the greater will be the reactance which it will set up to oppose any A.C. that may flow in it.

Later in this series it is hoped to show how the precise amount of reactance depends partly on the

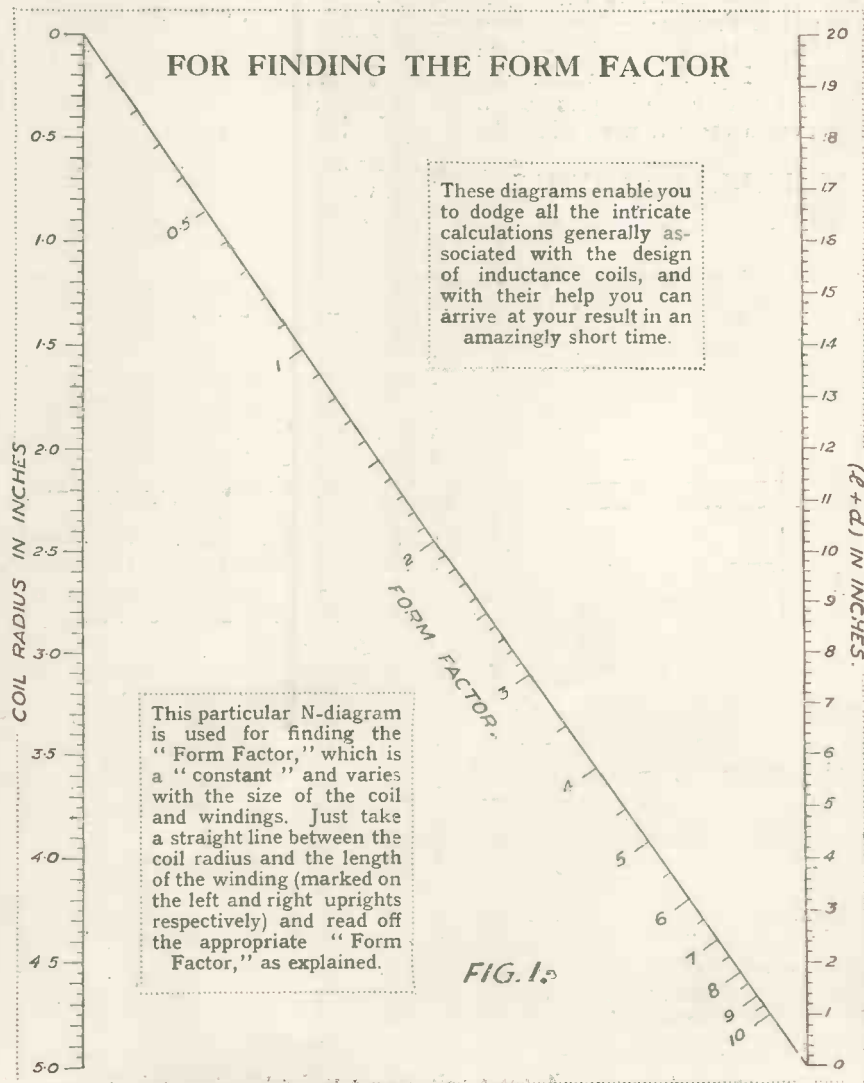

inductance of the coil and partly upon the frequency of the A.C. in question. For the present we shall consider in rather more detail the nature of inductance, and how we may measure it.

To explain the phenomenon of inductance we have to fall back upon the fundamental connection which exists between magnetism and electricity, which was first noticed over a century ago.

An A.C. Effect

Everybody knows the peculiar properties of a magnet, by virtue of which it can attract pieces of iron to itself, and also, when suspended as in the form of a compass, tends to assume a north and south position.

Physicists are accustomed to regard the space surrounding a magnet as full of a magnetic influence, which they call a magnetic "field." In 1820, Oersted, a Dane, was the first to show that a current of electricity passing along a wire creates a precisely similar magnetic field in the neighbourhood of the wire.

We may represent this field as shown in Fig. 2a, in which the central black circle represents a section cut across the wire, while the

current ceases altogether, the field also ceases to exist, as in Fig. 2b.

A further connection between the current and the surrounding magnetic

CONDUCTOR'S "MAGNETIC FIELD"

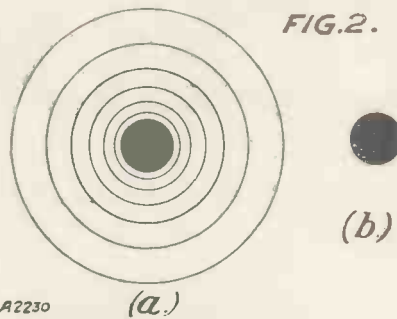

A2230 (a.) This shows the distribution of magnetic lines of force around a current-carrying conductor. The black circle at the centre represents a section across the conductor. (b) Here you see the conductor when no current is flowing.

field was established by Faraday, who discovered that a changing magnetic field would of itself cause electricity to flow in a neighbouring conductor.

What Inductance Is

Hence, if we create a growing magnetic field around a wire by causing an increasing current to flow in it, the magnetic field will, in turn, cause a current to flow in the wire, but in the opposite direction to that of the original current.

That is to say, that the original current, so long as it is increasing in amount, will experience a certain amount of opposition to its progress, due to the varying magnetic field which it creates. It is this opposition which is termed "inductance."

Obviously, this effect of inductance will be strongly marked in the case of alternating currents, since these are continually changing, and consequently the magnetic fields which they create are also continuously varying.

Coil Construction

For direct currents, once established, the effect is absent, since the magnetic field remains unchanged.

So far we have considered the current as flowing in a single wire, as in Fig. 2. If the same current were made to pass in two adjacent wires, as in Fig. 4, the magnetic field would be much increased, and, therefore, reacting back on the individual wires, the inductive effect would be greater.

If the wire be wound in the form of a coil, taking care that the windings

are all in the same direction, the induction will be considerable, and the effect will be to "choke" back the A.C. which may flow in it.

For this reason such inductance coils are often referred to as "chokes."

If two turns of a coil are wound in opposite directions, their magnetic fields will cancel each other, so that the sole opposition to current will be the ordinary resistance of the wire.

In fact, this principle of "reverse" winding is often made use of in the so-called "non-inductive" resistances, where it is desired to wind a considerable length of resistance wire in a coil of small dimensions without inductive effects.

The Iron Core

A further important means of increasing the inductance of a coil is to provide it with an iron core. This device considerably increases the magnetic field, and has many practical applications in L.F. work, e.g. chokes, transformers, etc.

The amount of inductance necessary to "choke" back the delicate currents met with in radio work is very small indeed. Ordinarily, a few score of turns of wire on an open or "air-core" former will be sufficient.

MULTI-LAYER COILS

FIG. 3.

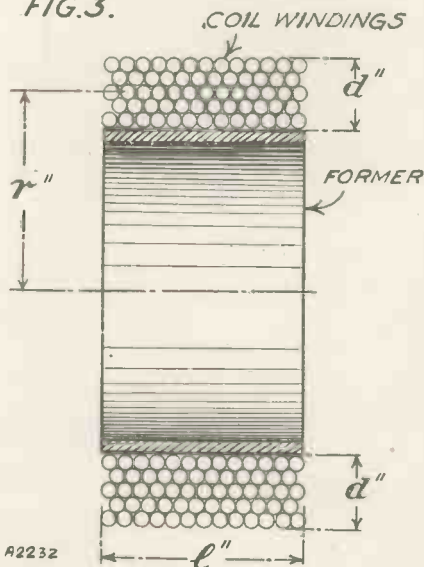

In the case of coils with more than one layer of wire, the radius (r) is reckoned as the distance from the centre of the former to the middle of the layers.

surrounding circles indicate the magnetic influence or "field."

Now, as long as the current flowing in the wire is steady, the magnetic field remains unchanged. If, however, it varies in amount, the magnetic field varies likewise, and if the

PULLING TOGETHER

Fig. 4.

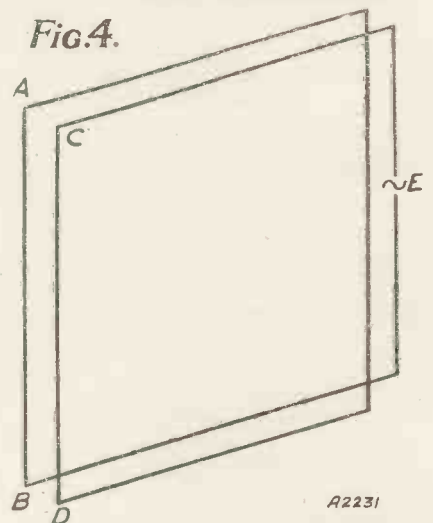

If several turns of wire are all wound in the same direction, their magnetic fields assist each other and increase the inductive effect.

The scientific unit in which inductance is measured is the "Henry," but this amount is far too large for radio work. In practice it is convenient to use the millionth part of a henry, or "microhenry," as our unit.

It is usually rather a difficult matter to find the value of inductance which any given coil may possess;

No More Intricate Calculations

the usual mathematical formulae being somewhat complicated.

However, it is possible to arrive at quite a good approximation without any figuring at all by the use of N-diagrams, the principle of which is already familiar to readers of this series.

The first thing we have to do is to find the value of a certain factor which depends on the measurements of the coil, and which is thus called the "Coil Form Factor." Let us refer to Fig. 3, which shows the cross section of a radio coil; the small circles represent the individual wires composing the winding.

Take An Example

We shall suppose that the coil is wound to a length of l inches, and to a depth of d inches, as shown in the figure. We now find the mean radius of the coil r inches. This is the distance from the centre of the former to the mid-point of the winding depth.

That is, $r = \text{radius of coil former} + \frac{d}{2}$.

If the coil has only a single layer of wire, r may be taken as the radius of the former itself.

Now we turn to the first N-diagram, shown in Fig. 1, and find on the two outer scales the points corresponding to the values of r and $l + d$. Then, a straight line through these will meet the centre scale in the required value of the "Form Factor."

Let us take, for example, a coil of the single-layer type. Suppose we have 30 turns of wire wound on a former of 2.4 in. radius, the length of the winding being 3.8 in.

Easily Answered

We can thus neglect d , the depth of the winding, and thus have

$$r = 2.4 \text{ in.}$$

$$l + d = 3.8 \text{ in.}$$

Joining these points on Fig. 1, we easily find the Form Factor to be almost exactly 4.

The final step is now to multiply the square of the number of turns by the form factor as thus found. In the present case the square of 30 is 900, so that the required product is four times this, or 3,600.

Turning to the second of the two N-diagrams, Fig. 5, we seek the value of this product on the centre scale. Then, joining it to the same value of r as before on the left scale, the required value of coil inductance

is read off in alignment on the right-hand scale.

In our example, since r is still 2.4, the approximate value of the inductance of our coil is read off as 86 microhenries.

It should be noted that the above

is the best I have had yet, my linen one is not a patch on it. My work takes me round to different houses, but I back my speaker against them all, although I live a hundred yards from the electric power station and surrounded by gas sheds, also a high-

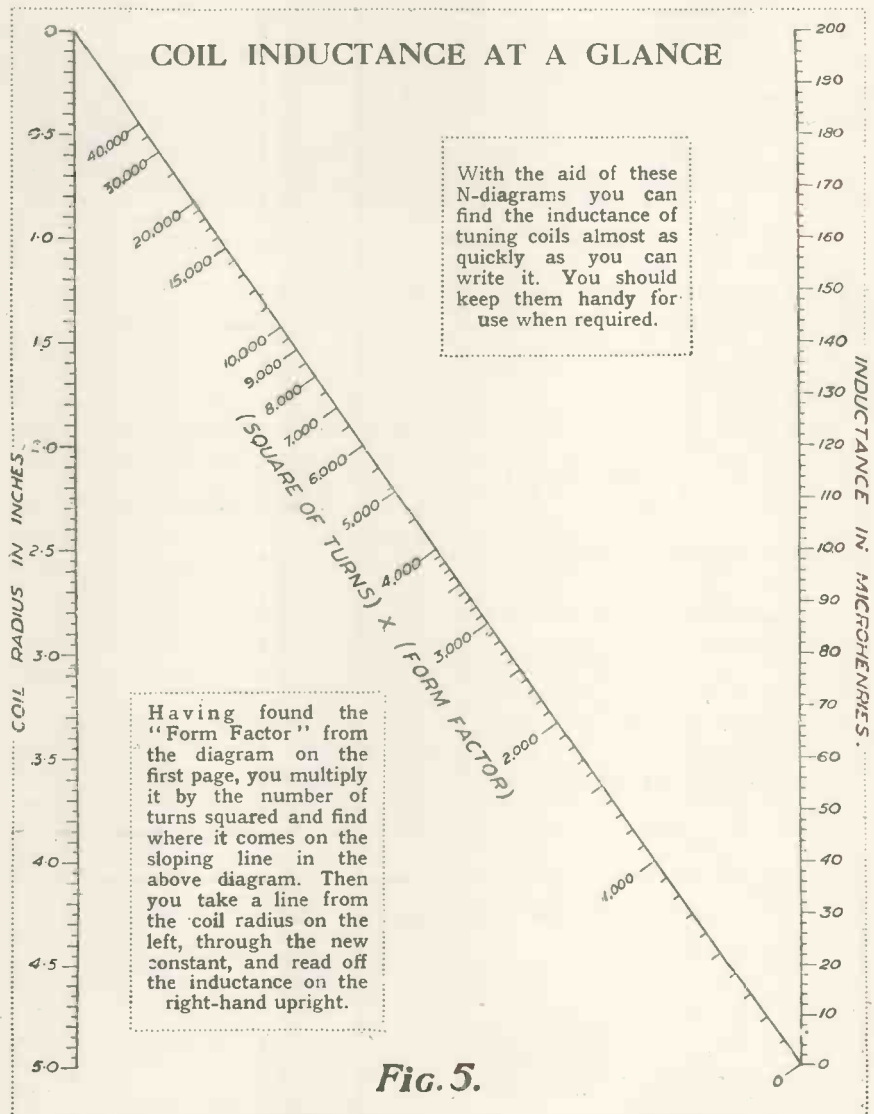

charts have been constructed only for coils of circular section, with air core.

* * * * *
 A Reader Thanks Us for
THE "M.W." INTER-AXIAL
 * * * * *

Sir,—It is with pleasure I write these few lines to thank you for the instructions how to make a cone loud speaker in MODERN WIRELESS. It

pressure cable runs clean round my house. I also must thank you for the paper pattern which I sent to London for, and I made it exactly to your instructions, but two inches larger in size. The bass notes are not too deep, and the voice is as clear as a bell.

Now all I can wish you is an increase in your sales by thousands.

Yours respectfully,

FRANK BRIDGES.

Castle Street,
Shrewsbury.

The "M.W."



As you will see, it is an attractive-looking instrument.

THE Extenser has opened up a new range of possibilities in the design of radio receivers. No longer need a multi-valve set be a fearful engineering feat, with a panel crowded with knobs and dials, for nowadays the tuning can be carried out by the tuning condenser, and by this condenser alone.

"Extensered" Tuning!

Until recently one had to manipulate wave-change switches and all sorts of gadgets, often including such things as pre-set condensers and tapping clips, before one could tune both medium- and long-wave bands satisfactorily. We need put up with that sort of thing no longer. To-day a four- or five-valve set, even with two S.G. stages, need have only two

tuning controls, both these controls automatically selecting the wave-band as well as the station required.

It is difficult in print to give an adequate expression of what the Extenser really means, and probably to some people used to using wave-change switches it will appear that we are making much ado about nothing, and to them the only thing we can say is "just you try it and see." It is impossible to describe the peculiar and fascinating sensation of complete and perfect control which one obtains through the use of this remarkable condenser.

For it is a condenser, and it would give a wrong impression if we asked you to think of it as anything else. It is purely and simply a condenser which, in addition to the selection of

stations, will look after the wave-change switching.

You turn the dial in the usual way, and when you have had enough of the medium wave-band you simply go on turning, and, lo and behold, the long-wave band is automatically switched in and you find yourself tuning to the long-wave stations!

A Joy to Handle

Nothing could be more simple, and nothing could be more effective in operation.

With a set of the description of the four-valver described here and a couple of Extensers one obtains perfect tuning control. Vernier drive is incorporated in the condensers, and by the method of dial marking one can see at a glance whether one is on the long or medium waves, and which station is being tuned in.

The circuit employed for the "M.W." "Hi-Mag" Four is quite straightforward, but it uses the new "Pop-Vox" coils which we introduced to MODERN WIRELESS readers last month, though in this set they are in what might be called a "junior" form.

Special Coils

They have been specially designed for use in H.F. circuits where a certain amount of

TAKE YOUR CHOICE OF COMPONENT MAKES FROM THIS LIST

PANEL
18 x 7 in. (Permcot, or Goltone, Red Seal, Parex, Becol, Wearite, Lissen, etc.).

CABINET
Panel space 18 x 7 in., baseboard 10 in. deep (Camco, or Pickett, Osborn, Lock, Kay, Gilbert, etc.).

VARIABLE CONDENSERS
2 .0005-mfd. Extensers (Wavemaster, or Cyldon, Formo, etc.).
1 .0001-mfd. or other differential reaction (Wavemaster, or Lotus, Ready Radio, Igranic, Ormond, Polar, J.B., Dubilier, Lissen, Magnum, Parex, Burton, Formo, Telsen, etc.).

ADJUSTABLE CONDENSER
1 .001-mfd. max. (Formo, or Polar, Sovereign, Lewcos, R.I., Lissen).

SWITCH
1 push-pull on-off (Bulgin, or Ready Radio, Goltone, Lissen, Igranic, Lotus, Benjamin, W.B., Keystone, Magnum, Red Diamond, Wearite, Junit, Ormond, etc.).

RESISTANCES
1 25,000-ohm "Spaghetti" (Magnum, or Ready Radio, Lewcos, Bulgin, Keystone, Sovereign, Graham Farish, Lissen, etc.).
4 600-ohm "Spaghetti" (Bulgin, or Magnum, Ready Radio, Lewcos, Keystone, Sovereign, Graham Farish, Lissen, etc.).

1 15,000-ohm "Spaghetti" (Lewcos, or Bulgin, Lissen, Ready Radio, Keystone, Sovereign, Graham Farish, etc.).

1 2-meg. leak and holder (Lissen, or Dubilier, Telsen, Ferranti, Ediswan, Igranic, Mullard, Graham Farish, Watmel, etc.).
1 2-meg. leak (Igranic, or Lissen, Graham Farish, or other terminal type).
1 filament rheostat (value, see text) (Geophone, or Wearite, Lissen, Igranic, etc.).

VALVE HOLDERS
2 horizontal 4-pin type (Parex, or Bulgin, W.B., Lotus, Junit, etc.).
2 ordinary 4-pin (Benjamin, or Telsen, W.B., Igranic, Lotus, Lissen, Clix, Bulgin, Junit, Formo, Wearite, Dario, Magnum, etc.).

FIXED CONDENSERS
1 .01-mfd. (T.C.C., or Ready Radio, Telsen, Dubilier, Ediswan, Lissen, Ferranti, Mullard, Igranic, Watmel, Formo, Graham Farish, etc.).
2 .001-mfd. (T.C.C. and Ferranti, etc.).
1 .0003-mfd. (Lissen, etc.).
4 1-mfd. (T.C.C. and Franklin, etc.).
2 2-mfd. (Lissen and T.C.C., etc.).

CHOKES
2 H.F. (Lewcos and Telsen, or Keystone, R.I., Ready Radio, Parex, Varley, Dubilier, Lissen, Lotus, Wearite, Magnum, Watmel, etc.).

1 output (Igranic, or R.I., Lissen, Magnum, Bulgin, Varley, Ferranti, Atlas, Wearite, etc.).

TRANSFORMER
1 L.F. (R.I., or Telsen, Igranic, Varley, Ferranti, Lotus, Mullard, Lewcos, Lissen, etc.).

COILS
3 (home-made) coil quirts (Keystone, or Wearite, Ready Radio, etc.).
2 Paxolin, or Pirtoid formers (one 2½ x 2 in. diam.; one 1½ x 2 in. diam.), and 6 oz. of 30 D.S.C. Wood for mounting, etc. (see text).
Medium-wave coils can be obtained ready made. Required: one P.J.2, one P.J.3 (Wearite, Formo, R.I., Ready Radio, A.E.D., Atlas, Keystone, etc.).

MISCELLANEOUS
2 wooden screens, 5½ in. high and 10 x 8½ in. long respectively.
1 sheet of metallised paper, such as Conductite, etc.
1 terminal strip, 16 in. x 2 in.
16 terminals (Igranic, or Belling & Lee, Eelox, Clix, etc.).
4 crocodile clips.
G.B. and H.F. plugs, spade terminals, etc. (Clix, or Belling & Lee, Igranic, Eelox, etc.).
Wire (Lacoline, or Glazite, etc.).
Flex, screws, washers, etc.

"Hi-Mag" Four

Our new policy in regard to high-efficiency dual-band coil systems advances a step farther in this outstanding receiver. Due to the inclusion of special but inexpensive inductances, it achieves an all-round standard of efficiency superior to that hitherto possible with a similar fundamental circuit arrangement. It is a set that should have a very wide appeal, and we advise all "M.W." readers at least to read about it.

adjustable selectivity is desired, and H.F. intervalve coupling required.

But we will discuss these coils farther on.

All Switching Automatic

Both tuned circuits comprise a medium- and a long-wave unit, these units being joined together or one of them short-circuited, according to the wave-band required. This, as we explained before, is done automatically by the Extensers.

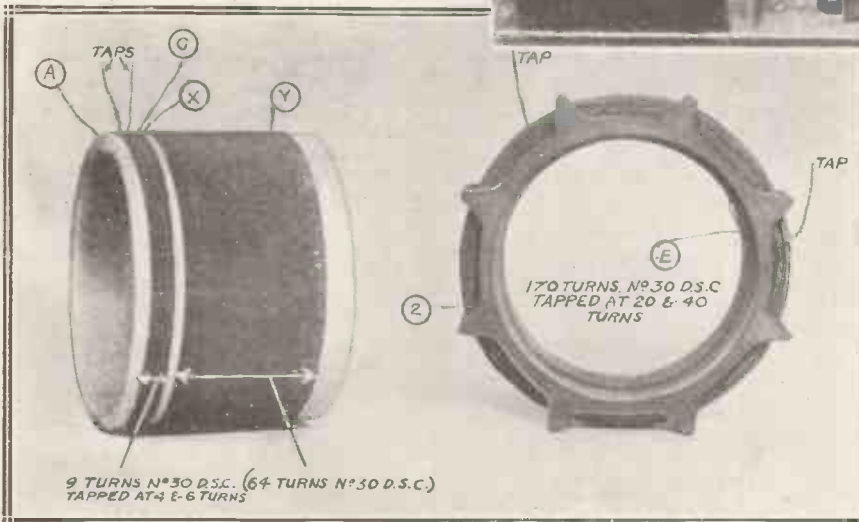
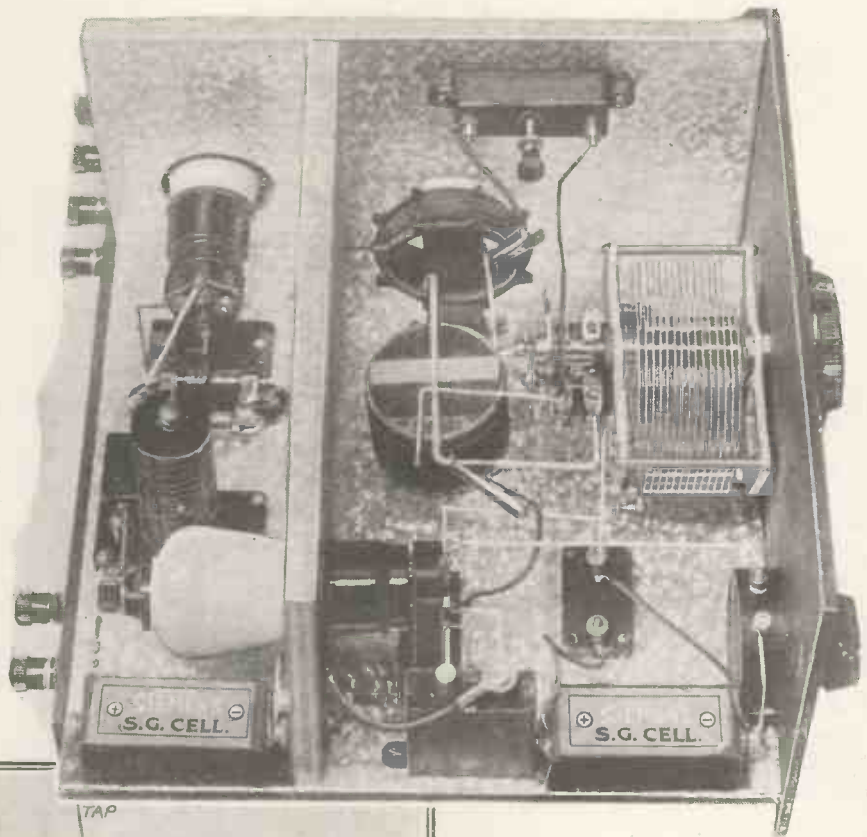

STRENGTHENING A VITAL STAGE

On the left is P.J.2, one of our new coil units for medium waves, and, on the right, the long-wave winding used in conjunction with it. This is wound on a coil quoit. These two items figure in the first stage.

Reaction is applied to the detector grid circuit, and you will notice that in the long-wave circuit of the first valve a pre-set adjustable condenser is included. This is in order that the selectivity of the long waves may be controlled to a fine degree, and it is so placed that the

condenser has no effect whatever on the medium waves—a great advance over the usual form of pre-set condenser arrangement, which was so arranged that it effected both medium and long waves, so that very often it had to be altered every time one changed the wave-band.

A tapped aerial circuit is provided in the first tuning stage, so that either four, six, or nine turns of aerial coupling can be employed, the aerial coil being tapped at four and six turns from the end (X) of the winding.

The long-wave coil is also tapped, so that one has a choice of using twenty or thirty turns in the aerial circuit, which, as you will see, is auto-coupled to the grid circuit.

Unique Construction

The second (detector) tuning circuit has a very similar arrangement in it, though what would be the aerial winding on the medium waves is now, of course, a primary winding which is placed in the anode circuit of the second screened-grid valve, and this winding consists of thirty turns, tapped at ten and twenty. The long-wave section is also tapped, three tappings being used this time, at twenty, forty, and sixty from the earth end of the secondary. In this circuit reaction coils are also used for providing regeneration between the detector plate and the grid circuit.

You Can Make All the Coils Yourself!

The rest of the receiver has everything standard, as you will see if you look at the theoretical circuit closely. The construction is somewhat unique, however, and it is advisable that we go into this fairly closely.

First of all, the panel. Looking at the diagram you will see that it appears to be a perfectly normal

arrangement, though if you look closely you will see that the on-off switch is well below the line joining the reaction and two Extensers and the volume control.

Hidden Wiring

This is because the panel is arranged so that a certain amount of sub-base-

board wiring can be carried out, and 1½ in. of the panel project below the baseboard.

At the back of the set a terminal strip stretches not quite the whole length of the baseboard, and this projects below the latter.

The baseboard is of the usual size, 18 in. by 10 in., and is covered all

The Wiring Has Been Greatly Simplified

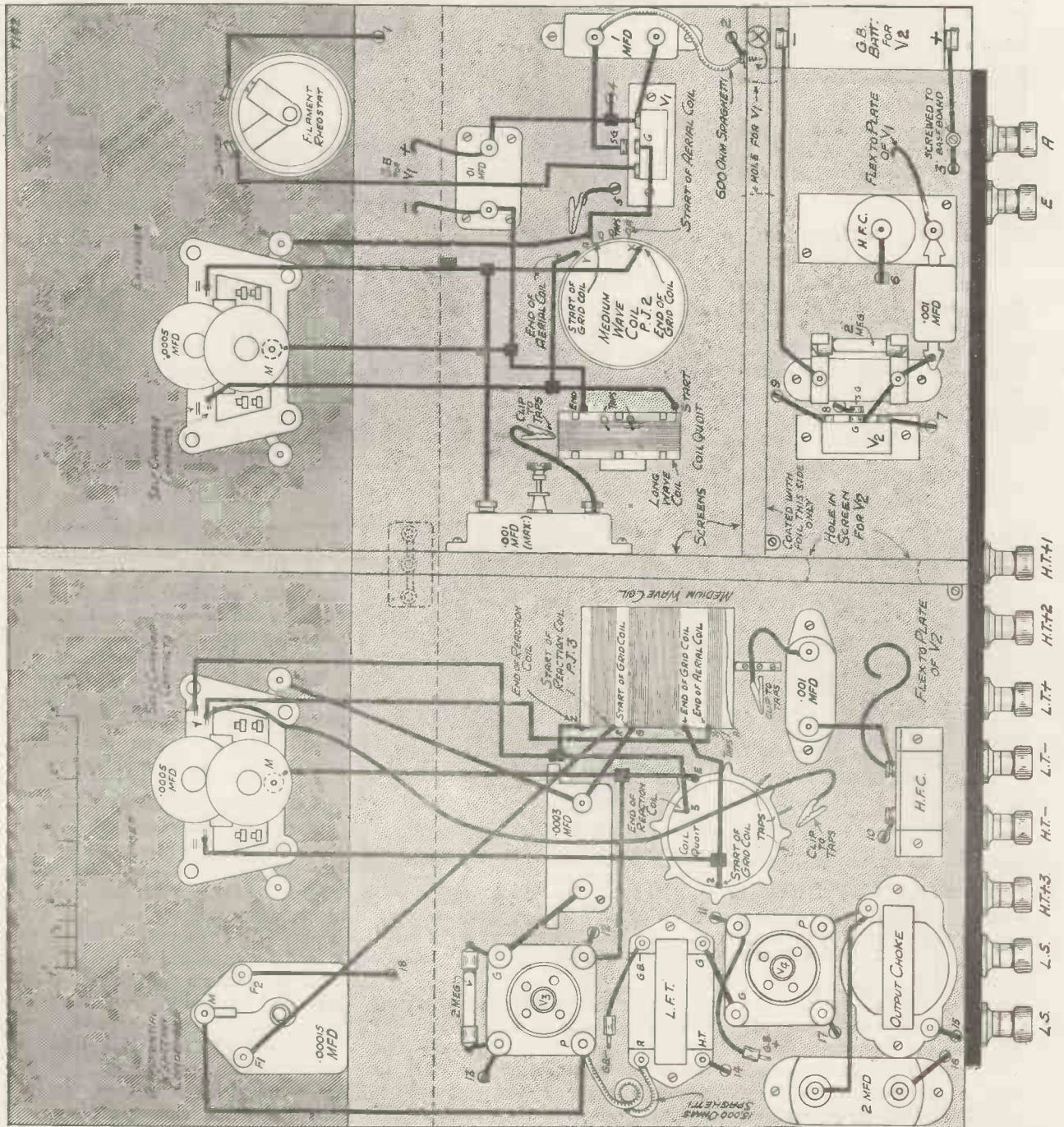

When two Extensers are used, as in this set, you do away with all wave-change switches and all their mounting, wiring and operating difficulties.

over with a special metallised paper which is very useful when one requires a totally screened baseboard, and is very easily fixed. This paper is also used for the screening.

sort of wood as the baseboard, namely, five-ply, and are covered on both sides with this special metallised paper with the exception of the screen parallel with the panel, which is

also is extremely easy to work. It is much easier to cut an ordinary wooden screen and to make a hole in it for the screened-grid valve than to work with metal, and if you make

This Circuit is Particularly Interesting

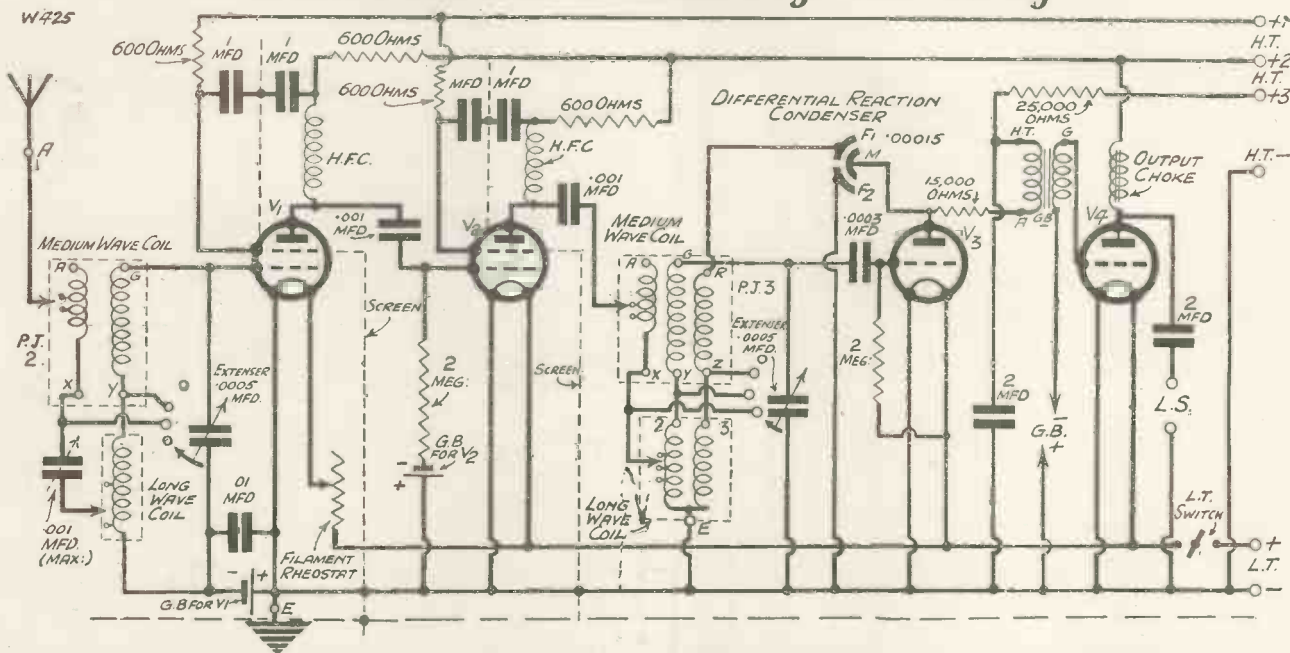

The two-band switching, with separated long- and short-wave units, enables optimum effectiveness to be attained on both long and ordinary waves. Observe the new Extenser symbols; these are, of course, novel, but essential, as no ordinary theoretical symbol will serve.

The two screens which you see only covered on one side (farthest your screens of wood and use this in the photograph run at right angles from panel). This gives the set not paper you will find that you have to each other, are made of the same only a very nice appearance, but just as efficient screening as you

These Coils Continue the Good Work

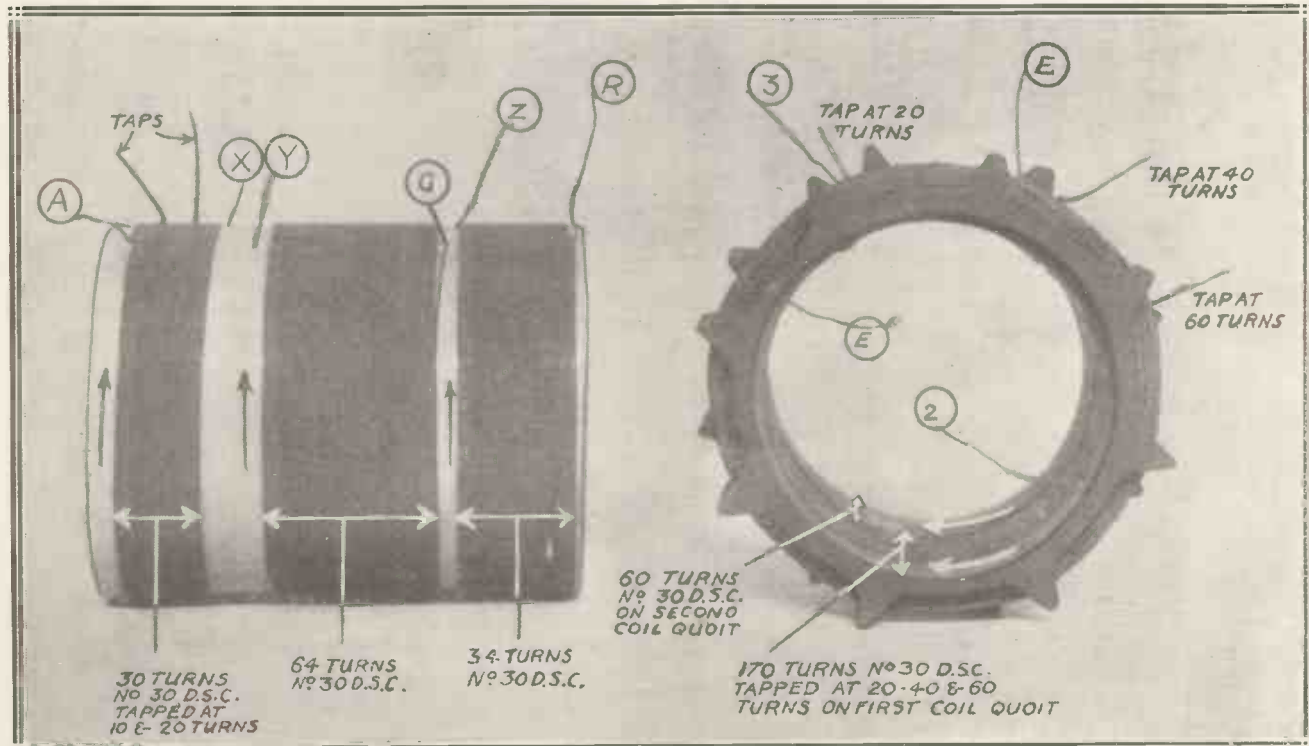

Here we have P.J.3 and its coil quit companion for medium- and long-wave intermediate coupling. Be careful that you get all the winding ends connected up correctly. If you buy the coils you will find indicating colours are used (see text), but if you make your own we advise you to put on small paper labels.

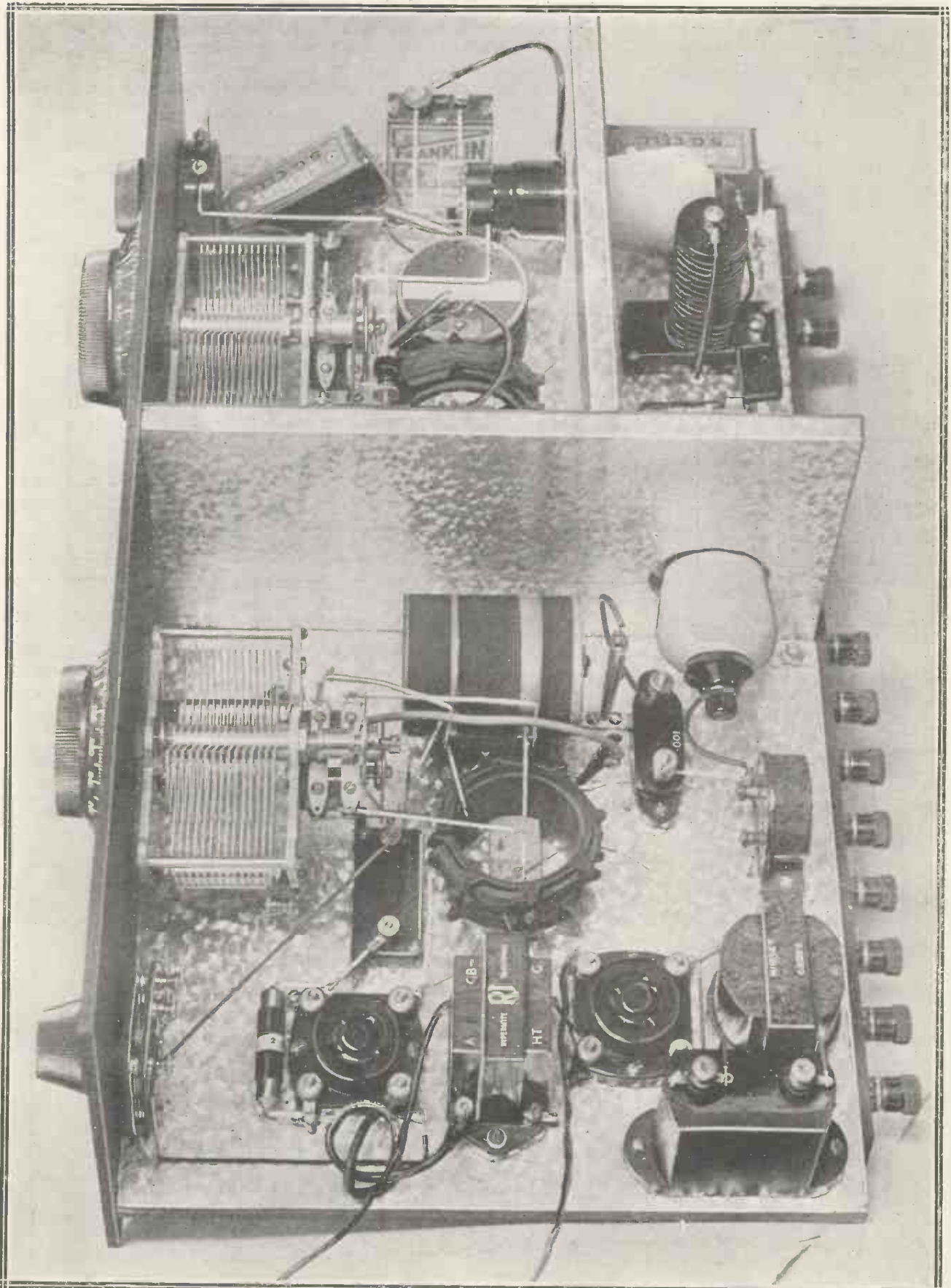

This is the detector and L.F. end of the receiver, the valves have been removed so that you may see the various components. You can, however, see the second S.G. valve poking through the screen. Note the Extenser, and also the new coil quits, two of our latest contributions to radio.

You Will Like this Set's Flexible Controls

would in the case of metal, but you will be able to fit them in half the time.

The screens are attached by screws projecting up through the bottom of the baseboard, care being taken to earth the foil on the baseboard and on the screens by means of screws and washers connecting these to the earth terminal in the set. For the purpose of connecting the screens little tabs can be used, these being left on the paper before it is stuck to the screen. The fitting of the paper, by the way, is done by ordinary *Siccotine* or some form of paste or glue, and it is extremely easy to work.

Mounting the Components

After securing the screen and the baseboard, one can carry out the mounting of the main components. The Extensers, reaction condenser, volume control and on-off switch should be mounted, and the panel placed in position before anything further is done. Then the terminal strip at the back should be placed in position so that the baseboard is lifted above the table, and one can then proceed with the rest of the mounting of components.

The coils require the most care, for these must be mounted well above the baseboard in order to avoid loss of inductance due to the presence of the metallised paper. The long-wave coil in the case of the detector circuit can be mounted fairly close to the

baseboard, the reaction section of the coil (which is wound on two different coil quirts) being at the bottom, fixed tightly on to a piece of wood which is screwed to the baseboard.

The long-wave coil in the other section of the set should be mounted well above the baseboard and should be attached in a horizontal position. How this is done can be easily seen

WHAT THE EXTENSER DOES

- (1) Simplifies set construction.
- (2) Simplifies set operation.
- (3) Increases receiver efficiency.
- (4) Eliminates wave-change switches.
- (5) Enables one set of dial readings to cover both long and ordinary waves.
- (6) Makes dial readings logical and definite instead of merely arbitrary.

The "Hi-Mag" uses two Extensers, to its double advantage.

from the photographs, where it will be noticed that it is mounted on a small wooden pillar fixed to the baseboard at one end, and to a piece of wood fitting inside the former at the other.

The medium-wave coils have similar types of mountings, pieces of wood being jammed into the paxolin formers and these mounted either by wooden pillars or by metal strips to keep the coil well above the baseboard.

Care must be taken that the orientation of the coils is correctly carried out so that their fields are at right angles, and it is best to carry out the wiring as closely as possible to the original arrangement.

Coil Construction

Before we leave the question of the coils perhaps it would be better to go into their construction carefully in case many of you want to make your own coils rather than purchase them ready-made, otherwise they can be obtained from most of the coil manufacturers who go in for the marketing of components for home-construction sets.

The long-wave coils you have to wind, as they are not available ready-made. So we will deal with them first. In the first tuned circuit the long-wave coil consists of a winding of 30 gauge D.S.C. on an ordinary coil quirt, there being 170 turns. This can be wound either in a clockwise or anti-clockwise direction, and the two ends are labelled 2 and E respectively. This is clearly seen in one of the photographs.

How it is Done

We commence winding at 2, securing the wire in the usual way through a couple of holes which you will find are already drilled in the former, and wind round and round until you have put on 130 turns. Then

Making the Constructor's Labours Lighter

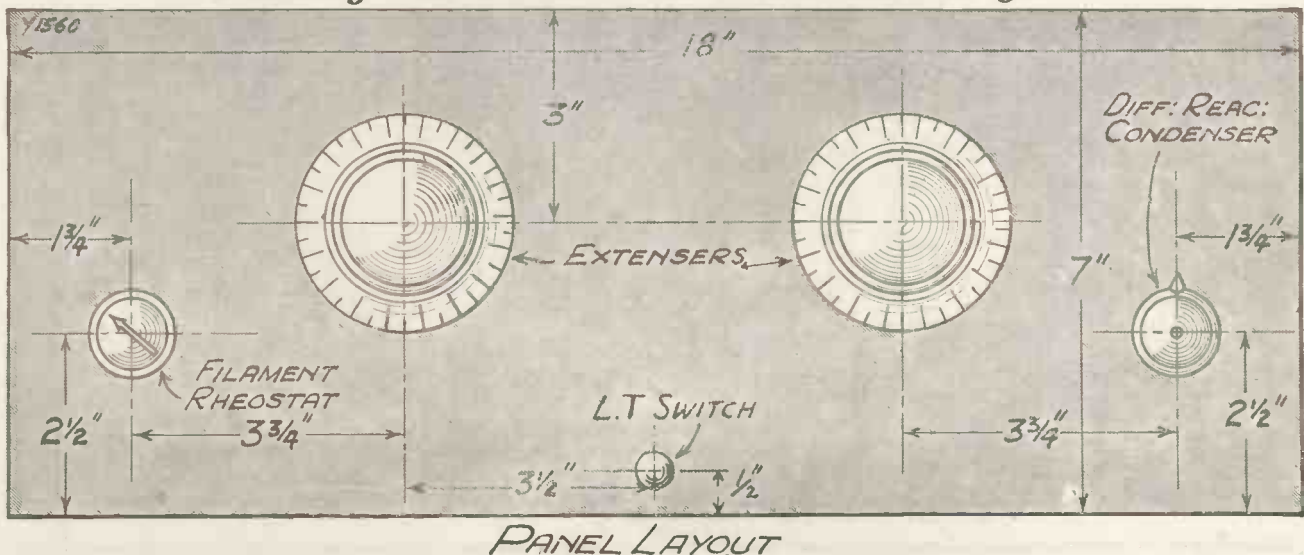

Each Extenser saves a wave-change switch, and the record-radio change-over is effected by the same switch that turns the set on and off. So you see, there are at least three panel components fewer than there would otherwise have been.

WHY SHOULDN'T IT BE UNDERNEATH?

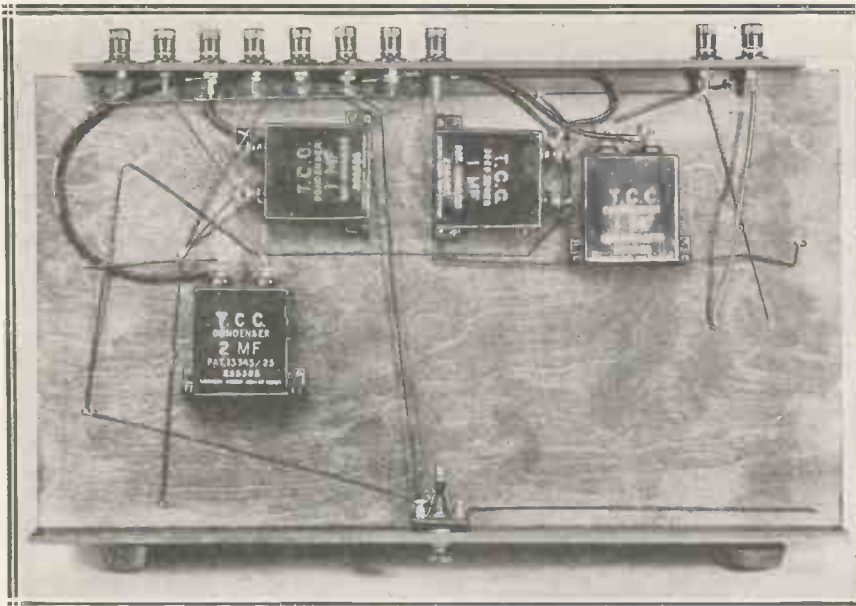

All the "de-coupling" gadgets are neatly tucked away underneath the baseboard, and, as you will see if you glance at the photo on the opposite page, the set's appearance is vastly improved.

a tap should be made by twisting a loop in the wire and the winding continued for another twenty turns, then another tap should be made by means of another loop and a further twenty turns put on, finishing off

through a hole and bringing out a length which is marked E. In this way you wind on 170 turns tapped at 20 and 40 from the end marked E, which is to be the earthed end.

It is advisable when winding this

coil to leave the ends 2 and E of suitable lengths for wiring up to the rest of the set so that the soldered leads of wire need not be affixed.

The long-wave coil in the grid circuit of the detector valve consists of two coils wound on separate coil quirts, these quirts being secured together by means of shoulders which are provided. The tuned winding is the same as that which has just been discussed, with the exception that there is an extra tap on it, so that we have 170 turns wound in the same way, starting at 2 and tapped at 20, 40 and 60 from the earth end. So we wind on in this case 110 turns, take a tap, another 20, make a tap, a further 20, another tap, and a final 20 to the end of the coil.

A Query Answered

You might wonder why we do not say that the coil is tapped at 110, 130, 150 and 170, rather than, say, at 20, 40 and 60. This perhaps would be quite correct from a winding point of view, as we start the winding at No. 2, but actually the aerial or the primary consists of either 20, 40 or 60 turns, as the tapping is made at these points from the end marked E.

So you see, though correct perhaps

Hidden Wiring That Solves Awkward Problems

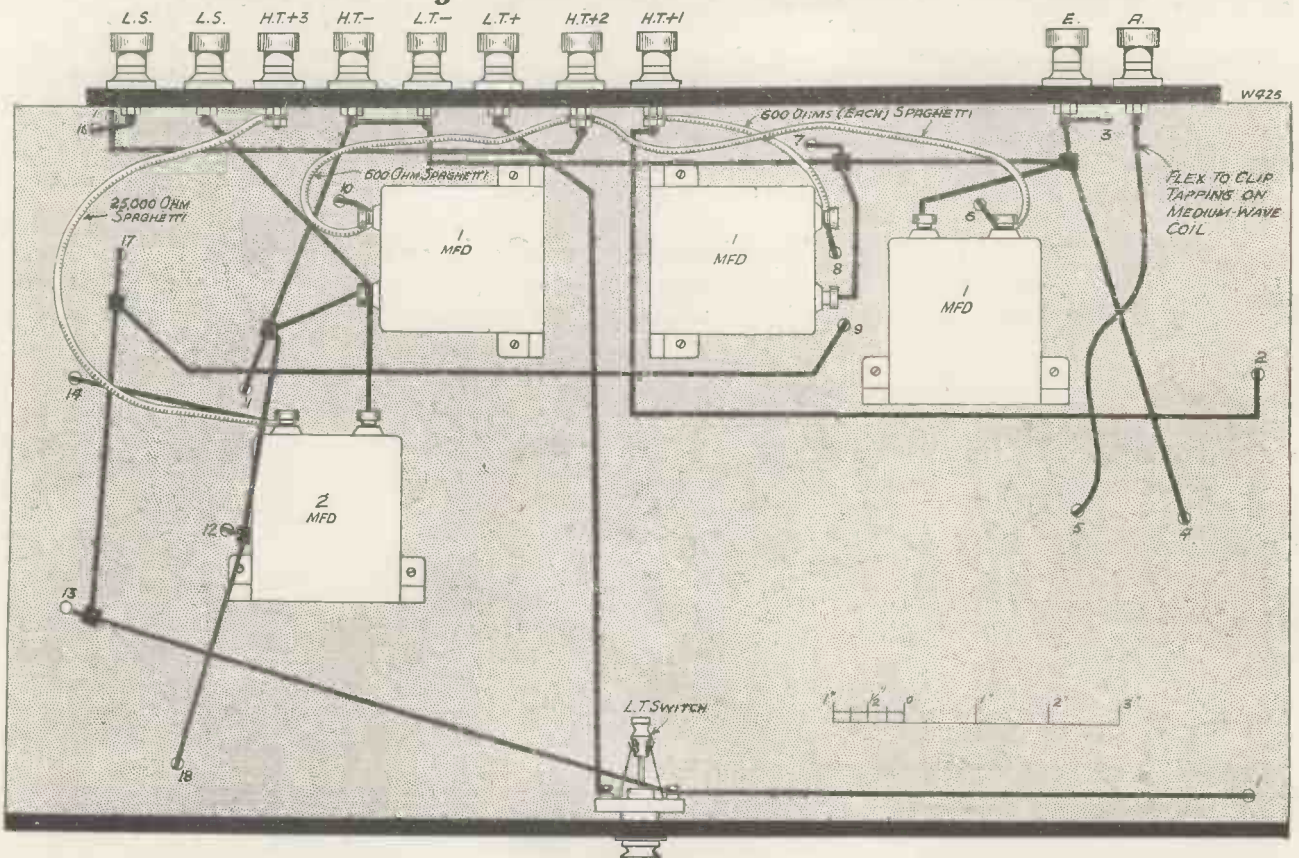

The constructor will appreciate the great gain that results in the disposal of the Spaghettis and de-coupling condensers in this manner.

Realistic Reproduction of Both Radio and Records

mechanically, it would not be quite correct electrically to say that the primary was tapped at 110, 130 and 150, and when we refer to a tapping point (say 40) later on in the article, and we say that you can tap the primary at 40 turns, this obviously must be considered from an electrical standpoint, indicating that you should have 40 turns in the coil section which is used as the primary coil, and that obviously is the 40 turns starting from the E end of the coil.

The Reaction Windings

You will see this very clearly if you look at the theoretical diagram, where you will see that a lead comes down from the condenser coupling the anode of the second screened-grid valve to a tapping point on the coil which is placed between No. 2 and E, and these tapping points are marked, as you see, at 20, 40 and 60.

Well, so much for the long-wave tuning coils. Now this second circuit has also a coil quoit joined to the long-

throughout for these coils, wound in the same direction as the long-wave coil.

In order to get the reaction right

SUGGESTED ACCESSORIES

Valves. 2-, 4-, or 6-volt valves may be used, types required being: 2 S.G. (metallised for preference), 1 det. (H.L., or special det. type, such as 2D.X.), 1 power valve (such as the P.2, P.215, P.220, or P.220A.). Valves used in set were: S.G.'s (Cossor metallised S.G.215), Det. (Mazda H.L.210), L.F. (Six-Sixty 220P.). Other suitable types are obtainable from Mullard, Osram, Marconi, Eta, Lissen, etc.

Batteries. Super (or triple) capacity type. H.T., 120-150 volts, and G.B. battery up to 18 volts. (Drydex, Pertrix, Ever Ready, Grosvenor,

Oldham, National, Lissen, Fuller, Siemens, G.E.C., etc.)

Two 9- or 1.5-volt S.G. G.B. batteries (Siemens, etc.).

Accumulators. 2-, 4-, or 6-volt, to suit voltage of valves (Oldham, Fuller, Exide, Pertrix, Lissen, Ediswan, etc.).

Mains Units. State voltage and type of mains, and give details of set when ordering. (Varley, Junit, Westinghouse, Tannoy, Regentone, Ekco, R.L., etc.)

Loud Speakers. (Undy, Celestion, Blue Spot, B.T.-H., Amplion, Mullard, Donotone, Ormond, etc.)

wave quoit for reaction purposes, and this consists of 60 turns of the same wire (30 D.S.C.), which is used

it is advisable to have the two coil quois fixed together for winding the

(Continued on page 90.)

Simplified Screening is Another Special Feature

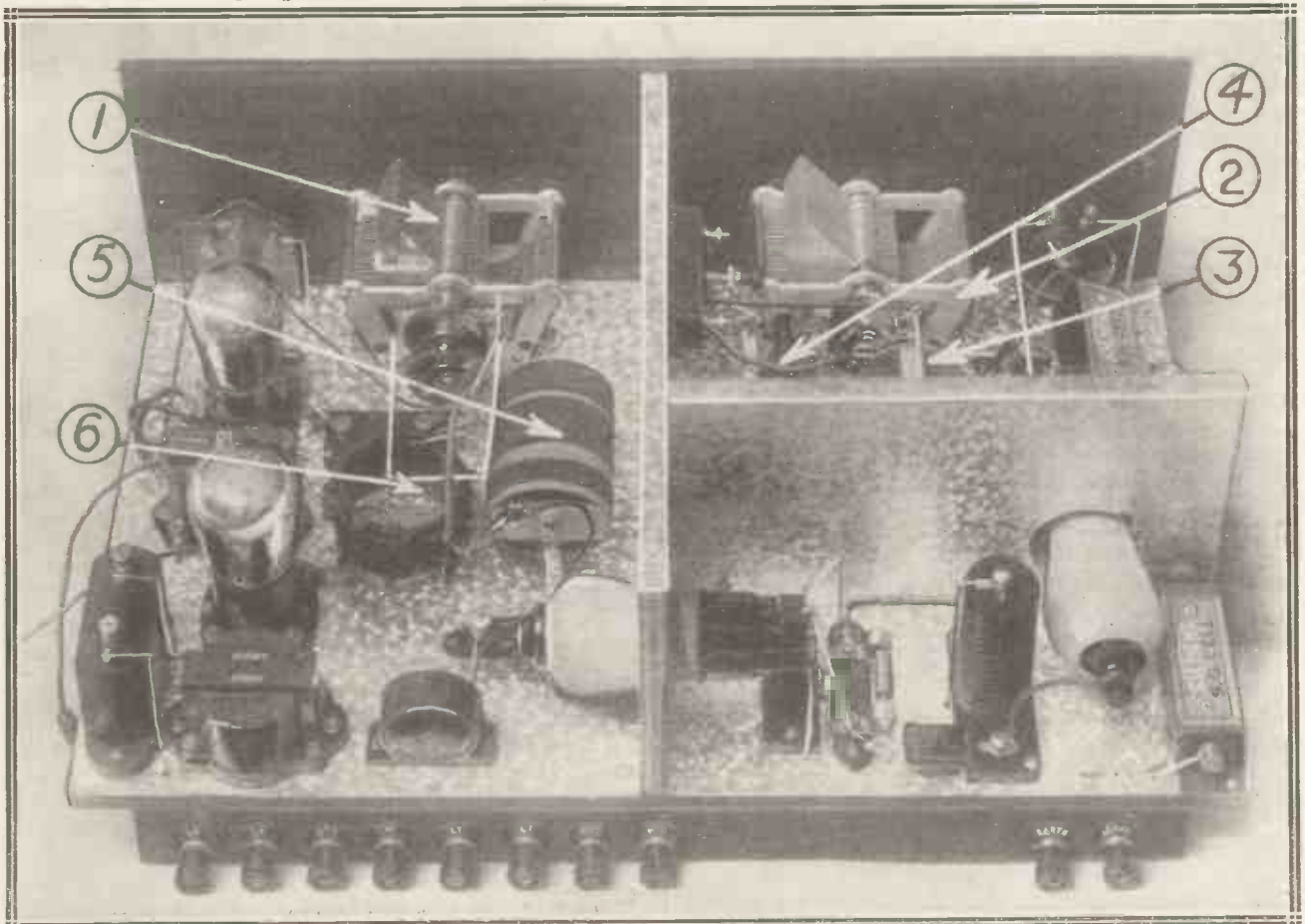

The screening, including that of the baseboard, is carried out on a foil-on-wood principle, which makes for inexpensiveness and ease of construction. The numbers indicate: (1) and (2), the Extensers; (3), the P.J.2 coil; (4), the long-wave coil that accompanies P.J.2; (5), the P.J.3 coil; and (6), the remaining long-wave coil, which comprises two coil quois—one to accommodate a reaction winding.

H. G. WELLS WAS RIGHT!

In this spirited letter to the Editor an "M.W." reader points out the truly wonderful accuracy of some of the great writer's forecasts, and gets in a shrewd stroke or two for his own point of view.

Sir,—As a humble admirer of the work of Mr. H. G. Wells, I must protest against the statement made in the June number of MODERN WIRELESS, by Mr. Harold A. Albert, to the effect that the great writer made little mention of wireless in his early books.

In "The Sleeper Awakes" there is a description of a future London with loud speakers in the buildings and in the streets. They were called, appropriately, "Babble Machines," for they were chiefly used for giving out news and propaganda.

London's Loud Speakers

They greeted one's ears with a "violent, loud hoot, followed by a vast leathery voice." This description may well apply to what is belched forth by many a wireless shop to-day.

When the hero has to address the people of the world, he stands before a machine and speaks, and he is heard and seen all over the world. Here is an anticipation not only of broadcasting, but of television also!

In "The War in the Air," to which your contributor refers (but which, apparently, he has not read!) there is a description of the stranding of a German airship in a remote and desolate region, and of how the crew manage to rig up a wireless transmitter which enables them to send out weak signals, and so to be rescued. Almost exactly similar events occurred when the airship Italia was wrecked in the Arctic not so long ago.

"S.O.S." from the Moon

In "The First Men in the Moon," a Mr. Julius Wendigee, who is attempting to establish communication with Mars, picks up a message by wireless from a Mr. Cavor, who has flown to the moon and is stranded there.

"... his communication comes and goes in our records in an extremely fitful manner; it becomes blurred; it 'fades out' in a mysterious and altogether exasperating way." Fading!

These few examples show that Mr. Wells was fully aware of the possibilities of wireless for broadcasting, television, propaganda, rescue work,

and long-distance communication. He could foresee, long ago, that man would attempt to extend his natural powers, with such things as the aeroplane, time machine, "babble machine," Cavorite, and so on.

Man!—Not Machines

But anyone who has read many of his books can scarcely avoid the conclusion that Mr. Wells is far more interested in man than in machines. In "The War in the Air" the aeroplane is brought in to show how man, with more power at his command, might easily wreck his own civilisation.

It is not surprising, then, to learn

"THE SLEEPER WAKES!"

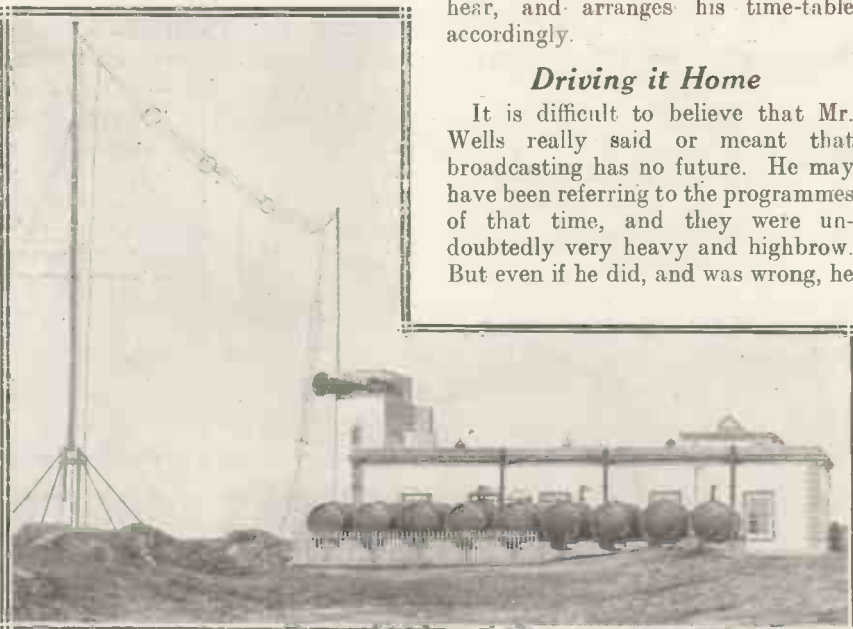

See the battery of loud speakers on the roof? It roars out a warning to ships from Cumbrae Lighthouse, in the Firth of Clyde, greeting the ear with "a violent loud hoot, followed by a vast leathery voice"! Mr. Wells was quite right!

that Mr. Wells is far more interested in international affairs than in broadcasting; but to suggest, as a reason for this, that he is piqued because he was not handed big bouquets after his broadcast talk shows appalling ignorance of his work.

If there is any wounded vanity knocking around it belongs to Mr. Albert, for it is painfully obvious that he is very annoyed with Mr. Wells for being too busy to give him an

interview. These interviewers seem to think that they have only to appear and the great ones of the earth are going to run around and alter all their arrangements to suit!

A True Saying

Mr. Albert, then, to give vent to his slighted feelings, rakes up something which Mr. Wells said in the dim and distant past in circumstances which are not clearly revealed. If he said that wireless involved "wonder followed by disillusionment," I agree with him, and so will every listener who is honest with himself.

It was inevitable, when we were promised speeches, concerts, and plays from all over the world, that we should not realise that the medium had limitations. We were not even agreed as to what we wished to hear. Some wanted this and others that, so that the patchwork programmes which were designed to please everybody naturally pleased nobody.

The wise listener reviews forthcoming programmes and picks out those items which he would like to hear, and arranges his time-table accordingly.

Driving it Home

It is difficult to believe that Mr. Wells really said or meant that broadcasting has no future. He may have been referring to the programmes of that time, and they were undoubtedly very heavy and highbrow. But even if he did, and was wrong, he

has so many successes to his credit that there is no excuse whatever for the very foolish attitude which tries to make out that his statements about wireless are not his real opinions, but expressions of his wounded feelings. As I have pointed out, the boot is on the other foot. The would-be interviewer is hurt.

Yours faithfully,

C. E. T. MAGUIRE.

Peckham, S.E.15.



ALL the recent trend in radio design is towards simplification. This is no mere passing fad, but is an inevitable step in the evolution of the radio set as part of the home.

For several years radio designers laboured under the disadvantage of not knowing quite what they wanted themselves. But now they have to meet a precise demand—a demand for a small set, of good appearance, inexpensive to run, powerful enough to work a moving-coil loud speaker, capable of quality musical reproduction, really realistic speech, and able to produce plenty of programmes from abroad as well as those of the B.B.C.

Simple to Operate

In addition to all this the set must be simple enough for all members of the family to handle, it must be able to sweep from programme to programme at the will of any unskilled member of the household, and it must be reasonably robust, to withstand fair wear and tear!

We may not yet have reached the ultimate perfection of radio design, but the fact that we are well on the way to it will be evident if the above ideal of a set is compared with the actual performance of a modern radio receiver. The set that we have just tested was model 313, produced by E. K. Cole, Ltd., "Ekco" Works, Southend-on-Sea.

Low Running Costs

This model can be obtained for running from A.C. mains, or from D.C., and the set tested was of the former type suitable for A.C. mains of any voltage between 200 and 250, periodicity 40 to 100 cycles. The

Don't fail to read this account of a recent test. It is of interest to all listeners, and of real importance to those who think of buying a new set, but are undecided about what to expect from it.

price is £22 10s., and on the mains in question, where electricity costs 6d. per unit, the running costs of the receiver work out at twelve shillings for one thousand hours.

In a house where the set is switched on, say, for a total of twenty-five hours during a whole week, the cost of the power for the set comes out at just over ten shillings for every eight months.

Some households may, of course,

use the set more than twenty-five hours a week; but, on the contrary, many electricity supply companies charge less than sixpence per unit, and in any case the running costs of a set of this type are so low compared with old-fashioned battery methods that they can be considered negligible.

Amazing Efficiency

What of the results? It can be said right away that they will be a revelation to anyone who has not had experience of the amazing efficiency of A.C. valves. There are only three valves—one of the S.G. type (Mullard P.M.S.4V.A.), one detector (Mullard P.M.254B.), and one pentode (Mullard P.M.24B. or P.M.24A.).

These three valves, due to the high

THE INSIDE OF THIS MODERN A.C. RECEIVER



When the one-piece back is removed the interior is seen to be arranged in self-screened units, with the dry-rectifier on the right. Note that virtually all the wiring is kept out of sight and harm's way.

A Receiver that Matches Up with any Speaker

efficiency of A.C. characteristics, develop a really tremendous volume on local stations, and strength which is completely satisfying from most of the important continental stations.

Record Playing

Big volume, however, is of little merit unless the quality is really first-class, and great attention has been given to this feature. Apart from the elementary precaution of removing all trace of hum so that the music is not superimposed on a whine from the mains, but is beautifully clear and distinct, due regard has been paid to other refinements of reproduction, such as adequate volume control,

ebonite, but it is of moulded bakelite—a really handsome job, with no panel, but just a small “window” in front to show the wave-length adjustment. The photograph at the heading of the article and the one on this page show the neat and clean lines of the receiver, which is obtainable in three different finishes—dark jade, dark mahogany, and medium oak—to suit different styles of furnishing.

A very ingenious feature of the design which is not apparent from the photograph is the fact that the cabinet is shaped so that the Ekco moving-coil loud speaker, which has a similar handsome moulded cabinet, can be stood on the set, thus forming one

speaker which may be required to be used with it, either of the cone or moving-coil type.

Any Aerial Will Do

The set is not a bit particular about the kind of aerial you use with it, for it has three aerial terminals, to suit different aerial conditions. Even if you have no aerial at all you need not despair, for on the lead which joins the set to the mains there is a small spare plug which when placed in one of the aerial sockets enables the electric light mains themselves to be used as an aerial!

This is a distinctly valuable feature of the receiver and one that is certain to give enormous convenience to the flat-owner where the difficulties of erecting an aerial are considerable.

Another good point in the design is the provision of a pair of sockets from which the field of a moving-coil loud speaker can be supplied and controlled by the on-off switch.

Delightful to Operate

In operation the set is delightful. A central tuning knob controls a plainly-marked wave-length scale running from 200 to 600 metres for medium waves, and from 900 to 1,900 metres for long waves.

Directly below this is the wave-change switch, which goes to the right for long waves and over to the left for medium waves. The on-off switch is to the right of the wave-change switch, and to the left of it is the volume control, which was found to give efficient regulation over a wide scale.

Of the two small knobs on either side of the main control that on the left is adjusted once only, being a “trimmer” or compensator to bring the two tuning condensers to exactly the same capacity. The small knob on the right is the reaction control, with the aid of which dozens of foreign stations can be tuned in without difficulty.

Extremely Compact

The length of the set is 17½ in., its width 12 in., and height 10 in. And into this space the makers have packed a really well designed modern receiver, of first-class performance, which will give the lucky owner plenty of alternative programmes without the slightest trouble.

ONE CONTROL, WHICH SHOWS WAVE-LENGTHS



The very easy station selection is obtained by means of the central knob, which turns a wave-length scale inside the recessed “window.”

and variations in loud-speaker impedances.

The would-be owner who possesses a gramophone will be interested in the possibility of electrical reproduction of his records. This has been arranged for, and the pick-up may be attached quite easily by means of special sockets plugged into the back.

Handsome Cabinet

An instruction book is supplied with every set, and this not only tells you exactly how to set about putting the set into commission, what to do first, what next, and so on, but illustrates the various stages by means of sketches, which make the whole operation absurdly easy.

Following the latest practice, the set's cabinet is not of wood and

apparently complete article of furniture. Alternately, of course, any other make of speaker may be used, standing apart from the set if this is preferred.

Concise directions enable the valves to be placed into position with an absolute minimum of trouble, there being only one connection to make inside the set. The whole of the back of the cabinet is removable for this operation, being a single piece of bakelite.

At the back of the instrument there are four sets of sockets, all neatly recessed out of the way, and yet all easily accessible. At one end are the two loud-speaker plugs, underneath which a plug and a little group of three sockets enable the output of the set to match up with any loud

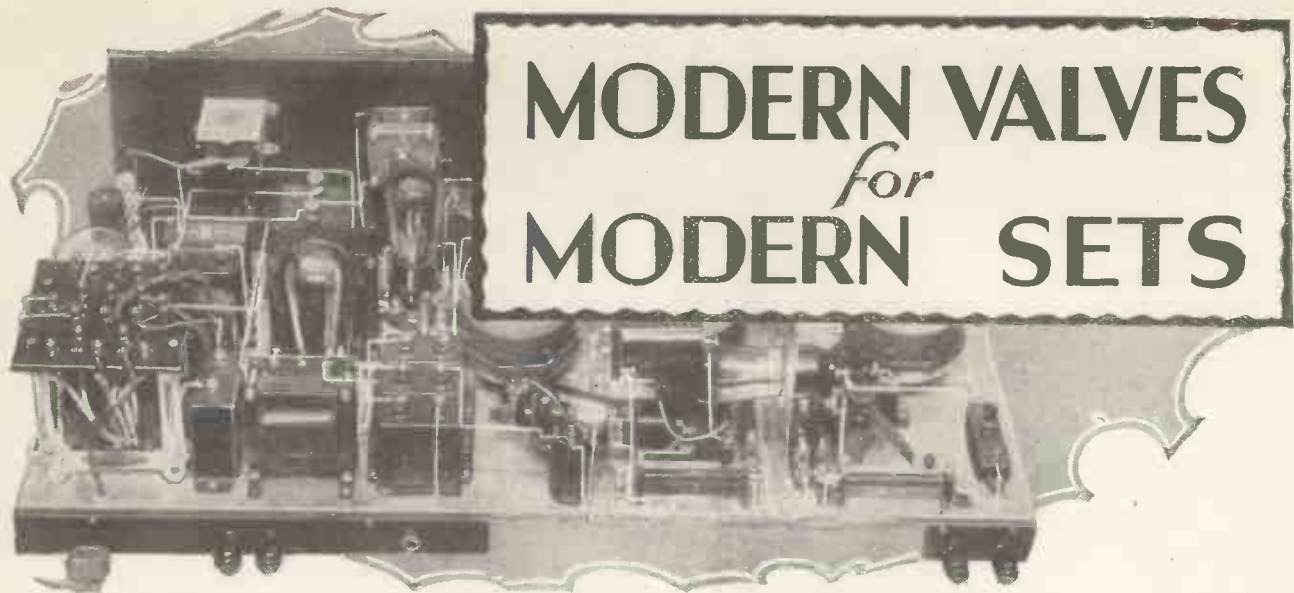

MODERN VALVES *for* MODERN SETS

LAST month in these pages I discussed the use of the new metallised screened-grid valve which had recently been brought out, and this month you will notice that these valves have been used in two of the sets described, namely, the super-het and the four-valve receiver.

Using Ordinary S.G.'s

Before I go farther, however, I should like to point out that there is no necessity for this type of screened-grid valve to be employed, and, if you so desire, you can use the ordinary S.G. valve quite well. But the metallised valve gives one an added advantage in screening, and those of you who want to get new valves would do well to get this type.

And now I ought to say a few things about the valves used in the various sets, and particularly about the choice of an output valve. This is the most difficult task that any home-constructor, or set designer for that matter, has to decide. The H.F. valves, of course, are obvious. The detector is nearly always of the H.L. type, having an impedance of anything from 15,000 to 20,000 ohms, or is of the special detector type, such as the Mullard P.M.2D.X.; but the L.F. valves are more difficult to choose.

The Output Valve

In a case where two L.F. valves are used (which does not occur in the sets described this month), usually the ordinary 210 L.F. is O.K. for the first stage, but in all cases the output valve requires a little thought.

The perfect way, if one has a large set and volume-control devices to

This article should be read in conjunction with those describing the sets in this month's "M.W.," for below Mr. K. D. Rogers gives some valuable data concerning the valves most suitable for those receivers.

prevent overloading, is to have two output valves in your possession. To use the larger of the two for "local" work if you are likely to be tuned-in for a long time, and the smaller output valve when one is searching for distant programmes.

The reason for this is pretty obvious. The smaller output valve will give

more magnification than the larger one, but will not carry so much power, and consequently will not give to the loud speaker such punch on loud local programmes as you can get from the larger valve.

Reception of Local

Such valves are the P.220, L.P.2, P.M.2A, etc. They are excellent valves for ordinary output purposes where distant stations are to be listened to, and the receiver is to be used as a general type of set; but for loud-speaker reproduction on the local station, for anything but a two-valve set, such valves are likely to be seriously overloaded before they give you the

GETTING THE MOST OUT OF IT

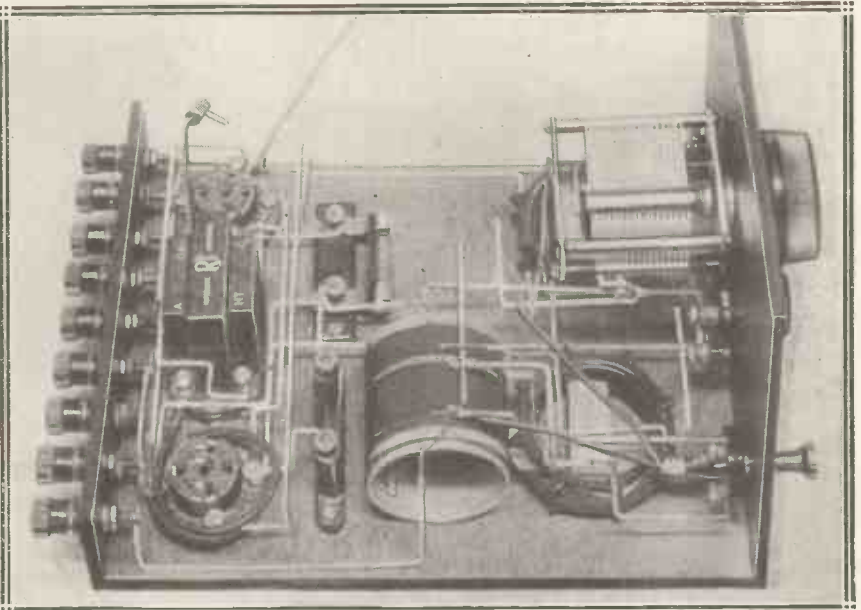

This is the "Compact" Two, described elsewhere in this issue. The valves best suited to this set are discussed above.

The Detector is Easily Overloaded

volume which you will be expecting.

The drawback of using a large output valve, of course, is also obvious: it requires more H.T. current, and this is not easily supplied by dry batteries. If one is using a mains unit, I should say definitely use a large output valve wherever possible, as it greatly obviates the danger of overloading; and a very large percentage of the distortion heard in home-made receivers (and in a number of commercial ones, too) is undoubtedly due to the overloading of the last valve, simply because the owner of the set does not realise that he cannot tune fully to the local station without using either his volume control to cut down strength or else a very much larger output valve than he is already employing.

This Month's Sets

Now let us take the sets concerned with this month's "M.W." and see what can be done. The first one, the "Compact" Two, is fairly straightforward. One has an ordinary H.L. valve as detector, followed by a "220 class" of valve as the output. This is all right for most purposes, and will be very useful for distant searching, though not quite large enough for close local work.

For this you want to be able to tune fully in, and I would advise a 220A., P.2, or P.M.252. But do not forget that when you change your valve you will have to change your G.B. voltage.

If you are deciding to get a set, no matter how many valves (over two), and you think it would be a good idea to use different output valves for different purposes, then I would strongly advise you to get a grid-bias battery of 18 volts, and to use this no matter what type of output valve you have got. It's no good getting a battery of 9 volts simply because you say: "I will be using the smaller output valve mostly," because as soon as you go over to the larger output valve you must have a bigger grid-bias voltage.

Use Sufficient H.T.

And do not forget, also, that to get the best out of a large output valve you must have plenty of H.T. Although a small valve might work very well on 120 volts, if you give 150 volts to the P.2 or the 220A. you will get very much better results

than you would if you cut them also to 120.

And now let us have a look at the four-valver. This consists of two H.F., detector and one output. Here you find the detector will have to be of the H.L.210 type (or of the special detector type), and you will also have to be prepared to use the volume control on the first screened-grid valve on quite a number of stations in order to avoid detector overloading.

Input Too Large

This type of overloading is just as frequent in multi-valve receivers as is the type of overloading with which we are more familiar, namely, that of the output valve. If a detector valve is overloaded it does not necessarily mean that the output valve is also overloaded, but it *does*

THE "LEAGUE OF STATIONS"



Do you recognise him? He is Arthur Burrows, one-time B.B.C. announcer, and now Director of the "League of Stations" at Geneva.

mean that you will get distortion, and you will find that that distortion is not cured by using a larger output valve. In this case you must cut down your *input* to the set when listening to powerful stations, as well as giving the receiver quite a reasonably large output valve.

In the case of the four-valver I would suggest the P.220A. or P.2 for powerful stations, and nothing smaller than the P.220 type even if you are only going to use the receiver for long-distance working.

To Suit All Purposes

As a matter of fact, I think that the P.220 type would probably be a little on the small side even for the majority of distant stations, and I think you would be far safer if you used the larger throughout. Volume controlling could then be carried out for the local, and the same valve would do for "all stations."

The super-het can be placed in exactly the same category as the four-valver. You have one detector, not counting, of course, the first detector, and one output valve, and here again one meets the same problem of overloading, either of the detector (which is very probable in a large number of cases in a super-het) and also of the output valve. So here again it is advisable to use the same type of output valve as I have suggested for the four-valve receiver.

And now I want to run over one or two of the Cossor valves of the metallised type which were released last month.

The Cossor mains detector valve of the H.L. type is particularly efficient, having a wonderful characteristic of 11,500 ohms with an amplification factor of 52, giving a mutual conductance of 4.5 milliamps. per volt. As a grid-leak detector, of course, the automatic biasing problem does not arise, and one takes the cathode direct to the grid leak.

A Good Detector

Messrs. Cossor have also metallically screened the Cossor 41M.H. valve, another detector which has a higher impedance and a very much greater amplification than the valve previously mentioned. The impedance in this case is 18,000 ohms and the amplification factor 72, giving a mutual conductance of 4 milliamps. per volt. It is a very fine valve, and is particularly useful as a detector when no preceding H.F. stages are employed. If an H.F. stage is employed in front, then it is very easy to overload the detector on powerful programmes, and it is better to use the 41M.H.L., having an impedance of 11,500.

AT YOUR SERVICE



by
OUR TRADE COMMISSIONER



A Well-Arranged Catalogue

I HAVE just received from Messrs Radio Instruments, Ltd., their latest catalogue containing full details of mains transformers, mains units, coils, etc., and I am particularly struck with the way the mains transformer section has been laid out.

Unfortunately, there are few catalogues in which it is really easy to turn up any particular section and find out what is available for any specified purpose. Most firms' literature has to be searched almost right through before one can find whether or not the concern in question markets the component one requires.

Lissen Spaghettis

Some really fine Spaghetti resistances are now being marketed by Messrs. Lissen, Ltd., and they are, in the main, heavy-duty ones. They have been designed to appeal to the man who wants high quality resistances to carry a really useful number of millamps. Accordingly, there is a 600 to 2,500-ohm range quite capable of carrying 40 milliamps., from 5,000 to 20,000 ohms they will carry 15 milliamps., and from 25,000 to 50,000 ohms, 7 milliamps. Above these there are 80,000-, 100,000-, 150,000- and 200,000-ohm resistances, at prices of 1s. 6d., 1s. 9d., 2s., and 2s. 6d., all rated to carry 7 milliamps.

A Novel Poster

Radio Turin is an enterprising Continental broadcaster which comes over well in this country. The directors are also ingenious, as the following will show. The latest idea is to provide facilities for listeners to submit in writing particulars of their ailments. Subsequently these ailments and their remedies are discussed by a medical man before the microphone, and it is reported that

Here is some varied news of the trade that should interest all readers, whether or not they are connected with the radio industry. Manufacturers, dealers, home constructors and general readers are invited to send items of interest to be included under this heading.

already many cures have been made. I commend this idea, or something similar, to the B.B.C., as no doubt it would prove both extremely popular.

A New Photo Cell

The General Electric Co., Ltd., has just produced a gas-filled photo cell having a considerably higher sensitivity and greatly improved frequency characteristics over the caesium cells previously marketed. This improved cell incorporates all the advantages of its predecessor: high sensitivity to white light and infrared rays, together with the provision

of a standard valve base to the anode pin of which the cell anode is connected, and the addition of a very large insulation resistance between the electrodes, ensuring freedom from parasitic noises and giving extremely long life. The sensitivity is about 75 micro-amps. per lumen.

The Stenode Radiostat Receiver

An attractive little booklet is published by Radio Instruments, Ltd., giving details of the Stenode Radiostat receiver, which they market. At the beginning of the book an interesting diagram is provided which shows how an ordinary set of average selectivity will fare on the broadcast band when the Regional Scheme is complete, and how great lumps of the broadcast band will be blotted out by the British Regional stations, whereas to the user of the Stenode every station will be available and no

THE MARRIAGE OF "MR. BUGGINS"



Mr. Michael Hogan, better known to you as "Mr. Buggins," on the occasion of his marriage to Miss Madge Saunders, the well-known actress. They are here seen outside the Fulham Registry Office with Miss Mabel Constanduros, also of "Buggins" fame.

Interesting Items from the Radio Trade

station will be lost through jamming.

There follows a brief description of the Stenode, what it does and how it works, ending up with the specification of the R.I. Stenode Radiostat receiver and photographs of that wonderful set.

A Reduction in Price

I understand that from June 1st all Polar Pre-set condensers have been reduced in price, and that they are now available also in additional capacities of .0002 and .0005 mfd. Six capacities, therefore, are now on the market: .0001, .0002, .0003, .0005 and .001, being sold at 1s. 6d., and a .002 at 2s.

The Diehl Motor

Some little time ago we gave a brief review of the Diehl Aristocrat motor marketed by Claude Lyons, Ltd. We have since received notification from

what's what in the fixed condenser line, and is published by British Insulated Cables, Ltd., concerning the Helsby condenser. In table form one is able to see at a glance not only what condensers are available and at what price, but also the working voltages, the test voltages, and the widths, depths and heights of the cases in inches.

Condensers from .1 up to 12 mfd. are available, varying in working voltages from 250 up to 2,000, and in prices from 1s. 8d. to 120s. This constitutes a most extensive range and the booklet should be of value to all home constructors.

A Loss to the Trade

We learn with regret that Mr. Horace S. Wynn, the popular sales director of the Fuller Accumulator Company, Ltd., died recently with unexpected suddenness at the age of 46. Mr. Wynn had a distinguished

career in prices together with a new range of components of various sorts. The Telsen Radiogrand transformer has now come down to 8s. 6d., and the Ace to 5s. 6d., while the Radiogrand Super is now obtainable at 12s. 6d.

Valve holders have dropped to 6d. with the four pins and 8d. for the five-pin type, while the Telsen standard H.F. choke is now available at 2s. Grid leaks are only 9d., and mica fixed condensers have dropped down to 6d. These astonishing reductions will be of vital importance to the constructors of radio sets.

Down Again!

The Decca Record Company has announced a price reduction in their ten-inch record from 2s. to 1s. 6d., and of the twelve-inch from 3s. 6d. to 2s. 6d.

E. K. Cole Again

Messrs. E. K. Cole, of Southend-on-Sea, have branched out in quite a new line of business, the "Radiocorder." It is an instrument which enables the user to make his own gramophone records in music and speech and radio, and to reproduce them electrically. This instrument sells complete for five guineas, and should be of interest to a very large number of radio set owners.

An Automatic Changer

The Sun Electrical Company, Ltd., have recently put on the market the "Capehart" record changer, which enables the radio-gram enthusiast to play records for an hour on end without having the bother of changing them. It is a neat instrument, absolutely automatic, and plays ten- or twelve-inch records. Radio-gram enthusiasts can obtain full particulars from the Sun Electrical Co., Ltd., 118-120, Charing Cross Road, London, W.C.2, and I am also informed that a test report of the instrument will be given in next month's "M.W."

New H.M.V. Appointment

In view of the exceptional range of new "His Master's Voice" instruments to be released in time for the coming season, H.M.V. have appointed Mr. Richard Arbib, who has been in the service of the company for some years, as Technical Press Representative. He will work in conjunction with Mr. Allin Green, H.M.V.'s General Press Representative.

LETTING IN THE RAYS



One of the manufacturing shops of Ferranti, Ltd., which this up-to-date firm has glazed with Vitaglass.

that firm that they have decided to include with each motor sent out a copy of a very complete set of full-size drawings showing how the motor is mounted and the correct placing for various types of pick-ups. This makes the mounting of the motor, which in normal events is not a particularly easy job, a very simple affair indeed.

Helsby Condensers

A very interesting little brochure is available for those who want to know

career in the electrical industry and became sales director to the present Fuller company at their formation in 1926, having joined Messrs. United Electric Works, Ltd., as sales manager in 1919. Following a business visit to Birmingham, Mr. Wynn was suddenly taken ill with pleurisy and congestion of the lungs, the trouble unfortunately developing into pneumonia.

The Telsen "Axe"

The Telsen "Axe" fell on June 12th, bringing with it a tremendous reduc-

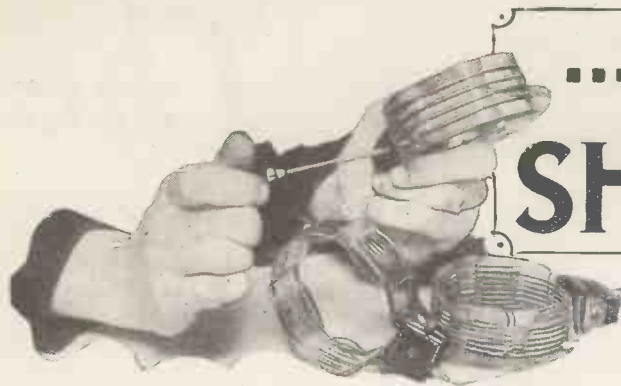

... ON THE ... SHORT WAVES

By W.L.S.

Our short-wave expert tells you something about the history of amateur transmission, and its remarkable fascination as a hobby. He also reminds us of the enthusiastic international friendships which are made possible only by this thrilling pastime.

THERE seems to be so much interest evidenced by readers of MODERN WIRELESS on the subject of amateur transmission that I have decided to let loose a few thoughts on the subject this month. The amateur transmitter, popularly known as the "ham," is regarded among the uninitiated as a peculiar phenomenon. He has his own points of view, however, and when one gets to know them one's views are apt to undergo a change.

The "Good Old Days"?

Without waxing historical, I may as well point out that amateur transmission commenced with the pastime of signalling over very short distances with untuned spark signals, generated by a "power buzzer" or a Ford coil, connected directly to an aerial. This pernicious form of signal, if heard to-day, would justify the immediate execution of its originator, and for this reason it is "taboo."

This, naturally, developed into the transmission of tuned spark signals, and the amateurs were given a wavelength of 1,000 metres on which to work. Until about 1921 this was in practically exclusive use.

About a year before the coming of broadcasting, however, the "hams" were forcibly removed to the new wave of 440 metres, owing, be it said, chiefly to interference with aircraft signals on 900 metres; "440" was quite short in those days!

Real "Pioneers"

By 1922 spark had become a rarity. C.W. and telephony were the order of the day, and it is much to the credit of the pioneers that several of them were habitually turning out telephony and music that would not have disgraced Writtle or Marconi House. And ever since then the British amateur (with the exception of the usual small minority) has set himself a high standard, and kept to it very successfully.

Successively on 440, 200, 130, 100, 90, 40 metres, and so on, the amateurs "went down," discovering each time that the seemingly impossible waves to which they were relegated were extremely valuable for long-distance work. And who can deny that this is the reason for the flocks of commercial stations now operating on the short waves with mere fractions of the powers that used to be necessary up in the "thousands"?

Amateur transmission must be regarded purely as a hobby; no profit can be made from it except the joy of doing a thing well, and of creating a world-wide circle of friends.

Listen at any time to the cheery greetings flying about on the short-wave bands between this country and the U.S.A., for example. "Hello, Bruce, old man. Glad to see you again. You're looking fine to-night!" And so on.

Thousands of Them!

There are probably nearly 50,000 of these kindred spirits in the world; all as keen as mustard about their own particular hobby, which has, I think, no parallel whatever.

Another aspect of the amateur game is the "QSL card," a written confirmation of long-distance work.

NAUEN'S SHORT-WAVE EXPERIMENTS

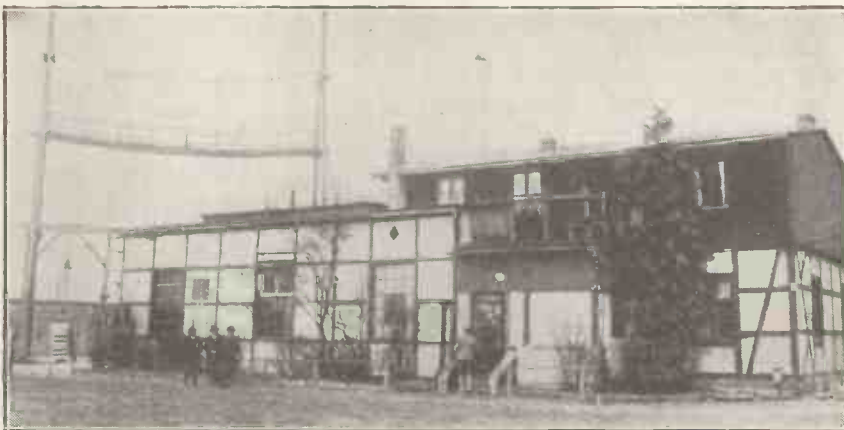

This is the old transmitter building at Nauen, which is now employed to house the experimental apparatus. The experiments are very largely concerned with the development of short-wave transmission.

And this "ham friendship" is a wonderful thing. For instance, if I were on holiday in the Malay States, and were to look up the amateurs in the call-book, the mere introduction of myself by my call-sign would ensure that I should immediately be treated like a brother! That seems fantastic to some, but every amateur knows it to be the truth.

Every amateur, too, has friends abroad that he has never seen, but has heard and conversed with so frequently that he knows their character as well as if they lived with him

"World-Wide Wall-Paper"

This generally takes the form of a postcard bearing all the details of the transmitter and receiver, and overprinted with the station call-sign in large and gaudy letters. Most amateur walls seem to be efficiently papered with "world-wide wall-paper" of this type.

On the walls of my own den are cards from some 90 different countries with which I have been in touch at various times, and, let it be said, some of them are really artistic.

The

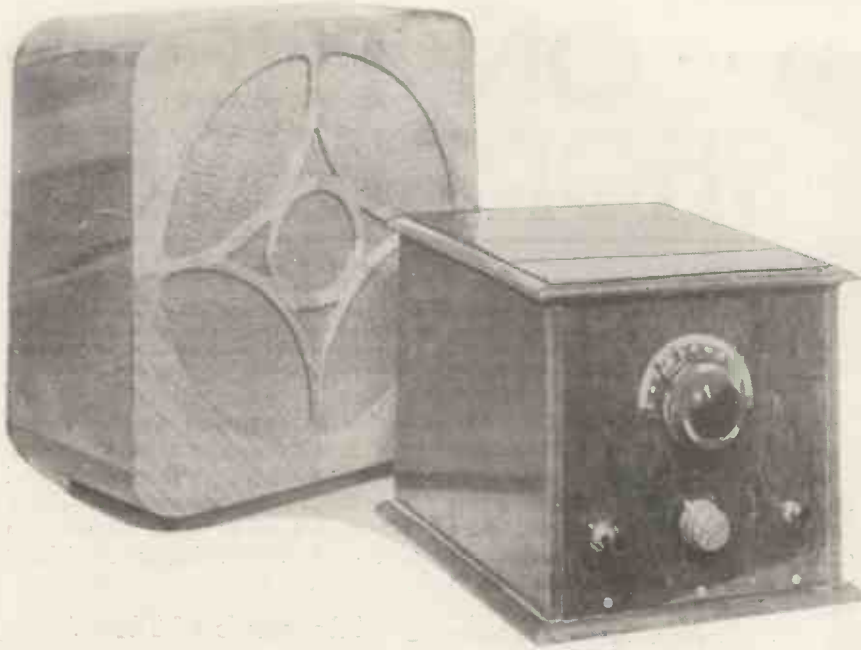

A handy little two-valve loud-speaker receiver which will tuck away in almost any odd corner, and for this reason should appeal to those with only limited space available. It is an exceedingly simple set to build, and is capable of remarkable results. Besides the locals it should bring in several of the high-power continental programmes.

"I WANT a general-purpose two-valver," said the Chief. "One I can stick in a corner of the bookcase with the batteries tucked away somewhere out of sight, the whole thing to be as compact as it is possible with efficiency.

"And it is not only myself who wants a set of that description," he continued. "I am sure there are hundreds of readers who would welcome the simple design of a two-valver that can be tucked away in any odd corner, a set that can always be ready, but not conspicuous."

And that's how it all began!

The Best Size

We set to work to get out the design. All sorts of schemes were tried and discussed: sloping panels, triangular cabinets, long, thin ones, and short, fat ones; but eventually all were discarded in favour of the quite plain

8-in. square panel in a cabinet about 10 in. deep. In short, the type you see in the photograph.

Obviously if the set is to be tucked away somewhere as suggested it is likely to be far easier to hide it if it is rectangular than if it were built on the futuristic principle. Odd shapes look attractive, but are sometimes difficult to "park" when parking space is limited.

Carefully Chosen Circuit

Well, as we said before, a straightforward cabinet was decided on, and then the design of the set itself was discussed. Being just a two-valver, it was not very difficult to decide the type of circuit, though the odd details wanted more thinking out.

Obviously a detector and one transformer-coupled note-magnifier was desirable to give good loud-speaker strength from the local station, and a

limited number of Continentals.

The next question was the usual compromise of sensitivity and selectivity. These depend upon the circuit, and here a discussion arose as to what type of coils should be used. In a set of this size the "P.W." dual-range coil is out of the question. It could be used, but it would be too much of a squash, and, furthermore, it is more expensive than two or three small home-made coils.

Another Fine Receiver designed and described by the Research Department.

A home-made coil sounds a very nasty sort of business to some people, but the coils used in this receiver are extremely simple to make. There are only three—a short-wave, a long-wave, and a little one which acts as a contra-dyne coil to prevent the short waves breaking through on the long.

The switch is of the usual type, with three spring contacts, but it is necessary to have one which has

PARTS FOR THIS WONDERFUL SET

PANEL

7 in. x 7 in. (Permcot, or Becol, Wearite, Goltone, Lissen, Keystone, Parex, etc.).

CABINET

1 cabinet to take above, and baseboard 9 in. deep (Cameco, Pickett, Osborn, Lock, Gilbert, Kay, etc.).

VARIABLE CONDENSERS

1 .0005 with vernier control (J.B. "Tiny," or Polar, Cydon, Lotus, Lissen, Ormond, Formo, Burton, Dubilier, Ready Radio, Igranic, Astra, Wavemaster, etc.).

1 .0001 to .00015-mfd. differential reaction (Telsen, or Ready Radio, Lotus, Igranic, Ormond, Polar, J.B., Dubilier, Lissen, Formo, Parex, Burton, Magnum, etc.).

COILS

1 former, 2 in. dia. x 2½ in. (Pirtoid, or Paxolin, etc.), or ready-made coil as below.

1 PJ1 coil (Wearite, Ready Radio, Goltone, Parex, Formo Atlas, Keystone, R.I., A.E.D., etc.).

2 coil quoits (Keystone, Ready Radio, Wearite, etc.).

4 oz. 30-gauge D.S.C., for winding coils.

L.F. TRANSFORMER

(R.I. "Hypermite," or other small type, such as Lewcos, Mullard, Igranic, Lisseu, Lotus, Ferranti, Telsen, etc.).

VALVE HOLDERS

2 four-pin (Telsen, or W.B., Igranic, Lotus, Lissen, Benjamin, Clix, Bulgin, Junit, Formo, Wearite, Magnum, etc.).

FIXED CONDENSER

1 .0003-mfd. (T.C.C., or Telsen, Dubilier, Ediswan, Ready Radio, Ferranti, Lissen, Mullard, Graham Farish, Watmel, Formo, Igranic, etc.).

RESISTANCES

1 grid leak and holder, 2 meg. (Dubilier and Ediswan, or Lissen, Telsen, Ferranti, Igranic, Mullard, Graham Farish, Watmel, etc.).

1 15,000-ohm Spaghetti (Bulgin, or Magnum, Lewcos, Ready Radio, Sovereign, Keystone, Graham Farish, Lissen, etc.).

SWITCHES

1 on-off (Junit, or Ready Radio, Goltone, Igranic, Lotus, Lissen, Benjamin, Bulgin, W.B., Keystone, Magnum, Red Diamond, Ormond, Wearite, etc.).

1 3-point wave-change, with metal end to plunger (Wearite). (Remove ebonite spacer behind nut at end and replace with metal washer, afterwards replacing nut, so that contact is made between metal band and spindle.)

TERMINALS

9 indicating terminals (Belling & Lee, or Clix, Eelex, Igranic, etc.).

MISCELLANEOUS

1 terminal strip, 7 in. x 2 in. Glazite or Lacoline, for wiring.

Flex, screws, etc.

G.B., H.T., and L.T. plugs and spade terminals (Clix, or Eelex, Belling & Lee, Igranic, etc.).

"Compact" Two

some means of connecting a piece of flex wire to the plunger so as to make it in reality a four-point switch. That is why the type as stated in the list of components was chosen.

An ordinary J.B. "Tiny" condenser is employed, though there is no reason why a small type of Extenser should not be used, in which case, of course, the design of the set could be altered slightly; the three-point switch would be obviated, and the reaction condenser could go over to the position now occupied by the three-point switch. We will discuss the wiring of an Extenser in this receiver farther on in the article.

The Medium-Wave Coil

If you look at the theoretical diagram you will see that it is perfectly normal with the exception of the coils, and you will also notice that the medium-wave coil is marked A, G, R, X, Y, Z, and the long-wave 1, 2, 3, and E.

The medium-wave coil consists of a primary, a secondary, and a reaction winding on a 2-in. former about $2\frac{1}{2}$ in. long, placed horizontally as shown in the photographs and wiring diagram. The windings consist of: Aerial about 4 turns (we shall have more to say about that in a minute), the grid winding, which comes next, about a quarter of an inch away, has 64 turns, and the reaction winding has 34 turns.

All these windings are carried out in the *same* direction, with No. 30 D.S.C. wire, so that if you start the coil at the aerial end and you wind clockwise, when you have finished the aerial coil you break the wire off, and then you start the grid coil in the same direction. Having finished the grid coil you break it off also, leaving a short length of wire sticking out for soldering, and commence the reaction coil, still winding in the same direction.

Marking the Ends

When you have finished the three windings you obviously have six "ends," three beginnings and three finishings. The connections are as follow:

Beginning of the aerial winding goes to the aerial terminal, that's simple. The beginning of the grid winding goes to the grid condenser

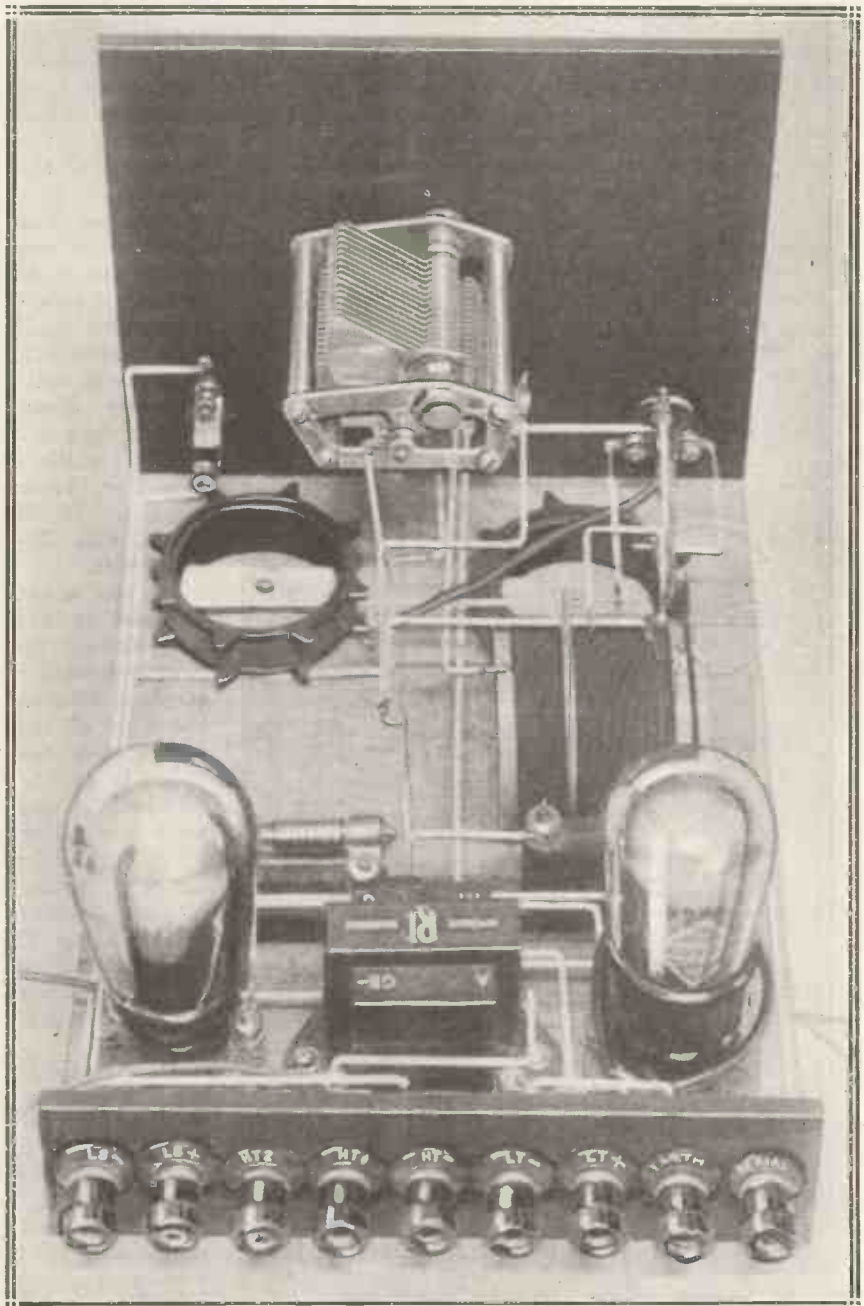

This photograph shows you the "works" of this neat two-valver. The two coil quots can be seen fixed to the baseboard, one either side of the variable condenser.

and the tuning condenser. The beginning of the reaction winding does *not* go to the reaction condenser; it goes instead to what is marked 3 on the long-wave coil. It is the *end* of the reaction winding which goes to the reaction condenser.

It is not a bad plan when you have finished winding your short-wave coil to stick little bits of paper on the

ends of the coils, marking them so that you will know how to connect up when you have finished the rest of the coil. For this you will want six pieces of paper, marked A, G, R, X, Y and Z respectively. Stick A and G on the beginning of the aerial and the beginning of the grid winding, and R on the *end* of the reaction winding. X, Y and Z are placed on the end of the

WIRED WHILE YOU WAIT

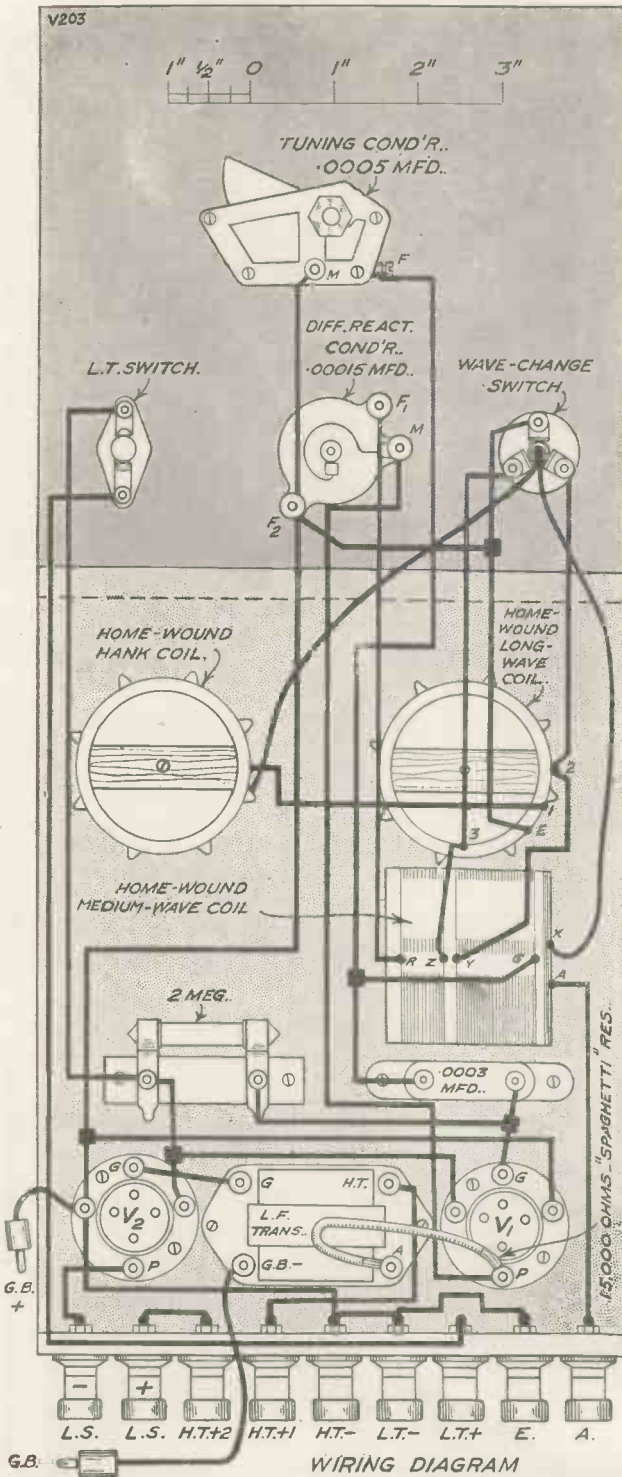

This set is exceptionally easy to wire up. Once you have all the components screwed in position it should not take you more than an hour or so.

aerial, end of the grid, and beginning of the reaction winding respectively. Very good—now we can leave that coil.

We are assuming you know how to finish coils off—simply by making a couple of small holes in the former, sticking the wire through one and back through the other so as to lock

the way, place a layer of empire tape or medical tape over the reaction winding. Then wind the grid winding in the same direction as you did the reaction (make sure of this, because it is very important), and go on winding until you have wound 120 turns. At that point make a big loop in the wire about 2 inches long, twist it up tight

it. We will now go on to the long-wave coil.

This is wound on one of the formers known as coil "quoits," and it is very simply carried out. The quoits can be obtained with holes drilled in them for the anchorage of the wire at the beginning and ends of the windings, and the process of winding is as follows. First of all wind on either in a clockwise or anti-clockwise direction—it does not matter which—the reaction winding. It is wound with 30-gauge wire.

The wire is anchored at the beginning by passing through a couple of holes at the edge of the former, and at the end it is also anchored in the same way, either by passing through another couple of holes or by linking it through one or two of the turns and pulling it tightly.

After completing the reaction winding, label the beginning with a piece of paper marked "E," and the end should also have a piece of paper stuck on it marked "3."

Now keeping "E" well out of

and go on winding until you have made another 40 turns, then finish the wire off by passing through a couple of holes or anchor in some other convenient way, and snip the wire off fairly short. This end is now twisted round the end of reaction marked E and the ends soldered together.

The Contradyne Winding

The beginning of the grid winding should be marked "2." The tap, which in this case is a loop, should be bared and marked "1," and then we can go on to the third coil. (By the way, when winding coils in each case it is best to bring the ends out on the one side of the coil to facilitate wiring.)

This consists simply of a hank coil (wound in any direction) of 60 turns of 30 gauge wire on another of these little coil quoits. The ends need not be marked, as it does not matter which way the coil is connected up.

We can now put aside the coils and carry on with the construction of the receiver. The mounting of the components on the baseboard is so simple that we do not think we need discuss it in any detail except to say that it should be kept as closely as possible like the original layout.

Mounting the Coils

After you have mounted the valve holders and the grid condenser, grid leak, L.F. transformer, and, of course, the terminal strip at the back, and the panel components, we start the mounting of the coils. This is quite simple.

The short-wave coil is mounted with its axis running across the set horizontally, and is screwed down by a couple of small wood screws placed near the edge of the paxolin former. It should be mounted, of course, so that all the leads coming out from it are at the top.

The long-wave coil marked 1, 2, 3, and E, is mounted alongside as shown in the photograph by placing a small piece of wood across the top and running a wood screw through it. The same happens to the hank coil, which is placed on the other side of the set just below the L.T. switch, and is mounted in the same way.

Simple Coil Connections

We are now ready for wiring up, and this is carried out quite simply from the wiring diagram, but make sure that the leads marked A, G and R go to the right places, and that X, Y, Z are joined up so that X goes to the hank coil, other side of hank coil to 1, Y goes to 2 and Z goes to 3. The switch contacts are also taken to four points, and to act as an

A Sensitive No-Trouble Receiver

A STRAIGHTFORWARD CIRCUIT

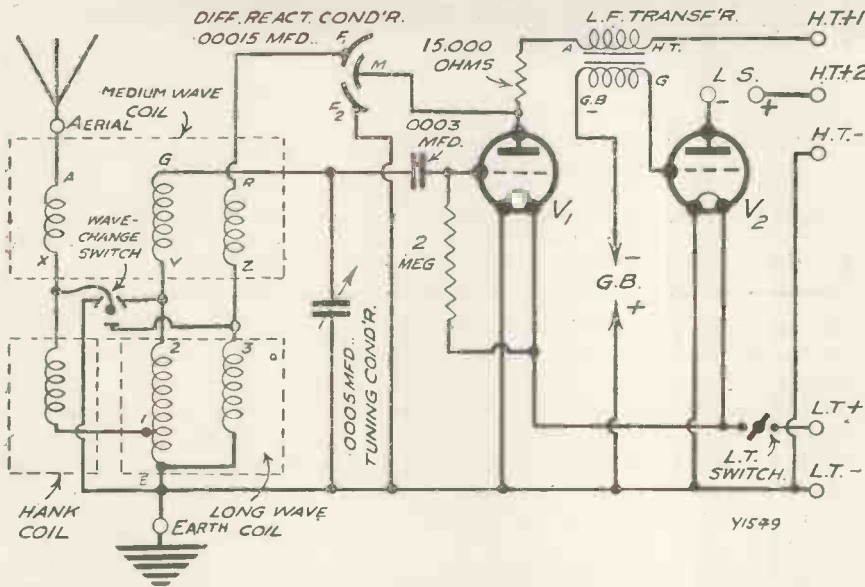

The theoretical circuit of any receiver is always most interesting. Two outstanding points in this particular circuit are the simple wave-change switch and the use of a high resistance instead of the more expensive H.F. choke.

additional check upon the wiring I will enumerate these points, which are as follow.

Centre of the switch to a junction between X and the hank coil, or you can take it direct to X; that is, the end of the aerial winding. The other contact of the switch goes to E on the long-wave coil and, of course, to

earth terminal and filament wiring of the set. Another one goes to a junction between Y and 2, it does not matter whether it goes to one or the other, and the last one goes to a junction between Z and 3.

Then you see what happens. When the plunger is pulled out all the contacts are made and the whole of the

long-wave section of the coil and the hank coil is short-circuited. When the plunger is pushed in then the long-wave and hank coils come in series with the short-wave coil unit, and you are on the long waves.

When you have wired up the set it is easy enough to test it out. The valves suitable are H.L. type as detector and an ordinary small power or P.220 type in the L.F. stage; probably the latter type of valve would be better on the local station, because this set does give a lot of magnification.

Easy Operation

The grid-bias battery should be 9 volts or more and can be easily placed on the back of the cabinet by means of proper grid-bias clips. Either 2-, 4-, or 6-volt valves can be employed, and the H.T. battery should be of the order of 108 to 120 volts. The detector should have about 60 volts, and the last valve, of course, the total voltage.

Operation is very simple, reaction is controlled in the usual way and the tuning is carried out on the one tuning dial. On the short waves, as we said before, you pull the switch out, and on the long waves you push it in.

There is one point as regards selectivity which we ought to

Constructing the Coils for the "Compact" Two

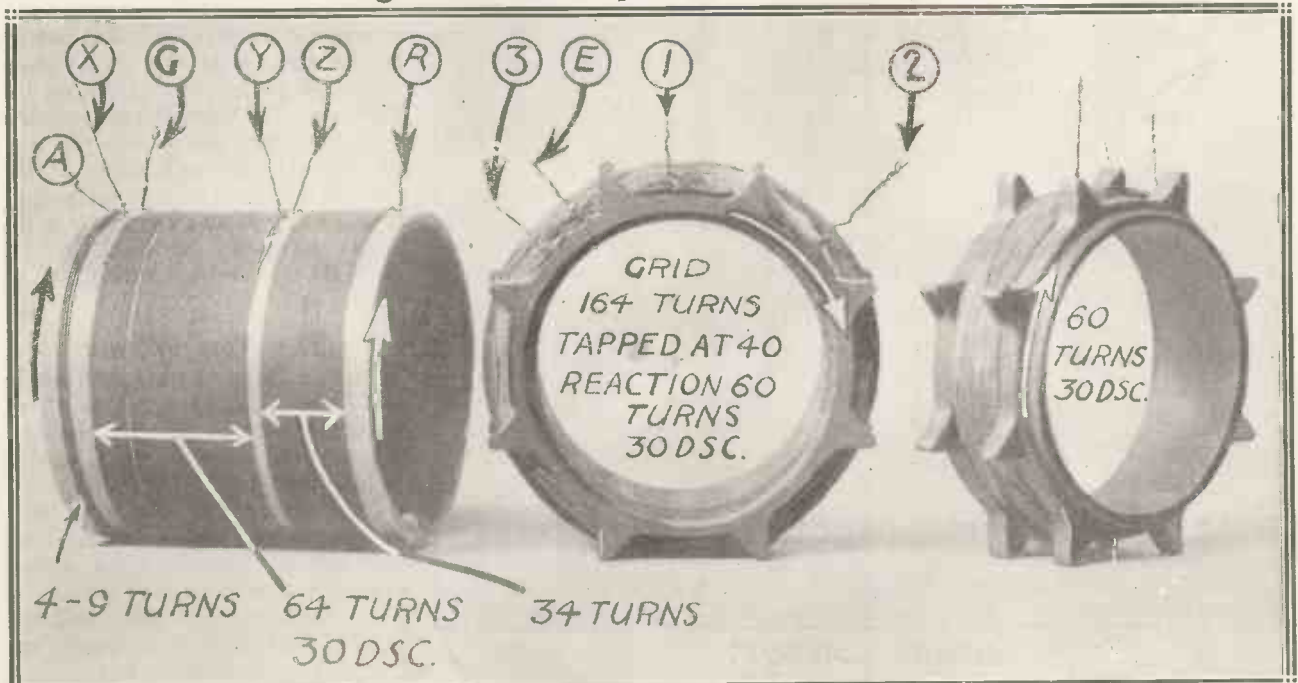

These coils are very easy to make, and even if you have never made any coils before you should have no difficulty. Follow the instructions carefully and you will be agreeably surprised when you find how quickly it can be done.

Economical to Run and Easy to Tune

mention. On the long waves you will find the selectivity is probably all you require, but on the medium band you may find that you can do with a little less selectivity and a little greater signal strength, though you will find the signal strength is remarkably good. On the other hand, if you are very near to a local station it is just possible that you may want a little bit more selectivity and do not mind a drop in signal strength.

Adjusting Selectivity

In the former case sensitivity is added and selectivity decreased by increasing the number of turns on the aerial winding. These can be carried up to about 15 with success. In the latter case you can either put a semi-variable condenser of .0002 to .001 maximum capacity in the aerial lead external to the set and turn this till you get the selectivity you require, not forgetting to put this condenser at maximum when you are on the

long waves, or you can decrease the number of turns on the aerial winding, cutting it down to two or three in cases where you are very close to a local station. But do not forget that whichever means you use to increase selectivity you are bound to decrease the sensitivity of the set in some way or another.

There is nothing else to add regarding the construction of this set. You will find it capable of remarkable results, and with a good aerial and

earth you should get several stations on the short and the long waves on the loud speaker. As a compact family two-valver it is ideal, and, as we said at the beginning of the article, it can be stored away in an odd corner with the greatest of ease.

Using an Extenser

And now a word or two about the wiring necessary when an Extenser is used instead of the ordinary tuning condenser. The alterations in the wave-change switching connections are very simple, but so as to avoid any chance of a mistake occurring we will go into the matter in more detail.

As the set now stands (see diagrams) we have a four-point switching scheme. With the Extenser used we only need three points, for the earthed point now becomes the moving vanes of the Extenser.

The other three connections, including the two flex leads that now go to the plunger of the wave-change switch, go to the three points on the Extenser. The wave-change switch is done away with and—there you are! To complete the symmetry of the panel it is a good plan in such cases to move the reaction condenser to the point previously occupied by the wave-change switch, wiring it up exactly as before.

The New Wiring

The new Extenser wiring will now be as follows: Moving vanes to F_2 on reaction filaments on valve holders, L.T. —, H.T. —, G.B. +, E, and E on long-wave coil.

One contact of Extenser self-changer switch to X on medium-wave coil and to hank coil; a second contact to 3 on long-wave coil and to Z on medium-wave coil; and the third contact to 2 on long-wave coil and to Y on medium coil.

The fixed vanes of the Extenser go to G and to grid condenser.

ACCESSORIES FOR THE "COMPACT" TWO

Valves. 2, 4, or 6 volts. 1 H.L. type, 1 power type, such as P.215, P.2 or P.220. (Mazda, Mullard, Osram, Marconi, Eta, Six-Sixty, Cossor, Lissen, etc.)

Loud Speakers. (Mullard, Ormond, Donotone, B.T.H., Blue Spot, Celestion, Undy, Amplion, etc.)

Batteries. H.T., 108-120 volts (double capacity preferable). (Ever Ready, Drydex, Pertrix, Grosvenor, Lissen,

Oldham, National, G.E.C., Siemens, Fuller, etc.)

G.B., 9 volts (or more if large power valve used), makes as above.

Accumulator. 2, 4, or 6 volts (according to voltage of valves). (Fuller, Oldham, Ediswan, Exide, Lissen, Pertrix, etc.)

Mains Units. (State voltage of mains and type of set when ordering.) (Regentone, Ekco, Tannoy, Varley, Junit, R.I., Atlas, Westinghouse, etc.)

A MINIMUM OF CONTROLS

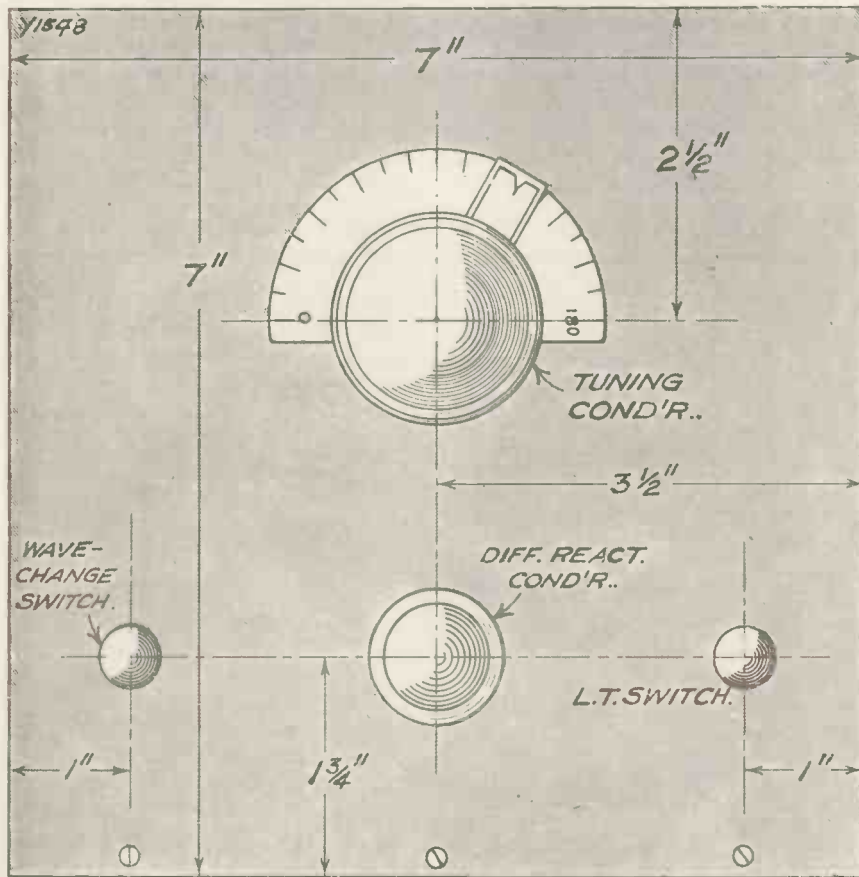

PANEL LAYOUT.

There are very few knobs on the panel, which always helps when a neat appearance is desirable. All the panel components are one-hole fixing, so you only have to drill seven holes altogether.

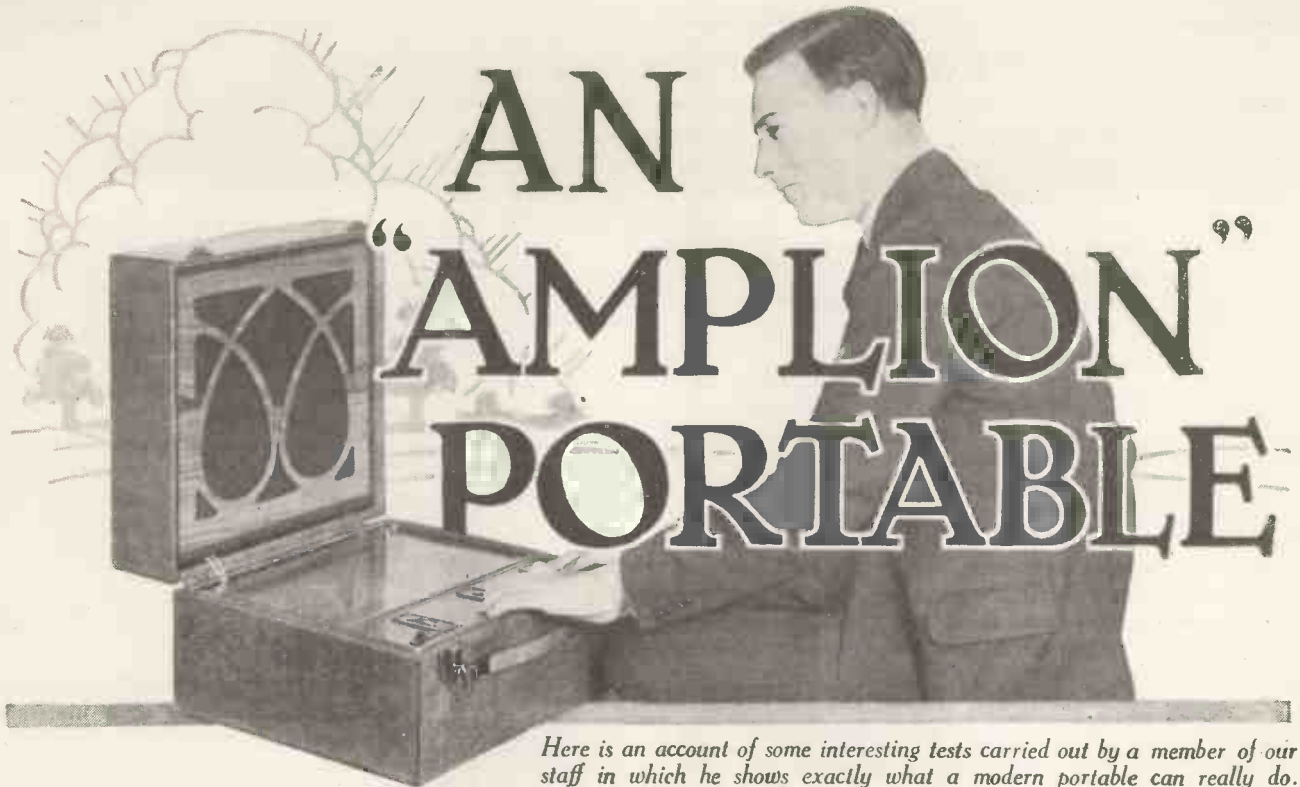

Here is an account of some interesting tests carried out by a member of our staff in which he shows exactly what a modern portable can really do.

THE summer is with us at last, and no doubt many people will be turning to portable receivers for entertainment. At this time of the year a set of such type is a very desirable possession, and will put the finishing touch to many a picnic.

I recently had the pleasure of testing out one of the new Amplion suitcase receivers. It was Friday morning when it was handed over to me, and as I was going away the same evening to spend the week-end with some friends I thought it would be a good opportunity to put the set through its paces.

It is a really wonderful receiver, which is no more than one would expect from a firm of such repute as Messrs. Graham Amplion.

Excellent Reproduction

Four valves are used in this set, namely, two screened-grid H.F. stages, a leaky-grid detector, and a pentode output valve. Of the high-frequency valves, only the first one is tuned, the second being aperiodically coupled to the detector valve.

The aerial is wound inside the lid, where the loud speaker is also fitted; and this accessory, needless to say, gives excellent reproduction and is absolutely free from chatter. It is of the balanced-armature type and will handle any amount of power.

All the batteries are housed in a special compartment behind the

valves, and they all fit in very nicely. There is a 108-volt H.T. battery, a 2-volt non-spillable accumulator, and a 9-volt grid battery.

I understand from the makers that the life of the high-tension battery is about three months, which I should say is a very conservative estimate, as the total H.T. consump-

tion is only about 10 milliamps.

And it must have taken a great deal of very careful thought and consideration to produce such an economical set and yet preserve all its good qualities.

Well, a very strange thing happened when I caught my train at London Bridge. No sooner had I

A WONDERFULLY COMPACT RECEIVER

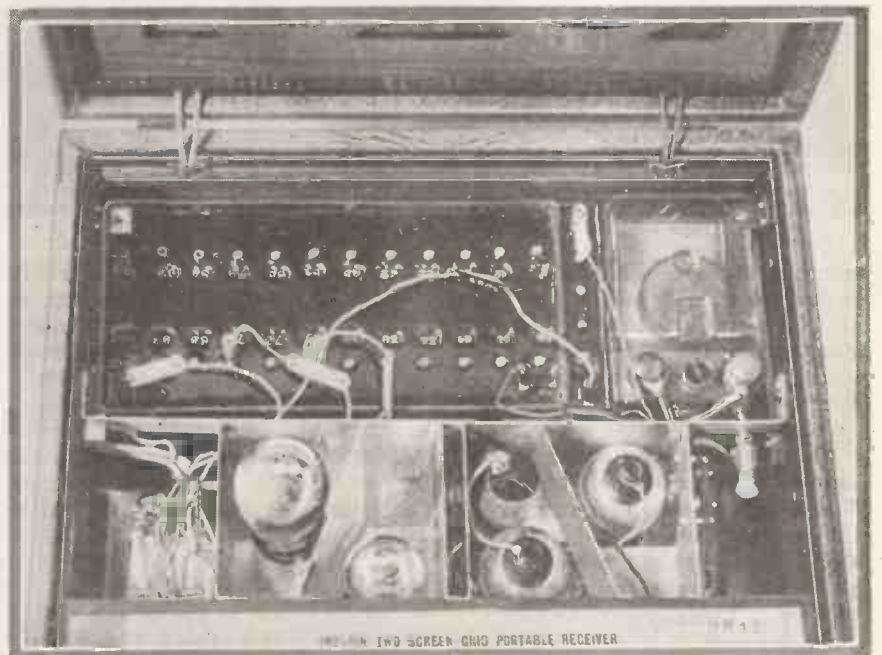

This is a view of the battery and valve compartments with the cover removed, showing how neatly everything fits in. The screening of the valves, etc., is most elaborate, and no doubt contributes greatly to the excellent performance of the set.

A Portable for those Picnic Parties

made myself comfortable in the carriage—not forgetting the portable, which I had put on the rack—than another passenger got in with a similar set. About five minutes later a third somebody else got in, also with a portable! Out of the six of us in the compartment, three had wireless sets. Could you beat it?

Good Daylight Results

The place I was going to was a quiet little town on the south coast between Brighton and Eastbourne. It turned out to be an excellent locality to test a set, and the results obtained were most interesting.

Even in broad daylight quite a number of stations came in at very good strength. After dark the trans-

All the different circuits are completely screened; and this makes the set easy to handle. The controls are also conveniently placed, there being a reaction and two tuning condensers. There is also a combined “on-off” and wave-change switch. The three condensers are fitted with drum-drives, and both the tuning controls can be worked together with ease; in fact, ganging seemed unnecessary.

A Bold Attempt

It was this case of control that made me decide to stay up late on Saturday night to see what could be got. I had been told that the American stations were coming in fairly well on the medium wave-band, although I had not recently heard them myself.

still on the air. (The time, by the way, was about 11.30 p.m.)

Hearing America

Well, I hung on to Lwów until about ten minutes past midnight, when he closed down. And as soon as his carrier had died away I turned the two tuning condensers about half a degree lower, and sure enough there was my old friend W G Y.

America on a portable set, I thought. What more can you want? And when you consider the small pick-up of the frame aerial it is certainly a fine performance. Many people would say that it is not possible to enjoy music from such a distance. I quite agree, but the fascination of it is tremendous.

Here you have a portable set that has all the qualities of a first-rate open-aerial receiver with the portability of an ordinary suitcase. It is beautifully finished, being covered in leather, and will stand up to any amount of knocking about.

NAILING THE NIGHTINGALE!

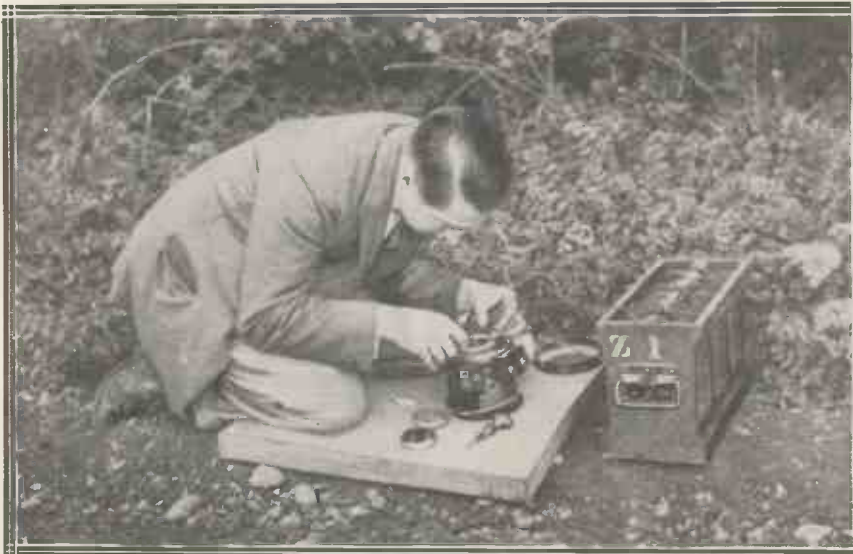

A great deal of careful preparation is necessary to enable you to hear the song of the nightingale over the radio. Here you see the engineer in charge making adjustments to the delicate microphone used for these broadcasts.

missions were available by the dozen; in fact, there were so many of them that it would be almost impossible to give a complete list. Stations like Rome, Brussels, Toulouse, and all the high-power Europeans fairly “knocked your head off.”

One great advantage of the portable receiver is its directional properties. This is a great aid to selectivity. As an instance, it was found quite possible to separate the London Regional and Mühlacker simply by taking advantage of these directional effects.

Quite a number of stations could be separated in this way which on an ordinary open-aerial receiver would be impossible.

It seemed to me that Schenectady would be the most likely station, as his power is about 50 kw. Schenectady has always been my pet American station, the reason being that it was the first broadcasting station I ever heard from the other side of the Atlantic. This was way back in the winter of 1923, when radio from an entertainment point of view was in its infancy.

On 380 Metres

Getting back to the present day, I saw that W G Y (this is his call-sign) was transmitting on a wave-length of 380 metres, and on tuning in to that wave I found that Lwów was

 * * * * *
A REVELATION
 * * * * *
*The experience of a reader over an
 “Inter-Aerial” loud speaker.*
 * * * * *

Sir,—Some months ago I had the pleasure of witnessing Matheson Lang’s entrancing acting in “Such Men Are Dangerous,” performed at a Cardiff theatre. Seats heavily booked, mine had to be one in the orchestra stalls, somewhat too near the stage. But—ah, me! There I learned the disappointing truth, the fact how behind-hand my loud speaker at home was, that it failed me in several respects.

Time passed, yet how that orchestra plagued my imagination and saddened my soul, so steeped in discontent.

Came a morning, a chance glimpse of a new number of “M.W.,” a random run through its ever-captivating pages. A pause! “Aha! But absurd to attempt it, I fear,” I told myself.

To cut a long story short: Many a magic hour, passing all hoped-for imaginings despaired of before. Merely by means of a simply but roughly-built brown-paper and three-ply contraption, put together by a pair of clumsy hands!

STILL A YOUTH THO’ FIFTY-SIX.
 Merthyr Tydfil

QUESTIONS ANSWERED



Resistance Coupling

L. S. (Bromley).—“My receiver is of the detector and two resistance-coupled L.F. stages type, and has, until recently, given splendid results. “I now find, however, that when I switch on no signals are heard for several seconds, and even then they sometimes fade away again. Can you tell me what is likely to be the cause of this mysterious behaviour?”

The most likely cause, L. S., is a faulty grid resistance. Have a look at both of your grid resistances and test them by substitution. See that they make good contact with their holders and make quite sure that your grid-bias leads and wander plugs are correctly connected to the G.B. battery.

Grid-Bias Batteries

F. K. (Leeds) wishes to know how often he should renew his grid-bias battery, and also asks if a run-down battery is likely to cause trouble.

The grid battery requires replacement about every nine months, but no period can be stated definitely. The question is solely dependent upon the “shelf” life of the battery, and, to be on the safe side, nine months should be taken as the maximum.

A run-down biasing battery will produce distortion and may even result in loss of emission in the case of a power valve. So it is unwise to economise in this direction.

Paralleling Earths

H. K. (Bedford).—“I am at present using an earth taken to the main water supply pipe, and it gives excellent results. I have been wondering whether it would be possible for me to improve on these results if I employed a good buried earth in conjunction with the one to the water supply. It is quite easy for

me to join the two earth leads together and to take them to the earth terminal on my set.”

No, H.K., nothing would be gained by paralleling the two earths. In fact, the result might be a loss of efficiency. If your present earth is giving excellent results stick to it, or alternatively you can use a buried

production. In any case you will probably be able to employ your existing condenser at some future date for H.F. de-coupling purposes, so it will not be wasted.

“H.F.” Valves

D. E. S. (Minehead).—“Will you please tell me why an “H.F.” type of valve is so often specified for use in the detector or first L.F. stages of a receiver. Surely such valves are really intended for H.F. amplification?”

It is probably true that these valves were primarily designed to be employed as H.F. amplifiers, but their characteristics often render them particularly suitable for detecting or L.F. amplifying.

For instance, a valve having an impedance of, say, 20,000 ohms and an amplification factor of about 20 makes an excellent detector in certain circuits, and may also give a splendid response curve if employed in conjunction with a suitable transformer.

It is simply a question of the characteristic of the valve. To specify an “H.F.” type is a convenient method of indicating which class of valve should be chosen for that particular position in the circuit.

Nickel Iron

O. D. (Cranbrook).—“Will you please tell me what nickel iron is and whether it has any advantages over ordinary iron for transformers?”

Nickel iron is an alloy of iron containing a small percentage of nickel. The alloy has a very high permeability and is therefore suitable for use for transformer cores. The high permeability makes it possible to obtain a large primary inductance for a given number of turns as compared with ordinary iron. Nickel-alloy transformers have the advantage of compactness.

TECHNICAL QUERIES DEPARTMENT

Are you in trouble with your set?

The MODERN WIRELESS Technical Queries Department is in a position to give an unrivalled service. The aim of the department is to furnish really helpful advice in connection with any radio problem, theoretical or practical.

Full details can be obtained direct from the Technical Queries Department, MODERN WIRELESS, Fleetway House, Farringdon Street, London, E.C.4.

A postcard will do. On receipt of this all the necessary literature will be sent to you, free and post free, immediately. This application will place you under no obligation whatever. Every reader of MODERN WIRELESS should have these details by him. An application form is included which will enable you to ask your questions so that we can deal with them expeditiously and with the minimum of delay. Having this form you will know exactly what information we require to have before us in order to solve your problems.

London readers, please note: Inquiries should not be made in person at Fleetway House or Tallis House.

earth. But don't employ both of them together.

Filter Condensers

W. N. B. (Billericay).—“I have a .5-mfd. condenser on hand, and since I am adding an output filter to my set I should very much like to use this condenser. Will you please say whether you consider it to be suitable.”

If you wish to obtain the best results, W. N. B., you should use a condenser of not less than 2 mfd. Your .5-mfd. condenser would work, but it is desirable to use a larger value from the point of view of re-

By the
Technical
Editor

On the



The R.I. "Parafeed" Transformer

ONE of the most interesting tendencies in radio during the past two or three years has been the development of the nickel-iron L.F. transformer. It was found that very high permeabilities could be achieved in transformer cores by special alloys of nickel and iron.

This enabled high primary inductances to be obtained in small structures using much smaller windings, and this meant lower self-capacities and, consequently, good frequency characteristics.

But nickel-iron transformers in general tend to suffer from what has hitherto been regarded as a disadvantage, that is, they cannot, comparatively speaking, carry much in the way of current before their inductances fall off.

Now, however, Messrs. Radio Instruments, Ltd., who were always

well to the fore in the development of these special nickel-iron components, have thrown down the gauntlet for generalised shunt feeding. They have introduced an L.F. transformer designed especially for this purpose.

The "Parafeed" cannot be used in the ordinary way; indeed, to all intents and purposes, it ceases to function in such circumstances, but employed in the intended manner it gives extraordinary results.

Proof of this can be found in the N.P.L. curve which is reproduced on this page. The "Parafeed" is the smallest transformer that has yet been placed on the market, and it weighs only $3\frac{3}{4}$ ounces, therefore it will be seen that both on account of its weight and size it is ideal for portable sets, although, of course, its efficiency is such that its applications cannot stop there.

It is always necessary to use a resistance and condenser in addition; but in view of its dimensions and the price, that can hardly be cited as a disadvantage. Indeed, even when you include the cost of these extra

items the price seems absurdly low in view of the very meritorious performance given.

Quaker Safety Double-Pole Connector

Silas Quaker, Ltd., recently sent us a sample of their new safety Double-Pole Connector. It is of the non-reversible variety and is strongly made and nicely finished. It is supplied in black, mahogany, walnut or oak bakelite finishes, and will safely handle any current up to 5 amperes.

Marconiphone Loud Speaker

We have recently had the opportunity of testing a Marconiphone Model 131 permanent-magnet moving-coil loud speaker. It is a particularly handsome instrument and the cabinet work is of first-class quality.



The Marconiphone Permanent-Magnet Moving-Coil Loud Speaker.

Regarded technically, one of its most interesting features is the incorporation of a special transformer to enable it immediately to be adapted to any class of set output from the ordinary open anode to plain pentode or special transformer.

The necessary adjustment is by means of easily accessible plugs and links. The loud speaker is sensitive and will operate successfully even with a two-valver, but you are not using a moving-coil speaker to its full advantage unless you feed it with plenty of power, and so enable good bass to be present.

This the Marconiphone 131 handles well, while it is particularly good on the upper register, where it is that so many of the early moving coils failed hopelessly. The Marconiphone 131 is certainly an attractive proposition.

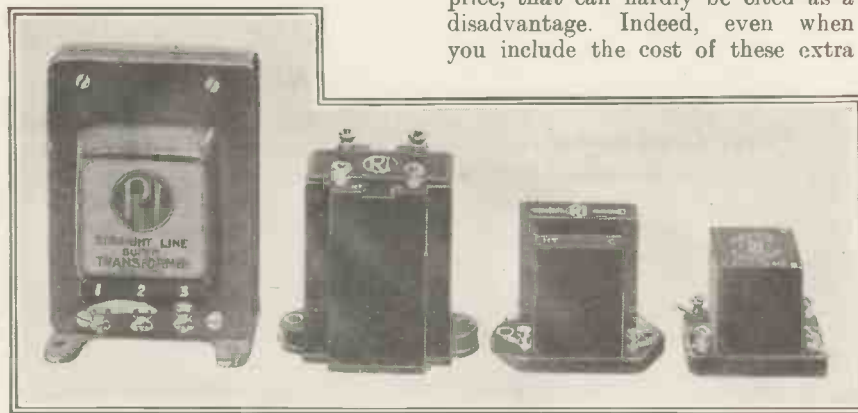

The "compacting" of R.I. From left to right you see their Straight Line Super L.F. Transformer—the first of their more modern products. Then came the "Hypermu," shortly to be followed by the even smaller "Hypermite." And now we have the "Parafeed"! If they go on like this we'll want a microscope to see future R.I.'s!

Test Bench

R.I., Marconiphone, Varley and Ferranti products are among those given impartial and critical reviews this month.

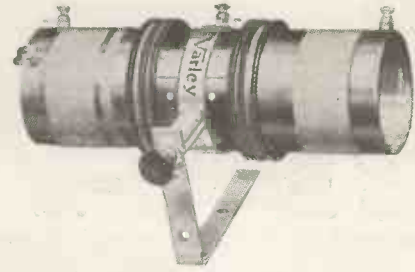

The New Varley Coil.

Ferranti Volume-Control Condenser

Ferranti, Ltd., have produced a useful little component in the form of a volume-control condenser. It has a capacity of .00025 mfd., and is designed for placing in series with the aerial of a set.

It has a cut-out contact so that when it is turned fully in the one direction it is shorted out of action. It could, of course, replace with advantage any aerial series condenser of somewhere around about the same capacity fitted in any existing "M.W." set.

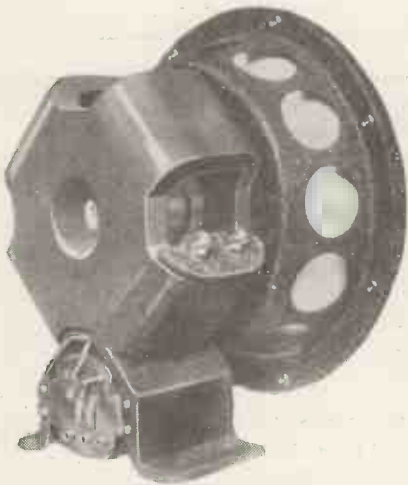

The unit and chassis of the new Marconiphone Moving-Coil Loud Speaker can be purchased separately.

The cut-out is a particularly valuable feature. Naturally enough, in view of its Hollinwood origin, it is a soundly constructed and well-made article, and at the price of 6s. 3d. it should find many purchasers.

Amulet Valve Seal

However carefully the screening of an H.F. stage is arranged, it is almost inevitable that leakage at one certain point will occur, and this in the aperture through which the valve passes. The metallised S.G. valve assists in closing this gap very considerably, but there still must be space between the screen and the valve itself.

Messrs. Graham Farish, Ltd., have produced a little gadget that puts in

the final touch. It is called the Amulet Valve Seal and comprises a circular metal spring which can be slipped on the valve. The price of this useful device is 6d.

New Varley Component

One of the most pressing problems of the day is that of obtaining selectivity in simple sets. In view of this, the success of the latest Varley component seems to be completely assured.

It is known as the Constant Square Peak Band-Pass Tuning Unit, and this name, though unusually bulky, does seem justified in that it fully describes the article.

It comprises two sets of windings with two ranges of wave-lengths, the ordinary and the long wave-range controlled by the one simple push-pull switch.

There is also an aerial coupling winding that can be used for reaction purposes.

As the windings are extremely closely matched it is possible to use a ganged condenser for tuning, or, of course, separate variables are permissible.

A new band-pass scheme, involving the employment of a special non-inductive condenser such as is made by Messrs. Dubilier, figures in this unit. It is far from being bulky, and there cannot be many existing sets into which it could not be fitted.

You can use it in a Det.-L.F. or Det.-2 L.F., and the selectivity is equal, if not superior, to that given by most outfits having an H.F. stage. The loss in sensitivity is inappreciable; indeed, there is no loss if you compare the results with existing standards.

We feel sure that this Varley Constant Square Peak Band-Pass Tuning Unit will be very largely used during the coming season, for it is

undoubtedly one of the most successful components of its kind that has as yet been produced.

Two Eelex Products

Messrs. J. J. Eastick & Sons recently sent us one of their Eelex Earth Bowls. It is an object something of the dimensions of a large pudding basin, and to it is attached a stout connecting lead. It is made of heavily galvanised metal, and we can recommend it to the attention of those "M.W." readers who desire to instal an efficient direct earth connection.

It is certainly not so easy to place in position as an earth tube, but it has definite advantages that will appeal to the amateur who desires to get the most out of his outfit.

Another interesting and useful Eelex line are Spring Loaded Testing Prods. These should prove useful alike both to the listener and to the man who has to test sets and batteries in the course of his professional duties.

These prods have sprung metal needles which normally are concealed within the insulated handles, but pressure on the spring tops causes them to emerge and, if necessary, they can be retained in their exposed position by means of a half-turn. They are safe and convenient accessories which should find a very ready sale.

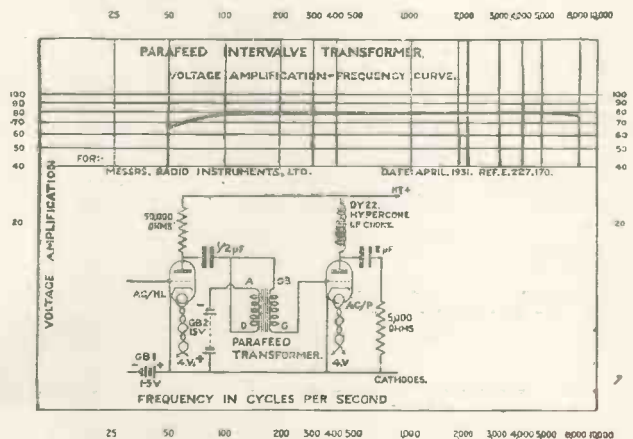

An N.P.L. curve showing the performance of the R.I. "Parafeed" when used with the mains valves specified in the inset diagram.

IS BAND-PASSING WORTH WHILE?

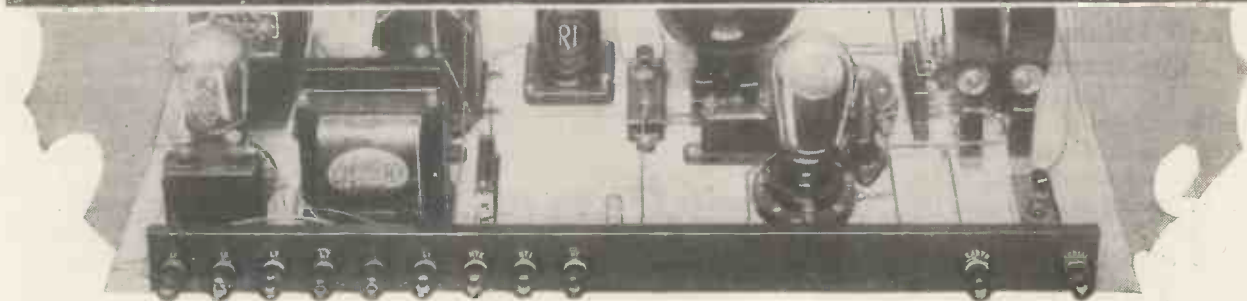

THE PROS AND CONS OF AN INTERESTING SELECTIVITY SYSTEM.

THIS is a question that many constructors must have asked themselves of late, for there has been a marked revival of interest in band-pass methods of achieving selectivity.

There is little that is fundamentally new in any of the systems that are being discussed. Indeed, the only real scope for novelty appears to lie in its schemes of application. And it is to developments of this nature that attention is being paid.

The Principle Involved

Band-passing of one form or another has been liberally used in "M.W." set designs for many years—no doubt there is a great number of readers who remember, appreciatively, our "B.P." sets, in which a particularly useful form of simplified band-passing was employed.

But perhaps a few words on the principle in general may prove useful before we weigh up the pros and cons. Band-passing is the application of a particular kind of high-frequency filter arrangement.

And, as the term suggests, its purpose is to pass a definite band of frequencies to the exclusion of others. There are other forms of filter designed to pass high and low frequencies and suppress the appropriate opposite, but we are not concerned with these.

Forms of Filter

The usual form of filter comprises a chain of tuned circuits. And to achieve a perfect "band-pass" an infinite number of these would be required. But in practice satisfactory results are possible with a com-

parative few providing they are properly planned.

For example, with only two tuned circuits a quite good result can be obtained. But it should be noted that even a dozen would fail to exclude transient frequencies such as are originated by atmospherics.

Band-passing can be applied to the simplest of sets. An ordinary detector-L.F. two-valver usually employs but one tuned circuit coupled to the aerial fairly loosely by an untuned "aerial" winding.

Moderately good selectivity results, and there is only the one tuning control to handle, but there are cases

valve interrupting the chain of circuits.

Amplification Plus Selectivity

Actually, it is well within the bounds of possibility that the apparent improvement would be negligible if such a course were adopted, for the greater amplification resulting might bring in many other stations and increase the strengths of existing stations so that they tended further to encroach upon the channels of others.

But this condition could be met by the introduction of further band-passing, and band-passing in its more widely accepted sense. The H.F. amplifier could be coupled to the aerial by a chain of two tuned circuits instead of the much more useful single tuned circuit.

The effect then is that the greater amplification is retained plus an increased selectivity that enables it usefully to be used to its fullest extent.

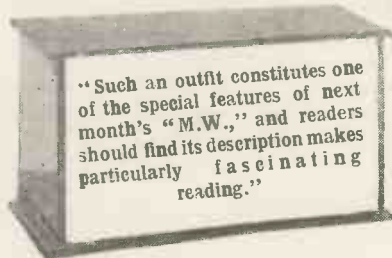

where the need for greater selectivity is felt. Band-passing will provide this at the expense of the addition of a further tuning control, or, alternatively, the provision of a more expensive type of tuning condenser, i.e. a ganged two-section variety.

All that has to be done, theoretically at least, is to insert another tuned circuit between the aerial and the existing grid circuit and couple these in the proper manner.

It may be that the only way to achieve the desired separation of stations is to use an H.F. stage of amplification, but, after all, this is only another kind of band-passing, a

Approaching the Ideal

In fact, we approach the ideal arrangement. The double-band-passing contributes a sharply defined receptivity that is yet able to take in the whole of the side-bands of each transmission handled. There is amplification, selectivity, and unimpaired quality; but, we must add, you get this in practice only when an efficiently designed set incorporating efficiently designed components is used. Such an outfit constitutes one of the special features of next month's "M.W.," and readers should find its description makes particularly fascinating reading.

CHOSEN BY THE DESIGNER!

Buy your "Simplicity" Super Frame Aerial and Kit from Ready Radio and make sure of reception as good as the designer's!



Can be obtained from your local dealer.

READY RADIO FRAME AERIAL

Dual - range, centre - tapped. Actually specified for the "Simplicity" Super. Price, complete **£1:0:0**

TO INLAND CUSTOMERS

Your goods are despatched post free or carriage paid.

TO OVERSEAS CUSTOMERS

All your goods are very carefully packed for export, and insured, all charges forward.

Cash, C.O.D. or Easy Payments

We can also supply Kits of Parts for the "Hi-Mag" Four and "Compact" Two. Write for price lists.

KIT "A" (less valves and cabinet) **£7:7:6**
or twelve equal monthly instalments of 13/8

KIT "B" (with valves, less cabinet) **£10:15:0**
or twelve equal monthly instalments of 19/9

KIT "C" (with valves and cabinet) **£12:0:0**
or twelve equal monthly instalments of £1:2:0



THE "SIMPLICITY" SUPER

Completely assembled, with valves, cabinet and wound frame aerial, ready for use and aerial tested. **£14:0:0**

or twelve equal monthly instalments of £1:5:8

THE "SIMPLICITY" SUPER

	£	s	d.
1 Black polished etonite panel, 16" x 7" x 3/16", drilled to specification	4	9	
1 Oak polished cabinet with 10" deep baseboard	1	5	0
1 ReadRad centre-tapped frame aerial	1	0	0
2 J.B. .0005-mfd. variable condensers, with 40-l slow motion dial	1	1	0
1 Cydon .0001-mfd. Bebe reaction condenser		5	0
1 Rolls-Caydon filter and single intermediate unit, and one oscillator coupler with on-off wave-change switch	2	10	0
3 Telsen 4-pin valve holders	1	6	
1 Telsen "Radiogrand" L.F. transformer	8	6	
1 Telsen .001-mfd. fixed condenser		4	
4 T.C.C. 1-mfd. fixed condensers	11	4	
1 T.C.C. 2-mfd. fixed condenser	3	10	
4 Lewcos 1,000-ohm flexible resistances	3	0	
1 Bulgin 1,500-ohm flexible resistance	1	0	
1 ReadRad 15,000-ohm flexible resistance	1	3	
1 Magnum 50,000-ohm potentiometer with special on-off switch	8	6	
1 ReadRad 3-point strip for frame connections		6	
1 Ebonite terminal strip, 3" x 2" x 3/16"	1	3	
1 ReadRad fuse and holder	1	3	
2 Belling-Lee "R" terminals marked LS+ and LS-		6	
8 Belling-Lee wander plugs, 2 for G.B. and 6 for H.T.	1	4	
2 Spade terminals		3	
1 Packet ReadRad "Jiffilinx" for wiring	2	6	
5 Valves as specified: 2 Ososor S.G., 1 Mazda H.L.210 and P220, and 1 Mullard P.M.1 L.F.	3	7	6
Screws, flex and etc.			9
TOTAL (including valves, frame aerial, and cabinet)	£12.0.0		

Recommended Accessories

	£	s	d.
1 Fuller 2-volt 30-amp. S.W.X.7 accumulator	11	0	
1 Fuller 9-volt W.O.9 "grid" bias battery	1	6	
1 Fuller 120-volt W.O.120 "high-tension" battery	15	10	
1 Celestion C.10 in oak	3	0	0

Buy all your radio from
Ready Radio
159, BOROUGH HIGH STREET,
LONDON BRIDGE, S.E.1.
Telephone Map 5355 (Private Exchange)
Telegrams: RFADIRAD. SEDIST

IMMEDIATE DESPATCH ORDER FORM

To **READY RADIO (R.R.) LTD.**, 159, Borough High Street, London Bridge, S.E.1

CASH ORDER FORM. Please despatch to me at once the goods specified, for which I enclose payment in full of £.....

C.O.D. ORDER FORM. Please despatch to me at once the goods specified, for which I will pay the full sum of £.....

EASY PAYMENT ORDER FORM. Please despatch my Easy Payment order for the goods specified, for which I enclose first deposit of £.....

Name.....

Address.....

KIT REQUIRED.....



BROADCAST "TENS"

LET'S begin our review this month with a broadcast (radio) favourite—Bobbie Comber. He is full of "pep" in his latest recordings: (714), *We Won't Go Home Till Morning—And Then We Won't Go Home*, together with *Tell England*, the latter being a pseudo-serious patriotic effort that is sure to give rise to many a laugh.

Charles Higgins provides different fare: *Sh! There's a Ghost in the House!* and *The Girls of the Old Brigade* (713) being a couple of "comics" worth hearing.

A third comedian has faced the Vocalion "mike" during the last few weeks. He, Sandy Powell, has let himself go in a couple of mouth-organ band records. On the one side is *Old-Time Song Medley*, including "Sheik of Araby," "Bubbles," "Nellie Dean," etc., and on the other a modern dance number, *River Stay 'Way From My Door* (716)—three good bobs' worth!

"TWELVES"

And now for a couple of "Twelves." Charles Cunliffe and his Orchestra make a couple of recordings that should not go unheard, on 5239, when they give an *Intermezzo Selection* and a *Further Selection of Waltzes*. These are arranged by Cunliffe, and are well executed.

Frank Nichols, the boy soloist, is following other boy sopranos' leads and recording religious items. This month he gives us *He Shall Feed His Flock* ("Messiah," Handel) and *I Know That My Redeemer Liveth*, from the same oratorio. This is a disc of merit, but somehow we are not too keen ourselves about these "boy sopranos" in recorded form (5236).

"SUPER TWELVES"

As we have remarked before, the pick of the Broadcasts are to be found in the Super Twelves. We speak from a recording standpoint—not that of sheer merit of choice of item. No. 3053 is, we think, likely to prove extremely popular. Excellently sung throughout, this is one of the best chorus and solo vocal excerpt records Vocalions have turned out. The subject is *The Belle of New York*.

Another Super-Twelve we want to bring to your notice is the *Medley of British Songs*, played by the Band of H.M. Welsh Guards. A good band, well recorded. (3056.)

Finally, three dance discs: (1) *Bubbling Over With Love and Would You Like to Take a Walk?* (3060); (2) *Walkin' My Baby Back Home and Reaching for the Moon*, vocal items by Bob and Alf Pearson; (3) *Wabash Moon and Good-night, Sweetheart*.

COLUMBIA

One of the most spectacular musical comedies is *White Horse Inn*, which is played at the Coliseum, and the London Theatre Orchestra has made a very fine selection record of that show. It is listed DX246, and whether or not you have seen the show we are sure you'll thoroughly enjoy it.

Heavier stuff is the Bayreuth Festival recording of "Ride of the Valkyries," in two parts, on L2017. This is a superb record, and Wagner's wonderful descriptive and dramatic music is given full value. Get it, you won't be disappointed if you are a Wagner "fan."

Radio listeners will be pleased with the B.B.C. Wireless Military Band in *Carmen—Fantasia* (DX243). It is exceedingly well played and exceptionally well recorded. It is not often that we hear such popular classics played by this band, and the fact that such a general favourite has been chosen in this case makes the record all the more welcome.

Norman Allin, bass, gives us a couple of dialect songs, *Richard of Taunton Dene* and *The Crocodile*, with chorus. The former is the better of the two—probably because the ridiculous adventures of the shipwrecked sailor in the latter are too far-fetched even for this type of "traditional" song. (DB492.)

The Big Four, in *Darling, I'm Longing to Greet You*, and *Good Friends* (DB488), are good, as they are in a second recent record of theirs, *DB497*. In this latter they sing the great Continental hit, *Drink, Brothers, Drink*.

Layton and Johnstone are their own inimitable selves on *DB495*, where they sing *River, Stay 'Way From My Door*, a typical negro plantation song, and *I'll Keep You In My Heart Always*. These two singers are not everybody's favourites, but there is no denying their artistry.

And now for some good dance numbers, some by our radio favourite, Jack Payne, and "His Boys."

As this is being written, J.P. and his boys—"in the flesh," by radio—are hard at it, and it is easy to compare their records with the broadcast versions of the same items. The result of such a test is to give one further evidence of the great advances that have been made in the "canned" music industry. The Jack Payne records especially are wonderful examples of mechanised music.

The items we want to put before you are *Laughing at the Rain*, with *Parade of the Minutes* (CB266); *Oh, Rosalita*, and *Hawaiian Stars* are *Gleaming* (CB263); and *Pretty Kitty Kelly*, with *Bubbling Over With Love* (CB277).

There are two other dance records by different bands we must mention. Billy Cotton plays

A brief selection from some of the records released during the month. They have been chosen because of their special value to the pick-up user. The merits or demerits of records are reviewed solely from the point of view of electrical reproduction in the home.

Walkin' My Baby Back Home and *Fall In Love With Me* (CB268), and *Debroy Somers' Band* provides *Just Two Hearts* and a *Waltz*, with *Lovely Lady* (CB283).

DECCA

This month the popular and fascinating minuet from *Berenice*, by Handel, is recorded by the Hastings Municipal Orchestra, together with Tchaikovsky's *valse Eugen Orégin*. Both are well up to this enterprising orchestra's usual standard (K578).

Desirée Ellinger, the popular actress, sings *Oh, Why and Within My Heart*, on F2303; while a particularly interesting record is the novelty disc, *At the Races*, F2334. We won't spoil the surprise by telling you all about it; just go and hear it and you will get a very good picture of the race-course; while another novelty record, *Around the Coast With Lawrence Wright*, is also a great success.

Of the dance numbers we consider the following will be most likely to suit pick-up users. The *Phantom Players* in *Under the Spell of Your Kiss and Blue Lagoon*, F2306; *You Didn't Have to Tell Me*, with *Would You Like to Take a Walk?* (that popular modernised theme song from "Sweet and Low"), played by Roy Fox and His Band, F2318; and, finally, again by this band, *Ya Got Love and My Temptation*, F2320.

H.M.V.

The coming of summer found "His Master's Voice" prepared with a host of light, tuneful

music of all kinds for the long evenings at home and abroad. Among the new dance numbers are four notable efforts by Ambrose and his Orchestra, three being fox-trots: *I Surrender, Dear*; *Laughing at the Rain*, and *You'll be Mine in Apple Blossom Time*, and a waltz, *Wabash Moon*.

Bert Ambrose has just completed a two years' contract with the *May Fair Hotel*, London, at a payment of £50,000, and he has renewed the engagement for a further two years, so that his orchestra remains the highest paid dance band in Great Britain. Ambrose and his men search the world for likely airs, and have an elaborate system for being first in the field to introduce novelties.

There are eleven musicians in the Ambrose Orchestra, each man a virtuoso of his instrument; five of them are expert arrangers, and some of them receive from £1,500 to £2,100 a year, apart from their shares in performances for recording for the gramophone two or three times a month.

Ambrose, who leads his party by playing the violin, made his first appearance at the age of twelve, when he deputised for an absent fiddler and received half a crown in payment.

From the enormously successful "White Horse Inn," at the London Coliseum, a further batch of hits is now issued. The *New Mayfair Orchestra* most refreshingly gives a selection of six merry pieces; *Stuart Robertson* and his virile-voiced chorus are superb in the theme song of the play; *Winnie Melville* and *Derek Oldham* sing *Your Eyes and My Song of Love*, and *Jack Hylton* with his Orchestra enchantingly play a *waltz medley* and a *fox-trot medley*.

A very entertaining record is provided by *Fritz Kroeger*, that master of the xylophone, who, with two gay little creations, *Espanita* and *The Dreaming Snowdrop*, provides a light "cocktail of melody."

Fascinating arrangements of *Rubinstein's Melody in F* and the *Romance in E Flat* are supplied by the *New Light Symphony Orchestra*, who produce a wealth of tone-colour round these popular pianoforte pieces.

Before you close the garden doors at dusk listen to the *Cedric Sharpe Sextet* in those *moreaux of Drigo, Valse Bluette* and *Les Tresors de Columbine*; they breathe of gladsome night of laughter and dalliance. These are H.M.V.'s own words, and we cannot better describe the records in question.

All the happiness of a stroll on the illuminated seashore promenade can be recaptured by listening to the band of H.M. Coldstream Guards in the ever-welcome *Tales of Hoffmann*.

Another winner, giving the flavour of the *Royal Tournament* and the *Trooping of the Colour*, is *Jack Hylton* and his *Boys* with *When the Guards are on Parade*.

Of heavier music we bring to your notice the two discs of the *Welsh Rhapsody*, by the *London Symphony Orchestra* (D1939-1940), and the *Prelude to Act 4 of Carmen* (on B3623), by the *Symphony Orchestra*.

ZONOPHONE

The Zonophone Company have issued only eighteen records this month, and we have received a selection of such variety that it speaks well for the rest of the list.

On No. 5877, *Maurice Elwin* sings two very hot favourites of the moment: *When You Were My Sweetheart* and *I Was the Kid Next Door*, and *Lady, Play Your Mandoline*, two strongly contrasted numbers which show well how versatile is this artist's voice. You should ask your dealer for a complete Zonophone catalogue and try some recent Elwin "hits"—they're worth it!

Next, on No. 5879, we have a record by a new Zonophone artiste, *Sidney Crooke*, a really "star" pianist, and his performance of these well-known compositions is excellent: *Alice, Where Art Thou?* (Ascher); and (a) *Waltz in D Flat* (Chopin); (b) *The Bees' Wedding* (Mendelssohn). His fine technique and style have been recorded faithfully with wonderful clearness, and all interested in solo pianoforte should hear this record.

The *International Novelty Quartette* are continuing to make new admirers each month with their jolly renderings of popular pieces, and they give us this month a fine recording of *Estudiantina*, *Waltz (Walduffel)*, and *That Tiny Teashop, Serenade* (Raymond) (5881).

Then comes *Clarkson Rose*, as a real old soldier, in *A Day in the Army*. This is a funny record, which should not be missed on any account (5882).

Only two dance records were issued, and of the two we think No. 5883 is the better. *I'm Ticked Pink With a Blue-eyed Baby* (with Vocal Trio); and *Between the Devil and the Deep Blue Sea* (with Vocal Trio). Both are excellently played and really snappily orchestrated. The *Rhythmic Eight* is a fine combination of picked players and all their records are up to high standard.

A re-recording on No. 5885 of two popular marches will be enormously appreciated by the older folk. The *Black Diamonds Band* are veteran recorders for Zonophone, there being many good records to their credit in the Zonophone main catalogue.



MAKING METAL RECTIFIERS

By Our Special Representative.

Who describes a tour of one of the most interesting factories in the country.

As the tube train thunders through the tunnel a red light flashes, and with a deep sighing sound the powerful brakes bring the hundreds of tons of metal smoothly and safely to rest. It is ten to one that both the signal and the brakes originated from the gigantic Westinghouse factory at Chippenham.

Supplying the World

To these huge works flows a steady stream of the rawest of raw materials. They are flung into roaring furnaces, ground in mighty grinders, torn, cut, pared and spun by every conceivable kind of machine, finally to emerge as compressed air and electric brakes for trams, trains and buses, and as everything in the way of railroad signalling from simple wayside station signals to complete automatic systems capable of an almost miraculous control over dizzily complicated junctions.

The making of metal rectifiers occupies but a comparatively small part of the great Westinghouse factory, although the space so occupied is at least equal to the whole of some quite respectably sized industrial premises.

It was not my first visit to the Westinghouse factory, but I had not before had the opportunity of closely inspecting the manufacture of Westinghouse metal rectifiers. These devices consist of discs of oxidised copper spaced by washers and heat radiating fins. That's all—but they aren't as easily made as their apparently simple constructions might lead you to believe.

An Army of Robots

However, the majority of the intricate processes are carried out by machines! These, or at least some of them, are veritable robots that seem to be able to do anything but answer you back when you speak to them.

For instance, there is one robot that sorts out the oxidised discs according to their electrical characteristics. You

could give this wonder-worker a few thousand discs, press a switch and then go out into the bright sunshine for a walk through the leafy lanes of Wiltshire.

Returning a few hours later you would find that the robot had finished its job and that the discs were arranged in neat little piles; class one here, type two there, throw-outs in that pile, and so on.

And the machine that stamps out the original discs from sheets of shining new copper cuts up the waste metal into little pieces which fall into sacks all ready to be returned to the foundry for re-smelting.

No Waste

As my guide said: "You could examine the whole factory with an economic microscope and not find a ha'p'orth of wasted material or wasted labour." There may be some British factories that badly need reorganising, but it very obviously isn't that big one at Chippenham!

The discs are oxidised by being

enclosed in large electric furnaces and the temperatures of these are regulated as delicately as the hair-springs of chronometers. I saw several of these furnaces opened. They are not unlike gas-ovens inside, but the interior walls are packed with whitely-glowing spirals of wire similar to those you see in domestic electric fires, except that they are thicker and hotter.

Colossal Furnaces

Very much hotter, in fact. The scorching heat hits your face in a withering blast even at a distance of twenty feet, and the glare is blinding.

After the various types of rectifiers are assembled (this is a fairly simple manual process) they are most carefully tested, and the tests include both individual disc and over-all tests. It would seem quite impossible that any unit not right up to standard could possibly creep through, and I don't suppose for a minute it ever does. Certainly, I've never heard of a dud Westinghouse rectifier having been bought either separately or in a mains set or unit.

But there, they can do things thoroughly at Chippenham. I saw over-load tests and life tests that would seem fantastically unnecessary to most engineers. I suppose it is the brake and signal business that has made them so scrupulously careful. Flaws in things like that might mean something more than the necessity of mere mechanical replacements. One train carrying thousands of valuable lives, a faulty signal

IS HE SATISFIED?



Christopher Stone listens critically to his own voice as recorded on H.M.V. discs.

An American Idea

Another example of the thoroughness of these Westinghouse people is to be found in the extraordinary number of uses they have found for metal rectifiers. The metal rectifier originated in America, but Westinghouse of Chippenham are certainly teaching their American friends how to get the most out of this modern scientific development.



A Trip with the "Bisto Kids" and a Portable

I LIE by the pleasant waters of a Cotswold stream, with pen and pad, idly "pricking down a few things," as Pepys quaintly said. Strange, now, to think of London's noontide roar, the clamour of a Cup-Tie crowd or the sounds of war; for I am alone with the voices of the water gossiping with its stony bed. Only the occasional "plop" of a water-rat breaks in upon that dialogue. I feel detached; even a cow would be a crowd at this moment.

Balancing Out!

So much for the physical! Mentally, I still make contact with the hurly-burly, workaday world of divers men—witness the pen and pad and these random notes. The totally detached, self-sustained mind attracts and repels me in turn.

I admire the hermit whose mind is a kingdom to him; I recoil from the contemplation of a mind which lurks deep in a man like a pearl in an oyster, a man who nourishes his mind from some secret inner store of pabulum, as the frog lives during the winter on its internal deposits of fat!

Give me to live and confer with men of normal minds! Duffers, if you like, but with headpieces which are screwed on the right way round.

Fixed Tuning!

Send me no more professors with one subject paramount in their skulls! These one-idea'd fellows give me the "creeps." Why, I heard of a wireless enthusiast who had spent ten years in listening on 33-4769 metres and

thus came to believe that all other wave-lengths were spurious. Someone who told him about the "National" was enjoined by him not to be superstitious!

A Hopeless Man

And I must not forget to mention Dr. Jonathan Kiff, of Oregon, whose only aim in life is to invent a circuit with which he can detect the thoughts of an elephant! He has declared that he will not give up till elephants get creases down their back trousers! Goodness knows they need 'em!

I came down here in order to recuperate after a very trying experience, which I propose to describe, provided the flies allow me to do so. I find

WITH PEN AND PAD



"I find that I am not so solitary as I thought! That earwig looks as though it had a rendezvous up my left trouser leg!"

that I am not so solitary as I thought! That earwig looks as though it has a rendezvous up my left trouser leg!

"Had nowt" Bykins little knows what I have been through on account of his father's hospitality. We called him that because he was a daft, soft,

Yorkshire boy when he came to our school. He heard the fellows at call-over shouting "Adsum," and when his name was called replied, "Had nowt"!

Bykins's father, a professor of something at Leeds University, retired and bought a place near Canterbury, because Mrs. Bykins was a Kentish woman and craved for the land of hope and cherries.

Live Wires?

Thus it fell out that the British Association met at Canterbury this year and Bykins senior offered his hospitality to two delegates—and secured a brace of the most rabid specialists imaginable—Dr. Think and Mr. Bint!

These beauties were hardly installed in the Bykins's home before old Bykins went down with a spectacular attack of liver, leaving "Had nowt" to do the honours, for Mrs. B. wore a lace cap and read Mrs. Henry Wood's remarkable works!

Then Fate and the old school dragged me into the drama. "Had nowt" wrote: "Ebury Old Boys' match is on Saturday, and I'm booked for it—'mid on,' as ever—beyond redemption. There is no meeting of the British fossils on that day, which leaves us with Flotsam and Jetsam on our hands.

Do or Die!

"The guvnor is laid aside, and the mater is dreaming of General Gordon and them there days, so come down like a sport and cart F. and J. around for me. I'll relieve you about 7.0 p.m."



The WIZARD of WIRELESS

The fine materials and high-class workmanship used in the manufacture of the LEWCOS H.F. CHOKE make it supreme. This component is specially constructed to eliminate self-oscillation. A fully descriptive leaflet giving tested values will be sent on request. Please quote Ref. No. R.33.

The LEWCOS H.F. CHOKE is specified for the "M.W." "Hi-Mag" Four, and LEWCOS 1,000-ohm SPAGHETTI RESISTANCES are specified for the "Simplicity" Super, both described in this issue.

The LEWCOS *Regd.*
H.F. CHOKE, PRICE 7/9



LEWCOS RADIO PRODUCTS FOR BETTER RECEPTION

THE LONDON ELECTRIC WIRE COMPANY AND SMITHS LIMITED, CHURCH ROAD, LEYTON, LONDON, E.10

If you could X-Ray a T.C.C. Condenser!



WHEN you buy a Condenser you buy on faith. Even its capacity you take on trust, it may—or may not be—correct. And as for the materials within you cannot see them. Take for example the insulation in a Paper-type Condenser. We use only the purest Rag Tissue. By using inferior paper we could produce a cheaper condenser—but this would jeopardise its working life. We cannot afford to risk our 25-year-old reputation. No matter what capacity T.C.C. Condenser you buy, you get the same high quality—the same remarkable dependability. That is why you can always trust a T.C.C. Condenser to do its job.

You are safe when you choose

T.C.C. "Green for Safety"

Advertisement of Telegraph Condenser Co. Ltd., N. Acton, W.3.

My Portable Saves the Situation

I loathed the prospect—but what was the answer? A lie? Heaven forbid! There would be no profit in a lie, which alone could justify one. Let the old House down? I should never sleep peacefully again were I to do that, such are we fools of Englishmen!

So I wrote and took it on. "Coward," I ses, an' swep' out, 'aughty like! Well, some of the finest-looking deeds have been done by men who were too cowardly to be brave enough to hang back!

A Cute Old Boy

Dr. Think is by way of being an astronomer. Not the spy-glass sort, but the *a* and *b* sort. He does all or most of his star-gazing on paper. *Alpha Thinkii* is a star to which Think has devoted twenty-seven years of a mis-spent life, and what Think doesn't know about Alphie is exactly equal to what Alphie knows and cares about Think.

They understand each other perfectly. Let Alphie waggle a bit too much to the south-west—and Think has him nailed down to ten decimal points! And exposed in the Transactions of the Royal Society! Occasionally Think will pretend to be studying *Beta Thinkii*, but really he is trying to catch Alphie bending

THOUGHT READING!



"Dr. Jonathan Kiff, of Oregon, whose only aim in life is to invent a circuit with which he can detect the thoughts of an elephant.

and is looking out of the corner of his eye to see if Alphie will try to start something.

Alphie is not a tractable star by any means. In 1889 he developed a wobble with a red glow, and Think had three weeks of bad algebra before he succeeded in proving that Alphie really couldn't wobble, and that the telescope at Greenwich Observatory was back-firing. Think is a stayer.

Mr. Bint was born to know more about moss than any other man. He had hunted moss in every nook of the earth and still hungered for more. A savage little bloke, he was. He had been known to threaten a yak! Buffalo fled from him, yelping like Poms!

MR. BINT AND DR. THUNK

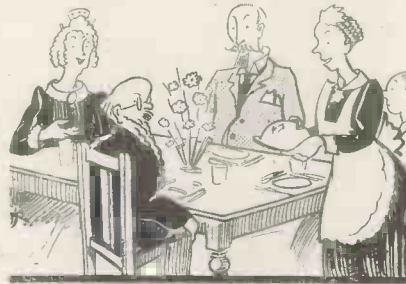

"We three met again at lunch, a horrifying ordeal."

No lion cared to lie down if Mr. Bint was around, in case some moss should be crushed—a thing which Mr. Bint regarded very severely; in fact, he once made an example of a hartebeest in Kenya Colony, because of some edible moss. A rotten affair, which was hushed up.

"Domes of Silence"

Well, I anchored at The Laurels, Canterbury, and was introduced to these curios. They gave me fishy hands, blew slightly into their beards, and then turned away in deep thought. "I'll just slip off now," muttered Bykins. "Good luck! Try 'em with billiards."

We three met again at lunch, a horrifying ordeal, during which old Mrs. Bykins spoke at length on the claims of Spurgeon to the mantle of Demosthenes and the crown of St. Paul. Flot and Jet merely chewed and swallowed, showing no other signs of life. No, I'm wrong! When Gorgonzola was served old Bint had to take a pocket microscope to it; he thought that he detected moss in it! To see Think sneering soundlessly at the moss-hunter was a slight compensation.

Radio to the Rescue

After lunch Ma Bykins drifted off to snooze, and I was left to handle the situation. I tried billiards, but Bint soon discovered that the ivories were not moss-bearers, and Think tried to arrange the balls as a model of the Third Galactic System in

Omicron Centauri—a pub with which I am not familiar. Then I bethought me of my Morris and my portable, and suggested a spin into the country. They bit!

Away we went, down into the Elham Valley towards Folkestone, all cylinders clacking as requisite. Think went into a sort of trance, but Bint seemed sociable. He wanted to know whether the moss of Romney Marshes was a true sphagnum or merely a congener. "I'll buy it," I said, dodging a cow. "Tut! No need to purchase it at all. Describe its life-history, with special emphasis on the sexual characteristics of the chromosome!

Drawing Diagrams

"If moss has a life-history," I said, "it was published before my time.

"Draw a diagram of the specimen, indicating the venation, if any; the metamorphosis of the proododlum and the syncopation of the pseudo-brachial ducts!

"Look at Dr. Think's mandibular hirsute appendage," I rejoined. "Just like a natural screen-wiper."

"Face moss, distributed asymmetrically round the buccal organs," said Mr. Bint. At this juncture Dr. Think came to life—as he knew

LOOK OUT! A BULL!



"The radio suddenly burst into a blare of dance music, which moved the bull to think again; he snorted and retreated sullenly."

it!—and said: "When you and Mr. Water-cresses have finished babbling inanities I might, perchance, venture to direct your attention to the insignificant fact that the moon is in apogee; this connotes a time-space pro-angularisation of the declination of Capricorn, which expressed in light-years comes to—er—wait a moment and I will—er—" He fumbled for pencil and paper. At

(Continued on page 88.)

PARAFEED

THE BETTER WAY to AMPLIFICATION

86



Patent No. 316449.
 Size: 2½ x 1½ x 1½ inches.
 Primary D.C. Resistance: 1,100 ohms.
 Secondary D.C. Resistance: 2,800 ohms.

Remarkable development of Parallel or Shunt Feeding with New L.F. Transformer weighing 3½ ozs. only.
 Amazing Primary Inductance of **80 HENRIES**

PARAFEED ADVANTAGES IN BRIEF:

1. Increased bass and high note response.
2. Absolute freedom from electrolysis and breakdown.
3. Much lower values of speech current flowing through H.T. source render the "Parafeed" less liable to motor boating than other transformers.
4. 3 variations of ratio by auto connection. 2 : 1, 3 : 1, and 4 : 1.

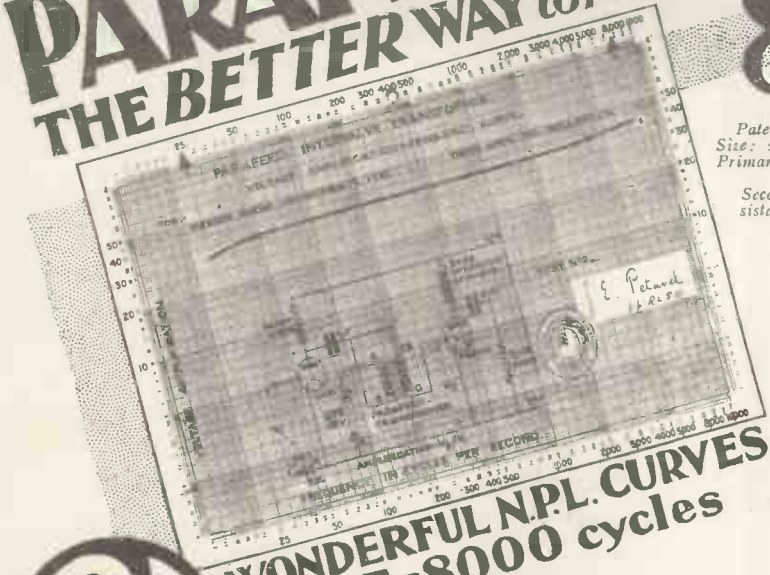

WONDERFUL N.P.L. CURVES
25-8000 cycles

THREE FURTHER N.P.L. CURVES, SIX CIRCUIT DIAGRAMS and full technical descriptive matter are contained in the 16-page Parafeed Booklet. ASK YOUR DEALER OR WRITE FOR A FREE COPY.



A TRIUMPH OF R.I. RESEARCH AND PRODUCTION

Advertisement of Radio Instruments Ltd., Madrigal Works, Purley Way, Croydon. 'Phone: Thornton Heath 3211.

A Sumptuous Magazine for Home Lovers

TOWN AND COUNTRY HOMES will help you towards your ideal of a perfect house and garden. It gives you the newest furnishing ideas, the latest kitchen and household equipment, interior decoration, the planning of gardens, happy little notions for the nursery, together with many pages of photographs and eight pages printed in rich photogravure. Buy it regularly.

TOWN & COUNTRY
HOMES
 MONTHLY—At all Newsagents—1/-

MODERN WIRELESS

Advertisement Rates

SINGLE Insertion - - -	£45 0 0
per page and pro rata	
6 CONSECUTIVE insertions	42 10 0
per page and pro rata	
12 CONSECUTIVE insertions	40 0 0
per page and pro rata	
ONE INCH single col. (2½ in. wide)	1 15 0
Minimum Space, half-an-inch	17 6

IMPORTANT. Copy and Blocks must be in hand by 14th of each month for issue published 1st day of following month.

All communications respecting advertising must be made to JOHN H. LILE, Ltd., 4, Ludgate Circus, London, E.C.4 and NOT to Editorial or Publishing Offices

Three in One!

Provision for the three most important requirements of modern Receivers is made in the latest Heayberd contribution to the radio public—the new

ALL-ELECTRIC UNIT

Built in a distinctive Metal Case, and ready to plug in for immediate use, this Unit carries a signed warrant against breakdown—the Heayberd

Two Years' Guarantee

Send 3d. stamps for descriptive coloured List 959

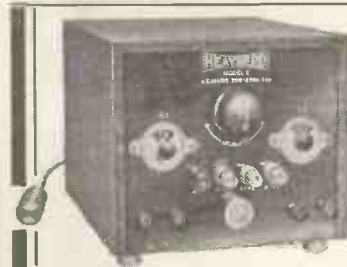

MODEL E.150

H.T., 150 volts at 25 m.a.
 L.T., 4 volts 4 amps. for A.C. Valves.
 L.T., 2 volts Trickle Charger.
 Westinghouse rectification throughout.
 Three H.T. Tappings: 60/80-v. Variable S.G., 120 and 150-v. H.T. and L.F. silver-embossed Control Switches Pilot Lamp and Terminals mounted on Bakelite Panel.
 Price Complete **£6:15:0**



10, Finsbury Street, LONDON, E.C.2

TROUBLE TRACKING

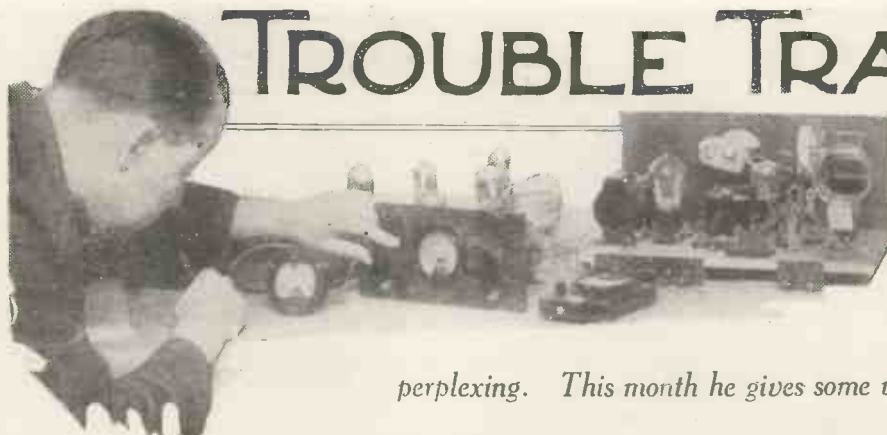

On this page the Chief of the "M.W." Query Dept. discusses, month by month, some of those common difficulties and troubles which can be so

perplexing. This month he gives some very useful hints on portable sets.

THIS month I want to talk about portable sets. The average portable doesn't give any real trouble provided it is used intelligently, but there are a few possible "snags" that must be guarded against.

The first is perhaps rather obvious, and that is loose connections. Any portable is bound to be carried from room to room, and may at times be taken into the country on a summer outing.

Loose Joints

Naturally, it is treated a little more roughly than a set of the non-portable type, and such items as terminals, soldered joints, and wander-plug connections may become loosened or displaced. A loose joint usually shows itself in the form of crackling noises in the speaker, and if such noises do occur it is just as well to open up the set and to tighten up all terminal nuts and to see that the valves are snug in their holders, etc.

Also have a look at the various wander plugs and make sure that the contacts are all O.K.

Another possible fault is one which I dealt with on this page some time back. It is the only case of its type I have ever met with, but since it has occurred on one occasion there is always the possibility of the same trouble in other sets.

Acid Fumes

In the case I have in mind the two-volt L.T. battery was housed in close proximity to the two leads to the speaker. The acid fumes, or possibly some of the acid solution, had in some way come into contact with these two flexible leads and had actually "eaten" the copper wire away, so that a complete break resulted. I think that the trouble was more likely to have been caused by fumes than by the accidental spilling of acid, since the L.T. battery

itself was of the unspillable type, and as an experiment I tried shaking the battery in an inverted position with the idea of persuading a few drops of acid to emerge through the vent plug. In this I was quite unsuccessful, so the battery was certainly truly unspillable.

For this reason I recommend an examination of all flexible leads in a portable from time to time, just in case . . .

cient space available for a "super-power" type of H.T. battery.

Grid Bias

Thus it is essential for the L.F. valves to be adequately biased, and also for the S.G. valves to have 9-1.5 volts negative bias applied if the anode current is to be kept down to a reasonable figure. So never neglect these biasing batteries. Replace them every six months, otherwise you may be overloading the H.T. battery, in which case it will run down in a very short time.

Also, if the set is designed for use with a power valve, don't employ a super-power valve unless you are prepared to renew the H.T. battery every few weeks.

I often receive queries concerning L.F. instability in portables, and I have traced a large number of faults to the H.T. supply. Battery coupling tends to show up quickly, because there is no earth to assist in "holding down" the L.F. side.

De-Coupling Units

De-coupling is very effective up to a point, but there are limits, and the average "anti-mobo" device will not cope with a battery when it gets badly run down. I also find that the L.T. battery is not properly looked after in many instances. I expect it is because it is tucked away in the case, and is, therefore, out of sight and out of mind.

The modern accumulator will stand any amount of abuse, but it will give much better service if it is charged at regular intervals and topped-up when necessary.

The easiest way to ruin an accumulator is to let it run down and then to leave it for a while in a discharged condition. This procedure leads to sulphation, and the appearance of greyish-white patches on the surface of the plates means that the battery has lost its maximum efficiency.

WATCH THIS POINT!



Don't forget to keep an eye on the leads to the frame aerial and loud speaker if they pass close to the L.T. battery. Do not let them come into contact with any of the acid.

One of the chief "snags" in a portable receiver, and the *bête noir* of designers, is the question of anode current. The most popular types of portables are probably those which employ four or five valves, and in order to work a speaker it is necessary for the output valve to be of the power type. This, coupled with the fact that one or two S.G. stages are required on the H.F. side, make the anode current consumption rather heavy, since there is normally insuffi-

LABOUR SAVING and ESSENTIAL

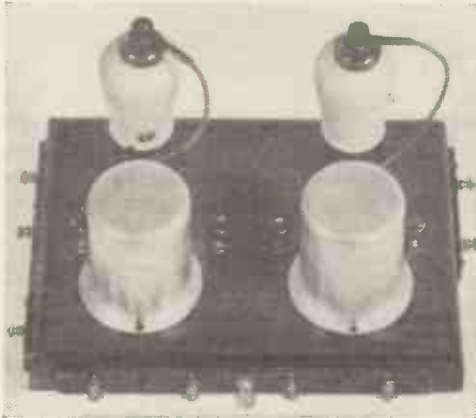

INTERMEDIATE UNIT

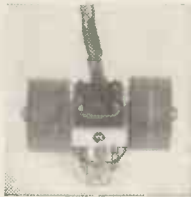

OSCILLATOR UNIT

Intermediate and Oscillator Units complete, ready wired.

50/-

ROLLS-CAYDON BLOCK INTERMEDIATE AND OSCILLATOR UNITS EXCLUSIVELY SPECIFIED for the "SIMPLICITY" SUPER

All the advantages of these wonderful EXCLUSIVE units are described on page 13 of this issue.

YOU CANNOT MAKE THE "SIMPLICITY" SUPER WITHOUT THEM

Rolls-Caydon will supply specially matched Valves for their units as **£2-8-6** specified. 2 S.G., 1 L.F.

Constructors of the "Simplicity" Super are strongly recommended to use the Rolls-Caydon Frame Aerial and Loud Speaker as well.



THE ROLLS-CAYDON COMPENSATOR FRAME AERIAL

42/-



THE ROLLS-CAYDON BI-TONE LOUDSPEAKER

OAK **37/6**
WALNUT **42/6**

SPECIALLY DESIGNED, SPECIFIED and RECOMMENDED for the "SIMPLICITY" SUPER
ROLLS-CAYDON SALES, 77, ROCHESTER ROW, LONDON, S.W.1. Telephone: VICTORIA 6986 (5 lines) **DEPOTS IN PROVINCES**

"MODERN WIRELESS" RECOMMEND

FOR THE

"M.W." "HI-MAG" 4 and "COMPACT" 2

"WEARITE"

MEDIUM-WAVE COILS

These coils were chosen by the designer of these sets because of their dependability. You cannot do better than follow his example and fit "Wearite" components. Types P.J.1. —P.J.2.—P.J.3.

Price **7/6**

per set of three.

The famous "Pop-Vox," as described in "Popular Wireless." Wearite Dual-Range Coil at 15/-, and Wearite "Star Turn" Selector Coil, price 12/6, were recommended.

Write for free lists and leaflets.

WEARITE

COMPONENTS

WRIGHT & WEAIRE, LTD.
740, High Rd., Tottenham, N.17.
Phone: Tottenham 3847/8/9.

THE CHEAPEST A.C. MAINS UNIT ON THE MARKET

REGENTONE MODEL W.I.F. FOR A.C. MAINS (H.T. ONLY). OUTPUT 120 V. AT 12 M.A. THREE FIXED TAPINGS: S.G., DETECTOR, and POWER. SIZE 7 1/2" x 4 1/2" x 2 1/2". Price 47/6 Write for FREE Art Booklet, "The Simple Way to All-Electric Radio," giving full details of the Regentone range.



MODEL 47/6
W.I.F.

REGENTONE, LIMITED, Regentone House, 21, Bartlett's Buildings, E.C.4. Tel.: Central 8745 (5 lines).

Irish Free State Distributors: Kelly & Shield, Ltd., 47, Fleet Street, Dublin.

If your garden does not please you

If your garden does not please you, and you wish to alter it, or if you have a new garden and would like to know how it can best be laid out, you can have it planned FREE by one of the garden planning experts at the disposal of readers of POPULAR GARDENING, the garden picture paper for amateurs.

POPULAR GARDENING

Every Saturday - - - - - 2d.

RADIO NOTES and NEWS of the MONTH



LISTENERS, especially those with small sets, need no longer be subject to the vagaries of local broadcast programmes if the latest innovation of our Chief Consultant, Capt. P. P. Eckersley, proves to be satisfactory.

The discovery means in brief "programmes to suit every taste." No longer will lovers of music have to be bored by long discourses of politicians or dry market reports, and, on the other hand, those who want to hear market reports could have them by the hour from every country.

A Simple Scheme

The scheme is a system of wired wireless. Wireless would be transmitted to all homes over the electric light wires. The loud speaker would be plugged into an ordinary electric light socket, just like an iron or

vacuum cleaner, and the programme would come out very clearly, whether it was being transmitted from a local B.B.C. station or a foreign transmitter any distance away.

The supply of programmes would be effected by co-operation of the B.B.C. and the existing electric light companies. There would be no longer any question of picking up stations by means of wave-lengths.

The actual receiving set would be done away with. Its place would be taken by a super-loud-speaker, equipped with a series of buttons.

Captain Eckersley, who calls this new system "rediffusing," pointed out recently that a large receiving station could be erected in the Kentish

hills. This station would pick up programmes from everywhere, and divide them up into different sections—music in one, talks in another.

These would be transmitted over telephone wires to various power stations, and redistributed along the electric wires. Listeners could then obtain, by merely pressing a button, the type of programme they required.

"There is absolutely no difficulty in the way of the listener, providing that he has electric light," Captain Eckersley told me.

Reliable S.W. Telephony

An invention of a Londoner, Mr. A. H. Reeves, was recently tried out in Paris. It is described as the "Short-Wave Single Side-Band System," and it is claimed that it makes long-distance short-wave radio-telephony practically as reliable as wire or cable telephony.

The inventor claims that the receiver can be kept in tune by means of a separate faint wave called "the pilot wave."

It is also claimed that various causes of distortion are eliminated, resulting in greater clearness of speech. Finally, the operation of nearly twice as many radio stations, without

(Continued on page 86.)

MAGNUM

Now Enjoy the Short Waves

This Short-Wave Converter enables you to enjoy a host of short-wave stations on your present set. No alterations or extras are required and it is instantly connected.

Complete with coils 20/40 and 40/80 metres, wire and plug **£3:15**

To enable you to test, without obligation to purchase, a Converter will be sent on

10 DAYS' FREE TRIAL against cash.



SPAGHETTI RESISTANCES

WIRE-WOUND

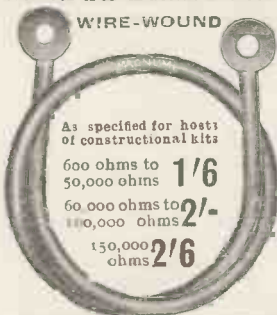

As specified for hosts of constructional kits

600 ohms to 50,000 ohms **1/6**

60,000 ohms to 1,000,000 ohms **2/1**

150,000 ohms **2/6**

We specialize in "Simplicity" Super, "M.W." "Hi-Mag" Four, "Compact" Two and other leading constructional sets, which are supplied ready wired and tested, in kit form or any parts separately.

Full range of pamphlets, including list of leading short-wave stations, Free on request.

BURNE-JONES & CO. LTD.

"MAGNUM HOUSE," 296, BOROUGH HIGH STREET, LONDON, S.E.1.
Telephone: Hop 6257 and 6258.
Scottish Agent Mr. Ross C. Wallace, 54, Gordon Street, Glasgow, C.1.

WAVEMASTER

Variable Condensers specified for the

"Hi-Mag" Four

Slow-Motion Extenser

with the following outstanding features:

- 1 Guaranteed to stated capacity as tested and approved by "Popular Wireless."
- 2 A Precision Instrument of rigid construction.
- 3 Insulation of best quality Bakelite.
- 4 Removable spindle may be gauged to any number of Extensers.
- 5 Definite pigtail connection to rotary vanes.
- 6 Stop on rotary vanes, giving 360° of movement on dial. (Patent pending.)
- 7 Cone bearings giving a very smooth movement.
- 8 Double locked one-hole-fixing bush, ensuring perfect alignment of vanes.
- 9 Special fixing nut makes loosening of Extenser on panel impossible.
- 10 Wavemaster five-point switching device, giving a very smooth and quick movement, contact points are self-cleaning and give correct time-change over from short to long waves.

Cat. No. 90 EXTENSER - - - - - **12/-**

Cat. No. 90/a SLOW-MOTION DIAL - - - - - **4/6**

Cat. No. 95 Slow-Motion Extenser, COMPLETE WITH KNOB AND DIAL **15/6**

Differential Reaction Condenser

A newly designed and much improved condenser with phosphor bronze spring contact, rigid construction and smooth movement. Fully tested and guaranteed. '0001 and '00015. 2/9

SUPPLIES NOW AVAILABLE.

From all Retailers, or in case of difficulty apply to the Manufacturers:

The Webb Condenser Co., Ltd.,
42, Hatton Garden, London, E.C.1.
Tel.: Holborn 2260.

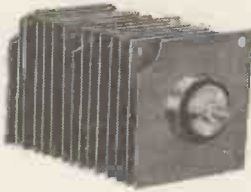

Make sure this is in the Set you buy

For your own sake you should make sure that the mains receiver you buy incorporates a Westinghouse Metal Rectifier. The metal rectifier, unlike its valve and chemical alternatives, does not burn out or deteriorate in any way. It gives good, trouble-free service in your set as long as the set itself lasts. That is why most of the leading receiver-makers now fit the Westinghouse Metal Rectifier as standard.



Also made in a series for amateur constructors, and described in our booklet, "The All-Metal Way."

The Westinghouse Brake & Saxby Signal Co., Ltd.,
York Road, King's Cross, London, N.1. 'Phone: North 2415.

IGRANIC Components Satisfy

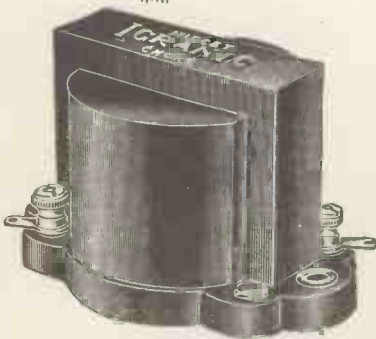

When you embody Igranic Components in your set, you are assured of extreme satisfaction. They are specified by experts because of their known quality and efficiency.

IGRANIC MIDGET CHOKE

PRICE 10/6



Specified for the "M.W." "HI-MAG" 4

If you cannot obtain Igranic Components locally, write Dept. J. 1131. We will supply C.O.D.

The **EFFICIENCY** of a Set depends on the quality of its **CONDENSERS** ... and that's why experts Choose **DUBILIER**

No matter how expensive may be the rest of the components ... no matter how skilfully designed the circuit ... if the condensers are of doubtful quality a Set can never give of its best.

That's why the experts choose Dubilier.

They have proved time and time again that a Dubilier Condenser will stand up to its job ... and more than its job ... with a robustness that has earned the Dubilier reputation for infallible dependability.

Follow the experts' lead and get the most from your radio. Choose Dubilier every time.

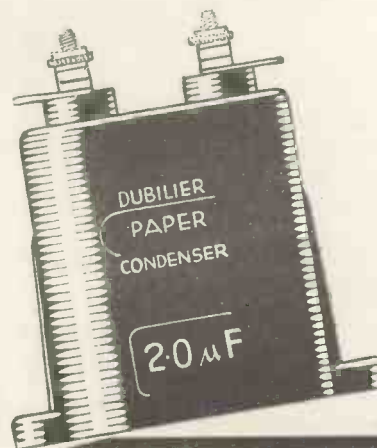

PRICES

TYPE BB.	
Up to 0.09	1/9
0.1	1/10
0.2	2/-
0.25 to 0.3	2/3
0.5 to 1.0	2/6
2.0	3/6

DUBILIER CONDENSER CO. (1925) LTD.
Ducon Works, Victoria Rd.
N. Acton, London, W.3.

OHMITE

WHEN YOU SEE



SPECIFY



OHMITE

Anode Resistances. All values, 100 ohms to 500,000 ohms.

2/3 each

MEGITE



MEGITE

Grid Leak. All values, 1 meg-ohm to 5 meg-ohms.

2/- each

Ohmite and Megite Resistances are constant in value, of negligible self capacity and non-inductive. Dead silent and always reliable, they provide the most effective resistance on the market, giving the full range of values required. Supplied with vertical or upright holders of superior brown bakelite construction 6d. extra. *Graham Farish components carry a written guarantee of accuracy.*

Ask your dealer to obtain, or write to

GRAHAM FARISH LIMITED BROMLEY, KENT

RADIO NOTES AND NEWS OF THE MONTH

—continued from page 84

interference between them, is made possible.

Grand Opera Subsidy

The Assistant Postmaster-General, in reply to Sir Kingsley Wood, stated in the House of Commons recently that a supplementary agreement with the British Broadcasting Corporation, which will include the provisions as to the opera grant, is in course of drafting and will be laid before Parliament as soon as it has been executed.

Radio Improves Milk

A Halewood, near Liverpool, farmer has discovered that cows give more and better milk when wireless music is played to them. He has fitted a loud speaker into the shed where his twenty cows are kept.

Every time they come in for milking the set is switched on, and the splash of the milk in the pails is accompanied by dance music.

"Radio Milk," or "Jazz Milk," seems indicated in the near future.

Going Ahead

I hear that the cost of the North Regional Station at Moorside Edge is about £150,000.

The North Regional station is now complete, but similar stations are to be erected in Scotland and the West of England. The studio accommodation at Leeds and Newcastle is being modernised, and I understand that the six-year-old transmitter at Belfast is also to be brought right up to date.

Short-Wave Medicine

News is hand from Vienna that a doctor has utilised short radio waves as a cure for paralysis. Judging by the reports received, it seems these short waves are made to pass through the body of the patient, thus causing a rise in temperature and a high fever. (People who suffer from paralysis, it seems, are greatly improved if from time to time they suffer from a high fever.)

Better Than Malaria!

A well-known Viennese doctor discovered the treatment and says that results are even more surprising than in cases where paralytic patients are made feverish by the injection of malaria.

Some Real Cures

The report goes on to say that the patient is "over-heated" by radio short waves," sometimes temperatures of 40 degrees centigrade being obtained without danger to the patient. The doctor who invented the malarial injection cure treated 129 paralytic patients from 1922 to 1924, and out of the 67 patients who are still alive, 53 are perfectly well and have been cured of paralysis.

And it is said that the new radio cure will prove even more successful.

Fixing Frequency

One of the problems discussed by the visitors to the Union Radio Scientifique Internationale at Copenhagen was the exact measurements of the wave-length or frequency of broadcasting stations. According to Professor Appleton, the head of the British delegation at Copenhagen, a few years ago wave-lengths could only be measured to one part in 5,000, but in these days an accuracy of one part in 100,000 is essential.

Wave-Length Accuracy

Without such accurate measurements the interference between various transmitting stations would be greater than it is through stations carelessly getting away from their allotted wave-lengths. At the Copenhagen Conference arrangements were made for the international comparison of the methods for measuring wave-lengths employed in various countries.

Mr. Shaw and St. Joan

There has been a great deal of fuss, and unnecessary fuss, over Mr. Bernard Shaw's broadcast talk on St. Joan, and the B.B.C. has, of course, been dragged into it; but we are glad to note the B.B.C. is standing up for its rights to invite Mr. Shaw to the microphone and to allow him to express his own independent views.

It is all nonsense to say that people can be offended because an eminent author and a great thinker puts forward a point of view which may be a little unorthodox. Let us hope the B.B.C. will invite Mr. Shaw again to broadcast, and that they will not be deterred by those who take offence because a new viewpoint is expressed.

A Viennese Tonic

Apropos of the news from Vienna that short radio waves will be of great value to cure paralysis, there is another story from Vienna which

(Continued on page 87)

RADIO NOTES AND NEWS OF THE MONTH

—continued from page 86

says that a method of using radio waves as a stimulant has been discovered.

It appears that the invention is based on a device which generates high-frequency currents which, when applied to the body, seem to drive away fatigue and to exhilarate the mind just as a glass of alcohol would. But, it is reported, there are no after-effects. When anybody who is run-down has had a dose of these exhilarating waves he feels refreshed and revitalised.

"Eighth World Wonder"

An invention for reproducing sounds that has been described as the "eighth wonder of the world" is now being used by the B.B.C.

This is the Blattner "Stillephone," the invention of Dr. Stille, a German scientist.

Used by B.B.C.

It is based on the fact that sounds can be electrically recorded on a strip of metal passing between electromagnets. The process causes a change in the molecular structure of the metal, which remains in that state until it again meets a magnet, when it reverts to its original condition and can be used for fresh recording.

The metal is in strip form, like a tape. It rolls on a spool and is portable, unbreakable, and unwearable.

The B.B.C. has been using the device for rehearsals, for the recording of special programme items, and for special speeches, such as those made by the Prince of Wales.

New King's Microphone

The new microphone which is to be used by the King for broadcasting is a beautiful affair, embellished in gold and silver, and standing on a chromium-plated stand rather like a heavy music-stand.

At its base is a large silver plate on which will be engraved a record of the occasions on which the King speaks into it.

An Important Denial

A recent circular containing a questionnaire issued by the B.B.C. to 3,000 artistes on its waiting list seemed to suggest that the B.B.C. meant their exclusion from broadcasting engagements.

One of the questions asked was whether music was their whole-time occupation.

A B.B.C. official has since explained that there had been no decision to exclude amateur or part-time musicians, but the number of applicants was constantly increasing and it was necessary periodically to re-classify them.

Banned Radio Exchanges

Camberwell Works Committee recommend that no action be taken with respect to three applications for consent to instal "broadcast exchanges" to relay wireless programmes. The committee state:

"We do not consider that wireless relay systems are desirable in the borough."

Several cases have come to our notice lately of these exchanges being banned. It is just as well; their popularity can hardly last long, for the service offered must of necessity prove very restricted.

AN "INTER-AXIAL" IN SOUTH AFRICA
From an enthusiastic user of this speaker.

Sir,—I believe you like to hear from your readers, so I should like to thank you for the article in the February number of MODERN WIRELESS on loud speakers. I have been interested in reproduction for some time and made dozens of cones, both of my own design and those published in various papers, and so far this one which I made up has beaten the rest.

I tried your method of fitting the ring round the edge of the cone—that of cutting the serrated edge—and found it extremely difficult to get a true flat, and remembered my old method of doing it. I tried that with perfect success and in half the time.

My method is to obtain a round piece of ebonite, hard wood, or similar substance, about a quarter of an inch in diameter, and cut a slit about $\frac{3}{16}$ in. deep in one end with a fretsaw. This is slipped over the edge of the cone and the paper bent gradually, working all round. The edge is seccotined and placed on the circle of paper to form the baffle.

When set the inside waste of paper is carefully cut away with curved nail scissors, and not only is a perfect cone formed, but a perfectly flat baffle ring.

Yours sincerely,
GEO. K. MALLORY.
South Africa.

PETO-SCOTT

BRITAIN'S LEADING FRAME AERIAL DESIGNERS

Recommended for the "Simplicity" Super



- EACH STRAND OF WIRE ENAMELLED AND COVERED OVERALL
- ACCURATELY SPACED LOW-LOSS INSULATED WINDING SUPPORTS
- TRIPLE LOW-CAPACITY AERIAL LEAD FITTED SIX SPACER BARS
- BOTH WINDINGS PARALLEL INSTANTLY AND AUTOMATICALLY BY SWITCH
- OAK POLISHED SOLID BASE

The only Frame Aerial fitted with Wave-change Switch and Base at the price of £1. Beware of buying inefficient imitations.

TRADE SUPPLIED. TERMS UPON REQUEST.

Super-Het. efficiency depends largely upon the Frame Aerial used, and as the leading makers of Frame Aerials in the industry, the most prominent set designers place their full confidence in Peto-Scott to design and manufacture this vital component. We have made Frame Aerials for 10 years.

£1

CASH or C.O.D. You pay the Postman.

"SIMPLICITY" SUPER

As described in this issue.

KIT "A" Less Valves, Cabinet and Frame Aerial
or 12 monthly payments of 13/5 **£7:5:9**
As above with Frame Aerial or 12 monthly payments of 15/3 **£8:5:9**

SPECIAL SUPER-HET. ACCESSORIES.
CASH or C.O.D. You pay the Postman.

One Rolls-Caydon Oscillator Coupler and ON-OFF Wave-Change Switch. One Rolls-Caydon Filter and Single Intermediate Unit, complete with valve holders and **£2:10:0**
Coupling Components.

Rolls-Caydon Frame Aerial **£2:2:0**
Complete as specified
ANY PARTS SUPPLIED SEPARATELY.

COIL QUILTS

Peto-Scott first and best. As specified and included in latest "M.W." and "P.W." Sets. Bakelite moulding with winding holes ready drilled, shoulder for coil assembly and lug for base-board mounting. Ask your dealer.

6d.

Post Free 8d. EACH

P.J. COIL FOR "M.W." SETS

No. 1 Coil, 2/9. No. 2 Coil, 2/-. No. 3 Coil, 2/9.
Postage and Packing on all orders over 10/-.

PETO-SCOTT CO. LTD.

77 City Road London, E.C.1
Phone: Clerkenwell 9406-7-8.
62 High Holborn, London, W.C.1
Phone: Chancery 8266.
33 Whitelaw Rd., Chorlton-cum-Hardy, Manchester
Phone: Chorlton-cum-Hardy 2028.
7 Albany Road, Newcastle, Staffs. Phone: 61790.

FORMO
ARTHUR PREEN & CO. LTD.

MAINS CONDENSER
CAP. 2 3/3

FORMO MAINS CONDENSERS

It has been the aim of condenser engineers for years past to produce a condenser having a high test and working voltage, a high insulation value and long life, at a low cost. The new Formo condensers have a high insulation value which makes leakage infinitesimal, and are tested by the sudden application of the test voltage, and not, as is usual, through a non-inductive series resistance. Catalogue of the complete range of Formo quality components sent on request.

MID LOG LINE VARIABLE CONDENSER 4'6"

DUAL RANGE COIL 12'6"

VERNIER DIAL 3'

ARTHUR PREEN & CO., Ltd.
Golden Square, Piccadilly
Circus, W.1
FACTORY: Crown Works, Southampton

TAXING THE LISTENER
—continued from page 44

yet some of our leading preachers are as great a "draw," and I write this without any lack of reverence, as our great exponents of the dramatic and operatic arts.

Many facilities have been given by the B.B.C. for charitable appeals. Yet all these are lumped together as "entertainment" and used as an excuse for levying this tax on the licence money.

Performing a Duty

Then there are the purely public services performed by the B.B.C., such as broadcasting time signals, gale warnings, and weather forecasts, of great value to mariners and airmen. The police are assisted by the sending out of S.O.S.'s for missing persons.

Yet the conception of the B.B.C. in the eyes of the Treasury still seems to be that it does nothing but broadcast vaudeville and chamber music; and this is presumably their excuse for taking more than half the money brought in by the 455,174 new licences issued last year!

My own view is that there ought to be no tax on the B.B.C. at all. It would be just as sensible to tax newspapers, or golf, or tennis. Let the Post Office take its proper charges for distributing the licences, which could not possibly be more than £50,000 a year, and let the remainder of the money for licences be used for developing and improving the service.

There is much distress amongst musicians and vaudeville artistes owing to the growth of the cinema and the "talkies," and with more money better entertainments could be provided at higher remuneration to those providing them.

Give the B.B.C. its Share

The educational facilities could be improved also, and the best talent in the nation enlisted for the benefit of the public through this great medium of information and enlightenment. There is a great future for Imperial broadcasting in the use of wireless for knitting closer together the scattered parts of the Empire. We are only at the beginning of developments here. But this will cost money.

At the same time the benefit, nationally and internationally, through an improved and extended service is beyond computation.

IN PASSING
—continued from page 80

this moment I chose to run over a hedge and ditch rather than slaughter several sheep.

We came to a stop in a glorious bit of scenery, and I proposed a disembarkation and a test of my new portable.

"What do you say, my dear Mister Bint?" boomed Dr. Think. "Shall we descend and permit our young friend to divert himself?"

"As you please, doctor, as you please! Moss is ubiquitous, thank heaven! I shall not disturb the lad."

I backed her into the shade of a mossy old oak—Bint had his nose in the moss within ten seconds and was snorting with enjoyment—and began to camp.

Dr. Think wandered off, hands clasped behind his back and nose directed towards *Alpha Thinkii*. Did he detect an unauthorised movement in that star?

Those "Talks" Again

Having had a furtive pull at a Thermos, a ceremony which I dared not share with F. and J., both of whom imbibed carefully distilled water, I turned on the five-valve portable and slewed her round till I found something.

Of course, it was a talk! At the noise my boy friends pivoted their heads round. "... these enormous fish are almost entirely vegetarian. They devour..." droned the voice.

"Moss-consuming *pisces*," rumbled Mr. Bint, "are found only in certain littorals of the East Indies. A well-defined moss-feeder..."

I wangled the turntable away from fish and found—"... fifty million light years. This nebula, so far as one can judge, is receding from the earth at a mean velocity of 19.5 million miles per annum..."

Old Think's head bobbed up at this. "What? Mean velocity? I don't know who this ignoramus is, but I tell you, young man—" Here a virile bull approached from the north-west and persuaded Think to retreat with no mean velocity. Bint was lying at full-length at the roots of a tree, and did not notice the new turn of affairs. The bull gave a snort. "I opine, my young

(Continued on page 89.)

Make
The DAILY SKETCH
YOUR Picture Paper.

Advertisements

As far as possible all advertisements appearing in "Modern Wireless" are subject to careful scrutiny before publication, but should any reader experience delay or difficulty in getting orders fulfilled, or should the goods supplied not be as advertised, information should be sent to the Advertisement Manager, "Modern Wireless," 4, Ludgate Circus, London, E.C.4.

IN PASSING

—continued from page 88

friend," remarked Mr. Bint, without removing his eyes from his moss, "that your gramophone has sustained a broken spring. I heard it go."

I dodged behind the tree and replied: "Look out! A bull!"

"Aha! my young friend," chuckled he. "I am too old a traveller to be caught like that. Hum! this spore seems to be slightly alar. I must have him." He pulled out a little pill-box and began to shake something into it.

Radio to the Rescue!

The bull lowered his head. I turned to run—and hang me if Dr. Thunk wasn't calmly lying on his back, bossing at the sun through a piece of blue glass. The radio, which was still coming over, suddenly burst into a blare of dance music, which moved the bull to think again; he snorted and retreated sullenly. Just then Mr. Bint turned and saw the bull.

"I say, Thunk," he drawled, "yon Taurus is a celestial omen. I opine that something has gone wrong aloft. Is *Centauri* or *Thunkii* all in order?"

Dr. Thunk lowered his blue glasses and replied, impatiently: "Taurus? Don't bother me! *Go and milk it!*" Mr. Bint winked at me.

A Surprise for Bykins!

When I handed the Bisto Kids over to Bykins that night, he said: "Sorry, old man, for loading a pair like them on to you. How you must have suffered!" "On the contrary," I answered, "they are the toughest old sports I have ever made listen to my portable. You simply can not rattle 'em! If I could study radio with the single mind and concentration which those old johnnies bring to moss and stars, Marconi would have to buck up."

Gentlemen—a story with a moral. Sorry!

A PRECISION PAIR



J.B. JUNIOR LOG



PRECISION INSTRUMENTS

Advertisement of Jackson Bros., 72, St. Thomas' Street, London, S.E.1. Telephone: HOP 1437.



J.B. ILLUMINATED VERNIER DIAL

Read your condenser settings at a glance with the J.B. Illuminated Vernier Dial. Takes panels up to 1/4". Fitted easily—only one round hole to cut. Scale mounted neatly behind panel. Smooth action.

Price 5/- complete with lampholder
THE J.B. JUNIOR LOG—used in leading circuits. Hard brass end plates and hard aluminium vanes give great rigidity. Pigtail to rotor.

'0005, 7/-; '0003, 6/9; '00025, 6/6; '00015, 6/6.

4" J.B. Bakelite Dials: Black 1/6 extra, Mahogany 2/- extra.

"De-Luxe" Radio-Gram CABINETS!
HUGE REDUCTIONS for ONE MONTH!
£12/12/- reduced to £8/8/-
£27/7/- reduced to £4/18/-
£3/3/- reduced to £2/15/-
(Cash or deferred.)
The Superior QUALITY delights! A fine charm of style that people desire. Advantages also of PIANO-TONE Baffle and sound chamber (no distortion, no drumming). Quite new—as supplied to leading experts, B.B.C. and Radio Press. You may have ON APPROVAL and return at OUR expense if you wish to part with it. This bargain offer is open for ONE MONTH. Photographs and full details FREE!
PICKETTS, Radio Furniture Works (M.W.), Albion Road, Bexleyheath, Kent.

WILL DAY LTD.
The Radio Gramophone Experts
Large Selection of Components and complete Instruments in stock.
New Junior Paillard Induction Gramophone Motor with 12" Turntable £2.5.0
With Large Motor Plate and Automatic Stop £2.15.0
WILL DAY LTD.
19, Lisle St., Leicester Sq., London, W.C.2.
Phone: Regent 0921/2.

Buy YOUR Children
The CHILDREN'S NEWSPAPER
Every Thursday, 2d.



NEW SIX-SIXTY VALVE SCREEN 1/3

SAY SIX-SIXTY

Six-Sixty Radio Co., Ltd., Six-Sixty House, 17/18, Rathbone Place, Oxford St., W.1. Tel.: Museum 6116/7.

THE SIMPLEST WAY TO SCREEN YOUR VALVES.

The most effective form of screen for high-efficiency Screen-Grid and Detector Valves. Simplifies and cheapens the construction of new receivers—as easy to fit as a valve! Fitted in a moment to existing receivers with marked gain in stability.

The valve lies close to the screen, and its earthed filament or heater pin passes through a lug in the screen base, earthing the screen.

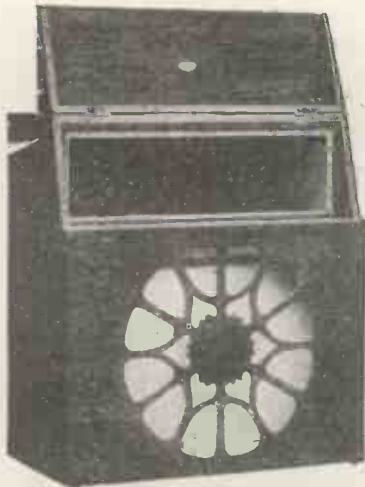

THE "IDEAL" CABINET FOR YOUR PORTABLE

Here is just the cabinet you need for your portable. The Gamco "Ideal" Portable Cabinet is lightly yet strongly constructed. It is handsome—worthy of any set. Dimensions are approximately 18" x 17" x 8 1/2". Space for loud speaker cones up to 12" in diameter. Well finished in Oak, 52/6. Mahogany, 58/-. Special discount of 10% if ordered before July 31st.



Send coupon for FREE Catalogue to:
CARRINGTON MFG. CO. LTD.
 24, Hatton Garden, London, E.C.1.
 Phone: Holborn 8202. Works - S. Croydon.

NAME.....
 ADDRESS.....
 M.W.3

AN IDEAL COMBINATION

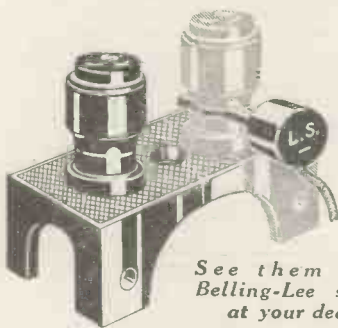

See them in the Belling-Lee showcase at your dealers.

A BELLING-LEE TERMINAL MOUNT fixed anywhere, vertically or horizontally — on baseboard, window ledge, wall or skirting. Price 8d. each.

BELLING-LEE TERMINALS securely fixed in the Terminal Mount—all-insulated, with clearly engraved non-rotating heads. Price 6d. each. Other models 4 1/2d. and 3d.

BELLING-LEE SPADES holding the Terminal stems in a spring grip, and held themselves by the massive Belling-Lee Terminal heads—the neatest and the most secure form of connection. Price 2d. each.



Advt. of Belling & Lee, Ltd., Queensway, Ponders End, Mdx.

THE "M.W." "HI-MAG" FOUR
 —continued from page 55

coils, and as soon as you have finished the long-wave coil you can go right on to the other coil and wind that.

In this case the end of the reaction coil is marked 3, and the beginning of the reaction is joined to the E lead of the long-wave coil which is marked E itself. In the photographs you will see there are two leads sticking out from the coil, the one at the top is the E of the long-wave coil, and the one at the bottom is the E, or beginning, of the reaction coil, and these two leads are joined together and taken to the tuning condenser; that is, to the moving vanes and to the L.T.—circuit.

Small Coils

The end of the reaction coil marked 3 is taken to one of the switch contacts and to Z on the medium-wave coil. And now we will discuss the medium-wave coils.

The first one in the aerial circuit is wound on a piece of paxolin or pirtoid former about 1 3/4 in. long and 2 in. diameter, and as you will see from the photographs consists of 9 turns tapped; that is, you wind on 3 turns, then a further 2, and then the final 4, and the beginning and end of the windings are marked A and X.

The secondary winding consists of 64 turns, the beginning marked G and the end marked Y, and the beginning of this winding should be about 3/8 in. away from the aerial winding. The medium-wave coil in the detector circuit consists of a 30-turn primary winding tapped at 10 and 20 turns, and this is placed 3/8 in. away from the grid winding, which is 64 turns, and this latter is about 1/4 in. away from the reaction winding, which consists of 34 turns. No. 30 D.S.C. is used throughout, and always wind in the same direction.

Identification Letters

The markings are as follow: Beginning of primary A, end X; beginning of secondary G, end Y; beginning of reaction Z, and end R. In the event of your desiring to purchase these coils, you will have them provided with flex leads of different colours. A will be red, and X will be blue; G will be white, and Y will be black; Z will be green, and R will be yellow. And the ends marked A (red) should be cut short to take the crocodile clip used for the tappings.

Having mounted the coils, place the rest of the components in their respective positions, and the rest of the wiring can now be carried out by means of 18-gauge Glazite in accordance with the wiring diagram.

Direct wiring should be used, and no attempt should be made to make it that beautiful right-angled neatness which looks so nice but, in a set of this description, can be so inefficient. The shortest and most direct path should be taken wherever possible, except perhaps in the case of filament and H.T. wiring.

Watch the Wiring

You will notice that a photograph and wiring diagram are given of the under-baseboard wiring, and it is here the de-coupling resistances and the de-coupling condensers are placed. The holes through which the wires go are numbered, so that you will be able to connect the upper-baseboard and the under-baseboard wiring together without any trouble.

Only three of the four connections on the Extensers are employed, and the moving vanes are mechanically connected with the switching points when the medium waves are being tuned in.

It will be noticed that the metallised screened-grid valves are employed, but this is not essential, though it is, of course, a step forward towards obtaining perfect screening. But if you attempt to use metallised valves, make absolutely sure that you get the filament connections of the valve holders exactly as shown in the wiring diagram, because the right-hand filament socket of each valve holder, when looking at it with the plate leg towards you, should be the one that goes to L.T.—

Earthing Points

There are one or two earthing points by means of screws and washers to the coils, and these are clearly shown in the diagrams. All these should be carefully soldered, and the greatest care should be taken that the coils are connected up the right way round. Note, however, the screw marked * in one of the screens. This must not make contact with the metal foil.

As regards operation, this set is perfectly simple. Two-, 4-, or 6-volt valves can be used, with accumulator to match, and the H.T. voltages are, of course, quite usual. About 80 on the screening grid, 120 to 150 on the anode, 70 to 80 on the detector, and the maximum H.T. on the last

(Continued on page 91.)

**THE NEW W.B.
PERMANENT MAGNET
MOVING-COIL
SPEAKER**
for £4:10:0

So sensitive that any 2- or 3-valve set will drive it! No mains or batteries needed. Identical in design with the very successful model introduced earlier this season.

Don't be put off —insist on a demonstration.

Type PM2 chassis, assembled with 11½" x 11" baffle board, £4:10:0. If fitted with a double-ratio step-down transformer, 15/- extra.

Ask your dealer for the free colour-folder, or write to us direct.

Made by the Makers of the famous W.B. Cone Speakers, Switches, and Valve Holders.

Whiteley Electrical Radio Co., Ltd., Radio Works, Nottingham Road, Mansfield Notts.
Irish Free State Distributors: Kelly & Shiel, Ltd., 47 Fleet Street, Dublin.



THE "M.W." "HI-MAG" FOUR
—continued from page 90

valve. The grid-bias batteries for the screened-grid circuits are the special Siemens '9, which are easily placed in position.

The set is switched on by pulling out the L.T. switch, and tuning is carried out in the usual way by turning the variable condenser knobs. We suggest that you set them both together and gradually go up in wave-length, keeping them in step as closely as possible.

Automatic Wave-Changing

From 0 to 99 your tuning is on the medium waves, and from 100 to 200 you are on the long waves, so that it is easy to tell at a glance whether you are on the medium or long waves, because all the medium-wave readings come below 100 and all the long-wave readings are above the 100. This is automatically allowed for in the condenser, and there is no pre-setting to be done.

Now to test the set. Place the clip from the aerial terminal on to tap 6 on the aerial coil, and the tapping from the anode of the second H.F. valve on to 20 on the second short-wave coil. Then tune-in your local station and notice the selectivity. If it is quite sufficient, and you could do with a little less, increase your tappings to maximum on the second coil (that is, on the end A), and on to end A on the first coil.

If, however, selectivity is not sufficient, leave the second coil as it is and move the tap on the aerial coil down to 4, and this should give you all the selectivity you require. Should you, however, require still a little more, move the tapping on the second medium coil down to 10.

Easy to Tune

You will soon get the hang of the tuning of the set, the main idea, of course, being to keep the condensers in step as closely as possible; but you will not find the tuning at all critical. Volume is controlled by means of the variable resistance on the left of the panel, and reaction is applied in the usual way with the reaction condenser.

When you turn your tuning dials over past the 100 mark and on to the long waves, then you will find that

(Continued on page 92.)



**instead of this—
a neat alternative**

Bulgin Miniature Jacks and Plugs represent the neatest possible connection for loud speakers. Leads cannot get reversed accidentally, and injury to the delicate loud-speaker movement is avoided. The Jack is simply connected. The loud-speaker leads are securely held to the Plug by set screws. Due to its unique design this Plug projects less than others.



SINGLE CIRCUIT JACK. List No. J.3. each
EMBOSSED TELEPHONE PLUG. Black or Brown Bakelite. each

Send 2d. postage for 60-pp. catalogue

A. F. BULGIN & CO. LTD.
9/10/11, Cursitor Street, Chancery Lane, London, E.C.4
Phones: Holborn 1072 & 2072.

The Picture Paper with—the MOST News—
SUNDAY GRAPHIC

Specified for the
"SIMPLICITY" SUPER
The **CLIX VALVE HOLDER**

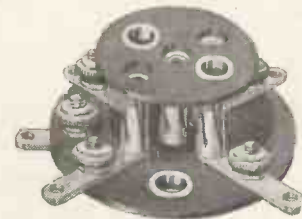

No. 27. Pro. Pat. Re. Design.

**Built for Efficiency
Not for Appearance**

Type B for baseboard mounting.
4 pin Model with scr w terminals - 10d.
4 pin Model with .ut screw terminals - 8d.
5 pin Model with scr w terminals - 1/-
5 pin Model without screw terminals - 9d.

From most Dealers. If any difficulty, order direct.
LECTRO LINX LTD., 254 Vauxhall Bdg. Rd., S.W.1.

**ALL APPLICATIONS for
ADVERTISING SPACE in
"MODERN WIRELESS"
must be made to the
Sole Advertising Agents,
JOHN H. LILE, LTD.,
4, LUDGATE CIRCUS, LONDON, E.C.4.
Phone: City 7261.**



**The World's
best Stories**

The ARGOSY offers a splendid variety of really first-class fiction. Every story sets a standard of excellence, for the policy of this magazine is to print those stories which are indisputably great, and written by acknowledged masters of the past and present day.

The **ARGOSY**
Magazine 1/-
Published Monthly.

THE "M.W." "HI-MAG"
FOUR
—continued from page 91.

the long-wave coils are automatically placed in circuit in series with the medium-wave coil so that you tune above 1,000 metres.

In this case one has to re-adjust the selectivity in order to get it right on the long waves. This does not mean that this has to be readjusted every time you switch over. You do it once and leave it set.

The medium-wave selectivity control is set by means of the tappings, and you now transfer your attention to the crocodile clips which have to be placed on the long-wave coils. In the first circuit one clip comes from the pre-set condenser (which should be screwed right in), and the tapping is taken on turn number thirty. Then, if selectivity is not sufficient, it will have to be shifted; but before moving it we must put the tapping right on the second long-wave coil, and in this case the crocodile clip coming from the Extenser is the one to be considered and should be connected to the 40-turn tap on the long-wave coil.

Long-Wave Selectivity

Now tune in 5 X X and see how many degrees it occupies on your tuning dial. It should not spread very much, but it must be well clear of Radio-Paris. If it is not, decrease the capacity of your compression-type condenser which is in series with the long-wave circuit (that is; the condenser mounted on the side of the main screen) and notice whether the selectivity improves. If when the condenser has been completely unscrewed the selectivity is still not sufficient, then move your tapping point on to the 20-turn tap.

No Further Adjustment
If you are badly jammed by 5 X X (which will only occur if you are fairly close to that station), move your tapping on the second long-wave coil downwards to 20.

Probably you will find you can easily separate them, and then you will get louder signals by increasing your tapping point up to 60 in the second case. A little practice at moving the crocodile clips about will soon enable you to find the exact setting which will give you the best compromise between selectivity and sensitivity, and once you have found this nothing else has to be touched. You do not touch the semi-variable condenser again, and you do not have to move any more crocodile clips. These are left set, and the receiver is ready for normal operation.

THE "SIMPLICITY" SUPER
—continued from page 19

Volume control is carried out by the potentiometer on the right of the set, and this varies the screening voltage on the intermediate H.F. valve. Put it fully to the right and place both condensers at zero, now rotate the oscillator condenser very slowly upwards until it is at about 10 degrees, and then vary the aerial condenser backwards and forwards over about 20 degrees. At one or two points you should hear a sort of slight rushing noise showing that the two are in tune.

Then continue up degree by degree on the oscillator, varying the frame aerial condenser over about 20 degrees, and it will not be long before you pick up a powerful station. When you have got a station leave it tuned in on the frame and turn the oscillator carefully in one direction and then the other, and you will find that there are two

readings where the station is received. Usually the most powerful reception is obtained on the lower reading of the oscillator condenser.

Testing the Set

Having noted this lower reading and the reading on the frame condenser, move the two up step by step, always adjusting the oscillator condenser very, very slowly, and the frame condenser being adjusted over a few degrees to keep it in step with the oscillator.

The reaction control on the left of the set is only used on very weak stations. It will probably not help you to pick up any but the very distant ones, which you may find by means of picking up their carrier and then resolving them on the reaction in conjunction with the oscillator condenser, the frame aerial being left set tuned to the carrier.

You will be surprised to find that on powerful stations the reaction seems to have no effect. You'll hardly have to use it at all on the lower waves, except, as we said before, on very distant stations.

A Point to Remember

The long-wave procedure is exactly the same as for the lower waves.

Do not forget when you switch off the set by means of the wave-change switch in the centre of the panel (placing this in the centre position) that you also turn the volume control hard over to the left, as this switches off the H.T., which would otherwise run to waste through the filament wiring and through the L.T. battery.

When a station is tuned in, rotate the frame through, say, 90 degrees or so, to see if any difference in the signal strength is obtained, because, as you know, the frame must be "pointing" towards the station you are receiving if you want to get the maximum power.

INDEX TO ADVERTISERS	
	PAGE
"Argosy Magazine"	91
Belling & Lee, Ltd.	90
British Blue Spot Co., Ltd.	Cover iv
British Insulated Cables, Ltd.	Cover iii
Bird, Sydney S., & Sons, Ltd.	1
Bulgin, A. F., & Co., Ltd.	91
Burne-Jones & Co., Ltd.	84
Carrington Manfg. Co., Ltd.	90
Cossor, A. C., Ltd.	2
"Children's Newspaper"	89
Day, Will, Ltd.	89
Dubilier Condenser Co. (1925), Ltd.	85

	PAGE
General Electric Co., Ltd.	Cover ii
Graham Farish, Ltd.	86
Heyberd, F. C., & Co.	81
Igranic Electric, Ltd.	85
Jackson Bros.	89
Lectro Linx, Ltd.	91
London Electric Wire Co. & Smiths, Ltd.	79
Peto-Scott & Co., Ltd.	87
Pickett's Cabinet Works	89
Preen, Arthur, & Co., Ltd. (Formo)	88
"Popular Gardening"	83
Radio Instruments, Ltd.	81
Ready Radio	75
Regentone, Ltd.	83

	PAGE
Rolls-Caydon Sales	83
Six-Sixty Radio Co., Ltd.	89
Telegraph Condenser Co., Ltd.	79
"Town and Country Homes"	81
Varley Products	Cover iii
Webb Condenser Co., Ltd.	84
Westinghouse Brake & Saxby Signal Co., Ltd.	85
Whiteley Electrical Radio Co., Ltd.	91
Wright & Weaire, Ltd.	83

All communications concerning advertising in "Modern Wireless" must be made to John H. Lile, Ltd., Ludgate Circus, London, E.C.4. Telephone: City 7261.

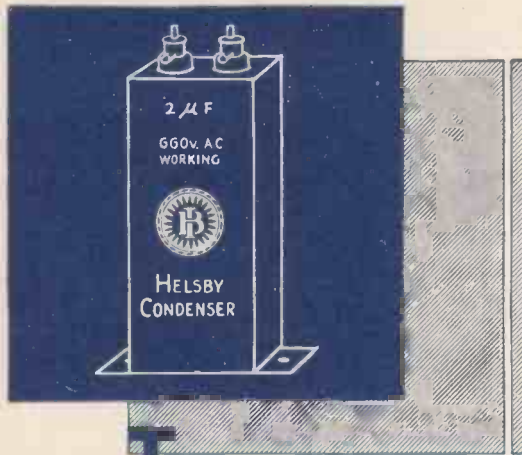

TESTED TO DOUBLE WORKING PRESSURE

Helsby Condensers have been supplied to the G.P.O. and to large manufacturers for thirty years. They are engineer-built, with plates of pure foil, non-hygroscopic, fully tested, and the capacity rating is guaranteed. A boon to the experimenter, for their reliability is unailing.

Ask for Helsby Condensers by name—there is a full range to cover every purpose. Types 212 and 212T are particularly suitable for eliminator circuits.

TWO POPULAR SIZES:

Type 209T. Working voltage. 250 D.C.	
1 mfd ..	2/7
2 mfd ..	3/6
Type 212. Working voltage. 400 D.C.	
1 mfd ..	3/7
2 mfd ..	4/9

HELSEBY CONDENSERS

BEST FOR THE CONSTRUCTOR

If any difficulty in obtaining from your local dealer, please send us his name and address.

BRITISH INSULATED CABLES LTD
 PRESCOT... LANCASHIRE
 MAKERS OF B.I. CABLES



TENFOLD INCREASE IN SELECTIVITY!

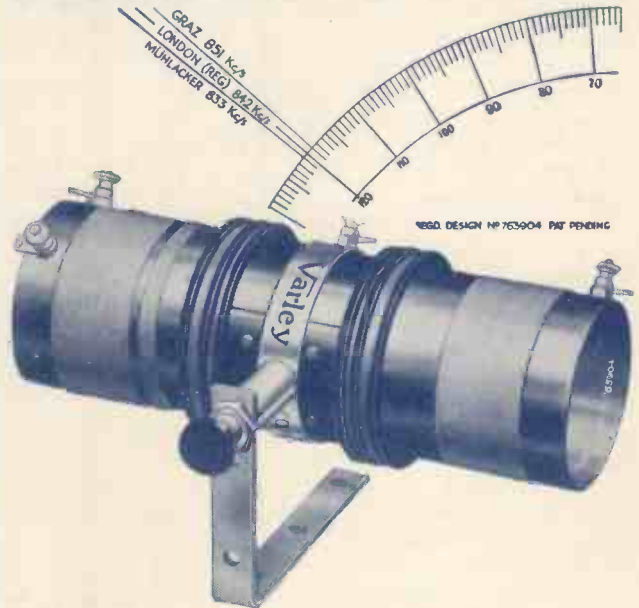

CONSTANT SQUARE PEAK COIL 15/-

The Varley Constant Square Peak Band-Pass Coil. The ideal pre-selective device for any set—S.G.. Reacting Detector or Super-het.

Confines local station to 3-4 degrees on the simplest set. Enables programmes now swamped by powerful transmissions to be heard and enjoyed. Actually improves quality of reproduction. Abolishes all interference by medium waves on long waves. Supersedes wave-traps. Easily replaces existing aerial coils. Needs no screening.

This new coil combines *negative* inductance and capacity coupling, so giving a constant square-topped peak and separation of substantially 9 kilocycles over the whole of both wavebands.

Supplied complete with extension rod for switch and universal mounting bracket.

Ask your dealer for the Free Colour Folder, or write direct.

It is desirable to use a non-inductive coupling condenser (.04 mfd.). THE DUBILIER CONDENSER CO. (1925), LTD., are manufacturing a special condenser, Type 9200, for use with this coil.



Advertisement of Oliver Pell Control Ltd., Kingsway House, 103, Kingsway, London, W.C.2. Telephone: Holborn 5305

HEAR

a Blue Spot Speaker AND YOU WILL KNOW

how good it is!

BLUE SPOT'S reputation for quality and fine performance is based on facts—not words. Every sound, spoken, sung or played, is faithfully rendered exactly as the original. Blue Spot never gives an interpretation of its own—never blurs—never distorts—never garbles. It adds nothing and takes away nothing. It is the supreme reproducer, always accurate, always exact. It makes all the difference between hearing and enjoying.

Blue Spot is the Speaker for which you have been searching. It makes indifferent sets good; it makes good sets better. Whether you buy or build, get a Blue Spot. Were you to pay twice or thrice its price you could not better it. Ask your dealer to let you HEAR and you will KNOW.



BLUE SPOT SPEAKERS

41K	13½ in. high, 12½ in. wide, 6 in. deep ..	Price 50/-
51R	15½ in. high, 14½ in. wide, 9½ in. deep ..	Price 84/-
71R	14 in. high, 18½ in. wide, 7 in. deep ..	Price 95/-

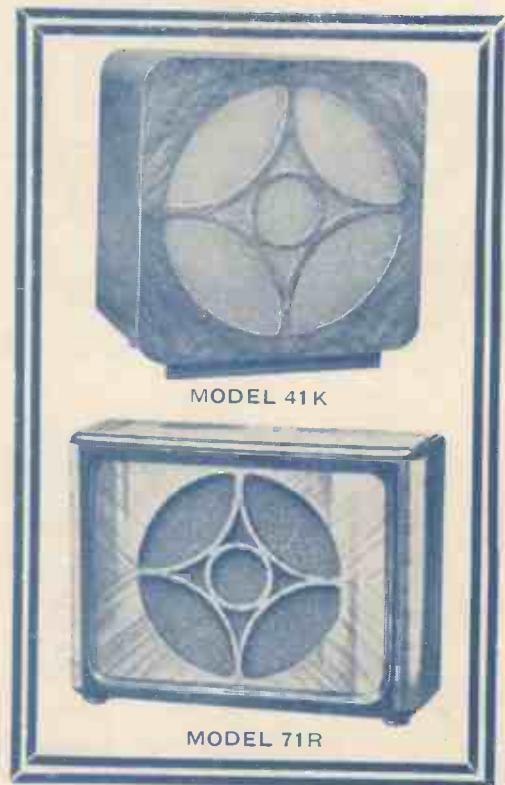

THE BRITISH BLUE SPOT COMPANY LTD.
 BLUE SPOT HOUSE, 94/96, ROSOMAN STREET, ROSEBERY AVENUE, LONDON, E.C.1.

Telephone: Clerkenwell 3570. Telegrams: "Bluospot, Isling, London."
 Distributors for Northern England, Scotland and North Wales:
 H. C. RAWSON (Sheffield and London) LTD., 100, London Road, Sheffield; 22, St. Mary's Parsonage, Manchester; 183, George Street, Glasgow.



TRADE MARK